

# The Wireless Constructor

6<sup>d</sup>  
MONTHLY

EDITED BY  
**PERCY W. HARRIS, M. I. R. E.**  
Vol. XI. DECEMBER, 1930. No. 50.

How to Make  
**YOUR OWN**  
COMPONENTS  
AND  
ACCESSORIES  
by  
The "Wireless Constructor"  
Research Department

PRICE  
**6!**

**THIS  
BOOK  
FREE**

*Inside!*



DESIGNED BY  
**VICTOR KING**  
*The* "PARATUNER"

IN THIS ISSUE

*Try-*

# POWER GRID DETECTION..

*with the*

## L210

Power grid detection has been proved to give far better quality than the anode bend method while being at the same time considerably more sensitive. Rectification is linear, providing the correct values of grid condenser and leak are used. Get full details from the "Wireless World" for May 7th, 1930 and try it out with the Mazda L.210—one of the best valves for the purpose.



THE AMAZING

# MAZDA

## RADIO VALVES

### CHARACTERISTICS

Fil. Volts - - - -	2.0
Fil. Amps - - - -	0.1
H.T. Volts - - - -	150
Amplification Factor - - - -	15.5
Impedance (ohms) - - - -	10,000
Mutual Conductance (mA/V) - - - -	1.55

**MAZDA L.210 PRICE 8/6**



THE EDISON SWAN ELECTRIC CO., LTD.  
*Incorporating the Wiring Supplies, Lighting Engineering, Refrigeration and Radio Businesses of the British Thomson-Houston Co., Ltd.*

Radio Division:

1a Newman Street, Oxford Street, W.1  
 Showrooms in all the Principal Towns

# EDISWAN

V.44

# CONTENTS

	Page		Page
The Editor's Chat . . . . .	71	The "Paratuner" . . . . .	93
North Regional Progress . . . . .	72	In the Radio Den . . . . .	96
The "International" Three . . . . .	73	Radio Economies . . . . .	99
Points for Purchasers . . . . .	78	With Pick-up and Speaker . . . . .	103
Savoy Hill News . . . . .	79	A Practical Man's Corner . . . . .	107
The "Eaglet" . . . . .	81	In Lighter Vein . . . . .	111
Queer Queries . . . . .	86	Radio "Fairways" . . . . .	115
Economising Valves . . . . .	87	High Quality From High Power . . . . .	118
The "Tapper" Tester . . . . .	89	Our News Bulletin . . . . .	124
As We Find Them . . . . .	91	Wave-Change Ganging . . . . .	129

*As some of the arrangements and specialities described in this Journal may be the subject of Letters Patent the amateur and trader will be well advised to obtain the permission of the patentees to use the patents before doing so.*

Edited by PERCY W. HARRIS, M.I.R.E.

Chief Radio Consultant:  
Capt. P. P. ECKERSLEY, M.I.E.E.

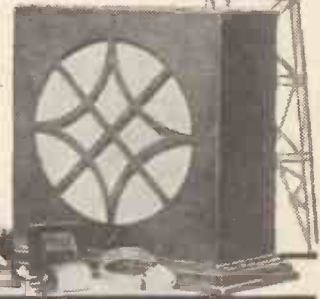

## The Radio of To-morrow is here to-day

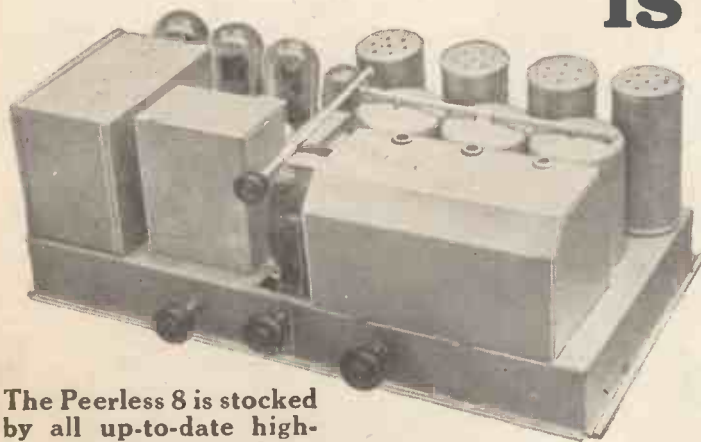

### Peerless A.C. Screen Grid 8

The new Peerless Screen Grid Eight is undoubtedly the finest value in A.C. operated radio sets. The design and performance of the Peerless is unchallenged and embodies improvements which are years in advance of all other types of radio receivers. Consider the following outstanding units of the Peerless Eight and consider the marvellous value which you receive.

3 SCREEN GRID RADIO FREQUENCY POWER DETECTOR. POWER OUTPUT. OVERSIZED POWER PACK. DYNAMIC SPEAKER REPRODUCTION. COMPLETE WAVE LENGTH RANGE 200-2,000 METRES. MARVELOUS SELECTIVITY. SENSITIVITY AND TONE. COMPLETELY SHIELDED AND A.C. OPERATED. ILLUMINATED DRUM DIAL TUNING. NOISELESS VOLUME CONTROL.

The Peerless 8 is stocked by all up-to-date high-class dealers throughout the country. Write to-day for full details.

**The Rothermel Corporation Ltd.**  
24, Maddox Street, London, W.1.

'Phone: MAYFAIR 0578/9.

Continental Sales Office: 27, Quai du Commerce, Brussels, Belgium

**£36**  
COMPLETE WITH DYNAMIC SPEAKER AND VALVES  
NET £2  
110 volt or 220-240 volt 50 cy. A.C.

# Highest effective amplification

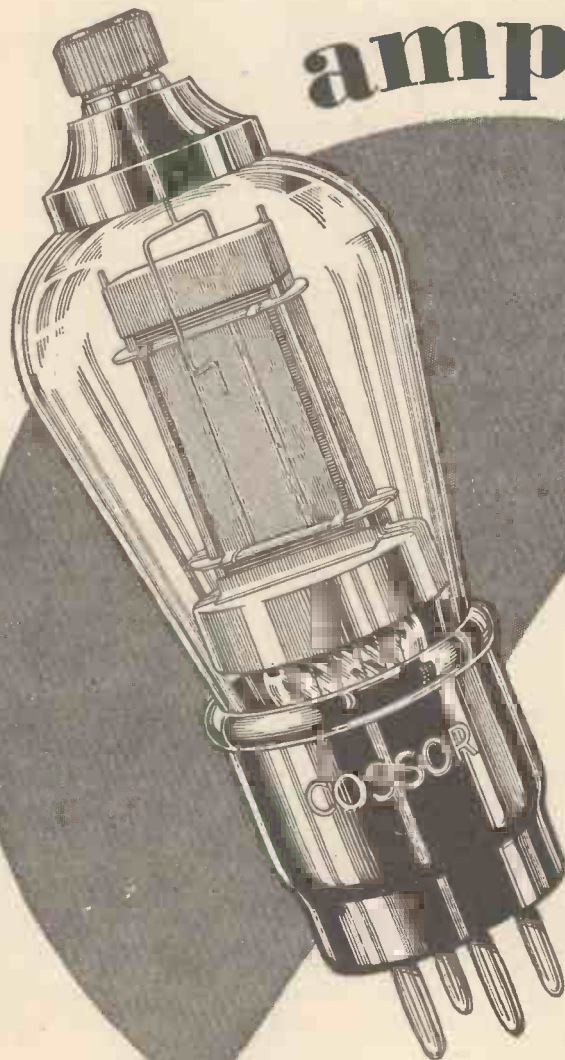

Greater *effective* amplification is definitely ensured by the New Cossor Screened Grid Valve. This is due to its minute inter-electrode capacity which has been reduced to the order of .001 micro microfarads—lower than that of any other Screened Grid Valve on the market. Because of this and because grid current has been eliminated, the use of this New Cossor Valve will considerably increase the efficiency of your Receiver.

Write for free fully descriptive Folder on "How to increase the range of your Receiver," mention No. L35 W.Cons.

Cossor 215 S.G. 2 volts, .15 amp. Impedance 300,000. Amplification Factor 330. Mutual Conductance 1.1 m.a./v. Normal working Anode Volts 120. Positive Voltage on Screen 60-80. Price **20/-**

## THE NEW **COSSOR** 215 S.G.

# The WIRELESS CONSTRUCTOR

Published by the Amalgamated Press, Ltd., Fleetway House,  
Farringdon Street, London, E.C.4.

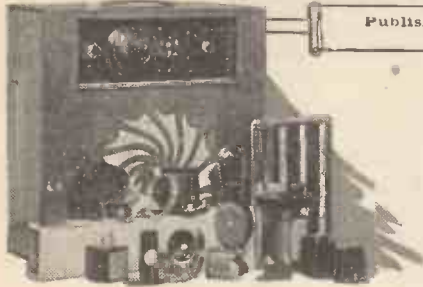

## THE EDITOR'S CHAT

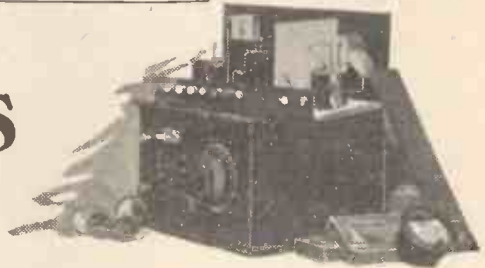

Our Great Gift—An Invaluable Book—Nothing Like it on the Market—The “Paratuner.”

**T**HIS month's WIRELESS CONSTRUCTOR—as no doubt you have noticed—is a Special Number. In fact, it deserves to be called a Very Special Number.

For with it every reader receives a copy of our Free Book, “How to Make Your Own Components and Accessories.”

You may have peeped inside your copy already. And, if so, you will have noticed that it “looks good.”

### Our Gift Book

Even the first inspection shows that it is going to be an invaluable book—one that will stand by you all the time, full of helpful hints, useful gadgets, practical ideas, and workshop wrinkles. But there is a lot more in it than you will see at first.

For nothing like it has ever before been available to the set-builder. Nothing like this book has ever before been published, *at any price!*

You cannot buy a similar book anywhere to-day. Ask your newsagent. Tell him you are prepared to pay for a really expensive publication on these lines, and he will confess that he does not know of one.

There is, of course, a reason for that. And the reason is that nowadays so keen and exacting are the demands made by the wireless constructor that only a journal having the resources of the WIRELESS CONSTRUCTOR can satisfy them!

### Absolutely Unique

This is the day of specialisation, and behind our Gift Book, backing it up in every detail, is the accumulated experience of the WIRELESS CONSTRUCTOR laboratory. Such an organisation enables us to give away a book that cannot be purchased anywhere at any price!

“How to Make Your Own Components and Accessories” may seem to be a very comprehensive title. But you will find that the whole wide subject is quite comprehensively dealt with.

As a matter of fact, I am a little surprised, as well as pleased, to be

### PORTLAND PLACE PROGRESS



The new B.B.C. building in Portland Place, London, W., is now well advanced, as shown in this recent photograph.

able to include so many “request” articles that were specially and repeatedly asked for. At times it seemed impossible to get them all in.

Yet somehow the task has been accomplished, and the book contains a veritable mine of constructional information.

All of it has been subjected to the most exhaustive practical tests and tried out under every conceivable

working condition. All of it has passed the tests with flying colours.

Even if you are not thinking of making a set just at the moment our Free Book will make a strong appeal to you, for you never can tell when you will want to know this, that, or the other, in connection with radio construction.

### Packed with Facts

Having the how-to-make details by you may mean that you can get a four-valver instead of a “three”; or it may enable you to get over a nasty little selectivity problem that otherwise would have cost you money for new coils, or, perhaps, for a more elaborate set.

Knowledge is power, and it's nice to *know*, for instance, how to cut out an overlapping programme, even if your own set does not require that knowledge at the moment. Or you may be glad to have on hand constructional details of an H.F. choke, or of a coil, etc. Little radio emergencies are always “emerging” when you don't know just where to turn for information, and *that*, I am sure, is just when our book will stand readers in good stead. When the unexpected comes along, or when a surprise bit of constructional work is necessary, you can always turn with confidence to “How to Make Your Own Components and Accessories.” It is crammed full of just-what-you-want facts.

### The “Paratuner”

I have left room to say only a few words about the other features of this issue. Among a host of good things I have secured one very special tit-bit—the “Paratuner.”

Mr. Victor King has been at work on this for some time, and the result is a triumph of simplified selectivity.

# NORTH REGIONAL PROGRESS

From a Special Correspondent

*It will not be long before the new twin-wave station at Moorside Edge is "on the air."*

THE new Regional station at Moorside Edge, near Huddersfield, is nearing completion. The masts can be seen for miles around, and they attract crowds of sightseers.

The station will be in full service, radiating two programmes simultaneously, early next year, and it is even possible that one of the two transmitters will be "on the air" by Christmas. First it will carry out test transmissions, outside of normal programme hours, on a wavelength of 479 metres. Gradually its periods of transmission will be extended until finally (perhaps in January) it will give a complete daily programme.

## A Smooth Change-Over

The second transmitter will be brought into use in similar easy stages, the idea being to give listeners ample opportunity to adjust their receiving apparatus to the new conditions of reception. The second transmitter will broadcast on 301 metres wavelength, and will give the "National" programme. The 479 metres transmitter will transmit a "North Regional" programme.

When the new station is in operation the present B.B.C. transmitters in the North of England will be dismantled with the exception of Newcastle. The engineers at the dismantled transmitters will be transferred elsewhere. A staff of about twenty engineers will be required at Moorside Edge. The studios and offices at Leeds and Manchester will be retained for the provision of the "North Regional" programme.

## Providing Its Own Power

Each of the transmitters at Moorside Edge will be capable of operating with a maximum power of 50 kilowatts (300 times the power of the present Leeds transmitter). The station will generate its own power. Four six-cylinder Diesel engines, each of 300 horse-power, are now being assembled, and they will drive four dynamos which will generate current at 230 volts 2,700 amperes. When both transmitters are working, three

dynamos will supply the current, the fourth being a stand-by. Outside the power-house there will be tanks to hold about 75 tons of crude oil for the engines, the exhaust gases of which will be utilised to heat the building.

Next to the power-house there is a room which will contain the accumulators. In the event of a complete breakdown of the power plant these would be capable of running one of the transmitters. Next comes the generator room, containing motor generators driven by the current from the power-house. These machines will generate

## A CURIOUS COLLECTION



*Music symbolised in the form of a model exhibited at the Berlin Radio Show. It comprised a collection of various musical instruments, including the cello, violin, organ pipes, wind instruments, and the piano keyboard.*

the various currents required for the transmitters, ranging from the 12,000 volts high-tension current to low-tension currents of 15 to 20 volts for lighting the filaments of the transmitting valves. All the ap-

paratus will be duplicated against breakdown.

The biggest room in the building is the transmitter hall, next to the generator room. The switchboards, the two transmitters, and the control desks for the engineers on duty are yet to be installed here. The transmitters at the new London Regional station at Brookmans Park have proved so satisfactory that those at Moorside Edge will be similar. Each transmitter will have approximately 36 valves, and will be cooled by water, to dissipate the heat generated. The water will flow through a jacket enclosing each valve and will be conducted to radiators outside the building. Here it will be cooled, and then returned to the valves.

## The Highest Aerials

The two aerials (one for each programme) will be supported by three steel lattice masts, each 500 ft. high. The site of the station being 1,000 ft. above sea level, the tops of the masts will be 1,500 ft. above sea level, which is higher than the tops of any other radio station masts in the country. Two of the masts are nearly finished, and one is in course of erection. Each mast rests on a large ball which allows it to sway slightly with wind pressure, guy-wires holding it secure. From the centre of each aerial a vertical "lead-in" wire will go to a small building immediately below, whence wires held above the ground on posts will go to the two transmitters in the main building.

The masts are spaced 600 ft. apart, but the aerials will not occupy the complete space. The B.B.C. is at present carrying out experiments with various designs, and the lengths of the Moorside Edge aerials have yet to be decided. It is also uncertain whether the B.B.C. will be required by the Air Ministry to fit flashing lights at the tops of the masts as a warning to aircraft (as at Daventry).

Listeners should have no difficulty in receiving the transmissions.

## Reception Range

They should easily be received over many hundreds of miles, but they are not expected to give consistently strong and undistorted reception beyond the North of England, the North Midlands, and North Wales. The 479 metres transmission will give the widest satisfactory reception. Its area is expected to include most of Yorkshire, Lancashire, the Isle of

*(Continued on page 131.)*



This is a set specially suitable for the short-wave beginner, but it is more than that, for it is a design in which all the problems that beset the short-wave enthusiast have been solved. Threshold howl, "dead spots," "ploppy" reaction—all have been overcome and eliminated from the "International" Three. And, moreover, it is a broadcast receiver as well.

Designed and Described by G. T. KELSEY.

HAVE you ever heard American and Australian broadcasting direct? Or are you one of the old school who regard short-wave searching as a technical business calling for expert skill to achieve success?

**Everything is Easy**

As a matter of fact, there are now so many stations transmitting on wave-lengths below 50 metres—literally dozens more than at this time last year—that with quite a modest operating knowledge and a really good set you simply cannot help finding them.

Station after station, from all parts of the world, can be received with little more operating skill than is required for some of the Continentals on the normal broadcast band.

**FROM SHORT TO MEDIUM WAVES IN A SPLIT-SECOND**

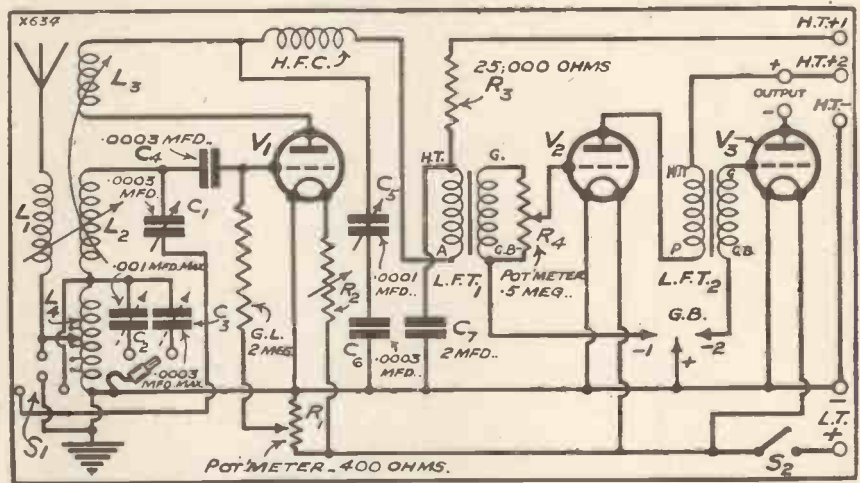

By means of the switch S<sub>1</sub>, the receiver can be changed over from short to medium waves, and vice versa, "in a flash."

**THESE ARE THE PARTS YOU WILL REQUIRE**

- |  |   |   |
|--|---|---|
| <ul style="list-style-type: none"> <li>1 Ebonite panel 18 in. x 7 in. (Lissen, or Paxolin, Red Seal, etc.).</li> <li>1 Cabinet for above, with baseboard 10 in. deep (Pickett, or Camco, etc.).</li> <li>1 .0003 variable condenser, slow motion, or with slow-motion dial (Polar, or J.B., Ormond, Formo, etc.).</li> <li>1 .0001-, .00013-, or .00015-mfd. differential reaction condenser (Lotus, or Lissen, Dubilier, Ready Radio, Ormond, Bulgin, Wearite, J.B., Magnum, etc.).</li> <li>1 Three-contact type push-pull switch (see text). (Wearite, or Ready Radio, Magnum, Paroussi, Bulgin, Ormond, etc.).</li> <li>1 .5-megohm potentiometer volume control (Lissen, or R.I., Gambrell, Varley, Igranic, Wearite, Magnum, etc.).</li> </ul> | <ul style="list-style-type: none"> <li>1 L.T. switch (Junit, or Lissen, Igranic, Benjamin, Lotus, etc.).</li> <li>3 Sprunz-type valve holders (Benjamin, or Lotus, Telsen, W.B., etc.).</li> <li>2 Compression-type variable condensers, 1 .001 mfd. max., and 1 .0003 mfd. max. (Formo, or Lissen, Lewcos, R.I., Polar, etc.).</li> <li>1 30-ohm filament resistance, baseboard-mounting type (Wearite, or Lissen, Igranic, etc.).</li> <li>1 .001-mfd. fixed condenser (Lissen, or Ediswan, Dubilier, T.C.C., Mullard, Igranic, Ferranti, Telsen, Goltone, etc.).</li> <li>1 .0003-mfd. fixed condenser (Dubillet, or Lissen, etc.).</li> <li>1 Short-wave H.F. choke (Bulgin, or Wearite, Magnum, etc.).</li> <li>1 400-ohm baseboard-mounting potentiometer (Igranic, or Lissen, Wearite, etc.).</li> </ul> | <ul style="list-style-type: none"> <li>1 25,000-ohm resistance (Lissen, or Ready Radio, Varley, Igranic, R.I., Bulgin, Magnum, etc.).</li> <li>2 L.F. transformers of fairly low ratio (R.I. "Hypermite" and Lotus in set, or Varley, Lissen Ferranti, Telsen, Igranic, Mullard, Lewcos, etc.).</li> <li>1 Grid-leak holder and 2-megohm leak (Ediswan, or Lissen, Igranic, Dubilier, Mullard, etc.).</li> <li>1 2-mfd. Mansbridge condenser (Lissen, or T.C.C., Dubilier, Ferranti, Hydra, Mullard, etc.).</li> <li>Piece of ebonite for terminal strip 18 in. x 2 in.</li> <li>9 Engraved terminals (Igranic, or Eelex, Belling &amp; Lee etc.).</li> <li>2 Sockets and 1 plug, and 3 wander plugs (Clax, or Eelex, etc.).</li> </ul> |
|--|---|---|

# The "International" Three—continued

Provided you use a set that is capable of doing the job, there is really no limit to the distances that can be covered.

But on short waves, as on all other bands, you mustn't expect "A1" results from a "C3" set.

We are now enjoying the season when most short-wavers come in with real punch, and if you think that you would be thrilled by hearing signals from a station 11,000 miles or so away, then forget the fact that you have never previously handled a short-wave set, and set to and build the "International" Three.

### Local Listening, Too!

This is a set for the short-wave beginner, but it is more than that. It is, indeed, an "A1" design in which all the problems to do with short-wave reception have been given very careful consideration. Threshold howl, "ploppy" reaction, aerial "dead spots"—these, and many similar troubles, are all overcome in the "International" Three.

And, what is perhaps equally as important, it is *not* a set required

So that when you have finished with it on short waves you merely move the switch  $S_1$  and then, by means of the plug and sockets on the panel, you select a local programme without in any way re-tuning.

coupled L.F. stages, and at close distances on the broadcast waves this would give a much greater output than is required for normal domestic purposes. Consequently a volume control is included in the design, by

### EVERYTHING AT YOUR FINGER TIPS

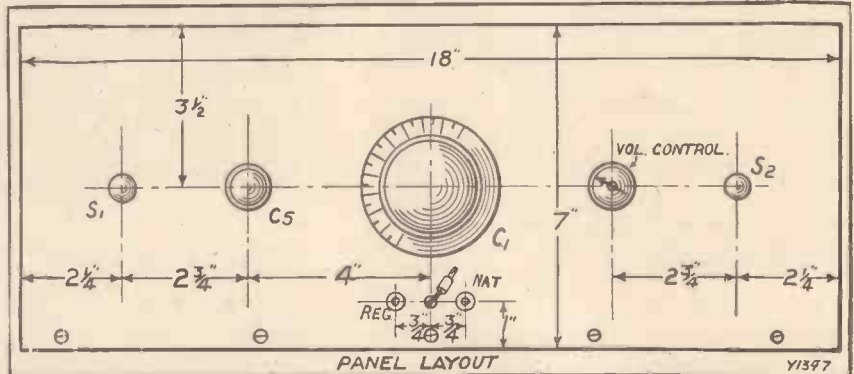

The control of the "International" Three is amazingly simple. The set is "self-tuned" for the broadcast waves, and the handling on the short-wave side is perfection itself.

In so far as the broadcast side of the set is concerned, once the preliminary adjustments have been carried out it resolves itself into an absolutely "foolproof" arrangement

which it is possible to limit the output to your own particular requirements.

A complete list of the parts required with which to build this set is given elsewhere in the article. Following the usual procedure, the component used in the original set is in each case given first. As a matter of fact, the design is not at all critical in the matter of components, and you can quite safely

### LOW LOSS—HIGH EFFICIENCY

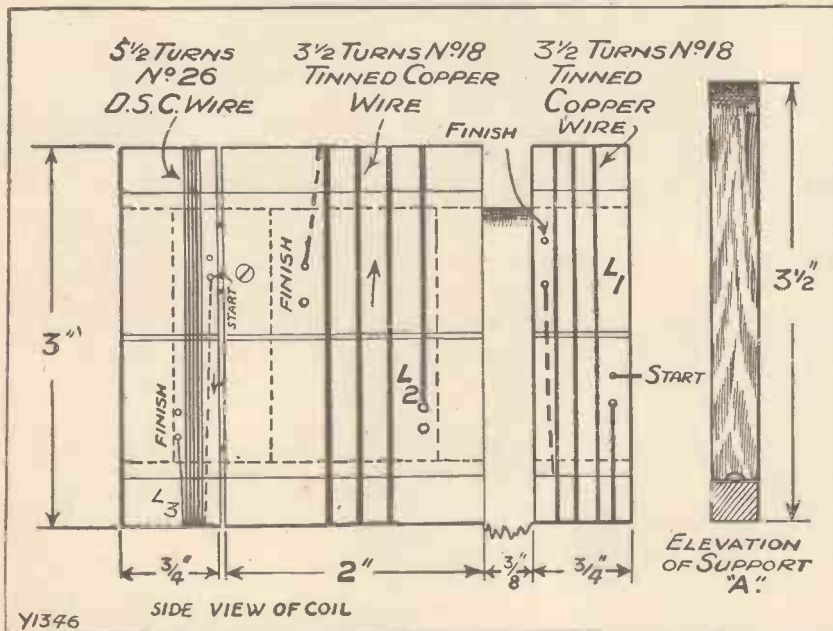

You will find no difficulty in making the short-wave coils from this diagram, which clearly shows the simple windings that are employed.

**COIL MATERIAL**  
**SHORT-WAVE COIL UNIT:**  
 Three lengths of 3 in. diameter ribbed ebonite former (diameter to outside of ribs), one 1 1/2 in. long and two 3/4 in. in length.  
 (NOTE.—You can obtain one 3-in. in length and cut it to the appropriate sizes if you wish.)  
 Small quantity (1/2 lb. will be more than enough) of No. 18 or 20 tinned copper wire.  
 Few yards No. 26 D.S.C. wire.  
 Wood, etc., for mounting.

**BROADCAST COIL:**  
 One 2 1/2 in. length of 2 1/2 in. diameter tubing (Pirtoid, Paxolin, etc.).  
 1/2 lb. No. 24 D.C.C. wire.

in addition to your existing broadcast receiver. It is a broadcast receiver, as well as being a super-efficient short-waver.

which any member of the family can use.

The circuit consists of a detector followed by two powerful transformer-

make your choice from any of the alternatives given. Make a special note of the type of switch required for  $S_1$ . This must be of the three-contact type, with a central metal plunger which in one position short-circuits the contacts.

You cannot go very far with the actual construction until you have



## The "International" Three—continued

made the special short-wave coupling unit and the coil for the broadcast waves, so that it would perhaps be as well to deal with these first.

The former for the short-wave coils ( $L_1$ ,  $L_2$  and  $L_3$ ) is of the ribbed variety, with a diameter of 3 in. to

each of these in exactly the same way as for  $L_2$ .

Before you can proceed you will next require the upright support on which the complete unit is mounted. This consists of an inverted "T"-shaped piece of wood

$3\frac{1}{2}$  in. high and about  $\frac{3}{4}$  in. wide. It is screwed to one of the end pieces in the coil  $L_2$ , and  $L_1$  is secured to the other side of it by a single screw placed near the top of the wooden cross support inside the former. The remaining  $\frac{3}{4}$ -in. former on which  $L_3$  is wound is similarly fixed to the vacant end of the centre former.

You will find the construction quite simple if you follow the diagram, but be very careful to mount the reaction coil in such a way that the winding runs in the *same* direction; that is, as if it were a continuation of the grid coil  $L_2$ .

### For "Broadcast Band"

The "broadcast" coil is a very straightforward job, and consists simply of 50 turns of No. 24 D.C.C. wire on a  $2\frac{1}{2}$  in. diameter plain former, with tappings at 5, 10, 15, and 20 turns from the bottom end.

When you have completed the coils you can carry straight on with the drilling of the panel, an operation for which you will have to refer to the panel layout diagram. This can be followed up with the mounting of the various components both on the panel and on the baseboard.

By the way, if you are situated in a locality not served by the Regional transmitters, if the wave-length of your local station is below 350 metres, the pre-set condenser  $C_2$  and the

### THE SECRET OF SUCCESS

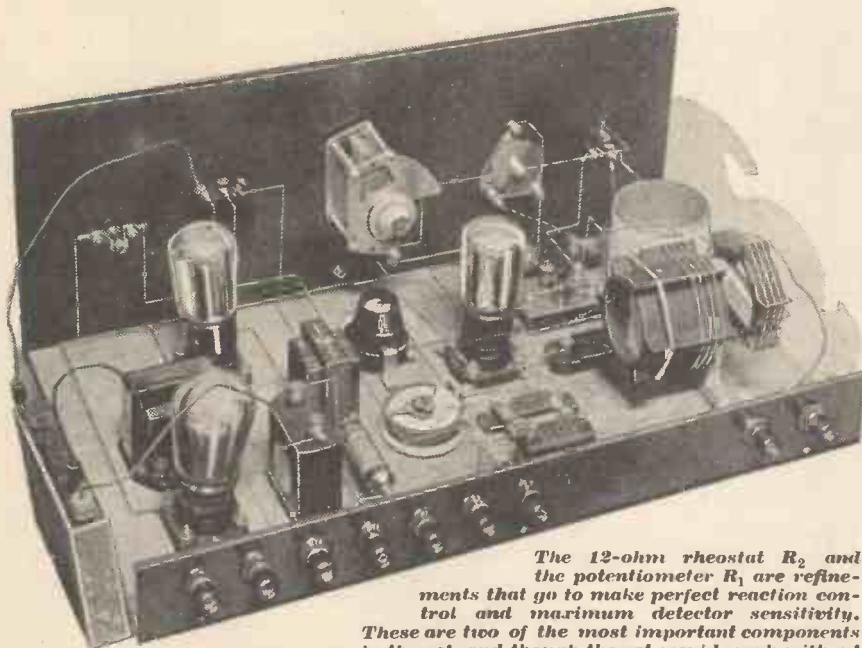

*The 12-ohm rheostat  $R_2$  and the potentiometer  $R_1$  are refinements that go to make perfect reaction control and maximum detector sensitivity. These are two of the most important components in the set, and though the set would work without*

*them, and you may be tempted to omit them at first and try the set without, it would be a very false economy, for they are essential to perfect control and freedom from those peculiar set-backs that are so often encountered in short-wavers.*

the outside of the ribs. Three pieces in all are required, and you can either obtain one piece and cut it up yourself, or else obtain the lengths ready cut. The centre piece on which the grid coil  $L_2$  is wound is  $1\frac{1}{2}$  in. long, and you can obtain details of the winding from the special diagram provided.

Accurate spacing of the turns in the case of  $L_1$  and  $L_2$  ( $\frac{3}{16}$  in. between each) is best obtained by filing small niches in the ribs of the former before the turns are put on.

### Mounting the Coil

To complete the construction of the centre-piece, mount in each end a piece of  $\frac{3}{8}$ -in. thick wood (plywood is very suitable). The pieces need only be about  $\frac{3}{4}$  in. wide, and they can be secured either by Seccotine or by small wood-screws passed through the ebonite former.

The width of the formers for  $L_1$  and  $L_3$  is  $\frac{3}{4}$  in., and a piece of wood should be mounted in one end of

### DIAL-TWIDDLING REDUCED TO A MINIMUM

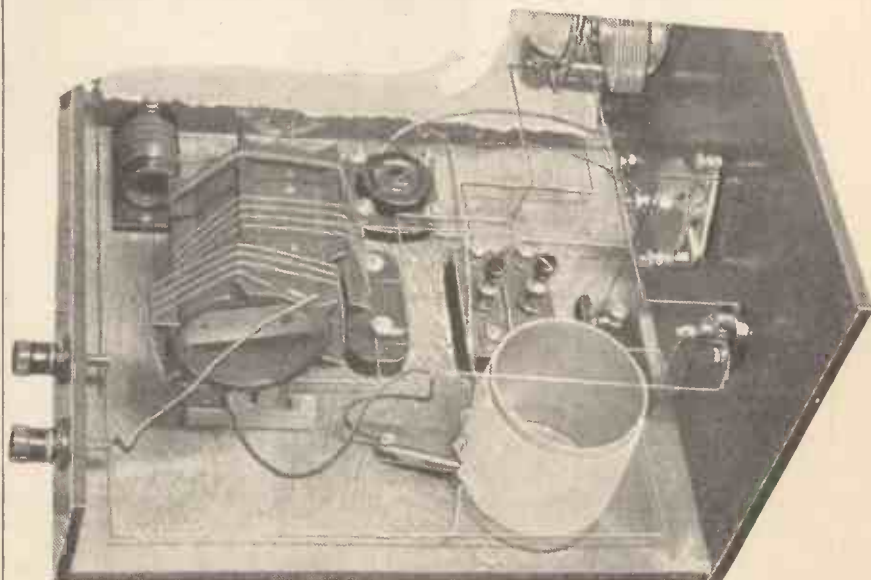

*This is the input end of the set, showing the broadcast (right) and short-wave coils. The switch on the panel enables you to go over from one wave-band to the other instantaneously. And the medium-wave stations are tuned-in ready; there is no dial-twiddling to be done. So you can have three stations tuned-in at once, and select which you prefer—the short-waver or one of the two locals.*

## The "International" Three—continued

socket on the panel to which it is wired can be omitted. If, on the other hand, the wave-length of your local station is above 350 metres, you should leave  $C_2$  in and omit the other compression condenser.

You can next proceed with the wiring, all of which is clearly shown in the back-of-panel diagram. When you are wiring-up the switch  $S_1$  be sure to see that the flexible lead is soldered

to the metal part of the plunger that it short-circuits the three contacts in one position. (In some makes this is not necessarily the metal knob at the extreme end of the plunger.)

### The First Try-Out

Be careful also to see that the connections to the short-wave coil unit are carried out exactly in accordance with the diagram.

With the wiring completed the next job is that of giving the set a try-out, but before this can be done you will need accessories. For details you should refer to the WIRELESS CONSTRUCTOR operating panel given elsewhere in the article.

Join your aerial and earth and a pair of 'phones to the appropriate terminals at the back of the set, and with the switch  $S_1$  in the position

**COPY THIS LAYOUT IN EVERY DETAIL TO ENSURE SUCCESS**

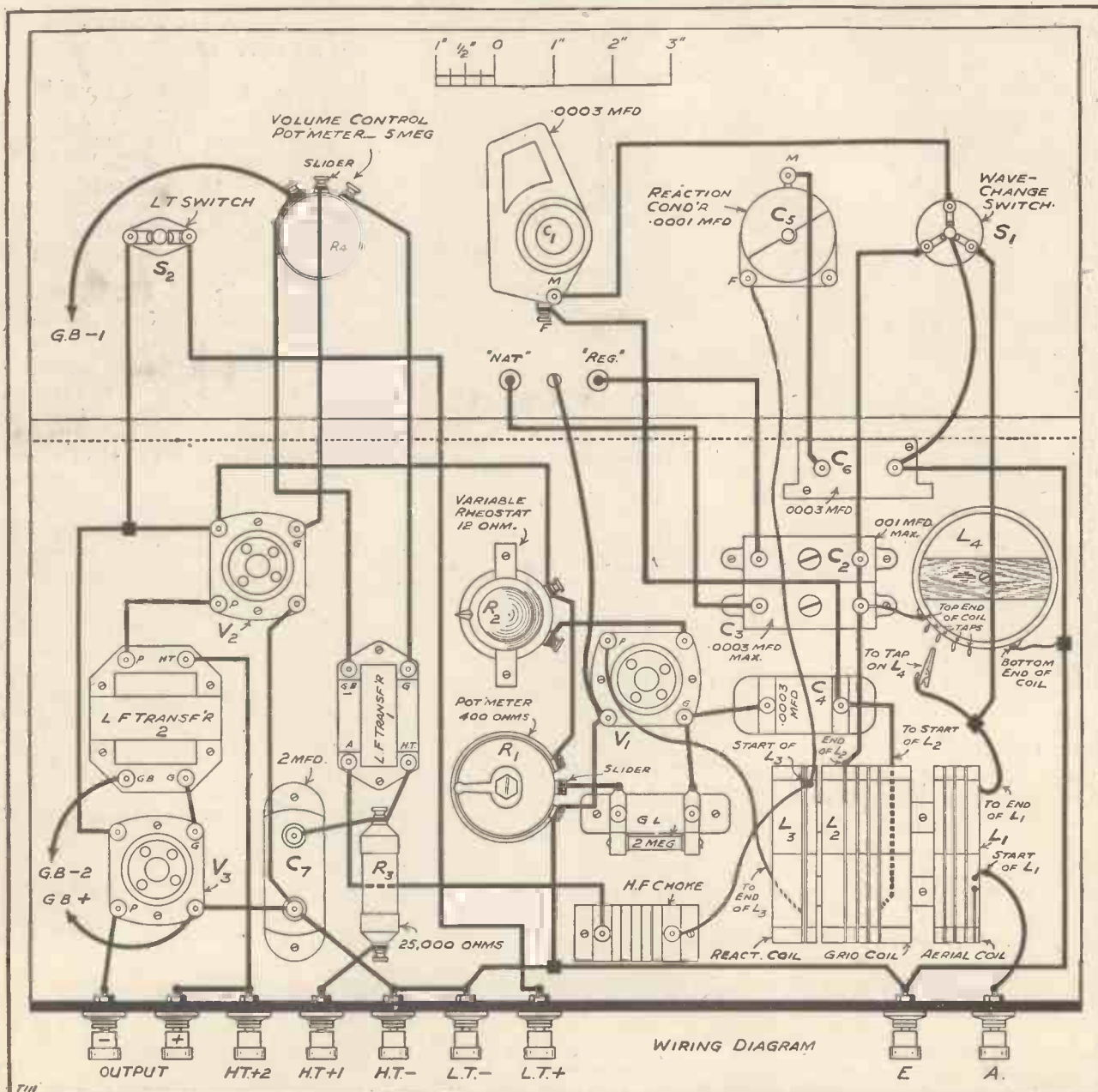

Study this wiring diagram carefully, for if you want your set to emulate the results obtained by the original you should copy the layout and positions of leads as closely as possible. Every wire in the original receiver was carefully thought out, especially on the short-wave side of the set.

# The "International" Three—continued

whereby the three spring contacts are short-circuited, switch on the L.T. control  $S_2$ . For these preliminary tests the filament resistance ( $R_2$ )—just below the variable condenser inside the receiver—should be set with the resistance all-out.

## ADJUSTABLE AERIAL COUPLING

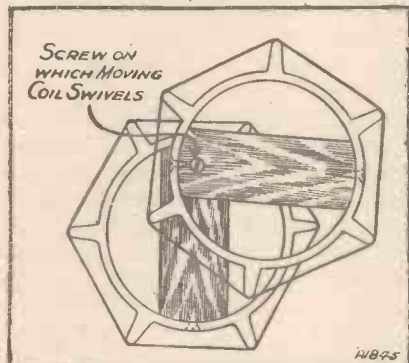

The short-wave aerial coil is made to swivel so as to enable coupling variations to be carried out.

Now for the controls.

Commencing with the tuning condenser (the centre knob and dial) at about 20 degrees, slowly increase the capacity of the reaction condenser ( $C_5$ ) until the set breaks into oscillation. You will easily be able to tell when this condition has been reached because the set will suddenly become very lively or "crackly."

In any case, if you are in doubt a moistened finger placed on the fixed plates terminal of the variable

condenser  $C_1$  will produce a loud double click in the 'phones when the set is in an oscillating condition.

## "Dead" Spots

Before you commence to listen for stations, readjust the tuning condenser 5 degrees at a time and see if the set will oscillate over the whole range. Do not be unduly alarmed if you find bands of 5 degrees or so here and

there over which the set will not oscillate, because these will very probably be due to an effect of the aerial, and can usually be shifted, if not entirely removed, by loosening the coupling between the grid coil  $L_2$  and the aerial coupling coil  $L_1$ .

Reduction of the coupling between these two coils will help if you have difficulty in making the set oscillate.

(Continued on page 132.)

## HOW YOUR SET SHOULD LOOK

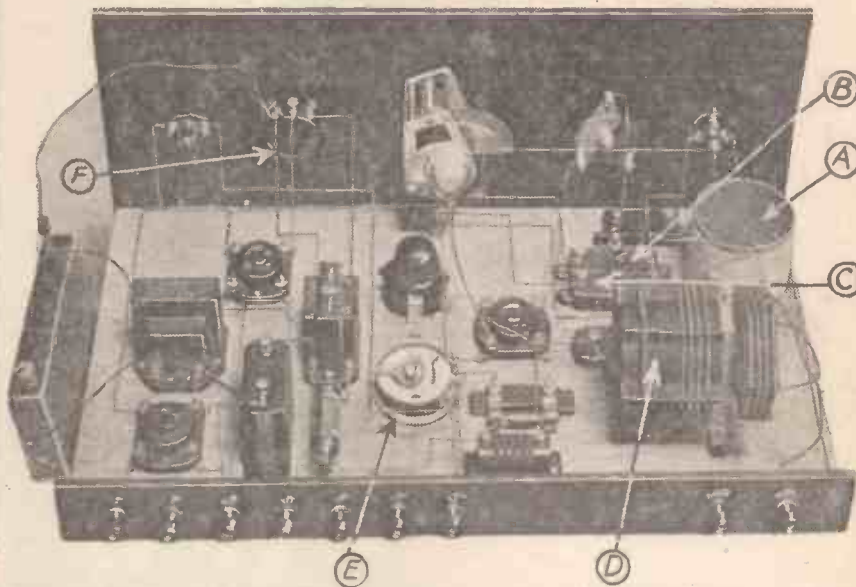

Your set should look exactly like this one when you have finished. The letters indicate some of the more important components. (A) and (D) are the broadcast and short-wave coil units respectively, while (B) and (C) are the two compression type condensers used for setting the broadcast wave-length. (E) is the detector potentiometer, and (F) the L.F. volume control across the secondary and the first transformer.

## THE "INTERNATIONAL" THREE

(THE CIRCUIT CONSISTS OF A DETECTOR AND TWO L.F. VALVES.)

### VALVES.

- 1st: H.F. or special detector type (impedance between 20,000 and 30,000 ohms).
  - 2nd (nearest panel): L.F. type valve.
  - 3rd: Power or super-power (choice depending upon nature of H.T. supply and strength of output required).
- Note: 2-, 4-, or 6-volt battery-driven valves are quite suitable for this set.

### NOTES

- To Cure Ploddy Reaction:
- 1 Move slider of potentiometer towards negative end.
  2. Decrease coupling between reaction and grid coils in short-wave coil unit.
  3. Decrease H.T. voltage on H.T. + 1.
  4. Only if above fail take a turn off short-wave reaction coil.

### Threshold Howl:

1. Bring filament resistance on baseboard into use.
2. Vary potentiometer setting.
3. Reverse primary and/or secondary windings of first L.F. transformer.

### Aerial "Dead-Spots":

1. Alter aerial coupling by varying position of aerial coil.
2. Only in bad cases use a neutralising type condenser in series with aerial lead.

### H.T. AND G.B. VOLTAGES.

- H.T. + 1: 50 to 80 volts.
- H.T. + 2: Maximum H.T. voltage rating of power valve or nearest available voltage.
- G.B. - 1:  $1\frac{1}{2}$  to  $4\frac{1}{2}$  volts negative.
- G.B. - 2: Value to suit particular valve chosen. May be as high as 20 or 30-volts with some valves (see maker's instructions).

### CONTROLS

- Centre Knob and Dial: Main tuning control on short waves.
- Knob to Left of Centre: Reaction control
- Extreme Left-hand Knob: Switch for changing set from short to broadcast waves.
- Knob to Right of Centre: Volume control.
- Extreme Right-Hand Knob: Filament switch.

### BROADCAST WAVES.

- Tune Regional with semi-variable condenser nearest panel on baseboard inside set and plug on panel in left-hand socket
- Tune National with other semi-variable condenser and with plug in right-hand socket on panel.
- Altering the position of clip on broadcast coil increases or decreases selectivity.

## POINTS FOR PURCHASERS

Some interesting items from the radio manufacturers and distributors about their latest lines.

By Our Special Correspondent

PRICE reductions are always welcome, and in this connection we are glad to bring to the notice of readers the fact that the Wates Star Unit, formerly sold at 36s., was reduced to 25s., in view of increased production and sales. There has been no alteration whatsoever in the construction or design of this unit, say the makers, The Standard Battery Company, Ltd., so purchasers are a clear 11s. to the good.

### A Handy Notebook for Broadcast Listeners

Wireless experimenters will be interested in the new Osram Guide, containing details of the firm's valves, and lists of stations, notes, etc., in a convenient and compact form.

In addition the G.E.C. has forwarded us a book on the Osram H.T. mains and rectifying valves, and another on Osram valves for power amplification, both containing much practical information of value to those interested in real quality reproduction.

Many or all of these publications can be had by WIRELESS CONSTRUCTOR readers on application to the G.E.C., Ltd., Magnet House, Kingsway, London, W.C.2.

### Moving Coil Booklet

Moving-coil enthusiasts will welcome the appearance of the Grassmann moving-coil loud-speaker booklet, published by the Rotor Electric, Ltd., 2-3, Upper Rathbone Place, London, W.C.1. This includes some very interesting data of tests carried out, as well as recommended circuits, etc., and although small it is packed with information.

### Trade "Shorts"

Substantial reductions in the prices of Obeta high-tension dry batteries are now in force, no less than seven radio lines being reduced in price.

Representative alterations are: the 99-volt is reduced from 13s. to 12s., the 120-volt double-capacity power-battery 21s. 6d. to 20s., and the 60-volt treble-capacity Goliath from

17s. 9d. to 16s. 6d. (All Obeta H.T. batteries are provided with tapplings at every 3 volts.)

An interesting announcement is made from the Six-Sixty Radio Co., Ltd. This firm is marketing a complete range of grid leaks available in fourteen different resistances, from .01 to 20 megohms. They will sell at 1s. 6d. each, and the bakelite holder for use with them retails at 1s.

From Burndept's Wireless, Ltd., comes the news that during the Zurich Radio Exhibition the chief engineer of the Zurich broadcasting station saw

### AFTER-SALE SERVICE



As technical knowledge is advantageous to the dealer in radio goods, the Marconi-Phone Co. has recently inaugurated instructional classes conducted by the firm's technicians.

a Burndept portable in action and immediately ordered one by air parcel post. A feather in the cap of Burndepts!

### For Set Builders

Since the last number of the WIRELESS CONSTRUCTOR a large number of catalogues have been received, and among those of great interest to the experimenter and set builder are the following:

*Edison-Swan Electric Co., Ltd., 123-5, Queen Victoria Street, London, E.C.4, detail and illustrate the*

Ediswan radio apparatus in its many guises in this book, which gives particulars of attractive receivers of different types, speakers, including the famous B.T.H. R.-K. (senior, junior, and permanent-magnet types). There is also described a host of subsidiary apparatus, and details of the Ediswan hire-purchase scheme are included.

### H.T. Batteries

*The Ever-Ready Co. (Gt. B.), Ltd., Hercules Place, Holloway, London, N.7, now devote a separate catalogue to batteries and accumulators for wireless work, which contains much to interest the purchaser.*

A particularly valuable feature is the clear and straightforward method of showing the correct discharge rate for high-tension batteries, which ranges from 6 m.a. for the small series to the super-capacity batteries capable of standing up to a 15-30-milliamp. discharge.

*Igranic Electric Co., Ltd., 149, Queen Victoria Street, London, E.C.4, issue their catalogue in detachable loose-leaf form, and it is always up to date. The one just received covers a wonderful variety of apparatus, and the accompanying illustrations and letterpress give the fullest details of the Igranic components.*

From Igranics also comes "The Link Between," a booklet dealing with matters whereby H.T., L.T., and grid bias can be obtained from A.C. mains simply, efficiently and inexpensively.

### "The Easy Way"

*The Peto-Scott Co., Ltd., 77, City Road, London, E.C.1, have revised their well-known publication "The Easy Way Catalogue," and applications for copies should be made at the above address.*

In addition to their own original products, Peto-Scott extended their activities to supply components, etc., of all the leading makes of radio and gramophone apparatus.

*Varley, Ltd., Kingsway House, 103, Kingsway, London, W.C.2, have forwarded a number of instructional booklets, as well as a new catalogue, showing the whole range of Varley products, well-illustrated and in gettable form.*

In our October issue the illustration (on page 304) of the Belling-Lee insulating terminals shows the old price on the carton. It should, of course, be 6d., not 9d.



*Elgar Festival in 1932—Grenadier Guards and the B.B.C.—Upheaval in Scotland—Alarm of the Concert Interests—A Canadian Choir—Modern Music—Mr. Filson Young's Future—Regional Progress—Royal Choral Society—B.B.C. Officials for Canada—"Peter the Miner."*

By OUR SPECIAL COMMISSIONERS.

**Elgar Festival in 1932**

THE B.B.C. has practically decided to go ahead with the arrangement of a gigantic Elgar festival in 1932. There will be a day of chamber music with six complete concerts, three choral and three orchestral.

The whole festival will be built round the seventy-fifth birthday of the great British composer. The credit for originating the suggestion rests with Sir Landon Ronald, who brought it forward over a year ago. Recently Sir Henry Wood raised the matter afresh, and now Dr. Boulton has accepted it.

**Grenadier Guards and the B.B.C.**

The Grenadier Guards' Band is cross with the B.B.C. It is understood that representations have been made to Savoy Hill that the music department there has neglected this band.

It is indeed an open secret that the B.B.C. thinks its own military band is a lot better than the best outside band. This being the case, it is not likely that the Grenadiers will be given the special series they desire.

**Upheaval in Scotland**

After two years of tranquillity—a very long time for Scottish broadcasting—there is a fresh and violent outbreak of unrest in the North-East. The sinking of Aberdeen to the status of a relay and the simultaneous retirement of Mr. Neil MacLean started the trouble.

Many hard things have been said of the B.B.C. by the newspapers, but there is some reason to doubt whether the agitation is a real one; whether,

in other words, the average listener in the North is actually so anxious to hear only local talent and material in his programmes.

The movement for more autonomy in broadcasting is gradually aligning itself with Scottish Nationalism, already a force to be reckoned with. The basis of unrest is probably more political than artistic.

Whatever the cause, the organs of nearly all shades of opinion seem to agree in their criticism of the B.B.C. policy of concentration upon London. The only way the B.B.C. can meet this campaign is to hurry on with the Scottish regional station, and then give two well-contrasted programmes, one of them genuinely representa-

tive of Scots art and opinion.

It is, of course, all nonsense to talk about setting up advisory committees to recommend on the special requirements of each part of the country. This would lead to nothing but chaos and much aggravation of ill-feeling.

**Alarm of the Concert Interests**

The ambitious policy of the B.B.C. in concert-giving causes it trouble of an entirely different kind from that of as recently as two years ago. Then the B.B.C. was blamed for having only a "cheap and nasty" orchestra.

It was complained that the B.B.C. paid both instrumentalists and artistes "abominably." And so on. And now there is criticism just as violent,

**STUTTGART'S STUDIO SOUND EFFECTS**



*Producing the "noises off" for a radio play at the Stuttgart station. The engineer on the right is operating a small musical instrument and you will notice other similar instruments among the group of queer devices on the desk affair. Modern radio engineers are able to make all sorts of noises, from door slams to bomb explosions, with articles sometimes no larger than matchboxes.*

## Savoy Hill News—continued

based on exactly opposite reasons, and from some of the same people.

By its "excessive rewards" the B.B.C. is "stealing" the best musicians from orchestras up and down the country. And by giving the public favourable opportunities of attending great concerts for themselves the B.B.C. is "ruining the industry through unfair competition."

And so it goes on. Meanwhile, the B.B.C. goes steadily ahead undeterred by these attacks.

If the concert interests ever had a hope of curbing the B.B.C. it was at the time of the Crawford Committee in 1925-26; but they put up a very poor show there, and their next chance in 1936 will be much slimmer.

### A Canadian Choir

A champion Canadian choir of seventy voices is visiting England

eighth festival of the International Society, which was held a few weeks ago at Liège and Brussels.

The next big festival is to be in London and Oxford next summer, and we suppose the B.B.C. will be the principal hosts. We hope that this new recognition will not mean any increase in the already substantial proportion of "crazy" music in the programmes. Dr. Boulton should see to this.

### Mr. Filson Young's Future

I hear that Mr. Filson Young has been persuaded, albeit reluctantly, to stay on a little longer as chief programme adviser to the B.B.C. There was some thought of getting Mr. Young to take a big administrative post, but this fell through. So, anyway, for the next six or seven months, Mr. Young will continue to

B.B.C. and Wales in the past two or three years that I would not be at all surprised to see the B.B.C. clear out of the Principality entirely.

There has been some careful analysing of licence figures and possibilities. Wales comes out rather badly, and it is believed that the B.B.C. has come to the conclusion that whatever is done for Wales there will be no thanks or return anyway. By concentrating on the West of England better results are hoped for.

### Royal Choral Society

The B.B.C. will broadcast nationally the Popular Carols Concert to be given by the Royal Choral Society at the Albert Hall on December 20th at 2.30 p.m.

### B.B.C. Officials for Canada?

A cinema journal announces that several of the B.B.C. officials who joined the Gold Rush to Elstree, and who are now out of work, or about to be so, are going to Canada in response to invitations from the two rivals in broadcasting there, the Canadian National Railway and the Canadian Pacific Railway.

Mr. R. E. Jeffrey, Mr. MacDonell, and other names are mentioned in this connection. There is also a rumour that raids may be made on the programme staff at Savoy Hill; but if so they will be resisted rather more vigorously than former attempts of the kind.

### "Peter the Miner"

Ysaye's opera, "Peter the Miner," which was successfully broadcast from Brussels last summer, is likely to be given by the B.B.C. in March.

## ON THE CONTINENT

Rome—Stockholm—Radio Paris.

Rome and Stockholm are easy to identify. Rome has a woman announcer, and very clearly she enunciates "Radio Roma" at frequent intervals.

Stockholm's call is "Stockholm—Motala," followed by the names of relay stations taking the programme.

Radio-Paris will shortly be transmitting with 60 kw., and when this comes about there is considerable danger of its "submerging" Daventry.

### "BUY, BUY, BUY"—RADIO



A Berlin hawker who uses a portable radio set to attract customers.

from Bradford, Ontario, next year. This choir will enter for the Blackpool Festival, and will be broadcast by the B.B.C. nationally.

### Modern Music

That element in the staff of the music department at Savoy Hill that is keen on modern music of the weird and eccentric varieties has scored a distinct success in securing the affiliation of the B.B.C. to the International Society for Contemporary Music.

Mr. K. A. Wright and Mr. Edward Clarke represented the B.B.C. at the

sit at the right hand of Mr. Roger Eckersley.

### Regional Progress

Slaithwaite will be on the air in complete operation under service conditions by April 14th. The new Scottish transmitter will be ready in March, 1932, and the West Country will hear the signals of its new high-power twin transmitter probably before the end of 1933.

It is highly unlikely that the last-mentioned will be in Wales. There has been so much trouble between the



# The "EAGLET"



*A splendid long-distance H.F. and detector set, with simplified switching to change from one wave-length to another. Tuning is thumb-controlled, and you can swing from programme to programme with uncanny ease.*

By A. S. CLARK.

If you look up the meaning of inductance in a radio text book you will find that it means something like this: "The property of an electrical circuit which tends to prevent any change in the current flowing."

### The Tuning Coil

Very often, however, the term is used as another name for a tuning coil; the reason being that it is the coil which provides the inductance in a tuned circuit. A tuned circuit, of course, consists mainly of a combination of inductance and capacity.

In a modern receiving set the capacity of a tuned circuit nearly always takes the form of a conventional variable condenser with interleaving plates. The inductance, on the other hand, can be provided by all sorts of different kinds of coils.

### Special Types

You can have solenoid coils, ordinary two-pin plug-in coils, or hank-wound coils, for instance. Then there is no limit to the special dual-range type of coils that can be employed. Whatever the coil, it must be

efficient under working conditions if the set is to be selective and give good volume on distant stations. It is for this reason that special coils are often designed for a particular receiver.

selection of standard components when he makes up a set. But this does not mean that their construction has not been kept so simple that anyone can make them up with ease.

### PREPARED TO POUNCE ON THE FOREIGN PROGRAMMES

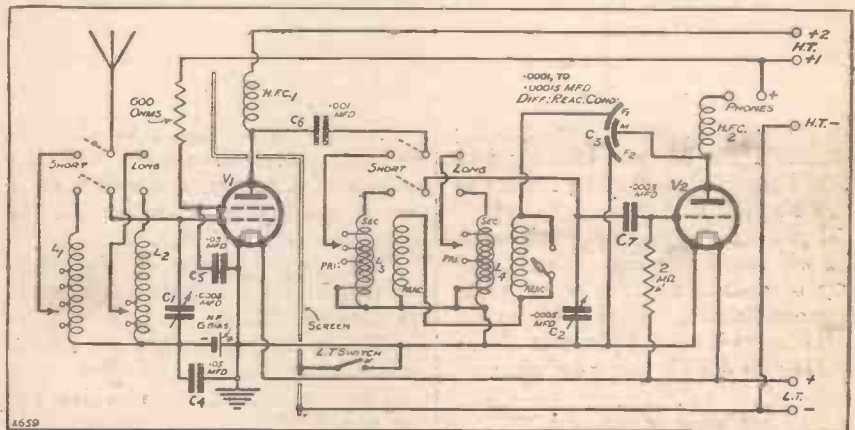

"X" coils are employed for  $L_1$  and  $L_2$ , but they are of the easily-made-at-home type, wound on a tube.  $L_3$  and  $L_4$  are a little more elaborate, but they are quite easy to make from the instructions given on following pages. The switches, though shown separately here, are ganged, and act as one switch.

The "Eaglet" has special home-wound coils, and will therefore appeal greatly to the constructor who likes to do more than just assemble a

Since the main features of this receiver are its home-wound inductances, there was not considered to be any point in adding a conventional

### YOUR SHOPPING LIST WHEN BUYING THE PARTS FOR THE "EAGLET"

- 1 Panel 14 in. x 7 in. x  $\frac{3}{16}$  in. or  $\frac{1}{4}$  in. (Lissen, or Paxolin, Goltone, etc.).
- 1 Cabinet for above, with baseboard 10 in. deep (Pickett, or Camco, etc.).
- 1 Standard screen, 10 in. x 6 in. high (Ready Radio, or Magnum, Paroussi, Keystone, Wearite, etc.).
- 1 Double-drum variable condenser, .0005 mfd. each section (J.B., or similar type).
- 1 .0001- to .00015-mfd. differential type reaction condenser (Lotus, or Lissen, Magnum, Igranic, Formo, Dubilier, Polar, Wearite, Ready Radio, Parex, J.B., etc.).
- 1 L.T. switch (Lissen, or Igranic, Lotus, Benjamin, Bulgin, Red Diamond, Ready Radio, Wearite, Junit, Keystone, Goltone, Ormond, etc.).

- 1 Double two-pole change-over switch, complete with ganging rod and panel control (Bulgin).
- 1 Panel-mounting socket with plug to fit (Clix, or Eelex, etc.).
- 2 Sprung type valve holders (Igranic, or W.B., Benjamin, Lissen, Lotus, Junit, Bulgin, Telsen, Dario, etc.).
- 2 .05-mfd. fixed condensers (Lissen, or Dubilier, T.C.C., Mullard, etc.).
- 1 600- or 500-ohm fixed resistance and holder (Bulgin, or Wearite, Parex, Magnum, Ready Radio, etc.).
- 1 .001-mfd. fixed condenser (T.C.C., or Lissen, Dubilier, Ediswan, Ferranti, Formo, Mullard, Igranic, Goltone, Ready Radio, Watmel, etc.).
- 1 .0003-mfd. fixed condenser (Lissen, etc.).

- 2 H.F. chokes (R.I. and Telsen, or Leweos, Lissen, Varley, Dubilier, Ready Radio, Watmel, Lotus, Wearite, Magnum, Igranic, Keystone, Junit, Climax, etc.).
- 1 2-megohm grid leak and holder (Lissen, or Ediswan, Igranic, Dubilier, Mullard, Ferranti, etc.).
- 9 Indicating terminals (Igranic, or Eelex, Belling & Lee, etc.).
- 2 Ribbed formers, 3  $\frac{1}{2}$  in. dia. and 2 in. long (Becol).
- 2 Plain formers, 2  $\frac{1}{2}$  in. dia., one 3 in. and one 2 in. long (Pirtoid, or Paxolin, etc.).
- $\frac{1}{2}$  lb. 24 D.S.C. wire and  $\frac{1}{2}$  lb. 26 D.S.C., and about 12 yds. 30 D.S.C. wire.
- Screws, battery plugs, crocodile clips, flex, etc.

# The "Eaglet"—continued

## THE "WIRELESS CONSTRUCTOR" "EAGLET"

Circuit : S.G., H.F. and Det., which may be used on 'phones or followed by amplifier.

### VALVES.

- 1st: Screened-Grid.
- 2nd: H.F. or special det. type.

### VOLTAGES.

- L.T.: 2, 4, or 6, according to rating of valves chosen.
- H.T. + 2: 120 to 150 volts.
- H.T. + 1: 60 to 80 volts.
- H.F., G.B.: 1½ to 4½ volts.

### CONTROLS.

- Left-hand knob switches set on and off.
- Left-hand drum dial tunes H.F. stage; right-hand drum detector stage.
- Wave-change switch is immediately below drum control. Pull up for long waves, push down for medium waves.
- Knob on right controls reaction.
- Plug below should be put in socket for medium-wave working.

### DETAILS OF CLIPS WHICH GO TO COILS.

#### POSITIONS :

- On H.F. side of vertical screen, the clip joined to the switch contact nearer to panel goes to coil nearer panel on same side of screen. Other clip goes to ribbed former on this side of screen.
- On L.F. side of screen, the clip joined to switch contact nearer panel goes to taps on winding on plain former, and the remaining clip goes to remaining coil.

#### ADJUSTMENT :

- Start with all clips on largest taps. In case of coils on H.F. side of screen these are the taps highest on coils, whilst on other coils they are the lowest taps.
- If set is not now sufficiently selective, use smaller taps on coils on H.F. side of screen. If when using smallest taps on these coils the degree of selectivity is still not large enough, use smaller taps on the other coils.

L.F. amplifier after the detector valve. It can be used direct on to telephones, or it may precede a one- or two-valve amplifier. Also there is no reason why the present L.F. end of an existing set should not be used with it; just the H.F. and det. part being rebuilt to the "Eaglet" design.

If you look at the circuit diagram you will see that a complete change-over of coils is affected when going from one broadcast band to the other. This change is made by means of two double-pole double-throw switches.

### Ganged Switches

But the fact that there are two separate switches has not made two control knobs for them necessary. They are ganged together so that one

centrally-placed control serves for them both.

### Aerial Coupling

The aerial is coupled to the grid coil of the screened-grid H.F. valve by means of a tap on the coil. There are several taps provided, so that the best one may be chosen.

The coupling between the H.F. valve and the detector is by means of a shunt-fed H.F. transformer. Here again taps are provided, and the most suitable one is used.

The reaction windings, which are on the H.F. transformers, are connected in series. The one on the long-wave transformer being shorted when working on the medium band.

It is necessary for this winding to

be shorted to avoid a tendency, which would otherwise be present, for the plate circuit of the detector valve to come into tune with the grid circuit at certain frequencies. A plug and socket on the panel were considered to introduce less complication than an extra set of contacts on the wave-change switch.

### Dozens of Stations

The use of a double-drum condenser keeps the panel quite neat in appearance and gives a real up-to-date look to the set. Also it helps to keep the operation really simple.

With the "Eaglet" you should be able to bring in dozens and dozens of Continental stations, and its selectivity will be found good enough for

### MEDIUM-WAVE TRANSFORMER

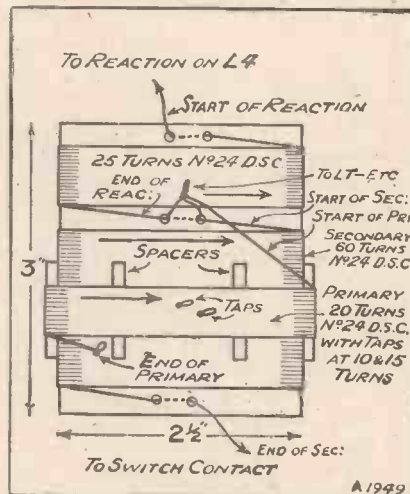

Note how the direction of winding is indicated above by arrows.

### AN EASY-TO-HANDLE RECEIVER

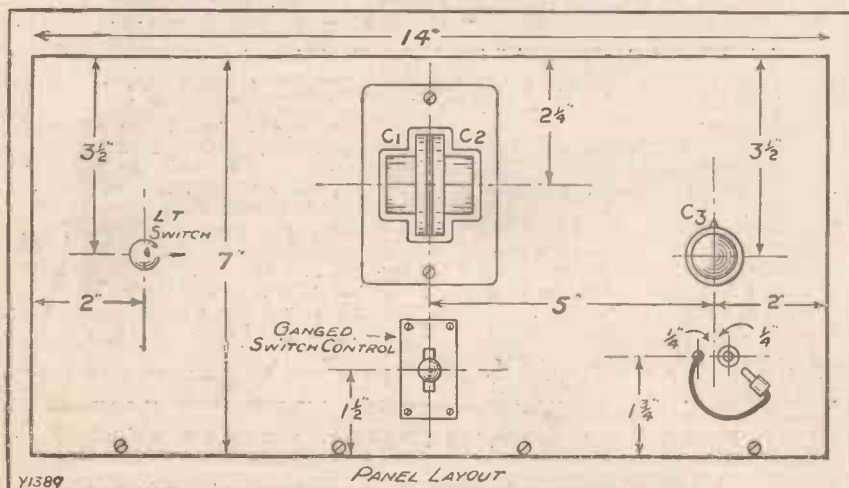

Thumb-control for the tuning ensures easy station finding, and the ganged switch control changes you over to long or medium waves in a second.

all but the worst Regional swamp areas. And now let's get down to the constructional details.

First of all we will consider the H.F. transformers. You will find diagrams showing all the details of these, but no diagrams of the aerial coils are given, because, as you will see later, they are not necessary.

The medium-wave transformer (above) is wound on a plain former 2½ in. in diameter and 3 in. long. Pierce two small holes about ¼ in. from one end of the former and secure the end of the 24 gauge D.S.C. wire by threading it through them twice, allowing sufficient for joining-up purposes.

Now, holding the former so that you wind towards yourself, wind on 25 turns in a clockwise direction. You



## The "Eaglet"—continued

should wind the wire on tightly with the turns close together, and secure it at the end of the 25 turns with two more small holes.

Next, starting at this same point, wind on 60 turns of the same wire in the same direction, and finish it off in

This is wound on a ribbed ebonite former having eight or nine ribs, and  $3\frac{1}{2}$  in. in diameter across the outside of the ribs. This diameter is not important to an eighth of an inch. The former should be 2 in. deep.

The secondary has to be put on first. Start by securing the end of the 26 D.S.C. wire with two small holes in one end of the former. Then with this end next to you, wind 35 turns in a clockwise direction in the slot nearest to you.

After that go on to the next slot and wind on another 35 turns in the same direction. Carry on in this manner until all five slots have 35 turns in them and then fasten off the wire.

### CORRECT WINDING IS OF "PRIMARY" IMPORTANCE!

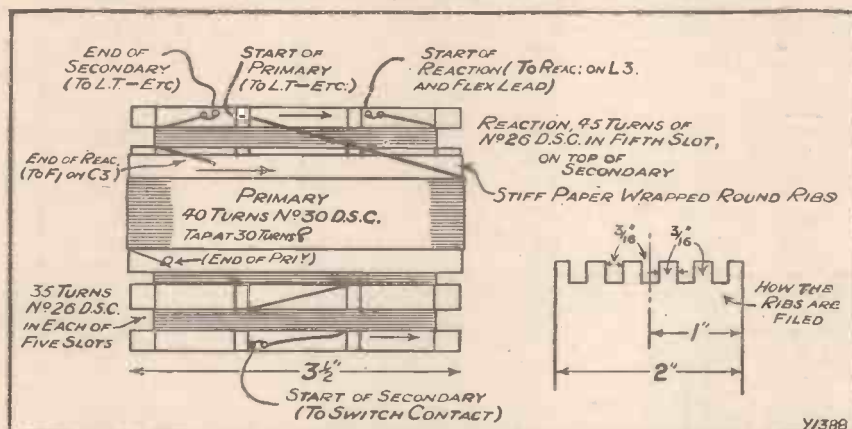

You will find it quite easy to make the long-wave transformer from the details given here.

the same way also. The two windings you have put on are the reaction and the secondary, and we now come to the primary.

This has to be wound on top of six spacers placed equidistantly around the secondary winding so that the primary winding will come over the centre turns of the secondary. The spacers may be short lengths of round stick or pieces of ebonite about  $\frac{3}{16}$  in. square.

The beginning of the primary winding, which is also of 24 gauge D.S.C. wire, has to be joined to the end of the reaction winding and the start of the secondary. There are therefore three wires to be twisted together at this point and soldered.

### Easy, Isn't It?

Wind the primary on top of the spacers in the same direction as the other windings. When you have put on 10 turns, make a small loop and carry on for another 5, and then complete the winding.

The insulation should be completely removed from the loops, which should then be tightly twisted up to form taps. The end of the primary should also be finished off so that it can be used as a tap.

This completes the winding of the medium-wave H.F. transformer, and you can now make the long-wave one.

First of all there are five slots to be filed in each rib (see diagram). These slots should be  $\frac{3}{16}$  in. wide, and  $\frac{1}{16}$  in. apart, as indicated on the diagram.

### A FEW OF THE FINE FEATURES

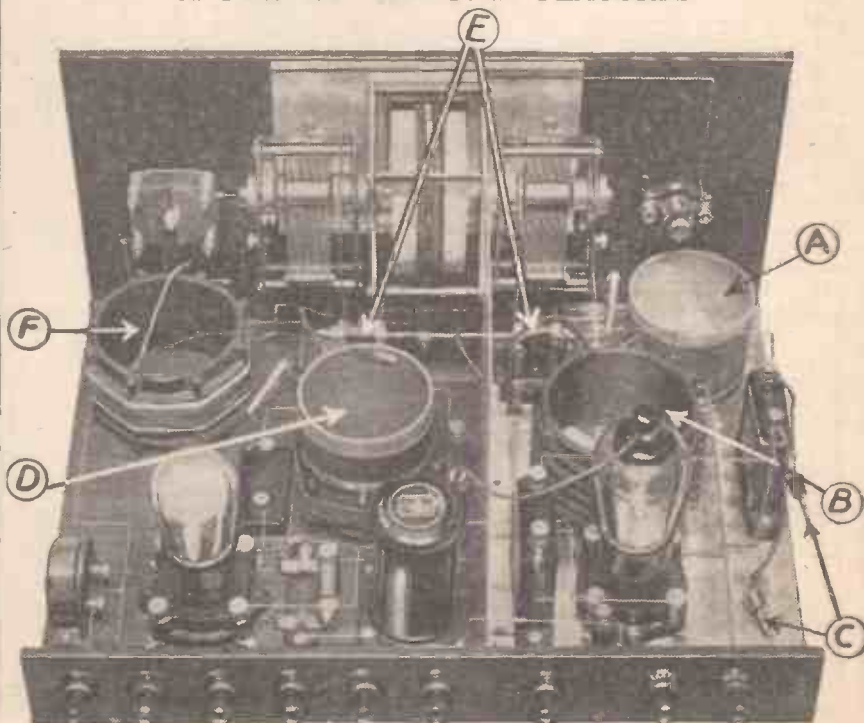

"A" and "B" are the special aerial coils, and "C" indicates the grid-bias leads for the H.F. valve. "D" is the H.F. transformer for ordinary waves, "E" the ganged switches, and F the long-wave H.F. transformer.

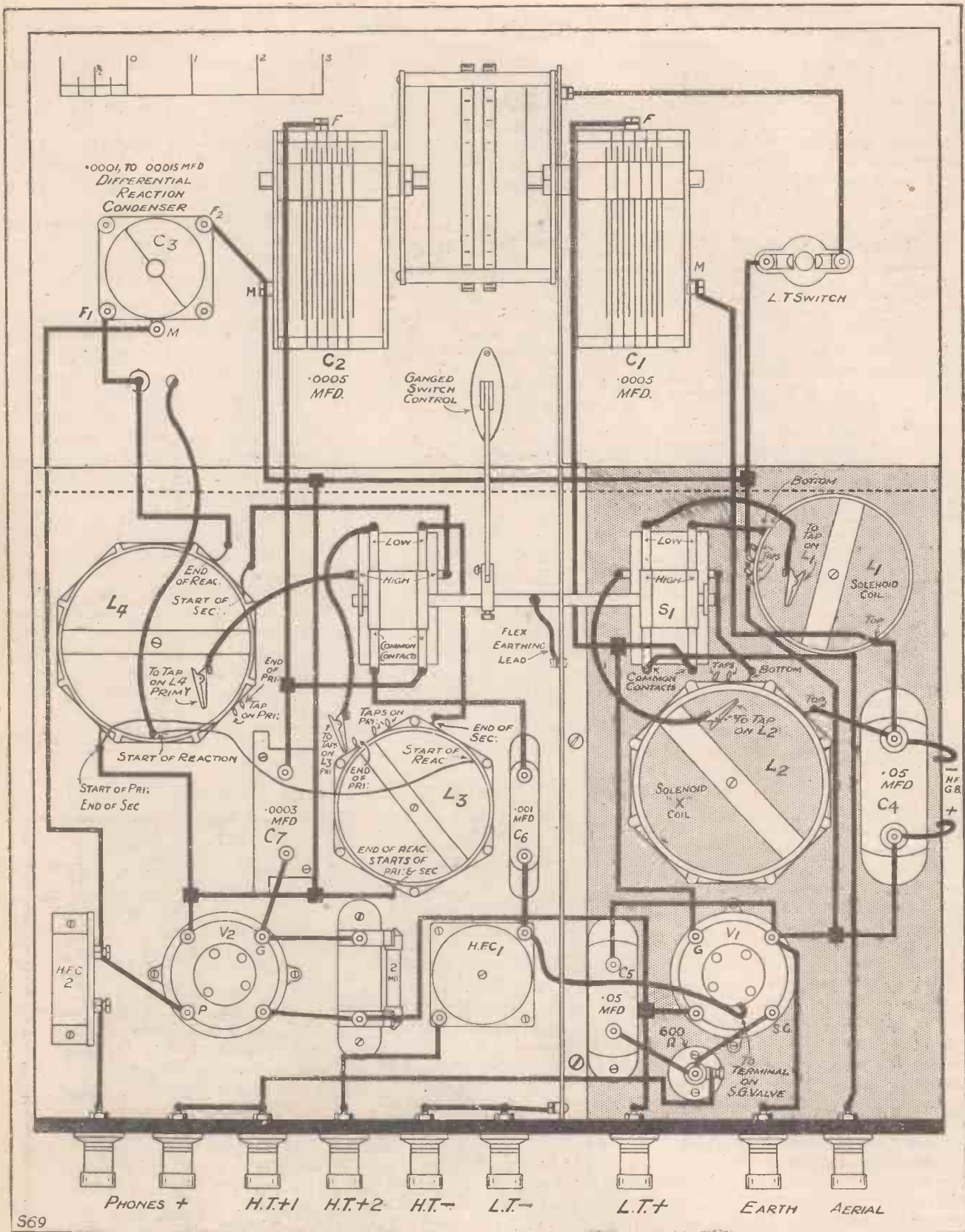

S69

At the H.F. end of the set the baseboard is covered with copper foil to provide adequate screening. This is arranged for quite easily, the rectangular piece of foil being secured flat under the screen and extending from there to the edge of the baseboard. The simplicity of the controls does not mean that there is complexity behind the panel, for as a matter of fact the set is quite an easy one to build. Note the simple method of gunging the switches.

## The "Eaglet"—continued

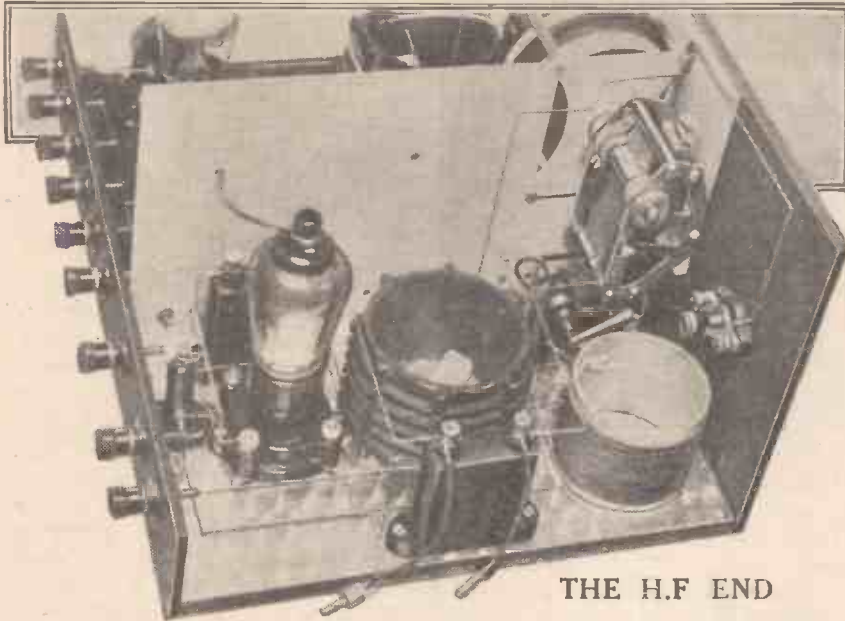

THE H.F. END

To reduce the H.T. consumption of the S.G. valve as far as is consistent with efficiency, a small grid-bias battery is connected across the .05-mfd. fixed condenser.

The primary is wound with 30 gauge D.S.C. It is started at the same end as the start of the reaction, and is wound in the same direction as the latter.

### The "X" Coils

It consists of 40 turns in all, but a tap should be made at the 30th turn. This tap and the end of the primary should be treated in the same way as the taps on the short-wave primary.

All that remains to complete the transformers is to fix a piece of wood across the inside of each former at one end. This is to enable them to be screwed to the baseboard.

The two formers for the aerial "X" coils are similar to those used for the H.F. transformers, with the exception of the medium-wave one being 1 in. shorter. We will deal with the medium-wave coil first.

This coil is wound with the same gauge wire and in exactly the same manner as the secondary of the medium-wave H.F. transformer, with the addition of four taps. These taps should be made at 5, 10, 20 and 30 turns.

### An Important Point

The same applies to the long-wave "X" coil, but in this case there are two taps at 35 and 70 turns. When connecting up these coils, in each case the end nearest the taps should be considered the "bottom" end.

slot in it to permit the ganging rod of the switches to slide in.

A large square has to be cut out of one corner of the vertical screen where it comes up against the frame of the variable condensers.

You can see the approximate amount to cut away from the photographs, in which you will also be able to see how the screen is bolted to the condenser frame.

### Selectivity Control

You will see a short flex lead running from the screen to the connecting spindle. Don't omit this lead or you will most likely get instability through the two switches becoming capacitatively coupled.

The smaller the taps on the coils to which the clips are attached, the greater is the selectivity of the receiver. This applies both to the aerial coils and the H.F. transformers.

The best tap to use on the "X" coil will naturally depend chiefly upon the particular aerial in use. Generally speaking, the aim should be to use as large a tap on the H.F. transformer as possible, and to obtain sufficient selectivity on the "X" coil taps if you can. If you cannot, it will be necessary, of course, to use a lower tap on the transformer.

### IN THE DETECTOR DIVISION

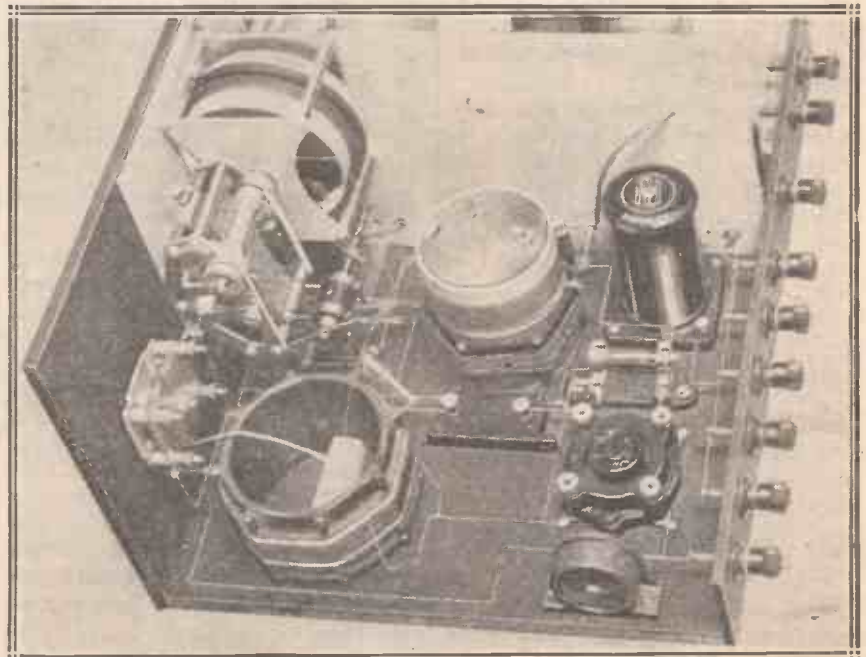

Differential reaction is one important factor in the success of the "Eaglet," and the fact that the coils are specially made for the circuit has undoubtedly given it much of its distance-getting distinction.



Some typical radio faults reviewed and questions answered.

By P. R. BIRD.

### A "Shocking" Query

"I AM shocked," wrote an Aldershot reader. "I always understood that one of the advantages of fitting a loud-speaker output filter (choke and condenser) was that it took the H.T. off the loud-speaker leads that ran to the other room, and so prevented the possibility of shock.

"Secure in that belief, I laughed at my wife when she said the loud-speaker tingled as she touched it the other night, and to demonstrate her error I boldly clutched hold of both the loud-speaker terminals. Ten thousand prickles ran up my spine, a long big word escaped my lips. My wife was shocked and I was shocked. So what is the matter with the output filter circuit?"

As a matter of fact, it was subsequently found that nothing was wrong with the circuit at all, but the set in question was a powerful one, and the trouble arose from the fact that its owner did not realise that such a receiver develops quite big voltages across its output terminals during the reception of a programme. No direct current flows through the loud speaker, owing to the presence of the condenser in series with it. But, nevertheless, the programme causes voltage variations, and in the case of a powerful set these are quite sufficient to result in a shock.

### Potentiometer Puzzles

Quite a crop of queries about potentiometers seems to point to the fact that these simple components are nevertheless sometimes puzzling to owners of sets in which they are incorporated. Writing from Sheffield,

a reader who assumes the non-deplume "Mickey Mouse" says:

"The end of the grid leak instead of going to L.T. + goes to the slider on the potentiometer, which is fitted on the baseboard. One of the ends of this goes to L.T.—, the other to L.T.+, and no matter how I twist the slider round it does not seem to affect the volume at all. Why is that?"

The answer to this question is, of course, that a potentiometer fitted in the manner indicated is not (in the

ordinary sense) a volume control at all! Such an arrangement has very little in common with the potentiometer which is fitted to reduce a loud-speaker volume down to a whisper, for in that case a high-resistance potentiometer is used, while for the connection named one of the low-resistance types is employed.

Your true volume-controlling potentiometer is connected to one of the L.F. grids, or in the output circuit, but when a low-resistance potentiometer is used to form part of the detector circuit the idea is that of improving reaction. The position of the slider arm in such a circuit, in conjunction with alterations in the

H.T. positive applied to the plate of the valve, will enable smooth reaction to be obtained instead of the "ploppy" condition so fatal to good long-distance work.

Actually, too, if you are receiving very weak signals you will find that the potentiometer slider position will affect the sensitivity of the detector valve, but generally this effect is less important than obtaining good reaction control, and, in any case, it is only really noticeable on very weak signals.

### Adding a Valve

"I always thought it was a simple matter to add an L.F. valve to a set, but not an H.F.," wrote a distracted Deptford reader, "but although I am told the simple circuit enclosed herewith works well, I have been unable to get it to function."

Enclosed with his letter was a sketch of the additional apparatus, showing it to be purely a standard L.F. circuit of the well-tried type, as innocent of snags as a new-born babe. Perhaps you have already guessed why it would not work in his case?

Yes, it was simply a case of adding an extra valve to the set, but failing to provide the necessary smoothed H.T. for it! Just because he was using a mains unit this reader thought that it was capable of passing any amount of current from the mains without

### IS YOUR SET "PLAYING UP"?

Present-day radio is remarkably reliable. But every set "goes off" sometimes, and it should not therefore be assumed that it is wearing out. All it wants is proper maintenance—like a car or a bicycle, or any other similar contrivance.

If you have any knotty little problem requiring solution, remember that the WIRELESS CONSTRUCTOR Technical Queries Department is in a position to give an unrivalled service.

Full details, including the scale of charges,

can be obtained direct from the Technical Queries Department, WIRELESS CONSTRUCTOR, Fleetway House, Farringdon Street, London, E.C.4.

A postcard will do. On receipt of this all the necessary literature will be sent to you, free and post free, immediately. This application will place you under no obligation whatever.

London Readers, Please Note: Application should not be made by telephone or in person at Tallis House or Fleetway House.

trouble. Actually he was already working it not far from the instability mark with the set as at first installed.

When he added an extra valve he was trying to take more from the mains unit, and to get greater amplification, but without providing additional smoothing. The unit protested by introducing vigorous howling. It was not the extra valve or its circuit that was wrong, but the fact that the unit was not intended to supply a four-valve set.

The provision of a unit with a little greater output and better smoothing completely cured the trouble and enabled the owner to work the extra valve satisfactorily.

# ECONOMISING VALVES



**H**ow many valves do you use in your set? And do they all "pull their weight"?

This latter is a very important feature, for a slight lack of amplification here and there may mean that you have to use another stage—a stage that is really unnecessary.

## Waste Not, Want Not

Let me explain what I mean. Take the screened-grid valve. Assume for the moment that we are using a S.G. valve that is not properly screened. What happens? Either we have to reduce the voltages on the screen and the anode, insert damping in the circuits, or else use a low-impedance anode circuit to keep the valve from going into oscillation.

The result is, of course, that we do not get the full amplification, and we are really wasting a valve—or "part" of a valve. And it is these "parts" of valves that add up and constitute quite a serious wastage by the time the last stage is reached.

Grid bias on the screened-grid valve helps to get maximum results, as well as to keep down the anode current—a double economy—while proper screening is always a real saving in valve power; for if we take adequate precautions against feed-back we can use far more efficient coils, and get much more amplification.

Ordinary H.F. valves are often more or less wasted because they are not used properly. Neutralising is not always an easy thing to carry out, but some form of neutralising must be undertaken if a good measure of amplification is to be obtained.

## About the Detector

Now let us take the detector stage. This is often regarded as a sort of "foolproof," sure-to-work stage, but

*An article dealing with an unusual aspect of radio reception.*

By G. W. EVANS

this is not really so. It is true that the average detector valve in an ordinary detector circuit will work fairly well, but we can save quite a noticeable amount of amplification if we take care.

We will assume that grid-leak rectification is taking place—that is, rectification by means of operating the valve at the bend on the grid-current-grid-volts curve.

Now if the conditions are not right it is obvious that the valve will not be operating at the proper point on this

curve—and rectification will not be complete.

One of the most valuable aids to "perfect" rectification in the ordinary receiver is the grid-leak potentiometer control. This enables the grid to be made anything between zero or full positive—the full positive being the 2, 4, or 6 volts of the L.T. supply. In lieu of a potentiometer, positive bias is very useful.

## That G.L. Return

I have several times found in a six-volt valve detector stage that the full positive bias (taking the grid leak to the positive filament connection) is too much, it takes the point too far up the grid current curve, and although the carrier-wave tends to

## IS THAT VALVE NECESSARY?



*Some radio amateurs discussing the circuit of a five-year-old five-valve receiver—a set that could probably be cut down very greatly by using modern valves. The "mike" was presented to them by 3 L O, for short-wave successes.*

## Economising Valves—continued

cause the grid to become negative it cannot as a rule bring the point back again to the bend, and so we get insensitivity and poor rectification.

Reducing the positive bias has the desired effect of readjusting things, and the rectified signals increase in strength and purity. *But* this positive bias should really be adjusted according to the strength of the input

Make sure your valve is getting the H.T. volts intended for it, or it will be seriously handicapped in its operation.

voltage. On a local and powerful station we can employ more positive than on a distant transmission. Unfortunately, reaction is usually "ploppy," but for local reception I strongly recommend an adjustable bias on the detector valve.

### They Want Watching

Another little refinement that counts a lot in some sets is a small by-pass condenser between anode and L.T.— of the detector. The condenser should be of about .0001 mfd. capacity. Just try it and see if it does not increase results slightly. (It often gets rid of the unwanted H.F. in the anode circuit.)

And now about the valve itself. If we have transformer coupling it is silly to use an R.C. valve as detector, while with resistance coupling we must not forget that we may lose a great deal of H.T. voltage if the resistance is a high one; 100,000 ohms is quite sufficient as a rule in modern sets.

On the L.F. side of the receiver quite a lot of little things want watching. Such things as grid swing, anode voltages, grid bias, impedance and magnification factor all combine to give good or poor results, according to the wisdom of the choice. The subject is too vast to go into here, but I should like to draw readers attention to one point. I have already mentioned it in connection with the detector, and it is very important. It is the drop of voltage that occurs across the anode resistance.

### How Much H.T.?

Suppose we have a 7,500-ohm valve in series with a 50,000-ohm resistance in a first stage of L.F. amplification. And suppose we apply 150 volts to the circuit. How much will actually reach

the valve? It is difficult to work out actually, for it depends upon the bias used. In a particular case I found that at 4.5 volts bias only 2 milliamps were flowing. Now the total resistance of the circuit is equal to 50,000 + "X"—the resistance of the valve. That is easily found by Ohm's law:

$$R = \frac{V}{C}$$

$$\therefore 50,000 + X = \frac{150}{.002} \text{ (amps.)}$$

$$\therefore X = \frac{150}{.002} - 50,000 = 25,000 \text{ ohms.}$$

Now we have the operating D.C. resistance of the valve as 25,000 ohms.

### BROADCASTING AT ITS BEST



The standard broadcast receiver at the Science Museum; S. Kensington, where demonstrations of quality broadcast reception are given daily.

To find the voltage applied to the valve we take the proportion of the external resistance to the valve resistance, and that gives us the proportionate voltages across each portion.

Thus we have 150 volts to be divided between 50,000 and 25,000 ohms.

It will obviously be expended in the ratio of 50,000 to 25,000—or 2 to 1. That is, the voltage drop across the 50,000-ohm resistance will be 100 volts, leaving the valve with only 50 volts.

Now we see that we are not getting the results out of the valve that we thought we were. To do this we shall have to increase the applied voltage

until the voltage across the valve reads 150.

We can assume that the valve resistance will remain at 25,000 ohms (we are working on the straight portion of the anode-current grid-volts curve), and so if we want 150 volts across the valve the applied voltage will have to be such that the ratio is still 2 to 1 in voltage drop. Thus we need to allow for a voltage of 300 across the anode resistance—giving a total of 450 applied.

### "Plenty on the Plate"

Terrible, isn't it? This simple case proves how wasteful resistance-coupling is in L.F. circuits, and how easy it is for us virtually to waste a valve, because we forget that it is working well under its proper voltage.

Thus if you want the maximum results it is often more advantageous to use a low anode resistance and to get more H.T. on the valve (and therefore a better available grid swing) than to try for higher voltage amplification by using a large resistance (and limiting the grid swing).

Using too large a valve in front of a L.F. transformer is a wasteful procedure sometimes, for it may cause saturation of the core, and thus loss of amplification, and also distortion. The big valve is then more or less wasted.

### Careful Choice Pays

If you think a little about the L.F. side—about such things as output chokes and their sometimes unnecessarily high resistance, about transformer saturation, about pentode valves and their outputs, about anode resistance values, and the loss of H.T., you will realise how important it is that the valves be chosen carefully, otherwise a really fine valve may be

### NEXT MONTH

The  
SPECIAL XMAS NUMBER  
of  
"The Wireless Constructor"

On Sale December 13th.

Price 6d. as usual.

handicapped so much that it gives but a small proportion of the results it could provide under better conditions.

In other words, the valve will have been wasted, and we shall be disappointed with the results we get from our sets.

# THE "TAPPER" TESTER



Full details of the construction and use of an extremely useful and efficient unit which greatly simplifies the tracing of obstinate faults.

By C. MAXWELL.

**H**AVE you ever experienced that utterly helpless feeling after testing a set which "won't work" when, although you have tried everything you can think of, you have failed to locate the trouble? If so, I expect you have also wished that you could carry out the analytical test of each stage separately which becomes necessary, without having to half-pull the set to pieces.

under test is removed from its holder, the "Tapper" Tester put in its place, and the valve inserted in the top of the tester.

The telephones or milliammeter, as the case may be, is connected to the two terminals on the tester. The wander-plug on the tester is taken either to an H.T. positive tapping on the high-tension battery or placed in the plate socket of the

The flex lead attached to one of the terminals has to be two or three feet long, so that it can be run to the H.T. battery outside the set. No plate pin is provided on the bottom of the unit.

## What You Require

The plate of the valve, instead of being connected up to its usual socket, goes direct to one of the terminals via the plate socket on the top piece of ebonite. The filament and grid sockets on top of the unit are joined direct to the grid and filament pins on the bottom, since it is not required to break the circuit at these points.

The odds and ends which you require for the construction are as follow: Two pieces of ebonite, 2 in. by 2 in. by  $\frac{3}{16}$  in. or  $\frac{1}{4}$  in.; two pieces

## ONLY A FEW HOLES HAVE TO BE DRILLED

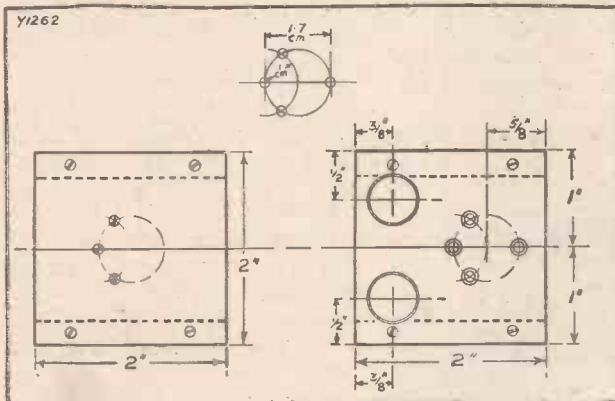

The drilling, which is quite simple, constitutes the greater part of the constructional work. Here are full dimensions for the marking out of the positions of the holes.

This wish need not remain unfilled any longer, for the "Tapper" Tester enables you to try out each valve and its associated circuits separately. Apart from this, it also enables one or more valves to be cut out on a set which has no valve switching.

## A Valuable Gadget

Another of its uses is that of enabling a meter to be connected in the plate circuit of any valve. In spite of its simplicity, both as regards connection and construction, it is a really useful little gadget which will repay anyone for the making.

It is used in a very similar manner to a gramophone pick-up adaptor. That is to say, the valve of the stage

valve holder, according to the purpose for which the tester is in use. Further details in this connection are given later.

## Easy to Make

The unit consists of a kind of little box, two of the sides of which are left open. The other two sides consist of pieces of wood to which the top and bottom are screwed.

The top and bottom are two square pieces of ebonite. The bottom one carries three valve pins, and the top four valve sockets and two terminals. The photographs show the construction very clearly, and also indicate how it is used in a normal receiver.

## JUST FIVE WIRES

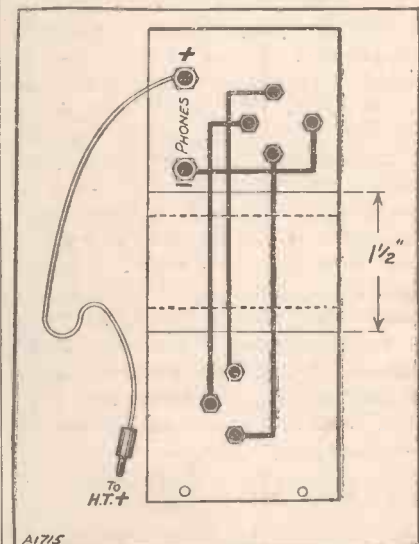

Here is the diagram of the wiring, which is absurdly simple. The lead from "phones + " to "H.T. + " is a length of flexible wire.

## The "Tapper" Tester—continued

of wood, 2 in. by 1½ in. by ¼ in.; two terminals, marked "phones + " and "phone—" respectively, four valve sockets (any type of sockets of suitable size will do); three valve pins; eight wood screws; wire; and battery wander-plug.

First of all, you attach a pair of telephones to the terminals on the tester, and then remove the detector valve from its holder and place it instead in the sockets in the top of the unit. Now place the unit in the socket of the holder from

If you cannot hear the local station you will have ascertained that the trouble lies in the first valve's grid circuit somewhere, or in the aerial circuit. Should all be well with the detector valve, you can next plug into the first L.F. valve in exactly the same way.

The reaction will now, of course, be brought into circuit. By the above means you will soon be able to locate in which part of the set the trouble is situated.

When you are using the unit to enable one or more valves to be cut out the procedure is just the same. The valves not in use should be removed from their sockets to save current.

### INSERTING 'PHONES AFTER ANY VALVE

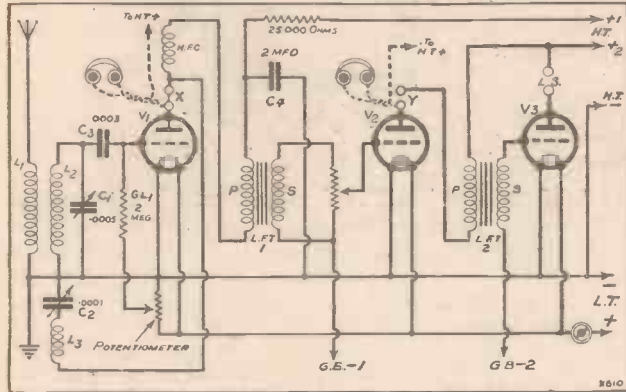

The effect of inserting the tester is to break the anode circuit at the points marked X or at Y. This effect is, of course, obtained quite automatically.

First of all, mark out the positions of the holes to be drilled in the two ebonite pieces. These positions must be marked very carefully as regards those for the valve pins and sockets.

### The Valve Sockets

A special little sketch is given above the main diagrams in the drilling layout showing exactly how the positions for the valve legs and sockets should be marked out. The holes for these should be such a size that there is a little clearance round the pin and socket shanks.

When you have finished the drilling, mount the parts. While tightening the nuts on the valve pins, insert them in a valve holder so that a good fit will ensue.

Apply the same scheme when tightening the socket nuts, this time inserting a valve in the sockets. The wiring itself requires very little comment. It may be done before or after screwing the top and bottom to the sides.

If you do not use insulated wire for connecting up, make sure that none of the leads touch one another. As previously mentioned, the flex lead should be two or three feet long.

### Stage by Stage

The chief use for the unit is testing out obstinate receivers stage by stage. The theoretical circuit diagram on this page will make quite clear how this is done.

which the detector valve was removed and put the wander-plug in a positive tap on the battery near the one which was previously supplying the detector valve via the set.

If all is well with this detector part of the set you will hear the local programme in the telephones.

### READY TO "TAP"

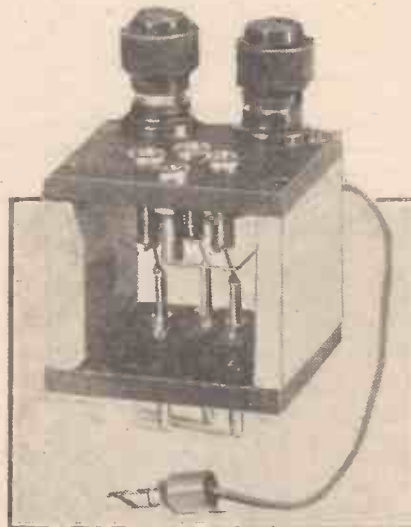

Here is the neat little gadget completed and all ready to work as your radio "detective."

Distant stations will not come in, as the reaction control will now be inoperative, but the local station is all that is required for test purposes.

### Cutting out a Valve

If you have a three-valve set, and wish to use two instead of three valves on the loud speaker, connect the loud speaker up instead of the telephones and plug into the second valve holder in the usual manner. Instead of putting the first L.F. valve in the unit, you should put the power valve in, and adjust the grid bias to the second stage to suit your power valve.

With the above scheme place the wander-plug of the unit into the tap which usually supplies the power valve.

To insert a milliammeter in the plate circuit of a valve the unit is used in a manner very similar to that already described. The milliammeter is, of course, connected into circuit by being joined to the telephone terminals.

### An Important Point

Instead of taking the wander-plug to a positive tap on the H.T. battery; it should be plugged into the plate-socket of the valve holder into which the unit is to be plugged.

There is one important point about the wander-plug, and that is that it must not be very long in the insulated portion. If it is, when the unit is being used for milliammeter connections it will prevent the valve pins from entering into the grid and filament sockets of the valve holder.

It is usually quite an easy matter, should it be found necessary, to cut the insulating part down short to overcome the above trouble.



# AS WE FIND THEM



## British Blue Spot Speaker

THE British Blue Spot Co., Ltd., 94-96, Rosoman Street, Rosebery Avenue, London, E.C.1, have sent us one of their model 41K loud speakers. This speaker retails at the extremely moderate price of 50s., and is attractively finished in walnut.

The driving movement is the well-known Blue Spot 66K and needs no introduction to readers.

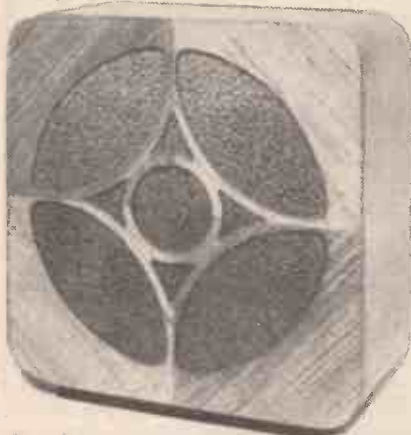

*The Blue Spot type 41K loud speaker. It is nicely finished, sensitive, and is excellent value for money.*

We tested this loud speaker in our laboratory on a straight three-valve receiver, with an ordinary power valve in the last stage, H.T. 120 volts, grid bias — 9 volts. Sensitivity was excellent, the volume obtainable without noticeable "blasting" being fully up to that required for normal domestic purposes. (The movement is, of course, adjustable.) The reproduction over the musical range was very good indeed. This loud speaker is excellent value for money.

## Exide Battery Connectors

The Chloride Electrical Co., Ltd., has produced a new type of connector for coupling together their Exide H.T. units types W.H. and W.H.G. One of these connectors is supplied with each 10-volt unit. The connector, which is of a soft thin lead strip, has four holes. If a long connector is required the two outside holes are used, and if a short connector is needed the inner holes are employed, the excess strip being cut off with a pair of scissors. Full instructions are given on the card supplied with each connector.

## Ganging Switches

The majority of present-day receivers incorporate wave-changing. Various schemes are used and perhaps the most popular method from the viewpoint of the listener is that which employs a single knob on the panel. To achieve this desirable state of affairs frequently entails the use of ganged switches terminating in some kind of lever or link.

Messrs. Burne-Jones & Co., Ltd., the makers of "Magnum" components, have recently brought out a series of ganging switches suitable for wave-change circuits employing one or more tuned stages. Any number of these switches can be ganged together and operated by means of a single push-pull control.

The sample submitted was of the three-way type and consisted of a light skeleton framework with three self-cleaning, low self-capacity contacts on either side. The complete change-over is effected by 90-degree

movement of the ganging spindle. Substantial soldering tags are provided and the switch is reasonably small in size.

Tested at 500 volts D.C. the insulation proved to be above suspicion.

The three-way switch retails at 3s. 6d., and the push-pull assembly at 1s. 6d.

## Becol Coil Formers

The British Ebonite Co., of Nightingale Road, Hanwell, W.7, have submitted two of their latest coil formers for our inspection. These ebonite formers are suitable for constructors who are desirous of winding their own coils, and plug-in to special six- or four-contact bases.

The bases have been reduced in size in order to facilitate handling,

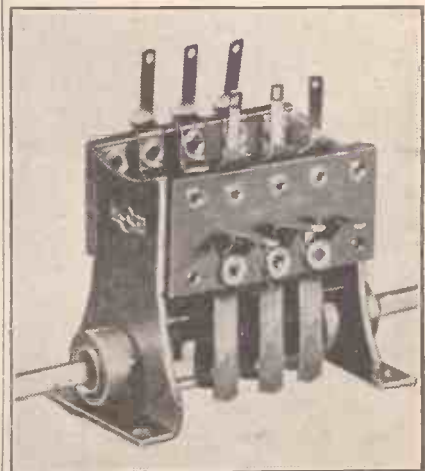

*One of the latest "Magnum" ganging switches. The square section rod is supplied in any desired lengths and two or more of these switches may be operated by means of a simple push-pull control.*

## As We Find Them—continued

and the contacts are now flush with the ebonite. The formers are ribbed and slotted, and we can commend them to the notice of those readers who appreciate mechanical strength in addition to high electrical efficiency.

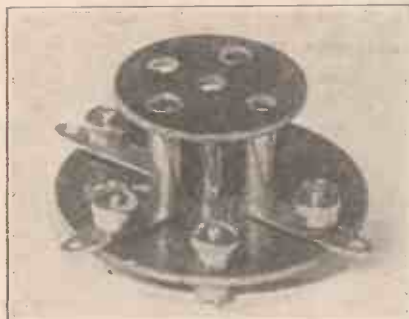

This is one of the new "Clix" valve holders which may be obtained with soldering-tags alone, or with both terminals and tags.

We have also examined a number of this company's small choke formers. These are obtainable in various types, and are valuable in connection with short-wave designs where special H.F. chokes are required.

### Telsen Components

The Telsen people have re-designed many of their components for 1931. For instance, the well-known "Radiogrand" L.F. transformer has been improved beyond recognition.

It is now neatly enclosed in an attractive brown bakelite moulding. The terminals are hexagonal so that they can be tightened up with the aid of a small spanner if desired, and there is also an extra terminal for earthing the core.

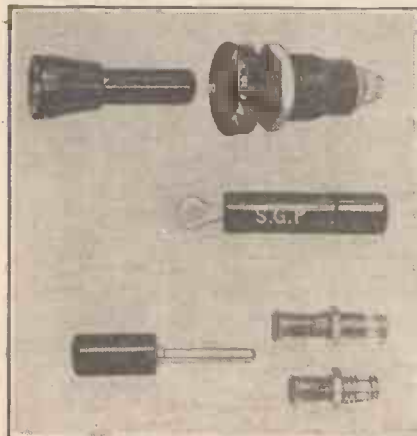

At the top may be seen one of the "Clix" "All-in" terminals, and below it an anode connector. Resilient sockets also are shown.

The sample sent us had a ratio of 3-1. On test we found that both in quality and amplification the instrument was fully up to the standard expected from transformers of the moderately priced type.

For the best all-round results the 3-1 ratio model should be preceded by a valve of medium impedance, 15,000 to 20,000 ohms. The insulation between windings and from windings to core showed a reading of "infinity" at 500 volts. Messrs. Telsen are also marketing an H.F. choke of the universal type. Like the "Radiogrand" transformer, the choke is enclosed in a bakelite moulding. Our choke tester showed no "peaks" at any portion of the medium or long wave-bands, and there should be no danger of the windings "coming into tune" on any of the wave-lengths commonly employed for broadcasting.

Here are some of the 1930-31 Telsen components. The L.F. transformer has been re-designed, and is a most attractive-looking instrument. The terminal on the side is for earthing the core. The Telsen Universal H.F. choke may be seen underneath the valve holder. Brown moulded bakelite is employed for all of these components, which are both well-made and effective.

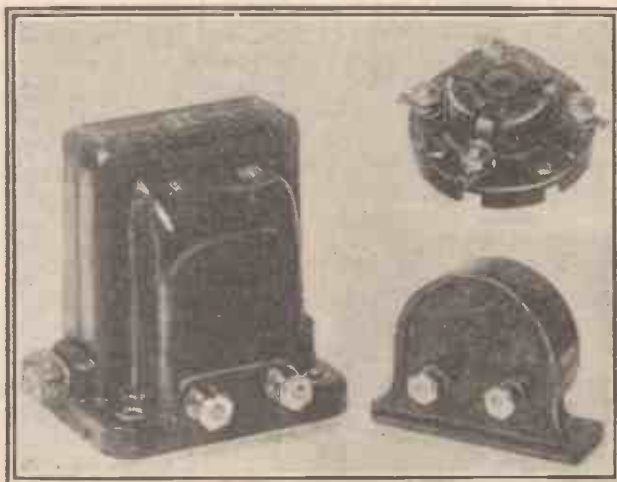

On test in a broadcast receiver the component enabled effective and smooth reaction control to be obtained.

The "Radiogrand" transformer retails as 12s.6d., and the choke at 2s.6d., and both are excellent value.

### Clix Specialities

Lectro Linx, Ltd., 254, Vauxhall Bridge Road, London, S.W.1, have sent us samples of their new lines for the 1930-31 season.

Among these is a very reasonably priced 4-5-pin valve holder, designed to have low H.F. losses.

The valve holder is somewhat uncommon in appearance since there is no solid dielectric between the sockets. These are, in fact, "air-spaced," and the only solid material is the insulating base and the top disc, which forms the

guide or template for the valve pins.

The price (complete with screw terminals) is only 10d., or 8d. without terminals. There is also the Clix "All-in" terminal, which is completely insulated and is intended to prevent any possibility of burning out valves by shorting.

Another useful component is the anode connector, a neat little gadget for connecting the end of the flexible H.T. lead to the anode terminal on the top of a screened-grid valve.

We also liked the Clix solid plugs and resilient sockets. There is something definite and certain about their contact.

All these Clix specialities are well made and moderately priced.

### A Suggestion

Components are equipped with various types of terminals. Some of

these have milled edges and are intended solely for finger tightening. Others are hexagonal, and a third type have a screw-cut head. It is the latter we have in mind at the moment. In some cases a special pronged screwdriver is required if the screw-cut head is to be of any practical value. An ordinary screwdriver can only be used if the terminals are employed for gripping fairly stout wire, such as 18 or 20 gauge.

If soldering tags are placed under the head a "pronged" screwdriver is essential, owing to the fact that the terminal shank projects beyond the screw-cut head. This can easily be overcome by shortening the shank so that it only just reaches the bottom of the screw-cut when the head is tightened right down.

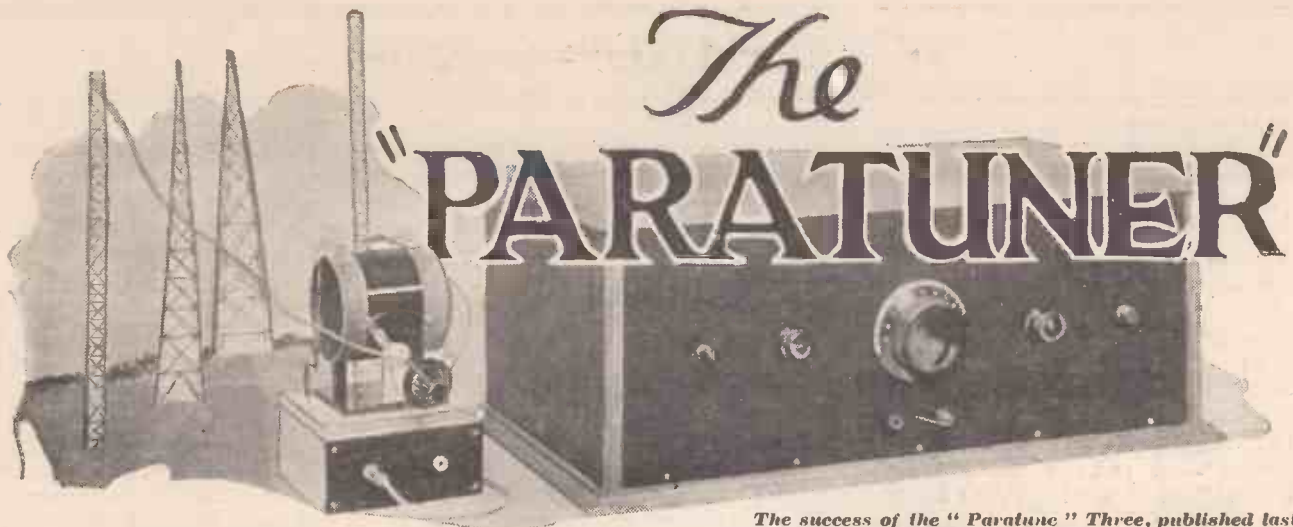

# The "PARATUNER"

*The success of the "Paratune" Three, published last month, was instantaneous. All over the country sets have been built, and reports from all round echo and re-echo praise for the marvellous little tuner that made such superb selectivity, such startling sensitivity, possible. Well, here is the little marvel in unit form, so that anyone and everyone can add it to existing sets, and so partake of the benefits it offers.*

Designed and Described by VICTOR KING.

JUDGING by what I heard at the Radio Show, quite a number of readers are still in difficulties with the National and Regional programmes. Some cannot get a sufficiently silent band between the two stations to allow of the reception of others in between, and many, in fact hundreds, cannot even receive one of the Brookmans stations free of interference from the other.

### Entirely New Circuit

In practically every case the trouble is due to the use of "old"—yet in regard at least to components, "new"—receiver designs. Sets which had been built only a matter of six, or perhaps nine, months ago, and which the owners feel reluctant to dismantle, even though they are old in the sense that they were not intended originally to cope with regional conditions.

Those of you who have been following the experiments I carried out recently in conjunction with the Research Department, will remember that we have evolved an entirely new circuit for "Brookmans areas" which, with the simplest control imaginable, will do the job, and do it thoroughly.

### Months of Research

I refer, of course, to the "Paratune" principle of reception, which with a straightforward detector circuit and only one tuning condenser will separate the twin Brookmans stations and, more than that, will separate them to the extent of allowing the reception of stations in between *without any loss of volume.*

The "Paratune" scheme is the outcome of months of intensive

research work, and represents a very gratifying solution to a problem that has been troubling us ever since the Regional idea was first introduced. What, then, could be more suitable for those readers who are in difficulties with their existing sets than a simple unit built up on this principle?

The "Paratuner" can be fitted to any set in which an ordinary "X" coil is used for aerial coupling, without fear of losing any volume at all. As a matter of interest, I have proved that, in certain circumstances, the strength

of distant stations *is improved* by the use of this unit; particularly was this noticeable on the Rome transmission.

### Separating Powerful Locals

I wish to stress the point about sets in which an ordinary "X" coil is used, because I made a careful analysis of the cases brought to my notice at the Show, and by far the majority of the existing sets which were giving trouble (mostly of the "det. and one," or "det. and two L.F." type) were coupled to the aerial in this way.

### ENSURES SELECTIVE AND SENSITIVE SETS

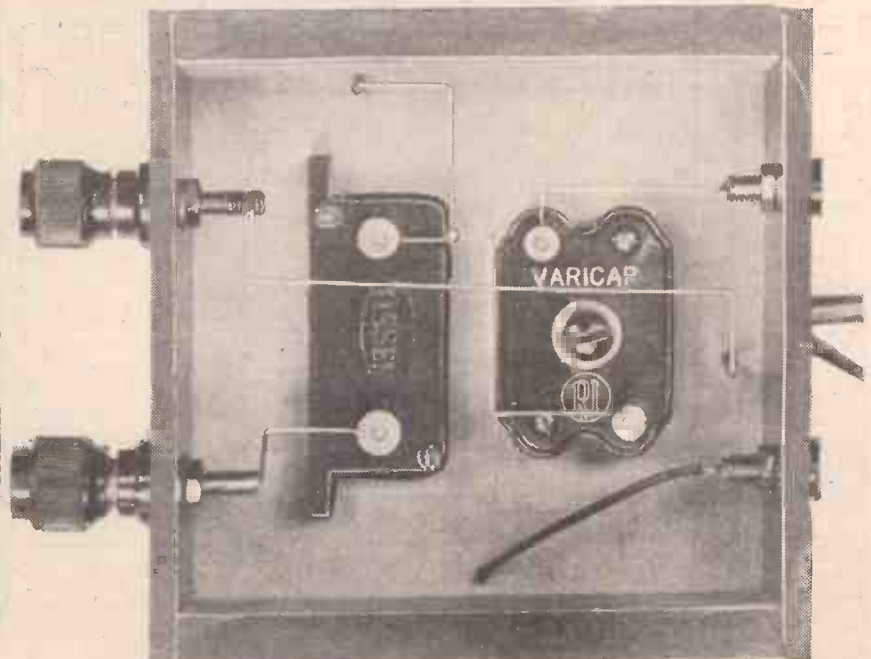

*Tucked away in the base of the "Paratuner" unit are the two components shown above. And to them is due much of the superb selectivity for which the "Paratune" principle is rapidly becoming world-famous.*

## The "Paratuner"—continued

In consequence, it was necessary to bear this closely in mind when producing a "Paratuner" design.

But the separation of powerful local stations is not the only use to which the "Paratuner" can be put. It has a much more universal appeal; in fact, an application that will affect listeners living in all parts of the country.

For a long time now we have been receiving reports from readers who are mystified by the presence of the local station on the long-wave band. And the trouble is that this "breaking through," as we call it, is not confined to any particular part of the tuning dial. It seems to start very loudly at the bottom end of the tuning range and to spread upwards to such an extent that the reception of long-wave stations is rendered practically impossible.

### Easy to Operate

Those of you who have read about the "Paratune" Three in the last issue of the WIRELESS CONSTRUCTOR will already have seen a reference to this breaking through difficulty and to the really effective way in which we have overcome it in the research laboratories.

It is logical to suppose that there will be many readers unaffected by

those unconcerned with ordinary selectivity problems are faced with the long-wave interference difficulty?

In other words, I am confident that this little unit is just the thing that has been wanted for a long time.

### NO UNWANTED STATION CAN COME IN

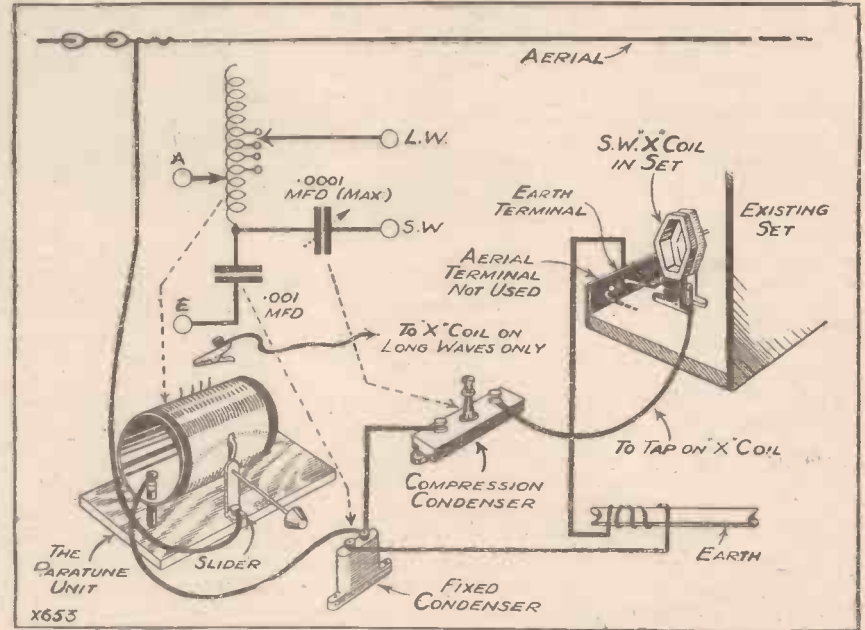

A diagrammatic representation of the "Paratuner" coupled to a set using an "X" coil.

If the many letters I receive from month to month can be taken as a pretty good indication of the state of affairs generally, I've got a feeling

Whether you use it as a station-separating device, or for the elimination of local station interference on the long waves, you can be certain that it will not in any way interfere with the performance of the set as a distance-getter. In addition, the unit is about as simple to operate as can possibly be imagined, and it is but the work of a few moments to fix it.

### THE "PARATUNER" IS NEVER IDLE

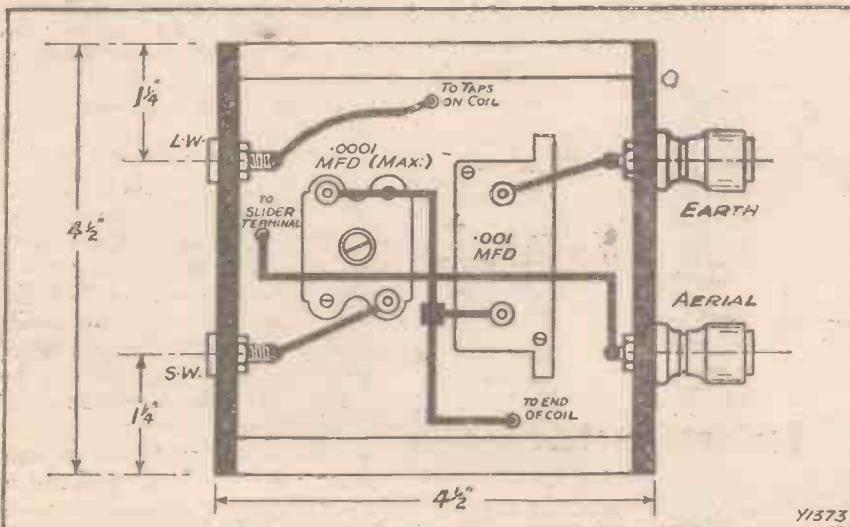

Whether you are listening on short or on long waves you want the "Paratuner." It has a beneficial effect on either wave, for it is not merely a "one job" unit. It pulls its weight all the time. This diagram shows the connections underneath the unit.

the Regional scheme to whom the "Paratuner," purely and simply as a selectivity device, will not be of much interest, but how many thousands of

that the application of the "Paratuner" as a long-wave interference eliminator will be almost as popular as its use for reducing normal "jamming."

### Easy to Make

The components needed to build this unit are few, and consist of the "Paratune" coil unit—which you can make yourself from the diagram provided or procure ready-made from Messrs. Wright and Weaire or Ready Radio—a compression condenser with a maximum capacity of .0001 microfarad, a .001-microfarad fixed condenser, and sundry terminals and sockets which you may happen to have on hand.

There is nothing very difficult in the construction of the unit, and you can start off by making the small box on which the "Paratune" coil is mounted. All the dimensions for the construction of this mount are given in the diagrams, and when you have finished making the box and have fixed the components on and in it,

## The "Paratuner" —continued

you can complete the job by making what few connections are necessary.

There is just one other point which, perhaps, I should mention for those of you who undertake to make your own coil unit. It is vitally important for the slider arm to make very firm but smooth contact with the winding, and I strongly recommend you to make this arm from moderately thick phosphor-bronze in order to obtain a good spring contact.

### The Unit in Use

When the unit is completed it should be connected up to your existing set in the following manner. First of all remove the aerial wire from your receiver, and join it instead to the terminal on the unit marked "Aerial." The earth lead should be left on the normal set earth terminal, but an additional lead should be taken from this terminal to the terminal on the unit marked "Earth."

On the front of the unit there are two sockets. Dealing, first of all, with the application of this unit as a selectivity device, the socket on the left-hand side (marked "S.W." in the diagram) should next be joined

its maximum capacity (screwed right down) and proceed to operate the set exactly as before. The only difference is that when you have found the desired station (and be careful, with this device in circuit, that you don't miss it!) you simply adjust the slider arm of the coil unit until the loudest signals are obtained.

Slight readjustment of the main tuning condenser may be required on distant stations when the "Paratune" unit has been brought into tune, but you are not likely to find this necessary on the local stations.

As a matter of fact, when once you have become thoroughly acquainted with the operation of the "Paratuner" you will find it a quite simple matter to keep the unit in tune with the set as you go up or down in wave-length. Readjustment of the controls will not then be necessary, and when you have found the station you want, well, you will just sit and listen to it.

### Reduced to a Whisper

The use of the "Paratuner" to eliminate interference on the long waves is simple enough. You leave the connections exactly as before,

coils in the set, but beyond this there is nothing else that requires to be touched.

Turning once again to the unit, the tapping clip should next be attached

### A STALWART SENTINEL

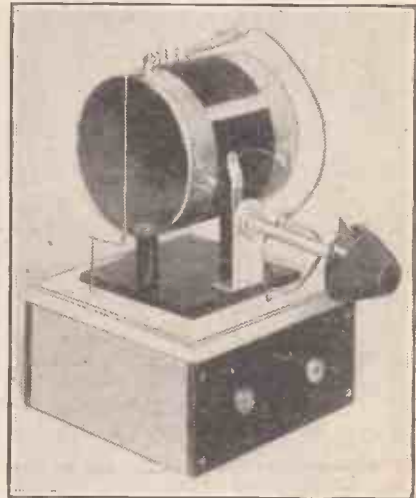

*It prevents any unwanted station from "blotting" on your reception.*

to the "Paratune" coil and, as a start, I suggest that you fix it to the tapping which corresponds to forty turns from the end.

If you now turn your set tuning control until the interference is heard at its loudest strength, and slowly move the slider arm from right to left across the winding, you will find a position at which the interfering station is either reduced to a whisper or has disappeared altogether.

### Fixing a Tapping

You can now proceed to operate your set in the normal manner, but this time once the "Paratuner" has been set it should not be touched again until it is once more desired to use the set on the medium broadcast band. It is only on this latter band that the unit requires to be adjusted for every alteration in wave-length.

You will notice that there are four tapping positions on the coil, and if you are unable completely to silence the unwanted station on long waves when using the tapping at the fortieth turn you can try the effect of moving the clip down towards the start of the coil. I rather imagine, however, that in almost every case the tapping at the centre will be the one to give the best results.

### SIMPLE TO MAKE AND EASY TO EMPLOY

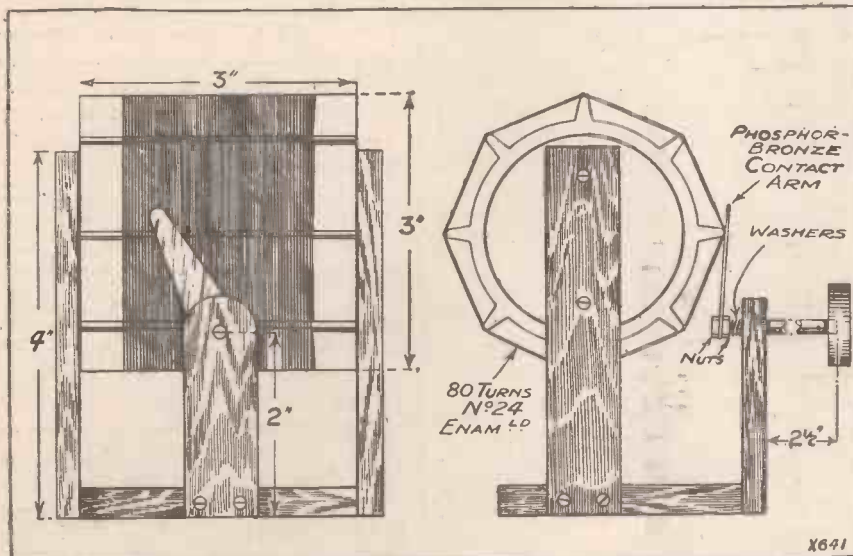

*The coil is a simple one to construct, full details being given in the above diagram.*

to the normal aerial terminal on the set. The tapping clip is only used when the unit is performing its other function, and for the time being can be left loose.

All that you now have to do is to adjust the compression condenser to

with the exception of the lead from the aerial terminal of your existing set. This lead should be joined this time to the right-hand socket at the front of the unit. Naturally, since the receiver is going to be used on long waves, you will have to change the

# IN THE RADIO DEN

*"Starting" Small Nuts—Retaining Loose Terminals—Baring Insulated Wire.*



## "Starting" Small Nuts

It is often a tedious job to "start" small nuts which are situated in some rather inaccessible portion of the receiver. Nuts, for instance, which are provided on small fixed condensers, or those which are placed up against the cases of transformers and similar components.

There is, however, a very simple way of getting out of this practical difficulty.

## NO MISLAID TERMINALS



When you have occasion to remove the nut from a terminal, a spring clip used in this way will prevent the terminal dropping out of the panel or terminal strip.

Break off the point of a lead pencil, and then insert the blunted point into the nut. A little manipulation will then suffice to "start" the nut on its thread, after which the pencil may gently be removed, and the nut screwed tightly home with the fingers or by the aid of a small pair of pliers.

## Retaining Loose Terminals

Sometimes when repairing a receiver, or when making alterations to a set, it is necessary to unsolder connections and to unscrew the retaining nuts of several terminals.

Under these conditions it becomes difficult to upturn the panel for close inspection without the loosened terminals dropping out.

The difficulty, however, is easily overcome by placing a small clip of one variety or another on the shaft of each of the loosened terminals.

When the panel is upturned the clipped terminals remain in position, and the necessary work on the set can be carried on without any fear of the terminals being lost or misplaced.

The photograph herewith depicts a single terminal "clipped" in the manner described above.

## Baring Insulated Wire

Wire which is provided with a canvas or rubbered-fabric insulation is often favoured by the wireless man for the construction of earth leads, indoor aerial work, and the like.

The only disadvantage of it for these uses lies in the fact that it is ordinarily somewhat difficult to remove the insulative covering when required.

Many workers attempt to burn away the insulation of the wire. At the best, however, this is a smelly job.

A really practical method of removing the insulation from such wires will be seen herewith. Merely make a series of sharp but gentle taps on the wire with a light hammer.

## A TIME-SAVING TIP



A useful scheme when removing heavy insulation is to give it a few sharp taps with a hammer before attempting to cut it off.

This will serve to break the insulative covering, after which the latter may be stripped away with comparative ease. You must, of course, be careful that you do not fracture the actual wire. It is best to lay the lead on wood.

## FIRST-AID FOR THE CARPET

If you ever have the misfortune to spill accumulator acid on a valuable carpet don't tear your hair and bemoan the fate of the carpet, but rush for some ammonia, soda, bicarbonate of soda, or even soap, and completely smother the spot where the acid lies. Quickly applied such remedies completely neutralise the acid.



# A MIGHTY good TRANSFORMER WITH A CURVE!

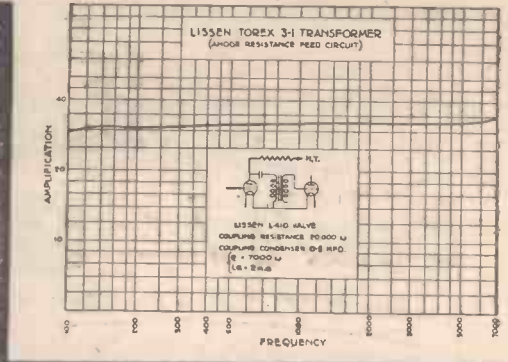

for **5'6**

This new Lissen Torex Transformer enables you to make a big cut in the cost of building amplifiers. It is a high-grade silicon-steel core transformer, with remarkably even amplification over the whole band of audible frequencies (see curve). It is a neat, compact component; moulded bakelite case which is hermetically sealed and completely insulates the windings. Proof against shorting, leakage, or moisture.

### WHERE TO USE IT

Use this Lissen Torex Transformer for the first L.F. stage of any amplifier. Use it where big amplification is desired at small cost. Use it for all temporary "hook-ups"—you can change it from set to set because it is a "general purpose" transformer. Particularly fine results are obtainable when this transformer is used in an anode resistance feed circuit.



**LISSEN**  
**TOREX**  
**TRANSFORMER**

LISSEN LIMITED, Worples Road, Isleworth, Middlesex

# LEWCOS

Regd.

## NEW DEVELOPMENT

### GREATEST YET



**THE**  
*The*  
**New Lewcos  
D.C.G. Unit**

PRICE  
**45/-**

The Lewcos Dual Screened Coil Unit DCG/2 consists of a tapped aperiodic aerial coil and screened grid H.F. Transformer covering the medium broadcast waveband of 235 to 550 metres and the long waveband of 1,000 to 2,000 metres.

Both coils are astatically wound, i.e. fieldless, and are enclosed in a metal screen, as illustrated.

The push-pull switch operating mechanism supplied free of charge with this unit on request.

Write for leaflet Ref. R.66.



**NONE  
GENUINE UNLESS  
IT BEARS  
THIS LABEL**



THE LONDON  
ELECTRIC WIRE  
COMPANY AND  
SMITHS LIMITED

WRITE FOR  
LEWCOS FREE  
SHEET OF  
BLUE PRINTS  
OF FOUR SUG-  
GESTED CIR-  
CUITS UTILIS-  
ING LEWCOS  
COMPONENTS.

Please quote Ref.  
R.70.

Church Road,  
Leyton,  
London, E.10

STOCKS HELD AT  
THE FOLLOWING  
BRANCHES:  
BELFAST  
BIRMINGHAM  
CARDIFF  
DUBLIN  
GLASGOW  
LEEDS  
LIVERPOOL  
LONDON  
MANCHESTER  
NEWCASTLE  
NOTTINGHAM





# RADIO ECONOMIES

*Mr. Victor King recently placed a number of particularly knotty problems before the "Wireless Constructor" Ideas Committee. And here you have an excellent precis of the very interesting discussion that followed.*

**I**F you had to economise very severely in the construction of a radio outfit—and many constructors must find themselves obliged to do this—how would you set to work? That is the question that was placed before a recent meeting of the WIRELESS CONSTRUCTOR Ideas Committee.

The following "leaders" were given by Victor King as a guide so that the discussion should not travel on too-broad lines.

## The Questions Asked

"Would you go for the biggest possible set built of the cheapest possible gear, or would you build a small outfit using the best of everything throughout?"

"On the other hand, would you compromise and build a set composed here of cheap gear and there of the most expensive items you could afford? If so, where would you economise, and where would you go 'all-out' in proportion with your means?"

"Would you economise in accessories and, if so, where? Or would you go 'all-out' in respect of such things as valves and loud speaker?"

As Mr. Victor King said, such queries can be answered only in a general way, and no hard-and-fast rules can be laid down, but he considered that the opinions of the various members should prove of vital interest to readers.

After a certain amount of general discussion, Mr. A. S. Clark made the following remarks relative to set economies:

## Making Compromises

"Set designing is always a matter of compromise. The designer in the WIRELESS CONSTRUCTOR Research Dept. has to compromise between such things as technical desirabilities, appearance, expense, ease of control and construction, etc.

The constructor, in the case we are considering, is definitely limited so far as expense, but has to compromise between elaborate components and the cheapest possible. The one thing which really matters as regards the set is results, and results should be the one guide to how to compromise.

It should be his aim to get the maximum results for the amount of money available, but I do not consider that obtaining maximum results necessarily means having the largest possible number of valves. Rather it consists of getting the most out of each stage of the set, cutting expense only where it will not affect results.

## "An Obvious Answer"

"Of course, the question of compromise comes in again when we decide what is meant by 'maximum results.' However, it largely depends on what is required in the way of selectivity, distance reception, volume, etc., but this resolves itself largely into the type of circuit to employ.

"Mr. Victor King has asked where we consider economy should be carried

the farthest. Personally, I think that is a matter which, considered technically, has an obvious answer.

"As long as a component does its job really efficiently, so far as results are concerned, the cheaper it is the better. For instance, a wooden panel can be used instead of ebonite, if connections are arranged properly. Again, all a variable condenser need do is to tune. Providing it has good insulation it need not be ball-bearing or have a drum drive.

## Plenty of H.T. Essential

"Expense, of course, can be very, very greatly cut down by making components at home where possible." (In this connection, the handbook in this issue is a whole mine of information.—Ed.)

"A point where economy simply cannot be made is in regard to H.T. It is possible to get more out of a good two-valver with the maximum H.T. voltages desirable than from a 'three' which is being run, as so many unfortunately are, on a partly run-down battery which even when new was only rated at perhaps 100 volts.

"Good valves of a suitable type must be used, particularly as regards the output valve, but an expensive loud

## WHAT WOULD YOU DO?



*Mr. Victor King, second from the left, gets the Committee busy on the subject of little-and-good and big-and-not-so-good radio receivers. We should be interested to receive postcard comments from readers.*

## Radio Economies—continued

speaker is not necessary. When the set is good and the power valve is *not overloaded*, it is a very poor loud speaker which will not give results sufficiently good for the man whose first consideration is expense.

### "Far, Far, Better . . ."

"To generalise, I should say economise wherever appearance and convenience are concerned, but as far as possible not where results will be affected, and don't forget quality. Two or three stations with purity on a two-valver are far, far better than horrible noises from all over the continent!"

Mr. Kelsey then said:

"Would I build the biggest possible set from the cheapest possible gear? Well, as Mr. Victor King has rightly said, the question can only be tackled

ting distance, I should not be very concerned with quality reception, and in consequence I should aim at the largest set possible within the limited means.

"On the other hand, if I wanted my radio as a source of musical entertainment, where quality would certainly be an important consideration, my choice would be a small set built from first-class components.

"In this case I should have to be content with the local stations, and economies effected by the omission of wave-changing would help towards the cost of decent accessories.

"It would, I suppose, be possible to compromise between the two, but if I were faced with a choice I should go for the 'quality and only local' combination, and possibly at a later date I would build a cheap

and I should discriminate in the selection of fixed condensers, grid leaks, H.F. chokes, etc., according to the part of the circuit in which they were to be used.

"I should certainly not use cheap and shoddy accessories, because no doubt in the long run that would prove to be false economy.

### "Unnamed" Components

"The loud speaker is the only accessory on which I should endeavour to save money, because there are now so many excellent cone units available at reasonable prices that quite a considerable economy could be effected in this way."

Mr. A. Johnson-Randall ventured the following remarks:

"Mr. Victor King has set us a rather difficult problem. It is never easy to economise in set construction, because high-class components cost money, and if you endeavour to cheapen the set by purchasing low-priced parts it means that you have to buy components of the 'unnamed' variety, and in using these you take a big risk, because you haven't the backing of a reputable maker behind them.

"If I were compelled to choose between a small set built of first-class parts or a big set made up of cheap ones, I would choose the former. My reasons are twofold. First, I like to have a set that I can rely on—one that will give me the maximum amplification per stage, and yet will not give trouble through the breakdown of any of its parts.

### Running Costs

"Secondly, if it were necessary for me to economise so severely in the construction of a radio outfit, it is also probable that my shallow pocket would compel me to cut down running costs.

"The construction of a small set would enable me to do this, whereas a bigger set might require more H.T., and it would most certainly need more L.T. Of course, the problem is largely dependent upon the constructor's individual requirements.

"Some people want distance, while others are quite content to listen to their local transmissions. If the set is to have an H.F. stage, there is no reason whatever why the enthusiast

(Continued on page 134.)

### EUROPE'S BIGGEST BROADCASTER



This is a part of the colossal transmitter the Polish Broadcasting Co. are going to instal near Warsaw. Its power will be 160 kilowatts—over four times the power of 5 X X I!

in a general way, but, personally, it would depend entirely upon what I intended to do with the finished receiver.

"Naturally, one must impose limits even on the cheapest possible gear, because otherwise the question would resolve itself into one of results or no results! But if my aim were simply to see how many stations I could log—in other words, if my radio amusement were to consist simply of annihilating

short-wave adaptor to work with my local set so that I could experience the fascination of listening to distant stations on the short-wave band.

### A False Economy

"If I were asked to build a set for someone else in such a way as to effect a compromise between the two, I should spend the most money on the L.F. intervalve couplings and the valves.

"The coils I should make myself



**TROUBLE-FREE SET BUILDING**      **USE READY RADIO APPROVED NON-SOLDERING KITS ONLY**      **USE JIFFILINKS FOR WIRING-UP**

**COMPLETE KITS OF PARTS FOR ALL SETS**

**IMMEDIATE DESPATCH—FOR CASH OR EASY PAYMENTS**

**THE 'INTERNATIONAL' THREE**

PRICE LIST OF APPROVED PARTS.

	£	s.	d.		£	s.	d.
1 Ebonite panel, 18 x 7 x 3/16 in.	6	0		1 Hypermite L.F. transformer	12	6	
1 Ebonite strip, 18 x 2 x 3/16 in.	2	0		1 Lotus L.F. transformer	12	6	
1 Hand-polished cabinet, 18 x 7 x 10 in., with baseboard	1	10	0	1 ReadRad 2-meg. grid leak and holder	1	4	
1 ReadRad -0003 variable condenser and duograph dial	11	0		1 T.C.C. 2-mfd. condenser	3	10	
1 ReadRad -00015 differential condenser	5	0		9 Engraved Belling-Lee terminals, type "B"	4	6	
1 ReadRad 3-point switch	1	6		2 Lengths ribbed ebonite former, 3 in. diam. x 1/2 in. long	1	6	
1 Igranite 5-meg. megostat	6	0		1 Length ribbed ebonite former, 3 in. diam. x 1 1/2 in. long	1	1	
1 ReadRad on-off switch	4	6		3 Belling-Lee indicating wander plugs	11		
3 Benjamin vibrolders	1	6		1 Paxolin former, 2 1/2 in. diam. x 2 1/2 in. long	8		
1 Formodensor, type G	1	6		1 1/2-lb. reel 18 g. round tinned copper wire	8		
1 Formodensor, type J	1	6		1 1-oz. reel 26 D.S.C.	10		
1 ReadRad b/m filament resistance, 30 ohm	2	0		1 1-lb. reel 24 D.C.C.	1	1	
1 ReadRad -001 fixed condenser	10			1 Set ReadRad Jiffilink	2	6	
1 ReadRad -0003 fixed condenser	10			1 Crocodile clip, flex, screws, etc.	1	0	
1 Bulgin H.F. choke (short-wave)	3	0		3 Valves, as specified	1	7	6
1 Igranite 400-ohm preset potentiometer	1	8		2 Clix sockets; 1 Clix plug	6		
1 ReadRad 25,000-ohm resistance	2	6		<b>TOTAL (including valves and cabinet)</b>	<b>£7:12:6</b>		

**THE "EAGLET" TWO**

PRICE LIST OF APPROVED PARTS.

	£	s.	d.		£	s.	d.
1 Panel, 14 x 7 x 3/16 in.	4	6		1 ReadRad -0001 fixed condenser	10		
1 Strip, 14 x 2 x 3/16 in.	1	9		1 ReadRad Hilo choke	4	6	
1 Hand-polished cabinet, 14 x 7 x 10 in.	1	3	6	1 Varley H.F. choke	9	6	
1 ReadRad standard screen, 10 x 6 in.	2	0		1 ReadRad 2-meg. grid leak and holder	1	4	
1 J.B. double gang -0005 condenser with drum	1	6	6	9 Belling-Lee "B" terminals	4	6	
1 ReadRad -00015 differential condenser	5	0		2 Ribbed ebonite formers, 3 1/2 in. diam. x 2 in. long	2	0	
1 ReadRad L.T. switch	10			2 Pirtooid formers, 2 1/2 x 3 in. and 2 1/2 x 2 in. long	1	6	
1 Double-pole change-over switch, complete with ganging rod and panel control	5	6		1/2 lb. 24 D.S.C. wire	2	6	
2 Benjamin vibrolders	3	0		1/2 lb. 26 D.S.C. wire	2	9	
1 Clix plug and socket	4			1/2 lb. 30 D.S.C. wire	3	0	
2 T.C.C. -05 condensers, type 40	3	6		Screws, crocodile clips (4), flex, etc.	1	6	
1 ReadRad 600-ohm resistance and holder	2	6		1 Set ReadRad Jiffilink	2	6	
1 ReadRad -001 fixed condenser	10			2 Valves, as specified (S.G. and Det.)	1	8	6
				<b>TOTAL (including valves and cabinet)</b>	<b>£7:4:8</b>		

- KIT A** less valves and cabinet £4:15:0  
or 12 monthly payments of **8/9**
- KIT B** with valves less cabinet £6:2:6  
or 12 monthly payments of **11/3**
- KIT C** with valves and cabinet £7:12:6  
or 12 monthly payments of **14/-**

**THE "PARATUNER"**

	£	s.	d.		£	s.	d.
2 Ebonite strips, 4 1/2 x 2 in.	1	3		1 ReadRad -001 fixed condenser	10		
2 Wooden strips, 4 1/2 x 2 in.	9			1 R.I. Varicap condenser, -0001	2	6	
1 Baseboard, 4 1/2 in. x 4 1/2 in.	8			Wire, screws, etc.	6		
2 Clix sockets with plugs	8			<b>COMPLETE</b>	<b>16</b>	<b>0</b>	
2 Belling-Lee "B" terminals, A and E	1	0					
1 ReadRad Paratune coil	8	6		<b>PARATUNE COIL AS SPECIFIED AND APPROVED BY "WIRELESS CONSTRUCTOR" .. each</b>	<b>8/6</b>		

- KIT A** less valves and cabinet £4:12:8  
or 12 monthly payments of **8/6**
- KIT B** with valves less cabinet £6:1:2  
or 12 monthly payments of **11/2**
- KIT C** with valves and cabinet £7:4:8  
or 12 monthly payments of **13/3**

Any components can be supplied separately if desired.

**TO OVERSEAS CUSTOMERS.**  
All your goods are very carefully packed for export and insured, all charges forward.

**TO INLAND CUSTOMERS**  
Your goods are despatched post free or carriage paid

**Immediate Dispatch**

**Reedy Radio**

159, BOROUGH HIGH STREET, LONDON BRIDGE, S.E.1.

Telephone: Hop 5555 (Private Exchange)      Telegrams: READIRAD, SEDIST.

**Cash or Easy Payments**



# DUBILIER RESISTANCES NOW COST YOU LESS



DUMETOHMS reduced to 1/9 All values.

There is no excuse for using inferior resistances because Dubilier now pass on to you the benefits of increased production, namely—lower price.

Good resistances are essential if the best results are to be obtained, so ask for Dubilier next time. Use Dubilier Condensers, too!



DUWIROHMS now from 4/6 to 17/6 according to value.

## FIXED CONDENSERS

TYPES 610 and 620

·00005 to ·0009	1/3
·001 and ·002	2/8
·003, ·004, ·005	2/-
·006 ... ..	2/6
·01 ... ..	3/-



Use Dubilier Components and be certain of satisfaction.

# DUBILIER CONDENSERS

Dubilier Condenser Co. (1925) Ltd.,  
Ducon Works, Victoria Road, N. Acton, W.3.

# No. 2 of the NEW LONDON MAGAZINE

at the NEW PRICE

6<sup>d</sup>.

SPECIAL XMAS NUMBER

The amazing success of the first issue of the NEW LONDON—the bigger, brighter and better LONDON—has more than justified the confidence with which the Editor introduced the rebirth of an old favourite to the public. Readers have realised that here is indeed wonderful value for sixpence—splendid fiction, fascinating articles, yes, and a beautiful FREE plate. And No. 2 worthily maintains the standard. Look at the contents list.

Brilliant Stories by :

- E. BARRINGTON—GILBERT FRANKAU
- DENIS MACKAIL—DON PORTBURY
- SELWYN JEPSON—A. J. ALAN

Fascinating Articles Include :

Housekeeping for a Genius by Mrs. EDGAR WALLACE

“Behind the Scenes of Great Paris Costumiers”

By JAMES E. ABBE

AND ALL SORTS OF IDEAS FOR CHRISTMAS GIFTS

**FREE FLOWER PAINTING**  
IN FULL COLOUR  
by  
**H. DAVIS RICHTER,**  
R.I., R.O.I.



Now on Sale

6<sup>d</sup>.

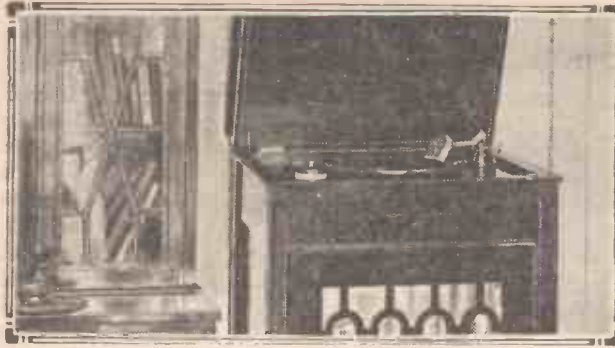

## WITH PICK-UP AND SPEAKER

*Converting Your Set for Use with a Pick-Up—'Ware Instability—Earthing the Tone-Arm, etc., etc.*

Conducted by **A. JOHNSON-RANDALL.**

**T**HIS month I want to say a few words about the little troubles that sometimes arise when an ordinary wireless set is converted into a radio-gram. It seems to me that far too many readers get whistling and distortion directly they switch their pick-ups into circuit.

Now this should not occur with the average two-stage transformer-coupled amplifier, if the arrangements for bringing the pick-up into use have been properly carried out.

### Those Long Leads

In most cases the pick-up switch is inserted in the grid circuit of the existing detector valve, and I think that most of the troubles are caused by the way in which the leads to the pick-up are taken from the set. Only too frequently do we see long, straggling leads from some point on the panel or terminal strip taken right over the L.F. side of the set to the gramophone turntable in some other part of the room.

In one case I remember seeing these leads tied to the loud-speaker leads for neatness, and the owner of the set wondered why he got a high-pitched whistle directly he switched the pick-up into circuit. This, of course, is an exceptional case, but to do a thing like this is to ask for trouble, because it completes the L.F. "chain" from the loud speaker to the first amplifying valve, and is probably the best way of producing instability.

### A Simple Safeguard

The same thing is liable to happen if you allow the leads to the pick-up to pass over any portion of the L.F. side, and you should always take the leads direct to the pick-up and keep them well away from the set itself.

In spite of this, trouble does sometimes occur, and it is a good plan to increase the value of the anti-mobo by-passing condenser from 2 mfd. to 4 mfd.

In modifying the set itself great care should be taken to keep the leads

from the grid of the detector valve to the switch as short as possible.

I always earth the tone-arm of my pick-up as a precautionary measure, and I advise readers to do this also. It very often makes all the difference in the world, and I have known cases of instability to be cured by this simple measure.

It is possible for trouble to occur through the use of filament switching. If you include a scheme for switching out the filament of the H.F. valve when the pick-up is brought into circuit, make quite sure that it does not break the earth connection to the amplifier. This is only likely to happen when the switch contact is

I once had a super four-valver consisting of a stage of screened-grid H.F. and two-stages of L.F., resistance coupled. I took particular pains in laying out the set to guard against any possibility of trouble, especially on the L.F. side.

### The Pick-Up that Moaned!

A de-coupling device was employed and also a filter output. The L.F. stages were carefully screened with metal, and yet after a while I found much to my bewilderment that when the pick-up was in use the set tended to develop a low moan which completely spoilt the record music.

I couldn't understand this happen-

### A PORTABLE GRAMO-AMPLIFIER



*This is a super portable gramophone amplifier made by Celestion's. When not in use the equipment can be packed away in the trunk seen underneath the amplifier. On the front are the volume and tone adjusting knobs and the two winding handles for the turntable motors.*

connected to the negative side of the filament circuit.

It is practically essential for the average two- or three-stage amplifier to be earthed, and many of them become unstable if the earth lead is removed.

ing, because the whole set was perfectly stable on broadcasting, and one does not expect a comparatively low-magnification L.F. amplifier of the resistance-coupled variety to oscillate with a pick-up.

At the time I was using 200 volts

## With Pick-Up and Speaker—continued

H.T., derived from a battery of accumulators, and I finally discovered that two of the cells had commenced to sulphate rather badly with the result that the internal resistance of the battery had greatly increased.

It is a surprising thing that instability should occur in spite of the precautions taken to avoid it, but there it is, these troubles will happen even though we try to guard against them.

### A New Needle

By the way, there is a new gramophone needle on the market called the "Electrocolor." It is not a metal needle—it is somewhat similar to the Burmese needle, and it needs re-sharpening occasionally.

Actually the needle will play about 20 records with one sharpening. All you need for the sharpening process

to the singing voice. There was also a marked absence of surface noise, but I have a feeling that the higher musical frequencies were being suppressed somewhat, and for piano records, brass bands, etc., I must confess a preference for the steel variety.

### One Word of Warning

I expect that many listeners will like the tone which these needles give, and they are certainly worth trying—one word of warning, and that is: these needles are not suitable for every type of pick-up, so if your particular pick-up happens to be of the needle-armature type, stick to the needles recommended by the makers.

Most of the queries we receive are applicable only to one particular design, but occasionally we get questions asked which are of general interest. Here are a few:

October issue, arrange two extra terminals on the terminal strip and also a small two-way switch. Remove the lead which at present goes from one side of  $C_7$  to  $G$  of  $V_2$ , and instead connect this side of  $C_7$  to one contact of the two-way switch (not the arm).

Take a lead from  $G$  of  $V_2$  to the arm of the switch, so that with the switch arm in one position  $G$  is joined via the switch to  $C_7$ , and the 2-meg. grid-leak holder.

Next join the remaining switch contact to one of the new "pick-up" terminals on the terminal strip. Connect the other terminal to a length of flexible terminating in a wander plug. This should go to the  $1\frac{1}{2}$ -volt tapping on the grid-bias battery.

### Cutting Out Scratch

L. N. (Chislehurst).—"My pick-up seems to accentuate needle scratch, and I would like to cut some of it out if possible. Can I do this without introducing any complicated filter circuits in between the pick-up and the set?"

The fact that you hear the scratch proves that your pick-up is amplifying the higher musical frequencies, and this in itself is a good point. However, if you find the scratch disagreeable you can try a very small condenser across your pick-up. I can't give you any values—you will have to experiment.

Why not get one of those pre-set condensers with a range of something in the neighbourhood of .00015-.0001 mfd.?

Connect this across the pick-up terminals and vary it until some of the scratch goes. A resistance of between 5,000 and 10,000 ohms does the trick sometimes.

Have you tried different types of needles?

### Buzzing Noises

M. N. (Barnet).—"When my pick-up is working it makes a dithering sound on the record. Sometimes it buzzes as if there were something loose. Is anything the matter?"

If the lid of the cabinet is left open you can usually hear a certain amount of buzzing from the pick-up. The remedy is to shut out the noise by closing the lid and making it as sound-proof as possible. At the same time you might make sure that the needle and various small screws, etc., are quite tight.

### A SIMPLE MODIFICATION

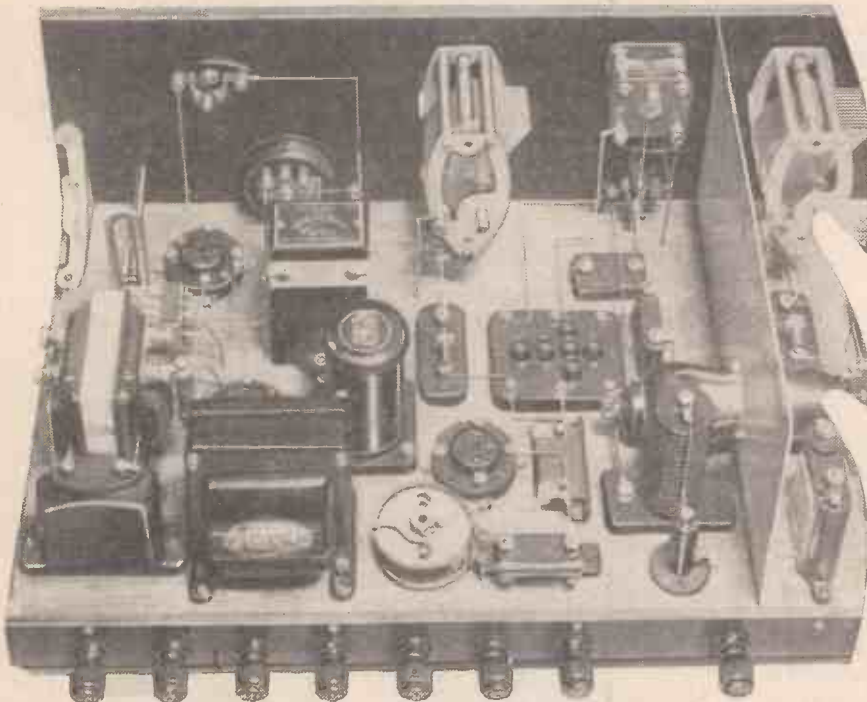

The "Explorer" Four with its two transformer-coupled L.F. stages readily lends itself to radio-gram work. The point-to-point wiring for the pick-up switch is given on this page.

is a little pad of fine sandpaper, and it is claimed that one needle can be played 200 times.

I attended a demonstration of these new needles, and I thought that they suited some records more than others. They gave rather a soft and pleasing tone to the various instruments, and a pleasant "roundness"

### The "Explorer" Four

P. N. G. (Bristol) AND OTHERS.—"I am keen to build the 'Explorer' Four and would like to incorporate a switch for a pick-up. Will you please explain in simple language how this alteration may be carried out?"

Well, P.N.G., this is how it is done. Refer to the diagram on page 290,

# VALVE EFFICIENCY !

## MARCONI ML-4

### SCIENTIFIC FACT

### EXPERT APPRECIATION

### PUBLIC APPRECIATION

FOR THE FINAL STAGE OF THE A.C. ALL-ELECTRIC RECEIVER — MARCONI ML-4, an indirectly heated output valve of exceptional efficiency, combining an amplification factor of 9 with an impedance of only 3,000 ohms—mutual conductance 3.0 M.A/VOLT. ML-4 provides a stage magnification which hitherto has only been possible with valves of much higher impedance; at the same time its undistorted output is ample for most requirements. In construction it retains the essential features of all Marconi A.C. valves—lasting emission, permanency of characteristics, special mesh anode and exceptional vacuum. ML-4 is the ideal output valve for most A.C. Receivers. ITS DEPENDABLE EFFICIENCY HAS BEEN PROVED BEYOND DOUBT—MARCONI ML-4 IS ALL BRITISH—AND COSTS ONLY 17/6.

#### CHARACTERISTICS.

Amp. factor—9	Fil. volts.—4.0
Impedance—3,000 Ohms	Fil. amps.—1.0
Mut. Conductance—3.0 MA/V.	Anode Volts—200 max.

MARCONI ML-4—THE FOREMOST INDIRECTLY HEATED OUTPUT VALVE FOR A.C. RECEIVERS—PRICE 17/6

Marconi Valves are used by The B.B.C., Imperial Airways, Croydon Control Tower, Metropolitan Police, Trinity House Beacon Stations and Lightships, Empire Wireless Communications, Large Passenger Liners, &c., &c., because of their longer life—clearer tone—greater range and volume.

*A letter typical of many received regarding the splendid service given by Marconi Valves:—*

"On May 1st, 1924, I purchased two of your valves—2-volt General Purpose Type, costing at that time 21/- each.

These valves have been in daily use ever since, and to-day are giving me fine results. I have also another one bought three years ago, and these three are working on a P.W. Magic 3 set which I constructed a few weeks ago . . . . Your notice re long life attracted my attention, and I thought how true it was, as I have found it out myself. . . . The volume and selectivity are wonderful, considering I have no Power Valve in my set."

W. S. R., Swansea.

# USE A MARCONI THE VALVE THE EXPERT USES





Each circuit (except the 2-valve Battery Receiver) incorporates attachment for a gramophone pick-up.

# BUILD YOUR OWN FERRANTI

The whole radio world is talking of the superb reproduction afforded by the Ferranti receivers. Free constructional charts have now been prepared, so that with the very minimum of trouble you may be assured of identical results. Whether you require a two-valve or a three-valve receiver, battery-operated or mains-operated, there's a chart to meet your needs. Get the one you want without delay!

# FERRANTI

FERRANTI LTD.

HEAD OFFICE & WORKS: HOLLINWOOD, LANCASHIRE.  
LONDON: BUSH HOUSE, ALDWYCH, W.C.2.

## IT GRIPS THE COVER TOO

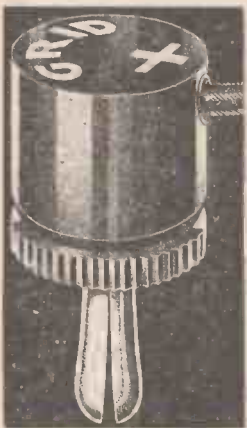
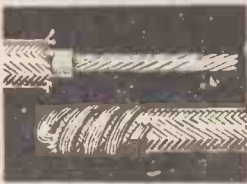

Guaranteed to grip any battery socket, the Belling-Lee Wander Plug also makes an exceptionally neat connection. It grips the whole flex—copper, rubber and braiding—putting an end to frayed, straggling ends. No tools are required. Having bared the wire for three-quarters of an inch, wind it back tightly over the cover for about a quarter of an inch. Then loosen the lower portion of the plug sufficiently to allow of inserting the prepared end of the flex into the hole provided in the side. Tighten up again—that's all.

Special 'D' section hard-drawn wire prongs. Hand engraved—12 letterings to choose from. Price 3d.

The same efficient loading method is employed for all Belling-Lee Plugs and Sockets, Anode Connectors, etc.

Write for Free Belling-Lee Handbook "Radio Connections" (2nd Edition).

BELLING-LEE BATTERY CORD complete with engraved wander plugs and spade terminals 9-way (for all Mullard Orgola 3 circuits) **5/9**

Also made in 5, 6, 7, 8, and 10-way

Advertisement of Belling & Lee, Ltd., Queensway Works, Ponders End, Middlesex.

**BELLING-LEE**  
FOR EVERY RADIO CONNECTION



## TO TRACE DISTORTION

It requires the accuracy and sensitivity of a Weston Mil-Ammeter to tell you exactly at which particular stage in your receiver distortion begins.

Try it in your H.T. leads in turn. Should the needle kick strongly either backwards or forwards when signal strength varies it indicates transformer distortion, over-saturation of the valve, incorrect grid bias, filament temperature or H.T. Potential.

A Weston Mil-Ammeter is the only instrument sufficiently accurate to be of any value to you when making readings. Weston Instruments are standard the world over, and since 1888 have been unrivalled for scientific precision, uniform accuracy and unvarying reliability.

Weston Model 503 Mil-Ammeter, Price 35/-

# WESTON

ELECTRICAL INSTRUMENT CO., LTD.,

15, Great Saffron Hill, London, E.C.1. A.5.



# A PRACTICAL MAN'S CORNER



A special section for the set-builder in which he will find many valuable hints.

By R. W. HALLOWS, M.A.

## Metal Shears

It is said that tinsmiths develop in course of time a special muscle of the hand which enables them to use tin snips such as those seen in Fig. 1 as easily and almost as quickly as the ordinary mortal uses a pair of scissors.

Tin snips usually form part of any tool kit recommended for those who are going to work in metal and they are exceedingly useful for numerous purposes. Without the special muscle in question, though, it is not too easy to operate them anything like quickly.

It is simple enough to make a cut by squeezing the handles together, but whereas the professional tinsmith opens the shears again for the next cut without the slightest apparent

## CUTTING THOSE SCREENS



You have to be careful you do not nip a bit off your hand with the ends of the handles of these snips.

effort the amateur workman not infrequently finds it necessary to employ two hands at this stage.

Another little point of some importance is that if care is not taken the ends of the handles come sharply together when one is using strength to make a cut in rather hard material, with the result that a piece of the palm is caught between them and a painful blood blister results.

My own method of holding tin shears is shown in Fig. 2. They are held in the palm of the hand with the thumb and the first and second fingers

*Metal Shears—An Alternative—And Another—A Use for Valve Legs—Frame Aerial Making—Combs and Windings—Mounting the Frame.*

round the handles. The lowest joint of the third finger rests on the inside of the handles and the little finger is more or less curled up. This grip allows a good squeeze to be given and the third finger is able to open the handles again after a cut has been made.

Held in this way the shears cannot possibly nip the palm of the hand. If, though, the shears are large ones, and the metal somewhat tough, the third finger is apt to become sore in time. In such cases an old glove is a great help.

## An Alternative

Really, I think the tool that we might almost call "power scissors," illustrated in Fig. 3, is really more useful than tinsmith's shears to the amateur.

The universal shears, as they are technically known, can be purchased at any good tool shop and their price is five shillings or a little more. They are made on the lines of tailor's

## GETTING A GRIP



This is how Mr. Hallows advises you to manipulate the cutters.

scissors with large "loops" at the ends of the handles. The blades are short, but very strong.

I have had a pair of these universal shears in use for a long time now and I must say I find them extraordinarily useful for sheet-metal cutting, particularly if any shaping has to be done. It is easy enough to cut straight lines or very large curves with tin snips, but when it comes to rather more intricate shaping work the universal shears are very much more convenient.

One piece of advice, though, I must give to any fellow wireless men who purchase this tool. And that is, NEVER LEAVE IT LYING ABOUT. The reason why I say so is that someone is sure to find it simply invaluable for all kinds of household and garden

## "POWER SCISSORS"



An excellent alternative to the usual tinman's snips.

jobs, so that if you are unwise enough not to keep it concealed it will probably vanish in a mysterious way from your tool kit.

## And Another

It is possible, though, to carry the war into the enemy's camp, if I may so put it, though I beg you not to quote me as recommending that anything of the kind should be done.

Some workbaskets—I merely mention this in passing—are equipped with remarkably attractive-looking tailor's scissors intended for cutting-out purposes.

## A Practical Man's Corner—continued

I have heard it said that if by any chance one's own shears cannot be found, or even if one has omitted to purchase a pair, these scissors are astonishingly good performers upon thin sheet metal. I have found—that is to say, I have been told—that if you are cutting out such things as the plates of fixed condensers or grid-battery holders from an old tin, or grid-leak clips from similar material, these scissors are simply invaluable.

Again, I would mention, though I am not, of course, offering advice, that the Christmas season is approach-

### USEFUL ADAPTORS

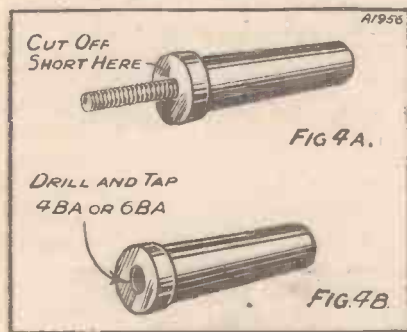

How the valve-leg adaptors are made.

ing, and that if any husband can't think of a suitable present for the wife of his bosom she is sure to be most appreciative of the gift of a pair of tailor's scissors.

### A Use for Valve Legs

In Fig. 4 is seen a very useful method of making adaptors from valve legs for rapid connections and disconnections to terminals. It frequently happens that when a set or a circuit is being tried out it is necessary to discover by experiment which of certain terminals on a particular component will give the best results.

### QUICK CONNECTIONS

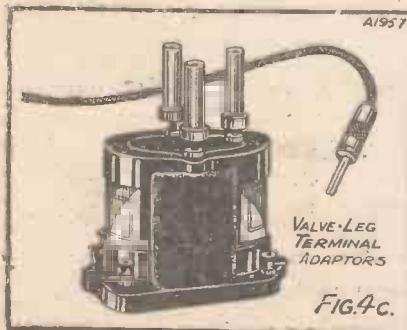

The adaptors applied to an anti-mobo unit with several high-tension positive taps.

Examples are anti-mobo units which contain three alternative high-tension positive terminals, or an output transformer with a tapped secondary and tapped primary. Making

### MAKING A FRAME

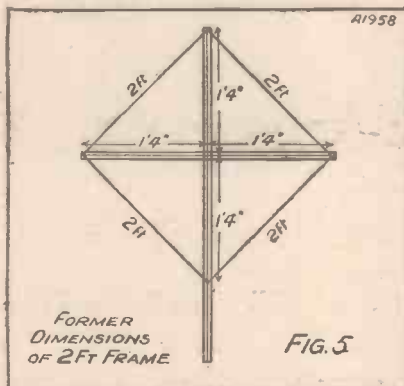

The dimensions of a frame aerial of useful size.

and unmaking connections with milled nuts and plain flex is rather a slow and unsatisfactory method of undertaking the job.

Milled nuts, if they are properly tightened down, make the hardest of fingers sore in time, and flex has a horrid way of getting nipped in the threads and coming unstranded.

My own scheme is to keep by me three sets of valve leg adaptors, one for 4 B.A. terminals, one for 5 B.A., and

### THE MIDDLE JOINT

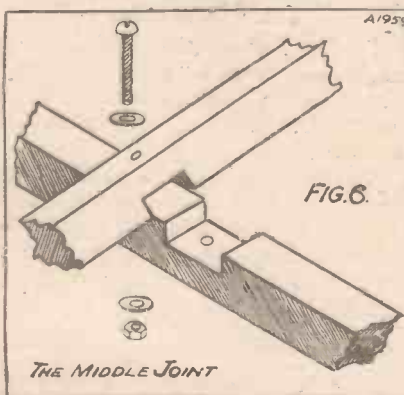

The centre of the frame should be secured by glue and a nut and bolt.

one for 6 B.A., so that if, as sometimes happens, a component with those miserable 5 B.A. terminals turns up, I am still undefeated.

To guard against possible losses, each set contains six adaptors. Diagrams A and B in Fig. 4 show how the adaptors are made. A rather stout and solid valve leg is best for the

purpose. Cut the shank off short, as shown at A, and file the base flat.

The next business is to make a punch mark as near the centre as possible. In case you find this difficult, put the valve leg into the chuck of your hand-drill, fix the latter horizontally into the vice by means of the grip intended for the left hand,

### EBONITE COMBS

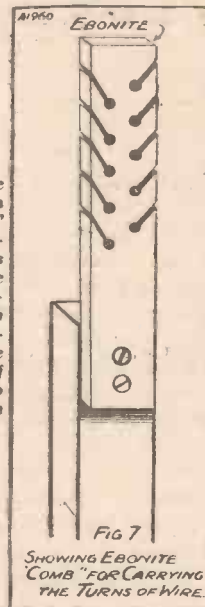

Pieces of ebonite should be cut in this "comb" fashion, and secured to the ends of the arms. The number of hacksaw cuts in each comb will correspond with the number of turns of wire you wish to accommodate on the frame.

spin the valve leg, and you will have no difficulty in marking the centre with a pencil.

This done, drill and tap 4, 5 or 6 B.A., as the case may be. The third diagram, C in Fig. 4, shows how the adaptors are used on the terminals of a tapped anti-mobo unit. A wander-plug is fixed to the end of the flex lead and

(Continued on page 135.)

### STARTING THE WINDING

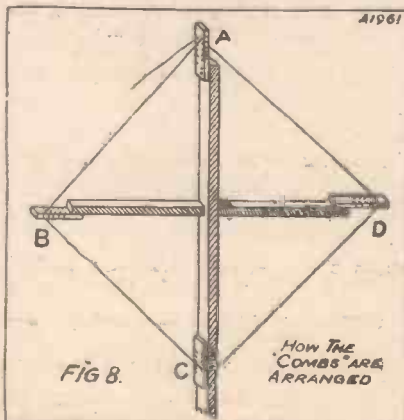

And here you see how the wire is wound on.

**The most economical H.T.** The Exide Battery gives the cheapest form of H.T. Instead of replacing it, as you would a dry battery, you merely recharge it—and it costs much less than a mains unit.

**Makes reception pure**—an Exide adds no noise to your reception—no buzz, no crackle, no howl. It's silent right to the end of its charge—helps to eliminate harshness too—distant stations come in clearer. Aids selectivity—helps to cut out interfering stations because voltage does not fluctuate.

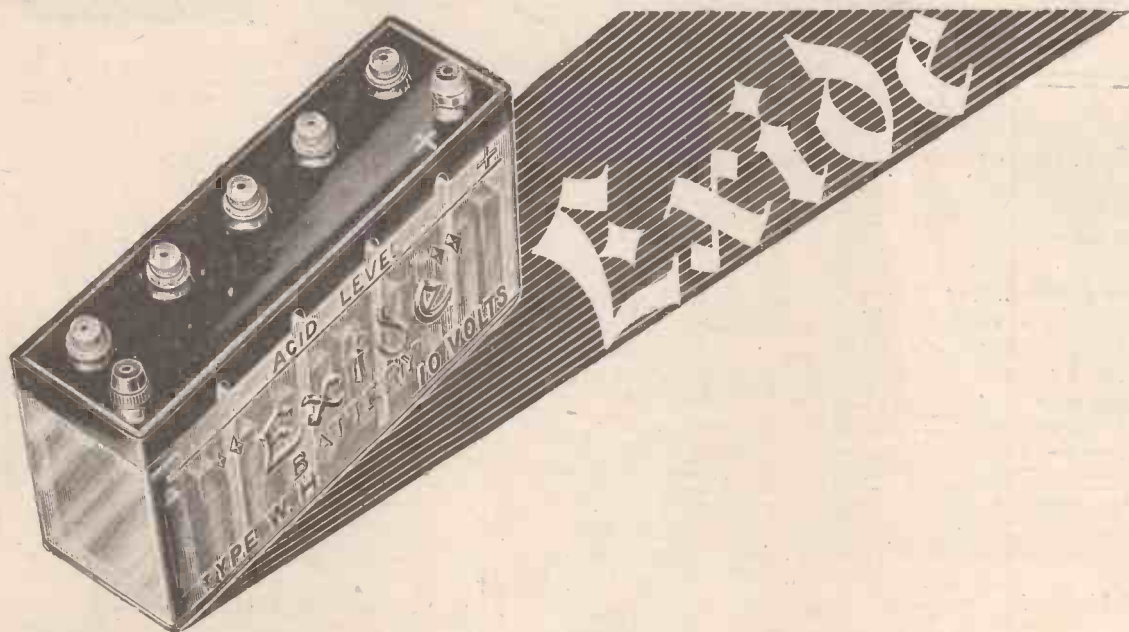

The Exide Battery is in almost all the big speech amplifiers. Wherever clarity and reliability are vital they choose an **Exide**

Prices per 10-volt unit: W.J. 2,500 milliamps 5/- • W.H. 5,000 milliamps 6/3 • W.T. 10,000 milliamps 12/-

Obtainable from Exide Service Stations or any reputable dealer. Exide Service Stations give service on every make of battery

Exide Batteries, Clifton Junction, near Manchester. Branches at London, Manchester, Birmingham, Bristol and Glasgow

LIX

# No slip or backlash

Even good sets, may appear unselective through inefficient tuning dials.

The J.B. Drum Dial will separate every programme for you. It is the most up-to-date Drum Dial on the market. Its powerful friction drive is exceptionally smooth in operation. It will move your condenser vanes the merest fraction of an inch and hold the setting indefinitely.

Moreover, you can earth the Drum and use it as an anti-capacity shield, since all parts of the Dial are insulated from the Condenser.

Vernier Ratio, 16/1. Drum Diameter, 4".  
Supplied in bronze or oxidised silver finish.

Also supplied complete with Lampholder for illumination at same price.



The scale is Ivorine, reading 0-100, and is reversible so that reading may be altered to 100-0.

The scale is flush with the panel, making it exceptionally easy to read

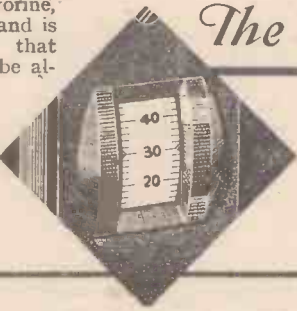

## The J.B. DRUM DIAL Price 10/6



PRECISION INSTRUMENTS

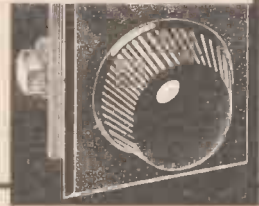

By a patented method the Control Knob is placed immediately below the scale—the most convenient place for it. The powerful friction drive prevents backlash and slip.

Advertisement of Jackson Bros., 72, St. Thomas' Street, London, S.E.1.

Telephone: Hop 1837.



## Smooth Sailing DEMANDS Control

Regattas are won when Control is at the Helm. Every carefree gust of wind must be controlled... every sail bellying properly, working the sloop smoothly, surely around the final buoy and down the last leg, the winner. In millions of homes radio skippers are cruising round the dials with CENTRALAB Controls at the helmsman's hand. With CENTRALAB Control at the helm there is always smooth, noiseless reception. Be sure it's a CENTRALAB Control.

Write for complete CENTRALAB Catalogue—it's FREE.

# Centralab

THE ROTHERMEL CORPORATION LTD.  
24, Maddox Street, London, W.1.

Phone: MAYFAIR 0578/9.

Continental Sales Office:  
27, QUAI DU COMMERCE, BRUSSELS, BELGIUM.

LOCAL STATIONS  
REGIONAL STATIONS  
FOREIGN STATIONS

PICK THEM OUT!

Why worry about old fashioned plug-in coils when the new British General Aerial Tuning Unit covers the full tuning range of 200 to 2,000 metres by means of a single dial. Easy to fix, simple to tune and guaranteed effective.

From all dealers of repute or direct from the manufacturers.  
PRICE 14/6

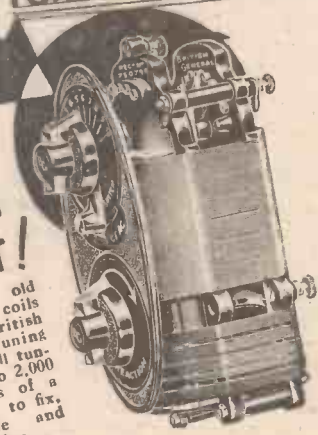

BRITISH GENERAL

MANUFACTURING CO., LTD.  
Brookley Works, LONDON, S.E.4

IN  
LIGHTER  
VEIN  
By  
WAYFARER

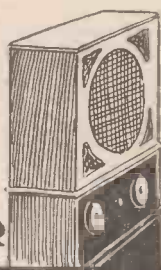

"ALL QUIET — !!!"

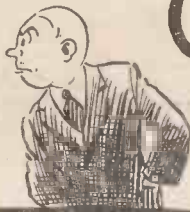

# OUR WEEK-END PROGRAMMES

"It is disgusting," observed the Professor, sinking into a chair and rising hastily from it with little Bingo attached to the seat of his trousers. Next moment he was flying round the room at about forty miles an hour.

"Pull him off!" he yelled. "How can I pull him off if you don't stop and let me catch him?"

"But how can I stop," screamed the Professor, "when the little brute's chewing steaks out of me?"

## Two Retirements

"Remember centrifugal force," I shouted above the din. "Run round in small circles."

Round and round dashed the Professor with little Bingo streaming behind him like the tail of a comet. Then suddenly with a noise like a long atmospheric the Professor's pants gave way, and little Bingo, flying off at a tangent, hurtled through the window. The little hound retired under a bush to chew the piece of the Professor that he had taken with him, whilst Professor Goop retired upstairs for first-aid and a fresh garment.

## WITH BINGO ATTACHED



... like the tail of a comet!

On his return he was forced to continue the conversation standing, and he has had to take his meals off the mantelpiece ever since.

"What was I saying before that regrettable incident?" he inquired.

I told him that he merely remarked that it was disgusting, without having time to explain exactly what "it" was.

"Ah, yes," said the Professor. "I was about to remark how disgraceful is the way in which people constantly hurl adverse criticism at the beautiful programmes that the B.B.C. provides for our delectation."

I cordially agreed. "What," asked the Professor, "is the king of musical instruments?"

"The saxophone," I suggested, after a little thought.

"No, no. Think again." I began thinking again and my eyes dropped shut.

"Wake up!" cried the Professor, kicking me upon the shins.

Dr. Yupushoff travels all the way from the town of Nastikoff, in Yugo-Toblasia, to spend a radio week-end with Wireless Wayfarer.

"The trombone," I suggested. The Professor shook his head. I went through all the musical instruments I could think of, from the bombardon to the triangle, and none of these appeared to be right, and the Professor was showing signs of rising irritation as I made shot after shot.

"Idiot!" he screamed. "Why, the organ, of course. Surely any fool knows that."

"Ah, yes, indeed, I had forgotten that. Of course, the organ is admitted to be the finest of them all."

"And," said the Professor, "do you find that the B.B.C. neglects the organ?"

## The Organ at Work

"Why, no," I answered. "Nobody could say that. In fact, whenever I switch on, no matter which of our home stations it may be, I invariably find the organ tootling and rumbling away."

"Well, there you are," said the Professor. "The public wants the best; the public is getting it. And what else does the public want?"

"Beer," I said after a moment's hesitation.

"My dear fellow," cooed the Professor, "we are talking about broadcasting. You can't broadcast beer. Still, that gives me an idea. One of these days I may perfect the Goop-Teleboozer."

I urged the Professor to begin at

once upon the development of his invention, and I have no doubt that in the near future he will evolve something thoroughly satisfactory unless, of course, his projected British Beer-casting Corporation gets into the hands of the cocoa people.

The Professor then told me the answer to his previous conundrum. The British public's next obvious requirement was for quintet music. "We have nothing," he said, "finer in that line than the Worsun-Barkinson Quintet, and no one can say that we are not given a full ration of their performances."

## Education Wanted

Again I heartily agreed, admitting that in the past fortnight, whenever I had not found an organ on tuning-in, I had invariably found this wonderful quintet.

"Next," said the Professor, "the British public is longing to be educated. Lives there a man who does not yearn to know all about the childhood of beetles, or the life-history of the rather more disgusting fungi?"

"Is there anyone who is not thrilled to the marrow by a discourse upon how to prevent waterpipes

## BEER BROADCASTING



The Goop "Teleboozer."

freezing, especially if it is delivered during a heat-wave? Is there a soul so dead that it does not overflow with joy when its owner, hanging, so to speak, upon the lips of the loud speaker, is told how to convert scraps of linoleum into a bread-and-butter pudding?

"Can any Briton fail to rise to his feet and metaphorically raise the hat that he should not be wearing in the house when one of our more arid statesmen dilates upon the policy of self-determination amongst the Hottentots?"

## In Lighter Vein—continued

I admitted that these things were so and then some.

"And yet," said the Professor in the same kind of sad, sweet voice that one's father used to use when he remarked that this was going to hurt him much more than it was going to hurt you, "and yet there are still people who grouse about our glorious programmes."

"There are," I concurred. "The soulless stinkers!"

The Professor and I agreed to conduct a little crusade against these absurd grouzers, and during the next few days both of us were able to put in quite an amount of good work with people such as Tootle, Pimple-son, and Captain Bucket.

### Driving it Home

"See that you drive your arguments home," had been the Professor's parting injunction to me, and I jolly well drove them home with an earth-tube to Pimple-son. During the ensuing week-end I had an opportunity of carrying the good work still farther afield.

It happened that my old friend Dr. Yupushoff was over on a brief visit from his native town of Nastikoff, the capital of Yugo-Toblazia. Naturally he spent the Saturday to Monday in a visit to me. He has often done so before, and it usually means that he never stops talking, whilst I never stop snoozing.

This time it was a very different pair of sleeves, and I was able to get some pretty useful propaganda off my chest. There is nobody I hate so much as the fellow who runs down his own country to these foreign johnnies.

### An Early Arrival

Dr. Yupushoff arrived in what he called the middle of the Saturday morning, though as it was barely half-past eleven I should term it more like the middle of the previous night. I mean to say I wasn't exactly dressed when he arrived. To be more accurate I wasn't out of bed, and to be still more accurate I was still sound asleep.

However, he burst into my bedroom and, knowing from past experience that he would desire to plant a kiss upon my chaste cheek, I made one bound for the wardrobe and conducted the conversation through the chink in its door.

"Vell," he said at length, "I leave you now vilst you put on the pantaloons and the chemise. But make no 'urry. I amuse myself till you are invested. I go to the vireless set. I sveetch on. I rrrrrrevel in the music so beautiful, yes, no?"

He departed, and I hastily locked the door. Presently I opened it cautiously, saw that he was not in the offing and slipped into the bathroom. I was singing happily in my bath when there came a crashing upon the door.

### KEY-HOLE CONVERSATION



"... out on the pantaloons and chemise."

"Hi! You push off!" I roared.

"Yes; dear friend," came a voice.

"It is I, Yupushoff. Your vireless set she is vot you call bust. She make no music."

"Never mind," I said, "sit outside the door and hear me sing 'Sloppy Boy.'"

### The Weekly Tub

"I will not disturb you," said the voice. "I know your English customs. It is Saturday. You are 'aving your weekly."

Before I could think of a suitable retort he was gone. When I got down an hour or so later he was still trying

### QUIET RECREATION!



"... that is where broadthrowing comes in."

to tune in music from the local station.

"I am sorry," I said, "I ought to have remembered to tell you that on Saturday we don't have any broadcasting during the mornings. Now let me tune in Radio-Paris or Nastikoff for you. In fact, you can have almost any of the Continental stations."

"But I do not vish a Continental

station. I 'ave come to 'ear English broadthrowing. All the world knows that the veek-end is the English 'oliday, when your splendid countrymen entertain themselves. Vere is the broadblowing at this time ven you make merry?"

I explained that the holiday naturally extended also to the B.B.C., for even the meanest in the land were entitled to their rest. So we tuned in Nastikoff, and then we had Motala, and then Hilversum, and then Huizen; and then the Eiffel Tower, and then Kalundborg, and then Radio-Paris, and then Lahti, and then Zeesen.

### "English Broadblowing"

After lunch the Doctor rushed with a beaming smile to the wireless set.

"Now at last," he cried, "I vill 'ear the English broadblowing!"

With a sad smile I told him that the B.B.C.'s holiday extended until half-past three. So we had Nastikoff, and then Motala, and then Hilversum, and then Huizen, and then the Eiffel Tower, and then Kalundborg, and then Radio-Paris, and then Lahti, and then Zeesen.

After that we got rather engrossed in conversation for a time, and when we switched on we found the Children's Hour in progress from one station and a talk on pig's feet from another. However, that did not matter a bit, for we had Nastikoff, and then Motala, and then Hilversum, and then Huizen, and then the Eiffel Tower, and then Kalundborg, and then Radio-Paris, and then Lahti, and then Zeesen.

### All Over Again

During the evening we went to see Professor Goop, and could not hear any wireless at his house since a slight accident had eliminated his eliminator. We got back to my place at half-past ten, and once more the Doctor dashed to the wireless set.

"Now at last," he cried, "I vill 'ear your British broadthrowing. Ve, though ve do not know the veek-end, have our most wonderful programmes on Saturday night. Yours must indeed be superb."

He spun the dials to the tuning of the Regional and switched on. There was lots of silence. The National was doing dance music, so he did not want that. So we had Nastikoff, and then Motala, and then Hilversum, and then Huizen, and then the Eiffel Tower,

(Continued on page 134.)

# LIFELIKE REPRODUCTION *demands perfect* RADIO COMPONENTS

"GOOD ENOUGH" is not "Good Enough" in the Telsen laboratories! Here, they realise that the public are getting keen judges and critics of radio reproduction. Here, they select and adopt the principles that will give trouble-free and faithful reception. Here, they build their Components as well as it is possible to build them, and only the finest materials and craftsmanship are employed . . . and yet their prices still remain—one of their attractive features.

ASK YOUR DEALER TO SHOW YOU THE COMPLETE RANGE OF TELSEN COMPONENTS; EACH ONE EMBODIES SOME EXCLUSIVE FEATURE THAT WILL TEND TO INCREASE YOUR ABILITY TO GET "LIFE-LIKE REPRODUCTION."



**TELSEN VALVE HOLDERS.**  
Low capacity, self-locating, supplied with patent soldering tags and hexagon terminal nuts. Price 1/-

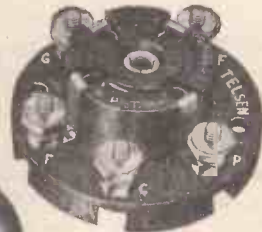

**TELSEN FIVE-PIN VALVE HOLDER.** Pro. Pat. No. 20286/30. Genuine Bakelite Mouldings fitted with Nickel Silver shock-absorbing spring contacts. Price 1/3 each.

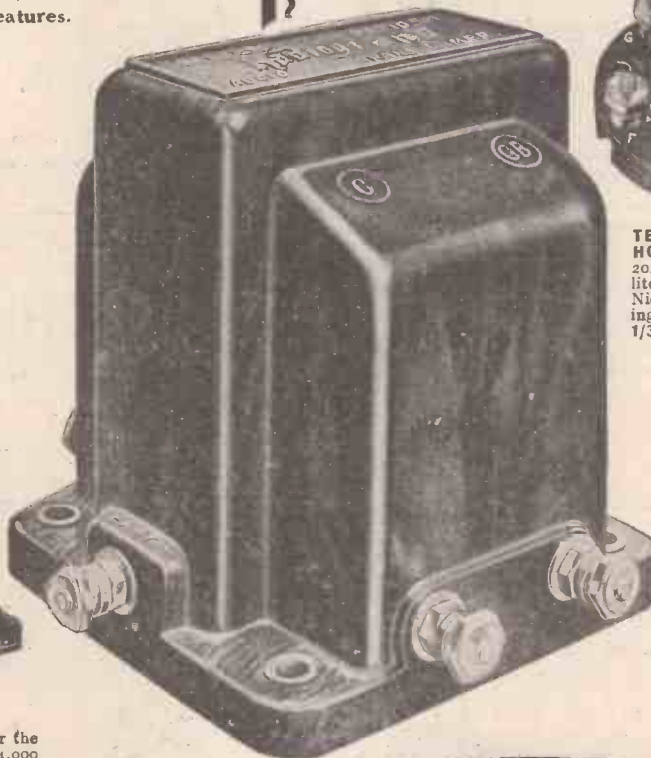

Telsen "Radiogrand" Transformer, new model, shrouded in Genuine Bakelite, with new windings and core, fitted with earth terminal. Made in ratios 3-1 and 5-1. Price 12/6 each.  
Telsen "Ace" Transformer, the ideal model for all Portable Sets, and where space is limited. Made in ratios 3-1 and 5-1. Price 8/6 each.  
Telsen 7-1 Super Ratio "Radiogrand" Transformer, giving enormous amplification with perfect reproduction, shrouded in Genuine Bakelite, with new windings and core, fitted with earth terminal. Price 17/6 each.



**TELSEN H.F. CHOKES.** Designed to cover the whole wave-band range from 18 to 4,000 metres, extremely low self-capacity, shrouded in Genuine Bakelite. Inductance 150,000 henries. Resistance 400 ohms. Price 2/6 each.

**TELSEN FIXED (MICA) CONDENSERS.** Shrouded in Genuine Bakelite, made in capacities up to .002 mfd. Pro. Pat. No. 20287/30. .0003 supplied complete with Patent Grid Leak Clips to facilitate series or parallel connection. Can be mounted upright or flat. Tested on 500 volts. Price 1/- each.



# TELSEN COMPONENTS

Advt. of Telsen Electric Co., Ltd., Birmingham.

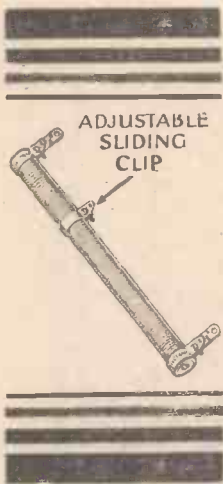

# Dependable Resistances ELECTRAD

You can overcome all your resistance troubles if you specify Electrad when purchasing and ensure that only Electrad units and not imitations are supplied.

Truvolt fixed resistances constructed of Nichrome Wire on asbestos cord and Isolantite tube are thoroughly dependable units and can be relied upon to give lasting and satisfactory service. Three distinct sizes of Truvolt fixed resistances are available, each unit being provided with a sliding clip so that resistance may be varied if desired.

Type B, 2' long, rated at 25 watts.		Type C, 4' long, rated at 50 watts.	
100-7,500 ohms	each 3/6	100-5,000 ohms	each 5/3
8,000 ohms	3/9	7,000-3,000 ohms	5/6
10,000-15,000 ohms	4/3	10,000-15,000 ohms	6/-
20,000-25,000 ohms	4/9	20,000-50,000 ohms	7/6
30,000-50,000 ohms	5/-	100,000 ohms	8/6
Type D, 6' long, rated at 75 watts.			
100-5,000 ohms	each 7/6	15,000-50,000 ohms	each 8/6
7,000-10,000 ohms	7/6	100,000 ohms	11/6

**The Rothermel Corporation Ltd.**  
24, Maddox Street, London, W.1.

'Phone MAYFAIR 0578/9

Continental Sales Office 7, Quai du Commerce, Brussels, Belgium.

It will pay you to get the new Electrad Catalogue describing the complete range of Truvolt variable and fixed resistances, grid resistors, Royalty potentiometers and the famous Loftin White direct coupled amplifiers. Write for your copy to-day—it's free.

## MAGNIFICENT 4/- GIFT FOR CONSTRUCTORS

Eight Sixpenny Blueprints  
of New Tested and  
Guaranteed Sets are

## PRESENTED FREE

With Every Copy  
of the November

## MODERN WIRELESS

NOW ON SALE EVERYWHERE, PRICE 1/-  
MAKE SURE OF YOUR COPY.



# RADIO "FAIRWAYS"

Some new and very interesting applications of short-wave transmission are described in this informative article.

By J. C. JEVONS.

IN the early days of wireless it was thought that long-distance communication would prove impossible because of the curvature of the earth's surface. Marconi, by transmitting messages in 1901 from Poldhu to Newfoundland, across the Atlantic, first showed these fears to be groundless.

We know now that there is a girdle of ionised particles high above the earth's surface which is impervious to the passage of wireless waves. Although the waves tend to travel, like light, in a straight line, the ionised layer reflects them back again to the ground, so that they "keep the course" from transmitter to distant receiver.

## Shooting Into Space

The part played by the Heaviside layer is more important in the case of short waves than long. Owing to their lower frequency the latter have a natural tendency to cling to the earth's surface, just as a high-frequency current clings to a metallic conductor.

For higher frequencies, i.e. for wave-lengths of 100 metres or less, the radiation travels more nearly in a true straight-line path. In other words, it tends to shoot upwards into space, and would be lost if it were not reflected back again by the Heaviside layer.

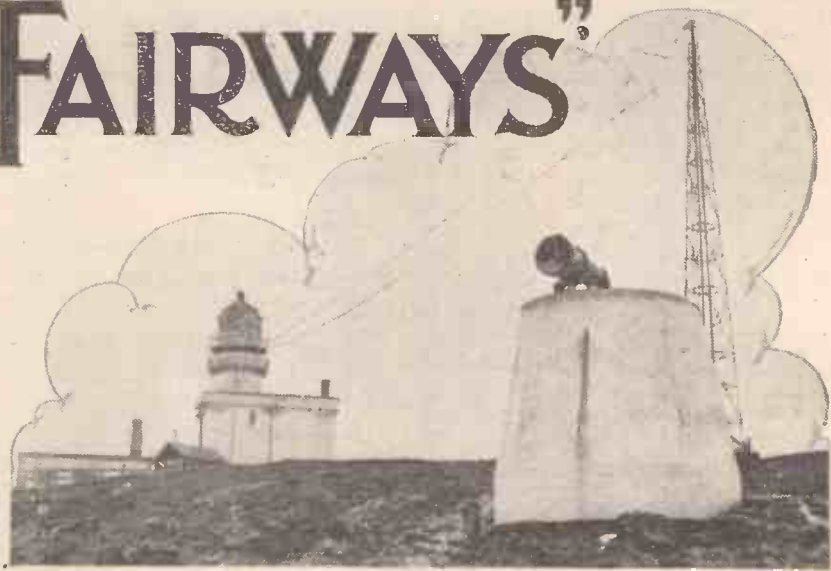

For still higher frequencies, i.e. for waves below the 10-metre mark, even the layer becomes more or less transparent. Experiments have shown that a large proportion of energy radiated between five and eight metres breaks

total loss from this cause over long distances.

This is the border-line beyond which long-distance signalling becomes impossible. In one sense we have progressed in a circle because modern methods of generating power on wave-lengths varying from five metres down to half a metre, and even less, have really justified the misgivings of the early pioneers. With this type of radiation the range of transmission is absolutely limited by the curvature of the earth's surface.

## RANGE OF VISION

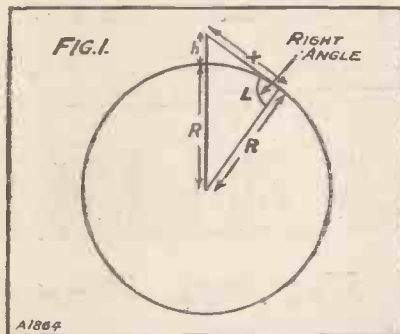

The extreme range of vision is the point where a straight line, X, from the eye strikes the earth's surface.

through the Heaviside "ceiling" and is lost in outer space. On still shorter wave-lengths there is usually a

## Radio Reflectors

At the same time, new and interesting applications are being found for ultra-short radiation. For instance,

## MIND THOSE ROCKS

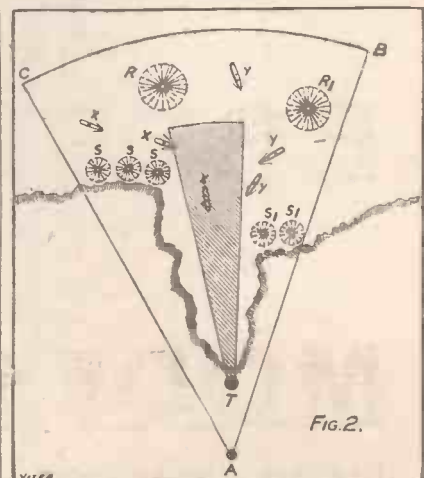

The directional radio divides the harbour area into sections, and so makes it safe for mariners.

wave-lengths of 1 or 2 metres can be focussed by means of a simple and compact parabolic reflector into a clean-cut signalling ray. Such a ray



The entertainment aspect of radio is not forgotten by the airlines, and you see here a number of passengers on an Imperial Airways machine whiling away the journey with a portable. Aeroplanes use radio very extensively for weather reports and direction finding.

## Radio "Fairways"—continued

travels like light in a straight line, and its range is strictly limited, so far as distance is concerned, by the height at which the transmitter is located above the earth's surface.

There is a well-known rule for finding the greatest distance over which a man can see when he is situated a given height above sea-level, taking the curvature of the earth into consideration. Very approximately the square root of one and a half times the height of the observer in feet is equal to his range of vision in miles.

For instance, a man 6 ft. high can see roughly  $\sqrt{9} = 3$  miles on all sides over an unobstructed sea or "flat" plain.

When simplified out, this gives  $x^2$  in miles =  $1.5h$  (in feet) approximately, or, as stated above,  $x = \sqrt{1.5h}$ .

This principle has recently been applied to ultra-short-wave transmitters in order to simplify the problem of marine navigation in foggy weather.

### Limiting the Range

Suppose, for instance, that it is desired to mark out the fairway to a harbour by wireless so that a ship can be navigated safely past various obstacles in a more or less automatic fashion.

One of the great difficulties in such a case is to be able to provide a

At some distance outside the town T a directional short-wave transmitter is erected at such a height above sea-level that its range of transmission is limited to a definite range, say, of 20 miles, the horizontal "spread" of radiated energy being confined by directional methods to the sector A, B, C.

At the harbour head T is another short-wave station having a lower elevation and a more sharply-directed field, shown shaded in the diagram. A series of still lower aerials are arranged on the shoals S, S<sub>1</sub>, so as to emit a non-directional field limited, say, to an effective range of two or three miles, whilst the rocks R, R<sub>1</sub> are guarded by transmitters elevated to such a height as to have an effective range of, say, three or four miles.

### FLYING ALONG A BEAM



New apparatus installed at Washington for sending, automatically, weather reports to aeroplanes flying on the Atlanta-Boston service. Additionally, this gear will emit a wireless beam for direction-keeping purposes.

For those interested, the derivation of this rule is shown in Fig. 1. The extreme range of vision is the point where a straight line  $x$  from the eye ( $h$  = feet above the ground) strikes the earth's surface tangentially. As the angle L is a right angle,

$$x^2 = (h + R)^2 - R^2.$$

Since  $h^2$  is negligibly small, this can be written:

$$x^2 = 2Rh.$$

Now  $2R$  is 8,000 miles, i.e. the diameter of the earth, whilst  $h$  is the height of the man in feet.

sufficient number of definite and distinct signals without filling the ether with confusing and overlapping messages. If, however, the range of each transmitter is limited to a comparatively small area, dependent in each case upon the height of the transmitting aerial above sea-level, the problem is greatly simplified.

Fig. 2, for instance, illustrates the harbour entrance to a town T, dangerous shoals being marked at S and S<sub>1</sub>, and submerged rocks at R and R<sub>1</sub>.

### The Warning Signal

A ship, X or Y, when it first enters the area controlled by the main transmitter A, receives a characteristic Morse signal as a warning that it is approaching the harbour. The navigator is now on the alert for signals from the transmitter guarding either the rocks R, R<sub>1</sub>, or the shoals S, S<sub>1</sub>. He finally picks up the characteristic signal from the transmitter T, from which point he is brought safely and directly to his destination simply by steering so that he keeps the note from station T always in the 'phones.

\*\*\*\*\*  
\*  
\* **FLEX LOOPS** \*  
\*  
\*\*\*\*\*

HERE'S a way which makes a really sound job of flex lead ends. Bare about  $1\frac{1}{4}$  in. at the end of the lead, and then twist the strands as tightly together as you can.

Next take a round piece of metal, such as the shank of a drill just a little larger in diameter than the terminal that the loop is intended to fit. Turn the bared end of the flex round this so that the insulation comes within about  $\frac{1}{4}$  in. of the metal rod.

Take a couple of turns with the end of the flex round the wire between the metal rod and the insulation. Then simply hold on and twist the rod round and round until all is tight. Loops made in this way never come adrift, and they wear well if you have to make and unmake connections.

# FERRANTI AGAIN!

For the second year in succession the FERRANTI MOVING COIL SPEAKER has been selected as the best in the "Wireless World" Olympia Show Ballot for "Loud Speakers of all Types."

Chassis only, as shown. £9-10-0.

Also available in Table and Pedestal Cabinets in Oak, Mahogany and Walnut, and a Table Model in Rexine covered Metal Case. Ask your dealer or write for descriptive pamphlet.



# FERRANTI

Moving Coil MAGNO-DYNAMIC SPEAKERS

FERRANTI LTD. Head Office and Works: HOLLINWOOD. LANCASHIRE  
LONDON: BUSH HOUSE, ALDWYCH, W.C.2.



Steady-constant power for your valves

through an eliminator with the Heayberd L.T. Transformer

Accumulators have been proved inconsistent in their output, but the mains will not vary and this is the ideal source of power for modern types of valves. The Heayberd low-tension transformer is designed for use with Westinghouse metal rectifiers for supplying steady, constant, hum-free power for the filaments of the modern radio valve. Make an eliminator, but specify Heayberd Low-Tension Power Transformers.



F. C. HEAYBERD & CO.  
10, Finsbury Street, E.C.

'Phone: Metropolitan 7515;



D.C. or A.C. 'Portable' Combined Units (H.T. WITH L.T. CHARGER)

They fit inside any portable and are equally suitable for all 0.5 watt, 1, 2 & 3-Valve Receivers. Write for new FREE BOOKLET, S.M. 1 REGENT RADIO SUPPLY CO., 21, Bartlett's Buildings, Holborn Circus, London, E.C.4. Telephone Central 8745 (5 lines.) Irish Free State Distributors Kelly & Shiel Ltd., 47, Fleet Street, Dublin.



Big Illustrated CATALOGUE OF WIRELESS CABINETS

from CARRINGTON MFG. CO., LTD., 24, Hatton Garden, London, E.C.1. (Factory: Croydon)

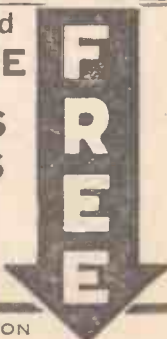

SEND THIS COUPON

Name.....

Address.....

The "Waverley."

# HIGH QUALITY from HIGH POWER

Obtaining good quality from a very near and powerful broadcasting station is not quite such "child's play" as you may think. The drawbacks of too much power, and methods of overcoming them, are dealt with in this unique article.

By R. B. HORSEFIELD

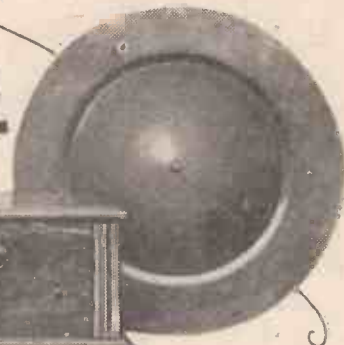

WE are often told that the weak point about long-distance reception is that it is exceedingly difficult to obtain anything like good quality from a feeble signal at a great distance. This is perfectly true, but it is also sometimes difficult to get perfect reproduction in one's home from a powerful station at short or moderate range.

Many people living in or near London found that when the Brookmans Park Number One transmitter first took over the programmes they were obtaining great strength and excellent quality without any trouble at all. A few evenings later matters became rather different, for though the strength was undoubtedly there the quality showed distinct signs of deterioration. Had the transmitter "gone off"?

## What Actually Happened

On the contrary, it had come on! Just what happened was this: Brookmans Park made its bow rather modestly, using a comparatively small degree of modulation. The grid voltage swings were not excessive; all valves were working comfortably within their powers and reception was excellent.

But shallow modulation means, unfortunately, rather short ranges for a transmitter, and the main object of building Brookmans Park was to increase the London service area. The modulation was, therefore, made much deeper—and then the trouble began. Brookmans Park Number Two started in just the same way.

Perhaps the most puzzled man was he who is particularly anxious for fine quality in reproduction and keeps a milliammeter in the plate circuit of his output valve in order to avoid the distortion due to overloading. He uses the volume control until the needle of the instrument remains perfectly steady, when he knows

that the output valve is working as it should.

When the Brookmans Park transmitter really began to modulate he found that the output valve had apparently gone mad, for in many cases no alterations of the grid bias or of the plate voltage would keep it steady even when signal strength was quite moderate. The reason was that not the last valve in the receiver

condenser detector may be found unsatisfactory where a high-frequency amplifying stage is used. The virtues of this kind of detector are many: it is simple to adjust and to use, it gives remarkably smooth reaction, and it is particularly sensitive to weak signals.

## Anode-Bend Rectification

For the last reason especially it is very suitable for long-distance work. One of its worst faults, however, is that it cannot deal effectively with a strong signal, which means, of course, a large grid voltage swing. Further, it does not make for selectivity, owing to the damping effect of the grid current whose flow is necessary to its functioning.

For these last two reasons the anode-bend detector is probably better suited to the broadcasting conditions of to-day. It can deal with a much more powerful signal without introducing distortion, and it helps selectivity because its grid is so biased that no grid current can possibly flow unless the valve is hopelessly overloaded.

## Greater Selectivity

A further reason why selectivity is improved in this way is that the impedance of the valve itself is increased by heavy biasing, and the higher the impedance the better the degree of selectivity.

Now let us see how the very best quality may be obtained from the anode-bend detector when a strong signal is being received. It cannot be too strongly emphasised that the detector must be absolutely free from overloading, for if it is overloaded it will itself distort by mutilating wave-forms, and the distortion will be magnified and made infinitely worse by succeeding stages.

Look at Fig 1, which shows a "family" of characteristic curves for a typical anode-bend detector

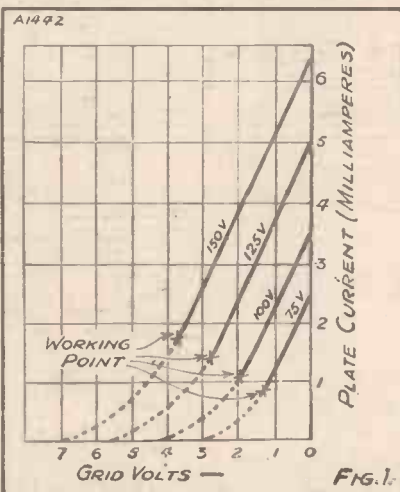

Care must be taken to see that the detector valve is not overloaded, and the curves above show how the valve will handle greater signals when the anode voltage is increased.

ing set, but the detector valve, was being overloaded.

## On the "Doorstep"

Before we had high-power stations the grid voltage swings reaching the rectifier when the local station was coming in were quite modest unless one lived, so to speak, upon its doorstep. The "doorstep" of Brookmans Park is a very wide one, and those of us who are within fifteen, twenty or even more miles of him must realise that we now have to budget for grid voltage swings of quite a high order.

For this reason the grid leak and

# Varley

## FAMOUS SINCE BROADCASTING BEGAN



Impedance Matching Output Transformer  
£1 : 2 : 6

6 ratios : 8-1 10-1, 12-1 15-1, 20-1, 25-1.



Long before Broadcasting became what it is to-day, Varley had won fame for their coil winding.

On this experience is founded Varley's latest achievement in radio. Varley Impedance Matching Output Transformer—a new component of advanced design—gives six different ratios. Accurately and without difficulty you can match loud-speaker and output valves.

Remember that Varley Components are descendants of a long line. Since radio came Varley ideal has been quality. The Varley Impedance Matching Output Transformer is the only adequate answer to a modern radio problem.



Advertisement of Oliver Pell Control Ltd., Kingsway House, 103, Kingsway, London, W.C.2. Telephone: Holborn 5303.

### INSPIRED LEADERSHIP!

**FOR ALL CONDENSERS**

**VERNIER DIAL**  
3/-

Easy reading. Smooth action. Metallic continuity. No crackle.

The lightest, lowest loss & most efficient Condenser extant.

Capacities:  
·0005  
·00035  
·00025  
·00015

**500-1000 LINE CONDENSER**  
4/6

Higher test, lower loss, great longevity. Capa mid 2 1 5 25 1

Cap. ·00015

**3/9**

Bakelite cased 600 volt test minus Condenser.

Prices:  
3/-  
2/6  
2/-  
1/9  
1/6

A great little variable compression type condenser

F ·0001 } 1/6  
J ·0003 }  
G 001 }  
H ·002 } 2/3

Drum dial condenser with trimmer control.

Drum dial 8/6 with one Condenser, 13/- with two, 17/6

**BRITISH LEADERSHIP**

**SUPPLIERS TO THE LEADING SET MAKERS OF THE COUNTRY**

CATALOGUE FREE. GERRARD 1863. GOLDEN SQ. PICCADILLY CIRCUS, LONDON.

7 of our 35 Lines

## High Quality from High Power—continued

valve with various plate voltages. The higher the plate potential the longer is the straight portion of the characteristic to the left of the zero line, and it is just this long, straight portion that we must have for first-rate reproduction.

Suppose that we give the plate of the detector valve only 75 volts, applying  $1\frac{1}{2}$  volts negative grid bias, an arrangement which is far from uncommon. The signal from the local station produces, we will say, a grid swing of 4 volts on the detector

the grid a little positive and it begins to attract electrons to itself. A small part of the stream from the filament is caught by the grid.

This means that at each positive half-cycle the plate is robbed of a proportion of its electrons, and that the corresponding wave-form in the plate circuit is slightly flattened. With a valve commonly used for anode-bend rectification, grid current may reach 20 micro-amperes when the grid goes half a volt positive.

different characteristics which will allow strong biasing to be employed with a lower plate voltage.

The ear is seldom a completely infallible guide to the quality of wireless reproduction. It may tell us that *something* is wrong, but too often it cannot show us just *what* is wrong. Is there a simple means of discovering whether an anode-bend detector is or is not being overloaded?

Fortunately there is, and the method is one that I can recommend to readers. It consists in making use of that faithful servant of the wireless man, the milliammeter.

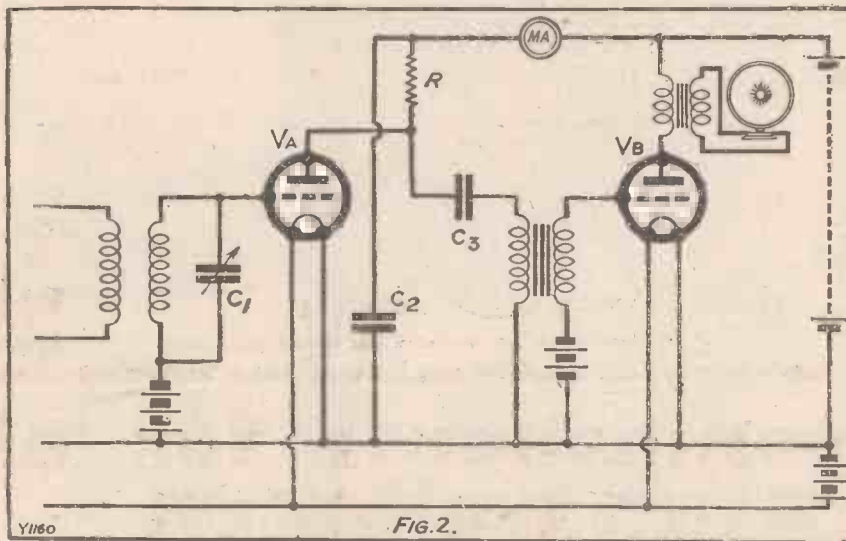

**FIG. 2.**  
This is the type of circuit which you should employ if your receiver is situated very close to a powerful broadcasting station. The bottom-bent rectifying valve is followed by an L.F. resistance-capacity-jel transformer stage.

valve; that is to say, positive half-cycles make the grid 2 volts more positive, negative half-cycles 2 volts more negative. What will take place in the plate circuit?

### The Deceptive Slope

Clearly each positive half-cycle carries the working point well to the right of the zero grid-volts line. If we prolonged the characteristics shown in Fig. 1 they would be quite straight for some little distance beyond this line, but that straightness is deceptive, for this part of the curve is quite useless for anode-bend detection or for amplification. The reason is that when the grid becomes ever so slightly positive what is known as grid current starts to flow.

Imagine the rush of electrons that takes place from filament to plate. When the grid is at zero volts or slightly negative these are repelled by its meshes and pass through them, making their way to the plate; make

### Handling Large Inputs

Normally, grid voltage swings may not rise anything like as high as 4 volts, but if we want to avoid distortion it is the occasional very large swings that we have to bear in mind. When the modulation is deep, a sibilant speech sound, a loud musical passage, or a very deep note are likely to produce swings of abnormal size. Unless our detector can deal properly with them the ear becomes conscious of hissing, or blaring, or harshness.

From a high-power station at short or medium range abnormal grid swings may easily reach 6 volts or more. We should therefore so arrange matters that we can apply at least a grid bias of 3 volts to the detector. This can be done, as an examination of Fig. 1 will show, by increasing the plate voltage of the particular valve under discussion to 150.

Or if this voltage is not available we may make use of a valve of rather

### Use a Milliammeter

Fig. 2 shows how the instrument is connected into the plate circuit of the detector valve. If you do not possess a milliammeter and are dissatisfied with the reception of a local high-power station beg, borrow, or steal one—at any rate, acquire one somehow.

As you tune watch the needle of the instrument. Its reading is, we will say, normally .5 milliamp. Start with your condensers well away from the readings required for the high-power station. Gradually approach resonance. You will see that the needle records a higher and higher reading as resonance is approached.

### WATCH IT!



Don't push your accumulator under the table and forget it until it runs right down. It is impossible to get good quality from an accumulator which wants charging, so test yours occasionally with a voltmeter while the set is working.

Tune to the strength that you ordinarily find satisfactory, and see what the needle has to say about it. If it remains perfectly steady whether speech or music is coming in, then all is well.

But it is more than likely that long before you are properly tuned to the

# Practical Proof of Quality



is furnished by the fact that Polar Condensers are in use in the majority of better-class sets, and are regularly specified by the technical writers.

### THE POLAR "IDEAL."

A condenser with both fast and slow motion. Velvet-smooth movement. Built in sturdy framework. Rotor suspended in ball races, ensuring accurate adjustments. One-hole panel fixing.

·0003, 12/-    ·00035, 12/3    ·0005, 12/6

Phosphor Bronze Balls, 6d. extra.

### THE POLAR DIFFERENTIAL.

A carefully designed differential with insulated spindle. Smooth action ensures accurate adjustments.

·0001, 5/-    ·00015, 5/-    ·00025, 5/6    ·0003, 6/-

*The Polar Tuning Graph.* A 2½d. stamp will bring you, post free, this tuning graph, which enables you to record and instantly identify any station by its wave-length. Ask also for FREE 24-page CATALOGUE.

WINGROVE & ROGERS, LTD.,

188-9, Strand, W.C.2.    Polar Works, Old Swan, Liverpool.



# The best components for all CONSTRUCTOR SETS

## DUAL RANGE TUNER (W.C.2).

Single-Hole fitting Inductance covering Broadcast and Daventry Bands. The short-wave section is single-layer wound and the long-wave portion section wound to avoid losses due to self-capacity in winding. Changing from long to short band is operated by a switch which is controlled by a small knob on top of dial. Dimensions 3½" deep x 3½" x 3".

Price **15/-**

## SPECIFIED

BY  
ALL LEADING  
SET  
DESIGNERS

## An entirely new L.F. COUPLING UNIT

Something really new for your set—an addition which will make a remarkable difference to your reproduction.

Complete with Switch for Tone Control

**20/-**

## THE "PARATUNE"

COIL

Price  
**10/6**

Send for Illustrated List of new Components.

# WEARITE

## COMPONENTS

### WRIGHT & WEAIRE, LTD.

740, HIGH ROAD, TOTTENHAM, LONDON, N.17.

Phone: Tottenham 3847-9.

## H.F. CHOKE

Range, 10-2,000 metres.  
LIST H.F.O.

Price

**6/6**

Also supplied Centre-Tapped.

## High Quality from High Power—continued

local station the needle will have begun to waggle a little, or possibly quite a lot. Sec, first of all, whether the valve will stand a stronger negative bias.

If it will this may have the effect of giving you good volume whilst the needle remains steady. If it will not, and you are using all the available plate voltage, then you must realise that to avoid distortion you must be content with rather smaller signal strength. You can, in fact, "tune in" the local station with the milliammeter, the maximum strength permissible being the greatest at which the needle shows no wobble.

Note particularly the coupling circuit of the rectifier VA and the output valve VB in Fig. 2, which is probably the best inter-valve coupling of the day.

### The Resistance Value

Generally speaking, the value of the resistance R should be about four times that of the impedance of the valve. Don't use anything bigger.  $C_3$  is a coupling condenser whose value may be .25 mfd., or more.

Instead of connecting  $C_3$  direct to the grid of VB we join it by a lead to the primary of an inter-valve transformer. The other terminal of the primary goes to earth. The secondary is connected between the grid of VB and the negative of the grid battery. Owing to its step-up ratio the transformer magnifies the voltages reaching the grid of VB, so that much greater amplification is available than if plain resistance-capacity coupling were used. But the good points of the system do not end here.

### Effect of Heavy Current

In order to obtain good reproduction of the bass notes it is most important that the inductance of the transformer primary should be high. Now supposing that we purchase a really good transformer with a well-designed primary and connect it, not as shown in Fig. 2, but in the ordinary way, a fairly heavy direct current flows through the primary windings.

The bigger the current the smaller is the actual inductance of the primary. In the circuit shown in Fig. 2 there is no D.C. through the primary, and the inductance is therefore maintained at its maximum figure. Three im-

portant results follow: (1) a first-rate transformer will give a wonderful account of itself; (2) even a cheap transformer, whose comparatively small primary inductance might in the ordinary way be swamped by the D.C. flow, will do remarkably well; (3) a transformer with quite a high step-up ratio may be employed if big magnification is required after the detector valve.

transformer earthed. To sum up, quality from high-power stations at short range is very largely a question of the ability or otherwise of the detector valve to deal with large grid swings. The anode-bend detector excels in this way, especially if it is given a fair chance of having a high plate voltage and a correspondingly strong negative grid bias.

### LEARNING TO FLY BY RADIO



Wireless is being put to a novel use at Heston aerodrome. When flying pupils are able to make solo flights they are instructed, through the medium of radio, by pilots who watch them from the ground. This photograph shows the transmitter in the control tower.

Don't forget, too, that you cannot burn out the primary of a transformer through which no D.C. is flowing, and that there is a very considerable advantage in having both primary and secondary of the

If you find the reception of a high-power station at short range rather rough, try the anode-bend detector and make quite sure that it is not being overloaded by using the milliammeter as shown in Fig. 2.

\*\*\*\*\*  
\* **GENTLE REMINDERS** \*  
\*\*\*\*\*

Don't omit to include a fuse in your set—fuses are cheaper than valves.

Don't economise by using thin ebonite, as it may easily split.

Don't forget that ebonite varies vastly in quality.

Don't run your accumulator beyond its rated output.

Don't forget to make sure that the mains unit you propose buying is suitable for your set.

Don't over-run the filament of a valve—the volume may be increased for a short period, but the valve will not last as long.

Don't try to obtain a greater output from a mains unit tapping than it was designed to give.

Don't remove a valve by its glass bulb. The base is the correct place to grip.



# The beauty is missed...

The full beauty of the bass notes and the brilliance of reproduction when using electrically recorded records can only be obtained by placing a Novotone in your amplifying circuit.

Even in present-day recording there are still serious losses which must be compensated for if realistic reproduction is to be obtained.

The NOVOTONE imparts to your records:

- Full-bodied and true reproduction of the bass notes.
- Appreciable brilliance of the higher notes.
- An increase in general amplification.

There are three models of the Novotone:

- Type S for Standard pick-ups ... £5
- Type H for High resistance pick-ups ... £5
- Type J exactly as Type S, but having less amplification £3:3



## The Gam-brell

### VOLUVERNIA

A scientifically designed volume control which does give perfect control from zero to maximum volume with one turn of the knob. No moving metal parts in contact with the resistance, movement therefore being silent, firm and smooth. The perfect volume control for Radio or Radio-Gramophone. May be fitted to any panel.



6s. 9d.

## The Gam-brell

### MULTITEST

Seven Ranges in One Meter.

This instrument can be used as Milliammeter, Ammeter, and Voltmeter. Ranges covered are 5 m/a., 50 m/a., 5 a., 5 v., 50 v., 250 v. No external shunts or resistances required, simply plug into range required. Accurate readings easily taken. Robustly constructed, but with light movement. Supplied with flex leads with special spring test clips. £3



ILLUSTRATED LEAFLETS OF FULL GAMBRELL RANGE OF COMPONENTS, COILS, AND ALL-ELECTRIC RECEIVERS ON REQUEST

GAMBRELL RADIO LTD., 6, BUCKINGHAM STREET, LONDON W.C.2.

# If YOU BUILD YOUR OWN SET



Wire it up without SOLDER TOOLS or TROUBLE

Here's an easier way to build your radio —with Simple Strip, the very latest method of connecting up the various sections. Simple Strip is 10 times easier to fix than wire. Just bend with fingers to any angle required, and snip off with scissors. Economical, too! With one 4 B.A. nut you can make as many connections as you like, and use the Strip again and again. No tools. No Solder. No trouble. Just the simplest way of wiring with out wire! Build up your radio with Simple Strip!

use **SIMPLE STRIP**

The NEW LONDON ELECTRON WORKS Ltd. 76 EAST HAM LONDON.E.6

2/-

## ALL MAINS COMPONENTS

### WESTINGHOUSE RECTIFIERS

require the best Condensers, Transformers and Chokes.



FILTA-BANK Condensers.

2 mfd (By-pass) ...	3/3
4 mfd (Reservoir) ...	5/3
4 4.4 mfd (Voltage Doubler) ...	15/0
4.4.2.2 mfd (Half-Wave) ...	15/6

THE MAINS POWER RADIO CO. 57, Farringdon Street, London, E.C.4  
Writes for Full List.

## WIRELESS CONSTRUCTOR

### Advertisement Rates

- Single Insertion - £60 0 0 per page and pro rata.
- 6 CONSECUTIVE Insertions 55 0 0 per page and pro rata.
- 12 CONSECUTIVE Insertions 50 0 0 per page and pro rata.
- ONE INCH single col. (2 1/4" wide) 2 5 0
- Minimum Space, half-an-inch 1 2 6

IMPORTANT. Copy and Blocks must be in hand by 24th of each month or issue placed on sale 15th day of the following month.

ALL communications respecting advertising must be made to:

JOHN H. LILE, Ltd., 4, Ludgate Circus, London, E.C.4  
Phone ITY 7261.



HERE'S some information which might interest readers who like figures. It has been calculated that all the German stations together use a power of 535 kilowatts, while England comes next with 470, and Russia, Sweden and Czecho-Slovakia follow on with 222, 120, and 107 kilowatts respectively. France only uses 64 kilowatts, and it has not yet been worked out what America consumes.

**Wise Words**

Speaking at a luncheon at Folkestone the other day, Sir Henry Wood, the famous conductor, whose name is indelibly associated with the Promenade Concerts at the Queen's Hall, gave it as his opinion that the man-in-the-street, by means of wireless and gramophones, is becoming more and

more acquainted with orchestral works, of which he could never have known by any other means.

Sir Henry said, quite frankly: "I am in favour of the progress of mechanical music; but," he added,

**VICTOR KING**

designs sets

**Exclusively**

for the

**"WIRELESS CONSTRUCTOR"**

"provided it does not interfere with the performance of good orchestral work. The man who hears this music

by wireless or gramophone will want to hear it played for himself."

We commend these very sensible remarks to Sir Thomas Beecham, Sir Hamilton Harty, and others.

**The Hallé Concerts**

We understand that arrangements have been made with the Hallé Society by which eight of the Hallé Concerts may be broadcast during the 1930-31 season. According to the B.B.C., there is every likelihood of these concerts being broadcast, although no definite arrangements have been made, and listeners will be glad to know that there is no deadlock between the B.B.C. and the Hallé Society—despite the recent remarks made by Sir Hamilton Harty in which he severely criticised the B.B.C.

**Rugby's Range**

The Postmaster-General, speaking recently at a Civil Service Dinner, said that at Rugby we possessed the largest and most powerful wireless station in the world. Rugby was originally built for wireless telegraphy, and it could at a moment's notice broadcast a message so powerfully that it could be picked up practically by every ship in any part of the world.

(Continued on page 126.)

**MAGNUM**

Adapt your Set for Short-Wave Reception

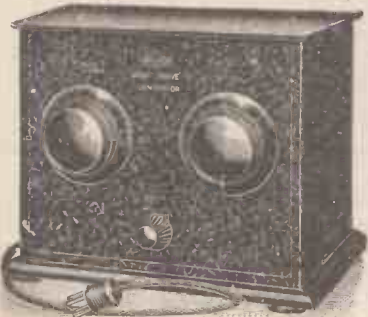

**SHORT-WAVE CONVERTOR**

Enables you to enjoy Short-wave reception on your present set, if battery operated, without any alterations or extras.

TRY IT YOURSELF, WITHOUT OBLIGATION TO PURCHASE.

Sent on 10 days free trial against cash, £3-15-0.

Full particulars, with a list of leading Short-wave stations, free on request.

**'BAND-PASS' FOUR**

Entirely mains operated. The selectivity, volume and tone are truly amazing. One-knob tuning, the circuit includes two S.G., Detector and Power output with provision for pick-up.

**£30**

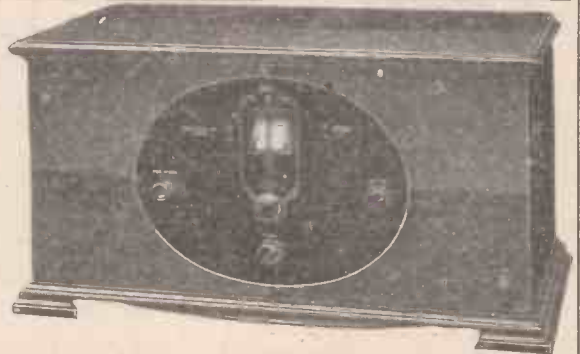

**MAGNUM**

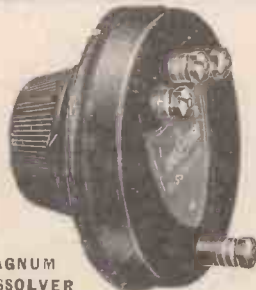

**MAGNUM DISSOLVER**

Fades from Radio to Gramophone or two electrically operated Gramophones. Specified for "Olympia" Five and many other modern sets and Radio-Grams. **10/-**

**THE "PARATUNER" "INTERNATIONAL" THREE**

and all sets described in "Wireless Constructor" can be supplied as constructional kits, ready wired and tested, or parts separately.

Full range of lists free on request.



**SPAGHETTI WIRE-WOUND RESISTANCES**

Fitted in a few seconds. These replace the expensive Cartridge Resistances

Adaptable for numerous purposes. Supplied in stock sizes from 600 ohms to 50,000 ohms .. 1/6 80,000 and 100,000 ohms .. 2/- 150,000 ohms .. 2/6 Special sizes to order.

**BURNE-JONES & CO., LTD., "MAGNUM" HOUSE, 296, BOROUGH HIGH STREET, LONDON, S.E.1.**

# Tip-Top Books for Boys



## MODERN BOY'S

Annual 6/-

This is the biggest value gift book that any boy can have! It is new in every way, and is packed with interesting and entertaining features which tell all about the marvels of Railways, Aeroplanes, Ships, Motor-cars, and Motor-cycles, etc. There are also lots of wonderful photographs and thrilling adventure tales. If you want a present for a boy you cannot do better than to get the MODERN BOY'S ANNUAL.

## HOLIDAY

Annual 6/-

Every boy will revel in the budget of ripping school yarns and thrilling adventure stories in the HOLIDAY ANNUAL. Here they can meet all the jolly schoolboy characters of Greysfriars, St. Jim's, and Rookwood Schools, whose merry pranks cannot fail to entertain. There are lots of other interesting features, too, including pithy poems, puzzles, and eight beautiful plates.

## BRITISH BOY'S

Annual 5/-

Here's a book for the boy who likes thrilling stories—a wonder book of exciting Tales of School Life, Sport, Mystery, and Adventure. It is lavishly illustrated with clever drawings, and also contains beautiful coloured plates. The boy who has the BRITISH BOY'S ANNUAL will have a book that he will want to read again and again.

## CHAMPION

Annual 6/-

A budget of thrills, mystery, and adventure—that's the CHAMPION ANNUAL. Here are stories of hazardous exploits in all parts of the world. True-to-life stories of School, Sport and many thrilling tales that carry you breathlessly to the last word. There are also many clever illustrations. This is a book that every boy will want.

## EVERY BOY'S HOBBY ANNUAL

6/-

The boy who is keen on making things, and finding out how things work, will find much to his liking in EVERY BOY'S HOBBY ANNUAL. This fascinating book is crowded with wonderful "How-to-make" articles, which tell all about Railways, Speed-boats, Wireless, and Woodwork, and many other hobbies. There are hundreds of photographs, diagrams, and sketches, and two folding plates of aeroplanes and motor-cycles. This is just the book that will keep boys happy during the long winter evenings.

## Popular Book of BOYS' STORIES

2/6

Here's a splendid book of thrilling adventure stories that's too good to be missed—a book packed full of swift moving action that will hold every boy spellbound until the last page! That's what you get in the POPULAR BOOK OF BOYS' STORIES. Here are gripping sea mysteries, stirring tales of the Wild West, and exciting tales of Speed-boat Racing, Scouting, Motor Racing, Cricket, Flying, and, in fact, every phase of adventure is represented in this grand all-fiction annual, which is splendidly illustrated.

At all Newsagents and Booksellers.



**OUR NEWS BULLETIN**

—continued from page 124

**All-Round Aerials**

"If you visit Rugby," said the Postmaster-General, "you will find an aerial system pointing to the United States; a few yards, and there is a section plotted out in which there will be an aerial system pointing to Canada. A few yards in another direction and there is a system pointing to South Africa, and a few more yards away one to India, and again one to Australia.

In this way, when the system is complete, the world voice of Great Britain will speak from Rugby not only to the Dominions but to all the more important countries of the earth."

**The World's Best**

The Postmaster-General went on to say that a subscriber to the telephone in Vienna can speak to a subscriber in Montreal, provided the message goes through Rugby; and a subscriber in San Francisco can speak to a subscriber in Stockholm, provided the message goes through Rugby.

Rugby is undoubtedly the greatest commercial telephone service in the world.

**Moorside Edge**

Early in the New Year six B.B.C. stations will close down for good, for by then the Northern Regional twin-wave transmitter at Moorside Edge will be on the air. The six stations to be closed are: Liverpool, Manchester, Stoke, Sheffield, Leeds, and Bradford.

Moorside Edge will give excellent service, and that nobody will be dissatisfied.

**Bangkok Broadcasts**

News comes to us that wireless sets have become very popular in Bangkok, the capital of Siam. When listening-in to religious broadcasts, the Siamese light candles and behave with the same reverence as if they were being addressed by a preacher in church.

**More New Stations**

New broadcast stations have been ordered for Italy and Finland from the Marconi Company. The one for Italy is to go to Trieste, and will cover 200 to 545 metres, although the normal wave-length for the station will be 247.7 metres.

**Criticising Critics**

Critics of the B.B.C. were themselves recently criticised at the Radio Exhibition in Manchester, when Sir John Reith said:

"Critics we will always have with us. There are some critics who—and it is a common phenomenon in all lines of activity—themselves unable to do, are always ready to teach.

(Continued on page 128.)

**A Wonderful Gift!**  
**EIGHT BLUE PRINTS**

**FREE!**

with the November issue of  
**"MODERN WIRELESS"**

On Sale Everywhere **1/-** Usual Price.

Listeners should not suffer by this, for the new Regional transmitter will more than compensate. It is just possible, however, that Hull will not be satisfied—at least, that is what Hull thinks; but we are assured that

**The BurTon Valve Holder**

(Special Five Pin Type)



Suitable for A.C. Valves, etc.  
Price 1/3 each.

**PERFECT PARTS  
MAKE THE  
PERFECT WHOLE**

BurTon COMPONENTS enjoy an unrivalled reputation for their efficiency and reliability. Every part is built on sound scientific lines to give best results at lowest cost.

All BurTon Components are registered designs, and manufactured under various patents or patents pending.

**ASK FOR**

**BURTON COMPONENTS**

**The Bur-Ton BAKELITE (D)electric CONDENSER**

Entirely eliminates shorting, and ensures a perfectly clean contact with centre spindle at all times. Supplied with pointer knob, one hole fixing. Two capacities. Price 2/9 each.

C. F. & H. BURTON



**The Bur-Ton BINOCULAR H.F. CHOKE**

Scientifically designed to avoid peaks and external magnetic field. Covers wave band of 50-3,000 metres. Price 5/9 each. Also highly efficient model covering wave band of 20-2,000 metres. Price 3/9 each.

PROGRESS WORKS, WALSALL

LITTLE STORIES OF GREAT MOMENTS



**"Look!**  
**It's going-it's going!"**

There was gladness in some hearts and consternation in many when Stephenson's Rocket started on its first perilous journey. Long embittered critics were confounded and the habits of a nation transformed. It was the complete triumph of a lifetime spent in doing one thing and doing it well.

It is this same spirit of "doing one thing and doing it well" which has, for years, been behind all T.C.C. endeavour. That is why T.C.C. have never made anything but Condensers, and that is why T.C.C. Condensers are unmatched—for accuracy and for dependability.

One of the many types is shown here. It is the T.C.C. .0003 mfd. Upright Mica Condenser. Price 1/6.



TELEGRAPH CONDENSER CO., LTD., N. ACTON, W.3.

♡ 6431

**HARRODS**  
**A.C. Battery Eliminator**



This Eliminator has been entirely re-designed and embodies many new improvements, including Harrods own special Rectifiers (covered by provisional patents). The cost of renewing a Rectifier is 1s. 3d., and the average life is two years if refilled. An output of 125 volts at 20 milliamperes is provided with eight different voltage tapings. Assembled in a well-made Walnut finished moulded Bakelite Cabinet measuring 10 ins. deep by 5 ins. high by 5 ins. wide. Carriage paid in Great Britain. Price £2 . 10 . 0

HARRODS LTD

LONDON SW1

**Wireless Books**  
for the  
**Home Constructor**

**"BEST WAY"**

**4 CHEAP to MAKE Sets**

(Book No. 367)

Contains complete constructional details for making four inexpensive and easy-to-build receivers. All have passed the most exacting tests before being published.

**"BEST WAY"**

**4 SUPER SETS**

(Book No. 368)

These Super sets are for MODERN CONDITIONS, and will enable constructors to take full advantage of the dual programmes under the Regional Scheme.

**6**  
EACH

from all Newsagents and Booksellers everywhere, or 7d. post free (Home or Abroad), from "Best Way," 291a, Oxford Street, London, W.1.

**OUR NEWS BULLETIN**

—continued from page 126

“There are other critics the ferocity and absurdity of whose criticism proclaims an ulterior motive in that criticism, or also incapacity in their judgments.

**Sir John Continues . . .**

“But still others there are,” he continued; “critics who bring to the consideration of the multifarious and vexed problems of broadcasting a sympathetic mind with an appreciation of the likes and dislikes of other people, even perhaps some measure of good will to the B.B.C., and as a result come to the B.B.C. with criticism which is reasoned and reasonable and constructive.

“Such criticism, unlike the rest, is heard, and, more than that, is sought.”

**For the Blind**

The B.B.C. announces, in connection with a concert in aid of the Wireless for the Blind Fund, that free sets have now been distributed to 6,500 blind persons. It is estimated that this number will be increased to 8,000 by the end of the year.

The distribution of sets is being regulated in accordance with the development of the Regional Scheme; and the time has not yet come to undertake any widespread distribution in those Northern areas which are outside the crystal range of the Manchester station. Such areas,

**XMAS!**

The January Number of the  
**“WIRELESS CONSTRUCTOR”**  
 will be a  
**SPECIAL XMAS NUMBER**  
 Order Your Copy Now.  
*On Sale*                      *Usual Price*  
**Dec. 13th**                      **6d.**

however, will come within the service area of the North Regional transmitters at the beginning of next year, and the distribution of sets to blind persons will follow in due course.

**The Empire Station**

As we go to press, no details are yet to hand of any decision regarding

an Empire broadcasting station, but the matter has been closely examined by the Imperial Conference Committee on Communications, and Sir John Reith has given expert evidence.

It is more than likely this station will be built in due course, but we understand that another expert Committee will be appointed to discuss the details and suggestions put forward by those who have given evidence before the Committee on Communications.

**Higher Power**

Wireless listeners to foreign stations will find that considerable changes in power have been effected during the last year.

In many instances the Continental stations have increased their power. As remarkable instances, Rome has increased from 3 kilowatts to 75, and Stockholm from 15 to 75. Motala is now using 40 kilowatts.

**A Falling Off**

One or two stations, formerly good, are not now giving such satisfactory reception. Madrid Union Radio and Budapest are two examples, though Hamburg is excellent this year.

**WESTINGHOUSE  
 METAL  
 RECTIFIERS**

ARE NOW AVAILABLE

FROM 15/-

When asking for METAL rectifiers specify “Westinghouse” and do not be put off with so-called “metal” rectifiers which depend upon electrolytic action, and so have a limited life.

Westinghouse Metal Rectifiers are purely electronic in action.



H.T.7  
 200 v. 28 m.a.

21/-

**“The All Metal Way, 1931”**

now enlarged to 40 pages, a valuable book for mains users, giving circuits, technical information, etc., regarding these new units, and instructions for constructing all types of A.C. Mains Eliminators and Chargers, will be sent on receipt of 3d. stamp.



# WAVE - CHANGE GANGING

Wave-change switching was introduced to simplify going from one broadcast band to the other. Here is a scheme for simplifying wave-change switching when more than one coil unit has to be employed.

By P. C. BAKER.

two sets of contacts are really needed.

By using a switch with three sets of contacts and earthing the centre set, the outers may be used for wave-change switching with little likelihood of oscillation occurring. The switch wiring in Fig. 1 shows what I mean.

When two reaction coils are used the switch contacts must be placed on the farther side of contact No. 3, and the lead must be kept right away from the H.F. grid lead.

### Mechanical Linkage

This scheme is all right when you have your own separate coils, but in many cases the coils used are those incorporating their own switches. In this case a mechanical method of linking the switches has, of course, to be found.

Take the case of the Colvern dual-range coils. Here we have coils

which contain their own switches in the coil base. The switch is operated by turning the knob through 90 degrees. Two of these coils are shown with the switches linked up in the heading photograph.

Three links about 1 in. long are cut out of strip brass of a suitable size. Two of these are fixed on the switch spindles of the coils, and the third on to the spindle that is to come through to the front of the panel and operate the switches.

This may be done by soldering them on, or by drilling and tapping them, whichever you find the easier.

The other ends of the links should be drilled and tapped 6 B.A., and the long link rod is cut and drilled with 6 B.A. clearance holes at the requisite points.

The operating spindle passes through a bush which is fixed to a

THE average set user nowadays wants his set to be a wave-change set where he can turn over from the broadcast band to the long-wave band without having to change coils.

It is especially inconvenient to have to do this when a screened-grid valve is used, and one or both of the tuned circuits is entirely boxed.

### TWO COILS—ONE SWITCH

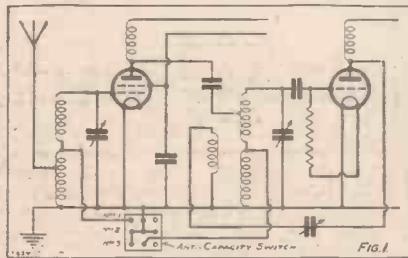

With some special types of coils it is possible to wave-change two circuits with one switch, in a manner somewhat similar to the above.

At the same time, if he has a set with two stages of H.F. he does not want to have to manipulate three switches every time he changes over.

In the case of a single stage of H.F., using a screened-grid valve, provided that the tuned circuits were not too efficient, I have found it possible to put all contacts on one switch. The connections must be made in one particular way as a rule, otherwise unwanted reaction is introduced and the H.F. stage becomes unstable.

### Common Reaction Winding

In the case of the Fig. 1 circuit, where a common reaction winding is used for both long and short wavebands, and fairly tight coupling used on the aerial for the long-wave by the use of a wave-change circuit, only

ONE KNOB TO DO THE WORK OF TWO—EFFICIENTLY, SIMPLY, QUICKLY

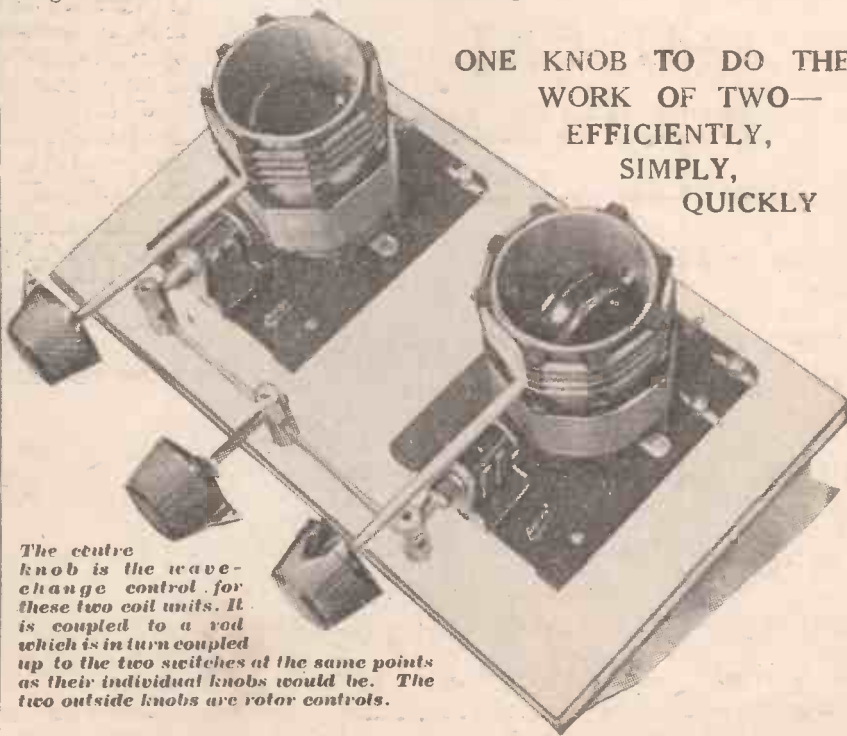

The centre knob is the wave-change control for these two coil units. It is coupled to a rod which is in turn coupled up to the two switches at the same points as their individual knobs would be. The two outside knobs are rotor controls.

## Wave-Change Ganging—continued

bracket screwed to the baseboard.

The link rod is now put into position and three 6 B.A. screws are screwed into the short links and lock-nuts put on so as to prevent them turning farther after the correct adjustment, which allows the long rod just to move freely, has been found.

### Travel Stops

Two stops are fixed to the baseboard, so as to limit the travel of the switch-gear, and the job is done. The sketch in Fig. 2 gives constructional details, while the photograph will also be found of assistance in clearing up any doubtful points.

Another method is shown in the photograph of the two Wearite coils. These coils incorporate two midget

### LOCKING THE LINK

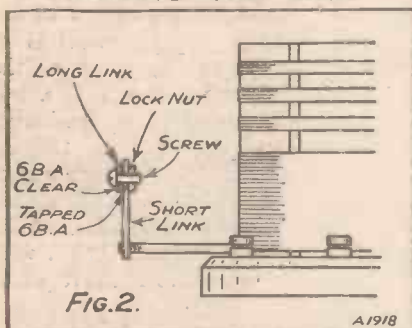

The constructional details of one type of ganging for wave-change switches.

switches, which are linked together in a rather similar way by means of a long link rod. In this case the short links, or cranks, are made from solid brass rod cut and drilled as shown in Fig. 3.

They are fixed to the switch spindles by means of small set-screws, while the slot cut in one end allows the linked rod to be fixed into position.

Since the centres of these switches are rather higher than we want the control on the panel to come, the

### PREPARING THE CRANKS

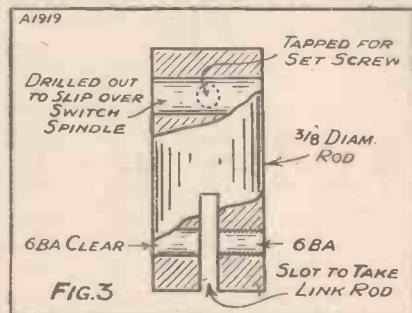

Here are the details for another method of attaching a ganging rod.

cranks are dropped below the switch centres and not lifted above.

A variation of the method of fixing the operating spindle bush is used. Instead of fixing it to the baseboard, a hole is drilled in the panel and the bush fixed to the panel. This method is all right provided that a very long spindle is not used.

### Another Simple Scheme

Where the coils have push-pull switches they can be joined together with a flat strip of brass as shown in Fig. 4, and then operated from a common point. The strip must be quite firmly fixed to the switch spindles, and there must not be any signs of give or tendency to twist.

Care should be taken to find out whether the spindles of the switches are in electrical contact with any portion of the coil, for if they are it may be necessary to use ebonite instead of brass for the linking strip. Paxolin strip may also be used and is tougher than ebonite, weight for weight, and it is less likely to warp than ebonite.

### Positions of Switches

As a general rule, it is far better to have the switch mounted close to the coil, for this makes for electrical efficiency, even if it slightly complicates the mechanical linking up of the switches. It is also often advantageous to mount the coils and switching arrangements on a sub-

### FOR PUSH-PULLING

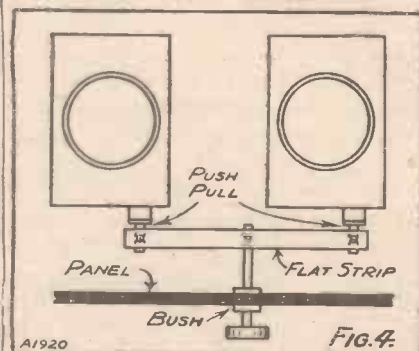

A simple scheme as shown here can be used when push-pull switches are fitted to the coils.

diary baseboard for mounting in the set proper, rather than mount them direct on the main baseboard of the receiver.

Sir,—During my visit to the Radio Exhibition on the afternoon of Wednesday, one of your experts very kindly went over the wiring of the "Vee-Kay" Three with me, as I could only get the two London stations—viz., 261 and 356 metres, and no reaction.

### Wrongly Informed

I feel it my duty to write you as to the extraordinary circumstances which led to the cause of this shortcoming. Within a few minutes of leaving you I came to the T.C.C. stall. I noticed a series-parallel fixed condenser, 0003, with three terminals. I explained to the gentleman in attendance that a local dealer had sold me one such, as he had run out of the

### JUST A LITTLE POINT

The story of how a puzzling fault was cured with half an inch of wire.

two-terminal type, and that he had told me to use the two outside terminals.

Well, sir, you can guess the rest. If he had not informed me at all I should probably have put it to the test by trial, but I did not doubt his statement for one moment.

The significance of the parting remark to me on the Wednesday, "It is some little thing," is truly interesting. It was half an inch of wire to bridge two terminals.

The power of this set is so great that I now have to use the volume control for London stations always. Reaction is great, and foreign stations are consequently coming in on both "long" and "short."

### Everything Else O.K.

Coils now in use: 40 and 60, with 60 aerial "X," and 250 and 150, with 250 aerial "X" type, wound with 24-gauge D.C.C.

This error, the only one that was made from first to last, gave me a chase, but it was worth it.

Trusting I have not encroached too long on your time.

Yours faithfully,  
F. C. H. COLE.

N.W.10:



## NORTH REGIONAL PROGRESS

—continued from page 72

Man, Cheshire, part of North Wales, and parts of Staffordshire, Derbyshire, Nottinghamshire, and Lincolnshire.

The area of the 301 metres transmission will not be so extensive for first-class reception, but it will certainly include the main areas of population of Yorkshire and Lancashire. In towns such as Leeds, Bradford, Doncaster, Sheffield, and Huddersfield both programmes will be received at considerable strength, but listeners residing more than about 15 miles from Moorside Edge may expect to obtain louder reception of the 479 metres transmission than of the 301 metres transmission.

### A Wave-length Puzzle

The "Times" recently pointed out that many listeners must be puzzled with the way in which the wave-lengths of 1,071 metres and 1,875 metres are used by the two Dutch stations, Hilversum and Huizen. Some listeners, it appears, have complained that one of these stations has been heard one evening on one wave-length and the next evening on the other. Such changes are, however, part of a definite scheme which has been worked out to give exactly equal facilities to all the various Dutch organisations which are interested in broadcasting. Each station maintains the same wave-length for a period of three months, at the end of which a change-over takes place. At present, and until the end of the year, Hilversum will transmit on 1,071 metres and Huizen on 1,875 metres. On January 1st Hilversum will change to 1,875 metres and Huizen to 1,071 metres. On April 1st the wave-length will be as at present.

### Identity Details

In order to assist listeners in identifying these two stations the "Times" gave a few particulars as follows, and which we think may interest our readers. Hilversum—Wave-lengths: 298 metres; after 5.40 p.m. G.M.T., 1,071 metres; power (aerial), 6.5 kw.; call, "Hier Hilversum, Holland," with which is always coupled the name of the association providing the broadcast—e.g. A.V.R.O. (Algemeene Vereeniging Radio Omroep), V.A.R.A. (Vereeniging van Arbeiders Radio Amateurs), V.P.R.O. (Vrijzinning Protestantsche Radio Omroep). An-

nouncements are given in Dutch, sometimes in other languages. Huizen—Wave-length, 1,875 metres; power (aerial), 6.5 kw.; call, "Hier Huizen, Holland," with which is always coupled the name of the association providing the broadcast—e.g. Katholieke Radio Omroep (K.R.O.), Nederlandsche Christelijke Radio Vereeniging (N.C.R.V.). Announcements are given in Dutch.

### D.X. for Crystal Sets!

Baron von Ardenne, the German radio engineer, has worked out a scheme by which listeners, even with crystal sets, could hear London,

Paris, or Rome as distinctly as the local stations without any interference.

His plan is to construct about five receiving stations in different places, well outside the city. Each of these stations would receive the programme of one of the most important foreign broadcasting stations.

The receiving stations would relay the programmes to small transmitting stations within the city, which would broadcast in the same way as the local stations. Baron von Ardenne claims listeners with the simplest apparatus would daily have

(Continued on page 132)

## Radio is becoming All-Electric

You can make your battery set All-Mains quite simply. No need even to alter it. Think of the added power—constant, unlimited, unflinching; the added range, selectivity. Think of being able to use the Six-Sixty Mains Valves!

Convert your set with the Six-Sixty A.C. All-Mains Conversion Equipment—the great success this season! Price: Mains Unit only (H.T., L.T., and G.B.), £6:6:0. Complete Conversion Equipment from £8:5:0.

Dimensions do not exceed those of the batteries it replaces. No internal wiring alterations. Made to suit any A.C. supply. Specially selected Six-Sixty A.C. valves and Six-Sixty 5/4 pin valve holder adaptors.

Write for FREE Booklet giving full and interesting information on how to make your set up-to-date.

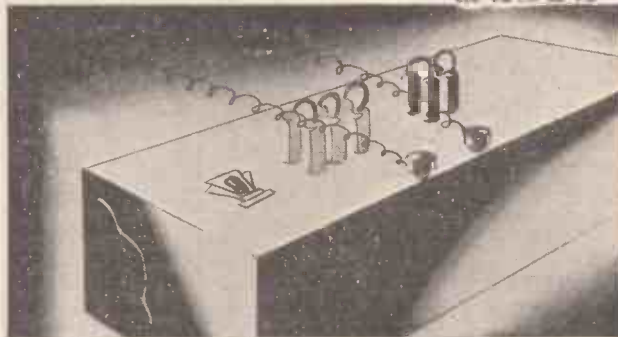

**AND  
ALL  
SAY**

# SIX-SIXTY

(B.V.A. RADIO VALVES AND EQUIPMENT)

SIX-SIXTY RADIO CO., LTD.,

SIX-SIXTY HOUSE, 17/18, RATHBONE PLACE, OXFORD STREET, LONDON, W.1

Telephone: Museum 6116/7.

# EASY TERMS

WE supply the following Radio Apparatus on deferred terms. We carry adequate stocks and can give prompt delivery.

**LISSEN 2-V. SET.** Battery model, including valves. A reliable Regional Receiver. Cash Price .. £3 10 0  
Or 5/6 with order and 11 monthly payments of 6/6

**NEW MULLARD ORGOLA 1931 3-V. KIT.** High-grade complete kit of parts, including valves and cabinet. Cash Price .. .. . £8 0 0  
Or 10/6 with order and 11 monthly payments of 14/6.

**NEW COSSOR EMPIRE 3 KIT.** A considerable advance on last season's 3-valve Kit and at a lower price. Cash Price .. .. . £6 17 6  
Or 10/- with order and 11 monthly payments of 12/6.

**N.K. FARRAND INDUCTOR.** Loud speaker unit, quality of reproduction almost equal to a moving-coil speaker. Cash Price .. .. . £3 10 0  
Or 5/6 with order and 11 monthly payments of 6/6.

**NEW BLUE SPOT 66R UNIT.** The finest balanced armature movement on the market. Complete with large Cone and chassis. Cash Price .. £2 10 0  
Or 5/- with order and 10 monthly payments of 5/-.

Send us your enquiry and a quotation will be sent by return

**London Radio Supply Company,**  
11, OAT LANE, NOBLE ST., LONDON, E.C.2  
TELEPHONE: NATIONAL 1977.



**THE VIBROLIDER**

1. Anti-microphonic — valve sprung on springs.
2. Self-aligning sockets—suitable for solid pins.
3. Sockets and tinned soldering lugs in one piece—no joints.
4. Screw terminals indexed in bakelite base.
5. Safety devices. No socket distortion or contact between pins and baseboard.

Write for Catalogue No. 1142  
THE BENJAMIN ELECTRIC LTD.,  
Tarrif Rd., Tottenham, N.17  
Tottenham 1930.

**BENJAMIN**

The Picture Paper with the MOST News  
**SUNDAY GRAPHIC**

## NORTH REGIONAL PROGRESS

—continued from page 131

the advantage of hearing perfectly about five foreign programmes.

In order to prevent one station from interfering with another the local wave-lengths would be carefully regulated.

The system could be just as easily adopted in England as in Germany, owing to the broadcasting monopoly, and to meet the cost the Berlin broadcasting authorities, for instance, would have to increase their income by about 10 per cent.

This scheme strikes us as interesting, but too "revolutionary" to have much chance of adoption.

## THE "INTERNATIONAL" THREE

—continued from page 77

When you have satisfied yourself that the set oscillates normally you can proceed to listen for transmissions. Remember that stations are very much more sharply tuned on short waves than is the case on the broadcast band, and that in consequence the tuning condenser *must* be operated very, very slowly.

Before leaving the short waves, to tell you something of the normal broadcast side of this design, here are a few hints which you may find helpful.

### Plippy Reaction

(a) If oscillation is inclined to be plippy or sudden, the slider of the potentiometer  $R_1$  should be moved towards the negative end.

(b) Only move the potentiometer slider to obtain smooth reaction control. Otherwise leave it set as near to the positive end as possible.

(c) If you experience threshold howl (which can be described as a "grunt" as the set goes into oscillation), bring some of the filament resistance  $R_2$  into circuit.

(d) The position of the reaction coil  $L_3$  in relation to the grid coil  $L_2$  should be found by experiment. Varying the coupling between these two coils may also help you to obtain smooth reaction control, which is vital for satisfactory results.

To bring the set into use on the broadcast band, push in the switch  $S_1$  and place the plug on the front of

the panel into the socket marked "Reg." Next turn the knob of the compression condenser  $C_2$  inside the set until you hear the Regional programme.

Whenever the set is in use on the broadcast band, by the way, the reaction condenser should be set at zero (plates out) and the reaction coil  $L_3$  in the position of minimum coupling with  $L_2$ .

Now change the plug on the panel to the socket marked "Nat." and proceed to find the National programme by varying the setting of the other semi-variable condenser ( $C_3$ ).

### The Tapping Clip

The correct position for the tapping clip on  $L_4$  will depend upon the degree of selectivity required in your particular locality to separate the two transmissions.

If you have only one local station and have accordingly omitted one of the semi-variable condensers, then, of course, you will only have just the one to adjust, and selectivity will not concern you. In case it is not quite clear, perhaps as a concluding remark it should just be mentioned that the main tuning condenser is completely out of circuit on broadcast waves, and however much you alter it it will not have any effect upon the tuning of the local transmissions.

\*\*\*\*\*  
\* THE "PARATUNE" \*  
\* ONE \*  
\* What a reader has to say about it. \*  
\*\*\*\*\*

The Editor, WIRELESS CONSTRUCTOR.

Sir,—I should like to thank you, and the others who assisted, for bringing out your wonderful little set, the "Paratune" One. Although I have never owned a set before, and am a complete novice, I have always taken a keen interest in unusual construction of sets, and I decided to build your set. I can only say that the result is simply wonderful. My friends would not believe it until they had heard for themselves. I can get heaps of continental stations as clear as a bell. Needless to say, I am now busy converting the set into the three-valver you have described in last month's issue of WIRELESS CONSTRUCTOR.

Once again thanking you.  
Yours sincerely,  
C. BACON.

Cockerton,  
Darlington

\*\*\*\*\*  
**THE "EXPLORER" TWO**  
*A Reader's Experiences with a Victor King Set.*  
 \*\*\*\*\*

Sir,—About a week after the "Explorer" Two was published I made it up. This is by no means the first set I have made up from designs published in your valuable mag., but taking everything into consideration it is certainly the best.

As a matter of fact, I have been using a two-valver for the last three and a half months, using the "Explorer" Three coil designed by Mr. Victor King; this is the most efficient dual-wave coil I have ever used, and I have tried nearly every method given in both your own mag. and others. The set worked O.K., but was not very good on S.W. work. So that when the "Explorer" Two came out I decided to alter the layout to conform with that.

**Quality and Power**

Owing to the fact that I have only an indoor aerial the coil itself is quite selective enough without the use of any series condenser, and is only necessary on S.W., so that I replaced this with a "Formo" .0002 mfd., arranging it so that it is shorted on M.W. and S.W. work. I am also using a "Utility" low-loss switch for wave-changing, and a "Telsen" 7-1 L.F. transformer.

Using a Mullard P.M.2D.X. valve as a det., and an Osram P.2 valve as output, with 120 volts H.T., at which the anode current is just 10 m.a., for the power valve, the quality on a linen diaphragm speaker is far above the average for this type of set, and volume is more than required long before the oscillation point is reached.

**"And Many Others"**

In conclusion, I do not think it necessary for me to say I am satisfied. After dark I can obtain several European stations; among the best are Cologne, Turin, Bratislava and Munich, and many others. I mention these because after about 9 p.m. they come in really well, and while not, of course, being up to the Reg. and Nat., they can be received comfortably without using excessive reaction. It is also very good on L.W. and on S.W. it is the best all-wave set I have tried. W 2 X A F, on 31.48 m., is receivable most nights after 11 p.m., and several others. I have not heard Australia yet, but live in hopes.

Yours faithfully,  
 NOEL G. HIGGS.

Clapham, S.W.4.



**What's the use?**

They are essential to the efficiency of all modern circuits. Incorporated in your set they stabilise the H.T., eliminate Motor coating, avoid multiplicity of H.T. tappings and prevent feed-back. The cheapest form of reliable decoupling ever devised. They actually form a flexible connecting link between components.

OBTAINABLE FROM ALL GOOD DEALERS

Send 2d. Postage for our new fully illustrated catalogue.

**BULGIN RESISTANCE LINKS**

	Price
600 or 1,000 ohms, 12M/A	0 9
2,000 ..	10 "
3,000, 4,000 or	
5,000 ..	8 " 1 0
10,000 ..	5 " 1 0
15,000 or 20,000	4 " 1 3
25,000 ..	3 " 1 6
50,000 ..	2½ " 1 9
60,000 ..	2½ " 2 0
80,000 ..	2 " 2 6
100,000 ..	2 " 2 9

**A. F. BULGIN & CO., LTD.** 9, 10, 11, CURSITOR STREET, CHANCERY LANE, LONDON, E.C.4.  
 Telephones Holborn 1072 & 2072.

**To House Your SET**  
 OR  
**RADIO-GRAM**  
 BUILT LIKE A PIANO  
 A SPLENDID XMAS PRESENT

Exclusive Craftsmanship—the sort people desire to possess and keep. (Over 3,000 delighted clients.) Direct from Craftsman's bench to your home. You may have **ON APPROVAL FREE TEST** and return at our expense if you wish to part with it. Prices run from £5 5 0 (or £10 to £15 15 0 for Exclusive models). Cash or Easy Payments. Photographs and full particulars **FREE**.  
**PICKETT'S**, Radio Furniture Makers (W. Con.), Albion Road, Bexleyheath, Kent.

**— SOLVE ALL H.T. TROUBLES —**

**WET BATTERIES**

**TAYLEX**

— SELF GENERATING —

Per doz. No. 1. No. 2. s. d. s. d.  
 Jars (waxed) - 1 3 1 6  
 Sacs - 1 2 1 9  
 Zincs - 10 11  
 Rubber Bands (24) 4 4  
 Terminals - 8 10  
 Trade Supplied.

**LONG LIFE : SILENT : ECONOMICAL**

Sample doz. (18 volts), complete with bands and electrolyte. No. 1, 4/1; No. 2, 5/-, post 9d.; terminals extra. No. 3, with terminals, 7/6 (10,000 milli-amps), sample unit 6d. Orders 10/- carr. paid. New illustrated catalogue post free.  
**FREE** Bargain List of Receivers, Amplifiers and Components.  
**C. TAYLOR, 57, Studley Road, Stockwell, London.**

**ALL APPLICATIONS for ADVERTISING SPACE in "WIRELESS CONSTRUCTOR" must be made to the Sole Advertising Agents, JOHN H. LILE, LTD., 4, LUDGATE CIRCUS, LONDON, E.C.4.**  
 Phone: City 261.

**A regular Book for a regular fellow**

Eight hundred and thirty two pages of gripping fiction and articles. Something like a book, that. It's **CHUMS ANNUAL** and there's no finer gift for a boy. There are twelve splendid colour plates and twelve pages of interesting photographs—just the sort of pictures boys like to look at.

At all Newsagents - 12/6 net.

# CLIX

For every form of contact

## CLIX VALVE HOLDER

Extract from a recent test report in a leading technical journal.

"We have no hesitation in saying that for the short wave receiver it is the best on the market. It is as nearly air supported as possible. An excellent feature is to be found in the new Clix slotted sockets giving positive contact to either split or solid valve pins."

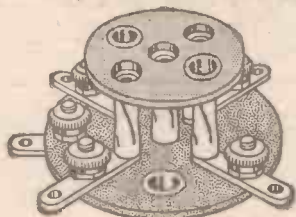

No. 27. Pro. Pat. Reg. Design.

Usual H.F. losses entirely eliminated. Resilient Sockets air dielectrically insulated and self-aligning. Impossible to blow valves.

Type B for baseboard mounting.

- 5 Pin Model with screw terminals - 1/-
- 5 Pin Model without screw terminals - 9d.
- 4 Pin Model with screw terminals - 10d.
- 4 Pin Model without screw terminals - 8d.

Clix 27 different devices for contact. Write for descriptive leaflets.

LECTRO LINX, LTD.,

254 VAUXHALL BRIDGE ROAD, S.W.1

IF YOU REQUIRE FIRST-CLASS



EBONITE PANELS & FORMERS

Look for this TRADE MARK. The Hall Mark of Quality.

Sole Manufacturers:

THE BRITISH EBONITE CO., LTD., HANWELL, LONDON, W.7.

High-Grade QUEEN ANNE STYLE WIRELESS CABINET. Hand French Polished.

- Figured Oak ... £5.5.0
- Figured Mahogany ... £6.6.0
- Figured Walnut ... £6.15.0

Carriage Paid.

THE ACME OF OUTFITSMAKERS. Models from £2.2.0 to £20. Thirty-page illustrated catalogue, post free.

GILBERT, Cabinet Maker, Established 1866 SWINDON.

ELEX

### T.14 PLUGS & SOCKETS

Standard sockets, 1d. each. Plugs 3d. each (6 colours). Name plates, 10 kinds, 1d. ea. Write or list T81

J. J. EASTICK & SONS, 118, BUNHILL ROW, LONDON, E.C.1

Plug-in parts

PLEASE be sure to mention "Wireless Constructor" when communicating with Advertisers. THANKS

## RADIO ECONOMIES

—continued from page 100

should not wind his own coils.

"In the 'Explorer' and 'Paratune' series, full details of the coils are given, and several shillings can be saved in this way.

"The man who wants to listen solely to his local transmission is probably a music lover, and he will be well advised to choose the best components that his pocket will permit, and make up a small, simple set.

### Choosing a Loud Speaker

"With regard to the loud speaker, there are several excellent, moderately-priced cone units on the market, and the cost of the cabinet, etc., can be saved by those who are willing to obtain a chassis, and to employ an ordinary wooden baffle.

"One reason I would choose a cone-type movement is on the grounds of sensitivity. The average balanced-armature cone can be operated quite successfully with a small power valve in the output stage of the receiver, a fact which renders a super-power valve unnecessary, and effects a considerable saving in H.T. consumption."

### Victor King's Tribute

"Well, people," said Victor King, in winding up the discussion, "once more I find myself in the position of an accountant of a bankrupt firm—nothing to add except," he continued, with upraised hand, to quell the protests of his colleagues, "that, far from a bankruptcy in ideas, we seem to have an entire adequacy, even a super-abundance. And, if I may say so, I think the subject of radio economies, in its general sense, has been admirably dealt with, and I do not think it is possible to add anything to what has been said."

## IN LIGHTER VEIN

—continued from page 112

and then Kalundborg, and then Radio-Paris, and then Lahti, and then Zeesen.

On Sunday morning, Dr. Yupushoff was positively embarrassing in his demands to hear our broadcast programmes. He seemed to find it rather difficult to follow my explanation, but was somewhat consoled when we had Nastikoff, and then Motala, and

then Hilversum, and then Huizen, and then the Eiffel Tower, and then Kalundborg, and then Radio-Paris, and then Lahti, and then Zeesen.

He scarcely seemed to grasp what I meant when I told him after lunch that Sunday with us was a day of rest and quiet recreation.

"But that," he said, with a puzzled look, "is surely vere broadthrowing comes in?"

### Did Not Appeal!

To silence him I turned on Nastikoff, and then Motala, and then Hilversum, and then Huizen, and then the Eiffel Tower, and then Kalundborg, and then Radio-Paris, and then Lahti, and then Zeesen.

At half-past three he insisted upon coming back to the home productions, but did not care much about the Children's Service that was in progress. So we went once more to Nastikoff, and then Motala, and then Hilversum, and then Huizen, and then the Eiffel Tower, and then Kalundborg, and then Radio-Paris, and then

All the Leading Radio Technicians

write for

"MODERN WIRELESS"

Britain's Leading Radio Magazine.

Lahti, and then Zeesen, after which we sallied forth for a constitutional. On our return broadthrowing was again his great desire, but as all the home stations had closed down we tuned in Nastikoff, and then Motala, and then Hilversum, and then Huizen, and then the Eiffel Tower, and then Kalundborg, and then Radio-Paris, and then Lahti, and then Zeesen.

### A Little Puzzled

The same thing happened shortly after half-past ten that evening.

"My friend," he said, after we had thoroughly enjoyed some jolly stuff from Hilversum and bedtime approached, "I do not understand your broadthrowing. Why does not the mayor—the head of a corporation is a mayor, yes, no?—why does not the mayor of the British Broadthrowing Corporation give the English people 'oliday entertainment at its 'oliday time?"

(Continued on page 135.)

# EASIER TUNING

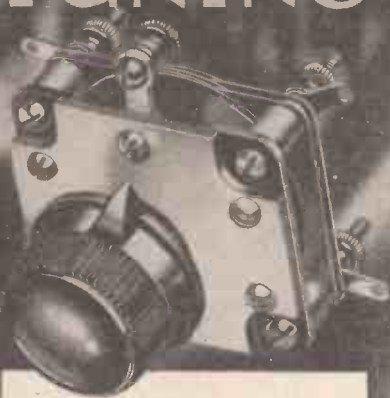

The Lotus Differential Condenser is made with moving and fixed vanes interleaved with bakelite discs of the highest possible dielectric qualities. All brass parts are chemically treated. Price from 5/3 From all Radio Dealers.

## LOTUS DIFFERENTIAL CONDENSER

Write for illustrated Catalogue to GARNETT, WHITELEY & Co., LTD., LIVERPOOL.

# EVERYTHING WIRELESS ON EASY TERMS

COSSOR EMPIRE MELODY MAKER, MULLARD ORGOLA, OSRAM 4, All-Mains Sets, EKCO H.T. ELIMINATORS, Loud Speakers, etc.

## Components for any Circuit

Send for our quotation for everything you require in Wireless. We pay carriage on all cash orders for delivery in U.K. or N. Ireland.

The P.D.P. CO., LTD. (Dept.)  
46, WATLING ST., LONDON, E.C.4  
Phone Central 4468

## The best Eliminators The best Mains Sets

## Use HYDRA CONDENSERS

LOUIS HOLZMAN, LTD.,  
37, NEWMAN STREET, W.1.

Telephone: Museum 2641

Make The **DAILY SKETCH** YOUR Picture Paper

## IN LIGHTER VEIN

—continued from page 134

This was a bit of a poser even for such an ardent supporter of our programmes as myself. Still, I think I got rather neatly out of it.

"You possibly do not know," I said, "that the head of the B.B.C. is a Scotsman."

"Ah, yes," said the Doctor. "Lord Scon Teeth, is it not?"

"Sir Scon Teeth," I went on, "has all the virtues and none of the vices of the Scotsman. Amongst those virtues is a hatred of any form of waste. He knows perfectly well that if we were encouraged we might simply let our wireless sets run riot at the week-end, spending any amount of bawbees on amps. and volts and things.

"In order to prevent any such profligacy on a national scale he has most thoughtfully arranged that at the week-ends nothing that might tempt us to expend good filament juice shall be broadcast at such times as might be most convenient for listening. In this way millions of pounds are saved annually, and it is largely to his saving us from ourselves that we British owe our present prosperity."

## A PRACTICAL MAN'S CORNER

—continued from page 108

connections are made or unmade in a moment.

### Frame Aerial Making

With the advent of high-power broadcasting in this country and the projected increase in the number of super stations, the frame aerial is becoming increasingly popular. These are rather expensive components to buy ready-made, but a very satisfactory one can be turned out at a cost that runs merely to pence in the home workshop.

A useful size is a frame with 2-ft. sides. Fig. 5 shows the dimensions of the crossbars required for making a frame of this size. It will be seen that the horizontal arm is 2 ft. 8 in. in length and the vertical arm 2 ft. 8 in. plus the length of the "leg" that carries the mounting of the frame. The arms can be made very well from a piece of walnut or other suitable wood of 1/2-in. square section.

Fig. 6 shows the simplest method of making the middle joint. Make the joint as tight a fit as you can and

(Continued on page 136.)



This well-known H.T. Battery recharges itself overnight: and provides unfluctuating trouble-free service for 12 months or more.

## STANDARD

Four hours a day, thirty hours a week and more! Smooth power, steady and strong, feeding H.T. to your set, making it give its very best, month after month. Also utterly reliable, the compact Standard Battery is the ideal power supply. For twelve months and even longer the cells do not need recharging, and when they DO, it is quite a simple and inexpensive matter to replenish with the cartridge refills.

For 2- or 3-valve Sets. 2 trays (as illustrated) of No. 2 cells, 96 volts, 7/6 down and 8 equal monthly payments of 7/6. Cash £2 2s. 11d. Spare No. 2 cells (complete except chemical), 1/3 volts each, 5/6 per dozen. Any voltage supplied.

D.6 Battery 108 volts Including oil and chemical, but without trays, £1 14s. 9d. All Batteries can be supplied on deferred terms if desired.

GREAT TEST HOME OPER

Write for full particulars of the complete battery range. THE STANDARD BATTERY CO. (Dept. W.C.), 184-188 Shaftesbury Avenue, London, W.C.2.

ONE FOR YEARS

Free! 128 PAGES

# ENGINEERS GUIDE TO SUCCESS

containing the widest selection of engineering courses in the world

GET IT

Quality for a well-paid post in Engineering by studying at home with the I.C.B. Become an A.M.I.C.E., A.M.I.E.E., etc. Training unit Successful is Guaranteed. WRITE NOW for "The Engineer's Guide to Success" and mention the branch, post or qualification that interests you, to T.I.C.B., 1, Temple Bar House, London, E.C.4. Founded 1917. 16,000 Successes

**A PRACTICAL MAN'S CORNER**

—continued from page 135

secure it with glue as well as by means of the bolt that passes through both portions. The next problem is to devise some suitable means of securing the turns to the arms and of keeping them firmly in place.

For this purpose I can strongly recommend the ebonite comb which is seen in Fig. 7. For the 10-turn frame that is required for the normal broadcast band this may be from 4 in. to 4½ in. in length. As will be seen from the drawing, holes are drilled slightly staggered on either side of the middle line, and hacksaw cuts are made leading into these.

The comb is secured to the ends of the arms by means of a couple of 4 B.A. bolts, or wood-screws may be used if desired. If the portion of the comb which protrudes beyond the ends of the arms is 4 in. in length, then each arm will be exactly 24 in. long, or 12 in. from the centre to the end.

**Combs and Windings**

Fig. 8 will make clear the way in which the combs are attached to the arms and the windings are put on. The comb marked C does not, of course, protrude beyond the end of the leg which carries the mounting of the frame.

It is fitted flat to the face of this leg, both holes and hacksaw cuts being made through the comb itself and through the wood of the leg. The ends of the windings are anchored to a small terminal panel fixed with wood-screws just below the comb C.

The first turn is attached to one of these terminals and taken round to the outermost notch of each comb,

all on the same side. Then a cross-over is made to the outermost notch on the other side.

The windings are thus kept beautifully spaced, and when all are in place the "out" end is anchored to the second terminal on the small panel. A larger frame for reception on the long waves can be made with the same combs, but here each saw-cut contains about five turns.

**Mounting the Frame**

An excellent way of mounting a frame on its base is to employ what is known technically as a heavy-duty jack and plug. The plug is attached to the end of the upright member of the frame, whilst the jack is mounted upon the top of a box of suitable size.

Short wires from the terminals of the frame are brought down to the contacts of the plug, whilst terminals upon the box are connected to those of the jack. This form of mounting is particularly useful, since there are no loose leads to become twisted when the frame is rotated for directional purposes.

\*\*\*\*\*  
 \* **STABLE H.T. SUPPLY** \*  
 \* Some notes about high-value \*  
 \* variable resistances. \*  
 \*\*\*\*\*

**A** WIRE-WOUND resistance has many advantages over the old carbon compression type. The resistance value, which in the old type was apt to vary, remains constant. The value when adjusted remains fixed until a fresh setting of the resistance is made. There is no possibility of burning-out through over-heating.

Of this construction is the new "Regentstat," manufactured by Regent Radio Supply Co., 21, Bartlett's Buildings, Holborn Circus, E.C.4.

The "Regentstat" has the distinction of being the only totally wire-wound resistance with values as high as 180,000 ohms, and capable of carrying current. It comprises a winding of wire so arranged that it will carry a relatively heavy current without over-heating.

**Special Formers**

The wire is wound on heat-resisting material, then wound on a Paxolin strip former, with a space of 1/16 in. between each turn. The contact arm does not pass over the fine wire, but over the nickel chrome wire wound on to the former on the remote side from the contact arm.

The former is fixed to a moulded bakelite cylinder. In Type B, the curved surface of this cylinder is serrated to permit ventilation of the resistance element.

The "Regentstat" has three terminals, two being joined to the ends of the resistance element, and the third to the contact arm. This disposition of the terminals allows the "Regentstat" to be used as an adjustable resistance or potentiometer.

**Two Types Available**

The "Regentstat" has been incorporated by the makers in the whole range of Regentone mains units—A.C., D.C. and Combined "Portable" models. It can be substituted for any resistance, whether fixed or adjustable, already in use in mains unit or receiver.

There are two types: Type A and Type B. Both types are 1½ in. in diameter and both require a single 3/8-in. hole for fixing. Type A occupies 1¼ in. behind the panel, but another ½ in. must be allowed for Type B.

Type A, priced at 9s. 6d., is available in values ranging from 500 ohms to 120,000 ohms, while Type B is available in values up to 180,000 ohms, and is priced at 11s. 6d.

**INDEX TO ADVERTISERS**

Amalgamated Press Boys' Annuals	PAGE 125
Belling & Lee, Ltd.	106
Benjamin Electric, Ltd.	132
British Blue Spot Company, Ltd.	Cover iii
British Ebonite Co., Ltd.	134
British General Manufg. Co., Ltd.	110
Bulgin, A. F. & Co., Ltd.	133
Burne-Jones & Co., Ltd. (Magnum)	124
Burton, C. F. & H.	126
Best Way Wireless Books	127
Carrington Manfg. Co., Ltd.	117
Cosser, A. C., Ltd.	70
Chums Annual	133
Dublilier Condenser Co. (1925), Ltd.	102
Edison Swan Electric Co., Ltd.—Mazda	
Vi-lves	Cover ii
Eastick, J. J., & Sons	134
Exide Batteries	109

Ferranti, Ltd.	PAGE 106 & 117
Formo Company	119
Gambrell Radio, Ltd.	123
Garnett Whiteley & Co., Ltd.	135
Gilbert, J. C. (Cabinets)	134
Harrods, Ltd.	127
Hayberd, F. C., & Co.	117
Holzman, Louis, Ltd.	135
Jackson Bros.	110
Lectro Linx, Ltd.	134
Lissen, Ltd.	97
London Elec. Wire Co. & Smiths, Ltd.	98
London Radio Supply Co.	132
"London Magazine"	102
Mains Power Radio Co.	123
Marconiphone Co., Ltd.	105
"Modern Wireless"	114
New London Electron Works, Ltd.	123
P.D.E. Co., Ltd.	135
Pickett's Cabinet Works	133
Radio Instruments, Ltd.	Cover iv

Ready Radio	PAGE 101
Regent Radio Supply Co.	117
Rothermel Corporation, Ltd.	69
"    "    (Electrad)	114
"    "    (Centralab)	110
Six-Sixty Radio Co., Ltd.	131
Standard Battery Co., Ltd.	135
Taylor, C.	133
Technological Inst. of Gr. Britain	135
Telegraph Condenser Co., Ltd.	127
Telsen Electric Co., Ltd.	113
Varley Products	119
Westinghouse Brake and Saxby Signal Co., Ltd.	128
Weston Electrical Instrument Co., Ltd.	106
Wingrove & Rogers, Ltd.	121
Wright & Weaire, Ltd.	121

All communication concerning advertising in "Wireless Constructor" must be made to John H. Lyle Ltd., 4, Ludgate Circus, London E.C.4. Telephone: City 7201. FOR ADVT. RATES SEE PAGE 123

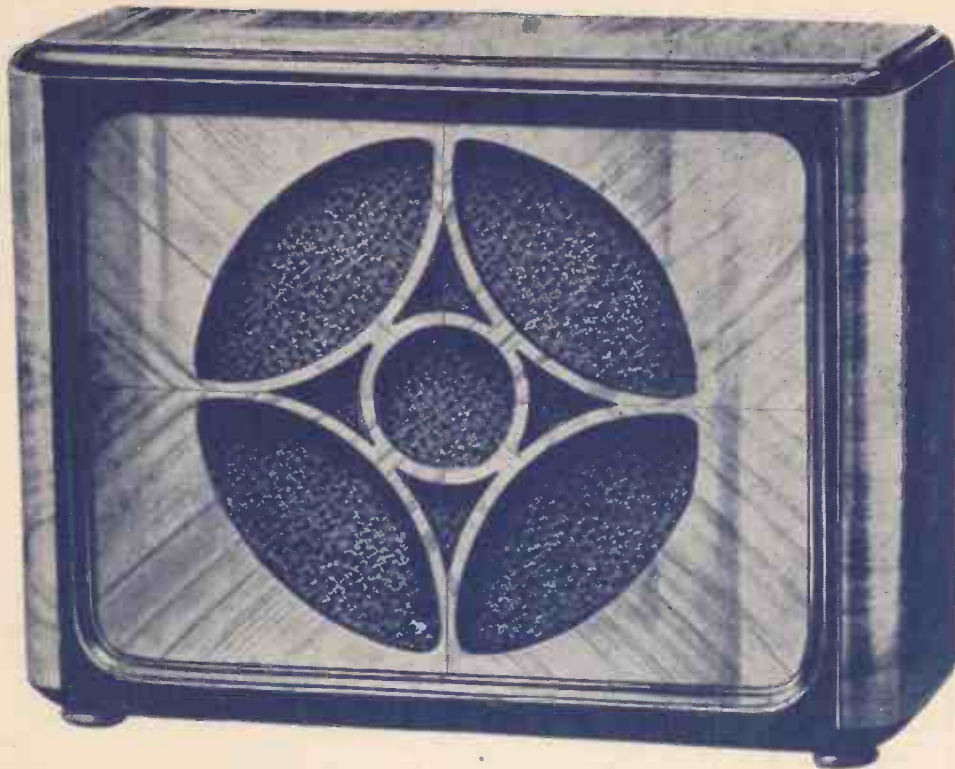

# BLUE SPOT 71R

A magnificent speaker. From its beautiful walnut cabinet 71R reproduces clearly and faithfully every sound the microphone receives. Ask at your dealer's to see and hear Blue Spot 71R for yourself. You'll be astonished how good it is.

PRICE

**95'.**



• **THE BRITISH BLUE SPOT COMPANY LTD.** •

BLUE SPOT HOUSE, 94/96, ROSOMAN STREET, ROSEBERY AVENUE, LONDON, E.C.1

'Phone: CLERKENWELL 3570.

'Grams: "BLUOSPO, SMITH, LONDON."

Distributors for Northern England, Scotland and Wales: H. C. RAWSON (Sheffield and London) LTD., 100, London Road, Sheffield: 22, St Mary's Parsonage, Manchester; 183, George Street, Glasgow.

# THE BIG THREE



Overshadowing all other developments in modern transformer and choke design, the utilisation of NIKALLOY as a core in the

## HYPERMU, HYPERMITE & HYPERCORE

has put these components in the forefront of modern radio design.

NIKALLOY renders these components the most efficient for modern compact set assembly and use with modern valves. Fit the "Hypermu" or "Hypermite" L.F. Transformer between your detector and power valves and the "Hypercore" Smoothing Choke after your output valve—the improvement in your reproduction will be almost unbelievable—louder, clearer, purer, better than ever before.

NIKALLOY is the latest phase in the triumphant progress of R.I. transformer and choke manufacture. Specialized experience must count.

*Tiny in Size but Mighty in Performance  
they dwarf all others to insignificance*

**HYPERMITE**  
Primary Inductance,  
50 henries. Ratio,  
3½ to 1.

**12/6**

**HYPERMU**  
Primary Inductance,  
85 henries. Ratio,  
4 to 1.

**21/-**

**HYPERCORE**  
Inductance, 30 hen-  
ries. Max. D.C., 75  
milliamperes.

**17/6**

*The leading makers have chosen the Big Three for inclusion in modern receivers—one or more of them are specified in most modern circuits. They are indisputably best.*



*Ask your radio dealer for the illustrated leaflets dealing with the Big Nikalloy Three. If he cannot supply you—please send us his name and address.*

**—AND IF IT'S**

**IT'S MODERN**

MADRIGAL WORKS,

LTD.

PURLEY WAY CROYDON.