

SPECIAL CHRISTMAS & NEW YEAR NUMBER

The Wireless 6^d Constructor

EDITED BY
PERCY W. HARRIS. M.I.R.E.
Vol. IX. JANUARY, 1930. No. 39.

IN THIS ISSUE

THE "SILVER CHAMPION"

DESIGNED BY PERCY W. HARRIS M.I.R.E.

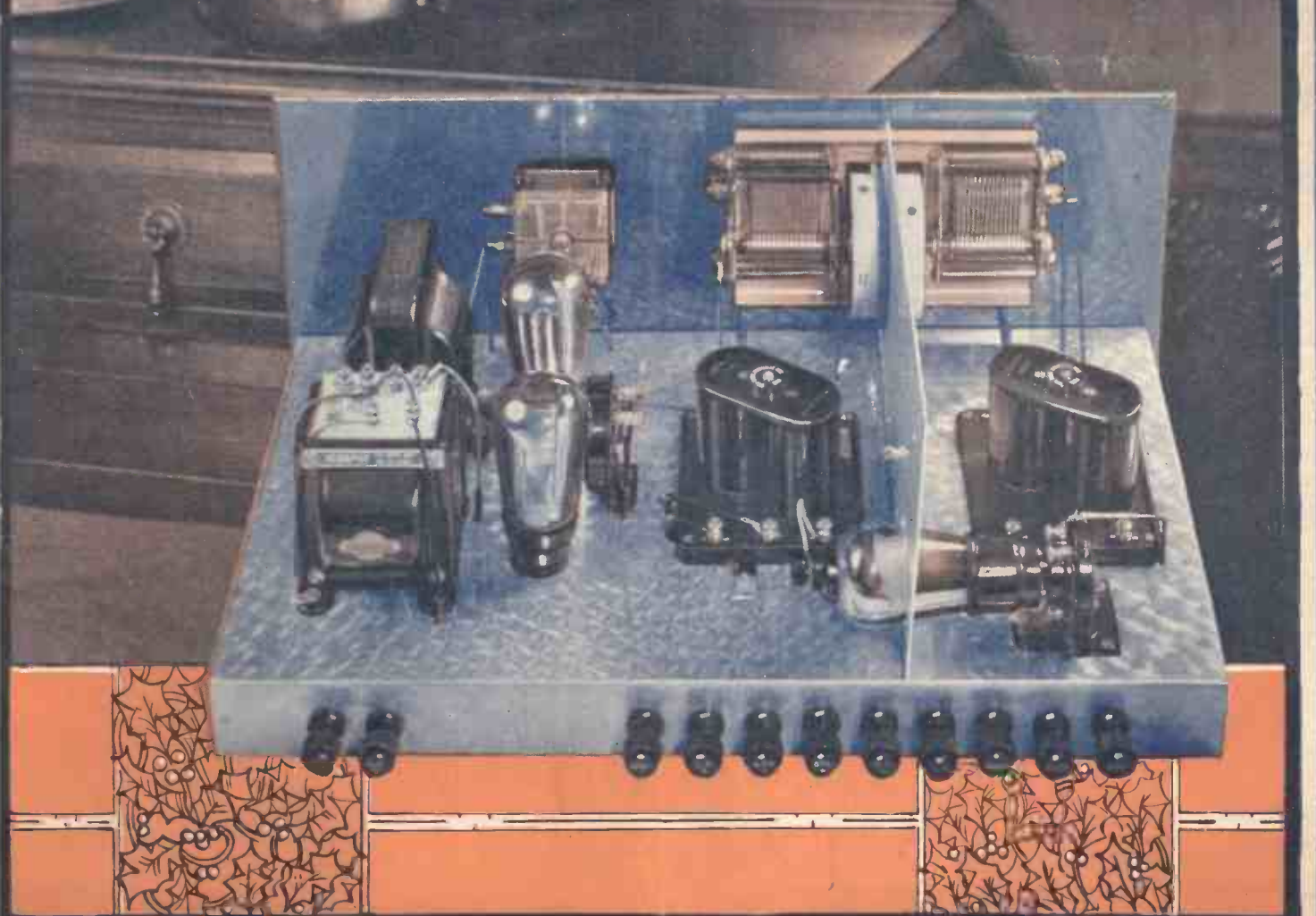

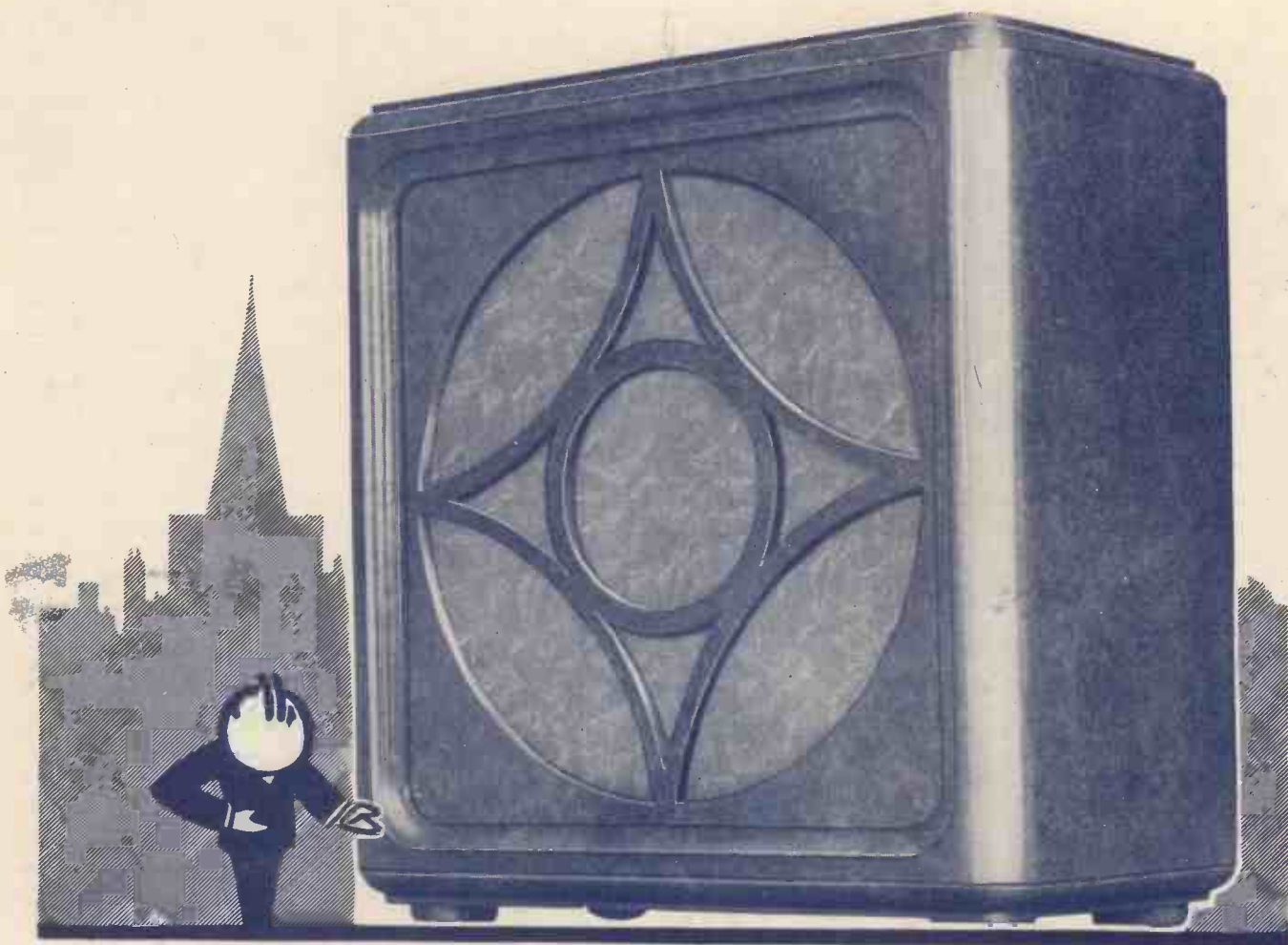

Usher in the New Year with "GOLIATH"

. . . ten—eleven—*twelve!* . . . 1930 is here! The thrill of the passing of the old year—the ushering in of the new . . . is intensified by Goliath.

The chimes, the songs and the music, the very spirit of the new year seems to creep into Goliath and burst forth in joyous frolic.

The Blue Spot Goliath is the 1930 speaker in every sense. It is true to life, natural and clear, it is, in fact, the finest speaker of the Blue Spot range, and the speaker which experts declare to be years ahead of any other speaker, both in performance and appearance.

You can hear it at your dealer's. Its price is £6. 6. 0.



F. A. HUGHES & CO., LIMITED, 204-6 Great Portland St., London, W.1

'Phone: Museum 8630 (4 lines).

Distributors for Northern England, Scotland and North Wales: H. C. RAWSON (SHEFFIELD & LONDON) LTD., 100 LONDON ROAD, SHEFFIELD. 'Phone: Sheffield 26006. 22 ST. MARY'S PARSONAGE, MANCHESTER. 'Phone: Manchester City 3329.

CONTENTS

	Page		Page
The Editor's Chat	167	Making the Most of a Loud-Speaker Unit	191
The "Maximum" Three with a Frame	168	Within the Vacuum	193
The Silver Champion	169	Aerials and Selectivity	196
Where Push-Pull Scores	175	Why Not Loud-Speaker Curves ?	199
The "Night Watchman"	177	In Lighter Vein	204
Queer Queries	182	As We Find Them	208
At Home with the "Chassis" Three	183	A Practical Man's Corner	213
With Pick-up and Speaker	185	The Ideal Meter	216
Voltage and Quality	187	Our News Bulletin	220
Savoy Hill News	139	Input Transformers and the Pick-Up	234

As some of the arrangements and specialities described in this Journal may be the subject of Letters Patent the amateur and trader would be well advised to obtain permission of the patentee to use the patents before doing so.

Edited by PERCY W. HARRIS, M.I.R.E.

Chief Radio Consultant: Capt. P. P. ECKERSLEY, M.I.E.E.

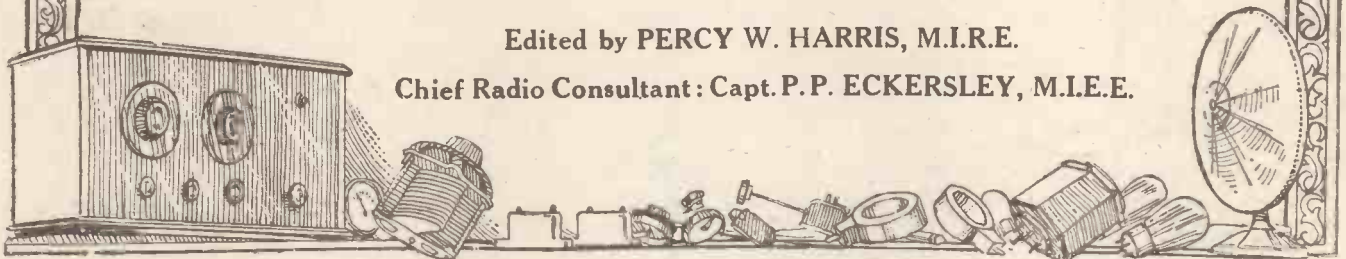

AMPLION

BALANCED ARMATURE UNIT B.A.2.

The Amplion B.A.2 Balanced Armature Unit has volume handling capacity coupled with a degree of sensitivity far beyond normal. With adaptor plate to fit different types of chassis and adjustable values of impedance for use with power valve or pentode. The B.A.2 means new power and mellow purity of reproduction. Ask your dealer for a demonstration.



AMPLION SPEAKERS.

STANDARD & JUNIOR MODELS
PRICES from 21/- to £4-17-6
10 models

"LION" SUPER SPEAKERS
PRICES from £8 to £16.
Chassis only £6 and £8



GRAHAM AMPLION LTD., 25, 26 SAVILE ROW, W.1. Works: SI OUGH



INTERLOCKED!

Braced to a girder-like rigidity—locked top and bottom the elements in the *NEW* Cossor Screened Grid Valve are immovable — they are proof against even the hardest blow. The Cossor system of Interlocked Construction ensures a degree of strength never before attained in any valve —it ensures that the Cossor Screened Grid Valve will retain its amazing sensitivity and efficiency throughout its exceptionally long life. Use the *NEW* Cossor Screened Grid in your Receiver—no other valve has Interlocked Construction.

2-volt type now available.

Cossor 220 S.G. (2 volts, 2 amp.) Max. Anode Volts 150, Impedance 200,000, Amplification Factor **22/6** 200. Price -

Cossor 4 and 6 volt Screened Grid Valves are also available with similar characteristics at the same price.

A. C. Cossor Ltd., Highbury Grove, London, N.⁴

The **NEW**
COSSOR
Screened Grid
Valve

THE WIRELESS CONSTRUCTOR



Edited by
PERCY W. HARRIS, M.I.R.E.



Published by the Amalgamated Press, Ltd., Fleetway House, Farringdon St., London, E.C.4

THE EDITOR'S CHAT

In this article Percy W. Harris, M.I.R.E., the Editor of the "Wireless Constructor," wishes all readers a very Merry Radio Christmas, and introduces another outstanding "chassis" design.

THIS being the January number of the WIRELESS CONSTRUCTOR, published just before Christmas, may we take this opportunity of wishing all our readers a very merry and enjoyable radio Christmas, and a happy and prosperous New Year? Dickens, had he lived now, would have woven a wondrous story around the romance of radio and the comfort and cheer it brings to so many at Christmas-time—indeed, throughout all the dark winter evenings. To the distant Colonies and Dominions the British Broadcasting Corporation's station 5 SW, working on short waves, gives a contact with home which can be fully appreciated only by those who have lived at such great distances.

Empire Broadcasting

Letters are continually arriving at the offices of the WIRELESS CONSTRUCTOR from distant readers asking for more and better use of 5 SW; but, as has already been explained by the British Broadcasting Corporation, funds do not permit of such fuller use of short-wave broadcasting. This trouble will, no doubt, be overcome at an early date. It is a poor Mother Country that cannot overcome such difficulties, and perhaps by next Christmas we shall see a considerable extension in the use of short waves for the British Empire.

Our Greetings over, allow me to thank readers for the wonderful support given to the special "free gift" issue of our journal. Great pains were taken to make this issue worthy of this support, and it is most gratifying to all concerned that such a hearty response was given.

Every endeavour was made to supply the enormous demand, and to

those readers who were unable to obtain their copies owing to the newsagents and bookstalls being sold out we can only express our regret and remind them that a safe insurance against this happening again is obtained by placing a regular order with their newsagents.

We are rapidly approaching the time when the Brookman's Park

During this Christmas, the eighth since broadcasting began in this country, it will be interesting to recall the progress that has been made in both transmission and reception.

The old order has given place to the new. No longer do we endeavour to pick-up rough and wobbly transmissions with flat-panelled sets containing inefficient H.F. stages "held down" by sheer force with positive bias, but we can fly hither and thither through the ether in search of programmes—and get them—with sets that will give us purity of reception as well as ease of handling.

The new "Chassis" method of construction is the last word in receiver design, and with a three- or four-valve "chassis" set the stations of Europe are yours for the asking.

So here's to a really jolly radio Christmas with lots of fun and heaps of stations on our dials.

transmitter will be simultaneously sending programmes on two wavelengths, and when, therefore, we shall need—at least those who live within fifty or sixty miles of Brookman's Park will need—sets far more selective than those which have been quite satisfactory in the past.

Alternative Programmes

When these two simultaneous programmes begin receiving conditions will be far worse than many people imagine, as on thousands of sets each

programme will spread over such an extent of the dial that it will seriously interfere with the other. At present, with only one powerful station, many people are quite happy, as this is the station to which they wish to listen, and no other is sufficiently strong to interfere. With the new conditions there will be, on thousands of sets, no position on the dial where two programmes will not come in simultaneously.

For some time the WIRELESS CONSTRUCTOR has borne in mind the new requirements and, of course, the "Chassis" Three will fully meet them. The "Silver Champion"—about which more later—also fits admirably into the new scheme, as do many other sets recently described.

The Second "Chassis" Set

The "Silver Champion" is the second of the WIRELESS CONSTRUCTOR "chassis" sets, and is designed for those who, without going to more than three valves, desire to obtain a first-class long-distance set, incorporating the useful features of simple tuning, switch wave-changing, first-class quality, output filter, etc., etc.

Its distance-piercing qualities are extraordinarily good and a night spent with this receiver would be a revelation to those who are accustomed to work with the older forms of one H.F. set. It is, par excellence, the three-valve receiver for the man who lives in a "difficult" or "dead" district, or who, through one circumstance or another, is compelled to work with an indoor or very small aerial. Its many features are fully described in the article, and we think all readers will agree that it fully maintains the high standard set by the first "chassis" set.

THE "MAXIMUM" THREE WITH A FRAME

The following article is the outcome of some experiments made with the "Maximum" Three (described in the November "Wireless Constructor") and a frame aerial.

By A. S. CLARK.

IN view of the greatly increased selectivity obtained with a frame aerial this article will be of special interest to those living near a powerful broadcasting station, particularly if it happens to be Brookman's Park.

Perhaps you may doubt whether such a set (namely, one employing only three valves) is sufficiently sensitive for use on a frame aerial. If you do, let me assure you right away by the following.

With the set working under the conditions to be described, with the exception that the frame aerial was replaced by an ordinary No. 60 plug-in coil, it was possible to obtain loud-speaker results from 2 L O in South-west London! So you will realise that the set certainly lives up to its title even when used on a frame.

Easily Made Aerial

The frame aerial employed was of the box type with sides 2 ft. long, each of its 11 turns of flexible frame-aerial wire being separated from the next by a space of about $\frac{1}{4}$ in. No taps are necessary, and in order to make connection to the set easy the two ends of the winding are joined to an ordinary single-coil mount. The tuned coil is removed from its holder and the mount just described is inserted in its place. The tuned coil is the one farthest from the terminal strip.

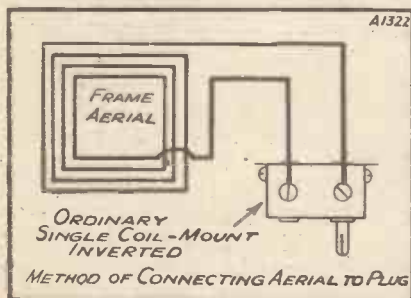

It is desirable that the H.F. transformer should be of the interchangeable primary type. Actually a Lewcos transformer with a No. 10 primary was used throughout the experiments. An ordinary coil was found quite satis-

factory for 2 L O and 5 G B, but it was difficult to tune-in Continental stations on it due to the fewer turns on the primary.

Incidentally, it will be found that neutralising is much more critical with the larger primary. If it is found impossible to find a definite neutralising point, the H.T. on the H.F. valve should be reduced by about 6 or 12 volts.

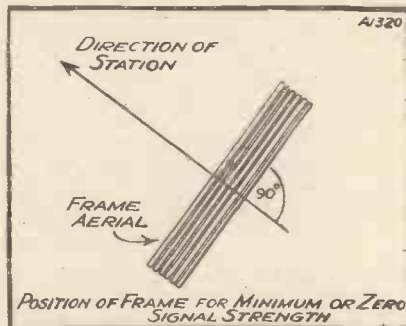

The input from the detector valve to the L.F. part of the set is naturally small with a frame, and therefore the use of a pentode valve is advised. It is usual with these valves to use a special output transformer, and the method of connecting it is indicated in one of the diagrams. Satisfactory results, however, may be obtained without this transformer.

In the actual case under description one was not employed, and the response of the loud speaker to high frequencies seemed improved in consequence.

The H.T. Values

Apart from the special output transformer just mentioned, the only other adjustment required for the pentode valve is to connect up the terminal on the side of it. This is quite simple, and merely consists of joining it to H.T.+3 with a piece of flexible wire. Needless to say, the more H.T. available, up to the maximum for the valves in use, the better, and it is necessary to get the right values on the various H.T. terminals.

H.T.+3 should be connected to the highest voltage available, as also

should +2 when reception from the local or very powerful stations which require only very little reaction is desired. The H.F. valve should have as high a voltage as possible consistent with proper neutralisation being obtained.

With most valves it was not found possible to increase it much above 90 volts. For distant reception, where critical adjustment of the reaction control is necessary, the voltage on +2, which supplies the detector valve, must be lowered. With some valves it may be necessary to go as low as 12 volts to obtain a smooth control.

Controlling Reaction

No hand-capacity effects at all were noticed on the tuning dials, the adjustment of them being remarkably easy. The approach of the hand to the reaction condenser dial, however, upset the adjustment of reaction, and an extension handle of at least 6 in. should be fitted to this condenser. With the extension handle adjusting reaction was very simple, and it remained constant over quite large portions of the tuning dials.

In the locality previously mentioned, 2 L O had to be detuned even with reaction at a minimum, and only the slightest hint of reaction was necessary to bring 5 G B up to full loud-speaker strength. This was with 120 volts on H.T.+2 and +3, and 90 on +1.

It was possible to hear Continental stations all the way round the dials.

A useful point noticed in connection with the frame was that so long as it

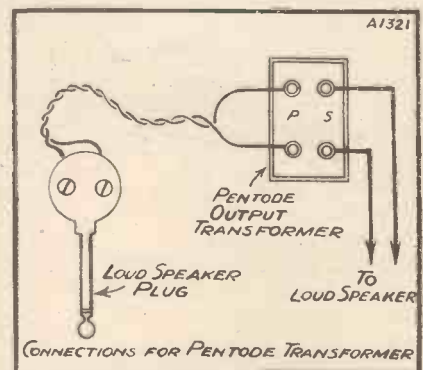

was not at the position of minimum strength for a given station (see diagram), or just near to it, it did not matter much in what direction it pointed.

Therefore, so long as a powerful "jamming" station is not in approximately the same direction as a "wanted" station, it can be cut out by the simple expedient of putting the frame aerial at right angles to it.

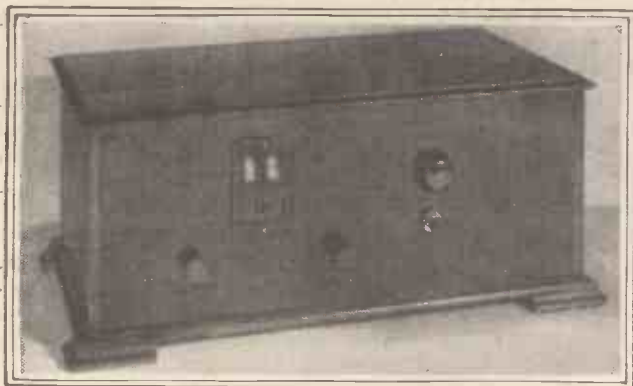

The SILVER CHAMPION

by PERCY W. HARRIS M.I.R.E.

A worthy successor to the already famous "Chassis" Three. This is a three-valve S.G. receiver with exceptional distance-piercing qualities, and capable of remarkable purity of reproduction.

THIS month the second of the WIRELESS CONSTRUCTOR chassis sets—the "Silver Champion"—makes its appearance. One might almost say that "the 'Champion' enters the Lists," for the list of stations obtainable with this receiver is surprisingly large. The adoption of the new WIRELESS CONSTRUCTOR metal chassis not only gives the set a handsome appearance unequalled by any other design, either commercial or home-assembled, but also simplifies wiring and layout, while adding to the electrical efficiency.

The New Method

A full description of the new method of construction was given in our last issue in connection with the "Chassis" Three, but for the benefit of new readers it may be said that the new WIRELESS CONSTRUCTOR metal chassis dispenses with panel brackets and terminal strips, and enables the greater part of the wiring of the receiver to be carried out on the underside, where also certain components can be attached in convenient positions. The chassis itself, built exactly to WIRELESS CONSTRUCTOR specifications, is supplied by a number of manufacturers at a reasonable price, being drilled at the back to take insulating terminals and having suitable apertures for the valve holders.

Alternative Components

In order that the reader may have the widest possible choice of components, and not be tied down, as is too often the case with commercial kit sets, to a particular list of parts, although he has other equally good components on hand, the design is so worked out that the attachment of any alternative components is made extremely easy. The chassis itself is constructed of stout gauge aluminium sheet which can be drilled with ease, without the use of any tools other

than those the home constructor has by him.

In every wireless circuit a number of points are attached to a common lead, such as negative L.T. and earth. In the present receiver, earth, L.T.—, H.T.—, grid-bias positive, and one loud-speaker terminal are all joined, whereas in the older form of construction using a wooden baseboard a number of wires would have to be used to join all these points and the components connected to them.

In the WIRELESS CONSTRUCTOR metal chassis the chassis itself is joined to L.T.—, etc., and this acts as the common lead, thus reducing the number of wires considerably. Furthermore, the wires and components underneath the chassis are effectively screened from those above, which is quite important in a case of a receiver using a high-frequency stage.

Last month, in the first of the chassis receivers, we adopted a circuit consisting of a detector and two low-frequency stages with several new modifications. The result was a set not only powerful and giving admir-

able quality, but at the same time highly selective, giving excellent reproduction, without interference, from a number of English and foreign stations when used within a few miles of Brookman's Park. Incidentally, a lengthy test report from a reader is published in the present issue.

Exceptional Receiver

For the second WIRELESS CONSTRUCTOR chassis set we have also chosen a three-valve arrangement, but in this case we are using a screened-grid valve, a detector, and a super-power valve in the output. The result is a receiver of exceptional distance-getting powers, while still giving admirable quality on nearer stations, and a degree of selectivity which makes it quite suitable for modern conditions.

Binocular or "fieldless" coils, which this magazine has done so much to popularise, are adopted in the "Silver Champion," a special form of binocular being adopted so as to enable a simple wave-change to be effected merely by the operation of

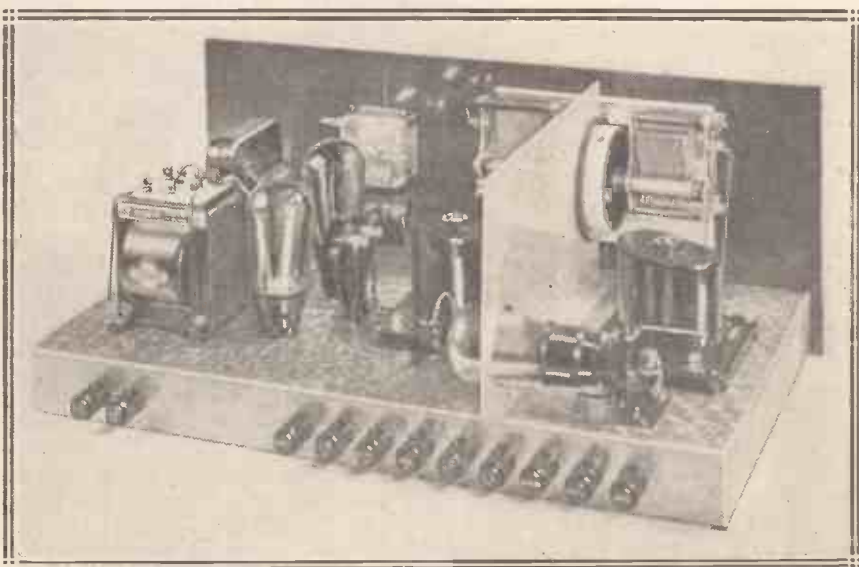

Nothing could be neater than the "baseboard" appearance of the "Silver Champion."

The "Silver Champion"—continued

two switches. The use of binocular coils, together with the efficient screening incorporated in this design, produces a set of exceptional stability and sensitivity.

Easy to Handle

The fact that there are two tuned circuits which must be simultaneously adjusted may lead the reader to think that the set is difficult to handle, but by the use of a special form of double-drum condenser, the controls of which are arranged side by side so that they can be simultaneously varied by one thumb, the disadvantages so often found in such a set are overcome. For very fine tuning one condenser can be adjusted apart from the other, thus giving the set an advantage over receivers in which "ganging" is adopted, but for general work one can run from station to station merely by moving the two drums simultaneously with the thumb.

Reaction is obtained by the differential method, this having proved to be particularly efficient. The circuit, as will be seen on this page, has an aerial coming to the special dual-range binocular aerial coil, which is tuned by a .0005 variable condenser, the twin-range effect being obtained by a special switch built into the base

automatically. The grid coil feeds on to the grid of the screened-grid valve, in the plate circuit of which is the primary of a special dual-range binocular coil, this primary being designed to suit the impedance of the modern screened-grid valve, while giving sufficient selectivity for our present requirements. The secondary of this binocular, the two windings of which are paralleled in a man-

ner similar to that of the aerial coil, is tuned by a second .0005 variable condenser and has a special reaction coil incorporated so that the device enables reaction to be obtained by the differential method.

The Reaction Condenser

With differential reaction zero setting means that the high-frequency component goes through the condenser to filament without passing through the reaction coil, and therefore without producing any reaction effect. As we turn the reaction dial to the "full-on"

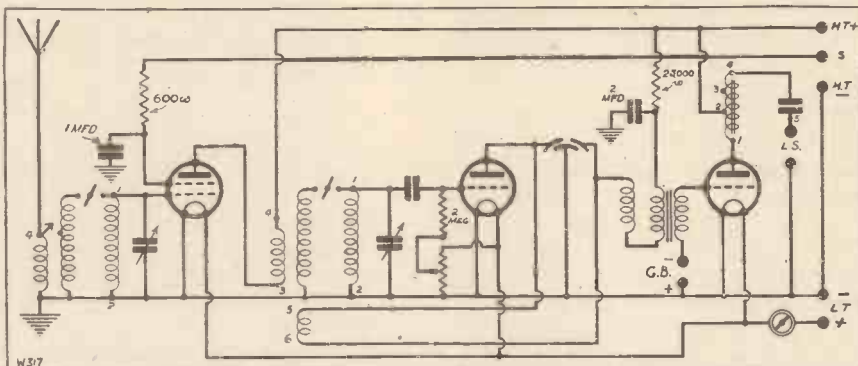

The circuit of the "Silver Champion" is very interesting. Note the new type of wave-change scheme, carried out in the coil units themselves, and also the differential reaction condenser and the auto-output choke.

ner similar to that of the aerial coil, is tuned by a second .0005 variable condenser and has a special reaction coil incorporated so that the device enables reaction to be obtained by the differential method.

position the path to filament is gradually cut out and an equal amount of capacity substituted; this time, however, the capacity being connected to the reaction coil.

At the "full-on" position the

COMPONENTS REQUIRED

NOTE.—The parts illustrated are named in brackets. Typical alternatives of good quality are also named.

Cabinet to take 18 in. x 7 in. panel and 10-in. baseboard (Cameo). Art-craft, Pickett, Raymond.

Panel, 18 in. x 7 in. (Resiston). Becol, Ebonart, Ripault, etc.

1 "Wireless Constructor" "Silver Champion" chassis fitted with two valve holders and screen (Ready Radio). Magnum, Paroussi.

1 S.G. valve holder (W.B.).

1 Double .0005-mfd. condenser with drum drive (Cylton Junior Synchra-tune).

1 Differential reaction condenser, .00013 or .0002 (Utility). Lotus, Ready Radio; Magnum, Lissen, etc.

- 1 On-off switch (Bulgin). Magnum, Lotus, Benjamin, Igranic, Raymond, etc.
- 1 Dual binocular coil unit, DBA (Lewcos).
- 1 Dual binocular coil unit, DBG (Lewcos).
- 1 R.F. choke (Igranic). R.I., Lewcos, Varley, Polar, Magnum, Wearite, Ready Radio, etc.
- 1 High-grade L.F. transformer (Lissen Super). Hypermu, Igranic, Brown, Ferranti, Nicore, etc.
- 1 Output filter combination (Igranic).
- 1 1-mfd. condenser (T.C.C.). Dubilier, Lissen, Hydra, etc.
- 1 2-mfd. condenser (T.C.C.). Dubilier, Lissen, Hydra, etc.
- 1 Fixed potentiometer (Lewcos).

- 1 Grid leak, 2 meg. (Lissen). Dubilier, Igranic, etc.
- 1 600-ohm resistance (Bulgin).
- 1 .0003-mfd. fixed condenser (Lissen). Dubilier, Igranic, Atlas, Magnum, etc.
- 1 20,000- or 25,000-ohm resistance and holder (Ready Radio). Ediswan, Loewe, Varley, Metro-Vick, etc.
- 11 Belling-Lee indicating terminals, type B, as marked on diagram.
- 6 Insulating washers, 5 metal washers, quantity 6 B.A. cheesehead screws and nuts (can be obtained with chassis).
- 1 Yard thick Systoflex.
- Black Glazite wire.
- 1 S.G. valve.
- 1 H.F. (or H.L.) valve.
- 1 Super-power or power valve.

of the dual coil and controlled by a push-pull switch on the front of the panel. Simplicity of construction is assured here by the fact that all switching is built into the coil, no special wiring for this being needed.

On the lower wave-band the windings of the grid coil are paralleled and a suitable aerial connection is also made

In differential reaction there is always a path to filament for the high-frequency component in the detector plate circuit, even when reaction is set at zero. In the older form of reaction, zero reaction setting meant that the high-frequency component had to get back to filament as best it could, an adequate path being pro-

vided, however, when the reaction condenser had its plates interleaved. high-frequency component has a path exclusively through the reaction condenser and reaction winding, the direct capacity to filament being cut out. At various intermediate positions various proportions of direct and reaction capacity are provided, so that whatever setting of the reaction condenser we choose there is always

The "Silver Champion"—continued

the same total capacity to filament.

In the plate circuit of the detector valve the radio-frequency choke provides the necessary deflection of the radio-frequency component away from the low-frequency circuit, and then we pass on to the primary of a high-grade low-frequency transformer feeding on to the super-power output valve. In compliance with the standard rule in WIRELESS CONSTRUCTOR sets, a decoupling or anti-motor-boating device is included in the plate circuit of the detector valve, this giving not only better quality than is generally obtained without this device, but enabling the set to be used very satisfactorily with all kinds of mains units.

Special Output Choke

Similarly, both quality of performance and efficiency are improved by the incorporation of an output choke and condenser filter. This device not only keeps the heavy direct plate current of the super-power valve out of the speaker windings, but also decoupling this circuit from the

battery, thus preventing undesirable feed-back effects, motor-boating, and poor quality.

Refinement in this receiver consists in the incorporation of a special choke-capacity output device, enabling

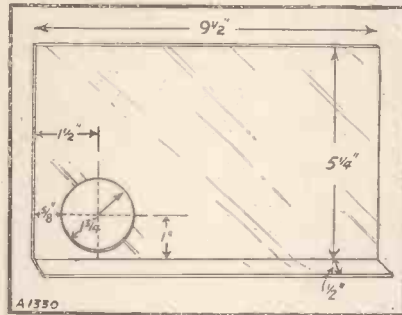

many different combinations of choke and condenser to be used, one of which will suit the particular loud speaker you have chosen. It cannot be too widely known that loud speakers vary considerably in their impedances and suitability for given valves, and while with one loud speaker you may get admirable results with one set, and poor with

another, a second loud speaker may reverse the order.

In the "Silver Champion" the incorporation of a tapped output device enables you to adjust the set to suit the particular loud speaker chosen, and the advantage of this will only be realised after you have tried it for yourself and found what excellent results you can obtain by careful preliminary adjustment.

The Panel Layout

Looking at the front of the panel, we see on the left the escutcheon revealing the two edge-control drum condensers, which over most of the tuning range run in step. On the right of this is a knob controlling reaction, while symmetrically placed each side of the escutcheon are two small knobs for wave-change. When both are pulled out the set is on the lower-wave adjustment, and when both are pushed in the set is on the long waves.

The on-and-off switch controlling the filament is placed immediately below the reaction condenser knob.

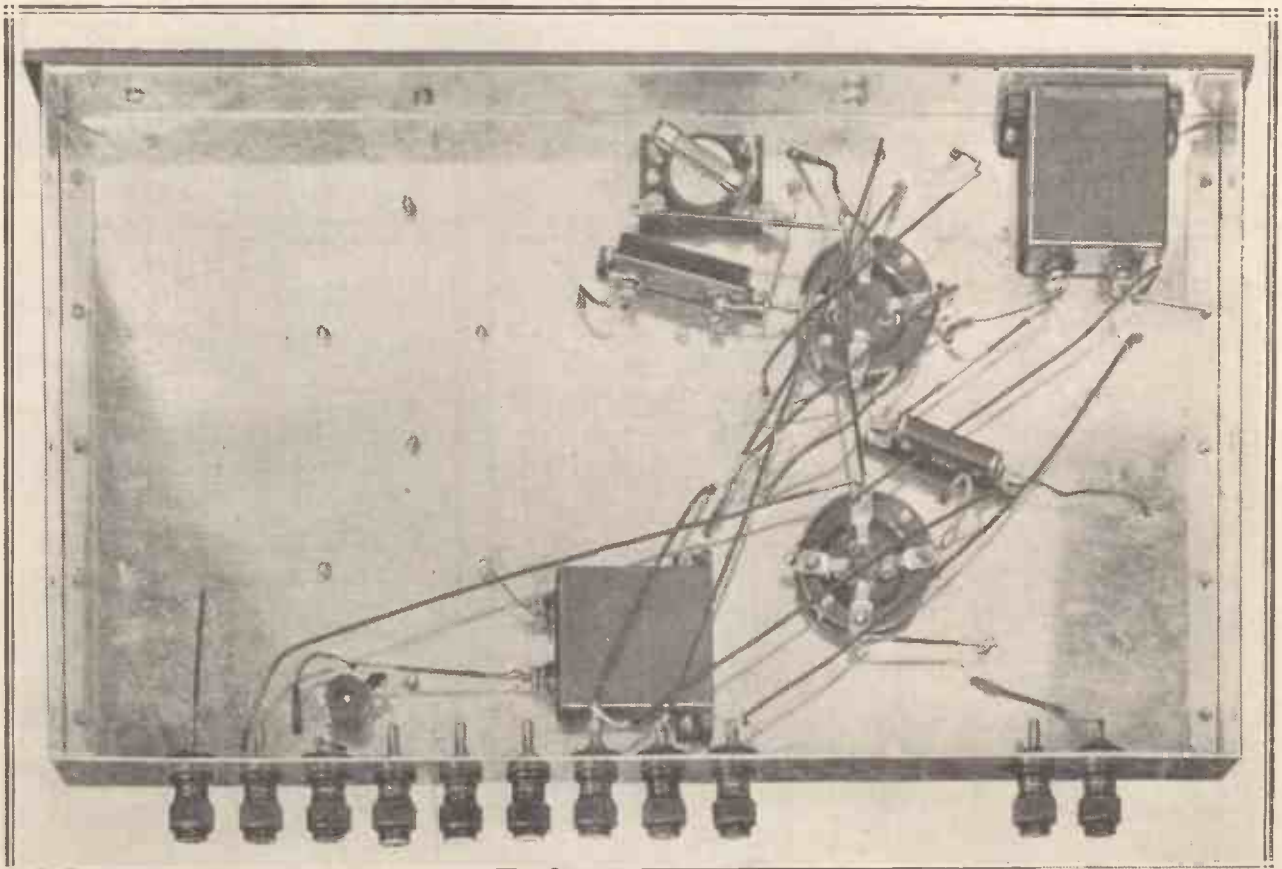

With the valve holders, fixed condensers, grid leak, and a-ride resistances placed below the chassis baseboard, nearly all the wiring can be carried out underneath, leaving the upper side untrammelled by untidy leads.

The "Silver Champion"—continued

Looking down upon the receiver we see on the left the vertical screen separating the aerial and first grid circuit from the plate circuit, the screen being so designed as to pass between the two drums, thus giving a very effective tuning. Sound electrical contact between the screen and the metal chassis is assured by means of the securing screws, and the two special dual-range binocular coils will be easily discerned.

How Components are Placed

The S.G. valve is mounted horizontally in such a way that it projects through the screen, thus effectively isolating the plate circuit from the grid. On the right of the binocular

transformer will be seen the radio-frequency choke, and symmetrically on each side of this the detector valve (nearest the reaction condenser) and the super-power output valve (alongside the special tapped output choke). The low-frequency transformer is on the right of the detector valve. The valve holders have been mounted so that only the sockets project through the chassis, and these have all their wiring on the underside, where are situated the grid condenser, the decoupling resistance for the screened-grid valve, a 1-mfd. shunting condenser for this resistance, the special detector fixed potentiometer, with grid leak, the grid condenser, a decoupling or anti-motor-boating re-

sistance for the detector valve and its 2-mfd. shunting capacity.

Five of the eleven terminals make direct connection with the chassis, and thus have no wires connected to them, while the remaining six terminals have insulated washers. The wiring of these various components is clearly shown on the diagrams.

Simple to Build

Although the "Silver Champion" has an appearance unsurpassed by any professional set, it should not be imagined that the constructional work is difficult. Indeed, many readers will find it simpler than the older form of construction. In the list of components on a previous page

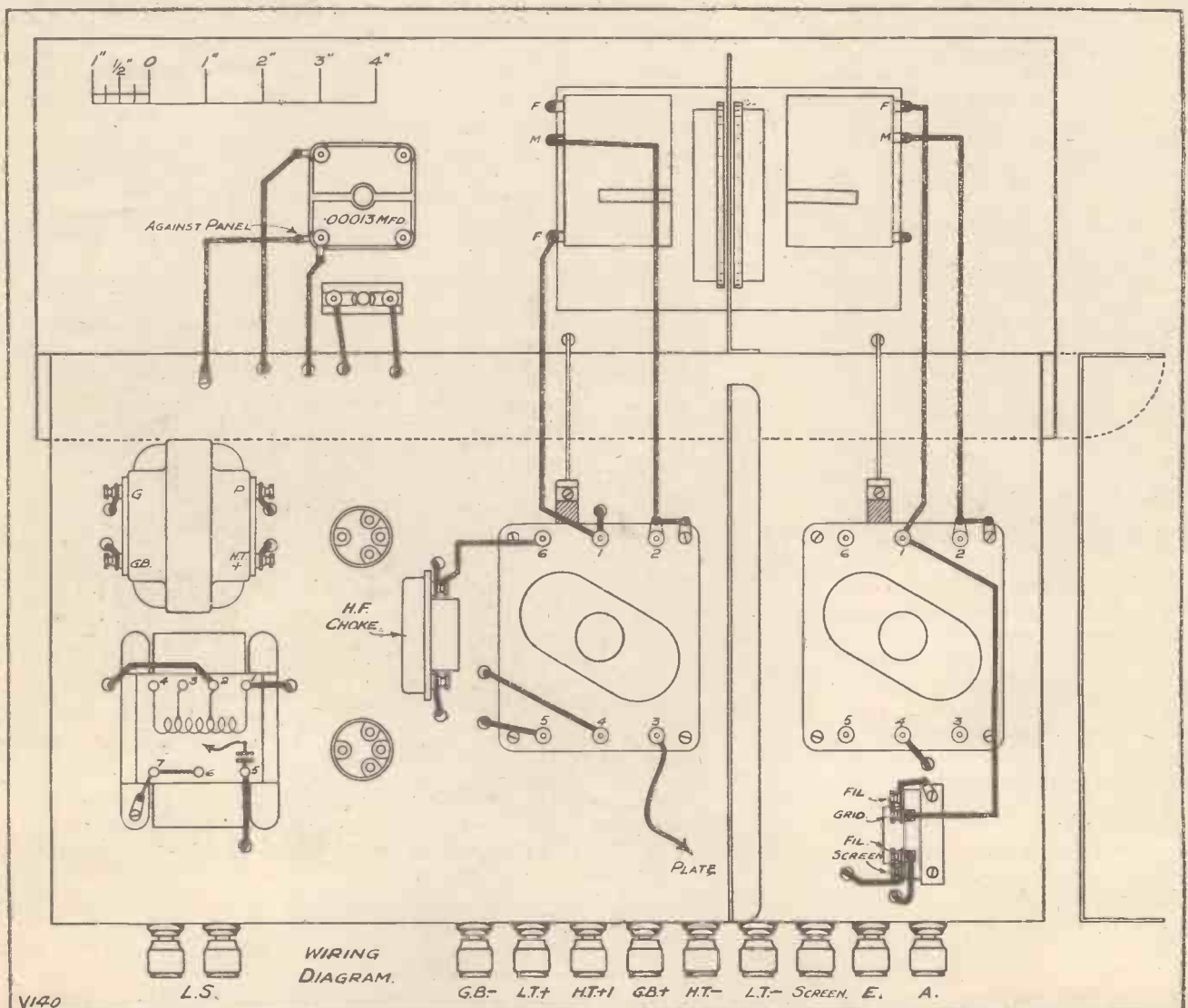

This is the "upstairs" wiring diagram, and should be used in conjunction with the diagram on the next page when wiring the receiver.

The "Silver Champion"—continued

names of the actual parts used in the model receiver illustrated are given in brackets, and, following these, names of suitable alternatives.

The terminals should first of all be fixed in position, making sure that the names are all the right way up and in line, after which the chassis

half an inch shorter, so as to allow the panel to project a quarter of an inch at each end. Be sure that the panel is so placed that there is an equal projection at each end, otherwise you may have trouble in sliding the completed receiver into its cabinet.

Three holes will have to be drilled three-quarters of an inch from the bottom of the panel, one in the middle and one at each end. The exact position of these holes is not important, as their sole purpose is to take three countersunk-head metal screws for the purpose of holding the panel against the front edge of the metal chassis.

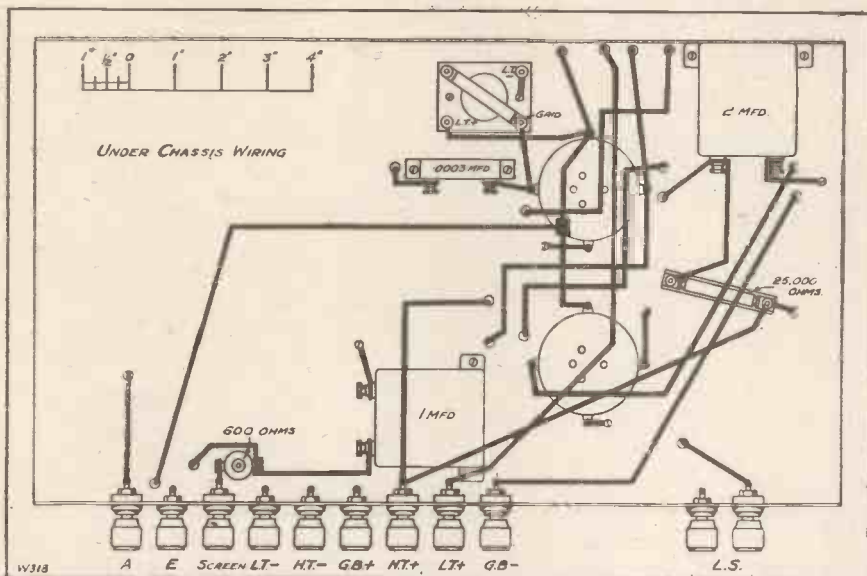

The underneath wiring diagram, which is a continuation of the diagram shown on the previous page.

As pointed out earlier in this article, one of the special features of the WIRELESS CONSTRUCTOR chassis construction is that a wide range of components can be used. In the few cases, however, where special components have no alternatives, these are clearly indicated. For example, in this design we utilize the Lewcos dual-range binocular coils, but in such matters as drum condensers, valve holders, radio-frequency chokes, low-frequency transformer, reaction condenser, etc., a wide range of alternative components is available.

Commencing Construction

The chassis itself needs to be bought ready for use, but here, fortunately, several well-known firms are able to supply them at very reasonable prices.

Before starting work see that you have all components to hand. The back of the chassis will be found drilled to take the Belling-Lee insulated terminals, and if you examine the chassis wiring diagram you will see that some of the terminals are arranged to make direct metallic connection with the chassis by means of metal washers and nuts, while others are insulated from the chassis at the back by means of special washers to be obtained from the firm supplying the chassis.

should be stood on a flat surface, the ebonite panel held up against the front edge, and a line scratched on the back to indicate how far up the chassis reaches. Whereas, in the older

Drilling the Panel

The holes in the panel should be drilled first, and then the panel held carefully in position as previously indicated. Mark through the panel (as if it were a template) the positions for three holes in the chassis. These can next be drilled, but do not yet attach the panel to the chassis.

The next step is to mark out the position of, and attach, the double-drum condenser. Full instructions as to the mounting of this condenser are given in the box, and on this point

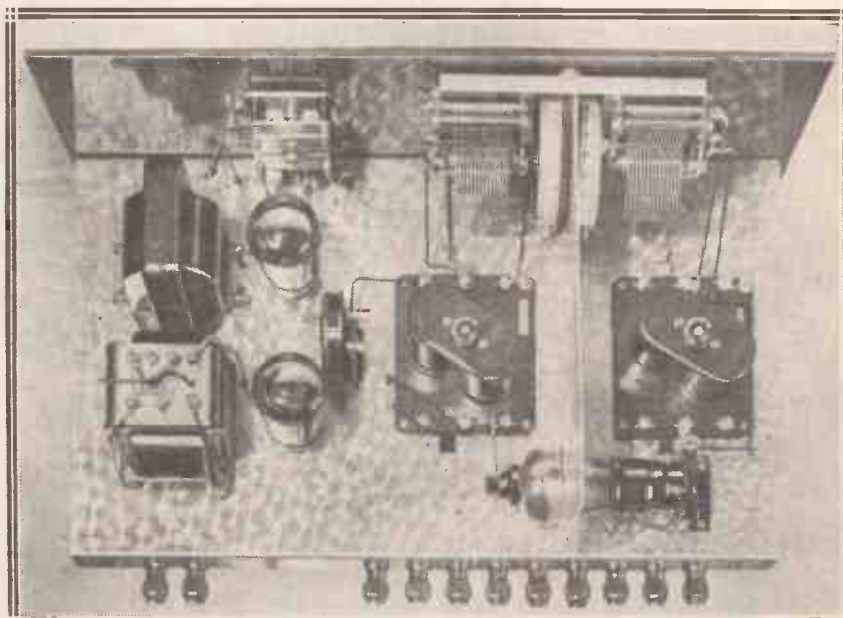

A general view of the "Silver Champion" which clearly shows the positions of the "upstairs" components and of the few wires that have to be "on top."

form of construction, the baseboard was generally made of the same length as the panel, in the WIRELESS CONSTRUCTOR metal chassis it is

I do not think it necessary to add anything in the present article except to say that personally I prefer the fretsaw method for cutting the hole

The "Silver Champion"—continued

in the panel rather than the series of small holes.

Two holes should also be drilled for the rods attached to the binocular coils. These holes should not be made too large, but only just a little bigger than the rods themselves. The differential reaction condenser and the on-and-off switch should next be mounted, after which the panel can be laid aside for the time being.

The "Baseboard" Components

Next mount the valve holders, including the special screened-grid valve holder, the radio-frequency choke, low-frequency transformer, choke output device, and all those components which are attached to the underside of the chassis. If the valve holders are not already attached to the chassis, reverse the terminals so that they do not foul the underside of the chassis. *Do not yet attach the vertical screen or the binocular coils.* Drill all the holes other than those relating to the binocular coil and the screen, and then mount the panel on the front edge of the chassis.

The vertical screen is specially made for this set and should now be put in

for the holes which attach the screen to the chassis, remove the screen, and

through the front of the panel and making sure that the binocular coils

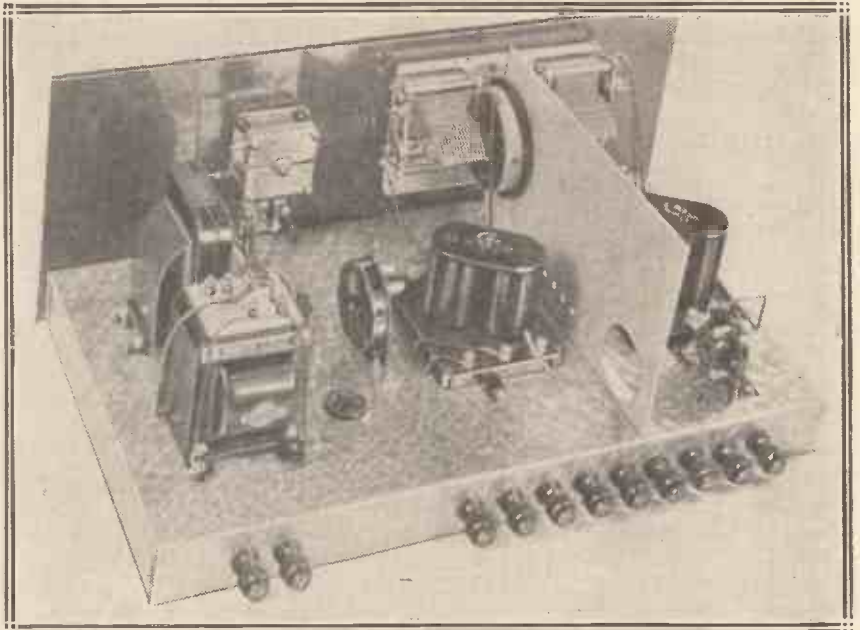

The L.F. end of the set, showing the auto-choke output filter, the fixed condenser of which is inside the component.

drill the holes. The screen can now be secured in place.

come in the correct positions behind them. The wave-change rods are secured into the switches themselves by means of two lock-nuts, which allow the positions of the rods to be adjusted to suit the particular set. The correct position here is such that when the switch is pushed in (looking from the front of the panel) the knob is almost up against the front of the panel. Lock these rods securely in place and attach the binoculars, drilling through the securing holes and using the binoculars as their own templates.

Wiring the Set

Before commencing to wire up the set examine all the diagrams carefully. Bear in mind that the metal chassis is joined to earth, L.T.—, H.T.—, grid bias+, and one side of the loud speaker. Thus when we want to join anything to L.T.— all we have to do is to connect it electrically to the chassis.

Take, for example, the first or aerial binocular coil. It is held to the chassis by four screws locked underneath with nuts. These securing screws are therefore all connected to L.T.—, and, as we desire to connect terminal No. 2 to L.T.—, we simply join it to the adjacent securing screw, under the head of which we have

(Continued on page 226.)

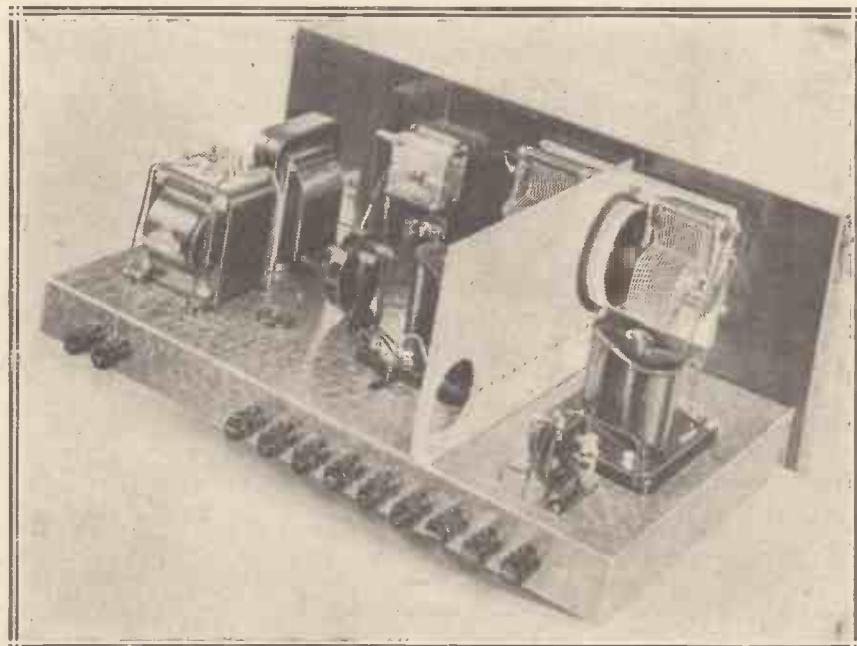

Special wave-change coils are provided, so that the control of the set is simplicity itself.

position. This is done by carefully sliding it between the two drums, making sure that it does not foul either of them. Now, holding it securely in place, mark the position

Now we come to the mounting of the binocular coils. Place these in the positions indicated in the wiring diagram and check up the positions by inserting the wave-change rods

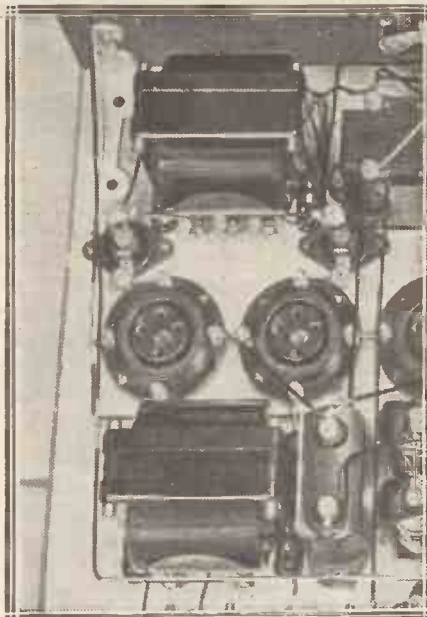

There are still quite a large number of radio users who do not have the great advantage of operating their sets from the electric mains. Either they live in a locality where there are no mains available, or else there are other inconveniences prohibiting the necessary installation.

The number of such users is, in fact, still so great that the purpose of the present article is to explain how they can obtain from relatively small capacity high-tension batteries results equivalent to those obtained by the more fortunate man who can operate his set from the mains without fear of using an excessive quantity of current. Electric current from lighting mains at 6d. per unit is very cheap when compared with about £3 per unit, which is the cost from a battery calculated at a nominal 6 m.a. discharge rate.

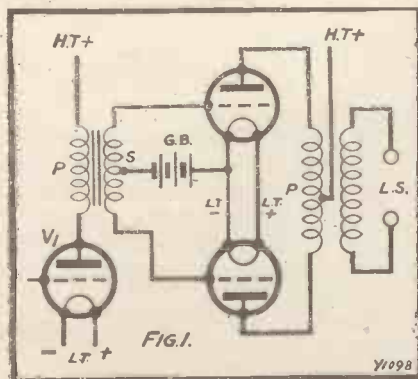

This certainly seems to be a staggering figure, but a very simple calculation will convince the reader that it is pretty near to the truth. There are very few modern sets in which the total high-tension current

WHERE PUSH-PULL SCORES

For those who use H.T. batteries push-pull amplification can be a very economical way of getting really "big" results.

By L. E. T. BRANCH, B.Sc.

consumed, excepting the output stage, is more than one or two milliamperes. We can therefore consider, for practical purposes, that by far the greater part of the high-tension current is necessary for the operation of the last valve, or valves, where two are used in parallel or push-pull.

Costly Current

Users of high-tension batteries of good make, costing about 14s. for 120 volts, know from experience that if their set consumes about 6 m.a., and it is used on the average for three hours a night, i.e. 21 hours per week, they will consider the battery has done extremely well if it lasts 16 weeks, which means a total of 336 hours.

Now, 336 hours at a discharge of 6 m.a. gives, on multiplying these figures together and dividing by 1,000, an answer of $\frac{336 \times 6}{1,000} = 2.016$ ampere hours. Since all our figures are approximate we will call this 2 ampere-hours. Now, if we multiply this figure by the voltage of the battery, namely, 120 volts, we obtain 240 volt-ampere-hours.

This is usually called 240 watt hours. The so-called unit of electricity which costs round about 6d. on the lighting circuit is 1,000 watt hours. Hence 240 watt hours, which is the amount of electricity delivered by one battery over its four months' life, is roughly one quarter of a unit, and costs in the battery about 14s.

An Economical Alternative

Battery electricity, therefore, has to be paid for at the rate of $4 \times 14s.$, i.e. 56s. per unit. We have assumed that the battery maintains its 120-volt pressure throughout the four months, whereas actually, of course, it falls all the time, so that the number of watt hours are really less than 240, and, in consequence, the figure we arrived at for the cost is too low. In fact, it should be over £3.

I have only considered the case as it applies to a man who aspires to a modest output, requiring only 120 volts at 6 m.a. With those who would like, say, 18 m.a., as required

for good super-power valves, the high-tension battery is beyond all reasonable possibilities.

I propose to show how the equivalent of even more than this high output can be obtained by simply using two valves in the well-known push-pull arrangement in the output stage. The whole secret of this economical scheme lies in the method of biasing the valves.

Fig. 1 shows a diagrammatic representation of one of the usual methods of connecting up two push-pull valves. V_1 is the low-frequency or detector valve in the penultimate stage, in the anode of which is the primary of a transformer.

Tapped Transformers

The secondary, S, of this transformer is tapped at its centre, which is connected to the negative tapping on the grid-bias battery, while the two ends of the secondary are joined to

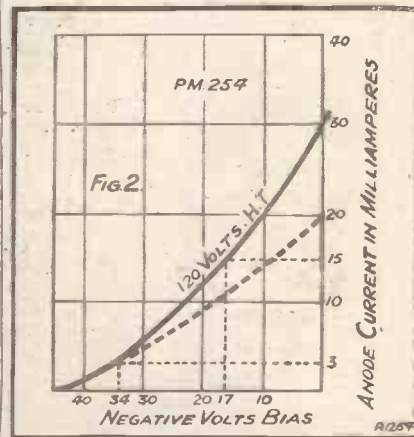

the grids of the push-pull valves. These two valves, which are identical in their properties, have their filaments connected in parallel and fed by the usual accumulator which supplies the rest of the valves in the set.

The anodes of the push-pull valves are connected to the ends of the primary of an output transformer. This primary is centre-tapped and joined at this point to the high-tension positive. The loud speaker is fed by the two ends of the secondary of the output transformer.

Where Push-Pull Scores—continued

Two valves operating a loud speaker in this way are working in what is known as opposite phase, that is, working electrically opposite to one another; when the current in the anode of one valve is increasing, the current in the other is decreasing.

Each of these changing currents passes through its own half of the primary of the output transformer in such a way that the combined currents induced by them in the secondary are in phase, or electrically working together.

Doubling the Grid Bias

All this applies to the case where the grid bias on the push-pull valves is the normal rated bias; for example, 17 volts negative for two P.M.254 valves at 120 volts H.T. The total steady current drain from the high-tension battery under these conditions as determined from the curve in Fig. 2 is 30 m.a., i.e. 15 m.a. for each valve, which is the same as it would be for two valves in parallel. For electric mains this quantity is not at all large, and is certainly inexpensive, but for batteries it is pretty colossal.

because as the voltage swings occur on the grids of the valves each valve can only respond to the swing in one direction, namely, from -34 towards zero, since in the other direc-

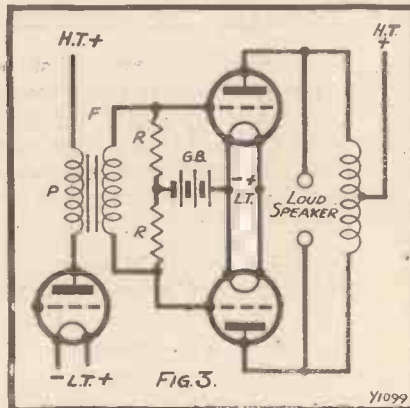

tion -34 towards 0 the anode current can only change 3 m.a., which is small compared with the change of about 20 m.a. which takes place for swings in the first direction. But the grids of the valves are, as we said, out of phase, so that one of them is always swinging towards zero.

From the valve curves one might

on the high-tension battery of only 6 m.a., which is the same as for a single P.M.2 at 120 volts and 9 volts negative bias. The advantage we have gained is that whereas with the P.M.2 the anode current could not change more than 6 m.a. each way without distortion, the push-pull arrangement of the P.M.254 valves allows of 20 m.a. change each way, which is over three times as great.

The Average Current

This means three times the current output into the speaker without extra cost in batteries. Some readers will immediately say that while this is perfectly true when no signals are being received, there will be an increase in anode current as soon as the station is tuned in.

While this is in part true, it must be remembered that only about ten per cent or less of the impressed waves get anywhere near the full 20 m.a. range, and taken over a number of minutes, or hours, the average drain from the battery will be hardly a bit more than 6 m.a.

It is clear, therefore, that for those who use ordinary high-tension batteries there is nothing to deter them from employing the powerful handling capacity of two super-power valves:

I have only instanced the use of P.M.254 valves. Of course, there is no reason why one cannot use a pair of P.M.252, or Marconi D.E.P.240 or P.425, or any other similar valve, so long as the grid bias is set at double the value recommended by the makers for "straight" purposes.

Another Method

In Fig. 1 I have shown push-pull employing an intervalve transformer, having a centre-tapped primary. For those who do not wish to purchase special centre-tapped transformers this push-pull arrangement can be equally well carried out by adopting the layout shown in Fig. 3, where F is an ordinary transformer, preferably, of course, one having a high primary inductance, such as Ferranti A.F.3.

Across the ends of the secondary of this there are connected two 1-megohm resistances, R, R, the junction of which is treated in the same way as the centre-tap in Fig. 1.

In the output circuit one can use a transformer as in Fig. 1, or in its stead a centre-tapped choke can be inserted.

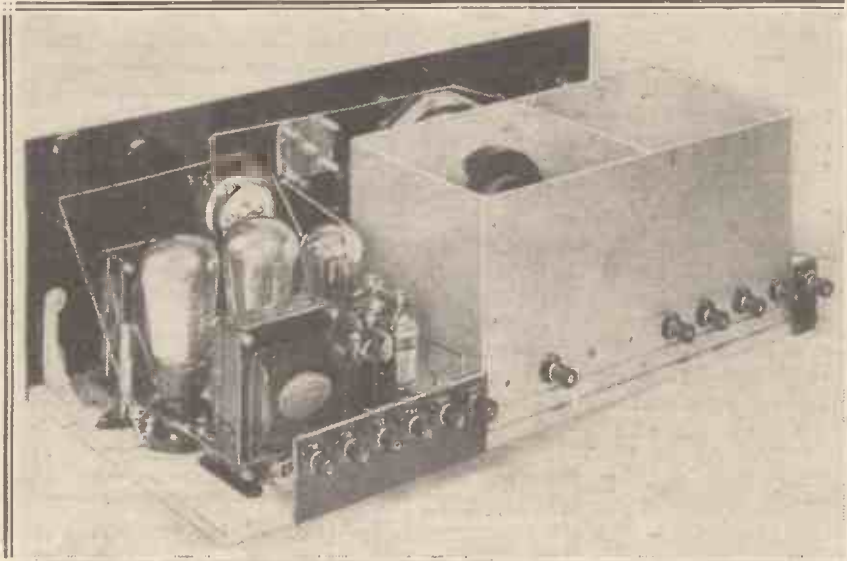

"The Push-Pull Five," described in our October number, gave a good example of the usefulness of push-pull amplification.

Now, if the grid bias on the push-pull valves is doubled, i.e. the grid-bias tapping on the grid battery is taken to 34 volts negative, instead of 17, we see from the curve that the steady current drain for each valve is reduced to 3 m.a., that is, 6 m.a. is the total for the two valves.

Under these conditions the valves are truly acting in a push-pull fashion,

expect that it would be up to 30 m.a., but the load of the loud speaker causes the curve to flatten out, and under working conditions it crosses the zero grid-bias line somewhere near 20 m.a., as shown by the dotted line.

By operating the two P.M.254 valves in this way with 34 volts negative bias we have a steady drain

THE "NIGHT WATCHMAN"

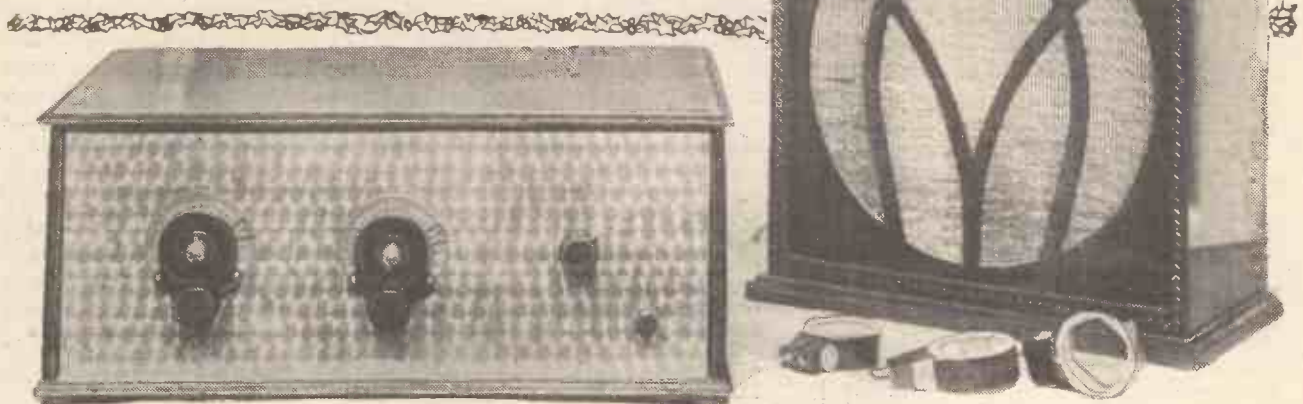

A FRIEND of mine recently observed that there were two kinds of receivers that kept one awake o' nights—those that work well and those that don't work at all. Without being unduly boastful about the "Night Watchman," I think I can claim that it is because it places itself in the first category that I have lost many hours of valuable repose.

Nothing to Go Wrong

It was designed primarily as a short-waver, but it was observed, as is so often the case, that the circuit was absolutely straight and of the "nothing-to-go-wrong" type, and accordingly a few modifications were made which enabled it to be turned into an excellent all-wave, all-purpose set.

Readers are doubtless tired by now of hearing my remarks on the subject of short-wavers which also work as broadcast sets, so that it will suffice to say that compromises have been effected in this case which ensure that, while the set is reasonably efficient for use as an ordinary distance-getting broadcast receiver, its suitability as a short-wave receiver has not been upset at all.

Perfectly Straight Circuit

The "Night Watchman" is a loud-speaker receiver of the screened-grid, detector and pentode type, and from the theoretical circuit diagram it will be seen that it possesses no peculiarities or freak arrangements whatever. From the aerial terminal right through to the loud-speaker terminals it is a logical, understandable circuit which should give no one the least trouble, and it is chiefly for this reason that it is so easy to make it

A short-waver, and "long-waver," too, of specially efficient design, built by one of our most experienced amateur short-wave transmitters.

By L. H. THOMAS (6QB)

give results which seem to be up to the same standard on whatever wavelength range it is being used.

After many lengthy tests on short waves with and without a stage of screened-grid H.F. amplification it was decided that it was always definitely worth while; at all events, for final results there was not much to choose between a detector and two note-mags., and a screened-grid, detector and one L.F. In this case, as the final valve is a pentode, the screened-grid stage was incorporated.

The only screening found to be really necessary was a single vertical screen between the S.G. stage and the detector, and matters were further improved by the use of a metal panel, which may be said to have the effect of continuing this screen round at right-angles.

"Dead Spots" Eliminated

If the screened-grid stage gave no amplification at all it would still be worth while, on account of the enormously improved control of reaction and, above all, the complete elimination of any "dead spots" due to the aerial and its tuned circuit.

All the big American short-wavers now have an S.G. valve introduced simply as an "antenna-coupling tube," and while we know that in the States they often use two or three

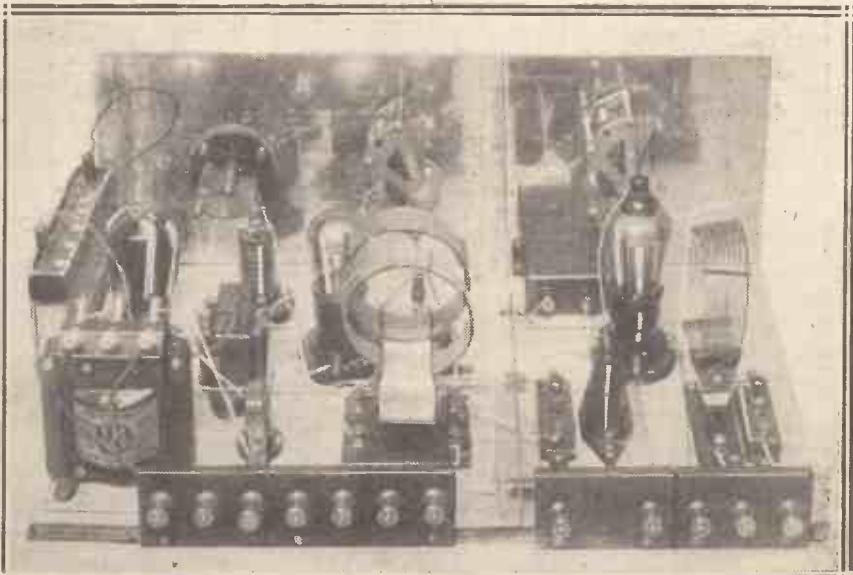

With coils and valves in position—the "Night Watchman" ready for action; and it is a sure "go-getter."

The "Night Watchman"—continued

valves more than are really necessary, they certainly would not incorporate this unless they had some degree of faith in it. When, as in this case, it can be proved that quite an amount of amplification can also be derived from it, there can be no question as to whether it justifies its existence.

The screened-grid stage is fully tuned, its grid-circuit coil being tuned by a .0003 variable condenser. Provision is made for the aerial either to be taken straight to the top of this coil or via a small condenser. A Formodensor has been used to permit of variation to suit the surroundings, after which the setting should not need to be altered.

Use a Reliable Choke

In the anode circuit of this valve is an H.F. choke, which should be of reliable manufacture. This is important, and if the reader intends to use the "Night Watchman" for short-wave work only he would be well advised to use one of the many excellent makes of "short-wave H.F. choke" now available.

As the original set was an all-purpose affair I used a standard choke, and this appears to give no trouble at all on the short-wave side.

The screening electrode has its own H.T. + terminal, and is bypassed to earth by a condenser of 2-mfd.

From now on the circuit is exactly that of a detector and L.F., with series-fed and throttle-controlled reaction for the detector. Incidentally, this scheme possesses the merit that the flex lead from the Formodensor may be removed from the plate of the

for an "all-wave" set, and although I find them unduly large myself for real short-wave work, I know of so many using .0005 condensers "down below" that I do not expect readers will feel that they are not suitable.

Ordinary plug-in coils have been

COMPONENTS REQUIRED

- | | |
|--|---|
| 1 Metal panel 18 in. x 7 in., with baseboard 18 in. x 10 in. (Magnum). (Paroussi, Ready Radio.) | 1 H.F. choke (Magnum). (See article.) |
| 3 Valve holders, sprung type (W.B.). (Benjamin, Lotus, Igranic, Wearite, Precision, etc.) | 1 H.F. choke (Wearite). (See article.) |
| 2 .0003 variable condensers, with slow-motion dials (Lotus). (Cyldon, Formo, Igranic, Lissen, etc.) | 1 50,000-ohm anode resistance (Igranic). (Varley, Precision, etc.) |
| 3 Single-coil sockets, base-mounting (Lotus, Raymond, etc.) | 1 Formodensor, Type F, and one Type J. |
| 1 .0001 reaction condenser (Keystone), (Ready Radio, Peto-Scott, Magnum, Utility, Lissen, Formo, etc.) | 1 Fixed condenser, .0003 (T.C.C.). (Lissen, Dubilier, Atlas, etc.) |
| 1 Intervalve transformer (Igranic). (Lissen, R.I., Igranic, Varley, Lotus, Lewcos, etc.) | 1 2-megohm grid leak (Dubilier). (Lissen, etc.) |
| 1 Pentode output transformer (R.I. "Pentamu"). (Igranic, Marconi, etc.) | 2 2-mfd. paper type condensers (T.C.C.). (Dubilier, Hydra, Lissen.) |
| | 1 Metal screen 6 in. x 10 in. (Magnum). (Ready Radio, Paroussi.) |
| | 1 On-off switch (Bulgin). |
| | Terminal strips, Glazite, wood screws, etc., etc. |

screened-grid valve and connected instead to the aerial, when the set becomes the usual detector and not-mag. arrangement with the capacity coupled aerial system favoured largely by short-wave enthusiasts. It is sometimes useful for checking purposes to be able to operate the set in this way, and, incidentally, is a sure

used, as they are both convenient and efficient. All the misgivings that used to exist concerning the mounting of a "low-loss" coil with a small number of turns on a standard ebonite base have, I think, been effectively dispelled, for this type of coil has obviously won itself a permanent place on the market and is undoubtedly among the most popular types of short-wave coil.

A second H.F. choke is necessary between the reaction coil and the transformer primary if the latter has a high self-capacity or is bypassed by a fixed condenser, as otherwise the "controllable" path for H.F. currents through the .0001 condenser C_5 loses its effectiveness, and reaction control is non-existent. It is not essential, however, that this second choke should be of very high efficiency.

Preventing Howling

In series with the transformer primary is an "anti-motor-boating" device, consisting of a 50,000-ohm resistance bypassed to earth with a 2-mfd. condenser. This improves reaction control and also proves one of the surest protections against "threshold howl." About the latter, however, I shall have more to say later on.

In the plate circuit of the last valve is a pentode output transformer which may be dispensed with if the

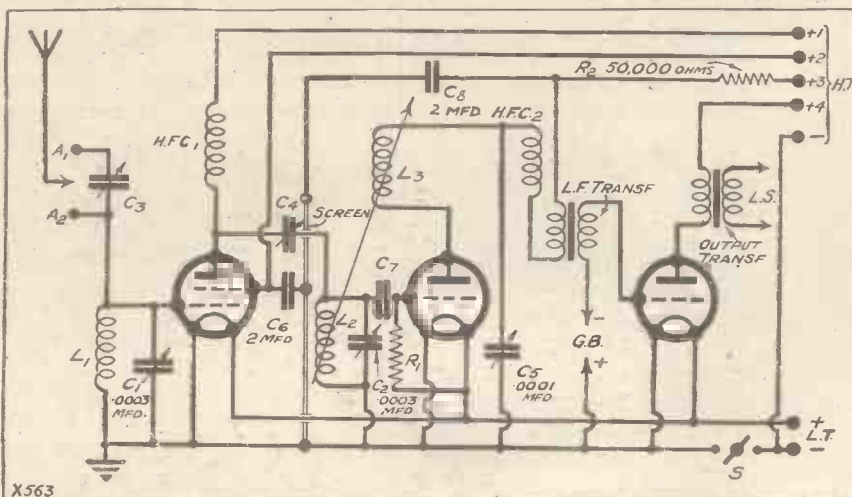

capacity, although anything down to about .25 should be suitable. The anode is coupled to the detector by another Formodensor, this time a type F, permitting the use of a very small coupling capacity. That in the aerial circuit, by the way, is a type J.

method of convincing the reader of the merits of the S.G. valve.

Passing on to the detector circuit, here the grid circuit is also tuned by a .0003 condenser, and the reaction condenser is a "midget" of .0001 capacity. The .0003 tuning condensers are quite a useful compromise

The "Night Watchman"—continued

reader does not wish to use a pentode. In that case the best procedure is to put in its place an output choke; from the plate terminal a 2-mfd. condenser is connected to one loud-speaker terminal, the other being taken to L.T.— and earth.

to take leads of any kind from the moving plates of the other condensers. Similarly, by this operation the bush and the moving arm of the L.T. switch are also connected to the filaments themselves; so that it is only necessary to connect the contact

connection shown in the back-of-panel diagram is quite correct. Two of the three terminals are blank, the other obviously being brought into connection with the panel and therefore the filaments when the switch is pulled out.

All the L.T. — connections that can conveniently be treated in this way are taken straight to the vertical screen, the L.T. positive and other connections being, of course, insulated and taken through the slots provided.

An Important Point

Incidentally, I have departed slightly from the usual practice by placing both the H.F. choke and the coupling condenser for the S.G. valve on the "H.F." side of the screen, not the detector side, but this is a small and relatively unimportant point.

A point more worthy of note is that the coils on opposite sides of the screen are arranged so that their planes are at right-angles to each other. This is important, and failure to arrange them in this way may cause the presence of all sorts of undesirable interaction effects.

We will now assume that the set has been completed and wired-up,

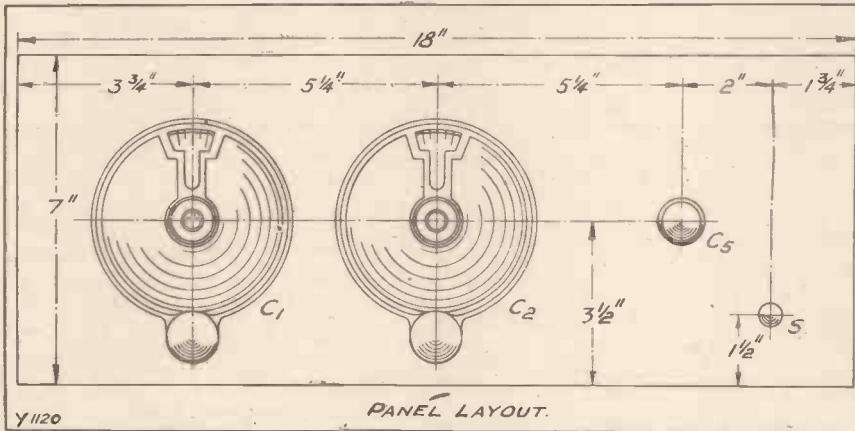

A pentode will, however, be found worth while if loud-speaker reception on short waves is wished for, and also appears to possess the distinct advantage of bringing up the signals by an amount out of all proportion to the "mush" and incidental background noises apparently inseparable from short-wave receivers.

The photographs accompanying this article give a very good impression of the "Night Watchman," and should clear up any doubts in the reader's mind as to the actual construction of the set. No particular difficulties are encountered in the wiring, which is reasonably short and quite of the simplest order. One or two points may be mentioned, however, in connection with the metal panel.

Avoiding Hand-Capacity

As is always desirable, the three variable condensers—two tuning and one reaction control—are all arranged so that their moving plates are earthed. Thus with all these three connected to the panel it will be seen that hand-capacity effects, which appear to present insurmountable difficulties to some folk new to the short-wave business, are virtually impossible.

In the actual wiring, the L.T. — terminal of one of the valve holders is connected to the moving plates of one of the variable condensers, thus connecting the whole panel and the other two condensers all to the same point. There is obviously no need

(or, in the case of a wave-change switch, one of the other contacts) to the L.T. — terminal to complete the whole circuit.

In this set a three-terminal wave-change switch has been used for breaking the L.T. circuit, and, although it may look peculiar, the

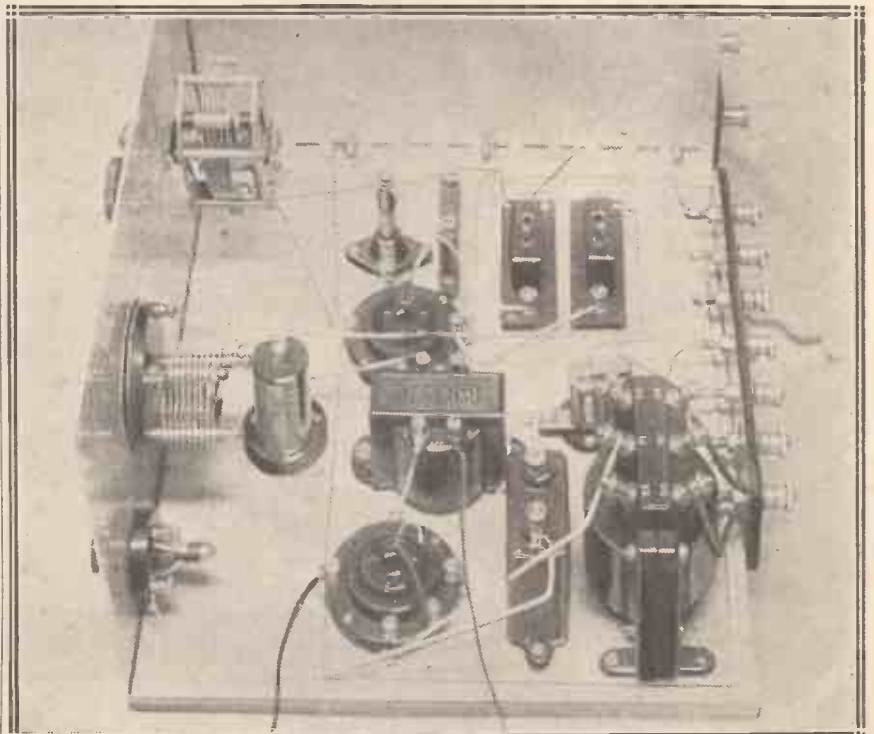

Layout is an extremely important feature of this receiver, which gives remarkable results.

The "Night Watchman"—continued

carefully checked, and presents a reasonable likeness to the original "Night Watchman" shown in the photographs. It will probably be best to give it its trial trip on the broadcast bands, where any unforeseen faults will be easier to detect than they would be on the short wave-lengths.

Insert suitable coils—a No. 50 or 60 as L_1 , in the aerial socket; another 50 or 60 as L_2 , the detector grid coil;

and a 30 or 35 for reaction. The H.T. should be connected—about 70 to 80 volts being applied to H.T.+2, the screening-electrode terminal; 120 to H.T. + 1, and 100 to 120 to H.T.+3 and H.T.+4.

Tuning-In

Valves for any filament voltage may be used, the detector being one of the popular "H.L." general-purpose type.

Screw the Formodensor C_4 (coupling the S.G. valve to the detector) right down, and the aerial condenser about half in, and switch on. If the two tuning condensers are brought roughly in step with each other and swung slowly round in this condition, stations should be heard without the necessity of using the reaction control at all.

As soon as you have got the "feel" of the two tuning condensers, stop on a station and gently bring up the

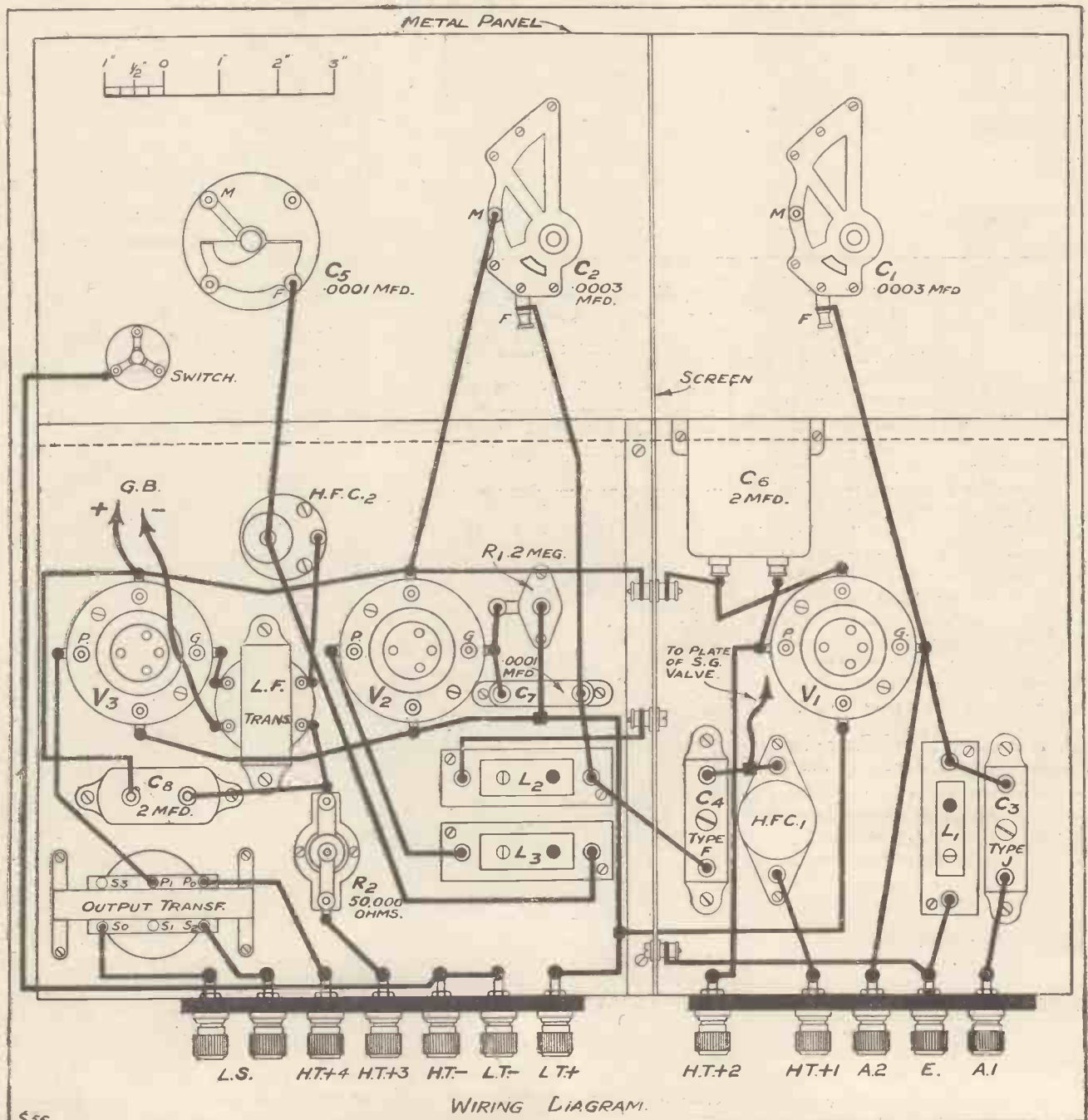

The "Night Watchman"—continued

reaction condenser. It will then be best to tune off the station on to a "quiet spot," where the reaction control can be brought right up to ascertain that the set goes smoothly into oscillation.

Unless unforeseen troubles are present there should be no difficulty whatever about this. Ploppy reaction, if present, is most probably due to unsuitable voltages on the detector and S.G. valves, and slight adjustment of these should not fail to put matters right.

Results Obtained

On actual test the "Night Watchman," during forty minutes between 10 and 11 p.m. on an average evening, brought in some twenty stations at full loud-speaker strength on a big moving-coil speaker.

free from any trace of 2 L O and, on a good night, almost equal in strength. Langenberg, Stuttgart, Turin, and Budapest were the best foreign stations logged. Since this first test the results have been repeated daily with equal success.

Now let us turn to the short-wave side. If "Atlas," "DX," "Igranic," or any of the well-known makes of short-wave coils are used, the 30-32-metre band, in which most of the interesting short-wave broadcast stations work, will be found with a six-turn coil in the aerial circuit, another for detector grid coil, and a four or another six as reaction coil.

If you need to use a nine-turn coil for reaction there is certainly something wrong with the set. Both the aerial and the coupling Formodensors

"threshold howl." I will give immediately a list of cures that should be tried if this should happen, though I do not think it likely, as the "Night Watchman" behaved in an exceptionally gentlemanly manner in this respect. Here are the usual cures:

(a) Reduce the filament voltage all round very slightly

(b) Connect a grid-leak of 1 meg. or $\frac{1}{2}$ meg. across the L.F. transformer secondary. (This is probably the most certain.)

(c) Increase C_8 , the "anti-mobo" condenser, to 4 mfd.

(d) Shunt a condenser of about .001 across the primary of the output transformer.

Prominent Short-Wavers

If none of these cures appears to work, the trouble is not threshold howl at all, and I am afraid I have no advice to offer about it. Seriously, however, none of the above should be necessary, but, if they are, the "grid-leak" cure is almost infallible.

Having now got things working smoothly, search round very deliberately (for tuning will be infinitely more critical than on the broadcast wave-lengths), and you should have no trouble in picking up short-wave broadcast. Prominent stations in the neighbourhood of 32 metres are: P C J (Hilversum) 7 L O (Nairobi), W 2 X A F (Schenectady), Doberitz, Copenhagen, and some smaller fry. Another interesting region is round about 25 metres, where 5 S W is to be found, together with Winnipeg, W 8 X K (the short-wave K D K A), and several others.

Below 14 Metres

The minimum wave-length at which the set has been worked is about 14 metres, but there seems no reason why it should not go a good deal lower. Amateur transmissions in the 20- and 40-metre bands can, of course, be logged at any time of day or night, and reception of the Antipodes is quite clockwork in its regularity in the early mornings.

On more than one evening stations from all continents have been logged, among them being W F A T, the Byrd-expedition in the Antarctic.

Probably a real "all-night" watch would result in reception of all the countries possessing short-wave stations!

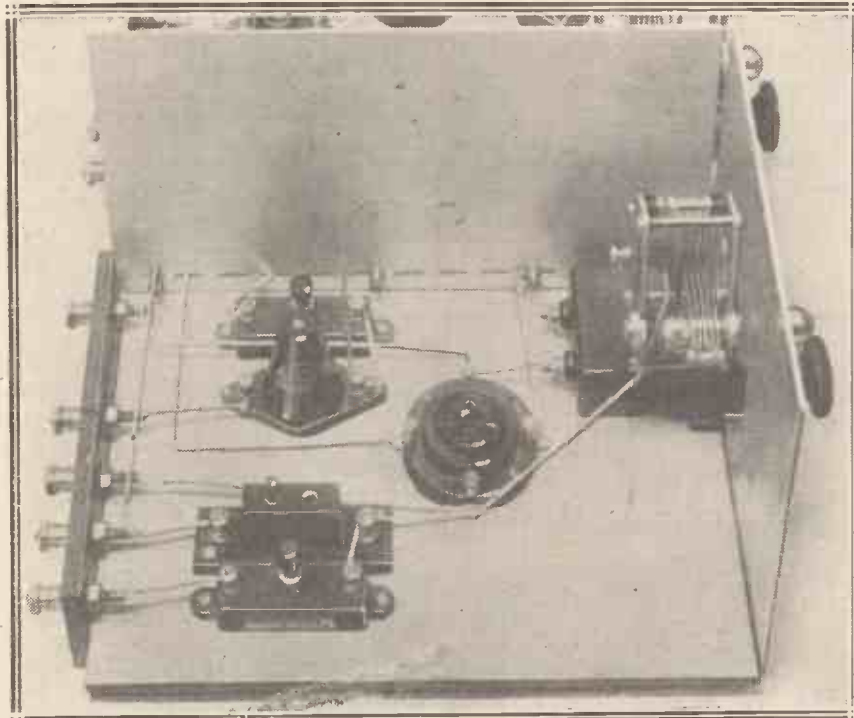

The H.F. end of the "Night Watchman." The components should be arranged exactly as shown above.

Lest the reader thinks that "full loud-speaker strength" is obtained by inserting one's head in the loud speaker, I will mention immediately the fact that the speaker is mounted high up on the opposite side of the room from the set, and that all tuning is done with it in this position.

At ten miles from Brookman's Park selectivity appears to be all that is necessary, Toulouse being completely

should now be set at the "all-out" position (i.e. unscrewed), and the tuning operation repeated. Reaction control should be every bit as smooth as on the broadcast wave-lengths.

If the set goes into oscillation with a loud howl, you have come against the bugbear of short-wave reception (unless you happen to be sufficiently "in the know" to cure it)—



Some typical radio faults reviewed and questions answered.

By P. R. BIRD.

Hot Stuff!

UNDER the spell of the highly-coloured covers of the Christmas magazines, uplifted by the yuletide spirit, and not yet snowed under with the Christmas bills, I was beginning to feel quite festive and Dickens-like about the coming festival until I got a letter from a chap in Coventry! Dipping his pen in gall, and distilling bitter aloes into his ink, he wrote bitterly, with black disgust and concentrated contumely, about the long waves. Ordinary broadcasting he likes, the short waves and the very short waves he adores, but the long waves—well, it is kinder to draw a veil!

If only for the vitriolic violence of its invective I enjoyed this letter. And I refer to it because it may help others not to form radio prejudices. Feeling sure that it was a case of misdirected indignation, I suggested that as the trouble of rather weak signals and noisy background appeared only on long waves, it was probably the long-wave coil that was responsible; and the question was raised as to whether the soldered joints on this were really soldered, or were they dry joints? Was every pin on the coil making good and tight contact with the socket?

The "Contact" that Wasn't!

Sure enough it proved that the end of the reaction winding was "soldered" by a large blob that had rested upon the pin, but was not making a sound electrical contact with it. When re-soldered the mysterious noises disappeared, strength increased enormously, and in fact the long

waves became thoroughly enjoyable.

The experience is worth passing on because it shows how bad contacts can not only spoil a programme, but can prejudice the listener against a whole section of the wave-band and thereby make him lose many a good

THE TECHNICAL QUERIES DEPARTMENT

Are you in trouble with your set?

Have you any knotty little Radio problems requiring solution?

The WIRELESS CONSTRUCTOR Technical Queries Department has been thoroughly reorganised and is now in a position to give an unrivalled service. The aim of the department is to furnish really helpful advice in connection with any radio problem, theoretical or practical.

Full details, including the scale of charges, can be obtained direct from the Technical Queries Department, WIRELESS CONSTRUCTOR, Fleetway House, Farringdon Street, London, E.C.4.

A postcard will do. On receipt of this all the necessary literature will be sent to you, free and post free, immediately. This application will place you under no obligation whatever. Every reader of the WIRELESS CONSTRUCTOR should have these details by him. An application form is included which will enable you to ask your questions so that we can deal with them expeditiously and with the minimum of delay.

London readers please note: Inquiries should not be made in person at Fleetway House or Tallis House.

programme that otherwise he would have enjoyed.

The Landlord and the Aerial

"My landlord lives next door and he is the biggest blackguard unhung," says a Staffordshire reader who does not believe in mincing his words. The trouble is the aerial, to which the landlord objects; and, from what I can gather, if the landlord so much as lays a finger on that aerial there is going to be the biggest bust-up that the Mid-

lands has known for years! ("And he'll be in it! Ay, lad, he will and all!")

The whole problem of the radio relations between landlord and tenant is a little thorny, but in most cases a spot of give-and-take is all that is necessary. It would take a good lawyer all his time to cover the points which may arise when one of the parties is unreasonable, but the best plan in such cases is for the aggrieved party to write to the B.B.C.

They have an excellent little book on the subject, entitled "The Listener's Aerial," in which a great deal of useful and practical information is set out in clear language, so those in doubt or difficulty should drop a line to the B.B.C. Bookshop, (2, Savoy Hill, London, W.C.2) asking for this, and if it does not satisfactorily dispose of their problems for them they can be sure that the B.B.C. will render them any further assistance in their power.

Over Eighty and Mad on Wireless!

"Although my father is over eighty, he is mad on wireless," writes a Burton-on-Trent reader, who is in difficulty with the switch for the loud speaker. Apparently his aged parent listens in upstairs until he feels sleepy, and then wants to cut out the bedroom loud speaker without affecting the one downstairs. But he finds that undoing the lead to the terminal upstairs stops reception on both speakers and wants to know how to overcome this difficulty.

In this case (where the loud speakers are wired "in series" with one another), all that is necessary is an on-off switch wired across the loud speaker upstairs. Or any other convenient method of joining the two loud-speaker terminals together, such as by means of a short piece of wire, can be employed. When this extra connection is broken (i.e. in the case of a switch, when it is in the "off" position) the speaker will receive the programmes as usual, but when the two terminals are shorted the upstairs speaker is cut out.

Watch Your Insulation

Following my recent remarks on metal screens and bad insulation, many cases are coming to light of mysterious faults due to this cause. Projecting spindles on variable condensers touching metal, switches that project to far, unwanted contacts through fixing screws, and similar stray pathways abound. Moral: Be specially careful of insulation when screens are used.

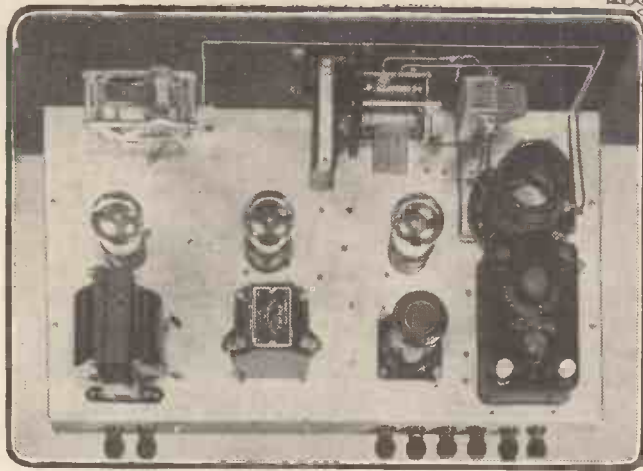

AT HOME WITH THE "CHASSIS" THREE

Here are given the experiences of a North London reader with the "Chassis" Three described last month.

By H. RADFORD.

As a reader of the WIRELESS CONSTRUCTOR from the very early days, I always get called upon by my radio friends either to advise them how to make a set or what to buy, or else to make a set for them; and this latter experience has been my lot with regard to the "Chassis" Three.

Apart from, perhaps, the "Radiano" Three, I can think of no other receiver which has created such interest amongst my friends, and as soon as parts were available one or two of us decided to make it up. I am now in the middle of making up a second set for a friend, but let me tell you my experience with my own receiver.

Easy to Build

I had little difficulty in getting hold of the metal chassis from a well-known advertiser, and as I had a large number of the parts on hand it was not long before I was hard at work constructing a set. I said "hard at work," but there is no doubt that this set can be constructed almost as quickly as one with the ordinary base-board layout when it comes to the mounting of components, and decidedly more quickly in the wiring, because one does not have to bother so much about the appearance of the wiring, it being tucked away underneath the chassis.

I suppose that from start to finish I took about six or seven hours over the whole job—that is, a couple of evenings' work. I did not hurry things as I was determined to get it absolutely right from the very first, and I have found it is a mistake to hurry anything in wireless construction.

Incidentally, I kept completely to the components and layout described by Mr. Harris, as I have found from

past experience that it very rarely pays to deviate from the specification of the designer, and very often such deviations land you in really serious trouble.

It was rather late at night when I first connected up the set, so that I had only dance music to test it on, but the strength was very good on 5 G B and 5 X X, and although I live but a few miles from the new Brookman's Park station I found that the selectivity unit kept him within bounds exceedingly well.

Since that evening I have had several most fascinating evenings on the set, and by the use of the selectivity unit and the aerial condenser I have got the selectivity so that there are few stations being missed owing to the presence of Brookman's Park, less than eight miles away.

On the long waves I have, so

far, logged Hilversum, Konigswusterhausen, both Paris's, 5 X X, of course, and one or two stations faintly which I could not identify. All these were on the loud speaker. Hilversum does not, as a rule, come in too well where I live, but strength on an Air Chrome loud speaker was quite sufficient for the ordinary room.

Plenty of Stations

Radio-Paris, of course, comes in at tremendous strength, and so does 5 X X and Konigswusterhausen. There is no difficulty in separating 5 X X and Radio-Paris provided careful use of the reaction is made. On the lower waves so many stations have been received and so many unidentified that it is impossible to give a list, but many of the most noteworthy stations, such as Langenberg, Brussels, Vienna, 5 G B, etc., have been received at

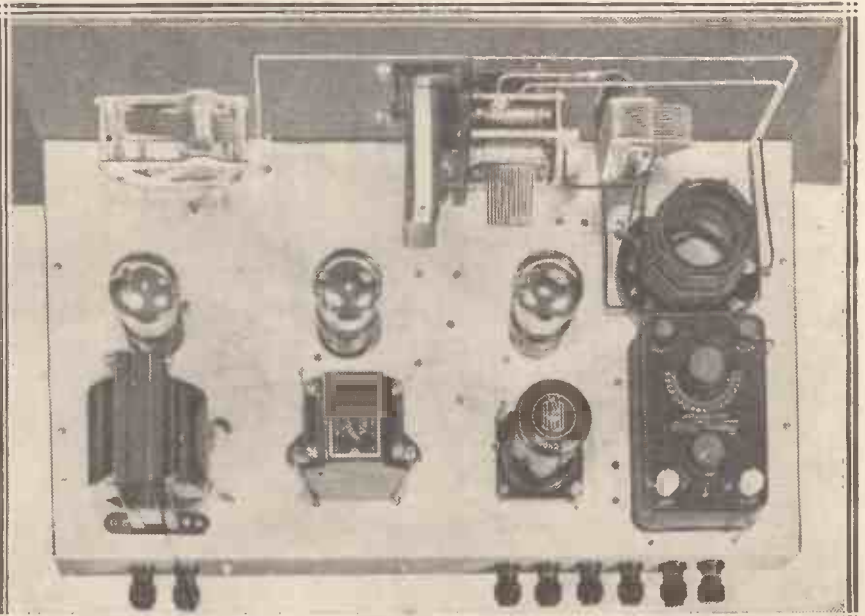

"I suppose the whole job took about 6 or 7 hours—a couple of evenings' work." The result—a neat, efficient, and economical set.

At Home with the "Chassis" Three—continued

good strength, though I am afraid that, owing to the local station (Brookman's Park), I am unable to get Toulouse clear of interference. I can hear him coming through very well, so that those fellow readers who are in a more favoured position may be certain that the "Chassis" Three will give them a really big bag of stations.

Remarkable Range

As for myself, I am perfectly content with the receiver, and, in fact, I am enthusiastic, for in spite of Brookman's Park it has given me a range of stations which I would have thought hardly possible with an ordinary three-valver. I say ordinary because there appears to be nothing extraordinary about the circuit, although, as usual, Mr. Harris seems to have put his finger on the spot, and once again has given us something which we really want.

The purity of the local station and of 5 G B is all that can be desired, and the reaction control on a .0003 variable condenser is perfect. When

on the panel, instead of at the back, like so many sets.

This variable condenser is of extreme use not only as a coupling condenser, but also as a fine control of reaction, for I found that by putting the reaction just on oscillation point, and bringing the set off oscillation a little farther by means of increasing the aerial condenser, very fine control can be obtained, although slight alterations in the aerial condenser have their effect on tuning.

At the present moment I am only using about 105 volts H.T., but I intend to increase it as soon as possible to 120, while the valves are two Mazda H.F.s. and a P.M.252. I find a super-power valve most necessary in the last stage, especially on the local station, and I am not sure that a larger valve in the intermediate stage would not be an improvement when I am listening to Brookman's Park.

Perfect Reproduction

Anyhow, the set gives perfect reproduction at more than sufficient strength for my needs, so that the

I am, or who like to be deafened by their results.

Personally, I find the results quite loud enough with the set as recommended by Mr. Harris, but with a super-power valve in the last stage instead of the power valve. One has to put up with increased H.T. consumption, of course, but being on the

"... in spite of Brookman's Park it has given me a range of stations which I would have thought hardly possible with an ordinary three-valver."

mains I intend building the Five-Guinea Mains Unit described in the same number of the WIRELESS CONSTRUCTOR, and can then banish all thought about H.T. batteries running down.

As I live fairly near Brookman's Park, it may be of interest if I add, for the benefit of others who are troubled by jamming from that station, that the Ready-Radio Selectivity Unit is most wonderfully effective, and that all reasonable selectivity can be obtained with the "Chassis" Three. I suppose my aerial is about 40 ft. long and about 30 ft. high.

"Local" Cut Out

With the variable aerial coupling condenser set well towards the minimum, and the selectivity unit properly set in the "Chassis" Three, I find very little bother with the local transmission. Brookman's Park is completely inaudible anywhere round about 5 G B's wave-length, so that one does not have to push reaction in order to gain selectivity as I have found necessary with some other home-made sets which I have built.

I am afraid this account is not particularly scientific, but it gives the personal experience of an ordinary home constructor who had a very pleasant surprise when he tried the "Chassis" Three.

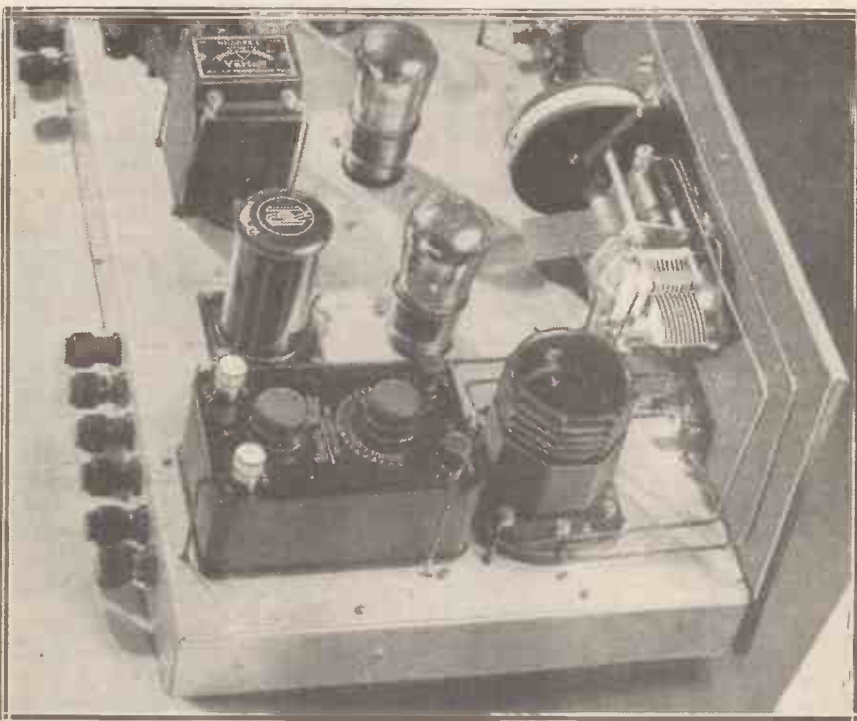

The detector end of the "Chassis" Three, showing the selectivity unit and the series aerial condenser which enables remarkably fine tuning to be obtained.

handling the receiver on stations near the local in wave-length it is most valuable to have the coupling condenser between the aerial and the set

question of a larger valve in the intermediate stage on Brookman's Park can be left to those who are perhaps more critical of the reproduction than

READ

POPULAR WIRELESS

BRITAIN'S BEST RADIO WEEKLY

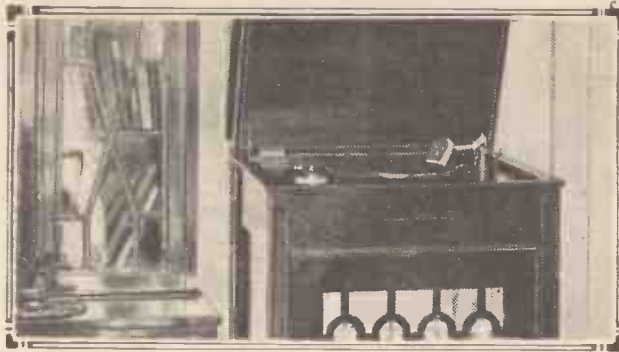

WITH PICK-UP AND SPEAKER

Two new pick-ups—A puzzling point about volume controls—“Fader” volume controls—“Mixing” radio and gramophone—Needles for the low notes.

Conducted by A. JOHNSON-RANDALL.

WE have recently received for test one of the new Bowyer-Lowe electrical gramophone pick-ups. The device is of conventional type, that is to say, it operates on the electro-magnetic principle, and it is a soundly constructed and well-finished component.

The internals are protected by a black bakelite casing and the pick-up is comparatively light in weight. The makers state that the device should be set at an angle of 63° to the surface of the record, and to



The Webster electrical pick-up and adaptor. This pick-up can be obtained complete with volume control.

ensure this they supply a cardboard template to assist the listener in fixing the angle.

The makers also give full instructions concerning the method of obtaining the correct tracking. It is claimed that the Bowyer-Lowe pick-up reproduces all frequencies from 25 to 6,000 cycles, but it is stated that the response of the higher frequencies depends to some extent upon the needles used. Loud needles are advised in preference to those of the medium and soft types.

Good Sensitivity

On test the device showed excellent sensitivity, and the reproduction was exceedingly good. It is a component that we can recommend.

We have also received one of the new Webster pick-ups, manufactured by the Webster Electric Company, of America, and marketed in this country by Messrs. Rothermel, Ltd.

The pick-up is conventional in principle, but the makers supply a neat little gadget to permit the component to be used with any ordinary radio set. This adaptor has two pin jacks to take the leads from the pick-up and a base which is slipped over the pins of the valve. The valve, which would normally be the detector, is then placed in the socket with the adaptor in position, and the pick-up is ready for use.

We cannot say that we feel enthusiastic about this scheme, since with some circuits the radio end of the set is not cut out of circuit.

We prefer to connect the pick-up leads across the grid and grid bias negative in the usual way, switching the H.F. side out of the gramophone circuit altogether.

The adaptor is also primarily intended for American bases. On test the pick-up showed high sensitivity, and the response over the musical scale was decidedly good.

We have also received for test one of the new Gambrell “Novotones,” and a full report will appear in our next issue.

Uneven Strength Control

Here is a point about volume controls which seems to puzzle some readers. Why is it that when one starts with the control at maximum and turns it in the direction of reduced volume, at first there is little perceptible effect, and then presently the volume begins to go down quite rapidly? This effect is often noticed, and, indeed, it is almost the rule to find that it is only the last half of the travel of the volume control which seems to make much difference.

Inexperienced users of electric gramophones are sometimes rather puzzled by this phenomenon, and the writer has even come across one case of a man who decided that there must be something wrong with his volume control, and replaced it with a new one, only to find that exactly the same thing happened!

The effect is really quite a natural one, and although this is not the place for considering the theoretical reasons for its occurrence, the reader can safely assume that it is bound to happen in a normal circuit where the volume control takes the form of a uniform resistance upon which a sliding arm travels. The only cure so far available is to be found in the use of a volume control with what is called a tapered resistance element, in which the actual resistance (in the electrical sense) increases more or more rapidly towards one end. With a nicely proportioned resistance of this kind a much more even control can be obtained.

Unusual Volume Control Devices

One is rather accustomed to think of volume controls as simply devices for altering the strength of the output from the amplifier, but there is another rather interesting use for them which has been developed of late. By using a special type it is



The Bowyer-Lowe pick-up is well-made, the windings being protected by a neat bakelite casing.

possible to make this single component serve also to give a switch-over action from one pick-up to another, or from pick-up to radio, and vice versa. An example of this type of control is that illustrated in Fig. 1 herewith, which shows how a volume control may be used to provide a gradual change-over from radio to gramophone.

With Pick-up and Speaker—continued

In this way the volume control replaces the change-over switch and also enables a gradual and "clickless" change-over to be obtained. With the aid of this device, by simply operating a single knob one can cause the radio reception to die down gradually to zero, and then go beyond this point and gradually bring in the gramophone reproduction.

The type of volume control required is still quite a simple one, and only

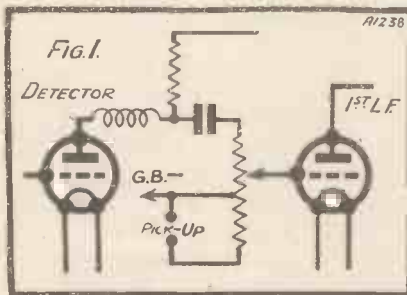

FIG. 1. A form of tapped volume control which enables you to "fade" from radio to gramophone and vice versa.

differs from the normal type in that it has a centre-tap on the resistance element. This centre-tap is the grid-bias connection, and one-half of the resistance forms a grid leak for the radio side of the amplifier and the other half goes across the pick-up. You will see readily on referring to the diagram that as the slider arm runs over the resistance it will naturally have the effect of fading out one type of reproduction and then fading in the other.

This type of "fader" volume control gives a gradual change-over between two sources of signals, passing through a silent point on the way. Some people sometimes desire to super-impose one type of reproduction upon the other with a variable proportion of each, so that, for example, they can run the gramophone at normal strength and add to this at intervals a faint background of radio to find out what is going on at the local station, so as not to miss some particular item.

A "Mixing" Scheme

This, again, can be managed with a volume-control scheme; two controls now being required. Two ordinary three-terminal types will meet the case, no special form being required this time. They should be connected up as shown in Fig. 2,

where one control governs the radio and another governs the strength of the pick-up. By setting volume control No. 2 to the normal position for full volume, and leaving volume control No. 1 near the "lower" end, we get the gramophone at full strength and radio as a faint background, which can be faded down to nothing when not required. This has a possible slight advantage over the other scheme in that one can keep the gramophone control at the normal position and just fade a little radio in as a background to find out what is going on.

Following the Low Notes

An interesting point which arises in connection with needles is the difficulty of getting some otherwise good pick-ups to follow the groove on really low notes. When using the H.M.V. constant-frequency records it is no uncommon experience to find that when we get down to the really low notes the needle begins to jump out of the groove, so that by the time we get down to, perhaps, one hundred cycles the pick-up no longer follows at all. Evidently such a pick-up will not respond to really low notes, but will simply jump out of the groove.

It might seem at first sight that such a pick-up would not be of much use in practice, but actually it may still be quite good for general purposes, because really low notes are decidedly rare. For example, one pick-up of very good general performance which is used a good deal by the writer will not follow the groove at all below 150 cycles per second, yet it was run over nearly one hundred records selected at random without finding any note low enough to make it jump out of the groove.

Try a Softer Needle

Evidently, then, a pick-up may still be used quite satisfactorily on the great majority of records, even if it does not follow the very low notes. One does occasionally meet with these low notes, however, and to make such a pick-up follow them is something of a problem. Something can sometimes be done by using a softer needle, and in the case of the one mentioned, for example, a half-tone needle lowered the "jump-

out" point of the pick-up just referred to down to about 120 cycles per second. Incidentally, on taking a curve with this needle it was found to be decidedly better over the whole scale than with the more usual loud needle, and so it is now always used for this particular instrument. Too soft a needle, while enabling you to get down lower still, is apt to reduce the higher-frequency response.

A rather useful needle for enabling this type of pick-up to follow very low notes which deserves mention is the Edison-Bell "Sympathetic Chromic." By using this needle so adjusted in the little chuck provided as to obtain a medium-loud effect the pick-up referred to above was able to follow the "Juba Dance" test record quite easily, and it did not appear to reduce the high-note response to any degree which could be detected by ear. A curve of the pick-up using this needle has not yet been taken, however, so one cannot be quite certain as to the exact effect.

Extension Lead Difficulties

Here is a tip for those who use rather long extension leads from the amplifier to the pick-up on a distant gramophone, and have a little trouble in getting perfect stability. It has often been mentioned in the past,

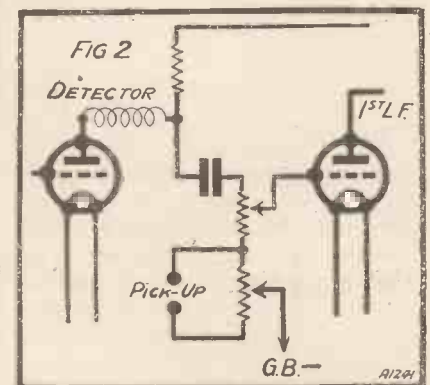
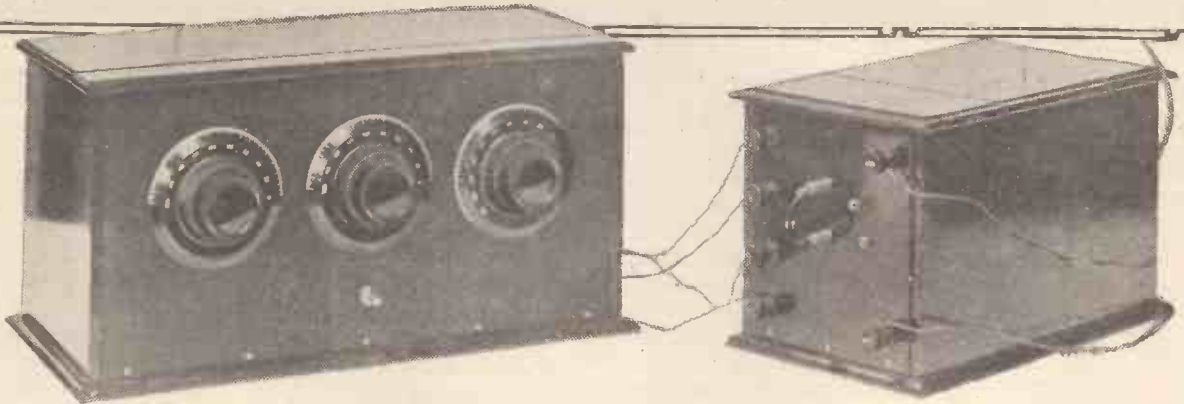

FIG. 2. How to use two volume controls to enable radio and gramophone reproduction to be "mixed" in varying proportions.

but it is so helpful that no apology is needed for referring to it again. The hint is just this; try running a connection to earth from the metal parts of the tone-arm and see whether that does not lead to further stability. In many cases it also helps to reduce any hum which is being picked up from the house lighting wires.

VOLTAGE AND QUALITY



PERFECT quality is the aim of all music lovers, but this ideal is so often not attained. Why is this? There is nothing wrong with the modern set. With two good L.F. transformers and a stable H.F. stage, or a detector used intelligently, with not too much reaction, it is surprising that so many listeners obtain distorted results.

Yet it is quite easy to get poor quality. The average enthusiast does not pay enough attention to his H.T. and grid-bias voltages.

A "Clean" Supply Essential

I venture to suggest that the H.T. supply is one of the most prevalent causes of poor reproduction in the modern receiver. In the first place, apart from the actual voltages applied, the supply must be "clean."

It doesn't matter whether the H.T. is derived from dry batteries, accumulators, or a mains unit, there is always a risk of battery coupling occurring, and, in consequence, a tendency towards L.F. oscillation takes place.

Therefore, it is essential to see that the dry battery or accumulator is in first-class condition, or, alternatively, that the mains unit is capable of supplying more than the total anode current required by the set. If the receiver takes 25 m.a., then the mains unit should be capable of supplying 30 m.a. Thus the eliminator will be working well within its capacity.

Then we come to the all-important question of H.T. voltages. Let us take the ordinary straightforward three-valve receiver, consisting of a detector and two L.F. stages transformer-coupled. This is one of the most popular types in use to-day.

The voltage applied to the detector valve is not very critical, and will not affect the reproduction to any extent,

Are you getting poor reproduction? If so, you will find many useful hints on the great importance of correct H.T. and grid bias in this interesting article.

By E. J. MEREDITH.

provided it is adjusted in such a way that smooth reaction control is obtained. It is on the low-frequency side where the trouble so often occurs.

In most cases the first L.F. valve will be of the "H.F." type. Now such a valve is one having impedance of somewhere between 15,000 and 20,000

ohms. Next we have to consider what degree of signal strength, or, in other words, grid swing, we are likely to apply to this valve for ordinary domestic loud speaking. I think that we shall be on the safe side if we take 1 volt as our maximum for all normal purposes.

The First L.F. Valve

That is to say, that if we apply a grid bias of $1\frac{1}{2}$ volts negative to the first L.F. valve there is little likelihood of any distortion occurring at this stage. In order to obtain the necessary conditions with the average "H.F." valve it will be advisable to

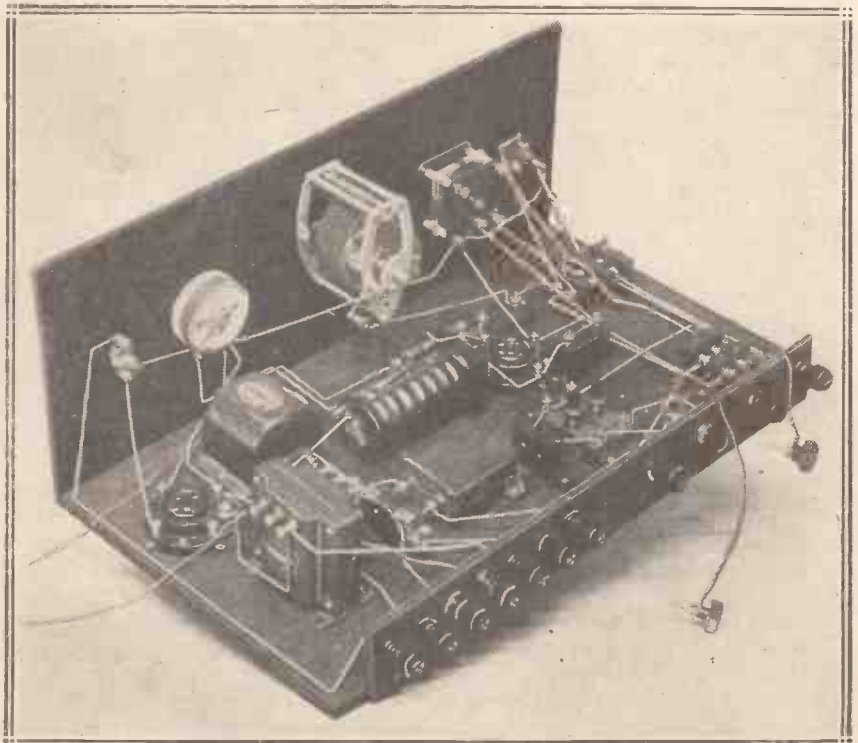

It is necessary to apply the highest possible value of H.T., together with the proper grid bias, if you wish to obtain undistorted volume from the last stage.

Voltage and Quality—continued

apply a voltage of about 80/90 volts to the anode.

Watch the Last Stage

It is in the last stage where distortion is so liable to occur. Valve overloading is very common indeed. What are the symptoms? Well, perhaps during the broadcast programme the voice of a singer increases in strength on a certain note and then suddenly breaks. This is one sign of distortion due to valve overloading. Perhaps there is a piano solo in the programme. The artiste strikes a chord and there is an unpleasant jar

or alternatively a suitable valve in the last stage.

I maintain that for full room strength with the average cone loud speaker it is necessary to use a minimum of 120 volts H.T., and 18 volts grid bias. This, of course, means that a super-power valve must be employed in the last stage. In addition, some form of volume control is practically essential if one is to keep the volume within the limits beyond which distortion occurs.

It is sudden increases in strength or peaks that we have to guard against. A sudden crescendo, the last full note

plenty of H.T. and a suitable valve.

The handling capacity of any valve can always be increased by the use of a higher value of H.T. and more grid bias. If you wish to be able to handle more volume and you have the H.T. available, try another 50 volts, and another 6 or 7½ volts negative grid bias.

The Question of L.T.

Do not forget, however, that there is a certain maximum H.T. voltage for any given valve beyond which it is unsafe to go. This maximum value is always given by the makers on the pamphlet which accompanies the valve, or, at any rate, you will find it in their list.

Then there is also the question of L.T. voltage. A valve is rated to give its normal emission at a certain filament voltage. Perhaps it is 2 or 4, or 6 volts, according to the class of valve. In any case, it is essential to see that the L.T. accumulator never gets into such a state that it cannot supply the full filament voltage. Directly it begins to run down, have it charged, otherwise you will get distortion.

Both H.T. and L.T. voltages are equally important, and do not neglect them if you desire to obtain really good quality.

* A WORKSHOP *
* WRINKLE *

MANY wireless experimenters who have become quite adept at soldering rarely use their skill in this direction for purposes other than soldering wires to lugs and terminals. Many useful storage boxes can be made with the aid of some old tins and a pair of tinsmith's snips.

Take, for example, a screw box. This can be constructed very quickly from a flat tin box designed to take a hundred cigarettes. Out of another old tin cut out pieces of various sizes for partitions, and these can then be soldered into place as partitions for different sizes of screws.

You may think this is not a very important piece of work, and truly it is not. But when you have done it it will have taught you how easy this kind of work is, and you will at once attempt many more ambitious jobs.

H. P. W.

DON'T WASTE YOUR H.T.

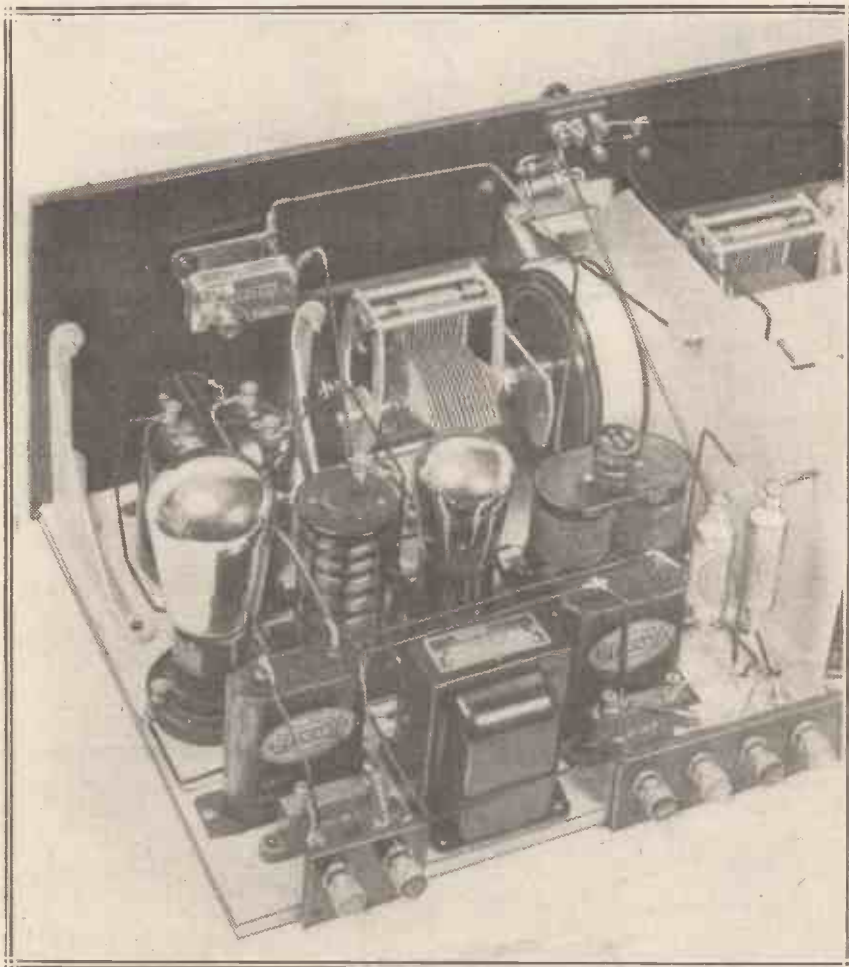

When a super-power valve is used an output filter is an extremely desirable fitting in order to avoid waste of H.T. volts.

or dither from the loud speaker. This is another symptom of overloading.

Jarring, dithering, and buzzing noises are all signs of this trouble, and can be cured by the use of the correct H.T. voltages and grid bias,

of a song, and the valve becomes overloaded. If our H.T. and grid bias are adequate this sudden increase above the normal grid swing will not produce distortion. It is because we have to cope with these peaks that it is necessary for us to use



Mystery of a Music Director

MUSICAL circles at Savoy Hill are still fluttered about what is happening to the job of music director shortly to become vacant on the retirement of Mr. Percy Pitt. Early last summer it was understood that the new music director would be Mr. Adrian Boult, of Birmingham. Then it was rumoured that, because of a misunderstanding, another famous British conductor was to have the job. The new B.B.C. Year-Book gives Mr. Boult's portrait as successor to Mr. Pitt.

Meanwhile, Savoy Hill will not say anything "official" on the subject. I gather, however, from the conversation of those who should know, that although various difficulties have been encountered it is likely that for all intents and purposes Mr. Boult will assume responsibility for B.B.C. music at the beginning of the year. There will be some months in which he will be engaged part time at Birmingham and in an American tour; accordingly, no "official" indication of his appointment can be expected until about the middle of 1930.

"Points of View"

The B.B.C. deserves great praise for the courage and enterprise displayed in connection with the now famous "Point of View" series, in which Mr. G. B. Shaw, Mr. H. G. Wells, Dean Inge, Professor J. B. S. Haldane, Mr. Lowes Dickinson, and Sir Oliver Lodge gave listeners an account of their characteristic philosophies of life.

The success of this series is due entirely to the initiative and energy of Miss Hilda Matheson, who would be well-advised to continue to pay more attention to this sort of thing

rather than to stereotyped "talks." I understand that there is to be another series early in the New Year, when the Catholic and Conservative standpoints will have their innings.

The first series caused heartburning at Conservative Party headquarters because several of the speakers said they were on the "left of politics." Some Catholics resented Dean Inge's remarks about them.

And not unnaturally the Christian Scientists and the osteopaths did not relish being blamed by one speaker as contributory causes to the increasing death-rate of adults in the United States. No doubt it will be the case that every address of any series of this kind will offend some minority; perhaps this is not a bad test of success and vitality!

The Governors Happier

There is always a great deal of gossip and talk about the Governors of the B.B.C. and their relations with the staff. Although most of this is fictitious, there is no doubt a strain of truth running through it. Anyway, I am pretty sure that the present state of affairs is a good deal better than it has been for a long time.

In other words, the new attitude of activity on the part of the Governors has been accepted and welcomed; and there is the beginning of co-operation where there was hostility before. The fact that Lord Clarendon and Mrs. Philip Snowden were accompanied by Sir John Reith when they paid their second visit to Birmingham

HUNTING FOR RADIO OSCILLATORS



The Post Office wireless detector van leaving Glasgow on a tour of Scotland to search for radio oscillators.

Savoy Hill News—continued

in November is symbolic of a new understanding.

Great Organists

The B.B.C. has decided to give, early in the New Year, a special series of six recitals by the world's leading organists. Each recital will last forty minutes and will be on either the organ of St. Margaret's, Westminster, or on that of All Saints, Margaret Street. The series will include four Englishmen, one Frenchman, and one German, and the following names are being considered: Karl Straube, Duprè, Kendrick Pyne, Alcock, Cunningham, and D'Evry.

Studio Religious Services

There has been much discussion at Savoy Hill concerning possible improvements of the musical side of studio religious services. The music authorities have expressed anxiety because in their view the music of the services is below B.B.C. standards. It is understood that Mr. Filson

Meanwhile, the popularity of all the religious parts of the programmes except the Epilogue and the daily morning services is sustaining a marked decline. Listeners are tired of the average broadcast preacher. Now that the "twin-wavers" are coming, and the long boasted alternatives will be attempted, the B.B.C. simply must do something to widen the basis of its Sunday programmes. Not to provide suitable musical alternatives to religious services is to invite discontent and to damage religion itself.

Captain Eckersley's Farewell

Captain P. P. Eckersley, the former Chief Engineer of the B.B.C., was given some beautiful presents by his old colleagues on the occasion of the official farewell recently. A cigarette-case, a watch, and match-box, all in gold, and a travelling case, were among the gifts, which were handed over at a rousing meeting of the whole staff presided over by Sir John Reith.

is still a good deal of resentment among the rank and file because of the failure to regularise the pension position. It seems that for five or six years members of the staff have been contributing to a Provident Fund in the hope that ultimately there would be a pension scheme.

But nothing has happened. Lately it has been realised that broadcasting will not provide a career for anyone, so the staff naturally want to be able to withdraw their money on the best terms possible when, as they believe inevitable, they move on to other jobs. There is really quite serious discontent on this subject.

Sir Walford Davies

Sir Walford Davies, whose programme work for years past has been of inestimable value, is to withdraw temporarily from the microphone in the New Year. It is to be hoped that he will benefit from the rest and be ready to rejoin the squad of "regulars" next autumn. There has been some tendency recently at Savoy Hill to question the wisdom of any kind of music appreciation such as Sir Walford has been doing.

The argument of the critics is that the only way to increase the appreciation of good music is to broadcast it regularly, and let it "sink-in" rather than be "expounded." My opinion is that there must be both; and that it would be a very serious mistake to dispense permanently with such courses in appreciation as Sir Walford has been giving to the edification and delight of millions.

A Question of Money

The B.B.C. still remains strangely inactive about its money affairs. When it is expedient to defend a measure of concentration on London, Savoy Hill is not averse from saying that Provincial orchestras cannot be afforded any more.

But when someone asks what is being done to get hold of the large balance of licence money pillaged by the Treasury, there is "no comment to make." If the real reason is that the Chancellor has told the B.B.C. not to ask for more money, then the position should be explained, and the suggestion of indifference and muddle would not continue to gain currency.

A NOTABLE TOKYO TRANSMISSION



Dr. Eckener, commander of the giant German airship, the Graf Zeppelin, broadcasting from the Tokyo Central Broadcasting Station. The doll was presented to him as a souvenir by the station staff.

Young is an active critic. But apparently there is as yet no agreement as to measures of reform.

Those who look after the religious services are anxious to introduce more militant music and hymns, such as are used by the Salvation Army and at regimental services. The Music Department is opposed to this policy. It will be interesting to see what happens.

No Governors were present. The impression conveyed by the speeches at the official farewell was that Captain Eckersley would soon be back in the saddle in some other important job in the B.B.C.

Pensions for B.B.C. Staff

Although the general feeling among the B.B.C. staff is definitely better than it was some months ago, there

MAKING THE MOST OF A LOUDSPEAKER UNIT

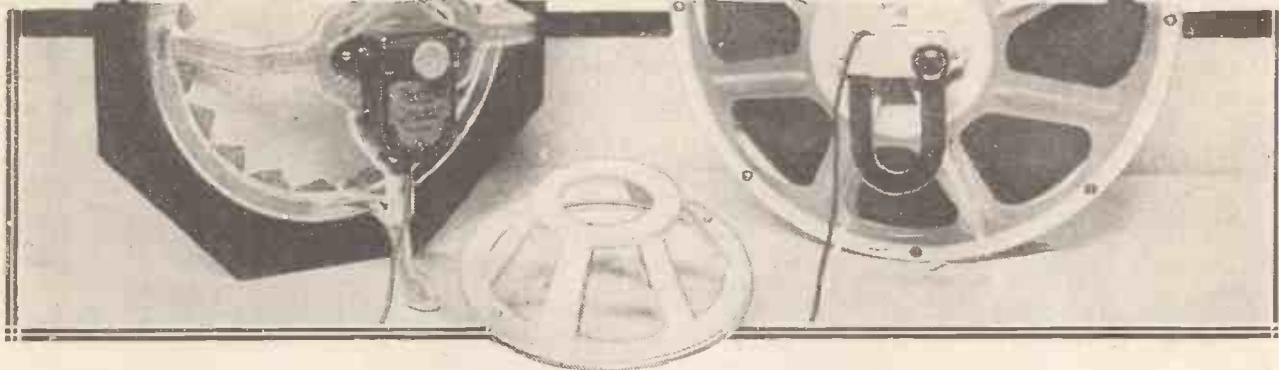

THE number of new loud-speaker driving units which have appeared on the market quite recently has been only a small indication of the activities which are going on behind the scenes in this branch of radio. Radio enthusiasts are realising more than ever that home loud-speaker construction is quite a practical proposition, the chief advantage, apart from the lower cost, being that one can combine a unit with a suitable cone so as to procure an effect pleasing to the hearing of those concerned.

The Question of Tone

One is tempted to add the word "tone" to the above comment, but actually there should be no such thing as an individual "tone" to a loud speaker, as for faithful, true reproduction a loud speaker must be "colourless" in its functions.

The perfect loud speaker, if ever possible, should reproduce without alteration just what is fed into it, and, what is more, should make the sound come from an appreciable "area" and not from a small point, as is usually the case. Nevertheless, as things are there is not the slightest doubt that every loud speaker does tend to "colour" the sound from it.

Unit Improvements

As this trouble cannot yet be entirely eliminated, it is reasonable to adjust the loud-speaker assembly so that the "colouration" is not unpleasant. Thus it will be found that the majority of constructors unconsciously prefer a mellow tone to an output punctuated by resonances, which "hit" one in the ears.

A further article on loud-speaker units, giving still more details of value to the home-constructor.

By G. V. COLLE.

We all have reason to be grateful to the thousands of constructors who make their own assemblies, because by so doing they enable certain manufacturers to concentrate their research staffs on improving the driving units and cone accessories.

To see exactly how far the improvements have affected speakers in general the writer paid two special visits to the last radio exhibition in London on purpose to examine and hear them. It was obvious at the

first visit that the standard of acoustic efficiency had been raised considerably. For instance, the results from the Lissen unit were most marked and it was particularly interesting to hear it under such operating conditions. The tone was particularly bright without undue resonances being noticed, while there seemed to be quite a good proportion of bass notes for this type of speaker.

Effect of Baffle

Since the Show the writer has had further opportunities of hearing the Lissen unit and cone under more favourable conditions, and his impressions were that a small "baffle" board might bring up the low notes a trifle, apparently a necessity with all normal units attached to small cones.

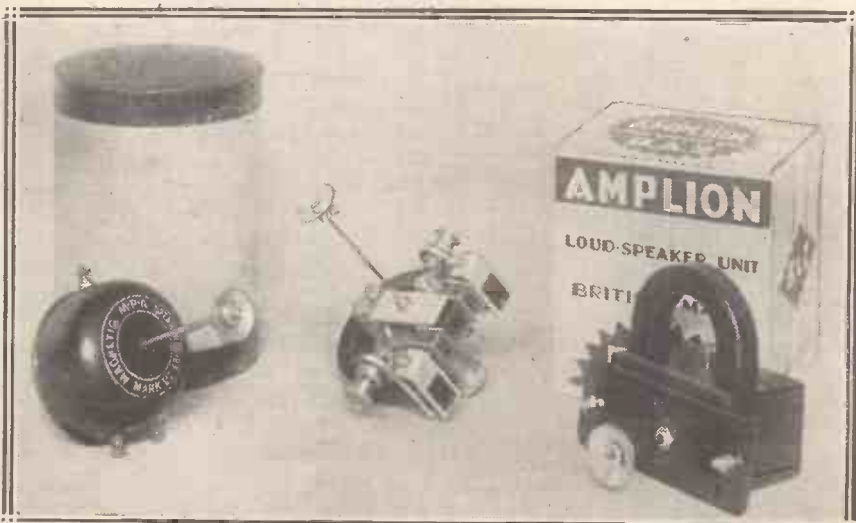

A group of three driving units mentioned in this article. The M.P.A. mechanism is on the left, the G.E.C. "Stork" in the centre, and the Amplion B.A.2 unit on the right.

Making the Most of a Loud-Speaker Unit—continued

Talking about "baffles," most readers may have observed the growing fastidiousness which many loud-speaker designers nowadays show in their choice of loud-speaker mounts. Cabinets for housing speakers are now less frequently recommended, but rather flat boards of five- or six-ply, about $\frac{3}{8}$ in. thick, and sometimes

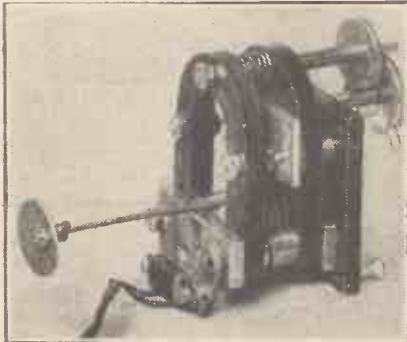

The Wates "Star" unit is very sensitive.

thicker. The reason is that the average loud speaker produces vibrations in the wood, which in turn cause all sorts of "box" noises. Most of these faults, of course, can be eradicated by increasing the thickness of the wood, though even then the "boominess" may persist.

Open Cabinet Results

Polished plywood "baffles," made up artistically, and to fit diagonally across the corner of the room, may become popular, though there is still another solution. Some time ago it was agreed that reproduction could



The performance of this unit is the subject of comment on the preceding page. It was shown for the first time at the last radio exhibition in London.

be improved by leaving the backs of loud-speaker cabinets open. Why not adopt this principle to the sides and top? The wood can be cut away so as to leave a frame and the hollow areas covered over with a gauze material.

Better and Better

Another batch of driving mechanisms came into the writer's possession the other day, and included the M.P.A. unit, the G.E.C. "Stork" unit, the Amplion B.A.2 unit, the B.T.H., the Wates' Star unit, and the Lissen already described. Further information was also available in respect to units mentioned last month, particular reference being made to the White Spot and the Ormond frames. Messrs. Wolverhampton Die-Casting Co., who market the White Spot frame, inform me that it is now arranged to take a number of driving units of various manufactures, instead of one particular model, while the Ormond Engineering Co. now supply a suitable cone and aluminium chassis for their unit, the total cost being the remarkable sum of £1, including the driving unit. (By the way, in last month's list, the Blue Spot should have been described as the 66K, not the 66Z.)

Most of the units mentioned above have already been subjected to various tests and have assisted to strengthen the belief that driving units are becoming better and better. Considerable ingenuity has been displayed in several of the constructions, as, for instance, the Amplion B.A.2, which is one of the first units to make use of tapped windings

Other Interesting Units

This unit, made by a firm renowned for its speakers, is sold without a cone or chassis, since the makers have fitted a special base-plate drilled for several types of cone frames, including the Squire and Gilman, which are specially recommended on account of their rigidity. Another interesting unit is the B.T.H., with its special cone assembly comprising a stamped metal frame and a rigid cone of "doctored" paper.

Then we come to the G.E.C. "Stork," which is a unit fitted to most of the loud speakers made by that firm. If anyone has preference for this unit he cannot do better than hear it in the G.E.C. speakers, as they

will give him a good idea of the performance likely to be expected.

A unit of considerable sensitivity is the Wates' Star driving unit. This is quite as sensitive as any I have tried, and will give a good performance with a cone of Kraft paper about 10½ inches in diameter, made under the directions given in last month's article.

The last unit which is in the collection is the M.P.A., and as this came to hand only at the very last moment it is impossible to describe its performance. From its shape it is difficult to state whether it includes mechanism similar to that used in the M.P.A. loud speakers, though I had a brief look "inside" and would add that judging from appearance it should operate at least up to the standard of this firm's well-known loud speakers.

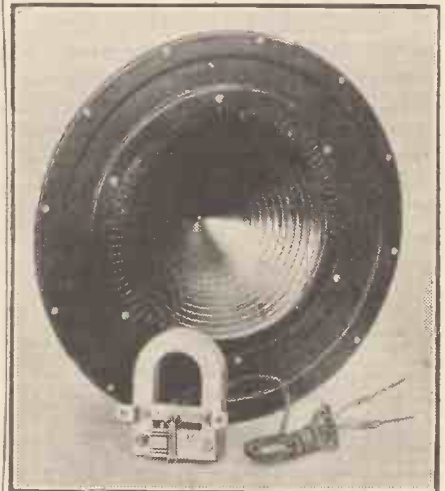

The B.T.H. unit and cone assembly.

* **THE CHOICE OF SCREWS** *

A GOOD assortment of wood screws is always useful, and as they are so cheap it is surprising that more experimenters do not take the plunge and buy one or two gross packets of them. The sizes most useful are the black japanned round-headed No. 6 and No. 8, the lengths most in use being $\frac{3}{8}$ in., $\frac{1}{2}$ in. and $\frac{3}{4}$ in. While there are a few cases in which brass screws are preferable to the japanned iron type, these latter are certainly stronger, and there is less risk of the head being twisted off when screwing them into hard wood.



With Christmas only a few days ahead many constructors will be rushing the building of their sets through in desperate endeavours to get them working in time for the festive season. Don't let your experience be that of the constructor whose story is told below.

By KEITH D. ROGERS.

It was Christmas Eve, and the new four-valver had but recently been completed and tried out. The constructor was sitting in front of the fire after the rest of the family had gone to bed, conscious that something was the matter in the new set, but quite at a loss as to exactly what it was.

Everything was new—valves, components, and even the moving-coil loud speaker, had all been put into use for the first time that evening. The results were good, but there seemed to be something lacking in brilliance, and also the loud bass notes did not seem to be too clear. They had rather rough edges.

Something the Matter

Still, the set worked all right, and was very sensitive, and though he had one or two valves on hand, the constructor did not feel the need for any more fiddling about. In any case, he could do little more because the local station had closed down and there was nothing available but distant stuff very badly heterodyned. So he was sitting quietly thinking over the set and wondering what he could do to-morrow to get those slight "somethings" righted.

The clock struck twelve, and in the ensuing silence the man before the fire was surprised to hear a faint sigh, followed by a stifled word as if somebody were rousing himself from a heavy slumber.

"Anybody awake?" queried a voice, apparently emanating from the loud speaker.

"Awake!" cried another. "I can't get a wink of sleep, my nerves are all over the place. I feel really jumpy."

"I don't wonder at it," replied the first voice, undoubtedly the loud speaker.

"Nor do I," agreed a third voice—a valve, "You milliammeters have a pretty rotten time sometimes."

"I should think we do," answered the milliammeter. "All this evening I have been jumping about all over the place, never still for a moment, and I positively ache all over."

"You must," answered the valve. "We are all of us horribly overworked, and I know it was as much as I could do to handle the stuff which was passed on to me from the first L.F. stage. He was turning out far too much, and I know a lot of it

"There never was really any question of getting high stuff through, because my friend the screened-grid valve was almost in a state of oscillation, due to the fact that he was not properly screened, and then the reaction, applied in the way in which it was, further spoilt the quality of the transmission. Consequently I did not have any good high notes to deal with at all."

"Something will have to be done about it," the loud speaker said. "I cannot put up with the stuff you chaps keep shoving on to me, and

IF YOUR LOUDSPEAKER COULD TALK?

What would your loud speaker tell you if it could speak? Would it tell of perfect reproduction, a pure output supply, or would it complain that it wasn't given a chance, that overloading was rife, and that the output was hopelessly distorted? Pure music cannot be provided by any loud speaker if the supply from the set is not above suspicion.



got all jumbled up before I passed it on to the loud speaker."

Ragged Bass Notes

"I should just think it did," said the speaker. "I didn't have an earthly chance of giving out good music. All the drums were ragged, and as for the treble—well, did you hear any high notes at all—really high notes, I mean—that had clear quality in them?"

By this time all the valves in the set were awake, and it was the detector that replied to the loud speaker.

this fellow will wear the milliammeter out altogether if he makes it jump about in the way he was doing this evening."

"Well, it's hardly his fault, you know," said the milliammeter charitably. "He's fairly new to the game, and has not had much experience yet."

The output valve snorted.

"There's no excuse in putting me here to carry the output of a powerful set just because he has not followed the designer's instructions. He should have used my cousin, the

Within the Vacuum—continued

super-power valve, instead of me, and then both you and the loud speaker would have had a far better time. It's positively dreadful the way we are overworked."

"And so am I," interposed the H.T. battery; "and I shall be worse still if he puts in a super-power valve. I am only supposed to supply seven milliamps, and there he is taking about ten, with a possible fourteen or fifteen or so if he changes to a super-power valve. He ought to use a mains unit if he wants to use really big valves, or else a very big super-capacity battery."

Obviously Overloaded

"As a matter of fact," said the first L.F., "I believe he has got a mains unit but hasn't tried it yet. I heard him saying something about it."

"Well, I wish he would put it on and give me something worth shouting about it," grumbled the loud speaker.

"He expects a valve to carry a grid swing of something like fourteen when it is designed to deal with only nine volts either way. Well, I did the best I could to show him what was happening." This from the milliammeter, who was obviously very agitated. "But he seemed to take no notice of my kicking at all. He seemed to think it was just the signal coming in and going through, and that it was quite a normal state of affairs."

"He did try playing about with the bias, you know," chimed in the power valve, "but, of course, that was useless because I was already frightfully overloaded to start with."

"Yes," answered the milliammeter, "but I was kicking both ways, not merely up or down. He should have known it was not the bias but simply that you were overloaded."

"I think matters would be better," put in the detector valve, "if he would use a little less reaction."

Bias the H.F. Valve

"And a bit more screening round me wouldn't hurt," the screened-grid valve complained. "He's giving me the correct voltages on the plate and screening grid and he wants me to give him the best results, but he'll find that a little grid bias, say about 1½ volts, and really proper screening, will have a wonderful effect."

"I am not so badly off," remarked the first L.F. valve, "I get all I can handle, but I am not really overloaded. Of course, the detector valve does not pass on to me any really high notes for the reason that they have already been cut out, but, after all, I cannot grumble."

The Milliammeter Test

"I should think not," growled the power valve, "you're a fairly reasonable size for the job you have to do. I'm quite a small member of the family and it is hopeless to expect me to do the work of a really large powerful valve."

"What do you propose to do?" asked the milliammeter.

"Tell him about it," said the loud speaker, "in every way we can. I'm going to distort as hard as I can, and I'm not going to give any high notes, bass notes are going to be rough, and I look to you fellows to make all the signs you possibly can to show him what is happening."

WATCH YOUR METER!



High kicking means high bias. If the needle kicks down the bias is too low. If it kicks one way and then the other irregularly, overloading is taking place.

"As a matter of fact, he is in the room now, so he may have heard what we said. I hope he has, we may get something better then," added the loud speaker.

"I hope so," muttered the output valve, "but he will never get anything right unless he does alter matters. I cannot possibly deal with the amount of stuff he's giving me, and so I rely upon the milliammeter to kick as hard as he can. I know it's tiring, but he must go on kicking. It's the only way we shall ever get

things remedied. Now I am going to try and get a bit of rest. He's sure to be hard at us again to-morrow, so good-night all you fellows."

With a final chorus of good-night they relapsed into silence.

It was broken by the astonished constructor, who had been listening awe-stricken.

"Well, I'm blowed," he remarked, "so that was the trouble was it! I'll see to it first thing in the morning. I'll screen that high-frequency valve a bit better and give it some bias; I'll cut out the reaction altogether for the local station, and use a super-power valve in the last stage, biasing it properly, and I'll try that mains unit."

Curing the Trouble

"I suppose it is rather too much for an ordinary small H.T. battery to tackle, and as for the milliammeter, what a blind fool I was. Fancy thinking that was the signals coming through. Though it did look like it, for every time they hit the drums the needle gave an extra big kick—extra big overloading, I suppose. Ah, well, what a mercy I overheard them talking about it. I might have gone on for weeks like this, hunting for a somewhat obscure trouble and never finding it. No wonder the high notes were a bit reedy and the bass sometimes had rough edges. Still, that will be remedied, and I can now go to bed and sleep in peace."

And he did, and there was no more overloading, no more rough edges, or abuse of reaction in that house.

*
* **CLEAN THOSE** *
* **SWITCHES.** *
*

As all the filament current of a receiver has to pass through the on-and-off switch, make sure that this is clean and makes good contact. In many cases noises and weak signals can be traced to this point, and if there is a high-resistance joint there may be a drop in voltage sufficient to bring the magnification down well below the normal figure.

Recently we had a set in the laboratory which, when connected to a six-volt accumulator, showed only 5.1 volts at the filament terminals. The whole of this voltage drop was traced to a dirty on-and-off switch.

**A REAL
LOW-LOSS
CONDENSER**

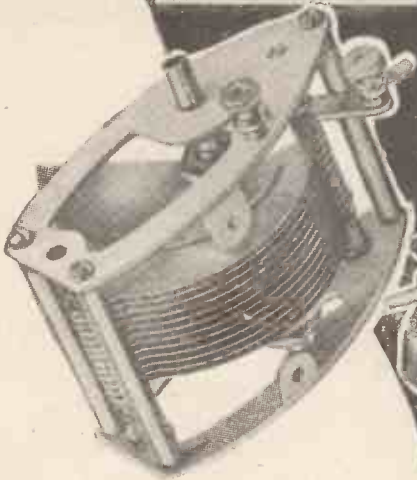

When you put a Lissen Variable condenser into your set, you get a new sense of mastery in the control. Because not only is the variation of capacity even and accurate over its capacity range, but movement is free without being slack. Notice the unshakable rigidity of the construction of the Lissen condenser—the long bearing and the absence of end pressure or distortion of the vanes.

The Lissen Condenser is a real low-loss condenser; because of this stronger signals are passed to your valves and you get greater volume from your set. It is fitted for one-hole fixing or baseboard mounting; the spindle is extended for ganging; ebonite bushes are available for metal-panel mounting—so that you can use it for absolutely any published circuit. If you are experimenting, you can use it for one circuit after another and it is universally adaptable. Remember this when buying a condenser and get a Lissen!

LISSEN
**LOW-LOSS VARIABLE
CONDENSERS**

PRICES:-

- CC01 mfd. capacity 5/9
- CC02 mfd. capacity 6/-
- CC03 mfd. capacity 6/-
- CC05 mfd. capacity 6/3
- CC06 mfd. capacity 6/6

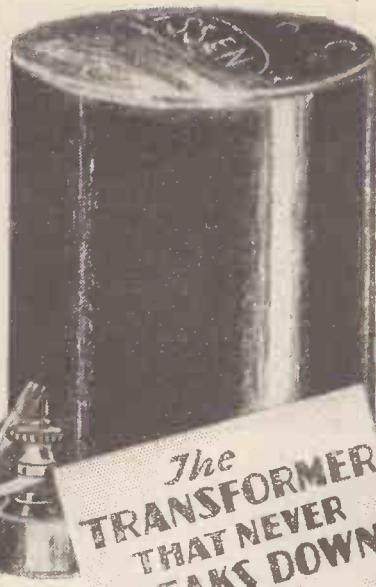

*The
TRANSFORMER
THAT NEVER
BREAKS DOWN*

The Lissen 8/6 Transformer gained fame in a single season because it gave to constructors exactly what was required of a transformer—a coupling device of almost universal utility at a moderate price. The extraordinary efficiency of this Lissen Transformer has been proved since then in hundreds of thousands of sets—in published circuits of all descriptions.

You cannot buy a transformer that offers you better value for money. And if you consider it by the results you get when you use it, you will find that there is hardly any circuit in which this transformer cannot be used with the most gratifying results.

Turns Ratio 3 to 1 **8/6**
Resistance Ratio 4 to 1

If your chosen circuit calls also for a Super Transformer, use a Lissen Super Transformer. You cannot get a better one. **PRICE 19/-**

LISSEN
TRANSFORMER

LISSEN LTD., Worplesdon Rd., Isleworth, Middlesex (Managing Director: T. N. GOLS.)

**CAPACITY
THAT
NEVER VARIES**

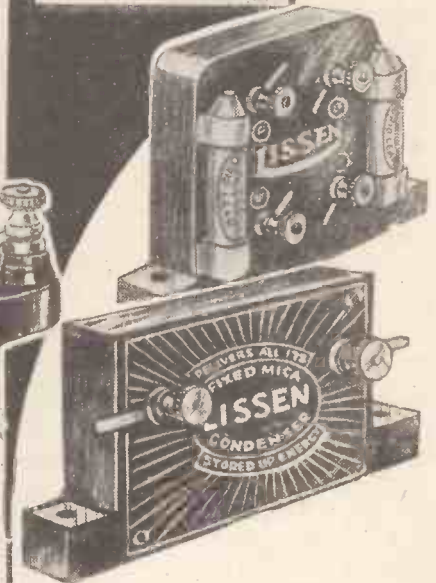

Upon the condensers you use depends to a great degree the volume you get and the purity you get. Use Lissen Fixed condensers—they deliver all their stored-up energy. Use them wherever fixed condensers are specified—in any circuit and for every purpose. They never leak, they never vary, and deliver all their stored-up energy all the time.

LISSEN R.C.C. UNIT
embodies an accurately rated .01 condenser which delivers all its stored-up energy and resistances that will never vary, no matter what the current load, interchangeably of resistance values. **PRICE 4/-**

LISSEN
**FIXED MICA
CONDENSERS**

.0001 to .001, price 1/- each.
.002 to .008, price 1/6 each.
.01 price 2/- each.
Obtainable of all radio dealers.

**LISSEN
FIXED
GRID LEAKS**
These resistances are unvarying in value, and all have been tested.

All values each **1/-**
With terminals **1/3** each.

AERIALS AND SELECTIVITY



At the present time the question of selectivity is a vital one. We have the powerful regional transmitters practically "on our doorstep," so to speak, together with a whole host of Continental stations which are easily within reach of the average up-to-date set.

It is therefore essential that our receiver should be capable of cutting out the regional transmissions, and of separating the Continental stations, so that each can be received clearly and without interference.

High Selectivity

The modern set is skilfully arranged to give a high degree of selectivity, but this valuable feature cannot be obtained without some slight sacrifice in simplicity. That is to say, if we demand maximum selectivity then the tuning necessarily becomes more complicated.

It is because of this that set designers are compelled to compromise if they wish to retain ease of operation.

Many listeners do not realise how great an effect the aerial has upon the selectivity of the receiver. With a poorly designed aerial and a given set the local transmission may spread over, say, 20 degrees of the dial setting. If the same set is connected up to a well-designed and selected aerial system the same transmission may only cover 7 or 8 degrees of the condenser dial.

Now you will see from this what a very important bearing the aerial has upon selectivity, and how it helps in reducing interference from unwanted stations.

One Wire Best

Let us take, for example, some of the aerials which we see from the train. You will observe that many of them have two parallel wires, while others are similar in appearance to

At the present time the question of selectivity is an all-important one. How an alteration in the size and shape of the aerial will help you to cut out unwanted stations is shown in this interesting article.

By J. BOSWELL.

the bird-cage aerial so frequently seen on the battleships and men-of-war generally. Then we have another type which consists of a long single-wire span passing close to the roof of a house or over the tops of trees.

These aerial systems are all inefficient, although many of them may by their owners be considered very pretty. A multi-wire aerial is no advantage from the point of view of reception. It is beneficial from the transmitting standpoint, and that is why you see more than one wire used on a commercial station.

An aerial which consists of two or

more wires has what is termed a high capacity, and this capacity, incidentally, is virtually in parallel with the aerial tuning circuit of the receiver.

It exercises what is called a "damping" effect, and robs the receiver of much of its selectivity.

Using a Fixed Condenser

In order to reduce this effect listeners are often told to insert a small fixed condenser in series with the aerial lead, and in nine cases out of ten they find that it greatly improves their selectivity.

If you look at the circuits of most of the designs which appear in this journal you will see that there are two aerial terminals. One of these enables a .0001 fixed condenser to be joined in series with the aerial. The designer has included this fixed condenser in the set because he has foreseen the possibility that many

(Continued on page 231.)

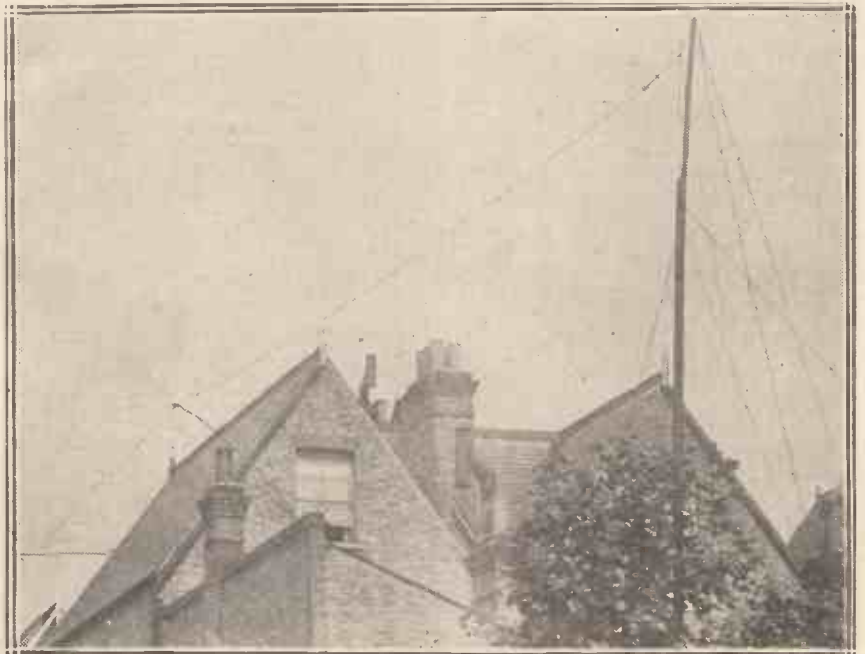

A long aerial is not conducive to high selectivity. It pays to shorten the horizontal span, and to keep the lead-in well away from the walls.

AMAZING SUCCESS OF The 'CHASSIS' THREE

by Mr. PERCY W. HARRIS, M.I.R.E.
PRICE LIST OF ALL CORRECT PARTS
AS USED IN THE ORIGINAL SET.

	f	s	d.		£	s.	d.
1 Hand-polished oak Cabinet	1	7	6	1 Dubilier .003 condenser, with series clips (type 610)		2	6
1 Ready Radio WIRELESS CONSTRUCTOR Universal Chassis, with mounted Lotus valve holders, and insulated washers	10	6		1 Lissen 2-megohm leak		1	0
1 Resiston panel, 18 ins. x 7 ins.	8	0		1 Lissen 1-megohm leak		1	0
1 Polar .005 drum-drive Vernier condenser	15	0		1 Leak holder			8
1 Utility .003 Mite condenser	6	0		2 Metro-Vick 100,000-ohm resistances and holders		4	10
2 Knobs (with pointers)	8			1 Ready Radio 25,000-ohm anode-feed and holder		2	5
1 Lotus .0025 variable condenser	5	3		1 Igranic .01 fixed condenser and base		3	0
2 On-off switches	2	6		3 Wander plugs			6
1 READY RADIO SELECTIVITY UNIT	1	0		1 20-ft. Glazito		1	4
1 R.I. Dual Astatic H.F. choke	7	6		1 Grid-bias battery, 9 volts		1	6
1 Varley Nicore J L.F. transformer	1	0		48 C/H screws and nuts, 6 B.A.		1	0
1 Ferranti Bi L.F. choke	1	1		1 H.F.-type valves		1	0
1 Colvern "Chassis" Three coil	8	6		1 Power-type valve		12	6
8 Belling & Lee insulating terminals	4	0					
2 Dubilier 2-mfd. condensers	7	0					
1 Pair of grid-battery clips			6				
				TOTAL (including Valves, etc.)	£10	17	0

Any of the above components can be supplied separately if desired.

COMPLETE KITS

KIT A	less valves and cabinet	£7 : 16 : 0
KIT B	with valves less cabinet	£9 : 9 : 6
KIT C	with valves and cabinet	£10 : 17 : 0

READY RADIO IMMEDIATE DESPATCH SERVICE

When you buy radio parts you naturally want exactly what you order and you want them quickly. You also would be happier with the knowledge that in the event of subsequent difficulties you can obtain technical advice without trouble.

TO HOME CUSTOMERS

Your goods are despatched post free in sealed cartons or carriage paid by rail.
NOTE.—You can if you desire avail yourself of the C.O.D. system.

TO OVERSEAS CUSTOMERS

All your goods are very carefully packed for export and insured, all charges forward.

1930 ILLUSTRATED CATALOGUE NOW READY, POST FREE 1/-.

Telephone No.:
Hop 5555
Private Exchange

Ready Radio

Telegrams:
Ready Hop 5555
London.

159, BOROUGH HIGH STREET, LONDON BRIDGE, S.E.1.

Ready Radio SELECTIVITY UNIT (PATENT PENDING) SAY "SUSIE" FOR SHORT



PRICE 20/-

IT IS ESSENTIAL IN THE
"CHASSIS" THREE

Mr. Percy W. Harris has chosen the Ready Radio Selectivity Unit on account of its immeasurable superiority over all other apparatus that has endeavoured to overcome the selectivity problem.

WHATEVER YOUR SET—YOU WILL NOT BE TROUBLED WITH INTERFERENCE FROM BROOKMAN'S PARK OR ANY OTHER HIGH-POWERED STATION IF YOU CONNECT A READY RADIO SELECTIVITY UNIT.

READY RADIO
Universal Chassis
Price, complete with mounted Valve Holders, and Insulated Washers 10/6

All parts can be supplied for the 'SILVER CHAMPION'—either in complete kits, or components supplied separately as desired. Send for list.

DO YOU REMEMBER?

Stand by for 5 MINUTES please!

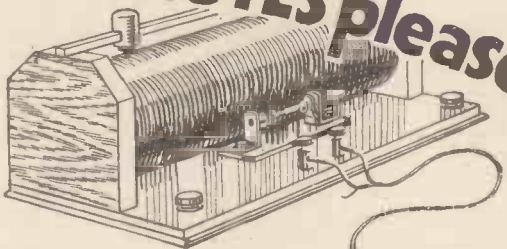

That used to be the usual finish to each broadcast item. Sometimes it was ten minutes—sometimes even fifteen, somehow we didn't seem to mind then. What was a few minute's silence here and there in a wonderful "Wireless" programme? It wasn't a programme as we know it now either—only a couple of hours in twenty-four—but we enjoyed it to the full. Now we ask for better things—but that was seven years ago. Yet, even then—and years before too—T.C.C. Condensers were being used in transmitter and receiver alike. They were the standard of those days—they are still the standard to-day. Remember this when next you want a condenser—use only the "condenser in the green case"—and be safe.



T.C.C. Condensers are made in types for all purposes. Here is illustrated a 2,000 mf. Electrolytic Condenser, price 15s. od. There is also the Double Type—4,000 mf.—price 27s. 6d., and the new 500 mf. 40 v. Type, price 20s. od.

T.C.C. CONDENSERS WERE USED THEN

Adv. Telegraph Condenser Co., Ltd., Wales Farm Rd., N. Acton, London, W.3

Ⓐ 2165

WHY PAY more than 5/6 FOR A UNIVERSAL VALVE

New Glass Bulb. Finer yet Tougher. 1

New Super Strength Grid. 2

New Non-microphonic Filament with Special Coating. 3

New Large Size Anode. Easier Flow of Electrons. 4

NEW 1930 TYPES!

NEW 1930 PRICES!

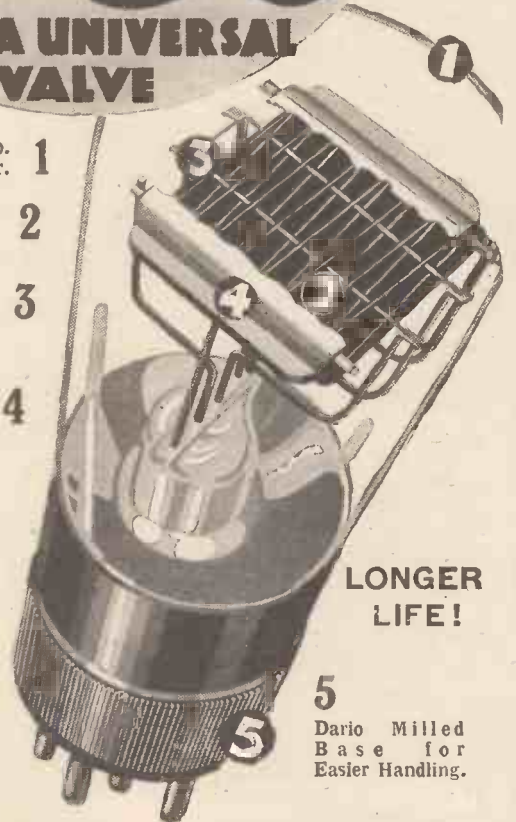

LONGER LIFE!

5 Dario Milled Base for Easier Handling.

WRITE FOR FREE FOLDER!

TWO VOLT

Universal	- 1 amp.	5/6
Resistron	- 1 amp.	5/6
Super H.F.	- 15 amp.	5/6
Super Power	- 18 amp.	7/6
Hyper Power	- 3 amp.	9/6
Pentodion	- 3 amp.	18/6

From your Dealer or direct:

FOUR VOLT

Universal	- .075 amp.	5/6
Resistron	- .075 amp.	5/6
Super H.F.	- .075 amp.	5/6
Super Power	- 1 amp.	7/6
Hyper Power	- 15 amp.	9/6
Pentodion	- 15 amp.	18/6



Best way to all Stations

IMPEX ELECTRICAL, LTD., DEPT. L, 538, HIGH ROAD, LEYTONSTONE, LONDON, E.11

WHY NOT LOUD-SPEAKER CURVES?

Details of a most ingenious device which has been specially designed for the accurate tracing of loud-speaker response curves.

By PERCY W. HARRIS, M.I.R.E.

WHILE component manufacturers vie with one another in producing curves indicating the performance of their low-frequency transformers and resistance-capacity units (not to mention pick-ups), there seems to be a conspiracy of silence with regard to loud speakers. The importance of a loud-speaker curve is obvious when we consider that the speaker is the last link in the chain from the studio to our ears.

Below 100 Cycles

The modern low-frequency transformer of good design is capable when correctly used (this is a very important point) of giving uniform reproduction of all frequencies from about 50 to 6,000 or so. Below this good reproduction can be obtained as low as 30, and, indeed, it is possible with the latest methods of designing and connecting low-frequency transformers to produce greater amplification below 50 than above it.

Against this must be set the fact that very few loud speakers are capable of producing low notes below 50. The average loud speaker gives little below 100, and quite a number of popular loud speakers give nothing to speak of below 200. There is no loud speaker made having a uniformity of response in any way comparable with the best low-frequency transformer curves.

Not "Real" Notes

"But," I can hear a reader saying, "my home-made loud speaker gives splendid reproduction of the drums, the cello, and the lunch-time organ recital! Many of the tones I hear go well below 100, although my speaker is not of the moving-coil variety!"

Here we come upon one of the most interesting phenomena in loud-speaker reproduction. In music there are no pure notes, each note played on any musical instrument being made up of a fundamental with a number of harmonics and overtones.

The proportion of harmonics and

overtones varies with each instrument and enables us to differentiate between, for example, the middle C on the piano and that on the violin or cornet. We will imagine, for example, that an organ is playing a note which is two octaves below the middle C (a periodicity of 64). If you are listening to reproduction of this organ music on a speaker using a balanced-armature unit you will hear a note which you will recognise as falling in its proper place.

Actually you will hear nothing whatever of the frequency of 64, for your loud speaker will not be able to reproduce that note, but you will hear most, if not all, of the harmonics of that note, from the lowest which the loud speaker can reproduce, and these will form in your ear a rough approximation to the sound given by the organ itself.

and with modern high-quality gramophones.

So you see the matter is not so simple as it appears at first! It is very advisable to have a loud speaker which will give uniform reproduction from one end of the scale to the other; and before we can do much intelligent design work it is necessary to be able to plot the response curve of the loud speaker with which we are experimenting.

How Curves are Taken

Unfortunately the apparatus needed to draw these curves is not only elaborate and expensive, but the response of the loud speaker (or rather effect on our ears produced by the sound from the loud speaker) varies according to the conditions in which the loud speaker is used.

The simplest case is that of a loud speaker used in a cabinet. The in-



A general view of an automatic response-curve device which provides a means of "looking" at the reproduction of a loud speaker. (Ultra Electric, Ltd.)

It has been shown in laboratory tests that if we reproduce all the harmonics of a note and miss out the fundamental, the effect on the ear is practically the same as if the fundamental were present, and it is this fact which enables such excellent reproduction of low notes to be obtained in many loud speakers

terior of many cabinets resonates at a definite frequency, which tends to accentuate the reproduction of that note. Take, for example, a loud-speaker unit or cone which shows a falling characteristic round about a frequency of 200.

If this is placed in a cabinet which tends to resonate at 200 the resonance

Why Not Loud-Speaker Curves?—continued

effect will bring up the overall reproduction, and to some extent compensate for the loud-speaker's deficiency. Intelligently used this phenomenon can be made to produce a pleasant effect, and a number of loud-speaker manufacturers have designed their cabinets with this in mind.

If, however, the resonance of the cabinet falls on a part of the scale at which the speaker itself tends to be resonant, one gets a booming effect which may quite spoil otherwise excellent reproduction.

Where Moving Coils Fail

Moving-coil speakers used in cabinets frequently have an unpleasant boom, and, indeed, unless the cabinet is very carefully designed a moving-coil speaker is better worked on a large and rigid baffle. The excellent low-frequency reproduction of a good moving-coil speaker has rather blinded us to the fact that the frequency response of these speakers is often very poor in the upper register. With some of them speech at the lower end

furniture. Compare the reproduction obtained in such conditions with that in a comparatively empty room, with a polished wooden floor and no curtains. Ten chances to one the latter room will have certain resonance effects tending to accentuate certain notes.

Eliminating Echo

Troubles of this kind led the British Broadcasting Company to design their earlier studios in such a way as to eliminate all possible room resonances and echo effects, and, incidentally, in overcoming some difficulties in this way they created others. The modern studio is so arranged as to give a little echo or resonance which is strictly controllable.

A very long article, and, indeed, a book, could be written about loud-speaker problems, but as the main object of this article is to deal with the reproduction of loud-speaker curves we can only consider those points which have a bearing on this point.

One of the most difficult matters is to decide just how we shall take

Fortunately, microphones can now be made (and measured) which give a substantially uniform reproduction over the whole of the scale with which we desire to deal. We can, therefore, suspend the microphone in front of the loud speaker and cause the reproduction from this speaker to produce modulated electric currents, which can be amplified by a distortionless amplifier, and the response on various frequencies measured.

Testing the Response

We can make the transmitter (either the actual transmitter for broadcasting or one produced for the purpose of the test), and run over the whole musical scale from the lowest to the highest notes, arranging the output to be uniform. If then the loud speaker itself is perfect, the electric currents produced in the microphone circuit of our measuring apparatus should also be uniform over the whole scale.

Now again we must return to our previously discussed room resonance phenomenon and consider what bearing it has upon our measurements. If there are reflections, standing waves, and echo effects in the room, then the response given by the microphone will vary according to the position at which it is placed.

We must, therefore, arrange a testing room in which the microphone is placed far enough away from the speaker to get its average effect, while the room must contribute nothing in the way of resonance or reflection. Such rooms can be built, and a good deal of research has been conducted for the purpose of finding roof, floor, and wall-lining materials of the necessary "dead" character.

Special Apparatus

A few of the leading manufacturers in England and the United States have designed and produced apparatus for the production of loud-speaker curves, notably the British Thomson-Houston Co., of Rugby, in England, the Bell Telephone Laboratories in the United States (this latter is an organisation connected with the American Telephone & Telegraph Co. and the Western Electric Co.), and the Temple Corporation, who make the Air Chrome loud speaker in America.

This latter loud speaker is now manufactured in England by The

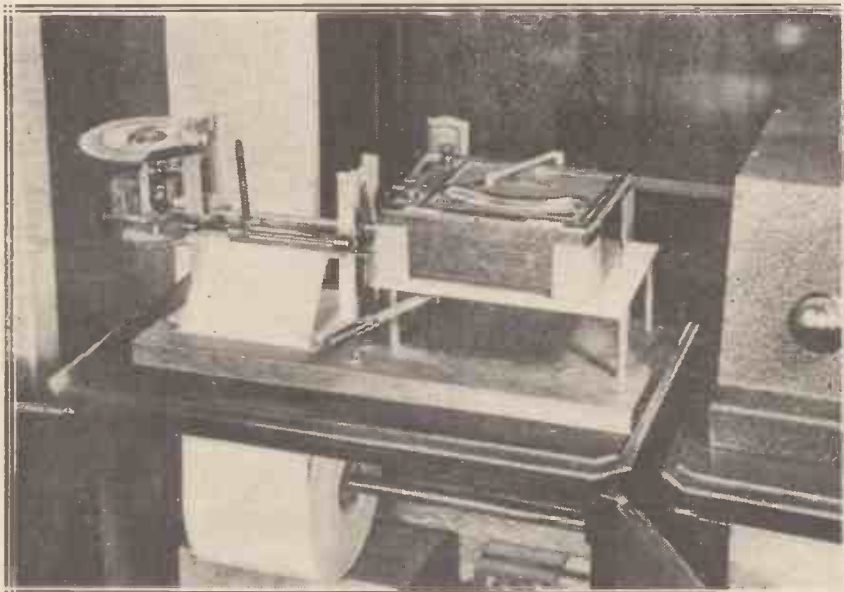

A close-up view of the device which traces the curve on a slowly-moving strip of paper. (Ultra Electric, Ltd.)

of the scale gives a booming effect, and at the upper end a woolliness or muffled effect. Many people think it is characteristic of all moving-coil-speaker reproduction.

Then, again, consider a loud speaker used in a small room, thickly carpeted, with heavy curtains over the window and doors, and many articles of

our curve, for the output of the loud speaker is sound obviously modified by the construction of the cabinet and its surroundings. Before any measurements can be taken these sounds must be reconverted into electricity and the apparatus used for this purpose must be entirely free from distortion.



The Ferranti AF3 is the Transformer of universal appeal. To the electrically critical! it shows an amplification curve that speaks volumes. To the musically critical it offers a revelation in faithfulness of reproduction.

Price £1:5:0



Enables Valves to be tested under WORKING CONDITIONS while the Set is in operation, ensuring accurate and reliable readings. Reads : Plate Volts, Plate Current, L.T. Volts, Grid Bias Volts, Grid Circuit, by merely turning the Switch. Each Valve is tested in turn without the inconvenience of making innumerable connections. Resistance 1,000 ohms per volt.

THE TESTING INSTRUMENT DE LUXE

Price £5:15:0

FERRANTI



Incorporates a Westinghouse Metal Rectifier and a Ferranti Transformer

Install a Ferranti Permanent Trickle Charger. No more run-down accumulators ; a little marvel of efficiency. Output half an ampere at 2, 4 or 6 volts. Absolutely safe and silent. No valves to burn out ; no chemicals to be replaced. Saves you a lot of trouble and gives you none.

Price £2:15:0

New model giving 2, 4, 6 or 9 volts, 1 ampere.

Price £4:7:6

GUARANTEED COMPONENTS

specialy designed for

H.T. SUPPLY UNITS
MAINS TRANSFORMERS
for use with Westinghouse Metal Rectifier and for Valve Rectifiers.

RECTIFYING UNITS
with Westinghouse Metal Rectifier.

CHOKES

CONDENSERS

ANODE FEED
RESISTANCES

SAFETY BOXES

with Automatic Switch and Fuses.

High Tension Supply Units constructed in accordance with the charts and full-size diagram published by Ferranti will be safe to use and entirely free from hum or "motor-boating."

FERRANTI

FERRANTI LTD.

HOLLINWOOD

LANCASHIRE

Centralab

Volume Controls Rheostats Potentiometers

Centralab resistances are now used as standard by all leading radio receiver and electric gramophone manufacturers throughout the country. They are also used and recommended by technical editors of this and other radio magazines. The foregoing is proof of Centralab superiority.

CENTRALAB POTENTIOMETERS AND MODULATORS

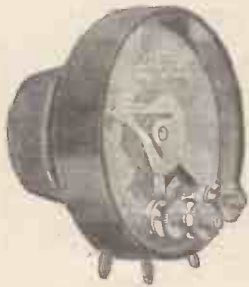

employ the famous rocking disc contact and pressure shoe. There is no sliding contact to wear out. All units have three terminals for potentiometer control, and are supplied complete with genuine black arrow knob.

TYPE P.109	200 ohms.
" P.110	400 "
" P.111	2,000 "
" P.112	10,000 "
" P.050	50,000 "
" P.100	100,000 "
" M.250	250,000 "
" M.500	500,000 "

ALL THE ABOVE 10/6 EACH.

CENTRALAB MODULATOR PLUGS

are ideal for controlling volume from radio set or electric pick-up. No. 1 is for receivers equipped with jack for speaker, while No. 2 type has cords and is for connecting across electrical pick-up or to radio-set speaker terminals. No. 3 type has a 20-foot extension cord, enabling you to control your volume from your armchair.

No. 1 and 2 types .. 10/6 each
" 3 type .. 12/6 "



Write for the Centralab Circuit booklet—it's Free on request.

Our new 68-page Great Voice booklet tells you all about Centralab Volume Controls, Pick-ups, Amplifiers and Dynamic Speakers. Write for your copy of this new issue to-day. Send 6d. in stamps for postage.

The
Rothermel Corporation Ltd.
24, Maddox St., London, W.1.

'Phone: MAYFAIR 0578/9



Type H.T.3. 120 v. 20 m.a.

21/-



METAL RECTIFIERS

HAVE

No fragile filaments to limit their life and consume energy.

AND

A higher efficiency than any other type of small rectifier. Moreover, this efficiency is maintained practically throughout their whole range of output.

Smoothing is easier than with any other type of rectifier, owing to the truer nature of their output waveform.

Westinghouse Metal Rectifiers are now used in the MAJORITY of modern mains receivers and eliminators, designed and marketed by experts who are satisfied as to their reliability, and whose aim has been to provide trouble-free radio equipment.

You should have Westinghouse Metal Rectifiers in your new set. The best way of using them is fully set out in our booklet "The All-Metal Way, 1930," 32 pages of circuits and information regarding A.C. mains operation.

Send a 2d. stamp for a copy to

The Westinghouse Brake & Saxby Signal Co., Ltd.
82 YORK ROAD, KING'S CROSS, LONDON, N.1.

Why Not Loud-Speaker Curves?—continued

Ultra Electric, Ltd., and the photographs accompanying this article show the apparatus used to produce the curve of the Air-Chrome loud speaker are reproduced by the courtesy of this company.

Sound-Proof Room

The sound-proof room, with the suspended microphone, is shown in the one picture, and the thickness of the carefully padded door should be noted. The walls, roof, floor, and door are all covered with material known as Celotex, which is manufactured, I believe, from waste material consisting of the fibre of sugar cane after the juice has been extracted. The room is entirely non-resonant, so that the sound impinging on the microphone comes solely from the loud speaker, none being reflected from the walls, roofs, etc.

In order to make the tests, a pure note is produced by an audio-frequency oscillator, the intensity being made uniform over the whole musical scale. This note can be varied from the lowest to the highest frequency required in the tests, and the sound picked up by the microphone is converted into electric current and amplified in a distortionless amplifier, the output being led to a sensitive and accurate measuring instrument.

The actual apparatus on which the curve is drawn is shown in another photograph, and the complete apparatus, with amplifier, etc., and a special oscillograph for visual observation is shown in a third picture. Returning to the second illustration, a large roll of paper will be seen on the spindle beneath the table.

Automatic Recording

This paper comes up through a slit and passes across a flat bar. Above this bar is a rod along which can be slid a penholder, while on the right of the paper is the measuring instrument, the needle of which varies in position according to the strength of the current. Above the scale will be seen a pointer which is pivoted at the rear of the instrument, and is connected with the handle which can be seen projecting from the underside of the measuring instrument.

By moving the handle the pointer can be made to follow the needle of the indicating instrument, and as

the handle is connected by a rod to the pen carriage the pen is made to travel backwards and forwards across the paper in accordance with the position of the pointer.

Now on the left of the instrument will be seen a variable condenser which controls the frequency of the audio-frequency oscillator producing the note for the loud speaker. The handle (on the left) which turns this condenser is also made to feed the paper forward, so that the reader will easily realise that if the paper is fed forward by the handle controlling the frequency, and if simultaneously the operator moves the pointer so as to follow accurately the movement of the needle of the measuring instrument (which is indicating variations in intensity of

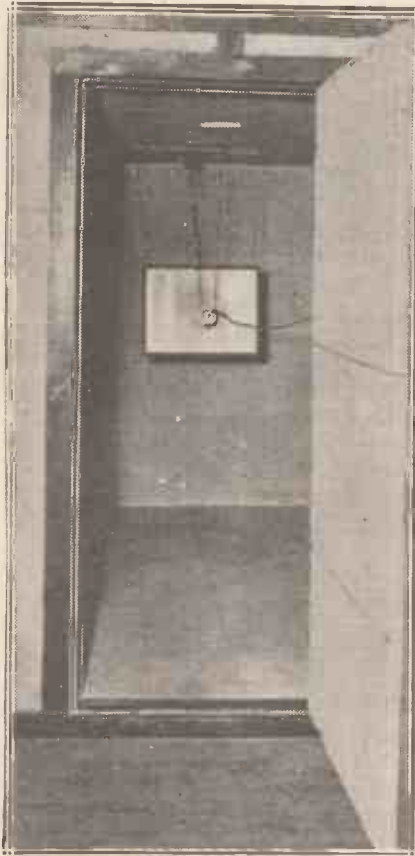

The sound-proof chamber in which speakers and the microphone are hung. (Ultra Electric, Ltd.)

sound given out by the loud speaker), curves showing the relation of intensity to frequency will be recorded by the pen.

The apparatus used by the British Thomson-Houston Co., of Rugby, is made to give a visual indication, a spot of light being made to travel across the

screen laterally, according to the movement of the controlling condenser of the audio-oscillator, and travelling vertically according to the intensity of the sound received by the microphone.

Very Effective

For visual indication of the performance of the loud speaker at, for example, lectures or demonstration halls, this latter method is very effective, and indeed was demonstrated to the scientific public at the exhibition of the Physical Society at the Royal College of Science last year.

Several other methods of showing and taking loud-speaker curves have been evolved in various laboratories, but those outlined in this article are representative of most.

*
* **A USEFUL TIP** *
* By H. P. W. *
*

THE various cures for audio-frequency howling and motor-boating are generally not considered until the set is found to be completely unstable, for which reason experimenters often forget that the quality of reproduction on a set may still be unsatisfactory due to feedback effects, although the set itself is completely stable and free from hum. For this reason it always pays to try reversing the secondary connections of the audio-frequency transformer in a set to see which way round gives the better reproduction.

Reversed Markings

In a well-designed and well laid-out receiver the maker's markings or recommendations are practically always correct, but it may be that in the particular arrangement you are using the "other way round" may give the better results. Similarly the introduction of an anti-motor-boating device in a detector plate circuit will very frequently bring about a marked improvement of quality, although without it the set is quite stable and does not howl or motor-boat. The reason for this is that there may be sufficient feedback to spoil the overall reproduction curve, but not sufficient to start howling or motor-boating.

IN LIGHTER VEIN

BY WIRELESS WAYFARER.

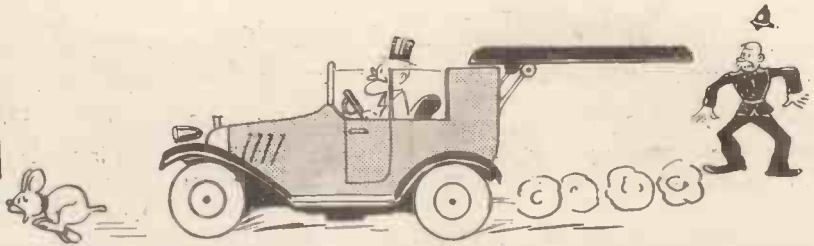

THE other afternoon when I went round to "The Microfarads" to see Professor Goop I found myself, on entering his den, in the midst of quite a little domestic scene. The professor and Mrs. Goop were both talking at the tops of their voices, neither listening to a word that the other let fly. When they had calmed down a little I gathered that there had been a slight misunderstanding.

The professor, it appeared, had conceived the brilliant idea of using the carpet sweeper for removing worm-casts from his lawn. It worked

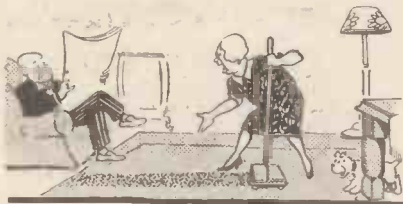

Mrs. Goop applied it to a light-coloured carpet.

beautifully, so he told me, but the first part of the trouble arose when Mrs. Goop, not knowing the use to which it had been put, applied it to the new and very light-coloured carpet which she had installed in her drawing-room.

The second part of the trouble was due to that unfortunate absent-mindedness from which the professor suffers at times. I have known him, for instance, when indulging in a bathe fling his clothes into the water and fold himself up on the bank, calling little Bingo to come and guard him.

The Goop Seaplane

I have seen him making up the fire with slice after slice of cake, and then proceed to make a hearty tea off coal. I have even heard him ring up the Official Receiver to come and wind him up because he was feeling rather run down.

On this occasion I learnt that he recollected that he had a job of clearing up to do, though for the life of him he could not remember what it was. Anyhow, instead of using the

carpet-sweeper on the lawn he had used the lawnmower on the carpet, with devastating results.

He pacified Mrs. Goop at length by promising her a new carpet-sweeper, a new carpet, a new lawnmower and even, if necessary, a new lawn.

We then settled down to serious business. He asked me first of all to inspect the model of his new seaplane for the next Schneider Trophy race. In the 1929 contest pilots suffered severely from draughts in their faces. This inconvenience is entirely obviated in the Goop seaplane, which flies backwards in order to keep the wind out of the pilot's eyes.

He is also patenting another invention which should ensure Great Britain's retention of the Trophy. It was found, if you remember, upon the last occasion that any pilot who took his corners sharply was apt to be blinded, since centrifugal force drained the blood out of the eyeballs.

Gyroscopic Eyeballs

Professor Goop has invented a little device which makes the eyeballs revolve several thousand times a second. A gyroscopic action is thus obtained which completely overcomes the little inconvenience mentioned. He believes, and I think that he is right, that his invention will have also a great future amongst "movie" villains and vamps.

I must mention, too, the professor's latest sunshine body for saloon cars. In ordinary models, such as the products of inferior brains recently seen at Olympia, arrangements are made for the roof to slide back at will. Too often the sliding back is, if I may so put it, at won't. Too often it lets in not only the sunshine when open, but also the opposite when closed.

The professor argues that it is quite wrong for the roof to slide. The roof of a car, like all other roofs, should be fixed and immovable, and the man who tries to make it slide must certainly have a tile loose. The professor's scheme is entirely new.

The roof stays put, but on pressing a button the entire body moves from under its shelter, carrying the occupants with it.

The advantages of this system are enormous. Since the roofing material is never concertained, it does not develop cracks. The same applies to the hats worn inadvertently when a roof is coming forward. According to the angle of the sun the body can be moved to provide adequate shade and cool, refreshing breezes. Further, the owner of a "baby" can double its length by the mere pressing of a button, subsequently driving about with that Rolls-Royce look.

The Universal Wave-Trap

But the climax of the professor's recent inventions is probably his Universal Wave-trap, which renders completely obsolete all other types of whatever kind they may be and whoever designed them. Instead of working upon only one principle (or upon no principles at all), as is the case with the traps of some unprincipled designers), the Goop Wave-



Gyroscopic eyeballs for villains and vamps.

trap involves two basic and fundamental principles. These are:

- (a) The toasted-cheese principle.
- (b) The energy-diverting principle.

Before the reader can thoroughly grasp the real working of this stupendous invention we must understand something of the theory and practice of traps in general. We may divide them into:

- (a) Traps for the unwary.
- (b) Traps for the wary.

Traps for the unwary include high-tension batteries made in Yago-Toblazia, and retailing at 2s. 11d., invitations to dinners in aid of some good cause at which a collection is

Just Perfection

GRAHAM FARISH

RADIO PRODUCTS

for Reception

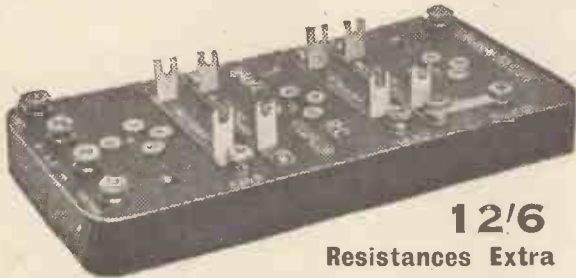

12/6
Resistances Extra
THREE VALVE R.C. COUPLER



.0003 . . 4/3 . . .0005 . . 4/6
"MICROFICIENT"
VARIABLE CONDENSER

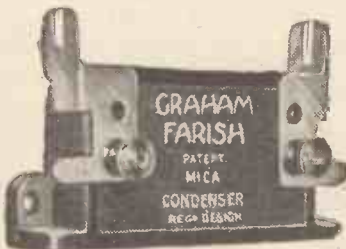

.0001 - .002
1/-
.003 - .006
1/6
.01 . . 2/6

FIXED MICA CONDENSERS

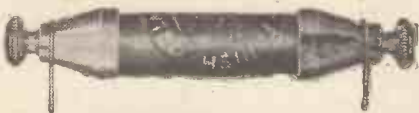

STANDARD
GRID LEAK 1/-



HORIZONTAL
HOLDER 6^D

6^D.
VERTICAL HOLDER



MOULDED
RESISTANCES
"OHMITE" 2/3
"MEGITE" 2/-



"MEGITE"
NEW
PROCESS
GRID
LEAK
2/-



"AUDION" RESISTANCE
CAPACITY UNIT 5/6

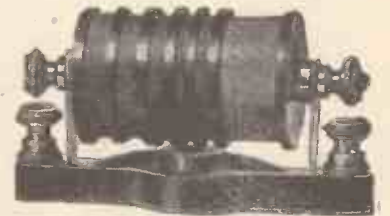

5/-
"MULTIWAVE" H.F. CHOKE



2/-
COMBINED FIXED CONDENSER
AND STANDARD GRID LEAK

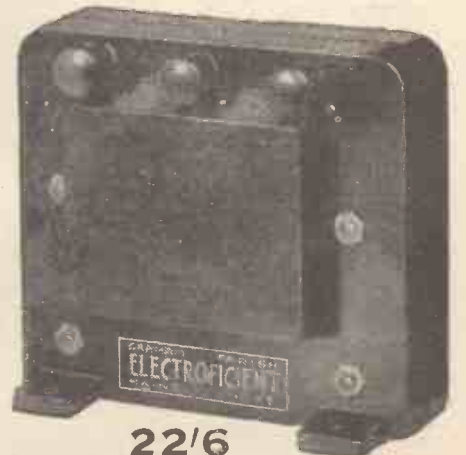

22/6
"ELECTROFICIENT"
ELIMINATOR CHOKE

GRAHAM FARISH

Write for descriptive leaflet to Dept. W.C.



BROMLEY

KENT.

124

THE NEW CELESTION LOUDSPEAKER

Z.20.

Holds undisputed rank as the finest of all Loud-speakers

"Finest loud-speaker I have heard . . . sets entirely new standard . . . worth every penny it costs." *"Help Yourself" Annual.*

"Nearest approach to the ideal that I have yet heard." *"Sphere."*

"Most critical musician could not find fault . . ." *"Evening Chronicle."*

Sets a standard. Amazingly true reproduction. Low frequencies as well as high." *"Daily Mirror."*

"Renowned for brilliancy and quality . . . speech and music particularly good . . . a handsome instrument."

PERCY HARRIS in "Wireless Constructor."

Designed specifically to give the finest possible results with any set from a Two-Valver to a Power Amplifier. Crowned with the Celestion hallmark—a beautifully designed and hand-polished cabinet.

In Oak £7 : 15 : 0,
Mahogany £8 : 5 : 0,
Walnut (to order)
£9 : 0 : 0.

Other Celestion models from £3 : 15 : 0.

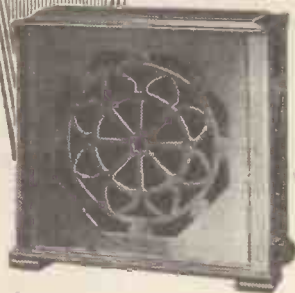

WRITE FOR AN ABSORBING FREE BOOK ON "SOUND RE-CREATION"

CELESTION

The Very Soul of Music

London Showrooms:
106, Victoria Street, S.W.1.

Write to: Celestion Ltd.,
Dept. L. Kingston-on-Thames.

FOREMOST NAME IN SOUND REPRODUCTION

WONDERFUL NEW BENJAMIN PRODUCTS



ROTARY BATTERY SWITCH
An attractive alternative to the usual Push and Pull type of Switch. All insulated, with indicating "On" and "Off" dial, pointer knob, and double contact. Each **1/9**



PENTODE
The famous Benjamin Clearer-Tone Valve-holder, with flexible connection for attaching to terminal on the pen-tode valve. Price, each **2/3**
Pentode attachment only for use with existing Clearer-Tone Valve-holders or Vibroholders, 5d. each.



5-PIN VALVE-HOLDER
Designed for use with the 5-pin valve with centre leg. The well-known Benjamin anti-microphonic feature is incorporated, and patented contact, which gives perfect contact when using solid or split pin valves. Price each **1/9**

NOT FORGETTING THESE

Fully illustrated leaflets on all our products will be sent on request.

The original CLEARER-TONE VALVE-HOLDER, in face of considerable low price competition, has more than held its own and will be continued at **2/-** price of

The BENJAMIN VIBRODER was last season's most successful accessory, the self-aligning feature ensuring positive contact with all types of English 4-pin **1/6** valves. Price, each

The popular Push and Pull double-contact Battery Switch, it's "off" when it's "in." Price with terminals, **1/3** each
Without terminals, **1/-** each

BENJAMIN RADIO PRODUCTS

THE BENJAMIN ELECTRIC LTD.
BRANTWOOD WORKS, LONDON, N.17

In Lighter Vein—continued

suddenly sprung upon the assembly, police traps, and the awfully jolly fellow you meet in the train who discovers with horror that he has left his purse on the piano.

With these we are not really concerned, since wireless waves (and particularly those of the Brookman's Park variety) are distinctly not in the unwary class.

We come, then, first of all, to traps for the wary, operating upon the toasted-cheese principle. Here the idea is to suggest to the intended victim by appealing to his sense of sight, sound, touch, taste, or what not, that there is something within the rather suspicious housing which he simply must have.

Diverting the Energy

Certain low-frequency transformers, for example, have an enormous vogue amongst dipsomaniacs since they claim to bring out the Bass. Similarly, that intelligent mammal, the mouse, entirely overcomes his scruples against entering the rather obvious wire cage when an appeal is made to his gastronomic system by means of carefully toasted and thoroughly ripened cheese.

Next we may profitably spend a moment or two upon the consideration of energy-diverting traps. A married man, for instance, who is being put through the hoops by his better-half, knows that the correct thing to do from both the theoretical and the practical standpoint is to



He just says "Why, of course," or, "Yes, m'dear."

mention casually (always provided that he can get a word in edgeways) that the beautiful Mrs. "X" cannot be a day more than twenty-five.

Energy is then diverted to a proof equal in length to the whole of Euclid's twelve books that she will never see forty again. The hoops having thus been banished into oblivion, the trapper is free to devote himself to the evening paper, provided that he just says "Why, of course,"

or "Yes, m'dear," or "How clearly you put it," every now and then.

In the ordinary wave-trap only the energy-diverting principle is made use of. When the heck of a wave comes along, you just nip in a circuit which (like the remark about Mrs. "X's" beauty and age) is pretty good for side-tracking purposes. You interpose this circuit between the receiving set and the interference, just as you place the evening paper between yourself and the domestic source of interference.

Circulating Currents

Very well, then. What happens? The wave finds a nice circuit tuned exactly to suit its mood. Just as your better-half puts all her vim, zip and pep into the congenial task of nailing down the vexed question of Mrs. "X's" age and charm once and for all, so the wave does its very darnedest in the circuit provided for its reception.

It sets up circulating currents, which are nearly as efficacious as the circulating currents in the cheeks of the infant prodigy who has been ordered to eat his beastly bun.

In both cases undesirable energy is frittered away and the setter of the trap is enabled to obtain a certain amount of freedom from interference.

But just as the missus may dry up on the subject of Mrs. "X" and come back to the hoops again, and just as the infant prodigy may eventually dispose of the bun, so the unwanted wireless signal trapped in the ordinary way has a nasty habit of pushing itself through despite all precautions. I mean, you may squeeze out Brookman's Park when you are tuned to Brookman's Park, but it is darned annoying to find that he is coming through when you are tuned to Nuremberg.

Two Methods

This is where Professor Goop's brainy combination of the two trapping methods previously mentioned scores so heavily.

He alone of all wireless experts has realised what a trap for the wary wave must contain.

The accompanying drawing will make plain the system upon which it works.

A is the aerial a-sway 'neath the sky, B is the battery low-tension or

high. . . . I beg your pardon, I was just going off into one of those jolly little rhymed alphabets. Let us begin again.

L is a coil, not fixed, but rotary, the former being mounted upon a spindle. Upon this spindle hangs a little hook by means of which is suspended a crystal marked X in the drawing. At each end of the spindle is a wipe contact, and by means of these the ends of the windings are connected to the terminals of the condenser C.

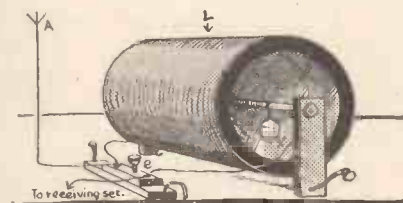

The Goop double-principle wave-trap.

The action of the trap is simplicity itself, only more so. Upon entering from the aerial the unwanted oscillation finds a tuned circuit consisting of L and C ready to receive it. So far there is nothing original about the trap. But note the crystal X.

Since it has been instilled into the Brookman's Park signal that its mission in life is to bring joy into the heart of the crystal user, it is irresistibly attracted by the bait. It strives conscientiously to reach it, zipping round the coil in an endeavour to find some path from L to X. Under the influence of the energy supplied by the unwanted signal the coil begins to rotate, and we have thus not only a circulating, but also a rotating, current.

A Valuable Invention

It will be obvious to the meanest intelligence (by which I mean yours) that the energy driving the coil is provided by the unwanted signal. It is thus made to squander all its vim in doing perfectly futile work, with the result that nothing at all gets through to the set. Professor Goop is receiving no less than £50,000 for this invention from the WIRELESS CONSTRUCTOR* (at least he hopes so), and the full constructional details of the trap will occupy the whole of the next issue.†

* A cheque will be sent on February 31st.—ED.

† The constructional details will appear on the same date.—ED.

"AS WE FIND THEM" NEW APPARATUS TESTED

All apparatus reviewed in this section each month has been tested in the Editor's private laboratory, under his personal supervision.

An Amplion Loud-Speaker Unit

THE Amplion loud speakers are well known, and we are interested to see that Messrs. Graham Amplion, Ltd., are now producing an Amplion standard balanced-armature unit type B.A.2 which should particularly appeal to home constructors.

Its general appearance can be gathered from the photograph herewith, and a commendable feature is the provision of three terminals so that three different impedances can be obtained. Thus the average figures as given by the makers for the low connection are a resistance of 500 ohms and an impedance at 1,000 cycles of 4,500 ohms. Medium resistance is 700 ohms, with 6,500 impedance, and high is 1,200, with 20,000 impedance.

The speaker can thus be used on the high position directly in the anode circuit of a pentode valve without the loss of quality which often characterises the direct connection of a loud speaker in such a circuit. The makers state that the D.C. load should not exceed 30 milliamperes.

On test with a suitable diaphragm constructed for the purpose the unit gave good quality with quite a reasonable proportion of low tones and without an undue sacrifice of the high frequencies. In common with other



The Amplion L.S. unit referred to on this page.

Amplion productions the device is very well made mechanically, and is easily and conveniently mounted. At 21s. it represents good value and should find a wide sale.

Excellent Small Condenser

It is always a pleasure to review the apparatus manufactured by Messrs. Sydney Bird, Ltd., as it represents the highest standard of British production. The Cyldon Junilog 0005-mfd. variable condenser, shown in

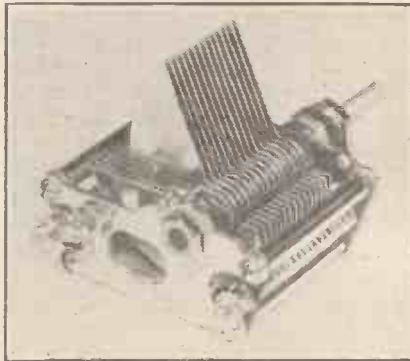

A "Cyldon" Junilog condenser.

the accompanying photograph, is a small variable condenser especially suitable for use in portable sets and in those receivers where limitations of space are severe.

It is made with both the electrical and the mechanical efficiency which always characterises this firm's products, the maximum capacity being well up to the figure mentioned, and the minimum being extremely low. One-hole fixing is adopted, but the end-plate is drilled with three holes, so that three-hole fixing can be adopted if desired.

This condenser can be fully recommended for all purposes where such a variable is desired and the price is particularly reasonable for such a finely-made component.

Interesting Battery Scheme

The high-tension battery, forming as it does such an important part of a



wireless outfit, has received a good deal of attention during the last few years. Not only is it now realised that the larger sizes are more economical to run, but also that when tappings are used one part of the battery runs down before another. The Leyton Battery Co. (successors to the Eton Glass Battery Co.) have sent us for report some examples of their latest products, together with interesting instruction sheet and price list.

This company supplies single cells of a triple capacity, shown on the left of our photograph, so that the home constructor can build up his own dry battery to any required voltage, with the advantage that poor or faulty cells can be removed and replaced by new ones, without scrapping the whole battery. The recommendation is that each cell, as shown, shall be dipped into hot wax and a case made or purchased to hold the requisite number of cells.

Strips of waxed cardboard are then fitted egg-box fashion and form a nest for each cell, all the cells being joined up in series. Tapping sockets can also be purchased very cheaply, so that wander-plug connections can be made to any portion of the battery. The same company also sell parts for what is called the "Leyton Dual Battery."



Cells of the Leyton Battery Co. reviewed above.



"Have always held a leading position . . . production of thoroughly sound variable condensers . . ."—*Vide Press.*

"1930" LOC (mid-line) CONDENSER

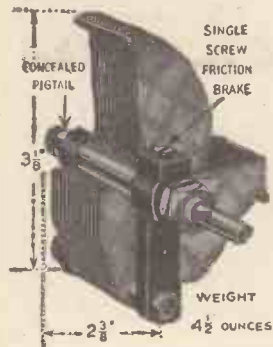

In four Capacities :

- 0005
- 00035
- 00025
- *•00015

4/6 each

*Double spacing of vanes for Ultra-Short-Wave work.

"MIDGET" Reaction CONDENSER

Capacity: •0002 mfd.

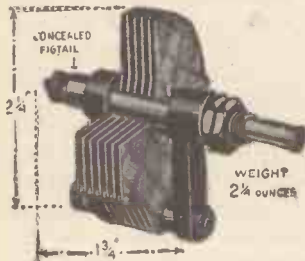

The FORMO "MIDGET" Reaction Condenser, like all other Formo Condensers, has incorporated the patented Formo internal "PIGTAIL," undoubtedly the finest collector or "Pigtail" yet devised, and thereby is absolutely noiseless in operation.

2/9

The Finest
VERNIER DIAL
obtainable.

MECHANICALLY PERFECT POSITIVE BRASS CONTACT drive on SOLID BRASS SCALE, ensuring smooth movement with absolutely NO BACK-LASH. ROBUST in Construction and Trouble Free. SMALL. EXTREMELY ELEGANT. EFFICIENT.

TUNING WITHOUT IRRITATING, UNCOMFORTABLE CROUCH or STOOP.

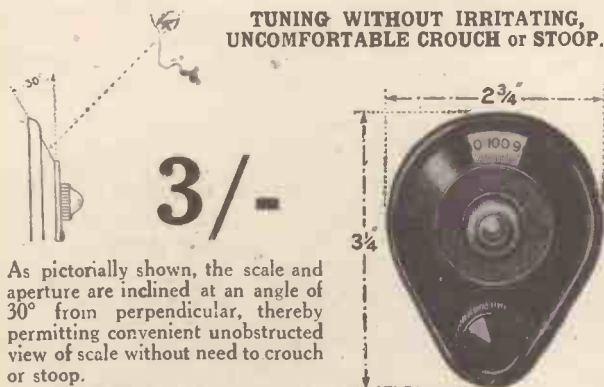

3/-

As pictorially shown, the scale and aperture are inclined at an angle of 30° from perpendicular, thereby permitting convenient unobstructed view of scale without need to crouch or stoop.

If unable to obtain from Dealer please communicate with us.
Full Catalogue sent post free on receipt of post card.

THE FORMO CO., CROWN WORKS, CRICKLEWOOD LANE, LONDON, N.W.2.

NO PEAKS in the VARLEY CURVE

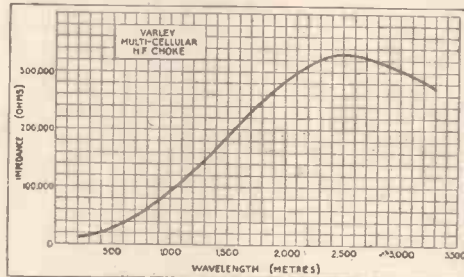

MULTI-CELLULAR H.F. CHOKE 9/6

Look at the impedance frequency curve of practically any other H.F. Choke. What do you see?

A series of small peaks pointing to the presence of minor resonances. This means that, suitable as they may be for use in the anode circuit of a reacting detector valve, they cannot be considered for a parallel feed circuit.

Not so the VARLEY H.F. Choke. A glance at the curve will show that, whilst resonance occurs at 2,500 metres, it is entirely free from subsidiary resonance. And the resonant frequency is well outside normal broadcast wave-lengths so that self-oscillation is impossible.

This H.F. Choke has VARLEY quality: it is a component with all the Varley research and painstaking workmanship behind it. Satisfaction is assured when you specify Varley—the best H.F. Choke on the British Market for choking efficiently up to 4,000 metres.



Write for a copy of Sections B & C of the Varley Catalogue.

Advertisement of Oliver Pell Control Ltd., Kingsway House, 103 Kingsway, London, W.C.2. Telephone: Holborn 5303

“As We Find Them”—continued

In this, small glass jars are used as shown on the right of our illustration, and individual cells dropped in and joined in series as before (without, however, being waxed). Connection between cells in this method is made, not by a wire as in the previous case, but by large, curved zinc clips, which embrace a good proportion of the zinc of the cell. The battery is used first of all as a dry battery, and, according to the instructions, “as each cell starts to give out fill the glass jar three-quarters full with water only.”

Interesting and Economical

It is well known that as a dry battery is discharged so the zinc is consumed, and presumably in this case there is in each cell an excess of chemical over and above that required for the zinc consumption, so that as the zinc thins and becomes caten away access is given to the water to remoisten the sal-ammoniac, while the large zinc clips provide the necessary new zinc surfaces.

The process appears interesting, but

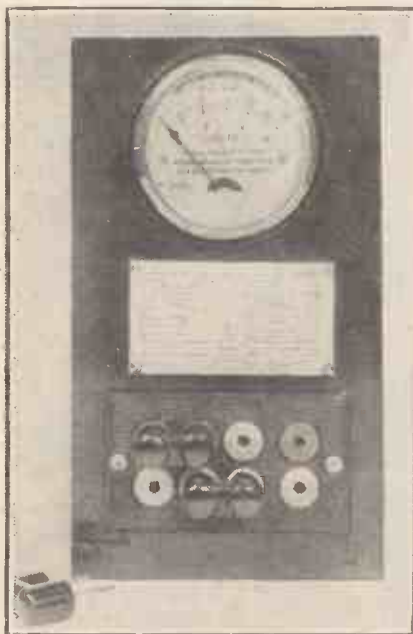

The Wates “Three-in-One” meter, for checking voltage and current.

only prolonged tests, which we have not been able to make with a single cell, would show whether the scheme is economical and satisfactory. As, however, the cells would appear to give quite a normal life before the second stage of the process is reached, economical working is certainly most probable.

A Useful Test Meter

The Wates three-in-one panel meter, illustrated in the accompanying photograph, is provided to enable accumulator, high-tension voltage, and current consumption of the set to be ascertained rapidly and with a minimum of inconvenience. The meter is mounted so that immediately below it a tablet shows the connections, and below this a bridging plate enabling the instrument to be connected to give high-tension voltage, low-tension voltage or milliamperes by inserting bridge links into the correct holes. The dial reads 0 to 30 milliamps, 0 to 6 volts, and 0 to 150 volts, and the whole device sells for the remarkably low price of 13s. 9d.

Bearing in mind the excellent value given, one must naturally not expect too much from an instrument of this kind. The resistance of the high-tension voltmeter, for example, is rather on the low side, taking as much as 30 milliamperes when applied to a 150-volt battery.

Taking the Readings

For this reason no attempt should be made to read the voltage of high-tension batteries while the set is switched on. At the same time it is only fair to say that a reading of the high-tension battery under this load will give a more accurate indication of its condition than it would with a very, high-resistance voltmeter and a negligible load.

Low-tension readings should be taken with the set switched on. The resistance of the milliammeter portion is rather higher than we care to use, and may, being in the common high-tension lead, give rise to undesirable feed-back effects even when shunted by a large condenser, as recommended by the makers.

Bearing in mind the few limitations referred to, the instrument should prove extremely useful, and the makers are to be highly commended for their enterprise in putting out such an ingenious apparatus at so low a price.

The Magnafilter

This useful wave filter has been sent to us for test and report by Messrs. Burne-Jones, Ltd., and is a neat device designed to be inserted between the aerial and the receiver for the purpose of cutting out or reducing interference from the local

station. Devices of this type are becoming increasingly important now that the London regional station is working.

In appearance the Magnafilter con-



A useful wave filter.

sists of a circular casing with a flat top carrying a control knob and indicating dial. Three sockets are fitted, one of which is designed to be connected to the aerial terminal of the set by means of a plug. The remaining two sockets, marked A_1 and A_2 , are alternative connections for the aerial, which is connected to a plug supplied. By plugging in the aerial into the socket A_1 , and by rotating the knob (after the unwanted station has been tuned-in in the usual way) a point is found where the strength of the unwanted station is at a minimum.

Practical Tests

With some aerials and adjustments the socket A_2 gives better results than A_1 , and the user must determine which is the better by actual trial.

Practical tests show that the use of the Magnafilter increases to a considerable degree the selectivity of a receiver consisting of a detector and two low-frequency stages, although the presence of the device altered the tuning readings of this receiver appreciably.

Used also with a receiver including a stage of high-frequency it was very effective, and in this case, owing to the comparatively loose coupling, the presence of the Magnafilter had far less effect on the tuning. The price of this device is 12s. 6d., both plugs and securing screws being provided. It can be recommended to all who desire to increase the selectivity of their receivers, and should find a wide field of applications.

Good points in a Good Condenser



Height of Knob and Dial together is only $1\frac{1}{8}$ in.—no more than the ordinary single Dial.

The Slow Motion Mechanism is exceptionally small in size, protruding only $\frac{1}{4}$ in.

Here is a small screw which is the simple method adopted for adjusting tension.

The Epicyclic Friction Drive employed in this D Type Slow Motion S.L.F. makes tuning an exceedingly smooth and accurate business. This instrument boasts a finish as good as can be found anywhere. It is sold in capacities from .00015 to .0005 and in prices from 12/6 to 14/-



Advertisement of JACKSON BROTHERS 72, St. Thomas' Street, London, S.E.1. Telephone: Hob 1837.

IT'S SO MUCH EASIER

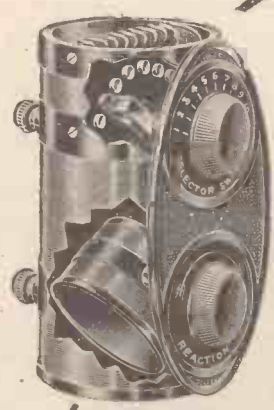

—to tune-in with a British General Aerial Tuning Unit. There is no fussing with plug-in coils. Tuning is on one dial and covers all wave-lengths between 220 and 2,000 metres. Easy two-hole fixing and connections are simple and clearly defined.

And this new model is not only better, but cheaper.

NOW ONLY
14/6

From all dealers of repute or direct from the Manufacturers.

BRITISH GENERAL
MANUFACTURING COMPANY, LTD.,
BROCKLEY WORKS, LONDON, S.E.4.

A WONDERFUL ACHIEVEMENT IN H.F. CHOKE DESIGN

WEARITE IRON-CORED



Inductance, 300,000 m/henries. Resistance, 200 ohms. Self-capacity, 3.5 mmf. Effective range, 10-2,000 metres.

Can be also supplied, centre-tapped.
PRICE 6/6

New A.C. Valve Holder, 5-pin, 1/3

Always use Wearite Components.

Write for Free Illustrated Lists.

WEARITE
COMPONENTS
WRIGHT & WEAIRE, LTD., 740, High Road, Tottenham, N.17.
Telephone: TOTTENHAM 3847/8.

For the "Silver Champion" Receiver— Smooth Reaction Control

*Provided by Lewcos
fixed Potentiometer*



FIXED POTENTIOMETER
Pat. No. 740579

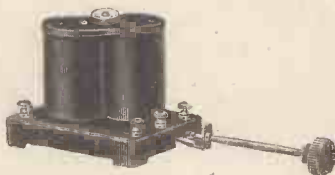

DUAL RANGE COIL
Pat. 277876

The Lewcos Fixed Potentiometer is designed to give smooth reaction control to all Radio Receivers, enabling maximum of volume to be received with an entire absence of distortion. Price 4/9 each

LEWCOS DUAL BINOCULAR COILS
The Lewcos Dual Range Binocular Coils have wave-length ranges of 235-550 m. and 1,000-2,000 m., the wave-length range being selected by a simple push-pull switch which protrudes through the receiver panel.

Ref. D.B.A. and D.B.G., Price 17/6 each.

Ganged Switching Mechanism, Ref. S.M.5, 3/-.
As specified for the "Silver Champion" Receiver described in this issue.



LEWCOS

(REGD.)

THE LONDON ELECTRIC WIRE COMPANY AND SMITHS LIMITED, CHURCH ROAD, LEYTON, LONDON, E15

INVALUABLE TO EVERY AMATEUR & CONSTRUCTOR "POPULAR WIRELESS" BLUE PRINTS of Tested Circuits

The following is a list of the "P.W." 6d. Blue Prints for Constructors in stock, showing the different circuits available:

P.W. BLUE PRINT Number.

1. DETECTOR VALVE WITH REACTION.
2. OUT OF PRINT.
3. 1-VALVE L.F. AMPLIFIER.
4. CRYSTAL DETECTOR WITH L.F. AMPLIFIER.
5. H.F. (Tuned Anode) AND CRYSTAL WITH REACTION.
6. H.F. & CRYSTAL (Transformer Coupled, without Reaction).
7. 1-VALVE REFLEX AND CRYSTAL DETECTOR (Tuned Anode).
8. 1-VALVE REFLEX AND CRYSTAL DETECTOR (Employing H.F. Transformer, without Reaction).
9. H.F. AND DETECTOR (Tuned Anode Coupling with Reaction on Anode).
10. OUT OF PRINT.
11. OUT OF PRINT.
12. OUT OF PRINT.
13. 2-VALVE REFLEX (Employing Valve Detector).
14. OUT OF PRINT.
15. OUT OF PRINT.
16. H.F. (Tuned Anode), CRYSTAL DETECTOR AND L.F. (With Switch for Last Valve).
17. CRYSTAL DETECTOR WITH TWO L.F. AMPLIFIERS (With Switching).
18. 1-VALVE REFLEX AND CRYSTAL DETECTOR, with 1-VALVE L.F. AMPLIFIER, Controlled by Switch.
19. OUT OF PRINT.
20. OUT OF PRINT.
21. THE 2-VALVE LODGE "N."
22. "THE GUARANTEED REFLEX."
23. THE 1-VALVE "CHITOS."
24. THE "SPANSACE THREE." Three-Valve Receiver employing 1 Neutralised H.F. Valve, Detector with Non-radiating Reaction Control and 1 L.F. Valve.

P.W. BLUE PRINT Number.

25. OUT OF PRINT.
26. A "STRAIGHT" 4-VALVER (H.F., Det. and 2 L.F. with Switching).
27. OUT OF PRINT.
28. A "MODERN WIRELESS" 5-VALVER (H.F., Det. and 3 L.F.).
29. AN H.T. UNIT FOR DIRECT CURRENT MAINS.
30. A REINARTZ ONE-VALVER.
31. OUT OF PRINT.
32. THE "CUBE SCREEN" THREE (H.F., Det. and L.F.).
33. A "KNIFE EDGE" CRYSTAL SET.
34. AN H.F. AND DETECTOR TWO-VALVER.
35. THE "UNIVERSAL THREE" (Det. and 2 L.F. stages resistance-coupled).
36. THE "SPANSACE FOUR" (H.F., Det. and 2 L.F.).
37. THE "LONG SHORT" CRYSTAL SET.
38. A TWO-VALVE L.F. AMPLIFIER.
39. THE "SYDNEY" TWO.
40. THE "SUPER SCREEN" THREE.
41. THIS YEAR'S "CHITOS" ONE-VALVER.
42. THE "Q AND A" THREE. A simple set (Det. and 2 L.F.).
43. THE "INEXPENSIVE FOUR."
44. THE "ECONOMY FIVE." For long-range loud-speaker work.
45. A SIMPLE A.C. H.T. UNIT.
46. THE "REGIONAL" THREE.
47. THE "WAVE-CHANGE" ONE.
48. THE "REGIONAL" CRYSTAL SET.
49. OUT OF PRINT.
50. OUT OF PRINT.
51. OUT OF PRINT.
52. OUT OF PRINT.

ALL "POPULAR WIRELESS" BLUE PRINTS 6d. EACH

All orders for these Blue Prints should be sent direct to the "Popular Wireless" Queries Department, Fleetway House, Farringdon Street, London, E.C.4, enclosing a stamped addressed envelope and a postal order for 6d. for each Blue Print ordered.

A PRACTICAL MAN'S CORNER

A special section for the set-builder, in which he will find many hints of value.

By R. W. HALLOWS, M.A.



Baffle Boards

WE see the baffle board to-day used in conjunction with loud speakers of many different types. To begin with it was employed only with the moving-coil speaker, but now its use has been extended to both the fixed-edged and freely-suspended cones driven by an electro-magnetic unit, usually of the balanced-armature type.

Any reader can very much improve the performances of an existing cone loud speaker if he possesses a good balanced-armature drive, or, again, he can construct very cheaply a loud speaker capable of wonderful volume and quality by purchasing one of the excellent driving units now on the market. I will show in a moment

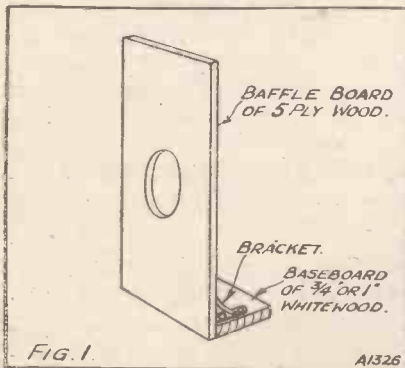

how the improvement referred to can be accomplished with little expense or trouble. But we must first consider the baffle board, which is an essential part in either case and will also be required by any who purchase or construct moving-coil units.

The purpose of the baffle board is, of course, to prevent the circulation of sound waves from the inside to the outside of the cone. The lower the note the more liable are its waves to travel round in this way, and they

may reach the outside of the cone so that they are almost or even exactly "out of step" with its vibrations. In this case they damp the vibrations, so causing the cone to respond very poorly to low notes. By using a baffle board we can insulate to a great extent the inside of the cone from its outside, so far as sound waves are concerned, and the result is that the low notes are well brought out.

Good Material

A material that I have found very good indeed for baffle boards is five-ply wood. This can be bought from almost any working carpenter or builder, and runs to about ninepence a square foot, according to the veneer.

Good veneers for loud-speaker purposes are walnut, oak or mahogany, according to the furniture of the room in which the instrument is to be used. Any of these, if previously well rubbed down with a fine grade of glasspaper, will take an excellent finish with either french polish or furniture polish applied with plenty of elbow grease. A baffle should not as a rule be less than 2 ft. square, and it is best, if space permits, to make it rather larger.

The board is mounted on a piece of 3/4-in. or 1-in. white wood of suitable breadth by means of ordinary angle brackets. It should be noted, by the way, that it is most important that the baffle board should be as non-resonating as possible.

One sometimes finds that the board shows a strong tendency to vibrate at its natural frequency when strong signals are coming through, and this causes an unpleasant form of peaking. The baffle board can be damped satisfactorily in the following way:

Stand the loud-speaker unit on a pad of folded material, and use

either felt or rubber from old inner tubes as a packing between the base-board and the edge of the baffle. Use packing of the same sort between the bracket and the two boards.

Since plywood is not the easiest material to cut cleanly, unless one has a sharp saw and a certain amount of skill in woodwork, many readers will probably find it best to let a carpenter cut out the board and make the necessary hole in the middle of it. This job, however, plus the cost of the board, will not cost more than a few shillings.

Converting Old Cones

Many loud speakers of the cone type possess excellent driving units, but cannot properly bring out all portions of the musical scale, partly because they do not make use of baffles, and partly because their cones are either too heavy or not suitably shaped. Fig. 2 shows diagrammatically how the conversion of an instrument of this kind may be carried out.

The original cone is removed, but the driving unit is left in position upon the frame of the instrument. A light wooden frame, supporting a freely-suspended cone, is now mounted

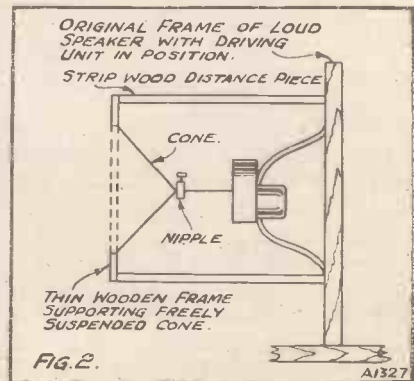

A Practical Man's Corner—continued

by means of distance pieces (which may be made of Meccano strips or of $\frac{1}{2}$ -in. strip wood) fixed by means of screws both to it and to the loud-speaker frame. Great care must be taken to see that the hole in the nipple of the cone comes in exactly the right position.

Easily Made

Before the set-screw is tightened it should move freely upon the connecting rod. Frames containing freely-suspended cones provided with suitable nipples are now obtainable at very reasonable prices. It will be found that if the converted loud speaker is tried without a baffle board its reproduction will be thin and reedy.

As soon, however, as it is placed in position on the baseboard behind the baffle an astonishing change takes place in the quality. It need hardly be said that though conversion to the freely-suspended cone and baffle board will in most cases effect a very great improvement, it cannot enable any-

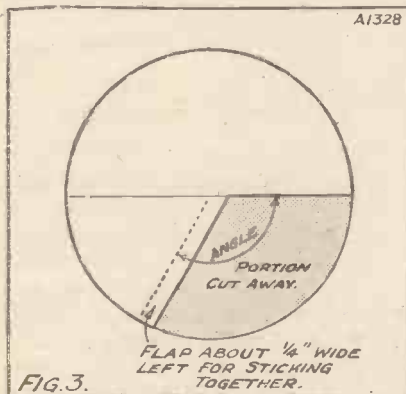

thing like perfect reproduction to be obtained unless the original driving unit is a good one.

Constructing Loud Speakers

The simplest way of constructing a balanced-armature plus freely-suspended cone loud speaker is to purchase a good driving unit and a chassis suitable for it. The chassis contains usually a metal ring to which a light cone is suspended. Attached to the ring by means of struts is a mount for the driving unit.

The unit is fixed to this, and when it has been properly centred up the set-screw in the nipple of the cone, or the nuts on the connecting rod, are tightened up. The chassis is intended in many cases to be attached

directly to the baffle board. This has the advantage of doing away with the necessity for making any kind of supporting frame, and in most cases it will be found a perfectly satisfactory arrangement.

Some units, however, produce very powerful vibrations, and it may be found that if the chassis is screwed to the baffle board unpleasant resonances result, since the baffle itself is set vibrating. If this is found to occur, a great improvement can be made by placing a ring of felt or of rubber between the chassis and the baffle.

A rubber ring, by the way, can be cut from an old hot-water bottle, or it can be made in four segments from an old motor inner tube. In some chassis the cones are rather large and are not freely suspended. Though good results are obtainable with these, I must say that most driving units of the balanced-armature type seem to work best with small light cones with the freest possible suspension.

Cones for Balanced-Armature Drives

Anyone who cares to experiment with cones will find that he is entering a very interesting field, for both the volume and the quality of reproduction are considerably affected not only by the shape, size and weight of the cone, but also by the material of which it is made. Cones for experimental purposes are very easily made in the way shown in Fig. 3. Draw on a sheet of paper a circle of the required size. Mark in a diameter and from this lay off with a protractor the angle required. Leave a flap about a quarter of an inch wide for sticking down purposes, and then cut away the portion shaded in the drawing. Stick the cone together with a very small quantity of Seccotine.

If you have two or three squares of plywood with holes of from 9 to 12 in. in diameter cut in them, you can suspend your horizontal cones in these by rings of kid, silk, or very thin rubber. The plywood frame can be mounted on to the upright supporting the drive in the way shown in Fig. 2, and the cones are secured to the connecting rods simply with a dab of ceiling wax.

It will now be of the greatest interest to compare the results obtained with cones of different diameters and different angles made from paper of

various kinds. A cone which seems to suit most units pretty well is one made from two-layer Bristol board, the diameter of the circle being about 12 in., with an angle for the cut-away portion of about 130 degrees.

Useful Mountings

Every constructor should keep by him some strips about half an inch in width cut in sheet brass or copper

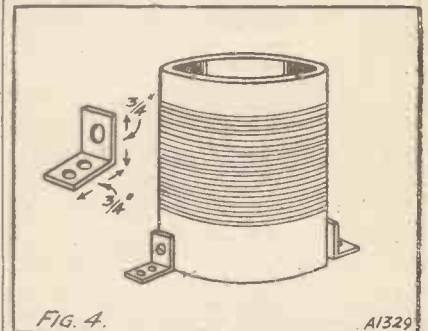

of reasonably stiff gauge. From these simple mountings for a variety of components can be made in a matter of moments. Fig. 4, for instance, shows how a solenoid coil can be fixed vertically to the baseboard by means of a couple of strip metal brackets.

To make those shown in the drawing, two pieces each $1\frac{1}{2}$ in. in length are snipped off, in each of which three holes are drilled, two for screws securing it to the baseboard and one for a 4 B.A. or 6 B.A. bolt for fixing it to the coil former. The strips are bent at right angles in the metal either with the fingers or in the vice, and the job is complete. Strip mountings can also be used for grid leaks, fixed condensers and numerous other components.

Screens and Insulation

One of the problems introduced by screening is that it enormously increases the chances of possible short-circuits, and therefore makes it desirable to take precautions against them. A case in point is that of a high-tension lead passing into a screening box.

Here is a tip which is perfectly satisfactory. Obtain some ebonite tube whose internal diameter is such that the wire which you are using will just comfortably pass through it. In the screen drill a hole which is a tight fit for the tube. Cut off a length of about half an inch and work it into the hole. If the latter is of the right size the tube will stay put.



MAGNAVOX X-CORE

You can now purchase your MAGNAVOX X-CORE dynamic speaker unit complete with a handsome genuine walnut fire-screen baffle which will harmonise with any kind of furnishing. The Belvedere Fire-Screen Baffle has been correctly designed in order to give the very best results in conjunction with either a Magnavox Standard or special model X-Core moving coil unit. The combination of a Magnavox X-Core Unit and Belvedere Baffle will enable you to secure the finest reproduction possible. What a splendid Xmas gift.



Standard Model Unit 10½" Cone Complete with Belvedere Baffle

No. 107.	110-180 volts D.C.	£12 5s. 0d.
" 109.	180-300 " D.C.	£12 5s. 0d.
" 201.	6-12 " D.C.	£12 0s. 0d.
" 401.	110 v. 50 cy. A.C.	£15 0s. 0d.
" 405.	200-240 v. 50 cy. A.C.	£15 0s. 0d.

Special Model Unit 7¾" Cone Complete with Belvedere Baffle

No. 106.	110-180 volts D.C.	£10 0s. 0d.
" 108.	180-300 " D.C.	£10 7s. 6d.
" 200.	6-12 " D.C.	£10 0s. 0d.
" 400.	110 v. 50 cy. A.C.	£12 5s. 0d.
" 404.	200-240 v. 50 cy. A.C.	£12 5s. 0d.



Write for the new 68-page "Great Voice" booklet. It tells you all about the operation of moving coil speakers, electrical gramophones, volume controls, eliminators, etc. This new enlarged edition should be in the hands of all "Wireless Constructor" readers. Send 6d. in stamps for postage.

The Rothermel Corporation, Ltd.

24, Maddox St., London, W.1

'Phone: Mayfair 0578/9

PURITY and PRECISION

Two IGRANIC favourites—use them for purity and maximum efficiency

TYPE "J"

L.F.

TRANSFORMER

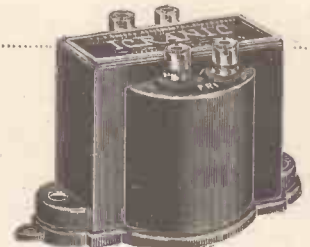

The wonderful small sized L.F. Transformer which gives performance superior to many larger and higher priced instruments. The published curves positively prove its outstanding performance. Made in two ratios, 3:1 and 6:1 and suitable for first or second L.F. stages.

PRICE 17/6 EACH



IGRANIC—ELKON METALLIC RECTIFIERS



The rectifiers definitely supersede valve rectifiers in performance and length of life. There is nothing to go wrong or deteriorate. Many thousands of hours after the normal life of a valve rectifier, the Igranic-Elkon Metal Rectifier will continue to give the same high performance as at first.

Send now for full details and prices to Dept. J.977.

IGRANIC ELECTRIC CO. LTD.
149, Queen Victoria Street, LONDON.



A moving-coil milliammeter.

FOR a long time past writers on wireless subjects—myself included—have recommended the use for battery testing purposes of a high-resistance voltmeter. As a result of a considerable amount of experimental work in connection with high-tension batteries and primary cells intended for filament heating purposes, I must admit that I have come to revise my view on the subject to some extent.

There is much to be said on both sides, but on the whole it would seem to me that the medium-resistance instrument, that is, one whose windings have on the high-voltage scale a resistance of from 5,000 to 10,000 ohms, is, taken all round, the most suitable for general wireless use.

Moving Coil and Moving Iron

Voltmeters and other measuring instruments fall into two sharply-divided classes: the moving-coil and the moving-iron types. In the moving-iron instrument the coils are fixed and a piece of soft iron moves, being influenced by the electromagnetic field produced, and carrying the pointer with it. Moving-coil instruments have permanent magnets of a fixed type with a pivoted coil placed in the field between the poles. The passage of current through the coil produces a magnetic field and causes it to move, and thus carries the pointer which is attached to it from zero to a position on the scale which denotes the amount of the current passed or the E.M.F. across the coil, according as the instrument is calibrated as an ammeter, a milliammeter or a voltmeter.

Dead-Beat Readings

The main advantage of the moving-iron instrument is that it is extraordinarily cheap to make, so that voltmeters, milliammeters, and am-

THE IDEAL METER

Should the volt meter be of high, medium, or low resistance? In interesting article on an important practical point.

By O. GERRARD.

meters can be turned out at a few shillings apiece. Its drawbacks, however, are many.

Unless certain provisions are made which bring its cost up to almost that of the moving-coil instrument it cannot give dead-beat readings. The scale is irregular, being cramped in some parts and comparatively open in others (see photograph). It is difficult to obtain a desirable degree of accuracy in cheap instruments.

Last, but not least, all cheap moving-iron voltmeters require a very considerable amount of current to give a full-scale deflection. In some this is as much as 250 milliamperes, or at least ten times as much as should be taken from a standard capacity high-tension battery even for a few seconds.

Questions of Cost

Much higher resistances can be used in the windings of moving-coil instruments, and a full-scale deflection can be obtained with a very small amount of current. It is comparatively easy to make them dead-beat

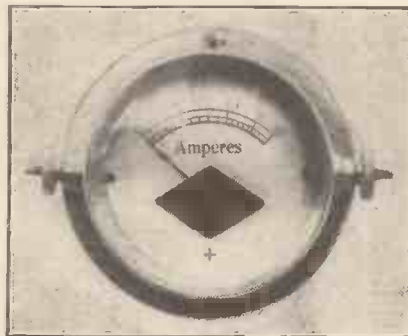

A moving-iron meter. Note the cramping of the scale towards the maximum end.

and something approaching precision is to be expected from such instruments costing from about fifteen shillings upwards. Further, the moving coil instrument, if well made, retains its accuracy for a very long time, though such is by no means the case with those of the cheap moving-iron type.



Note the long scale of this instrument.

We may put the low-resistance voltmeter out of court at once for wireless purposes except for keeping a check upon the filament battery. With either an accumulator or dry cells of large size it does not matter in the least if quite a big amount of current is taken by the voltmeter, unless, of course, the instrument is kept permanently wired across the low-tension busbars. For high-tension battery testing the choice must lie between the medium-resistance and high-resistance instrument.

Current Consumption

It has often been urged against the low-resistance voltmeter that it may give an entirely misleading account of the high-tension battery's condition. This is perfectly true, for as the battery ages its internal resistance rises and it becomes physically incapable of delivering even for a brief instant as much as 250 milliamperes of current. Hence, though the real E.M.F. may be, say, 60 volts, the battery may be unable to supply the current needed to move the pointer of the voltmeter across to so high a reading and it may show something a great deal less.

A case in point occurred to me some weeks ago when taking the voltage of a battery that was near the end of its life. The instrument normally used for the purpose has a resistance of 37,500 ohms. With this the battery showed 41.3 volts out of an original 66. As an experiment the voltage was then taken with an accurate meter whose resistance is only 3,000 ohms, and the reading obtained was a little under 6 volts!

Fallacious Readings

It must always be remembered that the voltmeter, unless it is of the electrostatic type, is a current-operated instrument and it cannot give a correct reading unless the

With Indicating
Floats.

P.G.F.5. 20 a.h.,
2-v., 11/9.
(as illustrated.)

P.G.F.7. 30 a.h.,
2-v., 13/9.

P.G.F.9. 40 a.h.,
15/9.



Non-Indicating.

P.G.5. 20 a.h.,
2-v., 9/-.

P.G.7. 30 a.h.,
2-v., 11/-.

P.G.9. 40 a.h.,
2-v., 13/-.

P.G.11. 50 a.h.,
15/-.

I know when my L.T. will run out

" My Peto & Radford P.G.F. Accumulator never discharges without warning me of its condition.

" Its three indicating floats—white, green, red—take care of that.

" When the accumulator is fully charged these rise to the top. Soon after I ' switch on ' the white float sinks to the bottom. At half discharge down goes the green, and not until the red falls is re-charging necessary."

Like every other Peto & Radford Battery the P.G.F. is

Guaranteed for 6 months

It embodies these further special features. The plates are sturdy. Paste is held in by interlocking grids. The lid is of crack-proof, acid-proof Dagenite, hermetically sealed at the edges. Terminals have acid-proof glands, and, because of their different diameters, they cannot be reversed. There is ample acid-room, and plates are held in place by glass key-ways in the box.

Send a postcard for Catalogue to :

PETO & RADFORD,
93, Great Portland Street,
London, W.1.

(Telephone . Langton. 1473)

Glasgow
Depot .
45, Clyde
Place.

P AND R

PETO & RADFORD

ACCUMULATORS

The beginning and the end in

POWER

W.R.5.

This announcement is issued by
THE NATIONAL ACCUMULATOR CO. LTD.



FOR ELIMINATOR CIRCUITS

You cannot afford to use any but the best Condenser in an eliminator circuit.

HELSEBY CONDENSERS

are made and guaranteed by a firm with 30 years' experience in condenser making, from small telephone and radio condensers to Power Condensers weighing upwards of 2 tons.

Guaranteed working voltages :-

Type M	-	-	150 volts D.C.
Type 2A	-	-	350 volts D.C.
Type 3A	-	-	450 volts D.C.
Type 4A	-	-	600 volts D.C.

All Helsby Condensers are vacuum dried and impregnated with a special non-hygroscopic material which renders them moisture proof.

If unobtainable from your dealer write to us giving his name and address.



BRITISH INSULATED CABLES LTD

PRESCOT - LANCS.

Makers of PRESCOT and HELSEBY cables

THE IDEAL METER

—continued from previous page.

battery whose E.M.F. is being measured can supply the necessary current to produce the deflection.

But if fallacious readings can be obtained with a low-resistance instrument, readings that are completely misleading from a wireless point of view may be obtained with one of high resistance. Take the case of the battery mentioned in the previous paragraph. Which instrument gave a true indication of the battery's condition as a provider of plate current? The answer is neither.

For Reliable Readings

The high-resistance instrument required only .55 milliampere for its deflection of 41.3 volts, an amount which the battery was well able to supply. To move the needle of the low-resistance instrument to the same reading, 13.77 milliamperes would have been needed, and this the battery could not give.

The average three-valve set prob-

ably uses a high-tension battery with an E.M.F. of about 90 volts, and passes 10 milliamperes of current. The combined filament-plate D.C. resistance of its valves is thus 9,000 ohms. The true "wireless" reading of the battery in question would therefore have been obtained if an instrument with a resistance of 9,000 ohms had been used.

ance voltmeter satisfactorily for testing wireless batteries is to switch on the receiving set and then to connect the voltmeter between the negative H.T. terminal or wander-plug and any positive point or points whose E.M.F. it may be desired to take. The instrument is thus placed in parallel with the receiving set, and if its own resistance is about four times that of the set, reliable readings will be obtained.

H.T. Battery Tests

For general use, though, I believe that the voltmeter with a resistance of from 5,000 ohms to 10,000 ohms is to be preferred. This should not be placed in parallel with the receiving set for taking readings, otherwise the total resistance will be too low. If, for example, both the receiving set and the voltmeter have a resistance of 9,000 ohms, that of the two in parallel will be 4,500 ohms, and the current taken from the battery will be doubled whilst the E.M.F. is being measured.

A false reading may thus be obtained for a battery that has seen a certain amount of service. The medium-resistance instrument has one very great advantage. It is not

ordinary way. An excellent idea of the battery's condition can be obtained even when it has been standing idle for some time by connecting the instrument to it and leaving it for a minute or two. There may be at first a fairly rapid falling off in the reading, for the battery will have to steady down after the pick-up due to its rest. If, however, the battery is in good condition this will not exceed from two to three per cent of the original reading.

As soon as the needle has settled down it should be watched carefully for a few moments. If it shows slight upward as well as downward movements then the battery is definitely noisy, for its current is fluctuating.

* **WHY NOT A SECOND** *
* **SET ?** *

THE fact that your present receiver gives you excellent reproduction on both local and distant stations, with all the volume you want, does not mean that you would not benefit by having a second set in the house.

In a very large number of cases the local station is near enough to get loud-speaker reproduction on a very simple set with the use of a small indoor or room aerial. If such a receiver is built and kept permanently tuned to the local station, and used in conjunction with a separate loft or other indoor aerial, the "main" set and the outdoor aerial will always be free for listening and general experimenting.

Simple Permanent Tuning

Such a receiver, to work on a very small indoor aerial with excellent quality, can be made up with an ordinary plug-in coil and tuned with an adjustable condenser such as the Formodensor or the Igranic Preset, a small indoor aerial being connected either across the whole coil, or across only a portion if the coil is of the "X" variety. The tuned circuit so formed can be connected to a detector valve using the ordinary leaky-grid condenser without any reaction, and one resistance and one transformer stage can follow it.

A still better arrangement with higher sensitivity consists in the use of a screened-grid valve coupled with a good H.F. choke to a detector using reaction and one low-frequency stage, transformer-coupled.

H. P. W.

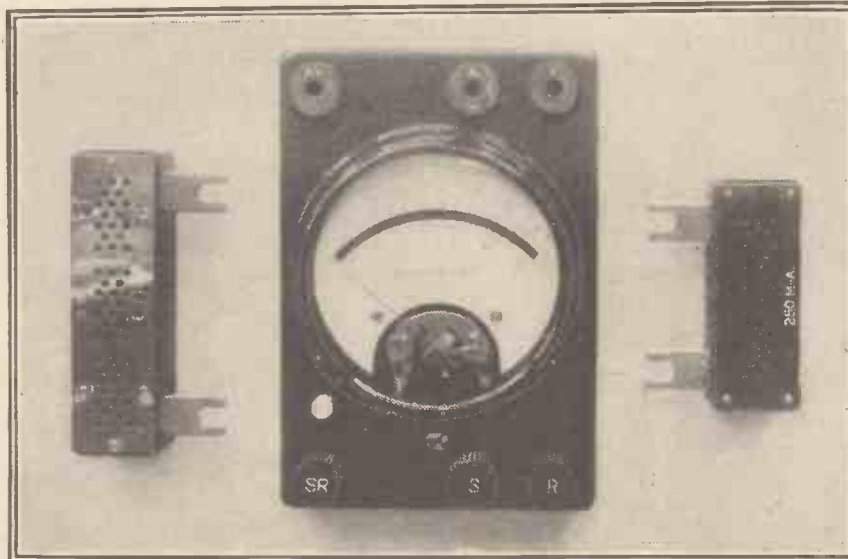

A multi-range instrument which, employing shunt resistances, can be used as a microammeter, milliammeter, ammeter, millivoltmeter, or for a voltmeter reading up to 500 volts.

The only way to use a high-resist-

necessary to place the set under load before taking a reading. The one that I use a great deal for practical work has a resistance of 5,000 ohms. It thus requires one milliampere of current for each 5 volts of the scale reading.

When testing a battery whose actual E.M.F. is 90 volts it passes 18 milliamperes, or rather more than the battery will have to supply in the

LOTUS LOGARITHMIC CONDENSERS

pass the test

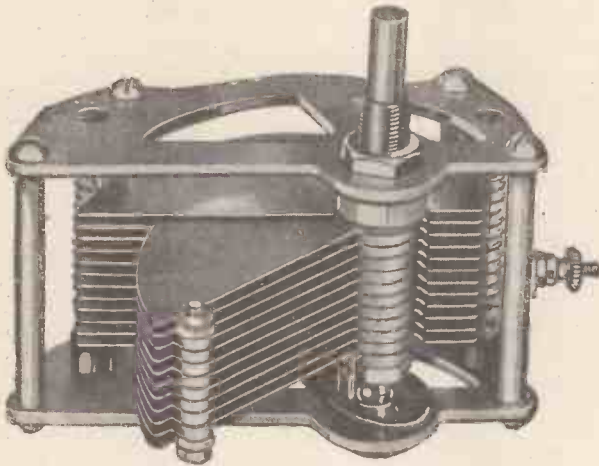

Technical writers, the press and the leading manufacturers of circuits are constantly recommending Lotus Logarithmic Condensers. Why not use these proved condensers in your set?

The ball bearings and the chemically-cleaned special brass vanes and end plates ensure a smooth, firm movement and perfect conductivity, and the ample spacing prevents any chance of short-circuiting of the vanes.

Every Lotus Component, from a variable condenser to a simple switch, is the product of experience and experiment—a masterpiece of mechanical perfection. Make a point of building your next set with Lotus Components.

- 0005 Condenser 5/9
- 00035 Condenser 5/7
- 0003 Condenser 5/6
- 00025 Condenser 5/3
- 00015 Condenser 5/-

FROM ALL RADIO DEALERS.

LOTUS

VARIABLE CONDENSERS

Made in one of the most modern radio factories in Great Britain.

You can get these Condensers fitted to the Lotus Dual and Single Drum Dials—Ask your Dealer.

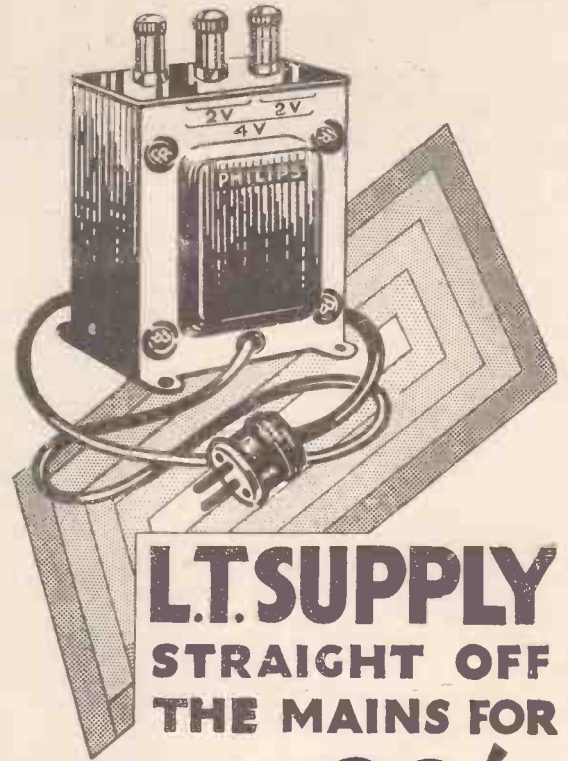

**L.T. SUPPLY
STRAIGHT OFF
THE MAINS FOR**

Fit a Philips A.C. Filament Transformer. Then you can use the new A.C. valves in your receiver and have no more trouble with L.T. accumulators. Philips A.C. Filament Transformer is low in cost and completely reliable in operation. Bring your set up to date by fitting one and using the new A.C. valves.

29'6

PHILIPS

A.C. FILAMENT TRANSFORMERS

Made by the manufacturers of the famous All-Electric Radio and Argenta Lamps.

**PHILIPS RADIO, PHILIPS HOUSE,
145, Charing Cross Road, London, W.C.2**

OUR NEWS BULLETIN

Some of the More Interesting Happenings in the Radio World this Month.

B.B.C. "Dictatorship"

MR. JOHN GALSWORTHY, the famous novelist, protested in a letter to "The Times" the other day against the dictatorship of taste which he imagines to have been established in dramatic criticism by the B.B.C.

Mr. Galsworthy suggests that one critic should not be allowed to broadcast his views about plays, for one critic can effect by radio a tremendous influence comparable to that of the dictator.

Mr. Galsworthy's Suggestion

Mr. Galsworthy suggests, instead—and it is a suggestion we rather agree with—that the B.B.C. should invite all the newspaper critics to take it in turn once a week to broadcast their views about current plays, etc. This would certainly be an interesting inno-

vation and, to begin with, it would also be amusing. Critics very seldom agree with each other. One critic might think a play good and write a eulogistic article to that effect, while another critic, writing for another paper, might condemn the play from start to finish.

Lots of Fun

Listeners who are interested in the theatre would certainly get a lot of fun out of listening to the various critics giving their individual views, and it certainly would seem a little bit fairer to the theatre if the B.B.C. were to broadcast criticisms giving the points of view of the leading critics of the day, instead of the points of view of one leading critic.

Plays to Come

The B.B.C.'s Christmas programme week will include "Cinderella"; and

"The Prisoner of Zenda," which was a successful broadcast last year, will be revived on December 17th and 20th. Shortly after Christmas the sequel to the play, "Rupert of Hentzau," will be given.

At the end of the year, Mr. Arnold Bennett's play, "Milestones," which he wrote in collaboration with Mr. Edward Knoblock, will be broadcast. The B.B.C. considers this a first-class play for the microphone.

Xmas Day Programmes

On Christmas Day there will be a variety programme of suitable music and dialogues lasting about an hour and a half, with Mr. Bransby Williams in the Christmas night programme as "Scrooge."

Sir John and Gipsy Smith

The "Daily News" recently printed an interesting story about Sir John Reith, the Director-General of the B.B.C.

Some years ago, Gipsy Smith, the well-known revivalist, was staying in the home of a Scottish preacher where there were several children. One day he took the youngest, a child of four, for a walk, when suddenly the little boy said:

(Continued on page 222.)

Magnum Auto Fuse



This indispensable little component protects your valves from accidental H.T. 'shorts' and will save you many pounds. It is simply connected in the H.T. negative lead.

Specified in many popular circuits, including the "Help Yourself" Magazine Set.

Price 1s. 3d.

Magnum Dissolver

A Dual Volume Control for controlling two sources of inputs such as Radio and Gramophone or two different gramophones. Fading one to zero and bringing the other to maximum volume.



Specified for the "Exhibition Five" and many other modern circuits.

Price 10s.

Build the

"SILVER CHAMPION"

	£	s.	d.
1 Oak Cabinet	1	0	0
1 Panel, ready drilled	0	7	0
1 Universal Chassis, fitted with 3 Valve-holders	0	10	6
1 Cydon Junior Dual Condenser	1	10	0
1 Utility Differential Condenser	0	6	6
1 Lewcos Dual Range Coil D.B.A.	0	17	6
1 Lewcos Dual Range Coil D.B.G.	0	17	6
1 Lissen Super L.F. Transformer	0	19	0
1 Igranic H.F. Choke	0	5	0
1 Igranic C.C. Output Unit	1	1	6
1 Aluminium Screen	0	2	3
1 Lewcos Potentiometer and 2-meg. Leak	0	5	9
1 T.C.C. 2-mfd. Condenser	0	3	10
1 T.C.C. 1-mfd. Condenser	0	2	10
1 Anode Resistance, 25,000 ohms, and Clips	0	2	6
1 Wearite Resistance, 600 ohms	0	1	6
1 Lissen 10003 Condenser	0	1	0
1 On-off Switch	0	1	6
1 Belling-Lee Terminals	0	5	6
1 Glazite	0	1	4
	£8-	2	6

Any of the above parts supplied separately as required.
Set of valves for above £2 5 6
The "Silver Champion," ready wired and tested, including Cabinet, Coils, Valves and Royalty £13 10 0
Catalogue and Lists free on request.

BURNE-JONES & CO. LTD.,
MAGNUM HOUSE
TELEPHONE: HOP 6257
296, BOROUGH HIGH ST.
LONDON. S.E.1



Magnum

Short-Wave Converter

This Unit used with the "Silver Champion" or other type of set, including Super-Heterodynes, enables you to enjoy short-wave reception from 20 metres upwards.

Price £4 10s. 0d.

Descriptive pamphlet containing a list of Short-Wave Stations free on request. All apparatus described in "Wireless Constructor" can be supplied in kit form or ready wired and tested.

Use



“MAJOR” Cabinet

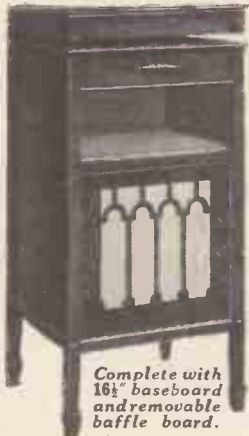

Complete with 16 1/2" baseboard and removable baffle board.

FOR YOUR
RADIO-GRAM

Especially suitable for
**MULLARD ORGOLA,
OSRAM MUSIC
MAGNET,**

and for panels up to 18" x 8".
Loud Speaker compartment is
18" x 18" x 16 1/2"

OAK - - - £7:10:0

MAHOGANY - £7:15:0

Call and see full range of "Camco"
cabinets at new London showrooms.

CARRINGTON MANUFACTURING CO., Ltd.
New Showrooms, 24, Hatton Garden, London, E.C.1.

© 2930.

Fighting Talk



If you're a drifter you won't read far in this advertisement. If you're not you will want to know who is responsible for your not getting ahead faster. We'll tell you. It's YOU! The man who won't be beaten, can't be beaten. If you're a drifter you'll always wish for success, but never do anything worth while to win it. The earth is cluttered with that kind of man.

If you're a fighter you will set about doing something. You'll get the special training that will qualify you for a better position and better pay.

In spare time, at home, you can acquire the training you need through the International Correspondence Schools. Thousands of other men have lifted themselves out of the rut and into well-paid, responsible positions by I.C.S. study. The time for action is this minute.

We have nearly 400 Standard Courses, including many in the following subjects:

- | | | |
|--|-----------------------------|-----------------------|
| Accountancy and Book-keeping | Engineering, all branches | Salesmanship |
| Advertising | French, Spanish and Italian | Scientific Management |
| Architecture and Building | General Education | Shorthand-Typewriting |
| Chemistry | Plumbing | Showcard Writing |
| Commercial Art | Poster Designing | Textiles |
| Commercial Training | Railway Equipment | Window Dressing |
| Draughtsmanship | and Running | Wireless Engineering |
| ALL EXAMINATIONS—Commercial, Technical, Matriculation and Civil Service. | | Woodworking |

Write to-day for free Booklet containing full information regarding the Courses in which you are most interested.

International Correspondence Schools, Ltd.,
172, International Buildings, Kingsway, London, W.C.2

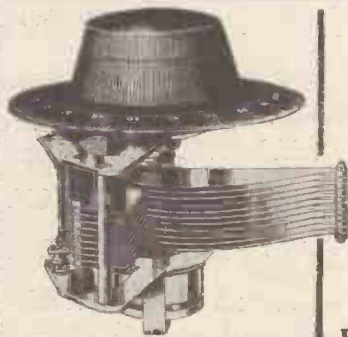

K.C. CONDENSER

With knob, dial and slow motion device, '0003 or '0005 .. 12/-
Without knob, dial or slow-motion device, '0003 or '0005 .. 8/-

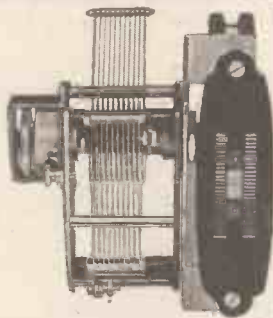

K.C. DRUM CONTROL CONDENSERS

With Drum Control and slow-motion device, '0003 or '0005 .. 15/6
Triple K.C., each condenser '0003 or '0005 .. 38/6
Triple K.C. Combinations of '0003 and '0005 .. 40/-

If unobtainable from your dealer, write direct to us giving his name and address



DUBILIER CONDENSERS

Dubilier Condenser Co. (1925), Ltd.,
Ducon Works, Victoria Road, N. Acton,
London, W.3. BC. 241/V



MIDGET CONDENSER

A small variable condenser for panel mounting, '00005, '0001 or '0002 .. 5/6

Something REALLY NEW This Time!

VIVID! LIVELY! TOPICAL!

THIS AND THAT tells you each week just what you want to know, gives you out-of-the-way information on almost every subject under the sun, brightly, clearly and entertainingly with a wealth of pictures. Familiar things are treated from absolutely new and startling points of view. THIS AND THAT is for men and women of all ages and all classes. It is unique—a bright, lively paper for the million.

What Do You Want to Know?

YOU'LL FIND IT IN

This and That

Every Thursday, 2d.

OUR NEWS BULLETIN

—continued from page 220

“Dipthy, Nanna always takes me to the cookie shop.”

“Very well,” said Gipsy Smith. “We’ll go in.”

According to the story, the child chose the stickiest cake he could find, and then turned to go out of the shop.

Gipsy Smith called:

“Hi, where’s the money for it?”

The little boy (now forty and over six feet high) looked up and said solemnly:

“Why, Dipthy, in your pocket!”

The child is now Director-General of the B.B.C.

Killing Criticism

There was a curious case in Budapest the other day of a machinist who was stabbed to death by a neighbour because he was so enraged that the machinist refused to turn off his wireless loud speaker. It appears that the unfortunate man kept his set tuned-in at all hours of the night, despite the Hungarian law which insists that loud speakers must not be used after 10 o’clock at night.

The crime committed, the murderer

fled, but not before he had completely smashed the offending wireless set.

Winnie-the-Pooh?

Mr. A. A. Milne, the famous author, recently wrote to “The Times” a letter in which he gave vent to the view that “if the B.B.C. wishes to be of economic service to its public, let it choose for its critic (dramatic critic) the most ordinary, undistinguished man it can find, a man who can say, not only truly, but contentedly, what I think the common man thinks.”

The B.B.C.’s Critic

Mr. Milne also went on to say that “if the B.B.C. wishes to be of æsthetic service to the public, then let it keep its present critic, and let him, as soon as possible after the production of a new play, implore his listeners, with tears in his voice, to go and see the play, so that, at the end of its run, they will be able to appreciate at its true value the criticism of it which he will then give.

“The commercial manager,” concludes Mr. Milne, “will not object.”

Robert’s Radio

It is understood that plans are now being considered for the installation

of radio at all of the two hundred police stations in the Metropolitan area.

It is anticipated that within a few months there will probably be a special wireless department of the police force.

S.O.S. for C.I.D.

The Flying Squad vans have made many successful wireless experiments in conjunction with the C.I.D., and radio communication is constantly used between Scotland Yard and the vans on patrol duty.

It is reckoned that the cost of equipping the London stations with wireless will amount to anything between £2,000 and £3,000.

“Still Going Strong”

A report from Washington states that the claim is made that television in the home and the theatre will soon be possible. An engineer of the Westinghouse Electric Company is reported to have invented a crystal globe which receives moving pictures transmitted by radio, and flashes them upon a screen.

There have been so many reports that television is absolutely ready for the home, and all the rest of it, that

(Continued on page 224.)

WHAT IS IT?



- that** TURNS HUGE LOSSES INTO GAINS.
- that** INCREASES OVERALL AMPLIFICATION.
- that** PUTS IN TRUE BASS WITHOUT BOOM.
- that** CAUSES AN APPRECIABLE STRENGTHENING OF THE HIGHER NOTES.
- that** IMPROVES REPRODUCTION BEYOND BELIEF OVER WHOLE MUSICAL SCALE.
- that** RESULTS IN A BRILLIANCE OF REPRODUCTION NEVER BEFORE OBTAINED.

THE NOVOTONE COMPENSATOR

This marvellous invention of Dr. N. McLachlan makes good electrically (without the use of extra valves or apparatus) all the huge losses which are inherent in records, pick-ups and amplifier, and thereby makes possible for the first time realistic reproduction of records.

EVERY USER OF AN ELECTRICAL PICK-UP SHOULD ASK HIS DEALER TO DEMONSTRATE THE NOVOTONE

GAMBRELL RADIO, LTD.,
6, BUCKINGHAM STREET, STRAND, LONDON, W.C.2.

*A car costs 2/6 per hour to run
 A wireless set costs less than
 1^d per hour with*



EVER READY
 BRITAIN'S BEST BATTERIES

EVER READY Batteries provide clear, strong power that makes wireless reception a delight. They were the first batteries made for wireless, and are still unapproached for consistent quality and guaranteed service.

OUR NEWS BULLETIN

—continued from page 222

perhaps we had better wait a little more for further details before we start to get ready for real television in the home.

Brookman's Second Wave

We understand that the second wave transmission from Brookman's Park will not take place until early in February, 1930. 5 GB will then revert to its role of Midland Regional transmitter.

Telling Figures

Figures given in the current issue of the B.B.C. Year Book show that in March, 1927, there were 2,269,595 licences in force; in March, 1928, 2,482,930; and in March, 1929, 2,731,968.

It is estimated that 6.27 per cent of the population are holders of wireless licences, and if we allow three listeners for each licence, it would seem that the listening public to-day is enormous.

How We Compare

In the United States, where it is reckoned that eleven million sets are in use, it is calculated that a percentage

of 10.4 set-owners of the total population is a reasonably accurate figure. In Denmark and Sweden the percentage is 7.7 and 6.7 respectively, in Austria 5.4 per cent, followed by Australia 4.98 per cent, and Germany with 4.5 per cent,

* **UNCLE SAM'S RADIO** *
* *****

WE have just been examining some statistics prepared by an American journal on the wireless exhibition held recently in Chicago. From it we note that out of models shown 45 per cent used screened-grid valves and 55 per cent do not. This is a very high proportion seeing that it is the first year that the A.C. screened-grid valve has been available to set manufacturers in the United States.

Another very interesting point is that out of 202 sets, 199 used push-pull in the output. Quite apart from the power-handling capabilities of the push-pull scheme, it has the great advantage that the filament ripple set up by A.C. heating balances out in the two valves and gives much quieter operation. (You will see the reason in a push-pull diagram.)

Ninety-seven per cent of the models shown used moving-coil loud speakers.

So far as the number of valves is concerned, 10 per cent used six valves, 23 per cent seven valves, 40 per cent eight valves, and 27 per cent nine valves.
H. P. W.

HAVE YOU SEEN
THE XMAS
MODERN WIRELESS?
A SPECIAL DOUBLE NUMBER
that no one should miss.
Make Sure of Your Copy.
On Sale Everywhere :: Price 1/6
Specially Enlarged Christmas Number

"Listeners All" will Regret

Listeners will learn with regret that the Tuesday evening broadcasts by Sir Walford Davies will come to a stop at the end of the year. Sir Walford has conducted the feature for the last four years without an intermission, and he now feels that a temporary change is desirable.

It is good news, however, to learn that Sir Walford will continue his school broadcasts.



**POLAR No. 3
CONDENSERS**

To the majority, Polar No. 3 Condensers need no introduction, but for the benefit of those who have not had the pleasure of using them, here are some details.

They are constructed entirely of chemically cleaned hard brass which ensures perfect electrical contact at all points.

They are robustly built throughout.

Their smooth yet precise action makes them almost equivalent to a Slow Motion Condenser.

Their silent movement (which can be still further enhanced by the use of Phosphor Bronze Ball-Bearings) makes them adaptable for short-wave working.

There are many other points about these condensers which make them superior. Write for the Polar Catalogue (C) and learn more about them. Also ask your dealer to show you a

POLAR No. 3 CONDENSER



PRICES OF THE POLAR No. 3
(without Knob-Dial).

·0005 5/9 ·00035 5/7
·0003 - 5/6

The Dial illustrated matches that used on the Polar "Ideal." Dial 1/- extra.
Phosphor Bronze Balls 3d. extra.

WINGROVE & ROGERS, LTD., 188-189, STRAND, W.C.2

The Sets for RESULTS

“Best Way” TITAN SETS

- The Titan One
- The Titan Two
- The Titan Three
- The Titan Four

are profusely illustrated with full diagrams and instructions for building in the
“BEST WAY” BOOK No. 350.

The reader has the choice of anything from a simple one-valver to a de-luxe 4-valve set with built-in wave-trap and wonderful long-distance loud-speaker performance



6^{D.}
Everywhere.



6^{D.}
Everywhere.

“Best Way” RADIO-GRAMPHONE SETS

“BEST WAY” BOOK No. 349.

“BETTER THAN RADIO”

is the verdict of large numbers of radio-gramophone users.

In order to get the best out of your gramophone records—and an amazingly fine “best” it is, too—you must use an electrical reproducer.

This is not difficult, and the “Best Way” Radio-Gramophone book tells you how to use your present set, your present gramophone, and your present loud speaker as an up-to-date electric gramophone.

The Best Way Radio-Gramophone Book is a mine of practical information on all phases of this latest branch of radio, and also includes full directions for building an up-to-date radio-gram. receiver, specially designed for the home constructor. It is amazingly simple to operate, and enables you to

CHOOSE YOUR OWN PROGRAMME.

You can easily build them

THE "SILVER CHAMPION"

—continued from page 174

previously placed a soldering lug. Terminal No. 2 of the second binocular coil is also connected to L.T.— in the same way, and the moving plates of the reaction condenser are connected to the chassis (and therefore L.T.—) by a wire which is soldered to a lug placed underneath one of the securing screws which holds the 2-mfd. condenser in position.

The "Earthed" Leads

Another case of such attachment is the L.T.— terminal of the screened-grid valve, which has a wire soldered to a lug secured underneath one of the screws holding the bracket to the chassis. On the underside are several cases where L.T.— connections are made by wires soldered to the ends of the nearest convenient securing screws. Soldered connections are made to the ends of these screws for the simple reason that we cannot solder directly to the aluminium. Remember this method of connection, otherwise you may be puzzled and wonder why some wires seem to go

through the chassis and actually do not!

In the laboratory model shown all connections are made with black Glazite, as this makes the few wires showing above the chassis quite unobtrusive. As, however, the holes drilled through the chassis have somewhat sharp edges, it is not wise to rely solely upon the Glazite insulation, and in all cases where a wire passes through a hole in the chassis a short length of thick Systoflex (large enough to slide over the Glazite wire) is fitted. A yard of this thick Systoflex will be found to be ample for the whole of the set, and can be ordered, to save time, with the other components.

Check the Connections

Two of the four leads going to the choke-capacity output device should be made of flexible wire to enable you to find the best connection for your particular valve and loud speaker. If you intend to use the set permanently with a particular loud speaker and output valve then you can, if you care, subsequently make these connections with rigid wire, but if, like most experimenters, you want to try different loud speakers and valves, then leave the leads of flex.

After all wiring-up is finished carefully go over all the nuts of the securing screws to see that they are quite tight. The vibration caused by moving the set about and turning it over on end may have loosened some of them, and in any case you will find it desirable after you have tightened the nuts of a particular securing screw to run on a second nut so as to lock it.

Valves and Accessories

And now as to valves and accessories. The first must, of course, be a screened-grid valve, and can be either the two-, four-, or six-volt variety. The second valve (that nearest the panel) can be either an L.F. and detector valve or one of the kind which we used to call an H.F. valve, but is now generally termed by the makers an "H.L."

This is particularly the case when we have a high-grade low-frequency transformer following. If, however, one of the less-expensive varieties of transformer is used, then often better quality is not quite so good magnification is obtained by using a valve of lower impedance, such as a detector and L.F. type previously mentioned.

The output valve can be either a

(Continued on page 228).

66 Volts
7/9

DUBILIER
H.T. BATTERY

Fit this long-life Battery — it will improve the quality of your reception

SUPERIOR (Single Capacity)	SUPREME (Triple Capacity)
9 volts — 2/6	60 volts — 13/6
63 " (with G.B. Tapp. Pcs) — 7/11	63 " — 14/6
66 " — 11/9	100 " — 22/—
99 " — 12/9	
108 " — 12/9	

Ask your dealer for a copy of "A Bit about a Battery."

DUBILIER
H.T. BATTERIES
BRITISH MADE
DUBILIER CONDENSER CO. (1925), LTD.
Ducon Works, Victoria Road, North Acton, London, W.3. B.14

MINIMUM LOSS

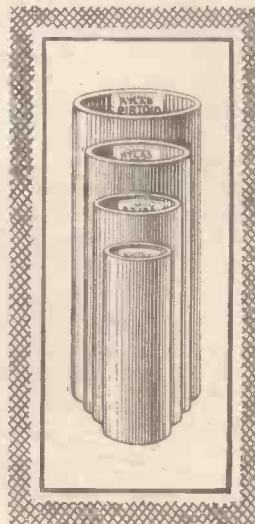

Hard and tough, almost unbreakable, "Atlas" Pirtoid Tubing is a unique and far superior material for High Frequency Transformers, Aerial Coils, etc. Drills and taps like hard wood or bone. "Atlas" Pirtoid Tubing can be obtained in any usual diameter, thickness of wall and length.

CLARKE'S
"ATLAS"
PIRTOID
TUBING

Write for full particulars to the Sole Makers:
H. CLARKE & CO. (M/CR) Ltd.,
Atlas Works
Old Trafford, Manchester.

Ideal Gift Books for Boys and Girls

Easy to Pack—Cheap to Post—Certain to Please

There is nothing that will please children better than one of these splendid gift books. They are packed with the jolliest stories, pictures, puzzles, riddles, games and entertaining features. Most of them contain beautiful coloured plates and many pages are printed in colour. These books are strongly bound in brightly coloured covers and are cheaper than the average toy and more durable. If you want a present for a boy or for a girl you should buy one of these bumper books. Each will give pleasure for many months.

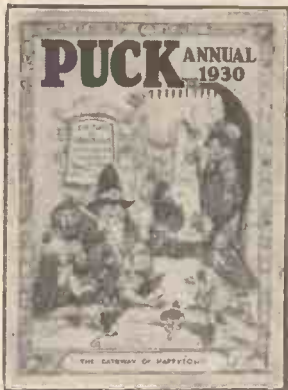

For children of all ages. Thrilling and amusing stories and scores of fine pictures **6/-** Net.



Adventure! Athletics! School! Fine stories and articles about schoolboy's life crowd its pages. **6/-** Net.



Amusing pictures and stories. A feast of entertainment for the little ones. **6/-** Net.



Pages of pictures of Tiger Tim and the popular Bruin Boys. Adventure stories and fairy tales, etc. **6/-** Net.

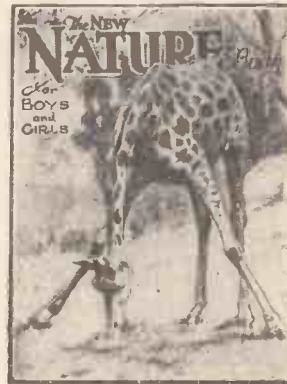

Deals with bird and animal life. Hundreds of wonderful photographs from life. **6/-** Net.

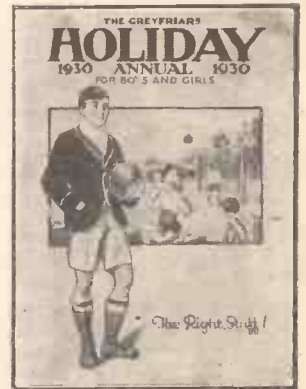

A book for the manly boy. True to life stories and school and sport, also thrilling adventure tales. **6/-** Net.

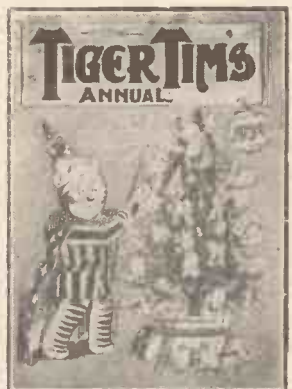

Tiger Tim's own book. Stories and pictures of the Bruin Boys. For children up to 12 years. **6/-** Net.



Nearly three hundred pages of entertaining stories and articles that will delight every schoolgirl. **6/-** Net.



250,000 words of splendid stories and articles. For children of school age. **5/-** Net.



An ideal book for boys. Stirring tales of adventure on land and sea, in the air, and among the Redskins. **2/6** Net.



For boys and girls up to 12 years old. Charming adventure, fairy animal, and humorous stories. Colour plates. **5/-** Net.

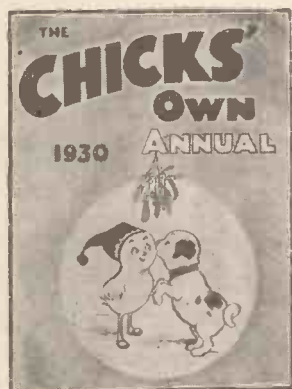

An entertaining book for little children just beginning to read. Large clear type. Pictures to paint. **3/6** Net.



New this year. A fascinating all-story gift book that will delight every girl. Illustrated by the best artists. **2/6** Net.



832 pages of reading. 12 colour plates. Thrilling stories, splendid articles, and pages of photographs. **12/6** Net.

22 Great Stories

Appear in the Enlarged Christmas "ARGOSY"

Despite the manifest popularity of the short story in this age, really great stories are difficult to find. The ARGOSY MAGAZINE has set up a new standard for fiction by finding stories that stand out of the rut. It publishes only the best that has been written by the masters of the short story. Here are some of the contributors to the enlarged CHRISTMAS issue:

- I. A. R. WYLIE
- BARONESS von HUTTEN
- A. QUILLER-COUCH
- MORLEY ROBERTS
- GILBERT PARKER
- SIR WILLIAM WATSON
- RICHARD CONNELL
- NEWMAN FLOWER
- J. J. BELL

and many others including

W. W. JACOBS

The Master of English Humour

who contributes a new comedy entitled "A DISTANT RELATIVE." Don't miss this enlarged Christmas-Number of

The ARGOSY
MAGAZINE

For January. Now on Sale 1/6

THE "SILVER CHAMPION"

—continued from page 226

power or a super-power. The former is cheaper and more economical to run with regard to high-tension, while the latter allows a louder signal to be obtained without distortion, but costs a little more and uses a good deal more high-tension.

Many beginners are under the impression that the super-power valve will itself give them louder signals, and are disappointed to find that when they substitute one of this kind for a power valve, signals are actually slightly weaker. This is due to the fact that the magnification given by the super-power valve is rarely as great as that given by a power valve, but whereas with the latter type a loud

bias. In the present receiver, which is more of a de luxe model, provision is made for external grid bias, as with a super-power valve we may require 16 or 18 volts grid bias, necessitating a larger battery than can conveniently be placed underneath the chassis.

With regard to the filament accumulator voltage, modern 2-volt valves are extraordinarily good and efficient, although the modern 6-volt valves are somewhat superior, when the last ounce is required from this set.

However, the difference between the 2- and the 6-volt types is far less than was the case a year or two ago, and many experienced listeners do not consider that the additional amplification obtained with the 6-volt valves justifies the higher first-cost of the accumulator and the higher costs of periodic recharging.

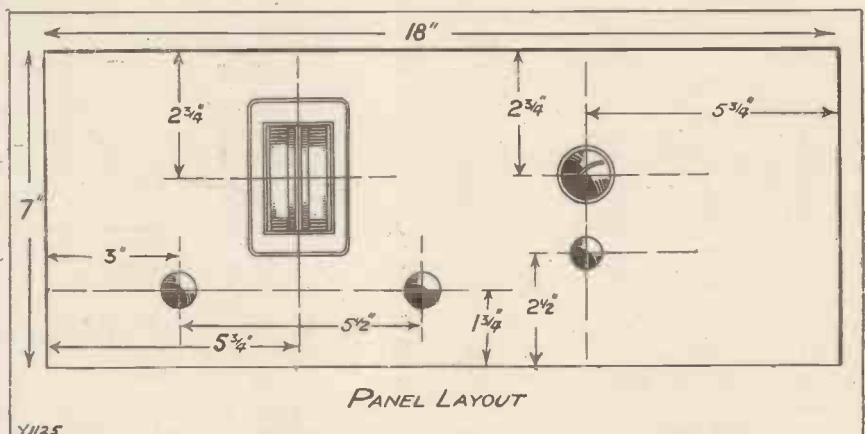

signal causes overloading and distortion, with the super-power valve overloading can only come with the strongest of signals.

Valve overloading is often the cause of faulty reproduction, attributed to overloading the loud speaker.

The Current Consumption

One is thus led to recommend the use of a power valve in the output or last socket when economy of running is important, and a super-power valve where the user does not mind the additional expense of a larger high-tension battery, or when he already has a high-tension mains unit. To give you an idea of the current consumption of the set in both cases it may be said that with the average power valve in the output and 120 volts H.T. the total consumption will be about 10 milliamperes, and with a super-power valve about 20 milliamperes.

In the "Chassis" Three provision was made for grid bias underneath the chassis, as it was thought the majority of users would use a power valve requiring not more than 9 volts grid

The H.T. Voltages

In view of the wide differences between the electrical characteristics of the screened-grid valves now sold we have reluctantly abandoned the scheme of using one high-tension throughout the receiver, dropping down the maximum voltage to that required for the screened-grid valve by means of a series resistance. While the method we have adopted in a number of WIRELESS CONSTRUCTOR sets of reducing the voltage down to that suitable by means of resistances is perfectly sound, and is always used in our laboratory sets, where we have facilities for measuring the screened-grid current, the fact that no one resistance can be specified to work satisfactorily with all valves, and that appreciable variations are often found between individual specimens, makes it impracticable to give values of resistances to suit all the different varieties.

Those readers, however, who have meters sufficiently sensitive to measure the screened-grid current can still

(Continued on page 229.)

THE "SILVER CHAMPION"

—continued from page 228

continue to adopt the "one-voltage" scheme if they so desire, in which case the 600-ohm resistance now shown in series with the screening grid should be replaced by a resistance calculated in the following manner.

With the valve connected in circuit and the correct filament and plate voltages applied, set the voltage of the screening grid at the figure recommended by the makers. Now break this lead and insert a sensitive and accurate milliammeter (preferably one of those reading with a 0 to 5 milliamp. scale). Note the current passing.

Calculating the Resistance

Nowadays this may be anything from a third of a milliampere to two and a half milliamperes, according to the make of valve. Assuming that your battery voltage is 150 and the recommended screened-grid voltage is 80, our problem is to reduce the voltage from 150 to 80, or otherwise to drop 70 volts. We must now calculate by Ohm's law what resistance is necessary to drop or lose 70 volts when passing the screened-grid current. As a simple example, let us suppose that the screened-grid current ascertained as previously indicated is half an ampere.

According to Ohm's law, the resistance in ohms equals current pressure in volts divided by current in amperes. We know the voltage, namely, 70, and we know the current, namely, .0005 ampere; 70 divided by .0005 equals 140,000, and thus 140,000 ohms is the resistance required.

Not Critical

Actually the voltage is not critical, and 150,000 or 200,000 ohms would probably be equally good.

In the case of a more extravagant valve, such as one taking 2 milliamperes as screened-grid current, the resistance would be a quarter of this, namely, 35,000 ohms; and if our high-tension voltage is 120, and not 150, and we have only to drop 40 volts, our calculation will be altered correspondingly.

In the "Silver Champion" we have, however, provided a terminal marked "screen" which is to be attached to a tapping on the high-tension battery or mains unit corresponding with that voltage recommended by the makers. The small 600-ohm resistance and the 1-mfd. condenser

(Continued on page 230.)

*The Better your Controls
the Better your Radio!*

Just as a good mechanic can do better work with fine tools, so can a radio receiver perform at its best when reliable parts are used. **ELECTRAD** Voltage Controls for every radio purpose have a world-wide reputation for superior quality. Use them and be **SURE**.

SUPER-TONATROL

5-Watt Volume Control



U.S. Pats. 1034103—1034104 and Pats. Pending.

Electrad's remarkable development for regulating volume in high-powered receivers. Different in principle, and LASTING beyond all expectations. Resistance element fused to enamelled metal base. Pure silver floating contact. Riveted metal cover. Bakelite insulation. Amazing smoothness that actually improves with use without change in resistance value. Seven resistance ranges.

12/6 and 15/- each.

ROYALTY

Variable High Resistances

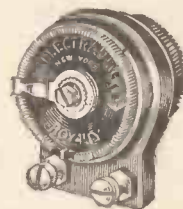

U.S. Pat. No. 1593658—1034103—1034104 and Pats. Pending.

The standard high resistance of dependable accuracy. Carefully made with the best insulating material and free from harmful inductance and capacity effects. Entire range of resistance covered with one turn of the knob.

A type for every purpose, including potentiometer.

12 resistance ranges. 7/- and 8/3 each.

U.S. Pat. No. 1676869 and Pats. Pending.

ADJUSTABLE SLIDING CLIP

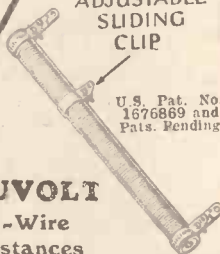

U.S. Pat. No. 1676869 and Pats. Pending.

TRUVOLT All-Wire Resistances

Truvolt Fixed Resistances may be adjusted to desired value by the sliding clip contact—an exclusive **Electrad** feature. **TRUVOLTS** are uniquely wound. They are accurate and they keep cool. Truvolt Variables simplify Eliminator Construction, by making difficult calculations unnecessary. Made in all desirable resistance values and current ratings.

COUPON.

The Rothermel Corporation, Ltd. (Dept. G.W.), 24 26, Maddox Street, Regent Street, London.

Please send **ELECTRAD** Voltage Control data to:

Name.....

Address.....

ELECTRAD

THE **ROTHERMEL CORPORATION LTD.**
24-26, Maddox Street, Regent Street, London.

The Air Chrome "Breakaway" from the conventional

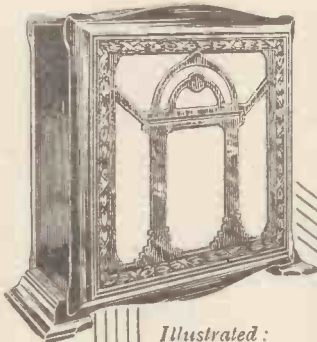

Illustrated:
Model U 14
£5:5:0



Gives —

★ a uniform frequency response from 60 to 10,000 cycles—an amazingly faithful performance unequalled by any other type of speaker, *Popular Wireless* says: "The 'Air Chrome' has qualities that have, hitherto, been almost peculiar to the moving-coil class. Bass notes come through excellently, while the harmonic range is so well embraced that high notes retain their individuality. Speech is crisp and natural." Remember that "Air Chrome" is the magic password to really natural radio.

CHASSIS PRICES:

Type L.	12" x 10" x 31"	42/-
Type K.	14" x 14" x 51"	52/-
Type F.	18" x 23" x 51"	84/-
Type J.	24" x 24" x 61"	105/-

In Attractive Cabinets, from £3 19s. 6d.
Stocked by all Radio and Music Dealers
from Lond's End to John o' Groat's.

ULTRA AIR CHROME

SPEAKER Pat. No. 295,025

Ultra Electric Limited, 661-663, Harrow Rd., London, N.W. 10, Tele.: Willesden 1616

Baldry Ad.

THE "SILVER CHAMPION"

—continued from page 229

are for decoupling purposes only, i.e. for the purpose of preventing undesirable feed-back effects getting on to the screening grid and spoiling reception.

As the screened-grid valve requires no neutralising, there are no special preliminary adjustments in the set; but before switching on it is desirable to set the reaction condenser at zero. In the case of the differential reaction condenser this is when the knob is so turned that the moving plates are completely meshed with those of the fixed plates on the left-hand side (looking down on the set from the front).

Tuning-In

Now place the drum condensers, both at approximately the same reading, about half-way up the scale, pull out the wave-change switches, connect up the batteries (making sure that you have correct grid bias for the output valve used), and switch on. With one thumb you can turn both tuning condensers, and you will soon pick up your nearest station. Fine tuning is done by moving the two condensers separately, and strength can be increased by turning the reaction knob to the right.

While it is advisable not to make the set oscillate, as this will cause distortion, it should be remembered that a set of this kind, using a screened-grid valve preceding the detector, will not cause interference with the neighbours when the set is made to oscillate, as the aerial circuit itself does not oscillate.

When both wave-change switches are pushed in you will be on the long-wave adjustment, and you should be able to obtain a number of stations on both bands of exceptional quality and purity. Before, however, settling down to use the set for general work, it is advisable to find the best arrangement of the terminals of the output-choke device.

Output Connections

Full details of the various connections for this are given on a leaflet supplied by the makers with the choke-capacity output, and the connections shown in the actual wiring diagram are those to which we settled down with our own valves and loud speaker so as to give the best quality. This arrangement may

be tried first, but by all means try others before finally deciding.

Using a Pentode

Those readers who desire to use a pentode valve in the output, instead of a super-power valve, can substitute a pentode output transformer for the choke-capacity output unit, all connections up to the grid of the output valve remaining as before. The lead which comes up on the left-hand of the choke-capacity unit nearest the low-frequency transformer will then be taken to one of the input terminals of the pentode output

SPECIAL NOTICE

Special Sets are described
and
Special articles written
by
Special authors in
the
Special Double Xmas Number

of
MODERN WIRELESS

which provides
a Very Special Christmas Treat.

Get a Copy NOW.
On Sale Everywhere.

Price - - - 1/6

transformer, while the lead on the right of the choke-capacity unit nearest the transformer will be taken to the other input terminal.

The lead taken to terminal No. 5 of the choke-capacity unit will go to one output terminal of the output transformer, while the lead which now goes to terminal No. 7 can be taken to the chassis via the securing screw, as is at present done with the choke-capacity unit. A flexible lead from the side terminal of the pentode should then be taken to the H.T. positive terminal (input side) of the pentode transformer.

* **IN THE STATES** *
* **Some Interesting Facts.** *

In America the sets are not so much designed for power as for selectivity.

Many tuned stages are required for selectivity if good quality is to accompany it.

Reaction is anathema to the standardised set manufacturer.

The MIRACLE

World's Wonder Sets STATIONS ROLL IN

Sold at FACTORY PRICES, complete with Cossor Valves, ready for listening-in, with Grand Model Cabinet Cone or Horn-type Loud Speaker. Yours for 5/- deposit. Nothing more to pay for a month. Purchase completed by easy payments.

£2 GRAMOPHONE Electric Pick-up

FREE to all who write NOW for Free Illustrated Art List and order WITHIN 10 DAYS.



SECURES a 2,3 or 4 VALVE SET

Special offer of SCREENED GRID & ALL ELECTRIC MAINS SETS.



CONE or Horn-type LOUD SPEAKER

Write for Lists

WORLD'S WIRELESS STORES, Wallington, Surrey.

SOLVE ALL H.T. TROUBLES

WET BATTERIES

TAYLEX

SELF GENERATING

Per doz.	No. 1	No. 2
	s. d.	s. d.
Jars (waxed)	1 3	1 6
Sacs	1 2	1 9
Zincs	10	11
Rubber Bands (24)	3	1
Terminals	8	10

Special sizes for Pentodes



LONG LIFE : SILENT : ECONOMICAL

Sample doz. (18 volts), complete with bands and electrolyte. No. 1, 4/1; No. 2, 5/-; post 9d. terminals extra. No. 3, with terminals, 7/6 (10,000 milli-amps), sample unit 6d. Orders 10/- carr. paid. New illustrated catalogue post free.

FREE Bargain List of Receivers, Amplifiers and Components.

C. TAYLOR, 57, Studley Road, Stockwell, London.

AERIALS AND SELECTIVITY

—continued from page 198

of the aerials with which it is used will be of a high-capacity type.

Even with a single wire it is possible to raise the capacity of the system by taking it close to walls or trees. A wire passing within a few feet of a roof is not efficient; neither is a lead-in which runs parallel to, and within a few inches of, a wall.

The most efficient type of aerial is one with a single wire which is erected clear of all neighbouring objects, and which has a lead-in which at no point is nearer than two or three feet to the wall.

Reduce the Length

Those of you who have trouble with interference, or who are unable to separate stations, would do well to improve the aerial. If the horizontal span is a long one, reduce its length by 20 ft. or so. Reducing the length of the aerial will increase the selectivity of the set. See that it does not pass close to earthed objects, such as drain-pipes, guttering, etc.

Try, if you can, to increase its height, using a short, horizontal span and a vertical lead-in. Remember that a short single wire is the best when selectivity is vital.

If the set is reasonably sensitive, much can be achieved by using an indoor aerial. Naturally, the pick-up of such an arrangement is not so good as that obtained with an aerial of the outdoor type; but a length of wire across the room or round the picture-railing is very often worth while trying when jamming is bad.

Of course, the most selective type of aerial is the frame. Unfortunately, in this case the receiver itself must be highly sensitive. It is practically impossible to receive distant stations

(Continued on page 232.)

EASIEST TO ERECT

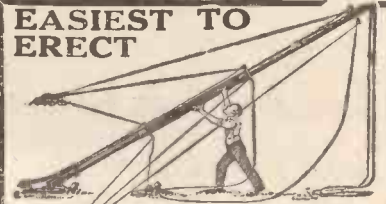

C.P. STEEL MAST

Height	STEEL MAST, tapering	Carriage	Weight
26ft.	1 1/2" to 1"	London, 1/6; Midlands, 2/6; Elsewhere, 3/6.	28 lbs.
30ft.	1 1/2" to 1"	London, 2/-; Midlands, 3/-; Elsewhere, 4/-.	36 lbs.
34ft.	1 1/2" to 1"	London, 2/-; Midlands, 3/-; Elsewhere, 4/-.	40 lbs.
40ft.	1 1/2" to 1"	London, 2/6; Midlands, 3/6; Elsewhere, 4/6.	50 lbs.

These Steel Masts are offered direct from factory to user. Order now and save dealers' and merchants' profits.

Outfit includes complete equipment, viz.: Best British Steel Tubes in sections, Mast Rings, ample galvanised Stay Wire cut to convenient lengths, Pulley, Cleat, solid Metal Foot Rest and strong galvanised Stay Fasteners. Our masts are stayed at 4 ground points (not 3) which ensures permanent stability.

Accessories: Best MANILLA Rope Halyards (will not rot), 60 ft., 1/6; 100 ft., 2/6. Special anti-rust paint (sufficient for one mast), 1/6. Coppered Earthing Tube, 1/9. C.P. Special Aerial has 14 strands of No. 28 gauge enamelled high conductivity pure copper wire, 100 ft., 3/9.

Money refunded if upon examination you are not completely satisfied and return the mast within 7 days.

C. P. MAST Co.

48B, HIGH STREET, PENGE, S.E.20.

REPAIRS

Any make of L.F. Transformer, Loudspeaker or Headphones repaired and despatched within 48 HOURS—TWELVE MONTHS' GUARANTEE with each repair. 4/- Post free.

Terms to Trade.

TRANSFORMER REPAIR CO.,

Dept. "C."

214, High Street, Colliers Wood, London, S.W.19.



For Radio from the Mains

The Picture Paper with the MOST News
SUNDAY GRAPHIC

SAVE YOUR VALVES

Take out a 6d Insurance Policy in the shape of a Compeza, the only really reliable one. Ask for COMPEZA in the little orange box.

A. F. BULGIN & CO.,
9-10-11, Currier St.,
LONDON, E.C.4.

TRADE MARK

PRICE 6D

THE WORLD'S SELECTED H.T. FUSES

ESSENTIAL FOR MAINS RECEIVERS

Look at it—completely insulated, essential where high voltages are concerned—ample contacts—impossible to burn out valves. Engravings on both Plug and Socket make for easy connections.

(Panel Portion 3d Price 9d. Flex Portion 6d.)
Ask your dealer for Belling-Lee Hand'oo'e "Radio Connections."

BELLING-LEE
FOR EVERY RADIO CONNECTION

Advertisement of Belling & Lee, Ltd., Queensway Works, Ponders End, Middlesex.



* The first plug and socket in which both parts are engraved and entirely insulated when connected or disconnected.

Make
The DAILY SKETCH
YOUR Picture Paper



BEAUTIFY YOUR WIRELESS!
Radio Craftsmanship DE LUXE
for ALL Sets.

Nothing to touch! The snug way those untidy dusty parts, trailing wires and batteries are compactly enclosed will delight you! An improvement the MODERN set demands! Enhances the home and a proud asset!
Craftsmanship of high repute, honoured in use by Famous People, Leading Experts, Radio Press and over 3,000 clients.

SENT ON APPROVAL FREE!
£3. 15. 0 or £5. 5. 0 up to £11. 11. 0 models, just as you wish to afford. A Guaranteed product. Hand-French-polished (Plane Finish), sturdy construction.

DIRECT FROM ACTUAL MAKERS.
The Soundness of our product brings orders for all we can make—without wholesalers or expensive showrooms. An exceptional value that needs to be seen to be realised. You may return at our expense if you wish to part with it.

XMAS Makes a splendid Xmas present—we supply ready for existing (or New sets) and send to any address packed FREE
PHOTOGRAPHS and Full Particulars Free!

PICKETT'S Wireless Furniture Makers,
"W.C." Workshop, Albion Rd., Bexleyheath, Kent
Established since the beginning of Broadcasting.



The Man of a Hundred Masks

Here is an enthralling mystery tale from the pen of GASTON LEROUX—master weaver of thrilling plots and creator of breathless situations.

"The Man of a Hundred Masks" is a narrative of amazing power.

Read the first instalment and many other fine stories in the CHRISTMAS

The Corner Magazine For January **7D**

NOW ON SALE. Buy a Copy TO-DAY

AERIALS AND SELECTIVITY

—continued from page 231

on a frame unless the set has one or more H.F. stages.

Those with an experimental turn of mind may like to try a frame for themselves. A suitable arrangement for the medium wave-band is a framework 2 ft. square, wound with 11 turns of No. 24 D.C.C. wire, spaced about the diameter of the wire.

The two ends of the frame are connected across the sockets or terminals to which the wires from the grid coil are usually taken. The grid coil is, of course, no longer required. Naturally, the earth is disconnected from the set, and I am assuming that there is an H.F. stage, with reaction on the detector circuit.

Screening is Advisable

Usually, however, unless the H.F. stage is screened the frame will tend to make the receiver become rather unstable, owing to the possibility of interaction between the frame winding and the H.F. circuit. Much, of course, depends upon the type of circuit employed.

Quite a good dodge with a sensitive receiver, in places where the local station interferes badly, is to disconnect the aerial lead altogether, leaving the earth connection joined up as before. With this scheme, especially if the earth lead is several feet in length, it is surprising how much can be received, and how often the interference from the local transmission is reduced.

* **TRADE JOTTINGS** *

THE Lewcos catalogue for the 1929-30 season takes the form of a 52-page booklet of convenient size, packed from cover to cover with information of interest to the home constructor. Some idea of the ramifications of present-day radio may be gained from the fact that literally scores of different coils are listed here, and, as this well-known firm believes in giving the purchaser plenty of information about its products, the 52-page book is none too big to contain the details embodied in it. In fact, many of the circuits are of the thumbnail type; but in all cases the references are

(Continued on page 233)

CPAREX
SCREENS & COMPONENTS

CHASSIS

Special stout aluminium chassis, as specified, drilled for Valves, **8/6**
Terminals and Panel. PRICE

FOR
THE "CHASSIS" THREE
AND THE
"SILVER CHAMPION"

Partition Screen (drilled as specified)	3/6
S.-G. Valve Holder, Type "L"	2/-
H.F. Choke	3/6
DIFF. REACT. CONDENSER	5/-

"NIGHT WATCHMAN"

Metal Panel, 18" x 7." Highly polished and mottled. Drilled as specified, with Alum. foil for covering baseboard	9/6
Partition Screen	2/-
H.F. Choke	3/6
Reaction Condenser	4/-
On-Off Switch	1/6

DIRECT FROM

E. PAROUSSI,
10, Featherstone Buildings,
High Holborn, London, W.C.1

'Phone: Chancery 7010



No. 15



No. 4

CLIX
for Contact

No. 15. CLIX ALL-IN PLUG AND SOCKET TERMINAL.
The only complete panel terminal entirely insulated from the panel as well as when connected or disconnected. It can be used wherever a terminal of any kind is required, and will give you safer, speedier and better contact.

Panel Portion 4d.
Flex Portion 4d.
Price complete **8d.**

(Supplies immediately obtainable through all dealers.)

No. 4. CLIX HOOK TERMINAL.

Ideal for speedy connection and sure contact. Lead coated for L.T., Nickel-plated for H.T. **2d.**
Red and Black

Write for the Clix folder containing details of the 21 varieties.

LECTRO LINX LTD.,
254, VAUXHALL BRIDGE RD., S.W.1.

EASY TERMS

We SPECIALISE in the supply of all Good Quality Radio Sets, Components and accessories on Easy Terms. We will give you efficient service. Send us your list of requirements and a quotation will be sent by return.

LONDON RADIO SUPPLY COMPANY
11, Oat Lane, Noble St., London, E.C.2
NATIONAL 1917.

PLEASE be sure to mention
"Wireless Constructor"
when communicating with
Advertisers. THANKS!

TRADE JOTTINGS

—continued from page 232

perfectly clear and, being printed on good paper, the connections can easily be traced.

In addition to clear photographs and explicit letterpress the catalogue contains, as well as to the diagrams above referred to, a number of curves which show relative amplification, etc., and the constructor who is interested in the behaviour of H.F. chokes, selectivity with different primaries, and similar questions, will find much to interest him in these and the kindred illustrations. Moreover, the catalogue contains some very useful wire tables, giving size of wire, resistance, current-carrying capacity, and similar useful technical data, so that the whole production is sure to find great favour with the experimenter and constructor who know a good thing when they see one!

The "Reliability" Wireless Guide

J. H. Taylor & Co., electrical and radio engineers, of Macauley Street, Huddersfield, issue the above-named publication in the form of a pamphlet. As it embodies a great proportion of all the popular goods of the principal manufacturers in the country, conveniently classified, it becomes a sort of encyclopedia. Being well illustrated, it is in itself a convenient guide to present-day prices.

The long, narrow shape of this "encyclopedia" makes it extremely easy to hold and convenient to handle, and as J. H. Taylor & Co. is a British firm of a century's standing the list is one from which orders can be given with confidence.

Six-Sixty Radio Co., Ltd.

Owing to the rapidly increasing demand for their products, the Six-Sixty Radio Co., Ltd., have been forced to remove to larger premises. From No. 122, Charing Cross Road, London, W.C.2, they have packed up and departed to Six-Sixty House, 17-18, Rathbone Place, Oxford Street, London, W.1. Note that the new telephone numbers are Museum 6116 and 6117.

In a circular to traders the Six-Sixty people say: "If you have a customer with a query on Six-Sixty valves will you please get in touch with us direct, and we will see that every genuine complaint is satisfied." That sounds good; but even if the dealer fails to do his duty, the purchaser is still protected by the terms

of the Six-Sixty guarantee, which runs:

"We guarantee that all Six-Sixty valves are thoroughly tested at each stage of manufacture, again before they leave our works, and finally before despatch. That should any Six-Sixty valve fail to give satisfactory service which, on test, we find to be due to the development of any fault in the valve, such valve will be immediately replaced by us, free of all expense to the purchaser."

Couldn't say fairer than that, could they?

The Loewe Radio Co., Ltd.

The general manager of The Loewe Radio Co., Ltd., tells me they are receiving numerous requests from people for wiring diagrams employing their R.N.F.7 valve. A diagram has now been prepared showing the connections to this multiple valve, and by the time these words are in print the diagrams will be available to the public. They can be obtained on request from The Loewe Radio Co., Ltd., 4, Fountayne Road, Tottenham, London, N.15.

A New Appointment.

I hear that in view of the steadily increasing activities of Graham Amplion, Ltd., their Mr. W. G. Davies, formerly sales director, has been appointed joint managing director of the company.

Mr. Davies has been in the service of the firm for several years, and is extremely popular with both the business friends of the company and with its employees. P. R. B.

ACCUMULATOR
DISCHARGE RATES
 By A. S. CLARK.

IF you are using accumulators of the thick plate or slow discharge type, do not overrun them, as this may easily account for distortion and poor results.

The larger the capacity of an accumulator, the higher the permissible discharge rate. But, contrary to the ideas of many, the increase of the discharge rate above that stated by the makers does not merely decrease the time taken to discharge the accumulator. It also has the effect of causing the voltage of the accumulator to drop.

You will therefore appreciate that if you try to run too many valves from one accumulator of this type its voltage will drop, with the result that the valves will not get sufficient current to work them properly.

RAYMOND'S

27 & 28a, LISLE ST., LONDON, W.C.2.
 Come to LEICESTER SQUARE TUBE
 This address is at the back of Daly's Theatre
 Phones: Gerrard 4637 and 2821

HOURS OF BUSINESS EVERY DAY 9 to 8
 SATURDAY 9 to 9
 SUN. MORN. 11 to 1

AMAZING OFFER IN LOUDSPEAKER RECEIVERS

DE LUXE MODEL
 READY TO USE.
 in Handsome Cabinet.
 Receives London, 56B, 5XX, and many Continental Stations.

MULLARD MASTER 3 STAR CIRCUIT SIMPLIFIED
 NO COILS TO CHANGE.
 JUST SWITCH ON—THAT'S ALL.

—**MULLARD MASTER 3* CIRCUIT**—
 This new and wonderful set must appeal to Young and Old amateur and experimenter—in fact, EVERYBODY COMPLETE, as shown, in Cabinet (Ringed lid), all parts enclosed, Tunewell Dual Coil 200/2000 metres. 3 Latest D.E. Valves, Grid Bias. Battery 69/6
 Cords, Slow Motion Tuning. READY FOR USE 69/6
 Packing & Carr. Pass. 1/-. NOT C.O.D

ABOVE ASSEMBLED IN CABINET
 Also Supplied with the LATEST TRIOTRON DARK EMITTER VALVES **75/-**
 Plus carr. 5/-

Or Supplied with MULLARD PM2, PM1 H.F., PM1 L.F. **89/6**
 Plus 5/- carr.

EXTRAS IF REQUIRED { L.T. 2 Volts, 8/6, 9/-, 10/6
 H.T. 100 Volts, 10/-, 12/11
 SPEAKERS: Amplion, 21/-
 Ormond 29/6, Marconi 30/-
 Etc., Etc., Etc.

RAYMOND'S CHALLENGE THE WORLD FOR VALUE & QUALITY

ENTIRELY UNSOLICITED TESTIMONIALS £50 TO ANY CHARITY ON ABOVE SET IF NOT GENUINE

From A. C. Morton, 9/11 Harley Winley, 31/6/29: Dear Sir,—Have received wireless set, etc. (yesterday). I am more than pleased with same. It has surpassed my expectations, and you can be sure I shall recommend your firm in future to my friends.—Yours truly, (Signed) A. C. Morton.

From G. A. Rotherham, 9/11/29: Dear Sir,—I have received the Mullard Master Three Star set you sent me, and after more than a fortnight's trial, I am fully satisfied. It is a bargain at the price. Many thanks. Yours sincerely, (Signed) G. A. Rotherham.

KITS of PARTS of your own selection
 Quoted for at a special cash price where possible on receipt of detailed list. **over 25/-** in value

WE STOCK
 J.B. Condensers, R.I. Chokes, Transformers and all usual products, Leeco Coils, Chokes, etc. Ekco Main Units, Amplion Speakers, Brown Speakers, and all components, phones, etc. Ferranti L.F. Transformers, Chokes, Anode Resistances, Cosor, Mullard, Osram, Ediswan, Marconi Valves, Varley Chokes and Transformers, Ormond Condensers, Dials, etc.

SPEAKERS, etc.
 Bluespot Unit 66K, 25/-; Chassis, 12/6; Do. Major, 15/-; B.T.H. Chassis, 12/-; Unit, 15/-; Brown's Vee Unit, 25/-; Chassis, 15/-; Amplion Cone, 21/-; A.C. 40, £3, A.R. 9 Horn, 27/6; Celestion G10, 75/-; Marconi Octagon, 30/-; H.T.H. 4.2, 37/6; Bluespot 49, £2.2.0.

TALISMAN 7/6 DUAL COIL (Wearite) Magnetic Reaction 200/2000 Metres.

ORMOND PRODUCTS.
 Always Large Stocks, 4-Pole Unit, 12/6; Chassis, 7/6; 5-V. Portable, £15; Cabinet Speaker (40 N.), 29/6; Do. Special Model, 50/-; Reaction, 4/-; Differential, 4/-; Friction Control Condensers: .0005 12/-, .00035 11/8, .00025 11/6; No. 3 Log., .0005 6/-, .00035 5/9, .00025 5/6; Slow Motion Dials, 5/- & 3/8; 55 to 1 Friction Dial (Dual), 7/6; Turntables, 5/-; Rheostats, 2/- (Postage under 6/-).

BRITISH VALVES
 Marconi, Mullard, Cosor, Osram, 10/6; Power, 12/6; 3-D, 15/-; S.C., 22/6; Pentode, 25/-; Sets of valves for all Cosor, Mullard and Osram kits of parts, etc.

TUNEWELL 7/9 DUAL COIL 200/2000 Metres.

THE MODERN MODE IN HOME MUSIC



RADIO OR
GRAMOPHONE MUSIC
AT THE TOUCH OF A SWITCH!

*The Instrument which converts
your existing Radio Receiver into
a modern Radio Gramophone*

Specification: Garrard double spring motor with
12" Turntable, B.T.H. Pick-up, double balanced
Armature Speaker, handsome Oak Cabinet, French polished
antique finish. Height, 3'; width, 23"; depth, 17".

PRICE £12 19s. 6d.

The Adaptagram is also supplied as a complete Radio
Gramophone, incorporating our famous 3-valve Screened
Grid Receiver in the following models:—
Model B.D., for Battery Operation ... £27 15 0
Model D.C., for D.C. Mains Operation ... £30 0 0
Model A.C., for A.C. Mains Operation ... £35 0 0
Stocked by all good Dealers.
Supplied on Hire Purchase terms.

Illustrated folder from:
THE BRITISH RADIO GRAMOPHONE CO., LTD
77, City Road, LONDON, E.C.1

You want an "ELECTRADIX"
Radio Tester to get exact results.

The
DIX-ONEMETER

is the Highest Grade possible.
Used in Admiralty, L.C.C.,
G.P.O., and the 'Varsities.

Price: "DIX-ONEMETER,"
in case, reading 40 Microamps.
per div., with 6 Multipliers,
£4 10s.



**A WONDERFUL STOCK OF RADIO AND
SCIENTIFIC APPARATUS.**

Send us your enquiries for Moving Coil Speakers
Mains Sets, Chokes, Gramo-motors, Microphones,
Recorders, Relays, Special Apparatus for Trans-
mission and Testing, Dynamos and Motors, all
sizes, Bridges, Galvos, Switch and Control Gear
of every description in stock. Now ready. New
Edition of 72 page Illustrated Catalogue, 4d.
Send Stamped Addressed Envelope for November
Sale List.

ELECTRADIX RADIOS

218, Upper Thames Street, London, E.C.4.
Telephone: City 0191.

**ALL APPLICATIONS for
ADVERTISING SPACE in**

"WIRELESS CONSTRUCTOR"

**must be made to the
Sole Advertising Agents,**

JOHN H. LILE, LTD.,
4, LUDGATE CIRCUS, LONDON, E.C.4.

**INPUT TRANSFORMERS
AND THE PICK-UP**

*An account of some interesting research that brought some remarkable
facts to light.*

By G. P. KENDALL, B.Sc.

THE usual way of connecting a gramophone pick-up nowadays is to place it straight across between the grid and filament or grid and grid-bias battery of the first valve in the L.F. amplifier which is being used for the reproduction of gramophone records, but just because it is the common practice it does not follow that it is necessarily the only, nor, indeed, necessarily the best, method.

Why Use a Transformer?

You may remember that in the Editor's recent design for an electric gramophone he placed a standard low-frequency transformer of good make between the pick-up and the first valve, in which position it is generally called an input transformer, and you may have wondered as to the whys and wherefores of this proceeding.

No doubt one reason why this was done was that the Editor had in mind the possible use of this amplifier for radio purposes, in which case some form of input coupling device was necessary for the connection to the preceding detector valve in a receiving set, but there are a number of other factors involved, and some of these are rather interesting.

Increased Volume

Now, in the early days of pick-up work the use of such an input transformer was by no means unusual, simply because many early pick-ups were rather insensitive, and in this way a considerable step-up in strength was obtained, since the voltages generated by the pick-up were magnified by something approaching the step-up ratio of the transformer. With the improvements in pick-ups which followed, this consideration was no longer of so much importance, and good strength could be obtained in the average amplifier by connecting the pick-up straight across the first valve. Consequently the use of input transformers never became really general, and nowadays they are comparatively rarely seen.

This question of the volume required is by no means the only one

involved, and careful observers have noticed that if a suitable input transformer is used the reproduction becomes brighter and generally more pleasing, and this was no doubt one of the considerations which led the Editor to provide such a transformer in the design to which I have referred.

This question of the effect of an input transformer upon the quality of reproduction is one which has always interested me, because I suspected that it was in some way related to the question of the balance of high and low notes, a subject of peculiar interest to me in view of many efforts which I have made to obtain an improved brightness of reproduction in moving-coil work, wherein, as the reader probably knows, it is no uncommon thing to find that high notes are not reproduced at their proper strength.

Useful Test Records

The opportunity to investigate this point arose recently when I purchased a set of the new H.M.V. special test records, known as "constant frequency" records. These records, it may perhaps be as well to explain, provide a series of pure musical tones, ranging from about 25 to over 8,000 cycles per second, of known strength and frequency, furnishing a very valuable means of testing for all sorts of pick-up work.

For example, one can take the "characteristic curve" of any given pick-up by measuring the voltage output which it gives at each frequency over the whole scale by means of a suitable valve voltmeter. One can then proceed to investigate the effects of certain changes, making some alteration in the circuit arrangement, and plotting a new characteristic which by its differences from the original one will show just what effect the alteration has made in the reproduction obtained.

Effect on Quality

One of my first experiments was to set to work to see whether I could find out what effect an input

(Continued on page 235.)

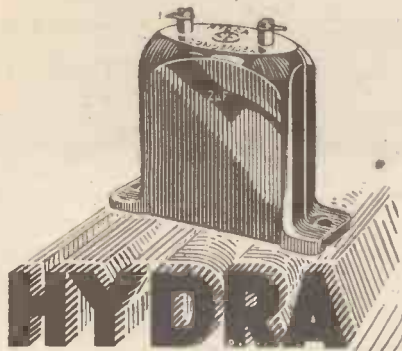

**THE STRONG POINT
IN ANY MAINS UNIT!**

The impregnable insulation of the paper dielectric in a Hydra Condenser is the "strong point" in any eliminator. When you put Hydra into the circuit you cut out once and for all the risk of condenser trouble—you safeguard your set and all who handle it.

The best eliminators you can buy contain Hydra Condensers—write for list of makers' names.

LOUIS HOLZMAN
37 Newman Street, London, W.1
Telephones: Museum 2641

Scrap Your Old Set!

BUILD AN UP-TO-DATE SET AND PAY AS YOU LISTEN.

EVERYTHING WIRELESS ON EASY TERMS

COMPLETE KITS supplied for all sets. **MULLARD ORGOLA KIT FROM STOCK. CASH £10.14.2**, including Valves and Cabinet. Send only 18/-, bal. by 11 monthly payments of 18/-. Also **COSSOR 1930 "Constructor" Circuits, Loud Speakers, H.T. Units, Accumulators, etc.** QUICKEST DELIVERY IN LONDON-CARRIAGE FREE

Call, or send a list of your requirements—**QUOTATIONS BY RETURN OF POST.** Fully illus. 123pp. CATALOGUE and terms for all popular sets FREE on application.

THE P.D.P. CO., LTD. (Dept. C.)
121, CHEAPSIDE, LONDON, E.C.2.
Telephone: National 9846.



Specially designed to meet every requirement of the enthusiast. All parts are interchangeable, made with coloured sleeves, and cost but 2d. each.

Write for List Y74.

J. J. EASTICK & SONS
118, BUNHILL ROW, E.C.1
Phone: Clerkenwell 9282/3/4

PLEASE be sure to mention "Wireless Constructor" when communicating with Advertisers. THANKS!

INPUT TRANSFORMERS AND THE PICK-UP

—continued from page 234

transformer had, and although this involved a great deal of rather laborious work, the results struck me as decidedly interesting, so much so that I think the readers of the WIRELESS CONSTRUCTOR would like to see them reproduced in the form of graphs.

What I did was this. First of all I took the characteristic of the particular pick-up I was employing, and you will see this reproduced the lower curve of the graph accompanying this article.

Getting the Curve Shape

This curve, by the way, was plotted with the aid of only 20 measurements instead of the rather bigger number generally employed in plotting pick-up characteristics, since for these purposes I was only concerned with the general shape of the curve and not with the numerous minor ups and downs. Something like double this number of measurements is usually required to plot fully a pick-up characteristic. In the present case, however, we are only interested in the effect on its general shape of the use or omission of an input transformer.

You will see that the general level of the curve from 200 to about 800 cycles is considerably higher than from 2,000 to 5,000 cycles, and this means that although the curve in general is a very good one, as pick-ups go (this is one of the best pick-ups I have yet tested), the general high-note response is not quite up to the level of the middle frequencies.

Representative Transformer Types

Next I arranged three representative L.F. transformers, with a switching arrangement, between the pick-up and the first valve of the measuring arrangement, and proceeded to take three more curves giving the effect on the characteristic of the three transformers. These transformers were, first of all, one of rather poor quality, representative of the decidedly cheap type. Next there was one of average quality, such as has been in general use up to the last twelve months or so. Thirdly, there was a transformer of the very latest and best type, such as in now used for all purposes where super-quality is desired.

The three upper curves show the results of including these transformers, and it should be noticed that Curve A

(Continued on page 236.)

The Easu Wau TO PERFECT RADIO

In addition to their own extensive range **PETO SCOTT** offer YOU every known Radio Receiver or Component. The list given below merely illustrates our terms for a few well-known lines and we ask you to fill in the coupon or send us a list of your requirements for which we shall be pleased to quote for cash or on our famous system of

EASY TERMS with SERVICE AFTER SALES

THE CHASSIS III (see last month's issue). Complete kit, including panel cabinet and valves, £11.6.8, or send only 30/-, balance in 11 monthly instalments of 19/8.

THE GIFT BOOK III. Complete kit, including panel, cabinet, coils and valves, £7.19.0, or send only 15/-, balance in 11 monthly instalments of 14/6.

OSRAM MUSIC MAGNET. Cash £9.0.0, or 12 monthly payments of 16/6. Valves included.

1930 MULLARD "ORGOLA", including cabinet and valves. Cash £10.15.11, or 12 monthly payments of 20/-.

LISSEN S.G.3 KIT, excluding valves, accumulator and cabinet. Cash £4.9.3, or 12 monthly payments of 8/3.

THIS MONTH'S SPECIAL FEATURE—SILVER CHAMPION
(described in this issue).

Complete kit of components, including drilled panel, cabinet and valves, £12.6.9, or 12 monthly payments of 22/6.

EXIDE 120-volt H.T. Accumulator, TYPE W.J. In crates. Cash £3.15.0, or 12 monthly payments of 6/11. **TYPE W.H.**, 120 volts, in crates. Cash £4.13.0, or 12 monthly payments of 8/6.

REGENTONE, EKCO and ALL LEADING MAKES OF ELIMINATORS from 4/7 first payment.

STANDARD WET H.T. 144-volt Battery, 10,000 m/a absolutely complete. Cash £3.18.6, or 12 monthly payments of 7/2. All parts for these batteries available.

CELESTION C.12 LOUD SPEAKER in Oak. Cash £5.12.6, or 12 monthly payments of 10/4; in Mahogany, £5.17.6, or 12 monthly payments of 10/9.

PHILIPS' CONE SPEAKER, Type 20.6. Cash £2.10.0, or 9 monthly payments of 6/-.

ULTRA AIR CHROME U.12 CABINET MODEL LOUD SPEAKER. Cash £3.19.6, or 12 monthly payments of 7/4.

ULTRA AIR CHROME TYPE F CHASSIS, 18 in. x 23 in. Cash £4.4.0, or 12 monthly payments of 7/9.

All goods sent carriage paid.

Everything available for cash if preferred.

OUR NEW CATALOGUE

contains 48 large pages profusely illustrated and with detailed descriptions of the 1929-30 products of ALL THE LEADING MAKERS. Get your copy now.

PETO SCOTT Co., Ltd.

Free Demonstrations and advice by Qualified Engineers at our Shops:—

- 77, CITY ROAD, LONDON, E.C.1. Telephone: CITY 9406-7-8.
- 62, HIGH HOLBORN, LONDON, W.C.1. Telephone: CHANCERY 8266.
- 4, Manchester Street, Liverpool. Telephone: CENTRAL 2134.
- 33, Whitelaw Road, Chorlton-cum-Hardy, Manchester. Telephone: CHORLTON-CUM-HARDY 2028.

Mail coupon in unsealed envelope under 4d. stamp.

COUPON.

Please send me your new 48-page Illustrated Catalogue.

NAME

ADDRESS

W.C. 1/30.

INPUT TRANSFORMERS AND THE PICK-UP

—continued from page 235

was with the rather poor quality instrument. You will notice that its general shape is very similar to the original pick-up curve, except that we now have a very considerable lift-up of the higher frequencies between about 3,000 and 5,000 cycles. This lift-up, while it might be regarded as valuable in some ways, is rather too sharply peaked to be altogether pleasant.

A Useful Effect

Next there is Curve B of the medium-quality transformer, which you will see again is a fairly close copy of the original pick-up curve, except that now we have a really substantial lift-up of the higher frequencies from 2,500 to 5,000 cycles, which might be expected to have a noticeable effect upon the actual reproduction. Finally, we have the curve taken with the super-quality transformer, and it will be noticed that this produces an even more satisfactory increase in strength of the higher frequencies, with an indication of somewhat better results at the lower end of the scale.

This curve is well worthy of serious consideration, and if you bear in mind the characteristics of the average loud speaker you will see that it gives promise of being exceedingly helpful in obtaining bright and natural reproduction. You must remember that many loud speakers fall off heavily at the higher frequencies, and this applies more particularly to the moving coil type such as is commonly employed on super-quality electric gramophone outfits. The effect now is to give a pronounced

lift-up to the higher frequencies, raising them well above the level of the rest of the scale, and the effect is to counteract to a considerable extent the unfortunate characteristic of the moving coil to which I have referred.

Well Worth Trying

It was assumed on the basis of these measurements that the possibility of obtaining improved reproduction with many loud speakers

decidedly rare in ordinary gramophone recording.

Before I leave you to try out the effect of an input transformer in your own installation there is perhaps just one point which I ought to mention. It is this: if your loud speaker chances to possess a tendency towards a resonance peak somewhere in the upper frequencies, the introduction of a general lift-up of the higher notes may give this peak a chance to show itself really prominently, and so the

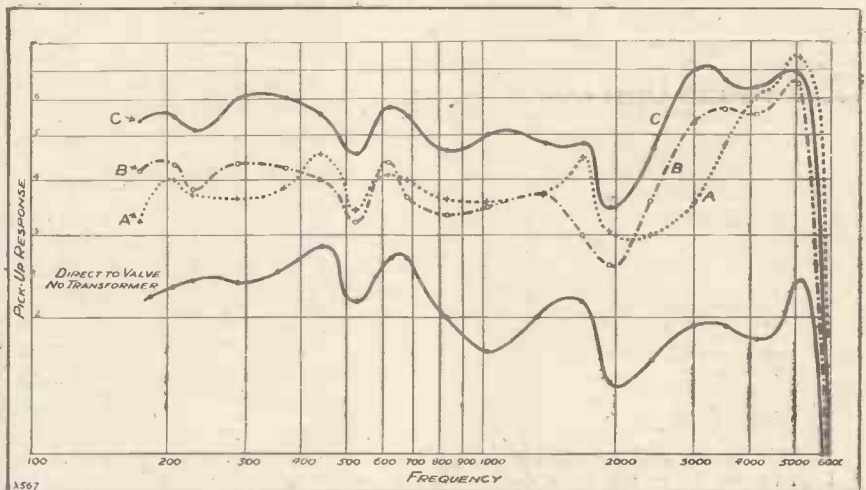

Here you see a graphic representation of the effect on reproduction of three different input transformers.

by the use of an input transformer for the pick-up is quite a serious one. The results obtained were got with only a single pick-up, but there is considerable reason to believe that they would be general for most types of electric reproducers, and the similarity between Curves B and C suggests that they can be obtained with any good L.F. transformer of the modern type. Further, there need be no fear of any sacrifice of bass, more particularly when we remember that frequencies of as low as even 150 cycles are

effect may not be altogether so pleasing as you would expect.

I am afraid that all I can say here is that you should try out the scheme and see whether you like it. In my own case, certainly, where the speaker is a good type of moving coil, the effect is extremely pleasant, and I have used no other scheme for some time past. I have found the improvement in brightness and brilliance of reproduction quite marked and well justifying the use of this extra component.

INDEX TO ADVERTISERS

Amalgamated Press Annuals	PAGE 227	Electradix Radios	PAGE 234	P.D.P., Co., Ltd.	PAGE 235
Argosy Magazine	228	Ever Ready Batteries	223	Radio Instruments, Ltd.	Cover iv
Belling & Lee, Ltd.	231	Ferranti, Ltd.	201	Raymond, K.	233
Benjamin Electric, Ltd.	206	Fermo Company, The	209	Ready Radio.	197
British General Mfg. Co., Ltd.	211	Gambrell Radio, Ltd.	222	Regent Radio Supply Co.	231
British Insulated Cables, Ltd.	217	Garnett, Whiteley & Co., Ltd.	219	Rothermel Corporation, Ltd. (Centralab)	202
British Radio Gramophone Co., Ltd.	234	Graham Amplion, Ltd.	165	" " " (Electrad)	229
Buzin, A. F., & Co.	231	Graham-Farish Radio Products	205	" " " (Magnavox)	215
Burne-Jones & Co., Ltd.	220	Holzman, Louis	235	Taylor, C.	231
"Bestway" Wireless Books	225	Hughes, F. A., & Co., Ltd.	Cover ii	Telegraph Condenser Co., Ltd.	193
Carrington Mfg. Co., Ltd.	221	International Correspondence Schools, Ltd.	221	Telsen Electric Co., Ltd.	Cover iii
Celestion, Ltd.	206	Igranic Electric Co., Ltd.	215	Transformer Repair Co.	231
Cossor, A. C., Ltd.	166	Impex Electrical, Ltd.	198	"This and That"	223
C.P. Maste Co.	231	Jackson Bros.	211	Ultra Electric, Ltd.	230
Clarke, H., & Co. (M/c), Ltd.	226	Lectro Linx, Ltd.	232	Varley Products	232
Corner Magazine	232	London Elec. Wire Co. & Smiths, Ltd.	212	Westinghouse Brake & Saxby Signal Co., Ltd.	202
Dubilier Condenser Co. (1925), Ltd.	221 & 226	London Radio Supply Co.	232	Wingrove & Rogers, Ltd.	224
Eastick, J. J., & Sons	235	Lissen, Ltd.	195	World's Wireless Stores	231
		Popular Wireless Blue Prints	212	Wright & Weaire, Ltd.	211
		Peto & Radford	217		
		Peto-Scott & Co., Ltd.	235		
		Philips Radio	211		
		Pickett Cabinet Works	232		
		Paroussi, E.	232		

All communications concerning advertising in "Wireless Constructor" must be made to John H. Lile, Ltd., 4, Ludgate Circus, London, E.C.4. Telephone: City 7261.

An Old Musician ~

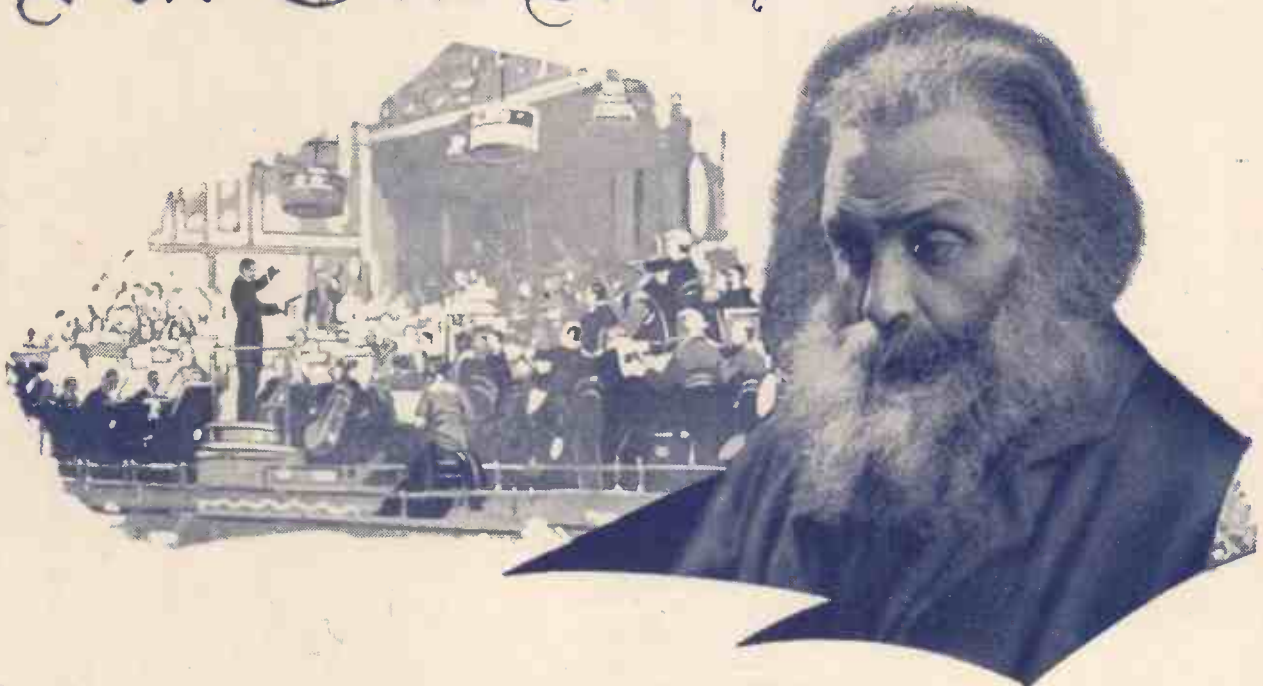

appreciates music
that he himself has
played to thousands.

No greater testimony for Telsen Transformers could be found than the artistic sense of a musician who writes to us of the wonderful balance of tone these Transformers give throughout the entire musical scale—which has now made it possible for him to hear as he once played to thousands.

Try one in your set—and have music in all its reality!

**RADIO'S CHOICE!—
AND A MUSICIAN'S, TOO!**



RADIOGRAND
12/6
Ratios 5-1 or 3-1

TELSEN

TRANSFORMERS

TELSEN ELECTRIC CO., LTD., MILLER STREET, BIRMINGHAM.

The Secret of the Set Success

THE HYPERMU

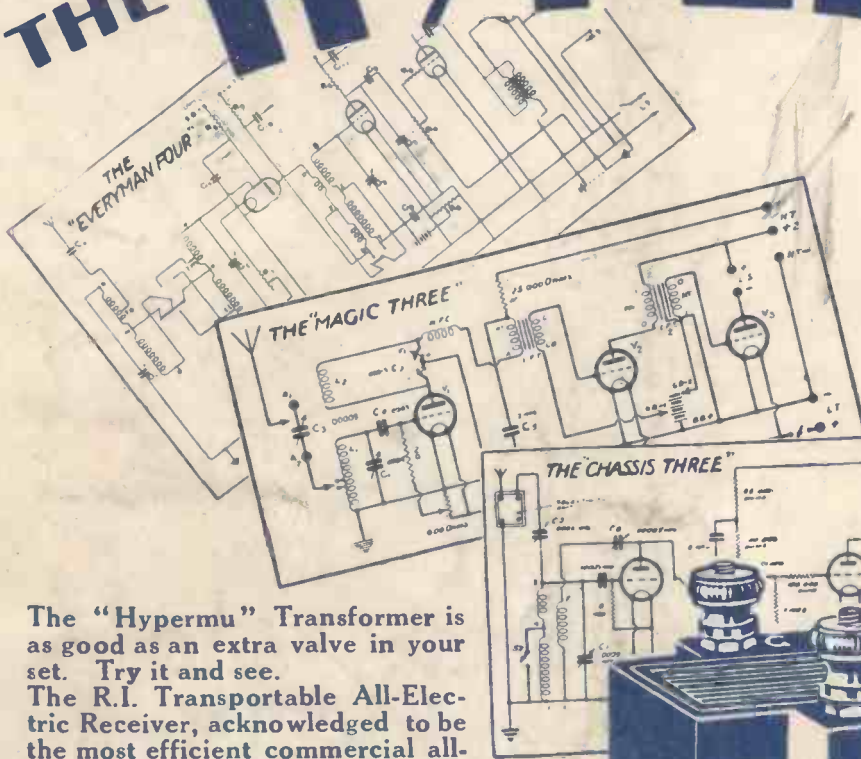

Improved valves, the "Hypermu" Transformer and other R.I. components used in modern British circuits give better results with three valves than five, as formerly employed.

The Technical Press are including it in all their modern receivers, such as the "Everyman" Four, the "Magic" Three and the "Chassis" Three.

The "Hypermu" Transformer is as good as an extra valve in your set. Try it and see.

The R.I. Transportable All-Electric Receiver, acknowledged to be the most efficient commercial all-mains set in existence, includes one "Hypermu" Transformer, which alone provides all the necessary low-frequency coupling, and delivers both volume and quality to satisfy the most exacting listener.

Musicians and sound critics consider the "Hypermu" to be one of the most valuable scientific aids to pure reproduction of music and sound yet devised.

A "Hypermu" makes an old set MODERN, and a modern set REMARKABLE. Fit the "Hypermu" to-day, and benefit by R.I. research.

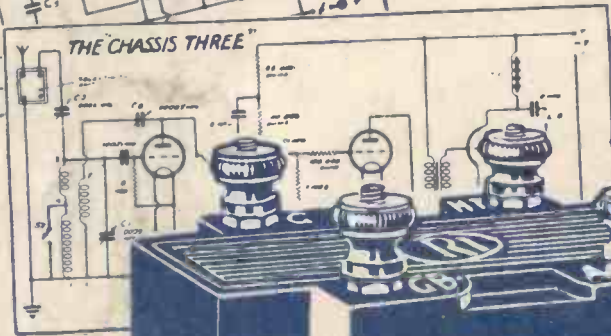

HYPERMU
Encased in Bakelite.
Size, 3x3x1 1/2 ins.
Weight, 14 ozs. **21/-**

Write for
Hypermu Folder and the new
R.I. Catalogue.

RADIO INSTRUMENTS, LTD., 12, HYDE STREET, LONDON, W.C.1.