

The **Wireless Constructor**

6^D
MONTHLY

EDITED BY
PERCY W. HARRIS, M. I. R. E.
Vol. V. NOVEMBER, 1927 No. 13

IN THIS ISSUE
**A "THREE" FOR THE
NEW VALVE**

**DESIGNED BY
PERCY W. HARRIS,
M. I. R. E.**

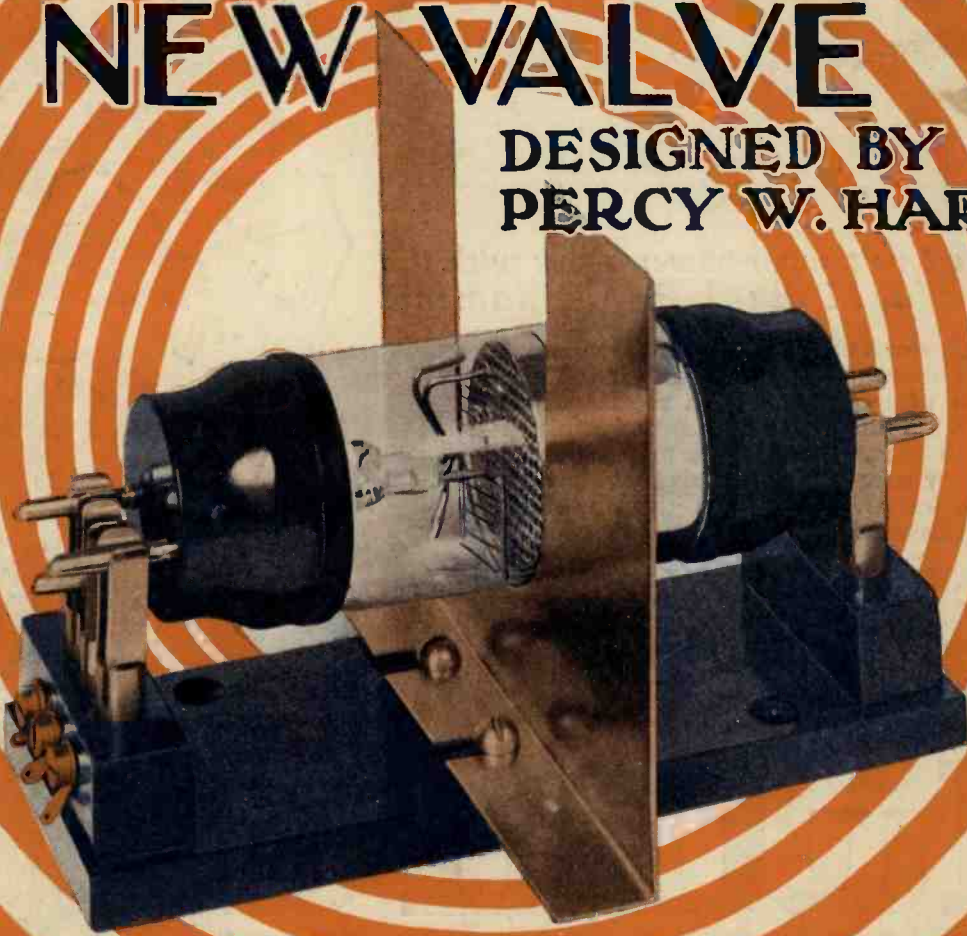



The
NEW VALVE
 you have been
 waiting for —
 and the label
 you should look
 for on every
Mullard P.M
 product

Now a 2 volt super-power valve with the wonderful Mullard P.M. Filament!

This new 2 volt super power valve completes the series of 2 volt valves. It is the only one of its kind and in the last stage of L.F. amplification handles powerful signals with ease, giving pure, majestic volume. Every user of 2 volt valves will welcome the improved reception given by this new Mullard Master Valve.

The Mullard P.M. 252 Price 20/-

Attached to this and to every Mullard P.M. product is the Mullard label, your assurance of satisfaction.



Mullard

THE · MASTER · VALVE

CONTENTS

	Page		Page
The Editor's Chat	5	The "Reactor" Four	41
A "Three" for the New Valve	7	Chats at the Work-Table	49
Secrets of Short-Wave Success	13	What's New	53
How the Screened Valve Works	15	More About the "Twin-Tune" Five	58
The "Chummy" Two	19	An Interesting Five-Valve Set	61
Rectifier Developments	23	More About the "Localong"	61
Cartoon	26	A Page of Readers' Results	62
Happenings at Savoy Hill	27	The Harvest of Invention	65
A Short-Wave "Super-Het." Adaptor	29	Our News Bulletin	68
At Home with the Ohm	33	Recent Valve "Releases"	72
In Lighter Vein	37		

EDITED BY
PERCY W. HARRIS, M.I.R.E.

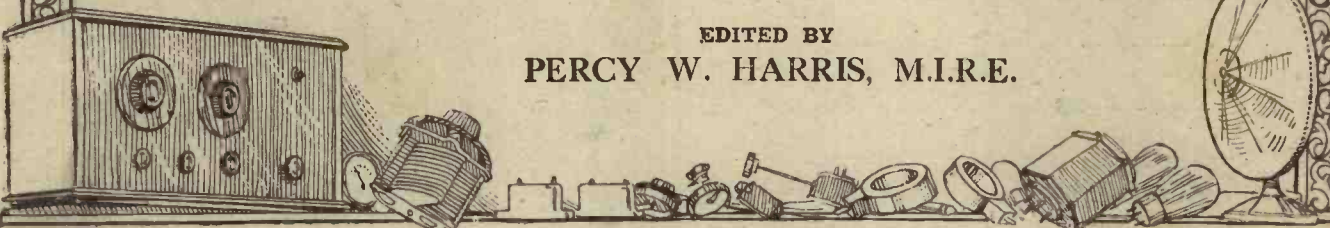

FREE

CIRCUITS FOR THE NEW MARCONI S.625 VALVE

T.1

A transformation in high-frequency amplification comes in with the startling development of the Marconi S.625 Shielded Valve. By this an amplification of 30-50 is possible for every H.F. stage, with absolute stability and uniform efficiency over a very wide range of wavelength. Two stages—using these new valves—have no difficulty for the constructor and, incorporated in these Marconiphone circuits, develop amazing sensitivity.

Two of these ultra-modern circuits are offered to the constructor. A FREE constructional booklet, including blue-print for either receiver, will be posted to everyone sending the coupon. The other booklet will also be supplied, if desired, for a nominal charge of 6d.

MARCONIPHONE

T.2

T.2. A 5-valve receiver, incorporating two S.625 shielded valves. Essentially a long-distance set. Stations hundreds of miles away can be tuned in with complete stability.

T.1. A 4-valve receiver, including 1 H.F. stage. Both sensitivity and purity of reproduction are excellent. Simple to construct, incorporating one S.625 shielded valve.

To the MARCONIPHONE Co., Ltd. (and reduced), 210-212, Tottenham Court Rd., London, W.1.

Please send me free constructional booklet, including blue-print for circuit..... I am also enclosing.....
for the other booklet.....

NAME..... TOWN.....
ADDRESS..... COUNTY.....

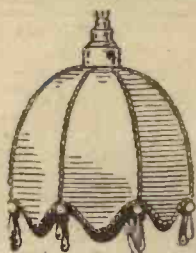

For working entirely off the E.L. Mains

The illustration shows the new Met-Vick 5 with the eliminators contained in the side cupboards. It can be plugged into a lighting circuit just like any other Electric appliance. If used with H.T. and L.T. batteries these can be accommodated in the cupboards. The circuit employs two phase-balanced and stabilized H.F. stages before the detector, and two resistance coupled L.F. stages.

Operation is extremely simple, the local station can be easily cut out and a wide range of alternative programmes obtained.

Special attention has been paid to running costs which are remarkably low.

The Met-Vick 5 is a really beautiful instrument and while a distinct advance on any 1926 model it still remains at a reasonable price. Obtain Leaflet 4117/9 for complete range of prices.

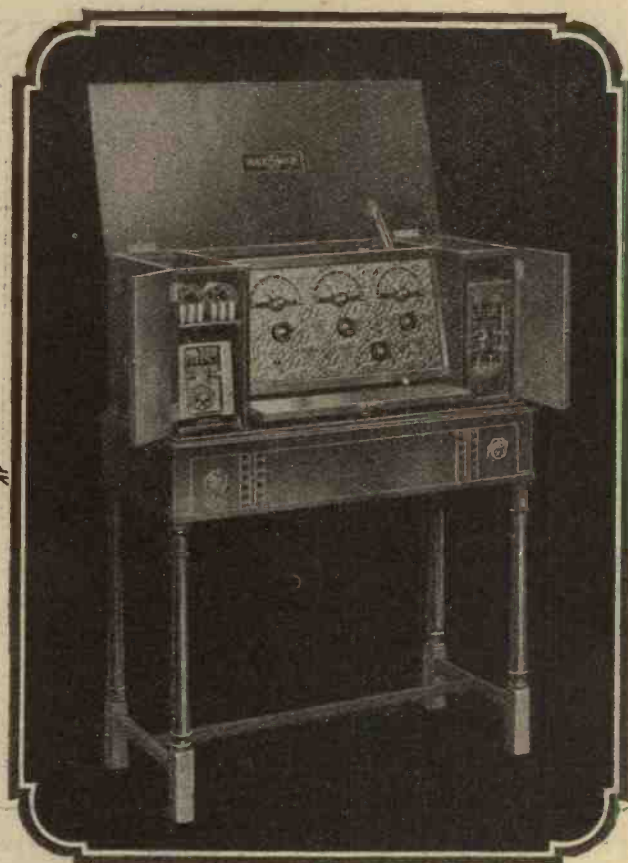

Battery Eliminators

Met-Vick Battery Eliminators are supplied in two models, one for providing filament current and the other for anode and grid currents, by plugging in on electric light mains. The H.T.-G.B. Model provides a high voltage (up to 250 V.) for the last valve (ensuring a large volume without distortion). It is fitted with a switch, a protective fuse and a distributor panel enabling it to be used on various supply voltages of 40-100 periods. Grid Bias tappings at 5, 10, 15 and 20 volts.

The smoothing system is of exceptional efficiency. The eliminator can therefore be used successfully with multi-valve and the most sensitive sets even in districts where there are considerable irregularities in the electrical supply.

The L.T. Model gives an output of 5 amperes at 4 volts and a potentiometer ensures complete absence of hum. Obtain copy of List 7117/8.



MET-VICK

(COSMOS)

METRO-VICK SUPPLIES LIMITED

(Proprietors: Metropolitan-Vickers Elec. Co. Ltd.)

155 Charing Cross Road - LONDON, W.C. 2

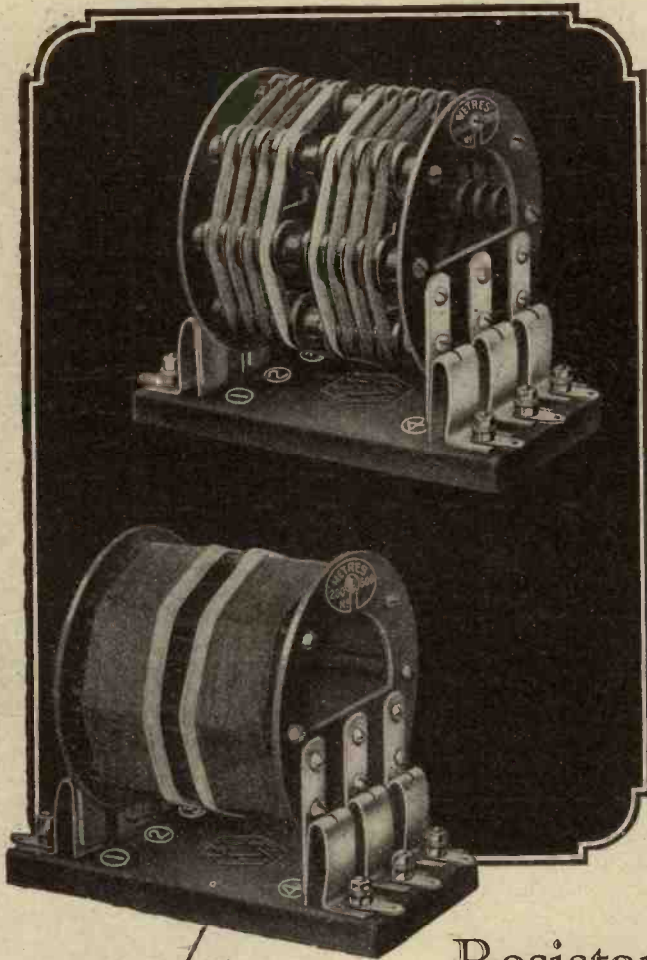

Zz

A·N·P

(Astatic-Non-Parasitic)

Coils

A CLEVER SOLUTION OF A DIFFICULT PROBLEM.

Patents pending.

Designed to overcome in a simple manner the three difficulties associated with high frequency amplification namely: Magnetic coupling between coils, Stabilisation, and Parasitic Oscillation. The first named is prevented by Astatic winding, obviating the necessity for metal screens with their disadvantages, the second is obtained by centre and quarter-tappings accommodating valves of various impedances, and the third is avoided by balanced self-damping windings, thus dispensing with the expensive double condenser and resistance method previously used.

List 4117/8 gives full details and prices.

Resistance Coupling Units

Thousands of radio enthusiasts are loud in their praises of "Cosmos" (Met-Vick) Resistance Coupling Units. L.F. stages coupled by means of these Units result in clear Loud Speaker reproduction without distortion. The 'V' type unit can now be supplied fitted with the new 'Met-Vick' A.C. Valve Socket for use when building a set for working off the E.L. mains. The A.C. Valve-socket is also supplied separately for panel or baseboard mounting. Obtain List 7117/8 for full details and prices.

MET-VICK

(COSMOS)

METRO-VICK SUPPLIES LIMITED

(Proprietors: Metropolitan-Vickers Elec. Co. Ltd.)

155 Charing Cross Road : : LONDON, W.C 2

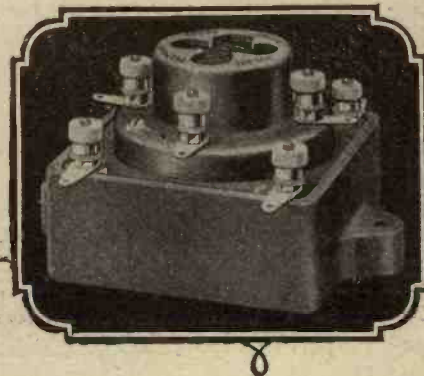

RADIO REVOLUTIONISED

- not a booklet
- not a Blue print

But
a wonderful
new system of
set building

HERE is news of the utmost importance to everyone who wants to enjoy the new B.I.C. Alternative programmes. The makers of Cossor valves have evolved a revolutionary system of set-building. Absolutely no skill is required—yet perfect results are guaranteed. Even if you don't know the first thing about Radio you can build the wonderful Cossor "Melody Maker" (the first set to utilise these new principles). Soldering is abolished—technicalities have been eliminated—success is certain. It costs you nothing to get full details of this new system—post the coupon to-day.



A simple efficient 3 Valve Receiver

Soldering abolished!
every detail as easy as ABC

Free

Post the coupon to-day
for your copy of
How to build the

Cossor "Melody Maker"

To A. C. Cossor, Ltd., Highbury Grove,
London, N.5.
Please send me free of charge one copy of
"How to build the Cossor 'Melody Maker'".
Name
Address.....
W.C.

The WIRELESS CONSTRUCTOR

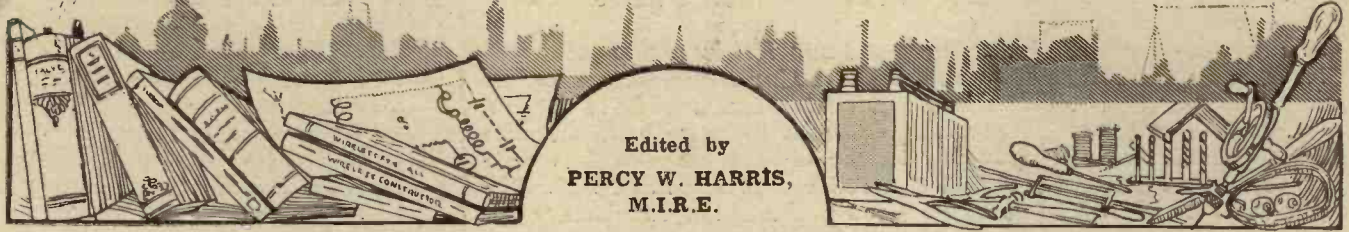

Published by the Amalgamated Press, Fleetway House, Farringdon Street, E.C.4.

THE EDITOR'S CHAT

In which Percy W. Harris, M.I.R.E., the Editor of the "Wireless Constructor," deals with some aspects of the reception of 5 G B, and other interesting radio topics of the moment.

DAVENTRY JUNIOR is already sharpening the wit of thousands of experimenters, who find perhaps for the first time that they have, as far as strength is concerned, the equivalent of two "local" stations, so that if they wish to get one satisfactorily clear of the other, their set must be really selective. If the set you are at present using gives trouble in this regard, now is an excellent opportunity to build something quite new.

"D.X." Reception

In order to meet the experimental requirements of all our readers, designs of practically every type of receiver are published during the year. Which of these types will form the starting point of your own experiments depends upon the type of work you wish to do.

Many constructors devote their time to improving the distance-getting powers of their receivers. Reception of the local station has no attraction for them. It is so easy that it scarcely seems worth while. The reception of distance stations, however, in any number and in good volume with quality, is something different.

Experiments With Aerial

A very interesting line of experiment, if you have built a receiver with really efficient high-frequency amplification so as to bring in distant stations, is to see what alterations in your aerial and earth conditions bring about the greatest improvements in general reception. Indeed, there is still a great deal to be done and much pleasure to be obtained in experiments

with both outdoor and indoor aerials. Far too much attention is devoted to the set itself and far too little to the humble wire which serves as a collector.

For example, I am convinced that many owners of really sensitive four- or five-valve sets use them with far

to identify than one which gives loud signals to the accompaniment of almost as loud crashes, bangs and crackles.

With crystal sets, of course, the largest possible aerial should be used, for here we are dependent entirely upon the amount of incoming energy

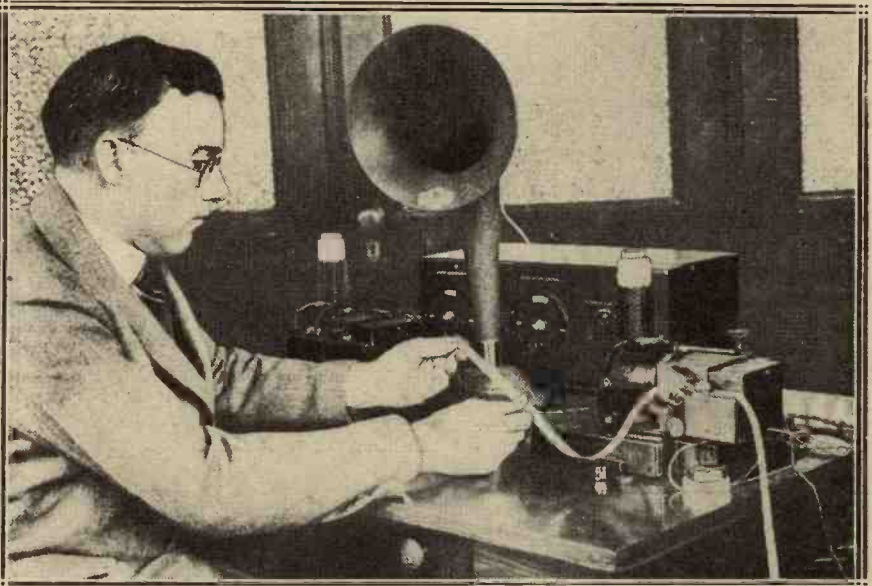

Wireless Aid for Airmen. This radio equipment, which has just been installed at Arlington, U.S.A., broadcasts weather news and forecasts to aviators in flight.

too big aerials. Large, high aerials are great collectors of static interference and those electrical discharges which cause the rumblings, crashes and cracks on certain evenings, particularly during summer-time. The aim of all our experiments should be to get the highest ratio of signal to background noise, and a station of medium strength against a practically inaudible "background" is far easier

we can intercept and we have not, as in valve sets, powers of amplification at our disposal.

Have you ever tried entirely disconnecting your aerial and joining the earth lead to the aerial terminal? You will be surprised what can be brought in with such an arrangement. Excellent work can also be done by burying a carefully insulated wire (the wire sold as "aerial lead-in" and

The Editor's Chat—continued

very thickly covered with rubber is best). If care is taken to prevent the wire coming in contact with the earth at any point—the end of the wire buried in the ground should be sealed with insulating tape or Chatterton's compound—and if an ordinary buried earth connection is used, a great deal of interesting information can be gathered. Buried aerials are by no means new, but for some reason or other they have received little attention from the amateur.

Sets in this Issue

As promised in our last issue, a full description is now given of a three-valve set utilising the new screened valve, particulars of which were first made public last month. Owing to the very great high-frequency amplification given by this receiver it is a particularly suitable type to use for the experiments described above.

The four-stage set described by Mr. K. D. Rogers in this issue should be carefully examined by all readers, even those who do not contemplate building so ambitious a set, for there are a number of very unusual features in its design.

Short-wave enthusiasts—a large and rapidly growing band—are catered for in the article by Mr. Thomas describing a short-wave adaptor. I have arranged for Mr. Thomas to follow this up in the succeeding issue with a full description of experiments possible with it. We are fast approaching the time of the year when short-wave reception is at its very best, and readers may be sure that all the latest developments of this form of reception will be described to them.

As much of the information given in the columns of this paper concerns the most recent developments in the Radio world, some of the arrangements and specialities described may be the subject of Letters Patent, and the amateur and the trader would be well advised to obtain permission of the patentees to use the patents before doing so.

Every editor of a wireless journal receives a constant stream of questions relating to low-frequency transformers and the "ratios" to use. An experimenter when building his own receiver frequently finds that he is offered a choice of several ratios in the same make of transformer, and is quite puzzled as to which to choose. The real trouble in this, as in many other wireless matters, is that we have grown up to the use of a highly unfortunate phraseology. For example, a "three to one" ratio means that the number of turns in the secondary winding is three times as great as in the primary, and a "six to one," six times, and so forth.

Transformer "Ratios"

The secondary of every transformer should have the largest number of turns practicable so as to get the maximum step-up effect. The primary on the other hand should be designed to have a suitable impedance for the detector or amplifier valve used with it. It will thus be seen that the user is concerned not with the particular ratio of turns in the primary and secondary, but with the primary impedance, and I am going to suggest that in future transformers be designated "high," "medium," and "low" impedance, instead of by the illogical number-ratio method.

If this scheme should be generally adopted the user will be saved a great deal of trouble, because he would almost automatically choose a high impedance transformer with a high impedance valve (such as is used for a detector) and a medium impedance transformer to follow a note magnify-

ing valve of the usual type. Seeing that crystals have a much lower impedance as a general rule than do power valves, he would naturally choose a low impedance transformer to follow a crystal detector.

I should be very pleased to receive the views of readers on this matter for publication in these columns, and the views of transformer manufacturers will also be welcomed. Any step which will serve to remove difficulties from the path of the experimenter is, I think, worthy of our most careful consideration.

* **SHORT-WAVES** *
* **FOR EMPIRE** *
* **BROADCASTING** *

SIR,—While testing a short-wave supersonic set which I constructed very much as advised by Mr. L. H. Thomas in the WIRELESS CONSTRUCTOR for June, 1927, at 2.30 p.m. this afternoon, I was pleasantly surprised to "hit upon" the new Langenberg short-wave transmission, and listened, off and on, to a most enjoyable musical programme at full head phone strength until 5 p.m.

This result indicates that before very long it will not be necessary to wait up until the early hours of the morning in order to enjoy European programmes, and that good reception during the daytime on short waves may be confidently anticipated.

Yours, etc.,

A. J. LANGLEY MOONE.

The Priory, Madras.

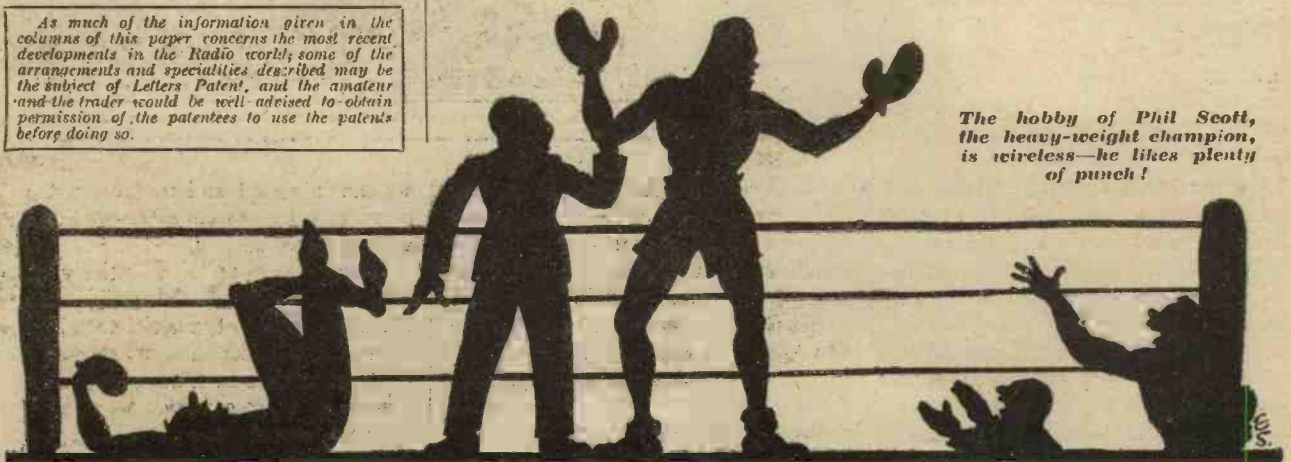

The hobby of Phil Scott, the heavy-weight champion, is wireless—he likes plenty of punch!

A "THREE" for the NEW VALVE

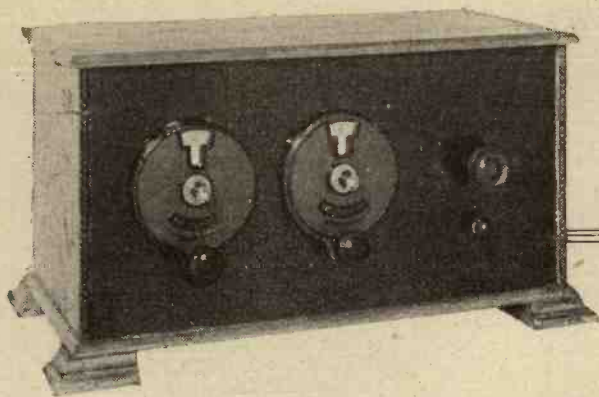

A sensitive receiver employing one of the new shielded-grid valves.

By PERCY W. HARRIS, M.I.R.E.

IN last month's WIRELESS CONSTRUCTOR I promised a design for a three-valve set utilising the new screened valve which has aroused so much interest at the show. Photo-

latest transformers, giving excellent amplification of both the low and the high tones, the quality of reproduction is up to the best of modern standards.

experiments with it, so that I need not deal here with its actual operation. By its use, the set is given a radio-frequency magnification previously unobtainable with a single high-frequency stage and equal to practically two ordinary stages. This means, of course, that distant stations can be brought in with remarkable volume and purity. At Wimbledon the reproduction in broad daylight from Langenberg and Bournemouth is of ample loud-speaker strength, while after dark dozens of Continental stations are brought in at such a strength that the set must be detuned to bring the sound down to a comfortable level.

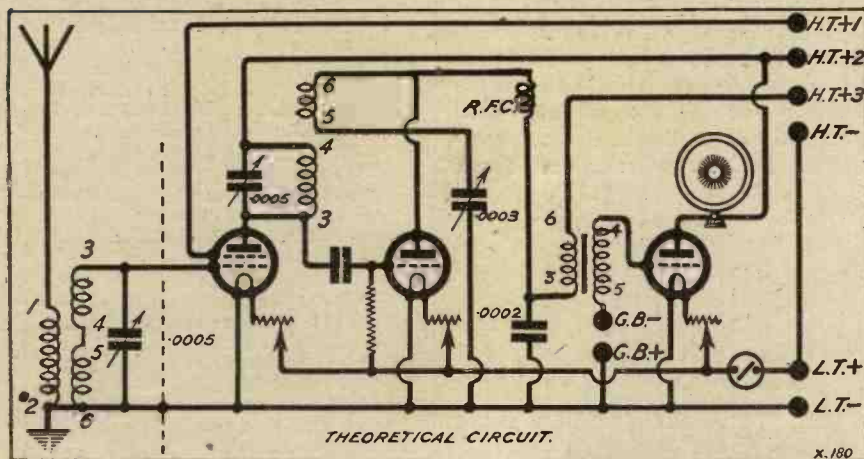

Equal to Four Valves

In view of the large number of stations working, the variations of conditions from night to night, and the fact that you never know which Continental stations will be heterodyned, I am inclined to discount the value of a list of "stations heard." The great joy of this receiver lies not so much in the number of distant stations it will bring in (any good

graphs were given showing the receiver in its "semi-final" form, and as at the time of writing the article exhaustive tests had not been completed, the complete design was not published. The receiver has now passed all tests, and full constructional details and photographs are therefore available in this article.

Remarkable Results

Before giving the experimenter particulars of how the receiver can be constructed, perhaps I had better tell you of the results obtainable with the set, and how it compares with others. The photograph of the front of the receiver shows that there are but two tuning dials, the knob on the extreme right being used for controlling reaction. The two dial readings come approximately the same for a given station, so that searching for distant stations is an easy matter. There is no particular novelty about the detector stage, and the audio-frequency stage is quite normal. By using one of the

The novelty, obviously, lies in the high-frequency stage, in which the new screened-grid valve is used. Mr. James, in his excellent article in the current issue, will tell you a great deal about the valve itself, and his

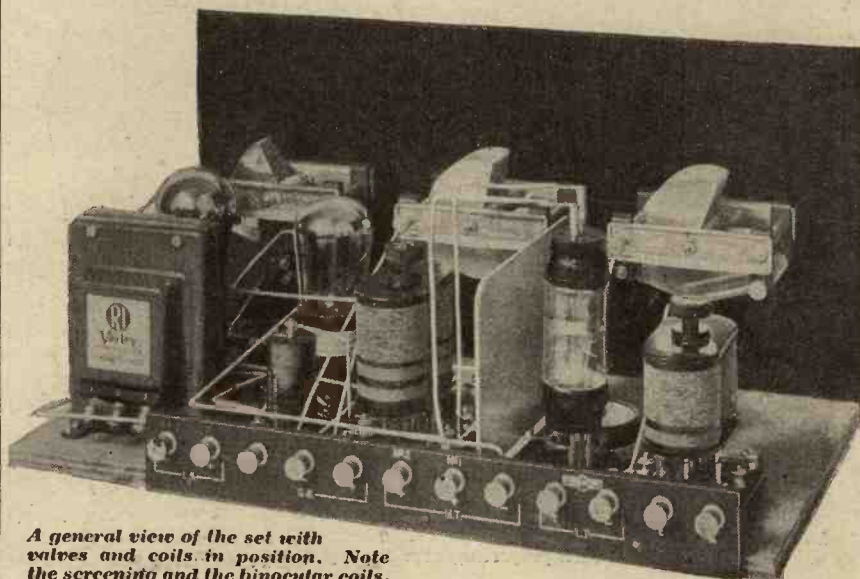

A general view of the set with valves and coils in position. Note the screening and the binocular coils.

A "Three" for the New Valve—continued

three-valve receiver should bring in scores in these days), but in the fact that these distant stations can be adequately received without bringing the set near the very verge of oscillation with the accompanying sacrifice of purity. Other experimenters who have visited my laboratory all tell me, when listening to this receiver, that they have never before heard a three-valve set which gives such good results on distance, and that in their opinion the results are quite equal to the best four-valve sets they have heard.

The mere fact that the receiver gives such great high-frequency magnification makes it far more important than usual to design the high-frequency portion with the greatest care. For this reason I would suggest that those experimenters who construct the receiver adhere to the actual components used in the high-frequency portion of the circuit. In

particular, the variable condenser shown should be used, as it was chosen, not because it was any better electrically than other high-grade condensers, but because its physical dimensions were small. Any good make of variable condenser can be used for detector tuning, and for reaction, provided the swing of the moving plates is not such that one condenser will interfere with the next. Similarly, any good make of radio-frequency choke and audio-frequency transformer can be used. I have tried several makes of radio-frequency choke in this set and all work equally well.

The Valves Used

The screened-grid valve can be obtained either from Marconi's or from the Osram people. It is known as the S.625. For the detector any good 6-volt detector valve can be used, and for the note magnifier either a 6-volt

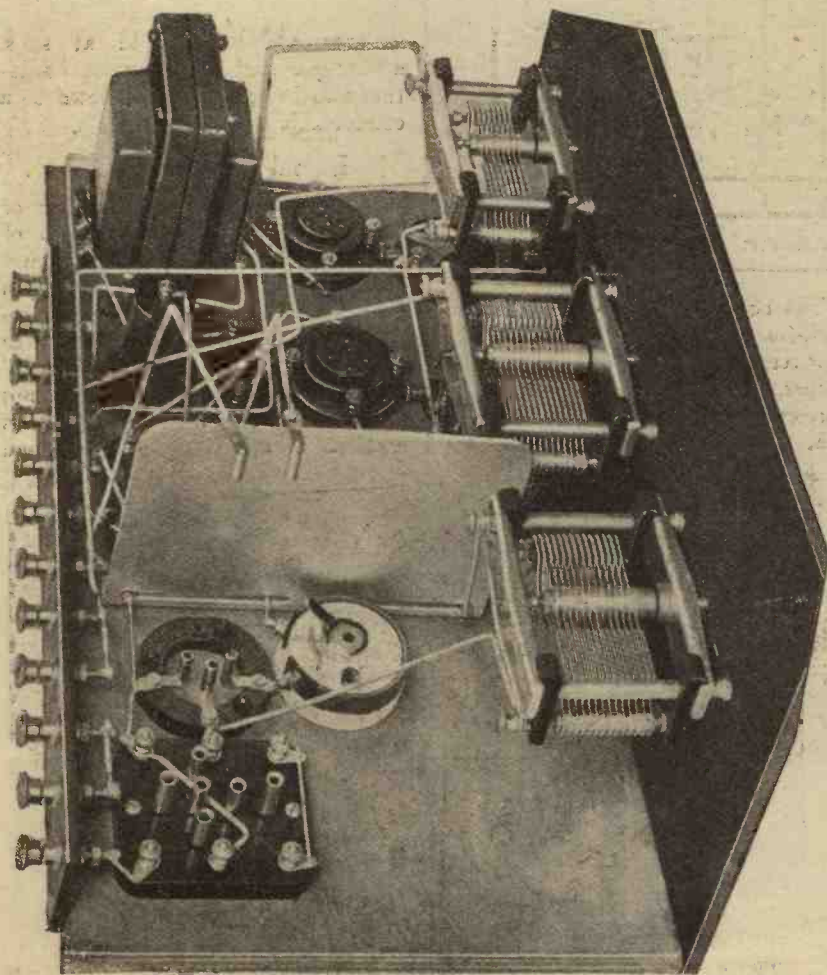

A photo taken from the H.F. end of the set. The H.F. shielded-grid and anode leads can be seen projecting over the top of the screen.

COMPONENTS REQUIRED.

Standard 16 in. × 8 in. panel. (Resiston, Ebonart, Pilot, Trelleborg, etc. The new Paxolin panels sold by Messrs. Wright & Weaire, and the panels sold by British Celanese, Ltd., are also equally suitable.)

1 cabinet to take a baseboard 8½ in. deep. (That shown is Caxton. Any of the leading makers of radio cabinets will supply you with suitable cabinet.)

1 terminal strip 12 in. long, with twelve terminals as marked in the wiring diagram.

2 variable condensers, .0005 mfd. and one of .0003 mfd. (Bowyer-Lowe "Popular" type.)

2 Indigraph dials. (Igranic Electric Co.)
1 standard 1½-in. knob for reaction condenser.

1 on-and-off switch. (L. and P., Igranic, etc.)

3 baseboard-mounting resistors to suit valves used. (Ten ohms is a suitable value for the screened valve. The other two should be chosen according to the detector and audio-frequency valves you select. Remember that you *must* use 6-volt valves in this receiver, as the screened-grid valve has a 6-volt filament.)

3 valve sockets. (For the detector and note-magnifying stages any of the standard anti-phonetic sockets are suitable, such as Benjamin, Lotus, Wearite or the new Bowyer-Lowe. For the screened-grid valve I have used a Bowyer-Lowe "Antipong" socket, for reasons which will be explained in the article.)

2 standard 6-pin coil bases. (Lewcos.)

1 Alcoa aluminium screen (Rothermel). Any piece of aluminium or copper sheet measuring 6 in. × 4 in., with means of securing it to the baseboard, will do here, but the Alcoa screen is in a very convenient form.

1 .0003 mfd. grid condenser with clips for series grid-leak attachment. (Dubilier with special series clips, Lissen with Lissen Combinator, or any other similar arrangement.)

1 2-megohm grid leak.

(SPECIAL NOTE.—The grid leak **MUST NOT BE CONNECTED ACROSS** the condenser, but between the grid terminal and the positive L.T. lead.)

1 standard radio-frequency choke. (Wearite, McMichael, Lissen, R.I.-Varley, etc.)

1 fixed condenser .0002 mfd. (Lissen, Dubilier, Igranic, etc.)

1 good modern low-frequency transformer. Any standard make. (As the R.I.-Varley is used in the set illustrated, the correct connections for the numbered terminals are given. If, however, a make is used in which the conventional ISOS, IP and OP terminals are marked, then "3" corresponds to IP, "5" to IS, "4" to OS, and "6" to OP.)

A "Three" for the New Valve—*continued*

small power—or, better still, a super-power valve such as the Stentor 6, Mullard 256, S.S.625, or the corre-

out to give extremely short wiring. As the screened-grid valve is double-ended, and as there are only three

be removed and used as is shown in the picture for making connection to one of the upper pins. I have used a second socket from a discarded "Antipong" holder to make a connection with the other pin at the top. If you have not such a spare socket available, a little coil of wire is quite sufficient to make a socket for the upperpin.

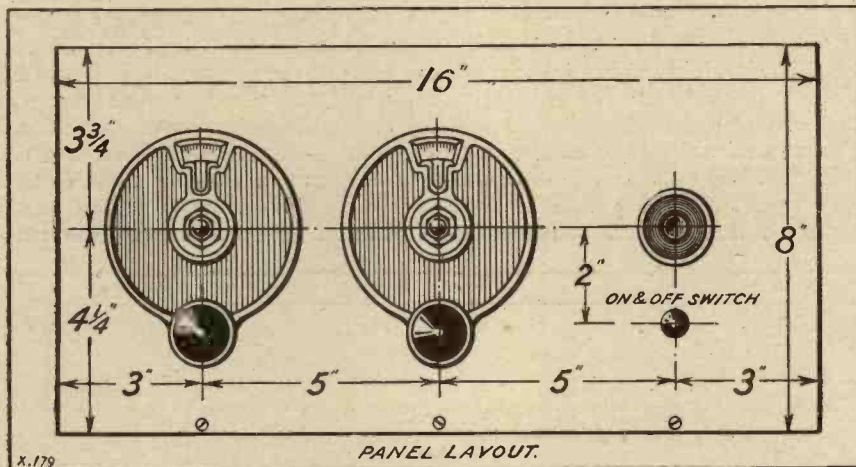

sponding Osram, Marconi, Ediswan, Cosmos, etc., valves.

Special Coils

Binocular coils *must* be used if this particular receiver is to function properly. The first socket takes a standard split-secondary binocular for either the short or the long range, whichever is to be used, and in the second socket a standard Reinartz binocular for one or other range is used. The Lewcos binoculars are shown, these being physically small and having very restricted fields. Other makes of binocular coils of similar dimensions also work well.

A 6-volt accumulator and 120-volt H.T. battery will be required. If you are not prepared to use 120 volts H.T., do not experiment with this set. The screened-grid valve is designed to use 120 volts on the plate; and while a lower voltage can be used the valve does not function efficiently under this figure.

Constructional Work

The three variable condensers and on-and-off switch should be mounted first of all upon the front panel, and this panel should be kept handy so that it can frequently be held against the baseboard to make sure that your baseboard components are following the correct layout. Notice particularly from the photographs the way the six-pin coil base, the "Antipong" valve socket, and the baseboard-mounting resistors are placed. This arrangement has been carefully worked

pins on the end which goes next to the baseboard, the fourth socket of the Bowyer-Lowe "Antipong" holder can

Tuned-Anode Coupling

To avoid the necessity of specifying specially made coils I have used standard binocular windings for both sockets. The first binocular is of the split-secondary type, but as there is no need to use the centre tap the two terminals marked 4 and 5 are joined by wire, while terminals 6 and 2 are also joined. Owing to the high impedance of the screened-grid valve it will not work satisfactorily with a high-frequency transformer, and tuned-anode coupling *must* be used. In order to obtain

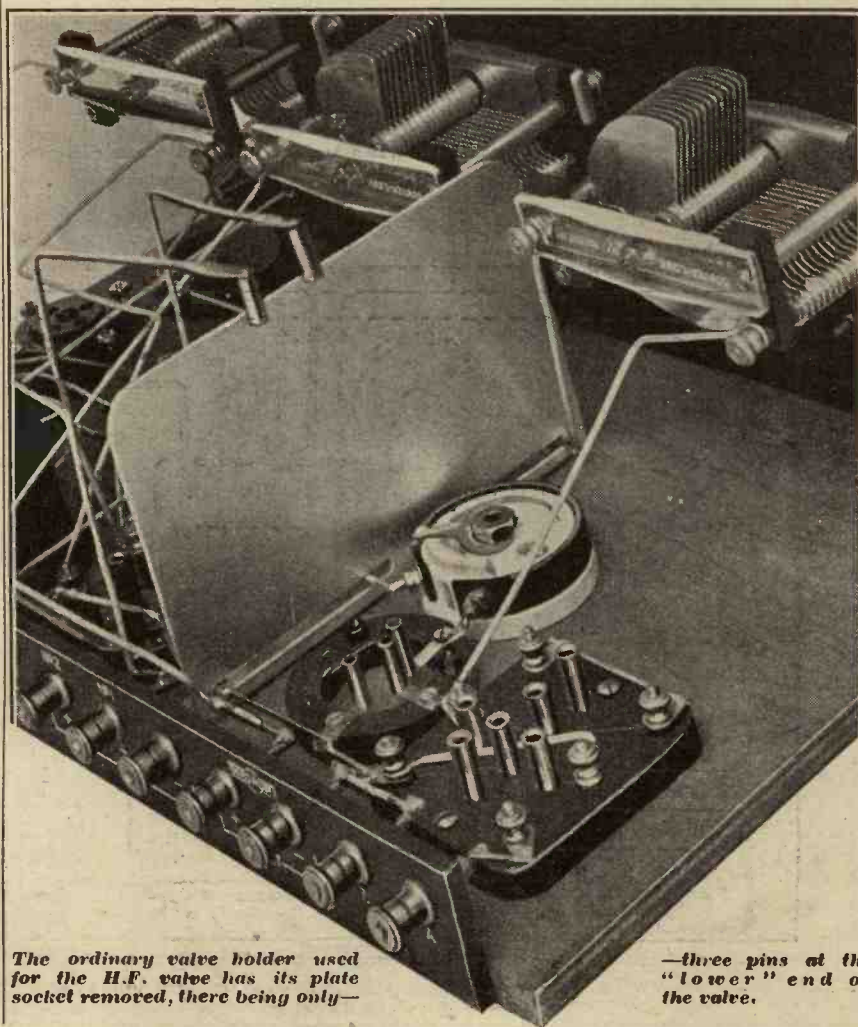

The ordinary valve holder used for the H.F. valve has its plate socket removed, there being only—

—three pins at the "lower" end of the valve.

A "Three" for the New Valve—continued

reaction on the tuned-anode I have taken a standard Reinartz binocular coil, using the connections between 3 and 4 and 5 and 6. The connections between 1 and 2, which are normally the primary, are not used in my arrangement, and therefore no connections are made to terminals 1 and 2 on the second base. Notice specially that the first and second bases are placed differently. On the first base terminals marked 1 and 2 come next to the terminal strip,

while on the second base the terminals marked 4 and 5 are those which come next [to the terminal strip. This simplifies wiring.

The Screening

The aluminium shield is screwed on the baseboard in such a manner that at one end it reaches almost to the terminal strip and the other goes just between the two variable condensers. It is not necessary that it should project farther than shown, but if

you are making your own screen there is no harm in prolonging it until it comes up to the panel. The screening shown, however, is quite sufficient.

As it is not possible to solder to aluminium conveniently by the ordinary methods, two 4 B.A. cheesehead metal screws are passed through the slot in the screen, one at each end, and held tight with nuts. Soldered connections can then be made to these brass screws so as to make electrical contact with the screen. The screen

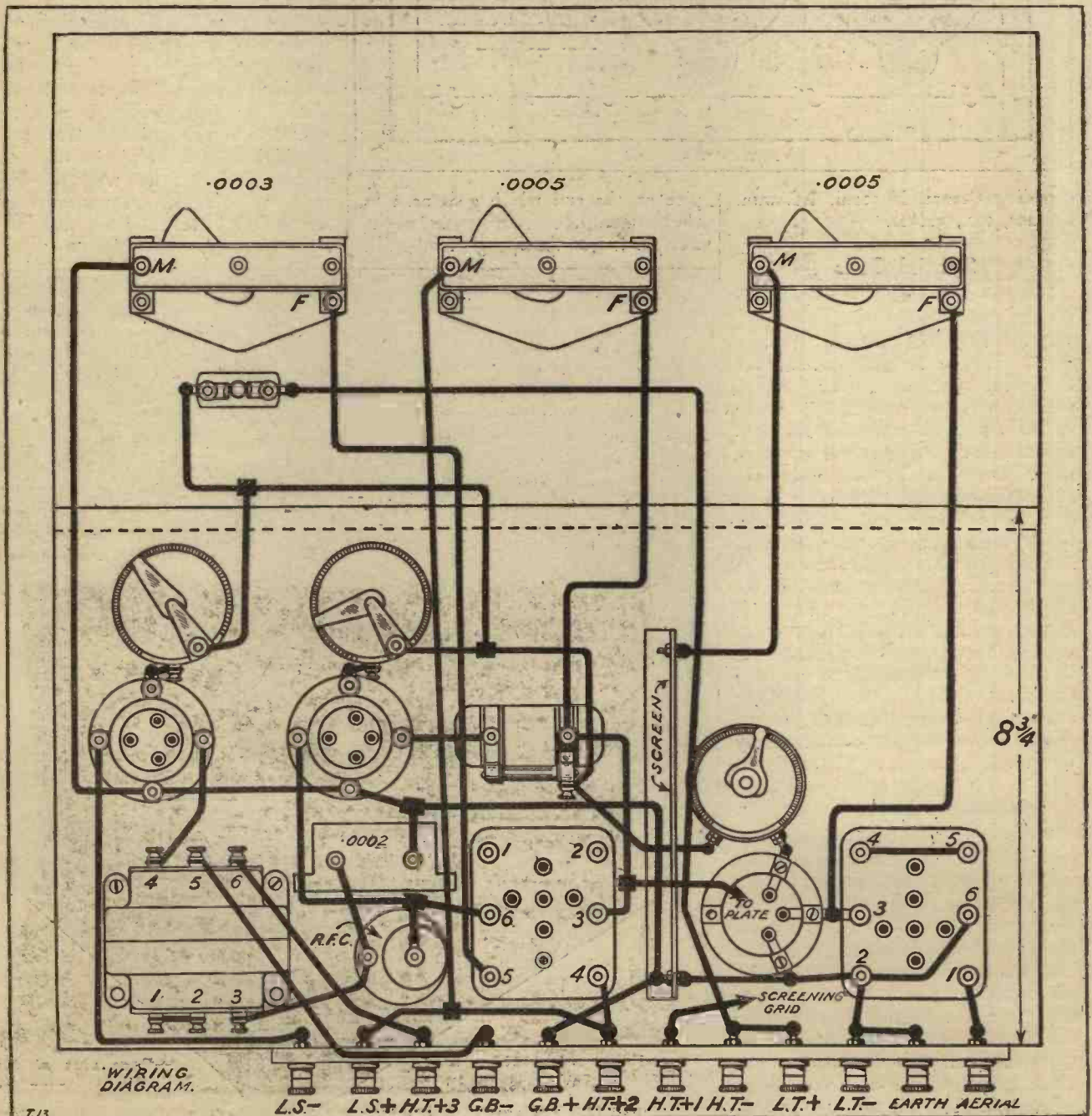

A "Three" for the New Valve—*continued*

is joined to L.T. negative and to earth, so that the lead from the moving plates of the first variable condenser which goes to earth can conveniently be joined to the screen at the panel end as shown.

The screened-grid valve is placed in the holder with three pins below and two projecting above. The upper

denser, the two other baseboard resistors, and the switch. Be careful that this wire does not make electrical contact with the screen, otherwise you will short-circuit your L.T. battery. The rest of the wiring is quite normal, and practically all of it can be carried out before the front panel is mounted in position.

that it, the screened-grid voltage, should be exactly 80 volts. H.T. +2 should go to 120 volts, and H.T. +3 to a suitable tapping for the particular detector valve you are using. You can vary this to find the best position, but usually 60 to 80 volts will be suitable. H.T. +1 should always be 80, and H.T. +2 always 120.

Testing the Wiring

The grid bias will, of course, depend upon the particular low-frequency valve you use. Follow the makers' instructions in this regard. It is as well to test out all the wiring, first of all, with an ordinary valve to make sure all your connections are correct, as you will not wish to risk spoiling the screened-grid valve. As the filament connections are the same for both a screened-grid valve and an ordinary valve it is not a bad plan to test with an ordinary valve you do not value so much, to see whether the filament circuit is correct. If so, you can place the screened-grid valve in position, and make the two connections for screening grid and plate as shown. After this, you simply tune in the station required. There is no fear of oscillation causing trouble to your neighbours, provided you have followed the layout shown. If you use the ordinary six-pin coil in place of the binocular you will get uncontrollable oscillation, and you will cause much trouble.

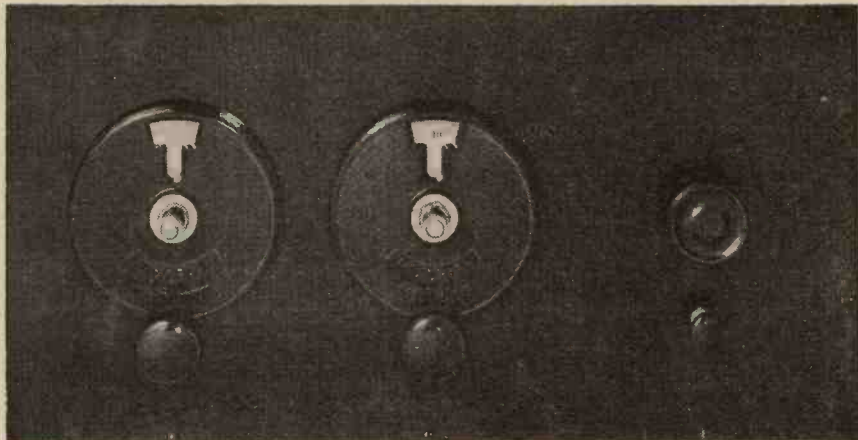

"Indigraph" dials were used on the two tuning condensers. The condenser knob (on the right) is for reaction control.

pin, which would normally correspond with the grid pin on an ordinary base, is connected to the screening grid, and a lead must be taken from this to H.T. +1. By taking your spare socket from the Bowyer-Lowe holder and soldering a stiff wire to it, you can slip it over the pin when you have inserted the valve. The pin which is normally joined to the plate on an ordinary base is also connected to the plate on this valve, and a similar connection is taken from this to the terminal marked 3 on the second six-pin base. If you use an ordinary anti-phonic socket for this valve you should make two small spirals of wire to slip over the upper grid and the upper plate pins respectively, and then take leads from these to H.T. +1 and to 3 on the second coil base.

Beware of Short Circuits

The rest of the wiring is carried out in normal fashion. Notice that H.T. +3 terminal is placed next to loud-speaker positive, for convenience of wiring.

It is as well to use insulated wire throughout. Notice that a positive L.T. lead going to the resistor for the screened-grid valve passes through the slot in the screen, this wire joining the insulated clip on the grid con-

Operating the Set

The operation of this set is extremely simple—much simpler than that of a neutralised receiver. All that is necessary is to set the reaction condenser at zero, join up aerial, earth, loud speaker, and batteries, and adjust the H.T. values.

If you have a voltmeter available, so much the better, for it is advisable

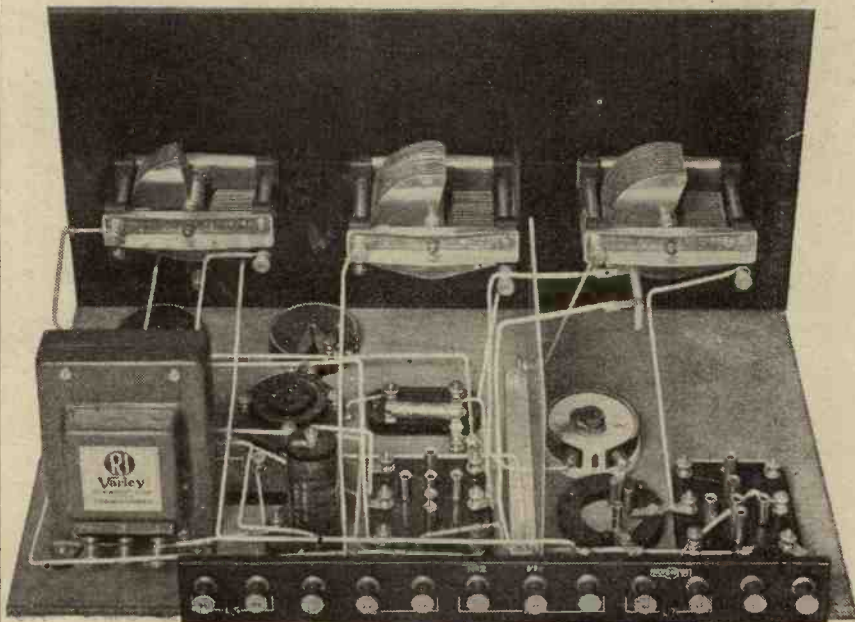

One stage of transformer coupling provides ample L.F. amplification in this receiver.

A "Three" for the New Valve—continued

Furthermore, the set will not function correctly. As mentioned before, the use of binocular coils of small size in this set is absolutely essential for its correct functioning.

"Feed-back" Effects

While it is possible to design a set using the ordinary six-pin coils, if this is done much more complete screening is required, and the design will differ from that I have worked out for WIRELESS CONSTRUCTOR readers. It should also be unnecessary to point out that the ordinary types of plug-in coil are quite unsuitable here. Screened-grid valves have been designed to give a very high magnification, and the elimination of internal feed-back effects occurs inside the valve itself. There is no magic about it, and it cannot possibly eliminate external feed-back effects, which are of far greater importance in this receiver than in the ordinary type, owing to the very high magnification obtainable. Remember, that instead of getting a magnification of about five or ten in your high-frequency

stage (usually you are lucky if you get this) with this particular receiver, you are getting a magnification of

cause oscillation in sets using an ordinary high-frequency stage, will be much more than sufficient to send

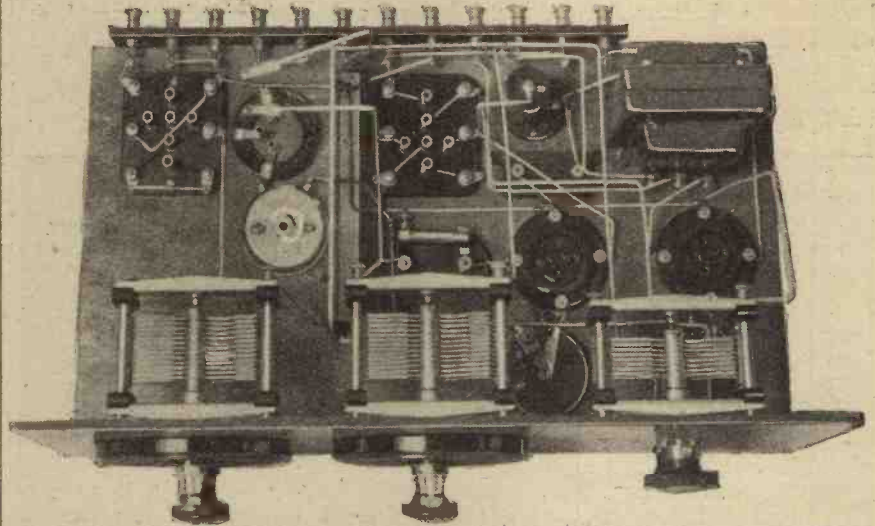

A view of the set which should be of great assistance when the wiring is being undertaken.

something between thirty and fifty in the first stage, so that a feed-back effect which would not be sufficient to

the whole receiver off into violent oscillation.

Both dials will read approximately the same if you use the binocular coils illustrated.

Not Very Selective

The design of a set using two stages of screened-grid valve magnification is a far more difficult task, and very complete screening is required. An experimental receiver of this type is at present undergoing tests in my laboratory, and I hope to be able to describe it in a very early issue.

While the amplification of the present receiver is, as previously stated, comparable with that previously obtainable with two good stages of high frequency, the fact that there is only one tuned circuit preceding the detector circuit means that the tuning is not quite so sharp as that obtainable with an ordinary two-stage high-frequency circuit, for each tuned stage adds very considerably to the selectivity of the receiver. At the same time the selectivity is quite good when the reaction control is operated, and in a very large number of cases will be sufficient for all ordinary work. Daventry Junior, for example, can be cleared free of Langenberg, and vice versa. If the reader is living close to a station, and this is causing more interference than he likes, it will be eliminated with great ease by the use of the Radiano Wave-Trap described in an earlier issue.

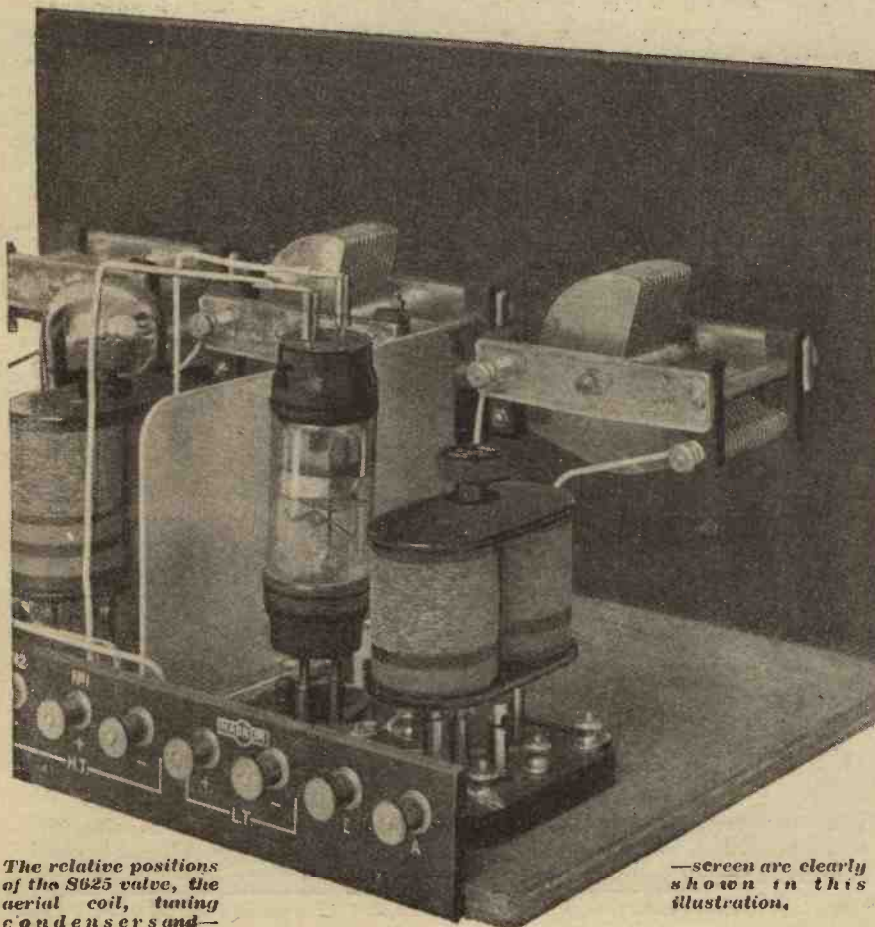

The relative positions of the S625 valve, the aerial coil, tuning condenser and—

—screen are clearly shown in this illustration.

SECRETS OF SHORT-WAVE SUCCESS

Some practical points that will help to improve your radio reception.

From a Correspondent.

If ever I am asked what is the most important factor in short-wave reception I have not the slightest hesitation in replying that it is smooth reaction control. On the medium and long waves it is possible to receive a certain number of stations even with reaction that is somewhat fierce or floppy; anything of the kind, however, is most likely to spell complete failure when reception below 100 metres is attempted.

Smooth Reaction Control

The reaction, again, must not greatly affect the tuning. It has not so far been found possible to devise any circuit for short-wave reception in which the reaction control has absolutely no effects upon the tuning, but in that shown in the accompanying diagram these are so small that they give rise to no difficulties.

It is one thing, though, to draw a circuit diagram and another to build an efficient receiving set from it. For this reason readers who contemplate the construction of short-wave receivers are strongly advised not to attempt to make their own designs, unless they have had a good deal of experience of short-wave work, but to copy faithfully one of those which appear frequently in the WIRELESS CONSTRUCTOR. If this is done, and if no alterations or "improvements" are made in the design, the necessary smoothness of reaction control will be obtained without difficulty.

Stupendous Speed

Next in importance to smooth reaction control we must place absence of body-capacity effects. It must be remembered that when we drop down below 100 metres we begin to encounter terrific frequencies. At 100 metres the frequency is 3,000,000 per second; at 40 metres, 7,500,000; at 30 metres, 10,000,000, and at 15 metres, 20,000,000. Some realisation of what such a stupendous figure as 20,000,000 really means may be obtained in the following way. If you count aloud as fast as you possibly can you will find that about 200 is your limit for a single minute. To reach

20,000,000 you would therefore require to count unceasingly and at top speed for 100,000 minutes.

In other words you would need to continue night and day for a few hours less than ten whole weeks to complete the task of counting the number of undulations performed in a single second of time by the carrier-wave of a 15-metre transmission!

Body-capacity Effects

It is mainly on account of the high frequencies involved that an ordinary broadcast receiving set is generally practically useless for short-wave work. The higher the frequency of the received signal the greater is the tendency for body-capacity effects to occur unless special precautions are taken to eliminate them.

In the circuit seen in the drawing it will be noticed that one set of vanes of each of the two variable condensers C_1 and C_2 is connected to earth. If this connection is made from the

The radio-frequency choke helps to reduce the amount of high-frequency oscillations passing in the remainder of the circuit, but it does not by any means entirely eliminate them.

The by-passing condenser C_3 again shunts away to earth a fairly large proportion and the resistance R_3 helps to prevent these impulses from reaching the grid of V_2 .

But if there were no filter in the plate circuit of this valve and the telephones were wired directly between its plate and H.T. positive it would probably be found, on wave-lengths below about 30 metres at any rate, that distinct and rather curious body-capacity effects were to be observed. When, for example, a telephonic transmission such as that of K D K A on 14 metres is tuned in with the telephones connected in this way it is quite likely, if they have metal headbands, that touching these will produce a plopping noise or even a howl in the receivers.

Fine tuning on the main dial is essential to successful short-wave working; and the reaction control must be evenly and accurately adjusted at the same time.

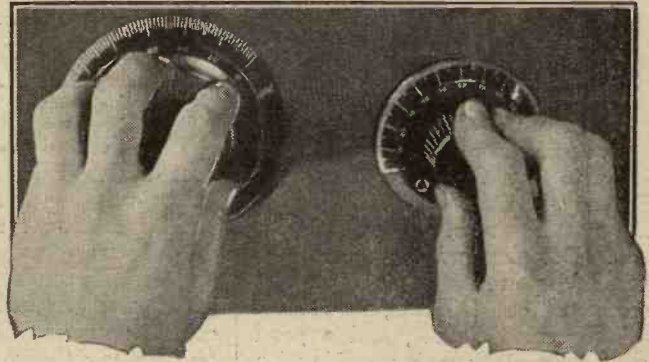

moving vanes body-capacity effects are decreased, since the vanes attached to the spindle with whose knob the hand comes into contact are at high-frequency earth potential. This precaution, excellent as it is, is, however, insufficient in itself on the very short waves owing to the difficulty of keeping high-frequency impulses out of the low-frequency parts of the circuit.

It might be thought that the output of the rectifying valve consists of audio-frequency impulses only, but in practice this is not the case, for in addition to the audio-frequencies there is also a high-frequency component.

If the telephones are removed from the head either the signal will disappear altogether or the set will howl dismally. When, whilst wearing the telephones, one's head is brought anywhere near the high-frequency end of the set the tuning alters completely. By the use of a filter circuit as shown in the diagram, and by connecting the telephones between the plate of the last valve and L.T. negative, with the large condenser C_6 in series, one end of their windings is kept at earth potential and these queer capacity effects are eliminated. The

SECRETS OF SHORT-WAVE SUCCESS

—continued

shunting condenser C_7 may not always be necessary, though as a rule it is a great improvement on the very short waves, for it helps to keep high-frequency impulses out of the telephone windings.

You may be surprised that I have mentioned smoothness of reaction control and absence of body-capacity effects as the most important factors in short-wave success, without so far

the best, and coils and so on that are not of the highest efficiency, provided that as regards the factors already discussed the set is all that it should be.

I have actually received all of the stations mentioned above in the course of experiments: (1) Without using aerial or earth at all; (2) using coils made of No. 30 D.C.C. wire wound without any spacing on formers that were anything but low loss; (3) with variable condensers that could not possibly be classed as first-rate components. I do not claim that in any of the cases mentioned signal strength was great or that signals

 * USING THE RADIANO *
 * SHORT-WAVER *
 * A READER'S RESULTS. *

SIR,—Having just completed your latest set, "The Radiano Short-Wave Two," and being very desirous of trying same, I decided to do so on a recent Sunday morning.

Commencing about 1 a.m., W G Y on 33 metres came in about 2 a.m., and I held that station until 3.45 to 4 o'clock.

Towards the latter part of that time I could have worked a small loud speaker, reception with two pairs of 'phones lying on the bench was all that could be desired, and every word distinct. Considering the time of year, I think this is very good, and speaks volumes for the efficiency of the receiver.

Having at previous times tried numbers of short-wave receivers, I really think this is the finest.

As regards the reaction control, this is absolutely the best that could be used. As I did not have a slow-moving dial on this condenser I put one of the usual neodyne condensers in parallel, the final adjustment of this condenser giving just that fine adjustment necessary.

The coils used were made by the writer on paxolin formers, with valve legs tapped into same, and the connections taken to these with tags and soldered, valve sockets being used on a strip of ebonite to make the connection to the receiver. I find this method very practicable and easy to use.

The valves used were S.P.18 Green Spot for detector and S.T. for L.F., both being 2-volt valves.

Yours truly,
 G. P

Uxbridge.

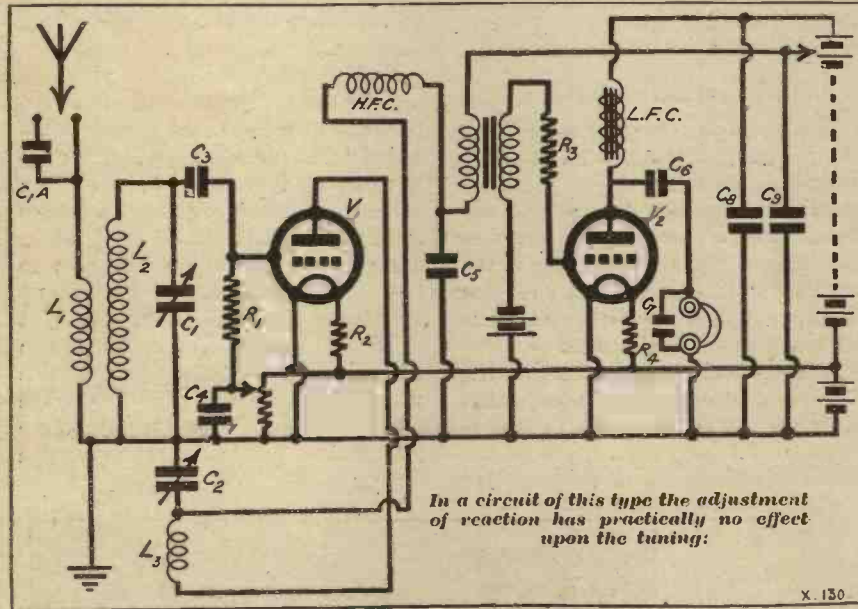

In a circuit of this type the adjustment of reaction has practically no effect upon the tuning:

x. 130

saying a word about aerial, earth, coil, or condenser efficiency. I am not going to say for a moment that efficiency in these departments does not matter; most emphatically it does. But short-wave transmissions come in so powerfully that fairly good reception of 2 X A F, 2 X A D, P C J J and K D K A, and a good many other stations, is possible with a poor aerial, an earth that is not of

could have been heard on bad nights.

The use of a really good aerial in combination with a first-rate earth enormously improves signal strength, besides making tuning easier. Cut down losses by using the best of coils and variable condensers, and you will find that even on those nights when conditions are at their worst there is nearly always something to be heard from distant short-wave stations.

IF ROBINSON CRUSOE WERE WRECKED TO-DAY



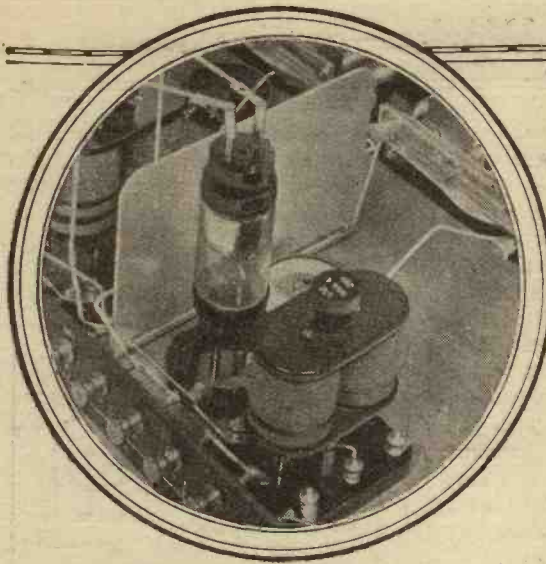

How the SCREENED VALVE Works

An essentially practical article describing the characteristics and the circuit requirements of the new S.925 valve.

By W. JAMES.

A NEW valve which, it would appear, is almost bound to have the effect of modifying the design of the radio-frequency portion of wireless receivers, in Great

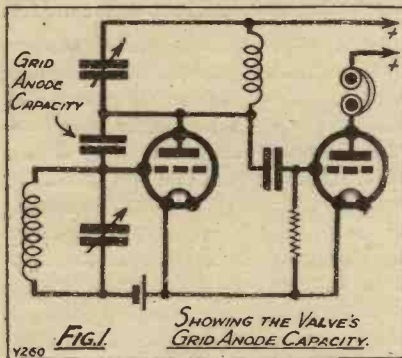

Britain at all events, is about to be marketed.

Grid-Anode Capacity

This valve has four electrodes—a filament, control grid, and anode, with a specially constructed metal screening grid located between the control grid and anode. It should not be confused with the ordinary four-electrode valve—the new valve has several quite distinctive features all its own. The valve is, in fact, so designed that the capacity of the control grid to anode is quite negligible when the screen is connected to a point of fixed potential such as the earth or the anode-circuit battery, and its anode impedance and amplification factor are of quite a different order of magnitude from those usual for the ordinary types of valve. But before we can fully appreciate the factors which led to its development we must consider in what way the original three-electrode receiving valve has proved to be defective.

An ordinary receiving valve has a considerable capacity between its

grid and anode. This capacity measured under "static" conditions—i.e. with its filament not heated—is found to be of the order of 6 to 10 micro-microfarads. But under working conditions the grid's effective capacity may increase to several times this value. This capacity provides a coupling between the anode and grid circuits, with the result that the ordinary three-electrode valve is not a unilateral device at all; that is to say, the grid and anode circuits

to the grid circuit the amplified voltage produced in the anode circuit, by normal valve action, causes a certain amount of current to pass back to the grid circuit through the grid-

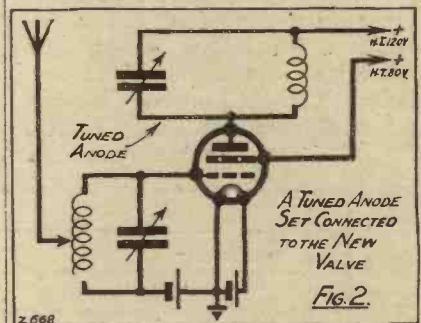

The valve has five pins, two at one end and three at the other. The two connect to the shielding grid and the anode respectively, while the other three make contact with the control grid and the two ends of the filament.



are not electrically isolated by the valve, but are actually coupled by the grid-to-anode capacity (Fig. 1).

Cause of Instability

It is this capacity which tends to promote instability in radio-frequency amplifiers, for when a signal is applied

to the grid circuit the amplified voltage produced in the anode circuit, by normal valve action, causes a certain amount of current to pass back to the grid circuit through the grid-

anode capacity. This current is usually of sufficient magnitude and acts in such a way as not only to strengthen the signals originally applied to the grid, but to cause the circuit to burst into oscillation. Thus radio-frequency circuits tend to suffer from chronic instability.

Neutralising Methods

So far as radio-frequency amplifiers are concerned, various methods have been devised for neutralising the valve's capacity or for stabilising the circuit. To be sure, there are other couplings besides that due to the valve's capacity which may be the cause of instability, but we must assume that stray magnetic and conductive couplings are eliminated by careful circuit design. This involves, in many instances, the complete screening of coils, tuning

How the Screened Valve Works—continued

condensers, and other incidental apparatus, and very often the provision of adequate by-pass condensers and choking coils.

But having removed all the stray couplings provided by the positions of

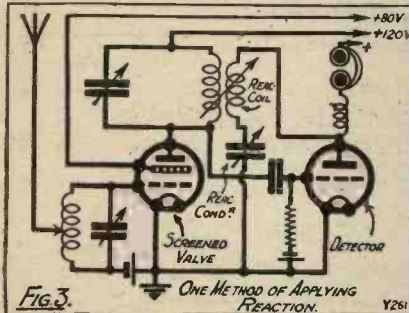

the parts of the receiver, we are still left with the capacity of the grid to anode, and modern practice would seem to indicate that the best way of dealing with this is by a simple circuit which allows of complete capacity neutralisation. This normally involves the provision of coils and condensers *additional* to those required for tuning the circuit; a

fairly simple matter, it may seem, but yet one which adds to the complexity of a receiver.

To be effective, certain precautions have to be taken, but with careful design and skilled adjustment it is possible so to arrange the radio-frequency stages that they remain in a stable condition for the whole of their tuning range. The neutralisation may not be perfect—in fact, in practice it very seldom is perfect—with the result that there is a varying amount of feed-back at the different wavelengths to which the receiver is tuned. This is not particularly troublesome, however, provided the amount of feed-back is not sufficient to produce a condition of instability.

Sacrificing Amplification

Many other schemes have been devised and used to stabilise radio-frequency amplifiers. Some of them really ought not to be classed as stabilisers at all, for they act effectually to limit the amount of amplification, which in turn reduces the amount of energy fed back from the

anode to the grid circuit. Thus the tendency for the receiver to be unstable is reduced, but at the expense of amplification and, it would seem, of selectivity as well.

Knowing that all the difficulties are primarily due to the valve's anode-

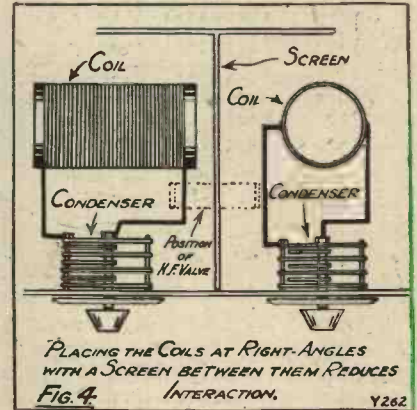

to-grid capacity, it seems strange indeed that only of late has a serious attempt been made to construct valves having a negligible anode-to-grid capacity, for with a valve of this type there would be no need to employ any of the special balancing or stabilising devices so necessary with ordinary receiving valves. Moreover, it would seem that with such a valve one would be able to secure a very high amplification with complete stability.

Stray Couplings

Naturally, one would still have *completely* to remove all stray couplings between the individual stages of a receiver, but this has to be done in any case, and by complete removal of stray couplings we mean the removal of magnetic couplings, which may be due to the interaction of tuning coils, of stray capacitive couplings due to the proximity of tuning coils and condensers, wires, and other apparatus, and of conductive couplings due to the impedance of connecting wires, batteries, and so on.

This involves the use of metal screens, by-pass condensers, and choking coils, according to the overall amplification obtained; but, as we have said before, these precautions have to be taken regardless of whether the valve's capacity is neutralised by a special circuit, whether other forms of stabilisation are used, or whether the valve itself is so designed that

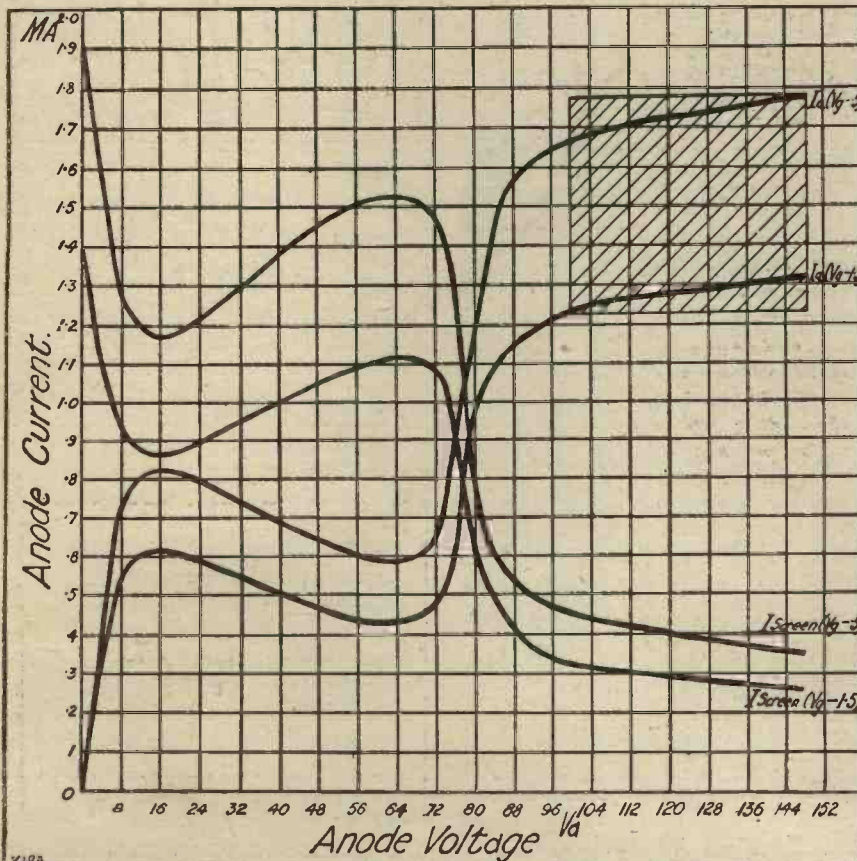

A characteristic curve of unusual type showing the anode current plotted against anode voltage for various grid voltages. The shaded area is the "operating" area of the curve.

How the Screened Valve Works—continued

its capacity is so small as to be of no account.

To effectually screen the anode of a valve from its grid may seem at first sight to be an utter impossibility; for one might think, and rightly, too, that were the screen so perfect as to eliminate completely

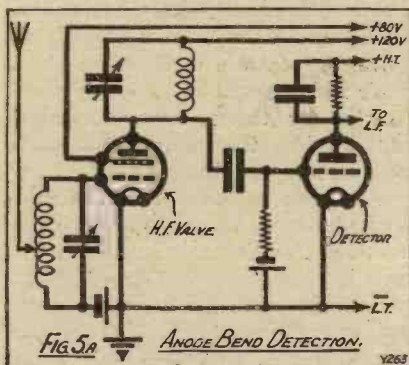

the capacity of the grid-to-anode the normal valve action would fail. One would think that while the grid would still be able effectually to control the stream of electrons emitted by the filament none of the electrons would reach the anode. In practice this is not quite true, and it is found that the anode current which flows is still under the control of the grid. However, the valve's characteristics are quite different from those we are accustomed to.

An accompanying figure shows the variation of anode current with grid bias under a given set of conditions. These are, a filament current of 5 volts 0.25 ampere, a screen voltage of 78, and an anode voltage of 120. Further readings were taken with an anode voltage of 140, and the second curve was drawn. This lies very near the first curve. A third curve was then drawn to show how the screen current varied whilst taking the 120 anode voltage curve. This curve shows the screen current varies from zero to 0.54 milliampere.

Remarkable Amplification Factor

By the usual methods the amplification factor was found to be 135 for an anode impedance of 300,000 ohms. These figures are remarkable enough in themselves and imply that special circuits have to be devised to suit the valves.

Fortunately the circuits are very simple ones, as presently we shall show, but for the moment let us look at another set of curves which has

been taken for the same sample valve. These curves show the variation in anode current with anode voltage for a fixed grid bias and screen voltage. For one curve the grid bias was set at negative 0.5 volt and for the other curve at negative 1.5 volts: in both instances the screen was joined to positive 78 volts.

These curves show that as the anode voltage is increased the anode current rises from a small value, until, at a certain point, it decreases rather rapidly, only to rise again and to remain practically steady for the higher anode voltages.

Normal Working Area

Readers will recognise here a characteristic similar in some respects to Dr. Hull's dynatron, which may give rise to negative resistance effects, but the part of the curve which we are interested in at the moment is the top part, corresponding to anode

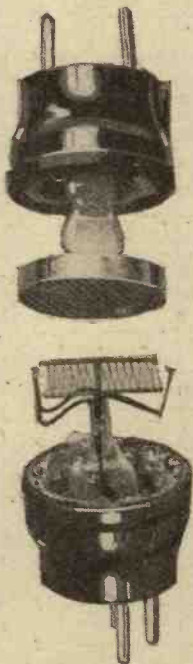

The works of the new shielded-grid valve. Fitting closely to, but insulated from, the plate, we have the shield—both shown in the top section of the photograph—while below is the usual grid and filament arrangement.

voltages of 96 to 148. This is not quite flat, although it is nearly so, and the two curves are roughly parallel. The curves show that the anode current can be changed by about 0.47 milliampere by one volt grid bias, and from these curves it is easy to see why the anode current changed by such a small amount in the previous test when anode voltages of 120 and 140 were tried.

The normal working area is indicated by the shaded portion. From

this it is clear that the voltage amplification obtainable, given an output circuit of suitable design, is very large indeed. In fact, we can get from the valve a voltage varia-

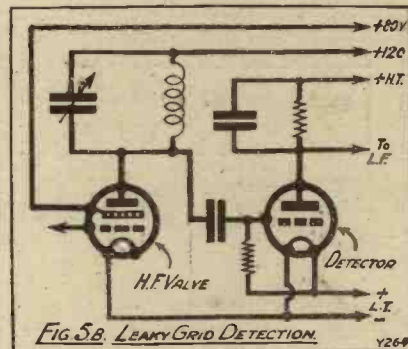

FIG. 5B. LEAKY GRID DETECTION.

tion of from about 100 to 148 volts for a voltage input, which will depend on the constants of the anode circuit. As the impedance of the anode circuit is made larger so shall we obtain this output voltage variation with a smaller input.

If the impedance of the anode circuit were made identical with that of the valve, we should obtain a voltage amplification of 135 divided by 2, or say, 67. If, therefore, we applied a high-frequency signal of 0.4-volt peak value, we should get out of the valve a high-frequency voltage of 27, which is within its limits.

Using the Valve

We have now to consider the use of this valve in a receiver, and we will consider the matter first from a theoretical point of view, and secondly from a practical point of view. In the first place, magnification depends upon the impedance associated with

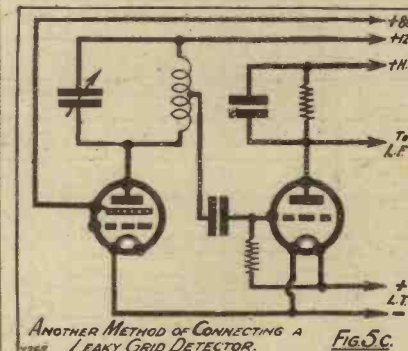

ANOTHER METHOD OF CONNECTING A LEAKY GRID DETECTOR. FIG. 5C.

the output circuit and the amplification increases with the impedance. I have worked out a few examples

How the Screened Valve Works—continued

to show this more clearly; these are given in Table 1.

It is assumed that the valve has an impedance of 300,000 ohms and a voltage factor of 135, and that impedances of various values are connected to the anode circuit.

TABLE 1.

Impedance connected to anode of valve.	Calculated value of magnification.
600,000 ohms	90
300,000 "	67
200,000 "	54
100,000 "	34
50,000 "	19
25,000 "	10

The table shows that as the impedance connected to the anode

circuit is reduced, so the magnification falls off. It is therefore obvious that to obtain a maximum amplification it is necessary to employ a circuit of very high impedance connected to the anode of the valve, and we have now to inquire as to how we can obtain the necessary high impedance with a practical circuit.

A tuned transformer is quite out of the question because the valve's impedance is so great. We must confine ourselves to the tuned-anode type of circuit, Fig. 2. Now, we can work out the effective resistance of a tuned-anode circuit if we know the inductance of the coil, the capacity of the tuning condenser at the wave-length considered, and the resistance of the circuit, and from previous measurements which I have made we

can write down the following values as being typical:

Tuned Anode Resistance

Wave-length, 400 metres. Inductance of coil, 290 microhenries. Maximum capacity of tuning condenser, .0003 mfd.

Such a coil will tune from about 200 to 600 metres, and, given coils of equal inductance, the only thing we have to concern ourselves with is their resistance at the working wave-length, for this is the factor which will decide the working effective resistance.

As the resistance of the coil is made lower by good design, so the effective resistance of the tuned-anode circuit will increase in proportion. Thus, a well-made tuned circuit comprising a coil of high-frequency cable will offer an effective resistance of about 250,000 ohms at the wave-length of 400 metres to which it is tuned.

Importance of the Coil

When a good coil of solid wire is used, the effective resistance will usually lie between 100,000 and 150,000 ohms, while, when an ordinary single-layer coil wound with a fairly fine gauge of wire, or an ordinary type of plug-in commercial coil, is connected the circuit will have an effective resistance of 40,000 or 50,000 ohms.

When the tuned circuit is one having a 200-microhenry coil and a .0005-mfd. variable condenser for tuning, the values of effective resistance will be rather lower.

If we put these values in tabular form we shall be able to make comparisons much more easily. This has been done, and the results are given in Table 2.

Using Reaction

It will be seen that it is theoretically possible to obtain an amplification of 61 with the coil wound with high-frequency cable. Good solid wire, single-layer coils will give with this valve a magnification of 34 to 45, whilst, when the tuning coil is an ordinary single-layer coil or plug-in coil, the magnification obtained will be from 16 to 23. We therefore see that it will pay us to use the best possible coil, since it is the coil which plays so large a part in deciding the magnification.

There now comes another question. We have so far been dealing with the

(Continued on page 82)

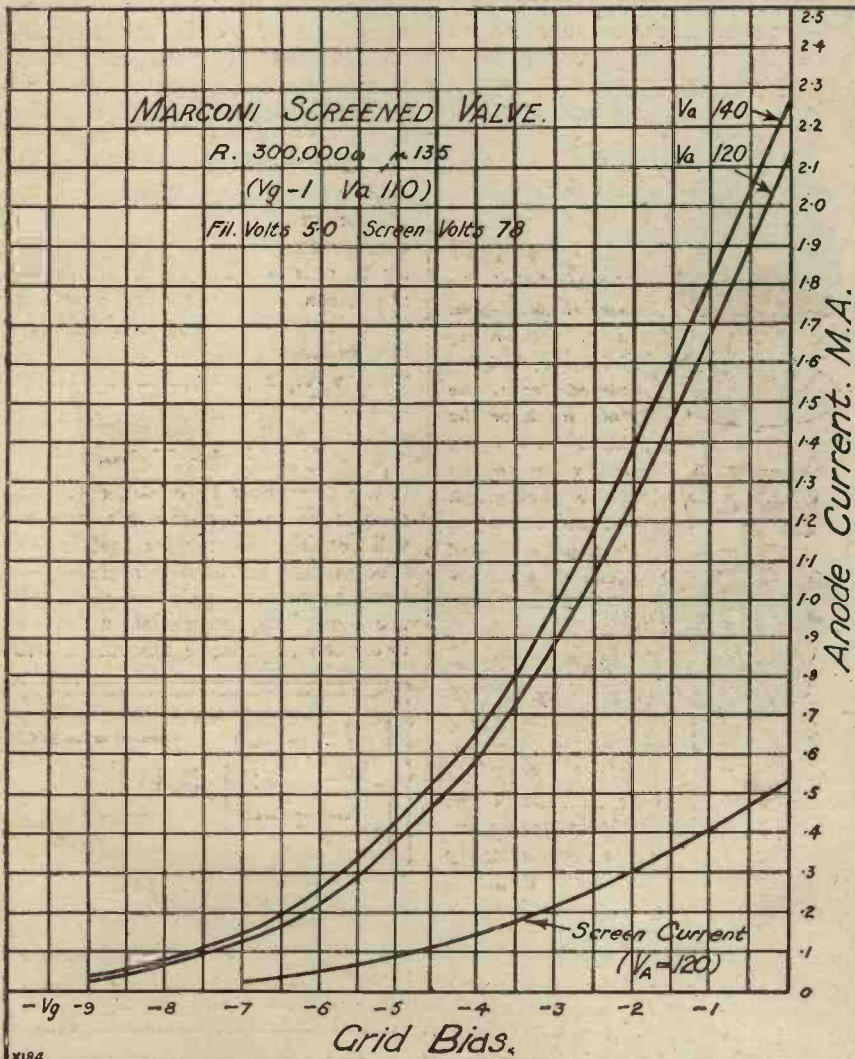

The Marconi screened valve gives a static curve as shown above when the anode volts are 140 and 120 respectively with the screen at 80 volts above zero. The screen current curve is taken with the screen at 80 volts and the anode at 120 volts H.T.

The "CHUMMY" TWO

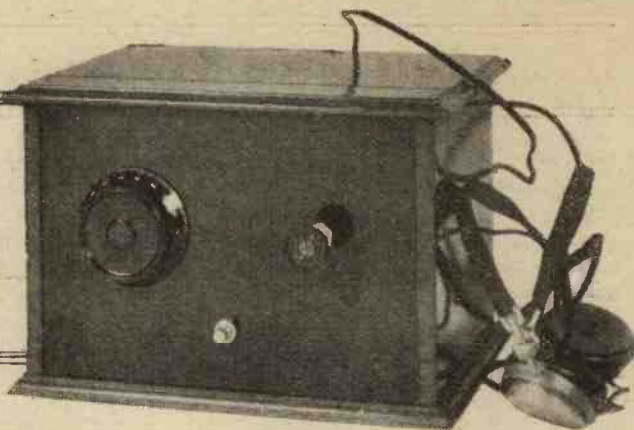

"WHAT is the best I can do with two valves?" is a question often asked by the home constructor, and particularly by residents in country districts where accumulator charging and the high-tension problem make valve economy essential. Properly speaking, there

COMPONENTS REQUIRED.

- 1 standard panel, 10 in. × 7 in. (Radion, Ebonart, Resiston, Paxolin, etc.)
 - 1 cabinet for same, taking a 7-in. baseboard.
 - 1 '0005-mfd. variable condenser, S.L.F. or S.L.W. (see note below).
 - 1 panel-mounting "neutrodyne" condenser. That shown is a McMichael.
 - 1 on-and-off switch. (Igranic, Benjamin, Lotus, etc.)
 - 1 baseboard-mounting Formodensor, '000025 mfd., or Excel Variodensor, model N.
 - 1 fixed condenser, '0003 mfd., with clips for grid leak of 4 megohms. (Lissen, Dubilier, Igranic, etc.)
 - 2 antiphonic valve sockets. (Benjamin, Lotus, C.E. Precision, etc.)
 - 2 fixed resistors to suit valves used. (Amperite, Tempryte, Lissen, etc.)
 - 1 radio-frequency choke. (The Ormond is shown, and occupies very little space, but any good standard make will do provided it will fit into the space available.)
 - 1 L.F. transformer. Care must be taken in choosing this, as the space available is not great. The C.A.V. All-Purposes is shown in the set.
- Terminal strip with ten terminals for Aerial, Earth, L.T. - and Grid Bias + combined, L.T. +, H.T. -, H.T. + 1, H.T. + 2, G.B. -, L.S. +, L.S. -.
- Glazite or other insulated wire.
- Split-secondary transformers for 250 to 500 metres and 1,000 to 2,000 metres are required.

A Det. and L.F. receiver, with the specially sharp tuning suitable for separating 5 G B.

By HARRY P. WOOTTON.

schemes of which the "Hale" is perhaps the most popular at the present time.

A Limited Choice

Any scheme for using two valves as an amplifier following a crystal detector means that one is limited to the local station for reception, and the writer has yet to find an efficient method of using a high-frequency

detectors, as well as reflexes of all kinds, we soon come to a choice between the detector and one note magnifier and the high-frequency valve preceding the detector. The latter, if properly designed, is the more sensitive in distance-getting powers, but it suffers from the disadvantage that even when the local station is very close it is impossible to obtain sufficient volume to operate a loud speaker. The detector and one note magnifier, on the other hand, is capable of no mean distance-getting achievements (although these are not so good as with the one high-frequency valve and a regenera-

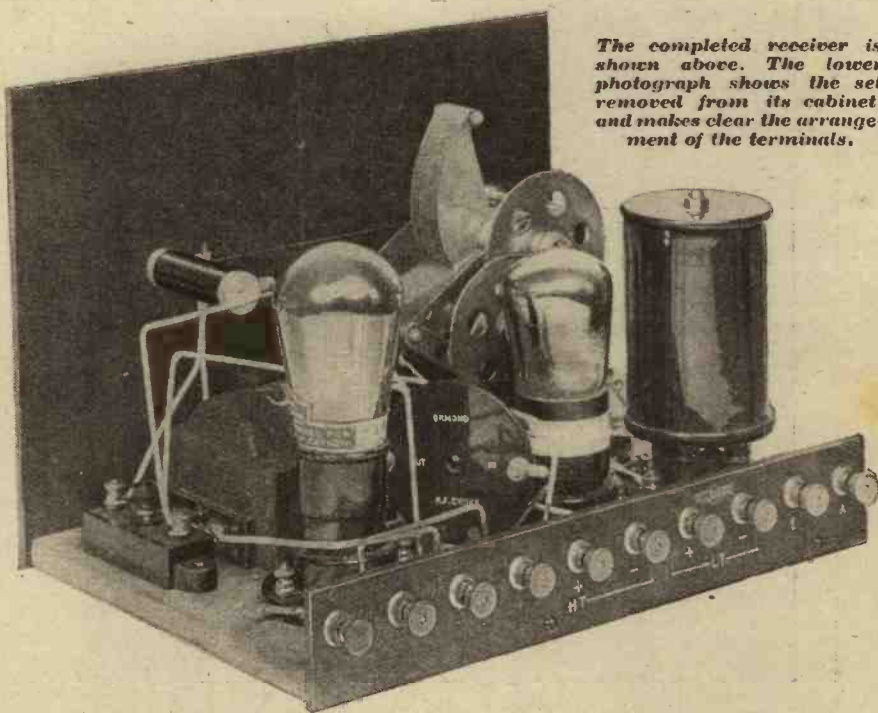

The completed receiver is shown above. The lower photograph shows the set removed from its cabinet, and makes clear the arrangement of the terminals.

are but two ways in which one can use a pair of valves, namely—as a detector followed by a note magnifier, or as a high-frequency valve preceding a detector (disregarding for the moment their use with crystal detectors). These are the two "straight" arrangements, but in addition we have several reflexing

valve preceding a straight crystal detector, for, while one gains from the high-frequency stage, the fact that neither amplification nor reaction is possible by the detector itself results in almost as much loss as gain. For the man who dislikes crystal

tive detector) while it also serves to give quite good loud speaking on the local station provided this is situated not more than ten or fifteen miles away. Many thousands of experimenters live within such a range, so that one can reasonably expect that

The "Chummy" Two—continued

the detector and note-magnifier arrangement will have a wide appeal.

There is, however, one other virtue associated with the high-frequency valve preceding the detector. Such an arrangement can be made to tune very sharply—no small advantage in these days of 5 G B and the excellent transmissions from some foreign stations. However, the writer has been experimenting for some time to find a really sharp tuning arrangement with a detector and one stage of note magnification. The circuit used in the "Chummy" Two is the result of much work, and is presented to the experimenter in the firm belief that in it he will find a solution to many of his problems of selectivity. All parts are standard and easily obtainable, and there is a wide variety of choice in every one of them. In particular, the set has been made exceedingly compact without sacrificing efficiency.

If the reader examines the circuit he will find that a standard split-

grid circuit, and the other half in the plate circuit, reaction being obtained by the manipulation of a small neutrodyne condenser mounted

Now, this arrangement has one very important advantage which has a big bearing on the problem of selectivity. The detector valve, being

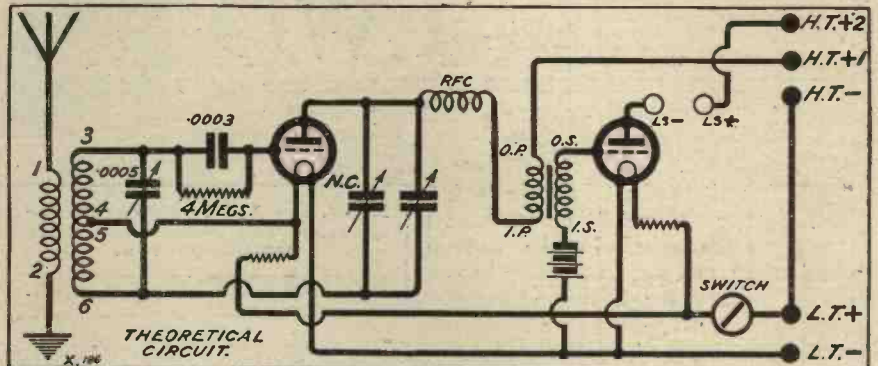

The theoretical circuit upon which the connections of the "Chummy" Two are based.

on the panel. In order to give a wide flexibility to the arrangement, so that it may suit all types of valves, a second small adjustable condenser is placed in parallel with the neutrodyne condenser, this being adjusted in the preliminary experiments so

shunted across only half of the tuning inductance, has a far smaller damping effect on this circuit than would be the case if it were across the whole, as in the usual Reinartz arrangement. Not only does this permit of very sharp tuning (Langenberg and 5 G B are easily separable), but a much smoother adjustment of reaction is possible.

The note-magnifying stage is of standard design, and presents no special features. Separate high-tension tappings are used for both detector and note-magnifying valves, and separate fixed resistors for each valve, while grid bias is, of course, provided in accordance with modern practice. In this way any combination of valves can be used, and when one is close to a station, a super-power valve in the last stage, with 120 or 150 volts, enables the maximum purity to be obtained.

Valves and Condensers

The first valve can either be one of the types specially sold as detectors or what is generally called a "high-frequency" valve having a magnification of 15 to 25. These latter make very good rectifiers in this circuit, and I prefer them for the purpose. The note-magnifying valve can be any standard small-power valve, or super-power valve if loud signals are being handled. The grid bias must be adjusted to suit the valve used. Two-, four-, or six-volt valves, all work well in this set. The 6-volt types are best.

SPECIAL NOTE.—The grid leak has a value of 4 megohms, and is *not* the conventional 2 megohm leak. While

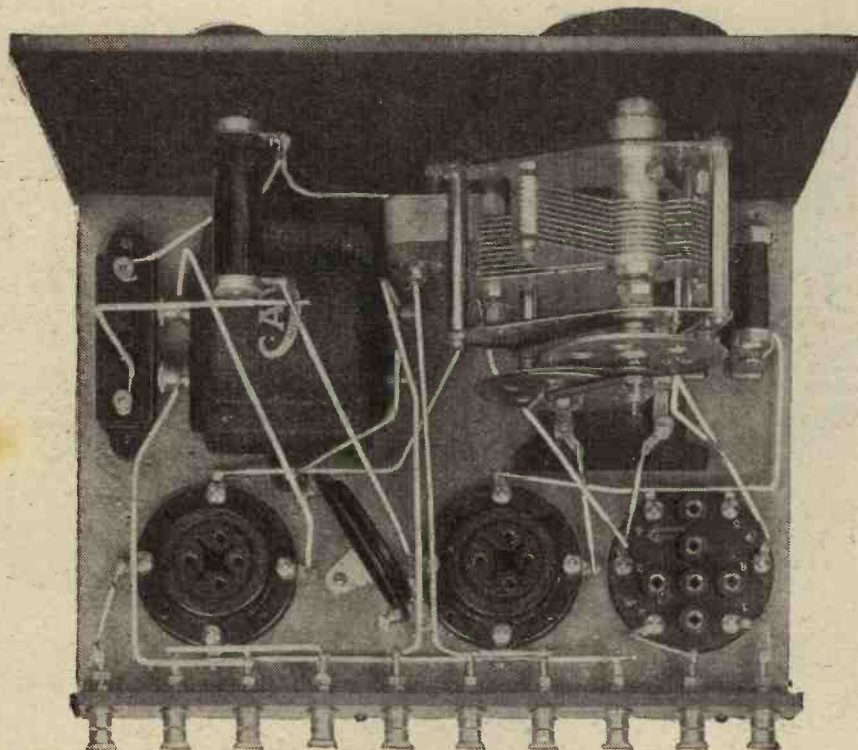

This photograph, taken directly from above the baseboard, shows in which positions the grid and plate sockets of the valve holders are placed.

secondary high-frequency transformer is used, one winding being connected to aerial and earth, the other being tuned by a 0005-mfd. variable condenser. Half of the winding is in the

that, at a maximum reading of the tuning condenser, the set can just be made to oscillate, using the maximum setting of the neutralising condenser mounted on the panel.

The "Chummy" Two—continued

the latter can be used, the reaction control will be much smoother with the 4-megohm value.

Tuning is so sharp on this receiver that it is essential to have a vernier

a coil in the base; you will then be able to see that all parts clear one another. Keep as closely as possible to the layout shown when first building this set. Afterwards, if you desire to

is screwed to the baseboard. You will find this a great convenience. When you have done all that is possible in this way, screw the front panel against the bottom of the baseboard (brackets are not required for such a small panel as this), and solder up the remaining wires. In such a compact set the writer strongly advocates the use of some form of insulated wire to avoid all possibilities of a short-circuit.

The neutralising condenser used as the reaction control must not be of the type in which it is possible to short-circuit the plates, as in the event of this latter happening, the H.T. battery will be short-circuited, with disastrous results.

Preliminary Adjustments

The operation of the set is extremely simple. Aerial, earth, valves, and telephones or loud speaker are joined up and the correct grid bias selected. The voltage on H.T. + 1 can be anything from 30 to 80, depending upon the type of valve; that on H.T. + 2 should be the maximum you have available. Before switching on, set the panel neutralising condenser at

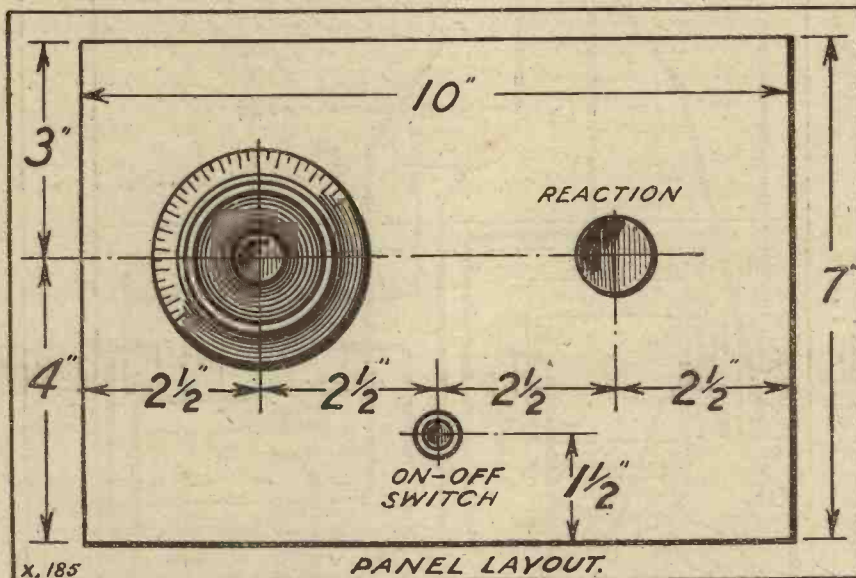

device. The writer, for this circuit, would give preference to condensers having a built-in vernier arrangement (such as the Gecophone illustrated, Brandes, Ormond, Jackson, etc.) The ordinary condensers with separate vernier dials, while excellent in some circuits, are not so desirable in this arrangement, as the metal plate tends to accentuate hand-capacity effects. The reason for this is that both fixed and moving plates of the condenser are above earth potential. Perfectly satisfactory results will be obtained with any of the condensers mentioned.

Some Constructional Tips

One terminal is used for both L.T. negative and grid bias positive. There is no reason for this other than the saving in space which the arrangement effects, as the space available for the terminal strip is only ten inches long. The cabinet should be cut to allow of the terminal strip fitting across the full width of the back.

The tuning condenser, reaction condenser, and on-and-off switch must first be mounted upon the front panel, and this held against the front of the baseboard while the other parts are laid out. It is not a bad plan, in laying out your parts, and before screwing them to the baseboard, to insert the valves in their sockets and

make changes in layout, you will have had the satisfaction of knowing how

Much of the wiring can be followed from this photograph, which should be compared with the wiring diagram.

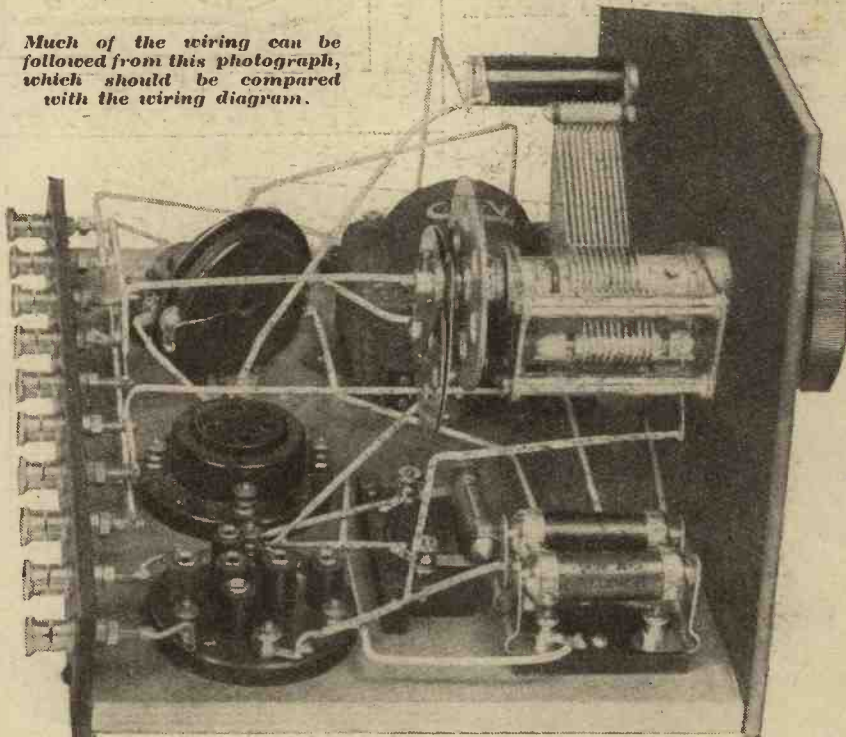

the set works when laid out as indicated in the design.

Practically all the wiring can be carried out before the front panel

minimum position (in the screw-down type this means the knob turned as far as possible to the left) and the baseboard adjustable condenser at

THE "CHUMMY" TWO

—continued

minimum also. It is better to make the preliminary adjustments with telephones rather than with loud speaker.

Now tune in the nearest station, whereupon you will find that by adjusting the neutralising condenser you can increase the volume very considerably. Be careful not to send the set into oscillation on this wavelength, or you will cause interference with your neighbours.

Controlling Oscillation

When you have tuned in this local station, try for another, such as 5 G B, and again try the reaction. When you have picked up two or three stations set the tuning condenser at its maximum position and, by carefully listening in the telephones, see whether the set can be made to oscillate by adjusting the panel neutralising condenser. At the full "on" position, if you have still not reached the oscillation-point (you will recognise this by the slight "plock" or a rushing noise in the phones when the set goes into oscillation) give a turn or two to the baseboard-condenser knob until the set just oscillates with the panel reaction condenser at the maximum position.

Remember in tuning that the higher the reading on the tuning condenser the more reaction condenser will be

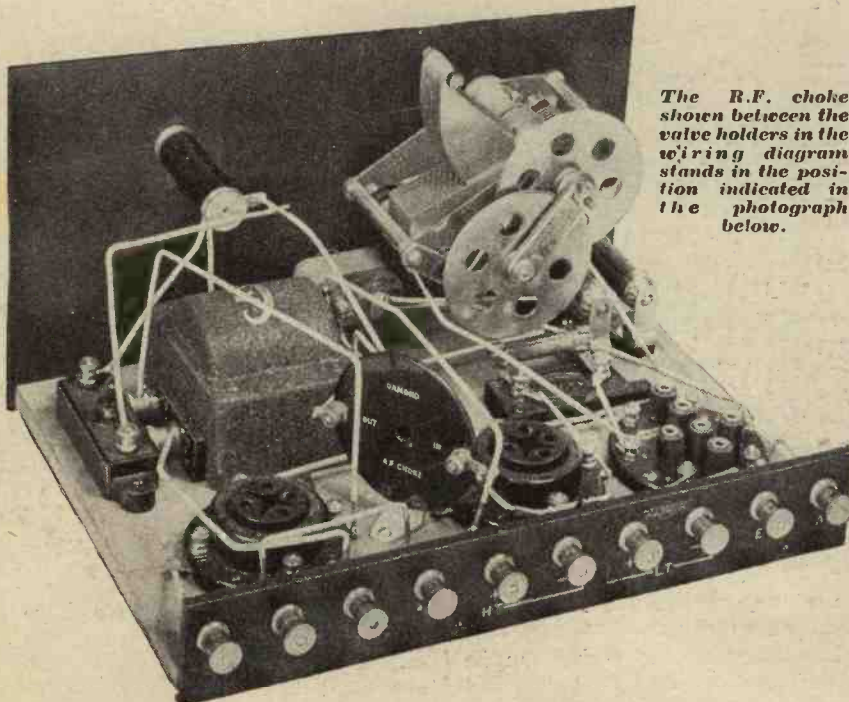
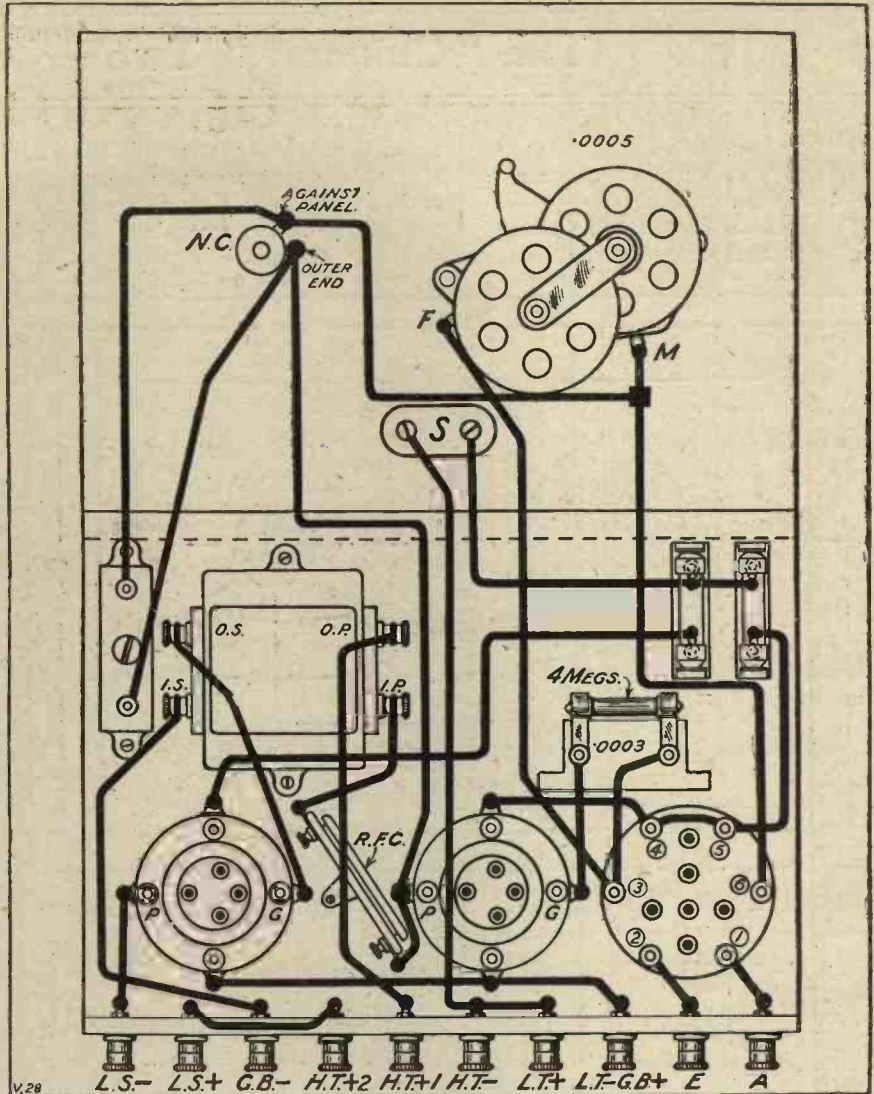

The R.F. choke shown between the valve holders in the wiring diagram stands in the position indicated in the photograph below.

required to make the set oscillate, so that if you are near the oscillation-point at the top of the scale do not immediately turn to the bottom of the tuning condenser scale without slacking off the reaction, otherwise you will cause interference by oscillation.

Smooth Reaction

You will find the reaction control delightfully smooth, and it is possible to discover a setting which will serve for a considerable portion of the tuning scale without resetting. Actual results obtained with this set when tested in the editor's laboratory at Wimbledon showed that 5 G B and 2 L O operated the loud speaker quite satisfactorily for a small room, and Langenberg, which could be tuned free from 5 G B, was as loud as anybody could require for 'phone reception in two or three pairs of telephones. Toulouse was also very strong and could be separated from London.

(Continued on page 80.)

RECTIFIER DEVELOPMENTS

An account of the important advances recently made for the provision of direct current from A.C. supply mains.

By Dr. J. H. T. ROBERTS, F.Inst.P.

A RECTIFIER is a device for converting alternating current into direct current. There are many cases in which this is necessary, the most familiar being where it is required to charge a battery of accumulators from alternating current electric supply.

The principal types of rectifier in use are:

1. Valve rectifiers.
2. Vibratory or mechanical rectifiers.
3. Chemical or electrolytic rectifiers.

An ideal rectifier would be, say, a short length of metal rod which had the property of opposing an infinite resistance to the passage of current through it in one direction and zero resistance to the passage of current through it in the opposite direction. Such a rectifier would be 100 per cent efficient.

In practice, however, the process of opposing a high resistance to the current in one direction involves certain losses in the rectifier and, furthermore, the rectifying device has an appreciable (in some cases a large) resistance in the "through" direction. The nearer a rectifier approaches

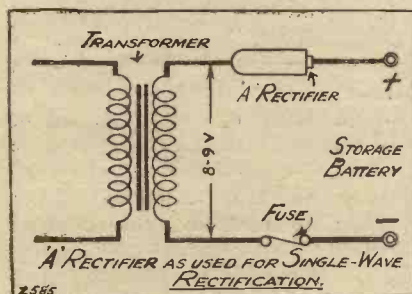

to the ideal conditions mentioned above the nearer its efficiency approaches to 100 per cent. The rectifiers of the various classes mentioned above all have advantages and disadvantages, and the choice of one or other will depend, to a large extent, upon the particular purpose for which the device is to be used.

The Various Types

For example, a valve rectifier, as a rule, gives very efficient rectification, in the sense that the reverse current is small compared to the "through"

current. A valve rectifier, moreover, is entirely silent and, as it contains no liquids, it can be operated in any position. Its principal drawback is

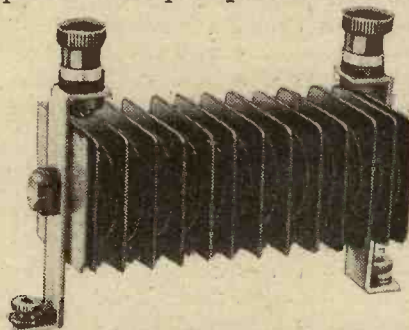

This is one of the new Kuprox Battery Charging Units. Each of these units embodies twelve of the Kuprox discs.

that it consumes a considerable amount of energy for the heating of the filament, and also it usually has a fairly high resistance.

The vibrating-reed rectifier, when properly adjusted, is very efficient as regards both rectification and low losses. A mechanical device, however, always requires a certain amount of attention; and a disadvantage of a vibratory rectifier is that it is apt to get out of adjustment and sparking occurs. In some circumstances even a reversal of the polarity of the D.C. terminals may take place.

Chemical or electrolytic rectifiers, except for the fact that they contain liquid and therefore are subject to certain obvious inconveniences, have many advantages. There is practi-

cally no attention required beyond the occasional addition of a little distilled water, and there is no energy consumed in a way corresponding to the heating of the filament in a valve rectifier. If the electrodes and electrolyte are suitably chosen the internal resistance of the electrolytic rectifier may be quite small; consequently there may be little heating in operation and little loss of energy in the rectifier.

A "Dry" Rectifier

There is another type of rectifier which I have not mentioned because it is only used for tiny currents, and that is the crystal rectifier so largely employed for wireless detection purposes. I mention this now because, in one of the new developments which I am about to describe, a principle analogous to that of the crystal rectifier is used. This point, however, will be raised again later on, in connection with the "Kuprox" rectifier.

The advantages of the electrolytic type of rectifier have led experimenters for some years past to endeavour to incorporate the essential features of the electrolytic rectifier into a device which would be free from the chief (almost the only) drawback of the electrolytic type—that is, the fact that it contains free liquid, and is therefore not strictly "portable" in the ordinary sense.

As a result of these investigations a low-tension rectifier has been produced and is now being marketed in

**

In the factory where the Kuprox Battery Charging Units are made the workers have to be protected by masks when opening the furnaces.

**

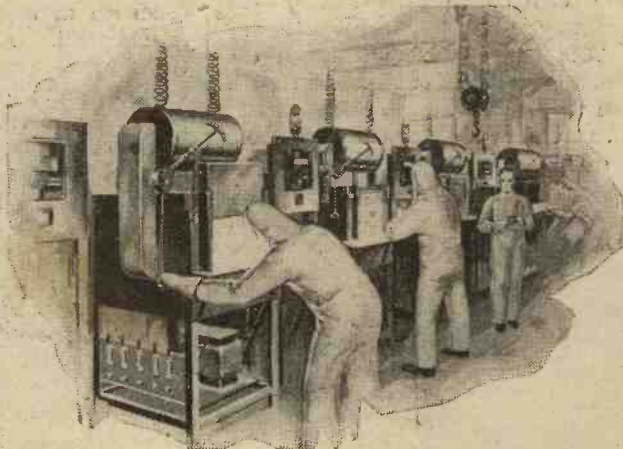

Rectifier Developments—continued

America (it can also be obtained in this country), known as the "Raytheon" rectifier, and which, whilst it utilises the principles of the electrolytic rectifier, is for all practical purposes a *dry* rectifier and can therefore be used in any position.

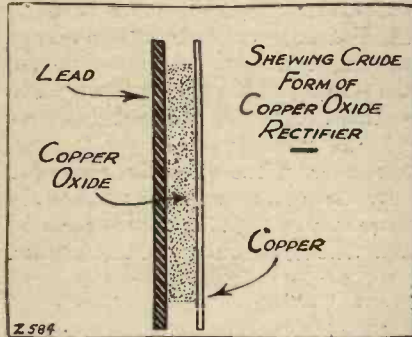

Its relation to the usual electrolytic rectifier is almost exactly the same as the relation between the small so-called "dry" cell (which constitutes the unit in an ordinary dry flash-lamp battery) and its larger cousin, the wet Leclanché cell which is used for domestic bell-ringing and such-like purposes. A small "dry" Leclanché cell is not *dry* at all. It is only "dry" in the sense that it is compact and sealed and that the liquids in it are held in suspension in a suitable medium. In fact, it is dry in the sense that it is unspillable and practically free from evaporation.

The Raytheon "A"

The new Raytheon rectifier is "dry" in an exactly similar sense. The rectifying electrode is surrounded by an acid paste which constitutes a porous anode. The whole rectifier is assembled in a container which is of a similar size and shape to the little zinc container of the unit of the ordinary pocket flash-lamp battery.

This new "dry" rectifier is the result of the work of M. Henri André, the well-known French scientist, and of a number of scientists with whom

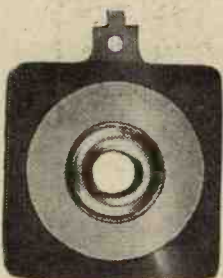

One of the Kuprox replacement units for electrolytic battery chargers. This type of unit is employed in all the Kuprox chargers and eliminators.

he has been collaborating at the Massachusetts Institute of Technology.

The internal construction of the Raytheon "A" rectifier will be seen from the accompanying figure. The cathode is of a special alloy (the composition of which is not disclosed) and the anode, which is in direct contact with the cathode, consists of an acid paste with pure silver. In order to obtain a "non-potential" and sure contact with the acid paste-porous-anode, a pure silver anode-contact is introduced at the bottom of the containing tube.

An "Oriented" Condition

Concentrated sulphuric acid paste is mixed in with the porous silver anode and this acid is thoroughly dehydrated (or freed from water) in order to avoid undesired chemical reactions. The container consists of a copper-plated steel tube and it will be noticed from the figure that the porous silver anode, as well as the silver anode contact, is in contact with the container. The porous anode contains in its interstices the non-conducting agent (concentrated sulphuric acid), which has free access to the junction between the metals. The purpose of the concentrated acid is to preserve the various metallic junctions in an "oriented" condition, but the actual conduction is through the metals themselves. The presence of the non-conducting agent not only creates but also maintains the oriented condition, and the rectifier will continue to operate satisfactorily even after it has been subjected to considerable excess current

Unilateral Conductivity

The oriented condition means a condition in which the conductivity is unilateral. A simple example of this may be given by considering a 6-volt accumulator. If an alternating potential of 6 volts be applied across this accumulator, owing to the oriented condition of the plates (which gives the positive plates a potential of about 2 volts higher than the negative plates in each accumulator) there will be about 6 volts opposed to the current when the current is trying to pass in one direction and 6 volts added to the voltage of the current when the current is trying to pass in the opposite direction.

Consequently, practically no current will pass through for one-half of the wave, whilst a considerable current will pass through for the other half. In this case which we are taking for illustration, the effect will be to "run down" the battery, and in course of time a state of affairs will be reached in which the two sets of plates are, on the average, at the same potential: thereafter, no rectifying action will take place.

Lower Power Losses

In the rectifier which we have been discussing, however, the passage of current in the "through" direction does not have the effect of bringing about chemical changes such as those in the discharge of the accumulator, and the oriented condition is main-

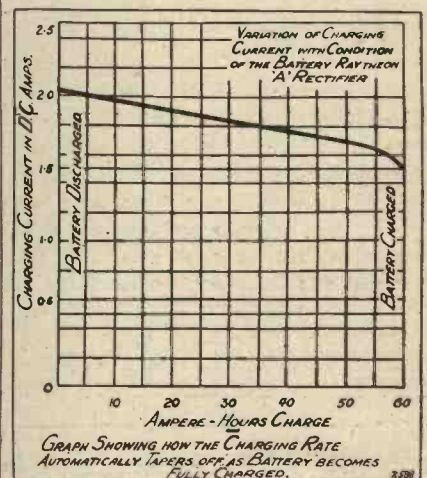

tained in spite of the passage of current. This, of course, is true of all electrolytic rectifiers.

Owing to the fact that the conduction in the Raytheon "A" rectifier is metallic, the internal resistance is low and, consequently, the power losses (I^2R losses, as they are commonly called) are low. The efficiency of a charger employing this new rectifier is found to be in the region of 60 per cent, which, as charger efficiencies go, is particularly good. Quite apart from the question of the saving in power during, say, a year's use, the low heat production permits of the rectifier being made in a very small and compact form (as mentioned above, the size of the rectifier complete is only about the same as that of a single unit of a flash-lamp battery).

The low losses in the rectifier also have an influence upon the design

Rectifier Developments—continued

and size of the step-down transformer. As this is called upon to supply only a little more energy than that which is actually delivered to the battery, it may be made smaller than is usual

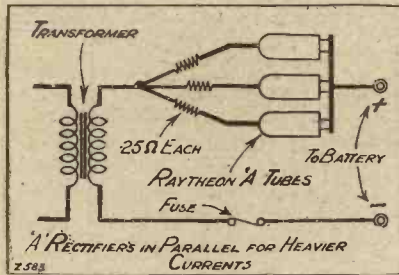

in cases where it has to provide for a considerable loss of energy in the rectifier.

Paralleled Rectifiers

These small Raytheon "A" rectifiers have a maximum charging rate of $2\frac{1}{2}$ amperes, but by using two rectifiers, with a centre-tapped transformer, in the usual way, the maximum current is increased to 5 amperes.

Larger currents may be handled by using several of the Raytheon "A" tubes in parallel, as indicated in the figure. Incidentally, it may be remarked that usually the paralleling of rectifiers, particularly electrolytic rectifiers, is found to be unsatisfactory, and frequently a better result is obtained from a single rectifier than from two or more in parallel. The reason for this is rather complicated and I would not have space to go into it fully at the present time. It is

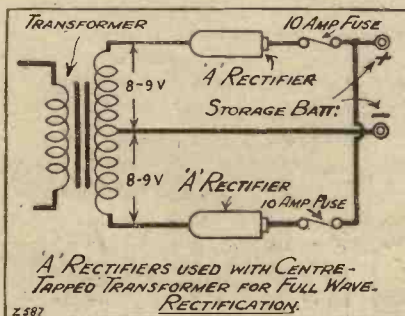

sufficient, however, to remark that with the Raytheon "A" tube, the paralleling appears to be quite satisfactory. It is only necessary to add small ballast resistances, one in series with each of the rectifier tubes, so as to ensure that any tube does not carry more than its share of the total current.

Another very important advantage of a low-resistance rectifier is that it permits a taper charge being given to the battery. This can perhaps best be explained in the following way:

Suppose we are charging a 6-volt battery and the output voltage on closed circuit on the L.T. side of the stepdown transformer requires to be 20 volts in order to pass the required current through the accumulator.

Then, if the accumulator has a voltage of 6 volts at the start, it means that there are 14 volts to drive the current through the rectifier in the "through" direction. When the accumulator is fully charged the voltage will be about $7\frac{1}{2}$ volts, and the voltage then available to drive the current through the rectifier will be $12\frac{1}{2}$ instead of 14 volts.

The difference between $12\frac{1}{2}$ and 14 being comparatively slight, the charging current when the accumulator is fully charged will be very little less than that when the accumulator was



The Raytheon "A" one of the new "dry" rectifiers.

first put on charge. According to the opinions of accumulator experts, it is desirable, where an accumulator has been pretty well run down, to give it a heavy initial charge, gradually tapering off as the accumulator reaches full charge.

Now, let us consider the state of affairs when the rectifying device has a very low internal resistance. Suppose the voltage required to drive the necessary current through the rectifier and a 6-volt battery is only 8 volts. If we start with the accumulator showing 6 volts, the voltage available to drive the current through the rectifier is only 2 volts.

"Taper" Charging

As the accumulator is gradually charged up and its voltage rises, a considerable decrease takes place in the voltage available to drive the current through the system, and when the accumulator is fully charged and is showing $7\frac{1}{2}$ volts, the difference between the applied voltage and the back voltage is only half a volt, that is, one quarter of what it was originally. In these conditions the battery receives a "taper" charge, starting at

a heavy current and dwindling off to a very much smaller current as the battery becomes fully charged.

Owing to the very low internal resistance of the Raytheon tube the

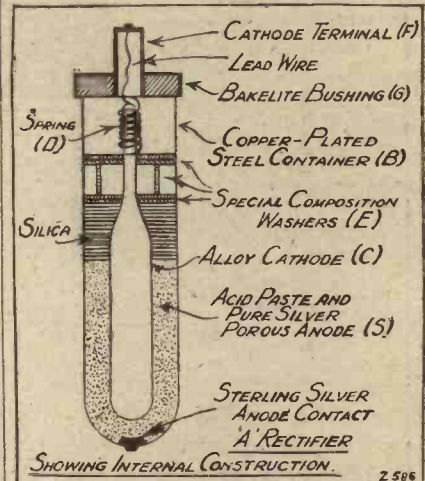

conditions are somewhat as considered in the previous paragraph. It is estimated that the open circuit voltage of the output side of the transformer need only be between 8 and 9 volts. With a centre-tapped transformer and full-wave rectification the total open circuit voltage should, of course, be 16 to 18 volts.

Now we turn to another type of L.T. rectifier, which is really dry in the true sense of the word.

It has been found that if a disc of lead and a disc of copper be pressed together, with a "sandwich" of copper oxide between the two, the unit has unilateral conductivity, and therefore acts as a rectifier. The exact mechanism of the rectification under these conditions is not properly

(Continued on page 78.)



The Kuprox Trickle Charger plugs into the mains and provides a constant charging rate of .8 to 1 amp. It may be used while the set is in operation.

AT THE WIRELESS EXHIBITION

TIMSON MERELY WENT TO THE WIRELESS

EXHIBITION WITH THE INTENTION OF HAVING A LOOK ROUND AND COLLECTING "LITERATURE" (BUT WE'LL LET THE PICTURES TELL THE REST OF THE STORY!)

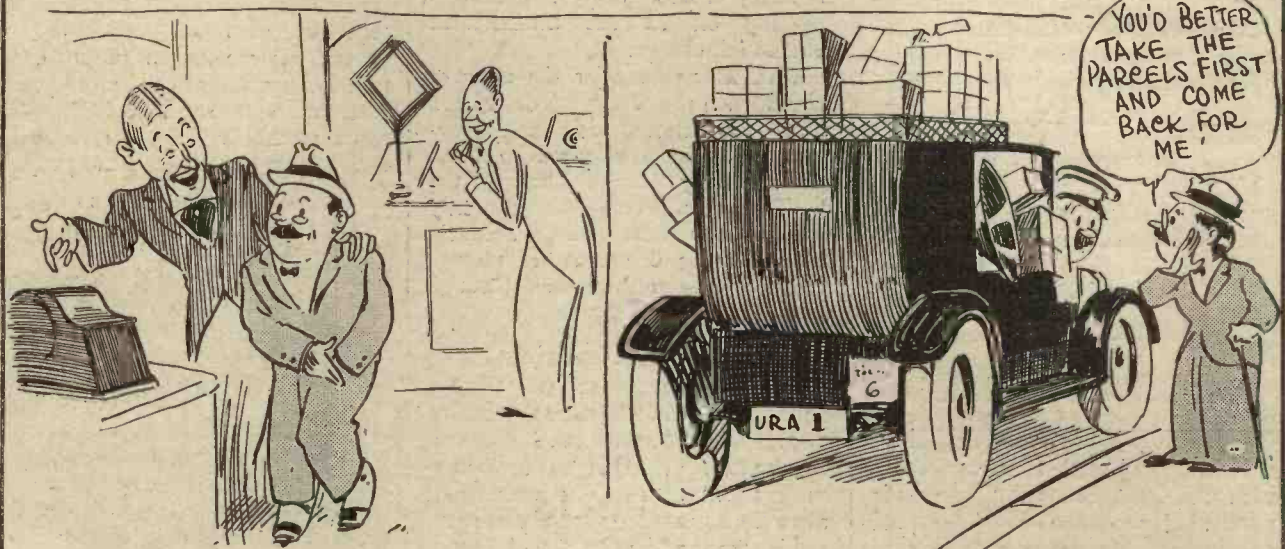

TON SHAW

Happenings at Savoy Hill—continued

entirely in vain. Despite the numerous non-committal, rather evasive statements emerging from the purlieus of the Savoy, my agents inform me that there is a good chance of the former vicar of St. Martin's becoming a regular programme official at B.B.C. headquarters. Whoever is responsible for the new formula deserves hearty congratulations. The influ-

Novelties Wanted

A close student of B.B.C. programmes tells me with conviction that there are far too few novelties and stunts just now. I agree with him that the tendency to settle down in an atmosphere of complacency is reflected somewhat in B.B.C. programmes. There is more than a suspicion that the improvement of

and most active minds will soon run fallow, particularly if they are fully employed. Therefore, constant change is necessary in the interests of listeners. As against this there is the natural tendency for the creation of a vested interest. The latter, while being very pleasant for Savoy Hill, is not necessarily to the advantage of the service. A complete change of staff on the programme side should be effected at least every three years.

Hook-Up Dangers

The technical editor of "Popular Wireless" was the first to call attention to the hook-up tendency of the B.B.C. engineers. He discovered on his recent visit to stations that a great deal of the transmitting equipment and accessories were hooked-up in a casual manner. This is most alarming. If the Engineering Department of the B.B.C. is starved financially, then it is a public scandal. If "hook-up" inherited from Writtle is being standardised, Captain Eckersley should reconsider the wisdom of his policy.

Money Problems

Licence revenue is going up still. The B.B.C. gets about £900,000 this year. There is naturally some curiosity as to how this vast sum is spent. All that the B.B.C. will say about it is that 10 per cent is absorbed in administration, and that the balance goes to programmes and engineering. This is admirable as far as it goes. But it would be a great deal more convincing to have a few more details. No reasonable person would ask for particulars of salaries, but the B.B.C. should certainly tell the public how much it spends on radio drama, the Queen's Hall, the National Concerts, and big items such as these. I suggest quite seriously to Savoy Hill that if they would avoid awkward questions in Parliament and in the Press, they should become a little more communicative about their finance. After all, it is listeners' money they are spending!

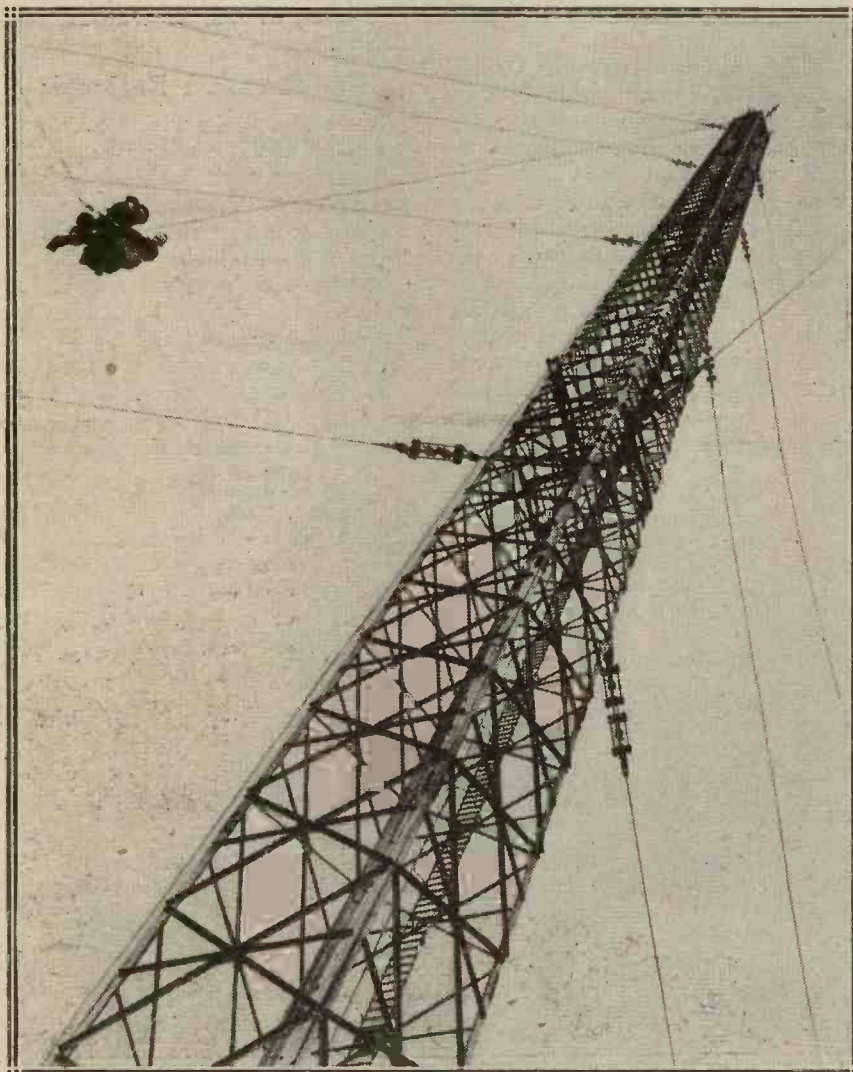

This unusual photograph, taken at Zeesen, illustrates the dangers and difficulties attending the erection of Germany's latest super-station.

ence of Dick Sheppard is much too valuable to be compressed into Sundays.

Let us hope that he will really get a free run at all the programmes. If this is done we should have greater variety, more real brightness, and no offensiveness whatever against the canons of good taste.

the "machine," while eliminating mediocrity, has also killed the "peaks."

There is still time to check this tendency before it becomes chronic. A fresh infusion of journalistic talent would put the matter right. Savoy Hill must learn that there can be no stability in the staffing of its Programme Department. Even the best

"POPULAR WIRELESS"
is the
LEADING RADIO
WEEKLY

A Short Wave "Superhet" Adaptor



This unit, placed in front of any set with H.F. amplification, takes the tuning down to below twenty metres!

By L. H. THOMAS.

A GAINST the many advantages possessed by wave-lengths of the order of 30 or 40 metres must be placed the one great disadvantage—that the average multi-stage or even single-stage H.F. receiver is quite useless for their reception. The vast majority of short-wave enthusiasts use a receiver comprising the much-vaunted "low-loss" detector followed by one or two

Morse from Australia and broadcast from the United States) and yet are not sufficiently keen to go to the trouble and expense of building a separate receiver for the purpose.

The writer has designed an adaptor, in the form of a single-valve short-wave oscillator (for it is in reality nothing more), which can simply be placed "in front of" any receiver embodying high-frequency amplification, enabling it to receive wave-lengths as low as 14 metres.

receiver is concerned—the adaptor is simply wired up, the aerial lead changed over from the big set to the appropriate terminal on the adaptor, and in come signals on 20 metres or so without further trouble! This adaptor is also capable of being used as a single-valve receiver, or may be followed by an L.F. amplifier.

The circuit of the adaptor is shown on this page. It is a perfectly "straight" Reinartz-type detector,

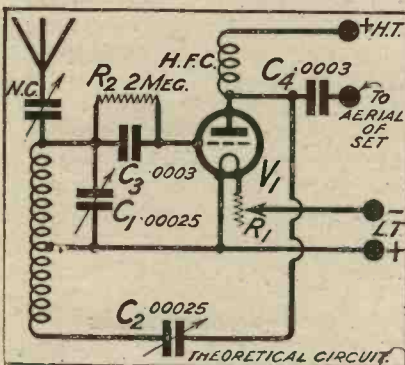

The circuit employed is similar to that of a straightforward detector of the Reinartz type.

stages of low-frequency amplification, and this combination is certainly very hard to beat. Here and there one finds an amateur sufficiently keen on short-wave reception to build a super-heterodyne specially for the purpose, and, in the writer's opinion, once a "super-het" has been made to function properly on these wave-lengths, nothing better could be desired from the point of view of general efficiency or ease of operation, although many do not seem to agree with the latter feature!

Special Set Unnecessary.

Many who are not really enthusiastic on the subject of short-wave work must at some time or other have felt a tinge of envy on reading of the exploits of some persevering single-valve owner (who regularly receives

No Alterations Required.

This is done by operating the H.F. stages of the existing receiver in a similar manner to the intermediate stages of a super-heterodyne—the receiver does, in fact, become a super-het. Yet no alterations are necessary, as far as the original

The wiring near the panel must be carefully done or hand-capacity effects may be troublesome.

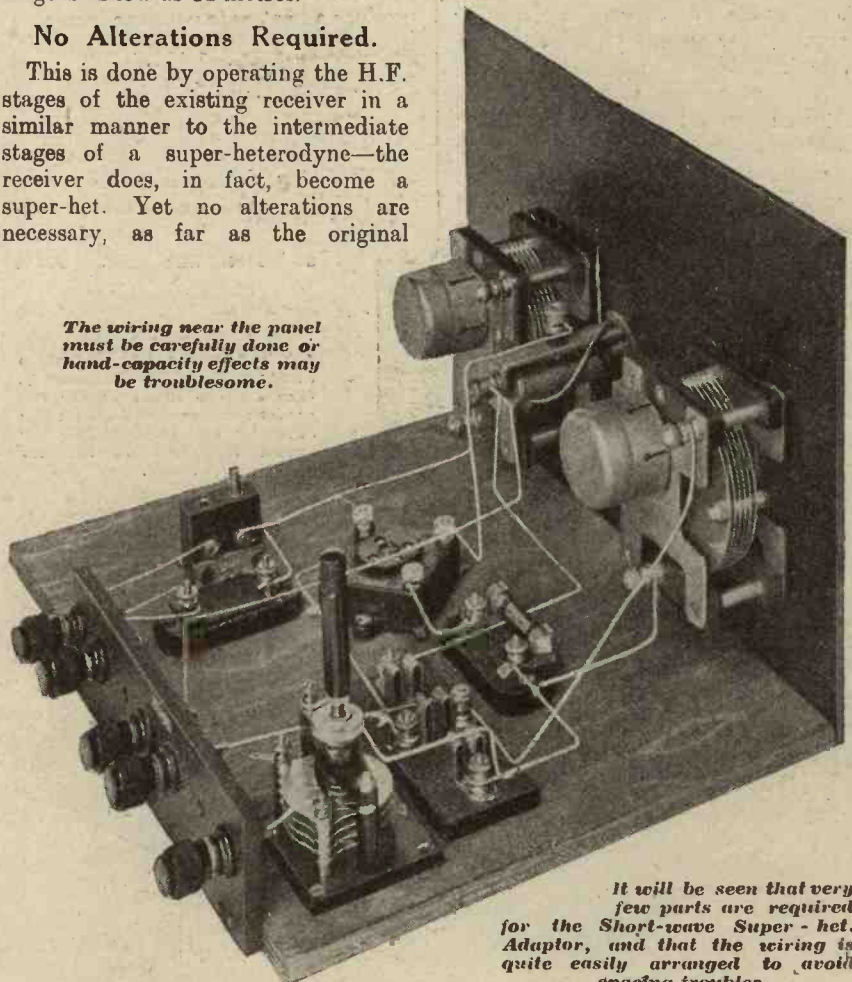

It will be seen that very few parts are required for the Short-wave Super-het. Adaptor, and that the wiring is quite easily arranged to avoid spacing troubles.

A Short-Wave "Superhet" Adaptor—continued

the aerial being coupled to the grid end of the coil through a very small variable capacity. This, of course, obviates the necessity for erecting a special small aerial. The centre-tapped coil is of the "Dimic" type, and short-wave coils of this type will tune down as low as 14 metres or so. A .00025 condenser with slow-motion drive is connected across half the coil and a similar condenser is employed for reaction control. As an H.F. choke a plug-in coil is used, as different sizes seem to give the best results on the various wave-lengths that are to be covered.

Easy Change-Over

When the terminal marked "To aerial of set" is connected up, the A.T.I. of the receiver is used either as the primary winding of an H.F. transformer or as a tuned-anode coil, "parallel feed" being used. If the A.T.I. of the main set is direct-coupled it may be said to become a tuned-anode coil, or, if loosely-coupled, the primary of a transformer.

It is, of course, well known that when a super-het is used on these very short wave-lengths it is unnecessary to use a separate oscillator or even a Tropadyne arrangement to produce the beat frequency which is to be

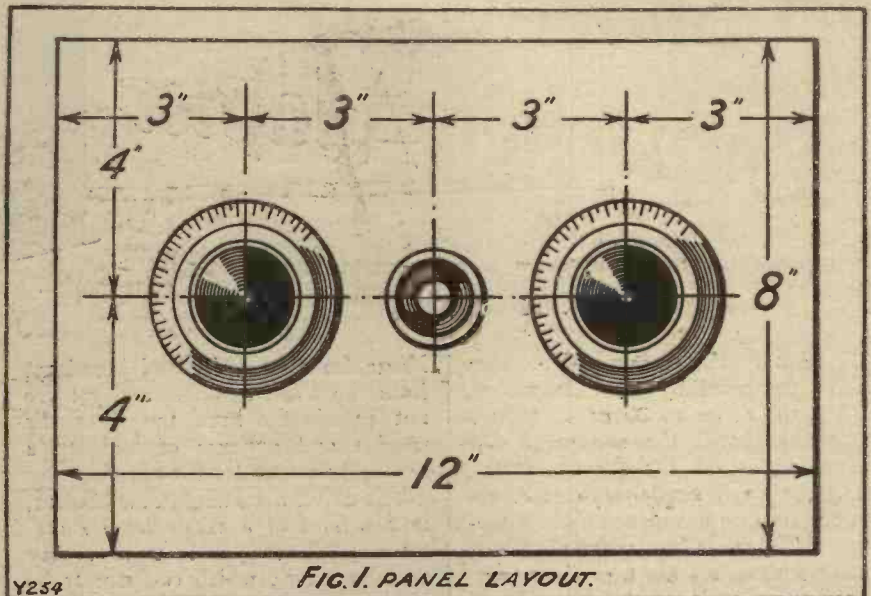

amplified. The amount of detuning of an ordinary oscillating detector such as this which is necessary to produce a beat-note with the incoming signal is so small as to be negligible. This, of course, greatly simplifies matters, for otherwise our adaptor would consist of a detector and a separate oscillator. (Its extreme simplicity being destroyed, there would naturally be less inducement to construct it—it would be as easy to make a "Det. and L.F." set!)

There are no terminals for Earth or H.T. —, since it is assumed that these two connections will be left untouched on the main receiver. All that is necessary, therefore, is to connect up the L.T. battery, the positive H.T. (a tapping from the battery used on the receiver), and the "To aerial of set" terminal, the aerial simply being changed over from the "big set" to the terminal on the unit. (See wiring diagram.)

Some Wiring Hints

Very little need be said about the construction of the unit. The writer has gone back to the practice, now almost obsolete, of placing the rheostat on the front panel; this is desirable, since filament control seems a trifle critical under certain conditions. It will be noticed that the components have been so placed that the grid and anode leads are as short as is practicable, and the coil is well away from any large components. The neutralising condenser, mounted on the baseboard, is simply in series with the aerial. When the wiring has been completed it should be checked in the usual manner, applying a voltmeter across the filament terminals with the H.T. connected up. Everything being satisfactory, it may be connected to the main set as previously described.

A valve of either the small power class or the "H.F. and detector" type (i.e. with an impedance between 6,000 and 20,000 ohms) should be inserted in the socket of the unit, the H.T. terminal should be connected

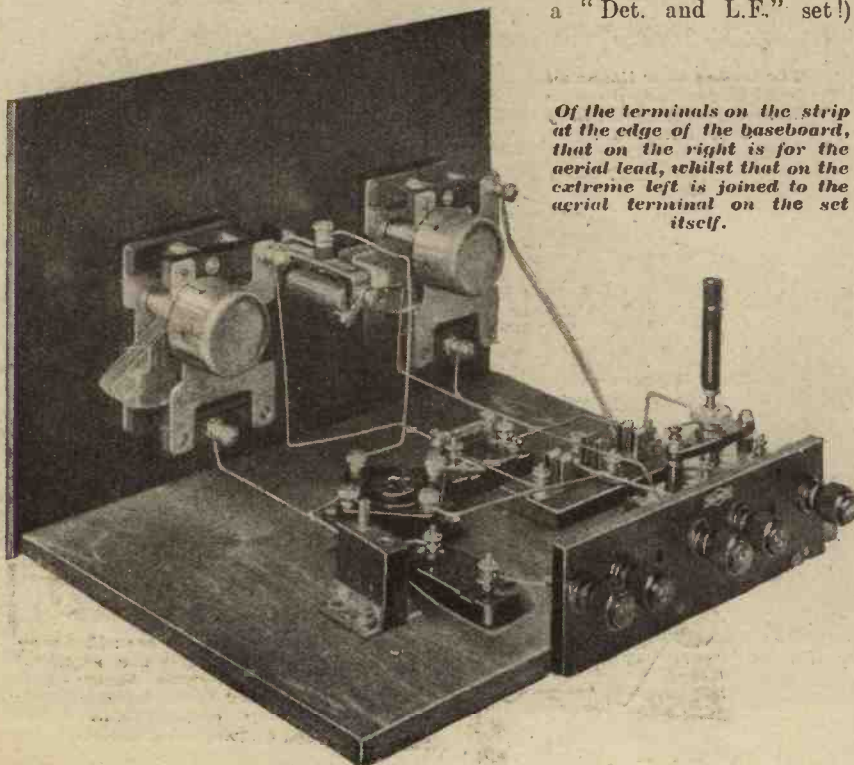

Of the terminals on the strip at the edge of the baseboard, that on the right is for the aerial lead, whilst that on the extreme left is joined to the aerial terminal on the set itself.

A Short-Wave "Superhet" Adaptor—continued

up to a point about 40 or 50 volts above filament potential (probably the detector tapping on the main set will be suitable) and a No. 50 coil inserted as choke. The modus operandi is now as follows :

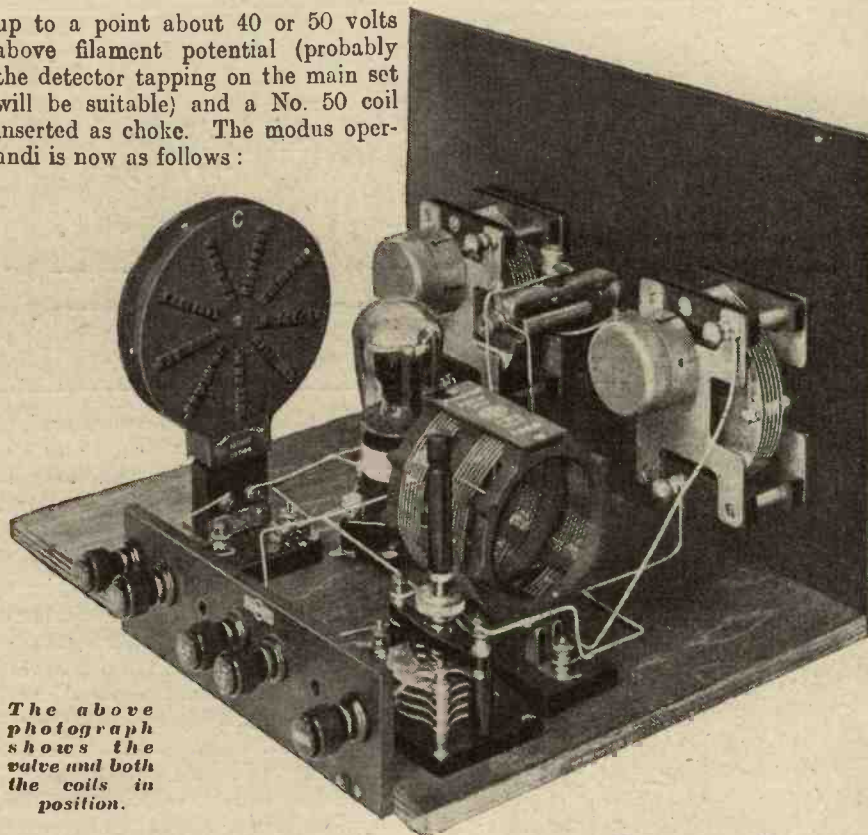

The above photograph shows the valve unit both the coils in position.

Carefully tune the main set to the highest point of its tuning range. If it is possible to receive Daventry, so much the better. The set should in this case be tuned to about 2,000 metres. In the case of sets which will not receive Daventry and the long-wave stations, it is usually satisfactory to tune to about 550 or 600 metres. Now insert a No. S.W.1 Dimic coil in the unit, set its neutralising condenser about "half in," and its main condenser (C_1) at zero. On rotating the reaction condenser towards the end of its travel, a point should be found at which the set bursts into a loud howl. Slacken the reaction condenser back until clear of this point, but make sure that the short-wave unit is still oscillating by tapping the grid terminal. Strong "double clicks" from the loud-speaker or headphones will indicate that all is satisfactory. Now rotate the main condenser on the unit very slowly.

Signals all Day

With the S.W.1 coil, 45 metres (on which wave there is usually a large volume of amateur traffic) will correspond with about 70 degrees on the dial of C_1 . Morse signals should be heard here at almost any time of day,

the general effect on the loud speaker being that of listening to strong Morse without oscillating. It does not matter how hard the short-wave unit is oscillating—all that is necessary is to produce a beat-note with the incoming signals. Slow searching should not really be necessary on account of the strength of the average signal on this wave-length, but it is, of course, advisable to go fairly carefully at first.

For a Long Aerial

No difficulty at all should be experienced in getting the unit to work, but if it does not seem to be oscillating, all that is necessary is to disconnect from the main set and insert a pair of 'phones between the H.T. + terminal and the actual H.T. tapping. It will then be used as a standard single-valve short-wave receiver, and any necessary "persuasion" may be easily administered. It should be mentioned that if the reader is using an aerial that is at all inclined to be long, the "neutralising" condenser may need to be placed nearly "allout."

For the benefit of those to whom the shorter waves appeal, but who do not possess a multi-stage receiver,

* * *

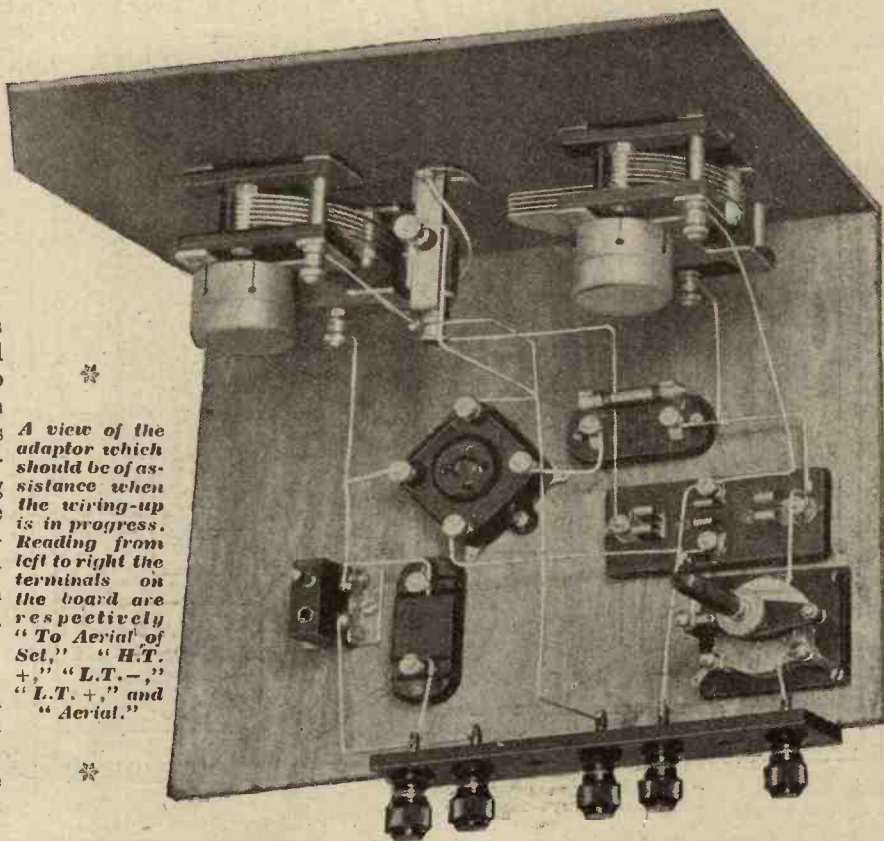

A view of the adaptor which should be of assistance when the wiring-up is in progress. Reading from left to right the terminals on the board are respectively "To Aerial" of Set," "H.T. +," "L.T. -," "L.T. +," and "Aerial."

* *

A Short-Wave "Superhet" Adaptor—continued

another simple unit will shortly be described which embodies all the necessary components to convert this "adaptor" into a full-blown superhet for short waves. Yet another method of using it is possible, however. If an L.F. amplifier is available, all that is necessary is to connect one of the "Input" terminals to the H.T. + terminal on the adaptor, and the other to the positive H.T. tapping.

Used as a One-Valve Set

An earth will then be necessary on the adaptor, and another terminal may be added for this purpose or the L.T. + terminal may be earthed. As has been mentioned, it may be

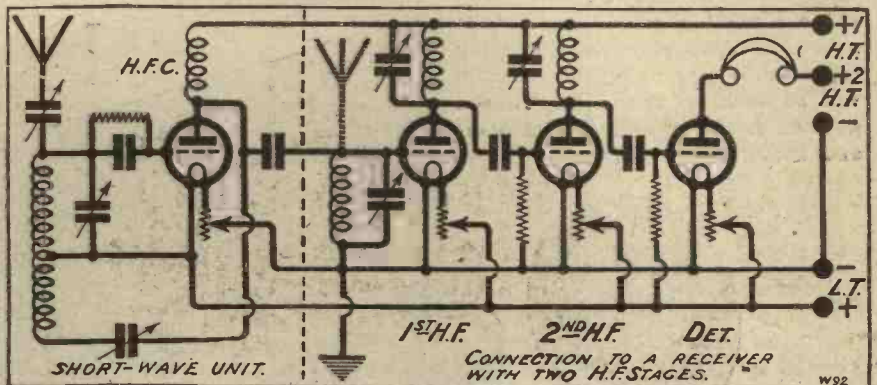

used as a single-valve receiver by connecting the 'phones between the H.T. + terminal and the battery.

Whichever method is employed, the wave-length range which the unit will cover remains unaltered, and the following indications will probably be useful.

Tuning Range

The S.W.1 coil covers, roughly, the range 36-60 metres. The calibration figures given on the coils themselves may be disregarded, since they only apply when the whole coil is tuned, and in this case the condenser is only across half. The bulk of amateur stations work between 36 and 48 metres, and are therefore to be found between zero and about 80 degrees on the main control. With the smaller coil, S.W.2, the range 26-40 metres is roughly covered. WGY on 32.79 metres is generally to be found at about 40-50 degrees, and various other American telephony stations between this reading and zero. On the S.W.3 coil the receiver will go down to about 18 metres or lower, and other telephony stations will be found, although the times at which they may be received are somewhat variable and weather conditions also seem to have a considerable effect. Reception is, in fact, decidedly freakish below about 23 metres.

The "Super-Het" Unit

Fuller details of the use of this unit in conjunction with the "super-het" unit will be given with the description of the latter which will appear shortly in the WIRELESS CONSTRUCTOR. But enough has now been said to show that in its one-valve form, described above, the short-wave "Super-Het" Adaptor is a fascinating and effective little instrument, well worth the time spent upon its construction.

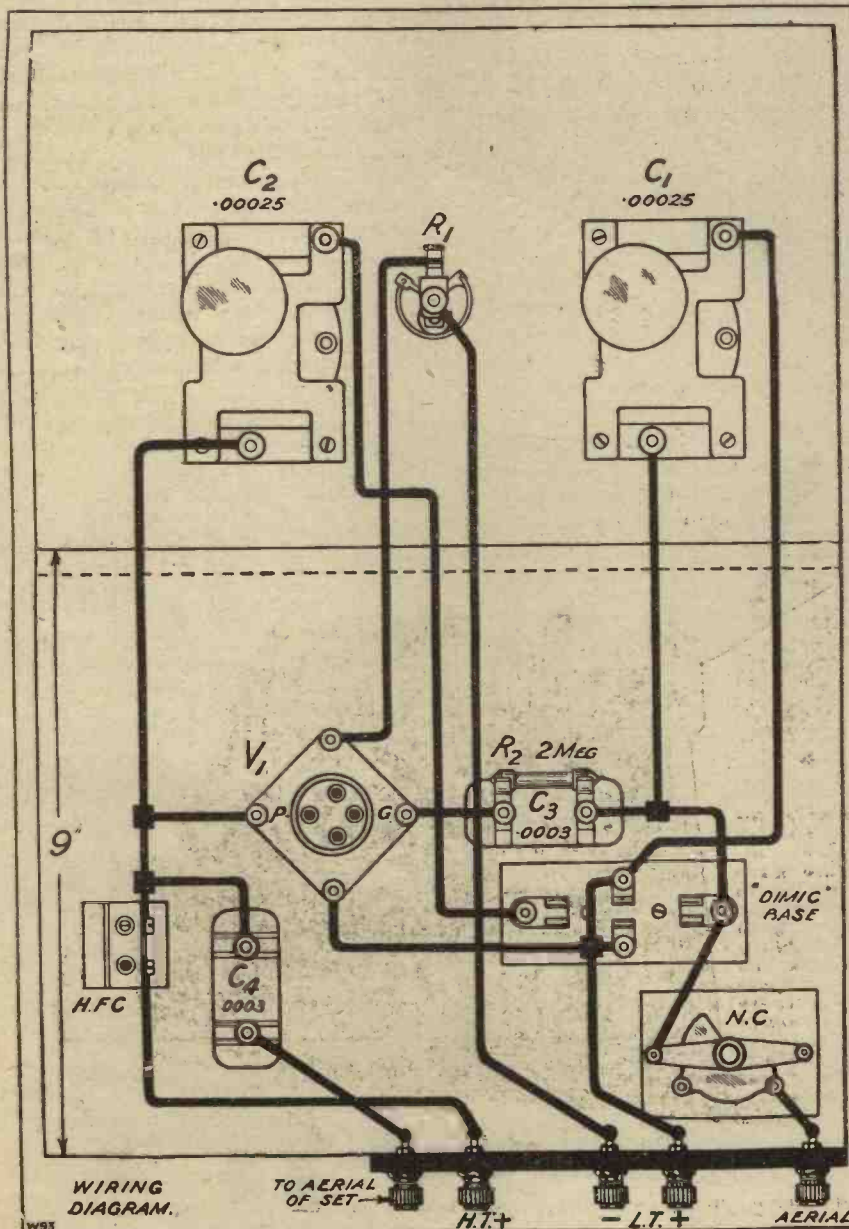

Do you "POPULAR WIRELESS" every? Read Every Thursday. It keeps you in touch with the trend of Radio. Price Threepence.

At Home With The Ohm



The results of a series of illuminating experiments.

By THE EDITOR.

IN the process of testing component parts and apparatus submitted to this journal for report under the "What's New" heading each month, I frequently have to make measurements of the electrical resistance of

this it must be explained that a coil may have a resistance of, say, 2 ohms to direct current, but it may offer a resistance of 50 ohms to an H.F. current of, say, 500 kilocycles, or at the frequency corresponding to a wavelength of 600 metres.

The simplest of all tests are, of course, the direct-current measurements, for such measurements offer practically none of the difficulties attendant upon the testing of H.F. resistance. The apparatus used in most D.C. resistance measurements is the Wheatstone Bridge. A photograph of the particular Wheatstone Bridge used in my laboratory is shown in the accompanying diagram.

For the benefit of those readers who are not acquainted with the instrument, which, incidentally, finds itself a multitude of uses in all electrical engineering, it will perhaps be advisable to explain the principles on which it is based. At first glance it appears to be a very complex piece of apparatus, but the complexity disappears when we examine it.

The Wheatstone Bridge

Let us consider, first of all, the diagram, which shows two resistances in parallel, so connected to a battery of 100 volts that current flows in each of them. We will imagine that the resistance of the upper is 10 ohms and of the lower 100 ohms. By Ohm's law we know that the current in amperes flowing in the circuit can be found by dividing the pressure in volts by the resistance in ohms. The familiar formula is

$$I \text{ (current)} = \frac{E \text{ (voltage)}}{R \text{ (resistance)}}$$

Now, as the resistance of the upper is 10 ohms, and the voltage applied

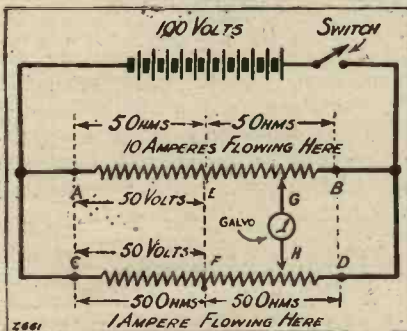

windings, grid leaks, anode resistances, and contacts. These measurements bring out so much interesting information that readers of the WIRELESS CONSTRUCTOR may like to know a little more about the subject—how the tests are made, and what actual results are obtained in some typical cases.

"Two Kinds of Resistance"

We have to deal with two kinds of resistance in our measurements. The first is called "high-frequency resistance," and the second the "D.C. resistance" or "direct-current resistance." In those parts of the circuit which do not carry radio-frequency currents, the D.C. resistance is all that matters, but in tuning coils, condensers, and parts of the circuit where high frequencies are dealt with, the H.F. resistance is the only thing that matters. In stating



The Wheatstone Bridge employed for the measurements described in this article

At Home with the Ohm—continued

is 100, a current of 10 amperes will flow in the circuit formed by the battery, the upper resistance, and the connecting wires. In the lower resistance (100 ohms), a current of 1 ampere will flow—in both cases neglecting the resistance of the wire from the battery to the point where the two resistances are joined at each end. Now, considering again the upper resistance, the current of 10 amperes is flowing through all parts, so that if we take one-half of this, having a resistance of 5 ohms through which the current of 10 amperes is flowing, then obviously a voltage of 50 is being applied to that particular half. Otherwise, Ohm's Law would be incorrect! We can thus say that the voltage between the points A and E is 50 and between E and B 50, while the voltage between A and B is obviously 100.

A Simple Explanation

Now take the lower resistance. A current of 1 ampere is flowing through this. Between the points C and D a voltage of 100 is applied. Between the points C and E the voltage is 50, and between E and D the voltage is 50 also. The points E and F are respectively in the centres of their particular resistances.

You may wonder what we are "getting at" in this argument, but you will now realise that if we join a wire between the two centre points E and F (shown dotted), no current

will flow, because both of these are at the same voltage. However low the resistance of the wire, if there is no voltage between the ends, no

if the ratio of the resistance AG to GB is equal to the ratio of CH to HD, no current will flow between the points G and H, and so on

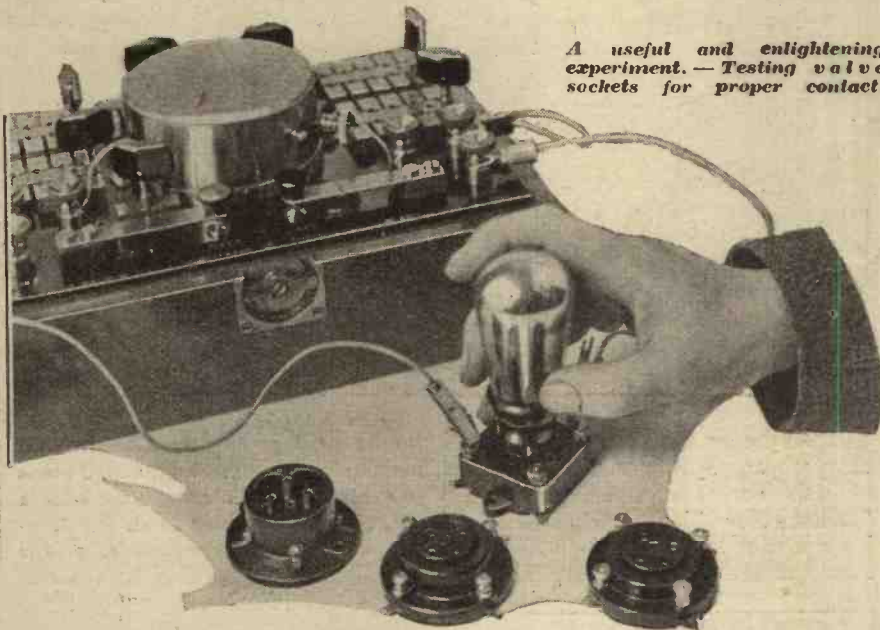

A useful and enlightening experiment. — Testing valve sockets for proper contact.

current can flow—again, according to Ohm's Law.

The "voltage drop," as we call it, is uniform along each resistance. Thus, if the distance between A and G is three-quarters of the total length of either resistance, the voltage between these two points will be three-quarters of the total, irrespective of the actual resistance. It will now be seen that

throughout various tappings on the resistance, as long as the ratios remain the same.

You will notice that, in the particular example, the resistance between G and B is but $2\frac{1}{2}$ ohms, whereas that between H and D is 25 ohms.

An Example

If we make up a piece of apparatus with an adjustable resistance of known value between, say, A and G, and provide terminals at G and B for the insertion of an unknown resistance, in place of that shown, and if similarly we have known variable resistances between C and H and between H and D, and if we arrange for a sensitive indicating instrument to be joined between G and H, then no current will flow between G and H (in consequence, there will be no indication on the instrument) when the ratio of GB to AG is the same as the ratio of HD to CH. If, for example, as is shown, the unknown resistance is inserted between G and B in place of the resistance shown in the diagram, and the value of AG varies until there is no reading on the indicating instrument between G and H, and we know that as CH is three times the value of HD, then GB must be a third of the resistance AG.

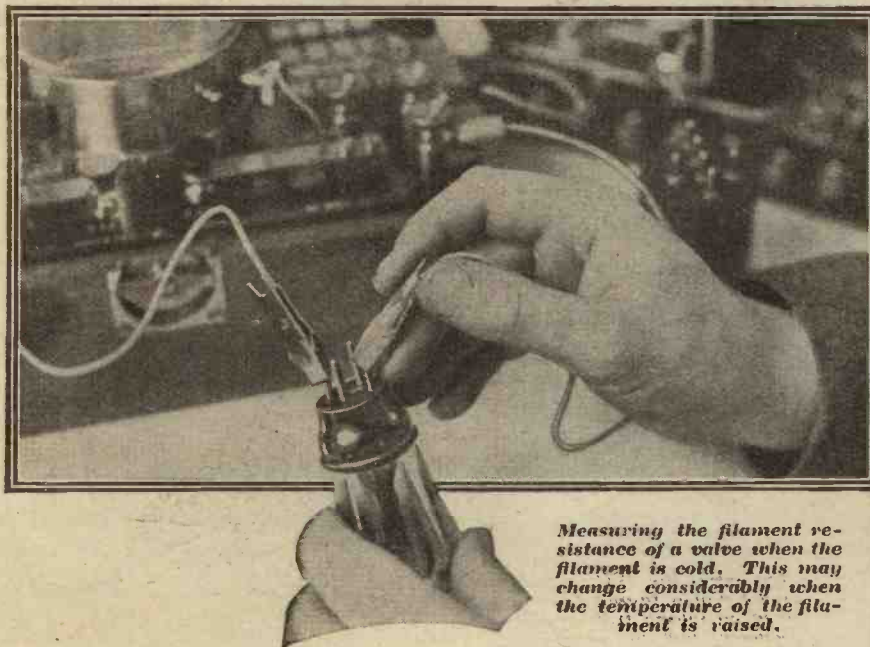

Measuring the filament resistance of a valve when the filament is cold. This may change considerably when the temperature of the filament is raised.

At Home with the Ohm—continued

This is precisely what the Wheatstone Bridge does. If you examine the photograph on this page, you will see in the middle a sensitive galvanometer which gives a deflection of the needle in one direction or the other when a current flows between the points we have called G and H (although these markings do not appear on the instrument). You will

resistance readings in fractions of an ohm the ratio can be altered in the other direction.

In operation the battery is joined to the two battery terminals, the unknown resistance between the two extreme terminals on the front of the instrument, and the two keys pressed. Plugs are then varied until there is no indication on the galvanometer, where-

ratios have been taken into account).

So much for the instrument itself. Now let us see what we can find with it. Look at the photo which shows a number of "Radiano" leads screwed under terminals so as to form a chain. In this chain there are nine Radiano leads, which means eighteen pinched-on contacts between the brass tags and the wire, and ten pressure contacts under terminals. This is far more contact in series than is ever found in a Radiano set, and as these Radiano leads were some of those used in the original Radiano Three, the test was made at least six months after the leads had been formed, and thus afforded a good opportunity of finding if these contacts offered any detrimental resistance to the flow of the current after a time. The measured resistance of the 4 ft. 6 in. composite lead proved to be exactly two-tenths of an ohm! This proves conclusively that the Radiano system of wiring up is perfectly sound in making contacts.

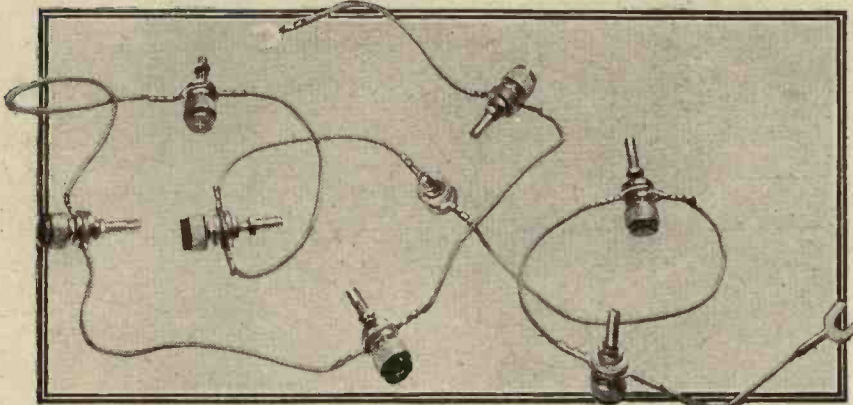

A "Radiano" test of a drastic nature. Eighteen "pinched-on" contacts and ten pressure contacts, in series, were measured for resistance with surprising results.

also see two keys, the one on the left marked GB being provided for joining the galvanometer across the points named and the B key for joining the battery. In most cases a 2- or 4-volt battery is quite sufficient.

Measuring Resistances

On each side of the galvanometer, and behind, you will see plugs and sockets. By having "units," "tens," "hundreds," and "thousands" sockets it is possible by means of the plugs to get any resistance value between 0 and 9,999. Behind the galvanometer are two plugs by which the ratios of the resistance called CH and HB in my diagram can be set. For example, we can make CH equal to HB, whereupon the actual resistance, which gives no deflection on the galvanometer, will be the resistance of the unknown resistance, which is connected between the two bottom terminals on the front of the instrument. If we want to measure higher resistances than 9,999 it is only necessary to make a change to the ratios between CH and HD, for if CH is, say, a tenth of HD, then the resistance we are varying between AG will be but a tenth of the unknown resistance between GB. Similarly, if we want to get very low

upon we know that the unknown resistance is calculable from that which gives no reading (when the

A Battery Lead Test

Strong spring clips are used for making sound contact to terminals, leads, etc., in these tests. Another very interesting measurement was that of battery leads, to see whether these cause too much drop in voltage for the valve current. It must be

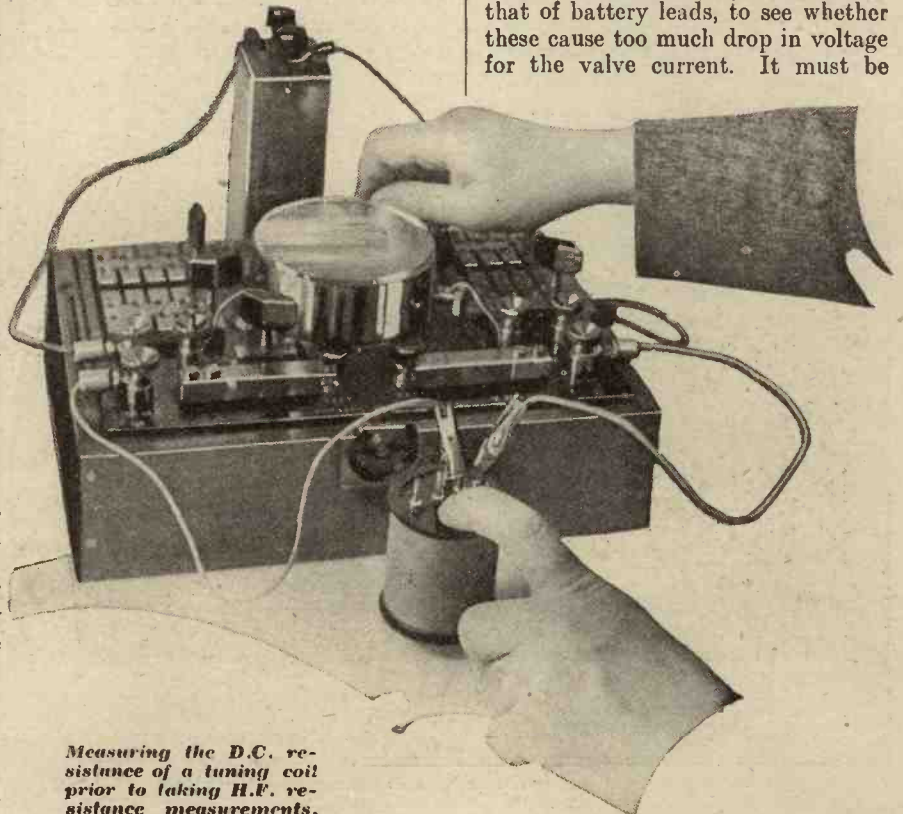

Measuring the D.C. resistance of a tuning coil prior to taking H.F. resistance measurements.

At Home with the Ohm—continued

remembered that as there is a voltage drop along the resistance, if our battery leads are of high resistance the voltage applied to the terminals of the valve will be lower than that of the battery itself. This aspect of affairs is important when using 2-volt valves, particularly when these valves use a good deal of current, for the greater the current the greater the voltage drop in the leads. Measurements showed that using 2-volt valves, and assuming the voltage on each must not drop lower than 1.8, then when the total current on the 2-volt battery is .6 of an amp. the permissible resistance of the lead is .33 of an ohm.

Battery Leads

The measured resistance of twenty feet of ordinary double silk-covered flex, such as is used for electric light fittings and obtainable from any electric shop, proved to be .6 of an ohm. This means that in the circumstances given, viz. maximum current of .6 of an ampere assuming no filament resistances, and a maximum drop of .2 of a volt, eleven feet of double flex can be used at most. It is rarely that battery cords are eleven feet long, and usually the wire used is thicker than that chosen for the test. From the figures given the reader should be able to work out whether his own battery leads are too long.

A commercial L.T. battery cord sold ready for fitting to a set proved to have a resistance of one-tenth of an ohm, which is quite a low enough

when cold. When the full filament current is passing the resistance of this valve is 55 ohms.

Coil Resistances

Another very interesting measurement related to the D.C. resistance

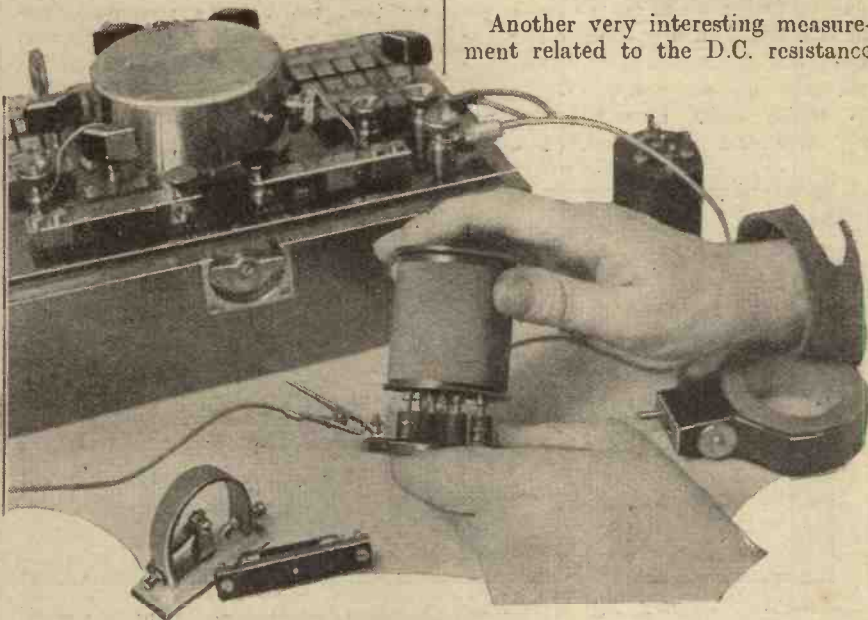

Good contact of all pins with the sockets of some six-pin bases is by no means certain. Results of the test illustrated are given in the article.

resistance for any practical purpose.

Speaking of valve current, do you know that the resistance of the filament when cold is much lower than that of the filament when hot? Using a very small current for measuring purposes (this can be arranged by choosing correct ratios and values) the resistance of a typical 6-volt modern valve proved to be 26 ohms

of the Daventry range of six-pin coils designed to go inside the circular screens, but now more generally used without screens. In order to make these coils compact a very fine gauge of wire has to be used. In spite of this I was very surprised to find that the direct-current resistance of a standard 1,000 to 2,000-metre split-primary aerial coil was no less than 76 ohms. As the high-frequency resistance is always higher than the D.C. resistance, you can realise that these coils are not at all efficient. The D.C. resistance of a corresponding ordinary type of plug-in coil was but 16.7 ohms.

Incidentally, it may be stated that the high-frequency resistance of the ordinary type of plug-in coil mentioned is distinctly lower than that of the ordinary six-pin single-layer coil.

Coil Bases

The 250/550 six-pin coils of fairly heavy gauge wire are generally far more efficient, but these differ between makes considerably so far as their D.C. resistance is concerned, some measuring as much as five ohms and others as low as one and a half ohms.

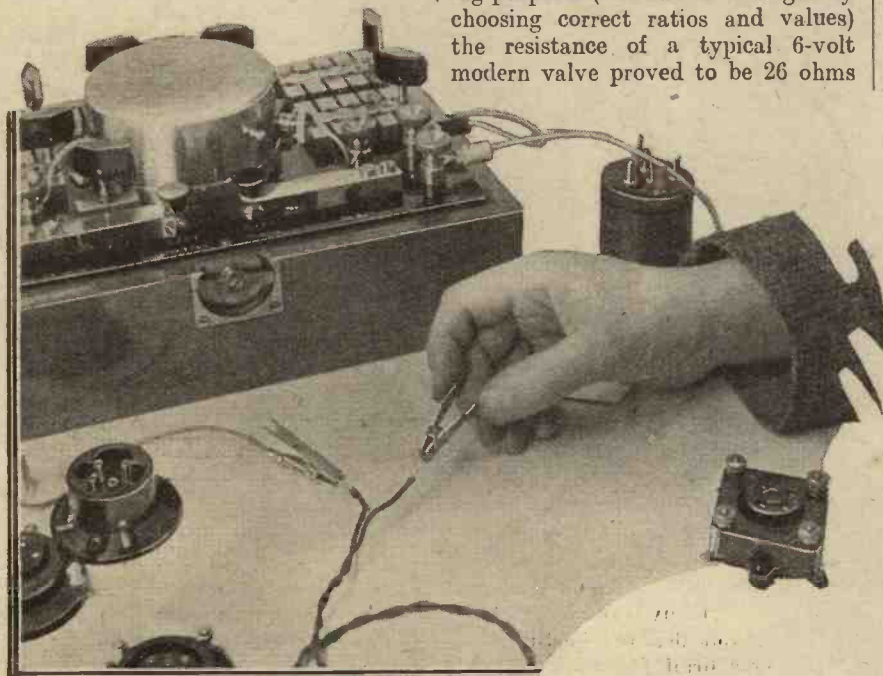

Are your battery leads reducing the voltage on your valve filaments? This test gave some illuminating results.

(Continued on page 82)

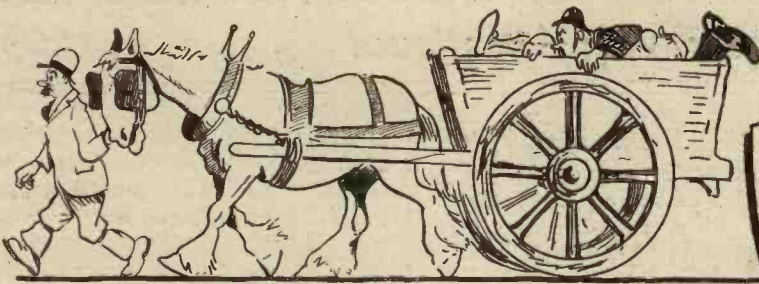

IN LIGHTER VEIN
By Wireless Wayfarer.

EVER since the unfortunate incident of the writing machine invented by the professor there has been somewhat of a coolness between him and Miss Worple. It all arose through a slight misunderstanding. The professor sent the first model along for her to try, accompanied by a note in which an unfortunate spelling mistake was made in an absent-minded moment. "Professor Goop presents his compliments



... The latter gets quite huffy about it! ...

to Miss Worple," he wrote, "and has much pleasure in sending for trial by her a tripewriter, which is his very latest invention.

"He is sure that it will be just the thing to help her in composing her verses."

"Sheer Misunderstandings"

It is jolly hard lines on the professor that he can hardly ever open his inkpot without putting his foot in it. Apart from the fact that he is apt to make little slips in moments of mental aberration, his handwriting is so bad that the recipients of notes from him frequently mistake his meaning. When a man writes to the vicar, "I would like to thank you for your striking concert," and the latter goes and reads, "I would like to spank you for your stinking conceit," and then gets quite huffy about it, it is pretty rotten, isn't it?

Having suffered two such reverses through sheer misunderstandings, the professor was not quite up to his usual form when I went round to see him. I was told when I inquired for him that he had taken to his bed, so going up to his room I knocked gently at the door, turned the handle, and peeped in. I was not in the least surprised to find that the professor had stuffed

his clothes into the bed and had folded himself up neatly upon the chair at its side. But he was very glad to see me, telling me that he felt a little cramped, but could not think why. I was able to straighten things out a bit, and once between the sheets the professor heaved a sigh of relief.

"I was sure there was something wrong somewhere," he said, "but for the life of me I could not think what it was."

Prof. Goop in Trouble

He went on to tell me that life seemed very dull and very grey, that nobody loved him, and that he was sure he had contracted housemaid's knee owing to the amount of kneeling that he had had to do on the previous day as the result of spilling a gross of 4 B.A. nuts on a sheepskin hearthrug.

He was, he assured me rather woe-fully, entirely unable to bend the knee, and he begged me to run my eye over it. After removing many layers of insulating tape that he had used as a dressing in default of sticking plaster, I found the entire knee embedded in a large lump of Chatterton's compound.

The professor is always very particular about pulling up his trousers when he either sits or kneels down, and it appeared that prior to going down in search of the nuts he had absent-mindedly gone on hitching at one trouser leg for some little time, and had then flopped down with his bare knee on the lump of Chatterton's, which he had dropped some hours previously and forgotten all about.

"This Ain't the Lido"

I had turned my head slightly to one side, still bending down over the ailing limb, as the professor told the story, and I was therefore not prepared for the sudden movement that he made which brought his knee sharply against my ear. I started backwards, but desisted hastily, for the ear, now firmly attached to the professor's knee, was in danger of being torn out by the roots.

"Take your ear away," cried the professor.

"Take your beastly knee out of my ear!" I retaliated. "Hi! Stop!"

It was a terrible predicament, for the bell was just out of reach, and even if we had been able to get to it, the professor told me that he was sure there was nobody in the house, for the maid who had admitted me was just on the point of departing for her evening out, and Mrs. Goop was at the seaside with the Microgoops.

"The only thing," I said, "is to make our way somehow round to the house of Captain Bucket. These sailors always know what to do in an emergency. By superhuman efforts I managed to get the professor's legs over my right shoulder and to tuck his head under my left arm. I then proceeded down the stairs and out of the front door.

We had got but a few steps along the High Street when a large hand was laid upon my shoulder.

"Ere," said a voice, "what's all this? This ain't the Lido. No, you can't go carrying people about the 'Igh Street in pyjamas, and 'im upside down, too." It was the arm of the law in the shape of P.c. Mugglewump, who looks after the lives and liberties of the citizens of Mudbury Wallow.

The Police Become "Involved"

"Ah, good-evening, Mugglewump," I said. "The professor and I find ourselves in something of a difficulty.



... He'd folded himself neatly upon a chair. ...

Undoubtedly you, with that versatility which is characteristic of the police, will find some way out of it. "You will perceive that the professor's knee has become accidentally attached to my right ear."

P.c. Mugglewump drew closer to verify my statement. As he did so,

In Lighter Vein—continued

Professor Goop, who was feeling a little cramped, made a slight movement under my arm, tickling my ribs, and causing me to start. Of course, I could not know, since I am unable to see out of the back of my head, that the rather short-sighted Mugglewump was bending closely over the point of contact between the professor and myself. Anyhow, it was not my fault that his nose, which is somewhat on the long side, also became involved.

"Ere, stand back!" said Mugglewump.

Crump to the Rescue

I stood forward, thinking that he must have meant that, and my movement was answered by a yell of pain from the constable. All his efforts and ours to effect a detachment were in vain. After some consideration, he decided that he must place himself behind me, with his arms round what I like to think of as my waist, and that we must continue our journey, keeping strictly in step.

We had not got very far when we fell in with Goshburton-Crump, who, seeing that something was amiss, came up to discover exactly what was happening. Being a schoolmaster, he told everybody just what to do, and assured us that if we came round to his place he would have us unstuck in a jiffy.

By this time, however, we were all growing so weary that we found further progress practically impossible. Luckily the dustcart, wearily plodding its homeward way, happened to be passing, and, with the aid of its guardian spirits and Goshburton-Crump, we were somehow got on board and conveyed to the schoolmaster's villa. He arranged us as comfortably



... "Ere! What's this? This ain't the Lido!"

as possible upon the floor of his sitting-room, bidding us be of good cheer.

Parted!

He informed us that he proposed to do the unsticking job with the help of a hot soldering iron. He promised that he would exercise the utmost care in the use of this somewhat formidable weapon. I must really say that he did the job very well, for about two minutes later we came apart with a noise rather like that made by pulling a foot out of a swamp. P.-c. Mugglewump immediately clapped his hand to his injured nose, and found that he could not remove it. The professor simultaneously brought his knees together, only to discover that they were as firmly locked as those of a competitor in a sack race. I was the only one who had the presence of mind hurriedly to wet my ear by squirting the contents of a siphon over it. A portion of the stream of soda flew over my shoulder into Goshburton-Crump's eye, causing him to start back and drop the soldering iron on to Mugglewump's toe.

Under Arrest!

Taken unawares, the constable wrenched his hand from his proboscis, drawing out long filaments of Chatterton's in the process. The hand descended involuntarily upon Goshburton-Crump's neck and remained fixed. By this time Mugglewump was getting a little worked up, for some reason or other, and he informed Goshburton-Crump that he was placed under arrest and charged with assaulting the police. He told the professor and me that we should be required as witnesses, and must accompany him at once to the police-station.

Things were looking pretty gloomy as we proceeded down the street. Goshburton-Crump could not escape, even if he would. The professor proceeded in a series of kangaroo-like bounds. I was the only member of the party completely free to move. I was cudgelling my brains to try to discover some way out of what might be justly described as a horrid, sticky business, when an inspiration came.

The Episode Concludes

"Look here, Mugglewump," I said, "I do not think that you quite realise your position. In the first place, you are inseparably attached to Mr. Goshburton-Crump, and will

probably have to have your right hand amputated in order to become free. Secondly, having ordered Professor Goop to accompany you to the police-station, you are aiding and abetting him in parading the High Street in pyjamas. Thirdly, that blob of Chatterton's that still adheres to your nose is far from becoming, and may lead to a most compromising attachment should you later on solace your nose with half a pint in a tankard. If I can see a way of getting us all out of this, will you call it quits?"

Mugglewump, who was getting a little tired of keeping his hand on Goshburton-Crump's neck, replied, after some thought, that he would.

"Then lead the way," I cried, "to the emporium of Mr. Bloopher, the grocer."

Surprised, but too cowed by their recent experiences to offer much resistance, the party made its way into Mr. Bloopher's shop. I guided them straight to the cheese department. There I pressed two half-crowns into the hand of the fellow



... The Professor proceeded with kangaroo-like bounds.

who slices cheese up with a wire, and explained our troubles to him. In a trice the professor had become a biped once more, whilst Goshburton-Crump and Mugglewump had ceased to be Siamese twins.

When I left him safe and sound that night, Professor Goop was well away with the business of inventing a non-sticky adhesive.

WIRELESS WAYFARER.

The Leading Radio Weekly

Popular . . .
Wireless

ON SALE EVERY THURSDAY.

THE SECRET IN THE TEST TUBES

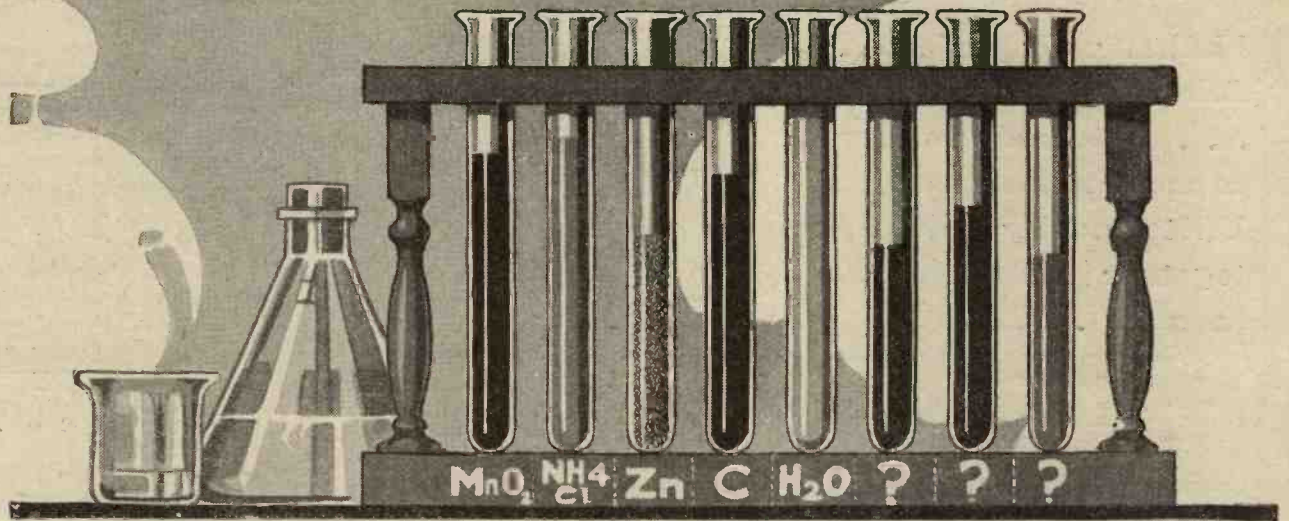

What are the secret chemicals?

YOU KNOW THAT TEST TUBES and the minds of chemists have held secrets which have baffled discovery, but you may not know there have been none more sought after by battery makers than the one so jealously guarded inside each cell of the LISSEN New Process Battery, which makes each cell yield oxygen for your valves in a way *no other cell* does or has ever done before. Copious does not adequately describe this oxygen liberation of the LISSEN New Process Battery.

Since this new energy became available for valves tens of thousands of loud speakers all over the country are reproducing radio broadcast with a freshness of tone and a clear volume which is adding delight to radio. Whenever there is fine music to be heard by broadcast see that you have a LISSEN New Process Battery in your set and hear your loud speaker voicing its appreciation.

You pay shillings for this battery which many others would pay thousands of pounds for, yet 10,000 dealers are selling it at a price which has been made low to bring it within the reach of all.

The next time you want a good battery get a LISSEN New Process Battery. Take no other and you will be rewarded for your insistence by a new power smoothness and new tone clarity in your loud speaker.



60 volts (reads 66) 7/11
 100 volts (reads 108) - 12/11
 9 volts (grid bias) - 1/6

LISSEN
 SECRET PROCESS
BATTERY

Now 10/6
7/11

LISSEN LIMITED, 26-30, FRIARS LANE, RICHMOND, SURREY.

THE LAST WORD IN CONDENSER DESIGN —KEYSTONE—

Universal Logarithmic Condenser

Mechanically perfect...
Selective to a degree
... Patented vernier
capacity adjustment...
Units easily ganged
together... Economical
in price...

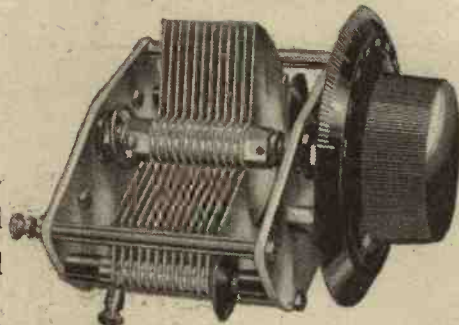

For sheer value for money there is no variable condenser to equal the Keystone Universal. It possesses all the attributes of the best type of variable condenser, and in addition it has several unique features which are not to be found in any of its rivals. Two or three of these condensers purchased as single units can easily be ganged together to form a double or triple gang. Alternatively, if you have used a Keystone Gang

Condenser in a set and wish to change your circuit to one using single condensers, you can readily make the necessary conversion in a few minutes without any special tools.

Both fixed and moving plates are insulated from the frame—another unique feature! Think of the many advantages offered by this condenser, and then compare the prices given below with those of other makes.

PRICES:

SINGLE:	.0005 mfd.	13/6	.0003 mfd.	12/6
TWIN GANG:	.0005 each section	27/6	.0003 each section	25/6
TRIPLE GANG:	.0005 " "	42/-	.0003 " "	38/6

Send for free folder of Keystone Condenser.

THE FINEST CONDENSER VALUE EVER OFFERED

Keystone "Midget" Reaction Condenser

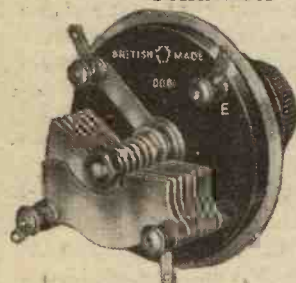

Ideal for the many positions where a small capacity condenser is required. An aluminium shield prevents hand-capacity effects, and a special taper bearing gives a beautifully smooth movement. Accurately designed and rigidly

constructed, this Keystone condenser is backed by the usual Keystone guarantee of efficiency. Capacity .0007 mfd. Price 5/6

Keystone Neutralising Condenser

Used in all the popular circuits this season. These condensers have been designed by experts, and they are suitable for neutralising the electrode capacities for all types of valves. Very low minimum capacity. The wide spacing of the vanes renders accidental "shorting" impossible. Very well made from best quality material and beautifully finished.

Board mounting 5/-
Panel mounting 6/3



Keystone H.F. Choke



The extremely high efficiency of this choke is due to a unique form of low-capacity winding. Range, 300/2,000 metres. Recommended for use in the "Solodyne Five," "All British Six," and many other efficient receivers.

Especially suitable for split-coil circuits
Price 8/6

Keystone Fixed Resistors No. 4 for .25 amp. valves with 6-volt accumulator. No. 17 for .06 amp. valves with 4-volt accumulator. And in many other values. Price 2/6 Resistor only 1/8. Base, 9d.



244 STATIONS

Received and Identified

Some months ago one of our standard 5-valve receivers was sent to Australia and back on a six-months' trip. In mid-Atlantic over 20 stations in Europe and U.S.A. were received on the Loud Speaker during a terrific storm. All results were logged and verified by independent witnesses. The tuning of the Five-Fifty-one is simplicity itself. One control only. All wave-lengths from 250 to 2,000 metres are covered without any coil changing—the movement of one switch only being required.

Write for particulars.

FIVE - FIFTY - ONE SET

COPEX SCREENS

BY TEST THE BEST

All Copex Screens are made from high-grade copper—the best metal for screening purposes. They are rigidly constructed, and polished and lacquered in order to preserve their handsome appearance.

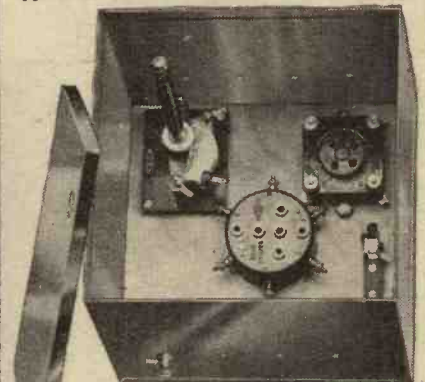

Copex Standard H.F. Screening Unit, as illustrated. Assembled and wired ready for use. Size 6½ ins. square by 6 ins. high. 25/-

COPEX SCREENING BOX "S" VALVE TYPE

Similar in appearance and construction to the unit illustrated above, but pierced on one side to take one of the new screened-grid valves. This box will accommodate a complete H.F. stage, the dimensions being 8½ ins. by 7½ ins. by 7½ ins. high. Price 16/6

COPEX "O.C." COILS

Higher Amplification...
Oscillation perfectly controlled...
Guaranteed matched within one metre...
Wound with Litz wire



100% efficient.

USED IN THE WORLD'S BEST RADIO RECEIVERS.

RECOMMENDED BY THE LEADING TECHNICAL EDITORS.

Prices:

	Aerial Coil	Split primary H.F. Transformer	Split Secondary	Reinartz Coil
Prices:				
250-550 m.	6/-	10/-	10/-	10/-
1,000-2,000 m.	8/-	10/-	14/-	14/-

COPEX 6-PIN BASE

Standard spacing with terminals arranged for easy accessibility. For use where the standard 6-pin coils are utilised without the actual screen. Price 2/9



Send three penny stamps for Catalogue of Components.

PETO-SCOTT CO., LTD.

Registered Office: 77, CITY ROAD, LONDON, E.C.1.

Branches:—62, High Holborn, London, W.C.1. 4, Manchester St., Liverpool. 29, Old Town St., Plymouth.

The "REACTOR" FOUR

A reliable and easily made set that will give a good variety of loud-speaker programmes. The circuit is H.F., Det., and 2 L.F., and a separate valve is employed for reaction.

By K. D. ROGERS.

THERE is an old adage that "there's nothing new under the sun," and though the expression may be strictly correct we do find, from time to time, novel arrangements and fresh methods of using the same fundamental ideas. The circuit incorporated in the set described here does not, in itself, contain anything new; but the arrangement of the various ideas incorporated in it will be fresh to the majority of my readers.

is not a *five-valve* set in the strict sense of the term for it contains only four *stages*, namely, high frequency,

The set was, as a matter of interest, tested both with and without this valve, i.e. using the special reaction valve and using the detector to supply its own reaction, and it was found that on all stations better results were obtained when the separate valve was used. Signals from distant stations could be brought up to a greater strength without distortion, while better quality on the local station could be obtained, especially if the local station happened to be close and *no* reaction was required. In this event the reactor valve was removed, and the detector acted as a rectifier pure and simple. In this way, a "one valve, one job" effect is obtained with its obvious advantages.

To make a detector valve also act as its own oscillator must necessarily introduce a certain amount of distortion,



Next to the main tuning dials are the reaction and volume controls. The on-off switch is on the extreme right.

In the first place, let me say that the receiver under discussion is not intended as a special long-distance set, and many will say that a more profitable use could have been made of the five valves it contains. In some ways I am of their opinion; greater range could have been obtained by using two H.F. stages instead of one, but the idea underlying the design of The Reactor Four was not so much that of originating a "hotted-up" set as that of building a set that will give really good reliable signals on a number of stations and which will satisfy the average constructor who requires several stations really well on the loud speaker but does not want a complicated set.

"One Valve, One Job"

The main points about The Reactor Four are the methods of volume control incorporated in the receiver, and the use of a separate "reactor" valve, from which the set gets its title. It

detector, and two low frequencies. The fifth valve is used solely as a means of obtaining reaction effects, and as such is well worth its inclusion.

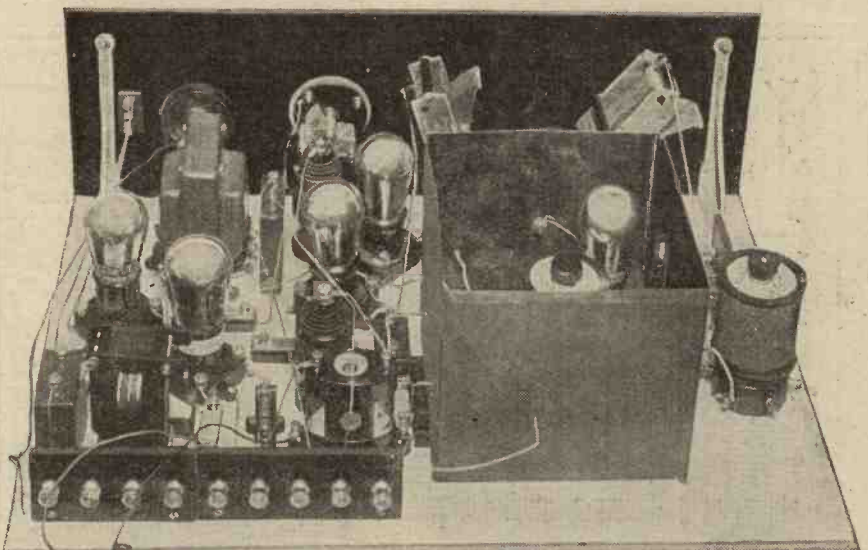

The use of a standard screening box greatly simplifies the wiring.

The "Reactor" Four—continued

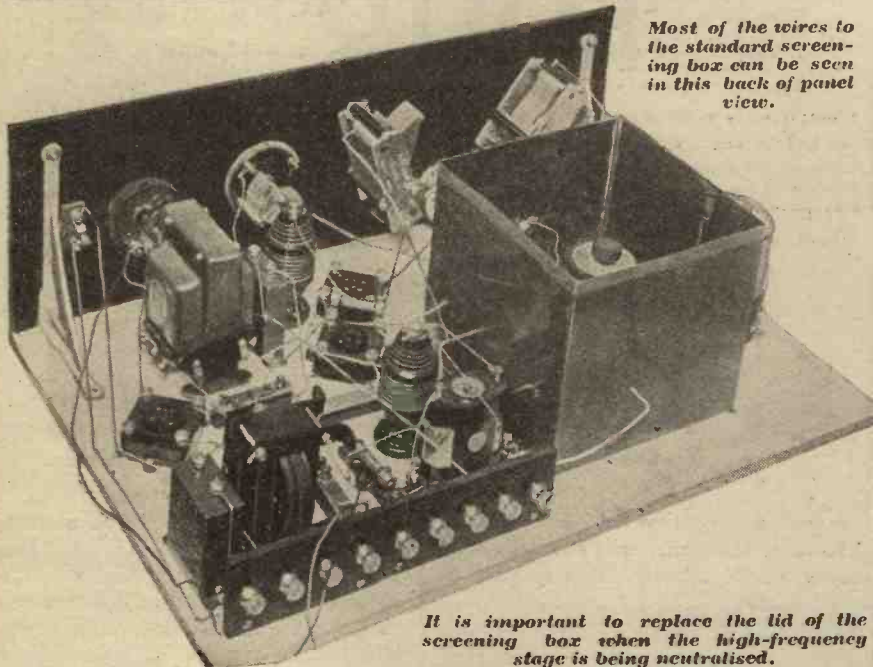

Most of the wires to the standard screening box can be seen in this back of panel view.

It is important to replace the lid of the screening box when the high-frequency stage is being neutralised.

besides enforcing a certain compromise in valve type if satisfactory reaction is to be obtained.

For example, a detector (followed by resistance coupling as is the case in this set) should be of the high-mag. type—up to 35 can be used satisfactorily if a very powerful input is not to be dealt with—whereas for smooth reaction a valve of a low-mag. type and with low impedance is advisable. Therefore, if the detector is to act as its own reactor, something has to be sacrificed, and generally it takes the form of smooth reaction, which is lost in order that a sensitive detector shall be maintained.

With the reactor valve in use we are enabled to choose our detector valve with one aim in view, that of obtaining a good detector—it may be a hopeless valve for supplying reaction; that doesn't matter, for the reaction is supplied by a valve

(Continued on page 45.)

COMPONENTS REQUIRED.

- 1 semi-variable condenser. (Formo-denser, .0005 mfd.)
- 1 standard screening box (complete). (Bowyer-Lowe, Peto-Scott, Burne Jones, Efesca, etc.)
- 1 unscreened six-pin coil base. (Peto-Scott, Leweos, Colvern, etc.)
- 1 Potentiometer. (Igranic, etc.)
- 2 .0005 variable condensers. (Any good make, S.L.F. or square law, and two slow-motion dials.)
- 1 .0001 variable condenser. (Peto-Scott, Midget.)
- 2 H.F. chokes. (McMichael, Ormonde, Lissen, etc.)
- 1 2-meg. grid leak. (Mullard, Lissen, Dubilier, T.C.C., etc.)
- 2 .0003 fixed condensers (Mullard, Lissen, Dubilier, T.C.C., etc.)

- 1 .01 fixed condenser. (Mullard, Lissen, Dubilier, T.C.C., etc.)
- 1 .0005 fixed condenser. (Mullard, Lissen, Dubilier, T.C.C., etc.)
- 1 2 mfd. fixed condenser. (Mullard, Lissen, Dubilier, T.C.C., etc.)
- 1 1 mfd. fixed condenser. (Mullard, Lissen, Dubilier, T.C.C., etc.)
- 4 valve holders. (Lotus, Benjamin, Burndep, Magnum, Precision, etc.)
- 3 filament resistors. (Peerless, etc.)
- 1 R.C. coupling unit. (Any good standard make, such as Mullard, Dubilier, etc. The one shown is the R.I.-Varley type A.)
- 1 25 meg. fixed resistance and holder. (Mullard, Lissen, Dubilier, etc.)

- 1 L.F. transformer. (Any of the well-known makes. That shown is the R.I.-Varley.)
- 1 volume control. (Centralab 500,000 ohm potentiometer. R.A. Rothermel, Ltd.)
- 1 L.T. switch. (Lissen, Lotus, L. & P., Igranic, etc.)
- 1 L.F. choke. (Any good make, of about 20 henries inductance. The one shown is a Pye.)
- 2 panel brackets.
- 1 panel, 21 in. x 7 in. (Radion, Ebonart, Pilot, or other good branded material.)
- 1 cabinet and baseboard, 14 in. deep.
- Terminal strips.
- 12 terminals.

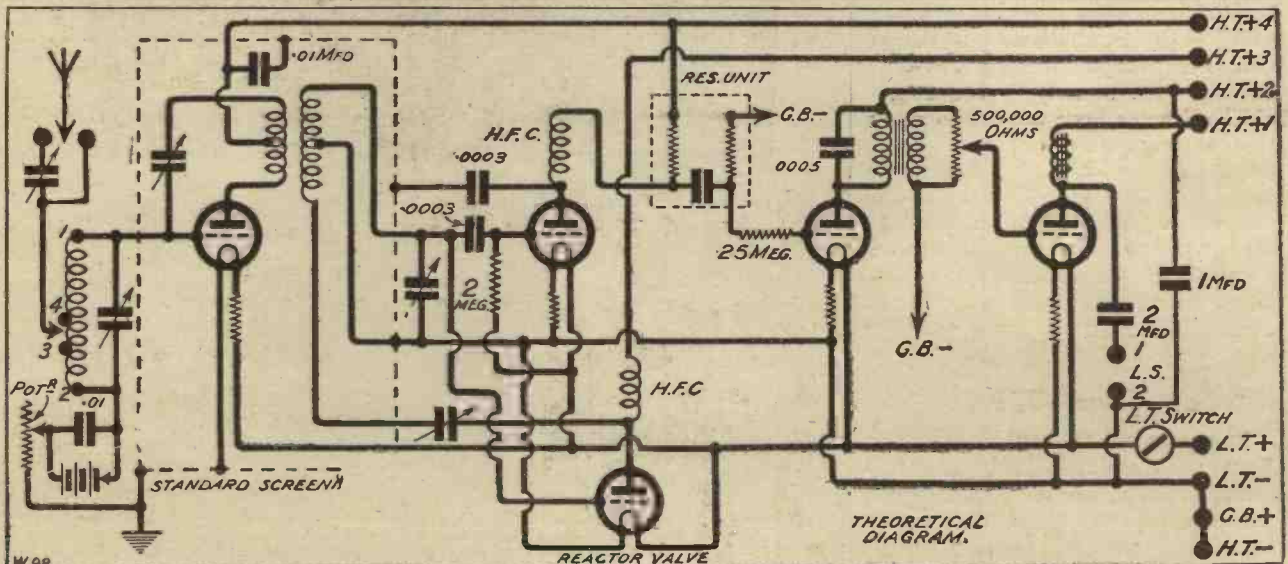

What GREAT BRITAIN thinks about the BRANDESET III^A

The great Public Test Scheme proved that the Brandeset IIIA is ideal from all viewpoints. You operate easily! You hear wonderfully! You pay reasonably! Fifty people carried out private tests in their own homes throughout Great Britain and pronounced it the receiver which will revolutionise wireless entertainment. The map shows the different localities where the receiver was publicly tested before being put on the market. Read what some of the fifty say about this ideal loudspeaker set:



—from **MOFFAT, SCOTLAND**

"We had it working on Daventry to-day, and it is an ideal loud-speaker Set. We were particularly struck with the absence of impurity."

—from **FORT WILLIAM, INVERNESS**

"For volume and purity it beats any 3-Valve Set I have heard. The Set is simplicity itself—a beginner can master it without the least trouble or tuition. My friends are delighted with the results."

—from **CREDITON, DEVON**

"As a 3-Valve Set it is the limit of efficiency—excellent in tone, volume and simplicity. It is really remarkable the number of European stations that are perfectly available."

—from **RHYL, N. WALES**

"We found the Set in every way a splendid job, and at about 11.50 p.m. on August 1st, we tuned in on the speaker on the short wave band 16 stations in approximately one minute."

—from **ROCHESTER**

"The tuning is very simple and gives great selectivity, and my small son of seven can tune in any station as quickly and as quietly as I myself. . . . The Set is undoubtedly the very best 3-Valve Set yet devised."

—from **KENSINGTON**

"The absolute realism of everything I heard on this Set was, I thought, really wonderful, and I would go so far as to say that consummate excellence has been reached."

THE BRANDESET IIIA

Distinct simplicity and perfect efficiency at low price. Single control, 3 valves, improved station selector, sensitivity and selectivity adjustable, polished oak cabinet. Absolutely no equal at its price in distance, selectivity, tone quality and ease of control. Fine technical and mechanical features and a definite official guarantee. (Width 16ins., depth 8 ins., height 9½ ins.)

£6 - 15 - 0

(Excluding Royalty)

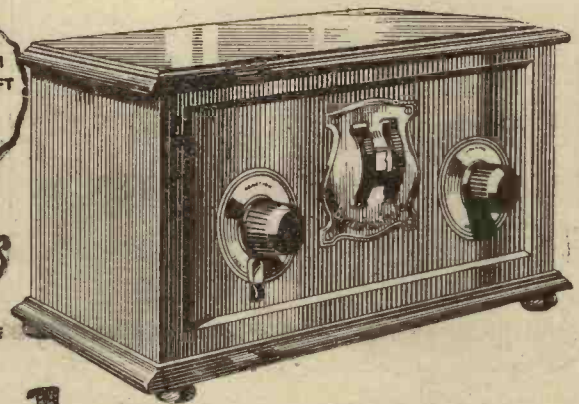

Brandes

The name to know in Radio

Brandes Limited • 2 & 3 Norfolk Street, Strand, W.C.2

GREATLY REDUCED PRICES

The Ellipticon, 95/-; The Brandola, 57/6; The Table-Talker, 30/-; The Variable Condensers, 15/- & 15/6; The Audio Transformers, 15/- & 15/6; The Matched Tone Headphones, 13/6.



THE SIGN OF THE GOOD DEALER

It hangs outside every shop authorised to sell Brandes Products. This sign is for your protection. It means reliable service and guaranteed satisfaction.

Your
T.C.C. Condensers
now cost you less

NOW there is no excuse whatever for buying a cheap condenser. For T.C.C. Condensers are reduced in price. It costs you less, now, to buy the finest condensers made—condensers that are guaranteed up to the hilt. In capacity and in insulation. Ask for T.C.C. Condensers—in the green cases. Green for safety!

Here are the Reduced Prices:

Mica Condensers.

Capacity Mfds.	Prices		Capacity Mfds.	Prices	
	Old	New		Old	New
'0001-'0009 S/P type	2/10	2/4	1	9/-	8/-
'0001-'0009	2/4	2/4	125	10/9	9/6
'001-'004	2/4	2/4	15	12/6	11/-
'005-'009	3/-	3/-	2	16/-	14/6
'01	3/6	3/6	25	19/6	18/-
'05	5/8	5/6	3	23/-	21/6

Mansbridge Condensers.

Capacity Mfds.	Prices		Capacity Mfds.	Prices	
	Old	New		Old	New
'005-'009	2/-	1/8	2	4/8	3/10
'01-'09	2/4	1/9	3	7/-	6/6
1	2/6	1/10	4	9/-	7/6
25	3/-	2/3	5	11/-	9/6
3	3/-	2/3	6	13/-	11/6
3	3/4	2/7	8	17/-	14/9
1	3/10	2/10	10	21/-	18/6

EFESCA CENTADYNE Screened Coils

Efesca Centadyne Screened Coils are constructed in accordance with the standard specification laid down by the technical Press and will compare favourably with any on the market.

Split Primary H.F. TRANSFORMER with optional reaction.

250 to 550 metres: 8/6 each.
1000 to 2000 metres: 8/6 each.

Aerial Coil

250 to 550 metres: 5/- each.
1000 to 2000 metres: 5/- each.

Split Secondary H.F. TRANSFORMER.

250 to 550 metres: 8/6 each.
1000 to 2000 metres: 10/6 each.

Reinartz Coil

250 to 550 metres: 8/6 each.
1000 to 2000 metres: 12/6 each.



EFESCA VARIABLE H.F. CHOKE.

The Efesca Variable H.F. Choke is subdivided into sections and tapped by a switch enabling equal efficiency to be obtained over all frequencies. Wound in staggered slots to minimise self-capacity, with tapping brought to a dead-ending switch.

12/6 each.



EFESCA H.F. CHOKE.

Wound on polished Ebonite Former with heavy gauge wire to possess low resistance, minimum self-capacity and appropriate inductance suitable for wave-lengths up to 2600 metres.

7/6 each.

FALK, STADELMANN & CO., LTD.,

Efesca Electrical Works,

£3/93, Farringdon Road, London, E.C.1.

And at Glasgow, Manchester, Birmingham, Dublin, Newcastle, Cardiff

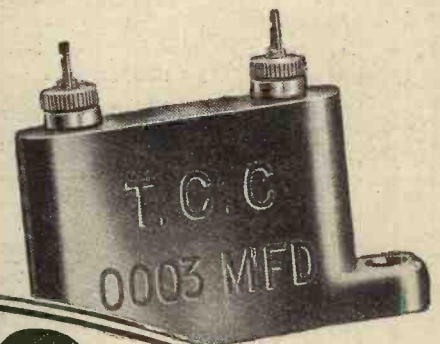

T.C.C. Condensers

Always dependable

Advt. Telegraph Condenser Co., Ltd., Wales Farm Rd., N. Acton, W.3.



The "Reactor" Four—continued

which can also be chosen with that one aim in view.

With the advent of the dull-emitter of low filament current, like the

The small terminal board for aerial and earth leads will be seen near the aerial coil-base with the semi-variable condenser beside it.

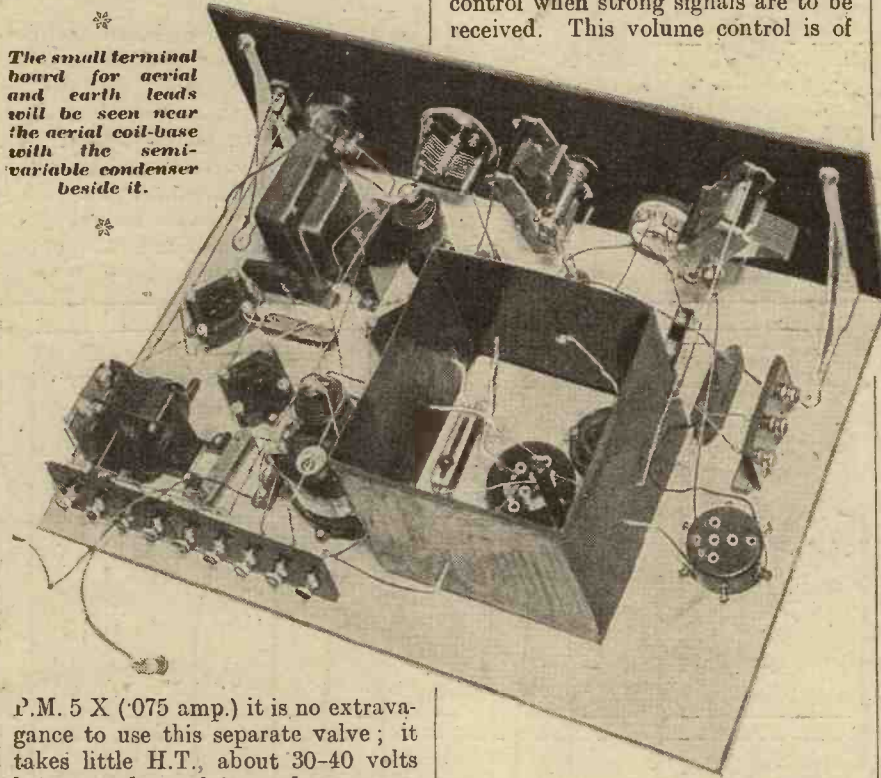

P.M. 5 X (.075 amp.) it is no extravagance to use this separate valve; it takes little H.T., about 30-40 volts being ample, and it needs no extra control. But it *does* supply a very definite advantage when searching for distant stations, especially on the low wave-bands, for reaction can be perfectly smooth and well controlled, and can be taken right up to the point of oscillation without noticeable distortion occurring, for it must be remembered that it is the reactor valve which oscillates, not the detector. Therefore no mutilation of the incoming signals occurs until heterodyning takes place; the introduction of negative resistance into the grid circuit of the detector valve allowing greater sensitivity and greater volume. As the point of oscillation is approached, a certain amount of sideband "cut off" must take place, owing to the lowering of the damping of the detector grid circuit, but this cut-off is not accompanied by the distortion that occurs when the detector is operating as its own reactor.

The Volume Controls

Now let us examine the theoretical diagram of the circuit employed. Here it will be seen are used a neu-

tralised H.F. valve with complete screening as designed by Mr. G. P. Kendall, together with a grid "losser" method which gives smooth volume control when strong signals are to be received. This volume control is of

load on each valve throughout the set. Another volume control is used—for the grid of the last valve—and this is useful if a very close station is being received when the first lossor may not be sufficient, or if the broadening of tuning inevitable with the use of a grid lossor is to be avoided owing to any kind of jamming.

For instance, if Langenberg is being received at too great a volume for the constructor's requirements he can cut it down by the second control rather than the first, which might upset the selectivity of the set sufficiently to bring in traces of 5 G B if the listener happens to be fairly close to the latter station. As a rule, however, the selectivity of the set is not sufficiently impaired by the slight "lossing" required to cut down such stations as Langenberg, Hilversum, Frankfurt, etc., all of which come in at really good strength. In the writer's opinion a finer control of distant stations can be obtained by the use of the second control—the potentiometer across the secondary of the R.I. transformer.

The biasing of the H.F. valve is important if overloading is to be avoided on strong signals and if full amplification and good selectivity is to be obtained. It requires about 1.5 volts. And, talking about selectivity, an idea of the capabilities of

great advantage, for it cuts down the strength of the signals at their source, so to speak, and thereby reduces the

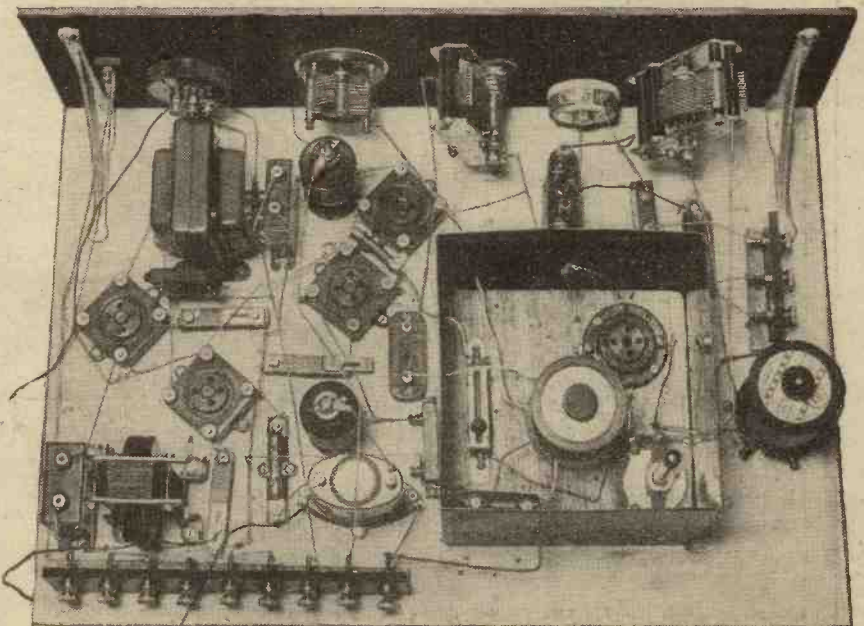

This plan view should be compared with the wiring diagram given on the next page.

The "Reactor" Four—continued

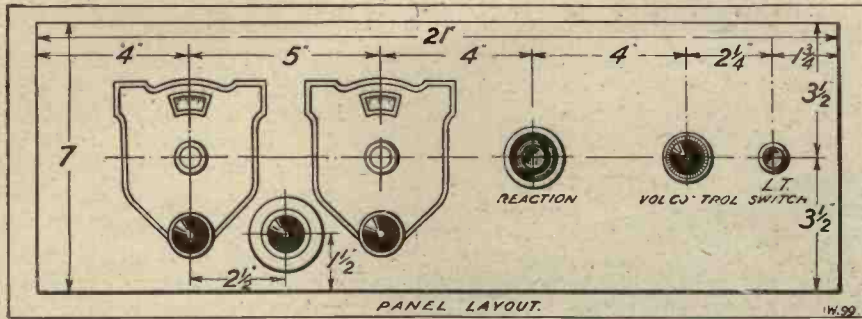

the set can be judged by the fact that in London, and at a point twenty miles N.W. of London, a silent point

between 5 GB and Langenberg can be obtained without the use of reaction to sharpen the tuning. In fact,

when reaction has been used the writer has several times missed 5 GB altogether when he has been searching rather hurriedly on the "Reactor Four."

Grid leak and condenser rectification is used owing to its simplicity; while resistance coupling for the first stage, and then the new R.I. straight-line transformer for the second, were found to give excellent purity.

The actual construction of the set is not difficult if the constructor carefully follows the diagrams and photographs.

(Continued on page 77.)

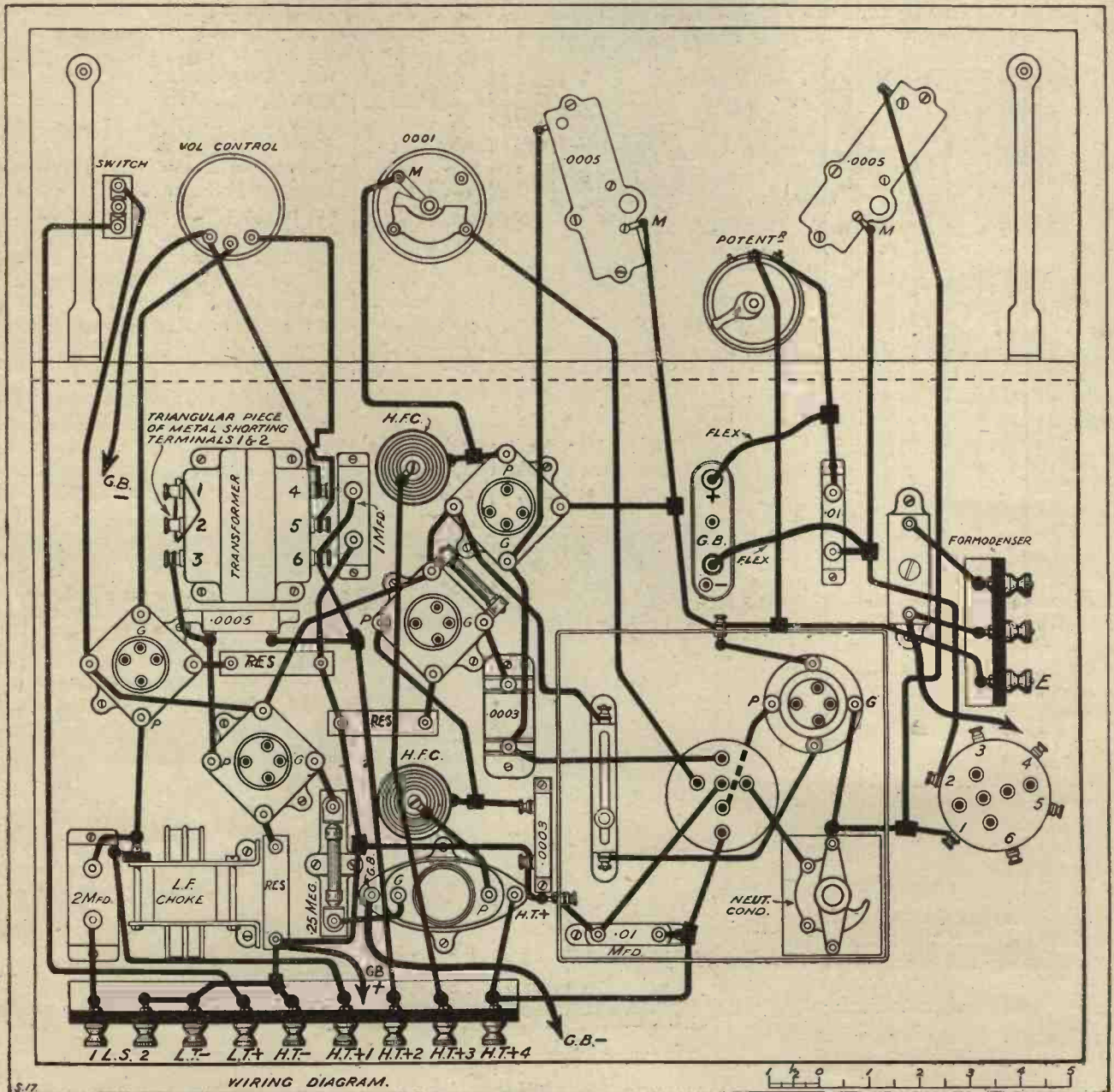

The ORMOND SLOW-MOTION DUAL INDICATOR DIAL

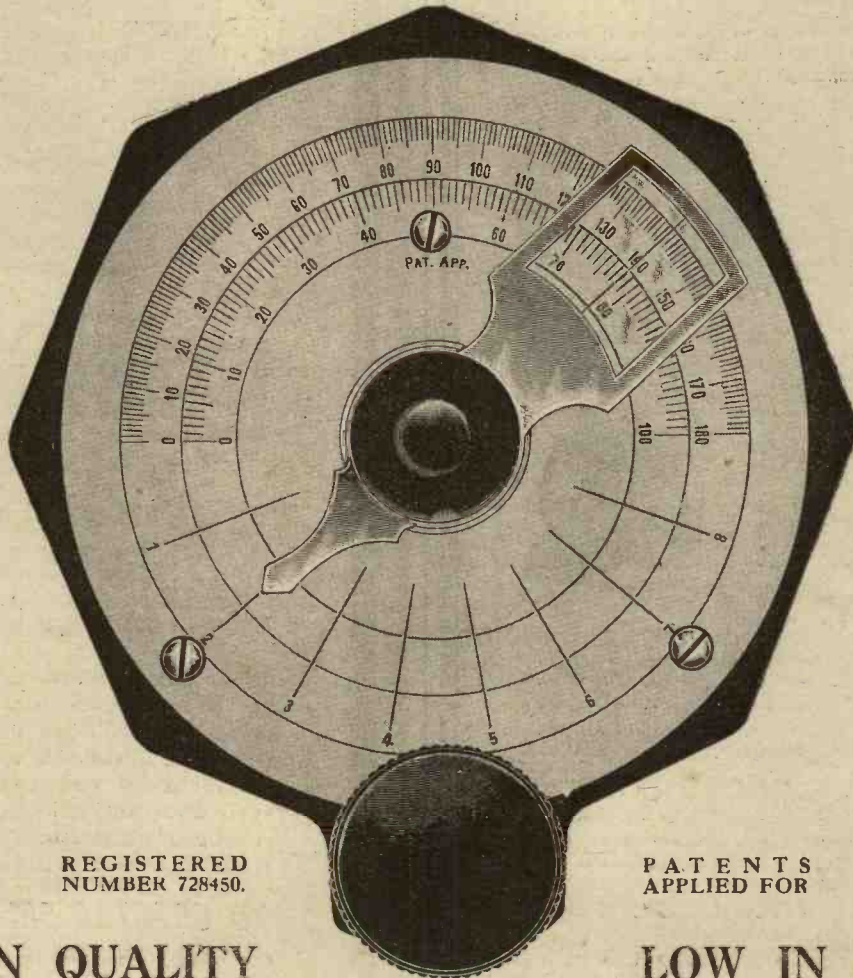

REGISTERED
NUMBER 728450.

PATENTS
APPLIED FOR

HIGH IN QUALITY

LOW IN PRICE

This is the popular Ormond Dual Indicator Dial now fitted with a slow-motion drive, with an ideal reduction ratio of 16-1. Fast enough for easy searching, slow enough for finest tuning. Fine hair line for accurate reading, suitable for the most discriminate user. An "ORMOND" feature. The cursor moves in the same direction as the rotation of the knob.

PRICE

5/-

Another "ORMOND" feature. A terminal is provided for separately earthing the dial, the latter then may be used as an anti-capacity earthing shield.

Easy to mount and may be used on one-hole-fixing condensers, plain type.

Orders in strict rotation

199-205, Pentonville Road,

Telephone: Clerkenwell 9344-5-6

FACTORIES:

Whiskin Street & Hardwick Street,
Clerkenwell, E.C.1



King's Cross, London, N.1

Telegrams: "Ormondengi; Kinross."

Continental Agents:

Messrs. Pettigrew & Merriman, Ltd.,
"Phonos House," 2 & 4 Bucknall Street,
New Oxford Street, W.C.1

13 to 550 METRES!

WITH AERO SHORT-WAVE APPARATUS

AERO Short-Wave Inductance Units, of very advanced design, ensure easy reception of U.S. short-wave stations. Full instructions and prints are supplied with each kit of coils. The I.N.T. 4 and 5 coils enable reception up to 550 metres, or to 750 metres by insertion of a .0001 fixed condenser across the rotor and stator of the .00014 variable condenser.

AERO SHORT-WAVE TUNER KIT

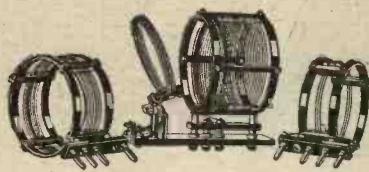

Contains a complete range of Aero Inductance Units covering a wave-band of 15-130 metres by means of 3 coils. Mounting base is supplied

with the kit. Uses .00014 condenser on secondary and .00025 on feed-back control.
No. L.W.T. 125 S.W. Outfit 52/6



AERO INTER-CHANGEABLE COILS
Nos. 4 & 5

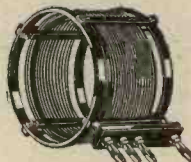

I.N.T. Zero Increase the range of the Aero S.W.

No. 5

Receiver to cover wave-lengths up to 550 metres, thus making reception possible from 15-550 metres.

No. I.N.T. 4. 125-250 metres .. 16/6 each.

No. I.N.T. 5. 235-550 metres .. 16/6 each.

EXTRA S.W. COIL.

No. I.N.T. Zero. 13-29.4 metres .. 16/6 each.

AERO R.F. CHOKE COIL



Specially designed for the Aero S.W. Receiver. Has a uniform action over a wide range, including Broadcast and Amateur S.W. Bands.

No. 60. R.F. CHOKE COIL 6/3 each.

AERO FOUNDATION UNIT

For short-wave receiver. Consists of a finely drilled and engraved (Westinghouse Micarta) front panel, and wood baseboard of proper size. Two sets of blue-prints are furnished, with complete layout and diagrams.

Price 27/6

AMSCO S.L.F. CONDENSERS

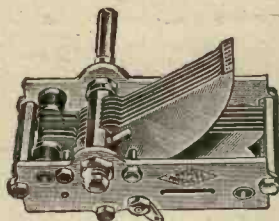

The Aero panel of the Foundation Unit for the S.W. set is drilled to accommodate the well-known Amsco S.L.F. condensers. These condensers are supplied as follows:

.00014 .. 11/6 each.

.00025 .. 11/6 each.

Hamleys
ESTD 1760
HAMLEY BROS. LTD.

Telephone :
Regent 3160
(6 lines).

200/202, REGENT STREET, LONDON, W.1

Telegrams :
"Pleasingly Piccy."

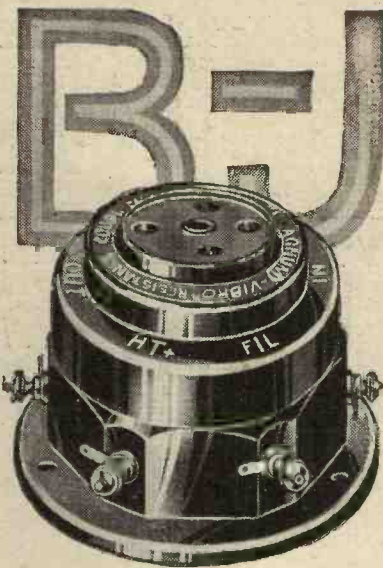

MAGNUM
R C
COUPLING UNIT

INCORPORATING A VIBRO VALVE HOLDER.

With this economical unit, your set will reproduce with an astounding purity and faithfulness. It embodies a correctly proportioned condenser, anode resistance and grid leak, sealed in a Bakelite moulding, together with a Vibro Valve Holder.

TO CRYSTAL SET USERS

One of the recommended uses for the Magnum R.C. Unit is in a two-valve amplifier, the complete set of parts (which can be assembled in 30 minutes) cost £1 : 10 : 0 only. Write for a leaflet giving wiring diagram.

Price 10/6

DESIGNED AND MANUFACTURED BY

BURNE-JONES
& CO. LTD.,

MAGNUM HOUSE

TELEPHONE : HOP 6257

288, BOROUGH HIGH ST.

LONDON. S.E.1

CHATS AT THE WORK-TABLE

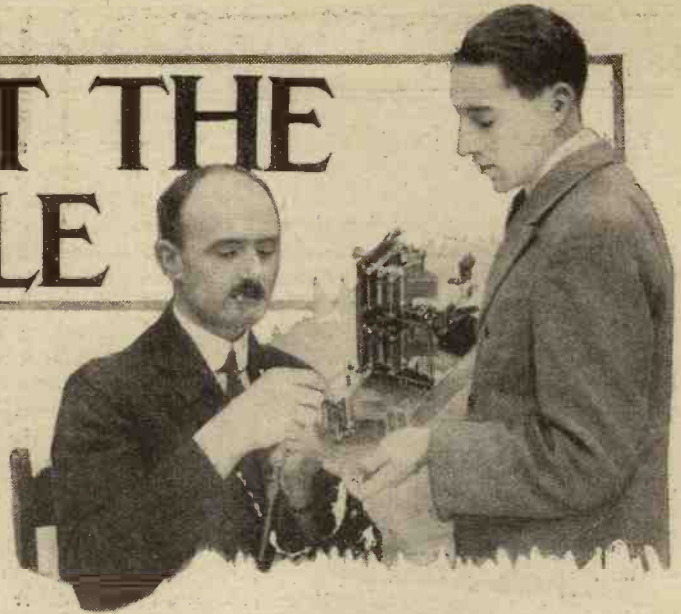

Many problems of practical interest to all radio constructors are dealt with this month, including

The Construction of Home-made Cabinets—Panel Mounting Problems—A Template Difficulty—Home-made Anti-microphonic Valve-holders—Converting a Jack, etc., etc.

By R. W. HALLOWS, M.A.

Handsome Home-made Cabinets

FOR some time past I have been trying to work out a design for home-made cabinets that, besides being simple enough to interest even those who do not care very much about woodwork, will enable a cabinet

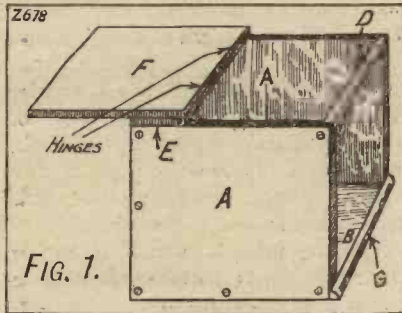

FIG. 1.

to be made which, despite the small amount of time and money spent upon it, is really worthy of a first-rate receiving set. In previous chats I have described various methods of making cabinets from plywood with a veneer of rosewood, mahogany, walnut, or oak. These are satisfactory enough up to a point, but they have not quite the solidity that one likes. I also gave some time ago a design for cabinets made from ordinary wood. That type, again, had a good deal to recommend it, but the cabinets were not too easy to make.

Made of Mahogany

I have just evolved a third type of home-constructor's cabinet which will, I feel, meet the requirements of most readers. These cabinets are constructed of mahogany from $\frac{3}{8}$ to $\frac{1}{2}$ in. in thickness, according to their

size. Naturally, one must use thicker wood for a large cabinet than for a small one, in order to obtain the necessary stiffness. There are no difficult joints of any kind to make, and if the wood is ordered ready-cut the business of putting the cabinets together can be accomplished easily and quickly with nothing but the simplest of tools.

Figs. 1 and 2 show the design of the completed cabinet. It will be noticed that it departs somewhat from conventional designs. Instead of being hinged directly on to the back, the lid is attached to a narrow top piece E, which enables it to be opened right back, as shown in Fig. 2, without any risk of straining the hinges. Since the top piece is only $1\frac{1}{2}$ in. wide, every part of the set within the cabinet is accessible when the lid is opened.

Practically Dust-Proof

In most cabinets of conventional design there is a top piece at the front from 2 to $2\frac{1}{2}$ in. wide against which the front edge of the lid fits. When the lid is closed there is often a slight gap between it and this top piece through which dust finds its way into the set. By hinging the lid to the back piece E a close-fitting joint is easily made which, if the hinges are carefully recessed into the wood, is practically dust-proof. The front edge of the lid projects $\frac{1}{2}$ in. or so beyond the sides, and is rounded off. To the front edge of the bottom B is attached a light beading of the same wood as the body of the cabinet.

The lid may be made to overlap at the sides as well as in front, and a beading with mitred corners may be

fixed to the sides A, A, as well as to the front of the cabinet. The necessary stiffness is obtained by the use of the batten D, which can quite conveniently be halved-in to the side pieces A, A. This makes a very firm and strong joint, but it is not absolutely necessary.

The Dimensions

A cabinet to fit any receiving set with horizontal baseboard and vertical panel can be made from pieces of wood measured up in accordance with the following table:

SIDES (A, A).—Height: height of panel plus thickness of bottom B plus thickness of batten D.

Width: width of baseboard plus thickness of panel plus thickness of back C.

BOTTOM (B).—Length: length of

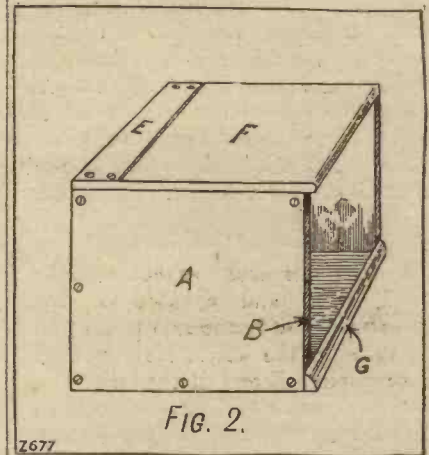

FIG. 2.

baseboard plus a small fraction of an inch for clearance.

Width: width of baseboard plus thickness of panel.

Chats at the Work-Table—continued

BACK (C).—Height : height of sides A, A.

Width : length of B.

BATTEN (D).—Length : length of panel full *plus* thickness of one side piece (if to be halved-in; if not to be halved-in, length of panel full).

Section : $\frac{1}{2}$ in. square.

TOP PIECE (E).—Length : length of bottom *plus* thickness of both side pieces.

Width : $1\frac{1}{2}$ in.

LID (F).—Length : length of top piece.

Width : width of side pieces less 1 in. (this gives an overhang in front of $\frac{1}{2}$ in.).

BEADING (G).—Length : length of E.

Width : at bottom $\frac{1}{2}$ in. to $\frac{3}{4}$ in.

The Wood To Use

With the exception of the bottom and the back, which should be of white wood, the cabinet is made from a good-looking wood such as mahogany, oak, teak, or walnut. I rather advise the use of one of the lighter-coloured mahoganies, for these, besides having an excellent appearance, are fairly soft and quite easy to work. It may come as a surprise to some readers that there should be more than one kind of mahogany. I believe that actually there are only two or three kinds of true mahogany, but the number of woods sold as mahogany runs into well over a hundred. The kind that I have in mind is hard enough to be thoroughly strong, and to take a fine polish, but not so hard as to blunt ordinary wood-working tools rapidly. Its colour is not the deep red of true mahogany, being, in fact, not unlike that of the cedar wood of which cigar boxes and pencils are made. The softer mahogany is not so liable to split as the very hard stuff.

Construction

Having purchased or cut out the wood, drill and countersink the necessary holes in the side pieces and fix these to the base. Next put on the top piece E and fit the batten D. The back piece will now fit in flush with the rear ends of the sides. Any holes required for terminal panels should be cut before it is fixed in position. We are now ready to fit the beading G. A handy way of doing this is to smear its inner edge with

Seccotine or glue and then to fix it with a few small sprigs. The last process is to fix on the lid by means of the hinges. An extremely neat and solid job is made if instead of a pair of small hinges a single long piano hinge of the required dimensions is obtained. Nothing remains but to finish up the cabinet with one of those simple but most effective french polishes now obtainable for amateurs. If you have used the lighter grade of mahogany and desire to obtain a red colour you can very easily do so by staining the cabinet before you polish it with permanganate of potash dissolved in water. The stronger the solution the darker will the wood become.

Pigtail Leads

Nothing makes a receiving set look more untidy than a tangle of loose leads running from its terminals to

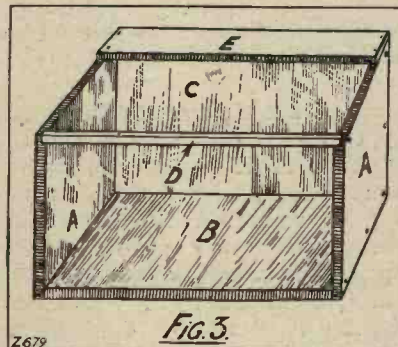

the batteries. An exceedingly neat job can be made by working leads into what for obvious reasons is called a pigtail. The greatest number of wires required will usually be six : H.T.+ for H.F., H.T.+ for detector, H.T.+ for L.F., H.T.—, L.T.+ and L.T.—. Each should consist of good quality flex, with an inner rubber covering and an outer casing of silk or cotton. Each lead should be of a different and quite distinctive colour. A combination that I find useful is red for the maximum H.T.+ tapping, yellow for the intermediate voltage, white for the detector tapping, black for H.T.—, blue for L.T.—, and brown for L.T.—.

Contrasting Colours

Flex wire of two contrasting colours is purchasable at most wireless shops, and a length of this forms the foundation of the pigtail. For the other leads single flex is required and if you cannot obtain this, buy double and

untwist it. Pieces left over will always come in handy for Radiano or for making odd connections. Cut off the length of double flex required and measure off a similar length of the other colours, allowing about twenty-five per cent extra in each case. Draw the ends level and either splice the leads with a seizing of silk or knot them together three or four inches from the ends. Attach the end of the pigtail to a door knob or something of the kind so that it can be stretched out. Now take one of the single leads and start to work it in.

Making The Lead.

¶ We will suppose that the foundation is double red-and-black flex. You will find that your white lead runs easily into the groove between the two. Be careful to put it on evenly; it is easy to do this if you just watch the sequence of colours and see that it is always the same. Thus if you start putting it on above the black lead the sequence will always be white, black, red. Having wound on the white lead almost to the ends of the other two, tie a piece of string round the three to keep them from untwisting and deal with, say, the blue wire in the same way. The sequence of colours will now be blue, white, black, red all the way down the pigtail. The process continues until all the leads have been worked in and fixed.

Another method which is rather easier and gives quite respectable results is to use three lots of contrasting double flex, such as red and black, yellow and white, and blue and brown.

Another Method

Measure off equal lengths of these and knot or splice them together near the ends. Then simply plait them and make off near the finishing end with a knot or a splice. So that the ends of the wires may be neat enough to be in keeping with the pigtail it is best to tag them. For this purpose I know of nothing better than Positive Grip terminals, which besides securing the leads with a vice-like hold, also ensure that no unsightly ragged ends are left of the fabric covering. The only snag is that these terminals are obtainable in only four colours, red, black, yellow and green, though it is as well to give each lead a tag of its own colour so that no mistake can possibly be made when connecting up. I get over the difficulty when

(Continued on page 78.)

*Six-Sixty "every time!"
says the Constructor*



"I want certain results," says the constructor, "and I know that with Six-Sixty I shall get them. Firstly, it is a well-known fact that each Six-Sixty Valve is tested under actual broadcasting conditions before being passed on to the public. This is the most exacting test that any valve can undergo. Then, again, what further proof of the excellence of Six-Sixty Valves do I need, when I know that most of the leading Set Manufacturers in the country standardise Six-Sixty in their Receivers? A.J.S., The Langham Portable, General Radio Company's Receivers, MacMichael, Truphonic, are but a few of those universally known Receivers in which Six-Sixty are standardised. Manufacturers know the best valve, and their choice is mine. They are the experts, and what they select is bound to be the best, so I say 'Six-Sixty every time.'

"Then remember that eight of the famous range of Six-Sixty valves consume only '075 amp. filament current.

"I recommend fellow constructors to write for the most attractive booklet describing in detail the full range of Six-Sixty Valves. It is sent post free on receipt of a post card."

**SIX-SIXTY
GLOWLESS VALVES**

THE ELECTRON CO., LTD., 122-124 CHARING CROSS ROAD, LONDON, W.C.2.



**C. E. PRECISION
WIRE WOUND
ANODE
RESISTANCE**

—the wire costs fifteen pounds a pound!
The wire used in their manufacture is specially made for the purpose, and the component is designed and most carefully manufactured to give the purest reproduction obtainable. Each value is absolutely constant.

PRICES:

20,000 to 50,000 ohms	-	-	3/9
60,000 to 100,000 ohms	-	-	4/9
150,000 to 200,000 ohms	-	-	7/-
250,000 ohms	-	-	8/-
500,000 ohms	-	-	15/-

Other values to order. Clips and base, 1/3 extra.

C. EDE & CO., Ltd., BYFLEET, SURREY

Telephone: Byfleet 228
Telegrams: 'Ceprecise,' Byfleet.



There are also the famous C. E. PRECISION Rheostats, Dual Rheostats and Potentiometers, Sectionally Wound Fixed Resistors, Coils, Grid Leaks and Floating Valve Holders. The latter, as illustrated, are anti-capacity and non-microphonic, and cost 2/- each.

WRITE FOR FULL LIST OF C. E. PRECISION COMPONENTS AND FOR CIRCUIT DIAGRAM OF "THE ORCHESTRAL THREE"

AERO COIL

SUPER-SENSITIVE INDUCTANCE UNITS.

The Perfect Inductances for all S.W. Work.
(Fully Patented.)

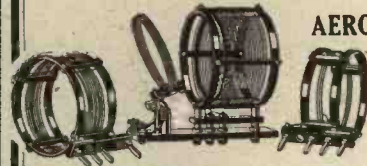

AERO S.W. RECEIVING KIT
Completely interchangeable. Range from 15 to 130 metres. The kit includes 3 coils and mounting covering U.S. Bands of 20, 40 and 80 metres. You can increase the range of the Aero S.W. Receiver to cover wavelengths up to 750 metres with coils Nos. I.N.T.4. and I.N.T.5.



	Each.
Aero S.W. Kit 15-130 M.	List Price 52/6
Extra coil, No. I.N.T.4.	" " 16/6
" " " I.N.T.5.	" " 16/6

AERO SHORT-WAVE SET.

Its performance makes it the leading short-wave set for distance getting, selectivity, volume, and easy control. Used by the United States Government, Broadcasting Stations, University Laboratories, the MacMillan Expedition, University of Michigan Greenland Expedition, and adopted by leading experts and amateurs throughout the world.

Send for details To-day and get to know the marvellous results of S.W. reception.

THE ROTHERMEL RADIO CORPORATION OF GREAT BRITAIN, LTD.,
24-26, MADDOX STREET, LONDON, W.1.

Tele. Nos.:
Mayfair 578 and 579.

'Grams':
Rothermel, Wesdo, London.

**ARE HYDRA
CONDENSERS
IN YOUR
ELIMINATOR**

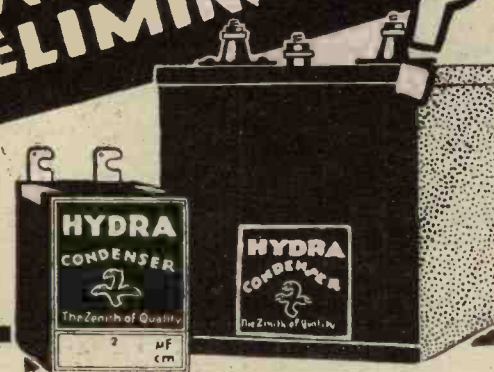

THEY SHOULD BE! **WHY?**
Because they are obtainable tested on 750 volts, they have the lowest leakage of any condenser in the world, and are better value all round.
1 mfd. - 3/- 2 mfd. - 4/- 4 mfd. - 6/9
Tested on 750 volts D.C., working voltage 375 volts. Obtainable at all dealers, if any difficulty
LOUIS HOLZMAN, 109, Kingsway, London, W.C.2.
Irish Free State Distributors: Briscoe Importing Co.,
9, Astons Quay, Dublin.

Make your own H.T. Eliminators and Battery Chargers

POWER TRANSFORMERS FOR H.T. ELIMINATORS



For supplying H.T. current up to 6 valves.
T.P.1—110 volts 50 cycles ... 16/6
T.P.2.—220/240 volts 50 cycles ... 17/-

FILTER CHOKES

S.F.1—50 henries ... 16/6
S.F.2—20 henries ... 5/9

Power Transformers for Battery Chargers

T.R.1—110 volts 40/60 cycles ... 18/6
T.R.2.—225 volts 40/60 cycles ... 17/-

The "Sensittie" High Tension Eliminator, complete kit of parts contains: Super-Power Transformers, Chokes, Variable Wire-Wound Tapped Resistances, and necessary Condensers, all fully guaranteed, prices from 19/6. Wiring diagrams and blue prints free.

Write to-day, stating A.C. or D.C. Mains.
The WHOLESALE WIRELESS Co.,
103, Farringdon Road, London, E.C.1.
Telephone: Clerkenwell 5312.

CUT THIS OUT FOR CABINETS

and post to us for new FREE list illustrating Cabinets as shown in "Wireless Constructor," etc., etc.

NAME

ADDRESS



(Write in block letters, please.)
CARRINGTON Mfg. Co. Ltd.,
Camco Works,
Sanderstead Road, South Croydon
Telephone: Croydon 0623 (2 lines).

WHAT'S NEW

An Interesting New Low-Frequency Transformer

THE new R.I.-Varley straight-line low-frequency transformer has aroused more than usual interest in view of the standing of the old R.I. transformer which it is to replace. We can say at once that this transformer is a very considerable advance on the previous quite excellent instrument. Apart from the tests to which this transformer has been submitted in this



The new R.I.-Varley straight-line L.F. transformer.

laboratory we have had the opportunity of examining the amplification curve, prepared by the National Physical Laboratory, which proves that the name "Straight Line" transformer is no mere fancy designation. The amplification curve is a dead straight line over the whole range of frequencies that the ordinary type of loud speaker is able to reproduce, and is still very high on frequencies well below the lower range of practically all the cone types. Even at 25 cycles the amplification is considerably greater than with many transformers at 100 cycles, and on direct comparison with resistance-capacity-coupling units of high quality, using a high-grade cone speaker, the reproduction seems as good with one as with the other.

A MONTHLY REVIEW OF TESTED APPARATUS

(NOTE: All apparatus reviewed in this section each month has been tested in the Editor's private laboratory, under his own personal supervision.)

The make-up of the transformer is different from that of the previous Radio Instruments transformer, the terminals (of which there are six) being so placed that the modern sub-baseboard wiring method can be applied very successfully. The new transformer has been prominently displayed at the Wireless Exhibition, and many readers have examined it for themselves.

A Useful Station Chart

Messrs. Redfern's Rubber Works, Ltd., makers of the well-known and excellent Ebonart wireless panels, are now issuing in each damage-proof carton with their panel an "Ebonart Station Log Chart," a useful card measuring 8½ in. by 5 in., and ruled off into twenty-four sections, each section being subdivided so as to enable the user to record the name of the station, wave-length, aerial dial number, first H.F. or oscillator dial number, and second H.F. or detector dial number. This chart can be fastened inside the lid of any wireless cabinet, and should prove a most useful addition to any set. As the chart will be issued free with every panel, we are quite sure it will enhance the sale of this company's products.

A New Meter

The Wet H.T. Battery Co., of London, have submitted to us the "Wates Universal Wireless Meter," a small and well-finished voltmeter with a double scale so that L.T. readings up to 6 volts, or H.T. up to 120 volts, can be taken. The pointed stud on the meter being the negative terminal, a black connecting lead is

positive for the L.T. reading and a red connection positive for the H.T. Tested against our laboratory standard the readings were found to be accurate, and the resistance of the voltmeter high enough to prevent the false readings which low-resistance H.T. voltmeters will often give. While being well finished and accurate the instrument is quite low priced for its class, the figure of ten shillings being well within the reach of most experimenters. On the instruction sheet provided with the meter particulars are given of the method of measuring milliamperes, by connecting the meter in a particular way and using a conversion chart so that the 6-volt scale reading can be converted into the equivalent milliamperes.

Although this method of using the instrument will be useful in many cases, there are some in which it would be misleading and inaccurate. However, its use in this way can cause no harm to the battery, set, or instrument, and is certainly interesting to try. As a voltmeter for H.T. and L.T., however, the instrument can be well recommended, particularly in view of its excellent value.

A Good Switch

The London and Provincial Radio Co., Ltd., have submitted for test their latest-pattern on-and-off switch, the appearance of which can be gathered from the accompanying

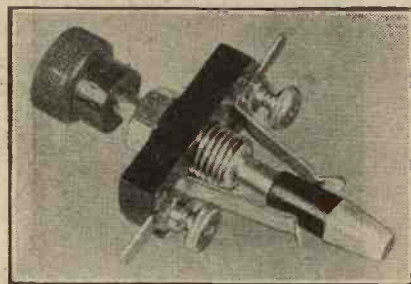

A well-made switch by L. & P. Radio Co.

photograph. We particularly like the movement of this switch, as it gives good positive contact which is self-cleaning, and there is a very definite

What's New—continued

on-and-off position. Both terminals and soldering lugs are provided, and the switch fits by the well-known "one-hole" method. At its price (2s.) it is distinctly superior to many we have tried at more than twice this figure, and the component can be recommended for any set.

A Useful Two-Coil Holder

The General Electric Company, Ltd., have submitted for test and report a specimen of the Gecophone

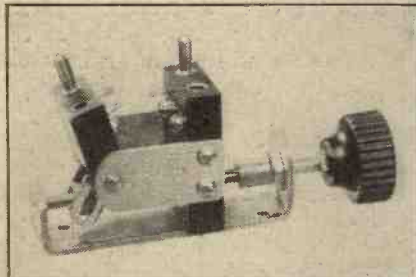

The new G.E.C. two-coil holder for panel mounting.

two-coil holder for back-of-panel mounting. This is a particularly useful and well-made component, which, as will be seen from the accompanying photograph, occupies very small space behind the panel. The device is mounted by being screwed to the baseboard of the set by two convenient holes in the base provided for this purpose, the knob projecting through to the front of the panel.

The moving socket is pivoted, and its angle relative to the fixed socket



A Gecophone transformer for use with K.L. and K.H. valves.

is varied by an ingenious and smooth-acting worm action, which is so constructed that the heaviest coil will not make the moving socket fall down, as happens occasionally in some of the holders in which the moving socket is held in position by a spring.

The sockets themselves, into which the standard coils fit smoothly, but with the requisite tightness, are cut from pure ebonite, and high-frequency tests indicate that the losses here are negligible. The connecting wires are joined to soldering lugs on each of the two sockets. Altogether a useful and soundly designed component which can be recommended to readers.

A New R.C. Unit

From the Carborundum Co., of Trafford Park, Manchester, we have received specimens of their new R.C. coupling unit, consisting of a neat moulding measuring 3 in. by 1½ in., and carrying the coupling condenser, the value of which is .002 mfd. The anode resistance and grid leak respectively are held in spring clips mounted on the top of the moulding, the terminals being clearly marked. Both anode resistance and grid leak are of the same size, being distinguished by different coloured labels.

Both resistances are made of carborundum compound. In this way they differ from many of the anode resistances and leaks now sold, which consist of carbonised material, the resistance of which frequently changes in value as time goes on. The values provided in the carborundum unit were found, on test, to be suitable for the now popular R.C. valves.

K.L.1 Transformer

Readers who are experimenting with the K.L.1 valve will be interested in the Gecophone transformer illustrated herewith and specially designed for the purpose. Unlike several transformers sold for use with this valve, it is very soundly and safely designed, with adequate arrangements for cooling and excellent protection against shock from "live" terminals. It can be thoroughly recommended as an exceptionally well-made transformer for the particular valves mentioned.

Coil Holder with Dial

From the London and Provincial Radio Co. we have received an excellent two-coil holder, the moving socket being controlled by a rotating knob so as to give a fine adjustment of the movement. In addition, a geared dial is provided, so that when the holder is mounted with the coils inside the cabinet, the operator can tell the relative positions of the coils quite accurately.

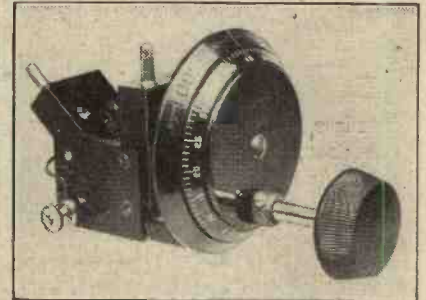

The coil-holder with vernier movement and indicator dial made by the L. and P. Radio Co.

The holder is well made and of good appearance, while electrically it passed all tests satisfactorily and can be recommended.

A Cartridge Crystal Detector

Messrs. A. W. Griffin & Company, of Reading, have submitted the Gripco "Permanent Fixed Detector." As will be seen from the illustration, this consists of an insulating cartridge carrying terminals at each end. The screw thread at one end is longer than at the other and carries, as well as the terminal, a nut. This enables simple adaptation of the detector to be made. First of all, it can be mounted between any standard clips by suitably adjusting the position of the nut and the terminals; secondly, it can be mounted on a panel by drilling a single hole and inserting



A popular rectifier, the "Gripco" permanent crystal detector.

the shank through the panel. The nut is then fixed at the back of the panel and the terminal at the front. Tests with several of these cartridges show very reasonable sensitivity, and

(Continued on page 57.)

THE FERRANTI PERMANENT TRICKLE CHARGER

(Incorporating the Westinghouse Patent Metal Rectifier)

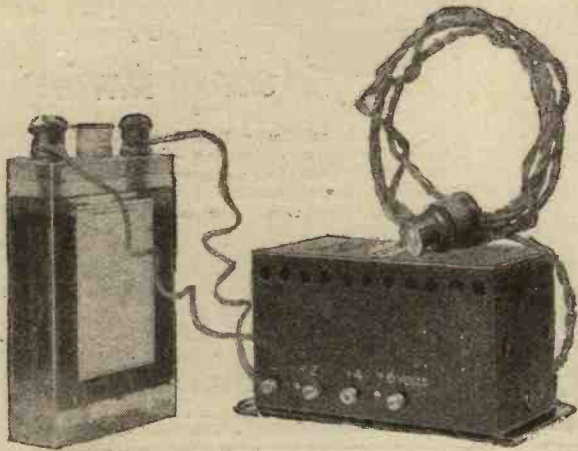

For charging accumulators at home from the Alternating Current Mains. Suitable for use on voltages from 200 to 250, and 40 to 60 cycles.

PRICE
55/-

Dimensions : $7\frac{3}{4}'' \times 4\frac{3}{4}'' \times 4''$

NO VALVES TO BURN OUT
MOVING PARTS TO GET OUT OF ORDER
CHEMICALS TO RENEW

NO MAINTENANCE COSTS

OUTPUT: The Charger will supply $\frac{1}{2}$ ampere continuously to 2-volt, 4-volt, or 6-volt cells.

The FERRANTI Trickle Charger consists of a step-down Transformer designed for operation from Alternating Current Mains having any voltage from 200 to 250, and frequencies from 40 to 60 cycles, feeding a Westinghouse patent metal rectifier. The Unit is silent in operation and will last indefinitely.

The Charger is simple and safe

The FERRANTI Trickle Charger takes 12 watts from the Alternating Current Lighting Circuit, and gives $\frac{1}{2}$ an ampere Direct Current to the Low-Tension Accumulator, or during 83 hours' use the Charger will consume one Unit of Electricity from the A.C. Mains.

**FERRANTI ELECTRIC
LIMITED**
Toronto, Canada

FERRANTI LTD.
Hollinwood, Lancashire

FERRANTI INC.
130, West 42nd Street,
New York, U.S.A.

£300 A YEAR FOR YOUR SPARE TIME!

Wonderful New Invention YOU can Make and Sell
under My Patent!

REALLY, genuinely, you can make at home and in your spare time a sum of extra money up to £300 per year. The work is of fascinating interest. It will open up to you new ideas, new vistas of money-making; provide many of those luxuries and necessities which you have so long wished for, and give you occupation just at those hours when time is apt to hang heavily on the hands.



IN THE COMFORT OF YOUR OWN HOME YOU CAN DOUBLE YOUR INCOME. The work is a delight. You can keep at it just as long as you like each day or week. No "plant" or machinery is needed. A spare-room or even the kitchen table can serve as your profit-making "factory"—and the children can help too!

Others are doing this by working my enormously successful patents. Why not you? It costs you nothing to write for full particulars, and you can then see for yourself exactly what you can do.

My patents are in very great demand in the field of wireless and electricity—so much so that

I GUARANTEE

your profits, and further guarantee to protect you against any infringement or interference with your market. Only one person in 50,000 of the population is allowed

to manufacture under my Royal Letters Patent, in order to ensure unrestricted marketing. Let me hear from you NOW before somebody else is granted the licence and the extra income that can so easily become yours.

Simply fill in and forward the coupon and, by return of post, I will send you every par-

ticular with which you may wish to be acquainted. It is those who

seize opportunities who succeed. Take this opportunity NOW.

"MAKE-MONEY-AT-HOME"

COUPON

To THE ENGLAND-RICHARDS CO.,
83, King's Lynn, Norfolk.

Sirs.—Please send me at once, and FREE, full details as to how I can Make Money at Home in my spare time. I enclose 2d. stamps for postage.

Print your name and address boldly in capital letters on a plain sheet of paper and pin this coupon to it. The Wireless Constructor, Nov., 1927.

You must have a
precision instrument

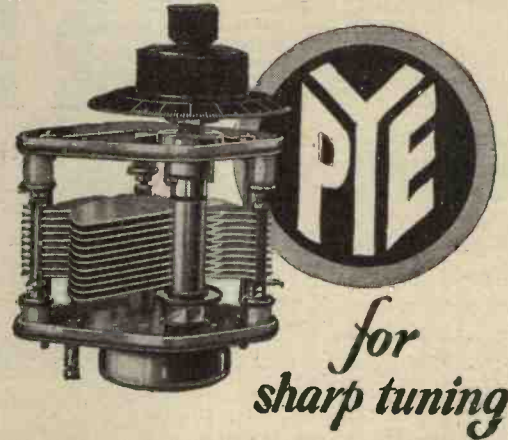

for
sharp tuning

Modern radio circuits call for critical tuning—critical tuning demands precision condensers—precision condensers means Pye condensers for accuracy and reliability. Pye precision condensers are scientific instruments made one at a time with great care. You need them to get the best from your set.

PRICES—'0001, '0002, '0003 Mfd. 17/6 each;
.0005 Mfd. 18/6 "
'00075 Mfd. 22/6 "



W. G. PYE & Co.,
"Granta Works," Montague Rd.,
CAMBRIDGE.

FREE! EIGHT SIXPENNY BLUE-PRINTS

Do not fail to secure your copies of
"POPULAR WIRELESS"
for weeks ending October 15th and October 22nd

With these two special issues are being presented a new series of the famous "P.W." 6d. blue-prints as follows:

With "Popular Wireless" week ending Oct. 15th

1. A D.C. MAINS H.T. UNIT.
This will operate on any voltage mains up to 500, and will give three different values of H.T.
2. A STANDARD TWO-VALVER.
A detector and low-frequency receiver suitable for long-distance work on 'phones and for local station loud-speaker reception.
3. A REINARTZ ONE-VALVER.
Capable of providing alternative programmes anywhere in the country.
4. THE "CUBE-SCREEN" THREE.
A long-range receiver of really up-to-date design, embodying one stage of high-frequency amplification, and suitable for loud-speaker work from many stations.

With "Popular Wireless" week ending Oct. 22nd.

5. THE "KNIFE-EDGE" CRYSTAL SET.
This is the receiver for 5GB and the "loca."
6. HIGH-FREQUENCY AND DETECTOR.
A simple neutralised set for really long-distance telephone reception.
7. THE "UNIVERSAL" THREE.
A "Det.-2 L.F." R.C. set which, using valves of any voltage class, will give distortionless loud-speaker results.
8. THE "SPANSACE" FOUR.
A sensitive and selective receiver of modern design for long-distance loud-speaker reception.

ORDER YOUR COPIES NOW

"Popular Wireless."

Price 3d. As usual.

What's New—continued

the adjustment made at the factory is maintained constant when submitted to any reasonable vibration such as it is likely to receive in ordinary daily use. Unlike most types of cartridge detectors now sold, the "Griphco" contains not two different crystals, but one crystal and a cat's-whisker type of contact.

An Ingenious R.C. Unit

Messrs. Burne-Jones & Company, Ltd., makers of the "Magnum" components, have submitted for test an example of the new Magnum R.C. unit, an illustration of which appears on this page. Although of quite small dimensions, the device contains a valve holder, of the anti-phonic type, an anode resistance, coupling condenser, and grid leak, together with terminals which are symmetrically placed around the moulded casing of insulating material in which the whole is contained. Laboratory measurements show that the values have been chosen with the high-magnification R.C. valves in view, and

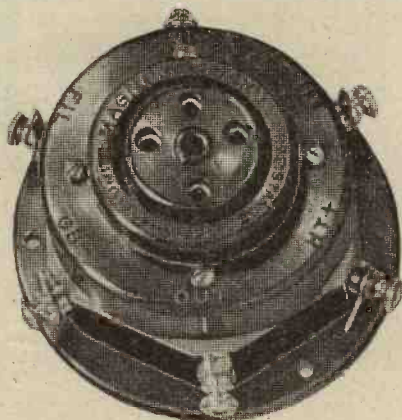

The "Magnum" Resistance-Capacity Coupling Unit, complete with valve holder.

for such the unit is quite suitable. The inclusion of the valve socket very considerably simplifies the wiring of a receiver using such a component, and also economises very considerably in space.

New Resistance Holder

The R.I.-Varley Company are now supplying a greatly improved holder for their well-known wire-wound anode resistance. This, as will be seen from the illustration, can be mounted vertically or horizontally on the baseboard to suit the particular receiver lay-out. It is but the work of

a moment to insert or remove the resistance, which makes good, sound contact at each end. Adequate terminals and soldering lugs are provided, and altogether it is a very handsome component.

A Good Aerial Wire

From Messrs. Ward & Goldstone, Ltd., of Manchester, we have received for test their "Goltone" Negrolac Radio Aerial, for which claims of special excellence are made.

Examination of the wire showed it to consist of forty-nine separate enamelled strands of No. 34 gauge wire, the cable so formed being covered with special braid which is heavily enamelled with waterproof insulating composition. This, it is claimed, will withstand the severest atmospherical conditions.

The only satisfactory test for an aerial wire is to erect a full-size aerial and to try it out under practical working conditions. The existing 7/22 "common or garden" aerial was first re-tested and micro-ammeter measurements on signals from London and Daventry taken, using a straight crystal set. This aerial was then lowered and replaced by an aerial of identical dimensions but made of the Negrolac wire. Distinctly better results were obtained on the Negrolac wire than on the standard aerial wire, but in forming an opinion upon this allowance must be made for the fact that the old aerial had been in position for some time, and had probably lost a little efficiency through corrosion.

At the same time, the Negrolac wire gave better results than had been obtained with any aerial wire previously tested. In our opinion, however, the chief virtue of this wire lies in its remarkable flexibility and ease of handling. In paying it out there is not the slightest tendency to kink, or for turns to fly off the hank and fall in the usual inextricable mess. Another virtue of its flexibility is that when properly supported a good taut aerial is easily obtained, and there is very little strain upon the contact at the terminal of the lead-in insulator. The ordinary fairly stiff aerial frequently breaks away in high winds, and if the wire is old and corroded six of the seven strands may, perhaps, break away and leave only a precarious contact with one strand.

Tests of the insulating properties of the wire-covering were made, and showed it to be of a high order. In order to get the best from this wire, it is advisable that the end which is



The new R.I.-Varley Resistance Holder can be mounted either vertically or horizontally.

to be connected to the lead-in should have the insulation removed for an inch or two and the forty-nine wires separated out and each individually scraped free of the enamel. The wires should then be tinned, twisted together, and a good soldered joint made of all the strands.

It is not a bad plan to solder the end of the wire so prepared to a stout brass spade or eyelet terminal which will fit over the threaded rod in the lead-in tube. The terminal of the lead-in can then be screwed on tight and a sound joint made. It is not sufficient to bare a few of the strands and make a pinching contact under the terminal. If this is done a large number of the strands of the wire will be "dead."

The price of an 80-ft. length of this aerial is 15s., and 100 ft. is 18s. While this is much dearer than the ordinary aerial wire, the convenience of handling alone makes it well worth the difference in price.

**MORE ABOUT THE
"TWIN-TUNE FIVE"**

By A. JOHNSON-RANDALL.

IN my article last month I stated that I would describe the construction of an aerial coil which would enable those who wished to make one to suit their own desires regarding selectivity.

This coil can be wound on a Collinson Featherweight former with a detachable primary.

An efficient secondary winding can be obtained by winding on 50-55 turns of 9/38 Litz wire, unspaced. The upper end of the winding is connected to pin No. 1, and the lower end to pin No. 2.

The Aerial Winding

Great care is necessary in handling the Litz wire. The covering should be removed from each strand in turn with the aid of a sharp knife or safety razor blade.

The primary or aperiodic aerial winding may consist of 30 turns of No. 26 or 28 D.C.C. with a tapping at 20 turns. One end of this winding is joined to pin No. 3 and the other end to pin No. 5. The tapping is connected to pin No. 4. Pin No. 5 is joined to pin No. 2 and to earth, and the aerial is taken to No. 3 or No. 4.

This winding is not necessarily the best for any particular aerial, and the constructor may vary the turns to suit himself. In some cases, such as those where the aerial is on the small side, an increase in the primary turns will increase signal strength.

In the final tests the neutralising condensers used have been of the Jackson screw-down type, and, as indicated last month, the stability in many cases is improved by the addition of a 0.1 mica Dubilier condenser directly across H.T.+1 and H.T.—.

Anode Rectification

If this condenser is connected close up to the terminals inside the set removing the lids of the screening-boxes does not seem to affect neutralisation.

Although the original receiver incorporated grid condenser and leak rectification, I have tried the anode-bend method and I find that the decrease in sensitivity is not great. There is, in my opinion, a gain in

quality. It is a fairly simple matter for those who wish to try the anode-bend method for themselves. The grid condenser can be left in circuit, and instead of connecting the grid leak to L.T.—, the clip on the positive filament terminal of the detector-valve holder can be removed and employed for the purpose of joining the leak to the negative tapping on a small 3-volt battery. The positive socket of this battery, which may be of the Hellesen 4.5-volt type, tapped

too far away. Then very slowly adjust the first neutralising condenser until the signals become inaudible. At very short distances from the local station this may not be possible, and the position of minimum signal strength may be taken as the correct setting. This point is rather critical, and some care must be taken in carrying out the adjustment, since it is quite easy to turn the condenser through the "silent-point," in which case signals will again become audible. When the adjustment has been found replace the fixed resistor and carry out the same procedure with the second H.F. valve.

Reaction Control

A very large number of stations have been received at good loud-speaker strength, but at the moment I cannot give a complete list owing

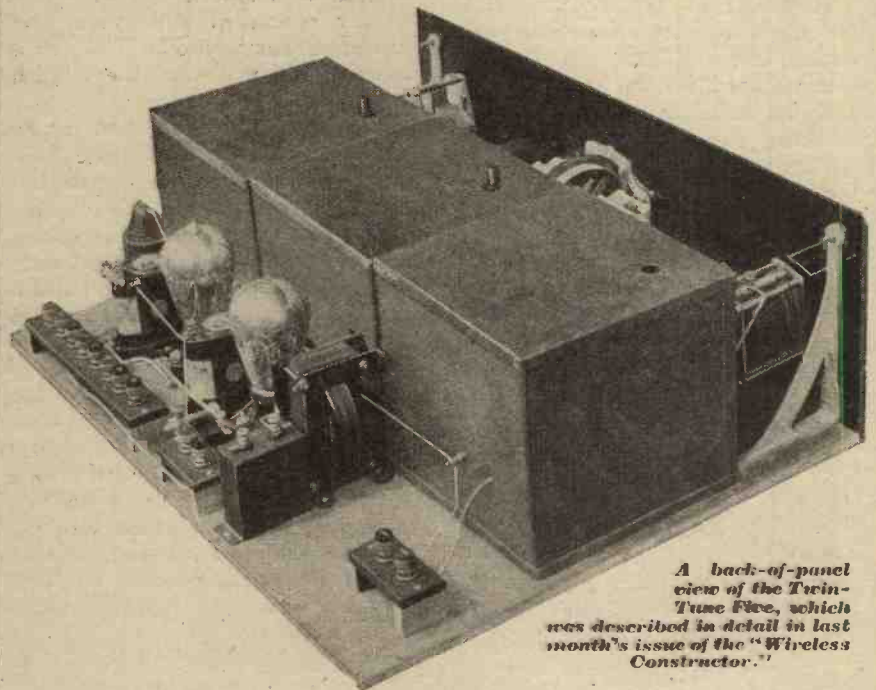

A back-of-panel view of the Twin-Tune Five, which was described in detail in last month's issue of the "Wireless Constructor."

at 1½ and 3 volts, is connected to L.T.—. A short length of flex can be used from the tapping to the grid-leak clip. Any H.F. or R.C. valve will serve for the detector. On the H.F. side I have obtained good results with the new Marconi and Osram D.E.L.610.

Incidentally, the original receiver does not require reneutralising on the longer waves. For those who prefer the "silent-point" method of neutralising the following method can be adopted. Place the reaction condenser at its minimum setting and tune in the local station. Then remove the first fixed resistor, and it will be noted that signals are still audible, that is provided the local transmitter is not

to the difficulty in identifying many of the stations.

This applies in particular to the German stations. On the long waves, Hilversum, Daventry, Radio-Paris, and two or three unidentified stations have been received at good strength. I recommend constructors to use 6-volt valves in preference to the 2- and 4-volt types. The standard coils used were primarily designed for the 6-volt H.F. class, and other types usually give poor results.

The control of reaction may be varied by altering the size of the small series fixed condenser. A smaller fixed condenser will, in effect, decrease the maximum capacity of the reaction condenser.

Electrify your Gramophone!

GRAMOPHONE results never before obtainable are now made possible by the **Brown Electrical Pick-up**. 'Wonderful reproduction' was the description given by the "Wireless Constructor"

No need now to buy a new gramophone to appreciate fully the new standard of reproduction set by the electrical record. Just electrify your present gramophone by fitting a **Brown Electrical Pick-up** in place of the sound box and connecting to an amplifier and loud speaker. The result will be an entirely new pitch of tone

perfection that will command instant admiration. Reproduction will be infinitely purer; the lower notes with equal fidelity to the high notes.

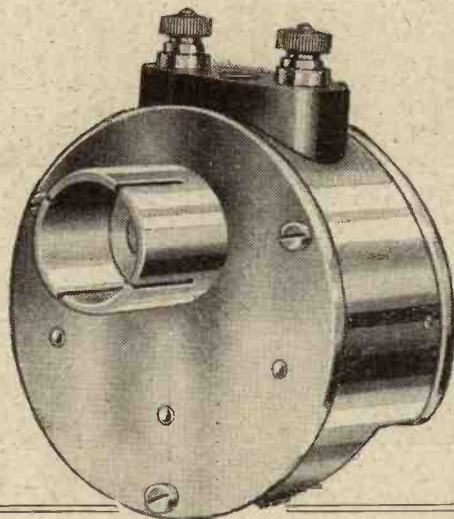

and get
Greater tone perfection.
Large increase in volume
Reduced needle scratch.
Controllable volume.
Will fit any model—no alteration necessary.

The **Brown Electrical Pick-up**, with an amplifier and loud speaker, will give you unlimited volume. It is invaluable whenever there is dancing, and an orchestra is not possible or desirable. For the first time, too, volume can be controlled. With this new instrument, gramophone reproduction is infinitely nearer the original. Needle scratch is nearly eliminated. Old gramophones are rejuvenated; old records are re-born.

The **Electrical Pick-up**, price £4, can rapidly be fitted to any gramophone, and an amplifier connected. No alteration to the gramophone is necessary.

Ask your Dealer to demonstrate; or in case of difficulty, write mentioning your nearest Dealer, to **S. G. Brown, Ltd., Western Av., N. Acton, London, W.3.**

£4

Brown

ELECTRICAL PICK-UP

P u t s L i f e i n t o y o u r G r a m o p h o n e

THE GUARANTEE OF THE PERFECT TERMINAL

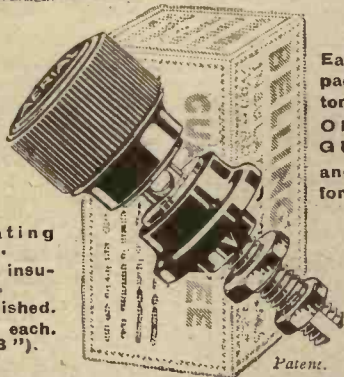

Each terminal packed in a carton with a printed ONE YEAR'S GUARANTEE and instructions for mounting.

Non-rotating name.
Bakelite insulated.
Highly finished.
Price 9d. each. (Type "B").

THE BEST DESIGNED TERMINAL IN THE WORLD.

Other types available—

- Type M. Nickel-plated Metal with non-rotating name **6d.**
- Type R. Small with insulated head and rotating name **3½d.**

ALL TYPES SUPPLIED IN 30 DIFFERENT LETTERINGS.



Obtainable from all Dealers, or in case of difficulty send your order to us, enclosing your Dealer's name and address.
BELLING & LEE Ltd., Queensway Works, PONDERS END, MIDDLESEX.

Made with the accuracy of a Gun !!

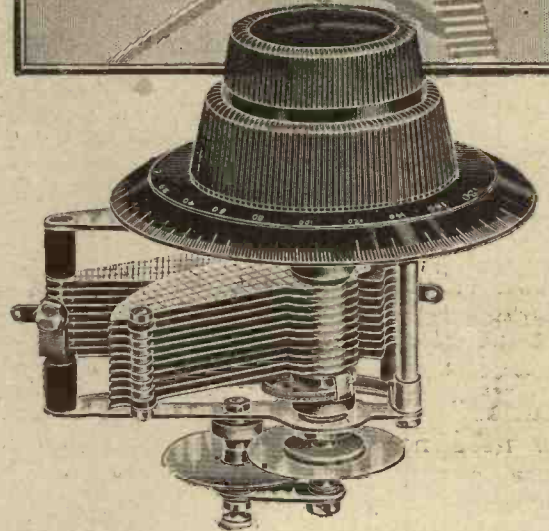
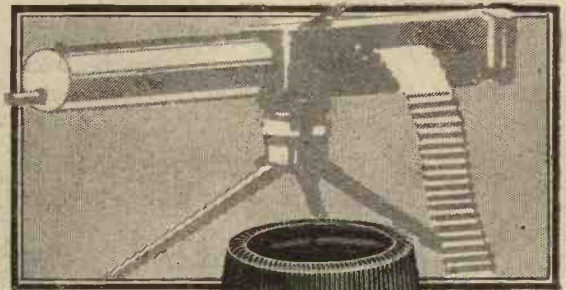

The same care and attention which are exercised in the design and construction of the most delicate mechanism of a gun are displayed in all J.B. Condensers.

Accurate to the finest point, and perfectly finished, J.B. Condensers can be well compared to the finest gun ever made.

There is no sign of backlash in the J.B. models. The dial is turned and the stations come in with unflinching regularity.

THE PERFECT FIVE.

1. J.B. S.L.F. Slow Motion. (J.B. True Tuning S.L.F.) Double Reduction Friction Drive. Ratio 60-1. Prices, complete with 4-in. Bakelite Dial for coarse tuning and 2-in. Bakelite knob for Slow Motion Device. '0005 mfd. 16/6; '00035 mfd. 15/6; '00025 mfd. 15/-; '00015 mfd. 15/-.
2. J.B. S.L.F. Prices, complete with 4-in. Bakelite Dial. '0005 mfd. 11/6; '00035 mfd. 10/6; '00025 mfd. 10/-; '00015 mfd. 10/-.
3. J.B. Log Plain. Prices, complete with 4-in. Bakelite Dial. '0005 mfd. 11/6; '0003 mfd. 10/6; '00025 mfd. 10/-; '00015 mfd. 10/-.
4. J.B. Log. Slow Motion. Double Reduction Friction Drive Ratio 60-1. Prices, complete with 2-in. Bakelite knob for vernier control and 4-in. Bakelite Dial for main control. '0005 mfd. 16/6; '0003 mfd. 15/6; '00025 mfd. 15/-; '00015 15/-.
5. J.B. Neutralising Condenser. Price 3/6.

JACKSON BROS.
8, POLAND ST- OXFORD ST
LONDON - W.1. Telephone - GERRARD 7414



A Guide to Good Reading

T.P.'s WEEKLY is an inspiring and instructive journal of everything that matters in life and letters of to-day—a kindly guide to richer and fuller knowledge. It will tell you what to read and when to read it. Leaders of modern thought, famous writers and great publicists, all contribute to its pages. It is a paper of the highest educational value. Buy it regularly.

T.P.'s Weekly
Every Saturday 2d.

An Interesting Five-Valve Set

Some Details of a new American Receiver.

ONE of the most popular American commercial receivers — The Crosley "Five-Fifty" — is now being placed on the British market. The general appearance of this set can be gathered from the accompanying photograph, which gives the reader at once the impression of simplicity of control, which, in fact, it possesses in a marked degree. The tuning is effected by the single control drum, controlled by a knurled ring, seen at the upper right-hand end of the panel, a space being provided so that when the set is calibrated the names of the stations and their

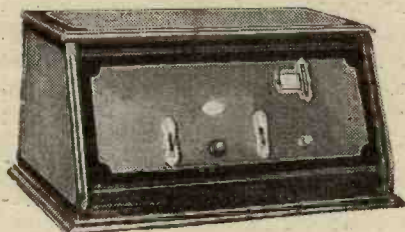

The Crosley "Five-Fifty" Receiver.

readings can be written in. For very close tuning two small projecting levers enable a still finer control to be obtained, but generally these are not used and all the tuning the average person requires can be conducted on the single drum. Two further knobs are a very smooth reaction control and an on-and-off switch.

Twenty-seven Stations

A specimen of this receiver was recently brought to the WIRELESS CONSTRUCTOR laboratory for test and gave a very remarkable performance. Without touching the small levers for close tuning, some fourteen or fifteen stations were rapidly tuned in on the single drum at loud-speaker strength. After about five minutes' experience with the set, twenty-seven stations were tuned in on the loud speaker in two minutes thirty-five seconds. This tuning, however, required the simultaneous manipulation of the tuning drum and the reaction control. There was no time to stop and identify the stations, but they were obviously separate and distinct transmissions, each free from the other, and all sufficiently clear to identify the programmes had time

permitted. It is not suggested that such a performance could be put up so rapidly by the inexperienced, but a non-technical listener, after half an hour's practice with the set, should be able to tune in well over a dozen stations at full loud-speaker strength on any reasonable aerial.

Careful manipulation of the two levers in conjunction with the reaction control enables a very high degree of selectivity to be obtained.

The quality of reproduction is reasonably good provided too much reaction is not used. The set will thus be seen to be, first of all, a fool-proof receiver on which a dozen or more stations can be obtained after dark on the loud speaker by any user, and, secondly, a remarkably sensitive "distance-getter" for the more skilled.

ADJUSTABLE TELE- PHONES

MANY people use the type of tele- phones which are adjusted by means of a milled knob on the back of the earpiece. The effect of adjusting this knob is to bring the diaphragm nearer to the pole-pieces. Now, since the distance of the diaphragm from the poles of the magnet varies according to the amount of steady current flowing through the telephones, it stands to reason that what is a correct adjustment for a valve set is not correct for a crystal

MORE ABOUT THE LOCALONG

IT will probably interest readers to know that the "Localong" set, which was primarily designed for a quick change-over from the ordinary broadcast band to the Daventry range, can be used for an equally rapid change-over from your local station to 5 G B without structural alterations.

If the reader examines the diagrams given in last month's issue he will see that when the switch is put over to the long-wave side the loading coil is placed in series with the main inductance, while simultaneously the small adjustable variable condenser is placed in parallel with the ordinary tuning condenser.

Now, if it is desired to use the "Localong" for quick change-over from the local station to 5 G B it is only necessary to withdraw the loading coil and short-circuit the socket either with a shorting plug, which is easily obtainable, or simply with a piece of wire. The effect of the change-over switch will then be merely to place the adjustable condenser in parallel with the main condenser.

Now, every main station within crystal range of 5 G B works on a wave-length below it. This means that in using the change-over switch for 5 G B you will always need to place the adjustable condenser in parallel with the main condenser on

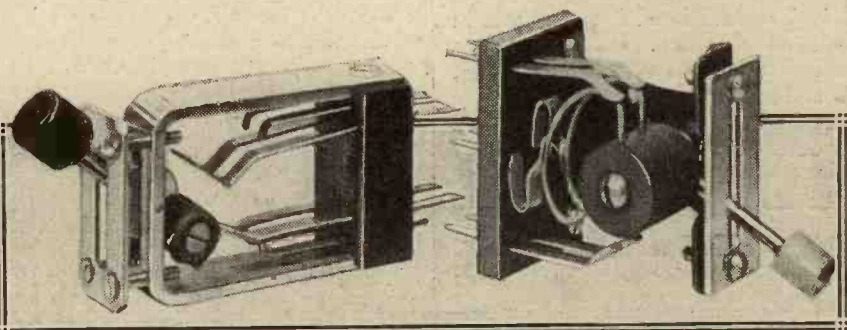

Types of double-pole, double-throw switches that are suitable for use in the "Localong" (The "Wearite" and the "Utility").

In order to work with the tele- phones as sensitive as possible, a habit should be made of adjusting them immediately on connecting up a different set. It will also be found an advantage to readjust the 'phones when listening to very weak signals, because when signals are weak it is possible to have the diaphragms closer to the magnets without "dithering" than with loud signals.

the long-wave side, and this connection should be made as indicated in the practical wiring diagram in last month's article. Tuning will be carried out just as before. The sharpness of tuning of the "Localong" is such that listeners in the London area can separate 5 G B from 2 L O quite easily, provided the latter station is not nearer than five or six miles.

H. P. W.

A Page of Readers' Results

"I could not have believed it."—"Very cheering to one who has been cut off from all music for nearly ten years in India."—"Greatly satisfied."

The Radiano H.F. Unit

SIR,—During the week-end I built the H.F. unit in the September issue. I have only built it as a hook-up with spares from the junk box, and I must say it is the best H.F. method I have tried. I could not have believed it if I had not tried it!

I have put it in front of a straight three-valve set—1 D., 2 L.F.—and the improvement is a fine few hours' work; stations are a lot clearer, speech and songs are as clear as being in the studio. Hilversum, to-day, came in on the loud speaker nearly as loud as Daventry, and foreign stations

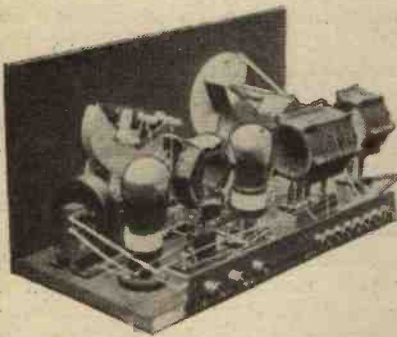

The Short-Wave Radiano Set, built by Mr. J. J. McConochie, to which he refers in a letter published in the August issue of the "Wireless Constructor."

only just audible on 'phones come in well on the loud speaker. I can highly praise the circuit and intend to build it up in a straight four-valve set; hoping to see more about it and of other readers' success.

Yours sincerely,
Sheffield. JOHN SUTTON.

An Indian Success

SIR,—It may interest you to know that, having had about eight months experience of radio reception, I have just made my first excursion into the realm of the short waves, using for the purpose the Short-Wave "Radiano" set described by you in the June number of the WIRELESS CONSTRUCTOR.

I was fortunate in being able to procure all the components in India—a country not always too well supplied with up-to-date radio goods. The only departure from your specification was the substitution of two '00025 mfd. "Ormond" S.L.F. condensers

in place of the two '0003 mfd. instruments recommended.

The layout and wiring were exactly in accordance with instructions, except that I used "Junit" connecting wire, and soldered all my connections, as I prefer this method to your arrangement with pinch-tags. I also used a variable rheostat to control the detector-valve filament supply.

Using a D.E.5B in the detector stage, and a D.E.5 as the second valve, I then proceeded to test the set, and to my intense satisfaction I found that with a 25 coil as H.F. choke it oscillated gently but freely all round the condenser scale, and required no adjustment whatever.

The following night I sat up to see if I could get P C J J, about which I had heard a great deal, and which comes in here about midnight or a little later, rigging up for this purpose an indoor aerial of "Electron" wire 14 feet high and 20 feet long. Not being sure whereabouts on the dial the station would come in, I went very carefully round the scale, keeping the set just oscillating, and was very thrilled when at 25 degrees on the grid condenser dial I heard muffled speech coming through what I took to be the carrier-wave. A little manipulation served to find the "silent point," and thereafter P C J J's speech and music came through at good headphone strength. Curiously enough, the first words heard clearly were: "the more we are together," which was the title of a foxtrot just concluded, and which seemed to me a good omen!

So slight are body-effects with this circuit that, when I was satisfied with the reproduction, I was able to sit back in my chair, light a cigar, and listen in comfort to the various items of music rendered, all of which had a light Continental quality about them, very cheering to one who has been cut off from all music for nearly ten years in India.

I am writing, therefore, to thank you very much indeed for the excellent set which your article referred to above has made available to the amateur, for the clarity of your instructions, and for the ease with which results

can be obtained if your directions are followed. I am looking forward to the arrival of the July number of the WIRELESS CONSTRUCTOR for the further hints you have promised on the working of this set.

Again thanking you for a great pleasure which you have made possible for me.

I am, Sir,
Yours faithfully,
J. H. MOORE,
M.B., B.Ch., B.A.O.
Chief Medical Officer,
Travancore Medical Fund.

Pothupara,
Peermade P.O.,
S. India.

The "Spanspace Three"

SIR,—I think it may interest you to know that I have constructed the "Spanspace Three," described by G. P. Kendall, B.Sc., in the November, 1926, issue of the WIRELESS CONSTRUCTOR, and should like to congratulate Mr. Kendall on the performance of the set. I constructed the set some months ago, and I am greatly satisfied with its results, and think it is a good three-valver.

It may interest you to know that I had not reached my thirtzenth birthday when I built the set.

Yours truly,
ALBERT SIMMONS.

Leicestershire.



The "Spanspace Three" built by Mr. Albert Simmons.

The "Long-Wave Special"

SIR,—I have just constructed the "Long-Wave Special." Your remarks in the article aptly apply to this district, where, in addition to interference from shipping, our local station—Hull—is so badly heterodyned that it is unpleasant to listen to, and Daventry is therefore "our" station. I only hope the circuit becomes as widely known as it deserves to be. I shall do my share.

Yours faithfully,
P. WITHERS.

Grimsby, Lincs.

JUST A REMINDER! FULL LISTS FREE

FERRANTI A.F.3. 25/1; 4, 17/6. Output 1.1, 20/25-21/1. Marconi Ideal 25/1. Pyc. 17/6. 20/1. MULLARD, B.T.H. Ediswan, Cossor, Cosmos, Marconi valves, latest stocked. WEARITE 2-way coils, switches, M.C. 3 and 4 coils, Screening Boxes, etc. P.E.T.O.-SCOTT (Keystone, Copex), screens, bases, H.F.T. Neutralising, 1/1. Parts, Screening Boxes. PEERLESS RESISTORS, 3/3. BURNDIPT Rheostats, Dials, Potentiometers, Resistors, and Holders. R.I.-VARLEY R.O.C. Unit, 20/1; Tuner, 39/6; Anode do., 25/1; Multi L.F., 25/1; Perm. Detector, 6/1; Chokes, 7/6; Anode res., 9/6 to 13/1. Double Choke, 32/6; Latest Tuner, 47/6. DUBILIER Grid Leaks, W.V. Anodes, Mansbridge Condensers, fixed do. LEWCOS C.T. Coils, wound Lilz wire, 60, 3/6; 200, 5/3. Frame aerial wire, 3/10. 100 ft. coil: Multiway Battery Leads, 4-way, 5/6, 5-way, 6/6. 6-way, 7/6, 7-way, 8/6 (5 feet in length); Glazite, 10 ft., 1/2 (4 colours); Screens, Bases, H. F. Transformers, Inductance Coils, 25, 35, 50, 3/6 each; 75, 100, 4/1; each; 150 and 200, 4/6 each; 250, 5/1. LISSEN Valve-Holders, 1/1; Fixed Gon., 1/1. Switches, 1/1. B.C.K. 3/3; Latest 2-way Cam Vernier, 4/6; Rheostats, 2/6; B.B., 1/6; Lissenola, 13/6; L.F. Transformers, 8/6; 100v. H.T. 12/11; 60 v. H.T., 7/11; Coils, 60X, 6/4. 25X, 9/9. Stacks, minor, major, all parts. C.A.V. Multiple, 5/1; CARBORUNDUM Units, 12/6; Detector, 5/1. FORMO Variable Condensers, 7/6. FORMODENSER, .0005 and .0001, 2/6 each. CYLON, IGRANIC, WEARITE, RESISTON, BENJAMIN, NEWEY, P.YE, BOWYER-LOWE, COLVERN, PEERLESS components all stocked here. ZAMPA (mils), Tuner, 200/2000, metres, 19/6. MARCONI Switches, Leaks, Condensers, Valves, etc., etc. LOTUS V-Holders, 2/3, 2/6. Remote Control, 30/1. Coil Plug, 8d. GAMBRELL Coils, 4/10 to 10/1. C.T. 6d. each extra. LOUD SPEAKERS: Dr. Nepper Cabinet, 52/6. Ampion Cone A.O.S. 75/1. Celestion, 110/1. 140/1. Sterling, 3d. all good makes. McMICKAEL Unimic, 5/1; Dimic, 10/1; Bases, 2/6; Fixed Cond., 2/6, 3/1; Bases, 1/1; 3-pt. Switch, 3/6; 6-pt., 4/6. BREMER TULLY S.W. outfit, 41/6. BULGIN B. Pull, 1/6; Dials, 2/6. B.C.K. 3/3. PANEL, 2-way, 3/11, 4/6, 7/6. BELLING-LEE Terminals, BRITIMAX Tuner, 18/6. VERNIER Dials, Ethovner, 9/1. K.K. Port Dial, 10/1. Pilot, 4/6. Ormond, 5/1. All makes stocked. UTILITY Friction, .0002 for S.W., 13/1. Switches from 2/6. Push-Pull, 4/6. 7 B. Condensers, 2/6. 250 v. Ver., .0005, 16/6; .00035, 15/6; .00015, 15/1; S.L.F., .0005, 11/6; .00035, 10/6; .00025, 10/1; .00015, 10/1; S.Q. Law, .001, 9/6; .0005, 8/1; .0003, 7/1; Neutralising, 3/6. MANSBRIDGE Condensers, T.O.O. mfd., 3/10; mfd. 3/1. All cap. stocked. High Voltage (200 v., 4 mfd., 13/10; mfd., 7/10; 1 mfd., 5/8). (Dubilier and Lissen stocked).

WE STOCK ALL LINES IN GENERAL DEMAND. SPECIAL WEST-END AGENT FOR BURNE-JONES (MAGNUM). BEST WAY IS TO MAKE OUT A LIST WITH MAKERS' NAMES AND ASK FOR QUOTATION. IT IS IMPOSSIBLE TO ADVERTISE EVERY COMPONENT NOW ON THE MARKET.



THREE-VALVE LOUD-SPEAKER SET. NOTE THE WONDERFUL VALUE. TRY ONE OF THESE! (The set shown is two-valve.)

Gets Local, Davenport and many Continental stations. THIS MAGNIFICENT 3-VALVE SET (D. & L.F.), includes Handsome Polished American Cabinet, 12" x 12" x 12" parts enclosed, 3 Dull Emitter Valves, Tuning Coils, H.T. & L.T. Batteries, Aerial Equipment, Leads, Loud Speaker or 'Phonoc, Tax paid. Carr. forw. case 25. JUST THINK of a 3-Valve for 55/19/6! It sounds unbelievable, doesn't it? 2-VALVE SET EXACT TO ABOVE £4/12/6

SETS OF COMPONENT PARTS

RADIANO "THREE" (March, '27, Wireless Constructor). All parts as specified with Terminals. 2 Ormond S.L. Variables, with friction gear; 3 Coil Sockets; T.C.C. .0003 and Clips and 2-meg. Leaks; 3 Benjamin Valve Holders; 3 Fixed Resistors and Bases; On and Off Switch; Geophone 1st Stage L.F.; B.T.H. 2nd Stage L.F.; Engraved Strip, with Terminals and Nuts; 2 B.L. Terminals for Front Panel; 1 Gross Pinch-on Spades; Rubber Flex. £4/10/0 lot, post free U.K. EDISWAN R.C. THREESOME Set of Parts; 2 Ediswan B. Lenses; 1 Ediswan 1/2 Valve; 2 Ediswan R.C.2; ditto; 3 Lotus V.H.; 3 Fil. Rheostats; 9-v. Grid Bias; Lotus 2-way L.H.; .0005 Tuning Condenser. £3/5/0 the lot, post free U.K. SIGNAL BOX (P. Harris, May, '27, W. Cons.). 1 Ormond L.F. .0005 and 2 .0003, with friction gear; 2 6-pin bases; 1 Neutrovania; Neutralising; 4 V.H.; 4 Resistors; .0001 and stand; R.F. Choke; 100,000 Anode and Base, 3 o/o Switches; Carborundum Unit; R.I. Multi; Ferranti do.; 4 Strips and Terminals; .015 Dubilier; Glazite; 6-pin H.F. Trana, S.S. type; Do. S.P. for Broadcast Range. Components as specified. The lot, post free net, £7/10/0 U.K. FAMILY FOUR PARTS (Percy Harris, Aug., '27). 14 Belling-Lee Terminals; 4 Anti-Micro V.H.; 4 Burndipt Res. & Bases; 1 30-ohm B.B. Rheostat; 2 six-pin Bases; 1 Formodensers; Dubilier .0003, with clips; 4 meg. & 1 meg. Leaks; .015 Fixed, 6/10. 1 1/2 Valve, 2 Series Clip; 100,000 ohm Wire Wound; 300,000 ohm ditto Resistances (Dubilier or R.I.-Varley); Neut. Condenser, B.B.; R.F. Choke; Geophone L.F.; 2 "J.B." .0005 and 2 S.M. Dials; Popular .0003; Igranico O Switch; 2 Lotus C. Jacks and Plugs; Binocular Coils 250/550; S.P. H.F. Transformers, 250/550 and 1,000/2,000 metres; 3 Secondary ditto for Davenport. THE COMPONENTS, ALL AS SPECIFIED, SENT POST FREE NETT FOR £8/8/0 U.K. PANELS, CABINETS, VALVES, PHONES, LOUD SPEAKERS, TO YOUR REQUIREMENTS.

PERSONAL SHOPPERS.

WE ARE OPEN ALL DAY SATURDAY ALL DAY THURSDAY ALL DAY EVERY DAY 2 Shops, if one is closed the other is open. Sat. 9 a.m. to 9 p.m. Sunday morning 11-1

NOTE WONDERFUL OFFER BELOW! STUPENDOUS BARGAINS

BE SURE YOU ARE AT RAYMOND'S! These SPECIAL LINES ARE SOLD TO CALLERS ONLY who are purchasing their regular wireless supplies at the same time. ALL BRAND NEW.

YOU CAN ONLY BUY THESE AT RAYMOND'S WHEN BUYING OTHER GOODS. NOT SOLD AT THESE PRICES ALONE OR BY POST. 1/11 and 2/3 each. Brand new Var. Condensers. .0003 and .0005 S.Q. Law. Log Mid-Line, S.L.F. (Usual price 4/11 & 5/11). 3/11 each. Brand new D'ble Reading dead beat VOLTMETERS (Usual price, 7/6). 3/1 each. Split Primary H.F. Transformer, Brand new, 6-pin, London or Dav. (Usual price, 10/-). 3/1 each. Split Sec. Ditto, London, 3/9 Dav. (Usual price, 10/- and 14/-). H.F. CHOKES, 2/6 each, absolutely guaranteed, brand new. (Us'1 Price, 5/-). 100-v. H.T. BATTERIES, tapped, very good make, all brand new and fresh. Us'1 price 12/11; now 5/11.

PLEASE READ TERMS OF SALE FOR ABOVE GOODS.

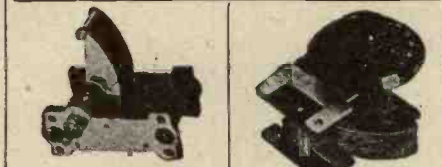

LOG-MID-LINE

Try our NEW VARIABLE CONDENSERS, made on the Log-Mid-Line principle. .0005 or .0003, with a 4-in. Trilite Dial, the best you can buy for the moderate price of 5/11 each, post free.

LOW LOSS SQUARE LAW

.0003 4/11 This variable Condenser is each simply marvellous value. It cannot be 5/11 equalled in price or quality With VERNIER 1/- extra.

HELLENSE

(Post free), 65-v., 12/6, 99-v., 23/1; 100-v. Grid Bias, 9-v., 2/1; 4-v., tapped 11-v., 1/2. PANELS. Grade A, cut to size, 1d. ea. 1/16 or 1/2 for 1 in. Reduction Large Sizes. CABINETS, Large stocks of really useful cabinets kept, or made to order. Solid oak. Glass finish. American type, hinged lid, baseboard. Post 1/6 each extra. 9 x 6 x 7 ins. deep ... 7/11 10 x 8 x 8 ins. deep ... 8/11 12 x 8 x 8 ins. deep ... 10/6 14 x 7 x 9 ins. deep ... 13/6 16 x 8 x 9 ins. deep ... 15/11 24 x 7 x 9 ins. deep ... 27/6 Extra quality in Oak or Mahogany, 5/- each extra, worth of any set.

RADIO MICRO

2-v. .2, 5/11; 3.5-v., .06, 5/11; 2-v. Power, 10/6; SUPER POWER, 3.5-v., 1/9 each, latest valve, 10/9 each. Post 6d. each.

NEUTRALISING, Peto

Scott, 5/-; 6/3, 7/6. Ormond, 4/-. Bowyer-Lowe, 7/-; Magnum, 5/-; McMichael, 4/9. Reaction (Ormond) .0001, 4/-. J.B., 3/6.

THE NEW No. 3 ORMOND

S.L.F. CONDENSER .00025, 5/8. .00035, 5/9. .0005, 6/-. With 4' Dial, With Friction 55-1 4-in. Dial, 6/- ea. extra. OROMOND Square Law Low-Loss, .0005, 9/6; .0003, 8/6 (1/6 each less no vernier) Friction, .0005, 15/-; .0003, 14/6; .00025, 13/6. Straight Line Frequency Friction Geared, .0005, 20/-; .00035, 19/6. S.L.F., .0005, 12/-; .00035, 11/- S.Q. LAW LOW-LOSS DIAL, .0005, 16/- each. Ormond Friction Dial, 10/-. Filament Rheostats, Dual, 2/6; 6 chms, or 30 ohms, 2/- Potentiometer, 400 ohms, 2/6. .0001, Reaction, 4/-; Air Dielectric, 2/-; Neutralising, 4/-; Neutrodyne, 2/-; Twin Gang, .0005, 32/-; Triple, 40/-; H.F. Choke, 7/6. Geared Dial, 5/-.

USE BRITISH VALVES

New reduced prices. MULLARD 10/6 COSSOR MARCONI 12/6 P. B.T.H. EDISWAN 20/- S.P. COSMOS

VALVE HOLDERS. Non-microphonic. — Benjamin, 2/9; Lotus, 2/6, 2/3; W.B. 2/1; Magnum, 2/6; Raymond, 1/9; Harlic, 1/4; Standard, 9d., 1/-.

ACCUMULATORS.

2-v. 40, 7/11; 2-v. 60, 9/6; 2-v. 80, 12/6; 2-v. 100, 14/6; 4-v. 40, 13/11; 4-v. 60, 17/11; 4-v. 80, 23/6; 6-v. 60, 26/6; 6-v. 80, 35/6. ALSO another good make, 1/6 extra on each of above. Post 1/- each. BENJAMIN — Battery Switch, 1/-; Valve Holder, 2/-; with Grid Leak, 5/3. With Condenser and Leak, 7/-; Rheostat, 2/9.

BRETWOOD—Grid Leak

de Luxe, 3/6; with condenser, 4/6. Anode, 3/6.

BURNDIPT ETHOVNERIE DIAL

(with Ethovner Station Indicator, 18-9).

CARBORUNDUM.

Detector only (No. 30), 5/-; Stabilising Detector Unit, with No. 30 Detector, 12/6.

CELESTION Loud Speaker

—Oak, 10/10; Do., 'A2', 13/0/-; Do., 'A3', 15/0/-; Mahogany same price; walnut extra.

CLIMAX. — Potential Divider, 5/-; Special Choke, 10/6. Shock Absorbers, 3/-; Earth Tubes, 5/-; L.L. Insulators, 1/- pair.

COLVERN SCREENED COILS, &c.

Former & Base, 5/-; 6-pin Base, 1/6. Former only, 4/-; London and Base, 8/6; S.P.H.T., 9/6; S.S. do., 9/6; 2 Monodial, 19/-.

DUBILIER Duvirhom

Wire-wound, 20,000 to 100,000 ohm resistances, 5/- each; Base, 1/6; 200,000 ohms, 8/-; 200,000 ohms, 7/6; Duvirhom Leak, 7/6. Dumstohm Holder, 1/-.

DUBILIER MANSBRIDGE

1, 2/6; 2, 2/8; 25 to 3, 3/-; 4, 3/3; 5, 3/6; 1 mfd., 4/-; 2 mfd., 5/-; 3 mfd., 8/-.

DUNN & WATSON TUNER

—'ALL-WAVE' Tuner will enable you to dispense finally with troublesome Vernier coil-holders and sets of coils. Covers all wave lengths from 150 to 2,000 metres, and is complete with reaction. 'All-wave' Tuner, 9/6.

EVER-READY H.T.

Popular 66-v., 9/6; Do. 108-v., 15/6. Standard 66-v., 12/6; 108-v., 21/-; L.T. 3, 7/6 (4-v.). Flash Lamp 4.5, 6/- dozen. Grid Bias 9 Tapped 11-v., 2/-.

USUAL LINES STOCKED.

FORMO Individual-Gang Control Condenser.

Twin-Gang, £2 12s. 6d.; Triple-Gang, £3 3s.

GANG Dual .0005.

Ormond, with dial, 32/-; Cydon, no dial, 50/-; Triple .0005, 50/-; Ormond, with dial, 40/-; Cydon, no dial, 70/-; Igranico, no dial, 75/-; Bowyer-Lowe, no dial, 70/-.

IGRANIC TRIPLE HONEYCOMB INDUCTION COILS.

30, 2/9; 40, 2/9; 50, 2/9; 60, 3/-; 75, 3/3; 100, 3/6; 150, 3/9; 200, 4/-; 250, 4/6; 300, 4/9; 400, 5/6; 500, 7/-; 750, 9/6; 1,250, 14/-; 1,500, 18/-.

ALL PARTS STOCKED.

GRAHAM FARISH Bakelite Mica Condensers.

have S.P.G.L. clip. .0001 to .002, 1/-; .003 to .006, 1/6; .007 to .01, 2/6; Grid Leaks, 1/3; .0003 and Leak, 2/-.

H.F. CHOKES. — Walmel

5/-; T.S. 4/6; McMichael, 9/-; R.I. Varley, 9/- (Split Coil type, 12/6); Success, 10/6; Cosmos, 6/6; Bowyer-Lowe, 9/-; Lissen, 5/6; Climax, 8/6. Special for Eliminator, 10/6; Wearite, 6/6.

R.C. UNITS. — Ediswan

7/-; Dubilier, 7/-; Cosmos, 8/6 with V.H. 10/1; Magnum, 10/-; R.I. Coupler, 20/-; Graham Farish, 3/6.

CALLERS' COLUMN

AERIALS.—100 ft. 7/22 Hard drawn, 1/11. Extra heavy 2/2. Phosphor 4/3 strands, 1/6. Electron stocked. Special INDOOR Aerials, phosphor, with ebolite separators and rubber rings, 4/6. 80 ft. strands, total 100 ft. 4/6. O.V., 2/6. Rubber Lead-in, highest quality, 10 yds. 1/1; 10 yds. 1/3; 10 yds. 1/6. Extra heavy, 2d. and 3d. yds. R. & B. Twin Flex (best), 6 yds. 10d.; 12 yds. 1/6; 56 yds. 4/-; Ins. Hooks, 2 for 1 1/2. Egg Insulators, 2 for 1 1/2. Ins. Staples, 4 1/2. Earth Tubes, Copper, extra value, 2/6. Climax, 5/- (also at 2/6). EASY FIX AERIALS with 2 Insulators and lead-in, 1/3. EBONITE G.R.A.D. 6 x 6 and 7 x 6 sizes, 6 x 6 and 7 x 6, 1/3; 8 x 6, 1/6; 9 x 6, 1/9; 10 x 8, 2/9; 12 x 6, 1/9; 12 x 8, 3/6; 12 x 9, 4/6. 100 ft. 1/6. OUT TO SIZE wire on wait at 4d. per sq. inch 3/16th, and 1d. sq. inch for 1 in. Special cheap panels for Crystal Sets. TERNIUM, 2/6. Nickel W.O. Pillar, Phone 1/1; doz. 3 for 4d. with N. and W.; Brass do., 10d. doz. (1d. each with N. and W.); all high quality. Valve-Plugs, 2/6. 2 1/2 in. Ormond Screws, 6 or 4 B.A., 6d. dozen with nuts; washers 1d. 1d. Red and Black Spades, screw at side, 3/4d. pr. Plug and Socket, Red or Black, 3/4d. Wacker Plugs, Red or Black, 3/4d. pr. (Large, good). 'Phone Connectors, 1d. Flush panel sockets with 2 pins for 4d., 10d. dozen. Brass Spade Tags 6 1d. Nickel Solder Tags, 4 1d. 2 1d. 4 B.A. Rod, 3d. foot. Nickel Solder, 1/6. Nuts, 1d.; 8d. dozen. Stop Pins, 2 1d. H.T. BATTERIES. Highest quality only at lowest prices. Adico (Trade Test award best given) 60-v., 6/11; 100-v., 12/11. Thera, 60-v., 5/11; 100-v., 10/11 (with extra Grid Bias). Eveready, 66-v., 9/6; 108-v., 15/6. meters, and is complete with reaction. 'All-wave' Tuner, 9/6. Adico, 1/8; B.T.H., 2/-; Flag, 2/-; British, 1/6.

FLAME LAMP. 4.5

Adico, 4/4d., 4/3 doz. British, 6d., 3 for 1/6. SOLDER, with resin, 2d. foot, 1/16 sq. Bus Bar, 2 ft. 1d. Tinned copper, 16 and 18 gauge, round, 9d. per lb. D.O.C. 20 gauge, 8d.; 22 gauge, 9d.; 24 gauge, 10d.; 26 gauge, 11d.; 28 gauge, 1/-; 30 gauge, 1/2.

MANSBRIDGE CONDENSERS.

Hydra, 2/6; 2 mfd., 3/6; 0-1, 1/9; 25 and 5, 2/3. SWITCHES on Porcelain, S.P.D.T., 1/3; S.P.D.T., 8/1d. and 10/1d. Sound meters at special prices. S.P.D.T., 1/1; D.P.D.T., 1/6. Insulating Tape, 4/1d. Copperfoil, 4d. foot (6 in. wide). Grid Bias Coils, 6/1. Panel Brackets, 9/1d. 1/1 pr. Shorting Plug, 3d.

PERMANENT DETECTORS.

Red Diamond (a topper), 2/-; Lion Micro (not cut cannot be equalled), 2/6. Brownie, 3/-; Enclosed Kay Ray, 1/-, 1/3. Service Micro-meter with crystal, 2/9; 4/6. GEMSTARS, Super-tube, 1/8; Shaw's sealed genuine Hertzite, 8d., 1/-; Wray, 1/8. HEADPHONE CORDS. Good, 1/1; 1/3, 1/6. L.S. Cords, 1/1. 1 1/2 way H.F. and L.T. Leads, 1/9. 2/- Lewcos Stocked. COIL PLUGS. Ebonite on Base, 6/1d.; 7/1d. Lotus, 8d. Burne-jones, 8d. Panel Bias Variator, 1/6. Geared COIL STANDS, 2-way, 2/3, 2/6; 2/11 up. 3-way, grand value, 5/11. Back of panel from 2/11. All ebonite.

K. RAYMOND LEICESTER SQ. TUBE 27 & 28a, LISLE ST., LONDON, W.C.2. (Important) Ask for back of Daly's Theatre This address is opposite.

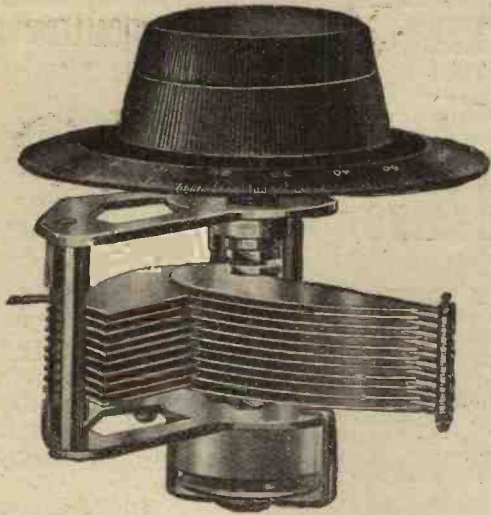

The K C Condenser

SINCE the increase in the number of European Radio stations has led to the adoption of Kilocycle spacing, it has been the constant aim of designers to produce variable condensers giving true Kilocycle (S.L.F.) tuning. Many condensers have been put forward whose long-sounding names suggest the subject is unduly complex. The DUBILIER K.C. Condenser will and does give true Kilocycle reading throughout its capacity range when used in conjunction with either the Broadcast or the Long Wave Dubilier Toroid (it being of course essential when claiming true Kilocycle tuning on behalf of any variable condenser to specify the constants of the circuit in which it is to be used).

The maximum capacity of this K.C. Condenser is 0.0005 mfd., its minimum capacity having been expressly designed to be of the high order of 16 microfarads in order that true Kilocycle readings might be obtained. In all other respects, both electrically and mechanically, this is a highly efficient condenser and one which we do not hesitate to recommend to all wireless constructors.

Price **12/-** each



Advt. of the Dubilier Condenser Co. (1925), Ltd.,
Ducon Works, Victoria Road, North Acton, W.3

TC49

Components of Distinction & Quality

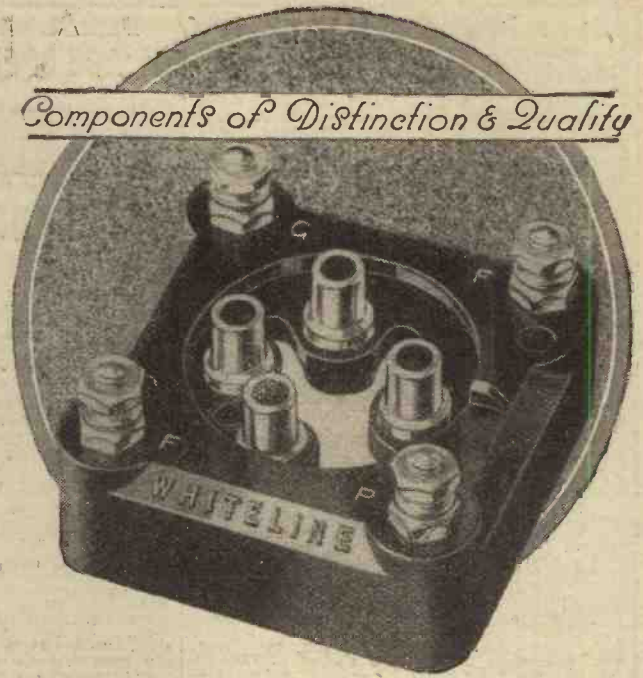

White Line Valve Holder

A great advance over all previous types of "Springy" valve holders. Inter-electrode capacity is reduced to a minimum and is constant. Thus the "Whiteline" holder is admirably suited for super-heterodyne and short-wave receivers. The springs are so designed that while the initial amplitude to any given shock is as large as required, the damping is quick and gentle. Made of genuine Bakelite and supplied with terminals, soldering tags and fixing screws. Overall dimensions of base, 1½ ins. square.



UNIVERSAL H.F. CHOKE.

List 288 - 9/-



L.F. TRANSFORMERS.
List 284. Ratio 3-1. 22/6.
List 285. Ratio 6-1. 25/-.
Also in Multi-ratio giving 1-8, 3, 3-66, 4-5 and 6 to 1.
List 286 - 27/6.
Also LOW FREQUENCY CHOKE
List 287 - 20/-.

THE "WHITELINE" FOR SAFETY

List 282 - 2/3

Send 1½d. in stamps for the new Bowyer-Lowe Catalogue



BOWYER-LOWE CO. LTD., LETCHWORTH



THE HARVEST OF INVENTION

Some Important Steps in Radio Development.

By **SEXTON O'CONNOR.**

IN one of Mr. H. G. Wells' scientific romances the principal character is a biologist, who, as the result of a profound investigation into the processes of animal and vegetable growth, discovers that the living organism grows larger, not in a uniformly progressive manner, but by a succession of sudden and erratic movements.

Spasmodic Progress

From this observation he proceeds first to the discovery of the essential stimulus or cause of growth, which he christens the "Food of the Gods," and then to the production of a super-race of giant men and women.

However far the famous novelist may have strayed from strict veracity in his analysis of the processes of human growth, the principle of development in sudden stages is remarkably true when applied to the progress of any scientific creation such as that of wireless communication.

In such a case expansion undoubtedly takes place in a series of spurts and starts, under the intermittent stimulus of human inspiration and invention, which may therefore fairly be compared in its action with Mr. Wells' famous elixir.

Historical Developments

The existence of electro-magnetic waves, for instance, was accepted on mathematical grounds for twenty years before Heinrich Hertz succeeded in actually producing long-wave vibrations in his laboratory in 1887.

There they remained more or less as a scientific curiosity for nearly ten years, until Marconi invented the elevated aerial in 1896. Even then progress was slow. Six or seven years elapsed before the discovery of the principle of electric tuning, together with the use of a coupled secondary circuit for transmission and reception, enabled reliable wireless communication to be maintained over distances of several hundred miles.

Once this stage had been reached, wireless was definitely established as

a commercial proposition, and subsequent developments followed somewhat more leisurely lines, though still in distinct steps or stages under the impulse of various inspirations, some of which may be worth further consideration.

One of the most interesting speculations of the earlier days concerned the apparent paradox of long-distance wireless propagation over the surface of the earth. If the ether waves were of the same nature as light, how was it they followed the curved surface of the earth instead of shooting out in a straight line into interstellar space?

transmitted signal waves are propagated inside the spherical zone so formed.

The Heaviside Layer

It is significant to note that the action of the Heaviside layer still plays a prominent part in the latest developments of wireless technique. In particular, the revival in the use of short-wave transmission springs largely from the better understanding of the manner in which "space waves" are reflected from these upper regions.

By travelling through the atmosphere, instead of clinging to the

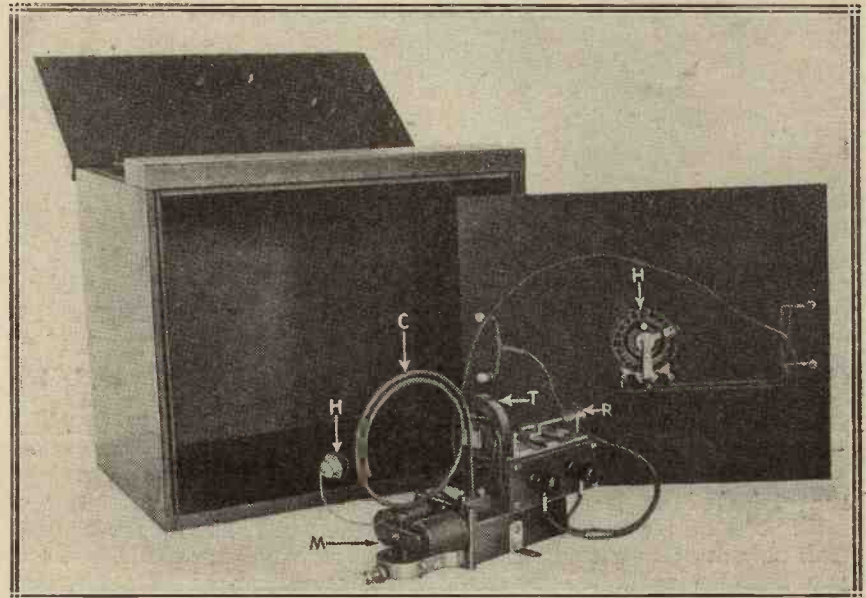

New York's Automatic Time Chime. This electro-magnetic pick-up mechanism is used by station W R N Y to automatically broadcast a chime every hour.

The solution to this mystery was first advanced by Heaviside, who suggested, on grounds since verified by observation and experiment, the existence of an ionised strata of rarefied air (now known as the Heaviside layer). This is located some forty or fifty miles above sea level, and acts partly as a barrier to prevent the escape of the transmitted waves from the confines of the earth, and partly as a conducting medium lying parallel to the earth's surface. The

earth's surface, as is the case with the longer wave-lengths, the short "space waves" suffer less from absorption losses en route, and so can cover greater distances with less expenditure of power at the transmitting station.

Similarly, a clearer insight into the conditions of reflection and absorption in the Heaviside region has prompted the use of polarised waves as a means for overcoming the peculiar fading effects to which short-wave transmission is liable.

The Harvest of Invention—continued

It is probable that even now we are only on the verge of what may ultimately be accomplished with the help of the upper ionised "ceiling," our knowledge of which springs from the original inspiration of Oliver Heaviside.

A proposal has already been made by Hettinger to utilise beams of ionised air as a substitute for the ordinary elevated wire aerial. If these beams were made sufficiently powerful they would penetrate the Heaviside layer. The latter could then be utilised as a distributing medium for conveying messages to a receiving aerial, formed of a similar

same time as the discovery of the rectifying properties of carborundum and other crystals, De Forest inserted the grid and so produced the prototype of the modern three-electrode valve.

Discovery of Reaction

In this form it became possible to amplify the received signals, in addition to rectifying them, but the valve still remained in practical desuetude until the discovery of the principle of reaction in the year 1913.

By coupling the grid and plate circuits together the valve was converted into an oscillation-generator

Owing to the high vacuum none of the electrons liberated from the filament lose energy by impact with stray gas molecules. Further, there is no secondary emission caused by collisions between the electron stream and free gaseous particles.

The result is that the erratic behaviour of the older type of soft or gas-filled valve has been reduced to order and discipline. The type of valve now in use is a steady and reliable appliance capable of reproducing any desired set of working conditions at will.

Future Developments

Future developments appear to lie in the direction of increasing the number and function of the various electrodes inside the valve. Two-grid valves are already commonplace, whilst a double filament is utilised in the recently marketed K.L.1 valve. Double-plate tubes have also been designed for push-pull amplification and other purposes, whilst the Loewe multiple-stage amplifiers represent a further development along the same general lines.

The heterodyne principle of reception, in which two continuous oscillations are combined together to give a resultant beat-note, is another "master principle," which has had an effect on the development of wireless practice.

The first heterodyne receiver was due to Fessenden about the year 1907, although in this form the beat-note was obtained by combining the rectified signal frequency with a second local low frequency introduced into the telephone windings.

The idea of utilising the original radio frequency in combination with another frequency of the same order, and then rectifying the resultant beat-note, does not appear to have been thought of until some five years later, when Lee and Hogan, two American inventors, produced the first modern type of heterodyne receiver.

As a final illustration, it may, however, be interesting to refer to the development known as "wired wireless."

This, in short, is the application of high-frequency methods of communication to the older systems of telegraphy and telephony, in which a line wire or metallic conductor is used to carry the signalling currents.



Radio and the Army. One of the wireless sets used to link up field guns with the front line.

beam of ionised air, located at any desired point on the earth's surface.

This may at first sight appear too fantastic to be worth serious consideration, but in these days of intensive scientific achievement it is a bold man who will dare to put a limit to the bounds of wireless progress.

The Thermionic Valve

Turning next to the case of the thermionic valve, we find a similar history of delayed action interspersed with sudden and intermittent periods of expansion.

The original two-electrode tube, as invented in 1904 by Fleming, at first proved an unsuccessful competitor to the coherer and the magnetic detector. In 1906, about the

as well as an amplifier and detector. As such it entered into a new lease of life and activity, particularly for C.W. signalling and low-powered telephony.

One other forward step was necessary, and this was supplied by Langmuir, Dushman, and Richardson, in producing the high-vacuum or kenotron type of valve.

By using the Gaede pump they succeeded in exhausting practically every trace of residual gas from inside the glass bulb, reducing the internal pressure to the order of one ten-millionth of a millimetre of mercury. In the latest type of valve even this degree of vacuum is exceeded, but such refinements spring from the original work of Langmuir and his colleagues in 1915.



CARBORUNDUM IN RADIO



A NEW DEPARTURE in R.C. Coupling

Faithful
Reproduction

Reduces
H.T. Consumption

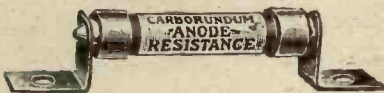

THE



CARBORUNDUM RESISTANCE CAPACITY COUPLING UNIT.

THIS Unit is quite different from any other at present on the market, presenting as it does many distinct advantages over Units employing ordinary Grid Leaks and Anode Resistances. The Resistances used in the Carborundum Resistance Capacity Coupling Unit are solid rods of unbreakable Carborundum, which is created in the largest electric furnaces in the world, at the terrific temperature of 4,060° F. They cannot burn out, present no capacity effects and are absolutely non-microphonic. The Unit takes up far less room than the smallest L.F. transformer, and the complete absence of background noises enhances the already great possibilities of R.C. Coupling. Not being dependent on a metallic film the resistances will not disintegrate and are unaffected by atmospheric changes.

No. 73. Price 8/6.

CARBORUNDUM ANODE RESISTANCES AND GRID LEAKS in all standard values.

Price - each 2/6.

CARBORUNDUM STABILISING DETECTOR UNIT. The most satisfactory method of crystal detection.
Price 12/6 (Dry Cell 5d. extra).

SEND FOR NEW 24-PAGE BOOK CONTAINING
CIRCUITS AND MUCH USEFUL INFORMATION.

All Carborundum Radio Products are sold under our complete guarantee
that they will operate satisfactorily in properly designed circuits.



THE CARBORUNDUM CO. LTD. MANCHESTER



OUR NEWS BULLETIN
*Some of the More Interesting Happenings
 in the Radio World this Month*

Long Distance on a Crystal Set

The coming of 5 G B has had one very unexpected effect—it has revived interest in the possibilities of long-distance reception with a crystal set. Many a listener, who has tuned his set to try and hear the alternative programmes provided by Daventry Experimental, has astonished himself by picking up a foreign programme, instead! Langenburg, whose wave-length happens to be near that of 5 G B, was picked up at such strength by one Essex listener that it was assumed to be Daventry Experimental until the announcer said a few kind words in unmistakable German!

Re-radiation Ruled Out

If anyone tells you that such results can always be explained by re-radiation from a valve set, don't

believe him. It is tommy-rot to say that crystal sets cannot pick up a foreign station unless a near-by valve set, tuned to that station, is helping. Why, some lucky crystal-set owners, situated in exceptionally favourable conditions, can actually tune in *more than one* foreign station, almost any night they choose!

Why this is so is a bit of a mystery, for people living near and using similar sets may be quite unable to duplicate the performance. Yet so many instances of non-re-radiated reception are authenticated that the "Can't-be-done" Bogey has been killed, and buried far beyond the resurrection-point.

Lunch-Time Tunes

This new idea of giving us lunch-time music from 5 X X and 2 L O on Saturdays is a winner. At that witching hour of 1 p.m. most of us are

turning our backs upon a week's hard work. And to reach home and find the loud speaker tootling a pleasant tune in the corner, whilst we are doing our best with the Prime English—or Imported—is to start the week-end in a sound and satisfactory manner.

New Season's Cars by Radio

The General Motors Corporation of U.S.A. is no friend of Mr. Ford's—in fact, they are trying to "beat him to it" in the cheap-car stakes—and in order that their latest car might be copied by their agents all over the world simultaneously, they *wirelessed* it everywhere. Radiophotographs of it, rushed from New York by radio to London and to Honolulu, and distributed by aeroplane from those points, enabled their world-wide organisation to start speeding up with the 1928 model production. Full specifications of it were cabled or wirelessed at the same time, and now everybody is wondering how Mr. Henry Ford is going to beat that?

A Successful Show

Looking back at Olympia, one can't help being struck by the National Radio Exhibition's liveliness, and

(Continued on page 70.)

MAGNUM
 R C
COUPLING UNIT



WHICH INCORPORATES A VIBRO VALVE HOLDER

This instrument has been designed to meet the modern demand for true reproduction now made possible by the recent introduction of valves specially designed for Resistance Capacity Coupling, the inherent virtues of which are now fully recognised, the principal one of which, however, is faithful and pure reproduction over a wide scale of frequencies.

This Unit contains a correctly proportioned Condenser, Anode Resistance, and Leak of a special design to eliminate all possibility of variation due to climatic conditions. These elements are sealed in a Bakelite Moulding, which, as will be seen in the illustration, embodies a Magnum Vibro Valve-Holder. Nickelled terminals and also solder tags are provided.

The Unit is supplied in neat carton, including fixing screws and circuit diagram, the general finish of the instrument being of the high standard associated with Magnum Products.

PRICE **10/6**

Size: Height 1 1/2 in. Overall dia., 3 in.

A highly efficient 3-valve Receiver can be simply and cheaply constructed by the use of two of these Units. Full particulars and constructional details will be supplied free on application. **BLUR PRINTS 1/6 EACH.**

A Three for the New Valves

as described by Mr. P. W. Harris.

	£	s.	d.
1 Mahogany Cabinet with 9-in. baseboard	1	4	0
1 Polished Ebonite Panel, 16 in. x 8 in. x 3/16 in. ready drilled	0	7	6
1 R.I. Straight-Line L.F. Transformer	1	5	0
2 Popular Condensers -0005	1	1	0
1 Popular Condenser -0003	0	10	0
1 Knob for Reaction Condenser	0	0	6
2 Indigraph Dials	0	15	0
1 Engraved Terminal Panel with 12 terminals	0	5	0
1 Lewcos Binocular Split Secondary Coil	0	10	0
1 Lewcos Binocular Reinartz Coil	0	10	0
2 6-pin Bases	0	4	0
1 Wearite Choke	0	6	6
1 Anti-pong Valve Holder	0	3	0
2 Vibro Valve Holders	0	5	0
1 Dubilier Fixed Condenser -0003 and Leak	0	5	0
1 Igranite Pacent B/B Rheostat, 10 ohms	0	2	6
2 Lissen B/B Rheostata	0	3	0
1 Lissen Fixed Condenser -0002	0	1	0
1 L. & P. Push-Pull Switch	0	2	0
1 Aluminium Shield, 6 in. x 4 in.	0	2	6
Connecting Wire and Sundries	0	2	6
	£3	5	0

Any of the above components supplied separately as desired.

Note.—Where a complete set of components is purchased together, Marconi Royalities at the rate of 12/6 per valve-holder are payable.

Components supplied for all sets described in this issue.

Send stamp for our New Season's Catalogue which contains full instructions for building and operating the Magnum Series of Screened Receivers.

BURNE-JONES
 & CO. LTD.,
MAGNUM HOUSE
 TELEPHONE: HOP 6257
288, BOROUGHS HIGH ST.
LONDON. S. E. 1

MAGNUM
SQUARE SCREENING BOX

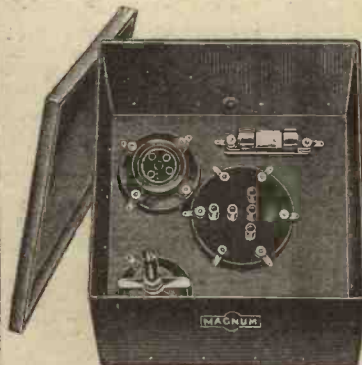

The Latest Development in SCREENING

Copper Screening-Box with detachable Lid. Oxidised Copper Finish, 12/6. Copper Screening Unit, as illustrated above, with the following components mounted on baseboard:

- 1 Magnum Neutralising Condenser
- 1 Magnum Vibro Valve-Holder
- 1 Magnum Fixed Resistor
- 1 Magnum 6-Pin Base

25/-

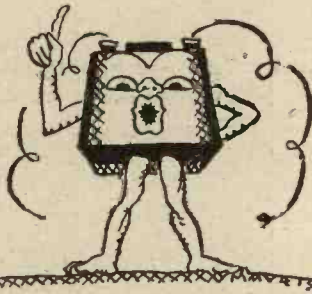

Here's a candid friend

The Peto and Radford Indicating Accumulator never lets you run out of low-tension without telling you well in advance. It's candid. It never pretends to the voltmeter that it's good for several hours yet, only to fade away and die within a few minutes.

A glance at the Ball-Floats tells you whether the battery is full, half-discharged, or nearly right down.

This P. & R. Battery, too, embodies all the features which have made P. & R. famous. And then it costs very little more—about 2/- more, in fact—than the ordinary battery. If you think it's worth knowing more about, write for our booklet to Peto & Radford, 50, Grosvenor Gardens, S.W.1.

P AND R

AND
PETO & RADFORD

ACCUMULATORS

The beginning and the end in
POWER

Indicating accumulators from 20 to 60 amp. hours capacity actual.

Indicating Accumulator PC5F. 20 amp. hours actual, 2 volts. Price 13/-.

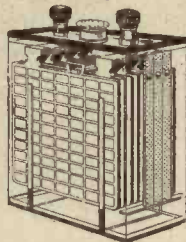

Also made in non-spill type to fit all well-known portable sets.

WESTON

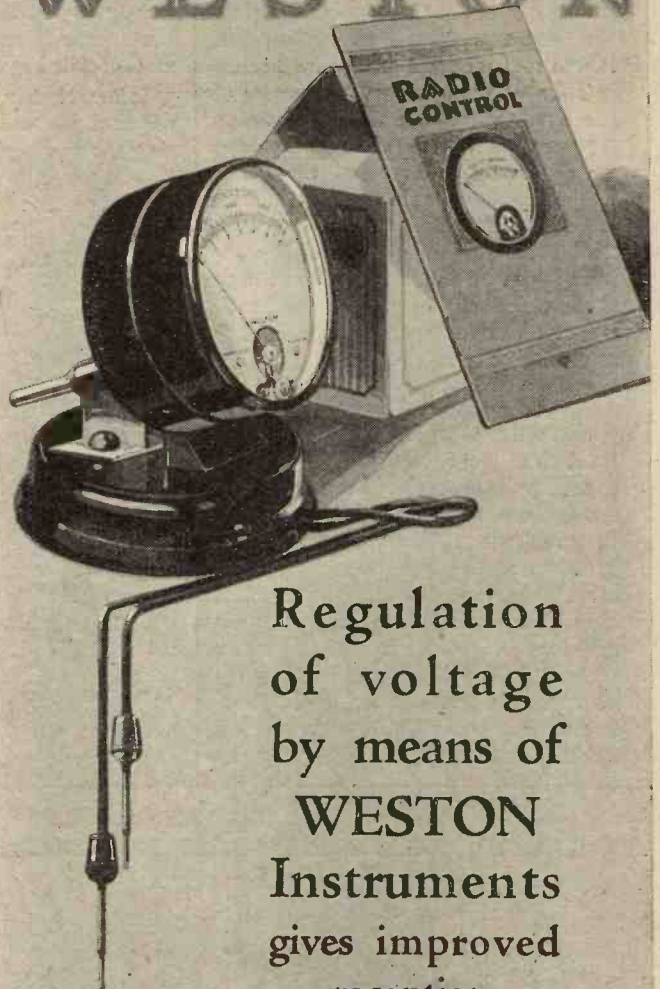

Regulation of voltage by means of **WESTON** Instruments gives improved reception

To obtain maximum results from your receiver you must be sure that the H.T., L.T. and G.B. voltages are regulated correctly. For an exact measurement of these variable voltages use a Weston Pin-Jack Voltmeter with high-range stand. Only the Weston standard of accuracy and reliability is sufficiently fine to be of any use for such measurements.

The Weston free booklet "Radio Control" explains the necessity for accurate electrical control of your radio receiver and gives much helpful advice. Let us have your name and address.

MODEL 506 Pin-Jack Voltmeter complete with high range stand and testing cables £2:10:0

WESTON

STANDARD THE WORLD OVER
Pioneers since 1888

Weston Electrical Instrument Co. Ltd.
15, Gt. Saffron Hill,
London, E.C. 1

OUR NEWS BULLETIN

—continued from page 68

promising vitality. It wasn't merely the improvements, but, better still, it was real progress along new lines.

Take valves alone. When some of these new valves are improved a step farther they'll be so far ahead of those we are using to-day that the latter will look like blunted cat's-whiskers which have lost their crystal sets. And some day our vaunted "high-mu's" will be mewing so darned high that we shall open the bedroom window and sling boots at them—anything to shut them up!

A Promising Prospect

Honestly, though, it is doubtful if there has ever been quite such a promising prospect held out to listeners as there is at this present moment. There's no doubt that the real bargain-counters of the entertainment world are all upstairs on the Ether floor. John Listener is only waiting for a few more aerials to go up, a few more prices to come down, and oh, boy!—he'll get his new-mu, sky-high, long-strong, four-valve lash-up, and reach out for Creation!

Alternative Programmes to Stay

Since our last issue the B.B.C. has made the welcome announcement that 5 G B has come to stay. For another year we can definitely count upon Daventry Experimental, and during that period no other new B.B.C. station will begin transmissions.

When that year is up the B.B.C. regional pie will be opened, the new stations will begin to sing—and won't that be a pretty dish to set before the loud speaker?

Whetting the Appetite

Have you noticed how fashion now demands that listeners on the Continent should have a little hors d'œuvre before broadcasting begins? Milan, for instance, dishes up a few charming chords upon a harmonium before serving up the main programme. Our old friend Paris P T T never thinks of beginning without first whetting the appetite by playing a tuneful gramophone record, and several other stations have adopted similar stunts. The next time you catch Continental stations starting up, just notice the charming way they come on—it's much nicer than that siren-like earsplitting shriek that the B.B.C. believe in!

He Knew!

Wife: "Did you see this in the paper about the London pastor who left the church and took up mending wireless sets for a living?"

Hubbie: "Yes, dear! And if he gets many sets like this one to put right, he'll be very glad that he hasn't got a congregation listening to every word!"

Those Short-Wave Experiments

By the time these lines appear in print the B.B.C.'s promised experiments with regard to the proposed short-wave station for Empire broadcasting should be going forward.

It is understood that the first experiments will be confined to reception. But a B.B.C. official told the Press that when the apparatus is assembled the transmitting station will not be at Daventry, but on a site near London, "which cannot yet be revealed." Somewhere near the Neverneverlands Estate, perhaps!

Television Demonstrations

The television and noctovision experiments and demonstrations which recently have been staged have failed to hit the public imagination. Quite

(Continued on page 76.)

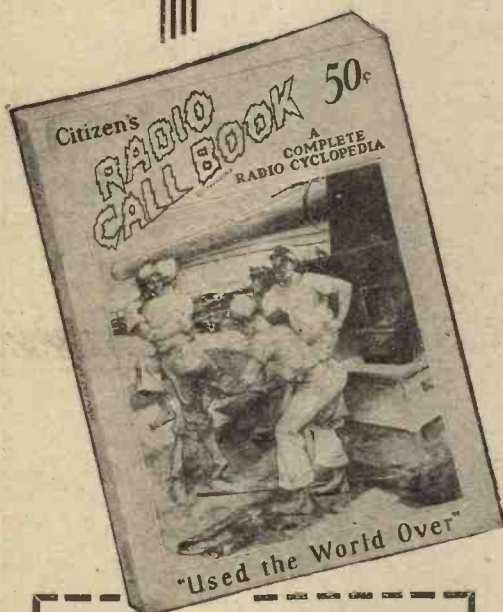

The component parts for making these sets are distributed throughout Great Britain by the ROTHERMEL RADIO CORPORATION of 24, Maddox Street, W.1, and may be obtained from all high-class dealers.

A RADIO BOOK EVERY ENTHUSIAST SHOULD HAVE

SET BUILDERS! The World's Greatest Radio Publication is Here.

EUROPEAN EDITION OF CITIZEN'S RADIO CALL BOOK

Contains full details of very latest American Circuits and Receivers. Graphic illustrations and diagrams, constructional data and other information enabling the novice to construct the World's finest sets. Full list of Broadcasting Stations, helpful hints and tips. Unquestionably the finest value and most useful book of the day. Over 200 pages, size 9" by 12", crammed full of information and hundreds of illustrations. Sept. issue is now ready—Secure your copy at once and get to know about the most up-to-date developments in Radio.

The European Edition of the Citizen's Radio Call Book is on sale at all W. H. SMITH & SONS' Book Stalls and can be obtained also from The ROTHERMEL RADIO CORPORATION of GREAT BRITAIN, Ltd., of 24, MADDOX STREET, W.1. In France, BRENTANOS LTD. Price 3/- per copy. Send P.O. to-day.

Published by

THE CITIZEN'S RADIO SERVICE BUREAU,
CHICAGO, ILLINOIS, UNITED STATES OF AMERICA.



IGRANIC ELECTRIC CO. LTD.
 149, QUEEN VICTORIA STREET, LONDON, W. 2.
 BIRMINGHAM BRISTOL CARDIFF LEEDS MANCHESTER NEWCASTLE

FREE TO YOU

—this new IGRANIC PUBLICATION

It's full of good things—those Igranic components which have *proved* themselves to be second to none in radio, and many interesting new inventions without which your constructional work will soon be out-of-date. There is the "G" Type Transformer whose faithful reproduction of all notes, low as well as high, excels that of any transformer at present on the market; a Tapped Triple Honeycomb Inductance Coil which can also be used as an aperiodic coupler; the C.C. Output Unit which prevents loud-speaker demagnetisation and increases sensitivity; the Absorption Wavemeter for measuring wave-lengths and which is also a very efficient wave-trap.

But there are many more! You can read all about them yourself by sending for a copy of publication No. J.287.



Igranic Choke-coil acuity Output Unit.

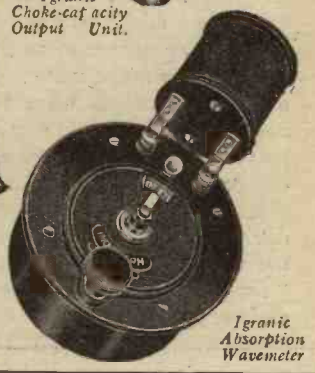

Igranic Absorption Wavemeter



Igranic G Type L.F. Transformer



Igranic Tapped Triple Honeycomb Inductance Coil.

IGRANIC ELECTRIC Co., Ltd.,
 149, QUEEN VICTORIA STREET, LONDON.

Works: BEDFORD.
 Branches: Birmingham, Bristol, Cardiff, Glasgow, Leeds, Manchester, Newcastle.

20 metres—3,000 metres It's all the same to the "EDDYSTONE" SCIENTIFIC H.F. CHOKE



WHETHER it be for use in a broadcast receiver working on Daventry, or in a short-wave set receiving 2 XAD New York, this "EDDYSTONE" H.F. CHOKE will do its work perfectly. We have proved it in practice.

Note the reasons for success:—

- Multi-slot winding
- Tapered bobbin
- Small magnetic field
- Raised mounting

Price **6/6** each

Sole Manufacturers:
 Stratton & Co., Ltd.,
 Bromsgrove Street,
 BIRMINGHAM.



London Service Depot:
 Webb's Radio Electric
 Stores,
 164, Charing Cross Rd.,
 W.C.2.

The REDFERN PNEUMATIC ACTION VALVE HOLDER

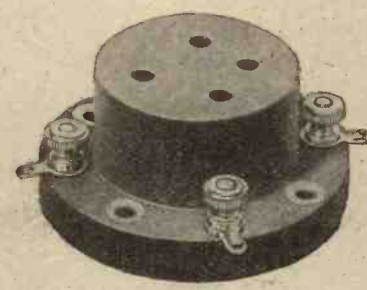

Patent No. 269,388.
 Recognise them by the well-known yellow carton.

Pneumatic action absorbs microphonic noises at their source. Take an ordinary Valve Holder and "twang" the springs. You will find each spring emits a note. Springs have a natural frequency.

The Redfern Pneumatic Valve Holder has no springs, and therefore no natural frequency. It absorbs 100% vibration whether coming from extraneous sources or from the Loud Speaker itself.

SOLD BY ALL REPUTABLE DEALERS.

Price **2/6** each

SEND FOR THE BOOK OF EBONART.
 REDFERN'S RUBBER WORKS, LTD.,
 HYDE, CHESHIRE.

RECENT VALVE "RELEASES"

By K. D. ROGERS

WITH the passing of the Radio exhibition we have entered what is usually described as another wireless "season," and things are beginning to "look up" again in the radio world. The summer months are always inclined to be "dead" from the point of view of wireless trade, though development goes on just the same, and this past season has been no exception to the rule.

All kinds of new ideas have been born, and many fresh inventions have seen the light of day. But no more interesting advances have been made than in the sphere of radio occupied by the thermionic valve. Many outstanding advances have been made, and the "show" has emphasised the fact that behind the scenes the valve designers are very much alive.

Many people have come to me during the past few months and asked me whether I would advise them to "fix up a wireless" now, or wait and see if new developments will take

place? A hopeless question where radio is concerned. Development is bound to take place, and it will keep on taking place, and rapidly at that, for a long time yet. My advice has always been: "Go ahead and fix it up; the developments will not be rapid enough to leave you stranded, and minor alterations can usually be made to keep your receiver up-to-date."

Great Advances

And this year's exhibition has shown that, although great advances have been made, with the exception of one valve—I am discussing the picture with the valve as the centre figure—little alteration in most receivers will have to be made in order that they shall incorporate many of the latest improvements.

The new Daventry experimental station—5 G B—has come to stay at least a year, and so we know where we stand with regard to the question

of set design, while it acts as a useful guide from the point of view of obtaining selectivity in readiness for the regional scheme.

But I am digressing. Let us get back to the subject of valves and see where the trend of things is leading us.

The most outstanding advance is the production of the shielded-grid valve, of which you have already read a great deal in the WIRELESS CONSTRUCTOR. That valve is a really good one, but you must use it properly if you are to benefit by it, and it is only useful—so far, at any rate—as a high-frequency amplifier.

It may largely change high-frequency practice; it will certainly give an impetus to the "screening movement," for it needs really good screening, and it will lead to the design of new high-frequency coils and transformers, and will have an effect on the question of selectivity. It is a very good valve, and you should all try it, taking care you give it a chance to act properly by screening it adequately and screening the external circuits, especially the tuning condensers, for feed-back is fatal to its operation.

Another valve which has just made

(Continued on page 74.)

CAV THE WORLD'S BEST BATTERIES for RADIO

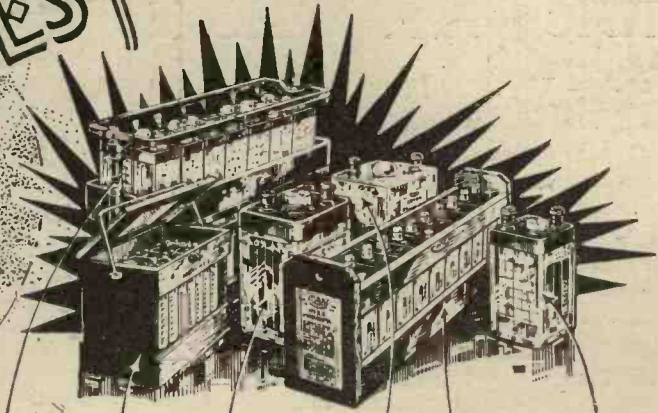

THERE IS A TYPE FOR EVERY RADIO USER —

SALES AND SERVICE DEPOTS.
Belfast, Birmingham, Bristol, Coventry, Dublin,
Glasgow, Leeds, Manchester and Newcastle.

Battery Service Agents in all important centres throughout the country.

CAVandervell & Co. Ltd.
ACTON, LONDON, W 3

Telephone: Chiswick 3801 (Pls. Branch Exchange).
Telegrams: "Vanteria, Act., London."

<p>H.T. 2. 2500 Mf/1000 Hz. The original H.T. Accented for compact design. Entirely self-contained and maintained a hard seal. Tappings can be taken from any side. Obtainable in 10, 20 and 30 cell units. 60 cells Fully charged £3 0 0</p>	<p>ACTON CELLULOID. Supplied in all capacities, this range of four vacuum batteries is offered in compressed form, while the quality is as every new representative of our 10 years experience in battery manufacture. 2 cells 10 amp. actual 13 6</p>	<p>A.G.M. MASS PLATE. The 20 amp. 2 cell mass plate (H.T. 2) of the 50 sets was taking more than 10 years. The charge can be carried over months without danger of sulphation. Supplied dry charged 8/-</p>
<p>H.T. 18. 2500 Mf/1000 Hz. A large capacity battery of novel constructional design. Suitable for large receiving sets, public address systems and small motor-cars. 60 cells 10 amp. actual 13 6</p>	<p>ACTON GLASS. The "Acton Glass" low tension range provides an alternative to the celluloid glass battery and is also suitable for range of chassis. All repairs made. 2 cells 10 amp. actual 13 6</p>	<p>H.T. 250. 2500 Mf/1000 Hz. The ideal High Tension supply for the average Broadcast Receiver. Any voltage obtained by tapping a variable number of cells. A 10 cell tapping point provided. Supplied dry charged 15/-</p>

No coil changing!
No removable screens!
Perfectly balanced coils!

Panel Control
on multi-coil units!

Wave-length range
250/550 and 1,000/2,000
metres in one unit!

Convert your existing Solodyne

The set of coils DSP/3 will fit exactly into the space occupied by the old type of three separate screens and bases.

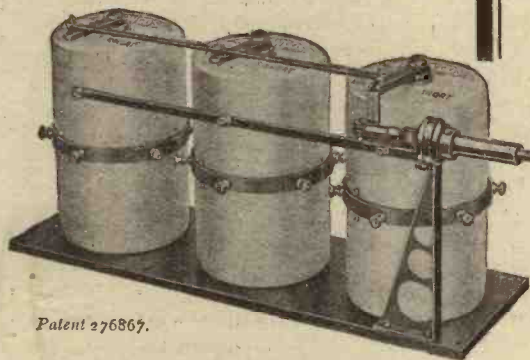

Patent 276867.

Another LEWCOS triumph!

THE LEWCOS DUAL-SCREENED COILS have been designed to facilitate the change from the 250-550 Broadcast Band to the longer waves used by Hilversum, Radio Paris, and Daventry. The change is effected by a switch incorporated in the coils and operated by a single panel control in the case of multi-coil sets and a lever in the case of the single Reinartz Aerial Coil. The two and three gang sets are perfectly balanced before leaving the factory, and are suitable for use with dual or triple gang condensers.

Ref. No. DRA/1	Single Coil Units Reinartz Aerial Coil	Each £1 12 6
Ref. No. DSP/2	Multi-Coil Units. The SP Aerial Coil and one split Primary HF Transformer with Reinartz Reaction	Per unit £3 7 6
Ref. No. DSP/3	One S.P. Aerial Coil and two split Primary HF Transformers, the last with Reinartz Reaction	Per unit £5 0 0

Note.—Multi-Coil Units are supplied complete with panel control as shown.

Obtainable through all wireless dealers. Full particulars from
The LONDON ELECTRIC WIRE CO. & SMITH'S Ltd.
Playhouse Yard, Golden Lane, London, E.C.1.

LEWCOS DUAL SCREENED COILS

ARTCRAFT RADIO CABINETS BRITAIN'S BEST VALUE. NEW 1928 MODELS.

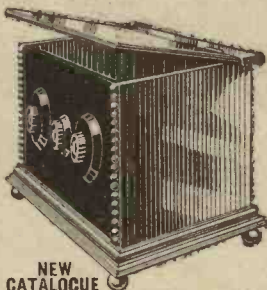

NEW CATALOGUE FREE

AMERICAN POPULAR TYPE (as illus.)

Panel Size	Baseboard Depth	Price in	
		Oak	Mahogany
9 x 6 x 6	6	8 0	12 0
10 x 8 x 6	6	10 0	14 0
12 x 8 x 8	8	14 9	18 0
16 x 8 x 8	8	17 6	22 6

Baseboards Free. Hinged Lids 1/6 extra. Add 1/- for crate. All Cabinets sent Carriage Paid.

RADION, RESISTON and EBONART PANELS AT STANDARD PRICES.

The Artcraft Company,
156, Cherry Orchard Rd., Croydon

CENTRE-TAPPED COILS and HOLDER

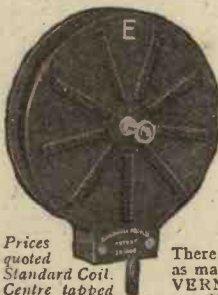

Prices quoted Standard Coil. Centre tapped 6d. extra.

Universal Coils—use not being limited to centre-tapped circuits, fit any standard socket, easily interchangeable, and occupy minimum baseboard space.

Size.	Price.	Approx. No. of Turns.
a2	4/10	18
a	4/10	25
B1	5/3	30
B	5/3	40
O	5/6	50
D	5/9	75
E1	6/3	100
E	6/9	150
F	7/9	200
F	8/6	300
G	10/-	500

There is no neutrodyne condenser with as many good points as the NEUTROVERNIA. Cap. Range, approx. 2/38 m/mfds. Will not Short. Dust and Damp proof. Price 5/6



Coil Holder, specially designed for Gambrell Centre-Tapped Coils, does away with flexible leads. 1/9

Write for Booklet (G.F. 12) Free!

GAMBRELL BROS. LTD.
76, Victoria Street, London, S.W.1

WIRELESS CONSTRUCTOR

Advertisement Rates

Single Insertion - per page and pro rata	£60 0 0
6 CONSECUTIVE Insertions per page and pro rata	55 0 0
12 CONSECUTIVE Insertions per page and pro rata	50 0 0
ONE INCH single col. (2 1/4" wide)	2 5 0
Minimum Space, half-an-inch	1 2 6

IMPORTANT. Copy and Blocks must be in hand by 20th of each month for issue placed on sale 15th day of the following month.

ALL communications respecting advertising must be made to:—

JOHN H. LILE, Ltd., 4, Ludgate Circus, London, E.C.4

Phone: CITY 7281.

Cheaper than using the mains.

WESTAM

Everlasting H.T. ACCUMULATORS.

Will hold each charge for six months.

Mr. ———, Tottenham, writes:—

Will you send along a positive and negative plate as I have accidentally broken one on my H.T. Accumulator after rendering very good service for 6 months on the first charge. Thanking you for placing on the market such an efficient and cheap accumulator.

6d. a Volt. 2 Amps. Entirely British. FULLY GUARANTEED.

60 Volt Model 30/-, 20 v. 10/6, 30 v. 16/-, 90 v. 45/-, 100 v. 50/-
120 v. 60/-

MACOS BATTERY MFG. CO., Ltd. Scrap your dry battery. Write for new season's catalogue of all models. Spares parts from any dealer, or Clements Road, London, E.6

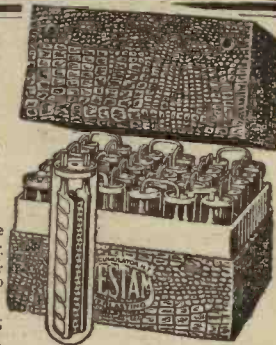

Pat. No. 1093626.

RECENT VALVE "RELEASES"

—continued from page 72.

its appearance is the Robinson self-balancing valve. At the time of writing it is not yet on the market, but I am told it will be available to the public very shortly.

Useful Characteristics

As has been explained by Mr. Harris in these pages, this valve has a second plate and grid (both dummies as far as electron activity goes) placed above its ordinary three-electrode assembly, and these dummy electrodes are used to provide a plate-grid capacity equal to the capacity between the active plate and grid. Thus the "dummy" capacity can be connected in a way similar to the neutralising condenser in order to neutralise the capacity feed-back of the main electrodes. So, with a split-primary circuit the valve is self-balancing.

Up to the present the models sent to me for test are identical in characteristics with the P.M.5X (impedance = 19,000 and the magnification factor = 17.5). Consequently

results are, or should be, similar to those obtainable with the P.M.5X and a neutralising condenser in a split-primary circuit, but without the usual bother of neutralising. In practice I have found it necessary to take extra precautions against external feed-back due to magnetic or capacitive coupling between the leads and components. In other words, I find the set works better when a little shielding is employed.

The price of the new valve is not yet divulged, and I hope it will be not more than that asked for the P.M.5X plus the price of a good neutralising condenser, for, after all, with the latter one does automatically neutralise the external capacity of the leads, etc., as well as the inter-electrode capacity of the valve, albeit the process is a tricky one. Whether the new Robinson valve will oust the ordinary valve plus neutralising condenser remains to be seen, and when the valve is available for general use I shall be pleased to have readers' opinions and experiences of it, especially where truly comparative results can be given.

Talking about the P.M.5X reminds me that the Mullard people have reduced the filament consumption of this valve and its fellow the

P.M.5B, together with the consumption of the P.M.3 and 3A, to .075 amp.—a drop of .025 amp. Also they have shown considerable enterprise by producing a 2-volt super-power valve—the P.M.252. This valve has admirable characteristics. Impedance = 3,800, magnification = 3.8, and filament current = 0.3 amp. It will stand a considerable input, and should prove a popular little valve, for I found it had plenty of "punch" behind it.

New A.C. Valves

It is well known that more "punch" is obtainable from indirectly heated cathode valves than from the ordinary direct heating type. Thus it came as no great surprise to find that the famous K.L.1 and its successor the K.H.1 have been outdistanced to a certain degree by the Cosmos A.C. valves. These take the form of a new detector and general-purpose valve—the A.C./G., having a mean impedance of 16,000 with a μ of 35, and a power valve with a mutual conductance of 4. This is a little wonder, for its impedance is 2,500–3,000 ohms, and its magnification factor is 10. Incidentally, but of real importance, the filament consumption is only 1 amp.,

(Continued on page 76.)



HANDBOOK

1/-

A fully illustrated, well-compiled work on the construction and uses of Formo components, including

- BLUE PRINTS of 2 SETS.
- SPECIAL TEST REPORTS
- FORMO-DENSORS.
- SELF-SUPPORTING AIR COILS.
- L.F. AMPLIFICATION
- LOG CONDENSERS.

Mr. J. H. Reyner,
B.Sc., A.C.G.I., D.I.C.,
A.M.I.E.E., M.Inst.R.E.

Mr. H. J. Barton Chapple,
Wh. Sch., B.Sc. Lond.,
A.C.G.I., D.I.C., A.M.I.E.E.

COMPLETE COLLAPSIBLE SCREENS

To facilitate wiring the screens are made so that the lid and sides may be removed very simply without in any way disturbing the components.

Complete with Ply Mounting Board **9/6**

22, Cricklewood Lane, N.W.2.
Phone: Hampstead 1787

Full Catalogue free on request.

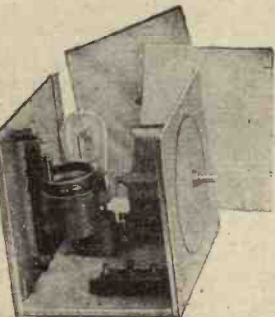

Use



RADIO PANELS

for

easy working, positive insulation, beautiful appearance, and an entire freedom from surface leakage. In black and beautiful mahogany grain, in nine standard sizes and prices. The "Ebonart Station Log Chart" given with each panel.

REDFERN'S NEW 7-PIN COIL FORMER AND BASE

This new and highly efficient model is sold complete with base and seven brass pins and sockets, ready for winding.

Price, complete - - - 5/6 each.
Spare Coil Former with fittings 3/9 ..

Send for The Book of Ebonart.

OBTAINABLE FROM ALL REPUTABLE DEALERS
REDFERN'S RUBBER WORKS, LTD.
HYDE, CHESHIRE

This NEW Work is essential to a full Education
—IT SHOULD BE IN EVERY HOME

The story of Man's adventure on the earth from the earliest time until to-day, told in

33 CHRONICLES

giving a continuous and world-wide narrative of events and

200 STUDY CHAPTERS

dealing in detail with the events, movements, and social life of the period covered by each chronicle.

9,000 PICTURES

each, as far as may be, contemporary with the event or period described. The great museums of the world have been ransacked to bring together this vast and immensely valuable collection of pictorial documents.

150 LEADING HISTORIANS

have combined to write the **UNIVERSAL HISTORY**, under the direction of J. A. Hammerton, the well-known editor of "The Universal Encyclopedia." Their contributions have been assembled into a brilliant whole, embodying the cream of the world's historical knowledge.

OVER £200,000

is being expended by the Publishers on the production of this monumental work. Its publication in part form enables you to obtain it for 1/3 per fortnight—only just over

ONE PENNY PER DAY

In the finished work you will possess a complete historical library of the utmost possible value and interest to you and every member of your family.



No man is truly educated without a knowledge of world history. New methods of writing history, new discoveries, and the focussing of modern thought less upon rulers than the people they ruled over, have rendered a new and up-to-date History imperative. A vast undertaking has been attempted and triumphantly achieved. Fortnight by fortnight until it is completed, HARMSWORTH'S UNIVERSAL HISTORY will unfold the history of the world as a living story—the record of the growth of men's ideas and hopes and the reaction of great events upon the common people; no mere accounts of kings, dates, and battles, but the *real* history of man—an enthralling and instructive romance of the undying past.

HARMSWORTH'S

UNIVERSAL HISTORY

Part 1 is now on sale at all Newsagents, Booksellers and Bookstalls.

If you have any difficulty in obtaining a copy, send 1/6 to the Publishers, The Amalgamated Press, Ltd., The Fleetway House, Farringdon Street, London, E.C.4.

Buy Part 1 TO-DAY 1/3



Plantations and Panels.

1. The panel is born . . . way back in a Pacific Island tree.

IT is a far cry from Malay to your Wireless Set in Manchester or Mitcham or Maidenhead or wherever you may live in England. Yet way back in a Malay rubber plantation is the tree from whence came the ebonite panel upon which your components are mounted.

This is how they do it. First, an incision is made in the bark of the tree. Then a little cup is placed in position at the point of the tap. Into this flows the latex, the fluid which, in time, becomes rubber. Only the pick of this rubber is selected for the manufacture of Radion and Resiston Panels. From the day the Native gathers the latex to the moment the lustrous Panel leaves the Radion factory almost finical care has been taken to ensure the absolute purity of the rubber. The native, would, indeed, be surprised if he could see what strength and what beauty had been given to the milky fluid he once knew.

You, too, will be surprised when first you see a Radion Panel. Such strength! Such a smooth even surface! Such exquisite colouring! Such superb finish! It is only a Radion or Resiston Panel which will give so aristocratic an appearance to your Set. Such a high standard of efficiency too. Ask your Dealer.

Radion and Resiston Panels come in 13 stock sizes, from 6 in. x 9 in. at 3/5 in Black to 8 in. x 30 in. at 25/- in Mahogany.

RESISTON
PANELS

"24 hours Cut Panel Service"

Adv. American Hard Rubber Co. (Brit.) 132 Fore St., E.C.
9552

RECENT VALVE "RELEASES"

—continued from page 74

while special adaptors make the valves usable in any set without alteration being necessary in the wiring.

Messrs. A.C. Cossor have also produced some new A.C. valves, and these have special connections in the valves themselves for the cathode-heating current. So in this case, also, no alterations are necessary in the wiring of the set. I have not yet tested these valves, so can make no further comment upon them than that they appear to be "the goods." No doubt the K.L.1 and the K.H.1 will have further companions from the same "stable" before long, so the popularity of the "mains" receiver is finally assured. It is a thoroughly reliable and economical proposition for the man with A.C. electric-light supply.

OUR NEWS BULLETIN

—continued from page 70

good results were obtained, but somehow this seeing by wireless in the dark before we can see by it in daylight makes the whole thing look unreal.

At the moment of writing, a Post Office committee is sitting to consider the sending of a television picture to the U.S.A. via the Rugby station, so before long their report will be issued, and then we shall see—or shan't we?

A Trade Announcement

The sole manufacturers of the Paxolin materials announce that, in view of the increasing demand, they have appointed Messrs. Wright & Weaire, Ltd., sole distributors to home constructors and to the trade. Enquiries should be addressed to Messrs. Wright & Weaire, at 740, High Road, Tottenham, London, N.17.

Empire Broadcasting

The Empire broadcasting situation hasn't yet reflected a ha'p'orth of credit upon the B.B.C. In one instance which came to light recently, an Australian journal wirelessly its London agents—that 3 A.R., the Melbourne station, proposed a 55-metre transmission, and asked the B.B.C. to co-operate. But the mandarins of Savoy Hill couldn't soil their hands by a bit of experimental spade-work, so they replied "in the

obstructionative," and the project fell through.

2 N M Carries On

Meanwhile, Mr. Marcuse has been scoring some pretty points for the amateurs. Programmes from his station at Caterham, Surrey (2 N M), have been picked up and re-broadcast in Australia, whilst New Zealand and many distant Dominions have testified to the excellence of the transmission. His modulation, they say, is perfect, his carrier is absolutely steady, but best of all, his *enthusiasm*—well, they can't praise that enough!

And after all, you know, if Drake and Wolfe, and some of those long-wave adventurers hadn't been enthusiastic, we shouldn't have had an Empire there to broadcast to!

Birmingham and 5 G B

Following a spirited protest by a Birmingham clergyman, and scores of complaints from listeners, a special wireless-equipped van was sent to Birmingham to investigate reception conditions in that city. As a result the B.B.C. is satisfied that 5 G B's signals are getting there all right, the poor reception is due to the "crude apparatus" used by certain Birmingham listeners.

No doubt better apparatus and good outdoor aerials would work wonders in improving reception, but the tragedy lies in the fact that if you happen to live "up a court" an outdoor aerial is out of the question, money for new apparatus is hard to find, and the poorer you are the harder you're hit!

Continental Relays

Evidently the B.B.C. is contemplating savouring this season's broadcast fare with a nice strong dash of Continental programmes. With a view to finding a really good route for same, a repeater station has been erected at Ostend. Programmes will be amplified there, sent across the Channel on the new submarine telephone cable, and brought to Savoy Hill with all their body and bloom intact, absolutely indistinguishable from the local vintage.

BRITAIN'S

LEADING RADIO WEEKLY

POPULAR WIRELESS

On Sale Every Thursday. Price 3d.



D's for D.E's

DAIMON. The L.T. Battery made by the most experienced battery firm in Europe. Half the size! Half the weight! Double the service! Yet see how moderate the prices are:

TYPE K - 2/- each
TYPE G - 4/6 "

Also H.T. Batteries, 60 volts, 10/6. 100 volts, 17/6.

From all good dealers or direct:—
S. D. H. MANUFACTURING CO.,
Colindale Avenue, Hendon,
LONDON, N.W.9.

daimon



THE TAYLEX WET H.T. BATTERIES

Solve all H.T. troubles. Self-charging, silent, economical.

JARS (Waxed) ZINCS SACS
2 1/2 x 1 1/4 sq. 1/3 doz. new type 1/- doz. 1/6 doz.
Sample dozen (18 volts), 3/6, post 9d., sample 6d.

BARGAIN LIST FREE.
Amplifiers. 1-valve, 19/-. 2-valve, 30/-.
2-valve all-station set, £4. Approval willingly.

C. TAYLOR, 57, Studley Rd., Stockwell, London.

The HOME for your *WIRELESS SET*



OUR STANDARD CABINETS

are DUSTPROOF and house the whole apparatus, leaving no parts to be interfered with. Beautiful in Design and Finish—Made on mass production lines, hence the low price. Provision is made to take panels up to 30" and base-board 20" deep. Special Cabinets for the Solodyne, New Family Four, Long Range Five, "M.W.", Five, A "Three" for the New Valve, All-British Six, etc., now ready.

From £4 : 15 : 0

Write for full particulars FREE.—
MAKERIMPORT CO.,
(Dept. 20) 50a, Lord Street, LIVERPOOL.

DAREX

Safety First

Accidental Damage avoided

TERMINALS Descriptive List free on request.

DAREX RADIO CO.,
Waldram Rd., Forest Hill, London, S.E.23.
TRADE SUPPLIED

WHEN replying to advertisements please mention "The Wireless Constructor" to ensure prompt attention. THANKS!

THE "REACTOR" FOUR

—continued from page 46

The wiring should be carried out systematically, the filament wiring being done first; and I think it a good plan to wire up "backwards," as it were. By that I mean wire the output circuit of the last valve, then its grid and the plate of the preceding valve, and so on back to the aerial and earth. In this way I have found it easier to arrange the leads. And, what is more important, the detector and L.F. end of the set can be tested on aerial before the H.F. portion is added. This ensures that the last stages are O.K., and if anything is wrong it can be traced more readily than if the H.F. valve is also in operation. Testing in these circumstances needs the use of aerial and earth on grid and filament leads of the detector valve, the test being carried out on the local station. If all is in order the H.F. stage can be wired up, taking care that the few pieces of glazite or covered wire (all the rest is bare) that go through the screen do not get cut by the edges of the screen, so that no shorting takes place. Many sets have proved faulty due to carelessness in this respect, and so when passing the leads through the screen do not drag on them so that the insulation is impaired and possible shorting can take place.

The Fixed Condensers

Note also the positions of the various by-pass condensers and the chokes. These are important and should not be omitted, as they make very considerably for pure reproduction and "no trouble" operation. All should be of good manufacture, and the condensers should preferably be tested for insulation and charge-holding capabilities before use. The writer got badly let down by the 1 mfd. condenser between the H.T. contact of the L.F. transformer and the negative filament leads. He found signals were poor and that an unnecessary amount of sparking took place on the H.T. + 2 lead. Finally he traced the trouble to the condenser, which was all but "dead" shorting. So watch those condensers, for if one is faulty it may throw the whole set out of operation. Having built the set it can be tested on aerial, the correct valves having been chosen and inserted in their sockets. I assume, of course, that the wiring has been thoroughly checked. Watch those screen connections and make

(Continued on page 80.)

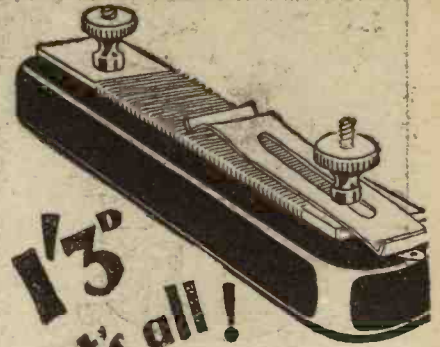

1/3 that's all!

You should not pay more than 1/3 for a fixed resistor when you get a "Peerless" for that sum. "Peerless" is not only the trade name — it is a complete description. The base is moulded from first-class insulation that will not break. The former is cut from a strong impregnated material that atmosphere does not affect. Each turn of wire is wound tightly and evenly—it will not loosen after a while. Terminals are fitted, but soldering tags are also provided in case you wish to use them. A spring arm is now supplied free with each resistor, so that the exact resistance for a particular valve can be found and "fixed".

"PEERLESS" FIXED RESISTOR

Please give description of valves when ordering.

From all good dealers or direct.

THE BEDFORD ELECTRICAL RADIO CO., LTD.,
22, Campbell Road, Bedford.

LONDON: 21, Bartlett's Buildings, Holborn Circus. E.C.4.
GLASGOW: 113, St. Vincent Street, C.2.



RADIO METERS

permit
"SCIENTIFIC TUNING"

Voltmeters - Moving Iron from 7/6
 - Moving Coil from 25/-
Milliammeters - Moving Iron 10/-
 - Moving Coil from 25/-

EQUIP your set with a Sifam Voltmeter and Milliammeter and make your Reception as accurate as Station transmission. These unconditionally guaranteed meters enable you to avoid sudden breakdowns and the consequent expense of over-discharged battery repairs; to trace distortion, and attain "perfectly balanced" reception. Sifam Meters are

USED AND RECOMMENDED BY THE WIRELESS PRESS

on their own sets. Come into line with modern developments. Fit Sifam Meters and make your set a precision receiving instrument.

9/6
NEW MODEL
 Pocket Voltmeter
 High resistance
 4,000 Ohms.
 Double reading
 Heavy nickel-plated case.

Ask your dealer to show you complete range.
 (Dept. C.)
SIFAM ELECTRICAL INSTRUMENT CO. Ltd.
 10a, Page Street, Westminster, London, S.W.1

Remember!

TEST YOUR SET TO-NIGHT
 WITH A **SIFAM** METER
 GUARANTEED
 and it won't let you down to-morrow.
 M. B. 19.

CABINETS OF DISTINCTION.
 Send your requirements to—
H. CATTERMOLE, 227 Anlaby Road, HULL.

BUILD ONE OF THE SETS DESCRIBED IN THIS ISSUE

A P.C. will bring you price lists of components for Sets described in this Magazine, viz.:-

- (1) A "THREE" FOR THE NEW VALVE.
- (2) THE "REACTOR" FOUR.
- (3) THE "CHUMMY" TWO.

We specialise in radio components for all "Wireless Constructor" Circuits and supply to Exact Specification.

The City & General Radio Co. Ltd.
 79, CANNON STREET, LONDON, E.C.4
 Phone: City 9280.

RECTIFIER DEVELOPMENTS

—continued from page 25

understood, but it seems probable that it is closely related to the rectifying action which takes place at the contact between a crystal detector and the cat's-whisker. The voltage required to drive a considerable D.C. current (2 or 3 amperes) through such a unit is quite small—of the order of a volt.

A Good Rectifier

Starting from the above-mentioned discovery, investigations have taken place with a view to finding more suitable material and, as a result of these investigations, a commercial rectifier has now been placed on the market (in the United States) under the name of the "Kuprox," the name itself implying the use of copper and copper oxide. In the commercial device a number of these rectifying units are joined together in series in order to give to the device a sufficient breakdown voltage to enable it to withstand the reverse voltage of perhaps 15 volts, which is built up against it when charging a 6-volt battery. The discs of Kuprox are of reddish appearance and about the size of a half-crown. In operation this rectifier is absolutely noiseless and, being perfectly dry, it involves no trouble either in care or maintenance. The efficiency is very high, and the Kuprox does not deteriorate either in use or disuse. The metal discs are bolted solidly together and cannot break or develop other mechanical trouble unless deliberately mishandled.

You will see from what I have said about the dry electrolytic rectifier and about the Kuprox that these represent important advances in the subject of alternating current rectification and, quite apart from their many practical uses, their discovery and development provide an encouraging exemplification of the fact that there is still a great deal to be discovered even in the most familiar fields.

WARNINGS TO ACCUMULATOR USERS

DON'T connect up your accumulator to the set and then forget all about it until signals fade away and the valve filament dims, showing that it is running down.

DON'T allow the voltage of your accumulator to fall below 1.8 volts per cell. Take readings with a voltmeter.

DON'T omit to take readings with a hydrometer, if you have no voltmeter. The condition of the accumulator will be indicated by the specific gravity of the acid.

DON'T keep your accumulator lying about in a discharged condition, or it will deteriorate, and sulphating will take place.

DON'T test your accumulator by short-circuiting the cells, even momentarily, with a piece of wire.

DON'T charge your accumulator at a higher rate than that specified by the makers. You will not save time, as the life of the accumulator will be shortened.

"POPULAR WIRELESS"
 The
LEADING RADIO WEEKLY
 Every Thursday. Price 3d.

DON'T allow the level of the acid in your accumulator to fall below the tops of the plates. Keep the level $\frac{1}{4}$ in. above the tops of the plates, by adding pure distilled water to make up for evaporation, or by adding sulphuric acid of the correct specific gravity if acid has been spilt.

DON'T allow acid or water to lie on the tops of the cells.

DON'T allow the terminals and connecting lugs to become corroded with acid. Smear them all over with a little vaseline, except on the faces of the terminals which grip the connecting leads.

DON'T disconnect the accumulator leads from the receiver until you have first removed at least one lead from the accumulator itself. In this way you will avoid the risk of accidental short-circuits.
 A. V. D. H.

CHATS AT THE WORK-TABLE

—continued from page 50

making pigtails by roughening the insulated portion of tags with emery cloth and then covering them as required with one of the cellulose paints that are obtainable everywhere nowadays. I always find it a good tip to write on each tag in black or white indian ink according to its colour the

(Continued on page 79.)

CHATS AT THE WORK-TABLE

—continued from page 78

name of the terminal to which it properly belongs. It is possible in a moment of madness such as comes the way of most of us at times to forget that red signifies H.T.+ and not L.T.+; if, however, the tags at each end of every lead are plainly lettered one can hardly go wrong even in one's most insane moments.

Panel-Mounting Problems

Many components—probably the majority nowadays—that are intended to be mounted upon the panel of the set are of the one-hole fixing type, which is excellent so far as ease of fitting is concerned, though a fixing of this type is scarcely secure enough to be relied upon where it is essential that the component shall remain absolutely in the same position without the possibility of movement. Suppose, for example, that a one-hole fixing condenser is used in a wavemeter intended for accurate work, and that a slow-motion dial of the type anchored by a stud driven into the panel is used in conjunction with it. The dial cannot shift, but the body of the condenser may do so, should the fixing nut work loose, as even the best of nuts will in time.

Locked In Place

Should this happen the whole calibration of the wavemeter would be upset and extraordinary readings might be obtained, since a movement of the dial might cause not merely a rotation of the moving vanes, but also a slight change of position of the body of the condenser. Personally, though I am duly thankful for the labour-saving qualities of the one-hole fixing, I never rely upon it in a wavemeter or in any calibrated circuit. Once a condenser of the one-hole fixing type has been mounted I make a hole with a No. 33 drill right through the panel, and the plate of the condenser, which is drawn up against it by the fixing nut. This hole, after being countersunk, is tapped 4 B.A., and a screw is then driven in, locking the condenser solidly in one position. This is a most satisfactory method, and I strongly recommend it to all those who construct a wavemeter.

Popular Wireless

LARGEST CIRCULATION OF ANY RADIO WEEKLY
Price 3d. On Sale every Thursday



No. 4780. High Capacity, 60 volts, weight 13 lbs.

MANY years ago Was introduced your friend The first High Capacity Battery—**A Columbia**

Hard was the fight; Small Batteries Were its enemies And yours.

Small Batteries are so cheap—**At first.**

But thousands have learned At vast expense That big Batteries **Are cheaper.**

Quit buying experience Buy Columbias They last longer

Columbias are high capacity batteries of exceptional efficiency; they are built to meet the demand for something better. They will give you longer and better service; they will positively save you money. Your dealer stocks them.

TELL US ABOUT YOUR BATTERY TROUBLES. Drop a p.c. for Lists.

J. R. MORRIS,
15, Kingsway, London, W.C.2



No. 4486. "Layerbilt," 45 volts, 15 lbs.

SPECIAL OFFER!
CANNOT BE REPEATED.
One hundred Genuine "Magnavox" Speakers — Mahogany Cabinets, wonderful tone, including cord, 9 1/2 ins. high by 1 3/4 ins. wide by 9 1/2 ins. deep. List price £8.
OUR SPECIAL PRICE **£4**
The **WHOLESALE WIRELESS Co.**,
103, Farringdon Road, London, E.C.1.
Telephone: Clerkenwell 5312.

Free!
ENGINEERS
Here is a Wonderful Opportunity

A book that will throw a new and startling light on the possibilities within your grasp—will show you how you can prepare for the A.M.I.E.E., A.M.I.Mech.E., A.M.I. Struct.E., A.M.Inst.C.E., A.M.I.A.E. and any other engineering qualification quickly, and in the privacy of your own home. 60 engineering Diploma (A.M.Tech.I.) courses are described—64 pages of vitally interesting matter to the ambitious engineer. **The book is FREE.**
Write for your copy at once, stating branch of Eng. or Exam. which interests you.
The Technological Institute of Great Britain, 200, Thanet House, Strand, London, W.C.2.

Spend 4⁰ and save £4

1000 BARGAINS
Are listed and hundreds illustrated in our **NEW 72-PAGE CATALOGUE**
Now Ready
SEND 4d. IN STAMPS TO
ELECTRADIX RADIOS
218, Upper Thames St., London, E.C.4.

THE PERFECT WET H.T.
Assured with our new Insulating Liner, Jars, 1/3 doz. plain; 1/6 doz. waxed; Special Zincs, 1/- doz.; High-Capacity Sacs, 1/6 doz.; Perforated Liners, 4d. doz. Post Free on three dozen Units and over, including special divided carton suitable as a container. Send 6d. for sample complete unit, particulars and instructions. We stock Seamless Moulded One Parts. Telephones and Loud Speakers Re-wound.
SPENCERS STORES LTD.
4-5 MASON'S AVENUE, COLEMAN ST., LONDON, E.C.2.
Phone: London Wall 2292 (Nr. Bank.)

Cabinets of Quality for every Set.
Full illustrated particulars from the Actual Manufacturers, V. C. Bond & Sons, 61, Hackney Grove, Mare St., London, E.8

REPAIRS
to HEADPHONES, LOUDSPEAKERS, TRANSFORMERS, COILS.
First-class workmanship only. This is just the vital difference. We are specialists with almost 30 years' experience in every form of intricate and accurate coil winding, and we guarantee that work entrusted to us will be returned to you as good as new, if not better. This is no idle claim, but the unsolicited opinion of scores of satisfied clients.
THE VARLEY MAGNET COMPANY
(Proprietors: Oliver Pell Control, Ltd.)
BLUOMFIELD ROAD WOOLWICH, S.E.18.
Telephone: Woolwich 0888.

Wireless in every room this Winter!



THE LOTUS REMOTE CONTROL enables you to listen-in in the dining-room, sitting-room, bedroom, kitchen — everywhere, anywhere — simultaneously and without interference with each other.

Simply place the Lotus Relay near receiving set, wire to rooms desired and connect with Wall Jack and Plug. No technical knowledge is needed.

The same volume of sound throughout. The last one to switch off automatically disconnects the set. Suitable for any valve set.

FREE! Write to the address below for **FREE BLUE-PRINTS AND INSTRUCTIONS** explaining how two rooms can be wired in half-an-hour.

Complete Outfit for Wiring Two Rooms:	
1 Lotus Radio Relay,	
2 Lotus Relay Filament-Control Wall Jacks,	
2 Lotus Jack Plugs,	
21 yards Special 4-Strand Wire.	30/-
Each Additional Room	7/6

Made by the makers of the world-famous Lotus Valve Holders, Coil Holders, Jacks, Switches and Plugs.

From all Radio Dealers.

THE LOTUS REMOTE CONTROL

(Dept. W.C. 11) Garnett, Whiteley & Co., Ltd., Lotus Works, Broadgreen Road, Liverpool.

THE "CHUMMY" TWO

—continued from page 22

This is very good selectivity at seven miles from 2 L O, for Toulouse works on a wave-length of 392 metres as against London's 361. The kilocycle separation is 65. Brussels, Vienna, Rome, Frankfurt, and what seemed a host of German relays, were excellently received in the telephones, and later in the evening, when 2 L O had shut down, Madrid and other "Spaniards" were almost too loud for headphone reception.

The "Daventry" Range

On the long-wave range the set did not prove quite so selective as on the short band. 5 X X and Radio Paris, however, were separable. Quite a difference was found on different makes of split-secondary coils, when used on this range. This is probably due to the fact that the primary winding, which is joined to the aerial, together with the aerial itself, may naturally tune to something near the wave-length of London on some coils. If the reader should notice very flat tuning on this range, or if he finds he cannot get rid of his "local," there is a very simple remedy, viz. : to insert a fixed condenser of .0001 or .0002 mfd. in the aerial lead. This trouble does not occur on the ordinary band and probably will not happen, in nine cases out of ten, on the Daventry range. If, on the Daventry range, uncontrollable oscillation is found in spite of adjustment of the neutralising condensers, the trouble is likely to be in the radio-frequency choke. Unfortunately, a number of unnamed and inferior chokes are being sold which are totally unsuitable for the Daventry range, on this or on any other set. If you select one of the leading makes you will not have any trouble. The point is mentioned here not because this set is specially prone to radio-frequency choke troubles, but because the writer in building up a set recently came across this particular difficulty and thinks others may have suffered similarly.

THE "REACTOR" FOUR

—continued from page 77

sure the L.T. does not get shorted anywhere, for the screen is "earthed" to L.T.—, and as such is used as a conductor between various leads and connections.

For the H.F. valve I use a P.M.5 X, or Cossor H.F., but any valve of the "20,000-20 mu" type will do, either in the 2-, 4- or 6-volt classes. The latter should be preferred, however, and the neutralising system is more suitable for those valves than for the 2- or 4-volt types. As detector I have used the D.E.5B, P.M.5B, D.E.H. 610, etc., with success, while for the first L.F. a P.M.6, D.E.5, S.S.610P., and their similar confrères, are O.K.

Super-Power Valve

The last valve should be a super-power valve and should be "hard." I have found several super-power valves lately that have gone soft after a little use; they shall be nameless, as I believe the makers are looking into the matter, but it is as well to keep your eye on this valve and if it shows any signs of getting hot (assuming no more than 150 volts H.T. are used) or giving distorted results when properly biased, or causing noises, it should be sent back for examination. I have used the P.M.256, D.E.5A, with success in this position, using 120-160 volts H.T. and suitable grid bias.

When placing the split-primary transformer in position, be careful to take the H.T. + plugs out, as when the screening box is used it is not always easy to get the pins "right" first time, and a short across H.T. may mean a burnt-out primary winding. At least, that's what occurred to me one day, and I had to rewind the primary which was badly burnt out.

Neutralising

Neutralising is not a difficult task if the following instructions are carefully followed :

Set the reaction control at minimum, and likewise the neutralising condenser. Now, on setting the tuning condensers so that the two tuned circuits are in step with each other, it will probably be found that the set is oscillating. To test for oscillation, touch the moving sets of plates of the tuning condensers. You will probably find that the set will only oscillate under the above conditions when the two circuits are in tune with each other, and this can be used as an indication. It is convenient to perform the operation at some point near the middle of the tuning range. Now increase the capacity of the neutralising condenser.

Test at intervals for oscillation as this is done, and you will presently

(Continued on page 81.)

To-day the only truly up-to-date condenser is the "CYLDON" log mid-line

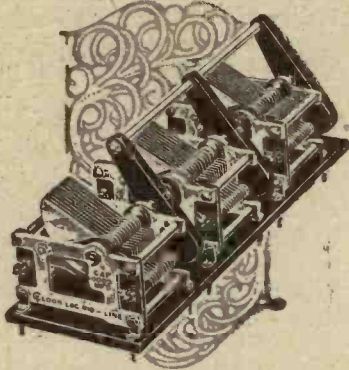

The "Cydon" Log Mid-Line is the condenser of to-day and the future. It spreads all the stations evenly over the whole dial. It prevents any "falling out-of-step" at the beginning or end. It simplifies tuning in multi-tuned circuits when individual condensers are used, by making all the dial readings exactly the same. It is the only condenser you should fit to your set now. Experts insist on using them—and recommending them.

PRICES:

'001 - 19/- '0005 - 15/6 '0003 - 14/6
'00025 - 14/- '0002 - 13/6
With 4" knob dial 2/- extra.

GANG CONDENSERS

Twin Gang - - £2 : 10
Triple Gang - - £3 : 10
Four Gang - - £4 : 10

Thick aluminium plates. Large adjustable non-wearing bearings. Pigtail rotor connection. Precision finish and electrical efficiency.

IMPORTANT NOTICE.

The products of the world's best brains and manufacturing resources in any trade or profession have always interested the "Cheap-Jack" imitator, the worthlessness of whose products can only be compared with his lack of originality. "Cydon" products, unfortunately, have not been spared this form of unwelcome flattery. Every genuine "Cydon" Condenser bears our registered trade mark on the end plate. Insist on seeing this before purchasing.

CYLDON products can be obtained from stock by return; and do not believe any statements to the contrary. If any difficulty Phone: Enfield 0672. Wire: Capacity, Enfield, or use the C.O.D. system.

Sole Australian Agents:

E. V. Hudson, 55/7, Charlotte Street, Brisbane, Queensland.

SYDNEY S. BIRD & SONS,
LTD.,
Cydon Works,

Sarnesfield Rd., Enfield Town

Contractors to B.B.C., H.M. R.A.F., H.M. Office of Works, and all manufacturers of quality receivers.



THE "REACTOR" FOUR

—continued from page 80.

find that the set has ceased to oscillate, and will not recommence even when the tuning dials are slightly readjusted. Now increase the reaction a little, until the set once more oscillates, and again increase the neutralising condenser setting until oscillation ceases. Slightly readjust the tuning condensers again to make sure that the set is completely stable once more.

Correct Adjustment

Proceed in this way until it is found that the correct adjustment of the neutrodyne condenser has been overshoot. Once this point has been passed it will be observed that further increases of the neutrodyne condenser no longer stop oscillation, but cause it to become stronger.

The object is to find such an adjustment of the neutralising condenser as will permit the greatest setting of the reaction condenser to be used without producing oscillation. It will then be observed that when the two tuned circuits are in step and the set is brought to the verge of oscillation a slight movement in either direction of the neutrodyne condenser will cause the receiver to break into oscillation.

H.T. Values

Remember, the tuning will be sharp, especially on the aerial condenser, and the Formodenser should be adjusted when the set is working till best results from your own individual aerial are obtained. The writer has found that the aerial lead on the first terminal (Formodenser in series) is best with the aerial flex on 3 on the coil base. This will vary with different aeriels and should be given careful consideration when testing the receiver. Once set, the Formodenser can be left, as can be the neutralising condenser, unless the valve is changed, or the listener changes over to 5 X X range, when I find it best to readjust the neutralising condenser. Neutralisation should be carried out with the screening box lid "on," of course.

H.T. values used by the writer for 6-volt valves were: H.T.+1, 120-160; H.T.+2, 120; H.T.+3, 30-40; H.T.+4, 120 volts. A large-capacity battery should be employed, as the total plate current of the set comes to about 20 milliamps when a super-power valve other than the D.E.5 A is used. With the latter it is somewhat less than this, dependent on the actual H.T. voltage employed.

PERMANENT BEAUTY



COFFER by **BENVENUTO CELLINI**
(16th Century.)

Admittedly one of the treasures of the world and of incalculable value, the material chosen for this masterpiece was gold. Gold lent itself to the niceties of fine craftsmanship, enhanced the beauty of the piece and set that beauty in permanence. It is precisely these qualities—adaptability, service, and beauty that decide both expert and amateur in favour of Trolite for every purpose of

INSULATION

- (1) Trolite is ideal for panels and stub panels.
- (2) Trolite is easily drilled, sawn, and machined, and being soluble in acetone, a perfect and permanent joint can be made without the labour and disfigurement of screws.
- (3) Trolite does not fade or discolour.
- (4) Trolite panels are distinctive and can be obtained in the following varieties of beautiful finishes: (1) Black Polished; (2) Mahogany Polished; (3) Walnut Polished; (4) Wavy Design; (5) Cubes Design.
- (5) Mirror-like polish, but no surface leakage.
- (6) The price of Trolite is within the reach of all constructors, but you do not sacrifice efficiency for effect by using Trolite: you have both in the Panel de Luxe.

PRICE per square inch

Polished Black		Mahogany Cubes	
		Walnut Wavy	
3/8 in.	1/2 d.	1/2 in.	1 d.
1/2 in.	1 d.	3/4 in.	1 1/2 d.

TROLITE

THE RADIO PANEL DE LUXE

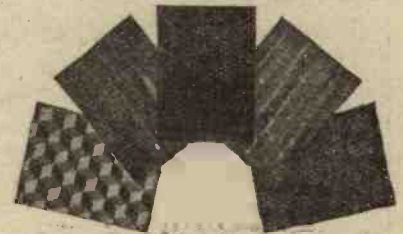

F. A. HUGHES & Co., Ltd.,

204-206, Great Portland Street, W.1.

Telephone: Museum 8630 (3 lines).

Telegrams: Distancing, Wesdo, London.

Manchester Office: 6, Booth St. East,

C. on M., Manchester.

Telephone: Ardwick 3709.

LIFELONG SERVICE



LAKER STEEL MASTS
are 100 per cent. efficient
They are made by engineers and supplied to H.M. Government, the B.B.C., and to Colonial and foreign stations throughout the world. There are 50,000 "Laker" Masts in daily use. By mass production we are able to offer a wonderfully efficient and handsome Steel mast at the extraordinarily low price of 22/6 complete, as illustrated. Send 1/- extra for part carriage. We pay the rest. Buy a Laker Mast for good reception.

LAKER & Co., Engineers,
BECKENHAM, KENT

30 ft. STEEL MAST 22/6

AGENTS

Large German Factory of Wireless Sets and Accessories requires Agents in various districts of Great Britain and Ireland. Offers with references to

A. GÜNTHER,
FURTWANGEN, BADEN, GERMANY.

TRADE MARK "RED DIAMOND"



THE RECOGNISED DETECTOR FOR ALL CIRCUITS USING CRYSTAL RECTIFICATION.

RD40 2/-
Shield for same, 6d.

By Insured Post 2/3 or 2/9 with shield. Can be mounted on brackets or through panel. Once set always ready. Not affected by vibration. Each one is tested on broadcast before despatch, and is perfect. Of all high-class Radio Dealers or Sole Makers:—

JEWEL PEN CO., LTD.
(Radio Dept. 41), 21-22, Gt. Sutton St., LONDON, E.C.1

PICKETT'S CABINETS

For Your HOME Radiola! Wireless Furniture 3 ft. high—taking your Set, Batteries, etc., complete.

BUREAU Models from 23 3 0
"RADIOLA" Jacobean from 25 5 0
"Radiola" Queen Anne from 28 15 0
High Grade Work and finish

GUARANTEED and Sent on APPROVAL

Lists of Cabinet Designs No. 21 FREE.
Pickett's Cabinet (W.C.) Works, Bexleyheath.



EBONITE BUSHES FOR MOUNTING ON METAL OR WOOD.



PERFECT INSULATION
Two required for each hole.

Orders under 1/- send 1d. Postage.

NUMBER 0 1 2 3 4 5 6
Hole in Bush 3/8", 1/2", 5/16", 1", 7/16"

Price each: 1d. 1d. 1d. 1d. 2d. 2d. 2d.

(Complete List of sizes free on application.)
DAREX RADIO CO.,
Waldram Rd., Forest Hill, London, S.E.23
TRADE SUPPLIED

EVERYTHING RADIO ON EASY TERMS

WOOLDRIDGE RADIO CO. LTD.
26 LISLE ST. LEICESTER SQUARE LONDON, W.C.2.

AT HOME WITH THE OHM

—continued from page 36

A much more important point in relation to six-pin coils is the contact resistance between the pins and the sockets. If the pins are badly made, and if inferior sockets are used, you may have more resistance in the contacts than in the whole coil itself. For example, in the experiment shown in Fig. 4, a whole series of different values was obtained. First of all, the total resistance of the coil and the base (not the same make as that shown in the photograph) was 14.6 ohms. Pulling out and plugging in the coil again brought it down to 6.9; "wagging" this brought it down to 6.7, and by removing the coil, opening out the pins with a pocket knife, and replacing them in the socket, the total resistance came down to approximately the resistance of the coil alone.

Bad signals are often caused by imperfect contact in valve holders, and experiments as in Fig. 6 were undertaken to make sure that a number of standard valve holders were perfectly satisfactory. Most of the commercial holders proved quite good, but in one or two cases a higher resistance than should be was found, and this was traced to imperfect contact between springs and sockets, where these had been clipped together and not soldered.

H.F. Chokes

The D.C. resistance of a radio-frequency choke is a matter of some importance, for if this is too high it may occasion a reduction in the actual voltage applied to the plate of a valve. It is not very important in high-frequency valves, but if for experimental work a radio-frequency choke should be used in series with a modern power valve of low impedance, the drop might be appreciable. It is therefore interesting to compare the D.C. resistances of a number of radio-frequency chokes which were all known to be good in their radio-frequency work. Four well-known chokes, all equally satisfactory from the radio-frequency point of view, were measured and were found to be 221 ohms, 139 ohms, 296 ohms, and 380 ohms respectively.

A very interesting measurement was that of the resistance of the output side of a well-known make of transformer in a 25 to 1 ratio. This particular transformer is designed to operate a coil-driven loud speaker of the Rice-

Kellogg type, such as that described by Capt. Round in the WIRELESS CONSTRUCTOR for July. The D.C. resistance proved to be 1.1 ohm, and as there is such a big step down it is obvious that a very large current can flow in any circuit connected to this if there are strong signals in the input side. The transformer was thereupon connected to a six-valve receiver consisting of three stages of radio-frequency, a detector, and two really "hefty" audio-frequency stages, and the set tuned to London.

Lamp Burnt Out

An ordinary flash-lamp bulb connected across the output terminals burnt out with a flash before the aerial dial was within twenty degrees of the London resonance-point, and on resonance the current was found to be sufficient (albeit very variable!) to light a small electric lamp belonging to a child's cinema projector! An alternating-current ammeter was then joined up and a current of no less than 0.4 of an ampere was frequently registered!

The measurement of radio-frequency resistance is a far more complicated matter, and the apparatus I use for this purpose comprises a powerful oscillator capable of producing a radio-frequency current of any desired frequency on the broadcast band, a special and expensive instrument for measuring radio-frequency current, and tuning devices for adjusting circuits to resonance. A description of the methods employed would occupy more space than is available this month, and this must be reserved for a subsequent article.

HOW THE SCREENED VALVE WORKS

—continued from page 18

simple tuned-anode circuit shown in Fig. 2, but it is well known that if we apply reaction to the anode circuit from the detector (Fig. 3) we shall effectively reduce its resistance, or, in other words, raise the impedance of the circuit.

In this way, then, we shall be able to gain in magnification. If, for instance, we were using an ordinary sort of coil giving a magnification of 16 to 23, according to its construction, by applying reaction to the circuit to reduce its loss resistance we should bring up its effective resistance to perhaps 250,000 ohms, when the magnification would rise to 61.

(Continued on page 83.)

HOW THE SCREENED VALVE WORKS

—continued from page 82

The question as to whether reaction is a desirable thing will be left to the reader. The writer prefers so to design his coil that reaction is not required. Such a coil is, of course, expensive—it costs about five shillings—but we dispense with reaction (which sometimes involves an extra condenser, choke, etc.), so that not only do we save several shillings in the long run, but we simplify tuning.

Associated with this question of the design of the anode circuit, however, are further practical things which we meet with immediately we experiment with a receiver, and the first question is this: "To what extent has the grid-anode capacity of the valve been eliminated?" If there is a slight capacity remaining there will be a slight but perfectly definite tendency for a current to flow from the anode circuit to the grid circuit, and so to tend toward the production of self-oscillations.

Question of Screening

Practical experience and theory indicate that the tendency for the circuits to oscillate depends upon the impedance associated with the anode circuit. In the case of the tuned-anode circuit, the higher the impedance the greater the tendency for the circuit to oscillate, for the simple reason that the higher the impedance the larger are the voltage changes in the anode circuit.

This means that when a coil of high-frequency "cable" is connected in the anode circuit the tendency for the circuits to oscillate through the very slight anode-grid capacity will be much greater than when an ordinary single-layer or plug-in coil is used.

The second practical point is this: "To what extent can we isolate the anode circuit, which comprises the anode tuning coil and condenser, from the grid coil and condenser, and the aerial?" If by complete shielding we can do this, then we have only the valve's capacity to consider. But complete shielding is expensive and difficult to carry out. With one stage of high-frequency amplification we would prefer to use a very simple form of shielding, and the question we have to ask ourselves is this, "Will the simple form of shielding allow sufficient stray coupling to exist for the circuits to oscillate?" If with

(Continued on page 84.)



THAT SMASHED THE GLASS!

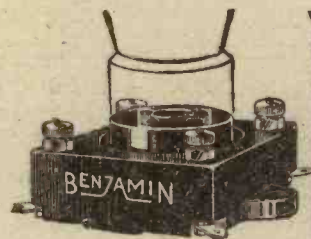

BENJAMIN Clearer-Tone Anti-Microphonic VALVE HOLDER

Make sure that the anti-microphonic valve holders you buy are Benjamin, because in these alone you get these 5 essential features:—

- (1) Valve sockets and springs are made in one piece with no joints or rivets to work loose and cause faulty connections.
- (2) Valves are free to float in every direction.
- (3) Valves can be inserted and removed easily and safely.
- (4) Valve legs cannot possibly foul the base-board.
- (5) Both terminals and folding tags are provided.

Price 2/- each

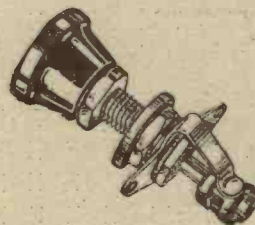

BENJAMIN BATTERY SWITCH

A sturdy positive action switch for high or low tension. It's OFF when it's IN, thus preventing the accidental turning on of current. Single contact. One-hole fixing.

Price 1/- each

There is a story told of a famous singer that he could sing a certain note into a wineglass and smash it into fragments by the vibration.

This is an extreme instance of the damage vibration can do. Nearer and dearer to you is the damage vibration does to the delicate filaments of your valves.

Every time a lorry rumbles past your house a wave of vibration travels to your radio set. Every time you walk across the floor another wave is sent.

The only way you can thoroughly stop vibration reaching the filaments is to fit Benjamin Anti-microphonic Valve Holders.

The smallest shock and vibration is quenched by the wonderful one-piece springs. Microphonic noises are entirely eliminated. The life of the valve is trebled at least.

BENJAMIN

ANTI-MICROPHONIC VALVE HOLDER

PRICE 2/- EACH

THE BENJAMIN ELECTRIC LTD.

Brantwood Works, Tariff Road, Tottenham, N.17.

HOW THE SCREENED VALVE WORKS

—continued from page 83

this simple form of shielding it becomes necessary very carefully to locate the tuning coils and condensers in order to prevent oscillations, then we have to see what can be done to modify the circuit.

Here again, when tuned circuits having a high effective resistance at the resonant frequency are used, i.e. a circuit with a low-loss coil and tuning condenser, the tendency will be for the circuits to oscillate with only a slight amount of coupling.

In practice, then, one has to balance up the various factors. We have on the one hand cheapness and simplicity

of construction, and on the other hand complete freedom from instability.

My experiments have definitely indicated that provided the two tuning coils, Fig. 3, are placed at right angles with a metal screen between them, as in Fig. 4, the circuit is quite stable even when the best possible—i.e. low-loss—tuned circuits are used. Thus, when coils wound with high-frequency "cable" are used the circuit is stable, but when we come to apply reaction to a circuit using ordinary tuning coils there is likely to be some difficulty as the anode circuit is brought near the point of oscillation. The circuit I prefer, then, is the simple one shown in Fig. 3, with low-loss tuning coils.

Attached to the anode circuit is a detector. This may be of the anode-bend or the leaky-grid type, and the

amplification and selectivity will depend very considerably upon which method of rectification is adopted. If we choose an anode-bend rectifier, as shown in Fig. 5A, we shall hardly affect the constants of the tuned-anode circuit at all.

Leaky-Grid Detection

In the case of the leaky-grid detector, however, we have to be very careful that we do not materially lower the amplification and spoil the selectivity. This is because the working resistance of the leaky-grid detector is fairly low, of the order of a few hundred thousand ohms, and is connected in parallel with the anode circuit. Thus it will tend to lower its effective resistance.

This will be a very serious matter when a low-loss coil of high-frequency "cable" is used, but will hardly have any effect at all when a plug-in coil is fitted. If the purpose for which the circuit is to be used renders it necessary for a leaky-grid detector to be connected, we might find an actual gain in signal strength by connecting it as shown in Fig. 5c, that is across part of the anode circuit instead of across the whole of it.

Coils of 290 microhenries	Effective Resistance at 400 metres. Ohms.	Calculated Magnification
H F. "cable"	250,000	61
Good solid wire single layer	100,000 to 150,000	34-45
Ordinary single layer and plug-in	40,000 to 60,000	16-23

Pay for that set bit by bit!

PERHAPS you want a set, perhaps only components or accessories. Whatever your purchase, price need be no worry. Our instalment system—the first ever tried in Radio, is safe and generous. Send enquiries to desk 'C.'

New Times Sales Co., 77, City Rd., London, E.C.1 9516



Obtain wonderfully improved reception at less cost. All parts are BRITISH MADE and the BATTERY itself is home assembling—silent in action—permanent, no charging required. All parts are replaceable and the Battery can be assembled from 90 volts upwards in an hour or so.

Write for Our Booklet. Everything is Explained, from Assembling to Spare Parts. POPULAR MODEL, 90 volts, 60 cells. No. 1. Sac for soldering 21/9 WITH DETACHABLE TERMINAL 25/1 Trays for above, 7/-

Free advice given as to best battery for your set on hearing number and type of valves.

Install once & for all A STANDARD WET H.T. BATTERY

WET H.T. BATTERY Co. 12, 13, BROWNLOW STREET, HIGH HOLBORN, W.C.1.

DIGBY'S CABINETS
WRITE FOR NEW 16 PAGE CATALOGUE
F. DIGBY, 9, BANBURY ROAD, SOUTH HACKNEY, LONDON, E.9.
PHONE: CLISSOLD 5458.

LONDON LISTENERS! —improved reception ensured

If you have your accumulators correctly charged by our skilled maintenance service. We collect weekly, fortnightly or monthly within 12 miles of Charing Cross, and exchange your accumulator (H.T. or L.T.) for one fully charged. If yours are not serviceable, you can hire ours. Both trouble-free, money-saving services. Terms—weekly, fortnightly or monthly—no deposit required. And you can depend on our service for a solution in every wireless trouble.

Our service—the speciality of experts
Write for full details and terms: RADIO SERVICE (London) Ltd., 195, Tottenham Avenue, Camden Rd., N.W. 5. Phone: North 0623 (3 lines)



INDEX TO ADVERTISERS

American Hard Rubber Co.	70
Arcraft Co., The	73
Belling & Lee, Ltd.	60
Bedford Electrical & Radio Co., Ltd.	77
Benjamin Electric, Ltd.	83
Bird, Sydney S., & Sons	81
Bond, V. C., & Sons	79
Bowyer-Lowe Co., Ltd.	04
Brandes Limited	43
Brown, S. G., Ltd.	59
Burne-Jones & Co., Ltd.	63, 48
Cattermole H.	78
Carrington Mfg. Co., Ltd.	52
Citizen's Radio Service Bureau	70
City & General Radio Co., Ltd.	78
Cossor, A. C., Ltd.	4
Carborundum Co., Ltd.	67
Dubiller Condenser Co. (1925), Ltd.	64
Darex Radio Co.	77, 82
Digby F.	84
Ede, C. & Co., Ltd.	52
Electradix Radios	79
Electron Co., Ltd.	51
England-Richards Co.	50

Falk Stadelmann & Co., Ltd.	44
Ferranti, Ltd.	55
Forno Co., The	74
Gambrell Bros., Ltd.	78
Garnett, Whiteley & Co., Ltd.	80
Gunther, A. (Germany)	82
Hamley Brothers, Ltd.	48
Harmsworth's Universal History	75
Holzman, Louis	52
Hughes, F. A., & Co., Ltd.	81
Igranic Electric Co., Ltd.	71
Jackson Bros.	60
Jewel Pen Co., Ltd.	82
Laker, J. & J., Co.	82
Lissen, Ltd.	39
London Electric Wire Co., & Smiths, Ltd.	73
Makerimport Co.	77
Marconi-phone Co., Ltd.	1
Metro-Vick Supplies, Ltd.	2, 3
Morris, J. R.	79
Millard Wireless Service Co., Ltd.	Cover ii.
Macos Battery Manufacturing Co., Ltd.	73
New Times Radio Co.	84
Ormond Engineering Co., Ltd.	47
Peto and Radford	69
Peto Scott Co., Ltd.	40
Pickett's Cabinet Works	82
Pye, W. G. & Co.	50
"Popular Wireless"	50

Radio Service, Ltd.	84
Raymond, K.	63
Redfern's Rubber Works, Ltd.	74, 71
R. I. & Varley, Ltd.	Cover iv.
Rothermel Radio Corporation, Ltd.	52
S. D. H. Manufacturing Co.	77
Sifam Electrical Instruments Co., Ltd.	78
Spencers Stores, Ltd.	79
Stratton & Co., Ltd.	71
Taylor, C.	77
Technological Institute of Great Britain, The	79
Telegraph Condenser Co., Ltd.	44
Tungstone Accumulator Co., Ltd.	Cover iii.
"T. P.'s Weekly"	60
Vandervell, C. A. & Co., Ltd.	72
Varley Magnet Co., The	79
Weston Electrical Instrument Co., Ltd.	69
Wholesale Wireless Co., Ltd.	52, 79
Woolldridge Radio Co., Ltd.	82
Wet H.T. Battery Co.	84
"Wireless Constructor" Rates	73

All communications concerning advertisements in "Wireless Constructor" must be made to John H. Lile, Ltd., 4, Ludgate Circus, London, E.C.4. Telephone: City 7261.

Not Necessary to Buy a Tungstone Twice in a Lifetime

Because Standardised and Interchangeable renewable Die Cast and Machine Pasted Plates PERPETUALLY replace a set of Used Plates. Dry Plates partially first charged are ready for immediate use. Can be stocked for unlimited period in dry place. Spare Plates sold at reasonable prices with allowance of 4d. per lb. for returned disused Plates. Anyone can quickly and easily slip Set of New Plates into the Indestructible Guaranteed Metal Containers in use.

TUNGSTONE'S "REVOLUTIONARY" SCIENTIFIC "DISCOVERY" COMPLETELY & RELIABLY REVERSES WORLD'S BATTERY PRACTICES AFTER 50 YEARS' STAGNATION

Without Cost to Purchaser, all Plates when made at the Works, are Fully Formed also given a Partial First Charge. All Plates are made chemically and electrically safe. Mechanically secure. Absolutely sure Preventative against damage to Plates on First Charge or shortened future Working Life. Also highest possible ratio of Storage Capacity is secured during working life. British Government's World's Record Test at 96 % Amp. Hr. 88 % Watt. Hr. are fully maintained.

ALL THE WORLD'S MAKERS DISPATCH THEIR PLATES IN AN INCOMPLETE DELICATE UNRELIABLE MANUFACTURED CONDITION Some are ONLY slightly formed. NOT all completely formed. NONE are Partially First Charged at the Works as Tungstone without cost to Purchaser.

ALL THE WORLD'S MAKERS "PASS ON" TO THE PURCHASER the many serious risks of Forming, and giving the First Full Charge, also the increased cost of a necessary and exceedingly long first charging period extending from 24 to 72 hours and longer.

First Charge Only 4 Continuous Hours

FOR ANY TUNGSTONE STORAGE BATTERIES RATED FROM 6 TO 5,000 AMPS.

On Car or Bench Portable Batteries, charging rates from 6 to 30 amps. based on rated amp. hour House Lighting Works Central Station Batteries can be discharged for light ONLY during the first charging period.

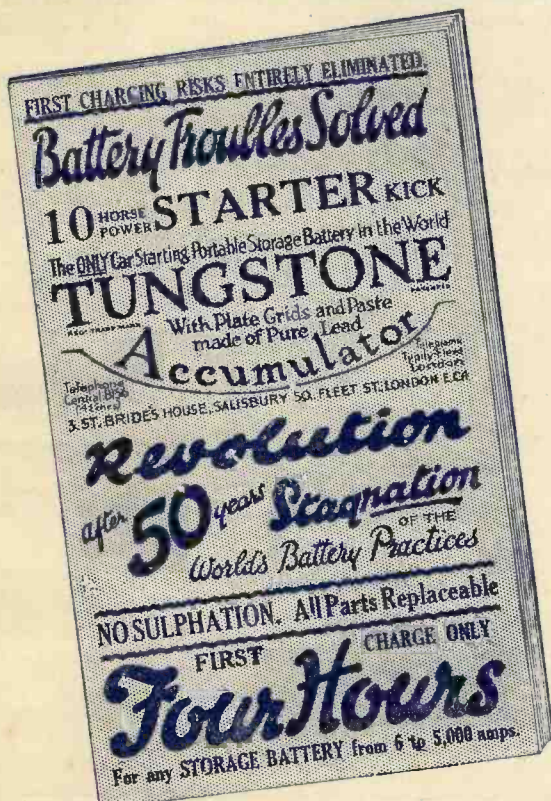

FREE FOR THE ASKING

112 Pages Battery Pocket Guide containing Special Illustrated Articles on—

MODERN BATTERY FAILURES

Ask Local Wireless and Motor Dealer or send Name on Postcard

The Independent Battery of the British Empire.

Tungstone Accumulator Co., Ltd., 3, St. Bride's House, Salisbury Square, London, E.C.4

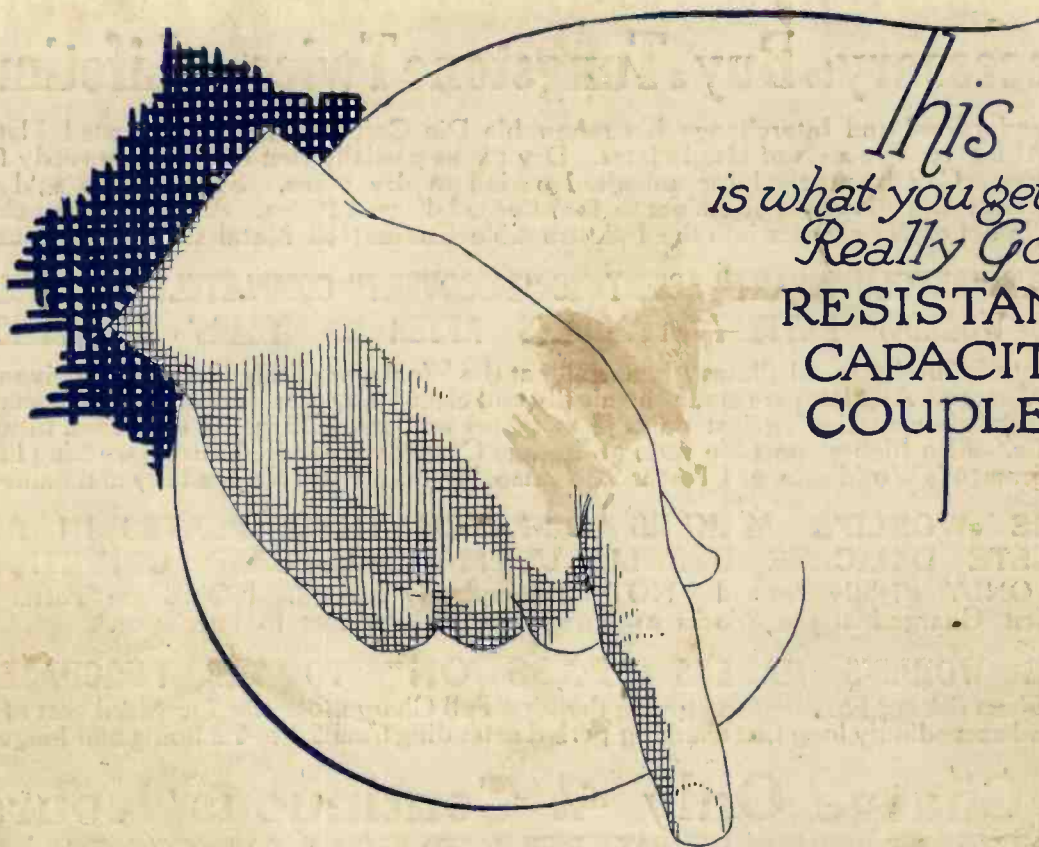

This
is what you get with a
Really Good
RESISTANCE
CAPACITY
COUPLER



Type A. Suitable for use after Valves with A.C. Resistance (Impedance) of 15,000 - 40,000 ohms .. **20/-**
 Type B. Suitable for use after Valves with A.C. Resistance (Impedance) of 30,000 - 100,000 ohms .. **22/6**
 Write for our new Booklet "Low Frequency Amplification," Price 1/-.

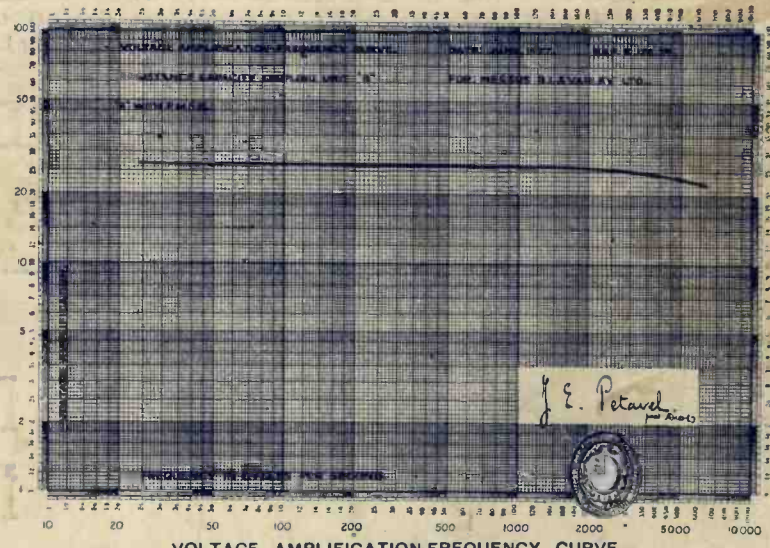

Uniform Amplification at all frequencies
 The efficiency of this perfectly designed component is backed by the authoritative seal of the National Physical Laboratory. The new R.I. and Varley Resistance Capacity Coupler is beautifully finished, and every detail is perfectly matched and accurately balanced.
We have specialised in every form of L.F. Amplification and invite you to write for our leaflet "L.F. Transformers" (free), giving particulars of our new Straight Line Super Transformer.



THE MARK OF BETTER RADIO

Kingsway House, 103, Kingsway, London, W.C.2.

Telephone: Holborn 5303