

The Wireless Constructor

6^D
MONTHLY

EDITED BY
PERCY W. HARRIS, M. I. R. E.
Vol. IV. JUNE, 1927 No. 8

In this Number
How to Build

a Short-Wave

“**RADIANO**”
TWO VALVE
SET”



NOW you may have all the advantages of the wonderful P.M. Filament in new special P.M. Valves for resistance capacity amplification *

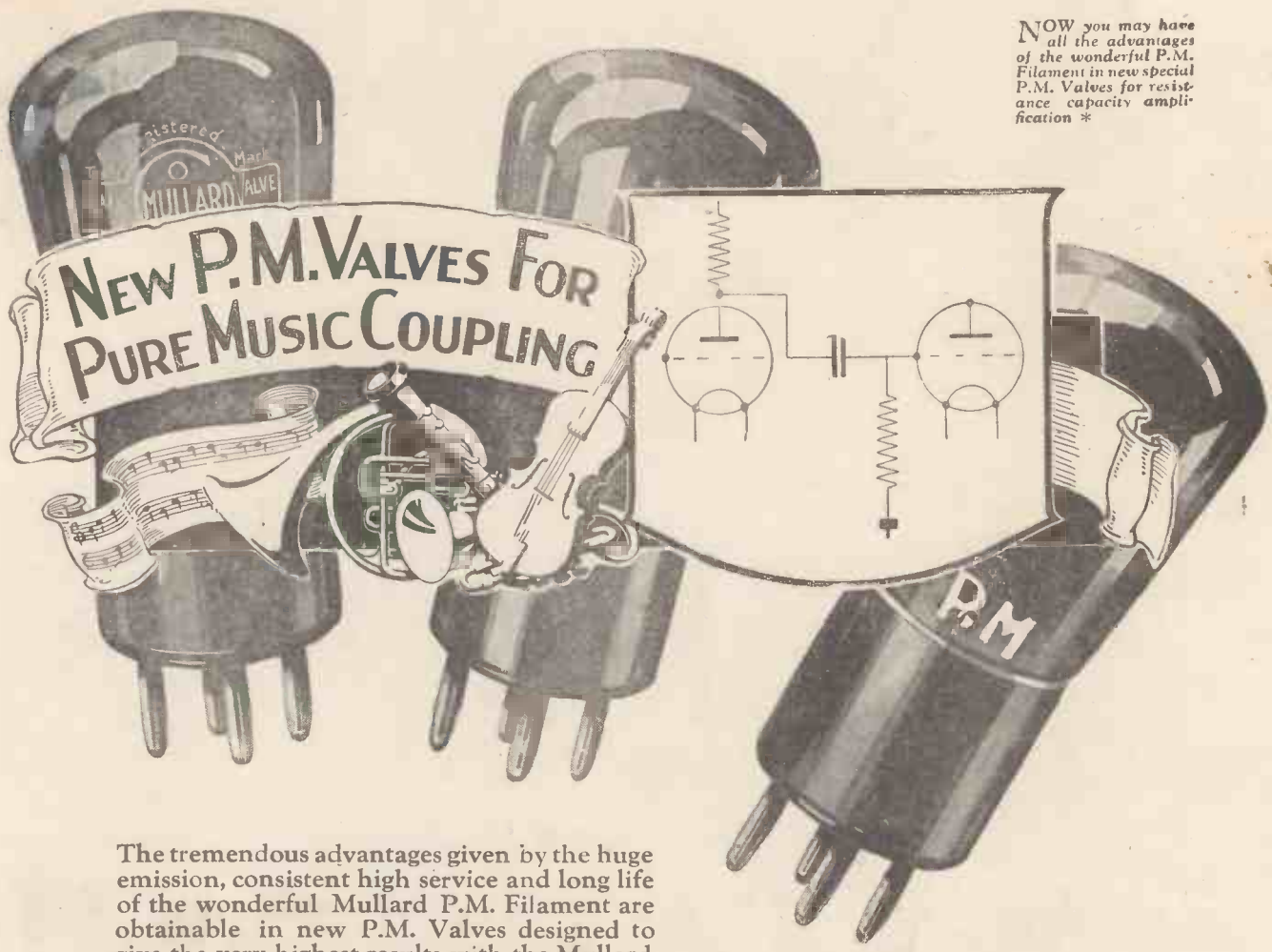

The tremendous advantages given by the huge emission, consistent high service and long life of the wonderful Mullard P.M. Filament are obtainable in new P.M. Valves designed to give the very highest results with the Mullard Pure Music Coupling (the ideal method of low frequency amplification approved by the Mullard Engineers and employed so successfully in Mullard P.M. Receivers described in "Radio for the Million.")

These new P.M. Valves are available for 2 volt, 4 volt and 6 volt accumulators. Apart from absolute purity in music and speech reproduction, abundant volume is obtained and H.T. Battery consumption is considerably reduced.

Let these new Mullard P.M. Valves bring you unequalled results in the resistance coupled stages of your receiver, and give you the master service and long life universally associated with the valves with the wonderful Mullard P.M. Filament.

Obtainable from all Radio Dealers

**British Made
in a
British Factory.**

Mullard

THE MASTER VALVE

- For 2-volt accumulator
 - P.M.1 H.F. 0.1 amp. 14/-
 - P.M.1 L.F. 0.1 amp. 14/-
 - * P.M.1A (Resist. Capacity) 0.1 amp. 14/-
 - P.M.2 (Power) 0.15 amp. 18/6
- For 4-volt accumulator or 3 dry cells
 - P.M.3 (General Purpose) 0.1 amp. 14/-
 - * P.M.3A (Resist. Capacity) 0.1 amp. 14/-
 - P.M.4 (Power) 0.1 amp. 18/6
- For 6-volt accumulator or 4 dry cells
 - P.M.5X (General Purpose) 0.1 amp. 14/-
 - * P.M.5B (Resist. Capacity) 0.1 amp. 14/-
 - P.M.6 (Power) 0.1 amp. 18/6
- Super power valves for last L.F. Stage
 - P.M.254 (4 volts, 0.25 amp.) 22/6
 - P.M.256 (6 volts, 0.25 amp.) 22/6

CONTENTS

	Page		Page
The Editor's Chat	75	The War Between the Music Halls and the B.B.C.	103
A Short Wave "Radiano" Set	77	The Resistance Three	105
Cartoon	84	Further Notes on the Trickle Charger	110
In Lighter Vein	85	Chats at the Work-Table	116
New Lamps For Old	87	Are Valves Improving ?	122
Savoy Hill Happenings	91	What's New	126
More About the "Signal Box"	93	Fill Up Your Battery Card	130
Further Radiano Successes	96	Our News Bulletin	132
A Super-Het for the Short-Wave Enthusiast	97	Some Practical Notes	142
Within the Vacuum	102	Comparisons Made Easy	144

EDITED BY
PERCY W. HARRIS, M.I.R.E.

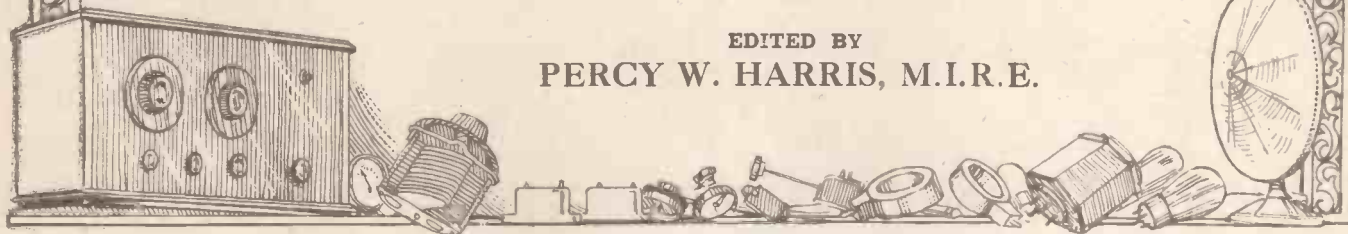

NEW MARCONI 4 VOLT ECONOMY VALVES

Outstanding features—very low filament consumption—only 1 ampere—remarkably rigid construction, and high standard of performance.

D. E. H410. D. E. L410. D. E. P410.
14/- 14/- 18/6

A high magnification valve for radio frequency circuits where some method of stabilising is used; for resistance capacity amplifiers; also an excellent detector.

Fil. volts 4.0 max.
Fil. current 0.1 amp.
Anode volts 150 max.
Amp. factor 40
Impedance 70,000 ohms.

A general purpose valve for radio frequency circuits, for grid rectification and in the first audio-frequency stage with choke or transformer coupling.

Fil. volts 4.0 max.
Fil. current 0.1 amp.
Anode volts 120 max.
Amp. factor 13
Impedance 14,000 ohms.

A power valve for last stages of receivers operating loud speakers. Will handle enough power to fill a large room.

Fil. volts 4.0 max.
Fil. current 0.1 amp.
Anode volts 120 max.
Amp. factor 6.25
Impedance 6,250 ohms

Full particulars and characteristic curves of these three new Marconi 4-volt valves on request from your dealer, or direct from

THE MARCONIPHONE COMPANY, Ltd.
Head Office:—210-212, Tottenham Court Road, W.1
Regd. Office:—Marconi House, Strand, London, W.C.2

Cossor

—the melody maker
**gives
you**



The sweet high notes
of the Violin



The liquid tones of
the Cornet



The throbbing of the
Drums



The majesty of the
'Cello

Cossor Valves are
now available for
2, 4, and 6 volt
Accumulators in a
wide range of types.



The rich harmony of
the Piano

USE the new Cossor Valves and enjoy the thrill of true-to-life Radio. No longer an inanimate and mechanical reproduction, but living music—exactly as it sounds in the studio and the concert hall. Hear every instrument in all its natural beauty. No harshness—no discordant sounds—no distortion. The underlying reason for such marked

superiority of tone and volume lies in the Kalenised filament—an exclusive Cossor feature. No other valve gives such purity of reproduction and long service with such a meagre consumption of current. Your Dealer stocks them—let him advise you which types are best suited to your Receiving Set.

The valve with the Kalenised filament

The WIRELESS CONSTRUCTOR

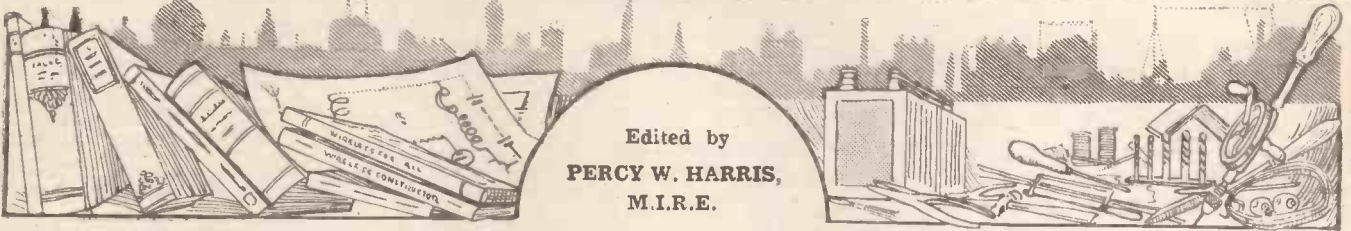

Published by the Amalgamated Press, Fleetway House, Farringdon Street, E.C.4.

THE EDITOR'S CHAT

Percy W. Harris, M.I.R.E., the Editor of the "Wireless Constructor," discusses the romance of short-wave reception, and has something to say about the contents of this issue.

HAVE you yet joined the ranks of those who keep a second set especially for short-wave work? If not, I strongly advise you to lose no time in doing so, for such receivers are simple to make, surprisingly sensitive, and wonderful distance getters. More and more stations are coming into the very short wave regions. Every night there is something of interest to be heard, while, if you take the trouble to learn the Morse code, you can pick up signals from amateur transmitters as far distant as Australia and New Zealand.

Amateurs' Pioneer Work

All wireless is tinged with romance, but short-wave work most of all. Heinrich Hertz, pioneering in his German laboratory to produce the first artificially-created wireless waves, made apparatus utilising a wave-length of a metre or two. Marconi, with his primitive apparatus in an Italian garden, used waves of a somewhat greater length; and as commercial wireless came into being the wave-lengths became longer and longer. The early crude and practically untuned ships' sets used a wave round about 100 metres long, and when more accurate tuning came into vogue, 300 and 600 metre waves were adopted. Meanwhile, long-distance work with higher powers was adopting longer and longer waves until, when transatlantic telegraphy became commercially practicable, the wave-lengths used could be measured, not merely in metres, but in miles, a ten-mile wave-length being quite common!

But what was the story on the amateur side? Being desirous of working for themselves, private experimenters obtained permission to transmit on wave-lengths of their own. As the professional tendency

in England, so that the U.S. amateurs were able to progress far more rapidly than we could do. One day they conceived the wild idea of attempting transatlantic communication on the $\frac{1}{2}$ -kilowatt power allowed them.

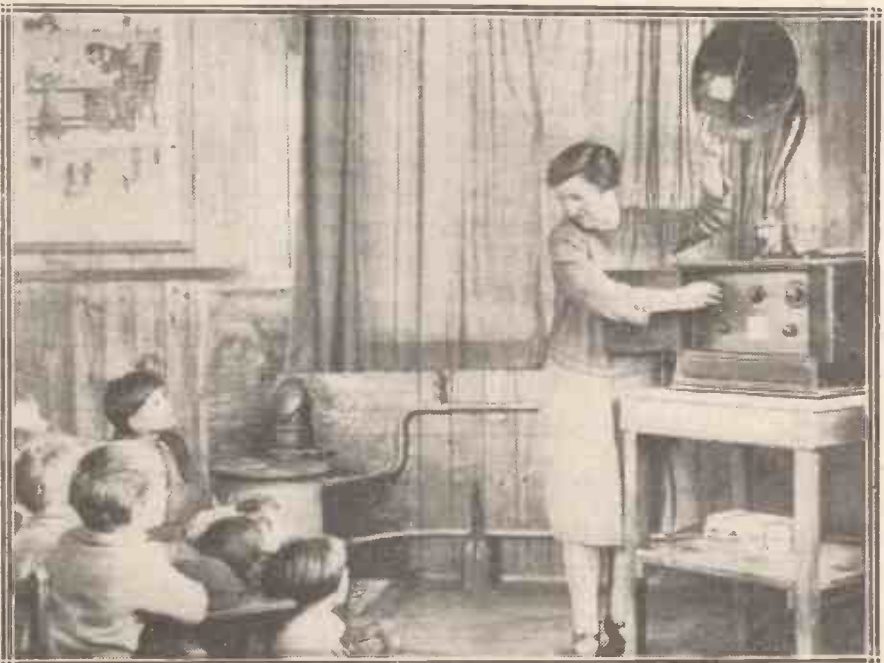

The children at the Stow St. Mary School, Essex, listen to the children's hour from 3 I. O.

was all towards the use of longer wave-lengths, it was assumed by the authorities that short waves were useless, especially for long-distance work; and so, after a short period of 1,000 and 700 metre licences, the 200-metre band was graciously given to the amateur. It so happened that experimental facilities were much more freely granted in America than

Early Short-Wave Experiments

Professional radio engineers on both sides of the Atlantic openly laughed at the idea, pointing out that wave-lengths below 300 metres were valueless for long-distance work; and if by any remote chance signals should be heard on this side of the Atlantic, it would be purely in the

THE EDITOR'S CHAT

—concluded from previous page.

nature of a freak. Most of them, however, disbelieved that even a freak success was possible.

The winter-time was chosen for the first experiments, which, however, were a failure, bringing a chorus of "I told you so's" from "superior" people. The following year a further attempt was made, and I well remember Paul Godley, the famous American experimenter, coming over here with American apparatus to see whether it were possible to hear American "hams." He brought most elaborate apparatus, and succeeded; but so did a number of English amateurs with far simpler apparatus, and thus the great attempt at spanning the Atlantic with low-power, short-wave wireless signals was a success.

Two Years Ago

When amateur transmissions came down to 100 and 80 metres, most astounding achievements were recorded, for it was found that the world could be spanned with almost negligible power. I remember, two years ago, sitting in the laboratory in which I am writing this article, at the key of a transmitter using a receiving valve as oscillator and an input power of exactly 10 watts. I had already established communication with amateurs in Europe up to 1,000 miles distant, using this low power, and was anxious to get still further afield. Late in the evening I suddenly heard quite a clear signal from some distant station calling a Canadian amateur in Morse, and, although I could not hear the Canadian reply, I could follow everything transmitted by the man who was calling him. After a little time the unknown station signed off.

I had noticed his call letters, so I gave him a call. This was promptly answered, and for nearly half an hour we were in communication with one another. My fellow ham was in Mosul, Mesopotamia, some three thousand miles away! The energy consumption of my transmitter was exactly a tenth of that needed to run the electric soldering iron with which I had constructed it! Nowadays short-wave work has been adopted for professional wireless, and the pioneer work of the experimenter fully justified.

A Short-Wave "Radiano" Set

One of the most successful receivers ever published in the WIRELESS CONSTRUCTOR was that called "Australia on Two Valves." This month I am showing you how to build a "Radiano" short-wave receiver. Only two valves are employed, but it is so sensitive that on almost any night you can hear Pittsburg and Schenectady direct. Why not build it for yourself as a companion to any other receiver you have? I can promise you many hours of enjoyment with it.

For the home constructor of experience I can recommend the remarkably simple and efficient short-wave super-heterodyne described by Mr. L. H. Thomas, an ardent short-wave enthusiast who is well known to WIRELESS CONSTRUCTOR readers.

Another important contribution for the reader who rightly attaches great importance to perfect reproduction from his nearest station deserves special mention. This is the "Resistance Three," by Mr. A. Johnson-Randall—a 3-valve receiver which has been designed to give a high degree of purity of reception from the local station.

Next month particulars will be given of a 4-valve receiver of exceptional interest.

* READERS' RADIANO *
* RESULTS *

SIR,—I have just completed your "Radiano Three." I have used practically all Lissen parts—transformers, rheostats, switch, etc., and I must congratulate you. The volume on London is terrific, and reproduction is purity itself. There are stations all round the condenser (by the way, Brandes latest). The reaction control is smooth and fine. Altogether it is the best set I have constructed, and anyone can go straight ahead and build it with confidence. I am using two power valves in the last two stages, a P.M.2 and Stentor 2, working from 2-volt battery on just an ordinary aerial.

Yours faithfully,
L. P. HAYNES.
1, Bridge Road, Merton Abbey,
S.W.19.

The Radiano Silencer

SIR,—It is with the greatest pleasure that I write regarding the "Radiano Silencer" in the WIRELESS CONSTRUCTOR of April, 1927.

My set is detector and two L.F. As the crow flies I am situated about a mile and a half from the transmitting aerial. Now I can receive all British and quite a number of foreign stations on the loud speaker without the least interference from the local station.

Without the Silencer I can receive no other station while our local aerial is transmitting.

Wishing the WIRELESS CONSTRUCTOR every success.

Yours faithfully,
GEORGE M'LEAN.
152, Glanworth Drive,
Antrim Road, Belfast.



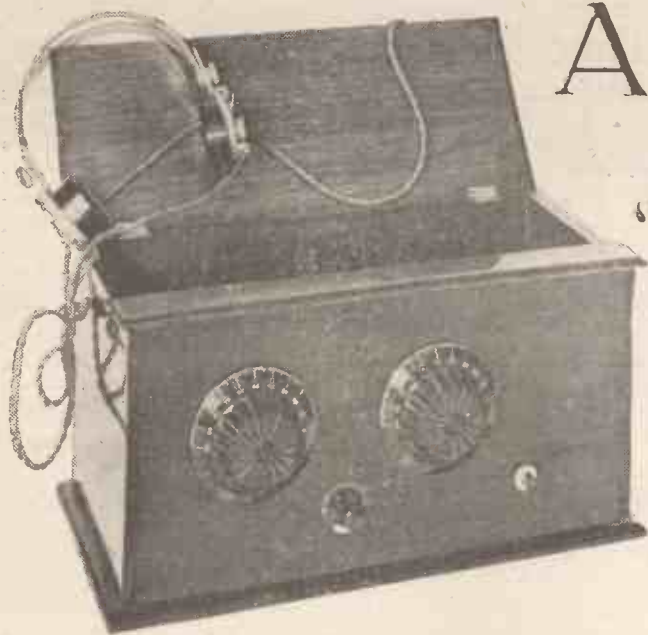

A SHORT WAVE "RADIANO" SET

by Percy W. Harris

M.I.R.E.



The popular new method of simplified set construction has been applied to the building of a short-wave receiver capable of giving extremely good results.

THE wonderful efficiency of short-wave communication makes it possible to build up a very simple receiver which will pick up signals over almost incredible distances. There is no need to place any H.F. valves in front of the detector for short-wave work, and a receiver consisting of a detector valve followed by one stage of note-magnification, is quite good enough to hear KDKA on 63 metres, and WGY on 33 metres, as well as a number of broadcasting stations which are experimenting on these short waves. In addition, amateur telephony and Morse signals from all over the world come pouring in. It is not difficult to learn the Morse code sufficiently well to identify amateur call signs, and when this is done a whole new field of interest is opened up.

Smooth Reaction

The purpose of this article is to tell you how to make a short-wave "Radiano" set capable of being tuned down to wave-lengths as low as 20 metres or less. The reception of 63-metre signals from KDKA is simplicity itself, and those of WGY only a very little more difficult. On the very short waves care in handling the tuning controls is necessary, but after a little practice even this becomes easy.

The most important point in the design of a short-wave receiver is the method of obtaining the reaction control, for unless this is extremely smooth and completely free from "plop," short-wave reception is impossible. Furthermore—and this is

an equally important point—the reaction increase and decrease must have a negligible effect on the tuning, which completely rules out the old swinging-coil reaction method. The only satisfactory way is generally called "Reinartz" reaction, although for accuracy it should be termed "Weagant" control.

As no one coil can be made to cover all the wave-lengths we desire to receive, it is necessary that the coils should be interchangeable, while, as I have shown in previous "Radiano" sets, and as many readers have found for themselves, conventional plug-in coils of the very small sizes can be used, for the highest efficiency single-layer windings of the correct

design are desirable. Fortunately there are available several good makes of interchangeable short-wave coils, and it is not a very difficult matter to make them for oneself. This month I am using a commercial form of interchangeable short-wave coil, but next month I will tell readers how they can make their own.

The Circuit Chosen

Fig. 1 shows the circuit. The aerial is connected to a coil which is pivoted, so that coupling may be varied, and is "untuned." For most of the short-wave work a five-turn aerial coil will be found sufficient. Coupled to this aerial coil is a fixed single-layer winding made up of two equal halves,

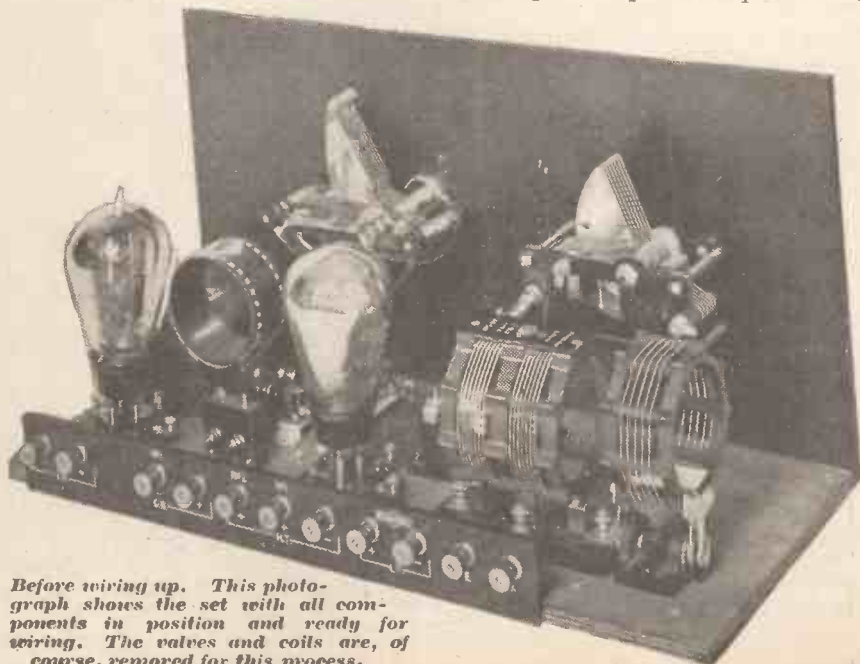

Before wiring up. This photograph shows the set with all components in position and ready for wiring. The valves and coils are, of course, removed for this process.

A Short Wave "Radiano" Set—continued

one serving as the inductance for the grid circuit (it is shunted by suitable variable condenser), and the other as the reaction winding. This is joined on one side to the plate, and on the other side to the reaction condenser, which is also variable.

To aid in the smooth control of reaction, the grid return of the detector valve is taken, not permanently to the positive leg of the valve, as is the more general practice, but to the slider of a potentiometer, so that the grid potential can be varied between zero and a maximum positive value depending upon the voltage of the accumulator used. I described a set in the first issue of the WIRELESS CONSTRUCTOR, using this form of grid variation, and more recently Mr. S. G. Rattee used it in the "Attaboy Two."

Low-Loss Valve Holders

Notice that the position of the radio-frequency choke is somewhat different from the usual. At this point let me say that there is no novelty in the circuit used, as the arrangement shown has been practically standard among short-wave enthusiasts for a year or more. Slight differences, such as the position of the radio-frequency choke, are occasionally adopted, but so far nothing has been found to improve upon the general arrangement given.

The rectified signals are passed through the radio-frequency choke and the primary of an L.F. transformer, the variations of potential set across which are applied to the grid of the note-magnifying valve. Telephones are used for reception—it is only on rare occasions that the strength of a two-valve set such as this will be sufficient to operate a loud speaker.

As the set is designed specially for short-wave work, it is necessary to choose certain components with particular care. For example, the valve holders must be of a real low-loss variety or the minute amounts of energy available will be lost. Valve holders which show up excellently

set, which requires all the components to be fitted with terminals, we are more limited in our choice of high-grade condensers. The Cyldon used in this set, the Brandes, as used in the "Radiano" Wave-trap, the Ormond, the Bowyer-Lowe, and the J. B., are a few suitable condensers which occur

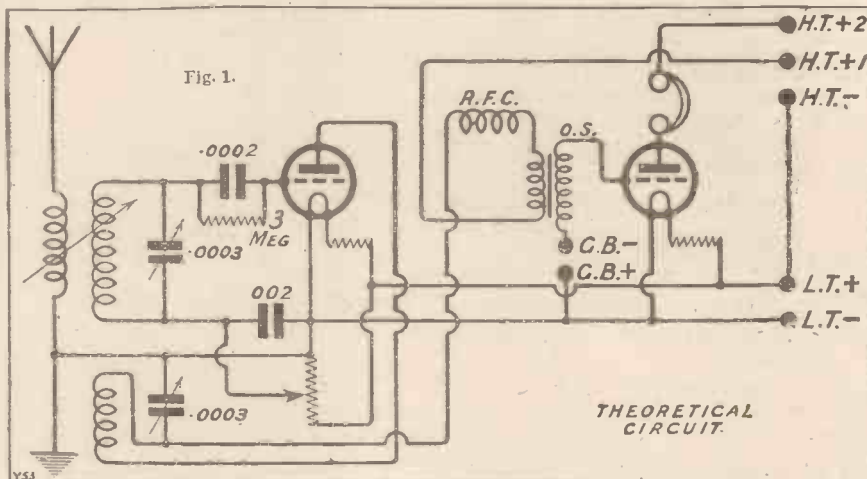

on the ordinary broadcast waves often prove hopeless on very short wave work. While those shown in this set are not the only holders that can be used, I have not found any better, as their design is such as to remove all solid material from between the sockets themselves.

Good Condenser Essential

The first tuning condenser is also very important. A really good quality condenser should be used here, as an inferior condenser will be very inefficient and noisy on short waves. Here again, many condensers which serve excellently on the ordinary broadcast band are unsuitable for short-wave work. In a "Radiano"

to me at the moment, and which I have found to be efficient on short waves. There are others, and the fact that I have omitted to name some does not necessarily mean that they are bad.

The reaction condenser can be quite an inexpensive pattern without any loss of efficiency, and the money saved here can be used to go towards a better condenser for tuning the first grid circuit. Again, as loud-speaker work of the highest quality is not aimed at (nor for that matter achievable), one of the lower-priced L.F. transformers can be used quite effectively if desired. Any good L.F. transformer will do.

The H.F. Choke

The remaining components are of standard pattern. It should be pointed out that the radio-frequency choke is preferably an interchangeable plug-in coil. Do not attempt to use one of the commercial radio-frequency chokes designed for the broadcast band. While the best of these will go down to 40 or 50 metres, they are not really designed for this work. Furthermore, you can buy two or three plug-in coils for use as radio-frequency chokes as cheaply as one of the commercial types of chokes, which in any case would probably be useless on the shortest waves this receiver will take. Choking problems are different on the broadcast band.

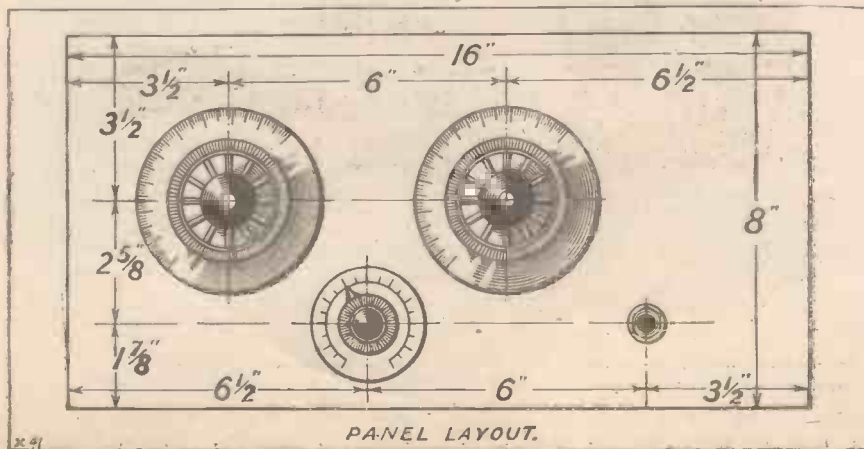

A Short Wave "Radiano" Set—continued

The short-wave Dimic coil is a single-layer winding on a skeletonised former, the winding being broken in

COMPONENTS REQUIRED

- 1 standard 16 × 8 in. cabinet. (Cameo, Caxton, Artercraft, Pickett, etc.)
- 1 16 × 8 × $\frac{1}{4}$ or $\frac{1}{8}$ in. panel. (Becol, Ebonart, Radion, Resiston, etc.)
- 2 variable condensers, .0003 mfd. (I have used Cyldon Mid-Line as the first and an Etherplus as the second. (See note in article re condensers.)
- 1 potentiometer. (Lissen, Igranic Precision, etc., or other well-known make.)
- 1 on-and-off switch. (Igranic, Decko, etc.)
- Baseboard, as provided with cabinet.
- 2 Antipong valve sockets. (Bowyer-Lowe. The first is the important socket, the second can be any socket which has previously given you satisfaction. It is not affected by the short waves.)
- 2 baseboard resistors to suit valves. (Etherplus, Amperite, Peerless, Temperite, Lissen, Magnum, etc.)
- 1 Dimic base.
- 1 Unimic base.
- 1 Dimic S.W.1.
- 1 Dimic S.W.2.
- 1 Unimic No. 5.
- 1 .0003 mfd. fixed condenser with clips and 2 megohm grid leak. (Any standard make.)
- 1 .002 mfd. fixed condenser. (Dubilier, Lissen, T.C.C., etc.)
- Baseboard-mounting coil socket with terminals.
- 1 L.F. transformer. (Any good make. That shown is a C.A.V. All-Purpose.)
- Terminal strip as shown, with terminals for aerial, earth, L.T. negative, L.T. positive, H.T. negative, H.T. positive 1 and 2, grid bias negative, grid bias positive and telephones.
- Finally, for appearance and convenience, two Radion 4-in. dials. These have a very large knob and are easily handled for fine tuning. A further improvement is to fit instead one of the excellent makes of vernier dials, although these are not strictly necessary. Of course, if the condensers are themselves fitted with vernier dials, all the better.

the middle and brought out to two spring clips, spring clips being fitted to each end of the winding also. The Dimic base has four terminals, two in the middle and one at each end. When the two middle terminals are joined the whole winding can be used as one, and incidentally the calibration marked on these coils is for the whole winding. In the present receiver I am using only half of the winding for tuning and half for reaction, so that the actual wave-lengths marked on

the coil should be ignored. For example, the S.W.1 coil is marked "70 to 150 metres with a .00025 mfd. condenser." This coil in the "Radiano" short-wave set goes down to a much shorter wave than 70, and the 63-metre K D K A transmission comes in at about the middle of the condenser.

The Unimic coil is a small single-layer winding of similar construction, and the Unimic base allows this to be moved backwards and forwards on a hinge, thus giving one the opportunity of varying the coupling, which is quite useful. The reaction winding and the grid-coil winding are fixed in relation to one another, and, as previously explained, reaction is controlled on the variable reaction condenser. The fixed relationship of the windings is one of the reasons why a variation of reaction makes comparatively little variation of tuning.

You will want half a gross of pinch-on tags and about 14 ft. of flexible wire to make the leads. Leads are shown full size in the accompanying drawings, and the method of making them is as follows.

Take your coil of flexible wire and measure off lead A against the chart. Cut off the exact length and bare

the point shown and an extra tag pinched on.

To wire up the set it is only necessary to screw tag A₁ under terminal A₁, and tag A₂ under terminal A₂, and so on until all the leads are in position. Make all your leads first and lay them on the table in order. You will then make sure of using all the leads.

Suitable Valves

Two-, four- or six-volt valves can be used, but the first valve should be one of the modern "high-frequency" valves, having a magnification of about 20 and an impedance of 15,000 to 25,000 ohms. These valves work better in this set than the conventional detector valves, as they come into oscillation more smoothly. The voltage on H.T. + 1 can be anything from 40 to 60, and on H.T.2 about 60 or 80. There is no point in making the voltage on this valve much higher when using telephones. It is also preferable to join up a 1- or 2-mfd. condenser across each H.T. tapping. To do this join one side of one of the Mansbridge condensers to H.T. + 1, and the other side to L.T. —. Similarly, join one side

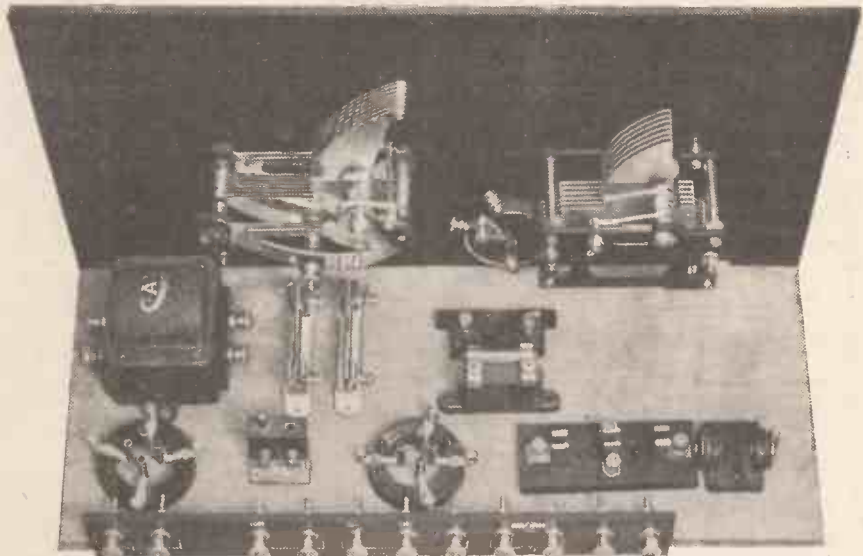

A good idea of the layout of components can be obtained from this illustration.

about a quarter of an inch of wire at each end. Lay the bared wire inside the clips of the tag and pinch firmly into position. The length of the wire is shown as the length of the wire itself, and the finished leads with tags will be longer than the line shown. Only one lead has more than two tags, and in this case the wire is bared at

of the other Mansbridge to H.T. + 2, and the other side to L.T. —. also.

I have not included these condensers in the set, as it is not necessary to have separate Mansbridge condensers for each receiver. I generally recommend that these condensers be left outside the set for general

A Short Wave "Radiano" Set—continued

experimental work. Grid bias should be used according to the figures given by the makers of the valve; $1\frac{1}{2}$ to 3 volts will usually suit.

Preliminary Tests

To test out this set, join up your batteries and telephones, put the valves in place, and as a trial put the S.W.1 coil in position with the Unimic 5 in its particular socket. As no terminals are provided on the Unimic coil base the brass tags are slipped into the spring clips which hold the ends of the Unimic coil itself.

Now place a No. 35 coil in the radio-frequency choke socket and set the slider of the potentiometer about half-way round. It is presumed that the on-and-off switch is "on." Do not join up aerial and earth yet. Set the reaction (right hand) condenser at zero and the tuning (left hand) condenser at zero also. Now listen in the telephones and slowly turn the reaction condenser towards its maximum position until you hear a rustling sound, which indicates that the set is in oscillation. Try various positions of the first tuning condenser and see

whether you can make the set oscillate freely and smoothly at all points.

It is probable that at one or other end of the scale the set will either oscillate freely with the reaction condenser at zero, or not at all at any position of the reaction condenser. This indicates that the value of the choke is wrong. If this is so, change from a 35 to a 25 for this band of waves. In fact, 25, 35, 40 and 50 coils should be kept handy for quick changes when necessary.

When the set is gently oscillating, and as you turn the tuning condenser

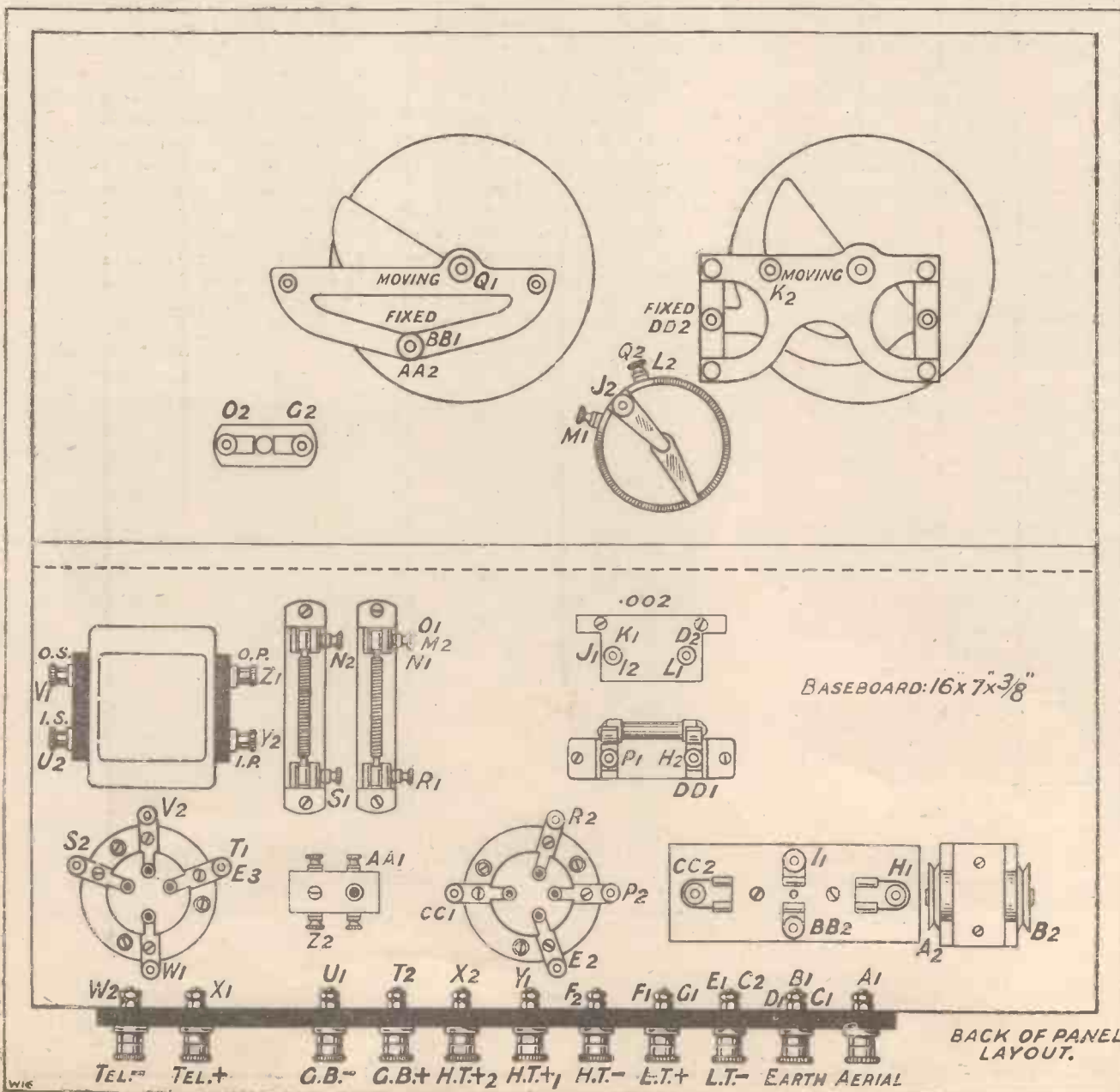

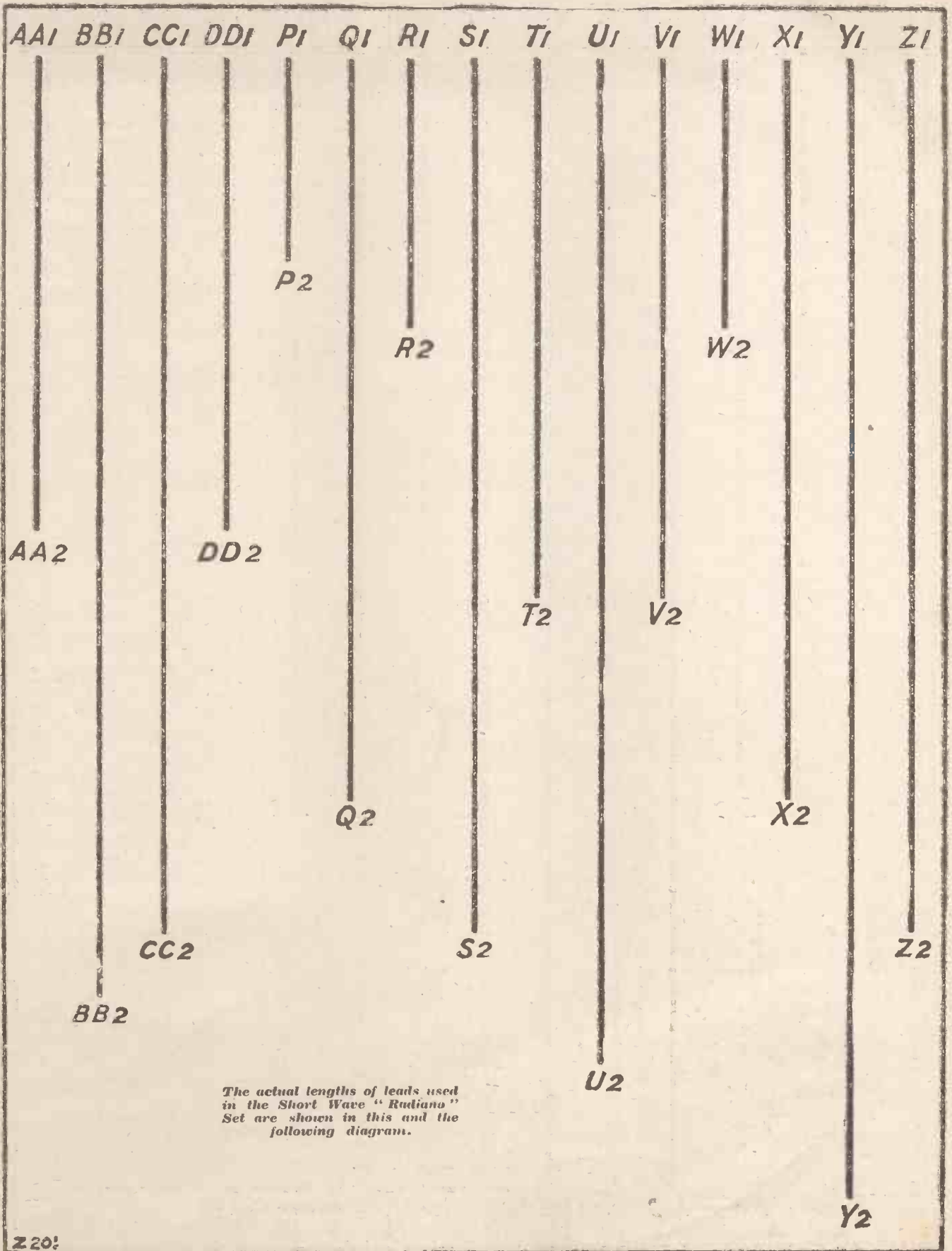

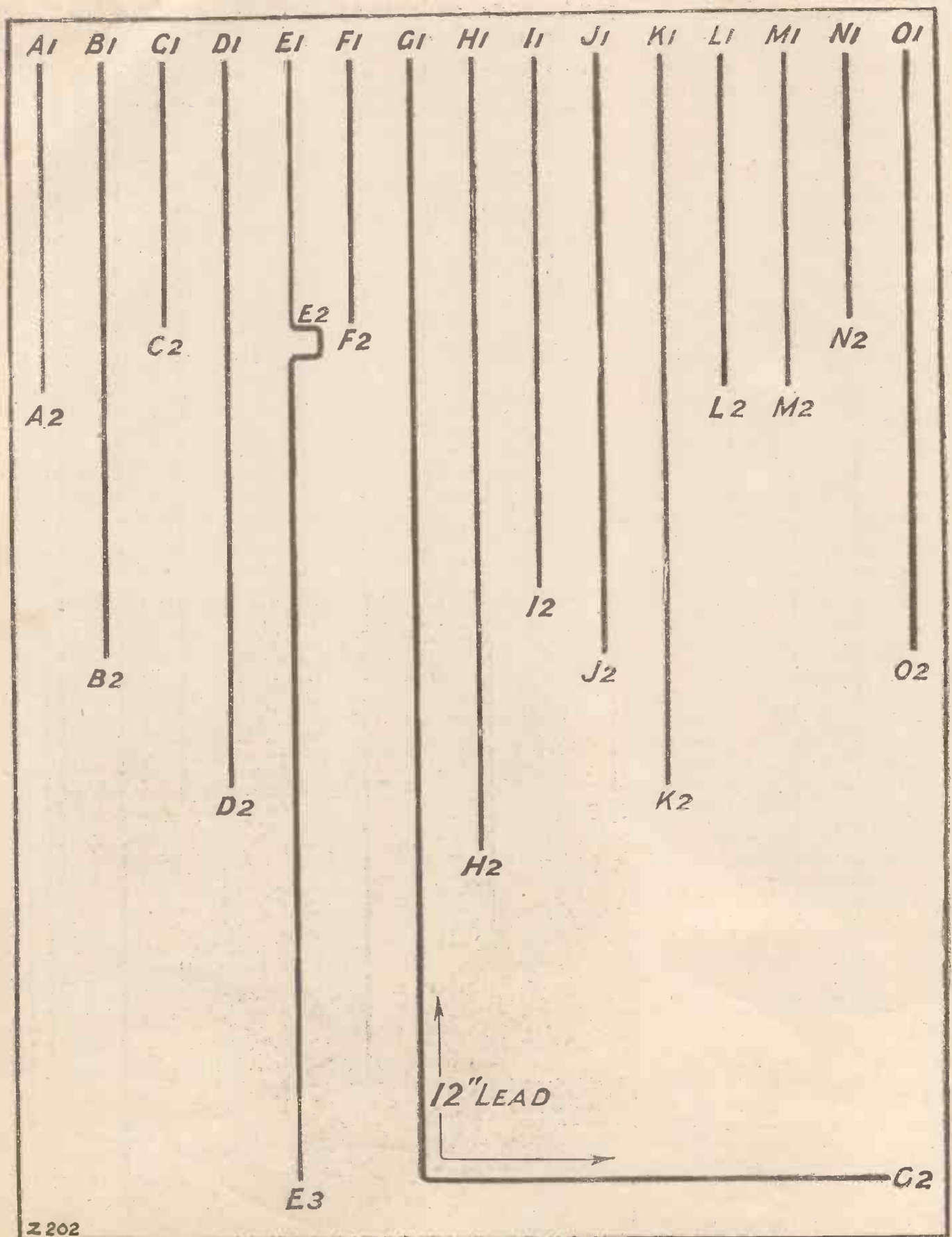

Z 202

A SHORT WAVE "RADIANO" SET

—concluded.

you will probably hear a large number of whistles, indicating continuous-wave stations. You will also be able to hear that they are sending Morse. The efficiency of short-wave reception is such that you will hear many stations quite loudly without any aerial or earth connected.

When you have become used to handling the reaction on this set (and in finding the best adjustment you should vary the potentiometer, as the reaction will probably be smoother to control at one end than at the other) you can also try varying the H.T. voltage on the detector.

Now join up aerial and earth and try the reaction control again throughout the scale. It is very probable that you will find a blank space where the set will not oscillate, due to the aerial tuning to that wave-length or to the wave-length you want to receive coinciding with a harmonic of the natural wave-length of the aerial. It is useful to have available a .0001 mfd. fixed condenser which can be inserted when necessary in series with the aerial coil to remove such "bad places."

Operation

The manipulation of a short-wave receiver is somewhat different from that of the normal, and there are many hints and tips I can give on how to get the best results. Next month such particulars will be furnished. Meanwhile, as a guide you should find K D K A on the S.W.1 probably somewhere between 40 and 60 degrees, and W G Y on the S.W.2 coil at about the same position. To pick up these stations make the set oscillate gently until you hear the carrier wave, and immediately you hear this slacken off the reaction slightly so that the set is not oscillating.

If you do not find the carrier wave quickly, be careful to see that everything is correct in your receiver before you start oscillating up and down the wave-band, thus causing a lot of interference to others who may be trying for the same station.

W G Y may be sometimes heard quite early in the evening, but generally both K D K A and W G Y, on their short waves, will be heard at their best after half-past ten or eleven at night. W G Y usually announces itself as 2 X A F, the experimental short-wave station of the G. E. C.

FOR SLOW- MOTION DIALS

IN certain cases it may be found that when slow-motion dials are fitted they cannot be made to lie tightly against the outer surface of the panel. This may be due to two causes. Some one-hole fixing condensers are provided with rather thick nuts for securing the spindle bush to the panel. Should the nut be too thick the slow-motion dial rests upon it and stands off a little from the surface of the panel. The remedy is either to obtain a thinner nut or to file down the existing one.

Preventing Slip

It may happen, again, that the threaded part of the bush is rather long, for some makers design one-hole fixings so that they may be used in panels up to $\frac{3}{8}$ in. in thickness.

Here the cure is to slip a $\frac{3}{8}$ in. washer (or possibly two of them) over the

bush before it is put through the hole in the panel. The protruding portion is then quite short, and clears the underside of the dial.

No Backlash

Many kinds of slow-motion dial are prevented from turning by a stud fixed in the panel and engaging in a slot in the underside of the body of the dial. A method that the writer has found very satisfactory for fixing such dials absolutely rigidly is as follows: With a small round file a hollow about $\frac{1}{8}$ in. in depth is cut in the edge of the body of the dial at any convenient point. The dial having been mounted in the ordinary way, a No. 36 Morse drill is placed in this notch and a hole is made with it through the panel. A round-headed 4 B.A. screw is now inserted, a nut being run on and tightened hard down.

The underside of the head of the screw bears upon the face of the dial, whilst the threaded portion fits tightly into the notch. The dial is thus absolutely prevented from making any movement whatever in either direction, and all backlash is eliminated.

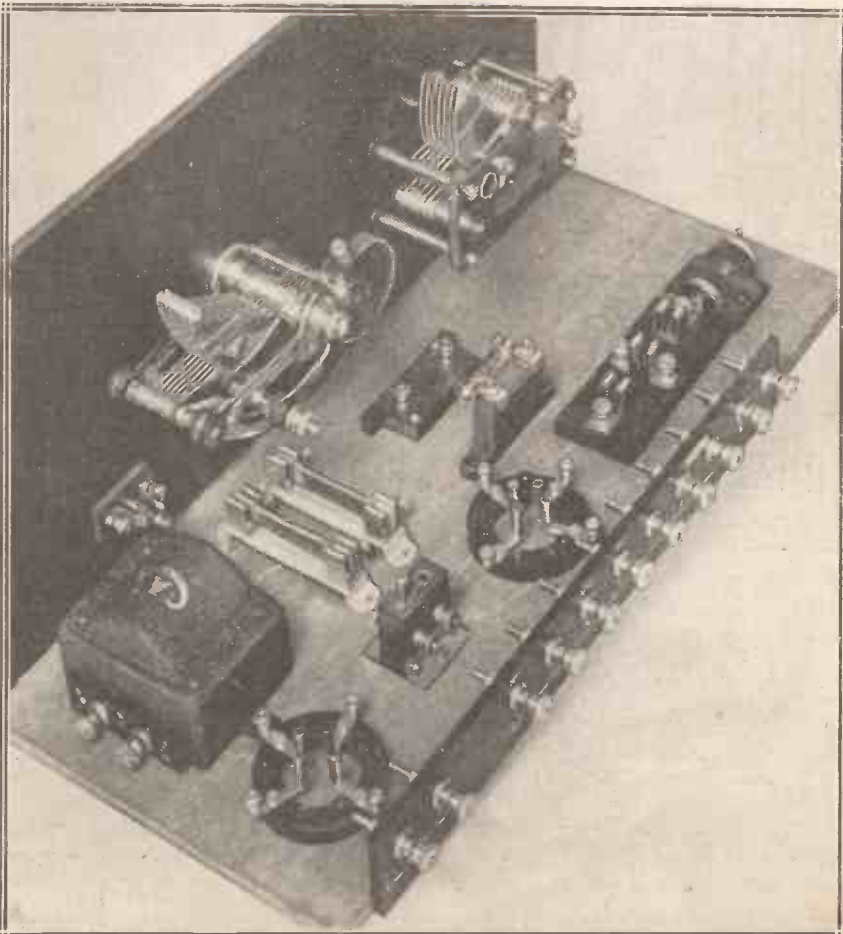

A view of the receiver taken from the L.F. end, showing the arrangement of the L.F. transformer, filament switch and coil mounts.

- SIMPKIN LOOKS A HARMLESS SORT OF CHAP



- HE'S KIND TO DUMB ANIMALS -



- GENEROUS TO A FAULT - A GOOD HUSBAND AND FATHER -
NEVERTHELESS - EVERYMAN'S HAND IS AGAINST HIM - BECAUSE



THE BLIGHTER WILL OSCILLATE !!!

Edn Shaw '27



THE curious thing about fellows like Primpleson is that when they come to build new receiving sets they cannot do it quietly and privately as you or I would; they must needs call in their friends at every stage, nominally to ask their help, but actually to show their own superiority by imparting information on every conceivable subject.

One should always be careful, I think, about asking for assistance, especially in a place like Mudbury Wallow, where people are as a rule only too ready to lend a hand in anything that concerns wireless. Only the other afternoon, for example, Pottleson, finding that I was out when he dropped in to see me, spent a whole half-hour in improving my set, and it took me the whole evening to find out what was the matter with it.

Poor Sir K. N. Pepper was nearly killed by similar kindness. I met him in the High Street one day crawling along and looking rather



Spent a whole half-hour improving my set.

like the fellow in one of those every-picture-tells-a-story advertisements. I hate seeing a man looking miserable, so naturally I gave him a cheerful whack on the back. I mean, how was I to know that he had lumbago? Anyhow, when he had relieved himself by talking for a bit mostly in asterisks, he calmed down quite nicely and told me all about the terrible handicap under which he was labouring.

A Magnificent Aerial

It appeared that with that fine fresh enthusiasm that always distinguishes the beginner, he had put all the wire that he could into his aerial when he had erected it some time previously. He was now frightfully worried about the lack of selectivity that his apparatus showed.

"If only I could shorten that wretched wire by five yards," he said. "I'd be absolutely all right. But with this wretched lumbago I simply cannot tackle the job. I wonder if you would be kind enough to come in this evening and do it for me?" Though I was desolated at doing so, I had to tell him that I had already promised that evening to help Miss Worple with the spring-cleaning of her set. "Tut, tut," growled poor Sir K. N. Pepper, "I seem to be having no luck just now. Every one of the fellows that I have asked, and you are the fifth, has been booked up in some way or other."

I Lend a Hand

As luck would have it Miss Worple telephoned during the afternoon to say that she was prostrated by an attack of poet's brainstorm, so that I found myself unexpectedly free. Seizing a pair of cutting pliers I went round to Sir K. N. Pepper's garden to see what I could do to help him. On examining the aerial it struck me that he was carrying his craze for shortening it rather far, for the roof portion consisted entirely of rope, and the aerial itself was only a vertical wire going up to one of the insulators at the house end. However, since he desired it to be shortened, shortened it should be. On letting down the halliards I found that the vertical piece was just six yards long.

I therefore lopped off five of them, tied a piece of cord to the remaining bit, fixed this to the insulator and hauled up taut. As I wanted the improvement to be a surprise, I did not go to the house to announce that I had carried it out.

On my way back I met Captain Bucket, who remarked with a smile that Sir K. N. Pepper would be agreeably surprised when he came to use his apparatus that evening. "I expect he will," I said. "But how do you know?" "Know?" cried Captain Bucket. "Why, of course, I know, I did it myself. He asked me this morning to go round, and I told him then that I couldn't manage it; but this afternoon I had

half an hour to spare— Why, hullo, Mr. Tosher, what are you looking so pleased about?"

"Pleased?" bleated Aloysius. "Well, perhaps, if I may say so without undue immodesty, that emotion arises from the delightful consciousness that I have been able to do a good turn in my small way to an old friend. Only this morning I was asked by Sir K. N. Pepper to give him a little assistance with his aerial. I had most regretfully to decline since a mothers' meeting required my presence. At the last moment, however, the vicar decided to preside himself, thus releasing me. Need I say that I simply flew round to our good friend's garden, took off the required five yards, and departed, saying nothing about it since I desired to give him a little surprise."

Further Assistance

It was at this moment that we ran into Goshburton-Crump, who was carrying in one hand a pair of cutting pliers, and in the other a little coil of 7/22's. "Going to stick up a new aerial?" I inquired. "Ah, no," cried Goshburton-Crump. "Early this afternoon I discovered that, contrary to expectations, it would be possible for me to go round to Sir K. N. Pepper's to do a little job that he had begged me to undertake on his behalf. He wanted five yards taken off his aerial, and these are, so to speak, the spoils of the chase."



I lopped off five of them.

"On my way back I called upon Glump, with whom I have been since then. My only fear is that Sir K. N. Pepper will now find his set too selective, for when I reached Glump's house I learnt that he had preceded me at the task, so between us we have reduced the length by ten yards instead of five."

In Lighter Vein—concluded

Captain Bucket and I exchanged glances.

"I have a sort of feeling," I said, "that poor Sir K. N. Pepper is going to find a mysterious fault when he switches on to-night. I think that we had better suggest to Primpleson, without, of course, telling him anything of our suspicions, that he should go round to Delhi Villa to see whether the invalid requires any assistance."

When I met Primpleson next morning he was looking both pained and puzzled. He could not understand, he told me, why Sir K. N. Pepper had flown at him like a man-eating tiger, when, on being ushered into the den, he had announced in the friendliest possible way that he had come round to see if he could give any help.



Sir K. N. Pepper had flown at him like a man-eating tiger.

And that brings me back to that new set of Primpleson's that I was talking to you about. When he had got us all assembled and had told us how glad he was to see us since he knew that we should be so helpful, he straightway took the floor and talked for about an hour on the wonders of the thing. "You see," he remarked at length, "the output of the rectifier gives the original signal magnified thirty-three times. Now my first L.F. stage will give a magnification of seventeen, so that the total of these valves in use will thus be seventeen multiplied by thirty-three, that is——" He seized a scrap of paper and began to hunt through his pockets for a pencil.

An "Easy" Method

"My good fellow," exclaimed Goshburton-Crump, "you don't mean to tell me that you work out a sum of that kind with pencil and paper? That would be an appalling waste of time. Now let me show you how to find the answer in a jiffy without making a single calculation." From his pocket he produced a thing that looked like a cross between a trombone and a foot rule. He pushed the

to-and-from thing up and down several times, said "tck-tck," then pulled it right out, turned it over and shoved it back again.

Then, with a smile of triumph, he handed the thing to me. "My eyes," he said, "are not quite as good as they were, but if you will kindly read off under the 1 on the scale marked C we shall obtain the answer."

"D. Quot: plus one," I read. Goshburton-Crump looked annoyed, lugged out his spectacles, seized the contrivance, examined it and proceeded to do some more conjuring. The thing must have been pretty well red hot when Pottleson said with a superior smile that Goshburton-Crump's jiffy must be just about up.

We Try Logs

"I never thought much of slide-rules," he told us. "By far the simplest and best way of doing a multiplication sum is to make use of logarithms." Had Primpleson got a book of log tables? Primpleson hadn't, but Mr. Glump felt sure that he had one somewhere at home, and volunteered to go and fetch it. We spent the half hour or so that elapsed before his return in telling Primpleson how rotten his set was and how easily he could make improvements in every circuit. When Mr. Glump got back he handed a little thin brown book to Pottleson, who told us that in less than two ticks we would understand the real meaning of the old proverb, "As easy as rolling off a log." He said that it would be best for one of us to work out the simple calculation under his directions so that we should all see how it was done. "Turn to the table," he said, "and find first seventeen and then thirty-three on the column on the left and then you will get the logs from the other columns. I flicked over the pages and came to a table labelled Anti-logs.

As the title exactly expressed my feelings it seemed to be just what was needed. Opposite seventeen I found 1479, and this under Pottleson's directions I wrote down, putting a one and a decimal point in front of it. Pottleson spent the next half hour in telling us all about characteristics and mantissas and things.

When he was at length ready to get on I looked out thirty-three in the same way and wrote down 1.2938.

"Now add up," instructed Pottleson,

I found that the answer was 2.3617.

"We now look this up in the Anti-log tables" said Pottleson reaching for the book, which I handed him open at the right place, "and the answer is 230. Simple, isn't it?" We hastened to point out to him that it did not look quite right. He seized the paper upon which I had written down the figures, verified my addition, and retired to a corner with a ruffled look. There must, he informed us, be some stupid mistake.

"Meantime," I said, "perhaps I may be allowed to show you my own rapid way of doing multiplication sums. I call it the graphic method. Has anybody got a sheet of squared paper? After much searching through drawers Primpleson produced the required article, and I gathered them round for the demonstration. Pottleson and Goshburton-Crump decided to leave their particular little problems for the moment and to join the throng. "This," I said, "is the simplest, quickest and most certain of all ways of multiplying. I make a dot at the corner of this square.

A Final Attempt

"Now I go seventeen squares upwards and make another dot. Thence I proceed horizontally for thirty-three squares and make a third dot. I now drop seventeen squares down, marking my fourth and last dot. I rule lines joining my dots, obtaining, as you see, a very pretty rectangle. All that Tootle, whom I shall ask to complete the calculation for me, has to do is to count the squares within the rectangle, and there you are."



Going to stick up a new aerial?

If Tootle had not kept on losing count, and if in the excitement of the moment I had not taken in eighteen instead of seventeen squares, we would have had the right answer in the twinkling of an eye. It just shows you how much better these common-sense methods are than all your slide-rules and logs and things.

WIRELESS WAYFARER.



HIGH up in the list of sets for which I have been asked to give modernising particulars stands the "Special Five," a multi-valve receiver first described in November, 1925. The design was the result of a number of investigations and tests I had made in the United States during the summer, for which reason it seems to have aroused more than ordinary interest.

The theoretical circuit is given in Fig. 1, which shows two H.F. valves, a detector, and two note-magnifying valves, the first of these being transformer and the second resistance coupled. Two points of special interest in the set were the neutralising circuit and the special H.F. transformers used to apply the principle.

The Circuit Employed

That the theoretical circuit is really efficient may be gauged from the fact that nearly a year later it was adopted for the "Solodyne," the only essential difference being that in the "Solodyne" reaction on the detector was applied by the Reinartz method, whereas in the "Special Five" I had obtained reaction by upsetting the neutralising balance. So far as the audio-frequency side is concerned, the "Solodyne" has two transformer-coupled valves, whereas in the "Special Five" one of the L.F. valves had resistance coupling. Personally I prefer one transformer and one resistance coupling to two transformers, but this is a matter of taste.

In the practical make-up, of course, the "Solodyne" and the "Special Five" are quite different, as the former instrument utilises a triple-gang condenser, which had not been developed at the time of the "Special Five," together with more efficient transformers. In this regard it may be of interest to quote the following paragraph from

Some further notes on the modernisation of one of the most popular sets of the past,

THE "SPECIAL FIVE."

By **PERCY W. HARRIS, M.I.R.E.**
(Editor of the "Wireless Constructor.")

my original description of the "Special Five": "The final point refers to the question of the tuning controls. In many of my designs I have used a double condenser requiring matched

But in many cases trouble has arisen through bad matching. We have by no means reached finality in H.F. transformer design, in view of which I have designed the present receiver so that once it has been made all kinds of H.F. transformers can be experimented with. For this reason separate condensers are used for each of the H.F. stages. There is then no possibility of trouble with regard to matching, and the widest flexibility is obtainable."

As predicted, H.F. transformers have developed considerably in efficiency since the "Special Five" was produced, and a whole range of really excellent H.F. transformers is now available, the "Special Five" windings now being known as the standard "split primary." For this reason it is an extremely simple matter to bring the "Special Five" right up to date in such a way that it will quite worthily hold its own in competition with many far more "modern" receivers.

Some Simple Alterations

The actual structural changes in the receiver are very simple to make, and several alternative methods are possible. So far as the detector and audio-frequency stages are concerned, there is no need to make any change, unless, of course, the reader cares to use one of the latest L.F. transformers of high quality, in place of the one he may have fitted at the time. Much better valves, of course, are now available both for the H.F. and L.F. sides, and a change of valves alone can be made to effect very considerable improvements.

At the H.F. end the changes I suggest are the following:

"NEW LAMPS FOR OLD."

To the Editor,
WIRELESS CONSTRUCTOR.

Sir,—Your article entitled "New Lamps for Old" came at a most opportune time. I was considering how I could make my Anglo-American set, which has given such good results, more selective and up to date, when the WIRELESS CONSTRUCTOR settled the difficulty. After reading the article I immediately rewired the set, including new condensers and screened coils. The results are that I consider I have a set second to none. It is now very selective and extremely powerful. The distant stations come through wonderfully clear and loud, and I am extremely pleased with the results achieved.

Many, many thanks for publishing such a good circuit. At first I had slight distortion when using full power, but by changing the last valve, which was a Marconi D.E.5, for a "super" valve S.T.63, the difference in clearer reception was most marked, and the change was worth while.

I have built many sets, but this is by far the best.

Yours faithfully,
J. B. COLE.

Grosvenor Lodge,
Jersey.

transformers. Some manufacturers of H.F. transformers have been very successful in their matching, as have some makers of variable condensers.

New Lamps for Old—continued

1. Substitution of the standard six-pin split-primary H.F. transformers for those described in the original set. (These can be screened or unscreened.)

2. Removal of the neutralising condensers from the front of the panel and the substitution, for them, of baseboard-mounting neutralising condensers in a more efficient position.

The Aerial Connection

Everything else can remain as it is. If I were designing the set at the present time I should use fixed resistors in place of the variable variety, but as these latter are provided there is no need to change them.

With regard to the aerial coupling, the tuning of the set will probably be

six-pin variety may be found a slight advantage. Connections for the

coils will be determined by several considerations. Screening of the coils

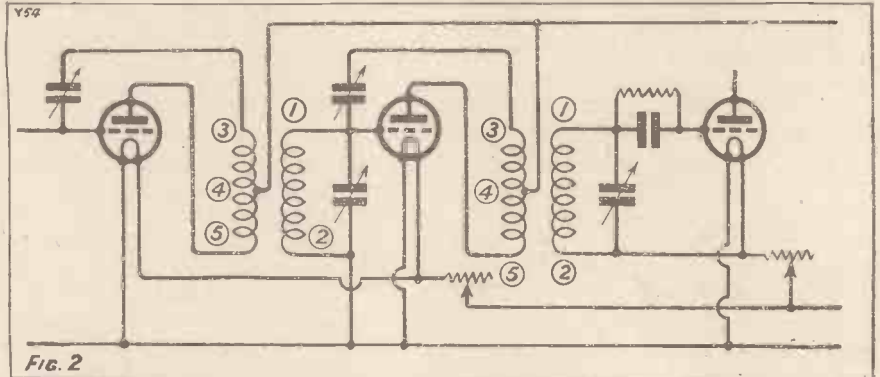

Fig. 2

“Special Five,” using the existing aerial coupling and split-primary transformers, are given in the drawings. The detector and note-magnifying

undoubtedly reduces interaction effects between circuits, but the price for this is paid in a certain loss of efficiency due to the screen being placed so

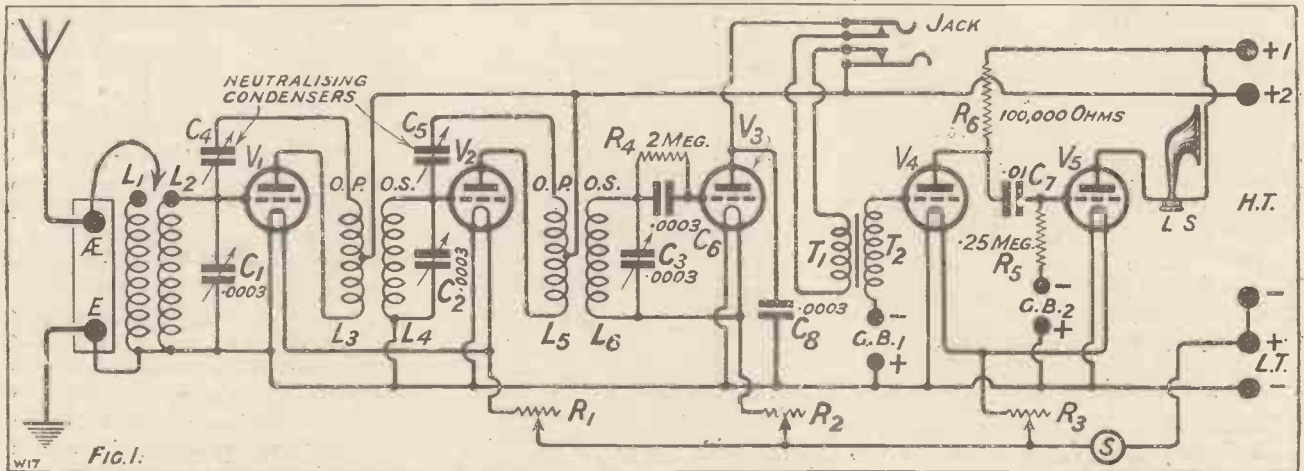

Fig. 1

found quite sharp enough if the existing method is retained, but where space permits the substitution of a split-primary aerial coil of the

stages of the receiver have been omitted from the diagrams, as no changes will be made there.

Whether or not you use screened

close to the winding. In a receiver which has to be compact, screened coils are undoubtedly an advantage, but in the case of a receiver such as the “Special Five,” where the parts are well spaced, it is generally possible to use the unscreened six-pin coil without trouble arising. The screen also tends to reduce “pick-up,” by the coils themselves, of strong signals from a station within a mile or so, and I would therefore recommend the use of screened coils when a user is practically in the shadow of his local station.

Coil Considerations

If you are situated more than four or five miles from a station, you need not trouble about direct pick-up effects, as my experience is that, using six-pin or other coils in which the windings are in a horizontal plane, the pick-up effect is negligible

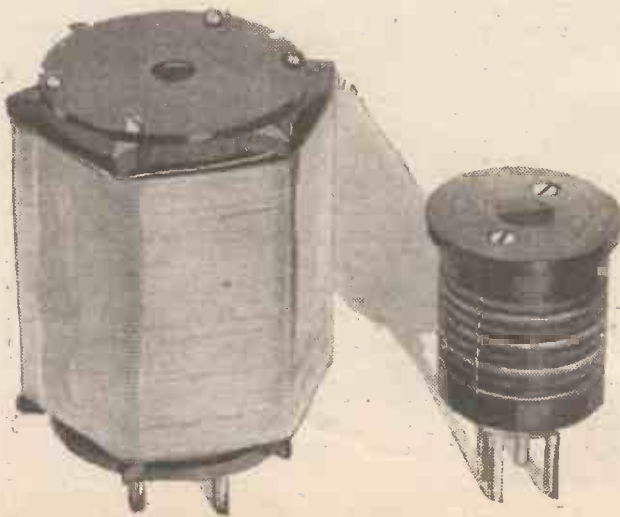

Two types of H.F. transformers on the market. To the left is shown a low-loss method of winding, and the other transformer is an example of what is popularly known as the barrel type.

HOW TO MODERNISE "THE SPECIAL FIVE."

This diagram shows only the first three valves, as the modifications dealt with in the accompanying article are not concerned with the low-frequency portion of the set.
 Instead of the original H.F. transformers standard six-pin split-primary coils are used, as shown. The neutralising condensers are removed from the panel, and baseboard-mounting neutralising condensers are employed in the positions indicated below.

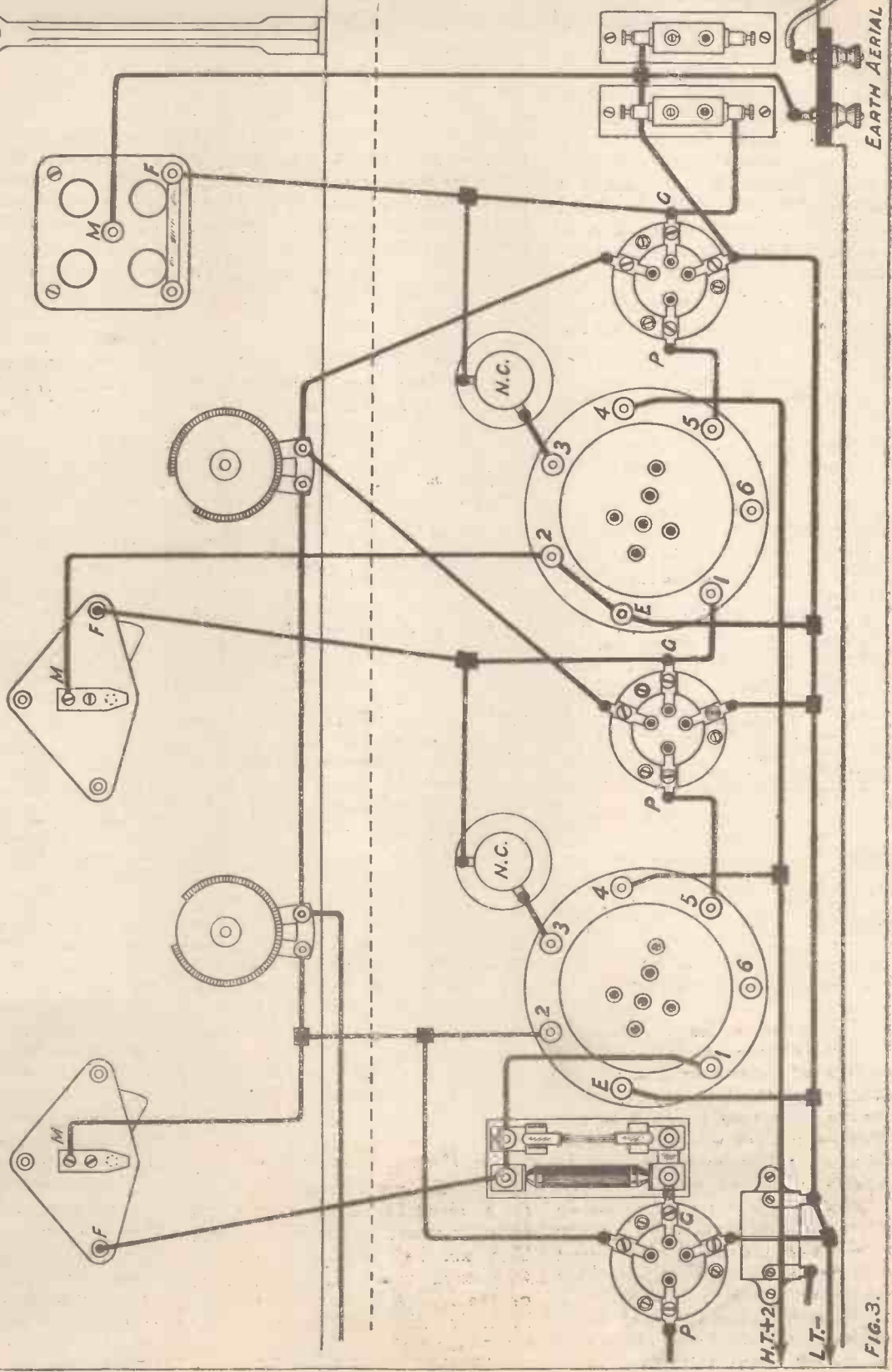

FIG. 3.

V10

New Lamps for Old—concluded.

at such a distance. So far as binoculars are concerned, these possess practically all the advantages of the screened coil so far as reduction of interaction between coils and lack of pick-up is concerned, but they are not yet available in "split primary" windings. Their H.F. resistance is intermediate between that of the completely screened coil and that of the unscreened single-layer transformer.

Choosing the Condensers

You may find that a little rearrangement of components in your set is necessary, but in the majority of cases you will find that the only parts you will need to change are the coil bases and the neutralising condensers. The numbers given in the practical wiring diagram are those corresponding with the numbers on the bases of the six-pin coils. The numbers will be the same whether you use unscreened or screened split-primary coils.

You will need to buy two new neutralising condensers for baseboard mounting. Fortunately there are a number of excellent makes available. In choosing your condensers see that they are mechanically well made, and have a very low minimum. The small interleaving-plate type or those which increase in capacity by a moving plunger are both quite suitable. The best positions for these condensers are given in the drawings, and if you should make any change in the positions, see that the leads are kept quite short.

Suitable Valves

To get the very best out of the modernised "Special Five," you should use types of valves which have appeared on the market since the original article was written, for the windings of the six-pin H.F. transformers have been designed to suit the more modern valves. There are so many makes available that to compile a list of suitable valves, mentioning every make, would be rather tedious. It is far simpler to say that the H.F. valve should have an impedance of round about 18,000 to 25,000 ohms, with an amplification factor of 20 or thereabouts. Practically all the good makers sell valves which will fit this specification; they are generally called "high-frequency" valves. In the

six-volt class typical specimens are Osram or Marconi D.E.5B., Mullard P.M.5X, and Cossor 610 H.F. For the detector I would recommend the same type of valve. The first note-magnifier should preferably be one of the new valves designed for resistance-capacity coupling, and for the last valve a small power valve; or, better still, one of the modern super-power valves, if you have H.T. accumulators or really big H.T. dry batteries to supply the heavy anode currents needed.

The Filament Voltage

If you have been in the habit of using either four- or two-volt valves

fully wrap a piece of thin paper round one filament leg, and re-insert it in the holder. If you have done this properly the valve will not light, owing to the paper insulation between the socket and the valve pin. As, however, the grid and plate connections are still made, there will probably be sufficient transfer of energy by the grid-to-plate capacity to enable signals to be heard. Now carefully turn the neutralising condenser, and the signals will be reduced to a zero point, while as you turn the condenser still further they will reappear. Turn back again and leave the neutralising condenser on the point where no sound can be heard,

One of the popular receivers designed by Mr. Harris—the Transatlantic Five.

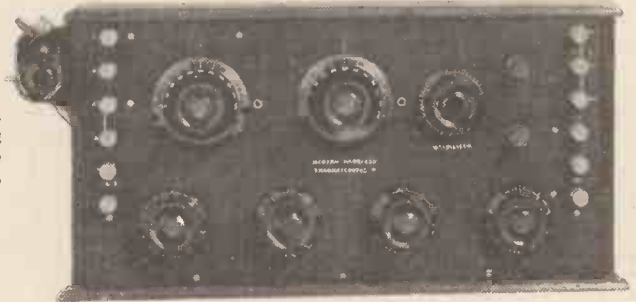

in this set, you will be able to obtain the four- or two-volt equivalents of the types I have named. Six-volt valves are slightly better than four-volt, and the four-volt are slightly better than the two-volt; but there is not a great deal of difference nowadays between the six-, four-, and two-volt valves of good makes.

The neutralisation of this set is not a difficult matter, but unless carried out systematically and carefully the process might be found difficult. With the newer H.F. transformers neutralisation is a much more precise matter than with the older coils, and therefore the following instructions should be carefully adhered to.

How to Neutralise

With the neutralising condensers set at about half of their maximum capacity, tune in to the local station. This can be done either on the telephones, using three valves, or on the loud speaker, using all five. Probably when all the dials are turned the station will be heard with considerable distortion, or even oscillation may be noticed. Now remove the first H.F. valve, care-

or, if you are very close to a station, where a minimum sound is noticed. Withdraw the valve, remove the paper, and re-insert. Then repeat the process with the second valve in exactly the same manner. The minimum position should be very clearly marked in each case. When you have performed this process with both valves the set will be properly neutralised.

Considerably Improved

If you are situated so far from the nearest station that you do not get loud signals, neutralising is a little more difficult to perform, and is preferably done by means of telephones. With a set such as this there is always some station after dark which gives loud enough signals to enable you to neutralise in the manner described, either by listening on three or on five valves with telephones.

The changes suggested will very considerably improve the "Special Five" in regard to selectivity and sensitiveness, while by utilising the more modern valves you will get a big increase in all-round efficiency.

The Fallacy
 of Advisory
 Committees—Reviv-
 ing Morale—Stabilising
 at Savoy Hill—Broadcast-
 ing and Temperance—
 Position of the Mon-
 opoly — Daventry
 Junior.

Savoy Hill Happenings

By OUR SPECIAL COMMISSIONER

THE new B.B.C. began by invoking more advisory committees than its predecessor, the Company, had ever thought of. This was a natural outcome of the recommendations of the Crawford Committee on the subject of committees. It seemed that the Crawford Committee were a little uneasy that the old B.B.C. resorted too rarely to the consultative method of conducting their service. Thus, with the coming of the new body, the committees in existence, namely those on adult education, music, and education, acquired a new importance, and were joined by two new committees, one representing the wireless trade, and the other the wireless organisations. Now the trade committee, curiously enough, has not adopted the popular adjective "advisory" in its designation; but is known officially as "The Wireless Trade Committee on Broadcasting."

The "Listeners' Committee"

Of course, this Committee has much greater authority and freedom by virtue of the fact that it is not in the normal category of B.B.C. advisory committees. Then the other new committee represents the Wireless League, the Wireless Association, the Radio Association, and the Radio Society. It was hailed and is still described in the Press as a "Listeners' Committee."

Its only claim to this title would appear to be the fact that its chairman, Captain Ian Fraser, M.P., was commonly regarded as a very able representative of the "man-in-the-street" on the Crawford Committee.

So far as the membership of the

constituent societies is concerned, this is negligible in comparison with the main body of listeners. What is happening with regard to this committee is that its members are gradually and laboriously acquiring some knowledge of the difficulties and intricacies of the Broadcasting business.

To the extent to which they become informed on this subject some good will accrue ultimately, for the reason that they perforce become missionaries of the policy and effort of the Savoy Hill people. But those competent to judge of such matters hold out no hope that the influence of this Committee on programmes will make any difference. Effective programme policy must be primarily and principally arbitrary. If things are not going right, the remedy is to change the officials in charge, not to set up advisory committees.

Reviving Morale

I am glad to hear of strenuous efforts on the part of the B.B.C. to stimulate a revival of the *morale* of the wireless trade. A kind of prevailing attitude of defeatism has become the worst enemy in the way of the progress of the whole industry. Those whose livelihood depends on the sale of receiving apparatus have been known to apologise for programmes to prospective clients.

First of all, there is no reason to apologise for the programmes. The B.B.C. has gone ahead lately, and the programmes are not only better in themselves, but are more generally acceptable than they ever were. The programmes now should be made to sell sets, not to discourage possible buyers. And secondly, even if the salesman is in doubt about the programmes, what chance has he to sell his wares if he discounts the messages

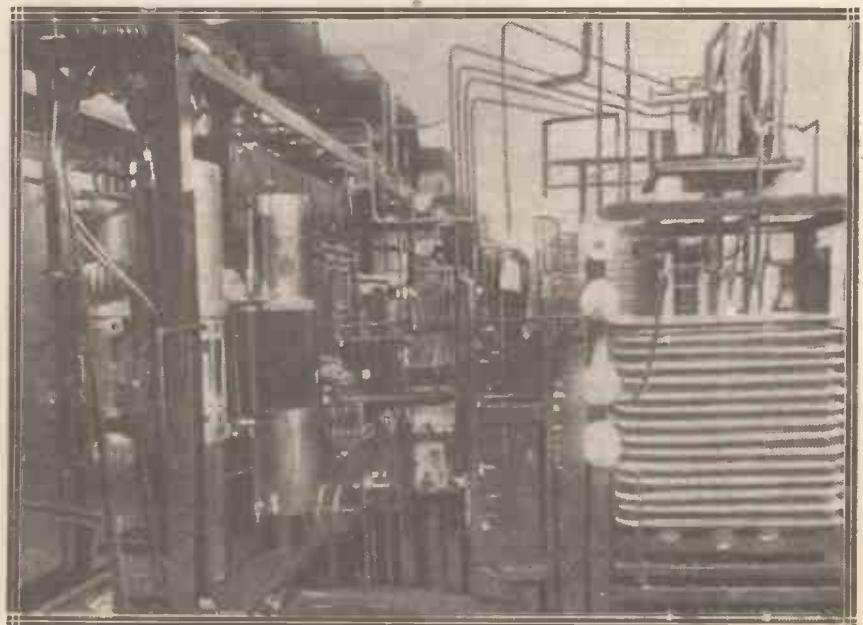

A portion of the transmitter at the Colombo broadcasting station.

Savoy Hill Happenings—concluded

which are to be received through them. The new trade committees on broadcasting set up in London, Belfast, and elsewhere should go a long way to eliminate the prevailing pessimism.

Stabilising at Savoy Hill

Most of the staff changes attendant upon the change over from Company to Corporation have now taken effect, and the staff tends to settle down on a permanent basis. But it is quite wrong to imagine that the conditions of employment with the B.B.C. are even remotely like those of a Civil Service Department. The sound business training and conceptions of Sir John Reith have been a complete safeguard in this important respect.

It is essential to the public interest that the staff arrangements of the Broadcasting Service for at least three years more should be as loose and fluid as possible. Thus, while, of course, the best talent should be

secured it should not be given any security.

Where a service is growing so rapidly and changing so radically almost from season to season, an official may be efficient to-day and quite inefficient in the autumn. The mind that grows and adapts itself in the process is a *rara avis*. Thus, there are bound to be many casualties in the path of the progress of the B.B.C. It must therefore be possible to shake off any official at short notice.

Broadcasting and Temperance

Various temperance bodies are concerned about the number of jokes with a "liquor" flavour, which creep into the lighter programmes. There have also been references to Empire wine in talks sponsored by the Empire Marketing Board. Then again, some of the publications of the B.B.C. have been accepting Empire wine advertisements.

A kind of ultimatum is being con-

templated by the anti-liquor interests, and if this is disregarded, then they will launch a campaign against the B.B.C. on the liquor issue. Meanwhile, the brewers and distillers are alive to the danger of the situation, and are mobilising in their interests. A campaign of this kind would do quite a deal of good during the "silly season," a time when the B.B.C. is glad of discussions of all sorts.

Position of the Monopoly

Secret Wireless, Ltd., with the new-found support of Mr. Charles Gulliver, are still at work on their new device for relaying music and speech over electric light wires. Owing, however, to a premature exposure of their plans (of which I believe something is known at Savoy Hill) the Post Office are now alive to the possibilities of the situation.

It is understood that if this enterprise fails, then Secret Wireless propose to go abroad and make an arrangement with a Continental station for English programmes to be sent out on high power. There have been rumours of significant conferences in Paris of late. Those concerned are proposing to break away from the Geneva Union of Broadcasters, and attempt to rival both them and the B.B.C. With this Continental enterprise Secret Wireless would be getting nearer effective competition with the B.B.C. than in any of the schemes so far launched. But it is difficult to see how they would support the programmes. Certainly no licence-money would be available. Perhaps there are enough general advertisers in this country who would be prepared to co-operate on the American plan. A group of British newspapers is reported to be in association with this Continental move.

Daventry Junior

Daventry Junior, promised definitely for November, will probably be ready earlier. But that does not mean that it will be broadcasting earlier. The Post Office permission to the B.B.C. is merely to carry out tests, upon the results of which the Post Office engineers themselves propose to adjudicate. It almost goes without saying that there will be a marked cleavage of opinion in interpreting the results of the experiments now being completed.



The latest in wireless equipped tanks belonging to the French Army Authorities.

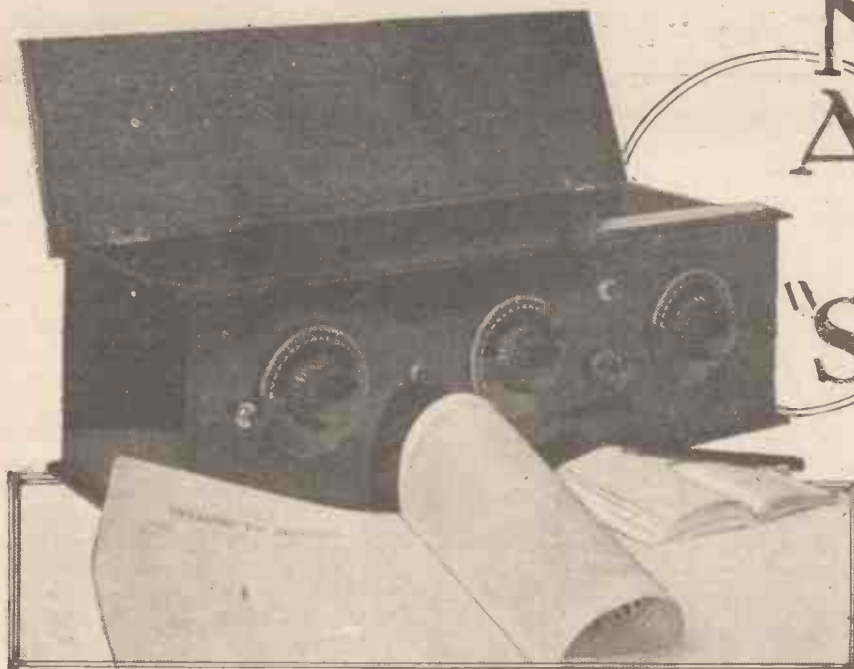

MORE ABOUT THE "SIGNAL BOX"

Some listeners' comments on the very successful set that was described in the "Wireless Constructor" last month.

THE wireless public is becoming accustomed to hearing great claims for new wireless sets, and owing to the multiplicity of stations "on the ether" it is comparatively simple to log a large number with any reasonably efficient set. The "Signal Box," however, stands in a class of its own, combining as it does an astonishing volume and purity on the nearer stations with a distance-getting power so far unknown in a 3-valve set.

is capable was adequately demonstrated.

Langenberg, Frankfurt, and several other German stations were then quickly tuned in on a Radiolux loud speaker and the sharpness of tuning demonstrated. A little later the audience were able to hear a Spanish station broadcasting dance music, although the aerial arrangements were by no means efficient.

The next experiment was to show not only the perfect neutralisation of the set, but the entire absence of "pick-up" of signals by the set itself, although no screening is used.

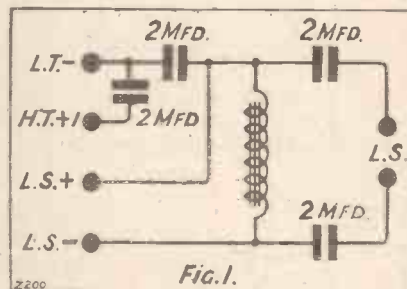

London was tuned in at maximum strength on the loud speaker—really tremendous volume!—and the fixed resistor of the first valve was then

THE FINEST THREE-VALVER

"Mr. Harris has certainly demonstrated the finest 3-valve set ever heard by this society . . ." (Chairman of the Wembley Wireless Society in a speech.)

In order that a group of enthusiastic listeners might have a demonstration of its powers the "Signal Box" was recently demonstrated by Mr. Harris before a meeting of the Wembley Wireless Society. After a short lecture, illustrated by diagrams, on the principles of the Hale circuit, London was tuned in with such volume that it was very easy to demonstrate that only a super-power valve could handle the output without marked distortion. An ordinary small-power valve with 120 volts on the plate and correct grid bias gave considerable distortion, but on replacing this by a super-power valve and about 15 volts grid bias, all signs of distortion disappeared and the true purity of which the receiver

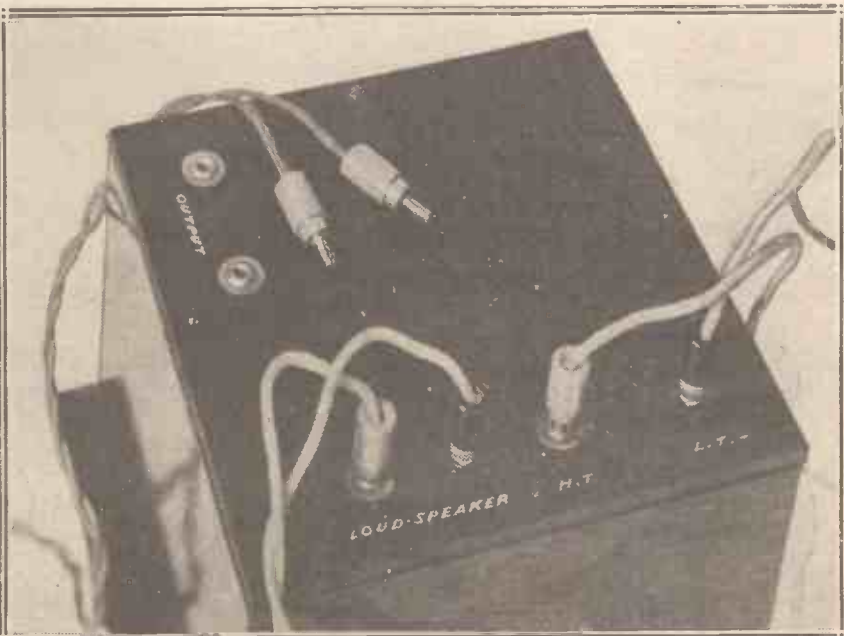

Outwardly the appearance of the "Signal Box" filter unit is simplicity itself.

More About The "Signal Box"—continued

removed. The result was dead silence, and after the chairman had been invited to listen as close as he

over, members of the audience were invited to test the set for themselves, and in particular to note the remark-

"Signal Box" was the finest 3-valve set they had ever heard. They would all look forward eagerly to the publication of particulars of how to make it.

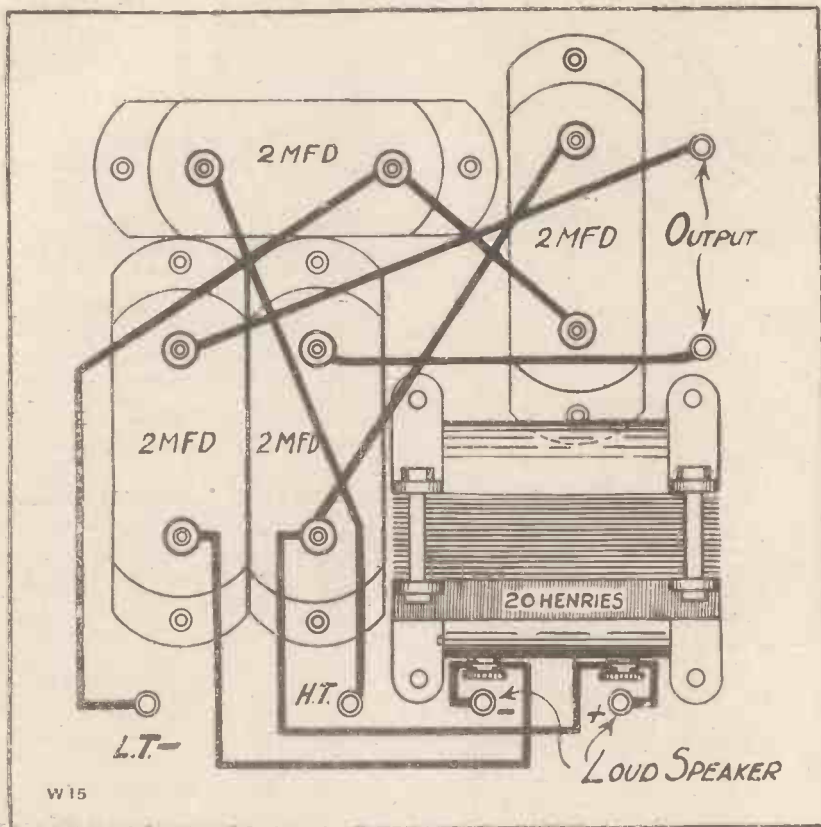

BACK OF PANEL SHOWING WIRING.

Wonderful Sensitivity

One of the most fascinating demonstrations of the remarkable sensitivity of the "Signal Box" is to connect it up in the usual way and then, at the bottom of the tuning scale, to apply a little reaction so that the set is kept just below oscillation-point. After this, the reader should tune on the first two dials from the bottom of the scale to the top. It will be found that, without any alteration of the reaction control, stations can be picked up on the loud speaker right up to the maximum reading of the condensers. Searching is thus made very easy. Once a particular station has been picked up, its strength can be gradually increased by turning the reaction condenser. Dozens of stations can thus be heard at full loud-speaker strength and properly identified.

A Useful Accessory

Readers who build the "Signal Box," and who use a super-power valve in the last stage, are recommended to build for themselves a simple filter unit to prevent the direct current passing through the loud-speaker windings. A very simple filter unit is shown in the accompanying photographs and drawings, consisting of an L.F. choke coil and two fixed condensers. The box which contains this filter unit can also be made to contain the fixed condensers for shunting the H.T. battery, and when made up like this the filter unit can be made to serve for any set.

The parts needed for this filter box are as follow: One cabinet, 6 in. by 6 in.

could to the horn of the loud speaker he reported that he could not hear a sound. A slight turn of the neutralising condenser in either direction brought in London on the loud speaker, thus showing that the instrument was a good example of a perfectly neutralised radio receiver.

Remarkable Reaction Control

As soon as the demonstration was

ably smooth reaction control. This is so well graduated that it is almost impossible to tell when the set passes into oscillation, except by distortion of the signals themselves.

The chairman of the Society, after expressing the thanks of the meeting for such an interesting demonstration, said that they had had some remarkable receivers demonstrated to them in the past, but without question the



More About The "Signal Box" —concluded

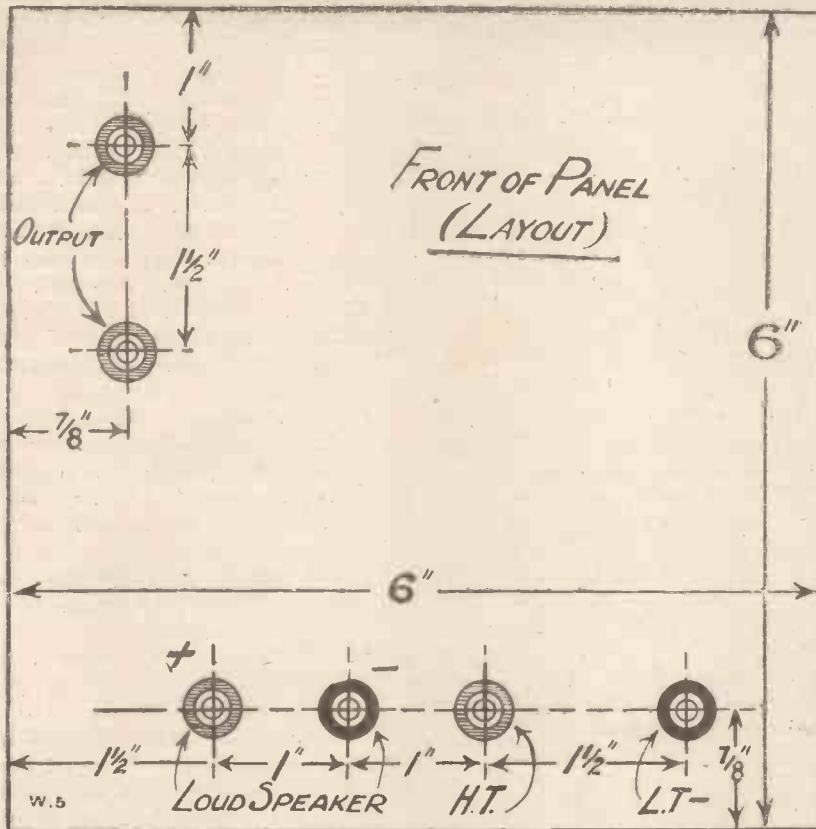

set. "Output" is joined directly to loud speaker, and "loud speaker" on the filter box to "loud speaker" on set. When thus joined up there is a 2-mfd. Mansbridge condenser joined from H.T. positive (1) to L.T. negative and another from H.T. positive (2) to L.T. negative, while the plate current of the last valve passes through the choke winding and not through the loud speaker. Differences of potential set up across the choke are transmitted through two further Mansbridge condensers to the loud speaker, which thus carries only the speech and music currents.

L.S. Protection

The filter unit will be found very valuable in protecting the loud speaker and in enabling it to carry louder signals without overloading. It can be used with any set not incorporating a filter, whether Mansbridge condensers are included in the receiver itself or not. If Mansbridge condensers are already fitted, those in the filter are placed in parallel with the existing ones, simply adding to the shunting effects.

by 4½ in. deep internally (this is a standard size of box obtainable from Camco, Caxton's, and other cabinet-makers), one good audio-frequency choke (Success, Radio Instruments, etc.), four Mansbridge condensers of 2 mfd. each (Dubilier, T.C.C. Lissen, etc.), six plugs and sockets, four red and two black (Lisenin), ebonite panel 6 in. by 6 in. by ¼ in. or ⅜ in., stiff wire (Glazite, etc.).

Theoretical Circuit

Fig. 1 shows the theoretical diagram, for which it will be seen that there are four terminals for L.T. negative, H.T. positive (1), loud-speaker positive, and loud-speaker negative respectively; while on the right there are two terminals for connection to the loud speaker itself. In the "Signal Box" and most other sets the loud-speaker positive connection is joined directly to H.T. positive (2) inside the set, and thus one terminal on the filter unit can be used for the filter itself and the shunting condenser across H.T. positive (2). The L.T. negative terminal on the filter box is connected to the L.T. negative on the set, and H.T. positive (1) on the filter box to H.T. positive (1) on the

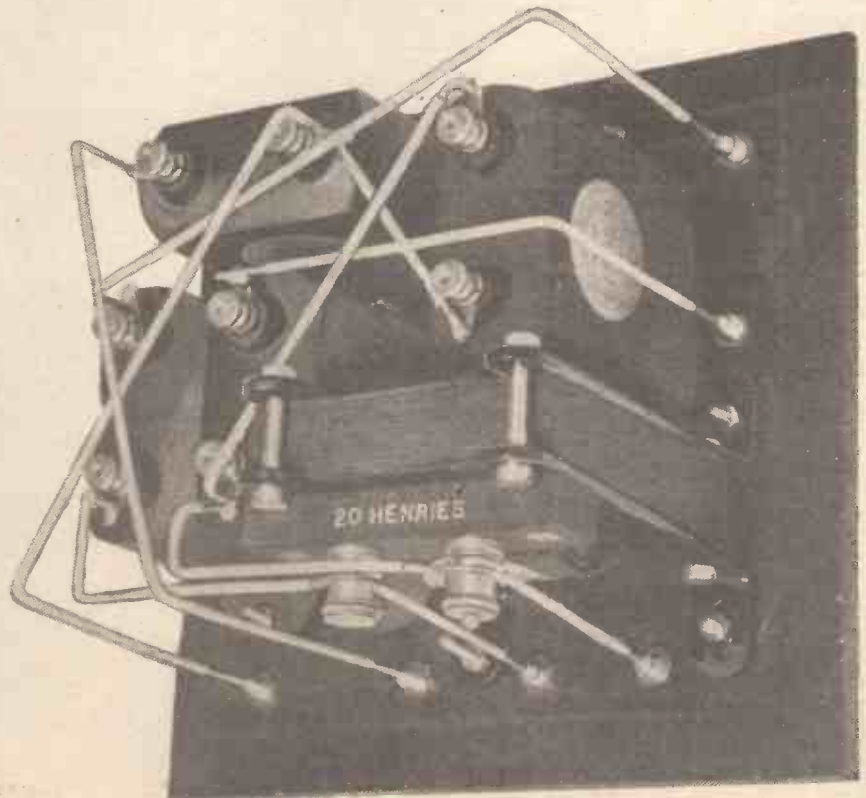

Practically all the wiring can be seen in this back-of-panel photograph.

FURTHER RADIANO SUCCESSES

A few of the many enthusiastic letters from readers who have built Radiano Sets.

The Radiano Three-Valve Set

SIR,—Having been a firm "All-concert" adherent, I have tried the "Radiano Three," and find I get wonderful results on loud speaker, i.e. Daventry, Radio Paris, three German, one French, and several English stations on the 400 and upwards band.

I am now waiting for the Radiano 2-valve circuit or something similar from Mr. P. Harris.

Yours faithfully,

T. C. SCOTT.

Weirnook, Totnes, S. Devon.

A Midland Reader's Success

SIR,—Stations heard on loud speaker with 60 X Lissen coil, with 60 reaction. Condenser reading:

- 45 *N.K. Weak.
 - 50 *N.K. Weak.
 - 62 *N.K. Weak.
 - 64 *N.K. Weak.
 - 81. Nottingham. Good, but noisy.
 - 105 Newcastle. Weak.
 - 108 Dublin. Fair, but fades.
 - 112 Birmingham. Good, but noisy.
 - 128 London. Very good.
 - 133 Madrid (Union Radio). Weak.
 - 135 *N.K. Fair.
 - 138 *N.K. Weak.
 - 140 *N.K. Weak.
 - 148 *N.K. Weak.
 - 158 Langenburg. Good.
 - 163 Bournemouth. Weak.
 - 167 Radio Wien (Vienna). Weak.
- Stations on L.S. with 250 X coil:
- 58 Hilversum. Weak, but clear.
 - 94 *N.K. Weak.
 - 134 Daventry. Very good, clear and loud.
 - 145 Radio Paris. Fair and clear.
 - 179 Eiffel Tower. Weak and noisy (when Daventry is not working on Sunday morning).

NOTE.—N.K. = Not known.

Named stations identified by announcement.

Please let me have a Radiano 4. Same kind of circuit.

Yours faithfully,

T. C. HOWARD.

61, St. Giles Street,
Northampton.

Distance and Purity

SIR,—As I mentioned in a previous letter, I intended making up the

"Radiano Three" in place of my "Powerful Three." I have now done so, and am very satisfied with the results obtained.

I was well pleased with the old set, but the new one gives better results still, with far greater ease of control.

I have made just a few small deviations from the blue-print, as follows:

A separate rheostat for each valve. Three H.T. tappings instead of two. C.A.T. instead of tapped coil. A two-way coil-holder instead of the separate holders for A. and R. A .0003 A.T. condenser. A .006 fixed condenser in series with the reaction condenser—to avoid shorts.

I also made my battery earth connection direct to L.T.+, instead of via the first valve filament resistance as per diagram. I have used a brass panel, which, of course, eliminates all hand-capacity effects, while shortening the wiring.

My components are as follow:

Ferranti A.F.3 Transformers. Mullard P.M.1 H.F. P.M.1 L.F. P.M.2. Everything else of the best, while separate H.T. batteries are used.

With an Amplion A.R.19 (choke output filter) quality is remarkable, and I have yet to hear anything to beat it, using 3 valves, for volume on the local station.

I thank Mr. Harris very much for what is really a modern edition of the "Powerful Three," and although I shall continue to read of more elab-

orate receivers, I fancy that this will "do me for keeps."

I append a list of some of the stations received, though, of course, conditions vary nightly.

(I have experimented with a 6 and a 9 turn in the aerial holder with appropriate reaction, and a variable coupling condenser between aerial and set, but although oscillation is easy, I cannot find K D K A or any other short-wave telephony station. Plenty of deafening C.W. stations abound, but I cannot determine on what wavelength I am working.)

6 L V. Full L.S. Too loud.

2 Z Y. Full L.S. No interference from 6 L V.

2 R N. Full L.S. Interfered with, during intervals.

5 X X. Full L.S. O.K.

Langenberg. Good L.S. (Varies.)

Hamburg. Good L.S. (Varies.)

Frankfort. Good L.S. (Varies.)

Stuttgart. Good L.S. Interfered with by Manchester.

Madrid (375). Fair to mod. L.S.

Radio Toulouse. Weak L.S.

Oslo. Weak L.S.

Radio Wien. Fair to mod. L.S.

Varies greatly.

Radio Paris. Fair L.S.

5 I T. Weak L.S. When 6 L V not working.

Received at odd times on 'phones: Copenhagen, Bergen, Bilbao, Brunn, Aberdeen, Bournemouth, Brussels, Berlin, Prague, Newcastle, Stoke, Elberfeld, Leipzig, Stockholm, Cadiz, Madrid (306 m.), Barcelona, Koenigs-wusterhausen, Breslau, Hilversum, Radio Bern, and also many unidentified, some on loud speaker.

Yours faithfully,

W. J. JAMES.

1, Winslow Street,
Walton, Liverpool.

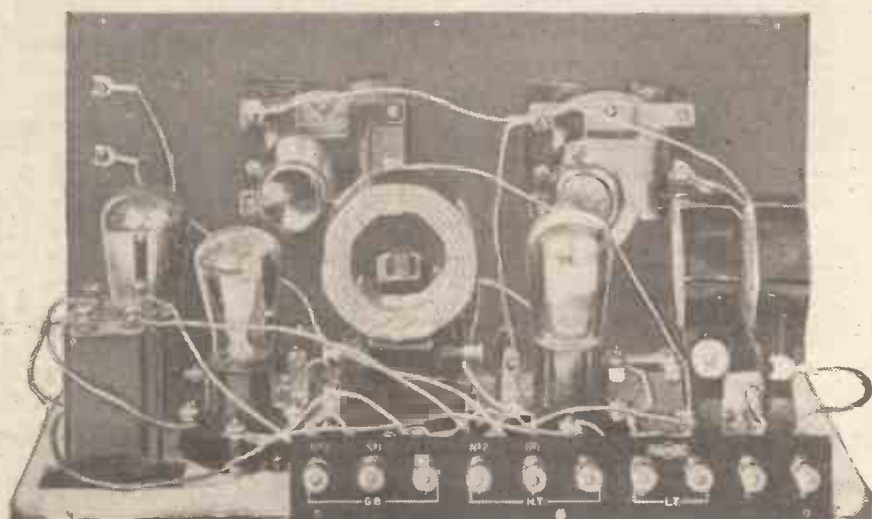

A general view of the "Radiano Three," with valves and coils in position.

SUPER-HET FOR THE SHORT WAVE ENTHUSIAST

For both telephony and C.W. reception on the short waves a super-heterodyne is extremely useful for "logging" distant stations, owing to its extreme sensitivity and ease of control. The one described here has been specially designed for short-wave work and has given excellent results.

By L. H. THOMAS (6 Q B).



Most short-wave enthusiasts will declare very emphatically that there is no receiver that can equal a "detector and note-mag." of the usual type; furthermore, they will often be heard to say that very few people know what a set of that type is capable of doing. Pro-

from great distances, it is seldom that such signals can be received at really good loud-speaker strength. Further, the addition of a second note-magnifier often renders the set rather troublesome on account of the uncomfortable dimensions reached by the extraneous noises and interference. Thus, for loud-speaking work, or even for the purpose of holding a particular signal for a very long time, the two-valve receiver does, unfortunately, leave something to be desired.

especially from the point of view of consistency, have been so satisfactory that it is hoped that the following description of the set will be useful.

Easy to Operate

It seems a prevalent idea at the present time that the super-heterodyne, besides being a lot of trouble to construct, is a very complicated affair to operate, and presents problems incapable of solution by anyone but a "wireless wizard." Fortunately, this is not the case; the super-het is certainly much easier to construct than a "straight" six-valve receiver would be, and, after the initial tests, the operation is of such

COMPONENTS REQUIRED.

- 1 Radion panel, 24 by 7 by 3/16 in. (American Hard Rubber Co.).
 - 1 Cabinet for above, with loose base-board, 7 in. deep, and one pair of aluminium brackets (Camco).
 - 1 Filter transformer and 3 intermediate-frequency transformers, and 1 potentiometer (L. McMichael, Ltd.).
 - 6 "Clearer-Tone" valve holders (Benjamin Electric Ltd.).
 - 1 .00025 and 1 .0003 square-law condensers with slow-motion drive (Ormond Engineering Co.).
 - 2 .0003 fixed condensers, with clips, 1 2-megohm leak, and 1 4-megohm leak (Dubilier Condenser Co.).
 - 1 dual rheostat (Bedford Electrical Co.)
 - 1 base-mounting 30-ohm rheostat (Lissen Ltd.).
 - 1 Amperite, Type 1A, and 1 Frost toggle switch (Rothermel Radio Corporation).
 - 2 base-mounting coil sockets.
 - 1 single-circuit open jack.
 - 1 neutralising condenser, panel-mounting type (Peto-Scott Co.).
 - 1 7-terminal strip and 1 2-terminal strip.
- Mount for coils, and sundry wood-screws, brass bolts, tinned copper wire, etc.

The writer has for some considerable time been experimenting with a super-heterodyne on the shorter waves, and the results obtained,

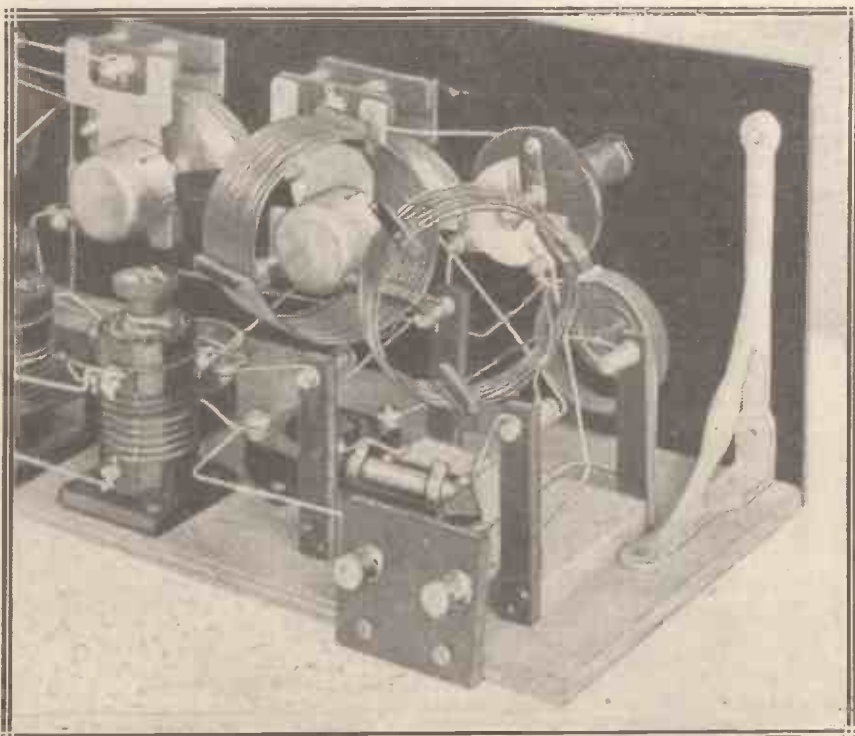

The placing of the short-wave coils is clearly shown in this illustration.

bably they are quite correct in both of these statements. The writer has a very "soft spot" for this excellent type of receiver, and this article has certainly not been written with the object of belittling the standard two-valve short-wave receiver.

While two valves are very excellent, however, for ordinary work, such as the logging of amateur telegraphy

Super-Het for the Short-Wave Enthusiast—continued

a simple order that all other forms of receiver are left standing. One has only to glance at the photographs and wiring diagram to satisfy oneself as to the truth of the first statement, and the next is realised on the second or third day after the set has been completed.

that C.W. signals may be received. For telephony reception this is simply switched off. As a matter of fact, if the receiver is to be used chiefly for telephony, this valve may be dispensed with altogether, since the intermediate stages may be made to oscillate by means of the potentiometer

employs a detector valve tuned to the wave-length of the incoming signals, and a separate oscillator which produces a beat note. Suppose the detector is receiving a signal on 300 metres (1,000 kilocycles). The separate oscillator may now be tuned to a frequency of 1,010

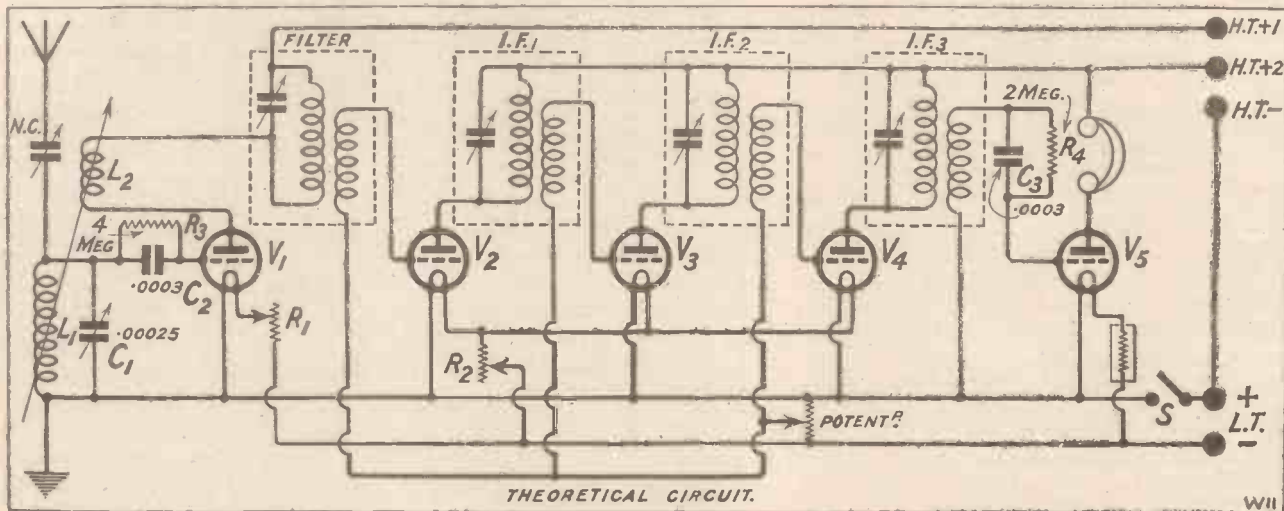

It will be noticed that no note-magnifier has been incorporated—a testimonial to the efficiency of the "super-het" system, since the receiver is intended for loud-speaker work.

The C. W. Oscillator

Six valves have been used; of these, one is merely a long-wave oscillator, whose function is to give a beat note, when desired, with the intermediate-frequency amplifiers, so

meter for C.W. reception, if desired. This method, however, does not produce nearly such a "clean" background as can be obtained when using a separate oscillator, which is the chief reason for the inclusion of the latter.

It is assumed that the reader is fairly familiar with the principles of supersonic reception; a word or so may be necessary, however, concerning the action of the first detector valve. The normal super-heterodyne

kilocycles (which is a wave-length of about 297 metres), and a "beat note" will produce with a frequency which is represented by the difference between frequencies of the incoming signal and the oscillator, *i.e.*, 10 kilocycles. Now, 10 kilocycles represents a wave-length of 30,000 metres, so that it would obviously be possible to amplify the "artificial signal" which has been produced at this wave-length. Actually, this "intermediate frequency" is never as low as 10 kilocycles, but is usually somewhere in the region of 60 kilocycles, corresponding with a wave-length of 5,000 metres.

The First Detector

The object in producing this "artificial signal" at such a high wave-length as 5,000 metres is simply to effect a greater degree of H.F. amplification than would be possible at 300 metres; it is well known that the lower in the scale of wave-lengths one goes the more difficult it is to persuade an H.F. amplifier to work really efficiently. When this "artificial signal" has been amplified to taste, so to speak, it must be handed on to the second detector, and, after this, it may be amplified further at

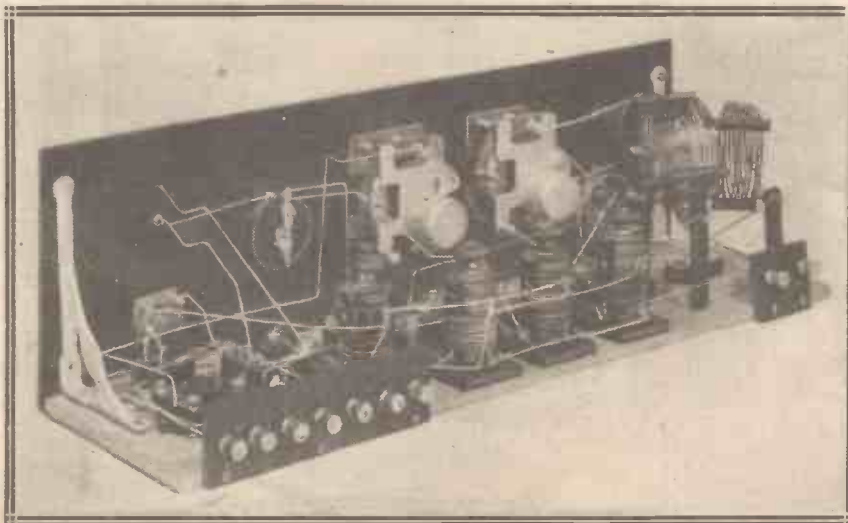

A general view of the back of panel, showing the set with valves removed.

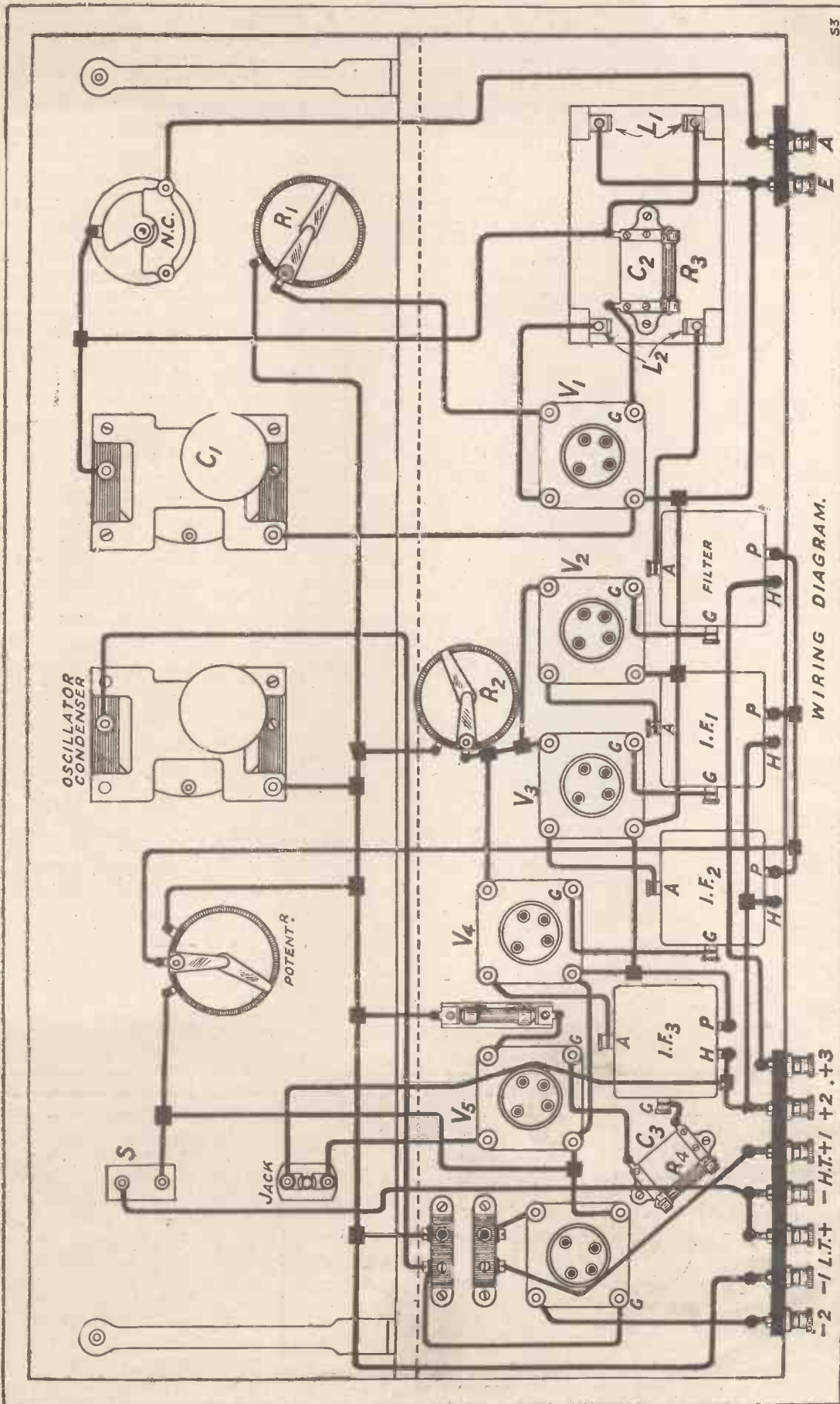

The panel and baseboard layouts should be quite clear from this diagram. Note the short leads from the valve holders to the I.F. transformers and also the placing of the oscillator coils (on the extreme left). The resistance seen between V₄ and V₅ is an "Amperite" controlling the current of the latter valve. R₁, on the panel, controls the filament of the first detector, and R₂, mounted on the baseboard, the filaments of the three I.F. amplifiers. The long-trave oscillator on the left is provided with a separate L.T. terminal, and, if necessary, a separate rheostat can be placed in circuit with this valve.

Super-Het for the Short-Wave Enthusiast—continued

audible frequency by the conventional note-magnifier.

This is a bare outline of the usual method adopted for super-heterodyne reception. Sometimes one or two stages of H.F. precede the first detector, and sometimes the "Tropadyne," which is a combined first detector and oscillator, is employed.

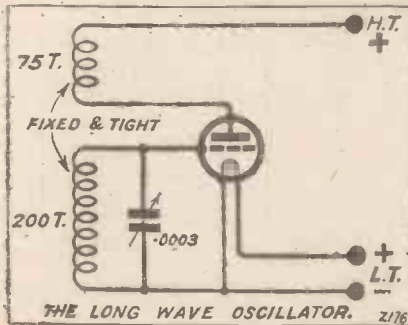

For short-wave work it is found that the frequencies under consideration are so enormous that there is really no need to use a separate oscillator at all. Whereas the chief reason for its use on the broadcast wave-lengths was that, to produce a beat or heterodyne note of the required frequency, the detector would have to be seriously detuned from the signal, it is found on the shorter wave-lengths that the percentage amount of detuning necessary is practically negligible.

One Tuning Control

For this reason no short-wave oscillator has been incorporated in this receiver, and the beat note is produced by means of an ordinary oscillating detector. This reduces the number of controls and makes the set more

easy to handle without reducing the efficiency to any noticeable extent.

In practice, the only control which has to be manipulated during searching is the condenser across the A.T.I. The other condenser mounted on the front panel is connected with the long-wave oscillator, which is only necessary for C.W. reception, and even then this control is of the set-and-forget type, since its only function is to tune the long-wave inductance to produce the necessary beat with the I.F. stages. The potentiometer, again, need not be adjusted once the set has been brought just above the oscillation-point (for C.W. reception), or just below (for telephony).

A separate resistance has been placed on the front panel for controlling the filament of the first detector; this is very helpful from the point of

in the filament circuit of the second detector. The long-wave oscillator has a separate terminal for its filament supply, so that a 2-volt or 3-volt valve may be used if desired.

Regarding the wiring of the H.T. terminals, three H.T.+ terminals are incorporated in the set. H.T.+1 supplies the necessary potential to the plate of the first detector *only*. H.T.+2 supplies the three I.F. stages and the second detector, while H.T.+3 is again exclusive to the long-wave oscillator.

The S.W. Coils

All other details concerning the arrangement of the set may be seen from the circuit diagram.

As will be seen from the photographs, spaced wire coils are used, and are mounted well up above the

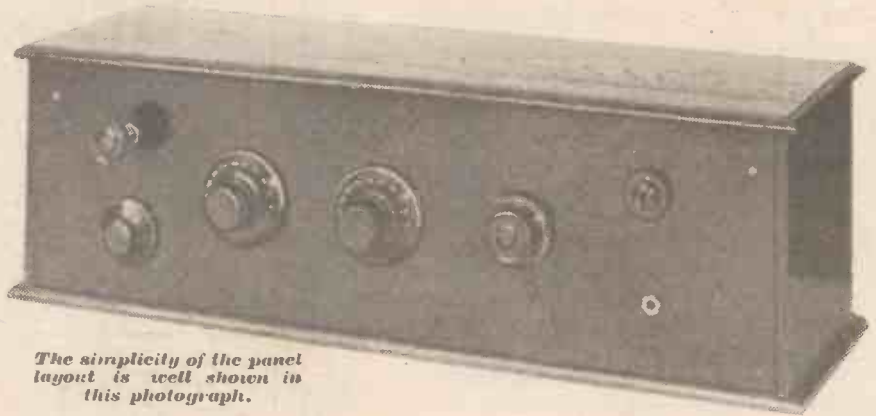

The simplicity of the panel layout is well shown in this photograph.

view of obtaining a smooth control of reaction. The three I.F. stages are controlled by a filament rheostat of the baseboard-mounting type, and an "Amperite" has been wired

baseboard. The mounting consists of a small wooden platform, 4 in. by 3 in. by 1/2 in., with a 3 in. ebonite upright at each corner. The latter are drilled at the tops to take 2 B.A. telephone

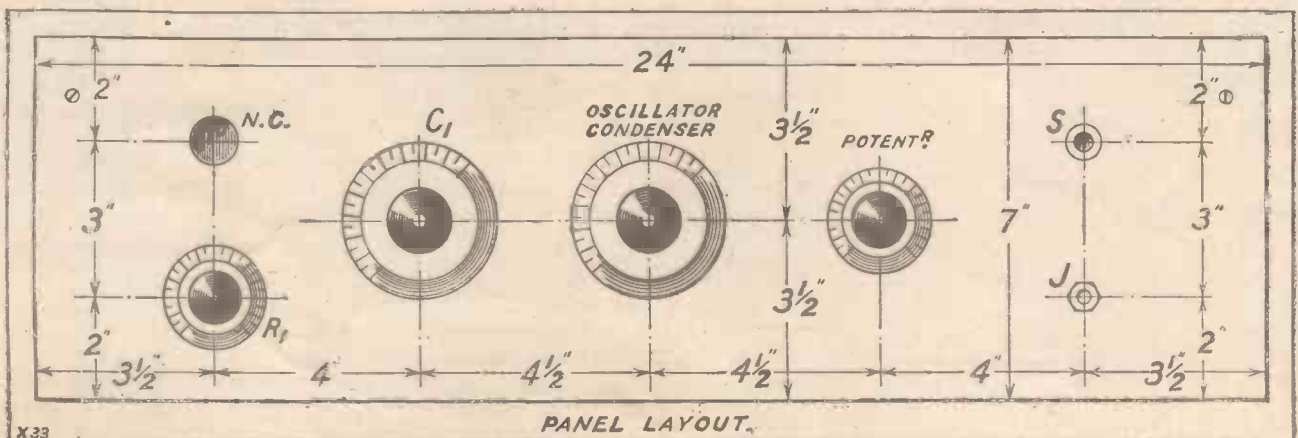

Super-Het for the Short-Wave Enthusiast—concluded

terminals and the ends of the coils are simply inserted in these. The centres of the coils are thus at least $4\frac{1}{2}$ in. above the baseboard.

The aerial is taken to the top of the grid coil, in series with a small neutralising condenser, always used, by the way, in the "all-in" position, although different adjustments would, of course, be necessary to suit different aeriels. A small capacity such as this provides ample coupling on all waves below 100 metres or so. An alternative method of coupling the aerial to the set would be to use a separate primary coil consisting of a single turn of wire. This would, however, add complications to the scheme of mounting at present in use.

The turn numbers of the coils used are as follow :

20-45 metres,	A.T.I. 7 turns,	Reaction 9 turns
33-60 "	A.T.I. 9 "	Reaction 7 "
40-105 "	A.T.I. 12 "	Reaction 7 "

The wire is No. 18 enamelled, and the turns are spaced $\frac{1}{8}$ inch apart.

The actual components used in the set appearing in the photographs are listed on page 97, although, of course, it is not necessary to adhere to them, provided that where variations are made the sizes of the two components do not differ too widely.

Construction

The actual construction of the set should present no difficulties at all. As will be seen from the photographs, surprisingly little wire is used, and most of the connections are very short. The leads to the jack, filament rheostat in the first detector circuit, and the variable condensers, should not be left too late in the proceedings, or they may be found unduly difficult to get at. The wiring of the I.F. transformers is, of course, of the very simplest order, and if they are placed as indicated in the photographs and diagrams, all the leads to them will be very short indeed. The rough positions in which the coils should be placed on their "platform" are also shown.

Care should be taken to connect the long-wave oscillator coils as they are shown in the diagram, as the failure of this side of the set to oscillate is at times very annoying and rather baffling. Incidentally, care should be taken that none of the leads to these coils comes in contact

with the panel bracket, which is rather close to them.

Operation

It will probably be desired, first of all, to test the set out on wavelengths between 30 and 50 metres. This band is certainly best from the point of view of the large number of stations that may always be heard working, and there will be no lack of

for the I.F. stages, and a P.M.2, S.P.18/R., S.T.22, etc., for the detectors. Forty-five volts H.T. proved sufficient for the first detector, 70 volts being used for the other valves.

As it will be best to test the set out at first on C.W., the long-wave oscillator filament should also be switched on. A separate tumbler switch outside the set may conveniently be used for this purpose, since this valve has a separate filament terminal. The writer uses an ancient 2-volt dull emitter in this position—it is of no use for any other purpose! A No. 200 coil should be plugged in the grid socket (nearest the panel) and a No. 75 as reaction coil. The short-wave inductances should be fairly tightly coupled, and if the neutralising condenser in the aerial circuit is placed nearly "all out" the set should begin to howl at an audible frequency. Increase the damping effect of the aerial by increasing the capacity of this condenser until the set has stopped howling. If the A.T.C. is now rotated, signals will be heard at various points round the condenser, the general effect being that of a set just below the oscillation-point—no heterodyne whistles will be heard, but Morse signals will come in as a series of gentle "hisses."

Telephony Reception

If the long-wave oscillator condenser is now rotated, one point should be found at which the whole set apparently begins to oscillate, *i.e.* signals will come in in the normal way, and will, of course, be very much stronger. This means that the long-wave oscillator is now correctly tuned to produce a beat note with the intermediate-frequency stages, and C.W. is heard in the usual manner. Telephony is extremely easy to tune in, and when a telephony station is heard at all it is usually very strong.

During these preliminary tests the position of the potentiometer arm does not really matter, but after the set has commenced to work properly, final adjustments should be made with this and the small balancing condenser in the I.F. transformers.

As with most other sets, the great point about operating one of this type is to get the "knack." After a few hours' searching one rapidly becomes an expert.

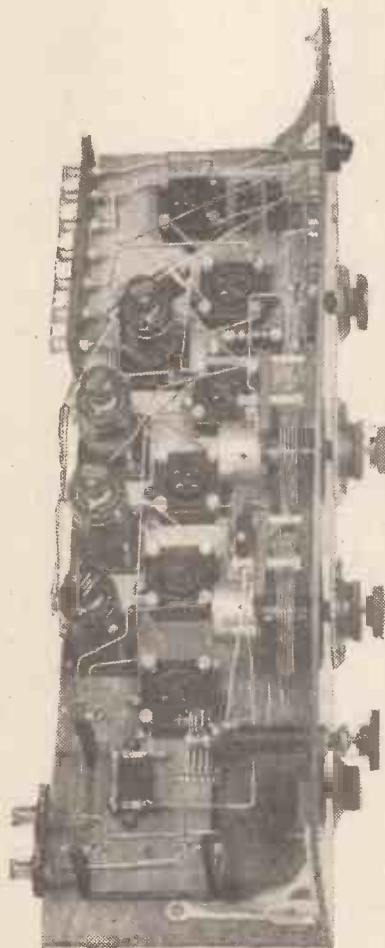

An unusual view of the set which gives a clear idea of the general layout and wiring.

"testing material." Plug in a 9-turn coil as A.T.I., and a 7-turn as reaction, connect the aerial through the neutralising condenser (this being about "half-in") to the top of the latter coil, and switch on, after having made the usual preparatory tests of the wiring. To burn out *six* valves at one fell swoop is no joke! The valves used were of the D.E.5 type for both detectors, and the high-impedance D.E.5 B. type as I.F. amplifiers. In the 2-volt range such valves as the P.M.1, S.T.21, etc., would be suitable

WITHIN THE VACUUM

By KEITH D. ROGERS.

(Asst. Tech. Editor of "Popular Wireless.")

A few of the many valves released to the public during the last month are discussed from a purely practical standpoint in these columns.

I HAVE received so many new valves for test during the last few weeks that it will be impossible to discuss them fully in these columns, so we will just examine closely a few of the outstanding ones, and the others in less detail. It must not be thought, however, that those



The interior of the new S.S.9T non-microphonic valve has the same construction as the S.S.9 but is mounted on a different base. Its characteristics are, of course, unchanged.

not fully described are inefficient in any way: it is merely a consideration of space that forces me to be brief in some cases.

Perhaps the most interesting of all the new valves is the Ediswan E.S.5, which is placed on the market in two forms, for H.F. and L.F. amplification. This valve is exceedingly interesting inasmuch as it departs considerably from conventional design, having two grids and two filaments, all surrounded by a large anode. By this means it is claimed that a more efficient control of filament emission is obtained, for the filaments are in series (being for $2\frac{1}{2}$ volts each), and each filament is surrounded by its own grid connected up to the main grid pin of the valve.

Good H.F. Valve

In practice both the H.F. and L.F. types give good results, though I was more pleased with the efficiency

of the H.F. than with the operation of its companion. The former has an impedance of about 30,000 ohms, with a magnification factor of 20, and is, therefore, very suitable for all forms of H.F. circuits, and for detection where the rectifier is followed by a high-impedance anode circuit. It will operate as an anode-bend detector fairly well, while for a second-stage resistance-coupled L.F. valve it certainly excels. With 80-100,000 ohms in its anode circuit, and a suitable coupling condenser, it gives very good amplification indeed. In every case, however, it is essential not to over-run the valve, for at 5-3 volts I found signals dropped off considerably. Kept at 5 volts it will give exceedingly satisfactory service.

The L.F. valve can be used as a first L.F. or as a detector, where an anode impedance that is not too high is employed. The Ediswan people advise the L.F. valve for detection instead of the H.F., but I must say I prefer the latter in most cases, for the impedance of the L.F. valve is 10,000 and the amplification factor only 7. Followed by a Ferranti transformer (AF3), or other with high-impedance primary, the H.F. valve has (in the tests I have carried out), given much better and clearer results. It certainly has more "pep" than its companion. I must say I am very favourably impressed by it.

A New Idea

Next must be mentioned an interesting method of solving the microphonic problem by the Electron Company as exemplified in their new S.S.9 (called S.S.9T). This valve remains in characteristics just the same as the S.S.9, but is totally enclosed in a vacuum envelope covered inside with a metallic coating, and inside this glass vacuum the real valve is mounted on shock absorbing material. The result is a valve, rather more bulky than usual, which can be banged and rattled about in a

valve set without a single "pong" making itself heard. Furthermore, the oft-noted howl that arises from the sound waves from a loud speaker impinging on the valves in a set is made totally impossible if valves of the type of the S.S.9T are employed. I gather that the Six-Sixty people will carry this non-microphonic design to include all their L.F. valves, in which event it should prove very valuable in many cases.

Two-Volt "Super-Power"

The makers of the famous S.P. 55/R Cosmos valve have recently concluded their 2-volt class with a very good power valve. As a matter of fact it is almost a super-power valve as it has an impedance of 4,500 ohms, and a considerable straight portion to its curve, enabling a fair volume to be handled without distortion. This valve, the S.P.18/RR, costs 18/6, and has a filament voltage of 2 volts.

The latest addition to the Cosmos range is the S.P.18/RR, a very efficient two-volt power valve.



It is constructed on the short-path principle, a method of construction which has justified its continuance by providing some surprisingly good results. This valve is similar in appearance to the S.P.55/R type, and is notable among 2-volt power valves by the absence of visible "get away," the glass of the bulb being perfectly clear so that the electrodes can be seen from every position. Among the many valves I have handled

(Continued on page 136.)



The War Between the Music Halls and the B.B.C.



By OUR BROADCASTING CRITIC.

THE history of wireless during the last few weeks has been, to say the least of it, quite lively. In connection with broadcasting, for example, we have seen the declaration of open warfare between the B.B.C. and the music halls. Mr. Charles Gulliver, one of the leading spirits on the music-hall side, very ably backed by Sir Oswald Stoll, who controls numerous variety theatres in London and throughout the country, has had a lot to say about broadcasting.

Mr. Gulliver has stated that he thinks wireless is the finest invention



Mr. Bransby Williams, the well-known entertainer.

of the last twenty years, but he also thinks that it will one day become the most serious opposition to be faced by theatres, music halls and concert halls. "I know I can't stop it," he said; "it is bound to come; but unless I come to some commercial arrangement with it in my own theatrical interests I must hinder it as much as I possibly can."

"Holding the Baby"

He declares the B.B.C. began all the trouble by approaching artists under contract with him with inducements to broadcast. Mr. Gulliver protested, and then the B.B.C. asked him to come to some arrangement. The figures were satisfactory, but other managers implored Mr. Gulliver not to come to an agreement and so he turned that arrangement down. Then he found that nearly every manager except himself permitted his shows to be broadcast!

In other words, Mr. Gulliver "held

the baby;" and to-day he claims that he is the only theatrical manager who is standing firmly against the B.B.C.

Sir Oswald Stoll has also given some interesting views on the situation. He says that the music halls challenge the monopoly of the B.B.C., and they assert that variety is much more popular than any other form of broadcasting entertainment. They claim that variety broadcasting should be in the hands of the only variety specialists—the music halls.

"The defiance of the music-hall artists recently," said Sir Oswald Stoll, "has stiffened our resistance to the encroaching of the B.B.C." And further, he says that certain managers with music-hall interests have banded together and decided that the only solution to the problem is to do their own broadcasting! Sir Oswald claims that no monopoly has a right to take variety out of the music-hall interests for broadcast or any other purpose. But, according to his argument, he wants a monopoly of B.B.C. variety!

B.B.C. Monopoly Threatened?

Sir Oswald is optimistic about his own profession's abilities to broadcast. "We can broadcast as well as the B.B.C.," he has said, "as we merely have to acquire the technical experts. We shall need the support of the public, for only through Parliament can the legal monopoly of the B.B.C. be qualified."

Sir Oswald's idea of easily acquiring technical experts is rather humorous. He seems to think that they grow like weeds in a garden. As a matter of fact, the B.B.C. have so many technical patents and have so much of the cream of technical engineering in this country that any other interest, starting broadcasting, would find itself very severely handicapped on the technical side, quite apart from its lack of experience on the organisation side. However, it seems likely that the music-hall interests will approach the Post-

master-General (and may have done so before these words are read by our readers), with a view to obtaining a licence to broadcast variety programmes.

A Bright Idea

This bright idea seems to have caught on in the music-hall world, although we are pretty confident that it will meet with very little success. The Postmaster-General has power to license other interests to broadcast, but he is not likely to exercise that power, for if he gave the music-hall interests permission to broadcast their own programmes he would undoubtedly be inundated with requests from other commercial interests for permission to do the same. Big newspapers, big stores and large manufacturing concerns throughout the country would jump at the prospect of broadcasting their own programmes because of the potential advertising value of the concession.

One of the great grumbles about the B.B.C.'s business negotiations with the theatres and music-hall interests is that the fees offered are inadequate. Personally, we think



Mr. Archibald de Bear, who has already arranged a successful broadcast programme.

on the whole the fees are very satisfactory. We understand that when Mr. Bransby Williams recently broadcast he received a fee of forty or fifty guineas a time. An artist of Mr. Bransby Williams' qualifications should not have found it very difficult to improvise a programme suitable

THE WAR BETWEEN THE MUSIC HALLS & THE B.B.C.

—concluded.

for broadcasting without necessarily broadcasting excerpts from his music-hall and theatre repertoire, and for half-an-hour or so's broadcasting a fee of forty or fifty guineas is not to be sneezed at.

No Subsidy from Listeners

It is a mistake to assume that because the broadcasting audience runs into hundreds of thousands, and even millions, that fees can be paid in proportion to the number of people in the audience, and it is also a mistake to assume that the B.B.C. have a limitless bank balance. For instance, Mr. Archibald de Bear a few weeks ago decided to produce a wireless revue himself. He says that he put himself into a dilemma, for, as a man who finds his livelihood in the theatre he did not know whether to broadcast a success or not, because he did not know whether it would do him more harm than a failure! Mr. Archibald de Bear has some very good ideas about broadcasting. Here is one of them:

"I think one must be terribly careful to be as brief as possible. If you get a good idea you must deal with it rapidly, despite the fact that you might be able to carry on amusingly for a long time."

Mr. Archibald de Bear's revue, on the whole, was very good. It was bright and snappy, although some of his artists seemed to be treating the whole performance rather carelessly. But one could see that the planning of the revue was on the right lines, for no item was carried on for an excessive length of time, and the result at the end of the programme was one of variety, humour, and a fairly good sustained interest.

Finding New Microphone Talent

However, it is very unlikely that anything serious will come of this so-called warfare between the B.B.C. and the theatrical interests. Whatever happens, the B.B.C. will not be hindered in progressing nor will their programmes suffer very much, if at all, if a ban is placed on theatre and music-hall artists with regard to broadcasting. It is a fallacy to assume that a successful music-hall comedian will also make a successful radio comedian. The technique of the music-hall comedian depends so

much on personality and the appeal to the eye.

For instance, though Mr. George Robey on the stage can be extraordinarily funny, and he has a well-deserved reputation for being a great comedian, that does not mean that he can maintain that reputation as a radio comedian broadcasting from a studio with only his voice, his patter, song, etc., to hold the interest and amusement of his listeners.

The B.B.C. realise this and they are devoting a considerable amount of trouble, time and money to the seeking out of new talent and for the training of this talent specially for studio purposes. In time, no doubt,



Listening-in at Keston before relaying one of the Tuesday evening 2 XAF concerts from Schenectady, N.Y.

the B.B.C. will have its books filled with a very large list of artists who have developed the special technique necessary for amusing broadcasting audiences, and there will be no need to make offers to variety and theatrical people who, after all, will always be at their best on their own legitimate medium, the stage.

POPULAR WIRELESS

Gives all that's best in British Radio.

IMPARTIAL,

ENTERPRISING,

AND UP-TO-DATE.

EVERY THURSDAY - PRICE 3d.

A VALVE TIP

OWING to the methods of standardisation employed by manufacturers to-day, valves of the same type do not differ appreciably from one another in their working characteristics. In fact, if half a dozen of the same batch are tested out it will generally be found that their curves are practically identical. There is, however, one point in which they may differ considerably, and this is in the extent of their microphonic qualities. You may, for example, find amongst a batch of dull emitters that though none of them is remarkably microphonic, one or two are much better in this respect than all the rest.

Choose Your Detector

Now, in the wireless receiving set it is always the rectifier that is most likely to produce microphonic effects, as you can discover for yourself by tapping each of your valves in turn with a finger nail. You will probably find that little or nothing is heard when the H.F. or L.F. amplifiers are treated in this way, but that the rectifier produces some kind of a pong—sometimes a very loud one, indeed.

Clearly, then, it is good practice to choose as rectifier the least microphonic valve that you can find.

Why it Howls

If a very microphonic valve is used as rectifier it may lead to unpleasant noises in the loud speaker when the set is subjected to the slightest jarring. These may occur when a person walks across the floor of the room, and in very bad cases an audio-frequency howl may be set up through the impact of sound waves from the loud speaker upon the rectifying valve. In such instances the microphonic noises are amplified and passed back to the loud speaker, setting up stronger sound waves at the resonant frequency, which travel through the air to the valve. A howl is thus started which may build up to deafening proportions.

By exercising care in the choice of a rectifier, microphonic troubles may to a very great extent be eliminated. One thing is quite certain; whatever kind of holders are used for the other valves, that in which the rectifier is mounted should certainly be of the shock-absorbing kind.

The RESISTANCE THREE

By
A. JOHNSON-RANDALL

An easily made and easy-to-operate receiver that a novice can build, and which cannot fail to give good results if the instructions given in the following article are carefully followed.



ABOUT two years ago I described a receiver designed for those listeners whose chief interest in broadcasting was to obtain faithful reproduction from the local station. This set employed three resistance-coupled L. F. stages and was given the title "Resistance Four."

Many enthusiastic constructors wrote to me in appreciation of the results obtained, some of them stating that they had been anxiously awaiting the publication of such a set before laying aside their headphones in order to enter the "loud-speaker class."

Since that period I have tried a multitude of L. F. circuits, and the "Resistance Three" is, I consider, one of the best "local station" combinations that it is possible to obtain at the present time.

Range

The receiver itself has been made up twice, each layout differing in regard to the make and position of the components. The results have been identical in each case. The set exactly as described is employed regularly for the reception of 2 L O at a distance of 15 miles. Using a good "crystal" aerial it operates two "cone" loud speakers in series at good strength. There is only one tuning control, the set will not interfere with others, and it may be said with certainty that if the constructor can obtain reasonably good telephone signals from the local station when using a crystal receiver, then the "Resistance Three" will give him satisfactory loud speaking.

Slightly greater amplification could have been obtained by using a resistance stage followed by a transformer, but the even frequency amplification obtained with pure resistance coupling makes the small loss well worth while,

particularly if the set is to be used only for reception from the local station. For all-round work, however, including the reception of very distant stations, I consider the resistance-transformer combination very hard to beat. This also applies when the input to the L.F. side is likely to be of considerable magnitude, as would be the case if two or more efficient H.F. stages preceded the detector valve.

In designing a set employing resistance coupling many points have to be considered. One of them concerns the method of rectification to be used. Another is to decide what values of anode resistances, grid resistances and grid condensers will give the best all-round results with the valves available at the present

time. Regarding the first point, viz. that of rectification, I decided to employ the anode-bend method. The more popular means of detection by the use of a grid condenser and leak is acknowledged to be inefficient from the standpoint of quality when compared with anode-bend rectification.

Anode Rectification

It is true that when the bottom-bend method is employed with the average high-impedance valve and L. F. transformer, quality is not by any means satisfactory. This is due, however, not to the system of rectification employed, but to the fact that the valve impedance and the transformer primary impedance are unsuitable.

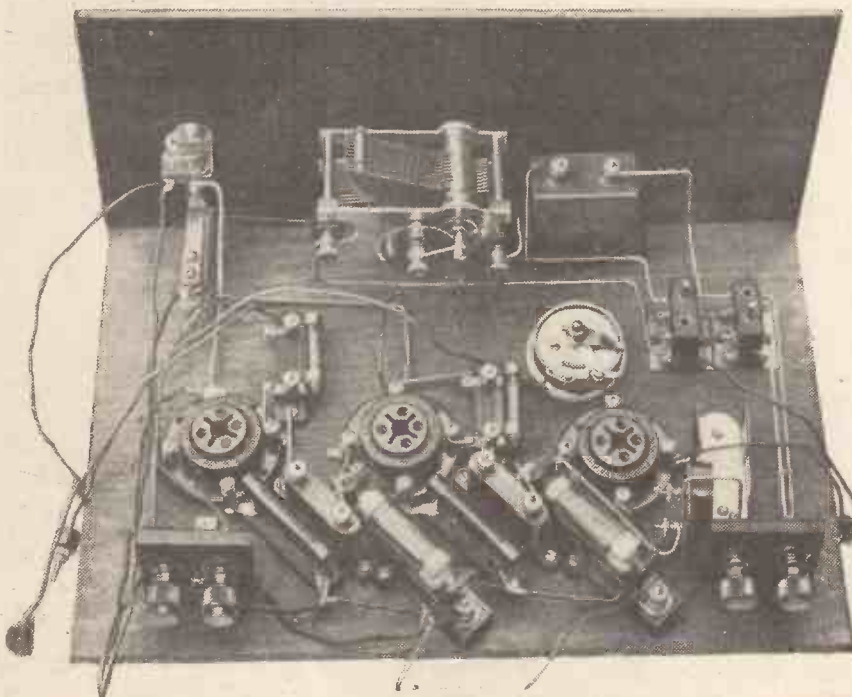

A general view of the baseboard layout and wiring of components.

The Resistance Three—continued

COMPONENTS REQUIRED

- 1 cabinet, 14 in. × 7 in. × 9 in., with baseboard (Cameco).
 - 1 insulating panel, 14 in × 7 in. × $\frac{1}{8}$ in. (Cameco).
 - 1 small angle bracket of the stair-rod type.
 - 2 baseboard-mounting coil holders

 - 1 grid-battery clip, 4½-volt size (A.F. Bulgin).
 - 2 short strips of ebonite 2 in. × 2 in., two small securing angle brackets, and four Belling-Lee terminals, marked, Aerial, Earth, L.S. + and L.S. —.
 - 3 valve holders (C.E. Precision anti-phonetic).
 - 2 "Dumetohm" holders and two 2-meg. grid leaks
 - 2 .01 mica fixed condensers
 - 2 wire-wound anode resistances with holders. (See note on this page.)
 - 2 fixed-resistors to suit valves (Burne Jones & Co., Ltd.).
 - 1 baseboard variable 30-ohm resistor (A.F. Bulgin).
 - 1 double-circuit jack (Igranic-Paceni).
 - 1 "Yaxley" switch (R.A. Rothermel).
 - 1 .0005 S.L.F. slow-motion condenser (Jackson Bros.).
 - 1 .0002 fixed condenser, Type 610 (Dubilier).
 - 1 2-mfd. Mansbridge-type condenser (T.C.C.).
 - 4 negative plugs (3 for grid bias and one H.T. —).
 - 4 positive plugs (2 grid bias and two H.T. +).
- Some flexible wire and Glazite for wiring.

It is, as a matter of fact, practically hopeless to expect first-class quality from an anode rectifier and the average transformer.

With a resistance in the anode circuit of the detector valve this does not apply, and all the good points of

It is as well to point out, however, that the use of these high resistances tends to lower the amplification of the higher musical frequencies, and I find that a good all-round combination consists of a .5 megohm resistance in the anode circuit of the

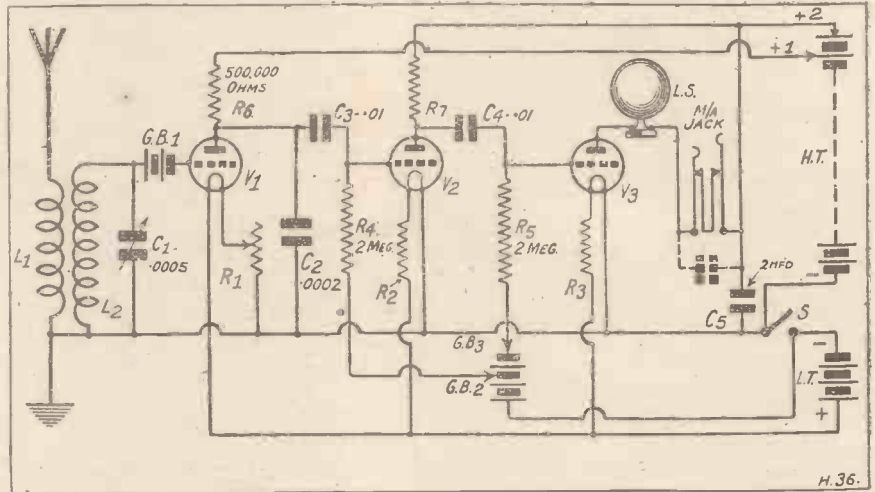

anode rectification can be obtained with beneficial results to quality. In order to ensure maximum magnification, the anode resistances finally chosen had a value of .5 megohm. These were inserted in the set after several other values had been tried and the amplification obtained is very close to the theoretical magnification of the valve itself.

detector with a .1 megohm resistance in the first L.F. stage. The magnification is, of course, not so great. I have also found that the .5 megohm resistance in the detector circuit can be replaced by a good quality half-megohm grid leak, a point which is worth bearing in mind when the cost is a consideration. A good grid leak is quite silent.

The grid condensers employed have a value of .01, and readers will note that I have specified the mica type. This is very important since defective insulation here will permit a positive potential to be impressed upon the grids of the L.F. valves with detrimental results.

Using a Milliammeter

The values of the grid resistances are 2 megohms. A lower value will reduce the amplification and a higher value may produce "choking."

On the panel of the receiver you will notice a double-circuit jack which is included to enable you to plug a milliammeter into the anode circuit of the last valve. If you possess a milliammeter reading up to about 20 milliamperes, the procedure is to attach a flexible lead to the terminals of the instrument, taking the remaining two ends to an ordinary 'phone plug.

In this way the milliammeter can be inserted in circuit when it is desired to check quality.

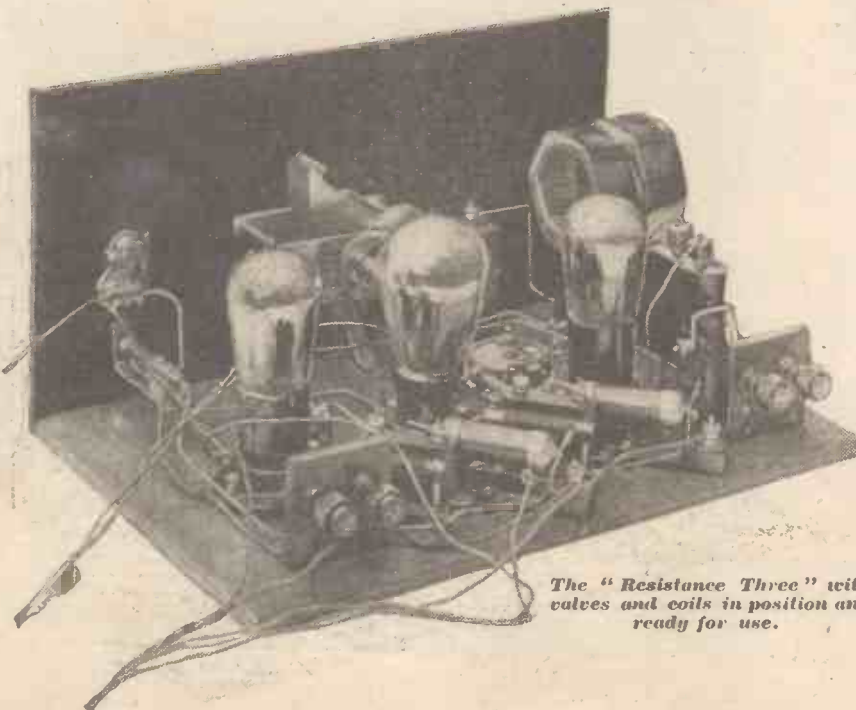

The "Resistance Three" with valves and coils in position and ready for use.

The Resistance Three—continued

In practice the needle should take up a position determined by the H.T. voltage and grid bias you are employing.

During the transmission there should be no variation on either side of this steady value. I mean by this that apart from an occasional slight flicker

the local station, the chances of running into another station when mistuning slightly are very remote.

I have not included an output transformer in the receiver because of the large variety of different loud speakers in existence. If an output transformer is to be used, I recom-

Construction

The actual construction of the receiver is really a very simple matter, partly owing to the easy panel layout. The variable condenser is placed in the centre, and the filament switch and jack at a convenient distance from the right-hand end (looking at the front). Only three holes are necessary, since these three components are of the one-hole fixing type.

The variable condenser requires a $\frac{3}{8}$ -in. hole, but the switch and jack need $\frac{7}{16}$ -in. holes for easy mounting. Two $\frac{3}{8}$ -in. holes, reamed out, will suffice, if a $\frac{7}{16}$ -in. drill is not available. The jack used is, I believe, of American manufacture, and most English makes require a $\frac{3}{8}$ -in. hole. Any jack of reputable make will be quite satisfactory.

Mounting the Components

The panel is secured to the baseboard by three wood-screws along the bottom edge, and by a single small angle bracket in the centre. These small brackets may be purchased at the local ironmongers.

After having drilled the panel and secured it to the baseboard, mount on it the three components mentioned, and then proceed with the baseboard layout.

The positions of the components on the baseboard do not appear to be particularly critical, but it is as well to follow the general scheme shown in the photographs.

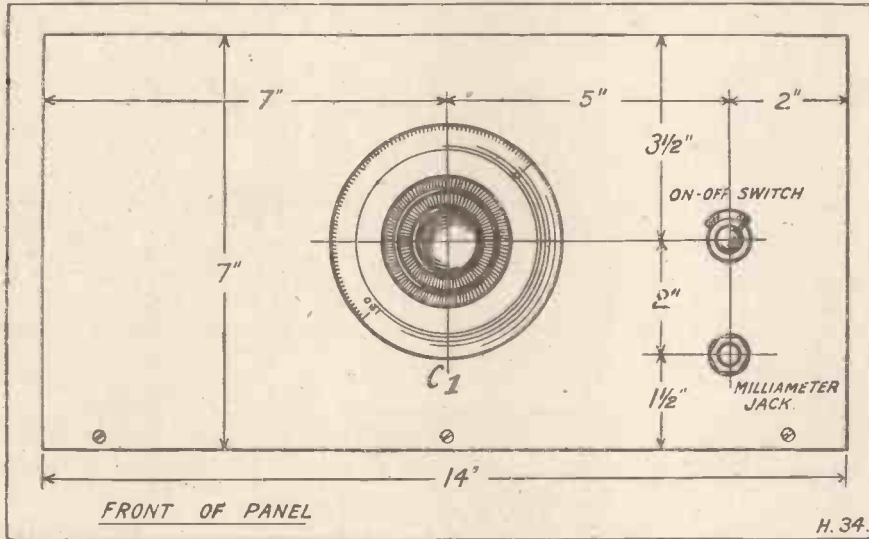

of perhaps half a milliampere above or below this mean value, no violent kicks should occur.

At least 120 volts H.T. should be used, and the grid bias adjusted in conjunction with the milliammeter. If no alteration of grid potential stops violent kicks from the needle you are possibly using a valve with an unsuitable characteristic. This may occur if the signals are very loud. I use a super power valve with $22\frac{1}{2}$ volts grid bias, and the needle is perfectly steady. A very lightly damped needle will, of course, have a tendency to kick more than a heavily damped needle.

Controlling Volume

If you do not possess a milliammeter, the jack can be included until such time as you may decide to purchase one. If you are in a position to use a higher value of H.T. than 120 volts, by all means do so: 160 volts will give superior results.

The tuning control consists of a single variable condenser, and the reader may ask why a slow-motion type has been used.

I decided that such a device would form a very convenient control of volume, since, with a set of this type, designed solely for reception from

mend its employment as a separate unit, unless, of course, the set is to be used with one particular loud speaker. In any case, only a few loud speakers require this refinement. It is good practice to use one in conjunction with the Western Electric type "Kone", for instance, although no harm results if this loud speaker is connected directly in the anode circuit.

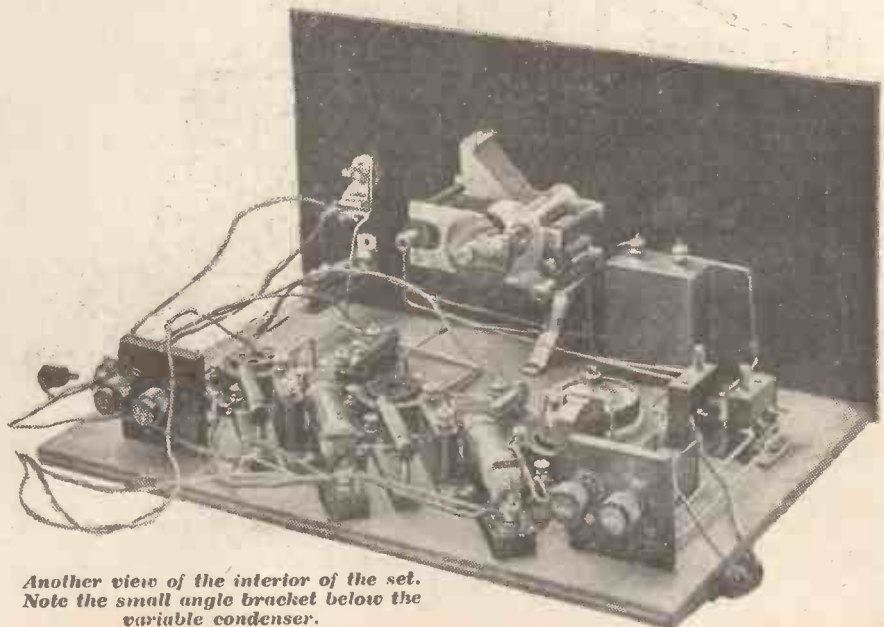

Another view of the interior of the set. Note the small angle bracket below the variable condenser.

The Resistance Three—concluded

above this I can secure to the inside of the case another 9-volt battery if necessary, thus using the two in series for a super-power valve.

Another plan would be to run the batteries on a bracket along the back of the cabinet, taking the grid bias

15 volts negative bias are required. After all, the cabinet design is largely a matter for the individual taste of the constructor. Many prefer more elaborate types, made in accordance with their own ideas.

Wiring-Up

Wiring-up the set should present little or no difficulty.

For the L.T. and H.T. leads I recommend an insulated wire such as Glazite, since the danger of short circuits is thus minimised. For the other wiring, apart from the flex leads, tinned copper busbar, well spaced, is quite satisfactory.

The leads from the H.T. and L.T. batteries consist of lengths of ordinary lighting flex. These are taken direct to the terminals concerned. In

filament voltage, current consumption, and voltage of the accumulator are given.

Operation

To operate the receiver, connect up aerial and earth and also the loud-speaker leads to the terminals marked. Place three valves in the valve holders, using a high-magnification type for the detector and another for the first L.F. stage. In the last socket insert a good low-impedance power valve.

Insert the grid-bias plugs to the L.F. grid battery in accordance with the valve maker's instructions, and connect up the H.T. battery.

Place a No. 35 or 40 coil in the aerial coil socket and a No. 60 in the grid-circuit coil holder. Use about 3 volts negative bias on the detector valve to start with and rotate the variable condenser until the local station is heard. For those with small aeri-als a larger aerial coil may be necessary for the best results. This is a matter for experiment. Tune in the local station as loudly as possible and then adjust the detector valve. You will find that it is possible to operate this valve with a considerable amount of filament resistance in circuit, so try varying the moving arm on the rheostat. Use about 100-120 volts H.T. and try different adjustments of the detector negative grid-bias plug.

Results

I have had this receiver in use for some time. The aerial consists of a single wire 100 feet in length, including the lead in, and situated approximately 15 miles S.E. from 2 L O.

For the first L.F. valve I use a D.E.5B, P.M.5X, or Cossor 6-volt H.F.

In the last socket I prefer a really low-impedance valve, and I have recently been using a P.M.256. Other valves with suitable characteristics are the D.E.5A, L.L.525 and Stentor Six. With the two L.F. valves I like to use a high value of H.T. such as 150 volts.

For the detector use one of the special high-magnification valves designed for R.C. coupling.

For the reception of Daventry I use a Gambrell E1 coil in the aerial socket and an F in the grid coil holder. In the numbered types this would be approximately equal to a No. 150 and a No. 250 or 300 respectively.

WIRING INSTRUCTIONS

Join aerial terminal to pin of aerial coil holder and join socket of same to earth terminal.

Join socket of aerial coil holder to pin of grid coil holder, thence to moving vanes of tuning condenser, to L.T. negative terminal on V_2 valve holder, and to one side of 2-microfarad condenser.

Join fixed plates of tuning condenser to socket of grid coil holder and to short length of flexible wire with red plug for detector grid battery positive (+).

Join short flexible lead with black plug to grid terminal of V_1 valve holder. This is detector grid battery negative.

Join one side of each of the two fixed resistors R_2 and R_3 to positive filament terminals of valve holders V_2 and V_3 . Connect a common lead to the remaining tags of these two fixed resistors and also direct to the positive filament of the V_1 valve holder. The red lead of a length of twin flexible wire has one of its ends joined to this common positive lead. This is L.T. +.

The black lead of the length of twin flexible for L.T. - goes direct to one side of the filament switch S, the same side of which has a short length of flex terminating in a red plug for grid bias +. The other side of the switch goes to negative filament of V_3 , negative filament of V_2 , and to one of the tags on the variable resistor R_1 . The other side of R_1 goes to filament negative of V_1 .

Filament negative of V_2 valve holder is joined direct to a length of flexible wire for H.T. -.

One H.T. + flexible lead is joined to one side of the first anode resistance R_6 . The other side of R_6 goes to the anode of V_1 , and to one terminal of the .01 grid condenser C_3 .

The other terminal of C_3 is joined to the grid side of the "Dumetohm" holder R_4 and to the grid terminal of the V_2 valve holder.

The remaining terminal of the "Dumetohm" holder is joined to a length of flexible wire terminating in a black plug for the grid-bias negative to V_2 .

The anode of the V_1 valve holder is also joined to one terminal of the fixed condenser C_2 , the other terminal of which goes to earth.

The second H.T. + flexible lead goes to one side of the remaining anode resistance R_7 , the other side of which is connected to the anode of the V_2 valve holder and to one terminal of the .01 condenser C_4 . The remaining terminal on this condenser goes to the grid of the last valve V_3 and to one terminal of the remaining "Dumetohm" holder. The other terminal on this holder is joined to a length of flexible wire terminating in a black plug for grid-bias negative to the last valve.

A length of flex is joined from the H.T. + side of the second anode resistance R_7 to the upper contact of the milliammeter jack, which is also connected to the remaining terminal of the 2-microfarad condenser.

The two middle contacts of the jack are joined together. The bottom contact goes to the loud-speaker + terminal on the baseboard. The remaining loud-speaker terminal is joined to the anode of the valve holder V_3 .

flex leads through and underneath the baseboard in order to clear the wiring. These suggestions, of course, only apply in cases where more than



The resistances and coupling condensers are so placed that exceedingly short grid and plate connections are obtained.

practice it is a very simple matter to tie them down to the baseboard at a convenient point by means of a small clip or piece of arched wood, faking them to the batteries through a single 1/2-inch hole in the back of the cabinet. This is what I actually do. The aerial and earth leads are taken through another hole and so also are the two loud-speaker or output leads.

Fixed Resistors

The values of the two fixed resistors depend upon the types of valves used. There are so many different valves on the market that it is impossible to give values to suit all of them. The makers of the resistors will supply the correct value if the

FURTHER NOTES ON THE TRICKLE CHARGER

This article continues the discussion on Trickle Charging which commenced in the February issue of the "Wireless Constructor."

By Dr.
J.H.T.ROBERTS,
F.Inst.P.
(Scientific Consultant.)

CONTINUING the recent discussion upon Trickle Charging we now come to the charger itself. This consists (assuming the supply to be alternating current) of a small step-down transformer combined with a rectifier. The rectifier should preferably be of the electrolytic type, as this requires practically no attention—at any rate, no more attention than is required by the battery itself.

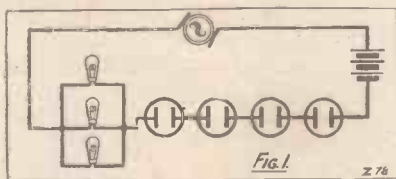

The transformer may have a single secondary or low-tension coil, or it may be of the split-secondary type, which is equivalent to two secondaries in series. If the transformer is of the single-secondary type, the electrolytic rectifier may have only two electrodes, one a passive or neutral electrode and the other the rectifying electrode, in which case single-wave rectification will be obtained.

Full-Wave Rectification

Or else three or four rectifying cells may be used, arranged in what is known as the Gratz or bridge formation, in which case double-wave or full-wave rectification is obtained. For a given voltage developed at the terminals of the secondary of the transformer, the current passed through the battery will be approximately twice as great when a full-wave rectifier is used as when a single-wave rectifier is used, or, putting the matter in a different way, to obtain a given current with a

single-wave rectifier a higher voltage must be used than with a double-wave rectifier.

The use of a transformer with a double or split secondary, however, is more satisfactory than either of the arrangements just mentioned, and in this case the whole of the rectifier may be contained in a single cell, one neutral electrode being used and two rectifying electrodes.

Correct Polarity Essential

The centre of the secondary is connected (via the battery to be charged) to the neutral electrode of the rectifier (a suitable ammeter being preferably also inserted in this arm), whilst the two ends of the secondary

are connected directly to the two rectifying electrodes. Of course, when I speak of the battery being connected in circuit I mean to one pair of end-terminals of the double-pole double-throw switch. Care should be taken to ascertain the polarity of the rectified current delivered from the rectifier, so that the battery may be introduced into circuit in the correct sense.

The Rectifier

For the rectifier there are several types from which to choose, one of which is the well-known aluminium-in-borax or ammonium-phosphate solution, which, although it has rather a high internal resistance, operates quite well at very small currents. Another and much more efficient rectifier is the tantalum-in-sulphuric-acid



A practical form of tantalum-electrode trickle charger.

Further Notes on the Trickle Charger—continued

rectifier. This latter rectifier has a very low internal resistance, and consequently the energy losses in the rectifier are comparatively small, as is proved by the fact that the rectifier, even using quite a small quantity (say 4 oz.) of electrolyte, will pass half an ampere indefinitely without getting more than slightly warm. The tantalum rectifier consists in its simpler form of a lead electrode and a very narrow strip of tantalum immersed

development, and which shows excellent results on extended test, but I cannot say any more about this at the moment. When the tests are complete this new rectifier will be fully described.

There are two questions with regard to trickle charging which are very frequently asked by amateurs and which I may as well answer right away.

The first one is: Does the tiny current really charge up the accumulator plates as effectively as a heavy current? The second question is: When using the trickle-charging arrangement is there not a danger, if the charge and discharge are not accurately balanced, of the battery, in course of time, being either heavily overcharged or more and more discharged, according as the charging rate exceeds or falls below the discharge rate?

extent "living on its own fat" or "eating into its own bank balance," to use homely phrases. This again is a matter which is very easily corrected, for the actual trickle current may be increased (by means of an adjustable resistance or otherwise), or once a fortnight the set may be given a day's holiday, the trickle charger being left working.

There is nothing really new or revolutionary in this system of trickle

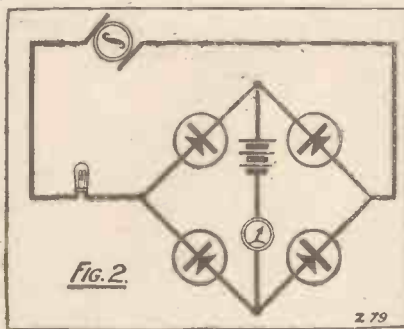

in dilute sulphuric acid of ordinary battery strength, the lead being the neutral electrode and the tantalum the rectifying electrode. For full-wave rectification, using a split-secondary transformer, the rectifier consists of a single lead electrode and two tantalum electrodes, the lead electrode being connected through the battery and ammeter to the centre point of the transformer secondary, whilst the two tantalum electrodes are connected directly to the two ends of the transformer secondary.

It should be mentioned that certain patents exist with reference to the tantalum rectifier, and the constructor desiring to use a rectifier of this type

Two Pertinent Points

In answer to the first of these questions, the trickle charge is not only just as effective as a heavy charge in reconditioning the accumulator plates, but it actually has advantages over the heavy-charge method. The reconditioning of the plates which takes place during charging is purely an electro-chemical matter, and there is a definite relation between the amount of chemical action which takes place and the quantity of electricity which passes through the cell, whether the rate of charge be great or small. On the contrary, the heavy rate of charge is apt to disintegrate the plates and loosen the paste.

Dealing with the second question, it is better to arrange that the charging rate is slightly in excess of the estimated requirements. This ensures that the battery is not, as it were, falling more and more behind in the race. It does mean that the battery will occasionally be slightly overcharged, but this is a matter of no practical importance, for even if the charging current be left on for, say, six hours after the battery is fully charged, this only represents (assuming a charging current of one-tenth of an ampere) a total of about one-half ampere-hour.

On the other hand, if more electricity is taken out of the battery than the trickle charger can put back per day the battery will be to some

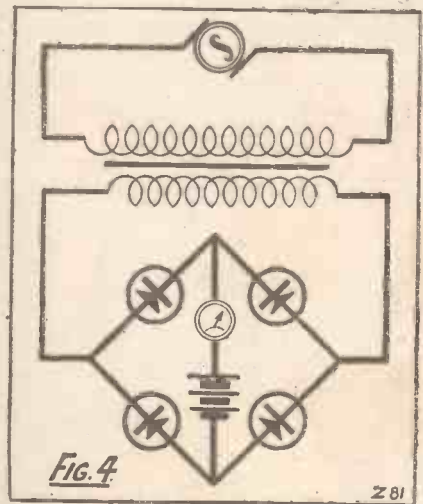

charging, and it is based upon the very simple "discovery" that a small current for a long time yields precisely the same results as a large current for a short time. Like many simple truths, it is perfectly obvious when pointed out. Such is the force of habit, however, that it has taken people quite a long time to waken up to a realisation of this very simple fact.

The Average Discharge

The idea or principle of trickle charging, as I have explained, is to use a charging arrangement which delivers a very small current, so that when the charging current is left on for (say) 20 hours, it puts back into the battery the same amount of electrical energy which has been drawn from the battery during (say) four hours' use of the wireless receiving set. In this way the battery stands every evening "ready for its work," so to speak, having in the 20 odd hours since the previous evening received a charge balancing the energy taken out of it on the previous occasion.

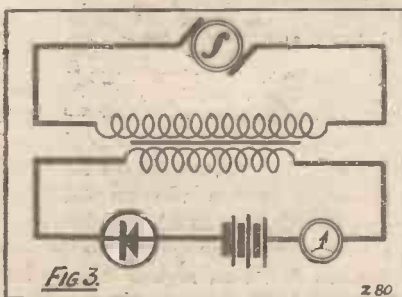

should satisfy himself that he is not infringing any patent rights.

There is also another very efficient and advantageous rectifier which has recently been placed in my hands for

Further Notes on the Trickle Charger—continued

Whereas ordinary charging rates for wireless batteries vary between 2 amperes and 6 or 7 amperes, an average value for a trickle-charging rate will be 0.1 ampere to 0.25 ampere. The first-mentioned rate will obviously give a total in 20 hours of 2 ampere hours, and the second will give a total in 20 hours of 5 ampere hours. There are not very many modern wireless receiving sets that consume much more than 1 ampere for the valve filaments, and therefore a total consumption of 5 ampere hours in an evening's working may be taken to represent decidedly above the average.

For A.C. Mains

We therefore have to provide for a current in the neighbourhood of 0.1 to 0.25 ampere running steadily through the battery whenever the battery is not actually in use on the set.

Perhaps I ought to explain at once that trickle charging from ordinary direct-current mains, although it may be a convenient method, does not result in any saving, as the current

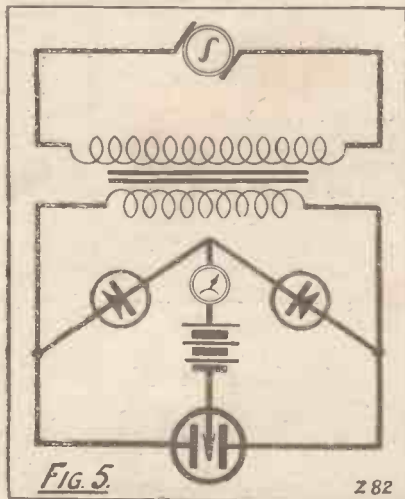

(apart from the use of any particular type of battery charger) is drawn directly at the voltage of the mains (say 200 volts), and therefore it makes no difference to the total energy consumption whether a current is drawn at 0.1 ampere for 20 hours or 2 amperes for 1 hour.

The trickle-charging system is more particularly useful on alternating current mains, where advantage may be taken of the step-down transformer principle.

In Fig. 1 is shown a simple arrangement working straight from the A.C. mains without any step-down transformer. In this figure will be seen a set of four electrolytic rectifying cells in series, the 6-volt battery to be charged and a balance lamp resistance

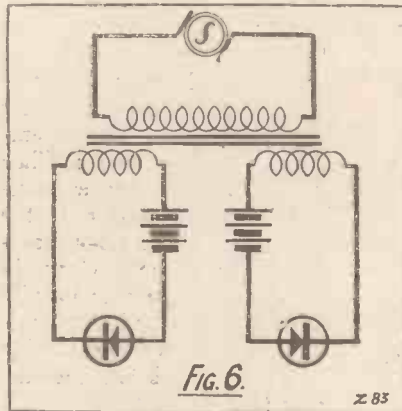

being also included in series with the rectifier. If the current delivered through a single electric lamp is not sufficient, extra electric lamps may be placed in parallel with the first one to reduce resistance and so to increase the charging current.

The number of four rectifiers is taken at random; the actual number required in such a case will depend upon the "back electro-motive force" which each individual rectifier can withstand. If the voltage of the mains is 200 volts (say), there will be (when the current is trying to go through the battery in the "wrong" direction) about 200 volts against the set of rectifying cells, that is about 50 volts against each. If the cells are of a type which will withstand more than that amount, a smaller number of such rectifying cells may be used, and *vice versa*.

The Gratz Method

The arrangement shown in Fig. 1 is more by way of explanation than by way of indicating a method which would, in practice, be used.

In Fig. 2 is shown another arrangement, which is sometimes called the "Gratz," by means of which both halves of the alternating current wave are utilised. You will notice that in each of the four rectifying cells one of the electrodes is indicated by an arrow and the other by a bar. The arrow is intended to indicate the direction in which current

can pass through the rectifying cell. For example, supposing the rectifying cell happened to be a tantalum-lead cell, the current would be able to pass into the cell via the lead electrode and out at the tantalum electrode, but *not in the opposite direction*, and so in Fig. 2 the arrow electrode in each cell would represent the lead and the other electrode would be the tantalum.

Utilising Both Halves

In Fig. 2 you will see that the current can pass up the top left-hand arm of the "bridge," through the battery section in a "downward" direction ("downward" in the figure, that is) and along the lower right-hand arm. It cannot pass through the other two arms of the "bridge." When the current reverses, it is only able to pass up through the top right-hand arm, down the central battery arm and along the lower arm. The important point is that, in each case, it passes in the same direction through the battery, which thus receives a charging current from both halves of the wave.



A successful American charger with which the charging rate can be varied over wide limits.

The arrangement shown in Fig. 2, although it has the advantage of giving full-wave as distinct from half-wave rectification, is no better than that in Fig. 1 as regards energy consumption, for, as you will see in Fig. 2, the voltage at which the charging current is drawn is the full voltage of the mains, no step-down transformer being used. A lamp used as a resistance is indicated in the figure, which may be employed for the purpose of

WHEREVER RADIO PARTS ARE WANTED—USE LISSEN

NO matter what may be mentioned or used in any circuit of any booklet or periodical you may be building from, remember that the best parts have not necessarily been used. There are many advertising manufacturers—all expect a share in the use and mention of their products, and they usually get it. LISSEN gets a share, too, but obviously it is not possible for the periodical to use all one maker's parts, although they may be known to be the best. Remind yourself of that when building—remember, too, that the best parts are LISSEN, and that if you build with them you will use all the energy available, and get louder, clearer signals from near and far in consequence.

FACTS OF IMPORTANCE ABOUT LISSEN PARTS—

LISSEN SWITCHES

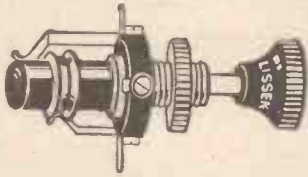

LISSEN
2-way Switch.

There is one for every switching need in radio. Designed for radio work where currents are small—they will not waste current. They fit easily—take up little room. LISSEN ONE HOLE FIXING OF COURSE.

	Previously	NOW
LISSEN 2-way	2/9	1/6
LISSEN Series-parallel	3/9	2/6
LISSEN Double Pole Double Throw	4/-	2/6
LISSEN Key Switch	2/6	1/6

LISSEN FIXED CONDENSERS



Fixed condensers should be leak-proof, and if they are LISSEN which DELIVER ALL THEIR STORED UP ENERGY ALL THE TIME, nothing is lost. Note the case in the LISSEN condenser, how it can easily be used upright or flat. Then the price of LISSEN FIXED CONDENSERS is half what it was a year ago. The plates are properly laid in a LISSEN—they are homogeneous with each other, and cannot move or come apart. Capacities .001 to .001, 1/- each (much reduced). Capacities .002 to .006, 1/6 each (much reduced).

DEMAND LISSEN FIXED CONDENSERS.



LISSEN VALVE HOLDER

Has both low losses and also low capacity, twin virtues found in few valve holders. Sent out ready for baseboard mounting but can also be used for panel mounting by bending springs straight.

Patented, Previously 1/8.
NOW 1/-.



LISSEN FIXED GRID LEAKS

They do not alter—they are perfectly silent. You can put a LISSEN half-megohm leak in circuit direct on to a 220 volt supply and leave it on indefinitely—it will not alter. It can then be put straight into a critical radio circuit—it will be absolutely silent. LISSEN grid leaks have been further tested by exposure to rain and sun on the roof of the LISSEN factory. They never altered, never varied. Patented.

All resistances—Previously 1/8, NOW 1/- each.

BASEBOARD RHEOSTATS

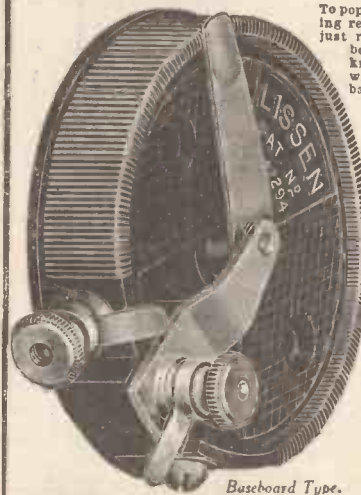

Baseboard Type.

Reduced from 1/6 to—

To popularise baseboard mounting resistors, LISSEN has now just reduced the price. Baseboard type are without knob, dial and pointer, which are not needed for baseboard.

	From	Jan.
Previously	24	
Prices 7 ohms 2/6	1/6	
35 ohms 2/6	1/6	
400 Potentiometer	2/6	1/6

QUALITY RHEOSTATS FOR PANEL MOUNTING—previously 4/- NOW 2/6

LISSEN quality—look how they are made, and note the irresistible appeal of price.

	Previously	NOW
LISSEN 7 ohms, pat. ...	4/-	2/6
LISSEN 35 ohms, pat. ...	4/-	2/6
LISSEN DUAL, Pat. ...	6/-	4/6
LISSEN Potentiometer, pat. ...	4/6	2/6

LISSEN ONE HOLE FIXING, OF COURSE.



LISSEN COMBINATOR

Into it fixed condensers and resistances can be clipped in a moment and a complete resistance capacity unit quickly formed. Useful for mounting condenser and grid leak in the ordinary way without soldering, although soldering tags are also provided. PRICE 1/-

HOW TO MAKE H.T. BATTERIES LAST LONGER.

Every ordinary H.T. battery can be made to yield more energy if a LISSEN 2 mid. (or 1 mid., but the larger capacity is the better) is put across it. It will absorb all the noises when the battery gets old. Your dealer will be pleased to show you how to connect it easily.



LISSEN (Mansbridge type) Condenser
2 mid. 4 8 ; 1 mid. 3 10.

.01	2 4	1	2 6
.025	2 4	.25	3/-
.05	2 4	.5	3/4

Specially moulded case makes it impossible for the condenser to short circuit on to case—a feature exclusive to LISSEN.

USE ANY CIRCUIT BUT ONLY LISSEN PARTS, NO MATTER WHAT ELSE MAY BE NAMED, and you will gain in volume and eliminate distortion. LISSEN PARTS—WELL THOUGHT OUT, THEN WELL MADE.

LISSEN LTD., 26-30 FRIARS LANE, RICHMOND, SURREY

Managing Director: THOMAS N. COLE.

L.215A

Further Notes on the Trickle Charger—continued

limiting the current. Alternatively, a choke coil may be used for the same purpose.

In Fig. 3 a much superior arrangement is shown, in that the voltage of the mains is stepped down by means of a step-down transformer to a value more in the region of the voltage of the battery to be charged. Here a single rectifying cell is shown in series with the battery, and with an ammeter which indicates the value of the charging current.

Rectifier Resistance

Fig. 3 shows a single-wave rectifying arrangement, one-half of the wave being extinguished. The voltage which it will be necessary to generate in the L.T. or secondary winding of the step-down transformer will depend upon the voltage of the battery to be charged and upon the resistance of the rectifier. In the case of a tantalum electrolytic rectifier, the resistance in the "right" direction is comparatively low, and a total voltage of about 12 volts A.C. developed at the secondary of the transformer will be suitable. In the case of the conventional aluminium-iron-in-ammonium-phosphate rectifier the resistance will be much higher and a correspondingly higher voltage will be necessary, with, of course, greater energy losses.

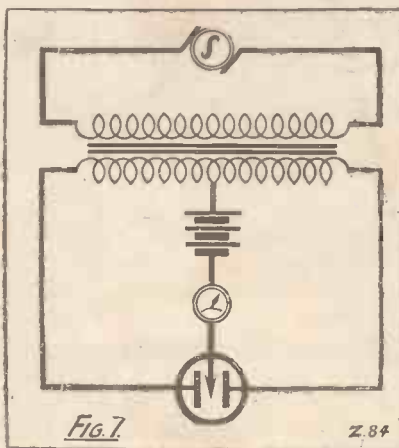

In Fig. 4 an arrangement is shown similar to that in Fig. 2, except that a step-down transformer is used, with consequent great economy of electrical energy consumption, and full-wave rectification is obtained. It should be noted that with the Gratz arrangement, as shown in Fig. 2 and in Fig. 4,

the current through the battery is always passing through *two* rectifying cells in series. In the arrangement, as shown in Fig. 2, where a high voltage is available, this is of little importance; in fact, it may even be

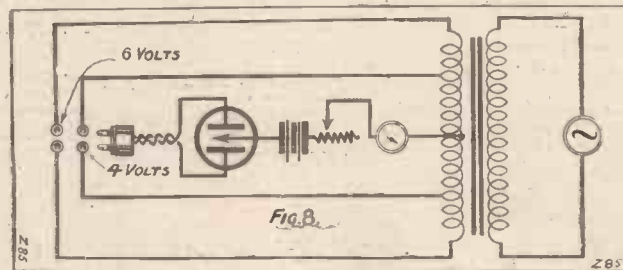

necessary to introduce two or more rectifying cells in each arm of the "bridge" so that the current which is trying to pass in the "wrong" direction is always "up against" a sufficient number of rectifiers.

But in the arrangement in Fig. 4, where the voltage used is intended to be as low as possible, the fact that the combined resistance of two rectifiers in series has to be overcome is somewhat of a disadvantage.

In Fig. 5 is illustrated an arrangement precisely similar to that in Fig. 4, except that two of the rectifying cells are combined together into a single vessel. The two which are capable of being combined are the two which have their neutral electrodes connected together. For example, in Fig. 2 the two rectifiers in the two *lower* arms would be capable of being combined together in a single vessel. In the case of tantalum rectifiers the combined vessel would contain one lead electrode and two tantalum electrodes. The point to be noticed is that the two outside electrodes of the three which are introduced into the common vessel must be such that the current cannot flow directly across from one to the other. This will provide the answer to a question which no doubt has already arisen in the reader's mind, namely, as to why the remaining two cells cannot be combined into a single one.

A Convenient Arrangement

In all the arrangements shown in Figs. 1 to 5 we have been dealing either with current straight from A.C. mains or with current from a step-down transformer with a single—

that is, untapped—secondary winding. With such a single winding, if we want to obtain full-wave rectification, it is necessary to employ the Gratz arrangement either in the four-cell or in the three-cell type, as

indicated in Figs. 4 and 5 respectively. It is possible to obtain full-wave rectification much more conveniently, however, by using a transformer with a "split" secondary, that is with a secondary which has a centre tapping. Of course, such a transformer is not always available, and if an ordinary transformer only is available the Gratz arrangement is quite a useful one.

But in setting out definitely to build a rectifier for trickle-charging purposes it is better to make up a centre-tapped transformer which reduces the need for multiple rectifying cells.

Continuous Charging

Fig. 6 shows the centre-tapped secondary of the transformer in two parts. This is not intended to represent an arrangement which would actually be used, but is merely for the purposes of explanation. It will be seen that each of these two parts is exactly the same except that the rectifiers are in the opposite sense, so that when the alternating current is passing in one direction the left-hand circuit is charging its battery, whilst when the current reverses the right-hand circuit is charging *its* battery.

Now let us pass on to Fig. 7, which shows the two secondary circuits of Fig. 6, and also the two batteries and the two rectifiers all respectively combined. This arrangement, shown in Fig. 7, is actually the best arrangement with a rectifier of this kind. If the rectifier is of the tantalum type the central electrode will be a lead electrode and the other two tantalum electrodes. If it is of the aluminium—

(Continued on page 138.)

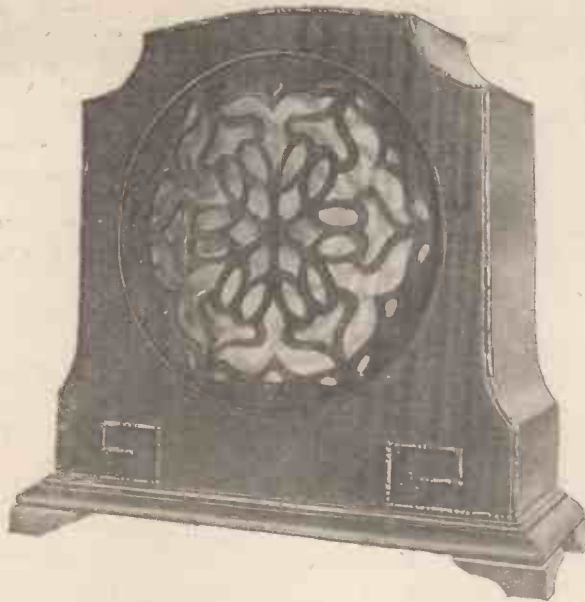

Radio Realism

No longer is there need to suffer from the well-known "phonograph effect" so commonly associated with wireless loud speaker reproduction, even of the best obtainable quality. The new **AMPLION** Cone Speaker — designed and constructed by the manufacturers of the world's Standard Wireless Loud Speaker—gives the correct pitch and equal balance to to all notes, bringing out the subtle shades of tone which characterise the different musical instruments and human voices. It affords for the first time what may be truly termed "**RADIO REALISM.**" Your dealer will gladly demonstrate.

**CONE
AMPLION
SPEAKER**

The model illustrated above is the Amplion "Chippendale" Mahogany Cabinet at £7:0:0. Other models from £3:15:0.

Send for Illustrated Booklet WL5
**GRAHAM AMPLION
LIMITED**

25, Savile Row, London,
W.1

CHATS AT THE WORK-TABLE

An article of particular interest to the practical amateur.

By R. W. HALLOWS, M.A.



In these notes I mentioned recently some of the uses of copper foil; I did not, however, describe one very convenient purpose which this material may be made to serve. It not infrequently happens that a spindle which we wish to secure firmly, by means of a setscrew, to a knob, a collar, or to a metal coupling link, is a very loose fit in the existing hole. To secure it as shown in Fig. 1 is to ask for trouble, since the spindle will be eccentric. Suppose, for

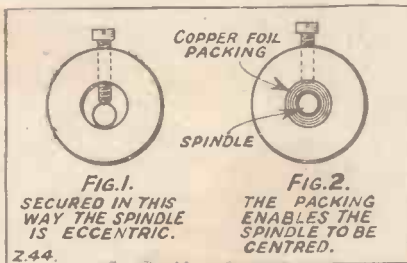

example, that you wish to attach a slow-motion dial, whose boss is drilled $\frac{1}{4}$ in., to a $\frac{1}{16}$ -in. spindle, or even to an alleged $\frac{1}{4}$ -in. spindle which is considerably under size.

Uneven Action

To do the job in the way shown in Fig. 1 will lead to very unsatisfactory working. Instead of a pleasant, smooth action from end to end of the scale, you will find that there are certain parts where the movement is very stiff; the dial may even swing a little to the right when the knob is turned in one direction and to the left when it is turned in the other. By using copper foil in the way shown in Fig. 2, you can avoid all bother of this kind. Cut out a strip of the foil whose width is equal to the length of the portion of the spindle that is to be inserted into the hole. Wrap this tightly round the spindle, using just enough to obtain a good push fit. When now you tighten

down the setscrew, the spindle will be nearly central.

A Setscrew Tip

Though the spindle may be quite a good fit for the collar, or to whatever else it is secured by means of a setscrew, it is sometimes found very difficult to secure it in such a way that it will not slip. I have had bother in this way with both plain and slow-motion dials, as well as with the links of certain gang-control condensers. Naturally, any slip in such cases is a very great nuisance, since it entirely upsets adjustments that may have taken a long time to make. Here is a simple tip that comes in very useful at times. When you have found the position in which to fix whatever it may be that you are dealing with, turn the setscrew as hard down as you can; then loosen it and remove the spindle. You will find that the point of the screw has made a little mark on the brass. Make a punch-mark here—first of all, of course, supporting the spindle on the jaws of the vice or on a block of metal so that it cannot be bent. Then with a small drill make a little hollow. The point of the setscrew will fit into this, and the spindle will

be held as securely as could be desired.

Pinning

Where an absolutely immovable connection is required between knob and spindle, as in the case of condensers in wave-meters or in cali-

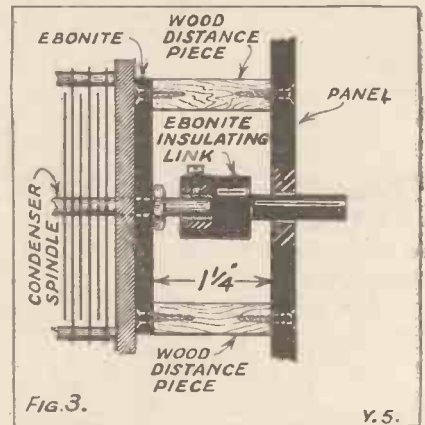

FIG. 3.

V. 5.

brated circuits in the receiving set, I would strongly advise that a pin should be used instead of a setscrew. Pinning is best done in this way. Completely mesh the plates, set the dial at 100 (or 180 if it is marked off in degrees), and tighten the existing setscrew. Starting at a point a little



A wooden egg-stand, which can be purchased for a few pence, makes an excellent valve tray.



The Crystal Gazer sees the condenser of the future

The Condenser of the future is evolved on the logarithmic principle—thus avoiding in the only possible manner the defects inherent in both Square Law and Straight Line Frequency types. Only by designing a condenser on the "log" principle is it possible to spread stations really satisfactorily over the whole dial, without any falling out of step at the beginning and the end. By using individual "log" condensers in multi-tuned circuits remember that all dial readings are the same. Thus tuning is an extremely simple matter,

In time all condensers sold will be designed on the "log" principle, but so far CYLDON Log Mid-line Condensers—just placed on the market—are the first log-principle condensers to be made in this country.

And just as CYLDON Condensers, of whatever type, are reckoned in the very highest class of all, so CYLDON "Log Mid-line Condensers" are not only the first out, but will remain the best. Prices:

•001	-	21/-	•00025	-	16/-
•0005	-	17/6	•0002	-	15/6
•0003	-	16/6			

Prices include 4" Knob dial. If dial is not required, deduct 2/-.

This new condenser is such a great improvement that in future all our gang condensers will be built up with Log Mid-Line Units. If you are building a receiver using gang control, bear in mind that the CYLDON Log Mid-Line is the only correct condenser. Prices:

2-GANG £2-10-0. 3-GANG £3-10-0. 4-GANG £4-10-0.

LOG **CYLDON** MID-LINE

CYLDON Temprytes, the best means of valve control, are guaranteed to function perfectly with any type of valve. Comprehensive valve chart, showing correct Tempryte for every valve, free on application to your dealer.

CYLDON TEMPRYTES, 2/6 each.

HOLDER MOUNTINGS, 1/6 each.

Don't be put off with the remark "CYLDON Condensers and Temprytes cannot be obtained." We have LARGE STOCKS OF ALL OUR LINES AND DELIVERY IS ABSOLUTELY GUARANTEED BY RETURN. If any difficulty send direct, Telephone: ENFIELD 0672. Telegrams: ENFIELD 0672. Or use the C.O.D. system.

SYDNEY S. BIRD & SONS,
CYLDON WORKS, SARNESFIELD ROAD, ENFIELD TOWN, MIDDLESEX.

Chats at the Work-Table—continued

removed from the setscrew, drill right through both boss and spindle with a fine drill. Pass through the hole a tightly fitting pin with a small head at one end, cut off the other end fairly close, and rivet over with a light round-headed hammer. If the job is one which makes riveting difficult, an 8 B.A. tapped hole may be made right through the boss and the spindle, and a screw of this gauge used instead of the pin.

Avoiding Awkward Capacity Effects

In not a few types of tuned circuit neither end of the inductance is at earth potential. This means, naturally,

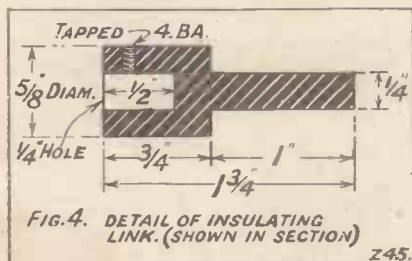

that both the fixed and the moving plates of the variable condenser are at something different from earth potential. The spindle is electrically connected to the moving plates, so that the tuning may be seriously affected as one's hand is placed on the knob or withdrawn from it. This condition of affairs is made worse when a slow-motion dial is used, for here we have a large metal disc electrically connected to the spindle which carries the moving plates.

Fine Tuning

A method of overcoming such unwanted hand-capacity effects which I have found quite successful is illustrated in Fig. 3 and Fig. 4. The first step is to set the condenser itself a little way back from the panel. By means of its one-hole fixing it is secured to a strip of $\frac{1}{4}$ -in. ebonite of suitable length and about $1\frac{1}{2}$ in. in width. To each end of the ebonite is fixed a batten of $\frac{1}{2}$ -in. wood, $1\frac{1}{4}$ in. in length and $1\frac{1}{2}$ in. deep, countersunk wood screws being used for the purpose. Similar screws are used to fix the battens firmly to the back of the panel. The use of the ebonite insulating link illustrated

means that there is now no electrical connection between the moving plates of the condenser and either the boss or the disc of the slow-motion dial. Owing to the way in which the condenser is set back, hand-capacity effects no longer occur, and the tuning of even the most delicate circuit now becomes a perfectly straightforward matter.

The Link

Details of the ebonite link are shown in Fig. 4. To make it is a lathe job, but if you are unable to tackle it yourself you will have no difficulty in getting it carried out for you at small cost. The only materials required for each link are a $1\frac{1}{4}$ -in. length of $\frac{5}{8}$ -in., or $\frac{3}{4}$ -in. ebonite rod and a 4 B.A. screw. In one end of the rod drill a $\frac{1}{4}$ -in. hole $\frac{1}{2}$ -in. or a little less in depth. Drill and tap a 4 B.A. hole running into this. Turn down the other end of the rod for a length of 1 in. to a diameter of $\frac{1}{4}$ in.

A more secure job can be made either by pinning the link to the spindle, or by securing it with an 8 B.A. screw driven right through, as described in an earlier paragraph. It is essential that the $\frac{1}{4}$ -in. end of the link should have a fairly close-fitting bearing in the panel. If, therefore, this has already been drilled $\frac{3}{8}$ in. to accommodate a one-hole fixing bush, it will be necessary to use a brass bush with an internal diameter of $\frac{1}{4}$ in. These are obtainable for about two-pence apiece from any shop which deals in small wireless parts.

Prevention of Back-Lash.

If the end of the link does not pass through either a bush of this kind or a $\frac{1}{4}$ -in. hole in the panel, the dial will not behave properly; it may, in fact, be found that there are several degrees of back-lash. This is caused by the fact that when the dial is moved in a clockwise direction the link is thrust over to the right. When now the movement of the dial is reversed no motion in the opposite direction will be imparted to the plates until the spindle has travelled from right to left of the hole through which it passes. Thus, though the dial moves the plates do not. No trouble of this kind will be experienced if a proper bearing in the panel is provided.

Economy in Wire

To many it will seem unnecessary to describe the proper method of securing the end of the wire on a reel; it is such a simple business that one might think that everybody knew how to do it, and did it. You have only to visit a few wireless workshops to realise that this is not the case. Your own may be one of those in which the ends of all reels are carefully secured, but I am willing to wager that matters will be very different in the workshops of a good many of your friends. It may not matter very much if the end of a reel of stout double cotton covered wire, such as No. 18, is left unsecured. A number of turns will "spring"; that is about all. It is when you come to fine stuff, such as No. 30 or smaller gauges, that things really begin to happen.

When Winding Coils

The other day I helped a friend to wind a choke with No. 40 D.C.C. from one of his reels. All went well until we had put on a thousand turns or so, with about another thousand still to go. Then we discovered that the wire was not paying out properly from the reel; there was, in fact, a "snarl," and it was clearly only a matter of time until a break took place, which it did very little later. Not caring about a soldered joint in the middle of a choke, we had to scrap the wire that had already been put

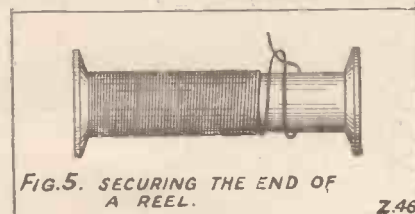

on and to start all over again. If the end of that reel had been properly fixed that mishap would never have occurred, and goodness knows how many yards of wire would not have been wasted.

Think, again, of fine enamelled wire; whenever a snarl occurs you are almost bound to damage the insulation in sorting it out. Anyhow, prevention is better than cure, and here is a means of keeping the wire on your reels always tightly and evenly wound. When you have taken what wire you require, hold the reel in your left hand and put your thumb

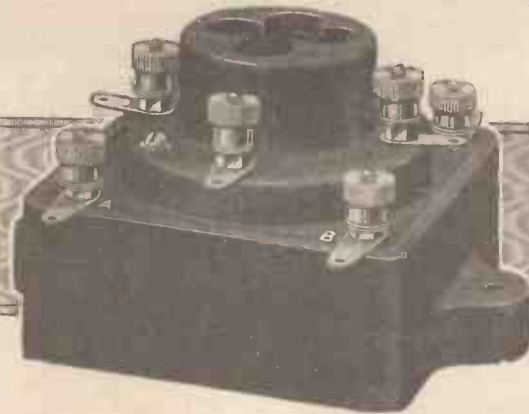

The "Multum in Parvo" of Resistance Capacity Coupling

There is not much more could be said for any Wireless component than that it will give—
 Much Better Reproduction
 At Lower initial cost.
 At Lower running costs.

All this is said about the "Cosmos" Resistance Coupling Unit.

All agree that resistance coupling in the Low Frequency stages is by far the best method for obtaining purity of tone. Now that valves, which possess a high amplification factor, are available—such as the "Cosmos" S.P. 18/B and S.P.55/B valves—magnification equal to the best Low Frequency transformer can be obtained with the added advantages of real purity of tone and faithfulness of reproduction.

The "Cosmos" Resistance Capacity Coupling Unit is a self contained component comprising, correctly proportioned, a condenser, an anode resistance and a grid leak. This saves the constructor trouble in selecting correct values. The condenser has a mica dielectric and is constant in value. The resistance and grid leak are not made by a surface deposit as is usual, but of a moulded conductive material the whole of which forms a solid & invariable resistance.

It is impossible for the "Cosmos" Unit to break down or become noisy, and it is guaranteed unconditionally against trouble of this kind.

A good transformer costs 20/- to 25/- whereas this very compact "Cosmos" Coupling Unit only costs 8/6 or, complete with spring valve holder as illustrated, 10/6.

RESISTANCE

Cosmos
COUPLING UNIT

CAPACITY

Other "Cosmos" Wireless Components of outstanding merit are:—square-law variable condensers, double-wound rheostats, Permacons (fixed condensers), two-coil holders, etc.

"He builds well who builds with 'Cosmos'."

METRO-VICK SUPPLIES LIMITED

(Proprietors: Metropolitan-Vickers Elec. Co. Ltd.),

METRO-VICK HOUSE, 155 Charing Cross Road, LONDON, W.C.2.

Chats at the Work-Table—continued

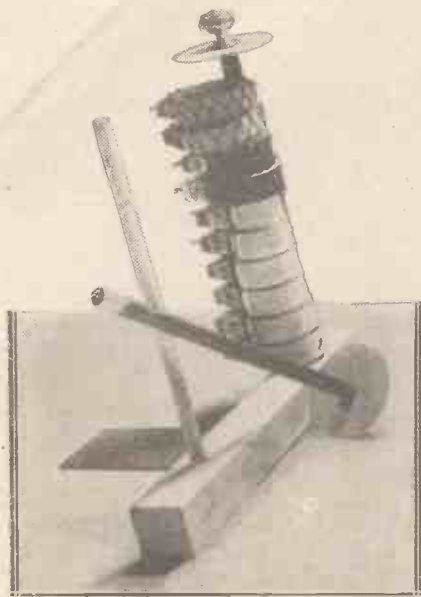

This photograph and the one below show how a wooden rod and ebonite tube can be used to solve the problem of storing coils.

firmly on the last turn before you cut. Now pull off about 6 in. of the wire and double it back into a loop, as shown in Fig. 5. Pass the end round the reel and through the loop. Then pull tight, and the job is done.

A New Use for Rubber Beading

The rubber beading which is sold for fixing to the edges of doors in order to exclude draughts can be very useful in wireless work. It consists of a tube and a flat strip moulded in one, the section being of the same shape as a key viewed end on. The rubber beading is obtainable quite cheaply from almost any ironmonger's shop. If you keep your accumulator on the floor below the wireless table and bring its leads up to an ordinary plug point fixed to the wall on a level with the top of the table—this by the way, is a most convenient method—you can secure the wires very neatly to the skirting board, wall, window frame, and so on by passing each of them through a length of this beading and fastening the flat part down with tacks.

Since rubber is a first rate insulator you also minimise the risk of shorting the L.T. battery should there be any defect in the coverings of the leads. Rubber beading is very handy outside the house for fixing both the aerial lead-in and the earth wire in

their proper places. It is also particularly useful when employed in the way shown in Fig. 6 for securing leads inside the wireless cabinet where bare wire is used. A short length of the beading, slipped over a lead at a point where it is crossed by another carrying current at a different potential, will ensure that a short circuit cannot take place.

In hook-ups small tabs of the kind illustrated in Fig. 6 are very convenient. They are slipped over leads and fixed to the baseboard with tin-tacks, thus holding leads, even where fine wire such as No. 26 is used, securely in position. Dozens of other uses for the rubber beading will probably suggest themselves to the reader.

Using Letter Punches

The lettering of panels for the indication of the proper connections to the terminals of home-made receivers has always been rather troublesome to the amateur constructor. Panel transfers are satisfactory up to a point, but lettering done in this way has the disadvantage of being unable to stand up to much hard wear. To have panels engraved is rather an expensive business and there are comparatively few amateurs who have sufficient skill to

do such a job for themselves. Letter and figure punches are obtainable in sets at reasonable prices from most tool shops, and these provide the simplest means of doing the job. But I find, though I have not a drop of Irish blood in my veins, that the best way of doing letter punching is not to punch at all! Ebonite is a rather queer material to work with in many ways, owing to its natural resilience. If you endeavour to punch letters or figures upon it in the ordinary way, the odds are against your getting really neat and satisfactory results. It is highly likely that if you essay to punch say, "H.T.+" the top of the H will be deeply marked, whilst its lower parts are indicated only by shallow depressions; the T on the other hand may be deep at the bottom and shallow at the top, and the plus sign may be equally unsatisfactory. Further, a good deal of force is needed when punching is done to make the letters and figures deep enough to take the white filling properly. You may in fact easily crack the panel in the process. It is very much better if you can manage to set aside a number of punches for ebonite work only, and to treat them as branding irons rather than punches. Pick out the punches that you will need for the job in hand and fix each into a tool-handle. Now

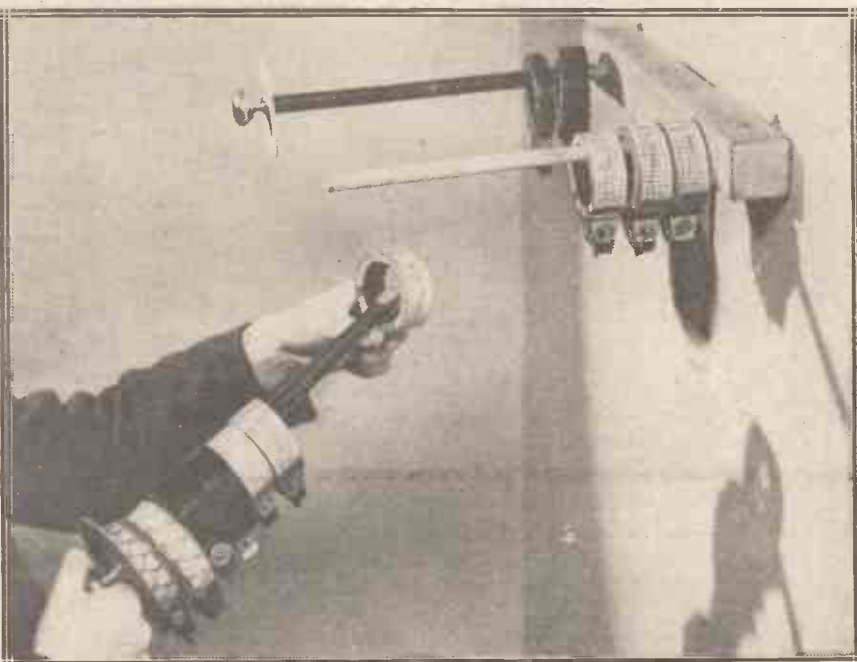

By sliding the tube from the rod (which is mounted on the wall) any desired coil can be removed or replaced in position in a moment.

Chats at the Work-Table—concluded

warm them up in the flame of a bunsen burner or a gas ring until they are just hot enough to singe a piece of paper. You will find now that the lettering can be done quite simply by pressing the required punch against the ebonite. Do not hold it there for long; a brief period of firm pressure suffices. Before you undertake a job on the panel, practice a little with a piece of scrap ebonite; this will enable you to ascertain the

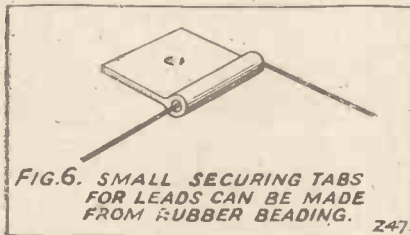

temperature required for the punches and the pressure that you need apply. Having marked your panels in this way, smear over each set of letters and figures with white paint and then wipe off the surplus with a rag. Neat, clean-cut letters that will last for ever will result. It is as well to letter panels before the final polish is given to their surfaces, for any discolouration produced by the hot punches can thus be removed.

Another Method

Apart from the use of letter punches the best method that I know of marking connection indications upon ebonite is to make use of white ink. The words sound almost a contradiction in term, but white waterproof drawing ink is readily obtainable from any stationer who deals in draughtsman's supplies. Make sure first of all that your panel is quite free from grease, then do the lettering with a mapping pen. Unless you are exceptionally skilled as a penman the results will not be quite so neat as those produced by engraving or by punching, but lettering done in white ink has the great advantage of lasting well, for this ink really is waterproof, and will stand ordinary wear and tear for a long time. When you are using white ink be careful, by the way, always to shake the bottle well. If you do not the letters will have a sickly greyish hue instead of that whiteness which contrasts so pleasantly with the black panel.

On Drills

Strictly speaking, one should keep two sets of drills for wireless constructional work, one being used only for ebonite, and the other only for work upon metal parts. Most of us, however, manage to rub along pretty well with only one set so long as we exercise a little care in their use. The worst of ebonite is that despite its apparent softness it has an extraordinary blunting effect upon steel tools of all kinds. To cut brass properly very sharp tools are needed, so that a drill which has been used carelessly for ebonite working may seem to have no edge at all when we essay to tackle with it the job of drilling brass. The great thing is to give your drills every chance when using them on ebonite. They are most likely to lose their edges if you do not lubricate them properly with a little oil or turpentine, and if you try to go too fast and with insufficient pressure. If you whiz the crank of bench or breast drill and do not press hard enough when boring through ebonite the point of the drill does not obtain sufficient grip of the material; in fact, instead of cutting as it should, it merely polishes, with dire results to its edges. Brass, on the other hand, demands a high speed and no lubricant. The risk here is that if you are drilling a deep hole with a small drill you may heat it up so much that it will lose its proper hardness. When, therefore, a job of this kind is being tackled, a little plain water may be used, not so much as a lubricant as to keep the drill reasonably cool.

When Drilling Brass

Always be careful to see that the drill is clearing itself properly in a deep hole. If its channels are becoming clogged towards the point with little pieces of material, it is more than likely that it will eventually seize up and break. Whenever a drill begins to scream in a piece of brass withdraw it at once and clear the channels. It pays to have your drill trimmed up every now and then on an emery wheel. This is a skilled job which I do not advise you to tackle yourself unless you have had some experience. You will, however, probably find that at the local garage there is an engineer who understands this business and will undertake it for you.

Counterboring

The recessing of clearance holes in order to enable the heads of countersunk screws to lie flush with the surface is a pretty straightforward job, which most constructors are capable of undertaking successfully. There is, however, another type of recessing, which is extremely useful on occasions; this is known as counterboring, and it is used not for countersunk but for cheese-head screws. For some reason or other, it is often quite difficult to obtain long B.A. screws with countersunk heads, though those of the cheese-head type can be bought at almost any wireless shop in lengths up to 1½ inches or more. Merely to insert these screws into clearance holes and to leave their heads protruding above the surface of the panel produces a very unsightly job.

To Sink Screw-heads

Countersinking is of no avail, since the recesses so made are dish-shaped and have not the straight sides required. The only effective method is counterboring (Fig. 7), which means making a straight-sided recess of the same diameter as the head of the screw. Once you know how to do it this is quite an easy job with a bench drill. Drill your clearance holes first of all, then pass the head of a screw through the drill plate until you find

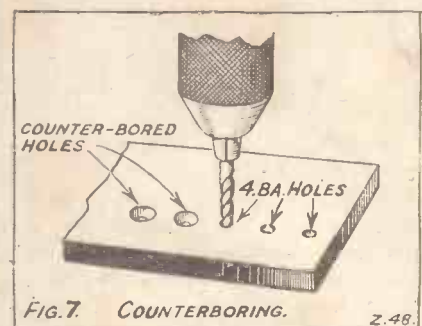

a hole into which it will go just comfortably. Take a drill of this size from your container. Leave the clearance drill in the chuck first of all, and fix the work so that this drill is exactly centred in one of the holes. Now raise the chuck and put in the larger drill. Bore until the head of the screw will lie just flush with the surface. Counterbore all of the holes in the same way, the work being always centred up first with the help of the clearance drill.

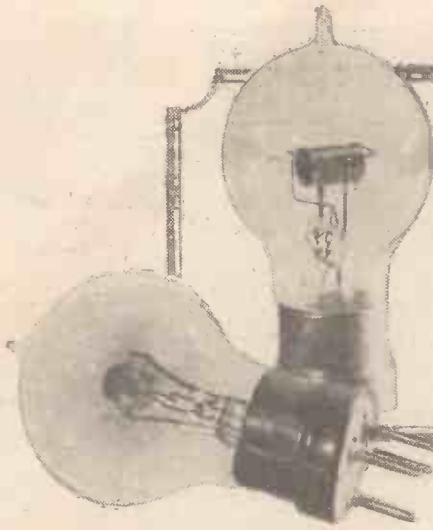

Are Valves Improving

*The rapid development in valve design is discussed in this interesting and informative article.
From a Correspondent.*

If you have been interested in wireless for a good number of years you probably have in your possession a few ancient valves ("ancient" as used in the wireless sense!), which it is most interesting to compare with those of to-day. I still have half a dozen D.E.V.'s and D.E.Q.'s bought in pre-broadcasting days, which, though they are somewhat tired after the thousands of hours of

of the ".06" class), and quite a number of others, bringing one down to the valve of the present day with its pipless bulb, its neat ebonite cap, and its vastly improved pins.

Comparing the old-stagers with the new models, one cannot help being struck first of all with the wonderful differences in their appearance. Practically all of the early valves were hand-made. The demand for them was small in those days, when the man who owned even a crystal set was regarded by his friends as dabbling in something closely akin to the black magic and the witchcraft of the Middle Ages. Mass production on a large scale and mechanical methods of manufacture were hardly worth while from the makers' point of view. The hand-made valve was a fine piece of work, but the trouble was that mankind (or perhaps one should say womankind, for most of the early valves were made by girls) is liable to make small errors. It was a rare thing to find five or six years ago two valves of the same make which were exactly alike in their characteristics or their performances.

Better Standardisation

Turning back through my files, I find myself recommending again and again in articles the advisability of discovering by actual test which of a batch of valves of the same make and type would give the best results in various positions in the set. In those days if the rectifier burnt out one could not be sure that another valve put into its holder would give precisely the same results. Such a piece of advice would be quite superfluous to-day, for valves are now so standard-

ised that it is rare to find one that differs at all from its fellows of the same make. In this standardisation we can see one of the biggest advances made in valve manufacture.

Heavy Prices

Those who have known nothing more expensive in the way of bright emitters than the 12s. 6d. valve (the price is now 8s.) may be amazed to learn that at one time we were paying 22s. 6d. for anything with four pins, and that one had frequently to wait quite a long time for delivery after the order had been placed. My D.E.V.'s and D.E.Q.'s cost respectively £2 10s. and £2 15s. apiece; whilst my first L.S.2 ran, unless my memory is at fault, into a good deal more. The price of D.E.R.'s was once £2 10s., and for some little time there was no dull emitter obtainable at a lower figure. We have certainly progressed a little since then!

The first valve placed on the market at a more or less popular price was



An old type of bright emitter "R" Valve, which used to be employed in all stages of receivers a few years ago.

use that they have had, work fairly well yet. And lying at the bottom of a drawer I have an old D.E.R., an "R" valve dating back to just after the end of the War, one of the original Oras, and a few curiosities such as the R.4c, a Siemens-Haelske valve captured during the war, one of the old Air Force "C" valves, and an L.S.2. The last of these was the pioneer of the modern small power valve. It worked excellently—but, oh, the current it ate! Round about 2 amperes, if I remember aright! I have also, somewhere or other, one of the original Round valves, a queer contrivance whose vacuum had to be adjusted at times by heating it up. Those are the veterans. Dating from rather later times I have very early models of the L.S.5, the American U.V.199 (the first

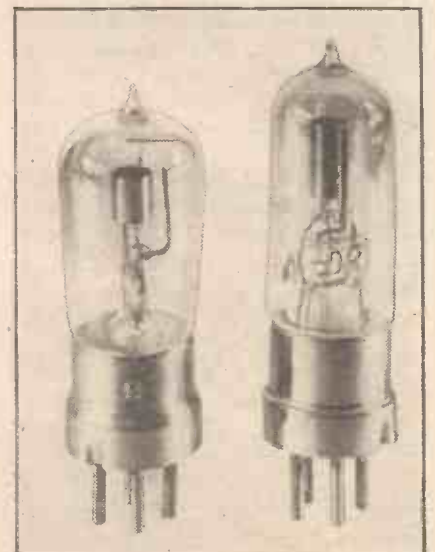

The popular "ORA" valve (left) and one of the first of the modern dull emitters, the A.R.D.E.

*The Magic Touch
of Genius*



You take it for granted that all good variable condensers are designed on scientific laws and principles. The reason why Ormond Condensers are superlatively better is because the magic touch of genius has been added—to the experimental work, to the designing, to the manufacture. This reveals itself instantly you tune in. See for yourself by fitting, say, the new Ormond "No. 3" S.L.F. Condenser illustrated.

PRICES:
 Complete with 4-inch Plain Dial
 .00025 mfd. .. 5/6
 .00035 " .. 5/9
 .0005 " .. 6/-
 Complete with Friction Control Dial 6" extra respectively.

The New Ormond "No. 3" S.L.F. Condenser is the precision Straight Line Frequency Condenser with a greatly reduced frame and highly finished Bakelite end plates. Specially shaped vanes give high maximum and low minimum capacity with TRUE S.L.F. readings throughout the full 180 degrees scale. No bunching of half the wave-lengths between 0 and 27 degrees—all stations are spread evenly over the dial. Supplied either with 4-inch Bakelite Plain Dial or 4-inch Bakelite Friction Control Dial. Each is engraved in 180 single degrees, showing 0 at the shortest wave-lengths—stations are still referred to in metres—and towards 180 for longer wave-lengths. Easy to mount. One-hole fixing. Terminals and Soldering Tags for connections.



199-205, PENTONVILLE ROAD, KING'S CROSS, LONDON, N.1.

Telephone: Clerkenwell 9344-5-6.

Telegrams: "Ormondengi. Kincross"

FACTORIES: Whiskin Street & Hardwick Street, Clerkenwell, E.C.1.

Continental Agents: Messrs. Pettigrew & Merriman, Ltd., "Phonos House", 2 & 4 Bucknall Street, New Oxford Street, W.C.1.

Are Valves Improving—continued

the Mullard Ora, then a thin tubular affair, which was offered to an astonished world of wireless enthusiasts at the hitherto unheard-of price of 15s. Then more and more valve factories sprang up in this country, whilst competition from foreign valves, chiefly of French and Dutch make, became fairly keen. Prices dropped rapidly for the bright emitter type, whilst dull emitters were gradually

volts. Then came rumours of a wonderful valve made on the far side of the Atlantic, and before very long the "06" valve was placed on the English market by numerous firms. In its early days it was hardly what you might call robust; in fact, when the first three that I ordered were sent to me by post, packed in simply acres of corrugated cardboard, two arrived with broken filaments. It

demand for battery-charging facilities soon created a supply, and there are now very few places in this country of ours where accumulator-charging is impossible.

Distorted Results

Until comparatively recent times most of us had perforce to make use of general-purpose valves throughout our wireless sets. Some people used tubular "anti-capacity" valves on the H.F. side, because with them less damping was required to hold the set down to earth (remember, that the neutrodyne circuit was unheard of); but for the rectifier and for the two or more note-mags, which followed it the general-purpose valve was the only thing available. The average general-purpose valve of a few years ago had an impedance of round about 40,000 ohms, and it could deal properly with a grid-swing of not more than about 4 volts at the outside. You must imagine, for I cannot describe it, the extraordinary cacophony that was produced when by means of a couple of note-magnifying stages the local station was worked up to big loud-speaker strength! Fortunately, we were not critical in those days.

The average general-purpose valve of a few years ago had a magnification factor of about 8, but except possibly on the L.F. side (and then only if we were content to put up with hideous distortion) we were completely unable to make full use of even this. Supposing that you had two H.F. stages, you were thought to be doing quite well if you got an actual magnification of about 2 from the first and something rather less from the second.

Such things as resistance-capacity and choke-capacity L.F. amplification were almost out of the question owing to the poor results that they gave.

Modern H.F. Practice

In my humble opinion it is only quite recently that we have come to realise what the valve can do and to understand its design properly. With the coming of the neutrodyne circuit many of us received a severe blow. We had preached for so long the desirability of a small inter-electrode capacity (to reduce this we had cut away the ebonite of valve holders, and had done all kinds of other queer things). Then we suddenly found ourselves rather lost when a means of

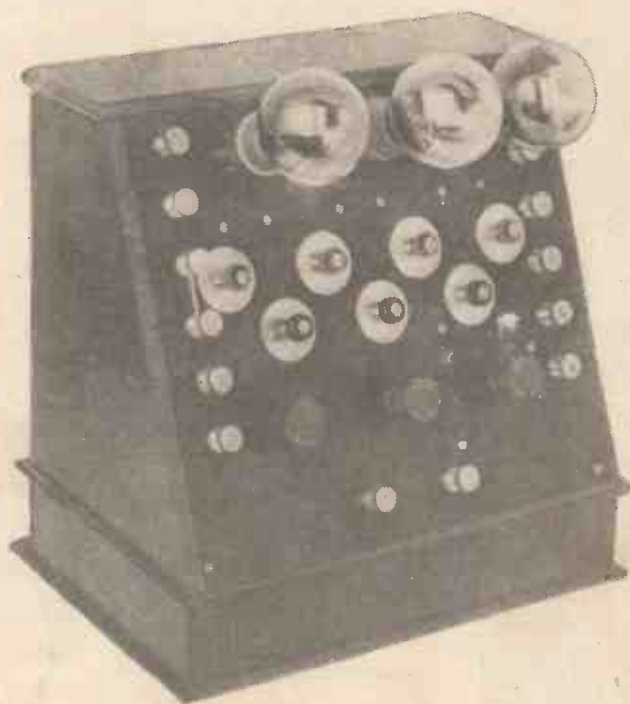

An old fashioned resistance-capacity amplifier, using bright emitters and variable anode resistances and grid leaks.

Such an arrangement gave very poor amplification and the purity of reproduction very often left a great deal to be desired. The advent of high mu valves has revolutionised resistance-capacity amplification.

evolved in a more or less popular form.

For a long time a battle raged between those who favoured the dull emitter and the opposite camp, which held that a valve consuming but a fraction of an ampere of current, and working with its filament only red hot, could never be so efficient or so reliable as those which devoured a full ampere and produced a blinding glare from their filaments. Slowly the dull emitter forged ahead, and to-day the bright valve is rarely seen.

Arrival of the "06"

The D.E.R., which was, I believe, the first of all dull emitters, consumed .4 ampere of current at a potential of slightly less than 2 volts. Armed with the two-handed sword of progress, manufacturers hewed steadily away at the filament watts. The first A.R.D.E. took only .3 ampere at 1.8

was so microphonic that if one raised one's eyebrows whilst sitting near the set a loud pong was popularly supposed to ensue.

Still the first "06" valve performed a wonderful piece of work; at the time when it arrived accumulator charging stations were not so common as they are now, and there were countless thousands of people who were debarred from becoming valve users simply because they had no means of having their L.T. batteries recharged. Owing to its small current consumption the "06" valve made it possible to work even a multi-valve set from dry cells. The result was that valve sets increased and multiplied in the remotest parts of the country. To-day no one would heat his filaments (except in a portable set) by dry cells, if he could possibly use an accumulator, and there is practically no need to do so, for the

Are Valves Improving—concluded

neutralising this capacity was discovered. We found to our horror that anti-capacity valves on whose possession we so prided ourselves were of no special value and practically useless; owing to their small capacity it was most difficult to neutralise them. It dawned upon us that for neutrodyne sets the capacity within the valve had no apparent disadvantages.

We suddenly found by making use of sound methods on the H.F. side that we could take full advantage of the valve's amplification factor—we could go further; we could get a real step-up effect by employing a properly designed transformer. Manufacturers stepped nobly into the breach. The old general purpose valve practically disappeared, its place being taken by a valve which on the one hand permitted easy neutralisation over a wide range of wave-lengths, and on the other enabled us to obtain really enormous amplification from a single H.F. stage. The set which I am using at the present time has only one H.F. valve, yet its range, its sensitiveness, and its signal strength are far greater than sets of older type in which two H.F. valves held down by positive damping were employed.

Better Amplification

On the L.F. side great developments have taken place. The first of these was to be seen in the introduction of a medium-impedance valve with a moderately large permissible grid-swing. Such valves would give what we should now call rather small loud-speaker strength without overloading or appreciable distortion. But they were not quite good enough; something better was needed. There arrived the small power valve, which has slowly become more and more efficient. The filament current was cut down from 3 amperes to .75 ampere, from .75 ampere to .25, from .25 to .1. To-day we have valves whose filaments never become hot enough to produce a visible glow, which, with a filament current of only 100 milliamperes, require with 100 volts on the anode a grid bias of $7\frac{1}{2}$ to 9 volts. This means that the permissible grid-swing is from 15 to 18 volts and that a loud speaker can be worked from them without a trace of overloading or distortion.

Choke-capacity and resistance-

capacity coupling would have become popular long ago if only suitable valves had been available. When coupling of either of these types is used, amplification must be done entirely within the valve itself, for there can be no step-up. What was the use of using two or three resistance-coupled or choke-coupled valves to produce about the same signal strength as that given by one coupled by a transformer? A good transformer will give an amplification of the order of 30 or so without any detectable distortion if used with a suitable



An example of modern design: the K.L.1 valve, designed to operate off A.C. mains.

valve. Could a valve be produced which would allow a similar degree of amplification to be obtained with choke or resistance? For some time this question remained unanswered; then one firm placed on the market two valves with different filament voltage requirements each of which had an actual amplification factor in the neighbourhood of 35. These were rapidly followed by others; the amplification was improved, and to-day there is actually in the experimental stages a valve which has an amplification factor of round about 70.

Meantime it was found that even the small power valve hardly sufficed to deal with grid-swings big enough to give undistorted loud-speaker reproduction of the kind that would fill large rooms or halls. The "super" power valve made its appearance. The most ambitious type requires a filament current of about three-quarters of an ampere, and a plate potential of approximately 400 volts; This, however, will deal with grid-swings so enormous that they are never likely to be required by the average amateur. The super power-valve that appeals to him is one of which not a few types are available at quite reasonable prices. Its filament current is but a quarter of an ampere or less; it needs no more than from 100 to 150 volts on the plate. Yet it will deal with, without any tendency to "grid currenting" or "bottom bending," grid-swings big enough to enable a full-sized loud speaker to be worked at top strength almost anywhere.

Wanted—A Rectifier

The five-valve set of to-day shows a total filament-current consumption of between .5 and .7 ampere; it is not long since this was about what was required by a single valve. We have now really efficient valves for all purposes on both the high- and the low-frequency sides of the receiving set. We have, too, great numbers of valves which will give much better performance as rectifiers than those of a few years ago. The valve has become altogether more stable; we no longer need the vernier rheostat or even a rheostat at all; such are the valves of to-day that a fixed resistor will do all that is required. Use them carefully, and modern valves will serve you well; they will possibly not give quite so long service as the dull emitters of some years ago—but remember that their price is far less. There is no need nowadays to have a plate battery tapped in $1\frac{1}{2}$ -volt steps. You will notice little difference if you increase or decrease the plate potential of any of your valves by 6 volts or more. The valve, in a word, is less finicky and therefore far easier to use.

There is, however, one point in which I would like to see progress made; that is, a really good valve specially designed for rectification alone, using the "leaky grid" method.



A VALVE socket which at first glance appears to have been made for some "baby" valve rather than for the full-size tube, has been sent to us for test. It is known as the "Cason," and is made in two patterns, the simpler of which is shown in our illustration. In most valve sockets the pins of the valve push into four holes suitably spaced in a ring or disc of some suitable insulating material. In the "Cason" socket the holder comes *within* the



The Cason valve holder.

pins, spring contact with each pin being made by a strip of metal as shown. Very little solid material is used in this holder—a distinct advantage in all valve sockets, as tests have shown. Connection is made to four soldering lugs, and it is impossible to insert the wrong pin in the socket in the form of construction used.

As far as the electrical properties of valve sockets are concerned, it is impossible to judge by ocular inspection, for which reason all sockets submitted to this laboratory are given an H.F. test to determine their losses. The "Cason" proved to be quite satisfactory in this respect, while the anti-microphonic properties are also good. The very low price of these components is noteworthy, the more expensive of the two patterns (for baseboard mounting) being only a shilling.

A MONTHLY REVIEW OF TESTED APPARATUS.

(NOTE: All apparatus reviewed in this section each month has been tested in the Editor's private laboratory, under his own personal supervision.)

A Good Variable Condenser

The Ormond straight line frequency condenser shown in detail in our illustration is already known to readers of the WIRELESS CONSTRUCTOR, as it was used in the "Signal Box" described in our May issue. The construction is mechanically strong, the H.F. losses negligible, and the slow-motion fitting smooth and completely free from backlash. A screening disc is also provided, together with a handsome dial and knob of satisfactory proportions. It is, in short, a good job both electrically and mechanically.

A Handsome Loud Speaker

A handsome addition to the line of loud speakers sold under the Amplion trade-mark is the Amplion Cabinette, which is obtainable in oak or mahogany, the oak model being shown in our photograph. Although comparatively small (it measures about 16 in. by 5½ in. high by 6 in. deep), there is none of the "thin" tone

which so often characterises small loud speakers, as by an ingenious arrangement of a specially shaped horn adequate volume and quality are both obtainable. The actuating mechanism is of a standard Amplion pattern, access to the adjusting screw being obtained by a small door on the right. For those who desire a reasonably priced loud speaker of a pattern which harmonises admirably with the ever-popular oak furniture, this instrument can be thoroughly recommended.

A Good Electric Soldering Iron

The Igranic Electric Co. have submitted to us for test their electric soldering iron and stand, shown in an accompanying photograph. As it happens to be of a similar pattern to that which I have used for all my soldering work for the last four years—which means, in effect, as much soldering as the average home constructor would do in a lifetime!—I am in a position to know something of its capabilities.

The instrument is convenient to handle, the bit itself is made of 3/8-in. copper rod, which is slipped into the heating tube and held in position by a grub screw. When this copper bit has worn too short for

✱ This illustration shows the Ormond .0005 variable condenser, as used in the construction of the "Signal Box" described in the "Wireless Constructor" last month.

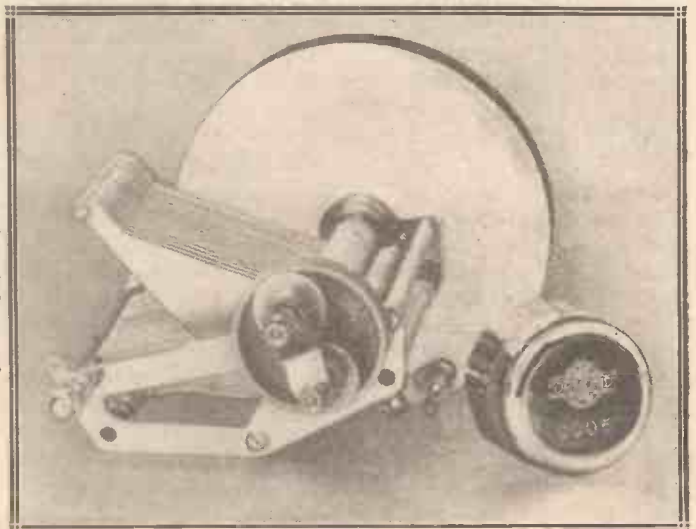

You will need
these parts to
build your



“Resistor 3”

and they are all made and guaranteed by Dubilier.

- 1, 0.00025 mfd. Fixed Condenser, Type 610 with clips.
- 2, 0.001 mfd. Condensers, Type 610 with series clips.*
- 4, 2MΩ Dumetohm Leaks.
- 1, Dumetohm Holder.
- 1, Duvarileak, 0 to 5MΩ.
- 1, Condenser, 0.00025 mfd., Type 610.

* For those who already possess Type 610 condensers of this capacity, these series clips can be obtained for 6d. each.

The entire set listed above costs only 30/- and your usual Dealer will supply. In case of difficulty apply to us direct.



Advt. of the Dubilier Condenser Co. (1925), Ltd., Ducon Works, Victoria Road, North Acton, W.3.

M.C. 274



TEST UNDER
WORKING CONDITIONS

It is essential that the variable voltages applied to a radio set, which are under your own control, must be regulated while the set is actually in operation. Open circuit tests, that is, tests made direct from the battery terminals, are useless, as the voltage drop due to resistance in the circuit is very misleading.

In order to ascertain correctly the actual voltage applied to the valve electrodes readings must be taken from different points in the circuit with a Weston Model 506 Pin Jack Voltmeter, which is supplied with a High Range stand, Pin Jacks and Long Testing cables. These enable you to reach any part of the set and take accurate high and low tension readings.

For voltage adjustments which, you must remember, are equally as important as tuning adjustments, only a Weston instrument is sufficiently accurate to be of any use. Weston Instruments are standard the world over, and on their unvarying reliability you may depend entirely for more economical and efficient operation of your set. Full detailed information supplied on request.

WESTON Model 506 Pin Jack Voltmeter

Price complete with testing cables

£2 : 10 : 0

WESTON

STANDARD THE WORLD OVER

Pioneers since 1888

Weston Electrical Instrument Co. Ltd.

15, Gt. Saffron Hill,
London, E.C. 1

What's New—continued

further use it can be taken out in a moment and a new piece of copper rod inserted, the replacement being quite cheap. I have used at least a dozen pieces of rod in my own iron,

part of the house desired. The idea is to turn the set on and off from a distance, the actuating energy for the relay being provided by the L.T. accumulator itself. One push of the

two parts (see photograph). One part fastens to the receiving set and contains several split pins and a larger guiding pin, while the other part consists of the female portion of the plug to which the various battery leads are connected. The large guiding pin ensures that the plug is not incorrectly fitted. On the set portion connection is made by soldering lugs while the part connected to the leads themselves is so made that the connections can be electrically sound while concealed from view, the cable containing the leads passing out from a large hole not shown in the photograph. This is a most useful device and occupies very little space. It can be recommended to all who require such a device.



✱
The *Amplion*
"Cabinette"
Loud Speaker.
✱

but so far as the heating element is concerned—the main part—this has never given the slightest trouble.

The iron can therefore be thoroughly recommended to all home constructors who like to do their soldering neatly and in comfort.

A Useful Distance Control Relay

A few months ago the Goswell Engineering Co. submitted for test to the WIRELESS CONSTRUCTOR a distance control relay known as the "H. B. H." consisting of a small box fitted with six terminals. Two of these terminals go to the L.T. accumulator, two to the L.T. terminals of the set and two to a pair of wires terminating in an ordinary pear-shaped bell push, which can be taken to any

switch turns the set on and the next push turns it off, the only current consumption being that taken momentarily to actuate the magnet when the push is used.

✱
A useful electric
soldering iron,
complete with
stand. (Igranite
Electric Co., Ltd.)
✱

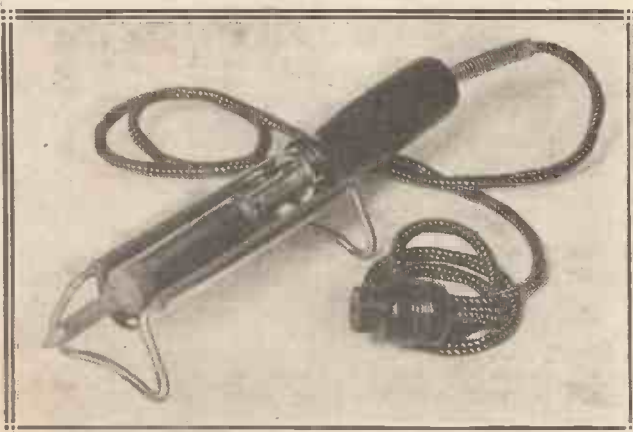

The test report on this relay has been held up until the device had been tried out in actual practice for several months. The relay was connected to the Editor's "home" set, which is kept permanently tuned to the London station. The set itself is placed in the laboratory and the loud speaker in another part of the house. Leads were taken from the laboratory to the room in which the loud speaker is situated.

The relay has now been used for about five months, and the set has been turned on and off by no other means during that time. As it has not failed on a single occasion, we feel justified in recommending the device to all who require a satisfactory distance relay. The price is one guinea.

An Ingenious Plug Connector

Messrs. Wright & Weaire, Ltd., have submitted for test and report a multi-plug connector consisting of

Two Double-Pole Double-Throw Switches

The same company have submitted a very strongly made and sound push-pull double-pole double-throw switch in two patterns.

The switch, which is of the one-hole-fixing variety, has sound electrical contacts which "wipe" slightly, so that no trouble is likely to be experienced through imperfect contact.

When the knob is pushed in the spring contacts are sprung apart, transferring connection from one pair of points to another.

The difference between the two patterns is simply that one is fitted with soldering lugs and the other with terminals for "Radiano" or other sets where terminals are preferred.

The finish of these switches is particularly good, and the workmanship of a very high order.



The "Wearite" multi-plug connector.

whichever way you look at it—

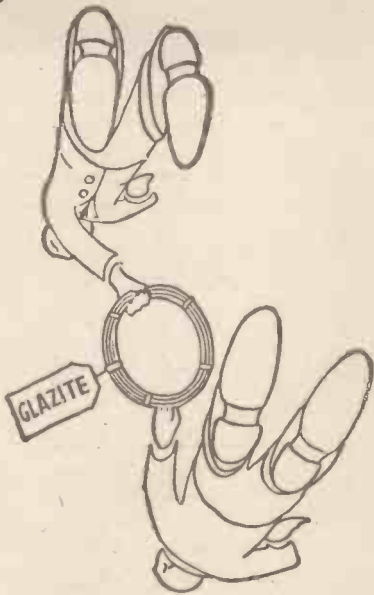

you can't beat
Glazite for wiring!

If you want ease of wiring—GLAZITE. If you want neatness—GLAZITE. If you want economy—GLAZITE. If you want perfect insulation—GLAZITE.

In every way GLAZITE is the best way to wire a set! Flameproof and damp-proof, it will not deteriorate in use. Try GLAZITE next time.

GLAZITE
BRITISH MADE REGD.

COLOURED CONNECTING WIRE
[RED · YELLOW · BLUE · BLACK · WHITE and GREEN]

Obtainable in ten-foot coils, price 1s. 2d. per coil. Or in two-foot lengths—four assorted colours—1s. per packet. From all radio dealers. Write for interesting descriptive leaflet to

The
**LONDON ELECTRIC WIRE
COMPANY & SMITHS, LTD.**
Playhouse Yard, Golden Lane, London, E.C.1

Makers of Electric Wire

for over  40 years

JUDS

The
C.A.V.

H.T. ACCUMULATOR

“The Silent Sixty”

Will bring them in

Clearer



60 Volts
60-

FULLY CHARGED
READY FOR
IMMEDIATE USE
SYPHON FILLER
SUPPLIED FREE

30 & 90 VOLTS
AT PRO RATA RATES

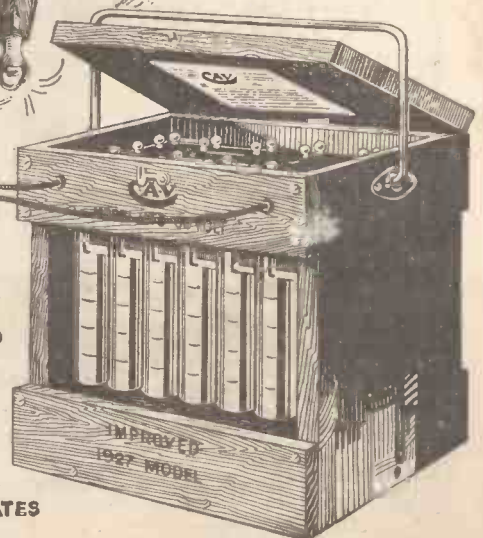



Fill Up Your Battery Card

By
Capt. JACK FROST,
 M.I.R.E.

ACCUMULATORS, because they contain acid and need occasional recharging, are shunned by many and liked by none. So very often they seem to need recharging that one is inclined to doubt whether the charging depot has done its job properly. If you take that accumulator to a reputable charging station you need have little fear on that score.

"Filling Up"

You would hardly compare that essential part of your "wireless" with your body, would you? Yet it is liable to disease. Space forbids even a summary of those illnesses, but one or two hints upon the way in which your accumulator may be made to give you longer and more efficient service, and, incidentally, spare unnecessary expense, may be welcome.

First of all, when you purchase the accumulator, it must be filled with acid and "stocked" with energy—the electrical necessity to the filament of your valves. The supplier of the battery will do this for you.



Batteries should always be kept "topped up" with distilled water.

By "test and trial," estimate the length of time for which your accumulator will last before it needs recharging.

The supplier will be able to give you a rough idea. Then—and the trouble

MAKE OF ACCUMULATOR	<i>Xyz Co</i>		
DATE PURCHASED	<i>31 Decr 1926</i>		
ACTUAL CAPACITY A.H.	<i>30</i>		
CURRENT CONSUMPTION OF SET	<i>1 Ampere</i>		
MAXIMUM HOURS USABLE ON ONE CHARGE	<i>30</i>		
CHARGING DATES			
<i>31st Dec</i>	<i>3, 1, 4, 1, 1, 5, 2, 6, 2, 1, 1,</i>		
<i>20 Jan</i>	<i>3, 3, 2, 3, 1, 6, 4, 1, 2, 3, 1, 1,</i>		
<i>21st Feb</i>	<i>1, 2, 4, 6, 1, 1, 1, 2, 2, 3</i>		

An example of a simple form of battery card.

is really worth while—keep a rough tally of the number of hours for which the valves are working day by day. When the number of hours (or days) are nearly "up," and even if your battery shows no sign of running down, get it recharged.

Keep Dry and Clean

It is far better to have it recharged before it is necessary than to wait until it runs "dry" and fails to give you service. To overrun an accumulator is to injure it internally in course of time, and this will shorten its life.

Keep the top dry and free from dust, keep the screw terminals clean, and clean away any deposit which may

collect. Never leave it standing idle (whether fully charged with energy or not) whilst you go away for a few days' holiday. Leave it in the care of your charging depot. Don't jolt or jar the accumulator, for it is delicate and will suffer harm. Be very careful that you don't upset the acid, for not only will the acid ruin clothing, etc., but the plates inside the accumulator will, by becoming uncovered, suffer as the result.

Housing the Battery

The best place for such a piece of apparatus is well tucked away in a cool, dry, shady corner beneath the table on which the receiving set is placed. Why in a shady place? Because sunlight will harm the accumulator and will draw from it the energy which you have paid the charging station to put into it.



The white marks on this accumulator show where the plates have "sulphated" owing to neglect.



Got Company?

WE do get surprises nowadays! We visit the Smiths, for instance, whom we know to be the most unmusical of families . . . none of them could even play a mouth-organ! The moment the door is opened we hear the strains of a violin. "Hullo! Got Company?" we ask. Smith smiles, and passing into the room we see . . . a Brown Loud Speaker.

You do not know to what heights of reality radio reproduction has risen until you hear the Brown No other Loud Speaker gives such a life-like rendering of the broadcast. Even the Brown instruments of a year ago—undoubtedly good as they were—have been left far behind.

Particularly in this new Brown Sphinx Loud Speaker is this advance noticeable. Its reproduction is as faithful as the reflection your mirror casts. An almost uncanny reality which seems to bring the living artiste to your room. "Got company?" your friends may well ask when they first hear the strains of Brown reproduction. Ten models from 30/- to £15 15s. Sphinx Loud Speaker, shown above £12 10s.

Brown

SPHINX LOUD SPEAKER tells the truth

S. G. BROWN, Ltd., Western Ave, N. Acton, W.3.
Retail Showrooms: 19, Mortimer Street, W.1; 15, Moorfields, Liverpool; 67, High Street, Southampton. Wholesale Depots throughout the Country.



For all receivers BUILD WITH IGRANIC RADIO DEVICES

and assure yourself of lasting satisfaction. Every Igranitic component is designed and manufactured with scrupulous care by highly skilled engineers, and each component contains special features which make it unique.

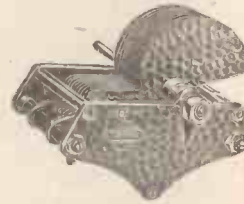

IGRANIC SQUARE LAW LOW LOSS VARI- ABLE CONDENSER

The condenser which is used so frequently in receivers described in the radio journals that it has become known as the "choice of experts." Prices: '00015 mfd. 17/-; '0003 mfd. 18.6; '0005 mfd. 21/6; '001 mfd. 25.-

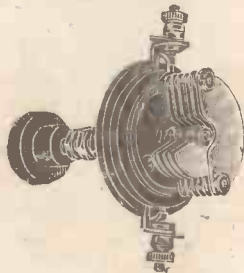

IGRANIC MICRO CONDENSER

A miniature condenser particularly suitable for neutralising and for all circuits in which very small-capacity variations are needed. Ample spacing and insulation between knob and vanes prevents hand-capacity effects. Price 5/6. Bracket for baseboard mounting, 6d.



IGRANIC RADIO SWITCH

Self-contained, completely enclosed and exceptionally reliable, one hole, heavily nickel-plated and of refined appearance. Price 2/6.



IGRANIC FIXED CONDENSERS AND FIXED GRID LEAKS

Fixed Condensers—
'0001 to '0002 .. 1/6 each
'003 to '006 .. 2/- "
Fixed Grid Leaks.. 2/3 "

Send immediately for your copy of the New
Igranitic Catalogue. (List No. J243.)

IGRANIC ELECTRIC CO LTD

149, QUEEN VICTORIA STREET, LONDON
Works: ELSTOW ROAD BEDFORD

OUR NEWS BULLETIN

Some of the More Interesting Happenings
in the Radio World this Month

A Short-Wave Schedule

If you build the Radiano Short-Waver described in this issue—and you might just as well, you know, for some day the short-wave fever will get you, too!—be sure and listen for 2 X A F, 32.79 metres, on Thursday nights.

"2 X A F" is the short-wave alias of W G Y, and as W G Y is one of the best stations in the U.S.A. you can always have a first-class American programme so long as this dual broadcasting stunt continues. Try any time after 10 p.m. on Thursday—not Friday, which, as you probably know, is Amami night!

Going Some!

An Australian correspondent informs me—with justifiable pride—that during experiments with the new "beam service" to the Antipodes, the

Melbourne station was pumping 225 words per minute into the Skegness receiving aerial!

I can assure him that the return service, from Grimsby to Rockbank (Melbourne), does not disclose any pronounced loitering, either, for at one hectic period well over 300 words per minute were sliding over the beam into Australia. The wave-length used is about 26 metres.

East or West

One extraordinary feature of this British-Australian Beam Service is the fact that the beam can be "directed" to pass either over the Pacific and America to England, or else via Asia and Europe, according to whether the eastward route or the westward route is better at the moment of sending.

The words themselves don't seem to mind much which way round the

world they go. They have to do the 10,000-mile journey in about one-eighteenth of a second, so probably when going at that speed the Pacific route looks to them very much the same as the Indian Ocean one!

New French Station

Have you heard Radio-Vitus dance? In case not, you ought to know that Radio-Vitus is a new French station, broadcasting from Paris. And its programmes dance along the ether on 308 metres on Sundays, Wednesdays and Fridays, from 9 p.m. till 10.30 p.m.

British listeners who pick up this station are invited to send reports to the Station Director, 90, Rue Damrémont, Paris, stating set used, quality of modulation, and strength.

The New 2 L O

The rumour that a new site in Essex had been chosen for 2 L O, in accordance with the B.B.C.'s regional scheme, does not appear to be well founded.

Enquiries at Savoy Hill elicited the statement that the Corporation have not yet even considered the purchase of a site for the new 2 L O—if or when it moves from Oxford Street.

(Continued on page 134.)

A NEW DEPARTURE
IN RADIO RECEIVERS
THE CUBE 3



An entirely self-contained Receiver specially designed for perfect reproduction, utilizing the latest method of Resistance Capacity Coupling. No aerial, no earth, no trouble. All batteries, valves, etc., are housed in an artistic oak cabinet, 12 in. cubical. Loud-speaker reception at 10/15 miles from a main B.B.C. station.

Can be placed anywhere in any room.

Price, complete and ready for use, £10 10 0
Plus Royalty £1 17 6

Total weight: 26 lbs.

For use with the above we recommend the Orphean Loud Speaker, Price 70/-.

Demonstrations given daily at our showrooms.
Can be supplied on Easy Payment System.

Send stamp for comprehensive range of lists, including latest star sets described in several Radio publications.

CONSTRUCT the
Short Wave Radiano

As described in this issue by
Mr. Percy W. Harris.

	£ s. d.
1 Mahogany cabinet, 16 x 8 in., with base-board	1 4 0
1 Ebonite panel, 16 x 8 x 1/2 in., ready drilled	0 7 6
2 Cydon var. condensers .0003 (Less dials)	1 9 0
1 Lissen potentiometer, P.M. type	0 2 6
1 On and Off switch with terminals	0 1 6
1 Antipog valve holder	0 3 0
1 Magnum Vibro valve holder	0 2 6
2 Magnum fixed resistors and bases	0 5 0
1 Magnum coil socket with double terminals	0 1 9
1 Magnum terminal strip with 11 terminals and double nuts	0 4 0
1 M.H. Dimic base	0 2 6
1 Unimic base	0 2 6
1 Dimic coil S.W. 1	0 10 0
1 Dimic coil S.W. 2	0 10 0
1 Unimic No. 5	0 5 0
1 Dubilier .0003 condenser and 2 meg. leak	0 5 0
1 Dubilier .002 fixed condenser	0 3 0
1 C.A.V. L.F. transformer	0 15 0
2 Radion 4-in. dials	0 6 0
4 gross Brass pinch-on spade tags	0 1 2
Supply of Rubber-covered single flex	0 0 9
Any parts supplied separately as required.	£7 1 8

All parts supplied for "The Short-Wave Super-Het" and "Resistance 3" described in this issue.

BURNE-JONES & CO., LTD.,

Manufacturing Radio Engineers,
MAGNUM HOUSE,

288, Borough High St., London, S.E.1.

Telephone: Hop 6257;
Telegrams: "Burjomag, Sedist, London."
Cables: "Burjomag, London."

MAGNUM CALIBRATED
RHEOSTAT
FOR BASEBOARD
MOUNTING.



MADE IN 2 SIZES

Zero to 6 ohms; Zero to 30 ohms. PRICE 3/-
Fitted with terminals and solder tags. EACH

INTRODUCING TWO NEW
MAGNUM COMPONENTS

Magnum
Grid Leak

Manufactured under a new process, ensuring the Resistance value remaining constant. Absolutely silent in operation. Made in all values from 5 to 5 megohms. Price, Leak only, 1/6
Base fitted, with clips, terminals and solder tags, 1/-.



MAGNUM CARTRIDGE RESISTOR

An entirely new design, ensuring perfect electrical contact. The design of the cartridge and clips permits of easy removal and replacement. Made in all values from 3 ohms to 50 ohms.



Price, Cartridge only, 1/6

Base fitted, with clips, terminals and solder tags, 1/-.

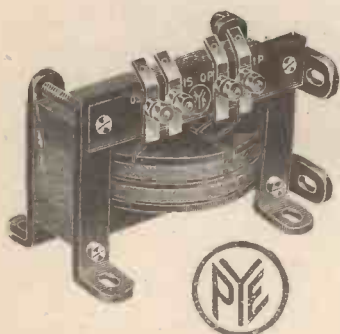

FAMOUS COMPONENTS AS USED IN PYE RECEIVERS ARE NOW AVAILABLE FOR HOME CONSTRUCTORS

ALL PYE COMPONENTS ARE GUARANTEED FOR ONE YEAR AND ARE OBTAINABLE FROM ALL HIGH-CLASS WIRELESS DEALERS OR POST FREE C.O.D. FROM OUR WORKS

DISTORTIONLESS L.F. TRANSFORMERS

Cat. No.	Ratio.	Price.	Price Tapped
651	2.5:1	17/6	20/-
652	4:1	17/6	20/-
654	6:1	20/-	22/6

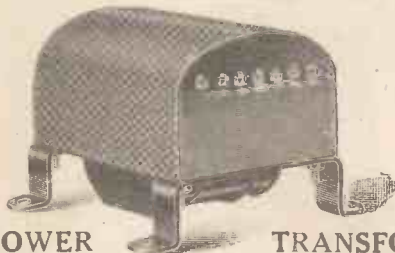

POWER TRANSFORMERS

- No. 675. For use in H.T. battery eliminators for A.C. Mains of 200, 220 or 240 volts - £1 : 15 : 0
- No. 676. For use in H.T. & L.T. battery eliminators or receiving sets taking their current direct from A.C. Mains, using K.L.I. valves - £1 : 17 : 6 For 200, 220 or 240 volts.
- No. 677. For heating the cathodes of K.L.I. valves. For use on A.C. Mains of 200, 220 or 240 volts. £1 : 10 : 0 Overheating eliminated. Electrical breakdown impossible.

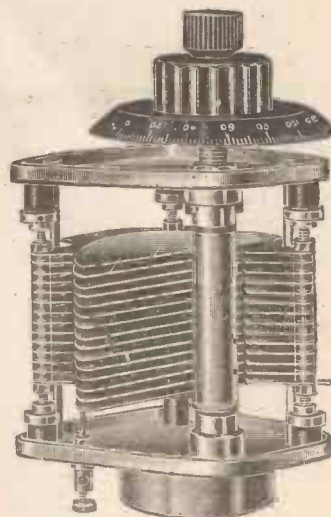

GEARED CONDENSERS

Cat. No.	Capacity.	Price.
900	.0001	22/6
902	.0002	22/6
904	.0003	22/6
906	.0005	22/6
908	.00075	27/6

LOW FREQUENCY CHOKES

Cat. No.	Res. Ohms.	Inductance.	Price.
658	750	32	12/6
659	2500	110	12/6
660	3000	150	12/6
661	3500	200	17/6
662	6000	350	20/-

If with two equally turn spaced tappings 2/6 extra

W. G. PYE & CO., CAMBRIDGE, ENGLAND

Ask for "Pan-Tabs"

PAN-TAB—the better Jack—does more than serve as a Jack. It makes a fine angle bracket between panel and baseboard, inverted, it may be used as a bracket for mounting sub-panel. Made of finest materials. Hard brass frames. Nickel silver springs. Sterling contact points Formica insulation. No other Jack combines these features, and the prices are low;—

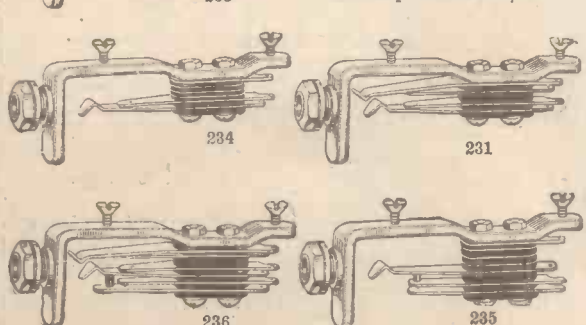

- 233. Open Circuit 1/10
- 234. Closed Circuit 2/-
- 231. Double Circuit 2/2
- 235. Single Filament Control 2/3
- 236. Double Filament Control 2/6

Hamleys
Estd 1760
HAMLEY BROS. LTD.

200-202, REGENT STREET,

LONDON, W.1. Telegrams: "Pleasingly, Piccy." Telephone: Regent 3160 (6 lines)

HYDRA

The condenser you should be using



The first to be tested on 500 volts D.C. If you want to build an Eliminator, use Hydra A.C. Condensers tested on 500 volts A.C. equalling a test of 750 to 800 volts D.C. and costing :- 1 mfd., 3/3d.; 2 mfd., 4/3d.; 4 mfd., 7/-; etc. All Capacities up to 10 mfd.

Ask your dealer, or if any difficulty send direct to:

Louis Holzman
109 KINGWAY LONDON, W.C.2 TEL: HOLBORN 6209

CUT THIS OUT FOR CABINETS



and post to us for FREE list illustrating Cabinets as shown in "Wireless Constructor", etc., etc., and for our additional Bulletin No 2.

NAME ADDRESS



(Write in block letters, please.)
CARRINGTON Mfg. Co. Ltd.,
Cameo Works,
Sanderstead Road, South Croydon.
Trade enquiries especially invited.
Telephone: Croydon 0623 (2 lines).

OUR NEWS BULLETIN

—continued from page 132.

A Television Triumph

According to reports from Washington, a real advance in the science of television has been made in America. A selected audience sitting in New York heard and saw Mr. Herbert Hoover deliver an address 250 miles away!

Although less distinct than an ordinary cinema picture, Mr. Hoover's face was quite clearly recognisable. A head-and-shoulders view brought him up on the screen like a movie-star, and when he puffed his cigar he so impressed one New York onlooker that this worthy remarked, "Gee, Bo! This television will soon be smelly-vision. I sure gotta whiff of Herb's cigar, that time."

Turkish Delight

A famous French wireless company—Cie. Generale de Telephonie Sans Fil, Paris—has put up the first Turkish broadcasting station at Stamboul, and this is now flinging its programmes across every Dardanel in the country.

The power employed is 6 kw., and it is hoped that eventually every one of Turkey's 14 million Turks will listen in. But won't they have an awful time putting up their aerials if they still persist in wearing that fan-dangle footwear with the curl-over toe-caps?

The Myth That Keston Killed

If Keston never does anything else, it can certainly claim to have laid to rest the great American Bogey. We have heard so much about the perfection of broadcasting in America that we believed a lot of it—until Keston's Tuesday-evening relays proved it to be a myth. So far as programme-procedure, timing the turns, and announcements are concerned, the B.B.C. has got the American stations right where the chicken got the axe! Listen-in to Keston's relays late on Tuesday evenings, and you'll realise that Savoy Hill in its silky studio-routine is far ahead of the U.S.A.

Scotland's New Station

A new Post Office receiving station for the Transatlantic telephone service is now prepared at Kembach, and linked up with the main telephone lines at Cupar, Fife.

Special precautions are to be taken to prevent the troublesome "singing round the ring" which caused the whole Transatlantic service to howl like a coyote when the British receiving end was situated at Wroughton, which is too near to Rugby.

Rugby's Time Signal

Britain gave Greenwich Time to the whole world, but in the past British ships have had to check their chronometers from a foreign radio time signal. Although it is Greenwich Time, when received in this way it has a foreign accent that Sailors Don't Care about. So now Britain is to have a radio Time Signal of its own, sent out daily from the Rugby station.

Polluting the Programme Pauses

"Perhaps you are not receiving these words with complete satisfaction on your loud speaker this afternoon? If not, the use of the So-and-so loud speaker will improve your reception greatly."

The above announcement was actually made from an American broadcasting station, and I would commend it to the notice of those

(Concluded on page 136.)

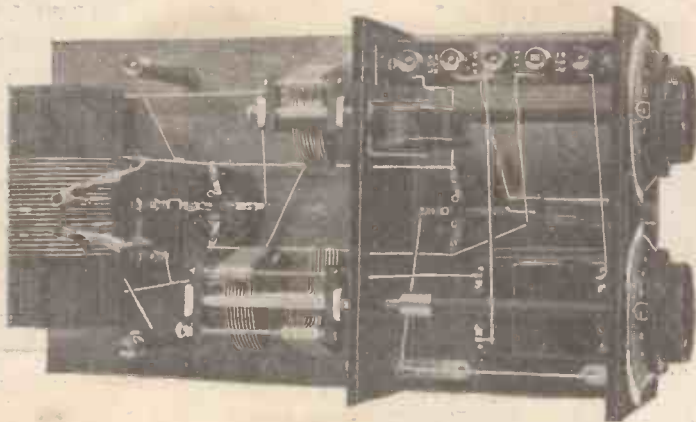

THE BOWYER-LOWE SHORT-WAVE RECEIVER

is a direct result of the use of Bowyer-Lowe components—the best obtainable. Each component is carefully designed and tested and made to rigid specifications for lasting and perfect service.

This Short-Wave Receiver is a remarkably efficient set, and letters of congratulation come in every post from enthusiasts everywhere.

Send 1/- NOW for the Booklet giving the whole interesting story of its uses and capabilities.

Announcement of the Bowyer-Lowe Co., Ltd., Letchworth, Herts.

Bowyer-Lowe

YOUR GUARANTEE - SEE IT ON YOUR COMPONENTS

*Ashley
Radio*

Guaranteed Components for high efficiency Sets.

JACKS

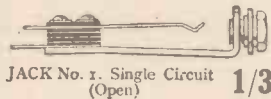

JACK No. 1. Single Circuit (Open) **1/3**



JACK No. 2. Single Circuit (Closed) **1/6**



JACK No. 3. Double Circuit **1/9**

JACKS No. 4 and 5 for Filament Single and Double Control **1/9 and 2/3** respectively.

Positive in action, these Jacks were designed by telephone engineers whose experience in other directions has enabled them to simplify the movements; embody refinements, and to recommend the materials and methods for their construction. Tags are tinned and spread fanwise for easy soldering.

Guaranteed to be manufactured of materials which have secured the approbation of experts associated with this and other journals Ashley Components can pass any examination with distinction. Cheaper than others they may be, but nevertheless they are a repeated feature in many valuable sets.

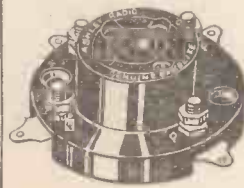

VALVE HOLDER

This Valve Holder has been adopted by B.T.H. for their R.K. Loud Speakers, a tribute to its high insulation and anti-capacity properties. Bakelite. **1/3** each.



Patented construction differing from all others and undoubtedly superior. each **2/6**
50,000 W. to 2 megohm. Bakelite Base. **1/-**

STANDARD TELEPHONE PLUG

The neatest finish to any pair of leads. Equally adaptable to spade or pin



tags, rigid or flexible wire. **1/6** each



RESISTORS

The modern method of ensuring correct and unvarying L.T. Supply. Obtainable in any desired value for inserting in circuit with any make of valve. Guaranteed accurate to within 2%.

The base is moulded of genuine Bakelite, with nickelled Phosphor-bronze clips, which grip with firm contact but permit of easy extraction.

All Standard values - **1/6**
Base - - - - - **1/-**

**ASHLEY WIRELESS TELEPHONE CO. (1925) LTD.,
17, FINCH PLACE, LONDON ROAD, LIVERPOOL.**

If unobtainable mention local dealer and we will send post free.

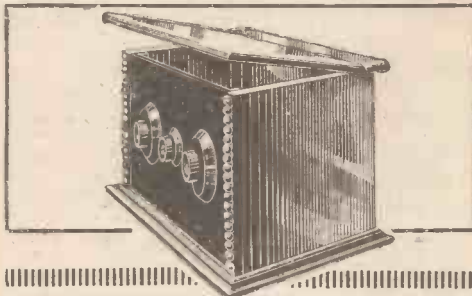

Popular Type.

ARTCRAFT CABINETS FOR RADIO RECEIVERS.

Artcraft Cabinets are made in Oak or Mahogany, properly hand French Polished, and are of very attractive and pleasing design. **BETTER VALUE IS UNOBTAINABLE.**

"Artcraft Popular Type" Cabinets

WRITE NOW for ILLUSTRATED CATALOGUE. POST FREE. All Artcraft Cabinets are guaranteed.

Panel Size Depth	Price in Oak	Price in Mahog.
9 x 6 x 6	6/0	10/0
10 x 8 x 6	8/0	12/0
13 x 6 x 6	10/0	14/0
12 x 10 x 8	12/0	16/0
14 x 10 x 8	14/0	19/0
16 x 8 x 8	14/0	19/0
18 x 12 x 9	21/0	29/0

Baseboards Free. Hinged Lids 1/6 extra.

**EBONART,
RADION AND
RESISTOR**
Panels supplied and fitted free at standard prices.

Owing to increased railway charges enclose 1/- extra for crate. All above Cabinets delivered passenger train FREE. Delivery by Return Guaranteed.

Special sizes made to order. Estimates free.

Cabinets for R.C. Threesome: Oak, 15/6, Mahog. 20/-
Solodyne from 45/-

THE ARTCRAFT CO., 156, Cherry Orchard Road, Croydon. Phone: Croydon 1981

Parr's Ad.

HARDLY a Set is described in the Wireless press nowadays in which the Designer does not use and recommend T.C.C. Condensers. He knows that he is safe in specifying T.C.C., for the twenty years' Condenser experience behind it ensures a never-failing reliability. He knows that only the most exacting standard of accuracy can possibly pass the stringent T.C.C. tests. Follow the experts' lead—specify T.C.C. Condensers in your next set.

T.C.C. Condensers



Adv. Telegraph Condenser Co., Ltd., Wales Farm Road, North Acton, W.3.
G.A. 8682

OUR NEWS BULLETIN

—concluded from page 134.

critics of the B.B.C. who think that we should follow the American plan of broadcasting advertisements.

Speaking for myself, I would sooner hear a bald-headed Bash Bazouk, with an impediment in his speech, singing a tribal lay and accompanying himself on a cracked zingwob, than listen to such sickening drivel as the thinly-disguised radio advertisement.

A Long-Wave Surprise

Listeners who like to tinker around on the big coils have recently been getting a delightful surprise in the way of good Swedish programmes. These emanate from Motala, the new high-power station that has been testing on 1,350 metres.

At the time of writing no regular programme schedule appears to have been adopted, but the station is well worth listening for upon any set with tuning that goes up Hilversum way.

Could They ?

"It's only an inexpensive one-valve made by a workman, but I gets

German and anythink with it, what do you say to that?" asks a reader.

I say the same as Jack Edge—"Could Lloyd George do it? Could Winston do it? Could Baldwin do it? No!"

National Wireless Exhibition

The National Association of Radio Manufacturers and Traders—familarly known as "The NARMAT"—announces that this year's officialy blest National Wireless Exhibition is to be opened on September 21st.

It will be held in the New Hall at Olympia, London, and, in addition to complete sets, apparently every transformer, leak, resistance, insulator, coil, condenser, component, what-not, and doo-hickey known to radio men, will be on view. The Exhibition will close on October 1st.

A Novel Programme

Amidst all this talk about brightening up the programmes, I have not seen a more original suggestion than that put forward by a provincial newspaper, which recently announced that, "What listeners really want really is Htlemton% G£ ½ J£@cZ."

It would be quite a pleasant change from chamber music and those *conversazioni*, wouldn't it?

WITHIN THE VACUUM

—continued from page 102.

handled I can honestly say the S.P.18/RR is well among the first of the powers, almost equalling some six-volters in the volume it will handle with perfect results. As a last-stage valve it can be recommended to readers with every confidence, for provided its input is without blemish it will reproduce that input with wonderful fidelity.

Further Valves

The other valves I must mention are the Marconi and Osram 4-volt series, the D.E. H410, D.E. L410, D.E. P410, all efficient valves in their classes, taking, as their nomenclature suggests, 1 amp at 4 volts; the Mullard P.M.1A and P.M.3A, and the S.T.21A and 41A, 2- and 4-volt valves for resistance coupling and having amplification factors of over 30 and impedances round about 60,000 ohms. All are excellent valves and capable of giving good results when used in suitable circuits. I do not agree with the makers of the P.M.1A and P.M.3A, that anode resistances of

(Concluded on page 138.)

NI+FE **STEEL PLATE ACCUMULATORS**
FOR **HIGH TENSION**
Only 1/- per volt.
*Absolutely Noiseless.
No Acid. No Fumes.
Last a Lifetime.*
BATTERIES, LTD., REDDITCH
LONDON OFFICE:—220, Shaftesbury Avenue, W.C.2.

Don't Despair
We will make your broken or burnt out valve as good as new. Simply pack it up and send it to us together with your name and address, and remittance.
ALL TYPES OF VALVES REPAIRED AT HALF LIST PRICES. (Minimum charge 5/-)
Weeco, S.P.'s and low capacity types not repairable. Minimum D.E. current 0.15 amp. when repaired.
Satisfaction Guaranteed or Money Refunded.
Valco Ltd. (DEPT. C) Tabor Grove, Wimbledon, S.W.19
VALCO will mend it

FORMO **TRUE TUNING**
"INDIVIDUAL-GANG" CONTROL CONDENSER
again to the fore!
FIRST we gave our customers a highly efficient and low-priced Variable Condenser and L.F. Transformer. Now we lead in the design of a Gang Control Condenser with individual adjustment which has all the advantages of the ordinary Gang and Single Condensers without ANY of their disadvantages.
**CROWN WORKS, Dept. 6,
Cricklewood Lane, N.W. 2.
Phone: 1787 Hampstead.**
Manchester: Mr. J. B. Leves, 23, Hartley St., Levenshulme. Phone: Heaton Moor 475.

TWIN-GANG **£2:12:6**
TRIPLE-GANG **£3: 3:0**
TUNE with the centre dial until you hear your station.
ADJUST with the side dials for maximum signal strength.
**IT'S SIMPLE!
IT'S EFFICIENT!!
IT'S GOOD!!!
IT'S FORMO!!!!**



C.E. PRECISION WIRE WOUND ANODE RESISTANCE

—the wire costs fifteen pounds a pound!

The wire used in their manufacture is specially made for the purpose, and the component is designed and most carefully manufactured to give the purest reproduction obtainable. Each value is absolutely constant.

PRICES :

20,000 to 50,000 ohms	- -	3/9
60,000 to 100,000 ohms	- -	4/9
150,000 to 200,000 ohms	- -	7/-
250,000 ohms	- -	8/-
500,000 ohms	- -	15/-

Other values to order. Clips and base, 1/3 extra.

C. EDE & CO., Ltd., BYFLEET, SURREY

Telephone: Byfleet 226
Telegrams: 'Ceprecise,' Byfleet



There are also the famous C.E. PRECISION Rheostats, Dual Rheostats and Potentiometers, Grid Leaks and Floating Valve Holders. The latter, as illustrated, are anti-capacity and non-microphonic, and cost 2/3 each.

The "FINAL" CONDENSER

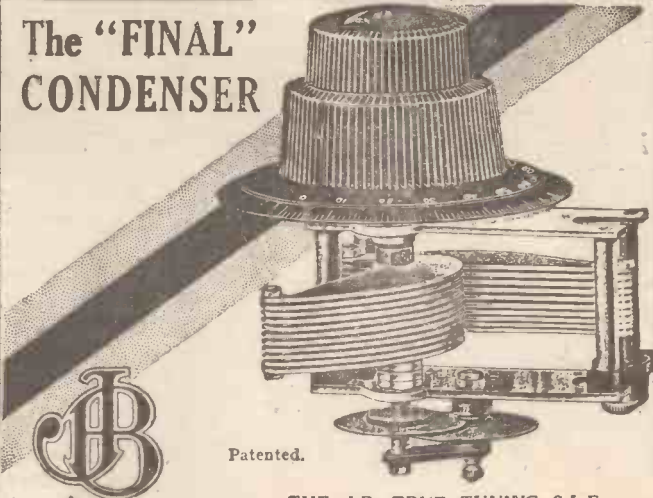

Patented.

THE J.B. TRUE TUNING S.L.F.

J.B. S.E.F. Condensers are known throughout the country as the "Final" Condensers because they have reached the highest possible degree of perfection. For accuracy in tuning, efficient workmanship and delightful finish J.B. Condensers are unsurpassed. Incorporate them in your set and see the difference

The J.B. True Tuning S.L.F. complete with 4-in. Bakelite Dial.	The J.B. S.L.F. complete with 4-in. Bakelite Dial.
Double reduction friction drive, eliminating all possibility of back-lash, ratio 60:1.	·0005 mfd. ... 11/6
·0005 mfd., 16/6; ·00035 mfd., 15/6; ·00025 mfd., 15/-.	·00035 mfd. ... 10/6
For Short Wave Receivers	·00025 mfd. ... 10/-
·00015 mfd. ... 15/-	For Short Wave Receivers
	·00015 mfd. ... 10/-

JACKSON BROS.
8, POLAND ST—OXFORD ST
LONDON—W.1. Telephone—GERRARD 7414

Heard in the bus between Clarence and Gus
Clarence: "Do you know, Gus, I'm not satisfied with my 'Whooperset' since hearing yours last night. Good loud speaker, valves, and all that sort of thing, and yet the tone and volume are nothing compared with yours. Tried all kinds of gadgets, but they don't improve it." Gus: "Is your H.T. all right?" Clarence: "Oh, yes, bought a new dry battery only last week. In fact, I have a new one about every month." Gus: "What! Throwing money away on dry batteries and spoiling your concerts into the bargain! That's where your trouble is, old man. I had the same bother before I fitted a Westam H.T. Accumulator nearly a year ago; only had it charged twice since. No, there's nothing special about my set, and you can get the same results. 60-volt model costs 30/-. Try it." Clarence: "I'll get one to-night. Oherio! Getting off here."

WESTAM
EVERLASTING H.T. ACCUMULATORS.
6d. a Volt. 2 Amps.
Entirely British. Fully Guaranteed.



Pat. No. 1093026.
60-Volt Model 30/-, 20 v. 10/6, 30 v. 16/-, 90 v. 45/-, 100 v. 50/-, 120 v. 60/-.
SCRAP YOUR DRY BATTERY.
All models, catalogues and spare parts from any dealer, or
WESTAM ACCUMULATORS, LONDON, E.6.

Eleven Blue Prints for 6d.!

The "Best Way" Pictorial Blue Prints book consists of an up-to-date and comprehensive range of blue print diagrams drawn in a simplified pictorial style so that the amateur constructor cannot possibly go wrong when building up a set on the lines of any of the circuits with which the book deals. There are 11 circuits in all. Buy a copy To-day.

"BEST WAY" PICTORIAL BLUE PRINTS
6d. Of all Newsagents, etc.

"P.W."

Stands for "Popular Wireless" and all that is best in weekly radio journalism.

The most up-to-date weekly radio paper, "Popular Wireless" has an unrivalled circulation because its readers know that they will always find the best and only the best, in each week's issue.

Place a regular order with your news-agent NOW and take

"Popular Wireless"

On Sale Every Thursday Price 3d.

A NEW "KEYSTONE" COMPONENT THE "MULTI-NEUT" CONDENSER

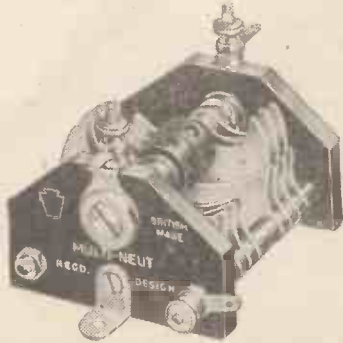

THIS condenser has been designed to meet the need for a twin neutralising condenser as used in Mr. Percy Harris' "SIGNAL BOX" and "BLACK PRINCE" Receivers, but it can also be used for balancing out stray capacities, as a "trimmer" between gang condensers, and in endless other ways. Its many applications are dealt with in the Keystone Folder now in course of preparation, "Multi-Neut Condenser." Send for your copy to-day.

Price **6/6**

KEYSTONE "MIDGET" CONDENSER

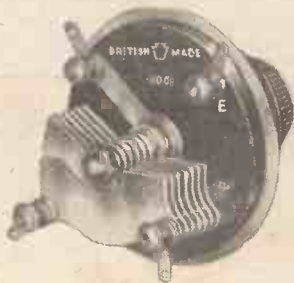

Ideal for the many positions where a small capacity condenser is required. An aluminium shield prevents hand-capacity effects, and a special taper bearing gives a beautifully smooth movement. Accurately designed and rigidly constructed, this Keystone condenser is backed by the usual Keystone guarantee of efficiency. Capacity '0001 mfd.

Price **5/6**



Special Six-pin Base. To replace the more expensive standard screened coil base in sets where the actual screen is not required. Standard spacing with terminals arranged for easy accessibility. Price **2/9**

Keystone Fixed Resistors. No. 4 for *25 amp. valves with 6-volt accumulator. No. 17 for *06 amp. valves with 4-volt accumulator. And in many other values. Price **2/6**. Resistor only 1/9. Base. 9d.



The New "PILOT" Manual

Containing details and prices of the most modern and efficient receivers. Much useful constructional information also included. Post Free 3d.

PETO-SCOTT Co., Ltd.,
Regd. Office: 77, CITY ROAD,
LONDON, E.C.1

Branches: LONDON—62, High Holborn, W.C.1.
WALTHAMSTOW—230, Wood Street. PLYMOUTH
—4, Bank of England Place. LIVERPOOL—4, Man-
chester Street. P.S. 8661

WITHIN THE VACUUM

—concluded from page 136.

2-3 megohms can be advised. These are a bit *too* high in my opinion, and more generally satisfactory results and better reproduction, albeit less amplification per stage, will be obtained by not exceeding the 500,000-ohm mark.

Fixed Resistors

By the way, the fixed resistor seems to have come into its own, largely to the exclusion of the rheostat, but constructors should be careful how far they carry the "no rheostat" idea.

It must be remembered that when an accumulator has just been charged it usually gives above the rated voltage, and I have known 6-volt accumulators that give and keep for several hours voltages round about 6.4 or 6.5 after they have been charged. A fixed resistor of the ordinary wire type cannot be expected to deal with such emergencies, and I would strongly advocate the use of a master rheostat of about five ohms on all sets.

By the way, while discussing fixed resistors, many people seem to be of the opinion that "Amperites" are just wire-wound resistors. They are a little different, however, being what are known as "barreters." They limit the *current* and do not merely cause a voltage drop. Thus they limit the current automatically to the required value within comparatively wide limits of applied voltage.

You must, however, use the correct Amperite for any particular valve and a change of valve may necessitate a change of barreter. The correct Amperites for the chief valves on the market are as follows:

For the B.4, D.E.5, S.P.55R., P.V.5, D.E.5B, L.525, and valves having the same L.T. consumption, a No. 1A is required, using a 6-volt battery. For the .06 valves and a 4-volt battery the No. 4 V.199 is necessary. For the same valves if a 6-volt battery is used the No. 6 V.199 should be employed, while P.M.4's, P.M.3's, etc., need No. 120 when used with a 4-volt accumulator.

The popular 2-volt "point one" series of Cossor valves, the A.R.D.E., D.E.R., S.P.18's, etc., when used with their proper L.T. voltage should have a No. 18 barreter, while the D.E.11 Cosmos and Weco valves should have the No. 1A, a 2-volt L.T. supply being employed.

FURTHER NOTES ON THE TRICKLE CHARGER

—concluded from page 114.

iron type the central electrode will be iron and the two outside electrodes aluminium. The battery is always in the common lead between the central electrode and the centre tap of the secondary of the transformer. You will sometimes have seen it stated in articles on this subject that the whole of the voltage generated in the secondary is used in charging the battery.

This is quite wrong, however. Only the voltage in one half of the secondary is in use at any time. Thus, supposing you had a single secondary with a single rectifier (giving single-wave rectification) and you found that (say) 20 volts were required to produce 0.1 ampere through the battery, then if you wanted to pass on to the centre-tapped transformer, with the combined rectifier and full-wave rectification, you would require to add about as many turns again for the other half of the "split" secondary, and you would then obtain a current of about twice as much, that is about 0.2 ampere at 20 volts. In other words, the *action* of the system is very approximately that indicated in Fig. 7; the two circuits, although combined, each deliver only a half contribution to the total result.

Final Considerations

Finally we come to the more elaborate arrangement indicated in Fig. 8. Here we have matters in principle the same as in Fig. 7, but the secondary of the transformer has extra tappings, so as to deliver voltages suitable for charging, say, 4-volt and 6-volt accumulators. A two-pin plug is shown, the two pins of which are connected to the outside electrodes of the rectifier. These may be plugged into the 4-volt or the 6-volt tappings of the transformer.

An ammeter is shown in series with the battery and also a variable resistance: this variable resistance is merely to give a final vernier adjustment to the charging current, so that if it should be found, after a few days or a week or two, that the charging current was a little too high, it could be slightly reduced, and so on. For practical purposes, however, it is better to choose tappings which give approximately the correct voltage, as this avoids loss of energy in the rheostat.

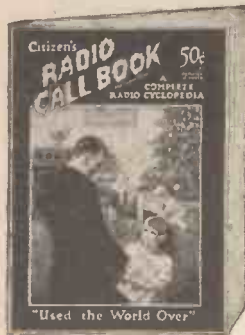

The Truth about American Radio

Owing to the fact that practically no opposition, Legislative or otherwise, has curtailed Radio Research or Development in the United States, America is to-day acknowledged as the producer of the best Radio Sets and Apparatus in the World. Many leading manufacturers maintain fully equipped Research Laboratories staffed by highly-paid wireless experts, whose sole business is, by experiment and test, the improvement of sets and equipment. As a result, the total value of Trade in Radio Sets and Accessories

in the United States of America during 1926 reached the enormous total of £60,000,000.

With such strong financial backing, equipment and brains, it is not surprising that Tone Quality has reached an almost unbelievable degree of perfection—that the size of the country has made "reaching out" imperative, and that the highest degree of Selectivity has been reached because the 600 Broadcasting Stations make this imperative.

THE CITIZEN'S RADIO CALL BOOK

America's leading Radio Publication has a circulation of over one quarter of a million, and is used in every country in the world. It is published four times yearly, September, November, January and March. Sells for 3/- in the British Empire and Continental Europe. This publication contains complete Constructional articles of sets (12 or more in each issue) that are all built and tested in The Citizen's Radio Service Bureau Laboratories, where the investments of Radio Testing Apparatus value over £6,000. The articles contain the very latest information

obtainable, are clearly and non-technically described. Graphic illustrations and schematic diagrams make it possible for the novice, who has perhaps never constructed a set before, to build the very best at a moderate price without fear of failure.

Much other valuable data is contained in this publication, complete list of world's Broadcasting Stations, Wave-lengths, Schedules, Slogans, etc., Photographs of Station Announcers, Entertainers, etc., etc.

Published by

Citizen's Radio Service Bureau
CHICAGO, ILLINOIS, U.S.A.

THE MARCH ISSUE
HAS JUST ARRIVED—
240 PAGES.

Distributed to Radio Trade by The Rothermel Radio Corp., of Gt. B., Ltd., 24, Maddox St., London, W. 1, also distributed in Great Britain by W. H. Smith & Sons. If your dealer cannot supply you send postal order for 3/- to The R. R. C. of Gt. B., Ltd., 24, Maddox St., London. Copy will be sent prepaid.

On Sale in France—
Brentanos — Paris.

Cabinets of distinction

The "Solodyne" Cabinet and "Solostand" illustrated here are fine examples of the cabinet-maker's craft. In common with other cabinets of our design and construction they are unequalled for price and quality. Cabinets of similar quality are made to customers own designs in a special section of our works at moderate prices.

An illustrated folder of specimen cabinets and prices will be gladly sent on application.



Cabinet only (Panel size 21 in. by 7 in., Baseboard 21 in. by 16 in.)
Oak 55/-. Mahogany 65/-
The "Solostand" (Height 2 ft. 6 in., Length 2 ft. 2 1/2 in., Depth 1 ft. 10 1/2 in.) the ideal table for the "Solodyne" Cabinet, in Oak 55/-. Mahogany 65/-
SOLODYNE "PEDESTAL" (Cabinet and Solostand in one piece)
Oak £5 : 5 : 0. Mahogany £6 : 6 : 0.
Baseboards Free, Carriage Paid.



V. C. Bond & Sons, 61, Hackney Grove, Mare St., London, E. 8.

HAVE YOU SEEN
THE MAY NUMBER
OF

MODERN WIRELESS ?

This Special number includes contributions from Sir Oliver Lodge, F.R.S., Capt. P. P. Eckersley, M.I.E.E., Capt. H. J. Round, M.I.E.E., Percy W. Harris, M.I.R.E., St. John Ervine, the famous Dramatic Critic, and Stenson Cooke, Secretary of the A.A. and M.U.

BUY YOUR
COPY NOW

PRICE
1/-

The FUTURE of The Varley Bi-duplex winding.

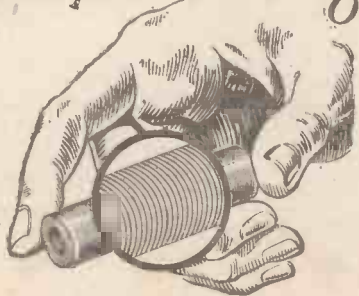

The success of the famous Varley Bi-duplex winding has been so marked that in response to a general demand on the part of the public we are adding new Bi-duplex wire-wound components to our existing range.

For resistance-capacity coupling Varley Bi-duplex wire-wound Anode Resistances ensure a real degree of tonal purity and a consistency of perfect reception under all conditions. Again, it is a generally admitted fact that the efficiency of any receiver employing one or more stages of H.F. amplification is increased by using the Varley Multi-Cellular H.F. Choke. Thirty years' experience in the design and construction of every description of coil winding has been applied with equal success to the manufacture of wire-wound radio components, and to-day, just as in the electrical world proper the Varley Bi-duplex winding has built up a reputation for real reliability, so in the radio industry to-day the name Varley stands for the really efficient wire-wound product.

This is only the beginning of big developments of our wireless activities—activities which will mark a real advance in modern science, and result in a vast improvement in existing radio reception.

Descriptive leaflets with full particulars of Varley Bi-Duplex wire-wound Anode Resistances up to 500,000 ohms, Tapped Resistances and H.F. Chokes.



The VARLEY MAGNET COMPANY,
(Proprietors: Oliver Pell Control, Ltd.)
Granville House, Arundel St., London, W.C.2.
Telephone: City 3393.

* LETTERS TO THE EDITOR *
* A Queer Valve Fault—Results with the Night Hawk *

SIR,—I am enclosing part of a 0.06 valve (A foreign make—Ed.) which has, I think, a rather unusual fault, obviously caused through gross negligence.

I purchased the valve from a dealer in Southampton, and decided to try it on a single-valve set first. The filament was turned on, but there were no results. Thinking possibly that the valve pins were not making proper contact in their sockets, I caught hold of the valve and found it abnormally hot.

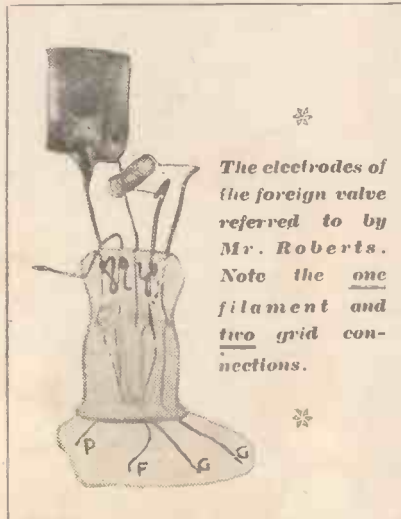

*
The electrodes of the foreign valve referred to by Mr. Roberts. Note the one filament and two grid connections.
*

On examining the valve closely I found that the filament was not glowing, but the grid was; so I removed the base and bulb, and found that the two sides of the grid were connected to the filament pins, and that there was only one lead from the filament, which was connected to the grid pin. You will notice that the other filament lead is cut off at the pinch.

I thought this might be of some interest to you.

Yours faithfully,
KENNETH F. ROBERTS.

Minstead,
Near Lyndhurst, Hants.

EDITOR'S NOTE.—We have carefully examined the valve in question and confirm the writer's statements. Readers who buy foreign valves should realise that when faults of this kind occur there is little likelihood of redress, whereas British makers will always replace faulty specimens at once, free of charge.

SIR,—I have just completed building the "Night Hawk," and I must say that I am extremely pleased with the results.

Although I am not in a good situation for DX work I can receive over thirty stations on the loud speaker.

The best among these are Radio Paris, Daventry, Konigswusterhausen, Soro and Berlin on the long waves and Hamburg, Langenberg, Stuttgart, Madrid, Barcelona, Münster, Toulouse and all the B.B.C. main stations on the broadcast band.

Many people have expressed their liking for it and say that it is one of the best sets they have heard.

Wishing the CONSTRUCTOR success in the future, as in the past,

Yours faithfully,
W. L. DAVIES.

High Moor,
Whitchurch, Salop.

Remarkable Selectivity

SIR,—Having built your "Night Hawk" set, and tried both the original coils and the later ones, as suggested in the February Number of the WIRELESS CONSTRUCTOR, I thought it might be of interest to you to know the result.

I am only about half a mile from the Plymouth broadcasting station, and with the original coils I was able to tune in to 20 metres either side of Plymouth with no interference from that station, but with the later coils I find that I cannot cut it out within about 75 metres. I wondered if this great difference was to be expected; if so, then it means that anyone "on top" of a station must use the former coils.

Yours faithfully,
R. B. MARTIN.

16, Carlisle Terrace,
Plymouth.

EDITOR'S NOTE.—As indicated in the article, the new windings add to signal strength at the expense of selectivity. The results obtained half a mile from the Plymouth station are certainly interesting.

POPULAR WIRELESS

The Progressive Weekly
Radio Journal.

Price 3d. Every Thursday.

SMOOTH STEM

The Smooth Stem ensures that strands of wire will not bind up with the thread.

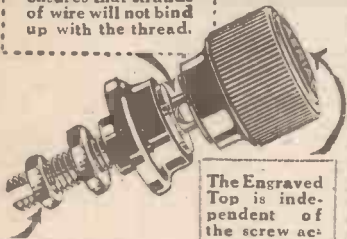

The Engraved Top is independent of the screw action head and does not rotate.

Transverse Slot with clamping nut eliminates soldering.

The Belling-Lee Patented Terminal is Perfectly finished throughout, and is made with 30 different engravings.

Used by the manufacturers of all the best battery eliminators.

Standard large insulated model (Polished black Bakelite) Type B. 9d. each.
Popular model (non-insulated) Type M. 6d. each.

Illustrated catalogue free on request. Obtainable from all Dealers, but in case of difficulty send your order to us, enclosing your dealer's name and address.

BELLING-LEE TERMINALS

BELLING & LEE, LTD., Queensway Works, PONDERS END, MIDDLESEX.

* "SAMSON" SCORES *

SIR,—“Samson”—the Powerful Twin. The name sounds good, but the set is better! I have used different makes of components from those given in WIRELESS CONSTRUCTOR, i.e. Ormond condensers, Gambrell first-stage transformer, B.T.H. 4 to 1 ratio transformer, R.I. choke, and Lewcos H.F. transformer. I was struck by the unusual features of the set as soon as I saw it in WIRELESS CONSTRUCTOR, and decided to build it. Upon completing it and testing the L.T. and H.T. circuits, and finding it all serene, I plugged in the valves and connected up batteries and 'phones. Upon testing I found I could not stop it oscillating, until I discovered I had omitted the G.B.—1 lead, but when that was put right it was all O.K. On Sunday evening, about 6.30, I donned the 'phones to see what I could get. Result: ten stations in ten minutes. I daresay there were more to get, but I was called away. I might say that the above results are upon a badly screened aerial and Radio Micro 4-volt valves. I must conclude by saying that anybody is welcome to come and hear the set at work, and if they don't want to make it after hearing it I shall be surprised. Thanking you very much for such a splendid circuit.

I am, Yours faithfully,
R. J. HALLETT.

88, Villa Street,
Walworth, S.E.17.

"POPULAR WIRELESS"

is the leading radio weekly. All constructors who wish to keep abreast with both technical and broadcasting developments should read "Popular Wireless"

Price 3d. Weekly.

* SHORT WAVES ON THE *
* "FOUR-VALVE FAMILY" *

SIR,—I feel I must write to you to tell you what excellent results I am getting with the "Four-valve Family" Set. On Tuesday night and Wednesday morning I got 2 X A F very clear indeed, except for a wee bit of fading which varied from loud telephone strength to crystal strength. I started with 4 turns ordinary D.C.C. bell wire for aerial, 6 turns for anode, and 9 for reaction, but I couldn't get rid of the oscillation so I took 2 turns off the reaction, leaving 7 turns—a great improvement. I was using P.M.3 Mullards, and I have had another station which I imagine to be K D K A, although I didn't hear his call-sign; he was linking all the stations together, calling them all together such as "Right down Chicago"; "Right down Portland No. 2," etc., etc. He was at it a long time. I am sure I am getting wonderful results on the short waves with it. Yours faithfully,

R. G. ROBERTS.

Llys Berwyn, Pwllheli,
North Wales.

2 X A F was heard just after midnight.

The DIX ONE-METER

is a beautifully finished Moving Coil instrument of wonderful precision and delicacy. Measures microamps to 20 amps, millivolts to 2,000 volts, and 50 ohms to 50 megohms. INSTRUMENT ONLY 55/- MULTIPLETS 6/6 ea. "VIOLIN" LOUD SPEAKERS are elegant furniture, as delightful as a violin. Model-de-luxe hornless mahogany cabinet type for lid of set or on wall. Liquidation stock of brand-new original 5-guinea Violins, fitted 2,000 ohm. Viola reed reproduce, 25/-, packing & carriage, 5/- HEAR-EASY 'PHONE EARPADS. List Price, 2/- pr. Sale, 6d. pr. Free to Blind. Half-price to Hospitals.

SALE OF RECEIVERS BY MARCONI CO. and other Leading Makers. M. Crystal Cabinets, with 'phones, 15/6. The Bargain of the Year. The B.B. 10 1-Valve and Crystal Reflex Sets, with Osram Valve. As new, in Cabinet, with lid, 30/- Usual price, 25. A number of 2, 3, 4, 5 and 6-Valve Sets at Bargain Prices.

TEXAS CONE LOUD SPEAKER with the Golden Voice. 3-guinea Model, bronze, for 30/-, complete with cord. THOSE HARD-TO-GET THINGS. Relays, Wheatstone Bridges, Micro-Galvos, Univ-Shunts, Res. Boxes, Thermo- and Electro-static Meters, Cell Testers, Capacity Meters, all at low price.

NOW READY OUR NEW CATALOGUE 68 Pages, Novel Apparatus. Profusely Illustrated. Numerous New Lines. Over 1,000 Splendid Bargains. Send 4d. Stamp and Save Pounds. ELECTRADIX RADIOS 218, Upper Thames St., London, E.C.4.

TO ADVERTISERS

ALL communications concerning advertising in the "Wireless Constructor", "Modern Wireless", and "Popular-Wireless", must be sent to

JOHN H. LILE Ltd.,
4, LUDGATE CIRCUS, London, E.C.4
(Phone: CITY 7261)
and NOT to the Editorial or Publishing Offices.

PICKETT'S CABINETS

For Your HOME Radiola! Wireless Furniture 3 ft. high—taking your Set, Batteries, etc., complete. BUREAU Models from 23 3 0 "RADIOLA" Jacobean from 25 5 0 "Radiola" Queen Anne from 26 15 0 High Grade Work and finish GUARANTEED. GRADUAL PAYMENTS arranged. Lists of Cabinet Designs No. 21 FREE. Pickett's Cabinet (W.C.) Works, Bexleyheath.

WHEN replying to advertisements please mention "Wireless Constructor" to ensure prompt attention. THANKS!

STANDARD WET H.T. BATTERIES

(Leclanche Type) 1 1/2 volts each cell.

Separate Parts			Separate Parts	
Jars (waxed)	1/3 doz.		Box Rubber Bands for 12 Sacs No. 2	6d.
Zincs	1/0 ..	Shellac Varnish	6d.	
Sac No. 1	1/6 ..	Suitable oil for use on electrolyte for 60 cells	9d.	
Do. with terminals	2/3 ..	Sample doz. cells with No. 1 Sac. Elect. and Rubber Bands.	4/6.	
Sac No. 2	3/0 ..			
Do. with terminals	3/9 ..			
Electrolyte for 20 cells	9d.			
Box Rubber Bands for 12 Sacs No. 1	6d.			

60 cell, 90 volt battery—Price of complete set £1 1 0. Varnished Mahogany Tray 9/6 extra. Each cell comprises Jar (Waxed), Zinc, Sac Element with rubber insulating band and electrolyte.

NO CHARGING—ECONOMICAL—PERMANENT—SILENT
Send 1 1/2d. stamp for illustrated list giving full particulars, maintenance hints and useful information. We shall be pleased to advise the best battery to suit your set on receipt of full details.
WET H.T. BATTERY CO., 12, BROWNLOW ST., HIGH HOLBORN, W.C.2
By First Avenue Hotel.

K. RAYMOND
 27 & 28a, LISLE ST.,
 LEICESTER SQ., W.C.2

Hours: 9.15 to 7.45 Back of Daly's Theatre
 Saturday: 9 to 8.45 Nearest Tube, Leicester Square
 Sunday: 11 to 1 Phone: Gerrard 4637

Send Postcard, or CALL, for REPRINT of our
 £80 ADVT. "P.W." DATE APRIL 30th, and
 for latest data of WORLD'S BROADCASTING

SETS REPAIRED or RECONSTRUCTED
 Panels Drilled. Low Charges.

SETS OF COMPONENT PARTS

RADIANO "THREE." Original Component Parts.
 List price, £5 5s. 10d. Post free £4 12s. 6d.
2-VALVE REINARTZ ("P.W.") List price, 49/-
 Post free, 44/- "A.W." BALLOT. Original Parts.
 Total list price, £4 15s. Post free, 85/- **EDISWAN**
R.C. THREESOME. List price, 91/5. Post free,
 £3 19s. 6d. **MONODIAL RECEIVER.** List price,
 £8 4s. 9d. Post free, £7 7s. **ELSTREE SOLO-**
DYNE 5. Original parts. Total, £13 2s. Post free,
 £11 nett. **NELSON P.M.** Post free, £6 10s.
LODGE "N" CIRCUIT, including Silvertown Trans-
 former, post free, 32/6. **M.C.3** List price, 98/6. Post
 free, 85/- **BABY HALE.** List price, 66/4. Post
 free, 57/6. **H.D.L.3.** List price, £7 4s. 3d. Post
 free for £6 6s. **ALL-WAVE REINARTZ.** Post
 free, 36/- **R.C.4.** List price, £7 12s. 6d. Post
 free, £6 13s. 6d.

**FULL DETAILS OF ABOVE AND
 MANY OTHERS FREE.**

SHORT WAVE RADIANO

As described "Wireless Constructor," June, 1927.
ORIGINAL COMPONENTS

2 Variable Condensers, .0003 Cydon Mid Line and
 Elicrius, Precision Potentiometer, 0/0 Switch,
 1 Boyer-Lowe Induction V. Holder, 1 Magnum Dillo,
 2 Magnum B.B. Resistors to suit valves, 1 Dimic Base, 1
 Unimic ditto, 1 Dimic Coil S.W.1, 1 Dimic S.W.2, 1
 Unimic No. 5 (all McMichael), .0003 Condenser, Clips,
 and 2-meg Leak (Grah. Farish), 1 .002 Fixed Lissen,
 1 Magnum B.B. Coil Socket, with Terminals, specially
 made for Radiano, 1 C.A.V., all-purpose L.F.,
 Magnum, engraved strip with Terminals, 2 Cydon 4-in.
 dials with large knob, suitable for fine tuning.

List price of above components, £5 2s. Sent post free for
 £4 12s. 6d.
 Voltage of H.T.1 can be from 40 to 60. H.T.2 60 or
 80. It is also preferable to join up one or two mfd.
 condensers to each H.T. Battery.

**FORMO
 S.L.F. CONDENSERS**



With handsome
 4" TRIOLITE By Post
 dial and knob. 7/6
 7/11

ANOTHER GOOD MODEL
 S.L.F., with 4-inch Dial. .000
 and .0003, each 5/-. By post 5/8

LOW LOSS SQUARE LAW.

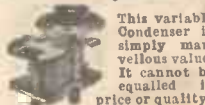

This variable
 Condenser is
 simply mar-
 vellous value.
 It cannot be
 equalled in
 price or quality.

.0003 .. 4/11 each
 .0005 .. 5/11.
 By Post 5/11.
 With VERNIER 1/- extra.



**VARIABLE
 CONDENSERS.**
 A new type now evolved.
 This condenser MUST even-
 tually take the place of the
 Sq. Law and S.L.F. types,
 as it is a combination of
 the two.
 With this condenser tuned
 circuits are balanced over
 the whole scale.
 .0003 .. 5/11 each
 .0005 .. 6/11.
 Post 6d. extra.

IMPORTANT

**LEADING DISTRIBUTOR OF
 LISSEN G.E.C. BURNDEPT.
 WEARITE DUBLIER, EDI-
 SON BELL, COSMOS, MIL-
 LARD, COSSOR, EDISWAN,
 E.P.H. MARCONI, STERLING,
 GAMBRELL, MAGNUM, EVER-
 READY, RESISTON, T.C.C.,
 IGBANIC, FERRANTI, LEW-
 COS, "J.P." BENJAMIN,
 LOTUS, NEWBY, FIVE C.E.
 PRECISION, EUREKA, UTIL-
 ITY, FORMO, BOWYER-LOWE,
 COLVERN, R.I., PEERLESS,
 ETC., ETC.**

**WE "AVE THE
 GOODS!"**

ANY SET OF PARTS OVER 20/-
 GIVEN A SPECIAL QUOTA-
 TION. PLEASE MAKE OUT
 LIST (Postage refunded)
 ORDERS DESPATCHED BY
 RETURN.

**2-VALVE SETS IN
 AMERICAN CABINET**
 12in. by 8in. 45/-. Post 2/6

RADIO MICRO
 (Guaranteed genuine).
 3.5-v. .06-a., G.P. 5/11
 1.8-v. .2-a., G.P. 5/11
 3.5-v. 1-a., Power 9/6
 1.8-v. .2-a. 10/6
 Post 1/ each per valve

**ALL CIRCUITS, PARTS,
 COILS & SITS STOCKED.**

**EVERYMAN 4,
 SOLODYNE 3,
 RADIANO 3, etc.**
 On show in our windows

**THE NEW No. 3
 ORMOND S.L.F.
 CONDENSER**
 .00025, 5/6. .00035, 5/9,
 .0005, 6/-.
 All with 4-in. Ormond Dial
**ALL ORMOND
 PARTS STOCKED.**

 * BE FAIR TO THE *
 * LOUD SPEAKER *
 * ***** *

MANY loud speakers in use to-day
 are not giving the result
 that they should, simply
 because they are not being fairly
 treated. One well-known make of
 cone-shaped loud speaker, for example,
 is designed to operate at its best with
 quite a low output impedance—this
 impedance is actually of the order of
 about 3,500 ohms. If it is connected
 directly into the plate circuit of a
 small power valve of the 6,000 to
 7,000 ohm impedance type, the tone
 is apt to be lacking in brilliancy and
 reproduction seems somewhat "card-
 boardy." The bass comes out well
 enough, but the treble is dull; with
 speech one gets the impression that
 the speaker is talking through a thick
 curtain. Instruments of this kind
 are at their best with a small power
 valve when a transformer with a
 step-down ratio of rather less than
 2 to 1 is used.

Shunt H.T.

The impedance of the super-power
 valve is almost exactly suited to such
 a loud speaker, but it is hardly fair to
 pass through the windings the steady
 plate current, which is of a compara-
 tively heavy order. Here the well-
 known choke-and-condenser filter
 circuit should be used. With a suit-
 able choke and a coupling condenser
 of 1 microfarad extraordinarily good
 results are obtainable.

It is unfair to place a high-resistance
 loud speaker directly into the plate
 circuit of a small power valve. If the
 resistance is 2,000 ohms there is an
 appreciable potential drop across the
 windings. With the super-power
 valve matters are, of course, still
 worse. In either case the current
 passed through the windings is too
 heavy. Here again the filter should be
 employed.

Improving the Tone

We may, in fact, say that whatever
 the type of loud speaker—unless it is
 specially designed for the purpose—it
 should never be connected directly
 into the plate circuit of a note-
 magnifying valve of the power or
 super-power type. The use of a
 suitable transformer, or of the filter
 circuit, generally improves the tone,
 and it always saves the windings from
 carrying the quite unnecessary steady
 plate current.

 * A PANEL - DRILLING *
 * HINT *
 * ***** *

WHEN drilling a smooth-surfaced
 ebonite or composition panel
 many amateurs often experi-
 ence a very great difficulty in
 maintaining the drill in a perfectly
 vertical position, and consequently the
 hole through the panel is not straight.

A good tip to remember when
 engaged on work of this nature with
 smooth-surfaced panels is to observe
 the reflection of the point of the drill
 on the ebonite surface. If the point
 of the drill is not entering the panel
 in a perfectly straight manner the
 fault will be exaggerated enormously
 in the reflection. Always, therefore,
 see that the line formed by the drill
 point and its reflection is perfectly
 straight, and you will then have no
 difficulty in obtaining perfectly true
 holes in the panel.

This hint, of course, cannot be
 applied to dull-surfaced panels, in
 which no reflection can be seen.

 * SHORTING CELLS OF *
 * H.T. BATTERY *
 * ***** *

BEFORE throwing away an H.T.
 battery it is as well to test the
 individual tappings. This
 should be done with a voltmeter while
 the battery is in use on a receiver. If
 you find that only some of the cells
 are run down, while others show
 nearly their full voltage, it is possible
 to obtain a new lease of service
 from the battery by just shorting
 the cells which are run down. This
 may be carried out with wander plugs
 connected with a short piece of wire.
 If sufficient wander plugs are not
 available, shorting links may be
 made out of thick wire.

 * A GRID - BATTERY *
 * TIP *
 * ***** *

ONCE the grid-biasing voltage
 for an L.F. amplifying valve
 has been found one has not, as
 a rule, to make any alteration unless
 either the valve is changed for one of
 (Concluded on page 143.)

**"PEERLESS"
DUAL RHEOSTAT**

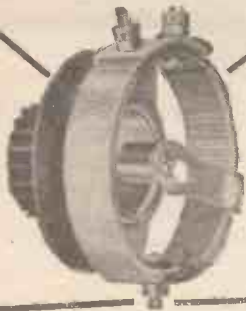

Specially made to meet demand for a Rheostat covering needs of both bright and dull emitter valves. Has two windings—a resistance of 6 ohms with a continuation on to a 30-ohm strip winding. Resistance wire wound on hard fibre strip under great tension and immune from damage. One-hole fixing, terminals conveniently placed. Contact arm has smooth, silky action. All metal parts nickel-plated. Complete with ebonite combined knob and dial.

PRICE 3/9

The Bedford
Electrical & Radio Co Ltd
22, Campbell Road, Bedford

£5 brings the World to your Fireside!
We will instal the Magnificent
"SOLODYNE"

Complete with all accessories
In Your Home For £5 Down.
With this wonderful Set anyone can get as many as 50 stations on the Loud Speaker. Send for Illustrated Art Brochure about it.

Also send for Folder about the wonderful—
EMERALD WAVEMETER.

A precision instrument of laboratory standard, giving direct reading, no charts required, for £1 down.

Send for Catalogue giving particulars of many other sets on same easy terms.

New Times SALES CO.,
77, City Road, London, E.C.1.
8691

AMPLIFIERS: 1-VALVE 19/-; 2-VALVE, 30/-
2-Valve All-Station Set, £4. Approval willingly.
Wet H.T. Batteries—Jars, Zincs and Sacs complete, 3/6 per doz. (15 volts). Post 9d. extra. Sample 6d.
3 doz. upwards post free, in divided cartons.
Bargain List Free.
C. Taylor, 57, Studley Rd., Stockwell, London.

REPAIRS

to HEADPHONES, LOUDSPEAKERS, TRANSFORMERS, COILS.

First-class workmanship only. That is just the vital difference. We are specialists with almost 30 years' experience in every form of intricate and accurate coil winding, and we guarantee that work entrusted to us will be returned to you as good as new, if not better. This is no idle claim, but the unsolicited opinion of scores of satisfied clients.

THE VARLEY MAGNET COMPANY
(Proprietors: Oliver Pell Control, Ltd.)
BLOOMFIELD ROAD, WOOLWICH S.E.14

Telephone: Woolwich 0888.



A GRID BATTERY TIP

—concluded from page 142.

a different type or the battery becomes run down through old age. There seems, therefore, no good reason for making permanent use of wander plugs, whose real mission in life is to enable changes in the voltage to be made quickly. It is extremely important that all connections in grid circuits should be good, for a defective contact may easily lead to a very great deal of noisiness, especially where a high degree of amplification is employed. For these reasons the writer uses wander plugs for grid-battery connections only in hook-ups and experimental layouts. In finished circuits he much prefers to employ another method which gives connections that are most unlikely to lead to poor contacts or noisiness.

Secure Connections

The diameter of the sockets employed in the majority of grid batteries is rather greater than 4 B.A. tapping size and rather less than 4 B.A. clearance. If you mount a 4 B.A. second-cut tap in a wrench you will find that you can work it fairly easily into each socket in turn. So long as you go carefully there is no risk of wrenching the sockets adrift. Though the tap will not make a full thread it will cut sufficiently deep to enable a short piece of 4 B.A. studding to be turned in quite tightly. This is locked into place by means of a nut, screwed hard down against the socket. There is no need to fit each socket of the grid battery with pieces of studding in this way. When ordinary small power valves are used three lengths of studding will suffice in the 0, 6, 7½ and 9 volt sockets. For super-power valves a battery capable of supplying a potential up to 18 volts is needed, and here studding may be inserted into the 0, 15, 16½ and 18 volt sockets. If the same battery is used for grid biasing both a power valve and a super-power valve, then obviously, two sets of studs should be fitted. When a battery has been mounted in the receiving set, connections to the appropriate pieces of studding are made by means of stiff wire. A small loop is made in the end and the lead is secured to the studding by means of either a milled headed or hexagonal nut. It is not a long job to tap the sockets and to fit the pieces of studding, and it is very well worth while to undertake the work.

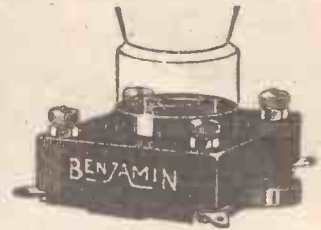

600,000 last year!

Sales of this famous valve holder for the past 12 months have exceeded 600,000—a sales record that speaks for itself! The enormous popularity of the BENJAMIN is mainly due to the following five vital features:

1. Valve sockets and springs are made in one piece, with no joints or rivets to work loose and cause faulty connections.
2. Valves are free to float in every direction.
3. Valves can be inserted and removed easily and safely.
4. Valve legs cannot possibly foul the base-board.
5. Both terminals and soldering tags are provided.

Install BENJAMIN yourself—you will improve reception and treble the life of your valves.

BENJAMIN

Clearer-Tone Anti-Microphonic VALVE HOLDER

Patent No. 250,431 Reg. Design No. 714,847
PRICE 2/9 EACH.

THE BENJAMIN ELECTRIC LTD.
Brantwood Works, Tariff Road, Tottenham, N.11

The HOME for your
WIRELESS SET

OUR STANDARD CABINETS

are DUSTPROOF and house the whole apparatus, leaving no parts to be interfered with. Made on mass production lines, hence the low price. Provision is made to take panels from 16 by 7 up to 30 by 18in. Special Cabinets for the ELSTREE SOLODYNE, NIGHT HAWK, ALL BRITISH SIX, etc., now ready. Write for free particulars.



MAKERIMPORT CO.
(Dept. 20), 50a, Lord Street, LIVERPOOL.

WIRELESS ROOM



For experiments, assembling, etc. Strongly made in sections. Easily erected in two hours.
8 ft. x 6 ft. 170/- Floor 80/-
9 ft. x 7 ft. 195/- " 36/-
12 ft. x 8 ft. 275/- " 50/-

Every kind of wood or asbestos building. **LISTS FREE.**
PERCY WHITE (Dept. CX) Thames St. Works, Staines



WE

You can ride a
After
install
" MARY
Satisfactions
Factory & son
and Tyres at
for illustra
models, also

Mead CYCL SPAE

Lotus Relay

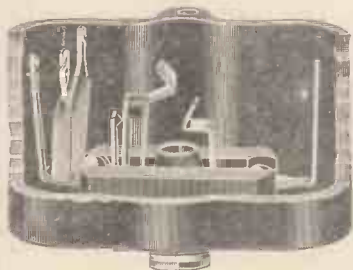
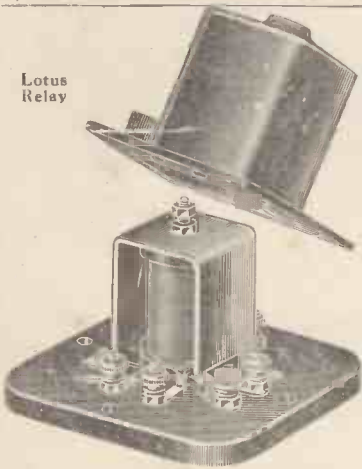

Lotus Wall Jack

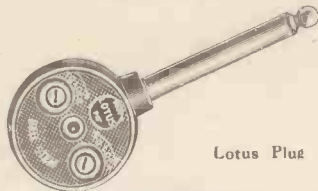

Lotus Plug



4 Strand Wire

COMPLETE OUTFIT FOR WIRING UP TWO ROOMS

1 "Lotus" Radio Relay, 2 "Lotus" Relay Filament Control Wall Jacks, 2 "Lotus" Jack Plugs, 21 Yards of Special 4 Strand Wire. Price **30/-**

EACH ADDITIONAL ROOM :-

1 "Lotus" Relay Filament Control Wall Jack, 15 Yards of Special 4 Strand Wire. Price **7/6**

THE LOTUS REMOTE CONTROL

gives simultaneous reception in every room!

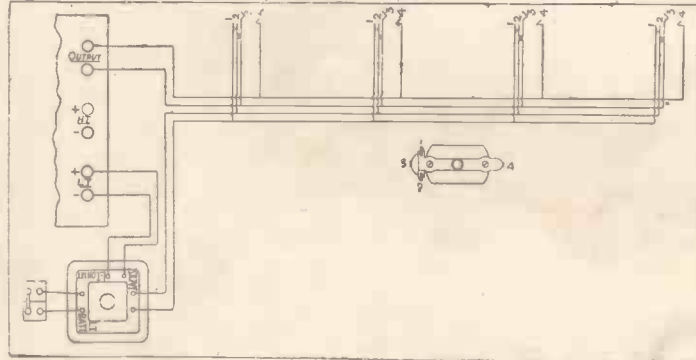

It is impossible for one listener to interfere with another.

The last plug to be withdrawn cuts off the Filament Circuit—there is no uncertainty. The Receiving Set is controlled from any point where a wall-jack is fixed, distance does not matter. Suits any wireless set.

SEND FOR FREE BLUE PRINTS AND INSTRUCTION FORMS

THE LOTUS REMOTE CONTROL

GARNETT, WHITELEY & CO., LTD., BROADGR.

Makers of the Famous "LOTUS" Coil Holder and "LOTUS" Buoyancy Valve Holder.

FILL IN THIS COUPON

To ADVT. DEPT. LOTUS WORKS:

for Free Blue Prints and instructions explaining how two rooms can be wired in half-an-hour. W.C.2

Name.....
Address.....
.....



Right, First Turn

THERE is no quicker or easier way of finding any station between 200 and 4,000 metres than with the R.I. Retroactive Tuner. Right, first turn, is the rule with this time-, and money-saving instrument.

All bother with coils is eliminated and a greater efficiency is gained, for the R.I. Retroactive Tuner secures the correct aerial reaction over the whole range of wave-lengths covered. In addition this tuner costs appreciably less than a set of coils with coil holder to cover the same range.

The R.I. Retroactive Tuner provides the easiest, most efficient and most economical method of tuning which you can incorporate in your set. Follow the lead of all the famous set designers and constructors and improve your tuning arrangements from to-day with the R.I. Retroactive Tuner.

PRICE 39/6

Write for the R.I. Green and Gold Catalogue



Get R.I. Ltd., 12, Hyde St., New Oxford St., London. W.C.1.