

# The Wireless Constructor

6<sup>D</sup>  
MONTHLY

EDITED BY  
**PERCY W. HARRIS, M. I. R. E.**  
Vol. III. FEBRUARY, 1927 No. 4

IN THIS ISSUE  
How to Build

## "Samson"

THE POWERFUL TWIN

By Percy W. Harris, M.I.R.E.



**SOMETHING  
WORTH  
KNOWING**

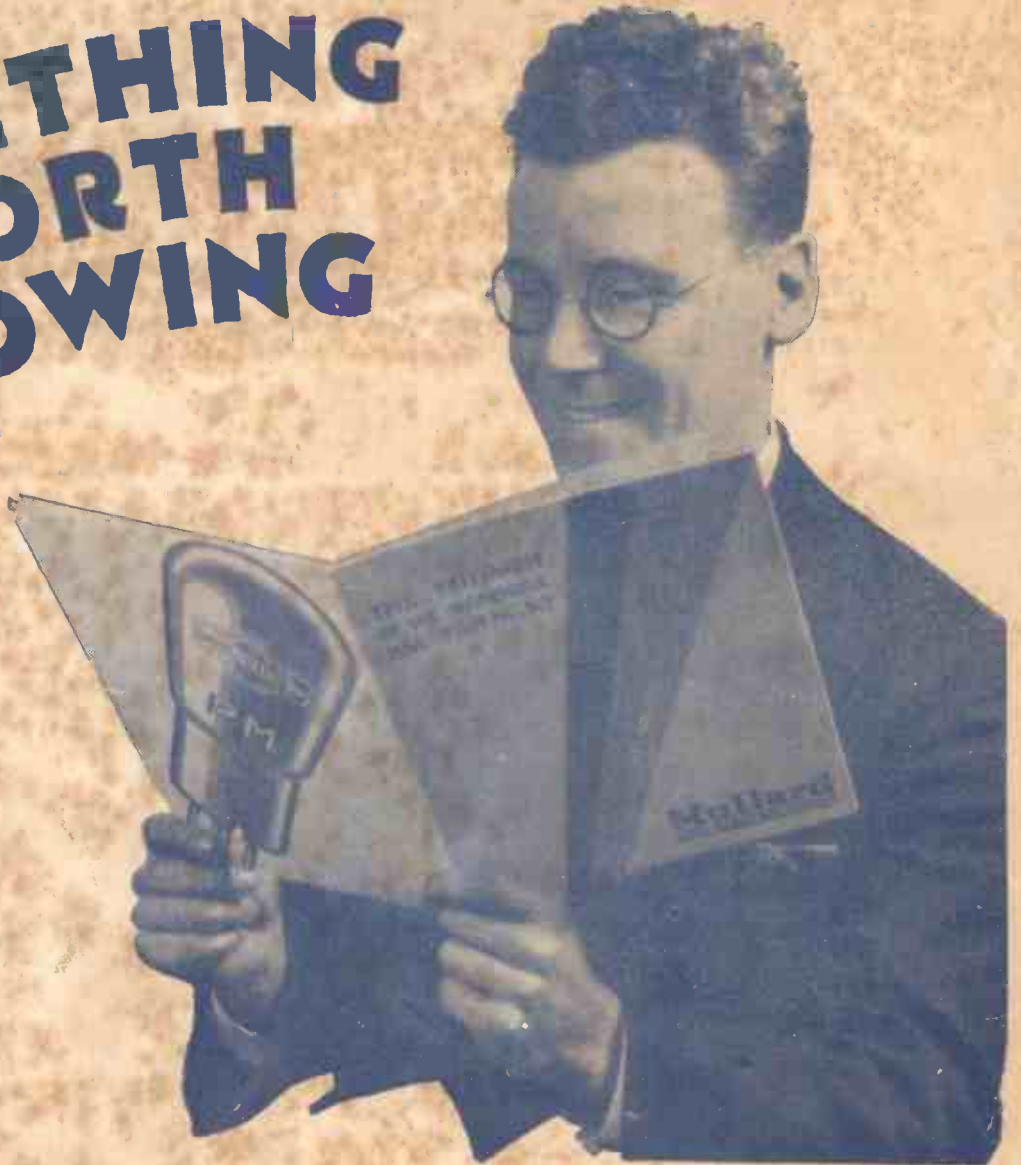

*Every valve user should get this book*

In it is convincing National Physical Laboratory Test proof that Mullard P.M. Valves continue to give the finest results after a year's broadcasting service of a thousand hours' life. A complete and valuable valve guide to improve your radio reception is included. Do not lose this opportunity to secure the best from your receiver.

Write for your copy to-day, post free on request.

*For 4-volt accumulator  
or 3 dry cells*

THE P.M. 3 (General Purpose) 0.1 amp. 14/-

THE P.M. 4 (Power) 0.1 amp. 18/6

*For 6-volt accumulator  
or 4 dry cells.*

THE P.M. 5 (General Purpose) 0.1 amp. 18/6

THE P.M. 6. (Power) 0.1 amp. 18/6.

*For 2-volt accumulator*

THE P.M. 1 H.F. 0.1 amp. 14/-

THE P.M. 1 L.F. 0.1 amp. 14/-

THE P.M. 2 (Power) 0.15 amp. 18/6

*These prices do not apply in  
Irish Free State.*

**British Made  
in a  
British Factory**

**Mullard**  
**THE · MASTER · VALVE**

ADVT THE MULLARD WIRELESS SERVICE CO. LTD., MULLARD HOUSE, DENMARK STREET, LONDON, W.C.2

# CONTENTS

	PAGE		PAGE
"Samson"—The Powerful Twin ...	293	The Editor's Chat ... ..	318
The "Night Hawk" ... ..	298	A Simple Three-Valver ... ..	321
The Home Built Basket Aerial ...	299	Rectifier Problems ... ..	329
A Reinartz One-Valver ... ..	301	Rheostat or Fixed Resistor? ...	333
Wire for Fixed Resistors ... ..	304	Economy in Resistance Amplifiers	334
The Truth About H.F. Valves ... ..	305	The Wireless Experimenters' Workshop	337
Notes on Aerial Insulators ... ..	307	Music and the Loud-speaker ... ..	342
The Conversion of Mudbury Wallow	308	Time Saving Tips ... ..	345
Cartoon ... ..	310	The Query Corner ... ..	349
"The Changeover" ... ..	311	Poachers on the Broadcast Wavelengths	350
Hunting the L.F. Howl ... ..	315	The "Cheat" Resistor ... ..	362
		Apparatus Tested ... ..	365

EDITED BY  
**PERCY W. HARRIS, M.I.R.E.**

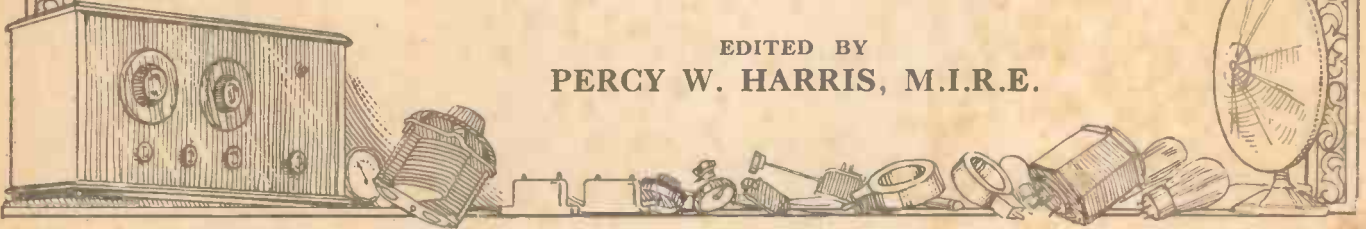

**MARCONIPHONE IDEAL TRANSFORMER**  
 (Flat Model, ratio 3 to 1.)

Highest guaranteed performance, at minimum cost. Guaranteed distortionless. May be used in any type of circuit, and with any desired value of H.T. ... **18/6**

**MARCONIPHONE SUPERSONIC TRANSFORMER**  
 For intervalve coupling in the intermediate stages of Super-Het. Receivers. Approximately equal amplification over a narrow band of frequencies and sharp "cut-off" at each side of the band ... **20/-**



## Marconiphone and STERLING TRANSFORMERS



**MARCONIPHONE IDEAL TRANSFORMER**

The finest transformer that human skill and ingenuity have yet devised. Guaranteed distortionless. The "Ideal" will amplify at all frequencies, without defect. Windings are specially protected against deterioration or corrosion. Tested at each stage of manufacture, and unconditionally guaranteed **25/-** for 12 months from date of purchase. All ratios

Write for Publication Number 425 C, to

**THE MARCONIPHONE COMPANY, LTD.**

Sole Agents for Sterling Telephone and Electric Co., Ltd.,  
 210-212, Tottenham Court Road, London, W.1.

M.P.O.08.



**STERLING L.F. TRANSFORMER**  
 (Type L.F. 3.)

Corrected to give distortionless amplification. Suitable for all stages of L.F. amplification, and guaranteed against breakdown under **20/-** all normal conditions for twelve months

**MARCONIPHONE POWER TRANSFORMER**  
 Designed for use in rectifiers for H.T. Supply from A.C. Mains. This transformer gives in a single instrument all supplies for the U 5 valve, which ordinarily takes three trans- **35/-** formers of normal type



## A Real "Distance Getter"



*The  
European  
Five*

This really efficient receiver designed by Stanley G. Rattee, M.I.R.E., is fully described and illustrated in the January issue of MODERN WIRELESS (now on sale, 1/-). The home constructor will find "The European Five" quite easy to build with the aid of the clear diagrams and concise directions given.

Other special features include:—"The Tranode Two," by K. D. Rogers, which describes for the first time a novel two-valver which is sure to become very popular; "Curious Crystal Circuits," by J. F. Corrigan, M.Sc., A.I.C.; and many other articles by well-known radio experts which will appeal to all classes of amateurs.

An announcement is made also concerning a new Queries Service for readers, with a special offer of assistance to inventors by the journal's new Scientific Adviser, Dr. J. H. T. Roberts.

Be sure you ask for

# MODERN WIRELESS

Edited by NORMAN EDWARDS, M.I.R.E., M.R.S.I., F.R.G.S.

Monthly at all Newsagents, etc.

**1/-**



# The little brown box that brings Valve results to Crystal users

**W**HERE is the owner-of-a Crystal Set who has not longed for the results enjoyed by his friend the valve user? Who has not envied those able to fill their whole room with the music and speech of the night's broadcast? But now since the advent of the little 'brown box', anyone with a Crystal Set living within fifteen miles of a broadcasting station [or eighty miles of Daven-try] is on a complete level with the Valve Set owner. The **Brown Crystal Amplifier**, brings to the Crystal Set user the priceless



boon of Loud Speaker reproduction without any of the upkeep cost and trouble inseparable from the valve. Get your Dealer to demonstrate the **Crystal Amplifier** to you on one of the nine **Brown Loud Speakers**. You'll be charmed. Most probably you'll agree with most people that Wireless reproduction is at its very best when the **Crystal Amplifier** and a **Brown Loud Speaker** is used. A purity that is unrivalled. Volume full and adequate. A fidelity of reproduction which is almost uncanny. Yours for £4 4s 0d. and whichever **Brown Loud Speaker** you desire,

**Brown Crystal Amplifier**  
puts Crystal users on a level  
with the Valve Set owner



The Disc.  
2000 ohms.  
Black and gold  
£7. 7. 0.  
Oxydised Silver  
£8. 8. 0.



The H1.  
120 ohms. £5. 5. 0.  
2000 ohms. £5. 8. 0.  
4000 ohms. £5. 10 0.

**S. G. BROWN, LTD., Western Avenue. North Acton, W.1.**

Retail Showrooms: 19, Mortimer Street, W.1; 15, Moorfields, Liverpool; 67, High Street, Southampton.  
Wholesale Depots: 2, Lansdowne Place, West Bath; 120, Wellington St., Glasgow; 5-7, Godwin Street, Bradford; Cross House, Westgate Road, Newcastle; Howard S. Cooke & Co., 59, Caroline Street, Birmingham; Robert Garmany, Union Chambers, Union Street, Belfast, N. Ireland.



**There's nothing "just as good" as an S.T.**

"I've known Scott-Taggart's work on valves for years and read his wireless journals from the start. That's why I wanted his valves now he has gone in for the valve business.

"I specially wanted three of his new 2-volt valves. The fellow behind the counter hadn't got any S.T.'s, and wanted me to buy another make. Said they were 'just as good.'

"He argued a bit. Evidently thought I was fresh to wireless and would buy a valve like I would a cake of soap, the actual make not mattering much.

"I suppose he wasn't one of S.T.'s agents or was trying to sell a valve giving him a greater profit. Anyway, I was so aggravated that I bought some other gear I wanted at a shop where they *did* sell S.T.'s.

"But when I got home my ruffled feelings soon wore off. There was a first-rate concert and the new S.T. valves seemed to change the whole set.

"The music came in much louder and was clear-cut and vivid and without that fuzziess which so often spoils the tone."

**Every S.T. Valve now has its life insured.**

S.T. Valves are the only ones in the 22 years of valve history that an insurance company has been prepared to insure against loss of life. This is a milestone in the history of valve manufacture, and has been made possible by the introduction of a filament made of torodium and the use of the Barguet process which produces the most perfect vacuum known to science.

The life of every S.T. valve is now insured by Lloyd's—the most famous insurance organisation in the world. Any S.T. which does not give long and faithful service will be replaced instantly by the manufacturers.

And remember that S.T.'s do not vary. As the recently published declaration before a Commissioner for Oaths stated: Every S.T. is tested on four separate occasions. One of the tests is on actual signals, while two others each include taking a minimum of nine electrical measurements. Only when he is thoroughly satisfied with that particular valve does Mr. John Scott-Taggart, F.Inst.P., A.M.I.E.E., personally initial the test certificate on the valve-box.

The glorious Strength and Tone of every S.T. has been tested before you get it. Now you have a complete guarantee that it will last. Cut-out speculation and enjoy from to-day the advantages you can only get from genuine S.T. Valves.

2-VOLT.		4-VOLT.		6-VOLT.	
S.T.21 (H.F.) 0.1 amp.	14/-	S.T.41 (H.F. and Det.)	14/-	S.T.61 (H.F. and Det.)	18/6
S.T.22 (L.F. and Det.)	14/-	0.1 amp. ....	18/6	0.1 amp. ....	18/6
0.1 amp. ....	18/6	S.T.42 (Power) 0.1 amp.	22/6	S.T.62 (Power) 0.1 amp.	22/6
S.T.23 (Power) 0.15 amp.	18/6	S.T.43 (Super Power)	22/6	S.T.63 (Super Power)	22/6
		0.25 amp. ....		0.25 amp. ....	

**S.T. LTD., 2, Melbourne Place, Aldwych, LONDON, W.C.2**  
(Next to Australia House)



# The WIRELESS CONSTRUCTOR

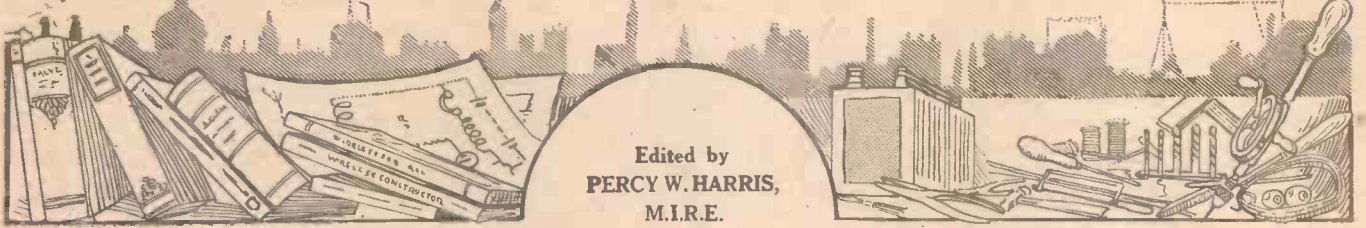

Edited by  
**PERCY W. HARRIS,**  
 M.I.R.E.

Published by the Amalgamated Press, Ltd., Fleetway House, Farringdon Street, E.C.4.

## “SAMSON”—THE POWERFUL TWIN A “Hale” (and Hearty!) Circuit for Frame Reception

By **PERCY W. HARRIS, M.I.R.E.**  
 (Editor of “The Wireless Constructor.”)

*Not everyone can arrange for the erection of a good outdoor aerial. This set will give good loud-speaker results using only two valves on either frame or outdoor aerial—up to ten miles in the case of the frame and appreciably greater distances with an outdoor aerial.*

WHILE many people are interested in the construction of modern multi-valve and neutralised sets, obtaining from these instruments results which were beyond hope of achievement a year or two ago, there are still a number who are anxious to make the best possible use of, say, a couple of valves, at the same time being prepared to sacrifice real long-distance reception for good local and medium distance work.

“Samson,” the powerful two-valve receiver, falls within the latter class of sets, and while utilising a crystal detector together with two valves, is free from many of the disadvantages which have usually attached themselves to valve and crystal combinations. The circuit used is that known as the “Hale,” which I first introduced to the home constructor in *Popular Wireless* last November. A theoretical circuit is given in Fig. 1, and will be seen to differ in several important essentials from previously popular circuits. Simply explained, the function may be as follows:—

The incoming current from the aerial energises the first tuned circuit consisting of  $L_1 C_1$ , and the differences of

pressure set up across  $C_1$  are applied to the grid and filament of the first valve  $V_1$  in rather an unusual way. It will be seen that a lead is taken from  $C_1$  to the lower end of the secondary of a low-frequency transformer. Now, every winding has a certain capacity, and while in modern

which is connected to the upper end. You will see in the diagram that I

have dotted in two fixed condensers representing the capacities in the transformer through which the high-frequency currents pass to the grid.  $V_1$  now amplifies the signal tuned by the circuit  $L_1 C_1$ , and the amplified output is fed back to the first circuit by means of the condenser  $C_2$  and the coil  $L_2$ . Incidentally I may

state that this form of reaction is particularly easy to control, and when the values are suitably chosen, variations of the reaction condenser  $C_2$  make practically no difference to the tuning of  $C_1$ . However, the circuit works very well indeed with the ordinary magnetic reaction, and this form of “feed back” is not a special feature of the Hale circuit.

You will now see that it is possible to make the set oscillate by variation of the condenser  $C_2$ , and by keeping the set below oscillation point we can get all the advantages of reaction amplification. So far, of course, we have been considering the high-frequency current without detection. Let us now see what happens in the rectification of the signal.



*The pleasing simplicity of the set is indicated by this photograph. Note the convenient position of the controls as shown above.*

transformers the self-capacity is reduced to a negligible figure so far as audio-frequency currents are concerned, the capacity still present is quite sufficient in this case to convey the high-frequency current from the lower end of the windings to the grid

## "Samson"—The Powerful Twin—continued

You will notice that a low-frequency transformer primary in series with a crystal is also shunted across  $C_1$ .

### The Grid-Bias Battery

The low-frequency pulsations so obtained induce current in the secondary of the transformer, one end of which is connected to the grid and the other, you will notice, is connected

### COMPONENTS REQUIRED FOR THIS SET

- Suitable Cabinet.
- Panel for same (see note below).
- One six-pin coil base (standard).
- One high-frequency transformer, split secondary type.
- Two low-frequency transformers (see note below).
- One crystal detector.
- One variable condenser .0005 mfd.
- One variable condenser .00025 or .0003 mfd.
- One radio frequency choke.
- Two valve-holders.
- One Mansbridge condenser, 1 mfd.
- One on-and-off switch.
- Six terminals.
- Two ebonite strips.
- Brackets for Panel if necessary.
- Two filament resistances.

to the filament through  $L_2$ . The inductance of  $L_2$  is so small compared with that of the transformer secondary that, so far as the low-frequency func-

tions are concerned, the effect is precisely the same as if the lower end of the transformer secondary were connected direct to filament. You will no

valve  $V_1$  to work on a suitable portion of its curve for amplification purposes.

On the output side of  $V_1$  you will see a radio-frequency choke in series

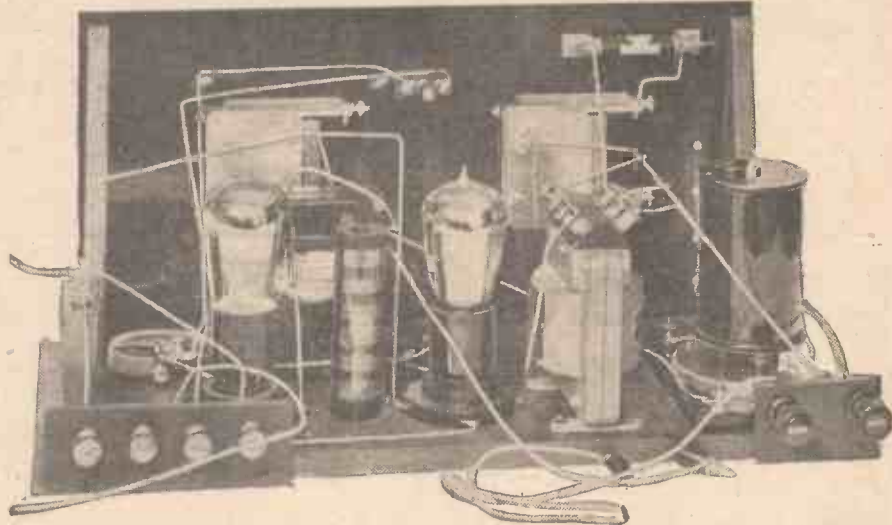

A back-of-panel view showing the valves in position, and the arrangement of components when the set is ready for use.

doubt have noticed by now that between the grid return and the filament is placed the grid-bias battery.

### Dual Amplification

By adjusting this we can cause the

with the primary of another low-frequency transformer. This radio-frequency choke prevents the passage of high-frequency current through the primary of the transformer, but permits the low-frequency current to pass

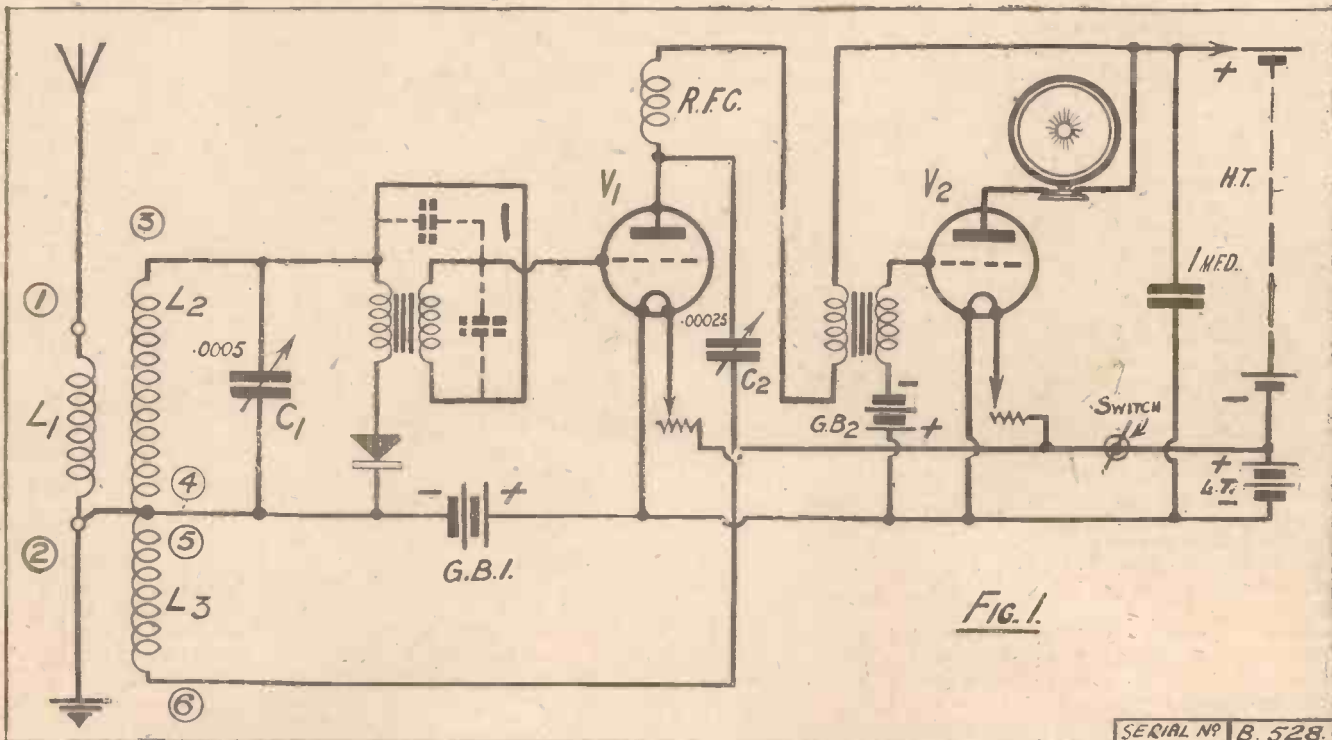

The theoretical connections of the "Samson" set are shown by this diagram. The dotted fixed condensers across the transformer represent the self-capacity of this component, and not external condensers.



## "Samson"—The Powerful Twin—continued

so that the first valve acts not only as a high-frequency amplifier, but also as a low-frequency magnifying valve, the output side of which is applied to the grid of a second low-frequency valve through a second low-frequency transformer. We thus obtain in this set high-frequency magnification, detection and audio-frequency magnification in two stages. In practice the set has been found to give excellent magnification of weak signals, and, as I shall show you later in the article, the circuit itself is so efficient that with a suitable frame aerial real loud-speaker results can be obtained over quite considerable distances.

### Notes on Components

The size of "Samson" is typical of a lot of other sets, and a standard size of cabinet is readily available. The standard cabinet used to take a 16-in. x 8-in. panel can be adopted, and if this is used a 16-in. x 8-in. panel will be required. If, however, you care to use one of the newer type of cabinets with what is called a "vignette" front, as shown in the photographs, then a panel 15 in. x 7 in. can be used. The cabinet shown in the photograph was made by the

Unica Cabinet Co., but similar excellent cabinets can be obtained from "Camco," "Caxton," "Pickett," and other well-known makers.

Baseboards are now supplied with all cabinets, and some makers, including Caxton and Unica, supply wooden brackets fixed to the baseboard. If your baseboard is not supplied with such brackets you will need two metal brackets for the panel attachment. The panel itself can be chosen from any of the reputable makers of guaranteed ebonite, and if purchased in such a brand as "Radion," "Resistor," "Ebonart," "Paragon," "Becol," "Pilot," or "Trelleborg," to mention some of the leading makes, you will be sure of a good article.

Similarly, so far as the six-pin coil base and the H.F. transformer are concerned, you have a wide choice. You will notice that I am not using the screened coils here, but only the base and the coil itself without the screen, as the screen is not necessary in this particular arrangement, there being no possibility of interaction. Furthermore, the sockets in the coil base are very convenient points of attachment for the leads of a frame aerial, should you use one. So far as the variable condensers are concerned, many good makes are obtainable, and will do provided the capacity values are those stated.

### The Valveholders

I have the new Ripault, which, by means of its 360-deg. adjustment, gives a very smooth control both of tuning and of reaction. Any reliable make can be substituted here without any loss of efficiency, and as most readers probably have their own tastes in such matters the choice can be left to them.

Valve sockets

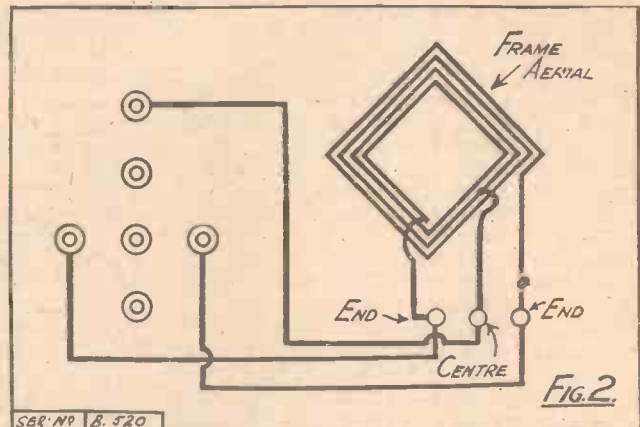

The method by which a frame aerial can be used is shown above.

should be of the modern antivibratory type, of which Lotus, Burndeft, Benjamin, and W.B. are a few representative types. The on-and-off switch I have used is an inexpensive but efficient type made by Bulgin, and the radio-frequency choke is a Varley. Any good radio-frequency choke can be used here, and as it is not a neutrodyne set, the precautions sometimes necessary with regard to the choke need not be taken in the present set.

### Importance of L.F. Transformers

The Mansbridge condenser shown in the photograph is a T.O.C., but other efficient makes are also obtainable. The two small ebonite strips for terminals are of sizes to suit the cabinet, and can be cut from any odd scrap that happen to be handy. So far as terminals are concerned, I have used both Belling-Lee indicating terminals and the ordinary type. Here again the constructor's taste is the best guide. As readers of my articles know, I am distinctly in favour either of the fixed resistor or of the baseboard type of filament resistance with no external knob. In the present set I have used the Lissen baseboard mounting filament resistances, which are set once and for all to suit the particular valves to be used, but those who prefer them can use the Amperite, Tempryte or other fixed resistors.

An important point in this set is the choice of low-frequency transformers. The Hale circuit will work excellently with a large number of different makes of low-frequency transformer, but where two transformers are used, howling may occasionally occur if unsuitable types are chosen. While I do not wish to indicate that those used in the present set are the only ones possible (this is far from being the case), the choice of these two in the particular set will give good results with good amplification and quality. Those amateurs who care to experiment may

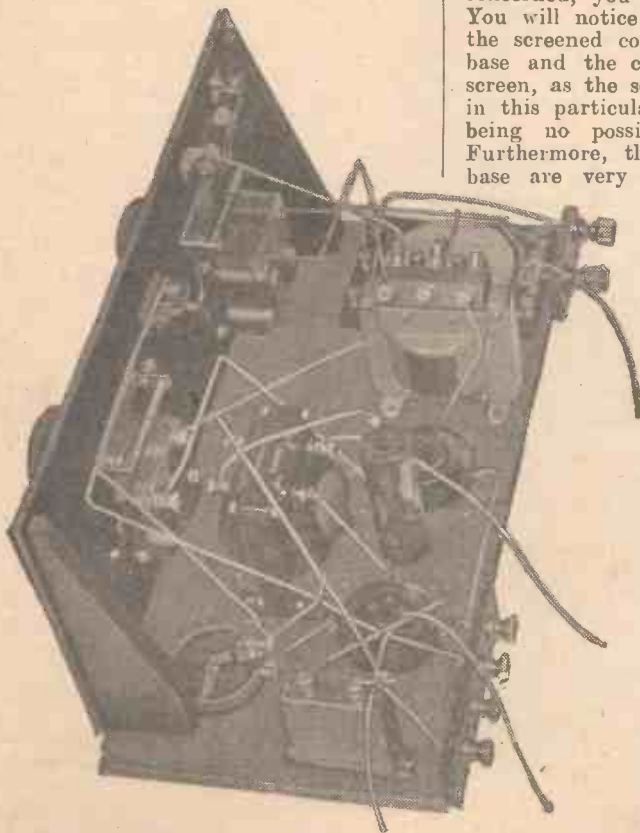

Looking down on the baseboard. The general disposition of the components will be clear from this photograph.

## “Samson”—The Powerful Twin—continued

try other makes, and will probably obtain with many combinations just as good results.

I have used many types of crystal detector with the Hale circuit, but find that most reliable results are obtained with the “permanent” type, consisting of two crystals in contact with one another. The crystal detector used in the Hale circuit is not only a rectifier but also has a considerable influence upon the reaction effect, and the preliminary adjustment of the crystal is not quite so easy as in the ordinary straightforward crystal set. Many readers have obtained good results with the catswhisker type, but the higher resistance detectors certainly seemed better with this circuit. The R.I. detector has proved very suitable, and others of a similar type have also given satisfactory results.

### Constructional Hints

Constructional work of this set is quite straightforward. The first step should be mounting of the two variable condensers, the on-and-off switch, and the brackets for the permanent detector on the front panel. At the same time holes should be drilled to attach the panel to the brackets. Laying the panel aside, the mounting of the components on the baseboard can be proceeded with, the general arrangement of parts as shown being adhered to.

Changes in components will necessitate slight changes in the disposition

of one or two of the parts, but as far as possible follow the lines indicated. Whatever makes of variable condensers you use, see that the moving plates

should be joined to the wires shown to avoid unnecessary hand-capacity effects.

You will see that a good part of the

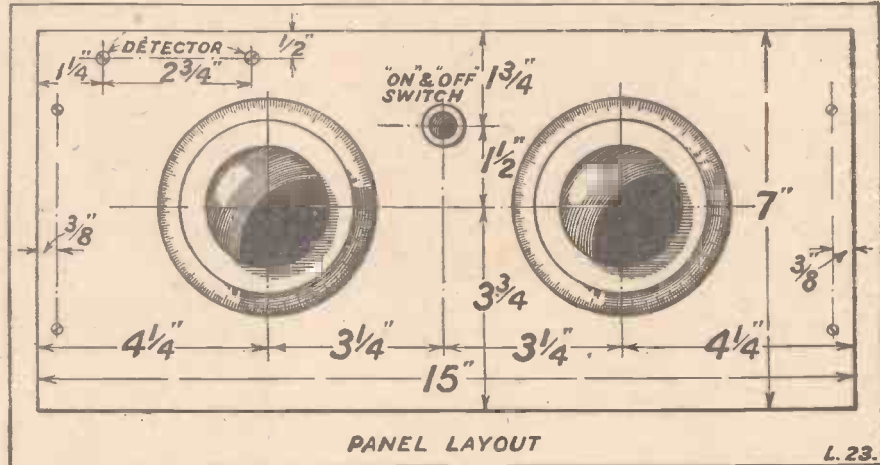

All the essential drilling dimensions for the panel are shown above.

and the fixed plates of each condenser are joined to the points shown.

### Coil-Base Connections

It should be realised that hand-capacity effects are greatly reduced when the moving plates are connected to the low potential end of the circuit. When in a wiring diagram certain terminals are marked “moving” and “fixed,” this is an indication that these points

wiring can be carried out on the baseboard before the front panel is attached. I would advise you to wire up as far as possible on the baseboard before attaching the front panel. This will give you a freedom of movement not otherwise obtainable.

The actual coil base I have used is a “Copex.” The disposition of terminals in other makes is not quite the same, but provided the number of terminals are joined as shown you will get just as good results. Note particularly that terminals 4, 5, and 2 are joined together.

It is important to notice that two distinct grid-bias batteries are used, and I advise you to use two separate batteries rather than to use one battery with different tapplings.

I have found it of distinct advantage to use a high-impedance valve in the first socket. The high-impedance valve gives a smoother reaction effect and louder signals. The second valve can be any suitable power valve of the ordinary types. While valves of the good makers work satisfactorily here, it is necessary to specify for the first socket a valve recommended for high-frequency magnification, if results comparable with those of my own set are to be obtained.

### Adjustment

The preliminary adjustments of this set are not quite so easy as with some others, but results obtainable are well worth a little extra trouble at the beginning. I suggest you use a fairly high H.T. voltage, say 100 or 120, while your low-tension voltage will, of course, be two, four, or six, depending upon the particular makes of valves you are using.

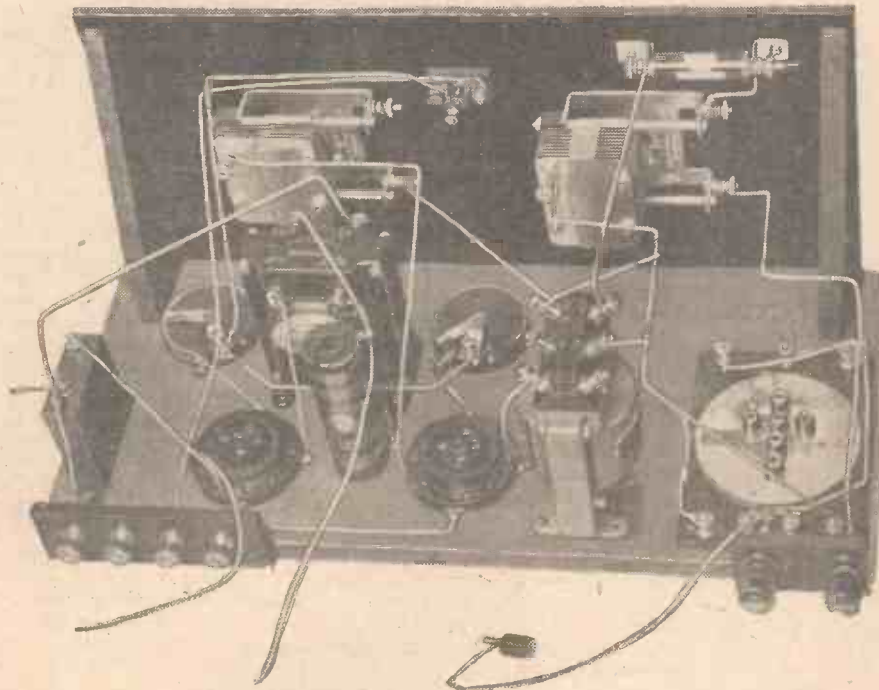

This view of the wiring should be compared with the wiring diagram during construction, and will give a clear idea of the actual spacing between leads.

## "Samson"—The Powerful Twin—continued

Set the reaction condenser at zero and the tuning condenser at zero or a low reading, plug in your split secondary coil and do not trouble to join up aerial and earth. Set the grid-bias tapping for the second valve to a value recommended by the makers for the particular high-tension voltage you are using, and the tapping for the first grid bias at about three volts (the second wander plug socket from the positive end). The two crystals of the permanent detector will be in contact, and for the moment I do not suggest you touch these.

### The Reaction Control

Now slowly turn the reaction condenser and see whether within its range the set can be made to oscillate (do not worry about interference to other people, as your aerial and earth are not connected). If you can make the set oscillate and come in and out of oscillation easily, your crystal is properly set. If you cannot properly do this, then carefully reset your detector and try again. It may be necessary to make several trials in order to get the best position on the crystal.

Once it is found, it will stay set for a reasonable time. After you have found the best position of the crystal try lowering the grid-bias voltage on the first valve. This will be found to make a considerable difference in reaction control.

Now join aerial and earth, tune in your local station with the tuning condenser, and obtain the volume you want by adjustment of the reaction condenser, being careful to keep the set well below oscillation point. The

(Continued on page 334.)

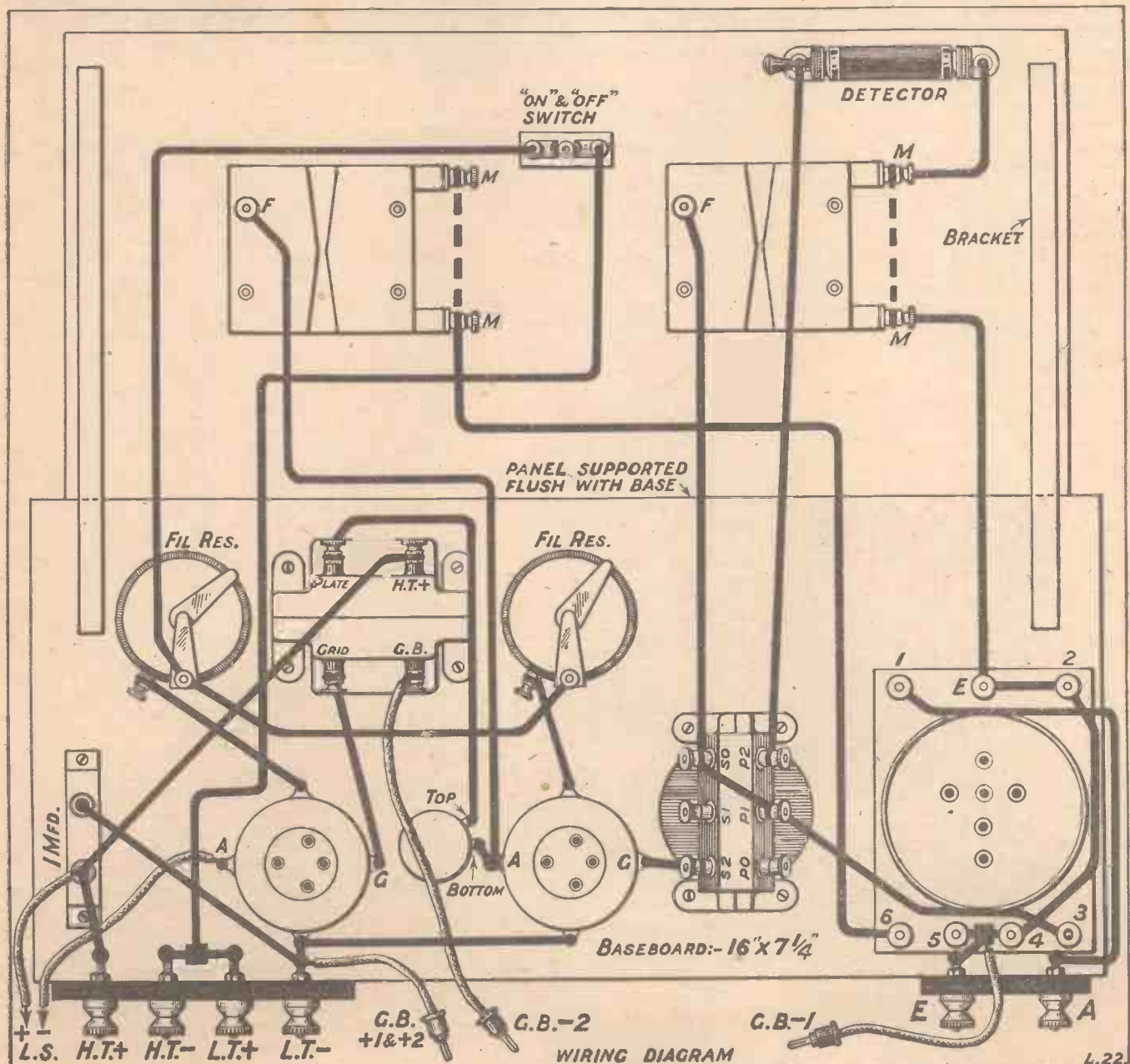

The relatively simple nature of the wiring can be seen from this wiring diagram. Note the flexible leads to the grid-bias batteries, and to the loud-speaker.

# THE "NIGHT HAWK"

A Selection of Readers' Queries Answered by the Editor

In resuming the editorship of *THE WIRELESS CONSTRUCTOR* after an interval of several months, I have been inquiring into the correspondence received from readers in relation to the Night Hawk receiver described in this journal for October.

In addition to the many gratifying successes with this instrument, there appear to be a number of readers who are having slight difficulty, particularly in regard to volume on distant stations, and a study of their problems, together with further experiments I have made on the receiver, suggests to me that further notes will perhaps be useful.

## Departures from Design

A neutralised receiver, when the high-frequency side is at all efficient, is particularly sensitive to changes in layout, and in personally examining several sets which have seemed "dead" I have traced the trouble to departure from the published design. Other receivers I have tested, while made up exactly as shown in *THE WIRELESS CONSTRUCTOR*, have given inferior results due to an unsuitable selection of valves, or in some cases to

\* \* \*

*The "Night Hawk," as originally described in the October issue of "The Wireless Constructor."*

\* \* \*

the use of valves which have lost their sensitiveness. Generally, too, I find a widespread desire that the set should work with as many kinds of valves as possible, and this has led me to see what can be done to increase the broadness of its scope.

## Increasing the Volume

Now the tuning of the Night Hawk, when functioning correctly, is exceedingly sharp—so sharp, in fact, that some builders of the set have found difficulty in tuning, due to lack of experience. Further experiments with the Night Hawk have shown me that its selectivity is so high that some of it can be sacrificed without loss of

efficiency, at the same time giving a greater latitude in the choice of valves, and in many cases an appreciable increase in volume.

Those readers who are experimentally inclined may care to make the following changes in those cases where, with their particular valves and apparatus, the set is not working up to their expectations. Take the binocular coils and count the number of turns in the primary windings (in the later coil it may be necessary to remove an insulating covering to get at the windings, but in the earlier binoculars sold for this set the windings were exposed). You will probably find twenty; strip off these primary turns (having carefully noted their direction and connections) and re-wind with thirty of a finer wire so as to occupy approximately the same space as the twenty before used. Be careful to make the same connections as before, and repeat the process with all three coils. The result of the change will be that in most cases volume will be increased at the expense of a little selectivity. Tuning, however, will still remain exceedingly sharp, enabling you to tune out interference and receive a large number of stations on the loud-speaker.

## No Change in Operation

There will be no change in operating the set, but you will find that the neutralising condensers may have to be reset. Better still, you can obtain a further set of coils ready wound with the new ratio, keeping your first set for those occasions when you want extremely sharp tuning.

As the result of examining a large number of letters from readers expressing their appreciation of the set and also telling me of their troubles, I have come to the conclusion that a larger number of turns on the primary

(Continued on page 362.)

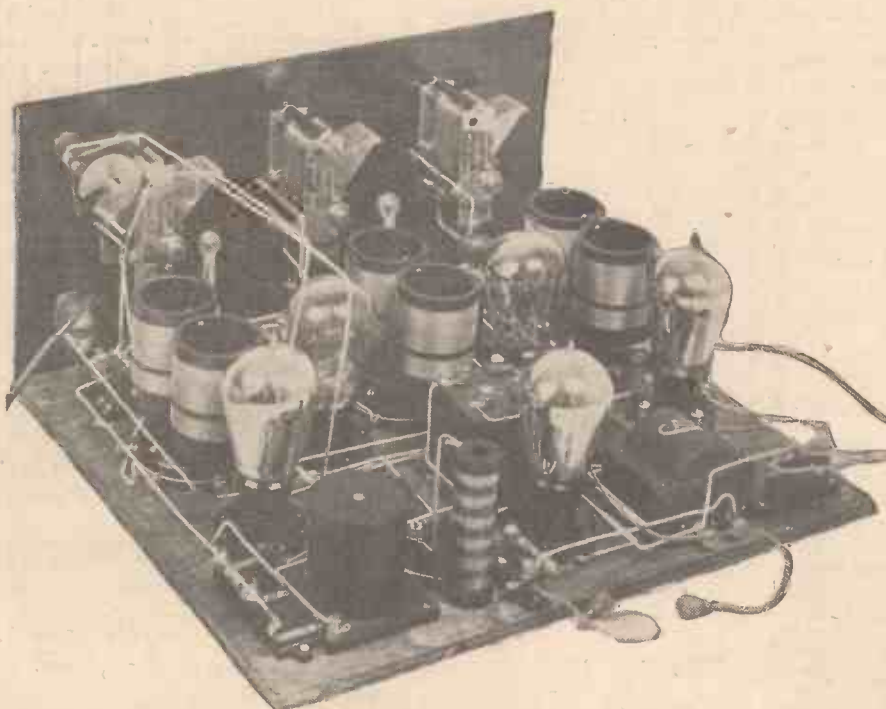

The fieldless plug-in coils and other components referred to are shown in this behind-the-panel view.

# The HOME-BUILT BASKET AERIAL

By D. CHARLES

*The total cost of this extremely simple and useful aerial does not exceed twenty-five shillings.*

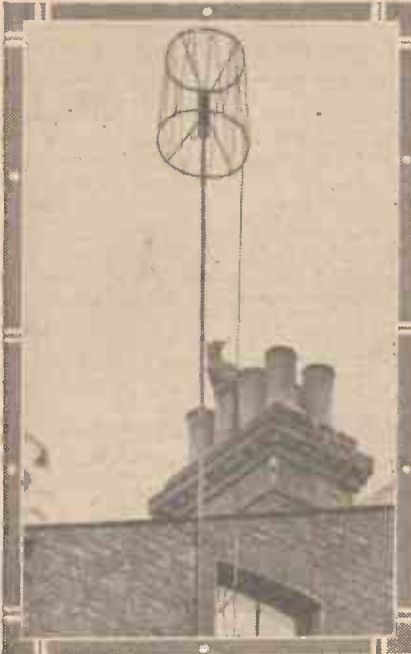

*Fig. 1.—The aerial forms a solution to the problem which faces amateurs whose out-of-doors space is restricted.*

MY first aerial was a couple of wires across the parlour ceiling, and my set a crystal receiver with valve amplifier. The nearest water pipe being some thirty feet away, a temporary earth wire was clipped on to that of my post office telephone.

Later the wires were removed to an upper chamber and a little more added. The improvement was sometimes noticeable but was certainly not great.

When the battery was really fully charged (at home and tested) and a new high-tension bought, and 2LO and all our neighbours proved kind, and the cat-whisker was just so, and (this is the biggest AND of them all) there were no visitors; no praise could be too great for the results obtained.

## Getting to Work

Unfortunately, the general conditions were very poor, and something had to be done. Requests for estimates for erecting aerials were broadcast among the local builders. One condescended to survey the property and suggest a price. Not being a plutocrat I had to find some other way.

Somebody suggested a basket aerial, so I bought a couple of child's wooden hoops (6½d. each) and conveyed them home under darkness of the night.

A couple of dozen insulators with brass screws to match were also purchased, while four strips of iron half an inch wide and an eighth inch thick were obtained, and a hole drilled at each end. Work continued with drilling a pair of holes at the centres three or four inches apart. A piece of iron gas pipe a yard or so long and about an inch outside diameter was next

fixed in a wooden casting made as in the first diagram. The four pieces of strip iron were then bent each in the form of a weird "W," so that they could be screwed at the middle to the aforesaid wooden casing and the outer ends to the wooden hoops. The whole effect is clearly seen in the photograph in Fig. 3. It will also be seen that the insulators are screwed on at moderately equal intervals around the hoop. Before fixing these, however, a fairly liberal coating of Brunswick black was given to the whole framework in order to assist, if possible, in preventing the onslaught of weather conditions.

## Fixing the Mast

The next thing was to wind a hank of enamelled aerial wire in zig-zag fashion from insulator to insulator, and on reaching the last free insulator the wire was lashed on it, leaving the spare end of aerial to hang loosely. The mast itself consists of two straight lengths of gas-barrel of an inside diameter of 1¼ inch so that the piece fastened into the aerial can slip into it. The two lengths of gas-barrel referred to are each nine feet long and joined in the middle with a socket, since some difficulty was experienced in obtaining the whole in a single length. To the lower end of the mast is screwed an ordinary gas tee-piece.

The method of supporting this is simple in the extreme, but possibly not so simple to explain. A further short length of gas-barrel about a foot or fifteen inches long and screwed at both ends was obtained of the same diameter as the piece fixed into the basket aerial. At one end of this short length was screwed very tightly an elbow, when by dint of knocking out half a brick and with the aid of a small bag of cement, that end of the bar was fixed securely so that it projected five or six inches at right angles to the wall face, just below the top room window.

## A Permanent Fitting

On reference to the photographs and to the diagram, Fig. 4, it will be seen that this forms an admirable support for the mast, simply by slipping the

tee-piece which forms the base of it over the projecting bar, and in order to prevent the same from slipping off a cap is screwed on to the end of it.

Two or three days were allowed to elapse to give the cement time to dry before the weight of the mast was applied to the arm or bracket. On a level with the top of the window was fixed a pipe clip also obtained from



*Fig. 2.—Showing how the mast was securely fixed in position and the down lead arranged.*

the same plumber who supplied the gas-barrel, and this made it possible first to slip the base of the mast upon the arm arranged for it and afterwards to secure it firmly at a higher spot upon the wall.

## The Home-Built Basket Aerial—continued

The basket aerial, of course, was slipped into the end of the mast before erection, but in view of the possible need for overhauling at some future time, the gas barrel stem which slips into the mast was liberally smeared with motor grease.

### Arranging the Lead-in

There are two ways of erecting such a mast. One of them is first to raise the lower end of it, slip the tee over the projecting arm, screw on the cap, and then tie a piece of strong rope to about the middle of the mast, hauling it up by main force. The other method is to hold it up vertically the whole time, and although the latter requires greater energy, it seems by far the safer plan, for the leverage exerted by the eighteen feet of "inch-and-a-quarter" gas-barrel is considerably more than might be imagined, and if the rope should snap the consequences might not be too comfortable for the person down below.

The top window shown in the photograph was chosen for the lead-in,

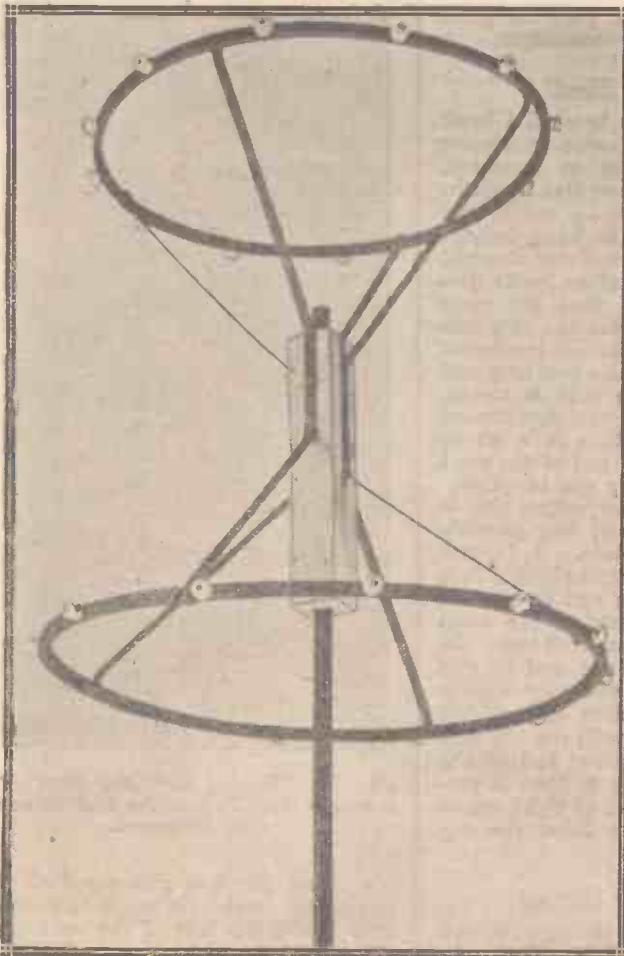

Fig. 3.—A "close-up" of the frame-work before the wire was wound on.

partly because there happens to be a waterpipe making a very convenient earth in that particular room. The woodwork around the window, however, is particularly narrow, so that I had to bore the hole for the lead-in in the moving window frame. For this reason the free end of the aerial wire which was hanging loose was looped to an aerial-earth switch upon the said window frame, and in order to make a satisfactory outside earth in case the mast should act as a lightning conductor, a lead was taken first from the earth terminal of the aforesaid switch to the base of the mast where it was given a few tight turns, and then again downwards outside the house to another waterpipe.

It was found, naturally, that the free loop of wire hanging from the basket being left somewhat loose, in order that the window might be opened and shut, would swing about in the wind and sometimes would touch the brickwork of the house. In order to prevent this, another length of wire was lashed to what might be termed the

"straight line" portion of the down lead, and to the lower end of this extra wire was hung a weight. It might be added that this weight was home-made, too. Some bits of old compo gas pipe found in the coal cellar were cut up into bits and dropped one by one into a cocoa tin placed upon a gas ring.

### Very Satisfactory Results

When all were in a molten state a meat hook was just pushed into the mass and the gas turned out. When the lead had set the top ridges of the tin were hammered inwards so as to make a level job, and in practice this simple device, illustrated in the second photograph, figure two, has been found to work just as well as though a solid fixture with the necessary insulator at the end of it had been fixed to the wall.

The actual trouble involved in fixing up this aerial has been actually very little greater than that involved in any of the indoor aerials with which I have experimented, and the result has proved indeed well worth the trouble involved. The adjustment of

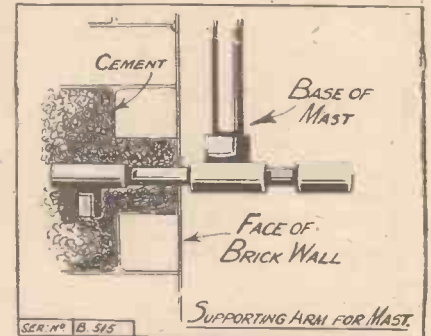

Fig. 4.—One of the important details clearly explained diagrammatically.

the cat-whisker instead of being a continual source of annoyance is hardly ever necessary more than once a week or so.

Although the volume is not very much greater than the maximum obtained before, it is almost always as strong as anyone could wish. That is to say, that satisfactory volume instead of being a rarity is now the rule. The total cost of this aerial with its mast, including some paid assistance, did not exceed twenty-five shillings.

### A TELEPHONE HINT

BE careful to see that the tag of the telephone marked "positive" is connected to the correct terminal on your set. Many sets are marked with "positive" and "negative" on the telephone terminals, but if your set is not so treated look inside and see which of the two telephone terminals is connected directly to the high tension positive. That so connected is the positive telephone terminal, and your positive telephone tag should *always* be connected to this particular terminal.

This is not a fad, but is due to the fact that if your telephones are properly connected, the steady plate current continually passing through them will add to the permanent magnetism of the telephones themselves, whereas if they are wrongly connected this current may steadily tend to demagnetise your 'phones, reducing their sensitivity considerably.

Telephones which have been dropped frequently often are far less sensitive than those which are properly kept. The reason for this is that any jolt or jar tends to upset their magnetism.

# A REINARTZ ONE-VALVER.

Simple to Build and Operate.

By A. JOHNSON-RANDALL.

*The circuit used for this set is a straightforward Reinartz, and on test the results obtained were thoroughly satisfactory in every respect.*



TO state definitely that a certain circuit is the best possible single-valve arrangement would be a sure means of starting a stream of correspondence from enthusiasts each of whom would probably say that his own particular scheme gave better results than any other.

Of the many arrangements capable of giving good and reliable results, however, the simple straightforward Reinartz circuit certainly takes a lot of beating.

## Smooth Reaction

This type of circuit has among its special advantages the fact that reaction control can be made, with proper adjustment, very smooth and progressive. For this reason it is frequently possible to receive distant stations at fair strength, which with some other forms of reaction control would not be comfortably audible, owing to oscillation occurring before signals were properly tuned in.

In the little set described in this article I have chosen a straightforward tuned grid circuit with Reinartz type reaction, utilising an inductance unit to plug into a standard six-pin base. The constructor can obtain a blank former and wind the coil for himself, a procedure which enables him to vary the number of aerial turns to suit his own particular aerial and also to adjust the reaction winding to suit one of his stock valves. In this way he will be able to obtain the best possible results with the additional satisfaction of knowing that his set is not a compromise designed to suit any aerial and any type of valve with only average efficiency.

On looking at the theoretical circuit in Fig. 1 the reader will notice that a small fixed condenser  $C_3$  is joined between the moving vanes of the reaction condenser  $C_4$ , and terminal 6 on the coil base. This is a convenient scheme to decrease the value of  $C_4$ , its advantages becoming very

apparent when an attempt was made to use an ordinary standard split-primary coil. Without the series condenser reaction was rather sudden, and very little capacity was required with  $C_4$  to produce oscillation. When  $C_3$  was included, however, a much more gradual "build up" of signal strength was obtained, and it became quite possible to use the coil with a good degree of efficiency. Another point is that if, without the use of  $C_3$ , the moving vanes of  $C_4$  should happen to touch the fixed vanes a short circuit will be produced across the H.T. and L.T. batteries with detrimental results. The insertion of  $C_3$  entirely prevents this.

## The Components

A list of the components actually used is given separately, but it is not essential that these should be adhered to. As a matter of fact, equivalent components of any reputable make can be used provided baseboard and panel space permits. The actual construction of the receiver is quite simple.

The two variable condensers and the filament "on-off" switch are of the one-hole fixing type, and require  $\frac{3}{8}$ -in. holes. Two aerial terminals are employed in order that alternative arrangements of aerial turns may be tried.

Only three different sizes of drills are essential, and these are:  $\frac{3}{8}$ -in. for the two condensers and the filament switch, a 2B.A. clearing drill for the five terminal holes, and a small one to serve for the securing screws, viz., the three wood screws at the bottom of the panel and the two 6B.A. screws for the angle brackets. A rose bit is useful for countersinking.

Having drilled the panel in accordance with the drilling diagram, mount on it the components and secure it to the baseboard.

## Layout Not Critical

The baseboard layout is not critical, and provided that adequate clearance space is permitted there should be no difficulty in obtaining satisfactory results. The wiring up can be carried



*The tuning and reaction-condensers, and an on-off switch, are the main features of the panel, all being readily accessible.*

## A Reinartz One-Valver—continued

out either with 16 gauge bare copper wire or with some covered wire such as Glazite. The latter is safer in a beginner's hands.

Four lengths of flexible wire will be necessary for the H.T. and L.T. connections. Ordinary house lighting flex is quite suitable. Use red leads

The four leads should be clamped together under a short strip of fibre or wood in order to obviate a direct strain on the soldered joints.

### The Coil-Winding

To wind the coil take a standard former—I used one supplied by the

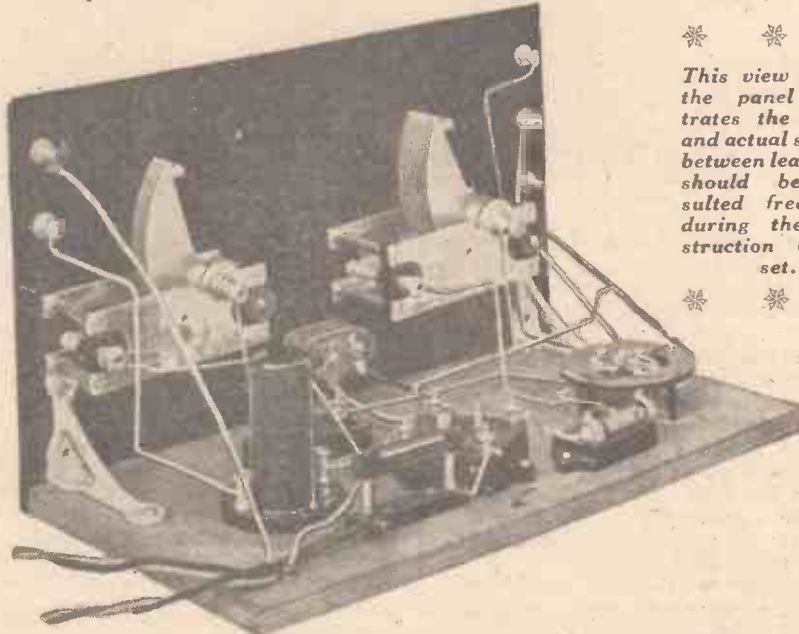

\* \* \*

*This view behind the panel illustrates the wiring and actual spacing between leads, and should be consulted frequently during the construction of the set.*

\* \* \*

for the two positive connections (L. T. + and H.T. +) and black for H.T. - and L.T. -. A better plan would be to employ four leads of different colours, but these might be difficult to obtain. Personally, I prefer always to use red for positive connections.

Two wander plugs will be necessary for the H.T. leads to the battery and two large terminal tags for the L.T. battery leads.

Collinson's Precision Screw Co.—and wind on 60 turns of No. 30 s.w.g. double silk covered wire. No. 32 or 34 could be used if convenient. If you use a Collinson former you will find that the ribs are threaded for ease of winding. This forms the grid coil  $L_2$ , and the upper end of the winding is taken to pin No. 1, which goes to the grid condenser. The lower end of the winding is joined to pin No. 2,

which is joined to L.T. + and earth. Carry on in the same direction with this grid winding for another 25 turns, this being the Reinartz reaction winding  $L_3$ . The upper end of the reaction winding goes to pin No. 2, and the lower end to pin No. 6. This latter winding need not be in one layer, and I allowed a space of about  $\frac{1}{4}$  in. between the  $L_2$  and  $L_3$  windings. The aerial coil consisted of 35 turns of No. 30 gauge wire wound in a single layer on a home-made waxed cardboard former and pushed inside the standard former, about half of the

### COMPONENTS REQUIRED.

- One Cabinet 12 in. by 7 in. by 7 in. (Carrington Manufacturing Co., Ltd.)
- One Ebonite Panel, 12 in. by 7 in. by  $\frac{1}{8}$  in. (Camco, or any good brand.)
- One Baseboard, 12 in. by 6 $\frac{1}{2}$  in.
- Two small angle-brackets. (Burne-Jones & Co., Ltd.)
- One .0005 S.L.F. variable condenser. (Jackson Bros.)
- One .00025 S.L.F. variable condenser. (Jackson Bros.)
- One Filament "on and off" switch. (Igranic.)
- One Radio-Frequency Choke, No. 2. 150-4,000 metres. (Radiax.)
- One Valve Holder. (Etherplus.)
- One .0002 fixed condenser and 2 meg. grid leak. (Dubilier.)
- One .0001 fixed condenser type 610. (Dubilier.)
- Five terminals—Aerial, Aerial 2, Earth and two for telephones. (Ealex.)
- One blank coil former (Collinson); or one ready wound split primary coil as described. (Burne-Jones & Co., Ltd.)
- One standard 6 pin base. (Collinson's Precision Screw Co., Ltd.)
- One fixed resistor and base (to suit valve). (Burne-Jones & Co., Ltd.)
- Glazite or tinned copper wire for wiring up. Flex for battery leads.

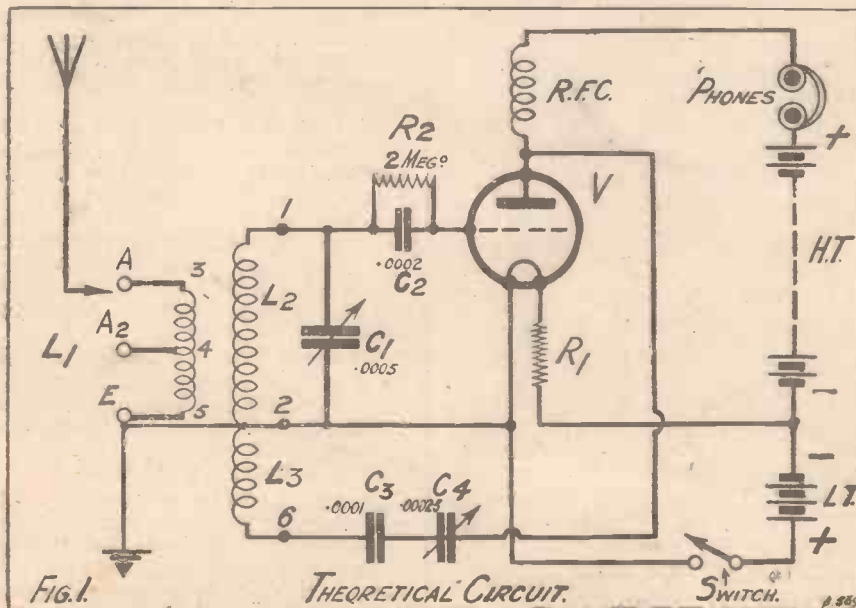

FIG. 1.

THEORETICAL CIRCUIT.

way down. A tapping was taken at 25 turns. The lower end of this winding goes to pin No. 5, the tapping to pin No. 4 and the upper end to pin No. 3. The coil should be a sliding fit inside the main former.

Various arrangements of turns may be tried for the reaction and aerial coils. For instance, with some valves 20 turns may be too many or too few for perfectly smooth control. In the same way a constructor with a very small aerial may get better signal strength by using more aerial turns.

### Standard Split-Primary Coils

A perfectly standard Magnum split primary coil (without screen) was also tried. This was found to tune from a little over 300 metres to about 650 metres.

For those who do not wish to go lower than this one of these coils would be quite satisfactory. By stripping 30 turns off the secondary,



## A Reinartz One-Valver—continued

winding (the outer one) the whole broadcast band could be covered. Slightly smoother reaction was obtained by taking five turns off the reaction winding, but this is a somewhat tricky business for the novice to attempt. Those who wish to obtain a ready-wound coil may do so. Messrs. Burne-Jones will supply one of their split primary coils with the reaction and secondary turns adjusted to suit.

### The Valves to Use

As stated previously, practically any valve can be used. I have tried the D.E.5b, S.T.61, H.512, and Cosmos Blue Spot. In the case of the standard Magnum coil smoothest reaction was obtained with a D.E.5b and 75-90 volts H.T. With the reaction winding adjusted the other valves were quite satisfactory.

and, with a valve in the valve holder, switch on. If the valve lights plug in the H.T. + plug and note whether a "plonk" is heard in the 'phones. Now rotate the condenser  $C_1$  (with aerial and earth connected) and search for the local station. Keep  $C_1$  at zero. When signals are heard rotate  $C_2$  and signals should increase in strength. Failure to obtain an increase generally indicates that the reaction winding needs reversing in direction.

Both aerial terminals should be tried; one will give greater signal

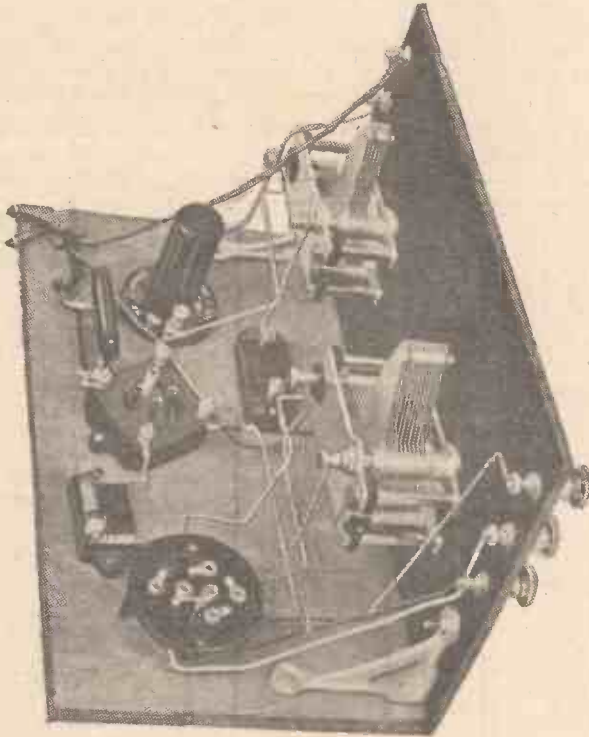

The lay-out of the baseboard is clearly shown, and also the wiring to the coil-holder and valve-holder.



### POINT TO POINT WIRING

- Join Aerial terminal to 3 on six-pin base.
- Join Aerial 2 terminal to 4 on six-pin base.
- Join Earth terminal to 2 on six-pin base.
- Join 2 and 5 together.
- Join one side of  $C_2$  and  $R_2$  to 1 on six-pin base and also to fixed plates of  $C_1$ .
- Join moving plates of  $C_1$  to Earth and to L.T. + on valve holder, also join L.T. + on valve holder to one side of "on-off" switch.
- Join other side of  $C_2$  and  $R_2$  to grid terminal (G) on valve holder.
- Join 6 on six-pin base to one side of  $C_3$ , and other side of  $C_3$  to moving plates of  $C_4$ .
- Join fixed plates of  $C_4$  to anode terminal (A) of valve holder and also to one side of Radio Choke.
- Take the other side of Radio Choke to lower telephone terminal.
- Join H.T. + flex lead to remaining (upper) 'phone terminal, and connect H.T. - flex lead to one side of fixed resistor  $R_1$ . To same side of  $R_1$  join L.T. - flex lead.
- Take remaining side of  $R_1$  to L.T. - terminal of valve holder.
- Join L.T. + flex lead direct to remaining side of "on-off" switch.

strength and the other better selectivity. In a circuit of this type a high-impedance, high-magnification valve usually gives the best results, but careful adjustment of the high-tension voltage is essential with every type. In fact, it may be said that the success of any small set such as this depends largely upon careful adjustment and operation. A tapped H.T. battery is very necessary if proper reaction control is to be obtained.

With regard to the fixed resistor the value of its resistance is determined by the voltage of the accumulator and the rating of the valve. For the 6-volt .25-amp. type 4 ohms is usual.

### Foreign Stations Received

On test with a high-magnification valve and 90 volts H.T., on a good aerial at 15 miles from 2LO, the local station was obtained at excellent strength. A number of other stations could be received with practice in tuning. Among these may be mentioned Hamburg, Birmingham, and Bournemouth. A number of Continental stations which came in at fair 'phone strength could not be identified, although in most cases the language spoken was apparently German.

(NOTE.—The wiring diagram will be found upon the next page.)

Constructors, however, must state that this particular type of coil is desired and say that it is intended for the set, unless they require the standard windings.

### Operation

Plug in the coil unit, join up the L.T. and H.T. batteries, leaving the H.T. + plug out for the time being

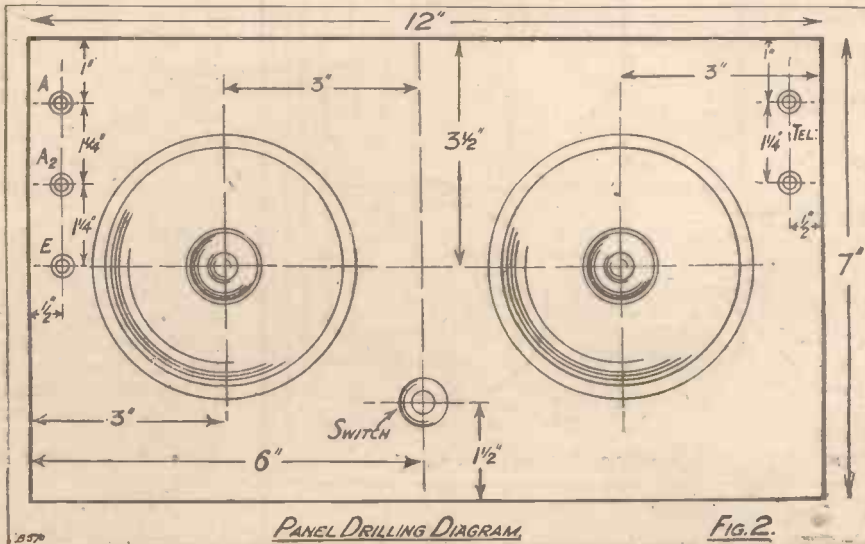

PANEL DRILLING DIAGRAM

FIG. 2.

# WIRE FOR FIXED RESISTORS

FIXED resistors to replace rheostats are easily and cheaply made at home, but some constructors may be rather puzzled to know what kind of wire and just how much of it to use. The best wire for the purpose is that known as Eureka, which can be obtained readily in any of the even-numbered standard wire gauges, either bare or with the usual insulating coverings. For making fixed resistors the writer prefers enamelled or double cotton-covered Eureka, since when these are used there is little or no liability to a short-circuit between adjacent turns on the former.

The first thing to decide is the gauge of the wire. This is determined by the current load that the resistor will be called upon to carry. Most modern dull emitters pass from .06 to .25 ampere, and where the resistors are intended to control the filaments of single valves of this type quite fine wire may be used.

For bright emitters, which may pass up to an ampere of current apiece or where several dull emitters have a common resistor, heavier wire is needed. Safe loads for different gauges are given in the table at the end of this note.

The total resistance required is found by the well-known formula: Divide the volts to be dropped by the current passed. Thus suppose that you wish to make a resistor for a .25-ampere valve, which requires a potential of 5.5 volts, with a 6-volt accumulator the calculation is: 5 volt divided by .25 ampere equals 2 ohms. In the table below is given the resistance in ohms of 1 yard of Eureka wire of various gauges. No. 26 might be selected as having an ample factor of safety, since it will carry up to 1 ampere.

This wire has a resistance of 2.6 ohms per yard. The amount required is therefore  $\frac{2}{2.6} \times 36$  in., or approximately 27  $\frac{3}{4}$  in. Or we could use No. 28, whose resistance is 4 ohms per yard; in this case 18 in. would be required.

WIRING DIAGRAM FOR THE REINARTZ ONE-VALVER.

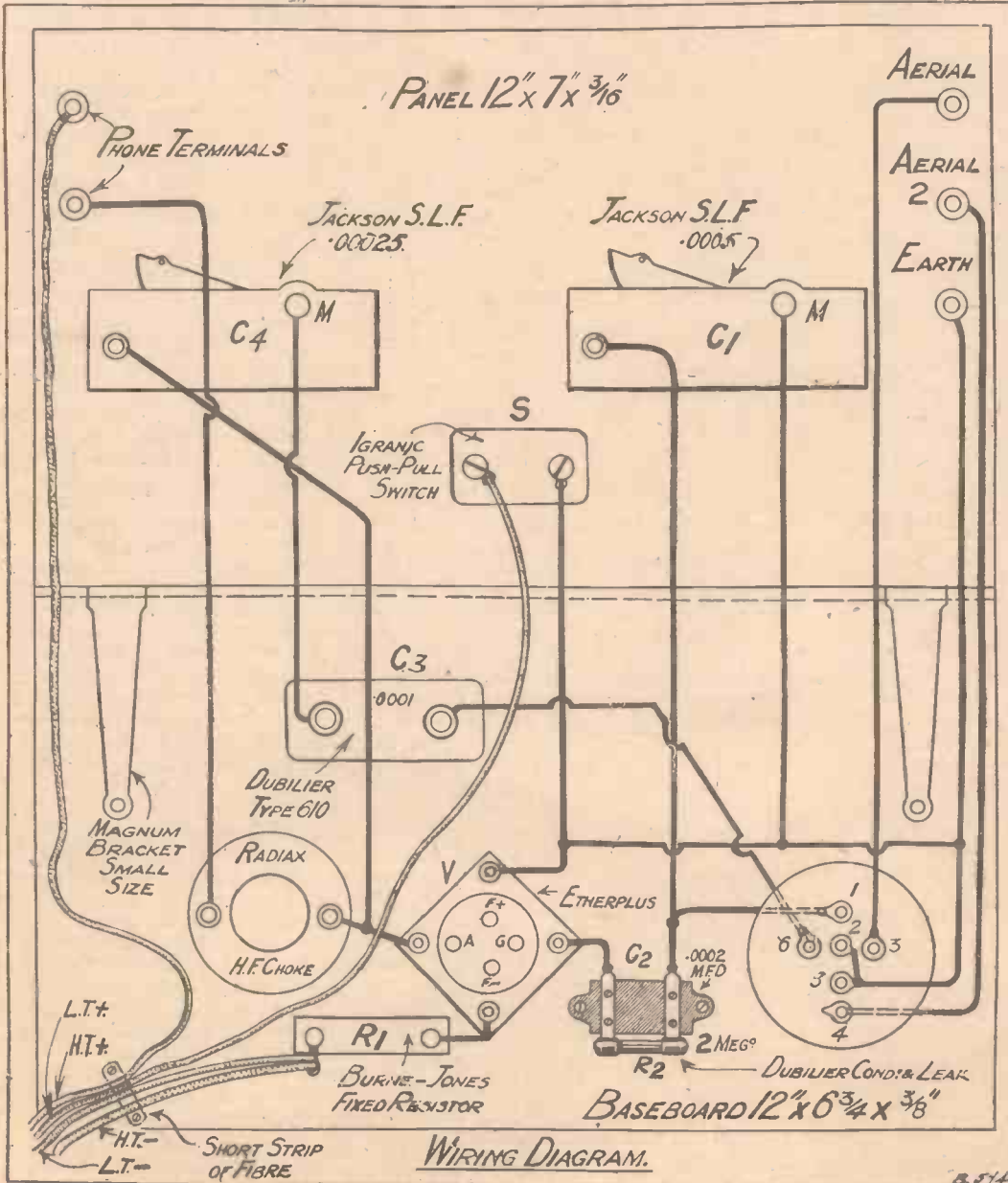

TABLE OF RESISTANCES

S.W.G.	Ohms per yd.	Safe Load Amperes
18	.37	4
20	.7	3
22	1.1	2
24	1.8	1.25
26	2.7	1
28	4	.7
30	5.6	.5
32	7.4	.4
34	10	.35
36	14.8	.2
38	24	.15
40	37.2	.1

## A READER'S RESULTS WITH THE "NIGHT HAWK."

DEAR SIR,—I am writing to let you know the results of the "Night Hawk." I get stations all round the dial at good loud-speaker strength. I might mention that we are in a very bad dip here, and badly screened; in fact, it is hard to get 5XX without one H.F. stage). Yet with the "Night Hawk," six to seven miles from 2LO, I can cut out London with ease, and get any station 5 degrees away any way without a trace of London.

To-night I have heard full loud-speaker strength, Hamburg, Oslo, S.F.R. Paris, Berlin 1,800 two stations on the 1,000 mark (cannot get the call sign), Dublin, and two Spanish stations; all that you can hear all over the house.

Yours truly,  
J. A. LAIRE.

# The Truth about High-Frequency Valves

By J. H. REYNER, B.Sc. (Hons.), A.C.G.I., D.I.C., A.M.I.E.E.

*Modern radio practice demands that a special valve shall be used for the H.F. stages of a receiver. In this article Mr. Reyner deals with extremely important questions concerning the characteristics of such valves and the necessary requirements for obtaining best results.*

IT is now generally accepted that the use of a special valve for the high-frequency stages of a receiver is desirable, and almost every valve manufacturer rates some of his valves as specifically suitable for high-frequency amplification.

We have, however, a variety of types of valves ranging in impedance from 20,000 to 60,000 ohms, all of which are labelled as suitable for high-frequency amplification. Yet there is no question that some valves falling within this category will give very much better results than others. The question arises, therefore, as to what characteristics are required in a valve in order that the best results may be obtained.

## The Tuned Anode Circuit

Now there are two principal classes of high-frequency coupling. The first of these is the simple tuned-anode circuit, such as is shown in Fig. 1. Here the variations of the anode of the valve  $V_1$  are transferred directly to the grid of the succeeding valve through a small condenser  $C_3$ . This condenser is inserted simply for the purpose of preventing high positive potentials of the anode circuit from being applied to the grid of  $V_2$ .

The voltage variations of the anode of  $V_1$  depend entirely upon the nature of the external anode circuit. If the anode were connected directly to the filament, its potential would be fixed so that there would be no variations at all, and, consequently no amplification would be obtained.

## Effective Amplification

As we increase the impedance in the anode circuit, so we get increasing variations of potential up to a limit, when we obtain from the valve the full amplification which is to be expected from the voltage amplification factor. This occurs when the impedance in the anode circuit is practically infinite, and for any intermediate point we obtain an amplification less than the theoretical value by an amount which can be mathematically determined, and depends on the ratio between the impedance of the valve and that of the external circuit.

The principal point, however, is that the total amplification obtainable can

never exceed that of the valve. It is, therefore, necessary to use a valve with a high amplification factor. At the same time, the impedance of the external circuit should be made, as far as possible, large compared with that of the valve, in order that the actual amplification factor may approximate to the theoretical value.

Now, an average tuned-anode circuit has an impedance of the order of 100,000 ohms, the actual value depending on the ratio of inductance to capacity, the resistance of the coil, etc. In order to obtain a high amplification factor, we must necessarily in-

crease the impedance, since both these parameters go more or less hand in hand.

plification is of prime importance, and a valve with a  $\mu$  of 20 and an impedance of 20,000 ohms would be better than one with a  $\mu$  of 16 and an impedance of 60,000 ohms, from the point of view of signal strength.

## Selectivity

So far, we have taken no account of the selectivity of the circuit, but the valve exercises a very considerable influence in this connection. It acts, in effect, as a high resistance across the circuit, introducing similar results to a leaky condenser. This obviously increases the losses in the

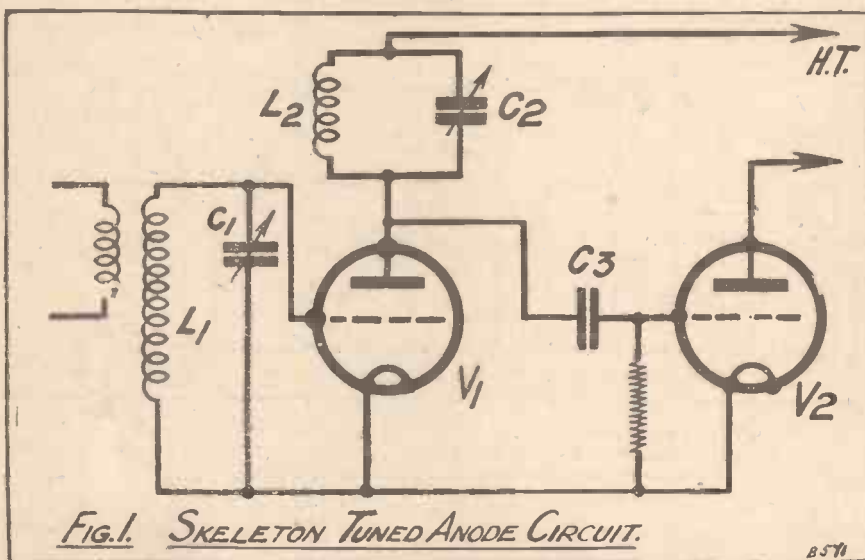

FIG. 1. SKELETON TUNED ANODE CIRCUIT.

In a tuned anode circuit of this type Mr. Reyner says that, generally speaking, in order to obtain a high amplification factor a valve having an impedance of about 50,000 ohms and a "mu" of about 25 is most suitable.

The limit occurs when the impedance becomes nearly equal to that of the tuned circuit, but for other reasons it is preferable to stop at a point somewhat earlier than this. Generally speaking, therefore, a valve having an impedance of about 50,000 ohms, with an amplification factor of about 25, is most suitable for this class of work.

This must not be taken as a hard and fast rule, but only as indicating the type of valve required. High am-

plification is of prime importance, and a valve with a  $\mu$  of 20 and an impedance of 20,000 ohms would be better than one with a  $\mu$  of 16 and an impedance of 60,000 ohms, from the point of view of signal strength.

plification is of prime importance, and a valve with a  $\mu$  of 20 and an impedance of 20,000 ohms would be better than one with a  $\mu$  of 16 and an impedance of 60,000 ohms, from the point of view of signal strength.

plification is of prime importance, and a valve with a  $\mu$  of 20 and an impedance of 20,000 ohms would be better than one with a  $\mu$  of 16 and an impedance of 60,000 ohms, from the point of view of signal strength.

## The Truth about High-Frequency Valves—continued

the two considerations, by tapping the valve across a small portion of the coil only, which reduces its effect on the tuning of the circuit.

### Centre Tapping

This tapping may be done in two ways:—First, there is the practice of centre-tapping a coil in order to obtain a neutralising arrangement. Such a circuit is shown in Fig. 2, where the H.T. connection is taken to the centre point of the coil. In this case the valve is only connected across half the coil, and it can be shown that this divides the damping effect not by two, but by four, the effect being proportional to the square of the tapping.

At the same time, however, we have reduced the effective value of the external impedance, so that the amplification falls off, and with a circuit such as this we cannot compensate for this loss. The difficulty may be over-

come by using transformer coupling, and this is one of the reasons for the increased popularity of this type of circuit.

### High-Frequency Transformers

quence, the voltage on the secondary is stepped up. The transformer effect is not perfect, owing to leakage, but nevertheless a definite increase in voltage is present.

We have, therefore, to design our transformer from the following considerations:—As we reduce the number of turns on the primary we improve the selectivity continuously, and with increasing rapidity. At the same time, the amplification obtained from the preceding valve falls off, this latter effect being to some extent counteracted by the step-up obtained in the transformer. Up to a point, this step-up more than compensates for the decrease in amplification from the valve, but beyond this critical point a rapid decrease in the amplification will set in.

ated for by the fact that the higher impedance valve usually has a higher amplification factor, but the two effects do not balance each other.

We can, however, increase the number of turns on the primary, so that the transformer again matches the valve. This will bring back the selectivity to the same order as before. The signal strength will tend to increase because of the increased impedance of the transformer, but will also tend to decrease because the step-up ratio of the transformer has been reduced. Which of these two effects predominates depends on circumstances.

### Experimental Tests

Some experiments which I have conducted indicate that, as the impedance of the valve is increased, the primary turns being increased at the same time to give equal selectivity in all cases, the signal strength increases until about 20,000 ohms impedance is obtained. After this there is very little in it, provided that the transformer in each case is made to suit the valve.

The types of six-pin H.F. transformer which have come into use lately have been designed to suit a 25,000-ohm valve with a  $\mu$  of about 20. If they are used with a 50,000-ohm valve the signal strength will suffer, although the selectivity will be increased, and to get best results in such a case the primary should be increased.

### Latitude Permissible

At the same time, a small latitude is permissible. Moreover, there are cases where a valve other than that given above would be just as good, or better. In the experiments and calculations just referred to, it was necessary to assume a certain relation between impedance and amplification factor. This was based on existing types of valve, the approximate figures being as follow:—

Impedance.	Amplification Factor.
10,000	9
20,000	15
30,000	20
40,000	24
50,000	27
60,000	30
80,000	35
100,000	40

Some valves fall below this standard, while others are better. For example, the ST61 has an impedance of 20,000 ohms, with a  $\mu$  of 20, as against 15 in the above list. It would, therefore, give better signal strength than a valve having the characteristics previously cited. In a similar manner,

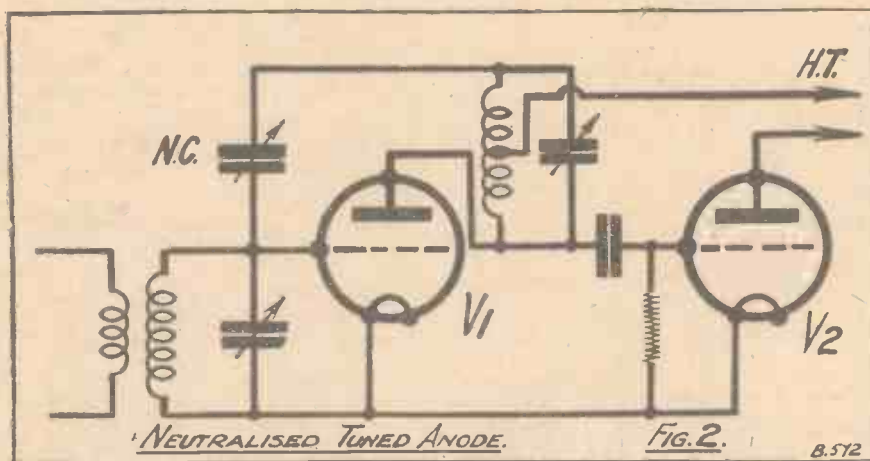

The H.T. connection is taken to the centre point of the anode coil in this circuit and this divides the damping effect by four, as the effect is proportional to the square of the tapping.

### Step-Up Effect

With a transformer, the whole of the tuned circuit is connected, as a rule, across the grid and filament of the second valve, while the anode of the first valve is tapped across a portion of the coil only. From other considerations (principally arising from the fact that the anode circuit is usually at a high potential due to the H.T. battery) a direct tapping is not used, but a separate winding is employed for the anode circuit of  $V_1$ , as shown in Fig. 3.

The important point is that the number of turns on the secondary winding is several times as great as that on the primary, and, in conse-

quence, the skill of the transformer designer is consequently aimed at the reduction of this critical point, so that he may make his primary windings very small, thus obtaining enhanced selectivity, without losing in overall amplification, and in this respect the actual construction of this transformer is of great importance.

### Suitable Valves

Returning now to the question of suitable valves for this type of circuit, we have the following considerations to face. If we increase the impedance of the valve the damping effect will be reduced. Thus, if we keep the number of primary turns the same; the selectivity will be increased. On the other hand, the impedance of the transformer will no longer suit that of the valve, and the amplification will fall off. This is partly compen-

**THE TRUTH ABOUT H.F. VALVES**—continued

there are other cases where latitude is permissible, and a broad view must be taken in dealing with the subject.

**A Solution**

While such a wide discrepancy exists between the various classes of valve there is bound to be a certain amount of chaos. Transformers are designed to suit certain types of valve, but the user of the receiver does not wish to have to purchase that particular type in order to get the best results. He may prefer, for other reasons, a different type altogether.

One of the most interesting solutions to the difficulty is that evolved by the Collinson Precision Screw Co., who have brought out a special form of their six-pin former with an interchangeable primary former. This fits snugly inside the outer former, giving a very tight coupling, but it enables the constructor to suit his set to his valves.

**Extreme Flexibility**

I have had occasion to try some of these transformers recently, and have been very pleased at their usefulness. There are a number of types, each suitable for a variety of valves, and there is no doubt about the difference obtained by using the correct one.

The enthusiastic constructor, however, will find the greatest pleasure in winding his own primary, and finding by experiment what is the best ratio of the turns in his own case. He will then obtain a good idea of the exact effect of altering the valve in a high-frequency circuit, and will be able to bear out for himself the experiments just described.

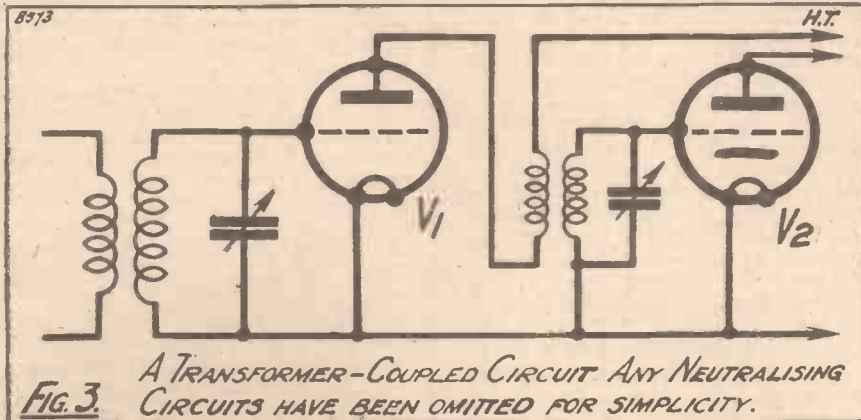

**"POPULAR WIRELESS"**  
(Incorporating "Wireless")  
On Sale Every Thursday. Price 3d.  
The Wireless Weekly with the Largest Circulation.

**NOTES ON AERIAL INSULATORS**

IT is surprising to find, in spite of all that has been written on the subject, how many amateurs there are—by no means all of them beginners—who still make mistakes about the position of their aerial insulators. Out of any ten aerials of the double-wired type, it is pretty safe to say that three or four have the insulators placed as shown in Fig. 2—that is, between the wires and the spreader, instead of between the main supporting rope and the yoke, as shown in Fig. 1.

Losses take place in two ways. There is, first of all, direct leakage over the surface of the insulator, which is most liable to occur when it is covered with a coating of dust and grime. But it is probable that even more important than direct losses due to surface creeping are those which take place by capacity through the insulator.

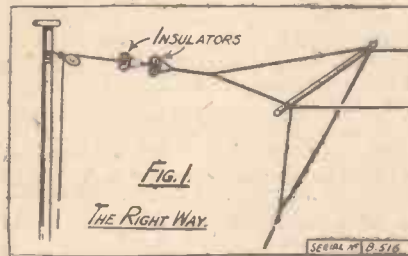

These will be at their worst during the reception of ultra-short wave transmissions. From this it appears that we must use every endeavour to make the resistance of the insulators as high as possible, and to reduce their capacity to the lowest possible limits.

Now consider the case of insulators placed as shown in Fig. 2. Let us suppose that they are of equal resistance, which we will call x megohms.

Then, since the two insulators connected to one wire are in series, the insulation of that wire, taken by itself, has a resistance of 2x megohms. But the two wires and their insulators are in parallel. When insulators of equal value are in parallel, the total resistance is half that of either; hence, the resistance between the suspended wires and the supporting rope in Fig. 2 is  $\frac{2x}{2}$  megohms, or x megohms. The four insulators placed in this way thus offer only as much resistance as would be provided by a single insulator wired in the position shown in Fig. 1—that is, between the yoke and the main supporting rope.

**Correct Use of Insulators**

Now for the capacity. Let us call this x microfarad. Then, for each of the wires in Fig. 2 the total capacity will be  $\frac{x}{2}$  mfd. since the capacities are in series. But since the two arms are in parallel, the total capacity is  $\frac{x}{2}$  mfd. +  $\frac{x}{2}$  mfd., or x mfd. Again we find that the four insulators placed as in Fig. 2 are doing the same work as one wired in the Fig. 1 position.

In Fig. 1, since the insulators are in series, the resistance between the suspended wires and the supporting rope is 2x megohms, whilst the capacity is  $\frac{x}{2}$  mfd. Two insulators in this position thus provide twice the resistance and half the capacity of the four wired in the other way. It follows that an insulator between the main supporting rope and the yoke is, as regards both the highness of its resistance and the lowness of its capacity, four times as efficient as when used in the wrong position.

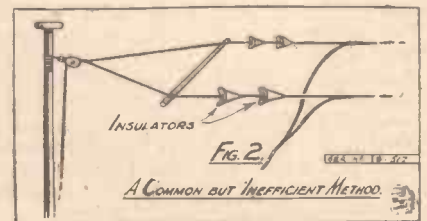

The only case in which insulators should be used between the suspended wires and the spreader is when the latter is provided with guys, which act as steadiers, and prevent it from swaying unduly when a wind is blowing. Here the guy ropes, especially if they are wet, are more or less at earth potential, and may occasion big losses unless insulators are provided in the Fig. 2 position.

**Resistance Values**

Now, when resistances of equal value are placed in series, the total resistance is double that of either of them. Similarly, when equal capacities are in series, the total capacity is half that of either. Hence, clearly insulators must be placed in series.



# The CONVERSION of MUDBURY WALLOW

AS the possessor of the lowest brow in Mudbury Wallow, I must confess that I find life in that aesthetic townlet a little trying at times. The straight portion of my own characteristic curve from the eyebrows to the upper bend of the roof measures a bare three inches, but I am sure that both Primpleson and Miss Lavinia Worple would pan out at least three times as well if you ran a ruler over their foreheads, even with-



Miss Lavinia Worple is amongst the most advanced of modern poetesses.

out previously removing their hats. Ever since I came to live at Mudbury Wallow they and the rest have been educating me for all they were worth. Miss Worple, who is amongst the most advanced of modern poetesses, has proved to me over and over again that both metre and sense are mere drags upon the wheel of verse, whilst Tootle, who composes queer things such as sonatas for six foghorns, two klaxons, and a Jew's harp, with interludes by a vacuum cleaner, never ceases his endeavours to instil into me a proper appreciation of what he calls "the horrid beauty of the crashing discord." Primpleson, the artist fellow, has shown me over and over again that to the eye that can really see, human beings have pea-green or purple faces, limbs like aerial masts, and huge, shapeless hands as big as dinner plates. He has also explained, though I have really forgotten how it all worked out, why it is that his masterpiece, which looks like one of Euclid's problems mixed up with a catastrophe at a dye factory, is really the most perfect representation of "Evening in Summer Time" ever produced with paint and canvas by mortal man.

## No Aerial in the Place

I would not so much mind their goings on—in fact, I have always done my level best to follow their great and noble teaching—if only they did not expect one to be so strenuously high-brow all the time. When, for instance, I let fall the word "wireless"

at a meeting of the Literary and Artistic Circle some time ago, the horrid silence that ensued was of such a frigid nature that I came out chilblains all over. Nothing more was said at the meeting, but afterwards several of them came up and spoke to me in the kindest possible way for my own good. Sir K. N. Pepper, the retired Indian judge, intimated that such an indiscretion must never occur again, whilst Goshberton-Crunp, the schoolmaster, informed me in the most tactful manner that broadcatching is simply not done, or even spoken of, in genuinely artistic circles. It was the proud boast of Mudbury Wallow that there was not an aerial in the place, and at one time it looked as if there never would be.

## The New Arrival

It was not long after my dreadful *faux pas* at the Literary and Artistic Circle that our little society was thrown into the wildest state of excitement by the arrival of an army of painters and decorators at the small house which had stood empty ever since the departure from our midst of the Bumpleton-Smythes, who had been amongst the highest of all high-brows. It was not known who had taken the house, but indignation ran high when it was heard that the Bumpleton-Smythes' black ceilings had been whitewashed, and that the walls, previously distempered in orange and magenta, had been papered. Miss Worple told me that she feared the worst, and Primpleson was so affected, by observing as we passed the house together one day that the front door was being painted brown and the window frames white, that he went on shrugging his shoulders until he broke his braces. Consternation reigned when it was seen that the name on the gate had been changed from "Vortex" to "The Crow's Nest."

## A Momentary Lapse

A day or two later I found Miss Worple almost swooning when I called upon her to return a novel (all written in words of one syllable and without any stops), which she had been good enough to lend me. "Dreadful, dreadful," she sighed weakly. "I have seen the creature. Worst still, I have heard him. As I was passing his garden a short time ago, he came out of the gate whistling something with a positive tune in it. A tune,

my dear friend. I felt absolutely ill." "Come, come," I said, "you must pull your—er—that is to say, you must not be downhearted. It was probably a mere momentary lapse on his part, the effect of high spirits caused by surveying his new abode. I am sure that under the splendid influence of Primpleson and yourself he will soon become as tuneless as the rest of us."

## The Human Battering Ram

Turning the corner after leaving her house, I collided violently with a sturdy figure, bounced off it, and sat down. With the most profuse apologies, this human battering-ram picked me up, and introduced himself as Captain Tobias Buckett, late of the Mercantile Marine. "Makin' a bad impression, I am afraid, on my first day in Mudbury Wallow," he remarked affably. "On the contrary," I replied, with old-world courtesy, "I am deeply impressed." This was perfectly true, for the point of impact had been half a brick which some careless person had left upon the pavement. Captain Tobias Buckett went on to tell me all about his new house, and asked if I was interested in wireless.

"Sh!" I said, "don't say it out loud." Making my way through a forest of whiskers, I placed my lips close to his ear, and breathed, "I am, but I daren't." Captain Buckett looked a little surprised, and, after a short and pithy talk about the weather, we parted.

When I met Miss Worple in the High Street next day she was positively boiling over with fury. "Do you know," she gurgled, "that awful man has put up a flagstaff in his



The Captain's Visitors

garden? A terrible eyesore, my dear friend! Tall and straight, with never a curve in it. If only he had had a twisted one, or put it up askew, it would not have been half so bad; but as it is, the thing is too dreadful for words. I suppose that he will soon

## The Conversion of Mudbury Wallow—continued

be flying flags of hateful colours without any true design in them." I agreed that possibly that might happen, though inwardly I was pretty sure that a still worse shock was in store for Miss Worple. Sure enough, that very evening I observed a slender wire stretched between the top of the mast and one of the chimneys of the Crow's Nest.

At the meeting of the Literary and Artistic Circle that night there was quite a scene. Sir K. N. Pepper told



A Painful Introduction.

us with bated breath that, though he hardly liked to use the word, he was convinced that before very long Captain Buckett would instal a wireless set. On the following night it occurred to me that it would be a good idea if I went round to the Crow's Nest just to see what had happened. Disguising myself carefully by turning the brim of my hat down and the collar of my coat up, I lighted a gasper to steady my nerves, and crept out into the dark. On approaching the Crow's Nest I noticed that a thin streak of light was coming from the bottom of one window, whose blind had not been pulled right down. I advanced on tip-toe and looked in.

### The Extra Phones

Captain Buckett was stamping about the room looking, I thought, a little annoyed. On the table was a thing with knobs and dimly-glowing bulbs. In the most comfortable arm-chair by the fire sat Pimpleson, and upon Pimpleson's head was a pair of telephones. He was shrugging his shoulders so hard that I wondered if even his new braces would stand it, and over his countenance stole every now and then the beginnings of a little smile, which he hastily nipped in the bud and changed to a look of loathing and disgust. I tapped three times on the window pane and hooted like an owl. Before ducking out of sight I had just time to see Pimpleson tear off the 'phones as if they had been red hot and dive under the table. After about five minutes I heard the back door open quietly and saw the dim figure of Pimpleson stealing cat-like down the path towards the tradesmen's entrance. The coast being now clear I rang the front-door bell. It was Captain Buckett himself who let me in, and I noticed that he did not

seem overjoyed by my visit. "Urrr," he grunted, "another of you. I suppose you will want to use the 'phones all the rest of the evening?" But when I produced from my pocket a pair which I had bought with great secrecy he cheered up at once. As soon as I had seen that the blind really was pulled right down we fixed both pairs to the set and sat contentedly on either side of the fire until closing down time.

"That man Pimplenose . . ." said Captain Buckett, refilling his pipe. "Pimpleson," I corrected. "Oh well, Pimpleson. Anyhow, his own mother won't know him if he comes round bothering me much more. He crawled in at seven o'clock, told me how digusting wireless was, and then said that he thought he ought to sample it for himself so that he could realise its full beastliness. He went on samplin' it for three solid hours, monopolizin' my own pair of telephones. There he sat, sayin' every now and then 'Loathsome,' 'Beastly,' 'Five minutes of this would kill me.' I suppose the whole circus'll sneak in one by one. I want to use my own set sometimes, so I've ordered another pair of 'phones to-night."

### The Captain Goes on Strike

The new 'phones did not, after all, do the Captain very much good, for on Pimpleson's next visit he brought Goshberton-Crump with him so that he too could feel the full horror of the thing, and the two of them sat, so Captain Buckett told me, wearing the 'phones and looking like a couple of boiled owls the whole evening. In self-defence the Captain ordered a third pair. When Pimpleson and Goshberton-Crump turned up, bringing Tootle with them, they told Captain Buckett how lucky it was that he was able to let all three of them hear the hateful thing so that they could warn the rest of the community against it. When the Captain asked whether, after all this time, they had not heard enough to satisfy them that listening-in was utterly degrading, they replied that they had heard more than enough; but they turned up two days later (when the fourth pair of 'phones had arrived), bringing Pottle-son, the sculptor, with them. It was after this evening that the Captain went on strike, declaring that he would not have more than two of them in the house at the same time.

### An Indoor Aerial

After this they ceased from inflicting their presence upon the Crow's Nest for a bit. The Captain thought that it was his insults that had done the trick, but I had a different idea. Anyhow, he and I had some thundering good evenings together both at the Crow's Nest and at my own house,

where I had rigged up a topping little set with an indoor aerial. I am quite sure that if Miss Lavinia Worple could have seen us listening to the programmes or could have heard us subsequently discussing hysteresis losses and convection currents and grid voltage swings, and things of that kind, she would have gone up in a blue flame with rage and indignation. Luckily for her, and also for us, she did neither.

### A Disgrace to Mudbury Wallow

It was in the Post Office a few days later that the most thrilling scene of all was enacted. Choosing a time when no one was about Goshberton-Crump had crept in and uttered a whispered demand for a wireless licence to the damsel behind the counter. She was engaged in making it out when Pimpleson entered unheard and stood behind him, waiting his turn. "Receiving, not transmitting, licence, I suppose?" asked the damsel in a loud, clear voice. "What's that?" cried Pimpleson, suddenly revealing himself, "you buying a wireless licence?" Goshberton-Crump tried to deny it, but could not do so in view of the document that was now handed across the counter to him. Pimpleson fairly went in off the deep end, lashing Goshberton-Crump with bitter words and telling him that he was a disgrace not only to the literary and artistic circle but also to Mudbury Wallow, to the county, to the country, and to civilisation. He was thoroughly warming up to his work when the damsel inquired if she could do anything for him. "Twelve stamps, please," snapped Pimpleson. "I am afraid that I have nothing smaller than a note."

### The Biter Bit

He extracted a folded paper from his pocket book and passed it across. The damsel unfolded it. "I am afraid



Moments Too Tense for Words.

that I cannot change this," she said, laying it face upwards upon the counter. Instead of an undertaking from Mr. Fisher to pay the sum of ten shillings upon demand, it was a permit from the Postmaster-General to one Horatio Habbakuk Pimpleson to erect and maintain a wireless receiving set. There are some moments too tense for any words.

WIRELESS WAYFARER.

**S.B.**

THE B.B.C. KINDLY EXPLAINS THAT THESE LETTERS STAND FOR "SIMULTANEOUS BROADCAST"— OF COURSE THEY HAVE OTHER MEANINGS:

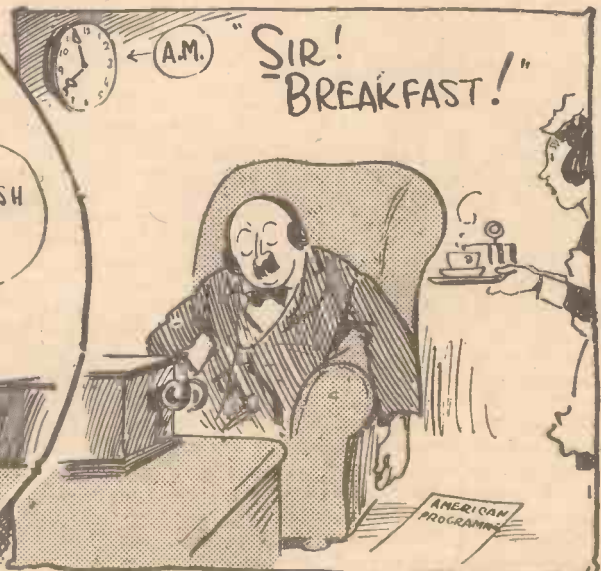
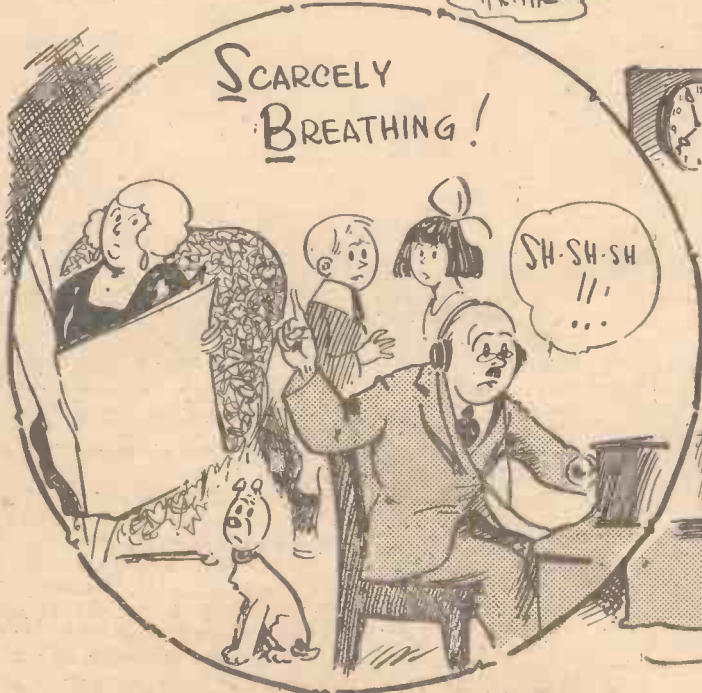
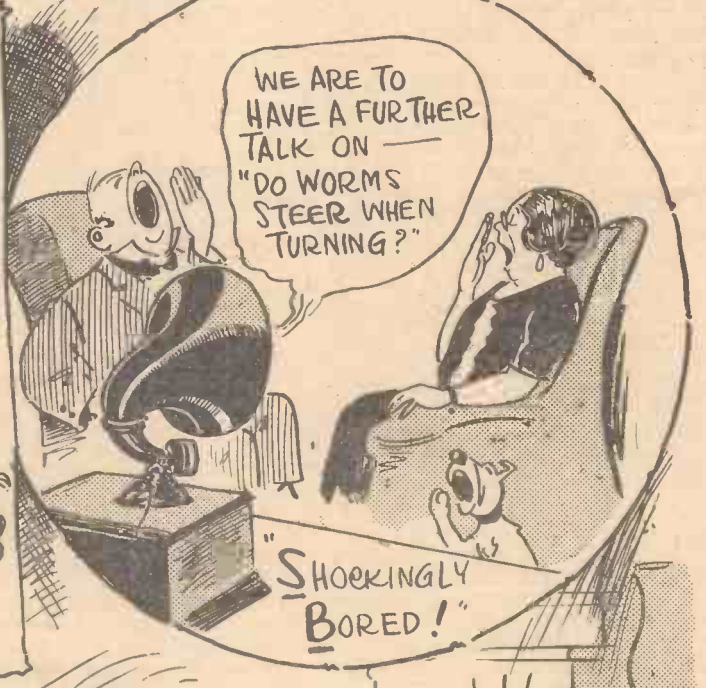
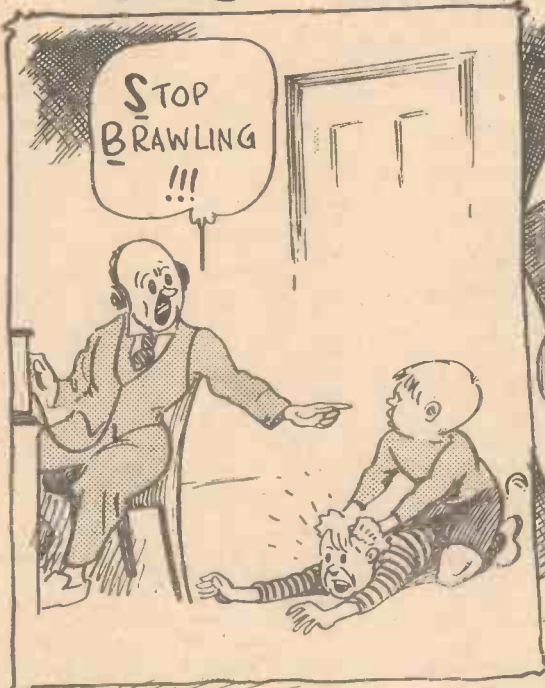

CON SHAW





# “THE CHANGEOVER”

The set designed, built and described

By A. S. CLARK

*This is a novel and simple crystal receiver, with which it is possible to switch from the local short wave station to Daventry without any retuning being necessary.*

**S**TRANGE as it may seem, there are many people who do not listen to Daventry because it is too much trouble to change plug-in coils. This is a pity, because often Daventry is broadcasting a programme different from the local station. Also, in some cases, Daventry will give louder results.

There are obvious advantages in building a quick change-over set. For instance, if interference is experienced on the lower broadcast band, it is only the matter of a second to see if it is just as bad on Daventry's wavelength. Or, again, if you think the lecturer at the local station is particularly "dry" you can switch on Daventry and possibly listen to a programme which is more to your taste.

Having decided that the type of set outlined above will fill your requirements, we can turn our attention to the design described in this article, and which I have called "The Changeover." I have used home-wound coils, of which there are two; one for Daventry and one for the lower band of broadcast wavelengths. These two coils are mounted inside the cabinet, and are each separately tuned by one of the variable condensers. Two of the semi-permanent type of crystal detectors are employed, and can be seen mounted either side of the change-over switch. The whole set presents quite a neat and pleasing appearance.

### Not Expensive to Build

The theoretical circuit of the set is shown in Fig. 1. It will be seen that the variable condensers and the crystal detectors are duplicated. It must not be thought, however, that this will make the set expensive to build because a great saving is effected by using home-made coils. Direct coupling has been employed. In some cases the use of semi-a-periodic aerial circuits results in a marked loss in signal strength. This is especially noticeable in my own case, although there is a great increase in selectivity. But it is only in very exceptional circumstances that one can afford to sac-

### COMPONENTS REQUIRED.

- Panel 12 in. by 8 in. by  $\frac{1}{4}$  in. (Camco).
- Cabinet for same with 12 in. by 9 in. by  $\frac{3}{8}$  in. baseboard (Camco).
- Two .0005 variable condensers (Formo).
- Two 4 in. dials for same (Igranic).
- Two semi-permanent crystal detectors (Magnum).
- Two-pole change-over switch. One hole fixing (Utility).
- 6 oz. 24 g. d.c.c. wire.
- 4 terminals.
- Glazite wire, Empire Cloth, ebonite, etc.

rifice signal strength to selectivity in a crystal set. I have therefore not employed aerial taps on the tuning coils.

### Making the Coils

A list of the components required to build this receiver is given elsewhere in the article, and having procured them the constructional work may be commenced. First of all the coils should be wound. These are made in hank fashion, that is to say, the turns are wound "anyhow" on a former, and are then removed and bound together in some suitable manner. This may not sound a very scientific method, but the coils are very efficient, in fact, the loudest crystal set signals I have ever heard were obtained when using a coil of this

type. Gauge 26 d.c.c. wire is employed, and for the Daventry coil 150 turns should be wound on a  $2\frac{1}{2}$ -inch former. Personally, I find a glass tumbler is very suitable as a former since, as it is tapered, the turns of wire are easily removed.

### The Panel Drilling

Approximately 35 turns on the same diameter former will be required for the smaller coil. It is possible, however, that with this number of turns you will not be able to tune in your local station properly. Should you find that the local station comes in best with the variable condenser "all out," a few turns should be removed from the coil. Whilst if it comes in best with the condenser "all in," a few more turns should be added.

Having ascertained that the smaller coil is of suitable size by roughly connecting up to aerial and earth with the variable condenser, detector and 'phones, the coils may be bound with empire cloth. This not only makes them look neater, but keeps out moisture, which would make them inefficient. Do not pull the empire cloth too tight or you may increase the self-capacity of the coil too much, and this, of course, is undesirable.

In Fig. 2 will be found a dimensioned drawing of the front of the panel. This should be used as a guide when marking out. All points where



The controls are symmetrically disposed upon the panel face as shown.

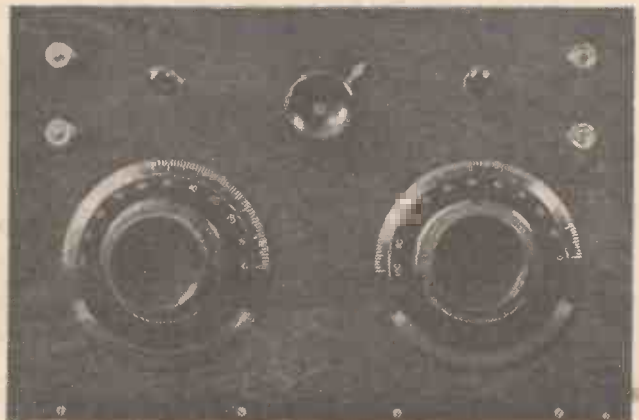

## "The Changeover"—continued

holes are to be drilled should be centre-punched, and where large holes have to be made, it is as well to drill a small one first. This will act as a guide for the large drill.

### Mounting the Components

All the holes, except those for the terminals and the screws for fixing the panel to the baseboard, are for "one-hole fixing" components. Before you have marked the holes, the panel should be tried in the cabinet to see that it fits properly. If it does not the panel can be scraped where necessary with the edge of a knife. A file is not much good for this job, although it may be found useful for smoothing the edges off after they have been scraped.



*This theoretical diagram of the connections shows how the switch is arranged for long and for short waves.*

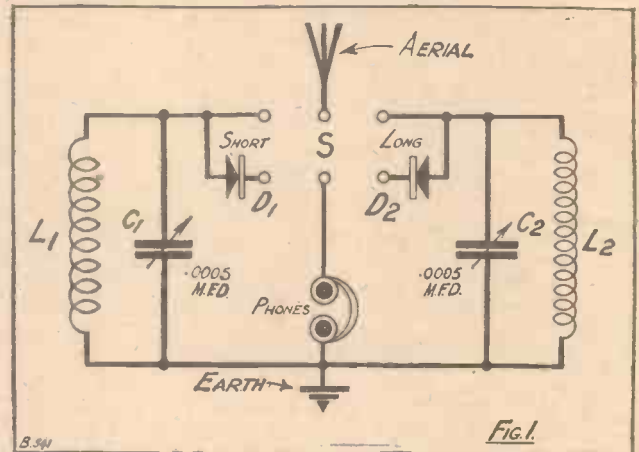

S.54

*Fig. 1.*

### WIRING INSTRUCTIONS.

*(Looking at the back of the panel.)*

Join bottom tel. terminal to moving plates of C2, one side of L2, one side of L1, moving plates of C1 and Earth.

Join aerial to centre back (nearest panel) contact of S.

Join right-hand front contact of S to back contact of D1.

Join left-hand front contact of S to back contact of D2.

Join remaining tel. terminal to centre front contact of S.

Join right-hand back contact of S to remaining contact of D1, fixed plates of C1, and remaining side of L1.

Join left-hand back contact of S to remaining contact of D2, fixed plates of C2, and remaining side of L2.

The components can now be mounted on the panel. The small ones such as the terminals and the detectors should be put on first, and the variable condensers last. A small piece of wire should be twisted round the shank of the detectors before they are pushed through the panel. This is for making contact, since if a thick piece of wire is inserted there will not be room on the shanks at the front of the panel to screw on the detector caps.

Having mounted all the components the panel and baseboard should be inserted in the cabinet and the panel screwed to the baseboard. This will ensure that it will always be a good fit for the cabinet.

### Easily-fixed Coils

Now remove the panel and baseboard and fix the coils in place. Fig. 4 will make it quite clear that these are mounted by being clamped to the baseboard with pieces of ebonite.

Attention may now be turned to the wiring. In Fig. 3 a wiring diagram is given, and this must be carefully followed. To make this easier wiring instructions are given elsewhere in the article. These are described looking at the set from the back. Before the actual wiring is commenced, it will be as well to "tin" all points to which soldered joints are to be made. The wiring of the actual set was carried out with Glazite wire, but if desired ordinary wire or square section wire may be used. A finishing touch may be given to the receiver by fixing panel transfers in accordance with the lettering on the front-of-panel diagram of Fig. 2.

### Crystal Adjustments

When the set is completed, it can be tried on the aerial. Connect the aerial, earth and telephones to their terminals, and put the switch over to "short." Now tune signals in to their loudest by means of the variable condenser C1, and then adjust the detector D1 until a good point is obtained.

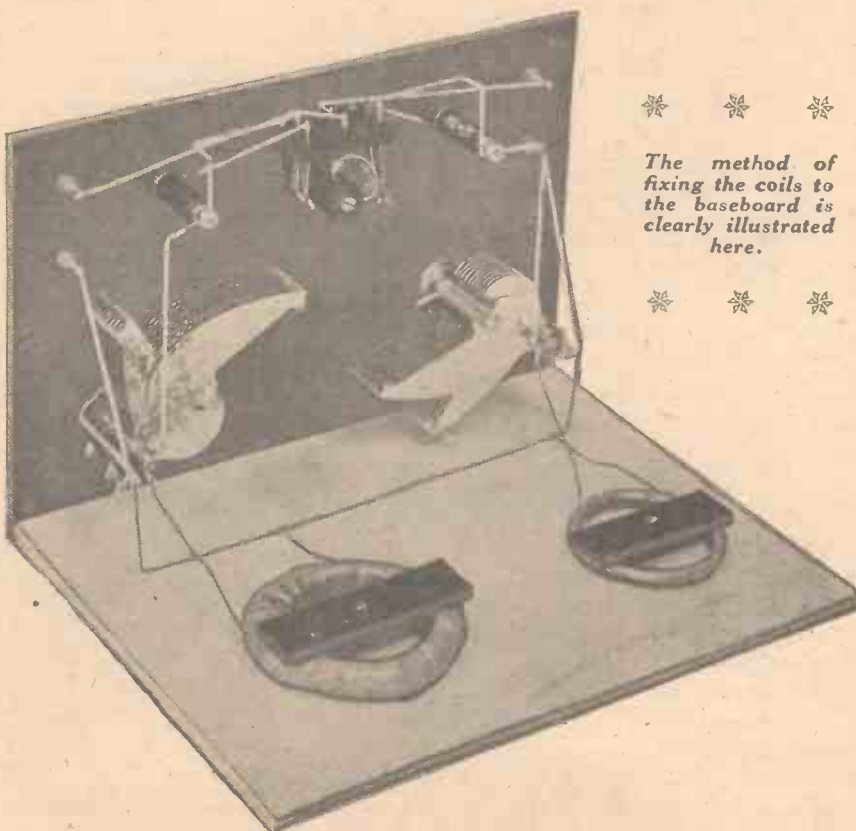

*The method of fixing the coils to the baseboard is clearly illustrated here.*



*A general view of the wiring behind the panel.*

“The Changeover”—continued

Do not twist the little knobs on the detectors round while they are in, always pull them out first. Care should be taken when replacing the cap not to knock the detector out of adjustment.

The set should now be tried out in the same way on the “long” position. It is very unlikely that the Daventry coil will be found either too large or too small for this station, but should this be the case it can be treated in the same way as the lower-wave coil, by removing or adding a few turns of wire.

Clear of Interference

The performance of this set on the author’s aerial at 8 miles from London was very good. Signals from the local station were so loud that it was possible to hear that something was being broadcast when the telephones were lying on the table. Daventry was also received at very good strength, and there was no background from the local station. The quickness with which one can change from the local station to Daventry is a great asset, and should be greatly appreciated by those who listen frequently.

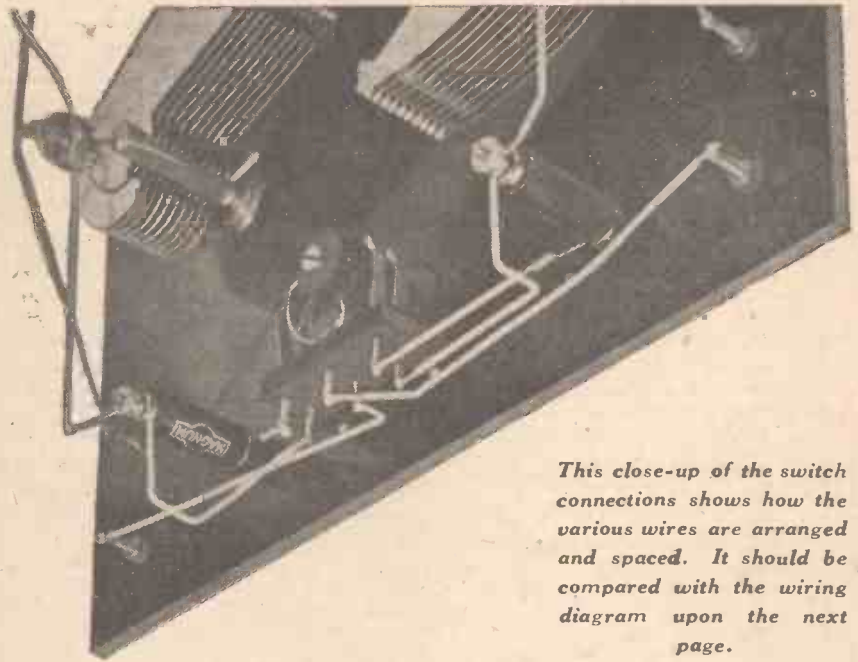

This close-up of the switch connections shows how the various wires are arranged and spaced. It should be compared with the wiring diagram upon the next page.

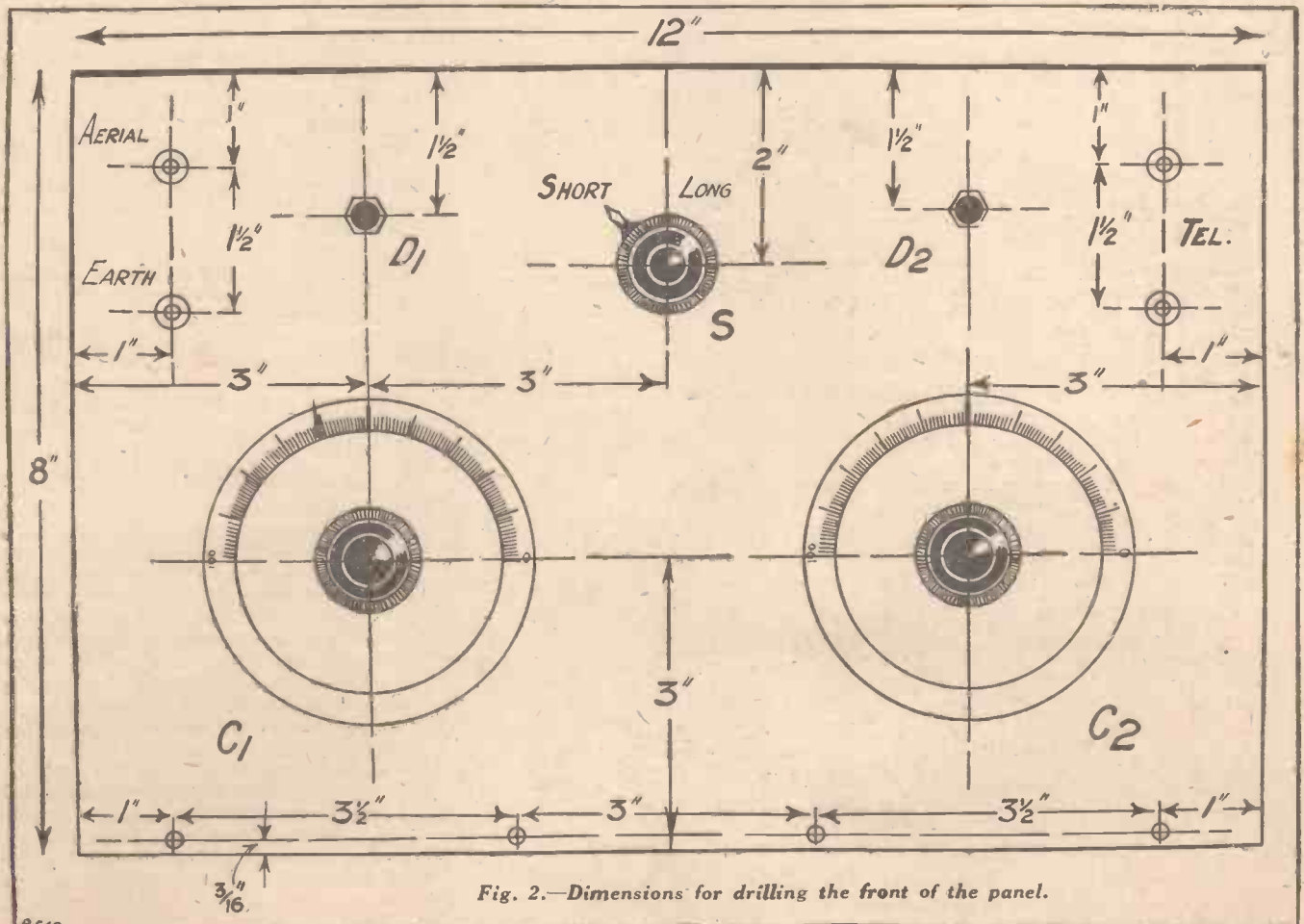

Fig. 2.—Dimensions for drilling the front of the panel.

“The Changeover”—concluded.

In case the constructor has ordinary tuning coils on hand, it may be as well to mention that these can be used instead of the home-made ones, if desired.

The number of turns for such coils would be the same as mentioned for the home-made coils—i.e., about 35 turns for the local station, and 150 or so for the Daventry station. Any convenient method of mounting may be adapted, as there is plenty of room on the baseboard to mount the usual type of plug-in coil-holders.

Care should be taken, however, that the two coils are not coupled together magnetically, or this will affect both the tuning and the selectivity of the

receiver. The best method of avoiding undesirable coupling of this nature is to mount the two coils as far apart as possible, and to arrange that they are placed with their axes at right angles to each other.

Upon the original set shown in the photographs, the writer found that there was no necessity for a telephone condenser, as the self-capacity of the 'phone leads, etc., was sufficient in itself, without an external capacity. If, for any reason, the con-

structor prefers to shunt his telephones by, say, a .001 or .002 condenser, it can easily be connected across the telephone terminals. In this position it

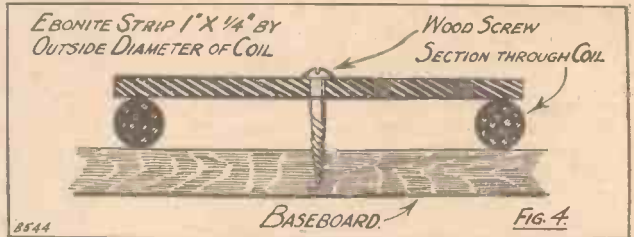

will support itself by its own connections.

CHOOSING A LOUD-SPEAKER

MANY people make the mistake of thinking that a small set will only operate a small loud-speaker, and that the larger types are only suitable for powerful receivers. This is quite a mistake, for with a given strength of signal the reproduction from the larger types will nearly always be of better quality.

At the same time if you have a small loud-speaker, do not imagine that by purchasing a very large one that you will get a greater volume. Remember that the loud-speaker is merely a sound distributing device, and is not in any way an amplifier itself.

Scientists have shown that to get the best reproduction the sound wave must be distributed in a certain fashion, and that with the horn type a fairly large horn is really essential. The loud-speaker makers meet the public demand and sell excellent small instruments, but while these are good value they must not be expected to compete with the full-size types.

A Hint for the Purchaser

If the loud-speaker is to be used in a living room, and it is desired to maintain a harmonious note in the furnishing, cabinet loud-speakers in oak or mahogany are obtainable from a number of firms. Generally these cost a little more than the horn type, but the interior mechanism is much the same in both kinds, and there is no essential difference in construction.

If possible try and arrange to have a demonstration on your own set with the loud-speaker you intend to buy, and if you have purchased an expensive loud-speaker and are disappointed with the quality make sure it is not your set which is causing the trouble.

Much distortion heard from loud-speakers is due not to the instrument itself but to overloading the last valve.

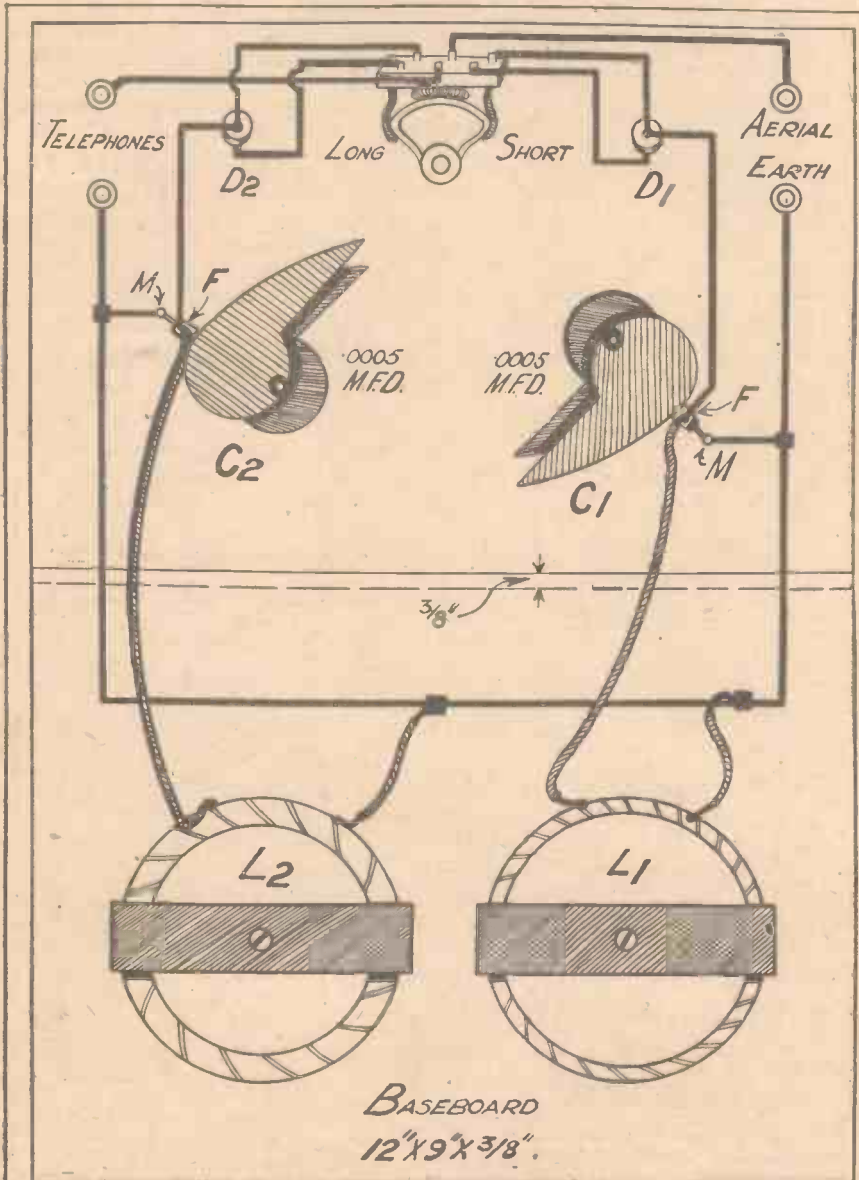

WIRING DIAGRAM FIG. 3.

B543.



# HUNTING THE L.F. HOWL

*Some practical notes for amateurs who have built sets only to find that "they won't go properly."*

By  
**G. V. DOWDING,**  
Grad.I.E.E.

Technical Editor of  
"Popular Wireless" and  
"Modern Wireless."

I WONDER how many of my readers have had that annoying experience of building a perfectly straightforward sort of set that just "won't go properly" no matter what one does with it. I must admit that I have faced this contretemps several times, more especially with three-valve sets employing two stages of transformer coupled L.F. amplification. Nothing short of completely dismantling the wretched instrument and re-assembling it with different components seems to be effective in some cases, or at least, that would seem in the end to be the quickest way to surmount the trouble.

### Most Exasperating

And judging by the letters I have received from time to time, and from conversations with friends, I imagine that there must be hundreds, perhaps even thousands, of receivers in use whose "last" valves are never switched on because it is impossible

to do so without frightful distortion or howling immediately occurring.

Most of these sets doubtless incorporate a circuit similar to that shown in the diagram Fig. 1. The detector might be a crystal instead of a valve (crystal and 2 L.F.), and further, the detector might be preceded by one or more high frequency amplifying stages, but these alternatives do not affect the main problem.

It is most exasperating to be faced by an apparent deadlock in such a straightforward sort of circuit. First of all one carefully varies the H.T. and casts suspicious eyes on the source of this, whether it be a dry battery or an accumulator. Then grid biases are varied or introduced if such were previously "non est." Subsequently, if the howling or terrible distortion persists, one commences to take more drastic measures. Valves are changed, transformer connections are changed over, changed back and changed over again, fixed condensers become suspect

and are replaced or removed or others of different values introduced, and so on.

It is a hard case indeed that is not cured after a period of such intensive doctoring, but the type of circuit we are discussing would appear to abound in "hard cases." But there is no need completely to dismantle one such as this, or even to use it with its last and apparently offending valve cut out. Let me start where most amateurs leave off, i.e., at the conclusion of all the stock fault finding hints and tips such as I have just mentioned. Let me address myself to all those who have turned away in despair, and with their faith in the genius who invented cascade amplification completely shattered.

### Taken for Granted!

I will take it for granted that the wiring is well spaced and that all joints are good ones, and that all the accessories (including the batteries!)

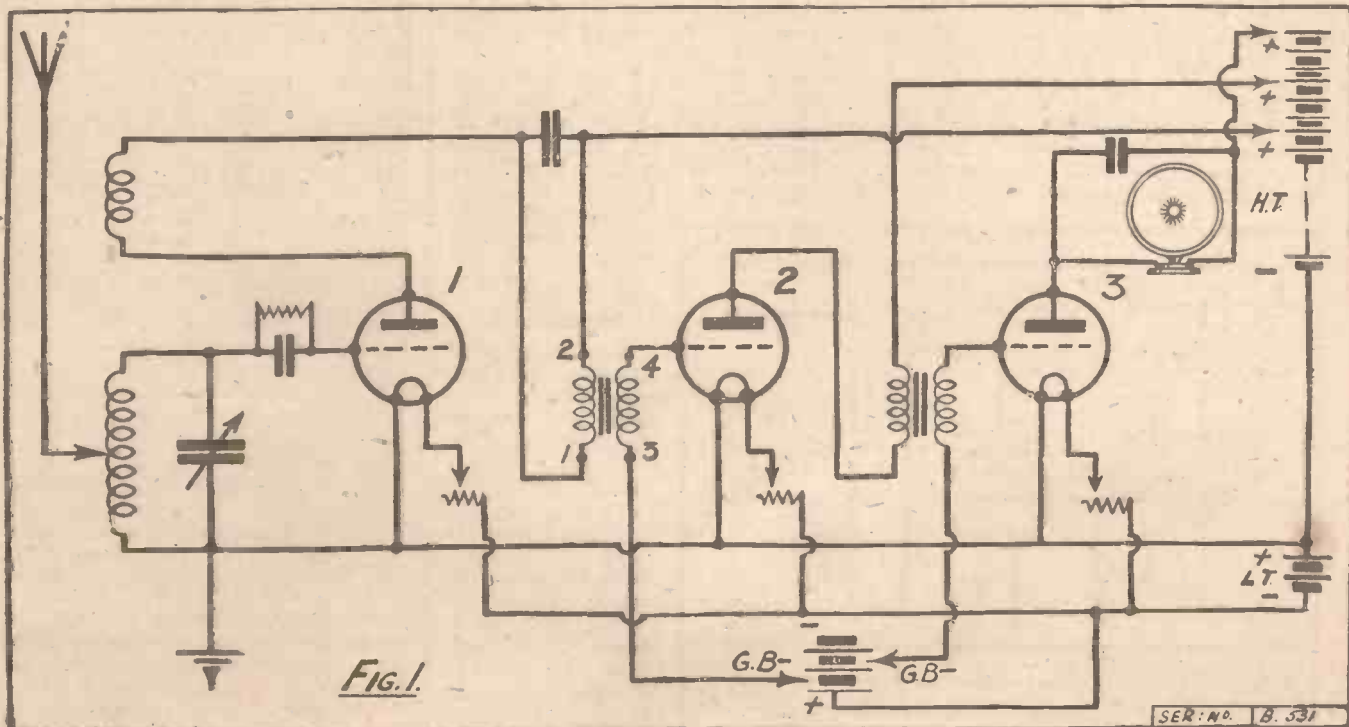

FIG. 1.

SER: No. B. 531

If you experience L.F. howling with a set using a circuit similar to this, the accompanying article will help you to eliminate the trouble.

## Hunting the L.F. Howl—continued

are above suspicion. Also I will presume that the components are efficiently laid out and that the transformers are not attempting to work in beauty side by side. The fact that the howling ceases when the last valve is

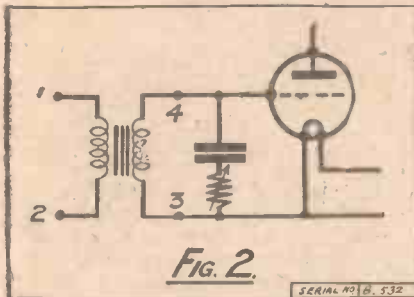

Fig. 2. A fixed condenser and a variable resistance placed across the transformer secondary.

cut out of circuit does not necessarily indicate that such components as this are proved innocent or even components that are not incorporated in the last stage.

### Microphonic Causes

The trouble might be due to oscillation of the L.F. valves. In an emergency this can sometimes be stopped by connecting that lead from the secondary winding of the first L.F. transformer which usually goes to the L.T. negative or to a grid bias plug to L.T. positive, thus giving the grid of the first amplifying valve a positive bias and increasing its effective resistance. This "cure" is not recommended, as it is inevitably accompanied by distortion. An alternative is to connect a variable anode resistance of a not too high value and a fixed condenser of about .002 mfd. capacity across the

secondary of the first transformer as shown diagrammatically in Fig. 2.

In order to render these various alterations perfectly clear, I have numbered the connections to the first transformer, and these numbers, which are also applied to a small pictorial diagram, Fig. 1a, are rigidly adhered to through all the diagrams accompanying this article.

Now, before we go any further, it should be remembered that the trouble might be due to, microphonic causes. Even though the loud-speaker is situated some distance away from the set and pretty good "anti-pong" valve holders are employed throughout, vibration can still be transmitted to the valves with sufficient intensity to cause serious "noises" if the valves are of a very microphonic nature. Badly assembled transformer laminations are capable of initiating the vibrations. Again, reflected sound waves from the loud-speaker impinging on the valves and producing a cumulative microphone effect must be guarded against by keeping the speaker in a suitable position.

Serious "howling" can sometimes be eliminated by reducing the H.T. very considerably on one or other of the amplifying valves, but if signals are strong, freedom from howling is merely gained at the expense of purity.

Reducing the L.T. has a similar result.

### A "Choke" Experiment

But the effect of altering the first stage to conform with the choke-coupling method is well worth trying. It is quite easy to do this, for the transformer can be used as a choke. Both its windings can be placed in series, or, as a quick experiment, just the primary winding alone can be employed. All that one has to do is to disconnect both leads from

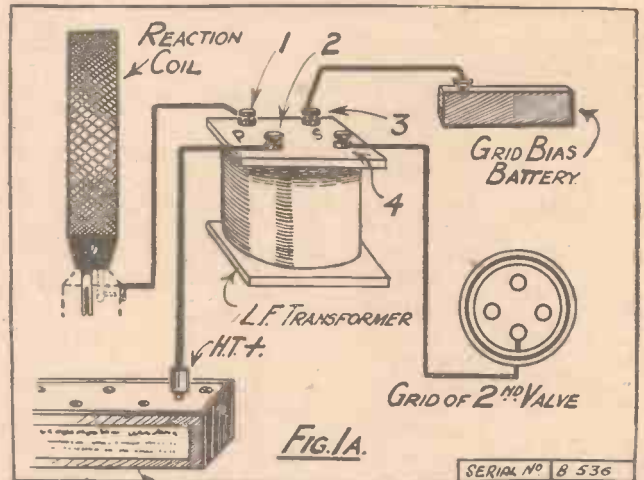

Fig. 1A. Showing pictorially the essential connections referred to in the text.

the secondary winding terminals, connect a  $\frac{1}{4}$  megohm resistance between the grid of the valve and L.T.—or grid bias negative and a fixed condenser of at least .002 mfd. capacity (preferably more) between the grid of the valve and the "plate" terminal of the transformer. See Fig. 3, where A is the fixed condenser and B the resistance that are added as described. It may be necessary to place a small fixed condenser of about .0002 mfd.

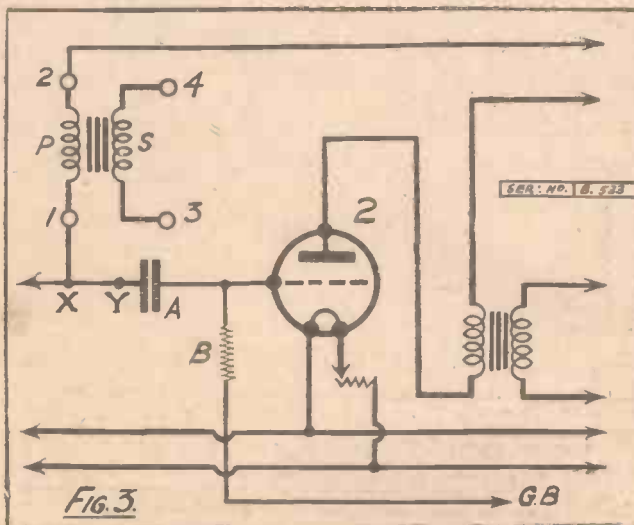

Fig. 3. How an L.F. transformer can be used to provide choke-capacity coupling.



Inserting a fixed condenser (1) and an L.F. choke (2) as per Fig. 5.

across the transformer primary if no condenser is already in that position. Also the addition of an H.F. choke between the points marked X and Y may improve results considerably.

It has been suggested that interaction caused by both stages of amplification and the detector using the

## Hunting the L.F. Howl—continued

same H.T. battery is often the cause of L.F. "howling." And, no doubt, this is frequently the case. Anyway, if a spare H.T. battery happens to be handy the effect of using this for either the detector or for the first L.F. valve can very quickly, in cases, be tested without upsetting any of the other battery connections, and with no alteration in the wiring of the set.

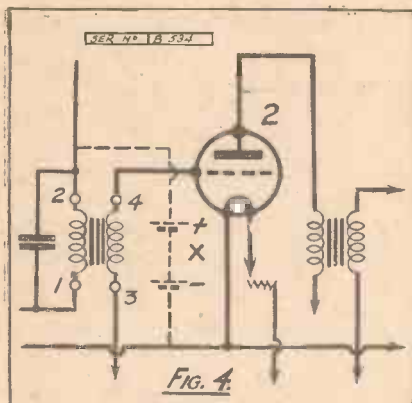

The dotted lines show how a separate H.T. battery (X) can be inserted.

For instance, supposing we want to use a separate H.T. battery for the detector stage in the circuit shown in Fig. 1. We connect the negative terminal of the battery to the positive L.T. terminal on the panel of the receiver (externally in the same way as all the other battery leads are connected). Then we remove the H.T. plus wander plug serving the detector stage from the existing H.T. battery

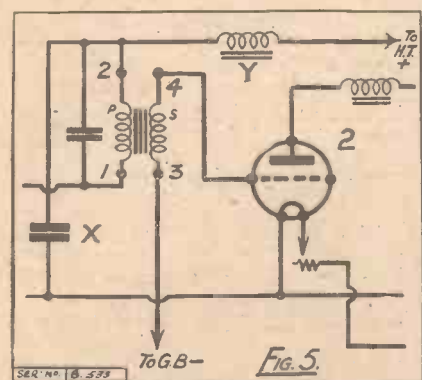

A choke-condenser H.T. by-pass system sometimes completely cures an L.F. howling trouble.

and plug it into the additional H.T. battery.

If a common H.T. plus terminal serves both the detector and the first L.F., or all three valves (very bad practice that!) then the connection between the primary of the transformer and the H.T. plus terminal must be removed and a flexible lead run from the transformer terminal to the H.T. plus

of the new battery. This arrangement is shown diagrammatically in Fig. 4, and it will be seen that the same scheme can be applied to the first amplifying stage.

If all else fails, there is one more suggestion that I would like to make. It involves a by-pass scheme and necessitates the use of an L.F. choke and a fixed condenser, in addition to everything else. It can be applied to any of the stages, although it is shown diagrammatically in Fig. 5 as applied to the detector. It might with greater advantage be applied to the first amplifier, but it is just as easy to do this, and constructors will see that the method is identical in both instances. I show the detector stage in order to retain uniformity.

### A Choke Condenser By-pass

The L.F. choke, which can be of any of the standard types, is introduced into the anode circuit of the detector in series with the primary of the L.F. transformer as at Y. A lead is connected between these two components which goes to one terminal of a 2 mfd. fixed condenser, the other terminal of this being connected to the common L.T. lead. And that is that! Thus the L.F. impulses are by-passed through the fixed condenser and the result is theoretically similar to that attained by the use of a separate H.T. battery.

In conclusion, just one word of warning. It is quite unnecessary to summon the fire brigade to extinguish



If two L.F. transformers are used they should be well separated and placed at right angles to each other as shown in the above photograph.

a cigarette end that is scorching the carpet. And so with our amplifier, again please remember that I have been addressing the owners of real "hard cases" and not those whose amplifiers are merely howling through lack of ordinary precautions.

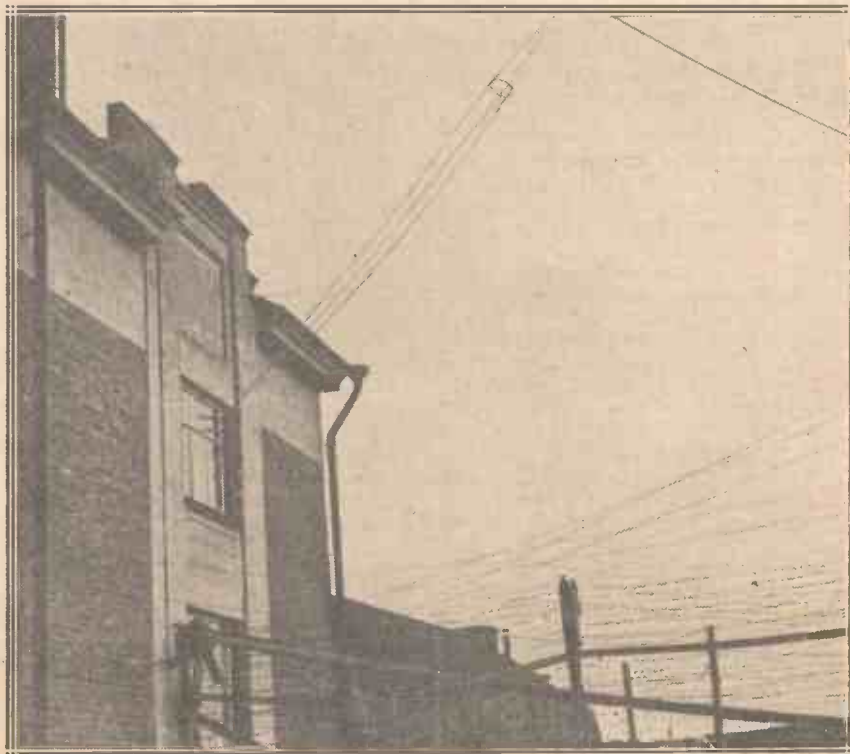

The aerial lead-in and the counterpoise at the Helsingfors (Finland) military wireless station which is used for broadcasting.

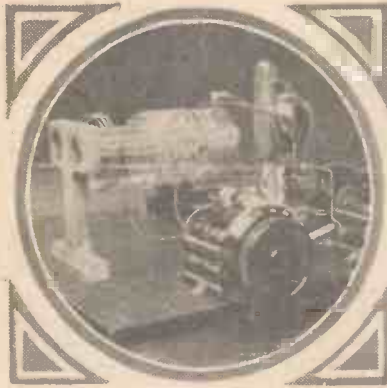

# The Editor's Chat

*NOTE: All communications, MSS., etc., for the Editor should be addressed, The Editor, "The Wireless Constructor," Fleetway House, Farringdon Street, London, E.C.4.*

READERS of THE WIRELESS CONSTRUCTOR will be interested to hear that this journal, together with *Modern Wireless* and *Wireless*, has been acquired from Radio Press, Ltd., by the Amalgamated Press, Ltd., on the retirement of Mr. John Scott-Taggart, F.Inst.P., A.M.I.E.E., from the publishing business. *Wireless*, as many of my readers will have noticed, has been incorporated with *Popular Wireless*, while *Modern Wireless* and THE WIRELESS CONSTRUCTOR will be continued as before.

The new proprietors have done me the honour of placing the editorship of THE WIRELESS CONSTRUCTOR in my hands, and thus, under new proprietors, I am able to resume the position from which I resigned in September last. The constructional supplement entitled "The Radio Constructor," which I have been conducting in the pages of *Popular Wireless*, will now be incorporated in THE WIRELESS CONSTRUCTOR.

## Some Outstanding Sets

With these few words of explanation let us look at the contents of this month's issue, in which I think you will find a full measure of interest from the growing circle of "home builders." "Samson—the Powerful Twin"—a name, by the way, which you will agree is fully justified once you have tried the set!—is a two-valve receiver, built around the remarkable "Hale" circuit which has brought about a revival of interest in valve and crystal combinations. Many readers have asked for a good loud-speaker set for indoor aerials, and here is one of astonishing efficiency. Even if you do not wish to build this set, try out the circuit experimentally. It is very fascinating.

All listeners are agreed upon the need for good alternative programmes, yet we are still without a practical scheme. At the same time, Daventry is often useful as an alternative to the local programme, particularly when the listener is within good range of this station. I have asked Mr. A. S. Clark—whose ingeniously made "Midget" sets have proved so popular with WIRELESS CONSTRUCTOR

readers—to describe this month a crystal receiver he has built upon rather novel lines. The idea of a "change-over" crystal receiver by which one can switch from the local station to Daventry is by no means new, but in the arrangements so far published the change-over by a switch is always accompanied by a readjustment of the tuning condenser. In Mr. Clark's set (really two crystal receivers in one) this defect is removed, each part of the set being tuned to the sta-



*Dr. Lee de Forest, the inventor, with his audio-amplifier, which is used in connection with the phono-film.*

tion for which it is designed, and each having its own crystal detector. Fortunately good class components are now obtainable at very reasonable prices, so that the cost of building this "dual" set is well within the reach of everyone.

## An Easy Change-Over

It might be called a lazy man's receiver, for if through a breakdown at the local station, the broadcasting of an item not exactly to our taste, or perhaps interference, we wish to

change over—a touch of the switch will give the alternative programme without any other adjustment. Even if one crystal detector should fail we need not trouble to reset it, as the second programme on a different detector is immediately available.

## Articles by Favourite Authors

Mr. L. H. Thomas, another regular contributor to our columns, is describing this month a three-valve receiver of the modern and highly efficient type which is doing so much to make listening to distant stations a regular, instead of an occasional, event. Helpful hints on building all of the sets described, and others yet to be published, will be found in the articles of "The Wireless Experimenter's Workshop," "Time Saving Tips," "Rheostat or Fixed Resistor?" and "Chats at the Worktable." Mr. R. W. Hallows, M.A., in an important interesting article, "Poachers on the Broadcast Band," provides definite facts and figures on the interference to which our broadcast programmes are now subjected; while Mr. G. P. Kendall, B.Sc., who, by the way, was Chief of the Technical Query Department of THE WIRELESS CONSTRUCTOR, will continue to give readers the benefit of his long experience. Next month he will describe "Note Magnifiers for All Purposes."

## Valuable Hints on H.F.

The newcomer to radio is often puzzled by the multiplicity of valves now available, and may wonder just why this or that type of valve is recommended in some particular circuit. Mr. J. H. Reyner, B.Sc., whose brilliant investigations are so well known to readers of THE WIRELESS CONSTRUCTOR, has written for us an important article on "The Truth About H.F. Valves," throwing a great deal of light on the problem of selection. A careful study of this article is recommended to every home constructor who desires to get the utmost from the apparatus he is building.

Slowly but surely we are approaching the time when every set-owner with electric light in his house will  
(Continued on page 360.)



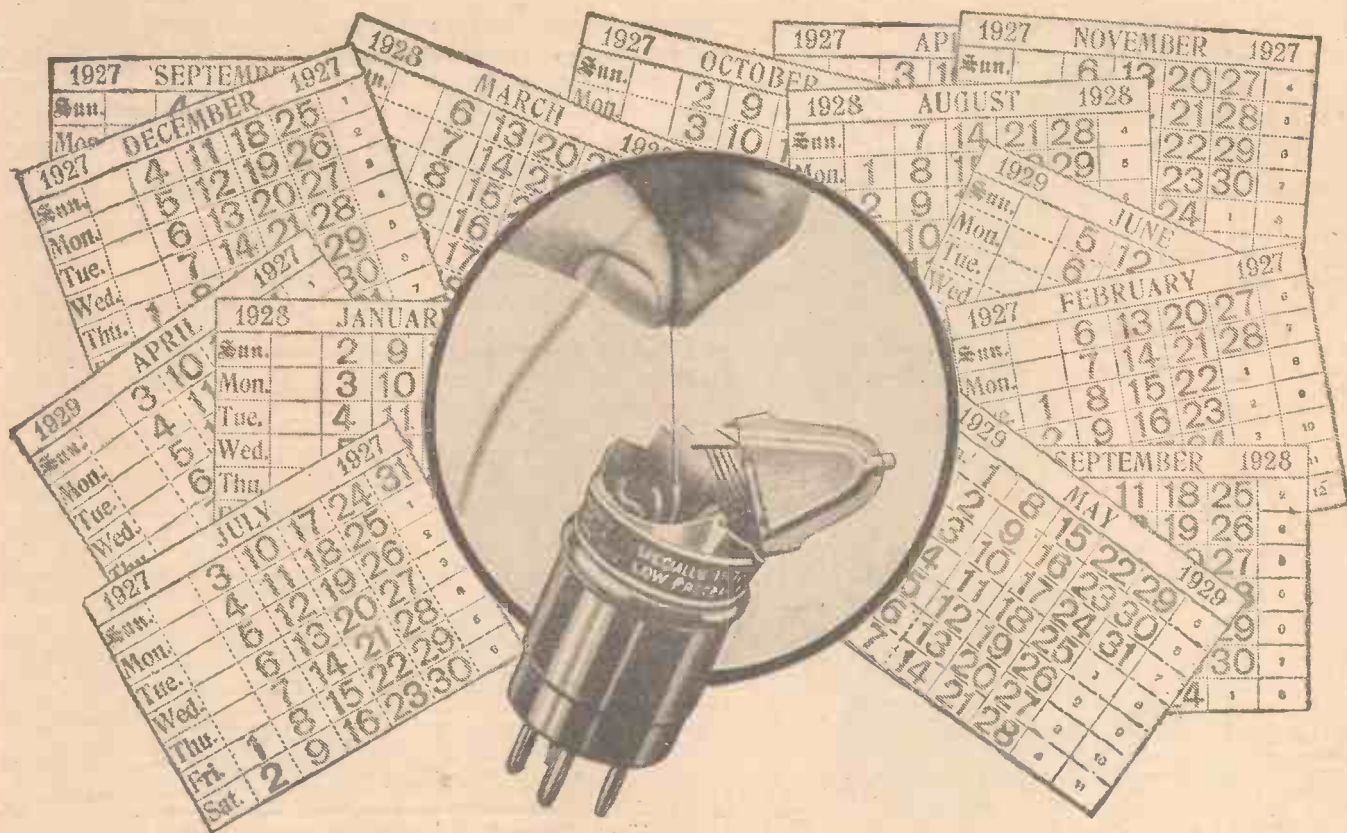

# 1927-1928-1929

—the Cossor Kalenised Filament sets new record for long life

**A**FTER an ordinary life test of 2,500 hours at 1.8 volts the Cossor Point One valve shown above was broken open and suspended by its filament. Even after this amazing test the Kalenised filament was still pliable and supple. There were no signs of brittleness. Indeed, the valve could have given satisfactory service for an even greater period. Based upon an average of 20 hours per week this is equivalent to 2½ years' regular use.

Never before in the history of valve making have such remarkable results been possible. Only the new Kalenised filament could have successfully withstood such a drastic test.

The reason is obvious. The Cossor Kalenised filament gives off a torrent of electrons practically without heat. Certainly no glow is visible when the valve is working. Heat is the destructive influence which sets up crystallisation in the ordinary filament. The molecules become displaced—a weak spot occurs—and, suddenly without warning, the filament fractures.

All this is now ended. The Cossor is the only valve to be fitted with the Kalenised filament. It is, indeed, the real long life valve. You, as a shrewd wireless enthusiast, will choose the valve which will last longest with the least consumption of current. That is why you will want the Cossor Point One—the 2-volt Dull Emitter taking only one-tenth of an ampere. 210D Detector and 210H H.F. Amplifier 14/- each. Stentor Two Power Valve 18/6. From all Dealers.

# Cossor

—the Valve which serves you longest



The "Cosmos" Rheostat.



The "Cosmos" Permacon.



The "Cosmos" Coupling Unit and spring valve holder.



Ask your dealer for these attractive folders on "Cosmos" Valves Sets and Components.

# Cosmos

## RADIO COMPONENTS

ensure reliable sets.

Constructors who desire smooth working and efficient sets use "Cosmos" Precision components.

The "Cosmos" Rheostat. The principal features of the "Cosmos" Filament Rheostat are its sturdy construction and reliable, smooth movement. The contact arm cannot easily be damaged, having its movement on the inner side of a porcelain bobbin which carries the windings. Other pleasing features of this Precision Rheostat are the handsome knob and dial, ONE HOLE fixing, and the small space it occupies.

Made in four types, two of which are double-wound for DULL or BRIGHT Valves and one a Potentiometer.

Description	Ohms	Current	Price
Single Wound	6.0	1.0 amp.	4s. 6d.
Double "	20	.4 "	5s. 0d.
" "	34	.2 "	5s. 0d.
Potentiometer	300	—	6s. 0d.

The "Cosmos" Permacon is an ideal fixed condenser, being light in weight, of guaranteed accurate capacity, and having the lowest possible losses.

The dielectric is mica, and each condenser is tested at 500 volts during inspection. Nickel-plated cases give them a particularly neat appearance.

.0001 mfd. .. .. .	1/6	.001 mfd. .. .. .	1/8
.0002 " .. .. .	1/6	.002 " .. .. .	1/10
.0005 " .. .. .	1/6	.005 " .. .. .	2/8
.0003 " (with clips for grid leak)	1/8	.01 " .. .. .	3/9

The "Cosmos" Resistance Coupling Unit. Real purity of reproduction can only be obtained with resistance capacity coupling. The "Cosmos" Coupling Unit with a suitable valve is as effective as an ordinary transformer-coupled stage. It avoids all distortion and effects considerable economies in first and operating costs. Designed primarily for use with the "Cosmos" S.P. Blue Spot Valves, it can be used successfully with any valve having an amplification factor of 30 or more. Special attention is directed to the following advantages of the "Cosmos" Coupling Unit:

- (1) It takes up little space in a set.
- (2) It is not liable to be broken.
- (3) It has permanent resistance values.
- (4) It allows for simplified wiring.
- (5) It is economical in L.T. current (S.P. Blue Spot Valves consume 0.09 amps).
- (6) It is economical in H.T. Battery consumption (less than 1/20 normal).

And lastly its use results in purity of reproduction without loss in volume.

Type "O," the Unit alone .. .. . 8/6.  
 Type "V," the Unit incorporating spring valve holder (as illustrated), 10/6.  
 Suitable valves for use with this unit are "Cosmos" S.P. 18/B at 14/-, and "Cosmos" S.P. 55/B at 18/6.

## Metro-Vick Supplies Ltd.

(Proprietors: Metropolitan-Vickers Electrical Co., Ltd.),  
 METRO-VICK HOUSE,  
 155, CHARING CROSS ROAD, LONDON, W.C.2

The receiver designed,  
constructed  
and described for  
"The Wireless Constructor"

By  
L. H. THOMAS

## A SIMPLE THREE-VALVER

*Ease of operation is the keynote of this useful and inexpensive set. It incorporates one stage of neutralised H.F., a screened aerial coil and transformer being used, followed by a detector, with Reinartz reaction, and a transformer-coupled L.F. amplifier.*

IT has for some time been the ambition of the writer to produce a receiver comprising a stage of H.F. amplification, a detector valve, and a note magnifier, the ease of operation of which would bear comparison with that of a "straight" detector and two note magnifiers. The set with one H.F. stage would have much in common with the other as far as performance was concerned, but would, of course, be considerably more selective, and therefore more suitable for those living within short distances of main stations.

### The Reaction Control

The receiver described in this article incorporates one stage of neutralised H.F. amplification, a screened aerial coil and transformer being used; this is followed by a detector with reaction on the Reinartz principle, and a transformer-coupled L.F. amplifier.

There are only two main controls, and a reaction control which is of the "set-and-forget" type, so that tuning becomes a matter of setting the two dials to the same reading.

The screened coils have a double purpose—they minimise the "direct pick-up" of the local station that too often goes on in a receiver of the usual type, and they have the great advantage that interaction between the two tuned circuits, with consequent loss of energy, is to a great extent avoided. Selectivity is, therefore, greatly improved by the screening of the tuned circuits, since the received energy has, practically speaking, no alternative but to pass through the various filter circuits prepared for it.

As the first tests of this receiver were carried out on an aerial less than five miles from 2LO, a few words on its capabilities will probably not be out of place.

### Results

2LO is, of course, received at rather more than comfortable loud-speaker strength, yet a rotation of either dial over 4 deg. will reduce him to inaudibility. If the two dials are rotated simultaneously and in the same direction a 2-3-deg. movement will cut out 2LO. As far as reception of other stations is concerned, it will probably be sufficient to say that 22 stations have been clearly received on the loud-speaker, and a further 12 when head-

phones have been in use. The "star turns" on the loud-speaker were Hamburg, Madrid, Bournemouth and Cassel. Toulouse was also very well received at times, but appeared to be extremely irregular and unreliable.

The front of panel layout, as shown in Fig. 3, is extremely simple, and will present no difficulty to the would-

be constructor. The two main condensers tune the aerial circuit and the secondary of the H.F. transformer, and their settings are almost identical, as will be explained later. The upper of the two knobs in the centre of the panel is the small neutralising condenser used as a reaction control, and below this is the filament switch. On the right is the loud-speaker jack.

Referring to Fig. 2, the back-of-panel diagram, and the photographs, the neutralising condenser affixed to the baseboard towards the centre is used in the ordinary manner, correct stabilisation of the H.F. valve being

accomplished by means of this and the special neutralising winding incorporated in the screened transformer. This condenser should not be confused with that mounted on the panel, which is purely a reaction control.

The valves are controlled by "Amperites," since present-day valves vary very little in their characteristics, and should seldom require individual filament control.

### Preliminary Details

The most satisfactory method of constructing this receiver is first of all to assemble all the panel components upon the panel. The baseboard components should then be placed in their appropriate positions, and the panel affixed to the baseboard by the right-angled brackets. The connections to the switch, the neutralising condenser proper (N.C.1), and the jack should be made before others, or they will be found difficult to get at. After this the wiring is quite straightforward and no special order need be observed.

The actual components used by the writer are listed as a guide to those who wish to make their receiver an exact replica of that seen in the photographs.

The actual wiring should be quite clear from the photographs, although



The controls are few and accessible and the panel layout is symmetrical.

### COMPONENTS REQUIRED

- One panel, 21 in. by 7 in. by 3/16 in. (American Hard Rubber Co.).
- One cabinet and baseboard for above, 7 in. deep (Carrington Manufacturing Co.).
- One pair right-angled brackets.
- Two .0005 straight-line frequency condensers (Ormond Engineering Ltd.).
- Two slow motion dials. (Ormond Engineering, Ltd.).
- One aerial coil and one split-primary H.F. transformer, with screens and bases (Burne-Jones & Co.).
- Three Clearer-Tone valve-holders (Benjamin Electric).
- Two neutralising condensers (L. McMichael, Ltd.).
- Three Amperites, Type 1A, and one Frost toggle switch (Rothermel Radio Corporation).
- One L.F. transformer, 5.1 ratio. (Igranic Electric, Ltd.).
- One H.F. choke. (Metro-Vick Supplies, Ltd.).
- One .0003 condenser and one 2-megohm leak. (Dubilier Condenser Co.).
- One single-circuit open jack (General Radio Co.).
- One seven-terminal strip and one two-terminal strip.
- Glazite or tinned wire for wiring, brass screws, bolts, etc.

## A Simple Three-Valver—continued

it is not strictly necessary to place the components in the exact manner in which they were spaced out in the original set.

The screened coils lend themselves to a layout which gives extremely short grid and anode leads, a very desirable feature. The figures against the various points of the coils in the circuit diagram correspond with those on the coil bases. These figures are also seen in the back-of-panel diagram.

### Testing Valve Connections

It will be noticed that the reaction condenser C2 has neither set of plates at earth potential, since the "Reinartz" system is used. No capacity effects are noticed, however, if the metal screen provided with the condenser is earthed. Both condenser screens have been connected to the L.T. lead.

Having completed the receiver, the reader would be well advised to check the wiring carefully before inserting the valves in their sockets. About 6 volts should be connected across each pair of H.T. terminals (i.e., across H.T. - and H.T. + 1, and then across H.T. - and H.T. + 2), and the valves then inserted. If no glow of any kind is visible, it will be safe to connect up the correct values of high tension. If valves of the type that do not show a visible glow are used, it will be as well to connect up the full high-tension voltages *without* placing the valves in their sockets, and to take readings with a voltmeter across the filament terminals.

If all is in order, the first tests may now be carried out. Suitable valves for use are as follows:—H.F.: D.E.5b type (D.F.A.4, etc.). Detector: D.E.5b or D.E.5 (or D.F.A.4 or

D.F.A.1). L.F.: D.E.5 or D.F.A.1. Similar 2-volt valves may, of course, be used, but the writer has a preference for the 6-volt type.

Two H.T. voltages are provided for, the detector and H.F. amplifier working on the same voltage, and the note magnifier being wired separately. In the case of the original receiver, 45 volts were used for the detector and H.F. valves, and 90-120 volts for the

The 'phones may now be plugged in, and the filaments switched on. The local station should be easily found by rotating the two main dials simultaneously, keeping them as nearly "in step" with one another as possible. The reaction condenser (N.C.2) should be in its minimum position during these first searching operations.

The H.F. valve should now be cor-

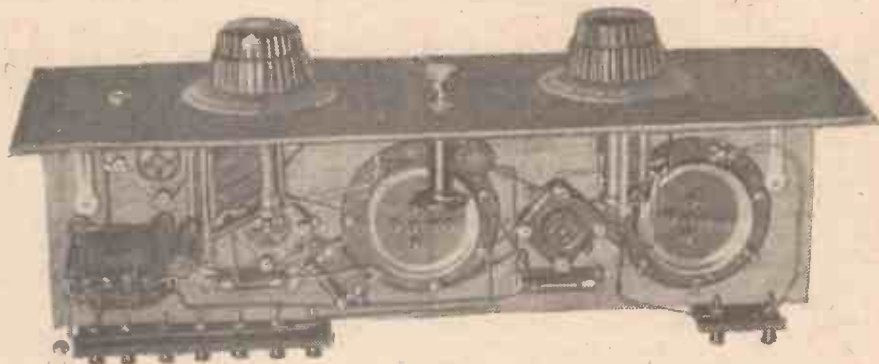

This photograph will assist the constructor when mounting the components.

L.F. With 120 volts on the anode of the last valve, about  $7\frac{1}{2}$  volts negative bias was required. A 9-volt grid-bias battery will certainly be sufficient to meet all needs.

### Neutralising

The aerial should at first be connected by means of a flex lead to terminal "4" on the coil. If, however, it is a particularly long aerial, terminal "3" will probably give better results as far as selectivity is concerned. The earth lead is, of course, always connected to its appropriate terminal, which is connected to the negative side of the L.T. battery.

rectly neutralised by the following method:—Tune in the local station accurately; then remove the "Amperite" controlling the H.F. valve from its holder—*do not* remove the valve. Now gradually increase the capacity of the neutralising condenser on the baseboard (N.C.1), until the local station is no longer heard. When this point is reached, the capacity of the H.F. valve will be accurately balanced out. Now give the condenser a *small* fraction of a turn further, so that the capacity will be rather more than sufficient for correct neutralisation. This will be found the best point for searching for more distant signals.

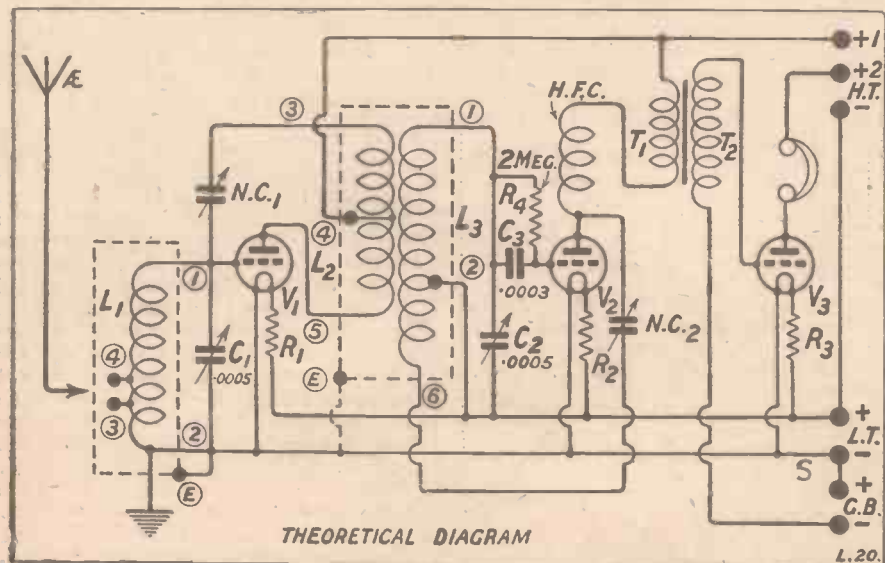

Fig. 1.—The circuit incorporates a neutralised H.F. stage and the Reinartz form of reaction control. The position of the filament switch is indicated by the letter S.

### The Aerial Connections

At this stage it will probably be as well to rotate the two main controls slightly (with the filament of the H.F. valve still out) to make quite sure that neutralisation is effective. Now replace the "Amperite," and tune in the local station once more. Note the settings of the two condenser dials. If that of the aerial condenser is higher than that of the other, and the aerial is connected to terminal "3," transfer it to terminal "4." If, on the other hand, it is connected to "4," and the reading seems low, transfer it to "3." In any case there should not be more than 2 or 3 deg. difference between the settings of the two dials.

If the setting of the neutralising condenser has been arranged according to the directions given, the circuit should now be perfectly stable over the whole range of the tuning. Starting with the local station, rotate the dials

Guaranteed for 12 months.

Turns ratio 3 to 1.  
Resistance ratio 4 to 1.  
Use it for 1, 2, or 3 stages L.F.  
It is suitable for all circuits and all valves you will want to use.

8/6



## PERFORMANCE WINS!

**C**URVES, curves, curves, and talk, talk talk about a transformer, curves and claims and claims and curves—all mean nothing against performance under actual working conditions :

AND WHO ELSE BUT LISSEN HAS THE COURAGE TO GIVE YOU A 7-DAY TRIAL OF A TRANSFORMER WHICH HAS REVOLUTIONIZED ALL PREVIOUS IDEAS OF PERFORMANCE AND PRICE ?

Who else but LISSEN has removed the last obstacle of price which stood in the way of the widespread use of loud speakers and powerful amplification ?

Who else but LISSEN NOW GIVES YOU SUCH A TRANSFORMER AT SUCH A PRICE WHICH AMPLIFIES EVERY TONE, EVERY HARMONIC, EVERY OVERTONE ?

Never again be ill-advised enough to pay a high price for a transformer—LISSEN has unhesitatingly withdrawn all their own expensive transformers which have been on the market and largely sold for several years past, IN FAVOUR OF THIS NEW LISSEN—A BETTER TRANSFORMER THAN ANY THAT HAVE BEEN BEFORE.

### 7 DAYS' TEST OFFER

If within 7 days of purchase you can find a better transformer at any price, take the LISSEN back to your dealers and get your money back.

Obtainable at any dealers, or direct from factory. If any difficulty post free, but please mention dealer's name and address.

This new LISSEN will replace any transformer mentioned or used in any circuit. Choose your own transformer and your own parts. Remember there are many advertising manufacturers and that they all expect their products to be mentioned in any circuit published in any periodical. You gain in performance and in economy if you choose your own transformer and other LISSEN parts, for LISSEN now gives you keen prices as well as LISSEN quality—remember the 7 days' test offer.

# NEW POWER SMOOTHNESS

—your loud speaker needs this Lissen Battery.

**B**BETTER energy and more energy is put into this Lissen battery than into any other battery its size. This is done by means of an unique new process making use of a combination of chemicals discovered by us and not hitherto used in battery making. This energy stays therefore providing your loud speaker with an abundant supply to work on. Not only that—you get a new power smoothness which improves your loud speaker reproduction, making it clearer and more powerful over a much longer time than before.

This Lissen Battery shows a stubborn resistance to volt drop—it is splendidly efficient. Naturally the unique new process is closely guarded and its success is now an established fact.

Yet another supreme advantage—every Lissen battery is absolutely fresh and brimful of new energy when you put it into your set. Rated at 60 volt but goes considerably over.

10/6

(Price would have been 13/- but for new policy.)



**IMPORTANT TO THE TRADE.**  
Retailers who have not already been notified should write at once for details of the new LISSEN direct-from-factory-to-dealer-policy of distribution — all orders for LISSEN products must now be sent direct to us at Richmond, not to usual factors.

Hear your LISSENOLA working off this battery to know what a good loud speaker and a good battery can do together.

**LISSEN LIMITED, 26-30, Friars Lane, Richmond, Surrey.**

Managing Director : Thomas N. Cole.



*"Sou-west by West —  
a Quarter West!"*

**S**ETTING the course of a ship so that she takes the most economic route to port calls for great skill and long experience.

Making up for errors in navigation is costly in fuel, and a missed tide may cost thousands.

Wherefore the navigator makes every possible allowance for stray currents, varying magnetic fields, and any factor which may affect his calculations and send the ship off her course.

The design and manufacture of condensers for wireless sets also calls for great skill and long experience. Condensers which are faulty in design or construction are constantly drawing upon your valves and batteries to make up for their deficiencies, even if they do not cause you to miss the programme.

Wherefore we make every possible allowance to ensure that Dubilier Condensers, under the conditions of high frequency and high voltage obtaining in wireless circuits, shall be as efficient as our 16 years' specialised experience can make them.

Your wise course is to specify "Dubilier."

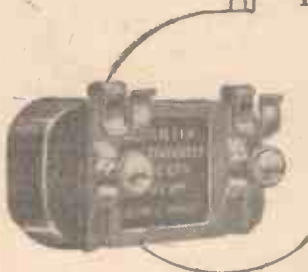

ADVT. OF THE DUBILIER CONDENSER CO. (1925), LTD.,  
DUCON WORKS, VICTORIA ROAD, NORTH ACTON, W.3

## A Simple Three-Valver—continued

slowly, keeping a look-out for the slight "hiss" that is evidence that the circuits are correctly in tune. If the controls are only moved a little at a time there will be no difficulty in keeping this slight rushing noise as a guide.

Stations should now be heard at various settings of the dials, but it is important to note that they will not be heard unless both the dials are correctly set.

### On Test

If the adjustments of the set have now been thoroughly mastered, the reaction condenser may be brought into use as follows:—Set the dials so that the circuits are in tune (as shown by the rushing sound), but preferably so that no station is tuned in. Then increase the setting of the reaction condenser (N.C.2) very gradually, until the set is heard to go into oscillation with a very slight click, or even a hiss. Then reduce the capacity slightly, so that the set is just below the oscillation point. It should now be in its most sensitive condition for searching.

On the first trial of the receiver in this condition it is advisable to be ready to reduce the capacity of the reaction condenser quickly, should the set burst

over the whole range of the tuning. If the receiver oscillates feebly, say, at the bottom of the dials, no serious loss in strength upon the higher



A back-of-panel photograph which shows the wiring, and the general disposition of the components.

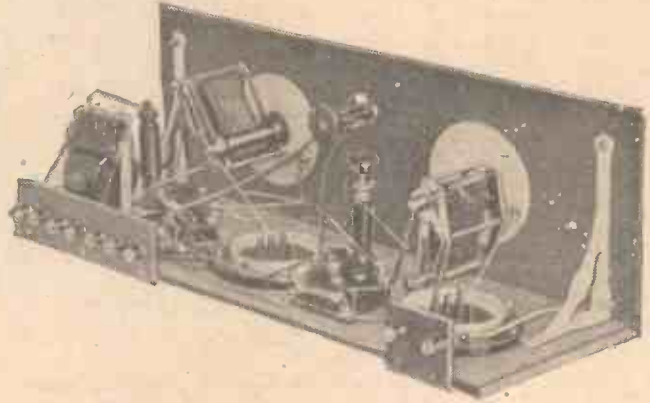

into oscillation at any point on the dials.

The original set, however, was capable of being set so that the reaction control did not need to be touched

settings will result if the reaction condenser setting is decreased slightly, and the great advantage of being able to leave this control alone will certainly be appreciated.

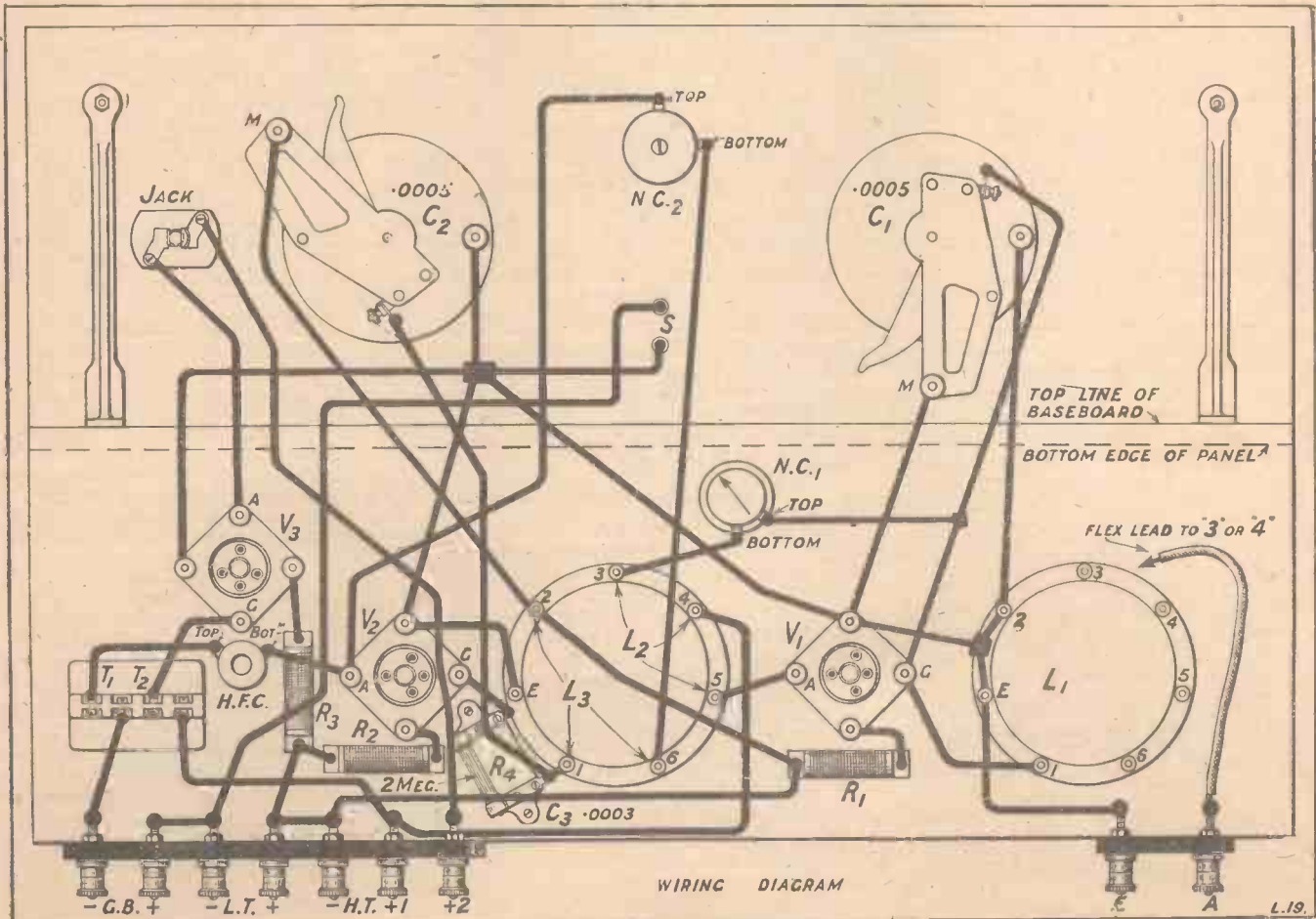
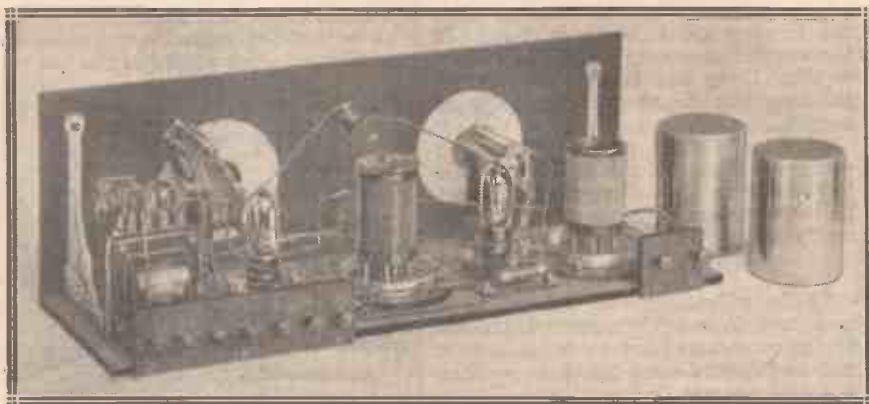

Fig. 2.—This wiring diagram is made very clear by the insertion of the letters and numbers, which are shown on the theoretical diagram.

## A Simple Three-Valver—concluded

The chief thing to remember is that the best results will be obtained, not when the receiver is just on the oscillation point, but when it is just far enough below this point to be in a perfectly stable condition.

The following is a list of the stations received on two evenings between the hours of 6 p.m. and 9.30 p.m. Since straight-line frequency condensers are used, the European stations are almost perfectly evenly spread out over the dials. There is a station at about every eighth degree over the whole scale:—Stettin, Elberfeld (L.S.), Cassel (L.S.), Toulouse, Brussels, Hamburg (L.S.), Madrid (L.S.), Aberdeen, Swansea, Belfast, Manchester, Dublin, Bournemouth (L.S.), Plymouth, San Sebastian, Munster, Birmingham, Cardiff, Barcelona, Bradford, London (L.S.), Newcastle.



Another back-of-panel photograph, taken from a different angle.

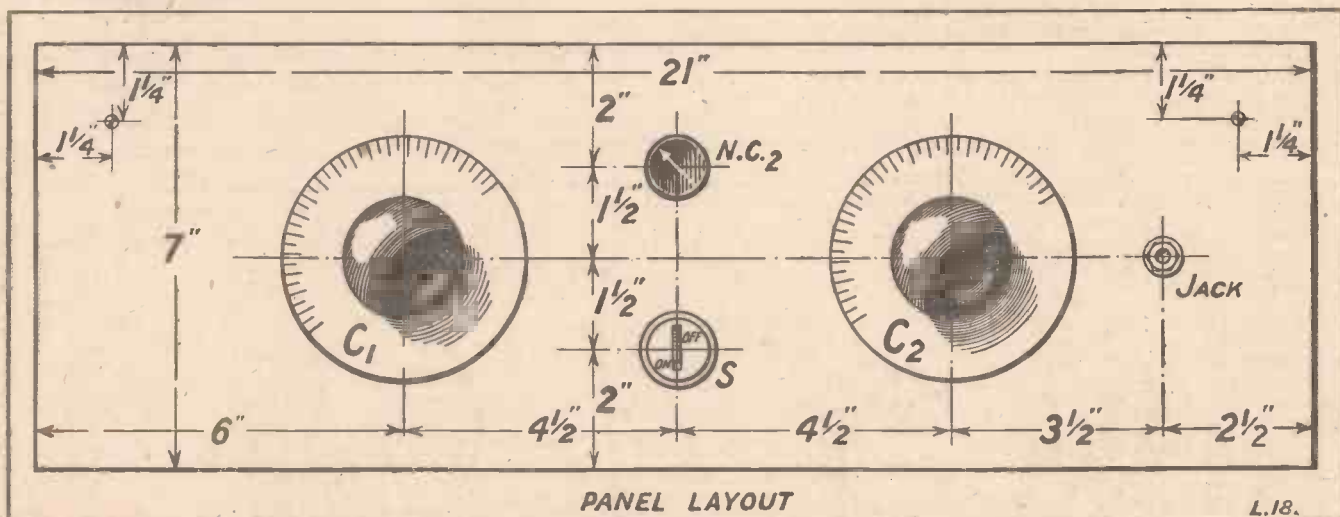

Fig. 3.—The panel drilling is quite straightforward as this diagram shows.

- A SIMPLE THREE-VALVER.**  
CHECK YOUR WIRING BY THIS LIST OF CONNECTIONS.
- Aerial flex lead to 3 or 4 on L1. 2 on L1 to E on L1, to earth terminal, to earth-plate of C1, to one filament connection on V1, to moving vanes of C1, to one side of filament switch, to one filament connection on V2 and V3, to earth-plate of C2, and to E on L3.
  - Other side of filament switch to L.T.— and G.B. +
  - L.T. + to HT —, to one side of R1, R2, and R3, to 2 on L3, and to moving vanes of C2.
  - Other side of R1 to remaining filament socket of V1.
  - Other side of R2 to remaining filament socket of V2.
  - Other side of R3 to remaining filament socket of V3.
  - 1 of L1 to G of V1, to top of NC1, and to fixed vanes of C1.
  - Bottom of NC1 to 3 of L2.
  - 5 of L2 to A of V1.
  - 4 of L2 to HT + 1, and OP of LF transformer.
  - 6 of L3 to bottom of NC2.
  - Top of NC2 to A of V2, and to bottom of HFC.
  - 1 of L3 to one side of R4, to one side of C3, and to fixed vanes of C2.
  - Other sides of R4 and C3 to G of V2.
  - Top of HFC to 1P of LF transformer, 1S of LF transformer to GB—, OS of LF transformer to G of V3.
  - A of V3 to one side of phone-jack.
  - Other side of jack to HT + 2.

\* \* \* \* \*

### TWO HINTS

\* \* \* \* \*

**H**AVE you realised how much a smart dial improves the appearance of your set? Many home users are not aware of the fact that dials can be purchased separately from condensers themselves in a variety of patterns and in several sizes. Save in the case of those special condensers having dials which are virtually a part of the condenser themselves, the work of removing the old and fitting a new dial takes only a few moments. Examine the knob and you will find a small screw at right angles to the main shaft of the condenser, which, when released, will enable the dial to be lifted off the shaft.

New dials of either the plain or vernier type are sold by every wireless dealer. If you purchase one of the plain type I would recommend a 4-inch

in place of the older 3-inch, and with a large knob.

Whenever you purchase a new dial, make sure before setting out for the shop that you ascertain the diameter of your condenser spindle. Some condensers are made with 1/4-inch shaft and others with 3/16-inch shaft.

**“WILL** it pay me to use bright emitter valves in my set, as they are so much cheaper than the dull emitter kind?” asks a reader in South London. He mentions that he has bought a three-valve set and has a 4-volt accumulator. I would strongly recommend him to buy dull emitter valves, for the additional cost of the valves should not be more than eighteen shillings for the three, while his accumulator will last six or seven times as long without charging, using the dull emitter type, provided he chooses an economical kind. The difference in cost between the two kinds of valves will be saved during the year, owing to the fewer charges necessary.



# THINK THIS OUT—

*your judgment will improve your set and save you money.*

WHEN you see Radio parts mentioned in any circuit or receiver built up for publication in any radio journal it does not follow that the best parts have always necessarily been used for that circuit, because naturally advertisers expect a share in that kind of mention and **USUALLY GET IT.**

Always remind yourself of that when building. Remember, too, that you are free to choose your own parts, and should do so if you can benefit. **HOW TO GAIN, AND GAIN**

**CONSIDERABLY**—let LISSEN parts predominate in your receiver. You gain in clarity of signals and in wealth of volume, you gain in money saved. Before you buy any radio part ask yourself "Can I get it in the LISSEN range?" If you can, then insist upon seeing the LISSEN part side by side with anything else mentioned, and you will buy LISSEN, for your own judgment will then convince you that LISSEN is pre-eminent in the making of fine parts for radio.

**FOR AN AMPLIFIER—**  
 1 LISSEN Transformer, 8/6,  
 1 LISSEN Wire Rheostat 2/6,  
 1 LISSEN Fixed Condenser, 1/-,  
 1 LISSEN Valve Holder 1/-; you can see it is not dear, and **IT IS CERTAIN IN PERFORMANCE.**

## ON FIXED CONDENSERS.



You gain in this way if you use a LISSEN—you get a condenser accurate to 5% of its marked capacity, and a condenser which will never leak, never vary. You get, too, a condenser which **LESS THAN A YEAR**

**AGO WAS BEING SOLD AT TWICE ITS PRESENT PRICE—AND NOW YOU ACTUALLY GET A BETTER CONDENSER, TOO, THE FINEST FIXED CONDENSER THAT IS MADE TO-DAY.**

LISSEN Fixed Mica Condensers:—.0001 to .001, 1/- each (much reduced). .002 to .006, 1/6 each (much reduced). (Every grid condenser has a pair of clips included free.) Note the new improved case which enables the LISSEN condenser to be fitted upright or used flat. Note the convenient grid leak fixing.

**Add 10 percent. to the life of your H.T. Battery**



Put a LISSEN 2 mfd. condenser across it (1 mfd. will do, but the larger size is better). Your H.T. battery will then **GROW OLD WITHOUT YOUR KNOWING IT.** Your dealer will tell you how easily to fit.

LISSEN (Mansbridge type) Condensers:—  
 2 mfd., 4/8. 1 mfd., 3/10.  
 Other capacities are:—

.01	...	...	2/4
.05	...	...	2/4
.25	...	...	3/-
.025	...	...	2/4
.1	...	...	2/6
.5	...	...	3/4

**YOU PAY NO MORE FOR A LISSEN, YET GET A BETTER CONDENSER.**

To a fine quality condenser has been added a specially moulded case, which, itself a solid insulator, gives you much needed protection when you use big capacity condensers for eliminator circuits. The LISSEN condenser cannot short circuit on to its case—that is an important advantage which is exclusive to this LISSEN condenser.

## SILENT GRID LEAKS.

Never a sound do they make in use, for they never alter. This has been proved by the drastic step of testing them by exposure to rain and sun on our factory roof—once made, **THEY ARE FIXED IN THEIR RESISTANCE VALUE.** All resistances one price—Previously 1/8. NOW 1/-.

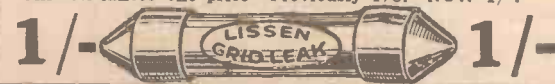

**BUILD WITH ALL LISSEN PARTS**—and your receiver will yield clearer and louder signals than ever you can get with parts of assorted make, because every LISSEN part will pull strongly with the other.

**LISSEN PARTS—WELL THOUGHT OUT, THEN WELL MADE.**

**LISSEN LIMITED, 26-30, FRIARS LANE, RICHMOND, SURREY.**

Managing Director: THOMAS N. COLE.

L 171.

## NEAT SWITCHES, EFFICIENT SWITCHES.

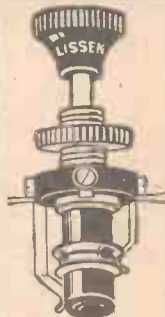

LISSEN 2-way switch.

LISSEN switches, one for every switching use in radio. Every one LISSEN **ONE-HOLE FIXING, OF COURSE.**

Previously. NOW

LISSEN 2-way	2/9	1/6
Series-Parallel	3/9	2/6
Double Pole		
Double Throw	4/-	2/6
Key Switch	2/6	1/6



LISSEN Key Switch.

## Quality RHEOSTATS—previously 4/- NOW 2/6.

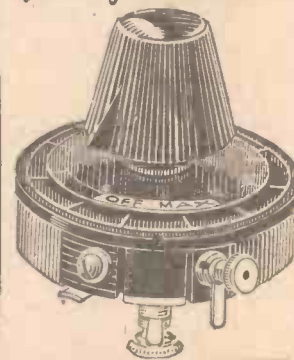

Made as LISSEN only can make—LISSEN quality, and note the irresistible appeal of the price.

Previously. NOW

LISSEN 7 ohms, patented	4/-	2/6
LISSEN 35 ohms, patented	4/-	2/6
LISSEN Dual, patented	6/-	4/6
LISSEN Potentiometer, patented, 400 ohms	4/8	2/6

**LISSEN ONE-HOLE FIXING, OF COURSE.** Baseboard mounting type same prices as above.

## SCOOPED OUT TO YIELD CLEARER AND BETTER SIGNALS—



Low capacity, low loss, therefore stronger, clearer signals. You cannot get a good valve holder less than LISSEN sell this one for. Patented. Shown ready for baseboard mounting, can also be used for panel mounting by bending springs straight. Previously 1/8. NOW 1/-.

**IMPORTANT TO THE TRADE.**—Retailers who have not already been notified of our new direct-to-dealer policy of distribution should, in their own interests, communicate with us without delay. All orders must now be sent direct to us at Richmond, and not to usual factors.

# No. 1 of a GREAT NEW WIRELESS JOURNAL



## HAS ELSTREE DIED ?

YOU know what Elstree has done ; how its sets have won championships and prizes at Amsterdam, New York and Chicago. The Radio Press periodicals have now come under new proprietorship, but Elstree remains as it was. You can still read of its activities, because very shortly a new journal is being issued, entitled :

## The "Elstree Radio News"

The Elstree Laboratories, with John Scott-Taggart, F.Inst.P., A.M.I.E.E., once more in charge, will publish star set designs and research articles. But you won't be able to buy the "Elstree News" on the bookstall. You can get free a full year's subscription to this magnificent new journal by simply buying an S.T. valve of any type and sending your name and address, together with the test certificate cut from the cardboard box in which every S.T. valve is packed. Send this coupon (or your name, etc., on a separate sheet) with the test certificate, carefully addressed to: "Elstree Radio News," c/o, S.T., Ltd., 2, Melbourne Place, London, W.C.2.

S.T., LTD.,  
2, MELBOURNE PLACE, LONDON, W.C.2.

Dear Sirs,—

Please put me down for a year's FREE subscription to "Elstree Radio News." I enclose test certificate cut from one of your valve boxes.

Name .....

Address .....

[Write in block capital letters.]



FOR some years past the wireless listener and experimenter has struggled along in the face of difficulties with his high-tension and low-tension batteries constantly requiring attention or renewal. The advent of the dull-emitter valve has done a great deal to reduce the cost and trouble of maintaining the low-tension battery. At the same time, high-tension batteries have been considerably improved, and the dry H.T. battery of to-day is as different from that of three or four years ago as chalk from cheese.

But the fact remains that, even with the dulllest of dull-emitters, the filaments still require current, and with the most efficient of circuits the high-tension battery is called upon to perform a heavy duty. In fact, whilst improvements in circuits and in valves have resulted largely in the reduction of the filament current, they have at the same time tended rather in the opposite direction with the anode current, and a modern multi-valve set may impose a load of as much as 20 or 30 milliamperes upon the high-tension battery.

### Replacing the Batteries

With the trend of development and improvement, it was, therefore, inevitable that the principal item in the upkeep and maintenance of the wireless receiver should be the object of special attention. The course of radio development during the past two years, and particularly during the past twelve months, has been especi-

ally associated with the introduction of various devices either for charging and maintaining the high-tension and low-tension batteries, or for replacing them altogether. Battery chargers, of course, have been well known since long before wireless broadcasting, but, at the same time, rapid advances and marked improvements have been made in devices of this kind during the last year or two.

The devices referred to above, which have as their object, not the charging of the high-tension and low-tension batteries, but the replacement of such batteries altogether, are now generally known as high-tension "eliminators," or low-tension "eliminators," as the case may be. The word "eliminator" speaks for itself, and appears to be a term introduced first in the United States, where the state of radio progress is usually six to twelve months ahead of that in England.

### The Need for Rectifying

In designing a battery eliminator, one of the first points to consider is whether it is to be used on alternating

#### FROM THE EDITOR.

Dr. J. H. T. Roberts, F.Inst.P., who writes so interestingly on rectifiers in this article, has had a wide experience in many branches of science, and in view of the overlapping of chemistry, physics, and electricity in the art of wireless, I have asked Dr. Roberts to accept the position of Scientific Consultant to "The Wireless Constructor." I am glad to say he has consented.

current supply or on direct current supply. I suppose it is hardly necessary to say that the eliminator draws its supply from the electric light mains, and converts it into a form suitable for use in the L.T. or H.T.

parts of the circuit. Since the current for the valve must be of the d.c. variety, it will be necessary, in the case of alternating current electric supply mains, to introduce some form of rectifier—that is to say, a device which will allow current to pass in one direction only.

A.C. current applied to a rectifier will give direct current on the other side of the rectifier, so that from this point onwards the problem becomes pretty much the same with rectified a.c. as it does with d.c. taken straight from the supply.

### Smoothing Devices

But in either case the current is not sufficiently smooth for direct application to the wireless set. In the case of d.c. there will be the well-known commutator ripple or other irregularities, and in the case of the a.c., even after rectification, the current, although not alternating, will be intermittent, and will produce in the set a loud hum, commonly known as "a.c. hum."

It is necessary, therefore, both in the case of direct current from the mains and in the case of rectified alternating current from the mains, to use some form of smoothing device in order to get rid of these irregularities in the character of the current supply. The smoothing devices employed consist almost invariably of choke coils and condensers, the choke coils being inserted in series with the supply, and the condensers (of large capacity) being connected across the supply leads at various points.

In this article, however, I wanted more particularly to deal with the types of rectifier which are available for use with an eliminator to be used on a.c. mains.

### Rectifiers for Charging

For general battery-charging purposes there are several types of rectifier which may be used, and, since the character of the current supply to a battery is for practical purposes immaterial—provided the current is in one direction only—almost any device which will convert alternating current into uni-directional current will serve the purpose: for example, an alternating-current motor driving a d.c. generator forms an excellent converter for battery-charging purposes.

## Rectifier Problems—continued

Again, a synchronous vibrating reed or rotating contact-maker, when properly adjusted, serves the purpose quite well, and is capable of handling comparatively heavy currents. But for the *eliminator*, the rectifier requires to be of special type, and any old rectifier will not do.

So-called chemical rectifiers are very convenient, and usually fairly cheap to set up and maintain, the commonest of these being the familiar aluminium electrode in borax or ammonium phosphate solution.

Another familiar type is the valve rectifier, in which the uni-directional emission characteristic of the heated filament is taken advantage of.

There are also other types of rectifier, such as the crystal type and the dry-oxide type (which is closely allied to the crystal type).

### Importance of Smoothing

Now, in designing and making an eliminator, as I have already indicated above, the rectification of the alternating current is a comparatively simple matter, but what requires much more care is the subsequent smoothing out of the uni-directional current thus obtained. The smoothing out of the *high-tension* supply is not nearly so difficult as the smoothing of the *low-tension* supply; this is due to the fact that the current in the H.T. supply is only a small fraction of that in the L.T. It is not a difficult matter to smooth out the ripples or irregularities in a current of very small amperage, but as the amperage is increased, the size of the chokes and condensers which are required for efficient smoothing is apt to increase very rapidly. A few comparatively small chokes and condensers will suffice to smooth out the high-tension supply for an average receiving set, but to produce the same effect upon a total filament supply of, perhaps, 1 ampere to 1½ amperes is quite another matter, and the chokes and condensers required will be found to be of considerably greater bulk.

In view of these foregoing very important considerations, it, therefore, behoves the designer to use such means of rectification as will leave in his rectified current the minimum of irregularities to be smoothed out.

### Natural and Mechanical Rectifiers

For example, if a vibrating reed rectifier were used, it would be found that the subsequent smoothing out of the rectified current would be a matter of considerable difficulty. On the other hand, if a valve rectifier be used, it will be found that the irregularities in the rectified current are of a much more manageable character: the same remarks apply to the current which is rectified by means of an electrolytic or chemical rectifier.

In fact, rectifiers might, perhaps, from this point of view be divided into what one might call "natural" rectifiers (such as valve, electrolytic, chemical, crystal, dry-oxide) and "mechanical" rectifiers (motor-generator, vibrator, commutator, etc.).

Having made this general class division it may now be laid down that only the "natural" type of rectifier should be used for the *eliminator*,

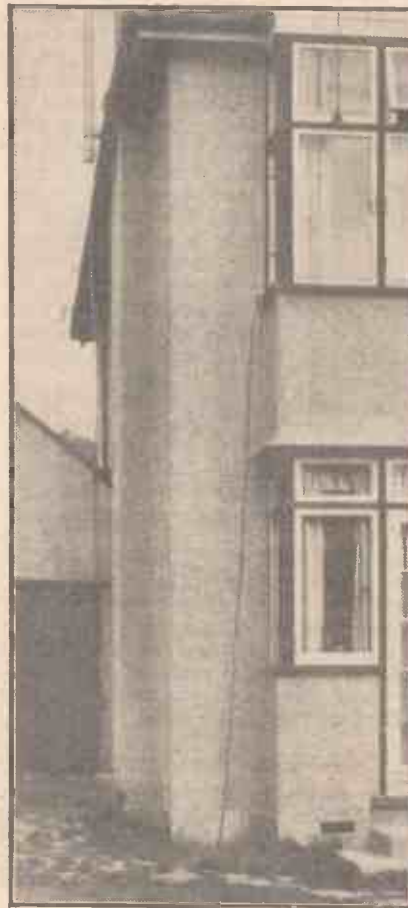

*Earthing from an upstairs room. The earth-lead will be seen coming from the window-sill direct into the ground, whilst the aerial lead passes through the window-frame.*

although, as already indicated, any of these types may be used for a *battery charger*.

Now we come to the interesting comparison of the two most suitable and most favoured rectifiers for use in battery eliminators, namely, the valve rectifier and the electrolytic rectifier (in the latter term I will include the so-called chemical or colloidal rectifier). In making an eliminator your choice of rectifiers is limited to these two classes, and therefore you have to decide whether to employ a valve rectifier or an electrolytic rectifier.

The valve rectifier has its own particular advantages. It is clean and silent; it is reliable and constant; and it is very compact and can be used in any position. It has also the merit that what we might call its "break-down voltage" (that is to say, the maximum "reverse" voltage which it will withstand) is very high. It must be remembered in this connection that when alternating current is applied to a rectifier the rectifier has to withstand the full peak voltage of the alternating current when the latter is endeavouring to pass through in the direction in which it is checked by the rectifier.

If this reverse voltage exceeds a certain critical value, which depends upon the type of rectifier, a break of the rectifying property will result and current will be able to pass through not only in the "right" direction but also in the "wrong" direction. The conductivity of the valve rectifier (assuming for the moment that it is of the "hard" type) depends simply upon the electron emission from the filament, and when the alternating current seeks to pass in the direction which would tend to drive electrons from the anode to the filament there is simply nothing to carry the current and consequently no current can pass.

Perhaps I should mention at this point that rectifying valves for battery chargers and battery eliminators are now frequently made of the "soft" variety, that is, containing a small quantity of residual gas; this lowers the impedance of the valve and makes for much greater efficiency, although at the same time it tends to reduce the breakdown voltage.

### Royalty on Valve Rectifiers

Having considered the advantages of the valve rectifier, we now turn to its disadvantages. The first of these, of course, is its comparatively high cost (rectifying valves to be used with eliminators in general cost more than ordinary receiving valves), its liability to breakage, the fact that its life (although under normal circumstances this should be at least 1,000 hours), is definitely limited, and the fact that a royalty of 12s. 6d. per valve is payable as in the case of valves used for receiving purposes. Another disadvantage of the valve rectifier arises on the score of the efficiency: the functioning of the valve depends upon the filament being maintained in a heated condition, and for this the expenditure of a certain amount of energy in the form of filament current has to be incurred.

Moreover, the impedance of the valve has to be overcome and consequently certain losses are accounted

(Continued on page 358.)



## 30 PER CENT MORE ELECTRICITY PRODUCING MATERIAL

Improvement on top of improvement has been the history of COLUMBIA Radio Batteries. Here, in the radically different COLUMBIA Layerbilt, is the H.T. Battery which tops them all. The ability of this battery to give unrivalled service and economy is due to its unique internal design. Instead of the usual assembly of round cells, it is built of flat layers of current-producing

materials pressed firmly together. This construction makes use of the spaces now wasted between the round-type cells and avoids the usual soldered wire connections. COLUMBIA Layerbilt is every inch a battery. This exclusive COLUMBIA development packs more active chemicals in a given space, produces more current from them and gives longer life.

### HIGH TENSION

The ordinary H.T. Battery is composed of cylindrical cells. The new COLUMBIA Layerbilt H.T. Battery is made of flat layers of electricity producing material. In this way every available cubic inch produces power. This not only means greater efficiency but longer life.



### BATTERY No. 4486.

The illustration shows the unique internal construction of the Layerbilt Battery. This exclusive feature makes it the most economical of all H.T. Batteries. It will be available after JANUARY 1, 1927. From any good dealer.

“Layerbilt”

Manufactured and  
guaranteed by:  
NATIONAL CARBON CO.

Scotland  
John T. Cartwright,  
3, Cadogan Street,  
Glasgow.

# Columbia

## Radio Batteries

For full particulars apply to:

J. R. MORRIS,  
Imperial House,  
Kingsway, W.C.

Telephone: - - Gerrard 3038  
Telegrams: "Colcarprod, London."

they last longer.

# The More Modern a Circuit the Greater the Need for Igranic Modern Radio Devices



## Igranic Centre Tapped "XLLOS" Coils (Extra Low Loss)

Igranic Centre Tapped "XLLOS" Coils actually contain two separate inductances which may be used singly or may be joined in series to form one coil to which a centre tapping may be taken.

Igranic Centre Tapped "XLLOS" Coils consequently have a number of uses and are particularly suitable for modern receivers and experimental circuits.

The special windings are of very high efficiency and are totally enclosed in a Bakelite shell as a protection against dust, damp and damage.

Prices from 7/- each. Mounting Base 4/6. Send for Publication No. 6264a, showing some of their many uses.

The success of modern circuits depends upon the efficiency of the components used. One unsatisfactory component is sufficient to nullify all the excellent features of the other parts. The safest plan is to use Igranic Radio Devices always. Here you have superiority equally distributed throughout the whole range; there isn't a weak link in the complete chain.



## Igranic-Pacent S.L.F. Condenser

Tune by frequencies according to the Geneva Plan with Igranic-Pacent Straight Line Frequency Condensers. Plates are of brass riveted together and soldered. Minimum capacity is extremely low and losses are negligible. Substantial bearing gives smooth turning movement.

Prices - .00035 mfd. 14/6  
 .0005 " 18/6

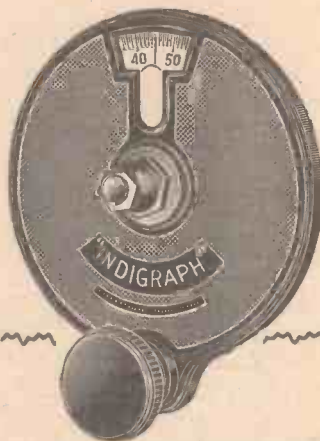

## Igranic "INDIGRAPH" Vernier Knob and Dial

A handsome slow-motion dial which greatly facilitates fine adjustments. Two scales of 0 to 100 each are provided, reading in opposite directions, making the "Indigraph" suitable for different types of condensers. Space is provided opposite the scales for recording station settings. The metal dial acts as a shield against hand capacity effects.

Price 7/6.

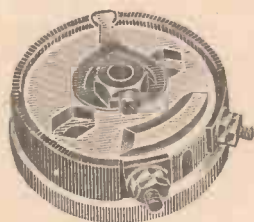

## Igranic-Pacent "Pre Set" Resistor

Igranic-Pacent "PRE SET" Resistors have all the uses of fixed resistors and yet are almost as easily variable as rheostats. Their use prevents over-running of valves and reduces the number of controls on a panel. Made with resistances of 6, 10, 20, 30 and 50 ohms. The position of the contact finger is easily variable over the whole range.

Price 1/8 each.



## Igranic "NONMIC" Valve Holder

Igranic "Nonmic" Valve Holders have extremely low self-capacity, and are therefore particularly efficient for short wave work.

Igranic "Nonmic" Valve Holders hold the valves securely and ensure perfect contact with the pins. The special springs absorb all shocks and prevent microphonic noises. Made in two types suitable for panel or baseboard mounting, both of which are easily fixed.

Price 3/- each.

## Igranic-Pacent Super "Audioformer"

A low frequency transformer which is remarkable for its unique amplification curve, making it quite different from all other transformers. The special construction of the core and coils gives uniform amplification over a very wide range of audible frequencies, resulting in perfect distortionless amplification of speech and music. The Igranic-Pacent Super "Audioformer" can be relied upon for full amplification and perfect reproduction. Its robust construction and the care taken in its manufacture give immunity from the risk of break downs or other troubles so frequent with inferior transformers.

Price 24/6.

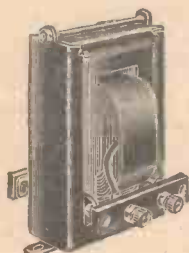

## Igranic Gang Condensers

Igranic Gang Condensers are fitted with special equalising devices which enable the sections to be accurately matched without altering the relative settings. The square law characteristic is thus preserved and the full tuning range is maintained.

Igranic Gang Condensers are built up from Igranic-Pacent .0005 mfd. Square Law Condensers.

Twin Gang	..	..	..	£2 10 0
Triple Gang	..	..	..	£3 15 0



**IGRANIC ELECTRIC CO. LTD.**  
 149 QUEEN VICTORIA STREET, LONDON  
 Works: BEDFORD

WRITE FOR LIST No. J.199

# RHEOSTAT OR FIXED RESISTOR ?

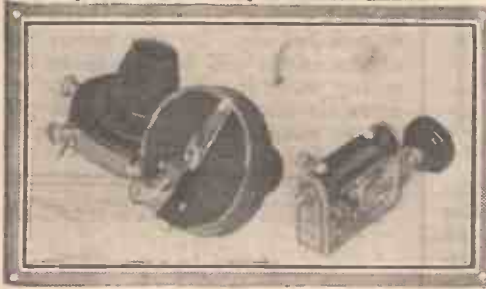

by  
A. V. D. HORT BA.

*A practical article about these important components and their relation to modern design in wireless receivers.*

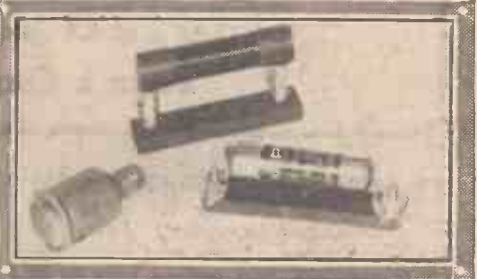

**A** GLANCE at the photographs of receivers in wireless periodicals of a year or two ago will reveal the fact that there are certain fundamental differences between the appearance of those receivers and the modern designs, such as are to be seen in the pages of this issue of THE WIRELESS CONSTRUCTOR. The principal difference which strikes the eye is that in general the panel layout of the modern receiver is far simpler than that of the older set.

There will always be some people who like to have "full control" of everything in the receiver, and who prefer to accomplish their end by making the panel like a complicated switchboard. The demand of the present day, however, is rather for simplicity of design, so that novices need not be scared by the sight of a mass of dials and switches. This does not imply that there is any less "control" over the receiver, since modern developments have shown that it is unnecessary and even undesirable for the best results to have a large number of components in the receiver variable at will.

## Modern Practice

By reason of the function which they have to perform, variable filament rheostats have in the past always been mounted on the panel of the receiver. The rheostats for a multi-valve set may take up a considerable amount of panel space, and unless a master rheostat or main switch is included in the design each rheostat has to be turned round to the correct setting every time the receiver is used.

Not long ago components of a new type made their appearance, these being fixed resistors to be inserted in the filament leads to the valves. These fixed resistors take various forms. There is first of all the type which consists simply of a length of resistance wire, wound into a compact form on an insulating bobbin. Such resistors represent in practice that portion of the resistance wire of the variable rheostat which is left in circuit when the rheostat has been correctly adjusted. They are obtainable in various values of resistance to suit the valves and the voltage of the accumulator or dry battery employed.

Another form of fixed resistor operates on a slightly different principle. This is the "barretter," a device which consists of a wire enclosed in a glass tube sealed at the ends, with metal caps as contacts.

## How "Barretters" Operate

Within certain limits of voltage this device will only pass a certain amount of current. For example, a "barretter" which is designed to pass 1 amp. when in the filament lead between a valve and an accumulator may be used either with 2-volt 1-amp. valves or with 6-volt 1-amp. valves, and the leads may be taken to the 6-volt terminals in either case. The "barretter" is not a new device, since it has been used in electrical work for some considerable time. It is, however, only



*A well-known and modern type of fixed resistor.*

quite recently that it has been introduced to any extent into wireless receiver designs.

Now, it will be obvious that it is impossible with either of these two types of resistors to turn on the valve filaments slowly or to adjust them within fine limits once they have been turned on, unless, of course, a master rheostat is included. Even in that case the filaments of all the valves in a multi-valve set will be varied simultaneously and individual control will not be possible. An on-and-off switch has to be used to light or extinguish the valves, setting them to their correct operating temperature at once.

## Where Care is Necessary

The use of fixed resistors possesses the advantage that no error can be made in the running of the valves, since so long as the accumulator voltage is maintained, they will always be run at their correct temperature. When changing valves, on the other

hand, care has to be taken to see that the resistors, too, are changed, if valves of a different type are to be inserted. Anyone who has become accustomed to the variable rheostat should be particularly careful about this, since it is only too easy to forget to change the resistors when changing from, say, 6-volt .25-amp. to 3-volt .06-amp. valves, with disastrous effects on the latter.

## Filaments at Full Brilliance

As was mentioned in "Notes and Jottings" in the December issue of THE WIRELESS CONSTRUCTOR, it appears from recent research work that good rather than harm is likely to result from switching valves on straight to their correct temperature, and that probably this method is to be preferred to the slow increase of temperature provided by a variable rheostat.

Under certain circumstances, however, the rheostat may serve a valuable purpose. Valves employed as low-frequency amplifiers may usually be run at their full brilliance; in fact, this is necessary if a high value of high-tension voltage is used, in order to avoid saturation. With high-frequency amplifiers, on the other hand, it is sometimes possible to effect a slight improvement in selectivity by turning down the filaments of the H.F. valves slightly.

## Rheostats Sometimes Essential

Filament control of a detector valve is quite often desirable. When the grid condenser and leak method of rectification is employed, variations in the filament temperature will rarely make much difference, but when anode bend rectification is used, the filament adjustment for the best results may be quite critical. This applies particularly to "soft" valves, which in America are popular as detectors, though they are not so widely used in this country.

It will be found, however, that even with the "hard" valves to which we are accustomed, adjustments of the filament brilliancy as well as of the potentiometer will facilitate the finding of the best setting for anode bend rectification.

In instruments used for valve testing or for the plotting of valve char-

*(Continued on next page.)*

## ECONOMY IN RESISTANCE COUPLED AMPLIFIERS

From a Correspondent

**R**ESISTANCE coupling is becoming very popular for low-frequency amplification, partly owing to the inexpensive nature of the components required, but mainly because it is the simplest method of obtaining a large volume of sound combined with real quality. One of the objections urged by some to the use of resistance-capacity coupling is that it necessitates the use of a large high-tension battery voltage, and that, since high-tension batteries are expensive, it must be an uneconomical method. It should be remembered that it is the current, and not the voltage, that involves the real expense in the case of high-tension batteries. Where a large amount of current is needed big, heavy cells must be used; but where the current drain is small, light cells of the type used in flash-lamp batteries will provide the necessary potential for a very long time without running down.

### Low Current Consumption

Consider the case of a low-frequency valve in whose plate circuit there is a 100,000-ohm resistance. By Ohm's Law the current flowing through a resistance is always equal to the voltage divided by the resistance. Hence, if we placed a resistance of this value directly across the extreme terminals of a 100-volt high-tension battery only one milliampere could pass.

In an amplifier of the type under discussion, the plate-filament resistance of the valve is in series with the coupling resistance, so that the two values must be added together. Thus, with a 100,000-ohm resistance and a 150-volt high-tension battery, the current will always be less than 1.5 milliamperes; even if a 50,000-ohm resistance is used with a low-impedance valve, it will be only between 2 and 3 milliamperes. Since even the lightest type of high-tension battery of good make can supply up to 5 milliamperes without suffering, a battery of this kind is all that is required to supply the extra voltage for the valves concerned.

The drawing shows a very simple method of working resistance-coupled low-frequency amplifiers in the most economical way. To the high-tension terminals to which run the busbars supplying the high-frequency valves, the rectifier and the last note-magnifier is connected a heavy high-tension battery, for here the current load may be considerable.

The negative pole of a small-cell

battery is connected to the positive of the big battery, and the positive of the small battery is taken to an "extra" high-tension positive terminal, to which runs the busbar supplying the resistance-coupled valves. A 66-volt small-cell battery will usually be sufficient to supply the extra voltage needed, and this should work two resistance-coupled valves for many months.



Showing how an additional H.T. battery of small capacity can be used to supply the extra voltage required for one or more resistance-coupled stages.

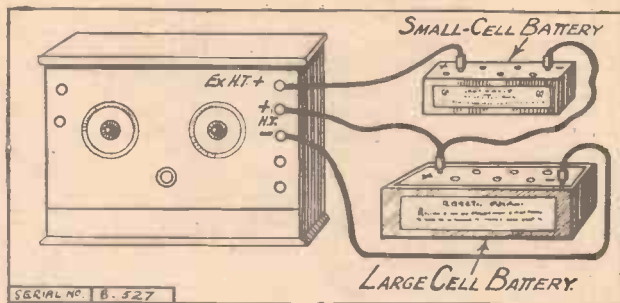

### RHEOSTAT OR FIXED RESISTOR?

(Continued from previous page)

acteristic curves there is a good deal to be said for the inclusion of the variable rheostat and not the fixed resistor. Meters form part of the equipment of such instruments, so that it is easy to set the rheostat to the adjustment that provides the manufacturer's voltage rating. Also, since all types of valves are likely to be tested, it would be inconvenient to change resistors for each different valve. A variable rheostat of sufficient maximum resistance to reduce the terminal voltage of the battery to the lowest voltage required for any valve is most suitable for this class of work.

### In Conclusion

Generally speaking, then, it would appear that for special purposes rheostats have a useful application, while for ordinary everyday reception with broadcasting receivers fixed resistors are very convenient, especially in the hands of inexperienced operators. A combination of both rheostats and fixed resistors gives perhaps the ideal arrangement, providing full control in a multi-valve receiver. In this case fixed resistors may be included in the filament leads to all the valves, while a filament rheostat may be mounted on the panel and connected in the fila-

ment circuit of the detector valve in series with a fixed resistor.

This fixed resistor should be of the normal value, that is to say, of 4 resistance to run the valve at its normal rating when the rheostat is turned full on. By this means none of the valves will be run above their rating, while it will be possible to turn down the filament of the detector valve to a more suitable adjustment if required.

### "SAMSON"—THE POWERFUL TWIN

—concluded from page 297

tuning will be found to be very sharp for such a simple circuit, and the volume and purity remarkably good. On a good outside aerial I have had as many as ten stations audible on the

loud-speaker, from weak loud-speaker strength to full loud-speaker volume, within five minutes, but the set is not primarily designed for long-distance reception, and you are liable to cause interference to your neighbours if you are continually using the set near the oscillation point.

### Use With a Frame Aerial

This set gives remarkably good results on the local station using a frame aerial. You will need one of the centre-tapped variety, which you can either make yourself from one of the designs already published in this paper or purchase one. To use a frame aerial with the set it is only necessary to pull out the H.F. transformer and connect three points of the frame to the sockets shown in Fig. 2.

Clix terminals or ordinary H.T. battery wander plugs can be used for plugging in the sockets in the base, or if you prefer a more permanent connection than this you can take the centre tap of the frame to terminal four, one end of the frame to terminal three, and the other to terminal six.

At Wimbledon, seven miles from 2LO, a centre-tapped frame with 2-ft. sides is sufficient aerial to give full loud-speaker strength on London, and late in the evening I have heard Madrid on the same frame aerial in the loud-speaker, not at loud-speaker strength, but quite sufficiently loud to identify the transmission 2 ft. or 3 ft. away from the speaker.



# THE BRANDES AUDIO TRANSFORMER



Connect it this way:—

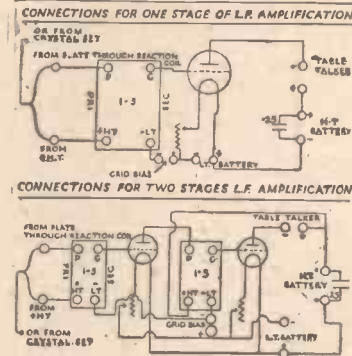

- (1) Connect Pri. P. to plate of det. valve through reaction coil or direct to plate if 2nd stage L.F. connection is being made.
- (2) Pri. + H.T. to + terminal of H.T. Battery.
- (3) Terminal marked G. Sec. to grid of next valve.
- (4) Terminal - L.T. Sec. to - of grid batt.
- (5) + of grid batt. to - terminal of L.T. batt.

## HIGH AMPLIFICATION OF APPLIED VOLTAGE AND A STRAIGHT LINE AMPLIFICATION FREQUENCY CURVE

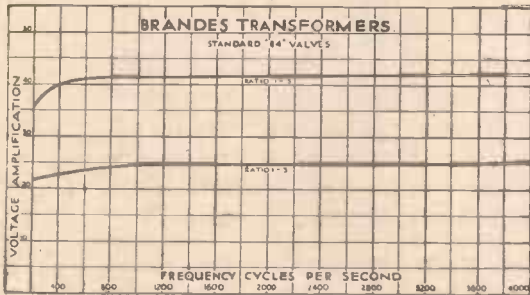

The unit is well protected mechanically, and the shielding is such that transformers may be placed close together without interaction. The insulation between primary and secondary coils and also from these to laminations is very high. Each transformer is tested against a Standard before leaving the factory at 200, 600, 1,600 and 4,000 cycles per second. The ratio of turns between secondary and primary is 1 to 5 for the First Stage Transformer and 1 to 3 for Second Stage Transformer. They are ideal in first and second stage work respectively.

As well as ordinary terminals for connection, soldering tags are provided, giving the user a decided advantage.

Ratio 1-5  
**17/6**  
(Black case)

**Brandes**  
AUDIO TRANSFORMERS

Ratio 1-3  
**17/6**  
(Brown case)

BRANDES LIMITED, 296, REGENT STREET, W.1.

WORKS: SLOUCH, BUCKS.

For many years Brandes specialised in acoustical research and the improvement of the audio circuit of the receiving set, which so essentially determines the quality of reception.

One result is the Brandes *Audio Transformer*. Developed along sound engineering lines, the main object in view is a high constant voltage amplification frequency curve. That is to say, for a given input voltage the amplification is constant over a wide band of frequencies, thus eliminating resonance. The inductance of the primary winding is much larger than usual, giving good amplification at low frequencies, and bringing beautiful reproduction, more particularly in the lower registers.

No condenser need be shunted across the primary winding. When used, it may be found necessary to use grid cells for biasing purposes to obtain purest results. To use grid bias all that is necessary is to insert cells between L.T. Sec. and the negative terminal of the L.T. Battery, such that the L.T. Sec. terminal is connected to negative terminal of cell, and the negative terminal of L.T. Battery is joined to positive terminal of cell. Cells from 1.5 to 3 volts should be tried.

G. P. Kendal, B.Sc., writing in the *WIRELESS CONSTRUCTOR* on the building of the "Spanspace Three," recommends the inclusion of the Brandes L.F. Transformer.



# Are you making the famous R.C. Threesome?

**T**O get the wonderful results obtained with the original R.C. Threesome Set, you should use identical components.

The Coil Holder used is a "Lotus" Left-Hand Two-Way Coil Holder; the three Valve Holders are "Lotus" Buoyancy Valve Holders, with Terminals.

Wireless experts decided that these were best for a very important experiment; that they would get most out of the set on which depended the very high reputation of the famous Ediswan Valves.

They were not disappointed. YOU will be more than pleased with the R.C. Threesome's performance if you fit "Lotus" Valve Holders and Coil Holder.

*From all Radio Dealers*

## LOTUS COMPONENTS

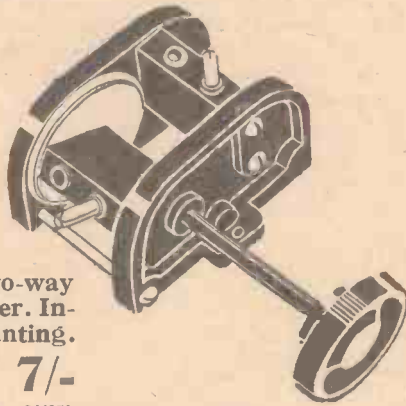

Lotus Two-way Coil Holder. Inside mounting. Left-hand. **7/-**  
Patent No. 244251.

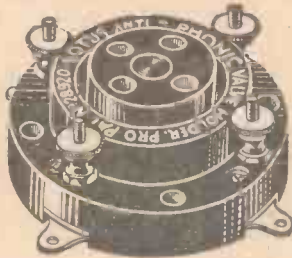

Lotus Buoyancy Valve Holder with Terminals. **2/6**  
Patent No. 256833.

GARNETT, WHITELEY & CO., LTD., BROADGREEN ROAD, LIVERPOOL

# The Wireless Experimenters'

by C.P. Allinson AMIRE Workshop



“A BAD workman blames his tools” is an old proverb of rather dubious merit. If the tools are exactly suited to the work being undertaken, and the work turns out badly, then undoubtedly the workman is to blame. When, however, he is “making do” with tools of a rough-and-ready description, entirely unfitted for the purpose to which they are being applied, then if the job does not turn out just as it should do he is certainly entitled to blame his tools.

It is important that the enthusiast who is taking up wireless as a hobby should be suitably equipped if he is to derive the full enjoyment and benefit of what is a very fascinating side of science.

## The Equipment Required

When I first started wireless as a hobby somewhere about the year 1911 my workshop equipment consisted of a pair of pliers, a screwdriver, a file,

and a watchmaker's drill. It was all I had to assist me in the construction of my first wireless set, and when I look back I realise how handicapped I was by the lack of suitable instruments with which to carry on my constructional work.



A scribe and a centre-punch; the latter has a heavy end for hammering.



When I wished to drill a large hole in a piece of ebonite I had to start with the watchmaker's drill and enlarge the resulting hole with the tang of a file until the hole was of the required size. Sheet-metal for making switches was cut with an old pair of scissors. Threads were cut in ebonite

by forcing a screw in with a screwdriver, and innumerable other methods of “botching” the work in hand had to be adopted.

As a result of my experience I would therefore like to offer a word of advice to the beginner at wireless, and that is, spend as much money as you can afford on tools. Do without that extra valve and the loud-speaker, and instead buy yourself a brace and drills, a scribe, a square, a pair of dividers and a centre punch. You will be well repaid by the greater speed and facilities with which work can be carried out.

The equipment required by the radio experimenter can be divided into two sections, the one being mechanical, and covering the question of all tools that he needs. The other is electrical and may be applied to certain measuring instruments and accessories that must be obtained if any serious work of value is to be undertaken.

I propose to deal with the mechanical side first, and will enumerate the various tools required in the order of their importance, and in cases where they merit it, a short description of their employment. Much will depend, of course, whether the intending experimenter is going to devote himself to assembling sets from component parts or whether he intends making a number of these components himself. In order that this survey of requirements may be as complete as possible, I will assume that he intends doing a considerable amount of constructional work from the raw materials.

## Sizes for Screwdrivers

First of all, the tools which are absolutely necessary are screwdrivers, pliers, file, soldering iron, a small brace, drills and a hack-saw. With regard to screwdrivers, the choice of these will largely be governed by the depth of one's purse. Two screwdrivers are advisable, a small one with

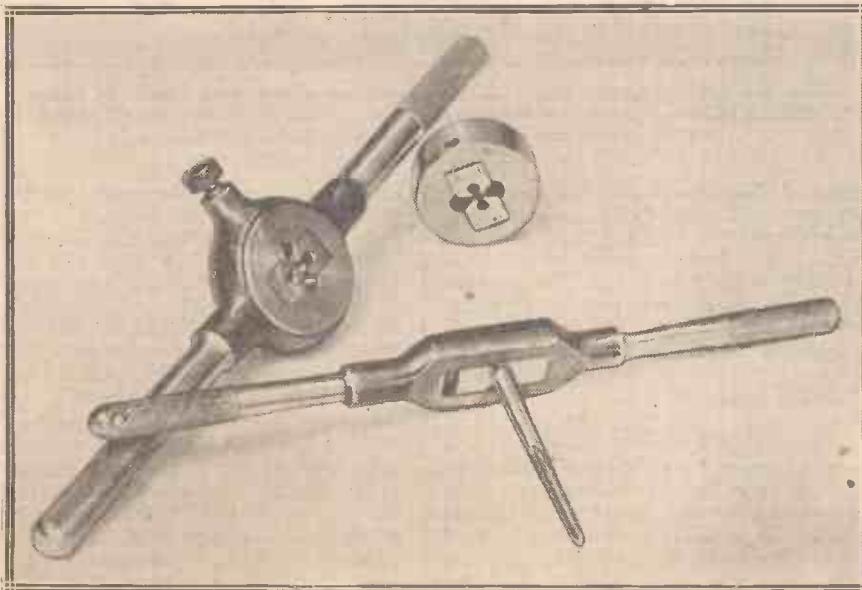

A stock with two dies, and a tap-wrench with tap in position.

## The Wireless Experimenters' Workshop—continued

a long, thin blade, and one suitable for larger screws. These can be purchased for a matter of a shilling or so. For those that can afford them, a spiral ratchet screwdriver will be found a great boon. The spiral ratchet in particular is an extraordinarily handy tool, especially where long screws have to be driven home, since this can be done far more quickly than with a plain screwdriver, while a real luxury is afforded by the spiral ratchet with a return spring. This enables screws to be driven in or taken out with one hand at great speed, and is of particular use where the work is such that only one hand on the screwdriver can be employed.

As regards the size of the blades for the large and small screwdrivers respectively, the width of the small screwdriver should preferably be about  $\frac{1}{4}$ th of an inch, while the larger may be a  $\frac{1}{2}$  of an inch. For the amateur who wishes to make his own screwdriver I would say, use silver steel for your blades. The working end can be filed up to shape and a square tang put on the end to which the handle is fitted. The blade may then be suitably hardened and tempered, and this tool will last far longer than a cheap screwdriver of which the blade is made of poor metal.

### How to Choose Pliers

With regard to pliers, a useful selection would be to have three of these, one large side-cutting pair for cutting heavy wires, small screws, etc., and other rough work of this description, one flat-nosed pair, which can also be used for cutting fine wires, and a small pair of round-nosed pliers, which are particularly convenient for making loops in the ends of the wire intended to go under terminals.

If possible, a good selection of files should be obtained, for practically every piece of constructional work will require the use of one or more files. For instance, after a panel has been cut it is desirable to trim up the edge, first of all with a rough file to get the saw marks out, and then with a smooth file to give a good smooth finish. A square file will be found of great use when mounting certain types of switches on a panel, and a round file again is required under various circumstances.

When metal work is being done it is also useful to have a couple of smooth and dead smooth files, in order that a good surface may be put on to any metal parts which are being worked. For very heavy work a milling file such as the Dreadnought will be found of extreme use, since this will take a very heavy cut at a stroke and is particularly useful where a large quantity of material has to be removed. Some hints and tips on the

use of files may be of interest here, as the first thing to learn in order to acquire skill in the use of a file is the correct way to hold it. The handle should be held in the right hand with the thumb uppermost lying along the top of the grip, while the left hand either grips the end of the file between thumb and forefinger, or else rests lightly on its upper surface, according to the type of work being undertaken.

The right elbow should be kept well into the side when filing, and particular care should be taken not to let the file rock, otherwise a flat surface will not be obtained. If good work is to be turned out it is important that the height of the vice be suitable, and an average figure for the distance between the top of the jaws of the vice and the floor is 3 ft. 6 in.

In straightforward filing the cut is taken on the forward stroke, and a fair amount of pressure should be

part a dead-smooth file may be obtained. One or two very small files, round, square, flat, etc., will also be found invaluable for small jobs.

When working with brass and copper it is advisable to dress the files with chalk, so as to prevent them being clogged up by the particles of metal removed. Ordinary blackboard chalk will serve this purpose very well, and the files should frequently be cleaned and re-dressed if a smooth surface free from scratches is to be obtained.

### Some Useful Drills

The final finish may be put on work by draw-filing it. In this case the file is held so as to be parallel with the body, and is moved to and fro across the work at right-angles.

In order that pieces of threaded material may be held in the vice with-

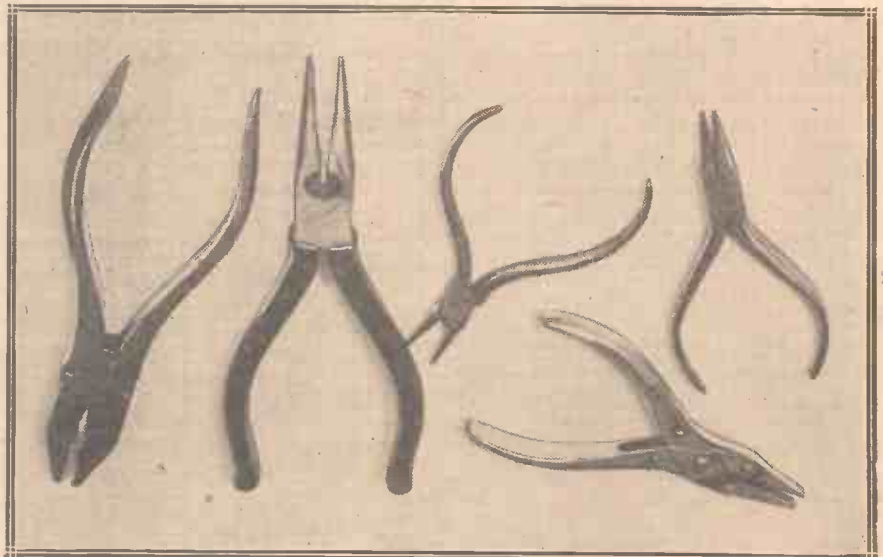

*On the left are shown heavy flat-nose cutting pliers, and insulated taper cutting pliers. Above the flat-nosed pliers to the right are small round-nosed pliers, and (right), a pair of small taper pliers.*

exerted. The file should not be pushed forward at right-angles to the work, but should be slightly moved across from right to left, so as to obtain a slightly sideways cut. The return stroke is taken light, care being taken at all times to keep the file at right-angles to the work, except, of course, in cases where it is desired to obtain a bevelled edge.

### Dressing the Files

A coarse-cut file is very seldom required in ordinary wireless work, but a useful file for all-round purposes would be a 8-in. second or bastard cut. For finer work, a 6-in. smooth-cut file would be suitable, while for getting a very high finish on metal

out injury, and softer metal such as brass and copper be gripped without marking the surface, a couple of lead vice-guards should be kept on hand. These merely consist of small pieces of sheet lead about  $\frac{1}{8}$  in. thick, bent so as to fix over the jaws of the vice. Work may then be put between them, and owing to the softness of the lead, will not be marked or injured.

For drilling work a small hand brace, such as a miller's fall or a similar type, will be found the most suitable. It is advisable that the chuck be large enough to take a  $\frac{3}{8}$  drill, especially in view of the fact that most of the one-hole fixing components used in wireless work require a  $\frac{3}{8}$  hole for fixing. The most useful sizes of drills

# SUPER POWER



Try this experiment. Tone down your signals. Does the music come in more clearly and undistorted? If so, you have been overloading the last valve of your set and you need an S.T. super power valve. If, however, on toning down the strength of signals, distortion still remains, you must look elsewhere than to your valves for the cause.

An ordinary power valve will handle music of medium strength, but when you want to get a real life-like effect

you must have a reserve of power to provide for the sudden large increase in "grid volt swing" caused by the high note of a soprano or the rich deep swell of the organ. Fit an S.T. 63 (or S.T. 43) **Super Power Valve** in your last valve holder whenever you have two stages of L.F. You only need one valve, but the clear-cut and vivid music you will get will astound you.

Price

S.T. 63 for 6-volt accumulator **22/6**  
S.T. 43 for 4-volt accumulator

*The Valve with the Golden Voice*

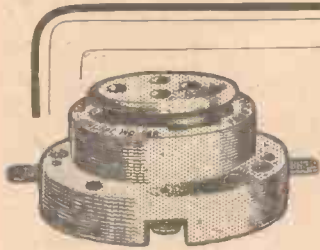

# For Best Results Build your set with BURNDEPT COMPONENTS

## ANTI-PHONIC VALVE - HOLDER

End your valve troubles by fitting anti-phonic valve-holders to your receiver. They eliminate microphonic noises, and tend to lengthen the life of any valve by protecting the filament from shock. The name "Anti-phonic" was coined by Burndept, the makers of the first valve-holder of this type.

PRICE **2/9**

## ETHOVERNIER DIAL

Fit this component, and those elusive stations can be brought in again and again. It is free from backlash, silent, fits practically any type of condenser, and has a high ratio of 18-1.

**ETHOLOG.** A unique feature which fits snugly round the dial, being kept in position by pressure of a spring. Contains a changeable card on which you can mark the position of any station or various wavelengths. It obviates further exploration once stations have been logged.

Ethovernier, with Etholog and Card Scales - 9/-  
Ethovernier without Etholog - - - 8/-  
Etholog only, with spare Card Scales - - 2/-

Write for Booklet; or ask your local Burndept dealer about Burndept Components.

## New Type FIXED Resistors

Embody these in your set, one in series with each valve, you can then adapt your receiver for use with any valve you choose, with any accumulator within practical limits. Burndept Fixed Resistors give a definite resistance which is not materially affected whether they are hot or cold. They protect the valve filament.

Supplied in 18 different values from 0.5 ohms to 1/8

EACH **2/-**

Screw holders in cartons containing two

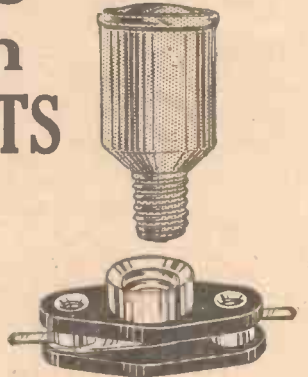

**BLACKHEATH, LONDON, S.E.3.**

Agents and Branches Everywhere.

## Safety **EELEX** First!

BE PREPARED FOR STORMS—  
WINTER and SUMMER—by FIXING THE  
"EELEX" SAFETY SWITCH

Comprising: Switch, Lightning Arrester, Lead-in Tube and Weatherproof Cover.

The Ealex safety switch, the latest development in Safety First devices, enables the operator to earth the aerial outside the house. By pushing the knob the set is at once connected to the aerial. A pull instantly disconnects the set from the aerial system, automatically earthing the aerial. The spark gap provides ample means of by-passing any electrical discharge which may occur while set is in operation.



6 in. Tube  
PRICE  
**5/6**

12 in. tube 6/6. 18 in. tube 7/6.

## KNIFE SWITCHES

D.P.C./o 2/6 each.  
S.P.C./o 1/6 each.

S.P.C./o  
1/- each

S.P.S.T.  
1/- each.

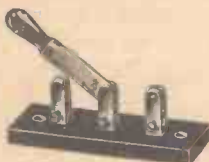

Please Write for Entire List of Switches.

MINIATURE KNIFE SWITCHES for Panel Mounting as illustrated 1/6. S.P.C./o 1/-.

Write for New Ealex Catalogue W.C.1



**EELEX HOUSE, 118, BUNHILL ROW, E.C.**

Phone: Clerkenwell 9282/9283.

### JACKS 4-POINT



1-Hole 1/9

### S.L.F. CONDENSER



With 4-in. dial. '0003 .. 7/- '0005 .. 7/8

### RELIABILITY CONDENSERS



Mansbridge Mids. Type. '25, 1/6 mfd., 2/6 '5, 1/9 2 mfd., 3/6

### WIRELESS CABINETS

For Panels 7 in. High Width 8 in. Hinged Lid Oak 12 in. 17/- 14 in. 17/6, 18 in. 18/6. Mahogany 1/- extra.



### DEWAR SWITCH



12-Contact 2/6

### READ THIS LIST AND SAVE MONEY ON COMPONENTS

**RECENT REDUCTIONS.**—Sterling '0005 Square Law Condensers with Vernier, 9/6; Geared 12/-; Miniloss, 15/-; '00025, 8/6; Geared, 10/6; Miniloss, 14/-; Marconi Automatic Detector, 2/6; Series Parallel Variometer, 10/6; Eddystone Absorbos Feet, set of 4, 2/3; Benjamin S.P. Switch, 1/3; N.P. Clix Plug & Insulator, 2/-; Adaptor, 1/-; Socket, 2/-.

**LATEST COMPONENTS.**—6-Way Coil Stand, 2/9; Colvern Low Loss Inductance Former, 5/-; Formo Straight Line '0005 Condenser, 7/6; Success, 18/6; Eureka, 15/6; Cydon, 15/6; Lissen 60 v. H.T. New Process Battery, 10/6; Valve Vibrating Springs, 6d. set of 4. **EBONITE.**—Any size cut; Claytombrand, 1/4 in. sq. in.; 9 in. by 6 2/2; 12 in. by 9 7/8; 15 in. by 9 5/8; 3/16 in. 25 per cent. less. Paragon and Radion, 1d. per sq. in.

**TERMINALS & ACCESSORIES.**—Single W. Office N.P. or Pol. Brass with nut and washer, 1/-; Phone and Castle type, 1/-; Double Mark, 3. 2d.; 4-way Phone Connector, 6d.; Pole-finding paper, 3d.; Fluxite, 8d.; Black Tape, 6d. per coil; 1/4 in. Empire Tape, 6d. dozen yards; Insulating tube, 3d. yard; Glazite, 1/2, 10 ft. coil; Shellac Varnish, 6d.; Mica 2 in. x 1 1/4 in. 4d. dozen; Chatterton's Compound, 9d.; Hand Drill, 3/6; Drill, 1/-.

**INSULATORS.**—Large Shell, 3d.; Reel or Egg, 1d.; Climax, 6d.; Ditto, with shock absorbers, 3/-; Gal. Pulleys, 4d.; 100 ft. Gal. Straining Wire, 1/6; Straining Bolts, 6d.

**ACCUMULATORS.**—Ealde, D.T.G., 4/6; D.F.G., 8/6; W.J., 20 v., H.T. type, 15/-; Oldham H.T., 10d. per volt, complete; Duros, 20 v., 11/-; 10 v., 5/6; Repairing Outfit, 1/6.

**BATTERIES.**—Reliability, 80 v., 11/-; 60 v., 7/6; 36 v., 4/6; 15 v., 1/10; Ever Ready, Siemens, Hellesen, 100 v., 21/-; 66 v., 12/6; 36 v., 7/6; Flashlight Battery Cases for 14 Batts., 3/6; 4 1/2 v. Batts., 4d.; 60 v. Unequalled, 8/6; Wan. Flugs, 1/-; Clix Type, 2d.

**CONDENSERS.**—Low Loss, Square Law, with knob and dial, '0005, 5/-; '0003, 4/6; with Vernier Bell, 1/-; extra; Twin '0005, for Elixres Six, unequalled value, 9/6; Cydon Twin for ditto, 27/6; Ormond, J.B. Utility, Sterling, Polar, Formo, Igranite, G.E.C., Var. in all capacities, Neutrodyne type, Ormond, 2/-; Colvern 3/6; Gambriel, G.E.C., FIXED CONDENSERS.—Dubilier, Edison Bell, Lissen, Watmel, Mullard, McMichael, at advertised prices. Special Reliability Fallon—'0003 mfd. 2 meg. Leak, 1/3; Cases only 4d.

**L.F. TRANSFORMERS.**—R.I. Multi-Ratio, 25/-; Marconi Ideal, 25/-; Junior, 18/6; Perant & P. 3, 25/-; A.P. 4, 17/6; Formo, 10/6; H.T.C. Empire, 7/6; Croix 5 to 1, 6/-; Lissen new type, 8/6; Igranite, 16/-; Eureka Concert Grand, 25/-; No. 2, 21/-; Baby Grand, 15/-; Ormond, 15/-; Royal, 20/-; Success, All Black, 21/-; Silvertown, 21/-; G.R.C., 15/-; Brandes, 17/6; Burndept, 16/6; Special Value, 7/6; Modulation, 7/6.

**HEADPHONES.**—B.T.H., 15/-; Brown's "F" Type, 20/-; Reliability, 7/6; Adjustable, 8/-; Dr. Nesper, 12/11; T.M.C.O., 17/6; Western Electric, 20/-; all 4,000 ohms; Sullivan, 120 ohm Double Ex-Govt. New, 4/-; 120 ohm Single Phone, 2/6; Long Phone Cord, 1/-.

**AERIALS.**—100 ft. 1 in. copper tape, 1/9; 7/22's Bright, 2/3; Enamelled, 3/6; Electron, 1/8; Superial, 2/6; Mars, 9/6; Ashton Spreaders, 12/- per pair; O.V. complete, 2/6.

**VALVE HOLDERS.**—Anti-Phonic Benjamin, 2/9; Lotus, 2/3; with terminals, 2/6; Burndept, 2/9; Barlie, 1/6; Reliability, unequalled, 2/-; all baseboard types, ord. ditto, 6d.; N.P. Valve Sockets, Rush Biting, 1d.; Superior Panel Type, 6d.; All Ebonite, 10d.

**VALVES.**—"Radion" all types, Frelat 2 volt, 3 amp, 4/11. All advertised makes stocked.

**EXPERIMENTERS' PARCELS.**—Accessories of Various Types, worth 20/-, post paid, 5/6

Send for New RELIABILITY WIRELESS GUIDE No. 9 Free on Request Trade Supplied.



Orders 5/6 Value Carriage Paid. Under 5/6 2d. per lb. for Packing, etc.

## The Wireless Experimenters' Workshop—continued

are as follows:—A  $\frac{1}{8}$ -inch for small holes through which fixing screws are passed in order to secure ebonite panels to baseboards or cabinets. This size also provides clearance holes for 6 B.A. screws, and can be used as the tapping size for 4 B.A. The clearance size for this gauge of screw is  $\frac{3}{32}$ -in. For 2 B.A. screws, a  $\frac{1}{16}$ -in. is suitable for tapping, and a  $\frac{3}{32}$ -in. for clearance; and finally a  $\frac{1}{4}$ , a  $5/16$ , and a  $3/8$ -in. drill will also be required. The  $\frac{1}{4}$ -in. will be found to be the right size for counter-sinking 2 B.A. screws, while the 2 B.A. clearance drill will be found the right size for counter-sinking 4 B.A. screws.

### Accuracy in Drilling

Where it is desired to drill work with any degree of accuracy it is necessary that a centre punch be used for marking the point at which the drill is to start. If this is not done it will be found that the point of the drill will be liable to wander, with the result that the hole when drilled may be as much as  $\frac{1}{8}$  in. out of true. For those who can afford it, an automatic

centre punch will be found a great boon, since this enables "pop" marks to be made with one hand only. When drilling large holes it is usually advisable to pass a small drill through the work first, so as to ensure that the point on the larger drill shall follow the correct path.

to the work, and if a deep hole is being drilled, the drill should be removed periodically to clear it of accumulated cuttings.

It is occasionally required to drill holes, and sometimes tap them, in the

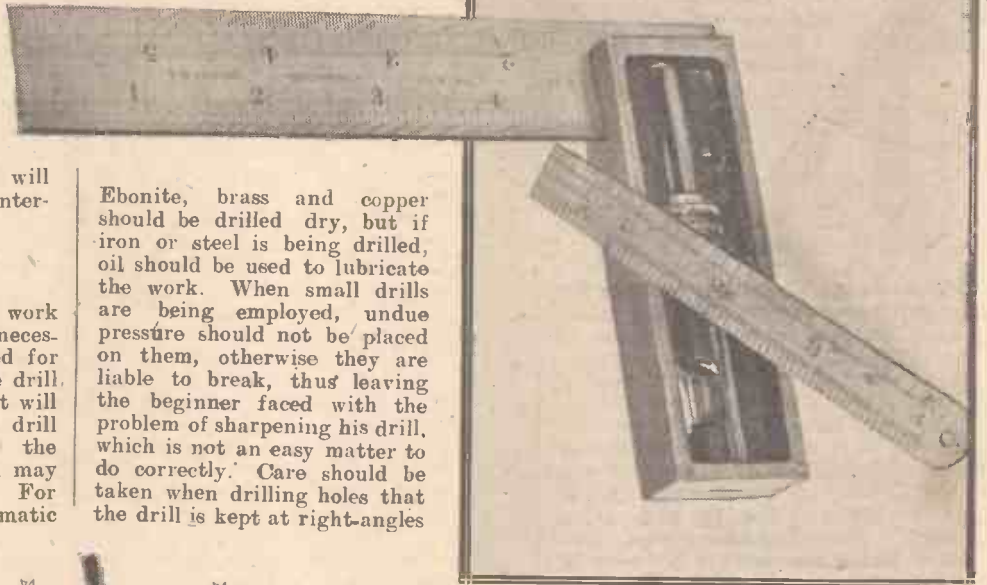

A "Starrett" adjustable square and rule, and a plain steel 4-inch rule.

Ebonite, brass and copper should be drilled dry, but if iron or steel is being drilled, oil should be used to lubricate the work. When small drills are being employed, undue pressure should not be placed on them, otherwise they are liable to break, thus leaving the beginner faced with the problem of sharpening his drill, which is not an easy matter to do correctly. Care should be taken when drilling holes that the drill is kept at right-angles

Every constructor finds something tools, and the photographs on this pages will assist in making a wise experimenter there is no more im-work than that of proper equipment

of interest in good and the preceding choice. For the important aspect of his in the workshop.

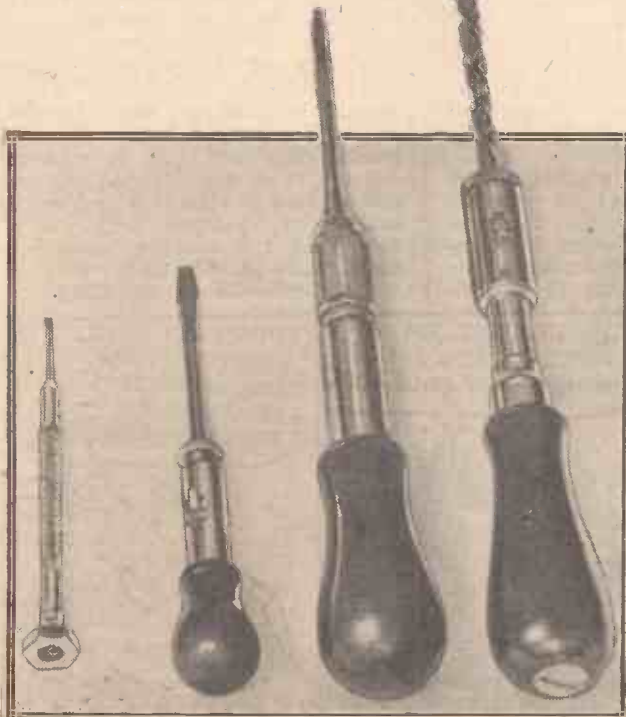

A watchmaker's screwdriver (left), two types of plain ratchet screwdrivers, and a spiral ratchet screwdriver (right).

edge of an ebonite panel or similar piece of material which is somewhat liable to split. In such a case a tool maker's clamp, as shown in one of the photographs, will be of the greatest use. This is placed in position and tightened up on either side of the panel, so that the greatest pressure is exerted at the point where the drilling is to be done. The position of the hole should then be carefully marked and centre-punched, and the work may then be carried out without risk of the panel splitting out sideways.

### Taps and Dies

Other exceedingly useful tools are taps and dies, but except where a good deal of constructional work is being undertaken these will hardly be required by the average wireless amateur. In any case, you will probably not require other than the 2, 4, and 6 B.A. gauges, which are almost solely employed in wireless work to-day.

Every Constructor should read  
**"POPULAR WIRELESS"**

(Incorporating "Wireless")

Britain's Best Radio Weekly.

Every Thursday - - Price 3d.

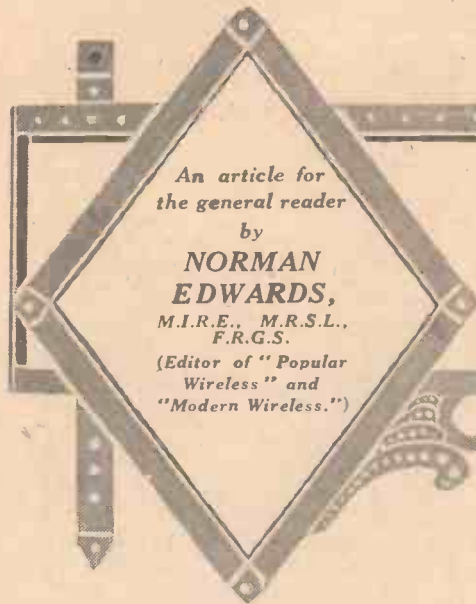

# MUSIC AND THE LOUD-SPEAKER

IT is always interesting to have the criticisms of a well-known music critic, and in a recent issue of the *Observer*, Mr. A. H. Fox-Strangways devoted a very interesting article to wireless reproduction. This well-known critic recently listened in to a programme consisting of the *Egmont* and *Hebrides Overtures*, the *Jupiter Symphony*, Bach's *E Major Violin Concerto*, and other pieces. Mr. Fox-Strangways confessed in his article that hitherto he had heard nothing but "sketchy reproductions, whistling upper notes, confused middle ones, and no bass to speak of."

On the particular set on which he listened to these items he admits that everything was at least audible, though in varying degrees and qualities, and he found it possible to form an opinion on the value of the music. The receiver seemed, he said, to have solved its problem, and the responsibility to rest now with the transmitting end.

Now Mr. Fox-Strangways is an experienced critic and his opinions on music are valuable. Here are some of the criticisms he made:—

Flute and piccolo, weaker than one expected; in balance about right.

Oboe, especially good at middle pitch; upper notes a little scrannel.

Cor Anglais, startlingly clear and resonant.

First bassoon, excellent; in clarity leaning to the Cor Anglais rather than to horn side.

Horns and trumpets, normal, but little bite or brilliance.

Drum, tuning heard well; C drum a little sharp for part of "Jupiter."

Violins, first too prominent—probably too near the transmitter; notes in high positions undistinguishable from flute; dragging up-bows came out with a vengeance; seconds heard even less than usual on lower strings.

Violas, sounded muddy, but they happened to have no solo work which might have been clear.

The above concise criticisms are very interesting, and Mr. Strangways points out the fact that the beauty of music depends largely on the difficulty of performance. An organ toccata, for example, misses its effect when arranged for the orchestra, where those complexities which tax the solo player's brain powers suddenly become child's play.

This sort of beauty wireless cannot in any way increase; its greatest merit can only be not to have diminished it. Concluding his interesting article on broadcasting, the author says that to those whose busi-

ness it is to write about performances of music, wireless comes as an unmistakable boon, because it increases the circle of their readers, while the audience benefits from its concerts being edited by the wisdom of the B.B.C.

It is indeed pleasant to read Mr. Fox-Strangways' critical but impartial review of the symphony concert he listened to by wireless, and one can only hope that one day Sir Thomas Beecham will have the patience to sit down in front of a good receiver and judge what he hears on its merits and not on his own prejudices.

The above short extracts from Mr. Fox-Strangways' article remind one inevitably that some of the most difficult problems in radio are connected with loud-speaker reproduction. Every amateur knows how easy it is to obtain a very fine volume of sound, enough, indeed, to blow the roof off, as one might say; and every amateur knows that it is quite easy to cut down that volume so that it is not a raucous cacophony. But there is a lot to be done between those two points, and perfection is extremely difficult to obtain. If you sit down one evening and make a very careful analysis of what you hear, you will note that the average loud-speaker deals quite satisfactorily with the  
(Continued on page 356.)

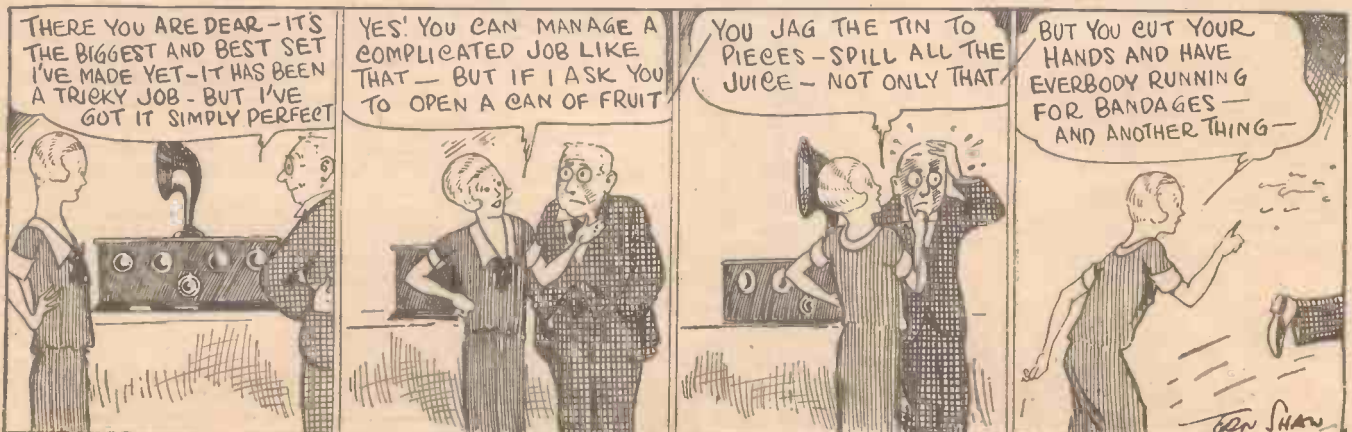



# HOW CAN A FIXED RESISTOR BE VARIABLE?

—an open letter to the Wireless Public.

Gentlemen,

Certain advertisers are making extravagant claims and state that the Fixed Resistor is fast becoming obsolete! This is entirely wrong.

"Cyldon" Temprytes are guaranteed 100% efficient. They cannot be otherwise if manufactured the "Cyldon" way—that is Wire Wound, therefore absolutely noiseless. Carbon mixtures or chemical combinations change their characteristics as often as the English climate and cause home-made atmospheric.

Supposing your valve requires a resistance of 4 ohms to run it at the correct temperature. With a variable resistor (glorified filament rheostat), you start off with an unknown resistance, maybe too high

Cyldon Works,  
Sarnesfield Road,  
ENFIELD TOWN, Middx.

or too low. If it is too low, your valve will probably be ruined for the rest of its life.

With "Cyldon" Temprytes you *must* be right because they are definitely designed to suit the particular valve you are using and it is impossible to run that valve at anything but its correct temperature.

We issue a very comprehensive valve chart which shows the correct resistance for every valve in existence, and is free for the asking.

The cost of 2/6 for a "Tempryte" is much less than 15/- to 22/6 for a ruined valve through starting with an unknown resistance which may only be *approximately* right.

Yours faithfully,

S. S. BIRD & SONS.



## CONDENSERS.

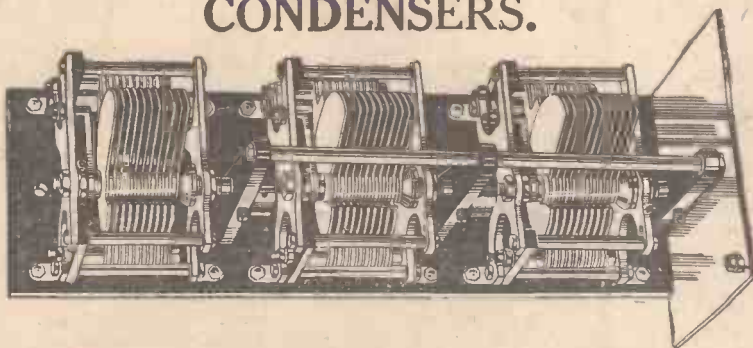

The famous CYLDON range of variable Condensers embraces every type likely to be specified or required, and every CYLDON Condenser is as faultless in design as in finish. Once constructors buy CYLDON they never go back to other makes. We know this from the scores of unsolicited testimonials that reach us every week.

### PRICES

SQUARE LAW. .0005	17/6. .0003
16/6. .00025	16/- .0002
Complete with dials.	
S.L.F. .0005	15/6. .00035
.00025	14/6. Dials 2/- extra.
DUAL CONDENSER. .0005 mfd.	
27/6. .0003 mfd.	25/- . Complete with dials.
2-GANG	£2. 10. 0.
TRIPLE GANG	£3. 10. 0.
4-GANG	£4. 10. 0.

} Prices without dials.

## TEMPRYTES.

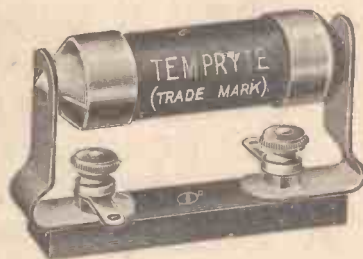

The best means of Valve control. Wire wound, therefore dead silent in operation. British made and unconditionally guaranteed. Can be supplied in correct resistance for any Valve. State resistance (ohms) required when buying or be sure to give name of Valve and voltage of Accumulator supplying current to the Valve.

Cyldon Temprytes .. 2/6 each  
Holder mountings .. 1/6 each

If unable to obtain CYLDON products locally, write direct to:—

**SYDNEY S. BIRD & SONS,**

CYLDON WORKS, SARNESFIELD ROAD, ENFIELD TOWN, MDDX. Telephone: Enfield 0672.

whichever way you look at it—



## you'll find the Glazite way better!

There isn't a single way in which GLAZITE isn't better. It's easier. It's neater. It gives perfect insulation. It's flameproof. It's damp-proof. It won't deteriorate in use. And it's cheaper!

Next time, use GLAZITE—the better way of wiring!

# GLAZITE

BRITISH MADE REGD.

COLOURED CONNECTING WIRE

[RED · YELLOW · BLUE · BLACK · WHITE and GREEN]

Obtainable in ten-foot coils, price 1s. 2d. per coil. Or in two-foot lengths—four assorted colours, 1s. per packet, from all radio dealers. Write for interesting descriptive leaflet to

The  
LONDON ELECTRIC WIRE  
COMPANY & SMITHS, LTD.  
Playhouse Yard, Golden Lane, London, E.C.2

Makers of Electric Wire

for over  40 years



JUDD

## “Ham-handed Henry” at the Garage down the road can't ruin this Accumulator.

WE have all had painful experiences with “Ham-handed Henry.” He is the man who takes our accumulators and puts them on charge without worrying overmuch about the charging rate. Sometimes they are charged too quickly, and sometimes they are taken off the mains before they are fully charged. In any case such rough-and-ready treatment is very bad for any Accumulator. That is to say, any accumulator *except* an Oldham O.V.D. This new Accumulator defies rough treatment. Although a slow discharge Accumulator it can be recharged rapidly. In fact, we ourselves have charged one fully within four hours and the cell was quite unharmed.

The ordinary slow discharge Accumulator, however, requires

a slow charge of not less than 30 hours. It takes a long time for the electrolytic action to percolate through to the centre of its thick plates. In the Oldham O.V.D., however, all the advantages of the slow discharge — its freedom for sulphation and its ability to hold a charge over long periods—are obtained by the use of a special laminated plate (patent applied for). The acid can act upon its several surfaces immediately. And because a girder-like construction is employed buckling is quite impossible.

An Oldham O.V.D. will save you money because it holds its charge longer than any other type of Accumulator. Call in for one this evening on your way home: Fill it up with acid and it is ready for immediate use.



**5/6**  
Charged  
ready for use  
—merely add  
acid.

Made by  
**OLDHAM  
& SON, LTD.**

Denton, Manchester

London Office—

6, Eccleston Place, S.W.1

Glasgow Depot—

120, Wellington Street

# Time Saving Tips

**L**OOKING around my friends who build wireless sets regularly, I am rather surprised to find, that whereas one man seems to complete his set very rapidly, another, with just as good equipment and technical knowledge, takes twice or three times as long. Investigating the matter, it occurred to me that a study of the reasons for this difference would be of interest to readers of *THE WIRELESS CONSTRUCTOR*, and might help them in their own work.

## Preliminary Preparations

The construction of a wireless set can be divided into three parts. Firstly, we have the assembly of the various components and accessories required; secondly, the securing of these components in their proper positions (this includes drilling the panel), and thirdly, the wiring up. Under all three headings there are great possibilities of wasting time.

Take, first of all, the assembly of the parts. Let us imagine that you have chosen a particular published design, and in the article accompanying it, you will find a list of components. Some of these you will have to buy new, and others will probably be found in your stock; but let me warn you at once to beware of falling into the error of supposing that you *always* have enough terminals, fixed condensers, grid leaks, valve sockets and other generally used components. Most home constructors do their work in the evening, and if even a single component is missing when we start work, a whole day may be wasted.

For this reason I suggest that before deciding what new apparatus you need, you make a point of actually placing *in front of you* those parts which you think you have in stock, not forgetting the necessary wood screws.

## A Universal Mounting Screw

It is surprising how many wood screws are used in making up a wireless set; for the majority of the components used are screwed to the baseboard and are now no longer attached to the panel in the old-fashioned way. I have just looked at my latest set—a three-valver of no particular complication—and found that over four dozen wood screws are used in securing the components to the baseboard.

You will find it a real economy as well as a convenience to go to your ironmongers and buy a gross packet of half-inch No. 5 round-headed brass screws. The price will vary slightly in different districts, but round about

By **PERCY  
W. HARRIS,**  
M.I.R.E.



2s. 9d. a gross seems to be the average figure charged. Put these screws into a flat, empty cigar box, and reserve this box for nothing but wood screws, placing in it any you take from an old set you may be disassembling. The practice of keeping all screws, metal and wood, together with nuts and other small pieces of apparatus in a single box is a fruitful cause of time wasting. You may consider this a trivial point, but a few minutes saved on every operation mounts up in all to a very considerable economy of time.



*The right method of stripping insulation from a covered wire.*

*The wire is held between the thumb and the knife blade. A quick twist and sharp pull severs the insulation cleanly.*

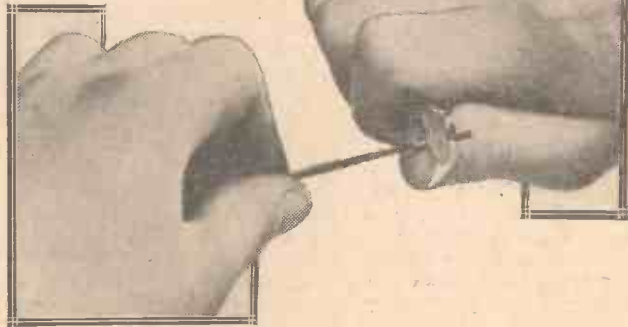

I have just referred to a three-valve set in which this size of screw is used. You may be interested to know that every board-mounting component is satisfactorily held in position by this size of screw. The only other securing screws used in the set are two 6BA countersunk head brass screws passed through holes in the panel for attaching the panel brackets. In passing, I may mention that half- and three-quarter inch 6BA screws with nuts will generally be found to be of adequate size to take the few components which are mounted on the panel itself.

## A Valuable Instrument

You will be very surprised to find how quickly the parts can be assembled in position if you have handy an adequate supply of the right size of wood screw.

The next time-saving device to which I wish to direct your attention is the centre punch. Having marked out your panel with the positions of the holes to be drilled, take a centre punch (it costs but a few pence) and a hammer, and make a small depression with it exactly where the drill is to be placed. This depression will take the point of the drill at once with no un-

certainty, whereas if you have no punch mark to guide you you will probably waste a good deal of time (and temper) finding the exact position to start the drill. Probably, you will make a bad error with one of the holes, particularly if you are working in a light which is none too good.

## Some Wiring Hints

Wiring up a set can be carried out by several methods. Some people prefer to use square-section tinned copper wire, others similar wire of round section, while still others have a liking for the glazed insulated wire which is also sufficiently stiff to hold its shape and position when bent. Personally, I rather favour the last type, as properly handled the set can be given just as neat an appearance, and the insulation is a useful safeguard if

## Time-Saving Tips—continued

anything should fall on the set and bring two wires close to one another.

A large number of components are now made with good serviceable terminals, so that connections can be made to them without the need of soldering. The use of these terminals is frequently a snare and a delusion for many home constructors fall into the trap of assuming that a neat connection between terminals is easily made. Do you remember what usually happens? A length of bare wire is taken, a loop bent in one end with a pair of round-nosed pliers, a quick measurement made between the two terminals

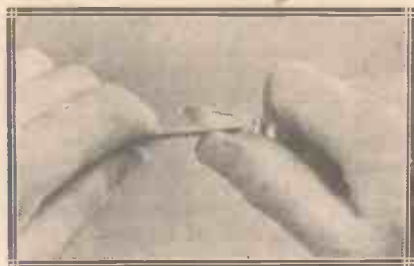

*Cutting the insulation is the first step in preparing insulated wire for soldering.*

and a further loop made at the other end of the piece of wire. Much to his annoyance, the set builder finds in nine cases out of ten that he has considerably shortened the wire by bending this loop—far more than he had anticipated—so that this particular lead has to be thrown away and another one made. Even an expert takes an appreciable time to cut off, measure and bend loops in a wire so as to make a neat connection between two points. A slight error in judging the size of the loop may render a lead useless, and I recommend you to avoid this method as one of the fruitful sources of time wasting.

### Is Soldering Quicker?

A much better method is to loop only one end of the wire and then to cut off the wire to such a length that it reaches within, say, an eighth of an inch of the terminal to which it is to be joined. Now place under the second terminal a soldering lug, and with the aid of a hot soldering iron a neat connection can be made very rapidly. By adopting this method an hour or two can quite easily be saved in wiring up simple sets, and the cost of the soldering tags is negligible. Excellent tags of this type can be obtained from several advertisers in this paper, and almost every wireless dealer selling small parts has a good stock of suitable lugs.

As a matter of fact, I doubt whether much time is saved by not soldering all connections, although if you are not used to a soldering iron you may make

a more satisfactory job at the beginning by adopting the looping method.

Many people like the appearance of the glazed insulated wire, but find trouble in using it owing to the ragged appearance the leads may take if the insulation is not properly removed. A very simple way of handling this wire is to hold it between the thumb, on one side, and the blade of a sharp pocket knife on the other, rotating the wire between the fingers of the left hand (the knife being held in the right), thus cutting through the insulation. A quick twist and a sharp pull on the insulation at the end which is to be bared will result in a neat, clean lead which can easily be soldered. Do not try to remove the insulation by the simple process of scraping. The insulation will be removed, but the appearance of the lead will be most unsightly. If by any chance you should leave any stray ends on the insulation hold a lighted match by them when they will burn off, leaving the wire much neater.

### Avoiding Mistakes in Wiring

Wiring up is always much quicker if one follows a definite plan. Some people prefer one method and some another, and it is not possible to find any one method which will suit all tastes. However, it will generally be found satisfactory if the blueprint or diagram is placed alongside of the set, and as each lead is made the corresponding line marked off on the diagram with a coloured chalk or red ink. As one lead after another is finished, you will soon find which remains. I strongly recommend you to follow some such method, even when working in conjunction with a "wiring in words" scheme, as it affords a double check. Nothing is more annoying than to find, after a set has been joined up to the batteries, that an important lead has been missed out, requiring the set to be placed on the work bench once more and the soldering iron heated up again.

It is always worth while carefully to examine the wiring diagrams of a set to see which lead should be placed in position first, for if the wiring is at all complex it is quite possible to find that a particular component is directly in the way of a connection which should have been made earlier, and that you cannot get the soldering iron near enough to the lug to make a joint. It is generally good practice to attach all possible wiring to the panel before this is joined to the baseboard, even if long, projecting leads are left for the time being. It is far easier to cut off the extra lengths than to add wire once the panel is in position.

Although it possibly belongs to an article on soldering, it is worth mentioning here that speed in making sol-

dered connections can only be attained if all points to be soldered have been previously well tinned. Take particular care to tin all terminal ends before you attempt to solder the wires to them. When this has been done and the terminals are again cool re-tighten all lock nuts which, in nine cases out of ten, will be found to be loosened by the heat applied. A properly tinned terminal shank can be soldered to a wire with a very rapid application of the hot soldering iron, and before there has been time for the heat to creep along the shank and soften the ebonite a second time. In any case, run over all nuts after soldering to make sure that they have not been loosened once more.

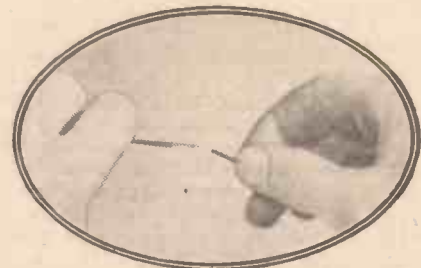

*When the knack has been gained by experience the insulation comes away cleanly; leaving the wire bare and no ragged edges.*

Another good soldering tip is to keep handy an old piece of rag (cotton, not wool) so that the dross can be wiped from the end of the soldering iron before new solder is applied. A quick wipe every time the soldering iron is used will do much to ensure a clean joint, for a dirty soldering iron will transfer much of the scum to the point to which it is applied.

### When Wiring up

The trouble about using components provided with terminals is that it is so difficult with milled-headed nuts to make connections which will remain tight. If the nuts are merely screwed down with the fingers, they are almost certain to become loose eventually, particularly if the set is moved about much. One can use pliers for tightening down terminals, but this is not a very satisfactory process, since they are liable to slip and disfigure the milling. The method which the writer has found most satisfactory is this:—The milled-headed nuts are removed from all terminals, and a loop is made in the end of each lead to be connected up. The loop is slipped over the shank of the terminal, a washer is placed over it, and a 4 B.A. or 6 B.A. nut, as the case may be, is then run on. The nut can be made really tight by using a box spanner and connections effected in this way are quite reliable.

# ORMOND TWIN CONDENSERS

ARE RECOMMENDED FOR USE IN THE "ALL-BRITISH SIX"

as described in the December "Wireless Constructor."

NOTE THE VERY LOW PRICES.

## LOW LOSS STRAIGHT LINE WAVELENGTH (SQUARE LAW).

Slow motion friction control movement with the ideal ratio of 55 to 1. Fitted with ball bearings to ensure smooth action. Rigid construction: moving vanes connected to heavily nickelled and polished brass end-plates. Negligible losses. Fixed vanes supported on best quality ebonite strips. No gears—absolutely silent action on shortest wave-lengths. The ratio is high enough for finest tuning: low enough for easy searching: direct drive used for rough setting. Terminals and soldering tags for connections. An ideal condenser for tuning two circuits simultaneously when stations received are referred to under the wavelength description. ONE-hole fixing. Complete with 3" knob and dial and slow motion knob.

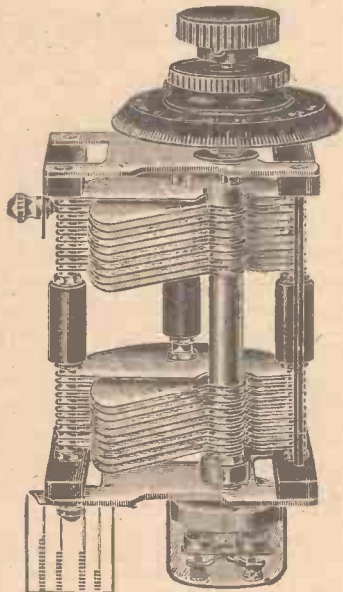

.0005  
(as illustrated)  
**23/-**

Patent applied for.  
Registered Design No. 719828.

### Other Capacities:—

.00025 " " 19/-  
.0003 " " 21/-

## LOW LOSS SQUARE LAW.

This Condenser was primarily designed for the purpose of tuning the anode circuits of two succeeding Radio Frequency Amplifiers when used in conjunction with matched coils or Radio Frequency Transformers. The centre lower terminal is connected to part of the circuit common to both amplifying stages usually positive High Tension, whilst the remaining two terminals are connected to the two anodes respectively. When used in this manner each circuit is tuned with its own .00025 mfd. condenser operated by one control knob. When used for tuning one circuit only, similar to a standard type variable, one of two methods of connection may be employed. If the centre lower terminal be ignored, and the upper and lower plate terminals be used, a variable condenser having a maximum capacity of .000125 mfd. is the result. Should a variable condenser having a maximum capacity of .0005 mfd. be required, use the centre lower terminal and the upper and lower plate terminals as one by bridging them with a connecting wire. Usual fine Ormond finish and ONE-hole fixing.

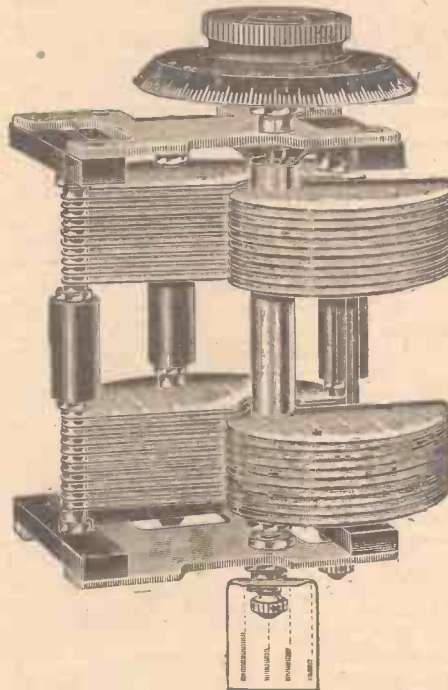

.0005  
(as illustrated)  
**16/-**

### Other Capacities:—

.00025 " " 12/-  
.0003 " " 14/-



199-205, PENTONVILLE ROAD, KING'S CROSS, LONDON, N.1

Telephone: Clerkenwell 9344-5-6.

Telegrams: "Ormondengi, Kincross."

FACTORIES: WHISKIN STREET AND HARDWICK STREET, CLERKENWELL, E.C.1  
Continental Agents: Messrs. PETTIGREW & MERRIMAN Ltd., "Phonos House," 2 and 4, Bucknall Street, New Oxford Street, W.C.1

# EFESCA



## "CENTADYNE" Screened Coils FOR NEUTRALISED CIRCUITS

Standard Coils Below Standard Prices.

SUITABLE for all star and other circuits described in "Modern Wireless" and "Wireless Constructor," employing 6-pin standard coils.

PRICES OF COILS WITH 6-PIN PLUGS.

	250 to 550 metres.	1,000 to 2,000 metres.
Aerial Coils, split primary	4/6	4/6 each
H.F. Transformers, split primary and optional reaction	7/6	7/6 each
H.F. Transformers, split secondary	7/6	7/6 each
Reinartz Coils	7/6	10/- each
Copper Screen with 6-pin base		15/- each
Unshielded 6-pin base for standard Coils when used without screen		5/- each

Ask your retailer or write direct for catalogue 573/1 of Efesca Components and circuits employing them.

FALK, STADELMANN & CO., LTD.,  
83/93, Farringdon Road, London, E.C.1.  
and at Glasgow, Manchester, Birmingham, Newcastle and Dublin.

### THE EFESCA FIXED RESISTOR

Comprising base with "Plug-in" resistance bobbin instantly interchangeable without disturbing wiring connections, for baseboard mounting.

Made in six sizes, 2/6 each.  
Spare resistance bobbins, 1/9 each.

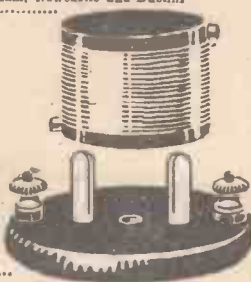

### THE EFESCA "CONCENTRA" NEUTRALISING CONDENSER

A new departure in design. The moving electrode telescopes into a fixed cylindrical plate being operated by a wormed spindle with long insulated handle providing 6 to 1 ratio vernier movement. While primarily designed for neutralising, it is equally suitable for use as a midget reaction Condenser. Arranged for either baseboard or panel mounting.

6/-  
EACH.

*Efesca Headphones  
Reduced to 15/-  
British and Best.*

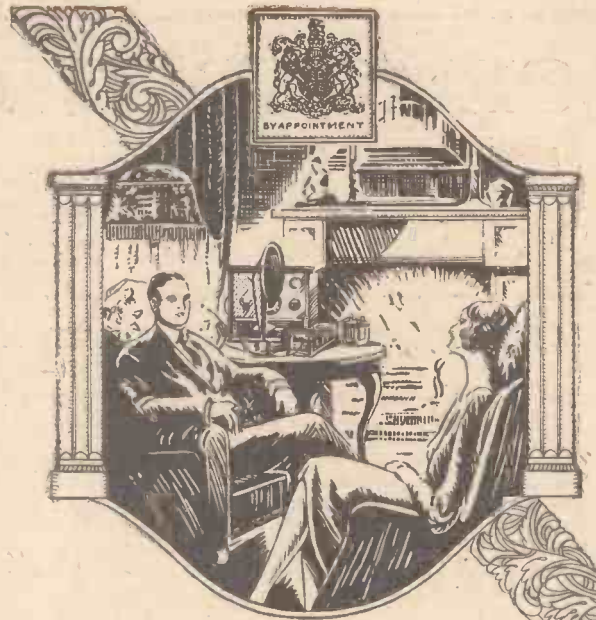

## Ideal Evenings with your Wireless Set

FOR real wireless enjoyment—purity of reproduction, freedom from distortion and ample volume of tone are, of course, essential.

Use "HART" BATTERIES with your set for both Low and High Tension supply and "wireless" will reveal new charms to you; their steady voltage, low resistance and exceptional reserve of power ensuring reception at its best.

Discard your dry batteries to-day and substitute the "HART" "RAY" type of High Tension Accumulator (20 volts 14/8, 30 volts 22/-, carriage paid). The marked improvement in reception will certainly surprise you.

# HART

THE BATTERY OF QUALITY

There are "HART" Batteries for all Low and High Tension Circuits. Write to Dept. "W.C.5" to-day for illustrated lists and full particulars.

HART ACCUMULATOR CO., LTD  
STRATFORD, LONDON, E.15



# The Query Corner

By JOHN UNDERDOWN

**E**VEN defective components have their uses. As the "wireless doctor" to a large group of friends, I learn much from these bad parts, for if it is possible for my friends to incorporate a defective component in a receiver invariably I am the victim. Recently I have experienced, or come into contact with, rather more trouble than is usually my fate, and this month I propose to deal with several faults which should prove of general interest.

## A "Kettledrum" Background

For some time a friend, who has been experimenting to obtain maximum purity of reproduction from the local station, has employed a three-valve receiver consisting of an anode bend rectifier, without reaction, followed by two resistance-coupled note-magnifiers, the last valve being of very low-impedance type to suit a number of cone-type loud-speakers.

The reproduction, excepting, perhaps, on speech, was exceptionally fine until, without warning, the background developed a noise which is best likened to the sound of kettledrums.

## Megger Tests

The set and the two cone speakers in use first came under suspicion and were tested with a megger, the batteries being dismissed after a cursory checking with a high-resistance voltmeter. All the components in the set came through the megger tests successfully, and the next step taken was to disassemble the cones, a step which I would strongly advise the average listener not to attempt; but on connecting up again the kettledrum background was as much in evidence as ever.

## The H.T. Supply

The H.T. supply, which consisted of three 45-volt batteries of the largest type obtainable, was the last to be suspected, since the batteries were practically new and three of the same make had rendered yeoman service for a year under much more exacting conditions. A high-resistance voltmeter was connected in turn across each 45-volt battery and was watched for five to ten minutes. Each battery showed

## "THE Wireless Constructor" Queries Department

### REVISED RULES

Letters should be addressed to Technical Query Editor, "The Wireless Constructor," The Fleetway House, Farringdon Street, London, E.C. 4.

They should be written on one side of the paper only, and MUST be accompanied by a stamped addressed envelope.

Queries should be asked in the form of the numbered questions: (1), (2), (3), etc., but may be accompanied by a short letter giving any necessary additional particulars as briefly as possible.

For every question asked a fee of 6d. should be enclosed. A copy of the numbered questions should be kept, so that the replies may be given under the numbers. (It is not possible to reproduce the question in the answer.)

A selection from the queries sent in by readers will be dealt with under this heading every month.

**BLUE PRINTS.** A series of 20 Blue Prints can be obtained from the Query Dept., price 6d. per Blue Print.

At the moment only a limited number of circuits are covered in these series and full details of the circuit arrangements available in Blue Print form are published monthly in the advertisement columns of this journal, but the series will shortly be extensively enlarged.

All other back-of-panel diagrams are specially drawn up to suit the requirements of individual readers at the following rates: Crystal Sets, 6d.; One-Valve Sets, 6d.; One-Valve and Crystal (Reflex), 1s.; Two-Valve and Crystal (Reflex), 1s.; Two-Valve Sets, 1s.; Three-Valve Sets, 1s.; Three-Valve and Crystal (Reflex), 1s. 6d.; Four-Valve Sets, 1s. 6d.; Multi-Valve Sets (straight-circuit), 1s. 6d. Except SUPER-HETERODYNE DIAGRAMS, all of which, irrespective of number of Valves used, are 2s. 6d.

If a panel lay-out or list of point-to-point connections is required an additional fee of 1s. must be enclosed.

Wiring diagrams of commercial apparatus, such as sets of any particular manufacture, etc., cannot be supplied. (Such particulars can only be obtained from the makers.)

Readers may submit their own diagrams, etc., for correction or for criticism. The fee is 1s. per diagram, and these should be drawn large, and as clear as possible.

No questions can be answered by phone.

Remittances should be in the form of Postal Orders.

its correct voltage at the beginning of the tests, but one, after a few minutes, gave a reading which continually fluctuated between the expected reading and one of three or four volts lower. On replacing the defective battery normal working was obtained.

## Daventry or the Local Station

A type of receiver which has many staunch adherents is the so-called Reinartz detector arrangement followed by one or two note-magnifiers, and when switching is incorporated so that Daventry or the local station may be obtained without changing coils the set becomes an ideal one for family use. The "Davlow Three" is on these latter lines, and it is with a set based on this design that the following unusual sequence of faults occurred.

I called some evenings ago at the house of a friend, and found him performing the last rites of wiring a receiver of the kind previously mentioned. The wiring finished, the set was connected up in the usual way, and, on applying to all valves an H.T. voltage of a low order, the brilliancy of the filaments did not increase, so that it was considered safe to proceed further. Suitable H.T. voltages were, therefore, applied, and, with the switch adjusted to bring the short-wave coil in circuit, an attempt was made to obtain 2LO. After some minutes the transmission was heard, but only at a whisper on the 'phones.

Something was obviously radically wrong. The telephones were therefore connected across the second choke—i.e.,  $Z_2$  of the filter circuit—in order to determine if the fault was in the latter arrangement. With this change of connection signal increased to good telephone strength, but was by no means what it should have been, reviewing the fact that the set was situated at only 15 miles from the London station.

## The Filter Circuit

However, it was decided to rectify the fault in the filter circuit before proceeding further, and with this object in view the 'phones were again

(Continued on page 367.)



## POACHERS ON THE BROADCAST WAVELENGTHS

The new Geneva wavelength scheme has by no means rid the broadcast waveband of interference, as our contributor very clearly proves in the following article.

By R. W. HALLOWS  
M.A.

**T**HOUGH it has done a very great deal to make reception conditions better, the new wavelength scheme now in operation has by no means rid the broadcast band of all interference. The spacing of stations so that there is a frequency difference of ten kilocycles between the carrier wave of any main station, or of any group working upon a common wavelength, and those immediately above and below, has done much towards the elimination of one very unpleasant source of interference, the jamming caused by one station directly heterodyning another.

### When Multi-Valvers were Useless

Before the change was made conditions were so bad that it was not uncommon to find as many as three or four stations on wavelengths close together all heterodyning each other and producing an amazing medley of whistles and squeals. On most nights, in fact, the multi-valve set was of little more real use than the single-valver or even the crystal, for the local station was the only one that could be received with any pleasure, and even its transmission at times might suffer in this way.

### A Pressing Problem

To-day, with an efficient set incorporating one or more stages of high-frequency amplification, one can be fairly certain of finding at least a score of stations, home and foreign, which are coming through without any heterodyne. So far, so good. But how many of this score will be free from undesired accompaniments of other kinds? Some will undoubtedly be spoilt by mush, others by continuous wave transmissions, and others again by spark signals. To-day the most pressing problem confronting the broadcasting authorities in all European countries is that which is concerned with the encroachment upon the broadcast band by large numbers of transmissions which have nothing to do with broadcasting.

Under the new scheme wavelengths lying between 196 metres and 577 metres are assigned to broadcasting stations. In theory this band should be almost exclusively theirs, with certain small exceptions. Ships and shore stations, for example, are authorised to carry on Morse traffic on 300 metres, and the 450-metre wavelength is allotted to direction-finding services. If the "exceptions" were confined to these two wavelengths we should have nothing much to grumble about; unfortunately, they are not in actual practice.

### Why Coast-dwellers Suffer Most

It is impossible to tune a spark transmitter very sharply at the best of times, and the tuning may become very flat indeed if tight coupling is used; it may, in fact, take somewhat the form of the curve shown at B in

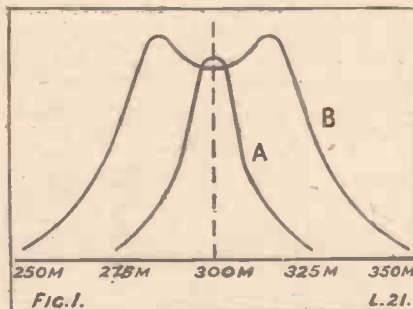

Fig. 1. The double hump, caused by a tight coupled transmitter.

Fig. 1, with two pronounced humps. A transmitter tight coupled so as to produce such a curve would, when tuned nominally to 300 metres, radiate signals very powerful on 275 and 325 metres and be capable of causing considerable interference on all wavelengths between about 260 and 340 metres at short or medium range. The maximum percentage of coupling permissible with a spark transmitter is laid down in the regulations, but to judge by some of the signals that one hears, the rules are not always strictly complied with.

Even under the best conditions the nominal 300-metre and 450-metre transmissions are not confined to these two wavelengths, but cover bands on

either side of them whose width depends partly upon the degree of coupling used, partly upon the power behind the signal, and partly upon the distance between the transmitting aerial and that of the would-be listener to broadcasting stations. It is by reason of this last consideration that those who live on or near the coast suffer more from spark interference than dwellers inland.

But the breadth of the interference band is not due entirely to any of the reasons already given. Some operators who have important messages to transmit and are unable to establish communication on either the 600-metre or the 300-metre wavelengths, make use of others. Hence we not infrequently find spark signals occurring on wavelengths where they have apparently no right to be; so much depends upon the individual operator's idea of the "importance of the message" and of the "impossibility of establishing contact" on the normal shipping waves!

### Invasion of the Broadcast Band

One seems to remember having heard long personal conversations about nothing in particular between ships' operators, on wavelengths far removed from those allotted to them, at times when one could detect no undue amount of traffic on either shipping band. No one would maintain for a moment that any consideration for broadcasting should hamper the sending of a really important communication between two ships, from ship to shore or shore to ship; we all realise the importance of wireless to the seaman in the conduct of his hazardous calling.

Nothing must prevent him from making full use of his transmitting and receiving gear in times of emergency or stress; but there is no doubt that not a little of the spark interference from which we suffer at present is due to certain operators—particularly foreign ones—spending little time in endeavouring to get through on their proper wavelengths and to the occasional abuse of the spark  
(Continued on page 353.)



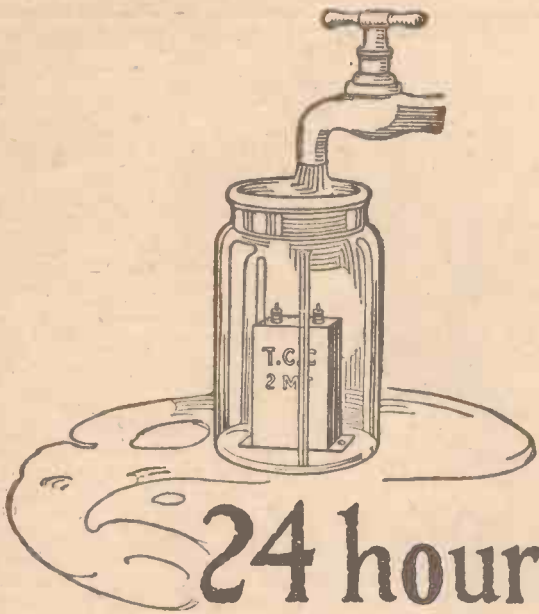

**24 hours**  
of this cannot  
harm the T.C.C.'s  
insulation

**THAT'S** some test, isn't it? Think of it. A whole day and night totally submerged in water! Even after this stringent experiment the insulation of the T.C.C. Mansbridge Condenser is unharmed. Thus, once more, our claim for 'metal for perfect insulation' is vindicated.

The metal case of the T.C.C. Mansbridge is impervious, not only to these conditions, but to every climatic change. Nothing can penetrate it; for insulation it is supreme. This is but one reason why you should choose T.C.C. There are others, numerous and convincing. The twenty years experience which is behind every T.C.C. is another. An experience which makes it possible to produce a Condenser which is guaranteed up to the hilt. To be dead accurate in its capacity. To be leak-proof. To be breakdown proof. In short, to be utterly reliable.

When you build your next Set, make sure that, at any rate, your Condensers are beyond fault. Even though they cost a little more, see that they have the letters 'F.C.C.' stamped on the side of their green metal cases. It may mean just the difference between success and failure. T.C.C. Mansbridge Condensers come in capacities from .009 to 2 mfd., priced 2/- to 4/8. From all Dealers.



**T.C.C. Condensers**

Adv. Telegraph Condenser Co., Ltd., Wales-Farm Rd., N. Acton, W.3. G.A. 6706



# Details

"Take care of the pence and the pounds will take care of themselves," is an adage well worth considering if you want really fine Radio reproduction. Small details, especially where anode and filament currents are concerned, unless carefully checked, frequently ruin an evening's programme.

Economical operation of your Set is only possible by correct adjustment of filament, plate and grid voltage.

See that your low and high tension supply is absolutely correct—test it with a reliable High Resistance Instrument, that is, a Weston Voltmeter with a sensitivity of 125 ohms per volt. Weston Model 506. Pin Jack Voltmeter is designed specially to measure accurately both filament and plate voltage, but will prove of great service for ordinary continuity tests. It is another of the wide range of WESTON products that are now recognised as standard throughout the world, and it reveals that same excellence of design and workmanship for which the name WESTON has been famous since 1888

## WESTON Pin Jack Voltmeter

Price complete with testing cables

£2 : 10 : 0

**WESTON**  
STANDARD THE WORLD OVER  
Pioneers since 1888

Weston Electrical Instrument Co. Ltd,  
15, Gt. Saffron Hill,  
London, E.C. 1

## Announcing the COPEX "POPULAR MODEL" Copper Coil Screen and Base



Copper Screen and interchangeable 6-pin base: (Patent No. 259,459) Beautifully finished:

# 9/6

As the originators and patentees of the Interchangeable Coil Screen, we have used our utmost endeavours to make the Copex Copper Coil Screens superior to all imitations now on the market. The salient features of these Screens are as follows:—

- (1) High Grade Copper is used for the screen—other metals cannot give the same degree of efficiency.
- (2) Copex Screens are sprung on to the copper base, and may be revolved on the base, thus giving perfect electrical and self-cleaning contact.
- (3) The novel arrangement of the terminals entirely prevents accidents when replacing the screen.
- (4) The lacquered finish of the screens prevents tarnishing.

The "de luxe" (original) model is still available at 15/-.

**Copex "O.C." type Screened Coils for use with above** embody a special patented feature which makes them far superior to other types of screened coils.

The chief advantages gained by the use of Copex "O.C." coils are:—

- (1) Oscillation is rendered perfectly under control.
- (2) Higher amplification is obtained.
- (3) All Copex Coils and Transformers are matched within one metre, this accuracy being attained by testing against Quartz-Oscillator.

**PRICES:**

Type.	Split Primary.	250-550 M.	1000-300
Aerial Coil ..	—	6/-	6/-
S.P. type ..	10/6	10/-	10/-
S.S. type ..	10/6	10/-	14/-
Reinartz type	Coil ..	—	10/- 14/-

### Special Six-pin Base.

To replace the more expensive standard screened coil base in sets where the actual screen is not required: Standard spacing with terminals arranged for easy accessibility



2/9

### Keystone Fixed Resistor.

No. 4 for .25 amp. valves with 6 v. accumulator.

No. 17 for .06 amp. valves with 4 v. accumulator.



2/6

### Keystone Neutrodyne Condensers.

For use in the "King of the Air" and many other popular circuits. Beautifully made and fully tested and guaranteed.

Board Mounting - 5/- Panel Mounting - 6/3

Balancing Condenser, equally well made - 7/6

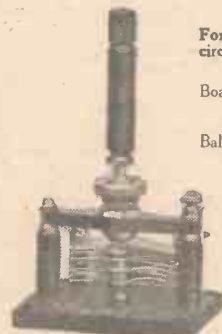

Do not fail to send for the new edition of the "Pilot Manual." Fully illustrated and containing much useful advice, this book should be in the hands of every enthusiast. 6d. Post free.



### THE PILOT MANUAL

## PETO-SCOTT CO., LTD.

Head Office & Works: 77, City Road, LONDON, E.C.1

Branches: 62, High Holborn, London, W.C.1. WALTHAMSTOW—230, Wood St. PLYMOUTH—Bank of England Place. LIVERPOOL—4, Manchester St.

P.S.6705

## a new and better valve holder



When we introduced the C.E. PRECISION RHEOSTAT, we thought that in quality, in efficiency and in price, this Component could not be beaten.

Now that we have added the C.E. PRECISION FLOATING VALVE-HOLDER, we find it even excels the former in these respects to such an extent that the demand has been amazing and we are working to maximum capacity to keep pace with the orders.

Before purchasing other makes just ask your dealer to show you ours. We are confident that after comparison they will have the preference.

C.E. PRECISION FLOATING VALVE-HOLDERS, anti-capacity, non-microphonic, 2/3 each.

C.E. PRECISION RHEOSTATS, efficient and velvety, 50 and 30 ohms, 3/- each; 7 and 15 ohms, 2/9 each. Dual Rheostats and Potentiometers, 3/9 each.

C.E. PRECISION GRID-LEAK, an entirely original and accurate component, 2/- each.



FOR UTMOST  
C.E. PRECISION  
EFFICIENCY

If unobtainable, please send us the name of your dealer.

C. EDE & CO., LTD., BYFLEET, SURREY

Telephone: Byfleet 226.

Telegrams: "Ceprecise, Byfleet."

# THIS IS THE VERNI-NOB!

The Verni-Nob does all the work of a Vernier attachment or Vernier dial and increases the selectivity of your set.

PRICE

## 6d.

From all dealers,  
By post, 7d.

Positive drive. No backlash. 10 to 1 reduction with 3" dial, 16 to 1 reduction with 4" dial. Over 8,000 were sold during the Wireless Exhibition at Olympia.

Fitted in a few moments.

Prov. Pat. 27071 and 22489

THE  
M.A.P  
Company,

246, Gt. Lister Street,  
BIRMINGHAM.



## Poachers on the Broadcast Wavelengths—*continued*

transmitter for sending trivial communications during broadcasting hours and upon broadcast wavelengths.

Fig. 2 represents diagrammatically the amount of the broadcast band which is taken up by spark interference. The heavily shaded portions show the wave-bands upon which such interference is the rule rather than the exception, whilst those lightly shaded indicate the areas in which it is frequent. Were we to shade in also the portions in which occasional spark interference occurs there would be few or no white areas in the diagram.

### D.F. for Trawlers

Those readers who have endeavoured to tune in stations, such as Bordeaux PTT, Belgrade, or Karlstad, must certainly have come across very flatly tuned and very powerful spark transmissions whose messages are sent so slowly that it becomes quite difficult for those used to greater speeds to read them. If you care to take down one of these transmissions you will find that it is something like this:—

"Fifty-five forty long four twenty" (standing for: Latitude 55° 40', longitude 4° 20'), which is sent three times or more, the numbers being spelt out letter by letter. This appears to be a direction-finding service for trawlers, and any such service must do an enormous amount of good work. One could, however, wish that the tuning was a little sharper, for as it is signals are very clearly audible between 220 and 240 metres, even at my station, which is some eighty miles from the coast.

### The Spark Accompaniment

Of the 300-metre band we have spoken already. Above it is shown a lightly shaded portion extending up to 340 metres, upon which interference is frequent. Another lightly shaded band occurs between 415 and 430 metres, and above this comes the band surrounding the 450-metre wavelength. A little higher up we reach another area of frequent interference, the offenders in this case being mainly French coastal stations. I sometimes wonder whether there is something in the air of France that causes operators to wander about the wavelengths! Certainly few finer examples of such straying could be found than Toulouse under the old broadcasting scheme and the French coastal stations. From about 535 metres upwards we come into the tail end of the nominal 600-metre transmissions, and it is seldom that broadcasting stations with wavelengths higher than this can be heard without a spark accompaniment.

The worst of spark transmissions is that in addition to their flat tuning they have much the same effect upon

our aerials, if the range is not very great and the power used is fairly big, as atmospherics. Both consist of heavily damped wave-trains, which are liable to cause aerials to oscillate at their natural frequency; the result is that, no matter how selective the receiving set may be, the interference cannot be got rid of.

### Out of Date Apparatus

The spark transmitter is really out of date to-day for many reasons. It is almost, if not quite, as expensive to instal as valve-transmitting gear, and it requires far more power behind

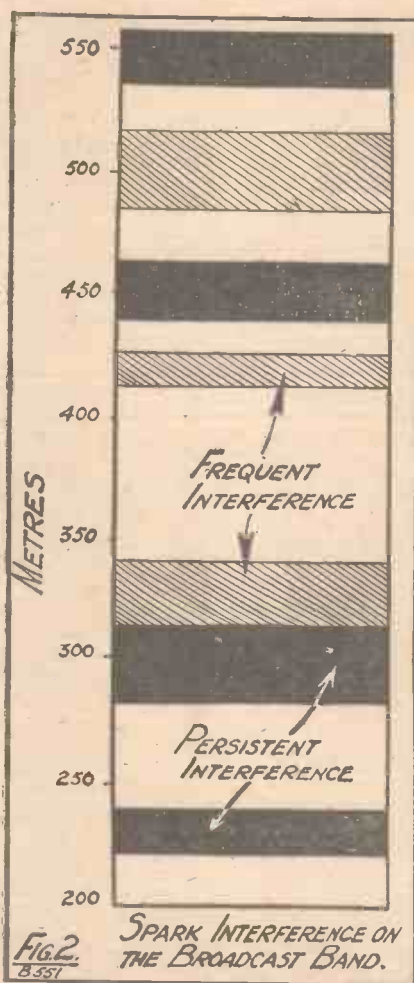

How badly broadcasting is jammed by spark interference can be seen from this diagram.

it to cover a given range. It is apparently still retained for shipping use, largely because its signals can be heard upon the simplest form of crystal receiver. Most valve sets, however, designed nowadays for shipping use can make use of tonic train or chopped C.W. instead of continuous

waves, and this kind of transmission can be received with the crystal. Until the valve transmitter comes into universal use we shall, I fear, always experience interference upon the broadcast band.

Next in importance to spark signals comes mush—that queer confused background of noise due to harmonics of continuous-wave and arc stations that all long-distance workers know so well.

When mush is bad it forms a kind of impenetrable screen covering the broadcasting stations upon the wavelengths where it occurs; if it is only mild it provides an irritating little accompaniment to their signals, making both speech and music sound unnatural and unpleasant. The engineers who designed the great station at Rugby have shown that if due care is exercised and modern methods are employed, harmonics can be eliminated entirely from the transmissions of powerful stations. It is to be hoped as time goes on that more and more of these will be brought up to date and that mush will gradually disappear.

### Harmonics from 5XX

In some cases C.W. harmonics are to be heard as distinct signals, not as mush. If the carrier wave of a C.W. transmission happens to heterodyne that of a broadcasting station, the signal may be heard, though the receiving set is not oscillating. Continuous wave harmonics used to cause a great deal of interference with Birmingham when he was on his old wavelength, and they are now often to be heard accompanying the transmissions of foreign stations on wavelengths between 460 and 500 metres. They occur also in the band immediately below London's wavelength.

Continuous wave stations, however, are not quite the only providers of harmonics; in certain parts of the country those of 5XX are at times very powerful. At my station I have logged at one time or another the fourth, fifth, sixth, seventh, eighth, ninth and tenth harmonics of this station. The fifth was at one time so strong that it was possible on any morning to receive Daventry's programme on 320 metres between eleven o'clock and one on the loudspeaker, using only three valves. Of late I have not noticed this harmonic, or, indeed, any of the others, except on a few odd occasions.

### Can Poaching be Stopped?

It is clear, then, that poaching upon the broadcast wave-band is very widespread, and that the regions free from interference are very few and far between. This is not as it should be, considering that the enormous importance of broadcasting to-day has

**POACHERS ON THE BROADCAST WAVELENGTHS**

—concluded

been admitted by our own Government and those of other countries. The band allotted to broadcasting is a small one, covering as it does only 381 metres. It is surely not too much to ask that, at all events during the evening hours, it should be kept free from poachers. One of the difficulties of the British Broadcasting Company in the past was that its complaints about interference were frequently overlooked since the authorities would not recognise that it had any official standing.

Now that the Broadcasting Board of Control is virtually a Government department, the position will be very much stronger, and one may well hope that something will be done. In the majority of European countries Governments have at any rate a partial control of broadcasting, and there seems to be no good reason why a united stand should not be made to get rid of the widespread and totally unnecessary interference, which does not add to the efficiency of the marine and coastal service, and which at present so often spoils reception.

\* \* \*

*How America solved the problem of gang control in variable condensers.*

\* \* \*

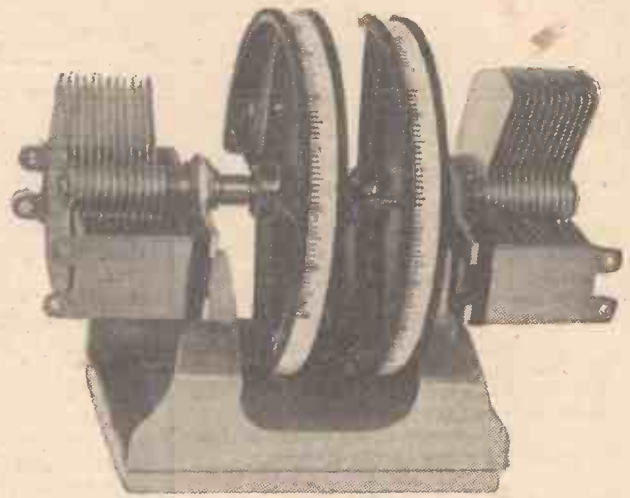

**POSITION OF CONTROLS**

**M**OST amateurs, in common with most ordinary people, are right handed and, therefore, the primary tuning controls should occupy a right-hand position on the panel.

An aerial tuning condenser is a "primary control," but a reaction adjustment should be treated as a secondary control inasmuch as it will (or should!) require smaller and fewer variations.

In a set employing but the two above controls the solution of the panel posi-

tion problem is easy, but when a receiver is to incorporate several tuning controls the question becomes more difficult.

It is nice to have all the dials and knobs symmetrically arranged, but if this condition cannot be attained without sacrificing accessibility and operating convenience, then it will be as well to eschew the former consideration.

Constructors building sets with no other guidance than that provided by a theoretical circuit diagram should bear the above points in mind.

**MAGNADYNE**

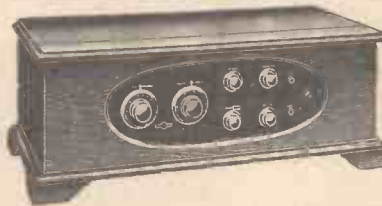

**Super-Het.**

With all the recent remarkable improvements and developments in High Frequency Amplification, the Super-Het, properly designed and constructed, still stands pre-eminent as a super-selective long-range receiver. No pains have been spared to bring the Magnadyne to a pitch of perfection hitherto unapproached by any other type of receiver. A switch is provided in order that the local station may be received on 4 valves only, thereby economising H.T., L.T. and the life of the valves. Perfect reproduction is assured, and the range of reception is limited only by atmospheric conditions.

In order to assure ourselves that every Magnadyne fulfils the claims made we are not supplying the component parts for home construction.

Every receiver is thoroughly tested in our works and carries a year's guarantee. Any fault which may develop in workmanship or material within this time will be rectified or replaced free of charge.

**THE NEW MAGNADYNE**

in finest quality hand polished Mahogany Cabinet, with Calibration Chart, including Folding Frame Aerial, Extra Oscillator, H.F. Transformer and Loading Coil for high wave-lengths and Eight Valves.

**£45:0:0**

Plus Marconi and Western Electric Royalties, £6 10s.

**MAGNUM SCREENED COILS**

**NEW STANDARD COILS and PRICES.**  
MAGNUM Screening Box, complete with 6-Pin base (Standard spacing and cross formation) .. 15s.



<b>Split Primaries.</b>		<b>s. d.</b>
Aerial Coil ..	250/550	6 0
H.F. Transformer, 250/550		10 0
Aerial Coil ..	1000/2000	6 0
H.F. Transformer, 1000/2000		10 0
<b>Split Secondaries.</b>		
H.F. Transformer, 250/550		10 0
H.F. Transformer, 1000/2000		14 0
Reinartz Coil ..	250/550	10 0
Reinartz Coil ..	1000/2000	14 0
Price per set of 3 Screens and Coils, 250/550, for the Elstree Solodyne ...		£3 11 0

**MAGNUM RESISTORS.**



No. 1059.

Supplied in ranges to suit all types of Valves.

Note.—When ordering, state make and type of Valve used and voltage of accumulator.

Magnum Resistors eliminate unsightly knobs, ensure correct filament temperature, and prevent overrunning.

Price:

Resistor on Base ..	..	2/6
Resistor only ..	..	1/9
Shorting Plug ..	..	1/-

Size:

Overall size of base	2 1/2 in. x 1 1/2 in.
Overall height	1 1/2 in.

**BURNE-JONES & CO. LTD.**

Telephone: Hop 6257.

Send stamp for comprehensive range of Lists.

Manufacturing Radio Engineers, 288 & 296, Borough High St., London, S.E.1

**MAGNUM HOUSE,**  
Cables: "Burjomag, London"

# 30 STATIONS ON THE LOUD SPEAKER

during a three-day gale in the  
**BAY OF BISCAY!**



These remarkable results were achieved—appropriately enough—by a “PILOT” set.

We print below—exactly as received—a letter which reached us on 11th December, 1926, concerning the performance, under enormous difficulties, of a standard “PILOT” receiver.

**THE ORIGINAL OF THIS LETTER MAY BE SEEN AT OUR HEAD OFFICE—77, CITY ROAD, LONDON, E.C.1**

To Messrs. Peto-Scott, Ltd.  
77, City Road, E.C.1.

s.s. \_\_\_\_\_ at \_\_\_\_\_ U.S.A.  
November 21, 1926.

Dear Sirs,  
I wish to heartily congratulate you and Captain Tingey on the results attained by the “Solodyne” you supplied to me.

It has come through a trying ordeal with flying colours—it resides in an unused bath-room, just over the steering engine and adjoining the engine room—in spite of that and a three-day gale in the Bay the set functioned perfectly and the calibration of it is excellent.

The vibrations are so intense, even in a calm sea, that the valves are never still—your set is invincible, and I am giving our cousins over here quite a surprise; they are full of admiration—the wiring and cabinet coming in for great praise.

Yours truly,

P.S.—At a position 720 miles west of Finisterre the set brought in—Aberdeen, Dublin, Oslo, Stockholm, Lemberg, Rome, K.D.K.A., and twenty odd others at loud-speaker strength, this during the last of a really bad three-day gale. This gives you some idea of the range although handicapped with only 84 volts H.T. instead of 120 volts.

**U.S. STATIONS—63 TO DATE.**

The ship has come out in ballast, so you can imagine the sort of vibrations when her engines raced—in spite of which your work is as good as when it left your hands.

## THE SOLODYNE

(5 Valves—1 Dial—50 Stations).

Easily the most popular set this season. Merely rotating the one dial brings in station after station at full loud-speaker strength. The set is so simple that a child could operate it, and yet its range includes all the important B.B.C. and Continental Broadcasting stations, which can be heard with amazing clarity.

	£	s.	d.
Finished instrument, complete with B.B.C. coils, but less valves, etc., Marconi Royalty paid ...	27	7	6
Complete set of parts ...	13	17	0
Polished and drilled Ebonite panel ...	0	11	6
Polished Mahogany Cabinet ...	4	5	0

**ALL BRITISH MONO-MODEL. Finished Instrument ... £41 0 0**  
(exclusive of accessories and Marconi Royalties)

**BUY YOUR “PILOT” SOLODYNE NOW—**

**THERE IS NO FIVE VALVE SET TO EQUAL IT.**

Installation free within 50 miles of any of our branches—Every set tested and calibrated by Capt. R. W. TINGEY, M.I.R.E.

\* If a complete set of parts is ordered Marconi Royalties at 12/6 per valve holder are payable.

**THIS MONTH'S SETS.**  
Parts for all the sets described in this month's issue are now available. Save time by ordering all your parts from us in one parcel, and remember that our Technical and Service Dept. will advise and help you free of charge. Detailed price lists for new sets on application.

Details of the above and many other up-to-date sets appear in the new edition of the “Pilot Manual.” Fully illustrated and containing much useful advice, this book should be in the hands of every enthusiast. Post free



## THE PILOT MANUAL

# PETO-SCOTT CO., LTD.

Head Office & Works: 77, CITY ROAD, LONDON, E.C.1

Branches: 62, High Holborn, London, W.C.1. WALTHAMSTOW: 230, Wood Street; PLYMOUTH—Bank of England Place. LIVERPOOL—4, Manchester St.

P.S. 6705

*21 days test at our expense*



## 1927 IMPROVED MODEL H.T. ACCUMULATOR

**T**O prove our absolute confidence in these accumulators, we guarantee, if you are not satisfied, to accept return within 21 days from purchase date, and refund money in full provided battery is returned intact to the Agent from whom it was purchased.

C.A.V. H.T. Accumulators represent an epoch-making advance as compared with dry batteries. When dry batteries are down they are done, and frequent renewals make them more expensive. C.A.V. H.T. Accumulators will last for years, and only need recharging approximately every four months. They give bigger volume and are silent in operation. Every Accumulator is supplied fully charged ready for use, absolutely complete in case, and with distilled water filler, all included in the price, viz.:

**60 Volts 60/-**

Size 8½ ins. by 7 ins. by 7½ ins. high.  
Catalogue supplied on application.

**C.A. Vandervell & Co., Ltd.**  
ACTON, LONDON, W. 3.

Telephone: Chitwick 3601  
(Private Branch Exchanges)

Telegram: Vandervell-Act-London

**MUSIC AND THE LOUD-SPEAKER**—continued from page 342

higher notes, indifferently with those in the second octave below the middle C, and scarcely at all with those that are still lower. Now no musical note has a really pure single pitch. It is, indeed, a chord consisting of the fundamental or original note and its harmonics or overtones. And the reason why the same note affects the human ear with a different tone when played on a different instrument is the simple fact that each produces its own set of harmonics.

**“Putting In the Bass”**

For example, when a very deep note is played in the studio, it is quite likely that the loud-speaker with which you receive it will suppress the fundamental owing to its inability to deal with a low-pitched sound, but it will, on the other hand, bring out the harmonics of that note and these will allow the listener quite unconsciously to supply the fundamental. In fact, when listening to a loud-speaker the ear is assisting you to enjoy the notes you hear in a very extraordinary way, for it would seem that the ear has the gift of “putting in the bass,” which makes it possible for listeners to obtain enjoyment from the repro-

duction of music, whether by loud-speaker or gramophone, even though that music is a long way from being perfect.

**An Initial Requirement**

Subconsciously, of course, the ordinary listener knows that there is something lacking, and the trained critic has that feeling even more strongly. Some people complain that loud-speaker music often sounds thin, that the low notes are being suppressed to such an extent that even the wonderful human ear cannot make up for the deficiency. But just remember what a tremendous task it is for the loud-speaker; just look at the diaphragm of a loud-speaker, and then try to realise what an extraordinarily sensitive thing it is and how really well it does behave on the whole, despite the criticisms of an often over-critical audience.

To get the best out of a loud-speaker and to minimise its limitations as much as possible that loud-speaker must be given fair play. Remember that what you put into a loud-speaker it will just as surely give out again, and, in most cases, in a more emphasised manner. In other words, if a loud-speaker is given an inferior input it will inevitably give an inferior output. If we are going to bring out the best notes we must make certain that the transformers

used in the low-frequency side of the receiving set are the very best obtainable.

The valves must suit the transformers as well, for it is not generally appreciated that valves in the low-frequency circuit of a receiving set must be chosen with due observation of their relationship to the transformers. If good reproduction is to be obtained the last valve should be a power valve with adequate high tension, in order that it may deal with the big swings in voltage that will be imparted to its grid.

**Overloading a Speaker**

Grid bias must be used so that no flow of current occurs in the grid circuit. If transformers are not used, their place being taken by the properly designed resistance capacity method couplings, it will be found that signal strength is reduced but that a considerable improvement in quality will result, and whereas two low-frequency stages would be enough if transformer coupled, probably three stages would be required if the resistance-capacity method were used. In other words, what one loses on the swings one gains on the roundabouts, and people who prefer quality to quantity will realise, if they experiment, that resistance-capacity coupling is superior to transformer coupling.

(Continued on p. 358.)

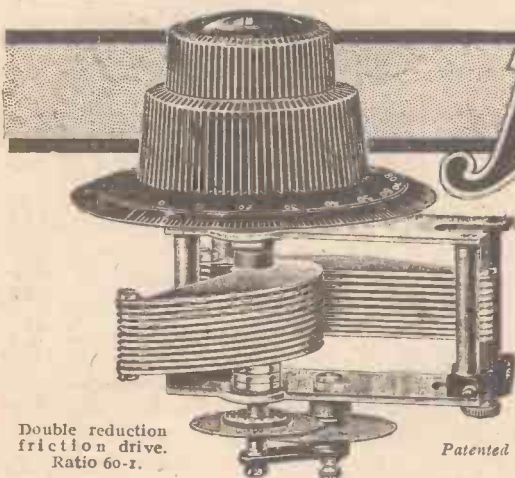

Double reduction friction drive. Ratio 60-1.

Patented

**THE J.B. TRUE TUNING S.L.F.**

The J.B. True Tuning S.L.F. embodies new and vitally important improvements, and solves for ever the tuning evils of the past. The J.B. True Tuning S.L.F. spreads stations so evenly over the dial that all stations on all wavelengths can be quickly and easily tuned in or out, and accurately logged. Ball-bearings ensure a wonderfully smooth control, and the beautiful finish of the complete condenser forms a perfect parallel to its real efficiency in tuning.



**THE J.B. TRUE TUNING S.L.F.**

PRICES, complete with 4in. Bakelite Dial :

.0005 mfd.	.. 16/6
.00035 mfd.	.. 15/6
.00025 mfd.	.. 15/-

**THE J.B., S.L.F.**

PRICES, complete with 4in. Bakelite Dial :

.0005 mfd.	.. 11/6
.00035 mfd.	.. 10/6
.00025 mfd.	.. 10/-

**JACKSON CONDENSERS**

**THE FINAL CONDENSER**

The Technical experts of all the leading Wireless Journals of to-day recommend the J.B., S.L.F. in the strongest of terms. The vanes in both the original J.B., S.L.F. and also the True Tuning S.L.F. are designed on a new principle which obviates crowding at any part of the scale.

The J.B., S.L.F. is more compact than most condensers on the market to-day. End plates are highly polished, all fittings are heavily nickel-plated, and it is fitted with a beautiful 4in. Bakelite Dial, which in itself adds distinction to any Receiver.

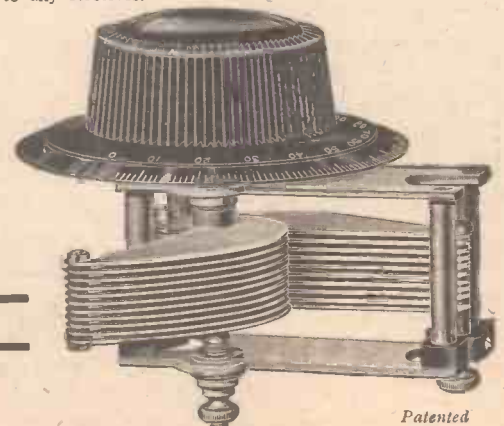

Patented

**JACKSON BROS.**  
 8, POLAND ST- OXFORD ST  
 LONDON - W.1. Telephone: GEFIRARD 7414  
 (First Floor)

# How to improve your Radio

Fit

# FERRANTI TRANSFORMERS



Type A.F.3 25/-

Type A.F.4 17/6

IN IRISH FREE STATE 32/6 and 23/-

## FERRANTI LTD.

HOLLINWOOD,  
LANCASHIRE.

Ferranti Ltd., Ferranti Electric Limited, Ferranti Incorporated,  
Bush House, W.C.2. Toronto, Canada. 130, W. 42nd Street, New York.



## Ever Cracked Walnuts?

The shell looked all right ; big, brown, inviting. In fact, you picked it out on size. It *looked* good. But when you cracked it—nothing.

There are batteries like that. To look at 'em, you'd think they housed a power station. But give them a clock-and-ammeter discharge test. That is—crack them . . . nothing.

Get a P. & R., though, and you get *capacity*, you get service ; plates sturdied to work and keep working ; terminals petroleum-jelly packed to stop creep ; a "Dagenite" cell case which is leak- and acid-proof ; wood interplate separators tested and re-tested ; a battery with a guarantee ; which costs no more than the ordinary kind ; the battery which is fitted to Rolls Royce cars.

Isn't it worth writing to us for particulars? Especially since any one of the P. & R. range of all types and sizes costs no more than an ordinary battery.

PETO & RADFORD,  
50 GROSVENOR GARDENS, LONDON, S.W.1

# P AND R

AND  
PETO & RADFORD  
ACCUMULATORS  
*The beginning and the end in*  
**POWER**

D 3

**MUSIC AND THE LOUD-SPEAKER**—continued from page 356

Much could be written about transformers in their relation to loud-speakers, and much, much more, could be written about the proper way to handle a loud-speaker, but for the purpose of this article it is enough to point out in a general way the simple and fundamental fact that what you put into a loud-speaker it will turn out in a much more emphasised form. Therefore, if you overload your loud-speaker, that is to say, if you push it beyond its capacity, the results will also sound overloaded. They will be raucous, harsh, thoroughly unmusical, but whereas if you take all possible pains to see that the quality of the input to the loud-speaker is of the highest possible class, you will find that the average high-class loud-speaker is faithful and will reproduce it relative to what you have put into it.

You do not expect to put a rabbit into a mince grinder and have that grinder produce you a fully baked rabbit pie. You will get the rabbit again, perhaps in a different shape, but fundamentally the same, with possibly its more unpleasant points emphasised. The same with a loud-speaker. The analogy holds good.

**RECTIFIER PROBLEMS**  
—continued from page 330

for by this cause also. In discussing the question of efficiency with a valve rectifier for eliminator purposes, it is only fair to say that since the total amounts of electrical energy are comparatively small, the question of electrical efficiency (considered from the engineering or scientific definition of "efficiency") are of quite minor importance compared with the considerations of convenience and proper functioning. It is usual to employ a stepdown transformer for the purpose of providing filament current at about the correct voltage, and a few extra turns of wire on the low-tension side of the transformer serve to provide the heating current for the filament of the valve rectifier.

**Patent Royalties**

Now let us turn to the electrolytic rectifier. Its first advantage is its comparative cheapness and the readiness with which it may be set up and maintained. Like the valve rectifier, it is absolutely silent in operation and, apart from the renewal of the elements at long intervals, it requires no more attention than the occasional addition of a small quantity of dis-

**SCHEDULE**

of Comparative Advantages and Disadvantages of Valve and Electrolytic Rectifiers.

VALVE.	ELECTROLYTIC.
High Initial Cost.	Small Initial Cost.
Royalty Payable.	No Royalty Payable.
Fragile.	Robust, Nothing to Get Out of Order.
Limited Life.	Unlimited Life.
No Attention Required.	Slight Attention. Occasional "Topping" with Distilled Water.
Energy Losses Unimportant.	Energy Losses Unimportant. Sufficiently High Breakdown Voltage. Two or more may be Used in Series.
High Breakdown Voltage.	Excellent Rectification, with Best Types.
Excellent Rectification.	Rectified Current Easily Smoothed Out.
Rectified Current Easily Smoothed Out.	Fairly Compact. Contains Liquid, Produces Moisture. Must be Kept Vertical.
Compact. Can be Carried in any Position.	Foolproof.

tilled water. It has the incidental advantage that no royalties are payable.  
(Continued on p. 360.)



**LOW-LOSS CONDENSERS.**

	Without Vernier.	With Vernier.
*001	12/-	17/6
*0005	9/6	15/-
*0003	8/6	14/-
*00025	8/-	13/6
*0002	7/6	13/-

**Utility**  
**GUARANTEED**  
**COMPONENTS**

These components are approved and preferred by Wireless Enthusiasts everywhere. In the "Utility" Low Loss Condenser, illustrated at side, the centre spindle rotates on ball bearings, all brass parts are nickel-plated, and all sources of loss removed. The "Utility" Gang Condenser (illustrated below) is the most efficient on the market. All the undesirable features usually found in this type have been eliminated.

Ask your Local Dealer to show you these and other "Utility" Guaranteed productions.

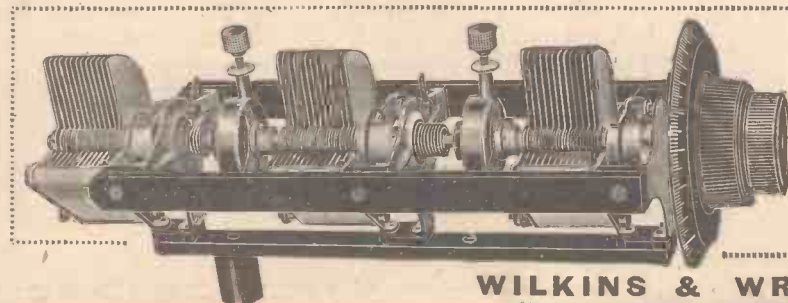

**"Utility" Gang Condenser**

Prices: \*0005

Quadruple Gang Condensers ...	£3 2 6
Complete with "Utility" Micro Dial ...	£3 10 0
Triple Gang Condensers ...	£2 7 6
Complete with "Utility" Micro Dial ...	£2 15 0
Double Gang Condensers ...	£1 14 6
Complete with "Utility" Micro Dial ...	£2 2 0

**WILKINS & WRIGHT LIMITED,**  
UTILITY WORKS, KENYON STREET, BIRMINGHAM.



# AMPLION Radio Valves



THERE ARE MANY LINKS IN THE CHAIN from the microphone in the studio to the loud speaker in your home. There are many transformations; each with its possibilities for interference and distortion. Your aerial circuit, your receiver, your batteries, your valves and your loud speaker—each may contribute its share. The Amplion Loud Speaker has proved itself the world over. Ask those who know—they will tell you that it is one of the reliable links. Another is to be found in the new Amplion Valve.

SEE YOUR RADIO DEALER—  
A DEMONSTRATION WILL CONVINCE.

*"No Better Radio Reproduction"*

Announcement of Graham Amplion Limited, 25, Savile Row, London, W.1

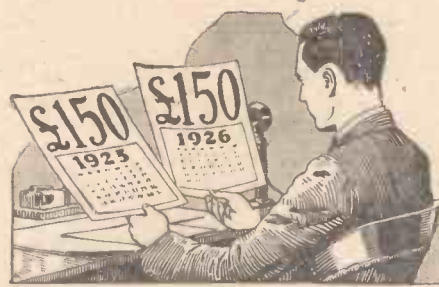

**"Two years' delay cost me £300"**

"I was £3 a week poorer for fully two years because I hesitated so long about starting an I.C.S. Course. That's clear enough. Since I woke up and began my vocational training with the I.C.S. I've been given a rise of £150 a year, but I'm certain I would have got it two years sooner had I sent in that I.C.S. Coupon when I first saw it.

"It's strange that so many young men fail to see that they don't get more money because they don't qualify for it—that they are losing £ s. d. all the time through neglecting to obtain a special training."

Get out of the rut by taking an I.C.S. Course. It will provide you with a sound and practical training in your own home and in your own time, all by correspondence and at a cost well within your means. There are no real difficulties and no heavy demands upon your time. The I.C.S. method is simple and practical. Let us tell you just how you can use it to your own great advantage.

Write to-day for full information as to how the I.C.S. can help you in your chosen vocation. There are 300 I.C.S. Courses, of which the following are the most important groups:—

The I.C.S. is the oldest and largest correspondence school in the world

## WIRELESS ENGINEERING (an entirely new Course)

- |                     |                            |                     |
|---------------------|----------------------------|---------------------|
| Advertising         | Engineering (all branches) | Professional Exams. |
| Architecture        | French and Spanish         | Salesmanship        |
| Building            | General Education          | Showcard Writing    |
| Commercial Art      | Market Gardening           | Textiles            |
| Commercial Training | Plumbing                   | Window Dressing     |
| Draughtsmanship     |                            | Woodworking         |

(Please mention the subject in which you are most interested.)

International Correspondence Schools, Ltd.  
172, International Buildings, Kingsway, London, W.C.2

NECESSARY for the EFFICIENCY of your RECEIVER.



ELECTRICAL MEASURING INSTRUMENTS.



PRICE 25/-

All SIFAM Voltmeters are now made with a minimum resistance 200 ohms per Volt.

SIFAM Instruments are GUARANTEED for RELIABILITY and SERVICE.

Sifam instruments can be obtained from all bona-fide Wireless Dealers. If any difficulty write to:—

The SIFAM ELECTRICAL INSTRUMENT CO.,  
Dept. C., 10a, PAGE STREET, WESTMINSTER, S.W.1.

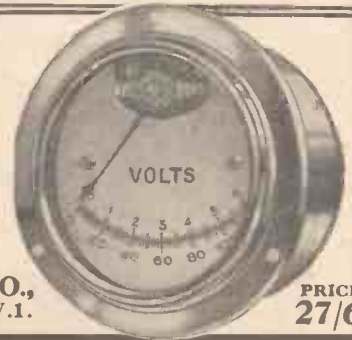

PRICE 27/6

## 9 FINE DESIGNS 25 SIZES ARTCRAFT CABINETS

MADE IN OAK AND MAHOGANY

"Artcraft Popular Type" Cabinets

Panel Size	Depth	Price in Oak	Price in Mahog.
10 x 8	6	8/0	12/0
12 x 10	8	12/0	16/0
14 x 10	8	14/0	19/0
16 x 8	8	14/0	19/0
18 x 12	9	21/0	29/0

Baseboards Free. Hinged Lids 1/6 extra.

CARRIAGE PAID England & Wales. Scotland, 1/- extra.

Radios, Resistors and Ebonart Panels Supplied.

THE ARTCRAFT COMPANY,  
156, CHERRY ORCHARD ROAD, CROYDON.

Parr's Ad.

ILLUS. CATALOGUE FREE.

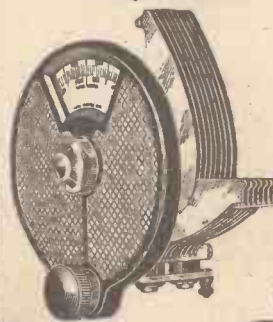

## ULTRA LOW-LOSS

Straight Line Frequency Condenser.

Cone Bearings. Braced Vanes. Positive Collector. A real precision job.

Condenser only, '0003uF., '0005uF. 7/6

New Vernier Dial 6/-

Reduction Ratio 16-1, No Backlash.

THE FORMO COMPANY,  
Crown Works, Cricklewood, N.W.2.

'Phone: Hampstead 1787.

Manchester: Mr. J. B. Levee, 23, Hartley St., Levenshulme. 'Phone: Heaton Moor 475.

**RECTIFIER PROBLEMS**

—continued from page 358

able for its use (that is to say, there are several electrolytic rectifiers on which no royalties are payable, although, of course, there are also many patented types). It occupies quite a small space and is at least as easy to pack away into the eliminator container as is the valve rectifier.

**Breakdown Voltage**

It has practically an indefinite life and the cost of maintenance is negligible. Its breakdown voltage depends upon the particular type of electrode and electrolyte used, but can easily be made sufficiently high for the purpose in view. Under proper conditions the rectification ratio is satisfactory and the energy losses in the rectifying cell are not important.

Its particular disadvantage is the fact that it contains a liquid, and therefore is apt to produce fumes or, at any rate, moisture, within the eliminator container, and it must also be maintained in a vertical position.

**A "Floating" Accumulator**

The electrolytic rectifier, and particularly the tantalum type, owing to

the peculiar mechanism of the rectifying action, gives a rectified current which is especially adapted to subsequent smoothing out. In fact, I have myself used a tantalum rectifier in series with the low-tension output side of the transformer and straight on to the filament of the set, the only smoothing device being a small "floating" accumulator bridged, of course, across the filament input terminals of the set, without the slightest trace of hum being perceptible.

**Hard to Choose**

The reader will see from the foregoing that it is impossible to state which of the two—the valve rectifier or the electrolytic rectifier—is to be preferred, as this depends upon circumstances. Broadly, I should say that for commercial eliminators, to be manufactured and issued complete and to require little or no knowledge on the part of the user, the valve rectifier was the more suitable; but for the home constructor and the experimenter I should say that the electrolytic rectifier, and particularly the tantalum rectifier, has much to recommend it. Personally, I have used the latter type of rectifier very considerably and I believe not only that it has come to stay, but that increasing applications will be found for it in the future.

**THE EDITOR'S CHAT**

—continued from page 318

use the mains supply as a substitute for the present accumulators and dry batteries. While considerable progress has been made in this direction, there are still many points of difficulty, and Dr. J. H. T. Roberts, F.Inst.P., elucidates some of them in his article "Rectifier Problems." Dr. Roberts has promised some further articles on the subject at an early date.

**Modernising Popular Sets**

Next month the important subject of bringing your old set up to date will be discussed. Thousands of readers possess sets which are quite satisfactory in many respects, but lack the advantages which come from modern improvements. Many of these improvements can be incorporated at a relatively small cost, and make a remarkable difference to efficiency. Practical details of the changes necessary in some of the most popular receivers of the last few years will be given, together with general hints applicable to all sets.

Readers who are anxious to have details of how to modernise some particular design are invited to drop a postcard to the Editor naming the set in question.

**Look out for this S.T.61A**

—a new resistance-capacity valve



**WE** are daily being asked for a 6-volt resistance-capacity valve having a specially high amplification factor. We are now able to state that, after months of experiment on numerous models having amplification factors ranging from 20 to 50, we have arrived at the best design—which, moreover, will embody the new torodium filament. It will be non-microphonic, and will not sacrifice life for performance.

Supplies of this valve (S.T.61A) will shortly be available. Orders will be carried out in rotation.

Meanwhile, have you tried "the valve with the golden voice"—our S.T.63 (S.T.43 in the 4-volt class)—the prince of super-power valves, which in the last stage gives incomparable quality?

S.T. Ltd., 2, Melbourne Place, London, W.C.2.





**The name does not rotate**

The head does not come off!  
The slot and nut eliminate soldering.  
The finish is perfect throughout.

Complete patent No. 248,921, 4th March, 1925, and registered designs.

Standard Large Insulated Model (polished black bakelite), Type B, 9d. each. Popular Model (non-insulated), Type M, 6d. each.

28 different engravings stocked. Catalogue free on request.

# BELLING-LEE TERMINALS

Advt. of BELLING & LEE, Ltd., Queensway Works, Ponders End, Middlesex. E.P.S. 14.

## Cut out the WORRY

of uncertain High Tension Batteries.

Install one of



**CLARKE'S "ATLAS" "B" BATTERY ELIMINATORS**

and lead the way to Brighter Radio.

Models for A.C. and D.C. Current. Variable Voltages. Grid Bias. Full wave rectification.

Upkeep negligible. Silent & Efficient.

WE GUARANTEE every instrument.

*We make them good Good judges make them famous*

Manufacturers of the famous "ATLAS" Plug-In Coils, and Fixed and Variable Condensers; also sole manufacturers of the Super Selective Reactor Formers.

H. CLARKE & CO. (Mer.) Ltd., "Atlas" Works, Old Trafford, Manchester

### RADIAX GUARANTEED COMPONENTS AND SETS

COMPONENTS KITS.

2 Valve Loud Speaker Set	£1 11 6
3 Valve H.F. Det. L.F. Set	£3 2 6
3 Valve Challenge Set	£5 5 0
3 Valve Monotone Set	£5 16 0
4 Valve Number Thirty Set	£4 5 6

**CONDENSERS VARIABLE**

H.T. Accumulators, 6d. per volt, 20 volt units.	10/-	S.L.F.	'0003 '0005
H.T. Batteries, 108 v., 18/-, 60 v.	9/-	S.L.F. Low	7/6 8/3
Rheostats, Popular, 6, 12 or 30 ohms	1/11	Loss	9/- 10/-
H.F. Choke, Low Capacity, 8/-	1/11	S.L.F. Low	16/6
L.F. Transformer, Herald Shrouded. Ratios: 3:1 or 5:1	12/6	Loss Dual	5/6 6/-
Geared 2 Coil Holder	4/-	Square Law	6/6 7/-
		Low Loss	

**SUPER LOW LOSS COILS.**

Split Anode or Tapped Aerial	6/9
H.F. Transformer, Split Prim. or Sec.	10/6
3 Pin Base	2/3
6 Pin Base	2/6

Send stamp for lists of Radiax Components and Receivers.

**RADIAX LTD., 44, Palmer Place, Holloway Road, London, N.7.**

Paris Advt.

CHEAPER THAN USING THE MAINS

## WESTAM EVERLASTING H.T. ACCUMULATORS

Requires re-charging twice a year only.

Mr. Biggleswade, writes: "I have had one of your batteries in constant service on a four-valve set (including power valve) since the Wireless Exhibition, and it has stood up to it really well. They are the finest value possible at the price."

**6<sup>d</sup> a Volt. 2 Amps.**

ENTIRELY BRITISH. FULLY GUARANTEED.

**60 Volt Model - 30/-**

20 v. 10/6, 30 v. 16/-, 90 v. 45/-, 100 v. 50/-, 120 v. 60/-.

SCRAP YOUR DRY BATTERY.

All models, catalogues and spare parts from any dealer, or

**WESTAM ACCUMULATORS, Clements Road, London, E.6.**



## HYDRA CONDENSERS

Specify "Hydra" and you take a big step towards better reception. Hydra Condensers operate up to 700 volts D.C. without risk of breakdown or overheating. Obtainable in capacities .0011-.0013 mfd., 1/6, up to 10 mfd. Tested on 500 volts D.C. 15/-.

Tested on 500 volts A.C., 2/- to 16/-.

From your dealer, or write direct to—

**Louis Holzman**  
109, KINGSWAY LONDON WC2  
PHONE: HOLBORN 6209

**THE FINEST CONDENSER MONEY CAN BUY**

## CUT THIS OUT FOR CABINETS

and post to us for FREE list illustrating Cabinets as shown in "Wireless Constructor" etc., etc., and for our additional Bulletin No. 1.

NAME \_\_\_\_\_

ADDRESS \_\_\_\_\_

(Write in block letters please.)



**CARRINGTON Mfg. Co., Ltd.**  
18-20, Normans Buildings, Mitchell St., Central St., E.C.1.  
Telephone: Clerkenwell 6903.  
Trade enquiries especially invited.

THE "CLEAT" RESISTOR

HERE is a delightfully simple type of fixed resistor, which anyone can make up at absurdly small cost. The only materials required are a small piece of ebonite from the scrap box and a supply of suitable double cotton-covered Eureka resistance wire (Fig. 1).

Close to either end drill a pair of small holes A B C D. Pass the end of your wire up through A, down through B, up through A, and down through B once more. Leave sufficient at the end, and pull tight. Now wind on the remainder of the wire as tightly and as evenly as you can, and when this is done, anchor the far end as before by means of the holes C and D.

If loops are made in the ends of the wire, one can be attached to a filament terminal of the valve holder, and

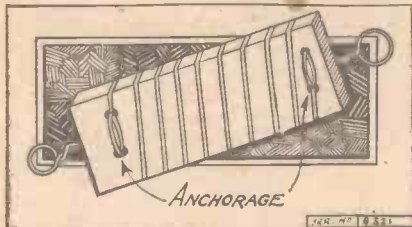
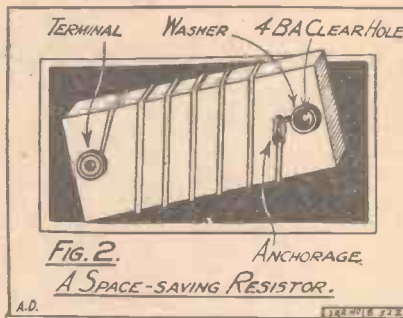

Fig. 1.

the other to the low-tension negative terminal.

A second very handy form of resistor is seen in Fig. 2.



At either end of this is drilled a 4 B.A. clearance hole, a terminal being mounted in one of them. Close to the unoccupied hole two small holes are made to form an anchorage. The end of the wire is secured to the terminal, after which the turns are put on neatly. The "out" end is then anchored by means of the two small holes, and a loop is made in it to go over the 4 B.A. clearance hole. This resistor is mounted, as shown in Fig. 3, directly on the valve holder, and the low-tension lead is connected to the terminal provided. R. W. H.

THE "NIGHT HAWK"

—continued from page 298

will suit the average conditions better than the smaller, and have therefore informed the various firms manufacturing binocular coils for this set so that they may supply coils wound with the larger number of turns.

Whichever coils you are using you will perhaps sometimes find that tuning becomes exceedingly flat in the aerial circuit. This is due to the fact that the primary winding of the first binocular coil, which is in series with the aerial, happens to tune roughly to the wavelength you are trying to receive. The matter is remedied in a moment by using the fixed condenser in series with the aerial, or, if such a position is found when the series condenser is used, short circuit this condenser as explained in the first article.

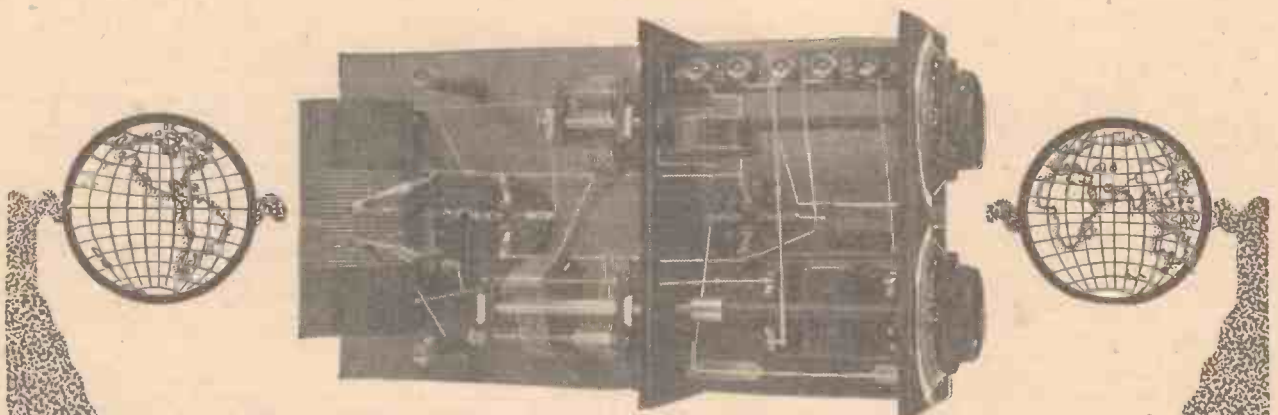
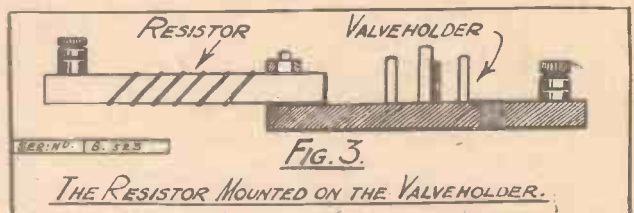

Explore the Ether on Short Waves

THE New Short Wave receiver (20 to 200 metres) designed by Bowyer-Lowe for compactness, ease of operation and stability is without equal. This remarkable production is another instance of the advancement in Radio by Bowyer-Lowe. The name guarantees its quality and perfect operation, and its price is low because production is simplified and each component is standard. Send 1/- now for your copy of booklet with constructional details and blue print, and explore the ether from your armchair.

Made by the Makers of

the "Popular" Condenser.

**Bowyer-Lowe**



ANNOUNCEMENT BY THE BOWYER-LOWE

COMPANY LTD. LETCHWORTH HERTS

**Another Reason** why you should use

**BRETWOOD  
S.L.F. CONDENSERS.**

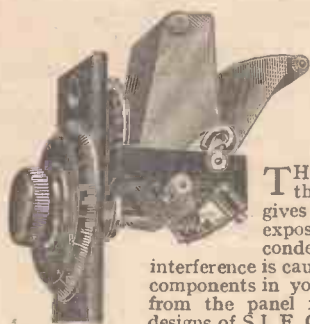

The Elimination of Hand and Body Capacities.

THESE are eliminated by setting the thin edge of vanes to face panel, which gives 70 to 90 per cent. less surface area exposed to body or hand than any other condenser on the market. Again, no interference is caused by stray field effects with other components in your set, because the vanes move away from the panel instead of across it, as in all other designs of S.L.F. Condensers.

The Bretwood design gives a great saving of back-of-panel space and enables one to place their inductances immediately behind the condenser, causing a close magnetic field, which produces an increase of selectivity.

PRICES:—.0005 - 17/6; .0003 - 14/9; .00025 - 14/-; .00015 - 13/6

**Another Component** that will greatly help in securing selectivity and ease in distant station tuning.

**The BRETWOOD  
Grid Leak de Luxe**  
Constant—Silent—Efficient

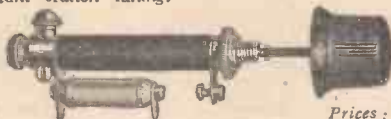

This improved type has a syphon container which prevents all possible leakage of resistance element and guarantees the even distribution of it.

Prices:  
Grid Leak de Luxe .. 3/6  
Grid Leak (with Condenser) 4/6  
Anode Resistance .. 3/6

For accuracy of readings (50,000 ohms to 10 megohms) it is on a par with those of our straight-line frequency condenser.  
For baseboard mounting a special mount is now available .. Price 3d.

Obtainable from all dealers or direct from sole manufacturers:

**BRETWOOD LTD.,**  
16, London Mews, Maple Street, London, W.1.

*Parr's Ad.*

**THE  
NEW No 7**



**RECUPERATING AGENT  
IN THE  
HELLESEN  
DRY BATTERIES**

Try any number of new gadgets you like, they add a little interest to radio, but commence the new year with the New No. 7 Recuperating Agent controlling your H.T. Supply. If your power supply is efficient and economical, the question of trouble-free radio is solved.

When radio was in its infancy users of dry batteries regarded the name Hellesen as being synonymous with the best in dry battery construction.

To-day they meet your special need with a special recuperating agent and they are still

*The Best in the World*

You can now buy Hellesen Dry Batteries at a competitive price and whatever your requirement there is a Hellesen Dry Battery to meet it.

60 volt "WIRIN" 12/6  
99 volt "WIRUP" 21/-  
(Postage Extra.)

All types, voltages, etc., in Double and Treble capacities for H.T. and L.T. Supply. Ask your dealer for the type to suit your set and get the maximum service, or write us for full particulars.

Obtainable at all Radio, Electrical and General Stores, Harrods,

Selfridge's, Barkers, etc., or direct from

**A. H. HUNT LTD., Dept. 5, CROYDON, SURREY**

TRADE

**HUNT'S**

MARK

*They Last Longer*

*Write for  
Free List.*

look  
for it

Quality counts in every component. "Wearite" is the sign of the best your set can have. Say "Wearite" and see the mark.

Illustration shows "Wearite"  
Multi-Plug Connector M.E.8.4/6.  
Cap for protecting leads, 1/6.

WEARITE  
COMPONENTS

Lancashire Agent:  
Alexander  
Scandlers,  
1B, Cooper Street,  
Manchester.

Glasgow Agent:  
C. G. Tideman,  
47, Garrick Street,  
C2, Glasgow..

**WRIGHT & WEAIRE Ltd.,**  
740, High Rd., Tottenham, London, N.17.

Telephone: Tottenham 3132. Telegrams:  
(Inland) "Writwea, Tottenham, London."  
Telegrams: (Foreign) "Writwea, London."

186-43

# Silvertown

WIRELESS ACCESSORIES

## SILVERTOWN WIRELESS ACCESSORIES

INCLUDE—

- Batteries (High Tension).
- Condensers (All Types).
- Crystal Holders.
- Dials and Knobs.
- Earth Plates.
- Inductance Switches (to-way, etc.).
- Insulators ("Everdry," "Featherweight," Cone Lead-in, Window Pane, etc.).
- Potentiometers.
- Rheostats, Filament (One-hole fixing, etc.).
- "Silvovox" Loud-Speakers.
- Testing Buzzers.
- Transformers (All Types).
- Valve Holders, Anti-Micro-phonc.
- Verniometers, Etc., etc.



Quality guaranteed by over 50 years' electrical manufacturing experience.



### STRAIGHT LINE FREQUENCY CONDENSER (Low Loss)

A precision instrument, the design of which ensures perfect mechanical construction with high electrical efficiency. The rotor plates are earthed, eliminating hand-capacity effects. It is also completely silent when adjustments are being made. Perfect electrical contact is obtained by means of a flexible phosphor bronze pigtail connection.

each  
B.615 (0.00025 mfd.) .. 11/6  
B.616 (0.0005 mfd.) .. 13/6

**THE SILVERTOWN CO.**  
106, Cannon Street, London, E.C.4.  
Works : Silvertown, E.16.  
Belfast ; Birmingham ; Bristol ; Cardiff ;  
Dublin ; Glasgow ; Leeds ; Liverpool ;  
London ; Manchester ; Newcastle-on-  
Tyne ; Portsmouth ; Sheffield.



## GAMBRELL Centre-Tapped COILS

These retain all the low-loss features embodied in the famous Gambrell design. They can be plugged into any standard coil socket. Are readily interchangeable. Baseboard space occupied is very small compared with other types. They are universal coils, their use not being limited to centre-tapped circuits.

**GAMBRELL L. F. Transformers** were designed to reduce to a minimum self-capacity and other defects which cause distortion. They give you a great degree of amplification as well as constant amplification over a wide band of frequencies, resulting in ample volume with perfect reproduction.

**PRICES:**  
Stage 1, Ratio 3½ to 1.  
Stage 2, Ratio 5 to 1.  
25/6 Each.

SIZE.	PRICE.	Approx. No. of TURNS.	SIZE.	PRICE.	Approx. No. of TURNS.
a/2	4/10	18	D	6/3	100
a	4/10	25	E1	6/9	150
A	5/-	30	E	7/9	200
B1	5/3	40	F	8/6	300
B	5/6	50	G	10/-	500
C	5/9	75			

Above prices are for the standard Gambrell Coils. Centre-tapped coils 6d. extra.

### NEUTROVERNIA CONDENSERS.

These are ideal universal units for use as balancing condenser, capacity reaction control or vernier condenser. Capacity range approx. 2/38 m/mfds. For panel or baseboard mounting **5/6 Price** Can be fitted with Direct Reading Dial, enabling a return to be made to exact settings previously logged. **Price 1/8 extra.**

FREE ON REQUEST. Complete details of all our Components and Sets.

**GAMBRELL BROTHERS LTD.**  
76, VICTORIA STREET—LONDON, S.W.1

Parrs Ad.



## STEEL PLATE ACCUMULATORS FOR HIGH TENSION

Only 1/- per volt.

*Absolutely Noiseless.*  
*No Acid. No Fumes.*  
*Last a Lifetime.*

**BATTERIES, LTD., REDDITCH**  
LONDON OFFICE:—220, Shaftesbury Avenue, W.C.2.



## VELVET CONTACT

The **ETHERPLUS VELVET CONTACT RHEOSTAT** gives perfect contact. It is a neat, well-finished, compact component. An attractive pointer knob fits flush with the engraved dial over one-hole fixing nut.

ETHERPLUS +  
2/3 EACH.

PRICE  
6, 15 or 30 ohms, 2/3 each  
BRITISH MADE.

From all dealers or from  
**M. & A. WOLFF,**  
9-15, WHITECROSS STREET,  
LONDON, E.C.1.

**ETHERPLUS**

*Superfine Quality Only—!*

Superfine Quality  
**Trelleborgs**  
GUARANTEED  
GENUINE EBONITE

120000 VOLTS PER INCH  
National Physical Lab Repair

Size Thickness Finish  
LOCK

18

*Truest Quality holds Unchallenged Supremacy*

NO 'SECOND' QUALITY

WE DO NOT MANUFACTURE LOW GRADE MATERIAL

PRICES

THICKNESS.	HIGHLY POLISHED.	MATT.	STANDARD GLOSSY.	MAHOGANY.
¼ in.	Per sq. in. 1d.	.9d.	.8d.	11/3d.
½ in.	Per sq. in. 75d.	.66d.	.6d.	1d.

Address Trade Enquiries only to:—P. C. MICHELL, Managing Director.  
**TRELLEBORGS EBONITE WORKS Ltd., AUDREY HOUSE, ELY PLACE, E.C.1**

*from good dealers*

## VALCO MAGIC!

**WILL MAKE YOUR BROKEN VALVE AS GOOD AS NEW.**

ALL TYPES OF VALVES REPAIRED AT HALF LIST PRICES (minimum charge 5/-).

∴ Satisfaction Guaranteed or Money Refunded. ∴

An unsolicited testimonial from one of our many satisfied customers: **GORLESTON-ON-SEA, 1/12/26.**—Having received the valves quite safely, I find them to be equal to all that you advertise. I am sending seven more to be repaired.—F.P.W.

*Weco, S.P.'s and low capacity types not repairable. Minimum D.E. current 0'15 amp. when repaired.*

**VALCO LTD.** Dept. "G.", TABOR GROVE, WIMBLEDON, S.W.19.

# Apparatus Tested



## The S.T. Valve

THE new series of valves recently placed on the market by Mr. Scott-Taggart's new company, S.T., Ltd., has been subjected to a prolonged test in THE WIRELESS CONSTRUCTOR laboratory, not merely for the purpose of ascertaining their general characteristics, but under practical working conditions in a variety of sets. These valves are made in two-, four- and six-volts series, there being three types in each series.

The external appearance of all the valves is practically identical. The modern pipless bulb is used, and the process of obtaining the high vacuum gives the usual mirror appearance, obscuring the electrodes from view. On breaking open the valve the mechanical arrangement of the electrodes is seen to be sound and robust, while the insulating base (in mottled black and brown) is fitted with a good type of modern spring pin.

## The Two-Volt Range

Dealing first with the two-volt valves, we find the S.T.21 a valve of fairly high impedance, designed for high-frequency amplification and resistance-capacity coupling. It is also excellent as a detector valve. The filament voltage rating is 1.8, but this voltage is not critical and in practice no harm will be done if it is run at 2 volts. The filament current is but a tenth of an ampere, and as is the case with all of the S.T. valves, there is no means of telling by the appearance of the valve whether it is alight or not, owing to the low temperature at which the filament operates and the "silvering" of the valve due to evacuation processes. The S.T.22 is called an L.F. valve.

The designations H.F., L.F., etc., used by valve manufacturers are, it may be stated in passing, rather arbitrary, seeing that a so-called H.F. valve may be used quite effec-

tively in circuits not dealing with high-frequency currents. The S.T.22 has the same filament voltage and current consumption as S.T.21, and is a very useful valve in the first stage of a low-frequency amplifier, as it will handle considerable energy without distortion. It will also be found to suit certain high-frequency and detector circuits. The third valve in the two-volt series is the S.T.23, and has the same filament voltage but a slightly higher current consumption (.15 ampere). This is a low-impedance valve capable of handling considerable energy without distortion as the last valve in a loud-speaker set.

## Economical Four Volters

We are afraid that the majority of wireless listeners do not realise the importance of choosing for the last valve one which really can handle powerful signals, and we have frequently found loud-speakers and transformers blamed for "overloading" or "distortion" when the sole trouble has been that the last valve was quite

is grossly extravagant in plate current and will distort just as badly as any other valve. It is also wrong to imagine, as some people do, that a modern super power valve is necessarily extravagant, for with the correct grid bias the plate current is cut down considerably. Nevertheless, we do not recommend the use of any super power valve unless the user has a high-tension battery made up of dry cells of the larger size, or better still, a high-tension accumulator.

The S.T.43 is run at a filament voltage of 3.8 and takes a quarter-ampere filament current; 120 volts is recommended for high-tension battery, and on practical test a loud-speaker set with this voltage gave excellent reproduction of a quality many people would not consider possible. In the six-volt series there is again a nominal H.F. valve, a power valve, and a super power valve. The filament voltage of all three is 5.6, the first two taking a tenth of an ampere and the super power valve a quarter of an ampere.

## A Further Check

As previously mentioned, all of the valves have been tried under practical conditions for a considerable period, the emission being periodically checked to see that there was no falling off. All have proved suitable for the purposes for which they have been designed, and the individual specimens have shown themselves well up to the published characteristics. In fact, in practically every case they have been distinctly superior. As a further check on these valves we visited the valve store of S.T., Ltd., and ourselves picked specimens of the valves at random from stock, further tests being made on these, in addition to those we had given to other specimens in the laboratory. Again all were better than published characteristics and two specimens were distinctly superior.

## A Good Valve Socket

A GOOD example of a modern type of anti-vibratory valve socket sold as the "W.B." has been submitted to us for test. In a general appearance it resembles a number of this type of valve socket at present marketed, but a close examination shows that it is distinctly superior to some. Both terminals and soldering lugs are provided as usual, but a good practical point for the home constructor is that the lugs are marked A., F., F., G. not only on

(Continued on page 366.)

Apparatus sent for test with a request for a published report should be addressed to: Test Room, "The Wireless Constructor," Fleetway House, Farringdon Street, London, E.C.4.

incapable of handling the energy available.

In the four-volt series we have the S.T.41, 42 and 43 working at a filament voltage of 3.7 in the case of the first and 3.8 in the other two. The S.T.41 is nominally a high-frequency valve but might just as well be called a general-purpose valve, for we have tried it in H.F. detector and L.F. positions in a set with excellent results. The S.T.42, called a power valve, is a power amplifier able to handle considerably more energy with distortion than many so-called power valves, and will give excellent results as the last valve in a loud-speaker set, save where very strong signals are being put out, when the super power valve, the S.T.43, comes into its own.

This valve, properly used, gives remarkably good reproduction on strong signals with adequate plate voltage. It is necessary to say "properly used" in this connection, as without proper grid bias such a valve



The 'PEERLESS' Junior RHEOSTAT

Sales now over 1/2 MILLION

The amazing popularity of "Peerless" products can be judged from the fact that the Rheostat illustrated here has already passed the HALF MILLION Sales figure.

It has many good selling features. An OFF position is provided, while definite stops make SHORT CIRCUIT IMPOSSIBLE. The resistance element is immune from damage. Will safely carry current of two valves.

Complete with nickelled dial and one hole fixing. Three types. Size, 1 1/2" dia. 1" high, 6, 15 or 30 ohms.

2 1/6

Write for full details.

The Bedford Electrical & Radio Co Ltd  
22, Campbell Road, Bedford.



APPARATUS TESTED

—continued from page 365

top but underneath. A sound soldered connection is made between the lug and the actual metal socket into which the valve fits, while the insulation between the sockets has been removed by coring out. The whole device is moulded in bakelite and proved perfectly satisfactory with the heaviest and largest valve in general use.

The Brandes Audio Transformer

A NEATLY-MADE low-frequency transformer which on test gives excellent reproduction is a Brandes audio transformer, submitted to us for test. On practical trial the reproduction was found to be up to a very high modern standard. We are pleased to see that the more intelligent method of marking the transformer has been adopted rather than the old and conventional IP, OP, IS and OS respectively.

This marking should be abandoned by all transformer makers, as the user is not particularly interested in which is the beginning and which is the end of the windings. He certainly does want to know which terminal to connect to grid and which to high-tension positive. At the same time, we are rather surprised that the makers have marked one terminal "L.T. negative," as in practically all cases this terminal is *not* connected to negative low tension but to grid bias negative. However, this is quite a small point and it does not affect the working of a really good transformer. The price, by the way, is 17s. 6d. for both the 1-5 ratio and the 1-3 ratio. The 1-5 ratio is in a black and the 1-3 ratio is in a brown case, but otherwise there is no indication on the instrument itself. We would suggest that the manufacturers mark the ratio on the transformer.

Aerial Pulley

WE have received from the S. H. Collett Manufacturing Co. a specimen of their "Collett" self-hoisting aerial pulley. This is rather an ingenious fitting for a mast, designed to make aerial erection easy and to permit aerials to be raised in a few minutes. An endless halyard runs through a separate groove in the sheave and the aerial is simply connected to this halyard and hauled into position. The device is made in brass with a tinned finish to resist the weather. The only criticism we would make is that the holes for the securing screws should be somewhat larger than those in the specimen submitted, so that a heavier screw for fixing the device to the mast could be used. However, it is quite a simple matter to enlarge the hole before fitting should this be desired. A 30-ft. end-

(Continued on page 367.)

"VIOLINA"  
All Wood Loud Speakers

Offer the highest standard possible in the reproduction of Radio Reception, Minus the BLARE of a TIN trumpet, but with the pure natural sweetness of a violin or 'cello.

Beautifully polished Walnut or Mahogany and designed as a cabinet lid, forming PRICE an artistic concealed Loud Speaker. 12/6

Or fitted with Brown's or other Reed Reproducer and Cord, 27/6. Post 3/6.

In our New Winter List, containing over 500 Illustrations, you will find 1,000 Wonderful Bargains. For 4d. we will post a copy at once.

Our Showrooms are open from 9 a.m. to 6 p.m.

ELECTRADIX RADIOS,  
218, UPPER THAMES STREET, E.C.4.  
Parre Ad.

ALUMINIUM COIL SCREENS !!

Constructors save money and get perfect results by using our Screens. Suitable for Solodyne, Mewflex, and all screened coil receivers. Beautifully made of heavy gauge metal.

COMPARE	Polished 3/6 each.	Base Extra.
PRICES!	Frosted 3/3 "	Special Prices for Quantities.

SEND TO-DAY!!! B. SIMMONS & Co., 81, Costa St., South Bank, YORK.

WET H.T. BATTERIES

British made (round or square) Leclanché Glass Jars 2 1/2 x 1 1/4 x 1 1/4, for wet H.T. Units. Waxed 1/3 doz. plain 1/2 doz., zinc 1/2 doz. Grade 1 sacs 1/3 doz. Grade 2 sacs 1/3 doz. Special Non-Solder and non-corrosive Plug-Socket Connector and Zinc combined. Reg. design. Each cell a tapped unit, 2/6 doz. Large sacs 3/- doz. Acid proof varnish 6d. Jar (Black). Carriage and Packing extra. Send 11d. Stamp for instructions and List. Ask us about the "Unique" Voltmeter.

ETON GLASS BATTERY CO.  
46, St. Mary's Road, Leyton, E.10

COIL SCREENS

with 6 PIN BASES and GOOD TERMINALS  
9/6 each to clear.

UNBREAKABLE PAXOLIN PANELS  
Mahogany, Oak, or Black Finish,  
all 12/6 per square foot, any size.

RONNEBECK MACHINING CO.,  
203, Marton Road, MIDDLESBROUGH.

ACCUMULATORS  
ON EASY PAYMENTS

High Tension Accumulators built up from 20 Volt sections (15/- each). Example: 60 Volt H.T. 45/- CASH or 12/6 DOWN and 6 monthly payments of 6/- Carriage Paid. Satisfaction or money back.



Write for Lists to DEPT. 13, COVENTRY DIRECT SUPPLIES LIMITED, 23, Warwick Row, COVENTRY.

Any Wireless Goods supplied on easy payments.

PICKETT'S CABINETS

FOR BRITAIN'S BEST

H. H. Ansbach, 1st Prize Chicago, writes: "My success was greatly helped by your splendid Cabinet work."

R. W. Emerson, International Gold Medalist: "The workmanship and finish was all that could be desired."

"Elstree Solodyne," "Drawing Room Five," and "All British Six," from 45/-

For every Receiver or your OWN SIZE, Envelope of Cabinet Designs No. 21 FREE. Pickett's Cabinet (W.Cr.) Works, Bezeleyheath.





The TANGENT  
**"TOUCHSTONE"**  
Loudspeaker



This loud-speaker is designed on quite new and original acoustic lines. It is possible on this to get the lowest bass notes as well as the highest treble notes in a perfect form of reproduction.



For distinction of design and construction it stands alone, the attractive cabinet harmonises with any furniture. Over four feet of curving flute lies in the Touchstone cabinet to preserve the overtones of perfect rendering.

Price in Oak.....£6 : 6 : 0  
" " Mahogany.....£7 : 0 : 0

Write for full illustrated leaflet 141 giving all particulars.



LONDON: 125, Victoria Street, S.W. 1.  
NEWCASTLE-ON-TYNE: Tangent House, Blackett Street.

**GENT & CO., LTD.,**  
FARADAY WORKS, LEICESTER.

**APPARATUS TESTED**

—continued from page 366

less halyard is provided with the device, the cost of which is 2s. 6d.

**An Inexpensive Vernier Fitting**

FROM The Standard Insulator Co., Ltd., we have received for test a specimen of the "Midget" friction tuning device. It consists of a small insulating knob with a bush, and is simply fitted in a single hole drilled in the panel. The base of the knob is a soft rubber ring which bears against the edge of the existing dial on the receiver in such a way that on turning the small knob the main dial is made to rotate at a very slow speed, thus giving a vernier movement without backlash or slip. The price—9d.—is very reasonable, and the gadget should be found useful by many readers who find the ordinary dial a little too clumsy to use for very sharp tuning.

**QUERY CORNER**

—continued from page 349

connected across the loud-speaker terminals, whilst the 2-microfarad Mansbridge type condenser was shorted by means of a short length of wire. Signals were again heard at good telephone strength, showing, since the 'phones were now in parallel with the choke only, that either the choke or the condenser was defective. Removal of the shorting wire across the latter at once gave a serious decrease in strength, and, as application of the telephones and dry cell test across the choke showed its winding to be continuous, the condenser was replaced. The filter circuit then appeared to function correctly, and attention was devoted to the tuning circuits.

**Inter-Connected Tuning**

Here the behaviour was very extraordinary. The tuning of the grid circuit, being extremely flat and being largely dependent on the adjustment of the reaction condenser, the set could be made to oscillate, but in certain cases this would only occur by reducing the capacity of the reaction condenser instead of with an increased reading, as is normally the case. With other settings of C<sub>1</sub> oscillation was found to take place more or less normally, but each adjustment of the one variable condenser seriously affected the setting of the other.

**The Wiring**

I was asked to check the wiring with the wiring diagram, and all appeared to be correct. But as I, so to speak, have been brought up in the test room on theoretical diagrams, which usually I carry in my head, and find it diffi-

(Continued on page 368.)

The **Varley**  
Bi-duplex  
Winding

9/6 complete

**MAKES ALL THE DIFFERENCE**

THE Varley Multi-cellular H.F. Choke, wire-wound on the famous Varley Bi-Duplex system—in this particular component not only are the bare turns of wire separated by pure silk, but in addition the individual layers are air spaced in a special manner—has opened up fresh possibilities in wireless science and enabled the leading Radio Scientists of the present day to develop circuits which, without the Varley Bi-Duplex winding, would have been out of the question.

The Varley Multi-cellular H.F. Choke possesses all the qualities of a really efficient H.F. Choke. In addition to having high inductance, low self-capacity and small electrical losses, the Varley H.F. Choke has an extremely small external field. Now this means that there can be no interference due to the H.F. Choke acting as a Frame Aerial and picking up outside noises, nor, unlike other H.F. Chokes, is there any possibility of interaction with other coils.

PRICE complete only 9/6.

The Varley Multi-cellular H.F. Choke for circuits of the SPLIT COIL Type - 12/6

Descriptive leaflets giving full particulars of our complete range of Bi-Duplex Wire-Wound Anode Resistances up to 500,000 ohms, free on application.



THE VARLEY MAGNET CO.  
(Proprietors: Oliver Pell Control Ltd.)  
Granville House, Arundel St., London, W.C.2,  
Telephone: City 3292.

# The best British at Continental PRICES Jacks, Plug, and Resistances

Manufactured in the latest materials and design. Approved by the Elstree and other famous laboratories. Tested to withstand many times the conditions imposed in ordinary practice.

## JACKS

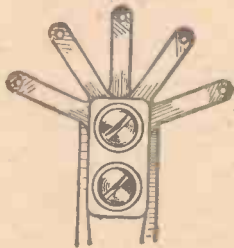

One hole fixing. Neatness combined with efficiency.



## Plug

Actual size, conforms to spade tags, pin tags, flexible or rigid wire leads. Genuine Bakelite. Neatly finished.

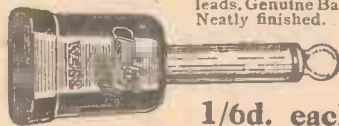

1/6d. each

**ASHLEY-LEDWARD RESISTANCES**  
(Anode and General Purpose).



Absolutely stable at ordinary temperatures & under high impressed voltages. Capacity free. Impervious to moisture. Each component is subjected to a 48 hour test, during which it is continuously under pressure at a minimum of 230 volts.

**2/6d.**  
each

The uniform qualities of this component under adverse conditions (left out of doors several days) are worthy of notice and it can be recommended with confidence.

with clips.

ASHLEY WIRELESS TELEPHONE CO., (1925) LTD.,  
17, FINCH PLACE, LONDON ROAD, LIVERPOOL.

*Ashley Radio*

## QUERY CORNER

—continued from page 367

cult to read actual wiring diagrams, I dispensed with the latter, and began to see light. A likely cause of the tuning of one condenser affecting the setting of the other obviously would be due to connecting the grid tuning condenser across the aerial half of the coil. Careful investigation of the switch connection showed this to be the case.

The two tapped coils for the local and Daventry stations respectively were each wound continuously on circular ebonite formers, which latter were shown in plan only on the wiring diagram. The two leads to the two top ends of the coils had, in mistake, been joined to the two lower outside contacts, while the other leads were taken to the two upper contacts of the switch. As a result of the small combined aerial and reaction coils being thus connected in place of the larger grid coils, which latter took over the functions of the former, the previously mentioned puzzling behaviour resulted. Reversal of the leads at once gave satisfactory working.

## “POPULAR WIRELESS”

Incorporating “Wireless.”

Britain's Brightest and Best Weekly Radio Journal.

“Popular Wireless” is on Sale every Thursday, price 3d., and every issue contains:

**BROADCAST NOTES:**—An inside survey of the B.B.C.'s activities;

**RADIO NOTES AND NEWS. QUESTIONS & ANSWERS:** Readers' real problems dealt with helpfully week by week.

**THE P.W. VALVE GUIDE:**—An analysis of all the valves now on the market.

**CURRENT TOPICS:**—By the Editor, and many other splendid features of interest to every radio enthusiast.

In addition P.W. offers to readers an unrivalled service of Technical Queries, answered by post.

## “POPULAR WIRELESS”

Incorporating “Wireless.”

Every Thursday - Price 3d.

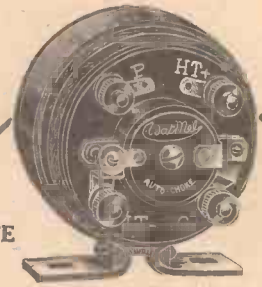

PRICE

18/6

## A mile of wire wound the Watmel way

The special windings of the Watmel Auto-Choke are done by expensive and absolutely up-to-date machines which lay the wire exactly parallel and interweave cotton strands between each layer. Cotton acts as binder, and insures perfect insulation. Get to know the other reasons for the fine amplification and natural-toned reproduction possible only with the

**WatMel**  
**AUTO-CHOKE**

From your dealer or direct from—

**THE WATMEL WIRELESS CO., LTD.**  
332a, Goswell Road, London, E.C.1.  
Telephone: Clerkenwell 7990.

Lancs, Yorks and Cheshire Representative,  
Mr. J. B. Leves, 23, Hartley St., Levenshulme,  
Manchester. Telephone: 475 Heaton Moor.

## 2-VALVE AMPLIFIER 35/-

1-Valve Amplifier 20/-, as new. Valves, D.E. '06 7/-, Headphones 8/8 pair. New 4-Volt Accumulator 13/-, New 60-Volt H.T., guaranteed, 7/-, 2-Valve All Sun Set, 24. Approval willingly. Write for free bargain list.

C. Taylor, 57, Studley Road, Stockwell, London.

## THE FINEST VALVE CONTROL

Can be assured by using only the



## NEW T.C.B. GUARANTEED RESISTANCE

(PATENT No. 225,132)

Perfect contact; smooth and dead silent in operation; perfect insulation; positive stops for “Off” and “Full On” positions; a travel from “Off” to “On” in two turns of the knob; easy to fit; occupies minimum panel space (illustration is three-fifths actual size). Every one carries our written guarantee to replace it free if the slightest defect be found within three months from date of purchase.

Resistance 8, 13, or 30 ohms	..	..	2s. 6d.
Resistance 50 ohms	..	..	3s. 0d.
Potentiometer 300 ohms	..	..	3s. 6d.

## BRITISH THROUGHOUT.

Of all dealers or direct post free, from the sole manufacturers. If ordering direct, state whether one or two hole fixing is desired.

Send Postcard for Descriptive Folder.

## Wavio Ltd

DEPT. C, QUEEN STREET, HITCHIN.

**WHEN** replying to Advertisers please be sure to mention “Wireless Constructor.”

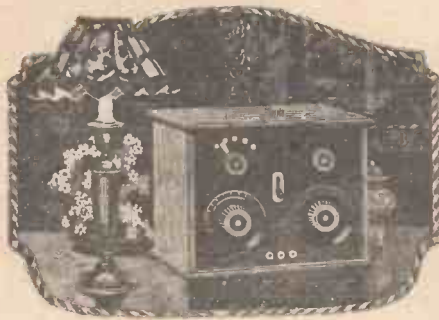

# free— details for building four unique Receivers

HERE'S an invaluable book for constructors. The "Radion Book." It's a practical manual which tells you how to build four unique Receivers. The explicit working drawings and complete illustrated descriptions make it possible for the most unskilled to build a One-Valve Receiver (which has a 250-400 mile range on headphones), a two-valve Amplifier, a self-contained Loud Speaker Set and a Five-Valve Neutrodyne.

Anyone could follow the easy instructions, and build a Set as good as a professionally-made one. In addition, the Radion Book contains useful information on Aerial erection and Set installation and gives easy-to-follow tool hints for "working" panels.

Send the coupon below for the Radion Book and an interesting booklet called "The Gentle Art of Choosing One's Panel." It tells you all about the superb panels, Radion and Resiston, which increase the appearance and efficiency of your Set a hundredfold. Write to-night

—Send for the "Radion Book"—  
Please send, free, the "Radion Book" (which describes four unique Sets) and, also, "The Gentle Art of Choosing One's Panel."  
Name .....  
Address .....



American Hard Rubber Co., Ltd., 13a Fore St., E.C.2

G. A. 6998.

## ODD PARS FOR AMATEURS

### Valves for Loud-Speaker Work

ALTHOUGH the currents set up in a receiving aerial by the signals from a wireless station are very minute compared with those we are accustomed to handle from house lighting, we must remember that they are considerably amplified before they are made to work a loud-speaker. If faithful reproduction is to be obtained from the signals being passed into a valve, it is necessary that the fluctuations of voltage applied to the grid should not at any time make that grid positive. For a valve to function correctly, it is therefore necessary to have a negative bias on the grid at least equal to the maximum voltage likely to be applied at any given moment, and as these swings will be on each side of the working point, the valve curve must be long enough to encompass these swings.

This means in practice that if the incoming signal is going to make the grid fluctuate four volts either side of the working point, then there must be at least four volts grid bias, and, what is equally important, the curve must be approximately straight from zero grid volts to eight volts negative. In point of fact, fluctuations of voltage on either side of the working point will considerably exceed four volts with loud signals, and only the power and super power valves have long enough characteristics of reasonably straight form to give undistorted reproduction.

You will now understand that no matter how good your power valve may be, unless you use sufficient grid bias, strong signals can make the grid positive and give the distortion you are trying to avoid. Carefully examine the maker's instructions on every power and super power valve, and make sure you use not only correct grid bias but correct plate voltage.

### Facts About Loop Aerials

THE loop, or frame aerial, which appears to be so convenient to the flat dweller, has a number of grave disadvantages which are not always pointed out by those who advocate its use.

First of all, a frame aerial is very insensitive compared with the outdoor aerial, and, roughly speaking, five valves are generally required with a frame aerial to do what three valves will do with a normal outside affair. This is not a hard and fast rule, particularly as regards reception of the local station, but is some indication of the difference in sensitivity.

While a frame aerial is directional in its receiving effects, in practice this



## FRANKLIN NELSON RODNEY GRENVILLE

NAMES that are the personification of action. In war and peace the need has always found the man, and today in the radio world the name Mullard implies decisive progress.

Radio appeals to the million. Mullard has brought radio within reach of the million. The Franklin, Rodney, Nelson and Grenville P.M. Receivers are the result of the remarkable success achieved by the Mullard P.M. Valves, and the research, construction and organisation which has made the finest valve is the basis of the Mullard Ever-Rest Wire Wound Anode Resistance.

A Resistance wound on a textile fibre core, perfectly covered and interlayered with the same material, eliminating all self capacity, and also renders the fine metallic wire free from every particle of mechanical shock.

The temperature coefficient is negligible, since the resistance is not set in wax, but only covered by a thin layer of wax allowing perfect dissipation of heat.

**MULLARD EVER-REST Wire Wound**  
Anode Resistance (80,000 and 100,000 ohms) - - - - - 5/-  
Complete with Holder 6/6

Other Values to Specification.  
Mullard Grid Leaks and Condensers,  
Type Grid B 0.5 to 5.0 megohms - - 2/6  
Type Grid B combined with .0003 mfd.  
Condenser Type MA - - - - - 5/-  
Type MA Condenser .0001 to .0009 mfd. 2/6  
Type MB Condenser .001 to .01 mfd. - 3/-



The MULLARD WIRELESS SERVICE Co., Ltd.  
Mullard House, Denmark St., London, W.C.2

# CAXTON WIRELESS CABINETS

All Polished with new enamel that gives a glass hard surface that cannot be soiled or scratched. Ebonite or Radion Panels Supplied and Perfectly Fitted at low extra cost. SENT FREE.— Catalogue of Standard Wireless Cabinets in various sizes and woods.

## THOUSANDS OF SATISFIED CUSTOMERS.

**ELSTREE SOLODYNE.** Panel 21" x 7" fitted 16" Baseboard, drop-down Beaded Front Door. Fumed Oak 61/-, Dark Oak 65/-, Mahogany polished 68/6. Raised Panel 5/- extra. Packing Case 5/- extra.

**ELSTREE SIX.** Panel 42" x 9" fitted 13 1/2" Baseboard. Open Type. Fumed or Dark Oak 80/-. Mahogany polished 90/-. Packing Case 7/6 extra.

**MONODIAL.** Panel 14" x 7" fitted 14" Baseboard. Fumed Oak 33/6, Dark Oak 35/-. Mahogany polished 39/6. Packing Case 6/- extra.

**NIGHT HAWK.** Panel 16" x 8" fitted 14" Baseboard. Open Type. Fumed Oak 33/6, Dark Oak 35/-. Mahogany polished 39/6. Packing Case 7/- extra.

**FIVE FIFTEEN.** Panel 24" x 7" fitted 8 3/4" Baseboard two Front Doors. Fumed Oak 40/-. Dark Oak 42/6, Mahogany polished 48/-. Packing Case 7/6 extra.

**THE 1927 FIVE.** Panel 27 1/2" x 7" Sloping Front, as originally described. Fumed or Dark Oak 38/-. Mahogany polished 48/-. Packing Case 7/6 extra.

**EVERYMAN THREE.** Panel 20" x 8" fitted 8" Baseboard. Fumed Oak 33/6, Dark Oak 35/-. Mahogany polished 39/6. Packing Case 6/- extra.

**EVERYMAN FOUR.** Panel 26" x 8" fitted 8" Baseboard. Fumed Oak 35/6, Dark Oak 37/6, Mahogany polished 41/6. Packing Case 7/- extra.

**CASH WITH ORDER. CARRIAGE PAID U.K. PROMPT DELIVERY.**

Packing Case Money repaid if Case returned within 14 days  
Carriage paid to Works.

## CAXTON WOOD TURNERY CO., MARKET HARBOROUGH.

**£2?** WOULD you like a Multi-Valve Receiver for 40/- down? In our Catalogue 'W' are details whereby many well-known Sets are obtainable on easy terms. Accessories too! Our technical advice is yours without charge. Write to-day to:

**New Times SALES CO.**  
77, CITY ROAD, E.C.1

### WIRELESS

Capable, trustworthy men with spare time who wish to substantially increase income required where we are not fully represented. Applicants must have practical knowledge of installation of Set and Aerial, be a Householder or live with parents, and be able to give references; state age and experience. Address Dept. 20, GENERAL RADIO COMPANY LIMITED, Radio House, Regent Street, LONDON, W.1.

### WIRELESS WAREHOUSE

Buy your Wireless parts direct from the Warehouse at Warehouse prices. Every known component in stock. Write NOW-for list.



**BUSH HOUSE** 35, Shudehill, MANCHESTER

### EBONITE BUSHES

FOR MOUNTING ON WOOD. PERFECT INSULATION. Orders under 1/- send 1/4d. Postage. Two required for each hole. NUMBER 0 1 2 3 4 5 6 Hole in Bush 3BA, 4BA, 2BA, 1/4", 5/16", 3/8", 7/16" Price each: 1d. 1d. 1d. 1 1/2d. 2d. 2d. 2 1/2d. **DAREX RADIO CO.,** Waldram Rd., Forest Hill, London, S.E.23. TRADE SUPPLIED

### A HOME FOR YOUR WIRELESS SET

**OUR STANDARD CABINETS** are DUSTPROOF and house the whole apparatus, leaving no parts to be interfered with. Made on mass production lines, hence the low price. Provision is made to take panels from 16 by 7 up to 30 by 18in. Special Cabinets for the ELSTREE SOLODYNE, NIGHT HAWK, ALL BRITISH SIX, etc., now ready. Write for free particulars. **MAKERIMPORT Co.** Dept. 20, 502, Lord Street, LIVERPOOL.



### ODD PARS FOR AMATEURS

—continued from page 369

directional property is not of so much value as might be anticipated in the elimination of interference. If your set is tuned to a particular station and the frame is rotated a point will be found where signals become inaudible, and this is approximately at right angles to the line joining you and the station. The minimum is not very sharply defined, but if you desire to listen to a station which gives the maximum effect when your frame aerial is at right angles to the line joining you and the local station, then this directional effect will be very valuable. On the other hand, if there is a difference of, say, 25 or 30 degrees between the local station and the one you wish to receive, the frame aerial will not help you a great deal.

Many sets, which are quite stable when used with an outdoor aerial become extremely unstable and even unworkable when used with a frame. This is in a large measure due to the fact that the frame is but a large coil of wire having quite a strong magnetic field, and this spreads out round about the frame interacting with the coils and wires in the set itself, giving most undesirable reaction effects.

### INSULATED AERIAL WIRE

SO far as reception of the ether waves is concerned, it does not matter whether the aerial wire is insulated or bare, for it must not be forgotten that the air itself is an insulator, and that the ether waves penetrate the insulation round the wire in just the same way as they penetrate the air.

The advantages which are often found in the use of enamelled or other insulated wire are not electrical, but are connected with the deterioration of the copper surface when exposed to the elements.

An ordinary copper or bronze aerial wire, when first erected, is quite bright, but after a time it becomes discoloured, and, if examined at the end of six months or more, will be found to be extremely dirty and with some amount of surface corrosion, if, as is frequently the case, the wire has been exposed to the fumes or smoke from a near-by chimney. This surface corrosion is neither a good conductor nor an insulator, and it may occasion quite appreciable losses. With enamelled aerial wire the good conductivity is preserved for a much longer period.

## REPAIRS

Headphones, Loudspeakers, and Transformers re-wound & reconditioned equal to new. **AN UNSOLICITED TESTIMONIAL.**

"Thanks to the excellent manner in which it was reconditioned, the results achieved have been astounding. It is very gratifying to find a firm that really turns out a first-class job, as I have had very disappointing experiences with firms who have advertised as experts, and whose workmanship has been far from good."

Varley Magnet Co.,  
Coil Dept.  
Woolwich,  
S.E.18.

**VARLEY**

Proprietors,  
Oliver Pell  
Control, Ltd.

**ALL APPLICATIONS FOR ADVERTISING SPACE IN "WIRELESS CONSTRUCTOR" MUST BE MADE TO THE SOLE ADVERTISING AGENTS JOHN H. LILE, LTD., 4, LUDGATE CIRCUS, LONDON, E.C.4.**

**WHY AERIALS BREAK**

MANY people who wake to find their aerial broken and lying on the ground do not realise the importance of allowing for the contraction of hemp rope when it becomes wet. If you have a tall mast and the aerial is held up by a rope halyard this rope may shrink a foot or two on becoming wet, and the additional strain so created may be quite sufficient to break an aerial wire.

**Avoid Soldered Joints**

Again, many people buy good strong aerial wire and use only the flimsiest wire to join their insulators to the aerial and to the halyards. Remember the old saying . . . "the strength of the chain is that of the weakest link" . . . See that your aerial is free from such weaknesses.

Try to arrange for your aerial wire to be continuous from the outer end right to the lead-in insulator. If you do this you will avoid the necessity of soldering anywhere, for the insulators can be attached by tightly wound strands of wire round the main aerial instead of using solder. A soldered joint very frequently corrodes owing to the electrolysis set up by the contact of two dissimilar metals, solder and the copper, aided in very many cases by the action of the soldering flux which was used and which will work its way in between the strands of the aerial wire.

**Effect of Friction**

Friction set up by the rubbing of a wire against the sharp edge of a pulley or any projecting woodwork is a fruitful source of trouble, particularly in windy weather. The best kind of aerial is that which is so stayed that there is no possibility of any part coming in contact with the house or woodwork during the highest of winds.

**'MODERN WIRELESS'**

The February Number of "Modern Wireless" will contain, amongst other special features, a full description of a powerful and selective long - distance receiver called

**'The Wanderer Five'**

On Sale Feb. 1st. Order Your Copy Now.

**THERE ARE OTHERS**

You can get other anti-microphonic valve holders besides BENJAMIN—just as you can get inferior substitutes for every first-class article made. But it is a poor policy.

BENJAMIN Anti-Microphonic Valve Holders—the first and the finest on the market—have built up their enormous popularity chiefly through the following five exclusive and essential features :—

- 1 Valve sockets and springs are stamped in one piece; there are no riveted, soldered or clamped joints to work loose and create microphonic noises.
- 2 The springs allow the valve to float in any direction.
- 3 Stops controlling spring movement enable valves to be inserted without damage to valves or springs.
- 4 Valve legs, however far pushed home, cannot foul baseboard.
- 5 Terminals and soldering tags are fitted for easy wiring-up.

The BENJAMIN Anti-Microphonic Valve Holder again was the first to incorporate a grid-leak or condenser and grid-leak attachment, already mounted for your convenience — and there is still no better combination to be obtained.

Price of valve holder alone :

**2/9**

**BENJAMIN**

**Clearer-Tone Anti-Microphonic VALVE HOLDERS**

From all radio shops or direct :  
**THE BENJAMIN ELECTRIC LTD.,**  
 Brantwood Works, Tottenham,  
 London, N.17.

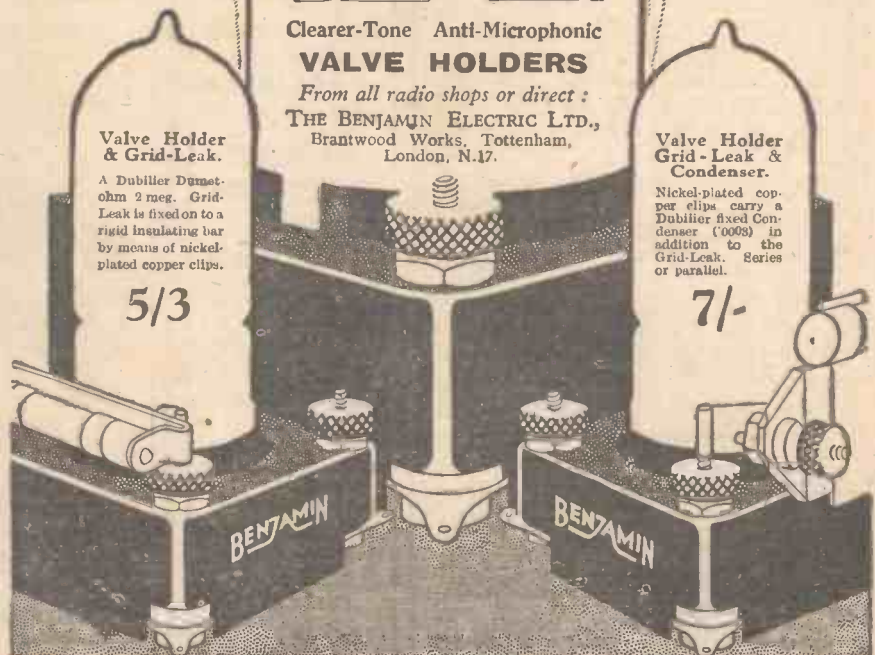

**Valve Holder & Grid-Leak.**

A Dubilier Dumet-ohm 2 meg. Grid-Leak is fixed on to a rigid insulating bar by means of nickel-plated copper clips.

**5/3**

**Valve Holder Grid-Leak & Condenser.**

Nickel-plated copper clips carry a Dubilier fixed Condenser (0008) in addition to the Grid-Leak. Series or parallel.

**7/-**

**KAYRAY**  
S.L.F. CONDENSERS  
LATEST MODEL  
NOW READY.  
6/11  
Post od. set



•0003  
•0005

6/11 each  
With 4 in. dial 7/11

**LOW LOSS SQUARE LAW**  
This variable Condenser is simply marvellous value. It cannot be equalled in price or quality.  
4/11 each  
By Post 5/11  
With VERNIER 1/- extra.



**EDISWAN R.C.R. THREESOME R.C.R.**  
2 Ediswan R.C. Units, 3 Valve Holder, Left-hand 2-way Coil Holder, 2 R.C. Valves, 1 P.V. do., 3 P.L. Rheostats, 9-v. Grid Bias. 0005 Tuning Condenser.  
SET OF PARTS 67/6  
All Accumulators, Panels, L.T. Batteries stocked.

**LISSEN**—Lissenola, 13/8. L.F. Transformer, 9/6. 35 ohm Rheostat, 2/6. H.P. or L.F. Choke, 10/- Fieldless Coils, 13/8. Grid Leaks, P., 1/- Ditto, variable, 2/8. All parts available.

**MONODIAL RECEIVER COMPONENTS**, 23 8s. od. All as specified.

**BURNE - JONES, LEWCOS, PETO-SCOTT, BOWYER-LOWE COLVERN SCREENED COILS, BASES AND SCREENS.**

**ALL CIRCUITS, PARTS, COILS AND SETS STOCKED.**  
**HEADPHONES**, all 4,000 ohms, N. and K. Standard Pattern, 7/11 pair. N. and K. Genuine, new lightweight, 11/6, 13/8. Dr. Nesper, 10/6 and 12/11. Teletunken, adjustable genuine (20/- model), 14/11. Branet, 11/9, 12/11, 14/8, 3 models.  
**ERICSSON (Continental) E.V.**, 7/11 pair. (Post, 6d.)

**BRITISH HEADPHONES**—Brown's Featherweight, 20/- Brown's A Type (Reed), 30/- B.T.H., 15/- Sterling, 20/-  
**VALVES**—Cosmos S.P.18, Red or Green, 14/-, New Blue Spot, 14/-, All Mullard, Ediswan, Osram, Marconi, Cossor, Bright D.E. and Power, 8/-, 14/-, 18/6, 22/6, 24/6, 30/-, 22/- Mullard PM 1, 2, 3, 4, 5, 6 stocked.

**CRYSTAL AND ONE VALVE AMPLIFIER (L.F.)**, in handsome polished cabinet, tested for use, 22/6. Post, 1/6. (With D.E. valve, 30/-) Or Complete Set, valve, H.T., L.T. units, aerial equipment, 5XX coil, 45/11. Post 2/-. Extraordinary Offer.

**ASTOUNDING VALUE in L.F. Amplifiers in handsome polished box, 1 valve, 18/11. Carriage 1/6.**

**CHOKES**—Cosmos H.F., 6/6; Lissen H.F. or L.F., 10/- each; Success L.F. or H.F., 10/- each; Bowyer-Lowe H.F., with base, 9/-.

Buy IGRANIC Parts if you want the best.

**CALL HERE FOR LISSEN, COSMOS, MULLARD, EDISWAN, MARCONI, COSSOR, OSRAM, JACKSON'S (J.B.), DUBILIER, McMICHAEL, SUCCESS, BEARD & FITCH, BOWYER-LOWE, LEWCOS, IGRANIC, EUREKA, ORMOND, UTILITY, FORMO, EDIS, BELL, FERRANTI, R.I., POLAR, NEWY P. & M., MAGNUM. WE HAVE THE GOODS! CALL AND SEE US. ALL LINES IN DEMAND STOCKED. SPECIAL TERMS, RADIO CLUBS, GENUINE EXPERIMENTERS.**

**BE SURE YOU ARE AT RAYMOND'S!**  
**K. RAYMOND**  
27 & 28a, Lisle St., Leicester Sq., W.C.2  
Hours: 9.15 to 7.45  
Saturday: 9 to 8.45  
Sunday: 11 to 1

**THIS MAGNIFICENT 2-VALVE SET**  
(D. and L.F.) as shown, in Handsome American Type Cabinet, 12 by 8 Panel.  
ALL PARTS ENCLOSED.  
Complete with British D.E. Valves, Tandco latest Coils, British L.T., Super 100-v. H.T. Aerial Equipment, 4-way Leads, B.T.H. 4,000 ohm 'Phones, O.R. Lissenola, O.R. £5 5 0  
Loud Speaker 'Taz Paid.  
Carriage and Packing, 6/-.

**CALLER'S COLUMN NOT SENT BY POST.**  
Terminals with N. and W., 1d.; Nickel, 1d.; Spade Tags, 6 a 1d.; Soldering, doz. doz. E6 Bushes, 1d.; Screw Wander Plugs, 2d., 3d., 4d. pair; Plug and Socket, R. or B., 3d.; Stapler, 4 a 1d.; Valve Pins, 2 a 1d.; 4 or 2 B.A. Rod, 3d. ft. Earth Tubes—Copper, 2/3; Climax, 5/-; Pine 7/22 Aerial, 100 ft., 1/11; Special Heavyweight, 2/8; Phosphor Bronze, 48 strands, 100 ft., 2/- (limited); Twin Flex, R. and B., 12 yds., 1/4, 1/8, 2/-; Miniature Silk Twin Flex, 6 yds., 6d. Maroon Lighting Flex, 9 yds., 9d. Insulators, 2 for 1/4; Tinned Copper, 1/16th sq. in., 12 ft. D.C.C. Wire, 1 lb. reel, 20s, 9d.; 22g., 10d.; 24g., 11d.; 26g., 1/-; 28g., 1/1. Battery Boxes, with clips, covered leatherette, 2/11; Metal 3/8, Ebonite, Grade "A," cut while you wait, 3/16th in. id. sq. in. 1 in. is id. sq. in. Stock sizes cheaper: 7 by 5, 1/3; 6 by 9, 1/3; 8 by 6, 1/9; 9 by 6, 1/11; 10 by 8, 3/-; 12 by 9, 4/- Also cheaper quality for crystal sets. Special Offer in Crystal Sets, 6/11, 7/6, 8/11, 9/6, 12/6. Also in enclosed cabinet, wonderful value, 18/11. AMERICAN Type Oak Cabinets, with base-board, take 12 by 8 ebonite, 10/8, 12 by 9, 11/9; 16 by 8, 16/11, 18/11. Any size in three days. Handsome Panel switches—DPDT, 1/8, SPDT, 1/- (Highest quality). Lightning Arresters, 1/- Wave-length Permanent Det., 6d. Red Diamond Perm. Detector, 2/-; Liberty, 3/8; Brownie, 3/-; R.I., 6/-; Crystals: Shaw's Genuine Hertzite, sealed, 8d.; Neutron Wray, 1/8; Dayzile, 2/8; Splendid enclosed Crystal Detectors, on base, 1/-; 1/3, 1/8. Micrometer, 1/9; Service Do., 2/9 (with crystal). P. and P. switches, 1/- Non-microphone V.H., 1/3; Bold Red Eb., 1/4; Baseboard, 8d. 2-way Cleared Coil Holders, 2/11, 3/11. Penton, Lotus, Polar, Newey stocked. Back of panel, W.L.L., 4/11; Kay Ray, 3/11; 3/8th drills for 1-b. pins, 1/3; Phone Cords, 1/-; 1/3, L.S. d., 1/8, 1/9. H.T. and L.T. Leads, 4-way, 1/11. Our old friends ADICO Batteries, 60-volt (not one in a 1,000 has to be returned. I will change any faulty). Price 6/11. Ever-ready, Siemens, Hellesena, 60-v. and 100-v., all 1.5 Batteries here. (Columbia always stocked).  
Dr. Nesper L.S. Unit, nickel, 4/11. Dr. Nesper De-Luxe Setor, 4,000 ohm Loud Speaker, 35/-. Radio Micro "Safir," fine value, 22/6.  
STOP.—Adjustable 4,000 ohm Headphones (Nesper pattern), double leather headbands, 7/11 pair.

**CALLERS: MAKE OUT YOUR LIST FOR A SPECIAL QUOTATION.**

INDEX TO ADVERTISERS

	Page		Page
American Hard Rubber Co. (Britain), Ltd.	369	Lissen, Ltd.	323, 327
Arctcraft Co., The	359	London Elec. Wire Co., & Smiths, Ltd.	344
Ashley Wireless Telephone Co. (1925), Ltd.	368	Makerimpot Co.	370
Batteries, Ltd.	364	M.A.P. Company	352
Bedford Elec. & Radio Co., Ltd.	366	Marconiphone Co., Ltd.	289
Belling & Lee, Ltd.	361	Metro-Vick Supplies, Ltd.	320
Benjamin Electric, Ltd.	371	"Modern Wireless"	290
Bird, Sydney S., & Sons	343	Morris, J. R.	331
Bowyer-Lowe Co., Ltd.	362	Mullard Wireless Service Co., Ltd.	Cover ii, 369
Brandes, Ltd.	335	New Times Sales Co.	370
Bretwood, Ltd.	363	Oldham & Son, Ltd.	344
Brown, S. G., Ltd.	291	Ormond Engineering Co., Ltd.	347
Burndept, Ltd.	340	Peto & Radford	357
Burne-Jones & Co., Ltd.	354	Peto-Scott Co., Ltd.	352, 355
Bush House Radio	370	Picketts Cabinet Works	366
Carrington Manufacturing Co., Ltd.	361	"Popular Wireless"	368
Caxton Wood Turnery Co.	370	Portable Utilities Co., Ltd.	Cover iii
Clarke, H., & Co. (Manchester), Ltd.	361	Radix, Ltd.	361
Cossor, A. C., Ltd.	319	Radio Instruments, Ltd.	Cover iv
Covenry Direct Supplies, Ltd.	366	Raymond, K.	372
Darex Radio Co.	370	Ronnebeck Machining Co.	366
Dubilier Condenser Co. (1925), Ltd.	324	Sifam Electrical Inst. Co.	359
Eastick, J. J., & Sons	340	Silvertown Co., The	364
Edo, C., & Co., Ltd.	352	Simmons, R. & Co.	366
Electradix Radios	366	Stratton & Co.	372
Eton Glass Battery Co.	366	S.T., Ltd. (Valves)	292, 328, 339, 360
Falk, Stadelman & Co., Ltd.	348	Taylor, C.	368
Ferranti, Ltd.	357	Taylor, J. H., & Co.	340
Formo Co., The	359	Telegraph Condenser Co., Ltd.	351
Garnett, Whiteley & Co., Ltd.	336	Trelleborg's Ebonite Works, Ltd.	364
Gambrell Bros., Ltd.	364	Valco, Ltd.	364
General Radio Co., Ltd.	370	Vandervell, C. A., & Co., Ltd.	355
Gent & Co., Ltd.	367	Varley Magnet Co.	367, 370
Graham, Ampion, Ltd.	359	Watmel Wireless Co., Ltd.	368
Hart Accumulator Co., Ltd.	348	Wavio, Ltd.	368
Holzman, Louis	361	Westam Accumulators	361
Hunt, A. H., Ltd.	363	Weston Elec. Instrument Co., Ltd.	351
Igranic Electric Co., Ltd.	332	Wilkins & Wright, Ltd.	358
International Corres. Schools, Ltd.	359	Wolf, M. & A.	364
Jackson Bros.	356	Wright & Weaire, Ltd.	363

TO ALL ADVERTISERS

Please note that communications concerning advertising in

WIRELESS CONSTRUCTOR

MODERN WIRELESS

POPULAR WIRELESS

must be made to

**JOHN H. LILE, LIMITED,**  
4, Ludgate Circus, LONDON, E.C.4  
(Phone: City 7261).

AND NOT to the Editorial or Publishing Offices.

LISTEN to AMERICA

on your own set and ASK YOUR FRIENDS TO HEAR

A short-wave receiver can be easily built and will bring in the AMERICAN S.W. broadcasting stations at good strength.

"EDDYSTONE" SHORT WAVE APPARATUS ENSURES THE BEST RESULTS.

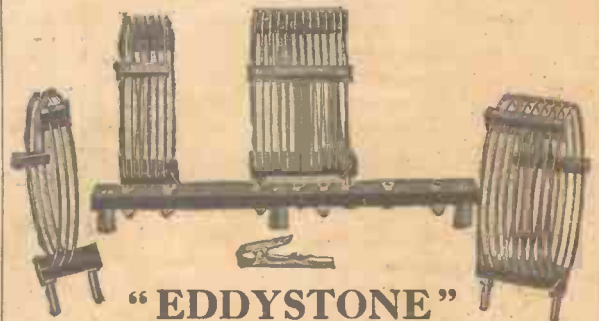

S.W. Inductance Unit as illustrated—15-150 metres **15/6**

"EDDYSTONE" Special S.W. Choke **10/6**

"EDDYSTONE" S.W. Condenser, 00015 capacity **15/6**

2-valve Short wave Receiver, 15-150 metres **£11 5s.**

(including Royalty)  
Send for Catalogue and Short Wave Diagrams.  
STRATTON & CO., LTD. BALMORAL WORKS, BIRMINGHAM.

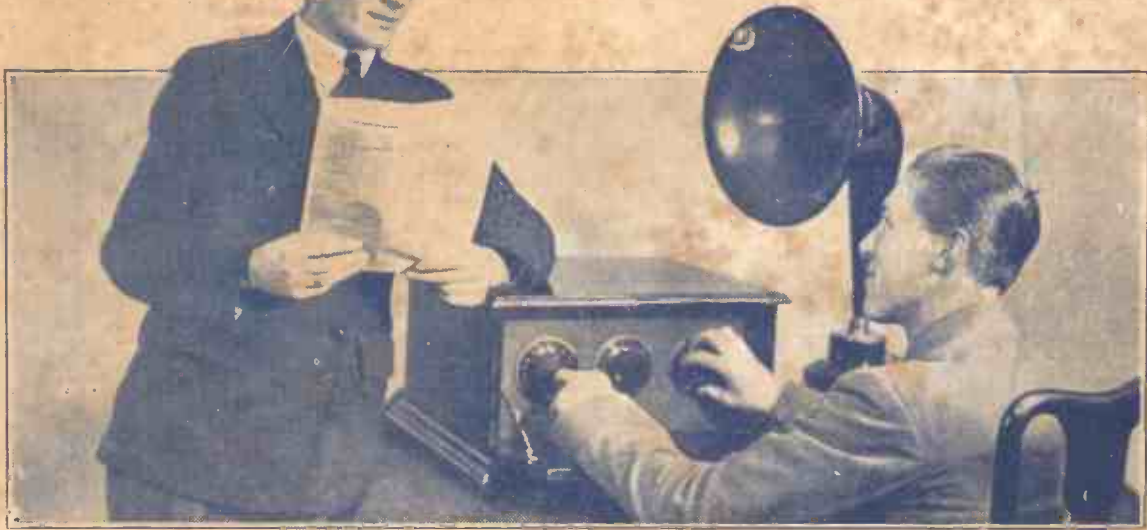

*Just a smooth, regular movement of the dials and station after station wings its way in.*

**T**RAFFIC tangles of the air are solved. Under Eureka Ortho-cyclic principles, stations—instead of being jumbled together—are evenly separated, no matter whether they are at the commencement or end of the dial. Compare this simple test. An ordinary condenser crowds 51 Geneva wavelengths within its first fifteen degrees on the dial. More than 3 wavelengths—each of 10 kilocycles separation—to each degree. No wonder accurate tuning is impossible!

The Eureka Ortho-cyclic, on the other hand, under identical circumstances shows only 15 wavelengths. But even more important, the same precise separation is shown all the way up the dial. One wavelength to each degree—no more and no less. Think of it. No more complicated wave traps—no more

irritating jamming. Under the Geneva wave plan each station will be separated from its neighbour by ten kilocycles. A smooth regular movement of the dials—degree by degree—and station after station wings its way in. Instead of being over-worked at one end of the dial the Eureka Ortho-cyclic gives you precisely 10 wavelengths each of 10 kilocycles separation from one end of the scale to the other. As regular, in fact, as the rungs of a ladder.

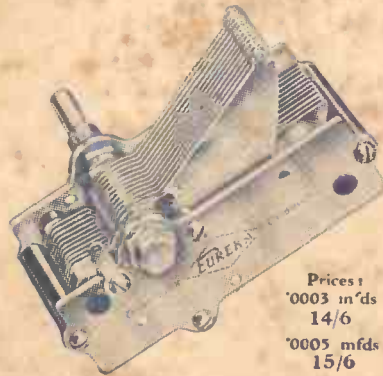

Prices:  
 '0003 in' ds 14/6  
 '0005 mfd's 15/6

The New Eureka Dial  
 Engraved 0-100 right to left for kilocycles and 0-100 left to right for wavelengths. Fits any condenser. Price 4/6

With its stout metal and plates—earthed rotor following latest low-loss practice—dual contacts, ball-bearing and self-centring shaft, the new Eureka Ortho-cyclic is the most handsome Condenser on the market. It is a worthy “stable companion” of the famous Eureka Transformer and covered by the same generous guarantee. Your Set deserves them.

# EUREKA ORTHO-CYCLIC CONDENSER

Advt. Portable Utilities Co., Ltd. (Eureka Radio Products), 8, Fisher Street, W.C.1.

Gilbert Advt. 6697.

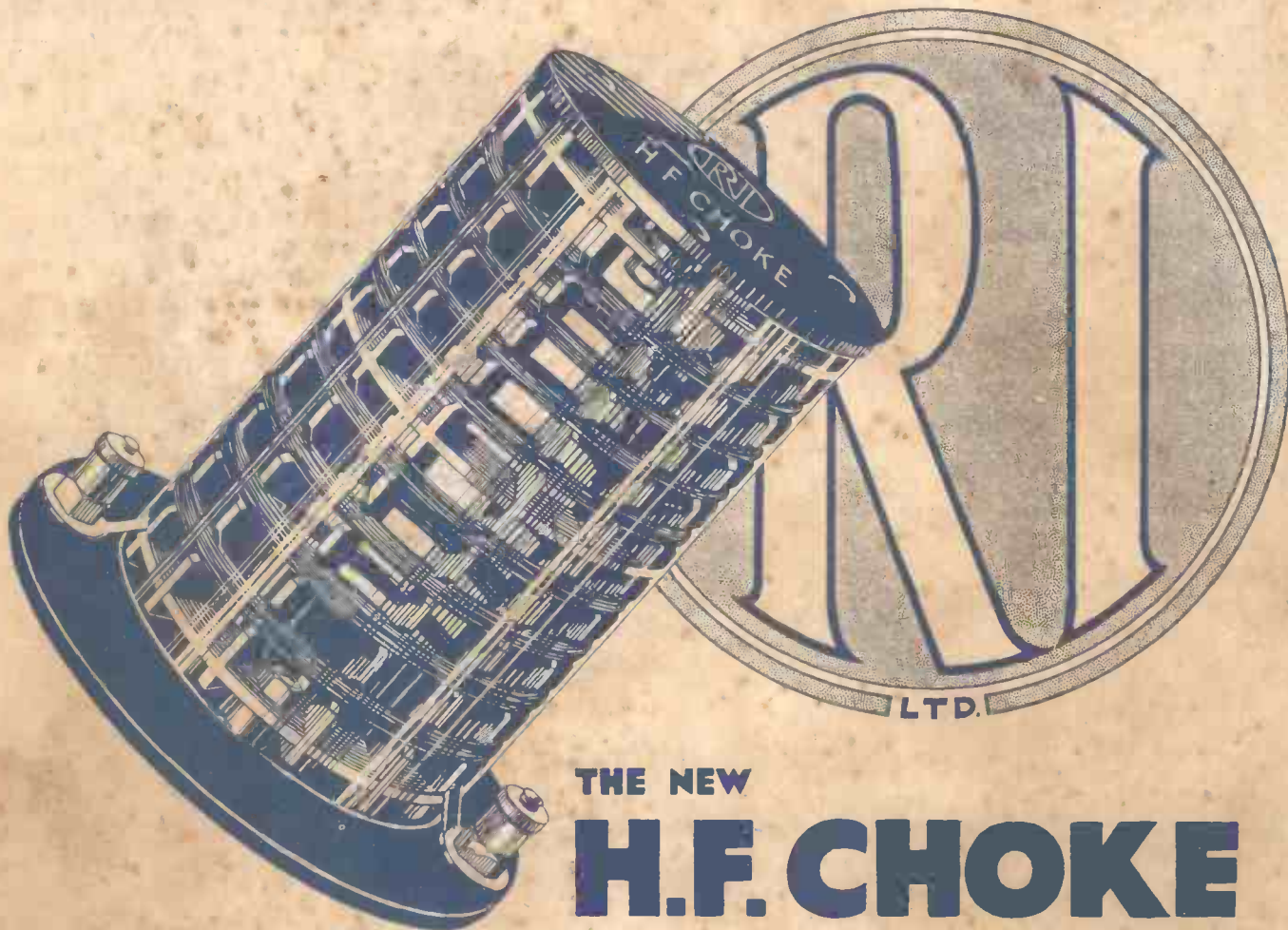

THE NEW  
**H.F. CHOKE**

**WILL BE THE BIGGEST  
FEATURE THIS YEAR**

Here is another remarkable R.I. component designed for circuits where a tuned-grid circuit is employed.

Being an R.I. product it has all the features necessary to give improved working of this circuit, for, as it is used virtually in parallel with the tuned circuit it is important that the high-frequency resistance and self-capacity are negligible in order to maintain selectivity and efficiency.

Hence the New R.I. H.F. Choke possesses a high impedance value and is wound in well-spaced sections on a low-loss skeleton former.

For wavelengths of from 50 to 4,000 metres it is quite suitable and no observable increase in the H.F. resistance of the parallel tuned circuit will result.

It is a precision instrument well in keeping with the sound engineering tradition of R.I. Ltd. Perfect in design and workmanship it is an outstanding example of the dominating influence of this progressive company in the wireless field.

As  
recommended  
and used in  
Mullard  
P.M. Circuits

**PRICE 12/6**

*Write for the R.I. Catalogue.*

THE MARK OF



BETTER RADIO

*Adv. R.I., Ltd., 12, Hyde Street, New Oxford Street, London, W.C.1.*

Published by THE AMALGAMATED PRESS (1922) LTD., The Fleetway House, Farringdon Street, London, E.C.4, on the 15th of each month, and printed by THE AVENUE PRESS (L. Upcott Gill & Son, Ltd.), 55-57, Drury Lane, London, W.C.2. Address for advertisements only. JOHN H. LILE, LTD., 4, Ludgate Circus, London, E.C.4. Phone: City 7261. Registered for transmission by Canadian Magazine Post. Subscription Rates: Single copies, 1s. 3d.; inland and abroad, 15s. per annum. Sole agents Australasia, Gordon & Gotch (Australasia), Ltd.; South Africa, Central News Agency, Ltd.; Canada, Imperial News Co. (Canada), Ltd. February, 1927.