

NOVEMBER 1924

25 CENTS

Wireless Age^{*}

The Radio Magazine



REVERE F.
WISTEHUFF

**Quality
plus
Service
since
1915**



C-12—Similar to C-11 with standard base



C-11—1.1 Volt .25 amp. Dry Battery Det. and Amp. Special Base



C-299—3 Volts .06 amp. Dry Battery Det. and Amp.



C-300—6 Volts Gas Content Detector



C-301A—6 Volts 1/4 amp. Amplifier

Cunningham RADIO TUBES

For Clear Reception

To perfection in design are added the productive resources and scientific skill of the great General Electric Laboratories.

The result—a series of Radio Tubes that give peak satisfaction in detection, amplification, and rugged long life.

Amazing accuracy governs every step in Cunningham manufacture. Testing is carried to extremes in order to give to every purchaser a tube as nearly perfect as is humanly possible.

Knowledge of Cunningham methods and policies is the answer to the why and wherefore of Cunningham preference.

PRICE THE SAME ON ALL FIVE TYPES

C-301 A C-299 C-300 C-11 C-12

PATENT NOTICE

Cunningham Tubes are covered by patents dated 2-18-08, 2-18-12, 12-30-13, 10-23-17, 10-23-17, and others issued and pending. Licensed only for amateur, experimental and entertainment use in radio communication. Any other use will be an infringement.

E. J. Cunningham Inc.

Branch
CHICAGO

HOME OFFICE
182 Second Street, San Francisco

Branch
NEW YORK

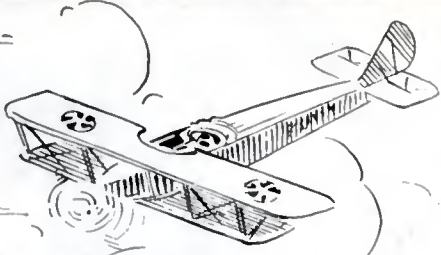
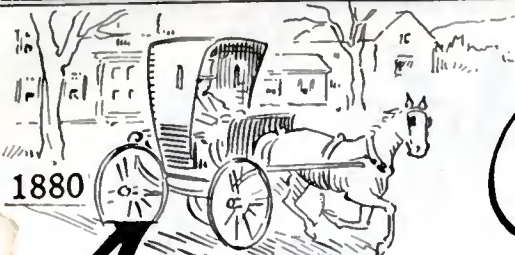

American Genius *To-Day* IN RADIO HEADSETS

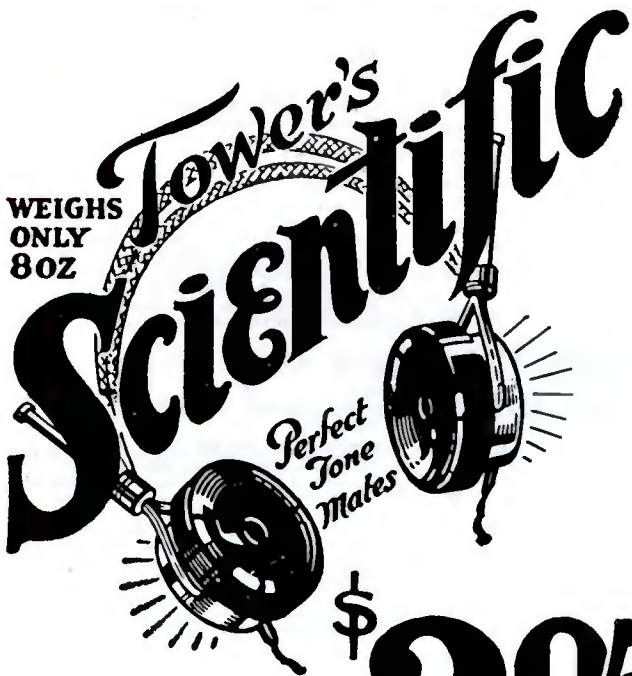

As in Transportation, American Genius has progressed from the old-fashioned, clumsy, obsolete phones of uncertain accuracy to the modern

TOWER'S SCIENTIFIC HEADSET

Lightest of all in weight, higher resistance, with elimination of distortion. Longer cord (full 5 ft.)

With increased production follows price reduction. As the **LARGEST EXCLUSIVE MFGRS.** of headsets in **THE COUNTRY**, we are able to produce the **TOWER'S SCIENTIFIC Headset** at the low price of \$2.95.

Companies of more limited production could not afford to sell such quality phones at anywhere near this price.

NOW \$2.95
Plus a few Cents Postage
YOUR PROTECTION

Every set tested and approved by licensed radio operators. Every set covered with money-back guarantee.

Production, over one million double headsets for this season.

Order at once by post card and we will ship immediately by Parcel Post C. O. D.

THE TOWER MFG. CORP.

98 ^{Dept.} _Q Brookline Ave, Boston, Mass.



Wireless Age

The Radio Magazine

Vol. XII

No. 2

November, 1924—Contents

Editorial Chat - - - - -	14
Radio on the Farm - - - - -	17
Harvest Time on the Air, <i>By William A. Hurd</i> - - - - -	19
Sports, <i>By Stuart Hyde Hawkins</i> - - - - -	22
Alias Slimmy O'Dyne, <i>By F. R. Buckley</i> - - - - -	27
The Study of Mars, <i>By David M. Todd, A.M., Ph.D.</i> - - - - -	30
A Villainess With Real Golden Hair, <i>By Golda M. Goldman</i> - - - - -	32
Starting with a Pick and Shovel, <i>By Richard Lord</i> - - - - -	33
Exit the Jonas Hayseed of 1880, <i>By Christine Frederick</i> - - - - -	34
The Family Receiver, <i>By R. A. Bradley</i> - - - - -	36
World Wide News, <i>By C. S. Anderson</i> - - - - -	38
Musical Sounds, <i>By John P. Minton B.S., Ph.D.</i> - - - - -	40
The 5½-Oz. Head Set, <i>By Duryea Bensel</i> - - - - -	42
Third National Radio Conference - - - - -	43
Getting the Rural Vote, <i>By Secretary Henry C. Wallace</i> - - - - -	45
One-Tube Circuits, <i>By John R. Meagher</i> - - - - -	46
Afloat and Ashore With the Operator, <i>By W. S. Fitzpatrick</i> - - - - -	48
Broadcasting Station Directory - - - - -	49
Close-Ups in the Industry - - - - -	51
New Appliances and Devices - - - - -	52
Title Contest Winners - - - - -	54

Your Authors

PROFESSOR TODD, as director of the Lowell Expedition to the Andes in 1907, went to Northern Chile to observe Mars when it came within 35,000,000 miles of the earth and took 12,000 photographs of the planet.

Again in 1922 he organized the Mars Expedition to the Bahamas, when Mars came again within 35,000,000 miles of the earth. He states that radio brought greater results from the study of the 1924 opposition, when Mars was within 34,630,000 miles of the earth, than had been possible to obtain in former years.

GOLDA M. GOLDMAN (A Villainess With Real Golden Hair) is an instructor of English in a New York High School, the Juvenile Critic of the New York Sunday World, and editor of "The Candle-Light Page" of The Candle-Light Lady. She has been writing radio personality sketches since the old WJZ days in Newark. Her interviews reflect her own vivacious interest in others, and certainly contain the feminine "interviewer" point of view that strikes a good balance with the all-too-masculine in radio.

JOHN R. MEAGHER (One Tube Circuits) originally designed the Uni-Control Receiver that brought out such remarkable response from our readers, and in this, the result of several months' experimentation and investigation, he has incorporated the best of his findings in a single article, and enough, to be sure, in one sitting.

PUBLISHED MONTHLY AT WIRELESS PRESS, INC., 326 BROADWAY, NEW YORK

Los Angeles, Calif., 1116 Chapman St., Coast Publishers Co. Chicago, Ill., Wrigley Bldg., Wheeler & Northrup. Boston, 18 Stewart St., Charles M. White.
 San Francisco, 821 Market St., Coast Publishers Co. Great Britain, 12-13 Henrietta St., London. Australia, 97 Clarence St., Sydney, N. S. W.
 Yearly subscription in U. S. A., \$2.50—Outside U. S. A., \$3.00; Single Copies, 25 cents. Entered as second class matter Oct. 9, 1913, Post Office, New York, N. Y., under the Act of March 3, 1879. Copyright, 1924, Wireless Press, Inc. When subscription expires you will find a renewal blank enclosed. Return with remittance promptly.

James G. Harbord, Pres. Pierre Boucheron, Vice-Pres. and Gen'l Mgr. L. MacConnach, Secy. George S. DeSousa, Treas. H. H. Reber, Bus. Mgr. C. F. Boag, Adv. Mgr.
 C. S. Anderson, Managing Editor W. A. Hurd, Associate Editor R. A. Bradley, Technical Editor

Because certain statements and expressions of opinion from correspondents and others appearing in these columns from time to time may be found to be the subject of controversy in scientific circles and in the courts, either now or in the future and to sometimes involve questions of priority of invention and the comparative merits of apparatus employed in wireless signaling, the owners and publishers of this magazine positively and emphatically disclaim any priority or responsibility for any statements of opinion or partisan expression if such should at any time appear herein. Printed in U. S. A.

THE WIRELESS AGE is a member of the Audit Bureau of Circulations

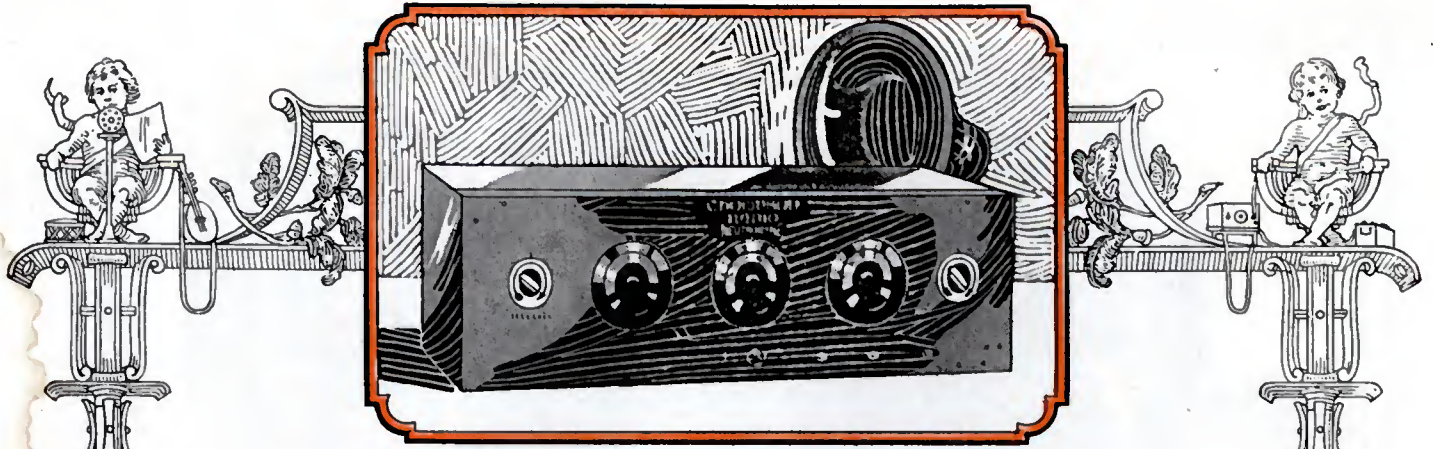

"EXPERIENCE IS THE VITAL FACTOR IN EXCELLENCE"

THOMPSON RADIO

Thompson radio products are as fully developed and as standardized in radio as is the telephone in wire communication. Thompson owners do not worry about how their set and speaker will compare with "next year's model." Perfection remains Perfection.

Thompson simplicity of operation as well as Thompson range and power makes it possible to receive the desired radio program just exactly as it is given before

the microphone. Those who wish *real* radio entertainment at low cost will be decidedly interested in the Thompson Neutrodyne Radio Receiving Set—NOW \$125—and the Thompson Speaker—NOW \$28.

The fully developed Thompson Radio Products at such reasonable prices are possible only to an organization that has been making radio products *exclusively* for many years.

If your dealer does not handle Thompson radio products, write to us for descriptive literature and the name of a Thompson dealer near you.

R. E. THOMPSON MANUFACTURING CO.
 Manufacturers of Radio Apparatus for the U. S.
 Army and Navy and numerous foreign governments
 30 CHURCH STREET - NEW YORK, N. Y.
 FACTORY: JERSEY CITY, N. J.

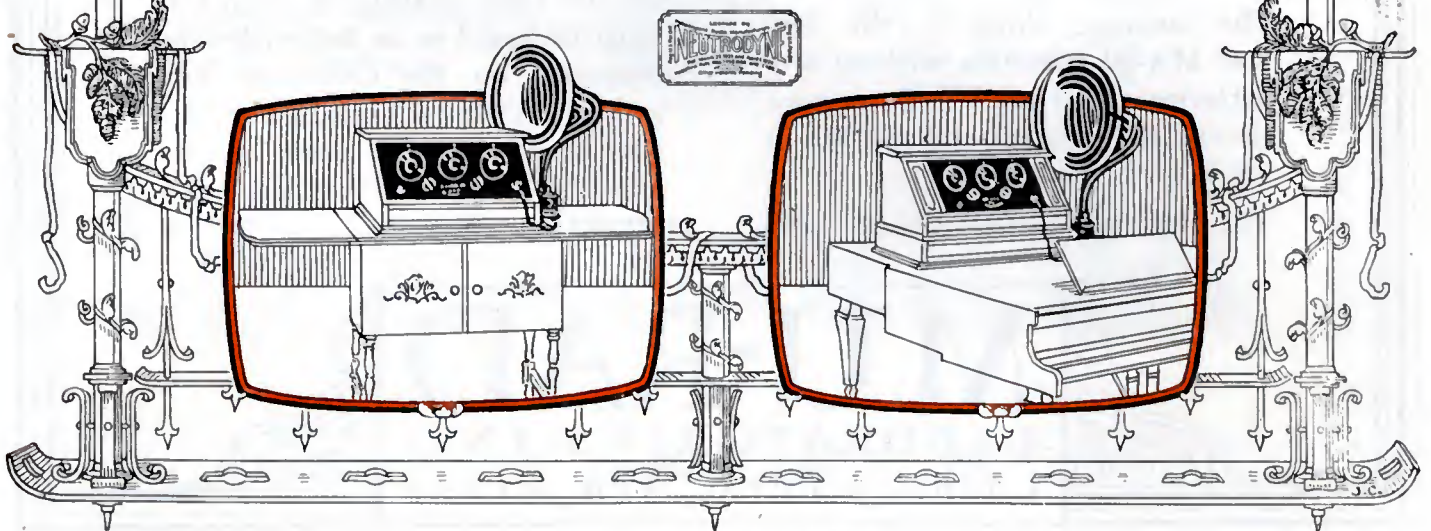

"Quality Goods for Quality Readers"

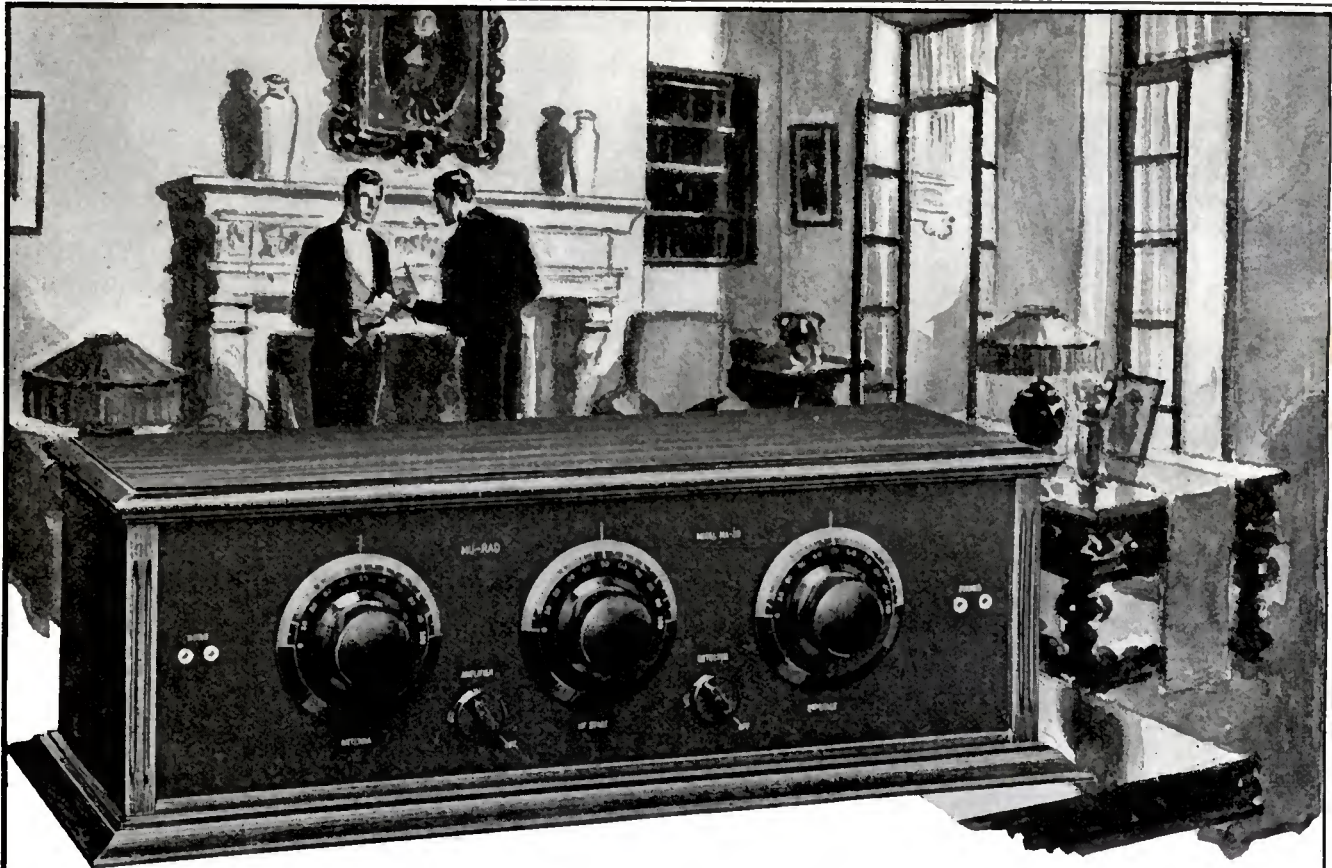

MU-RAD MA 20

Turn your switch and get Cuba or Seattle

IT is no trouble at all for a person in Dallas, Texas, to pick up either Seattle or Cuba with a Mu-Rad MA-20! Mr. K. H. Wiggett in Sherbrooke, Quebec, got Los Angeles and "heard them perfectly."

The amazing thing is, the Mu-Rad MA-20 does this without any batteries. Just hook it up to your electric light socket and you are in touch with the continent.

The Mu-Rad is so easy to operate!

It will select stations with such rare delicacy that even a person with no knowledge of radio whatever may get any desired program that is in the air quickly and easily.

As for tone quality, the Mu-Rad must be heard to be believed. Get prepared for the Christmas programs. Write for literature on Mu-Rad Receivers and proof of the amazing results owners get. Address Dept. A.

MU-RAD
LABORATORIES, INC.
Asbury Park, New Jersey

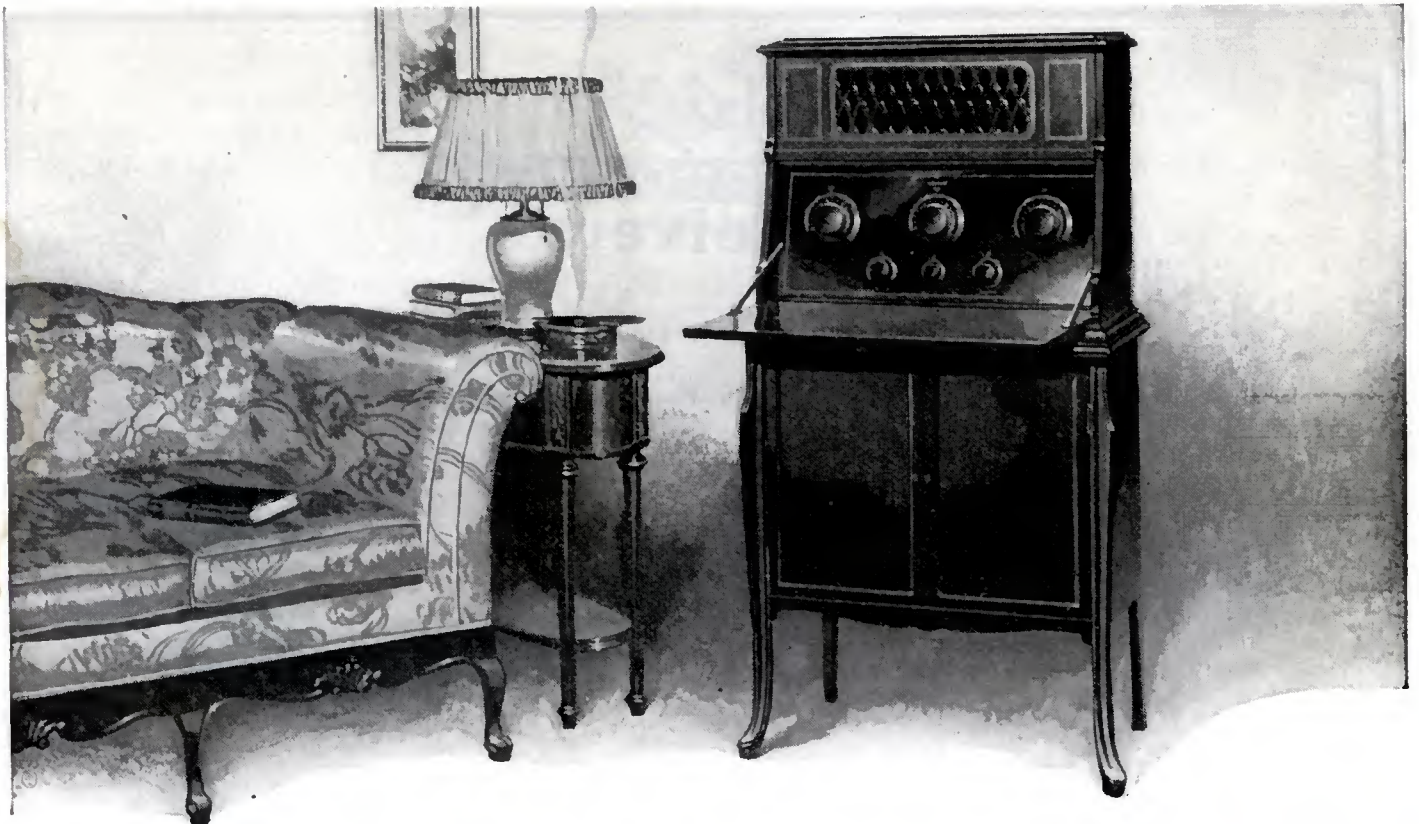

The FADA Neutrola Grand

new beauty, new perfection in Radio

AN EXQUISITE instrument. Encased in beautifully finished genuine mahogany. A gem of the cabinet designer's art. A piece of furniture that will adorn any home.

Here in this new FADA Neutrodyne is a real achievement in receiving beyond anything you ever heard. Wonderful naturalness of tone. The high C of the coloratura soprano and the lowest bass of the human voice are reproduced precisely as sung. In selectivity the FADA Neutrola is remarkable.



FADA Neutrola Grand

The deluxe five-tube FADA Neutrodyne, with self-contained loud speaker. Receiver and cabinet in genuine mahogany, artistically decorated with wooden inlay. Ample space for all batteries and charger. Drop desk lid that hides receiver when not in use. Price, exclusive of tubes and batteries, \$295.

Ease and simplicity of tuning make it the ideal receiver for all the family.

The FADA Neutrola Grand is the finest of the

complete line of FADA Neutrodyne, which includes a model to suit every taste, every radio requirement, every pocketbook. Three, four and five tube FADA Neutrodyne receivers in plain or de luxe cabinets are now available at your dealer's. See them today and make your selection. You will never regret buying a FADA.

You have a range from \$75 to \$295 from which to select — six models, each extraordinary in results; each a remarkable value.

F. A. D. ANDREA, INC.
1581 Jerome Avenue, New York

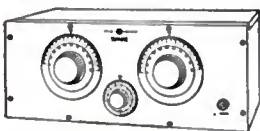

FADA Neutro Junior
No. 195

Three-tube Neutrodyne. A wonderful performer. Price (less tubes, batteries, etc.) \$75.

FADA Radio

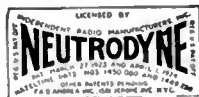

"Quality Goods for Quality Readers"

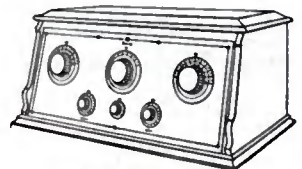

FADA Neutroreceiver
No. 175-A

Mahogany cabinet. Inclined panel and roomy battery shelf. Five tubes. Price (less tubes, batteries, etc.) \$160.

Ware

NEUTRODYNE

Receivers

The popularity of Ware Neutrodyne Receivers is evidenced on every hand by the justifiable pride of their owners—pride in the name, beautiful appearance, and their remarkable performance. To own a Ware is to have at your command the best that radio has to offer.

And there are good reasons for Ware supremacy—a well organized, well financed company; radio engineers of exceptional ability; exclusive inventions; the use of the best materials available; and craftsmanship of the highest order.



TYPE T

Mahogany cabinet, 10 $\frac{1}{2}$ " high, 14" wide, 13 $\frac{1}{2}$ " deep. Dry-cell "A" and "B" batteries enclosed in cabinet. Reflex Neutrodyne circuit. Three dry cell tubes, one reflexed; equivalent to four tube circuit; one stage tuned radio frequency amplification, detector, two stages audio. Operates loud speaker. Outside antenna.

\$65.00 without accessories



TYPE X

Walnut cabinet, 8 $\frac{1}{2}$ " high, 21 $\frac{1}{2}$ " wide, 10 $\frac{1}{4}$ " deep. Dry cell "A" and "B" batteries enclosed in cabinet. Reflex Neutrodyne circuit. Four dry cell tubes, one reflexed; two stages tuned radio frequency amplification, detector, two stages audio, equivalent to five tube circuit. Double-scaled voltmeter indicates voltages of "A" and "B" batteries. Indoor or outdoor antenna.

\$150.00 without accessories.



TYPE W

Walnut cabinet, 8 $\frac{1}{2}$ " high, 21 $\frac{1}{2}$ " wide, 10 $\frac{1}{4}$ " deep. Neutrodyne, not reflexed, using five vacuum tubes—two radio, detector, two audio—and storage battery. "B" batteries enclosed in cabinet. Double-scaled voltmeter indicates voltages of "A" and "B" batteries. Indoor or outdoor antenna.

\$175.00 without accessories.

Progressive Musical Instrument Corp.,
New York, N. Y.
Dalrymple-Whitney Radio Corp.,
New York, N. Y.
Cohen & Hughes, Inc.,
Philadelphia, Pa.
Pittsburgh, Pa.
Baltimore, Md.
Washington, D. C.

There are three types of Neutrodyne receivers now being marketed by the Ware Radio Corporation, described in detail underneath the illustrations on this page. The beautiful tone quality is the same in each type.

Type T is the first three tube reflexed Neutrodyne, and the first Neutrodyne to be operated on dry cell tubes. It is sold at a very moderate price, but its performance is so remarkable in every way that it will more than meet every requirement of most radio users, except that of extreme distance.

Type X is a four tube reflexed Neutrodyne, also operating on dry cell tubes. This instrument has a greater range than the three tube receiver.

Type W is designed for those who desire the maximum of sensitivity and selectivity, and greater volume than can be obtained with dry cell tubes. It is operated with a six volt storage battery. This instrument has won an enviable reputation for all-round efficiency, and represents the highest development in radio reception.

Types TU, XU and WU are the same circuits as described above, contained in handsome cabinets with built-in loud speakers.

Investigate the various receivers on the market, but be sure to hear the Ware before reaching a decision.

Send for Catalog

Ware

RADIO CORPORATION

529-549 WEST 42ND STREET
NEW YORK

DISTRIBUTORS

Illinois Phonograph Co.,
Chicago, Ill.
Yahr & Lange Drug Co.,
Milwaukee, Wisc.
Ohio Musical Sales Co.,
Cleveland, Ohio.
Lucker Sales Co.,
Minneapolis, Minn.



TYPE TU

Brown mahogany or walnut cabinet, housing Type T circuit. Panel exposed by raising lid. Loud speaker concealed behind grille. Dry cell "A" and "B" batteries enclosed in cabinet. Dimensions: 34 $\frac{1}{2}$ " high, 18 $\frac{1}{4}$ " wide, 18 $\frac{1}{4}$ " deep. \$150.00 without accessories.



TYPE XU

(See WU for cabinet open)
Brown mahogany or walnut cabinet, with panels of contrasting shades. Embodies Type X circuit. Loud speaker concealed behind grille at top, below which a desk leaf turns down, exposing the panel. Dry cell "A" and "B" batteries enclosed in cabinet. Dimensions: 44" high, 27 $\frac{1}{4}$ " wide, 18 $\frac{1}{4}$ " deep.
\$275.00 without accessories.

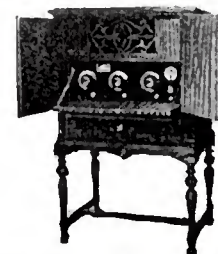

TYPE WU

(See XU for cabinet closed)
Brown mahogany or walnut cabinet, with panels of contrasting shades. Embodies Type W circuit. Loud speaker concealed behind grille at top, below which a desk leaf turns down, exposing the panel. Storage and dry cell batteries enclosed in cabinet. Dimensions: 44" high, 27 $\frac{1}{4}$ " wide, 18 $\frac{1}{4}$ " deep.
\$300.00 without accessories.

New England Phonograph Distributing Co., Boston, Mass.
Commercial Associates, Inc., Los Angeles, Calif.
D. H. Holmes Co., Ltd., New Orleans, La.
C. A. Richards, Inc. (Foreign Distributor), New York, N. Y.

Licensed by the Independent Radio Manufacturers, Inc., under Hazeltine Patents Nos. 1,450,080 and 1,489,228 and patents pending, and the trademark "Neutrodyne" registered in the U. S. Patent Office, Certificate No. 172,137.

"Quality Goods for Quality Readers"

Fit for a King



Britain's greatest engineers in designing receiving equipment for his Majesty, KING GEORGE V, chose *Resistance Coupled Amplification*. None other would do.

RESISTANCE COUPLED

The Aristocrat of Amplifiers

The Concert Halls and the Chambers of *Buckingham Palace* that in years gone by have resounded with the sweetest of melody and voices, will find the new notes that art and science have spun across the skies no less sweet. The RESISTANCE COUPLED AMPLIFIER will render the harmony of distant players as no other system could—even as if the receiver were not, and musicians flung their symphony directly against the portières of the palace.

The DAVEN RADIO CORPORATION is the pioneer in the manufacture of RESISTANCE COUPLED AMPLIFIERS—the Royal Amplifier—specializing in complete sets, parts, and construction kits. The story of auditively perfect amplification is told in the Daven "RESISTOR MANUAL," by Zeh Bouck. This manual contains the how-to-make-it data on Resistance Coupled Amplifiers. At all first class dealers.

Price, 25 Cents

THE DAVEN SUPER-AMPLIFIER UNIT

The Super-Amplifier Unit of molded bakelite (illustrated), in which sockets and all necessary essentials are inserted, is the most compact amplifier unit on the market. It is the simplest method of adding distortionless Amplification to any receiver.

Recommended to those who desire the advantages of Resistance Coupled Amplification, but who have hesitated in consideration of the perplexities of obtaining the proper unit. All connections invisible beneath the base.

At Your Dealers

DAVEN RADIO CORPORATION

"Resistor Specialists"

NEWARK

NEW JERSEY

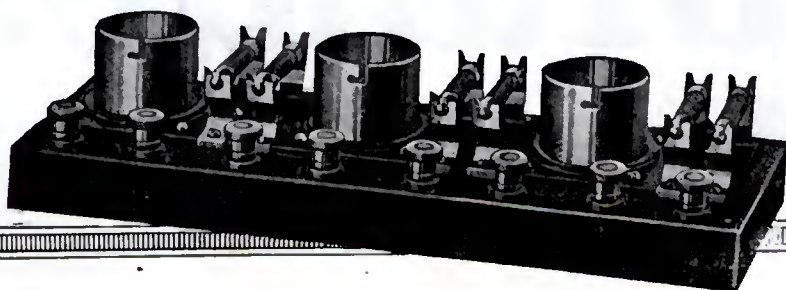

DAVEN RADIO

"Quality Goods for Quality Readers"

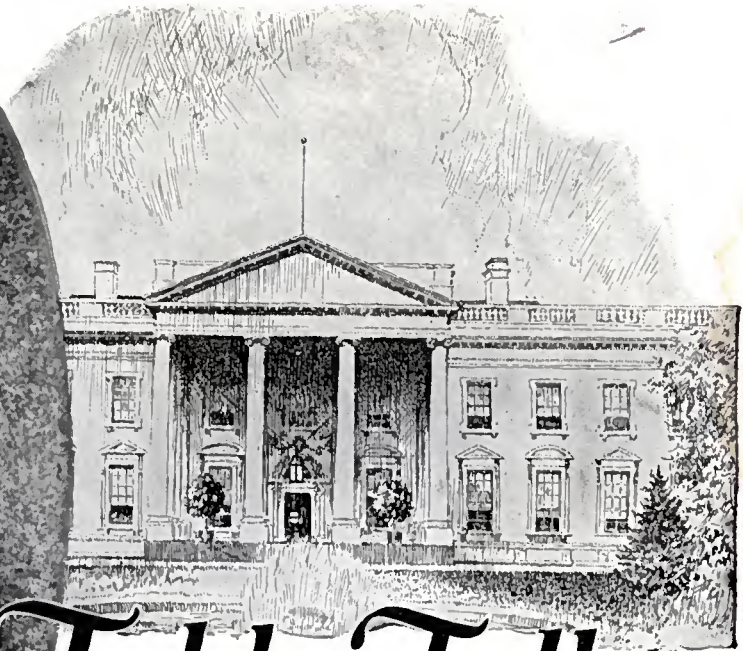

Table-Talker

Keep in touch with National Events

PRICE
\$10

The final desperate spurt as the Presidential campaign draws to a close! The returns as they pile up on election night. Great speeches and vital messages—the inaugural address, the later congressional messages—hard, slow reading, but easy to listen to—with a *Table-Talker*.

And, too, there's everything from football to recipes, from grand opera to market reports, from prize fights to bedtime tales. All brought to your home—shared with your family and your friends by the *real* reproduction of the *Table-Talker*.

Brandes

The name to know in Radio



PARAGON FOUR \$65



A **BASICALLY** new four-tube receiver employing the new Paradyne Circuit. Capable of loudspeaker reception over practically unlimited range. Extremely simple to operate. Major dial control. Operates either as a three-tube or a four-tube set. May be used with any standard tubes of either dry cell or storage battery type. Handsome mahogany cabinet. Cheap in no respect but price.

REVOLUTIONARY!

EVERY year there's a big advance in radio knowledge. This year's advance has revolutionized Paragon Receivers and produced a brand new line having all the Paragon fine tone, sensitivity, selectivity and high quality of the past with new *simplicity of control* and new *lower prices*. In addition to this new four-tube set, there are also

The New Paragon *Three*, price only.....\$48.50
 And the New Paragon *Two* at..... 27.50
 Ask to see these new receivers at your radio dealer's.
 Free descriptive folder on request.

ADAMS MORGAN CO., Inc., 8 Alvin Avenue,
 Upper Montclair, N. J.

DEALERS: Write for attractive new Dealer Proposition and address of nearest Paragon Distributor

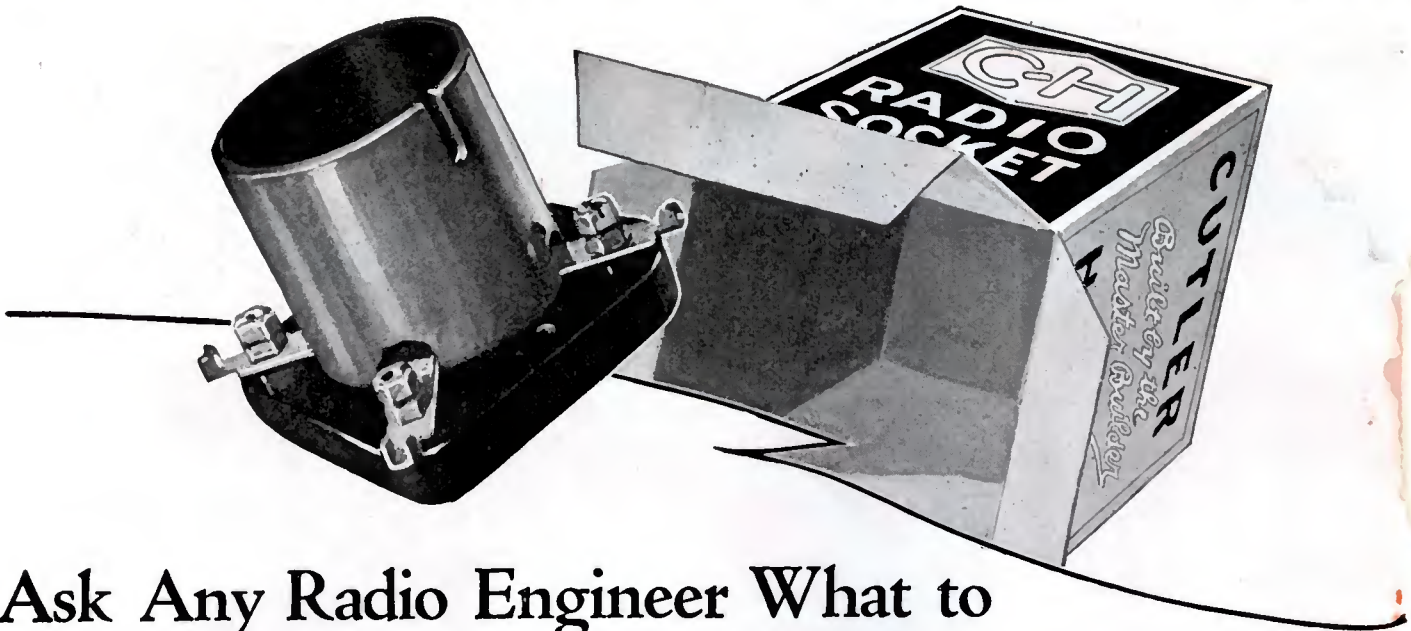

Ask Any Radio Engineer What to Look for When You Buy a Socket!

Radio experts are continually stressing the necessity of using good sockets. In some of the more sensitive circuits such as the Superheterodyne, poor sockets often completely destroy results. In fact, in thousands of sets today, with scores of different circuits, the so called "static" often mentioned, or "battery noises," are in reality merely the result of poor socket contacts—certain proof of dissipation of the feeble currents that we rely on for distant reception.

Minimum Dielectric Capacity

In the Cutler-Hammer Socket, designed by the same engineers whose precision rheostats and other radio current control apparatus have justly become world famous, every effort has been bent toward greatest efficiency. Custom has no consideration—and from its striking color scheme to its novel contact construction, the design is radically new.

It embodies a minimum of both insulation and metal; capacity absolutely minimized without sacrifice of mechanical strength. The insulation materials (shell of thin orange Bakelite and base of genuine Thermoplax) are ideal—high in quality and dielectric strength; low in dielectric capacity and losses. And all metal parts are widely separated, both in the insulation and in air to conserve every last bit of energy received.

Its contacts—the source of losses and noise in most sockets—are of entirely new construction. Each one is a springy clip

Maximum Dielectric Resistance

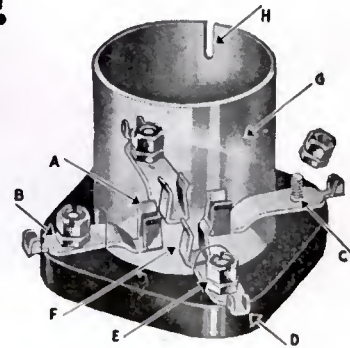

These Exclusive Features Assure Better Reception

- A Perfect contact. Both sides of tube prong cleaned when inserted—no contact or wear on soldered end.
- B All metal parts *silver* plated—perfect contact for the life of the set. Silver may tarnish but its contact resistance does not change.
- C One piece contact construction. The binding post is NOT a part of the circuit—the wire to the socket always touches the contact strip which carries the current direct to the tube prong—no joints to cause losses.
- D Convenient terminals for soldering—full length to allow bending down for under-wiring. Ears hold wire in place for soldering.
- E Extra handy binding posts—tight connections with either wrench or screw-driver. Lock washers hold terminals rigid.
- F Wide spacing of current carrying parts both in air and insulation—true low-loss construction.
- G A minimum of both metal and insulation for low capacity. Shell of thin Bakelite—the base of genuine Thermoplax.
- H The tube is held in place by merely a vertical motion—no twisting to separate bulb from base.

"Built by the



The Perfect

that clinches the tube prong without strain; yet cleans it bright whenever the tube is inserted or removed. These contacts are formed of phosphor bronze and *silver plated*—because the contact resistance of silver does not increase as it stands exposed to air. The area of contact is greater than that found in any other socket; and the construction is such that these feeble currents which mean so much in radio pass directly from the wire to the prong of the tube without meeting a single joint. (*In so many sockets the wiring is attached to a binding post to which the contact strip is in turn attached below. This presents a joint which causes noise and losses. The C-H Socket affords perfect connection even if the screw that holds the contact strip in place is entirely removed.*)

Silver Plated Phosphor Bronze Contacts

No Joints to Cause Noise or Losses

In this socket the tube is inserted and removed without turning—just pushed in and pulled out—to prevent twisting the bulb from its base. And the tube is held tight, absolutely rigid so that any vibration cannot cause contact noises. Its small size and convenient soldering terminals, too, mean a great deal in most sets for space is usually at a premium. The Thermoplax base is only $2\frac{1}{8}$ " square—scarcely more than the diameter of the tube, and the soldering terminals extend out far enough from the rounded corners that they may be turned down for under-wiring when this system is used. These terminals have handy ears which are bent up to hold the wire while the solder is being applied—adding much to the ease with which this work is accomplished. For temporary connection, or where soldering is not used, a slotted hex-nut is provided which securely clamps the wire against the contact spring with either wrench or screw-driver.

Convenient and Efficient Terminals

No Twisting to Damage Tube

In all it is as perfect a socket as engineering skill can devise. It offers maximum efficiency and ease of installation, coupled with an appearance that adds much to any set. And best of all you will like the price, 90c. *This socket that meets the specifications of the most exacting radio engineer costs no more than most of those on the market today!* If your dealer has not been stocked, you can be supplied direct from the factory at list price plus 10c for packing and postage.

THE CUTLER-HAMMER MFG. CO.

Member Radio Section, Associated Manufacturers of Electrical Supplies
MILWAUKEE, WISCONSIN

Master Builder"

RADIO SOCKET

"Quality Goods for Quality Readers"



Instruments of Guaranteed
Quality Assure Success
in Radio

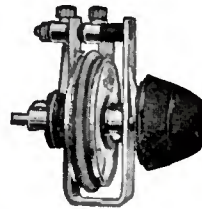

The C-H 4 Ohm Vernier Rheostat
Perfect detector tube control. Also furnished without vernier for amplifier tube control.

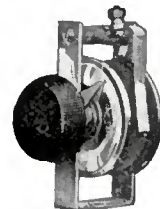

The C-H 30 Ohm Radio Rheostat
For control of the $\frac{1}{2}$ ampere, "UV201-A-C301-A" type receiving tubes and the "UV199-C299" type; also made in 125 ohm size.

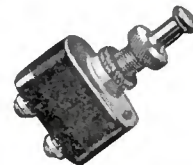

The C-H Radio Switch
The switch with the perfect mechanism for providing easy control of the most delicate circuit without introducing microphonic noises—one hole mounting.

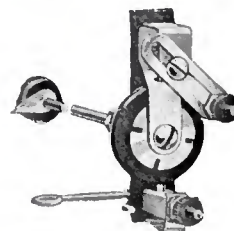

The C-H Variable Grid Leak
Mounted on the tube socket-panel controlled. Adjustable for all grid condensers.

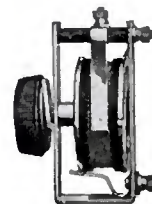

The C-H Radio Potentiometer
The potentiometer with the resistance unit that does not wear and cannot be displaced under constant use.

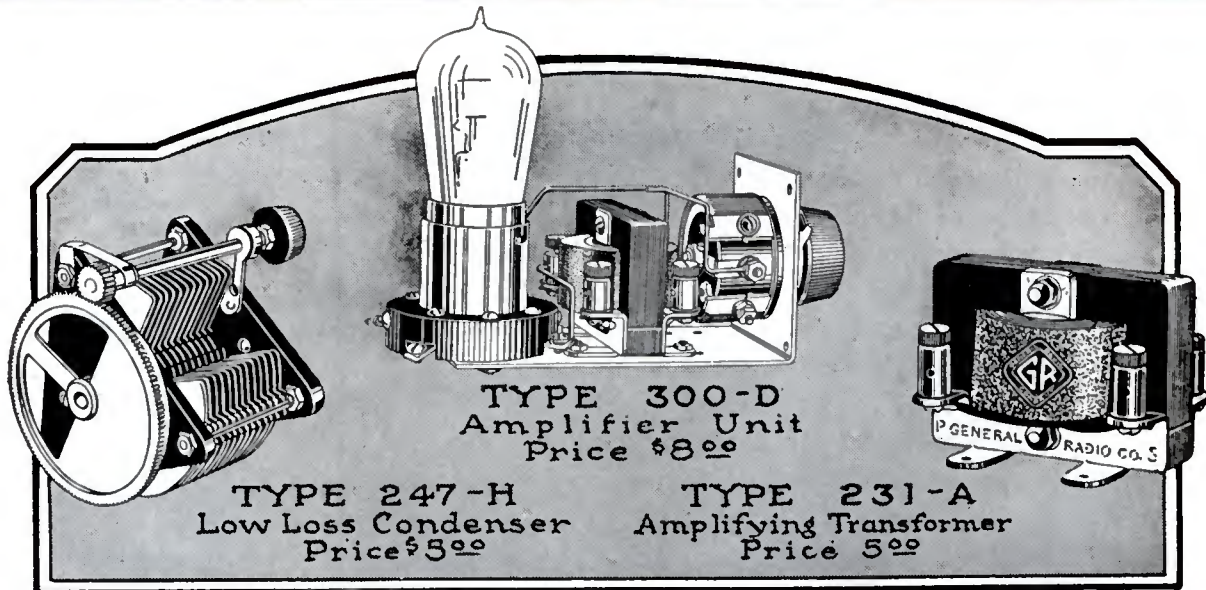

GENERAL RADIO Parts Give Super-Reception

Selectivity, distance, clarity, and volume are the qualities which constitute *good reception* and are what you may expect from your set if you build with **GENERAL RADIO** parts.

For over a decade **GENERAL RADIO** Condensers have been the *universal favorites* because of their *low losses* and over-all efficiency.

Since 1917 **GENERAL RADIO** Amplifying Transformers have been the leaders—not only in an

historical sense but in *undistorted amplification*.

The Type 300D is an amplifying unit designed for the convenience of amateur set builders. It combines the advantages of an efficient transformer, rheostat, and socket compactly assembled and ready for easy installation.

Whatever your circuit—build with **GENERAL RADIO** parts—for *Super-Reception*.

GENERAL RADIO Co.
Cambridge, Mass.



Ask Your Dealer or Write for
Our New Radio Catalogue

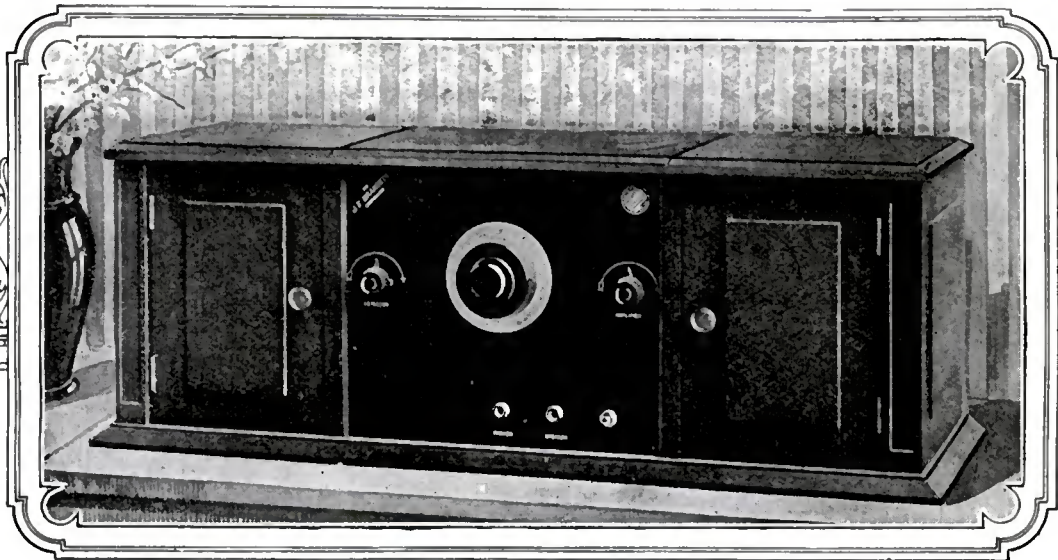

The Ultimate Radio Receiver ONE DIAL ~ SIX TUBES

THE "BRANDOLA" is the latest achievement in radio. In its simplicity of control, purity of tone, volume, extreme sensitivity and clear reception of distant stations combined with its very accurate logging, the "BRANDOLA" is far in advance of any radio receiver now offered to the public.

OPERATION. As you will note in the illustration, the "BRANDOLA" has but one dial to adjust—so simple, that a child of six years can tune in local and distant stations with the same ease and confidence as its parents. It is very selective in its operation—a simple adjustment of the one dial and you may choose between the many programs in the air.

TONE QUALITY. The newest and most improved method of amplification is employed exclusively in the construction of this wonderful receiver. By the use of Resistance Coupled Amplification, reception of music has been transferred into the realms of higher musical expression.

LOGGING. The "BRANDOLA" logs perfectly. When you listen in, note the position of the dial, jot it down in your log book for future reference. Because of its simplicity of operation, the number of stations you may listen to in one evening, is only limited by the number you may choose to hear. The slightest turn of the dial absolutely eliminates one station and brings in another.

The "BRANDOLA" may be purchased at any first class Radio Store. If you cannot obtain it, write us and we will mail list of nearest dealers.



Any Dealer will be glad to demonstrate the "BRANDOLA" for you.

List Price	\$125.
West of Rockies	135.
Canada	165.

The Brandola

The J. F. Brandeis Corp., 37 Oxford St., Newark, N. J.

Editorial Chat

IN this age of marvels, "We are not as happy as kings." There are many marvels, and life is brief. The railroads saw the birth of a wood burner on iron rails, and the growth of an electric mogul, giving way to automobiles, increasing at a prodigious rate under the shadow of soaring planes. Now, the ZR-3 makes the trans-Atlantic flight because of radio—the universal Red Book of the airways—and the government builds a radio highway for 24-hour continental mail delivery. Not satisfied, we turn from the spill-over of a radio show to crush each other in another, seeing far too little, and yet determined to know the last word in radio!

The Fall Shows

The crowds crowding the radio shows are mass evidence of the tremendous impetus given radio this fall. Amateur interest is large, but overshadowed by women-appeal designs in complete set displays. This means recognition of radio in the light of wholesome household approbation—a stamp of approval issued to commodities of merit by the family institute.

Phonograph manufacturers were quick to appreciate the sight-selling value in merchandising home furnishings, and have established a show-room display precedent the radio industry is not slow to follow.

Program Standard

After the first flush of novelty appeal, radio becomes a service, and in that service, must maintain a standard of some sort. If the broadcast stations are unable to hold general interest, then they will gravitate naturally to the specific.

In this issue of your magazine, you will find the November schedule of agriculture programs in "Harvest Time on the Air." December, and the 1925 schedule, is included. Then turn to "Sports" for the football programs, but before reading it again, you might browse through the contents a little further on. The Third National Radio Conference is opened by Secretary Hoover in a lucid review of the past and a prophetic vision of the future.

Fiction—interviews—opinions of national figures—all yours for the reading.

A Family Receiver

Technical articles are selected on the premise that there are only a few outstanding subjects in one month the reader cares to assimilate over one month's span.

The 6-Tube Family Receiver, this month, can be built by the family, the ease of operation being to the family's taste, and a tone quality above distance; though DX hunting is the individual's prerogative. Blessed be distance!—if we don't have too much of it.

This—your issue of WIRELESS AGE—is another you'll enjoy.

—THE EDITORS.



Hear the difference!

A loudspeaker is a critical thing. Any vibration in the horn adds sounds that nature never gave to the speaker's voice. And limited range thins down the tone to flat, unreal quality. Some people think that a near-real voice is the best that radio can give . . . but not after they have heard a Radiola Loudspeaker!

The difference is the result of elaborate experiment and extended scientific study. The Radiola Loudspeaker has an extraordinary range—gets the full richness of tone. And it adds no sound of its own. To know how clear—how mellow—how *real* your music can be—ask to hear a Radiola Loudspeaker.



Radiola Loudspeaker
Type UZ-1325
Now \$25.00

Radiola

REG. U. S. PAT. OFF.

LOUDSPEAKER



RADIO CORPORATION
OF AMERICA
Sales Offices:
233 Broadway, New York
10 So. La Salle St., Chicago, Ill.
28 Geary St., San Francisco, Cal.



Imported



N & K Phones, Model D, 4000 ohms, reproduce more clearly because of their watch-like accuracy of construction, and the increased diaphragm area. The slightly larger ear caps and the sanitary leather covered head bands make them the most comfortable head set. Price \$8.50.

PHONES

Built like a watch

THE scientific design and painstaking workmanship of European watches have earned a worldwide reputation. These identical qualities are what have given N & K Phones their remarkable reputation.

As in fine watches, the design is absolutely scientific, the workmanship the highest type of delicate hand-craftsmanship. The magnets are made of a special magnetic metal of a quality that insures uniformity and long life. The ohmage (4000 ohms total D. C. resistance) has been proved by tests to be the most efficient for all general purposes. The diaphragms are peculiarly and unusually sensitive and have a *greater area*. The spacing between the diaphragms and the magnet poles is scientifically correct.

Clear, mellow Tone

The results of this scientific design and painstaking workmanship are evident from the first moment you listen to broadcast music through N & K Phones. The entire reproduction is clearer, mellower, more natural. Every note, highest to lowest, of voice or musical instrument is heard distinctly. Compare them with any other phones you know of and you'll prefer N & K. Sold on a money-back guarantee.

Made by the makers of N & K Imported Loudspeakers, \$27.50; and N & K Imported Phono-units, \$7.50

Dealers: N & K Head Sets mean easy sales, excellent profit. Use them to demonstrate your radio sets, especially the small ones. They'll sell the set for you every time. Show your customers the sanitary leather-covered head bands—so easily cleaned. And take advantage of the important fact that there are no come-backs on N & K Head Sets. As an N & K dealer said after handling them for a year: "I have yet to see one pair come back for repairs." We guarantee it fully and carry a complete stock of spare parts. If your jobber is not yet supplied with N & K Head Sets, write us.

TH. GOLDSCHMIDT CORP., Dept. W11, 15 William St., NEW YORK

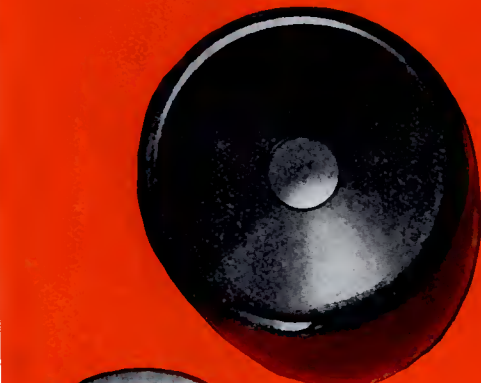

Ear caps accurately machine threaded, to insure proper seating of diaphragm.



Extremely sensitive diaphragm, 2 1/4 in. diameter.



Thin, calibrated metal washer maintains accurate spacing between magnet and diaphragm.

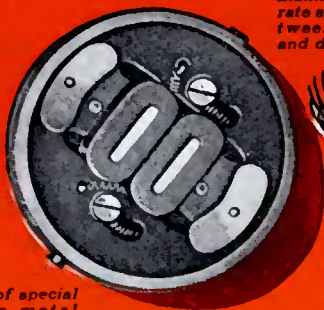

Magnets of special magnetic metal wound to 4000 ohms resistance.





Radio on the Farm

MRS. CLAWSON wiped her florid face with the blue-checked apron girdling her rotund figure, placed herself at the table and waited expectantly. The others waited, too, for the signal that would occasion well nigh hysterical outbursts of emotion.

Hiram Clawson, prelate *magnificent* of the farmstead, skillfully balancing a knife in his right hand, clutched a fork in his left. The attitude was portentous. A posture suggestive of the imminent, terrifying onslaught.

"Well, stranger!" he commenced. "Just received a bulletin from the Commission Brokers' Exchange showing up the reason for poor farming conditions."

The stranger, a chance visitor, and city-bred, understood the situation. Having just come from the city, he represented the evil cult of trade unionism, the sharp practices of business magic and the glamour of carbarret tinsel. He represented, in truth, danger with the element of injury removed. A situation always alluring.

"Yes?" he encouraged.

Everyone leaned forward. The moment has arrived.

"Yes, sir!" Hiram affirmed. "The bulletin said that labor was responsible for poor prices on produce. Suppose I wanted to hire a painter for the day? It would cost me about 23½ dozen eggs. That's what one hen lays in 272 days. Suppose I wanted a mason for a day's job? It would cost me about 42½ pounds of butter, which represents the care, feeding, and milking of 14 cows. And that's a big item. Then suppose I needed a carpenter for one day? Just one day! I'd have to pay him one hog weighing around 170 pounds. That's the care and feeding of a pig for eight months."

"Yes?" the stranger still encouraged.

Hiram scored his bull's-eye.

"That's why you city folks can't tell the farmers how to run their business!"

AFTER dinner the stranger announced the purpose of his visit.

It seemed that he had brought a radio set to this isolated farm with the sole intent of providing entertainment and instruction, but particularly information. Market and weather reports, he indicated would prove invaluable to the planting, harvesting, and marketing of produce. Likewise for livestock shipments.

Candidly, Hiram Clawson was dubious. But the stranger was not offended.

Lively music intrigued the gathering. Good humor heightened their spirits. Pulses quickened with the rhythm of old-time songs. Hearts warmed as youth and vigor and life itself flowed from the loud speaker.

Then came the bolt from the ether. Agricultural reports!

Eyes sought eyes. Was this a service or a presumption? Did this portend a valuable acquisition to the day's labor, or warn them of another attempt at meddling?

Hiram Clawson leaned forward, intent. A painter must pay \$15.00 for 23½ dozen eggs. A mason must pay \$23.00 for 42½ pounds of butter. A carpenter must pay the sum of \$70.00 for a 170-pound hog!

Turning he stared at the stranger. "What," he demanded, "becomes of the difference between the prices in eggs, butter and pork that I pay to labor for a day's work and the price *they* pay to secure the food?"

The stranger laughed. He laughed long and uproariously.

"That," he replied, "shall be answered by radio. What you have now unwittingly learned is the proper use of radio facilities. I have brought to you the radio. It remains for you to use it."

"Who are you?" Hiram asked.

There was no answer. The stranger had gone.



HARVEST TIME ON THE AIR

Fay Bainter and Walter Woolf in Shubert's Operetta, "The Dream Girl," broadcast through WJZ. The farmers enjoyed this show as much, if not more, than city folk—except, of course, those who saw it—and it is well worth seeing

"When the corn is in the shock"

Harvest Time on the Air

Broadcast programs scheduled for this winter will surely promote a contented agriculture—
A contented agriculture in America means our individual betterment economically

By WILLIAM A. HURD

RADIO will be more alluring to the farmer when we stop talking about the fireside. True, there is a strong appeal in the picture of the family hearth. Whittier added a touch of romance with his "Snowbound." But the fireside on a farm is isolation. Crackling embers punctuate the moan of a north-east wind and the tempo is loneliness. Wintry blasts sweep across the barren fields to sigh and whistle under the eaves of bleak isolation.

Radio alone can dispel the frozen silence of a rural winter. The play-grounds of the world may be selected on a circular scale. Sinbad, the Sailor, would envy the wonders of the twirl of a dial. Yet there are those of us who would presume upon the farmer's sphere.

Broadcast programs are an editorial function that cannot be performed by a cabaret artist. Those who broadcast to farmers sense this fact and diversify their programs with engineering, lectures, music and pertinent information. But the question arises as to how much of each should be broadcast.

THE Farmers' Union, functioning as a strong co-operative marketing and buying organization in the West, the Farm Bureau Federation in Chicago, operating as a political organization, and the National Grange Association in the East, with a social and fraternal objective, ought to know what to broadcast to farmers. But the programs would require careful editing. These three organizations, all powerful, are not friendly. Most broadcast stations now serving the farmers, blanket the entire country and can ill afford to favor one organization or offend the members of another.

How can a broadcast station in New York serve best the natives of Arkansas? Location of broadcast stations was not originally chosen with any consideration of the field to be served. And this in a land of 48 provinces, each with problems of its own and a perspective peculiar to its locality. Many farm publications knowing this are content with a concentrated, but altogether healthy circulation in a particular section. The most successful farm publication of national distribution calls the farmer a gentleman and prints material of real interest to city dwellers. The truth being that country gentlemen and city folk have more in common than is usually conceded.

WHAT the farmer will not read in a magazine he will not listen to on the radio. He wants variety. He is particularly keen for news because he cannot buy the five star extra before the print is dry. As a matter of fact, there are more things of real interest to the farmer than there are stations to broadcast them.

Put Luther Burbank on the air. Let the editors of farm journals each broadcast a five-minute talk. The moment the Ambassador of China lands, put him in a taxi and rush him to the nearest broadcast station. Agricultural conditions in China are much more impressive than identical conditions in the mountains of South Carolina.

Stations broadcasting livestock, grain, and general market reports serve the farmer much as the stock ticker serves the broker. One farmer receiving such reports acts as the central bureau for all his friends who have telephone service. If the estimated receipts of the governmental report indicate a shortage in the following day's shipments, the farmers rise at 3:00 A. M. to haul their hogs and produce to market. Prices are thus brought down. Likewise, the farmers avoid overloading the market. Prices go up. The result is a tendency toward stabilization of the market.

THE big stations should co-operate, and each help the smaller ones in disseminating information and amusement. The question of who will pay the broadcasting bill does not need to worry us now, as it is being paid. It only remains to make the radio so much alive, the farmers will be the first to offer a solution when the question arises. Radio will break down the isolation peculiar to the American farm. This alone justifies any precaution, any expense, to make the radio alive with world events at first hand.

The farmer makes his own radio, repairs his own tractor, and in short is fast becoming mechanized. Classes in domestic economics are maintained for farm women. The boys and girls in rural communities are organized to serve the farmers who do not have radio sets. These juvenile organizations spread broadcast reports across the countryside with astonishing effectiveness.

Why should the farmer of Iowa emigrate to California when the world at large can be brought to him? Competition between the Los Angeles Chamber of Commerce and Hollywood has been keen. Broadcast gossip of the film stars has finally won over weather propaganda. And Iowa no longer suffers the terrifying inroads on its population.

THE educational and cultural effect of radio on the farmer is felt in the Chautauqua circuit. Less comedy and better music distinguished the Chautauqua season of last summer. This is more significant when we pause to reflect that only two per cent. of thirty-six million farmers now own radio sets.

The percentage of radio equipped farms should be

higher. The farmer can purchase a good receiver for less than it will save him on crops. Approximately 117 stations broadcast daily weather reports and forecasts, a service that can be definitely calculated and figured in any medium of exchange.

Various writers, inspired with a sort of prophetic wisdom, have declared that the troubles of the farmer can be solved by placing a radio in every farm home. Just how this is to be accomplished is not a part of any one of the solutions offered. Perhaps giving the farmers what they want might do it.

THE Northwestern Farmstead working through WLAG was one of the prime movers in broadcasting agricultural service. Their programs consist of market reports, opening prices on all northern grown grains, livestock, potatoes, butter, cheese, milk, fruits and vegetables. Investments best suited to the farmers' interest are also broadcast as a permanent feature. These are supplemented with investment talks for the rural banks. Closing prices are given with time signals in order that last minute prices can be checked against the clocks in the warehouses and shipping rooms. In the evening, two or three short lectures on farm topics are delivered by experts, usually members of the State Agriculture College, commissioners of agriculture of other states, grain supervisors, men from the stock yards, experts of agricultural marketing organizations, and practical farmers. The lectures are on subjects dealing with farm supplies, seeds that will grow best in Minnesota, and a variety of informative suggestions.

THE Department of Chemistry of the University of Pittsburgh, broadcasts a series of radio talks through KDKA every Wednesday at 8:15 P. M. Their schedule for the remaining classes is: October 29, "Coal, a Factor in Industry and Health;" November 5, "Heat and Cold: What They Seem to Us," and November 12, "Glass, One of Man's Blessings."

A bulletin has been prepared briefly outlining the lectures and containing a list of reading references. This may be obtained by addressing the radio manager, University of Pittsburgh, Pittsburgh, Pa. The lectures will be printed in a bulletin at the close of the series and may be obtained at the same address.

The Missouri State Board of Agriculture at Jefferson City, operates WOS for the farmers of that section. This station is trying to standardize broadcast reports to facilitate ease of reception. The attempt is difficult. Potato quotations are not of value to a sugar cane district, nor do cotton growers have much in common with the farmer who is wondering what price he will get on his alfalfa crop.

WPG, Nushawg Poultry Farm, New Lebanon, Ohio, broadcasts poultry news and information. This station co-operates with the City National Bank of Dayton, Ohio,



What, may we ask, can the farmers desire more than to hear Lida Mae in "The Dream Girl," Shubert's broadcast success?

on the arrangement of programs.

The powerful Naval Station at Great Lakes, Ill., being in the corn belt, broadcasts proper programs for corn growers, six hours daily.

St. Louis University, WEW, broadcasts quotations on cabbage, fluctuating prices in beef, hay, fruits and vegetables.

THE air mail stations, identified with the distribution of data relating to farm products since the inception of radio crop and market-news service, continue as a useful link in the chain. North Platte, Rock Springs, Elko, Reno and Omaha are the air mail stations thus identified. Omaha is the western terminus of the leased wire of the Bureau of Agriculture and Economics. The leased wire service and the air mail station at this point form the connecting links with the East and the West. The section west of the Rocky Mountains resolves itself into a unit for

the development of a market news service. Representatives of the Department of Agriculture are maintained at San Francisco and Los Angeles and co-operate with the local broadcasting stations. Important crop and market developments in the East are transmitted by wire to the West and broadcast to the farmers of that section.

East or West, the country bank now has the appearance of a miniature stock exchange. These banks are actively co-operating with the local stores in a nation-wide drive under the auspices of the federal authorities to place at least 500,000 sets in farm homes.

The winter's program schedules for the following stations may be secured by addressing your requests to THE WIRELESS AGE.

Iowa State College at Ames, Ia.

University of Texas at Austin, Texas.

Ohio State University at Columbus, Ohio.

New Mexico College of Agriculture & Mechanical Arts

Nebraska Wesleyan University.

Wisconsin Department of Markets at Waupaca, Wis.

Sears-Roebuck Agricultural Foundation, Chicago.

THE Kansas State Agricultural College, this Fall, has made the first concerted effort of any educational institution to disseminate a systematic course of instruction by radio. They have prepared a thoroughgoing catalogue listing the radio extension courses. The agricultural, engineering, home economics and general science divisions of the college have earnestly co-operated with the Extension Service in the formulation of this radio program.

No attempt has been made to parallel the regular college course of instruction. Particular attention, however, has been given to the selection and treatment of subjects which have a ready and practical application in the home, on the farm, and in business. Faculty members who have prepared, and who will broadcast these lectures, are authorities in their respective fields of work. They have selected the most interesting material available, care-

fully prepared it with regard to continuity, practicability, applicability and timeliness.

HORTICULTURE, Fruit and Vegetable Gardening, September 15 to December 30, is a sixteen weeks' course designed to increase interest in the production and use of fruits and vegetables. Suggestions regarding selecting the site and soil, nursery and varieties, the procuring and setting of plants, and their cultivation and care will be embodied in the lectures. Making and handling hotbeds, and the forcing of early plants will be discussed in time to help the gardener with his plans. Spraying to prevent injury by insects and fungi will also be given attention.

Agronomy, The Wheat Industry of Kansas, September 16 to December 30, presents an opportunity to obtain the most recent information on the growing and marketing of wheat.

The Beef Cattle Industry from November 10 to December 29, in eight lectures, will discuss the development of the beef cattle industry in Kansas, The United States and the World, with export balance and import balance and the characteristics, adaptability and distribution of the different grades of beef cattle.

Dairy Husbandry, November 10 to April 20, by the Department of Dairy Husbandry, offers a series of seventeen radio lectures. This course contributes essential information on dairying, the selection of dairy cows, a description of the different breeds of dairy cattle and discussion of the essentials in the feeding, care and management of dairy cattle of all ages.

Electrical Engineering, Electricity in Home and on Farm, November 12 to December 31, treats with electricity today as an essential element in the home, in the automobile and on the farm.

Shop Practice, The Shop, Automobile, and Truck, November 12 to December 31, will give suggestions regarding selection and care of the tools needed, the construction and layout of the workshop, and the best ways to make and repair articles of farm equipment. The problems that concern the owners of automobiles and trucks in the winter season, and how they may reduce operating expenses and at the same time get more out of the equipment, are pointed out in this series of lectures.

Chemistry in Everyday Life, November 14 to January 2, will discuss the chemical action and changes within our bodies and the chemical nature of our foods. This subject includes even the chemical reaction of our emotions and the result on our state of health. There is a treat in store for those who are fortunate enough to tune in when

this course of lectures on the chemistry of everyday life is given.

Physics, Radio and Other Problems in Physics, November 14 to January 2. The first four lectures include many practical hints for the proper manipulation of radio receiving sets. The four additional lectures will include information of interest and value to persons concerned with the care and use of storage batteries, with artificial cooling and with the proper illumination of the home. The lecture on Weather Factors should likewise be of interest to everyone.

Textiles, November 13 to January 1, will aid the homemaker of today to judge the wide range of fabrics on the market at present, and suitability to the purpose for which the material is intended, as well as its serviceability.

The Hog Industry, from January 5 to February 23, will include the study of the development of the hog industry, the place of the hog on the farm, and hog statistics for Kansas, the United States and the World.

Incubation, January 6 to February 24. How eggs of high hatchability are produced, culled, cared for, shipped, and incubated will be discussed in this series of lectures.

Architecture, The Home, January to February 25, discusses the principles of house planning for rural and urban dwellings. Problems concerning equipment, conveniences, materials, and methods of construction will be dealt with, and special emphasis given to the subject of appearance. Helpful ideas in house designing will be developed. The landscaping of the home grounds, a very desirable part of any architectural effort, will receive due consideration. To anyone contemplating the building of a house or the improving of one already built, this course of lectures should prove to be very valuable.

Public Speaking Lectures and Readings, January 23 to January 30, includes reading of popular selections, lectures dealing with the correct idea or basis of modern public speech and its place in American community life, natural speech instead of the old time "elocution," arrangement and preparation of the speech and some suggestions for the person whose duty it is to plan a public program which

is to include speeches.

Food Economics and Nutrition, January 9 to February 26, deals with bread and cake making problems, the importance of fruits and vegetables in the diet, meat as a food, some reasons for using milk and milk products, why and how to use eggs and cheese to advantage in the diet, the cereal foods, and the place of sweets in the day's food.

(Turn to page 80)



Arthur Murray is broadcasting a series of lessons through WOR, and fifty other stations in this country and abroad. His program has a wide appeal for those who live in rural sections

S P O R T S

One allure of sports is the foregathering of fellow beings to yell, and stamp, and shout



The rhythmic cadence of a hard fought game comes to us—grips us—becomes alive for us—in our radio

Polo-Racing-Tennis-Baseball-and Football

By STUART HYDE HAWKINS

RADIO ATHLETICS" — the latest paradox which this complex civilization has created for its edification and enjoyment—has become so inherent a factor of modern life in these United States through the heretofore unprecedented activities between the two fields this Fall that its paradoxical nature has practically ceased to be regarded. The idea of "seeing" such sporting events as a horse-race or a polo game without leaving the peace and quiet of one's living-room—an idea the expression of which even the wildest dreamer of five years ago would have laughed into scornful oblivion—is not only complacently accepted by the majority of that conservative brotherhood, the American Public, but is even enjoyed with scarcely a thought as to the seeming incongruity of the act.

To be sure, the way was to some degree prepared, for radio fans have followed the hooks and swings of champion prize fighters for some three

years; and the home runs and the strike outs of two previous World Series have been visualized by the addicts to earphones and loud speakers. But in the mind of the sporting element of the radio audience the Fall season of 1924 will long retain an important position, for it was the greatest "Sport Season" the B. C. L. has ever known. Equally unforgettable will that season remain to those sport-lovers to whom radio had formerly meant little, for it was the radio which enabled them to follow Epinard around the tracks at Belmont Park and Aqueduct, to picture mentally the most widely heralded and eagerly awaited polo games in the history of that sport, to enjoy the thrills formerly reserved for the proud possessors of a World Series admission ticket, and to fidget and twist with excitement as the collegiate football teams crashed and strove upon the eastern gridirons.

The sudden increase in the number and nature of sporting events broad-

cast is directly traceable, of course, to the perfection by radio engineers of economical "remote-control broadcasting;" i. e., that type of broadcasting wherein the microphone is situated miles from the station studios, portable amplifiers boosting the voice of the announcer over the resistance of the direct-wire connection between microphone and station transmitter. Ever since the first broadcasting of a World Series baseball game—in fact, since radio fans heard the description of the first remote-control broadcast ever attempted, the Dempsey-Carpentier fight in 1921—sporting men have recognized the beneficial value of radio in the stimulation of public interest in the various sports. But until the early fall of this year the cost of transmitting a "direct-from-the-scene" description of most of the less-universally-popular sports was prohibitive to the station managers.

On the afternoon of Labor Day last, radio sets in practically every state in

SPORTS



*Tennis broad-
casts won favor
with the radio
audience this
season*

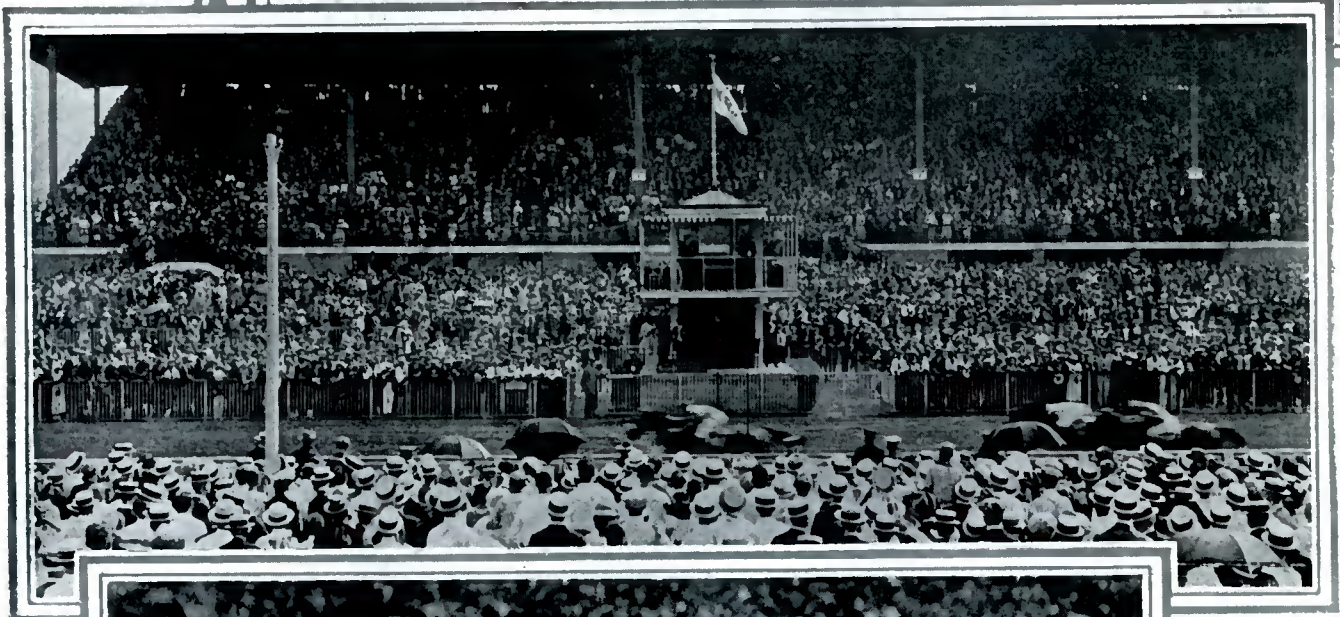
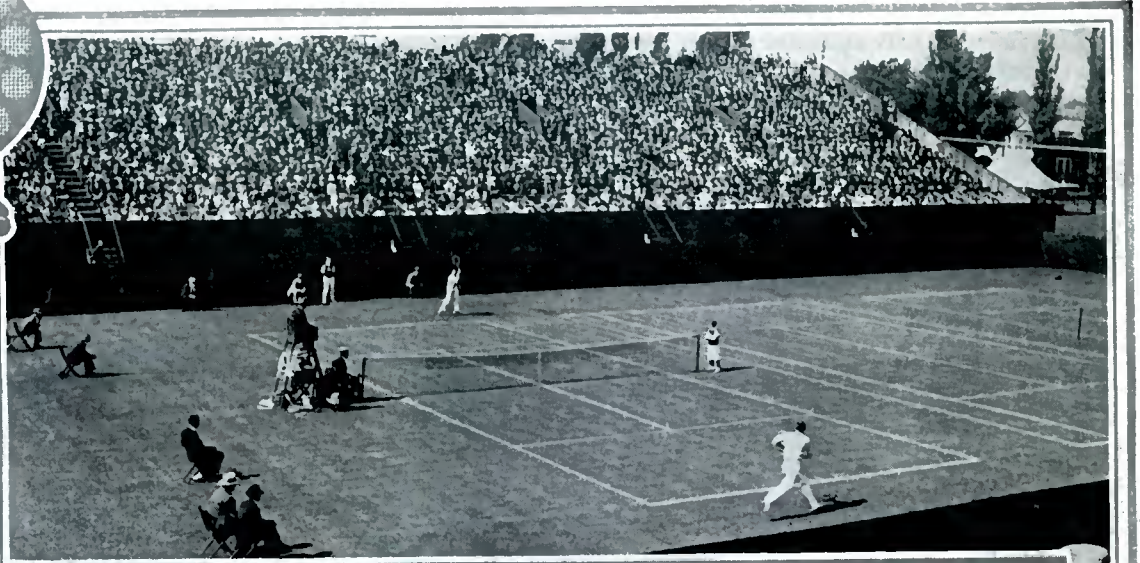

*The
finish
of the
first
Inter-
national
Horse
Race
broadcast
through
WJZ
and
WGY*



"Did you visualize the scene?"—One of the many movements of the International Polo Games described by Major Rudd, army polo expert, through WJZ and WGY. The important games, international, and major, are brought to those of us who could not otherwise attend

the Union and the greater part of Canada reproduced the words which precede the greatest thrill known to sportsmen—"They're Off!" And from a precarious perch on the railing of the judges' stand J. Andrew White, WJZ's famous sports announcer, juggled a microphone and a pair of field



That race—the "First Special" of the International Match Races between Epinard, four-year-old of Pierre Wertheimer's and the pride of France, and the best horses in the United States—was attended by the greatest crowd which has ever witnessed any race except the "Second Special" at the Aqueduct Track almost four weeks later; for while the grandstands held thou-

American sport-lovers; but through one of the unexplainable twists of popular fancy the International Polo Games assumed a position of importance in the public eye unexcelled by any sporting event of this season save that dearest of all American games, Baseball. Polo has always been replete with thrills not to be found in any other game—but it has hitherto

Left: Major J. Andrew White, WJZ's famous sports announcer describing the field at the Epinard race. The broadcasting equipment used on the fields is shown in the heading of this article. Below: How station WOAN of the "Scranton Times" served the fans with detailed reports of the world series. The radio director, furnished with reports of the press association over the telegraph wires, broadcasts each play, and alongside of him the scoreboard operator flashes the plays on the board. This method is widely employed to furnish immediate reports to listeners in, and at the same moment, supplement them with a visual diagram for those watching the boards outside

glasses the while he reported the progress of the greatest horse in Europe and the cream of American stables around the Belmont Park track. Between his words came the "thuddity - thud - thud" of the pounding hoofs, for microphones beside the track were switched on and off in turn as the horses approached and swept by them. Because White described the race as he saw it, and because he saw it with the

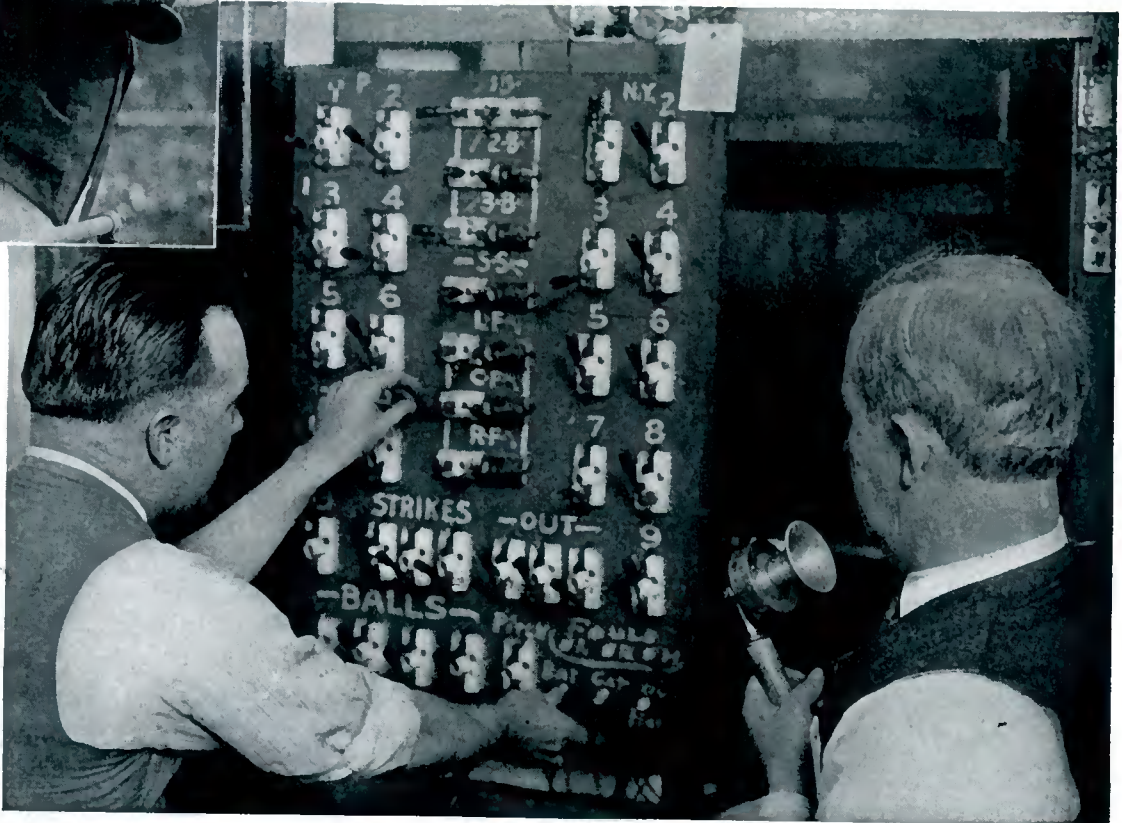

same exciting uncertainty as did every spectator there, the listeners were thrilled to exactly the same extent as were the eye-witnesses. That creepy feeling in the region commonly designated as the backbone, which comes never so strongly as when one is standing on tiptoe gazing at a close-grouped field of swift race-horses; that tantalization of the mind as the eye telegraphs "he's ahead—no he's not—yes he is;" that emptiness of non-realization or that exultant rush of victorious relief which comes as the horse of one's choice sweeps across the finish behind or ahead of his rivals; all those, and a thousand others too familiar or too intricate for description, were experienced by the unseen spectators whose eyes were those of Major White and whose imagination recreated the track so many miles away. I know, because I saw the race through my loud speaker!

sands, the radio increased the number a hundredfold. Racing, the Sport of Kings, and Radio, the Pastime of the Public, were united for the first time; and the union was a most happy one for all concerned.

Less than two weeks after Wise Counsellor defeated Epinard—long before the thrill of that event had departed—the listener heard a strange voice saying strange things; "chukker" —"backed the ball prettily"—"clever riding"—were but a few of the remarks which issued from the loud speaker. And then his wonder departed, for the voice explained—"This is Major A. G. Rudd describing the first of the International Polo Games through stations WJZ and WGY direct from the field at Meadowbrook, Long Island."

Until this year polo has been a game for a minority—a minority which has been steadily increasing in size, to be true, but nevertheless a minority—of

been very much of a closed book to the average citizen. The broadcasting of the games by stations WJZ of the Radio Corporation of America in New York and WGY of the General Electric Company in Schenectady, was scheduled solely because of the unprecedented amount of public interest in the match; it resulted in a most decided increase in the amount of that interest!

Major A. G. Rudd, U. S. Army, acted as verbal lens through which—or whom—the listeners could visualize the action on the field at Meadowbrook. Himself a polo player of repute throughout Army polo circles, the author of several magazine articles on polo, and so recognized an expert on the rules and play of the game as to be chosen as referee of the Intercollegiate Polo Games last year, Major Rudd was able to paint a moving-word-picture of the two games which held

the attention of every listener whether or not they had ever seen a polo game before. H. R. H. the Prince of Wales followed the action with no more interest than did Eddie Jones out in South Bend, Indiana—and it is probable that Eddie's sister followed the actions of the Prince with an even greater interest!

Almost immediately after the polo games came the second Epinard race, and close upon that followed the dearest treasure in the sports chest—the one and only event of complete national appeal, the World Series. Sports may come and sports may go, but none may attain the position occupied by that uniquely American game of Baseball. And in the broadcasting of the World Series the honors must go, not to one or two, but to many stations. To WJZ and to WGY may be credited the spirit of pioneering which was responsible for the dissemination of the description of the horse-races and the polo games to the millions—but in the case of the Game of Games let it be said that the larger stations stood united in their attempts to be of service to a clamoring public.

The World Series! Sufficiently explanatory of the Americanism of Baseball is the fact that the series has always been played on American soil between American teams. The possibility of an invasion of the realm of the diamond by any other nation is so remote as to be absolutely unthinkable. The strident bawls of "Strike Tuh!" and "He's out"—the sharp crack as bat meets ball—the dust-enveloped slide as runner matches the propulsion power of his nether limbs against the arms of an opposing team—these, and the hundred and one other moments peculiar to the game, are purely American institutions.

Until the advent of radio, those baseball fans in the smaller cities and towns were forced to expend their enthusiasm in rooting for the home team, be it the Backlot Bushers or the State University Nine; now, as everyone knows, all that is changed. Those

who have a radio set followed every play of the World Series in their own home; those whose neighbors had a set followed the games in their neighbors' homes or through their neighbor's window; those who possessed neither radio nor neighbor stood with a hundred or more kinspirits, before a loud speaker suspended over the entrance to a radio store and cheered or grumbled as they felt moved.

From microphones so close beside the press-stands that the click of the telegraph-keys was transmitted, came the quick, clear-cut word pictures which brought a whole nation to the front of its chairs. The groans which echoed from the grandstands were as whispers to the groans which eddied about the countless loud-speakers from Maine to Mexico; the crowds which stretched cramped legs in the bleachers during the "Lucky Seventh" were insignificant when compared to the millions who rose religiously in scattered homes as the radio waves transported the words "Beginning of the Seventh." Baseball is a National Institution, and the broadcasting of the World Series was one of the most truly National Services which this country has ever seen. How many radio sets there are in these United States it is impossible to say; certainly the number would run well into the six-figure class. And certain it is that the number of those who listened-in on the broadcasting of the World Series this year was at least ten times as great as the number of receiving sets.

And even as you, gentle reader, peruse this page, radio is making another strong bid for the favor of the radio sport-lover, for the 1924 football season is in full swing. And there is not a big game which radio will not carry

from the gridiron to the firesides of the nation. The schedules for stations WJZ and WGY—a schedule as complete as that of any station in the country—is included herewith for your benefit.

October 18th—Army-Notre Dame at Polo Grounds, New York City.

October 25th—Notre Dame-Princeton at Princeton.

November 1st—Army-Yale at New Haven.

November 8th—Yale-Univ. of Maryland at New Haven.

November 15th—Yale-Princeton at Princeton.

November 22nd—Harvard-Yale at New Haven.

November 27th—Cornell-Univ. of Pennsylvania at Philadelphia.

November 29th—Army-Navy at Baltimore.

WBZ—Football Schedule:

October 4th—Harvard-Virginia.

Oct. 11th—Harvard - Middlebury.

October 18th—Harvard-Holy Cross.

October 25th—Harvard-Dartmouth.

November 1st—Harvard-Boston.

November 8th—Harvard-Princeton.

November 15th—Harvard-Brown.

November 22d—Boston College-Vermont.

November 29th—Boston College-Holy Cross.

Here is the Chicago schedule. All games played on Stagg Field will be broadcast via KYW.

October 4..... Missouri

October 11..... Brown

October 18..... Indiana

October 25..Ohio State (at Columbus)

November 1.....Purdue

November 8.....Illinois

November 15.....Northwestern

November 22.....Wisconsin

Below: An exciting moment in a broadcast game. One of the men was knocked out of the battle with a damaged leg. The half-back is plowing head down into another player. The game was "put over" the air with thrilling exactness

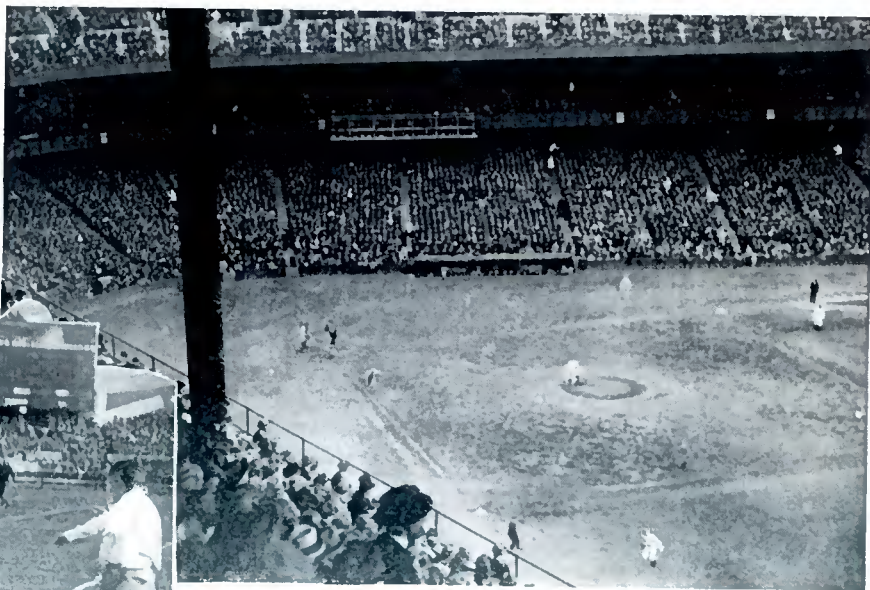

Above: The Yankee Stadium crowds at New York have seen some real games in baseball history. At our radio we hear the tumultuous clamor of care-free souls pledged to an afternoon of hilarious abandonment. It is infectious. Spontaneous cheering greets the team as it straggles out over the diamond. It all comes to us for the tuning in

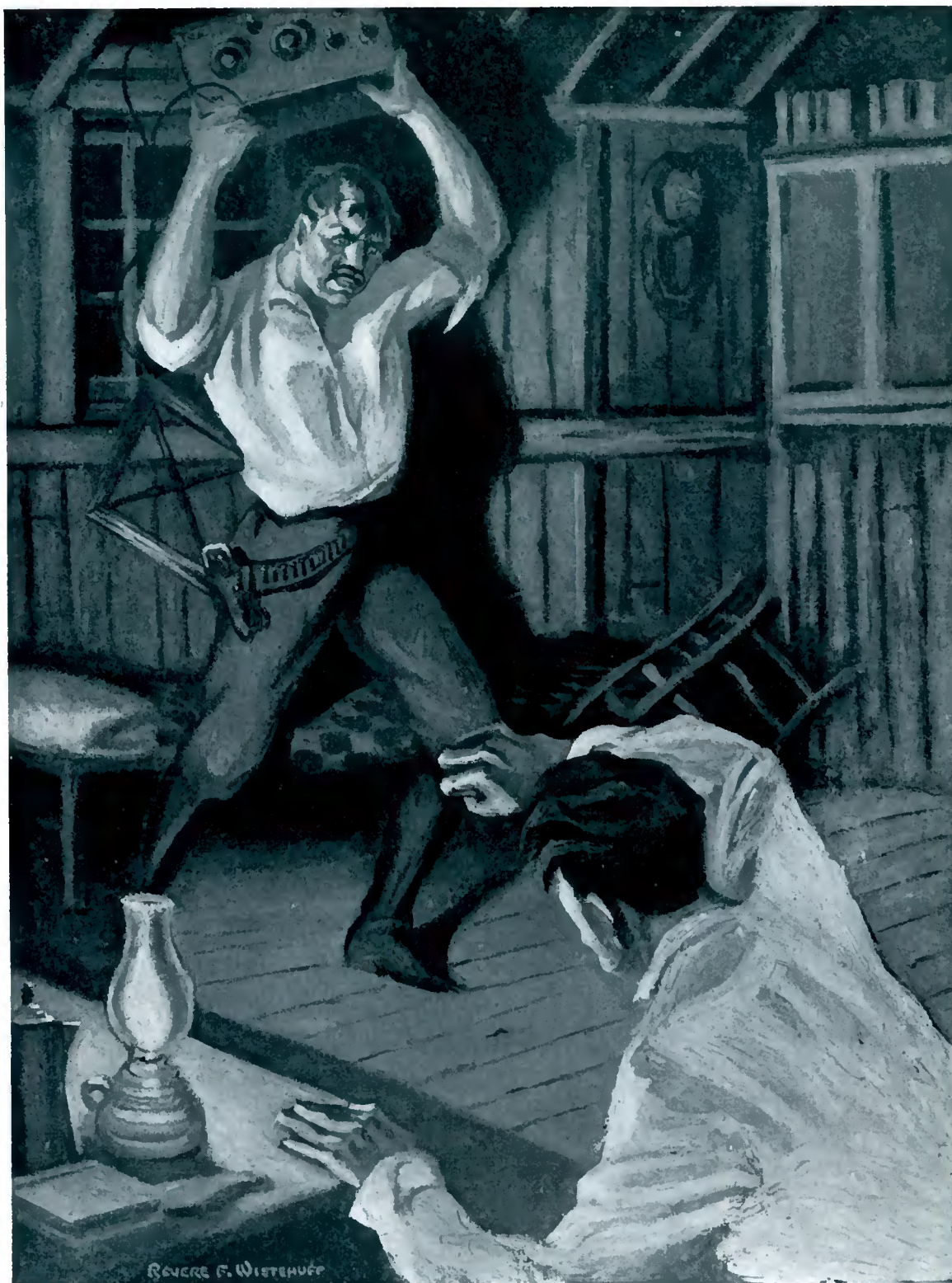

*“IT seemed to me that his safe-breaker’s tricks, if permitted to proceed, might do damage to the radio set; so I took a good spring, and, as you might say if you were so disposed, fell on Mr. St. John, with my knee on his nose. * * * In a fraction of a second he’d grabbed the whole works off the table—the box, and the aerial, and about a half dozen batteries that clung to it by pieces of wire, swung it around his head twice, and hurled it at me—it was the aerial that came undone and spun a cocoon around me. * * * I arose to find Grizzly Chase looking at me with the expression of a tiger robbed of its young.”*

Alias SLIMMY O'Dyne

Somehow Slimmy couldn't work the combination on the radio dials—but a radio is not a safe, nor is it safe to disturb a DX hunter in open season

By F. R. BUCKLEY

Illustrated by Revere F. Wistehuff

ONE of the most admirable qualities of the human race, if only the human race happened to possess it, would be Gratitude; by which I don't mean saying "Thanks" for \$5,920.24 handed to one on a golden platter, but the giving of credit or discredit where they are due. I know the above remark sounds kind of highbrow to be put in circulation by a mere uneducated Western sheriff (though really I am far from uneducated, and farther still from being mere); but I've had enough complicated trouble on my hands lately to make anybody highbrow, if not actually insane.

I have hereinbefore mentioned how I darn near failed to be re-elected recently, giving all the credit for my election to the radio or wireless telephone, which as a matter of fact didn't deserve more than thirty per cent. of it. And no doubt, at the end of that narrative the reader figured that I was due for a spell of peace and quiet. I did myself; but such was not to be the case. For while it looked as though I wasn't going to be sheriff next term, there had been quite an inflow of criminals to Prairie Dog; and the outflow which took place when the name of B. Pokeson was announced as heading the poll, didn't quite clear the tank. Excuse my circumstabilitiveness. I mean that after the district was supposed to have settled down again, a guy who could not be proved a criminal, but whose face was a good deal too clean-shaven to be honest, remained sitting pretty at the Stony Springs Ranch. His name was Adolphus St. John; and in addition to living at the Stony Springs place without making even a pretense at working, he was obviously laying his pipes to wed or marry Amelia Chase, the proprietor's daughter.

Being still in bed, pampering the remains of six or seven bullet-wounds, I heard about this from God-be-Good-to-us Wilson, whom I had kind of employed to make a survey of the county for me; and at first, I thought my emissary was mistaken, if not actually full of prunes.

"You mean to say that old Grizzly Chase is letting anything like that go

on under his very nose?" I inquired. "Tell me not in mournful numbers! Go boil your head!"

"All right," says Wilson, rising as if I'd insulted him or something. "Good afternoon."

"Why, it's only yesterday, as it were, that the old chap was arrested for firing both barrels of a shotgun at a puncher who'd only tipped his hat to—"

"Very likely," says Wilson, opening the bedroom door. "Good-by."

"If the old chap's sitting by and letting anything like this go on," I remarked hastily. "Some terrible change must have—"

Wilson was now entirely out of my presence, and closing the door behind him. At my last words, he turned and stuck his head back in, just far enough to be rude, and not far enough to give a really good target for a boot.

"Yeah," says he. "And suppose you amuse yourself by ridin' over there and findin' out what the change is? Suppose you do some of your own work, for once?"

Well, to swallow the crow at one gulp—I had to do what he said; and, to relieve the reader's mind of all unnecessary suspense, I found Grizzly Chase sitting in the attic of his house, which in summer resembles nothing so much as a bake-oven, with batteries to the left of him, batteries to the right of him, wires all around him, a radio headpiece over his ears, and an expression on his face like as if somebody was tickling the soles of his feet with a feather duster.

He nodded at me as I entered, but anybody could see it was just a mechanical motion, same as an eel makes in a frying pan. The old chap really didn't have the slightest idea that I was there or that, if I was, I could possibly have anything to say half as interesting as what he was hearing through the wireless machine.

"Who's this embezzler your daughter's fixing to marry?" I asked loudly, in an attempt to catch his attention.

He held up one finger for silence, and twiddled a couple of dials—there were about six of them, not to mention

a flock of little gadgets all decorated with "Off" "On," and curved arrows.

"His name is Adolphus St. John," remarked the old gentleman absently. "He—er—"

"Don't you know," I inquired, watching him twiddle another dial and forget my presence again, "that the name stated is an impossibility? There are no Adolphus St. Johns. They were all killed off in the frost of 1888."

"Beautiful!" says Grizzly Chase to himself; and then suddenly snatched the telephones off his head, and crowned me with them. "Listen to that! Do you know where that is? Listen to it! You're a witness that it's only three-thirty in the afternoon. Listen!"

Well, it was a long time before I could find anything to use my ears on at all; but finally, I did gain a consciousness of some jasper who apparently wore false teeth and lived in the bottom of a narrow-necked bottle, delivering a lecture.

"—dough is then put in the bumble-umble umble umble of the oven," says this voice from the unknown, trying to be cheerful in spite of everything, "and at the other end whorfle whorfle whorfle graaaaaaaa, OUT pop the biscuits we all love so much when we go to bed with our dollies clasped to our buzzbuzzbuzzbuzz—"

I took the headpieces off at this point.

"That's WEAF," says old man Chase. "WEAF! Think of that! Did you hear anything?"

"I heard a lot of buzzing," I informed him, putting the headpieces where he couldn't reach them.

"That's the bee battery," says the old lunatic, reaching for the forbidden phones. "I'll just—"

"I'm over here," I told him, "to discuss your daughter and this guy Aubyn Vere de Vere, or whatever his alias is."

"Yes?" says Grizzly, looking straight through me and twiddling dials.

"The fact of the matter is," said I, "that I'm kind of suspicious of all strangers who have come into the county since things generally got so upset as they have been lately; and

especially of strangers who call themselves—"

At this moment, the telephones I was holding interrupted me with a shriek of torment, which they continued until Grizzly, taking advantage of my surprise, grabbed them and retired into their shade.

"If this isn't PWX," he says, twiddling dials and fidgeting in his seat. "bee battery or no bee battery, I'll chop the set up into mincem—"

"The point is—" I began, beginning to feel as hot inside as I was out.

"Sssssh!" says Grizzly, waving one hand while he twiddled knobs with the other. "Ssssh! Quiet!"

I gave him thirty seconds more, and perspired another pint or so, then arose.

"Good afternoon," I said sternly.

"You're welcome," says old man Chase; and so I left him. It was my intention, at the moment, to keep my hands off, and leave PWX and WEA and the rest of the gang to look after the old bloke's domestic affairs for him; but the thought of Duty and my mileage, prevailed. I therefore sought out Henry McTee, the Stony Springs foreman, and asked him to tell this Adolphus St. John I should like to see him.

"Got anything on him?" demanded McTee hopefully.

"Have you?" I inquired.

"Naw," said the foreman with disgust. "An' I ain't tryin' to get anythin,' thanks. Have you seen Elmer Williams lately?"

I shook my head.

"No, nor you won't," says McTee, "for a week anyhow. He up and told Miss Chase that he didn't believe St. John's name would stand exposure to the elements."

"Well?" I asked. "What's that got to do with my not seeing—"

"He's naturally sensitive about his eye bein' blacked by a woman," says McTee.

I thought this over for some time; made it clear that I wanted Mr. St. John to come over *alone*; and then retired to my office, where I proceeded to dip into some of the books I'd laid in when I anticipated a few weeks of peace. One of them was by a jasper called O. Henry; and right here I want to live up to what I said on the first page of this exercise book, and give the guy credit. It was a story of his, called "Alias Jimmy Valentine" that gave me an idea.

I had just finished reading it, and said the last word of a long and disputatious phone talk with McTee, when there were footsteps on the porch, and Mr. Adolphus St. John entered, with his left hand clutching the bottom left hand edge of the skirt of his jacket. For the benefit of the uninitiated, I may

say that this was a highly suspicious circumstance. Men who carry revolvers with the idea of actually using them, wear the same on their left sides, butt forward, which naturally brings the nose of the holster where, in case of a quick draw, it can be grasped and held steady by the left hand. Mr. Adolphus St. John was holding down the nose of his holster as he entered; and it was with considerable difficulty that I greeted him with a winning smile.

"You wanted to see me?" he snapped.

I put the book down on my lap, keeping my thumb in the place.

"Eh?"

"You wanted to see me? The foreman over at Stony Springs said the sheriff left a message saying he wanted to see me. Well?"

I gave a pained chuckle.

"He got it wrong," says I. "What I said was, that I'd like to meet you. There's a difference."

"There sure is," says Adolphus St. John suspiciously, but still, at that,

Last month F. R. Buckley's "Per Land Line" brought so much enthusiastic response there was nothing for it but to have him do another. "Alias Slimmy O'Dyne" is certainly more humorous than any radio story written up to date.

Mr. Buckley has to his credit about 150 short stories and novelettes in various magazines; principally laid in the West, with occasional forays into the Italian Middle Ages, the sea, and the sky.

more lightsomely than he had yet spoken. "Well, now you've met me, what?"

"I hear," says I, rising and feeling in a cupboard, "that you have a nasty cough."

"I—" he began.

"This," says I, turning around with a bottle in my left hand, "is a sovereign remedy for coughs, colds, fevers, and pretty near anything else. It is also very good for acquaintances. Have some."

Honestly, you'd never have believed he was the same jasper who had entered so suspicious. He sneezed twice, just to show he had a genuine need for medicine; and then, with one motion of his powerful right arm, he flung four fluid ounces past his teeth.

"Wow!" says the visitor. "Aren't you having some?"

There were reasons why I didn't want to dr— take medicine with him; and these reasons had nothing whatever to do with my recent wounds. The wounds, however, were the reason I put forward.

"At the present moment," I exag-

gerated, "I resemble nothing so much as a coarse sieve; and it seems a pity to waste such good stuff."

"It seems to me it's a terrible waste to leave it there in the bottle," says Adolphus St. John greedily.

Accordingly, I poured him out what I myself might have taken under other circumstances, and he threw that after the other dose. It's possible he may have made swallowing motions with his throat, but I swear I saw none.

"Bing!" says he prayerfully; and immediately began to tell me about his family in Illinois. He seemed to have some difficulty in saying "Father," the word emerging more like "favvy" than anything else; but there was no doubt whatever about their respectability, his brerrer being no less than a banksheer, while his sissa was marred to a breaker.

"House-breaker?" I asked tactlessly.

"Stockbreaker," says Adolphus St. John. "Stobbroker, as the unhiducated call it. I have a tickling in the throat."

This was a hint, which I duly honored; and then, side by side, we sat on my porch with our feet on the railing, I myself wondering how to introduce the subject of literature without frightening my client.

He himself saved me the trouble.

"Sbookabout?" he demanded. "Read to me."

Now, this was just what I had intended to do, whether he liked it or not; but, being asked thus, of course I protested that in my weakened state, I couldn't think of it. And naturally, the more I refused, the more he insisted, and so finally, I read him this "Alias Jimmy Valentine" story from end to end.

Probably you don't think there was much to that; but that is because you don't know that Mr. Adolphus St. John corresponded very closely with the description of a safe-burglar wanted in Wyoming for robbery and manslaughter; or else because you've forgotten that this story is about a safe-cracker who had turned from his wicked ways, and who goes back to his trade, thus giving himself away, to rescue a child who's suffocating to death in a bank-vault. I'd got about half way through before Mr. St. John woke up; but from that point to the end, he didn't give me a moment's nervous peace. I shall never forget reading the description of how Jimmy Valentine sandpapered his finger-tips to pick the combination lock, with one eye; while my other eye was focused on Mr. St. John's hand, which was closing on the butt of his revolver. I have never walked on the tightrope across Niagara Falls, and now I don't need to. It would be comparatively a tame experience.

"Now, isn't that a good yarn?" I

demanded, getting to the end without bursting into tears, laughter, apoplectic fits, or any other nervous phenomena.

Without asking my permission, or even going through the ceremony of coughing, Mr. St. John walked over to the table by a curved route, and inhaled another dose of mescal. Mescal, I may say for the benefit of those who know no better, is the Mexican word for cough-medicine.

Having done away with this, Mr. St. John fixed me with a slightly blood-shot eye, and said that he disapproved of the story root and branch.

"Spreddy," he remarked however, holding on to the edge of the table. "But's sentimental. Heard enough of those bed-time stories lately. Over the radio. Well, good evening."

"Your cough," says I, watching him miss the doorway three times in succession. "Seems to have weakened you some. Would you like me to ride along with you?"

"No!" says Mr. St. John, little knowing what the night air (it was now evening) would do to him when he got outside.

"Well, I'm coming, nevertheless," I told him. "I never desert a friend in distress—much less you."

This remark ought to have made him bristle all over; but it didn't. Quite the reverse.

In fact, he kissed me on both cheeks, said I was his only benefactor, and permitted me to ride circles all around him all the way home—shoving him into the perpendicular from one side or the other as occasion required. I appreciated this—not that I shouldn't have followed him in any case; but his cooperation made it so much easier to get the revolver out of his belt, spill the cartridges on the ground, and put it back again.

"There mus' have been drugs in that stuff," said Mr. St. John, when we arrived at Stony Springs. "I'm goin' straight up an' turn in."

"Without sayin' good night to Mr. Chase?" I demanded with horror, pushing him half way up to the attic with a single shove.

"What's the use?" demanded St. John in a loud voice. "The old goat

can't hear anythin' nearer than Chicago from ten p.m. until the roosters start barkin.' However, if you insiss—Why, what the—"

It was the lamentable fact that old Grizzly Chase presented a surprising spectacle. Since last we met, somebody appeared to have tied him into the chair by his radio machine; to have stuffed about half of an embroidered pillow into his mouth for a gag, and to have deserted him. He was sitting there, with the headphones still on, all trussed up like a bull at a barbecue; and from where I stood, I could hear XYZ or somebody shrieking at the top of their voices. It seemed as though this howl,

"I found Grizzly with an expression on his face like as if somebody was tickling the soles of his feet with a feather duster"

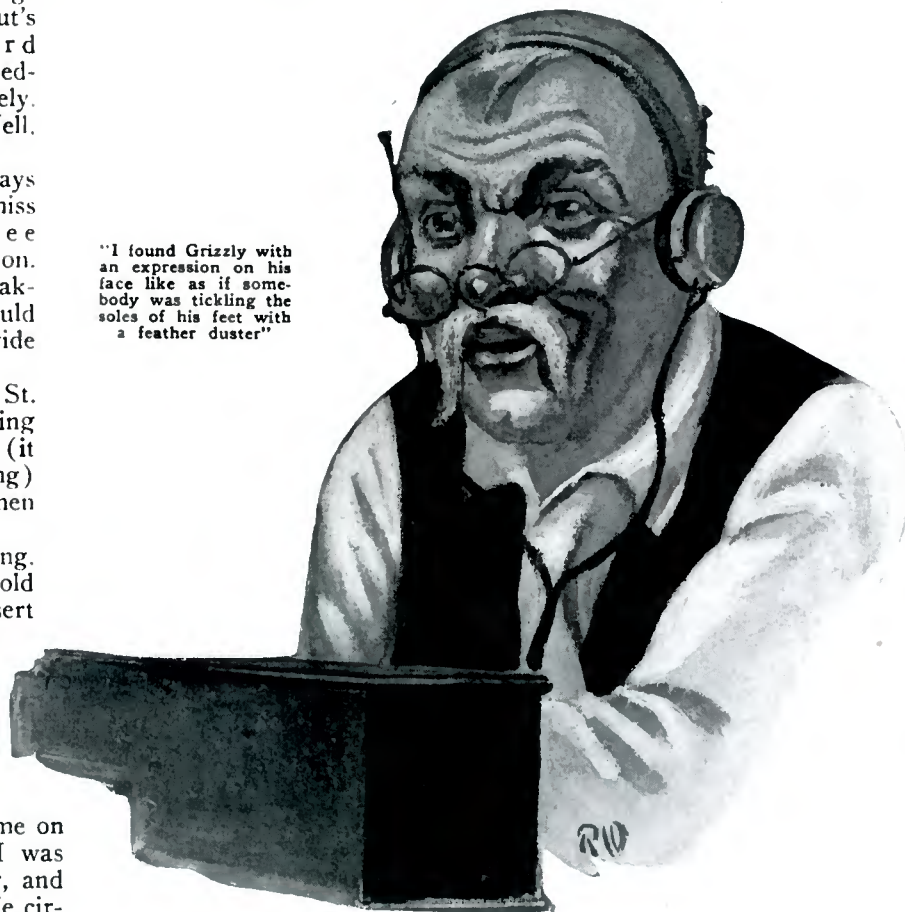

right up against his ear-drums, must pretty nearly have deafened him; and so it proved; for when I cut his bonds and got the bedding out of his jaws, he could do nothing but talk.

"That scoundrel McTee!" he roared. "He's taken my little girl away! Where's my guns? Where's my belt? I'll have his life! He came in here draggin' her by the wrist, and two more men with him, and he tied me up—"

"How long's he been gone?" I shouted, casting a look from the tail of my eye, at Mr. Adolphus St. John, who appeared to be thinking of bursting.

"He said he wasn't goin' to have any dudes with French names hanging around his girl, and that—"

"How long's he been GONE?"

"Hours! And why the devil—"

"Then he's over in Mexico with her by now," I shouted. "We can't pursue them in the dark, in a strange country, and all the rurales waitin' for a shot at an American citizen. We'll just have to throw out the dragnet; and all the telegraph offices are closed, and— Can't we send out an alarm on this radio thing?"

Well, of course I knew we couldn't, the thing being no use except for receiving. Yeah, I'd known that, even when I was dopping up the little stratum. But it made no difference. While old man Chase rushed around the room cursing and swearing and looking for the guns he'd laid aside when he took up radio; while Adolphus Alleged St. John stood holding onto the door-jamb, swelling visibly with rage and cough medicine, and while Havana, Cuba, lay on the table screaming its heart out, I rushed over to the radio machine, and started twiddling the knobs.

"Hello, hello!" says I, into one of the holes in the front of the box. "Hello! Is this the Texas Rangers? Get off the air! Hello! Is there no help for the widow's son? Hello!"

After about three minutes of this, I turned away with my best despairing manner, and shouted to old man Chase to tell me the combination. I was very careful not to shout until he had left the room and was half-way down the stairs; so naturally, I got no answer.

"We're ruined!" I then said to Adolphus St. John, tearing out a square inch of my hair, for which I have received no compensation, either from the State or from any private party. "I don't know the combination of this thing, and unless we can broadcast an alarm, McTee'll have married the girl before some jefe politico or other, and you'll have been made the laughing-stock of the State of Texas! And me too!"

Saying which, I dropped on my knees before the radio, and started to twiddle knobs in a last despairing effort, shouting "Hello!" at the top of my lungs all the time. For several

(Turn to page 82)



Astronomy Makes Its Bow to Radio

in

The Study of Mars

Scientific bodies and leading astronomers all over the world attempted to receive possible radio messages while studying Mars

By David M. Todd, M.A., Ph.D.

Emeritus Professor of Astronomy and Navigation and Director of the Observatory of Amherst College. Author of "New Astronomy," and Foremost Authority on Cosmogony, Mathematical Astronomy and Related Sciences

D ID the Martians try to radio to us on earth?
 Could the mysterious signals reported when Mars was closer to the earth than it has been for 120 years have been from Mars?

Is there any physical condition on Mars that would prevent the Martians from having radio?

If the Martians have mastered radio is there any basic reason why they should have fallen into the use of dots and dashes?

Is Mars likely to have an atmosphere like the earth's own, with a heavy-side conductive layer?

Was Mars responsible for surcharging the air with electric-energy and interfering with radio communication between ships at sea on August 24, when the planet was nearer the earth than it will be for centuries?

Before answering the first we must realize that

the Martians may have been trying to communicate with the earth for tens of thousands and millions of years, without sign of response from us, and they may have grown tired of trying, and have given our planet up as being

a lifeless world as we will be tempted to do if we do not note signs of response to our attempts to signal.

But radio played a large part in the Mars checkup independent of whether the Martians did or did not try to communicate with us.

In fact, radio made the study of this last Mars opposition a great success in many ways. It has opened new avenues for study that may establish whether Mars has two major magnetic poles and a magnetic equator and the occasional mysterious flashes on the surface of the planet heretofore registered by astronomers are huge curtains of auroral lights from 300 to 500 miles deep, similar to auroral displays that are registered in the Arctic and Antarctic regions of the earth, and caused by electric-magnetic discharges from the sun striking the planet's most intensive

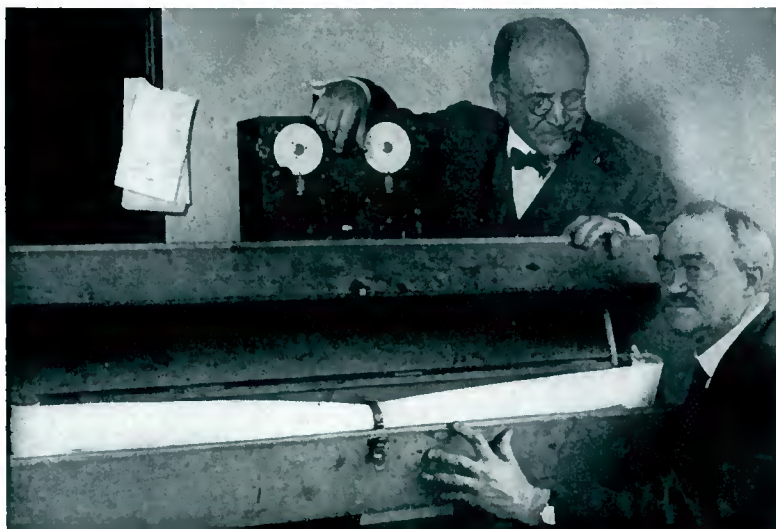

Professor David M. Todd (left) and Francis Jenkins (right) with the automatic recorder, containing a slow reeling tape, which was set up and run for 100 hours in the effort to pick up any unusual radio signals during the study of Mars. Photograph at top of the page: The Jansen Observatory, highest in the world, situated on Mont Blanc

magnetic fields in the magnetic polar regions.

RADIO'S PART IN THE MARS CHECKUP

Radio played an important part in the checkup on Mars in August, when the planet was within 34,630,000 miles of the earth, first by making possible world-wide action in listening to possible messages from that planet as it drew close to us.

It would have been unscientific to dismiss the opportunity for such a test by assuming that there cannot be intelligent beings on that planet. Science cannot assume a negative attitude about anything.

If Martians exist and happened to be observing the earth, as we observed Mars, during the week of August when the two planets were less than 35,000,000 miles from each other, they saw a planet looking not much different than Mars appeared to us, and that is very little.

It must not be overlooked that even when Mars was nearest, within less than 35,000,000 miles on August 24, 1924, the planet was still very far.

Thirty-five million miles is a vast distance, absolutely speaking; it is something like 150 times greater than the distance to the moon. With no telescopic power at our command could we possibly see anything on the moon of the size of the largest buildings or other works of human intelligence? We seem forever barred from detecting anything of the sort on Mars.

Nevertheless, the closest scrutiny of the ruddy planet by observers of great enthusiasm and intelligence, coupled with imagination and persistence, have built up a system of canals on Mars, covering the surface of the planet like spider webs over a printed page, crossing each other at intersecting spots known as "lakes," and embodying a wealth of detail which challenges criticism and explanation.

To see the canals at all requires a favorable presentation of Mars, a steady atmosphere and a perfect telescope, with a trained eye behind it. Not even then are they sure to be visible. The training of the eye has no doubt much to do with it. So photography has been called in, and very excellent pictures of Mars have already been taken, some nearly half as large as a dime, showing plainly the lights and shades of grander divisions of the Martian surface, but only in a few instances revealing the actual canals more unmistakably than they are seen at the eyepiece.

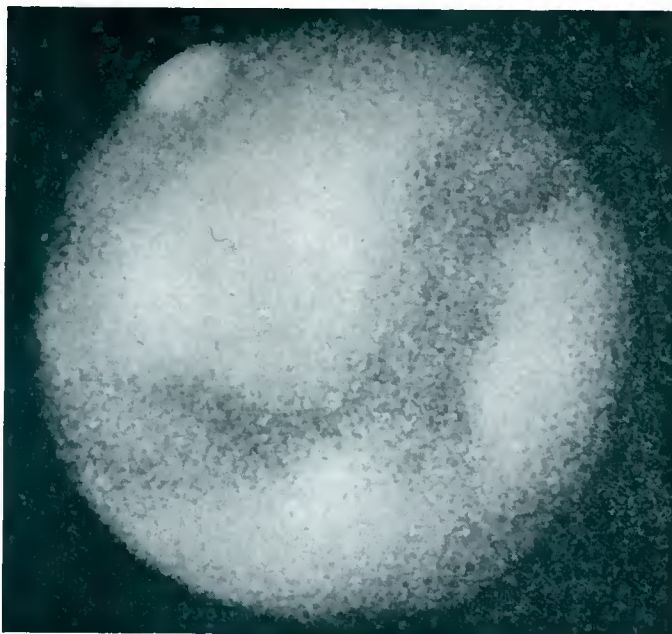

Actual photograph of Mars made at the Yerkes Observatory, Williams Bay, Wisconsin

While it may be true that the Martians, if there are any, may not be able

Professor David Todd, the dean of American astronomers, had been known since the year 1889 as "the man who beat the moon," owing to his feat during the New Year day eclipse of 1889, when he used the telegraph, which was then still in its infancy, to "beat the moon's shadow around the world," by telegraphing information of the approaching shadow of the moon to observation stations faster than the moon's shadow could travel.

This year, 35 years later, Professor Todd used radio to check up on Mars, as the planet was nearer to the earth than it had been for 120 years and than it will be within the lifetime of the people of this generation.

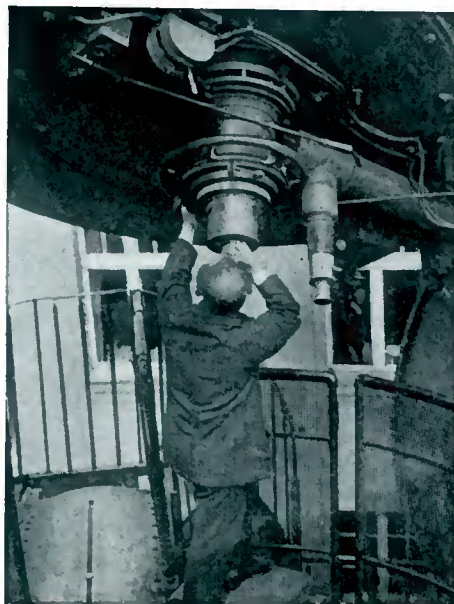

The largest telescope in the world, at Yerkes Observatory. The photograph of Mars (above) was taken with this telescope

to harness sufficient energy to flash messages to let us know that radio communication is possible on that planet, that is not necessary. The sun supplies the necessary energy to ascertain whether Mars is, like the earth, a gigantic magnet having two major magnetic poles, which are the areas of intensive magnetic force.

If Mars is like the earth in that respect, it is subject to having wide auroral curtains, and it is likely when near to the earth, to affect the earth's atmosphere, as one giant magnet would when coming close to the other.

Mars is a planet next in order beyond the earth, and its distance from the sun averages 141½ million miles. It has a relatively rapid motion among the stars, its color

is reddish, and, when nearest to us, it is perhaps the most conspicuous object in the sky.

Mars appeared to the ancients just as it does to us today. Aristotle recorded an observation of Mars, 356 B. C., when the moon passed over the planet, or occulted it, as our expression is. Galileo made the first observations of Mars with a telescope in 1610, and his little instrument was powerful enough to enable him to discover that the planet had phases, though it did not pass through all the phases that Mercury and Venus do. This was obvious from the fact that Mars is always at a greater distance from the sun than we are, and the phase can only be gibbous, or about like the moon when midway between full and quarter.

Many observers in the seventeenth century followed up the planet with such feeble optical power as the telescopes of that epoch provided: Fontana (who made the first sketch), Riccioli and Bianchini in Italy, Cassini in France, Huygens in Holland, and later Sir William Herschel in England.

It was Cassini who first made out the whitish spots or polar caps of Mars in 1666, but not until after Huygens had noted the fact that Mars turned round on an axis in a period but little longer than the earth's. Cassini followed it up later with a more accurate value; and observations in our own day, when combined with these early ones, enable us to say that the Martian day is equal to 24 hours 37 minutes 22.67 seconds, accurate probably to the hundredth part of a second.

Mars is a planet of intermediate size between the earth and the moon: twice the moon's diameter (2,160 miles), very nearly equals the diameter of

(Turn to page 88)

✂

Evelyn Herbert, the pupil of Caruso, and friend of Mary Garden, Scotti and Farrar

✂



✂

Evelyn's love for animals is equaled only by the love of the radio audience for her

✂

A Villainess with real *Golden Hair*

By GOLDA M. GOLDMAN

A CHARMING little lady with real golden hair and blue eyes came into the studio of the Capitol Theater carrying a cat. It was a Sunday night and the little lady was daintily attired in a powder blue gown ornamented with green and blue beads. But with no care at all for the loveliness of her frock, close against her she pressed this cat, and, if one may venture to announce it, it was not a very attractive cat at that. It was gray and not too plump, but the most astounding thing was that she had carried it all the way from Harmon-on-the-Hudson in a Pullman on a Sunday afternoon. Why? Because it had strayed into the house where she was visiting and had appeared to be attached to her. Not that this was the first time that Evelyn Herbert had displayed her fondness for felines. Several years ago when she was spending the summer at the Thousand Islands, she was out in a row boat one morning, when she discovered a kitten struggling in the water. Fearing that the poor little thing would be drowned, she reached over the side of the boat and found herself very unceremoniously floundering about in the water. An hour later the gardener

rescued her and the kitten, both very much the worse for wear, after Evelyn had held on to the side of the boat all that time.

Evelyn's love for animals is equaled by other people's love for Evelyn. When she was a very little girl, Mr. and Mrs. A. G. Miles, son-in-law and daughter of George C. Boldt of the Waldorf-Astoria, heard her sing and immediately began to help her to obtain a musical education. A few years later, by an interesting incident, she came under the recognition of the world's greatest tenor. At that time her father was manager of the Hotel Ansonia and at a benefit performance, he won a doll dressed as Rigoletto which had been donated by Caruso. When he presented it to his little daughter the next morning, in her wild excitement and delight she wrote to Caruso telling him of her own ambition to sing. The result was an invitation to let him hear her voice. So pleased with it was he that he henceforth directed her musical education and heard her sing yearly until she was fifteen.

During this time she owed many things to his interest in her, especially her acquaintance with the people of

the Metropolitan, including Scotti, Farrar and Mary Garden. He gave supper and dinner parties for her at little Italian restaurants and while she was abroad she visited his home in Italy. As her education included the study of both French and Italian, she was able to conduct her correspondence with him entirely in the latter tongue. At the age of eighteen Miss Herbert made her appearance as "Mimi" with the Chicago Opera Company, but after only a year she fell ill. For two years she was unable to use her voice. Then she found that it had suffered too much to be risked in the singing of leading rôles, so she entered the chorus of "Honey-dew." It was at that time that Samuel L. Rothafel persuaded her to go to the Capitol and that is how it came about that when "Roxy and his Gang" began to broadcast almost two years ago, she was one of the first to sing from his studio. Since then radio audiences have listened to her voice every Sunday night with interest and delight.

Last season she appeared as the villainess in "Stepping Stones" and everyone will remember this bright Spanish girl who added so much zest and real music to the play.

Starting with a Pick and Shovel

Raymond A. Heising manifested the instincts of invention while tamping ballast with a section gang. And so today he has the discovery of modulation to his credit—and we have the radio

By RICHARD LORD

THE life story of most inventors is a tale of insurmountable handicaps surmounted, of inviting temptations to abandon the apparently hopeless struggle, of family and friends in opposition, of financial hardships and suffering, with a climax of final success as the reward for indomitable persistence.

The story of Raymond A. Heising, the discoverer of the only practical method of modulation, is on the other hand one of extraordinary efficiency. His discovery followed his clear conception of the problem with astonishing rapidity. Nor was this the result of chance. It was an example of the clear thinking which is evident from the moment that you first speak to Mr. Heising.

"Heising speaking," were the first words I heard when I called his office on the telephone to make an appointment. There were neither lengthy explanations nor the customary cross examination by a private secretary. In one minute it was arranged for me to see him the next afternoon. When I opened the door of his office, he was seated behind his desk; he rose quickly, indicating a chair which was ready. Immediately he showed his readiness to answer questions.

Those who make inventions and discoveries which eventually have a profound effect on the lives of millions of people usually have their names engraved in gold letters on the pages of history and during their lifetimes are honored with interviews by reporters on every conceivable question and by places on the executive committee of every money raising organization. Heising remains in comparative obscurity. Yet there is no broadcast listener who is not indebted to him.

Before Heising, radio telephony was

a laboratory experiment; today it is a national and international fixture. Modulation is the process by which the

worked for years in a short six weeks?" I asked Mr. Heising bluntly.

"I realized at once that the microphone had, for many years, received the attention of men much more ingenious and capable than myself and obviously I could not hope to do what they had failed to accomplish. Therefore I sought an entirely different method. I realized that the microphone was satisfactory for controlling very small currents accurately. I therefore planned to use it in this way, instead of attempting as did my predecessors, to overload the instrument or to adapt it to carrying larger currents. I worked out a method whereby vacuum tube amplifiers were employed in successive stages to increase these microphone currents to considerable value, in fact, to the same order of magnitude as the continuous wave carrier which it was desired to modulate.

"In a nutshell, the system involved uses amplified audio frequency currents to control the source of plate potential of the oscillator tubes which supply the continuous wave carrier current."

"Solving the problem of modulation, while I was working on it, was a sort of a game. It was not until the principle was clear that its possibilities occurred to me. Within a very short time, compact aircraft radio telephone transmitters were developed and they did their bit on the western front. International communication occurred to me as the first possibility, but, as you see, broadcasting preceded it, although I am sure that international commercial telephony is simply a matter of continuing development work until the remaining obstacles are successfully surmounted."

(Turn to page 74)



Raymond A. Heising at work in his laboratory

characteristics of speech and music are impressed upon the carrier or radiating wave—a process which makes radio telephony possible.

For a moment, I hesitated, for Mr. Heising's directness left me without the usual preliminary meaningless pleasantries from which the interviewer glides imperceptibly to his subject. His keen blue eyes appraised me quickly but not searchingly, as he sat erect but not stiffly in his chair. He gestured little; his answers came in a firm clear voice, its quietness indicating not only reserve voice power but a seemingly immeasurable reserve of knowledge and diversity of interests.

"How did you succeed in solving a problem upon which so many had

Exit the Jonas Hayseed of 1880

Two bathrooms, electric toasters at breakfast—and lo! we have the modern farmer with an office, and radio his stock ticker

By MRS. CHRISTINE FREDERICK

TO properly appreciate the old and the new on the farm before the era of radio one must make a few comparisons.

Radio is a communication device. What were the most up-to-date devices which the farmers and their families had to rely upon before radio? The answer is, the rural telephone and the rural free delivery mail system.

It wasn't more than a decade ago that these two things looked like marvels. It isn't fair even now to say they are *not* marvels, for they certainly did great things for the farmer. The era of the rural telephone and free mail delivery is supposed to be an important one. Yet we have only to think back before their time! It seems like a vision of Colonial days!

You, perhaps can yourself recall how it was if you had a relative living on the farm, or perchance lived there yourself. I recall it well. It will do no harm, for contrast's sake, to draw the picture.

Six miles from the railroad station or the village was the farm; and in the spring rainy season, and in winter, it was an adventure to get there or leave it. The snows sometimes blocked the road, or the wheels of the buggy sank almost hub-deep in the mire. Once at the farm, you were literally cut off from the world. A buggy passing on the road gave you a flutter, for it was the only sign of life you got. The rural free delivery man arrived during forenoons and gave you another flutter, especially if you saw him stop and put something in the metal box on a post at the farm entrance. Even then it sometimes cost you a drenching or a chilling to walk out the length of a city block to your mail box!

The only three events of the year were Chautauqua, the county fair, and the annual Sunday School picnic. You never dreamed of going to church except on rare days, because there were services held only once a month, on an itinerant pastor's journey, and too often on that one Sunday the weather was too bad for the twelve mile drive.

As for the day when the rural telephone came, it was all very thrilling

for a time, but what did it actually amount to? The telephone line was brought to your farm sometimes by means of fence wire part of the way, and there was a constant hum and buzz in your ears, and you had to listen very sharply to hear at all. But that was the least of your troubles. It was, of course, a party line, and invariably when you wanted to use the phone, someone else was on the line and you hung up. Even supposing you could use it, what could you use it for? You could call up the immediate neighbors

Mrs. Christine Frederick reaches about 5,000,000 readers through her various syndicate features. Her experience as Household Editor for various leading women's magazines has taught her many practical lessons in the handling of household problems. She now wants "The Wireless Age" readers to write her on any home radio problem—artistic arrangement of sets—broadcast programs for women—anything to do with radio. Address your questions to the HOME RADIO BUREAU, "The Wireless Age."

or the village stores. If you wanted to talk and "visit" over the telephone, you simply had the whole countryside listening in. No, there wasn't very much to get excited about in the rural telephone, valuable as it was in emergencies. Nor was mail communication more exciting; there were few good magazines or newspapers, and not even lively advertising as there is today!

The farm people of those days went to bed at about 8 o'clock. They were bored to death, and sleepy. They couldn't go to the village without great effort and consumption of valuable horse-energy, to say nothing of needed human energy. There was little to enjoy in fact, at the village when they got there.

The coming of the moving picture and the auto did bring about some big rural changes—but I am of the opinion that neither of them, and certainly not telephones and rural free delivery, have had anything like the importance of radio for the farm.

Radio has been slow in coming to

the farm, and the effects of radio on farm life also are slow in evidencing themselves, for they are inner, not outer changes. Farmers driving autos are outward changes; farmers listening to grand opera, lectures, and jazz are inward changes. They take longer to show their effects.

The slowness of farmers in taking up radio is explainable precisely in the same manner as his slowness to take up automobiles. The expense and the technical complications are the reasons. A city man can get his radio set installed by someone around the corner from his house; and it doesn't cost much to take the set downtown to have it looked over if something goes wrong. The farmer hasn't such a simple problem. He has had to learn a lot of things about mechanics that his grandfather never knew, but radio is sheer mystical wizardry to him, and he probably never will get the real technical hang of it. Radio must be made exceedingly simple for him. He must be sold the counterpart of Ford cars in radio. Cheapness and sturdiness are his main requirements. He will get them—is getting them now.

So begins the farm radio era! And I assure you it is some era! I lecture considerably before State agricultural colleges and "grange" meetings, on home economics, and I am familiar with what is going on. You should see how the van-guard of farmers who already have radio are using it! Down in Illinois a farmer comes to my mind. He is far from a "bearded hayseed." I'll tell the world! He lives in a very modern home indeed—two bathrooms, electric toasters at breakfast (and using electricity generated on his own farm, too!) and he has an *office*! Ever hear of a farmer with an office? Well, there are a lot of them. He has a roll-top desk, a typewriter, and a filing cabinet.

And on his desk is a radio set. It is a business proposition, pure and simple. My friend, you will gasp as I gasped when you learn that *it is his stock ticker!* He is a raiser of live stock, and he studies the Chicago quotations with the acumen of a Joseph

Leiter. He is more than a producer, for he also sells cattle he doesn't raise. He buys and sells *on margin*, please be informed!

In the evening, he lifts his radio set into the living room, and he and his family get the entertainment that is on the air. His son is in college, his daughter goes to a music school in the next town (driving her own car), and altogether he's some farmer! Jonas Hayseed of the 1880's would swallow his whiskers in astonishment if he saw this man of today who wears the title of farmer!

I'm not saying he is at all typical, but merely that he is an augury of more cosmopolitan farmers to come. Our farmers, we are told, must be better business men. They are certainly learning, via radio. As I have a country home 35 miles out on Long Island, I know the farmers roundabout, and I hear them discussing La Follette's promises of farm relief (cabbages this year bring the farmers only one cent

each!)—as heard direct from his lips by radio. They listen for their politics via radio, instead of around the stove in the village store, as of yore. The village store, alas, has now a steam heating system. They hear the prices of every kind of commodity broadcast every day. They hear all the new music, and they are up on all the news. I broadcast from New York one day, and Farmer L— of whom I buy my potatoes, stopped me on the road and complimented me the next day on my excellent diction!

Of course there are farmers and farmers. There is one old man (old since I first saw him 15 years ago!) who lives near me. He'll never buy a radio set, because he's an old widower and a crank. He belongs to the degenerating days of native stock, thinned out by the live farm boys going to town, leaving all the poorer types behind. But the new farmers, new foreign blood coming out on Long Island and making good on truck

farms, have children who are live and alert. They are putting in radio sets and Americanizing themselves and their families thereby as nothing else could do. Imagine the educative effect of a loud speaker going daily in a farmhouse of foreigners! The parents never talk English, but now they learn English by the phonetic method merely by listening to radio entertainment.

The really basic effect of radio on the farm is that it makes farm life more livable by scotching the old snake in the agricultural Eden—*isolation*. You have heard how alarming numbers of farmers in isolated sections, and especially their wives, have become insane. The loneliness of some types of farm life is a terrible cross to bear. The rural free delivery, rural telephone, the phonograph, the auto, the movie have all hacked away at this farm isolation cross, but radio is the first real smashing blow it has had.

(Turn to page 60)



"The really basic effect of radio on the farm is that it makes farm life more livable by scotching the old snake in the agricultural Eden—"

THE Family Receiver

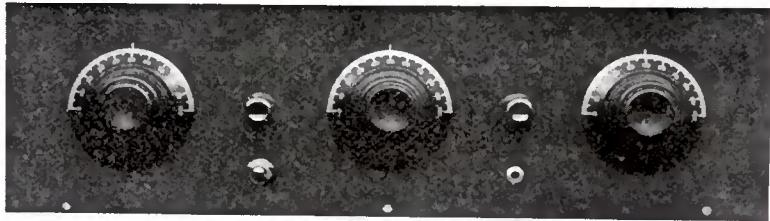

Designed for the family, for the family's use—believing the family wants a receiver with tone quality above all else

By R. A. BRADLEY

THESE are two kinds of radio enthusiasts. One kind buys their means of entertainment complete, the other buys the parts and puts them together. Of those sets which are put together some work fine, others fair and some not at all. Now this receiver is designed for those who "buy the parts and put them together" that they may be assured that the finished set will work and that it will work well. Keeping this in mind we used parts which will insure success, provided they are used correctly. These parts are also electrically and mechanically good, which of course is essential in a successful receiver. We called this the family set, because of its simplicity of operation. Nothing could be simpler than to turn three dials to previously determined and charted numbers. There is but one phone jack—Why?

Because only one is necessary. Volume can be entirely and instantly controlled by the rheostat on the resistance coupled stages of audio frequency. This not only further simplifies the operation, but also renders the construction easier. If the receiver is constructed properly it will be found

KFKX and WFAA from New York City—tuned in and held on the loud speaker—so it is truly a DX receiver.

The main tuning units consist of three General Instrument .000006—.0003 mfd. variable condensers and three special radio frequency transformers wound on the very efficient Isolantite tubing. The merits of this form of insulation were discussed in the last issue of THE WIRELESS AGE. By actual test the resistance at 1,000 cycles of an R.F. transformer wound on Isolantite was but 1.5 ohms compared with 4.3 for one similar in size, wound on ordinary tubing. These three units are obtainable in a kit and sold complete. There is no necessity for mounting the coils or condensers at the usual angle of 54 degrees as will be shown later on.

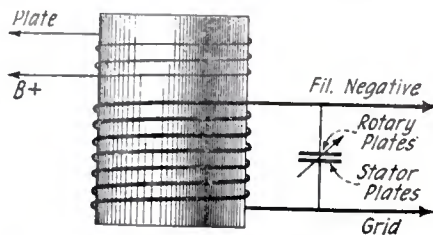
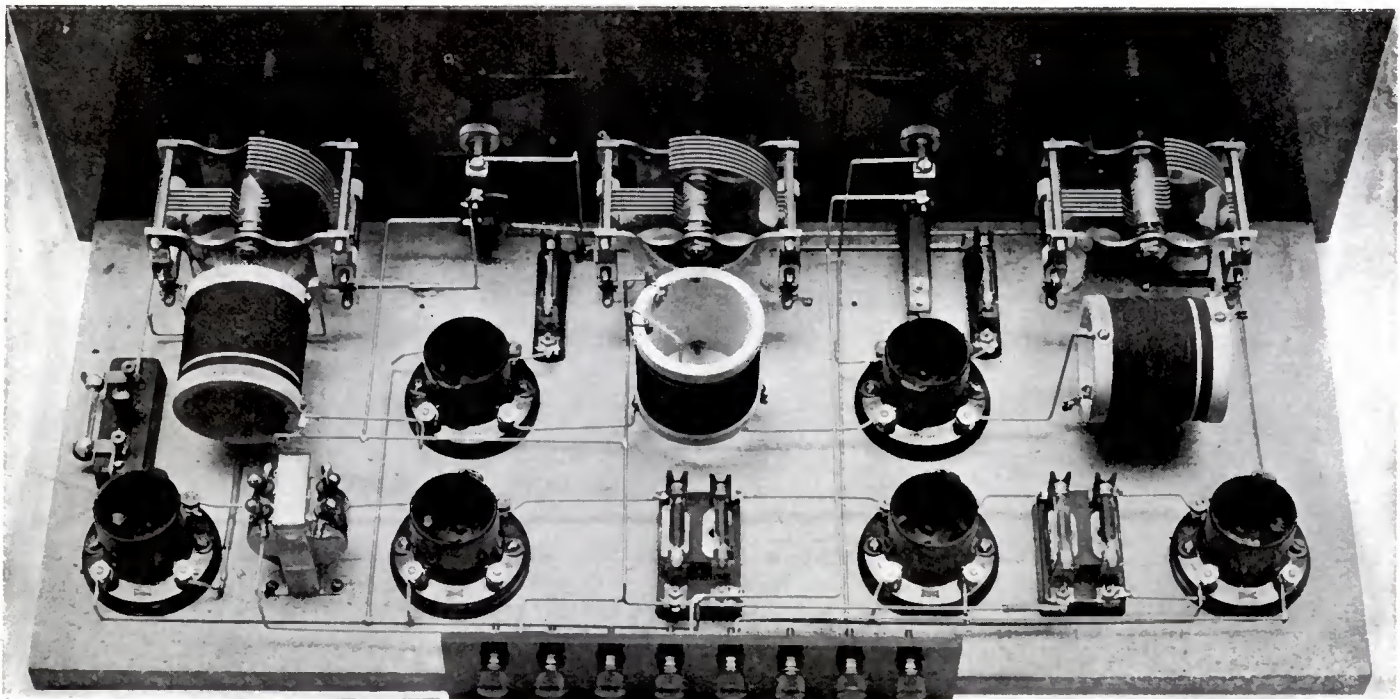

Diagram showing connection of leads

to give loud speaker reception in the early Fall of stations 1,500 miles distant. This distance should be doubled on a clear winter evening. We logged

The condensers are all mounted hori-



Rear view of the six-tube family receiver

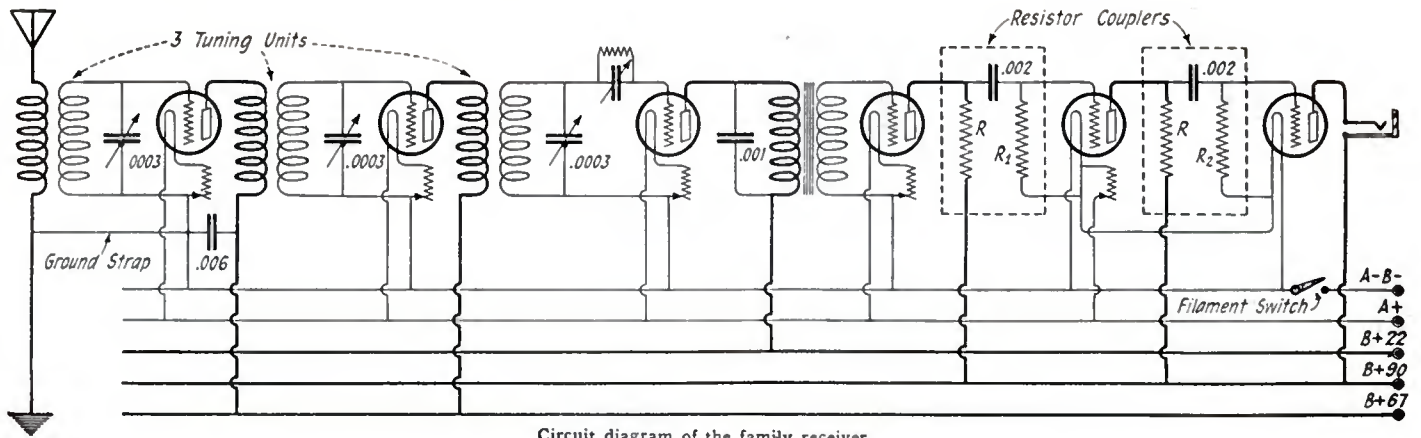

Circuit diagram of the family receiver

zontally while the three coils are fastened to their respective condensers so that each is at a 90 degree angle with respect to the other two. This alone prevents inter-stage coupling, and no neutralizing condensers nor resistances are needed when using the standard UV-201A or C-301A.

We recommend this receiver to our readers as one which will deliver the quality and distance which they expect from a WIRELESS AGE receiver.

CONSTRUCTION DETAILS

Secure a 7" x 24" Radion panel and mark with a lead pencil a line three and one-half inches from the edge. This center line furnishes the basis for drilling the holes for the condensers and rheostats which are to be mounted on the panel. Divide this center line into six sections of four inches each. Four inches from the left hand end drill the holes for the first condenser, making use of the template furnished with each condenser. The variable condensers are all mounted in a horizontal position instead of in an angular fashion such as is done on the average tuned R.F. receiver. The coils are mounted on the condenser in such a fashion that this angular mounting of condensers is rendered unnecessary.

LIST OF MATERIALS

- One General Instrument Co. tuned radio frequency kit including three transformers and three .0003 mfd. variable condensers.
- Six Na-Ald Standard sockets.
- One 7x24 Mahoganite panel
- Two Daven Resisto-Couplers including two 100,000 ohm resistances two .002 mfd. Dubilier fixed condensers
- one 1½ megohm gridleak
- one 1 megohm gridleak
- One .006 Dubilier fixed condenser
- One Carter Filament Switch
- One General Instrument audio frequency transformer, turn ratio 1 to 3.75
- One Radjo single circuit jack
- Two Marshallstats
- One Amplex gridenser
- One 2 megohm Daven gridleak
- Three Ballast resistances for ¼ ampere tubes Daven
- Eight Eby Binding posts
- One 9x2 Radion binding post strip
- Three Na-Ald Dials

The first coil is placed horizontally, the second vertically and the third horizontally and at right angles to the panel. Thus we have three coils mounted in 90 degree relation to each other. Eight inches from the left end drill a hole for the first Marshallstat.

and eight inches from this the second Marshallstat. Directly below the first Marshallstat is mounted the filament switch, which is a Carter single closed circuit jack-switch. Directly below the second Marshallstat and one and one-half inches up from the lower edge of the panel mount the Radjo phonejack. This type of jack was used because of the small amount of space which it occupied behind the panel. Next, drill the necessary holes for supporting the panel on the baseboard. There should be at least three screws to fasten this securely. When this is done mount the instruments on the panel and lay it aside until the baseboard arrangements are completed. Next secure for a baseboard a piece of soft white pine, nine and one-half inches wide by twenty-three inches long by three quarters of an inch thick. Two and one-quarter inches from the rear edge draw a line parallel to it. This will be a center line for the four sockets, audio frequency transformer and two resisto-couplers.

The two radio frequency tube sockets are mounted in a line, five and one-half inches from the rear of the baseboard and between the radio frequency transformers. Looking at the baseboard

(Turn to page 62)

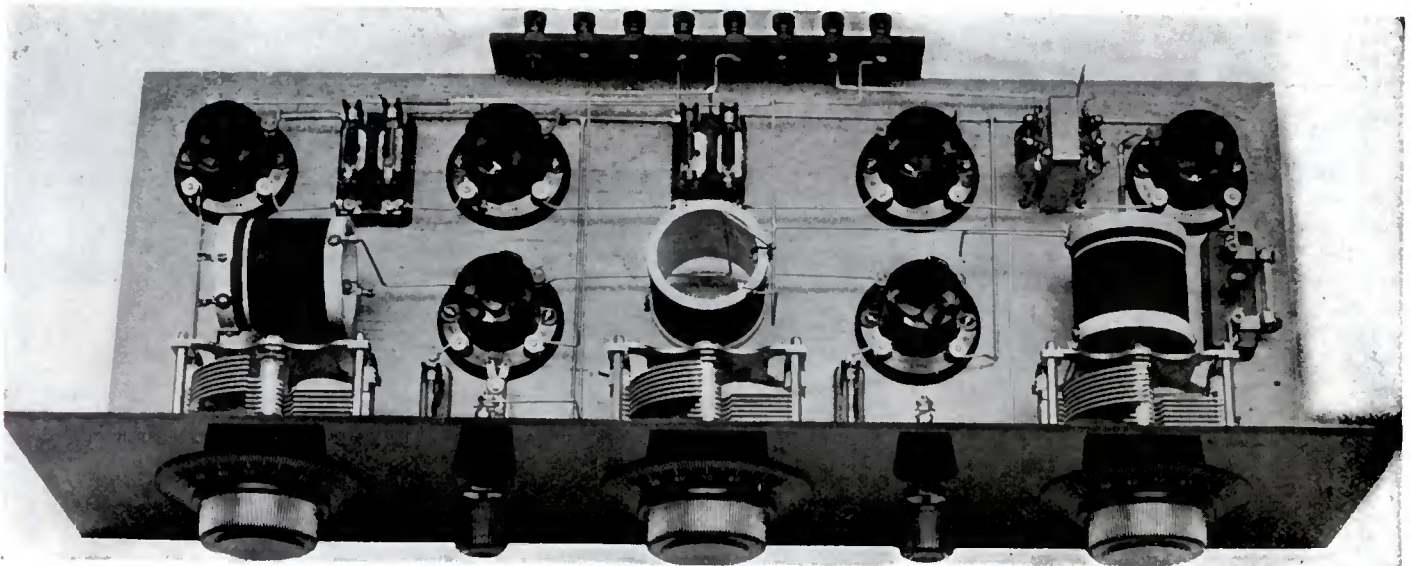

Top view shows clearly the relative position of all the parts of the family receiver



The gigantic cabin of the ZR-3, America's German built Zeppelin, and the radio receiver to be used in guiding her across the Atlantic watched over by Aro-G, a prize German police dog

World Wide News

Cape Town and Greenland Stations—Morse Code in Bengali—Transatlantic Broadcasting—R. C. A. Stocks Listed—Thirteen Thousand Seek Patents—Radio Interest World Wide

By C. S. ANDERSON

Managing Editor of the "Wireless Age"

Radio Interest Is World Wide

WHILE the activity in amateur radio work and in broadcasting is still greater in the United States than in any other nation, the past year has brought about marked changes in the situation in many foreign countries. Today, few are the nations which have not recognized the popular and growing interest in radio by the enactment or revision of regulations of one sort or another.

Naturally, the development abroad has had its greatest growth in Europe. In the British Isles, France, Germany, Sweden, Switzerland, Holland, Belgium, Denmark and Czechoslovakia, the broadcasting of programs of entertainment and news is on a rather regular basis, while in Italy, Finland, Spain and Austria, programs are sent out at irregular periods, with a decided likelihood of regular schedules being adopted in the no great distant future. In other countries of Europe, there has been some sale of long range sets to pick up British and French stations.

In South America, Argentina stands out as having made the greatest progress in the dissemination of music and other entertainment by radio telephony, with Chile also maintaining regular broadcasting service. For a time, regular services were also maintained in Brazil, and will, undoubtedly, be re-established in the course of time. Uruguay, as a result of broadcasting from Buenos Aires, has shown a con-

siderable interest in radio, and in Peru arrangements are going forward looking toward the establishment of regular service.

Australia and New Zealand have each displayed much interest in the new art, and in view of the recent lifting of hampering regulations in Australia, a marked expansion in radio interest in that country may be looked for. In the Orient, little has as yet taken place, though India and Ceylon are opening up, and intermittent broadcasting is being provided. In Japan, adequate legislation has been enacted, making provision for the establishment of broadcasting stations, but little progress has taken place. In China, radio is technically barred under an embargo forbidding the entry of anything usable as war material, though in the British port of Hong Kong and in the international settlement of Shanghai, some broadcasting has been done. In no country is the use of radio receiving sets as free and unrestricted as in the United States.

Future Arctic Exploration

SOME day soon, Donald B. MacMillan says, a dirigible will leave New York, sail over the Arctic, reveal to the eye of the camera a heretofore unseen continent at the North Pole, and return without ever having lost communication by radio with the world. The voyagers would come back knowing all that had happened while they were gone, and humming the latest jazz tunes of Broadway, he said.

The explorer says that contrary to the impression had by many, the aurora has no effect on radio. In fact, the best transmission he was able to obtain occurred in the midst of the most vivid displays.

"We could get stations in western United States and in Honolulu, but the East was 'dead' to us," he said.

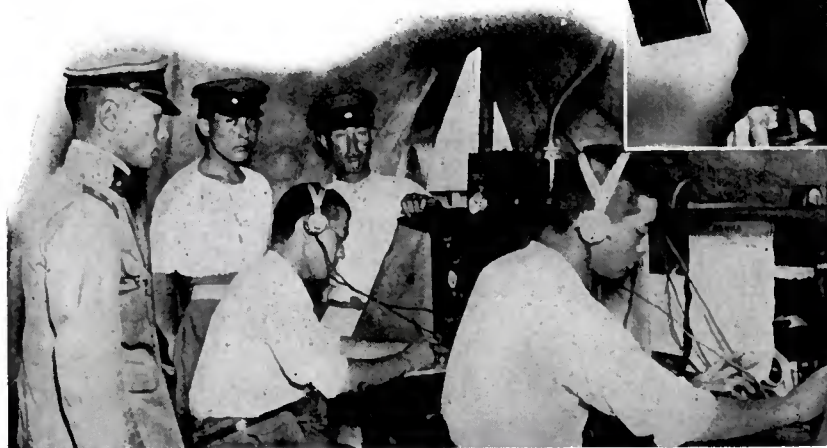
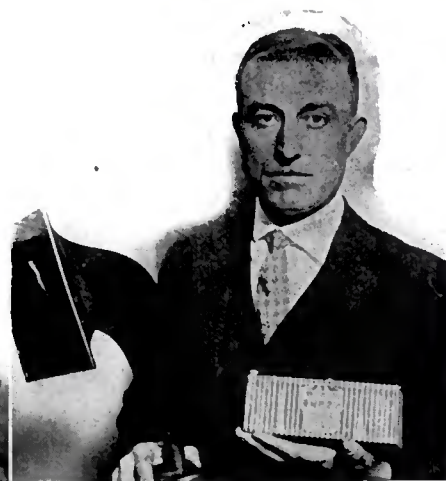

A loudspeaker and high voltage "B" battery of Japanese manufacture and the military corps sending Tokyo news by radio to the rulers of Japan while at Nikko

"It was a phenomenon we could not explain." The only theory for this he could evolve was that snow, blowing constantly over the intervening fields, had something to do with it, the flakes generating some sort of electricity.

Transatlantic Broadcasting

ONE of the many interesting features of the international broadcasting tests scheduled for the week of November 24-30 is the probable re-broadcasting of French, Dutch, German and Swiss radio programs by the stations of the British Broadcasting Company.

Nine stations of the British Broadcasting Company will have special programs arranged for the benefit of American radio listeners during the tests, but Captain West, assistant chief engineer of the British radio concern, plans to give the American listeners additional thrills by rebroadcasting Continental programs.

Such special tests are necessary because it is not possible to hear the British and Continental radio stations ordinarily, since they operate on practically the same wave length as the American stations. Allowing for that and the difference in time, it is not possible to hear the English stations when the American broadcasters are on the air.

Among the most recent broadcasters in this country to lend their co-operation to the international tests is the Westinghouse Electric and Manufacturing Company, whose stations WBZ, Springfield, Mass.; KDKA, East Pittsburgh, Pa.; KFKX, Hastings, Neb., and KYW, Chicago, will join in sending special features across the water.

Morse Code in Bengali

K. C. PURKAYASTA, scout-master of the Kurmagunj High School troop, is reported to have designed a Morse code for the transmission of Bengali messages. It

is also suitable for any language of the Indo-Aryan group, such as Assamese, Hindi, Marathi and Gujrathi.

Greenland Stations

GREENLAND is to have a complete wireless system, and in a country where communications are hampered by blizzards and snow it should prove of enormous value. Four stations will be erected, at Godthaab, Godhaven, Angmagsalik and Julianehaab, the latter keeping the others in touch with the Iceland station at Reykjavik.

R. C. A. Stocks Are Listed

THE common and preferred stocks of the Radio Corporation of America were admitted to trading on the New York Stock Exchange by the Board of Governors recently. This is the first stock of a radio company ever admitted to the big board. A total of \$19,779,870 of the company's Class A preferred stock and 1,155,400 shares of Class A common stock were listed.

13,000 Seek Radio Patents

SECRETARY WORK of the Patent Bureau has called his committee together to submit suggestions necessary for changes in practice that will result in bringing the work of the bureau to a current basis.

What this will mean to the radio inventors may be realized when it is learned that to date 3,000 radio pat-

Owen D. Young, Mediator on German Reparations and Chairman of the R.C.A. Board of Directors listens-in while sojourning in Berlin



ents have been granted and the eleven examiners under the very competent head of that division, C. E. Backus, have handled over 10,000 intended improvements in the science which could not be patented.

Radiograms From India

THE Eastern Telegraph Company's westward radioletter service from India is being extended to New York via Marconi-Radio. Service eastward from New York is not yet available.

Cape Town Station

THE Cape Town broadcasting station was opened on Monday, September 15th. It transmits on a wave length of 375 meters, the call sign being "WAMG." The installation consists of a Marconi 6 K.W. broadcasting transmitter and microphone, such as are used in six of the British main stations, and such as have been installed at Belfast, Brussels, Durban, Rome, Rio de Janeiro and Lima.

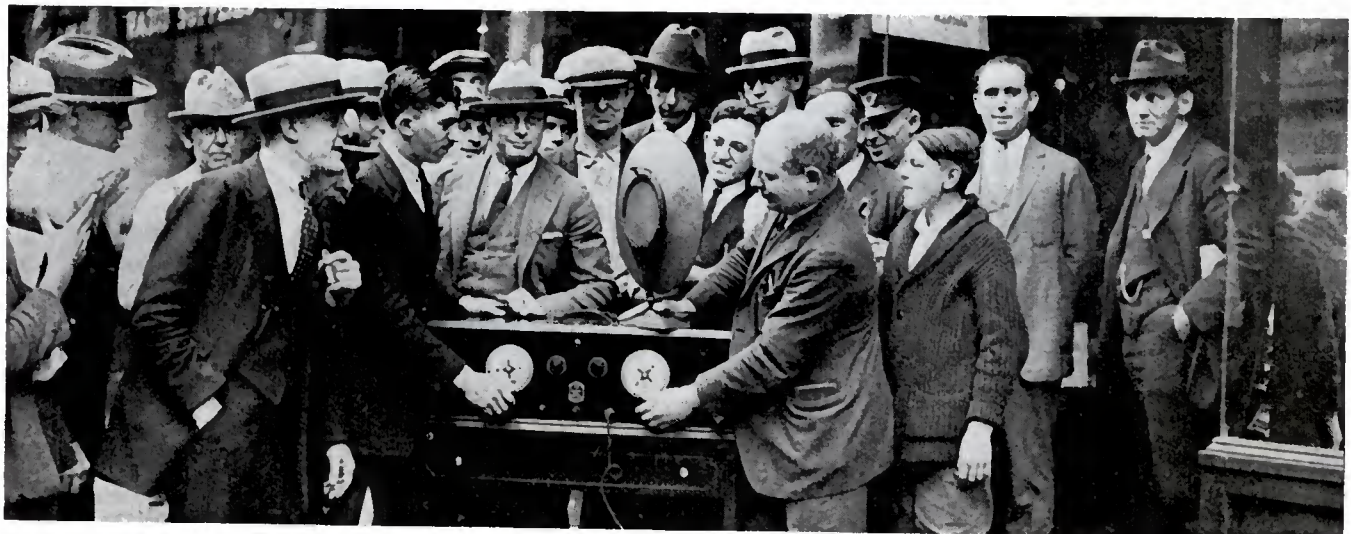

Street crowd in lower New York City listening to the broadcasting of the world's baseball series

The Physical Nature of Speech

and Musical Sounds

Peculiar combinations of pure tones—Analysis of vowel sounds and consonants—Sound spectra or typical musical sounds

By JOHN P. MINTON, B.S., Ph.D.

IN the Sept. issue of THE WIRELESS AGE we published our paper on "Speech and Music in the World of Sound." In that paper we described in a popular way and in some detail how all speech and musical sounds are made up of definite combinations of pure tones. These combinations make up the whole world of the beautiful sounds which give us so much pleasure and on which our very existence today depends.

So much of the beauty in art lies in the artist's conception that we are apt to find ourselves admiring the conception almost to the exclusion of the artistic rendition or execution itself. So it is in this world of speech and musical sounds. We are, perhaps, likely to find ourselves admiring the conceptions of speech and musical sounds as explained in the paper already referred to. In order to avoid this possibility, we should, I think, give a whole article to the physical nature of these special kinds of sounds. Such is the purpose of the present paper.

While the author was engaged for several years in acoustical research in the research laboratories of the Western Electric Co. he had occasion to study in great detail the reproduction and distortion of speech sounds by certain telephone apparatus. He devised and introduced a method of speech analysis which yielded most valuable information about speech and telephone apparatus and which has since become the standard method of testing not only by the Western Electric Co. and the American Telephone and Telegraph Co., but by all the workers in this field.

One of the results of these investigations was to demonstrate with certainty that speech sounds were peculiar combinations of pure tones. Each speech sound in all languages was shown to be a definite combination of the fundamental tone with a certain group of overtones. This combination of fundamental (lowest tone) and overtones remained practically the same for all persons. I say "practical" for two reasons. First, it is "practical"

because we can all recognize and understand the combination, let us say, for example, the sound of *o* in the word *hot*, no matter who says the word.

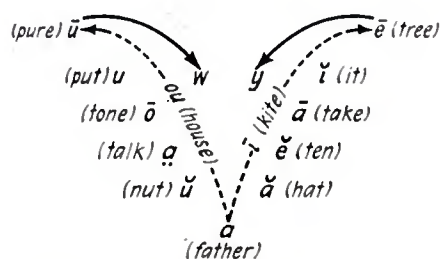

Figure 1. The pure and transitional vowel sounds used in the English language

Second, it is "practical" because the combination does change to a slight extent with various individuals and we are assisted, therefore, in distinguishing one person's voice from another. It is "practical" then for the reason of "understandableness" and for the purpose of "distinguishableness." What we have said about the letter *o* in *hot* is true about all the other vowel and consonant sounds.

The reason, then, that we fail at times to understand a spoken word is pretty largely due to the carelessness of

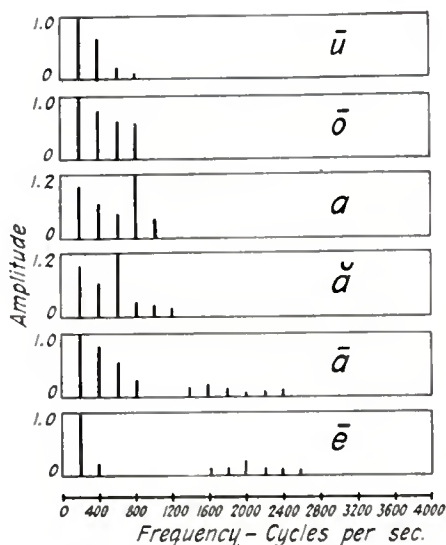

Figure 2. Sound spectrum for six of the pure vowel sounds

the speaker in forming the correct cavities of the mouth for the different speech sounds. As explained in the last portion of the preceding paper, the various mouth cavities during the process of speech determine entirely the particular groups of overtones for the speech sounds.

In connection with this phase of our subject it will be of much interest to describe briefly the relative shapes of these mouth cavities required to form the various speech sounds. The pure and transitional vowel sounds used in the English language may be arranged in a triangular arrangement shown in figure 1.

The vowel *ū* at the top, left hand side, of the figure is formed by rounding the lips, drawing back the tip of the tongue and placing it as low as possible while the back portion of the tongue is raised to practically close off the throat. The mouth cavity is thus formed into one single large chamber. This chamber forms a resonating cavity principally for those vibrations of the vocal cords in the region of 300 cycles, and thus form the characteristics of the vowel *ū*.

As we pronounce the vowel sounds, in the order indicated, on the left hand side of the figure beginning with *ū* and ending with *a* the lips open wider and wider and the lower jaw becomes lower and lower. The tongue remains raised at the back until *a* is reached when it is only slightly raised and the lips are wide open. In this formation of the mouth, lips and tongue those overtones in the region of 1,000 cycles are greatly reinforced and we have the characteristics of the *a* sound thus formed. As we proceed up the right hand side of the figure the lips come closer and closer together as though we were proceeding up the left hand side of the figure, except that the lips take on more and more the form of a slit as we proceed from *ă* to *ē*. At the same time the tongue, instead of being raised at the back, is now raised at the center to form a ridge across the roof of the mouth. As we proceed up the left hand side of the figure this

ridge advances farther and farther toward the front of the mouth. There is thus a fundamental difference between the vowels on the left and right hand sides of the figure. For the former the mouth with the tongue is formed into a single cavity, while for the latter the position of the tongue is such that two cavities in the mouth are formed. The former vowel sounds are called singly resonant vowels while the latter are called doubly resonant vowels. In the case of the *ä* sound the forward and rear cavities are nearly equal in volume. The rear one including the throat cause the overtones of the vocal cords in the region of 800 cycles to be considerably reinforced. The forward one causes those overtones in the region of 1200 cycles to be amplified. When we finally reach the *ē* sound the forward cavity is quite small and this one causes amplification of the overtones in the region of 2,500 to 3,000 cycles. The rear one, which has now become quite large, causes the overtones of the vocal cords in the region of 300 cycles to be greatly increased in magnitude. The difference, then, between the *ū* and *ē* sounds is caused by single and double cavities, both of which give a resonance at about 300 cycles and the latter of which, but not the former, give a resonance around 2,500 to 3,000 cycles. The vowel *ē* can be made to sound like *ū*, merely by eliminating the increased energy around 2,500 to 3,000 cycles and in an analogous manner the vowel *ū* can be made to sound like *ē* merely by introducing a suitable energy increase of those overtones in the region of 2,500 to 3,000 cycles. These remarks indicate quite clearly in a qualitative manner the distinguishing features amongst the various vowel sounds. Below we shall discuss the quantitative differences that exist amongst them.

In addition to the pure vowel sounds, we have the transitional vowel sounds *i* and *ou*, *w* and *y*. Ordinarily one thinks of the two former being pure vowel sounds while the two latter are consonants. However, both the long *i* and the *ou* (also *ow* as in *how*) sounds begin with the *a* sound as in far. The former sound ends with the long *e* sound while the latter ends with the long *u* sound. This explains why they are called transitional vowel sounds. In the case of *w* (as in *will*) the mouth, lips and tongue are formed to pronounce the long *u* sound and then one passes suddenly to any of the other pure vowel sounds. In the case of *y*, the initial formation of the mouth, lips and tongue are for the long *e* sound and they suddenly pass to any of the other pure vowel sounds. If *w* or *y* are followed by either of the transitional vowels *i* or *ou*, then there is a rapid succession of three pure vowel sounds instead of two as in the four

transitional vowel sounds. It may be pointed out, however, that there is a difference between the transitional vowels *i* and *ou* on the one hand and *w* and *y* on the other. The two former are sufficient unto themselves, so to

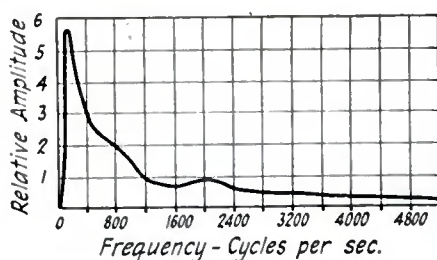

Figure 3. A composite curve for the English language

speak, and are followed by the consonant sounds, while the two latter are followed by pure vowel sounds.

The sound *h* has been classified as a

Then, the consonants have been divided into two classifications as illustrated in the table below:

This classification and description of the various vowel and consonant sounds will be found very helpful and interesting. It will be worth one's time to take a half hour or so to go through this description again, pronouncing each letter carefully and observing closely the formation of the mouth, tongue and lips for each of the sounds. One will then be able to more fully appreciate how well nature has endowed us in the art of communication by speech sounds.

It is of much interest from a quantitative viewpoint to study the distribution of the voice energy in speech sounds. By this means we get a sort of a sound spectrum of the energy in the various sounds. In figure 2 is shown such a sound spectrum for six of the pure vowel sounds.

STOP CONSONANTS

Voiced	Unvoiced	Nasalized	Formation of Stop
b	p	m	lip against lip
d	t	n	tongue against teeth
j	ch	...	tongue against hard palate
g	k	ng	tongue against soft palate

The sounds *m*, *n*, *ng* have been classified both as semi-vowels and stop consonants.

FRICATIVE CONSONANTS

Voiced	Unvoiced	Formation of Air Outlet
v	f	lip to teeth
z	s	teeth to teeth
th (then)	th (thin)	tongue to teeth
zh (azure)	sh	tongue to hard palate

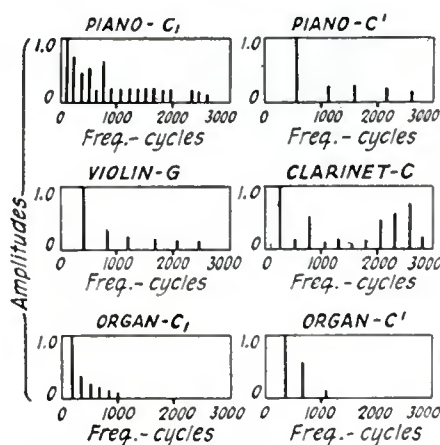

Figure 4. The curves or sound spectra for musical tones

transitional vowel, while *l*, *r*, *m*, *n*, *ng* have been classified as semi-vowels.

ANALYSIS OF VOWEL SOUNDS

The lowest tone in each of the various vowel sounds shown in the figure is in the region of 200 cycles. The magnitude of this tone, called its amplitude, shows how intensely it impresses the ear. These acoustical energies are impressed on the brain by means of the ear as explained in our July paper. Hence, the acoustical sensation registered by the brain is also determined by the ear characteristics. Consequently, these acoustic spectra of the sounds themselves do not represent the relative intensities of the fundamental and its overtones as recognized by the brain itself. If we call the amplitude of this lowest tone unity (1.0) and represent it by a vertical line one

(Turn to page 58)



How and Why I Designed the 5½ Oz. Head Set Without Headband Thin as a Watch—Yet 2200 Ohms

Large volume of tone and pure musical quality

By DURYE A BENSEL

IT has been repeatedly attempted to increase the sensibility of the telephone receiver, either by altering the membrane which is the diaphragm, or by modifying the magnet system, or by adopting fundamentally new principles of construction. It has also been attempted to lighten the units. These desirable improvements, however, have not been accomplished to any marked degree up to the present. Most of the telephone receivers now in use are practically the same in construction. They have the same type of pole pieces measuring anywhere from ¼ inch to ½ inch off center of the diaphragm.

Some time ago I came to the conclusion that head set reception had some advantages over loud speaker reception, and that conclusion has remained with me. The great drawback to telephone head sets of the present day is

the head band and the weight which causes discomfort. Three years ago I began thinking about designing a head set without the uncomfortable head band. It seemed a worth while thing to experiment upon, and I felt sure the desired result could be accomplished. However, three years ago I had no idea of the seemingly unsurmountable difficulties I would encounter, nor the amount of good material, to say nothing of the time and money that would be used before the practically perfect set could be made.

After considerable experimenting, I finally made a unit which weighed 3½ ounces. This unit was 1¼ inches thick by 2½ inches in diameter. The next thing was how to hold it to the ears

without the head band. I realized that such a contrivance must be simple, not alone to operate, but to manufacture, and also that it must be adjustable to fit any size or shape of ear. At last I perfected an ear clasp that was both simple to operate and cheap to manufacture, but when I attached them to my 3½ ounce unit, my troubles began. The units sagged away from the head and let in all the outside sound. This was caused by the greater part of the unit being fully an inch away from the side of the head, which acted as a leverage and pulled the ears down. To hold the unit firmly and securely to the ears in such a way as to exclude outside noises, they had to be lighter than 3½ ounces, and all the weight had to be close to the side of the head when they were on the ears to overcome the leverage.

With the present construction of telephone units, such a thing was an impossibility, and it was necessary to

(Turn to page 64)

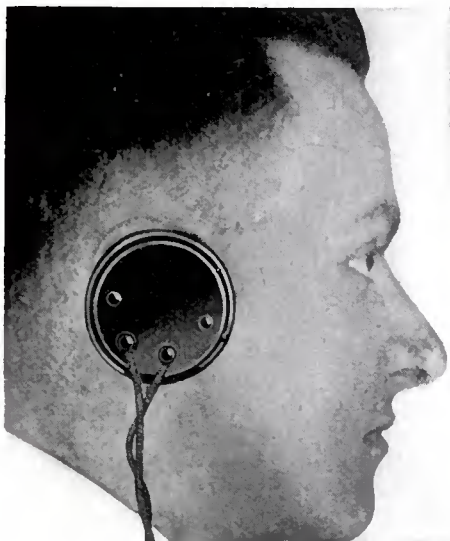

The receiver attached to the ear

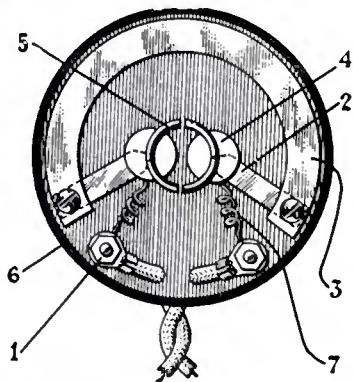

The inside works—1, terminal; 2, pole shoe; 3, magnet; 4, coils; 5, face of poles; 6, case; 7, terminal connections

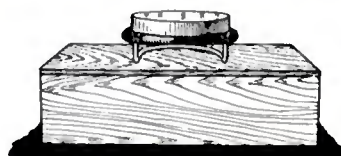

A unit resting on a cigar box makes a loudspeaker

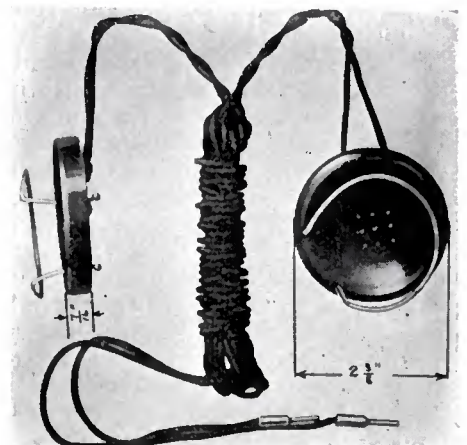

The complete headset

Third National

Secretary Hoover's opening address points out that Radio has passed from the field of adventure to that of public utility

"In the whole field of scientific discovery, there has never been a translation into popular use so rapid as in radio telephony"

Radio Conference

IT is a pleasure for me to open the Third Annual Radio Conference at this Department and to welcome you to its sessions. Your willingness to leave your usual business and give your time and attention to this conference bears witness both to the importance of radio in the lives of our people and to your desire to perform a public service.

Radio has passed from the field of an adventure to that of a public utility. Nor among the utilities is there one whose activities may yet come more closely to the life of each and every one of our citizens, nor which holds out greater possibilities of future influence, nor which is of more potential public concern. It must now be considered as a great agency of public service, and it is from that viewpoint that I hope the difficult problems coming before this conference will be discussed and solved.

At the first radio conference I hazarded some modest anticipations as to its development and use. Some thought them visionary—yet we passed every point of these anticipations within eighteen months. We have, in fact, established an entirely new communication system, national in scope.

In the whole history of scientific discovery there has never been a translation into popular use so rapid as in radio telephony. So late as the year before I became Secretary of Commerce there were no broadcasting stations. At the end of four years 530 are in operation, making radio available to every home in the country. The sales of radio apparatus have increased from a million dollars a year to a million dollars a day. It is estimated that over 200,000 men are now employed in the industry, and the radio audience probably exceeds 20 millions of people.

We may well be proud of this wonderful development, but in our self-congratulation let us not forget that the value of this great system does not lie primarily in its extent or even in



its efficiency. Its worth depends on the use that is made of it. It is not the ability to transmit, but the character of what is transmitted that really counts. Our telephone and telegraph systems are valuable only in so far as the messages sent from them contribute to the business and social intercourse of our people. For the first time in human history we have available to us the ability to communicate simultaneously with millions of our fellow men, to furnish entertainment, instruction, widening vision of national problems and national events. An obligation rests upon us to see that it is devoted to real service and to develop the material that is transmitted into that which is really worth while. For it is only by this that the mission of this latest blessing of science to humanity may be rightfully fulfilled.

The conferences of the past three

years have been called in the belief that it was by your coöperation that the requirement of the law could best be met which declares it to be the duty of the Secretary of Commerce to "foster and promote the commerce of the United States."

Beyond this, certain minimum regulatory powers rest in the Department. I have been convinced that development could only be accomplished by organized coöperation of the industry itself; and the industry is unique in that unless it has stringent rules of conduct to which all elements adhere it will die of its own confusion.

At each succeeding conference we have had more difficult problems to solve, and those which we present today are of a complexity greater than ever before. In a large sense the purpose of this conference is to enable the listeners, the broadcasters, the manufacturers, and the marine and other services to agree among themselves as to the manner in which radio activities are to be conducted.

Like the two previous occasions, this may be called an experiment in industrial self-government. Radio activities, so long as they remain within the legislative restriction which holds for the government the fundamental control of the ether, are largely free. The industry's future conduct with a single view to public interest, a voluntary imposition of its own rules and a high sense of service would go far to make further new legislative or administrative intervention unnecessary. The two past conferences have been successful in these purposes. With only slight modifications made necessary by changing conditions, the Department has been able to follow their recommendations in the performance of its duties. The industry has supported and conformed to these recommendations cheerfully and uncomplainingly, although at some self-sacrifice. I congratulate you on this spirit, and know

that you will enter upon your new deliberations in the same attitude.

BROADCASTING PROGRAMS

When broadcasting first started, the phonograph was a sufficient attraction to the radio telephone listeners, who were swayed chiefly by curiosity and marvel at the new discovery. Public interest has long since passed this stage. The radio telephone would now die in 24 hours if it were limited to transmission of phonograph records. We have made great improvements in material transmitted. Original music, speeches, instruction, religion, political exhortation, all travel regularly by radio today. Program directing has become one of the skilled professions. I have indeed a great feeling for the troubles of the director in his efforts to find talent and to give to his audience the best that lies at his command. He has done extraordinarily well.

But we require a still further advance in the character of material beyond the capacity of local station directors if the art is to emerge entirely from the curio and entertainment stage to that of fundamental service.

Experimental broadcasting upon a national scale during the past year has now brought us to the stage where we know it can be done. The local material available for the local program is not in my view enough to maintain assured interest, and therefore the industry, or to adequately fulfill the broadcasting mission. So far as the art has developed, I think we all agree that for accuracy and regularity of reception we can depend only upon the local broadcasting stations. My proposition is that the local stations must be able to deliver every important national event with regularity. The local station must be able to bring to its listeners the greatest music and entertainment of the nation, but far beyond this it must be able to deliver important pronouncements of public men, it must bring instantly to our people a hundred and one matters of national interest. To this it must add its matters of local interest. This can only be accomplished by regularly organized interconnection on a national basis with nationally organized and directed programs for some part of the day in supplement to more local material.

It may be stated with assurance that the greatest advance in radio since our last conference is the complete demonstration of the feasibility of interconnection. We owe a debt of gratitude to those who have blazed the way. The pioneers have been the American Telephone & Telegraph Company in wire interconnection, and the Westinghouse Electric & Manufacturing Company in radio interconnection through the use

of short wavelengths. Their experiments have involved technical skill of the highest character which could be found or contributed by few other organizations in the world. Their expenditures, running into the hundreds of thousands of dollars, have been made without direct consequential return. It has been possible to broadcast many national events over three-quarters of the United States during the past year, and the whole country has been covered twice. The service deserves the appreciation of the public, for it has demonstrated this great thing to be practicable.

It is our duty to consider the possibilities and potentialities of interconnection as a regular daily routine of the nation. Unless it be systematically organized we cannot expect its continuation. I realize that this matter, except in so far as it may be fostered and encouraged, does not lie in the Government. It would be unfortunate indeed if such an important function as the distribution of information should ever fall into the hands of the Government. It would be still more unfortunate if its control should come under the arbitrary power of any person or group of persons. It is inconceivable that such a situation could be allowed to exist. But I am not now dealing with monopoly. Nor is this a question where any one lays claim to a monopoly. Interconnection is going on to local extent and over the wires of the telegraph companies, the telephone companies, and by radio itself. We have promises of super radio and we have promises of interconnection of wired wireless. If there are several methods, it means that we might have several alternative programs always available. But whatever the method of interconnection may be, we are lacking in a definite organization of a national system of programs and a basis of support.

I believe that the quickest way to kill broadcasting would be to use it for direct advertising. The reader of the newspaper has an option whether he will read an ad or not, but if a speech by the President is to be used as the meat in a sandwich of two patent medicine advertisements, there will be no radio left. To what extent it may be employed for what we now call indirect advertising I do not know and only experience with the reactions of the listeners can tell. I do not believe there is any practical method of payment from the receivers. I wish to suggest for consideration the possibility of mutual organization by broadcasters of a service for themselves similar to that which the newspapers have for their use in the press associations, which would furnish programs of national events and arrange for their

transmission and distribution on some sort of a financial basis just as the press associations gather and distribute news among their members.

It may be that we cannot find a solution at this moment, but I believe that one result of this conference should be not only the consideration of this question but the establishment of a continuing committee for its further consideration.

There are other matters to which I hope the conference will give its attention.

THE PROBLEM OF WAVE LENGTHS

One of the most important subjects for your consideration is the providing of operating channels for broadcasting stations. Of the present 530 stations, 57 are Class B, operating on from 500 to 1,000 watts and having a wide range, and 387 are Class A, many using small power and covering small areas. There are still 86 Class C stations, most of which have low power, all on a wave length of 360 meters. Our chief trouble is with the Class B situation. They are all assigned within the band of 288 to 545 meters, within which there are, under the present system of allocation and excluding the Class C band, only 44 available channels, and only 33 that seem desirable at present. To assign these among the 57 stations necessarily means duplication, although it was the theory of the last conference that individual wave lengths could be assigned to each. At present, 23 stations either have exclusive wave lengths or are sharing with stations so distant that both may operate simultaneously, while the remaining 34 are compelled to divide time. The greatest congestion is in the large cities, New York and Chicago particularly. A recent survey made by the Supervisors of the various districts shows that 21 new Class B stations are now under construction and that 25 others are contemplated, so that the question of allocation is one of increasing difficulty. It was the recommendation of the last conference, and has been the practice of the Department, to separate stations in the same zone by at least 50 kilocycles, in adjoining zones by at least 20 kilocycles, and in separate zones by at least 10 kilocycles. In the light of scientific and technical development in both transmitting apparatus and receiving sets, it may be that a different plan of zoning or of station separation may now be used, thus creating additional wave lengths for assignment. It has been suggested also that the band now reserved for Class B might be somewhat broadened. Removals of Class C stations from the Class B band would likewise give some

(Turn to page 54)

Getting the Rural Vote

Candidates can reach the rural voter by radio, but in so doing he must limit his speeches to the real issues of the day

By HENRY C. WALLACE

Secretary of Agriculture

RADIO has grown enormously in the last two or three years, but we have yet to experience the important lasting effects which must be brought about by the widespread adoption of such a radical improvement in communication. We know that millions of people daily are making use of receiving sets for business, educational and entertainment purposes, yet we do not know what effects the reactions of these millions will have on the conduct of the Nation's affairs. The preliminary phase is much like the investigation of a scientific problem; the application of the facts will be made by the public after due deliberation.

I know from the experience the Department of Agriculture has had with the use of radio to disseminate agricultural reports and information that the farming population is finding it a welcome convenience which is rapidly becoming a necessity. We have received sufficient comment to convince us that farmers appreciate radio most as a practical help in carrying on their business, but that they also value it greatly for the educational and entertainment features.

Today practically every farmer, without appreciable expense, can receive almost immediately it is available the latest information on market and weather conditions. I do not mean to say that all farmers have receiving outfits, but there is efficient local distribution of information that is sent over the entire country by numerous sending stations. Daily weather forecasts are sent out by 117 stations in practically every State; crop and market reports and comments are put on the air by seven high-powered radio-telegraph stations of the Navy Department and 75 radio telephone stations owned by colleges,

newspapers and commercial concerns.

No one knows how many farmers have their own radio receiving sets, but the Department of Agriculture made a preliminary survey about a year ago

agents have a practice of relaying information received by radio to the neighboring farmers by telephone. By such a method the number of people benefited by up-to-the-minute information is multiplied enormously.

It is safe enough to forecast that radio will be a permanent factor in entertainment, education, business and politics. Many predictions have been made regarding specific changes. We hear that it promises to do away with the old-time political mass meeting, citizens staying at home and learning about the issues of the day without stirring from their easy chairs. Perhaps some such change may come about, but whether it does or not we can be sure that more voters are going to learn about the real issues than ever before. Neither weather nor stress of work, which might keep people at home, will prevent them from hearing the messages from candidates for office.

It is probable that more attention will be given to the contents of political speeches which will be heard in the calm of the fireside. The radio audience consists of persons of different political beliefs. Therefore, the effective talk will be one that is brief and limited to the real issues of the day. The

speaker does not have his audience at his mercy and can lose them with the same ease with which he secured them.

Since no party can ever obtain a monopoly of radio facilities, its use should result in a far larger number of voters becoming informed on the issues under discussion, and it may be instrumental in stimulating a larger vote at the polls. Obviously those candidates who can make the most persuasive arguments in their own behalf will reap the greatest benefit from the radio.

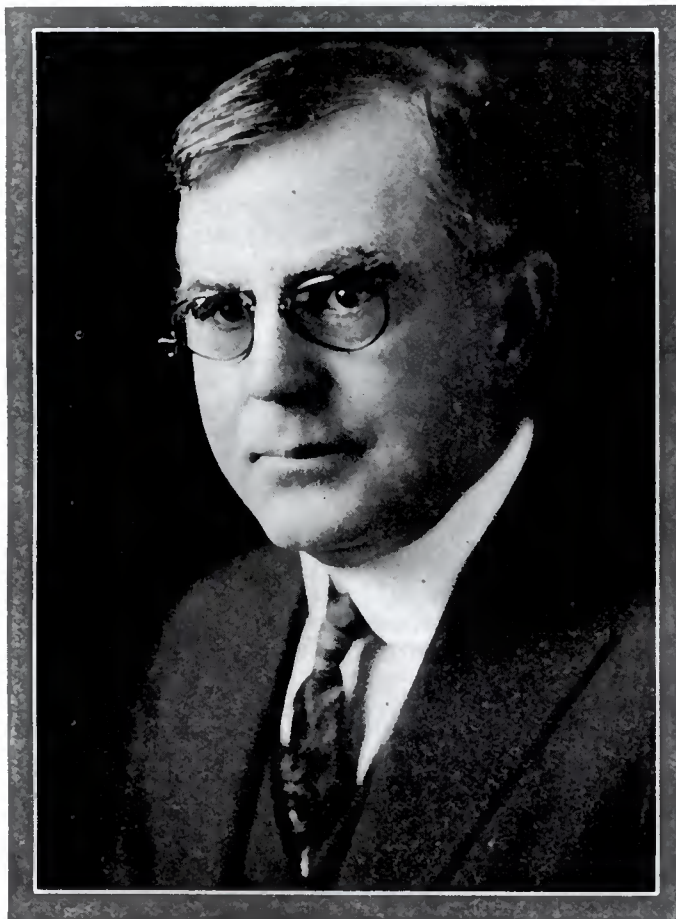

which gives some indication of the number. It was found that in a large number of counties investigated there were about fifty outfits on farms in each county. If that average held true for the entire country it would mean about 150,000 receiving sets on farms in the United States. Since the time of the survey the number undoubtedly must have increased greatly. The use the farmer makes of this convenience cannot be measured by the number of sets. Many banks in small towns and in some cases county agricultural

One-Tube Circuits

Analysis of the Copp, Kauffman, Reinartz, Ambassador, Haynes and other regenerative circuits using honeycomb, spider web and other lattice wound as well as tube wound coils

By JOHN R. MEAGHER

WE have selected a topic "near and dear" to a vast number of broadcast listeners; the much talked of and little understood subject of single tube regenerative receiving circuits.

What immediately comes to mind when we say "single tube circuits?" Why of course; all the numberless circuits that have appeared in radio papers. We have the Copp, the Kauffman, the Reinartz, the Ambassador, the Haynes, single, double and triple circuits of all kinds, the British aircraft, the honeycomb, the spider web, the variometer-variocoupler: and so on without end.

There is no reason why each should not have its distinctive name and yet as they are all alike, it is not correct to say they are different from each other.

It has been said that one regenerative circuit should work as well as any other regenerative circuit provided the design of each is equally good. Many readers accepted such a statement without a word, others doubted it and some thought it to be wrong. Among our own acquaintances in the radio field we do not know of a single person who would agree enthusiastically to the correctness of the statement. And yet now, in reaffirmation, we say that of all these circuits not one differs from the standard regenerator; even more, we say there is only one basic circuit and that all the others may be reduced to that simple one (shown in figure 1). Let us look into the matter.

Simple tuning circuits first: In figures A, B and C we have three tuning arrangements that look as though they were different. We can substitute B for A or A for B and, with proper design, cover the same wavelength range. The efficiency of one compared to the other depends upon the design; we are not concerned with that here. We point out merely that in effect A and B are alike. Now C is the same as B. To be sure, the shunt capacity across the coil is made of two condensers in series, and a resistance R as indicated, but the condenser across the coil in B could be represented with its equivalent resistance in series, thus taking care of R. If the condensers VC and C in C are designed properly, they, in combination with the coil in C, will cover the same wavelength range as the

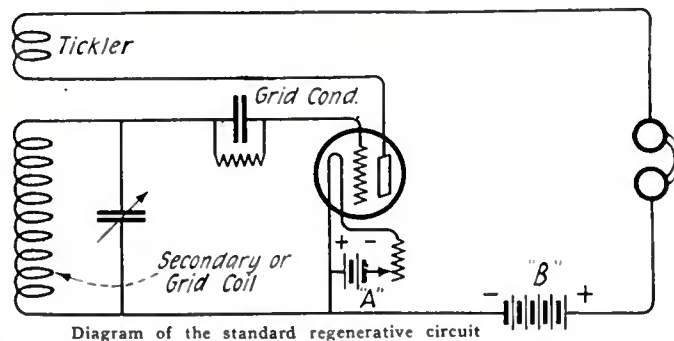

arrangement shown at B. Thus C and B are alike, but A and B are also alike so A, B and C are similar to each other. (C is meant to represent a single circuit aerial system with a shunt variable condenser VC; the antenna resistance is represented at R and the antenna-ground capacity at C.)

The fact that the relative efficiencies may be different, as stated above, should permit one to be sufficiently broadminded to accept the similarity of A, B and C.

Glance now at antenna circuits. At D is shown a loose coupled or double circuit arrangement. Note that the secondary is similar to B above and that B is the same as A. Now we know that it does not change the circuit to ground the filament in order to keep that section at ground potential, so the filament or bottom side of the secondary may be connected to the ground as shown in dotted lines. The circuit is not altered. Nor need we represent the primary as being to one side of the secondary; we may easily swing the primary about and without changing a single connection represent D as at E. Or, if we wish, instead of using a separate primary coil we may make dual use of a corresponding part of the secondary as shown at F. Here the primary is from the aerial connection on the coil to the ground.

The secondary is from the top of the coil to the ground. The primary and secondary turns may be the same as in E so that in effect, F is like E and as E is the same as D, all three are alike.

Again we shall say that the effect on efficiency does not concern us here.

Consider for a moment the two main types of regenerative circuits, the tickler feedback as at G and the tuned plate as at H. The antenna circuit does not bother us as we have shown at D, E and F, the similarity

of apparently different antenna systems. At G the grid is excited—caused to vary in voltage with changes in plate current—which changes are caused by initial variations of grid voltage—by magnetic coupling with the plate circuit and to some extent by capacity coupling between the grid and plate. At H, the grid is excited partly by magnetic coupling between the grid and plate circuits, but mainly through the grid-

plate capacity. The latter is here of more importance than in the tickler feedback because the variometer may be set to offer a higher impedance to the plate current variations than the untuned tickler can offer. Therefore the plate voltage variations in the case of the variometer — or otherwise — tuned plate may be considerably greater than the voltage variations on the plate with tickler feedback. Consequently, the small grid-plate capacity plays a more important rôle with the tuned plate system. However, in both methods both inductive and capacitive coupling is employed to a greater and smaller extent and, as in effect and results there is little actual difference between them, we may say that G is like H. Remember that in place of the variometer in H we may substitute the coil and condenser as from A to B.

Of course in detail we must realize there is a difference in these circuits, but in general principles there is a similarity, which it is worth while to recognize in order to properly classify our knowledge of radio.

Now examine a method of regeneration that appears radically different from either G or H; this is the Weagant X circuit as shown in K. Here the low frequency output is shunted by a series inductance and capacity. We like to think of this circuit as shown in L. Here the headset is represented by the inductance X_p , the resistance R_p and the distributed capacity of the headset, X_c . The total presents some low value of impedance to radio frequency variations, not sufficient however to make the plate voltage variations great enough to excite the grid through the small grid-plate capacity, but when the complete tuned circuit comprised of the headset (X_p , X_c and R_p), the coil and condenser is adjusted to the frequency of the plate

(Turn to page 66)

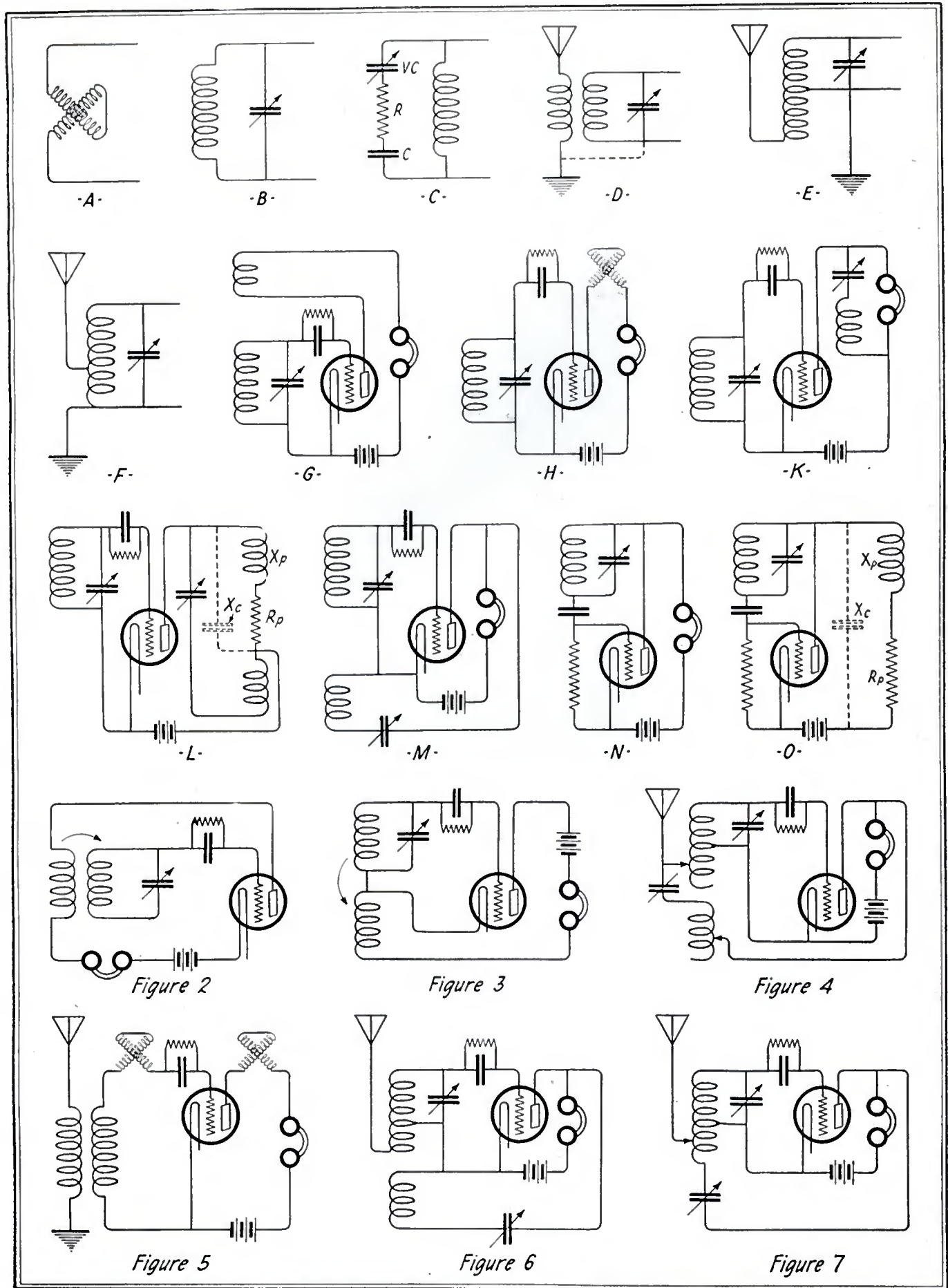

Circuit diagrams of popular one-tube regenerative receivers

AFLOAT AND ASHORE WITH THE OPERATOR



WONDER now, did you miss this page last month? How did you like the Marconi article instead? But, wait, you don't know what happened! After weeks of delving through old records, magazines and newspaper clippings, a chronologic record of fifty-one first events in radio was prepared—but the Ed sayeth he is running a magazine and not an almanac, so after wielding ye old blue pencil he called for something to take its place—hence the Marconi account!

You are not, however—and the determination is here—going to be the loser. Retaining the authentic dates and historic values, the different events are to be incorporated in a more readable article, offsetting the objectionable “dryness”—and you'll get it in the near future.

△ △ △

JUDGING from the response to this page during the past year, it seems evident that the greatest interest lies in the old time marine radio operators and their subsequent successes.

Through the courtesy of Mr. Arthur A. Isbell, manager of the activities of the Radio Corporation on the Pacific coast—including the sales, transoceanic and marine services—who is, himself, one of the original old timers, it has been learned that L. W. Sturdevant is now manager of the radio department of Sherman-Clay & Company, San Francisco, one of the largest distributors of musical instruments in the Pacific states and fast becoming equally prominent as radio jobbers. Sig. Goskey is still in Alaska with the Alaska-Packer Association.

△ △ △

A COINCIDENCE that has been brought to light through this page is that no less than eight well known old time radio operators were schoolmates at the same New York City public school—No. 29, in the Bronx—and all lived within two squares of the school.

They are Axel G. Berg, Donald J. Pieri, Richard G. Cuthbert, Nathan J. Ribler, Frank Rosenquist, R. J. Dean, W. W. Jablonsky and Herold McCormick.

△ △ △

AXEL G. BERG is quite prominent among the old timers and has had greatly varied experiences since his advent into the radio field much over a decade ago. He has been in more

By W. S. Fitzpatrick

than a hundred ports, visiting practically every country of importance, which must be of value to him in connection with the post he now holds in the Radio Corporation's export division.



Axel G. Berg, old time radio operator now holding important position in RCA export department

“My experiences would fill a good sized book,” commented Mr. Berg when asked to relate some of them. “I've been around some, in fact Africa is the only continent I have not been on.

“Aside from the thrill of sending out SOS calls, which has been my lot, what comes foremost to my mind just now is the two times that I was left ashore in foreign countries; once in far away Australia and another time in Mexico. I might laugh now, but it was no fun at the time. How did I get back? Well, in Australia I managed to convince the steamship agents that I was not at fault and that they should advance expenses to the ship's next port of call. I had to travel a considerable distance to the other port where I caught the ship a week later. In Mexico my ship was taken over by the government during the height of one of their rebellions. The days I spent there were most ticklish ones. I finally managed to connect with a passenger steamer which brought me to New York where quite a controversy was started as to who should pay my

fare. I believe the company operating the ship which brought me to Mexico eventually paid it—I know I didn't.

“I was rather ambitious when I went to sea. I studied navigation until I mastered it and on two occasions put my knowledge to use. Once on a sailing vessel when the third mate deserted I acted in his stead for the voyage. On a steamer at another time the second mate was taken sick, the third was promoted and I took his place.

“I also studied marine engineering and spent eight months in the engine room of a ship. Later I took up structural engineering.”

Mr. Berg was urged to continue, but without avail.

During the war Mr. Berg wore a U. S. Naval uniform. He was at the Sea Gate station, then transferred to Sayville, where he was placed in charge of a watch. Later he was made an inspector under the District Communication Superintendent of New York.

Following his release from the navy at the end of the war he took an interesting trip on a ship to Russia.

Returning to New York Mr. Berg decided to give up the sea. He became a motion picture actor and it was not long before he was playing important rôles, although never attaining the rank of star.

Seven months as a movie actor and we find him back with his old love, Radio.

He was appointed by the Radio Corporation to the position of traveling representative out of Chicago, covering the entire middle western territory from Duluth to New Orleans. It was a difficult task to open up new territory but Mr. Berg was found equal to it.

Some time later he was transferred to New York and when the new service division was organized by the Radio Corporation he was placed in charge of the New York office of that division.

Starting with a force of less than a dozen it was soon increased five fold. Here his earnest work and ability again showed itself and he was transferred to the head offices of the company in the Woolworth Building and later appointed to his present post.

Mr. Berg is keenly interested in old timers and finds great pleasure in recalling names of his former associates and their deeds. He has made the suggestion that an old time radio organization be formed along the lines of the Old Time Telegraphers Association.

BROADCASTING STATION DIRECTORY

The Most Authentic, Up-to-the-Minute List of Stations Broadcasting in the United States, Canada, England, France and Cuba

KDKA	Westinghouse Elec. & Mfg. Co., E. Pittsburgh, Pa.	326	KFKQ	Conway Radio Laboratories.....Conway, Ark.	250	KGO	General Electric Co.....Oakland, Calif.	312
KDPM	Westinghouse Elec. & Mfg. Co., Cleveland, O.	270	KFKV	F. F. Gray.....Butte, Mont.	283	KGU	Marion A. Mulrony.....Honolulu, Hawaii	360
KDPT	Southern Electrical Co.....San Diego, Calif.	244	KFKX	Westinghouse Elec. & Mfg. Co., Hastings, Nebr.	341	KGW	Portland Morning Oregonian.....Portland, Ore.	492
KDYL	Newhouse Hotel.....Salt Lake City, Utah	360	KFKZ	Nassour Bros. Radio Co., Colorado Springs, Colo.	234	KGY	St. Martins College.....Lacey, Wash.	258
KDYM	Savoy Theater.....San Diego, Calif.	285	KFLA	Abner R. Willson.....Butte, Mont.	283	KHJ	Times-Mirror Co.....Los Angeles, Calif.	395
KDYQ	Oregon Institute of Technology.....Portland, Ore.	366	KFLB	Signal Electric Mfg. Co.....Menominee Mich.	248	KHQ	Louis Wasmer (Excelsior Motorcycle & Bicycle Co.), Seattle, Wash.	360
KDZB	Frank L. Elfert.....Bakersfield, Calif.	240	KFLD	Paul E. Greenlaw.....Franklinton, La.	234	KJQ	C. O. Gould.....Stockton, Calif.	273
KDZE	Rhodes Department Store.....Seattle, Wash.	270	KFLE	National Educational Service.....Denver, Colo.	268	KJR	Berkeley Radio Service Co.....Seattle, Wash.	283
KDZR	Bellingham Publishing Co.....Bellingham, Wash.	261	KFLQ	Blizzell Radio Shop.....Little Rock, Ark.	261	KJS	Bible Inst. of Los Angeles, Los Angeles, Calif.	360
KFAD	McArthur Bros. Mercantile Co., Phoenix, Ariz.	360	KFLU	Rio Grande Radio Supply House, San Benito, Tex.	236	KLS	Warner Brothers Radio Supplies Co., Oakland, Calif.	360
KFAE	State College of Washington.....Pullman, Wash.	330	KFLV	Swedish Evangelical Mission Church, Rockford, Ill.	229	KLX	Tribune Publishing Co.....Oakland, Calif.	509
KFAF	Western Radio Corp.....Denver, Colo.	278	KFLX	George H. Clough.....Galveston, Tex.	240	KLZ	Reynolds Radio Co.....Denver, Colo.	283
KFAJ	University of Colorado.....Boulder, Colo.	261	KFLZ	Atlantic Automobile Co.....Atlantic, Iowa	273	KMJ	San Joaquin Light & Power Corp., Fresno, Calif.	248
KFAR	Studio Lighting Service Co.....Hollywood, Calif.	280	KFMB	Christian Churches of Little Rock, Little Rock, Ark.	254	KMO	Love Electric Co.....Tacoma, Wash.	360
KFAW	The Radio Den.....Santa Ana, Calif.	280	KFMQ	University of Arkansas.....Fayetteville, Ark.	263	KNT	Walter Hemrich.....Kukak Bay, Alaska	263
KFAY	Virgin's Radio Service.....Medford, Ore.	283	KFMR	Morningside College.....Spartanburg, S. C.	261	KNX	Electric Lighting Supply Co., Los Angeles, Calif.	360
KFBB	F. A. Buttrey & Co.....Havre, Mont.	360	KFMT	George W. Young.....Minneapolis, Minn.	231	KOB	New Mexico College of Agriculture and Mechanic Arts, State College, N. Mex.	360
KFBC	W. K. Azbill.....San Diego, Calif.	278	KFMW	M. G. Sateren.....Houghton, Mich.	266	KOP	Detroit Police Department.....Detroit, Mich.	286
KFBE	Reuben H. Horn.....San Luis Obispo, Calif.	242	KFMX	Carleton College.....Northfield, Minn.	283	KPO	Hale Bros.....San Francisco, Calif.	423
KFBG	First Presbyterian Church.....Tacoma, Wash.	360	KFNF	Henry Field Seed Co.....Shenandoah, Iowa	266	KQP	Apple City Radio Club.....Hood River, Ore.	360
KFBK	Kimball-Upson Co.....Sacramento, Calif.	283	KFNG	Wooten's Radio Shop.....Coldwater, Miss.	254	KQV	Doubleday-Hill Electric Co.....Pittsburgh, Pa.	270
KFBL	Leese Bros.....Everett, Wash.	224	KFNJ	Warrensburg Electric Shop.....Warrensburg, Mo.	234	KQW	Charles D. Herrold.....San Jose, Calif.	360
KFBS	Trinidad Gas & Electric Supply Co. and The Chronicle News, Trinidad, Colo.	280	KFNL	Radio Broadcast Assn.....Paso Robles, Calif.	240	KRE	Berkeley Daily Gazette.....Berkeley, Calif.	275
KFBU	The Cathedral.....Laramie, Wyo.	283	KFNV	L. A. Drake.....Santa Rosa, Calif.	234	KSD	Post Dispatch.....St. Louis, Mo.	546
KFCB	Nelson Radio Supply Co.....Phoenix, Ariz.	238	KFNY	Montana Phonograph Co.....Helena, Mont.	261	KTW	First Presbyterian Church.....Seattle, Wash.	360
KFCF	Frank A. Moore.....Walla Walla, Wash.	360	KFNZ	Royal Radio Co.....Burlingame, Calif.	231	KUO	Examiner Printing Co.....San Francisco, Calif.	360
KFCP	Ralph W. Flygare.....Ogden, Utah	360	KFOA	Rhodes Co.....Seattle, Wash.	455	KUY	Coast Radio Co.....El Monte, Calif.	256
KFCV	Fred Mahaffey, Jr.....Houston, Tex.	360	KFOC	First Christian Church.....Whittier, Calif.	236	KWG	Portable Wireless Telephone Co.....Stockton, Calif.	360
KFCZ	Omaha Central High School.....Omaha, Nebr.	258	KFOD	The Radio Shop.....Wallace, Idaho	224	KWH	Los Angeles Examiner.....Los Angeles, Calif.	360
KFDD	St. Michaels Cathedral.....Boise, Idaho	252	KFOF	Bohrer Elec. Co.....Marshfield, Ore.	360	KYQ	The Electric Shop.....Honolulu, Hawaii	270
KFDH	University of Arizona.....Tucson, Ariz.	268	KFOJ	Moberly High School Radio Club, Moberly, Mo.	246	KYW	Westinghouse Elec. & Mfg. Co.....Chicago, Ill.	526
KFDJ	Oregon Agricultural College.....Corvallis, Ore.	360	KFOL	Leslie M. Scharfuch.....Marengo, Iowa	234	KZM	Preston D. Allen.....Oakland, Calif.	360
KFDL	Knight Campbell Music Co.....Denver, Colo.	360	KFCN	Echophone Radio Shop.....Long Beach, Calif.	234	WAAB	Valdemar Jensen.....New Orleans, La.	253
KFDX	First Baptist Church.....Shreveport, La.	360	KFOO	Letter Day Saints University, Salt Lake City, Utah	261	WAAC	Tulane University.....New Orleans, La.	360
KFDY	South Dakota State College of Agriculture, Brookings, S. D.	273	KFOQ	Ora W. Chancellor.....Galveston, Tex.	240	WAAD	Ohio Mechanics Institute.....Cincinnati, O.	350
KFDZ	Harry O. Iverson.....Minneapolis, Minn.	231	KFOR	David City Tire & Elec. Co., David City, Nebr.	226	WAAF	Chicago Daily Drivers Journal.....Chicago, Ill.	226
KFEC	Meler & Frank Co.....Portland, Ore.	248	KFOT	College Hill Radio Club.....Wichita, Kans.	231	WAAM	I. R. Nelson Co.....Newark, N. J.	253
KFEL	Winner Radio Corp.....Denver, Colo.	254	KFOU	Hommel Mfg. Co.....Richmond, Calif.	254	WAAN	University of Missouri.....Columbia, Mo.	251
KFEQ	Scroggin & Co. Bank.....Oak, Nebr.	268	KFOX	Technical High School.....Omaha, Nebr.	248	WAAP	Omaha Grain Exchange.....Omaha, Nebr.	286
KFER	Auto Electric Service Co.....Fort Dodge, Iowa	231	KFOY	Beacon Radio Service.....St. Paul, Minn.	226	WABB	Harrisburg Sporting Goods Co., Harrisburg, Pa.	266
KFEK	Augsburg Seminary.....Minneapolis, Minn.	261	KFOZ	Leon Hudson Real Estate Co., Fort Smith, Ark.	233	WABD	Parker High School.....Dayton, Ohio	283
KFEY	Bunker Hill & Sullivan Mining & Concentrating Co., Kelso, Idaho	360	KFPB	Edwin J. Brown.....Seattle, Wash.	224	WABE	Young Men's Christian Assn., Washington, D. C.	283
KFFB	Jenkins Furniture Co.....Boise, Idaho	240	KFPG	Garretson & Dennis.....Los Angeles, Calif.	238	WABH	Lake Shore Tire Co.....Sandusky, Ohio	240
KFFE	Eastern Oregon Radio Co.....Pendleton, Ore.	360	KFPH	Harold C. Mailander.....Salt Lake City, Utah	242	WABI	Bangor Railway & Electric Co., Bangor, Me.	240
KFFP	First Baptist Church.....Moberly, Mo.	266	KFPL	C. C. Baxter.....Dublin, Tex.	242	WABL	Connecticut Agricultural College.....Storrs, Conn.	283
KFFR	Nevada State Journal.....Sparks, Nev.	226	KFPM	New Furniture Co.....Greenville, Tex.	242	WABM	F. E. Doherty Automotive & Radio Equipment Co., Saginaw, Mich.	254
KFFV	Graceland College.....Lamon, Iowa	280	KFPN	Missouri National Guard, 70th Infantry Brigade, Jefferson City, Mo.	242	WABO	Lake Avenue Baptist Church.....Rochester, N. Y.	283
KFFY	Pineus & Murphy.....Alexandria, La.	275	KFPO	Colorado National Guard, 45th Divisional Tank Co., Denver, Colo.	231	WABP	Robert F. Weing.....Dover, Ohio	226
KFGC	Louisiana State University.....Baton Rouge, La.	254	KFPP	G. & G. Radio & Electric Shop, Olympia, Wash.	236	WABQ	Haverford College Radio Club.....Haverford, Pa.	251
KFGD	Chickasha Radio & Electric Co., Chickasha, Okla.	248	KFPR	Los Angeles County Forestry Department, Los Angeles, Calif.	231	WABR	Scott High School.....Toledo, Ohio	270
KFGH	Leland Stanford Junior University, Stanford University, Calif.	273	KFPT	Cope & Johnson.....Salt Lake City, Utah	268	WABU	Victor Talking Machine Co.....Camden, N. J.	226
KFGL	Snell & Irby.....Arlington, Ore.	234	KFPU	Heintz & Kohlmoos.....San Francisco, Calif.	236	WABV	College of Wooster.....Wooster, Ohio	231
KFGQ	Crary Hardware Co.....Boone, Iowa	226	KFPV	St. Johns Church.....Carterville, Mo.	268	WABX	Henry B. Joy.....Mount Clemens, Mich.	270
KFGK	First Presbyterian Church.....Orange, Tex.	250	KFPW	First Presbyterian Church.....Pine Bluff, Ark.	242	WABY	John Magaldi, Jr.....Philadelphia, Pa.	212
KFGZ	Emmanuel Missionary College, Berrien Springs, Mich.	286	KFPX	Symons Investment Co.....Spokane, Wash.	283	WABZ	Coliseum Place Baptist Church, New Orleans, La.	253
KFHA	Western State College of Colo., Gunnison, Colo.	252	KFPY	The Principia.....St. Louis, Mo.	261	WBAA	Purdue University.....West Lafayette, Ind.	283
KFHD	Utz Electric Shop Co.....St. Joseph, Mo.	226	KFQA	Searchlight Publishing Co.....Fort Worth, Tex.	254	WBAB	The Dayton Co.....Minneapolis, Minn.	47
KFHH	Ambrose A. McCue.....Neah Bay, Wis.	261	KFQB	Kidd Brothers Radio Shop.....Taft, Calif.	227	WBAN	Wireless Phone Corporation.....Paterson, N. J.	214
KFHJ	Fallon & Co.....Santa Barbara, Calif.	360	KFQC	Chorin Supply Co.....Anchorage, Alaska	280	WBAO	James Millikin University.....Decatur, Ill.	275
KFHR	Star Electric & Radio Co.....Seattle, Wash.	283	KFQD	Dickenson-Henry Radio Laboratories, Colorado Springs, Colo.	224	WBAP	Wortham-Carter Publishing Co. (Star-Telegram), Fort Worth, Tex.	476
KFI	Earle C. Anthony (Inc.).....Los Angeles, Calif.	469	KFQE	Donald A. Boulton.....Minneapolis, Minn.	224	WBAV	Ermer & Hopkins Co.....Columbus, Ohio	423
KFIF	Benson Polytechnic Institute.....Portland, Ore.	360	KFQF	Southern California Radio Assn., Los Angeles, Calif.	226	WBAX	John H. Sterger, Jr.....Wilkes-Barre, Pa.	360
KFIO	North Central High School.....Spokane, Wash.	252	KFQG	Radio Service Co.....Burlingame, Calif.	369	WBAY	Western Electric Co.....New York, N. Y.	492
KFIQ	First Methodist Church.....Yakima, Wash.	242	KFQH	Thomas H. Ince Corp.....Culver City, Calif.	234	WBBD	Barbey Battery Service.....Reading, Pa.	234
KFIU	Alaska Elec. Light & Power Co., Juneau, Alaska	226	KFQI	Harbour-Longmire Co.....Oklahoma, Okla.	236	WBBD	Irving Vermilya.....Mattapoisett, Mass.	248
KFIX	Reorganized Church of Jesus Christ of Latter Day Saints, Independence, Mo.	240	KFQJ	Democrat Leader.....Fayette, Mo.	236	WBBD	J. Irving Bell.....Port Huron, Mich.	216
KFIZ	Daily Commonwealth and Oscar A. Huelman, Fond du Lac, Wis.	273	KFQK	Oklahoma Free State Fair Assn., Muskogee, Okla.	252	WBBL	Grace Covenant Church.....Richmond, Va.	283
KFJB	Marshall Electric Co.....Marshalltown, Iowa	248	KFQL	Texas Highway Bulletin.....Austin, Tex.	268	WBBL	Frank Atlas Produce Co.....Lincoln, Ill.	226
KFJC	Seattle Post Intelligencer.....Seattle, Wash.	270	KFQM	Third Baptist Church.....Portland, Ore.	283	WBBL	A. B. Blake.....Wilmington, N. C.	275
KFJD	National Radio Mfg. Co.....Oklahoma, Okla.	252	KFQN	Meler Radio Shop.....Russell, Kans.	261	WBBL	Petoskey High School.....Petoskey, Mich.	246
KFJI	Liberty Theater.....Astoria, Ore.	252	KFQO	George S. Carson, Jr.....Iowa City, Iowa	224	WBBL	Peoples Pulpit Association.....Rosalie, N. Y.	273
KFJK	Delano Radio & Electric Co.....Bristow, Okla.	233	KFQP	Walter L. Ellis.....Oklahoma, Okla.	250	WBBL	Lloyd Brothers.....Philadelphia, Pa.	234
KFJL	Hardsag Mfg. Co.....Ottumwa, Iowa	242	KFQS	Dickenson-Henry Radio Laboratories, Manitou, Colo.	246	WBBL	Jenks Motor Sales Co.....Monmouth, Ill.	224
KFJM	University of North Dakota, Grand Forks, N. D.	280	KFQT	Texas National Guard, 36th Signal Company, Denison, Tex.	252	WBBL	Johnstown Radio Co.....Johnstown, Pa.	248
KFJQ	Electric Construction Co., Valley Radio Division, Grand Forks, N. D.	280	KFQU	Taft Radio Co.....Hollywood, Calif.	369	WBBL	Rufner Junior High School.....Norfolk, Va.	222
KFJR	Ashley C. Dixon & Son.....Stevensville, Mont.	258	KFQV	Radheart Studio.....San Francisco, Calif.	280	WBBL	Washington Light Infantry.....Charleston, S. C.	288
KFJX	Iowa State Teachers' College, Cedar Falls, Iowa	280	KFQW	Echo Park Evangelistic Assn., Los Angeles, Calif.	278	WBBL	Noble B. Watson.....Indianapolis, Ind.	227
KFJY	Tunwall Radio Co.....Fort Dodge, Iowa	246	KFQX	Van Blaricom Co.....Helena, Mont.	360	WBBL	T & H Radio Co.....Anthony, Kans.	254
KFJZ	Texas National Guard, 112th Cavalry, Fort Worth, Tex.	254	KFQY	Tacoma Daily Ledger.....Tacoma, Wash.	252	WBBL	D. W. May, Inc.....Newark, N. J.	360
KFKA	Colorado State Teachers College, Greeley, Colo.	273	KFQA	Hallock & Watson Radio Service, Portland, Ore.	360	WBBL	Southern Radio Corporation.....Charlotte, N. C.	360
KFKB	Brinkley-Jones Hospital Assn.....Milford, Kans.	286	KFQB			WBBL	Westinghouse Elec. & Mfg. Co., Springfield, Mass.	337
			KFQC			WBBL	St. Lawrence University.....Canton, N. Y.	280
			KFQD			WBBL	Kaufmann & Baer Co.....Pittsburgh, Pa.	462
			KFQE			WBBL	Clyde R. Randall.....New Orleans, La.	268

WCAH Entekin Electric Co. Columbus, Ohio 286
WCAJ Menasha Wesleyan University, University Place, Nebr. 283
WCAK Alfred P. Daniel. Houston, Tex. 263
WCAL St. Olaf College. Northfield, Minn. 366
WCAO Sanders & Stayman Co. Baltimore, Md. 360
WCAP Chesapeake & Potomac Telephone Co. Washington, D. C. 469
WCAR Southern Radio Corporation of Texas, San Antonio, Tex. 360
WCAS William Hood Dunwoody Industrial Institute, Minneapolis, Minn. 280
WCAT South Dakota State School of Mines, Rapid City, S. Dak. 243
WCAU Durham & Co. Philadelphia, Pa. 276
WCAV J. C. Dice Electric Co. Little Rock, Ark. 563
WCAX University of Vermont. Burlington, Vt. 360
WCAY Milwaukee Civic Broadcasting Station, Milwaukee Wis. 266
WCAZ Carthage College. Carthage, Ill. 246
WCB A Charles W. Helmbach. Allentown, Pa. 280
WCB B University of Michigan. Ann Arbor, Mich. 280
WCB D Wilbur G. Voliva. Zion, Ill. 345
WCB E Uhart Radio Co. New Orleans, La. 263
WCB F Paul J. Miller. Pittsburgh, Pa. 236
WCB G Howard S. Williams. Passaic, N. J. 268
WCB H University of Mississippi. Oxford, Miss. 240
WCB I Nicoll, Duncan & Rush. Bemis, Tenn. 244
WCB J C. S. Mans. Jennings, La. 244
WCB K E. Richard Hall. St. Petersburg, Fla. 286
WCB L Northern Radio Mfg. Co. Houston, Me. 280
WCB M Charles Schwarz. Baltimore, Md. 229
WCB N James P. Boland, Lieut. U. S. A., Fort Benjamin Harrison, Ind. 266
WCB O Radio Shop, Inc. Memphis, Tenn. 250
WCB P First Baptist Church. Nashville, Tenn. 236
WCB R Charles H. Meester. Providence, R. I. 246
WCB T Clark University. Worcester, Mass. 238
WCB U Arnold Wireless Supply Co. Arnold, Pa. 254
WCB V Tullahoma Radio Club. Tullahoma, Tenn. 252
WCB W George P. Rankin, Jr., and Mittland Solomon, Macon, Ga. 226
WCB X Radio Shop of Newark. Newark, N. J. 233
WCB Y Focks Electrical Shop. Duck Hill Falls, Pa. 268
WCB Z Coppotelli Bros. Music House, Chicago Heights, Ill. 248
WCK Six-Baer & Fuller Dry Goods Co., St. Louis, Mo. 360
WCX Detroit Free Press. Detroit, Mich. 517
WDAE Tampa Daily Times. Tampa, Fla. 360
WDAF Kansas City Star. Kansas City, Mo. 411
WDAG J. Laurance Martin. Amarillo, Tex. 263
WDAH Trinity Methodist Church (South), El Paso, Tex. 268
WDA S Lit Brothers. Philadelphia, Pa. 395
WDA R Sam Waite's Radio Shop. Worcester, Mass. 360
WDA U Slocum & Kilburn. New Bedford, Mass. 360
WDAY Radio Equipment Corporation, Fargo, N. Dak. 244
WDBB A. H. Waite & Co. Taunton, Mass. 229
WDB C Kirk, Johnson & Co. Lancaster, Pa. 268
WDB D Herman P. Burns. Youngstown, W. Va. 246
WDB F Robert G. Phillips. Youngstown, W. Va. 246
WDB H C. T. Sherer Co. Worcester, Mass. 268
WDB I Radio Specialty Co. St. Petersburg, Fla. 229
WDB J Richardson-Wayland Elec. Corp., Roanoke, Va. 229
WDB K M. F. Broz Furniture, Hardware & Radio Co., Cleveland, Ohio. 248
WDB N Maine Electric Light & Power Co., Bangor, Me. 252
WDB O Rollins College. Winter Park, Fla. 240
WDB P Superior State Normal School. Superior, Wis. 261
WDB Q Morton Radio Supply Co. Salem, N. J. 234
WDB R Tremont Temple Baptist Church. Boston, Mass. 256
WDB S S. M. K. Radio Corp. Dayton, Ohio 233
WDB T Taylor's Book Store. Hattiesburg, Miss. 236
WDB U Somerset Radio Co. Skowhegan, Me. 258
WDB V Strand Theater. Fort Wayne, Ind. 258
WDB W The Radio Den. Columbia, Tenn. 268
WDB X Otto Baur. New York, N. Y. 233
WDB Y North Shore Congregational Church. Chicago, Ill. 258
WDB Z Boy Scouts of America (Ulster County Council), Kingston, N. Y. 233
WDM Church of the Covenant. Washington, D. C. 234
WDX James L. Bush. Tuscola, Ill. 278
WEAF Frank D. Fallain. Flint, Mich. 480
WEAL American Tel. & Tel. Co. New York, N. Y. 292
WEAH Wichita Board of Trade. Wichita, Kans. 280
WEAI Cornell University. Ithaca, N. Y. 286
WEAJ University of South Dakota. Vermillion, S. Dak. 283
WEAM Borough of North Plainfield, North Plainfield, N. J. 286
WEAN Shepard Co. Providence, R. I. 273
WEAO Ohio State University. Columbus, Ohio 360
WEAP Mobile Radio Co. Mobile, Ala. 360
WEAR Evening News Publishing Co. Baltimore, Md. 261
WEAU Davidson Bros. Co. Sioux City, Iowa 275
WEAY Iris Theater. Houston, Tex. 360
WEB Benwood Co. St. Louis, Mo. 273
WEBA The Electric Shop. Highland Park, N. J. 233
WEBC Walter C. Bridges. Superior, Wis. 242
WEBD Electrical Equipment & Service Co., Anderson, Ind. 246
WEBB Edgewater Beach Hotel Co. Chicago, Ill. 370
WEBK Grand Rapids Radio Co. Grand Rapids, Mich. 360
WEBP Spanish Fort Amusement Park, New Orleans, La. 280
WEY Hurlbert-Still Electrical Co. Houston, Tex. 263
WEW St. Louis University. St. Louis, Mo. 280
WFAA Dallas News and Dallas Journal. Dallas, Tex. 476
WFAB Carl F. Woese. Syracuse, N. Y. 234
WFAM Times Publishing Co. St. Cloud, Minn. 273
WFAN Hutchinson Electric Service Co., Hutchinson, Minn. 286
WFAV University of Nebraska. Lincoln, Neb. 276
WFB Galvin Radio Supply Co. Camden, N. J. 233
WFI Strawbridge & Clothier. Philadelphia, Pa. 395
WGAL Lancaster Electric Supply & Construction Co., Lancaster, Pa. 248
WGAN Cecil E. Lloyd. Pensacola, Fla. 360
WGAZ Yaurea Hotel. Shreveport, La. 252
WGB South Bend Tribune. South Bend, Ind. 275
WGI American Radio & Research Corp., Medford Hillside, Mass. 360
WGL Thomas F. J. Howlett. Philadelphia, Pa. 360
WGN Tribune. Chicago, Ill. 370
WGR Federal Tel. & Tel. Co. Buffalo, N. Y. 319
WGY General Electric Co. Schenectady, N. Y. 380

WHA University of Wisconsin. Madison, Wis. 360
WHA A State University of Iowa. Iowa City, Iowa 484
WHA D Marquette University. Milwaukee, Wis. 280
WHA H University of Cincinnati. Cincinnati, Ohio 222
WHA I Hafer Supply Co. Joplin, Mo. 283
WHA K Roberts Hardware Co. Clarksville, W. Va. 258
WHAM University of Rochester. Rochester, N. Y. 283
WHAR Seaside Hotel. Atlantic City, N. J. 273
WHAS Courier-Journal and Louisville Times, Louisville, Ky. 400
WHA V Wilmington Electrical Specialty Co., Wilmington, Del. 60
WHA Z Rensselaer Polytechnic Institute, Troy, N. Y. 360
WHB Swiney School Co. Kansas City, Mo. 243
WHK Radio Co. Cleveland, Ohio 243
WHN George Schubel. New York, N. Y. 500
WHO Bankers Life Co. Des Moines, Iowa 500
WHB Art. A. Jonsson Garage. Rockford, Ill. 202
WHC Gayveston Tribune. Gayveston, Tex. 300
WHD Howard R. Miller. Philadelphia, Pa. 294
WH E Journal-Stockholm Co. Omaha, Neb. 243
WHF Chronicle Publishing Co. Marion, Ind. 243
WHG Home Electric Co. Burlington, Iowa 204
WH H K. & L. Electric Co. McKeesport, Pa. 233
WH I Continental Electrical Supply Co., Washington, D. C. 350
WH J Gimbel Brothers. Philadelphia, Pa. 509
WH K American Electric Co. Lincoln, Neb. 249
WH L Jackson's Radio Engineering Laboratory, Waco, Tex. 360
WH M Norfolk Daily News. Norfolk, Neb. 283
WH N Clifford L. White. Greentown, Ind. 254
WH O D. M. Perham. Cedar Rapids, Iowa 268
WH P Peoria Star. Peoria, Ill. 283
WH Q The Outlet Co. Peoria, Ill. 283
WH R Putnam Radio Co. Pittsburgh, Pa. 293
WH S Union Trust Co. Cleveland, Ohio 398
WH T Chicago Radio Laboratory. Chicago, Ill. 269
WH U Denison University. Granville, Ohio 229
WH V R. C. A. New York, N. Y. 400
WH W R. C. A. New York, N. Y. 455
WH X H. F. Paar. Cedar Rapids, Iowa 278
WH Y Charles Looff (Crescent Park). East Providence, R. I. 240
WH Z W. S. Radio Supply Co. Wichita Falls, Tex. 360
WK A United Battery Service Co. Montgomery, Ala. 226
WK B Dutee W. Flint. Cranston, R. I. 360
WK C Radio Corp. of Porto Rico. San Juan, P. R. 360
WK D Michigan Agricultural College, E. Lansing, Mich. 280
WK E Laconia Radio Club. Laconia, N. H. 261
WK F Dutee W. Flint. Cranston, R. I. 360
WK G WKY Radio Shop. Oklahoma, Okla. 366
WK H Cutting & Washington Radio Corp., Minneapolis, Minn. 417
WK I Samuel Woodworth. Syracuse, N. Y. 234
WK J Naylor Electrical Co. Tulsa, Okla. 363
WK K Arthur Y. Schilling. Kalamazoo, Mich. 283
WK L Putnam Electric Co. (Greencastle community broadcasting station), Greencastle, Ind. 231
WL B University of Minnesota. Minneapolis, Minn. 360
WL C Wisconsin Department of Markets, Stevens Point, Wis. 278
WL D Sears, Roebuck & Co. Chicago, Ill. 345
WL E Crowley Radio Corp. Cincinnati, Ohio 261
WL F Glive B. Meredith. Cazenovia, N. Y. 261
WL G Round Hills Radio Corp. Dartmouth, Mass. 360
WL H General Supply Co. Lincoln, Neb. 254
WL I Lockport Board of Commerce. Lockport, N. Y. 273
WL J Trenton Hardware Co. Trenton, N. J. 256
WL K First Baptist Church. Columbus, Ohio 438
WL L Kings Daily News. Columbus, Ohio 438
WL M Alabama Polytechnic Institute. Auburn, Ala. 256
WL N Kingshighway Presby. Church. St. Louis, Mo. 281
WL O Mercer University. Macon, Ga. 260
WL P "Commercial Appeal". Memphis, Tenn. 500
WL Q Ainsworth-Gates Radio Co. Cincinnati, Ohio 309
WL R Doubleday-Hill Electric Co. Washington, D. C. 360
WL S Sineperla stores. Boston, Mass. 278
WL T University of Oklahoma. Norman, Okla. 360
WL U Wittenberg College. Springfield, Ohio 275
WL V First Christian Church. Butler, Mo. 231
WL W Lenning Brothers. Philadelphia, Pa. 360
WL X Henry Kunzmann. Fort Monroe, Va. 360
WL Y Dakota Radio Apparatus Co. Yankton, S. Dak. 266
WL Z The Organic Co. Lima, Ohio 266
WO A Midland College. Fremont, Neb. 280
WO B Tyler Commercial College. Tyler, Tex. 360
WO C Apollo Theater. Belvidere, Ill. 273
WO D Southern Equipment Co. San Antonio, Tex. 385
WO E Ervins Electrical Co. Parsons, Kans. 256
WO F James D. Vaughn. Lawrence, Tenn. 360
WO G Snyder Bros. Co. Mishawaka, Ind. 360
WO H Roy M. Hamp. Wilmington, Del. 360
WO I Pennsylvania National Guard, 112th Infantry, Erie, Pa. 242
WO J Woodmen of the World. Omaha, Neb. 526
WO K Franklyn J. Wolff. Trenton, N. J. 240
WO L Palmer School of Chiropractic. Davenport, Iowa 360
WO M Iowa State College. Ames, Iowa 360
WO N John Wanamaker. Philadelphia, Pa. 509
WO O Western Radio Co. Kansas City, Mo. 360
WO P L. Lamberger & Co. Newark, N. J. 405
WO Q Missouri State Marketing Bureau, Jefferson City, Mo. 411
WO R Pennsylvania State College. Pa. 283
WO S Donaldson Radio Co. Okmulgee, Okla. 360
WO T Doolittle Radio Corp. New Haven, Conn. 268
WO U North Dakota Agricultural College, Agricultural College, N. Dak. 283
WO V Avery & Loeb Electric Co. Columbus, Ohio 286
WO W Auernbach & Guetel. Topeka, Kans. 275
WO X Ward Battery & Radio Co. Beloit, Kans. 236
WO Y Concordia College. Moorhead, Minn. 286
WO Z John R. Koch (Dr.). Charleston, W. Va. 273
WQA A Horace A. Beale, Jr. Parkersburg, Pa. 360
WQA B Gish Radio Service. Amarillo, Tex. 234
WQA C Moore Radio News Station. Springfield, Vt. 275
WQA D Sandusky Register. Sandusky, Ohio 240
WQA E Electrical Equipment Co. Miami, Fla. 283
WQA F Seranton Times. Seranton, Pa. 280
WQA G Calvary Baptist Church. New York, N. Y. 360
WQA H West Texas Radio Co. (Abilene Daily Reporter), Abilene, Tex. 360
WQA I Prince-Walter Co. Lowell, Mass. 266
WQA J Radio Equipment Co. Peoria, Ill. 248
WQA K National Rainbow Broadcasting Co. Chicago, Ill. 448
WQA L Tull Radio Club. Leota, Ind. 224
WQA M Northern States Power Co., St. Croix Falls, Wis. 248
WQA N Lombard College. Galesburg, Ill. 244
WQA O Black Hawk Electrical Co. Waterloo, Iowa 236
WQA P St. Louis Radio Service Co. St. Louis, Mo. 360
WQA Q Antioch College. Yellow Springs, Ohio 242
WQA R Avenue Radio Shop. Reading, Pa. 238
WQA S Electric's Garage. Gloucester, Mass. 268
WQA T Immanuel Lutheran Church. Valparaiso, Ind. 278
WQA U Radio Corp. of America. Washington, D. C. 469
WQA V Doron Bros. Electrical Co. Hamilton, Ohio 360
WQA W Union College. Schenectady, N. Y. 360
WQA X University of Illinois. Urbana, Ill. 360
WQA Y City of Dallas, Police and Fire Signal Department, Dallas, Tex. 360
WQA Z Tarrytown Radio Research Laboratory, Tarrytown, N. Y. 273

WSAB Southeast Missouri State Teachers College, Cape Girardeau, Mo. 360
WSAC Clemson Agricultural Col., Clemson College, S. C. 360
WSAD J. A. Foster Co. Providence, R. I. 261
WSAI United States Playing Card Co. Cincinnati, Ohio 309
WSAJ Grove City College. Grove City, Pa. 258
WSAR Sunday Day Adventist Church, New York, N. Y. 263
WSAU Camp Marlenfeld. Fall River, Mass. 254
WSAV Clifford W. Vick Radio Construction Co., Chesham, N. H. 229
WSAY Irving Austin (Port Chester Chamber of Commerce), Port Chester, N. Y. 233
WSAZ Chase Electric Shop. Pomeroy, Ohio 258
WSB Atlanta Journal. Atlanta, Ga. 429
WSL J. & M. Electric Co. Utica, N. Y. 273
WSOE School of Engineering of Milwaukee, Milwaukee, Wis. 246
WSY Alabama Power Co. Birmingham, Ala. 360
WTAB Fall River Daily Herald Publishing Co., Fall River, Mass. 266
WTAC Penn. Traffic Co. Johnstown, Pa. 275
WTAF Louis J. Gallo. New Orleans, La. 268
WTAJ The Radio Shop. Portland, Me. 236
WTAL Toledo Radio & Electric Co. Toledo, Ohio 252
WTAM Willard Storage Battery Co. Cleveland, Ohio 390
WTAN Northern Electric Co. Ltd., Cambridge, Ill. 242
WTAQ S. H. Van Gordon & Son. Osea, Wis. 254
WTAR Reliance Electric Co. Norfolk, Va. 280
WTAS Charles E. Erbstein. Elgin, Ill. 286
WTAT Edison Electric Illuminating Co. Boston, Mass. 244
WTAU Ruegg Battery & Electric Co. Tecumseh, Neb. 242
WTAW Agricultural & Mechanical College of Texas, College Station, Tex. 280
WTAX Williams Hardware Co. Streator, Ill. 231
WTAY Oak Leaves Broadcasting Station, Oak Park, Ill. 283
WTAZ Thomas J. McGuire. Lambertville, N. J. 283
WTG Kansas State Agricultural College, Manhattan, Kans. 273
WTL H. G. Saal Co. Chicago, Ill. 268
WWAD Wright, Inc. Philadelphia, Pa. 360
WWI Ford Motor Co. Dearborn, Mich. 273
WWJ Detroit News. Detroit, Mich. 517
WWL Loyola University. New Orleans, La. 280

Canadian Stations

CKLC Wilkinson Electric Co., Ltd. Calgary, Alta. 400
CJCD T. Eaton Co., Ltd. Toronto, Ont. 410
CFCU Jack V. Elliot, Ltd. Hamilton, Ont. 410
CFLC Chas. Guy Hunter. London, Ont. 430
CHCS The Hamilton Spectator. Hamilton, Ont. 410
CHYC Northern Electric Co. Ltd. Montreal, P. Q. 441
CFCF Marconi W. T. Co. of Can. Ltd. Montreal, P. Q. 440
CKCO Dr. G. M. Geldert. Ottawa, Ont. 400
CHNC Toronto Radio Research Society, Toronto, Ont. 350
CKCH Canadian National Railways. Ottawa, Ont. 435
CJCM J. L. Philippe Landry. Mont Joli, P. Q. 312
CHCX J. R. Booth, Jr. Ottawa, Ont. 435
CJCE Western Canada Radio Supply, Victoria, B. C. 400
CKY Manitoba Telephone System. Winnipeg, Man. 450
CKCD Vancouver Daily Province. Vancouver, B. C. 410
CFCA Star Publishing & Printing Co., Toronto, Ont. 400
CFAC The Calgary Herald. Calgary, Alta. 430
CKAK La Presse Publishing Co., Ltd., Montreal, P. Q. 430
CFCH Ahlbitz Power & Paper Co., Ltd., Iroquois Falls, Ont. 400
CJCF The News Record. Kitchener, Ont. 295
CJCG London Free Press Printing Co., Ltd., London, Ont. 430
CFRF Queen's University. Kingston, Ont. 450
CFQC Radio Specialties, Ltd. Vancouver, B. C. 450
CFCD Sparks Company. Nanaimo, B. C. 430
CJCA The Edmonton Journal, Ltd. Edmonton, Alta. 410
CFCK Radio Supply Co. Ltd. Edmonton, Alta. 410
CJCE Sprott Shaw Radio Co. Vancouver, B. C. 400
CFCL Centennial Methodist Church. Victoria, B. C. 400
CJSC The Evening Telegram. Toronto, Ont. 430
CFYC Victor Wentworth Odium. Vancouver, B. C. 400
CFXC Westminster Trust Co. New Westminster, B. C. 440
CKCK Le "Soleil" Limitee. Quebec, P. Q. 295
CFCC The Electric Shop, Ltd. Saskatoon, Sask. 400
CHBC The Albertan Publishing Co. Calgary, Alta. 410

British Stations

ZLO London. 365
5IT Birmingham. 475
5WA Cardiff. 350
6BM Bournemouth. 385
2ZY Manchester. 375
5NO Newcastle. 400
58C Glasgow. 495
58D Aberdeen. 495
6SL Sheffield (relay station). 303

French Stations

YN Lyon. 2400
FL Paris (Eiffel Tower). 7,600
ESP Paris. 450
8AJ Paris. 1,780

Cuban Stations

PWX Cuban Telephone Co. Habana 400
2DW Pedro Zayas. Habana 300
2AB Alberto S. de Bustamante. Habana 240
20K Mario Garcia Velez. Habana 360
2BY Frederic W. Horton. Habana 260
2CX Frederic K. Horton. Habana 260
2EW Westinghouse Elec. Co. Habana 220
2EW Roberto E. Ramirez. Habana 230
2HC Heraldo de Cuba. Habana 275
2BD Luis Casas. Habana 250
2KD E. Sanchez de Fuentes. Habana 350
2MN Fausto Simon. Habana 270
2MG Manuel G. Salas. Habana 150
2JP Raul Perez Falcon. Habana 200
2HS Julio Power. Habana 180
20L Oscar Collado. Habana 290
2WW Amadeo Saenz. Habana 210
3EV Leopold V. Figueroa. Colon 360
6KW Frank H. Jones. Habana 275
6KJ Frank H. Jones. Habana 275
3EV Leopoldo V. Figueroa. Colon 360
6DW Eduardo Terry. Cienfuegos 225
6BY José Gandux. Cienfuegos 300
6AZ Valentin Ulvarri. Cienfuegos 200
6EV Josefa Alvarez. Calbarien 225
7AZ Pedro Nogueras. Camaguey 350
7BY Salvador Donda. Santiago de Cuba 240
8BY Alberto Ravelo. Santiago de Cuba 250
8FU Andrés Vinnet. Santiago de Cuba 225
8DW Pedro C. Anduz. Santiago de Cuba 275
8EV Eduardo Mateos. Santiago de Cuba 180
8GT Juan F. Chibas. Santiago de Cuba 260



The radio industries banquet at the Waldorf-Astoria Hotel, New York City

Close-Ups in the Industry

CONSIDERABLE interest has centered in the recent acquisition by The Crosley Radio Corporation of the controlling interest in the De Forest Radio Corp., Ltd., of Canada. This line opens a large field to the Crosley Products as the De Forest-Crosley receiving equipment will be of the type now manufactured by the present Crosley Radio Corp. of Cincinnati, Ohio.

ONE of the finest contributions to radio merchandising in the form of a book was recently made by the Music Master Corporation of Philadelphia, manufacturers of the Music Master Loud Speaker. It deals with advice of a special benefit to the dealer concerning the advisability of carrying only reputable well advertised stock and the effect on the buyer of sustained advertising. There is a full explanation on why a good loud speaker is necessary and why poor ones are harmful to the entire radio business. Detailed figures on advertising together with reproduction in colors of the covers of the magazines to be used in advertising are given so that the dealer knows exactly what sort of backing he is receiving. A very fine book and a welcome mile post in the radio merchandising field.

THE Carter Radio Co. has moved into its new large Chicago factory at 300 Racine Ave., Chicago. There are now plants at Bristol, Conn. and Hamilton, Canada, and at Chicago endeavoring to supply the ever increasing demand for Carter Radio Products. Mr. A. J. Carter, president of the company has been endeavoring to get manufacturers to standardize on radio equipment in the same way that manufacturers of automobile parts and other equipment manufacturers have done. Some of the most welcome suggestions coming from Mr. Carter are the standardization of mounting

screws to 6-32 plug and jack dimensions, condenser ratings, and color scheme for circuit diagrams to differentiate between plate, filament and grid circuits.

THE DX Instrument Co. recently inaugurated what we believe to be the first guarantee of its kind in the field of radio merchandising. One of their products the Fil-Ko Lightning Arrestor is guaranteed to such an extent that the DX Instrument Co. agrees to pay the owner of the Fil-Ko Arrestor, \$100 or repair the set if it is damaged by lightning when used with a properly installed instrument. This sort of business makes a friend of the dealer and the retail buyer and makes for better radio.

WORD comes from the Bel-Canto Manufacturing Co., manufacturers of the well known Bel-Canto Loud Speaker, that they have moved to a new location at 872 Broadway, N. Y. C. For the last three years they have been located at 34th Street which their great increase in business has rendered inadequate for their needs. The Bel-Canto Mfg. Co. will shortly bring out one of the most unique developments in headsets that has so far been developed.

THE How and Why of 'Resistance Coupled Amplification' is the title of a new bulletin prepared by the Engineering Department of the Daven Radio Corporation, specialists in resistor manufacturing. This very complete bulletin covers the work of considerable research on the part of the engineering department of this company. It is in the form of questions and answers which include every possible uncertainty which the average home builder would encounter. It is very interesting reading and is worded simply so that it presents a valuable addition to the layman's library. Copies may be

secured by writing the Daven Radio Corporation, Newark, N. J.

THE following changes have been made in the Eisemann organization: O. S. Stanley has been placed in charge of the Middle-western territory, with headquarters at 2005 So. Michigan Avenue, Chicago, Vice P. G. Sedley, resigned. Stanley has acted as Pacific Coast representative for the past year.

Irving W. Edwards, for a number of years connected with the National Carbon Company, has assumed the duties of District Manager, with headquarters at 85 Second Street, San Francisco.

THE latest report on the First Radio World's Fair which was held in Madison Square Garden and the 69th Regiment Armory recently indicates that it was without doubt one of the most successful radio trade expositions staged in America. The patronage exceeded that of previous radio exhibitions and the amount of business transacted by the concerns participating broke some records.

Figures compiled show an attendance of 175,000 people during the week and thousands were turned away daily. On a dozen or more occasions Fire Department officials temporarily closed the doors because of the fact that both huge auditoriums were packed to the rafters.

The exhibits were installed by 180 nationally known American manufacturers and 20 of the most prominent wireless laboratories of England, France, Germany and Japan.

Managers James F. Kerr and U. J. Herrmann have already completed arrangements for their 1925 Radio World's Fair which will be held in the new Garden soon to be erected. In spite of the fact that the new building will be twice the size of the present structure, Manager Kerr reports that eighty per cent of the available exhibiting space has already been contracted for.



NEW APPLIANCES AND DEVICES



The New Paragon Line of Receivers

THE new Paragon two-tube radio receiver is capable of giving loud speaker volume from stations within a moderate radius and head phone reception over an almost unlimited range. Major dial control. Simple mahogany finished cabinet. 10½ inches long by 6¾ high by 6¼ wide.

The new Paragon three is an exceptionally sensitive three-tube set. Major dial control. Amazing loud speaker volume. Solid mahogany cabinet. 16¼ inches long by 7¼ high by 8¾ wide.



The new Paragon four is a four-tube set capable of loud speaker reception of practically unlimited range. New Paradyne circuit. Major dial control. Handsome mahogany cabinet. 20¾ inches long by 8 high by 6¾ wide.

Cutler-Hammer Tube Socket

THE Cutler-Hammer Mfg. Co., have recently put on the market a new and distinctly designed socket which provides a perfect contact for radio reception. The

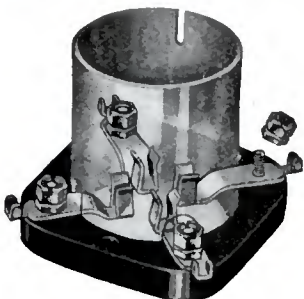

tube is simply pushed down—not twisted—into the socket, thereby preventing any chance of severing the bond between glass and base of tube. Each contact is a spring clip that clinches the tube prong without strain, and cleans it bright whenever the tube is inserted or removed. The contacts are silver plated so that their contact resistance does not increase even after years of operation.

American Brand Condenser

RADIO experimenters and set builders are appreciating the importance of a good low loss condenser which should be built so that the path of resistance set up by friction bearings is cut to a minimum.

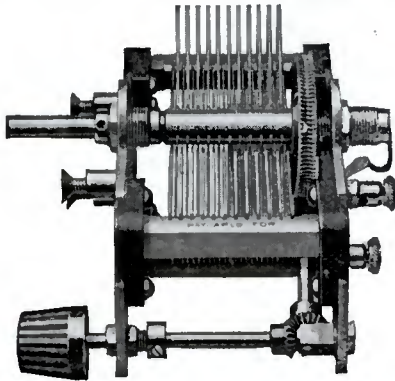

This is accomplished in the American Brand condenser by the use of a special "pig tail" which is directly connected to the rotor plates and the binding post for connecting purposes. Insulated with hard rubber and having the plates perfectly flat with their natural finish radio frequency losses are kept at a minimum. A hundred to one worm drive ratio geared vernier adjustment is a special feature of one type.

The phase angle difference of this condenser is less than 20 inches and the insulation resistance is 6 ohms at 1,000 cycles.

The Walbert Filament Lock Switch

THE Walbert Filament Lock Switch provides ordinary filament control as does any other switch. It has the added feature,

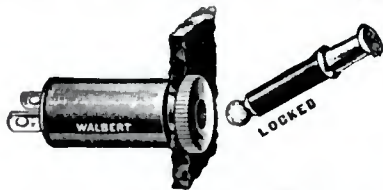

however, of permitting the operator to lock his set in such a way that no one can operate it without the key or plug of the switch.

This switch is attached in a few minutes. It is very compact and takes little room on panel or behind it. The key is smaller than a standard plug. Sturdy interior springs of phosphor bronze assure positive contact. The shell and key handle, unlike all other switches, are insulated from the circuit.

E-Z-Toon Radio Company

THE E-Z-Toon Radio Company have taken over the manufacture and sale of the Eztoon Dial, which was formerly manufactured by the Butler Mfg. Co. of Indianapolis, Ind.

Mr. Charles Sparks, formerly General Manager of the Kellogg Company, has joined the organization as General Manager.

Clear-O-Dyne Receivers

A NEW line of four and five tube sets has been designed and offered by the Clear-tone Radio Company of Cincinnati under the name Clear-O-Dyne. These sets employ tuned radio frequency amplification which is adjusted and stabilized for use on all antennas before the sets leave the factory.

The Super Clear-O-Dyne consists of two stages of tuned radio frequency amplification, a detector and two stages of audio frequency amplification. It has the selectivity that is characteristic of this construction, is capable of producing loud speaker volume

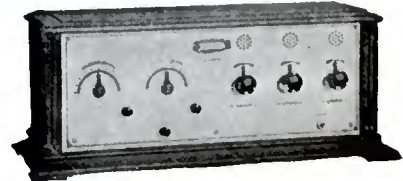

on distant stations, and is free from oscillation and distortion on all wave-lengths.

The Goldcrest Clear-O-Dyne—as the four tube set is called—consists of one stage of radio frequency amplification with detector and two stages of audio frequency amplification.

Jewett Reproducer and Loud Speaker

THE Jewett Radio and Phonograph Co. in their adaptation of their phonographs to radio found the need for a substitute for



the phonograph diaphragm. Their search for such equipment led them into the development.

(Turn to page 58)



EVEREADY RADIO BATTERIES FOR EVERY RADIO USE

Each one supremely economical and efficient for the use for which it is designed—each one made under the supervision of the world's greatest electro-chemical battery laboratory

Eveready "B" Batteries
THERE are Eveready Batteries for portable sets where small size and light weight are more important than long life. There are Eveready medium size batteries that come between the small and the standard size. There are Eveready large size "B" Batteries that afford maximum economy and reliability of service when used with average one, two, three or four tube sets. And now there is a newer Eveready heavy duty, extra large size "B" Battery that gives similar economy to owners of

multi-tube heavy drain sets and power amplifiers.

For maximum "B" Battery economy, buy Evereadys, choosing the large sizes (Nos. 766, 767, 772) for average home sets, and the heavy duty, extra large (No. 770) for multi-tube heavy drain receiving sets and power amplifiers. For portable sets choose the Eveready No. 764 medium size, unless space is very limited, in which case choose the Eveready No. 763 small size "B" Battery.

Eveready "C" Battery
Eveready makes a long-lasting

"C" Battery with terminals at 1½, 3 and 4½ volts. May also be used as an "A" Battery in portable sets.

Eveready "A" Batteries
Eveready offers you "A" Batteries for all tubes, both storage and dry cell. For storage battery tubes, use the Eveready Storage "A." For dry cell tubes, use the Eveready Dry Cell Radio "A" Battery, especially built for radio use only.

Manufactured and guaranteed by
NATIONAL CARBON CO., INC.
Headquarters for Radio Battery Information
New York San Francisco
Canadian National Carbon Co., Limited, Toronto, Ont.

BUY THEM FROM YOUR DEALER

TITLE CONTEST WINNERS

C. A. Reberger, 325 Central Ave., Newark, N. J., won the prize for the best letter on why "The Wireless Age" should retain its present name.

De Lyle Davis, 201 Cockerville Ave., Takoma Park, Ind., won the prize for the best letter on why "The Wireless Age" should change its name to "The Radio Magazine."

Of the great volume of letters, in response to the "What's In a Name?" contest, only a few were in favor of changing the name, and the consensus of opinion nearly approached a unanimous vote for "Wireless Age—The Radio Magazine."

And "Wireless Age"—The Radio Magazine, remains—the name you have known, identified for those who are less familiar with "wireless."

"B-T for Mine —for a Radio Good Time"—

Says W. Phillips of St. Louis, on Sept. 3rd, 1924, and adds:

"I am absolutely sold on the B-T Tuner and condenser. I enclose a list of stations in all parts of the country to which I listened on the evening of Labor Day. I was indeed surprised to hear KGO at this time of the year, using only one stage of audio and the head phones. Had the family not retired, I could have put them on the loud speaker."

He is one of thousands who have known B-T products for originality and excellence and used them with the satisfaction found only in Quality. Read this from Kansas City, September 11th, 1924:

"As an engineer and electrician using radio as a hobby, I have used dozens of condensers, but none equal the B-T vernier. I have just built a well known circuit and your condensers are the first with which I was able to get and hold stations while K. C. was on the air. The B-T excels anything I have ever used."

A. A. R. (615 Ewing Ave.)

He means the original B-T Tuner, designed two years before the magazines began talking "low losses." "It had the goods." It is still good—thousands will use no other.

150 m.m.f.	7 plates	\$4.25
250 m.m.f.	11 plates	4.50
520 m.m.f.	23 plates	5.00
800 m.m.f.	35 plates	6.50

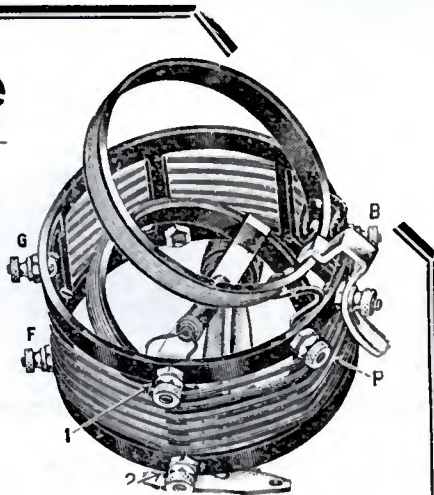
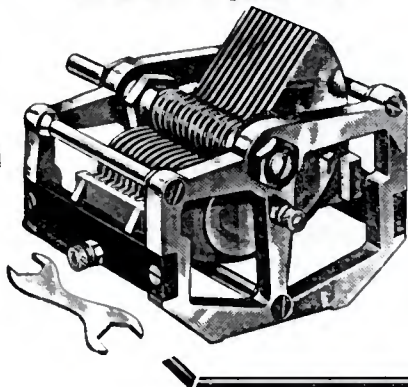

The "B-T" is the first Low Loss Short Wave Tuner. Type SW covers 50 to 150 meters with a B-T 11-plate Type L Condenser. Type B covers 200 to 565—no taps in either case and price is

\$5.00

And here's a Radio Magazine Editor:

"Tuesday evening, using a loud speaker and two stages of audio, we brought in practically every station worthwhile and at 2:10 a. m. tuned in KGO (Oakland) and held it until 3:05 with full volume. Such stations as Dallas and Springfield, Mass., came in easily without interference from the powerful Chicago stations. These stations have been brought in nightly, including KGO, showing that they were not accidents. Saturday evening, with Chicago stations on full blast, twenty-six outside stations were logged without any attempt to make a record."

He's talking about 1924 and the products pictured here.

Want to know more?

Our circulars will tell you. Ask your dealer or drop us a line.

WE BUILD GOOD PARTS FOR THOSE NOT RICH ENOUGH TO AFFORD POOR ONES.

BREMER-TULLY MFG. CO.

532 S. Canal Street

CHICAGO

Third National Radio Conference

(Continued from page 44)

relief, depending on what proportion of the present Class C stations qualify for Class B licenses. I am not advising any particular method of solution, but recommend the entire subject to your careful consideration.

POWER OF BROADCASTING STATIONS

Another question of importance is the limit of power to be used in broadcasting. Most Class B stations are now operating on 500 watts. A limitation of 1,000 watts is imposed in the license. I understand that there are several stations erected or in course of construction which contemplate the use of power up to 5,000 watts, and I am aware of the suggestions of those who would go beyond even this. There is opposition to the plan. Its advocates tell us of the great advantages in the way of louder signals and more distant transmission, while opponents complain of interference and the drowning out of other stations. The latter fear is particularly acute when the powerful station is located in a congested receiving center. From the viewpoint of nation-wide broadcasting, the question becomes as to whether we should aim to cover a large territory through a single powerful station, or through a number of interconnected smaller ones. We must not stifle progress in any direction. We must not do anything that will interfere with the programs of local stations on which many of our people depend, nor with the wide selective range which they now have. It may be that both purposes may be accomplished without loss to either. I recommend the subject for your most careful consideration.

GENERAL TENDENCIES IN DEVELOPMENT OF BROADCASTING

There seems at present some tendency towards a decrease in the total number of broadcasting stations. September 1, 1923, there were 563 licensed stations. On the same date this year,



Exact Size
Cut of the
Marshall-stat

M Marshall-stat M

Do You Want to Hear More Stations?

ADVANTAGES of the Marshall-Stat

Requires only one hole in panel. Can be inserted in hole from which old rheostat is removed.

Vernier all the way—but only one adjustment to make.

Only two terminals. Connections cannot be made incorrectly.

Can be used with any tube or combination of tubes.

Compact in size. (Note full size cut above). Takes up very little space. Can be fitted anywhere.

Working parts entirely enclosed in nickel-plated chamber.

Knob can be replaced with the knob of your set. Only one special screw (furnished at nominal extra charge) needed to make change.

Discs made of specially-treated material which is the result of years of experimental and research work by radio and electrical engineers. Are absolutely uniform throughout.

Mechanical construction and proportions of discs are such that breakage is impossible.

Getting more stations with the equipment which you have is largely a matter of adjustment on your tubes.

Then why not use the smoothest accurate-adjustment rheostat you can get—the Marshall-stat?

You will find in the Marshall-stat a means of obtaining any desired adjustment with absolute precision. The Marshall-stat varies the resistance, not step by step, but smoothly, continuously, and uninterruptedly from zero to maximum.

The Marshall-stat provides vernier precision throughout its entire range. Yet, there is only one knob to manipulate—no troublesome double adjustment to make.

It brings new stations to your receiving set and clears up for you the stations which you hear only occasionally and at those times indistinctly.

Without having to drill additional holes, any one can install Marshall-stats in his receiving set, whether it is home-made or factory made. And wherever Marshall-stats are used, the pleasure and fun of radio are enormously increased.

MARSHALL ELECTRIC COMPANY

3239 Locust Boulevard

Saint Louis, Missouri

Price \$1.75

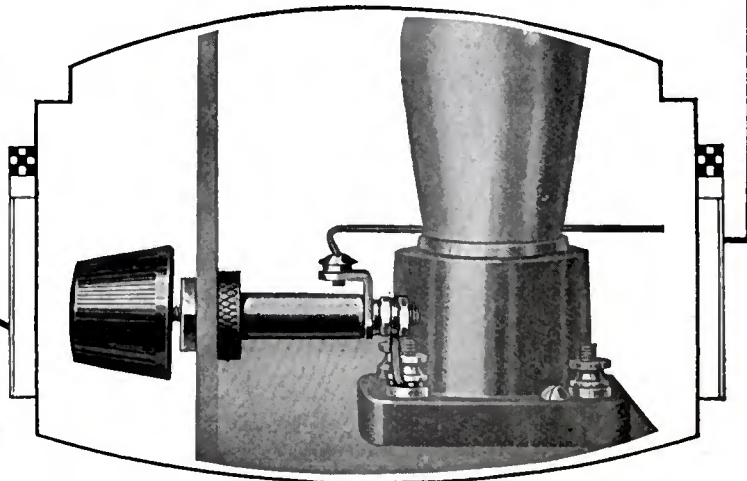

Send for Old Man Ohm's descriptive folder on the Marshall-stat.

THE IDEAL RHEOSTAT FOR ALL TUBES
"Quality Goods for Quality Readers"

the number had fallen to 533, a loss of 30. This decrease, however, has occurred entirely among the smaller stations in Classes A and C. The more important stations, those of Class B, have substantially increased, the number then having been 44 as against 56 at present, with 46 others either under construction or proposed. As to whether this shows a permanent trend toward an abandonment of the smaller stations, with a corresponding additional reliance upon the larger ones even though more distant, it is too early to determine.

It is of some interest to classify and study the ownership of the stations, to

know the probable motives that impel their owners to expend the large sums of money which are necessary for their construction and operation, and for which there is usually no direct return. So far as is known to the Department, of the present stations, 196, or over one-third, are owned and operated by manufacturers of or dealers in radio apparatus, whose interest is of course apparent. Department stores and similar mercantile concerns add 39 to this number, and publishers 41, making a grand total of 276 known stations, of which 44 are Class B, which may be said to have a direct interest in the publicity legitimately resulting from

their own broadcasting. On the other side we have 85 educational institutions, 35 churches, 12 city and state agencies, 12 clubs, of which 7 are Class B (4 schools, 2 state or city agencies, and 1 church), all of which may be said to operate from more altruistic motives.

MARINE SERVICE

Those who are engaged in the use of radio for marine services between ship and shore and ship and ship feel that the present band devoted to their use is too narrow. We must not forget that what is a convenience or a pleasure for us is a necessity for them and that life may depend on the efficiency of their communication service. There is undoubtedly congestion along our coasts particularly in the vicinity of such harbors as New York, Boston, and San Francisco. There are two fundamental troubles in the situation, and they are interdependent; first, the character of the apparatus used; and second, the fact that most ships operate on only two wave lengths, 600 and 706 meters. Practically all marine radio equipment is of the spark type. There can be no economical use of wave lengths until this condition is remedied.

The London Convention of 1912 contemplated that ship communication would be conducted either on 300 or 600 meters, an alternative of 1,800 meters being allowed under certain conditions. However advisable it may then have been to have all ships on two wave lengths, it is certainly not practicable now. We have here an example, and it is not the only one, of the folly of putting a strait-jacket on such a rapidly growing art.

CO-OPERATION OF THE DEPARTMENT

The officials of the Bureau of Navigation, which has direct charge of administrative features and full familiarity with the entire situation, are ready to give you the benefit of their information and advice.

The Bureau of Standards has prepared a report on many of the technical phases which will come before you, and its personnel and facilities are at your disposal. The Interdepartment Radio Committee has done preparatory work, and its members will, I am sure, be glad to co-operate with you in the consideration of all matters which have a governmental bearing. The Radio Supervisors from all districts of the country are in attendance, with first-hand information as to conditions, and their knowledge, based on actual experience in the field. In short, the Department of Commerce is at your command. I believe that your membership includes every angle of radio interest. I look forward to your conclusions as a great step in the development and progress of the industry.



This Certificate Opens the Way to the Best Radio Positions

Get It - And Earn Up To \$10,000 a Year

No previous experience in electricity or Radio is necessary. In a few months of pleasant study, right at home in spare time, you can easily get this certificate and qualify for one of the splendid, big money making positions in Radio.

John P. Zinno, who was a buck private when he enrolled, now, with his certificate, is earning over \$3500 a year in his own Radio shop. L. A. Godby has increased his pay \$1800 a year since he received his certificate. L. G. Biles

PAY INCREASES OVER \$100 A MONTH

I am averaging anywhere from \$75 to \$150 a month more than I was making before enrolling with you. I would not consider \$10,000 too much for the course.

(Signed) A. N. LONG,
121 No. Main St.,
Greensburg, Pa

DOUBLES SALARY

I can very easily make double the amount of money now than before I enrolled with you. Your course has benefited me approximately \$3000 over and above what I would have earned had I not taken it.

T. WINDER,
731 Belford Ave.,
Grand Junction, Colo.

holds a splendid position as Asst. Radio Editor of the Philadelphia Public Ledger. Emmett Welch is making over \$400 a month as a radio salesman. Hundreds of other men are occupying equally attractive positions after getting our Certified Radio-trician certificate.

Easy Now to Become a Certified Radio-trician

No other work in the world today offers such big money, such rapid advancement, such a promising future as does Radio. And the Certified Radio-trician is the man who is in a position to choose the best of these opportunities in this newest and fastest growing industry because he is recognized as an expert.

Become an Expert Radio-trician. You can easily and quickly. The National Radio Institute, one of America's first and largest Radio Schools, established in 1914, has devised a remarkable method that makes it easy for anyone to qualify right at home during spare time. Prominent radio experts give you personal advice and instruction through the mail. They grade your papers, answer your questions, and in every possible way help you in your work. And you learn the practical, wonderful side of radio by actual practice on patented instruments we send you free. The Certified Radio-trician Certificate awarded you on the completion of

your course is government recognized, counting for 5 to 10 points on all government license examinations.

Instruments Free to Students

An extraordinary feature of this course is the use of receiving set parts, which give practical training in radio operation, installation, maintenance and repair—all of which you must have to become a certified Radio-trician. All of these instruments are given free to students.

Send for FREE BOOK

Thousands of positions are open to Certified Radio-tricians. Our course is absolutely complete and qualifies you for a government first class commercial license. It gets you the bigger paying jobs in Radio. Find out what your opportunities are in this fascinating profession. Send for interesting book which gives complete details on plan by which the National Radio Institute quickly qualifies you at home in spare time as a Certified Radio-trician. Send the coupon or a postcard for free book NOW. For a short time we are offering a reduced rate to those who enroll at once. Act promptly and save money. NATIONAL RADIO INSTITUTE, Dept. 46LA, Washington, D. C.



NATIONAL RADIO INSTITUTE,
Dept. 46LA, Washington, D. C.

Send me your book, "Rich Rewards in Radio," with full particulars about the opportunities in radio, and how you will quickly train me in my spare time at home to get a Certified Radio-trician Certificate. Also about your employment service and special tuition offer.

Name..... Age.....
Street.....
City..... State.....

"Quality Goods for Quality Readers"

practical, wonderful side of radio by actual practice on patented instruments we send you free. The Certified Radio-trician Certificate awarded you on the completion of

Another step ahead!

ULTRADYNE

MODEL L-2

'Modulation System'

Plus Regeneration



Send for 32-page illustrated book giving latest authentic information on drilling, wiring, assembling and tuning the Model L-2 Ultradyne Receiver.

50c

THE new Ultradyne, Model L-2 surpasses all conceptions of sensitivity and selectivity—represents the peak of Super-Radio engineering skill.

To the "Modulation System" which has previously made the Ultradyne famous, regeneration is added in Model L-2. The result is ultra-sensitivity, never before thought possible. The regeneration of infinitely weak signals produces tremendous amplification.

Selectivity is so high and amplification so strong that distant stations can be tuned in through local stations and put on the loud speaker.

This use of regeneration is the latest development of R. E. Lacault, A.M.I.R.E., Consulting Engineer of this Company, and formerly Radio Research Engineer with the French Signal Corps Laboratories, since his perfection of the "Modulation System" which is used exclusively in the Ultradyne Receiver.

The Model L-2 Ultradyne compels so complete a revolution in all previous ideas of Super performance, that you can only comprehend its unusual selectivity, sensitivity, volume and range by operating this wonderful receiver.

Write for descriptive circular.

PHENIX RADIO CORP., 3-5 Beekman St., New York

Ultradyne Kit



Consists of one low loss Tuning Coll, one low loss Oscillator Coll, one special low loss Coupler, one type "A" Ultraformer, three type "B" Ultraformers, four matched fixed Condensers.

The Ultraformers are new improved long wave radio-frequency transformers, especially designed by R. E. Lacault, Consulting Engineer of this Company and inventor of the Ultradyne.

To protect the public, Mr. Lacault's personal monogram seal (R.E.L.) is placed on all genuine Ultraformers.

Ultraformers are guaranteed so long as this seal remains unbroken.

\$30

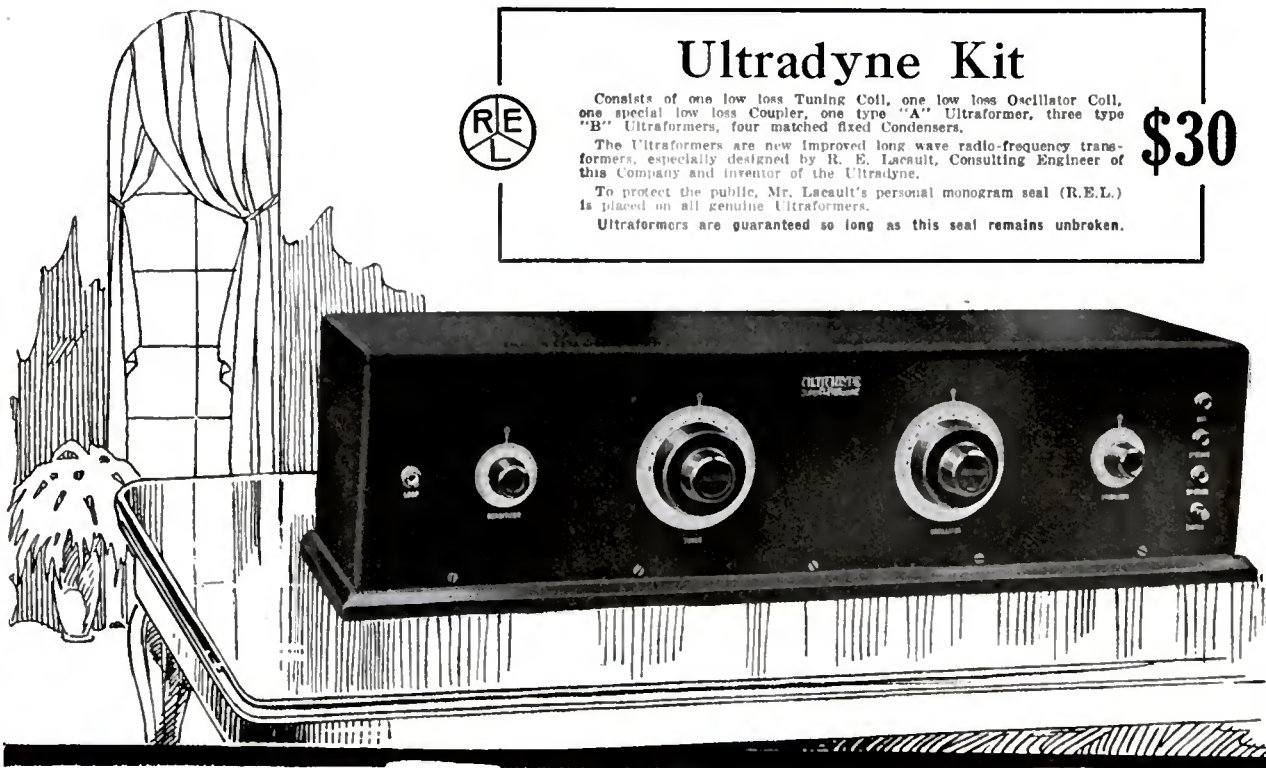

"Quality Goods for Quality Readers"



Improve



your set with
an AmerTran



Send for Circular giving helpful transformer information.

Price, either type, \$7, at your dealer's.

Made in two types:

AmerTran AF-6 (turn ratio 5) for use in the first stage.

AmerTran AF-7 (Turn ratio 3 1/2) the companion transformer for use in further stages of amplification where AF-6 is used in the first stage.

American Transformer Company, 179 Emmet St., Newark, N. J.
Designers and builders of radio transformers for over 23 years



The Oil-Sealed Storage Cell \$2.50

For all tubes. Always perfectly clean and dry. No acid seepage; no fumes. If you are interested in the care of a storage battery you should read our free booklet:

"THE LEAD STORAGE BATTERY"

Write for it.

THE VALLEY FORGE CHEMICAL CO., Valley Forge, Pa.

LATEST WHOLESALE
RADIO CATALOG

FREE Simply send name TODAY for big 48-page catalog of latest radio goods at Wholesale. Live dealers and agents wanted.

STANDARD RADIO CO., 110 East 13th, Kansas City, Mo.

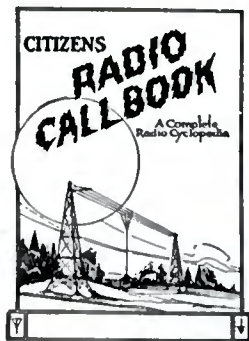

JUST
OUT!

A
COMPLETE

RADIO-CYCLOPEDIA

CONTAINS

fresh lists of all telephone broadcasting stations in the world, all standard hookups with a complete description of each, how to build thirty and fifty kilocycle Super-Heterodyne, Greene Concert Selector and Low Loss Tuner, complete article on receiver troubles and how to remedy them, maps, log sheets, distance chart and a world of information well worth \$5.00 of any radio fan's money.

ONLY FIFTY CENTS

When ordering direct, include fifteen cents for parcel postage. Dealers, write for our guaranteed plan of sale.

Citizens Radio Service Bureau
500 So. Dearborn St. Chicago, Ill.

Appliances and Devices

(Continued from page 52)

opment of the Vemco receiving unit—a phonograph adaptor of unusual qualities. The Vemco unit is sensitive, yet is able to withstand considerable energy without distortion. The adjustable feature regulates the volume of reproduction, enabling distant stations to be accentuated to the limit of the radio set.

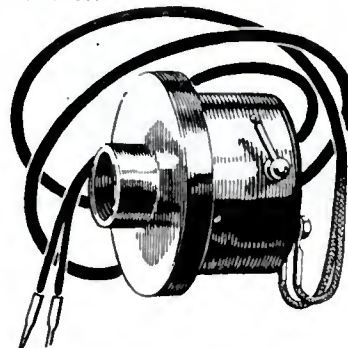

The Jewett Superspeaker retains at all times the full limit of reproduction. Harmonic vibrations have long been the nemesis of the musical instrument builder. Unless design has been carefully worked out, the instrument will, when certain notes are struck, develop a vibratory resonance of a most annoying character. By eradicating this nemesis, the Jewett people were able to develop volume to its logical limit. To acquire this result requires a definite minimum of size. The Superspeaker is therefore considerably larger than most devices of its kind. An adjustment in the base permits control of sound volume.

The Manhattan Junior Loud Speaker

THE Manhattan Junior is the outgrowth of a popular demand for a loud speaker at an inexpensive price. It reproduces with excellent musical quality, and has a unit especially and correctly designed to operate the long air column of the horn without batteries.



By means of the "Concert Modulator," the instrument can be satisfactorily accommodated to set, tubes and the strength of "B" battery current, so that the best results can always be obtained.

The Physical Nature of Speech

(Continued from page 41)

unit high, then the heights of the other vertical lines show how intense the overtones are compared to the fundamental or lowest tones. These vertical lines, then, give us a graphical picture or spectrum of how the sound energy in these particular speech sounds are distributed throughout the various frequencies. Note that the first two

At Last! Radio That Satisfies The Music Critic

THE DAILY NEWS, SATURDAY
Easton, Martinelli, Danise,
Strong Trio in "La Tosca"
BY MAURICE ROSENFELD.
High standards were maintained by the artists at Havana last night in their first performance of Puccini's "La Tosca" at the Metropolitan Opera House. The mechanism and the music from the stage were reproduced to the very best of the first-class Rauland-Lyric Transformer.

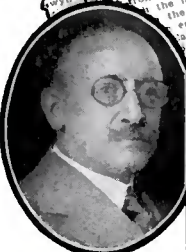

THE CHICAGO DAILY NEWS
EDITORIAL ROOMS
August 6, 1924.

E. K. Rauland, Pres.
Rauland Manufacturing Co.,
2650 Coyne Street., Chicago, Ill.

My dear Mr. Rauland:

I want to express my great pleasure in witnessing the recent test of amplifying transformers in your laboratory, and in selecting, from different instruments tested, the one which seemed to me to reproduce most exactly the artist's original tones. I was indeed gratified to learn, after the tests, that the instrument which I had repeatedly selected as by far the most successful in reproducing, not alone the music, but even the very personality of the artist, was none other than your own new "Rauland-Lyric" Transformer.

I feel confident that music lovers everywhere will appreciate the contribution you have made to their enjoyment in the creation of this reproducing instrument.

Very truly yours,
Maurice Rosenfeld
Music Critic,
Chicago Daily News



Price, \$9.00

In placing his mark of approval upon Rauland-Lyric, Mr. Maurice Rosenfeld has invested Radio with a new beauty and dignity. His words carry positive assurance, to music-lovers and trained musicians, that they can now admit Radio to their field of appreciation and enjoyment, with the certainty that all voices and instruments will be reproduced with their original and distinctive Tone Quality.

Mr. Rosenfeld, a veteran among metropolitan music critics, selected Rauland-Lyric, upon the sole basis of Tone

The RADIO KEY BOOK contains the clearest explanation ever given of the nature of audio amplification and equally valuable discussion of many other subjects in Radio. Sent for 10 cents, coin or stamps.

Quality, from a group of the world's best audio transformers.

Karleton Hackett, famous critic of the Chicago Evening Post, pronounced Rauland-Lyric a "distinct advance in the musical quality of radio reproduction."

You can have, in your home, the amplifying instrument which has been commended by eminent critics.

Rauland-Lyric can be installed in your present set, or one that you may buy, to replace any ordinary audio transformer.

Ask your dealer.

RAULAND MANUFACTURING COMPANY
Pioneers in the Industry
2674 Coyne St. Chicago, Ill.

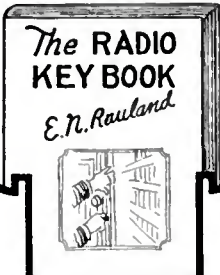

Precision Made for Reliability



<p>Standard Audio Frequency Transformers "All-American for Reliability"</p> <p>Ratio 3 to 1 . . . R-12, \$4.50 Ratio 5 to 1 . . . R-21, \$4.75 Ratio 10 to 1 . . . R-13, \$4.75</p> <p>Built by precision methods in a modern plant, All-American Standard Audios meet the demand of the public for a dependable, high-quality transformer at a price made possible only by enormous production.</p> <p>Long Wave Transformer For highest amplification of intermediate frequencies and perfect reproduction of side bands; 4,000 to 20,000 meters (75 to 15 kilocycles) R 110, \$6.00</p> <p>Power Transformers For Tone Quality in a Third Stage, or for Loud Volume with Clearness. Input type . . . R 30, \$6.00 Output type . . . R 31, \$6.00</p>	<p>The RADIO KEY BOOK E.N. Rauland</p>	<p>Self-Tuned Radio Frequency Transformers "Wound to Suit the Tube"</p> <p>Effectively amplifying all frequencies within the radiocast range. For "199" Tubes R-199, \$5.00 For "201A" Tubes R-201A, \$5.00</p> <p>10,000 Meter Transformer (Filter or Input). It gives superior results in beat reception, filtering out a 30 kilocycle frequency with high selectivity and no side-band distortion R-120, \$6.00</p> <p>Radio Frequency Coupler (Oscillator Coupler). A uniform output at 150 to 650 meters R-130, \$5.00</p> <p>Universal Coupler Sets a new standard of efficiency as an antenna coupler. As a radio frequency transformer in tuned stages it is unsurpassed R-140, \$4.00</p>
--	---	--

Largest Selling Transformers in the World

"Quality Goods for Quality Readers"

sounds have all the energy confined to a single lower frequency region and, as already stated, are singly resonant sounds. Note, also, that the \bar{e} , \bar{a} and \bar{a} sounds have their energies confined to two frequency regions, a lower one and a higher one, and are called doubly resonant sounds. Note, further, that

every one of the six graphs have characteristics which distinguish them from all the others. These are the reasons, then, why the ear can distinguish each of them and thus the basis for communication by speech sounds is established.

In figure 3 is shown a sort of a

composite curve for the English language. It shows the energy distribution at the various frequencies. The curve shows that most of the energy for speech sounds lies below 1,200 cycles and that in the region of the peak of the curve at about 250 cycles one finds most of the energy in speech sounds.

Before closing our discussion it will be in place to discuss some *quantitative data* for musical tones. In our preceding paper we discussed at some length the qualitative composition of musical tones. The curves or sound spectra for musical tones will be readily understood.

This group of curves, figure 4, shows that when a note, for example, lower c (c₁) on the piano is played there are many overtones accompanying the fundamental tone itself. If one compares this note with the corresponding one for the organ shown in the figure, he will observe a very great difference between the number and magnitude of the overtones. The piano note is much richer in overtones than the organ, consequently relatively more of the sound energy resides in the overtones of the piano than in the organ.

One can easily see now the quantitative differences amongst the tones of the various instruments.

Exit 1880

(Continued from page 35)

I have sat in a farmhouse in Utah, far up into the beautiful mountain section there, miles upon miles from the city, and heard the splendid broadcasting available and seen the farmers' faces shine with a real human interest and sociability. I sometimes think the stolid, set look upon peasants' faces is cut there by the fearful hand of isolation, the demon of the rural spaces. There farmers' boys and girls are *not* leaving home as farmers' sons and daughters have left for generations past. It is a statistical fact that there has been no increase in agricultural population since 1900. There are no more people on the farms now than in 1900; which in reality means that the rural districts have been greatly slumping in population, for of course there has been heavy increase in urban population. The reason for the alarming desertion of the farm is of course the isolation.

If we really want to make farm life better, we will now need to give closer attention to the radio needs of rural districts. We will need to do as the Extension Division of the University of Kansas, and other western colleges are doing—provide special programs of real value, not only to the farmers, but to farmers' wives. I am strong for the latter, for the farmer's wife has always had the very hardest lot of any woman in America, and has contributed, as a class, a greater share of national

When it is marked "PACENT" you can build with real confidence

Built into every Pacent Radio Essential is the experience of over 18 years in radio

When you purchase Pacent Radio Essentials, not only do you buy the utmost in engineering skill and precision, but you are following the judgment of the engineers of over 30 of the leading radio set manufacturers.

Being one of the pioneer manufacturers in the radio industry, the Pacent Electric Company has long recognized that quality and

precision were the outstanding requirements of parts for complete satisfaction in set operation. Every Radio Essential bearing the Pacent trade mark was built up to a standard and not down to a price.

Ask for Pacent Radio Essentials and build with confidence. Your favorite dealer carries them or will get them for you. Write for complete catalog.

PACENT ELECTRIC CO., Inc., 22 Park Place, New York City

Washington Minneapolis Boston San Francisco Jacksonville Chicago Birmingham Philadelphia St. Louis

Pacent
RADIO ESSENTIALS

DON'T IMPROVISE - PACENTIZE

PACENT
Radio Essentials
of known quality

- Adapters
- Improved Audioformer
- Audioformers
- Autoplug
- Balcon
- Coil Plug
- Coil Plug Receptacle
- Condensers
- Detector Stand
- Duojack
- Duoplug
- Duo Lateral Coils
- Headsets, Everytone
- Jacks
- Jacket
- Loops
- Loop Plug
- Loop Jack
- Multijack
- Plugs
- Potentiometers
- Rheostats
- Resistances, Cartridge
- Sockets
- Twinadapter, etc., etc.



Magnified Reproduction for Your Radio



Music as clear and melodious as the tinkle of silvered temple bells of Mandalay. That's what you'll get on your radio when you use the Rhamstine* Needlephone with your phonograph.

It is the principle of "magnified reproduction," an exclusive feature of the Rhamstine* Needlephone, that gives such mellow notes, such discrimination of tone values, such perfect reproduction. No other loudspeaker takes advantage of this "magnified reproduction" principle and the principles of acoustics (the laws of sound) as embodied in the phonograph.

RHAMSTINE*
NEEDLEPHONE

picks up the delicate impulses of high pitched notes and through the vibrations of the reed enlarges and transmits them through the needle of the phonograph to the mica diaphragm where they are transformed into sound, giving fuller, sweeter music and better tone reproduction. It can be attached more easily and does away with metallic noises.

Pay No Money Take No Risk

Rhamstine* will prove these claims, at his own risk. Send the coupon today, pay on delivery, and try the Needlephone with your own set and your own phonograph. Try it with a soft needle on local broadcasting for real mellowness of tone. Try it with a loud needle for greater volume. Then if you're not entirely satisfied, if you do not get greater volume, fuller and sweeter music and better reproduction, return it and we'll gladly refund your money in full.

J. Thos. RHAMSTINE*

RHAMSTINE*
Needlephone

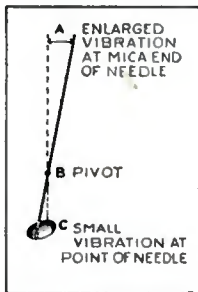

This illustrates the "magnified reproduction" principle of Rhamstine* Needlephone. The delicate vibrations of the reed at "C" are transmitted through the pivoted needle and magnified at "A."

*Radio and Electrical Products.

Mail
This Coupon
To-day

J. Thos. Rhamstine*
504 E. Woodbridge Detroit, Mich.
Send me the Needlephone. I'll pay the postman \$10 upon its arrival. It is distinctly understood I may return it if I desire, within 5 days, and receive a refund in full.
Name
Address



Ask your Dealer
for a Complete
Line of Kellogg
Radio Apparatus

KELLOGG SWITCHBOARD & SUPPLY COMPANY
1066 W. Adams St. Chicago, Ill.



wealth, than any other class of women in America. I want the farm woman to have plenty of entertainment via radio, and plenty of helpful lectures on farm woman problems. For best service such broadcasting must be done, not after 8:30 P. M., but between 7 and 9 P. M.—and particularly on Sundays. Sundays are very good broadcasting days for the farm, and I certainly would not be satisfied with religious programs alone. Nowadays the religion of service is as good as the religion of dogma and sects, and Sunday mornings and afternoons might very well be given over to home problems, many of which have vastly important ethical aspects, too. I stress this mat-

ter of Sunday broadcasting because I want to reach the women who most need it, and I know too well what a beast of burden most farm women are during week-days, their conscience or their duties preventing them from taking "time off" to listen in.

A farm is a veritable hall of industry for farm women; they have a thousand tasks which call for more information. The Government has scores of leaflets printed, but they are not usually read. Women learn better *by ear*. The productivity, happiness and livability of farmers and farm life are very dependent upon radio, and we must somehow turn the tide of population back toward the farm again.

The Family Receiver

(Continued from page 37)

from the rear, the detector tube socket is placed on the left and the first audio frequency tube socket is placed directly behind the second radio frequency tube socket as will be seen in the accompanying illustrations. The first resistance-coupled tube socket is placed directly behind the first radio frequency tube socket and the last resistance-coupled tube socket at the extreme right of the panel.

In connecting up the receiver connect all grid and plate leads first. The connections for the radio frequency transformers are shown in the accompanying diagram. The grid is connected to the end of the large winding and the plate to the beginning of the small winding. That leaves the two ends of the two coils which come closest together to be connected to the B plus for the small winding and the F minus on the large winding. A reversal of these connections will render the set inoperative so use care in hooking them up. Leads should be run from the R.F. transformer solder lugs directly over to the tube socket terminals and the leads from the condenser should then be bridged across these. After all the grid and plate connections are made start the filament circuit. On the two radio frequency tubes and first audio tube three Daven ballast resistances are used to control the filament. These provide automatic control of the filament temperature and require no adjustment. The first Marshallstat on the left of the panel controls the two resistance-coupled stages in parallel and the second Marshallstat controls the filament on the detector tube. These Marshallstats provide critical filament control where fine adjustment is needed. The UV-201A when operating with a resistance-coupled amplifier requires slightly higher temperature and a critical adjustment. This is not the case, however, with the radio frequency tubes nor the transformer-coupled audio tube. Insert in the resisto-couplers the proper leaks which are furnished with each unit—one-tenth megohm leak in the plate side in each stage, a one-and-one-half megohm leak in the grid side of the first stage and a one-megohm leak in the second stage. Be careful in mounting the resisto-couplers to follow the letters stamped on the base and run plate to plate and grid to grid, etc. A reversal of this will cost you some tubes. The Amplex Gridenser is mounted between the third variable condenser and the detector tube socket so that your grid leads may be kept as short as possible. The ballast resistances are placed in the negative lead of the R.F. tubes and the return lead from the transformer connected after the rheostat that

FRESHMAN MASTERPIECE

The Secret of the Success of the Masterpiece

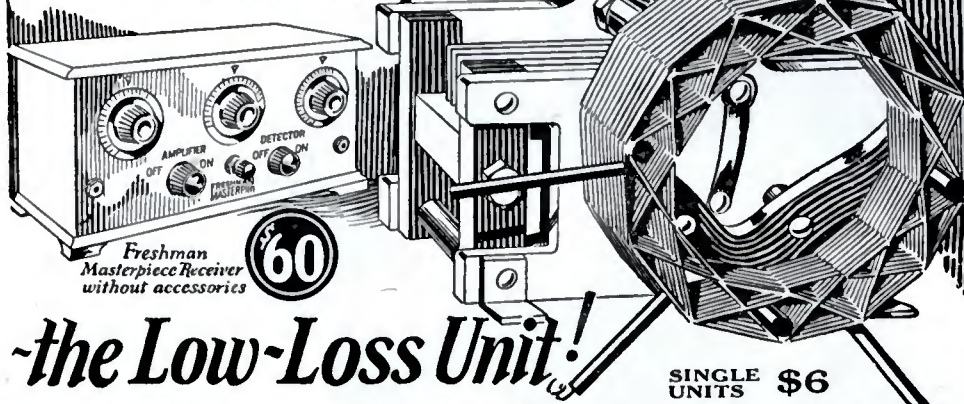

the Low-Loss Unit!
It's Easy to Build

A Five Tube Radio Frequency Receiver when you use the

FRESHMAN MASTERPIECE KIT

No Neutralizing or Balancing Condensers Required

when you build with the Masterpiece Kit which produces a tuned Radio Frequency Receiver, that will bring in even the most distant stations with the volume and clarity of locals. So selective that stations can be brought in day after day at the same dial settings. A set that is the equal, if not the superior, to any 5 tube receiver on the market, and what's more, it's the easiest set in the world to operate.

Each and every Freshman Masterpiece Coil bears a serial number and Trade-mark—our guarantee of electrical and mechanical perfection. Every genuine Freshman Coil is made of specially insulated wire to prevent short-circuiting, so often caused by inferior coils. For your protection demand only the genuine.

SINGLE UNITS \$6

For Reflex and other circuits MASTERPIECE TUNED RADIO FREQUENCY KIT COMPLETE

with 3 MASTERPIECE UNITS carefully matched and balanced. Complete with wiring diagrams and instructions for building any 5 tube Tuned Radio Frequency Receiver and drilling template for proper mounting.

\$17.50

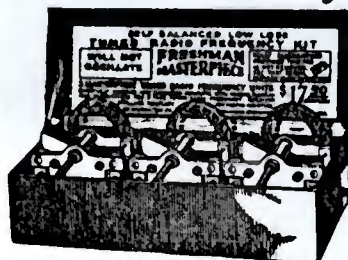

At your dealers, otherwise send purchase price and you will be supplied without further charge.

Chas. Freshman Co. Inc.
Radio & Condenser Products
106 Seventh Ave. New York, U.S.A.

"Quality Goods for Quality Readers"

RHEOSTAT TYPE 40

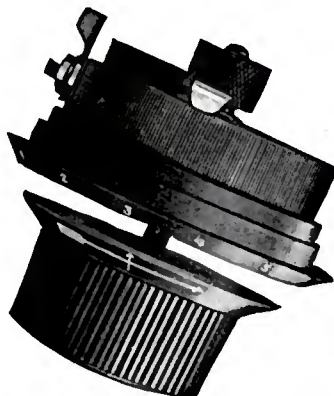

Embodying many new and original features. Solid Bakelite, of course. SEE IT AT YOUR DEALER.

We beg the public's indulgence in our effort to supply them with our NOLOSS Pyrex and Isolantite insulated variable condensers.

We are increasing our production facilities four-fold and hope to be in a position to supply the current demand by November 15th.

*General Instrument Products
cost a little more but are worth infinitely more*

BOOKLET UPON REQUEST

GENERAL INSTRUMENT CORPORATION

MANUFACTURERS OF LABORATORY EQUIPMENT

423 BROOME STREET

NEW YORK, U. S. A.

is between the rheostat and the A minus source. The Marshallstat on the detector tube is connected in a similar fashion in the negative lead. Likewise ballast resistances in the first stage of audio. In the resistance-coupled stages the return lead from the gridleak is connected directly to the tube socket terminals on the positive side and the second Marshallstat is connected after the return lead instead of before as in the R.F. stage. If these distinctions are taken note of before starting the connections, they will be easier to remember and there will be greater certainty of correct leads. The full 90 volts B battery is used on both the R.F. tubes and audio

frequency amplification while only 22 volts is used on the detector tube.

OPERATION

To put the set in operation turn the Carter jack-switch on and adjust the two Marshallstats until best results are secured. The three dials are then turned so that their readings are approximately the same and a signal tuned in. After a careful log of the stations is made it will be a simple matter to turn back to these calibrations and locate the station. In case an outside aerial cannot be erected, the antenna lead from the binding post marked short antenna is brought to the grid of the first R.F. tube through a .0005 mfd. fixed condenser.

5½-Oz. Head Set

(Continued from page 42)

develop a new idea so far as the inside working parts were concerned. It is necessary, as you know, in the telephone receivers, to have two pole pieces, a steel magnet, and many thousand feet of magnet wire. True, magnet wire is made in very small sizes, and when tightly wound does not take up a great deal of space. I presume that most every one has seen the inside of a receiver and will appreciate what had to be overcome to construct a thin, light unit which would be sensitive to weak signals.

After two and a half years experimenting, I succeeded in making a unit which was only 7/16 of an inch thick by 2¾ inches in diameter, and when all the working parts were assembled in the case, it weighed exactly 2 ounces. The inside space of this unit, that is, the space where the two pole pieces, magnet and magnet wire are placed, was only 7/32 of an inch deep by 1 13/16 inches in diameter. The case for the unit was made of pure hard rubber. With the case all assembled, it looked like a very thin watch. My experience with the patent lawyer when I called upon him to put through a patent for me was amusing. He said the idea of the ear clamps was very fine, but how about the weight of the units to be held to the ears? He advised me strongly against spending my money. It did not dawn on him, that the sample he held in his hand, contained all the necessary working parts, until I called attention to the fact.

The attachment for the ears is a friction spring, made in such a way that they can be taken off and placed in the proper holes, which are provided for large and small ears, and the entire unit can be put on in less time than it is possible to adjust the old fashioned head band type.

I found it necessary to develop a new type of pole piece, semi-cylindrical in shape, so that when the two were placed together with a gap of 1/32 of an inch between, they formed a perfect circle right in the center of the case. I found by adopting the semi-cylindrical pole pieces, I got a greater volume of tone and a purer musical quality. This increase of volume is due to the pull on the diaphragm around the entire center where it should be, and not off on either side.

In a unit as thin as the one I have developed, and which made it possible to do away with the uncomfortable head band, it would be absolutely impossible to employ the present type of pole pieces, the coils would be at least 2 inches in diameter, making the entire unit over 4 inches in diameter, which would be too large and too heavy in

A FRANK STATEMENT and Explanation to the Radio Public

From C. H. Thordarson, President
Thordarson Electric Manufacturing Co.



HERETOFORE, Thordarson Super Transformers have been mainly obtainable only by the manufacturers of quality radio sets. Fans, the world over, have of course noted the use of our transformers in a preponderance of leading makes of receivers.

Quite rightly they concluded that Thordarson transformers must be decidedly superior. And so they sought to buy the same transformers for replacing unsatisfactory types and for use in home-built sets.

Despite the fact that we lead the field in number of transformers produced, dealers were unable many times to supply Thordarsons to these customers. This led to some feeling that we might be purposely restraining the general sale of our product.

The truth is that the tremendous gains in sales enjoyed by the makers who standardize on Thordarsons, took nearly all we could turn out even though our production was continually multiplied.

Not until last summer were we able finally to increase the capacity of our immense six-story factory sufficiently to provide for supplying the needs of the general public in addition to the larger wants of more and more set builders.

From now on, however, you should experience little if any difficulty in being able to buy Thordarson transformers. My aim is to build enough Thordarsons this season to permit every store to handle them.

Six floors, 100,000 sq. ft., devoted to transformers.

THORDARSON ELECTRIC MANUFACTURING CO.
Transformers specialists since 1895
WORLD'S OLDEST AND LARGEST EXCLUSIVE TRANSFORMER MAKERS
Chicago, U.S.A.

THORDARSON
Super
AMPLIFYING TRANSFORMERS
Standard on the majority of quality sets

"Quality Goods for Quality Readers"

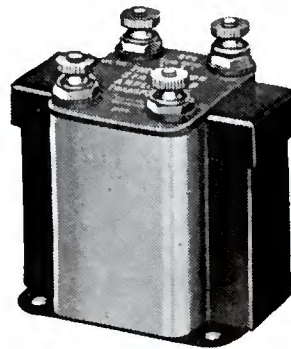

Thordarson "Super" Audio Frequency Transformers enjoy wider use because of the even volume and freedom from distortion with which they amplify over the entire musical scale and thereby make a good radio set a true musical instrument. **Unconditionally guaranteed.** Three ratios: 2-1, \$5.00; 3½-1, \$4.00; 6-1, \$4.50. Thordarson Power Amplifying Transformers, which equal our audio frequency types in tonal purity, are \$13 the pair. Write for latest bulletins.

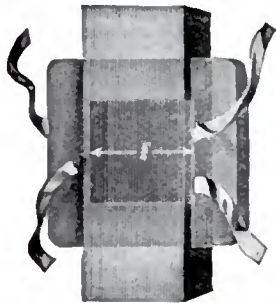

The Exclusive Thordarson Square Coil
Leak-Proof Construction

The Thordarson-made layer-wound SQUARE coil fits snugly around the square core. Coil can't turn—no open circuits due to layers slipping. No air spaces between coil and core (exclusive Thordarson feature!)—no lost energy, no lost volume (especially on low notes), no leaks from primary to cause howls in set. (Thordarsons are quiet, even on the third stage!) Over-size core (¾" cross section) provides 50% larger magnetic circuit—minimizes core losses, prevents over-saturation. Broad ribbon leads locked in the coil give short, direct and more durable connections to the patented inner-locked terminal posts—no tangled or broken wires inside case (exclusive!). Each Thordarson transformer comes completely protected, shielded and tightly clamped in a stout case. No rivets or screws through the special silicon steel core to cause short circuits or eddy current losses between the laminations (exclusive!). Do you wonder that Thordarson leads the field in output and produces more transformers for more makers of quality sets than all competitors combined?



The Bestone V-60 Five-Tube Receiver in beautiful, distinctive, antique polychrome cabinet, with built-in high-grade loud speaker and battery compartment.

List....\$165.



BESTONE
V-60

TRADE MARK

"The Aristocrat of Radio"

DIFFERENT FROM ANY SET YOU'VE EVER HEARD OR SEEN

- ¶ Its accomplishments have heretofore been thought impossible.
- ¶ The BESTONE V-60 has been developed with one idea in mind—to furnish Radio entertainment without apologies or excuses for ordinary radio annoyances.
- ¶ No other radio receiver incorporates such volume—distance—selectivity.
- ¶ Complete absence of whistles—howls and distortions.
- ¶ AND—simplicity itself. Nothing complicated in its make-up.
- ¶ **TRULY THE ARISTOCRAT OF RADIO.**

Write for Particulars

Manufactured and Guaranteed by
HENRY HYMAN & COMPANY, INC.
476 Broadway 212 W. Austin Ave.,
NEW YORK CHICAGO



Imperial Model—Bestone V-60 Five-tube Receiver, in beautiful mahogany cabinet.

\$115.

any event. With my new type of unit, I can get any ohmage up to 6,000 per unit, making a total of 12,000 ohms per set. However, through many tests covering a period of two years, with the best types of head set, I find that 1,100 ohms is the ideal for all broadcast reception.

My coils are wound with No. 44 B. & S. gauge enameled magnet wire .125 in depth by .425 in diameter. I used the No. 44 simply to keep the coils small and light. For 1,100 ohms I could use No. 38, but the increased weight of the coils would be double. The coils are wound in such a way as to make them uncollapsible. They are then insulated in the core with mica,

also the top and bottom of the coils are insulated with the same material.

Two people listening in with my type of head set, with its 72-inch cord, find it very simple to attach one to each person's ear. It has no head-band to unhook or adjust with only one phone on it while the other listener has to hold the unit to his ear.

I believe the wireless operators will welcome this new head set. They will be able to wear them twenty-four hours at a time without any annoyance whatever. Telephone operators in central stations, or anyone in the home or office, can use this head set to advantage. It will no longer be necessary to hold the receiver to the ear with the

hand in one case and will do away with the head band in the other case. There is absolutely nothing to catch in a woman's hair, which is a distinct advantage aside from all others over the old fashioned head band type.

The units are absolutely fool proof and cannot be taken apart. I have made them this way because of the extremely delicate construction inside, and so that they cannot be harmed even if they are thrown around though in that case the magnetism may be affected.

The head set is held so securely to the ear with the clamp device, that one can run and jump, stand on one's head and even dive into the water and it will not be displaced. Yet they can be taken off the ears with the slightest pull of the hand.

By extending the ear clamps to their full extent and placing the units on a cigar box with the springs down and plugging in on the second stage of any good set, signals about equal to a horn type of loud speaker can be produced.

To sum up, this featherweight headset has a genuine practical value for the professional operator as well as for the B. C. L.'s when comfort, facility of use, tone quality, sensitivity and volume of signal are considered.

One Tube Circuits

(Continued from page 47)

current variations, there is a considerable drop across the headset, or in effect their impedance is increased and the action is similar to a regular tuned circuit such as H. Indeed if we mentally substitute a condenser and coil in place of the variometer of H it will be noted that L is like H. K can also be shown as at M which is in every way identical with K. In M the plate coil may or may not be in inductive relation to the grid coil, if it is coupled to it, we could connect the aerial to a portion of it so the primary would be a section of the plate coil even as it may be a section of the secondary coil as shown at F.

We have to consider still another arrangement. The Ultra-Audion as shown at N. This can be represented as at O where the headset is shown as an inductance in series with a resistance and shunted by a condenser representing the distributed capacity X_p , R_p and X_c , respectively. This has a slight impedance to radio frequency variations so the voltage on the plate will vary as the grid voltage variations affect the filament-plate resistance. Ordinarily the voltage fluctuations, being small because of the small impedance of the headset or external plate circuit compared to the filament-plate resistance, would not be sufficient to excite the grid through the grid-plate ca-

SIX TUBES
- a single turn of the
SINGLE CONTROL
to the desired wavelength -
the station **SNAPS IN!**
that's *Thermiodyne* TF6
TRADE MARK - LICENSE UNDER TRADE PATENTS PENDING
(Ther-my-o-dine)

14 Points of Thermiodyne Supremacy

1. Single Control
2. No Outdoor Antenna Necessary
3. No Directional Loop
4. Meter or Kilocycle Pickup of Stations instead of meaningless numbers
5. CANNOT Squeal or Howl
6. CANNOT Radiate
7. CANNOT Distort
8. Newspapers Give Time and Wavelength
9. Thermiodyne Picks Them at Exact Setting Every Time
10. No Logging of Stations; Nothing to Remember
11. Stations of Different Wavelengths Cannot Interfere with Each Other
12. Three Stages Thermionic Frequency, Detector, Two Stages Audio Frequency
13. Distance, Volume, Clear as a Bell, without Fuss or Excuses
14. A 180 Degree Turn of the Single Control is Like a Tour of Dozens of Cities

The ONLY six tube receiver to bring in any desired station with a single turn of a single control to a single pre-determined dial setting. Tone purity and clarity unmatched by any other receiver.

May be used with any type antenna, or, under favorable conditions, with none; with dry or storage batteries and with any make tubes.

In exquisite genuine mahogany cabinet with ample space for all batteries for dry cell operation.

\$140

Insist on a Demonstration

Made and Fully Guaranteed by

SHEPARD-POTTER CO., Inc.

Dept. W, 33 So. River St.

Plattsburg, N. Y.

All radio endeavors in the past have been but strivings toward Thermiodyne - the ultimate

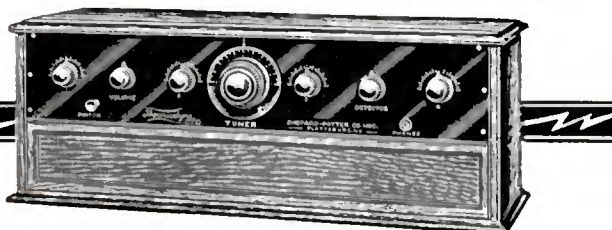

"Quality Goods for Quality Readers"

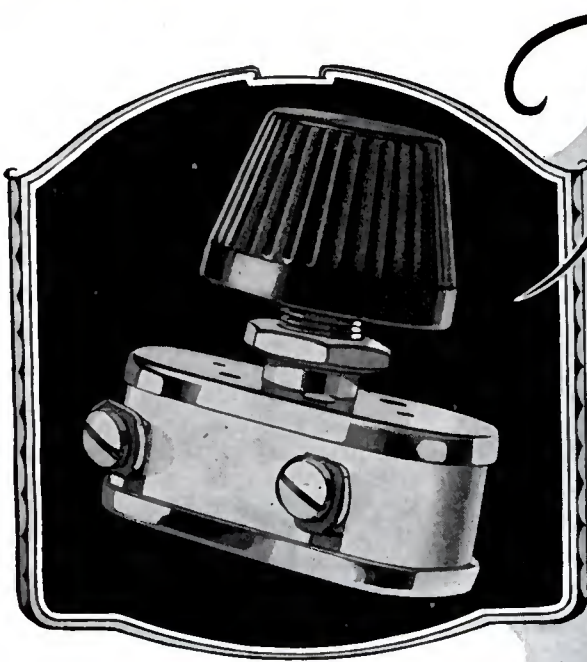

The New Bradleystat

A Remarkable Achievement

Many refinements are embodied in the new Bradleystat. The graphite disc columns are enclosed in a *smaller* container; *two* terminals suffice for ALL tubes; a *new mounting* simplifies installation; the *knob* is of a daintier pattern. And the noiseless, stepless, control of the old Bradleystat remains, unchanged. Such a combination of advantages can be found in no other filament rheostat.

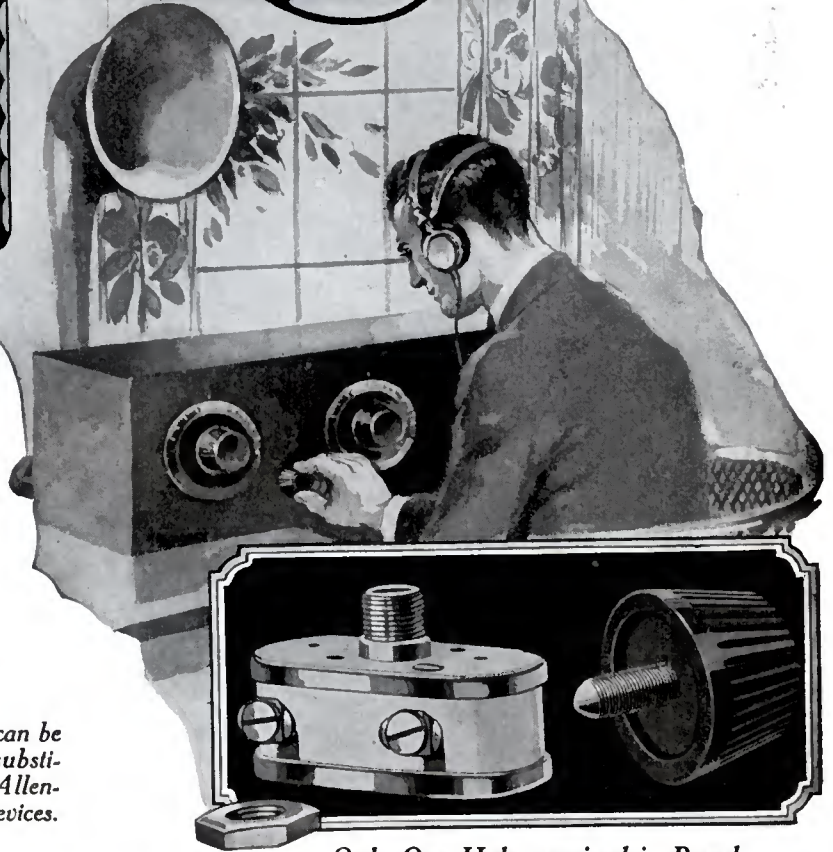

Every radio set can be improved by substituting the new Allen-Bradley radio devices.

Only One Hole required in Panel

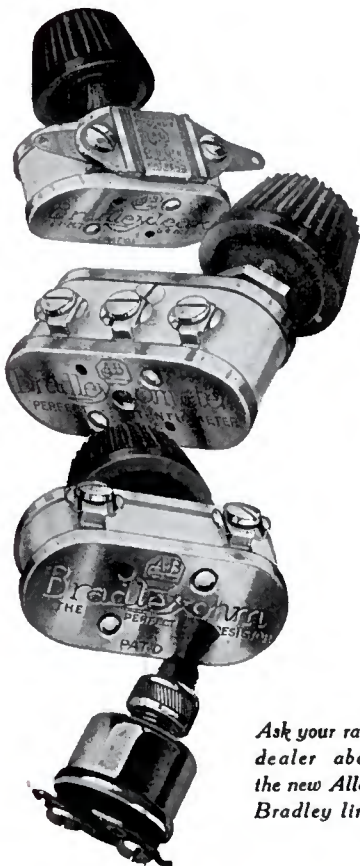

Ask your radio dealer about the new Allen-Bradley line.

A *DISTINCTLY* new and valuable contribution to radio! That is the verdict of all radio engineers and designers who have seen the new Allen-Bradley radio devices and have witnessed their amazing performance. The new "one-hole mounting," which replaces the older clip mounting, makes for marvelous compactness and simplicity of installation. The new Bradleystat, Bradleyleak and Bradleyohm require only a 11/16-inch space behind the panel, and the Bradleyometer only 7/8-inch. Thus, the new models can replace inferior wire rheostats and potentiometers without disturbing the arrangement of the set. Our new literature is ready. Send for it, today!

Allen-Bradley Co.
Electric Controlling Apparatus

283
Greenfield
Ave.



Milwaukee,
Wis.

Baltimore
Birmingham
Boston

Buffalo
Chicago
Cincinnati

Cleveland
Denver
Detroit

Knoxville
Los Angeles
New York

Philadelphia
Pittsburgh
Saint Louis

Saint Paul
San Francisco
Seattle



Adopted by Leading Manufacturers



Manufacturers

who desire to build quality into their products and who insist on speed and economy in their plants should write our nearest office for complete information on Spaulding Bakelite-Duresto.

Factory: Tonawanda, N. Y.
Sales Offices: Warehouses

484 Broome St., N. Y. C.
659 W. Lake St., Chicago.
141 N. Fourth St., Phila.
15 Elkins St., Boston.
310 E. Fourth Street, Los Angeles.
171 Second Street, San Francisco.
509 First Nat'l Bank Bldg., Milwaukee.

THE unqualified endorsement of these leading radio manufacturers is in itself the greatest recommendation of Spaulding Bakelite-Duresto quality.

These men know bakelite. They know quality depends solely upon manufacture. They know by actual experience that Spaulding Bakelite-Duresto panels possess high dielectric properties and great strength; that it drills, saws, engraves without chipping; that it will not warp; that it retains an everlasting lustre.

For efficiency and lasting beauty, you should use Bakelite-Duresto. Your dealer can furnish standard sizes, individually packed, special sizes to order. Look for Bakelite-Duresto panels on the sets you buy.

Write nearest office for descriptive circular.

SPAULDING FIBRE CO., INC., TONAWANDA, N. Y.

Spaulding
BAKELITE-DURESTO
Panels - Sheets - Tubes - Rods

capacity so the grid is connected, not to a point (the filament) of constant voltage, but instead to the plate, which varies slightly in voltage. These variations are impressed directly on the grid through the tuned circuit and the grid or stopping condenser. Thus the voltage variations on the plate, even though they are small, serve to excite the grid. In a way, then, O can be compared to H as the grid is excited by the voltage variations on the plate and the plate voltage variations are made to excite the grid partly through the grid-plate capacity, but mostly through the direct connection from plate to grid. If the external plate circuit impedance is below a certain value in comparison with the internal plate impedance or plate-filament resistance, self-oscillation could not be secured. This condition applies also to H.

And now for a second let us look at the standard regenerative circuit of figure 1. We can represent this in two similar diagrams, figure 2 and figure 3. At a casual glance they appear different, and indeed are known by different names, but a close inspection will show that they are alike.

Now to review the comparisons we have made. We have shown:

A equal to B equal to C.

D equal to E equal to F.

G equal to H.

K equal to L equal to H equal to M.

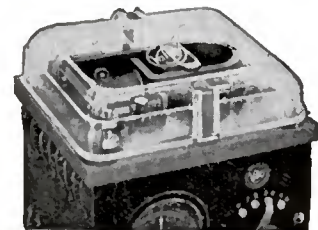

For All Batteries



Valley Battery Charger

For 2-volt peanut tube cells, for 6-volt A batteries and for 24-volt B batteries in from one to four units, the Valley Battery Charger is the one charger and the only charger which you need.

It plugs into the ordinary light socket like a fan or other household necessity, and is just as easy to operate. Takes about a dime's worth of current to bring your battery up to full charge.

It has a grained and engraved Bakelite panel which harmonizes with any radio set. Clear glass top shows the simple, patented working parts at all times. Scientifically planned and substantially made by experienced manufacturers of storage battery charging equipment.

At radio dealers everywhere. Further information furnished on request.

VALLEY ELECTRIC CO.
3157 S. Kingshighway, St. Louis, Mo.

Big Dealer discounts

Send for this catalog—It lists and illustrates absolutely dependable, guaranteed sets and parts. Give your customers what they want—when they want it; but buy it so that you can make a good profit. We're supplying hundreds of radio dealers satisfactorily every day. Write for catalog and discounts sheet. You'll be astonished at the prices quoted.

Ask for catalog No. 10.

W.E. Fuetterer
Radio Supply Co.
2123-25 Locust
St. Louis, Mo.

W.E. Fuetterer
Radio Supply Co.
Send for our latest catalog

RADIO EXPERTS EARN BIG MONEY

Thousands of big pay opportunities open to the radio trained man. Success easily won in the fastest growing industry of all time. From land and sea comes the urgent call for men who can construct, install, operate, repair, maintain and sell radio equipment.

CASH for Your Spare Time!

Take orders from your neighbors for radio sets. Get big fees for your services and advice. Home study qualifies you—short course, low cost, easy terms, money back guarantee.

FREE Wonderful tube receiving set of latest design. Range over 1000 miles. Write today for FREE copy of "Radio Facts".

A. G. MOHAUPT, Radio Engineer
RADIO ASSOCIATION OF AMERICA
4513 Ravenswood Ave., Dept. G-11, Chicago



The new Exide six-volt "A" Battery in one-piece case. Price, \$14.60 up, f. o. b. Philadelphia.

An even better "A" battery and at a much lower price

IF you are one of the thousands who have come to rely on the famous six-volt Exide "A" Battery, you will not recognize the new one when you first see it — but you will know it when you hook it up to your set, for it has the same old rugged power, the same constant efficiency, and the same long life.

You will say of this new battery: "Handsome is and handsome does." The composition case (including handles) is moulded in one piece. Beautifully stippled and finished in glossy black, it is an ornament to any room.

Broad inter-cell connectors fit close to the top of the battery. Offset terminal posts make it very easy to hook up. Filling plugs require but a quarter turn to remove. This new Exide is made in five sizes — 50, 75, 100, 125, 150 ampere hour capacity.

A complete line of radio batteries

If you use low-voltage tubes you have your choice of those sturdy midgets, the Exide two- and four-volt "A" batteries, weighing but five and six pounds.

In addition to the compact 24-volt Exide rubber case "B" battery of 4000 milliamper hour capacity there is the new Exide for those who desire visibility as well as capacity. This "B" battery is assembled in glass jars and is made in 24 and 48 volt sizes. Larger plates and greater space for the electrolyte give a capacity of 6000 milliamper hours.

The Exide Rectifier enables you to recharge your "B" battery from your house current at a cost that is insignificant.

Ask to see the Exide line at any Exide Service Station or Radio Dealer's.

Exide RADIO BATTERIES

For better radio reception use storage batteries

Prices Exide Radio Batteries							
Battery	Capacity	Voltage	Price F.O.B. Philadelphia	Battery	Capacity	Voltage	Price F.O.B. Philadelphia
3-LXL-5	50 A.H.	6	\$14.60	1-KZR-5	24 A.H.	2	\$ 5.40
3-LXL-7	75 A.H.	6	16.90	2-KZR-3	12 A.H.	4	7.30
3-LXL-9	100 A.H.	6	19.15	12-RB-2	4000 M.A.H.	24	10.00
3-LXL-11	125 A.H.	6	22.10	12-LR-2	6000 M.A.H.	24	12.00
3-LXL-13	150 A.H.	6	25.60	24-LR-2	6000 M.A.H.	48	23.30
				Exide Rectifier	\$2.00		

THE ELECTRIC STORAGE BATTERY COMPANY, PHILADELPHIA

In Canada, Exide Batteries of Canada, Limited, 153 Dufferin Street, Toronto

"Quality Goods for Quality Readers"

**\$25
for
\$10**



**Buy
Direct
and
Save
\$15**

*The
Famous*

THE ACOUSTICAL AMPLIFIER
BEL-CANTO
TRADE MARK

Loud Speaker

PRICE
DELIVERED
FREE TO
YOUR DOOR **\$10**

You can only buy the BEL-CANTO direct from us—the Manufacturers—
We save you these three profits—Distributor—Jobber—and Dealer

FIBRE HORN—ADJUSTABLE UNIT
—ANOTHER BEL-CANTO TRIUMPH—

The New BEL-CANTO Ear Set—As Accurate as a Watch
The New Bel-Canto Head Set is the only Head Set in the WORLD which Eliminates the uncomfortable Head Band.
The combined weight of the complete set—less than 6 ounces.
The units of this new Ear Set are only 7/16 of an inch in thickness and 2 3/8" in diameter.
From your dealer or direct from us.

GUARANTEE
Money back any time within ten days if dissatisfied. We further guarantee to the publication carrying this advertisement that each and every speaker will be sold on the above terms and the instrument will be exactly as offered in this issue.

Call at our Factory. Send us your check or money order, or pay postman \$10. Prepaid to any part of the U. S. and possessions.

BEL-CANTO MANUFACTURING CO.
BENSEL-BONIS CO., INC.
General Office and Factory Dept. W. A.
872 Broadway, New York City Tel. Stuyvesant 1921

N equal to O equal to H.
1 equal to 2 equal to 3.
And of course it can be seen that G is equal to figure 1 and as G is equal to H it follows that G, H, K, L, M, N, O, 1, 2 and 3 are equal to each other. Very simple, yes?

And now, just for fun, let us compare two circuits in ordinary use that do not look at all like each other. The Reinartz and variometer variocoupler are fairly good extremes. See figures 4 and 5.

First in accordance with (D equal E) change the antenna circuit of the variometer set to the still double circuit of E. In the secondary (figure 5) change the tuned circuit from A to B as we have shown A equal to B. Now for the plate circuit. We have shown M equal to L and H so we can replace H with M in our variometer set of figure 5. This looks like figure 6 now. And of course it is immediately apparent that the antenna coil may be changed as from E to F so the primary is part of the secondary coil, or as mentioned before, we can make the primary part of some other coil coupled to the secondary, in this case, the plate coil, as we have done in figure 7. This looks a whole lot like figure 4 now, doesn't it? Indeed the only difference between 4 and 7 seems to be in the plate coil arrangement. Actually they are alike for obviously it does not matter here whether the condenser is placed between two sections of the plate coil or at either end. As



'SHEPCO' All Wave Jr.
Non-Radiating DX Coupler

Exclusive "Shepco" bankwound and tapped primary and tapped secondary make the "All Wave" Jr. supremely responsive to ANY wavelength from 150 to 700 meters in triple circuit hook-ups and from 150 to 1000 meters in single circuits.

The ONLY coupler which may be used in both single and triple circuits.

Eliminates all variometers, vario-couplers and loading coils. Permits building one tube receiver with multi-tube distance, volume and selectivity.

**They're All Local Stations
With An "All Wave" Jr.**

6 efficient hook-ups with every coupler or sent for ten cents to cover mailing.
At your radio dealers or sent prepaid on receipt of **\$6** price.

Made and Fully Guaranteed by
SHEPARD-POTTER CO., Inc.
Dept. W. 33 So. River St. Plattsburg, N. Y.

Bruno 3 in 1
Ultra Vario Condenser
A balanced precision instrument scientifically designed.
Each condenser has three capacities .0005—.00025—.000125 mfd.
"The losses were so low that it could not be accurately measured on our capacity bridge."—Radio News, October, 1924.
Bruno Radio Corporation
NEW YORK

De Jur
ONE HOLE
RHEOSTAT
RADIO EDITORS AGREE
that the De Jur one hole genuine bakelite rheostat is the standard of comparison. De Jur Rheostats embody these exclusive features—non-corrosive and heat resisting, interchangeable resistance element held securely in place by special metal brackets. Sliding rod supporting the slide arm has long brass bearing, assuring absolute contact.
Guaranteed; any part replaced any time AT DEALERS EVERYWHERE
Jobbers and Dealers write for discount
De Jur Products Co.
Lafayette & Broome St., New York

The
RED SEAL

VARIABLE
CONDENSER

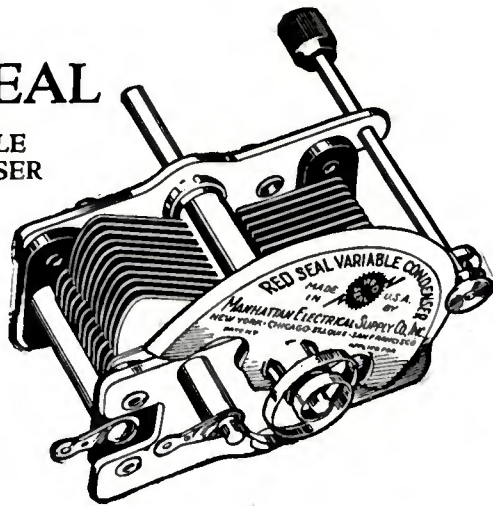

At Last — an ideal vernier to control a low-loss condenser

You have probably often wished for such a combination. Now for the first time the vernier of the Red Seal enables you to easily take full advantage of high condenser efficiency without turning right through the sharp peak of the wave.

No more slipping, lost motion, or tight bearings. No more tuning with one knob and adjusting with another. All the adjusting may be done with the vernier knob alone.

The above does not give you an adequate picture of the Red Seal Condenser. Go to your dealer and ask to see it. As you operate the vernier for yourself, note these six important features which make it the ideal control for this efficient, low-loss instrument.

1. The action of the vernier is *positive*, giving delicate, smooth adjustment.

- 2. There is no lost motion or play at any point.
- 3. All tuning may be done with the vernier alone.
- 4. Only one dial setting—stations easily logged.
- 5. There is no fibre, rubber, or gears. Nothing to wear or get out of order.
- 6. Plates turn freely. Balanced vernier eliminates need for friction at bearings.

The Red Seal has four other points of note:

- 1. Plates are of brass and are *soldered*.
- 2. Spring "pig-tail" connection employed.
- 3. End plates are grounded, eliminating the effect of hand capacity. For supercritical work, insist on the Red Seal Variable Condenser.
- 4. To facilitate tuning the movable plates are given a special shape, making the Red Seal of the "straight-line" type.

Manhattan Electrical Supply Co.
Incorporated
New York Chicago St. Louis
San Francisco



MADE BY THE MAKERS OF THE FAMOUS RED SEAL DRY BATTERIES

"Quality Goods for Quality Readers"



Manhattan Junior Loud Speaker

A real musical instrument containing a specially designed reproducer unit for loud speaker work. Not just a headset in a base. Has "Concert Modulator" adjustment giving best results under all conditions.
\$10.00

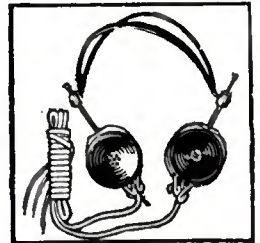

Red Seal Headset

Designed for "DX" work. Tone quality excellent. Workmanship the best. No distortion or chattering. Bakelite case, soft rubber sanitary headband.
\$6.00

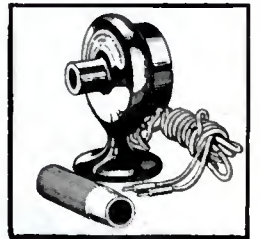

Red Seal Phonograph Attachment

Makes a loud speaker of your phonograph. A high grade reproducer reproducing the work of the broadcasting artists with fidelity.
\$5.00



Red Seal Batteries

The dependable dry battery for "A" circuits. Long operating life and great recuperative power make Red Seals ideal for radio work. Sold by all classes of dealers. Remember, fresh Red Seals bring in fresh stations.

It's Easy to Cut and Drill RADION PANELS

No special tools are required. Common home tools will turn out a clean hole and a straight edge, with no chipping.

There are 18 stock sizes to select from—literally a size for every set. This means less cutting and little waste, sometimes a definite saving in real money.

Exhaustive research has shown that RADION excels other insulations in the important electrical and mechanical characteristics. It's worth while to ask for RADION Panels and Parts. Be sure to get only the genuine.

Do not accept inferior so-called hard rubber panels that are not RADION and that do not have the insulating values of RADION.

Look for this stamp on every genuine RADION panel. Beware of substitutes and imitations!



18 Stock Sizes Mahoganite and Black

3/16 x 6 x 7	3/16 x 7 x 21
3/16 x 6 x 10 1/2	3/16 x 7 x 24
3/16 x 6 x 14	3/16 x 7 x 26
3/16 x 6 x 21	3/16 x 7 x 30
3/16 x 7 x 9	3/16 x 7 x 48
3/16 x 7 x 10	3/16 x 8 x 26
3/16 x 7 x 12	1/4 x 8 x 40
3/16 x 7 x 14	1/4 x 10 x 36
3/16 x 7 x 18	3/16 x 20 x 24

RADION

Panels, Dials, Knobs, Sockets, Insulators

American Hard Rubber Company

11 Mercer Street

New York

a matter of fact, in operation, 7 would have a point of advantage over 4 as change of aerial inductance in 7 does not change the plate circuit adjustment as much as an equal variation in 4.

Any one-tube regenerative circuit is like the standard regenerator of figure 1.

As a final word, the writer knows that it is essential to study this talk with an open mind. A great deal of information is presented here, which may enable the student to see circuits as a simple unit, rather than as a mass of unrelated details.

Takes the MYSTERY out of RADIO!

Just one book answers every question about this modern miracle

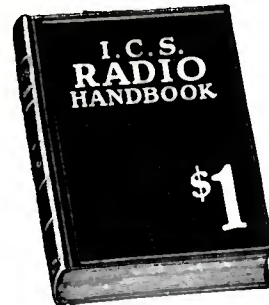

100,000 SOLD
514 PAGES

Compiled by
HARRY F. DART, E.E.
Formerly with the
Western Electric
Co., and U. S.
Army Instructor of
Radio.

Technically Edited by F. H. Doane

BE A RADIO expert—it's easy for the 100,000 who own this compact, complete Radio Handbook. Written in good, plain, understandable language. Cramped full of facts, every one useful and important. Explains how receivers and transmitters work, how to build and operate them. Whatever you or your friends want to know, it's here. Will save you many times its small cost.

TELLS ALL ABOUT: Electrical terms and circuits, antennas, batteries, generators and motors, electron (vacuum) tubes, every receiving hook-up, radio and audio frequency amplification, broadcast and commercial transmitters and receivers, super-regeneration, codes, license rules. Many other features.

Nothing else like it. Make this extraordinary book your radio library—just this one little giant is all you need. Everything in one index, under one cover, in one book, for one dollar. The biggest dollar's worth in radio to-day. Combines the knowledge of many expensive works. Buy this and save the difference. Stop experimenting in the dark. Before you spend another cent on parts or even touch a dial, sign and mail the coupon below and get this unique guide to successful radio. More than 100,000 sold.

Send \$1 to-day and get this 514-page I. C. S. Radio Handbook—the biggest value in radio to-day. Money back if not satisfied.

TEAR OUT HERE

INTERNATIONAL CORRESPONDENCE SCHOOLS
Box 6033, Scranton, Penna.

I enclose One Dollar. Please send me—post-paid—the 514-page I. C. S. Radio Handbook. It is understood that if I am not entirely satisfied I may return this book within five days and you will refund my money.

Name.....

Address.....

Check here and enclose \$1.50 if you wish the deluxe edition, bound in Leatheroid.



TRF-50
A handsomely carved cabinet—a most efficient 5-tube circuit with Unit Tuner—built-in Magnavox Reproducer. The receiver you have been waiting for; study the details.

MAGNAVOX

Receiving Sets which establish an authoritative standard of excellence for the daily enjoyment of radio.

LONG identified with the most efficient radio reproducing and amplifying equipment, Magnavox has developed its new Receiving Sets under conditions insuring superior design, precision of manufacture, and a gratifyingly low cost.

Exact tests prove that the Magnavox Receiver is not only the simplest to operate but one whose daily performance will satisfy the most discriminating.

Magnavox Radio Receivers, Vacuum Tubes, Reproducers, Power Amplifiers, and Combination Sets are sold by reliable dealers everywhere.

THE **MAGNAVOX** COMPANY, Oakland, California
New York: 350 West 31st Street San Francisco: 274 Brannan Street
Canadian Distributors: Perkins Electric Limited, Toronto, Montreal, Winnipeg

Receiving Sets

TRF-50 (as illustrated above)—is a 5-tube tuned radio frequency receiver with carved doors and built-in Magnavox Reproducer \$150.00

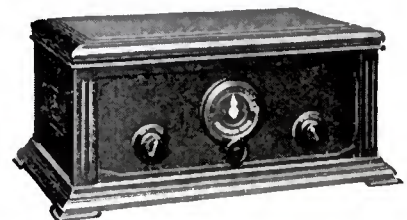

TRF-5 is identical with TRF-50 but encased in smaller cabinet without built-in Reproducer . . . \$125.00



Type A and Type D—Six-volt storage battery amplifier and detector tubes with standard base \$5.00

Starting With Pick and Shovel

(Continued from page 33)

Interviewing Mr. Heising is a pleasure because his answers are clear and direct. He is a successful lecturer at Columbia University; his scientific papers are so written that an expert is not required to decipher their meaning for the layman. His thinking processes bespeak not only an education but antecedents and boyhood circumstances and training fitting him for the career of an inventor. Hence I was surprised to learn that he came from a small North Dakota town and that he

swung his way out of it with a pick and shovel, tamping ballast with a railroad section gang. Even in boyhood, the instinct of invention manifested itself.

"A model steam engine was my first venture in experimental work," Mr. Heising said. "When I was fifteen years old, I took an old bicycle pump for the cylinder and cast a steam-chest on it with some babbitt metal. Then I improvised a boiler out of a tin can and after much adjusting the contrivance ran beautifully. One of the 'gang' was so much impressed that

he went off and bought some babbitt metal himself, but that was as far as he got. He hadn't thought of the patient, hard work that I had put into my model."

After some years of service as a section hand, Heising became a towerman. As towerman, he set out to learn the Morse code during his long trick, cutting in on a line for the purpose. When the unauthorized connection was discovered, the supervisor of signals yanked it out. But it had already served a purpose. Failing to obtain leave of absence to take college entrance examinations, Mr. Heising braved unemployment and was re-

**Further Indorsements of
The MOZART Baby GRAND**

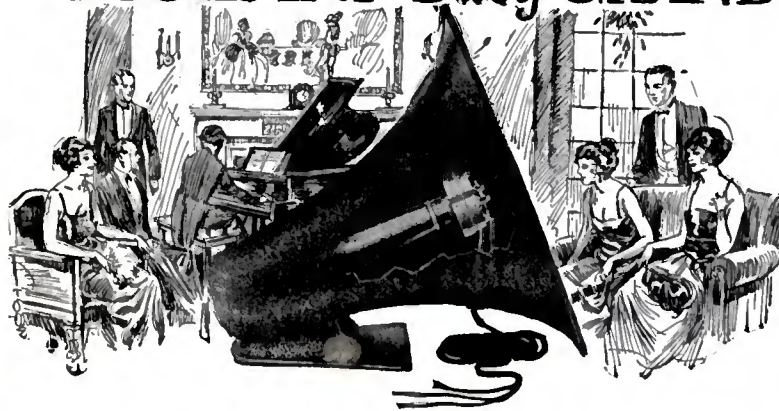

IT is a pleasure to quote this month part of an unbiased report from a noted firm of radio merchandisers, who have the reputation of knowing their business thoroughly.

"I made a personal test of your fine instrument in all of our five business places (cities as below) by direct comparison with (here are mentioned 14 of the leading instruments on the market today, including some which sell at more than three times our price).

The sets used for testing were: Reinartz 3 tube, Grebe 4 tube, Neutrodyne 5 tube and Superheterodyne 8 tube. The results follow:

City	Audibility	Resonance	Hyperacoustics	Percent
Fenton	Excel'.	Excel'.	Upper tones def'	95
Pontiac	Fair	Good	Flat	87
Detroit	Good	Excel'.	Thin at peak	90
Flint	Good	Excel'.	" " "	93
Lansing	Excel'.	Excel'.	Straight at curve	98
Total percent for your horn				92.60

Your highest competitive horns rank from total percentages of 42% minimum to 84.15 maximum.

Your instrument is easily worth \$40.00.

For the S. D. Radio & Elec. Co. (Signed) F. W. Dobbs, Fenton, Michigan.

PRICES F. O. B. Factory.

- Reproducer complete in black and gold crocodile finish with (gold plated) unit and cord..... \$12.00
- In black satin finish with nickel plated unit and cord..... 10.00
- Electro-Magnetic unit only (fits almost any horn or phonograph) with cord, gold plated, \$5.00; nickel plated, \$4.00.
- New Mozart-Radioceive Headsets..... 6.00
- Shipping weight of reproducer, 8 lbs. (approx.)
- Dimensions—Diameter of bell, 12 in. Length and height overall 12½ in. No extra Batteries required.
- Direct from the factory or through one of our authorized dealers.

The MOZART GRAND CO.

Manufacturers of Fine Instruments

NEWARK, N. J.

U. S. A.

Jones MULTI-PLUGS are supplied for panel mounting (see cut at right), for bracket mounting (see cut below) or for attaching to binding posts of any set (see cut at bottom of advertisement). Panel mounting type, complete with 8 foot cable, \$4.

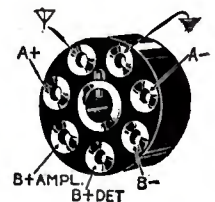

One pull!—



Bracket Mounting Type, complete, \$4.50
Mount bracket in set. Solder leads to the seven posts. Eight feet of cable supplied with each Jones MULTI-PLUG. All leads coded. Connect to ground, antennae, A and B batteries.

One pull on the Jones MULTI-PLUG instantly disconnects antennae, ground, A and B batteries from your set. One push reconnects. And it can't be plugged in wrong! Greatest convenience of the age. Eight foot cable permits placing batteries out of way—in basement, closet or elsewhere. Makes your set portable. All leads plainly coded.

**Jones
MULTI-PLUG
THE STANDARD SET CONNECTOR**

The only thing of its kind on the market. Enables anyone to connect your set with safety. Prevents burning out tubes or shorting batteries. Permits leaving a station in tune when you disconnect. Makes it easy to change tubes; to test sets; also to make adjustments in set without shorting anything.

100 per cent. foolproof. Standard on Zenith, Workrite and many other leading sets. Ask your dealer to put one on the set you buy, if it isn't already equipped. Carried by all jobbers. Any dealer can supply you. May be ordered direct by stating dealer's name. Folder mailed free!

Patent Applied For

HOWARD B. JONES
616 S. CANAL ST. CHICAGO

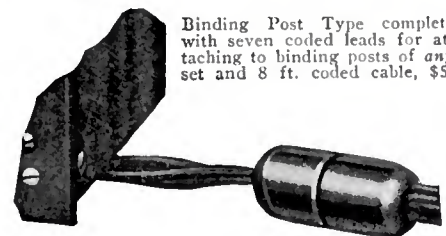

Binding Post Type complete with seven coded leads for attaching to binding posts of any set and 8 ft. coded cable, \$5.



A Message FROM MARS

THE possibility of radio communication with Mars is doubtful but the merit of the Rectigon battery charger is a certainty.

Tune up your radio batteries with the Rectigon. Keep the A and B batteries of your set in constant readiness to receive distant stations.

The Rectigon charges radio batteries over-night at less than one-tenth of the price paid for the same service at the battery station.

It charges Automobile batteries, too.

The Rectigon weighs only a few pounds and is no more trouble to install than a light bulb. Send for folders F-4584 and F-4585, they are revelations on battery charging.

Westinghouse Electric & Manufacturing Company
George Cutter Works South Bend, Indiana
Sales Offices in All Principal Cities of
the United States and Foreign Countries



Westinghouse

"Quality Goods for Quality Readers"

National VELVET VERNIER Condensers and Dials

TRADE MARK
REG. U.S. PAT. OFF.

PRICES of Condenser

(Including 3-inch Dial)

.001 \$7.00

.0005 \$6.00

.00035 \$5.75

.00025 \$5.50

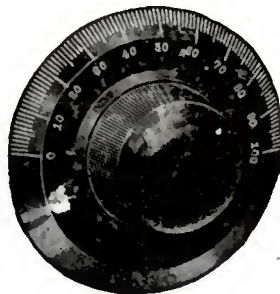
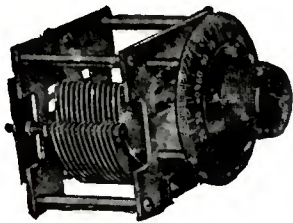

DIAL Only

4-inch, \$2.50

3-inch, \$2.00

“Perfect Resonance Control”

That's the way a satisfied purchaser of a NATIONAL VELVET VERNIER DIAL and CONDENSER describes the liquid smoothness and flexibility of this perfect slow-motion dial and low-loss condenser.

Perfect because of perfection of design and skilled craftsmanship. No grating — no backlash — no loss. Every part in perfect accord.

Lustrous finish and graceful lines give a “million-dollar-look” to the home-built set.

NATIONAL COMPANY

CAMBRIDGE

MASSACHUSETTS

warded by passing marks. He did well at the state university and went on to the University of Wisconsin for graduate study in physics. Then he became a Western Electric engineer and in six weeks had made his first invention.

During the famous transatlantic radio telephone tests in 1915, Mr. Heising had charge of the transmitting apparatus at Arlington. It was in the course of subsequent tests on experimental radiophone equipments that he devised the scheme of modulation which is used in all Western Electric radio broadcasting transmitters.

All this was still only a fair start for Heising. When the war came, he took radio up in the air. On July 2, 1917, he made the first talk from an airplane in flight to the ground. This followed his experimental work on the first airplane radio telephone.

Six weeks later he took part in the first conversation between airplanes in flight. When the experimental model was ready for production, Mr. Heising went to work on radio telephone sets for submarines, submarine chasers and tanks.

Since that time he has taken part in the development of ship-to-shore radiophone, short wave communication, and single-side-band high power transmission. In 1921, the Institute of Radio Engineers awarded him the Morris Liebmann Prize for his work on modulation in radio telephony.

While an invention needs that always intangible something which we call genius, it needs a mind with some very practical qualities, too. “An open mind, I believe, is one of an inventor's best assets.” says Mr. Heising, and no

Premier



This marvelous little audio frequency transformer requires half the space of any other. Unsurpassed for volume and tone quality. Unique construction. Self shielded core. Light and compact. Mounts anywhere. Ideal for portables. Write for Bulletin No. 94 showing full line of

Premier

Quality Radio Parts
PREMIER ELECTRIC
COMPANY

3807 Ravenswood Ave., Chicago

Ratios 1-3,
1-4, 1-5,
\$3.50
Ratio 1-10,
\$4.50

There is only one

GENUINE EBY Binding Post

“With Tops Which
Don't Come Off”

EBY Posts are scientifically designed, beautifully finished and their price is right.

This is our ENSIGN post which can be furnished plain or with engraved tops in 25 different markings.

EBYS are Binding Posts PLUS
H. H. EBY MFG. CO. Phila., Pa.



AMPLEX GRID-DENSER

More Distance!

WATCH the DX stations come tumbling in the moment you replace your fixed condensers with GRID-DENSERS. A turn of the knob and you have the exact capacity for your set. That's the secret of the GRID-DENSER!

When men like Cockaday, Haynes, Sleeper and Greff specify GRID-DENSERS in all circuits there must be a reason. Convince yourself by insisting upon GRID-DENSERS today! The louder and clearer signals will surprise you. In either the .0005 with \$1.25 or without gridleak clips or .001 type or type N (neutralizing)

FREE—Hook-up Booklet W-11

AMPLEX INSTRUMENT LABS.
88 W. 57th St., New York, N.Y.

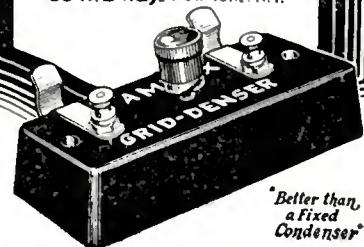

Better than
a Fixed
Condenser

“Quality Goods for Quality Readers”



"The Perfect Broadcast Receiver"

\$95⁰⁰

A New Superior Broadcast Receiver

**SIMPLE—LONG RANGE—HIGHEST QUALITY
NON-RADIATING—NON-REGENERATIVE**

**Completely Constructed
TRANSPORTATION PREPAID**

Two Stages Tuned Radio Frequency—Detector and Three Stages of Audio Frequency Amplification.



PLIODYNE 6
Front View Showing Simplicity of Control

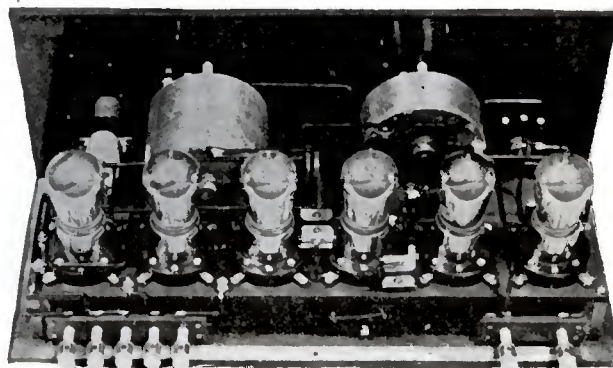

PLIODYNE 6
Interior View Showing Compact and Efficient Design

A New Marketing Plan

Rather than sell this high grade receiver to wholesalers at \$190.00 less 50% discount we are going to sell it direct to you at wholesale, saving you \$95.00 and at the same time giving you the finest set that can be bought for twice the amount.

Inspect the "PLIODYNE 6" at Our Expense

We will send the "Pliodyne 6" C. O. D. transportation prepaid with privilege of inspection. If it does not appeal to you as the finest medium priced broadcast receiver you ever saw, return it to us at our expense.

Otherwise take advantage of

A Free Trial

Accept the C. O. D. and try the "Pliodyne 6" for five days, if you are not satisfied in every way return it at our expense and we will return your money.

Our Guarantee

We guarantee every GOLDEN-LEUTZ "Pliodyne 6" to be the finest broadcast receiver that can be manufactured using 6 tubes or less and to be satisfactory to you in every way and to reach you in perfect condition.

You take no risk whatever in sending us your order for unless you are completely satisfied with the receiver and with your saving you may return the receiver to us and we will refund your money.

Address

GOLDEN-LEUTZ, INC.
476 BROADWAY NEW YORK CITY

Licensed under Farrand Agreement and Hogan Patent No. 1,014,002

Note:—We reserve the right to withdraw the Free Trial Offer if our Factory Production is exceeded.—Golden-Leutz, Inc.

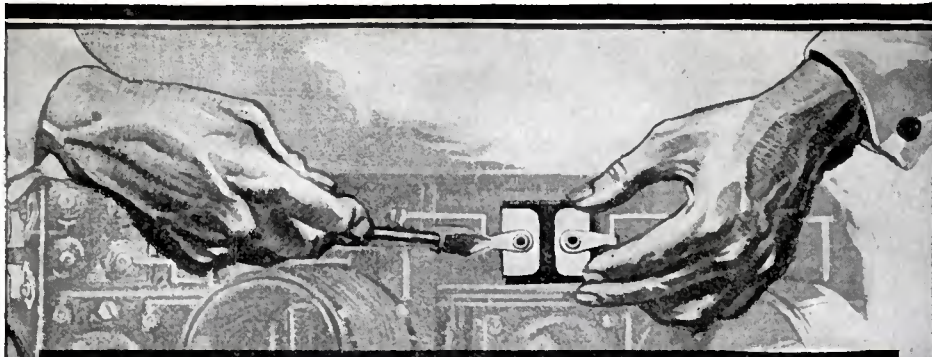

Nine out of ten sets use MICADONS

NINE out of every ten sets made use Micadons—the standard fixed radio condenser. Set builders choose them for many reasons.

They know that the Micadon is a Dubilier product: hence supreme in quality and efficiency.

They know that Micadons can be obtained in accurately matched capacities and the capacity is permanent.

They know that Micadons are easily installed, equipped as they are with extension tabs for soldering and eyelets for set screw assembly.

They know that Micadons are made with type variations to meet every possible requirement.

For best results use Micadons

Dubilier

CONDENSER AND RADIO CORPORATION

ZENITH Super-Portable

A six-tube radio set, completely self-contained. Does not need to be opened to operate. Write today for full particulars and name of nearest dealer.

ZENITH RADIO CORPORATION
McCormick Building, Chicago

YOUR CRYSTAL SET

will work 400 to 1,000 miles if made by my plans. No tubes or batteries. Copyrighted plans \$1.00. Satisfied customers everywhere. Particulars free.

LEON LAMBERT

674 Kaufman Bldg. Wichita, Kansas

MORE PROFITS

To Dealers Who Buy Nationally
Advertised Radio Goods from Our
Bargain Catalog! Write for It Today!
AMERICAN RADIO & CO.
Dept. 6 WEST 14th ST. KANSAS CITY, MO.

"Quality Goods for Quality Readers"

one is better qualified to speak than he. "By an open mind, I mean one that is receptive to new ideas—one that is in wide and eager contact with the world—not only the world of things, but that of people who are to use what is invented, or fit the new things into systems which now exist. Your traditional inventor, out-at-elbows and often on the ragged edge of starvation, may be correct enough on the technical side, but he isn't in close enough touch with people to be able to produce something that the public will pay for. When I am working out a problem lots of ideas come into my head. Most of them are thrown out because they fail to measure up to one or more of the yardsticks that my experience has set up. The ones that look promising I develop further and then talk them over with my associates. These informal conferences are one of the big advantages of the large engineering organization. Not only do they keep me in touch with developments in adjoining fields, but, by giving me others' points of view, they save me from following leads which others have proved to be blind."

Although it is probable that Heising will be best remembered for his discovery of modulation, his contributions to the radio art are by no means limited to it. He, more than any other man, is responsible for the development of single side band transmission, destined to make commercial transatlantic telephony a possibility.

Briefly, single side band transmission is a method of suppressing the carrier and one of the two side bands which are supplied to the antenna in

Right from the Sky with the

UNCLE SAM MASTER TUNING COIL

Mr. L. E. Brown, writing in the New York Sun Radio Section of August 30th, regarding the reception of Broadcasting from Lieut. Brandt's DeHaviland plane speeding at 75 miles per hour, 3000 feet above New York, states:

—"and N. T. G., who was at Pali-sades Park trying to pick him up with an EIGHT TUBE SUPER-HETERODYNE, SEEMED TO BE HAVING TROUBLE. Although we had only half of this, four tubes hooked up with an UNCLE SAM COIL we brought the whole thing in on the loud speaker as clear as a bell."

Price \$5.50 everywhere

FREE!

Ask your dealer or write direct for circuits in which this remarkable coil can be used.

UNCLE SAM ELECTRIC CO.
221 E. Sixth St.
Plainfield, N. J.

THE ONLY LICENSED ALL TUBE TUNER

for scientific tube tuning

With the new and improved FIL-KO-STAT you get a battery switch that fits the FIL-KO-STAT mounting screws. This switch—"at your finger tips"—enables you to turn the current "on" or "off" without disturbing the FIL-KO-STAT'S adjustment and it distinctly signals "on" or "off". FIL-KO-STAT is the only radio rheostat enabling you to get maximum reception, bringing in stations you never heard before and cutting out tube noises. It lengthens tube and battery life and permits infinite adjustment of any type tube in any hook-up. It's unconditionally guaranteed.

FIL-KO-STAT

SCIENTIFICALLY CORRECT RADIO RHEOSTAT



\$2

In Canada \$2.75

to eliminate leakage losses

You lose many DX stations through leakage in the antenna circuit. Make sure all radio impulses reaching the antenna reach your radio set. The FIL-KO Lightning Arrester will help you, because it's "Umbrella" shield keeps dust, rain, etc., from the moisture-proof, hermetically sealed Bakelite insulation and prevents partial grounding of the antenna. And what's more the FIL-KO-ARRESTER carries a guarantee that's virtually an added insurance policy. You get positive protection for \$1.50

The Use of
FIL-KO-PARTS
for Radio
Guarantees Satisfaction.
The Reputation
of the Makers
stands back
of the Guarantee!

FIL-KO-LEAK

SCIENTIFICALLY CORRECT VARIABLE GRID LEAK



individually calibrated

\$2

In Canada \$2.75

for correct grid bias

Unless the grid potential is precisely correct, incoming radio frequency impulses will be "blocked" FIL-KO-LEAK is the only variable grid leak that you can set for a specified resistance and adjust for best results. Each one is hand calibrated and doubly checked over the operating range for all tubes— $\frac{1}{2}$ to 5 megohms. FIL-KO-LEAK is not affected by atmospheric conditions or wear. Markings are read through panel peep-hole. Tablemounting bracket furnished. And it's unconditionally guaranteed for service and accuracy.

FIL-KO-ARRESTER

SCIENTIFICALLY CORRECT RADIO LIGHTNING ARRESTER



with the \$100 Guarantee

\$1.50

In Canada \$2.05

improved reception

Send 2c postage for our free booklet "Improved Radio Reception Through Scientific Tube Tuning." Tells about vacuum tubes, how to control them to get more DX, greater volume, etc. Write to Dept. RN 1124.

FIL-KO-SWITCH is made of non-magnetic metal. Wiping contacts, entirely insulated from the nicked brass housing and knob, assure sharp, clean "make and break." Scientifically correct to avoid current leakage and added capacity. And unconditionally guaranteed.

FIL-KO-SWITCH

SCIENTIFICALLY CORRECT "A" BATTERY SWITCH



Simple Sturdy Sure

50¢

In Canada 70c

DISTRICT SALES OFFICES
SAN FRANCISCO - 648 HOWARD ST.
SEATTLE - 101 SPOKANE ST.
Address All Mail to Dept. WA-1134, Harrisburg

MADE AND GUARANTEED BY
DX INSTRUMENT Co.
HARRISBURG - PENNSYLVANIA

DISTRICT SALES OFFICES
NEW YORK 342 MADISON AVE.
CHICAGO - MANHATTAN BLDG.
ST. LOUIS - 915 OLIVE ST.

EISEMANN

ELECTRICAL EQUIPMENT

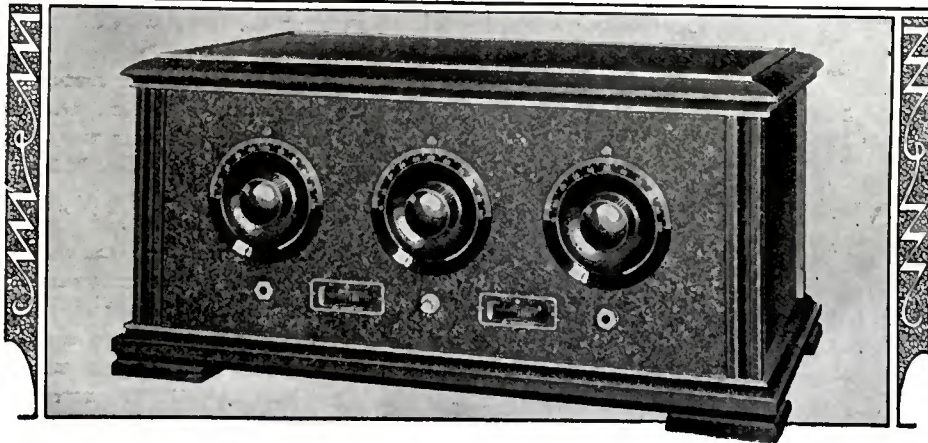

Choose Wisely

SPECIFICATIONS

Circuit: Two stages of tuned radio frequency amplification, detector and two stages of audio frequency amplification. Non-oscillating. Non-radiating. Astatic transformers used to minimize mutual induction.

Tubes: Five in all. Jacks provided for either five or four tube operation.

Batteries: Either storage or dry-cells.

Cables: Complete set supplied for "A" and "B" batteries.

Wave lengths: 200 to 600 meters, with uniform efficiency of reception.

Aerial: 75 to 125 feet, single wire.

Panel: Aluminum, with attractive crystal black finish. A perfect body capacity shield.

Dials: Sunken design. Shaped to fit the hand and permit a natural position in tuning.

Rheostats: Adequate resistance for all standard base commercial tubes.

Condensers: Single bearing, low leakage losses.

Sockets: Suspended on cushion springs which absorb vibrations.

Cabinet: Mahogany, with distinctive lines and high finish. Ample space provided for "B" batteries.

IN selecting a broadcast receiver, it is well to distinguish between essential and non-essential considerations.

The circuit is important, insofar as it affects performance, but the mysterious trick names now so much in vogue are not.

Type 6-D combines the only three things that constitute true value—efficient performance, attractive appearance and fair price.

Speech and music are reproduced without distortion. Far distant stations are received with generous volume. The selectivity is extraordinary—even powerful, local broadcasting stations tune sharply. The 6-D is non-oscillating and non-radiating, with unvarying reception efficiency at high and low frequencies.

In appearance, the 6-D is strikingly attractive—a handsome mahogany cabinet, symmetrical panel layout and perfectly proportioned interior construction.

Be sure to examine the Type 6-D Receiver before you make a final selection.

ordinary radio telephony. An analysis of a modulated wave shows that we have a central frequency—the carrier—and two side bands, or groups of currents, each the mirror-image of the other. The group below the carrier is known as the lower side band; the other is the upper. By suppressing one of these, a considerable saving in power is effected; only half the wavelength space in the ether is occupied; one of the principal causes of fading is overcome and reliability of transmission considerably improved.

Harvest Time on the Air

(Continued from page 21)

Applied Art, Household Furnishings, January 8 to February 26, includes problems involving the selection, construction and care of household furnishings needed in the average home.

Economic Aspects of Botany, February 6 to February 27. A few of the important phases of botany in relation to agriculture will be outlined.

Entomology, Insects and Their Control, February 6 to February 27, is a discussion of the part insects play in agriculture, the losses due to insects, and the more outstanding reasons for this damage. The course then deals with a summary of the life processes and activities of insects as a group, the fundamentals which form the basis of insect control and the agricultural practices which are of such importance in dealing with cereal crop insects.

Beginning with March the course includes, The Sheep Industry, March 2 to April 20; The Housing of Poultry, March 3 to April 21; Civil Engineering as applied to local road work and the State System, March 4 to April 22; Agricultural Engineering and Farm Tractors, March 4 to April 22; Interior Decoration, March 5 to April 23; Human Nutrition, March 5 to April 23; Bacteriology, Rural Microbiology, March 6 to April 24, Economics and Sociology, the Four Claimants to Great Wealth, March 7 to March 27; and, Practical Phases of Zoology, April 3 to April 25.

These agricultural subjects, each of which extends over a period of from eight to twenty-four weeks are scheduled for broadcasting on Monday and Tuesday nights during the thirty-two weeks radio term.

The radio course of the Kansas State Agricultural College, as outlined here, is but a poor tribute to the really worth while manner in which that institution has laid out their program for common and general education, and forward marching social enlightenment. The writer will gladly furnish any specific information desired, either

Price, Without Tubes and Batteries, \$125.00



For Sale by Reliable Dealers

EISEMANN · MAGNETO · CORPORATION

General Offices: 165 Broadway, New York

DETROIT · SAN FRANCISCO · CHICAGO

"Quality Goods for Quality Readers"



Easy to Operate

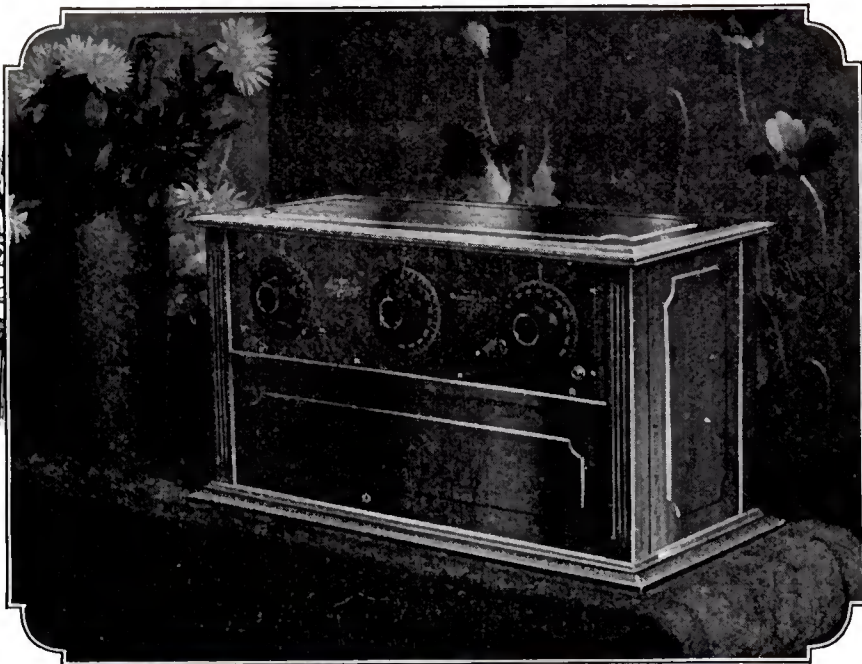

Simple to Control

WHEN you own a Radiodyne you can tune in on broadcast programs without wasting time tinkering. The Radiodyne shuts out interference from nearby stations. By simply adjusting the dials as indicated on the Radiodyne chart you can select the stations you wish to hear. All batteries are enclosed in the beautiful two-tone mahogany cabinet.

*Uses a 25 Foot Lamp
Coil for Summer
Reception*



*Wife Gets Good Results
After Two Minutes
Instruction*

"We are getting constant reception this summer from stations 500 to 1,000 miles away on loud speaker with a 25-foot length of lamp coil. I got Los Angeles, San Francisco and Cuba."

Bernard S. Slay, Minneapolis, Minn.

"I gave my wife two minutes instruction and left her alone with the Radiodyne. When I came back she said that signals had been roaring in all evening and had a log to prove it."

Robert Seldon Rose, Marquette, Mich.

Write for illustrated folder which describes the Radiodyne in detail. If you buy a radio before you have a demonstration of the Radiodyne you will surely regret it.

Western Coil & Electrical Co., 316 Fifth St., Racine, Wis.

"Quality Goods for Quality Readers"

Why be Satisfied with a Jumble of Interfering Stations?

Install a New York Low Loss Grounded Rotor Variable Condenser in Your Present Set and receive the Full Pleasure of Broadcasting

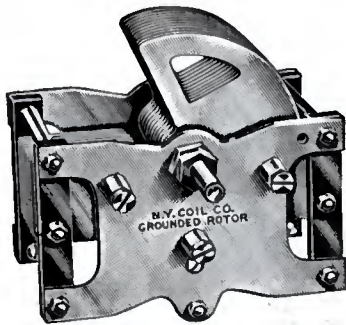

Without Vernier

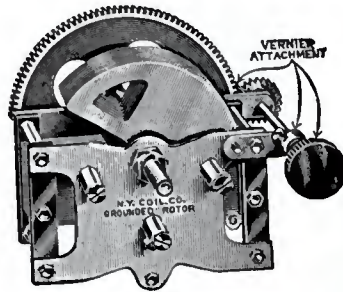

With Vernier Attachment

OUR NEW LOW LOSS CONDENSER is in a class by itself—superlatively better—no other condenser manufactured incorporates so many vital improvements.

.0005 (23 plate) without Vernier **\$4.50**

Geared Vernier attachment, complete, \$1.50

Unequalled for Super-Heterodyne, Neutrodyne and all exacting circuits.

New York Distortionless Audio Transformers

bring real music with true tone quality from the far distant stations instead of the undesirable noises you have been accustomed to hearing. No change in construction since their inception—three years ago. 4 1/4 to 1 ratio and correct engineering responsible for their superiority. Price \$4.00.



PRECISION MICA FIXED CONDENSERS

"More Uniform Capacity"



Adapted by Leading Heterodyne Manufacturers on account of truthful capacity rating

This is the only laboratory precision-built condenser on the market, yet sold at a commercial price. It is standard equipment with some of the largest and most discriminating set manufacturers.

Guaranteed for capacity and against leakage or breakdown.

The following sizes always in stock:

Capacity	Retail Price
.0001 Mfd.	.35
.00015 Mfd.	.35
.00025 Mfd.	.35
.0005 Mfd.	.35
.001 Mfd.	.40
.002 Mfd.	.40
.005 Mfd.	.60
.006 Mfd.	.75
.00025, with Grid Leak Mounting attached, 45e list.	Type C

NEW YORK COIL COMPANY

338 Pearl Street, New York City, N. Y.

Pacific Coast—MARSHANK SALES CO., 1240 S. Main St., Los Angeles, Calif.

concerning this or other broadcast station schedules for the season just begun.

Broadcast programs of this character will surely promote a contented agriculture. A contented agriculture in America means our individual betterment economically.

Alias Slimmy O'Dyne

(Continued from page 29)

sickening seconds. I thought my plan had failed; and then I was delighted to find myself shoved out of the way so violently that I rolled all across the room into a corner, while the voice of Mr. Adolphus St. John, exceedingly thick with cough medicine and fury, roared;

"Combination, eh? You get out the way and let somebody try that knows what's what. My Lord, what's in this darn thing, anyway? Bullion?"

In my corner, I got to my knees.

"You can't do anything with that,"

I said almost tearfully.

"I was crackin' tougher ones than this when I was fourteen years of age," says Adolphus St. John, putting his ear on the end of one knob and twirling it gently.

"We're wasting time while you fool around with it!" I shouted, getting to my feet, in which position I could reach my gun more quickly.

The speed with which he reached his, only one hand being at liberty, certainly did make me glad I'd spilled all the cartridges, back at Five Mile.

"You siddown," snarls Mr. St. John. "You siddown an' be quiet, mister. If you think Slimmy Peters is gonna have his girl taken from him, much less let any five cent combination stand in his way—"

Well, this confession that he actually was Slimmy Peters, and not a mere impostor I should get into trouble for arresting, was all I had wanted to know. And it seemed to me that his safe-breaker's tricks, if permitted to proceed, might do damage to the radio set; so I took a good spring, and, as you might say if you were so disposed, fell on Mr. St. John, with my knee on his nose. That should have settled him; it's been enough for many a better man than he was; but either from the effects of the cough medicine, or from suspicion that he was trapped, my prisoner seemed to draw new and unpleasant stamina. I shall never forget, if I live to be a hundred and four, the crisp, snappy way he caught hold of my ears and hammered my head against the leg of the table. I don't know now how I got loose and gained my feet; though the insertion of my thumb in his eye may have had something to do with it; anyhow, he was

Learn the Code at Home with the Omnigraph

"Just Listen—The Omnigraph will do the teaching"

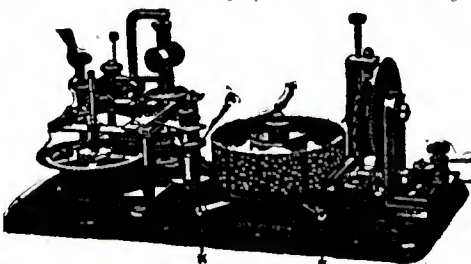

THE OMNIGRAPH Automatic Transmitter will teach you both the Wireless and Morse Codes—right in your own home—quickly, easily and inexpensively. Connected with Buzzer, Buzzer and Phone or Sounder, it will send you unlimited messages, at any speed from 5 to 50 words a minute. THE OMNIGRAPH is not an experiment. For more than 15 years it has been sold all over the world with a money back guarantee. THE OMNIGRAPH is used by several Depts. of the U. S. Govt.—in fact the Dept. of Commerce uses THE OMNIGRAPH to test all applicants applying for a radio license. THE OMNIGRAPH has been successfully adopted by the leading Universities, Colleges and Radio Schools. Send for FREE Catalog describing three models. DO IT TODAY.

THE OMNIGRAPH MFG. CO.
16B Hudson St. New York City

If you own a Radio Phone set and don't know the Code—you are missing most of the fun

"Quality Goods for Quality Readers"

Geared 80 to 1 Ratio

A ratio proven the most practical after scientific tests



Improved!
NO BACK LASH

No ordinary standards of tuning efficiency can be applied to the new improved Accuratune Micrometer Control.

Special construction of this new model offers these superior advantages:

1. **Eliminates all back lash**—Gears and gear train operation designed upon scientific engineering principles, producing quiet operation, eliminating all lost motion and back lash. The greatest advance in tuning devices. Increases the tuning efficiency over that of any known tuning device.
2. **Fits all standard Condenser Shafts**—Accuratune Micrometer Controls fit all standard shafts and mount to always operate parallel with panel.
3. **Flush Panel Mounting**—Take all standard condenser shaft lengths and fit flush with panel. Eliminates the necessity of cutting off shafts before mounting dial.
4. **Geared 80-1 Ratio**—Permits infinitely close tuning with perfect ease. A practical ratio—not too low nor too high.

Accuratune Micrometer Controls log station after station you never tuned in before. Indispensable on all Super-Heterodynes. Price, \$3.50. At your dealers, otherwise send purchase price and you will be supplied postpaid.

Beautiful silvered etched metal disks, making a pleasing contrast between bakelite panel and dial, with finer graduations for finer tuning.

A new principle takes up all lost motion and back lash and produces a very smooth operating instrument.

*Radio Ltd.
Montreal-Canadian
Representative*

ACCURATUNE

80 - 1

MICROMETER CONTROLS

THE MYDAR RADIO CO.,

9-A Campbell Street,

Newark, N. J.



So little to do—such great results

Never has there been entertainment, so much and so fine, that was so little trouble and expense as with radio.

Good programs without limit when that storage battery of yours is fully charged and ready. Perfectly easy and simple if you have the Tungar, which recharges the radio or auto battery overnight from the house current.

Sold by Electrical, Auto-accessory and Radio dealers.



Tungar is one of the many scientific achievements contributed by the G-E Research Laboratories toward the wonderful development of electricity in America.

Tungar Battery Charger operates on Alternating Current. Prices, east of the Rockies (60 cycle Outfits)—2 ampere complete, \$18.00; 5 ampere complete, \$28.00. Special attachment for charging 12 or 24 cell "B" Storage Battery \$3.00. Special attachment for charging 2 or 4 volt "A" Storage Battery \$1.25. Both attachments fit either Tungar.

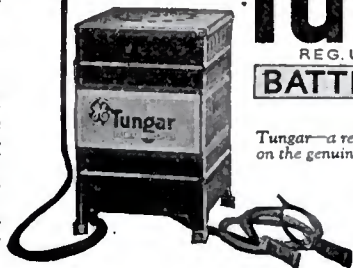

Tungar
REG. U.S. PAT. OFF.
BATTERY CHARGER

Tungar—a registered trade mark—is found only on the genuine. Look for it on the name plate.

Merchandise Department
General Electric Company
Bridgeport, Connecticut

GENERAL ELECTRIC

48E-12

Make \$100 Weekly—sell RADIO

Demonstrate once—results mean sure sale. Coast to coast, lowest prices, attractive four-tube instrument \$39.50. Big commission to you. Exclusive territory to proven salesman. Territory going fast, write today for large illustrated book No. 100. Don't fail to give name of your county.

OZARKA, INC.
822 Washington Blvd., Chicago, Ill.

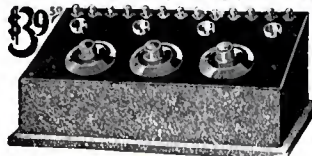

Big Profit

DEALERS WRITE FOR QUICK SELLING KITS RADIO PARTS WHOLESALE ONLY

HAROLD M. SCHWAB, INC.
55 VESEY ST., DEPT. WAN
NEW YORK CITY, N. Y.

"Quality Goods for Quality Readers"

blinking his off lamp when he rushed at me again. My idea was to keep him at arm's length, my arms being longer than his; but he wouldn't play that game—endeavoring instead to catch me around the middle and at the same time butt me in the stomach with his head. I thought I'd frustrated this knavish trick by stepping aside and letting him butt the radio table instead; but even this only struck him as an opportunity for further evil. In a fraction of a second, he'd grabbed the whole works off the table—the box, and the aerial, and about half a dozen batteries that clung to it by pieces of wire, swung it around his head twice, and hurled it at me. It was the aerial that came undone and spun a cocoon around me as I dived for Mr. St. John's ankles. If I hadn't ducked just in time, it would have been the receiving set that knocked my brains out. As it was, the machine landed at the head of the stairway with a sickening crash, and then slowly bumped from one step to another, all the way down. I heard a scream of agony, and knew that old Grizzly Chase must be somewhere near at hand; but I was too busy to do any comforting of him just then. Mr. St. John had got a grip on my throat, and was just strangling me over the borderline into unconsciousness, when I grabbed hold of something which I later learned was a battery containing 22½ volts, and hit him behind the ear with it. It wasn't a large battery, but it did the work. Mr. St. John rolled off me and lay perfectly still. Those volts must be mighty heavy things.

HOWARD



No. 1001
6½ Ohm Rheostat\$1.00
25 Ohm Rheostat\$1.10
40 Ohm Rheostat\$1.10

HOWARD



No. 1003
200 Ohm Potentiometer\$1.50
500 Ohm Potentiometer\$2.00

HOWARD



No. 1004
Multi Terminal Receiver Plug. Instantaneous connection for as many as six pairs of standard receiver plugs\$2.00
Patd. Aug. 28, 1923

HOWARD



No. 1002
6½ Ohm Rheostat\$1.50
25 Ohm Rheostat\$1.50
40 Ohm Rheostat\$1.50
Patd. July 10, 1923

HOWARD

Ask the man at the counter to show you the Howard line of Quality Radio Merchandise. Every piece is sold with the guarantee of satisfactory performance.

Our standard rheostats are SINGLE HOLE MOUNTING and are furnished with DIAL or with KNOB and pointer as desired.

Jobbers write for discounts. Send 2c stamp for wiring diagram and folder.



4248 N. Western Ave.



Positive Contact Always Maintained

Poly Plug

The tension slot, a big feature of POLY PLUG, permits the phone cords to be pulled and jarred without the slightest disturbance to the contact.

Eliminates every inconvenience so annoying in the operation of the unsatisfactory screw type plug.

No necessity to take POLY-PLUG apart—not a single screw to tighten.

At your dealers or sent post-paid on receipt of purchase price. **75c** "worth it"

Polymet Mfg. Corp.
70-74 Lafayette Street
New York City

The New ACORN Enameled RIBBON AERIAL

Now enameled and weather proofed—will give unlimited service, regardless of time or weather. Not a strip of flat copper, but a Laboratory product in which resistance, capacity and strength have been calculated for best results.



3 New Features

1. Pure Copper ENAMELED and weather-proofed.
2. Improved buckle, permits adjustment of length.
3. No-solder fastening gives greater strength

BETTER TONE Distance, Selectivity

Thousands of letters from users say their reception has been revolutionized by "ACORN" Enameled Copper Ribbon Aerials. Don't blame your set for poor results. Install this wonder-aerial on our positive guarantee to improve tone, distance and selectivity or money refunded.

New Window Lead-In

No. 1—Triple Insulated 35c
No. 2—Window Lead-In 25c

If your dealer will not supply you order direct from factory

ACORN RADIO MANUFACTURING CO.
Dept. 100A 307 W. Lake St. Chicago, Ill.

Members of R.M.A. and N.R.T.A.



take the key with you!

PROTECTION for tubes and batteries

WALBERT FILAMENT LOCK SWITCH

Safeguards Tubes and Batteries

New! 75c

The Walbert Safety Rim Socket is guaranteed not to break at the slot. Special heavy bakelite design decreases interelement capacity thereby utilizing all available grid voltage for producing signals. (New tubes have bakelite bases for same reason) Soldering lug and double-spring contact integral.

YOU don't need to worry any more about someone meddling with your radio set while you are away. Simply remove the key (smaller than standard plug) from the Walbert Filament Lock Switch and take it with you just as you'd take the ignition key from an auto. Your tubes and batteries will be fully protected.

Put this combination filament control switch and safeguard on your set today. Attach it in a few minutes. It's very compact—takes little room on panel or behind it. Sturdy interior phosphor bronze springs assure positive contact. Shell and key handle insulated from circuit. Costs no more than an ordinary battery switch.

WALBERT FILAMENT LOCK SWITCH 50c

At your dealer or sent postpaid on receipt of 50c. (Please mention dealer's name.)

Jobbers and Dealers: Write for Discounts.
THE WALBERT MANUFACTURING CO.
925 Wrightwood Avenue Chicago, Illinois

WALBERT Parts with a Purpose

Send 2c for UNIVERNIER Log-book.

ALL WALBERT PRODUCTS PROTECTED BY PATENTS OR PATENTS PENDING, U. S. AND FOREIGN

SOLDER WITH INSULATION

At Least 1,000 Miles More Distance is the usual reward if you can solder without impairing the insulation of your set.

If you are building a radio-frequency amplifier you should read our free booklet:

"HOW TO SOLDER RADIO SETS"

Write for it
The Valley Forge Chemical Co., Valley Forge, Pa.



AMERICAN BRAND CONDENSERS

with the ~100 to 1~ Worm Drive Vernier

Finest Condenser Made and the Greatest Radio Value Offered the Public

23 PLATE, only \$5.00 In Canada \$7.00

AMERICAN BRAND CORPORATION NEWARK, N.J.

fits Grid Leak any mounting

FRESHMAN PLUNGER TYPE VARIABLE GRID LEAK

was designed especially for the non-technical set owner who can replace in an instant the fixed grid leak with this new, efficient cartridge type Variable Grid Leak: without requiring the change of a single wire.

At your dealer or by mail post-paid. Write for free catalogue.

65c

106-7th Ave. New York



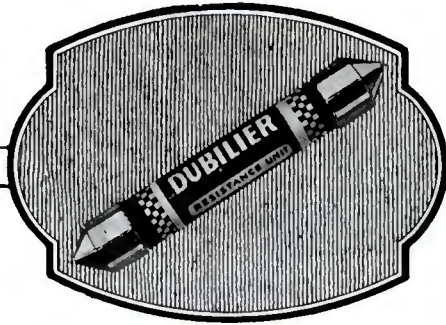

Price 50c.

Furnished in following Resistance values:
 .5 .75 1. 1.5 2. 2.5 3. 4. 5. megohms

The RESISTANCE UNIT

—Accurate and Efficient

A new Dubilier Product

The Dubilier engineers have perfected a resistance unit that is at once efficient, accurate and constant.

A good resistance unit will not change in resistance value with age. If it is marked 2 megohms it should have that same value to within commercial tolerance, after months of use.

It is easy to design a resistance unit but it has taken us years to produce one that is right—quiet, efficient and constant.

You will find that the Dubilier Resistance Unit greatly increases the range and efficiency of your set.

For a descriptive folder
 Address 43-45 West 4th Street, New York

Dubilier

CONDENSER AND RADIO CORPORATION

CARTER "IMP" BATTERY SWITCH

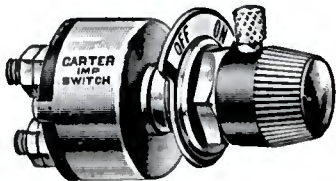

Actual Size—Pat. 1-30-'23

65c. each

Here's the switch you've been waiting for—again CARTER leads with an original Product. Small and compact in size. Mounts like a CARTER Jack. "On or Off" position clearly indicated at all times. Complete with name plate Knob and Pointer. Will carry 10 amperes. Ask your dealer to show you. Insist on the original.

In Canada—Carter Radio Co., Limited—Toronto

Factories:
 Chicago, Ill.
 Bristol, Conn.
 Hamilton, Can.



"Quality Goods for Quality Readers"

I arose to find Grizzly Chase looking at me with the expression of a tiger robbed of its young; while behind him stood McTee, and Pie Face Lammemoor, and Two-Toes Trotter, and several other folks, all staring at me with various degrees of pallor. Amelia Chase was among those present, too. She was bending over the slightly second hand form of Adolphus St. John, carrying on like a looney.

"We have with us tonight," says I, hoping to comfort her, and explain myself slightly. "Mr. Slimmy Peters, wanted in the State of Wyoming for breaking and entering, grand larceny, assault with a deadly weapon, manslaughter upon the person—"

She got to her feet and stared at me more like a hydrophobic wild-cat than anything else I can imagine in my present weak state.

"Was it to expose him you had these men kidnap me and keep me in a dirty tool-shed?" she stormed. "What do I care what he was—criminal or anything else? Look at his beautiful curly hair, all t-t-orn out by the r-r-r-oots!"

"Making a fool of me like this—and look at my radio set!" yells her papa.

Well, here we come back to what we started with—the inability to give credit where credit is due; the lack of justice, as you may say. Of course, Slimmy Peters got justice—fourteen years of it; but it's justice from private parties I'm thinking about.



TRADE MARK
REG. U. S. PAT. OFF.



Radio &

Audio Frequency

TRANSFORMERS

Buy one Now!
 you'll buy
 more later.

MARLE ENGINEERING CO.
 ORANGE, NEW JERSEY



Edson Will Allow You \$4.00 for Your Old Headset

Another Edson achievement—the creation of a 4000-Ohm Edson Super DX Phone—enables us to make a most unusual offer.

SPECIAL OFFER: We will allow you \$4.00 each on your old headsets—regardless of age, make, or condition—to apply on the purchase price of from one to four \$8.50 Edson Super DX 4000-Ohm Headsets. **YOU SAVE \$4.00** on each phone ordered by using the Special EXCHANGE COUPON below. Limit: four phones to a family at special introductory price. Simply mark your name and address plainly on the package containing your old headsets and send remittance by Money Order or Registered Mail, enclosing coupon below. Act quickly; quantity limited.

Dealers: Write for our wonderful selling plan.

Faithfully reproduces the lowest and highest tone signals that come in on your receiving set. Fully guaranteed. Regular price \$8.50. **SPECIAL INTRODUCTORY PRICE WITH COUPON, \$4.50**, including phone plug.



EDSON RADIO SALES CO.
ELMWOOD PROVIDENCE, R. I.

Special EXCHANGE COUPON

This coupon and your old headsets entitle you to an allowance of \$4.00 each on from one to four 4000-Ohm Super DX Phones, valued at \$8.50 each. You pay only \$4.50 for each phone ordered.

(WA-11)

FREE

To Each Purchaser of a **World Battery**

A 24-Volt "B" Storage Battery positively given FREE with each purchase of a WORLD "A" Storage Battery. The WORLD Battery is famous for its guaranteed quality and service. Backed by years of Successful Manufacture and Thousands of Satisfied Users. You save 50%.

Prices That Save and Satisfy

Auto Batteries	Radio Batteries
6-Volt, 11 Plate \$12.25	6-Volt, 100 Amps. 12.50
6-Volt, 13 Plate 14.25	6-Volt, 120 Amps. 14.50
12-Volt, 7 Plate 17.00	6-Volt, 140 Amps. 16.00

Shipment Express C. O. D. subject to examination. 5 per cent discount for cash in full with order.

2-Yr. Guarantee Bond in Writing With Each World Storage Battery

proves satisfactory World performance. Mail this ad with your name and address—we will ship battery day order is received; and give you your choice of "B" Storage Batteries or a handsome nickel finish Auto Spoilite. **FREE. Write TODAY.**

WORLD BATTERY COMPANY
1219 So. Wabash Ave. Dept. 27 CHICAGO, ILL.

This FREE "B" Storage Battery takes the place of dry cell "B" batteries. Can be recharged and will last indefinitely. To be sold retail for \$6.00. It is the only battery of its kind equipped with solid rubber case—and insurance against acid and leakage. Take advantage of this remarkable introductory offer NOW. (To those who prefer it, we will send FREE a handsome nickel finish Auto Spoilite, instead of the "B" Battery. Be sure to specify which is wanted.)

GIVEN FREE

To introduce this new and superior World "B" Storage Battery to the Public

The Complete Efficient and Economical Aerial

ANTENELLA

No Aerial or Antenna Needed

Why pay \$10.00 or more to have an aerial spoil the appearance of your home? Antenella eliminates all unsightly wiring, lightning arresters, etc., and precludes the possibility of dangerous grounding on a power line. It also stops "canary bird" re-radiation from nearby oscillating sets interfering.

\$1.25

ANTENELLA is not only a real distance getter, but also overcomes troublesome static.

At your Dealer, otherwise send purchase price and you will be supplied postpaid.

Gas. Freshman Co. Inc.
Radio Condenser Products
106 Seventh Ave. New York

HOLLOW Radio Aerial IS NOT A STRANDED WIRE

The Solid Core which means added weight and resistance has been eliminated! The Exposed surface which means Stronger Signals has been increased!

You wouldn't expect good results from a weak Battery—then why expect results from a weak Aerial? Write for Circular.

At Your Dealers or Sent Direct

The American Display Company
Dayton, Ohio U. S. A.

75 FEET **PRICE \$5.00**

BAKELITE

TRADE MARK U.S. PAT. OFF.

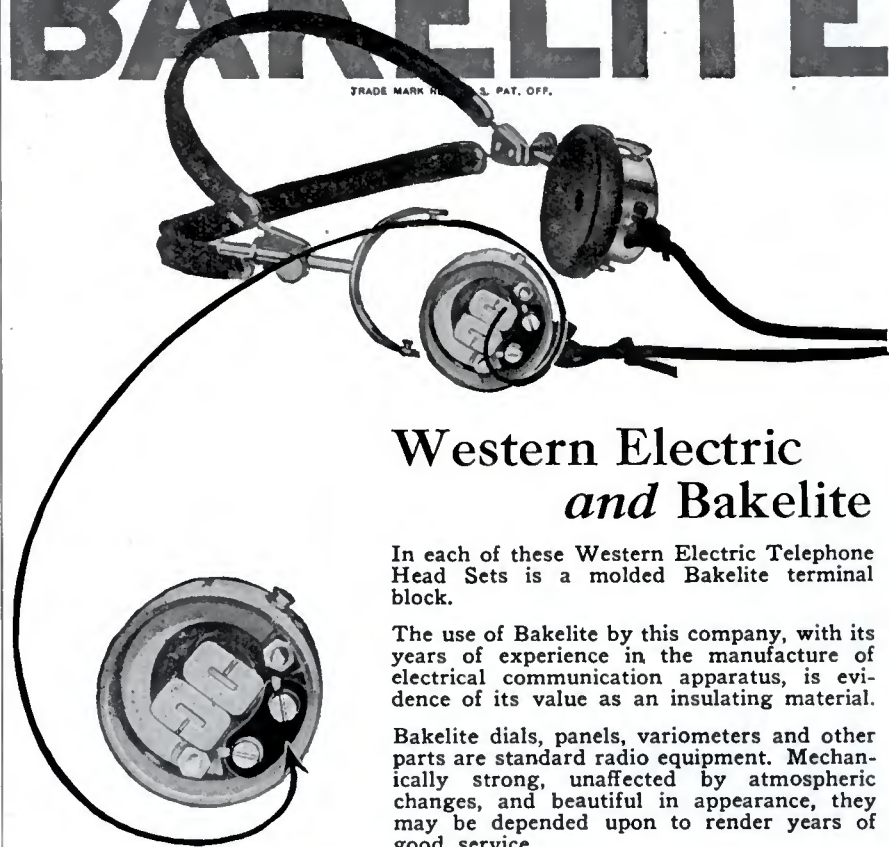

Western Electric and Bakelite

In each of these Western Electric Telephone Head Sets is a molded Bakelite terminal block.

The use of Bakelite by this company, with its years of experience in the manufacture of electrical communication apparatus, is evidence of its value as an insulating material.

Bakelite dials, panels, variometers and other parts are standard radio equipment. Mechanically strong, unaffected by atmospheric changes, and beautiful in appearance, they may be depended upon to render years of good service.

Send for our Booklet A.



BAKELITE
Condensite
REDMANOL

are the registered Trade Marks for the Phenol Resin Products manufactured under patents owned by **BAKELITE CORPORATION**

BAKELITE CORPORATION

247 Park Avenue, New York, N. Y.
Chicago Office: 636 West 22d Street

Send for our Radio Map

The Bakelite Radio Map lists the call letters, wave length and location of every broadcasting station in the world. Enclose 10 cents to cover the cost and we will send you this map. Address Map Department.

THE MATERIAL OF A THOUSAND USES

I mean—supposing old man Chase's radio set did get a bit smashed; still, how about me? Wasn't it my brains, and my mescal, and my book, and my play-acting, that saved him from having his daughter marry a criminal?

Yes—but he doesn't see that. All he does see is his machine, with all the microfarads knocked out of it.

Then on the other hand—even if I did have just a little to do with Slimmy Peters' capture, surely any reasonable human being can see that the radio machine was what really made him give himself away, it looking so much like the front of a safe.

But do you think Amelia Chase blames it?

No.

It was *my* face she scratched.

The Study of Mars

(Continued from page 31)

Mars (4,200 miles), and twice the diameter of Mars does not greatly exceed the earth's diameter (7,920 miles). As to the weights or masses of these bodies, Mars is about one-ninth, and the moon one-eightieth of the earth. The atmospheric envelope of the earth is abundant, the moon has none as far as we can ascertain; so it seems safe to infer that Mars has an atmosphere of slight density; not dense enough to be detected by spectroscopic methods, but yet dense enough to enable us to explain the varying telescopic phenomena of the planet's disk which we should not know how to account for, if there were no atmosphere whatever. One astronomer has, indeed, gone so far as to calculate that in comparison

Ingenious The "SELF ADJUSTING" Rheostat



\$1.10

Write for FREE Hook-ups

everywhere

AMPERITE controls perfectly and automatically the current flow from battery to tube. No Rheostat knobs on panel to turn. No ammeter needed. No worry. One AMPERITE for each tube inside the set regulates current on thermo-electric principle. Simplifies wiring and operation. Facilitates tuning. Proven in use. Adopted by 50 set manufacturers. Be sure your set is equipped with AMPERITE

RADIALL COMPANY
Dept. WA-3, 50 Franklin St., New York

AMPERITE

"means right amperes"

FARAWAY RADIO

\$29.50
Gets stations Far and near Loud and Clear

FARAWAY Radio Sets are amazing values at bargain prices. Users get stations from New York to Frisco—loud and clear. Operate with either dry cells or storage batteries. Beautiful cabinet finished in mahogany with new platinum-finished panel. SATISFACTION GUARANTEED. Don't pay \$100 to \$150. Write for our money-saving plan and literature.

2-Tube Set - \$29.50
4-Tube Set - 59.50

Dealers - Agents: Biggest possibilities you ever heard of. Write for plan and territory quickly.

THE FARAWAY RADIO CO., 636 W. THIRD ST., CINCINNATI, O.

TELEGRAPH AND RADIO INSTRUMENTS

FRAME CONNECTION No. 9007.

Open circuit Keys are recommended when it is desired to have two way communication between points without the use of closed circuit batteries.

Other types carried in stock.

No. 9037 Legless Key, Polished Brass Body.....6.00
No. 9035 Leg Key, Polished Brass Body..... 5.60

Send stamps for Telegraph Manual 43-W. Special Price to Dealers.

J. H. BUNNELL & CO. 32 Park Place, N. Y.

"Quality Goods for Quality Readers"

Why it is Better

LOOK at this illustration—see for yourself the eleven distinctive features in the construction of the Federal Condenser. Every feature is a distinct point of superiority—essential to clear, sharp tuning and clear reception.

You can get the outstanding advantages of Federal Tone and Federal Selectivity in your pet hook-up *only* by *insisting* on Federal Parts.

There are over 130 Federal Standard Radio Parts bearing the Federal iron-clad performance guarantee. Use them—for your own protection and enjoyment.

FEDERAL TELEPHONE and TELEGRAPH CO.

Buffalo, N. Y.

Boston New York Philadelphia Pittsburgh
Chicago San Francisco Bridgeburg, Canada



Federal

Standard **RADIO** Products

Original three point suspension assuring perfect alignment which prevents buckling or short circuiting of plates and affords 7/16 inch air dielectric between condenser head and panel. Template furnished with each condenser.

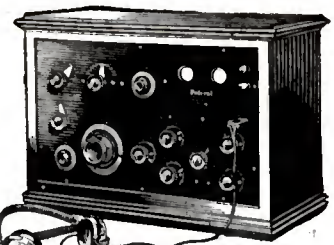

This is the rotor bearing with extra long brass bushing, machine-centered, true to 1/1000 of an inch.

Both rotor and stator plates are of aluminum of practically constant surface resistance, each held rigidly by large draw-bolts thus eliminating the use of solder and its inherent resistance.

All burrs are automatically removed from plates during a pack annealing process employed to straighten plates after punching.

Plates are micrometer calipered, positively insuring true spacing.

Over-size, hard brass jam nut affording a positive lock for rotor plates.

Special hexagon bearing lock nut.

Full quarter inch circular bakelite heads die-tapped and jig centered.

Exclusive female cone bearing, machine centered and provided with "star" spring to compensate for wear.

Federal 11 plate and 21 plate have minimum capacities never exceeding 10 micro-micro-farads while the minimum capacity of the 43 plate condenser is always less than 15 micro-micro-farads.

"Star" spring of special tempered steel to automatically correct alignment and maintain positive electrical contact.

Special jam nut and rotor terminal.

Machine ground male cone bearing Self centering.



THE SYMBOL OF SERVICE

CONTINENTAL

"New York's Leading Radio House"

Our Service is Your Service

Many years of both wireless and radio merchandising experience is back of Continental, "Service for the Dealer." This experience enables us to anticipate and meet the problems of the dealer in full measure.

We offer our Services as a dependable distributor to radio dealers who should logically buy in New York.

Remember! Dependability is an asset not to be considered lightly.

The Radiola Super VIII and Crosley 3-R-3 are two prominent receivers that offer great sales possibilities. We can supply you with these receivers. Write to us today!

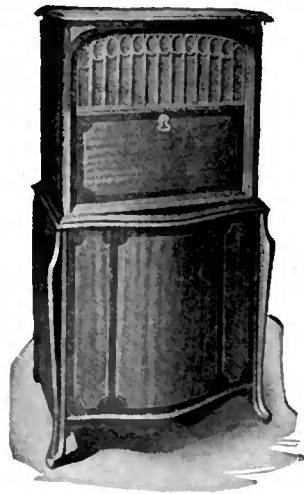

Radiola Super VIII



Trirdyn 3-R-3

Wholesale Distributors Only

2085-Q

CONTINENTAL RADIO & ELECTRIC CORPN.

15 Warren Street

New York, U. S. A.

"Quality Goods for Quality Readers"

The Powerful **GAROD** Neutrodyne*
Power + Plus



The Garod V
 Genuine mahogany highly finished cabinet—graceful 15° sloped genuine mahogany panel—carved feet, five-inch dials—double reading Weston volt-meter—5 tube model. Size 34 3/8" long—13 3/4" deep—11 3/8" high.
\$195.00

THERE'S far more than mere volume of tone in GAROD POWER.

For a more complete understanding of our meaning—we refer you to our old friend, Noah Webster—of dictionary fame. In his list of synonyms for POWER—you will find the following:—ability, energy, force, might, strength. Of these, we like "ability" best—but even Webster hasn't quite explained the meaning of POWER as applied to Garod.

GAROD POWER lies in the ability of the Garod to receive radio broadcasts in such a manner as to overcome the annoyances, interruptions and extraneous sounds commonly encountered in the ordinary "set," and receive precisely as is ideally and theoretically intended. The matter of distance is a mere detail of Garod reception.



To Own One is to Know
 the Best in Radio Reception

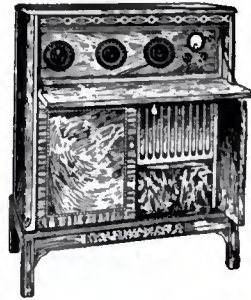

The Garod Georgian
 Rich brown burled walnut, with door-panel borders of inlaid ebony and holly—5 tube model—built-in loud speaker—battery compartments and accessory drawer. Will grace the finest drawing room—provide the best in radio reception. Size 35 1/2" long—16 3/8" deep—42 1/2" high.
\$400.00

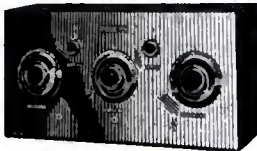

The Garod RAF
 The receiver that made GAROD famous. Added mechanical improvements—4 tube model—with which you are familiar. Size 19 1/2" long—7 3/8" deep—10" high.
\$135.00

THE GAROD CORP.
 120 Pacific Street
 Newark, N. J.

with our planet Mars is entitled to one-twentieth as much atmosphere as we have, and that the mercurial barometer at "sea level" would run about five and a half inches, as against thirty inches on the earth.

Southern summers on Mars, therefore, must be much hotter, and southern winters colder than the corresponding seasons of his northern hemisphere. Indeed, the length of the southern summer, nearly twice that of the terrestrial season, sometimes amply suffices to melt all the polar ice and snow, as in October, 1894, when the southern polar cap of Mars dwindled rapidly and finally vanished completely.

Conditions on Mars appear to be suitable for radio transmission.

Is Mars inhabited? The probable surface temperature is much lower than the earth's, because Mars receives only half as much solar heat as we do; and more important still, the atmosphere of Mars is neither so dense nor so extensive as our own. Seasons on Mars are established, much the same as here, except that they are nearly twice as long as ours; and alternate shrinking and enlarging of the polar caps keeps even pace with the seasons, thereby indicating a certainty of atmosphere whose equatorial and polar circulation transports the moisture poleward to form the snow and ice of which the polar caps no doubt consist.

There is a variety of evidence pointing to an atmosphere on Mars of one-third to one-half the density of our own; an atmosphere in which free hydrogen could not exist, although other gases might. The spectroscopic evidence of water vapor in the Martian atmosphere is not very strong. It is very doubtful whether water exists on Mars in large bodies: quite certainly not as oceans, though the evidence of many small "lakes" is pretty well made out. If, however, the past development of the planet has progressed in the way usually considered as probable, we may be practically certain that Mars has been inhabited in the past, when water was more abundant, and the atmosphere more dense so as to retain and diffuse the solar heat.

The Standard of the World



The base-type Freshman Variable Grid Leak

is the standard for those who build their own sets. It is the most compact and being entirely sealed it always remains unaffected by any climatic conditions.

Complete with either .00025 or .0005 Freshman Condenser—without condenser—75

At your dealer's, otherwise send purchase price and you will be supplied postpaid

Chas. Freshman Company, Inc.
 106-7th Ave., New York

RADIO long-distance COMPLETE sets

THESE are the finest long distance sets at the lowest prices in history. Wonderful new circuit that brings amazing results. SATISFACTION GUARANTEED. Everything furnished with complete sets. There's a set for every pocket-book.

- 4 tube set—with 3 dry cells, B Battery, 4 tubes, loud speaker, loud phone, antenna..... \$57.95
- 3 tube set—with 3 dry cells, B Battery, 3 tubes, loud phone, loud speaker, antenna..... \$49.95
- 2 tube set—with 3 dry cells, B Battery, 2 tubes, loud phone, antenna..... \$32.95

The above 3 sets can also be furnished for use with "A" storage battery instead of dry cells, \$12.00 extra.

- 1 tube set—with dry cells, B Battery, 1 tube, loud phone, antenna..... \$19.95

Sets also sold without accessories. Also full line of radio accessories, 1 and 2 stage amplifiers and portable sets. Write for FREE catalogue—don't say until you see it.

THE MELLODYNE RADIO CO., Dept. G CINCINNATI, O.

Write for free catalog today

EMPIRE Oiled Tubing



Real Radio Sets of today—the kind that last long and work best—are insulated with genuine Empire Oiled Tubing.

MICA INSULATOR CO.

68 Church St.
 New York

542 So. Dearborn St.
 Chicago

Works: Schenectady, N. Y. 2030-F

W. A. BARKER PRESIDENT
ANDREW MACDONALD VICE-PRESIDENT

PARKER S. WILLIAMS SECRETARY

J. M. S. DUNNE CHIEF OF HIGHWAYS
GEORGE C. ANDERSON SECRETARY

*The Commissioners of Lower Merion Township
Montgomery County, Pennsylvania
Township Building*

W. A. BARKER
HENRY DELAPLAINE
FRANK J. FLOYD
ALBERT R. GRAY
PETER S. HESS
WILLIAM H. McHUGHAN
ANDREW MACDONALD

CLIFFORD MACKAY
CHARLES SEIDEL
WILLIAM H. SHERWOOD
JAMES A. STRETCH
FRANK H. SYKES
A. D. WARNOCK

Ardmore, Pa. Gladwyne, Pa.
Sept. 19, 1924

Electric Specialty Company
Stamford, Conn.

Dear Sir:

Upon arrival of your type 80300 generator I immediately coupled it to a Westinghouse 1 Hp. motor. After running it about two hours I connected it to my transmitter which uses three 50 watt tubes. Not only did it work but IT PUT POWERFUL SIGNALS INTO HAMBURG, GERMANY and FLORENCE, ITALY.

I think the above statement shows how much I appreciate the generator.

My card from Italy reads as follows:

Radio 3BTA: Ur sigs hrd hr very very Qsa at 5.27 and 5.35 A.M. Both broad day-light. No Qss, Aug 20 U were one of the loudest of 14 American stns hrd at A.M.

Sig.

F.S. Huddy
U 111 12s

Since that time I have worked every district in the U.S. in one night, also three Canadian provinces.

Very Truly Yours,
Barrie R. Barker
u3bta

P.S.

You may use this letter in conjunction with any of your advertisements as I stand by and for the ESCO generators.

The Adventures of
BURGESS
RADIO BATTERIES

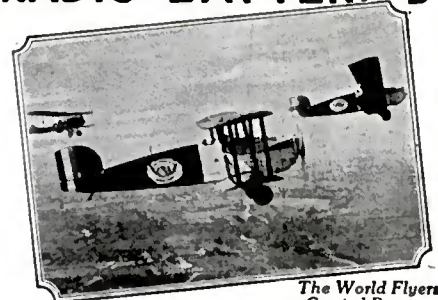

The World Flyers Carried Burgess



They're in the Wireless Room of the Leviathan



U. & U. Photos. Standard Equipment of United States Submarines.

Remarkable are the adventures of Burgess Radio Batteries. And where there's danger—upon, above or below the earth, sky and sea, will be found Burgess Batteries—laboratory products.

"ASK ANY RADIO ENGINEER"

Write to 163 Burgess Engineering Building, Madison, Wisconsin, for the Burgess Radio Compass. It is amusing, unusual and useful.

BURGESS BATTERY COMPANY
Engineers DRY BATTERIES Manufacturers
Flashlight - Radio - Ignition - Telephone
General Sales Office: Harris Trust Bldg., Chicago.
Laboratories and Works: Madison, Wisc.
In Canada: Niagara Falls and Winnipeg



Music Master

PROVEN RADIO PRODUCTS

Music Master Corporation
10th & Cherry Sts., Philadelphia

B-METAL
Crystals cannot be beat for Reflex Sets. Order them from your dealer now.
B-METAL REFINING CO.
10th Floor
525 Woodward Avenue
DETROIT, MICH.

Send For This Sensational Radio Bargain Book-FREE



Big Radio Book

Send For it At Once

American Bell Loud Speaker



With American Adjustable Unit. Wonderful volume, clear reception. Speaks for itself without coaxing. 10-inch bell—made of non-vibrating material.

\$3.95

\$6.95

Without unit

With unit

HEADPHONES

"Randolph Special"

2200 Ohm moulded head-set, properly designed to give strong and clear reception. Biggest head-phone value ever offered.



Our Catalog is Filled with

CONDENSERS		VARIOMETERS	
23-plate plain Condenser	\$1.29	Moulded Variometer	\$2.39
23-plate Vernier Condens'r	2.59	Bakelite moulded	3.45
RHEOSTATS and POTENTIOMETERS		HEADPHONES	
Bakelite Rheostat, 6-ohm	.38	Randolph Special, 2200-ohms	2.45
Bakelite Rheostat, 30-ohm	.59	Blue Bird Special	3.95
Bakelite Vernier Rheostat	1.15	LOUD SPEAKERS	
Bakelite Potentiometer, 200-ohm	.59	American Bell	3.95
TRANSFORMERS		With adjustable loud speaker unit	6.95
Randolph Special, 6 to 1, 2.16; 3 1/2 to 1	1.89	COUPLERS and COILS	
Sinclair Special, 6 to 1, 2.55; 3 1/2 to 1	2.24	180° Variocouplers	.95
TUBE SOCKETS and DIALS		Rehnartz Coils	1.25
4" Hygrade Dial	.29	Electric Soldering Iron	1.29
Bakelite Socket	.28	Cockaday Coil	1.65
Weston Plug	.75	Three-Circuit Tuner	2.95
		Ambassador Coils	2.95

BIG MONEY-SAVING RADIO CATALOG
containing a thousand bargains of everything on radio—parts, supplies, complete parts for sets, complete sets, etc., also a mine of very latest information on all different circuits, complete list of broadcasting stations, and other valuable, up-to-the-minute radio data. Send your name and address on a card or letter. We will send catalog free.

RANDOLPH RADIO CORP., 159 N. Union Ave., Dept. 73, CHICAGO, ILL.

"Quality Goods for Quality Readers"



Mr. F. E. Black, Chief Radio Officer, S. S. America—a former student of the Radio Institute of America.

Radio- your chance

From no knowledge of radio—to licensed operator. From operator up the opportunity ladder to the big jobs at the top. And a life of fascinating interest, well paid.

The Radio Institute of America is conducted under the auspices of the Radio Corporation of America, the greatest radio organization in the world. This insures the most thorough and up-to-date instruction, and therefore means preference for positions when you earn your government license.

The demand for trained men is great—and growing. Write today! Get your start—and grow with radio!

Home Study Course

Conducted from New York City. Full instruction for those who cannot attend the New York or San Francisco resident school.

A. Complete Home Study Course. From beginnings of magnetism through code and commercial practice. Prepares you for U. S. operator's license.

B. Advanced Home Study Course. For the advanced radio student and experienced amateur. Specializes in C. W., I. C. W., telephone and radio measurements.

Send the coupon for full information

Radio Institute of America

(formerly Marconi Institute)

Established 1909

Western District Resident School
28 Geary St., San Francisco, Cal.

HOME STUDY DIVISION

326 Broadway New York City

Indicate by a cross X the course you are interested in:

Radio Institute of America,
326 Broadway, New York
Please send me full information about
radio opportunities today and your
COMPLETE RADIO COURSE
ADVANCED RADIO COURSE

Name
Address

WHOLESALE DISTRIBUTORS
FOR
RCA Radiolas and Radiotrons
Radio Corporation of America
Sales Dept., Suite 2066: 233 Broadway, New York
District Sales Offices:
10 South LaSalle St., Chicago, Ill. 433 California St., San Francisco, Cal.

ILLINOIS

TUSCOLA RADIO SUPPLY
STATION

Dependable Radio Apparatus

TUSCOLA ILLINOIS

OHIO

THE MILNOR ELECTRIC
COMPANY

Large Stocks—Quick Service

129 GOVERNMENT SQUARE
CINCINNATI, OHIO

MAINE

ATLANTIC RADIO CO., Inc.

Complete **RCA** Service

21 TEMPLE ST. PORTLAND, ME.

PENNSYLVANIA

LUDWIG HOMMEL & CO

929 PENN AVENUE PITTSBURGH, PA.

WHOLESALES 100% THROUGH
DEALERS ONLY

WRITE FOR HOMMEL'S ENCYCLOPEDIA
OF RADIO APPARATUS 256-E

MASSACHUSETTS

F. D. PITTS CO., Inc.

Exclusively **RCA** Exclusively
Radio Wholesale

219 Columbus Ave. Boston, Mass.

Music Master Corporation

10th & Cherry Sts. 1005 Liberty Ave.
Philadelphia Pittsburgh

Special service to dealers on Radio Corporation of America products in Pennsylvania, New Jersey, Delaware, Maryland, District of Columbia, Virginia, West Virginia and Ohio.

ATLANTIC RADIO CO., Inc.

Complete **RCA** Service

727 Boylston St. Boston, Mass.

PENN ELECTRICAL
ENGINEERING CO.

Westinghouse Agent Jobbers
SCRANTON, PA.

MISSOURI

WESTERN RADIO CO.

Dependable Merchandise
from

America's Greatest Manufacturers
BALTIMORE AT FOURTEENTH
KANSAS CITY, MO.

THE PHILADELPHIA ELECTRIC
COMPANY SUPPLY DEPT.

130-32 So. Eleventh St.
Philadelphia

NEW YORK

CONTINENTAL RADIO
AND ELECTRIC CORP'N

New York's Leading Radio House

15 WARREN STREET
NEW YORK

WEST VIRGINIA

CHARLESTON
ELECTRICAL SUPPLY CO.

Electrical Jobbers

CHARLESTON, WEST VIRGINIA

TIMES APPLIANCE CO., Inc.

Approved Radio Merchandise
Wholesale Only

145 WEST 45th ST. NEW YORK

DEALERS

Here

you will find the
R. C. A. DISTRIBUTOR
who can serve you best

Tie up to him

TINNED "COPPERWELD"

ANTENNA WIRE

Maintains the highest conductivity and continues to give service, without stretching and breaking, under the most trying conditions—long after other antenna materials are wrecked.

RECOMMENDED BY THE LARGEST RADIO CONCERNS IN THE WORLD.



COPPERWELD STEEL COMPANY
New York Chicago San Francisco
Braddock P. O., Rankin, Pa.

3/4 of a million
in service

DEALERS SAVE MONEY
By Ordering from Our Bargain Catalog of Nationally Advertised Radio Goods. Write for It Today!
AMERICAN RADIO MFG. CO.
Dept. U 6 WEST 14th ST. KANSAS CITY, MO.

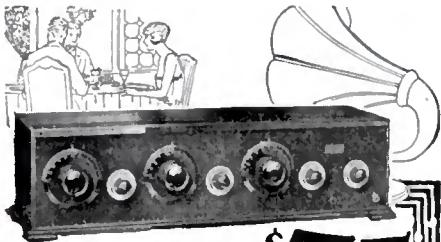

and now! for only \$75
The Marvelous
MIRACO
Ultra 5
Send for Bulletin Today

[FIVE TUBE OUTFIT]
Built for loud speaker reception from stations thousands of miles distant through local interference; composed of the finest parts; beautifully wired; encased in a beautiful hand rubbed solid mahogany cabinet; and fully guaranteed. At \$75 this fine, handsome, efficient Miraco "Ultra 5" five-tube outfit offers unquestionably the most astounding value the radio world has ever known.
UNSURPASSED SELECTIVITY, SENSITIVITY, RANGE, VOLUME AND TONE COMBINED
Non-radiating, non-howling, non-distorting. Equipped with filament switch, phone jack for tuning, bakelite panel, bakelite sub-base under which all wiring is concealed and other latest refinements. Two stages tuned radio frequency amplification, detector and two stages audio frequency amplification.

OTHER MIRACO LONG DISTANCE SETS \$14.95 up to \$29.50. Write for latest bulletin, testimony of users proving coast to coast reception. Agents, Dealers, write!
MIDWEST RADIO CORPORATION
Pioneer Builders of Sets
421-C East 8th Street, Cincinnati, Ohio

MIRACO RADIO GETS 'EM COAST TO COAST

CRESCENT LAVITE RESISTANCES
ABSOLUTELY NON-INDUCTIVE
12,000, 48,000, 50,000, 100,000 Ohms
List \$1.50 Each



Special Sizes to Order
USED IN ALL CIRCUITS AND RESISTANCE COUPLED AMPLIFIERS
When better resistances are made they will bear the Crescent label.
Dealers write for discount
CRESCENT RADIO SUPPLY CO.
3 LIBERTY ST. JAMAICA, N. Y.

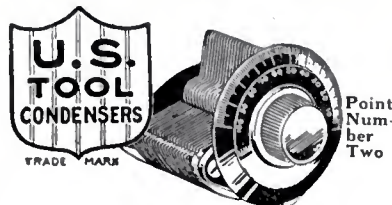

New Hexagon Shaft
The Second of Five
Unique Features

The rotor blades, stamped with hexagon hole, are gripped tightly by the hexagon shaft, preventing fanning of rotor blades. Found in four new types—types 3 (plain) and 4 (all-vernier), celoron end plates; types 5 (plain) and 6 (all-vernier). **LOW LOSS—METAL END PLATES.** Ask to see them at your dealer's.

100% Guaranteed
Write for Literature

U. S. TOOL COMPANY, Inc.
113 Mechanic St., Newark, N. J.
Manufacturers of Special Tools, Dies, Jigs, Automatic Machinery and Sub Presses

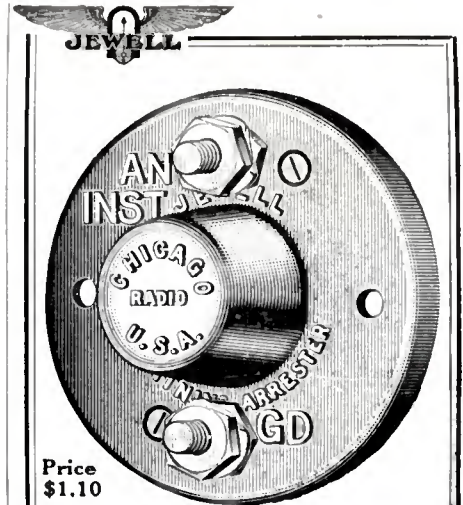

Price \$1.10

APPROVED BY UNDERWRITERS

The Jewell Lightning Arrester, in its brown porcelain case, has passed all underwriters' tests as required in their radio code.

Be on the safe side and use a Jewell Approved Arrester.

BUY FROM DEALER

Jewell Electrical Instrument Co.
1650 Walnut Street — Chicago

BUY FROM DEALER

"Over 60% of all radio trouble is traceable to run-down or poor batteries."

Check your "B" batteries daily with a Jewell Voltmeter No. 84. It is accurate and sturdy.



No. 84 Price \$2.75

HEATH Radiant Condensers

Permanently FLAT Plates

The well-known Heath process of stamping rotor plates to lasting flatness, makes the new Heath a permanently satisfactory instrument.

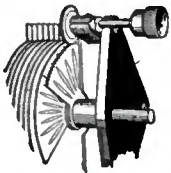
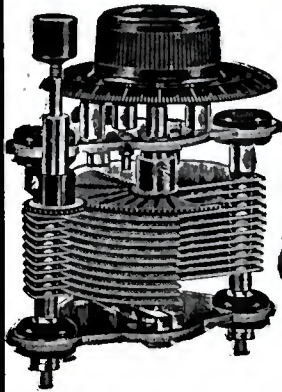

Micrometer Geared Vernier

Ordinary adjustments reduced by separate geared adjustment to half-breadth distinction. We guarantee the Heath Vernier Condenser to be more highly selective than any vernier condenser employing a vernier device which actuates ALL of the plates.

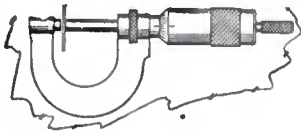

NON-DIELECTRIC Condensers

DIELECTRIC losses reduced to insignificant minimum as required by the latest circuits. *All-metal*—only enough dielectric material to properly insulate rotor from stator elements. Smooth, true-running shaft, like the jewel movement of bearings—pigtail connections insure **NO LOSS EFFICIENCY**. Equivalent series resistance of only 0.1 ohm and a phase difference of less than one minute.

PRICES FOR VERNIER CONDENSERS

	With Dial	Without Dial
No. 12AV—12 Plate....	\$5.00	\$4.35
No. 24AV—24 Plate....	5.50	4.85
No. 44AV—44 Plate....	6.50	5.85

Plain types in all sizes

*Ask Now for Heath
Sockets and Dials*

HEATH RADIO & ELEC. MFG. CO.

203 FIRST ST., NEWARK, N. J.

Canadian Distributors: Marconi Wireless
Telegraph Co., of Canada, Ltd.

"Just Be Sure It's a Hammarlund"

1. Clock spring pig-tail.
2. Ball bearing rotor shaft.
3. Cut back plates for easy tuning on low waves.
4. Strongest construction.
5. Losses too small to measure.
6. Soldered brass plates.
7. Micrometer vernier.
8. Takes any size dial.

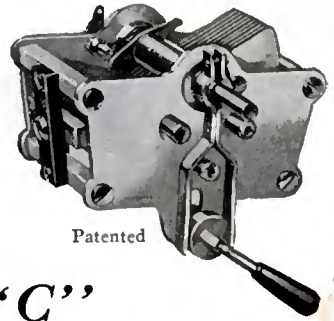

Patented

New Model "C"

Hammarlund Condensers

More Volume—Greater Distance

Write for New and Interesting Folder

HAMMARLUND MFG. CO., 424-438 W. 33rd STREET, NEW YORK

SMALL ADS OF BIG INTEREST

Space in this department costs only 80 cents a line
Minimum space 7 lines Payable in advance

IMPERIAL Four Tube Radio Frequency Receiver—\$45.00. Guaranteed one year. To see or hear the **IMPERIAL** means to buy it—and buying it means satisfaction. Write for literature on this and other types of receivers. Agents wanted—full or spare time. Write for our proposition. **IMPERIAL RADIO COMPANY, BINGHAMTON, N. Y.**

MAKE YOUR NEUT REACH OUT—Same panel, same layout, fewer parts. Our \$5.00 Kit includes the one different part, 22 feet real gold sheathed wire, lithographed print of Kladag Coast to Coast Circuit, and Complete, simple instructions. Nothing else to buy. Gives selectivity with deep, resonant volume. Not obtainable elsewhere. We originated this and can name scores of buyers it has delighted. Satis-

faction guaranteed. Details, 10c. Kit prepaid anywhere, \$5.00. New 48-page catalog, thousands of items, many exclusive, for stamp. We accept postage stamps same as cash. **KLADAG RADIO LABORATORIES, KENT, OHIO.**

158 GENUINE Foreign Stamps. Mexico War Issues. Venezuela, Salvador and India Service, Guatemala, China, etc., only 5c. Finest approval Sheets 50 to 60%. Agents Wanted. Big 72-p. Lists Free. We Buy Stamps. Established 20 years. **Hussman Stamp Co., Dept. 157, St. Louis, Mo.**

RADIO GENERATORS—500V 100 watt \$28.50. Battery Charging Generators \$8.50. High Speed Motors, Motor Generator Sets, all sizes. **MOTOR SPECIALTIES CO., Crafton, Penna.**



12 Cells
34 Cells
Solid
Rubber
Case

\$3.50 COD SPECIAL

INTRODUCTORY PRICE

For a limited time *only*, and to introduce this new and superior Storage "B" Radio Battery to the Public, we are selling it for \$3.50. Regular Retail Price is \$5.50. You save \$2.00 by ordering NOW. A finer battery cannot be built than the

World Storage "B" Battery

(12 CELLS—24 VOLTS)
To ten million homes with Radio Sets—and to countless millions of prospective buyers—this **WORLD STORAGE "B"** Battery brings a new conception of battery economy and performance. Here is a battery that pays for itself in a few weeks—will last for years and can be recharged at a negligible cost. And you save \$2.00 by ordering now.

A Superior Battery Equipped With Solid Rubber Case Has heavy duty 2-1/8 in. x 1 in. x 1-4 in. plates and plenty of acid circulation. Extra heavy glass jars allow ready observation of charge and prevent leakage and seepage of current. It holds its charge, while idle, at constant voltage. You will find this battery a boon to long distance reception. It does away with a great many noises so often blamed on "static." Mail your order today.

SEND NO MONEY

Just state number of batteries wanted and we will ship day order is received. **EXTRA OFFER:** 4 batteries in series (36 volts), \$13.00. Pay Expressman after examining batteries. 5 per cent discount for cash in full with order. Send your order NOW and save \$2.00.

WORLD BATTERY COMPANY
Makers of the famous World Radio "A" Storage Battery
1219 S. Wabash Ave., Dept. 79 Chicago, Ill.

SAVE \$2.00 BY ORDERING NOW!

In She Comes!

New
**NAA
Meter
Tested
Crystals**

TIP YOUR whisker to almost any point of an NAA Meter tested crystal and the full flow of the impulse instantly hits your phones, clean, clear, steady.

Reason—no guesswork in the test;—every, EVERY crystal meter-tested singly by specially made electrical instruments to a point away beyond normal sensitivity. In addition, the Newman-Stern mounting is new—patents pending—cold assembly, provides for refilling, and avoids damage to crystal by hot alloy; recessed for protection.

PERFECT FOR REFLEX

At all good jobbers and dealers, in neat turned wood box, 80c. If dealer can't supply, order direct and send dealer's name.

Newman-Stern Co.

1744 East 12th Street
Cleveland, Ohio

Originators of tested crystals in 1914. Oldest and largest producers.

Pioneers in Radio Equipment in Ohio



*Nuggets
of
Sensitivity*



"Quality Goods for Quality Readers"



The 40 Ft. HERCULES Mast in yard.

The HERCULES AERIAL MAST

This mast is made in sizes to get 20 ft., 40 ft. or 60 ft. clearance and is the answer to an efficient aerial system. What is more, this graceful mast is an improvement to any property, whether it is installed on the roof or in the back yard. It can be erected in a few minutes. It is shipped knocked down for convenience in handling. All parts are made of steel and are light and strong.

LONG RANGE RADIO RECEPTION

It has been said time and again that the best results are obtained only by the intelligent use of the best apparatus procurable. This is an oft repeated statement but the more it is propounded the truer it becomes and applies not only to the receiving equipment proper, but also to the antenna system. This applies most emphatically to receivers of the crystal detector type and to non-regenerative audio outfits. THE AERIAL MUST BE EFFICIENT if the reception of long distance stations theoretically within range of the receiver is desired.

PROPER AERIAL CLEARANCE

Very few novices realize the importance of good aerial installation. The feeble currents from long distance stations will never reach the receiving set if the aerial is strung too close to surrounding objects that tend to absorb the energy. It is with this interference that we have experimented for years—and present the answer—THE HERCULES AERIAL MAST.

HAVE BUILT RADIO TOWERS FOR YEARS

For years we have been building radio towers for important broadcasting stations. Included among the names of our customers is the UNITED STATES GOV-



20 Ft. HERCULES Mast on roof.

ERNMENT SIGNAL CORPS. Only after years of experience and development work have we been able to perfect this wonderful steel aerial mast to sell at a price within reach of the amateur.

20 Ft. Mast.....\$10.
40 Ft. Mast.....\$25.
60 Ft. Mast.....\$45.
Prepaid
Order from this "Ad" if you wish.

GIVE YOUR SET A CHANCE

Not only will the proper aerial clearance thus obtained give you the supreme pleasure of long distance radio reception but the appearance of this beautiful mast on your property will give you a reputation. This reputation will grow as you bring in stations such as you yourself never dared hope for.

MAIL POST CARD for full particulars and literature about the HERCULES Aerial Mast.

S. W. HULL & CO., Dept. D
2048 E. 79th St. Cleveland, Ohio



Greater Distance—Less Noise

TURN-IT

ADJUSTABLE GRID LEAK

Only \$1, at your dealer, or direct from us
TURN-IT RADIO SALES, Inc.
30 Church St., N. Y.

Advertisers' Index

Acorn Radio Mfg. Co.	85
Adams-Morgan Co., Inc.	9
Allen-Bradley Co.	67
American Brand Corp.	85
American Display Co. The	87
American Hard Rubber Co.	72
American Radio Mfg. Co.	78, 93
American Transformer Co.	58
Amplex Instrument Co.	76
Andrea F. A. D.	5
Bakelite Corporation	88
Bel-Canto Mfg. Co.	70
B. Metal Refining Co.	91
Brandels Corp., The J. F.	13
Brandes, C., Inc.	8
Bremer-Tully Mfg. Co.	54
Bruno Radio Corp.	70
Bunnell & Co., J. H.	88
Burgess Battery Company	91
Carter Radio Co.	86
Citizens Radio Serv. Bureau	58
Continental Fibre Co., The	95
Continental Radio & Elec. Corp.	89
Copperweld Steel Co.	93
Crescent Radio Supply Co.	93
Crosley Radio Corp., The	Third Cover
Cunningham E. T.	Second Cover
Cutler-Hammer Mfg. Co.	10, 11
Daven Radio Co.	7
De Jur Products Co.	70
Dubiller Condenser and Radio Corp.	78, 86
DX Instrument Co.	79
Eby Mfg. Co., H. H.	76
Edson Radio Sales Co.	87
Eisemann Magneto Corp.	80
Electric Specialty Co.	91
Electric Storage Battery	69
Faraway Radio Co.	88
Federal Telephone & Telegraph Co.	89
Freshman Co., Inc., Chas.	82, 85, 87, 90
Fueterer, W. E.	68
Garod Corp., The	90
General Electric Co.	84
General Instrument Co.	63
General Radio Co.	12
Golden-Lentz, Inc.	77
Goldschmidt Corp., The	16
Hammarlund Mfg. Co.	92
Heath Radio & Electric Mfg. Co.	94
Howard Mfg. Co.	84
Hull & Co., S. W.	95
Ilyman & Co., Inc., Henry	65
International Correspondence Schools	72
Jewell Elec. Instrument Co.	93
Jewett Radio & Phonograph Co.	96
Jones, Howard B.	74
Kellogg Switchboard & Supply Co.	61
Lambert, Leon	78
Liberty Mail Order House	95
Magnavox Co., The	73
Manhattan Elec. Supply Co.	71
Marlo Engineering Co.	86
Marshall Electric Co.	55
Melodyne Radio Co.	90
Mica Insulator Co.	92
Midwest Radio Company	93
Mozart Grand Co.	74
Mu-Rad Laboratories	4
Musie Master Corp.	91
Mydar Radio Co.	83
National Carbon Co.	53
National Company, Inc.	76
National Radio Institute	56
Newman-Stern Co., The	94
New York Coil Co.	82
Omnigran Mfg. Co., The	82
Ozarka, Inc.	84
Pacent Electric Co., Inc.	60
Phenix Radio Corp.	57
Polymet	85
Premier Electric Co.	76
Radiall Co.	88
Radio Assoc. of America	68
Radio Corporation of America	15; Fourth Cover
Radio Corporation of America Distributors	92
Radio Institute of America	92
Randolph Radio Corp.	91
Rauland Mfg. Co.	59
Rhamstine, Thos. J.	60
Schwab Inc., Harold M.	84
Shepard-Potter Co.	60, 70
Small Ads of Big Interest	94
Spaulding Fibre Co.	68
Standard Radio Co.	58
Thompson Mfg. Co., R. E.	3
Thorlanson Electric Mfg. Co.	64
Tower Mfg. Corp., The	1
Turn-It Radio Sales	95
U. S. Tool Company, Inc.	93
Uncle Sam Elec. Co.	78
Valley Elec. Co.	58
Valley Forge Chemical Co.	58, 85
Walbert Mfg. Co., The	85
Ware Radio Corp.	6
Western Coil & Electrical Co.	81
Westinghouse Elec. & Mfg. Co.	75
World Battery Company	87, 94
Zenith Radio Corp.	78

"Quality Goods for Quality Readers"

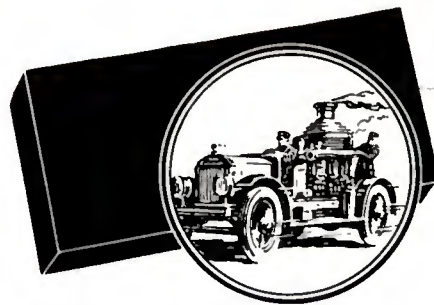

Resists Fire!

Extreme heat and bitter cold have little or no effect on a Bakelite-Dilecto panel. Neither do water, oil, steam, solvents and the milder acids.

Bakelite Dilecto

(Distinguished by Its Red Stripe)

Highest in dielectric strength. The most perfect paneling material known. Used successfully in the U. S. Navy and Signal Corps for ten years. Be satisfied with nothing else for your panels.

THE CONTINENTAL FIBRE CO.

Factory: Newark, Delaware

Service from:

New York, Woolworth Bldg.
Chicago, Wrigley Bldg.
Pittsburgh, 301 Fifth Av.
San Francisco, 75 Fremont St.
Los Angeles, 307 S. Hill St.
Seattle, 1041 Sixth Av., So.

BARGAIN CATALOG

Yours FREE! 100 Pages!

Just send your name

Get it now!

Crammed full of information & offers

of all kinds of complete RADIO SETS, Parts and Accessories

Including everything needed to construct the popular "Knock-Out" Sets

developed and approved by Radio Broadcast magazine, published by Doubleday, Page & Co., anything you may need to build or equip any set. You will enjoy dealing here.

It's easy to do business with us. For this is The Radio House of Friendly Service. All goods offered subject to examination and approval. No money in advance. Get this wonderful catalog—you need it—write today!

(And will you be so kind as to add the name of one or more friends you believe will soon want radio goods? Thank you!)

Liberty Mail Order House
Dept. 695Y 106 Liberty St., N.Y.C.



Have You a Screw Driver?

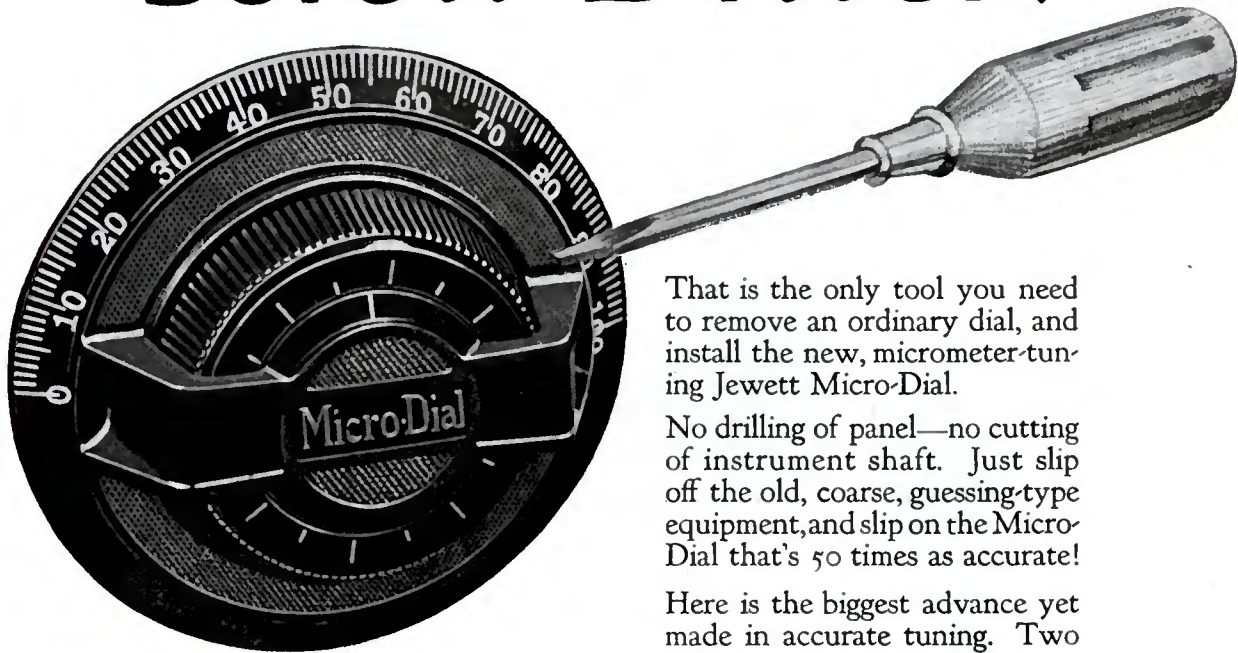

EXCLUSIVE!

Mounts where any four-inch dial will mount—Absolutely self-contained—Nothing to be attached to panel—Slight eccentricity or angularity of instrument shaft of no consequence; Micro-Dial will not bind—Absolutely noiseless—Knob mounted on double cone bearing, self-adjusting and self-aligning—No metal to tarnish or cause body effects; no rubber to deteriorate—Micrometer and coarse adjustments turn complete circle—Calibrations clockwise or anti-clockwise—Mechanism lubricated for life—Lasts forever—Improves with use.



That is the only tool you need to remove an ordinary dial, and install the new, micrometer-tuning Jewett Micro-Dial.

No drilling of panel—no cutting of instrument shaft. Just slip off the old, coarse, guessing-type equipment, and slip on the Micro-Dial that's 50 times as accurate!

Here is the biggest advance yet made in accurate tuning. Two dials in one. Main dial corresponds to your old equipment. Inner dial moves instrument at only one-fiftieth normal speed, permitting accuracy far beyond the former reach of human touch and vision.

More stations—more range—more volume—less interference. Transforms accurate tuning from an accident into a scientific certainty. Especially when coupled with a Jewett Superspeaker ensures the absolute limit of reproductive volume from any set.

Don't confuse the Micro-Dial with any other device for tuning improvement. Its compact neatness, and its complete freedom from wear or deterioration place it in a class all by itself and remember, you need only a screw driver to install.

Rejuvenate your set by Micro-Dial equipment!

If your dealer cannot supply you, we will ship direct to you, charges prepaid, on receipt of list price \$3.50.

JEWETT RADIO &
PHONOGRAPH CO.
5678 Twelfth St., Detroit, Mich.

The Jewett

Micro-Dial

"Quality Goods for Quality Readers"

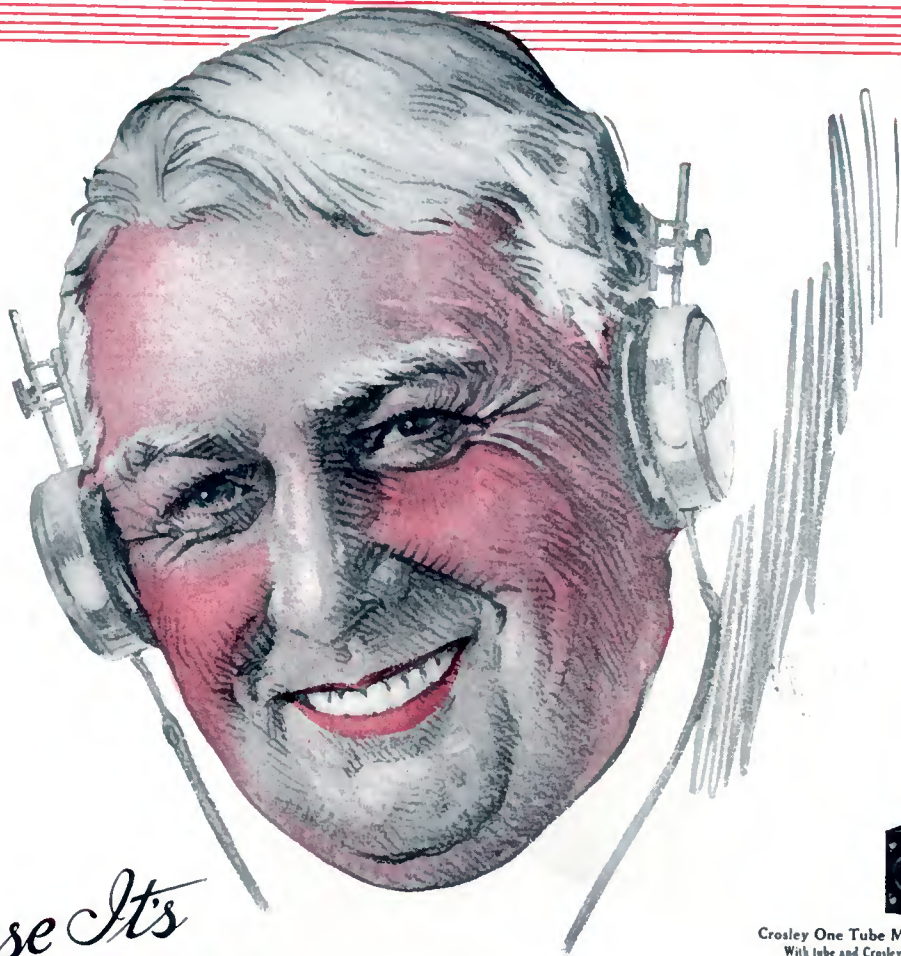

Of Course It's
a CROSLEY
 Better - Costs Less
 Radio

TO COMBINE the two most desirable things in radio—distant clear reception at the lowest possible price—there is only one radio receiver for you. That is a Crosley.

When you listen in on a Crosley—no matter what the price—you wonder, as thousands of others have, that such exceptional results can be obtained, and so reasonably.

The answer is simple—quality radio receivers built in quantity production. During the past twelve months, we believe Crosley made and sold more sets than any other manufacturer in the world. This is self-evident proof of Crosley Quality and Crosley Performance. Combined with Crosley excellence are such additional advantages as selectivity, ease of tuning, simplicity and beauty—all at the lowest radio cost.

Crosley has made it possible for everyone to own a radio receiver. You can start with the one tube Armstrong Regenerative Receiver at \$11.50, without accessories—\$22.25 with tube and head phones—the lowest priced regenerative set on the market, and equivalent in reception to many two tube receivers. Then as more volume is desired, you can add to it at a very low cost.

Or, you can purchase the three tube Crosley Trirdyn Regular, which has come through the summer period of comparatively poor reception with colors flying—for only \$65. In Special Mahogany cabinet to house necessary accessories, \$75. The combination of one stage of tuned radio frequency, with regenerative detector and reflexed amplification, has proven beyond a doubt that the features of selectivity, volume and ease of operation can be obtained with three tubes better than heretofore has been possible with five tubes.

We believe that no other set on the market combines these features so well incorporated in the Trirdyn.

In addition there are the Crosley 51, the two tube Armstrong Regenerative Receiver that became the biggest seller in the world in just 21 days, price \$18.50. This set will at all times bring in local stations on the loud speaker and distant stations can at all times be heard with ear phones. The three tube Armstrong Regenerative Receiver Crosley 52, that brings in distant stations with loud speaker volume under practically all conditions, price \$30; and the Crosley 50 and 51 set in portable cabinets at \$18 and \$25.

These receivers, each in its own class, though assuring you as good or better reception than any other instrument of the same number of tubes, are by far the least expensive ever offered to the public.

Before You Buy—Compare Your Choice Will Be a Crosley For Sale By Good Dealers Everywhere

Crosley Regenerative Receivers are licensed under Armstrong U. S. Patent 1,113,149. Prices West of the Rockies add 10%

Write for Complete Catalog

THE CROSLEY RADIO CORPORATION

Powel Crosley, Jr., President

1128 Alfred Street

Cincinnati, O.

Crosley Owns and Operates Broadcasting Station W'L II



Crosley One Tube Model 50, \$14.50
 With tube and Crosley Phones \$22.25



Crosley Two Tube Model 51, \$18.50
 With tubes and Crosley Phones \$30.25

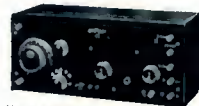

Crosley Three Tube Model 52, \$30.00
 With tubes and Crosley Phones \$45.75



Crosley Two Tube Model 51-P, \$25.00
 With tubes and Crosley Phones \$36.75



Crosley Trirdyn Regular, \$65.00
 With tubes and Crosley Phones \$80.75



Crosley Trirdyn Special, \$75.00
 With tubes and Crosley Phones \$90.75

Crosley
 Head Phones
 Better—Cost Less
 \$3.75



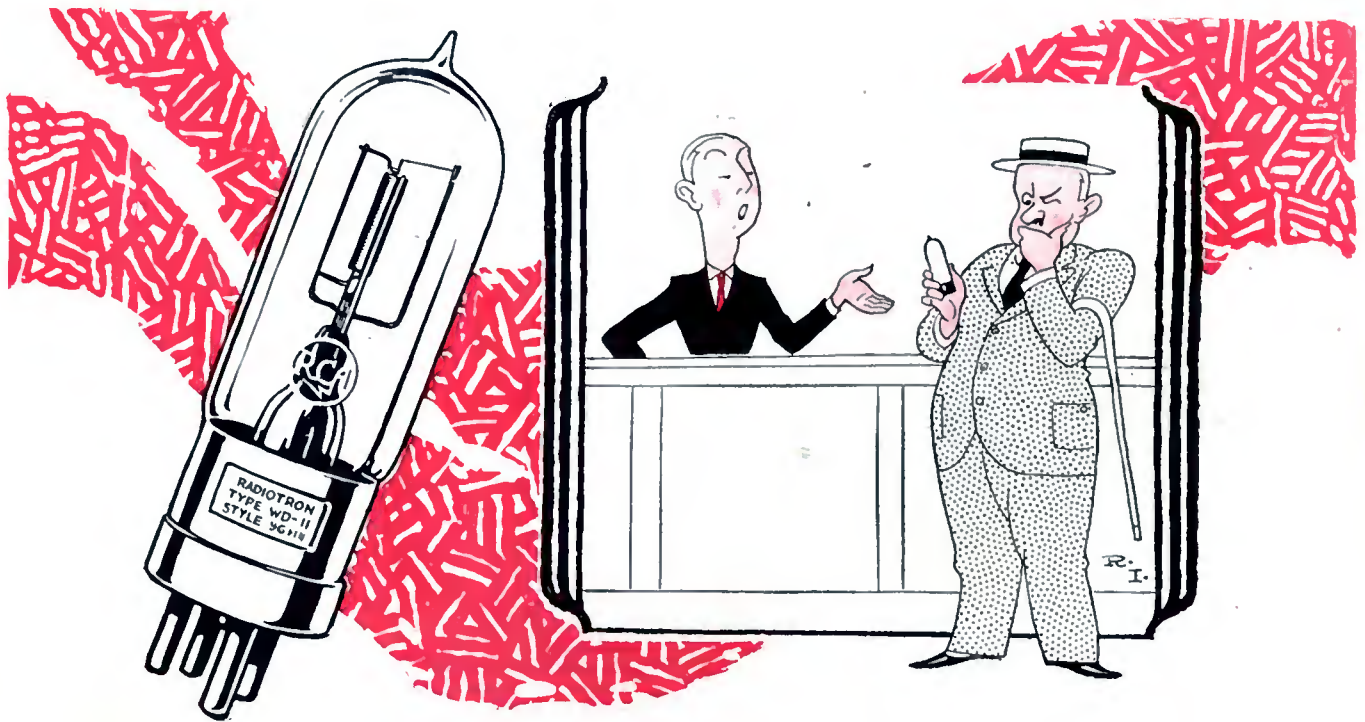

"Are those Tubes Genuine?"

All Radiotrons Now
Reduced to \$4.00

It isn't a genuine WD-11
unless it's a Radiotron.

It isn't a genuine WD-12
unless it's a Radiotron.

It isn't a genuine UV-199
unless it's a Radiotron.

It isn't a genuine UV-200
unless it's a Radiotron.

It isn't a genuine UV-201-a
unless it's a Radiotron.

The question is heard at every radio counter: "Is it a genuine Radiotron?" Almost every dependable manufacturer uses genuine Radiotrons in his sets. Everyone who builds his own knows enough about radio to know that nothing else but the genuine will do. And the man who replaces used-up tubes in his set knows that to get the same performance, he must have the same tubes—genuine Radiotrons only. So everybody asks "Is it genuine?" And asks to see the marks that prove it—the name "Radiotron" and the "RCA" mark.

Radio Corporation of America

Sales Offices, Suite No. 111

233 Broadway, New York

10 So. La Salle St., Chicago, Ill.

433 California St., San Francisco, Cal.



This symbol of
quality is your
protection

Radiotron

REG. U. S. PAT. OFF.