

# The WIRELESS AGE

JAN 21 1918

**Practical Training in Radio Communication,  
Aviation, Navigation and Military Signaling**



**How to Become an Aviator**  
*An Instruction Course by Henry Woodhouse*

**Wartime Wireless Instruction**  
*A Home Study Series by E.E. Bucher*

**Signal Officers' Training Course**  
*Conducted by Major J. Andrew White*

**Finding Your Way Across the Sea**  
*Practical Navigation by Captain F.E. Uttmark*

*And Other Exclusive Features*

# Serve Your Country

## During the War After the War

*To help meet the immense demand for trained men for the National Service, and to replace those called from the ranks of mercantile life, we now provide in the pages of*

## THE WIRELESS AGE

*PRACTICAL TRAINING COURSES in the following branches, of which there is urgent need.*

### Aviation—Conducted by **HENRY WOODHOUSE** Governor of the Aero Club of America

Principles and theory of flight—nomenclature, assembly, rigging,—care and repair of aeroplanes—operation and care of aeronautical engines—principles of general and cross-country flying—reconnassance, map reading, signaling and co-operation with military bodies—radio for aircraft and its uses—machine gunnery and bombing from aeroplanes.

### Signal Corps Work—Conducted by Major **J. ANDREW WHITE**, Chief Signal Officer, Junior American Guard

Function and operations of the Signal Corps and its relation to the line of the army—drill instruction, mounted and dismounted, for telegraph companies, radio and outpost companies, and battalions of Signal Corps—signaling by telegraph, heliograph, night lantern and flags, radio and service buzzer—camp and field telephones and their uses—radio apparatus of the Signal Corps—scouting, patrolling and tactical employment of field lines.

### Wireless Telegraphy—Conducted by **ELMER E. BUCHER**, Instructing Engineer, Marconi Wireless Tel. Co.

Code practise—elementary electricity and magnetism—primary and secondary batteries—electrical units and circuits—electromagnetism—electromagnetic induction—the dynamo, motor and motor generator—transmitting and receiving apparatus—transformers—tuning—modern wireless sets—measurements—undamped oscillation transmitters and receivers—regenerative receiving circuits.

### Navigation—Conducted by **CAPT. F. E. UTTMARK** Principal, Uttmark's Nautical Academy

Compass work—details of Mercator's chart—coastwise and ocean chart sailing—keeping the log book—the taffrail and chip logs—dead reckoning—care and use of the sextant and chronometer—correcting altitudes and declination—latitude by meridian observation of the sun—selection and use of logarithms—various kinds of time—longitude by solar sights—deviation of compass by sun azimuths, and by terrestrial ranges.

These courses are conducted exactly as lecturers give them to their classes.

The printed diagrams and charts take the place of regular blackboard exercises, and the text, covering description, principles and application, progresses step by step through elementary instruction, apparatus and practical operation.

The cost of similar instruction in regular training schools would be—

Aviation .....	\$75.
Signal Corps Work .....	\$75.
Wireless Telegraphy .....	\$65.
Navigation .....	\$100.
Total .....	\$315.

Offered in THE WIRELESS AGE for \$2.00.

#### SPECIAL CLUB RATES FOR CLASSES, ASSOCIATIONS AND SOCIETIES

If you are enlisted, eligible for enlistment or interested in any young man who would be benefited by a knowledge of the fundamentals of any one of these branches of skilled and remunerative work

**SUBSCRIBE TO-DAY**

---

---

**WIRELESS PRESS Inc., 25 Elm Street New York**



# THE WIRELESS AGE

## WORLD WIDE WIRELESS

### Marconi on the Advantages of Closer Co-Operation by the United States with Her Allies

**G**UGLIELMO MARCONI, who recently returned to Rome from a tour of the front from the mouth of the Piave to Monte Grappa, in the course of which he inspected the wireless apparatus on the battle lines, has commented pointedly on the advantageous effect of a closer co-operation by the United States with the Allies.

"What we desire ardently," he declared, "is the closest co-operation and union with America. I have been able already to appreciate the co-operation of the United States in this great war, but it would bring it home to the Italians more effectively if they knew that America also was at war with our nearest enemy, Austria."

As a representative Italian, Mr. Marconi speaks with authority. His statement was made before the United States had declared war on Austria.

Mr. Marconi also spoke encouragingly of conditions in the Italian army.

"The reorganization of the entire Italian army is proceeding apace," he said. "It makes us confident that the onward march of the enemy will be definitely stopped.

"I saw the Duke of Aosta (Commander of the Third Army), General Diaz (commander-in-chief), General Badoglio (second in command) and other leading commanders. All were filled with hope that the worst is over, that the revival of the morale of the soldiers, which is constantly more noticeable, may give unexpected results. I found everywhere that the spirit of the troops was very high. The men are desirous of taking revenge for the reverses suffered, and are furious at the thought that any Italians had been cheated into believing Austrian and German lies when the enemy announced the intention to lay down arms if the Italians did the same.

"The navy, operating with the army along the coast and in the lower section of the Piave, is gaining splendid successes, to which the British monitors are contributing. The Italian artillery is doing marvels, getting the last ounce possible out of all the guns along the Piave."

It has been announced that General Diaz, the new commander-in-chief of the Italian armies, will have the assistance of Mr. Marconi in driving back the Austro-Germans. Mr. Marconi has already assumed his duties as a member of the staff of General Diaz.

### Speculation Concerning the Electrically-Controlled Boat

**T**HERE is some diversity of opinion concerning the operation of the German boats officially described by the British as "electrically controlled." One of these craft made an attack on November 3 on British vessels patrolling the Belgian coast. The attack was unsuccessful and the boat was destroyed.

An official announcement later made in London said that four other electrically-controlled German boats had been destroyed. The naval authorities, it was said, had known of the boats for some time and regarded them as freaks. The first of these craft, according to this source of information, was wrecked a considerable time ago when it came into collision with a pier on the German coast.

In Washington this announcement of the use of a new machine of destruction by the Germans was interpreted to mean that the enemy had made an application of the device for which basic patents were obtained by Rear Admiral Fisk about twenty years ago. John Hays Hammond, Jr., made a practical application of the theory to boats and torpedoes, Congress appropriating nearly a million dollars to purchase his patents. A board, composed of Army and Navy officers, was formed to judge of the value of the device.

By means of the Hammond device a swift motor boat could be directed from the shore by means of the manipulation of a radio telegraph key in any direction in which the operator chose to send the craft. A similar control device, it has been pointed out, might have been employed by the Germans to propel their boats.

From Berlin came a dispatch to the effect that the boat was the invention of Christoph Wirth, a teacher at Nuremberg, Bavaria. Wirth's invention was told of in the *Mariner-Rundschau* approximately six years ago. By means of this device a crewless craft was directed from land about the waters of a lake, wireless being employed. The operator fired shots from the guns on the boat, hoisted flags and set bells a-ringing.

These theories all point to the fact that the boats which have come into notice recently, were wireless craft. On the other hand, a London report concerning the vessels says that they are operated from shore by wire which they pay out as they make their way through the water, an aeroplane in its wake signaling back to the gunners on land.

What has been told regarding the craft is too meagre to give basis for anything but speculation as to the methods employed in operating them. Reports to date, however, indicate that, as employed by the Germans, they are not as formidable as their U-boats.

### The Wireless Enemy in Our Own Country

**O**FFICERS of the Government continue to show by their activities that they are alive to the dangers from enemy wireless and wireless men in this country.

The president of a wireless concern in Elmira, N. Y., was arrested on November 12 because, according to the Department of Justice, he was "potentially able to do great harm to internal military and business interests of this country." He installed a wireless set on the Kaiser's private yacht and at one time was a member of the German emperor's personal retinue as a wireless operator.

In some instances the investigations of the Secret Service agents bring unexpected results. An agent visited a house in Providence, R. I., to investigate a wireless plant. In response to his rapping on the door a sad-faced woman appeared. The agent asked for her son, the operator of the wireless set.

"He is not here," she answered, with tears running down her face.

"Where is he?" asked the Secret Service man.

"Over in France, fighting for his country," was the proud reply.

The owner of the set had installed it for the purpose of practice. Afterwards he was called to the colors.

The activities of the Secret Service agents extend from coast to coast. Wireless apparatus has been confiscated recently in Freeport, Long Island;

Norwich, Conn.; Trenton, N. J., and San Francisco, Cal. In Norwich a wireless set was found secreted among the branches of a tree.

### **The Seeadler Heard of Again**

**T**HE German sea rover Seeadler is heard of from time to time in the South Pacific. A recent report says that the British steamship Matunga may have been captured by members of the crew of the Seeadler and may now be cruising about in search of prey.

The Matunga, bound from Brisbane to Rabaul District, reported to the latter place by wireless on August 5 that she would arrive there two days later. She has not been heard from since.

According to a report from Rabaul, a steamship closely resembling the missing craft, although painted slate color, has been seen on several occasions by different vessels. When the strange ship was asked by wireless to reveal her identity she extinguished her lights and steamed away on a different course.

### **The Employment of Wireless in the Halifax Disaster**

**T**HE advantage of having wireless at hand in times of stress was demonstrated when the disaster at Halifax, N. S., in which thousands of lives were lost, occurred. With the land line wires out of commission and the stricken city cut off from communication with the outside world, wireless still remained as a means of getting word to and from the scene of the catastrophe. It was used effectively, too, when a relief train was started from Boston and the War Department was asked to inform the Mayor of Halifax by radio that aid for the sufferers was on the way.

### **Sending American Propaganda from the Sayville Station**

**G**EORGE CREEL, Chairman of the Committee on Public Information, announced recently that he is utilizing the Sayville wireless station daily to send broadcast 1,000 words of American war news. This is done in the hope that the information will reach Germany. Of course he does not know that any part of it goes beyond the receiving operator or the officers in charge of the German stations, but it is transmitted notwithstanding.

### **The Proposed Trans-Atlantic Flight of the War Aeroplanes**

**I**T has been suggested that the thousands of United States aeroplanes which are expected to play an important part in winning the war make the flight across the Atlantic in order to reach the battle front. According to the plan outlined wireless will be employed as a means of piloting the flying machines. It is said that the flight can be accomplished in two "hops," the first to the Azores and the second to the continent.

Assuming that this plan is practical, it will result in the solution of the vexed question of how to get our aeroplanes to the front. It would require considerable time to transport the machines across the Atlantic, either shipped in parts or intact. However, it has been estimated that a flight of 3,000 miles would not take the modern aeroplanes more than forty hours, and, reckoning on this basis, the machines would be able to reach the fighting lines within two days after they were completed.

With the aid of the wireless direction-finder the guiding of the aeroplanes

to a given point on foreign shores would not be a difficult task. The piloting of the flying machines has been somewhat of a problem in the past, but with a wireless station established at the place of destination and the aeroplanes equipped with direction-finders, the flight across the Atlantic should not be filled with insurmountable obstacles.

### **The Frustration of German Plans in China**

**T**HERE is more than passing interest in the brief cable dispatch from Tien-tsin that attempts made by German interests to establish the system of a German wireless telegraph company in China have been defeated. The British Legation at Peking, it is stated, has definitely established the position of the Marconi Wireless Telegraph Company under the agreement signed in 1914. Arrangements had already been made, the cable dispatch said, to ship apparatus of the German company from this country where large stocks were available. There is no reason to believe, however, that the Chinese government was aware of these arrangements.

Germany would have obtained a valuable means of spreading her propaganda throughout China if the plan to install the German wireless telegraph company's system had been carried out before the latter country declared war against her. The transmission of pro-German propaganda and news by wireless from Berlin to the stations in China and the dissemination of this information throughout that country would have been considerably facilitated with a radio system in the hands of the enemy.

### **The World-Girdling Communication Plan Suggested for the Vatican**

**I**F THE suggestion to establish a wireless station on the dome of St. Peter's in Rome in order to keep in touch with the war situation all over the world is carried out the Vatican will have a news bureau without a peer. The plan was evolved for the purpose of obtaining independent transmission of foreign messages of diplomatic character in code as well as to receive confidential reports from the Vatican's representatives abroad.

There has been no complaint from the Vatican regarding the restrictions of censorship, but the advantages of sending and receiving communications by an independent system were doubtless considered in planning the installation of wireless. Since the European war began, special couriers have been employed to convey confidential messages from the Pope or Cardinal Gasparri, the Papal Secretary of State. Communications of less importance have been sent by mail.

The installation of wireless would permit the Vatican to establish communication direct with Switzerland, Austria, Germany and Sweden. The Vatican has been compelled to depend upon newspaper dispatches for news of the minute, but these have not served its purpose satisfactorily because there is always the well-founded suspicion that the items from Germany have been colored or deleted. The Vatican is also much interested in news from Russia, but the same doubt as to its accuracy is attached to the information sent out from there for publication.

It is pointed out that the Italian Government will not discourage the plan because the establishment of wireless would aid in doing away with the congestion on the existing lines of communication. Wireless seems to have solved another problem growing out of the war.

### An Exploit of the Moewe as Seen by the Enemy

**W**IRELESS is so closely interwoven with the history of the exploits of the German sea raider Moewe that a history of the exploits of the craft is incomplete without frequent reference to the art. This is shown in the published extracts from the diary of Count Schlodien, commander of the Moewe. In telling of the capture of the steamship Appam, which occurred before the United States declared war against Germany, he said:

" . . . fast steamers are usually equipped with wireless telegraphy, and if she (the Appam) should try to make use of it as soon as she suspected our intentions, we might be forced to take serious counter measures . . . However she showed no disposition to stop and I had to fire a shot across her bow . . . The Appam visibly decreased speed and soon stopped. But it was at once reported to me that she was sending wireless signals. This did not help her very much as our own wireless men at once jammed her messages so that it became unintelligible. Nevertheless, ships might have still discovered from the interrupted messages that everything was not in order hereabouts.

"I ordered our guns to be trained on her wireless telegraph room, which was in plain sight abaft the bridge. It was all that was needed. The signals stopped."

The capture of the Appam and her arrival in Hampton Roads with the Moewe have been described in a previous issue of *THE WIRELESS AGE*. Count Schlodien's recital, as far as it concerns wireless, concludes as follows:

"On account of our arrival in more northerly latitudes we received fuller wireless information from Germany, with a lot of good news. Particularly welcome was the notification contained in one message of the award of the Iron Cross to fifty members of our crew. I did not lose the opportunity of personally announcing the awards to the recipients, who were recommended by me for the honor."

### The Dependence of German Aviators on Wireless

**H**OW much dependence German aviators place on wireless is revealed by the views of one of the chief officers of the French Army aeronautical service. After examining some wrecked Zeppelins and one captured intact after a recent raid on London, he analyzed the causes for the failure of the attack.

The failure of the expedition, in his opinion, was due partly to atmospheric conditions and partly to failure to establish wireless communication. The vessels left for England in a moderate west wind, but it turned to the north and when they arose to escape the British anti-aircraft guns a strong gale was blowing in the upper altitudes.

These air ships depend for their guidance, it seems, on the wireless stations in Germany. This is due to the fact that no means have been found for calculating drift and the compass seems practically useless without that. But the German stations failed the vessels in question at a critical time because, perhaps, they were too hard pressed with demands from other airships which had gone astray.

### A Hero of the Key

**S**ECRETARY of the Navy Daniels has commended the conduct of C. L. Ausburne, radio electrician, first class, who lost his life when the United States Army Transport Antilles was sunk on October 17. In a letter to Robert Ausburne, brother of the radio operator, who is employed at the Union Club in New York, Secretary Daniels called attention to the bravery of the wireless man

as brought out in the findings of the court of inquiry. They related that Ausburne went to his station to send out a warning by wireless rather than attempt to save his own life.

When the ship was struck Ausburne and Radio Electrician MacMahon were asleep in adjacent bunks. Ausburne, fully alive to the danger of the situation, told MacMahon to put on his life preserver. As Ausburne was on his way to take his place at the wireless key he shouted to his companion: "Goodbye Mac." This was the last that MacMahon saw of him. Afterward he went to the wireless room, but it was locked. The ship was sinking fast and MacMahon attempted to get Ausburne out of the room but without success.

Ausburne first enlisted in the Navy at New Orleans, February 25, 1908. He re-enlisted on March 1, 1916, after eight years' service.

The death of another wireless man, Stanley T. Anthony, radio electrician, first class, occurred on November 19 when the American destroyer Chauncey was sunk in a collision in the war zone. Details of the exact manner in which Anthony met his death have not been made public.

### Linking North and South America by Wireless

THE recently announced plan of the Pan-American Wireless Telegraph and Telephone Company to establish communication by radio between North America and every South American state is a noteworthy development of expansion in the commercial wireless field. The plans of the new company include the use of both wireless telegraphy and telephony. Its president is Edward J. Nally, vice president and general manager of the Marconi Wireless Telegraph Company of America.

Argentina, Brazil, Uruguay, Chile, Peru and Ecuador will be brought into close touch with their northern neighbors by means of the Pan-American system, and early in the new year construction of the initial stations will be begun. Stations are also planned for Central America and Mexico.

The American Marconi Company's interest in the new company amounts to stock control; the new enterprise is entirely financed. Rights have been acquired by the Pan-American Company in the patents of both English and American Marconi companies, as well as the Poulsen-Pedersen system. It is announced that high speed transmission and reception during all the twenty-four hours is assured by new inventions and that selectivity and secrecy will also be thus obtained. The commercial service planned is expected to reach large proportions and users of the system are promised reliability, speed, accuracy and cheapness. It is also hinted that wireless telephony is destined to play a very important part in long distance communication. As the service expands and facilities grow, the Pan-American Company will introduce innovations from time to time, such as night letters and week-end letters at greatly reduced rates, a service which Marconi has found of popular appeal in trans-oceanic communication.

Mr. Nally, who as President will guide the destinies of the new addition to commercial wireless, has long been a prominent figure in telegraph circles. His career began in boyhood with the Western Union; he rose to the directorate and the office of vice president and general manager of the Postal, leaving that company to serve in the same capacity with the American Marconi Company. It was under his direction that the great network of high power stations was built, linking the United States by wireless with its dependencies and other continents with America. Further elements of success for the enterprise appear in the fact that business is begun with valuable concessions and that the U. S. Government, recognizing the need for better communication to further South American trade relations, has set its seal of approval on the new company.



# Radio Science

## A Valve Which Restricts the Flow of Electrons

**G**EORGE M. WRIGHT of London, England, has designed a special vacuum valve by which the flow of electrons between the filament and anode can be restricted in accordance with any particular set of requirements. The inventor lays stress on the fact that the apparatus shown in Figure 1 is particularly applicable to the elimination of atmospheric disturbances.

The vacuum valve tube shown in the drawing (Figure 1), consists of a coarse mesh grid, D, mounted on the outside of the bulb and a fine mesh grid, d, inside the bulb, which forms a complete screen across the path between the filament and the anode. A fixed potential is maintained between the grid, d, and the

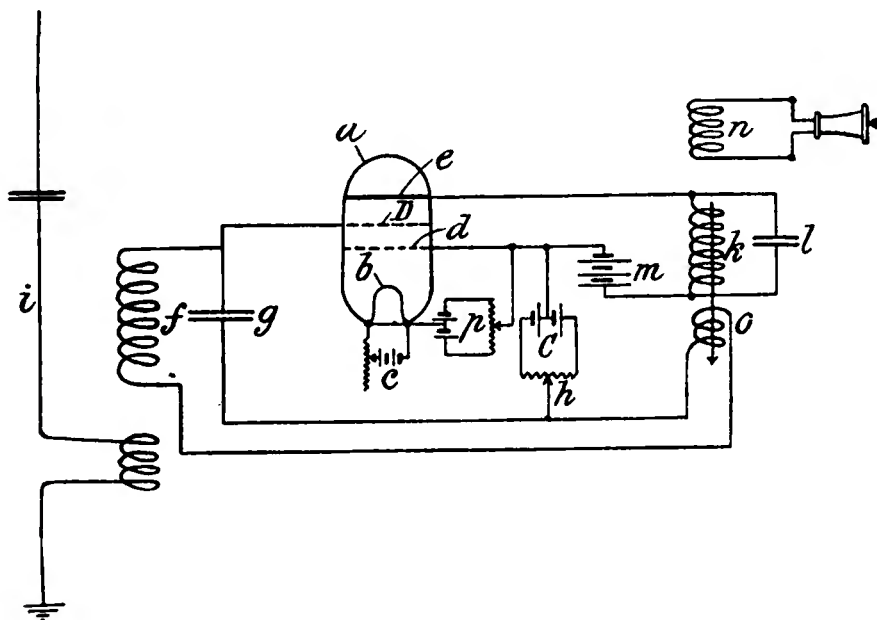

Figure 1

filament by means of a potentiometer, P. The secondary circuit; f, g, and the anode circuit, e, k, l, m, are coupled together at o and k. The outer grid, D, is connected to the inner grid, d, through the resistance, h, across the battery, C.

The important effect of this construction is that the strength of the current and the response in the head telephone in the anode circuit can be limited and, therefore, no matter how great the strength of the incoming signals, the response in the telephone will be limited by the operating characteristic of the circuit. Hence the interference of atmospheric electricity can largely be annulled and the signals from a given transmitting station read with less difficulty.

**The Detection of Undamped Oscillations**

IT is a well known fact that undamped oscillations cannot be detected by the ordinary radio frequency rectifier because of the continuity of the advancing wave train. Hence some means must be provided at the receiving apparatus

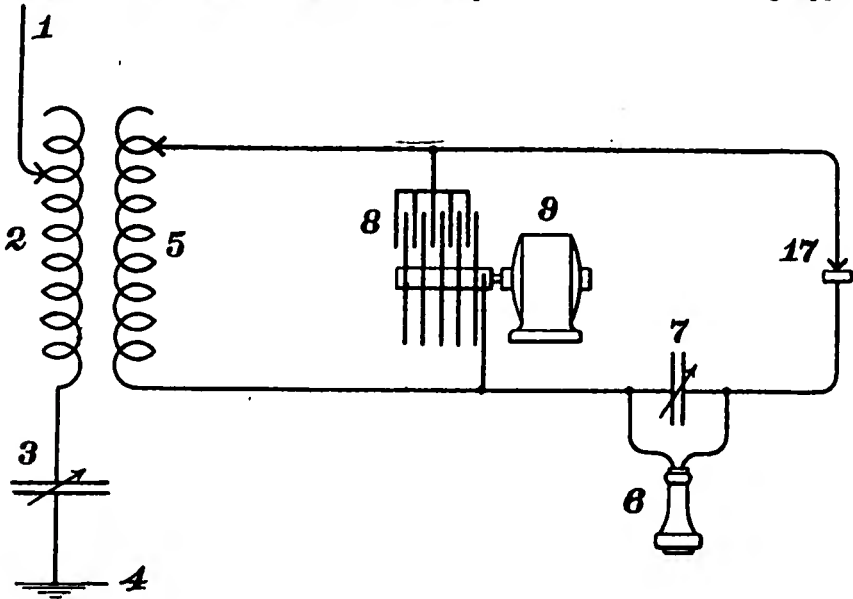

Figure 2

whereby the incoming signals can be converted into an audio-frequency current suitable for operation of the head telephones.

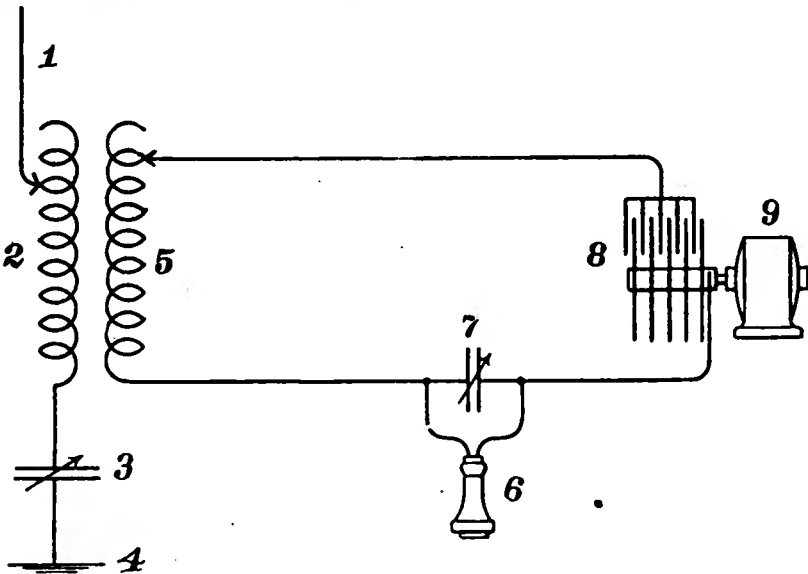

Figure 3

A recent United States patent granted to Elmer E. Bucher, shows a novel method for converting radio frequency currents to currents of audio frequency. The mechanical receivers heretofore adopted for such detection have been either

the tikker or the slipping contact detector, both of which possessed the disadvantage that they were somewhat troublesome in adjustment and would give an impure or imperfect note in the head telephone.

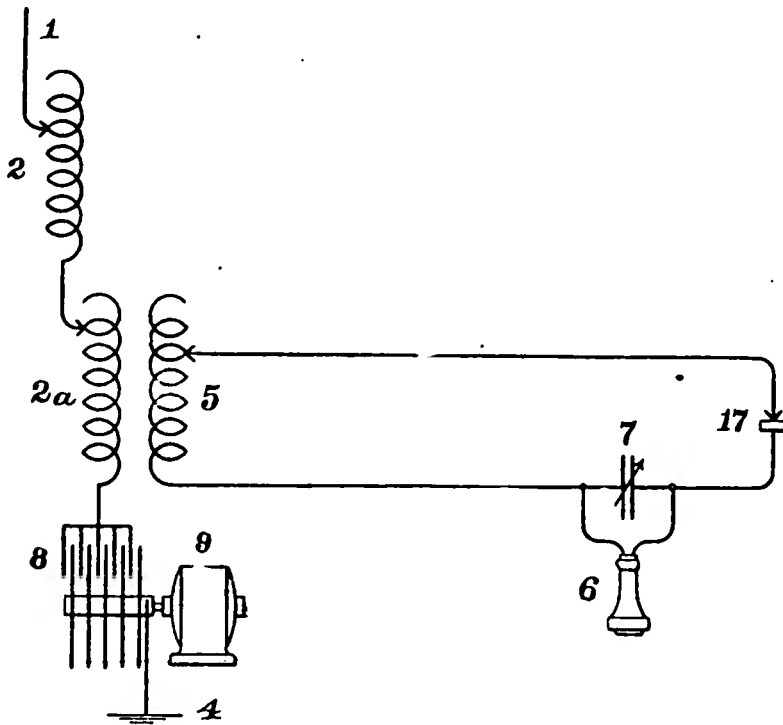

Figure 4

The novelty of the system disclosed by the inventor lies in the use of a rotating condenser of variable capacity which is placed in various positions in the receiving circuit to vary the amplitude of the incoming oscillations. One method of connection is shown in Figure 2, where the condenser is placed in shunt to the secondary winding of a receiving tuner. If the value of the secondary inductance, 5, is properly adjusted so that at a certain position of the revolving condenser, 8, the circuit is in resonance with the incoming oscillations, current will flow periodically through the crystal rectifier, 17, charging the condenser, 7, which discharges through the head telephone, 6. If the condenser, 8, is of such construction, or revolves at such speed, that the secondary circuit is thrown into resonance with the antenna circuit, say, 500 to 750 times per second, a very clear tone will be obtained in the receiver, 6. If condenser 8 is stopped at the required value of capacity, the circuit will respond to discontinuous waves as well.

Other arrangements of this circuit are shown in Figures 3, 4 and 5. The circuit shown in Figure 3 is of particular interest owing to its simplicity. Very good results have been obtained in the reception of undamped oscillations. A point of interest in connection with the operation of this device is this: if the receiving circuit is thrown into resonance by the rotating condenser at any other position than that of the maximum capacity of a particular set of plates, the circuit will be thrown into resonance twice for each set of stationary plates; once when the position of maximum capacity is approached and again when the position of maximum capacity is passed.

**An Oscillation Generator for Radio Telegraphy**

**A** METHOD for generating practically continuous oscillations from a source of direct current recently described by R. Heising is shown in Figure 6, the principal point of departure from common oscillating generator systems being the lack of a spark or arc gap.

The objects of the inventor's device are accomplished by means of two

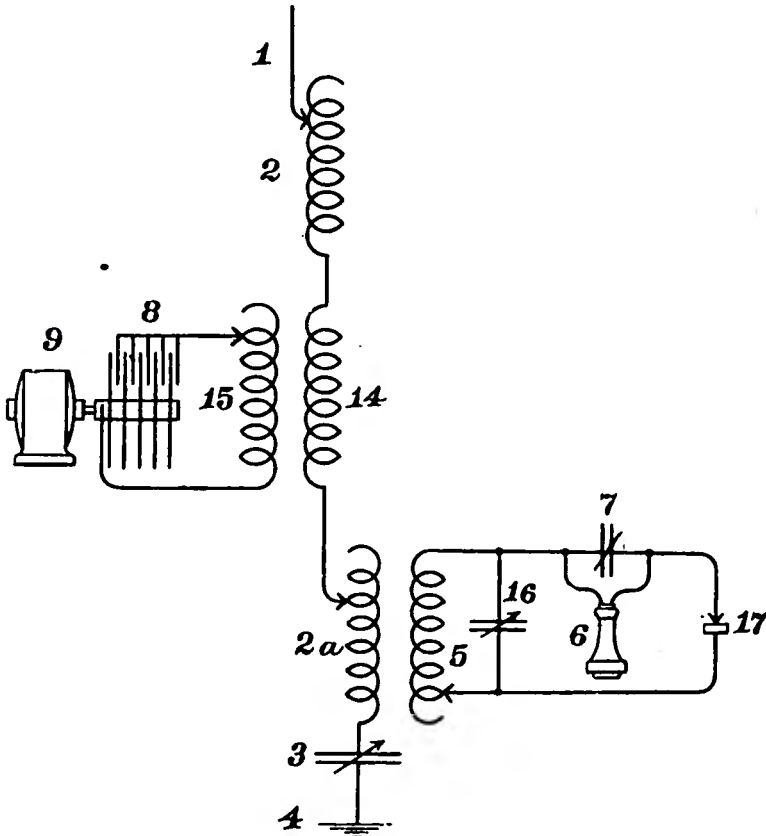

Figure 5

rotatable discs, 22, with the contact studs, 4, which make connection with the brushes, 6. An oscillation circuit consisting of the condenser, 7, and the coil, 8, is shunted directly across the two discs and the coil, 8, is in turn inductively coupled to the coil, 9, which is part of the antenna circuit, 10. A driving motor is shown at 11 and an alternator at 12 for keeping the device rotating at a constant speed.

The operation of the system is described as follows:

At the instant at which the brushes, 6, make contact with a pair of studs, 4, a rush of current from the generator takes place, which charges the condenser, 7, to a voltage equal to that of the generator. The contact is immediately broken with the discs, and the condenser discharges through the inductance coil, 8. Oscillations are therefore set up in the circuit, 7, 8, and after the lapse of a time equal to one cycle, the condenser 7 will again be charged to approximately its original potential difference, the actual value being slightly less than the original because of the damping of the oscillations. If at this time the brushes, 6, again make

generator and renew the charge on the condenser to its original value. Since, however, the loss of charge in the condenser during one cycle is relatively small, the potential difference between the brushes and the discs at the end of the first

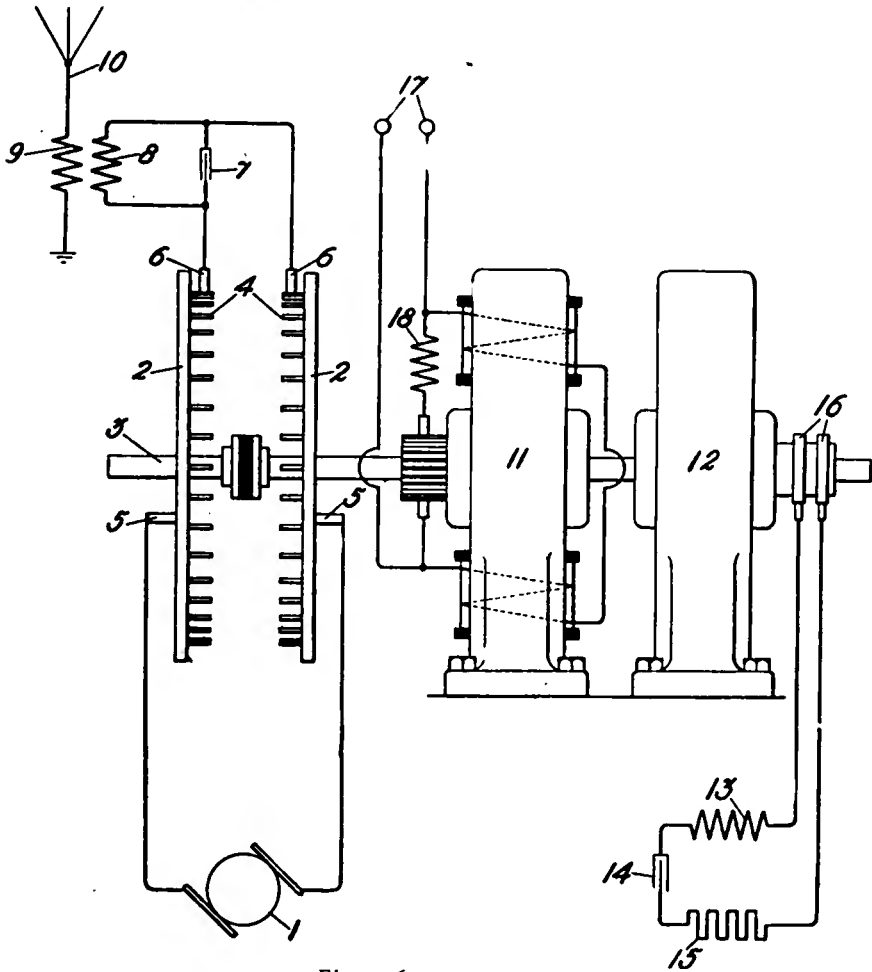

Figure 6

cycle will also be relatively small; therefore the transfer of power may take place without heavy sparking at the studs when the contact is broken.

The arrangement for maintaining the speed of these discs constant is of unusual interest. A regulating resistance, 18, is connected in series with the motor armature and the effect upon its operation is to lower the effective voltage over the terminals of the motor as the load increases. A resonant circuit, 13, 14, 15, is shunted across the collector rings of the alternator. If it is tuned to a frequency slightly higher than that which would be developed were the alternator running at the speed required for operating the contact-making device, and if for any reason the speed of the alternator increases, a larger current will be set up in the resonant circuit which will consequently increase the load upon the alternator, 12, and therefore on the motor, 11; but the effect of this increase in load is to lower the effective voltage over its terminals and the speed of the shaft will therefore tend to fall to its original value. On the other hand, if the speed of the motor is decreased the frequency developed by the alternator will depart still more from that required for resonance and therefore the load on the generator and motor will decrease. Consequently the voltage on its terminals will increase and the speed will tend to rise again to its correct value.



# Military Preparedness

## Signal Officers' Training Course

A Wartime Instruction Series for Citizen  
Soldiers Preparing for U. S. Army Service

### SEVENTH ARTICLE

By **MAJOR J. ANDREW WHITE**

*Chief Signal Officer, Junior American Guard*

*(Copyright, 1918, Wireless Press, Inc.)*

### Radio Apparatus of the Signal Corps

**T**WO types of portable field sets have been issued by the Signal Corps. The smaller size, known as a field radio pack set, is furnished to the Organized Militia as well as to the field companies. The range of these sets under normal conditions is about 25 miles over land, but much greater over water. Thus one of the one-eighth kilowatt sets, with a hundred-foot mast, at Habana has worked with the naval station at Key West, a distance of about 110 miles.

The larger size of field sets, known as a wagon set, is of 2-kilowatts output and is carried on a two-chest pintle wagon, one chest with the engine and generator and the other with the transmitting and receiving apparatus. The range of these sets varies from 75 to 800 miles, depending on favorable weather conditions, time of day or night, character of the land between the sets, and similar conditions.

### Field Wagon Sets

The following are general instructions for the operation and care of the two-wagon 2-kilowatt set:

Engine.—The engine supplied with this set is a water-cooled, single-cylinder gasoline engine with a normal speed of 1,500 R. P. M., and the same general directions as to care and operation which apply to water-cooled gasoline engines

in general apply in this case, and the principal points are briefly as follows:

Before starting make sure—

1. That the tank is full.
2. That all bearings have been oiled.
3. That the engine has sufficient lubricating oil by means of the stopcock on under part of crank case. If it drips when opened, there is sufficient oil.
4. That there is sufficient gasoline in the tank as indicated by the gauge on the front of the tank.
5. That the main switch of the generator is open.

To start—

1. Open gasoline feed cock.
2. Prime carburetor by plunger on top.
3. Set the governor control handle (just above the crank) vertically, i. e., halfway across the scale.
4. Set the spark-control lever on the magneto on bottom notch.
5. Crank.

After starting—

1. Make sure that the fan is running.
2. Close main switch.

Speed: The speed, as indicated by the tachometer on the engine, is controlled by the position of the governor control handle (directly over the crank) and by the position of the spark control lever on the magneto (at the right), and the best position of each for any particular speed is best and easily determined by experiment.

To shut down temporarily—

1. Open main switch of generator.
2. Press button on front of magneto until engine stops.

To shut down permanently—

1. Same as above.
2. Ditto.
3. Turn off gasoline.
4. In cold weather empty all water out of every part of cooling system by means of the cocks provided for that purpose.

*Generator.*—The alternating-current generator supplied with this set is of the inductor type with the field and armature winding stationary, and has therefore no brushes or sliding contacts of any kind. Its normal voltage is 85. The exciter is an ordinary low-voltage direct-current machine. The voltage of the alternating-current generator is varied by means of the rheostat in series with its field. The rheostat is located in the lower left-hand corner of the front part of the instrument wagon. The connections between the power wagon and the instrument wagon are made by means of a flexible armored four-conductor cable having the sockets so arranged that the terminals can be inserted only in the proper manner, the circuits of the alternator, exciter, etc., being shown in figure 3.

*Transmitter and receiver.*—The connections of both are clearly shown in the drawing and require no further description.

To adjust the transmitter for any wave length within the range of the set proceed as follows, assuming that the desired wave length is 1,000 meters:

1. If it is intended to send at full power, adjust the voltage of the generator by means of the slide rheostat (at the left) to about 85 volts.
2. If it is intended to send at less than full power, short-circuit one or more of the gaps by means of the clips provided and at the same time reduce the generator voltage about 10 per cent per gap short-circuited.
3. Set the primary variometer (at the left) at the wave length desired, viz., 1,000.

4. Put the aerial-coil plug (at the right) in hole No. 1, marked 680/1050. This adds sufficient inductance to the aerial to bring the final adjustment within range of the aerial variometer.

5. Make the final adjustment with the aerial variometer (also on the right and on one side of the aerial coils) by turning it slowly up from zero until the ammeter in the aerial or ground circuit indicates a maximum.

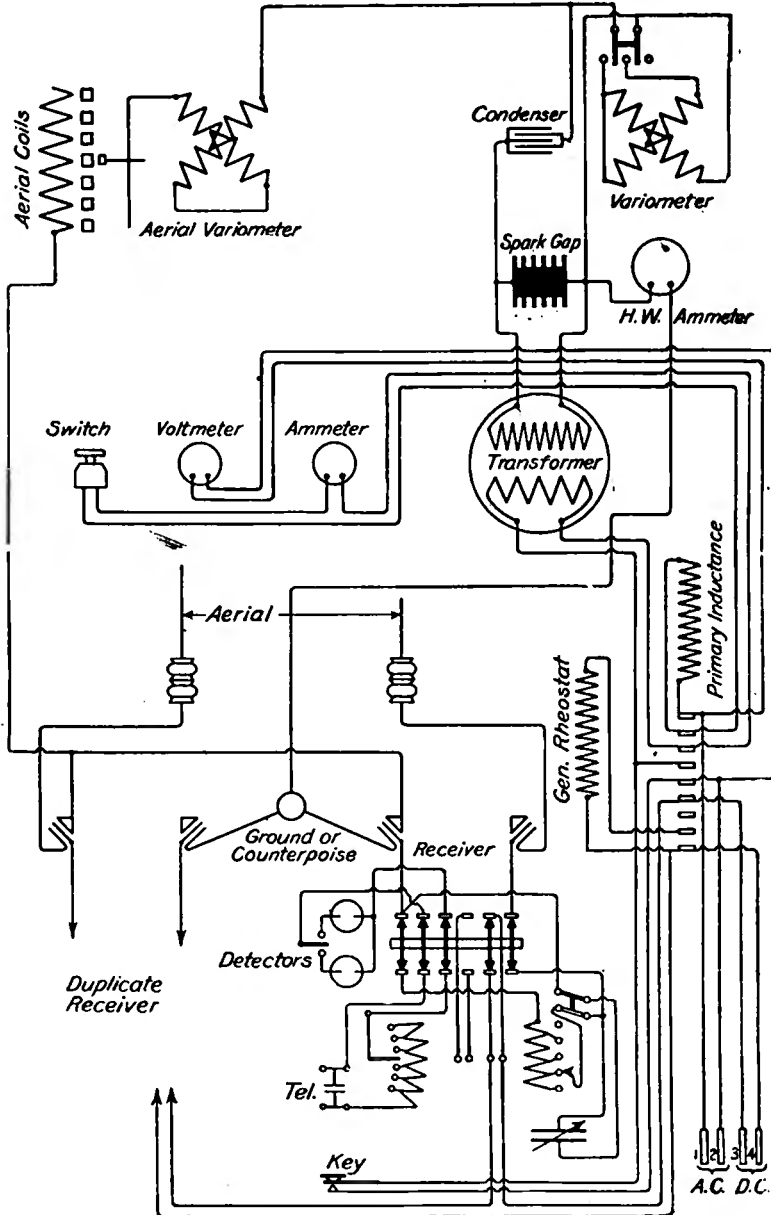

Figure 1—Connections of the 2-kilowatt field wagon set of the Signal Corps

6. The transmitter is now adjusted for the most efficient production and radiation of the wave length selected when used with the aerial and counterpoise supplied with the set.



**Receiver.**—To receive, close the large double-pole switch at the top of the receiver.

The plug holes marked with Roman numbers (at the right on the receiver) are connected to taps on the aerial or primary coil. The wave range of this coil is approximately as follows, with a proper aerial:

Plug.	Condenser switch at—	
	Short Waves.	Long Waves.
	<i>Meters.</i>	<i>Meters.</i>
I .....	260-400	500-600
II .....	310-510	640-910
III .....	370-730	900-1,410
IV .....	540-1,060	1,270-2,150
V .....		1,860-3,080
VI .....		2,700-4,000

The turns on the detector or loose coupling coil are variable by means of the switch located on its top, the wave range for each tap being marked.

Either of the two detectors can be used by means of the switch located between them.

For receiving a signal of a known wave length the following procedure can be recommended:

1. Use tight coupling.
2. Plug in on the aerial coil.
3. Set the switch on the detector coil at about " $\lambda$ —500-1000."
4. Turn the condenser very slowly over the entire scale.
5. Change the plug on aerial coil and repeat No. 4. When signals are finally heard, the coupling and the position of the switch on the detector coil are varied until the best results are obtained.

**NOTE.**—In some cases two combinations of the aerial plug and condenser give almost equally good results. The best one is that in which the larger part of the condenser is used with condenser switch at "short waves" and vice versa, with the condenser switch at "long waves." The aerial used with this set should have a capacity of 0.0011 mf and a natural period of 450 meters.

The following detailed notes on the circuits and operation of the set have been found useful as a result of actual work in the field:

### Power Circuits

Referring to connection diagram figure 1, it is seen that D. C. leads marked 3 and 4 go to both receiving switches in series. It is therefore necessary to have the main switches of both receiving sets in the same position—that is, cut off—when sending, even though one receiving set may have no aerial wire connected to it. A flash due to the breaking of this D. C. circuit will be seen at the rotary switch if the receiving set is cut in before the engine is stopped. The large double-pole switch at the top of the receiver when closed so as to connect the receiver to the aerial and counterpoise automatically disconnects the sending side from the aerial and counterpoise. This feature is not indicated in the diagram of connections where the receiving set when cut in is apparently shunted by the sending set.

### Transformer Primary Circuit

From A. C. lead No. 1 to the primary inductance, to the snap switch, to the ammeter, to the primary of the transformer, to the key, and via A. C. lead No. 2 back to the generator. The voltmeter is across the A. C. leads as shown. If the voltmeter shows voltage, but upon closing the key no spark takes place at the spark gap, the snap switch in the primary circuit is probably open.

The voltage, as indicated by the voltmeter, must never be more than 85. If it is desired to change the generator frequency and the pitch of the note

emitted), in order to secure greater selectivity for the set when working in the presence of other sets having about the same generator frequency, the engine may be slowed down or speeded up, but the drop or rise in voltage incident thereto must be compensated for by a change in the generator rheostat, so that the voltage will be kept constant at 85 when using all the gaps at the spark gap. *Any violation of this rule will cause a breakdown in the transformer.*

### High-Frequency Circuits—Transmitter

*Closed oscillating circuit.*—This consists of the condenser, variometer, and spark gap. It is to be noted that the variometer is common to both closed and open oscillatory circuits, and, therefore, that changing the variometer (which is the one at the left-hand side of the chest and has scale divisions in wave lengths marked upon it) not only changes the period to which the closed oscillatory circuit is tuned, but also slightly changes the tuning of the open oscillatory circuit. A

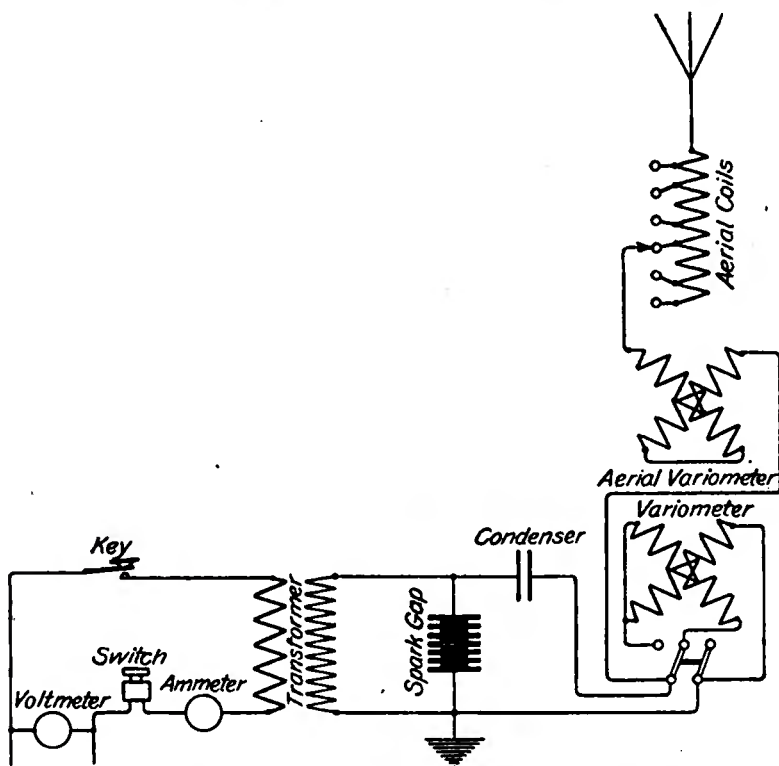

Figure 2—Simplified diagram of transmitting circuits

word of caution should be given concerning the switch marked "Little" and "Great" which throws the coils of this variometer from a parallel to a series connection or vice versa. This switch can only be moved to the right or left—to "Little" or to "Great"—when the index is directly opposite the dividing line between the red and the white divisions. *Any attempt to throw the switch when the variometer coils are in any position will only result in damage to the switch.*

### Open Oscillatory Circuit

This consists of the aerial, aerial or loading coils, plug for cutting in proper coil, the aerial variometer (marked from zero to 180°), the variometer common to both closed and open oscillatory circuits, the hot-wire ammeter, and the counter-poise or ground.

The antenna supplied by the Signal Corps for this set has a natural wave length of 450 meters and a capacity of about 0.0011 mf.

It is found by experiment that the set using the Signal Corps 80-foot mast and rubber-covered counterpoise works best at about 1,000 meters, where the antenna hot-wire ammeter reads about  $7\frac{1}{4}$  amperes.

### Coding of Wave Lengths

The great advantage of this set lies in the fact that any desired wave length from 675 to 2,220 meters can be sent out at will and if the wave length is changed after every word of a message, according to a prearranged code of wave lengths—for example, the first word sent with 700 meters, the next with 2,100, the next with 1,400, etc.—it will be difficult for any eavesdropping operator who has not the wave-length code to follow the changes of wave length with any success. Hence, messages may sometimes be kept confidential even when sent in plain English. This will take considerable drill on the part of two men, the operator and an assistant, who will rapidly make the necessary changes in the loading coils and variometers at a signal from the operator.

The first step will be to make experimental determination of the combinations of loading coils and variometers necessary to produce the best radiation for every wave length, within the range of the set and to set them down in the form of a table. Thus, starting with 700 meters, put the left-hand variometer at 700, put the plug in the hole marked 675-1,080, and then slowly move the aerial variometer from 0° toward 180° until the hot-wire ammeter shows the best reading. The various adjustments can then be noted in a table for future reference, thus: (The figures given are not the actual figures. These must be determined for each set separately.)

TABLE I.

Wave length.	Variometer.	Loading coil.	Aerial variometer.	Amperes on hot wire.
700	700	675-1,080	12	6.9
750	750	675-1,080	20	6.95
800	800	675-1,080	50	7
850	850	675-1,080	80	7.05
900	900	675-1,080	120	7.1
950	950	920-1,310	4	7.15
1,000	1,000	920-1,310	10	7.25
1,050	1,050	920-1,310	60	7
1,100	1,100	920-1,310	90	6.8
1,150	1,150	920-1,310	105	6.6
1,200	1,200	920-1,310	130	6.4
1,250	1,250	1,240-1,510	5	6.2

and so on, finding the best combination for every 50 meters increase in wave length up to the limit of the set.

### Limitations of System of Coding Wave Lengths

It will be noted that there is one best wave for the set, namely, about 1,000 meters. From some experiments made recently at Fort Leavenworth it is concluded that it is safe to state that, up to about 75 miles over average land, the falling off of energy due to the use of the longest wave lengths will not be so great as to prevent the use of any wave length within the limits of the set (675-2,220 meters), but that beyond that distance, up to the extreme daylight distance of the set (about 185 miles), it would be safer not to work with any wave length greater than 1,800 meters.

Only further experiments in the field, between two similar sets working at gradually increasing long ranges, will determine the greatest distance at which the whole scale of sending wave lengths may be used.

From the table plotted, different codes of wave lengths, differing by

many meters from each other, may be agreed upon, to be changed daily in actual work, and confided to all operators concerned.

### Receiving Circuits

*Primary or aerial circuit.*—One lead from aerial comes through combination switch to the primary of the transformer (shown on the left of figure 4), from there through plug contact to a point on the little switch marked "Long waves"—"Short waves"; and, if the switch is thrown to the long-wave side, the circuit goes direct to the ground; the variable condenser being then in parallel with the primary of the transformer. If the switch is thrown to the short wave side, the variable condenser is in series with the aerial, the primary of the receiving transformer, and the counterpoise or ground.

The secondary or detector circuit consists of the secondary of the transformer in series with the usual stopping condenser, connected through the main switch to the detectors. The telephones are in shunt to the stopping condenser.

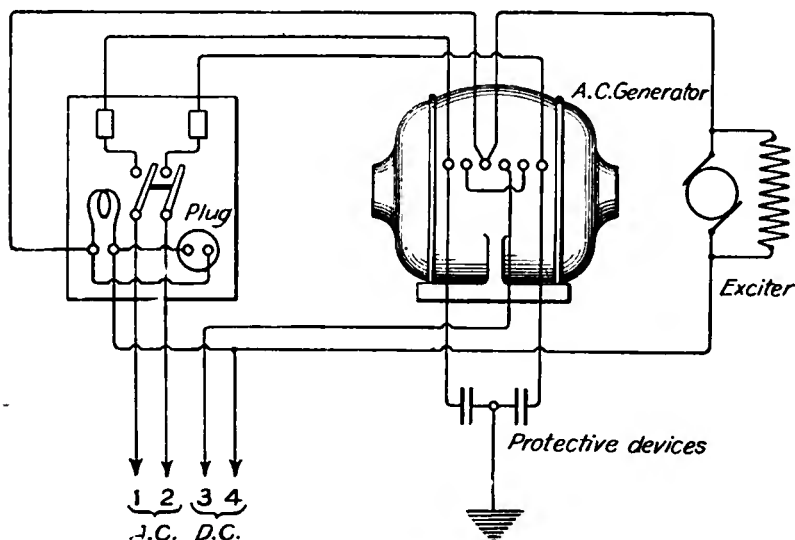

Figure 3—Generator circuits

The detector supplied is of the iron pyrites variety, which lacks the sensitiveness of the Perikon. Any other detector may easily be substituted for the detectors supplied with the set, the range of which may be thereby easily increased.

With the switch thrown to "Long waves" the operator will get the best results when using a small number of degrees of the variable condenser and as large primary as possible, and, vice versa, with the switch to "Short waves," which places the variable condenser in series with the primary coils. The largest possible amount of capacity of the variable condenser and the smallest amount of primary inductance should be used for maximum strength of signals.

The combination switch which is used primarily to cut the receiving set onto the antenna and counterpoise simultaneously performs several operations. Opening this switch disconnects the receiving set from the antenna and counterpoise; automatically connects sending set to the aerial and counterpoise; closes D. C. circuit of generator; disconnects detectors from secondary of receiving transformer, thus opening that circuit and preventing detectors from being affected by the spark when sending, and also opens the primary circuit of the receiving transformer. As the limits of the various coils

of the primary and secondary are marked, there should be no difficulty about setting the receiving apparatus approximately for the wave length of a station whose wave length is known. The operator then varies his condenser, and also the coupling between the primary and secondary of the receiving transformer, until he gets the best adjustment. Changing the coupling (that is, pulling the secondary away from or pushing it closer to the primary) changes the wave length, though to not as great an extent as does varying the condenser. Some stations can not be heard at all well unless the secondary coil is pulled some distance away from the primary. Practice is the best guide to a working knowledge of the tuning of the receiving set.

Figure 2 shows simplified schematic diagram of the transmitting circuits. Figure 3 shows the generator circuits.

### Calibration in Wave Lengths

The receiving set should be calibrated so as to locate the actual combinations necessary for receiving the wave lengths sent out by a similar sending set either by actual tuning to another set sending out successive wave lengths

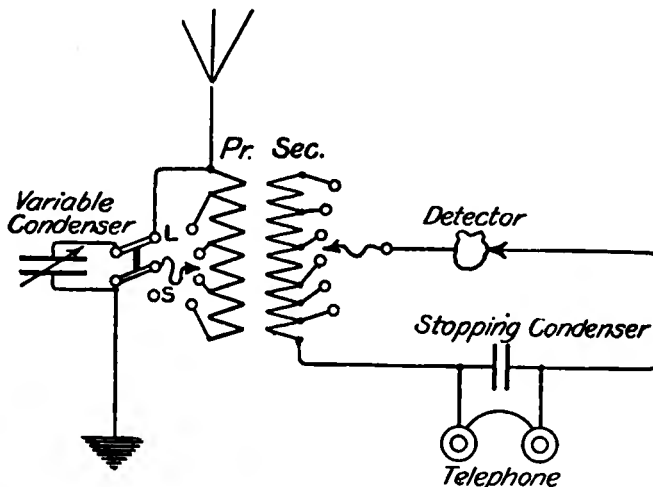

Figure 4—Receiving circuit

differing from each other by 50 meters, as outlined, or by using the wave meter provided with each wagon set as a sending device, and with its coupling coil held near the antenna lead, set up, consecutively, different wave lengths in the antenna and make adjustments of receiving set necessary to tune to the particular wave lengths sent out; then compile a table showing adjustments of condenser switch, primary, secondary, and variable condenser necessary for each wave length in turn, so that the receiving operator can at once adjust his receiving apparatus to any desired wave length, and, by quick changes, constantly follow, according to prearranged code, the message sent out by the other station.

It is recommended that, in order to eliminate one adjustment of the receiving set, the primary and secondary of the receiving transformer be kept in the same relative positions throughout; that is, as close to each other as possible. This, while possibly sacrificing efficiency, secures simplicity. The receiving operator's chart may be arranged as follows:

Best receiving adjustments necessary to tune to wave lengths used by similar wagon-set sending wave lengths shown in Table I.

TABLE II.

Wave length.	Switch.	Primary.	Secondary.	Con- denser.
700	Short waves.....	370-730	500-1,000	80°
750	Long waves.....	640-910	500-1,000	40°

And so forth for every 50 meters.

NOTE.—The condenser adjustments given above are not the actual ones necessary for wave lengths given.

Constant drill in changing sending and receiving adjustments, carried on between two or more similar sets, will result in remarkable efficiency and rapidity, and the time necessary for transmission of messages will be found to be but little increased over that required when sending on a single wave length.

### Receiving by Coding of Wave Lengths

Two complete receiving sets are provided with each wagon set, though ordinarily only one is used. Two messages from different stations may be copied from the same antenna without either operator hearing the message copied by the other. To do this it is, of course, necessary to have a lead from the aerial running to each of the receiving sets. A change in the tuning of one receiving set will call for a slight readjustment of the other receiving set, however, in order that the latter may stay in tune with the given wave length.

The use of two receiving sets in parallel makes it comparatively simple to follow a message sent according to a prearranged code of wave lengths, for it is perfectly practicable to so arrange the wave-length code that the waves of any length within certain limits will fall within the limits of the condenser of either one set or the other, and either one operator or the other, without making any change of adjustment other than a mere movement of



Field wagon radio set, U. S. Army, set up and working

the condenser handle, will have his apparatus constantly in resonance with the incoming waves.

Thus, let us say that in the code agreed upon, which includes all wave lengths between 900 and 2,150 meters, the first word will be sent with a 900-meter wave, the next with 2,100, followed by 1,500, 1,850, 1,050, 2,000, etc.

The two sets are cut in at the receiving station and are each manned by an operator. Operator No. 1, at the left, puts the plug in the hole of the primary of his receiving set marked "900-1410," couples his primary and secondary as closely as possible, throws his receiving switch to "Long waves," and puts the switch of the detector coil on whatever coil will give him the strongest signals. He can then, by merely moving the condenser from  $0^\circ$  toward  $180^\circ$ , tune his set to any desired wave between 900 and 1,410 meters, and it will be his duty to copy all words of the message which may fall within those limits.

Operator No. 2, on the right, similarly throws his switch to "Long waves" and plugs in primary coil marked "1270-2150," and makes the other adjustments as given for No. 1. He is then ready to receive any wave between 1,270 and 2,150 meters by merely setting the pointer of his condenser at the proper number of degrees on the condenser.

From Table II, prepared as before described, either operator can set his condenser accurately and instantly to the proper reading for any desired wave length within limits; hence when the message is to be received the first word sent as per schedule at 900 meters is copied by No. 1 operator, who has his pointer at the proper place on the condenser scale; the second word at 2,100 meters by No. 2, who has already set his pointer at the proper place. As the third word is sent at 1,500 meters, No. 2 readjusts his condenser for the next word, and later turns the pointer to the proper place for the next word at 1,850; then No. 1 comes in on his set and copies the next word at 1,050 meters, No. 2 the next at 2,000, and so forth, the words being placed together in accordance with the order of their receipt so as to make a complete message.

This method of using two operators saves time by dispensing with a number of switch and plug changes, which a single operator would have to make in using only one receiving set.

The method of using two receiving sets tuned as described could easily be worked by one operator who could wear the single head receiver of one set on one ear and that of the other on his other ear.

All these methods should be practiced continually to improve the skill of the operators.

Care must be taken to close or open both main switches of the receiving set at the same time when working both receiving sets in order to prevent sending into one of the receiving sets and burning it out.

### **"Mailed by Wireless"**

**A** WOMAN resident of Paris, Ill., is in receipt of a post card which was "mailed by wireless," by her brother, a member of an Ohio regiment of engineers which has landed safely in France.

The mailing of the card was accomplished in the following manner:

Before boarding the ship which was to take them abroad, many members of the regiment wrote post cards, announcing their safe arrival in France. These cards were held by the postal authorities of the Government, pending further instructions.

Upon the arrival of the regiment in France, a wireless message was sent to this country announcing the fact and the Post Office forwarded the cards to their destinations.

In this way the worry and anxiety incidental to sending letters across the Atlantic in these troublous times was avoided.

# How to Become an Aviator

The Fifth Article of a Series for Wireless Men in the Service of the United States Government Giving the Elements of Aeroplane Design, Power, Equipment and Military Tactics



By **HENRY WOODHOUSE**

Author of "Text Book of Naval Aeronautics"

*(Copyright, 1918, Wireless Press, Inc.)*

**M**AINTENANCE of aeroplane equilibrium is secured by (a) features of design, (b) controls operated by the pilot.

The following factors of stability and control are to be considered:

(1) **Stability**—The natural tendency of a body disturbed to return to normal position.

(2) **Longitudinal Stability**—The tendency of an aeroplane to maintain stability along the direction of normal horizontal flight and overcome pitching and tossing.

(3) **Lateral Stability**—The tendency to oppose rolling sideways.

(4) **Directional Stability**—The tendency to oppose swerving to the right or left of its proper course.

In dealing with these factors, one must dispose of the popular misconception that stability is fixed "steadiness" in flight, attained through skillful design. While it is not easily capsized, an inherently stable aeroplane does not respond readily to its controls; it is sensitive to all air disturbances and will roll and sway in response to air billows, whereas one of neutral stability answers its mechanical and automatic controls handily, and because it has no inherent tendency to hold a fixed position relative to the air, adjusts itself easily so that its position relative to the ground is not changed by air disturbances.



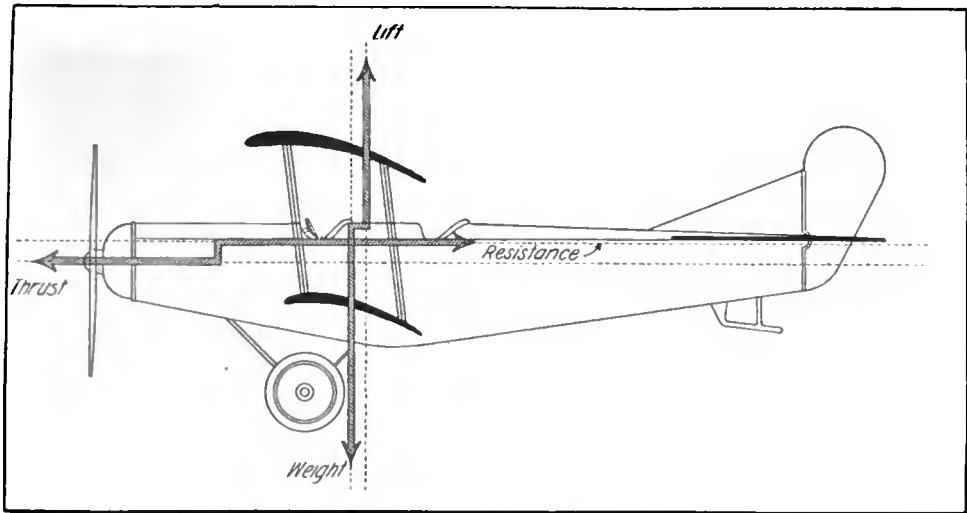

*Figure 14—Balance of forces for aeroplane equilibrium.*

## CENTER OF GRAVITY

The first consideration of aeroplane stability and general flying efficiency is the center of gravity, for the craft is suspended in the air and rotates about this point. The proper place for its location is where the forces of thrust, resistance, lift and weight act.

Ordinarily, the aeroplane is so designed that the thrust line passes nearly through the center of resistance, and the center of gravity is made in line with the weight and lift.

See figure 14.

The center of thrust is often placed below the center of resistance, for convenience. In pusher types the thrust is sometimes above the line of resistance. The tendency to nose down thus produced is overcome by having the center of lift back of the center of gravity. The principle of coincident centers is the factor of proper balance, but with variations in the position and strength of these forces produced in flight, the balance is restored by small forces, such as the tail of the aeroplane.

If the center of gravity is too low it produces a pendulum effect and causes a sideway roll of the aeroplane. When too high, if disturbed it seeks a position as far as possible from the original, tending to tip over the aeroplane.

## METHODS OF DETERMINING THE C. G.

- (a) Point of balance may be determined by placing a roller under the aeroplane.
- (b) The aeroplane swung from a point overhead and a plumb line dropped from this point.
- (c) With the machine supported at front and rear, the weight at each point determined and the distance between the two points measured. This is known as the method of moments.

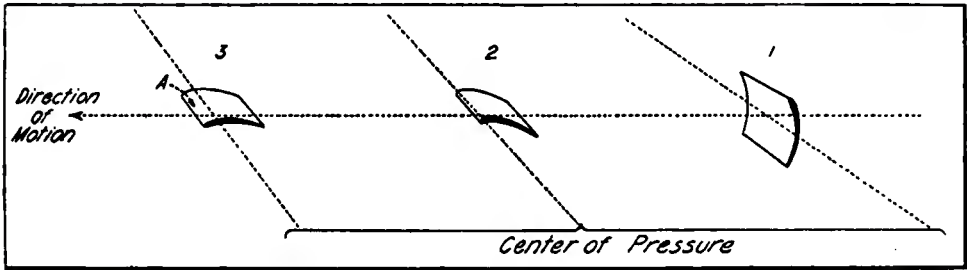

Figure 15—Instability of cambered surfaces

**Longitudinal Stability**

**LIFTING SURFACES**

Cambered wing surfaces are longitudinally unstable at angles of incidence below 12 degrees, at which angles fair lift-drift ratio is produced.

In figure 15, the centers of pressure of surfaces 1, 2 and 3 are indicated. The C. P. is the point at which all the air forces about balance.

Surface 1 is cambered and in a position approximately vertical, moving in a direction from right to left. Its center of pressure is along the exact center line of the surface.

With decrease in angle to one of about 30 degrees, the center of pressure moves forward to the position shown in Surface 2.

In Surface 3 the angle of incidence has so decreased that there is a downward pressure at point A. Corresponding depressions in such negative angles increase proportionately the pressure A. The center of pressure being the resultant of all air forces, it is affected by the downward pressure at A and moves backward. This pushes up the rear of the surface and increases the tendency to dive. But as the surface's angle of incidence is increased the pressure at point A decreases, whereupon the center of pressure moves forward and pushes up the front. If the angle is thus greatly increased the result is a "tail slide."

**STABILIZING SURFACE**

Since the cambered wing surface is inherently unstable, a stabilizing surface at some distance in the rear, or at the tail, is added. This tail surface has less angle of incidence.

Figures 16a, 16b and 16c illustrate the effect of the tail surfaces, the upper portions of the drawing showing main lifting surfaces at varying angles, and with tail attached in lower view.

In figure 16a, the lift force is in rear of the center of gravity, which tends to make the wing dive; in the lower view it is shown how the downward pressure on the tail counteracts this tendency.

Figure 16b shows a surface with lift passing through the center of gravity. The wing is therefore balanced and tail pressure is not needed unless a sudden change in angle is effected.

In figure 16c the line of lift force is ahead of the center of gravity. The tendency of the wing to rear up is here offset by the upward pressure on the tail, as shown in the lower view.

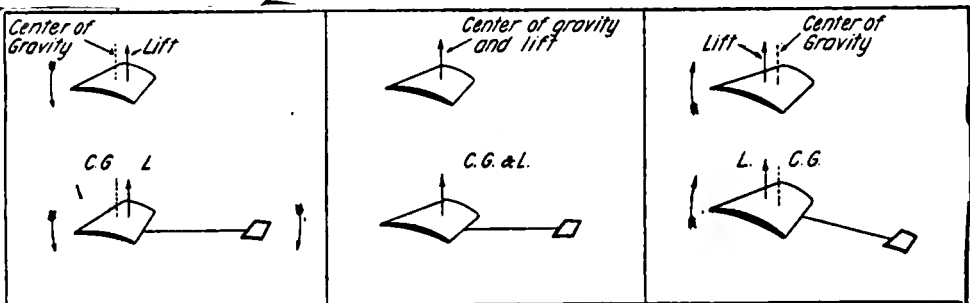

Fig. 16a

Fig. 16b

Fig. 16c

Balance of lifting surfaces by tail stabilizer.

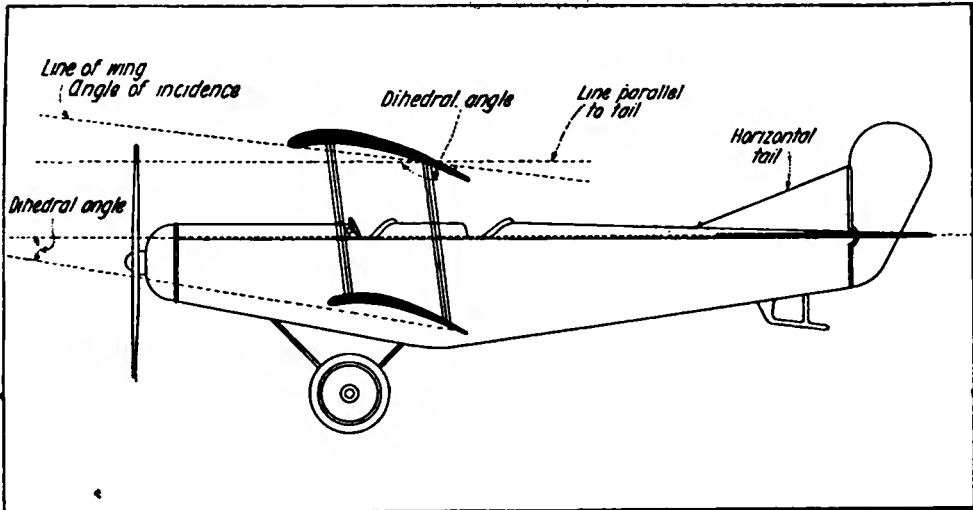

Figure 17—Dihedral angle formed by lifting surfaces and stabilizer

## LONGITUDINAL DIHEDRAL ANGLE

The tail must have an angle of incidence smaller than that of the wings. The angle of incidence of the tail stabilizing surface is ordinarily about one-third of the aerofoil angle. The neutral lift lines of each, when projected to meet, make a dihedral angle.

See figure 17.

Occasionally, the tail-plane's angle is the same as that of the main lifting surfaces, the lessened angle of incidence required of the former being secured by the downward deflection of air from the upper aerofoil.

To illustrate the effect of stability secured by the longitudinal dihedral, we may consider an aeroplane traveling a horizontal course; in this position the thrust and direction of motion are identical. The nose of the machine then being suddenly deflected by some air disturbance, the angle of incidence is changed with the downward position. Assume that on the horizontal course the aerofoil angle was 12 degrees and with the deflection the thrust line is lowered, say, 3 degrees. The angle of incidence is not changed in the same proportion, because the momentum of the former (horizontal) course pulls it off the direction of thrust.

The net change of angle of incidence will be assumed to be 2 degrees. Both main lifting surfaces and tail stabilizer are affected by the change because both are fixed to the aeroplane structure. Both have decreased, proportionately. The main lifting surfaces, with former angle of incidence at 12 degrees, have decreased to 10 degrees. The tail stabilizer, with former angle 0 degrees, has now a minus angle or negative of 2 degrees. Therefore, since the main surfaces have lost  $12^\circ - 2^\circ$ , or  $1/6$  of their lift, and the tail stabilizer is now at an entirely negative angle, the tail will fall faster than the main planes. The aeroplane in consequence rights itself, or readjusts to the former horizontal.

The reverse happens when the nose of the machine is tilted up by a gust of wind. While both main lifting surfaces and tail surface increase angles of incidence in the same amount, the angle (which determines the lift) increases in greater proportion with the tail than with the main surfaces, which lifts the tail faster. The aeroplane then assumes its first position at a slightly greater altitude.

The variation of angle of incidence is not as great as the variation of the aeroplane's angle to the horizontal.

Stability produced by the effect of the longitudinal dihedral exists only when there is momentum in the original direction.

The stability adjustments described are taking place almost continuously in flight, although not always perceptible to the aviator.

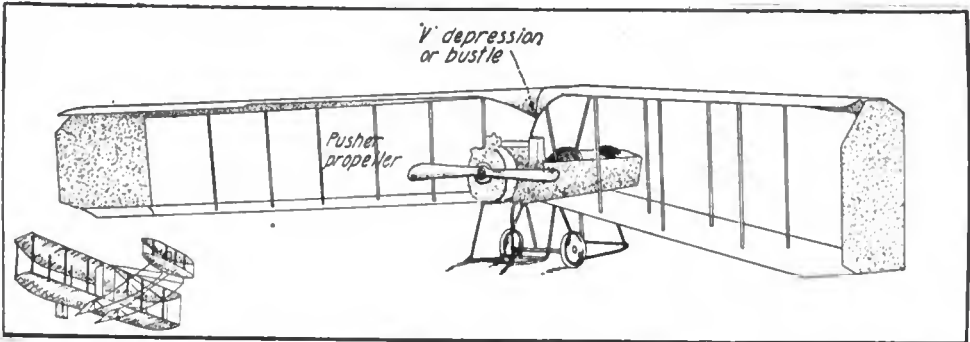

Figure 18

Figure 19—Aeroplane of the Dunne type, with longitudinal dihedral surfaces

## CANARD PRINCIPLE

In early types, such as shown in the lower left of the drawing on this page, figure 18, it was customary to place the stabilizing surface in front. The tail-first principle possessed obvious disadvantages, notably that sufficient longitudinal stability could be had only by giving this a greater angle of incidence than the main lifting surfaces. Thus if the wings had an angle of 5 degrees, the forward stabilizer was set at an angle of incidence of 15 degrees, which gave poor lift-drift ratio at high speeds.

Low velocities were the rule in the early days and the defect in design was not appreciated until increased speeds were required. The principle of the forward stabilizer, known as the canard, is now obsolete.

## MAIN SURFACE DIHEDRAL

Figure 19 shows a view of the Dunne aeroplane, from the right rear. This type has no stabilizing tail surface, longitudinal dihedral being given by the main surface having a decreasing angle of incidence toward the wing tips and corresponding camber. The theory is that the wing tips act as longitudinal stabilizers.

This design has the following disadvantages:

(a) Departure from the usual form of lifting surfaces, in plan a parallelogram, is a mechanical inferiority, requiring additional strength of construction. This increases weight.

(b) Aspect ratio is lowered because the leading edge of the aerofoil is not at a right angle to the direction of motion. Lift is lessened on account of lowered aspect.

(c) Drift is increased by the action of the air on the V-shaped depression in the center of the aerofoil. This dip is pointed in the direction of motion and when the aeroplane is turned off its course to a direction which is the resultant of thrust and momentum, or a sideways motion, the air pressure on the corresponding side of the V depression turns the machine back on its course. It is obvious that the air reaction set up by this depression increases drift.

(d) The necessity for decreasing the angle and camber toward wing tips increases time and cost of construction.

Vertical surfaces at the wing tips, as shown in the drawing, are sometimes added, set at an angle producing the same stabilizing effect. Drift is increased by this arrangement, and efficiency lowered.

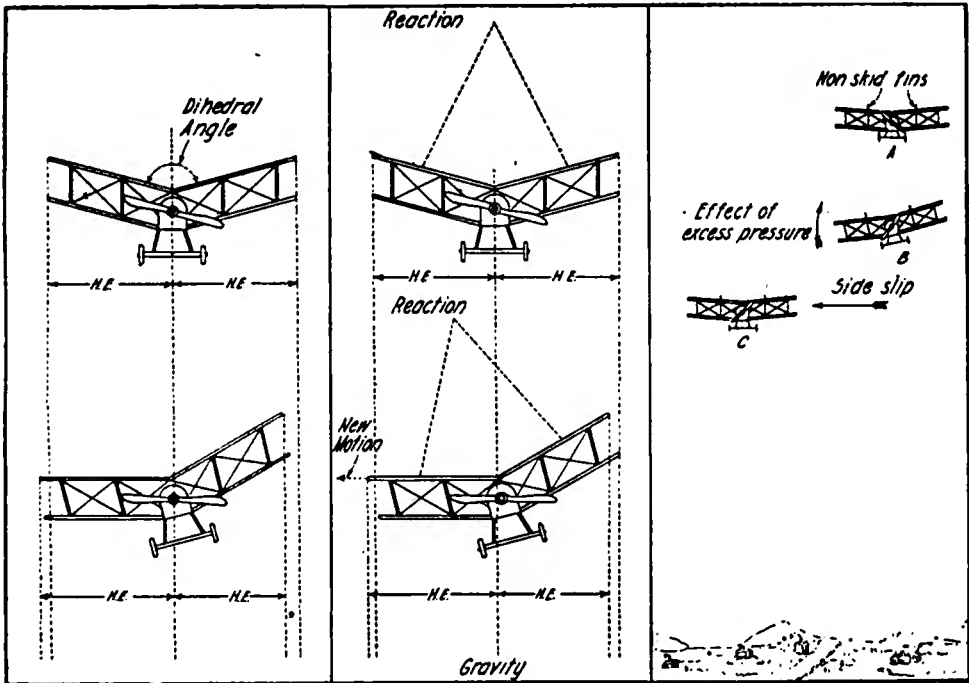

Figure 20

Figure 21

Figure 22

Lateral stabilizing effect of upwardly inclined wings

**LATERAL STABILITY**

Upward inclination of the lifting surfaces gives a degree of lateral stability, the wings forming a dihedral angle. The tendency to a sideways roll through air disturbance is thus corrected by the lower wing gaining greater pressure or lift and the consequent side slip restoring the machine to level position.

In the upper portion of figure 20 is a representation of a front view of an aeroplane in flight, lifting surfaces having equal horizontal equivalent. When the machine is tilted sideways, as shown in the lower view, the horizontal equivalent (H. E.) of the left wing, now horizontal, has increased; a decrease is seen in the right hand wing, the lower wing in consequence rising through its added lift. The aeroplane is thus restored to its first, or normal, position.

The righting effect is not, however, proportional to the horizontal equivalents of both wings. In the upper portion of figure 21 it is indicated that the reaction, when the aeroplane is at normal position, has a direction opposed to the gravity force, or weight, the two forces being evenly balanced, or equilibrium maintained. In the lower half of figure 21, with the aeroplane tilted sideways the force of reaction is at an angle or not directly opposed to gravity force. The direction of reaction is therefore no longer directly forward, the resultant of the thrust and momentum giving the added direction of motion indicated in the drawing. The aeroplane is thus moving sideways while flying forward.

To be effective, the angle of the lateral dihedral must be great enough to force the aeroplane back to equilibrium, and overcome the tendency to turning caused by the increased air pressure exerted on the keel surface, greatest in effect toward the tail.

Figure 22 shows the side slip, with non-skid fins added where excessive dihedral is needed to balance large keel surface.

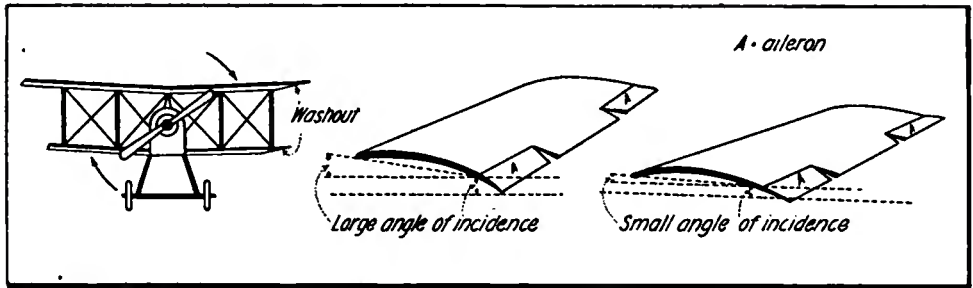

Figure 23—Washout

Figure 24—Ailerons attached to lifting surfaces

## WASHOUT

An aeroplane tends to turn over sideways in a direction opposite to that in which the propeller revolves. The adverse effect of propeller torque (drift) is neutralized by giving the wing tip on the side not affected a smaller angle of incidence.

The washout is shown in figure 23.

Where practicable, the angle of incidence is also *increased* on the side tending to fall, its lift thereby being increased. Washin is the term used to describe the increased angle.

Washing out the angle of incidence on both sides increases the drift, making possible lessened angle for the ailerons (the lateral controlling surfaces shown in figure 24) which gives them better lift-drift ratio.

## AILERONS

In figure 24, the drawing to the right, the smaller angle of incidence of the aerofoil (lifting surface) is given by washout. In comparing it with the other aerofoil (top center of page) it is noted that the ailerons attached to both have the same inclination, although the ailerons of the aerofoil with washout have considerably less angle of incidence, therefore greater efficiency.

## BANKING

When an aeroplane is turned off its course it does not instantly proceed along its new course. This is due to the momentum of the original course. The new direction is therefore the resultant of this momentum and the thrust, and the sideways skid caused by the centrifugal force turns the lifting surfaces away from their proper horizontal position, causing lessened lift. Neutralization of this effect is created by "banking," or tilting the aeroplane sideways.

With the angle of the lifting surface changed by banking, the inclination of bottom of the lifting surface makes the pressure or lift force a horizontal component of the centrifugal force. The velocity of the skid is that required to secure an air pressure or lift opposite and equal to the centrifugal force of the turn. The steepness of the bank is governed by the sharpness of the turn, increasing as the strength of the centrifugal force.

It is obvious that when banking the entire lift force is no longer vertical, and it is important that it be sufficient to support the weight of the aeroplane, or it will fall. Speed is a requirement to offset this.

*Pilots must not try to climb while banking.*

*Slight banking results in skidding, which is easily corrected.*

*Too steep banking, however, may result in a side slip inward, which is likely to be followed by a nose dive.*

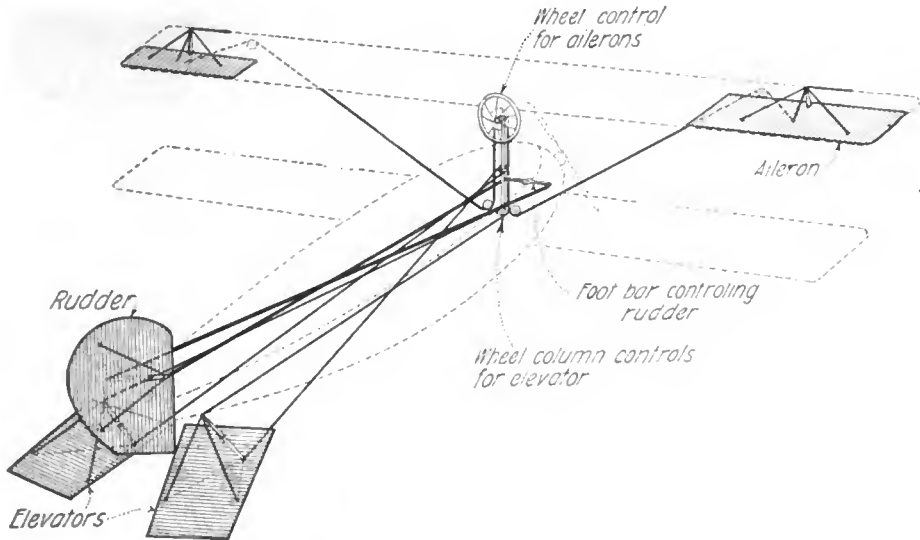

Figure 25—Mechanical means of directional and lateral control

## CONTROLS

The illustration above shows the aeroplane's mechanical means of directional and lateral control. These comprise operation of the elevators, ailerons (sometimes called "wing flaps," when attached to main lifting surfaces as shown in drawing), and the rudder.

All operate on the principle of air force derived from an inclined plane.

The elevators are controlled, in U. S. training machines, from the column which supports the wheel, as shown.

The ailerons, or wing flaps, for lateral control are moved by the wheel in the cockpit.

The rudder is controlled by a foot bar.

The elevators are inclined up or down to depress or lift the tail of the aeroplane.

The ailerons supply the difference in angle to the two tips of the wings, as needed, causing one to lift more than the other.

The rudder's action in turning the machine is due to the varying wind pressure exerted on the sides when moved to one side or the other.

# MILITARY AIRMEN



---

## MAJOR WALTER GLENN KILNER, U. S. A.

---

Skill and Daring the Predominant Characteristics of the Officer in Charge of the Government Aviation School at Mineola, Long Island

**F**EW of our Army aviators have seen such varied and spectacular service as Major Kilner. It is not generally realized that American airmen saw actual war service and distinguished themselves in it before any of the flyers in the European air fleets.

The first baptism of fire occurred during the Vera Cruz expedition. Later, in 1916, our airmen played a prominent part with General Pershing's punitive expedition. Major, then Lieutenant, Kilner first came into prominence while making daring flights over Mexican territory. When our troops were mobilized for the invasion eight tractor biplanes were shipped to the border and the unprecedented difficulties of the American flyers began. Major Kilner and his associates had never before faced such conditions. The water in the radiators of the aeroplanes stood at 120 degrees, and the propellers flew to pieces in the rarified air.

The deserts were covered with soft sand or small bushes which proved extremely dangerous to aeroplanes in rising or landing. Once aloft the flyers encountered perplexing air currents, even whirlwinds, which caught and overturned their machines. The aeroplane division, nevertheless, soon proved its usefulness. Lieut. Kilner and his associates quickly overcame this baffling situation and established regular communication with General Pershing's rapidly advancing column and its base. It required four days to carry dispatches by truck from the base to the head of the column, until the army aeroplanes established a regular mail service, covering the distance of 120 miles in sixty-six minutes. In March, 1916, Major Kilner and another Army aviator were reported lost in Mexico and the country anxiously awaited further news. He returned in safety to the United States soil, however, having been brought down during a flight by motor trouble.

Major Kilner attracted the attention of the entire country in the fall of 1916 when he acted as commanding officer of the first aeroplane squadron in America to go aloft on a pleasure cruise. The fleet, popularly known as the "football special," flew from New York to Princeton, N. J., where the flyers attended a football game, and returned without mishap. All of the machines arrived safely in time for the game.

Major Kilner was placed in charge of the Government aviation school at Mineola, Long Island, in September, 1916, where he has since served. He is generally recognized as one of the most skillful and daring aviators in the country. In September, 1916, he was married to Miss Grace Covell in New York City.



# Wartime Wireless Instruction

## A Practical Course for Radio Operators

### ARTICLE VIII

---

By Elmer E. Bucher

*Instructing Engineer, Marconi School of Instruction*

*(Copyright, 1918, Wireless Press, Inc.)*

---

**EDITOR'S NOTE.**—This is the eighth installment of a condensed course in wireless telegraphy, especially prepared for training young men and women in the technical phases of radio in the shortest possible time. It is written particularly with the view of instructing prospective radio operators whose spirit of patriotism has inspired a desire to join signal branches of the United States reserve forces or the staff of a commercial wireless telegraph company, but who live at points far from wireless telegraph schools. The lessons to be published serially in this magazine are in fact a condensed version of the textbook, "Practical Wireless Telegraphy," and those students who have the opportunity and desire to go more fully into the subject will find the author's textbook a complete exposition of the wireless art in its most up-to-date phases. Where time will permit, its use in conjunction with this course is recommended.

The outstanding feature of the lessons will be the absence of cumbersome detail. Being intended to assist men to qualify for commercial positions in the shortest possible time consistent with a perfect understanding of the duties of operators, the course will contain only the essentials required to obtain a Government commercial first grade license certificate and knowledge of the practical operation of wireless telegraph apparatus.

To aid in an easy grasp of the lessons as they appear, numerous diagrams and drawings will illustrate the text, and, in so far as possible, the material pertaining to a particular diagram or illustration will be placed on the same page.

Because they will only contain the essential instructions for working modern wireless telegraph equipment, the lessons will be presented in such a way that the field telegraphist can use them in action as well as the student at home.

Beginning with the elements of electricity and magnetism, the course will continue through the construction and functioning of dynamos and motors, high voltage transformers into wireless telegraph equipment proper. Complete instruction will be given in the tuning of radio sets, adjustment of transmitting and receiving apparatus and elementary practical measurements.

This series began in the May, 1917, issue of THE WIRELESS AGE. Beginners should secure back copies, as the subject matter presented therein will aid them to grasp the explanations more readily. If possible, the series should be followed consecutively.

## ELECTROSTATIC CAPACITY AND RADIO FREQUENCY CIRCUITS THE CONDENSER

(1) Up to this point, we have explained how alternating current can be obtained from a direct current source of supply through the medium of a motor-generator, and furthermore, we have shown how by means of a step-up transformer, a low voltage current can be raised to one of high voltage.

(2) The apparatus next in importance is the **high voltage condenser** which, when charged and discharged through what is known as a **closed oscillation circuit**, generates the extremely high frequency currents which are employed for the production of the electric waves of wireless telegraphy.

(3) The condenser possesses **electrostatic capacity**, i. e., the ability to store up energy in the form of electrostatic lines of force.

(4) The electrostatic capacity of a condenser or conductor is measured by the quantity of electricity in coulombs with which it must be charged to raise its potential to one volt.

(5) The **capacity** of a condenser is expressed by the unit termed the **farad**. A condenser has capacity of one farad when an E. M. F. of one volt will store up in it a charge of one coulomb.

(6) A condenser of one farad capacity would be too large for practical use. Hence, to make this unit applicable to every-day practice, the term **microfarad** is employed.

One microfarad =  $\frac{1}{1,000,000}$  of a farad.

It should be kept in mind, however, that the farad is a unit of such proportions as to compare with the volt and the ampere.

(7) A condenser, in practice, consists of two or more conducting plates separated by air or one of the well-known insulating substances, such as paraffine, hard rubber, ebony, or glass.

The insulating medium is termed the **di-electric**.

(8) If the coatings of a condenser be connected to a source of high voltage current such as that furnished by the secondary winding of a step-up voltage alternating current transformer, a powerful electrostatic field will be set up between its plates. And if afterward the plates are connected together by a stout copper wire with a spark discharge gap in series, a powerful spark will discharge between the terminals of the gap.

(9) A distinction must be made between condensers used with high impressed voltages, and those employed in circuits of the order of a few hundred volts. The **di-electric** of high voltage condensers is generally a glass plate, a sheet of micanite or ebony.

(10) The **di-electric** of condensers for low voltage circuits is generally paraffine paper, or thin sheets of micanite.

(11) The capacity of a condenser can be expressed in several ways. The following formula will perhaps be the most practical:

$$C = \frac{K \times A \times 2248}{T \times 10^{10}}$$

where C = capacity of the condenser in microfarads

A = the area of the conducting material of one set of plates

T = the amount of separation between plates

K = a certain constant termed the **di-electric** constant which varies with the texture or material of the di-electric.

(12) We see from this formula that the capacity of a condenser will increase as the distance between plates is decreased or, with a given separation, as the surfaces of the plates are made larger. The capacity also varies with the **di-electric**, the higher capacities, for instance, being obtained when glass is employed as the insulating medium.

(13) Comparisons made with different di-electric mediums indicate that the charge accumulated in the condenser is much greater when certain of the well-known insulating materials, such as glass, micanite, etc., are placed between its plates.

For example, if a sheet of glass is inserted between the plates of a condenser of given dimensions, it can store up nine times as much energy as with air at atmospheric pressure; with micanite, six times; with paraffine paper, two, etc.

These quantities are known as the **inductivities** of the di-electric or, more commonly, the **specific inductive capacity**.

(14) We may define **inductivity** as the ratio of the capacity of a condenser, when its plates are separated by an insulating substance, to that when they are separated by air.

(For table of Di-electric Constants, see author's "Practical Wireless Telegraphy.")

(15) Condensers may be connected in series or in parallel. **Several jars connected in parallel** act as a single jar of increased dimensions.

**Jars in series** act as a single condenser of small capacity. Parallel and series connections are shown in Figures 69 and 72, respectively.

## OSCILLATION GENERATORS

(1) In order to understand the necessity for the foregoing apparatus, i. e., the **motor-generator, the step-up voltage transformer and the condenser**, in a radio telegraph set, we must keep in mind that the **electric waves** of wireless telegraphy are set into motion by currents of extremely high frequency. These currents should oscillate at frequencies in excess of 10,000 cycles per second, and viewed from the standpoint of wireless practice aboard vessels, frequencies from 500,000 to 1,000,000 cycles per second are most desirable.

Currents of extremely high frequency are generated by discharging the energy stored up in a condenser through what is termed a **radio frequency circuit**.

(2) A **radio frequency circuit** may be either an **open or closed oscillation circuit**.

An **open circuit** of radio frequency dimensions, if set into excitation, will radiate **electrical waves** which travel through space at the rate of 186,000 miles or 300,000,000 meters per second.

A **closed circuit** set into excitation will **generate currents of extremely high frequency**, but there will be practically no radiation therefrom.

(3) A closed oscillation circuit of radio frequency dimensions generally consists of a **battery of high voltage condensers**, a coil consisting of a few turns of wire, and a **spark discharge gap**. The condenser is charged by a high voltage alternating current at pressures varying from 6,000 to 20,000 volts. The frequency of the charging current may vary from 60 to 500 cycles per second.

(4) An open oscillation circuit of radio frequency dimensions generally consists of a **vertical wire** (or a number of elevated wires) extended into space, thoroughly insulated from its supports and connected to earth at one end. Direct connection with the earth is not necessary—what is known as an **artificial earth** or **counter-poise**, which consists of a few wires placed underneath the vertical wire and insulated from the earth, may be employed. Counter-poises are frequently laid on the surface without regard to insulation.

(5) An open circuit may be set into oscillation by placing a **spark gap in series**, the terminals of the gap being connected to a high voltage current, such as that generated in the secondary winding of an induction coil or high voltage alternating current transformer; or, the open circuit may be **inductively coupled** to a closed oscillation circuit, the oscillations generated in the latter being transferred to the former by electromagnetic induction.



*Figure 68.—A battery of copper plated Leyden jars. This unit consists of six jars of .002 microfarad capacity each, making a total value of .012 microfarad, the correct value for a 2 K.W. 500 cycle transmitter. By a special process the inside and outside of the glass are coated with copper, making a very serviceable conducting material which will last for an indefinite period. This is a distinct improvement over the tin foil coated jar which, on account of blistering of the foil, became inoperative after about six months' use. A stranded copper conductor is connected to the inside of the jars and connection is made to the outside through the cups at the bottom. The entire rack is insulated by four electrose insulators*

(6) An oscillation circuit whether of the open or closed type possesses three qualities, namely, inductance, capacity, and resistance, and it is upon these three qualities, measured quantitatively, that the frequency of oscillation depends.

(7) The frequency of an oscillation circuit can be computed as follows:

$$N = \frac{1}{2\pi \sqrt{L, C}}$$

where L=the inductance of the circuit in henries.

" C=capacity in farads.

(This formula ignores the resistance R.)

Since the henry and the farad are too large for practical work, the centimeter and the microfarad are extensively employed.

$$\begin{aligned} 1,000,000,000 \text{ centimeters} &= 1 \text{ henry} \\ 1,000 \text{ centimeters} &= 1 \text{ microhenry} \end{aligned}$$

Then, if L be expressed in centimeters and C in microfarads, the formula for the frequency of an oscillation circuit becomes:

$$N = \frac{5,033,000}{\sqrt{L, C}}$$

An example of this formula appears in connection with Figure 73.

Generally, in radio frequency transmitting circuits we deal with capacities and inductances of a low order.

(8) We have employed the term **radio frequency** in several instances. This term has been adopted to distinguish the currents employed in radio telegraph work from those of a lower frequency corresponding to audible vibrations.

Currents at frequencies in excess of 10,000 cycles per second are termed currents of **radio frequency**. Those of a frequency less than 10,000 cycles per second are termed currents of **audio frequency**.

This distinction is made in recognition of the limits of the human ear in responding to vibrations in excess of 20,000 per second. Vibrations in excess of this number are generally above the limits of audibility. Since a current of 10,000 cycles per second (if, for instance, it actuated a telephone diaphragm) would correspond to a frequency of 20,000 vibrations per second, the figure 10,000 is employed as the dividing line between a current which would correspond to an audible vibration and one of a higher frequency which, under the conditions outlined above, is inaudible.

(9) Electrical circuits of audio frequency dimensions, in general, have condensers of rather large capacity or coils of high values of inductance, which may possess iron cores. These circuits form a complete contrast to those of radio frequency dimensions which have coils of a few turns minus an iron core or condensers of the order of, say, .001 to .1 microfarad capacity.

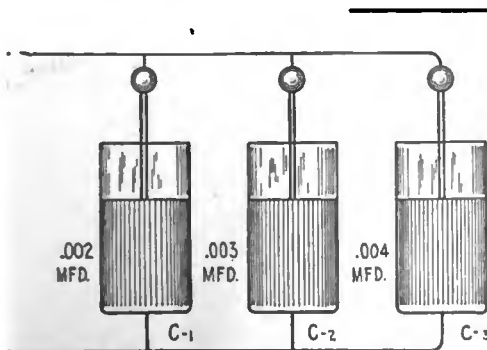

Figure 69.—Showing a battery of Leyden jars connected in parallel. With this connection, the battery acts like a single Leyden jar of enlarged dimensions. To find the capacity of a condenser battery connected in this way, add their individual values. Thus the battery in this figure has capacity of .002+.003+.004 or .009 microfarad.

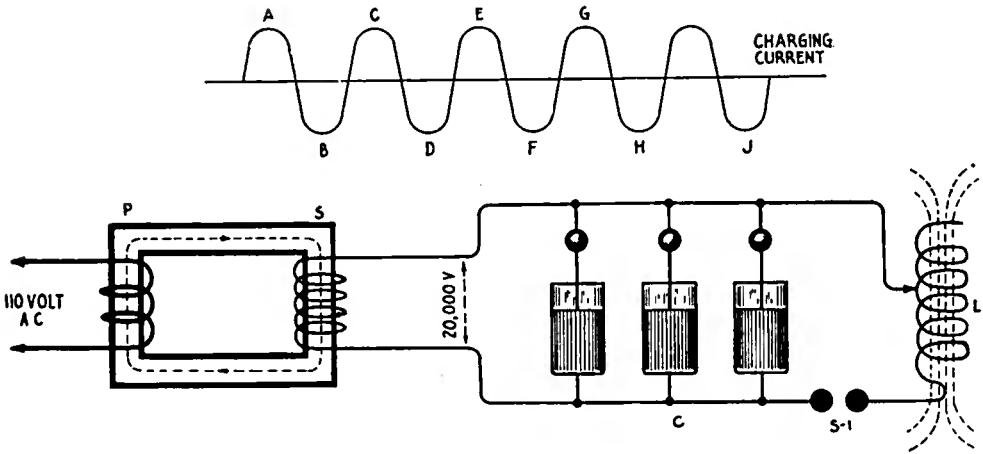

Figure 70

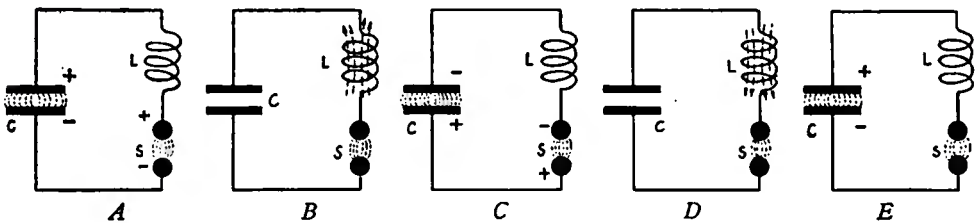

Figure 71

**OBJECT OF THE DIAGRAMS**

- (1) Figure 70: To show the circuits of the apparatus for the production of radio frequency currents.
- (2) Figure 71. To indicate the process of the discharge of a condenser.

**PRINCIPLE**

The energy furnished by the secondary winding of a high voltage transformer may be temporarily stored in a battery of condensers and thereafter discharged through a coil of wire across a spark gap in the form of radio frequency currents.

**DESCRIPTION OF THE DRAWING**

A closed core high voltage transformer (Figure 70) has the primary winding, P, and the secondary winding, S, current being taken in at the primary at 110 volts and delivered at the secondary at 20,000 volts. Shunted across the secondary winding of the transformer is a battery of condensers, C, the discharge circuit of the condensers comprising the coil, L, and the spark gap, S-1.

**OPERATION**

If alternating current is supplied to the primary winding, and the spark gap, S-1, is properly adjusted, a violent spark following each alternation of the current will discharge across the gap. The actual number of spark discharges will depend upon the length of the gap, the material of the electrodes, and the voltage of the charging source. For instance, if the spark gap is of such length that it will break down at 10,000 volts, and the potential of the transformer is 20,000 volts or more, two or three spark discharges may take place for each alternation of the current.

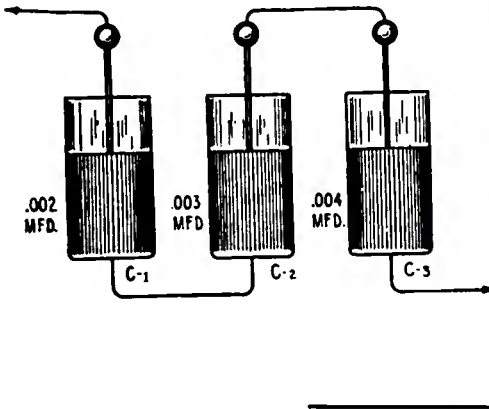

Figure 72.—Indicating a battery of Leyden jars connected in series. If the capacity of each jar has the same value, the resultant capacity will be that of one jar divided by the number of jars in the circuit, but if the jars have unequal capacities, then the following formula applies:

$$C = \frac{1}{\frac{1}{C-1} + \frac{1}{C-2} + \frac{1}{C-3}}$$

Hence the jars of Figure 64 have capacity of

$$\frac{1}{\frac{1}{.002} + \frac{1}{.003} + \frac{1}{.004}}$$

The advantage of this connection, particularly in radio transmitters, is that the voltage from a given source can be distributed among the three condensers, thereby reducing the strain on the dielectric of the individual jar, but since the capacity of the entire unit is thereby reduced, a greater number of jars will be required for the series connection than for a parallel connection of the same capacity. If the terminals of this battery of jars are connected to a 20,000 volt transformer, the voltage, if each jar possessed identical values of capacity, would be equally distributed, i. e., 6,666 volts across each jar.

A distinction should here be drawn between the radio frequency oscillations which discharge through the condenser circuit and the audio frequency current furnished by the charging source. The discharge at the spark gap, S-1, will take place at audio frequent rates, but the frequency of the oscillations composing the individual spark discharges depends upon the self-inductance and capacity of the circuit, L, C, S-1.

The complete cycle of events in the discharge of a condenser is shown in Figure 71. If the condenser C (Figure 71a) is connected to a high voltage transformer and at any particular instant the polarity of the charging source is (+) and (−) as indicated, then the energy at the beginning is all electrostatic in the condenser, C. The strain at the spark gap, S, is such that the surrounding air becomes ionized and a spark discharge takes place, whereupon the energy which was formerly electrostatic between the plates of the condenser now becomes electromagnetic, surrounding the coil, L, and leads connecting to the condenser (71b).

The collapse of the field around the coil, L, creates the condition of Figure 71c where the counter E. M. F. set up thereby charges the condenser, C, to the opposite polarity, but a charge less in quantity will be stored up at this instant than that originally supplied in Figure 71a.

The condenser discharges across the gap again, as shown in Figure 71d, and its energy once more is converted into a magnetic field about the coil, L. The collapse of the magnetic field charges the condenser to the polarity shown in Figure 71a, but the total amount of energy stored up between the plates of C will be less than at the beginning.

It is thus seen that when an isolated charge of electricity is supplied to the condenser plates, the charges do not completely neutralize at the first instant of discharge, but, in fact, several alternations of current take place at an extremely rapid rate before equilibrium is restored.

This gradual extraction of energy from the oscillations is termed the **damping of the oscillations** and the decrease in amplitude of successive cycles can be expressed in logarithmic percentage.

**SPECIAL REMARKS**

(1) The circuit, L, C, S-1, in radio telegraphy is called the closed oscillation circuit. This apparatus generates the radio frequent currents of wireless telegraphy.

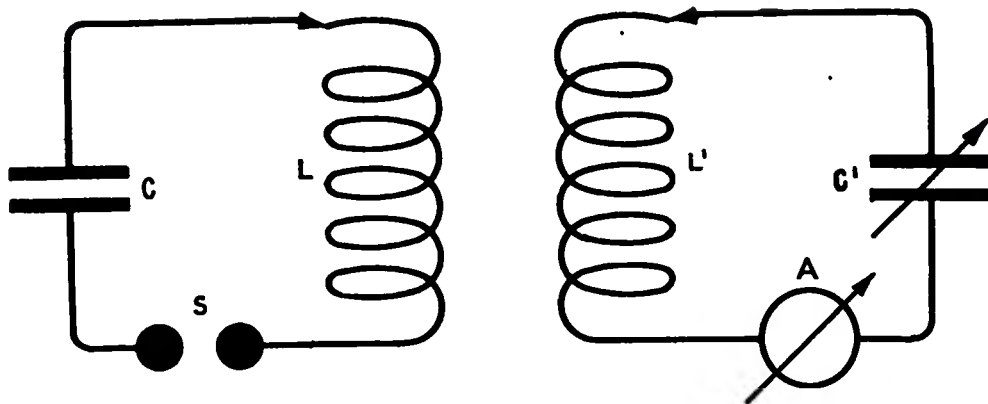

Figure 73

### OBJECT OF THE DIAGRAM

To illustrate the circuits of the apparatus for demonstrating the principles of electrical resonance.

### PRINCIPLE

In order to transfer energy most effectively from one radio frequency oscillation circuit to another, the product of the inductance multiplied by the capacity in each circuit must be equal, i. e., the two circuits must possess substantially the same natural frequency of oscillation.

### DESCRIPTION OF THE DRAWING

Circuit L, C, S, is the generating circuit; circuit L-1, C-1, A, the absorbing circuit which is to be placed in resonance with the circuit L, C, S.

C is a high voltage condenser, charged by a step-up voltage transformer; L, a radio frequency inductance comprising a few turns of stout copper wire or tubing; and S a spark gap.

L-1 is a variable inductance, C-1 a variable condenser, and A a hot wire ammeter.

### OPERATION

The two circuits may be placed into electrical resonance as follows:

Set L, C, S, into excitation by connecting C to the secondary terminals of a high voltage transformer. Place L-1 in inductive relation to L, and follow this by changing the value of L-1 or C-1 until the hot wire ammeter A indicates a maximum deflection.

If the resistance of the two circuits is not excessive, the resonant adjustment of circuit L-1, C-1, A, will be sharply defined, that is, a very slight change of inductance or capacity will cause a large decrease in the reading of the ammeter.

### SPECIAL REMARKS

(1) If the upper end of the coil, L-1, is connected to an aerial wire and the lower end to earth, the oscillations generated in L, C, S will act inductively on L-1, and if resonance is established, powerful currents will flow in the aerial circuit. Electrical radiation will then take place.

(2) The process of establishing resonance between the two circuits can be reversed. The values of L-1 and C-1 are set and the inductance of L or the capacity of C, varied until a maximum deflection of the ammeter, A, is obtained.

(3) If resonance cannot be established by this experiment, it is an indication that the values of L-1, C-1, and L, C, are incorrect for resonance.

(4) We may now state the general rule that two oscillation circuits of radio frequency are in electrical resonance when the product of the capacity multiplied by the inductance in one equals the product of the inductance multiplied by the capacity in the other. It makes substantially no difference whether the two circuits to be placed in resonance are open and closed oscillation circuits, or whether two closed or two open circuits are under consideration.

(5) To illustrate rule (4): If in Figure 73,  $L=25,000$  centimeters;  $C=.001$  microfarad;  $L-1=5,000$  centimeters and  $C-1=.005$  microfarad; then  $L \times C = L-1 \times C-1$  for  $\sqrt{25,000 \times .001} = 5$  and  $\sqrt{5,000 \times .005} = 5$ . The factor 5 is known as the oscillation constant of this particular circuit.



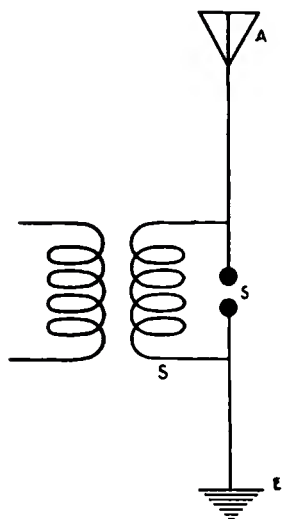

Figure 74

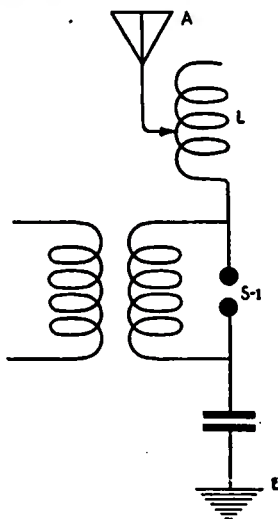

Figure 75

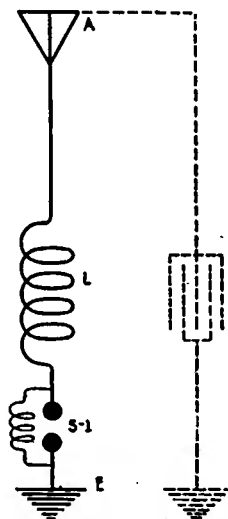

Figure 76

### OBJECTS OF THE DIAGRAMS

- (1) Figure 74. To indicate the simplest method of setting electric waves into motion.
- (2) Figure 75. To show how the length of the radiated wave can be artificially increased or decreased within the wireless telegraph station.
- (3) Figure 76. To illustrate how the effective capacity of a wireless telegraph aerial completes the circuit for high frequency currents.

### PRINCIPLE

If an insulated, elevated conductor is connected to earth with a spark discharge gap in series, and furthermore, the terminals of this gap are connected to a source of high voltage current, the vertical wire will be charged periodically, a series of sparks will take place across the gap, and radio frequent oscillations will traverse the aerial circuit. Part of the energy of these oscillations will be radiated in the form of a wave motion.

This wave motion will have a distinct length between points of maximum or minimum disturbance, the length of the waves being related to the frequency of the oscillations in the following way:

$$\lambda = \frac{V}{N}$$

where  $V$  = the velocity of propagation of electrical waves in ether.

where  $N$  = the frequency of oscillation.

where  $\lambda$  = the wave length in meters.

( $V$  = 186,000 miles per second or 300,000,000 meters per second approximately.)

### DESCRIPTION OF THE APPARATUS

In Figure 74, a spark discharge gap,  $S-1$ , is connected in series with the wire,  $A$ , and is connected in shunt to the secondary winding of high voltage transformer,  $S$ .

In Figure 75, a coil of wire,  $L$ , and a high voltage condenser,  $C$ , are connected in series with the aerial circuit to increase or decrease, respectively, the length of the radiated wave.

Figure 76 illustrates to the student how the electrostatic capacity of the vertical wire serves to complete the circuit between the aerial and the earth, but it should be understood that not only the upper portions of the antenna contribute to its capacity, but all parts from the earth up as well.

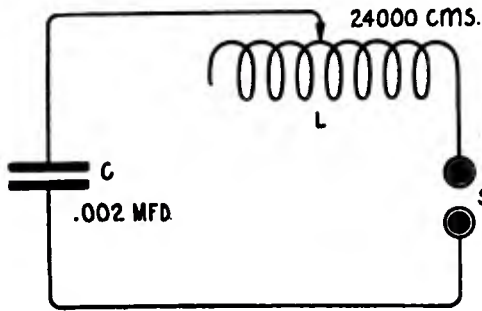

Figure 77.—Diagrammatic sketch of a closed oscillation circuit such as is employed in radio transmitters. If the coil, *L*, has inductance of 24,000 centimeters and the condenser, *C*, capacity of .001 microfarad, the frequency of oscillation is equal to

$$\frac{5,033,000}{\sqrt{24,000 \times .001}} = 1,027,142$$

The quotient of this problem does not imply that one million + cycles of current actually took place in one second of time, but that during the period of oscillation the condenser discharged through the inductance at this rate. To explain more clearly: If the frequency of the current at the charging source is 500 cycles per second, and the spark gap, *S*, is adjusted for one discharge for each alternation of current, then there will be 1,000 sparks per second and each spark will consist of from three to ten complete cycles before the energy has been dissipated.

Figure 78.—Showing the electrostatic field about a vertical oscillator previous to the discharge of the spark across the gap. When the electric strain about the aerial for a given voltage has reached its maximum value, a spark discharges across the gap and a part of the static field is converted into an electric current and the remainder into a wave motion. The current will oscillate to and fro in the aerial circuit at a radio frequency depending upon the distributed values of *L* and *C*, and the oscillations will be damped out at a rate depending upon the radiation characteristic of the aerial and the resistance of the wires and earth connection. The passage of this current to and fro in the aerial system is accompanied also by a magnetic field part of the energy of which contributes to the wave motion

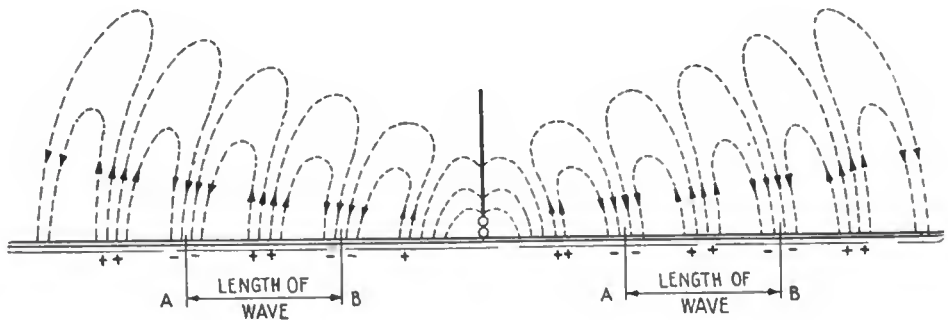
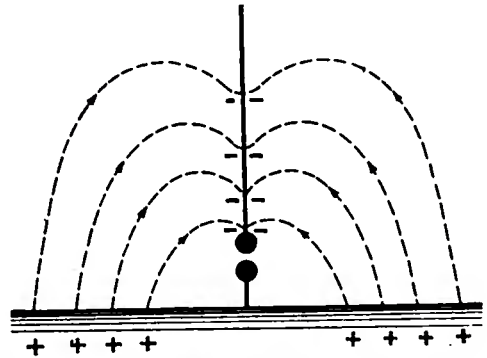

Figure 79.—Showing several groups of detached loops of electrostatic strain about a wireless transmitting aerial. The distance between two points of maximum or two points of minimum disturbance, where the electrostatic field is in the same direction, gives the length of the wave. Thus, the distance from *A* to *B* is the length of one wave. The electric waves used in the dispatch of wireless traffic from shore to ship and from ship to shore vary in length from 300 to 600 meters corresponding to 1,000 and 2,000 feet respectively.

If the frequency of the oscillations flowing in an aerial circuit is known, the length of the wave can be determined by dividing the velocity of propagation of electric waves (300,000,000 meters per second) by the frequency. For example, if the frequency of the antenna current is 500,000 cycles per second, then the length of a single wave in the resultant wave motion will be  $\frac{300,000,000}{500,000} = 600$  meters.

## OPERATION

If a high voltage transformer is connected to the spark gap S-1 in Figure 74, sparks will discharge across the gap at a rate depending mainly upon the voltage of the transformer, and the length of the spark gap, and each spark discharge will consist of radio frequency currents flowing up and down the vertical conductor. These currents will displace a portion of their electrostatic and electromagnetic energy about the aerial giving a shock to the surrounding ether, and setting into motion the electric waves of wireless telegraphy.

If turns are added at the coil L (Fig. 75) the currents will oscillate through the aerial circuit at a slower rate and the aerial will therefore radiate a wave of increased length, but if a capacity is inserted in series with the aerial as shown by the condenser, C, the current will oscillate at a higher frequency and the aerial will radiate a wave shorter than its natural wave-length.

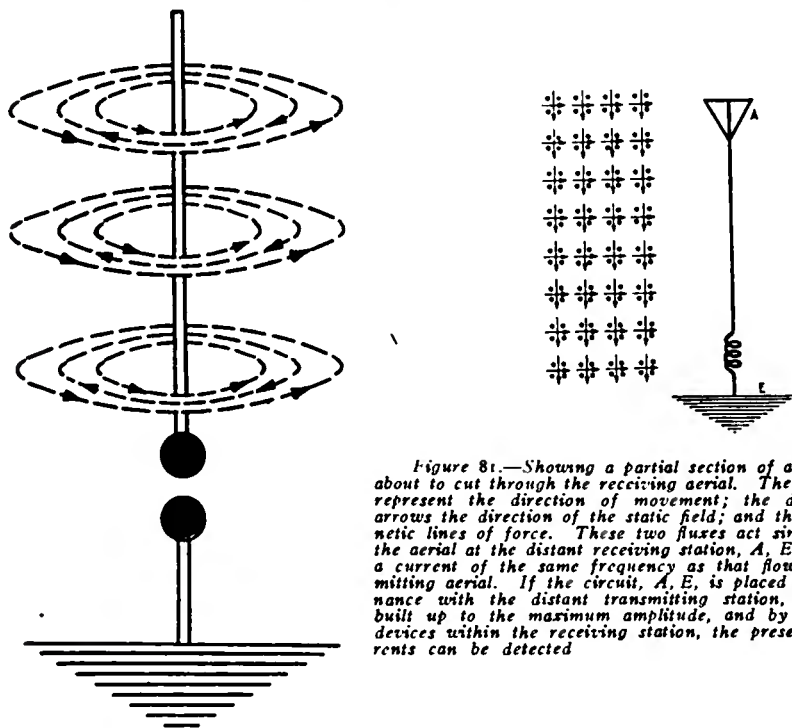

Figure 81.—Showing a partial section of an advancing wave about to cut through the receiving aerial. The horizontal arrows represent the direction of movement; the downward vertical arrows the direction of the static field; and the circles the magnetic lines of force. These two fluxes act simultaneously upon the aerial at the distant receiving station, A, E, inducing therein a current of the same frequency as that flowing in the transmitting aerial. If the circuit, A, E, is placed in electrical resonance with the distant transmitting station, currents will be built up to the maximum amplitude, and by means of proper devices within the receiving station, the presence of these currents can be detected

Figure 80.—Showing the magnetic field around an aerial for three alternations of current; both the static and magnetic fields in the process of radiation, give a shock to the surrounding ether setting up a wave motion which travels at the speed of light, viz., 186,000 miles per second

**QUES.**—What are the principal radio frequency circuits of a wireless telegraph transmitter?

**ANS.**—The open and closed oscillation circuits.

**QUES.**—What is the function of the closed oscillation circuit?

**ANS.**—To generate radio frequency currents.

*QUES.—What does the closed circuit consist of?*

**ANS.**—In spark telegraphy, it consists of a high voltage condenser, a radio frequency inductance, and a spark discharge gap.

*QUES.—What is the function of the open oscillation circuit?*

**ANS.**—To radiate a portion of the energy of the high frequency currents in the form of an electromagnetic wave.

*QUES.—What does the open oscillation circuit of the transmitter consist of?*

**ANS.**—It consists of one or more insulated, elevated, conductors connected to earth at one end, which may be set into electrical oscillation either by direct excitation or by indirect coupling to a closed oscillation circuit.

The open circuit of a modern wireless telegraph transmitter usually contains, in addition to the aerial wires, an aerial tuning inductance, the secondary winding of an oscillation transformer, a short wave condenser, and an aerial ammeter.

*QUES.—What are the functions of the spark discharge gap in the closed oscillation circuit?*

**ANS.**—The functions of the gap are:

- (1) to keep the condenser circuit idle until it is fully charged;
- (2) to discharge the energy of the condenser in the form of radio frequency currents;
- (3) to quench out the oscillations of the closed circuit at the proper time.

*QUES.—What is the usual capacity of the condenser of a wireless telegraph transmitter?*

**ANS.**—The capacity varies with the power, the frequency and the voltage of the current. For example, the capacity of the condenser of a 1 K.W. 500 cycle transmitter is .006 microfarad; of a 2 K.W. 500 cycle transmitter .012 microfarad. In transmitting sets operated at the commercial wave-lengths of 300 to 600 meters, the capacity of the condenser rarely exceeds .025 microfarad.

*QUES.—What voltages are employed to charge the transmitting condenser?*

**ANS.**—In the early stages of the wireless art, voltages from 25,000 to 60,000 were employed, but in transmitters of later design the voltage of the secondary rarely exceeds 15,000 volts, pressures as low as 6,000 volts having been used.

*QUES.—Why are 500 cycle alternators employed in wireless transmitting apparatus?*

**ANS.**—The tone of the spark discharge is faithfully reproduced at the receiving station. Since the spark discharge created by a 500 cycle current has a much higher pitch than that of a 60 cycle current, the former is employed. A spark of high pitch enables the receiving operator to discriminate between the signals of a given transmitting station and those due to the crashes of atmospheric electricity.

*QUES.—Name the principal parts of a radio transmitter.*

**ANS.**—The principal parts are:

- (1) Alternator
- (2) Step-up voltage transformer
- (3) High voltage condenser
- (4) Spark gap
- (5) Oscillation transformer
- (6) Aerial
- (7) Earth connection

---

EDITORIAL NOTES—The transmitter will be treated in detail in the next article of this series.

# Finding Your Way Across the Sea

A Practical Instruction Course in Navigation

By **CAPTAIN FRITZ E. UTTMARK**

## ARTICLE III

(Copyright, 1918, Wireless Press, Inc.)

### The Ship's Chronometer



*The chronometer*

**T**HE chronometer is simply a carefully made clock so constructed as to keep reliable time. The aim of the makers is to produce a time-piece that will gain or lose at a small, uniform rate (an absolutely accurate time-piece is not possible), so that the error at all times may be computed. Its chief feature is a variable level which enables the force of the mainspring to act uniformly even when the chronometer is exposed to great variation of temperature, such as would be experienced from extreme cold during a long voy-

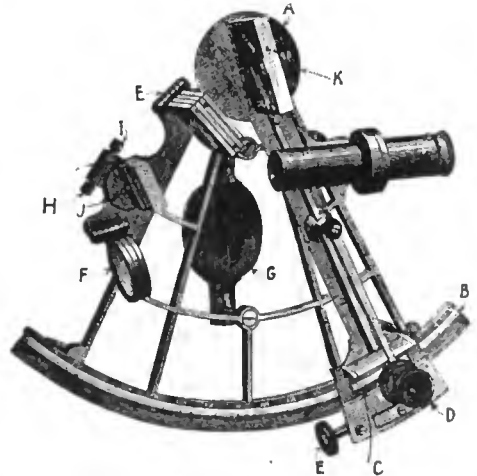

*The sextant—A, the index mirror; B, the arc; C, the vernier scale; D, the microscope; E, the tangent screw; F, shade glasses; S, handle; H, I, J, adjustment screws for horizon glass; K, adjustment screws for index glass*

age in the Arctic to extreme heat when crossing the Equator or at tropical ports. The chronometer as used on board the ship is generally regulated to keep Greenwich time and used in calculating the astronomical longitude of the ship.

### The Sextant

The sextant is an instrument of reflection used for measuring altitudes of heavenly bodies and angles in general. Its arc is generally graduated in degrees

and ten-minute divisions, and its vernier in minutes and ten-seconds of arc. It is a sixth part of a circle, or sixty degrees, and according to the law of reflection we can measure angles of double that amount or 120 degrees of arc.

### The Octant or Quadrant

This is an instrument belonging in the same class as the sextant and used for the same purpose, but which has a smaller scope when used for measuring angles. It may be defined as an instrument of reflection for measuring altitudes of heavenly bodies, or angles in general. The arc is graduated in degrees and fifteen or twenty-minute divisions and its vernier in minutes and fifteen or twenty-seconds of arc. This instrument will read to at least ninety degrees of arc. It is called an octant because it is an eighth part of a circle, or a quadrant because and according to the law of reflection we can measure angles of double that amount or ninety degrees of arc.

### Errors of the Octant or Sextant

These are found and corrected by going through the following four adjustments, namely of the index mirror of the horizon glass and of the telescope.

The first adjustment is to see if the index glass is perpendicular to the plane of the instrument; this is done by moving the sliding limb to the center of the arc; then noting if the arc reflected in the index glass and the arc seen direct form one unbroken line. If they do, the index glass is perpendicular, but if not, make this adjustment with the screw on the back of the index glass.

The second adjustment is to see if the horizon glass is perpendicular to the plane of the instrument; this is done by making the two zeros coincide with one another and then holding the instrument at an angle slightly inclined from the horizontal plane; if the reflected horizon and that seen direct form one unbroken line the horizontal glass is perpendicular, but if not make this adjustment with the top screw on the back of the horizon glass.

The third adjustment is to see if the horizon glass and the index glass are parallel to each other. To do this make the two zeros coincide, then hold the instrument vertically, and if the reflected horizon and that seen direct, form one unbroken line, the glasses are parallel; but if not, make this adjustment with the bottom screws on the back of the horizon glass.

If it is not possible to make the glasses parallel by the bottom screw, then make them parallel by using the tangent screw, and the amount the zero of the sliding limb is moved *on* or *off* the arc will be the index error, subtractive if *on* the arc, but additive if *off* the arc.

The fourth adjustment is to see that the axis of the telescope is parallel to the plane of the instrument. For this adjustment the inverting telescope is screwed in the collar of the instrument, and the telescope is turned until the parallel wires are parallel with the plane of the sextant. Two stars which are at least ninety degrees apart are then selected and an exact contact is made at the wire nearest the plane of the instrument. Next the sextant is moved so as to throw the objects on the other parallel wire, and if the angle remains the same this adjustment is correct, but if it is not perfect the collar adjustment must be made by the screws on the back of the telescope collar. An error in this telescope adjustment always makes angles too great.

## CHAPTER III

### Definitions of Terms Used in This Series

**The Right Angles.**—A right angle is an angle of ninety degrees (90°) or the fourth part of a circle. All the angles in Figure 1 are right angles.

**The Oblique Angles.**—An angle greater or less than  $90^\circ$  is called *oblique*.

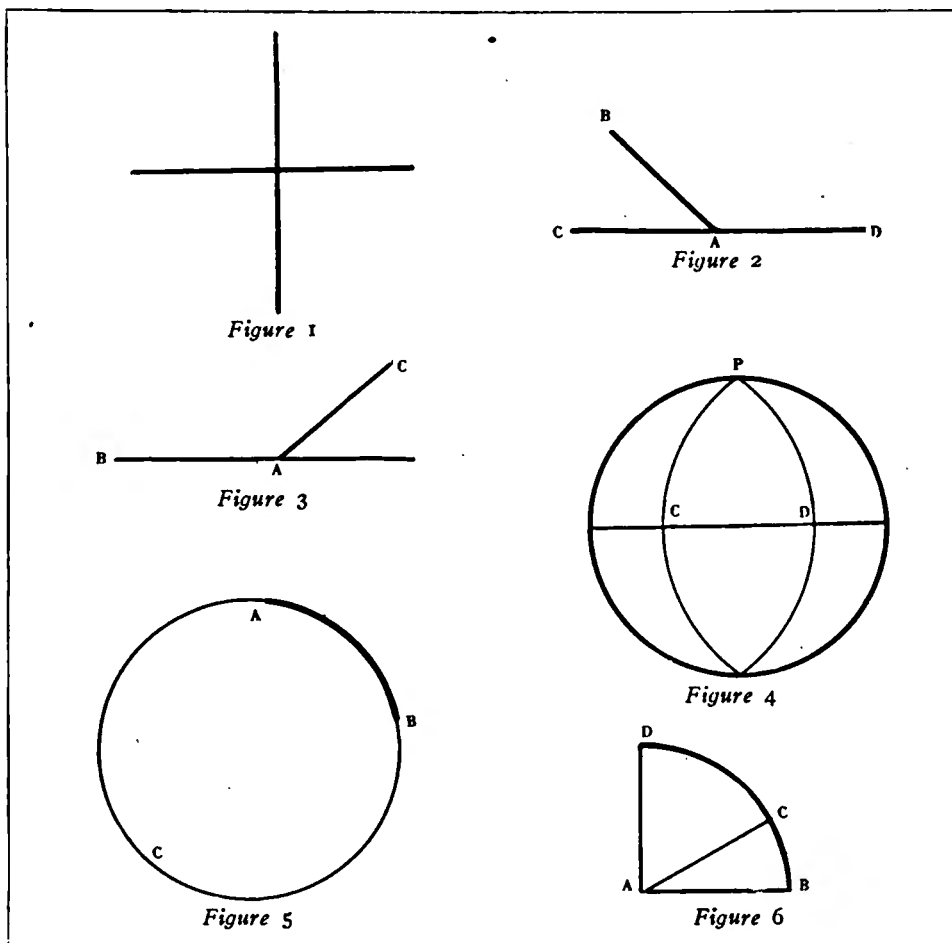

The angle B A C and B A D (Figure 2) are oblique angles.

**The Obtuse Angle.**—An angle greater than  $90^\circ$  is called *obtuse*.

The angle B A C (Figure 3) is an obtuse angle.

**The Spherical Angle.**—An angle formed by intersection of two great circles is called a *spherical angle*.

The angle C P D (Figure 4) is a spherical angle.

**The Arc.**—A part of the circumference of a circle is called an *arc*.

The curved line A B (Figure 5) is an arc of the circle A B C A.

**Complement of an Arc or Angle.**—The difference between an arc or angle and  $90^\circ$  is called *complement* to that *arc* or *angle*.

The arc, C B, (Figure 6) is the complement to CD. The angle, B A C, is the complement to C A D.

The angle, D A B, is a right angle.

**Supplement to an Arc or Angle.**—The difference between an *arc* or *angle* and  $180^\circ$  is called its *supplement*.

The arc, C B, (Figure 7) is the supplement to C D.

The angle, C A B, is the supplement to C A D.

**The Great Circle.**—A circle whose plane passes through the center of a sphere is called a *great circle*. All the lines in Figure 8 are great circles.

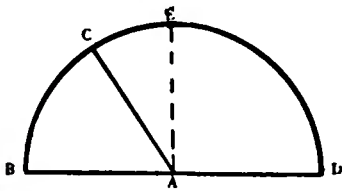

Figure 7

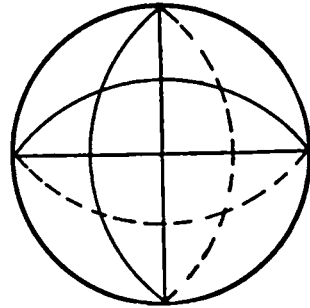

Figure 8

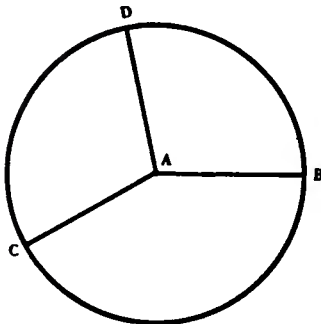

Figure 9

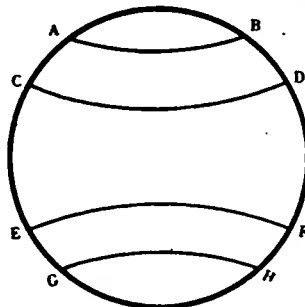

Figure 10

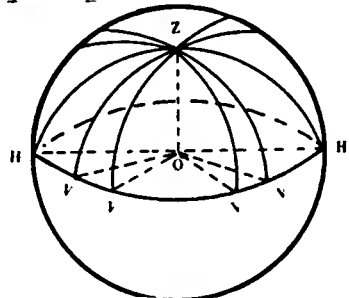

Figure 11

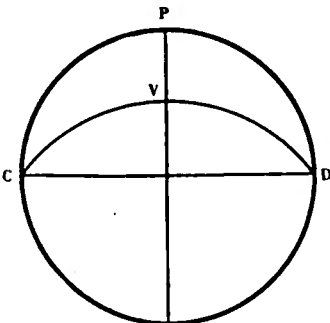

Figure 12

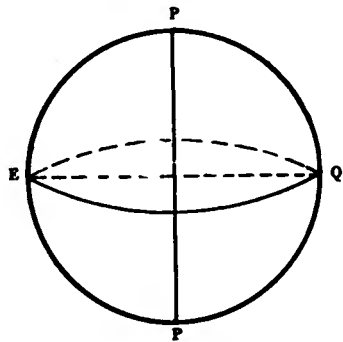

Figure 13

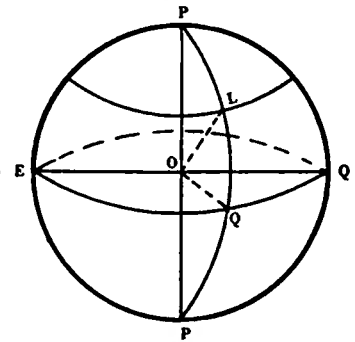

Figure 14

**The Radius.**—A straight line drawn from the center of a circle to its circumference is called *radius*. The lines, AB, AC and AD are radius to the circle in Figure 9.

**Small Circles.**—Circles whose planes do not pass through the center of the sphere are called *small circles*. AB, CD, EF and GH are small circles. (Figure 10.)

**Zenith and Nadir.**—The point vertically overhead of the observer is called *zenith* and the point vertically beneath is called *nadir*.

**Vertical Circles.**—Great circles passing through zenith perpendicular to the horizon are called *vertical circles or verticals*.

Z is the zenith.

O is the place of the observer.

H H' is the observer's horizon.

Z V are all vertical circles or verticals. (Figure 11.)



**The Vertex of a Great Circle.**—The point of a great circle which is nearest the pole is called its *vertex*.

CD is a great circle. P is the pole to the circle. V is the vertex of the circle C D. (Figure 12.)

**The Equator.**—The equator is a great circle formed by the intersection with the earth's surface of a plane perpendicular to its axis. The equator is equidistant from the poles. Every point of the equator is ninety degrees from the poles. The great circle, E Q, is the equator. (Figure 13.)

**Latitude.**—The latitude of a place or position on the earth is the arc of the meridian intercepted between the equator and the given place. Latitude is reckoned from the equator (Lat. 0) and expressed in *degrees, minutes* and *seconds* north and south, up to 90° at the poles.

P is the pole.

E Q E is the equator.

L O Q or L Q is the latitude of L. (Figure 14.)

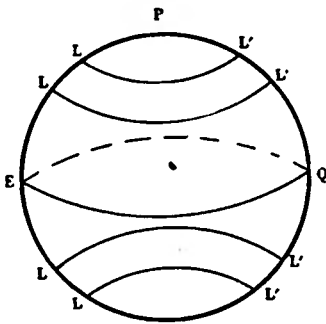

Figure 15

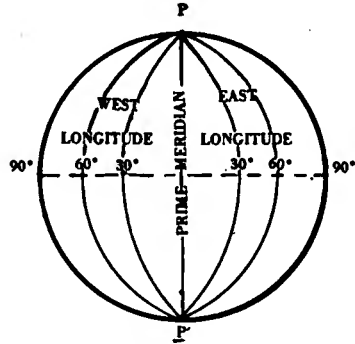

Figure 16

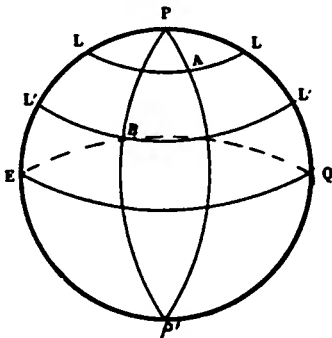

Figure 17

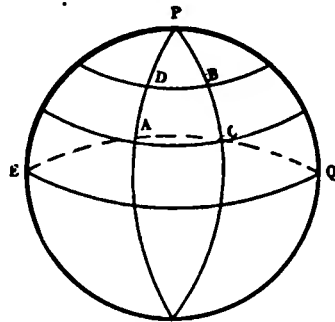

Figure 18

**Parallels of Latitude.**—Parallels of latitude are small circles formed by intersection of planes parallel to the *equator*.

E Q is the equator.

L L' are parallels of latitude. (Figure 15.)

**Longitude.**—The angle at the pole contained between the meridians of any place or position on earth and a certain meridian assumed to be the first or prime meridian. The longitude is measured on the equator and reckoned east or west up to 180°. The meridian passing through the observatory at Greenwich, (England), is generally accepted as the first meridian. Figure 16 illustrates east and west longitude.

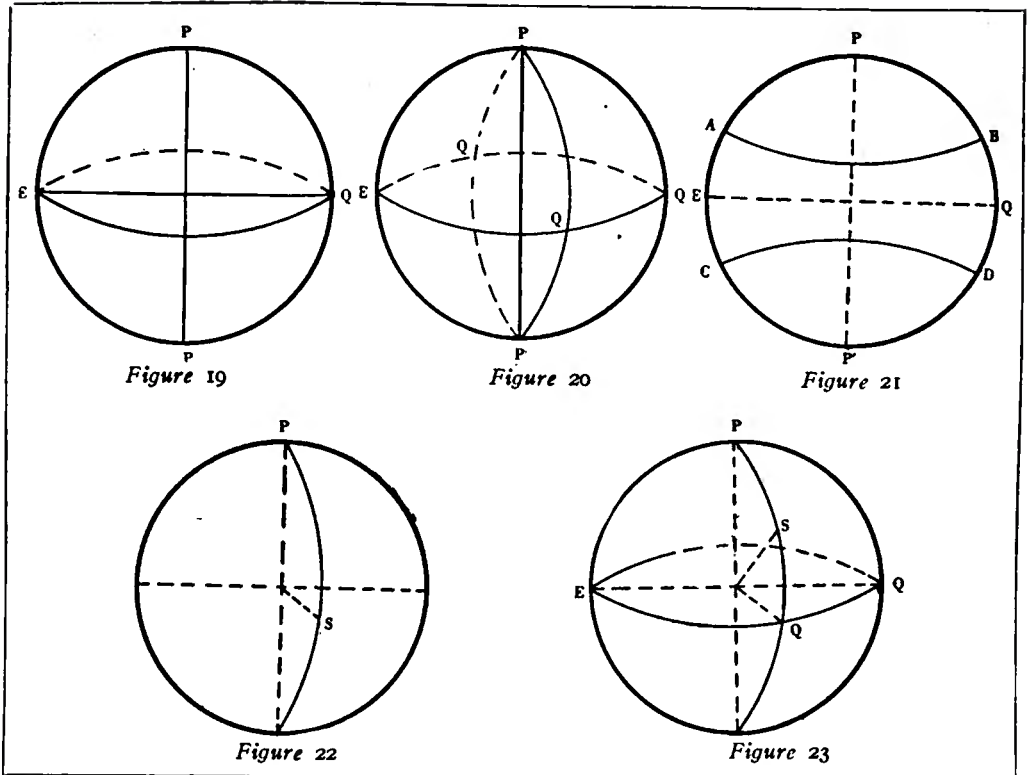

**Difference of Latitude.**—The *difference* of latitude between the two places, A and B, is the arc of a meridian intercepted between the parallels of latitude of the given places and is named north or south according to the direction from one place to the other.

The *difference of latitude* between A and B is  $L L'$  reckoned *south* from A or *north* from B. (Figure 17.)

**Departure.**—The departure is the distance east or west between the meridians of two places or positions and is reckoned in *miles*. We must note that this distance decreases as the meridians converge towards the poles.

The departure between the meridians of A and B is the distance A C in miles on the latitude of A or the distance, D B, in miles on the latitude of B. (Figure 18.)

**Terrestrial Poles.**—The terrestrial poles are the terminal points of the earth's axis around which the earth revolves.

P represents the north pole.

P' represents the south pole.

The line, P P', represents axis of the earth. (Figure 19.)

**Meridians.**—Meridians are great circles passing through the poles and cutting the equator at right angles.

The great circles, P Q P' Q, are all meridians.

E Q is the equator. (Figure 20.)

**The Tropics.**—The tropics are small circles approximately  $23\frac{1}{2}^\circ$  from the equator and mark the extremities of the sun's declination north and south.

A B in the northern hemisphere is called the *tropic of cancer*. C D in the southern hemisphere is called the *tropic of capricorn*.

**Polar Distance.**—The polar distance of a celestial body is its distance from

the elevated pole of the observer measured upon the circle of declination passing through the center of the body.

It is  $90^\circ$  plus declination if the *latitude* of the observer and the *declination* of the body is of opposite name, but  $90^\circ$  minus *declination* if of the same name.

P is the elevated pole.

P S is the polar distance of S. (Figure 22.)

**Declination.**—The declination of a celestial body is the angular distance from the equinoctial, measured upon the declination circle which passes through the center of the body. It is named north or south according to its direction from the equinoctial.

E Q is the equinoctial.

S Q is the declination of S. (Figure 23.)

(To be continued)

### The Outwitting of Germans by a Wireless Operator

A STORY of the wit and resourcefulness of Guy Duncan Smith, an English wireless operator, was brought out recently in the Prize Court, London, when the Government was asked to condemn the steamship *Edna* because of unneutral service and enemy ownership. The recital hinges upon the activities of a craft which flew two flags and was owned by Frederick Jebson. Sir Frederick E. Smith, the Attorney General, said that Jebson, who was a figure of consequence in the San Francisco shipping world, had used the vessel originally in his Mexican business. When hostilities began in Europe the *Edna* took aboard gun-sight apparatus and by means of her wireless attempted to inform the German cruiser *Leipzig* of the time of departure from ports of British vessels. These attempts, however, were defeated by Smith.

One night the wireless operator, listening in, in the radio cabin of the *Edna*, heard the steamship *Aztec* flash the news that war had been declared between Russia and Germany. Following this announcement, the name "Hamburg," displayed on the stern of the vessel, was removed, "La Paz" was substituted and the Mexican flag was flown from the mast head.

Smith then found himself in the midst of activities directed against the enemies of Germany. He had learned before the ship left San Francisco that coal taken aboard the vessel was to be transferred to the *Leipzig*. Those in charge of the *Edna* began to assume an aggressive attitude toward him. A German operator was taken aboard and Smith was informed that if he failed in his duty the former would displace him. But the German operator was not satisfactory. And Smith saw to it that his work was not made easy. The German attempted to call the *Leipzig* by wireless, but the English operator had adjusted the apparatus so that it was apparently out of order and the enemy wireless man spent three days and nights trying without success to obtain a response from the *Leipzig*. Smith, on several occasions, readjusted the set and established communication with the German cruiser, but he made certain always that the other operator's efforts were fruitless.

Threats from the German officers to shoot Smith and throw him overboard if he did not transmit a code message to the *Leipzig* were without effect, the only message that he sent to the cruiser being an inquiry as to where she was. This brought the response that she was waiting for the *Edna*. And notwithstanding the close watch the Germans kept on the operator he managed to send a message to the admiral on the American cruiser *California*. Eventually, however, the *Edna* was commandeered by the Mexican Government and conditions became more favorable for the English operator.

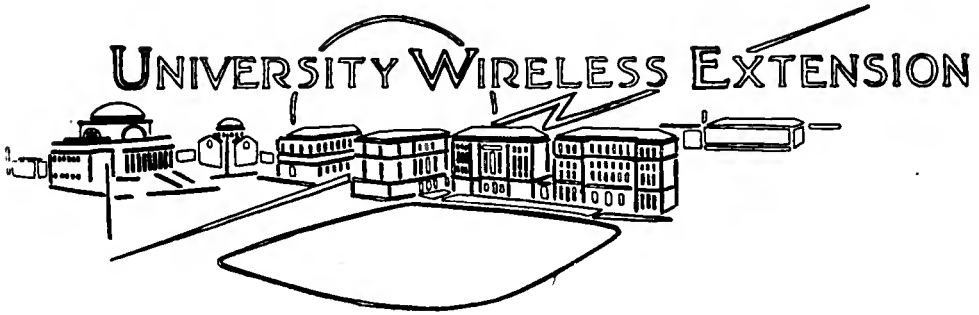

# Radio Telephony

By ALFRED N. GOLDSMITH, PH.D.

*Director of the Radio Telegraphic and Telephonic Laboratory of the College of the City of New York*

## ARTICLE XII

WE consider next the oscillation radiophone transmitters manufactured by the de Forest Radio Telephone and Telegraph Company. One type of these is illustrated diagrammatically in Figure 144, and this arrangement of circuits is due to Mr. C. V. Logwood. It will be seen that the direct current generator  $G$  (usually of 1,200 to 1,500 volts) is connected in series with the iron

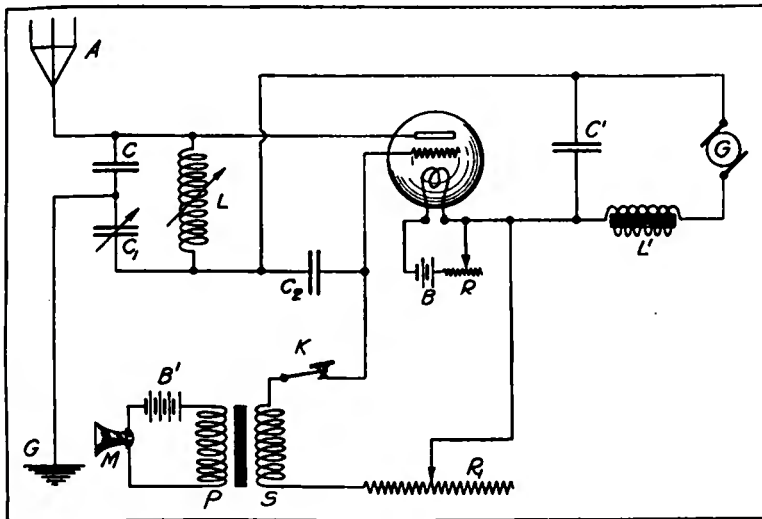

Figure 144—de Forest Company-Logwood radiophone transmitter

core choke coil  $L'$  and shunted by the condenser  $C'$ , the purpose of these being to cut down the "commutator ripple" thus giving a more nearly constant e. m. f. in the plate circuit. Failure to observe this precaution leads to a loud and objectionable hum corresponding to the frequency with which the commu-

tator segments pass under the generator brushes. The oscillating circuit used seems to be of the capacitive coupling type or ultraudion type according to the method of classification. It is clear that the antenna capacity is used to absorb the output of the bulb. Modulation is accomplished by impressing audio frequency potential variations, produced by the voice, on the grid. The microphone *M* causes varying currents in the circuit of the transformer primary *P*, whence the potential variations are produced by the secondary *S* in the filament-to-grid circuit. The resistance  $R_1$  in series with *S* serves to keep the grid strongly negative because of the difficulty experienced by any negative charges on the grid in leaking off to the filament. By varying  $R_1$ , the grid potential can be varied. For telegraphy, the key *K* is used. It merely opens the grid leak circuit, whereupon the grid immediately becomes so negative as to choke off all plate current and thus stop the oscillations entirely. Closing the key permits the excess negative charge to leak off the grid and the oscillations start again.

There is a marked tendency to increase the dimensions and available output of the tubes employed, and this is well illustrated in Figure 145. The left hand tube is of approximately the dimensions of the usual amplifier or "repeater" bulbs used by the Western Electric Company in trans-continental wire telephony.

This company is operating under exclusive patent licenses granted by the de Forest Company. The right hand bulb is one of the latest 0.25 kilowatt input oscillions. A 3 or 4 inch (7.5 or 10 cm.) "laboratory oscillion" is shown mounted on its panel in Figure 146. Such a device can produce conveniently a number of watts of radio frequency energy of constant amplitude.

A whole series of radiophone transmitters have been put on the market by the de Forest Company some of which are here illustrated. A low power set using what is practically one of the tubular receiving bulbs is seen in Figure 147. A larger type of transmitter and receiver, together with the requisite motor generator set appears in Figure 148. This set is stated to have a telegraphic range over water of 40 miles (64 km.) using masts 200 feet (60 m.) high and an antenna span of at least 250 feet (80 m.). The generator of the motor generator set in this case is for 1,000 volts and 100 watts output. A more recent set of this type is shown in Figure 149. The small ammeter at the top left indicates the filament current of the bulb, which requires somewhat careful setting for full output. The right hand top instrument is the antenna ammeter. A convenient form of protected change-over switch from sending to receiving is mounted on the back of the panel, the handle pro-



Figure 145—de Forest 0.25 K. W. Oscillation (as compared with type of bulb used in long distance wire telephony)



Figure 146—de Forest laboratory oscillion transmitter



Figure 147—de Forest low power radiophone transmitter (Type PJ)

jecting just to the right of the microphone arm. The bulb is also mounted back of the panel, and can be partly viewed through a slit under the microphone arm. The variable condenser to the left of the arm is condenser  $C_1$  of Figure 144. A filament rheostat and binding posts for the filament battery, antenna and ground connections, etc., complete the installation except for a short-circuiting bar between two binding posts. This latter may be removed and replaced by the Morse key, then permitting telegraphy.

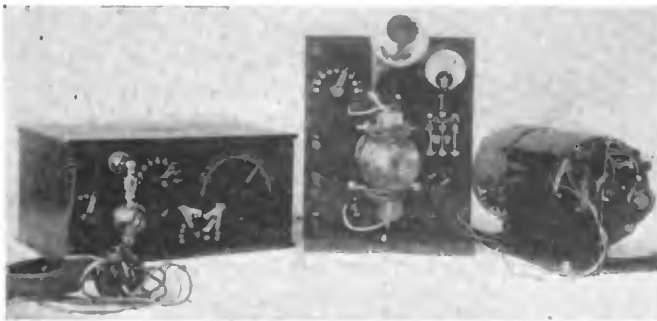

Figure 148—de Forest Oscillion radiophone and radio telegraph transmitter and receiver (Type OJ3)

“stream line” casing, the terminal leads being brought out of the rear end. The oscillion is mounted in a protective wire mesh casing and is suspended in such fashion as to be reasonably safe from breakage. The three top instruments are for antenna current, plate circuit current, and filament current. The Morse key is shown at the bottom of the figure together with the microphone. The latter is so arranged as to fit closely to the lips of the user and thus avoid picking up the extremely loud noise of the engine exhaust.

A more elaborate type of radiophone transmitter using three oscillion bulbs is shown in Figure 151. It includes a “modulator” or master oscillator bulb and two “radio” or amplifier bulbs. These are mounted back of the



*Figure 149—deForest 0.25 K. W. Oscillation radiophone transmitter*

is supplied with 1,500 volts for the plate circuit and an input of about 1.5 kilowatt. The telephone range over water is stated to be 400 miles (640 km.) and the corresponding telegraphic range 600 miles (1,000 km.). As

panel, and can be viewed through the three slits. The four instruments at the top of the board (starting at the left) are respectively the "modulator" current, plate circuit current, filament circuit current, and antenna current. The inductance and variable condenser of the master oscillator circuit are mounted directly below the corresponding ammeter at the left. An antenna loading inductance and a control switch for changing from receiving to transmitting are mounted to the right of the microphone transmitter. Under the slit of each bulb and at the bottom of the board are its filament and plate circuit switches and at the bottom of the board are the three filament rheostats. As before, two binding posts are provided at the bottom of the board for the insertion of a Morse key if radio telegraphy is desired. A set of this type

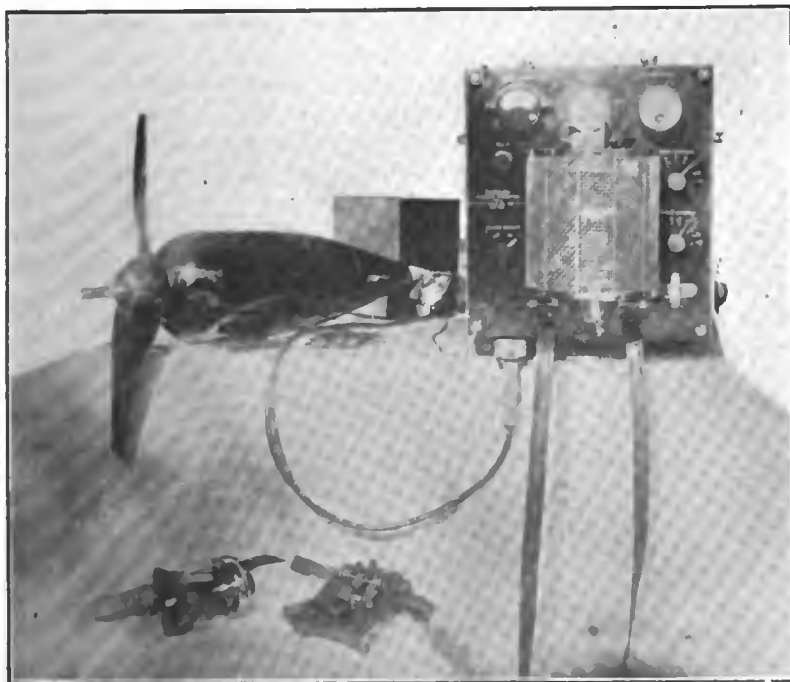

*Figure 150—de Forest 0.25 K. W. Oscillation radiophone and radio telegraph transmitter*



Figure 151—de Forest 0.25 K.W. 3 Oscillation radiophone transmitter

before, towers 200 feet (60 m.) high and 250 feet (80 m.) apart are presupposed. Arrangements were made by the de Forest Company with a phonograph company whereby almost every night records made by this latter company were played into the radiophone transmitter and thus rendered audible to a wide circle of listeners. One or two oscillations are used in the transmitter, each with a stated output of 0.25 k.w. The wave length used has been 850 m. This service has been given about five nights per week since October, 1916. The music has been heard a number of times as far away as Buffalo, New York, a distance of 306 miles (490 km.) and even at an extreme range at Mansfield, Ohio, a distance of 465 miles (750 km.). One interesting result of this work has been a "radio dance" given one evening at Morristown, New Jersey, a distance of 30 miles (50 km.) from the de Forest station. Music was transmitted from the latter station and received at Morristown on a receiving set with a three-step audion amplifier. The resulting "signals" were sufficiently loud to permit the dance to be conducted. Another novel field for radio telephony, which Dr. de Forest believes presents great promise, is that of news distribution in rural districts. There is no doubt that the dissemination of information and various types of entertainment in districts which would otherwise be isolated is a most valuable possibility for radio telephony.

As is well known, the Western Electric Company has been carrying on extensive research work in radio telephony for some time past. (Some of the types of tubes described in the patents of that Company are similar to those shown in Figure 86. Generally speaking, platinum filaments coated with metallic oxides are there indicated.) A method of modulation of the output of such

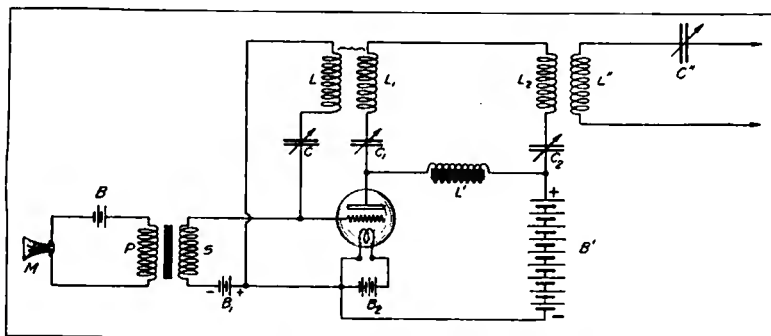

Figure 152—Western Electric Company-Colpitts modulation system, 1914



an oscillator has been developed by Mr. E. H. Colpitts. It is depicted in Figure 152. As will be seen, the plate oscillating circuit  $C_1L_1L_2C_2$  is coupled inductively to the grid circuit  $CL$  at  $L_1$ . It is also coupled inductively to the output circuit  $L_1''C''$  at  $L_2$ . A second grid circuit is also provided consisting of the secondary  $S$  of the audio frequency transformer, (the primary of which contains the microphone and battery  $B$ ), and the battery  $B_1$  for maintaining the grid at a negative potential. This system of modulation has the advantage of simplicity. On the other hand, it may easily become an unstable control system. The reason for this is the following: In any oscillating tube, the amplitude of the plate circuit oscillations increases until the losses in the tube, and in the external or output circuits which it feeds, utilize the entire available energy. The amplitude then remains constant. It is evident that if we make the grid potential extremely negative, so that the plate circuit oscillations cannot build up to this stable value just mentioned, the oscillations will simply cease entirely. Just above this extremely negative grid potential, there is a narrow range of grid voltages for which the plate circuit output depends on the grid potential, though only as a transient phenomenon. A static characteristic of such a relation between grid potential and oscillating current in the plate circuit is not obtainable because the effects do not persist. The oscillating current tends to rise either to its full and stable amplitude or to cease altogether. For audio frequency variations of moderate magnitude and sufficient rapidity of the grid potential the system is sometimes workable though always with the danger just mentioned for low tones or for extremely loud sounds.

A second system due to Mr. Heising\* of the same Company is free from the objections mentioned in that the tube is used as an *amplifier* and not as an oscillator. The method in question is shown in Figure 153. The radio frequency source  $A$  impresses, through the transformer  $P_1S_1$ , corresponding radio frequency potential variations on the grid  $G_1$  of the tube. There will, therefore, be produced in the output plate circuit of this tube radio frequency current variations. Hence there is an available output in the inductance  $L_2$ . The tube has a second grid  $G_2$ , and, as will be readily seen, there are impressed on  $G_2$ ,

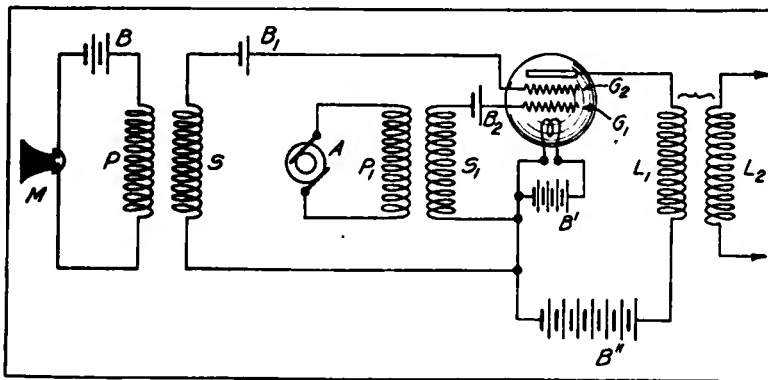

Figure 153—Western Electric Company—Heising modulation control system, 1915

potential variations corresponding to the speech amplitudes, these variations being produced in the customary way by a microphone circuit and a suitable trans-

\* Patent 1,199,180.

former. The source  $A$  may naturally be a vacuum tube oscillator. Each grid is maintained at a suitable negative potential by the battery  $B_1$  or  $B_2$ .

A series of long distance radiophone experiments were carried on by the Western Electric Company from the United States Naval Radio Station at Arlington, Virginia. This station has an antenna 600 feet (180 meters) high. Speech was transmitted by night from Arlington to the Eiffel Tower, Paris (a distance of 3,900 miles or 6,200 km. almost entirely over water), from Arlington to Mare Island, California (a distance of 2,400 miles or 3,800 km. overland), and from Arlington to Hawaii (a distance of 5,100 miles or 8,300 km., about half over water). While the transmission could be achieved only under exceptional conditions and was in no sense commercial, it is of marked interest in indicating how great a distance can be bridged by even a very moderate amount of power under favorable circumstances. One is reminded of the feat of Sayville, Long Island, in communicating with Nauen, Germany, a distance of 4,200 miles (6,700 km.) with only 6 kilowatts in the antenna.

The apparatus used at Arlington was constituted as follows: A small bulb (3 inches or 7.5 cm. in diameter) was used as a master oscillator. The filament was heated from storage batteries as usual, and the plate circuit was fed from 125 volts in dry batteries. The master oscillator had a fairly fine grid. Its output circuit was coupled loosely to the grid circuit of a 7-inch (17.7 cm.) "modulator" bulb with a coarser grid. Comprised in this grid circuit were a 150 volt battery, to give the grid the requisite negative potential, and the secondary of a 150-to-1 air core transformer in the primary of which was a button-type microphone and its supply battery. In this way, the voice potential variations were impressed on the modulator grid as well as the radio frequency variations. The plate circuit of the modulator was tuned, and included a 450 volt direct current generator.

The output circuit of the modulator supplied speech-modulated, radio frequency, potential variations to the fairly coarse grids of 7-inch (17.7 cm.) bulbs all connected in parallel. Their tuned output circuit in turn fed the coarse grids of from 300 to over 500 "power" bulbs in parallel. As before, these grids were kept at a constant negative potential of  $-150$  relative to their filaments. The plate circuit of the "power" bulbs was fed from a large 600 volt, direct current generator which was normally used for the Poulsen arc at Arlington. A few turns of heavy copper band in this last plate circuit were inductively coupled to the tuned antenna. About 60 amperes at 6,000 meters wave-length were normally produced in the antenna, this corresponding to something over 6 kilowatts. The efficiency of the set was about 20 per cent. In running the set, fairly frequent bulb renewals were required, thus rendering a high upkeep cost of operation inevitable (according to one statement, \$10,000 per month).

The apparatus used was mounted on a series of panels. The lower section of each panel had the necessary switches for controlling the filament and plate circuits of that section. The upper portion of each panel was in two halves. On each half were mounted 25 of the 7-inch (17.7 cm.) "power" bulbs, all cooled by air brought in ducts from a powerful blower. The cooling ducts were at the rear of the panel. All the bulbs on each panel portion were in parallel. Each bulb was provided with "Ediswan" socket base so as to be readily replaceable, i. e., all terminals were brought out through this base. The control and modulator bulbs were mounted on separate small panels.

We consider next a number of radiophone pilotron transmitters designed by the Research Laboratory and especially Mr. William C. White of the General Electric Company. The mode of producing reasonably constant sources of high potential (from alternating current supply) will be first considered.

The method referred to is illustrated in Figure 154. The alternator *A* sends current through the primary *P* of a transformer. This transformer has two secondaries. Of these one, *S*<sub>2</sub>, is arranged to light the filaments *F*<sub>1</sub> and *F*<sub>2</sub> of two kenotron rectifiers. There are comparatively few turns in the secondary *S*<sub>2</sub> because the filament voltage is low. A second secondary *S*<sub>1</sub> is of many turns so as to furnish a high voltage to the plates *P*<sub>1</sub> and *P*<sub>2</sub> of the kenotrons. It will be noted that there is a central tap of the filament-feeding secondary *S*<sub>2</sub>, the purpose of which is explained in connection with the description of Figure 64. It prevents injuriously excessive addition of the filament-heating and thermionic currents in either end of the filament. The middle point of the secondary *S*<sub>1</sub> is connected to one side of a large high voltage condenser *C* (e.g., of several microfarads), the other side of which condenser is connected to the middle point tap of the filament-heating secondary *S*<sub>2</sub>. It will be seen that the condenser will be charged during one

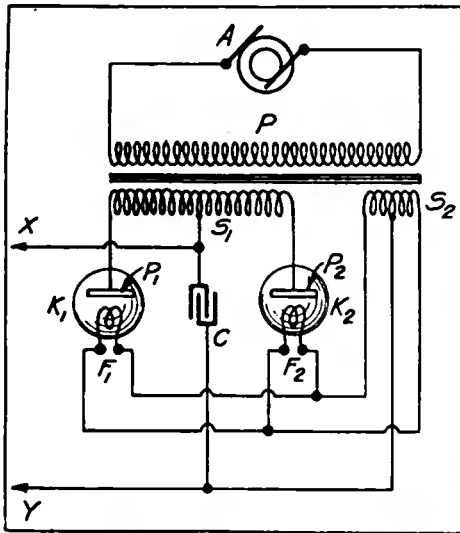

Figure 154—General Electric Company-White method of producing practically constant potential from A. C.

half of the cycle by the left hand half of *S*<sub>1</sub> in series with kenotron *K*<sub>1</sub> and during the other half of the cycle by right hand half of *S*<sub>1</sub> and the right hand kenotron *K*<sub>2</sub>. If the current drawn from the charged condenser is comparatively small (which will be the case if the condenser is very large and a small current at high voltage is drawn therefrom), the potential difference at its terminals

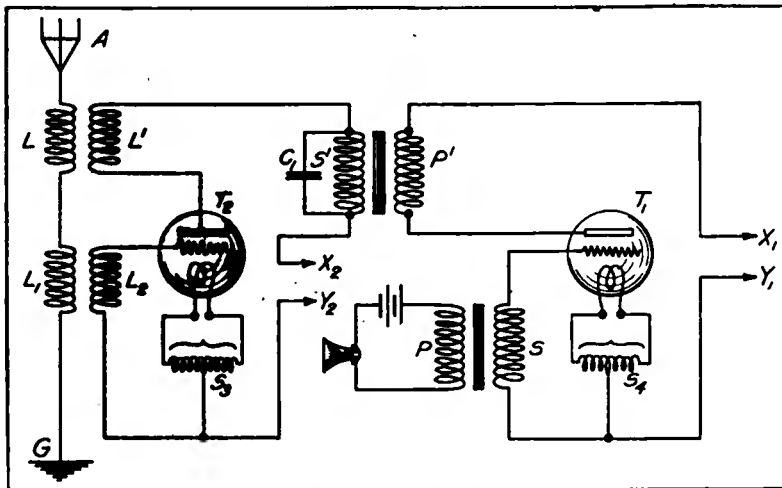

Figure 155—General Electric Company-White radiophone transmitter for alternating current supply

will remain appreciably constant. Experience shows, indeed, that this is the case, and it has proven possible to get so nearly constant a potential from an alternating current supply in this way that, when used in the plate circuit of a

normal plotron oscillator, the normal a. c. hum has been practically absent. The output is drawn from the condenser terminals, X, Y.

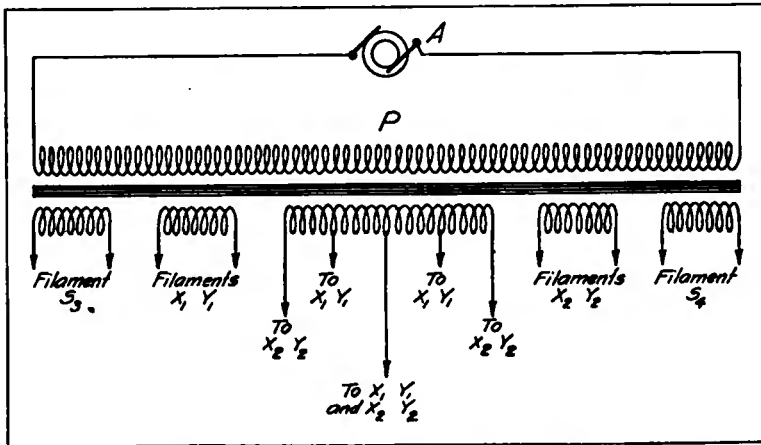

Figure 156—General Electric Company-White multiple transformer for feeding plate rectifier and filaments

Two of the earlier types of radiophone transmitters based on this principle will be next described, the description being due to Dr. Irving Langmuir of the General Electric Company.\*

"The first outfit has a capacity of about 20 watts in the antenna, the source of power being the local city supply, which is 118 volts, 60 cycle current. This is connected with the primary of a small transformer having two secondary windings. One of the secondaries is designed to give about 5 volts and furnishes the currents used for heating the filaments of the kenotrons and plotrons. The other secondary of the transformer is wound to furnish a potential of about 800 volts. This is rectified by means of a kenotron, and serves to charge a condenser of about 6 microfarads. In this way, a source of high voltage, direct current is obtained in a very simple manner. The plate of the plotron oscillator is then connected to one of the terminals of the condenser, while the filament is connected to the other. The plate of the second plotron is connected to the grid of the first, while the grid of the second is coupled by means of a second small transformer to the microphone circuit. With this small outfit, both plotrons may be relatively small. . . . .

"In the second outfit, which is suitable for use up to 500 watts or more, the high voltage direct current is obtained from a small, 2,000 cycle generator. The current from this is transformed up to about 5,000 volts, rectified by kenotrons, and smoothed out by means of condensers. By the use of 2,000 cycle alternating current instead of 60 cycle, it is possible to store up large quantities of energy at a given voltage and with a permissible fluctuation of voltage, and thus obtain as much as a kilowatt or more of power in the form of direct current with condensers of moderate size. This high voltage direct current is used, as before, to operate a plotron oscillator, the output of which is controlled by means of a small plotron connected to the telephone transmitter. . . ." Wire-line-to-radio telephone transfer has been accomplished with such sets.

Another form of radiophone transmitter of the General Electric Company, will be seen that the grid of plotron amplifier  $T_1$  is connected to the filament through the secondary  $S$  of a transformer, the primary of which contains a

\*Proceedings of the Institute of Radio Engineers, volume 3, number 3, Sept., 1915.

described in Mr. W. C. White's patent 1,195,632, is shown in Figure 155. It microphone and battery. The plate circuit is fed at  $X_1V_1$ , by exactly the same form of device as shown at  $XY$  in Figure 154. For the sake of simplicity, this device is not here repeated in the diagram. The output of pliotron  $T_1$  is fed into the plate circuit of pliotron  $T_2$  through the audio frequency transformer  $P'S'$ . The secondary of this transformer is shunted by the condenser  $C_1$  which acts as a practically perfect by-pass for the radio frequency currents in the plate circuit of  $T_2$  without passing any appreciable quantity of audio frequency current from  $S'$ . It will be seen that the tube  $T_2$  is an oscillator since its grid and plate circuits are coupled through the antenna circuit at  $L L'$  and  $L_1L_2$ . Obviously, the method of modulation control here shown is an extremely stable one. It consists in varying the plate potential of oscillator  $T_2$  in accordance with the speech. This implies, however, the injection of considerable energy into the plate circuit of  $T_2$  intermittently and hence the necessity for amplifier  $T_1$ .

For use with a radiophone outfit of this sort, a special transformer shown in Figure 156 may be used. This has the single primary  $P$  but a number of secondaries which supply the following circuits (starting from the left): filaments of the oscillator  $T_2$ , filaments of the kenotrons which feed the amplifier  $T_1$ , plate circuits of the kenotrons feeding the amplifier  $T_1$  and the oscillator  $T_2$  (at different voltages, and the greater for the oscillator), filaments of the kenotrons feeding the oscillator  $T_2$ , and filaments of the amplifier  $T_1$ . Thus the entire set is started by closing one primary circuit, an obvious advantage.

A radiophone transmitter for direct connection to 125 volt direct current circuits is shown in Figure 157. The plug at the left of the set is merely inserted (with correct polarity) into a lamp socket and the change-over switch thrown to "transmit" in order to start everything in the set. It will be seen that the set is self-contained. The usual microphone transmitter, which can be seen at a distance from the remainder of the set, is seen on the top of the box. Only direct current (obtained by bridging the microphone across a por-

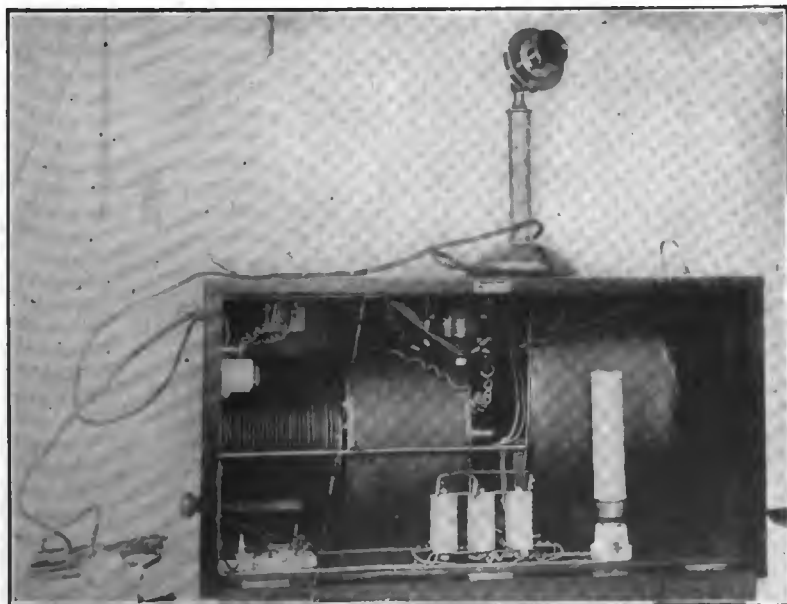
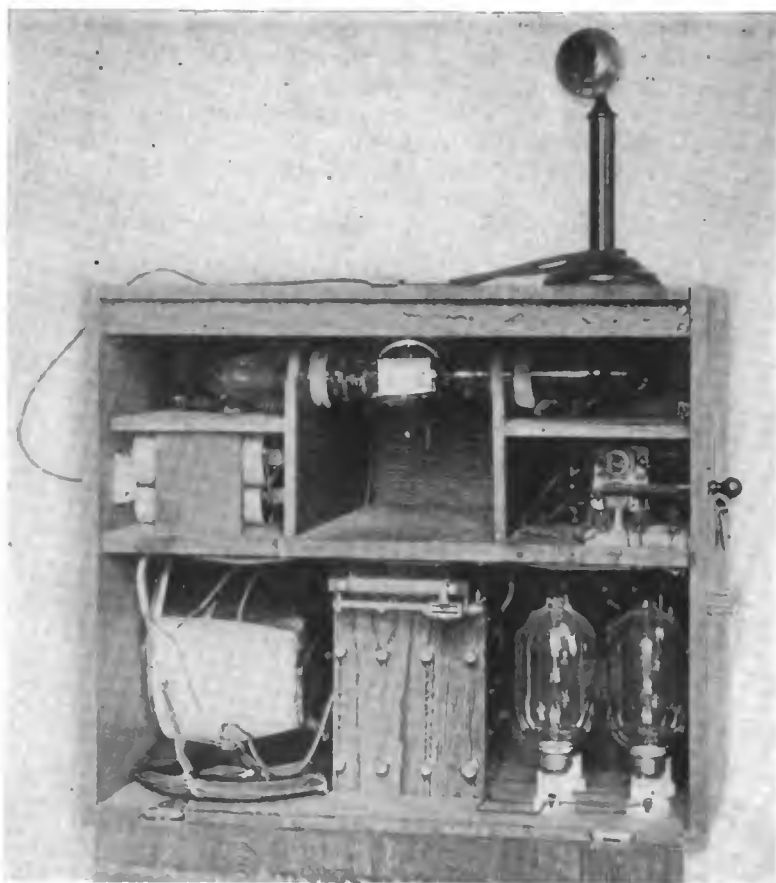

Figure 157—General Electric Company-White radiophone transmitter for direct current supply

tion of a 125 volt potentiometer) passes through the microphone. At the top of the box at the left is mounted a small fixed condenser which is placed across the feeding line to reduce commutator ripple and to act as a radio frequency shunt in the plate circuit. Thus the 125 volt current feeds the plate circuit of the pliotron which is mounted inside the various coils. The filament is lit from the 125 volt circuit through an appropriate resistance. These various resistances and potentiometer are shown in the foreground at the bottom of the box. The two left hand coils are the grid circuit coupling to the antenna and the coils at the right the plate circuit coupling, a circuit somewhat like that in Figure 155 being used. The entire set weighs only 54 pounds (20 kg.) complete. Completely satisfactory operation over 10 miles (16 km.) is possible, and laboratory tests have given ranges up to 65 miles (105 km.).

A more powerful set for use with 60 cycle alternating current supply is shown in Figure 158. The wiring of this set is almost identical with that shown in Figures 154, 155, and 156. The two pliotrons are mounted at the top of the box. To the left, under them, are the microphone dry batteries. To the right, under them, are the "smoothing condensers" (two sets) for the high voltage supply in the plate circuits. To the bottom left are mounted the radio frequency coupling coils and to the right the four kenotron rectifiers. The panel in the middle carries various filament resistances, and back thereof are mounted



*Figure 158—General Electric Company-White radiophone transmitter for alternating current supply*

the microphone transformer (*PS* of Figure 155) and the amplifier transformer (*P'S'* of the same figure). The entire set weighs 150 pounds (68 km.). The transmitting range for satisfactory service is 50 miles (80 km.).

We consider next the control systems suitable for use with the dynatron and pliodynatron tubes of the General Electric Company as developed by Dr. Albert W. Hull. A description of the dynatron (and pliodynatron) together with their mode of operation is given in connection with Figures 87 through 90b, and the reader is referred to this material as an introduction to the present discussion.

Figure 159 represents the cross section of a dynatron where *F* is the filament, *A* the wires, or solid portions, of the anode, and *P* the plate. The paths of a few electrons away from the filament and a diagrammatic representation of a few of the electrons leaving the plate by secondary emission are given for normal conditions in the left hand portion of the diagram. The effect on the electron

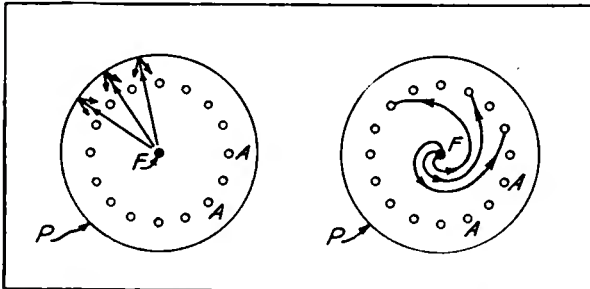

Figure 159—Effect of longitudinal magnetic field on electron paths in dynatron

paths of a longitudinal magnetic field (parallel to the filament) is shown in the right hand portion of the Figure. It will be seen that the electrons now pursue spiral paths and strike the anode very obliquely, particularly if the magnetic field is very powerful and the electron velocity small. In consequence, comparatively few will get through the anode with a high velocity,

and therefore the re-emission phenomena from the plate will be much diminished. The characteristics of the dynatron will be progressively altered, as indicated in Figure 160, whence the magnetic field is increased. The dotted

curve, *A*, is the normal dynatron potential-current curve. On applying a moderate magnetic field the dashed curve, *B*, is obtained. This shows no current reversal

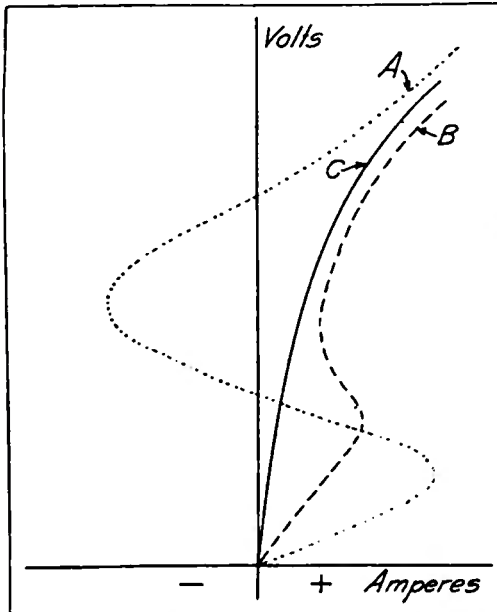

Figure 160—Characteristics of dynatron in various magnetic fields

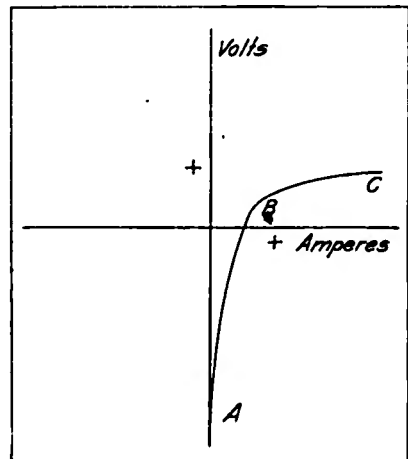

Figure 161—Grid potential-plate current characteristic of a pliodynatron

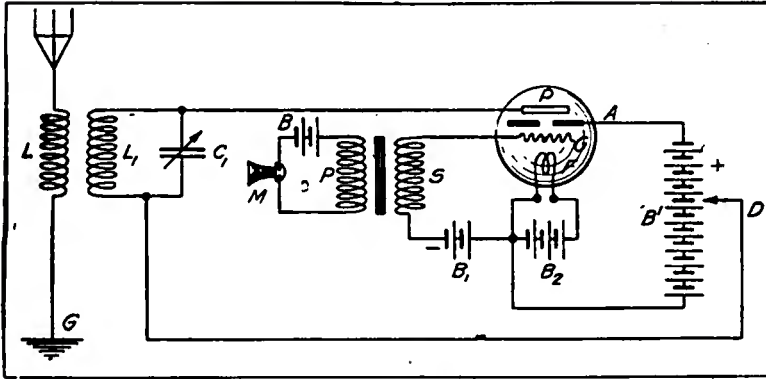

Figure 162—General Electric Company-Hull pliodynatron radiophone transmitter

since the secondary emission is already small. With a strong magnetic field, the characteristic becomes the full line curve, *C*, and shows very little of the usual dynatron effect. It is therefore possible to control the negative resistance (and hence the output) of a dynatron by the superposed magnetic field, and this field may be that due to the current from a microphone transmitter passing through a coil suitably mounted relative to the tube.

The method of controlling the output of a pliodynatron would naturally be by varying the potential of the grid. Offhand it might seem that this would either stop all oscillations (if the grid were sufficiently negative) or else let them remain at full intensity. As a matter of fact, because of the curvature of the dynatron characteristic under certain conditions, it is possible to get a control curve of the pliodynatron (grid potential-plate current) similar to that shown in Figure 161. This curve has a considerable straight line portion, and consequently between *A* and *B* thereon, it becomes possible to control the output of the tube by varying the grid potential. The actual arrangement is shown in Figure 162. As will be seen, the circuit  $L_1C_1$  is connected in the usual fashion for dynatrons between the plate and the battery tap point *D*. The potential variations corresponding to the speech are placed on the grid by the secondary *S* of the audio frequency microphone circuit transformer. The modulated output passes to the antenna circuit through the inductive or other coupling at *L*. In practice, radio telephony over a distance of 16 miles (26 km.) was easily accomplished with one pliodynatron; but this range could doubtless be much increased since no attempt was made at the time to get the greatest possible output or range.

---

This is the twelfth of a series of articles on "Radio Telephony," by Dr. Alfred N. Goldsmith. In the thirteenth article, to be published in the January issue, Dr. Goldsmith describes a system of radio telephone control involving both an Alexanderson alternator for the direct generator of the radio frequency energy and one or more pliotrons for the modulation and control thereof. He also takes up the ferromagnetic control systems wherein the magnetic properties or the iron cores of inductances are utilized.

---



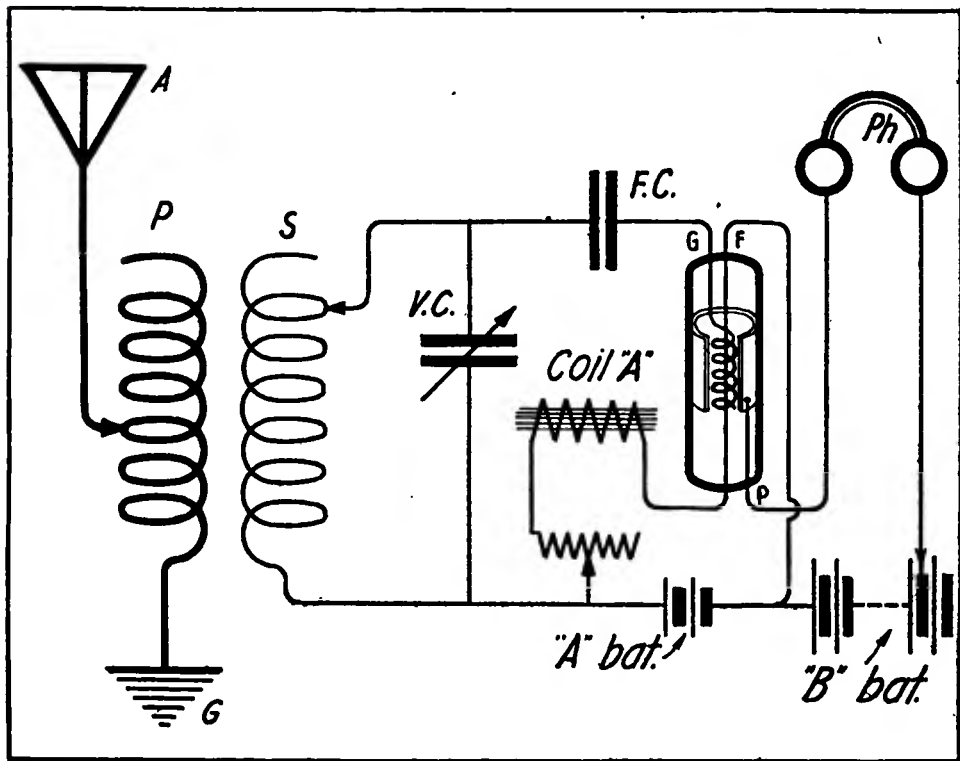
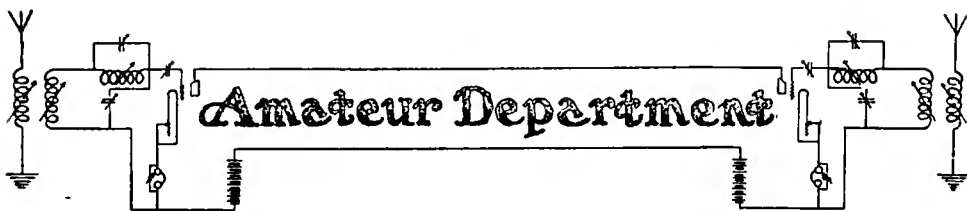

*Drawing, an amplifying circuit for tubular vacuum valve detectors*

### **An Amplifying Circuit for Tubular Vacuum Valve Detectors**

I have found that the application of a magnetic field, as shown by the accompanying drawing, will increase the strength of incoming radio signals several times. It will be noted that the magnetic coil, A, is placed near to the tubular vacuum valve and is also connected in series with the circuit from the lighting battery. The core of soft iron is about 1½ inches in diameter, 3½ inches in length and is made up of a number of soft iron wires of the grade used for the cores of spark coils.

In practice, the magnet coil is placed

about 1½ inches from the bulb and the strength of the filament battery is adjusted until a loud hissing noise is heard. Just below this point the signals come in very loud. Before I applied this arrangement to my apparatus I was hardly able to hear the time signals from Arlington, but after it was connected in the circuit and properly adjusted, I could hear this station with the phones lying on the table. My aerial is not very large; in fact, it is 80 feet in length and 55 feet in height. All my apparatus is home-made with the exception of the variable condenser and head telephone.

I have found this apparatus particu-

larly applicable for the reception of signals from amateur stations.

PETER HANSEN, *Minnesota*.

### An Efficient Station in the North

I know the readers of THE WIRELESS AGE are always interested in photographs of a first class radio station, and I therefore show in an accompanying photograph (1) the  $\frac{1}{2}$  K. W. transmitting set of 9 J.V., the station owned by Macy Q. Teetor of Hagerstown, Ind. This amateur is only seventeen years of age and has been experimenting for about four years. The photograph shows clearly

representative of good workmanship and, to my knowledge, is one of the neatest portable sets yet constructed by an amateur experimenter.

The operating room is shown in the photograph numbered 3. The receiving set, head telephones and operating key are placed in this room. The receiving apparatus has a range of from 200 to 35,000 meters and receives damped and undamped waves. A control apparatus for the transmitter is mounted in this room in an accessible place near to the transmitting key.

This amateur mounted an experi-

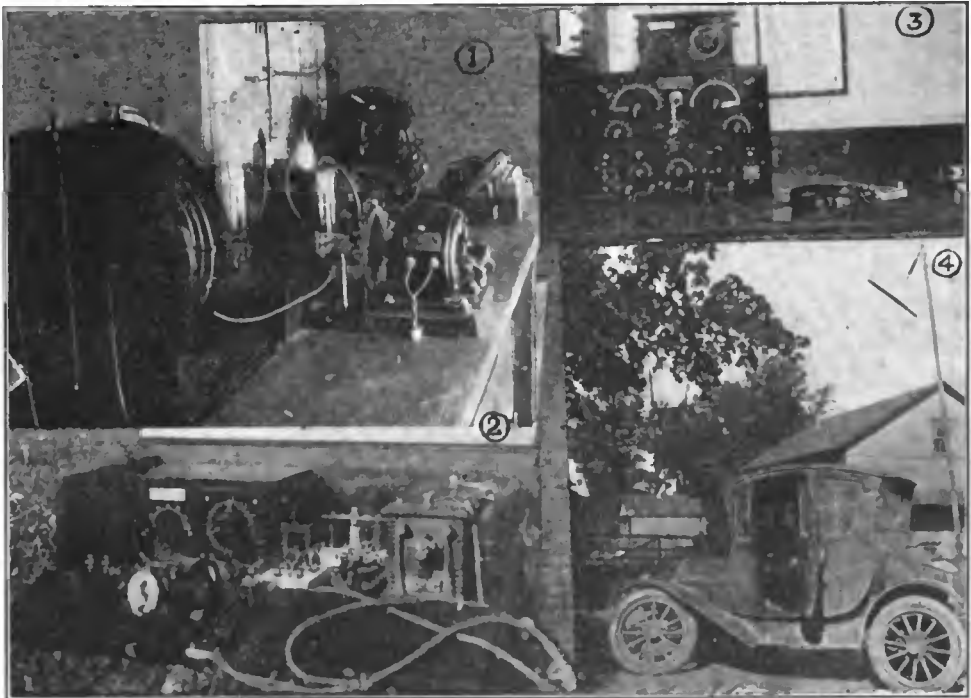

In these photographs are shown the wireless apparatus of Macy Q. Teetor, a young amateur of the Middle West

the closed core transformer, the high voltage condenser, rotary spark gap and the oscillation transformer.

Another photograph (2) shows a portable outfit mounted in a solid mahogany brass-point box which was designed by the same experimenter. It consists of a 2-inch coil, spark gap, key, condenser and eight dry cells, the latter being mounted in a separate compartment at the rear of the box. The entire equipment is

mental portable outfit on a Paige-Detroit coupe and after a series of experiments, succeeded in covering a radius of 4 miles with the small aerial mounted on the chassis shown in the photograph numbered 4.

R. A. Dio, *Minnesota*.

### Wireless Apparatus and Advertising

A Los Angeles inventor has perfected an apparatus which uses a wireless call

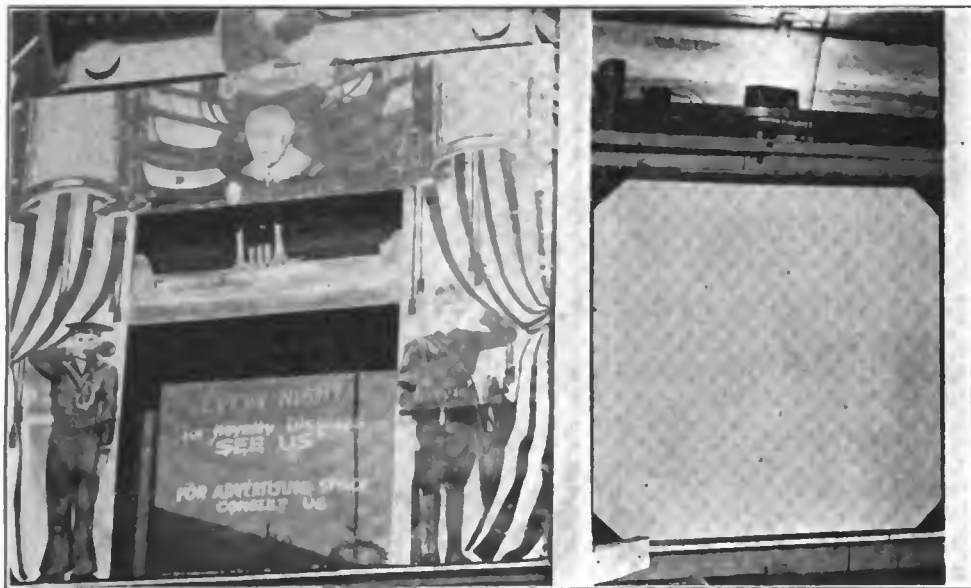

*Views of an apparatus which uses a wireless call to draw attention to an advertising window. Pictures are displayed on the screen (shown in the photograph at the left), and as they are changed S O S appeals are flashed*

to draw attention to an advertising window. The window has been equipped with a screen 6 feet square, upon which pictures are projected by means of a machine located on the inside of the room. This machine has twenty slides, and as the projector slowly revolves the various pictures are thrown on the screen. Each picture is held on the screen for fifteen seconds and as the pictures are changed, S O S calls are thrown from the masts of the battleship. The spark can be distinctly seen midway between the two masts in photographs.

A condenser made of plate glass and tinfoil causes the S O S call to produce a long drawn out, weird, crackling noise which attracts attention to the battleship. Two S O S calls are sent out and the projector operates in conjunction with the wireless apparatus, so that as soon as the wireless call is stopped the next picture is flashed on the screen and held for fifteen seconds. The S O S call is flashed again during the change to the next picture. Passersby watching the battleship necessarily see the picture which is thrown on the screen. Each of

these pictures is an "ad," and, of course, these "ads" not only make a vivid impression upon persons watching them, but the attention of practically every person passing along the street is attracted because the weird noise of the S O S causes them to search for the source of the crackling sparks.

A small motor gives the battleship an oscillating movement as if it were in a heavy sea. The waves are produced by a mechanical effect, also operated by the same small motor, and at night the sky effect produced by lights and painted canvas gives a very vivid impression of a ship sending out appeals for aid.

The projector and all machinery are set in motion and stopped by means of a clock arrangement. It can be started, say, at six o'clock in the evening and will automatically stop at any hour desired without the presence of an operator, the entire operation being automatic.

The projector is operated by a small electric motor. The clock turns on and off the power that operates the S O S calls and the projector at any set time.

CHARLES W. GEIGER, *California.*

# From and For those who help themselves

Experimenters'



Experiences.

## FIRST PRIZE, TEN DOLLARS A 1/2 K. W. 500 Cycle Motor-Generator and a 1/2 K. W. 500 Cycle High Voltage Transformer

Frequently I have observed, in THE WIRELESS AGE, the request from readers for the details of the design of a 1/2 K. W. 500 cycle motor-generator set. Realizing that the amateur would have some difficulty in obtaining these data I prepared a set of specifications which I believe will give a machine of good efficiency. The limitations of the experimenter's work-shop and the material he has on hand have been given thorough consideration.

In presenting the method of construction of this generator reference is first made to Figure 1. The laminations for the stator should be cut or stamped out of .014-inch silicon steel sheets and the loss should not be more than 1.2 watts per pound of material at 500 cycles. Approximately 186 sheets will be required. The laminations for the rotor should be cut from the same material. One hundred and eighty-six sheets will here be required.

The stator space block should be made of cast iron, 12 5/8 inch outside diameter and 8 5/8 inch inside diameter, finished, by 4 inches long. Four holes, 1/2 inch in diameter, should be bored equidistantly around circumference 1/2 inch from the outside edge. Through these should be driven 4 1/2-inch bolts, leaving 3 1/2 inches projecting on each side.

Next, lay the stator laminations in the circle made by the bolts until ninety-three pieces are placed. Then put on the end clamp shown in Figure 4 and set up the nut until they are fairly tight. Next, reverse the space block, put in the other half stator iron-end-clamp and set it up

in the same way. Next in the order of construction is to put the space block in the press and set it up until the spread of each stator pole is 1.5 inches. Make sure that all poles are in line when looking along the shaft. Then take up the nuts and the stator is ready for the coils. The method of clamping laminations is shown in Figure 2.

The coils, which are wound on a form 3/4 of an inch by 1 9/16 inches consist of three layers of seven turns each of No.

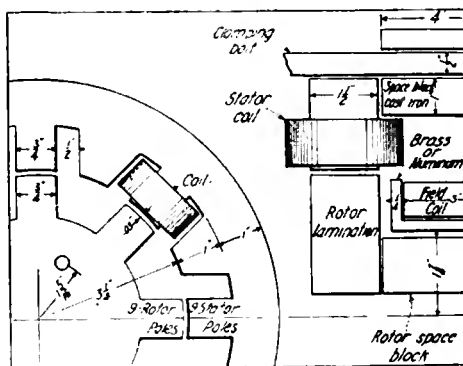

Figure 1, First Prize Article

12 B. & S. D. C. C. wire. If possible, stranded wire should be employed. Cover each coil with two layers of armature tape. Bring the leads out in "sleeving" and dip the coil into insulating paint, allowing it to dry. Place the coils on the poles, connect up alternating north and south in the proper way, and bring out the ends through holes in the end clamps with flexible rubber-covered cable. Before placing the coils, it will be necessary to grind out the inside face of the stator poles in a high speed rotary grinder.

The field coil holder is to be made of

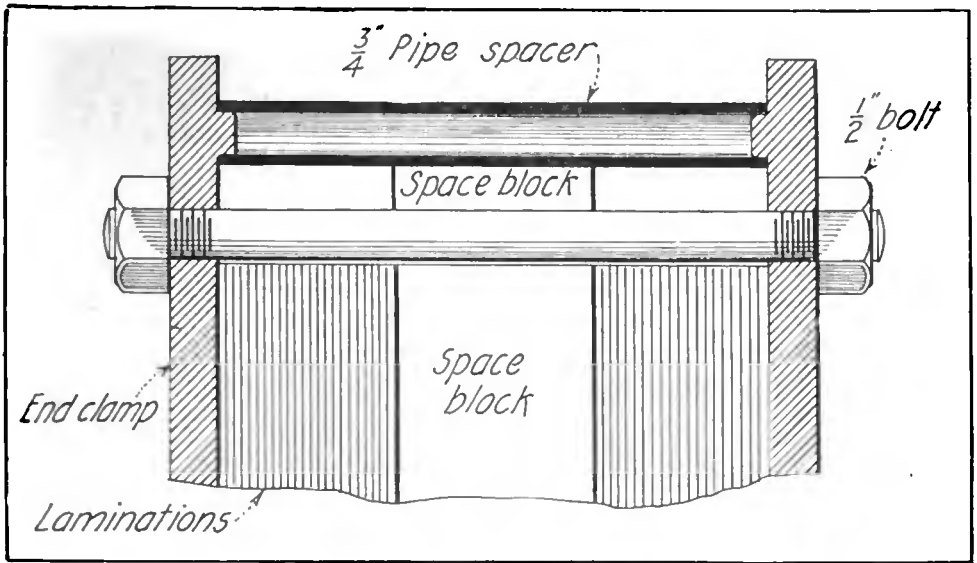

Figure 2, First Prize Article

brass after the dimensions shown in Figure 1. Three equidistant slots must be cut in the outside rim to a depth of  $\frac{1}{4}$  of an inch and a width of  $\frac{1}{2}$  inch. Two rows of  $\frac{1}{2}$ -inch holes are to be drilled in the bottom of this; there should be about four holes in each row.

The rotor space block should be made of cast iron after the dimensions of Figure 3. Drive in a piece of 1-inch shafting until one end of the shaft projects two inches. Fine threads should be cut, beginning at a point  $1\frac{1}{2}$  inches from the block for a distance of  $\frac{1}{2}$  inch. Turn down the shaft for the remainder of the distance,  $1\frac{1}{2}$  inch on one side and 3

inches on the pulley end, making the latter  $\frac{3}{4}$  of an inch in diameter.

Then put on the ninety-three rotor laminations and screw up the rotor clamp fairly tight. Slip on the field coil holder over the rotor space block, put on the laminations of the other rotor pole and place the second rotor clamp after making sure that poles are in a line along the shaft. Place it in a press and set up until the face of each rotor pole is  $1\frac{1}{2}$  inch measured along the shaft. Place the rotor in a grinder and grind to smoothness. This grinding must be carefully done as the air gap must not exceed .03 inch.

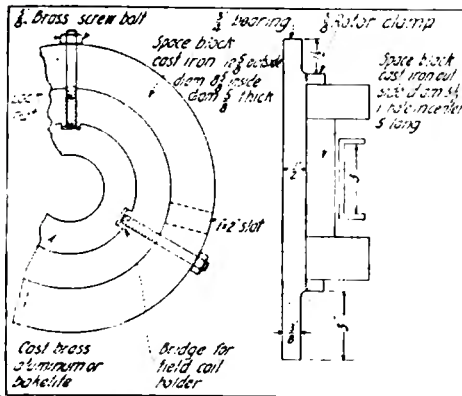

Figure 3, First Prize Article

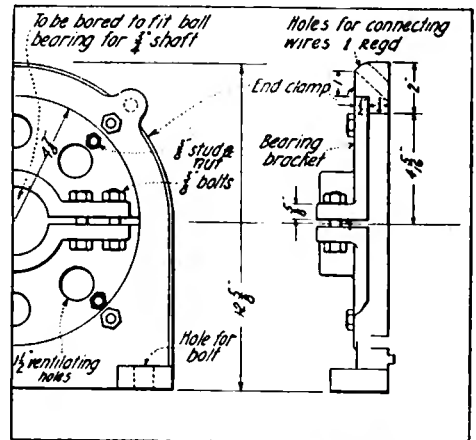

Figure 4, First Prize Article

The rotor should now be balanced by drilling the rotor space block through the holes in the field coil holder. Wedge the field coil holder in a central position by means of wooden wedges and insulate it; then wind on 13,000 turns of No. 33 B. & S. wire, bringing out rubber covered leads about two feet in length. The latter should be made of No. 18 wire. Next, place the three field coil holder bridges in position and fasten in place as shown in Figure 5. Follow this by cutting the key slot on the pulley end and give the field coil two coats of insulating paint. Then remove the wood wedges. Finally drive on a set of ball bearings and the rotor will be complete.

The assembly is as follows: Lay the

rotor directly coupled to a direct or alternating current motor, or gasoline engine. It should revolve at a speed of 3,330 revolutions per minute to give a frequency of 500 cycles. The efficiency will be approximately ninety per cent. The constructor is cautioned to give particular attention to the fitting of the ball bearings to the shaft, the bearing brackets to the end clamps, and the grinding of the stator and rotor. The balancing of the rotor will be found to be particularly important.

In connection with this generator, the specifications of a  $\frac{1}{2}$  K. W. 500 cycle high voltage transformer are given. The primary voltage is 110 volts and the secondary 6,600 volts. I shall not give

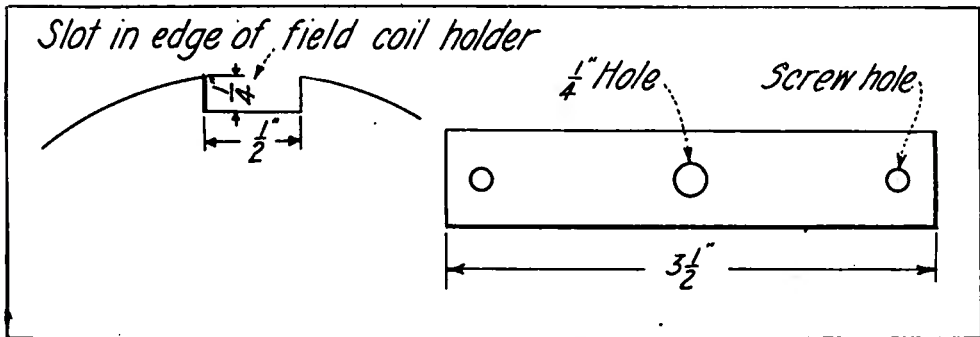

Figure 5, First Prize Article

field coil leads in spaces between the rotor poles and insert the rotor in the stator, fishing the field leads through the holes in the top of the stator space block. Next, put on the lower halves of the bearing brackets and see that the edge of the stator pole lines up fairly with the edge of the rotor pole. Put on the top halves of the bearing brackets and tighten up all bolts. I have given no dimensions for the inside bore of the end bearing brackets as they will be governed by the outside diameter of the ball bearing. The shaft will probably have to be turned to a different diameter to suit the ball bearing, but the writer does not recommend less than  $\frac{3}{4}$  of an inch. Now put the field coil holding screws in place and center the field coil by sighting through the ventilating holes in the bearing brackets; then tighten up on the lock nuts, as shown in Figure 3.

The dynamo can now be belted or di-

rectly coupled to a direct or alternating current motor, or gasoline engine. It should revolve at a speed of 3,330 revolutions per minute to give a frequency of 500 cycles. The efficiency will be approximately ninety per cent. The constructor is cautioned to give particular attention to the fitting of the ball bearings to the shaft, the bearing brackets to the end clamps, and the grinding of the stator and rotor. The balancing of the rotor will be found to be particularly important.

In connection with this generator, the specifications of a  $\frac{1}{2}$  K. W. 500 cycle high voltage transformer are given. The primary voltage is 110 volts and the secondary 6,600 volts. I shall not give the details of construction as they have been described so fully in previous articles in this magazine.

The core of the transformer is made of silicon steel .014 inch in thickness, of a quality that will give 1.2 watts per pound loss, at 500 cycles. It will be 1.7 inch square in cross-section and 6.5 inch outside length. The inside length will be 3 inches, and totally, there will be required about 15.2 pounds of iron. The loss will approximate 20 watts.

The primary core is wound with empire cloth to a depth of .25 inch, and the primary winding consists of 120 turns of No. 12 B. & S. D. C. C. wire wound in four layers of thirty turns each. The resistance will be about .17 ohms and the  $I^2R$  losses approximately 9.5 watts.

The secondary winding is insulated from the core by a winding of empire cloth having a depth of .25 inch. The same thickness is used between coils, and

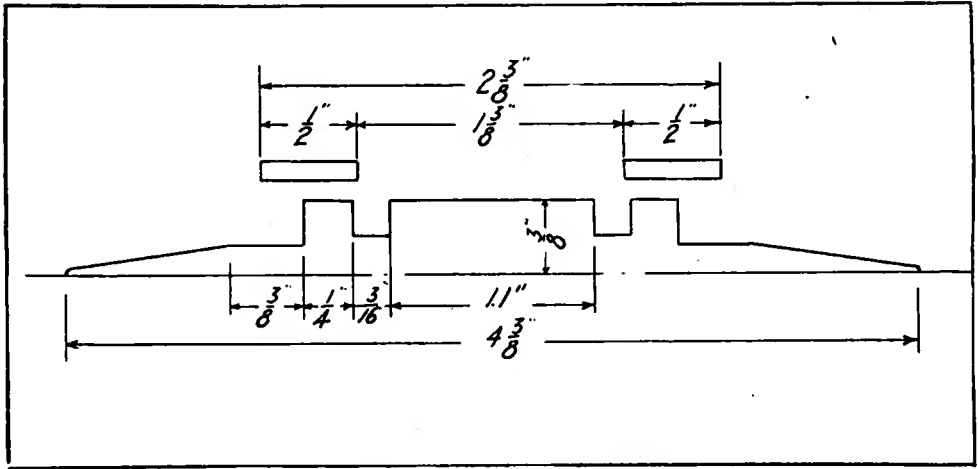

Figure 6, First Prize Article

between coils and core. Seven thousand two hundred turns of No. 28 wire wound in two sections of 3,600 turns each will be satisfactory. This will require about four pounds of wire with a resistance of 424 ohms. The  $I^2R$  losses will be seven watts and the efficiency ninety-three per cent. The primary current should approximate 7.75 amperes and the secondary current .125 ampere. This transformer is designed to be operated ten per cent. off resonance. The condenser to accompany this transformer can be constructed as follows: If we allow seventy-two square inches of dielectric for a capacity of .001 microfarad, considering the thickness of glass ordinarily used, we require eight plates, and inasmuch as the voltage of this transformer is low, photograph plates  $\frac{1}{8}$  of an inch or .125 inch in thickness will be satisfactory.

The primary winding of the oscillation transformer should be 10 inches in diameter and consist of four turns spaced one inch apart. The winding should be made of  $\frac{3}{8}$  of an inch copper tubing mounted on porcelain. The secondary winding should be made of 8 turns, 8 inches in diameter, spaced  $\frac{3}{4}$  of an inch apart and made of copper tubing  $\frac{3}{8}$  of an inch in diameter. Any type of oscillation transformer having primary inductance of 1.4 microhenries can be employed.

The apparatus can be mounted on a panel if the builder desires, and it will

not cost very much to construct. All the patterns required for the construction of this apparatus can be made in the average amateur workshop. The most difficult part will be the stamping out of the slots in the stator and rotor. Further difficulty may be experienced in grinding the stator and rotor iron after assembly.

I have shown in Figure 6 a half section of a spark gap plate suitable for this set. The plates will have a separation of ten mils and there will be approximately 1,100 volts per gap. Six gaps, which may be made of brass or copper, will be required. The washers between plates should be made of mica. About one pound pressure should be placed upon the plates by a 6-inch wrench with a thirteen-thread screw. The sparking surface of the gap should have a sparking surface of silver sweated on.

JOHN J. HOLAHAN, *Virginia.*

## SECOND PRIZE, FIVE DOLLARS

### The Elimination of End-Turns in Receiving Transformers

This article describes a dial switch for a wireless receiving set, the purpose of which is to eliminate dead-end resonance effects.

A circular fibre disc, D, mounted on an insulating support, W, carries near its outer edge a series of metal plugs, P, threaded into the disc so that their ends are exposed on both sides of the disc.

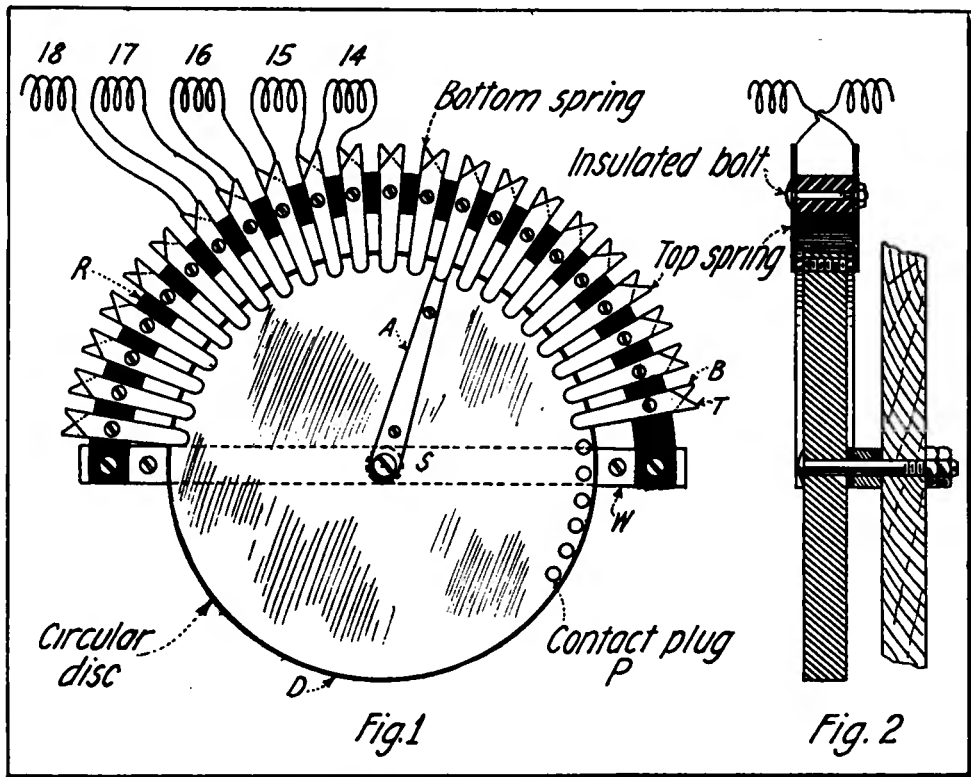

Drawings, Second Prize Article

These plugs make contact with a series of springs mounted on both sides of a semi-annular fibre ring, R, mounted concentric with the disc but fixed in position. Figure 1 shows the switch in plan and Figure 2 shows an enlarged cross-section. The row of plugs extend nearly but not quite half-way around the disc. There should be as many sets of contact springs on the ring as there are plugs on the disc. The springs and plugs should be accurately and uniformly placed.

In this particular switch the plugs were made from a piece of No. 6 copper wire threaded its entire length with a standard die. The holes in the disc were drilled and tapped with a standard thread. The end of the wire was then screwed into a disc until it projected slightly through the other side of the disc. The wire was then cut and the detached plug in the disc was filed down almost even with the surface of the disc and then rounded. All the plugs were inserted and finished in this manner.

The contact springs on the ring, R, are made from .013-inch spring copper cut in strips one inch long and tapering in width from  $\frac{3}{16}$  to  $\frac{1}{8}$  inch. These are bolted with insulated bolts to the fibre ring, with their narrow ends toward the center. As shown in Figure 2, there is a top and a bottom spring to each set. Both springs make contact with the same plug at the same time, but as the disc is rotated, each plug makes contact with each and every set of springs. The spacing of plugs and springs should be accurate and uniform.

The primary of the receiving transformer is cut in sections of thirty turns each, the ends of each section being brought out to the switch, and then soldered to the contact springs. As shown in Figure 1 the right terminal of each section of the coil is soldered to the bottom spring and the left end terminal of each is connected to the top spring. If, now, the top and bottom springs are brought in contact with each other, two



adjacent sections of the coil are thrown in series. This is accomplished by turning the disc until a plug is brought between the two springs. As the disc is further turned to the left, another section of the coil is placed in series with the first two. It will be noticed that each plug takes the place of the preceding one, thereby maintaining a series circuit as more are connected in by the leading plug. That part of the winding not in use is left open, in small sections, and therefore it cannot resonate except to exceedingly short wave lengths.

### THIRD PRIZE, THREE DOLLARS The Design of a 150 Watt Step-Down Transformer

A step-down transformer delivering convenient voltages is a requisite addition to a well-equipped amateur laboratory. The one described in this article is designed to operate, directly, on the 110 V. 50-60 cycle current.

Beginning with the core, it should be made of silicon and the laminations should be staggered. The core pieces are 1 inch by 4 inches and 1 inch by 3 inches

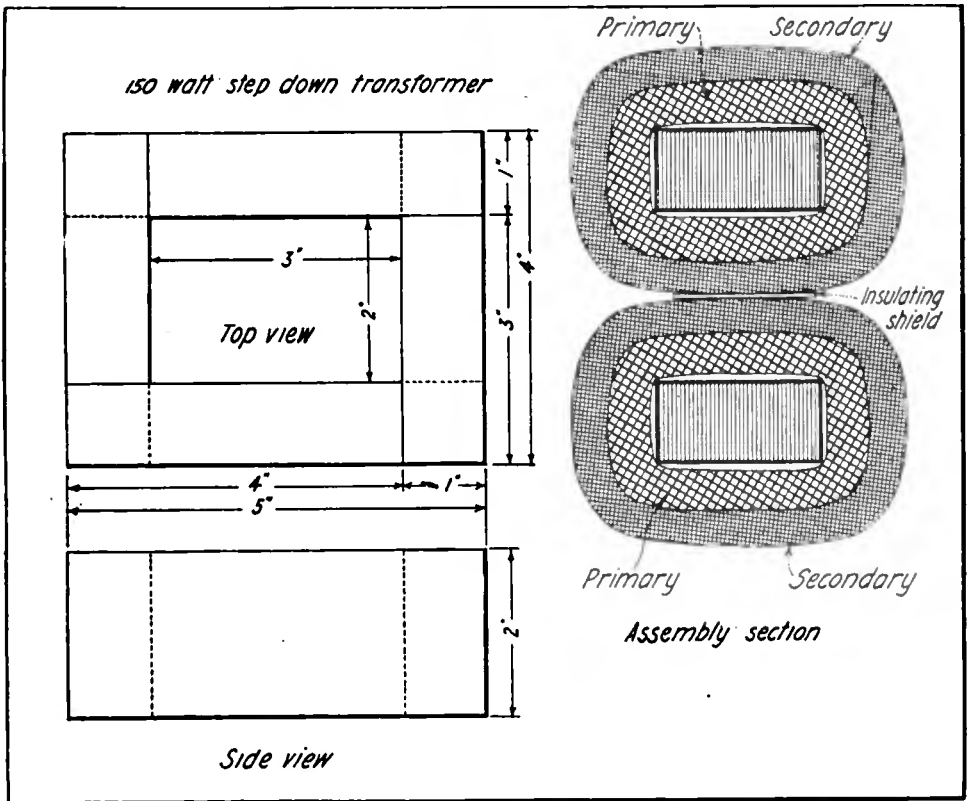

Figure 1, Third Prize Article

A strip of metal, A, extends from the central screw, S, to the leading plug, which makes contact only with the springs on the top. This brings each coil completely into the circuit at once. The end section of the winding (No. 1 in this case), was connected to a plain dial switch having thirty taps. This provides the necessary closeness of adjustment for accurate tuning.

H. D. McMURTRAY, Mississippi.

and should be built up 2 inches high, which gives a rectangular cross-section, as shown in Figure 1.

The longer legs are securely taped while tightly compressed to fully 2-inch thickness. The end legs are then removed to facilitate winding.

The primary coil consists of 360 turns of No. 18 D.C.C. wire and will require 2¼ pounds. This allows continual operation within the rated capacity. Three

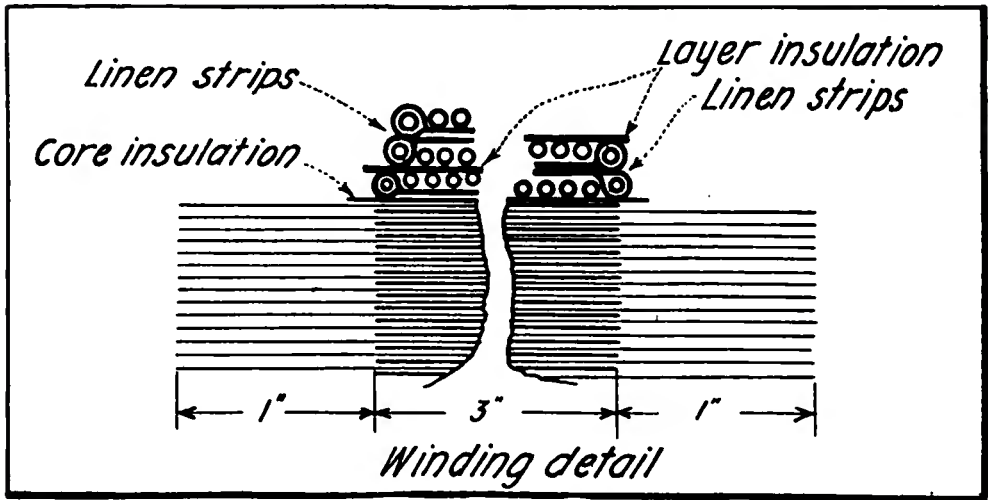

Figure 2, Third Prize Article

hundred and fifteen turns are wound on each leg and the two windings are connected in series (See Figure 1).

The winding of these coils is most easily accomplished in a lathe, but a serviceable jig can be made of wood as follows: One-inch blocks are fitted to the ends of the core to be wound by cutting niches 1 inch by  $1\frac{3}{4}$  inches to a depth of  $\frac{1}{2}$  inch. A small machine screw projecting through the center of one block serves as a bearing for that end and a small crank, the other. The core with blocks attached is supported on uprights which are fastened to a suitable base. A piece of hard wood, having its upper edge round and in line with the axis of the core, should be set up on the base several inches in front of the core. This serves as a guide and also places a tension on the wire and therefore removes all kinks as it is wound.

Fiber end plates could be fitted to the core, but the following method allows much better ventilation: First insulate the core with several layers of 4-inch empire cloth strips. Then, taking one of the narrow sides as the top, the first turn, having a piece of  $\frac{3}{4}$ -inch linen tape looped over it, is placed 1 inch from the ends of the core. The following turns are then wound over the linen strip, thus holding the first turn in position. (See Figure 2). The first layer continues to within 1 inch of the other end of the core,

which gives approximately a 3-inch layer which should contain 315 turns. The last turn is placed first to try the fit and then unwound and a 1-inch strip of thin linen cloth or empire cloth folded over it, edgewise or "U" shaped, and wound around with it, with the edges lying back on the former turns. This strip continues with the next turn which is wound directly over the other and as near the edge as possible. The following turns bind the edges of the linen strip firmly in place which keeps the end turns from falling down. (See Figure 2). This operation is repeated at the end of each layer.

It is best to wind four or five layers of manila wrapping paper between layers, extending from the edges of the linen. This compensates for the additional thickness caused by the linen strips and provides the insulation as well. The primary must not be allowed to bulge at the sides as the finished height from the core, in order to leave space enough for the secondary, should not exceed  $\frac{9}{16}$  of an inch.

The secondary consists of two pounds of No. 12 D.C.C. wire, or approximately 210 turns. The primary is insulated by eight or ten layers of wrapping paper followed by winding 210 turns over each leg. The ends of the layers are held in place as in the primary. Leads are brought out at the 35th turn, 70th turn,

and the 105th turn or the end, on each leg. These are made by soldering the hooked end of a 1/2-inch strip of copper ribbon (not smaller than 24 gauge) to the proper turn.

The following table gives the data regarding the switch connections:

Point No.	Effective No. Turns	Voltage	Connections
1	25	6	2 groups, 25 turns in parallel
2	70	12	2 groups, 70 turns in parallel
3	105	18	2 groups, 105 turns in parallel
4	140	24	140 turns in series
5	175	30	175 turns in series
6	210	36	210 turns in series

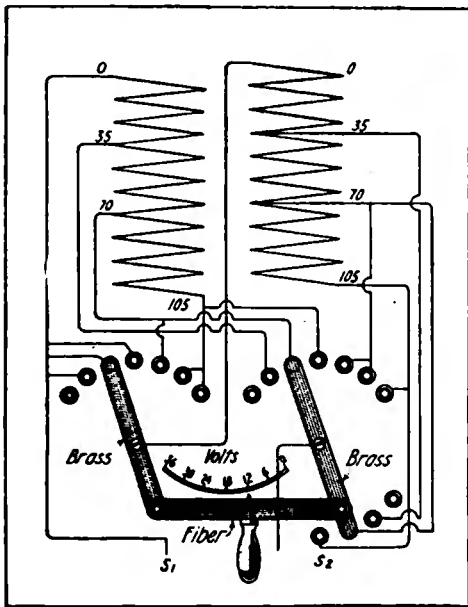

Figure 3, Third Prize Article

Both legs should be wound in the same direction and when "setting up" the beginning leads should be diagonally opposite, otherwise the wiring circuits will not work out properly.

The switches should be designed so that the blades do not short adjacent taps. Fiber headed chair tacks can be alternated with the points to raise the blade slightly as it passes. The ends of the arcs should not come too closely opposite or the connecting lever will be almost on dead center when on the first and last taps.

Figure 3 gives the connections and the general construction.

ALLAN THOMPSON, California.

### The Albany Signal Corps Ready for Instruction Work

Following the publication of the article in the November issue of THE WIRELESS AGE calling attention to the need of the Government for instructors in wireless and buzzer work, H. G. Mulligan, Acting Commander of the Albany (N. Y.) Signal Corps has announced that the organization is qualified to take up this task, and offers its services.

The Albany Signal Corps was organized in the Spring of 1916 for the purpose of training its members in the signaling methods employed in the United States Army. Five of its members are in the Government service. Two are connected with the regular Army Signal



A view of the Albany Signal Corps' auto tractor set. This organization is prepared to aid the Government in wireless and buzzer instruction work

Corps at Camp Vail, Little Silver, N. J.; one is a sergeant in the 303rd Signal Battalion at Camp Dix; one is taking the Army signal course at the College of the City of New York, and the fifth member of the Corps is in attendance at the Navy Radio School.

The Corps is equipped with a large auto tractor radio set, a photograph of which is shown in the accompanying illustration. The apparatus is of modern design and includes a Paragon tuner and vacuum valve detectors. The mast, when erected, extends sixty-five feet into the air. It is employed with a counterpoise ground. The set has been dismantled since the declaration of war against Germany by this country.

# The Monthly Service Bulletin

## of the

# NATIONAL AMATEUR WIRELESS ASSOCIATION

Founded to promote the best interests of radio communication among wireless amateurs in America

J. ANDREW WHITE, Acting President GUGLIELMO MARCONI, President ALONZO FOGAL, JR., Secretary

### NATIONAL ADVISORY BOARD OF VICE-PRESIDENTS

Prof. A. E. KENNELLY  
Harvard University

Maj. Gen. GEORGE O. SQUIER  
Chief Signal Officer, U. S.  
Army

Commander D. W. TODD, U.S.N.  
Director Naval Communica-  
tions

Major WILLIAM H. ELLIOTT  
Junior American Guard

Prof. ALFRED N. GOLDSMITH  
College of the City of New  
York

Capt. W. H. G. BULLARD,  
U. S. N.

E. E. BUCHER  
Instructing Engineer

Prof. SAMUEL SHELDON  
Brooklyn Polytechnic Insti-  
tute

Prof. CHARLES R. CROSS  
Massachusetts Institute of  
Technology

Colonel SAMUEL REBER  
Signal Corps, U. S. Army

WILLIAM H. KIEWIN  
Chief of Relay Communica-  
tions

Headquarters, 25 Elm St., New York

**A** FORMER amateur of the United States is a member of the Naval Reserve of the Government of N. S. W., Sydney, Australia. He writes:

"I am mobilized for duty at the Sydney radio station (VIS), having joined the Naval Reserve some time ago as electrical artificer.

"The station is a standard 40 K.W. Telefunken plant with an umbrella aerial, 400 feet high. With the receiving set, which is a regenerative valve apparatus, 'POZ' is picked up each morning at about four o'clock and copied for several hours. That is some distance, isn't it? We heard WGG (Tuckerton), once, also Darien, Koko Head (KIE), Pearl Harbor, Funashashi (Japan) (JJC), come in good at all times. . . .

"I have been a local subscriber to THE WIRELESS AGE for over two years, and think it one of the best."

\* \* \*

How would you like to be the radio operator on a Zeppelin? You wouldn't mind, we assume, if it belonged to the Allies.

If we are to judge by what the New York Globe's war correspondent tells us, the problems of these mid-air radio operators and the general operation are no different from those encountered in ship work.

The L-49 was recently captured intact

by the French authorities and the Globe's correspondent was one of the first to make an inspection of the Zeppelin after it had been taken under control by the French Government. It seems that when destruction or capture of the L-49 appeared imminent, the operator attempted to destroy the wireless apparatus. A French officer informed the correspondent that repairs could easily be effected as the damage to the apparatus was not great. The radio set of the Zeppelin, according to description, was not unlike that of an ordinary ship installation, and the appointments and general lay-out were a close duplicate of the commonly used commercial set. A passage way, 500 to 600 feet in length, ran through the Zeppelin.

\* \* \*

Members of the N. A. W. A. throughout the United States who are available as instructors in wireless telegraphy, either in theory or in code practice, are requested to communicate with the association immediately.

There is urgent need for several hundred instructors in radio to assist the United States Government in preparing men for war service, and the N. A. W. A. desires to have a complete list of names on file. Amateurs are urged to give this matter prompt attention.



# The Wireless Men's BOOKSHELF

We supply all books, in print, at publisher's prices, whether issued in the U. S. A. or imported. Please add charges for postage or expressage to remittances.

### RATE TABLE FOR PARCEL POST SHIPMENTS

All books sent by mail take parcel post rates. Packages up to 4 ounces in weight are carried at the rate of 1 cent an ounce, regardless of distance. Packages over 4 ounces are charged for by the pound. The rate per pound varies according to the distance, which is measured by the Government zone system, each zone covering a certain number of miles from point of shipment. Distances and rates are shown in the table below. Books carried by parcel post are handled just like any other mail matter. They are delivered to your box by your rural mail carrier if you live on a rural route, or delivered to your door if you live in a city where there is carrier service, or delivered to your local postoffice if you live where there is no carrier service.

Weight of Package	LOCAL ZONE	ZONES 1 AND 2	ZONE 3	ZONE 4	ZONE 5	ZONE 6	ZONE 7	ZONE 8
	For Shipments From Our Store in New York to Customers within New York.	Not Over 150 Miles From New York.	151 to 300 Miles From New York.	301 to 600 Miles From New York.	601 to 1,000 Miles From New York.	1,001 to 1,400 Miles From New York.	1,401 to 1,900 Miles From New York.	Over 1,900 Miles From New York.
	Charges Required	Charges Required	Charges Required	Charges Required	Charges Required	Charges Required	Charges Required	Charges Required
Over 4 oz. up to 1 lb...	5c	5c	6c	7c	\$0.08	\$0.09	\$0.11	\$0.13
Over 1 lb. up to 3 lbs...	6c	6c	8c	11c	.14	.17	.21	.24
Over 3 lbs. up to 4 lbs...	6c	7c	10c	15c	.20	.25	.31	.36
Over 4 lbs. up to 4 lbs...	7c	8c	12c	19c	.26	.33	.41	.48
Over 4 lbs. up to 5 lbs...	7c	9c	14c	23c	.33	.41	.51	.60
Over 5 lbs. up to 6 lbs...	8c	10c	16c	27c	.38	.49	.61	.73
Over 6 lbs. up to 7 lbs...	8c	11c	18c	31c	.44	.57	.71	.84
Over 7 lbs. up to 8 lbs...	9c	12c	20c	35c	.50	.65	.81	.98
Over 8 lbs. up to 9 lbs...	9c	13c	22c	39c	.56	.73	.91	1.08
Over 9 lbs. up to 10 lbs...	10c	14c	24c	43c	.63	.81	1.01	1.20

To points where parcels post charges exceed 8c per lb. books will be forwarded by BOOK EXPRESS, at the rate of 8c per lb.

Include the amount for postage charges in the money order, check or currency you send us. This charge for mailing must be paid in advance as the Government has not provided for the collection of mailing charge on delivery. If in doubt as to what amount is required for any order you are perfectly safe in adding even more than you think necessary, for we will ship by the most economical method and will return you any amount that is left over.

Within Local Zone and Zones 1 and 2 packages up to 50 pounds in weight are carried. The limit of weight for all other zones is 20 pounds.

**STANLEY, RUPERT, B. A., M. I. E. E.,** Professor of Physics and Electrical Engineering, Municipal Technical Institute, Belfast.

## TEXT-BOOK ON WIRELESS TELEGRAPHY

A Text Book for students with no previous knowledge of electrical matter; covers the technique and construction of all apparatus used in the principal Systems of Wireless Telegraphy. It deals with simple scientific facts concerning matter, air and ether, leading up to electrical and magnetic phenomena, explained on the modern electron theory in such a way that it can be easily understood.

Each chapter is followed by questions and examples; these enable the reader to test and revise his knowledge of the subject matter of the chapter. These questions will prove useful to teachers and students. The book is illustrated by over 200 diagrams and views; it also contains a very complete chapter on Tests and Measurements.

**CONTENTS**—The Earth, the Atmosphere and the Ether—Matter and Electrons—Magnetism and Magnetic Forces in the Ether—Electricity and Electric Strain in the Ether—Electrical Measurements and Calculations—Capacity and Induction Effects—Induction Coils, Alternators and Transformers—Oscillatory Discharges—Historical Development of Radio-Telegraphy—How Ether Waves are Propagated and Received—Coupling of Circuits—Transmitter Circuits for Spark Systems—Transmitting Apparatus—

Aerials, Insulators and Earth Connections—Receiver Circuits—Detectors—Receiving Circuit Apparatus—Undamped Wave Systems—Miscellaneous Apparatus, Measurements in Radio-Telegraphy.

**APPENDICES**—International Morse Code—Call Letters of British Stations—Extracts from the International Radio-Telegraphic Regulations—Eiffel Tower Time Signals and Weather Reports—Index.

Cloth Svo. 340 pages. Illustrated. PRICE \$2.50 net. Mailing weight 3 lbs.

*Add book postage as per schedule on second page.*

Specialists in  
Wireless Literature

Wireless Press, Inc.  
www.americanradiohistory.com

25 ELM ST.  
NEW YORK, N. Y.



## PRACTICAL WIRELESS TELEGRAPHY

By ELMER E. BUCHER

*Instructing Engineer of the Marconi Company*

Second Edition, enlarged, with new chapter on Location  
of Trouble—Maintenance—Repairs

This book is the last word in wireless text books. It furnishes much information of utmost value in regard to the very latest styles of wireless sets now in use, and which has not appeared in print before.

PRACTICAL WIRELESS TELEGRAPHY is the first wireless text book to treat each topic separately and completely, furnishing a progressive study from first principles to expert practice. Starting with elementary data, it progresses, chapter by chapter, over the entire field of wireless—fundamentals, construction and practical operation.

Three chapters are devoted entirely to basic electrical principles. The motor-generator, the dynamotor and rotary converter are treated in detail. The nickel-iron and lead plate storage batteries, now supplied for emergency purposes with all commercial radio equipments are the subject of an entire chapter, a description of the apparatus associated with the charging of batteries and complete instructions for their care being furnished.

The radio transmitter is treated both in theory and in practice. The book contains complete diagrams, photographs and descriptions of modern commercial marine transmitters and instructions for the adjustment and operation of the apparatus. Receiving apparatus is treated in like manner, descriptions and working instructions being given for all types of up-to-date receiving sets, including the two and three-electrode valves.

A full chapter is devoted to practical radio

The 340 illustrations alone, specially drawn, form a complete diagrammatic study and impress upon the reader's mind a pictorial outline of the entire subject. Many of these illustrations reveal details of construction of the newest types of sets and apparatus never before published.

PRACTICAL WIRELESS TELEGRAPHY is a practical man's book from cover to cover and *up to the minute*. Size 330 pp. 6 x 9 inches, handsomely bound in full cloth with cover stamping in gold and black.

Price \$1.50 net. Mailing weight 2 lbs.

Postage as per schedule on second page.

*This volume has been a very expensive one to prepare. Ordinarily it would be priced at \$2.50, but to meet the requirements of students and amateurs for a moderate priced, up-to-date text the lower price has been fixed.*



**BUCHER, E. E.,** *Instructing Engineer of The Marconi School of Instruction.*

## HOW TO PASS U. S. GOVERNMENT WIRELESS LICENSE EXAMINATIONS

Third Edition Largely Revised and Extended

142 Questions and Answers.

**CONTENTS**—Explanation of Electrical Symbols—Definitions of Electrical Terms—Part I. Transmitting Apparatus—Part II. Motor Generators—Part III. Storage Batteries and the Auxiliary Set—Part IV. Antenna or Aerials—Part V. Receiving Apparatus—Part VI. Radio

Laws and Regulations—Part VII. General Information Concerning Operator's License Examinations—Practical Equations for Radio Telegraphy—Equations for Ordinary Power Work.

PRICE 50c net. Mailing weight 1 lb.

With one year's subscription to THE WIRELESS AGE, \$2.00.

Add book postage as per schedule on second page.

**THOMPSON, SILVANUS P.**

## ELEMENTARY LESSONS IN ELECTRICITY AND MAGNETISM

NEW EDITION REVISED AND ENLARGED.

The complete revision of this standard text brings it abreast of the latest developments in both the theory and practice of the science. Topics treated in the older volume have been rewritten and expanded to include the recent advances in the subject. Additional chapters have been devoted to such newer phases as Wireless Telegraphy, the Electron Theory, the application of electric power to railroads and automobiles, and high power transmission. A thorough rearrangement of material has been made in the interest of greater clearness and continuity of treatment, while the increased use of illustrations and the introduction of up-to-date terminology increase the practical teaching value of the text.

Cloth. 706 pp. PRICE \$1.50 net. Mailing weight 2 lbs.

Add book postage as per schedule on second page.

**SWOPE, C. WALTON,**

*Member American Institute of Electrical Engineers.*

## PRACTICAL ELECTRICITY

An Elementary Textbook.

**Principles—Experiments—Arithmetical Problems**

This book combines the principles of electricity upon which the practical applications of to-day depend, with the experimental demonstration of these principles and the elements of the arithmetics of electricity used in making practical electrical measurements and calculations.

**CONTENTS**—Magnetism—Magnetisation—Magnetic Fields—Theory of Magnetism—Magnetic Induction—Magnetic Circuits—Earth's Magnetism—Voltaic Electricity—Batteries—Electrolysis—Measurement of Current Strength—Resistance—Ohm's Law and Battery Connection—Circuits and Their Resistance—Electromagnetism—Galvanometers—Electromagnets—Ammeters—Electrical work and Power—Measurement of Pressure—Measurement of Resistance—Electrical Development of Heat—Electrodynamics—Electromagnetic Induction—The Induction Coil—Dynamo Electric Machines—Armatures—Direct Current Dynamos—Direct-Current Motors—Electric Lighting—Alternating Currents—Tables—Formulas.

FIFTEENTH EDITION.

Cloth. 517 pp. 404 illus. PRICE \$2.00 net. Mailing weight 2 lbs.

With one year's subscription to THE WIRELESS AGE, \$3.50.

Add book postage as per schedule on second page.

## TRAFFIC RULES AND REGULATIONS FOR MARCONI OPERATORS

We issued this compact volume for the MARCONI WIRELESS TELEGRAPH COMPANY OF AMERICA. At the request of several radio schools, who believe it will be of the utmost value to their students now preparing for professional wireless service, we have secured permission from the MARCONI COMPANY to offer a limited number of copies for sale to persons who are deeply interested and who wish to master the details of practical wireless service.

It contains complete instructions covering every feature connected with the routing and handling of wireless traffic; an interpretation of the International Convention rules as applied to commercial practice; conduct of wireless operators at sea and the method of accounting for traffic with affiliated companies.

**CONTENTS**—General Instructions—Traffic—Apparatus—Clerical Duties—International Radiotelegraphic Convention—International Telegraph Convention—U. S. Radio Law—Rates Through All Stations of the United States and

Canada—Abstracting of Messages and Accounting of Ship and Shore Tolls—Map of Principal Trans-Oceanic Wireless Stations and Coast Stations of the World.

Cloth 12mo. PRICE \$1.00 net. Mailing weight 1 lb.

With one year's subscription to THE WIRELESS AGE, \$2.00.

Add book postage as per schedule on second page.



**FLEMING, J. A., M. A., D. Sc., F. R. S.,** *Professor of Electrical Engineering in the University of London, Member of the Royal Institution of Great Britain.*

Elementary Manual of  
**RADIOTELEGRAPHY AND RADIOTELEPHONY**

For Students and Operators.

This book contains complete information to enable students and operators and amateurs familiar with the elementary facts of electricity and magnetism to master RADIOTELEGRAPHY and RADIOTELEPHONY. It explains the scientific principles underlying the Radio art in a manner suitable for students, operators and amateurs and general readers. "WIRELESS" has gained such importance in Naval and Military signaling and in marine and land communication that adequate means of teaching the subject to electro-technical students and practical operators and amateurs are required. Dr. Fleming's book meets that demand.

**CONTENTS**—Electric Oscillations and Electric Resonance—Damped Electric Oscillations—Undamped Electric Oscillations—Electromagnetic Waves—Radiating and Receiving Circuits—Oscillation Detectors—Radiotelegraphic Stations—Radiotelegraphic Measurements—Radiotelephony.

**THIRD EDITION, REVISED AND ENLARGED.**

Cloth Svo. 360 pages. Many illustrations and diagrams. PRICE \$2.50 net. Mailing weight 2 lbs.

With one year's subscription to THE WIRELESS AGE, \$4.00.

Add book postage as per schedule on second page.

**FRANKLIN, WM. S., AND MacNUTT, BARRY**  
**ADVANCED THEORY OF ELECTRICITY AND MAGNETISM**

*A Text Book for Colleges and Technical Schools.*

To make the study of theoretical physics something besides a purely formal mathematical exercise, it is necessary to keep physical things always clearly and vividly in mind. It is comparatively easy to do this in the study of applied science, but it is extremely difficult to do it in the study of many of the unfamiliar topics which are here discussed. The character of the treatment in this book has been determined throughout by the desire to keep the student's mind concentrated upon physical things.

Cloth Svo. 300 pp. Illus. PRICE \$2.50 net. Mailing weight 2 lbs.

Add book postage as per schedule on second page.

**HAUSMANN, ERICH**

*Assistant Professor of Physics and Electrical Engineering, Polytechnic Institute of Brooklyn.*

**TELEGRAPH ENGINEERING**

*A Manual for Practicing Telegraph Engineers and Engineering Students.*

**CONTENTS**—Simplex Telegraphy—Duplex Telegraphy—Quadruplex Telegraphy—Automatic and Printing Telegraph—Telegraph Office Equipment and Telegraph Traffic—Miscellaneous Telegraphs—Municipal Telegraphs—Railway Signal Systems—Telegraph Lines and Cables—Theory of Current Propagation in Line Conductors—Submarine Telegraphy—Tables.

Presents in a logical manner the subject of modern overland and submarine telegraphy from an engineering viewpoint, its theoretical and practical aspects being correlated.

Cloth Svo. 416 pp. PRICE \$3.00 net. Mailing weight 2 lbs.

Add book postage as per schedule on second page.

**FLEMING, J. A., M. A., D. Sc., F. R. S.,**

*Professor of Electrical Engineering in the University of London, Member of the Royal Institution of Great Britain.*

**THE WIRELESS TELEGRAPHIST'S  
 POCKET BOOK OF NOTES, FORMULAE AND CALCULATIONS**

A book of practical working formulae and calculations for the student of radio telegraphy. An indispensable part of the working equipment of every wireless student.

**CONTENTS**—Mathematical Notes—Units, Dimensions and Systems of Measurement—High Frequency Resistance and Inductance Measurement—High Frequency Current and Voltage Measurement—Capacity Measurement and Pre-termination—Bridge Methods of Measurement of Resistance and Inductance—High Frequency Cymometer Measurements, Wave Lengths and Decrements—Aerials and Electric Radiation—Transmitters and Transmitting Circuits—Receiving Circuits and Detectors—Practical Information for Wireless Operators—Mathematical and Physical Tables—INDEX.

Bound in full flexible rich leather, stamped in gold with round corners and gold edges.

347 pp. PRICE \$1.50 net. Mailing weight 1 lb.

With one year's subscription to  
 THE WIRELESS AGE \$2.50

Add book postage as per schedule on second page.

**PROCEEDINGS OF THE INSTITUTE  
 OF RADIO ENGINEERS**

*Giving Every Modern Improvement and Advance—Always up-to-date.*

The most recent inventions in radio telegraphy and telephony are accurately and fully described by the engineers who discovered them.

There is no better way of following the trend of radio work than thru its pages.

Svo. 600 pp. Buckram Binding. Price \$7.00 net.

With One Year's Subscription to THE  
 WIRELESS AGE, \$8.50.





**BUCHER, ELMER E.**

## HOW TO CONDUCT A RADIO CLUB

**New Edition—Revised and Enlarged**

Completely revised and enlarged, this useful volume is once more presented to the great and growing field of radio students. It is a complete guide for the formation of a radio club or class, and an excellent manual for experimenter's shop work. It also contains a wealth of information that is indispensable to the radio student in commercial, navy, or army work.

Tutors in army and navy schools and commercial radiotelegraphic schools will find in this volume instruction of an advanced character in the design of certain parts of radiotelegraphic equipment.

The opening chapters review the amateur situation, showing what is expected of the amateur operator, and the requirements of a first-class amateur station. Another chapter is devoted to instruction in the telegraphic code, showing how to wire up a code practice table for the production of artificial radio telegraphic signals for one or more students at a time. Various modifications of buzzer practice systems are described.

The text matter rapidly leads into more advanced experiments, complete data being given, for instance, for the construction of a wavemeter, and instructions for its use under all conditions. This includes tuning, the measurement of inductance capacity of a wireless telegraph aerial, and general methods of calibration. The measurement of the logarithmic decrement is treated in a way easily understood by the beginner. The design and working drawings for several types of low power transmitters are included, covering the construction of a quenched spark gap and apparatus associated therewith.

The receiving apparatus and detectors of

wireless telegraphy are treated at length, practically every type of detector in use being described, together with the circuits best suited for the operation of each.

The two-electrode and three-electrode vacuum valves are described and every known circuit for their use is shown. This includes complete cascade amplification circuits, regenerative and beat receivers, heterodyne receivers, etc.

Long distance receiving apparatus for the reception of long waves which will permit the recording of signals over 6,000 miles are shown by diagram and by a complete set of dimensions.

The experimenter is shown how to construct a receiving tuner for any range of wave lengths; how to design a receiving tuner specifically for the reception of Arlington time signals; how to make use of the balancing-out aerial for the elimination of interference; one chapter is devoted to the construction of variometers in various forms.

The amateur is told how to construct a simple wireless telephone by use of a battery of vacuum valve oscillators. Numerous experiments are described, showing how to get the best out of a given transmitter and receiver.

This book will be found to be a first-rate reference work for students and amateurs. It presents the latest developments in the wireless art up to and including the latter half of the year 1917.

8vo. 6½ x 9½. 134 Illustrations. Price 50c net.

With One Year's Subscription to the Wireless Age \$2.00

Mailing weight one pound.

Add book postage as per schedule on second page.

Specialists in  
Wireless Literature

Wireless Press, Inc.

25 ELM ST.  
NEW YORK, N. Y.



**BANGAY, R. D.**

## ELEMENTARY PRINCIPLES OF WIRELESS TELEGRAPHY

### PART II

As this book is used largely in the training of telegraphists called upon to take charge of complete wireless telegraph installations the author covers all parts of transmitting and receiving apparatus in a way to give the student a sound working knowledge of such apparatus.

**CONTENTS**—Curve Diagrams—The Theory of the Dynamo—The Continuous Current Dynamo—Eddy Currents—The Theory of the Transformer—Phase Relation Between

Current and E. M. F. in tuned Circuits—Excitation of Spark Transmitters—Spark Dischargers—Oscillation Valves—INDEX.

Cloth 12mo. 241 pp. PRICE 75c net. Mailing weight 1 lb.  
With one year's subscription to **THE WIRELESS AGE**, \$2.00.

*Add book postage as per schedule on second page.*

**GOLDSMITH, ALFRED N., Ph. D.,** of the Institute of Radio Engineers and College of the City of New York.

## RADIO TELEPHONY

Dr. Goldsmith has been engaged for years in exhaustive research in this field, and gives complete descriptions of all existing operative systems of wireless telephony. He has secured large numbers of new photographs and wiring diagrams, previously unpublished. All this valuable material is available **FIRST** to the readers of **THE WIRELESS AGE**, in which the entire series, profusely illustrated, is now being published. All professionals and amateurs who hope to be able to carry on wireless telephony and stay at the front of the "radio procession" need this book.

### A Partial Summary of Topics

#### WORLD ASPECTS

#### PERSONAL ASPECTS

#### USES OF RADIO TELEPHONY

- Ship-to-ship and ship-to-shore
- Trans-oceanic and trans-continental
- Exceptional regions
- Train-to-train or train-to-station
- Underground, aeroplane, submarine, etc.

#### RADIO VERSUS WIRE TELEPHONY

- For land telephony
- For oversea telephony

#### BROAD PROBLEMS INVOLVED IN RADIO TELEPHONY

- Radiation of modulated energy
- Causes of speech distortion
- Distortion of "non-linear" type
- Secrecy in radio telephony
- Strays

#### SUSTAINED WAVE GENERATORS

- Arcs
- Radio-frequent sparks
- Vacuum tube oscillators
- Alternators of radio frequency

#### MODULATION CONTROL IN RADIO TELEPHONY

- Microphone transmitter
- High current microphones
- Vacuum tube types
- Magnetic amplifiers and other controls
- Combination systems
- Comparison of control systems

#### ANTENNAE AND GROUNDS

- For transmission
- For reception

#### RECEIVING SETS

- Proportional response
- Selectivity vs. aperiodicity
- Sustained wave beat interference
- Heterodyne radiophonic reception
- Stray interference
- Telephone receivers
- Range in radio telephony

#### RADIOPHONE TRAFFIC AND ITS REGULATION

- Long distance
- Ship-to-ship and ship-to-shore
- Two-way radio telephony

#### FUTURE DEVELOPMENT OF RADIO TELEPHONY

Cloth 8vo. Fully illustrated. PRICE—In advance of publication only—\$1.25. Mailing weight 2 lbs.  
With one year's subscription to **THE WIRELESS AGE**, \$2.50.

*Add book postage as per schedule on second page.*



**FLEMING, J. A., M. A., D. Sc., F. R. S.,** *Professor of Electrical Engineering in the University of London, Member of the Royal Institution of Great Britain.*

## THE PRINCIPLES OF ELECTRIC WAVE TELEGRAPHY AND TELEPHONY

The author deals with principles rather than details of apparatus. He gives a comprehensive view of the subject particularly on its scientific side, and that part of it which is concerned with quantitative measurements and the underlying theory. The immense attention which has been given to this attractive subject is a consequence of the interesting physical and important practical aspects of it, and no one at present can add to it who has not a firm grasp of the electrical principles and facts which lie at its root, as well as broad acquaintance with inventions and discoveries.

This third edition has been in great part, re-written and re-arranged. A new chapter has been added on the Transmission of Radio-telegraphic Waves over the earth. Much of the merely historical portions and of the descriptions of apparatus which had become antiquated, has been removed. Sufficient, however, has been kept to enable the student to appreciate the development of the subject.

**CONTENTS**—The Production of High Frequency Currents and Electric Oscillations—High Frequency Electrical Measurements—Damping and Resonance—Stationary Electric Waves on Wires—Electric Radiation—Detection and

Measurement of Electric Waves—The Apparatus of Electric Wave Telegraphy—Radiotelegraphic Stations—Radiotelegraphic Transmission—Radio-telephony.

Cloth 8vo. 912 pages. Many illustrations. PRICE \$10.00 net. Mailing weight 5 lbs.  
Add book postage as per schedule on second page

**KENNELLY, A. E. A. M., Sc. D.,**  
*Professor of Electrical Engineering in Harvard University.*

## WIRELESS TELEGRAPHY AND TELEPHONY

Gives in simple language an explanation of electro-magnetic waves and their propagation through space; also the fundamental and essential principles of both wireless telegraphy and wireless telephony. A complete, authoritative and popular presentation of these latest of modern scientific wonders, down to their latest developments.

**CONTENTS**—Introductory—Waves and Wave-Motion—Magnetism and Electricity—Electromagnetic Waves Guided Over Conductors—Electromagnetic Waves Guided by Single Wires—Radiated Electromagnetic Waves Guided by the Ground—Unguided or Spherically Radiated Electromagnetic Waves—Plane Electromagnetic Waves—The Simple Antenna or Vertical Rod Oscillator—Electromagnetic Wave-Detectors or Wireless Telegraph Receivers—Wireless Telegraph Working—Tuned or Selective Signaling—Measurements of Electromagnetic Waves—Industrial Wireless Telegraphy—Considerations Preliminary to Wireless Telephony—The Principles of Wire Telephony—Principles of Wireless Telephony.

**ZENNECK, Dr. J.,**  
*Professor of Physics at the Technical High School of Munich.*

## WIRELESS TELEGRAPHY

Translated from the German  
By A. E. SEELIG, E. E.

Dr. Zenneck's "Lehrbuch der drahtlosen Telegraphie" has been the standard of the military and naval service, as well as the technical schools, of Germany since first publication.

In the present authorized translation, the latest German edition has been used.

The work is the most scientific and thorough that has appeared on this subject. It covers all phases from physical principles to finished commercial apparatus. The method of treatment is technical and the scope of the book comprehensive.

An especially full and valuable bibliography is included.

**CONTENTS**—The Natural Oscillations of Condenser Circuits—Open Oscillators—The High Frequency Alternating-Current Circuit—Coupled Circuits—Resonance Curves—The Antenna—Transmitters of Damped Oscillations—High Frequency Mechanisms for Undamped Oscillations—Undamped Oscillations by the Arc Method—Propagation of the Waves Over the Earth's Surface—Detectors—Receivers—Directive Telegraphy—Wireless Telephony—Development of Wireless Telegraphy—Tables—22 Pages of Useful Tables—Bibliography and Notes on Theory—INDEX.

Revised and Enlarged Edition.  
Cloth. 279 pp. Illus. PRICE \$1.25. Mailing weight 2 lbs.

With one year's subscription to  
**THE WIRELESS AGE, \$2.50.**

Add book postage as per schedule on second page.

Cloth. 448 pp. Size 6 x 9. 461 Illus.  
PRICE \$4.00. Mailing weight 3 lbs.

With one year's subscription to  
**THE WIRELESS AGE, \$5.50.**

Add book postage as per schedule on second page.

# Queries Answered

Answers will be given in this department to questions of subscribers, covering the full range of wireless subjects, but only those which relate to the technical phases of the art and which are of general interest to readers will be published here. The subscriber's name and address must be given in all letters and only one side of the paper written on; where diagrams are necessary they must be on a separate sheet and drawn with India ink. Not more than five questions of one reader can be answered in the same issue. To receive attention these rules must be rigidly observed.

## Positively no Questions Answered by Mail.

L. B., Milwaukee, Wis.:

The international "stand-by" signal is Q. R. X. Q. R. T. is the signal to "stop sending," while Q. R. S. means, "send slower." Follow the official list and you will always be right.

\* \* \*

Q. V., Buffalo, N. Y.:

We regret that we do not possess detailed information concerning the construction of the Mignon undamped wave disc core radio controller. You probably can obtain this information by addressing an inquiry to the manufacturers.

\* \* \*

J. A., San Juan, P. R.:

The standard Marconi receiving apparatus shown on the cover page of THE WIRELESS AGE is fully described in the book, "Practical Wireless Telegraphy" which can be purchased from the Wireless Press, Inc., 25 Elm Street, New York City.

We do not know the composition of phonographic records because in the majority of cases these records are made by a secret process. We do not, in fact, know the insulating qualities of this material or whether or not it would be preferable to hard rubber, for instance.

Answer to third query: Complete diagrams of crystal detectors and associated apparatus appear in the textbook, "Practical Wireless Telegraphy."

Answer to fourth query: You may use brass or any other metal for the plates of a variable condenser. Sheets 1/32 of an inch will be more satisfactory, as they are not so apt to warp.

The notation, "6 amperes," on a fuse plug means that the fuse will burn when current in excess of six amperes passes the circuit. The circuit will then be automatically opened and the line protected.

\* \* \*

H. T., Pt. Richmond, Cal.:

You are quite right in your recent correction. Silver, obviously, is not an insulator but a distinct conductor. The word "silver" in the list mentioned should in reality have been "sulphur."

Platinum and silver electrodes, not cop-

per and silver, are the correct electrodes for the silver vollameter.

We regard the Omnigraph as a practical automatic sender and it will be found of great assistance to the beginner.

\* \* \*

V. I. M., Denver, Colo.:

The actual number of sheets required for a fixed condenser of the capacity you mention will vary according to the dielectric of the insulating material employed. Assuming it to be paraffine paper, you should make up a condenser of twenty-four sheets of foil, 2½ inches by 2½ inches. Twelve sheets are connected in parallel on either side.

The capacity of the condenser, of course, will depend upon the pressure applied and it is preferable that it be clamped between two pieces of wood.

The following dimensions are applicable to a 6,000-meter inductively-coupled receiving tuner. The primary winding should be 12 inches in length, 7 inches in diameter, wound closely with No. 24 S. S. C. wire. The secondary coil should be 12 inches in length, 6 inches in diameter, wound closely with No. 32 S. S. C. wire.

\* \* \*

W. T. G., Danville, Va.:

The question of wireless range has engaged the attention of radio telegraph engineers for a number of years, and even with the large amount of data on the subject collected by various organizations and individuals, it can be stated that the reasons for the fluctuation of wireless telegraph signals at night are not thoroughly understood. The theories advanced have been discussed from time to time, but no definite conclusions have been arrived at. Your observations are in accordance with results obtained in other stations and it is a fact, as you state, that it will sometimes be difficult for a receiving station nearby to receive the signals from a given transmitter while at the same time another receiving station, 700 or 800 miles away, will be able to hear these signals with considerable strength. This phenomenon is more often observed on the shorter wave-lengths, such as 200

The Marconi Trans-Atlantic  
Wireless Telegraph Stations  
of America, Canada, England  
and Italy are equipped with

## American Transformers

made by specialists in the  
design and construction of  
transformers for extremely  
high potentials for testing,  
ozone generation, wireless  
work, etc.

**American Transformer Co.**  
NEWARK, N. J.



**PREMIER  
METAL  
ETCHING  
CO.**

NAME PLATES, BRASS SIGNS,  
CLOCK AND METER DIALS,  
ADVERTISING NOVELTIES.

LONG ISLAND CITY, N.Y.

Tel. Madison Sq. 726

## Charles F. Campbell

**ELECTRICAL  
SUPPLIES**

WHOLESALE AND RETAIL

14 West 31st St. New York  
Bet. Broadway and Fifth Ave.

## WANTED

**THE WIRELESS AGE**

For January and February, 1917

We will give three months' additional  
subscription for each copy sent us  
which is in perfect condition.

Address

**THE WIRELESS AGE**

25 Elm Street

New York

## MILITARY SIGNAL CORPS MANUAL

By MAJOR J. ANDREW WHITE

*Chief Signal Officer of the Junior American Guard*

IN PRESS

This manual, the first of its kind, has been prepared for those who will respond to the call to the colors. It contains all the essential information on the broad subject of army signaling, including instruction, field work and tactical employment of visual and electrical signaling methods. Compiled to enable amateur wireless men to qualify for Signal Corps service, in which they may serve most efficiently. It supplies the basis of organization and training for those who will later be eligible for service with expeditionary forces or home defence bodies.

Prepared with the full co-operation and approval of the Chief Signal Officer, U. S. Army.

PRICE NOT FIXED

Telephone Bryant 5477

**Electrical Industries Mfg. Co.**

328 West 41st St.

New York

meters, than on the longer waves. It is quite probable, in a case of this kind, that the wave motion is reflected from the earth to the upper conducting shell above the earth's atmosphere, and if a receiving station happens to be favorably located in the torturous path of such a wave the aerial will receive induction therefrom, while another station 100 miles away, for instance, may receive no induction whatsoever.

You are advised to study the articles on the subject of radio range appearing in the September, October, and November, 1916, issues of *THE WIRELESS AGE*. The matter has also been discussed at some length in back issues of the "Proceedings of the Institute of Radio Engineers" and has received some attention in the "Year Book of Wireless Telegraphy and Telephony." The subject would require too much space for detailed discussion in these columns.

\* \* \*

J. A., San Juan, P. R.:

A slight rearrangement of the design of your spark coil will result in greater efficiency. We advise, for instance, that the primary core for the 2½-inch spark coil be wound with 210 turns of No. 16 magnet wire which is again covered with several layers of Empire cloth. The secondary winding should be wound with about two pounds of No. 36 enamel wire split into two sections. The primary condenser will require fully 2,500 square inches of foil, and since your sheets are 10 by 5 inches you will require from fifty to seventy-five sheets which will be separated by paraffine paper.

The sample of wire you enclosed was No. 36 enamel wire, but much finer wire can be obtained for winding telephone receivers if you desire it.

We do not know whether the number indicated on your receiver case is a stock number or designates the resistance of the particular receiver. It is quite likely, however, that each ear piece has resistance of 1,250 ohms and the two in series, 2,500 ohms.

\* \* \*

W. R. M., Bangor, Me., inquires:

Ques.—(1) Referring to the design of the receiving tuner given by John D. Coleman on page 849 of the August, 1917, issue of *THE WIRELESS AGE*, I do not fully understand the primary winding and its connections. How many turns are there on the complete coil?

Ans.—(1) There is an author's error in that article. The primary winding should have, when completed, ninety turns. The first ten single turns in groups of ten are brought to the points of an eight-point switch. By this method of connection the inductance of the primary winding of a receiving transformer can be varied from one turn to the maximum number which gives ease of control, does away with sliding contacts and permits flexibility of adjustment which is not otherwise possible.

Ques.—(2) Will the variable condenser

shown in Coleman's diagram reduce the strength of signals? The reason I am asking this is that in the September, 1917, issue of *THE WIRELESS AGE*, page 937, John M. Clayton stated that a condenser cut across the secondary windings of a receiving tuner, when used with the vacuum valve on short wave-lengths, would reduce the signals by fifty per cent.

Ans.—(2) The variable condenser shown in the diagram is not, strictly speaking, a secondary condenser, for you will note that while one terminal is connected to one terminal of the secondary winding, the other terminal is connected to the top condenser, B, and therefore the two condensers are in series. We believe that the variable condenser shown in this diagram gives an additional electrostatic coupling between the secondary and wing circuit of the vacuum valve.

Answer to the last three queries: We cannot give you specific dimensions for the transformer shown in the book, "How to Pass U. S. Wireless License Examinations," unless we know exactly what condenser capacity is to be used and to what source of current it is to be connected. We can, however, offer advice on the matter of the primary winding. It should not be tapped at intervals, but the flow of current can be controlled by an external reactance coil which can be wound with the same size wire as the transformer.

\* \* \*

H. H. S., Chicago, Ill.:

Data for a ½-K. W. cycle transformer appear on page 244 in this issue of *THE WIRELESS AGE*.

Answer to second query: A condenser capacity of .006 microfarad will do for the average 1 K. W. 500 cycle transmitting set provided the secondary voltage of the transformer is between 12,000 and 15,000 volts.

The dielectric constant of glass varies from six to nine, according to the texture.

A good average value of capacity for an amateur aerial would be approximately .00035 microfarad.

The form factor of an aerial can best be calculated by Mr. Blatterman's formula, published in the October, 1916, issue of *THE WIRELESS AGE* which is also published in the textbook, "Practical Wireless Telegraphy."

\* \* \*

E. S. R., Toronto, Canada:

We do not know whether you will be able to obtain the exact working dimensions for the construction of a Brown amplifying relay.

The coils, L-1 and L-2, in Figure 181, page 160 of "Practical Wireless Telegraphy," can have about the same dimensions as the ordinary loose coupler constructed for the wave-length of 300 meters.

\* \* \*

C. F. L., Milton, Mass.:

The problem of high speed mechanical circuit interrupters for use with induction coils has not yet been solved. Engineers



**TELEGRAPH PRACTICE SET**  
FOR LEARNING THE TELEGRAPH CODES

The Practice Set comprises a regular telegraph key, without circuit breaker, a special high pitch buzzer, one cell Red Seal Dry Battery, and four feet of green silk covered flexible cord. The main object of the set is to enable the beginner to master the various codes. The buzzer reproduces the sound of the air signals of the most modern telegraph stations perfectly.

- |  |        |
|--|--------|
| List No.   | Price  |
| 342. Practice Set, with Battery and Cord . . .   | \$2.70 |
| 344. Practice Set only, no Battery or Cord . . . | 2.55   |

Send for Copy of Our New Catalog N 28, 248 Pages, Ready About Sept. 1st.

**MANHATTAN ELECTRICAL SUPPLY CO., Inc.**

17 Park Place, NEW YORK 114 S. 5th Ave., CHICAGO 1106 Pine St., ST. LOUIS 604 Mission St., SAN FRANCISCO

**STANLEY & PATTERSON**  
ELECTRICAL SUPPLIES ·

DOWNTOWN-DISTRICT STORE  
23 MURRAY ST.—27 WARREN ST.  
(From Block to Block)

CENTRAL-DISTRICT STORE  
141 WEST 36th STREET  
(Just West of Broadway)

NEW YORK

Established 1905

**THE LUZERNE RUBBER CO.**

Manufacturers of Fine Quality

**HARD RUBBER GOODS**

STANDARD AND SPECIAL

Main Office and Factory:

TRENTON ····· NEW JERSEY

**A. J. Cox & Company**

WESTERN REPRESENTATIVES

28 South Jefferson Street CHICAGO, ILL.

**Aerial Spreaders**  
**Flag Poles**  
**Ladders**  
**Spars**

When in need of **Aerial Spreaders**, get in touch with us. We manufacture all kinds of **spars** and **flag poles**, from the largest to the smallest. **Ladders** of all descriptions.

We have supplied the Marconi Wireless Telegraph Co., of America with **Aerial Spreaders**, and various other kinds, since 1912.

**Jersey City Ladder Co., Inc.**

677 Montgomery Street  
Jersey City, N. J.

Telephone, Bergen 1988

**Service and Quality**

Drawing Materials  
Surveying Instruments  
Sensitized Papers

Quality products delivered when you want them.

Try our Gold Seal blue print paper—100% pure—100% satisfaction.

Working samples on request.

**New York Blue Print Paper Co.**

102 Reade St., New York City

Write for Catalog W

and inventors have experimented for a number of years, but so far they have not developed a mechanical or electromagnetic interrupter that will handle more than a kilowatt satisfactorily. The electrolytic interrupter operated from a direct current source gives a very high pitched note and a spark of considerable volume at the secondary winding of the induction coil, but this interrupter will not operate continuously without frequent attention. To be more exact, interrupters of all types operate most efficiently at powers less than  $\frac{1}{2}$  K. W.

You should have no difficulty in understanding the meaning of the term K. W., for the prefix, "kilo," simply means 1,000, and consequently, a kilowatt is 1,000 watts. It can also be shown that 746 watts equal one mechanical horse power, therefore, 1 K. W. equals approximately 1-1/3 horse power. See the book, "Practical Wireless Telegraphy" for a more detailed explanation.

\* \* \*

C. M., Watertown, Conn., inquires:

Ques.—Is it possible to construct a synchronous gap which is driven by a small alternating current motor, revolving at the same speed as the generator, and by putting the same number of studs on the disc as there are field poles on the generator?

Ans.—It is possible to obtain synchronous adjustments with a spark gap driven in this way, but difficulty is encountered when a load is thrown on the driving generator, due to the drop in voltage. It is quite possible that, when the telegraph key is closed, the generator armature and driving power will not reduce their speed in the same ratio as the motor of the synchronous gap. Hence, the gap motor and the generator would not operate in phase and the discharge would be non-synchronous. Independently driven synchronous rotary spark gaps have been employed commercially, and, we believe, were originally supplied to the trade by the International Telegraph Construction Company. Their use, however, has been discontinued. It would be well for you to take note of the fact that a 60-cycle synchronous spark gap set does not give as pleasing a spark note as the non-synchronous rotary gap, although it will be clear and uniform.

\* \* \*

M. T., San Antonio, Tex. :

Super-sensitive receiving sets of various types are described in the last edition of the book, "How to Conduct a Radio Club," which can be purchased from the Wireless Press, Inc., 25 Elm Street, New York City. The circuits of such apparatus are also considered in the textbook, "Practical Wireless Telegraphy."

\* \* \*

A. D. Z., St. Paul, Minn., inquires:

Ques.—(1) What type of receiver is employed by the United States Navy for the reception of undamped oscillations?

Ans.—(1) We understand that the three-electrode vacuum valve inserted in a special navy regenerative circuit is employed.

Ques.—(2) Is there any advantage in using a number of three-electrode vacuum valves in cascade?

Ans.—(2) A decided advantage is obtained by connecting the valves in this way, particularly if they are employed to amplify radio-frequency currents. The utility of such a method of connection was shown in a United States patent granted to G. Nicholls where a static eliminator was employed to balance out atmospheric electricity, and, due to the fact that the incoming radio signals were weakened by this process, steps were taken to bring them back to their original strength and increase their amplitude by means of several valves connected in cascade. There is another advantage in the cascade connection in that it increases the selectivity of the receiving set, much sharper tuning being obtained by this method than by the single circuit.

Ques.—(3) Where can I obtain information regarding the Marconi tubular steel masts?

Ans.—(3) The construction of these masts is described in the textbook, "Practical Wireless Telegraphy, on sale by the Wireless Press, Inc., 25 Elm Street, New York City.

\* \* \*

J. C. W., New Orleans, La., inquires:

Ques.—(1) Is it not a fact that by careful design of an induction coil the amateur could obtain better results than by accepting whatever design the manufacturer happens to present to him?

Ans.—(1) There is no doubt that if spark coils are to be used for direct excitation of a wireless telegraph aerial careful consideration of the design of the secondary is highly important. For instance, the voltage should not be too high nor too low, and the current output should be such that there will be no arcing at the spark gap, but a clear, clean-cut spark discharge. With small aeriels, a coil of high voltage is required, but with large aeriels a lesser voltage may be employed. The aerial of large capacity will, of course, require a coil with a greater secondary current output. If the induction coil is employed to excite the condenser of the closed oscillation circuit then there would be an advantage in designing the secondary to permit the use of a rather large capacity. Care must be taken, however, that the capacity of this condenser is not too great for the wave-length to be employed, i. e., in the case of the 200-meter wave it should not exceed .008 microfarad.

Ques.—(2) Will you please mention the name of a book devoted particularly to the construction of induction coils?

Ans.—(2) The book entitled "The Design and Construction of Induction Coils," by A. F. Collins, can be obtained through the book department of THE WIRELESS AGE.



**"THERE'S MONEY IN IT"**

**AT HOME LEARN TELEGRAPHY AT HOME**

**MORSE AND WIRELESS**

**TEACH YOURSELF**



in half usual time, at trifling cost, with the wonderful Automatic Transmitter, **THE OMNIGRAPH**. Sends unlimited Morse or Continental messages, at any speed, just as an expert operator would. Adopted by U. S. Government. 4 styles. Catalogue free. **OMNIGRAPH MFG. CO., 29-C. Cortlandt St., New York**

**WIRELESS**

**BOOKS, RAW MATERIALS**

While your station is dismantled you can study and build apparatus. Buy from our stocks which we still maintain complete. The Electro-set Co. now known as **THE NEWMAN-STERN CO., Dept. WA-18, Cleveland, O.**

**PATENTS**

**WRITE FOR HOW TO OBTAIN A PATENT** list of Patent Buyers, and inventions Wanted. \$1,000,000 in prizes offered for inventions. Send sketch for free opinion as to patentability. Our Four Books sent **FREE** free. Patents advertised Free. We assist inventors to sell their inventions. **VICTOR J. EVANS & CO., 703 Ninth, Washington, D. C.**

**DO YOU READ THE WIRELESS WORLD?**

In it you will find articles relating to the **PRACTICE** of Radiotelegraphy as well as to the **THEORY**. The **QUESTIONS** and **ANSWERS SECTION** is open to **YOU** for the **SOLUTION** OF YOUR **DIFFICULTIES**.

**INSTRUCTIONAL ARTICLES** for Home Study **WRITTEN BY EXPERTS**.

**REVIEWS OF BOOKS** useful to Wireless Students. The interests of Operators are well catered for.

**WRITE** for a Specimen Copy, post free to **THE WIRELESS PRESS, Ltd.** Marconi House, Strand, London, England

**"WIRELESS WORLD," \$2.25 per annum for America. Single Copies, 25c Post Paid**

**Radio Operators Needed**

Government Service      Merchant Marine

Wonderful opportunities offered daily

Complete course of instruction under expert teachers in shortest possible time.

**Special Women's class now forming**

Complete Equipment—Low Rates—Individual Instruction  
Rapid Progress—Dormitories—Employment Bureau

**START TODAY**

Write for Illustrated Booklet

**Y. M. C. A. Radio School**

161 E. 86th Street      New York, N. Y.

**BEST RADIO SCHOOL IN NEW YORK**

**FREE!**



A flying model aeroplane and all materials to build your own scale model, **Free** with our great Home Course in the Principles of Aviation. **Write at once—before this offer is withdrawn.** Learn the Science of Aviation at Home—under guidance of **Experts**. Tremendous demand for men who know aviation. Wonderful future. **Prepare now. Write us today.** **NATIONAL AERO INSTITUTE, Dept. 7499, Merton Bldg., CHICAGO**

**GRACELAND**

**"A College for Everyone"**

is splendidly equip to prepare radio operators for government service. Send today for your copy of our illustrated booklet in color, **"Why Graceland."** Altho free, it is worth many dollars to you.

**Radiotelegraph Department**  
**GRACELAND COLLEGE      LAMONI, IOWA**

**LEARN TELEGRAPH**

Morse and Wireless—R. R. Accounting (Station Agency) also taught. Tremendous Demand—much greater than supply—Permanent Positions Secured. Big Salaries—recently raised. Ideal Working Conditions—short hours, vacations with pay sick and death benefits, etc.—prevailing. Great Opportunities for Advancement. Women Operators also greatly desired by Railways and Western Union. Tuition reasonable. Cheap living expenses—can be earned. Oldest and largest school—two large school buildings, investment exceeds \$25,000.00—established 45 years. Endorsed by railway, Western Union and Marconi Telegraph officials. Large illustrated catalogue free. Correspondence courses also. Write today. Enroll immediately.

**Dodge & Telegraph, Ry. & Wireless Institute**  
**Green Street, Valparaiso, Ind.**

LICENSE PREPARATION  
FOR MASTERS, MATES  
AND PILOTS

WARRANT OFFICERS,  
PETTY OFFICERS AND  
SEAMEN IN THE U. S.  
NAVY PREPARED FOR  
THEIR EXAMINATIONS

# Uttmark's Nautical Academy

FORMERLY PATTERSON'S NAVIGATION SCHOOL  
ESTABLISHED 1882

8 STATE STREET, NEW YORK  
FACING BATTERY PARK

CAPTAIN FRITZ E. UTTMARK  
PRINCIPAL.  
PROFESSOR IN NAVIGATION AND  
NAUTICAL ASTRONOMY

PRACTICAL NAVIGATION  
FOR YACHT-  
OWNERS AND OFFICERS  
OF THE PATROL  
SQUADRON AND  
NAVAL MILITIA. COM-  
PASSES ADJUSTED



Facing South and overlooking the Bay, in a quiet place, the building offers for students the very best facilities for studying. Observations of the heavenly bodies will be taken from the bridge on the roof, which is being equipped with compasses, pelorus, and other instruments, and practical use of same will be demonstrated, also practical sextant work will be done and position found by observations taken from the bridge.

This academy has the reputation of being the oldest and best equipped navigation school in the United States and is up-to-date in every respect. All our instructors are experienced teachers and able to up-hold the excellent reputation which the school has attained by many years of efficient work.

The new school building is most conveniently situated at No. 8 State Street, opposite the Barge Office at Battery Park. It is within two minutes' walk of Bowling Green and South Ferry subway stations, all the elevated trains, South Ferry, Staten Island Ferry and Atlantic Avenue Ferry. The Custom House, where the Board of Local Inspectors holds the examinations for masters, mates and pilots is just around the corner. In other words this school forms the hub or center of everything connected with shipping and shipping interest.

You and your friends are cordially invited to visit the school and inspect the new equipment. You will receive a hearty welcome. Please tell your friends about it.



"Never Mind  
How Strong  
You Are—"

## What D'ye KNOW?"

Today it's a battle of wits—and brains win. Muscle and brawn don't count so much as they used to. The great question now is "What do you know?" It draws the line between failure and success.

What do you know? Have you special ability? Could you "make good" in a big job right now?

For 25 years the International Correspondence Schools have been training men for better work and bigger salaries. They can train YOU, no matter where you live, what hours you work, or how little your education. Mark and mail the coupon and find out—it won't obligate you in the least.

\*TEAR OUT HERE

INTERNATIONAL CORRESPONDENCE SCHOOLS, Box 6018, Scranton, Pa.

Explain fully about your Course in the subject marked X:

- |   |   |                                       |
|---|---|---------------------------------------|
| <input type="checkbox"/> Electrical Engineering | <input type="checkbox"/> ADVERTISING      | <input type="checkbox"/> CHEMISTRY    |
| <input type="checkbox"/> Mechanical Engineering | <input type="checkbox"/> Salesmanship     | <input type="checkbox"/> Illustrating |
| <input type="checkbox"/> Mechanical Drafting    | <input type="checkbox"/> Commercial Law   | <input type="checkbox"/> Farming      |
| <input type="checkbox"/> Civil Engineering      | <input type="checkbox"/> Bookkeeping      | <input type="checkbox"/> Poultry      |
| <input type="checkbox"/> Stationary Engineering | <input type="checkbox"/> Stenography      | <input type="checkbox"/> French       |
| <input type="checkbox"/> Mining Engineering     | <input type="checkbox"/> Civil Service    | <input type="checkbox"/> German       |
| <input type="checkbox"/> Architecture           | <input type="checkbox"/> Ry. Mail Service | <input type="checkbox"/> Italian      |
| <input type="checkbox"/> Architectural Drafting | <input type="checkbox"/> AUTOMOBILES      | <input type="checkbox"/> SPANISH      |

Name \_\_\_\_\_

Address \_\_\_\_\_



# WIRELESS

The Gov't and Merchant Marine need thousands of trained operators now, the demand far exceeding the supply. Men are needed urgently for the Naval Reserve, Aviation & Signal Corps, Marconi Co., etc.

Pick your rating before you are drafted

Special short code courses, Day or Evening, for Gov't Service. Students from all over the country. Classes now forming. Send in your enrollment today.

The Eastern Radio Institute is endorsed  
by the U. S. Government &  
Marconi Co.

## Eastern Radio Institute

899C Boylston St., Boston, Mass.

