

# Electronic Engineering

FEBRUARY 1954



*For -*

- Specialised remote control.
- Centimetre radio links.
- Ground radar.
- Outside broadcast.
- Television.

*and similar applications.*

**BICC**



**POLYPOLE**

*moulded - on*

**CABLE COUPLERS**

If you are interested in the uses of BICC Polypole Cable Couplers, we will be pleased to send you further information.

BRITISH INSULATED CALLENDER'S CABLES LIMITED



21, BLOOMSBURY ST., LONDON, W.C.1.

MUSEum 1600.

TWO SHILLINGS

# POLYTAGS...lead-through and stand-off insulators

Polytetrafluoroethylene (P.T.F.E.) is an outstanding insulator. It is tough, durable and will not crack or arc. Its dielectric properties are substantially constant over a frequency range of 60 c.p.s. to at least 300 Mc.p.s. and are unaffected by temperature changes between minus 100°C. and plus 288°C. It has zero moisture absorption and is water repellent. It is, therefore, a most suitable material for stand-off and feed-through insulator terminals and has been chosen by Ediswan for this purpose. Ediswan Polytags are available in five types as illustrated below.

## PT 1 & 2. Lead-through



	A	B	C
PT 1	.750	.375	.188
PT 2	.875	.500	.188
PT 3	.563	.375	—
PT 4	.688	.500	—

## PT 3 & 4. Stand-off

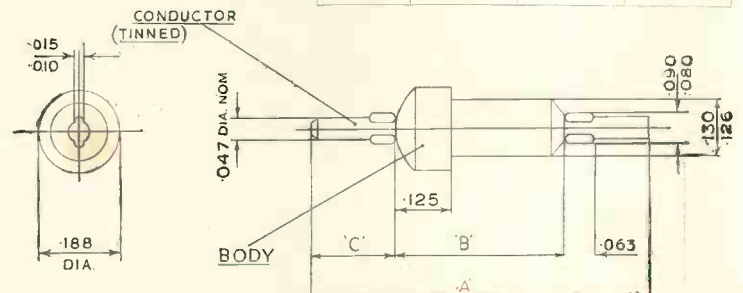

## PT 5. Component mounting

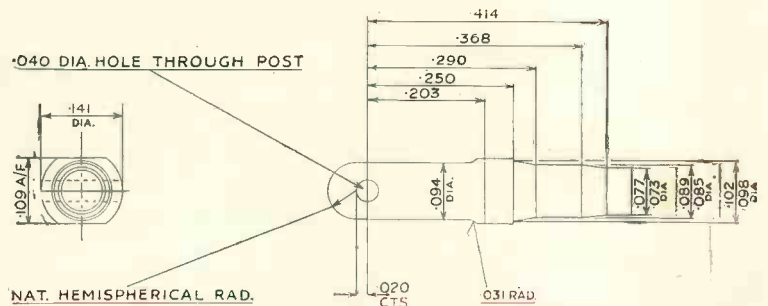

Fixing: Polystags are primarily designed for fixing with a 5 B.A. nut—PT 1—4 or an 8 B.A. nut PT 5. They are self-tapping.

We are equipped to produce components fabricated or moulded in P.T.F.E. to individual specifications and enquiries will be welcomed.

# EDISWAN



THE EDISON SWAN ELECTRIC CO., LTD.,

Sales Department P.T.F.E.4, 21 Bruton Street, London, W.1. Telephone: Mayfair 5543  
 Head Office: 155 Charing Cross Road, London, W.C.2. Member of the A.E.I. Group of Companies

ER24

## CLASSIFIED ANNOUNCEMENTS

The charge for these advertisements at the LINE RATE (if under 1" or 12 lines) is: Three lines or under 7/6, each additional line 2/6 (The line averages seven words.) Box number 2/- extra, except in the case of advertisements in "Situations Wanted," when it is added free of charge. At the INCH RATE (if over 1" or 12 lines) the charge is 30/- per inch, single column. Prospectuses and Company's Financial Reports £14.0s.0d. per column. A remittance must accompany the advertisement. Replies to box numbers should be addressed to: "Electronic Engineering," 28, Essex Street, Strand, London, W.C.2. Advertisements must be received before the 14th of the month for insertion in the following issue.

### OFFICIAL APPOINTMENTS

**ADMIRALTY—ROYAL NAVAL SCIENTIFIC SERVICE.** Engineers and Physicists (particularly with electronics) required for appointments in Experimental Officer and Assistant Experimental Officer grades in Experimental Establishments in London, Portsmouth, Weymouth, and Gloucestershire areas and Scotland. Candidates, British subjects, must possess one of the following qualifications: University Degree in Science, Engineering or Maths., Graduate Membership of appropriate professional institute, Higher National Certificate, Final Certificate of five-year grouped course in relevant subjects at City and Guilds of London Institute or comparable institution, Higher School Certificate, General Certificate of Education, Scottish Leaving Certificate, Scottish Universities Preliminary Examination, Northern Ireland Senior Certificate (all in appropriate subjects and at appropriate levels). London salary inclusive of pay addition (men) E.O.s £681-£838, A.E.O.s (according to age) £274-£607. All appointments unestablished, but with some opportunities to compete for established posts. Application forms from M.L.N.S., Technical and Scientific Register (K), 26, King Street, London, S.W.1, quoting A247/52/A.

**AIR MINISTRY** requires Experimental Class Officers at establishment near Marlow, Bucks. Duties concern installation design of static and mobile radar and radio systems used by R.A.F. Work of engineering rather than laboratory type, covering wide range of application of electronic engineering to meet operational needs of R.A.F. with which very close contact is maintained. Membership of Officers' Mess open to accepted candidates offering all forms of recreation in congenial surroundings. Qualifications: at least Higher School Cert. (Science) or equivalent although higher qualifications in Physics or Electrical Engineering may be an advantage. Salaries within ranges: Experimental Officer (min. age 26) £649-£799, or Assistant Experimental Officer £264 (at age 18) to £576. Appointments unestablished. Application forms from M.L.N.S., Technical and Scientific Register (K), 26, King Street, London, S.W.1, quoting D8/54.

**BRISTOL EDUCATION COMMITTEE.** College of Technology. Principal: F. W. Partington, M.Sc., A.M.I.Mech.E. Required, Lecturer in the Engineering Department, to teach mainly Electrical Measurements, Electronics and allied subjects in Higher National Certificate Courses. Burnham Salary Scale, £940 by annual increments of £25 to £1,040 per annum. Application forms, returnable within two weeks, from the Registrar, College of Technology, Unity Street, Bristol 1. (S.A.E.) Chief Education Officer, G. H. Sylvester. W 2987

**CITY OF WAKEFIELD EDUCATION COMMITTEE.** Wakefield Technical College. Principal: G. N. Blair, M.C., B.Com., A.C.I.S., F.I.I.A. A Senior Laboratory Steward is required for the Department of Engineering and Mining. Duties will be primarily concerned with the Electrical, Mechanics and Physics Laboratories. Salary scale £340 × £15 × £5 to £390 per annum. Applications are invited from men who have served an apprenticeship, preferably in some branch of engineering. Previous experience as a laboratory steward, although not essential, is desirable. Experience of storekeeping or of simple maintenance work would be an advantage. Further information regarding nature of work, hours of duty, superannuation, holidays, etc., may be obtained from the undersigned on receipt of a stamped addressed envelope. Applications should be returned within 15 days of the issue of this advertisement. C. L. Berry, Director of Education. W 3000

**COUNCIL OF SCIENTIFIC AND INDUSTRIAL RESEARCH.** India. Applications are invited for the post of Assistant Director, Electronics, National Physical Laboratory, New Delhi. Candidates should be of good academic standing and preferably over 30 years of age. They should possess outstanding research experi-

ence and thorough knowledge of all branches of electronics including physical electronics, thermionics, microwaves, propagation of radio waves, etc. Pay within scale Rs.600-1500 p.m. (approximately £540-£1350 p.a.). Contract for five years, including one year probation. Free sea passage to and from India. Contributory Provident Fund. Further particulars and forms of applications may be obtained on request, quoting 4/76C, from the High Commission of India, General Department, India House, Aldwych, London, W.C.2. Last date for receipt of applications is 1st March 1954.

W 3019

**DRAUGHTSMEN** are required with experience in the layout of telecommunication and electronic equipment, involving detailed mechanical design, preparation of all mechanical drawings, sub-assemblies and final assembly, circuits, specifications, and stock-lists; suitable for prototype and batch production manufacture. Practical workshop experience, and knowledge of modern methods, an asset but not essential. Salary: for a week of 44 hours, £374 0s. 0d. per annum at age 21, rising by annual increments of £20 to £597 0s. 0d. per annum. An extra duty allowance of 3 per cent will also be paid for working 45½ hours each week. Apply in writing: Personnel Officer, G.C.H.O., 53, Clarence Street, Cheltenham, Glos. W 2982

**HAMMERSMITH HOSPITAL** and Post-graduate Medical School, Du Cane Road, London, W.12. Senior Technician required for maintenance and development of electronic equipment: knowledge of E.H.T. and pulse circuits for Geiger and Scintillation Counting essential. Salary scale £540-£625 p.a. plus London Weighting. Age, qualifications, experience, names two referees to Secretary, Board of Governors, by 13th February. W 2988

**MINISTRY OF SUPPLY,** London Headquarters, requires Engineer for technical administrative duties, and to advise contractors in design and introduction to service of new sighting devices of electronic and instrumental nature. Minimum qualification: Higher School Cert. (science) or equivalent, but Degree, H.N.C. or Membership of an appropriate Institution may be an advantage. Experience of specifications, drawings and circuit diagrams required. Practical experience of servicing small mechanisms and electronic systems, and some knowledge of auto-controls desirable. Salary within range. Experimental Officer (min. age 26), £681-£838. Women somewhat less. Appointment unestablished. Application forms from M.L.N.S., Technical and Scientific Register (K), 26, King Street, London, S.W.1, quoting D491/53A. Closing date, 12 February, 1954. W 2969

**TECHNICAL INSTRUCTOR** (Broadcasting) required by the Nigerian Government on contract for two tours of 12-15 months. Possibilities of permanency. Salary, etc., according to experience in scale £1170, rising to £1269 a year. Outfit allowance £60. Free passages for officer and wife and assistance towards cost of children's passages or grant up to £150 annually for their maintenance in this country. Liberal leave on full salary. Candidates must have been employed at the BBC Technical Training School at Evesham and have reached Grade C minus or above. Write to the Crown Agents, 4, Millbank, London, S.W.1. State age, name in block letters, full qualifications and experience and quote M2C/30305/EK. W 2965

**THE UNIVERSITY OF MANCHESTER.** Applications are invited from graduates for the post of Assistant Lecturer in the Fluid Motion Laboratory. Candidates should have special qualifications in Electronics: the person appointed will be required to work on problems of instrumentation for the measurement and observation of fluid flow. Salary on a scale £450-£550 per annum with membership of F.S.S.U. and Children's Allowance Scheme. Applications should be sent not later than 16th February, 1954, to the Registrar, The University, Manchester 13, from whom further particulars and forms of applications may be obtained. W 3033

**UNIVERSITY OF CAMBRIDGE.** Department of Physical Chemistry. Vacancy for a Technical Assistant (Electronics) in the Research Laboratory on the Physics and Chemistry of Surfaces. Duties comprise (a) the design, construction and maintenance, with minimum supervision of electronic equipment required for the research programme of the laboratory, and (b) the supervision of an assistant similarly employed. Applicants should be experienced in the design and testing of electronic apparatus and competent in the use of hand tools. The post is at present unestablished and the salary will lie in the range £448½ to £565½ per annum. Applications, mentioning age and containing a brief résumé of qualifications and experience, should be addressed to the Secretary, P.C.S. Laboratory, Department of Physical Chemistry, Free School Lane, Cambridge. W 2996

**WIRELESS STATION SUPERINTENDENT** required by the Gold Coast Government Posts and Telecommunications Department for two tours of 18 to 24 months in the first instance. Salary, etc., according to qualifications and experience in consolidated scale £990 rising to £1230 a year, with gratuity of up to £150 a year. Outfit allowance £60. Liberal leave on full salary. Free passages. Candidates should possess a Higher National Certificate or equivalent, and have had practical experience in two or more of the following fields: V.H.F. link systems; H.F. communication network; frequency shift keying and teleprinter maintenance; V.H.F. and H.F. direction finding systems; aeronautical navigation aids (ground); manufacture of light engineering equipment. Candidates from the British Post Office should apply through departmental channels. Write to the Crown Agents, 4, Millbank, London, S.W.1. State age, name in block letters, full qualifications and experience and quote M2C/29100/EK. W 3014

### SITUATIONS VACANT

*The engagement of persons answering these advertisements must be made through a Local Office of the Ministry of Labour or a Scheduled Employment Agency if the applicant is a man aged 18-64 inclusive or a woman aged 18-59 inclusive unless he or she, or the employment, is excepted from the provisions of the Notification of Vacancies Order, 1952.*

**AN EXPANDING ENGINEERING PROGRAMME** has caused vacancies for Development Engineers experienced in one or more of the following fields: (a) Tuning Mechanisms and associated V.H.F. Circuits. (b) Switches for Radio and low-power Electrical Apparatus. (c) Variable Capacitors. A detailed knowledge of the material problems encountered in this type of development will be advantageous. The salary and future prospects are good, and the laboratory is situated in the London area. Please reply, giving full details of qualifications and experience, quoting Ref AD/EE, to Box No. W 3009.

**APPLICATIONS** are invited from Young Electronic Engineers for a position involving the development of V.H.F. Equipment and associated units. Prospective applicants should be capable of working from Circuit diagrams and specifications with a minimum of supervision and also be capable of original design of the more simple equipment, such as monitors, etc. Previous experience of this type of work or in allied fields, would be an advantage; good prospects are open to the right man. Write stating age and salary required to Airtech Limited, Aylesbury & Thame Airport, Haddenham, Bucks. W 1919

## SITUATIONS VACANT (Cont'd.)

*The engagement of persons answering these advertisements must be made through a Local Office of the Ministry of Labour or a Scheduled Employment Agency if the applicant is a man aged 18-64 inclusive or a woman aged 18-59 inclusive unless he or she, or the employment, is excepted from the provisions of the Notification of Vacancies Order, 1952.*

**APPLICATIONS** are invited for a number of senior positions in the Guided Weapons field. Posts are permanent and will be offered to suitable applicants who have had either at least 5 years' experience in industry or are Graduates with two or more years' experience. Salaries will be commensurate with experience and advancement will depend upon original contribution and enthusiasm for the work. The following positions are available: (A) Physicist with experience in electronics. (B) Circuit Engineer capable of original circuit development and familiar with low frequency circuit design and miniaturization, and (C) Servo Engineer experienced in design and development of light electrically controlled servo mechanism. Apply Box AC 85668, Samson Clarks, 57-61, Mortimer Street, London, W.1. W 2940

**APPLICATIONS ARE INVITED** for the position as Supervisor of the Test Department of a large established organisation engaged in expanding into a new factory on the South Coast. Essential qualifications are: Age 35-45 years. Good technical background in Electronics. Considerable factory experience of testing and control of staff, preferably in relation to Microwave Radar and Pulse Equipment. The appointment is subject to a probationary period in the existing organization, which will provide every opportunity to prove suitability. Write full details of education, experience and expected commencing salary to Box No. W 2999.

**A FIRST-CLASS OPPORTUNITY** exists in the London area for a development engineer familiar with the design and production of miniature or telephone type relays or similar electro magnetic devices. Excellent laboratory facilities are available and the successful candidate will be required to initiate new development projects and carry them through to production. The initial salary will be in accordance with qualifications, and generous advancement is possible for a man of initiative. Write quoting Ref. CB/EE and send details of qualifications and experience to Box No. W 3008.

**A LARGE COMPANY** engaged in system engineering and installation of Radar Equipment require a fully experienced Production Manager. This position is one of high responsibility, permanent, fully pensionable, and carries a substantial salary. Applications are invited from men who have an intimate knowledge of Radar engineering and, more particularly, with recent experience of equipment of American origin in the 3 and 10cm. bands. This is a position for a man seeking wider scope for proven capabilities in a rapidly expanding organisation. Full particulars of past record, age and salary required should be forwarded to The Personnel Manager, Box No. W 2975.

**AMERICAN COMPANY** seeks Chief Engineer fully experienced in design manufacture and testing of Carrier Telephone Equipment and filters. Vacancy is in Company's Italian works. Please give fullest particulars to Box No. W 1915.

**A PRODUCTION MANAGER** who has considerable experience in the production of all types of Paper Dielectric Capacitors is required by a large and well-known firm. This position carries high remuneration, and only men of proved ability should apply. Applicants reply, in confidence to Box No. W 1887.

**A.B. METAL PRODUCTS** require additional Technical Representatives. Connexions with leading Radio and Electronic Equipment Manufacturers essential. Apply in confidence, Sales Manager, A.B. Metal Products Ltd., 16, Berkeley Street, W.1. W 3018

**A SENIOR TRANSFORMER DESIGNER** with specialist knowledge of all types of small transformers used in electronics is required with a view to taking charge of a design section. Practical as well as academic knowledge essential. Pension Scheme available. West London. Box No. W 1922.

**A TECHNICAL SALES ENGINEER** possessing the ability to interpret electronic circuits is required by a large Radio and Electronic Component manufacturing firm. This post offers excellent opportunities to a man of the right calibre. Applicants, who should be over 30 years of age, please reply to Box No. W 1888.

**A TECHNICAL SALES REPRESENTATIVE** with specialized knowledge of the applications of electronic components is required by large Radio Component Manufacturers. The position offers excellent scope and prospects to a man of outstanding personality with the necessary experience and knowledge of the trade. Replies to Box No. W 1920.

**A TELECOMMUNICATIONS FIRM** in the North dealing with multi-channel carrier equipment for use on lines has a number of vacancies in the following fields: (1) Specialized Filter designers with experience in conventional type and quartz crystal filters. (2) Laboratory Development Engineers of Senior Grade. (3) Equipment Design Engineers. (4) Technical Writer for preparation of Handbooks. Services experience an advantage. Age of secondary importance. The positions are on the established staff of the Company, with contributory pensions scheme, the usual staff conditions. Applicants are invited to write, giving full particulars of experience, qualifications and age to Box 532 Dorland Advertising Ltd., 18/20 Regent Street, London, S.W.1. W 3015

**A VACANCY** occurs for a Development Engineer in a design group concerned with a wide range of small transformers and inductors of types used in radio equipment and electrical appliances. Preference will be given to applicants having experience of this class of work, but young engineers with a sound basic training and limited experience will be considered and, if successful, will have the opportunity of gaining practical knowledge of design problems met in fulfilling commercial and military specifications. An attractive salary is offered, together with good future prospects. The company's extensive laboratory and production facilities are situated in the London area. Please reply, quoting Ref. WG/EE, giving details of qualifications and experience to Box No. W 3012.

**CHIEF ENGINEER, MICROWAVE LINK DEVELOPMENT.** Decca Radar Ltd. is creating an appointment, at the rank of Chief Engineer, to lead a growing division engaged in the development and exploitation of microwave link systems. The successful applicant must have had, in either this or closely allied fields, considerable industrial experience at a senior level. This experience must provide evidence of a faculty for leadership, organizing ability, and a capacity for drive. British nationality essential. A starting salary commensurate with the level of the appointment will be paid. Replies, which will be treated as strictly confidential, should be addressed to the Research Director, 2 Tolworth Rise, Surbiton, Surrey. W 191

**DESIGN DRAUGHTSMEN/DRAUGHTSMEN** required with experience of electronic or electro-mechanical equipment. Applicants must be conversant with all phases of production and should have had workshop experience; they must be capable of originating new designs. Write stating age, experience and salary required to Chief Engineer, J. Langham Thompson Ltd., 88, High Road, Bushey Heath, Herts. W 2990

**DESIGNER DRAUGHTSMEN** with experience of light electro-mechanical apparatus. Workshop training preferred. H.N.C. standard. Good prospects. Superannuation. Apply stating age, experience and salary required to Personnel Manager, Muirhead & Co. Ltd., Beckenham, Kent. W 2995

**DRAUGHTSMEN REQUIRED.** Electronic instrument, or, radio experience. Salary according to qualifications. Saturday interview if required. Opportunity to broaden experience with reputable firm. Near City centre and all amenities. Within easy access to London. Marconi Instruments Ltd., Longacres, Hatfield Road, St. Albans, Herts. W 1896

**ELECTRICAL ENGINEER** required for Research work on Magnetic Circuits—B.Sc. essential. Exceptional opportunity to work on a new project for a man with initiative and energy. Applicant will also act as technical adviser to Sales Manager. Salary commensurate with experience and ability. Full details to Telcon-Magnetic Cores Limited, Industrial Estate Chapelhall, Airdrie. W 1928

**ELECTRONIC ENGINEER** to work within our trials division at Edinburgh. The nature of the work involves conducting trials and evaluating the performance of fire control; navigational and landing systems under development. Applicants should possess a Physics Degree or considerable recent practical experience in this field. Good opportunity in expanding department. Staff Pension Scheme. Apply quoting Ref. EE/TID and giving full details of qualifications and experience to the Personnel Officer, Ferranti Limited, Ferry Road, Edinburgh, 5. W 3036

**ELECTRONIC ENGINEER** with good technical qualifications, some designs and supervisory experience required as Section Leader in Engineering Division of expanding Company manufacturing variety of high grade equipment in audio, supersonic, and telemetering fields, and with future radio interests in V.H.F. Successful applicant will be given opportunity to become familiar with Company's products and current projects and will be required to direct and co-ordinate the work of several development engineers, also maintain liaison with Chief Draughtsman and production staff. Post offers considerable prospects for engineer of right type and experience. Please state age; full details, Box No. W 3032.

**ELECTRONIC ENGINEERS** with several years' research or development experience are invited to apply for posts with a well established Company engaged primarily on the development of precision electronic laboratory instruments. Applicants should preferably possess an Honours Degree or equivalent qualifications in physics or light electrical engineering, although this is not essential as considerable practice is equally acceptable. The appointments are of a permanent nature for Engineers able to undertake the responsibility for the development of new projects to the prototype stage, and they offer scope for the exercise of individual initiative. Furthermore, the work covers a wide range of electronic instruments and similar devices. Salaries are commensurate with qualifications and experience. Applications should be made in writing, stating full details to Chief Engineer, Furzehill Laboratories Ltd., Boreham Wood, Herts. W 2992

**ELECTRONIC ENGINEERS** are invited to apply for vacancies in the Design and Development teams engaged on the following: (a) V.H.F. circuits. (b) Domestic and car radio receiver design. (c) Television receiver designs. (d) Recording equipment. (e) Design and development of components associated with the above. Applicants should be of Degree or H.N.C. standard and capable of undertaking development work with the minimum of supervision in one of the above fields. The posts carry good salary with opportunity to progress. Please send full details to Personnel Dept. (ED/154) E.M.I. Eng. Dev. Ltd., Hayes, Middx. W 3045

**ELECTRONIC ENGINEERS** required by The General Electric Co. Ltd., Brown's Lane, Allesley, Coventry, in their Development Laboratories for work on: (a) Trials team in connexion with Guided Weapons; one Senior Engineer also three Engineers. (b) Servo-mechanisms; one Engineer. (c) Pulse Circuitry; three Engineers. (d) Microwave Circuits; one Engineer. (e) Test Equipment; two Engineers.

**CLASSIFIED ANNOUNCEMENTS**  
continued on page 4



Prov. Pat.  
10037/53

# Read what users say...

"I have purchased one of your H.F.1012 speakers, the results from which have astounded me. At the time of purchase I was sorely tempted to pay a much higher price for another make of speaker, but fortunately, I was able to try both under varying conditions good and bad, and then there was no hesitation about the decision. If the H.F.1012 has a good life, and there seems no reason why it should not, then it is a most outstanding achievement in performance and price".

"May I tender my thanks to you for providing such an excellent job at a price which poor mortals like me can afford. It certainly is a big step towards realism in sound reproduction which until now I considered out of my reach. More power to your elbow".

"After reading P. Wilson's report of your new 10" speaker, H.F.1012, in the 'Gramophone', I immediately purchased one. Used in conjunction with a Leak Amplifier and a Leak Pick-up, the results were indeed remarkable. One would be tempted to say that at three times the price it would be exceptional".

## Stentorian HIGH FIDELITY UNITS WITH THE PATENTED CAMBRIC CONE

- MODEL H.F. 610 (6" unit)  
£2. 10. 6 (Inc. P.T.)
- MODEL H.F. 810 (8" unit)  
£3. 0. 6 (Inc. P.T.)
- MODEL H.F. 912 (9" unit)  
£3. 7. 0 (Inc. P.T.)
- MODEL H.F. 1012 (10" unit)  
£3. 13. 6 (Inc. P.T.)

3 or 15 ohms impedance  
Transformer available if required.

### ...and remember what the experts said:

These new speakers have scored a sensational success: even we are amazed at the enthusiasm they have aroused. Hear what the experts say: "A great advance in speaker technique" (F. J. Camm); "A new thrill in high fidelity reproduction" (John Gilbert); "An extension of the bass response which is truly remarkable" (H. J. Barton-Chapple); "The smoothness of response is one of the really remarkable characteristics" (P. Wilson).

This consensus of opinion proves that the introduction of the cambric cone represents an amazing advance in loudspeaker design and performance. This achievement by W.B. engineers crowns thirty years' experience and progress in sound reproduction.

● Write for leaflet giving full technical details, or ask your dealer to demonstrate. Alternatively, these speakers may be heard at our London Office, 109 Kingsway, W.C.2, any Saturday between 9 and 12 noon.



WHITELEY ELECTRICAL RADIO CO LTD · MANSFIELD · NOTTS



## Working under water...

The world is submerged in a vast sea of water vapour and its effect on delicate processes and materials is often disastrous. To remove harmful moisture from vital production and storage departments and from gas or air services is the job of LECTRODRYERS\*— and booklet No. 80 tells how they do it.

\* LECTRODRYERS dry most gases and some organic liquids by adsorption, without expendable or corrosive chemicals, wearing parts or fuss.

DRYER DIVISION OF  
**BIRLEC LTD**



sm/b958,53

BIRLEC WORKS · TYBURN ROAD · BIRMINGHAM 24

## SITUATIONS VACANT (Cont'd.)

The engagement of persons answering these advertisements must be made through a Local Office of the Ministry of Labour or a Scheduled Employment Agency if the applicant is a man aged 18-64 inclusive or a woman aged 18-59 inclusive unless he or she, or the employment, is excepted from the provisions of the Notification of Vacancies Order, 1952.

(f) General Radar Circuit Development; two Engineers. (g) Power units, including electronic stabilizers and rectifier systems; one Engineer. (h) Magnetic Amplifiers; one Engineer. Applicants, preferably with a Degree or an equivalent qualification, should have had at least two years' experience in the development and engineering of Service equipment as well as experience in one of the above. Reply stating age, qualifications and experience to the Personnel Manager, Ref. R.G. W 3006

**ELECTRONIC ENGINEERS** to become Section Leaders of small teams responsible for the preparation, testing in the field, and further laboratory development of Guided Weapons. Applicants should have at least H.N.C. and five years' experience in the micro-wave, pulse or communication field. Equivalent training and experience in H.M. Forces will also qualify for these positions. Assistant Engineers to form such teams, either (a) with a similar background to the above or (b) having considerable experience of developing and testing small prototype electro-mechanical instruments. The vacancies, which offer exceptional scope for advancement, are at Heston Aerodrome, Middlesex. Periods of work at outstations in the U.K. are covered by adequate allowances and week-end leave privileges. There are likely to be opportunities for continuing some of this work in Australia at a later date. Good salary with bonus. Pension Scheme. Details of experience and qualifications should be sent to the Assistant Manager, Dept. E.E., The Fairey Aviation Company Limited, Research and Armament Development Division, Heston Aerodrome. Hounslow, Middlesex. W 3029

**ELECTRONIC ENGINEERS** are required by The English Electric Co., Ltd., Luton, for work on a high priority defence project. Applicants will be required to undertake the engineering of circuitry already developed which involves close liaison with, and the progressing of work through, the drawing office and production department. Applicants with experience of the engineering of radar and/or aircraft electronics for production will be especially welcome. The posts are permanent and progressive and a staff pension scheme is in operation. Applications to: Dept. C.P.S., 336/7 Strand, W.C.2, quoting Ref. 1211. W 2875

**ELECTRONIC ENGINEERS** required for research and development work on the application of electronic digital computing techniques to business accounting machines. There are vacancies for the following: (i) University graduates with Honours Degree in Physics or Electrical Engineering. One or two years' experience in electronic research and development field an advantage but not essential. (ii) Engineers holding Higher National Certificate, Ordinary National Certificate or similar qualifications and with practical experience of electronic equipment. Applicants without academic qualifications would be considered if they have had experience of electronic equipment, preferably of pulse technique as used in digital computing, radar, etc. Salaries will be based on qualifications, experience and age. Applications stating age, qualifications, experience, etc., to Personnel Officer, British Tabulating M/c Co., Ltd., Letchworth, Herts. W 1841

**ELECTRONIC INSTRUMENTS LTD.**, of Richmond, Surrey, has vacancy for Chief Inspector. Applicants must have sound practical experience in testing mechanical and electronic apparatus, together with administrative ability. A key post in expanding firm. Application in first instance by letter giving full details of experience and salary. Junior posts are also available for electronic engineers aged 23 upwards, having H.N.C. or equivalent qualification. W 1912

**ELECTRONICS DIVISION** of Murphy Radio have vacancies in their design unit at Ruislip for—1. Physics or Electrical Engineering Graduates preferably with experience of electronic design. 2. Draughtsmen with experience in this field. Applications should give full details of experience and qualifications and may be addressed in confidence to Personnel Department, Murphy Radio Limited, Welwyn Garden

City, when arrangements will be made for suitable applicants to be interviewed at the Ruislip Works. W 2978

**ELECTRONICS ENGINEER** required to handle design and development of industrial and special purpose electronic equipment. Supervisory experience an advantage. Qualifications and experience must be up to A.M.I.E.E. standard. Permanent, progressive position. Non-contributory pension, insurance and sickness benefit plan. Apply by letter to the Personnel Department, Kodak Ltd., Wealdstone, Middlesex. W 3016

**ELLIOTT BROS. (LONDON) LTD.** have several vacancies for Engineers to work on the development of magnetic amplifiers and their various applications. This is very interesting work and offers a considerable future. Candidates should preferably have a Degree or equivalent qualifications and have some experience of servo-mechanisms and control systems. Applications with full details of education, past experience and salary expected to Personnel Manager, Century Works, Conington Road, S.E.13. W 2994

**ENGINEER** required for Electrical Development Department of a progressive Communications Company. National Certificate Standard required. Salary according to ability. Write Box 444, Sells Ltd., Brettenham House, Lancaster Place, W.C.2. W 3050

**ENGINEER**, aged 26 to 34, required to take charge of Engineering Department of factory manufacturing Quartz Crystals. University Degree and experience of industrial or serviced electronic equipment essential. Rudimentary knowledge of chemistry an advantage. House could be made available to successful applicant. Write Box W.B. 8476, A.K. Adv., 212a, Shaftesbury Avenue, London, W.C.2. W 3044

**ENGINEERS** with Radio and Radar Installation and maintenance experience are required for interesting work which will involve working in various parts of Great Britain. Applications will be welcomed particularly from ex-Service men who have had extensive experience in this field. These positions offer good prospects in a large flourishing company which operates a generous pension scheme. Applications, which will be treated in confidence, should be addressed to Box EE 873, L.P.E., 110 St. Martin's Lane, W.C.2. W 3024

**ENGINEERS** required for responsible trials work in Warwickshire, on Guided Weapons. Good general scientific education up to Degree standard desirable. Enthusiasm for this interesting but often arduous work essential. A fair amount of travel may be involved. Preference given to candidates who have previously held responsibility for test and repair of electro-mechanical and electronics devices. Apply with full details including salary, quoting No. 1440, to Personnel Manager, Sperry Gyroscope Co. Ltd., Great West Road, Brentford, Middlesex. W 2893

**ENGINEERS** required for (a) maintenance and design of Electronic test equipment and (b) for Quality control and investigational work on radio valves and other Electronic devices. Inter B.Sc. or Higher National Certificate standard. Write giving experience and salary required to Personnel Superintendent, The Edison Swan Electric Co., Ltd. Cosmos Works, Brimsdown, Enfield, Middlesex. W 2883

**ERICSSON TELEPHONES LTD.**, have a number of vacancies in their Research Laboratories in connexion with Electronic Switching and Computing. The posts will carry starting salaries between £600 and £1,000 according to age and experience. (a) Electronic Circuit designers of all grades. Applicants should have Degree or equivalent, and several years' experience in the design of electronic circuits. (Reference L.E./1). (b) Electronic equipment engineers with experience in the layout and mechanical design of electronic instruments and equipment in the radio, radar or communication fields. They will be required to co-operate with the circuit designers in the early stages and may ultimately be responsible for development to the production stage. (Reference LE/2). Applicants who should be British born and between 25 and 35 years of age, should write quoting the reference above and giving details of age, experience, academic or other training, and required starting salary to the Personnel Officer, Ericsson Telephones Ltd., Beeston, Nottingham. W 2751

**EXECUTIVE ENGINEER** required by Company in West London area engaged on the development of a wide range of electronic and light mechanical equipments, to take full technical control of a large section of the work.

Applicants should have a good Honours Degree and have had first-class experience in a responsible position covering design, development and prototype production. Salary will be commensurate with responsibilities. Please apply with full details to Box No. W 3046.

**EXPERIENCED ENGINEERS** are sought by an established and well-known organisation, to assist in the development of wide band micro-wave telecommunication systems. Considerable effort will be put into this project and the appointments offer exceptional opportunities for advancement. As the successful candidates will be expected to make an immediate contribution it is essential that applicants should have had several years' research or development engineering experience in one or more aspects of the above field. Please apply, quoting ref. HBB to Box No. W 3025.

**EXPERIENCED** Fault-Finders wanted by Midland Manufacturers of Radio Equipment. Permanent posts located in the Midlands are offered to men with experience of Radar, Radio Control, V.H.F. Equipment. Write, stating fully, experience and salary required to Personnel Manager Box No. W 2840.

**EXPERIENCED** Radio Testers and Inspectors required for production of communication and radio apparatus. Also Instrument makers, wirers and assemblers for Factory Test apparatus. Apply Personnel Manager, E. K. Cole Ltd., Ekco Works, Malmesbury, Wilts. W 146

**EXPERIMENTAL AND RESEARCH STAFF** required by D. Napier & Son, Ltd., Acton. Vacancies exist in this well-known company in W. London for technical staff to undertake research and experimental work in mechanical engineering. Applications are invited for the following posts from suitably qualified candidates. Mathematicians with an Honours Degree in Maths. to undertake advanced calculations on vibration problems and stress analysis on engine components. (Ref. 320A.) Research Assistants to organize and carry out experimental tests, including the analysis of results and preparation of reports. (Ref. 455D.) Electronic Engineer to design apparatus for the measurement of pressure, temperature and flow. (Ref. 861C.) Applications should be sent to Dept. C.P.S., 336/7, Strand, W.C.2, quoting appropriate Ref. No. W 3001

**FERGUSON RADIO CORPORATION LTD.** offers exceptional opportunities to Draughtsmen wishing to make their career in the world of electronics, television and radio. Candidates preferably experienced in the Radio and Television industries, must have knowledge of mass production methods and workshop practice. Familiarity with Ministry requirements an advantage. Good Salaries; Pension Scheme. Well equipped Drawing Offices and good working conditions. Apply: Employment Manager, Ferguson Radio Corporation Ltd., Great Cambridge Road, Enfield, Middlesex. W 2946

**FERRANTI LIMITED, EDINBURGH**, have a vacancy in their Applications Laboratory for an Engineer-Physicist, for interesting development work with a control project opening up a new field and involving digital computers, data recording and servo-mechanisms. A Degree or equivalent in Electrical Engineering or Physics is essential, and experience in some, or all, of these fields is desirable. The appointment is permanent and offers excellent prospects

**CLASSIFIED ANNOUNCEMENTS**  
continued on page 6

**SLI**

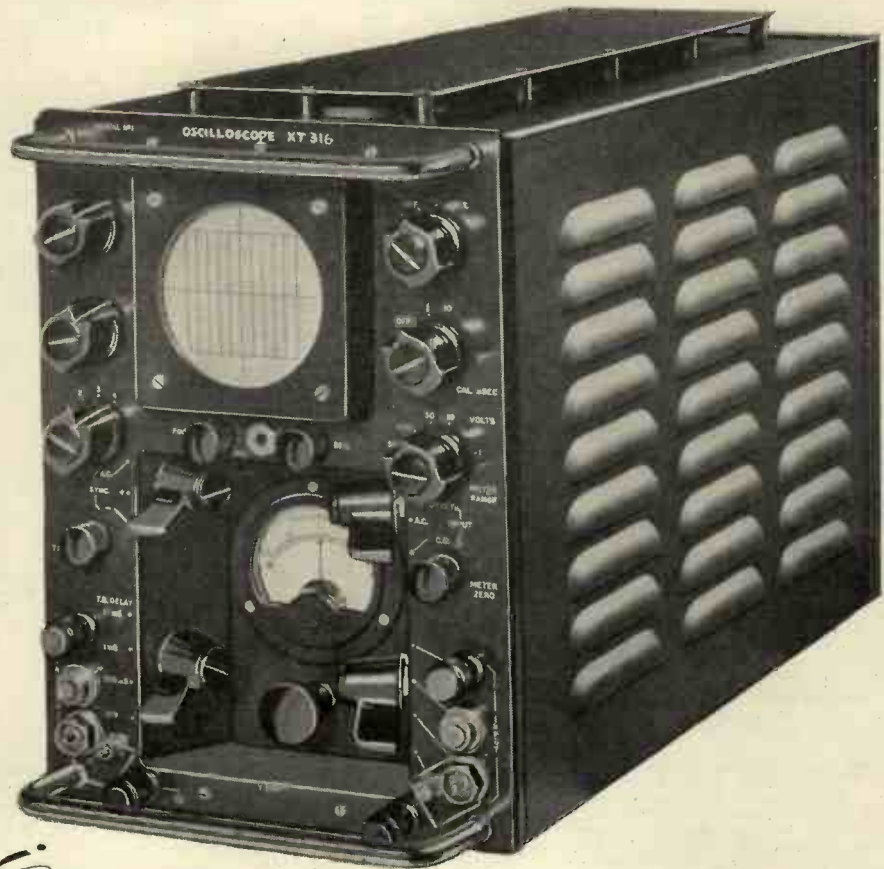

*New in*

*quantity production*

**The New R.R.E. |**  
**Solartron Oscilloscope** XT316 Model D300

Outstanding features :

- D.C. to 6 Mc/s.
- 1  $\mu$ sec maximum sweep speed.
- Built-in calibrator.
- Video and T.B. delays.
- Y shift meter.
- Fully tropicalised.
- Weighs under 50 lbs.

Designed at the Radar Research Establishment this new oscilloscope incorporates the latest advances in circuit technique and construction. It is eminently suited to the display and accurate measurement of the velocity and amplitude of pulse waveforms encountered in radar and communications equipment. **£145**

**SOLARTRON**

Full Technical details sent gladly on request.

ORDER NOW FOR EARLY DELIVERY

SOLARTRON LABORATORY INSTRUMENTS LIMITED  
SOLARTRON WORKS, QUEENS ROAD, THAMES DITTON. Tel: Emberbrook 5611 PBX

**SITUATIONS VACANT (Cont'd.)**

*The engagement of persons answering these advertisements must be made through a Local Office of the Ministry of Labour or a Scheduled Employment Agency if the applicant is a man aged 18-64 inclusive or a woman aged 18-59 inclusive unless he or she, or the employment, is exempted from the provisions of the Notification of Vacancies Order, 1952.*

inspection, particularly on 3 and 10cm. Radar and H.F. and V.H.F. radio equipment. Applications for both these positions, which would carry liberal salaries and would be in the Hunts. area, should be addressed to The Personnel Manager, Box No. W 2974.

**PROJECT ENGINEERS**—electronic—age 25-35, having Grad. I.E.E. or equivalent qualification in radio communications required for pre-production component studies of U.S.A. designed equipment to be re-engineered for production in this country. Long term project, offering good prospects to engineers with development and practical experience, knowledge of component sources, and ability to specify and follow-up technical requirements with prospective suppliers. Some experience in V.H.F. radio and miniaturized equipment an asset. Please state age, full details education, training and experience. Box No. W 3030.

**QUALIFIED MECHANICAL ENGINEER** required, age not over 35, with some knowledge of radio and electrical engineering and with an aptitude for experimental work to act as second in charge of newly formed Development Department at a factory in the West Midlands. The maximum salary for this post is £1,100 per annum and the starting salary will be calculated according to the qualifications and experience of the successful applicant. Box No. W 1914.

**RADAR ENGINEERING:** Two important vacancies exist on the permanent staff of an influential company concerned with high priority production and installation in Huntingdonshire of radar systems, much of which involves American equipment. Both positions are progressive, pensionable and well salaried. The first is for a Production Controller (Ref. P.C.), who should already have had first-class experience of a similar nature and be thoroughly conversant with radar and/or radio engineering production of a high order. He will be a competent executive who knows assembly line production, can handle production layouts, in fact, all aspects of this highly important function. The second vacancy concerns a Production Engineer (Ref. P.E.) who has already established his abilities in an efficient, well organized production unit, and who has an intimate knowledge of detailed engineering production in the radio/radar field. Apply, quoting above references, in strict confidence to Box No. W 2976.

**RADIO AND RADAR ENGINEERS** required for work in Test Department. Preference will be given to Radio Engineers with experience of testing Communication Receivers, or Radar Engineers with experience on HFS Aircraft Equipment. Successful applicants will be employed as Testers, and must be capable of working with a minimum of supervision. Attractive conditions and rates to successful applicants. Apply in writing, or phone to Airtech Limited, Aylesbury and Thame Airport, Haddenham, Bucks. (Telephone Aylesbury 1163.) W 1916

**RADIO AND RADAR TESTERS.** First-class men required for work on V.H.F. Communication Gear and Government Contracts for Radio and Radar Equipment by Midland Manufacturers. Men with wide experience of Fault Finding in any of the fields mentioned should write giving full details to Box No. W 2839.

**RADIO AND TELEVISION.** Junior Development Engineers required. Must have had previous experience in this field. Apply by writing giving full details of experience to Alba Radio, 52/58 Tabernacle Street, E.C.2. W 3002

**RADIO MAINTENANCE ENGINEER** required for staff post in Edinburgh to take charge of small radio workshop on airfield. In addition to maintaining standard air and ground radio and radar equipments (civil and military), applicant will be required to assist in field trials of new systems. Applicants must be in possession of M.C.A. radio licence: minimum "A", preference "A" and "B". Good prospects, Staff Pension Scheme. Apply giving full details of training, qualifications and experience to the Personnel Officer, Ferranti Limited, Ferry Road, Edinburgh, 5, and quoting Ref. RME/TID. W 3035

**RESIDENT SUPERVISING MAINTENANCE ENGINEERS.** Appointments are available in various parts of the British Isles for engineers having sound knowledge of centrimetric radar systems, to take charge of maintenance personnel and to be fully responsible for the serviceability of modern equipment. Successful applicants will be given a period of familiarization with the equipment. The posts are pensionable and, in addition to a good basic salary, generous subsistence allowance will be payable. Please reply quoting ref. ABCB. to Box No. W 3026.

**SENIOR DESIGN DRAUGHTSMEN** required by a large engineering company due to expansion of company's services and commercial business. Applicant should have a comprehensive knowledge of mass production of radio, television and services equipment. Salary up to £700 per annum; monthly status. The vacancies are of a permanent and progressive nature. Company superannuation and life assurance scheme in operation. Please reply giving details of experience to Box No. W 3027.

**SENIOR ENGINEER** and a Junior are required by a progressive firm of electronic instrument manufacturers for interesting development work on important projects. Experience in the design of small signal frequency transformers an advantage. Scope for initiative and self expression. Applicants should possess a Degree in physics or the equivalent and should have industrial experience and a practical mind. Pension scheme. Salary and prospects will be good for the right men. Apply Box No. W 2960.

**SENIOR ESTIMATORS** required by a large and progressive engineering company. These vacancies occur owing to normal expansion of company business. Applicants should have a comprehensive experience of the light electro-mechanical engineering fields, with special emphasis on ministry contracts. These are attractive vacancies and call for men with sufficient ability and initiative to justify a salary of up to £850 per annum. All staff privileges, including superannuation and insurance schemes, are available to the selected candidates. Applications, which should give full details of qualifications and experience, should be addressed to Box No. W 3011.

**SENIOR MICROWAVE ENGINEERS** are required by The English Electric Co., Ltd. at Luton, for work on a high priority defence project. Applicants should have a good theoretical background to Degree standard and experience of design or engineering of microwave equipment for development work on aerial and receiving systems. This work includes investigations of new methods of construction with a view to miniaturization and weight reduction, the design of new components and engineering to the production stage. Successful applicants will be required to take charge of a group and to be responsible for one or more aspects of the system. The posts are permanent and progressive and a staff pension scheme is in operation. Applications to Dept. C.P.S. 336/7, Strand, W.C.2, quoting Ref. 1160B. W 2876

(A) **SENIOR POSITION IN SERVO ANALYSIS GROUP** working on Guided Weapon control systems. Applicants should hold Honours Mathematics Degree, have some experience in servo mechanism systems or electrical engineering. Age 28 to 32 approximately. (B) Electronic Engineer with desire to produce instructional literature on new product. Engineering background, diplomatic approach and command of words more important than knowledge of printing. Will ultimately function as Technical Editor in charge of section of Publications Department. Please write in detail quoting reference of post sought to Personnel Manager, de Havilland Propellers Ltd., Hatfield, Herts. W 2943

**SENIOR Radio Receiver Designer** required. Several years' experience of similar work essential. Applications, which should include full details of qualifications and experience, may be addressed in confidence to Personnel Department (S.R.D.), Murphy Radio Limited, Welwyn Garden City, Herts. W 2997

**SENIOR TECHNICAL REPRESENTATIVE** required by Company in West London area to develop markets for electronic equipment. The successful candidate must have a sound knowledge of electronics and a proved record as a successful sales representative, together with drive and initiative. Please apply with full details to Box No. W 3047.

**SENIOR TELEVISION DEVELOPMENT ENGINEER** required by well-known radio and television manufacturer in London area. Applicants must have a wide experience in development for mass production of modern commercial radio and television receivers. A good salary will be paid to a person possessing drive and organizing ability and capable of carrying through projects from development to production stages, under the supervision of the chief engineer. Kindly state full particulars of technical education and experience to Box No. W 3003.

**SPECIFICATION ENGINEERS** are required by E.M.I. Engineering Development Ltd. for work in the preparation of production test specifications for radar and associated electronic equipment. Applicants should have reached H.N.C. standard and have a knowledge of production test methods and procedure and be familiar with the requirements of interservice specification documents. The work involves technical liaison and discussion with project development engineers and the collation of data from which can be formulated production test specifications acceptable to the Ministry of Supply. The appointments are permanent and progressive with good starting salary. Please write with full details to Personnel Dept. (ED/157), E.M.I. Eng. Dev. Ltd., Hayes, Middlesex. W 3048

**SUBMARINE CABLE EQUIPMENT.** Application of submerged repeaters to long distance submarine cables is a new and expanding field of opportunity in telecommunications. Standard Telephones & Cables Ltd., North Woolwich, London, E.16, have a number of vacancies for circuit development and mechanical design engineers for work on this type of equipment. Applicants should have either engineering or physics Degree for circuit development, or at least Higher National Certificate for Mechanical development. Apply Personnel Manager. W 3017

**TECHNICAL WRITER** required, to prepare technical instructions and information for Electrical Instruments, and equipment used in Aircraft Industry. Write in first place full details; age, etc., Employment Manager, Sangamo Weston Ltd., Cambridge Road, Enfield, Middlesex. W 2913

**TECHNICIANS** required for laboratory and inspection duties in connexion with design of quartz and synthetic crystals and associated circuits. Applicants should be between 24 and 35 years of age, and preferably have had some industrial or services experience in Radio techniques. Salary £500 to £700 per annum dependent upon qualifications and experience. The position is tenable in South West Lancashire and is on the established staff status with contributory Pension Fund and usual staff conditions. Applicants are invited to write to Box No. 530, Dorland Advertising Ltd., 18/20, Regent Street, London, S.W.1, giving full particulars of their qualifications, experience and age. W 3004

**TELEVISION PRODUCTION ENGINEER** is required by a large company on Merseyside. Knowledge of Radio and experience in manufacturing techniques with particular reference to the production of Television Receivers is essential. Reply stating age, experience and qualifications and quoting ref. ABAD to Box No. W 2984.

**TEST GEAR DESIGN ENGINEERS** and Maintenance Engineers required with practical experience of this class of work, based on sound knowledge of electronic principles.

**CLASSIFIED ANNOUNCEMENTS**  
continued on page 10



# Two NEW miniature Relays

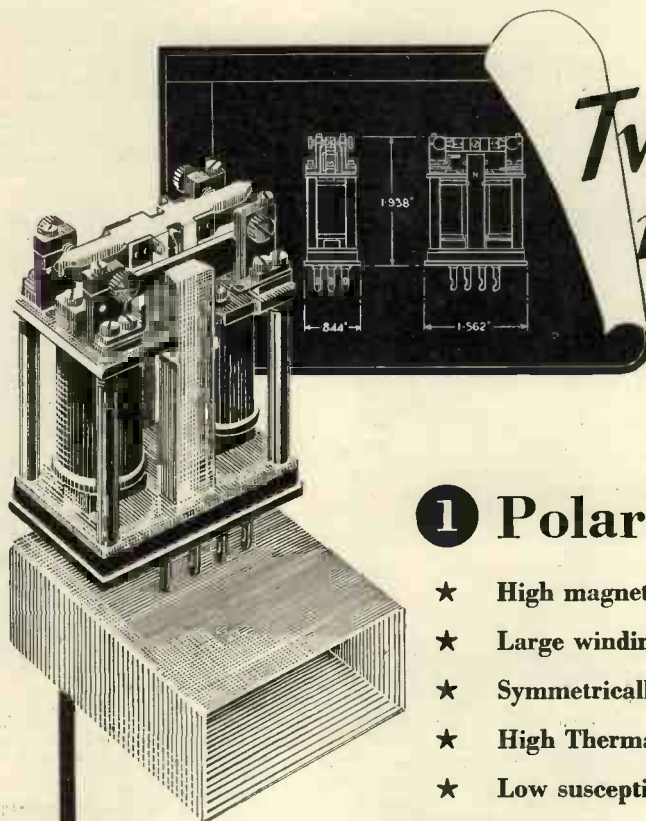

## 1 Polarised Relay

- ★ High magnetic sensitivity
- ★ Large winding space • High copper efficiency
- ★ Symmetrically balanced movement
- ★ High Thermal and Shock stability
- ★ Low susceptibility to magnetic interference

## 2 Type 1A Relay

- ★ Exceptionally high sensitivity
- ★ Balanced movement
- ★ High Thermal and Shock stability
- ★ Hermetically sealed

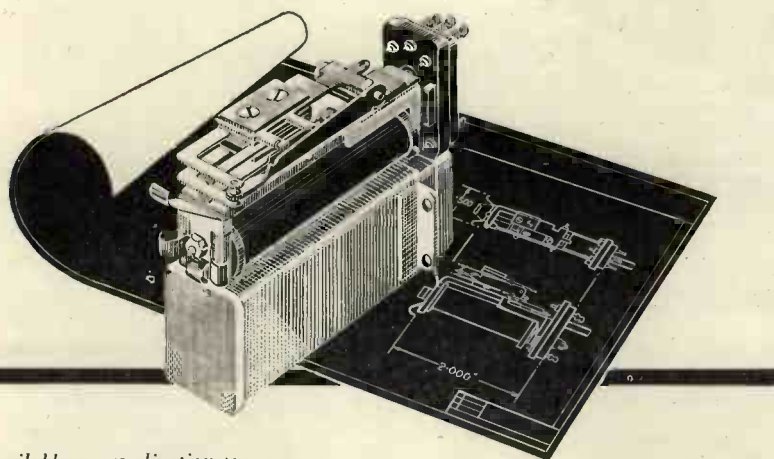

Catalogue available on application to: —

Head Office: 22 LINCOLN'S INN FIELDS LONDON WC2 Tel: HOL. 6936

## SITUATIONS VACANT (Cont'd.)

The engagement of persons answering these advertisements must be made through a Local Office of the Ministry of Labour or a Scheduled Employment Agency if the applicant is a man aged 18-64 inclusive or a woman aged 18-59 inclusive unless he or she, or the employment, is excepted from the provisions of the Notification of Vacancies Order, 1952.

These vacancies are permanent and progressive. A company pension scheme in operation. London area. Please write, in confidence, giving full details of qualifications to Box No. W 3028.

**TEST GEAR ENGINEER.** Company undertaking extensive long term contracts in VHF-UHF multi channel transmitter receiver equipment requires the services of a first class qualified radio engineer with laboratory and practical development experience to lead new section in Engineering Division concerned with design and development of production test equipment, also procurement of frequency and other standards for calibration and quality control. Duties of section will also include preparation of test specifications and instructions. Please state age, education, experience, and salary required. Box No. W 3031.

**THE G.E.C. STANMORE LABORATORIES** invite applications for the following vacancies for work on guided missile research. Excellent working conditions in modern, well equipped laboratories; sick fund and pension schemes. Experienced Electrical/Mechanical Engineers or Physicists with good Honours Degree or equivalent qualifications required for: 1. Responsible position in transistor circuitry work. (Ref. EE/TWS.1). 2. Junior position in transistor circuitry work—experience unnecessary—Degree essential. (Ref. EE/TWS.2). 3. Work on microwave components and circuits and/or microwave receivers. (Ref. EE/AGH.1). 4. Section Leader's post for work demanding experience of telecommunications with electronics bias. This is a senior post offering excellent prospects. (Ref. EE/SM.1). 5. Work on electronic analogue computer, experience in electronics and D.C. amplifiers essential. (Ref. EE/RHK.1). 6. Work on design and development of circuits and/or small servo mechanisms (age 30-35). (Ref. EE/GAG.1). 7. Work on new waveguide techniques, microwave design and measurement experience and a sound mathematical knowledge essential. (Ref. EE/RCM.1). 8. Work on performance of mechanisms for radar equipment. Advanced knowledge of dynamics and the theory of machines together with a marked practical ability essential. Responsible position for well qualified man. (Ref. EE/RHC.1). Applications should be made, in writing, to the Staff Manager, G.E.C. Stanmore Laboratories, The Grove, Stanmore Common, Stanmore, Middlesex, stating age, qualifications and experience and quoting the appropriate reference. W 3020

**THE GENERAL ELECTRIC CO. LTD.,** Brown's Lane, Coventry, require Senior and Junior Electronic Development Engineers for work on Guided Weapons and like projects, particularly in the field of Microwave and Pulse Applications. Mechanical Development Engineers, Designer Draughtsmen and Draughtsmen, preferably with experience of Radar type equipments, also required for the above projects. Salary according to age, qualifications and experience. Apply by letter, stating age and experience to the Personnel Manager (Ref. R.G.). W 169

**THE MULLARD RADIO VALVE CO. LTD.,** invite applications for vacancies on their Mitcham Plant on the staff of the Cathode Ray Tube Department. All applicants should be electrical engineers, physicists, or physical chemists and possess a good Honours Degree or equivalent specialized diploma obtained at a recognized technical college. The work covers all aspects of cathode ray tube manufacture and offers an ideal opportunity for men with initiative and a flair for production. Salary offered would depend on age, qualifications and experience. Applications which will be treated in the strictest confidence should be made to the Plant Personnel Officer, M.R.V. Co. Ltd., Mitcham Junction, Surrey, quoting Ref. JCR/1. W 3023

**THE STEEL COMPANY OF WALES LIMITED** (Tinplate Division) Trostre Works. Electronic Technician required for maintenance of various types of Industrial Electronic control. Consideration will be given to applicants without experience in the above, but with at least five years' experience in the radio industry on maintenance. Excellent wages and working conditions in modern Cold Reduction

Plant. Applications, giving details of age, qualifications and experience, should be submitted to: The Supt. Labour and Wages, The Steel Company of Wales Limited (Tinplate Division), Carmarthen Road, Swansea. W 2948

**THREE ENGINEERS** required for senior posts in the Apparatus Department of Telephone Manufacturing Co. Ltd., Martell Road, West Dulwich, London, S.E.21. Considerable former experience required in the development of light electrical apparatus to production standard. The positions offered require ability to give advice and service to the customer using the Company's apparatus; therefore circuit knowledge of an electronic nature is also desirable. Staff Bonus and Pension Scheme after qualifying period. Write, call or telephone Personnel Manager at above address. Gipsy Hill 2211. W 2998

**ULTRA-ELECTRIC LIMITED,** Western Avenue, Acton, London, W.3, announce a vacancy for a Senior Electronic Development Engineer to take charge of a Section (of Engineers) engaged on the development of sub-miniature V.H.F. Pulse, and other equipment. Applicants should have good academic qualifications, preferably a University Degree in Physics or Engineering, and should be capable of following through the project from early stages to production. Please write fully in confidence to the Personnel Manager (address as above) stating qualifications, experience, age and salary desired. W 2980

**VICKERS-ARMSTRONGS LIMITED, WEYBRIDGE.** Guided Weapons Development. Applications are invited against the following vacancies: Senior Staff Appointments for experienced engineers with suitable B.Sc. Degrees, or equivalents, as: Project Officers, Trials Engineers, Electronic Engineers, other Technical Staff as: Senior Intermediate and Junior Draughtsmen (with H.N.C. or equivalent), Technical assistants (mechanical and electronic—with H.N.C. or equivalent), Mathematicians (with Degrees). Laboratory and skilled workshop personnel as: Laboratory Assistants (electronic, mechanical, and electrical, with practical experience), Toolmakers, Fitters, Centre Lathe Turners, Universal Millers, Universal Grinders, Slotters, etc. Applicants should be in a position to travel daily to Weybridge or make their own housing arrangements. Assistance can be given to secure individual lodging accommodation. Apply to Employment Manager, Vickers-Armstrongs Limited, Weybridge Works, Weybridge, Surrey. W 2955

**VICKERS-ARMSTRONGS LIMITED,** Weybridge, Guided Weapons Development. A vacancy exists for an Experienced Engineer to take charge of a group engaged on the development of missile control systems and associated simulators. Applications, with the names of two referees, should be made quoting reference EO/G.W.1, to the Employment Manager, Vickers-Armstrongs Limited, Weybridge Works, Weybridge Surrey. W 2914

**VICKERS-ARMSTRONGS LIMITED,** Weybridge, Guided Weapons Development. A vacancy exists for a Senior Project Engineer to control a group on missile development. Experience in electronics and graduate or equivalent qualifications required. Applications, with the names of two referees, should be made, quoting reference EO/G.W.2, to the Employment Manager, Vickers-Armstrongs Limited, Weybridge Works, Weybridge, Surrey. W 2915

**VICKERS-ARMSTRONGS LIMITED,** Weybridge, Guided Weapons Development. A Senior Trials Engineer is required for work on Weapon Development. Experience of running

Field Trials and graduate or H.N.C. qualifications required. Applications, with the names of two referees, should be made, quoting reference EO/G.W.3, to the Employment Manager, Vickers-Armstrongs Limited, Weybridge Works, Weybridge, Surrey. W 2916

**WAYMOUTH GAUGES & INSTRUMENTS LTD.,** a subsidiary company of Smiths Aircraft Instruments Ltd., have vacancies in their Aircraft Fuel Gauge Laboratory for Assistant Engineers, required for development of electronic fuel gauging equipment. They should have an Engineering Degree or Higher National Certificate. Technical assistants are also required for experimental work in electrical measurements; preference will be given to applicants holding a technical qualification. Apply in writing to the Chief Development Engineer, Waymouth Gauges & Instruments Ltd., Station Road, Godalming, Surrey. W 2991

Further "Situations Vacant" advertisements appear in display style on pages 26, 63, 66, 71, 82, 87, and 90.

## FOR SALE

**MAGSLIPS** at 1/10th to 1/20th of List Prices. Huge stocks. Please state requirements. K. Logan, Grove Road, Hitchin 1744, Herts. W 183

**METALWORK.** All types cabinets, chassis, racks, etc., to your own specifications. Philpott's Metal Works Ltd. (G4BI), Chapman Street, Loughborough. W 2197

**SINE-COSINE RESOLVERS** (3" Magslip Transmitters No. 5, AP 10861). Brand new, each in maker's tin. Offered in quantity at less than one tenth of cost. Export inquiries invited. P. B. Crawshaw, 166 Pixmore Way, Lechworth, Herts. W 153

**WEBB'S 1948 Radio Map of the World,** new multi-colour printing with up-to-date call signs and fresh information; on heavy art paper 4s. 6d., post 6d. On linen on rollers 11s. 6d., post 9d. W 102

## MISCELLANEOUS

**A HIGH VACUUM IMPREGNATION Unit** or single or Batch Coil Impregnation service to RIC Specification 214 or individual requirements. Blickvac, 505 Lordship Lane, S.E.22. Tel. Forest Hill, 7089. W 182

**COMPANY** with tax loss wanted to purchase. Box No. W 1900.

## EDUCATIONAL

**CITY & GUILDS** (Electrical, etc.) on "No Pass—No Fee" terms. Over 95 per cent successes. For full details of modern courses in all branches of Electrical Technology send for our 144-page handbook—Free and post free. B.I.E.T. (Dept. 337C). 29 Wright's Lane, London, W.8. W 142

**FREE Brochure** giving details of courses in Electrical Engineering and Electronics, covering A.M.Brit.I.R.E., City and Guilds, etc. Train with the Postal Training College operated by an Industrial Organisation. Moderate fees. E.M.I. Institutes, Postal Division, Dept. EE/29, 43, Grove Park Road, London, W.4. W 190

**T/V AND RADIO—A.M.Brit. I.R.E., City & Guilds, R.T.E.B. Cert., etc., on "No Pass—No Fee" terms.** Over 95 per cent successes. Details of Exams., & Home Training Courses in all branches of Radio and T/V. Write for 144 page Handbook—Free. B.I.E.T. (Dept. 337G), 29 Wright's Lane, London, W.8. W 187

## WANTED

**BACK NUMBERS** of Electronic Engineering. The Publishers will buy copies of certain back issues of "Television," "Television & S.W. World" and "Electronic Engineering." Details, including date of issue should be sent to Circulation Manager, 28 Essex Street, Strand, London, W.C.2. W 3022

## SERVICE

**SPECIALIST** translator of German, Russian, Italian electronics and electrical literature seeks further commissions. Reasonable rates. Box No. W 1918.

# Now

# SERVOMEX



achieve an  
even higher  
standard of  
accuracy with  
the new . . .

## AC2 10 amp. Voltage STABILISER



Servomex AC voltage stabilisers have rapidly become standard equipment, and have been widely adopted by leading government and commercial laboratories throughout the country. The new model, type A.C.2, embodies several improvements, check these features:—

- Continuous servo gives accuracy of 0.25%
- True RMS stabilisation
- Zero distortion
- Velocity feedback gives complete stability, independent of friction
- Unaffected by changes of amplitude, frequency, waveform, or power factor
- High output, 10 amps. at 200-240 volts
- Efficiency 95%
- Brush changing in a few seconds
- Normally supplied for rackmounting, external case (as illustrated) optional extra

*Please write for new data sheet.*

*The Servomex range also includes low voltage, high current D.C. and A.C. Stabilisers, Magnetic Amplifiers, Motor Controllers, etc.*

### SERVOMEX CONTROLS LTD.

Servomex Controls Ltd., Crowborough Hill, Jarvis Brook, Sussex. 'Phone: Crowborough 1247



**Fans you can trust**

Dare you risk failure in valve cooling?  
Then remember that *Aerofoil* fans offer electronic engineers the same reliability that has made them the choice for mines, ships and numerous industrial applications. After all, it takes long experience and large resources to make fans and their motors that are completely dependable. Hence *Aerofoil* fans are used everywhere by engineers who play safe. Services specifications can be fulfilled. Ask to see samples.

We offer technical service in fans for electronic purposes. The assistance of our engineers is readily available.

Eleven sizes of *Aerofoil* fans are available: 4½ in. to 48 in. diam., in geometric progression. The fans and motors are made completely in our works, backed by 44 years' experience.

## *Aerofoil* FANS

**FAN PROBLEMS ANSWERED.** You will find a mass of helpful information on all aspects of fan design and performance, system resistance, cooling, etc., in *Woods Practical Guide to Fan Engineering*. 227 pages, 143 diagrams and illustrations, 61 tables, 33 charts, 9" x 6". Strongly recommended by the technical press. Price post free 10/6.

WOODS OF COLCHESTER LTD., Braiswick Works, Colchester.

*Fan manufacturers since 1909.* AN ASSOCIATE COMPANY of THE GENERAL ELECTRIC CO. LTD. of ENGLAND

# 5 Germanium Diodes

for the specialized  
equipment  
designer



Where small size and stability of characteristic, unaffected by repeated cycles of humidity, are of first importance choose STC diodes, which will give you complete reliability. The five types described below are available from stock, and others are in course of development.

Abridged Data at 20°C	TYPE NUMBERS				
	2X/102G	2X/103G	2X/104G	2X/105G (CV448)	2X/106G (CV425)
Peak Inverse Voltage (V)	85	30	30	100	70
Minimum Reverse Resistance (kilo-ohms)	500 (at 70V)	100 (at 20V)	100 (at 20V)	500 (at 50V)	50 (at 50V)
Maximum Forward Resistance (ohms)	500 (at 1V)	250 (at 1V)	1000 (at 1V)	333 (at 1V)	250 (at 1V)

Comprehensive data sheets may be obtained from :

**Standard Telephones and Cables Limited**

(Registered Office : Connaught House, Aldwych, London, W.C.2.)

**Radio Division**

OAKLEIGH ROAD, NEW SOUTHGATE, LONDON, N.11

# Level Stabilised Video Oscillator

10 KC/S—10 MC/S

An outstanding feature of the Wayne Kerr Video Oscillator Type O.222A is a thermistor bridge circuit stabilising the amplitude. Once set the output level will remain constant within 0.5 db while the oscillator frequency is varied over its full range of 10 kc/s to 10 Mc/s. Another advantage is its special facility for indicating the modulus of the load impedance to which the instrument is connected.

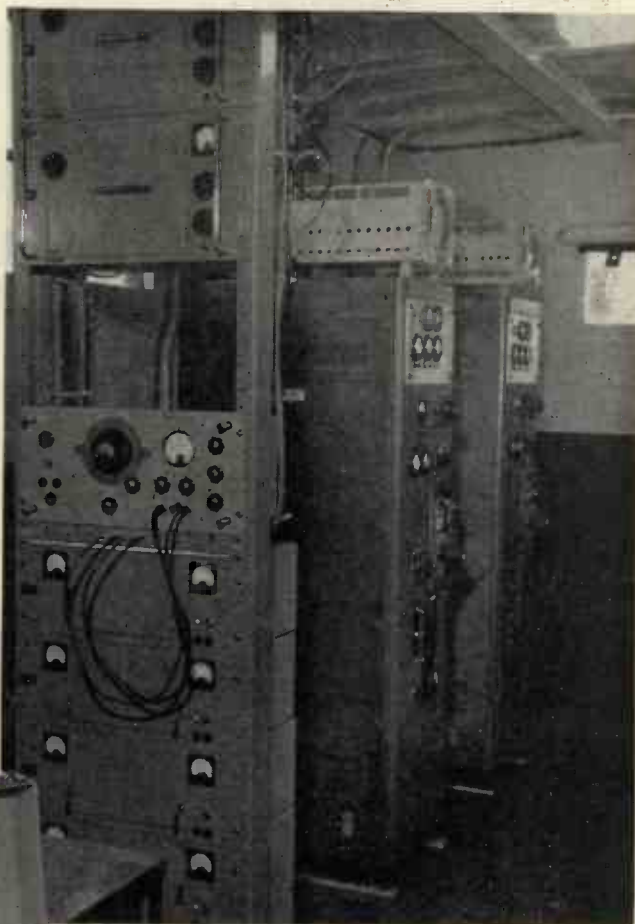

General view of the duplicate transmitters, distribution amplifiers, and testing equipment in the temporary television station at Truleigh Hill, near Brighton. The Wayne Kerr oscillator is used for checking the response characteristics of the vision transmitters over their full bandwidth.

Photograph by courtesy of the B.B.C.

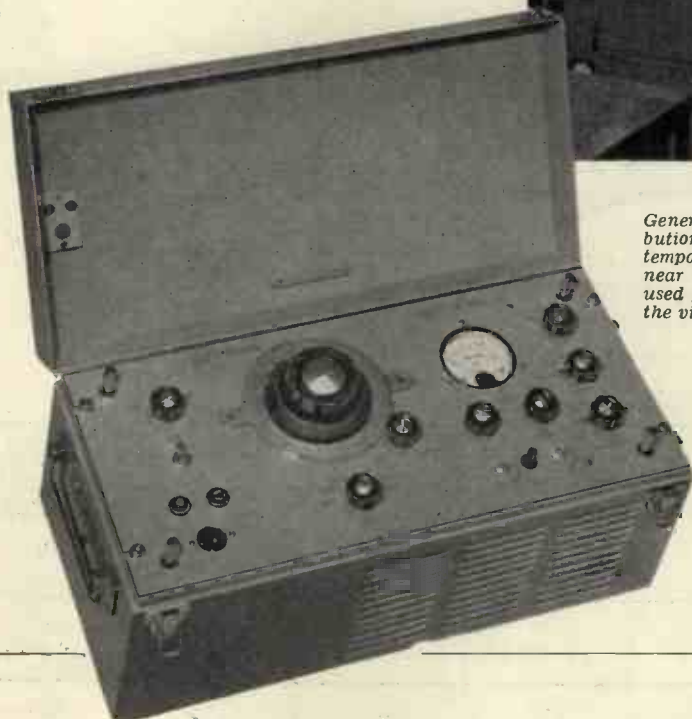

In transportable case £155, or for standard 19" Rack mounting £148.

## SPECIFICATION

Frequency Range:	10 kc/s—10 Mc/s in 6 ranges
Frequency Stability:	better than 1 in $10^3$ in 1 hour
Frequency Accuracy:	1%
Output Range:	+10 db to -50 db on 1V p-p.
Output Level:	Constant to $\pm 0.5$ db at any frequency [setting]
Output Impedance:	75 ohms
Total Harmonic Content:	less than 1%



THE WAYNE KERR LABORATORIES LTD. • NEW MALDEN • SURREY

# A N N O U N C E M E N T

Arrangements have recently been concluded whereby the products of

## **SORENSEN Inc.**

Connecticut, U.S.A.

will be manufactured in the United Kingdom under licence by J. LANGHAM THOMPSON LTD. These products comprise a range of A.C. and D.C. voltage and current regulators of extremely high accuracy, (up to 0.01%), and cover a wattage range of 150 watts to 15 KVA per phase. Immediately available will be the 1000-2S Sorensen Voltage Regulator, brief specification of which is given below.

Although in the initial stages it will not be possible to manufacture the complete range, this is intended at an early date. Engineers will be interested to learn that this range of exceptional instruments is now to be made available without dollar expenditure; descriptive literature will gladly be sent on request.

### **Sorensen 1000.2S Voltage Regulator**

#### *Specification*

RATING	1 KVA	REGULATION ACCURACY	$\pm 0.1\%$ max.
INPUT VOLTAGE	190-260	RECOVERY TIME	0.1 secs.
INPUT FREQUENCY	50 c/s $\pm 10\%$	HARMONIC DISTORTION	3% max.
OUTPUT VOLTAGE	220-240 (adjustable)	P.F. RANGE	Down to 0.7
	LOAD RANGE	No load to full load	

## **J. LANGHAM THOMPSON LIMITED**

BUSHEY HEATH · HERTFORDSHIRE

Telephone: Bushey Heath 2411

# The Vital

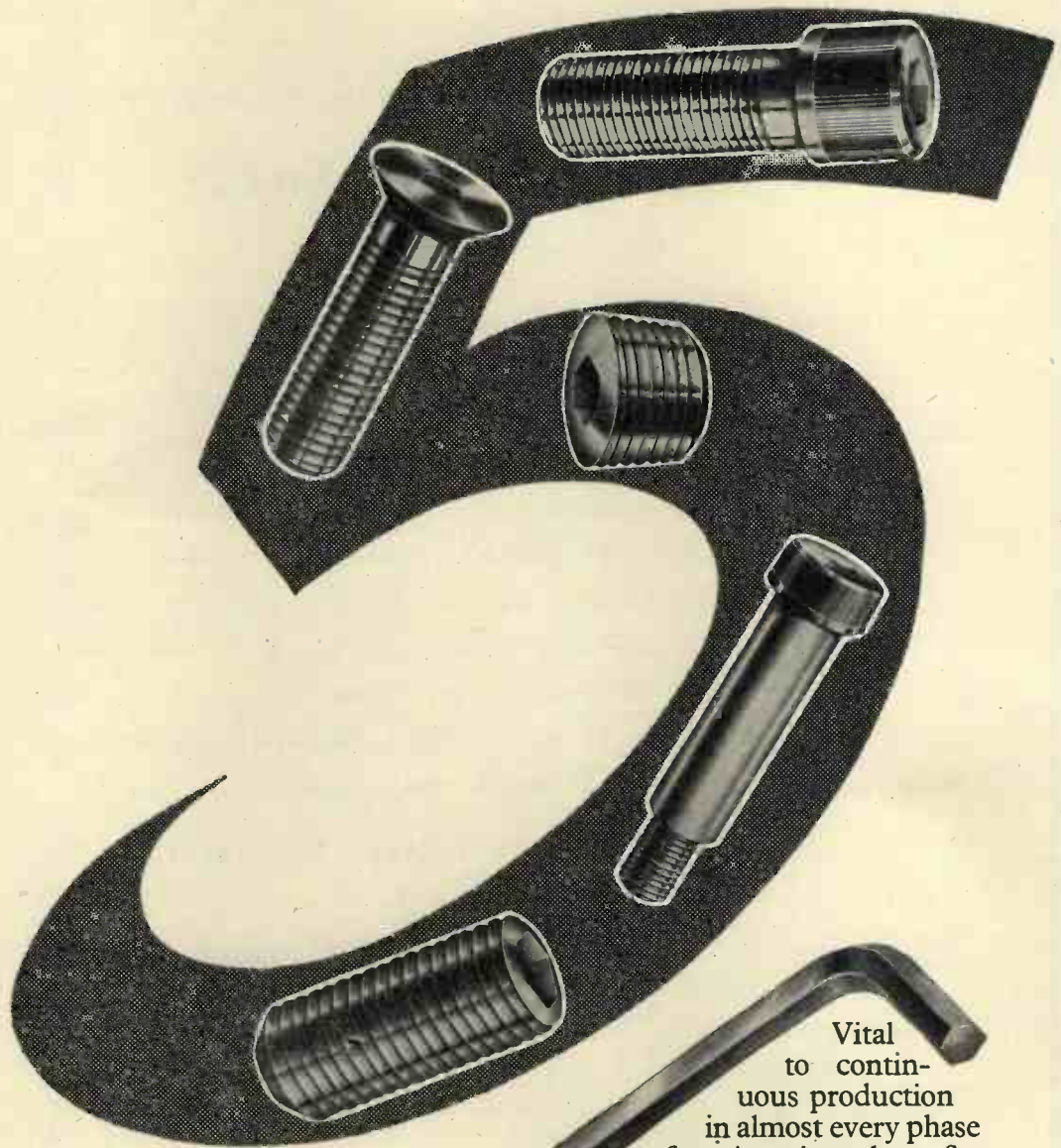

Vital to continuous production in almost every phase of engineering, these five Unbrako standard screw products are always available from Unbrako Distributors throughout the world in a wide range of sizes and threads.

Made to the exacting quality specification of the world's largest specialist screw manufacturers.

**UNBRAKO SOCKET SCREW CO. LTD.**  
**COVENTRY ENGLAND**



# Sealed *with 'Araldite'*

Outstanding adhesion to metals and excellent electrical and mechanical properties combine to make 'Araldite' "the resin of choice" for sealing electrical components. Exceptionally low shrinkage on setting plus resistance to high temperatures,

humidity and corrosive agents contribute further to the success of this new epoxy resin for potting or casting applications. 'Araldite' complies with the requirements stipulated for the sealing of Service equipment. Our illustration of a transformer potted in 'Araldite' is published by courtesy of the makers, Messrs. Evershed & Vignoles Ltd., who also use the same resin for sealing resistances and valve assemblies.

'Araldite' epoxies are simplifying production in many industries. Nowhere, however, is their contribution more important than in the potting and sealing of components for radio, electronics and electrical engineering generally.

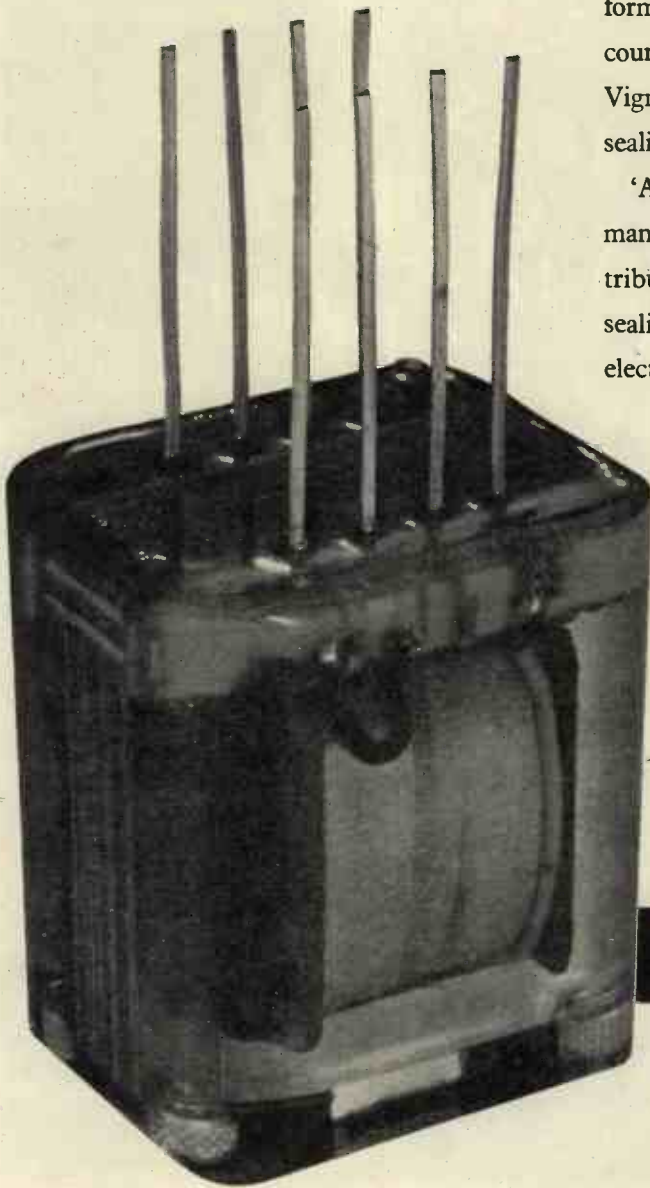

#### THESE ARE THE NEW EPOXIES!

'Araldite' (regd.) epoxy resins are obtainable in the following forms:—

*Hot and Cold setting adhesives for metals, and most other materials in common use.*

*Casting Resins for the electrical, mechanical and chemical engineering industries.*

*Surface Coating Resins for the paint industry and for the protection of metal surfaces.*

*Full details will be sent gladly on request*

## 'Araldite'

*casting resins*

**Aero Research Limited**

*A Ciba Company*

DUXFORD, CAMBRIDGE. Telephone: Sawston 187

Ⓢ 264-64A

Prompt delivery

Competitive Prices

LOW LOSS  
**CERAMICS**  
for the Electronic Industry

Write for full  
particulars from

**TAYLOR TUNNICLIFF (REFRACTORIES) LTD.**

ALBION WORKS · LONGTON · STOKE-ON-TRENT

Telephone: Longton 33122

London Office: 125 HIGH HOLBORN, W.C.1

Telephone: Holborn 1951/2



# First light Alloy transformer tank in this country in 'MG 5' by Ferranti

This 10 MVA 33/11 kV 3-phase transformer erected at Irving sub-station, Kilmarnock, by Ferranti Ltd. is the first to have tank and cover fabricated in light alloy. It is constructed in 'MG 5' plate and extruded sections welded throughout, the thickness ranging from  $\frac{3}{8}$ " to  $1\frac{1}{4}$ " with extruded stiffener sections where necessary. The tank, inside measurements 10' x 8 x 4' 6", is still only half the weight of its steel counterpart even with this added strengthening, and successfully retains hot transformer oil under conditions of alternating pressure and partial vacuum. New uses are continually being found for the versatile aluminium alloys comprised in the comprehensive range of specifications produced by James Booth, and our Development Department will be glad to discuss the use of these modern materials with any manufacturers entirely without obligation.

*The two photographs on the right, taken in the Ferranti Factory, and reproduced by courtesy of British Oxygen Co. Ltd., show the method of internal stiffening and various flanges in position prior to welding.*

*The illustration of the transformer shown below is reproduced by courtesy of Ferranti Limited and the South-West Scotland Electricity Board.*

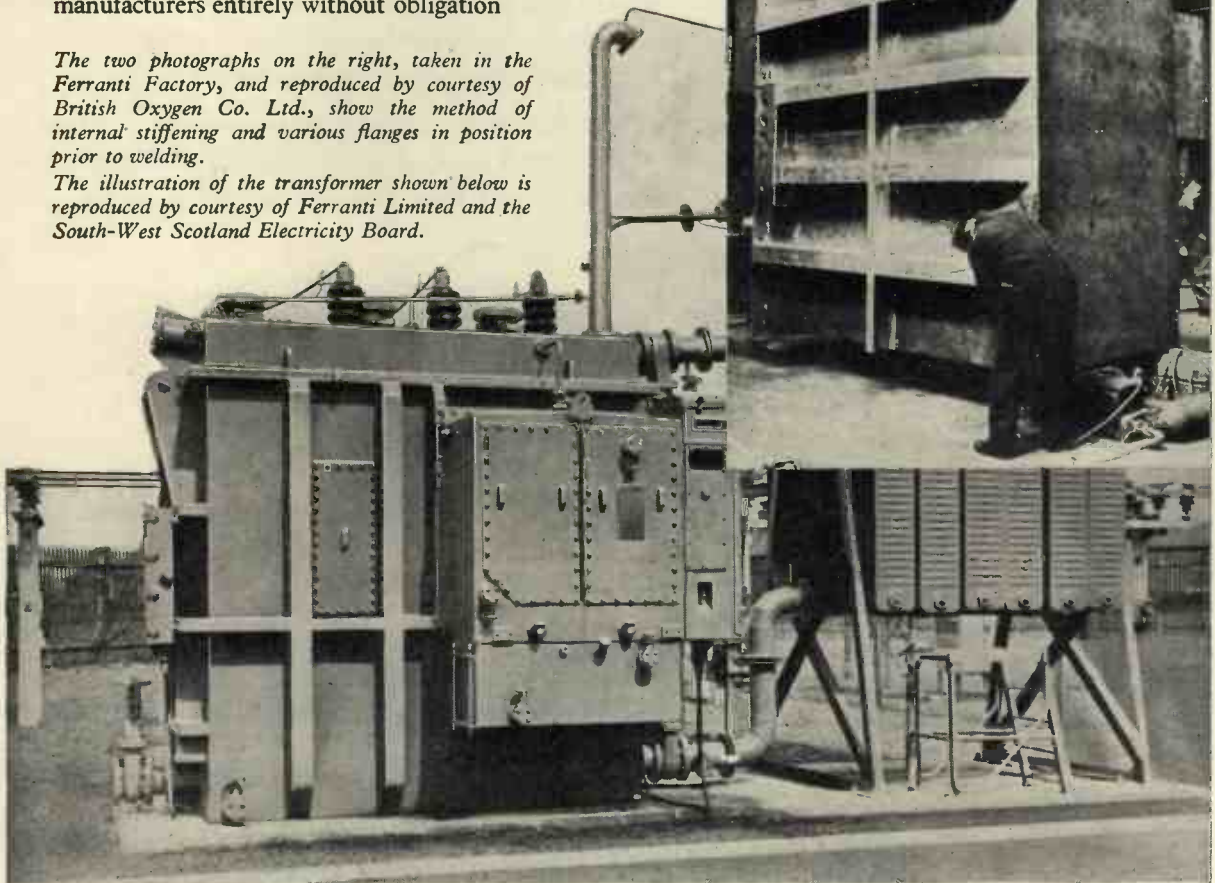

JAMES BOOTH & COMPANY LIMITED  ARGYLE STREET WORKS - BIRMINGHAM 7

TRI

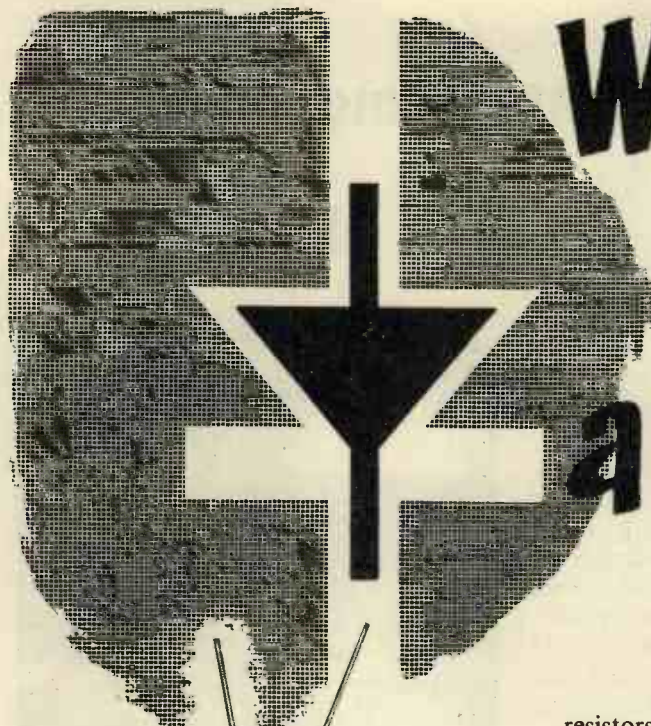

# When is this *NOT* a rectifier?



The answer, of course, is when it's a UNISTOR . . . from that useful range of asymmetric resistors made by *Standard*. SenTerCel Unistors have a wide field of application in electronic circuits, particularly those associated with digital computers and other equipments of a similar nature.

Four current ratings are at present available . . . 0.25 mA, 1.5 mA, 7 mA and 10 mA at various D.C. voltages between 20 and 100V.

*Here are some specimen data.*

Unistor Code	D.C. Current Rating in Max. Ambient Temp.		Maximum Continuous Inverse D.C. Voltage Volts	Maximum Instantaneous Inverse D.C. Voltage Volts	Capacitance at Approx. Zero Volts pF
	55°C.	71°C.			
	mA	mA			
Q1/1	0.25	0.25	20	56	20
Q3/1	1.5	1.5	20	56	65
Q6/1	7	3	20	56	500
Q8/1	10	4	20	56	1,000

## *SenTerCel* **UNISTORS** (asymmetric resistors)

*Standard Telephones and Cables Limited*  
Registered Office: Connaught House, Aldwych, W.C.2

**RECTIFIER DIVISION:** Warwick Road, Boreham Wood, Hertfordshire  
Telephone: Elstree 2401      Telegrams: Sentercel, Borehamwood

# G.E.C.

# QUARTZ CRYSTAL UNITS

## for Long Term Stability

### Q.C. 327

Frequency range 6,000 Kc/s to 16,000 Kc/s  
Tolerance  $\pm 0.01\%$  or  $\pm 0.005\%$

Type BA,  
frequency change not exceeding 0.01% from 0°C to +70°C

Type DA,  
frequency change not exceeding 0.01% from -30°C to +45°C

Type EA,  
frequency change not exceeding 0.002% from +65°C to +80°C

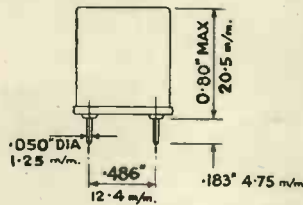
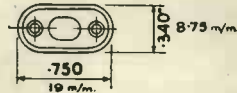

Gross weight 3.5 ozs (99 gms)  
Nett weight 0.15 oz (4.25 gms)

This style holder corresponds to Inter Services style D and the U.S. style H.C./6 U.

For further details please apply to:-

## SALFORD ELECTRICAL INSTRUMENTS LTD.

A SUBSIDIARY OF THE GENERAL ELECTRIC CO. LTD. OF ENGLAND

PEEL WORKS SILK ST. SALFORD 3 LANCS

There's 1 way  
2 store resistors  
X asperation  
to prevent



The **LAB**  
TESTED  
CONTINUOUS  
**STORAGE UNIT**

**T**HE LABpak Continuous Storage Unit has the maximum points in its favour when it comes to storing resistors. The permutations of the number of preferred values, ratings and tolerances amount to 870, yet the element of chance in selecting the desired resistor is eliminated by the LABpak.

The correct choice is a matter of seconds and certainty, for the resistors are carded in ohmic values etc., and selected with card index simplicity. Empty cards are merely replaced from stock.

This ingenious, foolproof, time-saving continuous storage unit is FREE with the initial purchase of 180 type "R" or 240 type "T" resistors of your chosen values. It will pay you dividends.

BRITISH PATENT No. 680632

**RESISTOR SPECIFICATION**

Ref.	Type	Loading	Max. Volts	Range	Dimensions
T	½-watt	½-watt	253	10 ohms	3" × 3/8"
R	½-watt	1-watt	500	to 10 megohms	3" × 1/2"

Tolerance available ±20%, ±10%, ±5%

The Lab Continuous Storage Units are available from your normal source of supply, but more detailed information can be obtained on request.

**THE RADIO RESISTOR COMPANY LTD.**

50 ABBEY GARDENS, LONDON, N.W.8 • Telephone: Maida Vale 5522



*By Appointment to the Professional Engineer*

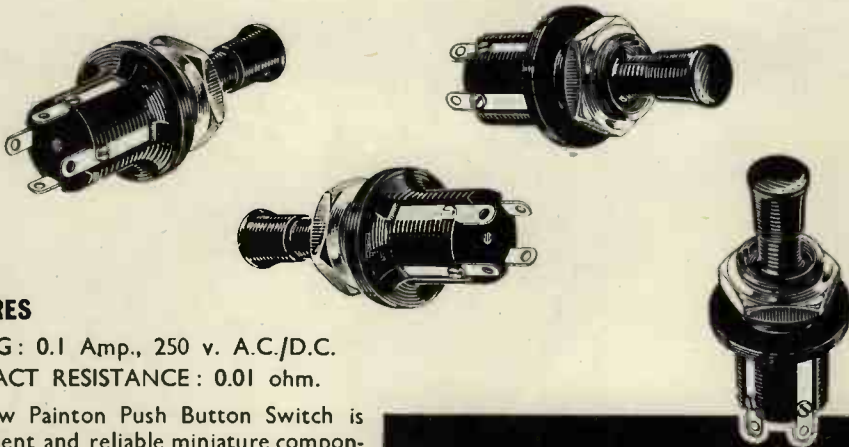

**MINIATURE  
PUSH BUTTON  
SWITCH**

**FEATURES**

**RATING:** 0.1 Amp., 250 v. A.C./D.C.  
**CONTACT RESISTANCE:** 0.01 ohm.

The new Painton Push Button Switch is an efficient and reliable miniature component combining safe electrical operation with robust mechanical action. The highest electrical grade material is used for the knob, shaft and inner body, which are produced as one solid moulding. The design of the contacts ensures minimum fatigue, and the retention of low contact resistance over a long period and under wide variation of atmospheric conditions.

The non-locking version is particularly suitable for metering, monitoring and also inter-communication system applications.

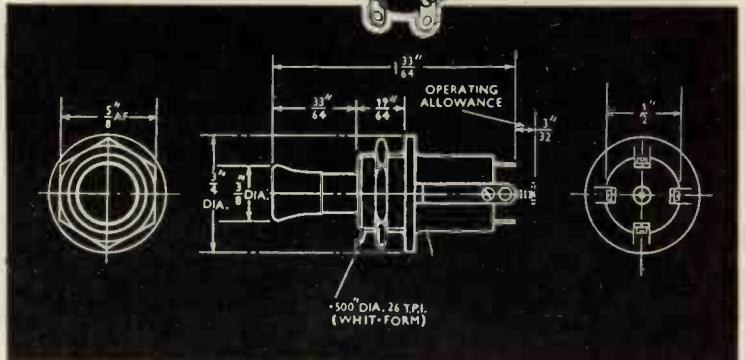

Cat. Number	501404	501405	501406	501407
<b>Mechanical Action</b>	Non-Locking	Locking	Non-Locking	Locking
<b>Electrical Action</b>				
501404 }	Switch in normal position: Contacts 1 and 2 made, Contacts 3 and 4 open. Switch operated: Contacts 1 and 2 open, Contacts 3 and 4 made. (By cross connection of the contacts, single pole changeover operation may be obtained).			
501405 }				
510406 }	Switch in normal position: Contacts 1, 2, 3 and 4 open.			
510407 }	Switch operated: Contacts 1, 2, 3 and 4 commoned.			

**PAINTON**  
*Northampton England*

**ATTENUATORS AND FADERS • STUD SWITCHES • FIXED AND ADJUSTABLE WIREWOUND RESISTORS  
WIREWOUND POTENTIOMETERS • MIDGET R.F. CHOKES • HIGH STABILITY CARBON RESISTORS • TERMINALS  
PLUGS AND SOCKETS • KNOBS, DIALS AND POINTERS • TOGGLE SWITCHES • PUSH BUTTON SWITCHES**



## Excellent Opportunities for the right men

We are a young firm just four years old. In these four years we have achieved an outstanding reputation for a vigorous policy of research, development, production and commercial enterprise. Working as a team we have secured the position of the world's leading marine radar company.

Our present programmes embrace a wide field of radar research, covering some of the most advanced techniques in the world, and the breadth and scope of these programmes ensures our future success. Our achievements have been won by team work, and we have now a unique group of men, able, experienced and, above all, enthusiastic and energetic. Our expanding activities however demand that we seek more men of this type.

Excellent opportunities exist at various levels in all branches of our organisation, and particularly in our Research and Development Laboratories for radar and electronic engineers, mechanical designers and draughtsmen. If you are experienced in these fields or feel you have qualifications which would enable you to make a real contribution to our activities please write to us at once. There is plenty of scope for men of ability to move forward in this progressive company. Your letter which will be treated in the strictest confidence should be addressed to :

**The Managing Director DECCA RADAR LIMITED, 1-3, BRIXTON ROAD, LONDON, S.W.9.**

D.R.335





Mullard Ferroxcube being extruded into rods for H.F. cores.

**MAGNETIC MATERIALS**

Extensive research and manufacturing facilities have established Mullard as the leading producers of magnetic materials. They were the first, for example, to introduce Ferroxcube, the world's most efficient magnetic ferrite; 'Ticonal' anisotropic permanent magnets, renowned for their high stability and high energy output; and Magnadur, an entirely new type of permanent magnet with the insulating properties of a ceramic.

The wealth of experience gained from these developments is available to all users of magnetic materials through the Mullard advisory service. An enquiry to the address below will put a team of specialised engineers at your disposal.



**Mullard**

'TICONAL' PERMANENT MAGNETS • MAGNADUR (Formerly Ferroxidure)  
PERMANENT MAGNETS • FERROXCUBE MAGNETIC CORE MATERIAL

MULLARD LTD., COMPONENT DIVISION, CENTURY HOUSE, SHAFTESBURY AVENUE, LONDON, W.C.2.

**THESE ARE OUR PRODUCTS**

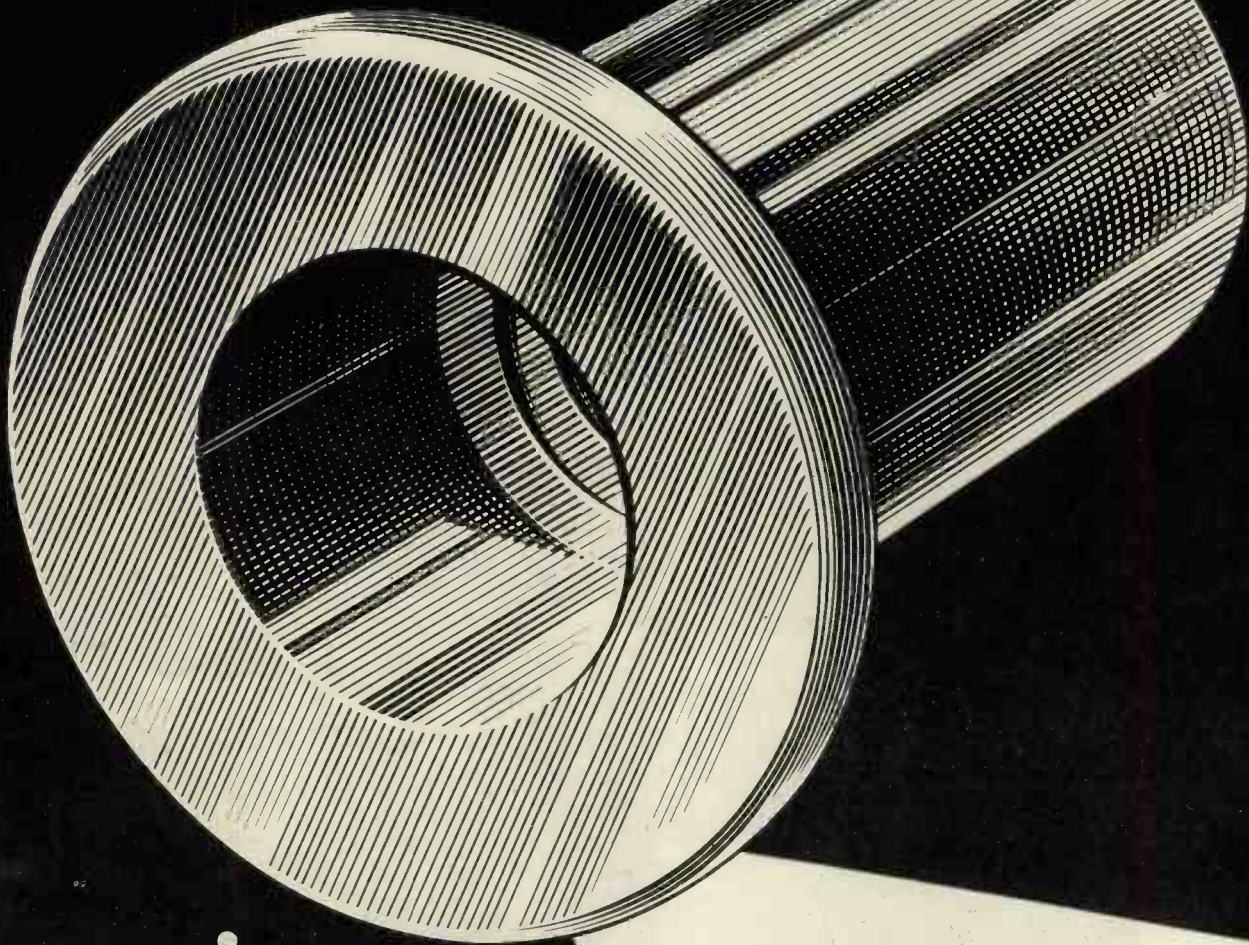

**No. 6** → **the rivnut**

The sixth and last in this series of advertisements devoted to our products, the very essence of the Rivnut is its versatility. You can fasten *with* it and *to* it—or do *both* at once. You can use it as a blind rivet or nut plate, or both. Strong, light and really simple to use, the Rivnut can be upset with a simple tool entirely from one side of the work, and is threaded internally to provide an additional firm anchorage to which further attachments may be made.

*This series of advertisements may serve to give some brief indication of the scope of our organisation, and our range of products: And everything we make reflects the experience of over a quarter of a century devoted to achieving the highest standards of quality and service.*

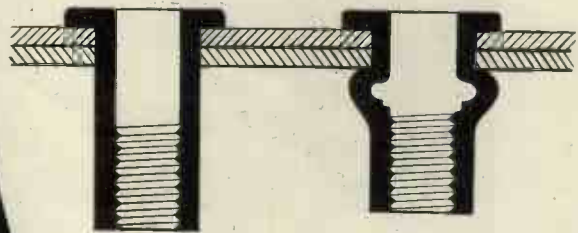

**Linread**

A28

# The *NEW* Muirhead-Wigan decade oscillator



TYPE D-650-A

**T**HIS precision laboratory oscillator, which covers a range of 1 to 111,100c/s with an overall frequency accuracy of  $\pm 0.2\%$  or  $\pm 0.5c/s$ , employs the decade tuning system, by means of which the frequency can be set quickly and accurately on four decade dials and a range switch. This system of tuning ensures the highest possible frequency accuracy and stability. It also enables a given frequency setting to be repeated exactly, and permits the addition or subtraction of a fixed number of cycles per second, thus giving an incremental accuracy of an extremely high order. No other type of oscillator possesses all these advantages.

## FEATURES

- Frequency range: 1-11,110c/s and 10-111,100c/s.
- Frequency accuracy:  $\pm 0.2\%$  or  $\pm 0.5c/s$ .
- Hourly frequency stability:  $\pm 0.02\%$  over most of range.
- Maximum output:
  - 2W into 8000 ohms above 20c/s.
  - 50mW into 8000 ohms below 20c/s.
- Harmonic content: 1% at 1W output.
- Hum level:  $-80\text{db}$  relative to maximum output at 1000c/s.
- Power supply: 200-250V, 50c/s; 90W. or 95-125V, 60c/s; 90W.
- Dimensions:  $17\frac{1}{2}$  in. wide x  $10\frac{1}{2}$  in. high x 13 in. deep. (43.8 cm x 26.7 cm x 33 cm).
- Weight: 83 lb. (38 kg).

MAIL THIS COUPON  
FOR DESCRIPTIVE  
BROCHURE

NAME \_\_\_\_\_

POSITION \_\_\_\_\_

COMPANY \_\_\_\_\_

ADDRESS to which BROCHURE should be sent  
\_\_\_\_\_  
\_\_\_\_\_



**MUIRHEAD & CO. LIMITED · BECKENHAM · KENT · ENGLAND**

HEAT STABLE, WATER REPELLENT

**SILICONE**

**Dielectric materials**

*Now available in the following forms*

### LIQUID DIELECTRICS

MS 200 fluids are clear, inert liquids having almost any desired viscosity; they are notable for their heat-stability and resistance to moisture. With a permittivity about 2.75 and a power factor of less than 0.0001 from 1 kc/s to over 10 Mc/s and from  $-35^{\circ}\text{C}$ . to  $+150^{\circ}\text{C}$ , MS 200 fluids are unique among liquid dielectrics.

*USES: Capacitors and small transformers.*

### DIELECTRIC COMPOUND

MS 4 compound is a non-melting, water-repellent paste which retains its grease-like consistency from  $-50^{\circ}\text{C}$  to  $200^{\circ}\text{C}$ . It is highly resistant to oxidation and deterioration caused by corona discharge. Power factor is less than 0.001 up to 10 Mc/s; volume resistivity is more than  $10^{12}$  ohm cms up to  $200^{\circ}\text{C}$ . Electric strength is more than 500 volts/mil at a 10 mil gap.

*USES: Potting and sealing compound for electronic components, disconnectable plugs and sockets. Lubricant and protective agent for plastic and rubber cables, grommets and seals. Damping medium in gramophone pick-ups.*

### \*SILASTOMER SILICONE RUBBER

Silastomer combines the remarkable heat stability and moisture resistance of resinous silicones with the physical properties of rubber, including resilience, shock-and-abrasion-resistance, and resistance to both mechanical and electrical fatigue. Its dielectric properties show little change over a wide range of frequencies, even after ageing at high temperatures. The surface resistivity of Silastomer is high, and its thermal conductivity is about twice as great as that of either organic rubber or resinous insulating materials. New Silastomer stocks and pastes with greatly improved physical properties are now available.

*USES: Flexible cloth, tapes and sleeving, grommets, gaskets and terminal bushings. Flexible heater pads. Primary insulation on cables and coil end flexibles. Impregnant for coils.*

### SILICONE GLASS LAMINATES

Thermosetting silicone resins are used to bond inorganic fabrics and finely divided particles such as powdered metals or mica. Typical  $\frac{1}{8}$ " silicone-glass laminates have a tensile strength of up to 30,000 lb./sq. in. Power factor 0.002 at 1 Mc/s. Wet insulation resistance greater than  $10^{10}$  ohms. Electric strength of 250-300 volts/mil. Effective temperature resistance of recently developed laminates,  $300^{\circ}\text{C}$ .

*USES: These laminates can be machined and are used as panels, coil formers and structural insulation.*

### ELECTRICAL INSULATING VARNISHES

MS 997 is a new, low-loss impregnating varnish. It has a thermal life of more than 1,000 hours at  $250^{\circ}\text{C}$ , and shows little tendency to bubble when cured at  $150^{\circ}\text{C}$  to  $200^{\circ}\text{C}$ .

*USES: Impregnating coils, resistors and components subjected to high temperature and humidity.*

\*SILASTOMER is a registered trademark of Midland Silicones Ltd.



Write for full information to:

**MIDLAND SILICONES LTD**

An Associate Company of Albright & Wilson Ltd.

FOR BRITISH MADE SILICONES 19 Upper Brook Street, London, W.1. Tel: Grosvenor 4551

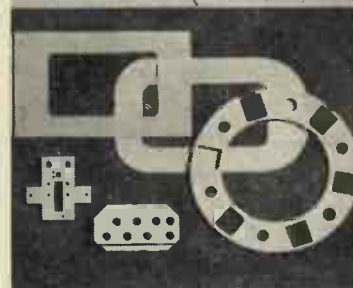
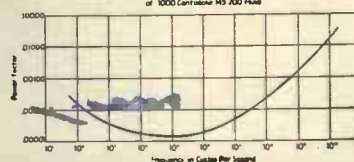

26R/828

# Portable Frequency Meter

MI

## TF 1026 (Series)

### Direct-reading from 250 Mc/s to 4,000 Mc/s

The Marconi Instruments TF 1026 (Series) directly-calibrated absorption wave-meters provide an easy means of checking the frequency of sources of power and together cover the range 250-4,000 Mc/s. Features include: excellent screening due to the type of fully enclosed construction employed; effective scale length of 9 inches; light weight (3 lbs. approx. each instrument); no power supply required.

The degree of coupling between input and resonant circuits is such that the accuracy of the calibration is substantially independent of changes in the type of input circuit, whether by stub aerial or direct by feeder.

Tuning is accomplished by means of a variable lumped capacitance across the line input. The effective Q is extremely high, due to the very low series resistance.

The meter covering the highest range, 2,000-4,000 Mc/s (instrument illustrated), has an additional wavelength calibration indicating in red each half-centimetre.

The meters are supplied, complete with appropriate feeder cables, etc., in polished hardwood carrying cases measuring 7 in.  $\times$  7 $\frac{1}{2}$  ins.  $\times$  8 $\frac{1}{2}$  ins.

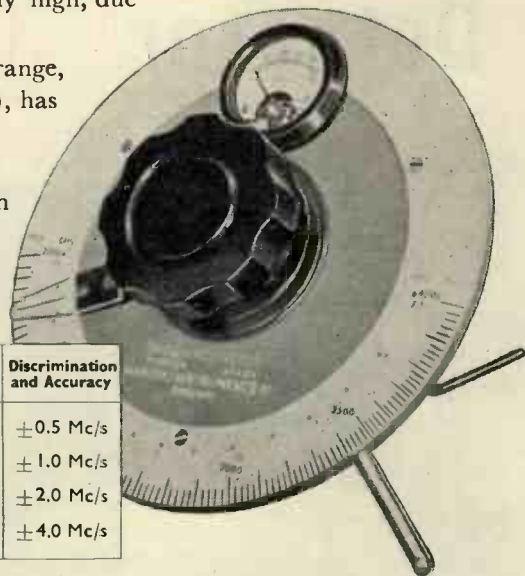

Type	Range Mc s	Temp. Coeff. per deg. C.	Discrimination and Accuracy
TF 1026/1	250/500	-1/30,000	$\pm 0.5$ Mc/s
TF 1026/2	500/1,000	-1/25,000	$\pm 1.0$ Mc/s
TF 1026/3	1,000/2,000	-1/50,000	$\pm 2.0$ Mc/s
TF 1026/4	2,000/4,000	-1/50,000	$\pm 4.0$ Mc/s

## MARCONI INSTRUMENTS

SIGNAL GENERATORS · BRIDGES · VALVE VOLTMETERS · FREQUENCY STANDARDS  
WAVEMETER $\ddot{s}$  · WAVE ANALYSERS · BEAT FREQUENCY OSCILLATORS · Q METERS

MARCONI INSTRUMENTS LTD · ST. ALBANS · HERTS · TELEPHONE: ST. ALBANS 6161/7

Midland Office: 19 The Parade, Leamington Spa. Northern Office: 30 Albion Street, Kingston-upon-Hull.

Export Office: Marconi House, Strand, London, W.C.2.

C 66

# Waveguide Impedance Measurement

Unique features of design  
give extreme accuracy

## Metrovick Standing Wave Detector TYPE 512

This instrument consists of a waveguide section built up from solid material, and a moving carriage, on which is mounted a tunable crystal detector.

The carriage is of the non-contacting type, and is located directly from the inside surface of the waveguide, thus eliminating any variation in probe penetration along the travel of the carriage.

This unique feature makes possible extreme accuracy in the measurement of waveguide impedances.

It has been designed for operation over the band of wavelengths from 10 cms. to 11 cms. in size 10 standard waveguide and it is fitted with Inter-Service Standard waveguide connectors.

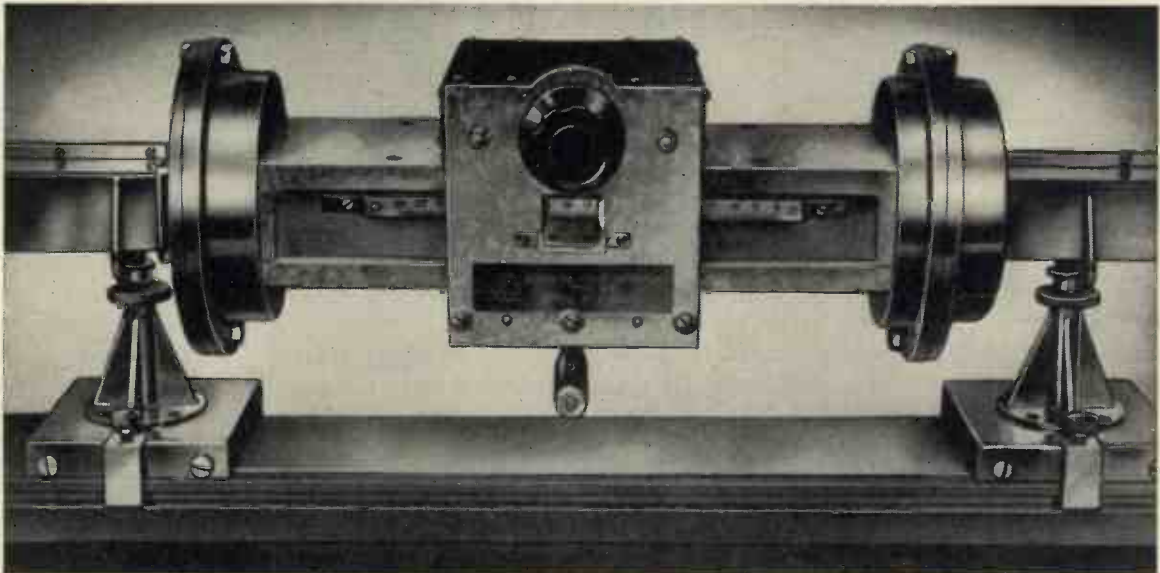

METROPOLITAN-VICKERS ELECTRICAL CO. LTD., TRAFFORD PARK, MANCHESTER 17  
*Member of the A.E.I. group of companies*

**METROVICK** *Test gear for the microwave laboratory*

R/E 204

# For a good rare atmosphere

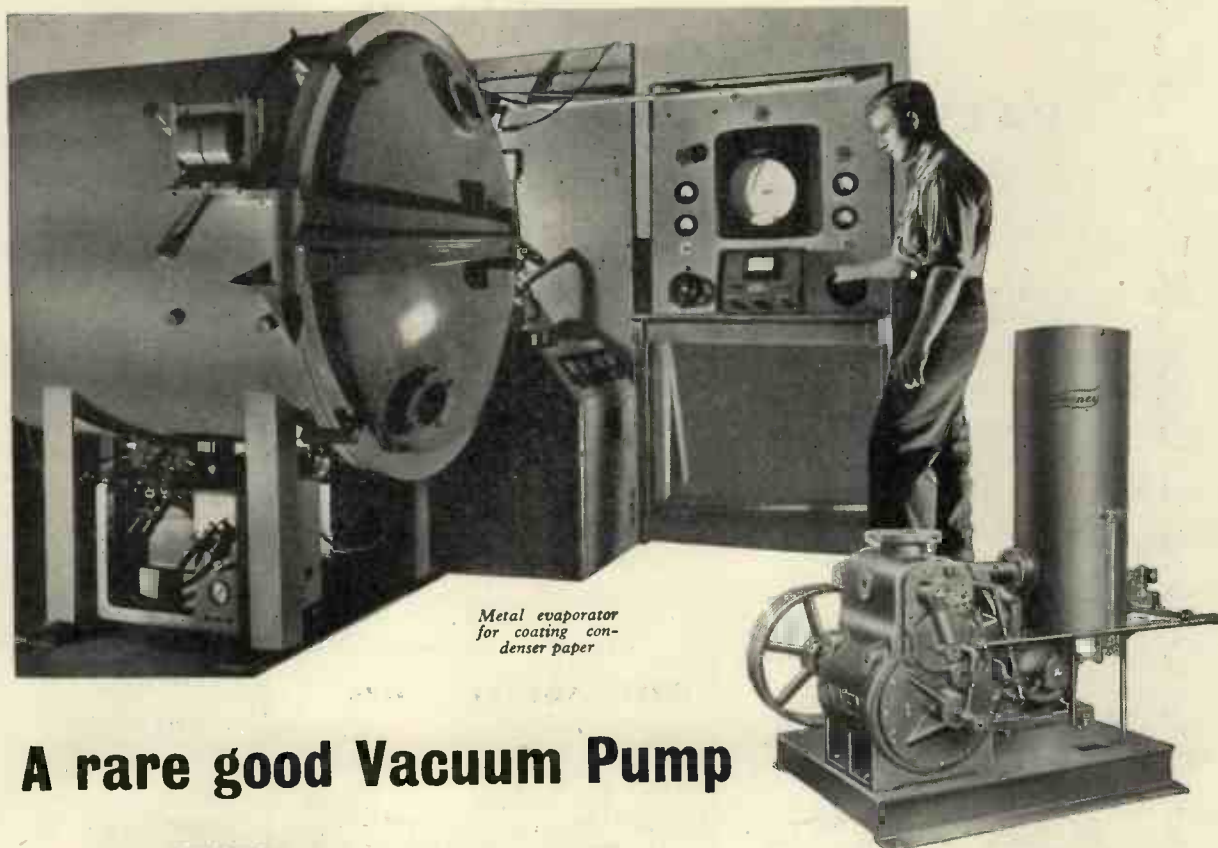

*Metal evaporator  
for coating con-  
denser paper*

## A rare good Vacuum Pump

# ... Kinney

Many of to-day's products take shape through being processed in atmospheres rarefied by Kinney Vacuum Pumps. Penicillin, titanium, cathode ray tubes, coated mirrors and lenses, blood plasma, dehydrated foodstuffs and oils, metal coated foils and condenser papers, orange juice, electrical impregnated components "improved" wood, are a few examples. Wherever vacuum processing is applicable, Kinney pumps give the lowest cost results.



**GENERAL ENGINEERING CO. (RADCLIFFE) LTD., Station Works, Bury Road, Radcliffe**  
Telephone RADcliffe 2291/3 (3 lines) London Office: 3rd Floor, 9 Victoria Street, London, S.W.1. Tel.: ABBey 5278

FEBRUARY, 1954

A 33

ELECTRONIC ENGINEERING



# Pointers for Designers

AND CONSTRUCTORS  
NUMBER ELEVEN

## VALVES FOR TAPE RECORDERS

Service in tape recorder amplifiers makes stringent demands on the valves used, particularly in the early stages.

Operation in high gain circuits with a considerable degree of bass boost, and in a confined space in close proximity to a loudspeaker, places a premium on freedom from microphony and hum.

The typical Osram valve line-up shown has proved entirely satisfactory in practice for tape recorder applications. The use of the Z729 low noise pentode, allied with a suitable circuit layout, ensures the virtual elimination of induced hum.

INPUT STAGE <b>Z729</b>	Tone correction and intermediate stages <b>B309</b>	Output and bias oscillator <b>N727/6AQ5 or N78</b>		Rectifier <b>U709</b>
<i>low noise pentode</i>	<i>double triode</i>			<i>full-wave rectifier</i>
$V_h$ 6.3V $I_h$ 0.2A $V_a$ 250V $V_{g2}$ 140V $g_m$ 1.85m/A/V $V_{hum}$ 1.5 $\mu$ V $R_{g1-k} = 470k\Omega$ Base B9A	$V_h$ 6.3V $I_h$ 0.6A $V_a$ 250V $g_m$ 5.5 mA/V $r_a$ 10 k $\Omega$ Base B9A	$V_h$ 6.3V $I_h$ 0.45A $V_a$ 250V $V_{g2}$ 250V $I_k$ 50mA $V_{g1}$ -12.5V $P_{out}$ 4.5W Base B7G	$V_h$ 6.3V $I_h$ 0.64A $V_a$ 250V $V_{g2}$ 250V $I_k$ 40 mA $V_{g1}$ -5V $P_{out}$ 4W Base B7G	$V_h$ 6.3V $I_h$ 0.95A $V_{h-k}$ 450V (max.) $V_{in}$ 350 rms (max.) $I_{out}$ 150 mA Base B9A <i>The heater-cathode rating of the U709 permits operation from a common 6.3V heater winding</i>

For further information and full technical data write to :

The Osram Valve and Electronics Dept.

THE GENERAL ELECTRIC CO. LTD., MAGNET HOUSE, KINGSWAY, LONDON, W.C.2



# A dependable low-frequency standard



The Ediswan Low Frequency Oscillator type R.666 provides a dependable low frequency standard for testing, calibration and set up of biological amplifiers and recorders, strain and vibration recorders, and low frequency wave analysers.

Production of this Oscillator has been stepped-up to meet the great demand for it and delivery can now be made with little or no delay. Complete the attached coupon or write for further details.

## Brief Specification of Ediswan Low Frequency Oscillator type R.666

**TYPE.** Resistance capacity, with automatic amplitude control effective over the whole frequency range.

**FREQUENCY RANGE.** 1.15 c.p.s. to 5,500 c.p.s. **INPUT.** 200—250 volts, 40—60 c.p.s.

**OUTPUT.** Sine wave 50 volts peak to peak, push-pull, with built-in attenuator.

**CONSTRUCTION.** Standard 19" rack mounting, but also suitable for bench use. Bench stands available.

**NOTES.** An incremental switch is fitted. Provision is made for modulation of output.

**PRICE** £75 nett      **STANDS** £1. 1s. nett



THE EDISON SWAN ELECTRIC CO. LTD.  
155 Charing Cross Road, London, W.C.2.  
Please send me full details of the Ediswan  
Low Frequency Oscillator Type R.666.

NAME.....

ADDRESS.....

.....

.....

.....

# EDISWAN

RADIO DIVISION

THE EDISON SWAN ELECTRIC CO. LTD.,  
155 CHARING CROSS ROAD, LONDON, W.C.2

Member of the A.E.I. Group of Companies

BP. 129

**AUTOMATIC  
FREQUENCY  
MONITOR (1 Mc/s)**

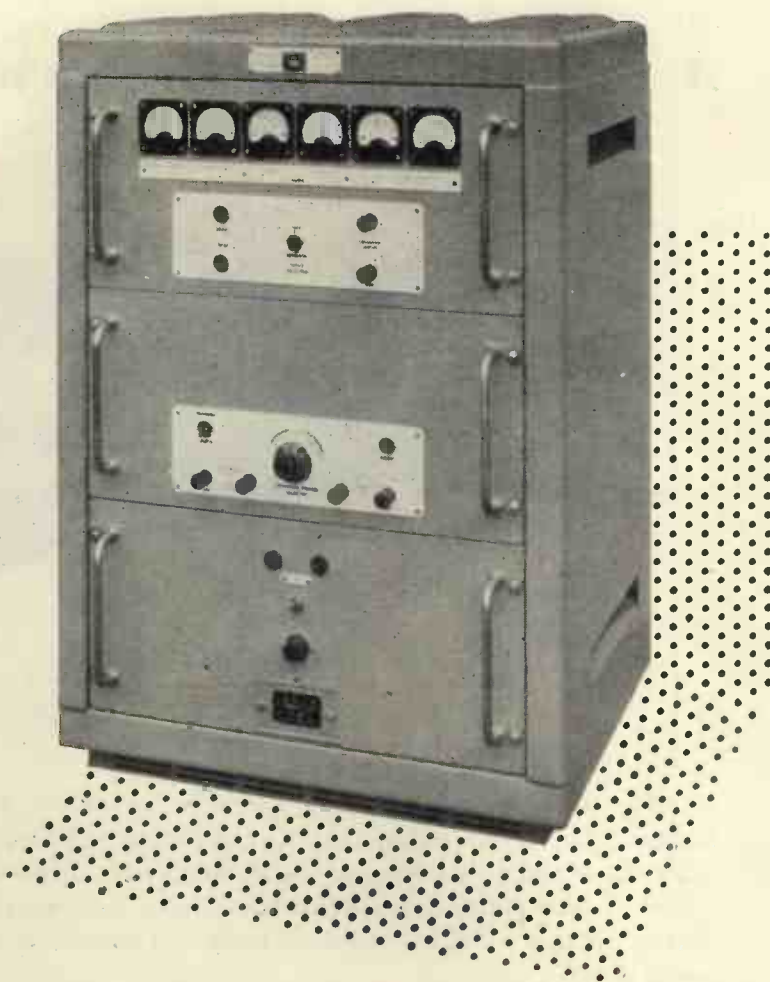

Designed for the measurement of any frequency in the range 10 c/s  
to 1 Mc/s with a basic accuracy of  $\pm 0.005\% \pm 0.1, 1.0, \text{ or } 10 \text{ c/s}$ .

Higher accuracies available if required. The unknown frequency is  
determined by counting the number of cycles that pass through a 'gate'  
open for a selectable time interval of 0.1, 1.0, or 10 seconds. The  
result is presented on six panel mounted meters each scaled 0 to 9  
and is in decimal notation. Full information available on request.

## **CINEMA-TELEVISION LIMITED**

A Company within the J. Arthur Rank Organisation

**WORSLEY BRIDGE ROAD · LONDON · SE26**

Telephone H1Ther Green 4600

SALES AND  
SERVICING AGENTS

F. C. Robinson & Partners Ltd.,  
287 Deansgate, Manchester, 3

Hawnt & Co. Ltd.,  
59 Moor St. Birmingham, 4

Atkins, Robertson & Whiteford Ltd.,  
100 Torrisdale Street, Glasgow, S.2

from 10 to 310 mc/s

Within the small compass of  $14\frac{1}{2}'' \times 12\frac{1}{2}'' \times 8''$ , this generator provides facilities as are normally available only in instruments of much greater size and weight—and with an accuracy which suggests something far more costly. Outstanding features include:

Frequency calibration  $\pm 1\%$  • Max. attenuation error at 300 Mc/s.  $\pm 4$  db. • Modulation (a) 30% sine wave at 1,000 c/s, (b) approximately 50/50 square wave at 1,000 c/s • Negligible stray field • Weight 34 lb.

*Fullest details contained in leaflet M6 sent on request.*

**D1**

**Advance**  
V.H.F. SIGNAL GENERATOR

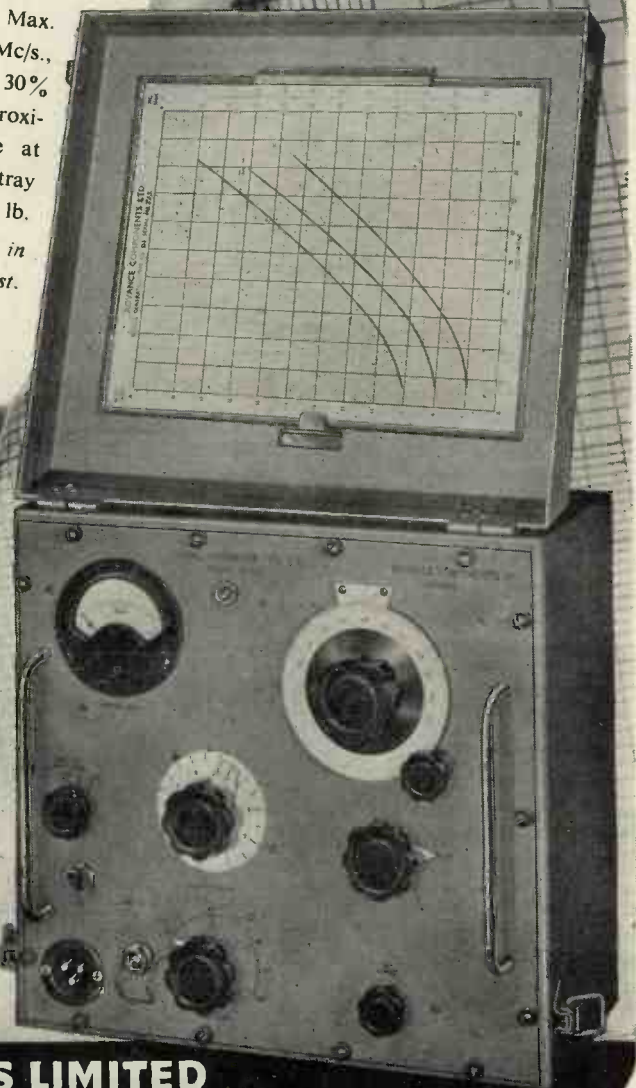

**ADVANCE COMPONENTS LIMITED**

BACK RD., SHERNHALL ST., WALTHAMSTOW, E.17. Phone: Larkwood 4366

# *the answer to many problems*



... will be found within the pages of the Pullin Electrical Measuring Instrument Catalogue. A copy by your side will enable you to plan the instrumentation of your electrical installations at the drawing board stage, and save much time and money later on. Write for a copy stating the particular range of instruments in which you are interested.

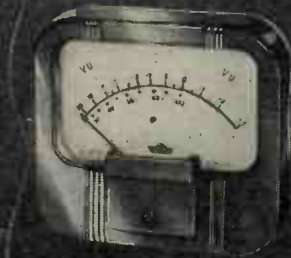

SERIES 35, 3½" DIAL V.U. METER for power level indication.



SERIES 20, 2" DIAL MINIATURE RANGE. Round projecting type also available in round or square flush pattern.



SERIES 25, 2½" DIAL MINIATURE RANGE. Square flush type also available in round projecting or round flush pattern.



ROUND PROJECTING TYPE SWITCHBOARD, INSTRUMENT (4" AND 6" DIAL SIZES). In pressed steel case. Convertible to flush mounting by separate attachment.



RECTANGULAR FLUSH PATTERN INSTRUMENT. With circular pressed steel base and moulded front cover. Heavy duty cast iron front cover also available.

instrumentation by

# PULLIN



Industrial  
Switchboard  
Voltmeters  
Wattmeters

Measuring  
Instruments  
Dynamometer  
Testing Sets  
Frequency Meters

Portable  
Testing Instruments  
Multi-Range  
Test Sets

MEASURING INSTRUMENTS (PULLIN) LTD., ELECTRIC WORKS, WINCHESTER STREET, ACTON, LONDON, W.3.

PHONE: ACORN 4651-3 AND 4995.

**For Quality  
in the Core  
and efficient  
Screening**

## **Electrical STAMPINGS and magnetic SCREENS by MEA**

Pacing progress in the ever expanding field of Electronics the extensive M.E.A. range of standard toolings, plus special patterns on request, are available in all grades of Silicon and Nickel Iron Alloys. Your requirements, standard or special, will receive immediate attention.

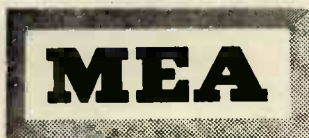

*For Service to Science and Industry  
throughout the field of Electronics*

### **MAGNETIC & ELECTRICAL ALLOYS LIMITED**

Head Office : 101-103, BAKER STREET, LONDON, W.1.

Works : BURNBANK, HAMILTON, LANARKSHIRE.

MANCHESTER : 33, BYROM STREET, DEANS GATE.

BIRMINGHAM : 12, WESTWOOD ROAD, SUTTON COLDFIELD, WARWICKSHIRE.

Tel : Welbeck 3381/2

Tel : Hamilton 932/3/4

Tel : Blackfriars 5223

Tel : Streetly 78586



*The following catalogues are available :—*

*Transformer and Choke Stampings,*

*F.h.p. Motor Stampings,*

*Magnetic Screening Tubes and Cases*

*Nickel Iron Alloys Data,*

*On request to our Head Office.*

*Dept. CF/k.*

# 'VARIAC' voltage regulating transformers

(Reg'd Trade Mark)



'VARIAC'—the original continuously-adjustable auto-transformer—is the ideal device for controlling any a.c. operated equipment. VARIACS not only supply perfectly smooth control of voltage from zero, but on some patterns, there is even an "over-voltage" feature. Illustration left shows the type 200 C.U.H. 'VARIAC'.



Type 50-B 'VARIAC'



Type 100-R 'VARIAC'

## SERIES 200 'VARIAC' TRANSFORMERS

SERIES "200" Variacs							
TYPE	LOAD RATING	INPUT VOLTAGE	CURRENT		OUTPUT VOLTAGE	NO-LOAD LOSS	NET PRICE £ s. d.*
			RATED	MAXIMUM			
200-CM } 200-CU }	860 va.	115 v.	5 a.	7.5 a.	0-135 v.	15 watts	7 17 6 6 15 0
200-CMH } 200-CUH }	580 va.	230 v. 115 v.	2 a. 0.5 a.	2.5 a. 2.5 a.	0-270 v. 0-270 v.	20 watts 20 watts	9 15 0 8 5 9

\* All 'VARIAC' prices plus 20% as from 23rd February, 1952.

Full details of this and other models in the 'VARIAC' range are contained in Catalogue V549, which will gladly be sent on request.

Request also our 20-page Supplementary Catalogue giving complete information on our new and complete range of a.c. automatic voltage stabilisers. These range from 200 VA to 25 kVA. Performance is excellent, from no-load to full load and stability is quite unaffected by frequency variations.

PRICES ARE EXCEPTIONALLY LOW

# CLAUDE LYONS LIMITED

ELECTRICAL AND RADIO LABORATORY APPARATUS, ETC.

180, Tottenham Court Road, London, W.1; and 76 Oldhall Street, Liverpool, 3, Lancs.

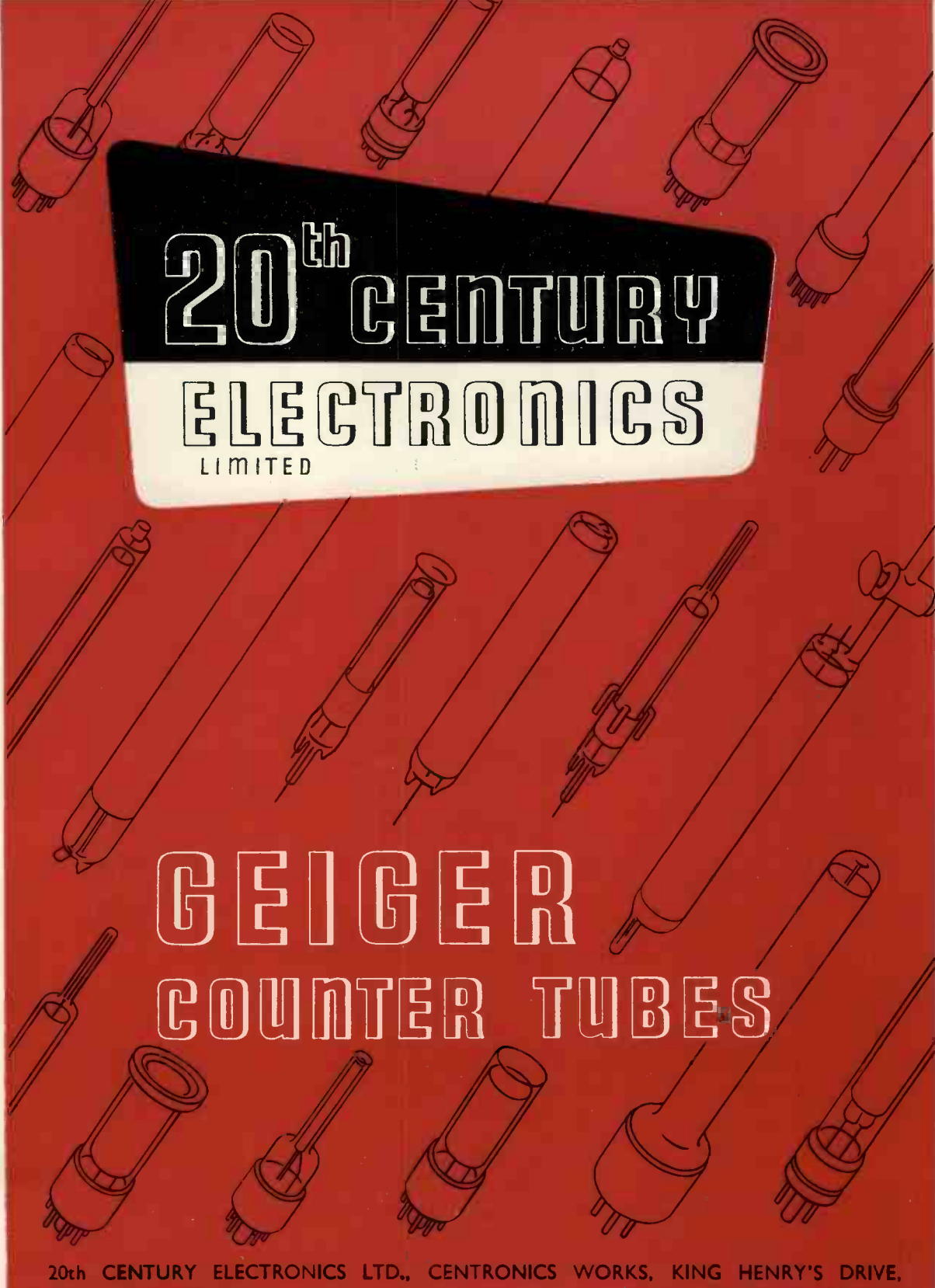

**20<sup>th</sup> CENTURY**  
**ELECTRONICS**  
LIMITED

**GEIGER  
COUNTER TUBES**

20th CENTURY ELECTRONICS LTD., CENTRONICS WORKS, KING HENRY'S DRIVE,  
NEW ADDINGTON, SURREY.

Telephone : Springpark 1026.

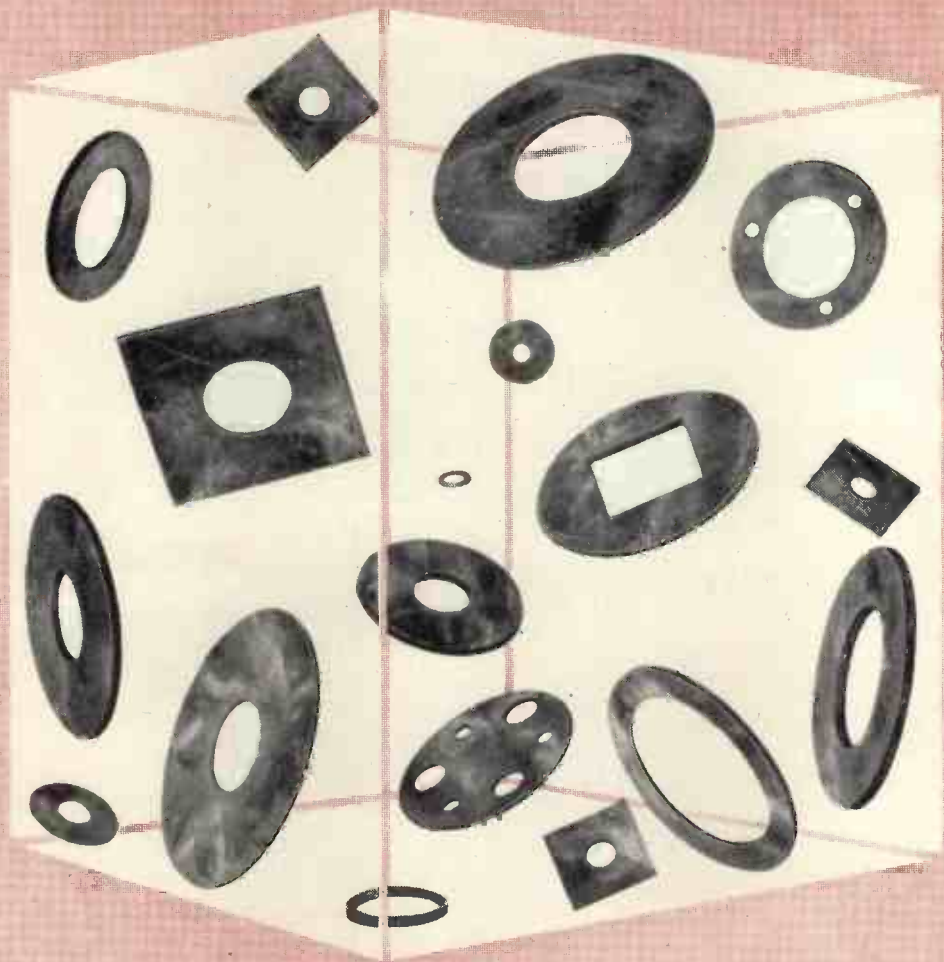

## Keeping Electricity in its proper place

MICA WASHERS are the economic and efficient answer to many problems in all forms of electrical apparatus. Produced in an almost endless variety of shapes and sizes, these washers can be manufactured in practically unlimited quantities by M & I with their unique facilities at Empire Works. Up to about 0.040" the block mica can be used in its natural thicknesses, but above this thickness it is customary to build up the block with a suitable cement.

The manufacture of washers from block mica is normally confined to diameters not exceeding about 2.5". Above this size it is more economical to machine washers from micanite sheet, the grade normally employed being Hard Micanite Board.

**m and i**

### THE MICANITE & INSULATORS CO. LTD.

Empire Works, Blackhorse Lane, Walthamstow, London, E.17

BRANCH OFFICES AT BIRMINGHAM, CARDIFF, GLASGOW, MANCHESTER AND NEWCASTLE-UPON-TYNE AND REPRESENTATIVES IN MOST COUNTRIES THROUGHOUT THE WORLD.

Manufacturers of MICANITE (Built-up Mica Insulation). Fabricated and Processed MICA. PAXOLIN Laminated Materials. PANILAX Laminated Materials and Mouldings. EMPIRE Varnished Insulating Cloths and Tapes. HIGH VOLTAGE BUSHINGS and TERMINALS. Distributors of Micoflex-Duratube Sleeveings, Micoflex-Durasleeve (Plastics-covered flexible metal conduit) and Kenutuf Injection Mouldings (in most thermoplastics including P.V.C.).





# SUNVIC TIME DELAY SWITCHES

- Adjustable delays from 15 sec. to 6 min.
- Ambient temperature compensation
- Accuracy of repeat operation
- Rating 5 Amp.

*For Interlocking, Sequence switching, Protection etc.*

*Manufacturers of Hotwire Vacuum Relays, Accurate Thermostats, Electronic Relays, Resistance Thermometers and Controllers, Energy Regulators, Automatic Cold Junction Thermostats, D.C. Amplifiers, etc. etc.*

**SUNVIC CONTROLS LIMITED, SUNVIC HOUSE, 10, ESSEX STREET, STRAND, LONDON W.C.2**

*Member of the A.E.I. Group of Companies*

*Orders and Enquiries: Sales Dept., No. 1 Factory, Eastern Industrial Estate Harlow Essex Tej: Harlow 2031*



# MOLYBDENISED LISTATE GREASE\*



**MOLY  
INSURES  
AGAINST  
GREASE  
STARVATION**

\* the perfect  
all purpose  
grease

Molybdenised Listate Grease consists of a special lithium base grease which is fully water repellent, plastic at  $-40^{\circ}\text{F}$ , with a melting point of  $350^{\circ}\text{F}$ , reinforced with Molybdenum Disulphide. The grease itself will give adequate lubrication in normal conditions whilst the Molybdenum Disulphide will build up a surface of extremely low coefficient of friction on all working surfaces to ensure efficient lubrication should the grease break down due to such causes as extreme conditions or lack of servicing. The use of Molybdenised Listate Grease will ensure efficient working of all grease lubricated components for a considerably longer period than any other grease.

**RAGOSINE  
MOLYBDENISED  
LUBRICANTS**



Write or brochure giving full details to :

**ROCOL LTD.**

(A subsidiary of Ragosine Oil Co. Ltd.)

**IBEX HOUSE, MINORIES, LONDON, E.C.3  
MINERVA WORKS, WOODLESFORD, NR. LEEDS.**

n.d.h. 01574/B.



**SEALED**

*against all conditions!*

We supply manufacturers of electronic equipment throughout the world, but, whatever atmospheric conditions our spools of fine gauge nickel-chrome resistance wire are subjected to before use, their air-tight plastic containers provide the complete protection against deterioration.

This special packing is but one of the precautions we take to "balance" perfectly the properties of consistency, durability and precision in Cromaloy V.

*Cromaloy V*

80/20%

**NICKEL-CHROME RESISTANCE WIRE**

**A. C. SCOTT & COMPANY LTD.**  
CROMALOY HOUSE · CITY ROAD · MANCHESTER

dm AS 23

# CAVITY WAVEMETERS



Models \*32/700 Absorption type 8880-10,000 Mc/s  
 32/750 Absorption type 8400-10,100 Mc/s  
 32/2000 Transmission 8880-10,000 Mc/s  
 \*32/2050 Transmission 8400-10,100 Mc/s  
 \* Available ex-stock.

"Q" Factor Absorption type 15,000  
 "Q" Factor Transmission 10,000

## OTHER INSTRUMENTS IN OUR X BAND RANGE ARE—

- STANDING WAVE INDICATORS
- VARIABLE ATTENUATORS
- COAXIAL WAVEMETERS
- BI-DIRECTIONAL COUPLERS
- KLYSTRON MOUNTS, etc., etc.

Let us quote for your special requirements. We will manufacture any microwave equipment to your drawings or design to your specifications.

## MICROWAVE INSTRUMENTS LTD.

WEST CHIRTON INDUSTRIAL ESTATE,  
 NORTH SHIELDS, NORTHUMBERLAND.  
 Telephone : N. Shields 2817.  
 Telegrams : Microwaves N. Shields.



FEBRUARY 1954

E

# Electronic Engineering

Incorporating *ELECTRONICS, TELEVISION and SHORT WAVE WORLD.*  
 Managing Editor *H. G. Foster. M.Sc., M.I.E.E.*

Vol. XXVI

FEBRUARY 1954

No. 312

## Contents

Commentary .. .. .	45
Electrical Measurements at Centimetre Wavelengths By J. W. SUTHERLAND	46
Step to Frequency Response Transforms for Linear Servo Systems (Part 2) .. .. .	51
By L. C. LUDBROOK	
Decimal Counting Tubes .. .. .	56
By K. KANDIAH	
A High-Voltage High-Current Pulse Generator ..	63
D.C. Amplifiers (Part 2) .. .. .	64
By J. YARWOOD and D. H. LE CROISSETTE	
A Rapid Flyback Miller Time-Base Circuit ..	71
By W. FRASER and M. W. JELFFS	
A Simple Electronic Multiplier .. .. .	72
By K. H. NORSWORTHY	
Reflexing Applied to Ultra Short Wave Circuits	75
Attenuator Design .. .. .	76
By N. H. CROWHURST	
Atomic Hydrogen in the Research Laboratory ..	78
By R. L. F. BOYD and N. D. TWIDDY	
Letters to the Editor .. .. .	80
Electronic Equipment .. .. .	82
Book Reviews .. .. .	84
Short News Items .. .. .	87
Meetings this Month .. .. .	88
Publications Received .. .. .	88

Published Monthly on the last Friday of the preceding month at  
 28 Essex Street, Strand, London, W.C.2.

Telephone : CENTRAL 6565

Telegrams : 'LECTRONING, ESTRAND, LONDON'

Subscription Rate:

(Home or Abroad) Post Paid 12 months 26s. or \$3.75 (U.S.)

Classified Advertisements, Page 1

Index to ADVERTISERS, 92

A45

ELECTRONIC ENGINEERING

# transistors

for circuit experiments



## a choice of **two** point-contact types

In the OC50 and OC51 point-contact transistors Mullard have varied point spacing to produce two transistors of markedly different characteristics. This choice of point-contact transistors now offered by Mullard will greatly assist electronic engineers to adapt to their own needs the circuits described in existing literature, and also to create new circuits of their own design.

Although, at the present state of development, some transistor parameters tend to be temperature-dependent and to vary between transistors of the same type, these effects can be largely overcome by suitable circuit design. Circuit engineers will find that they are able to achieve good results when they take the unfamiliar characteristics of the transistors fully into account. The Mullard circuit research and development organisation is actively exploring transistor circuit techniques, and designers interested in the OC50 and OC51 are invited to avail themselves of the assistance of the Industrial Technical Service Department at the address below.

● *The OC50 and OC51 are readily available for experimental purposes at a price comparable with that of subminiature valves.*



Point-contact transistor type No.	OC50	OC51
Max. negative collector-to-base voltage (V)	30	50
Max. collector current (mA)	-12	-18
Max. dissipation (mW)	120	100
Max. emitter current (mA)	10 <sup>†</sup>	12
Max. ambient temperature (°C)	40	55
Max. frequency (for α 3db down) (Mc/s)	1.0	1.8
"Full-on" voltage across transistor	★	
Collector "cut-off" current		★

★ Superior type for this characteristic

# Mullard



MULLARD LTD., COMMUNICATIONS AND INDUSTRIAL VALVE DEPT., CENTURY HOUSE, SHAFTESBURY AVENUE, LONDON, W.C.2  
MVT149

# ELECTRONIC ENGINEERING

VOL. XXVI

No. 312

FEBRUARY 1954

## Commentary

**T**HE award of the Faraday Medal by the Council of The Institution of Electrical Engineers to Isaac Shoenberg will give deep satisfaction to those who are acquainted with his work, but it will also provide the occasion for bringing his name before a much wider public and for according the recognition and credit which is so justly his due. Few men can have been responsible for technical developments which have so widely influenced the social habits of a community and yet remained unknown beyond a small circle of engineers. Fewer still have the modesty—and the generosity—deliberately to shun publicity and to enable their assistants to receive credit for their particular contributions.

We have been justly proud that our television service was the first high-definition system to be inaugurated anywhere in the world, but although it is now more than seventeen years since that service first commenced, there are still very few who realize that the guiding hand behind its technical development was that of Isaac Shoenberg. It is fitting, therefore, that at the close of Coronation Year, when the whole nation was enabled to participate in the pageantry and the intimacy of the Coronation ceremonies, due honour and recognition should be paid at last to the man who, more than any other single individual, was responsible for the development of our British system.

As Director of Research of Electric and Musical Industries from its formation in 1931, by the amalgamation of The Gramophone Company and the Columbia Gramophone Company, it fell to Shoenberg to form and lead the brilliant team of scientists and engineers which, during the next six years was to develop the E.M.I. system. Shoenberg brought to this task gifts which are rare indeed, for not only did he exhibit a judgment and foresight on many technical occasions which, looking back, has seemed little short of genius, but he had also the gift of instilling his confidence and enthusiasm into his fellow directors and thus of obtaining the financial support without which the very costly development work could not have proceeded. Finally, it was Shoenberg who presented the "evidence" on behalf of his Company early in 1935 to the Television Committee under the chairmanship of Lord Selsdon. The system he then described and the specification he offered was subsequently adopted almost unaltered as the basis for the Alexandra Palace television transmitter.

Isaac Shoenberg was born in Russia in 1880. He received his early technical education in Russia and subsequently took post-graduate courses at the City and Guilds College and the Royal College of Science. After serving as Chief Engineer of the Russian Wireless Telegraph and Telephone Company in Petrograd from 1905-1914, he came to this country and joined the staff of Marconi's Wireless Telegraph Company, subsequently becoming head of the

Patent Department and finally Joint General Manager. In 1928, he was appointed Joint General Manager of the Columbia Gramophone Company, and in 1931 he became Director of Research upon the formation of Electric and Musical Industries. The development of a system of high definition television became his immediate objective.

During the years which followed, Shoenberg was called upon to make many decisions of a fundamental nature, often in cases where technical opinion was almost equally balanced between two possible alternatives. In retrospect, some of these decisions now seem obvious, but in the light of the knowledge which existed at the time they were hard indeed, often calling for a faith and courage which is given to few. To name just some examples: there was the decision to develop a hard-vacuum cathode-ray tube to replace the uncertain gas-focused tubes of the day; there was the decision to put every effort into the development of a really high-definition system and to face all the unknown difficulties which then existed in the development of amplifiers using very wide frequency bands and operating on ultra-short wavelengths instead of adopting some medium standard of definition which would have been so much easier to achieve, but which could have yielded only mediocre results. There were the highly complex problems centred around the transmission of the D.C. component of the picture signals, and there were all the practical difficulties to face in the development of the Emitron camera. Perhaps the most difficult decisions were those involved with the synchronizing signals and the choice of the 405-line standard. In 1935, there were many who thought that the choice of such a standard with interlaced scanning was a wholly unnecessary risk, and though such a choice may now seem a low one, it required great courage at the time.

In case there still be some who suspect that British television owes any debt to the United States, it is permissible to remark that there were several fundamental differences—the form of the synchronizing signals, the polarity of the vision modulation and the transmission of the D.C. component. In all these respects British practice differed from the American.

It has long been a matter for regret that Shoenberg has not hitherto received wider credit for his courageous direction in the development of British television. His modesty, his retiring disposition and his readiness to give the credit to his staff—to A. D. Blumlein, C. O. Browne, G. E. Condliffe, J. D. McGee and P. W. Willans to name only a few at random—is undoubtedly responsible, but we are happy to believe that the award of the Faraday Medal just announced will serve to remind us that on all the fundamental issues, it was Isaac Shoenberg who gave the guiding hand throughout the formative years of British television.

# Electrical Measurements at Centimetre Wavelengths

By J. W. Sutherland\*, M.A., A.M.I.E.E.

*This article discusses the methods of measurement of impedance, attenuation and power in waveguide systems at centimetre wavelengths and describes the instruments used for these determinations. Particular attention is paid to the construction and use of waveguide standing wave detectors, the development and design of dissipative attenuator elements and the use of the thermistor bridge.*

**R**ADIO frequency energy at centimetre wavelengths is employed in a variety of fields including radar, radio communication, acceleration of electrons, dielectric heating, radio astronomy, etc. At these wavelengths, a new technique of electrical measurement must be evolved to measure impedance, attenuation, power, etc., and new ranges of instruments have been developed for this purpose.

The measurements are usually made in some form of transmission line, since normal circuit techniques are not applicable at ultra high frequencies. It is proposed to consider those measurements concerned with the waveguide type of transmission line.

## Measurement of Impedance

Impedance in a waveguide is measured relative to the impedance of the waveguide itself. It can be shown that if a transmission line of impedance  $Z_0$  and length  $l$  is terminated by an unknown impedance  $Z_t$ , then the impedance measured at the input to the transmission line:

$$Z_s = Z_0 \left( \frac{Z_t/Z_0 + \tanh \gamma l}{1 + Z_t/Z_0 \tanh \gamma l} \right) \dots \dots \dots (1)$$

where  $\gamma$  is a complex number called the propagation constant ( $\gamma = \alpha + j\beta$ , where  $\alpha$  is the attenuation constant and  $\beta$  the phase constant).

Impedances considered relative to the impedance of the transmission line are called normalized impedances.

Then:

$$Z_s = \frac{Z_t + \tanh \gamma l}{1 + Z_t \tanh \gamma l} \dots \dots \dots (2)$$

Therefore, if the impedance at any point in a waveguide is known, the impedance at any known distance from this point can be directly calculated.

Impedance is determined by the measurement of the position and amplitude of the voltage standing wave in the waveguide. The normalized impedance at a minimum of the standing wave is purely resistive, and equal to  $1/S$ , where  $S$  is the standing wave ratio. Therefore, the impedance at any other point can be calculated immediately from equation (2).

A convenient graphical method of evaluating this equation has been devised by Smith<sup>1</sup>. He has evolved a diagram, shown in Fig. 1, consisting of three sets of orthogonal circles. To use the circle diagram the impedance of a point is plotted in polar co-ordinates—the value of voltage standing wave ratio is plotted radially and the angle from vertical corresponds to the distance of the point from the minimum (expressed in fractions of a wavelength). The point defined in this way lies at the intersection of two orthogonal circles, whose radii determine the real and imaginary parts of the impedance of the point.

If the point is now rotated about the centre of the diagram (clockwise for movement towards the generator

and anti-clockwise for movement towards the load) through an angle corresponding to the distance along the transmission line (where one complete revolution is equivalent to half a wavelength) a new point is found again on the intersection of two circles whose radii correspond to the real and imaginary parts of the impedance of the new point. The centre of the diagram corresponds to an impedance

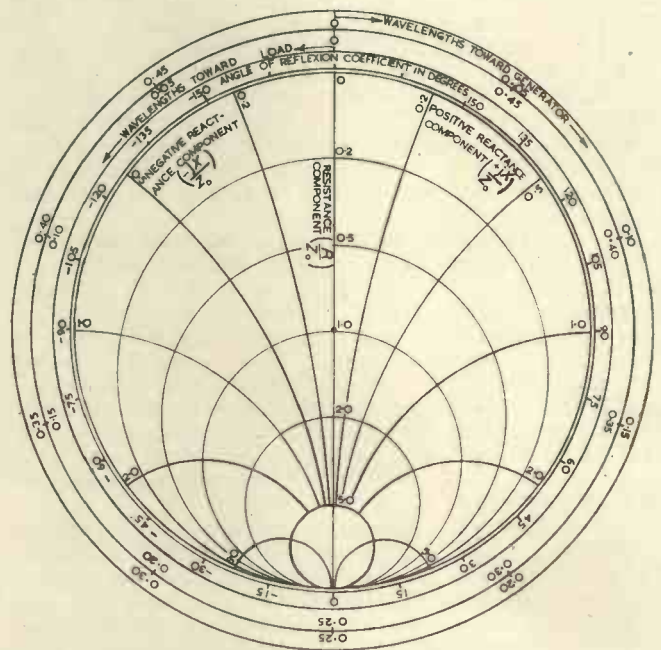

Fig. 1. Simplified Smith impedance chart

of  $1 + 0j$  which is the normalized impedance of the transmission line itself.

The amplitude and position of the voltage standing wave is determined with a standing wave detector. In the waveguide standing wave detector, a probe is inserted into the waveguide through a narrow slot cut longitudinally in its broad face, in such a way that the probe can be moved to and fro along the waveguide.

The current flow in the walls of a waveguide propagating the fundamental or  $H_{01}$  mode, is such that an infinitesimally narrow longitudinal slot in the centre of the broad side does not interrupt any current paths, and therefore no instantaneous E.M.F. is induced across the slot, and there will be no radiation from it. In practice the radiation is found to be negligible if the width of the slot is kept below one-tenth of the total width of the waveguide.

An E.M.F. will be induced on the probe proportional to the electric field in which it is located. The probe is connected to a detector, whose output bears a known relation-

\* Metropolitan-Vickers Electrical Co., Ltd.

ship to the E.M.F. on the probe. The E.M.F. induced on the probe for a constant amplitude of electric field will vary with the insertion into the waveguide. It is therefore most important that the insertion shall not vary as the probe is moved along the waveguide, otherwise there would be no true comparison of electric field strength. The initial probe penetration must be small, to prevent distortion of the electric field configuration, and a small variation would have a marked effect on the accuracy of measurement of standing wave ratio. Consequently, very great care and mechanical ingenuity is required in the design of a standing wave detector to ensure constancy of probe insertion.

A typical instrument is shown in Fig. 2. In this standing wave detector, an extremely rigid waveguide section is built up from a rectangular channel, and a flat plate. The

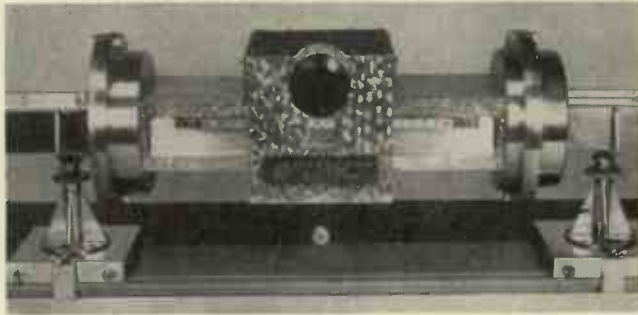

Fig. 2. Standing wave detector

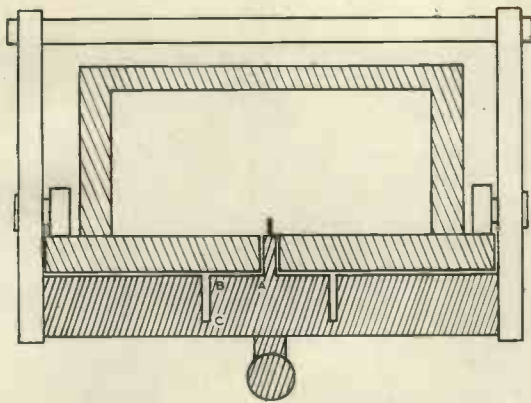

Fig. 3. Mechanical arrangement of standing wave detector

channel is machined and hand finished to fine dimensional limits, its inside surface is lapped to an average roughness of 4 to 6  $\mu$ in, and the top edges of the channel are "bedded" flat on a surface plate. The flat plate is of such a size that on assembly it projects slightly on either side of the channel. A narrow slot is milled right through the plate centrally for part of its length, and it is also "bedded" to a surface plate. The two halves of the standing wave detector are then clamped together.

The probe and detector are mounted on a carriage, which has a tongue located in the slot of the waveguide, and through which the probe passes. The cross section of Fig. 3 shows the relative position of the probe and carriage. A choke system cut in the carriage eliminates leakage of radio frequency energy from the waveguide. In Fig. 3 the distance AB and BC are each chosen to be approximately a quarter wavelength, so that the short-circuit at C is transformed to an open-circuit at B and a short-circuit at A.

To ensure constant probe insertion, the flat plate forming

the slotted inside broad face of the waveguide section is extended beyond the outside of the channel as shown in Fig. 3, and the carriage holding the probe rides on this surface on three ball races specially selected for concentricity. Therefore the only possible causes of variation in probe penetration are departure from true flatness of the plate forming the waveguide, and eccentricity in ball races. The former can be controlled within  $\pm 0.0001$  to  $0.0002$ in and the latter to considerably smaller limits.

The detector consists of a coaxially mounted silicon crystal diode. The mount can be tuned by varying the length of a short-circuited coaxial stub. The output of the detector is very carefully screened, and also fitted with bonded iron dust filters, to prevent direct pick-up of radio frequency energy at the detector, which would give a spurious reading. The accuracy of impedance measurement is also affected by the accuracy with which the law of the detector can be determined, i.e. the relationship between the crystal current in the detector and the electric field in the waveguide. Crystals can be selected so that the crystal current is approximately proportional to the square of the amplitude of the electric field for values of current less than about  $25\mu$ A.

A convenient method of checking the law of the crystal and galvanometer is to interpose a precision attenuator between the standing wave detector and the signal source. The voltage standing wave ratio is first determined as the square root of the ratio of crystal currents, and secondly as the difference between maximum and minimum decibel readings when the attenuator is adjusted to maintain constant crystal current as the carriage moves along the wave-

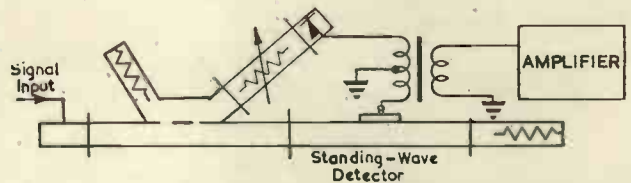

Fig. 4. Arrangement for testing standing wave detectors

guide. The difference between these two ratios indicates the departure from square law of the detector, and can be employed as a correction factor in the more accurate work.

The arrangement of Fig. 4 suggested by E. M. Wareham, formerly of T.R.E., is a convenient means of checking the reading accuracy of a standing wave detector. The apparatus consists of an oscillator feeding a waveguide, followed by a padding attenuator, a directional coupler to feed some of the power in the waveguide into a side arm, the instrument under test, and a load which is as nearly reflexionless as possible. The side arm contains a precision calibrated attenuator and a detector. The output of this detector, and of the standing wave detector are fed into the two halves of the primary of a balanced transformer. The oscillator is modulated with a square wave, and the secondary of the balanced transformer is connected to a selective amplifier tuned to the modulation frequency. The output of the detector will be at minimum when the amplitude of signal from each detector is equal. Small changes in output of the standing wave detector as the probe is moved along the waveguide can be measured directly in decibels by rebalancing the system with the precision attenuator and noting the change in its reading. An analysis of a series of such readings will give an indication of variations due to reflexions from the load, from the junction between the load and the standing wave detector, and from the end of the slot, and also of variations due to imperfections in the instrument itself.

#### Measurement of Attenuation

"Attenuation" is a concept for which it is difficult to find an exact definition. In a waveguide, solutions of

Maxwell's equations are:

$$\begin{aligned} E_z &= \sin k_1 x \cdot \sin k_2 y \cdot e^{-\gamma z} \\ H_z &= \cos k_1 x \cdot \cos k_2 y \cdot e^{-\gamma z} \end{aligned} \quad (3)$$

where  $z$  is the distance along the axis of the waveguide, and  $\gamma$  is the propagation constant ( $k_1, k_2$  constants).

$\gamma = \alpha + j\beta$  where  $\alpha$  is the attenuation constant  
 $\beta$  is the phase constant.

The value of  $\alpha$  therefore determines the extent to which the amplitudes of  $E$  and  $H$  diminish with increase in  $z$ .

For the present purpose, a four-terminal network will be considered, which is matched at both input and output. If the total power passing into the network is  $P_1$  and the total power passing out of the network is  $P_2$  then the attenuation of the network in decibels is:

$$10 \log_{10}(P_1/P_2) \quad (4)$$

Most practical methods of measurement of attenuation involve the comparison of the attenuation due to the item under test with a calibrated attenuator.

Attenuators at centimetre wavelengths fall into two main groups, the cut-off attenuator, and the dissipative attenuator. In a waveguide of particular dimensions, waves of wave-

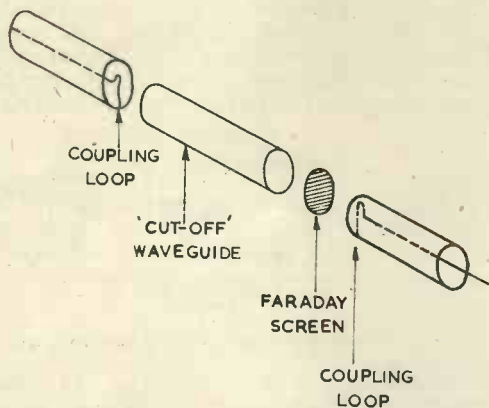

Fig. 5. Exploded view of piston attenuator

length greater than a critical value, known as the cut-off, will be heavily attenuated. This fact is utilized in the cut-off attenuator. A resistive film supported in a rectangular waveguide parallel to the electric vector will dissipate some of the power passing through the waveguide. This forms the basis of the dissipative attenuator.

If  $\lambda$  is the wavelength,

$\lambda_c$  is the cut-off wavelength for the particular dimension of waveguide propagating a single mode, then the field will be proportional to  $e^{-\alpha z}$

where  $z$  is the distance along the waveguide and  $\alpha = 2\pi\sqrt{1/\lambda_c^2 - 1/\lambda^2}$

In such an attenuator, the insertion loss of the instrument is high. Resistive attenuation is deliberately introduced to decouple the attenuator from the circuit in which it is being used, and a Faraday screen is often used to ensure that only the required mode is propagated in the cut-off waveguide. Fig. 5 shows a typical system. It is therefore obvious that the cut-off attenuator is normally employed as an incremental attenuator, and as such is extremely useful in a signal generator where a large amount of decoupling between the oscillator and load is desirable. The dimensions of the cut-off attenuator should be known very accurately, and the bore must be circular and "true". The piston of the attenuator is accurately located, and its position can be accurately measured. The necessary accuracy of dimension and measurement is considerably lower at lower

frequencies, which makes design and manufacture considerably simpler, and a number of elegant systems for measuring attenuation exist, in which the power at centimetre wavelength is converted to an intermediate frequency, the cut-off attenuator being designed to give an accurate determination of attenuation at this lower frequency.

On the other hand, the dissipative attenuator has an extremely low insertion loss represented by the attenuation when the resistive film lies right along the side wall of the waveguide, which can be neglected for most purposes. It is not a fundamental instrument since its attenuation cannot be calculated with any degree of accuracy. Its resetting accuracy is extremely good, however, and it is a most useful practical laboratory and field instrument, as a transfer standard from the absolute standard of the cut-off attenuator.

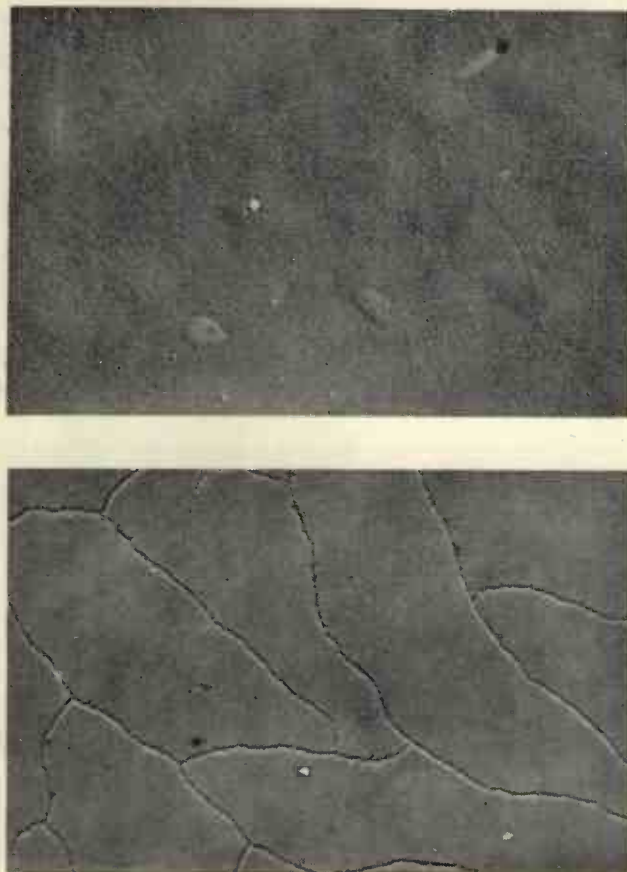

Fig. 6. Electron micrograph of evaporated film  
(a) (top) normal film  $\times 10,000$ , (b) (bottom) "crazed" film  $\times 6,000$

A practical form of dissipative attenuator element is a resistive film of nickel-chromium alloy deposited on a thin glass slide by evaporation in vacuo. The alloy is chosen because of its extremely low temperature coefficient of resistance, and its resistance to corrosion and abrasion. The method of preparation of the surface of the slide, and the technique of evaporation have been developed to give a hard uniform resistive film, and extreme care is needed to produce the required electrical characteristics in the finished vane. The accompanying electron micrographs show the metallic film. Fig. 6(a) is a normal film, but Fig. 6(b) shows the crazing of the deposit which takes place if all the precautions in manufacture have not been observed. This latter type of deposit has been found to give inconsistent electrical performance, and is probably responsible for most cases of variations in attenuation with time and



atmospheric conditions. The glass from which the slide is made is selected for its surface properties, and the ends of the vane are tapered to present a minimum mismatch when supported in the waveguide. It is found that the phase shift produced by the presence of the vane is small, and for most purposes may be neglected. Development work is continuing to find an alternative material to glass, which possesses similar electrical properties, a similar physical surface and the same suitability for use in a high vacuum, but which is more robust than glass.

The surface resistivity of the film is extremely critical; considerable experimental work is involved in determining the optimum value for each application, and careful process

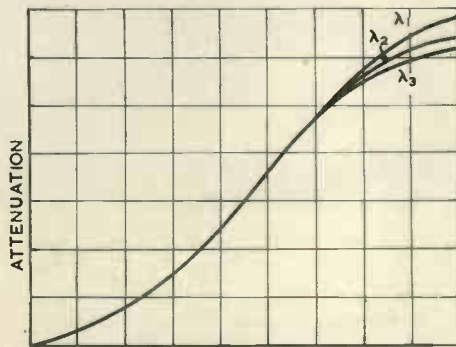

Fig. 7. Attenuation characteristics

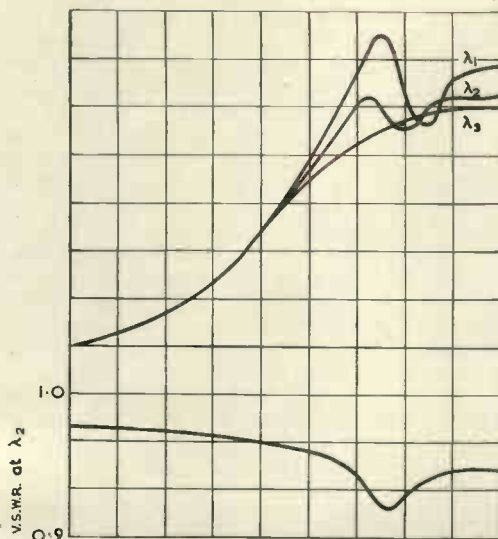

Fig. 8. Attenuation "resonance"

control must be exercised to give a consistent product once the value is known.

The distribution of amplitude of the electric field across a rectangular waveguide is sinusoidal (equation (3)), being zero at each wall, and maximum in the centre. If a resistive vane is supported in the waveguide parallel to the narrow side (i.e. parallel to the electric vector) and moved from the side into the centre, the attenuation caused by the vane will rise from zero to a maximum. Under the optimum conditions, the graph of insertion against attenuation takes the form of Fig. 7. The curve is smooth, and the variation of attenuation with frequency is beyond the limits of normal measuring accuracy except at the upper end of the range.

If, however, the surface resistivity of the film does not have the optimum value, the graph of insertion against attenuation is no longer smooth, and a typical set of results is illustrated in Fig. 8. At the upper end of the range, the

curve is peaky, and the value of attenuation varies rapidly with frequency. This effect is usually described as a resonance in the vane. It is found from experimental evidence that the position and frequency of the resonance is dependent on both the dimensions of the vane and its surface resistivity. It is also found from experiments, that resonance is accompanied by a sudden increase in the reflexion coefficient of the attenuator in the waveguide.

When the glass vane attenuator is used as a precision instrument an accurate mechanism is required to support the vane, move it across the waveguide, and measure its position. Fig. 9 and 10 show typical precision attenuators for the three centimetre and ten centimetre wavelength bands. The element is supported on pins, perpendicular to the axis of the waveguide, parallel to the broad side and



Fig. 9. Precision X-band attenuator

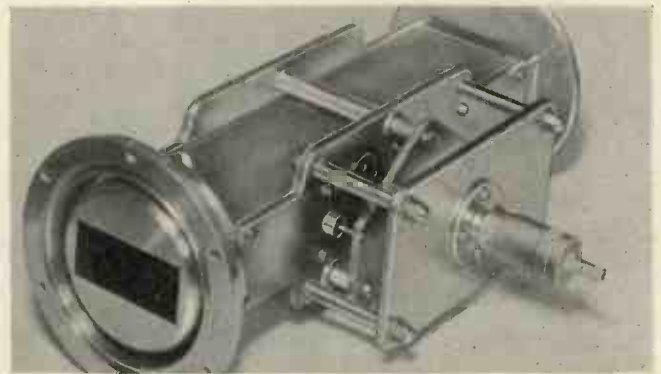

Fig. 10. Precision S-band attenuator

passing through the centre line of the narrow side. The pins are mounted on a rigid carriage which is constrained so that it may move only in the direction of the pins, and the pins are spaced longitudinally so that they produce a negligible reflexion of R.F. power in the waveguide. The vane is mounted exactly parallel to the axis of the waveguide, and is maintained in the same plane throughout its travel. Since this form of attenuator is a transfer instrument, or sub-standard, rather than a fundamental standard, it must be calibrated. Its most important feature is therefore its repeatability or resetting accuracy. In the instruments illustrated, the position of the vane is measured in one case by means of a clock gauge, and in the other with a micrometer head. The resetting accuracy is of the order of 0.04 to 0.05db in the X-band attenuator and 0.025 to 0.03db in the S-band instrument.

The substitution method of measurement of attenuation

is satisfactory for most purposes. The arrangement consists of a source of signal, a calibrated attenuator, the element under test, and a detector. It is important that padding attenuators of at least 10db be included immediately after the source and immediately before the detector, in order to minimize any error due to standing waves in the system. The source may be c.w., in which case the detector will be either a crystal and galvanometer or a superheterodyne receiver, or square wave modulated, in which case the detector will be a crystal, and selective amplifier tuned to the modulation frequency.

### Measurement of Power

The most fundamental determination of power which has been made is due to Cullen<sup>2</sup>. He has succeeded in measuring the force exerted on a vane supported in a waveguide by the wave passing through it. The power was directly measured in mass, length and time units. The measurement, while academically of great interest, has little practical value, and the methods of power measurement normally used in the laboratory and in the field depend upon the dissipation of a part, or all, of the radio frequency power as heat, and the measurement of that amount of heat. A water load is one of the most convenient forms of totally absorbing power measuring device, for the measurement of high powers, of the order of a few kilowatts to a few megawatts peak (or a few tens of watts to a few kilowatts mean). A hollow polythene wedge is mounted in the end of the waveguide. A septum divides the wedge internally into two compartments, and water is able to flow down one side of the wedge and up the other. The shape of the wedge is designed so that it presents a match to the waveguide over a wide band of wavelengths, and is therefore totally absorbing. The water temperature is measured as it enters and leaves the wedge by mercury thermometers or thermocouples. The water normally comes from a constant head supply, and is passed through a water flowmeter. If the flow is adjusted so that the temperature rise does not exceed about ten degrees, the cooling correction can be neglected (particularly as the incoming water is often a few degrees below ambient, and the outgoing water a few degrees above ambient). The method is capable of an accuracy of about 5 per cent on mean power. The accuracy of measurement of peak power depends on the accuracy with which the mark-space ratio and pulse shape is known.

As a monitor of peak power, the neon tube wattmeter is a convenient and reasonably accurate relative reading device. A thin straight glass tube containing neon intrudes slightly into the waveguide through a hole in the broad side. At the tip of the tube is a small straight or helical wire which ensures rapid striking. The portion of the tube outside the waveguide is encased in a metal tube, which is slotted so that the length of the discharge can be observed. The length of glow is proportional to the square root of the energy in the pulse, and therefore the power is proportional to the square of the length of discharge. If there is a standing wave in the guide, this can be misleading, and it is therefore usual to mount several tubes spanning half a wavelength. Fig. 11 shows a typical arrangement. The power will therefore be proportional to the product of minimum and maximum glow, since

$$L_{\max} \text{ is proportional to } E_{\text{transmitted}} + E_{\text{reflected}}$$

$$L_{\min} \text{ is proportional to } E_{\text{transmitted}} - E_{\text{reflected}}$$

$$L_{\max} \times L_{\min} = E_{\text{transmitted}}^2 - E_{\text{reflected}}^2$$

which is proportional to the power reaching the load. The instrument also gives an indication of voltage standing wave ratio in the waveguide.

An alternative, and more accurate, means of power measurement is to tap off a known amount of transmitted power by means of a directional coupler, and to measure

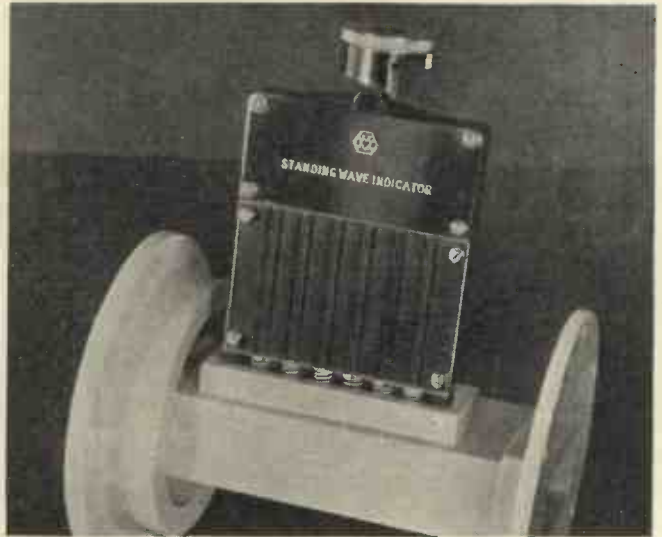

Fig. 11. Neon tube power monitor and standing-wave indicator

this power with a thermistor bridge. A directional coupler consists of a main waveguide and an auxiliary waveguide; power passing in the forward direction in the main waveguide is coupled in one direction only in the auxiliary waveguide and power in the backward direction couples only in the other direction. The ratio of the power in the forward and backward directions in the auxiliary waveguide (coupled by power in a single direction in the main waveguide) is known as the directivity.

A typical directional coupler is described by Surdin. The two waveguides lie with their broad faces in contact with one another, and with their axes perpendicular, as shown in Fig. 12. A uniform cross-shaped slot is cut in the interface, one-quarter of the way across the diagonal. The length and thickness of the slot determines the coupling, and the directivity of this type of coupler is high. Its properties are broad-band, with suitable precautions it will stand high powers, and it is easy to manufacture.

Having reduced the power to a suitable level, by a known coupling factor, its magnitude is to be measured by a thermistor bridge (Fig. 13). A state of thermal equilibrium is reached by passing a fixed D.C. or low frequency A.C.

Fig. 12. Directional coupler

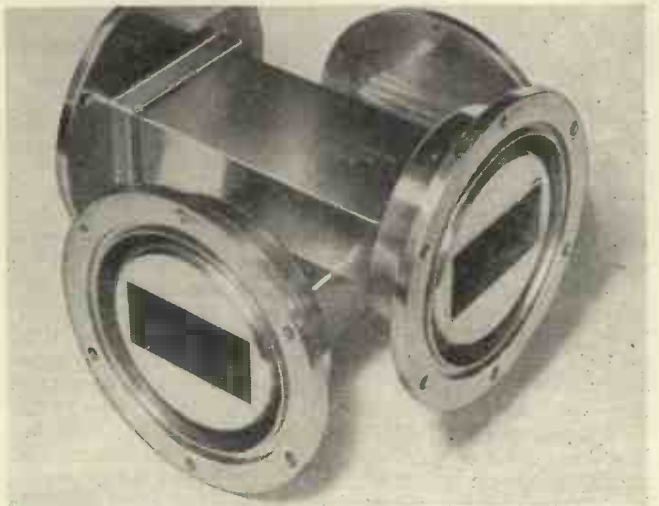



Fig. 13. Thermistor bridge

through the thermistor so that it has a fixed resistance. Radio frequency power is then dissipated in the thermistor, and this power is measured in two ways: in the balanced bridge, the direct current is reduced till balance is restored, and the reduction in power dissipated in the thermistor by the bridge supply is assumed to be equal to the R.F. power dissipated. In the unbalanced bridge, the change in resistance brought about by the application of the R.F. power is measured as the out-of-balance current in the bridge, and by a previous calibration, is related to the magnitude of the R.F. power. The former method is suitable for most purposes, since the law of the thermistor does not affect the reading, but only the sensitivity. The second method is sometimes more convenient to use in a direct reading bridge, but requires calibration and is dependent on thermistor characteristics which may possibly vary from day to day. It has been found possible to design a simple, direct reading, balanced bridge which has an accuracy of  $\pm 2\frac{1}{2}$  per cent over normal temperature ranges, and this

will be described in detail in a paper to be published shortly by D. C. Cooper. Balance is restored after the application of R.F. power by shunting the bridge circuit with a network containing a meter. The network is so devised that the current through the meter is directly proportioned to the R.F. power.

The method of mounting the thermistor is important since it must absorb all the power which is incident upon it. Care must be taken that no power is reflected by, nor radiated from the thermistor mount. The system must also be arranged so that the power dissipated other than in the thermistor itself is negligible. The thermistor element consists of a very tiny bead of material supported on very thin connecting wires. This is supported in a small glass bulb into which stouter leads are sealed. The element may be connected straight across the waveguide. It is usually easier from a design viewpoint, however, to build a transformer of the cone or bar and post type from the waveguide into a coaxial line, and to include the thermistor in the coaxial line. The coaxial line is terminated in a choke arrangement which permits the D.C. connexions to be made to the bridge, but which prevents leakage of R.F. energy. It is possible to match such an arrangement to a v.s.w.r. of 0.95 over a 5 per cent to 6 per cent band of wavelengths fairly simply. On replacing thermistors, it is usually necessary to adjust the position of the bead in the coaxial conductor to rematch the system.

Variations in ambient temperature will, of course, upset measurements by thermistors. Compensating thermistors mounted in another arm of the bridge may be used to minimize the thermal drift, but if the thermistor and mount are protected from draughts, and direct thermal radiation, satisfactory operation is obtained, provided that periodical checks of zero are made.

**Acknowledgment**

Acknowledgment is made to Metropolitan-Vickers Electrical Company Limited for permission to publish this article.

**REFERENCES**

1. SMITH, P. H. An Improved Transmission Line Calculator. *Electronics*, 17, 130 (Jan. 1944).
2. GULLEN, A. L. Absolute Power Measurements at Microwave Frequencies. *Proc. Instn. Elec. Engrs.* 99, Pt. 1V, 100 (1952). (Monogr. No. 23).

## Step to Frequency Response Transforms for Linear Servo Systems

(Part 2)

By L. C. Ludbrook\*, B.Eng., A.M.I.E.E.

**Checks of the Method on Known Functions**

**POSSIBLE RESTRICTIONS ON THE FORM OF  $(\theta_o/\theta_i)_{(t)}$**

These are most conveniently examined by applying the underlying theory (equation (1)) to limiting cases.

**Perfect Single Integrator**

If  $(\theta_o/\theta_i)_{(t)} = K \cdot t$  ..... (5)

Then

$(\theta_o/\theta_i)_{(H)} = K$  ..... (6)

and

$(\theta_o/\theta_i)_{(j\omega)} = \int_0^{\infty} K e^{-j\omega t} dt = -j K/\omega$  ..... (7)

This is the standard result with output always in quadrature

lagging and of amplitude inversely proportional to frequency.

**Perfect Multiple Integrator**

If  $(\theta_o/\theta_i)_{(t)} = K t^n/n!$  ..... (8)

Then

$(\theta_o/\theta_i)_{(H)} = \frac{K t^{n-1}}{(n-1)!}$  ..... (9)

and

$(\theta_o/\theta_i)_{(j\omega)} = \int_0^{\infty} K \cdot \frac{t^{n-1}}{(n-1)!} e^{-j\omega t} dt = \frac{K}{(j\omega)^n}$  ..... (10)

This standard result confirms that analytically both  $(\theta_o/\theta_i)_{(t)}$  and  $(\theta_o/\theta_i)_{(H)}$  can increase indefinitely with time. The graphical approximation is obviously not applicable to such cases.

\* British Thomson-Houston Co., Ltd.

**Perfect Differentiator**

If  $(\theta_o/\theta_i)_{(t)} = (K)_{(H)}$  (a hammer blow of area  $K$  at  $t=0$ ) ..... (11)

Then  $(\theta_o/\theta_i)_{(H)}$  is a doublet pulse at  $t = 0$  and is difficult to interpret directly.

This case may be treated by considering a  $CR$  coupling circuit followed by an amplifier of gain  $k$  and passing to the limit  $CR = 0$  while increasing the gain to maintain the product  $k \cdot CR$  equal to  $K$ .

If  $(\theta_o/\theta_i)_{(t)} = ke^{-t/CR}$  ..... (12)

Then  $(\theta_o/\theta_i)_{(H)} = (k)_{(H)} - (k/CR) e^{-t/CR}$  ..... (13)

and

$$(\theta_o/\theta_i)_{(j\omega)} = \int_0^{+\infty} (k)_{(H)} e^{-j\omega t} dt - \int_0^{+\infty} (k/CR) e^{-t/CR} e^{-j\omega t} dt$$

$$= k - (k/CR) \left( \frac{1}{1/CR + j\omega} \right)$$

$$= k - k/CR \left( \frac{\omega^2 CR + j\omega}{1 + \omega^2 (CR)^2} \right) \rightarrow Kj\omega \text{ as } CR \rightarrow 0 \dots (14)$$

This standard result confirms that analytically  $(\theta_o/\theta_i)_{(t)}$  can contain a hammer blow component, although the graphical method again breaks down.

**Undamped Oscillation**

If  $(\theta_o/\theta_i)_{(t)} = 1 - \cos\beta t$  ..... (15)

Then  $(\theta_o/\theta_i)_{(H)} = \beta \cdot \sin\beta t$  ..... (16)

and

$$(\theta_o/\theta_i)_{(j\omega)} = \int_0^{\infty} \beta \cdot \sin\beta t e^{-j\omega t} dt$$

$$= \frac{1}{1 - (\omega/\beta)^2} \dots (17)$$

This is the standard result for a series  $L$  shunt  $C$  filter section having  $\sqrt{LC} = 1/\beta$  and confirms that analytically  $(\theta_o/\theta_i)_{(t)}$  can contain an undamped oscillation. The graphical method again breaks down in practice, although by triangular approximation to the given  $(1 - \cos\beta t)$  step response, equation (3) leads to an infinite series giving the correct answer  $(\theta_o/\theta_i)_{(j\omega)} = -j\infty$  at  $\omega = \beta$ . This quadrature lagging transmission at resonance is not explicitly shown in the classical result, but is implied by the instantaneous change from in-phase below resonance, to  $180^\circ$  lag above resonance. Physically, the zero reactance circuit draws in-phase current from the source at resonance, and this current flowing through the capacitor develops the quadrature lagging output signal.

**Perfect Delay Line**

If  $(\theta_o/\theta_i)_{(t)} = \begin{cases} 0 & \text{for } 0 < t < T_D \\ K & \text{for } T_D < t < \infty \end{cases}$  ..... (18)

Then  $(\theta_o/\theta_i)_{(H)} = 0$  except at  $t = T_D$  where it is  $(K)_{(H)}$  a hammer blow of area  $K$  ..... (19)

and

$$(\theta_o/\theta_i)_{(j\omega)} = \int_{T_D}^{T_D+\infty} (K)_{(H)} e^{-j\omega t} dt = Ke^{-j\omega T_D}$$

$$= K(\cos\omega T_D - j\sin\omega T_D) \dots (20)$$

This standard result with amplitude transmission constant and phase lag proportional to frequency confirms that  $(\theta_o/\theta_i)_{(t)}$  can contain amplitude discontinuities. The one occurring at  $t = 0$  in high pass networks has already been included as the constant term  $A_o$  in the general equation (3); others occurring later in the step response of linear networks using delay lines are correctly taken into account by

the appropriate vertical straight line segment in the graphical method since at the discontinuity  $\Delta T$  is zero and equation (4) for the corresponding term correctly reduces to  $(\Delta A) (\cos\omega T_D - j \sin\omega T_D)$ .

**Low Pass RC Section in Tandem with a Perfect Delay Line**

If  $(\theta_o/\theta_i)_{(t)} = \begin{cases} 0 & \text{for } 0 < t < T_D \\ 1 - \exp \frac{-(t-T_D)}{RC} & \text{for } T_D < t < \infty \end{cases}$  (21)

Then  $(\theta_o/\theta_i)_{(H)} = \begin{cases} 0 & \text{for } 0 < t < T_D \\ \frac{1}{RC} \exp \left( \frac{-(t-T_D)}{RC} \right) & \text{for } T_D < t < \infty \end{cases}$  ..... (22)

and

$$(\theta_o/\theta_i)_{(j\omega)} = \int_{T_D}^{\infty} \frac{1}{RC} \left[ \exp \left( \frac{-(t-T_D)}{RC} \right) \right] \left[ \exp (-j\omega t) \right] dt$$

$$= \frac{e^{-j\omega T_D}}{1 + j\omega RC} = \left( \frac{1 - j\omega RC}{1 + (\omega RC)^2} \right) e^{-j\omega T_D}$$

$$= \left| \frac{1}{\sqrt{1 + (\omega RC)^2}} \right| \left/ -(\tan^{-1} \omega RC + \omega T_D) \right. \dots (23)$$

This standard result, with phase lag increased by  $\omega T_D$  radians, but amplitude transmission unaffected by the introduction of the delay line, could have been reached by more physical argument; for example, ignoring noise, ghosts, and other non-linear effects, the quality of a television picture is not affected by increase of distance and corresponding time delay from the transmitter to the receiver. A finite dead time at the start of the step response has already been allowed in setting up the general equation (3); a linear network giving staircase response to step function input signal could be made by combining the outputs from a set of properly terminated delay lines of different lengths or from intermediate tappings along one long line. The graphical approximation method with alternate horizontal and vertical segments would give the true frequency response since the horizontal segments have  $\Delta A = 0$  and therefore contribute no vectors to the total, but their effect correctly appears as an increase in the phase lag of subsequent vectors. In principle such a network could be adjusted to yield a wide range of transmission characteristics, but in practice it would be more complicated than those already devised by Levy<sup>11</sup> which take advantage of reflexions from deliberate mismatches at various points along the delay line.\*

**DISCUSSION OF THE FOREGOING THEORETICAL EXAMPLES**

The underlying theory permits the given step response to contain hammer-blows, horizontal and vertical segments, undamped oscillations, and terms increasing indefinitely with time. The graphical approximation method is, however, restricted to step responses which can be fitted by a reasonable number of straight line segments; this in practice means that the given step response must not contain hammer blows and must settle to a constant amplitude, but can contain a few horizontal and vertical portions provided these originate from linear elements such as delay lines.

The last example indicates that the amplitude response as a function of frequency is unaffected by dead time at the start of the step response. Practical servo responses to input position step often have appreciable "toe" due to the presence of several small time delays in the cascaded con-

\* Gimpel and Calvert have however selected this tapped delay line with summation circuits as a versatile compensating network. (GIMPEL, D. J., CALVERT, J. F. Signal Component Control. A.I.E.E. Paper 52-211.)

trol amplifiers, and to the limited acceleration available at the output shaft; this toe is very significant from the point of view of dynamic error, but it can be ignored during those stages of the design problem concerned with deliberate attenuation of undesired high frequency input signals without excessive resonant amplification at lower frequencies. Since the toe shows continuous though slight curvature, its effective duration depends on the design accuracy being attempted; for most engineering purposes it seems reasonable to assume that the amplitude transmission as a function of frequency depends only on the shape of the step response graph after the time at which 2 to 5 per cent of crest value is first attained.

Further horizontal segments may profitably be used when fitting the given step response graph in the regions of peak overshoot and trough undershoot, because they do not increase the number of terms to be computed; their effect is only to increase the mean times of occurrence of the later sloping segments, and the corresponding rates of

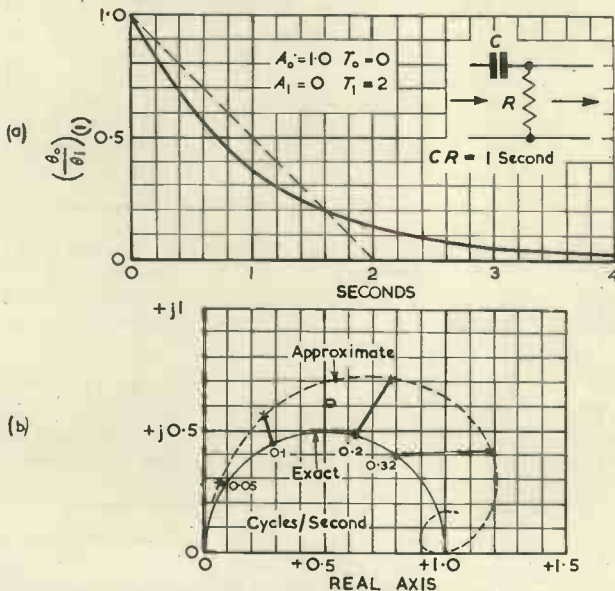

Fig. 6. High pass CR coupling (single segment approximation)

rotation of the dependent vectors. Vertical segments should only be used when the response really has an "all pass" component because they do add terms to be computed. In general the given step response should be fitted by horizontal and sloping straight line segments.

#### Checks of the Graphical Method on Analytic Functions

Elementary high pass and band pass networks are included here for completeness, but more attention is paid to low pass networks in an attempt to find simple approximate rules giving the cut-off frequency and the frequency and amplitude of maximum transmission in terms of the geometry of the step response.

#### High Pass CR Coupling (Single Segment Approximation)

The light solid lines of Figs. 6(a) and (b) show respectively the exact step and frequency responses of a high pass CR coupling having one second time-constant; the dotted lines show the single segment approximation and the corresponding frequency response which would finish at  $1 + j0$  after a contracting spiral. The heavy solid lines of Fig. 6(b) link points of equal frequency on the exact and approximate loci, and therefore show the vector error in the approximate method.

This crude single segment approximation gives gross errors above 0.05 to 0.1c/s, i.e. one-quarter to one-half cycle of test frequency in the duration of the given step response.

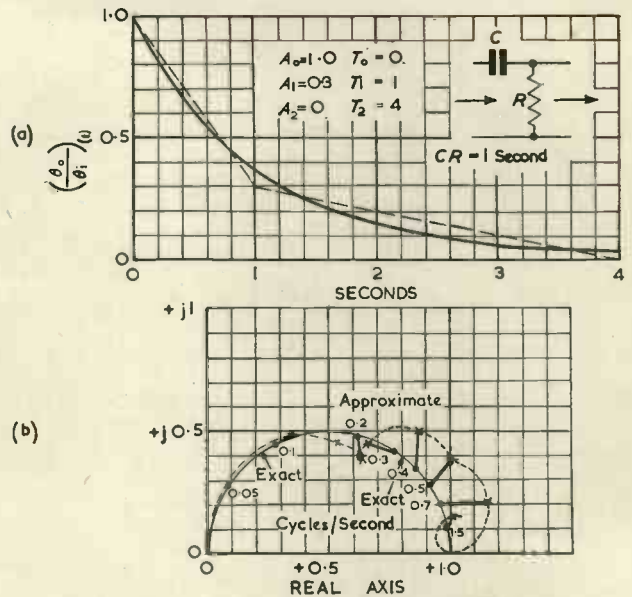

Fig. 7. High pass CR coupling (two segment approximation)

#### High Pass CR Coupling (Two-Segment Approximation)

Figs. 7(a) and (b) shows the results of a two-segment approximation to the previous example; in this case the errors are within engineering limits up to about 0.4c/s, i.e. almost two cycles of test frequency in the duration of the given step response.

#### High Pass CR Coupling (Three-Segment Approximation)

Figs. 8(a) and (b) show the results of a three-segment approximation to the previous example; in this case the errors are within engineering limits up to about 1c/s, i.e. four cycles of test frequency in the duration of the given step response.

#### Band Pass CR-RC Coupling

The light solid lines of Figs. 9(a) and (b) show respectively the exact step and frequency responses of an elementary band pass network comprising cascade buffered CR and RC circuits, each of one second time-constant. The dotted lines of Fig. 9(a) show the four straight line segments used to approximate the step response, and the points computed

Fig. 8. High pass CR coupling (three segment approximation)

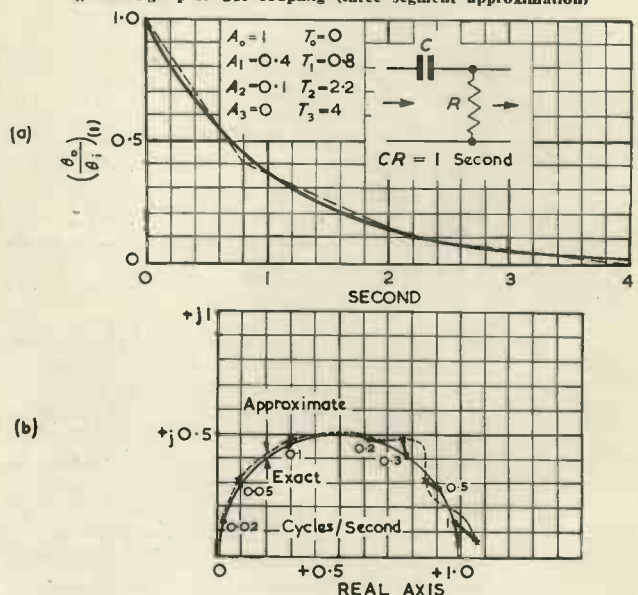

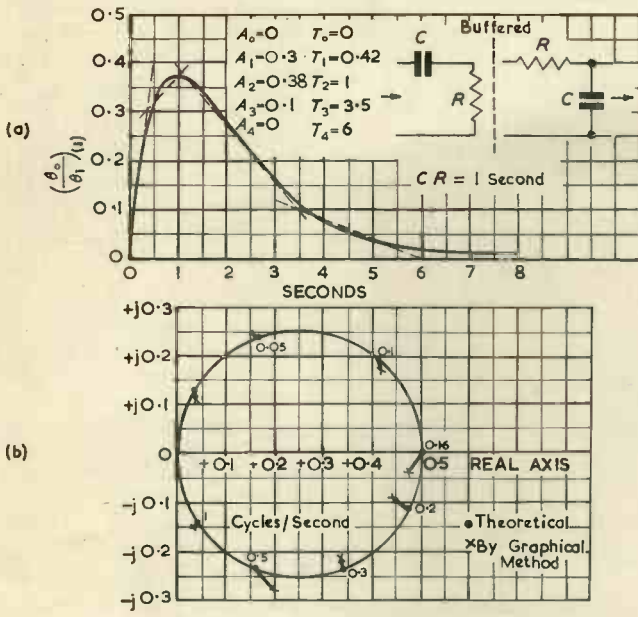

Fig. 9. Band pass CR-RC coupling

from equation (3) appear in Fig. 9(b) as crosses linked by the heavy "vector error" lines to the exact values on the circular frequency response locus. In this case the errors are within engineering limits up to about  $1c/s$ , i.e. eight cycles of test frequency in the duration of the given step response.

#### Low Pass LRC Section Critically Damped

Fig. 10 shows the circuit diagram and the exact step and frequency responses for this example in which critical damping is obtained by series resistance equal to twice the surge impedance. The three-segment approximation gives reasonable agreement with the exact values up to about  $0.5c/s$ , i.e. four cycles of test frequency in the duration of the given step response.

#### Low Pass LRC Section with 0.71 Critical Damping

Fig. 11 shows the responses of the same circuit with series damping resistance reduced to  $\sqrt{2}$  times the surge

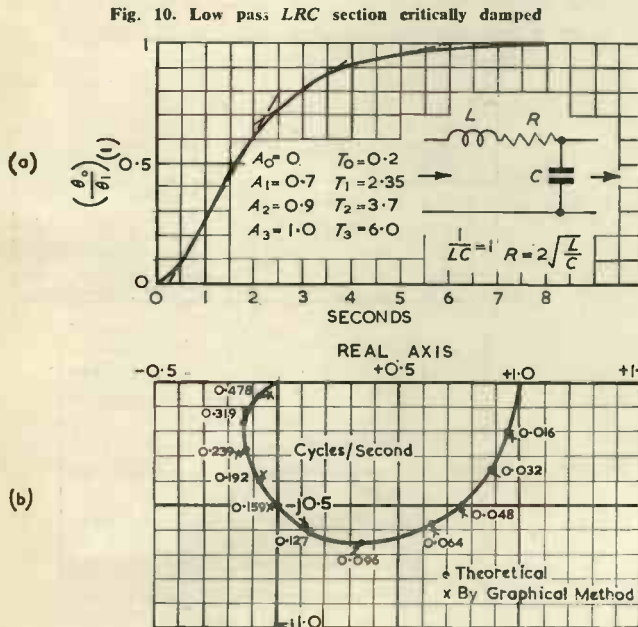

Fig. 10. Low pass LRC section critically damped

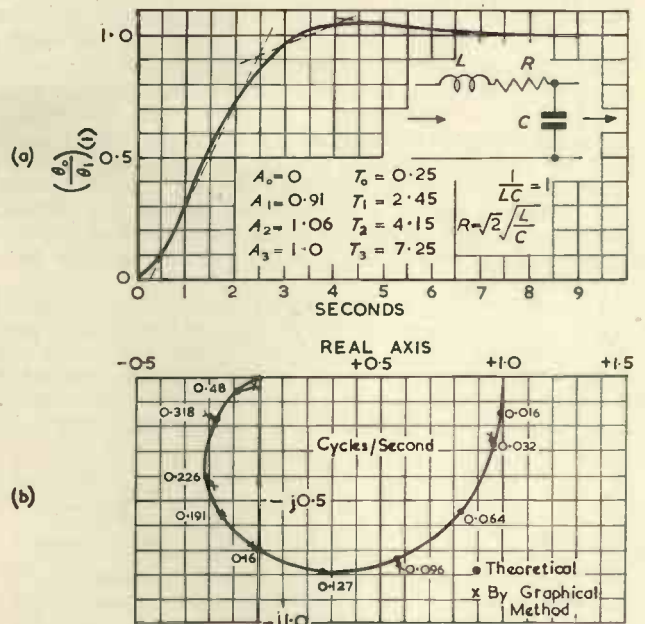

Fig. 11. Low pass LRC section with 0.71 critical damping

impedance, the limiting value before  $Q_{max}$  exceeds unity. The step response now peaks at 1.05, and the three-segment approximation gives reasonable agreement with the exact values up to about  $0.4c/s$ , i.e., three cycles of test frequency in the duration of the given step response.

#### Low Pass LRC Section with 0.5 Critical Damping

Fig. 12 shows the responses of the same circuit with series damping resistor further reduced to equal the surge impedance;  $Q_{max}$  is now 1.16 and the step response peaks at

Fig. 12. Low pass LRC section with 0.5 critical damping

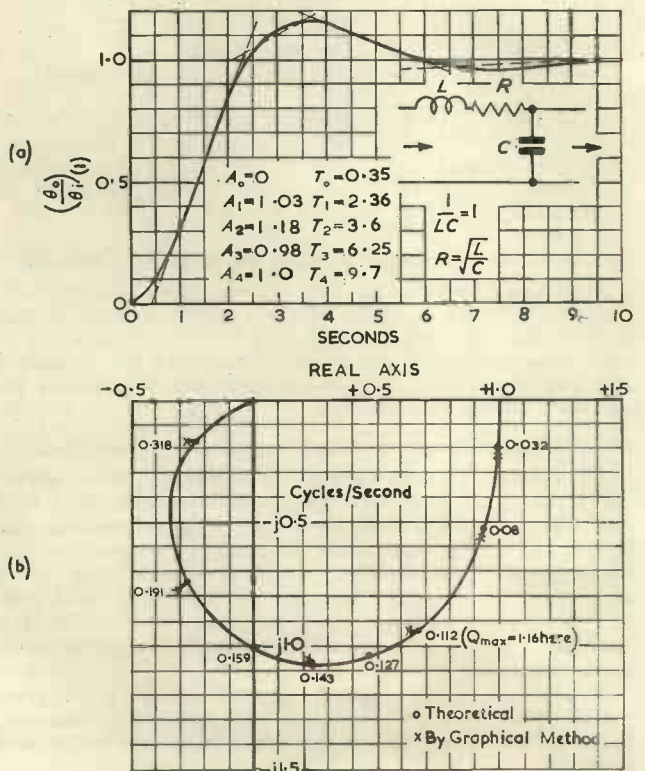

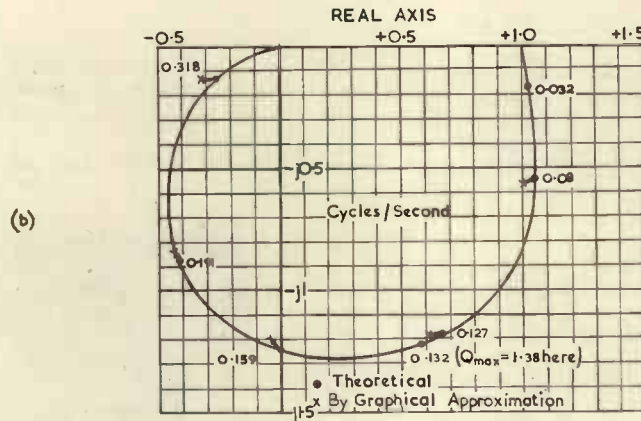
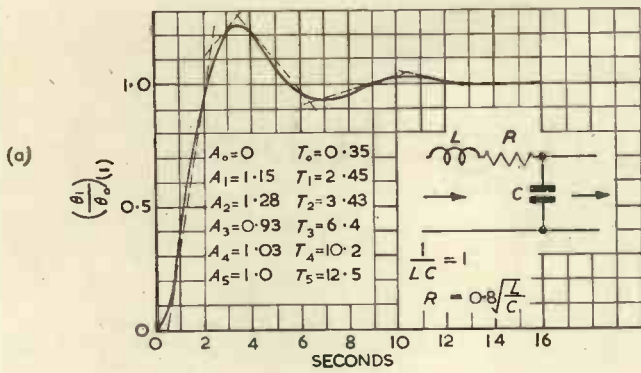

Fig. 13. Low pass LRC section with 0.4 critical damping

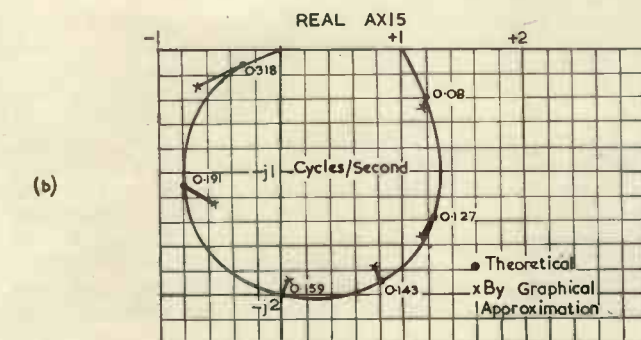
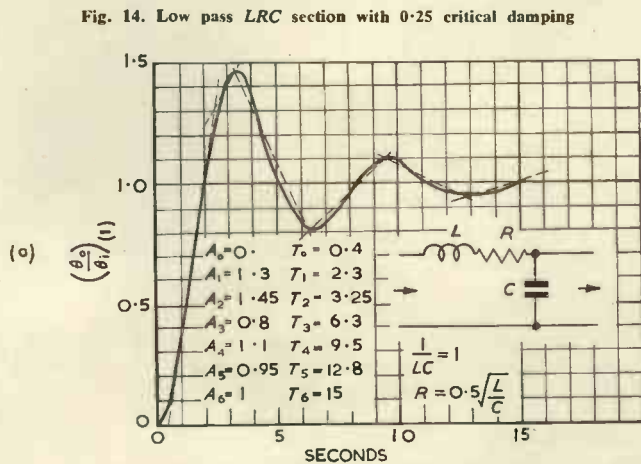

Fig. 14. Low pass LRC section with 0.25 critical damping

1.16. The four-segment approximation gives reasonable agreement with the exact values up to at least 0.3c/s, i.e. three cycles of test frequency in the duration of the given step response.

**Low Pass LRC Section with 0.4 Critical Damping**

Fig. 13 shows the responses of the same circuit with series damping resistor further reduced to 0.8 of the surge impedance;  $Q_{max}$  is now 1.38 and the step response peaks at 1.25. A five-segment approximation is needed in this case to give reasonable agreement with the exact frequency response up to 0.3c/s, i.e. four cycles of test frequency in the duration of the given step response.

**Low Pass LRC Section with 0.25 Critical Damping**

Fig. 14 shows the responses of the same circuit with series damping resistor further reduced to 0.5 of the surge impedance;  $Q_{max}$  is now 2.06 and the step response peaks at 1.45. For this poorly damped case six segments are needed, and even then the errors are only tolerable up to 0.16c/s, i.e. about three cycles of test frequency in the duration of the given step response.

**DISCUSSION OF THE FOREGOING EXAMPLES**

The last indicates that the graphical method becomes inconvenient when the given low-pass network step response contains more than one overshoot and one undershoot, but this is not a serious restriction in the field of servo synthesis because zero steady state acceleration error can be attained without further overshoot. The response of Fig. 14(a) would be considered unsatisfactory for servo duty; in fact, if this graph represented the theoretical behaviour of the idealized linear system, the practical version would probably show continuous oscillation unless heavily damped by friction\*.

The examples of Figs. 8 to 13 inclusive, indicate that the graphical approximation with about four straight line segments gives results within engineering limits up to a frequency such that about four cycles occur in the settling time of the given step response. In the case of well damped low-pass filters and servos the corresponding amplitude transmission is about 0.1—well below the value 0.5 usually taken as cut-off when considering attenuation of undesired signals.

The artificial slope discontinuities at the junctions of the straight line segments approximating the given step response are reflected as spurious ripples in the frequency response, and as shown by Figs. 6, 7, 8, increasing the number of segments reduces the amplitude of these ripples and increases the frequency at which they become obvious. Fig. 4 indicates that at large values of  $\Delta Tf$  the attenuating factor  $(\sin \Delta Tf)/\Delta Tf$  is a slowly decaying oscillatory function; the final stages of the frequency response loci are therefore contracting spirals around or near the infinite frequency point. Unless many segments are used these spirals must be arbitrarily disregarded and the graphical method used only up to frequencies such that three or four cycles occur in the duration of the given step response graph.

Referring to Fig. 9, the band-pass network could readily be converted to a "notch" or "null" network by addition of a vector about half the input amplitude and lagging 180° obtained, say, from resistive bridge arms or phase reversing transformer. This is a further example of non-minimum phase network correctly treated by the underlying theory and graphical approximation.

\* The response of Fig. 14 (a) would however be satisfactory for a process control since its subsidence ratio of 4.4 is better than the value 2.72 suggested by Rutherford. (RUTHERFORD, C. I. The Practical Application of Frequency Response Analysis to Automatic Process Control. Proc. Instn. Mech. Engrs. 162, 334 (1950).)

(To be continued)

**REFERENCE**

11. LEVY, M. The Impulse Response of Electrical Networks with Special Reference to the Use of Artificial Lines in Network Design. J. Instn. Elect. Engrs. 90, Pt. III, No. 12 (1943).

# Decimal Counting Tubes

By K. Kandiah\*, M.A.

*A survey of the currently available types of counting tubes is made with the emphasis on some of the limiting characteristics. Some of the important features which determine the resolving times of counting circuits using these tubes and tolerances of components and supply voltages are discussed.*

**E**LECTRONIC counting circuits find a large number of applications in research and in routine measurements in industry. The majority of these equipments use standard thermionic valves in well established circuits which can count up to many hundreds of kilocycles per second. Since many of these applications demand a decimal counting system, the number of valves and components used in each digit is very large. Apart from the complexity and cost of a complete unit which can store many digits, it is found that the probability of failure in such equipment is rather high.

In recent years a number of special tubes have been developed in order to meet the demand for a simple counting unit. Detailed descriptions of the principles of these tubes have been published and they have found many applications. It can be said that they have already widened the field in which counting systems are used. There are two major reasons for these developments. It is possible to reduce the cost and complexity of the equipment and, in some instances, it is also possible to increase the reliability. The present emphasis on the reliability of the various components and valves used in electronic equipment necessitates an appreciation of the features of the new counting tubes which may affect their reliability. This article is intended to be a survey of those tubes which are readily available at present with the emphasis on the permissible variations in the associated circuits and power supplies. The maximum counting speed of the new tubes is much lower than that of the normal circuits using thermionic valves. The permissible tolerances in the values of the components in counting circuits using thermionic valves at moderate speeds are very wide. It is therefore essential that the new circuits should accommodate at least as wide a tolerance in order to maintain a high standard of reliability.

The tubes discussed fall into three categories. The first of these contains a number of independent cathodes placed around a common anode in a gas-filled envelope<sup>1,2,3,4</sup>. There are ten index cathodes and they are separated by transfer cathodes. The number of transfer cathodes between any pair of index cathodes varies from one to three depending on the type of tube. A glow discharge is made to rest on one of the index cathodes and the tube is designed to count by moving the discharge from one index cathode to the next by the application of suitable pulses to the transfer cathodes. The resolving time between two consecutive counts varies from 30 to 250 microseconds depending on the geometry of the electrodes and the gas-filling.

Another category of tubes<sup>5,6</sup> uses thermionic cathodes in conjunction with an electrostatic focusing and deflexion system. A focused electron beam is arranged to have 10 stable positions by placing load resistors in series with plates which collect the beam current and connecting these to deflector plates. The application of a pulse to a deflector

plate causes the beam to move from one stable position to another. The position of the beam is indicated on a fluorescent screen and these tubes are therefore conveniently referred to as the C.R.T. type.

The last category of tubes<sup>7,8</sup>, called trochotrons, also use an electron beam from a thermionic cathode. In this case, however, the beam is confined to an equipotential path by means of crossed electrostatic and magnetic fields. The beam is made to take up one of the 10 stable positions by providing anodes and shields with load resistors which

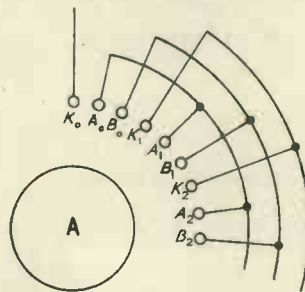

Fig. 1 (above) Arrangement of electrodes in the Ericsson Telephone GC10B

Fig. 2 (right) The electrode structure of the GC10B

By courtesy of Ericsson Telephones Ltd.



deflect the beam into one of 10 pockets. The application of a negative pulse to the anodes results in the movement of the beam from one pocket to the next.

## Gas-filled Tubes

The method of operation of the gas-filled tubes can be understood by considering the Ericsson GC10B which is of simple construction. The arrangement of electrodes and internal connexions are shown in Fig. 1. A central anode in the form of a circular disk is surrounded by 30 cathode pins arranged symmetrically around the anode as shown in Fig. 2. The 10 cathodes  $K_0, K_1, \dots, K_9$  are normally used as the index cathodes. The cathode  $K_0$  is brought out to a separate connexion in order to obtain an output pulse and reset the tube to zero. Between these index cathodes are the transfer cathodes connected in two groups,  $A_0, A_1, \dots, A_9$  and  $B_0, B_1, \dots, B_9$ . The external connexions are shown in Fig. 3 and a simple method of driving the tube with negative pulses is shown in Fig. 4. In this system all the transfer cathodes  $A$  and  $B$  are normally held at about +40

\* Ministry of Supply, A.E.R.E.



volts, so that the glow rests on one of the index cathodes—say  $K_0$ . The application of negative pulses to the  $A$  and  $B$  cathodes in turn transfers the glow to these electrodes and eventually to  $K_0$ . The current through  $R_2$  in Fig. 3 develops the output waveform as shown in Fig. 4. This output may be used to generate a pair of driving pulses for a succeeding tube. The minimum resolving time between two consecutive counts can be made as small as  $250\mu\text{sec}$  by making the duration of the pulses to the  $A$  and  $B$  cathodes approximately  $80\mu\text{sec}$  each.

A complete counting equipment with 4 or 5 decades with the GC10B in the system shown in Fig. 4 will require rather elaborate coupling circuits between the GC10B tubes. The two reasons for elaborate circuits are the necessity to provide two driving pulses for the GC10B and the fact that the output pulse from the GC10B is inevitably much smaller than the driving pulse. Some simplification can be

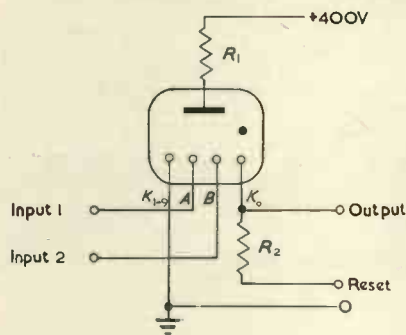

Fig. 3. Schematic representation of the GC10B

achieved by using cold-cathode trigger tubes as driving elements and shaping the output by means of a differentiating circuit and an integrating circuit in order to obtain a pair of pulses with the correct relationships. It is difficult to maintain accurate amplitudes and durations of driving pulses with such an arrangement. Although the range of pulse amplitudes and durations for satisfactory operation of a given GC10B are very wide, it is desirable to provide well-defined pulses in a complete equipment. This will ensure that the equipment will work satisfactorily in spite of production tolerances, ageing of the tubes and the

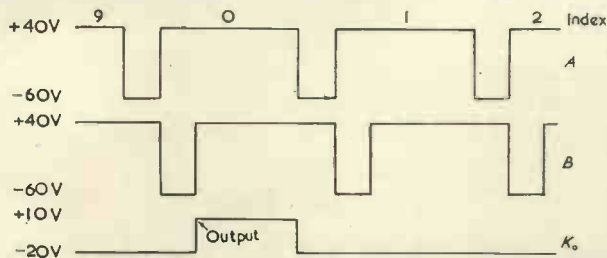

Fig. 4. Simple system of driving pulses for the GC10B

changes of pulse shapes that may occur due to the variations of mains voltage and drift in component values.

The circuit diagram of a system which provides well-defined driving pulses with simple coupling circuits between the GC10B counting tubes is shown in Fig. 5. In this unit the amplitudes and durations of the driving pulses to all the counting tubes are determined by a common pulse generator. The cold-cathode trigger tubes  $V_1$ ,  $V_2$ , act as gating elements so that the transfer by a digit in a particular GC10B is brought about if a carry pulse is received by the trigger tube preceding it. Only two decades are shown but 2 or 3 further decades, identical to the second stage shown in dotted lines, are normally used. The operation of the circuit can be seen by reference to Fig. 6 which shows the waveform at various points, corresponding to

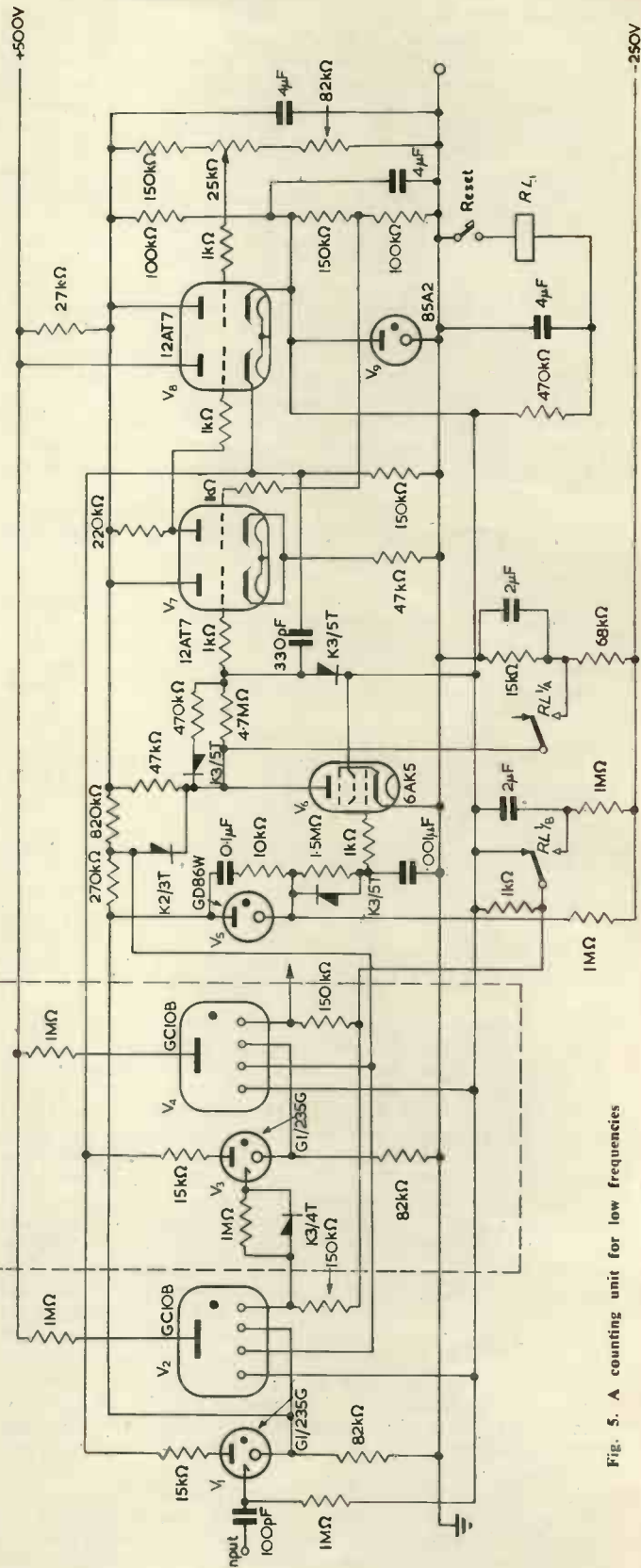

Fig. 5. A counting unit for low frequencies

the 9<sup>th</sup>, 10<sup>th</sup> and 11<sup>th</sup> input pulses. The counting tubes are used in this instance with the *B* cathodes as the index cathodes and the *K* and *A* cathodes as transfer cathodes. The trigger tube  $V_1$  is fired at each input pulse and produces a positive pulse of about 120 volts at the cathode. This positive step is fed to the common pulse generator consisting of  $V_5, V_6, V_7$  and  $V_{8a}$ . This pulse generator produces a driving pulse to all the *A* cathodes of the counting tubes as shown in Fig. 6(c). This pulse on the *A* cathodes acting in conjunction with that on the *B* cathodes of  $V_2$ , obtained from  $V_1$ , will transfer the discharge from one index cathode *B* to the next. The common pulse generator also produces a negative pulse at the cathode of  $V_{8a}$ , as shown in Fig. 6(d) which is applied as a quenching pulse to the anodes of the trigger tubes. On the 10<sup>th</sup> input pulse, the output from  $K_0$  of  $V_2$  fires the trigger tube  $V_3$  which applies a positive pulse to the *B* cathodes of  $V_4$ . The discharge in  $V_4$  then moves by one digit. The presence of the waveform shown in Fig. 6(c) at the *A* cathodes of the counting tubes which do not receive a pulse from the previous trigger tube does not produce a complete transfer by one digit, but the glow rests momentarily on the adjacent *A* cathodes. The resolving time between two input pulses

two-pulse system of the GC10B can be used to advantage in a counting system where addition and subtraction is required.

There are two gas-filled tubes with a resolving time of 50  $\mu$ sec. One of these is the Standard Telephones and Cables G10/241E which employs specially shaped cathodes<sup>1</sup> in order to obtain directional properties when the discharge is moved from one index cathode to the next. This tube therefore uses only one transfer cathode between any two index cathodes. The circuit diagram of one stage using the G10/241E is shown in Fig. 7. The index cathodes  $K_0, K_1, \dots, K_9$  are brought out to separate pins and each of them is connected to earth via a resistance and capacitance in parallel. The 10 transfer cathodes are con-

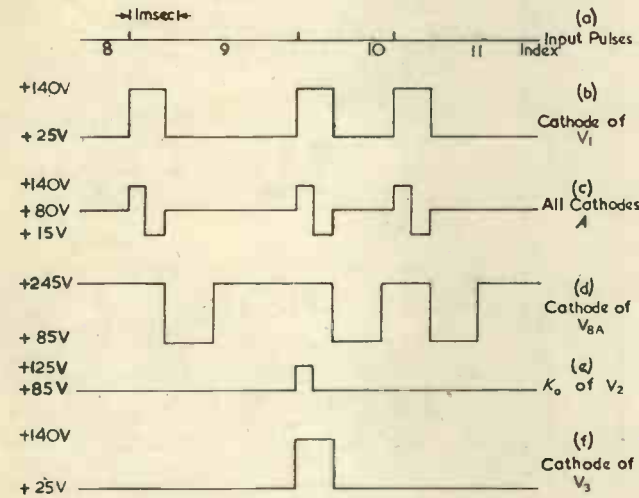

Fig. 6. Waveforms in circuit of Fig. 5

is about 2msec in this unit since the duration of the quenching pulse for the G1/235G trigger tubes should exceed 1msec. By using faster trigger tubes with appropriate changes of the component values the resolving time can be reduced to less than 400  $\mu$ sec. The counting tubes in Fig. 5 are reset to the zero position by pressing button  $S_1$ , which energises relay  $RL_1$  for a fraction of a second. The relay contacts  $RL_{1a}$  and  $RL_{1b}$  change over from the positions shown in the circuit and apply a large negative pulse to all cathodes  $K_0$  and a smaller negative pulse to all *A* cathodes. The power supplies required are 6.3V at 1A, +500V at 12mA, and -250V at 3mA, all of them unstabilized. The necessary stabilization is carried out by means of  $V_{8b}$  and  $V_9$ . One practical point should be borne in mind in the construction of any equipment using trigger tubes such as the G1/235G which are not primed. Satisfactory operation can be obtained only with a small amount of illumination on these tubes since they may fail to fire on some of the trigger pulses when in complete darkness. On the other hand, incipient breakdown will be experienced with strong illumination.

The GC10B requires two driving pulses which is a disadvantage in some cases and the resolving time is considerably longer than thermionic valve counting circuits. It possesses the advantage of stability of characteristics over long periods even when the glow is left stationary on one index cathode, and freedom from catastrophic failures. The

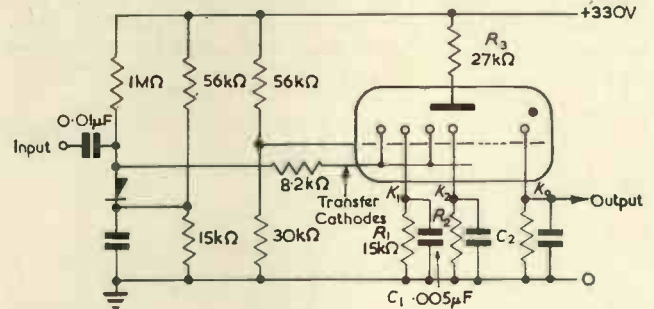

Fig. 7. Typical circuit for Standard Telephones and Cables counting tube G10/241E

By courtesy of Standard Telephones and Cables Ltd.

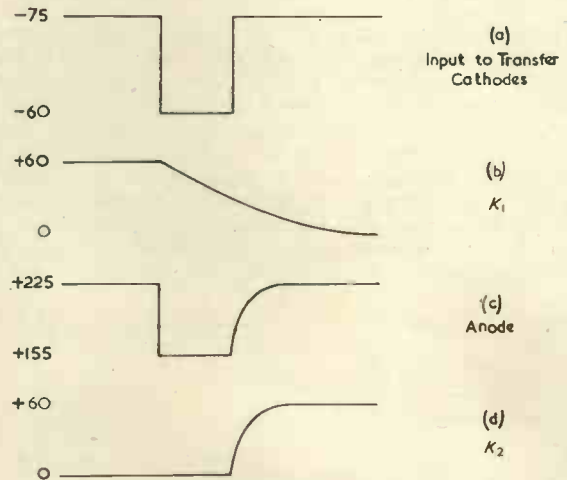

Fig. 8. Waveforms in circuit of Fig. 7

nected together internally and the negative driving pulse is applied to them.

The waveform obtained when a pulse transfers the discharge from  $K_1$  to  $K_2$  in the G10/241E is shown in Fig. 8. When the discharge is on  $K_1$ , the potential of this cathode is about +60 volts and all other index cathodes are at earth potential. There is no glow at the next transfer cathode since the potential of this cathode is +75 volts. When a negative pulse is applied to the transfer cathodes, the glow moves to the transfer cathode between  $K_1$  and  $K_2$  and the anode potential immediately falls to about +155 volts. Since the current through  $K_1$  is now terminated, the potential of  $K_1$  falls exponentially with the time-constant  $C_1R_1$ . The negative pulse on the transfer cathodes is removed before the potential of  $K_1$  has fallen below +20 volts, but the duration of this pulse should be long enough for the glow to spread completely over the transfer cathode. When the pulse is removed, the glow moves to the end of  $K_2$ ,

nearest to  $K_1$  and then to the farther end. The potentials of the anode and  $K_2$  rise exponentially as shown in Figs. 8(c) and 8(d) with a time-constant of  $C_2$  combined with  $R_2$  and  $R_3$  in parallel.

The time-constants in the cathode leads in the circuit of Fig. 7 should be chosen with some care. Since the transfer cathodes are not directional the glow can return to  $K_1$  at the end of the transfer pulse if both  $K_1$  and  $K_2$  are at the same potential. Owing to the effect of the time-constant  $C_1R_1$  the potential of  $K_1$  is considerably higher than that of  $K_2$  at the end of the transfer pulse. The region around  $K_1$  is therefore fully deionized before the potential difference between anode and  $K_1$  is large enough to maintain a discharge. The duration of the transfer pulse should be large enough to ensure this as well as to spread the glow on the transfer cathode. A pulse duration of  $15\mu\text{sec}$  meets these requirements. The time-constant  $C_1R_1, C_2R_2, \dots$  should be at least  $20\mu\text{sec}$  in order to prevent the glow from returning to the same index cathode after a transfer pulse. In

to that of the GC10B, but there are 40 cathode pins. The gas filling is also different in order to reduce deionization time. The four groups of ten cathodes designated groups,  $W, X, Y$  and  $Z$  respectively are similar in shape and arranged symmetrically around the anode as shown in Fig. 9(a). All the cathodes of group  $Y$  are connected together internally and so are all the cathodes of group  $Z$ . The cathodes  $W_1, W_2, \dots, W_9$  are connected together and so are  $X_1, X_2, \dots, X_9$ .  $W_0$  and  $X_0$  are brought out to separate pins on the base for obtaining an output pulse and resetting to zero. The external connections to the tube are shown in Fig. 9(b). This tube can be driven with negative pulses applied to the cathodes  $Z$ —and cathodes  $Y$  which are normally connected to cathode  $Z$  through a  $CR$  circuit. The cathodes  $X$  are used as the index cathodes in this case and are normally held at earth potential while the cathodes  $Z$  are held positive.

The  $CR$  circuits in the leads of cathodes  $W$  and  $Y$  provide the necessary directional property to enable the discharge to be moved in a clockwise direction, as viewed from the front. It is also possible to drive this tube with positive pulses applied to cathodes  $Z$  by maintaining these normally at a negative potential and using them as the index cathodes. This system will enable the use of a common pulse generator to drive a cascade of GC10D tubes using cold-cathode trigger tubes as gating elements as in Fig. 5. The common pulse generator will take the form of a simple circuit for generating the quenching pulses for the trigger tubes. The duration of the drive pulses for the GC10D can be as short as  $25\mu\text{sec}$  and the resolving time of the tubes is less than  $50\mu\text{sec}$ . As in the case of the G10/241E it is not advisable to leave the discharge stationary on one cathode for long periods.

Another gas-filled counting tube, the Bell Telephones 6167 has been described recently<sup>4</sup>, but this tube has not been tested by the author. This differs from the other gas-filled tubes in two respects. There are two sets of ten cathodes in this tube, but both sets have directional properties. One set is used as the index cathodes  $K$  and the other as the transfer cathodes  $B$ . Each cathode is shaped in such a way that the discharge is taken over from a preceding cathode at the end nearest to this cathode, but soon moves over to the other end so that it primes the succeeding cathode. If the glow is resting on the index cathode  $K_2$  then the glow is mainly at a point which is near to the transfer cathode  $B_1$ . When a negative pulse is applied to all the transfer cathodes the discharge moves to the side of  $B_2$  nearest to  $K_3$  and during this pulse the glow moves over to the side of  $B_2$  nearest to  $K_3$ . When the pulse is removed the discharge transfers to the side of  $K_3$  nearest to  $B_2$  and soon moves to the side of  $K_3$  nearest to  $B_3$ . This tube can be driven with a single negative pulse and does not require any  $CR$  circuits as do other tubes which are driven with single pulses. Another feature of this tube is that an auxiliary anode is built into the tube in close proximity to  $K_0$  so that when the discharge moves to this index cathode the auxiliary gap breaks down and produces a large negative pulse at the anode. This obviates the need for a separate trigger tube for coupling from one counting tube to another. Since the maintaining voltage of this tube is 110 volts it should be possible to operate it with an H.T. line of 250 volts and with transfer pulses of about 50 volts amplitude. The resolving time of the tube is given as about  $100\mu\text{sec}$  providing the auxiliary anode is not used in a self-quenching circuit.

### C.R.T. Counting Tubes

A tube that is currently available which uses a ribbon shaped electron beam<sup>5</sup> is the Philips EIT. A cross-section and schematic representation of the electrode system of the tube are shown in Fig. 10. The electron gun consisting of the cathode  $K$ , control electrode  $G_1$ , accelerating electrode  $G_2$ , and beam forming electrodes  $B$  produces a ribbon

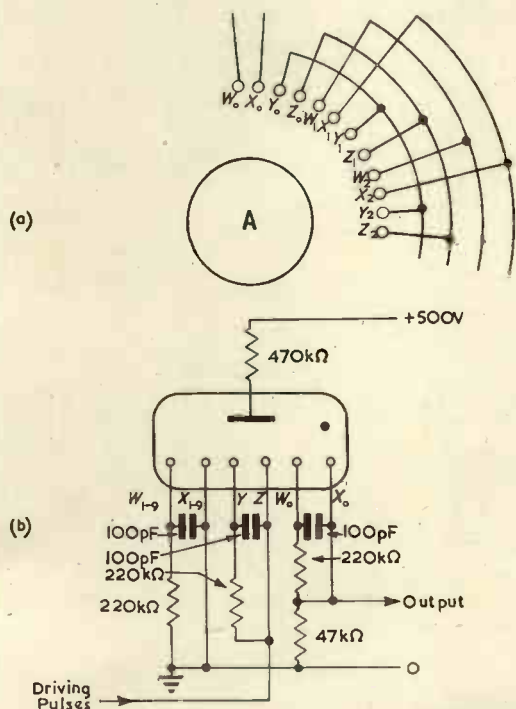

Fig. 9. Arrangement of electrodes and typical circuit for Ericsson Telephones GC10D

general it is advisable to make the cathode time-constant as large as possible, consistent with the required resolving time, by increasing the capacitance. This precaution will reduce the tendency for the tube to fail to transfer on the application of a pulse after the glow has been stationary on one index cathode for long periods. This tendency to stick in one position has been observed to a marked extent in most of the faster gas-filled counting tubes. This is due to changes in the glow maintaining voltage on the cathodes adjacent to one that has been carrying the discharge for a long period. When counting at low speeds it is not necessary to have a separate resistor and capacitor to each index cathode. It is sufficient to have one  $CR$  circuit for the output and zeroing cathode  $K_0$ , one for all odd cathodes  $K_1, K_3, \dots$  connected together and another for all even cathodes  $K_2, K_4$ , connected together. A unit containing a number of decades using the G10/241E with a common pulse generator can be made in a simple form if the coupling trigger tube will operate on negative pulses.

Another gas-filled tube for high speeds is the Ericsson GC10D<sup>3</sup>. The internal construction of this tube is similar

shaped electron beam, the plane of which is parallel to the leading edges of the deflector plates  $D_1$  and  $D_2$ . The beam passes between the deflector plates and then through the suppressor grid  $G_3$  to the slotted electrode  $G_4$ . This slotted electrode contains ten slots, some of which can be seen in the partially opened up view of the tube shown in Fig. 11. A large portion of the beam then proceeds through one of the slots and then through another suppressor grid  $G_5$  to the main anode  $A_2$ . A portion of the beam is allowed to go through further slots in the anode which are in line with the slots in  $G_4$  to provide indication of the position of the beam on a fluorescent screen  $L$ . These slots in the anode are about one-half of the height of the slots in  $G_4$  and they are staggered, as can be seen in Fig. 10, in such a way that the odd numbers are seen in a row lower than the row corresponding to the even numbers.

The static characteristics of the EIT are shown in Fig. 12. The current to the main anode  $A_2$  is plotted as a function of the voltage on the anode  $A_2$  and the right-hand deflector

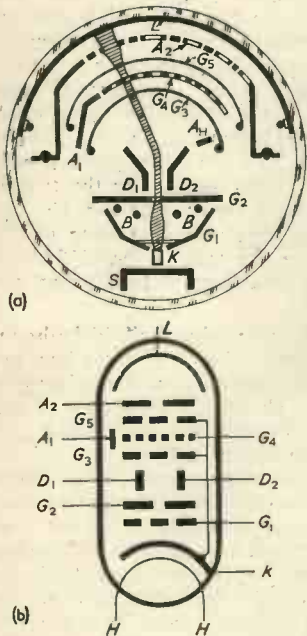

Fig. 10. Cross section and schematic representation of the EIT

By courtesy of the Mullard Radio Valve Co., Ltd.



Fig. 11. The structure of the EIT

plate  $D_2$  connected together, for two fixed values of the voltage on the left-hand deflector plate  $D_1$ . The maxima on these curves correspond to the greatest fraction of the beam going through the slots in the electrode  $G_4$ . The normal operating voltage on  $D_1$  is 156 volts and the curve for 170 volts on  $D_1$  corresponds to the conditions which apply at the instant when a 14 volt positive pulse is applied to  $D_1$ . Consider a load of  $1M\Omega$  from a 300V line to  $A_2$  ( $D_2$  is always connected to  $A_2$  for normal operation). The load line for  $1M\Omega$  is shown in Fig. 12 and the intersections  $a, b, c, d, \dots$  with the static characteristics correspond to the 21 possible values of current in the tube. The 11 points  $a, c, e, \dots, t, u$ , are the stable positions corresponding to digits 0, 1, 2,  $\dots$  9 and the reset point, whereas the 10 points  $b, d, f, \dots$  are metastable. Suppose that the anode current is at the point corresponding to  $b$  and a small disturbance shifts the beam to the left—corresponding to the point  $s$  on the characteristics. The beam will then move farther away from the point corresponding to  $b$  and soon reach the point corresponding to  $c$  at which it will remain despite any small disturbances. Similarly if the beam is moved from the metastable condition  $b$  towards

$r$  then it will quickly reach the stable condition  $a$ . The speed at which the beam will move from any point corresponding to  $r$  or  $s$  to the nearest stable position is limited only by the rate at which the stray capacitance at the anode  $A_2$  can be charged or discharged by the beam current. In general this is in the region of  $1\mu\text{sec}$ .

Suppose that the beam is stationary at digit 0 corresponding to the operating point  $a$  in Fig. 12(a). If a positive voltage step of 14 volts is applied to  $D_1$  the beam will immediately shift to the left towards digit 1 without appreciable change in the potential of  $A_2$  and the tube

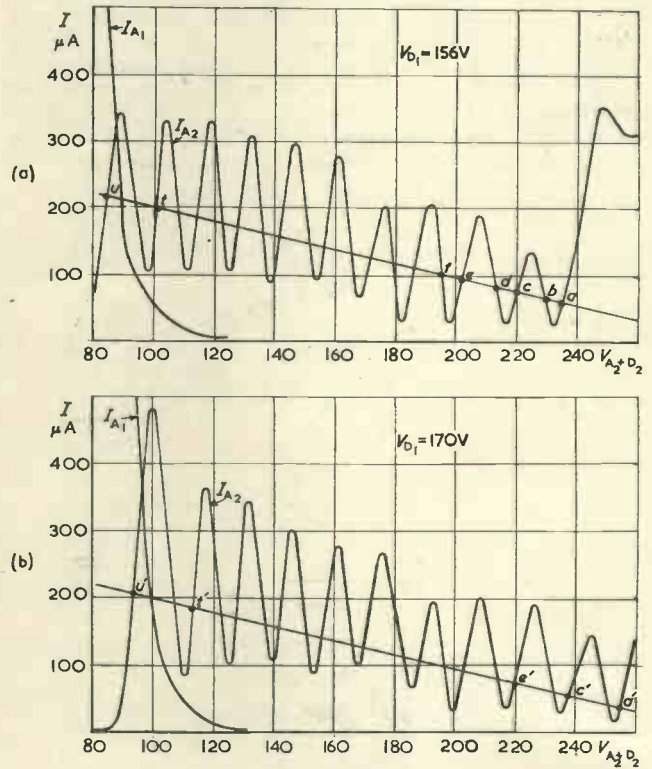

Fig. 12. Static characteristics of the EIT

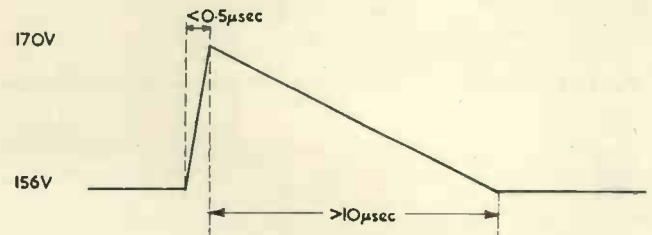

Fig. 13. The driving pulse for the EIT

characteristics that apply at this instant are as shown in Fig. 12(b). The tube will now operate at the point  $c'$  corresponding to digit 1 as long as the voltage  $D_1$  is maintained at the new value of 170V. If the voltage at  $D_1$  is brought back to 156V suddenly then the beam will switch back to position 0 corresponding to the operating point  $a$ . A rectangular pulse will therefore not shift the beam permanently to a new stable position. The tube can be made to count on the application of the pulse shown in Fig. 13. The leading edge of the pulse must be so fast that the beam switches to the next stable position, the stray capacitance at the anode maintaining an almost constant potential during this part of the pulse. The tube thus switches instantaneously from the characteristic of Fig. 12(a) to that of

Fig. 12(b). The trailing edge of the pulse on  $D_1$  must, on the other hand, be so slow that the beam remains in the new stable position corresponding to digit 1 while the potential of  $D_1$  is being returned to the original value. During this part of the pulse the potential at the anode  $A_2$  (and  $D_2$ ) falls by about 14 volts at the rate at which the potential of  $D_1$  falls. The stray capacitance with normal wiring is such that the leading edge of the input pulse must rise faster than  $20V/\mu\text{sec}$  and the trailing edge should fall slower than  $2V/\mu\text{sec}$ .

The amplitude of the driving pulse on  $D_1$  need not be precisely equal to the voltage difference between the points  $a$  and  $c$  in Fig. 12(a). The essential conditions are that the amplitude of the pulse should be greater than the voltage drop from the point  $a$  to the point  $b$  and should be less than the voltage drop from the point  $a$  to the point  $d$ . The ratio of amplitudes of the maximum pulse to the minimum pulse for shifting from a given digit to the next in one particular tube is therefore about 3. Allowing for the differences between digits in one tube and the difference between tubes this ratio is reduced to about 1.4. This imposes a strict limitation on the permissible tolerances in the component values associated with the counting tube and the trigger circuits which provide the driving pulse. Provided that

higher than that corresponding to point  $a$  in Fig. 12 and thus make the tube return to digit 0 at the end of this pulse. The resolving time of the tube is limited only by the time taken by the anode  $A_2$  to recover from the point corresponding to  $u$  in Fig. 12 to a point higher than that corresponding to  $a$ . With short leads to the anode this can be made about  $25\mu\text{sec}$  so that an overall resolving time of about  $30\mu\text{sec}$  can be obtained in practice. In addition to those already mentioned it is desirable to have close tolerance components in the trigger circuit if the output pulse is used to drive another EIT. The H.T. supply need not be stabilized since a tolerance of  $\pm 10$  per cent is generally permissible.

An interesting C.R.T. type of counting tube has been described by Holloway<sup>6</sup>. The electron gun in this tube is similar to that of a normal cathode-ray tube giving a well-focused beam. There are five deflectors arranged symmetrically around the axis of the electron gun. There are also two sets of collector plates designated the front and back collectors respectively with five sections in each. By providing suitable slots in these collectors and connecting each of the collectors to one of the deflectors the beam can be given ten stable positions. In each stable position the beam is displaced radially from the axis of the gun and

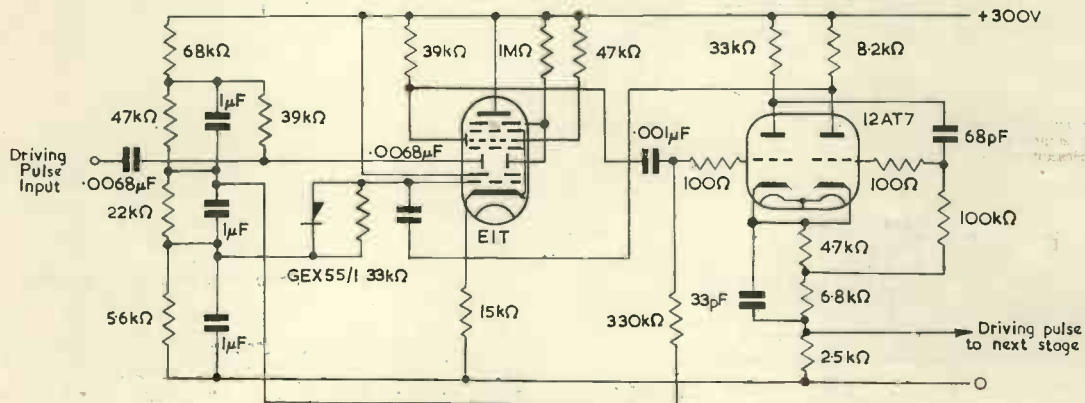

Fig. 14. Typical counting stage using the EIT

reasonably close tolerance components are used the effect of variations in H.T. supply can be made negligible by designing the driving circuit so that the pulse amplitude is proportional to the H.T. voltage.

The digit 9 corresponds to the operating point  $t$  in Fig. 11(a). When the tenth input pulse is received the beam will be switched further to the left and will fall on the reset anode  $A_1$  and tend to stay in the stable position corresponding to the operating point  $u$  in Fig. 12(a). There will then be a negative pulse at  $A_1$  in the circuit of Fig. 14. This pulse is used to generate a resetting pulse which switches the beam to digit 0 and also to provide a carry pulse to the next decade. The simplest method of resetting the tube to 0 from 9 is by cutting off the beam current for a period on receipt of the pulse from the reset anode. The potential of  $A_2$  will then rise to the H.T. potential and when the beam current is restored, the anode current will stabilize at the operating point  $a$  in Fig. 12(a) corresponding to digit 0.

The complete circuit diagram of one counting stage using the EIT is shown in Fig. 14. Degeneration by means of a cathode resistor is used to stabilize the total cathode current of the EIT and the operating potential for the deflector plate  $D_1$  is obtained from a potential divider across the H.T. supply. The stability of the values of the resistors in this potential divider and the anode load resistor of  $1M\Omega$  should be better than  $\pm 2$  per cent in order to cope with the variations in the tubes. The resetting pulse applied to  $G_2$  of the counting tube is derived from the trigger circuit using a 12AT7. The duration of  $25\mu\text{sec}$  of this pulse is adequate to allow the anode  $A_2$  to recover to a voltage

the beam rotates around the axis of the gun as it is shifted from one stable position to another. The transfer from one stable position to the next is by means of a positive signal applied to a trigger ring placed immediately in front of the collector ring. Although this tube is not currently available it possesses some notable features which affect the associated circuits. The tolerance in the driving signal amplitude is very wide and it can be driven with signals ranging from rectangular or triangular pulses to sinusoidal signals. Since the stable positions are symmetrical the resolving time is the same on all digits although this resolving time is not claimed to be better than that of the EIT. It would appear from the published information on the shapes of the deflectors and collectors that it may not be possible to manufacture this tube economically.

### The Trochotron

The L.M. Ericsson trochotron AD3 is the only counting tube in which a magnetic field<sup>7</sup> is used in addition to electrostatic fields in order to control the position of the electron beam. A section of the tube in a plane perpendicular to the cathode is shown in Fig. 15. The tube is a high vacuum type and consists of a cathode, a cylindrical anode and 10 spades symmetrically around the cathode and in front of the anode. A uniform magnetic field parallel to the cathode and covering the entire space inside the anode should be provided by means of an external magnet. If one of the spades, say spade 1, is kept at cathode potential and the anode and all other spades at

about +100 volts then the trajectory of the electrons is as shown in heavy lines in Fig. 15. The beam will remain in this position as long as the above potentials are applied since this corresponds to an equipotential path for the electrons. A small current will flow to the spade 1, but most of the electrons will proceed to the anode through the space between spades 1 and 2. If the potential of the anode is momentarily reduced to that of the cathode and at the same time spade 2 is brought to cathode potential and spade 1 taken to +100 volts permanently the beam will move to the position shown in dotted lines in Fig. 15. This corresponds to transfer by one digit.

The circuit diagram of a typical counting stage using the AD3 is shown in Fig. 16. A cathode resistor of 15kΩ is used to stabilize the current through the tube and this may need adjustment for individual tubes. The magnetic

Fig. 15 (right) Section of trochotron showing electron trajectories  
By courtesy of L. M. Ericsson

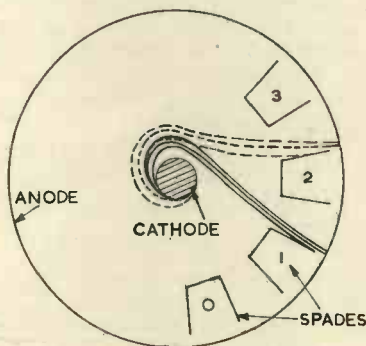
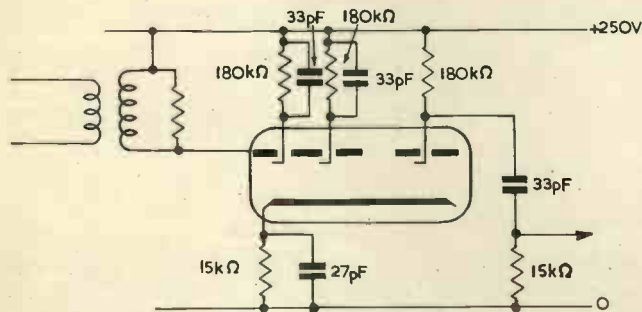

Fig. 16 (below) Circuit of one counting stage using the L.M. Ericsson AD3



field required is 320 gauss. Each of the spades is connected to +250V through a CR circuit and a negative pulse is applied to the anode through a pulse transformer. The tube will pass a total current of about 10mA and the cathode potential will be +150 volts. Assume that the beam is in the stable position shown in heavy lines in Fig. 15. Spade 1 will then be passing a little over 0.5mA and the potential of this spade will be slightly lower than that of the cathode. The anode will pass the remaining current and there will be negligible current to the other spades. The anode current and the current to one spade as a function of the potential of that spade are shown in Fig. 17 with a load line corresponding to 180kΩ. It should be noted that the cathode is assumed to be at zero potential in these curves.

Now consider the effect of applying a negative pulse of more than 150 volts to the anode in the circuit of Fig. 16. Most of the current will now flow to spade 2 and the potential of spade 2 will fall at a rate determined by the full beam current of 10mA and the capacitor of 33pF in the spade circuit. At the same time the potential of the spade 1 will rise exponentially with a time-constant corresponding to 33pF and 180kΩ which will therefore be much slower than the rate at which the potential of spade 2 is falling. If the negative pulse at the anode is terminated when the potential of the spade 2 has fallen to lower than

+150 volts then the beam will now be in the stable position corresponding to the dotted lines in Fig. 15. In order to effect this transfer by one digit the amplitude of the pulse at the anode should be greater than 150V. The duration of this pulse should be almost equal to the time necessary for the spade 2 to reach cathode potential. If the duration of the pulse is much greater than this the beam will move further forward and will transfer by more than one digit. The duration of this pulse is therefore rather critically related to the beam current and the time-constants of the spade circuits. A negative pulse output of about 50V is obtained from spade 0 when the beam is moved from digit 9 to digit 0.

### Some Comparisons

Since the counting tubes described have a multitude of applications it is inevitable that a type of tube which is ideal for one function may be useless for another. It is, however, possible to compare those tubes which can be

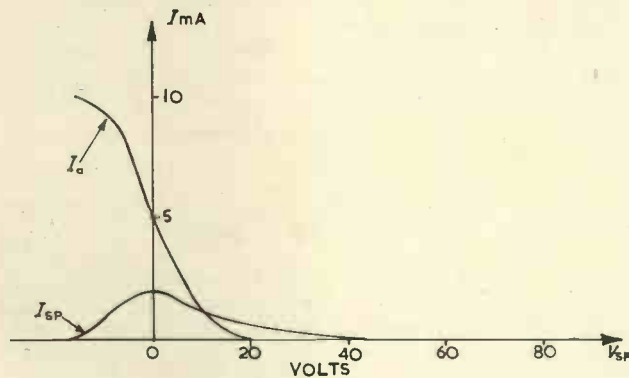

Fig. 17. Static characteristics of the AD3

By courtesy of L. M. Ericsson

used to perform the same counting operation. First consider the maximum counting speed. The L. M. Ericsson AD3 and the Philips EIT are considerably faster than the other tubes that are available. With simple circuits it is possible to obtain a resolving time of 20μsec with the EIT and 5μsec with the AD3. The resolving time can be reduced by almost a factor of 5 in each case by using more complex circuits and by providing adjustments in the circuit in order to operate individual tubes under optimum conditions. Both of these tubes are critical as regards the amplitudes and shapes of the driving pulses—particularly when they are used at high speeds. Some advantage is gained in the case of the EIT by driving it with negative pulses on the right-hand deflector  $D_2$  instead of the positive pulse on  $D_1$  since the speed of the pulse is unimportant when driven in this manner. The tolerance in the amplitude of the driving pulse will, however, be rather narrow even for this method of operation. There is little difference between these tubes as regards the complexity of the driving circuits. The tube described by Holloway<sup>6</sup> seems to overcome these circuit difficulties. If a tube of this type can be manufactured economically it would be ideal for the higher speed applications provided that the beam current is made higher than the value quoted.

Among the gas discharge tubes, the S.T.C. G10/241E and the Ericsson Telephones GC10D provide a resolving time in the region of 50μsec which is adequate for many applications. Both of these tubes, show some weak features when considered in terms of the usefulness in a standard equipment for routine measurement. Until these difficulties are overcome their use will be limited only to the higher speed applications where gas discharge tubes are preferred. The amplitudes of the driving pulses for these tubes need not lie within close limits. The GC10D can be operated with rectangular pulses with a tolerance in the

amplitude of more than  $\pm 20$  per cent provided that the duration is greater than  $25\mu\text{sec}$ . The G10/241E on the other hand requires a pulse duration lying within close limits. The driving circuits for these tubes are simpler than those for the AD3 and the remaining gas discharge tubes are relatively slow—the resolving time being in the region of  $250\mu\text{sec}$ . The Ericsson GC10B requires a pair of driving pulses for each transfer, but this can, in some instances, be an advantage. It is possible with this tube to devise circuit arrangements for a counting unit to add or subtract. The Bell Telephones 6167 requires only a single driving pulse and hence a very simple driving circuit. It possesses the feature of a built-in trigger tube associated with the digit 0. A carry pulse of sufficient amplitude to drive a succeeding tube may be generated at the anode of this trigger tube, but the resolving time of the counting tube is made considerably longer when this facility is used. These slow counting tubes do not show appreciable changes of characteristics even over long periods of operation and

are therefore very reliable. There is a need for a counting tube with the stability comparable to the GC10B and with simpler methods of driving one tube from the "carry" pulse of another.

**Acknowledgment**

The author wishes to thank the Director, Atomic Energy Research Establishment, Harwell, for permission to publish this article.

**REFERENCES**

1. HOUGH, G. H., RIDLER, D. S. Multi-Cathode Gas-Tube Counters. *Elect. Commun.* 27, 214 (1950).
2. BACON, R. C., POLLARD, J. R. The Dekatron—A New Cold Cathode Counting Tube. *Electronic Engng.* 22, 173 (1950).
3. ACTON, J. R. The Single Pulse Dekatron. *Electronic Engng.* 24, 48 (1952).
4. PECK, P. S. A Ten-Stage Cold Cathode Stepping Tube. *Elect. Engng. N.Y.* 71, 1136 (1952).
5. JONKER, J. L. H., VAN OVERBEEK, A. J. W. M., DE BEURS, P. H. A Decade Counter Valve for High Counting Rates. *Philips Res. Rep.* 7, 81 (1952).
6. HOLLOWAY, D. L. A Decimal Counter Electron Tube. *Austral. J. Phys.* 6, 96 (1953).
7. ALFVEN, H., LINDBERG, L. Theory and Application of Trochotrons. *Acta Polytech. Elect. Eng. Ser. 2*, No. 2, p. 106 (1949).

## A High-Voltage High-Current Pulse Generator\*

AN electronic pulse generator recently developed at the U.S. National Bureau of Standards provides nearly square-topped pulses at voltages up to 1 200V and currents up to several amperes. The pulse frequency is variable in steps of 10 between 10 and 60 pulses per second. Pulse duration, a constant 1 per cent of the period at each frequency, ranges from  $165\mu\text{sec}$  at 60c/s to  $1000\mu\text{sec}$  at 10c/s. This equipment was developed to supply the heavy pulses required in the study of vacuum-tube cathode emission. However, the instrument may find other applications where nearly square-topped pulses are required, at high voltages and heavy currents.

Output of the pulse generator is taken between ground and the cathode of a high-power 304TH triode switch valve. The

former would need to be insulated to withstand the high voltages involved, and it would be difficult to construct such a transformer having good response at the low repetition rates as well as good insulation. For this and other considerations, a circuit was adopted in which a keyed radio-frequency oscillator and rectifier take the place of a pulse transformer.

Pulses are generated initially by a twin-triode 6SN7 in an unbalanced multivibrator circuit. A six-position selector switch gives repetition rates of 10, 20, 30, 40, 50, and 60 pulses per second, with a constant 1 per cent duty cycle. The output of the multivibrator is amplified by a single 6J5 triode and coupled by a 6V6 cathode-follower to the screen-grids of a 4.2Mc/s radio-frequency oscillator using two 6L6's in parallel.

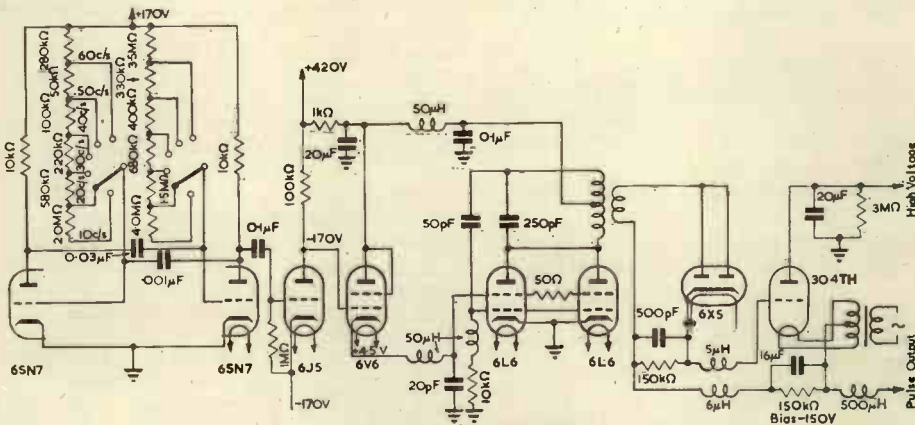

The circuit described.

anode voltage of the 304TH is supplied from an adjustable external source of up to 2000V. When the switch valve is receiving no pulse excitation, its grid is biased to cut-off, and its cathode is at ground potential. When a pulse drives the 304TH grid positive with respect to cathode—about 130V are used—the output voltage rises to a value determined by characteristics of the external power supply and load.

The main feature is the means by which the exciting pulse is supplied to the grid of the 304TH. The most obvious method might seem to be to couple a pulse-forming circuit to the 304TH by means of a pulse transformer. But the trans-

former would need to be insulated to withstand the high voltages involved, and it would be difficult to construct such a transformer having good response at the low repetition rates as well as good insulation. For this and other considerations, a circuit was adopted in which a keyed radio-frequency oscillator and rectifier take the place of a pulse transformer.

Pulses are generated initially by a twin-triode 6SN7 in an unbalanced multivibrator circuit. A six-position selector switch gives repetition rates of 10, 20, 30, 40, 50, and 60 pulses per second, with a constant 1 per cent duty cycle. The output of the multivibrator is amplified by a single 6J5 triode and coupled by a 6V6 cathode-follower to the screen-grids of a 4.2Mc/s radio-frequency oscillator using two 6L6's in parallel. The oscillator's output is inductively coupled to a 6X5 rectifier tube. The positive pulse output of the rectifier is applied to the grid of the 304TH output tube. The necessary high-voltage insulation between the two windings of the oscillator coil is readily provided. In practice, the amplitude of the output pulse decreases slightly in a linear manner at a rate of 0.1 per cent per microsecond of pulse duration. This die-away is due primarily to the decrease in anode supply voltage of the switch tube as the storage capacitor of the power supply discharges. Overshoot of amplitude at the beginning and end pulses is negligible, an important requirement in the intended application.

\* Communication from M. Lorant.

# D.C. Amplifiers

## Methods of Amplifying and Measuring Small Direct Currents and Potentials

(Part 2)

By J. Yarwood\*, M.Sc., F.Inst.P., and D. H. Le Croisette†, M.Sc.

### Operating Conditions for Electrometer Valves

TO obtain satisfactory results with electrometer valves when measuring currents less than  $10^{-10}$ A the following points must be observed:

- (1) Valve operated in the dark.
- (2) Valve and input circuit electrically screened. Brass chambers tend to give ionization troubles due to  $\alpha$ -particle emission<sup>23</sup>, but copper is satisfactory. Even with screening, the operation in the neighbourhood of inductors or high frequency machines should be avoided.
- (3) High capacity accumulators which are on the part of the discharge curve where there is a stable E.M.F. should be used, as far as practicable, for filament, anode and space-charge grid supplies. This will reduce fluctuations and drift. For electrometer valves with  $I_f$  less than 30mA a large capacity dry cell can be used if it is required to make easily portable apparatus.
- (4) The valve and input resistor should be in a chamber dried with silica-gel. This is not so important when using sub-miniature tubes with water repellent silicone lacquers on their glass envelopes, but such coatings must, in any case, be kept clean and dry.
- (5) To make connexions to the leads of sub-miniature tubes resin-cored solder is preferred.
- (6) Avoid contact potentials between dissimilar metals at the input circuit.
- (7) High quality, wire-wound resistors should be used in the circuit, except where impracticable for the high input resistor. It is especially important to choose wire-wound variable resistors which are free from contact troubles as far as possible.
- (8) Flexible mountings should be used to avoid mechanical disturbances.
- (9) Switch on the electrical supplies some 30 minutes before using the amplifier to allow thermal equilibrium to be attained.

### Methods of Measuring Small Direct Currents Using Electrometer Valves

There are two principal methods used:

- (1) Pass the current through a high resistance and measure the p.d. produced when it is made the input to the electrometer valve. This can be made a null method. (cf. Figs. 1 and 2).
- (2) Use a rate of charge of the grid method<sup>4,20,24</sup>, comparing with the method, described previously, of measuring very small grid currents.

Method (1) is conveniently discussed in relation to the work of DuBridge<sup>24</sup>, who employed an FP54 electrometer valve. (Fig. 7.)

The procedure in using this circuit is as follows:

- (a) Adjust the galvanometer deflexion to zero, using  $R_4$ .
- (b) Measure the voltage sensitivity by applying known

potentials to the grid. These potentials are produced across  $R_2$  and measured by the voltmeter  $V_1$ .

(c) Apply the input to be measured and bring the galvanometer deflexion back to zero by adjusting  $R_2$ . Measure the corresponding change of grid volts  $\Delta V_g$  by voltmeter  $V_1$ . Then the input current  $I = \Delta V_g / R$ .

With  $R = 10^{10}\Omega$  and a galvanometer of  $1/\sigma = 5 \times 10^{-10}$ A/mm, the voltage sensitivity of the circuit was 50 000mm/V and the current sensitivity  $2 \times 10^{-15}$ A/mm.

As pointed out by Burroughs and Ferguson<sup>25</sup>, the use of an input resistance  $R$  greater than  $10^{12}\Omega$  leads to difficulties because the time-constant of the input circuit becomes excessive. For example, suppose the total input capacitance, including leads, is 10pF. Then with  $R = 10^{13}\Omega$ , say,

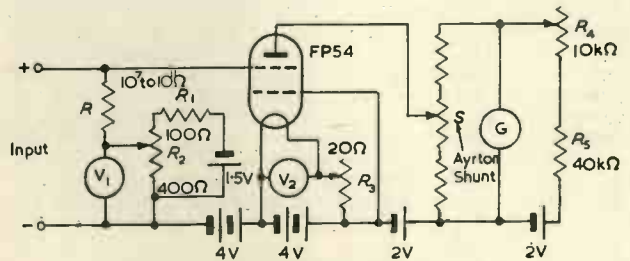

Fig. 7. Electrometer valve circuit (DuBridge)

the time-constant would be 100sec, implying that the potential change of the grid will only be approximately 60 per cent of the applied potential after this time.

In employing method (2) for the measurement of small direct currents the current from the input is effectively added to the grid current and the alteration in the rate of change of grid potential—as determined by the corresponding anode current variation—is determined. With an electrometer valve having a grid current at the operating potentials used of  $10^{-15}$ A an input current of  $10^{-16}$ A can be measured by noting the 10 per cent change in the rate of drift, provided the variation in grid current is not greater than  $10^{-17}$ A.

Thus if the grid current is  $I_g$  and the total input capacitance is  $C$  then the rate of change of grid potential will be  $I_g/C$ . If  $S_v$  is the voltage sensitivity of the amplifier in mm/V, then the rate of drift of the galvanometer deflexion due to grid current alone will be  $(I_g/C)S_v$ . If the input current to be measured is then  $I$ , so the rate of drift of the galvanometer reading will become  $(I + I_g / C)S_v$ .

Considering typical values,  $I_g = 10^{-15}$ A,  $C = 10$ pF,  $S_v = 10^5$ mm/V then the grid current alone will produce a rate of drift of the galvanometer deflexion of  $(10^{-15}/10^{-11})10^5 = 10$ mm/sec. This is normally constant after a lapse of at least 30min to allow thermal equilibrium to be established. If the input current to be measured is then  $I$  the new rate of drift =  $(I + I_g / C)S_v = (I/10^{-11} + 10^{-15}/10^{-11})10^5$ mm/sec =  $(I/10^{-16} + 10)$ mm/sec. Thus currents  $i$  of  $10^{-16}$ A can be just measured since a change in the rate of drift from 10mm/sec to 11mm/sec could be determined over a time of, say, 10sec, while larger currents, say  $10^{-15}$  to  $10^{-14}$ A are readily determined.

\* The Mathematics and Physics Department, The Polytechnic, W.I.  
† The Physics Department, The University of Southampton.



### Stabilized Electrometer Valve Circuits

The further difficulties associated with simple electrometer valve circuits can be summarized as follows:

- (1) Drift and fluctuations due to changes of the battery supply E.M.F.
- (2) Variations due to valve emission changes and contact potential variations.
- (3) The desirability of making a circuit which is not upset by changing the valve.

The variations due to changes in the supply E.M.F. were counteracted by DuBridge<sup>24</sup> using a balanced bridge two valve circuit (Fig. 8) following the practice of Wold<sup>26</sup>, Wynn-Williams<sup>27</sup> and Eglin<sup>28</sup>. The improved circuit stability enabled a more sensitive galvanometer of  $1/\sigma = 5 \times 10^{-11} \text{A/mm}$  to be used, so giving an overall voltage sensitivity of the circuit, using FP54 valves, of 250 000mm/V. A similar, simpler circuit can be used with triode electrometer valves.

This circuit can be used according to the methods (1) and (2), i.e. using an input resistor  $R$  or employing a rate of drift of grid potential method. To balance the circuit initially,  $R_A'$  (which is a fine adjustment in series with  $R_A$  where  $R_A = R_B$ , nominally) is adjusted to give zero galvanometer deflexion. Then  $R_3$  is altered. In general this will

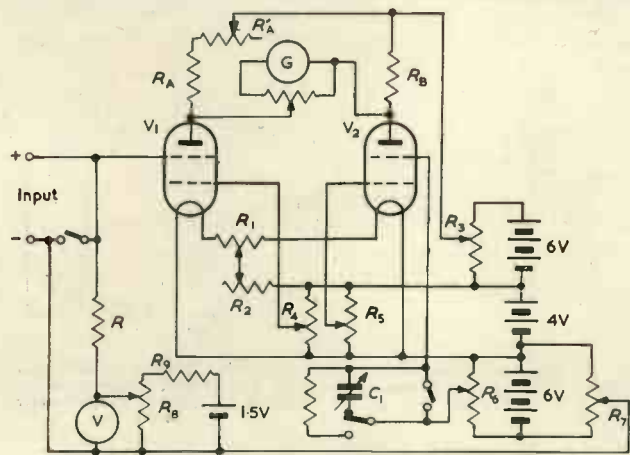

Fig. 8. Balanced bridge circuit for use with tetraode electrometer valves (DuBridge)

produce a galvanometer deflexion again.  $R_A'$  is then altered again and the galvanometer deflexion brought to zero by adjusting the grid potentials. Then  $R_3$  is varied again to see if the change of the galvanometer deflexion is smaller than before. This process is continued until the circuit is balanced. Similarly, a balance for filament voltage is obtained by altering  $R_2$  and  $R_1$ . With  $R = 10^{10} \Omega$ , using FP54 valves, the current sensitivity was  $4 \times 10^{-16} \text{A/mm}$ .

Employing the rate of drift of grid potential method, the valve  $V_2$  is arranged to be the one with the higher grid current. The capacitor  $C_1$  is then adjusted until the rate of drift is the same for both valves before the input to be measured is applied. In this case a current of  $5 \times 10^{-18} \text{A}$  could be detected, which corresponds to only 30 electrons per second. The sensitivity is then limited by shot effect and thermal agitation noise fluctuations.

This type of balanced bridge circuit is much more readily set up, and more stable if double electrometer valves such as the Ferranti types DBM4A, DBM6A, DBM8A, DBM12A, discussed previously, are employed. Thus Peirson<sup>29</sup> gives a useful design for a d.c. amplifier consisting of a Ferranti double electrometer valve DBM8A for the first stage followed by two stages of amplification using twin triodes 12SC7. This circuit is supplied from a highly stabilized power pack and has the minimum of pre-setting controls.

A much simpler, single valve circuit which is claimed to

be independent of small variations in the supply potential, where only one main source of supply and a small standard cell are used, is described by Morton<sup>30</sup> who used a British G.E.C. ET1 electrometer triode. (Fig. 9.)

In this circuit the anode potential is obtained from the P.D. across  $R_1, R_2, R_6$  and  $R_7$  in series—where  $R_1$  = filament resistance—through which the filament current flows minus the P.D. across  $R_4$  and  $R_5$  which carry the anode current. The grid bias is obtained because of the P.D. across  $R_1 = I_f R_1$  where  $I_f$  = filament current. In operation the filament current is initially adjusted to a standard value by balancing the P.D. of  $I_f R_2$  across  $R_2$  against the E.M.F. of the standard cell  $E$ . This balance is obtained by varying  $R_3$  to give a zero galvanometer deflexion when the D.P.D.T. switch  $S$  is connected to points A and B. Then, with correctly calculated values of the other resistances in the circuit, the grid bias, anode and filament voltages are all correct. In subsequent operation the switch  $S$  is connected to points C and D. A change in filament current, due to an accumulator E.M.F. change, is then transmitted to the galvanometer, which is connected to tapping points on  $R_1, R_5$  and  $R_6, R_7$ . According to Hardy<sup>31</sup>, this circuit is independent of accumulator E.M.F. changes when:

$$R_7/R_6 = \frac{R_1 + R_2 + R_6 + \mu R_1}{R_4 + r_a - \mu R_1} \dots \dots \dots (7)$$

where  $\mu$  and  $r_a$  are respectively the amplification factor and anode slope resistance of the valve.

Following the two-valve balanced circuit of DuBridge—which manifestly demands somewhat tedious manipulation

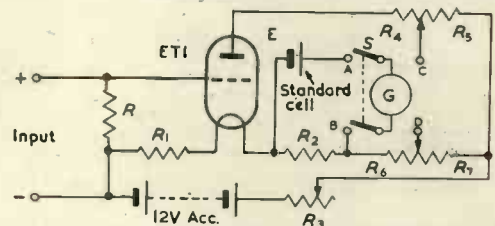

Fig. 9. Stable electrometer triode circuit (Morton)

to obtain an initial balance since two separate electrometer valves will always have different characteristics—a number of electrometer valve circuits using triodes were developed. The object of these circuits was to obtain a balanced circuit, independent of supply E.M.F. changes, using one tetraode only and to reduce the number of separate supply accumulators used by DuBridge in his early work.

Apart from the work on triode electrometers, of which Morton's circuit given in Fig. 9 is typical, one of the earliest balanced tetraode circuits was due to Soller<sup>32</sup> and much of the subsequent developments were based on Soller's arrangement. His circuit employed one tetraode electrometer valve (an FP54), a single accumulator and an auxiliary standard cell. It was independent of filament current variations. Turner and Siegelin<sup>33</sup>, a year later, modified Soller's circuit so that the electrometer valve was operated at more desirable potentials, a high resistance galvanometer of high sensitivity could be used, and the standard cell avoided. Soon afterwards DuBridge and Brown<sup>34</sup> produced an improved version of Soller's circuit where the standard cell was eliminated and also the space-charge grid potential was so arranged that filament emission changes—which might be independent of variations of filament current—were eliminated (Fig. 10).

The sole supply source for this circuit is an accumulator. As in Soller's circuit, the proper control grid bias and plate potential are obtained by tapping off from the resistances  $R_1$  and  $R_2$ . The essential feature of the DuBridge and Brown circuit is the method of connexion to the space-charge grid. This grid is positive and so collects four to five times as many electrons as the anode. If the filament emission changes, the current to the anode and the space-

charge grid change in about the same ratio. Therefore one can be balanced against the other so that the galvanometer is unaffected. Otherwise the circuit is like Soller's in that it can be regarded as a Wheatstone bridge where  $R_3$  (including fine adjustment  $R_3'$ ) and  $R_4$  form two resistance arms, while the filament to anode resistance and the filament to space-charge grid resistance, including the resistance  $R_5$ , form the other two arms.

The P.D. across the galvanometer =

$$e = R_4 I_s - R_3 I_a \dots\dots\dots (8)$$

provided the galvanometer current is much less than  $(I_a + I_s)$ .

At balance  $e = 0$  and

$$R_4/R_3 = I_a/I_s \dots\dots\dots (9)$$

This is the first condition to be satisfied. Once it is satisfied the galvanometer current remains zero with zero input despite fluctuations in emission—due to variations of  $E$  or variations in filament coating—which change  $I_a$  and  $I_s$  in the same ratio.

In addition  $e$  must be independent of changes of the filament current  $I_f$ , i.e.  $de/dI_f = 0$ .

∴ from equation (8):

$$R_4 dI_s/dI_f = R_3 dI_a/dI_f \dots\dots\dots (10)$$

is the second condition to be satisfied.

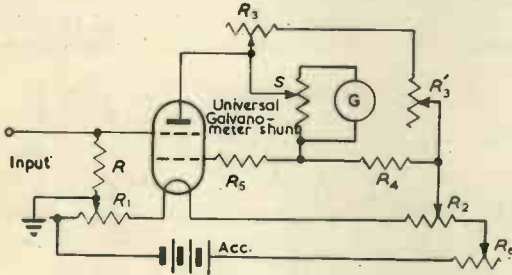

Fig. 10. Balanced single electrometer tetrode valve circuit (DuBridge and Brown)

If  $R_4$  and  $R_3$  are fixed values of resistance then it is readily seen that these conditions are satisfied if the characteristics  $I_a/I_f$  and  $I_s/I_f$  are straight lines which intersect on the  $I_f$  axis. This is not the case, in general, but is found to be true for electrometer valves over a small range of  $I_f$  sufficient for neutralization to be obtained.

This circuit using an FP54 valve and a galvanometer of  $5 \times 10^{-10}$  A/mm was found to be considerably more free of drift than the Soller circuit from which it was derived, the drift disappearing almost completely after the first 20 minutes.

To decide the values of the resistances required for a tetrode electrometer tube of known characteristics, the accumulator—which is best discharged to a stable E.M.F. and operated in a thermostat—has a known E.M.F., say 12V.  $R_1$ ,  $R_2$  and  $R_6$  are then chosen as wire wound resistors to give the filament current rating of the valve and the correct grid bias. DuBridge and Brown recommend fixed 50Ω resistors for  $R_1$  and  $R_2$  with taps at 10Ω intervals for adjustment, but these values are for the FP54 only and need to be modified in accordance with a simple calculation for other manufacturers' valves.  $R_3$  is a 10kΩ resistance with fine adjustment in 50Ω steps. With  $R_3$  decided,  $R_4$  follows from equation (9).  $R_5$  is then calculated from the bias required on the space-charge grid.  $R$  can be  $10^7$  to  $10^{11}$ Ω.

It is not necessary to determine the  $I_a/I_f$  and  $I_s/I_f$  characteristics of the valve to obtain a balanced circuit. DuBridge and Brown give the following alternative procedure:

- (1) Adjust  $I_f$  to rated value; bring galvanometer to zero

by adjustment of  $R_3$ . Connect the galvanometer so that as  $R_3$  decreases the deflexion decreases.

- (2) Reduce the galvanometer sensitivity by  $S$ . Slowly vary  $I_f$  by changing  $R_6$  so galvanometer deflexion increases. The galvanometer deflexion should then pass through a minimum. If it does not, change  $R_3$ .

- (3) If the value of  $I_f$  at the minimum differs from the rated value by more than 3 or 4 per cent, shift the  $R_2$  tap to a new position and repeat. Two or three trials may be necessary.

- (4) Increase the galvanometer sensitivity to its maximum and make a final adjustment for a minimum by adjusting  $R_6$  and then  $R_3$ .

If the final value of  $V_a$  obtained is more than 1 volt less than the rated value then the sensitivity of the circuit will be impaired. It is then best to alter  $R_2$  to increase  $V_a$ , and find the neutralization point by changing the control grid bias slightly.

A voltage sensitivity of 60 000 to 80 000mm/V should be obtained without difficulty. With  $R = 10^8$ Ω the current sensitivity was  $10^{-14}$  A/mm. For  $R$  as high as  $10^{11}$ Ω it is recommended that the grid leads and resistance should be in an evacuated container which also acts as a shield against electromagnetic disturbance.

Harnwell and Van Voorhis<sup>35</sup> criticized the DuBridge and Brown circuit on the grounds that it did not give

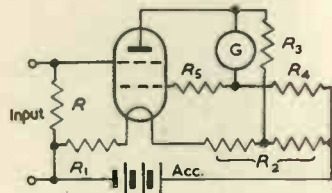

Fig. 11. Balanced single electrometer tetrode valve circuit (Barth and Penick)

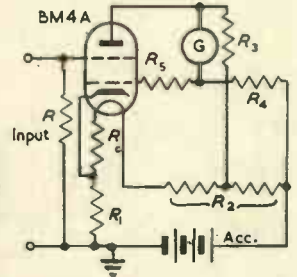

Fig. 12. Hughes modification of Barth-Penick circuit using an indirectly heated electrometer valve

enough latitude of adjustment for tubes with differing characteristics. They inserted a resistor between anode and filament of the DuBridge and Brown circuit and showed, on analysis and practical test, that it increased the control of balance satisfactorily. Such a resistor reduces the sensitivity of the valve to some extent, however.

Barth<sup>36</sup> and Penick<sup>37</sup>, independently, developed a circuit with a greater degree of flexibility than the DuBridge and Brown arrangement. This circuit has been widely and successfully used, especially in mass spectrometer practice. The modification from the DuBridge and Brown circuit consists in taking the leads from ends of the resistors  $R_3$  (joined to anode) and  $R_4$  and  $R_5$  (joined to space-charge grid) to separate taps on the resistor  $R_2$  instead of to the same point, (Fig. 11).

This enables the circuit to be more readily adapted to other electrometer valves. A very full mathematical analysis of this circuit is given by Hughes<sup>38</sup> who also shows how it can be adapted to the more readily obtainable Ferranti electrometer valve BM4A. The resistance  $R_6$  included between the cathode of this indirectly heated valve and the negative end of the heater—as recommended by the manufacturers to provide a P.D. 6 to 10 volts negative—gives an additional parameter which can modify the balance conditions and make the Barth-Penick circuit yet more flexible. (Fig. 12.)

If it is required to add an additional stage of amplification to the Barth-Penick type of circuit, or any of its predecessors as outlined above, the differential output E.M.F. across a resistor in place of the galvanometer would

have to be fed to a subsequent double valve balanced stage. To avoid this Caldwell<sup>39</sup> has designed a circuit in which, as discussed by Hughes<sup>38</sup>, the anode voltage, measured from the negative side of the grid bias resistor, is independent of the supply voltage. This circuit (Fig. 13) can have a succeeding single valve stage.

The circuits which have so far been considered have been designed to enable a small current or potential to be measured by means of a sensitive moving-coil galvanometer. In many cases this arrangement is sufficient and the data given enables the detection and measurement of such small currents and potentials to be achieved. The moving-coil galvanometer is not always a suitable instrument for use in this manner, however, and thus it is often necessary to amplify these small input potentials in order to produce an output of sufficient magnitude for operating a robust panel meter, a recorder, or for viewing on a cathode-ray tube.

The design of such an amplifier presents several problems. In the first place it must be directly coupled throughout. This implies that any supply variations will have a big effect on amplifier output. Both the power supply and the amplifier have to be designed with this in view. When extremely small currents are to be amplified

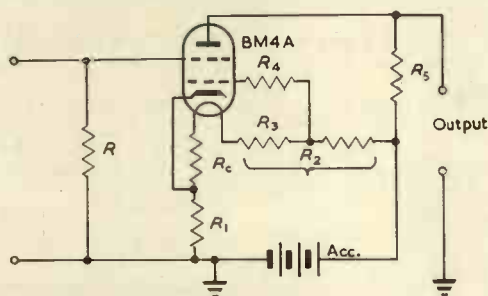

Fig. 13. Balanced single indirectly-heated tetrode electrometer circuit (Caldwell)

it is necessary to use an electrometer input valve and circuit and then to follow this input stage by further amplifying stages. It can be seen that if the gain of the input stage is low, the valve used in the second stage must be selected with care.

When a high gain directly coupled amplifier is required, the voltage level of the signal increases through every stage. The anode potential of each valve must be high enough to allow this level to be reached without distortion. Each anode must be directly coupled to the grid of the succeeding valve and hence inter-stage coupling presents a major problem in a multi-stage amplifier.

### Battery Power Supplies

Drifts, due to varying supply voltages, represent the limiting factor in the use of a directly coupled amplifier, unless extreme care is taken both in the design of the power supply and the amplifier.

In early work an accumulator was invariably used for supplying the L.T. requirements of the amplifier and dry batteries for the H.T. and bias potentials. In such a circuit any change in the bias supply produces an effective drift of that value at the grid of the valve supplied. The limitation in this amplifier is therefore set by the stability of the bias dry battery. Most modern circuits dispense with a grid bias battery, either by employing a resistor in the cathode circuit or by a tapping on the H.T. supply. Accordingly, only H.T. and L.T. supply drift will be considered here.

In order to ensure supplies of minimum drift, the following precautions should be observed.

- (1) The cells should be well charged and in a scrupulously clean condition.
- (2) The batteries should be of large enough capacity to

supply the rated current for many hours at a stable E.M.F. without running down.

(3) Total screening of all power supplies is advisable when very low currents are to be amplified.

(4) For extreme stability the batteries should be kept at a controlled temperature.

It can be seen that conditions (2) and (3) tend to make the power supply very bulky and expensive, while in many cases, it is an awkward complication to have to use thermostats to satisfy condition (4). The use of battery operated power supplies can be justified, nevertheless, in low gain amplifiers, for portable equipment and where the use of mains operated stabilized power supplies would render the equipment too complex.

In a battery operated amplifier the performance is often determined by the drift of the supply voltages with temperature. This may be calculated with a knowledge of the temperature coefficient of potential for the cells in use. Harris and Bishop<sup>40</sup> give a variation of  $+100\text{mV}/^\circ\text{C}$  for a 120 volt H.T. dry battery. For a lead acid secondary cell the coefficient has the low value of about  $+200\mu\text{V}/^\circ\text{C}$ <sup>41</sup>. High temperatures are to be avoided as having a deteriorating effect.

### Stabilized Power Supplies

Owing to the inconvenience and cost of primary and secondary cells, stabilized D.C. supplies obtaining power from the A.C. mains have been increasingly used in recent years. Such supplies must compensate for variations in the A.C. mains voltage and, in addition, must present a low output impedance to slowly varying loads. Provided enough care is taken in the design of the stabilizing unit, it is possible to use the A.C. mains as a source of power even for high gain, high impedance input, amplifiers.

The design of voltage stabilizers of all types has recently been reviewed by Benson<sup>42,42a</sup>. While no detailed discussion of such supplies will be given here, Fig. 14 gives the basic circuit of the most commonly used stabilizer. This employs a triode in series with the positive supply line. The difference between a fraction of the output voltage and a fixed voltage developed across a glow-discharge tube is amplified and fed to the grid of the series triode. The amplifier used is directly coupled and may consist of more than the one valve shown. The circuit is so arranged that degenerative compensation is afforded for any output voltage changes, whether the change be due to varying supply voltage or to varying load. By increasing the feedback in this circuit, the stabilization may be improved and the output impedance reduced. A constant voltage transformer, feeding the power supply, will reduce A.C. mains fluctuations to a large extent.

Designs of stabilizers for use with directly coupled amplifiers are given by Bishop and Harris<sup>43</sup>, Johnston<sup>44</sup>, Goldberg<sup>45</sup>, Miller<sup>46</sup>, Huggins<sup>47</sup>, Mezger<sup>48</sup>, and Harris<sup>49</sup>.

Ultimately, the performance of any stabilizer is determined by the voltage across the glow-discharge tube. Benson<sup>42,42b</sup> has measured many of the glow-discharge tubes now available and gives temperature coefficients of the order of 5 to 50mV/°C. Both the sign and the value depend upon the type of tube. Recent high stability neon tubes, e.g. Mullard 85A1 and 85A2, have been developed with the lowest coefficient and, in addition, with less variation between tubes and less variation with time. Resistance-capacitance smoothing filters should be included between the glow-discharge and the control valve<sup>44</sup>. In this way any small fluctuations in the reference voltage are minimized.

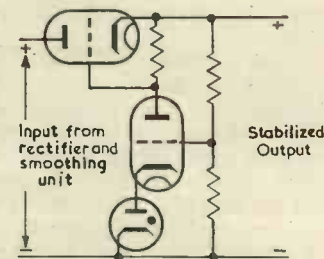

Fig. 14. Basic circuit of degenerative type stabilizer

Since the input stages require a highly stabilized supply, it is often convenient to use a separate stabilizer to feed these stages. In addition, a negative stabilized voltage is often required, so that a power supply having three or more stabilizing units is common.

The problem of stabilizing the heater voltage is more difficult. A barretter or a similar non-linear resistance may be used in series with the heaters themselves or in series with the transformer which supplies the heater current<sup>42</sup>. Benson<sup>42</sup> also describes bridge circuits containing non-linear resistance elements. Efficiency and performance are not very high and these methods are useful only when rough stabilization is required, such as in the output stages of an amplifier.

Attree<sup>44a, 44b</sup> describes a modulator controlled multi-vibrator which provides a constant current at low voltage where the filament of a saturated diode is across a low resistance shunt in series with the load. It demands four extra valves and a neon stabilizer, however.

It is advisable to feed the heaters of the input valves of a sensitive directly coupled amplifier with D.C. The performances of the first stages of an amplifier will usually depend somewhat critically on the heater voltage, even for some of the balanced circuits considered later. Thus good stabilization of heater voltage is essential to avoid drifts.

Good performance in this respect may be obtained by coupling all the heaters of the amplifier in series and placing them across the stabilized H.T. supply<sup>45</sup> with a ballast resistor to drop any excess voltage. This is normally only applicable to valves taking 150mA heater current, in view of the load on the power unit. When wiring such an amplifier, the heaters of the input valves should be placed in the earthy side to avoid leakage currents.

Johnston<sup>44</sup> has described an elaborate heater voltage stabilizer circuit of good performance using a series transformer arrangement. Where such complexity cannot be justified, it is possible to feed the heater of the input stage from an accumulator, and use a mains supply for the remainder of the amplifier<sup>43</sup>.

### Effects of Supply Variations

In spite of the attention normally paid to stabilizing the output of the power supplies, for most applications it is still necessary to design the amplifier circuit so that the effects of supply drifts are minimized.

A variation in H.T. voltage will, in most cases, alter the anode potentials of the valves in the amplifier. Since there is direct coupling between each anode and the following grid, this change will appear as a drift in the output voltage. In addition there is likely to be a second order change due to a variation of valve parameters, since the operating point on the valve characteristic has shifted. This is especially important in multi-stage amplifiers.

Williams<sup>50</sup> states that an increase in cathode temperature causes an increase in mutual conductance and a decrease in anode impedance, the value of the amplification factor remaining approximately constant. In addition, the direct current through the valve will alter.

Artzt<sup>51</sup> shows that a change in cathode potential causes two effects.

- (1) A variation in contact potential causing an effective change in bias and anode current.
- (2) A variation in anode impedance.

\* The effect of the contact potential is considered by Artzt using the following equation.

$$V_a = I_a R_a - \mu V_G + \mu V_0 \dots \dots \dots (11)$$

where  $V_0$  is the contact potential variation due to a heater voltage change.

This equation may then be used to determine overall performance and balance conditions when the valve is work-

ing over the linear part of its characteristics. Curves given in Artzt's paper show that, at high values of anode current, this equation accurately represents the circuit conditions. Valley and Wallman<sup>52</sup> estimate the value of  $V_0$  as 200mV for a 20 per cent change of heater voltage about the normal value for oxide-coated unipotential cathodes. Using a 6J6 balanced stage without cathode compensation, Bishop and Harris<sup>43</sup> found that a 10mV change in heater potential is equivalent to a signal of about 0.7mV at the input. They note that, for this reason, the provision of a sufficiently stable supply of heater current becomes the most critical feature in the design of their amplifier.

### Parallel Balance Circuits

The two-valve parallel balance circuit represents one of the first approaches to the problem of attenuating the effect of supply variations in an amplifying stage. Early users of this circuit were Wold<sup>53</sup>, Wynn Williams<sup>27</sup>, Brentano<sup>53</sup> and Malassez<sup>54</sup>. The basic battery circuit is shown in Fig. 15.

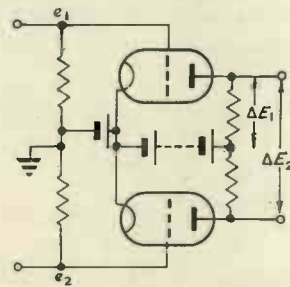

Fig. 15. Parallel balance circuit

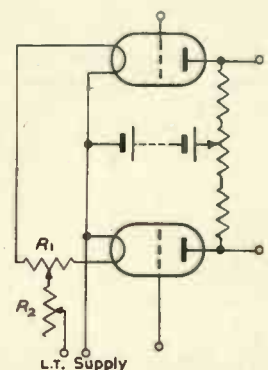

Fig. 16. Balance controls in anode and filament circuits

The circuit requires an input which is balanced with respect to earth, and an output is obtained across the anodes of the two valves. Assuming that the valves and corresponding resistors are identical, it can be seen that, to the first order, variations in the H.T. supply balance out in this arrangement. Any alteration in potential affects each valve similarly and hence the output, as measured between the anodes, is unaltered. The actual voltage level of this output is dependent on the H.T. supply, however, and in multi-stage amplifiers this may have to be compensated for.

A similar argument holds for variations in the L.T. supply. If the alteration in contact potential is the same in the two valves then full compensation will be achieved. In both cases, even with matched valves, any alteration in valve parameters consequent on an alteration of supply potentials is likely to vary the gain, and hence, the output.

When the two valves are not identical a complete balance is not achieved. Wynn Williams<sup>27</sup> ensured that the effect of altering filament voltage in the two valves was the same by the circuit shown in Fig. 16. Here  $R_1$  is varied until altering  $R_2$  does not alter the output.

In practice the anode currents of the two valves will not be exactly equal. A variable balance control is then introduced in the anode circuit as shown. This is adjusted under conditions of zero input, so that zero output is obtained. Its use does not materially affect the circuit conditions provided the valves are initially fairly well matched.

### Differential Input Circuits

Apart from the reduction of the effects of supply drifts, the balanced circuit has a property which has made it indispensable in electro-biological work<sup>55, 56</sup>. Here it is necessary to amplify potentials of the order of 50μV varying at low frequencies. Since the input impedance is normally required to be above one megohm,

the effect of stray pick-up is severe. In this work it is now usual to use two electrodes and connect these to the grids of a balanced valve stage, including a resistor of about one megohm between each grid and earth. Any interference will be picked on both grids. The required signal, that developed between the two electrodes, appears as an out-of-phase signal across the grids. The in-phase pick-up due to interference will affect both valves alike, consequently the output as measured between the anodes should be unaffected.

The gain ratio  $r$  for the stage shown in Fig. 15 is defined as:

$$r = \frac{\Delta E_1 \text{ for in-phase components of } e_1 \text{ and } e_2}{\Delta E_1 \text{ for out-of-phase components of } e_1 \text{ and } e_2} \quad (12)$$

and the output ratio  $r'$  as:

$$r' = \frac{\Delta E_2 \text{ for in-phase components of } e_1 \text{ and } e_2}{\Delta E_2 \text{ for out-of-phase components of } e_1 \text{ and } e_2} \quad (13)$$

where  $e_1$  and  $e_2$  are the total signals applied to the two grids respectively.

The value of  $1/r$  is often termed the discrimination ratio. It can be seen that the output ratio is zero for a matched pair of valves operating on the linear part of their characteristic. The aim of this type of circuit is to provide amplification of the out-of-phase signals with little or no amplification of the in-phase component, i.e. to provide an output ratio as low as possible. In multi-stage amplifiers it is also necessary to ensure that the gain ratio is low, since a large change in mean potential of the anodes of an early stage will drive a later stage off the linear part of its characteristic. The circuit shown in Fig. 15 has a gain ratio of unity and hence this simple form of the circuit is unsuitable for multi-stage amplifiers.

### Cathode Coupled Balanced Amplifiers

The use of a common cathode resistor as shown in Fig. 17 provides degeneration for the in-phase component. Out-of-phase components of the currents flowing through the common cathode resistor will cancel and no loss of gain will be experienced. The gain ratio may be calculated for perfectly matched valves. If the out-of-phase input signal as measured between the two grids, and the in-phase input signal are of equal magnitude  $e$ ,

$$\Delta E_1 \text{ for out-of-phase signals} = 1/2 \frac{\mu R_1}{R_a + R_1} e \dots (14)$$

$$\Delta E_1 \text{ for in-phase signals} = \frac{\mu R_1}{R_a + R_1 + 2R_c(\mu + 1)} e \dots (15)$$

$$\text{Thus the gain ratio} = \frac{2(R_a + R_1)}{R_a + R_1 + 2R_c(\mu + 1)} \dots (16)$$

As before, for matched valves the output ratio is zero.

For many applications in electro-biology, a directly coupled amplifier is not required, and it is sufficient if the frequency response of the amplifier is flat down to about 0.5c/s. Under these conditions, high value capacitance coupling may be used between stages and the drift considerations are not nearly so severe. Much work has been done on the design of these amplifiers, and Johnston<sup>44</sup> lists many references.

A modification of the cathode-coupled balanced amplifier stage has been given by Toennies<sup>57</sup> and Matthews<sup>58</sup>. A similar circuit has been considered in detail by Williams<sup>50</sup> and is shown here as Fig. 18. It consists of a common-cathode double triode stage with a load resistor in the anode circuit of only one valve. This circuit is useful as a differential input circuit with a single ended output. If the cathode load resistor is much greater than  $1/g_m$ , the stage gain is the same as for the balanced stage. The small amount of unbalance can usually be tolerated.

### Use of a Valve as a Cathode Load in a Balanced Stage

By reference to the equation (16) for the gain ratio for a common-cathode stage, given previously, it can be seen that an increase in the cathode load  $R_c$  will decrease the gain ratio. In this way the discrimination of the stage to in-phase signals may be increased. As the cathode resistance is raised, however, the bias is also increased. This high value of bias will eventually limit the permissible cathode load. A high effective differential resistance combined with a low voltage drop may nevertheless be obtained by using a valve as a cathode load.

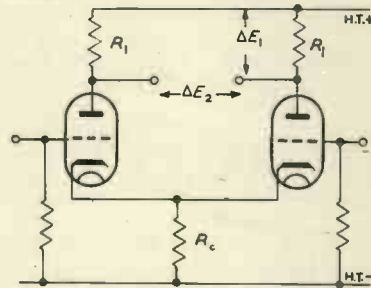

Fig. 17. Cathode coupled balance stage

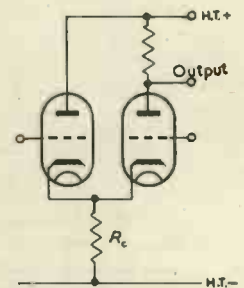

Fig. 18. Cathode coupled balanced input stage with single-sided output

A triode<sup>59</sup> or a pentode<sup>45</sup> may be used in this position. Fig. 19 shows a circuit using a triode where feedback of the mean level of the output is achieved from the centre-tapped resistance  $RR$ . This decreases the gain ratio of the stage.

The use of a pentode is discussed by Harris and Bishop<sup>40</sup>. The anode impedance of a pentode being of the order of one megohm, it can be seen that the gain ratio of the circuit is low.

By the use of valves as cathode loads in balanced stages and also by the use of mean level feedback, to be discussed later, the discrimination against in-phase signals may be

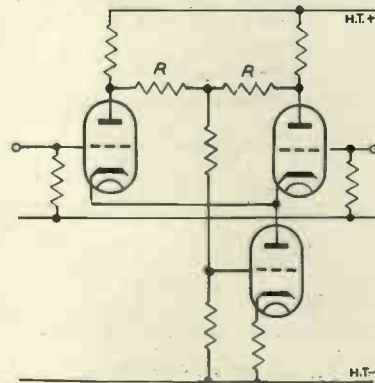

Fig. 19. Use of a triode as a common cathode load

made as high as necessary. As mentioned by Parnum<sup>56</sup> in a discussion on the differential input circuit, a gain ratio of 1 : 3 000 may readily be obtained, but such a good discrimination is usually unnecessary, since the interference pick-up on the two valves would be likely to differ by more than 1 in 3 000.

The effect of inequality between the two valves in a balanced stage has been discussed by Harris and Bishop<sup>40</sup>, Fuller<sup>60</sup> and Parnum<sup>56</sup>.

Pentodes may be used in place of triodes in the above circuits, due regard being paid to the higher value of anode impedance pertaining to their use. The effect of the component of the cathode current which is due to the screen grid must also be taken into account.

Although the parallel balance stages so far described

compensate fairly well for changes in H.T. voltage, variations in cathode temperature often produce a high measure of unbalance<sup>52</sup>. As previously noted, a change in heater voltage causes the contact potential difference between cathode and grid to vary. The value of this variation differs between valves. In general the double triode series of valves gives more compensation for this effect than two triodes in separate envelopes. In particular, where both sections of the valve are fed from the same cathode, the best compensation for changes in heater voltage will be obtained. The 6J6 is an example of this. It has been shown<sup>39,40</sup> for a 6J6 balanced stage that the L.T. supply must be stable to within 0.65mV. if the equivalent input change is not to exceed 50 $\mu$ V.

In order to more fully compensate for variations in the heater supply the circuit due to Miller<sup>45</sup> may be used.

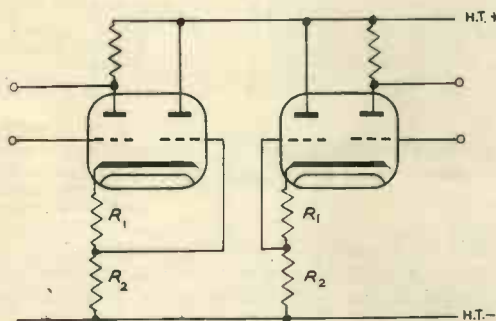

Fig. 20. Circuit for compensating for variations in the heater supply

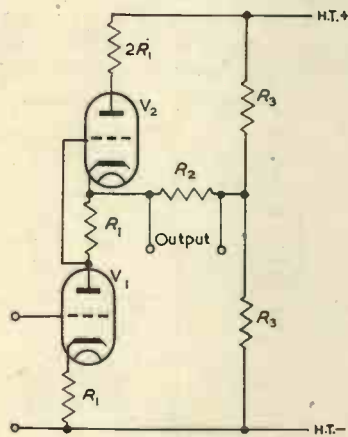

Fig. 21. Series balance circuit

This is shown as a balanced stage in Fig. 20. Two similar double triodes are used. The balance condition is that  $R_2 = 1/g_m$ , when the circuit will give approximately a 50:1 improvement with respect to heater voltage changes over the balanced stages so far considered. In this way, using 6J6 valves, the L.T. supply need now only be stable to within 30mV, if the equivalent input change is not to exceed 50 $\mu$ V.

In the case of valves, such as the 6J6, which require 0.45A heater current, it is not possible to supply the heater in series from the H.T. stabilized power pack. Thus this relaxation in the stability of the heater supply is very valuable and enables a simpler unit to be built. Artzt<sup>51</sup> discusses the use of a single stage using one double triode in the above arrangement, both with and without compensation for H.T. voltage change.

Artzt<sup>51</sup> has also described a series balance circuit, one form of which is shown in Fig. 21. Using equation (5) to represent valve performance, it is shown that compensation both for H.T. and L.T. variations may be obtained with similar valves with resistances as shown. The gain of the circuit is given as  $\mu R_2 / (R_a + 2R_2 + 2R_1)$  and when the load resistor  $R_2 = \infty$  the gain becomes  $\mu/2$ . In the latter case the gain is independent of  $R_a$ . Adjustment of the cathode load of  $V_2$  over a small range will enable the circuit to be balanced even though the two valves have slightly different heater voltage characteristics<sup>52</sup>.

(To be continued)

#### REFERENCES

23. BENNETT, R. D. An Amplifier for Measuring Small Currents. *Rev. sci. Instrum.* 1, 466 (1930).
24. DUBRIDGE, L. A. Amplification of Small Direct Currents. *Phys. Rev.* 37, 392 (1931).
25. BURROUGHS, R. E., FERGUSON, J. E. On the Use of the Vacuum Tube Electrometer with Extremely High Input Resistance. *Rev. sci. Instrum.* 4, 406 (1933).
26. WOLD, P. I. U.S. Patent No. 1232879 (1916).
27. WYNN WILLIAMS, C. E. A Valve Amplifier for Ionisation Currents. *Proc. Cambridge Phil. Soc.* 23, 811 (1927).
28. EGLIN, J. M. A Direct Current Amplifier for Measuring Small Currents. *J. Opt. Soc. Amer. and Rev. sci. Instrum.* 18, 393 (1929).
29. PEIRSON, D. H. A D.C. Amplifier Using an Electrometer Valve. *Electronic Engng.* 22, 48 (1950).
30. MORTON, C. A Portable Thermionic Electrometer for the Determination of Glass Electrode Potentials. *J. sci. Instrum.* 9, 289 (1932).
31. HARDY, D. R. The Measurement of Small Unidirectional Currents. *Students' quart. J. Instn. Elect. Engrs.* 19, 70 (1949).
32. SOLLER, W. One-tube Balanced Circuit for D.C. Vacuum Tube Amplifiers of Very Small Currents. *Rev. sci. Instrum.* 3, 416 (1932).
33. TURNER, L. A., SEGELIN, C. O. An Improved Balanced Circuit for Use with Electrometer Tubes. *Rev. sci. Instrum.* 4, 429 (1933).
34. DUBRIDGE, L. A., BROWN, H. An Improved D.C. Amplifying Circuit. *Rev. sci. Instrum.* 4, 532 (1933).
35. HARNWELL, G. P., VAN VOORHIS, S. N. A Balanced Electrometer Tube and Amplifying Circuit for Small Direct Currents. *Rev. sci. Instrum.* 5, 244 (1934).
36. BARTH, G. Über Ein Neuartiges Rohrengalvanometer. *Z. Phys.* 87, 399 (1934).
37. PENICK, D. B. Direct Current Amplifier Circuits for Use with the Electrometer Tube. *Rev. sci. Instrum.* 6, 115 (1935).
38. HUGHES, H. A. Electrometer Valve Balanced Circuits. *Electronic Engng.* 23, 217 (1951).
39. CALDWELL, P. A. A New Balanced Electrometer Circuit. *Rev. sci. Instrum.* 21, 85 (1948).
40. HARRIS, E. J., BISHOP, P. O. The Design and Limitations of D.C. Amplifiers. *Electronic Engng.* 21, 332, 355 (1949).
41. Standard Handbook for Electrical Engineers, Sect. 21, Art. 66 (McGraw-Hill, 1941).
42. BENSON, F. A. Voltage Stabilizers. (Electronic Engineering Monograph, 1950).
- 42a. BENSON, F. A. Voltage Stabilization. *Electronic Engng.* 25, 160, 202 (1953).
- 42b. BENSON, F. A. A Study of the Characteristics of Glow-Discharge Voltage Regulator Tubes. *Electronic Engng.* 24, 396 and 456 (1952).
43. BISHOP, P. O., HARRIS, E. J. A D.C. Amplifier for Biological Application. *Rev. sci. Instrum.* 21, 366 (1950).
44. JOHNSTON, D. L. Electroencephalograph Amplifier. *Wireless Engr.* 24, 231 (1947).
- 44a. ATTREE, V. H. Saturated-Diode Operation of Miniature Valves. *Electronic Engng.* 25, 27 (1953).
- 44b. ATTREE, V. H. A Low Voltage Stabilizer with Saturated Diode Control. *Electronic Engng.* 25, 71 (1953).
45. GOLDBERG, H. Bio-electric Research Apparatus. *Proc. Instn. Radio Engrs.* 32, 330 (1944).
46. MILLER, S. E. Sensitive D.C. Amplifier with A.C. Operation. *Electronics* 14, 27 (Nov., 1941).
47. HUGGINS, W. H. Stabilised Neon Tube Direct Coupled Amplifier. *Electrical Engng., N.Y.*, 60, 437 (1941).
48. MEZGER, G. R. Feed-back Amplifier for C.R. Oscilloscopes. *Electronics* 17, 126 (April, 1944).
49. HARRIS, L. D. Electronic A.C. Voltage Regulator. *Electronics* 19, 150 (Jan., 1946).
50. WILLIAMS, E. The Cathode-coupled Double Triode Stage. *Electronic Engng.* 16, 509 (1944).
51. ARTZT, M. Survey of D.C. Amplifiers. *Electronics* 18, 113 (Aug., 1945).
52. VALLEY, G. E., WALLMAN, H. Vacuum Tube Amplifiers (McGraw-Hill, 1948).
53. BRENTANO, J. C. M. The Measurement of Ionisation Currents by Three-Electrode Valves. *Nature* 108, 532 (1921).
54. MALASSEZ, M. J. Emploi de la Lampe à Trois Electrodes pour la Mesure des Courants d'Ionisation. *Comptes Rendus (Paris)* 172, 1093 (1921).
55. PARR, G., WALTER, W. G. Amplifying and Recording Techniques in Electro-Biology with Special Reference to the Electrical Activity of the Human Brain. *J. Inst. Elect. Engrs.* 90, Pt. 3, 129 (1943).
56. PARNUM, D. H. Biological Amplifiers. *Wireless Wld.*, 51, 337, 373 (1945).
57. TOUNNIES, J. F. Differential Amplifier. *Rev. sci. Instrum.* 9, 95 (1938).
58. MATTHEWS, B. H. C. A Simple Universal Amplifier. *J. Physiol.* 93, 25 (1938).
59. E.M.I. Balanced Output Amplifiers of Highly Stable and Accurate Balance. *Electronic Engng.* 18, 189 (1946).
60. FULLER, A. T. The Design and Limitations of D.C. Amplifiers. *Electronic Engng.* 22, 164 (1950).

# A Rapid Flyback Miller Time-Base Circuit

By W. Fraser\*, B.Sc., A.M.I.E.E., and M. W. Jeffs\*, B.Sc.

THE basic Miller time-base circuit employing a single pentode valve, as shown in Fig. 1, provides a simple time-base with good linearity. The valve is normally switched "on" and "off" by a rectangular pulse applied to the suppressor grid; the circuit is easily made self running if the fall in screen potential at the end of the rundown is arranged to make the suppressor voltage less than the anode current cut-off value. The coupling is via  $C_2$  and the whole circuit is thus a Miller Transitron time-base.

It can be shown<sup>1</sup> that for good linearity the gain of the valve should be high, and hence the value of  $R_2$  should be large. The condition for rapid flyback, however, is that  $R_2$  should be small, as the flyback time-constant is  $C_1 R_2$ . If a linear sweep and a short flyback are required, an unsatisfactory compromise has to be made.

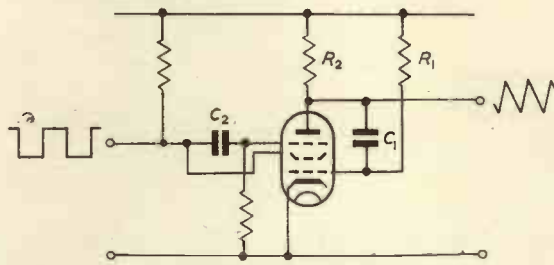

Fig. 1. Basic Miller time-base

In the course of measurements on this type of time-base,  $R_2$  was replaced by a valve which was cut off during the rundown period and conducting during the flyback interval. A somewhat similar arrangement has been used by Attree<sup>2</sup> and by Wells<sup>3</sup>. It was found, however, that the desired increase in flyback velocity was limited to frequencies lower than about 10kc/s. This is in agreement with Attree who has found that the improvement obtained with the use of a cathode-follower charging valve is most marked at sweep durations larger than about one millisecond. Further investigation showed that the transitron method of switching, with its relatively low loop gain, could be improved upon by using the voltage appearing at the anode of the charging valve. This produced a simple two valve circuit (Fig. 2) with an extremely linear sweep and relatively short flyback. If the capacitor  $C_1$  is varied from 500-50pF the circuit operates over the range of 40-250kc/s, with a sweep amplitude of approximately 150V.

The action of the circuit is as follows. During the rundown period the Miller valve  $V_1$  is conducting and discharging the timing capacitor  $C_1$  at a constant rate, thereby producing a constant voltage across  $R_3$ . The value of  $R_3$  is adjusted so that the charging valve  $V_2$  is cut off during the rundown. When the anode potential of  $V_1$  falls below the "knee" of the characteristic (at about 50V) the gain falls and the discharge current also falls. This causes the charging valve  $V_2$  to conduct slightly and its anode

potential falls, taking with it the suppressor grid of  $V_1$ . This results in a further reduction of discharge current and ultimately a further fall in the suppressor grid potential. The anode current of  $V_1$  is thus rapidly cut off, and  $V_2$  conducts with very little grid bias, charging  $C_1$  through the diode  $V_3$ . This valve is not absolutely essential, but relieves the grid of  $V_1$  from passing all the charge current which, together with the current through  $R_1$ , may exceed 40mA. When the anode potential of  $V_1$  has risen to a value at which the existing suppressor grid bias is insufficient to keep it non-conducting, the capacitor begins to discharge once more and  $V_2$  is then very rapidly cut off by cumulative action. At the same time, the suppressor grid of  $V_1$  is returned to zero potential.

The limiting factor at the highest frequencies is the presence of stray circuit capacitance, which has to be charged as well as  $C_1$ ; stray capacitance across the output terminals and between the anode of  $V_1$  and earth thus imposes a limit to the maximum operating frequency.

For low frequency operation, a variable capacitor

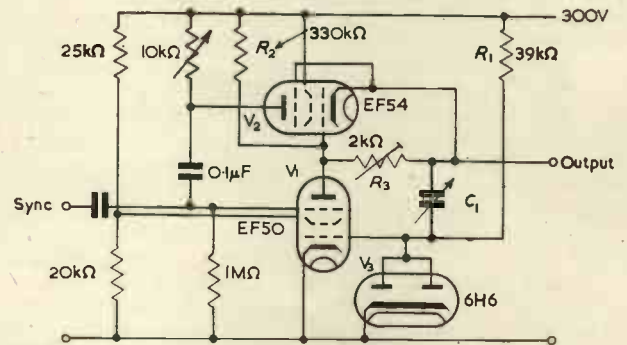

Fig. 2. The rapid flyback circuit

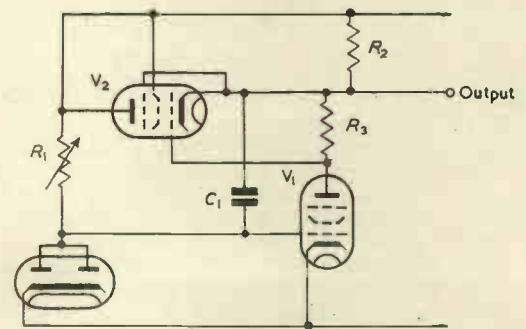

Fig. 3. An alternative arrangement

becomes impracticable and  $R_1$  has to be made variable. This means that the discharge current varies with frequency and  $R_3$  must then be varied correspondingly, to ensure that the charging valve is biased at cut-off during the rundown. If in Fig. 2 a variable resistor of 3000Ω is added in series with  $R_3$  and ganged with a variable resistor of 100000Ω connected in series with  $R_1$ , the circuit produced will operate satisfactorily down to about 2c/s.

The basic features of an alternative low frequency circuit arrangement which does not require ganged variable resistors, are shown in Fig. 3. The charging valve  $V_2$  is biased by the voltage drop across  $R_3$ . There is no switching voltage at the anode of the charging valve with this circuit, and transitron switching must be used.

## REFERENCES

1. PUCKLE, O. S. Time Bases. (Chapman & Hall Ltd., 1951.)
2. ATTREE, V. H. Improving Flyback Time on a Miller Timebase. *Electronic Engng.* 20, 97 (1948).
3. WELLS, O. C. The Miller Transitron-Grid Circuit Synchronization. *Electronic Engng.* 24, 407 (1952).

\*University of London, King's College.

# A Simple Electronic Multiplier

By K. H. Norsworthy, B.Sc.

*The article describes a simple electronic multiplier which uses the area under a triangular wave as a squaring device. D.C. accuracy to within 1 per cent has been obtained, and good results are expected for frequencies to about 50c/s.*

*The multiplier is capable of accepting positive and negative input voltages.*

**D**URING the last ten years the problem of multiplying two electrical voltages has become increasingly important. The problem is most commonly associated with electronic simulators, but it is certainly not restricted to this field. The author has recently been acquainted with a case where a multiplier was used in a servomechanism test set. Servomechanisms invariably give poor output waveforms and in order to measure the magnitude of fundamental in the output, the output voltage was multiplied by a clean sine wave of constant amplitude, fundamental frequency and variable phase. The maximum D.C. voltage which resulted with phase variation gave the required measurement.

In general, multipliers can be divided into two types. There are those which are completely electronic, and those which use small position servos and carry out multiplication by physically rotating the pointer of a potentiometer.

The electronic multipliers are usually found to be either insufficiently accurate, very complicated or difficult to line up. The servo type of multiplier does not have these faults, but has the one great drawback that its speed is limited by the inertia associated with the servo.

It is not usually possible to use the servo type of multiplier much above 10c/s. Electronic simulators often overcome this difficulty by altering the timescale of their system. This, however, is not desirable as it rules out all possibility of using the simulator in conjunction with elements of the true system.

The electronic multiplier described in this article has been designed primarily for simplicity of circuit and lining up procedure. The accuracy obtained is good, and although the output frequency range is limited to about 50c/s, the multiplier is sufficient for most applications.

Multiplication is done by the "difference of two squares" method (see equation (1)). The basic problem is, therefore, reduced to one of squaring.

$$K(X + Y)^2 - K(X - Y)^2 = 4KXY \dots\dots (1)$$

Methods previously suggested for squaring have included:

- (1) Diodes connected to a mesh of resistors and batteries.
- (2) A near parabolic relationship between anode current and grid voltage for a double triode connected in push-pull (see Fig. 1).

Each of these methods depends upon the shaping of valve characteristics. The first has given good results, but proves tedious to line up. The second method needs carefully matched valves and generally gives poor accuracy.

The method of squaring used in this article depends upon the fact that the areas of similar triangles are proportional to the square of their heights. The method has an implication of mathematical exactness which is lacking from the other two mentioned.

A completely different approach to multiplying is by varying the height and mark-space ratio of a square wave. This method appears very promising at first, but difficulties

arise when one requires to multiply both positive and negative voltages.

Williams<sup>1</sup> mentions an interesting multiplier which uses cathode-ray function generators to produce logarithms and antilogarithms. A "Step Multiplier" described by Goldberg<sup>2</sup> obtains accuracy at the expense of simplicity.

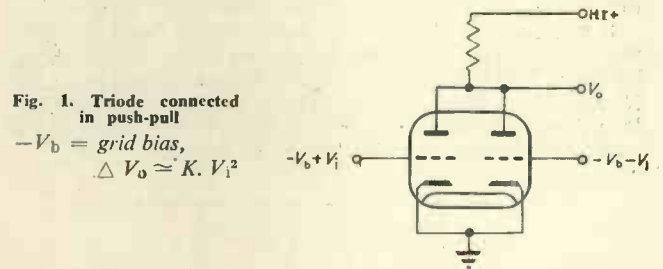

Fig. 1. Triode connected in push-pull  
 $-V_b = \text{grid bias,}$   
 $\Delta V_0 \approx K.V_1^2$

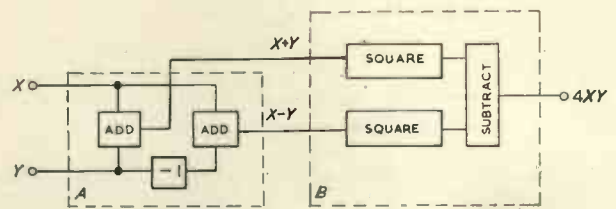

Fig. 2. Arrangement of the multiplier

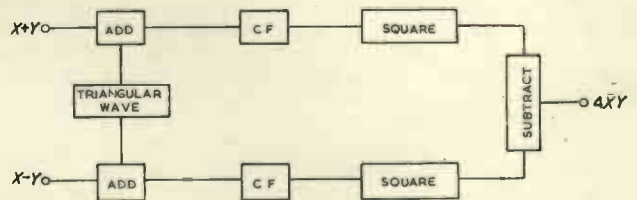

Fig. 3. Detailed arrangement of section B

## Operation of Multiplier

As mentioned earlier the multiplier uses the difference of two squares principle. This is shown in simple block form in Fig. 2.

The dotted lines are shown dividing the blocks into two sections. The left-hand section A is perfectly straightforward and merely obtains signals  $(X + Y)$  and  $(X - Y)$ . Little will be said of this section except that in practice scaling amplifiers may be included in it to make the swings of  $(X + Y)$  and  $(X - Y)$  large.



Section *B* squares the voltages from *A* and subtracts them. It must be realized that the squares do not square 10 volts to make 100 volts, or 40 volts to make 1 600 volts; it has a constant of proportionality which might be as low as one two-hundredth.

- i.e. 10 volts squared equals  $\frac{1}{2}$  volt
- 40 volts squared equals 8 volts

A slightly more detailed block diagram of section *B* is given in Fig. 3. It is seen that as subsidiaries to the squarers there are two cathode-followers and a triangular wave generator.

The cathode-followers are necessary because in practice the add boxes have considerable output impedance. The purpose of the triangular wave generator will be clear from what follows.

### Method of Squaring

The quantity to be squared, say  $(X + Y)$ , is added to a triangular wave which stands between zero volts and plus

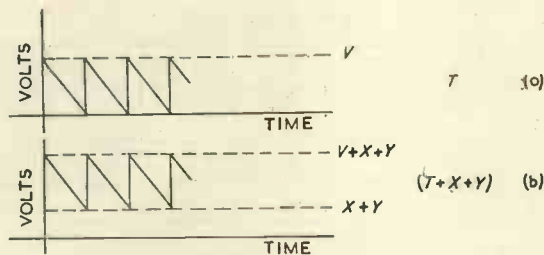

Fig. 4. Result of addition

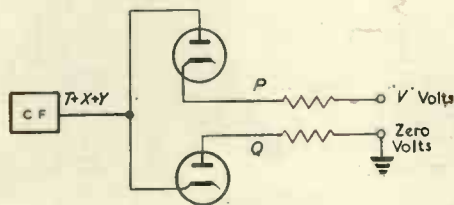

Fig. 5. Connexion of diodes

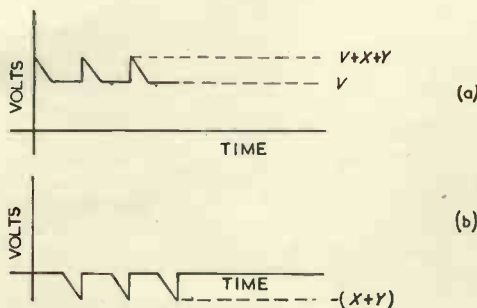

Fig. 6. Waveforms associated with circuit in Fig. 5

$V$  volts. The result of the addition,  $(T + X + Y)$ , will be the same triangular wave standing between lines  $(X + Y)$  and  $(V + X + Y)$ , see Fig. 4(a) and 4(b).

(N.B.—For simplicity any attenuation caused by the adding network is ignored here).

Now assume that diodes are connected to the low impedance point of  $(T + X + Y)$  as shown in Fig. 5.

Point *P* will always be at voltage  $V$  unless  $(X + Y)$  is positive, in which case its waveform will be as in Fig. 6(a). That is, voltage  $V$  plus triangular projections upwards of height  $(X + Y)$ .

The mean voltage of *P*,

$$V_P = \begin{cases} V + K(X + Y)^2 & \text{if } (X + Y) > 0 \\ V & \text{if } (X + Y) \leq 0 \end{cases} \dots (2)$$

Similarly, point *Q* will always be at zero volts unless  $(X + Y)$  is negative, in which case its waveform will be as in Fig. 6(b).

The mean voltage of *Q*,

$$V_Q = \begin{cases} -K(X + Y)^2 & \text{if } (X + Y) < 0 \\ \text{Zero} & \text{if } (X + Y) \geq 0 \end{cases} \dots (3)$$

The same constant  $K$  has been used in equations (2) and (3) since (assuming a perfect triangular wave) the apex angle of triangles projecting out of top and bottom is the same.

If now the voltage  $V_Q$  is subtracted from that at *P* we have:

- (a) When  $(X + Y) > 0$   
 $V_P - V_Q = [V + K(X + Y)^2] - \text{Zero} = V + K(X + Y)^2$
- (b) When  $(X + Y) < 0$   
 $V_P - V_Q = V - [-K(X + Y)^2] = V + K(X + Y)^2$
- (c) When  $(X + Y) = 0$   
 $V_P - V_Q = V - \text{Zero} = V + K(\text{Zero})^2$

Thus, ignoring the bias voltage  $V$ , we see that the subtraction of  $V_Q$  from  $V_P$  gives an output proportional to  $(X + Y)^2$ , and is correct for positive and negative values of  $(X + Y)$ .

(N.B.—The system would fail for magnitudes of  $(X + Y)$  greater than the height of the triangular wave).

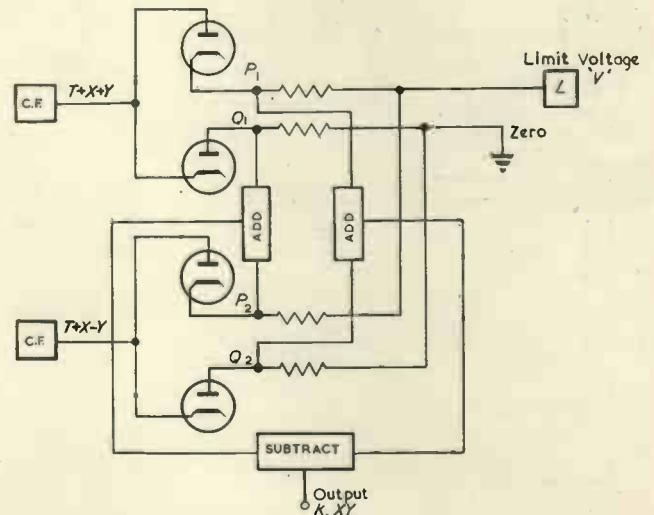

Fig. 7. Circuit for complete multiplication

The above explanation of the squarer has assumed D.C. inputs for  $(X + Y)$ . With alternating inputs mathematical analysis becomes extremely complicated due to the discontinuous nature of the triangular wave. It seems safe, however, to assume that good squaring will be maintained providing the triangular wave frequency is many times greater than that of the input.

In the multiplier it is required to square both  $(X + Y)$  and  $(X - Y)$  so two separate squaring arrangements will be necessary. If suffix "1" is allotted to that dealing with  $(X + Y)$  and suffix "2" to that dealing with  $(X - Y)$ , we have:

$$\begin{aligned} K[X + Y]^2 &= V_{P1} - V_{Q1} \\ K[X - Y]^2 &= V_{P2} - V_{Q2} \\ \therefore 4KXY &= [V_{P1} - V_{Q1}] - [V_{P2} - V_{Q2}] \dots (4) \end{aligned}$$

It is well known that subtraction of two voltages involves more circuits than addition. It is advantageous, therefore,

to rearrange equation (4).

$$4KXY = [V_{P1} + V_{Q2}] - [V_{P2} - V_{Q1}] \dots\dots (5)$$

A circuit for complete multiplication is indicated in Fig. 7.

The same triangular wave is used for both squarers so the same limiting voltage  $V$  is also used. In order that one squarer does not load the other it is necessary for the limiting points to have low output impedances. The point  $V$ , therefore, must be supplied from a cathode-follower; or better still a circuit especially designed for low output impedance.

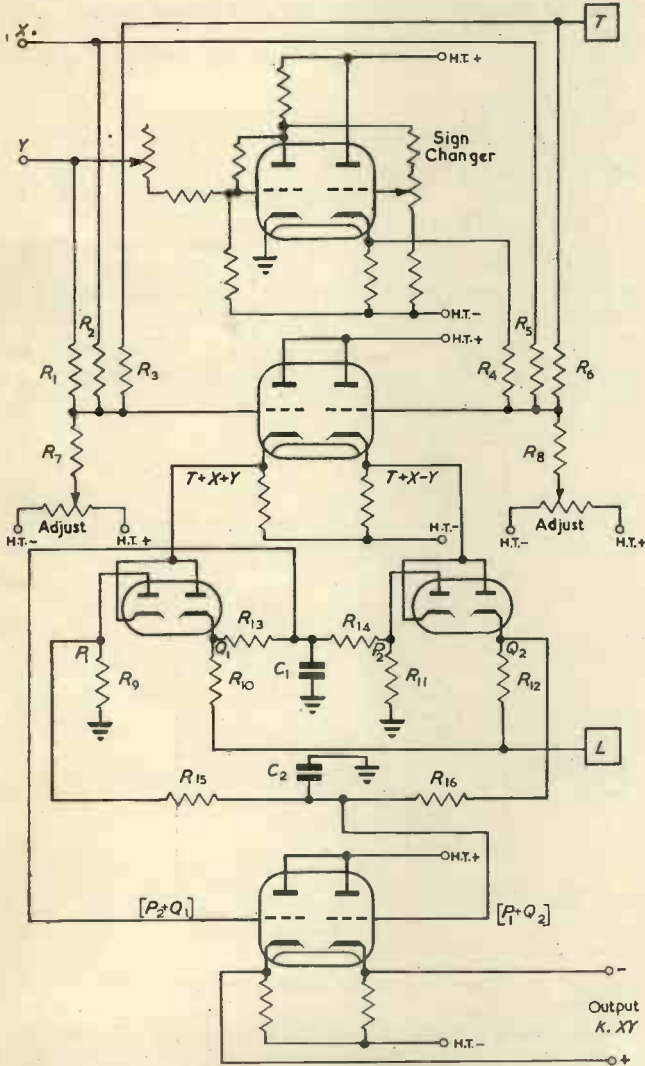

Fig. 8. Practical circuit of the complete multiplier

The zero volts limiting is done from earth (reference) which already has zero output impedance.

### Practical Circuit

A practical circuit of the complete multiplier is shown in Fig. 8. It is assumed that the input swings are sufficiently large not to require amplification. The method used for presenting the output was suited to the servo-test set mentioned earlier, in many cases, however, it would not be suitable since the output is in effect floating. Where an output relative to earth is required  $[V_{P2} + V_{Q1}]$  should be sign changed and then added to  $[V_{P1} + V_{Q2}]$  by a normal adding circuit.

Table 1 gives the value of the important resistors used in Fig. 8. In order to obtain good results from the multiplier it is necessary to match certain adding resistors. Matching should be done as accurately as possible before the resistors are wired into the circuit. An important point regarding resistance values is that resistors  $R_{13}$  and  $R_{14}$  are made considerably higher than  $R_{10}$  and  $R_{11}$  so as to limit the steady drain current through circuit  $R_{10}, R_{13}, R_{14}, R_{11}$ . In practice due to this drain current the effective limiting voltages are slightly above zero and below  $V$  volts. It is between these "effective limiting voltages" that the triangular wave must stand.

The capacitors  $C_1$  and  $C_2$  are required for smoothing. Their values, which are not critical, depend upon the degree of smoothing required and on the frequency of the triangular wave.

The sign changer is of standard design. It has been found that feedback across a single valve amplifier is sufficient. A three-valve amplifier, however, would ensure

TABLE 1  
Value of resistors in Fig. 8

RESISTORS TO BE MATCHED	$R_{11}, R_2, R_3$	$R_4, R_5, R_6$	$R_7, R_8$	$R_9, R_{10}, R_{11}, R_{12}$	$R_{13}, R_{14}, R_{15}, R_{16}$
VALUE (k $\Omega$ )	100	100	470	68	820

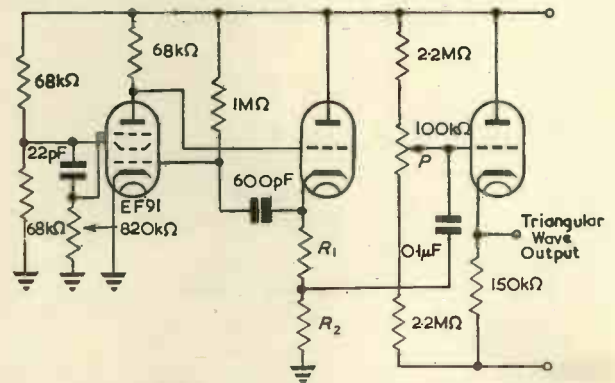

Fig. 9. Triangular wave generator

maximum linearity, so in cases where extra accuracy is sought it might be profitable to modify the sign changer accordingly.

Like most D.C. equipment the multiplier must be supplied from a stabilized power supply. Both positive and negative H.T. are required and for the circuit of Fig. 8 +350 volts and -350 volts were used.

### Triangular Wave Generator

A circuit for the triangular wave generator is shown in Fig. 9. It is, in effect, a Miller-Transitron circuit and gives a negative-going (stepped) sawtooth, see Fig. 4, the amplitude of which is fixed by the resistors  $R_1$  and  $R_2$ . The level of the wave can be adjusted by the 100k $\Omega$  potentiometer  $P$ . Frequency depends upon several component values and generally lies in the range 1kc/s to 2kc/s.

There are many circuits capable of generating triangular waves and investigation of these would quite likely produce a wave more suited to this multiplier. If the triangles were isosceles rather than stepped it would be an advantage, as stray capacitances would cause less rounding and a higher frequency could be used.

## Lining Up and Accuracy

The accuracy of the multiplier depends largely upon the care taken in lining up.

With both inputs at zero the level of the triangles is first adjusted so that an oscilloscope on points  $Q_1$  and  $Q_2$  just begins to detect projections downwards. The upper limiter  $L$  is then moved until projections begin to appear at  $P_1$  and  $P_2$ . Further fine adjustments are then made to the levels of the triangular waves (using "adjust" potentiometers in Fig. 8 in order that zero output is maintained for variations of either input while the other is held at zero.

As mentioned earlier it is required to match resistors as in Table 1. If this is not done much time can be wasted in lining up procedure and good accuracy cannot be obtained. High stability resistors should be used throughout in order to obtain consistent results.

The maximum accuracy of the multiplying system described in this article depends ultimately upon the quality of the triangular wave. For the circuits indicated in Fig. 8 and 9 a D.C. accuracy to within 1 per cent of full scale reading has been obtained.

The presence of the smoothing capacitors  $C_1$  and  $C_2$  will cause the multiplier to have a frequency response similar to that of a filter. In practice this characteristic might be used to advantage, or alternatively it might be overcome by using either cascade smoothing or a tuned rejecting circuit. It is interesting to note that the capacitors only effect output frequency. Where two sinusoidal inputs are multiplied to get a D.C. output,  $C_1$  and  $C_2$  would not cause inaccuracy.

## Conclusion

The value of this multiplier lies largely in its simplicity. The multiplier should be useful for input frequencies to the order of 50c/s, and this range might be extended if a good quality triangular wave was obtained having a frequency greater than 2kc/s.

## REFERENCES

1. WILLIAMS, P. D. L. An Electronic Multiplier. *Stud. J. Instn. Elect. Engrs.* No. 79. (March, 1950).
2. GOLDBERG, E. A. Step Multiplier in Guided Missile Computer. *Electronic* (Aug. 1951).

## Reflexing Applied to Ultra Short Wave Circuits \*

The practice of reflexing has long been known as one by means of which high gain can be achieved with a limited number of amplifier stages. In the past when the principle has found application it has normally been to receivers of the amplitude modulation type. There is, however, a useful scope for the method in broadcast V.H.F. receivers for frequency modulation, since these receivers tend to make use of a large number of valves and any method that will reduce this number is clearly of advantage from the set manufacturer's point of view.

The obvious way of carrying out the scheme in these circumstances is to employ the first audio valve as the reflex valve using this valve not only to drive the audio output stage, but also to provide amplification either at intermediate or radio frequency. So applied, there is no risk that the combined signals will tend to sweep beyond the limits of the grid base and there is no likelihood, therefore, of the low frequency signal causing modulation of the intermediate or radio frequency signal.

In some instances, however, there is either no first audio driver valve present in the receiver, the only audio valve being the output valve, or else it may be desired to use the output valve as the reflex valve on the ground of its steeper slope. In these conditions there is the grave risk with some settings of the volume control of a deep modulation of the I.F. or R.F. signal by the audio signal and it is desirable to provide some safeguard against this occurring. One simple method to this end is to make use of the so-called ratio detector for detecting the frequency modulated signals. Such a detector is known to possess inherent limiting properties and it can be arranged that the output from this detector will in no event load the audio output stage to the degree that intolerable modulation of the I.F. or R.F. signals occurs. As an alternative the limiter in the receiver may be arranged to limit at a sufficiently low level.

Figs. 1 and 2 show possible arrangements for the output stage when operated in reflex manner. In Fig. 1 the radio frequency signal derived from the receiving antenna is fed

to the grid of the audio output valve and the amplified radio frequency signals are derived from the anode circuit of this valve for application to the mixer. In Fig. 2 the circuit is additionally arranged to provide amplification at intermediate frequencies.

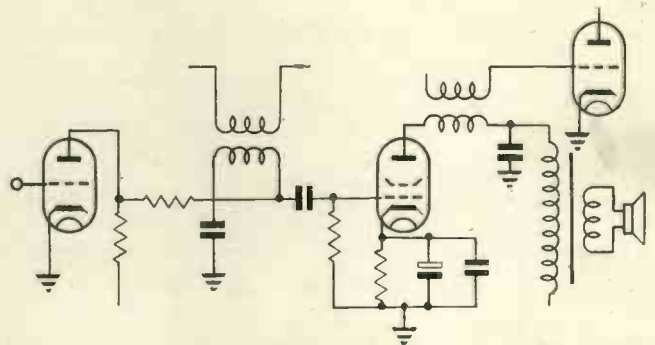

Fig. 1. Reflex operated output stage

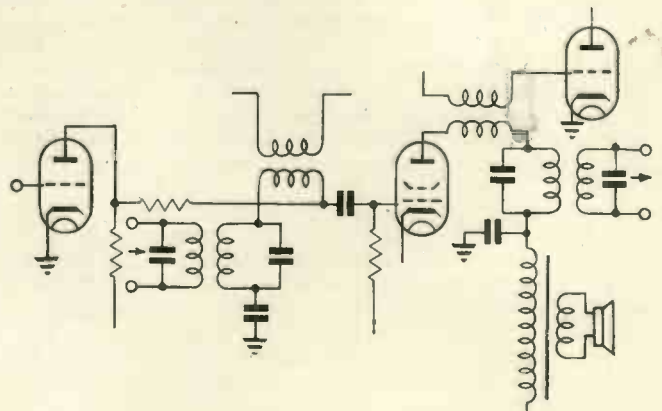

Fig. 2. Modification to include I.F. amplification

\* Communication from the Telefunken Co., via E.M.I. Ltd.

# Attenuator Design

By N. H. Crowhurst, A.M.I.E.E.

THE author has found that most charts published for the design of attenuators lack directness in use, in fact, it would probably be simpler to use the design formulæ and a slide rule for the purpose, except that the appropriate design formulæ always seem to be hidden away somewhere and recourse to logarithm tables or a table converting voltage ratio to decibels is also necessary. For this reason a chart that combines all these operations in one would seem to be very desirable where an appreciable amount of attenuator design is required.

Often an engineer comes suddenly upon the necessity for an attenuator and seeks out a quick means of design-

they are known as ladder networks, the constant resistance characteristic only applies in the first sense above defined. Provided they are terminated at the output end with the correct value of resistance, the impedance presented at the input end will be the same resistance value.

If any of these attenuator networks are connected to circuits having impedances other than that for which they are designed, the attenuation introduced will differ from the design value and also the impedance transfer presented will deviate from its nominal value. A later article will present charts to deal with mismatch of this nature showing the reduction in attenuation that occurs when wrong resistance values are used, and how the impedance at one end of a constant resistance attenuator is modified by connecting the wrong impedance to the other end. At the present stage it is sufficient to emphasize that these changes do occur.

Where it is necessary to match from one impedance to another introducing attenuation at the same time, matching pads can be used, designed so that when the correct resistance is connected to the output, a specified but different resistance appears at the input, and conversely when a similar resistance is connected as source at the input, the correct source resistance also appears at the output, so that correct matching obtains at both ends although the impedances differ. A chart to give design details of these pads will also appear in a later article.

The present chart is capable of being read to well within 5 per cent for any desired values, which is quite close enough accuracy for the majority of purposes. However, occasions sometimes arise where more accurate results are required, in which case it is best to use the correct design formulæ together with logarithm tables. For this purpose the appropriate formula for all the configurations shown in Fig. 1 are set out as follows:—

$$db = 20 \log_{10} k$$

$$R_1 = Z_0 \frac{k-1}{k+1} \quad R_2 = Z_0 \frac{k+1}{k-1} \quad R_3 = Z_0 \frac{k^2-1}{2k}$$

$$R_4 = Z_0 \frac{2k}{k^2-1} \quad R_5 = Z_0 (k-1) \quad R_6 = \frac{Z_0}{k-1}$$

$$R_7 = Z_0 \frac{k-1}{k} \quad R_8 = Z_0 \frac{k}{k-1}$$

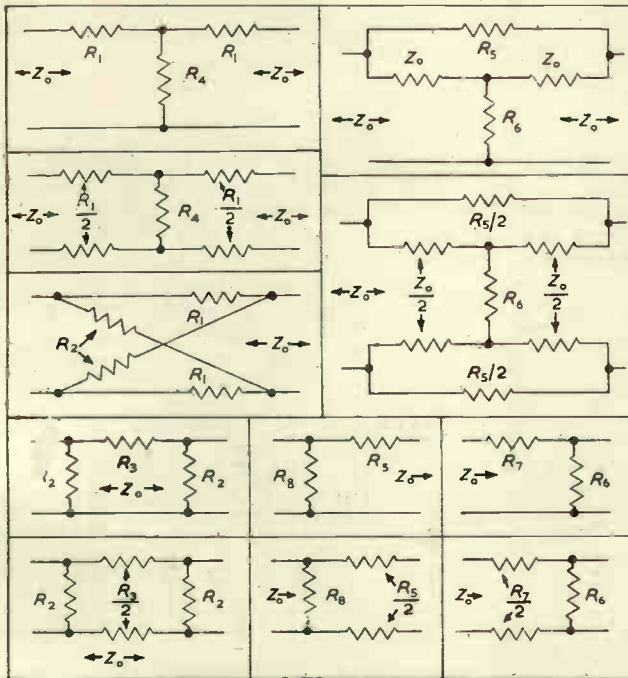

Fig. 1. The configurations with which the chart may be used

ing one to provide the attenuation required, frequently without a full appreciation of all the factors involved.

The attenuators given in this design chart are of the constant resistance type. This means that, provided they are terminated at the output end with the nominal value of resistance, the impedance presented at the input end by the attenuator will be the same value of resistance. This principle applies to all the configurations shown in Fig. 1.

Additionally, in the case of the *T*, bridged-*T*, *H*, bridged-*H*, lattice  $\pi$  and *O* networks, if the impedance of the source to which the attenuator is connected is also equal to the nominal working impedance, the same impedance will appear as source impedance at the output end of the attenuator. This is indicated in Fig. 1 by the symbol  $Z_0$  between arrows pointing both ways to show that the constant impedance characteristic of the attenuator applies in both directions.

In the remaining four networks, known singly as *L* pads, or when a number of them are used in succession

## Method of Reading the Chart

Fig. 2 shows the method of reading the chart. For values of  $R_1$ ,  $R_4$ ,  $R_6$  and  $R_8$  the reference  $Z_0$  is along the top of the chart and the resistance values appear down the left-hand side. For the remaining resistance values the reference for  $Z_0$  is along the bottom and the resistance values appear at the right-hand side.

The heavy lines on Fig. 2 show the simple reference necessary to design a 20db, *T*-type attenuator at characteristic impedance of 500 $\Omega$ ; both these resistance values appear on the left-hand side of the chart.

The  $\pi$  configuration uses the dotted reference, leading to values of  $R_2$  and  $R_3$  at the right-hand side of the chart. Other combinations of values are also shown in Fig. 2.

The chart is designed to cover values of characteristic impedance between 100 and 1000 $\Omega$ . Probably the commonest types of attenuator fall within this range, but it is

VALUES OF  $Z_0$  FOR  $R_1, R_4, R_6$  AND  $R_8$  OHMS

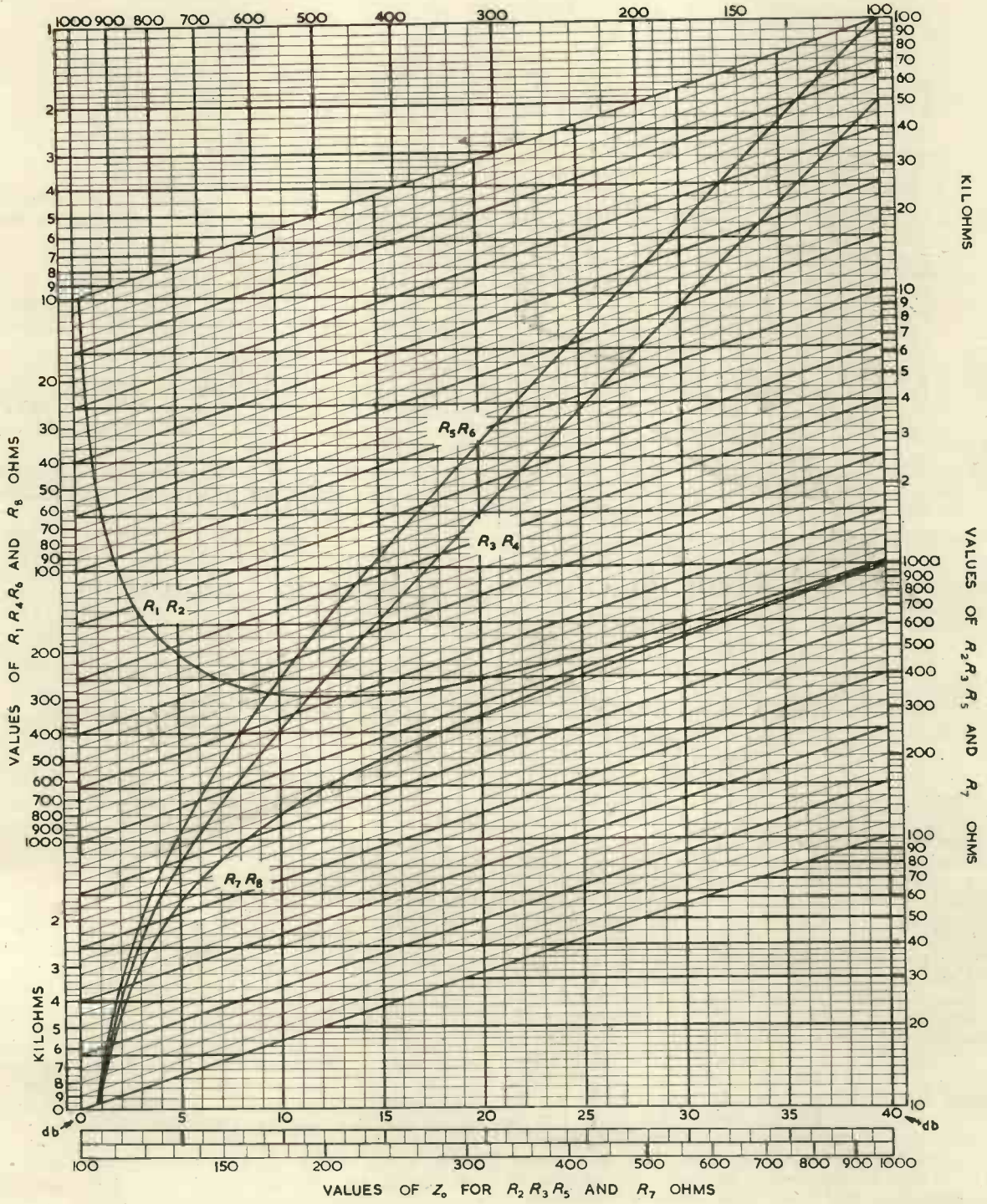

Chart 1. Attenuator design

a simple matter to move the decimal point a specific number of places in each calculation, if the actual working impedance is not within this range. Two of the examples given below illustrate this fact.

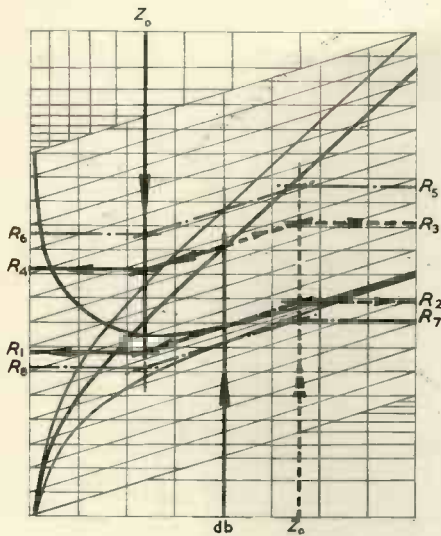

Fig. 2. The method of using the chart

These examples are given as a check so that the reader may be quite sure he is using the chart correctly before proceeding with the particular values he requires.

Example 1.

$T$  type attenuator for 20db, 500 $\Omega$ .  $R_1 = 410\Omega$ ,  $R_4 = 100\Omega$ . For an  $H$  pad, 4 resistors of 205 ohms would be required instead of 2 of 410 $\Omega$  in the case of the  $T$  pad.

Example 2.

Lattice type attenuator 12db, 600 $\Omega$ .  $R_1 = 360\Omega$ ,  $R = 1000\Omega$ .

Example 3.

$\pi$  type attenuator, 30db, 50 $\Omega$ . In this case the scale reference for  $Z_0 = 500$  is used and the values obtained from the chart divided by 10, giving  $R_2 = 55\Omega$ ,  $R_3 = 800\Omega$ . In the case of an  $O$  type attenuator 2 resistors of 400 $\Omega$  will be required instead of one 800 $\Omega$  resistor.

Example 4.

Bridged- $T$  type attenuator, 14db, 250 $\Omega$ .  $R_5 = 1000\Omega$ ,  $R_6 = 62.5\Omega$ . In the bridged- $H$  type attenuator, 2 resistors of 500 $\Omega$  each will be required in place of the single 1000 $\Omega$  resistor.

Example 5.

$L$  type attenuator, shunt resistor at input end, -26db, 15 $\Omega$ . Here the  $Z_0$  reference of 150 is used and the figures obtained are divided by 10, giving  $R_5 = 285\Omega$ ,  $R_8 = 15.75\Omega$ .

Example 6.

$L$  type attenuator, shunt resistor at output end, 26db, 15 $\Omega$ . As in the previous example, using the 150 $\Omega$  reference, the values for this configuration are  $R_6 = 0.8\Omega$ ,  $R_7 = 14.25\Omega$ .

Notice the difference in values required for the two  $L$  configurations, according to whether shunt resistor is at the input or output end.

## Atomic Hydrogen in the Research Laboratory

By R. L. F. Boyd, Ph.D., A.C.G.I., A.M.I.E.E., and N. D. Twiddy, B.Sc.

*The use of atomic hydrogen in welding and brazing is a well-known practice in engineering. The ordinary techniques are, however, unsuitable for fine and delicate parts. This article describes an instrument, capable of very well controlled operation, employing a R.F. corona to produce the dissociation. Heating is carried out in an enclosed space which thus ensures an atmosphere entirely of hydrogen.*

A FREQUENT problem in many research laboratories is the joining of small metal parts under conditions of great cleanliness. The importance of vacuum practice in many branches of science and the need often to eliminate all trace of oxides, from junctions and the surfaces of electrodes, are among the chief reasons for this.

In the authors' own work on atomic collisions, for example, the problem of building delicate electrode assemblies under such conditions constantly recurs. To meet this need the equipment described in this note was developed. As a general laboratory tool, however, it has proved to have much wider applications than originally envisaged, and for that reason this short account is given.

The value of the flame of recombining hydrogen atoms as a means of welding refractory metals, especially when used in an atmosphere of hydrogen gas, has been appreciated for many years, but the method has never had as much scope as might have been expected because of difficulty in attaining the necessary control of the tungsten arc. This is due to the need to maintain one at least of the arc electrodes at a thermionic emitting temperature. In the equipment described this problem is solved by employing a radio frequency arc to dissociate some of the molecules in a jet of hydrogen. In such an arc no electrode emission is required and the electrodes may be quite cold. In addition, by employing a frequency of about 100Mc/s a stable corona type of discharge (from a single electrode)

may be maintained over a wide range of powers, while the necessary transformation of the R.F. energy to a high voltage may conveniently be carried out by a quarter-wave concentric line.

### The Form of the Equipment

R.F. power up to about 1kW is fed to a resonant line from a tuned grid-tuned cathode oscillator, matching for optimum power transfer being obtained by a slot in the outer conductor of the line, which enables the tapping point to be varied.

The high R.F. potential generated at the open end of the line enables a corona discharge to be set up at its tip. The corresponding end of the outer conductor of the line joins into the side of the hydrogen-filled work chamber, so that the corona discharge occurs in an atmosphere of hydrogen. In our case the chamber is 8in diameter and is cooled by water flow through a few turns of copper tubing.

The tip at which the corona discharge takes place is normally a tungsten rod about 1mm diameter projecting through a nozzle connected to the inner conductor of the line. Hydrogen from the annular orifice around the rod, passes through the corona and issues as an intensely hot flame of atomic hydrogen.

For small work or for work in the less refractory metals only a few hundred watts are required, while for the finest work (e.g. the making of very small thermojunctions) the tungsten electrode and annular orifices are replaced by a

stainless steel tube (of the kind used for hypodermic syringes) having a fine tungsten wire projecting from the centre of the bore. The hydrogen which flows through this tube to issue at the heart of the corona on its tip also cools it and prevents it from melting.

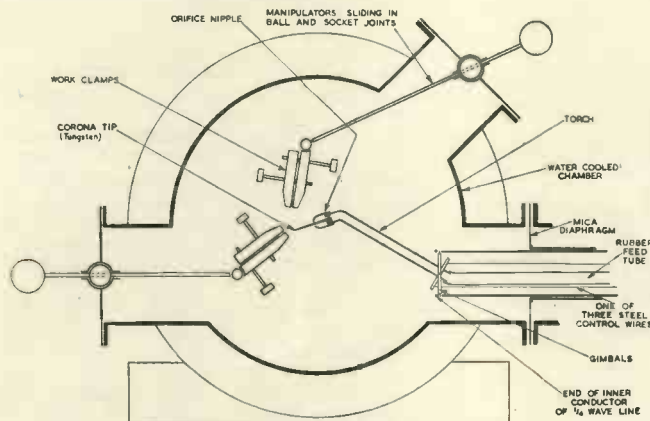

Schematic diagram of the equipment.

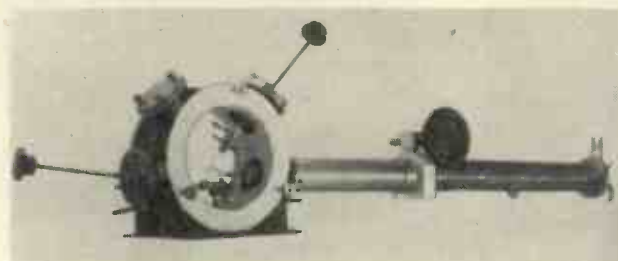

View showing  $\frac{1}{4}$ -wave line and handle controlling universal movement of torch (front window removed)

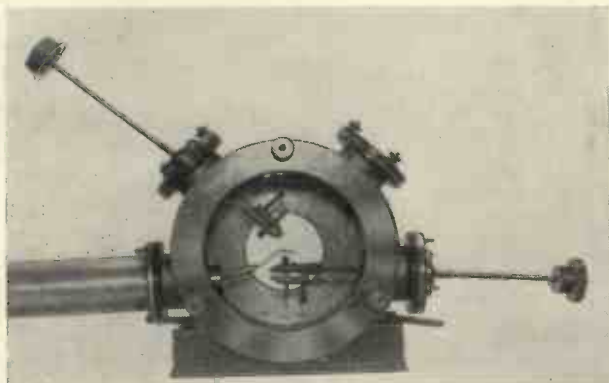

View through back window showing torch, manipulators and clamps

The equipment is simple, robust and easy to use. The life of the electrodes is almost unlimited, while the arc ensures that the "Q" of the resonant line is fairly low so that the tuning of the oscillator is not critical. In addition very little smoothing of the rectified A.C. used for the H.T. supply is necessary.

Two slightly different forms of the equipment have been used. In the first the corona electrode and nozzle are mounted directly on the end of the tubular inner conductor of the line which also serves to conduct the hydrogen to the orifice. In the second form of the instrument the corona electrode and nozzle are mounted on an arm carried in a small gimbal system in the end of the inner conductor of the line. A system of wires and levers makes it possible

to rotate the arm about its gimbal support in two orthogonal planes, to rotate the arm about the axis of the  $\frac{1}{4}$ -wave line and also to move it bodily into and out of the discharge.

Manipulation of the work itself is carried out by rods passing through universal ball joints and carrying small vices in other ball joints at their extremities.

Two simple safety devices have been employed. One is a gauze flame trap which prevents the flame of excess hydrogen (burning at the waste jet) from passing back into the work chamber should it be ignited before all oxygen has been blown out of the chamber. The other consists in making the window in the chamber which faces away from the operator larger and of thinner mica than that facing the operator, so that should the arc be struck before the chamber has been flushed this window is blown out.

### Some Examples of the Use of the Instrument

The features of the equipment that have proved most valuable may be listed as follows:—

(1) The atmosphere of hydrogen together with the presence of the very active atomic hydrogen have an unequalled cleaning action, so that metals flow and alloy readily, and fine systems that have become oxidized may be cleaned without the risk of damage attendant on the use of acids or mechanical processes. Welds and joints are of course bright and oxide free.

(2) In addition temperatures sufficient to melt the most refractory metals (e.g. tungsten) can be attained. In such cases the work is brought close to the arc electrode and the arc itself is allowed to strike the work.

(3) Varying the R.F. power generated provides a smooth control of the flame intensity from that, (for example) sufficient to melt a 5mm diameter molybdenum rod to that required to weld a 40 s.w.g. copper-eureka thermocouple.

The wide application of the instrument may be judged by the following examples of work which have already been carried out, though, of course, this list is not intended to represent the limits of the equipment.

- A 0.015in tungsten filament wire welded to molybdenum support.
- Seam welds in 0.01in molybdenum cylinders suitable for crucibles.
- A 1mm tungsten rod, for sealing through glass, butt welded to a copper nickel electrode support at one end and coppered for soldering to at the other (by flowing on copper).
- A tungsten sheet coppered to enable it to be hard soldered to a brass mounting ring.
- A wide range of thermocouples welded in various materials down to 42 s.w.g.
- Chrome-cobalt, stainless steel and nichrome welds on denture parts.
- A wide variety of welded brazed and soldered joints in many metals.
- A 0.001in molybdenum wire grid deoxidized.
- The fusing of refractory powder (at about 2000°C) in a molybdenum crucible.
- Fusion of a 0.004in bead of barium aluminate on a fine tungsten wire to provide a point thermionic source of electrons.

Among further suggested uses that have not yet arisen in our work are: the making of strain gauges; the fusion of metals in crucibles; the reduction of small quantities of ores; the mounting of electrical contacts.

The flame has also been used with nitrogen or a mixture of nitrogen and hydrogen. This may be of value in cases where metallic nitrides do not present a problem. It is also thought that in some very fine work dilution of the hydrogen with argon might be useful.

A patent application has been filed in respect of this equipment, the rights in which have been assigned to the National Research Development Corporation, London, W. 1

# LETTERS TO THE EDITOR

(We do not hold ourselves responsible for the opinions of our correspondents)

## A Simple Low Frequency Amplifier

DEAR SIR,—I have read with great interest the article by J. R. Beattie and G. K. T. Conn in your July, 1953, issue.

The authors make use of twin RC networks in the forward circuit of a "damped oscillator." The usual disadvantage of working near oscillation is the great sensitivity of the output voltage to changes in the amplifier. In the circuit described this is avoided by a local negative feedback around each valve.

The authors state, however, that the negative feedback applied by a purely resistive network makes no discrimination of frequency "so that the tuning is unaffected" that means the selectivity curve is only "scaled down" by the negative feedback factor  $1/(1 + A/C)$ .

In other words the statement is that the degenerative feedback affects only the overall gain of the amplifier without affecting its Q.

It seems to me that this can be true only if F, in accordance with equation (6) of the article remains unchanged by the introduction of the negative feedback.

This is only possible if simultaneously with the introduction of the cathode resistor (2.4kΩ) care is taken to change β to a new value β<sub>n</sub> so that

$$3 - A/\beta = 3 - A_n/\beta_n$$

It is only under this assumption that equation (9) holds good.

Yours faithfully,

AL. FUCHS.

Electronic Research  
Laboratory,  
Kiryat Motzkin,  
Haifa.

## The authors' reply :

DEAR SIR,—On page 2, column 2, line 5 of our article there is the sentence, "Thus the ordinates of all points on curve 2 in Fig. 3 are scaled down by  $1/(1 + A/C)$  where  $1/C$  is the new feedback ratio." This simple statement is not correct, as Mr. Fuchs points out the Q is altered unless β is altered.

Nevertheless, the tuning, that is the resonance frequency, is not affected by negative feedback. The general expression for the gain of the amplifier is

$$G = \frac{A/(1 + A/C)}{\alpha - 1/\beta \frac{A}{1 + A/C}}$$

where  $\alpha = 3 + j(x-1/x)$ .

At resonance

$$G_M = \frac{A/(1 + A/C)}{3 - \frac{A}{\beta(1 + A/C)}} \quad (1)$$

Differentiation of equation (1) gives for the stability

$$F = \frac{\delta G_M}{G_M} / \left( \frac{\delta A}{A} \right) = \frac{3/(1 + A/C)}{3 - \frac{A}{\beta(1 + A/C)}} \quad (2)$$

Moreover

$$Q = 2 / \left\{ 3 - \frac{A}{\beta(1 + A/C)} \right\} \quad (3)$$

so that

$$F = 3Q/2/(1 + A/C) \quad (4)$$

Negative feedback, introduced by the factor C, alters Q as Mr. Fuchs points out; to restore the previous value it is necessary to alter the positive feedback, that is alter β according to equation (3). In practice it is of little importance how a given Q is achieved provided the required adjustments do not affect the resonant frequency.

Yours faithfully,

J. R. BEATTIE,

G. K. T. CONN,

The University,  
Sheffield.

## A Comparison of the Properties of Certain Materials Used in Low-Power Microwave Attenuators

DEAR SIR,—We have read with interest Dr. Benson's and Mr. Pearson's article in your December issue. The most important parameter in the design of attenuator elements, irrespective of their material, is surface resistivity, a point which has been overlooked. Secondly, all the experimental work appears to have been done with a vane which has a taper of almost exactly three-quarters of a waveguide wavelength at the frequency quoted, which will, of course, give the worst mismatch conditions for a taper, and which may well account for the disappointing results in the v.s.w.r. measurements.

It would appear from a study of Fig. 4 and 5 that the vanes of resistance card and of loaded bakelite are subject to "resonance" (a term loosely used to indicate a condition when both attenuation and reflexion co-efficient are varying fairly rapidly with frequency) and consequently there may be a certain degree of unreliability in the attenuation characteristics. The gutta percha vanes do not seem to have this defect but are probably unsuitable on the grounds of low attenuation and poor mechanical properties.

The "violently fluctuating v.s.w.r." characteristic is probably not due to the causes described in the second column of page 504. It has been our experience in similar circumstances that the reflexion co-efficient of support pins is negligible (a v.s.w.r. of 0.97 or better is normal) and that the phase shift due to the vane is small (possibly λ/10 or λ/12 for a movement from the side to the centre).

It would have been interesting for the authors to have quoted the value of v.s.w.r. of the pins alone and the phase shift of the vane, which they had in mind at this time.

The unreliability of untreated carbon

resistance card has been recognized for a number of years because of variation in surface resistivity from sample to sample, and because of variations in surface resistivity with atmospheric conditions. If, however, card of the required resistivity is carefully selected and treated with a suitable tropical sealer, or good quality clear varnish, an attenuator vane can be designed with low reflexion co-efficient and consistent attenuation characteristics. It is not at present envisaged, however, that such a vane will ever achieve sufficient consistency to replace the metallized glass elements. A more likely future development is an evaporated metallic film deposited on some more robust medium than glass.

The carbon loaded bakelite elements have unfortunately been found inconsistent in production due to migration of carbon particles in the mix before and during mouldings. The formation of carbon "aggregates" gives rise to unreliable properties.

Yours faithfully,

J. W. SUTHERLAND,

D. C. COOPER,

Radio Engineering Department,  
Metropolitan-Vickers  
Electrical Co. Ltd.

## The Authors' reply :

DEAR SIR,—We thank Messrs. Sutherland and Cooper for their comments. The aim in our work was not to provide complete design data for carbon-material attenuators but to compare the properties of five carbon materials with a view to using them in this application.

The article does not primarily concern itself with shape of vane. It is not considered, however, that the length of taper is an important criterion on its own apart from saying the longer the taper the better the match, and it cannot be stated, as far as we know, that any length of taper is best without referring to the other properties of the material, e.g. resistivity of the glossy material and dielectric of the base material (whether glass or moulding compound).

If the length of taper is an important factor on its own then it is of interest to note that, in the absence of any concrete published data on vane-shape design, we took the dimensions shown on Fig. 2 for our test sample (with the exception of the distance between the holes for the support rods) from a Metropolitan-Vickers metallized-glass attenuator (Attenuator Type AVX-1, Attenuation 40db). Further, the vane length of Fig. 2 is that of the convenient standard available sheet of carbon-loaded bakelite. Tests carried out on 10 per cent carbon-loaded bakelite vanes of the same length but with different tapers showed that variations of taper length around the value given on Fig. 2 had quite a small effect on the power reflexion.



Even if we were working on the worst conditions for mismatch, however, then the mismatch, and consequently the power reflected, were not very large.

We do not agree that gutta percha is an unsuitable material on the grounds of low attenuation. An examination of Fig. 3 shows that gutta percha has the highest attenuation for a given guide position of any of the materials tested. This point is also stressed on page 505 of the article. The non-rigidity of the material and its susceptibility to change of attenuation with time are the chief factors against its use. If these could be overcome it would be an excellent material.

We shall be interested to have any further explanation of the "fluctuating v.s.w.r." The fact that the rods alone, in this case, produce very good reflexion characteristics cannot be any guide as to what their behaviour will be when an attenuating material is present since then the amount of reflexion from each rod will change. Incidentally, we agree that for the support pins alone a v.s.w.r. of 0.97 or better can be obtained at one particular frequency, but in our case such a figure could not be obtained at all points in the frequency range 9 050 to 9 650 Mc/s.

It seems obvious that variations in surface resistivity of a material with atmospheric conditions are largely responsible for the observed changes in the attenuation. Large variations in surface resistivity from sample to sample have not been noticed by us, probably because we have dealt only with small quantities. We are grateful to Messrs. Sutherland and Cooper for drawing attention to this point. It should be noted that we do state on page 505 of the article that the attenuation of Morganite alters with humidity and that it is possible to exclude moisture by coating the vanes with varnish. It would be interesting to know how the performance of Morganite vanes treated with a suitable tropical sealer, or good quality varnish, compares with metallized-glass elements.

Yours faithfully,

F. A. BENSON.

R. M. PEARSON,

Department of  
Electrical Engineering,  
University of Sheffield.

### -1.5V, 1A D.C. Stabilized Supply

DEAR SIR,—Having recently read the article "An Emission Stabilizer with D.C. Heater Supply" in the April, 1952, issue, I am submitting particulars of a stabilized -1.5V D.C. supply for filaments of sub-miniature valves which I designed while at E.M.I. in 1951 for a government department.

It has the advantage over Mr. Brown's circuit of not requiring the additional 3 stabilizer supplies (-150V, -300V, +250V) or any specially designed transformers or even a reference voltage (neon or battery) at the input of the D.C. feedback amplifier. This latter point, that a reference voltage is not necessary in low voltage stabilized supplies is not generally realized and deserves emphasizing.

$V_{5a}$  and  $V_{5b}$  (Fig. 1) form a conventional Wien oscillator at about 10kc/s capacitance coupled to control valve  $V_3$  and hence to grid of power output valve  $V_4$ , a 6V6, the associated transformer being a conventional loudspeaker output transformer type. Rectification is normal, using a selenium rectifier the hum level at the output being less than 1mV.

The output voltage in this case -1.5V is D.C. coupled directly to grid of feedback amplifier  $V_1$ , amplified and hence by altering the bias on control valve  $V_3$ , varies the level of voltage from the oscillator applied to output valve  $V_4$ .

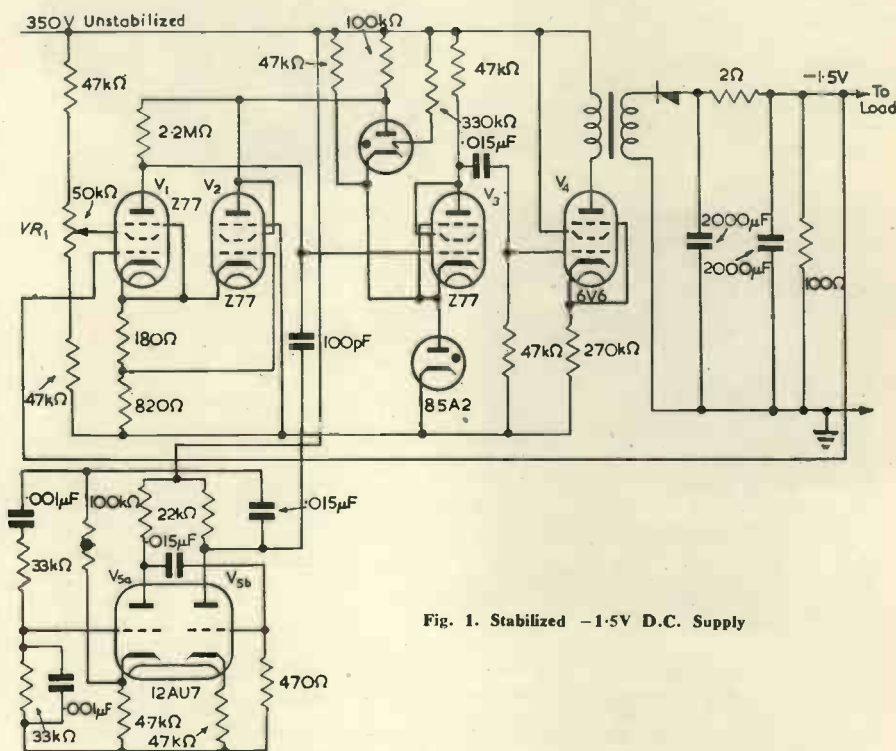

Fig. 1. Stabilized -1.5V D.C. Supply

Two neons are shown, one to provide bias for  $V_3$  and the other to stabilize the h.t. to  $V_1$  and  $V_2$ .  $V_2$  has the important function of compensating for filament variations at  $V_1$ , which otherwise would be amplified and appear at the output.  $VR_1$  controls the output voltage. The circuit can easily be adapted to give a longer output, and by "floating" the system, a positive or un-earthed output can be obtained. Stabilization for 10 per cent input variation and full to no load, is better than 1 per cent.

Yours faithfully,

I. J. HAMPSON,

Liverpool.

### The Author replies :

DEAR SIR,—I have read with interest Mr. Hampson's comments on my emission stabilizer circuit. The three stabilized h.t. supplies used consist of two neons and a shunt stabilizer valve for the

positive supply. This is only one valve more than the two neons which Mr. Hampson requires. I do not think that the suggestion of "floating" the whole heater stabilizer will lead to a more economical solution.

When designing an emission regulator the thermal time-constant of the heater must be considered. If a low-pass filter is used to reduce heater ripple then an extra time lag is introduced into the feedback loop and it is difficult to avoid oscillation in the stabilizer. The use of a square wave, which does not require filtering to give a ripple free supply, has

therefore a very real advantage for this application.

I would agree with Mr. Hampson that an external reference voltage is not worth while in a low voltage stabilizer if a valve D.C. amplifier is to be used. As suggested the grid base of the valve can be used to provide the reference but this does set a rather low limit of stability due to drift. The figure of  $\pm 1$  per cent in 1.5 volts or  $\pm 15$ mV quoted is about the practical limit and drift during the first hour after switching on is likely to be worse.

To conclude, I would like to draw Mr. Hampson's attention to an article by A. K. Solomon and David C. Caton in *Rev. Sci. Instrum.* for December, 1952, p. 757. This describes an emission stabilizer using a very similar circuit to the one which he has designed.

Yours faithfully,

D. E. BROWN,  
Standard Telecommunication  
Laboratories, Limited.  
Enfield.

# ELECTRONIC EQUIPMENT

A description, compiled from information supplied by the manufacturers, of new components, accessories and test instruments.

## A.C. Ionization Test Set (Illustrated below)

THE high voltage insulation test set type AC.1 has been developed for use in cases where a D.C. test is not acceptable and to give a quantitative assessment of the energy lost in an insulator due to ionization caused by the alternating stresses. This instrument can be used whenever a standard A.C. flash test has been used in the past with the advantage that the test can be stopped before the flash-over voltage is reached.

The test voltage is applied across the specimen through a filter which removes any noise generated in the test transformer which would interfere with the



operation of the amplifier. Test transformers have been specially designed to be noise-free up to a maximum of 25kV R.M.S. Maximum power available is 1kV and hence the maximum capacitance that can be tested at 25kV is approximately 0.002 $\mu$ F.

One side of the specimen is at earth potential. The other side, to which is applied the test voltage from the filter, is connected via a blocking capacitor to the input circuit of the amplifier.

The output of the amplifier is displayed upon an elliptical trace on a small cathode-ray oscilloscope. The magnitudes of these discharges can be measured by using the calibrator. It is thus possible to give an actual measurement of the magnitude of the A.C. discharges appearing in the specimen.

Hivolt Ltd,  
34a Pottery Lane,  
Portland Road,  
London, W.11.

## Oscilloscope Type XT.316 (Illustrated above right)

THIS oscilloscope has been designed by the Radio Research Establishment, Malvern, and represents a considerable improvement over its predecessor, the Monitor 56. It has a direct coupled de-



## Quartz Crystal Activity Test Set (Illustrated below)

A NEW low frequency quartz crystal activity test set is now being produced by Salford Electrical Instruments Ltd. Covering a frequency range from 50 to 2 000kc/s and known as the QC 166 test set, it is complementary to the older QC 57 test set which covers frequencies from 1 to 20Mc/s.

The new test set, although it necessarily incorporates a modified circuit, operates on the same principle as the older high frequency test set, in that it measures the apparent resistance, or the equivalent parallel resistance, of the crystal. In the QC 166 the equivalent parallel resistance range for the 50-2 000kc/s frequency range is from 30 to 600k $\Omega$  and the measurements are made, on four frequency ranges: 50-130kc/s, 130-330kc/s,



330-800kc/s and 800-2 000kc/s. In the first three frequency ranges the range of equivalent parallel resistance measured is 50 to 600k $\Omega$ , while on the fourth range the range of measurement is 30 to 350k $\Omega$ . This embraces all the limits specified in Quartz Crystal Specification RCS. 271. Measurements are made direct, input capacitances of 30, 50 and 100pF being selected as required.

The General Electric Co. Ltd,  
Magnet House,  
Kingsway,  
London, W.C.2.

## Rotary Pulse Generator (Illustrated above right)

THESE electro-magnetic units are intended to act as a transducer, or a transmitter of pulse energy as a function of angular rotation for the accurate remote indication of angular or peripheral velocity of heavy machinery.

While primarily designed for use in rolling mills to be coupled to the final stage of rolling by suitable gearing and thus produce a continuous train of pulses having a direct relationship to the linear motion of rolled strip rod, etc., it can, of course, be used in other applications in which a related function between distance travelled in a given time occurs.

The output from the unit is by a three wire low impedance balanced pair, in-

flexion amplifier of greater bandwidth and sensitivity, and a time-base with a maximum sweep speed of 1 $\mu$ sec and facilities for delaying the start up to 10msec. An internal sine wave calibrator provides a trace at 1Mc/s, 100kc/s or 10kc/s for measuring time-base velocities and linearity. Facilities for input signal measurement and signal delay are provided.

This oscilloscope conforms to the requirements of RCS. 1000 and K.114 for use in the Services. It is particularly suitable for use with all types of radar systems as well as for general purposes.

Solartron Laboratory Instruments Ltd,  
Solartron Works,  
Queens Road,  
Thames Ditton, Surrey.

## Megohmmeter (Illustrated below)

THE Myria megohmmeter, model 35, is a general purpose, mains operated, direct reading instrument for insulation testing or for the measurement of resistance over the range of 150k $\Omega$  to 200 000M $\Omega$ . Two stabilized test voltages are provided—150V and 500V. Indication is given on a six inch 80 $\mu$ A F.S.D. moving-coil meter.

Electronic Instruments Ltd,  
Red Lion Street,  
Richmond,  
Surrey.

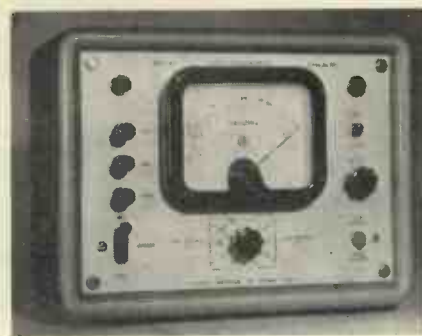

tended to be coupled to a special input transformer in a pulse shaping amplifier which can be quite remotely located, e.g., many hundreds of yards away from the heavy machinery, if desired in another building.

This method of input link enables the train of pulses to be free from interference pulses—from other switched large current machinery. Hence, the square wave constant amplitude output from the pulse-shaping amplifier has a numerical digital accuracy in relation to exact length. This unit forms an essential input link for high speed length measuring equipment, tachometer systems; input displacement measuring equipment, etc.

The standard unit, type RPG-4215/100 has been designed to run at any speed from 1 R.P.M. up to 4 000 R.P.M., and to deliver 100 pulses per 360° arc. The input shaft has a diameter of 1 in which is mounted on large self aligning ball races and requires negligible input power.



The unit is built to withstand very rough usage and it measures 8½ in by 6½ in by 10 in. Other types, with different angular pulse ratios as well as smaller units can be made to special order.

**Sargrove Electronics Ltd,**  
Alexander Road,  
Hounslow,  
Middlesex.

#### Variable Frequency Cut-off Filters

(Illustrated above right)

THE Equipment Division of Mullard Ltd has recently made available high- and low-pass filters based on an original Post Office design. The use of Ferroxcube pot cores for the inductances has made possible a considerable reduction in size coupled with excellent attenuation characteristics. Each filter is accommodated on a standard 19-in panel 3½ in high and a single selector switch enables the cut-off frequency to be selected. By connecting the high- and low-pass units in tandem and varying the cut-off frequencies the filters form a useful instrument for sampling and frequency analysis.

The input and output impedance of the filters is 600Ω, but the actual filter sections are designed for an impedance of 25 000Ω.



The high-pass cut-off frequencies are 440, 660, 990, 1 480, 2 222, 3 333, 5 000, 7 500, 11 250 and 16 800c/s, and the low-pass cut-offs are 400, 600, 900, 1 350, 2 025, 3 040, 4 500, 6 830, 10 250 and 15 400c/s. Stop-band attenuation is 50db at  $0.8 \times f_c$  for the high-pass and  $1.25 \times f_c$  for the low-pass sections and beyond these limits attenuation increases rapidly. Passband attenuation is 3db ± 1db (high-pass) and 2db ± 1db (low-pass).

**Mullard Ltd,**  
Century House,  
Shaftesbury Avenue,  
London, W.C.2.

#### Locking Washers

(Illustrated below)

THESE crinkled locking washers are made from beryllium copper, tempered, cadmium plated and passivated.

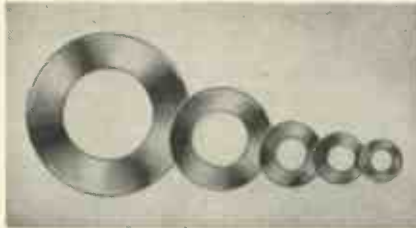

They have a high degree of recovery in relation to the load. Their resistance to corrosion is excellent. They are available in sizes from ½ in B.S.F. down to 8 B.A.

**David Powis and Sons Ltd,**  
Forward Works,  
Golden Hillock Road,  
Birmingham, 11.

#### Variable Capacitors

(Illustrated below)

THREE new ranges of variable capacitors has recently been added to the Eddystone range. They are transmitting variable capacitors, miniature microdensers and ceramic microdensers.

The transmitting type have ceramic end plates with brass metal work finished in dull silver plate. They are available as single section capacitors with one end plate, single section with two end plates, split stator and differential in a range of values from 25pF to 250pF according to type. The flashover voltage varies from 1 200 to 2 500V R.M.S. The end plates are 2 in or 2½ in square.

The miniature microdensers have a single ceramic end plate ¾ in square. Three



types are available; butterfly 25 + 25pF 90° rotation, split stator 25 + 25pF 180° rotation and single section 50pF 180° rotation.

The ceramic microdensers are available in a variety of types with either one or two ceramic end plates of 1 5/16 in square in a range of values from 12.5pF to 100pF.

**Stratton and Co. Ltd,**  
Eddystone Works,  
Alvechurch Road,  
Birmingham, 31.

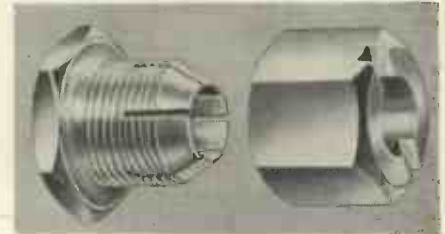

#### Pre-set Control Lock

(Illustrated above)

THIS component is designed to lock the spindles of potentiometers and other controls without causing rotational or lateral displacement of the shaft. It is threaded ½ in. by 32 T.P.I. for use with controls made to RCS 1 000. The normal finish is cadmium plate but it can be supplied either silver or bright nickel plated to order.

**Sutton Coldfield Electrical Engineers,**  
Walsall,  
Staffordshire.

#### Aircraft Intercommunication Equipment

(Illustrated below)

THE Airmec "Brick" intercommunication equipment for use in multi-seater aircraft provides clear undistorted communication, between up to ten stations, in even the highest noise levels. Two radio receivers and one associated transmitter may be connected to the system to enable the pilot to transmit, and all crew members to hear the signals received, with negligible cross-talk in the receiver circuits.



The equipment is compact, light in weight, and fully tropicalized, and is approved for use by the Royal Air Force. The simplest form of the equipment consists of three units, the amplifier type 873 (Air Ministry type A1961), the control unit type 876 (Air Ministry type 702) and junction box type 875 (Air Ministry type 154), but they are also available as separate items, if required, for incorporation in other wiring systems.

**Airmec Ltd,**  
High Wycombe,  
Bucks.

## Small Transformers and Inductors

By K. A. MacFadyen. 237 pp., 96 figs. Demy 8vo. Chapman & Hall. 1953. Price 37s. 6d.

THE book contains a fundamental account of a wide range of small transformers and chokes, and is primarily intended for the non-specialist at a level "well below physics or engineering degree standard". Special consideration is given to small supply transformers, wide band communication type transformers, instrument transformers, pulse transformers, high Q chokes, and chokes and transformers with magnetic polarization by direct current, including saturable reactors. About a third of the book is devoted to introductory theory of magnetic circuits, circuit theory, and equivalent circuits of transformers. The whole subject is treated from the communications aspect with emphasis on the impedance characteristic of the transformer, and the use of complex or "vector" perme-

# BOOK REVIEWS

reduce leakage flux or to ensure quiet operation. In this book, an attempt has obviously been made to state clearly these limiting factors in design, and also to give a thorough account of the fundamental theory. A defect is that the data provided, although quite extensive is not complete. It is specially important to provide design information in those cases where special facilities for measurement must otherwise be available to the designer, for without this knowledge a design virtually becomes experimental. If the author had aimed a little higher in this respect he would have made the book quite indispensable; as it stands, however, it is a very useful reference.

L. R. BLAKE.

## Automatic Digital Calculators

By A. D. Booth and K. H. V. Booth. 231 pp., 128 figs. Demy 8vo. Butterworths Scientific Publications. 1953. Price 32s.

MODERN electronic computers are the nearest approach to the robots, mechanical brains and thinking machines of current science fiction; and any book showing by what means and to what extent modern technology has managed to translate these dreams into reality, can be sure of considerable interest.

The present authors who have been engaged on the design of electronic calculating machines for several years are well qualified to write such an account. They have collected a large amount of material on the subject and managed to present it in extremely readable form.

Roughly speaking, their book can be divided in two parts, one treating the design of computers, the second their operation and application.

The first part starts with a brief historical survey from Pascal's first ideas right up to the present day, proceeds to explain the functional structure of automatic computers in general terms, and goes on to a detailed description of their various sub-units and components. Topics treated are input and output organs, arithmetic units and their parts (adders, subtractors, complementers, multipliers, etc.), stores, control units, and subsidiary circuitry such as gates, counters, switching trees and matrices. In every case, a variety of alternatives is described. Thus, the chapter on memory units (stores) mentions electro-mechanical devices, combinations of diodes with delay elements, flip-flops, thyatron, sonic delay lines, magnetic drums, electrostatic storage tubes of different types, dekatrons, storage elements based on the properties of magnetic hysteresis loops, and others.

Most of the second part deals with the technique of encoding and programming, the "training of the robot." After an explanation of the basic idea of a coded instruction, there follows a list of those operations which one would normally include in the code of a

machine, and a discussion of various coding techniques: use of subroutines, substitution of parameters, control of magnitude, floating-point techniques, and the over-all design of programmes.

These discussions are illustrated by a large number of completely coded examples, ranging from elementary operations such as division or binary-to-decimal conversion to subjects like the computation of trigonometric functions by means of interpolation of tables stored in the memory.

The section on machine applications describes in detail a problem of great practical importance, the analysis of crystalline substances by means of Fourier synthesis of X-ray diffraction spectra. Other chapters deal with topics of general philosophical interest, such as the ability of machines to play games, translate languages, acquire conditioned reflexes, and learn from experience. This leads to a concluding paragraph on the classical question whether machines can be said to have intelligence—or rather, whether intelligence can be defined in such a way that it can be attributed to automatic computers. An extensive bibliography and various indices are added to the book.

It may appear ungrateful not to be satisfied with such a comprehensive selection. Nevertheless, the reviewer may be permitted to list a few subjects which he would like to see included in future editions: the synchronization of a magnetic drum with a Williams store tube; the device, known as "B-tube," for modifications of instructions; procedures for machine testing and for checking of results; aids for the detection of programming errors; automatic coding; interpretative routines.

A minor criticism concerns the style of the book, there is an occasional irritating tendency to string two or more independent sentences together, the sequence you are reading now is treated in the same manner to illustrate this point.

However, these remarks are not meant to detract from the value of the book which should be indispensable to the electronic engineer wishing to enter the field of digital computers, or, for that matter, to anyone curious to know more about this fascinating subject.

D. PRINZ.

## Technical Aspects of Sound

Edited by E. G. Richardson. Volume 1, 544 pp., 294 figs. Demy 8vo. Elsevier Publishing Company, New York, Cleaver-Hume Press, London. 1953. Price 70s.

NOT so long ago, a general textbook might embrace heat, light and sound—with a very small "s". It is entirely attributable to modern methods of measuring, transmitting and receiving that the order is now reversed. Indeed,

## VOLTAGE STABILIZERS

By

F. A. Benson, M.Eng., A.M.I.E.E., M.I.R.E.

(University of Sheffield)

Price 12/6

This monograph describes the various devices employing saturated elements, glow-discharge tube circuits and thermionic valve arrangements for voltage stabilization. A comprehensive bibliography is included.

Order your copy through your bookseller or direct from

**Electronic Engineering**

28 ESSEX STREET, STRAND, W.C.2

ability, to the exclusion of "watts/lb" and "VA/lb", more familiar to power transformer engineers.

To be really helpful to the non-specialist, an account of this kind should contain the basic theory—with special emphasis on the limiting factors, and the relevant design information. As a simple example, it is time saving to be told, in the design of a small power frequency supply transformer, that the flux density is controlled by the magnetizing current tolerable, which can be made about 20 per cent of the load current, but lower densities may be necessary to

the current texts on various aspects of sound are legion.

Volume 1 of *Technical Aspects of Sound* suffers from shortcomings inseparable from such a compendium: it cannot be quite up to date, owing to the time taken to compile; and certain of the contents can only be abridged since they are adapted from other books and published matter. Book prices are now so high that one feels that certain of the subject matter, so often repeated elsewhere, might have been sacrificed to the extension of the original and outstanding sections.

The analytical introduction by Dr. Richardson is an excellent feature. This is followed by a rather abridged treatment of frequency sources, pressure and velocity amplitude measurements. A detailed and most interesting treatment of room acoustics is given in sections 4, 5, 6 and this includes much original work. Sections 7 and 8, on noise, are useful. Sections 9 to 13 inclusive are masterly and this is probably the most explicit treatment of speech and hearing yet to appear in print.

Sections 14 and 15, loudspeakers, telephones and sound recording, are rather untidy, refer largely to German practice, and the translation is very quaint at times—if not actually in error. For example, on page 400 the statement that an electrically heated stylus polishes the groove in an optical sound film reproducing system indicates rather haphazard editing of this section.

The other outstanding part of the book is Dr. Richardson's treatment of sound analysis and the design and performance of musical instruments. The development is precise and lucid, many quite new researches having been drawn upon.

The last section, on electrophonic musical instruments, is the least satisfactory in the book. It is, of course, a considerable condensation, but does not mention modern circuits and is definitely "pre-war". Figure 292 is not the Hammond organ, but part of an early Novachord circuit. The electrostatic generator shown is not that of the Compton Electrone.

Summing up, the sections on acoustics, speech and hearing, tonal analysis and physical musical instruments are quite the best of their kind. The other matter is perhaps best covered in specialized texts, but this volume is a noteworthy addition to the literature and will be much sought after as a work of reference. The bibliography is excellent.

ALAN DOUGLAS.

### Die Laplace-Transformation und ihre Anwendung (The Laplace Transformation and its Application)

By P. Funk, H. Sagan and F. Selig. 106 pp., 18 figs. Demy 8vo. Franz Deuticke, Wien. 1953. Price 16s. 8d.

THIS book is intended as a brief mathematical introduction to the Laplace transform for physicists and technologists. It has grown out of courses of lectures which the senior author (Professor Funk) has delivered over a number of years. Dr. Sagan has

edited the lecture notes for publication in book form.

A good grounding in analysis is assumed, in particular Theory of Functions up to contour integration and Cauchy's Integral Theorem, and some acquaintance with special functions such as Gamma and Bessel functions. Proofs are not always presented in full; instead an outline is given together with references to the literature. Not only various applications but also some historic aspects of the theory are discussed; thus a fairly detailed sketch of a rigorous proof of Heaviside's Theorem on asymptotic expansions is followed by a critical analysis of Heaviside's own arguments; and the book ends with a historical epilogue. The authors appear to have been greatly puzzled and perturbed by the rôle played by that unorthodox genius, Oliver Heaviside.

The applications and illustrations deal with such topics as the D.C. motor, a simple transformer, the propagation of earthquake shocks, brake-generated heating of a wheel, submarine cables. The last sections (by Selig) deal with feedback systems, and might therefore be of particular interest to electronic engineers, but they are too brief to include much detail. Tables of Laplace transforms are omitted because they are easily accessible in other works.

There are a number of (mostly minor) misprints. The printing is somewhat cramped, but formulae and diagrams are clearly printed, and the price of the book is very reasonable.

B. H. NEUMANN.

### Television Engineering Principles and Practice

By S. W. Amos and D. C. Birkinshaw. 300 pp., 188 figs. Demy 8vo. Iliffe & Sons, Ltd. 1953. Price 30s.

THIS is the first volume of a textbook on television engineering written by members of the BBC Engineering Training Department, primarily for the instruction of the Corporation's own operating and maintenance staff. The work is intended to provide a comprehensive survey of modern television principles and practice, on both the transmitting and receiving sides.

The technical level of the work has been devised to satisfy the student grade. Mathematical argument has been excluded from the text, but appendices are included where special treatment of particular subjects has seemed desirable.

### Introduction to Valves

By R. W. Hallows and H. K. Milward. 152 pp., 107 figs. Demy 8vo. Iliffe & Sons, Ltd. 1953. Price 8s. 6d.

THIS book describes the principles of operation of the radio valve and its uses in circuits of various types. Following an explanation of the fundamental thermionic valve, the book deals with diodes as rectifiers and detectors; triodes and their various applications; tetrodes and pentodes; multiple-grid valves for frequency changing; power output valves and valves for v.h.f. and e.h.f. operation. Other chapters discuss special purpose types and the construction of modern miniature and sub-miniature valves.

## CHAPMAN & HALL

JUST PUBLISHED

*A Revised Edition*

### of Sturley's RADIO RECEIVER DESIGN

PART 1

RADIO FREQUENCY

AMPLIFICATION & DETECTION

672 pages Illustrated 56s. net

### FIELDS AND WAVES IN MODERN RADIO

by

Simon Ramo

*Vice President, Hughes Aircraft Co.  
Research Associate California Inst. of Tech.*

and

John R. Whinnery

*Professor of Electrical Engineering  
University of California*

576 pages 266 figures 70s. net

37 ESSEX STREET, LONDON, W.C.2.

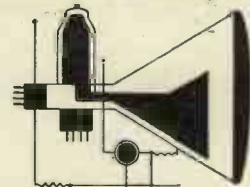

**Smith's**  
**for current**  
**"know how"**

From Smith's shops and book-stalls you can quickly obtain technical books on the latest developments in circuit design, new components, methods and new theories. Books not actually in stock can usually be supplied within a day or so. Smith's Postal Service can send books to any address at Home or Overseas. Lists of the standard works on any subject supplied upon request.

**W. H. Smith**  
**& Son**

FOR TECHNICAL BOOKS

HEAD OFFICE: STRAND HOUSE, W.C.2

# BOOK REVIEWS (Continued)

## Faster Than Thought

Edited by Dr. B. V. Bowden. 416 pp., 51 figs. Royal 8vo. Sir Isaac Pitman & Sons, Ltd. 1953. Price 35s.

"Faster Than Thought" is a symposium on digital computers by twenty-four experts. Its coverage is very thorough and it is instructive throughout. It abounds in the spirit that computers are for men whose scholarship has not robbed them of their sense of fun and of the curious, and it is full of entertaining interpolations; one had not realized before, for instance, that universal education brought a problem to the railways, who found that signalmen able to read had memories inferior to those of illiterate colleagues.

The book is in three parts: general principles, descriptions of existing computers, and applications.

The first part opens with an account of the history of computation and does not fail to make adequate mention of Charles Babbage and his far-seeing and detailed plans for computing machines over a hundred years ago. There follows an account of the basic electronic circuits and storage devices used in computers, and of the general organization of these machines. A chapter devoted to performance and maintenance forcibly brings home the immensity of the problem facing the designer to ensure that the computer is reliable. Lastly, programming is discussed: the machine can solve no problem until it has been supplied with instructions as to the course of procedure, and here it is that the highly-skilled art of the programmer is required.

The reader is likely to emerge from Part I with a less clear notion of the machine in action than of its component parts. The difficulty of explaining computers to beginners is admitted in one of the footnotes and the advice is given that, if the first explanation is not understood, the reader should not trouble himself unduly; he is told that his difficulties will probably disappear as the same topics will recur throughout the book in different contexts. This is hardly the most enlightened approach to the author's duty of exposition. It is rather like that of the Englishman who believes that his language will penetrate the foreigner's brain if he shouts, and shouts often enough, which policy is gently satirized elsewhere in the book.

Part II is a collection of factual and detailed accounts of computers, valuable for reference by the engineer whose work lies in this field.

Part III deals with the applications of computers and explains that not only are they of value where the calculations are complex, but equally so where the calculations are simple but the quantity of data overwhelming. This part is broad in outlook, and it shows a great understanding of the problems of maintaining our civilization in order. There is an

interesting analysis of the progress of design projects in engineering and the ways in which computers can help, particularly by relieving engineers of much calculation that is drudgery and wasteful of time that they would prefer to devote to original thinking. Applications of computers to large-scale business organizations are discussed, and it becomes evident that the way in which clerical operations have been broken down in such houses, so that each of hundreds of individuals has a small field in which to operate and make his contribution to the whole, paves the way for automatization. In government work and in economics the storage capacity and speed of computers can be of great value; so often in the past has it been the case that analyzed results have only become available so long after the collection of facts as to be of no value, or that the impossibility of handling all the data has necessitated simplifications of classification and consequent inaccuracies. The reader who is more interested in the technological applications of computers will find examples drawn from crystallography, meteorology, ballistics and astronomy. There are two most entertaining chapters on the performance of computers in handling problems of pure logic and in playing such games as chess, draughts and nim.

By the time he approaches the end the reader will have come to regard these machines as very lovable. They appear to be willing servants, but occasionally capricious ones. Let the programmer make the slightest slip, and they will spot it and gaily serve out the wrong answer. "That will teach him," we suspect them of saying, "to be more careful in future." But somehow one could never imagine them guilty of malice.

If a reader finds his emotions so affected, how much more the men who work day by day with these machines? It must therefore have been a considerable struggle to maintain a sober point of view in the final chapter where, after some intriguing accounts of the mental processes of calculating prodigies, there is discussed the question, familiar these days, as to whether or not a computer has, or could be made to have, attributes entitling it to be regarded as a reasoning brain.

Dr. Bowden's scholarly and witty preface is a joy to read.

T. L. CRAVEN.

## Radioactivity and Radioactive Substances

By Sir James Chadwick. 120 pp., 41 figs. Demy 8vo. Fourth edition. Sir Isaac Pitman & Sons. 1953. Price 12s. 6d.

THIS is the fourth, newly revised, edition of a volume first published in 1921, which deals largely with "classical"

radioactivity and presents the phenomena, so complex when seen from the viewpoint of historical discovery, as the direct result of the nuclear constitution of the atom.

The first three chapters are introductory in nature, and deal with the general subject of radioactive change, the ionization of gases and methods of measurement, respectively. Professor Rotblatt has brought Chapter III up to date by including an account of scintillation counters and the use of photographic emulsions, as well as of modern G.M. tubes.

Alpha, beta and gamma radiation each receive a chapter. The importance of scattering experiments with alpha particles in the derivation of the nuclear theory of the atom is explained rather more briefly than would perhaps be expected, and the energy and ionization data given in Table 1 require revision, as the values given differ appreciably from those currently accepted. The sections dealing with beta and gamma rays assume that the reader has some acquaintance with the general consequences of quantum theory and is familiar with the concept of stationary levels.

The statistical nature of the disintegration process and the invariability of the disintegration constant are considered in Chapter VII, which gives a clear account of the growth and decay of radioactive species. A very brief discussion of the difficult subject of nuclear isomerism again demands some knowledge of quantum theory.

A general outline of the three radioactive families, stemming from Uranium, Thorium and Actinium is given in Chapter VIII, together with a brief discussion of isotopy, and of chemical and physical methods of separation of the various elements. Radium is given Chapter IX to itself.

The penultimate chapter assembles a miscellany of subjects, such as the determination of the age of minerals from their isotopic content, and the radioactivity of elements lighter than lead. The empirical relations between nucleon energy and disintegration constant, found by Geiger and Nuttall for alpha particles and by Sargent for beta particles, are also given here.

The significance of these relationships is made clear in the new final chapter, which explains the modern theory of nuclear structure and brings out the significance of the binding energy of the constituents of a particular nucleus.

Consideration of stability criteria leads to a discussion of artificially produced radioactive materials, but, oddly enough, only of those showing beta activity. No mention is made of the artificial elements of atomic number greater than 92, and of their relation to the naturally occurring radioactive materials.

The foreword to the original edition by the late Lord Rutherford recommended the book as a simple, concise and accurate statement of the main facts and theories of radioactive phenomena. The fourth edition still justifies this recommendation, and at 12s. 6d. the book is well within the reach of students.

J. SHARPE.

# Short News Items

The City and Guilds of London established some twelve months ago the Insignia Award in Technology to provide a high qualification for persons in industry whose initial training was based primarily upon practical experience combined with theoretical study and who, having gained appropriate City and Guilds' Certificates as craftsmen or technicians, have now advanced in their industry by a combination of progressive experience and further study. The regulations stated that a candidate must be at least 30 years of age and be sponsored by three referees of appropriate standing. He must have been apprenticed or otherwise suitably trained in his industry he must hold relevant Full Technological Certificates of the Institute, and have had a minimum of seven years' progressive experience in his industry. He is then required to write a thesis of some 10 000 to 20 000 words on a technological topic associated with his work. If this thesis is reported upon satisfactorily by the Assessor appointed by the Institute, the candidate is required to appear for interview before an ad hoc Panel nominated by the Institute for this purpose. A candidate upon whom the Insignia Award in Technology is conferred will receive a Warrant specifying thereon the section of industry and the branch of technology in which his knowledge and skill are recognized, and under the Institute's Royal Charter he will be authorized to use the insignia letters C.G.I.A. There is no special time table involved in the scheme, each candidate is considered as a separate and self-contained case, and great care is taken to help him at all stages of his candidature. Further details may be obtained from the City and Guilds of London Institute, Department of Technology, 31 Brechin Place, South Kensington, London, S.W.7.

The Council of the Institution of Electrical Engineers have elected Mr. Ernest Leete to Honorary Membership of the Institution for his outstanding services to the Institution, in particular for his services as honorary treasurer, as an ordinary member of Council over a period of almost a quarter of a century and also for his work on behalf of the Benevolent Fund of the Institution. The Council have made the Thirty-second Award of the Faraday Medal to Mr. Isaac Shoenberg for his distinguished work in electrical engineering, in particular the outstanding contributions which he has made to the development of high definition television in this country.

The Ministry of Communications of the Argentine have placed an order for British tape recording equipment, to the value of £30 000. This is for 32 E.M.I. magnetic tape recorders similar to those used by the British Broadcasting Corpora-

tion, and for large quantities of recording tape. It is understood this equipment will be used in Argentina to develop broadcasting facilities throughout the country.

Cable and Wireless Ltd announce that a new radio telephone service between Hongkong and India has recently been opened. It is being operated by Cable and Wireless at Hongkong and by the Government of India Overseas Communications Service at Bombay.

Evershed & Vignoles Ltd have taken over the responsibility for distributing the products manufactured and previously marketed by Tinsley (Industrial Instruments) Ltd. In future all correspondence in connexion with Tinsley Instruments should be addressed to Evershed & Vignoles Ltd, Acton Lane Works, Chiswick, London, W.4.

The Council of the Royal Society have elected Dr. E. D. Adrian, O.M., as president for 1954. The treasurer and vice-president is Sir Thomas Merton.

The Association of Supervising Electrical Engineers announce that its third exhibition will be held at Earls Court from 16-20 March.

The BBC, as part of its plan to make local improvements in the coverage of the Home Service, has built a new low-power transmitting station at Mouswald near Dumfries. The new transmitter has a power of 2kW and will extend the area of improved reception to include Lochmaben, Lockerbie and Annan.

E.M.I. Factories Ltd have received an order in excess of £100 000 from the French Embassy in London, on behalf of the French Air Ministry, for 100 Airborne Navigational Aid Equipments, including spares and test gear. These are Rebecca Mark IV medium range homing devices which, used in conjunction with ground beacons, enable aircraft to be directed accurately to particular sites.

The University of London Department of Extra-Mural Studies and the Atomic Scientists' Association have arranged a course of six university extension lectures on Atomic Energy. The first two on "Atomic Research at Harwell" by Sir John Cockcroft and "Atomic Weapons" were held in January. The four subsequent lectures will be on 3, 10, 17 and 24 February respectively and the admission fee for single lectures is 2s. Applications for tickets should be addressed to the Cashier, University of London, Senate House, Malet Street, W.C.1, and marked "Extension Courses"

on the cover. Tickets may also be obtained at the lecture room on the occasion of each lecture which will be held in the Beveridge Hall, Senate House, at 7 p.m. on the dates mentioned.

The South East London Technical College is organizing a short course of six lectures on Automatic Process Control commencing on 9 March at 7 p.m. The fee for the course is £1 and should be of interest to engineers concerned with automatic control. It has been arranged in conjunction with Messrs. Elliott Brothers (London) Ltd, Century Works, Lewisham. Application for admission to the course should be made as early as possible to the Head of the Department of Electrical Engineering and Applied Physics, South East London Technical College, Lewisham Way, London, S.E.4.

The New Years Honours List includes the following persons in the electrical and allied industries.

A Knighthood has been conferred on Dr. W. G. Radley, C.B.E., Engineer-in-Chief, General Post Office.

Mr. N. C. Robertson, M.B.E., deputy managing director, E. K. Cole Ltd, and formerly Director General of Electronics Production, Ministry of Supply, is made a C.M.G.

New Commanders of the Order of the British Empire (C.B.E.) include Mr. N. C. Chapling, Managing Director, Cable and Wireless Ltd, and Mr. G. Darnley Smith, Managing Director, Bush Radio Ltd, and Chairman, Radio Industry Council.

Officers of the Order of the British Empire (O.B.E.) include Mr. A. S. Mitson, Assistant Director, Electronics Production, Ministry of Supply.

Mr. R. A. Moir, M.C., Chief Telephone Engineer, Standard Telephones and Cables Ltd.

Mr. M. J. L. Pulling, Senior Superintendent Engineer, Television, BBC.

Mr. W. H. F. Griffiths, Chief Engineer, H. W. Sullivan Ltd.

The Swedish International Press Bureau announce that what is claimed to be the world's quickest operating computing machine has just been put into use in Sweden. The new computing machine will shortly be used by industrial enterprises, insurance companies, scientists and others. A group of meteorologists is at present working out new methods of obtaining quicker and more exact weather forecasts by means of the machine.

The Engineering Standards Coordinating Committee, Ministry of Defence, has recently issued a specification DEF 14 for Radio Frequency Cables. This is a revision of GDES 23 which it replaces. An attempt has been made to standardize sizes and impedances and in so doing some new cables have been introduced and others listed as obsolescent. The specification is obtainable from Her Majesty's Stationery Office, price 7s. 6d.

# Meetings this Month

## THE BRITISH INSTITUTION OF RADIO ENGINEERS

Date: 17 February. Time: 6.30 p.m.  
Held at: The London School of Hygiene and Tropical Medicine, Keppel Street, Gower Street, London, W.C.1.  
Lecture: Electronics in Film Making.  
By: W. D. Kemp and B. R. Greenhead.

### Scottish Section

Date: 4 February. Time: 7 p.m.  
Held at: The Institution of Engineers and Shipbuilders, Glasgow.  
Repeat of London meeting above.

### North-Western Section

Date: 4 February. Time: 7 p.m.  
Held at: Reynold's Hall, College of Technology, Sackville Street, Manchester, 1.  
Lecture: Police Radio, its Past, Present, and Future Possibilities.  
By: I. Auchterlonie.

### North-Eastern Section

Date: 10 February. Time: 6 p.m.  
Held at: Neville Hall, Westgate Road, Newcastle-upon-Tyne.  
Lecture: Some Aspects of Microwave Aerial Design.  
By: J. Bilbrough.

### Merseyside Section

Date: 4 February. Time: 7 p.m.  
Held at: The Electricity Service Centre, Whitechapel, Liverpool, 1.  
Lecture: Microwave Test Gear.  
By: J. Bilbrough.

### West Midlands Section

Date: 23 February. Time: 7.15 p.m.  
Held at: Wolverhampton and Staffordshire Technical College, Wulfruna Street, Wolverhampton.  
Lecture: Applications of Electronic Techniques to the Testing of Magnetic Materials.  
By: J. MacFarlane.

## THE INSTITUTION OF ELECTRICAL ENGINEERS

All London meetings, unless otherwise stated, will be held at the Institution, commencing at 5.30 p.m.

### Ordinary Meeting

Date: 4 February.  
Lecture: The Manchester-Kirk o'Shotts Television Radio Relay System.  
By: G. Dawson, L. L. Hall, K. G. Hodgson, R. A. Meers and J. H. H. Merriman.

### Measurements and Supply Sections

#### (Joint Meetings)

Date: 23 February.  
Lecture: Some Applications of the Electrolytic Tank to Engineering Design Problems.  
By: H. Diggle and E. R. Hartill.  
Date: 8 February.  
Discussion: Will it be Possible to Abolish Meters Entirely?  
Opened by: H. S. Petch and M. Whitehead.

### Radio Section

Date: 10 February.  
Lecture: Basic Ground-Wave Propagation Characteristics in the 50-800Mc/s Band.  
By: J. A. Saxton, followed by Ground-Wave Field Strength Surveys at 100 and 600Mc/s.  
By: J. A. Saxton and B. N. Harden.  
Date: 22 February.  
Discussion: Acceptable Standards of Quality in Sound Broadcast Transmission and Reception.  
Opened by: J. K. Webb.

### Extra Meeting

Date: 11 February.  
Lecture: A Short Modern Review of Fundamental Electromagnetic Theory.  
By: P. Hammond.

### Education Discussion Circle

Date: 15 February.  
Discussion: The Teaching of the Subject of Insulating Materials.  
Opened by: Willis Jackson.

### Faraday Lecture

Date: 16 February. Time: 6 p.m.  
Held at: Central Hall, Westminster, London, S.W.1.  
Lecture: Electro-Heat and Prosperity.  
By: O. W. Humphreys.  
(Admission by ticket obtainable from the Institution.)

## Utilization Section

Date: 18 February.  
Three Lectures: Electronic Motor Control.  
By: A. O. Dalton.

Arc-Quenching Circuits.  
By: B. H. Stonehouse.  
A Survey of the Principles of the Contact Rectifier.  
By: D. R. Smith.

### East Midland Centre

Date: 2 February. Time: 6.30 p.m.  
Held at: The Cambridgeshire Technical College, Cambridge.  
Lecture: Industrial Application of Radioactive Isotopes.  
By: S. Jefferson.

### Cambridge Radio Group

Date: 16 February. Time: 6.30 p.m.  
Held at: The Cambridgeshire Technical College, Cambridge.  
Lecture: The Use of Radio in the Ascent of Everest.  
By: G. C. Band.

### Mersey and North Wales Centre

Date: 1 February. Time: 6.30 p.m.  
Held at: The Town Hall, Chester.  
Lecture: Faster Than Thought.  
By: B. V. Bowden.  
(Joint meeting with the North-Western Centre.)

North-Eastern Radio and Measurements Group  
Date: 1 February. Time: 6.15 p.m.  
Held at: King's College, Newcastle-upon-Tyne.  
Lecture: Telemetering for System Operation.  
By: R. H. Dunn.

Date: 15 February.  
(Time and place as above.)  
Lecture: Technical Arrangements for the Sound and Television Broadcasts of the Coronation Ceremonies on 2 June, 1953.  
By: W. S. Procter and F. Williams.

### North-Western Radio Group

Date: 17 February. Time: 6.30 p.m.  
Held at: The Engineers' Club, Albert Square, Manchester.  
Lecture: The Reproduction of Signals Recorded on Magnetic Tape.  
By: E. D. Daniel and P. E. Axon.

### South Midland Radio Group

Date: 22 February. Time: 6 p.m.  
Held at: The James Watt Memorial Institute, Great Charles Street, Birmingham.  
Lecture: What is an Amplifier?  
By: D. A. Bell.  
(Joint meeting with the Education Discussion Circle.)

### Southern Centre

Date: 3 February. Time: 6.30 p.m.  
Held at: The Municipal College, Portsmouth.  
Lecture: Network Analysers for A.C. Systems.  
By: A. W. Hales.  
(Joint meeting with the Southern Students' Section.)

Date: 18 February. Time: 6.30 p.m.  
Faraday Lecture: Electro-Heat and Prosperity.  
Held at: The Guildhall, Southampton.  
By: O. W. Humphreys.

### Western Centre

Date: 1 February. Time: 6 p.m.  
Held at: The Sophia Gardens Pavilion, Cardiff.  
(Repeat of Faraday Lecture above.)

### Western Utilization Group

Date: 22 February. Time: 7 p.m.  
Held at: Electricity House, Colston Avenue, Bristol.  
Lecture: The Application to Industry of Radio-active Isotopes.  
By: J. L. Putman.

### South-Western Sub-Centre

Date: 11 February. Time: 4.30 p.m.  
Held at: Dowlish Ford Mills, Ilminster, Somerset.  
Lecture: Printed and Potted Electronic Circuits.  
By: G. W. A. Dummer and D. L. Johnston.

## THE INSTITUTION OF POST OFFICE ELECTRICAL ENGINEERS

Date: 9 February. Time: 5 p.m.  
Held at: The Institution of Electrical Engineers, Savoy Place, Victoria Embankment, London, W.C.2.  
Lecture: Step-by-Step Auto-Exchange Maintenance in the U.S.A.  
By: E. Hopkinson.  
Date: 24 February. Time: 5 p.m.  
Held at: The Conference Room, 4th Floor,

Waterloo Bridge House, London, S.E.1.  
Lecture: Post-War Developments in Call-Office Equipment.  
By: R. T. A. Dennison.

## THE RADAR ASSOCIATION

Date: 10 February. Time: 7.30 p.m.  
Held at: The Anatomy Theatre, University College, Gower Street, London, W.1.  
Lecture: Some Unsolved Radar Problems.  
By: K. E. Harris.

## RADIO SOCIETY OF GREAT BRITAIN

Date: 26 February. Time: 6.30 p.m.  
Held at: The Institution of Electrical Engineers, Savoy Place, London, W.C.2.  
Lecture: Practical Aspects of Tape Recording.  
By: S. A. Lacey.

## THE SOCIETY OF INSTRUMENT TECHNOLOGY

Date: 23 February. Time: 7 p.m.  
Held at: Manson House, Portland Place, London, W.1.  
Lecture: The Development of an Automatic Tare and Net Weighing and Filling Unit with Remote Indication and Recording.  
By: A. Kennaway and R. A. Lolley.

## THE TELEVISION SOCIETY

Date: 12 and 15 February. Time: 7 p.m.  
Held at: The Royal Institution, Albemarle Street, London, W.1.  
The Fleming Memorial Lectures on Colour Television.  
By: G. G. Gouriet. (Admission by ticket only.)

### Leicester Centre

Date: 28 February. Time: 7 p.m.  
Held at: The College of Art and Technology, The Newarke, Leicester.  
Lecture: Modified Murphy Receiver using 24in G.E. Tube.  
By: H. Fairhurst.

## PUBLICATIONS RECEIVED

PROCEEDINGS OF THE WESTERN COMPUTER CONFERENCE contains the full text of all papers and panel discussions presented at the 1953 Conference in Los Angeles under the joint sponsorship of the American Institutes of Radio Engineering and Electrical Engineers, and the Association for Computing Machinery. The technical papers are concerned with the application of computers to business data handling, to aircraft design, and with recent developments in analogue and digital computing equipment. The Institute of Radio Engineers, 1 East 79 Street, New York 21, N.Y., U.S.A. Price \$3.50.

F.B.I. REGISTER OF BRITISH MANUFACTURERS 1954 is the 26th Edition of this standard export reference book to British industry. It is the only authorized directory of the Federation of British Industries and is compiled by Iliffe & Sons Ltd. in close collaboration with the Federation. Iliffe & Sons Ltd., Dorset House, Stamford Street, London, S.E.1. Price 42s.

MEASUREMENTS OF ATMOSPHERIC NOISE AT HIGH FREQUENCIES is a radio research report prepared by the Department of Scientific and Industrial Research and is based upon measurements made during the years 1945-51. The report discusses the accuracy of measurement of noise, the effect of receiver noise on the measurements and the way in which results are interpreted and analysed. A comparison is made between measured and predicted noise levels by night and by day and the report suggests further lines of investigation which might be expected to provide useful information in the future. Her Majesty's Stationery Office, Kingsway, London, W.C.2. Price 1s. 9d.

FUEL CONSERVATION is a report of a visit to the U.S.A. in 1952 of a specialist team, on the Conservation of Fuel, Heat and Energy under the auspices of the Anglo-American Council on Productivity and the Mutual Security Agency, now Foreign Operations Administration. The visit was arranged with a view to improving the efficiency of fuel utilization in British industry, and to indicate ways and means by which a national fuel policy might be developed. British Productivity Council, 21, Tothill Street, London, S.W.1. Price 5s.



*What goes on here?*

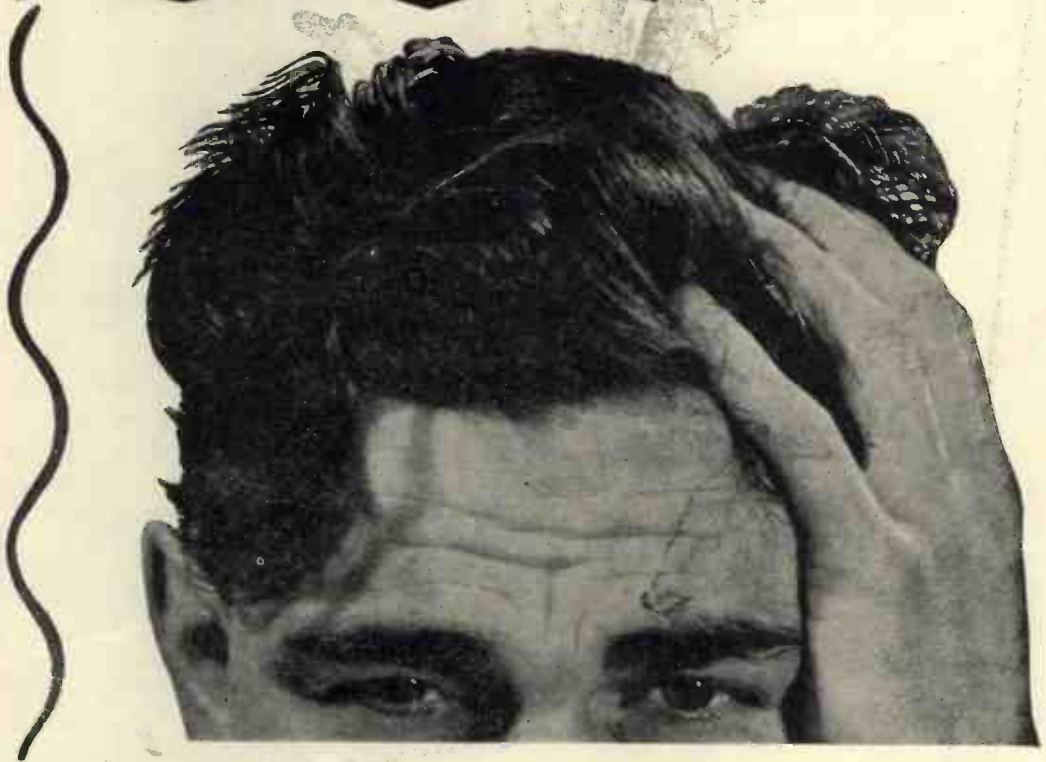

The success of an instrument, even of a whole project, frequently depends on the availability of the right material for a particular purpose. Electrodeposited rhodium is a versatile servant to instrument and electronic engineering, its unique properties often providing the solution to an otherwise insurmountable technical problem.

One of the Specialised Services of

**Johnson**   
**Matthey**

Data Sheet 2053, free on request, details the properties of rhodium and makes many suggestions for its application to instrument practice.

## ELECTRODEPOSITED RHODIUM

Low and stable contact resistance  
Great hardness and resistance to wear  
Complete resistance to corrosion  
High and constant reflectivity

JOHNSON, MATTHEY & CO., LIMITED, HATTON GARDEN, LONDON, E.C.1  
Telephone: HOLborn 6989 Vittoria Street, Birmingham, 1. Tel.: Central 8004. 75-79 Eyre Street, Sheffield 1. Tel.: 29212

E.3

# 1 kW Channelised Transmitter

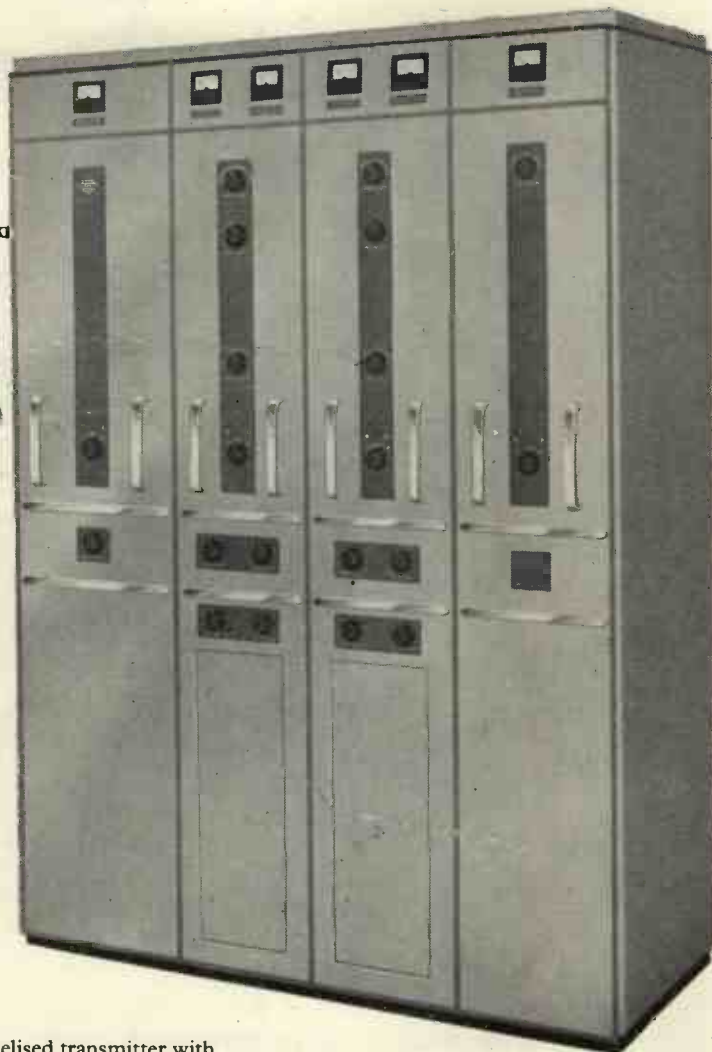

THE GFT.560 is a 1kW channelised transmitter with a frequency range of 1.5—30 Mc/s.\* It consists of three basic cabinets—r.f. unit, modulator unit, and power supply unit—combinations of which can be used to provide multi-frequency working as well as a number of different types of emission. The wave change facilities of the transmitter are both rapid and reliable—a valuable asset when the operating frequency is changed many times each day.

The GFT.560 is fully tropicalised, and its unit construction facilitates future expansion of the initial installation, should the need arise.

For use in conjunction with the GFT.560 there are ancillary units that enable the transmitter to be remotely controlled over a two wire telephone circuit: operational adjustments are dialled to the transmitter.

The versatility and reliability of this new Mullard transmitter make it particularly suitable for h.f. en-route, ground-to-air services and point-to-point communication networks. A team of Mullard communication engineers is available to advise on the use of the GFT.560 in such applications. They will also assist in planning complete communication systems, if required.

#### ABRIDGED DATA

Frequency Range 1.5—30 Mc/s  
 Frequency Stability To Atlantic City, 1947, standards  
 Power Output 1 kW  
 Types of Emission c.w., m.c.w., telephony, frequency shift, single and independent sideband. (A1, A2, A3, F1, A3a and A3b)  
 Output Impedance 600 ohms balanced twin feeder  
 Power Supply 400V, 50-60 c/s, 3-phase

# Mullard



**SPECIALISED ELECTRONIC EQUIPMENT**

MULLARD LTD · EQUIPMENT DIVISION · CENTURY HOUSE · SHAFESBURY AVENUE · WC2  
 (M1434)

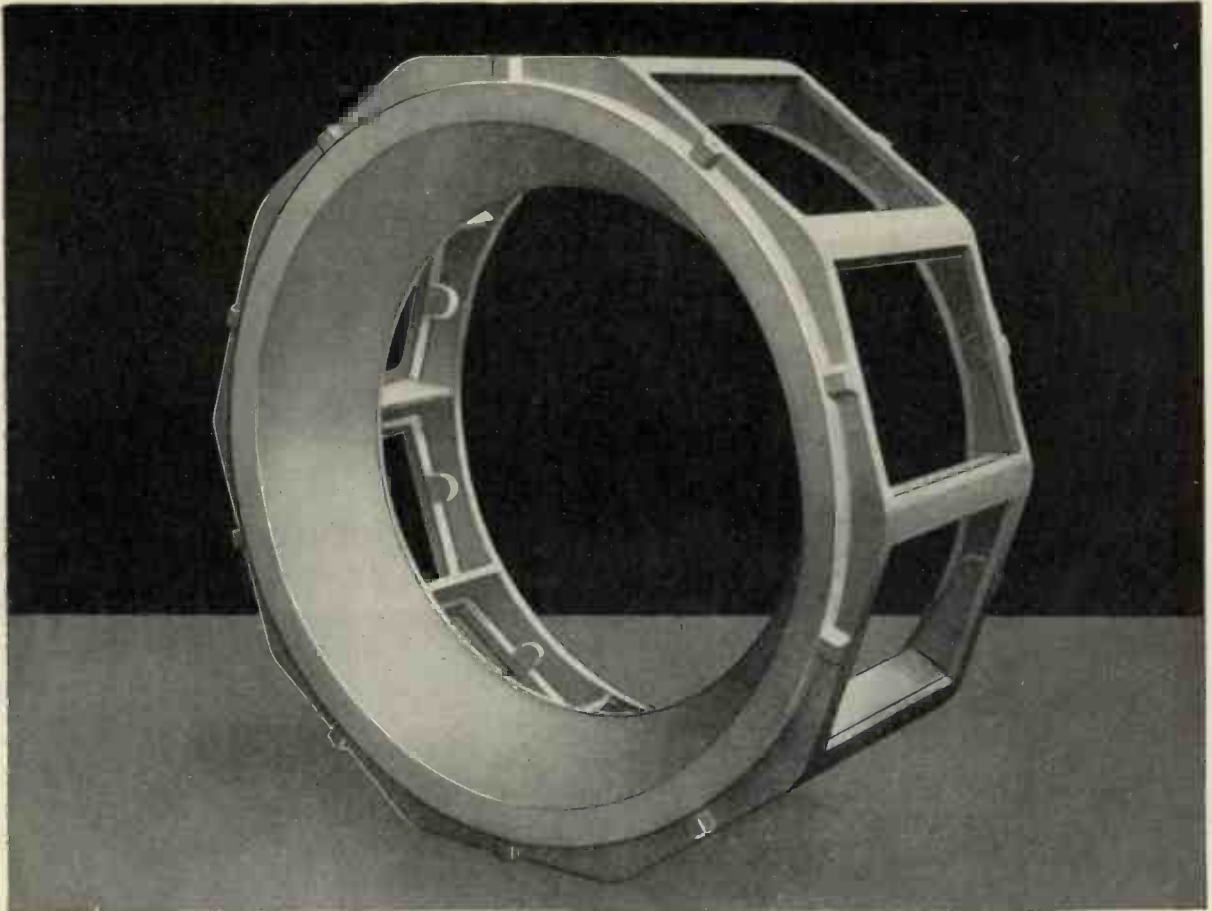

Aluminium Alloy 3L33  
Sand Casting  
Weight 435 lb.

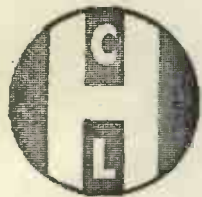

# C.&L. HILL LTD

*Manufacturers of*

Non-Ferrous Sand Castings, Brass, Naval Brass, Brazing Metal, Gunmetal, Phosphor Bronze, Aluminium Bronze, High Tensile Manganese Bronze, High Conductivity Copper, "Hilchil" Chill Cast Phosphor Bronze Bars, Cored and Solid. Sand Castings in all Aluminium Alloys, including Heat-treated Alloys, Aluminium Alloy Gravity Die Castings.

*Wood and Metal Pattern Shop. Fully Approved Laboratory and Test House with Inspection Organization. Facilities for Radiology.*

*Specialists in Development and Quantity Production of Castings for Radar.*

Design your Castings for  
**SHELL MOULDINGS**  
and Save Machine Shop Costs

**Stringes Lane, Willenhall, S. Staffs.**

Tel: Willenhall 227 (4 lines) Grams: Hill 227 Willenhall

Branch Works: Wednesfield Road, Willenhall

*Both our Foundries are available for Prototype Work*



WhiteAd.2738B

# 'ENGLISH ELECTRIC'

## 'C' type Cores



***for use in Transformers and Chokes  
to RGS. 214***

Details of these 'C' type Cores will be supplied on request to  
Transformer Sales and Contracts Department, East Lancashire Road,  
Liverpool 10.

THE ENGLISH ELECTRIC COMPANY, LIMITED, QUEENS HOUSE, KINGSWAY, LONDON, W.C.2  
WORKS: STAFFORD · PRESTON · RUGBY · BRADFORD · LIVERPOOL · ACCRINGTON

TL 5

# Electronic Instrument Cabinets, Racks and Cases

Your delicate and expensive Electronic Equipment deserves worthy housing. H.H. Cabinets and Racks add, to unique design and precision craftsmanship, the crowning merit of superb finish. Specialists in the production of precision sheet metal work, for many years, we are admirably equipped to provide cabinets to your own specification, at prices which, while allowing for a high standard of craftsmanship throughout, are extremely reasonable.

Our Design and Development staff is always at your disposal. May we serve you ?



We also manufacture precision components to users' designs : All types of Valve Screens, Coil Cans, Chassis, Panels, Condenser Mountings, Valve Mountings, Loud Speaker Chassis, and pressings and sub-assemblies in any metal.



## H.H. 120

Overall Height 49 $\frac{1}{2}$ "  
 " Width 27"  
 Depth at Base 31"  
 " at Top 23 $\frac{1}{2}$ "  
 " of Table 12"

# Hassett & Harper Ltd

REGENT PLACE · BIRMINGHAM · I

Tel : CENtral 6418 (4 lines)

LONDON : 140 PARK LANE · W · I

Tel : MAYfair 9651 (3 lines)

CONTRACTORS TO GOVERNMENT DEPARTMENTS

# **HIGH INPUT IMPEDANCE**

*coupled with rapid response*

THE **EVERSHED**

# **QUICK RESPONSE RECORDER**

*The Evershed Duplex Quick-Response Recorder  
Type QU/RD15 and Amplifier Type PA 10 M/A.*



The Evershed Quick Response Recorder is servo operated, and works in conjunction with an electronic amplifier. Recorder input is opposed by the feed back voltage from a resetting potentiometer controlled by position of the pen. The error (the voltage difference) drives the pen movement until the feed back voltage balances the input. Maximum sensitivity, with centre zero, plus/minus 4 volts full scale deflection.

The instrument will record sine wave voltages up to 15 cycles per second with amplitude error not exceeding 15% at a peak to peak amplitude at 1½ inches. At smaller amplitudes the frequency response will be higher.

Full details are given in Publication E.E. PL. 33

# **EVERSHED**

**EVERSHED AND VIGNOLES LIMITED**

ACTON LANE WORKS · CHISWICK · LONDON · W.4

Telephone: Chiswick 3670 · Telegrams: Megger, Chisk, London · Cables: Megger, London  
6/120

**YOU ASKED FOR IT -**

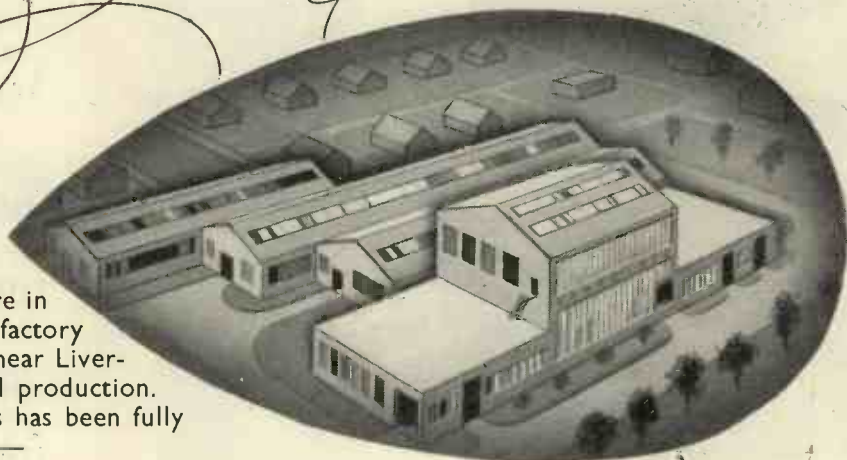

Connollys have much pleasure in announcing that their new factory on a 15 acre site at Kirkby, near Liverpool, is now coming into full production. Their range of winding wires has been fully extended and now includes :—

- Enamelled round wires. (Oil-base to B.S.S. 156)
- “Conymel” round wires. (Vinyl Acetal to B.S.S. 1844)
- “Conycote” round wires. (Intermediate type enamel)
- “Conybond” round wires. (Self-bonding Conymel)
- “Co-nambond” round wires. (Self-bonding oil-base enamel)
- “Conglass” round wires and strips
- Cotton covered round wires and strips
- Paper covered round wires and strips
- Silk covered round wires
- Rayon covered round wires
- “Conylitz” and other types high frequency strands
- Enamelled and Single fine paper covered round wires

*The largest manufacturers of fine enamelled wires in the world.*

## **CONNOLLYS** WINDING WIRES

**CONNOLLYS (BLACKLEY) LIMITED**

Kirkby Trading Estate, Near Liverpool

Telephone: SIMonswood 2664.

Telegrams: “SYLLONOC, LIVERPOOL.”

**Branch Sales Offices:**

**SOUTHERN:**  
34, Norfolk Street, Strand, London, W.C.2  
TEMPle Bar 5506

**MIDLANDS:**  
15/17, Spiceal Street, Birmingham  
MIDland 2268

**NORTHERN:**  
Blackley, Manchester, 9  
CHEetham Hill 1801



# Standard crystals

giving 140 radio channels

keep

## COMET

communications

"spot on"

frequency

**I**N the de Havilland Comet, as well as in most of Britain's other leading aircraft, **STC** Quartz Crystals maintain the highest standards of accuracy under conditions where accuracy is vital.

Available with accuracies better than 50 cycles in one megacycle; artificially aged, gold plated and wire mounted **STC** crystals greatly reduce drift under working conditions. Moreover, they will maintain this high degree of accuracy under severe vibration and sharply changing climatic conditions.



Standard  
quartz  
crystals

for frequency measurement and control



*Standard Telephones and Cables Limited*

Registered Office: Connaught House, Aldwych, London, W.C.2.

TELEPHONE LINE DIVISION

HARLOW INDUSTRIAL ESTATE (EAST), HARLOW, ESSEX  
HARLOW 2012/3/4



# 'UNITORS'

A range of miniaturised connectors  
by "Belling-Lee"

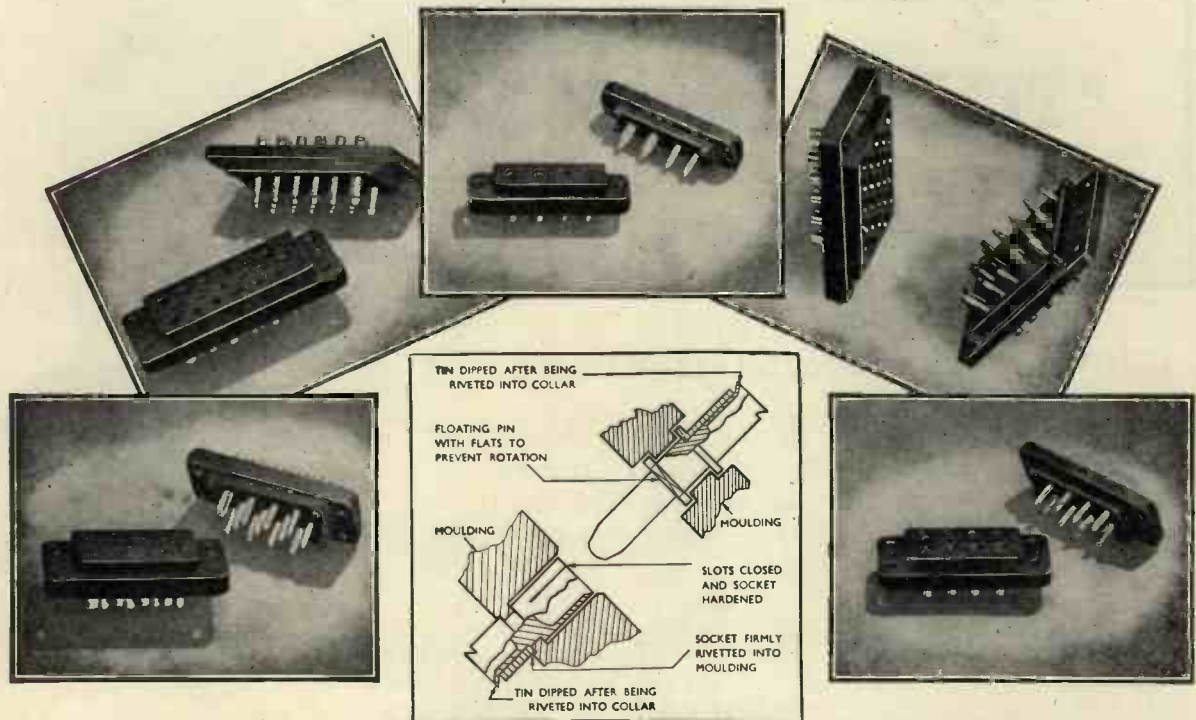

## 4 to 25-WAY FROM STOCK

"Unitors" are the links in the chain of electronic events. Any weakness means failure, and perhaps disaster. "Belling-Lee Unitors" are approved by A.I.D. and A.R.B., and have Joint Service Approval.

In recent independent tests, five pairs of 12-way "Unitors" made 16,335 insertions and withdrawals and were still serviceable.

The test apparatus was rigged in such a way that the plug portion was offered up to the socket with the pins at the maximum limit of float, and for individual pins to approach the relevant socket at various angles.

A coupling comprises a block of plugs and a second block of sockets, arranged so as to be non-reversible. Round pins are employed, turned from high grade brass, silver plated. The normal pins carry 3 amp., but each block has two large pins or sockets to carry 10 amp. All pins are fully floating, and the method of assembly is the subject of a patent.

Resilient sockets are of differentially hardened beryllium copper. All contacts, plugs and sockets are numbered on the face and reverse sides of the body. The distance between flanges when plugged together is 0.281 in.

U.K. PAT.  
649,739.

SWISS PAT.  
277,799.

*A cable cover for line connection is available, together with retainer for chassis mounting.*

LIST NO.	PINS
L.653/P&S.	4
L.654/P&S.	8
L.655/P&S.	12
L.656/P&S.	18
L.657/P&S.	25

# BELLING & LEE LTD

GREAT CAMBRIDGE ROAD, ENFIELD, MIDDX., ENGLAND

# Multi-channel tuning!

## Cyldon

### "TELETUNER"

(TRADE MARK)

#### Type TV.12

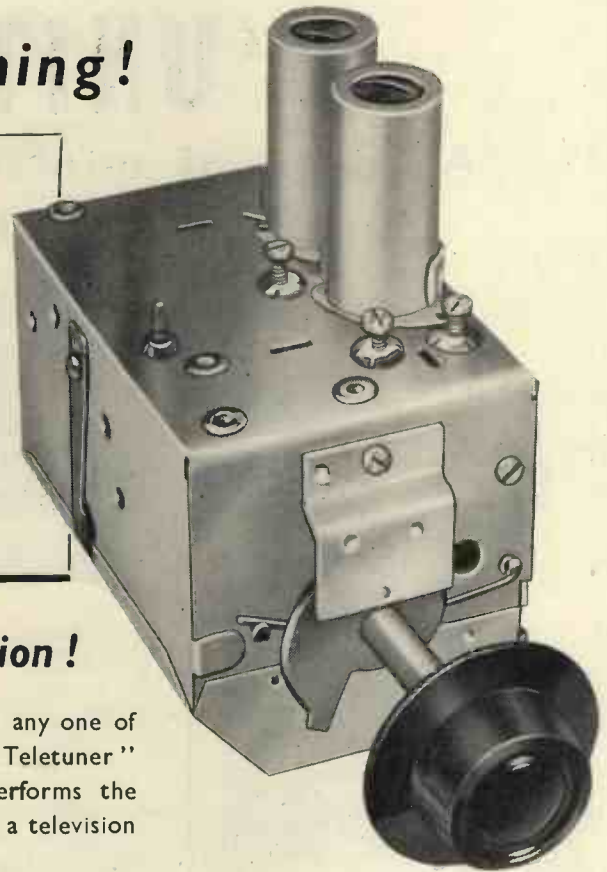

### Instant, single-knob selection!

Select a frequency in the 50-220 Mc/s range—select any one of twelve in fact—and this new Cyldon Multi-channel "Teletuner" will handle it. This compact two valve unit performs the functions of R.F. amplifier and frequency changer in a television receiver. **Write for Folder TV 1953.**

The Makers of "Cyldon," Trimmers and Variable Capacitors

ARE PLEASED TO ANNOUNCE

## FOUR NEW TRIMMERS!



No. 26. Mica Compression Trimmer.

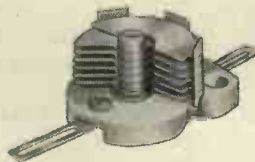

No. 28. Air Spaced Trimmer.



No. 29. Glass Trimmer.



No. 30. Ceramic Trimmer.

Full details and specifications available on application

R.E.C.M.F.  
EXHIBITION

April 6-8

See us on Stand No.

**53**

**SYDNEY S. BIRD  
& SONS, LTD.**

*Contractors to Ministry of Supply, Post  
Office, and other H.M. Government Depts.*

CAMBRIDGE ARTERIAL RD., ENFIELD, MIDDX.

Telephone: Enfield 2071-2.  
Telegrams: "Capacity, Enfield."

# ALL-POWER

## REGULATED POWER SUPPLIES

### SERIES 500

4 NEW MODELS

**RATED FOR 350mA OUTPUT**

The four models detailed below are similar to the existing 500 series units and have the same overall physical dimensions.

AVAILABLE FOR PROMPT DELIVERY



Model 501  
(fitted with end frames)

### ABRIDGED DATA

(Further information on request)

Data		Model 506	Model 507	Model 508	Model 509
Main +VE Stabilizer	Output	200-500V 350mA	200-500V 350mA	0-500V 350mA	0-500V 350mA
	Number of Rangés	2	2	4	4
	Voltage Stabilization	±0.02%	±0.002%	±0.1%	±0.002%
	Effective Output Resistance (max.)	0.2 Ω	0.02 Ω	0.5 Ω	0.02 Ω
	Output Ripple (rms. max.)	2mV	1mV	3mV	1mV
-VE Supply Stabilizer	Outputs	—	—	250V 25mA 0-250V 1mA	250V 25mA 0-250V 1mA
	Voltage Stabilization	—	—	±0.05%	±0.002%
	Output Resistance (max.)	—	—	1 Ω	0.01 Ω
	Output Ripple (rms. max.)	—	—	2mV	1mV
Unstabilized +VE H.T. Supply 350mA max.		470V 630V	470V 630V	320V 470V 630V	320V 470V 630V
Unstabilized A.C. Supply		6.3V 10A	6.3V 10A	6.3V 10A	6.3V 10A
Price		£77	£98	£88	£106

**STANDARD UNITS.** All models are supplied as standard for mounting in 19 in. racks and are fitted with fully protective covers.

**EXTRAS.** To convert from rack mounting to bench use the following extras are available :—

Polished hard-wood reinforced end frames ... .. £1 15 0 per pair  
Steel instrument case of new design ... .. £4 10 0 each

**PRICES.** Prices are quoted net ex works and are subject to variation without notice.

**ALL-POWER TRANSFORMERS LTD.** . . . . . **CHERTSEY ROAD, BYFLEET, SURREY**  
Tel. : BYFLEET 3224/5

AIRMEC

# STABILISED POWER SUPPLIES

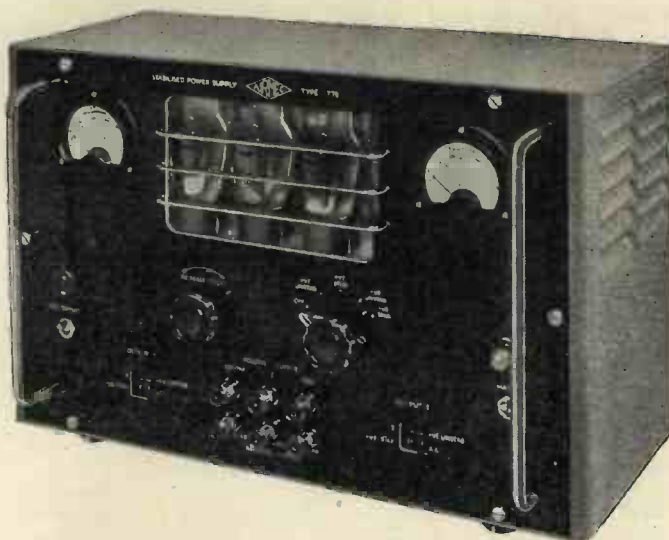

## Type 705

THIS unit provides a stabilised direct voltage, continuously variable from 200-350 volts, which may be used with either the positive or negative lines earthed, or with the output floating. An unstabilised alternating supply of 6.3 volts, the centre tap of which may be strapped to earth, is also available.

- Stabilised output continuously variable from 200-350 volts at maximum currents of 200-100 mA.
- Output change is less than  $\pm 0.5\%$  for  $\pm 10\%$  input change.
- Output change from full load to no load is  $+0, -0.5\%$ .
- Source impedance of 5 ohms.
- Both voltage and current meters incorporated.
- Suitable for operation on 100-130 and 200-250 volts 50 c/s mains.

## Type 776

POSITIVE and negative stabilised direct voltages, positive and negative unstabilised direct voltages, and an unstabilised supply of 6.3 volts are all provided by this Unit. Both voltage and current meters are included, and a meter switch enables any of the four direct outputs to be monitored.

- Stabilised positive output continuously variable from 200-350 volts at maximum currents of 200-100 mA.
- Positive output change is less than  $\pm 0.5\%$  for  $\pm 10\%$ .
- Stabilised negative output of 85 volts at 5 mA.
- Unstabilised positive output of 500 volts at 200 mA.
- Unstabilised negative output of 500 volts at 3 mA.
- Suitable for operation on 100-130 and 200-250 volts 50 c/s mains.

*Full details of these instruments, which are available for immediate delivery, will be forwarded gladly upon request.*

**AIRMEC LIMITED**

HIGH WYCOMBE, BUCKINGHAMSHIRE, ENGLAND.

Telephone: High Wycombe 2060.

Cables: Airmec, High Wycombe.

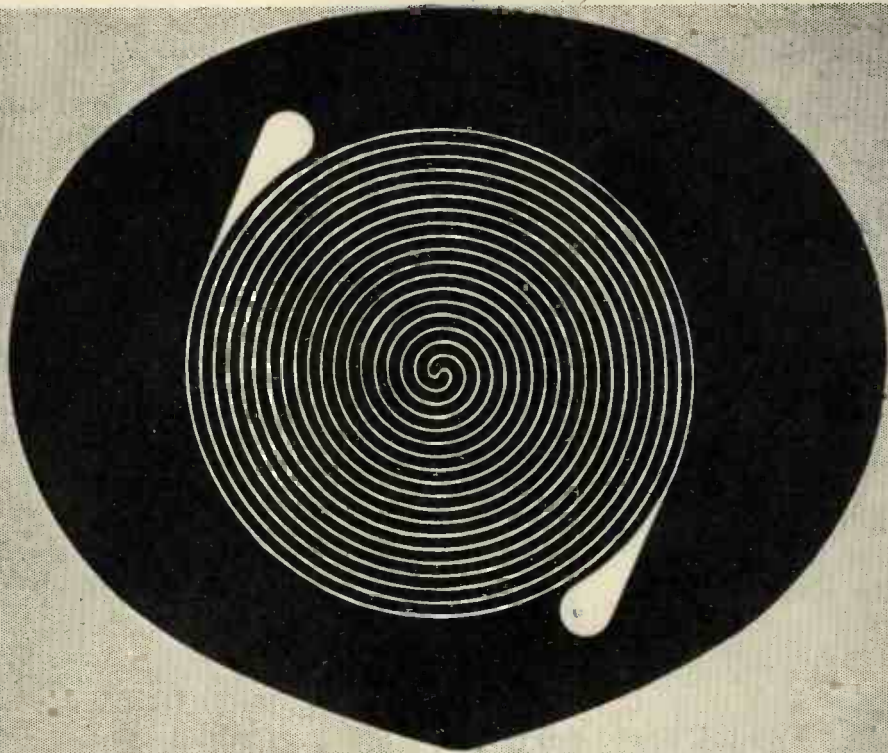

## The Saunders-Roe/Technograph Diaphragm Gauge

*British and foreign patents pending*

An elegant device for the solution of many problems of pneumatic or hydraulic pressure measurement. This strain gauge, of double spiral pattern, is applied to a diaphragm subjected to the pressure under investigation, and an electrical output/pressure calibration curve is taken. By integrating the circumferential strains over the diaphragm area, the double spiral pattern makes the most efficient use of gauge material and strain response of the diaphragm. The double spiral pattern does not sacrifice any of the advantages of the normal foil strain gauge.

*Available for immediate delivery*  
Effective gauge diameters:  $\frac{3}{8}$ " and 1". Material: Cu/Ni foil, Araldite lacquer backing.  
Resistance: 110 ohms central. Supplied in matched pairs to 0.5% resistance values.

# SAUNDERS-ROE LTD.

(ELECTRONICS DIVISION) OSBORNE · EAST COWES · ISLE OF WIGHT



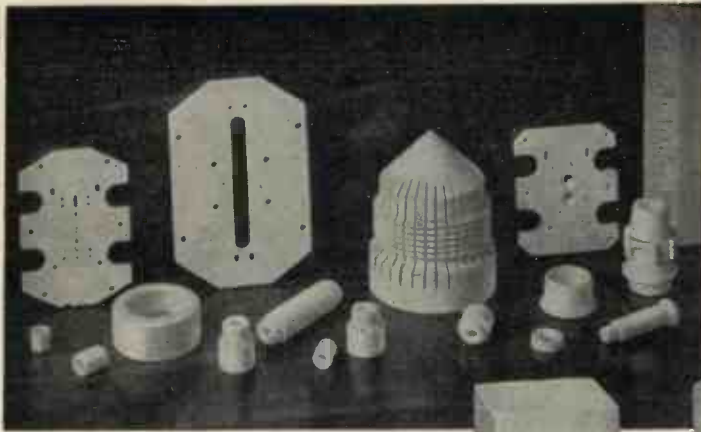

## STEATITE

... for all high  
frequency applications

Over a century of ex-  
perience in this highly  
specialised field.  
We invite your enquiries.



Machined to special designs and fine limits.



**WILLIAM SUGG & COMPANY LIMITED**  
RANELAGH WORKS, CHAPTER STREET, WESTMINSTER, S.W.1. VICTORIA 3211

# FAST NEUTRON

## monitor

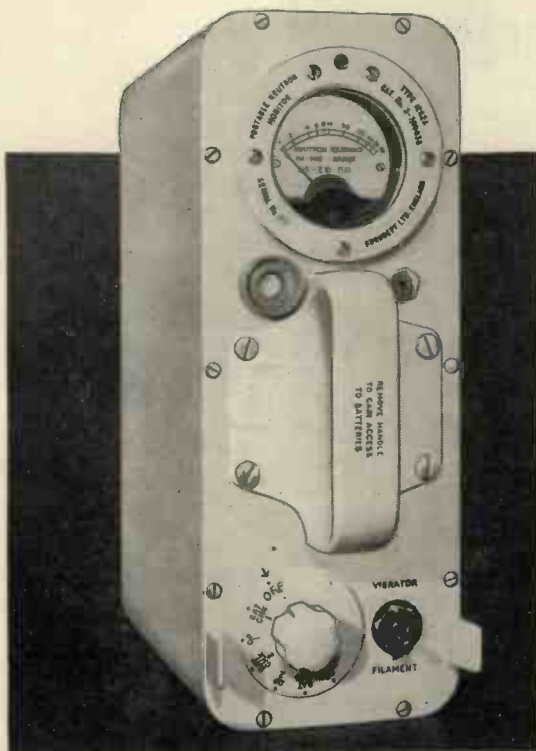

A completely self-contained and portable instrument  
for the measurement of Fast Neutrons of energies  
0.5. to 2MeV.

Scale . . . Logarithmic, calibrated 0-100 tolerances  
Simple operation . . . only 2 controls  
Special feature . . . Battery pack can be removed  
and replaced by mains-operated unit  
Instrument fully sealed and suitable for use in all  
climates.

**A NEW HEALTH INSTRUMENT**

by **BURNDIPT**  
of **ENGLAND**

Other Instruments available  
Scintillation Probe Units · Portable Beta Gamma  
Radiation Monitors · Rate Meters · Pulse Amplifiers

Nucleonics Division  
BURNDIPT LIMITED · ERITH · KENT · ENGLAND

# PRESSINGS & FABRICATIONS



The items illustrated show only a few of the electrical components manufactured by us for the electrical trade in our self-contained factory. We manufacture our own Press Tools; Fabrications, Spinings, Assemblies, and are able to undertake all kinds of metal finishes.

IMPELLERS • LAMINATIONS • METER COVERS

## ADAMS BROS. & BURNLEY LTD.

Elmgrove Road • Harrow • Middlesex  
Telephone : Harrow 6411 (5 lines)

*Economically  
produced with  
Multi-tool set up*

INSTRUMENT PANELS

MOTOR HOUSINGS

MICROPHONE COMPONENTS

ALWAYS "FIT"



## CASTORS

THE WORLD'S BEST

Loads up to **30 TONS** per castor. Wheel diameters from 2" to 44". All types of wheels and head fittings can be selected from our range of over

**7,000 TYPES & SIZES**

ASK FOR BROCHURE



*This may be news to you but it is not to thousands of satisfied customers!*

Engineers, Patentees and Sole Manufacturers,

**AUTOSET (PRODUCTION) LTD., Dept. O, Stour St., B'ham 18**

EST. OVER 30 YEARS.

EDG 1143/4

Please mention "Electronic Engineering"

AT 2

for

# SELENIUM RECTIFIERS

consult



WHETHER the need is for a single unit or a supply running into thousands . . . if it's a Selenium Rectifier that must fulfil critical requirements and maintain its characteristics over long periods . . . the answer is to be found with Electrix.

● Electrix Rectifiers are characterised by their cool running and consistent long-life conformity to stated specification.

● Manufacturers, Traders and Electronic Engineers, send us your specific requirements.

● Your needs may possibly be met from "standard" types, or

● "To specification" models can be quickly prepared.

● Quotations by return . . . and deliveries a matter of days only.

● We welcome export enquiries.

Here are some typical "standard" full-wave types

	each
Output 12/15 Volts D.C. 1 Ampere.	List Price 9/-
Output 12/15 Volts D.C. 2.5 Ampere.	13/6
Output 12/15 Volts D.C. 4 Ampere.	22/6
Output 12/15 Volts D.C. 6 Ampere.	35/-

Trade Supplied

● Heavy duty rectifiers with say 230/250 volts A.C. input and 220 volts D.C. output a speciality.

● We use only freshly manufactured selenium plates and components, no ex-W.D. materials whatsoever.

## HOUSEHOLD ELECTRIX LTD

47-49 HIGH ST., KINGSTON-ON-THAMES

Telephone : KINGston 4585



## Seating Through the Ages

The ducking stool was an effective if lusty deterrent to the nagging wife, but by no stretch of the imagination could it be termed comfortable. Most people prefer a seat designed for sitting upon — a seat which is comfortable because it has been anatomically designed — in fact, an Evertaut Seat.



The Evertaut range is wide enough to provide the correct seating for practically all workers irrespective of their job. When it comes to seating don't 'duck' the problem — ask Evertaut.

Please write for Catalogue S/L.



(Proprietors) J. B. Brooks & Co., Ltd.

WALSALL ROAD, PERRY BARR, BIRMINGHAM, 22B.

Phone : BIRchfields 4587 (4 lines)

Grams : Evertaut, Birmingham.

London Office Kern House, Kingsway, W.C.2.

Phone : HOL. 0238



## APPOINTMENTS

### IN AC AND DC LABORATORY AND ELECTRONICS LABORATORY

If you have outstanding ability and would like to share in the unique part this company is playing in aviation progress, our Personnel Department will be pleased to know of your qualifications. Immediate Vacancies are limited, but others occur from time to time due to continued expansion. Only men of high calibre, experience and technical attainment will meet the requirements.

#### DEVELOPMENT ENGINEERS

Minimum requirements are higher national certificate, but an engineering degree is preferred.

#### ELECTRONICS ENGINEERS

Should have experience in electronic servo systems and, preferably, experience of magnetic amplifiers.

*Write, as fully as possible, to The Technical Director, Group D, Rotax Ltd., Willesden Junction, London.*

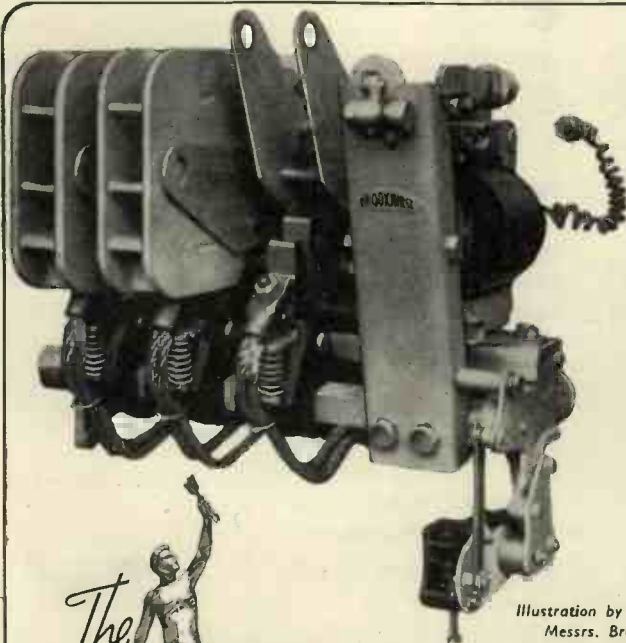

# When Designing

#### SWITCH and CONTROL GEAR

Two essentials are looked for in the contacts to be used. Firstly, the material specification, and secondly, the precise workmanship of the contact unit itself. "Thessco" and "Thessconite" contacts meet all requirements in the electrical field.

Contacts literature supplied on request.

Illustration by courtesy of  
Messrs. Brookhirst Switchgear Ltd.



## **SHEFFIELD SMELTING Company Limited**

**SHEFFIELD** · **LONDON** · **BIRMINGHAM**  
ROYDS MILL STREET, SHEFFIELD, 4. Phone: 26511  
1, BERRY ST., CLERKENWELL, LONDON, E.C.1. Phone: CLE 3156  
ST. PAUL'S SQUARE, BIRMINGHAM, 3. Phone: Central 6893

# THE NEW



## RADIO BATTERY B136



for  
cheaper  
radio listening



Plastic Plug Socket

### BATTERY PLUG

The new Ever Ready plastic 4 pin battery plug has been specially designed to ensure correct and easy battery connections. Plugs are fitted with four staggered metal pins, also four coloured wires 18" in length. List Price 2/- complete. Suitable for use with BSS. 1766-1951.

This new Ever Ready Battery, combining a 90 volt high tension unit and a 1.5v low tension section, has been designed for use with the latest Ever Ready low consumption valves, type DK96, DF96, DAF96 and DL96, which use only half the filament current (25mA) of the older series valves (50mA).

A balanced service life of 300 hours is obtained when the high tension current is 10.5 mA at 90 volts and the low tension current 125 mA at 1.4 volts; the respective cut-off voltages being 40v and 1.0v on load.

The maximum battery dimensions are  $7\frac{1}{2}'' \times 3\frac{3}{8}'' \times 4''$  and the weight is 5 lbs. 10 oz. Price 16/-.



**EVER READY DRY BATTERIES FOR RADIOS  
TORCHES · HEARING AIDS · CYCLE LAMPS**

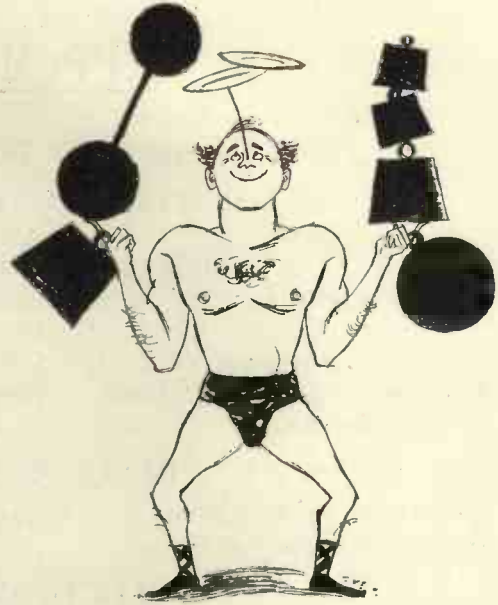

## WITH THE GREATEST OF EASE

Electrothermal Rubber Sheeting speeds up setting of adhesives, bonding, lamination

**E**LECTROTHERMAL RUBBER SHEETING is causing a revolution wherever quick setting of adhesives is called for. Safe, durable, completely flexible, **Electrothermal Rubber Sheeting (E.R.S.)** can be applied to practically any shape. E.R.S. is available insulated with Natural Rubber, P.V.C. Neoprene, Silicone Rubber, etc., and can supply controlled heat up to 350°C. The furniture industry, for instance, is using E.R.S. to eliminate gluing bottlenecks. It can be used to speed up setting of shapes, doors, cabinets, veneers, laminations . . . adhesives in aircraft construction and ship building. E.R.S. also functions efficiently for flat pad and strip-panel heating. Available in widths up to 6 feet, and in any length you specify. If you have any localised heating problem, whatever the nature, write or phone now to **Electrothermal Engineering Limited, 270 Neville Road, London, E.7.** (GRAnge wood 0055) for literature and prompt advice.

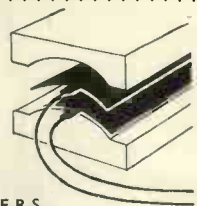

E.R.S. Supplying Heat to a Jig.

(Electrothermal products are covered by British and Foreign patents).

**ELECTROTHERMAL Turns on the Heat for Science & Industry**

Illustration shows :  
Master Power Unit,  
Master Energising Unit,  
Indicator with 3" meter.

## announcing the 'PENDEFORD' series.....



A compact, versatile system of Instrumentation for the measurement of force, load, displacement, thickness, pressure and weight—readily adaptable to your requirements from one to six channels with the utmost economy. A system of vital interest to users and makers of machine tools. A complementary range of transducers and load cells is available.

Write today for further particulars.

Manufacturers of Six Channel C.R.T. Film Recorders, Transducers, Strain and Load Indicators, Load Cells, Integrators and Timers, Precision Automatic Manometers, Stabilised Power Supplies, etc.



## BOULTON PAUL ELECTRONICS

BOULTON PAUL AIRCRAFT LTD.  
WOLVERHAMPTON

### INCREMENTAL ACCURACY *Within 1% up to 70 Mc/s* BACKED BY N.P.L. CERTIFICATE

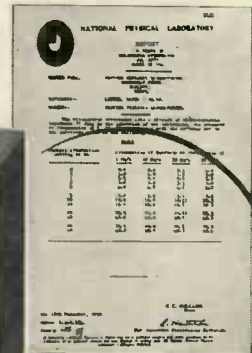

#### MODEL RA104 WIDE FREQUENCY RANGE ATTENUATOR

It is the only unit of its type, independent of frequencies up to 70 Mc/s designed to operate between 75 ohms resistive loads.

#### THE ONLY COMMERCIALY AVAILABLE INSTRUMENT

over the range 1-104 db in steps of 1 db. A National Physical Laboratory Certificate quotes the adjoining figures.

Please write for full details,

(EXTRACT)

Table

Nominal attenuation setting in db.	Attenuation in decibels at frequencies of			
	1 Mc/s	10 Mc/s	30 Mc/s	50 Mc/s
0	0.0	0.0	0.1	0.2
1	1.0	1.0	1.1	1.2
2	2.0	2.0	2.1	2.2
3	3.0	3.0	2.1	3.2
4	4.0	4.0	4.1	4.2
5	5.0	5.0	5.1	5.2
10	10.0	10.0	10.15	10.3
15	15.0	15.0	15.2	15.3
20	20.0	20.0	20.15	20.3
40	40.0	40.0	40.2	40.3
20	20.0	20.0	20.1	20.3
40	40.0	40.0	40.3	40.4

## BRITISH PHYSICAL LABORATORIES LTD

Tel: Radlett 5674-5-6



Radlett HERTS

dmBP11

## DE HAVILLAND PROPELLERS LTD.

require

### SENIOR DRAUGHTSMEN

- 10A mechanical—for servo mechanism and high-speed turbine design.
- 10B for installation of aircraft auxiliary apparatus.
- 10C for modification design work.
- 10F Jig and Tool.

### INTERMEDIATE AND JUNIOR DRAUGHTSMEN

- 10D mechanical and electrical design—O.N.C. standard.
- 10F Jig and Tool.

### ELECTRICAL ENGINEERS

- 40 both Senior and Junior—for work on light electro-mechanical devices.

### CALCULATORS (MALE AND FEMALE)

- 11 for weights section Stress Office. H.N.C. or equivalent qualification.

### TECHNICAL SPECIFICATION WRITERS

Senior—good experienced needed.  
Junior—aeronautical background.

### 12 TECHNICAL EDITOR

experience essential.

### 12A TECHNICAL ILLUSTRATOR

with ability to visualise and draw mechanical assemblies; preferably experienced in perspective line drawing.

### 12 ELECTRONIC ENGINEER

for ultimate position as Technical Editor in charge of section responsible for producing instructional literature.

### 19 INSTALLATION ENGINEER

for development work—interested in thermodynamics, test observing and preferably with some experience in air conditioning.

### 53 METALLOGRAPHER

for routine examination of mainly ferrous materials and works failures.

### 54 ASSISTANT FOR X-RAY LABORATORY

### 54B ASSISTANT FOR METALLURGICAL LABORATORY

### 39 ASSISTANT FOR ELECTRONIC LABORATORY

interested in circuitry investigation.

### 20 ASSISTANT FOR ELECTRONIC LABORATORY

Junior—Routine duties. Good opportunity for young man released from National Service.

### 14 WIREMEN

for interesting design and development work.

### 27 EXAMINER

with electrical knowledge.

### 42 INSPECTORS

mechanical and electrical.

### 26 ESTIMATOR

experience of aeronautical machine shop.

Write, preferably in tabulated form, and quoting reference number of position sought, to Personnel Manager—

**De Havilland Propellers Ltd.**  
**Hatfield, Herts.**

## High-Stability MAGNETIC AMPLIFIERS

SINGLE-UNIT or PUSH-PULL



- MAGNETIC AMPLIFIER RELAYS
- SATURABLE REACTORS
- AUTOMATIC VOLTAGE & CURRENT REGULATORS

AVAILABLE  
IN STANDARD  
RANGES OR  
MADE TO  
ORDER

## LOW-INERTIA INTEGRATING MOTORS



- for integrating minute voltages on a time basis;
- for driving light loads in instrument-type servo-mechanisms;
- for operating mechanical counters
- for use as small power generators
- in four types: 1.5, 6, 12 or 24 V. DC

Complete counter units and special gear-trains supplied.

PROMPT  
DELIVERY

**ELECTRO  
METHODS**

LTD  
OF STEVENAGE

— THE FIRST NAME FOR  
TEMPERATURE & HUMIDITY CONTROLLERS  
and PRECISION RELAYS

Full data from: ELECTRO METHODS LTD., Division ML 20  
CAXTON WAY, STEVENAGE, HERTS: Stevenage 780

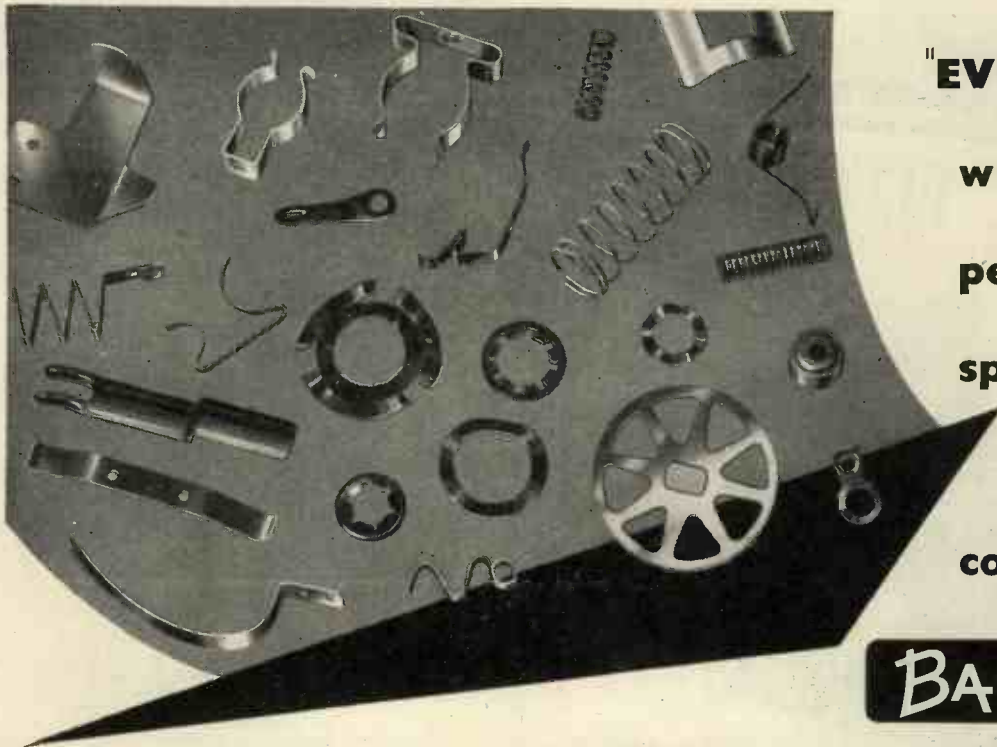

**"EVERLOCK"**

**washers**

**pen steel**

**springs**

**and**

**coils by**

**BAK-FIN**

**BAKER & FINNEMORE LTD · 197-207 NEWHALL STREET · BIRMINGHAM · 3**  
 TELEPHONE: CENTRAL 2838

## 26 Standard Models

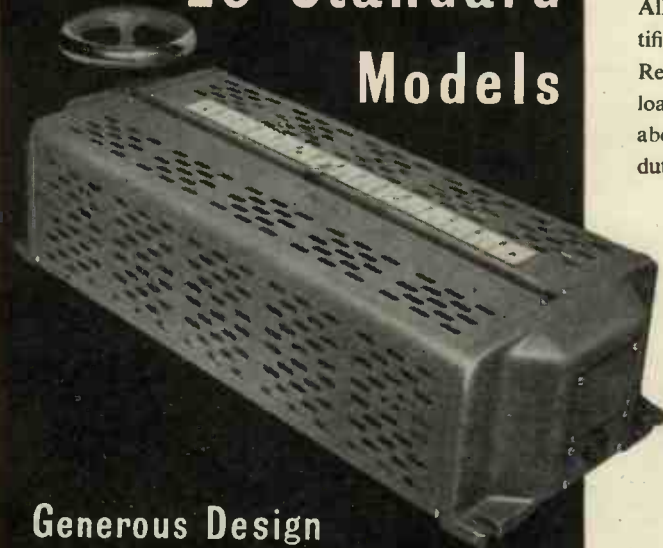

**Generous Design  
 Robust Construction  
 Rugged Self-lubricating Brushes**

All types of A.C. apparatus—motors, furnaces, rectifiers, transformers—can be controlled by a single Regavolt whose output can be set, regardless of the load current, precisely at any voltage from 0 to 30% above the supply. Its rugged design for heavy industrial duty ensures reliability under severe working conditions.

Special designs can be made for incorporation in your own apparatus in addition to the wide range of single, 3 phase, hand and motor driven models listed in our catalogue No. 3121.



**REGAVOLT**  
 REGULATING  
 TRANSFORMER

THE BRITISH ELECTRIC RESISTANCE CO. LTD.

*Specialists in the control of current and voltage for more than 25 years.*

Queensway, Ponders End, Middlesex

Telephone: HOWard 1492

Telegrams: Vitrohm, Enfield

BR.3121

*high impedance*  
**D.C. ELECTROMETER VOLTMETER**

for *precise* electrical measurements



Leaflet No. E434  
 on request.

This instrument is based on the well known Farmer cathode follower circuit. A positive ionising current of less than  $10^{-10}$  amps is injected into the circuit under test for all ranges.

**SPECIFICATION**

Ranges : 0-10, 20, 50, 100, 200, 500 volts.  
 Accuracy : Better than 1st grade B.S.89.  
 Zero Drift : Less than 1% of full scale deflection per hour after five minutes warming on 10 volt range, or less on higher ranges.  
 Mains Stabilization :  $\pm 10\%$  deviation from the nominal mains voltage will affect the zero and calibration by less than 0.2v. on all ranges.  
 Power Supply : 200-250 volts 50 c/s.

**BALDWIN INSTRUMENT COMPANY LTD. • DARTFORD • KENT**

Telephone: 2948 (3 lines)

**A quality multi-purpose switch  
 for only 10'6**

At last a compact, low priced rotary switch which will stand up to really heavy use. The Austinlite "TENAMP" is a slow make-and-break switch, capable of handling loadings up to 10 amps., at 250 volts A.C., or 5 amps., at 440 volts A.C. Fractional horse power motors up to  $\frac{3}{4}$  H.P. 230 or 440 volts A.C., can also be switched by it.

Fully maintaining every Austinlite quality, special features are the spring loaded roller mechanism ensuring immediate and positive location; wiping type line contacts with pressure exerted by an independent contact spring and a reversible handle for alternative mounting on panels of  $\frac{1}{4}$ " thickness up to  $\frac{1}{2}$ ".

Wiring instructions for 18 different circuit applications are supplied with each switch. These include:—

- Three phase motor reversing.
- Three heat series/parallel switching.
- Capacitor motor starting.
- Series motor reversing.
- S.P. 4 way tapping.
- D.P. ON/OFF.
- D.P. changeover.

Write for illustrated leaflet.

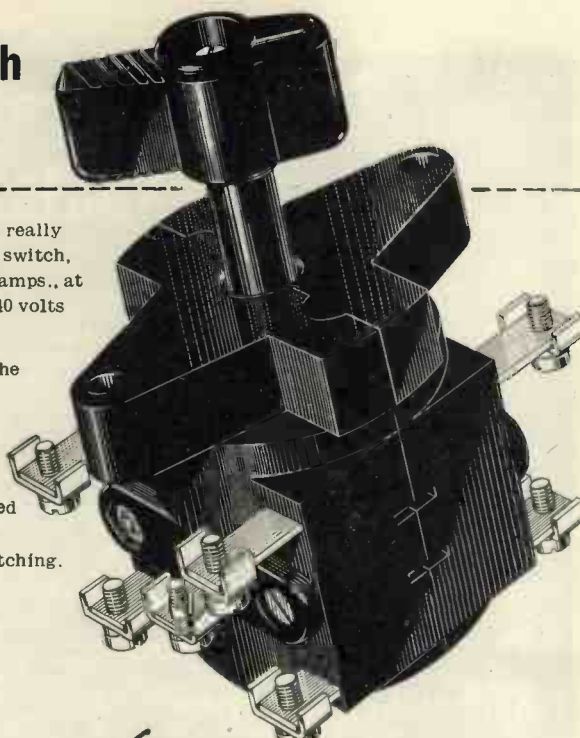

The Austinlite **Tenamp** switch is a *Chance* product

AUSTINLITE LIMITED, DEPT. A.5., LIGHTHOUSE WORKS, SMETHWICK 40, BIRMINGHAM. TEL: WEST BROMWICH 1824.



'The Thinker'  
by Rodin

## DYNAMIC REPOSE

This fine work by Rodin is surely the personification of latent power. In industry and commerce Tan-Sad chairs are, through correct posture, conserving this energy and producing mental alertness and efficiency. With Tan-Sad seating, man is indeed a giant refreshed.

May we send you details of

# Tan-Sad

POSTURAL SEATING

FOR INDUSTRY  
AND COMMERCE

THE TAN-SAD CHAIR CO. (1931) LTD.  
AVERY HOUSE · CLERKENWELL GREEN · LONDON · E.C.1

# 4 mmf/ft

AIR-SPACED ARTICULATED

## CO-AX CABLES

offer a unique combination of

- ✓ FRACTIONAL CAPACITANCE
- ✓ HIGH IMPEDANCE
- ✓ MINIMUM ATTENUATION

ALONG WITH

- ✓ EXCEPTIONAL FLEXIBILITY
- ✓ LIGHT WEIGHT

## 38 STOCK TYPES

FOR ANY OF YOUR STANDARD  
OR SPECIAL APPLICATIONS

A few of the very low capacitance types are:

Type No.	Capacit. $\mu$ F/ft.	Impedance ohms	O.D.
C.44	4.1	252	1.03"
C.4	4.6	229	1.03"
C.33	4.8	220	0.64"
C.3	5.4	197	0.64"
C.22	5.5	184	0.44"
C.2	6.3	171	0.44"
C.11	6.3	173	0.36"
C.1	7.3	150	0.36"

# TRANSRADIO

CONTRACTORS TO  
H.M. GOVERNMENT

LTD.

138A GROMWELL ROAD, LONDON, S.W.7



Our long association with the use and production of permanent magnets enables us to offer not only an advisory service of the most complete character, but the benefits of production technique and facilities based on wide knowledge and intensive research. Illustration shows the latest ignition half cycle magnetising equipment being used.

# THE DARWINS GROUP

SHEFFIELD · ENGLAND



## DARWINS LTD.

TOOL STEELS · HACKSAW BLADES · PERMANENT  
MAGNETS · HEAT & ACID RESISTING CASTINGS

## ANDREWS TOLEDO LTD.

CARBON & ALLOY CONSTRUCTIONAL STEELS

## ANDREWS TOLEDO (WIRE ROD) LTD.

SPECIAL CARBON & ALLOY WIRE ROD

## SHEFFIELD FORGE AND ROLLING MILLS CO. LTD.

CARBON & ALLOY STEEL BARS & SHEETS

## WARDSEND STEEL CO. LTD.

AGRICULTURAL & TOOL STEEL SHEETS

*Craftsmen in Steel*

D.52

# DAWE 'Q' METERS

*Instruments for the  
determination of 'Q' and  
relative R.F. measurements  
by resonance methods*

TYPE 622: 50 kc/s to 75 Mc/s  
TYPE 623: 25 Mc/s to 200 Mc/s

A special model (Type 620) for  
routine workshop use, range 100 kc/s  
to 25 Mc/s, is also available



**NOW AVAILABLE FOR  
IMMEDIATE DELIVERY!**

Technical data from: **DAWE INSTRUMENTS LTD., Instrument Division**  
99 UXBRIDGE ROAD, EALING, LONDON, W.5 · EALING 6215  
or from your Regional Agent

**Midlands**  
Hawnt & Co., Ltd.,  
59, Moor Street,  
Birmingham, 4  
Central 6871

**North of England**  
A. C. Farnell, Ltd.,  
15, Park Place,  
Leeds, 1  
Leeds 32958

**Cheshire**  
F. C. Robinson & Ptnrs.,  
287, Deansgate,  
Manchester, 3  
Deansgate 6601

**Scotland**  
Land, Speight & Co.,  
73, Robertson Street,  
Glasgow, C.2  
Central 1082

**West of England**  
Radford Electronics, Ltd.,  
4, Acraman's Road,  
Bristol, 3  
Bristol 64300

**Northern Ireland**  
James Lowden & Co.,  
11 Middlepath Street,  
Belfast.  
Belfast 57518



# FERGUSON RADIO CORPORATION LTD.

## HAVE VACANCIES FOR

**SENIOR ENGINEERS** with initiative and sound technical background for work on a wide range of projects in the field of Electronics including Television, Radio, Communications and Test Equipment. Permanent posts for men able to carry responsibility in rapidly expanding departments offering exceptional promotion and long term prospects.

**JUNIOR ENGINEERS** of ability for work on Development Projects offering a wide experience in the fields of Television, Radio, Communications and Test Equipment with excellent prospects for advancement.

Vacancies exist in Laboratories situated both at Enfield and Spennymoor, Co. Durham. These Laboratories are well equipped and working conditions excellent. Successful applicants eligible for Company's Pension Scheme. Housing assistance considered in appropriate cases.

Applications specifying the post for which application is made and giving full particulars as to age, qualifications and experience, etc., to **Employment Manager, Ferguson Radio Corporation, Ltd., Great Cambridge Road, Enfield, Middlesex.**

It's all plain  
sailing at  
G·G·L

Modern machinery and methods keep capstan and automatic productions and sheet metal pressings flowing to you on time, at a price you will like.

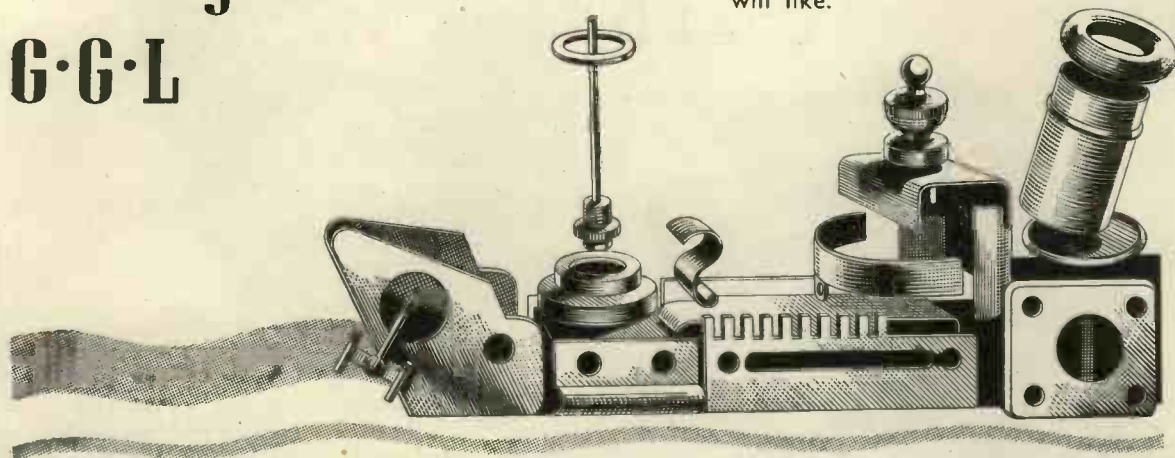

**GRIFFITHS, GILBART, LLOYD & CO. LTD.**

EMPIRE WORKS

PARK ROAD

BIRMINGHAM B18

Tel. : NORthern 6221.





*why call me a **STIFF** nut*

A Stiff Nut is a one-piece nut which complies with R.A.E. Specification No. A.D.114—a nut provided with means of increasing the friction between the thread of the nut and that of a standard bolt to an extent that the nut may be considered self-retaining. A Stiff Nut should be as light as is consistent with strength and be able to withstand all conditions of service use. It should be of a design which does not cause undue damage or excessive wear to the thread of the bolt on which it is mounted.

A perfect description, in fact, of the G.K.N. 'Aerotight' Nut—often casually referred to as a Lock Nut or Self-Locking Nut—which has the added advantages that it can be used over and over again without loss of efficiency. Its retentive properties are unaffected by oil, water or humidity.

## **GKN 'AEROTIGHT' STIFF NUT**

*Supplied in Steel, Stainless Steel, Light Alloy, Brass and Bronze in Whitworth, B.A. and B.S.F. Threads. Recommended for all applications where vibration is encountered. Economical in use. No need for drilled holes, cotter pins, lock washers, etc.*

**GUEST KEEN & NETTLEFOLDS (MIDLANDS) LIMITED.**

*Screw Division : Box 24, Heath Street, Birmingham, 18.*

5/A/2002

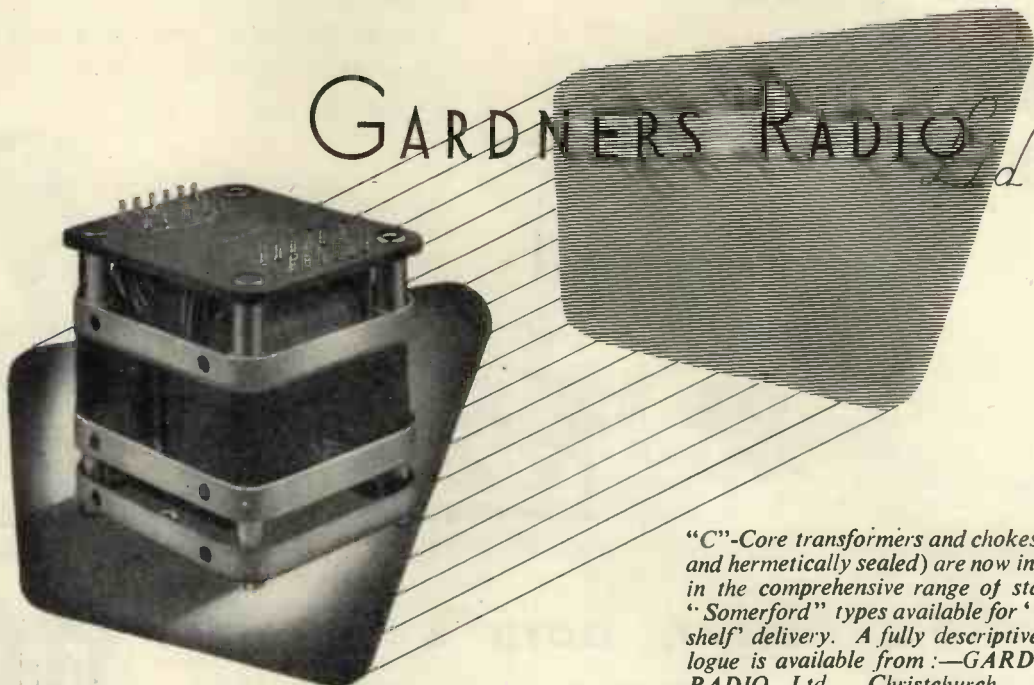

*"C"-Core transformers and chokes (open and hermetically sealed) are now included in the comprehensive range of standard "Somersford" types available for 'off the shelf' delivery. A fully descriptive catalogue is available from :—GARDNERS RADIO Ltd., Christchurch, Hants.*

# I.M.A. PRESSINGS

IN ALL METALS

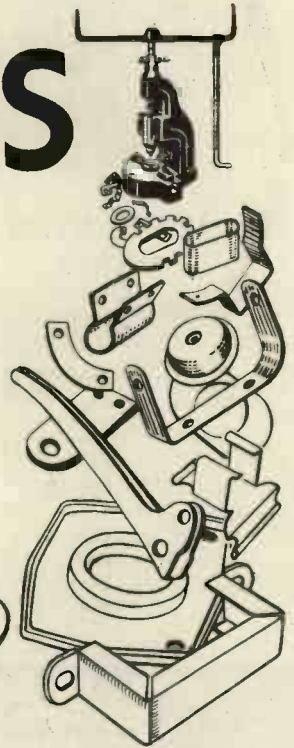
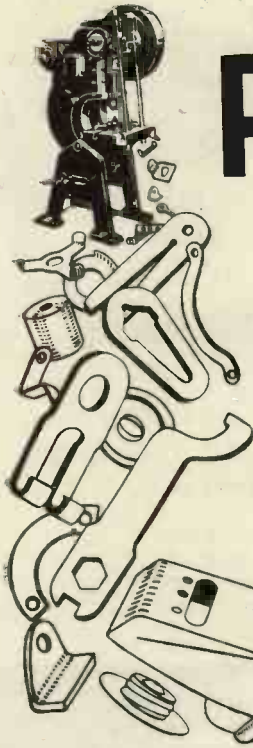

THE  
IMPROVED METALLIC APPLIANCES LTD.  
80, CHEAPSIDE, BIRMINGHAM 12.

Phone : VIC. 1221

Grams : I.M.A. Birmingham

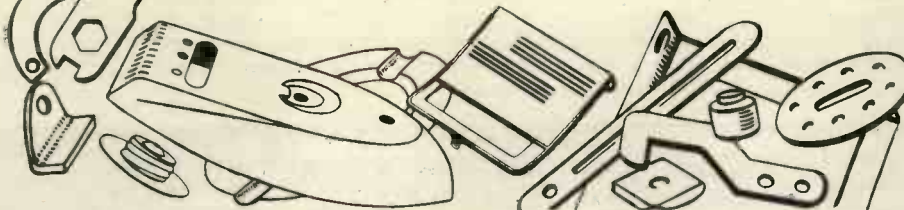

KH18A

**STRAIN** makes its mark...



*The equipment comprises three Units.  
The Oscillators and Power Supply Unit,  
the Bridge and Amplifier Unit, and  
that shown, the Recording Unit.*

## KELVIN HUGHES

### Four pen dynamic Strain Recorders

Employing four pick-off devices and recording their output simultaneously, the Kelvin Hughes Strain Recorder gives valuable information on the behaviour of a structure or a machine under conditions of dynamic loading. Resistance wire strain gauges, capacitance-change and inductance-change devices such as accelerometer pick-up systems may be used independently in each channel. Sensitivity is such that full-scale deflection for a 200 pF capacity pick-up is given for a change of approximately 1 pF, while with a 2000 ohms resistance gauge, full-scale deflection is obtained for about 0.006% change of resistance. Single channel instruments are also available.



**KELVIN HUGHES** PRECISION INSTRUMENTS

*Why not write for further details?*

**KELVIN & HUGHES (INDUSTRIAL) LIMITED, 2, CAXTON STREET, LONDON, S.W.1**

110 BOTHWELL STREET, GLASGOW C.2.



for  
**INSULATED  
WIRES**

**BARE & INSULATED**

# RESISTANCE WIRES



for  
**BARE  
WIRES**

## **EUREKA & VACROM**

REGD.  
(CUPRO-NICKEL)

REGD.  
(NICKEL-CHROME)

'Eureka' (Regd.) and 'Vacrom' (Regd.) Resistance Wires can be supplied BARE or with STANDARD COVERINGS of cotton, silk, rayon, enamel and glass.

These wires have been used for many years for winding resistances for instruments, control apparatus, etc.

'Eureka' with its low temperature coefficient is always in demand for precision work, while Nickel-Chromes are used where a high resistance is required in a limited space.

*Full details gladly supplied upon request*

**THE LONDON ELECTRIC WIRE COMPANY  
AND SMITHS, LIMITED**  
LEYTON, LONDON, E. 10.

**VACTITE WIRE COMPANY LTD.**  
75 ST. SIMON STREET,  
SALFORD 3, LANCs.

# HADDON

FULLY A.I.D. APPROVED

## **TRANSFORMERS LTD.**

27-37 MASONS AVENUE,  
WEALDSTONE, MIDDx.

Telephone :  
HARROW 9022/3/4/5.



**POWER and  
AUDIO FREQUENCY  
TRANSFORMERS up to 25kVA.**

**Open or Enclosed Types—Suitable for all climatic conditions**

CONTRACTORS TO ALL GOVERNMENT DEPARTMENTS

*For* **precise stable MEASUREMENT**  
 OF MEAN AND DYNAMIC *pressures*  
**and RECORDING**

with  
**Recording Camera, Oscilloscope or  
 Direct Writing Recorder**

Self-contained for measurement of mean pressure, this versatile A.C. mains-operated electro-manometer has one single pressure head for positive and negative pressures, and output sockets for all types of recording equipment. Developed from *hospital* requirements in analysis of heart and artery pressures, it incorporates the latest technique for *industrial* measurement of rapidly changing pressures.

Its capacity-type pressure head of low volume displacement and inherent high-frequency response is temperature-compensated and linear within 2 per cent. over each of five ranges : 4—10—40—100—400 mm./Hg. Power supplies are electronically stabilised.

Literature and further details promptly supplied on application and inquiries regarding *individual* requirements—gladly answered.



**CAPACITY-TYPE N.E.P. Electro-Manometer**

NEW ELECTRONIC PRODUCTS LIMITED, 9 NEW CAVENDISH STREET, LONDON, W.1 (WELbeck 1421-2)  
 Contractors to the Ministry of Supply, Ministry of Health, U.S.A.F., etc. A.I.D.-approved



**Economy begins  
 at the  
 design stage . . .**

The latest developments in permanent magnet materials and techniques can effect remarkable economies, provided they are introduced at the design stage.

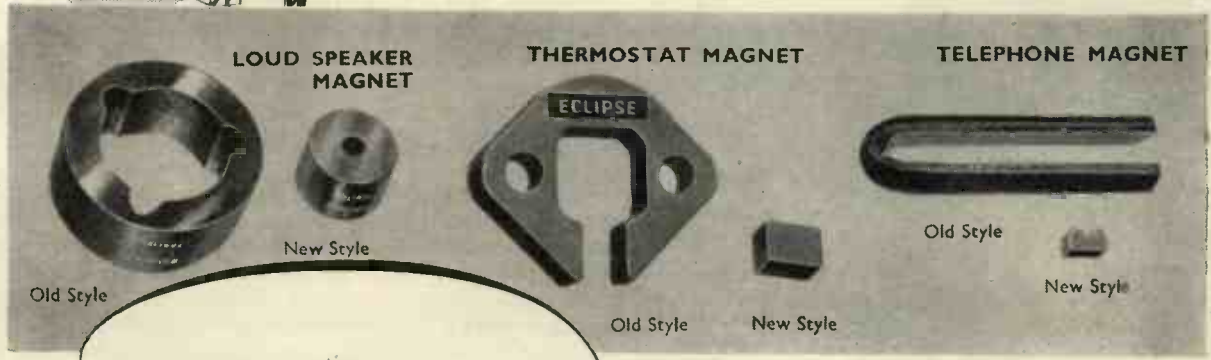

Send for Publication  
 P.M.131/51 "Design and  
 Application of Modern  
 Permanent Magnets"

Made by the makers of  
 "Eclipse" Permanent Magnet Chucks



JAMES NEILL & CO. (SHEFFIELD) LTD.  
 SHEFFIELD 11 ENGLAND

*They sought it with thimbles,  
they sought it with care;  
they pursued it with forks and hope,*

*"The Hunting of the Snark". Lewis Carroll.*

*The element of blind optimism has long disappeared from scientific research and the designer needs no such hit or miss methods today. His brain-child can be electronically tested and proved from the earliest stages of conception. The superhuman precision of electronics demands transformers of the highest characteristics—in fact, Partridge Transformers*



*P 3064 The latest development in Audio Transformers. Technical data sheet No. 5 on request.*



**PARTRIDGE TRANSFORMERS LTD**  
TOLWORTH • SURREY



*Catalogue Number E.E. 11025.*

#### BRIEF SPECIFICATION

Frequency Range.	20 c/s to 20 kc/s in three ranges.
Calibration Accuracy.	$\pm 0.5$ c/s up to 50 c/s. $\pm 1$ per cent above 50 c/s.
Distortion.	Not greater than 2 % of maximum output.
Hum Level.	Not greater than 0.2 % of maximum output.
Output.	20 volts into external load of 600 ohms, balanced or unbalanced.
Mains Supply.	200-250 volts, 40-60 c/s.

## AUDIO-FREQUENCY OSCILLATOR

This instrument employs a resistance-capacitance oscillator circuit, in which the frequency-determining elements have been carefully chosen to ensure stability of calibration. The oscillator section incorporates a control circuit which maintains the output substantially constant at all frequencies. This section is followed by an amplifier and power stage providing an output of 20 volts into an external load of 600 ohms. A surge-limiting circuit is incorporated to prevent sudden mains changes from affecting the output of the oscillator.

*Please write for descriptive leaflet*

SCIENTIFIC  INSTRUMENTS

W. G. PYE & CO. LTD., GRANTA WORKS, CAMBRIDGE, ENGLAND

# Waveforms

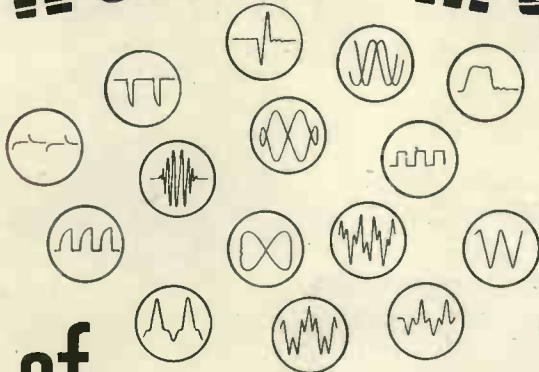

of

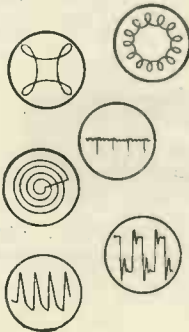

The expanding field of research and development means that a Cathode Ray Oscilloscope which will cope with the problems of today and tomorrow must be able to display and measure waveforms of infinite variety. However ubiquitous an instrument, no single type of Oscilloscope can be expected to cope with every kind of application. Thus, there are now ten Nagard Oscilloscope Models available with a wide range of calibrated sweep speeds together with D.C. Amplifiers.

This is the most comprehensive range ever offered to the Research Engineer and is made economically possible by unit construction and by the specialization of Nagard Ltd., in the development of this most useful of all electronic instruments, the Cathode Ray Oscilloscope.

## Infinite Variety

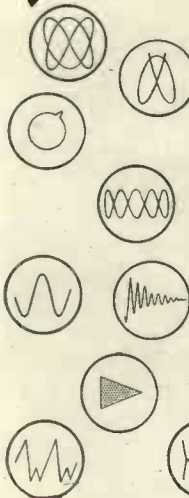

Double Beam Cathode Ray Tubes can be fitted to most models, thus extending still further the versatility of each type and giving signal handling performances unique in the field of simultaneous presentation of two variables.

Experience in a very wide variety of applications has led to the development of a number of useful ancillaries which take the form of units to be added to the Oscilloscope in order to provide the most suitable input conditions or as additional amplifiers providing two or more signal channels.

Nagard Ltd., welcome the opportunity of applying the Nagard Oscilloscope to your most difficult problem.

Write now for our new short catalogue.

**NAGARD**  
LTD

See what you measure!

18, Avenue Road, Belmont, Surrey VIGilant 0345

Isotopes in Industry and Research

## ISOTOPE DEVELOPMENTS ARE MAKING STANDARD EQUIPMENT

in the Radioactive field



### THE E.H.T. SUPPLY UNIT TYPE No. 532

The E.H.T. Supply Unit is a very stable source of high voltage designed for the operation of Geiger-Müller tubes, ionisation chambers and proportional and scintillation counters.

**OUTPUT VOLTAGE :** Continuously variable over three ranges: 300 - 3000 volts at 3 milliamps.

**OUTPUT VOLTAGE REGULATION:** Less than 0.05% change for 10% change in mains input voltage; mains frequency variations are included in this regulation.

Output ripple less than 0.03 volts R.M.S.

**OUTPUT IMPEDANCE:** Less than 500 ohms.

**STABILITY:** Short term drift less than 0.1% per 10 hours. Long term drift less than 0.2% per 100 hours.

**METER:** Five inch first grade rectangular scale.

Detailed specifications are available. Our electronics department is at your service on application.



120, MOORGATE, LONDON, E.C.2

Telephone: METropolitan 9641 (5 lines)

Midland Agent: HAWNT & CO. LTD., 59 Moor Street, Birmingham, 4.

Northern Agent: A. M. LOCK & CO., Crompton Street, Chadderton, Oldham, Lancs.

Scottish Agent: A. R. BOLTON & CO., 72 Haymarket Terrace, Edinburgh, 12.

# Protection from

# VIBRATION

Silentbloc mountings protect instrument panels and sensitive apparatus from vibration and shock. Easily fitted, they are available in several designs for loads ranging between a few ounces and 60 lb.

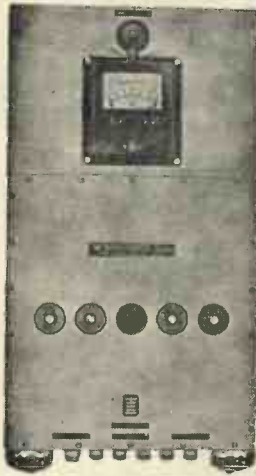

*This Engine Protection Panel (left) manufactured by Teddington Industrial Equipment Ltd., for Davey Paxman Ltd., is insulated from vibration by Silentbloc instrument mountings of the type illustrated right. Two of the mountings can be seen in their brackets at the base of the panel*

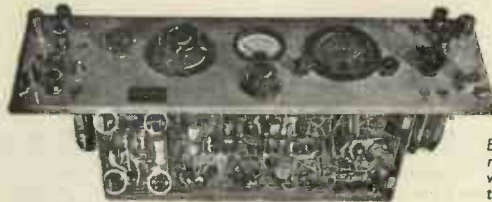

*Below: Bonded stud mountings for shear loads up to 12 lb. Rubber is bonded to metal studs*

*B.B.C. Outside Broadcasting Amplifier removed from its case to show sub-chassis wiring. Four Silentbloc "Bonded Stud" type mountings are fitted in each amplifier unit.*



DETAILS ON REQUEST TO

## SILENTBLOC

SILENTBLOC LIMITED VICTORIA GARDENS LONDON W11 TEL: PARK 9821

## Pressings and Fabrications...

to individual specifications

Whatever your particular needs in Metal Fabrication and Specialised Precision Work, our long experience in association with the electrical industry enables us to meet your most exacting requirements with speed and efficiency. Our productions include Control Panels, Cabinets, Transformer Tanks, Chassis Assemblies, Components and all kinds of Pressings and Fabrications for every application.

We welcome enquiries and we are always pleased to advise on any Specialised Metal Fabrication Problem without obligation.

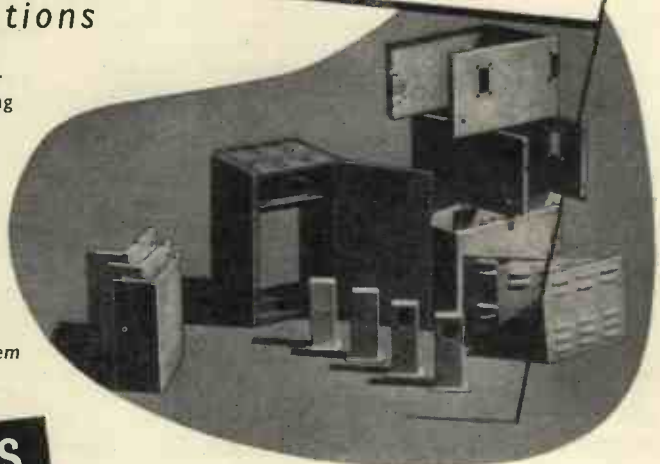

**SPENCER & SONS**  
(MARKET HARBOROUGH) LTD.

**METAL FABRICATION**  
for the Electronics Industry

GREAT BOWDEN ROAD · MARKET HARBOROUGH · LEICESTERSHIRE · Phone: 2651/2





Follow  
this  
man!

He is the 'Bostik' Man whose wide experience of adhesion and sealing in all industries will be of invaluable assistance to you. What he is anxious to do is to give you a realistic picture of how 'Bostik' Adhesives and Sealing Compounds can save you man-hours per job, cut production costs, step up production on efficiency. The 'Bostik' man is a specialist in solving tough problems of adhesion and sealing . . . and some have been very tough nuts indeed. It costs absolutely nothing to call in the 'Bostik' Man. Think what he might save you in production costs and headaches . . .

# Bostik

ADHESIVES AND SEALING COMPOUNDS

Write to B. B. CHEMICAL CO. LTD., Ulverscroft Road, Leicester. 'BOSTIK' is the registered trade mark of B. B. CHEMICAL CO. LTD.

IF YOUR PROBLEM IS

## COIL IMPREGNATION

The BLICKVAC HIGH-VACUUM IMPREGNATOR meets the rapidly growing demand for high-vacuum impregnation.

Full range of models available to meet the needs of

- ★ the large-scale Producer
- ★ the Research Laboratory
- ★ the small Rewind Shop

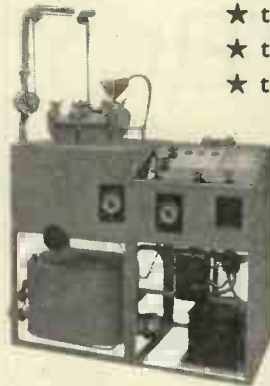

BLICKVAC UNITS MEET THE MOST STRINGENT SPECIFICATIONS.

Outstanding features :

- Ease in control
- Simple attachment of auxiliary autoclaves
- Best quality fittings
- Fully demountable to facilitate cleaning

UNEQUALLED FLEXIBILITY AND PERFORMANCE.

Units available for :

VARNISH  
WAX

BITUMEN  
POTTING RESINS

If your problem is Coil Impregnation, CONSULT BLICKVAC

Write today to Hamilton Road Works, Hamilton Road, S.E.27  
Associated with Blick Time Recorders Ltd., Blick Engineering Ltd.

## For HUMIDITY TESTING

under

CLOSELY CONTROLLED  
CONDITIONS



The "B-W" Climatic Testing Cabinet illustrated was specially developed for testing electrical and other components under a wide range of humidity and temperature conditions, and is the accepted unit for tests to Specifications RCS11, K114, etc. It is just one of the many products in our wide range of equipment designed by specialists to meet every industrial heating requirement.

Write for details today.

'B-W'

## CLIMATIC TESTING CABINETS

Also available as dry heat LABORATORY OVENS with close control.

'B-W' STANDARD PRODUCTS INCLUDE

- ★ FURNACES
- ★ GLUE HEATERS
- ★ DIP POTS
- ★ OVENS
- ★ WAX TANKS
- ★ HUMIDITY CABINETS

INDUSTRY NEEDS HEAT — YOU NEED 'B-W'

 Barlow-Whitney

COOMBE RD., NEASDEN LANE, LONDON, N.W.10. GLA 1152  
LONDON OFFICE: 2 DORSET SQUARE, N.W.1. AMB 5485

In the Winter Number of the

# BBC QUARTERLY

NOW ON SALE

## Proposals for a Programme Fading Circuit

by R. C. Whitehead, A.M.I.E.E.

Planning and Installation Dept., BBC Engineering Division

The author points out several disadvantages of conventional methods employed for fading sound and vision signals. He then proceeds to describe several alternative circuits designed to overcome these disadvantages and based on the use of combinations of resistive elements having positive and negative temperature coefficients.

The use of such elements in the circuits described is shown to eliminate many of the difficulties commonly encountered in programme fading networks.

## Standardisation of Magnetic Tape Recording Systems

by E. D. Daniel, M.A., A.M.I.E.E.

and P. E. Axon, O.B.E., M.Sc., Ph.D., A.M.I.E.E.

Research Dept., BBC Engineering Division

The recording characteristic of a magnetic tape system can be defined in terms of the magnetic induction at the tape surface. A method of measuring surface induction is described which employs a non-magnetic conducting loop as a reproducing head. Using tapes calibrated by means of this device, the action of conventional magnetic-core reproducing heads is examined and various empirical expressions are deduced for their response. It is shown that if suitable corrections are applied, conventional heads having either short or very long gaps may be also used for standardisation. Finally, the effects of various common imperfections and maladjustments in all types of reproducing heads are examined in detail.

## Technical Training for Broadcasting

by K. R. Sturley, Ph.D., M.I.E.E.

Head of Engineering Training Dept., BBC Engineering Division

Is technical training in broadcasting worthwhile? This problem is examined and details of the BBC's views on the matter and some of the methods employed by the Department, are stated. Information on the types of courses formulated for particular categories of staff under training for specific reasons, together with a chart showing the courses and the proportion of time spent on the various aspects of the work, is given.

Other contributors to this number discuss broadcast talks, television programmes, farm radio, music, and other subjects.

PRICE 2/6

Obtainable from bookstalls or newsagents or post free

from BBC Publications,

35 Marylebone High Street, London, W.1.

Yearly Subscription 10/-.

BRADMATIC LTD.

## HIGH QUALITY TAPE RECORDING EQUIPMENT

### THE MODEL 5D TAPE DESK (to take 10 $\frac{1}{2}$ in. NAB Reels)

Programme Time : 62 minutes at 7 $\frac{1}{2}$  i.p.s.  
124 minutes at 3 $\frac{3}{4}$  i.p.s.

Panel size : 20in. x 14 $\frac{1}{2}$ in.

Two speeds, 3 $\frac{3}{4}$  and 7 $\frac{1}{2}$  i.p.s. Double track heads. Push button control. Fast wind and rewind. Three heavy duty motors. Three separately shielded heads. Complete with NAB reel adaptors

PRICE : (fitted with 6RP heads) £50/-

### ALSO AVAILABLE

#### MODEL 5C TAPE DESK (to take 9 $\frac{3}{4}$ in. reels).

Programme Time : 55 mins. at 7 $\frac{1}{2}$  i.p.s.  
110 mins. at 3 $\frac{3}{4}$  i.p.s.

PRICE : (fitted with 6RP heads)

Large Panel (20in. x 14 $\frac{1}{2}$ in.), £47/10/-

Small Panel (13 $\frac{1}{2}$ in. x 15 $\frac{1}{2}$ in.), £42/-

#### MODEL 5B TAPE DESK (to take 7in. reels).

Programme Time : 31 mins. at 7 $\frac{1}{2}$  i.p.s.

62 mins. at 3 $\frac{3}{4}$  i.p.s.

PRICE : (fitted with 6RP heads)

Panel size (13 $\frac{1}{2}$ in. x 15 $\frac{1}{2}$ in.), £42/-

### PORTABLE RECORDERS

In rexine covered case, fitted with model 5B tape desk, type D.2. C.J.R. amplifier with monitoring. Provision for external loudspeaker.

PRICE : £117/- (without microphone).

High fidelity sound heads. Type 5RP (Record/play), £3/5/-. Type 6RP (super fidelity), £3/15/-. Type 5E (Erase), £3/5/-. Mumetal Screening cans, 8/6. Amplifiers, microphones. All types and sizes of magnetic tape.

Trade supplied.

Send for Lists

## BRADMATIC LIMITED

STATION ROAD · ASTON · BIRMINGHAM 6

Phone : EAST 2881 & 2. Grams : Bradmatic, Birmingham

Quantity production of small automatically made pieces in Steatite, Porcelain, and Rutile materials for electric cooking and heating equipment, and telecommunication apparatus.

# BRAY

GEO. BRAY & CO. LTD., Leicester Place, Leeds 2.  
Tel. : 20981/3. Grams. : "Bray, Leeds 2"

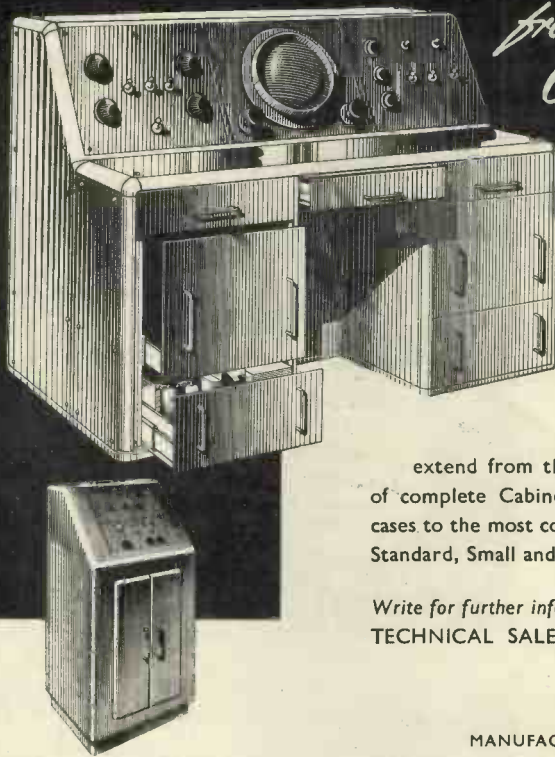

*from  
Cabinets  
to  
Consoles*

**Widney-**  
**DORLEC**

OUR  
**Design and  
Development.** . . . . .

department is available to help solve your Cabinet problem. The service can extend from the production of design sketches to the manufacture of complete Cabinets, which can vary in size from simple instrument cases to the most complicated consoles. Available in four gauges: Heavy, Standard, Small and Miniature.

Write for further information to  
TECHNICAL SALES OFFICE, 299 NEW KING'S RD., LONDON, S.W.6  
Telephone: RENOWN 1601

MANUFACTURERS

HALLAM SLEIGH & CHESTON LTD. · WIDNEY WORKS · BIRMINGHAM, 4.

WD1.

IT is admitted that the present reception of the BBC's medium and long wave transmissions is most unsatisfactory in many parts of the country.

The BBC is proposing to remedy these conditions by erecting a chain of some 51 v.h.f. stations, and it is almost certain that F.M. will be the type of modulation chosen.

The principle of Frequency Modulation technique is discussed fully in:—

**“Frequency Modulation”**

By K. R. STURLEY, Ph.D., M.I.E.E.

Price 2/6 (postage 2d.)

The construction of a suitable receiver for the existing F.M. transmissions from Wrotham is described in:—

**“A Home-Built Frequency Modulated Receiver”**

By K. R. STURLEY, Ph.D., M.I.E.E.

Price 4/6 (postage 3d.)

*These and other monographs are obtainable from*

28 ESSEX STREET,

**Electronic Engineering**

STRAND, LONDON, W.C.2

# PRODUCTION ENGINEER

required by

**SHORT BROTHERS &  
HARLAND LIMITED, BELFAST**

to organise the batch manufacture of high grade electronic equipment. Applicants must have had several years production experience of radio or electronic apparatus and be able to provide liaison between development laboratories and factory. Knowledge of work study an advantage.

Details, re salary and housing facilities, available on application. Write, stating age and experience to :—

**THE PERSONNEL MANAGER,  
SHORT BROTHERS & HARLAND  
LIMITED, QUEEN'S ISLAND,  
BELFAST**

# WILKINSONS



C.W 2415/150

# ABOVE ALL OTHERS

## POTTED AND COMPOUND FILLED TRANSFORMERS AND CHOKES

made by Woden are the answer when the call is for transformers to operate under exacting industrial conditions, coupled with adverse climatic conditions.



Every transformer leaving our factory is subjected to a rigid inspection, and is fully impregnated with moisture proof filling compound by the latest vacuum and pressure process. The fact that "WODEN" are the choice of many leading radio and television manufacturers is proof enough of the quality of our products.

Please send for latest Catalogue.

**WODEN TRANSFORMER CO LTD**

**MOXLEY ROAD, BILSTON, STAFFS.**

TELEPHONE : BELSTON 41959

# SCREENED CONNECTORS

for cables of 0.2" to 1.03" O.D.  
Single and multi-way types.  
Special types fitted with coupling rings.  
Cable joining connectors.  
U.S. Type Connectors as illustrated.

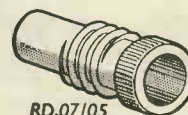
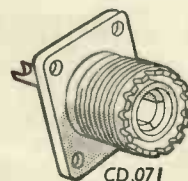
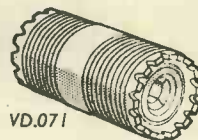
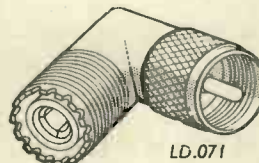
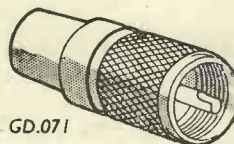

CABLE O.D.	TYPE	CODE NO.
0.41"	Straight plug Reducing adaptor Reducing adaptor	GD.071
0.25"		RD.07/05
0.2"		RD.07/03
fits on GD.071 CD.071 VD.071	Elbow plug adaptor	LD.071
fits on GD.071 LD.071	Bulkhead (Junction) adaptor	VD.071
fits on GD.071 LD.071	Chassis receptacle	CD.071

Other Transradio specialised products:  
CO-AX air-spaced articulated  
Very Low Loss Cables.  
Microdual Two-speed Precision Drives.

# TRANSRADIO LTD

138A CROMWELL ROAD, LONDON, SW7, ENGLAND

Telephone: FREmantle 4421 (P.B.X.)

# NEW!

## EXPERIMENTAL OUTFITS

### LEARN THE PRACTICAL WAY!

Whether you are a student for an examination, starting a new hobby, intent upon a career in industry or running your own business — these Practical Courses are intended for YOU — and may be yours at very moderate cost.

With these Outfits, which you receive upon enrolment, you are given instructions which teach you in easy stages the basic principles of the subject concerned. A tutor gives individual help and guidance throughout the Course.

**COURSES WITH PRACTICAL EQUIPMENT INCLUDE:**  
 Radio (Elementary & Advanced), Television, Mechanics, Electricity, Chemistry, Photography, Carpentry. Also Draughtmanship, Commercial Art, Amateur S.W. Radio, Languages, etc



EASY TERMS FROM £1 PER MONTH

**E.M.I. INSTITUTES**

The only Postal College which is part of a world-wide Industrial organisation.

**POST THIS COUPON TODAY**

Please send me your FREE book on Practical Courses:

I am interested in.....  
 To: E.M.I. INSTITUTES, Dept. 11x, 43, Grove Park Road, Chiswick, London, W.4.

NAME .....

ADDRESS .....

IC24

## FREQUENCY METERS

UP TO 5000 CYCLES  
 PROMPT DELIVERY



also the new **SYNCHROSCOPE M.C. KILOVOLTMETERS** and full range of Switchboard Instruments.

Ask for illustrated Catalogue

**THE ELECTRICAL INSTRUMENT CO. (Hillington) LTD.**

HILLINGTON, GLASGOW

London stockists, H. A. Patterson, 156 High Holborn.



## METERS

LARGE & VARIED STOCKS AVAILABLE FOR IMMEDIATE DELIVERY

EXAMPLES FROM OUR RANGE OF 2 1/2 inch FLUSH PATTERN (as illustrated)

50 - 0 - 50	Microamps	Moving Coil
100 - 0 - 100	"	" "
250 - 0 - 250	"	" "
500 - 0 - 500	"	" "
1 - 0 - 1	Milliamps	" "
1	"	" "
100	Microamps	" "
200	"	" "
300	"	" "
400	"	" "
500	"	" "
25	Milliamps	Moving Iron
50	"	" "
100	"	" "

We can supply meters with NON-STANDARD, CURRENT and VOLTAGE RANGES to any specification. DELIVERY 7-14 days

## ANDERS ELECTRONICS LTD.

91, HAMPSTEAD ROAD, LONDON, N.W.1.

Telephone: EUSton 1639

Suppliers to Government Departments, B.B.C.,  
 Leading Manufacturers & Research Laboratories

## Miniature bearings

TO ALL SIZES AND SPECIFICATIONS



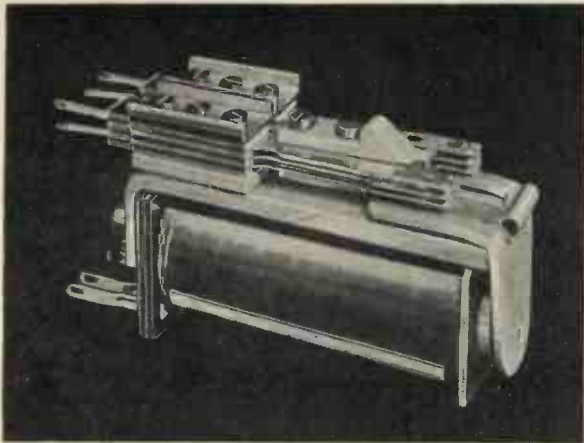

## RELAYS for TELECOMMUNICATIONS

A Quality Relay with Sensitive High Efficiency Magnetic Circuit similar to G.P.O. 3000 type. Improved design Coil Tags. Armature fixed with special clip for easy removal.

### CHARACTERISTICS.

**CONTACTS.** Nickel Silver Springs with Silver, Silver Alloys, Platinum or Heavy Duty Elkonite Contacts as required. Up to six sets of Change-over or eight sets of Make or Break Contacts.

**COIL.** Resistance from 1 to 100 000 ohms. Up to three windings on one coil.

Enquiries to :

## AUTOPHONE LIMITED

539/547, Wandsworth Road, London, S.W.8  
MACAULAY 2381/2.



Late ALEC DAVIS SUPPLIES LTD.

Dept. E.E.

12, STORE STREET,  
TOTTENHAM CT. ROAD  
LONDON, W.C.1.

Tel: MUSeum 2453/4539

Business Hours:  
Monday - Friday 9—5.30  
Saturday 9—1

## RELAYS

### D.C. COIL RESISTANCE

3,000 TYPES : 1.9Ω to 80,000Ω  
600 TYPES : 0.4Ω to 9,200Ω.

ALSO LARGE STOCKS OF  
DOUBLE & TRIPLEWOUND  
AND SLUGGED COILS.

### CONTACTS

3,000 TYPES : up to 8 sets.

600 TYPES : up to 4 sets.

3,000 TYPES: Make (M), Break (B),  
in Twin - silver, Twin - platinum,  
Dome-silver (2 amp.), Tungsten  
(5 amp.), and Flat-silver (8 amp.).  
Change-over (C), in all but  
Tungsten: Make-Before-Break (K), in  
Twin-silver and Twin-platinum.

600 TYPES : (M), (B) and (C), in  
Twin-silver and Twin-platinum.

### SPECIAL

High resistance slugged coils (up to  
10,000 OHMS with 1" slug) now  
available.

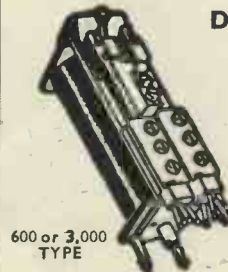

600 or 3,000  
TYPE

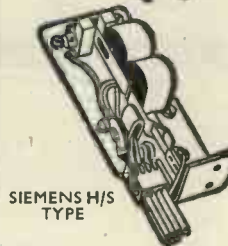

SIEMENS H/S  
TYPE

## Take the IMP out of IMPACT



To protect valuable equipment with the new METPAK SHOCK ABSORBER is the complete insurance against damage in transit. Tested and proved and used extensively by the Ministry of Supply and many industrialists. Why not make sure your equipment is received in good condition. Write for full details.

## METPAK REGD.

Sole licensed manufacturers:—  
BRAYHEAD SPRINGS LTD.  
Full View Works, Kennell Ride,  
Ascot Berks.  
Telephone: Winkfield Row 3115



## I've just realised FELT provides the answer



You would be surprised how many times felt does provide the answer. Seldom in the limelight, this amazingly versatile material serves industry in a thousand ways. If it is not already serving you, it will be worth your while to consult Coopers who will be pleased to discuss your problem.

## COOPERS FELT

Please send enquiries to :

Head Office & Works: COOPER & Co.  
(B'ham) Ltd. Brynmawr, Breconshire.

Tel.: 312. Telegrams: Felting, Brynmawr.

Registered Office & Works : Little King St.,  
Birmingham, 19.

# MOULDED RUBBERS

Our technical staff will welcome the opportunity to discuss your requirements in rubbers and to give you the benefit of more than 60 years' experience.

## Dainite

THE HARBOUR RUBBER CO., LTD.,  
MARKET HARBOUROUGH

*Graham Gear Co Ltd*

SPURS  
SPIRALS  
BEVELS  
8-100 D.P.

STATION ROAD  
BROOKMANS PARK, HERTS.  
Tel:- HATFIELD 3130

### REDUCE YOUR PRESS TOOL COSTS

THE HUNTON UNIVERSAL BOLSTER OUTFIT  
FOR SHEET METAL PIERCING AND  
BLANKING ON FLY PRESSES

Bolster Frame with 2 adjustable gauges and insertable steel holders for Dies  $\frac{1}{4}$  in. to  $3\frac{1}{2}$  in. bore diameter.

Two Punch Holders with detachable positive-action Strippers take the complete range of Punches  $\frac{1}{4}$  in. to  $3\frac{1}{2}$  in. diameter.

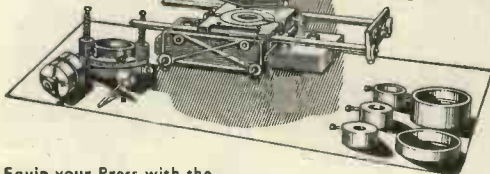

Equip your Press with the Hunton Outfit and use inexpensive standardised Punches and Dies  $\frac{1}{4}$  in. to  $3\frac{1}{2}$  in. diameter obtainable from stock—in  $\frac{1}{16}$  in. sizes—when you need them. Standardised Tools also available at short notice for Square, Oblong and other shapes, Louvre Forming (up to 8 in. long), Corner Notching, Corner Radiusing, Angle Iron Notching and Piercing, etc. Get the outfit now—Buy Punches, Dies and tools as you need them

Descriptive brochure and prices on request.

**HUNTON LIMITED**

Phoenix Works, 114-116, Euston Road, London, N.W.1  
Telephone: Euston 1477      Telegrams: Untonexh, London

**HIVAC**  
THE SCIENTIFIC  
VALVE  
BRITISH MADE

*Pioneers and specialists  
in Small Valves*

MIDGETS  
MINIATURES  
SUB-MINIATURES  
ELECTROMETERS

★  
COLD CATHODE TUBES

★  
INDICATOR LAMPS  
NEON INDICATOR LAMPS

**Hivac Ltd**

GREENHILL CRESCENT, HARROW-ON-THE-HILL, Middx.  
Telephone: HARrow 2655

# EQUIPMENT FOR RESEARCH AND DEVELOPMENT

- ★ Vibration Equipment
- ★ High Speed Electric Counters
- ★ Strain Gauge Equipment
- ★ High Accuracy Tachometers
- ★ Temperature Measuring Equipment



**NEOSTROM COUNTING UNIT**

Valve-triggered counting unit, incorporating D.W.A. High-Speed Pulse Register, for accurate timing applications where the instrument counts tuning fork oscillations, or any other rotary or oscillating motions using photo-electric or other pick-ups.

**DAVIS, WYNN & ANDREWS LTD**  
SCIENTIFIC EQUIPMENT

CHELTENHAM  
TELEPHONE 53406

ENGLAND  
TELEGRAMS "INVENTION"

K/DWA..X

## FREE

### A VALUABLE BOOK

which details the wide range of Engineering and Commercial courses of modern training offered by E.M.I. Institutes.

Engineering courses include training for:

City and Guilds Grouped Certificates in Telecommunications; A.M.Brit.I.R.E. Examination: Radio Amateur's Licence, Radio & Television Servicing Certificates, General Radio and Television Courses, Radar, Sound Recording, etc. Also Courses in all other branches of Engineering.

Courses from  
£1 per month

**E.M.I. Institutes**

The only Postal College which is part of a world-wide Industrial Organisation.

POST THIS COUPON TODAY

Please send, without obligation, the FREE book,  
E.M.I. Institutes, Dept. 11, 43 Grove Park Rd., Chiswick, London, W.4.

Name.....

Address.....

IC18

## INDUSTRIAL PROBLEMS

### No. 2. ULTRA-SONIC THICKNESS GAUGE (Dawe, Type 1101)

SHIPYARDS - PIPE MANUFACTURERS - BOILER MAKERS - Industrial INSURANCE COMPANIES - PLASTIC MANUFACTURERS.

The instrument YOU have always wanted Will measure the thickness, from ONE SIDE ONLY, of ALL metals, Plastics and Glass. Cuts out drilling and riveting. Cuts out guess work. Will read thickness directly and quickly.

For advice on your own problems, consult :-

**A. C. FARNELL LTD. 15 Park Place, Leeds, 1.**

Telephone: Leeds 32958/9.



## SPECIALISED PAPERS

for the  
Electrical  
Industry

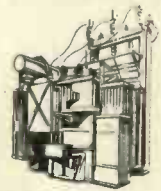

Whatever the purpose—transformers, telephone and power cables or anything electrical that needs a good paper, Watson of Linwood can supply to your particular specification. Advice is available from our skilled staff with details of the range which includes Plastic base papers, Presspapers and various Electrical boards.

**R. & W. WATSON, LTD.,**  
LINWOOD, RENFREWSHIRE,  
SCOTLAND.

London Office: Northgate House, 20-24, Moorgate, London, E.C.2.

Birmingham Office: 439, Belchers Lane, Birmingham 9.

Manchester Agents: Norbury Bros., 69, Piccadilly, Manchester.



## DONOVAN ACCESSORIES FOR THE ELECTRONIC APPARATUS MANUFACTURER!



**TYPE J.96 TERMINAL BLOCKS**  
Made in 15, 30 and 60 amp. sizes.



**Type C.30 PUSH BUTTON UNIT**  
arranged for mounting on customers' own cover plate.

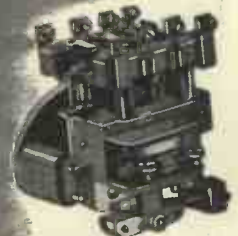

**Type A.11 A.C. POWER RELAY—4-pole with N.O. or N.C. contacts.**

**THE DONOVAN ELECTRICAL CO. LTD.**  
Safuse Works · Stechford · Birmingham 9



*Excellence in design..*

**AIR  
DIELECTRIC  
TRIMMER**

(Protected by  
Acetate Case)



TYPE APPROVED CAT. A. No. 464

Capacities from 4 to 70pF in  
voltages of 500 and 1000 D.C.  
Width 16.5 mm. Length 22 mm.  
Acetate dust cover optional.  
Insulation over 10,000 megohms.  
Power factor less than .001.

**O  
X  
L  
E  
Y**

**DEVELOPMENTS CO. LTD.**  
ULVERSTON, NORTH LANCs. Tel: Ulverston 3306

**FROM STOCK :—**

4 in. and 5 in. Square E.I.C. Meters  
(Special calibrations 14 days)

Total Operation Time Recorder  
Capacity Boxes Resistance Boxes  
and

A Wide Range of Electronic Instruments

E.H.T. Voltmeters, A.C. or D.C., up to  
100,000 V.

We specialise in Stabilized Power Supplies  
covering all voltages from 1 volt to 100,000 volts

Write for full specifications to :—

**Henry A. Patterson & Partners Ltd.**

ELECTRONIC LABORATORY FURNISHERS

156 High Holborn, LONDON, W.C.1.

Phone : CHAncery 7717

and at High Wycombe Phone : PENN 2334

**JOSEPH LUCAS (Gas Turbine Equipment) LTD.**

invite applications for

**ELECTRONIC ENGINEERS**

Some knowledge of servo mechanisms would be an advantage. Should have university degree. These appointments are pensionable and offer good prospects to individuals with initiative and technical ability. Salary will be in accordance with experience and qualifications. Details of experience and qualifications should be sent to :—

Personnel Manager, Joseph Lucas (Gas Turbine Equipment) Ltd., Shaftmoor Lane, Hall Green, Birmingham.

**FIRE!**

TRAGEDY AVERTED BY

**NU-SWIFT!**

"Escape seemed impossible... chemical machines spluttered and failed... acid squirted by one just missed my eyes... but reliable, non-damaging Nu-Swift saved us all."

NU-SWIFT LTD · ELLAND · YORKS

In Every Ship of the Royal Navy

**TYPE APPROVED VITREOUS WIRE WOUND RESISTORS — QUICK DELIVERY  
LOW PRICE**

*Labgear*

*Labgear*

***Labgear (Cambridge) Limited***

**WILLOW PLACE, CAMBRIDGE, ENGLAND**

Telephone : CAMBRIDGE 2494 (2 lines) Telegraphic Address : "LABGEAR, CAMBRIDGE "

# BERYLLIUM COPPER

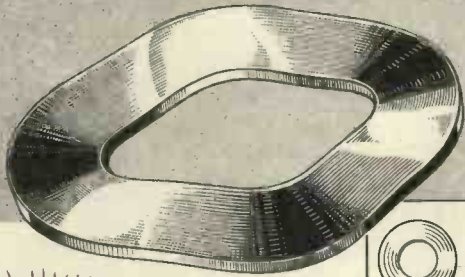

## CRINKLE washers

Heat treated and plated, giving corrosion resistance with high degree of recovery in relation to load, and resistance to "set". Spring locking action suitable for electronic and instrument components. Size range  $\frac{1}{2}$ " to 8 B.A.

Prices and samples sent on request.



CONTRACTORS TO THE ADMIRALTY • MINISTRY OF SUPPLY • OTHER GOVERNMENT DEPTS.

**DAVID POWIS & SONS LTD.**

FORWARD WORKS, SPARKBORO, BIRMINGHAM 11. PHONE: VIC. 1264-8

**'Radiospares'  
Quality Parts**

**THE SERVICE ENGINEER'S  
FIRST CHOICE**



**POTENTIOMETERS**

Wire-wound and Composition types. Single, Ganged, Tandem Units. Characteristics: linear, log., semi-log., non-inductive, etc. Full details on request

**RELIANCE**

**RELIANCE MFG., CO. (SOUTHWARK), LTD.**

SUTHERLAND ROAD, HIGHAM HILL, WALTHAMSTOW, E.17.  
Telephone: Larkwood 3245

## INSTRUMENTS

whose use has been restricted to computing and servo systems connected with radar and automatic control of anti-aircraft guns are now finding wide applications . . .

*for INDUSTRY*

Please write for informative Data Sheets on:—  
**MAGSLIPS** for Remote Indication, Electrical Differentials, Sine-Cosine Resolution, etc.  
**SELSYNS** for Remote Power Transmission.  
**IPOTS** for Electrical Computation.  
**VELODYNE MOTOR GENERATORS** for Servo Applications, Integration, etc.  
**SINE-COSINE POTENTIOMETERS** for Sine Wave Generators, etc.  
**WAVEFORM GENERATORS** for Low Frequency Sine Wave Generation.

to: **SERVO & ELECTRONIC SALES LTD.**  
No. 1 HOPTON PARADE  
STREATHAM HIGH ROAD, LONDON, S.W.16  
Tel.: STReatham 6165  
formerly SERVOTRONIC SALES

**. . . . those small  
components are important**

Keep them in RECEPTORAK. Well-stored, immediately accessible. Self-build tray storage units from only 5 basic parts.

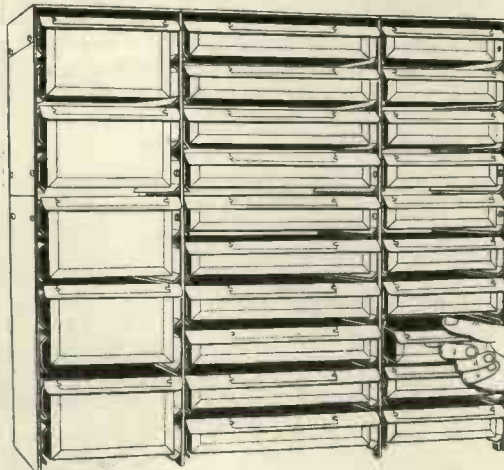

Pat. Applied For

Tray sizes  $5\frac{3}{8}$ " wide x  $1\frac{1}{2}$ " deep inside,  $5\frac{3}{8}$ " wide x  $3\frac{1}{2}$ " deep inside,  $8\frac{3}{8}$ " wide x  $1\frac{1}{2}$ " deep inside.

Write for details of RECEPTORAK to Dept. E.E.2.

**THE RANDALL ORGANISATION**

(JAMES H. RANDALL & SON LTD.)

PADDINGTON GREEN WORKS, LONDON, W.2.

AMBassador 1661.

## "SPEARETTE"

MINIATURE  
VALVE

**PIN  
ALIGNING TOOLS**

TYPES AVAILABLE FOR  
B7G - B8A - B9A  
VALVE BASES



**SPEAR ENGINEERING CO. LTD.**  
TITAN WORKS, WARLINGHAM, SURREY  
Telephone: Upper Warlingham 2774

## THOS. ALLNUTT & CO.



Metal Thread and Wood Screws,  
Turned or Pressed Nuts, Plain,  
Shakeproof and Spring Washers  
for all purposes. Wing Nuts.

**SOLDERING TAGS  
AND EYELETS**

**LEE CHAPEL LANE  
LANGDON HILLS, Essex**

Telephone: LAINDON 122  
Home & Export

## WE TALK YOUR LANGUAGE when it comes to TRANSFORMERS

- ★ designed for standard & special applications.
- ★ built for reliability.
- ★ engineered for trouble-free operation.



TRANSFORMERS BY *Amos of Exeter* A.I.D. APPROVED  
AMOS of EXETER, RTS WORKS, COMICA STREET, EXETER.

## HIGH SENSITIVE BUZZERS



Wound from 1.5 to 110 volts

Solid Construction

Quality Materials

Fine-Silver Contacts

Easily Adjustable

Compact in Size

FOR TELECOMMUNICATION WORK  
STANDARD FINISH OR TROPICALISED

Enquiries Invited for:  
CHOKES, POLARISED BELLS, INDUCTION COILS

## AUTOPHONE LTD.

539/547 WANDSWORTH ROAD,  
LONDON, S.W.8. MACaulay 2381/2

## MAGNETIC RELAYS

Built to your Specification

TYPES 3000 and 600

HIGH SPEED and A.C. to  
400 VOLTS

TROPICALISING — IMPREGNATING

## UNISELECTOR

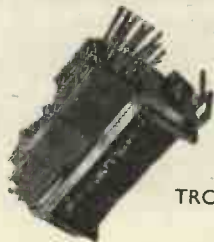

## SWITCHES

From 3 to 8 Bank — All Resistances

## KEY SWITCHES

Several types  
in stock

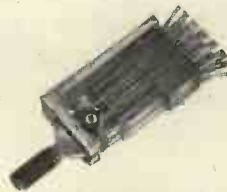

GOVERNMENT CONTRACTORS — SPEEDY DELIVERIES

## JACK DAVIS (RELAYS) LTD.

36 PERCY STREET · LONDON · W.1

MUSEUM 7960

LANGHAM 4821

## POLYTHENE

## H. F. EQUIPMENT

(AMBYTHENE BRAND)

ENQUIRIES INVITED  
FOR SPECIAL MOULDINGS OF  
COMPONENTS

## AMPLEX APPLIANCES (KENT) LTD.

19 DARTMOUTH ROAD, HAYES, BROMLEY, KENT.  
(RAVensbourne 5531)

All export enquiries to  
ANTEX LTD., 3, TOWER HILL, LONDON, E.C.3

## ★ ENGLAND'S SMALLEST TRANSFORMER

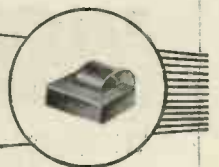

Keeping pace with modern developments, Belciere have developed a range of small and miniature transformers for all input, output and interstage purposes. The type "O" transformer, shown above approximately full size, has been specially designed for an all-transistor hearing aid. It measures only 2 1/2 in. x 3/4 in. x 1/4 in. Inductance 4 H at 0.4 mA. Mumetal core. Supplied with screening can if desired. Write for literature covering full range.

JOHN BELL & CROYDEN 117 HIGH STREET OXFORD

SINGLE-HOLE FIXING  
**SIGNAL LAMP FITTING**

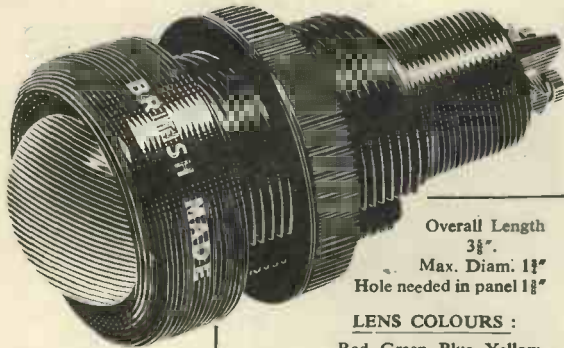

Overall Length  
 3½"  
 Max. Diam. 1½"  
 Hole needed in panel 1½"

**LENS COLOURS :**

Red, Green, Blue, Yellow,  
 Clear or Frosted. Flat frosted  
 glass is also available.

**CONSTRUCTION.**

Glass lens, ¼" thick, domed for  
 all-round vision.  
 A key prevents rotation in the panel.  
 The body, lens bevel and securing  
 ring are heavy black mouldings.

**LAMP.**

Ediswan or Cryselco 15w. 28mm.  
 S.E.S. sign lamp. 260 V Type is  
 suitable for 110 V to 260 V.

TYPE LONDEX 960



\* Write for LIST  
 142/E.E. giving  
 fuller details.

**LONDEX LIMITED**

ANERLEY WORKS, LONDON, S.E.20. 'Phone: \*SYD 6258

**PERSONAL**

The opportunity of a  
 lifetime is WAITING for  
 a man with a Good  
 Sound Product and real  
 knowledge of electronic  
 engineering principles  
 and practice.

We are Manufacturers of high-grade electronic  
 equipment interested in expanding our operations in  
 the diversified field of electronic engineering.  
**IF YOU HAVE AN IDEA AND YOU ARE ABLE TO ORGANISE  
 AND SET UP AN OPERATION WITH MODERN PLANT IN  
 YOUR OWN SPECIALISED FIELD.**

We will put a separate division at your disposal, staffed and  
 equipped to your specification. YOU will have complete  
 backing and co-operation and will earn and enjoy the highest  
 remuneration possible coupled with a profit-sharing arrangement.

If you have a  
 product you think has  
 possibilities and want the chance  
 to make your skill pay dividends, please  
 write giving your background and  
 details of what you have in mind.  
**STRICTEST CONFIDENCE.**  
 Box W 2900

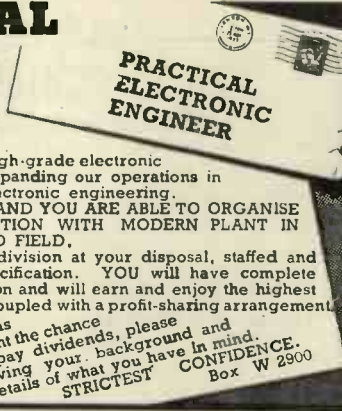

**INSULATION**

Our products include—  
 Presspahn and Leatheroid ; Pressboard ; Vulcanized Fibre ;  
 Cable and Red Rope Paper ; Bakelite and Ebonite ; Varnished  
 Paper and Tapes ; Varnished Silks and Tapes ; Varnished  
 Glass and Tapes ; Varnished Cambric, Silk, Glass and P.V.C.  
 Sleeveings ; Cotton Tapes, Webbing and Sleeveing ; Chatterton  
 Compound ; Adhesive and Rubber Tapes.

**PRESSPAHN, LTD.**

Bradford, Yorks, England  
 Established 1900

Telephone:  
 Bradford 25135 (Pvt. Br. Ex.)  
 Telegrams & Cables:  
 "Presspahn, Bradford"

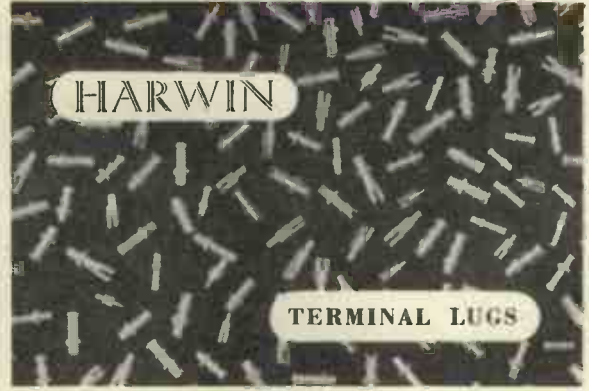

Harwin Engineers Ltd, 101 Nibthwaite Road, Harrow, Middlesex



**ANTI  
 VIBRO  
 CLIP**

Rubber  
 covered,  
 including extreme edges.  
 Eliminates metal to metal  
 contact, absorbs vibration.  
 Available in steel or alumin-  
 ium. Full circular or saddle  
 type. In nominal pipe  
 diameters. 3/16" to 2½"

**STIKASTRIP**

**SPONGE RUBBER  
 SEALING STRIP  
 STOPS DRAUGHTS  
 AND RATTLES  
 ABSORBS VIBRATION  
 NEEDS NO NAILS OR SCREWS**  
 Just moisten with petrol  
 or lighter fuel and press  
 in position.

AVAILABLE IN 10 FT. ROLLS  
 38 DIFFERENT SECTIONS.

DEPT. A.Q., HOWARD CLAYTON-WRIGHT LIMITED,  
 WELLESBOURNE WARWICKSHIRE



STOCKISTS OF

**BX**

**POLYSTYRENE**

A first-class rigid insulating material,  
 supplied in sheets and rods in a range  
 of thicknesses and diameters ex stock.

Information and guidance on manipulation,  
 machining and cementing available on request.

**MILTOID LTD.**

34/36 Royal College Street, London, N.W.1.  
 'Phone : EUSton 6467. 'Grams : Celudol, Norwest, London

**SPECIALISTS IN PACKING  
ELECTRONIC EQUIPMENT  
SYNTHETIC SUPPLIES LTD.**

ALBERT MILLS · SILK STREET  
ECCLES · MANCHESTER  
Telephones: ECCLES 1720 & 3225/6

Casemakers and general joinery : Packing and  
Preservation : Shipping and Forwarding Agents:  
Warehousing

Contractors to the Admiralty, Air Ministry, Ministry of Supply  
& G.P.O. Approval No. B23789/40

**METAL PRESSINGS**

(Power and Hand)

and

**ROLLED METAL SECTIONS**

**R. W. SPURRELL LTD.**

Empire Works, Guest St.,  
BIRMINGHAM, 19.

Telephones: Northern 0934 & 3520  
Telegrams: "Ricspur, Birmingham".

and Walsall Wood Works, Staffordshire.

Telephones: Brownhills 3302/3.



*If we had only  
been about in 1250*

we should have been fashioning natty suits of  
armour—styling them in the latest trends of  
fashion—and ensuring that they met the particular  
needs of the moment. That is our business.  
Fashioning metal—sheet metal—to do a particular  
job and do it well—as well as it can be done.  
If you have a job that should be tailor-made to  
your requirements, write and tell us about it, we  
can do it.



**RITHERDON & CO. LTD.**  
LORNE STREET, DARWEN.  
Telephone: Darwen 1028.

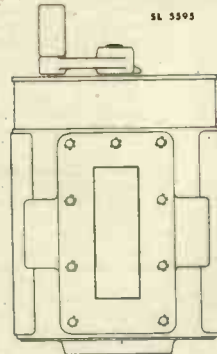

**WAVEGUIDE SWITCH**

for British 3" x 1" guide. High power type with VSWR of the order of 1.05 and crosstalk ratio up to more than 70 dB. Four flanges with one rotated bend. Dimension over flanges 4 3/4".

**PRECISION STANDING WAVE INDICATORS**

in all waveguide sizes, including the British, from 2,500 to 12,400 Mc/s. They have smooth drive with accurate scales, one reading small displacements to 0.01 millimeters. All models can be motor driven for semi-automatic measurements, giving high accuracy readings when drive is released.

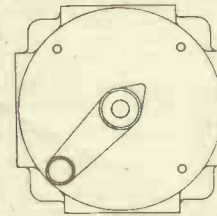

**FREQUENCY METERS**

direct reading in frequency on a counter to 0.1% or better. Four types cover frequency bands of 1 to 1.5 from 2,500 to 12,400 Mc/s. Accurate remote indication on linear counters or chart recorders easily arranged. Build-in models available.

Also SWR indicating amplifiers with input noise less than 0.01 μV into 6000 ohms, klystron power supplies and other microwave instruments.

WRITE FOR OUR COMPLETE CATALOGUE

**SIVERS LAB**

HÄGERSTEN  
STOCKHOLM  
SWEDEN

**PRE-SET CONTROL LOCK**

Designed to lock the spindles of pre-set potentiometers or trimmers without rotational or lateral displacement of shaft. Will accept a wide range of panel thicknesses.

Locking by coin slot or box key.

Send for leaflet L.3.

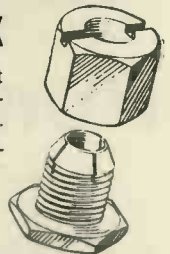

**SUTTON COLDFIELD ELECTRICAL ENGINEERS**

6, HIGH STREET, WALSALL, Phone: 2537

**TRANSFORMERS**

**CHOKES**

**SOLENOIDS**

**COILS**

- MADE TO YOUR SPECIFICATION IN ANY QUANTITY AT COMPETITIVE PRICES
- HIGHEST GRADE MATERIALS AND INSULATIONS USED
- DIE CAST FRAMES OR MOUNTING BRACKETS MADE FOR ALL FITTINGS

Send your enquiries to -

**W.L.R.S. LTD.**

DELTA HOUSE, 30 FAUCONBERG RD., CHISWICK, W.4  
CHIS. 0384

# INDEX TO ADVERTISERS

Adams Bros. & Burnley Ltd.	61	English Electric Co. Ltd., The	50	Nagard Ltd.	77
A.D.S. Relays Ltd.	84	Eric Resistor Ltd.	iii	Neill & Co. (Sheffield) Ltd., James	75
Advance Components Ltd.	37	Ericsson Telephones Ltd.	9	New Electronic Products Ltd.	75
Aero Research Ltd.	19	Ever-Ready Co. (Great Britain) Ltd.	64	Nu-Swift Ltd.	87
Airmec Ltd.	58	Evershed & Vignoles Ltd.	52		
Allnutt & Co., Thos.	89	Evertaut Ltd.	62	Oxley Developments Ltd.	87
All-Power Transformers Ltd.	57			Painton & Co. Ltd.	25
Amos of Exeter	89	Farnell Ltd., A. C.	86	Parmeko Ltd.	5
Amplex Appliances (Kent) Ltd.	89	Ferguson Radio Corporation Ltd.	71	Partridge Transformers Ltd.	76
Anders Electronics	83	Fischer Bearings Co. Ltd.	83	Patterson & Partners Ltd.	87
Autophone Ltd.	84 and 89			Powis & Sons Ltd., David	88
Autosef (Production) Ltd.	61			Presspahn Ltd.	90
		Gardner's Radio Ltd.	72	Pye & Co. Ltd., W. G.	76
Baker & Finnermore Ltd.	67	General Electric Co. Ltd., The	34		
Baldwin Instrument Co., Ltd.	68	General Engineering Co. (Radcliffe) Ltd.	33	Radio Resistor Co. Ltd.	24
Barlow-Whitney Ltd.	79	Goodman's Industries Ltd.	11	Radiospares Ltd.	88
B.B. Chemical Co.	79	Graham Gear Co. Ltd.	85	Ragosine Oil Co. Ltd.	44
B.B.C. Publications	80	Griffiths, Gilbert, Lloyd & Co. Ltd.	71	Randall & Son Ltd., James H.	88
Belling & Lee Ltd.	55	Guest, Keen & Nettlefolds (Midlands) Ltd.	72	Reliance Manufacturing Co. (Southwark) Ltd.	88
Bell & Croyden, John	89			Ritherdon & Co. Ltd.	91
Bird & Sons Ltd., Sydney, S.	56	Haddon Transformers Ltd.	10	Rotax Ltd.	63
Birlec Ltd.	3	Hallam, Sleigh & Cheston Ltd.	81		
Blickvac Ltd.	79	Harboro' Rubber Co. Ltd.	85	Salford Electrical Instruments Ltd.	23
Booth & Co. Ltd., James	21	Harwin Engineers Ltd.	90	Saunders-Roe Ltd.	59
Boulton-Paul Aircraft Ltd.	65	Hassett & Harper Ltd.	51	Scott & Co. Ltd., A. C.	44
Bradmatic Ltd.	80	Hill Ltd., C. & L.	49	Servo & Electronic Sales Ltd.	88
Bray & Co. Ltd., George	80	Hivac Ltd.	85	Servomex Controls Ltd.	13
Brayhead Springs Ltd.	84	Household Electric Ltd.	62	Sheffield Smelting Co. Ltd.	63
British Electric Resistance Co. Ltd.	67	Hunton Ltd.	85	Short Brothers & Harland Ltd.	82
British Insulated Callender's Cables Ltd.	Cover i	Improved Metallic Appliances Ltd.	73	Silentbloc Ltd.	78
British Physical Laboratories Ltd.	65	Isotope Developments Ltd.	77	Sivers Lab.	91
Buradep Ltd.	60	Johnson Matthey & Co. Ltd.	47	Smith & Sons Ltd., W. H.	85
				Solartron Laboratory Instruments Ltd.	7 and Cover iv
Chance Bros. Ltd.	68	Kelvin & Hughes Ltd.	73	Spear Engineering Co. Ltd.	88
Chapman & Hall Ltd.	85			Spencer & Sons (Market Harboro') Ltd.	78
Cinema-Television Ltd.	36	Labgear (Cambridge) Ltd.	87	Spurrell Ltd., R. W.	91
Clayton-Wright Ltd., Howard	90	Langham Thompson Ltd., J.	17	Standard Telephones & Cables Ltd.	15, 22 and 54
Connollys (Blackley) Ltd.	53	Linread Ltd.	28	Sugg & Co. Ltd., William	60
Cooper & Co. (Birmingham) Ltd.	84	Londex Ltd.	90	Sunvic Controls Ltd.	43
		London Electric Wire Co. & Smiths Ltd.	74	Sutton Coldfield Electrical Engineers	91
Darwins Ltd.	70	& Vactite Wire Co. Ltd.	74	Synthetic Supplies Ltd.	91
Davis (Relays) Ltd., Jack	89	Lucas Ltd., Joseph	87	Tan-Sad Chair Co. (1931) Ltd.	69
Davis, Wynn & Andrews Ltd.	86	Lyons Ltd., Claude	40	Taylor Tunnicliff & Co. Ltd.	20
Dawe Instruments Ltd.	70			Transradio Ltd.	69 and 82
Decca Radar Ltd.	26	Magnetic & Electrical Alloys Ltd.	39	Twentieth Century Electronics Ltd.	41
De Havilland Aircraft Co. Ltd., The	66	Marconi Instruments Ltd.	31		
Donovan Electrical Co. Ltd.	86	Measuring Instruments (Pullin) Ltd.	38	Unbrako Socket Screw Co. Ltd.	18
		Metropolitan Plastics Ltd.	12	Watson Ltd., R. & W.	86
Edison Swan Electric Co. Ltd., The	Cover ii and 35	Metropolitan-Vickers Electrical Co. Ltd.	32	Wayne-Kerr Laboratories Ltd.	16
Electrical Instrument Co. (Hillington) Ltd., The	83	Micanite & Insulators Ltd.	42	West London Rewind Service Ltd.	91
Electro-Methods Ltd.	66	Microwave Instruments Ltd.	45	Whiteley Electrical Co. Ltd.	3
Electronic Engineering Monographs	81 and 84	Midland Silicones Ltd.	30	Wilkinson's Tools Ltd.	82
Electrothermal Engineering Ltd.	64	Miltoid Ltd.	90	Woden Transformer Co. Ltd.	82
E.M.I. Institutes Ltd.	83 and 86	Muirhead & Co. Ltd.	29	Woods of Colchester Ltd.	14
		Mullard Ltd.	27, 46 and 92		
		Murex Ltd.			

## MUREX 'SINCOMAX' MAGNETS

ARE USED IN

## E.I.C. INSTRUMENTS



Photograph by courtesy of E.I.C. (Hillington) Ltd., Glasgow

The high magnetic stability and strength of 'Sincomax' magnets makes a robust job even of a sensitive Microammeter. In this application as in many others Murex Sintered Magnets continue to give accurate and reliable service.

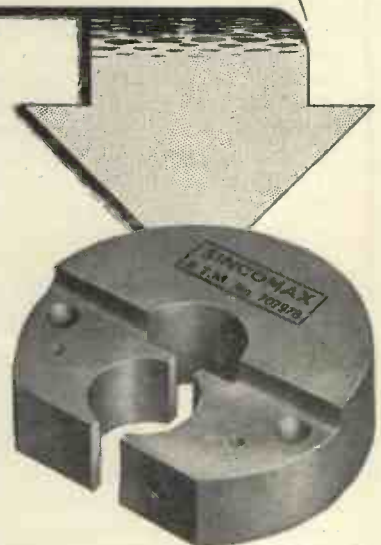

**MUREX LIMITED (Powder Metallurgy Division)**

RAINHAM • ESSEX • Rainham, Essex 3322

London Sales Office: Central House, Upper Woburn Place, W.C.1. Euston 8265

New!

# ERIE<sup>★</sup> 'Gimmicks'

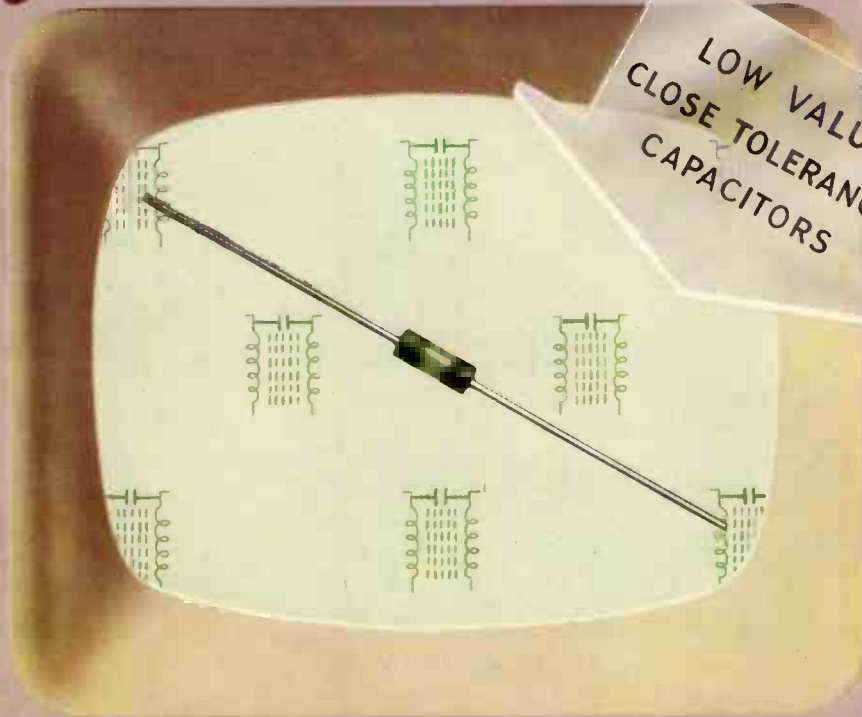

Illustration  
actual size

ERIE "GIMMICKS" have been introduced to meet a new, and urgent, demand from the Television Industry for reasonably priced, low value, close tolerance, capacitors, of a very small physical size, principally for top-end coupling.

"Gimmick" is American slang for a piece of apparatus said to be used by fairground people in manipulating prizegiving tumtables so as to determine the winners, from which it has generally become to mean anything used by magicians and such like for the purpose of trickery.

We do not claim any magical properties for the Erie "Gimmick", except, perhaps, its appearance

from the hat at precisely the right time, but we do claim fitness for the job, and reliability; attributable, not to trickery, but rather to those tricks of the trade which come from sound, painstaking engineering and from long experience.

In short, we apply the term "Gimmick" to these new capacitors because they really are devices for performing a trick, which cannot be achieved by the conventional capacitor, and, in this sense we feel the term is fit.



Manufacturers and  
Designers are  
invited to ask for  
advance information

# ERIE<sup>★</sup>

## Resistor Ltd

\* Registered Trade Marks

Carlisle Road, The Hyde, N. W. 9., England. Telephone: COLindale 8011. Factories:  
London and Great Yarmouth, England; Toronto, Canada, Erie, Pa., U. S. A.



## **S.L.I. HISTORY IN THE MAKING**

Across the River Thames and facing the lovely grounds of historic Hampton Court Palace stands the newly acquired factory of the Solartron Group of Companies. Working under ideal conditions, S.L.I. is now equipping for vastly increased production of traditional high quality electronic equipment. We extend a cordial invitation for you to inspect our achievements.

For problems in phase measurement from 0.5 c/s to 20 Kc/s consult :



*Typical of the new instruments shortly going into production is this phase sensitive voltmeter, Model VP 250.*

# **SOLARTRON**

**SOLARTRON LABORATORY INSTRUMENTS LIMITED,**  
Solartron Works, Queens Road, Thames Ditton. Tel.: Emberbrook 5611PBX