

Electronic Engineering

SEPTEMBER 1952



By Appointment to the Professional Engineer....

ATTENUATORS · FADERS · STUD SWITCHES AND TOGGLE SWITCHES
WIREWOUND POTENTIOMETERS · HIGH STABILITY CARBON RESISTORS
WIREWOUND RESISTORS · PLUGS AND SOCKETS · TERMINALS
KNOBS DIALS AND POINTERS

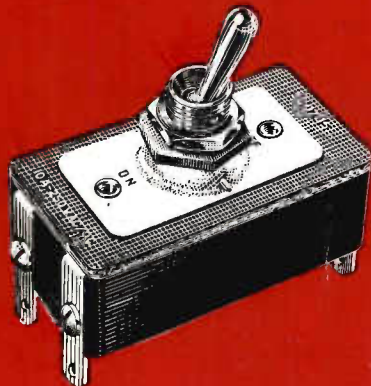

PAINTON
Northampton England

TWO SHILLINGS

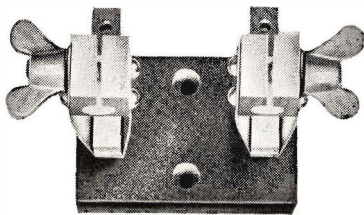
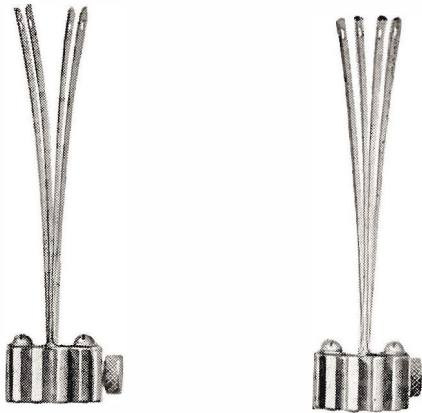

EDISWAN

SPECIAL PURPOSE VALVES

Of particular interest TO THE DESIGNERS OF R.F. HEATING AND DIATHERMY APPARATUS

The ES.833 is a high mu triode particularly suitable for use as an R.F. Power Amplifier, Oscillator or Class B Modulator. It is a direct plug-in replacement for the American type 833A.

The anode and grid connections are brought out at the top and are taken through metal-to-glass seals to heavy current terminals. As a result of this construction the valve is exceptionally efficient at higher radio frequencies, and may be operated under Class 'C' CW conditions at a maximum input of 2 kW at frequencies up to 30 Mcs. At a reduced input rating it is possible to operate the valve as high as 75 Mcs.

RATING	RADIATION COOLED	AIR COOLED
Filament Voltage (volts)	Vf	10.0
Filament Current (amps)	If	10.0
Maximum Anode Voltage (volts)	Va (max) 3000	4000
Maximum Anode Dissipation (watts) Radiation cooled	Wa (max) 300	
Maximum Anode Dissipation (watts) Forced Air cooled	Wa	400
Amplification Factor	μ	35
Maximum Operating Frequency at full rating		30 Mcs.*

* Operating frequency at reduced ratings up to 75 Mcs.

Prices and technical data upon application

EDISWAN

THE EDISON SWAN ELECTRIC CO. LTD., 155 CHARING CROSS RD., LONDON, W.C.2
Member of the A.E.I. Group of Companies (R.V.223)

CLASSIFIED ANNOUNCEMENTS

The charge for these advertisements at the LINE RATE (if under 1" or 12 lines) is: Three lines or under 7/6, each additional line 2/6. (The line averages seven words.) Box number 2/- extra, except in the case of advertisements in "Situations Wanted," when it is added free of charge. At the INCH RATE (if over 1" or 12 lines) the charge is 30/- per inch, single column. Prospectuses and Company's Financial Reports £14.0s.0d. per column. A remittance must accompany the advertisement. Replies to box numbers should be addressed to: "Electronic Engineering," 28, Essex Street, Strand, London, W.C.2. Advertisements must be received before the 14th of the month for insertion in the following issue

OFFICIAL APPOINTMENTS

APPLICATIONS are invited by the Ministry of Supply from Physicists and Engineers for appointments in the grade of Principal Scientific Officer and Senior Scientific Officer at London Headquarters for work concerned with the development of guidance and control systems and application of specialist techniques including radio, radar and electronics to such systems. Experience in the development of auto pilots and servo-mechanisms is desirable. Candidates should have a 1st or 2nd class Honours Degree or equivalent in Physics or Engineering followed by at least three years research experience. Salary and grade will be assessed according to qualifications and experience within the inclusive ranges: P.S.O. (minimum age 31) £1,075-£1,459 p.a. male. S.S.O. (minimum age 26) £812-£1,022 p.a., male. Rates for women somewhat lower. The posts are unestablished but carry F.S.S.U. benefits. Application forms obtainable from Ministry of Labour and National Service, Technical and Scientific Register (K), Almack House, 26, King Street, London, S.W.1., quoting A.206/52A. W 2881

APPLICATIONS are invited by the Ministry of Supply for appointments in the Experimental Officer class at the Atomic Energy Research Establishment, Harwell, Berks., for mechanical engineering experimental and development work. Selected candidates will be required to work as members of small research teams engaged in one of the following fields: heat transfer, fluid pumps, bearings and shaft seals, small electric power equipment and general instrumentation techniques. Candidates must possess at least a Higher School Certificate with physics as the main subject or equivalent qualification. A Higher National Certificate or a Degree in an engineering subject and/or previous related research experience, may be an advantage. Salary assessed according to age, qualifications and experience within the following inclusive ranges: Experimental Officer £597-£754, Assistant Experimental Officer £264-£555. Rates for women somewhat lower, posts are unestablished. Application forms obtainable from Ministry of Labour and National Service, Technical & Scientific Register (K), Almack House, 26, King Street, London, S.W.1., quoting A.209/52/A. Closing date 13th September, 1952. W 2890

APPLICATIONS are invited by the Ministry of Supply from Electrical Engineers and Physicists for appointment in the grade of Scientific Officer at the Royal Aircraft Establishment, Farnborough, Hants. Candidates must have a 1st or 2nd class Honours Degree or equivalent in Electrical Engineering or Physics. Experience in the design of electronic circuits in the L.F. and I.F. ranges is desirable and a knowledge of pulse techniques with some practical experience of the operation and design of radar sets would be an advantage. Salary will be assessed according to age, qualifications and experience within the inclusive range: £417-£675 p.a., male. Rates for women somewhat lower. The post is unestablished but carries F.S.S.U. benefits. Application forms are obtainable from the Ministry of Labour and National Service, Technical and Scientific Register (K), Almack House, 26, King Street, London, S.W.1., quoting D.302/52A. Closing date 12th September, 1952. W 2894

ASSISTANT (SCIENTIFIC) CLASS: The Civil Service Commissioners give notice that an Open Competition for pensionable appointment to the basic grade will be held during 1952. Interviews will be held throughout the year, but a closing date for the receipt of applications earlier than December, 1952, may eventually be announced either for the competition as a whole or in one or more subjects. Candidates must be at least 17 and under 26 years of age on 1st January, 1952, with extension for regular service in H.M. Forces, but candidates over 26 with specialized experience may be admitted. All candidates must produce evidence of having reached a prescribed standard of education, particularly in a science subject and of thorough experience in the duties of the class gained by service in a Government Department or other civilian scientific establishment or in technical branches of the Forces, covering a minimum of two years in one of the following groups of scientific

subjects: (i) Engineering and physical sciences. (ii) Chemistry, bio-chemistry and metallurgy. (iii) Biological Sciences. (iv) General (including geology, meteorology, general work ranging over two or more groups (i) to (iii) and highly skilled work in laboratory crafts such as glass-blowing). Salary according to age up to 25: £236 at 18 to £363 (men) or £330 (women) at 25 to £500 (men) or £418 (women); somewhat less in the provinces. Opportunities for promotion. Further particulars and application forms from Civil Service Commission, Scientific Branch, Trinidad House, Old Burlington Street, London, W.1., quoting No. S 59/52. Completed application forms should be returned as soon as possible. W 2927

BBC requires Engineer in Designs Department, London. Duties are concerned with design and development of sound recording equipment, etc., and entail work on own initiative with responsibility for production of original designs and for organising manufacture of pre-production models. Qualifications include wide experience of mechanical design and manufacture of light mechanisms and electro mechanical devices, good knowledge of low frequency electronics. Experience of sound recording not essential. Starting salary £795 with increments to £1,065 p.a. Applications to Engineering Establishment Officer, Broadcasting House, W.1., within 7 days. W 2875

B.B.C. requires a limited number of Technical Assistants aged 21 or over in Operations and Maintenance Department for service at Transmitter, Studio, Recording and Television Centres throughout the United Kingdom. Knowledge of mathematics, electricity and magnetism to School Certificate standard; experience in electrical or radio engineering an advantage. Salary £360 p.a. with annual increments to £470 p.a. maximum. Promotion prospects. Application forms from Engineering Establishment Officer, Broadcasting House, London, W.1. (enclosing addressed foolscap envelope). After completion forms to be sent to B.B.C., c/o Ministry of Labour, 211 Marylebone Road, London, N.W.1., making envelope T.A.11. W 2919

CHIEF LABORATORY TECHNICIAN. Nuclear Physics Laboratory, Queen Mary College (University of London), Mile End Road, E.1. Starting salary according to ability on scale £455 per annum by £26 to £559 per annum, plus London Weighting. Applicants must have Electronic, H.V. Electrical Engineering, or High Vacuum equipment experience. Pension scheme. Duties begin September/October by arrangement. Letters only to Registrar, stating age, experience, present work. W 2874

CROWN AGENTS FOR THE COLONIES. Wireless Station Superintendent (temporary) required by the Gold Coast Government Posts and Telegraphs Department for two tours of 18 to 24 months in the first instance. Commencing salary, according to qualifications and experience in the consolidated scale £955 rising to £1180 a year, with gratuity of £25 or £37 10s. 0d. according to salary, for each completed period of three months' service. Outfit allowance £60. Liberal leave on full salary. Free passages. Candidates must possess a Higher National Certificate in Electrical Engineering or equivalent, and have had practical experience in two or more of the following fields: V.H.F. link systems; H.F. communication network; Frequency shift keying and teleprinter maintenance; V.H.F. and H.F. Direction finding systems; Aeronautical navigation aids (ground); Manufacture of light engineering equipment. Apply at once by letter, stating age, full names in block letters, and full particulars of qualifications and experience, and mentioning this paper to the Crown Agents for the Colonies, 4, Millbank, London, S.W.1., quoting on letter M.29100.B. The Crown Agents cannot undertake to acknowledge all applications and will communicate only with applicants selected for further consideration. W 2915

UNIVERSITY OF GLASGOW. Lectureship in Electrical Engineering. Applications are invited for a Lectureship in Electrical Engineering. Salary scale: £500-50-£1100 (subject to efficiency bar at £800). The appointment will be made below the efficiency bar; initial salary according to qualifications and experience. F.S.S.U. and

family allowance benefits. Applicants must have an Honours Degree in engineering and industrial experience; some teaching experience is desirable. Duties consist of lecture, tutorial and laboratory teaching of electrical engineering experiences. A special interest either in electrical machines or in electronics will be a recommendation. Applications (5 copies), including the names of two referees should be lodged not later than 6th September, 1952, with the undersigned, George P. Richardson, Assistant Secretary of University Court. W 2926

VACANCIES IN GOVERNMENT SERVICE. Leading Draughtsman required in Government Department in Gloucestershire. The successful applicant would be required to serve in Kent for a short period initially. Salary (Provincial rate): Leading Draughtsman £540 × £20-£645; Draughtsman £320 × £20-£460 (maximum starting salary) thence to £545. There are prospects of promotion to Senior Draughtsman on salary scale £645 × £25-£785. A pay addition is made to the above rates as follows: 10 per cent on the first £500 per annum plus 5 per cent on the next £500 per annum. Candidates must be natural born British subjects of at least 21 years of age. They must be able to undertake detailed mechanical design on small and intricate radio, electronic and telecommunications apparatus; the preparation of circuit diagrams, layout and construction drawings; and the scheduling of electrical and mechanical components. They must have obtained the Ordinary National Certificate or equivalent, or have served at least 3 years in a drawing office. A knowledge of Ministry of Supply or Air Ministry procedure would be an additional advantage. The appointment will be unestablished in the first instance, but opportunities arise for establishment by examination. Fuller details of applications to Box No. W 2883.

SITUATIONS VACANT

The engagement of persons answering these advertisements must be made through a Local Office of the Ministry of Labour or a Scheduled Employment Agency if the applicant is a man aged 18-64 inclusive or a woman aged 18-59 inclusive unless he or she, or the employment, is exempted from the provisions of the Notification of Vacancies Order, 1952.

A PHYSICIST or ELECTRONICS ENGINEER is required for the development of Electronic Circuits for Servomechanisms and Instruments for Steel Industry. A high standard of design ability is called for and the applicant should have experience in design and building of Industrial Electronics and organising a small Development Team. The location of work is in the Sheffield area. Apply to Box No. W 2871.

A SENIOR COMMERCIAL APPOINTMENT is offered in the Equipment Division of Mullard Ltd., to an applicant having experience in the operational or systems planning aspects of radio communications and/or broadcast transmitters and systems. Candidates should have a University Degree or equivalent, an interest in the systematic organization and handling of various types of equipment and should be experienced in dealing with customers at all levels. Please forward personal details including salary required to the Personnel Officer, Mullard Ltd., Century House, Shaftesbury Avenue, W.C.2. Applications will be treated in confidence. W 2929

A VACANCY exists for an experienced Electronic Circuit Engineer in the Research Laboratories. Applicants should have had at least three years' experience in electronic circuit design, preferably as applied to instrumentation and should possess either a Degree, Higher National Certificate or equivalent qualifications. Commencing salary would be up to £700. Write Personnel Officer, Ericsson Telephones Limited, Beeston, Nottingham. W 2925

ADDISON ELECTRIC COMPANY LTD. require experienced electronic engineer to take charge of and build up new laboratory for prototype instrument development and design. Appointment will entail occasional visits abroad to Company's overseas clients. Interesting work, scope and opportunity for man with

SITUATIONS VACANT (Cont'd.)

The engagement of persons answering these advertisements must be made through a Local Office of the Ministry of Labour or a Scheduled Employment Agency if the applicant is a man aged 18-64 inclusive or a woman aged 18-59 inclusive unless he or she, or the employment, is excepted from the provisions of the Notification of Vacancies Order, 1952.

ideas. Full details and salary required to Addison Electric Co., Ltd., 10/12 Bosworth Road, North Kensington, London, W.10. W 2924

AERONAUTICAL SERVICE ENGINEER required. Duties will include installation, flight testing and servicing, for which a thorough practical and theoretical knowledge of A.C. and D.C. amplifier systems is required. A knowledge of electro-mechanical servo systems and synchronous transmission systems, would be an advantage. Preferential consideration will be given to applicants with previous electronic experience in possession of H.N.C. (or equivalent), or who have served a recognised engineering apprenticeship with subsequent experience in technical capacity. Must be prepared to travel. Position will be permanent and pensionable after qualifying period. Commencing salary £450 p.a. Apply with full details of age, qualifications and experience to Personnel Manager, Sperry Gyroscope Co., Ltd., Great West Road, Brentford, Middlesex. W 2905

AMBASSADOR RADIO & TELEVISION require Electronic Engineers for laboratory research and development work. Applicants must have had reasonable experience in electronic research and development. They should be graduates in Physics, Tele-Communications or Electrical Engineering, or hold the Higher National Certificate or City and Guilds Final in Radio subjects. Progressive positions are offered to men who can prove their ability. Commencing salary in accordance with qualifications and experience. Applications must be made in writing in the first instance, intimating availability for interview at Princess Works, Brighouse, Yorkshire. W 2879

AN ELECTRICAL ENGINEER required for investigation and quality control work in Radio Valves and other electronic devices. Inter B.Sc. standard or equivalent. Apply, Personnel Superintendent, The Edison Swan Electric Co., Ltd., Cosmos Works, Brimsdown, Enfield, Middlesex. W 2903

AN ELECTRONIC ENGINEER with development experience required to control small test department engaged on testing and calibrating all types of electronic test equipment. Please write stating age, experience and salary required to Box No. W 1550.

AN EXPERIENCED GRADUATE is required by the General Electric Co. Ltd., for work at their Stanmore Laboratories for responsible work concerned with the development of specialized test equipment for airborne radar. An original approach to the problem is necessary and a knowledge of microwave techniques or circuit design is essential. Apply to the Staff Manager (Ref. GBLC/S/509) G.E.C. Research Laboratories, Wembley, Middlesex, stating age, qualifications and experience. W 2909

BELLING & LEE LTD., Cambridge Arterial Road, Enfield, Middlesex, require research assistants in connexion with work on electronic components, fuses, interference suppressors and television aerials. Applicants must be graduates of the I.E.E. or possess equivalent qualifications together with similar laboratory experience. Salary will be commensurate with previous experience: five day week, contributory pension scheme. Applications must be detailed and concise, and will be treated as confidential. W 138

CARRIER TELEPHONE ENGINEER several years' experience required by American Company with Sales Branch in Southern Europe for sales and installation work. Young, preferably bachelor, considerable travelling involved. Box No. W 1542.

DECCA RADAR intend during the next few months to fill a few senior posts with Research and Development engineers of sound training and extensive experience. This is an opportunity for men with more than average ability and initiative to secure appointments which offer excellent remuneration, advanced work of vital importance and the very definite opportunity to obtain a key position in this young but soundly established company. Those who wish to discuss the matter further should write

in confidence to the Research Director, Decca Radar Limited, 2 Tolworth Rise, Surbiton, Surrey. W 2877

DECCA RADAR intend during the next few months to fill a few senior posts with Research and Development engineers of sound training and extensive experience. This is an opportunity for men with more than average ability and initiative to secure appointments which offer excellent remuneration, advanced work of vital importance and the very definite opportunity to obtain a key position in this young but soundly established company. Those who wish to discuss the matter further should write in confidence to the Research Director, Decca Radar Limited, 2, Tolworth Rise, Surbiton, Surrey. W 2916

DESIGNER, with Degree or H.N.C. and with experience in light mechanical engineering is required for work at Stanmore by the G.E.C. Research Laboratories, Wembley, Middx. This is a first class opening for an experienced engineer interested in working with experimental research and development teams. Apply to the Staff Manager (Ref. GBLC/S/987), stating age, qualifications and experience. W 2899

DESIGNERS required for Factory Test Apparatus. Experience in Pulse Techniques essential. Apply Personnel Manager, E. K. Cole Ltd., Ekco Works, Malmesbury, Wilts. W 2885

DEVELOPMENT ENGINEERS/PHYSICISTS. Senior positions with good prospects in connexion with the development of electronic computing and training equipment, including Flight Simulators. Experience in electronics essential. Good starting salaries, depending upon age, experience and qualifications. Location, near Waterloo station. Apply in writing to: Chief Engineer, Redifon Ltd., Broomhill Road, Wandsworth, S.W.18. W 2802

DRAUGHTSMEN. Senior and Junior Electro Mechanical and Circuit Draughtsmen required for work on electronic computing and training equipment, including Flight Simulators. Location near Waterloo station. Apply in writing to Mr. G. B. Ringham, Chief Engineer and Manager, Flight Simulator Division, Redifon Ltd., Broomhill Road, Wandsworth, S.W.18. W 2889

E. K. COLE LTD. (Malmesbury Division) invite applications from Electronic Engineers for permanent posts in Development Laboratories engaged on long-term projects involving the following techniques: 1. Pulse Generation and Transmission. 2. Servo Mechanism. 3. Centimetric and V.H.F. Systems. 4. Video and Feedback Amplifiers. 5. V.H.F. Transmission and Reception. 6. Electronics as applied to Atomic Physics. There are vacancies in the Senior Engineer, Engineers and Junior Grades. Candidates should have at least 3 years' industrial experience in the above types of work, together with educational qualifications equivalent to A.M.I.E.E. examination standard. Commencing salary and status will be commensurate with qualifications and experience. Excellent opportunities for advancement are offered with entry into a Pension Scheme after a period of service. Forms of application may be obtained from Personnel Manager, ECKO Works, Malmesbury, Wilts. W 2800

ELECTRICAL ENGINEERS with an interest in servo-systems and small mechanical devices are required by the Research Laboratories of The General Electric Co. Ltd., Wembley, Middlesex for work at Stanmore. University Degree or H.N.C. is essential plus some experience in the development of small mechanisms. Write to the Staff Manager (Ref. GBLC/S/574) stating age and record. W 2922

ELECTRICAL ENGINEERING LABORATORY. Senior Technician. Queen Mary College (University of London), Mile End Road, E.1. Starting salary according to ability on scale £338 p.a. by £13 to £442 p.a. plus (a) London Weighting, (b) possible special qualification pay up to £39 p.a. Preference to an applicant with Ordinary National Certificate or experience of electronic apparatus and measuring instruments. Pension scheme. Letters only to the Registrar, stating age, experience, present work. W 2882

ELECTRO-MECHANICAL ENGINEERS required with good academic qualifications, apprenticeship, theoretical background and knowledge of production methods for development work. Experience in electrical methods of computation, servo theory and instrument design desirable. Apply with full details of age, experience and salary required to the Personnel Manager, Sperry Gyroscope Co. Ltd., Great West Road, Brentford, Middx. W 2904

ELECTRONIC ENGINEER required by well known North London Company. Wide knowledge of low frequency circuit techniques with sound design ability. The Laboratory specializes in industrial and medical electronic apparatus for small scale production. Degree, corporate membership of I.E.E. or equivalent required. Interesting variety of work with good opportunities, pension scheme, etc. Write quoting reference EE stating education, experience and salary required to Box No. W 2892.

ELECTRONIC ENGINEER required for research and experimental work in North London factory. Should have reached Honours Degree standard in engineering or physics and should also have a knowledge of electronics including generation, transmission and matching of loads at frequencies between 1 and 20 megacycles per sec. An interest in administration and a good mechanical aptitude are desirable. Salary according to training and experience. Box No. W 2912.

ELECTRONIC ENGINEER urgently required by manufacturers of industrial electronic equipment. Applicants should have sound technical qualifications and have had some years of development work. Good salary and scope to suitable applicant. Write with full details to Box No. W 2928.

ELECTRONIC ENGINEER H.N.C. with circuit design experience, including some radio communication work, required for small organization on South Coast. First class opportunity for keen young engineer to take charge of project development. State full details and salary required. Box No. W 1546.

ELECTRONIC RESEARCH and Development Engineers and Physicists. Applications are invited by an old established London firm of repute for: (a) Two senior posts of a highly interesting nature with scope for individual work and advancement. (b) One junior post. (c) One draughtsman with electrical design experience. A first or second class Honours Degree in Physics or Electrical Engineering would be an asset for the posts (a) and (b). Applications will be treated in strict confidence. Write giving details of qualifications, experience and salary required, to Box No. W 1525.

ENGINEER OR PHYSICIST experienced in radar is required for work in connexion with flight trials of airborne and radar equipment. Degree on Higher National Certificate required. Experience of aircraft and flying desirable, but not essential. Apply in writing to the Staff Manager (Ref. GBLC/S/994), Research Laboratories of the General Electric Co. Ltd., North Wembley, Middlesex, stating age, qualifications and experience. W 2896

ENGINEERS required for interesting work on components for Telecommunications and Television Transmission Equipment. Should be capable of undertaking development work without supervision. Scope for men with enterprise and imagination with suitable experience. Degree or equivalent desirable but not essential. Apply Box No. W 2834.

ENGINEERS with H.N.C. or equivalent and some experience required for work of national importance on industrial electronic instruments. Salary £550 and upwards per annum, according to experience and ability. Age 25 to 35. Box No. W 2907.

ENGLISH ELECTRIC COMPANY LTD., Luton, invite applications for permanent posts in a department developing and engineering in a wide variety of specialized electronic circuits. Previous experience in such work would be an asset and, for one vacancy, some experience in optics or oscillography would be a recommendation. Salaries will be in accordance with qualifications and experience, up to £625 per annum. The laboratories are new and pleasantly situated. Please write, giving full details and quoting reference 1002, to Central Personnel Services, English Electric Co. Ltd., 24-30, Gillingham Street, London, S.W.1. W 2839

ENGLISH ELECTRIC COMPANY LIMITED, Luton, have vacancies for Designers and Draughtsmen for both light electrical and mechanical development work on guided weapons. Technical qualifications such as ordinary National Certificate desirable but not essential. This is an excellent opportunity in a new field. Please write, giving full details and marking your application "English Electric 144G" to Westminster Employment Exchange, Chadwick Street, London, W.1. W 2820

CLASSIFIED ANNOUNCEMENTS
continued on page 4

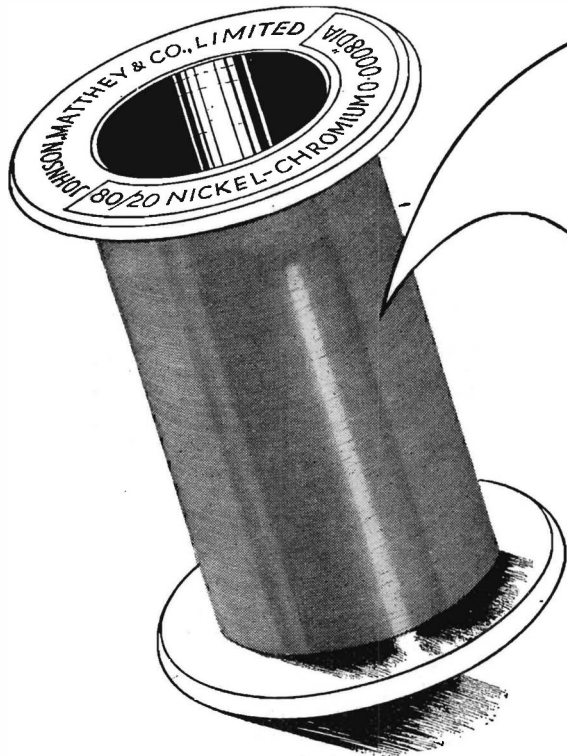

I, sir
will Resist...

... and my value may be relied upon, absolutely, for I am one of the J.M.C. precision resistance wires. I am found in any precision instrument where accurately controlled resistance is of prime importance.

Johnson Matthey precision resistance wires are produced to meet all requirements. Each spool is marked with an accurate resistance value for the wire it contains, a value that is maintained within *precise* tolerances throughout the entire spool. Publication 1440, "Electrical Resistance Materials," giving full technical data, is available on request.

And I will
protect you!



The J.M.C. plastic container ensures complete protection for the wire upon its light alloy spool up to the moment of use.

Specialised Products of

A series of technical data sheets descriptive of our materials and products for instrument manufacture is available on request.

Johnson 
Matthey

JOHNSON, MATTHEY & CO., LIMITED HATTON GARDEN LONDON, E.C.1
Telephone: HOLborn 9277 BIRMINGHAM: Vittoria Street, Birmingham 1

SITUATIONS VACANT (Cont'd.)

The engagement of persons answering these advertisements must be made through a Local Office of the Ministry of Labour or a Scheduled Employment Agency if the applicant is a man aged 18-64 inclusive or a woman aged 18-59 inclusive unless he or she, or the employment, is excepted from the provisions of the Notification of Vacancies Order, 1952.

EXCELLENT OPPORTUNITIES at Ferguson Radio Corporation Ltd., Gt. Cambridge Road, Enfield, for Draughtsmen fully experienced in Radio, Television or Electronic Design. Knowledge of Government Dept. practice an advantage. Good rate of pay. Vacancies offered subject to Notification of Vacancies Order, 1952. W 2886

EXPERIENCED Radio Testers and Inspectors required for production of communication and radio apparatus. Also Instrument makers, wiremen and assemblers for Factory Test apparatus. Apply Personnel Manager, E. K. Cole Ltd., Ekco Works, Malmesbury, Wilts. W 146

EXPERIENCED COMPONENT ENGINEERS are urgently required by the English Electric Co. Ltd. Applicants selected will be required to build up a new section specializing in selection and design of electrical and mechanical components for electronic equipment, together with associated light and medium heavy control gear, transformers and wiring. Applicants should have a full working knowledge of service specifications and type approval procedure, experience of component design and an understanding of ratings. Please write, giving full details of experience and qualifications and quoting reference 986 to Central Personnel Services, English Electric Co. Ltd., 24-30, Gillingham Street, London, S.W.1. W 2835

EXPERIENCED ELECTRONIC ENGINEER required by the English Electric Company Limited, Luton, for investigation into the nature of mechanical vibrations in connexion with guided missiles project. Position of responsibility in a new department is available for a well qualified man. Adaptability and ability to develop electronic measuring techniques required. H.N.C. or equivalent and some experience of vibration work essential. Salary according to qualifications. Please write giving full details of qualifications and experience and quoting reference "850 C" to Central Personnel Services, English Electric Company Ltd., 24-30, Gillingham Street, London, S.W.1. W 2846

EXPERIENCED ENGINEER required by company in North-West England for design and development of television aerials and associated components. Write giving age, experience and salary required to Box No. W 1524.

EXPERIENCED MEN (ex-Service Radar Mechanics preferred) are required for duties in the Electronics Division of Saunders-Roe Limited. Applicants should be capable of intelligent assembly and wiring of a wide variety of electronic apparatus from circuit diagrams. Write, giving details of experience, age, etc., to the Personnel Officer, Saunders-Roe Limited, East Cowes, Isle of Wight. W 2895

EXPERIMENTAL ASSISTANT required for materials laboratory associated with electronics research. Applicants should have had experience in one or more of the following fields: plastics vacuum techniques, ceramics, adhesives. Degree desirable but not essential. Apply to the Staff Manager (Ref. GBLC/S/572) Research Laboratories of The General Electric Co. Ltd., Wembley, Middlesex, stating age and record. W 2920

FERRANTI LIMITED, Edinburgh, require additional staff for their Engineering Division engaged on Electro/Mechanical instruments and radar equipment. Duties involve (a) the engineering and production design of new items to be put into production after the prototype has been evolved in the laboratories and (b) the clearing of technical snags during the various stages of production. Applicants should be fully qualified engineers and preferably have (a) Degree or Corporate Membership of one of the professional institutions (b) several years' experience in production design of instrument or radar equipment, and (c) knowledge of production methods. Opportunity for initiative, good prospects; staff pension scheme. Apply quoting reference "E.D." and give full details of training and experience in chronological order to the Personnel Officer, Ferranti Limited, Ferry Road, Edinburgh. W 145

FERRANTI LTD., Moston, Manchester, have the following vacancies for work in connexion

with the development of cathode ray tubes for television, oscillography and special purposes: (1) Senior Engineers and Scientists to take charge of research and development sections. Applicants should have a good Degree in physics, electrical engineering or glass technology, and have had experience in supervising development work. Salary according to qualifications and experience, in the range £750 to £1,250 per annum. Please quote reference GCT/1. (2) Engineers and Scientists for work in the following fields: Thermionic emission, vacuum techniques, electron optics, photo-electric phenomena, electronic circuits, glass technology and high-voltage techniques. Qualifications include a good Degree or equivalent. Previous experience would be an advantage, though not essential. Salary, according to qualifications and experience, in the range £450 to £1,000 per annum. Please quote reference GCT/2. (3) Mechanical or Production Engineers to undertake the development of machinery for mass-production of electronic devices. Qualifications etc. as in (2). Please quote reference GCT/3. (4) Technical Assistants for experimental work in the fields listed in (2) above. Qualifications are a degree or Higher National Certificate. Salary range £400 to £600 per annum according to age and qualifications. Please quote reference GCT/4. The Company has a Staff Pensions Scheme. Application forms from Mr. R. J. Hebbert, Staff Manager, Ferranti Limited, Hollinwood, Lancs. Please quote appropriate reference. W 2917

FERRANTI LIMITED, Manchester, have staff vacancies in connexion with long-term development work on an important radio tele-control project at their new laboratories at Wythenshawe, South Manchester. (1) Senior Engineers or Scientists to take charge of research and development sections. Qualifications include a good degree in Physics or Electrical Engineering and extensive past experience in charge of development work. Salary according to qualifications and experience in the range of £1,000-£1,600 per annum. Please quote reference WS. (II) Engineers and Scientists for research and development work in the following fields: Radar, radio and electronic circuits, micro waves, high power centimetric valves, vacuum and/or high voltage techniques, servo control and electro-mechanical devices. Qualifications include a good degree in Physics or Electrical Engineering or Mechanical Science, or equivalent qualifications. Previous experience is an advantage but is not essential. Salary according to qualifications and experience in the range £500-£1,000 per annum. Please quote reference WE. (III) Technical Assistants for experimental work in the fields listed in (II) above. Qualifications required: a Degree or Higher National Certificate in Electrical or Mechanical Engineering or equivalent qualifications. Salary in the range of £400-£600, according to age and experience. Please quote reference WT. (IV) Designers and Draughtsmen. Section leaders, leading draughtsmen, draughtsmen and junior draughtsmen, preferably with experience in any of the fields mentioned above. Salaries based on A.E.S.D. rates: in the range £330-£850 per annum with good allowances for special qualifications and experience. Please quote reference WD. The Company has a Staff Pension Scheme. Application forms from Mr. R. J. Hebbert, Staff Manager, Ferranti, Ltd., Hollinwood, Lancs. Please quote appropriate reference. W 2721

GENERAL ELECTRIC COMPANY have two vacancies for graduates for work at Stanmore. (a) An experienced man is required to take major responsibility for the design and operation of system test apparatus to be used in connexion with airborne radar equipment. (b) Physicist or engineer for work on electronic simulators. Apply in writing to the Staff Manager (Ref. GBLC/S/995). Research Laboratories of the General Electric Co. Ltd., Wembley, Middlesex, stating age, experience and qualifications. W 2897

GRADUATE physicists and engineers are required at the G.E.C. Stanmore Laboratories for work concerned with (a) electronic circuitry (b) electronic simulators and (c) magnetic amplifiers or small power electric motors. Experience in one of these fields will be an advantage. Apply to the Staff Manager (Ref. GBLC/S/575) Research Laboratories of The General Electric Co. Ltd., Wembley, Middlesex, stating age, qualifications and experience. W 2923

GUIDED WEAPONS DEVELOPMENT offers good opportunities for Senior and Junior Electronic, Electrical, Radio and Mechanical Engineers and Draughtsmen, Aerodynamicists, Technical Authors, and Computers (female); also for skilled and semi-skilled Fitters, Electronic Wiremen, Toolmakers and Machine Tool

Operators. Apply, quoting reference S.P. and giving particulars, qualifications and experience, to the Employment Manager, Vickers-Armstrongs Limited (Aircraft Section), Weybridge, Surrey. W 2914

HIVAC LIMITED, the rapidly expanding Electronics Division of Automatic Telephone and Electric Co., Ltd., will shortly open new premises at Ruislip, Middlesex, with excellent modern facilities for the development and manufacture of miniature and sub-miniature valves, cold cathode tubes and other electronic devices. Applications are invited from Engineers, Physicists and Chemists with previous experience in the valve industry or in precision engineering for posts in the Development and Production Departments which occur as a result of this expansion. The appointments, a number of which will be for senior positions, will all be pensionable, offer splendid opportunities for advancement, and good salaries. Preference will be given to applicants with a University Degree in Physics, Engineering or Chemistry, or who are members of an appropriate professional body. Applications, stating age, full details of qualifications and experience, together with an indication of salary expected, should be addressed to The Managing Director, Hivac Limited, Greenhill Crescent, Harrow-on-the-Hill, Middx. W 2794

JUNIOR DEVELOPMENT ENGINEERS are required to assist in development of precision electronic laboratory instruments. Successful applicants will be engaged on interesting long-term projects concerned with the development of a wide range of equipment. The appointments are of a permanent nature, they carry considerable technical responsibility and offer scope for the exercise of individual initiative. Applicants should have had previous practical experience of development, preferably in the instrument field. Theoretical qualifications ranging from O.N.C. (or an equivalent standard) to a University Degree in Communications Engineering or Physics are acceptable. Salaries are in the range of £350-£650 p.a. and are dependant upon age, qualifications and experience. Applications should be made to Personnel Manager, Furzehill Laboratories Ltd., Boreham Wood, Herts. W 147

LABORATORY ASSISTANT required (Male or Female) for Development Section. Age 21/25. Applicants should have some knowledge of the design of networks for telecommunications systems. The work will include computing and in this connexion experience of desk calculating machines is essential. Apply Personnel Manager, Telephone Manufacturing Co., Ltd., Sevenoaks Way, St. Mary Cray, Kent, Orpington 6611. W 2902

MURPHY RADIO LTD. have vacancies for designer draughtsmen in their Electronics Division. A varied programme ensures opportunity of widening experience with excellent prospects. Apply giving particulars of training and experience to Personnel Manager, Murphy Radio Ltd., Welwyn Garden City, Herts. W 2884

PHYSICIST OR DEVELOPMENT ENGINEER required for Research and Development of X-Ray and Electro-Medical equipment. Applicants should have a degree in Physics or Electrical Engineering. Salary according to age, qualifications and experience. General Radio-Portland Limited, 15-18, Clipstone Street, Great Portland Street, London, W.1. W 1356

PRACTICAL ENGINEER, with qualifications to about University Degree standard, and with good all round mechanical and electrical experience is required for the design of small components used in the field of electronic research. This is an attractive opening for work at Stanmore. Apply to Staff Manager (Ref. GBLC/S/573) Research Laboratories of The General Electric Co. Ltd., Wembley, Middlesex, stating age and record. W 2921

QUALIFIED RADIO, radar and servo control engineers and optical system designers, as well as physicists interested in these subjects urgently required for a guided weapons project by the English Electric Co., Ltd., Luton. Posts permanent and progressive. Please write, giving full details and quoting reference S.A.25, to E. K. Sandeman, English Electric Company Ltd., 24-30, Gillingham Street, London, S.W.1. W 2901

R.E. ENGINEER required for South West London area to take charge of Waveguide Development Laboratory. Applicants must have experience of the development of X-band wave-

CLASSIFIED ANNOUNCEMENTS
continued on page 6

A new and improved
EKCO LINEAR AMPLIFIER
TYPE 1049B

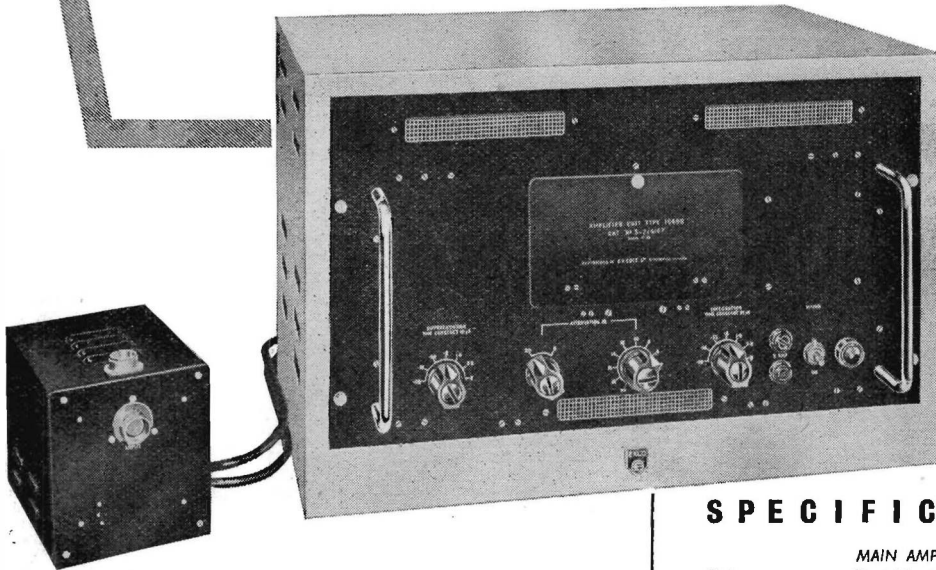

Developed in conjunction with the Atomic Energy Research Establishment, this highly stabilised wide-band amplifier incorporates the latest advances in the design of linear pulse amplifiers for use in nuclear physics. It comprises a main amplifier; H.F. head amplifier; and cathode-follower head amplifier for use with particle counters working in the proportional region. A maximum overall voltage gain of 1,000,000 is provided and gain stability is of the order of 0.1%.

Please write for illustrated catalogue of the complete range of Ekco electronic equipment for the radiochemical laboratory.

SPECIFICATION

MAIN AMPLIFIER

Gain: Variable in 2 db steps from 200 times (46 db) to 20,000 times (86 db).

Frequency Range: Constant within 3 db from 500 c/s to 2.8 Mc/s.

Input Impedance: 75 ohms.

Output Voltage: 50 volts maximum positive going.

Differentiating

Time Constants: Variable between .03 microseconds and 250 milliseconds.

Integrating

Time Constants: Variable between .08 microseconds and 0.8 milliseconds.

Gain Stability: Overall stability with either head amplifier is of the order of 0.1% for mains voltage variations of up to $\pm 10\%$.

Mains Input: 200 and 250 volts; 110-120 volts A.C. 50/60 cycles.

HEAD AMPLIFIER

Gain: Adjustable to 4 times or 50 times.

Input Impedance: 33 Megohms and 10 pf capacity.

CATHODE-FOLLOWER

Gain: 0.1 times.

Input Impedance: 10 Megohms and 10 pf capacity.

EKCO ELECTRONICS

E. K. COLE LIMITED, ELECTRONICS DIVISION, 5 VIGO STREET, LONDON, W.1, ENGLAND

SITUATIONS VACANT (Cont'd.)

The engagement of persons answering these advertisements must be made through a Local Office of the Ministry of Labour or a Scheduled Employment Agency if the applicant is a man aged 18-64 inclusive or a woman aged 18-59 inclusive unless he or she, or the employment, is excepted from the provisions of the Notification of Vacancies Order, 1952.

guide components up to and including full production drawings. Applicants should state full details of qualifications and experience, age and salary required. Ref. ME. Box No. W 2910.

RESEARCH DEPARTMENT of C. A. Parsons & Co. Ltd., Heaton Works, Newcastle upon Tyne, 6, has vacancies for Electrical Research Engineers and Assistants for laboratory and industrial applications; power station instrumentation; high voltage research and insulation development projects; vibration testing and strain measurements. There are also vacancies for electrical draughtsmen. Excellent working conditions in well equipped new laboratories. Applicants having a B.Sc. Degree, Higher National Certificate or equivalent will be considered. Applications giving age and experience should be addressed to the Personnel Manager.

W 1540

SENIOR AND JUNIOR Electronic Engineers required for development of Guided Missiles and other work of national importance. Good academic qualifications, a thorough knowledge of low frequency electronic circuits including D.C. Amplifiers, and practical design experience of lightweight electronic equipment are desirable. The posts are pensionable, and offer good scope for a man to learn and develop new techniques and advance his position. Apply to the Personnel Manager, Sperry Gyroscope Co., Ltd., Great West Road, Brentford, Middx., giving full details of age, qualifications and experience and salary required. W 2906

SENIOR APPOINTMENT. The Research Laboratories of The General Electric Co. Ltd., have a vacancy for a senior engineer or physicist at Stanmore (Middx.) to direct a small research team working in radiocommunications and radar problems. He must be interested in the fundamental aspects of such work and be familiar with centimetric measuring techniques, circuitry, aerials and propagation. He will also be called upon to advise project groups working in these fields. Attractive salary commensurate with experience and qualifications. Apply to the Staff Manager (Ref. GBLC/S/986), Research Laboratories of the General Electric Co. Ltd., Wembley, Middx. W 2898

SENIOR ELECTRO-MECHANICAL ENGINEER required by new division of prominent engineering establishment in Northern Ireland to lead section engaged in development work on guided weapons. Degree or equivalent in electrical or mechanical engineering, with good practical experience in design of small precision electro-mechanical devices, servo systems or instruments. Good salary and prospects for man with originality, assistance given with housing. Send full particulars of age, qualifications and experience to Box No. W 1541.

SENIOR ELECTRONIC ENGINEER required. Experience of Helicopter instrumentation and of analogue computers would be an advantage. Apply, stating experience, age, etc., to the Personnel Officer, Saunders-Roe Ltd., Southampton Airport, Eastleigh, Hants. W 2852

SIMMONDS AEROCESSORIES LTD., Treforest, Glamorgan, have vacancy for senior development engineer for work on electrical and electronic instruments for Industry and the Services. A salary around £800 p.a. is offered. Details of experience and qualifications to Chief Electrical Engineer. W 2876

ST. NICHOLAS HOSPITAL MANAGEMENT COMMITTEE. St. Nicholas Hospital, Gosforth, Newcastle-on-Tyne, 3. Applications are invited for the post of Electroencephalographic Recordist-Technician at the above hospital. The applicant should be familiar with low frequency electronic techniques. The post will involve taking records from patients and the maintenance of the recording apparatus. The successful applicant will receive a course of specialized training at the Electroencephalographic Section of the Department of Psychological Medicine, University of Durham, which will provide subsequent technical supervision. Salary £400 by £25 to £450 per annum. Applications stating age, qualifications and experience, together with the names and addresses of two referees should be addressed to the Physician Superintendent at the Hospital. W 1539

TECHNICAL ASSISTANTS required for the Development Laboratory of a prominent Engineering Company in Northern Ireland. Applicants should have served an Apprenticeship, possess Higher National Certificate or equivalent and have had good practical experience of one or more of the following: (a) Electronics, radar or television. (b) Light electrical equipment. (c) Precision mechanical or hydraulic apparatus. Reply, stating age, experience and qualifications to: T.A.3, Box No. W 1545.

TECHNICAL ASSISTANTS, experienced in dealing with electronic measurement and instrumentation, required for work on Aero Engines and their application. Candidates aged between 25 and 30, possessing Degree or Diploma and willing to deal with problems during flight preferred. Applications stating age, qualifications and details of experience should be addressed to the Divisional Personnel Manager, The Bristol Aeroplane Company Limited, Engine Division, Filton House, Bristol. W 2849

TECHNICAL ASSISTANT. The Aircraft Design Technical Office of the Bristol Aeroplane Company Limited have a vacancy for a Junior or Intermediate Technical Assistant in their Engineering Development Laboratory. The work is concerned with the vibration testing of aircraft structures and mechanical systems on an interesting range of Civil and Military aircraft and helicopters. Candidates should possess a Higher National Certificate in Electrical Engineering or equivalent qualification. Applications should be forwarded to the Ministry of Labour and National Service, 20, Nelson Street, Bristol, and marked for the attention of the Personnel Manager, The Bristol Aeroplane Company Limited, Aircraft Division, Filton House, Bristol. W 2893

TECHNICAL SALES MANAGER required by large well-known company, in the home counties. Qualifications to cover radio electronics, light electrical engineering and allied equipment. High level industrial contacts essential. Salary commensurate with experience and qualifications. Those not qualified to hold a four figure post are requested not to apply. Applications, which will be treated in strict confidence, should be made in writing quoting reference Y.78 to Box No. W 2870.

THE ENGLISH ELECTRIC Company Limited, Luton, invites applications for permanent posts in a Laboratory engaged in development work involving Radar Techniques. Senior and Junior positions are available to candidates possessing suitable qualifications and a knowledge of one or more of the following: (1) Centimetric systems and measurements. (2) Radar or Television receiver practice. (3) Mechanical layout and design work in connexion with the above. Salaries according to qualifications and experience in range £450 to £1,000. The laboratories are new and pleasantly situated. The Company also encourages further study in the case of Juniors. Please write, giving full details and quoting reference "English Electric 4561" to Westminster Employment Exchange, Chadwick Street, London, W.1. W 2823

THE ENGLISH ELECTRIC VALVE COMPANY. Chelmsford, Essex, has several attractive vacancies for Graduates to undertake research and development work on vacuum tubes. Applications from Graduates who have recently qualified as well as those with industrial or research experience will be considered. Please write, giving full details, quoting reference 419E to Central Personnel Services, English Electric Co. Limited, 24-30, Gillingham Street, London, S.W.1. W 2847

THE GENERAL ELECTRIC CO. LTD., Research Laboratories, Wembley, Middx., have vacancies for engineers and physicists for electronic research and development work in the microwave field. Applications will be considered from graduates and also from men with rather lower qualifications. Write to the Staff Manager (Ref. GBLC/S/988), stating age, qualifications and experience. W 2900

THE GENERAL ELECTRIC CO. LTD., Brown's Lane, Coventry, have vacancies for Developments Engineers, Senior Development Engineers, Mechanical and Electronic, for their Development Laboratories on work of National Importance. Fields include Microwave and Pulse Applications. Salary range £400-£1,250 per annum. Vacancies also exist for Specialist Engineers in Component design, valve applications, electro-mechanical devices and small mechanisms. The Company's Laboratories provide excellent working conditions with Social and Welfare facilities. Superannuation Scheme. Assistance with housing in special cases. Apply by letter stating age and experience to The Personnel Manager (Ref. CHC). W 2911

THE TELECOMMUNICATIONS DIVISION of the Plessey Company has immediate vacancies in its Engineering Department for the following personnel for work on long term defence and private venture projects. (1) Senior Engineers with experience in Electronic, Electro-Mechanical, or Line Telecommunications development Work. (2) Experienced Draughtsmen. (3) Experienced Drawing Office Checkers. (4) Experienced Tracers. Applicants should be of British birth. There are excellent prospects and very adequate salaries available for the right people. Apply, in confidence, quoting reference 4110 to the Personnel Manager, The Plessey Company Limited, Vicarage Lane, Ilford, Essex. W 2891

TUBE INVESTMENTS LTD., Dept. of Development & Research, require an Electrical Engineer for their Welding Section. Practical experience of electronic control gear and instruments, including use of cathode ray oscillographs, essential. Apply in writing giving full details of qualifications, age, experience and salary required to Tube Investments Ltd., Dept. of Development & Research, Plum Street, Aston, Birmingham, 6. W 1552

VACANCIES exist in the Design and Inspection Departments of a well-known firm in East Anglia manufacturing scientific instruments of an advanced electronic character. Applicants should have had similar experience with an electronics firm and have good electrical and mechanical background, combined with an ability to organize projects and control labour. Write in first instance stating qualifications, details of past and present employment and indicating salary required to Box No. W 1547.

VACANCIES exist for Senior and Junior Electronic Engineers, on work in connexion with the electronic measurement of physical variables and associated problems. This consolidation and expansion of a young department offers scope for men with enterprise and ability. Applications, stating age, full details of qualifications, experience and salary required, should be addressed to the Personnel Officer, Saunders-Roe Limited, East Cowes, I.O.W. W 2867

WAYNE KERR require several engineers for design and development work on electronic equipment. The development programme is varied and ranges from S band oscillators and Q meters to H.F. Signal Generators. Audio Tone Sources, and precision D.C. measuring equipment. Salaries for these posts are in the range £600-850 depending on qualifications and experience. There are also some vacancies for technical assistants to work on the same programme. Write to The Wayne Kerr Laboratories Ltd., Sycamore Grove, New Malden, Surrey. W 1548

WINWICK HOSPITAL, Warrington (2,200 beds) has a vacancy for a full-time trained Electro-Encephalograph Recordist to take charge of the Department and do a small amount of other electro-diagnostic work. Salary £300 x £15 - £360 p.a. Applications should be sent to the Medical Superintendent as soon as possible. W 2913

SITUATIONS WANTED

APPLICATION of Electronic Devices to Industrial Processes. A number of new firms are bravely pioneering in this field, but what will happen when the larger combines transfer their development and manufacturing potential from Guided Projectiles and Service Radar? Now is the time to consolidate. May I help you? Having acquired my knowledge in the Hard School, I can appreciate the layman's difficulty in grasping electronic principles, and ipso-facto am especially didactic to advise customers on the application of electronic control to their particular processes, and to note all relevant details for laboratory proto-types. I would accept responsibility for liaison with customer, laboratory, production, testing, installation and proving. Qualifications: (1) Initiative. (2) Originality. (3) 13 years' experience of Radio and Electronic devices, and the engineering industry. (4) Full time student of liberal education for 16 years in the Hard School, studying post-graduate esoteric subjects. (5) 300,000 miles of travel experience. Box No. W 1543.

Further "Situations Vacant" advertisements appear on pages 41, 53 and 59 in displayed style.

CLASSIFIED ANNOUNCEMENTS
continued on page 8

Invitation

Meet us at Stand 95 at the Radio Show, where we shall be pleased to demonstrate for you our Stentorian chassis range from 2½" to the famous 12" Concentric-Duplex.

Stentorian Chassis are specified in many new radio and television receivers for the home constructor—proof of their reliability and high performance. Literature describing full range sent on request.

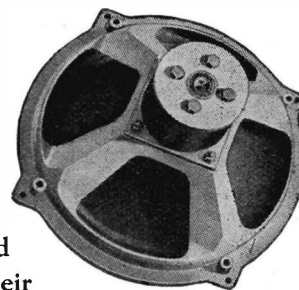

Our London showrooms at 109 Kingsway are now open every Saturday from 9 a.m. to noon. You are cordially invited to make an appointment to hear and examine the complete range of Stentorian speakers and to inspect our other radio components. Please write, or telephone HOLborn 3074 to arrange a convenient time.



Stentorian

SPEAKERS & RADIO COMPONENTS

WHITELEY ELECTRICAL RADIO CO. LTD · MANSFIELD · NOTTS

FERROXCUBE

FERROMAGNETIC FERRITE

FOR TELEVISION

THE improvement in television components, with their smaller size and greater efficiency, is largely due to Ferroxcube, the new Mullard magnetic core material.

The uses of Mullard Ferroxcube in the production of TV components fall into these three main groups:

LINE OUTPUT TRANSFORMER CORES

Since the advent of wide-angle television tubes, with the accompanying demand for increased E.H.T. supplies, the need for line output transformers of the highest possible efficiency has been greater than ever. Mullard Ferroxcube, with its low iron losses, completely fulfils this need—also facilitating the assembly of small, compact transformer units by means of solid, non-laminated U-shape cores.

DEFLECTION COIL YOKES

Mullard Ferroxcube cores in ring form are ideal for producing the magnetic circuit around deflection coils. Used in this way, Mullard Ferroxcube makes possible the construction of efficient deflector coils with a high Q factor. In order to simplify assembly problems, these ring cores are supplied either in the form of a complete circle, as two semi-circles, or as castellated yokes.

LINEARITY AND PICTURE WIDTH CONTROLS

Mullard Ferroxcube can very conveniently be extruded into rods and tubes. In this form it is ideal for use in linearity and picture width controls, providing a smooth control in a compact assembly.

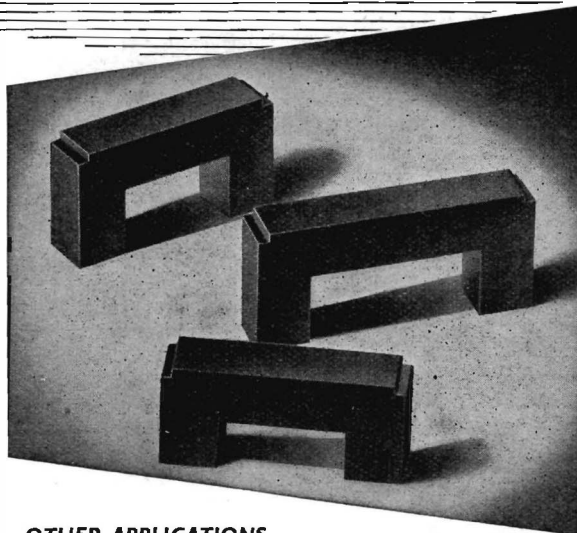

OTHER APPLICATIONS

In addition to its uses in television receivers, Mullard Ferroxcube is also being widely employed in line communications, radar, and other specialised electronic equipments. The purposes for which it is already being most successfully applied in such equipments include filter networks, wide band transformers, magnetic amplifiers, and pulse transformers.

PLEASE WRITE FOR FULL DETAILS



Mullard FERROXCUBE

FERROMAGNETIC FERRITE

MULLARD LIMITED · CENTURY HOUSE · SHAFTESBURY AVENUE · LONDON · W.C.2
(MF376)

ENGINEER, apprentice trained, 28, H.N.C., Grad.I.E.E. with several years experience in development and engineering seeks appointment in technical sales field. Box No. W 1551.

FOR SALE

ELECTRONIC COMPONENT SUPPLIES. We specialize in the supply of Electronic Components, Accessories, Test Equipment, etc., for Government Dep'ts., Industrial Concerns, Research Establishments, Laboratories, Colleges, etc. Your enquiries and orders will receive our prompt attention. Holiday & Hemmerdinger Ltd., 74/78 Hardman Street, Deansgate, Manchester, 3. Tel. Deansgate 4121. W 148

TOROIDAL COILS wound, and latest potted inductors to close limits. Bel Sound Products Co., Marlborough Yard, Archway, N.19. W 139

MINIATURE STEEL BALLS and Ball Bearings, Swiss and German Precision Work. Quick delivery. Distributors: Insley (London) Limited, 119 Oxford Street, London, W.1. Tel.: Gerrard 8104 and 2730. W 143

PURE BERYLLIUM FOIL, 0.005" thick and Beryllium Metal Discs for X-Ray Tube Windows: Elgar Trading Ltd., 240 High Street, London, N.W.10. W 141

AMERICA'S famous magazine Audio Engineering, 1 year subscription 28s. 6d.; specimen copies 3s. each. Send for our free booklet quoting all others; Radio Electronics, Radio and Tele. News, etc. Wilten Limited (Dept. 9), 101 Fleet Street, London, E.C.4. W 108

MAGSLIPS at 1/10th to 1/20 of list prices. Huge stocks. Please state requirements. K. Logan, Westalley, Hitchin, Herts. W 116

WEBB'S 1948 Radio Map of the World, new multi-colour printing with up-to-date call signs and fresh information: on heavy art paper 4s. 6d., post 6d. On linen on rollers 11s. 6d., post 9d. W 102

SINE-COSINE Potentiometers, Ipots, Magslips, Selsyns, 24v Klaxon Motors 1/20 h.p. Magslip accessories. All in new condition. Servotronic Sales, 1, Hopton Parade, High Road, Streatham, London, S.W.16. See our display advertisement on page 60. W 2918

WIRE RECORDER U.S. Navy type. Runs for 1/2 hour. £20. T. S. Davis, Pontyclun, Glam. W 1519

EDUCATIONAL

BOROUGH POLYTECHNIC, Borough Road, S.E.1. A course of thirteen lectures on "The Fundamentals of Pulse Techniques" will be given by specialist lecturers on Monday evenings, commencing on Monday, 6th October, at 7 p.m. Further particulars from the Secretary, Borough Polytechnic, Borough Road, London, S.E.1. W 1538

CITY OF COVENTRY EDUCATION COMMITTEE, Coventry Technical College. Session 1952-53. Electronic Engineering. A three-year full-time course will commence in September, 1952, planned to meet the needs of those requiring a comprehensive full-time training to an advanced level in Electronic Engineering, to qualify them for technical posts in radio, telecommunications, television and industrial electronics. The syllabus will cover the requirements of C. & G., Brit.I.R.E., and I.E.E. examinations. Entry age 16 years or over. Application forms and further information available from the Principal, Coventry Technical College. W. L. Chinn, M.A., Director of Education, Council House, Coventry. W 2888

CITY & GUILDS (Electrical, etc.) on "No Pass—No Fee" terms. Over 95 per cent successes. For full details of modern courses in all branches of Electrical Technology send for our 144-page handbook—Free and post free. B.I.E.T. (Dept 337C), 17 Stratford Place, London, W.1. W 142

FREE. Brochure giving details of courses in Electrical Engineering and Electronics, covering A.M.Brit., I.R.E., City and Guilds, etc. Train with the Postal Training College operated by an Industrial Organisation. Moderate fees. E.M.I. Institutes, Postal Division, Dept. EE29, 43, Grove Park Road, London, W.4. (Associate of H.M.V.). W 2808

SERVICE

TRANSLATIONS, technical and scientific, all languages, by highly qualified graduate engineers-scientists, speciality difficult translations. Smuts, Technical Services, 8, Palace Gates Road, London, N.22. W 1549

THE ELECTRICAL INSTRUMENT REPAIRERS. All kinds of meters, Volt, Amp, Galvo, recording, Electric Clocks, Aircraft instruments repaired. We are also skilled Horologists. Government Ministry enquiries invited. Ask for estimate. Send your enquiries to: Mr. J. R. W. Ridgway, F.B.H.I., J. R. Ridgway & Co., 341 City Road, E.C.1. TERminus 0641. W 1528

ALUMINIUM SHEET METAL WORK, Cases, Chassis, Brackets, Supports, Hoods, Screens, Racks, Spinnings, etc., Good range of Standard Press Tools. We specialize in runs of 50-500, and give real consideration to your needs. Very fast delivery. Full range of anodised or stoved finishes. Frank Brothers, 129, Kingston Road, New Malden, Surrey. Tel. Office: Mal. 2779. Works: Mal. 0925. W 1544

PATENTS

IT IS DESIRED to secure the full commercial development in the United Kingdom of British Patents Nos. 626,624—626,857 and 605,621 which relate to "Measuring Devices such as Barometers", "Fluid Flow Direction Indicators"—"Electronic Transmitters for Electrical Measuring Devices" either by way of the grant of licences or otherwise on terms acceptable to the Patentee. Interested parties desiring copies of the patent specifications and further particulars, should apply to Stevens, Langner, Parry & Rollinson, 5 to 9, Quality Court, Chancery Lane, London, W.C.2. W 2908

SANKEY

JOSEPH SANKEY & SONS LTD
BILSTON STAFFORDSHIRE

London Office
168 REGENT ST. LONDON W.1

Europe's largest
manufacturers of
laminations

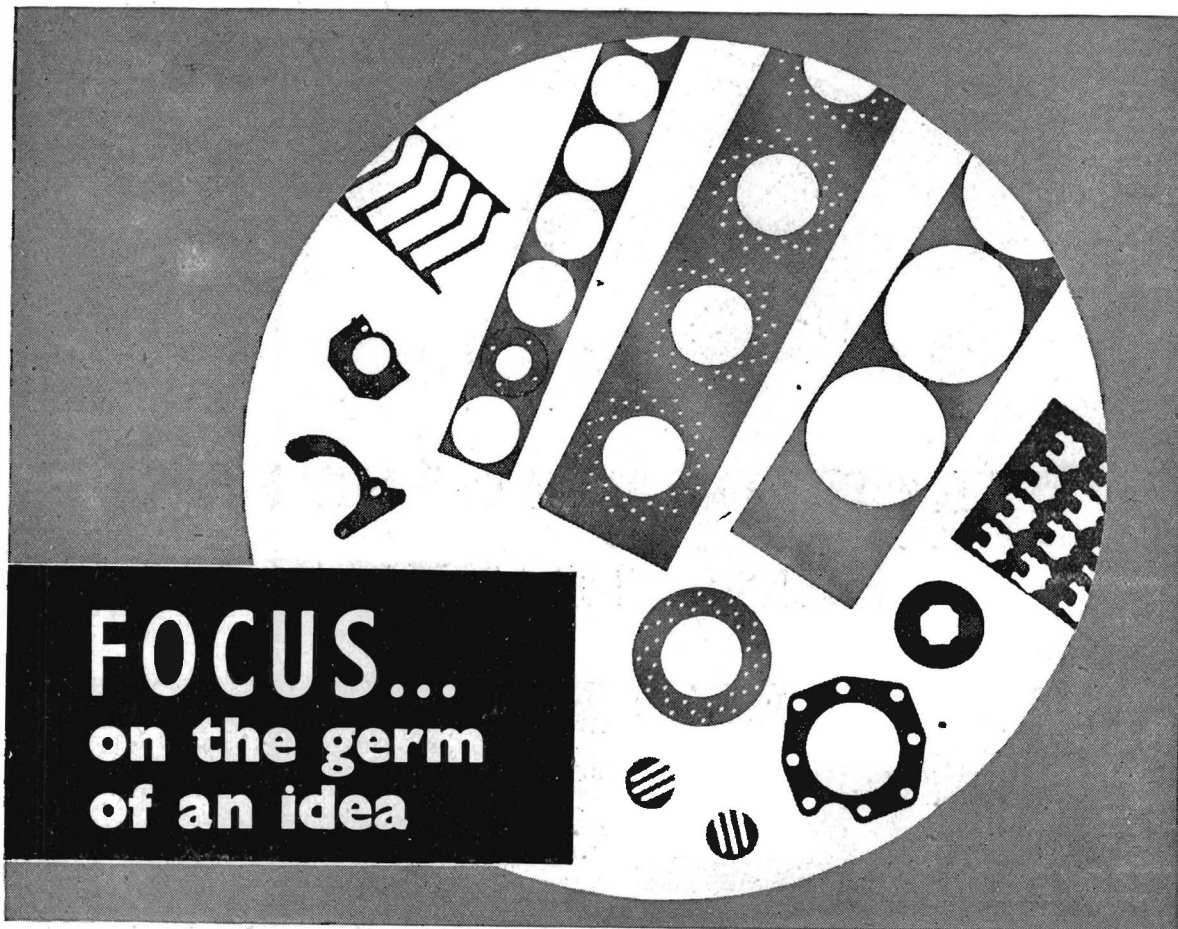

FOCUS... on the germ of an idea

These clean-cut Tufnol punchings serve to illustrate our theme, but actual contact cases invariably develop ideas rapidly. Handle some Tufnol. It is quite unlike any other material, yet it

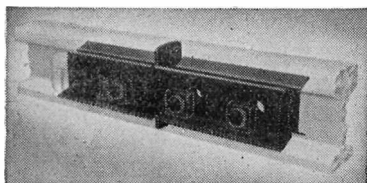

Tufnol is used for the electrical insulation of rail-track signalling systems and withstands extremes in climatic conditions.

combines the virtues of many. It resists chemical action, is a good electrical insulator, and possesses high compressive, shear and tensile strengths. It resists moisture and corrosion, is light in weight and above all, can be easily and accurately machined by the usual engineering methods.

Tufnol is supplied in sheets, tubes, rods, bars, angles, and channels — or in specially moulded shapes.

TUFNOL RESEARCH

Our Technical Department are always keen to 'get down to cases.' They have compiled a wealth of data which are included in our literature, together with examples of Tufnol in action — a record of remarkable achievement. But their greatest enthusiasm is for tackling NEW problems. If you have one — why not write TODAY?

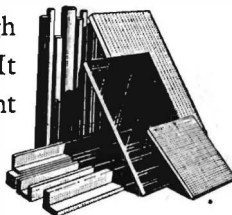
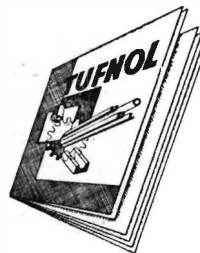

TUFNOL

REGISTERED TRADE MARK
An ELLISON Product

TUFNOL LTD • PERRY BARR • BIRMINGHAM • 22B

244

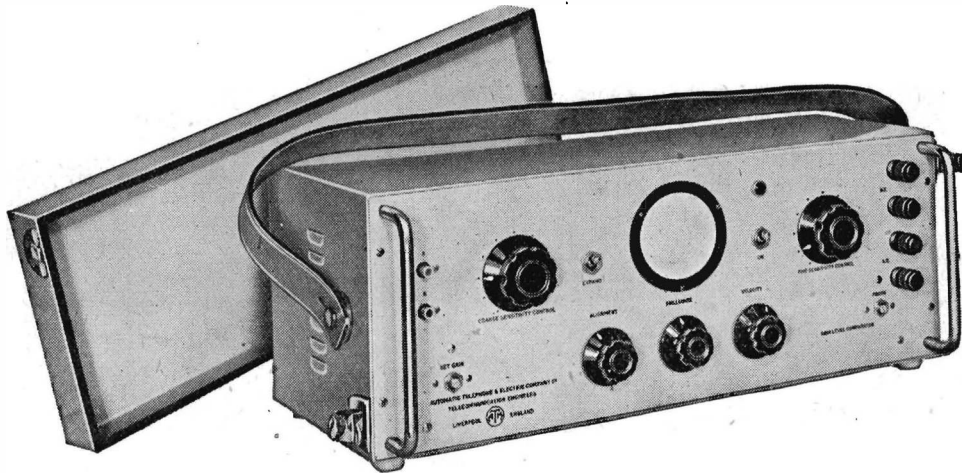

PRECISION MEASUREMENTS IN LINE TRANSMISSION

In the measurement of losses and gains greater accuracy can be achieved if a visual instead of an audible means is employed. The illustration depicts an electronic voltage comparator in which a cathode ray tube is used as an indicator of the relative magnitudes of a standard signal and the unknown signal to be tested. In the position of maximum sensitivity an input signal of 30 microvolts will give a 1 cm deflection on the screen which allows a comparison accuracy equivalent to 0.1db. Measurements can be made from 100 c/s to 200 Kc/s. This instrument, which is extremely simple to operate, is used as the sensitive detector in the measurement of losses in channelling equipment, amplifier gains, crosstalk and harmonic distortion in amplifiers, etc.



Distributor

AUTOMATIC TELEPHONE & ELECTRIC CO. LTD.

(Radio and Transmission Division), Strowger House, Arundel St., London, W.C.2
Telephone: TEMple Bar 9262. Cablegrams: Strowgerex, London.

Manufacturers

AUTOMATIC TELEPHONE & ELECTRIC CO. LTD., Liverpool & London
TELEPHONE MANUFACTURING CO. LTD., St. Mary Cray, Kent

ATE/TMC

A8411-B.105

Single anode mercury-arc rectifiers

'ENGLISH ELECTRIC' manufacture high and low voltage excitrons, supplied alone or in complete equipments, to cover the ranges from 0 to 15,000 volts at average single tube currents up to 33 amps for the lower voltages and up to 4 to 9 amps at the higher voltages. Control grids are included in all tubes and may be used for voltage control or arc suppression. The single anode construction and small dimensions permit mounting in difficult situations where floor area or height is limited.

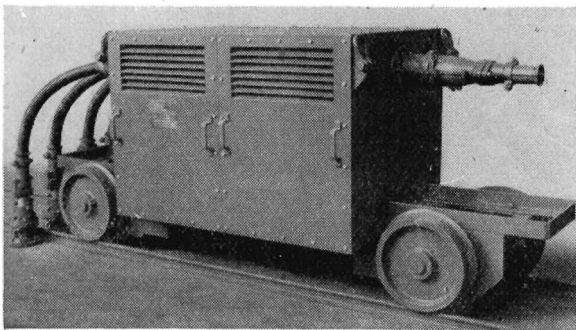

A 50 kW, 250 volt, six tube mining type equipment.

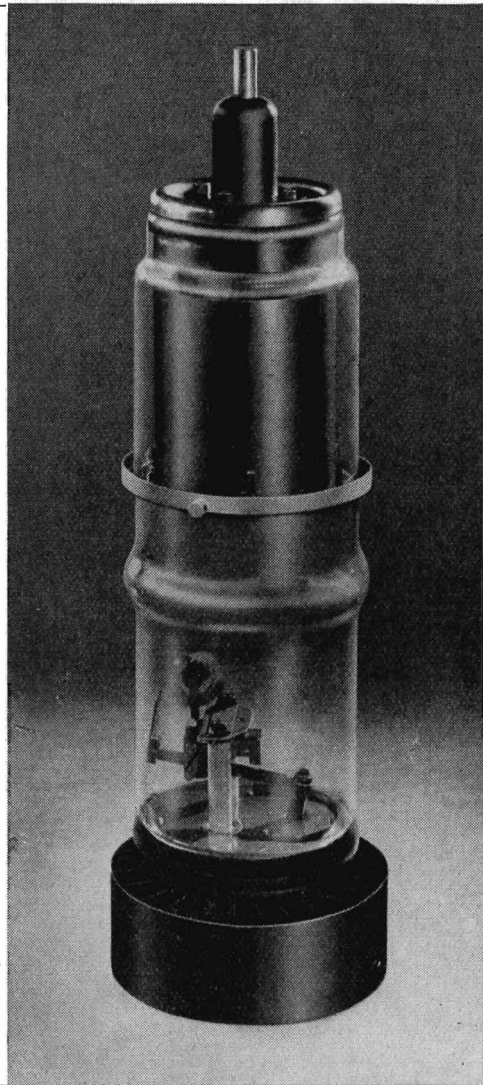

'ENGLISH ELECTRIC'

excitrons

THE ENGLISH ELECTRIC COMPANY LIMITED, QUEENS HOUSE, KINGSWAY, LONDON, W.C.2
Rectifier Substation Department, Stafford

WORKS: STAFFORD · PRESTON · RUGBY · BRADFORD · LIVERPOOL · ACCRINGTON

RMA.5

The "Belling-Lee" page for Engineers

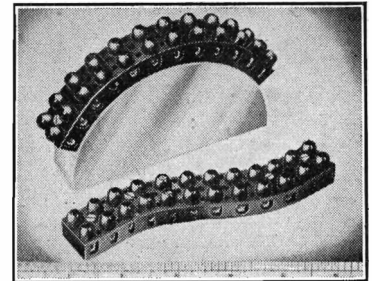
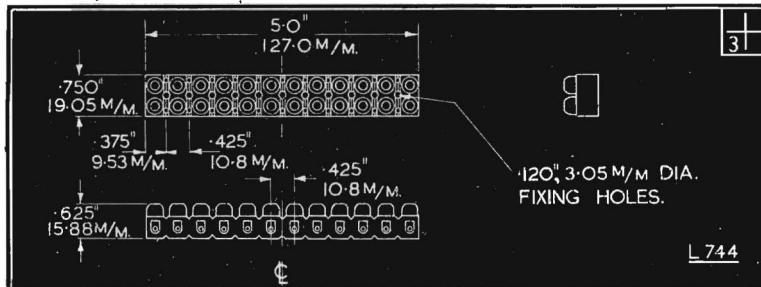

List No. L. 744

CAPTIVE TERMINAL SCREWS

FLEXIBLE

MECHANICALLY

SHOCKPROOF

EASILY SECTIONALISED

A UNIQUE 5-AMP FLEXIBLE TERMINAL BLOCK

Engineers, designers, and those in close touch with radio and electronic instrumentation, have been quick to appreciate the numerous possibilities and applications of this versatile component, which represents an entirely new departure in terminal block design.

First shown at the R.E.C.M.F. Exhibition, this terminal block aroused considerable interest, which has progressively increased in recent months.

Moulded in P.V.C., and in consequence very flexible, the moulding securely grips the terminal screws, which are so

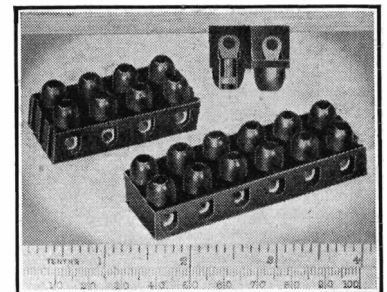
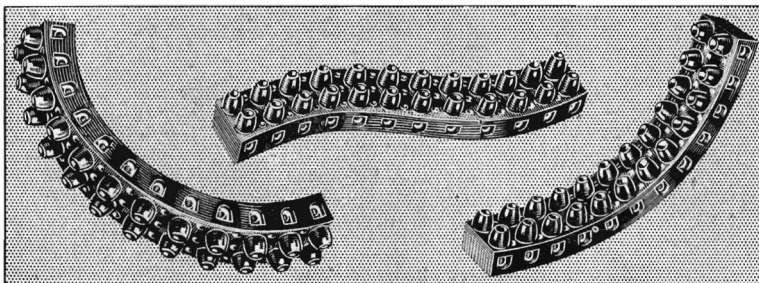

**WIDE WORKING
TEMPERATURE RANGE**

**FULLER DETAILS ON
REQUEST**

**PLEASE QUOTE
P.378/EE.**

dimensioned that they cannot fall out, *even if totally unscrewed from their inserts and the block mounted upside down.*

A very useful feature of this component is its great flexibility in both planes, which enables it to be snugly secured to irregular surfaces or over uneven contours.

The block is also mechanically shock-proof, the nature of the moulding rendering it safe against breakage due to vibration. It can easily be sub-divided with an ordinary knife, to make units up to 10-ways if required.

*We invite you to inspect our Stand No. 25 at the
National Radio Show.*

BELLING & LEE LTD
CAMBRIDGE APTERIAL RD., ENFIELD, MIDDX., ENGLAND

This is Britain's famous power amplifying tube... for years the favorite tube of experimenters and research laboratories, acknowledged in every country of the world to be the finest tetrode ever made. It is currently used in the Leak, Williamson, Radio Craftsmen and other fine amplifiers.

The KT66 is a versatile power tetrode with a number of useful applications. It may be used in the output stage of an audio-frequency power amplifier, either tetrode-connected for maximum sensitivity and power output or triode-connected for high quality working. In transmitting circuits using frequencies up to 30 Mc/s it may also be used as an oscillator or as a radio frequency amplifier.

A high slope, indirectly heated beam tetrode, the KT66 is suitable for either single or push-pull audio operation and may be employed as a beam tetrode with aligned grids. This alignment of the grids reduces losses in the screen and makes for the highest possible power conversion efficiency. With this system of construction high orders of power output may be obtained with a low screen dissipation, and the anode is designed to dissipate 25 watts continuously with a reliable life performance.

THE FINEST AUDIO TUBE EVER MADE! KT66

NOTE: The KT66 and the American tube 6L8 can work interchangeably in any circuit; the pins and connections of both are identical.

OPERATING CONDITIONS

Single Valve A.F. Amplifier	Tetrode connected		Triode connected	
	250	400	250	
Anode and Screen Voltage	250	400	250	volts
Bias Voltage	-15	-38	-19	volts
Anode Current	85	63	60	mA.
Screen Current	6.3	—	—	mA.
Input Voltage	15	38	19	volts peak
Bias Resistance	160	600	315	ohms.
Anode Load Resistance	2200	4500	2750	ohms.
Distortion	9	7	6	%
Power Output	7.25	5.8	2.2	watts

Two Valves Push-Pull, A.F. Amplifier.
(Data per pair of valves unless otherwise stated.)

Anode Voltage.	Full load	450v. supply	250v. supply
Screen Voltage	Full load	450v. supply	250v. supply

RATINGS

	Tetrode connected	Triode connected	
Heater Voltage	6.3	6.3	volts
Heater Current	1.27	1.27	amps
Anode Voltage	—	—	—
Screen Voltage	—	—	—

7-PIN "OCTAL"

Pin 1: Not connected
 2: Heater
 3: Anode
 4: Screen Grid, g₂
 5: Control Grid, g₁
 6: Omitted
 7: Heater
 8: Cathode

View looking on underside of base.

All dimensions are in mm. and are the maximum except where otherwise stated.

THE FAMOUS **KT66** . . . IN USE ALL OVER
 AMERICA AND ACKNOWLEDGED TO BE THE
 FINEST BEAM TETRODE EVER MADE
 IS AN **Osram** VALVE MADE IN ENGLAND

The photographic reproduction is taken from literature published in America by the British Industries Corporation and gives an entirely unsolicited tribute to this fine valve.

Distortion
Power Output	5000	...	5000
† Stabilised screen supply voltage	50

BRITISH INDUSTRIES CORPORATION
 164 Duane Street, New York 13, N. Y.

THE GENERAL ELECTRIC CO. LTD., MAGNET HOUSE, KINGSWAY, LONDON, W.C.2

What is **VF*** costing you?

If your plant or process depends on an absolutely constant mains voltage, then "V.F."* (Voltage Fluctuation) may be costing you much more than you realise. Every \pm variation results in loss of efficiency, and increases operating costs. That is why BERCO and BPT voltage control and regulating equipment plays an important part in well planned industries all over the world — keeping voltage under control!

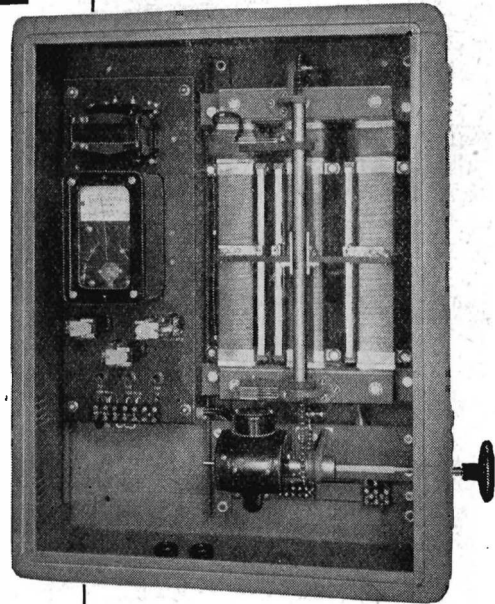

3-phase, air cooled, wallmounting model. Input 440V. \pm 10%, output 440V. \pm 1% 7½ amps.

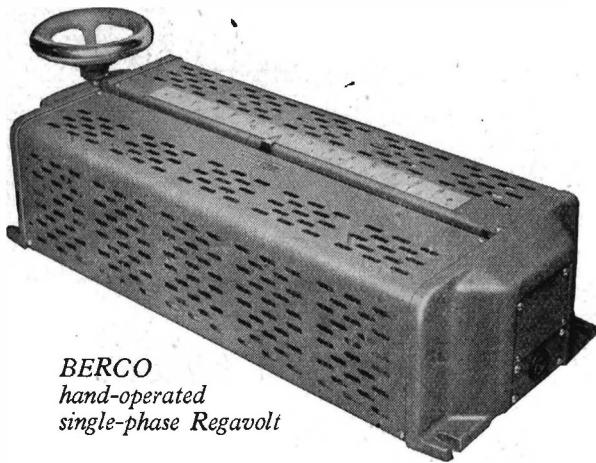

*BERCO
hand-operated
single-phase Regavolt*

For constant voltage use a model from the wide range of Automatic Stabilizers made by British Power Transformer Co. Ltd., for single and three phase supplies.

For variable voltage select a "Regavolt" from the wide range of models made by The British Electric Resistance Co. Ltd. Interesting information and full performance details given in booklet No. C1021.

**THE BRITISH ELECTRIC RESISTANCE CO. LTD.
BRITISH POWER TRANSFORMER CO. LTD.
Queensway · Ponders End · Middlesex**

Telephone: HOWard 1492

Telegrams: "Vitrohm Enfield"

BR/BP 1021T

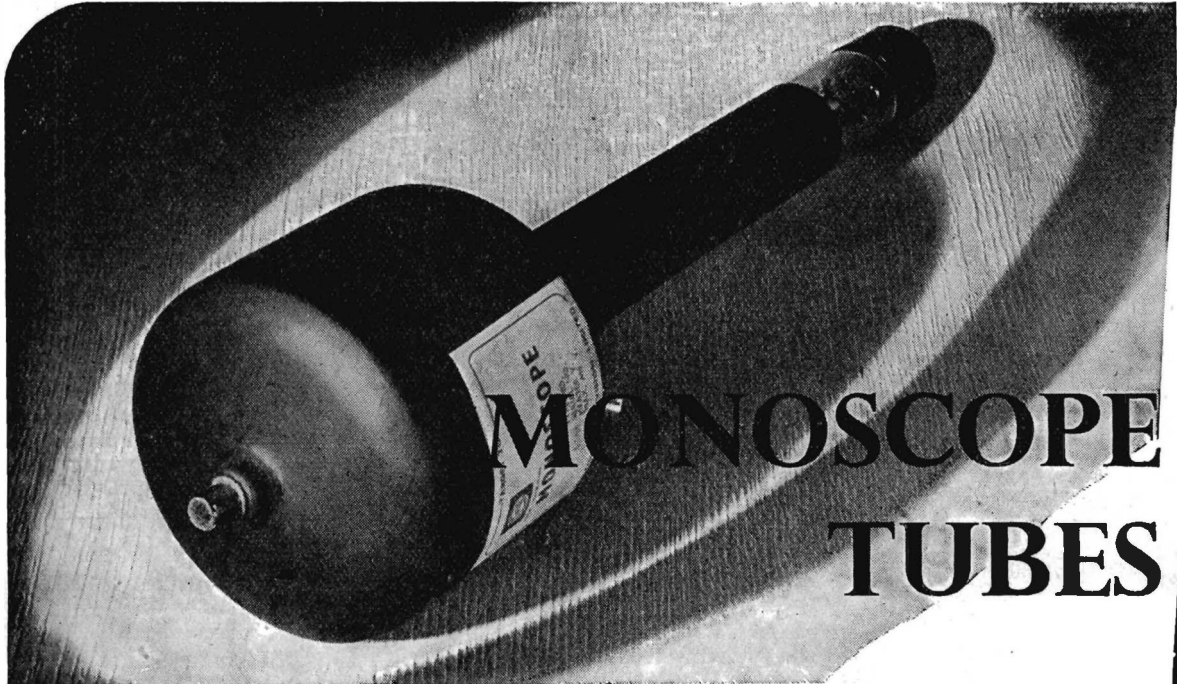

MONOSCOPE TUBES

THE Monoscope is basically a simple caption scanner apparatus capable of providing a video signal derived from a fixed pattern within the tube.

Almost any pattern comprising pure line, halftones or a combination of both can be supplied on receipt of specific requirements, and two standard types are available.

Type J.101 — Test Chart "A"

Type J.201/XI — Test Chart "C"

TYPICAL OPERATING DATA

Deflection	- - -	<i>electromagnetic</i>
Focus	- - -	<i>electrostatic</i>
V _h	- - -	6.3 V
V _g (cut-off)	- - -	-50 V
V _{a1}	- - -	1200 V
V _{a2} (focus)	- - -	800/850 V
V _{a3} (wall)	- - -	1200 V
V target	- - -	1160/1200 V
I target	- - -	5 μA

Resolution better than 500 lines

Video Signal 0.5 μA peak to peak (min)

CINEMA-TELEVISION LIMITED

A Company within the J. Arthur Rank Organisation

WORSLEY BRIDGE ROAD · LONDON · SE 2 6

Telephone: H1ther Green 4600

SALES AND SERVICING AGENTS

F. C. Robinson & Partners Ltd.,
287 Deansgate, Manchester, 3

Hawnt & Co., Ltd.,
59 Moor St., Birmingham, 4

Atkins, Robertson & Whiteford Ltd.,
100 Torrisdale Street, Glasgow, S.2



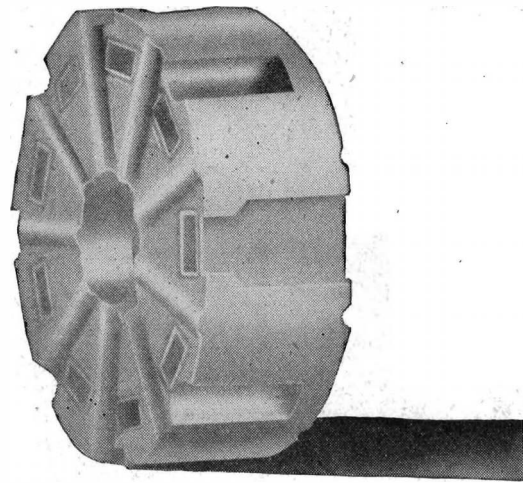
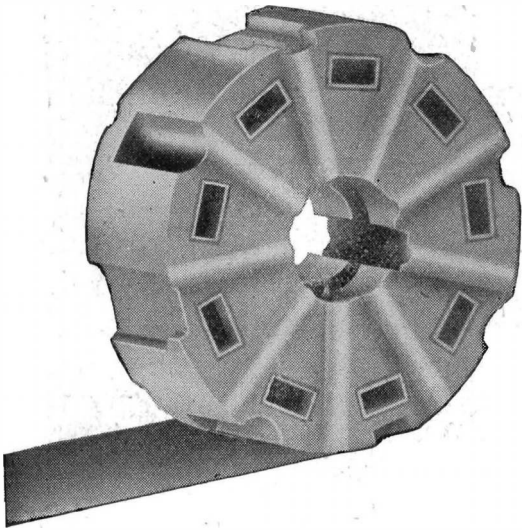

**from every
point of view**

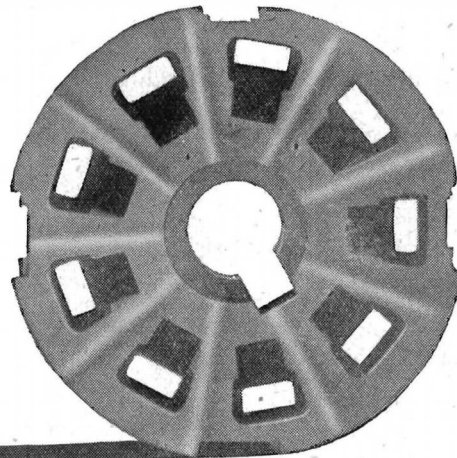

Frequentite is the most suitable insulating material for all high frequency applications. Seventeen years ago we introduced the first British-made low-loss ceramic, and consultation with us before finalising the design of new components is a wise precaution.

STEATITE & PORCELAIN PRODUCTS LTD.

Head Office: Stourport-on-Severn, Worcestershire. Telephone: Stourport 111. Telegrams: Steatain, Stourport



S.P.67

Modern in conception, design and performance, the E.2., with its exceptionally wide range, not only fulfils to-day's needs of radio and television, but anticipates the requirements of tomorrow. More than ordinary care has been used in screening and filtering. As a result, stray field is less than 3 μ V. at 100 Mc/s.

- Frequency accuracy of $\pm 1\%$ extends over the whole range.
- Output voltage 1 μ V. to 100mv. and approx. 1v. at full R.F. Socket.
- Internal modulation; external modulation to 80%
- A.F. Output variable 0-50v. at 400c/s.
- Size 13" \times 10 $\frac{1}{4}$ " \times 8". ● Weight 17 $\frac{1}{2}$ lbs.

Advance

signal generator

ADVANCE TYPE E2

100 Kc/s - 100 Mc/s ON
FUNDAMENTALS

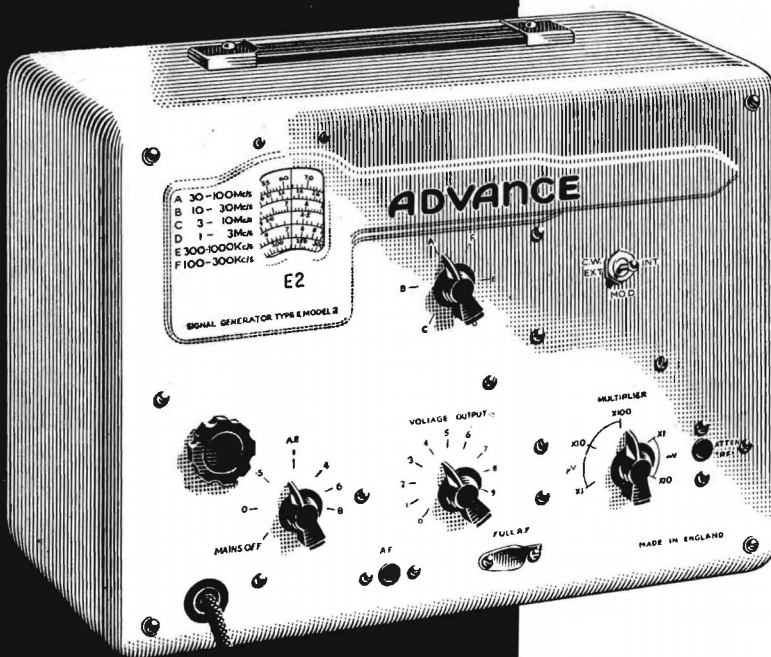

Full Technical Details available in
Folder S/14/L

CAPACITANCE

FIXED CONDENSERS: You see them every day in electronic equipment and take them at their face value. The condenser manufacturer can't — he must determine their capacitance, power factor and other important characteristics with the aid of high grade test equipment. When *you* want to make measurements of this type, remember that a range of Marconi instruments is available specially designed for the job.

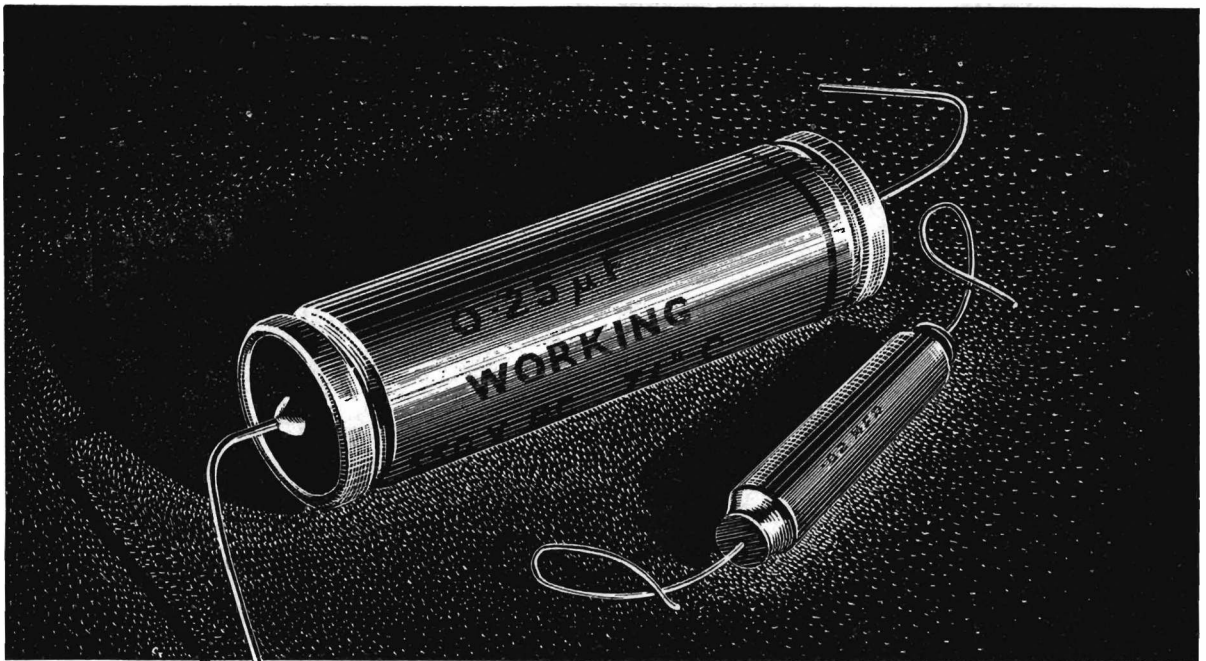

MARCONI *instruments*

SIGNAL GENERATORS · BRIDGES · VALVE VOLTMETERS · Q METERS · FREQUENCY STANDARDS
OUTPUT METERS · WAVE METERS · WAVE ANALYSERS · BEAT FREQUENCY OSCILLATORS

MARCONI INSTRUMENTS LTD · ST. ALBANS · HERTS · Phone: St. Albans 6161/7

Midland Office : 19 The Parade, Leamington Spa. Northern Office : 30 Albion Street, Hull.
Export Office : Marconi House, Strand, London, W.C.2

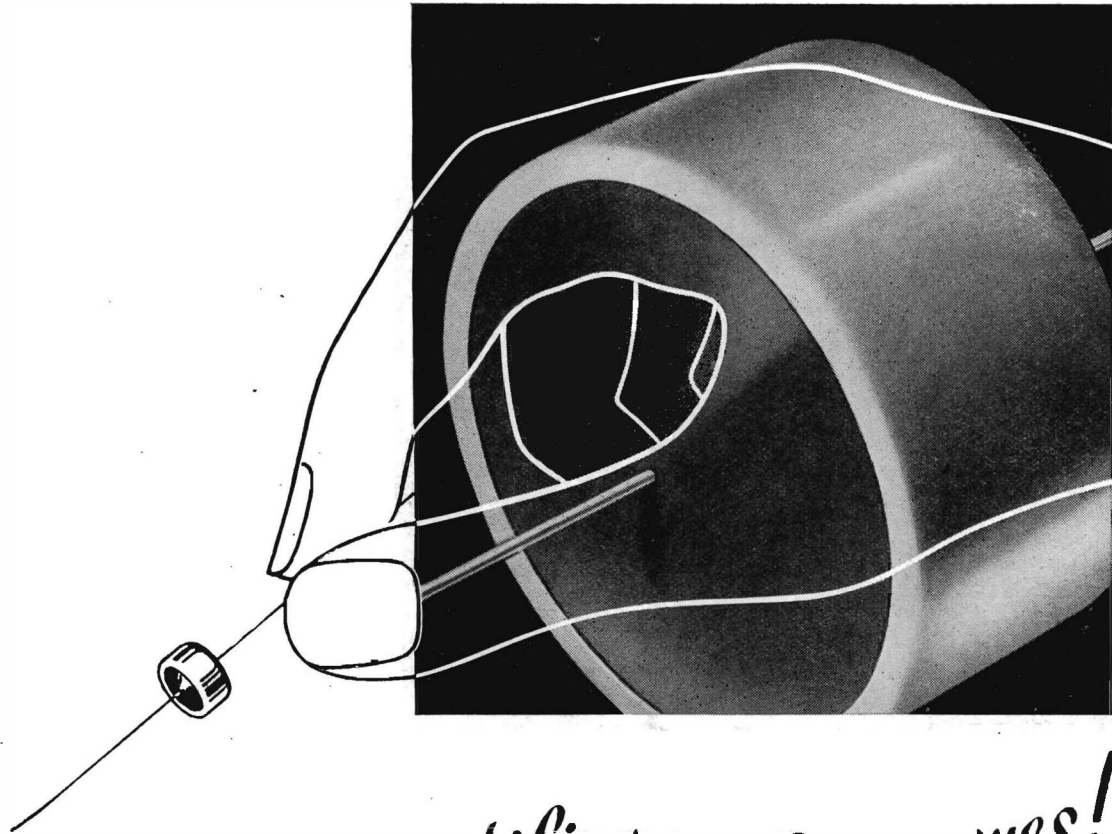

this smallest rectifier weighs only 2 grammes!

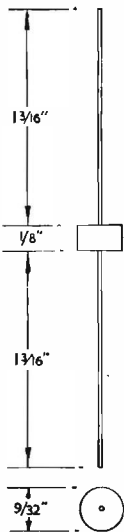

Only $\frac{3}{32}$ inch diameter and $\frac{1}{8}$ inch thick, this unusually small, single element SenTerCel rectifier, Type M-1, has been designed for use at input levels exceeding 0.5 volts at any frequency up to 5 Mc/s . . . weighs only 0.015 oz. Inexpensive, highly efficient, the M-1 in most cases will replace a thermionic rectifier, thus removing a source of heat as well as saving the cost and complication of a valve holder and its associated wiring.

AVERAGE CHARACTERISTICS

Self Capacitance	20 pf
Forward resistance at 5 V.D.C.	12 kΩ
Rev. resistance at 5 V.D.C.	20 MΩ
Max. peak inverse voltage	50 V
Min. A.C. input	0.5 V



TYPE M-1

for A.F. Second detectors · A.G.C. rectifiers · Muting circuits · Contrast expansion and compression · Level indicators · Modulation depth indicators · Ringbridge modulators · Limiters · Automatic frequency control · Non-linear resistances.

Standard Telephones and Cables Limited

Registered Office: Connaught House, Aldwych, London, W.C.2.

RECTIFIER DIVISION · WARWICK ROAD, BOREHAM WOOD, HERTFORDSHIRE
 Telephone: Elstrea 2401 Telegrams: SenTerCel, Borehamwood

PLASTIC MOULDINGS

**FOR THE
ELECTRONIC
AND
ALLIED INDUSTRIES**



- FULLY A.I.D. APPROVED FOR DEFENCE PROGRAMME REQUIREMENTS.
- AMPLE CAPACITY AVAILABLE FOR ALL COMPRESSION MOULDINGS, UP TO 250 TON PRESSES, AND SMALL PRECISION MOULDINGS IN THERMOPLASTICS.
- SPECIAL GRADE MOULDINGS IN MELAMINE AND NYLON-FILLED PHENOL.
- PROMPT ATTENTION TO ALL ENQUIRIES.
- GOOD, RELIABLE DELIVERY, AND FIRST-RATE QUALITY IN PRODUCTION.
- A REPRESENTATIVE WILL CALL, IF DESIRED.



NAME PLATES FROM STANDARD TOOL

Attractive name plates to your own wording at extremely keen prices.

VISCOSE DEVELOPMENT COMPANY LIMITED
WOLDHAM ROAD, BROMLEY, KENT. RAVENSBOURNE 2641

A New

MILLIVOLTMETER

by

RIVLIN INSTRUMENTS

The Rivlin Millivoltmeter Model MV.1 is a high quality instrument for measuring A.C. Signal Voltages in eight ranges from 10mv to 25v f.s.d. in the frequency range 20 c.p.s. to 500 kc/s. In this instrument, a high impedance cathode follower feeds a three valve amplifier through a range controlling attenuator, the output of the amplifier being connected to the meter through a crystal rectifier bridge. About 20 db negative feedback is applied around the amplifier system resulting in high gain stability and this together with additional electronic stabilisation ensures freedom from the effects of normal mains voltage variation.

The degenerative characterisation of the input cathode follower are used to provide a low capacitance input connection at the end of a coaxial cable, thereby dispensing with the need for a bulky probe.

Model MV.1 may also be used as a stable amplifier with a maximum gain of 10,000. Output connections at low impedance are provided and in this application the frequency response remains unaltered.

Construction of this Millivoltmeter is to the high standards associated with the products of Rivlin Instruments. Components are of high quality and conservatively rated, and no electrolytic condensers are used in H.T. circuits.

Model MV.1 is supplied in a case for bench use but, if required, the panel can be withdrawn and the instrument mounted in to a standard rack without modification.

Early delivery can be offered.

Descriptive literature and details available on request to Dept. 5.



R

RIVLIN INSTRUMENTS, 7A MAITLAND PARK VILLAS, N.W.3

Telephone - GULLIVER 2960

*Ceramic
Switches
by*

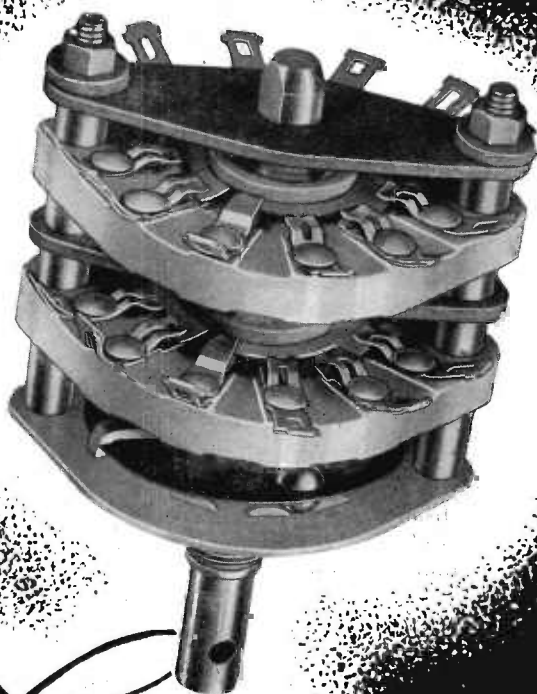

A. B. Metal Products are proud to announce that their famous H Type range of Switches is now available with "CERAMIC" insulation.

Stators and Rotors are manufactured in best quality electrical Porcelain, giving the highest degree of insulation, together with first-class Radio frequency Characteristics.

FULLY INTER-SERVICE TYPE APPROVED TO R.C.L. 151.12.

Early deliveries can be quoted, and we invite your enquiries.

Write for illustrated brochure :—



Metal Products Ltd

16, BERKELEY STREET, LONDON, W.1.

'Phone : Grosvenor 5206/7

A VOLTMETER PLUS



these
outstanding
features

- ★ Measures 1mV to 100v.
- ★ Frequency range
10 c/s to 0.5 Mc/s
- ★ Logarithmic voltage
scale.
- ★ Linear dB scale.
- ★ Constant reading
accuracy.
- ★ 2 Megohm input
impedance.
- ★ Null indication down
to 100 microvolts.
- ★ No set zero required.
- ★ Rugged construction.
- ★ Amplifier can be used
separately.
- ★ PROMPT DELIVERY.

Developed — as is the rest of the Furzehill range of instruments — by engineers, for engineers, this 378 B/2 has proved its value over and over.

Write for full particulars.

FURZEHILL LABORATORIES LTD.

BOREHAM WOOD — HERTS — ELSTREE 3940

ALL-ROUND DEPENDABILITY



UNIVERSAL BRIDGE

VALVE CHARACTERISTIC METER

ELECTRONIC TEST METER

ELECTRONIC TEST UNIT

THE D.C. MINOR

WIDE RANGE SIGNAL GENERATOR

HEAVY DUTY METER

UNIVERSAL MINOR

UNIVERSAL METER



Precision ELECTRICAL MEASURING INSTRUMENTS

For your "Avo"
Valve Characteristic Meter
or Valve Tester

Owing to the very large number of valves which have been introduced within the last two years, no further amendments will be issued for the original "Avo" Valve Testing Manual. A new, completely revised and fully up-to-date Valve Data Manual is now available from the Company at 15/- post free.

We shall be at the
RADIO SHOW
EARLS COURT
AUG 27 - SEPT 6

Stand
46

THE AUTOMATIC COIL WINDER & ELECTRICAL EQUIPMENT CO. LTD.
WINDER HOUSE DOUGLAS STREET LONDON S.W.1 Telephone: VICTORIA 3404-9



G.E.C.

SELENIUM RECTIFIERS

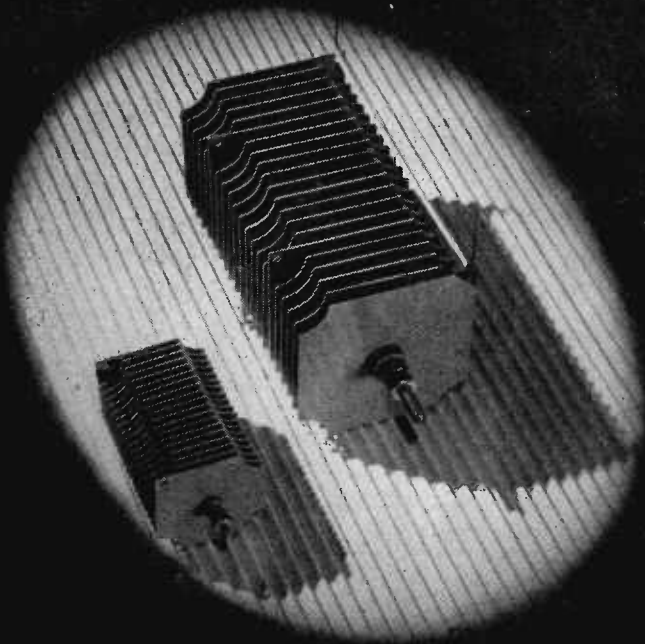

G.E.C. Selenium Rectifiers are ideal for all applications where a D.C. power supply is to be provided from an A.C. source. They are designed and rated for long life and reliable operation, have high operating efficiency and are economical in first cost. A comprehensive range is available for output currents from a few milli-amps. to thousands of amps.

Full particulars available on application to E.S.V. Dept., Magnet House, Kingsway, London, W.C.2, or the address below—

SALFORD ELECTRICAL INSTRUMENTS LTD · SALFORD 3 · LANCs

A SUBSIDIARY OF THE GENERAL ELECTRIC CO. LTD. OF ENGLAND

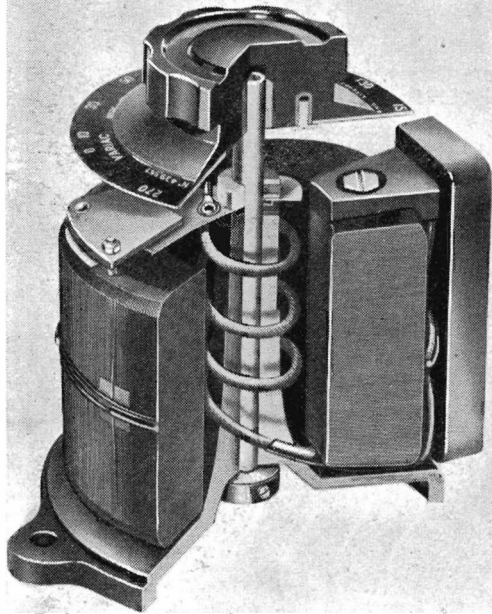

for smooth voltage
control
'VARIAC'

Registered Trademark.

— the original continuously-adjustable auto-transformer — is the ideal device for controlling any a-c operated equipment. VARIACS not only supply perfectly smooth control of voltage from zero, but some models also include an "over voltage" feature. VARIACS are designed and built for many years of trouble free operation.

S P E C I F I C A T I O N S

SERIES "50" Variacs							
TYPE	LOAD RATING	INPUT VOLTAGE	CURRENT		OUTPUT VOLTAGE	NO-LOAD LOSS	NET PRICE £ s. d.*
			RATED	MAXIMUM			
50-A	5 kva.	115 v.	40 a.	45 a.	0-135 v.	65 watts	44 18 6
50-B	7 kva.	230/115 v.	20 a.	31 a.	0-270 v.	90 watts	44 18 6

SERIES "100" Variacs							
TYPE	LOAD RATING	INPUT VOLTAGE	CURRENT		OUTPUT VOLTAGE	NO-LOAD LOSS	NET PRICE £ s. d.*
			RATED	MAXIMUM			
100-K	2000 va.	115	15 a.	17.5 a.	0-115	20 watts	17 17 0
100-KM	2000 va.	115	15 a.	17.5 a.	0-115	20 watts	18 12 0
100-L	2000 va.	230/115	8 a.	9 a.	0-230	25 watts	17 17 0
100-LM	2000 va.	230/115	8 a.	9 a.	0-230	25 watts	18 12 0
100-Q	2000 va.	115	15 a.	17.5 a.	0-135	20 watts	18 9 0
100-QM	2000 va.	115	15 a.	17.5 a.	0-135	20 watts	19 4 0
100-R	2000 va.	230/115	8 a.	9 a.	0-270	30 watts	18 9 0
100-RM	2000 va.	230/115	8 a.	9 a.	0-270	30 watts	19 4 0
100-LH	1200 va.	480/240	2 a.	2.5 a.	0-480	25 watts	21 15 0
500-L ⊕	1450 va.	180	8 a.	9 a.	0-180	25 watts	17 17 0
2000-K †	1000 va.	125	8 a.	9 a.	0-125	25 watts	17 17 0

⊕ For 500 cycles. † For 2,000 cycle service.

SERIES "200" Variacs							
TYPE	LOAD RATING	INPUT VOLTAGE	CURRENT		OUTPUT VOLTAGE	NO-LOAD LOSS	NET PRICE £ s. d.*
			RATED	MAXIMUM			
200-CM } 200-CU }	860 va.	115 v.	5 a.	7.5 a.	0-135 v.	15 watts	7 17 6 6 15 0
200-CMH } 200-CUH }	580 va.	230 v. 115 v.	2 a. 0.5 a.	2.5 a. 2.5 a.	0-270 v. 0-270 v.	20 watts 20 watts	9 15 0 8 5 9

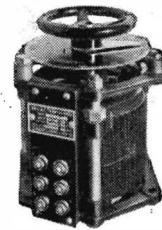

*All 'VARIAC' prices plus 20% as from 23rd Feb. 1952

Write for catalogue V549 which gives full details of 'VARIAC' transformers and suggestions for use, as well as data on other special patterns.

PROMPT DELIVERY OF "VARIAC" TRANSFORMERS

CLAUDE LYONS LIMITED

ELECTRICAL AND RADIO LABORATORY APPARATUS, ETC.

180 Tottenham Court Road, London, W.1; and 76 Oldhall Street, Liverpool 3, Lancs.



FREQUENCY STANDARD

TYPE 761

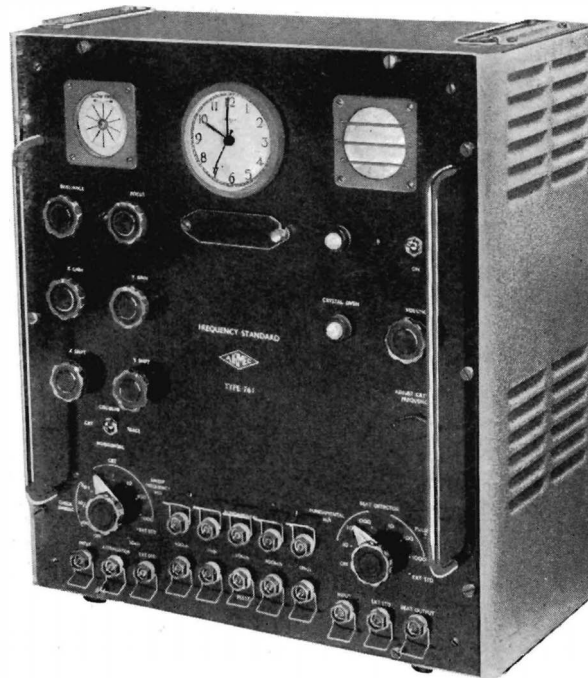

THE AIRMEC FREQUENCY STANDARD TYPE 761 has been designed to fill the need for a self-contained frequency standard of moderate cost and high accuracy. It incorporates an oscilloscope for visual frequency comparison, and a beating circuit and loudspeaker for aural checking. A synchronous clock, driven from a voltage of standard frequency provides a time standard and enables long time stability checks to be made.

- **Master Oscillator :** Crystal-controlled at a frequency of 100 kc/s. The crystal is maintained at a constant temperature by an oven.
- **Outputs :** Outputs are provided at 100 c/s, 1 kc/s, 10 kc/s, 100 kc/s and 1 Mc/s.
- **Waveform :** The above outputs are available simultaneously with sinusoidal or pulse waveform from separate plugs.
- **Stability :** Three hours after switching on a frequency stability of about 1 part in 10^6 over any 12-hour period is obtained.

Full details of this or any other Airmec instrument will be forwarded gladly upon request.

AIRMEC LABORATORIES **LIMITED**

HIGH WYCOMBE - BUCKINGHAMSHIRE - ENGLAND
Tel. : HIGH WYCOMBE 2060 Cables : AIRMEC HIGH WYCOMBE

for staking nags...



and making fags...

In countless instances where electro-mechanical devices have superseded older, cruder methods of operation or control, BURGESS Micro-Switches have been adopted by the designing engineers. To illustrate—the Tote mechanism that issues your ticket and works out the "odds" and the equally fascinating machine that rolls your smokes are both equipped with Burgess Micro-Switches. Here is further evidence of the wide adaptability of these fine-limit snap-action switch units... chosen by designers everywhere for their extreme reliability.

If you have not already done so, write for our 30-page Catalogue, No. 50/E.E.9.

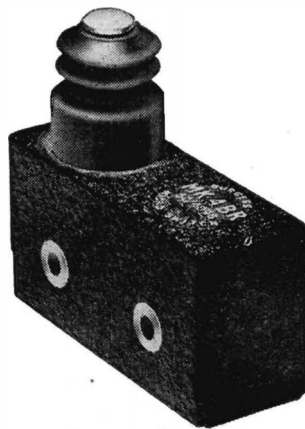

BURGESS
MICRO - SWITCHES

Industries Automatic Choice

ERIE

Reg. Trade Mark

Super-k-miniature Insulated Tubular Ceramicons

TYPE GP3

Higher capacitances, in standard sizes, than ever before

GP3 Ceramicons* go a stage further than GP2 by offering the designer an even higher capacitance (tube-size for tube-size) than ever before. They are manufactured from a new ceramic of high dielectric constant, designated Hi-K 35, which, after patient research has been developed from the well-known Erie Hi-K 15 material, which has enjoyed Government type approval ever since its introduction in 1943, and is still being used with satisfaction in tens of millions of Ceramicons* all over the world. Having been proved by normal and accelerated life tests since 1949, and in overseas markets since 1950, this new material is now being made available for home applications.

FLASH TEST: 1150 volts D.C.

INSULATION RESISTANCE: Greater than 7500 megohms.

LIFE TEST: 700 volts D.C. at 71°C. 1000 hours.



WORKING VOLTAGE: 350 D.C. at 71°C.

POWER FACTOR: Not greater than 2.5% when measured at room temperature and at 300 Kc/s. with an applied potential not greater than 5 volts R.M.S.

TOLERANCE ON CAPACITANCE: +80% --20%.

TEMPERATURE CHARACTERISTICS: The capacitance of GP3 Ceramicons* shall not decrease more than 50%, nor increase more than 25% from their value at room temperature as temperature is varied from +10°C. to +75°C.

* Registered Trade Mark

STYLE	CAPACITANCE
 GP3/AD MAX. DIMENSIONS 0.460" x 0.240"	1000 to 2000 mmfd (0.002 MFD)
 GP3/BD MAX. DIMENSIONS 0.710" x 0.240"	2001 to 5000 mmfd (0.005 MFD)



ERIE RESISTOR LIMITED

Carlisle Road, The Hyde, London, N.W.9, England. Telephone: COLindale 8011.
 Factories: London and Great Yarmouth, England; Toronto, Canada; Erie, Pa., U.S.A.



Q A NEW METER by Boonton - MODEL 190-A

The release of a new Q meter by Boonton is something of an event, and the model 190-A will arouse the immediate interest of all who are concerned with the accurate measurement, not only of radio frequency "performance" or Q but also with the determination of inductance, capacitance and resistance of coils, condensers, resistors and dielectrics.



In designing tuned circuits the effect on Q of adding capacitors, iron cores, or resistors must frequently be determined. These measurements made on Q meters formerly available required the use of a small difference between two large Q values in various formulæ, a measuring procedure which could lead to large errors.

Model 190-A reads the difference between the Q of a reference circuit and the Q of the same circuit when new components are added, the scale indicating the differential Q having 4 times the sensitivity of the Q scale.

Frequency coverage has been increased and now covers 20 mc/s to 260 mc/s continuously variable in four ranges, and having an accuracy of $\pm 1\%$.

Q readings between 5 and 1200, and differential Q from 0 to 100 are possible with an accuracy of $\pm 5\%$ up to 100 mc/s and $\pm 12\%$ up to 260 mc/s.

You are invited to write for data sheets which give the full specification of the Model 190-A, and also for technical information on other instruments in the ranges of BOONTON, CLOUGH-BREngle, BALLANTINE, FERRIS, and MIDGLEY-HARMER.

Boonton instruments are available, subject to import licence, from the SOLE CONCESSIONAIRES for the United Kingdom—

LELAND INSTRUMENTS LTD.

Electronic Engineers & Consultants

TELEPHONE: VICTORIA 3243 (FIVE LINES)

Plot Problems — electronically

The use of Nagard Oscilloscopes in resolving industrial and Service problems extends from phase plotting to explosion analyses. The embodiment of unit construction in Nagard instruments not only ensures considerable versatility in each type, but also permits easy modification to suit ever widening uses. The models listed below are typical of the range at present in production, but development continues apace and additional Nagard instruments are forecast which extend still further the uses of Nagard Oscilloscopes. D.C. Amplifiers are available as separately cased and powered instruments covering high gain requirements up to frequencies of 10 Mc/s.

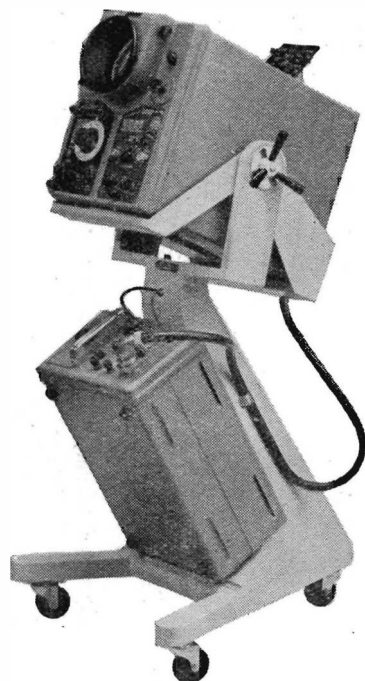

MODEL L 103 For High Speed Transients.

MODEL A 103 For Pulse Work and Repetitive Signals up to 10 Mc/s.

MODEL F 103 For General Work at Frequencies up to 1 Mc/s, High Gain D.C. Y Amplifier, Excellent Triggering.

MODEL G 103 As above but with Slow Speed Time Base.

MODEL H 103 Extra High Gain D.C. Y Amplifier up to 200 Kc/s

NAGARD LTD

See what you measure!

18, Avenue Road, Belmont, Surrey.

VIGILANT 0345.

Electronic Engineering

Incorporating *ELECTRONICS, TELEVISION and SHORT WAVE WORLD*
Managing Editor, H. G. Foster, M.Sc., M.I.E.E.

Vol. XXIV SEPTEMBER 1952 No. 295

Contents

Commentary	389
An Apparatus for Determining the Velocity of an Ultrasonic Pulse in Engineering Materials By E. N. Gatfield	390
Flight Simulators	395
A Study of the Characteristics of Glow-Discharge Voltage-Regulator Tubes (Part 1) By F. A. Benson, M.Eng., Ph.D., A.M.I.E.E., M.I.R.E.	396
A Simple Variable Frequency Phase Measuring Device By J. C. West, B.Sc., A.M.I.E.E. and J. Potts, B.Sc.	402
The Differential Amplifier with a Useful Modification By B. F. Davies	404
The Miller Transitron	407
By O. C. Wells	
A Dekatron Timer	408
By J. McAuslan, B.Sc., and K. J. Brimley, B.Sc.	
Paris-London Television	410
By T. H. Bridgewater, M.I.E.E.	
A New Frequency Divider	413
By J. A. Fitzgerald, A.M.I.E.E.	
A Radio-Frequency Micropotentiometer	415
By M. Lorant	
Tape Wound Magnetic Cores	416
By A. Langley Morris, M.I.E.E.	
Special Rectifier Circuits	418
By D. B. Corbyn, B.Sc., A.M.I.E.E.	
A Linear Transducer for the Electrical Measurement of Displacement	420
By M. J. Tucker, B.Sc.	
Very-High-Frequency Transistors	422
A Timing Circuit for Controlling Related High Energy Pulses	423
By K. S. W. Champion, Ph.D., A.Inst.P., and N. L. Allen, Ph.D.	
Improved "Bread-board" Construction	425
The Resolution of Complex Quantities	426
By N. H. Crowhurst, A.M.I.E.E.	
Notes from the Industry	429
Electronic Equipment	430
Book Reviews	432
Publications Received	434

Published Monthly on the last Friday of the preceding month at
28 Essex Street, Strand, London, W.C.2.

Phone: CENTRAL 6565. Grams: 'LECTRONING, ESTRAND, LONDON'

Subscription Rate:

(Home or Abroad) Post Paid 12 months 26s. or \$3.75 (U.S.)

Classified Advertisements, Page 1
Index to ADVERTISERS, 62

AMERICAN (R.T.M.A.) TYPES REPLACEABLE BY MULLARD VALVES

R.T.M.A. NUMBER	MULLARD REPLACEMENT	R.T.M.A. NUMBER	MULLARD REPLACEMENT
0A4G	1267	829B	QQV07-40
0E3	85A1	866A	RG3-250A
1A3	DA90	1267	1267
1AC6	DK92	5544	MT5544
1L4	DF92	5545	MT5545
1R5	DK91	5557	MT17
155	DAF91	5559	MT57
1T4	DF91	5861	ME1001
2D21	2D21	5866	TY2-125
3A4	DL93	5867	TY3-250
3A5	DCC90	5868	TY4-500
3B28	3B28	5894	QQV06-40
3NP4	MW6-2	5895	QQZ04-15
354	DL92	6155	QY3-125
3V4	DL94	6156	QY4-250
4B32	4B32		
5V4G	GZ32		
5Z4G	GZ32		
6AB8	ECL80		
6AK5	EF95		
6AL5	EB91		
6AM5	EL91		
6AM6	EF91		
6BE7	EQ80		
6BX6	EF80		
6C16	EL81		
6J6	ECC91		
6NB	EBF80		
6X2	EY51		
12AT7	ECC81		
15A6	PL82		
16A5	PL82		
FG17	MT17		
17Z3	PY81		
19X3	PY80		
19Y3	PY82		
21A6	PL81		
FG57	MT57		
FG105	MT105		
807	QV05-25		

NEAR REPLACEMENTS

R.T.M.A. NUMBER	MULLARD REPLACEMENT
2142	ME1101
4D21/4-125A	QY3-125
SCP1-A	DG13-2
SCP7-A	DP13-2
5D21/4-250A	QY4-250
5FP4-A	MW13-35
617GT	EF37A
616G	EL37
65L7GT	ECC35
65N7GT	ECC33
6X5G	EZ35
CK512AX	DF66
CK523AX	DL66
723A/B	ME1100
5800/VX41	ME1402
5802/VX32	ME1401

Mullard



This is a page from the new edition of "Valves
and Tubes for Industry and Communications."

WRITE FOR COPY TO ADDRESS BELOW

**MULLARD LTD., COMMUNICATIONS AND INDUSTRIAL VALVE DEPT., CENTURY
HOUSE, SHAFTESBURY AVENUE, LONDON, W.C.2**

Electronic Engineering

Vol. XXIV.

SEPTEMBER 1952

No. 295.

Commentary

THE 19th National Radio Show at Earls Court will be opened to the public by Lord Burghley, President of the Radio Industry Council, on August 27. This year's Exhibition will be similar, in essence, to that of last year with particular emphasis on radio, television and allied equipment for export and television receivers for the home market. The latter market should receive a considerable impetus from the opening of the high power transmitter at Kirk o'Shotts and the low power transmitter at Wenvoe, both of which events have taken place during August. This represents a great step forward in the BBC's plan to provide country-wide television coverage. The construction of the high power transmitters at Wenvoe is now well under way and when these are completed all that will remain will be the erection of the proposed five low power stations. This, unfortunately, will have to await the Government's approval, which of course is attendant upon a betterment of the Country's economic position. Nevertheless it is estimated that the BBC television programmes are now available to 78 per cent of the population of the United Kingdom which is, almost without doubt, the largest national coverage of any country in the world.

From a technical viewpoint it is of interest to note the development that has taken place in the vision transmitters during the construction of the five stations. In the two latest transmitters, at Kirk o'Shotts and Wenvoe, low-level modulation has been used with a consequent decrease in their size and power consumption. They are in fact little more than half the physical size of the transmitter at Sutton Coldfield and yet have a power output one-third as much again.

This has of course made necessary the design of wideband power amplifiers and it will be of great interest to see how they compare in service with the more conventional transmitters at the three other stations.

Metal rectifiers have also been used throughout, which considerably simplifies the switching arrangements, although on account of their large size and weight their rapid replacement may prove to be somewhat difficult.

* * *

Running concurrently with the latter half of the Radio Show will be the Society of British Aircraft Constructors' Exhibition which opens at Farnborough on September 1. This is an exhibition which year by year is assuming greater importance to the electronic engineer, for in addition to the display of a large range of communication equipment and navigational aids, the industrial application of electronics to the various difficulties of mechanical design, such as the measurement of strain and stress, is well demonstrated and, from the advance information available concerning the

exhibition, it is apparent that all the foremost airframe and aero engine manufacturers are well aware of the great help that can be obtained from the various forms of electronic measuring apparatus.

* * *

The adequate training of engineers is a subject that has been in the minds of a great many people for a long time and there are a large number, especially those industrialists who complain that the scope of training given to University students in engineering is too narrow, who will welcome the plan that has recently been announced for collaboration between the Imperial College of Science and Technology at South Kensington and the London School of Economics and Political Science. In addition to joint research between the two bodies with the object of "throwing light on the direction, strength and interplay of scientific, technological, social and market forces," arrangements have also been made whereby post-graduate students of either the College or the School can broaden and deepen their education. For instance, students of Imperial College who have been accepted for a post-graduate course in science or technology and who wish to acquire an introductory knowledge of such subjects as economics, law, history and administration will be afforded facilities to do so at the London School of Economics, while the Imperial College will provide, for students of the London School, special courses designed to illustrate typical developments in science and their application to industry and to give the student some acquaintance with industrial materials and products, manufacturing processes and equipment.

While it may be argued, and more especially probably by those concerned with the training of engineers, that the time available is already far too short in which to impart the abundance of basic technical knowledge, and that only by intensive specialization can an adequate supply of useful engineers be maintained, there are few who will deny that some knowledge of economics, for example, would be an extremely valuable adjunct to the best technical training, especially so in the case of those destined to fill the higher posts in industry. There are many industrialists who know, to their cost, that a large amount of time and money can be wasted if their designers and development engineers are not aware of the economics of a particular project as well as its technicalities. These arguments are just as well applied, in converse, to the economist and the industrial executive and we feel that the Imperial College of Science and the London School of Economics are to be congratulated on the steps they have taken, for at least it will provide an interesting and instructive experiment while all things point to its being an achievement that will prove of lasting value.

An Apparatus for Determining the Velocity of an Ultrasonic Pulse in Engineering Materials

By E. N. Gatfield *

The mechanical properties of several road materials, particularly concrete, may be determined by a non-destructive method based on measurements of the time of propagation of longitudinal vibrations at ultrasonic frequencies between two piezo-electric transducers placed in contact with opposite faces of the material. The distance between the transducers is accurately measured, and the results are usually presented as the velocity of propagation. The ultrasonic pulse technique is employed, and, for concrete, the ultrasonic frequency is usually 200kc/s, with a pulse repetition frequency of 50 pulses per second. Measurements of the time of propagation are made within the range 0 to 450 microseconds, covering thicknesses of normal concrete up to 6ft. The accuracy of measurement of the velocity is dependent on the path length and on the quality of the concrete, but is generally better than ± 0.5 per cent, corresponding to an error ± 0.1 microsecond for test cubes of 10cm path length. When longer path lengths are used, the accuracy is usually higher provided an adequate signal is received.

Details are given of the equipment developed at the Road Research Laboratory for this work, descriptions being given of the circuits and mode of operation of each of the units comprising the complete apparatus. A cathode-ray oscilloscope is used to measure the difference in time of transmission occurring when the transducers are in intimate contact and then separated by the thickness of material being tested. A trigger generator is used to control a time-marker generator simultaneously with an electrically shock-excited piezo-electric transmitter and a time-base sweep circuit. The timing marks appear on the cathode-ray tube superimposed on the signal generated by the piezo-electric receiving transducer.

THE quality of many of the materials employed in civil engineering, particularly concrete, may be determined from measurements of the time of propagation of an ultrasonic pulse through a known distance in the material. This article describes apparatus developed at the Road Research Laboratory for the precise measurement of the velocity of such a pulse between two piezo-electric transducers placed in contact with opposite parallel faces of specimens of the material; the apparatus is used to test both laboratory specimens and, in the case of concrete, full-scale structures. The electronic equipment is described, but no details are given of the results obtained in testing various materials; these are given elsewhere^{1, 2}.

The apparatus was designed primarily for testing concrete, but is also suitable for other materials. An ultrasonic frequency of 200kc/s was selected for concrete as being a reasonable compromise to give as directional a wave in the material as possible and also to avoid the attenuation associated with higher frequencies. The apparatus was planned to cover times of propagation from near zero to 450 microseconds, the maximum time corresponding to a path length of 6ft in good quality concrete. The range could be extended by suitably modifying the apparatus.

The repetition frequency of the pulses was fixed at 50 per second to give a reasonably long resting period which would permit the reverberations to die away and thus avoid interference between successive pulses.

The accuracy of measurement naturally depends upon the path length and the quality of the material under test. With concrete, the accuracy is usually better than ± 0.5 per cent which corresponds to an error of ± 0.1 microsecond

for test cubes of 10cm path length. Greater accuracy may be obtained over long path lengths provided an adequate signal is receivable.

Principle of Operation

A block diagram of the apparatus is given in Fig. 1 and the associated theoretical waveforms are reproduced in Fig. 2.

The trigger generator produces a negative rectangular pulse at a repetition frequency of 50 pulses per second, from the leading edge of which the transmitter, time-base sweep and time-marker generating circuits are all triggered.

The transmitter delay unit generates a rectangular pulse, accurately variable over a range of 10 microseconds, at the lagging edge of which the transmitter exciter is triggered. An ultrasonic pulse, consisting of a train of longitudinal wave vibrations, results from the shock excitation of a piezo-electric crystal transducer which is coupled into the concrete or other material being tested, by a thin film of lubricating oil. As will be described later, the variable delay of 10 microseconds in the transmission of the pulse is used to interpolate the propagation time between fixed 10 microsecond timing indices.

A similar piezo-electric transducer is used to receive the ultrasonic pulse, and the electrical signal thereby generated is fed through a high gain amplifier to the upper vertical deflexion plate of a cathode-ray tube.

Timing indices at intervals of 10 microseconds are applied to the lower plate of the cathode-ray tube. These indices are in the form of pulses, each having a steep leading edge and a duration of about 0.5 microsecond, and are produced by the time-marker generator from a 100kc/s oscillator. The timing indices are synchronized

* Road Research Laboratory, Department of Scientific and Industrial Research.

by pulsing the oscillator with the pulse from the trigger generator, a train of phase locked timing indices being produced for the duration of each trigger pulse.

The frequency of the pulsed oscillator, and hence the accuracy of the timing indices, is checked from time to time against that of an internal 100kc/s quartz crystal.

The time-base sweep generator is triggered from the lagging edge of a variable width pulse generated by the sweep delay unit. The variable delay so introduced makes

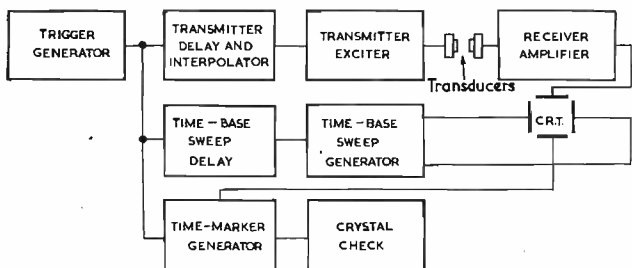

Fig. 1. Block schematic diagram

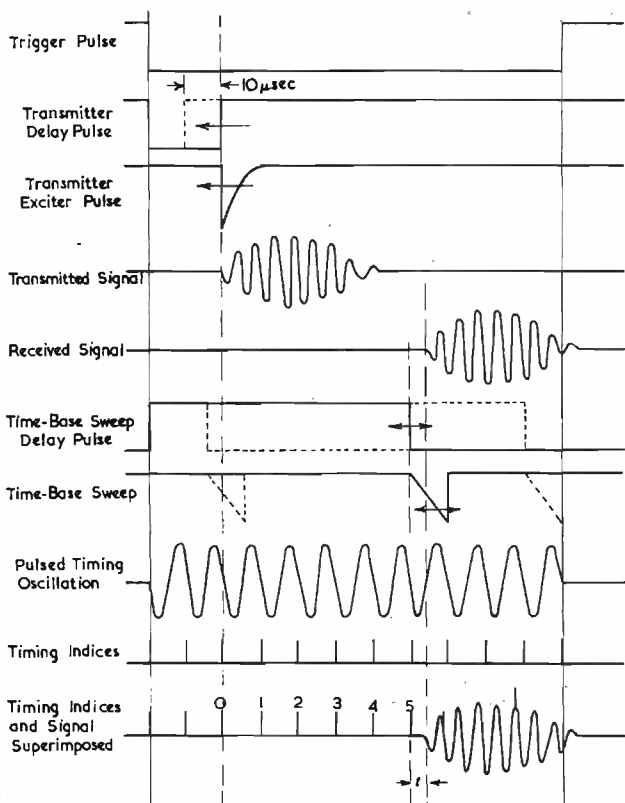

Fig. 2. Simplified circuit waveforms (Not to scale)

it possible to use an expanded time-base sweep with which to scan the time interval being measured between the transmitted and received ultrasonic signals. During the scanning operation, the timing indices which mark this interval pass across the cathode-ray tube screen and can easily be counted. Reference to Fig. 2, where five such indices are shown, will make this clear. The additional time, t , is evaluated with the interpolation control, which, by reducing the delay in the transmission of the pulse, is

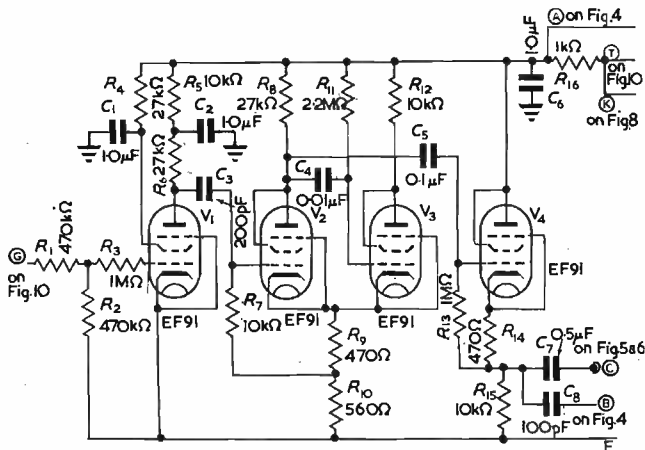

Fig. 3. Trigger generator

used to move the received signal with respect to the timing indices. In this way, the onset of the signal can be aligned in coincidence with the preceding timing index and the time, t , through which the signal has been moved can be read on the calibrated dial of the interpolating control.

The use of an expanded time-base sweep increases the precision with which this alignment can be made and makes it independent of the duration of the measured time interval, provided that the onset of the received pulse remains sharp. In practice the onset of the pulse becomes less sharp for the longer time intervals, but experience has shown that, for good quality concrete, durations of 20 and 160 microseconds can be measured to an accuracy of 0.1 and ± 0.2 microsecond respectively.

Circuit Details

TRIGGER GENERATOR (Fig. 3)

The frequency of repetition of the pulse is that of the 50c/s mains supply voltage. A square waveform of this frequency is produced at the anode of V_1 by limiting in the grid circuit a sinusoidal voltage obtained from one half of the H.T. transformer secondary winding. The valves, V_2 and V_3 form a cathode coupled flip-flop circuit³ which is triggered by the short positive pulse resulting from the differentiation by C_3 and R_7 of the anode waveform of V_1 . The duration of the negative pulse

Fig. 4. Transmitter delay and exciter unit

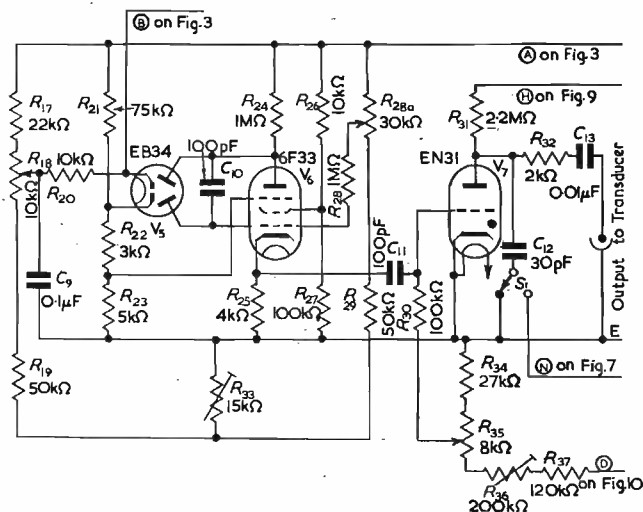

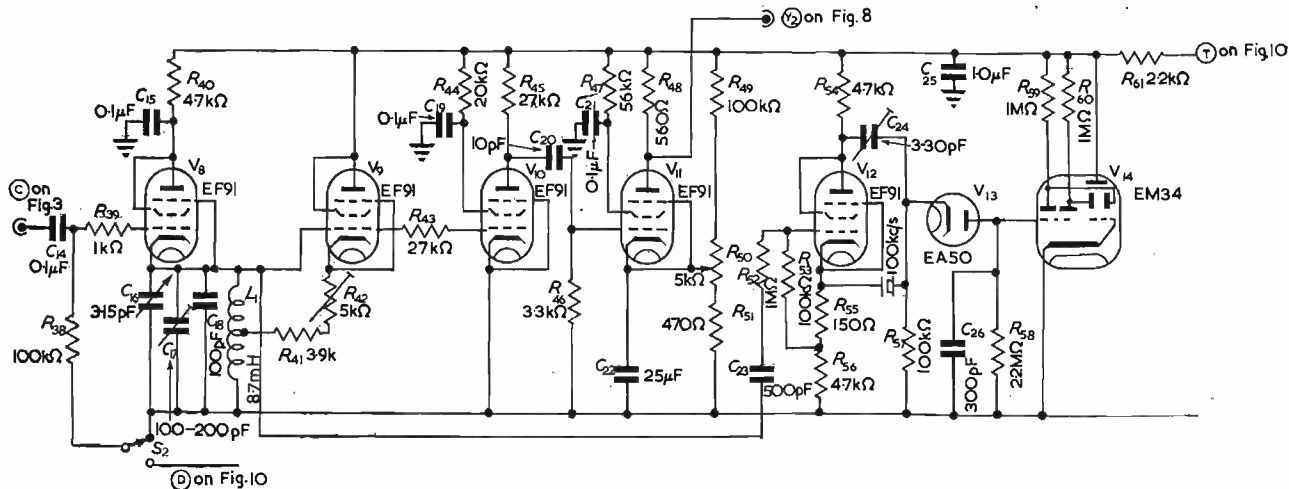

Fig. 5. Time marker generator

generated at the anode of V_2 determines the length of the train of timing indices derived from the pulsed oscillator. It is made to exceed the fixed delay in the transmitter and time-base sweep circuits plus the longest time interval to be measured. Distribution of the trigger pulse from V_2 is made from the low impedance output of the cathode-follower stage, V_4 .

TRANSMITTER DELAY AND EXCITER UNIT (Fig. 4)

After differentiation by C_8 and R_{20} , the leading edge of the trigger pulse is used to trigger the phantatron⁴ stage formed by V_5 and V_6 . At the cathode of V_6 , a negative going pulse is formed, having a duration of approximately 70 microseconds which may be varied in an accurately linear manner over a range of 10 microseconds. A wire-wound potentiometer, R_{18} , linear to ± 1 per cent, is used to control the width of this pulse and is provided with a calibrated slow motion dial for interpolating propagation times between the fixed timing indices. High stability resistors have been liberally used in this stage to obviate drift of the transmitted pulse with respect to the timing indices, and the necessity for frequent recalibration of the interpolating control.

The negative going pulse at the cathode of V_6 is

differentiated by C_{11} and R_{30} and the short positive pulse corresponding in time to the lagging edge is used to trigger the gas triode valve, V_7 , which acts as the transmitter exciter. In the period between pulses, the capacitance of C_{13} and the transmitting transducer, with its associated co-axial cable, is charged through R_{31} and R_{32} to a potential of nearly 1000 volts. The discharge of this capacitance by the conduction of V_7 causes the transducer to be shock excited and so produce a train of longitudinal wave vibrations at its own natural frequency. The valve, V_7 is normally prevented from conducting by a negative grid potential applied from the potentiometer R_{35} . Owing to the finite time of rise of the pulse applied to the grid, the time at which V_7 is triggered may be varied under the control of R_{33} . This control is used as a zero adjustment to enable the onset of the transmitted pulse to be accurately aligned on the cathode-ray tube display with a particular timing index. If too great a bias is applied to the grid of V_7 instability of the firing point may result. Initial adjustment should be made by first setting the bias potential to a minimum of R_{35} and then reducing the resistance of R_{36} until V_7 is observed to fire regularly.

Fig. 6. Delayed time-base sweep generator

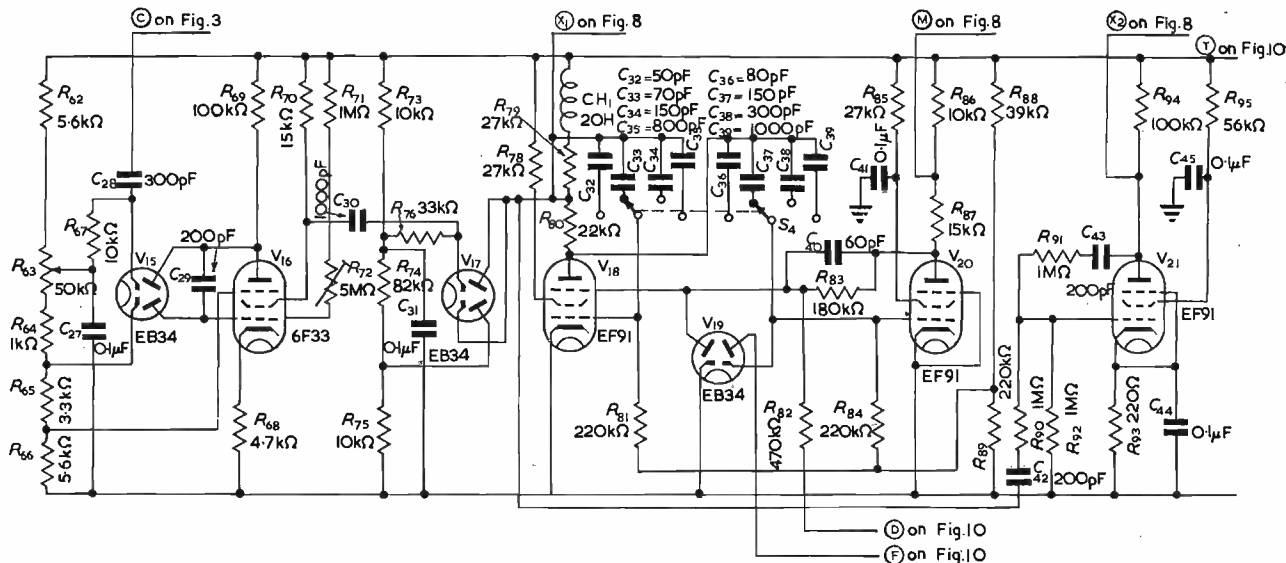

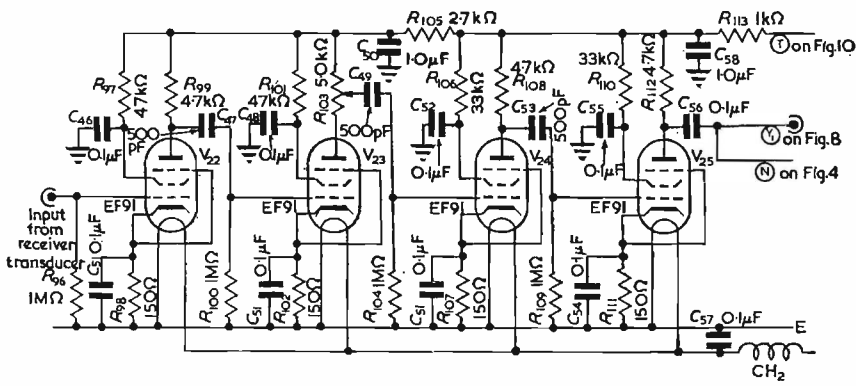

Fig. 7. Receiver amplifier

Closing the switch, S_1 , couples a small proportion of the negative pulse at the anode of V_7 to the signal plate of the cathode-ray tube, thus providing a marker pulse which may be used to identify the zero timing index when propagation times are being measured. The marker pulse is also used to calibrate the interpolation control R_{18} . With R_{33} set to give maximum delay of the transmitter firing point and the interpolating control, R_{18} , set to zero (i.e., maximum delay) the potentiometer, R_{28a} , is adjusted to bring the leading edges of the marker pulse and a particular timing index in exact coincidence. R_{33} is then adjusted until full rotation of the interpolation control moves the marker pulse through the required range of 10 microseconds. The adjustment of R_{33} may be found to affect the zero setting of the interpolation control, but R_{28a} may be used to select one particular timing index as the zero at which this effect is very small. One or two alternate adjustments of the two controls should then suffice to complete the calibration. With the present apparatus, it was found that once R_{33} and R_{28a} were correctly adjusted, no further adjustment was necessary and the interpolation has remained accurate.

TIME-MARKER GENERATOR (Fig. 5)

The tuned circuit of the pulsed oscillator⁵ is formed by the air-cored inductor, L_1 , and the capacitors C_{16} , C_{17} , and C_{18} , the cathode current of V_8 normally flowing through L_1 . Oscillation is normally suppressed owing to the heavy damping imposed on this circuit by the low impedance presented to it by V_8 . When V_8 is cut off, by the application of the negative trigger pulse to its grid, the rapid change of current in L_1 results in a shock excitation of the tuned circuit. Oscillation is maintained by positive feedback from V_9 , the degree of feedback being controlled by R_{42} . This is adjusted so that a constant amplitude of oscillation is maintained for the duration of the trigger pulse. Grid current flowing in R_{13} limits the positive half cycles of the sinusoidal waveform applied to V_{10} , the negative half cycles producing a rapid rise of voltage at the anode of V_{10} which is differentiated by C_{20} and R_{16} . Short positive pulses are thereby formed and amplified by V_{11} to produce timing indices with steep leading edges at the anode of this valve. To discriminate against the negative going pulses appearing at its grid, V_{11} is biased to beyond cut-off, the bias control, R_{30} , also serving as an amplitude control of the timing indices.

The frequency checking circuit requires the oscillator to be continuously running, and this condition is met by applying a large negative bias to the grid of V_8 by means of the switch S_2 . V_8 is then cut off, and its damping influence on the oscillatory circuit removed. In these circumstances a continuous wave signal is fed to the phase-splitting stage, V_{13} , the antiphase outputs of which are coupled respectively by C_{24} and a 100kc/s quartz crystal to a common load resistor, R_{57} . With the oscillator tuned slightly off the resonant frequency of the crystal, the pre-

set capacitor, C_{24} , is adjusted to balance out the capacitance of the crystal holder and so cause a minimum signal voltage to appear across R_{57} . When the oscillator is then tuned to the resonant frequency of the crystal, the out-of-balance voltage appearing across R_{57} is rectified by the diode, V_{13} , and a negative bias is thus applied to the grid of the tuning indicator, V_{14} . The frequency checking procedure is, therefore, to close the switch, S_2 , and tune the oscillator by the variable capacitor, C_{16} , for a maximum closure of the tuning indicator "eye". It is advisable to check the initial tuning of the oscillator against an external signal generator, using the pre-set capacitor,

C_{17} , to give correct tuning at the middle of the range of C_{16} .

DELAYED TIME-BASE SWEEP GENERATOR (Fig. 6)

A phantastron variable width pulse generator, V_{16} and V_{15} , is triggered by the leading edge of the trigger pulse via the differentiating circuit C_{28} and R_{37} . The duration of the positive going pulse generated at the screen of V_{16} is made variable between approximately 60 and 510 microseconds under the control of R_{63} . After differentiation by C_{30} and R_{16} , the lagging edge of the variable width pulse is used to trigger the sanatron⁴ time-base sweep generator formed by V_{18} and V_{20} . Thus R_{63} enables the time at which the sweep is started to be varied over a range of about 450 microseconds after the firing of the transmitter and so forms the scanning control. The pre-set control, R_{72} , is used to bring the transmitted pulse into position on the cathode-ray tube display when the scanning control is set at zero delay.

Negative and positive going saw-tooth waveforms are generated at the anodes of V_{18} and the para-phase amplifying stage, V_{21} , respectively and so provide push-pull deflexion voltages for coupling to the horizontal deflexion plates of the cathode-ray tube. A positive going brighten-up pulse of the same duration as the time-base sweep is taken from the anode circuit of V_{20} to the grid of the cathode-ray tube. The latter is normally blacked-out by a standing negative bias applied from the brilliance control so that the fly-back is rendered invisible. The capacitors which determine the rate of sweep are selected by the double-pole switch, S_1 , and make available four sweep durations, of 5, 15, 30 and 150 microseconds respectively.

SIGNAL AMPLIFIER (Fig. 7)

This consists of four similar resistance-capacitance

Fig. 8. Display unit

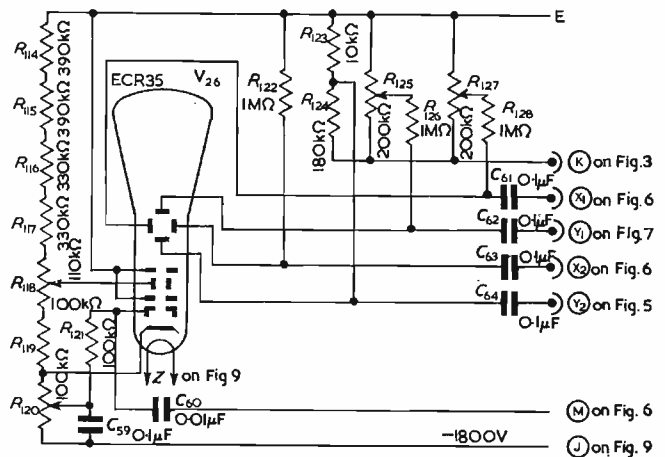

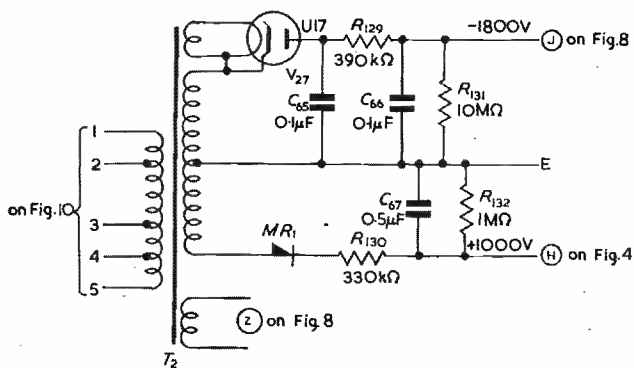

Fig. 9. E.H.T. Supply unit

coupled stages with an overall voltage gain of 4×10^5 and a bandwidth of about 500kc/s. The signal from the receiving transducer is fed directly into the grid of the first stage V_{22} . A simple gain control is provided by the potentiometer which forms the anode load of V_{23} and an

It was not found necessary to stabilize the h.t. supply unit (Fig. 10) which supplies power at 360 volts and negative bias voltages from the metal rectifier, MR_{27} , to the various units. Since the cathodes of valves V_5 , V_{15} , and V_{17} are at a relatively high potential to earth, their heater supplies are taken from a single separate winding on the power transformer.

TRANSDUCERS

Fig. 11 shows the construction of the type of transducer normally used. The crystal assembly is held in contact with the inner face of a brass diaphragm by a helical spring which also serves to make electrical contact between the co-axial cable and the crystal assembly. Acoustic coupling of the crystals to the diaphragm is made by a thin film of transformer oil.

Any one of a number of crystal assemblies, mounted on interchangeable diaphragms, may be used to provide the required sensitivity and frequency. For normal use, the assembly is made up of two X-cut quartz crystals, 1in. in diameter and 0.125in. thick, with electrodes of copper foil 0.002in. thick. Together with the diaphragm, this assembly has a natural frequency of vibration of about

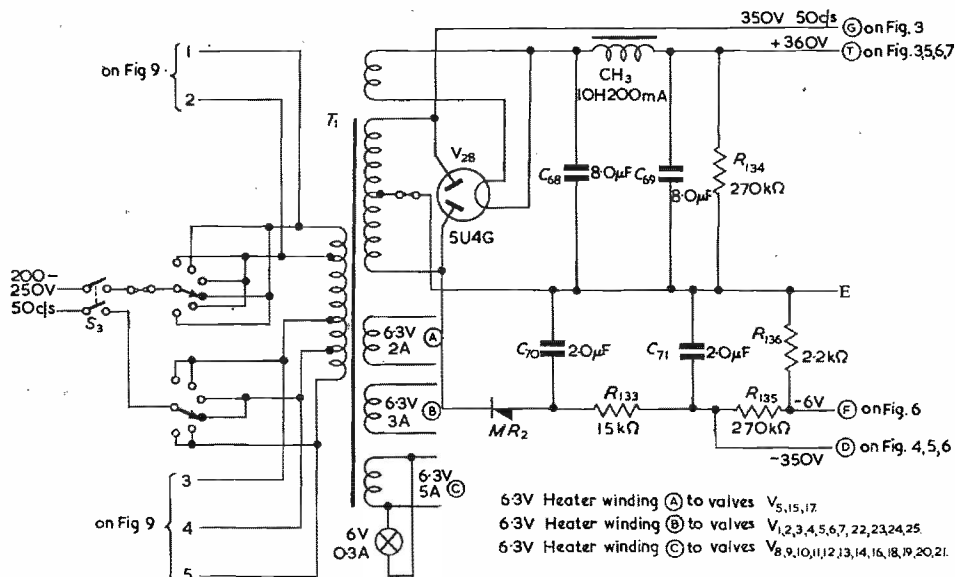

Fig. 10. H.T. supply unit

unbalanced output to the cathode-ray tube is taken from the anode of the final stage V_{21} . Overdriving of the later stages is allowed to take place on the build-up of the pulse since it is only to the start of the leading half cycle that measurements of time are made, and subsequent distortion is not important. The interstage coupling time-constants are sufficiently short to ensure that full recovery of the overdriven stages takes place in the period between pulses. In order to reduce undesirable break-through of the transmitter exciter pulse it was found necessary to include the low-pass filter formed by CH_2 and C_{37} in the heater supply line to this unit.

DISPLAY UNIT AND POWER SUPPLIES

The display unit (Fig. 8) consists only of the cathode-ray tube with the associated controls and requires little explanation. Coupling of the brighten-up pulse from the anode of V_{20} is made to the modulator grid by a capacitor of high working voltage, C_{60} , and resistor R_{121} .

A single transformer is used in the E.H.T. supply unit (Fig. 9) to provide 1,800 volts for the potential divider feeding the cathode-ray tube, and 1,000 volts for the transmitter exciter valve.

200kc/s. Other frequencies may be obtained by suitable choice of the number and the thickness of the crystals used in the assembly.

When a higher sensitivity is required, a Rochelle salt crystal assembly with a natural frequency of 55kc/s is used as the receiver. The sensitivity may be still further increased by using a second Rochelle salt assembly as the transmitter. This is usually necessary when testing concrete in which the length of path exceeds about 2ft and when testing materials, such as soil, which have high attenuating properties.

Fig. 11. Transducer with 200kc/s quartz crystal assembly

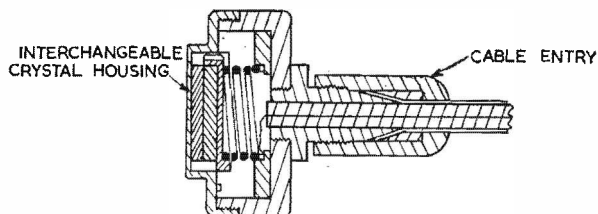

PRE-AMPLIFIER

When measurements must be made at a point which is inaccessible to the main body of the apparatus, the added capacitance of the longer length of cable needed to carry the received signal to the amplifier may seriously reduce the sensitivity of the receiving transducer. In such cases, a pre-amplifier is inserted between the transducer and the co-axial cable feeding the main amplifier. This consists of a single amplifying stage of low gain coupled to the co-axial cable by a cathode-follower with a very low output impedance. Full details of the circuit are given in Fig. 12.

CONSTRUCTION

The complete apparatus is shown in Fig. 13. To facilitate maintenance, and any future experimental modifica-

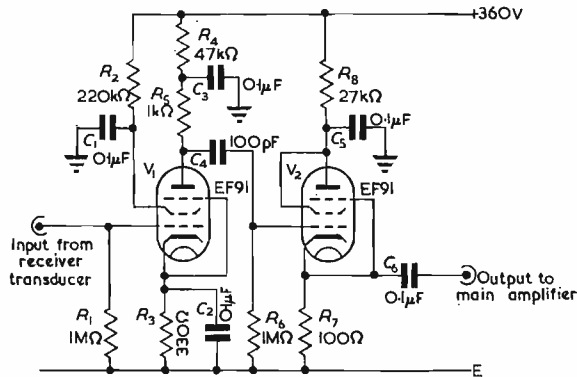

Fig. 12. Pre-amplifier

tion, compactness has been sacrificed and the apparatus built in seven separate units. Plug and socket interconnections are made by using co-axial cables for pulsed signals and multi-core cables for power supplies.

The units are mounted on separate panels and are carried by a tubular steel framework which is fitted with castor wheels for convenience of movement in the laboratory.

The cathode-ray tube, which is mounted vertically behind the centre panel, is viewed by means of a mirror set at an angle of 45°.

Acknowledgments

The apparatus described in this article was developed as part of the programme of the Road Research Board of the Department of Scientific and Industrial Research. The article is published by permission of the Director of Road Research.

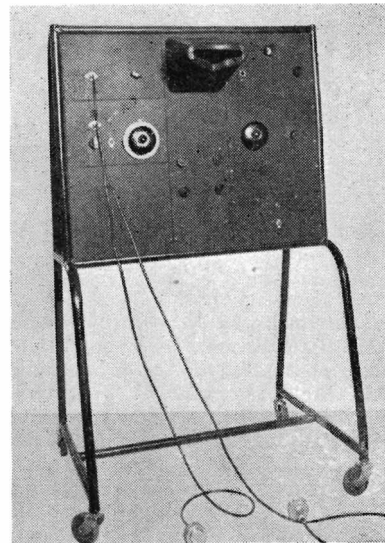
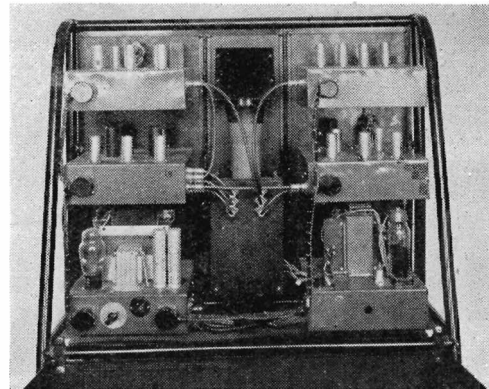

Fig. 13. Front and rear views of the complete equipment



REFERENCES

1. JONES, R. The Non-destructive Testing of Concrete. *Mag. Concr. Res.* 2, 67 (1949).
2. JONES, R. The Non-destructive Testing of Concrete. *Reinf. Concr. Rev.* 2, 315 (1951).
3. PUCKLE, O. S. Time Bases (Scanning Generators): Their Design and Development, with Notes on the Cathode-ray Tube. (Chapman & Hall Ltd., London, 1943).
4. WILLIAMS, F. C. and N. F. MOODY. Ranging Circuits, Linear Time-base Generators and Associated Circuits. *J. Instn. Electr. Engrs.* 93, Pt.IIIA, 1188-98 (1946).
5. Massachusetts Institute of Technology. Waveforms. *Radiation Laboratory Series, Vol. 19* (McGraw-Hill Publishing Co. Ltd., 1949).

Flight Simulators

The Canadian Government has recently placed an order, worth nearly three million dollars, for flight simulators for Sabre jet fighter aircraft, with Messrs. Redifon Ltd.

The flight simulator produces on the ground by electronic means the various conditions experienced by aircrews in actual flight. The flight deck is exactly reproduced complete with every instrument which is normally in the aircraft. The instruments continuously and cumulatively register in the same way as the corresponding instruments in actual flight.

Redifon have previously provided a flight simulator to train crews of the B.O.A.C. Stratocruisers and are now delivering one for the new Comet jet airliner. Simulators for other types of aircraft are now in the design or production stage.

The accompanying illustration shows the view on entering the Redifon C.700 Stratocruiser Simulator. In the forward part are the captain's, co-pilot's and flight engineer's positions, and at the panels in the foreground the chief and assistant instructors' positions.

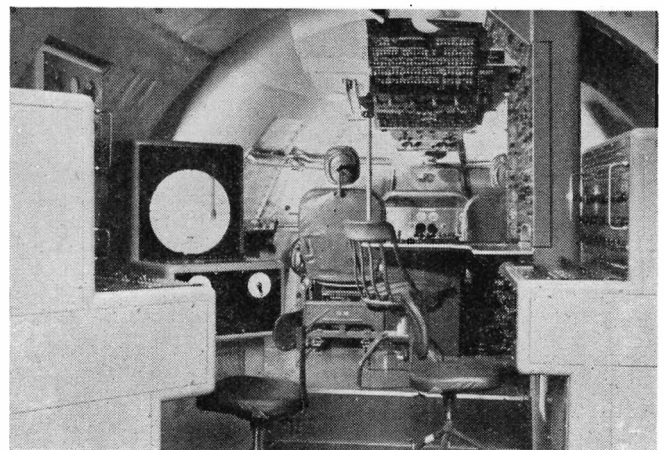

A Study of the Characteristics of Glow-Discharge Voltage-Regulator Tubes

((Part 1))

By F. A. Benson*, M.Eng., Ph.D., A.M.I.E.E., M.I.R.E.

The suitability of glow-discharge tubes for use in precision electronic circuits has been investigated. A large number of tubes of several types have been examined to determine whether they show appreciably different characteristics. The work includes detailed studies of the variations in striking and running voltages for both short and long-term operation, steps and hysteresis, the effects of temperature, current overloads, vibration, stray magnetic fields, and storage. It is found that published tube specifications and characteristics are generally misleading and glow-discharge tubes are unsuitable for precision circuits unless they are specially chosen and used under carefully controlled conditions.

IT is well known that a glow-discharge tube forms a very simple and inexpensive method of voltage stabilization. Such a stabilizer makes use of the substantially constant-voltage characteristic of the tube over a certain current range and is generally regarded as suitable and extremely useful for small load-current circuits¹. Glow-discharge tubes are also extensively used in electronic stabilizers of the degenerative type for providing a reference voltage which is essential for stabilization^{1,2}.

For both these purposes the ideal tube should have the following properties:—

- (1) There should be no drift in running voltage either due to changes of temperature or other causes when operated for any length of time and there should be an absence of spontaneous jumps in voltage.
- (2) For a given tube current the running voltage should be the same after any "strike."
- (3) The differential resistance should be very small.

Some work has previously been carried out by Lammchen³, Kirkpatrick⁴, Titterton⁵, Cain, Clucas and the author^{6,7} to determine certain characteristics of glow-discharge voltage-regulator tubes. Lammchen dealt with the variations of the characteristics with time for certain tubes, but the work was limited to periods of about 50 hours. Kirkpatrick has studied short and long-term voltage drifts together with temperature coefficient for the three American-type tubes VR75, VR105, and VR150. Titterton has examined many tubes in common use, namely types CV188, CV216 (VR150), CV1070, (7475), CV110 (S130) (VS110), VR105, 85A1, and the miniature types CV284, CV286, and CV287. His work did not, however, include measurements of long-term stability or of temperature coefficient. Cain, Clucas and the author confined their measurements to two types of tube only, viz. the type CV1070 (7475) and the type 85A1. The author⁶ has also studied for several tubes the initial drifts in running voltage, which occur during the first few minutes of operation after striking.

The present article covers a much wider field than the previous ones and gives the results of detailed investigations which have been carried out over a period of more than two years on 135 new tubes of 14 different types obtained from several manufacturers. The tests were made to determine the suitability of glow-discharge tubes for use in stabilized power supplies of high stability or other precision electronic circuits and whether different types show appreciably different characteristics. Many characteristics with which few engineers are acquainted are discussed.

The tube types examined are: CV45 (6), CV71 (6), CV188 (6), CV284 (2), CV1070 (36), S130 (19), 85A1 (34), KD60 (6), G50/1G (2), G120/1B (2), G180/2M (2), VR105 (2), VR150 (6) and NT2 (6). The figures in the brackets indicate the number of each type tested. The tubes investigated cover a voltage range of 50 to 160 volts and a current range of 0.1 to 75mA. It should also be noted that some special high-stability and miniature tubes are included as well as a few of American manufacture.

Studies of the variations in striking voltages and running voltages, including step and hysteresis effects, have been made. The temperature coefficient of each tube and its initial drift have been recorded. The effects of overloads magnetic and electric fields, vibration, and storage have been noted. Some figures for voltage drifts to be expected during the life of a tube are also included and it has been determined whether improvements can be made by ageing tubes before putting into service. In some cases tubes have been operated continuously for as long as 10,000 hours.

Striking Voltage

The striking voltage of each tube was recorded. The results, showing the upper and lower limits and the average value of striking voltage for each type of tube, are given in Table 1. In the Appendix detailed results are given for the cases where six or more tubes of one type were tested, to show the distribution of the striking voltage values.

Several tubes of each type were struck thirty times at half-minute intervals. The striking voltage of a particular tube is not constant. The maximum variations in striking voltage observed for a single tube are:

CV1070	3.5V
85A1	2.0V
CV45	10.0V with ignition electrode disconnected 4.0V with ignition electrode connected
S130	2.0V
CV71	25.0V
KD60	0.5V
CV188	1.0V
G50/1G	1.0V
G180/2M	5.0V with one anode used only 0.5V with anodes strapped or one used as ignition electrode
G120/1B	0.5V
VR105	5.0V
VR150	10.0V
CV284	10V
NT2	1.5V

* The University of Sheffield

Thus, large variations in striking voltage are obtained even for tubes of the same type. It follows that specifications for the tubes would be of greater value if they quoted striking-voltage limits rather than a single average or maximum figure. All the tubes tested met the present striking-voltage specifications.

Where an ignition electrode is fitted this lowers the striking voltage considerably and for the CV45 and G180/2M tubes tested also reduces the variations a good deal. In both VR105 and VR150 types of tube a starting probe is connected from the cathode and extends to within a short distance of the anode to lower the striking voltage. The starting probe is a permanent fixture, however, so tests could not be made without it. One tube of each of the VR105 and VR150 tubes tested showed a photoelectric effect. Placing such a tube in the dark caused an increase of striking voltage of about 12 per cent over that recorded in normal daylight. It will be observed that, in some cases a single new tube may show a considerable variation in striking voltage from strike to strike. This appears to be an ageing effect, possibly caused by changes

TABLE 1.—VARIATIONS IN STRIKING VOLTAGES.

TUBE TYPE	LIMITS OF STRIKING VOLTAGE (V)	AVERAGE VALUE OF STRIKING VOLTAGE (V)
CV1070*	111-134	120.7
85A1*	110.5-116.5	113.2
CV45	115-125†	120.6†
	145-158‡	153.2‡
S130	141.5-175	158.2
CV71	140-170§	151.2§
KD60	74-80	76.7
CV188	106.5-118	112.3
G50/1G	72.5-80	76.3
G180/2M	161-181	171.0
	159-161¶	160.0¶
G120/1B	94.5-102	98.3
VR105	111-125**	113.5‡‡
VR150	131-172††	154.0‡‡
CV184	87-97	92.0
NT2	61-72	64.7

KEY FOR TABLE 1

- * The tubes were not all obtained at the same time but in batches over a period of two years.
- † Ignition electrode connected to 220V D.C. positive through a 54kΩ resistor.
- ‡ Ignition electrode not connected.
- § Independent of whether glass bulb is rendered opaque, as required by specification, or not.
- ¶ With one anode used only, other disconnected.
- || With two anodes strapped or one connected to 220V D.C. positive through a 100kΩ resistor.
- ‡‡ For the tube influenced by amount of illumination falling on it, the figure obtained in ordinary daylight is used in calculating the average value.
- ** Includes one tube which was influenced by amount of illumination falling on it. This tube struck at 116 volts in ordinary daylight and 125 volts in the dark.
- †† Includes one tube which was influenced by amount of illumination falling on it. This tube struck at 131 volts in ordinary daylight and 147 volts in the dark.

at the cathode surface, the striking voltage starting at a high value and being reduced a good deal during the first few strikes.

Running Voltage

VARIATIONS IN CHARACTERISTICS

The current-voltage characteristic of each tube was obtained as the current was varied from its maximum to minimum value. Figs. 1, 2 and 3 show the wide variations obtained when a fairly large number of tubes are examined. The running-voltage variations from tube to tube of the same type and for a single tube are given in Table 2.

The characteristics of several tubes of each type were taken 30 times, the tubes being extinguished and restruck each time. Such characteristics differ slightly, but in general the voltage at a given value of current is reproducible to within less than 0.5V. The CV71 tube is an exception. In this case, for a given value of current variations of up to 5V are common after two successive strikes, and the large regulation associated with this tube seems

TABLE 2.—VARIATIONS IN RUNNING VOLTAGE

TUBE TYPE	VARIATION FROM TUBE TO TUBE (V)	VARIATIONS FOR SINGLE TUBE (V)	
		Maximum	Mean
CV1070	87.5-109.5	3.4	1.9
85A1	82.0-87.0	2.9	1.3
CV45*	115.0-121.5	3.0	2.5
S130	114.0-131.5	11.3	3.3
CV71	124.5-163.0	32.5	30.0
KD60	58.5-61.5	0.8	0.6
CV188	83.5-92.0	6.9	3.9
G50/1G	52.0-57.0	0.6	0.5
G180/2M	151.5-160.5†	7.2†	6.7†
	151.0-160.0‡	9.1‡	7.0
G120/1B	53.0-58.5	3.0	2.9
VR105	105-106.5	1.5	1.0
VR150	149.0-159.5	8.5	4.5
CV284	67-73.5	5.0	4.8
NT2	48.5-60.5	4	3.4

KEY FOR TABLE 2

- * Ignition electrode connected to 220V D.C. positive through a 54kΩ resistor.
- † One anode connected only.
- ‡ Both anodes connected in parallel or one used as ignition electrode.

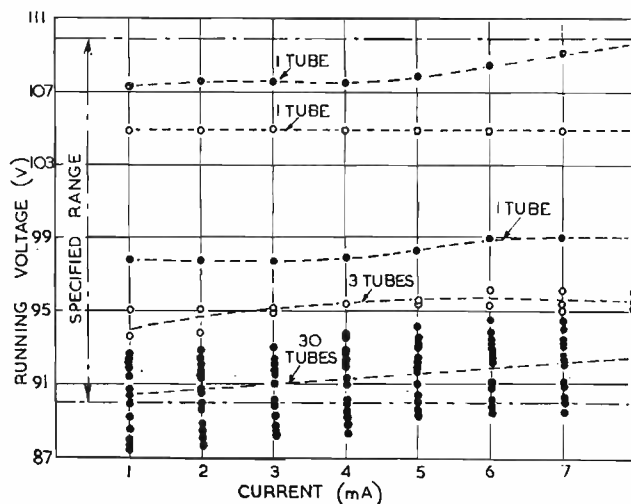
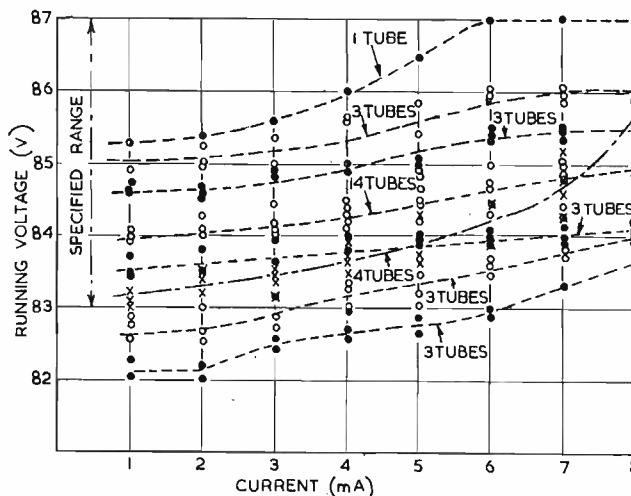

Fig. 1. Current-voltage characteristics of glow-discharge voltage-regulator tubes, type CV1070

The tubes are grouped into comparable characteristics; the dotted lines show the mean curves and the points indicate the spread about them. The specified range is also indicated.

Fig. 2. Current-voltage characteristics of glow-discharge voltage-regulator tubes, type 85A1



to suggest that the glow is abnormal. Further, for this type of tube, and this only, the running voltage is greater than the striking voltage over a large part of the current range. This is presumably due to the small electrode spacing for the gas pressure employed.

For the 85A1 type the current-voltage characteristic of a given tube is reproducible, within the range 3.5 to 8mA to better than 0.1V.

In any tube, apart from certain discontinuities to be described later, there is a rise of voltage with increase of current which is sometimes attributed to voltage-drop variations outside the cathode dark space.

Many of the tubes tested had running voltages well outside the limits quoted in specifications as can be seen from a glance at Figs. 1, 2 and 3, and Table 2.

To keep the variations in the characteristics of tubes of the same design and of an individual tube over a long operating period small, certain high-stability tubes have been produced. Jurriaanse⁸ has demonstrated that the glow discharge itself can liberate contaminations from the glass walls which contaminate the cathode and vary the working voltage. In the 85A1 high-stability tube there is a sputtered layer of molybdenum on the walls which serves as a shield between the glow discharge and the

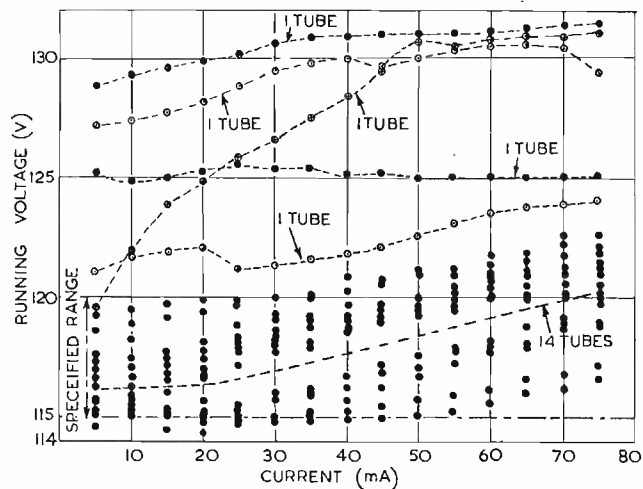

Fig. 3. Current-voltage characteristics of glow-discharge voltage-regulator tubes, type S130

envelope and also acts as a getter⁹. High-stability tubes can also be produced by using potassium-activated cathodes of the type described by Chilcot and Heymann.¹⁰ Such cathodes are obtained by coating a non-reacting metal base, which is usually nickel or nickel-iron alloy with potassium. The coating is produced by distillation in vacuo during the final pumping of the tube. The KD60 type is of this class.

It will be observed from Table 2 that even the high-stability tubes show considerable running-voltage variations, especially from tube to tube.

HYSTERESIS EFFECTS

The current-voltage characteristics of tubes are not the same for increasing and decreasing currents, but may vary considerably, giving a "hysteresis" effect which has previously been reported by Titterton⁴. For the majority of tubes the voltage is higher at a given value of current when the current is decreasing than when it is increasing. Some tubes, however, show the reverse effect while several of the S130 type give characteristics of the complicated nature shown in Fig. 4. The hysteresis effects in the CV71 and 85A1 tubes are of particular interest. In the CV71 types the characteristics for increasing and decreasing currents are usually identical below about 2mA (Fig. 5). In the 85A1 types, hysteresis is absent

above a current of about 3.6mA (Fig. 6) and even below this the effect is small. The hysteresis effect is reported to be dependent on the frequency at which the current is varied¹¹, but detailed work on these lines has not been undertaken in the present investigation.

Tube specifications make no mention of these hysteresis effects.

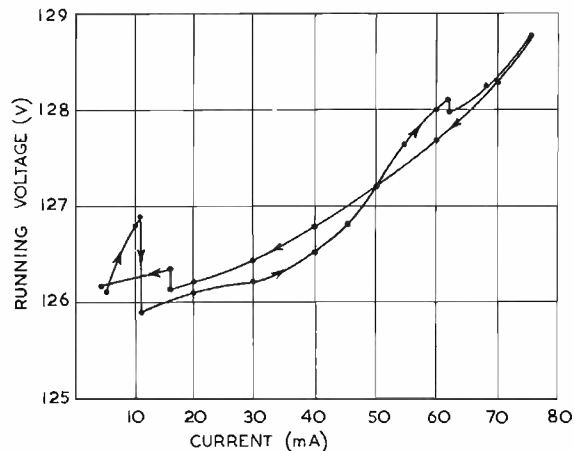

Fig. 4. Current-voltage characteristics, typical of several glow-discharge voltage-regulator tubes type S130, for increasing and decreasing currents

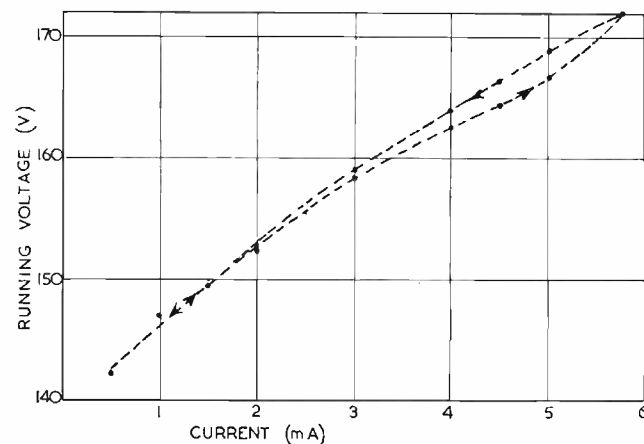
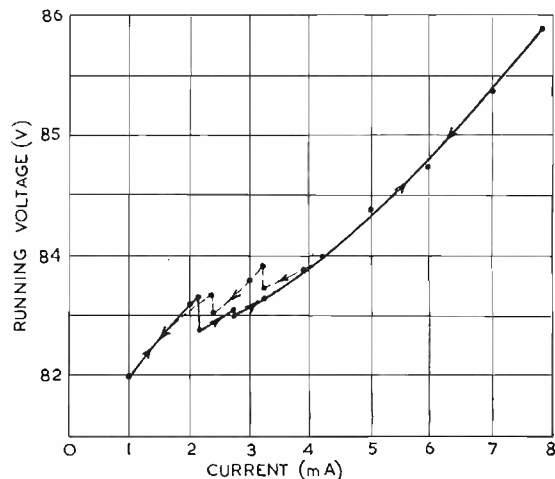

Fig. 5. Typical current-voltage characteristics of glow-discharge voltage-regulator tube type CV71 for increasing and decreasing currents

Fig. 6. Typical current-voltage characteristics of glow-discharge voltage-regulator tube type 85A1 for increasing and decreasing currents



STEP EFFECTS

As the current through a tube is varied slowly from one limit to the other, it is usual to observe sudden changes in voltage called steps, jumps, or negative-resistance discontinuities which generally occur simultaneously with pronounced changes in the area of the cathode covered by the glow. They can be explained by the fact that the cathode surface is generally not homogeneous. Thus, as the current is increased, the glow at certain points on the surface will be abnormal although it is normal for the major part.

In most cases these negative-resistance regions are mainly to be found at the lower end of the current-voltage characteristic. All tubes do not exhibit the steps, many show one only but several have up to 10 in the current range. The steps rarely occur at the same currents for increasing and decreasing paths, and there is frequently a different number in both directions. They are not always reproducible at the same current values in the characteristics.

The steps occur in tubes of all types tested except the CV71 which has a very large regulation. It sometimes happens in tubes of the S130 type that the voltage at maximum current is less than at minimum current due to the large steps. A typical example is illustrated in Fig. 7 where a step of about 2.4 volts is observed. In

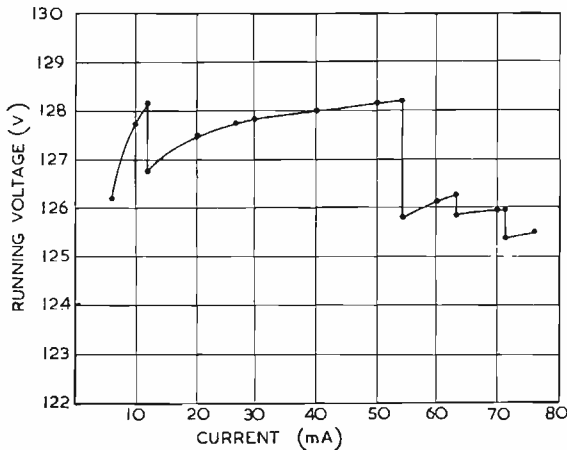

Fig. 7. Typical current-voltage characteristic of glow-discharge voltage-regulator tube type S130

the 85A1 tubes all steps occur below 3.5mA and are small. For these tubes the glow seems to expand uniformly over the cathode surface probably due to careful preparation and cleaning of the molybdenum.

Relaxation-oscillation troubles have been experienced when large capacitors are placed in parallel with glow-discharge tubes. Such oscillations are, presumably, associated with the negative-resistance portions of the current-voltage characteristic curves of the tubes.

As in the case of hysteresis effects it appears that steps are never shown on curves published by manufacturers or in valve manuals. Some care must be taken, however, when deciding on the value of current through a tube to avoid locating it near a step.

ANALYSIS OF STABILIZER PERFORMANCE FROM A KNOWLEDGE OF THE CURRENT-VOLTAGE CHARACTERISTIC

An analysis of a simple glow-discharge tube voltage-stabilizer circuit is readily possible and has often been made by assuming the current-voltage characteristic of the tube is linear^{12,13}.

If the equation of the characteristic is represented by the expression:—

$$V = xI + v \dots \dots \dots (1)$$

where V is the voltage, I is the current, x the slope of the curve and v the intercept of the characteristic on the V axis, then it is easily shown that for the circuit of Fig. 8

$$dV/dVi = x / \{x + R + Rx/R_i\} \dots \dots \dots (2)$$

if R_i is constant

and

$$dV/dI = -Rx / (R + x) \dots \dots \dots (3)$$

if Vi is constant.

In general the characteristic is very much more complicated than that represented by Equation (1). It is seen from Figs. 1, 2 and 3 that the values of both x and v vary over a wide range from tube to tube and x is also a func-

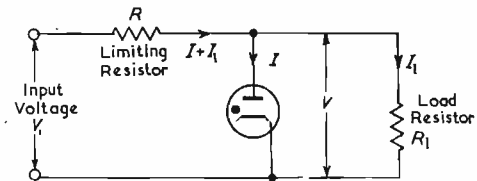

Fig. 8. Simple glow-discharge tube voltage-stabilizer circuit

tion of current. It is pointed out later that x is also a function of life. Thus, a value of x can only be ascribed to a specific tube and a given operating point at a given time.

Temperature Effects

VARIATION OF RUNNING VOLTAGE WITH TEMPERATURE

The tubes were each run at a constant current through a variation of ambient temperature from 20°C to 100°C by placing them in either a water-bath or a small electrically-heated oven. The maximum and average temperature coefficients of running voltage are given in Table 3.

TABLE 3—TEMPERATURE COEFFICIENTS OF RUNNING VOLTAGE

TUBE TYPE	TEMPERATURE COEFFICIENT OF RUNNING VOLTAGE mV/V/°C.	
	Maximum	Average
CV1070	-0.30	-0.07
85A1	-0.08	-0.03
CV45	-0.17	-0.11
S150	-0.35	-0.18
CV71	+1.89	+1.23
KD60	-0.28	-0.25
CV188	-0.36	-0.21
G50/1G	-0.86	-0.52
G180/2M	-0.05	-0.02
G120/1B	-0.26	-0.22
VE105	+0.14	+0.10
VR150	*	*
CV284	-0.37	-0.29
NT2	-0.28	-0.20

KEY FOR TABLE 3

* This type shows either positive or negative temperature coefficients. For the tubes tested the limits are -0.09 and +0.10.

VARIATION OF STRIKING VOLTAGE WITH TEMPERATURE

Attempts to measure the variation of striking voltage with temperature were unsuccessful because the variations obtained are of the same order of magnitude as those already discussed for the case of successive strikes of a tube at constant temperature.

DISCUSSION OF RESULTS

Most tubes exhibit a negative temperature coefficient, i.e. the running voltage drops as temperature increases, although three types of tube tested show positive ones. Tubes, even of the same type, give widely different results, in fact, some tubes have a practically constant running voltage throughout the whole temperature range.

Jurriaanse¹⁴ has ascribed the negative temperature co-

efficient to a small variation in the gas density in the region of the cathode. Considering the discharge tube divided into two parts (1) the cathode region with temperature T_c , volume V_c and gas density ρ_0 and (2) the rest of the tube with temperature T , volume V and gas density ρ then the density near the cathode is given by the expression:

$$\rho_c = \rho_0 \left\{ \frac{V_c}{V_t} + \frac{VT_c}{V_t T} \right\} \dots (4)$$

where $V_t = V_c + V$

and $\rho_0 = (\rho V + \rho_c V_c) / V_t$.

If the temperature T rises, ρ_c is seen to increase. It is found that an increase of ρ_0 produces a drop in tube running voltage.

It is thought that the few positive temperature coefficients observed may be caused by cathode-surface conditions in these tubes changing with temperature producing an increase of running voltage greater than the drop produced by gas-density variations.

Tubes operate normally at ambient temperatures of 0°C and 100°C for short periods. Life tests with such conditions have not been undertaken.

Temperature coefficient of running voltage decreases, in general, with life. The reduction amounts to about 25 per cent during the first 8000 hours of continuous operation in the case of 85A1 tubes.

Initial Drift

Measurements have been made of the high rates of drift in running voltage which occur in all glow-discharge tubes in the first few minutes of operation after striking. It is frequently desired to know what time elapses after striking a tube before this initial drift ceases or becomes negligible, particularly in the case of electronic voltage stabilizers where glow-discharge tubes are commonly used as reference elements. The magnitude, duration and direction of the drifts to be expected in the various types of tube have been determined. The dependence of the drift on tube current and tube age have also been noted.

Fig. 9. Curves showing typical initial drifts of S130 glow-discharge tubes. Over the region *aa* of the dotted curve the voltage was varying rapidly at random about the mean value indicated.

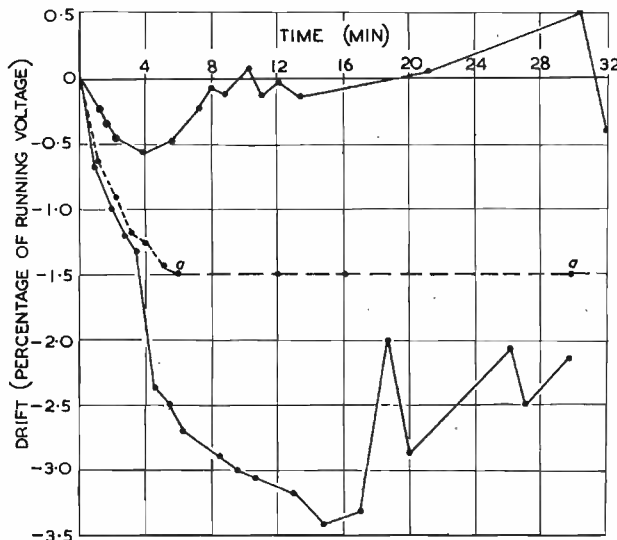

TABLE 4—MAGNITUDES AND DURATIONS OF INITIAL DRIFTS

TUBE TYPE	MAXIMUM DRIFT (percentage of running voltage)		AVERAGE DRIFT (percentage of running voltage)		TIME FOR RUNNING VOLTAGE TO BECOME APPROX. STEADY (MIN.)		TUBE CURRENT (mA)
	+	-	+	-	Max.	Average	
CV188 ..	0.61	0	0.25	0	17	10	10
CV1070 ..	0.05	0.23	0.03	0.17	12	11	8
S130 ..	3.39§	1.35§	1.55§	0.61	*	*	75
85A1 ..	0.21	0.06	0.16	0.01	2.5	2.0	8
KD60 ..	0.02	0.23	0.01	0.14	16	10	2.5
CV71 ..	2.65	0.58	1.68	0.33	8	5	6
G50/MG ..	0	2.20	0	1.73	19	15	0.5
G180/2M† ..	0.98	1.75	0.84	1.56	23	21	40
G120/1B ..	0	2.12	0	1.75	14	9	30
CV45‡ ..	2.78§	0.66§	1.88§	0.26§	*	*	75
VR105 ..	1.10	0	0.74	0	15	11	40
VR150 ..	0.48§	0.44§	0.32§	0.35§	¶	¶	40
CV284 ..	3.29	0	3.07	0	25	22	20
NT2 ..	2.21	3.29	1.78	1.66	**	**	1

KEY FOR TABLE 4

§ After 15 minutes operation.

* Still drifting at random after 30 minutes operation. The variations are accompanied by abrupt changes in the area of cathode covered by the glow.

† One anode only connected.

‡ Ignition electrode connected to 220V D.C. positive through a 54kΩ resistor.

¶ Some tubes still drifting at random after 20 minutes operation, in others the running voltage becomes approximately steady after 10-15 minutes.

** Still drifting at random after 30 minutes operation.

|| After 30 minutes operation.

MEASUREMENT OF DRIFT

The drifts of running voltage in the first few minutes of operation of the tubes were recorded several times. Tubes were allowed to cool down to ambient temperature each time before restriking. In each case a known fraction of the tube voltage was compared with the voltage of a standard cell using a potentiometer.

RESULTS AND DISCUSSION

Table 4 shows the magnitudes and durations of the drifts observed for the various types of tube when they were operated at maximum current. In each case this current was held constant to within ± 0.1 per cent throughout the test. Typical curves which give some idea of the manner in which the drifts vary with time are shown in Figs. 9-12.

Large variations in the magnitude of the drifts occur from tube to tube even of the same type and also from operation to operation for the same tube. The smallest drifts are obtained in the cases of the 85A1, KD60, and CV1070 types, but the 85A1 type has the advantage that its running voltage becomes steady in a very short time.

Fig. 10. Curves showing typical initial drifts of CV1070 glow-discharge tubes

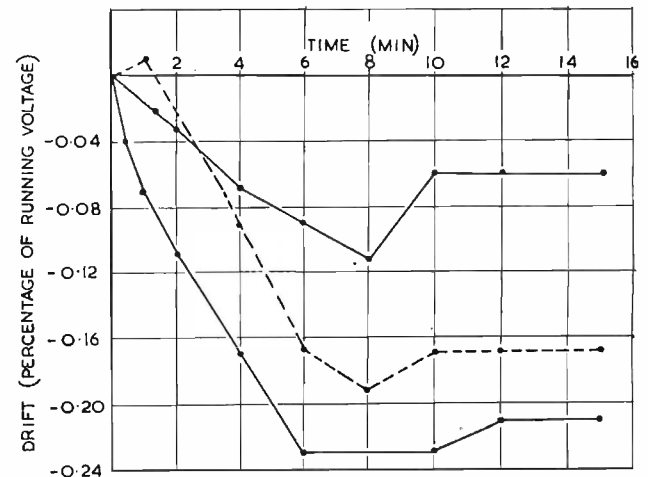

In fact, there is very little drift in most tubes of this type after 1 minute's operation. No negative drifts are observed in the CV188, CV284 and VR105 tubes and no positive drifts in the G50/1G and G120/1B tubes, but for the other types both positive and negative drifts are obtained.

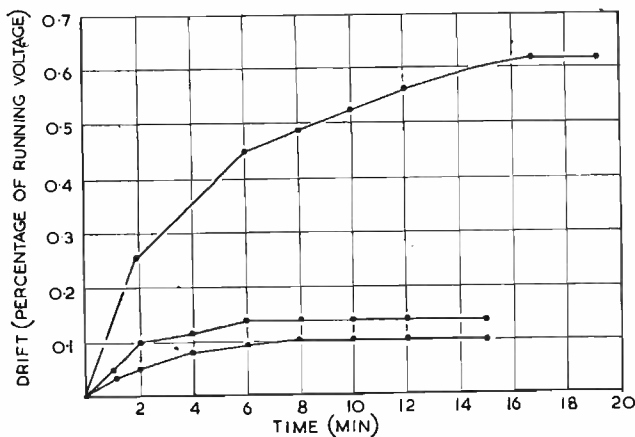

Fig. 11. Curves showing typical initial drifts of CV188 glow-discharge tubes

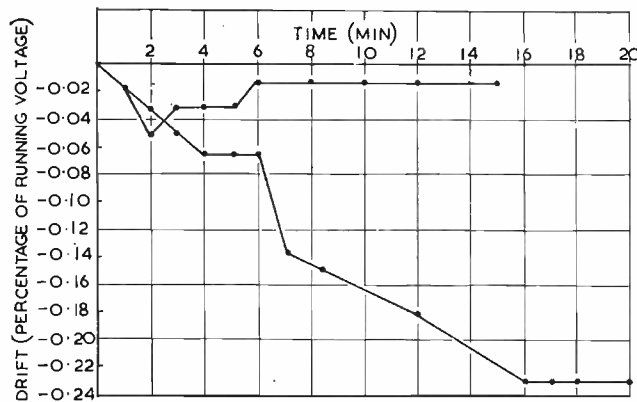

Fig. 12. Curves showing typical initial drifts of KD60 glow-discharge tubes

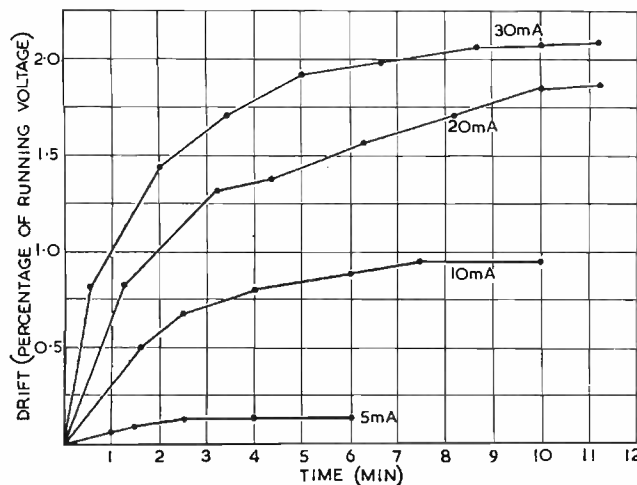

Fig. 13. Curves showing the initial drifts of a typical G120/1B glow-discharge tube at various currents

The largest drifts occur in the case of the S130 type tubes and may be as great as 3.39 per cent of the running voltage in the first 15 minutes.

One interesting fact arises from the tests in that it appears for a given type of tube that the duration of the drift can be predicted fairly accurately.

It is also of interest to note that the maximum drift for the 85A1 type tubes quoted in Table 4 is greater than the figure quoted by the manufacturers for the stability over a period of 1000 hours¹⁵. Presumably, therefore, the manufacturers ignore this rapid initial voltage-variation when quoting the characteristics of tubes.

The initial drift is markedly dependent on tube current and increases with tube age. From Fig. 13, it can be seen that both the magnitude and durations of the drifts increase with current. The curves illustrated are typical of the G120/1B tubes, but other types behave in a similar way. For example at 5mA, the drift in CV188 tubes ceases, in general, after 3 or 4 minutes' operation, while at 2mA there is practically no drift at all and what little there is ceases in a time less than 1 minute.

Accurate measurements to ascertain how tube age affects the initial drift were confined to the 85A1 type of tube. Several such tubes were tested after running continuously for 200, 500, 1500 and 7000 hours respectively. After both 200 and 500 hours operation there is little change in drift from when the tubes are new but noticeable increases in the magnitude of the drift may be detected after 1500 and 7000 hours respectively. Typical results are given in Fig. 14. There appears to be no change in the duration of drift with life.

It seems that while some of the initial drift observed may be due to changes of gas density in the region of the cathode caused by variation of temperature, much of it is produced by the surface conditions at the cathode changing slightly and hence varying the cathode drop during the warming-up period of the electrodes and envelope of the tube.

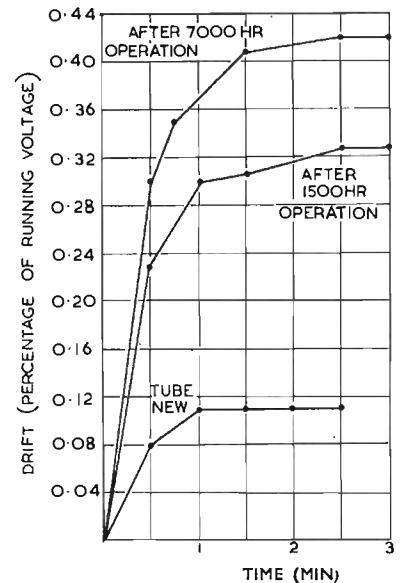

Fig. 14. Curves showing the initial drifts of a typical 85A1 glow-discharge tube at various stages throughout its life

(To be continued)

REFERENCES

- BENSON, F. A. Voltage Stabilizers. *Electronic Engg.* 21, 155 (1949).
- HUNT, F. V., and HICKMAN, R. W. On Electronic Voltage Stabilizers. *Rev. Sci. Instrum.* 10 6 (1939).
- LAMMCHEN K. Die Zeitliche Konstanz von Glimmstreckchen—Kennlinien und ihr Einfluss auf Spannungstabilisierenschaltungen. *Hochfrequenztechnik U. Elektroakustik.* 44, 193 (1934).
- KIRKPATRICK, G. M. Characteristics of Certain Voltage-Regulator Tubes. *Proc. Inst. Radio Engrs. N.Y.* 35, 485 (1947)
- TITTERTON, E. W. Some Characteristics of Glow-Discharge Voltage-Regulator Tubes. *J. Sci. Instrum.* 27, 33 (1949).
- BENSON, F. A., CAIN, W. E., and CLUCAS, B. D. Variations in the Characteristics of Some Glow Discharge Voltage-Regulator Tubes. *J. Sci. Instrum.* 26, 399 (1949).
- BENSON, F. A. Initial Drifts in Running-Voltage of Glow-Discharge Regulator Tubes. *J. Sci. Instrum.* 27, 71 (1950).
- JURRIANSE, T. A Voltage Stabilizing Tube for Very-Constant Voltage. *Philips' Tech. Rev.* 8, 272 (1946).
- JURRIANSE, T., PENNING, F. M., and MOUBIS, J. H. A. The Normal Cathode Fall for Molybdenum and Zirconium in the Rare Gases. *Philips' Res. Rep.* 1, 225 (1946).
- CHILCOT, A. L., and HEYMANN, F. G. Potassium-Activated Cold-Cathode Tubes. *J. Sci. Instrum.* 26, 289 (1949).
- ELMORE, W. C., and SANDS, M. *Electronics* p. 368 (McGraw-Hill Publishing Co., 1949).
- BERG, W. R. Optimum Parameters for Gas Tube Voltage Regulators. *Electronics* 20, 136 (Oct. 1947)
- SEELY, S. *Electron-Tube Circuits.* Section 14-7-(1950).
- JURRIANSE, T. The Influence of Gas Density and Temperature on the Normal Cathode Fall of a Gas Discharge in Rare Gases. *Philips' Res. Rep.* 1, 407 (1946).
- MULLARD ELECTRONICS PRODUCTS LTD. *J. Sci. Instrum.* 26, 245 (1949).

A Simple Variable Frequency Phase Measuring Device

By J. C. West,* B.Sc., A.M.I.E.E., and J. Potts,* B.Sc.

THE method described was developed to measure the phase shift for use in obtaining steady state frequency response loci or Nyquist diagrams¹ of four terminal networks.

The circuit (see Fig. 5) is a calibrated phase shifting network of simple design, whose gain and phase are independent of frequency over the working range of 100c/s to 25kc/s. By simple modification the circuit could be adapted for use in other frequency ranges.

The components, with the exception of a fairly good wire-wound output potentiometer, are of the normal 10 per cent tolerance type. Only four single valve stages are used.

The error in the measurement of phase-angle is less than $\frac{1}{4}$ of a degree over the working frequency range.

Principle of Operation

The phase shift in a network is measured by adjusting another calibrated network so that its known phase shift equals the unknown shift in the first network. This equality of phase shift is detected by feeding the two networks from a single source and applying their two outputs, one to the X plates, and the other to the Y

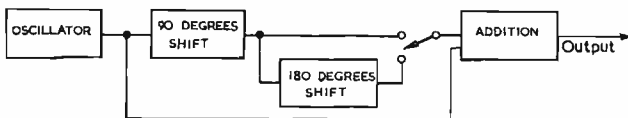

Fig. 1. The phase calibrated network

plates, of an oscilloscope. The Lissajous figure on the oscilloscope is an ellipse. This contracts to a single straight line when the phase shifts are either equal or differ by 180 degrees.

The phase calibrated network (shown schematically in Fig. 1) first modifies the phase of its sinusoidal input by 90 degrees and then adds together variable amounts of the input and quadrature component. The phase of the output varies through 90 degrees depending on the relative amounts of the two components. Thus phase-angles of 0 to 90 and 180 to 270 degrees may be measured. By shifting the phase of the quadrature component by -180 degrees, angles of 90 to 180 and 270 to 360 degrees may also be determined.

Theory

If to the two ends of a potentiometer signals ' $a \sin \omega t$ ' and ' $b \cos \omega t$ ' (i.e. components in quadrature phase) are applied, from sources of low internal impedances, fractions x of the first signal and $(1-x)$ of the second signal will be present on the variable contact. x is the fraction of the potentiometer between this contact and the end to which the second signal is applied. The output when taken from the variable contact is therefore

$$xa \sin \omega t + (1-x) b \cos \omega t = C \sin (\omega t + \phi)$$

$$\text{where } C^2 = a^2 x^2 + b^2 (1-x)^2 \text{ and } \tan \phi = b(1-x)/ax$$

Fig. 2 shows vectorially this addition of signals for the specific case of $a = b$. This condition is imposed in practice since it is necessary to keep the ratio of b to a constant and making them equal gives a more uniform scale and less variation of amplitude with phase-angle than any other ratio. It can be seen that the output signal is represented by the vector OR (where R may move to any position on the line PQ) and so varies in phase by 90 degrees. The amplitude of the output signal OR varies slightly from a at 0° or 90° to $a/\sqrt{2}$ at 45° i.e. a 3db variation.

To obtain a phase shift of 90 degrees independent of frequency, a Miller integrator² is used. This has a steady state transfer function of

$$-\frac{A}{1+j(1+A)\omega CR}$$

where A is the internal gain, R the input resistor and C the feedback capacitor. Thus the gain of the integrator is

$$\frac{A}{[1+(1+A)^2\omega^2 C^2 R^2]^{\frac{1}{2}}}$$

and the phase shift $\tan^{-1} (1+A)\omega CR$.

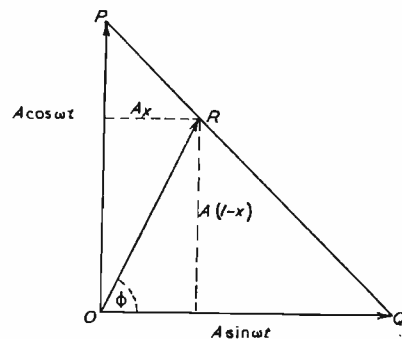

Fig. 2. Vectorial addition of signals

If the stage is to have unity gain so making $a = b$

$$\text{then } \omega^2 C^2 R^2 = \frac{1+A^2}{1+2A+A^2}$$

and since A is much greater than 1, ωCR approximates to unity. Assuming that $(1+A)$ is large and of the order of 100, the phase shift is 89.5 degrees.

Thus the integrator introduces an error of $\frac{1}{2}$ degree at 90 and 270 degrees and zero at 180 and 360 degrees. This error may be allowed for, however, by taking $89.5/90 \tan^{-1} (1-x/x)$ instead of $\tan^{-1} (1-x/x)$ in plotting the calibration curve.

* Servomechanism Laboratory, Manchester University Electrical Engineering Department.

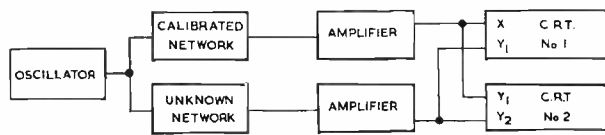

Fig. 3. The oscilloscope connexions

Experimental Procedure

It is necessary to determine the conditions giving equal amplitudes of the waveforms at the ends of the output potentiometer used for mixing the signals and also to detect the equality of phase of the output from the phase calibrated and unknown networks.

As the gain of the unknown network was also being determined it was found convenient to use two cathode-ray oscilloscopes, one of them a double-beam type. The first oscilloscope displayed a Lissajous figure to detect equality of phase and the second, operating on its internal time-base, was used for gain measurements and to determine equality of amplitude. (Two oscilloscopes are not necessary but use of them reduces the amount of switching required). Fig. 3 shows the oscilloscope connexions. The output of the phase calibrated network appears horizontally on the first oscilloscope and vertically on one beam of the second. The output of the network being analysed is displayed vertically on both oscilloscopes.

The procedure in taking readings is:—

- (1) Rotate the output potentiometer of the calibrated network to the end at which the non-integrated output is applied and adjust the oscillator output magnitude until the height of the appropriate trace on oscilloscope 2 is some convenient amount marked on the tube face.
- (2) Rotate the potentiometer to the opposite end and adjust C and R so that the trace on oscilloscope 2 regains its former height.
- (3) Rotate the potentiometer until the figure on oscilloscope 1 changes from an ellipse into a straight line and note the potentiometer dial reading.

By engraving a suitable scale the output potentiometer could be made to read in degrees but an easier way is to use a suitable dial in conjunction with a conversion graph.

To measure phase-angles of 90 to 180 and 270 to 360 degrees the integrator output is taken through an anode-follower of unity gain to the output potentiometer (see Figs. 1 and 5).

Fig. 4. Relation between dial reading and phase-angle

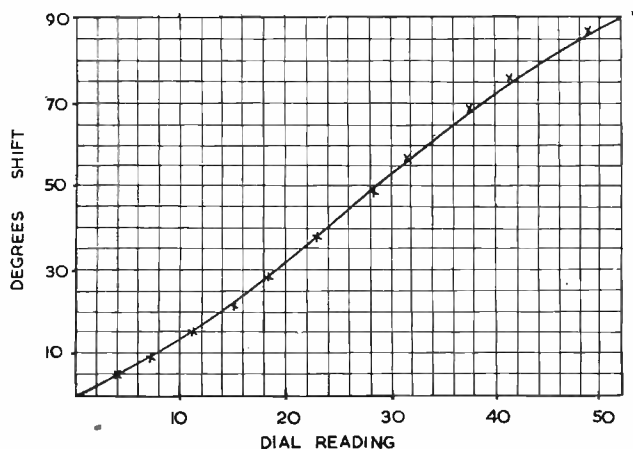

The 180 degree ambiguity in measurement may be removed and the phase-angle determined absolutely by observing the direction of slope of the straight line Lissajous figure.

Conclusion

Fig. 4 is a graph showing the relationship between dial reading and phase-angle as calculated from the formula. The points indicated by crosses were obtained by using an RC network of decade capacitor and resistor boxes, calculating the phase-shift introduced by these from a knowledge of their values and that of the frequency, and measuring this phase-angle with the network.

It can be seen that in no case does the difference between one of these points and the curve exceed $\frac{1}{4}$ of a degree.

Sets of readings taken at several frequencies within the working range showed the same accuracy as those plotted which were for 1 000c/s.

The method is therefore accurate to $\frac{1}{4}$ of a degree.

APPENDIX

Fig. 5 shows the complete circuit diagram of the device.

Four Mullard EF50 valves were used but many other types are suitable. The 100k Ω output potentiometer is a 3 inch diameter wire-wound one.

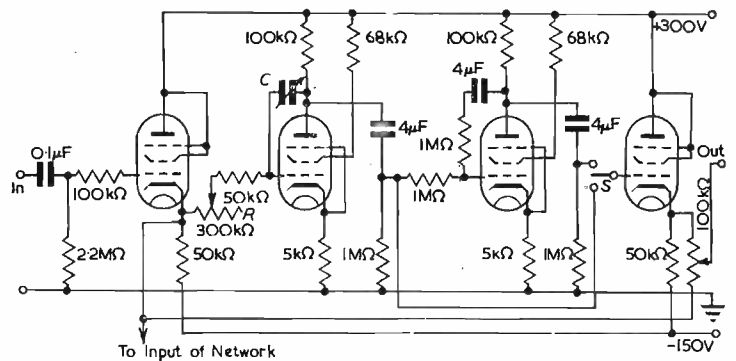

Fig. 5. Complete circuit diagram

A cathode-follower input stage is used to prevent loading of the oscillator by either the calibrated or unknown network, the input to the latter being taken from the cathode-follower output. The input resistor to the grid of the integrator valve is a 300k Ω variable and a 50k Ω fixed resistor in series thus enabling the value to be varied by a factor of 7. The anode to grid feedback capacitor is one of five switch selected ones of values 0.02 μ F, 0.004 μ F, 800pF, 150pF and 30pF.

By making the time constants of the interstage couplings and anode-follower feedback circuit each 4 seconds the phase shift introduced by these at 100c/s is only 1.5 minutes of arc and varies inversely with frequency. The errors so introduced may be neglected therefore.

To measure angles of 0 to 90 and 180 to 270 degrees the switch S should be down so that the anode-follower is by-passed, and to measure other angles the anode-follower is used.

The quadrature component is fed through a cathode-follower to the output potentiometer. Since this potentiometer is connected between the outputs of two cathode-followers the working of the circuit is unaffected by potentiometer setting or loading of the output.

REFERENCES

1. WEST, J. C. The Nyquist Criterion of Stability. *Electronic Engg.* 22, 169 (1950).
2. WILLIAMS, F. C. & RYSON, F. J. U. Electronic Servo Stimulators. *J.I.E.E.* 94, Pt. IIA, 112 (1947).

The Differential Amplifier with a Useful Modification

By B. F. Davies*

IN many electronic and audio circuits, the necessity arises for equipment which will amplify the voltage existing between a pair of wires while offering little or no amplification to voltages that are between wires and earth. A pair of telephone wires may not only have the desired signal between the conductors but will probably have an interference signal picked up between the wires and earth. The wanted signal can be referred to as the push-pull voltage and the unwanted signal, the push-push voltage.

A balanced transformer winding will, of course, be a solution to the problem of discriminating between push-pull and push-push voltages. Nevertheless, many cases arise where, due to space, expense or inherent electrical shortcomings, the transformer is not an ideal component to use. In electronic circuits where the transformer is often a disadvantage, the requirement of high discrimination can

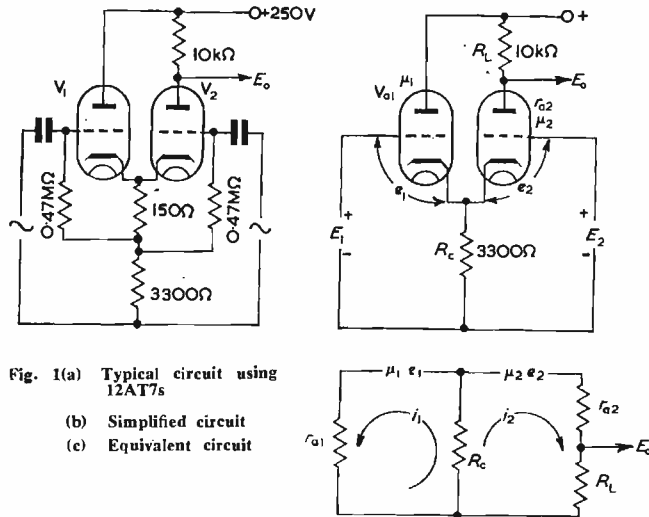

Fig. 1(a) Typical circuit using 12AT7s
(b) Simplified circuit
(c) Equivalent circuit

be very important. This is especially the case with the electroencephalograph, where the signal picked up by the electrodes on the patient's head is of the order of 50μV, while the 50c/s mains hum existing between the patient and earth may be as high as 0.1V.

The Double Triode Circuit

A well-known circuit possessing many advantages is shown in Fig. 1. A short theoretical analysis of the circuit will not be out of place as it will serve to show the capabilities of the circuit under actual working conditions.

Fig. 1(c) shows the equivalent circuit in which

$$e_1 = E_1 - R_c(i_1 + i_2)$$

$$e_2 = E_2 - R_c(i_1 + i_2)$$

The basic equations derived from the two meshes are

$$i_1[r_{a1} + R_c(1 + \mu_1)] + i_2R_c(1 + \mu_1) - \mu_1E_1 = 0$$

$$i_1R_c(1 + \mu_2) + i_2[r_{a2} + R_L + R_c(1 + \mu_2)] - \mu_2E_2 = 0$$

which can be rewritten for simplicity as

$$i_1a + i_2b - \mu_1E_1 = 0$$

$$i_1c + i_2d - \mu_2E_2 = 0$$

from which we obtain

$$i_2 = \frac{-[\mu_2E_2a - \mu_1E_1c]}{ad - bc}$$

and

$$i_1 = \frac{-[\mu_2E_2b - \mu_1E_1d]}{ad - bc}$$

or

$$i_2 = \frac{-(E_2\alpha - E_1\gamma)}{\eta} \dots \dots \dots (1)$$

and

$$i_1 = \frac{-(E_2\beta - E_1\delta)}{\eta} \dots \dots \dots (2)$$

where

$$\alpha = \mu_2a; \beta = \mu_2b; \gamma = \mu_1c; \delta = \mu_1d$$

$$\text{and } \eta = ad - bc.$$

The output voltage given by $E_o = i_2R_L$ will be considered for the two cases when equal input voltages to the grids are first of opposite phase and then in phase as in Fig. 2.

In the first case the push-pull gain of the amplifier will be given by

$$\frac{E_o}{E} = \frac{i_2R_L}{E} = \frac{(\alpha + \gamma)R_L}{\eta} = M_1 \dots \dots (3)$$

where

$$E_2 = -E_1 = E$$

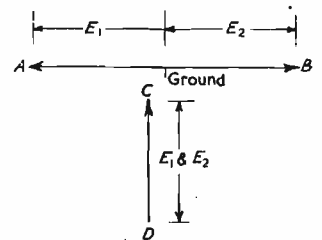

Fig. 2. The input voltage
AB = Push-pull voltage
CD = Push-push voltage

The push-pull gain with the grids driven by the same voltage will be given by

$$\frac{E_o}{E} = \frac{i_2R_L}{E} = \frac{-(\alpha - \gamma)R_L}{\eta} = M_2 \dots \dots \dots (4)$$

where

$$E_2 = E_1 = E$$

Thus, the discrimination factor k , of the amplifier under these conditions is

$$-\frac{M_1}{M_2} = k = \frac{\alpha + \gamma}{\alpha - \gamma} \dots \dots \dots (5)$$

The sign of M_1/M_2 denotes a 180° phase change of the output voltage under the two input conditions.

For an approximation, assume that

$$\mu_1 = \mu_2 = 55$$

$$r_{a1} = r_{a2} = 12000 \text{ ohms}$$

$$R_c = 3300 \text{ ohms}$$

then $k = 31.8$ or 30db.

This discrimination can be improved by raising the value of R_c , but this can only be done at the expense of an inconvenient increase of the H.T. voltage. It does not neces-

* Marconi's Wireless Telegraph Co. Ltd.

sarily follow that k is infinite when R_c is infinite as the complete expression for k becomes

$$\frac{\mu_1 + \mu_2 + 2\mu_1\mu_2}{\mu_2 - \mu_1}$$

Identical triodes would, therefore, have to be used.

It is evident that this double triode circuit has the advantage of converting a push-pull input voltage to a single-sided output voltage which can be further amplified without recourse to balanced valve circuits. With a practical value of R_c of about 3000 ohms, the discrimination will not be as great as that obtained with the well known long-tailed-pair shown in Fig. 3. The pentode in this circuit can present, say, 0.2 megohms between the triode cathodes and earth giving $k \approx 1000$ with the circuit values shown. The pentode does, of course, necessitate a voltage drop of

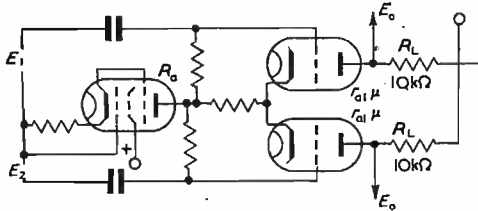

Fig. 3. Circuit using long-tailed-pair

$r_a = 12k\Omega$ $\mu = 55$ $R_a = 0.2M\Omega$

Push-pull gain = $A' \approx \frac{\mu R_L}{R_L + r_a} \approx 25$

Push-push gain = $A'' \approx \frac{R_L}{2R_a} \approx 1/40$

$k = A'/A'' = 1000$

at least 100 volts. It will be shown that a simple modification to the working conditions will give the double triode circuit powers of infinite discrimination without necessitating an inconvenient loss of effective H.T. volts.

The Modification

From Equation (1) it will be noticed that with E_1 and E_2 of the same polarity E_0 is zero when

$$\frac{E_2}{E_1} = \frac{\gamma}{\alpha} \frac{\mu_1 R_c (1 + \mu_2)}{\mu_2 [r_{a1} + R_c (1 + \mu_1)]} \dots \dots (6)$$

For the circuit values quoted the condition required for zero output is when $E_2/E_1 = 0.94$.

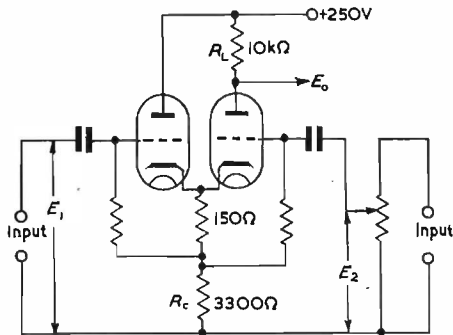

Fig. 4. Typical circuit arrangement

The practical significance of this relationship between E_1 and E_2 is that if a potentiometer or other device is used to reduce E_2 from the initial value, no output will be obtained from the anode when the circuit is fed with push-push voltages. Fig. 4 shows a typical arrangement. The circuit is easily "set up" by applying a single voltage to the input circuits in parallel and adjusting the potentiometer until E_0 is zero. The gain offered to the common push-

pull voltage is now zero and infinite discrimination is achieved.

A slight alteration of the push-pull gain will now take place as $E_2 = E_1 \gamma/\alpha$. This new relationship can be substituted in Equation 3 giving

$$M_1 = \frac{2R_L \gamma}{\eta} \dots \dots \dots (7)$$

while the proportional difference in gain will be $\frac{\alpha + \gamma}{2\gamma}$

With the circuit values quoted this difference is 1.03, which is negligible.

Stability and Actual Working Conditions

The true working conditions of the valve circuit will now be considered, as those shown are only an approximation. To ascertain the actual working conditions first assume that the I_a of each triode is to be 6mA. Reserving a 40V drop across R_c , there is an effective supply voltage of 210V. On the characteristics of the 12AT7, Fig. 5, the load line for 10 000 ohms is shown. At 6mA current $V_{a2} = 150V$, $V_{g2} = -1.3V$ and with $V_{a1} = 210V$, $V_{g1} = -2.1V$. Because the bias resistor is common to the two triodes, the resultant conditions will be such that I_{a1} increases and I_{a2} decreases. At a bias of $-1.8V$, $V_{a2} = 167V$, $I_{a2} = 4.3mA$ and with $V_{a1} = 210V$, $I_{a1} = 7.7mA$. The total current is approximately 12mA and the bias resistor necessary will be 150 ohms.

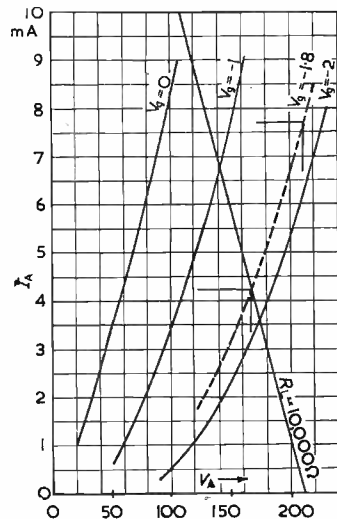

Fig. 5. Characteristics of the 12AT7

It is fortuitous that I_{a1} has increased because the anode impedance r_{a1} , as well as being lowered, is now less dependent on I_{a1} and V_{a1} , i.e., the characteristics are straighter and more parallel. Stability of r_{a1} is important for r_{a1} is contained in Equation (6). As the " μ " of a triode is reasonably constant with changing conditions we need only be concerned with variations of r_{a1} for determining possible changes in the "balance".

Variations of γ/α with r_{a1} is given by:

$$\frac{d \gamma/\alpha}{dr_{a1}} \alpha/\gamma = \frac{-r_{a1}}{r_{a1} + R_c(1 + \mu_1)}$$

At $I_{a1} = 7.5mA$, $r_{o1} = 11 000$ ohms and with $R_c = 3 300$ ohms and $\mu_1 = 55$, the expression becomes 0.0575. It has been shown that E_2/E_1 must equal 0.94, so a variation of 0.06 in γ/α will effectively amount to an error similar to that when $E_2 = E_1$. The discrimination before adjustment of E_2 was 30db and it would only fall to this figure if r_{a1} were to change by 105 per cent.

Allowing for a change of r_{a1} , after E_2 has been set, we

can rewrite Equations (3) and (4). Thus

$$\frac{M_1'}{R_L} = \frac{\gamma/a a' + \gamma}{\eta'} \text{ and } -\frac{M_2'}{R_L} = \frac{\gamma/a a' - \gamma}{\eta'}$$

where a' is the new value of a due to r_{a1} becoming r_{a1}' . The new discrimination factor becomes

$$-\frac{M_1'}{M_2'} = k' = \frac{\gamma/a a' + \gamma}{\gamma/a a' - \gamma} = \frac{a' + a}{a' - a} = \frac{r_{a1}' + r_{a1} + 2R_c(1 + \mu_1)}{r_{a1}' - r_{a1}} \dots \dots \dots (8)$$

Fig. 6 shows this equation plotted for variations in r_{a1}' with different values of R_c .

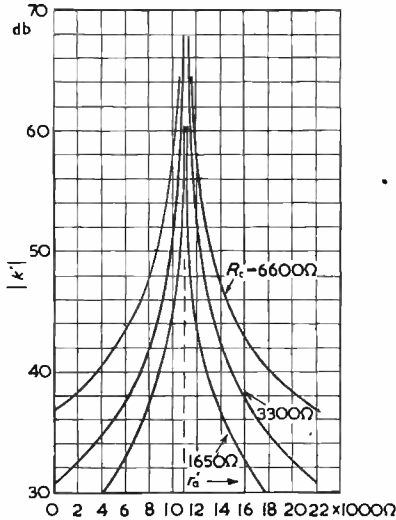

Fig. 6. Effect of Variations of r_{a1} when $E_2/E_1 = \gamma/a$

$$k' = \frac{r_{a1}' + r_{a1} + 2R_c(1 + \mu_1)}{r_{a1}' - r_{a1}}$$

$\mu_1 = 55 \quad r_{a1} = 11,000\Omega$

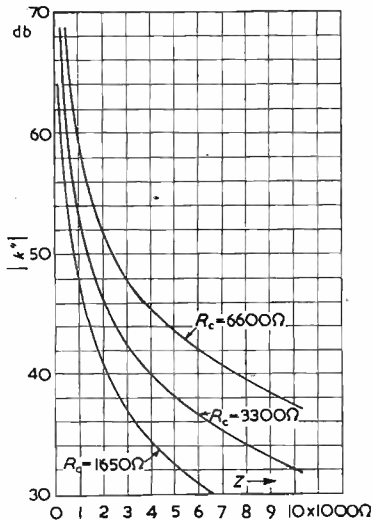

Fig. 7. Effect of Introduction of Impedance into Anode 1 when $E_2/E_1 = \gamma/a$

$$k'' = \frac{2[r_{a1} + R_c(1 + \mu_1)]}{Z}$$

$\mu_1 = 55 \quad r_{a1} = 11,000\Omega$

Effect of H.T. Impedance

Impedances to earth from the H.T. feed points may be evident due to the reactance of a decoupling capacitor or

the impedance of a stabilizer valve. In considering the effect of these undesirable impedances, two cases will be treated. First, where there is an impedance to ground in each triode and, second, where there is a common impedance to the two triodes. In either case the effect is to cause an output from anode 2 which would otherwise have been zero. The discrimination of the amplifier will thus be impaired and it will be shown that when the impedance is reactive it will be impossible to obtain the "balance" by adjustment of E_2 .

CASE (A)

If $(r_{a1} + Z)$ is substituted for r_{a1} in the general equations,

then for $i_2 = 0$,
$$\frac{E_2}{E_1} = \frac{\mu_1 R_c(1 + \mu_2)}{\mu_2[r_{a1} + Z + R_c(1 + \mu_1)]}$$

The impedance in series with R_L can be ignored as R_L does not appear in the equation. If Z is resistive an adjustment of E_2 will ensure balance. Assuming Z is reactive the discriminating factor k_1 , Equation (5) can be rewritten:

$$-\frac{M_1''}{M_2''} = k'' = \frac{\gamma/a a'' + \gamma}{\gamma/a a'' - \gamma} = \frac{a'' + a}{a'' - a} = \frac{2[r_{a1} + R_c(1 + \mu_1)] + jZ}{jZ}$$

where $a'' = [r_{a1} + jZ + R_c(1 + \mu_1)]$.

Fig. 7 shows the modulus of k'' assuming that $|Z| \ll 2[r_{a1} + R_c(1 + \mu_1)]$

CASE (B)

When there is a common H.T. impedance to earth from anode 1 and the load R_L , the circuit can be considered as shown in Fig. 8. The output voltage will now be:

$$E_o' = i_2 R_c + (i_1 + i_2)Z$$

When E_o' is zero,
$$\frac{i_1}{i_2} = -\frac{R_c + Z}{Z} \dots \dots \dots (9)$$

An equation for E_2/E_1 at "balance" will first be obtained for cases where the H.T. impedance, Z , is known and is

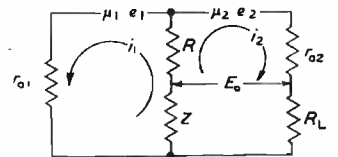

Fig. 8. Equivalent circuit with common H.T. impedance

constant. Now, from Equations (1), (2) and (9), allowing for the substitution of $(R_c + Z)$ for R_c ,

$$\frac{i_1}{i_2} = \frac{E_2 \beta''' - E_1 \delta'''}{E_2 \alpha''' - E_1 \gamma'''} = -\frac{R_c + Z}{Z}$$

therefore:

$$\frac{E_2}{E_1} = \frac{R_c \gamma''' + Z(\gamma''' + \delta''')}{R_c \alpha''' + Z(\beta''' + \alpha''')} \dots \dots \dots (10)$$

When Z is zero, this equation becomes the same as Equation (6) as $E_2/E_1 = \gamma/a$. If Z is reactive a phase shift between E_1 and E_2 will have to exist in order that a perfect "balance" is obtained. Taking the following circuit values:

$$\begin{aligned} R_L &= 10k\Omega & R_c &= 3.3k\Omega \\ r_{a1} &= 11k\Omega & r_{a2} &= 13k\Omega \\ \mu_1 = \mu_2 &= 55 & Z &= 200\Omega \end{aligned}$$

a "balance" is obtained when $E_2/E_1 = 0.955$ which is to be compared with 0.94 when Z is zero.

From the theoretical point of view only, it is interesting to note that when Z is very great E_2/E_1 becomes > 1 and

the potentiometer would have to be in the circuit of V_1 . The important practical case concerning the common H.T. impedance is when E_1 and E_2 are fixed for the normal "balance" condition and Z is introduced in the same way, as the reactance of a decoupling capacitor will be introduced at low frequencies. In obtaining an expression for the discriminating factor k''' , the push-pull gain without Z is compared with the push-push gain when Z is in circuit.

The former is given by $E_o = 2\gamma R_L E / \eta$ and the latter by $E_o' = i_2 R_L + (i_1 + i_2)Z$.

From Equations (1) and (2) and remembering that $E_2/E_1 = \gamma/\alpha$

$$\frac{i_2}{E} = -\frac{\gamma/\alpha \alpha''' - \gamma'''}{\eta'''} \quad \text{and} \quad \frac{i_1}{E} = -\frac{\gamma/\alpha \beta''' - \delta'''}{\eta'''}$$

thus:

$$\frac{i_1}{i_2} = \frac{(\gamma\beta''' - \alpha\delta''')}{(\gamma\alpha''' - \alpha\gamma''')} \quad \text{and} \quad E_o' = i_2 \left[(R_L + Z) + Z \frac{(\gamma\beta''' - \alpha\delta''')}{(\gamma\alpha''' - \alpha\gamma''')} \right]$$

$$= \frac{-E}{\alpha\eta'''} [(R_L + Z)(\gamma\alpha''' - \alpha\gamma''') + Z(\gamma\beta''' - \alpha\delta''')]$$

The new discriminating factor k''' will, therefore, be given by:

$$\frac{-E_o'}{E_o} = \frac{2\gamma R_L}{\eta} \cdot \frac{\alpha\eta'''}{(R_L + Z)(\gamma\alpha''' - \alpha\gamma''') + Z(\gamma\beta''' - \alpha\delta''')} \quad \dots \dots \dots (11)$$

If $Z \ll R_L$ and $Z \ll R_o$, and $\mu_1 = \mu_2 = \mu$, then Equation (11) can be modified to:

$$= \frac{1}{Z} \frac{2R_L R_o [r_{a1} + R_o(1 + \mu)]}{r_{a1}(R_L + R_o) + (r_{a2} + R_L)[(R_o + r_{a1}/(1 + \mu))]}$$

Thus, with the circuit values given above, the equation for

the discrimination is $k''' = \frac{5.7 \times 10^4}{Z}$. Fig. 9 shows this equation plotted against values of Z .

Conclusions

High discrimination factors of the order of 60db or more can be achieved if the H.T. line impedance is kept below 50 ohms. If the impedance is resistive an adjustment of the signal voltage to the grid of V_2 will ensure a perfect "balance" against push-push input voltages.

Although this simple double triode does not have some of the advantages accruing to the long tailed pair circuit, its simplicity and compactness are worthy of note. Some care in design is necessary to ensure that the discrimination can be attained as well as maintained. The design details given show the steps to be taken in this direction.

Fig. 9. Effect of Introduction of Common H.T. Impedance when

$$E_2/E_1 = \gamma/\alpha$$

$$k''' = \frac{2R_L R_o [r_{a1} + R_o(1 + \mu)]}{r_{a1}(R_L + R_o) + (r_{a2} + R_L)(R_o + [r_{a1}/(1 + \mu)]1/Z)}$$

$$\mu_1 = \mu_2 = 55$$

$$r_{a1} = 11,000\Omega$$

$$r_{a2} = 13,000\Omega$$

$$R_L = 10,000\Omega$$

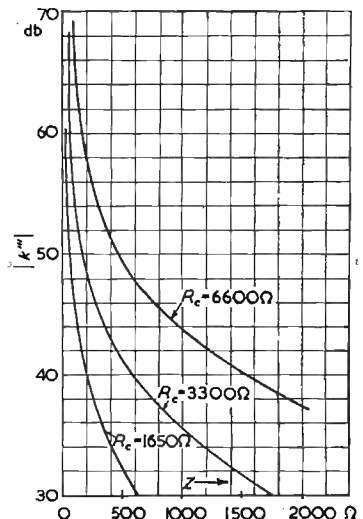

THE MILLER TRANSITRON

Grid Circuit Synchronization

By O. C. Wells

THE simple Miller Transitron time-base, using a single pentode, has the advantage of extreme simplicity and good linearity, but has distinct limitations as regards to scan to flyback ratio and synchronization. The usual method is to inject the synchronization signal on to the suppressor, but this has several disadvantages; it is difficult to prevent pulses from leaking from the time-base on to the Y plates through the synchronizing circuits and it is difficult to prevent the synchronizing signal from modulating the sweep velocity. Also it will sometimes be found that a quite small increase in synchronizing signal will produce a large reduction in sweep length. The present circuit was developed to overcome these troubles.

Attree¹ has described a method for increasing the speed of the flyback in Miller circuits by the use of a cathode-follower. In Fig. 1, V_3 is a Miller transitron valve and V_2 is the cathode-follower. If V_1 grid is sufficiently negative, this second triode will remain permanently non-conducting and will have no effect. If this grid is now allowed to become more positive a point will eventually be reached when the valve begins to conduct at the end of each sweep, hence reducing the gain of V_2 . This, in turn, reduces the negative feedback due to C_a , allowing the positive feedback between V_3 screen and suppressor to take charge, initiating the flyback. Thus V_1 grid potential determines the sweep length and may be used as a control, avoiding

the injection of signals on to the suppressor.

In the practical arrangement, V_1 and V_2 are the halves of a 6SN7, V_3 is an EF50, V_4 and V_5 are VR92. VR_1 and VR_2 provide amplitude and synchronization control, while VR_3 controls the velocity. V_4 prevents the suppressor from becoming positive, and V_5 is an anode catch-diode, preventing grid current in V_2 . The amplitude is thus determined by V_5 and the setting of the amplitude

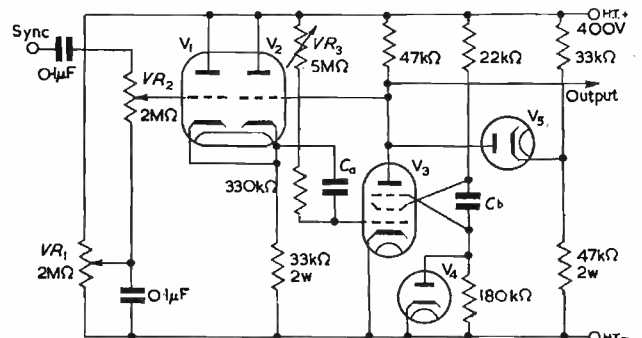

Fig. 1. The modified Miller transitron.

control, and is independent of the sweep velocity. C_a and C_b are switched to provide velocity ranges, with C_a ten times C_b . A separate heater winding on the mains transformer is desirable for V_2 and V_5 , to safeguard the heater-cathode insulation. This may be connected to V_2 cathode.

REFERENCES

1. ATTREE, V. H. Improving Flyback Time on a Miller Timebase. *Electronic Engng.* 20, 97 (1948).
- PUCKLE, O. S. Time Bases p. 171 (Chapman & Hall Ltd. 1951).

A Dekatron Timer

By J. McAuslan*, B.Sc., and K. J. Brimley*, B.Sc.

IN the routine measurements of the times of delay of detonators there are two ranges of products to be tested.

The first range from $\frac{1}{2}$ second to 12 seconds requires an accuracy of $\pm 1/200$ second, representing 1 part in 1200 on the longest times, and is covered by the Electronic Stopclock¹.

The second range, 25 milliseconds to 500 milliseconds, was the result of the later developments of "Short Delay" detonators, requiring an accuracy of ± 1 millisecond or ± 1 per cent whichever is the greater. A refined capacitor charge timing circuit has been used to accomplish this. Both instruments are used together to cover the whole range of 25 milliseconds to 12 seconds.

This article describes a single instrument designed to cover the whole range using cold cathode counters. (Ericsson Dekatron tube type GC10/B².) The use of electronic scalers driven from a constant frequency source is ideal for this type of work, but the apparatus is expensive and further complicated if presentation of results for routine measurements by unskilled operators is required. The main advantages of the instrument outlined below are: the ease with which the results can be read; the simplicity of operation; and the fact that, since it is crystal-controlled, no setting up is required. In addition, the cost is a fraction of that of a conventional scaler.

The glow discharge is localized and bright and is easy to read even under bright lighting. The four counting tubes, used to integrate the output from a 1kc/s crystal-controlled oscillator, are mounted side by side displaying the number of counts in decimal form. Resetting between measurements is carried out by pressing a spring-loaded switch in the centre of the front panel.

The instrument measures the time between two events. The first event is the voltage being applied to the detonator fusehead. The second is the bursting of the detonator, the sound of which is picked up by a protected microphone. These events operate a gating circuit between the oscillator and the counters.

The complete circuit diagram is shown in Fig. 1 and the appearance of the instrument in Fig. 2.

V_{1a} is used to amplify the voltage applied to the detonator causing it to strike thyatron V_2 . L_1 in the anode circuit of V_2 is one coil of a high-speed Carpenter relay type 5A3, which rapidly closes S_5 , thus connecting the crystal oscillator to the counter. The sound of the detonator exploding is picked up by a microphone connected to the grid of V_{7b} and the amplified signal used to trip thyatron V_3 . L_2 is the other coil of the relay and is connected in the opposite sense to L_1 , thus causing the relay to break S_2 by returning it to its original position.

The 1kc/s crystal-controlled oscillator (V_4 , V_5) does not give a satisfactory sine waveform at the anode of V_4 , and the output has been taken from across C_7 , where a pure output of smaller amplitude is available. This signal is amplified by V_6 , the L.F. choke in the anode circuit allowing the necessary anode swing to drive the first counter.

The sine wave provided by this amplifier is fed to the second guides of the first counter, while the first guides derive a phase-advanced sine wave from the phase shifting network $C_{17}R_{31}$. Starting from position O, i.e. with the glow on the output cathode, the glow will return there after 10 counts and when it does a positive signal will appear there for 1 millisecond. This signal is amplified and inverted by V_{1a} , thus providing a negative pulse of 1 millisecond which is used to drive the second stage.

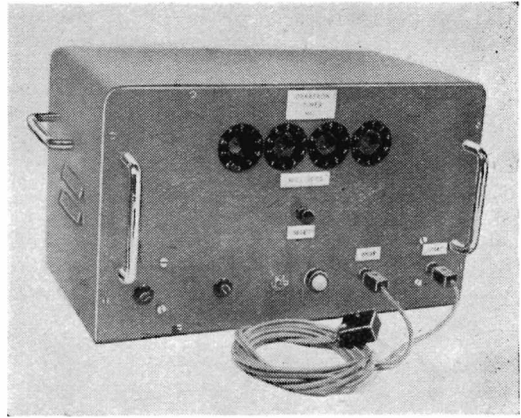

The external appearance of the Dekatron Timer

This coupling triode is held below cut-off to reject the small pulses obtained on the first nine counts, and also any positive pulses on the guide electrodes which will come through when the glow is on the output cathode.

This negative pulse from the coupling triode is fed to the first guides of the second counter, the second guides obtaining a delayed pulse from the integrating circuit $R_{16}C_{26}$. The remaining two stages follow the same pattern.

To reset the counters to zero, it is necessary to drive the glow back to the output cathode (zero or 10th position). This is done by isolating the connexion to cathodes 1-9 from -H.T. and also isolating the guides from the H.T. rails. The connexions are then replaced in the following order:—

- (a) H.T. to guide biasing potentiometer.
- (b) Earth to guide biasing potentiometer, and to the connexion to cathodes 1-9.

This order is necessary to prevent a discharge from the anode to the guides. It is also advisable to maintain the output cathode about 15V negative with respect to the other cathodes, to ensure that the glow does not move to a neighbouring cathode on restoring the -H.T. connexion.

Resetting is carried out by closing switch S_3 (a push-button spring switch on the front panel). This discharges an 8 μ F capacitor through relay L_4 . $S_{1,1}$, $S_{1,2}$, $S_{1,3}$ are arranged to open and close in the required sequence. Trouble was experienced with R.F. interference generated at the relay contacts, and picked up in the amplifiers V_{1a} and V_{1b} . This was suppressed with C_{31} .

Performance

To date the instrument has tested satisfactorily a very large number of detonators, and the only results lost have been due to a failure of one of the gating thyatrons.

The accuracy of the instrument is $+0.75$ to -1.25 milliseconds. This arises from the fact that the phase-shifted signal required to drive the first guides of the first counter requires time to establish the necessary phase relationship and amplitude to effect a transfer of the glow discharge. The time-constant involved is that of $R_{31}C_{17}$, and this has been kept down to 1/5th cycle, thus allowing the first negative half-cycle to be counted if switched on at or before the beginning of the negative swing. As the nominal steady speed of counting of these tubes has been found to be conservative, the transfer of the glow can be completed in the remaining quarter-cycle.

If we consider an infinitely sensitive counter (e.g. a binary type), fed by a sine wave, the maximum positive error of $1\frac{1}{2}$ cycles is obtained by switching on at position 1(a), Fig. 3, and off at position 1(b). The maximum negative error is $\frac{1}{2}$ cycle (positions 2(a) to 2(b)).

* Nobel Division, Imperial Chemical Industries, Ltd.

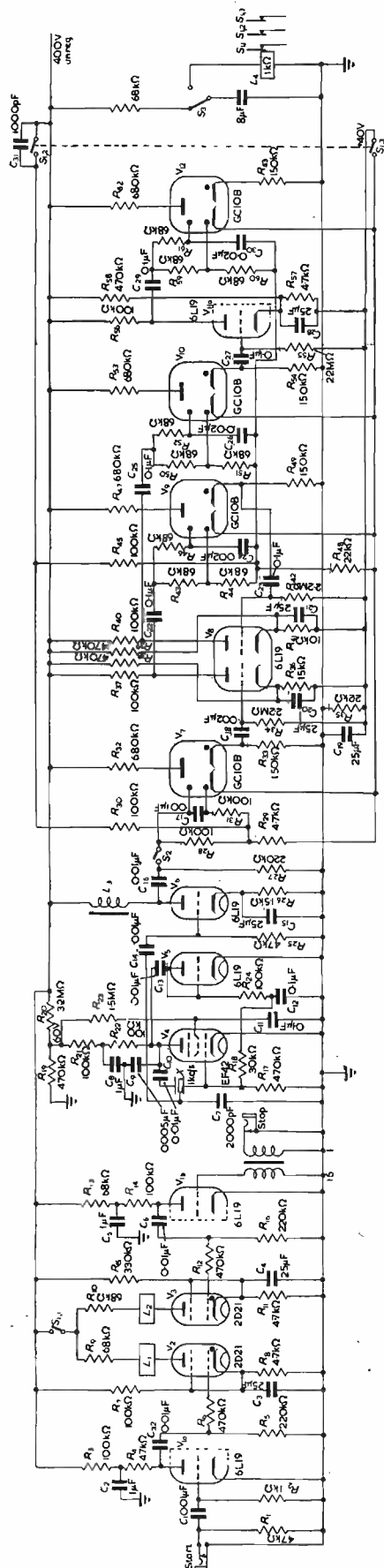

Fig. 1. Complete circuit diagram

If we consider the system requiring two signals of particular phase relationship as above, and arrange the time-constants accordingly, the maximum positive and negative errors (positions (3) and (4)) are $\frac{1}{4}$ and $1\frac{1}{4}$ cycles respectively.

Switching on at 3(a) allows the required time to establish the necessary relationships before the peak, and one count is made at 3(c) approximately. Switching on at 4(a) does not allow the necessary time

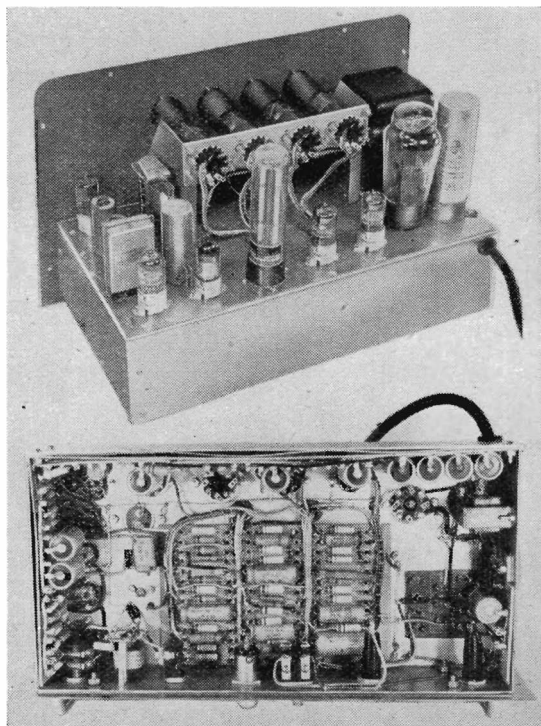

Fig. 2. The internal appearance of the instrument

and a count is lost. Switching off at 3(b) just after a count provides the maximum positive error. Switching off at 4(b) before the necessary amplitude has been reached loses one count and results in the maximum negative error.

The two systems of counting could be brought into line by squaring and differentiating the input and running a one shot multivibrator to provide a negative square wave to drive the first Dekatron counter. This complication is not considered necessary for the accuracy required in this application and has not been included.

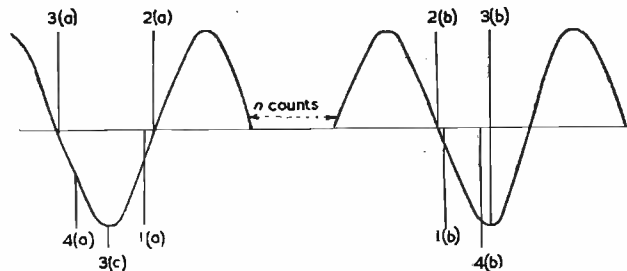

Fig. 3. The switching error

Considerable error does occur when the time-constant coupling a counter to the following triode is long compared with ten counts of the counter. The effect is due to the coupling capacitor becoming charged with grid current when the glow arrives on the output cathode and not having time to discharge during the following nine counts. For example, when $C_{18}R_{21}$ has a time-constant of 5 milliseconds the count is correct; if this is increased to 100 milliseconds the second Dekatron misses three or four counts in ten.

REFERENCES

1. BRIMLEY, K. J. *Electronic Engg.* 21, 180 (1949).
BRIMLEY, K. J. *Trans. Soc. Inst. Tech.* 2 (1950).
2. BACON, R. C., POLLARD, J. R. *Electronic Engg.* 22, 173 (1950).



PARIS . . . LONDON Television

Some of the BBC's Engineering Problems

By T. H. Bridgewater*, M.I.E.E.

THE second cross-channel television relay presented a number of problems; some of these were recurrent from the Calais project of two years ago; others, because of the more ambitious nature of the present attempt, were new. Fig. 1 indicates schematically the complete vision link between Paris and London (sound and communication circuits omitted for simplicity) and may give some idea of the scale of the operation. As may be seen, the main BBC contribution began with the "Convertor" at Cassel, followed by the radio links to and across England, all of which comprised British equipment and personnel. The remainder, that is everything on the Paris side of Cassel, was under R.T.F. control and largely embodied French equipment and personnel. There was, however, a British element in Paris where one of the three camera units in use was loaned and staffed by Pye Ltd. (with the help of two BBC cameramen). This equipment employed image orthicon pick-up tubes: one of the two French units also used this type of pick-up tube, the other the image iconoscope type.

It will be realized that, as compared with the Calais episode¹, there were several important differences and complications, e.g.:—

- (a) The total distance to be covered was more than doubled.

- (b) There were 17 broadcasts instead of 2.
(c) The pictures originated on an 819-line instead of a 405-line standard.
(d) The transmissions were broadcast simultaneously on the French and English television networks.

The principal features and problems facing those responsible for the BBC's contribution were:—

The method of conversion of standards.

The desirability of keeping to a minimum the number of radio links.

The difficulties due to anomalous propagation of centimetric waves over water.

It may be of interest to consider these in a little detail. First, the conversion of the standards.

The Convertor

As is by now generally known², the method adopted by the BBC is that of exposing a cathode-ray screen reproducing the 819-line picture to a camera scanning at 405 lines. Without special precautions this process can barely function and many undesirable beating and other effects are produced. Considerable study and experiment on the part of the BBC's Research Department was necessary before satisfactory results were achieved. A full report of their investigation will no doubt be published in due

* Superintendent Engineer, BBC Television O.Bs.

course: meanwhile one can only touch on the more prominent features. For example, it was essential to employ a cathode-ray screen having deliberate after-glow continuing throughout a frame period so that the camera tube should receive a continuous image rather than a single light spot. The phosphor eventually chosen—having regard also to the necessity for its colour to suit the chromatic characteristic of the pick-up tube—was zinc-beryllium-silicate. It was also important to make use of the storage properties of low-velocity pick-up tubes, particularly having regard to the possibility of hum trouble resulting from the difference in the frequencies of the two frame scans—the latter arising from the fact that the 819 picture would be locked to the French grid while the 405-line camera, although located in France, would be locked to the English grid system (by means of a control signal sent along a telephone line specially hired for the purpose). Thus, although earlier experiments had been done with a high-velocity tube, an image orthicon was used for this particular project, and it proved easily possible to adjust the 819-line image to suit the characteristics of this type of tube which, as is well known, functions best on low-contrast subjects: mainly a question of gain and brightness adjustment on the receiver.

Another problem linked with the differing mains frequencies—though a function of the 405-line camera only and not the convertor as a whole—was the fact that

The Radio Links

It may be recalled that the broadcast from Calais Hotel de Ville made use of four radio links—one to Dover and three between Dover and London. The distance to Cassel was over 30 miles further, but it still proved possible to deploy only the same number of links. This was because of the introduction during the past year of the E.M.I. high-power (5 watt) s.h.f. link^{3,4} capable of long range working (over optical paths). For present purposes path distances of 36 miles (Alembon-Swingate) and 49 miles (Swingate-Wrotham)—both greatly exceeding any of the Calais relays—were spanned by two sets of these equipments. For the Swingate-Wrotham link the transmitter had to be mounted at the 360ft level of the A.M. radar tower, while the receiver was at the extreme summit of the BBC's 470ft v.h.f. mast. Both ends presented erection difficulties and at the receiving end there were other problems besides—mainly the avoidance of interference from the local v.h.f. transmitters into the i.f. stages and down-leads. Overcoming such troubles and the establishing of a dependable link over this particular section demanded a good deal of development work which was carried out early in the year by a special experimental team.

The Channel Crossing

But for the presence of the English Channel it would

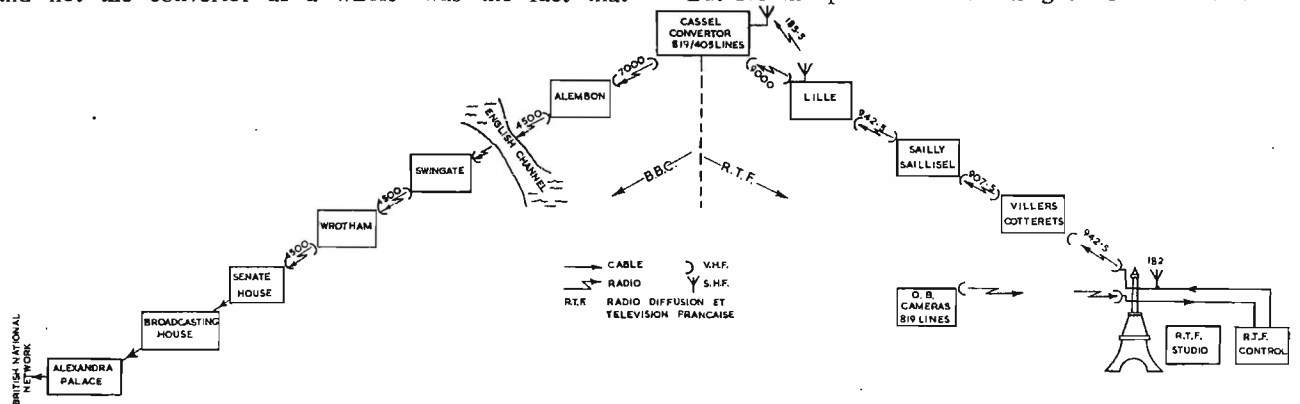

Fig. 1. Block Schematic of Paris-London Vision Circuit

Figures between stations indicate carrier frequency in megacycles per second.

although the frame synchronizing pulses were to be locked to the British mains the whole of the camera equipment received its power from the French mains. It became specially necessary therefore to select equipment free from any distortions attributable to the mains, such as a 50-cycle modulation of line scan (sometimes known as "positional hum"). Otherwise such effects, being unlocked to the British grid, might be unpleasantly distracting. To a small degree they were evident during the Calais broadcast: that was one of the lessons learned from it.

Special attention was given to maintenance of a high upper frequency response and in order to compensate for aperture effects in receiver and camera as well as other losses inherent in the conversion process a considerable measure of "top" correction was inserted both in the 819-line receiver as well as in the corresponding 405-line camera amplifier.

Performance of Converter

Resulting from these—among other features and precautions—was a most satisfactory efficiency of conversion. The actual degree of efficiency is a little difficult to express in simple terms, but it is probably true to say that when presented with a high-grade incoming signal (i.e. on 819-line standard) the convertor was capable of feeding out a 405-line picture having definition hardly distinguishable from normal quality (Fig. 3).

have even been possible to reduce the number of links between Cassel and London to a total of three—by beaming direct from Cassel to Swingate (a clear optical path), a distance of 56 miles. Tests had already shown that the high-power equipment referred to above could readily cover the distance, but the anomalous propagation associated with the over-water transmission of centimetric waves gave rise to intolerable fading which could only be kept within reasonable bounds by shortening the distance—hence the siting of the cross-channel transmitter at Alembon, 26 miles from Cassel and some 15 miles behind the coastline. Even then fading persisted throughout the tests and the broadcasts themselves (as indeed it did during the Calais broadcast), but luckily never became too serious during programme periods. The causes and character of this type of fading have been investigated and described by various research organizations during the past ten years and were discussed in some detail in papers before the recent Television Convention of the I.E.E.^{5,6} The BBC's recent observations were too brief to constitute any new information on the subject, though they certainly served to emphasize the extreme difficulty of tackling over-water transmission on these wavelengths and the necessity of a longer study before one could be confident of the ability to set up a workable service for use at any time of any day of the year. While in general it seemed to be inferred that the worst fading (and incidentally also the highest

signal strengths) occurred during the hottest, stillest days, there were also considerable variations in other weathers and it would be difficult to deduce any particular pattern from such limited sampling. Fig. 2(a), (b) and (c) shows the field strength variations for three typical days. On one of these the signal more than once fell below a usable level, but fortunately no broadcasts were in progress at these times. Nevertheless the knowledge of this possibility gave considerable anxiety to those responsible through the week of Anglo-French transmissions. The illustration at the top of the title page shows a view of the top of the temporary tower erected at Alembon, showing the receiving aerial and reflector of the Marconi links working from Cassel, also the transmitter and reflector (right top of platform) of the E.M.I. link working to Swingate.

Results

In the course of the whole series, consisting of 17 separate transmissions from Paris, there were no failures due to any of the equipment on the Cassel-London circuit: to this extent it may perhaps be concluded that the practicability of television from the Continent—including the translation of standards—has been amply demon-

strated. Such a conclusion must, however, be tempered with a reminder of the problem of fading. There is no reason to suppose that this could not be surmounted, given the time and facilities for further experiments, but it is something requiring solution, or at any rate better control, before one could confidently undertake another relay from the Continent.

No doubt our French collaborators in Paris and Lille who had many difficult, if different, problems to overcome, also learned much from this exploit, but it has not been the present object to attempt to report on their behalf: one hopes, however, that in due course they may publish a first-hand account.

REFERENCES

1. RICHARDSON, W. D., and ANDERSON, W. N. Television from Calais: The First Cross-Channel Broadcast. *J. Television Soc.* 6, 214 (1951).
2. Television from Paris. *Wireless World* 58, 298 (1952).
3. BRIDGEWATER, T. H. Recent Developments in Television Outside Broadcasts. *Elec. Engg.* 24, 158 (1952).
4. CUTTS, F. W. A Mobile High Power Microwave Link for Vision and Sound. I.E.E. Convention on "The British Contribution to Television." (April-May, 1952).
5. SMITH-ROSE, R. L. A Survey of British Research on Wave Propagation with Particular Reference to Television. I.E.E. Convention on "The British Contribution to Television." (April-May, 1952).
6. BRAY, W. J., and CORKE, R. L. A Technique for 4000 Mc/s Propagation Testing for Radio-Relay Systems. I.E.E. Convention on "The British Contribution to Television." (April-May, 1952).

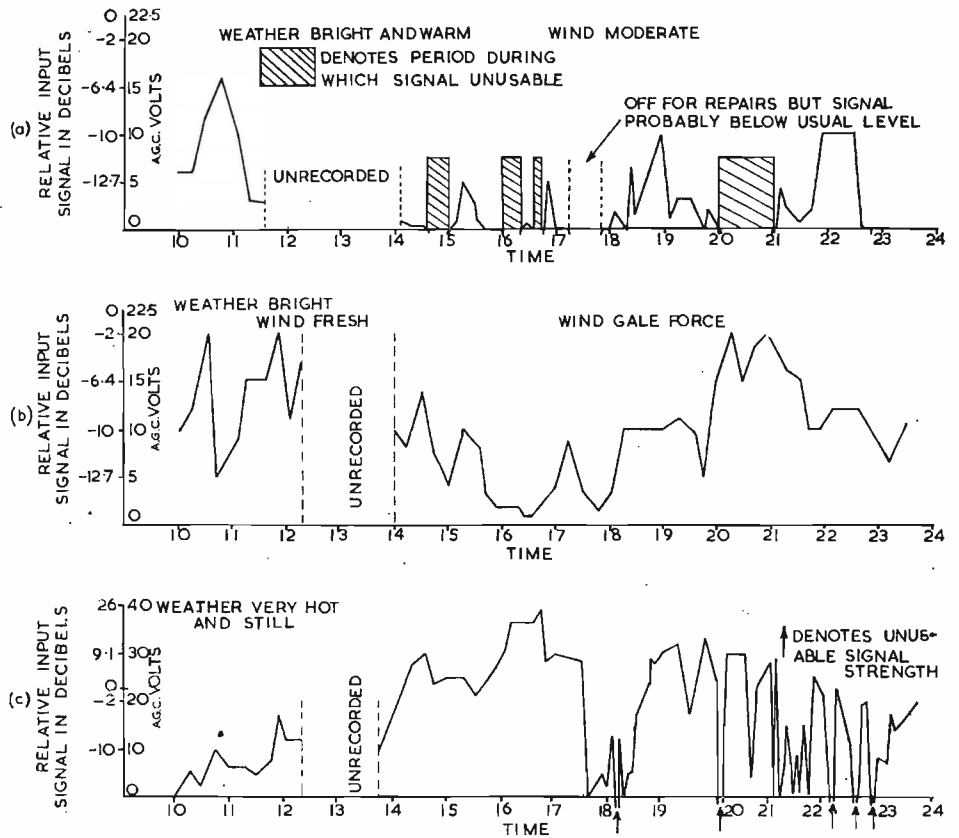
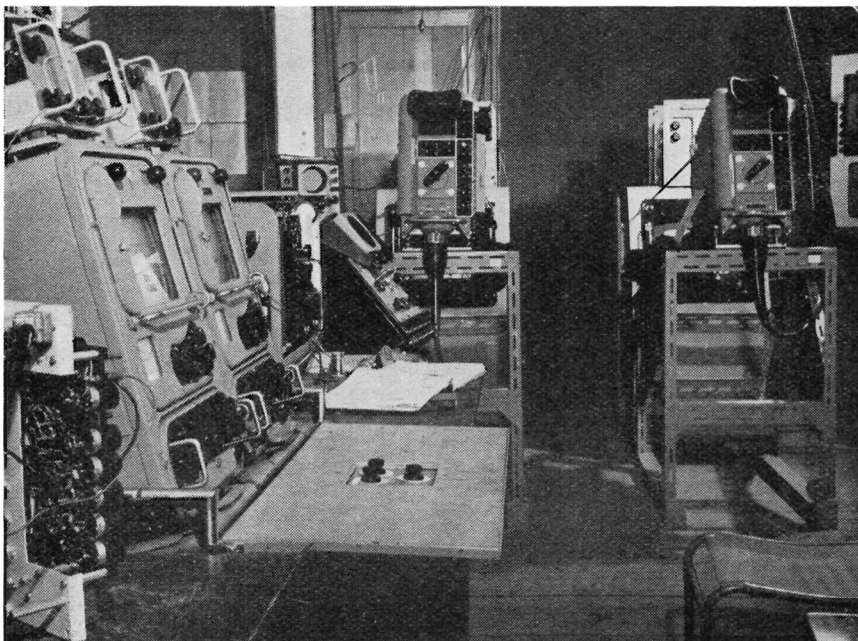

Fig. 2. Field Strength on Alembon-Swingate Link
(a) July 9, 1952. (b) July 8, 1952. (c) July 1, 1952.

Fig. 3. General view of converter equipment installed at Cassel

Centre are the two Marconi Image-Orthicon cameras used to scan the 819-line pictures received from R.T.F. Left are the two camera control units and auxiliary apparatus.



A New Frequency Divider

By J. A. Fitzgerald*, A.M.I.E.E.

In considering the design of a frequency divider the chief requirements are reliability, stability of operation, ease of alignment, simplicity of construction, and compactness of design. This account describes a frequency divider† which is a development of the well-known balanced-modulator type of divider and which is intended to incorporate all these desirable features.

BEFORE discussing the design of this new divider, it is desirable to consider briefly the construction and operation of earlier dividers in this particular class.

Fig. 1 shows the circuit of the well-known balanced-modulator divider providing a division ratio of 2:1. Its essential features are a balanced modulator connected between the input terminals and the grid and cathode circuit of the valve, a tuned circuit in the anode circuit of the valve, and provision for feeding the signal back from the anode circuit to the modulator. The modulator comprises two balanced transformers, T_1 and T_2 , and four rectifiers, W_1 , W_2 , W_3 , and W_4 , connected as shown between the secondary of transformer T_1 and the primary of transformer T_2 .

The starting of a balanced modulator divider circuit may be considered to take place as a result of changes in circuit conditions brought about either by the application of the supply voltages or by the application of the input frequency, and once started the circuit will maintain itself so long as the input frequency is applied. However, for the purposes of this account, it will be assumed that the starting of the circuit is due to the surge caused by the application of H.T. to the valve. In this case, on switching on the H.T. supply to the divider, with a signal of frequency f applied to its input terminals and the anode circuit of the valve tuned to a frequency of $f/2$, an oscillation of frequency $f/2$ is produced across the tuned circuit. This signal is fed back to modulate the input frequency, and the output of the modulator then contains components of the sideband frequencies $(f + f/2)$ and $f/2$. The tuned circuit in the anode circuit of the valve offers a low impedance to the oscillation at the frequency $(f + f/2)$, but a high impedance to the oscillation at frequency $f/2$, and the signal at frequency $f/2$ therefore forms the major component appearing at the output terminals of the divider.

This circuit provides a thoroughly reliable divider. However, it has not been found possible to make it produce satisfactorily division ratios of greater than 2:1, and a further disadvantage of the arrangement is the need for accurately balanced transformers, T_1 and T_2 , in the design. This is particularly so below 500c/s, when it becomes difficult to design reasonably compact transformers which do not shunt the feedback source to such a degree that it is impossible to obtain adequate feedback. When division ratios of greater than 2:1 are required and these ratios are divisible by 2, then it is possible to use the dividers in cascade. However, where greater division ratios are required, the arrangement shown in Fig. 2 is normally used, sometimes with an additional limiter valve coupling valves V_1 and V_2 . In this case, referring to the circuit, assuming the division ratio required is n and the input frequency is f , then the anode circuit of V_1 is tuned to f/n , and the anode circuit of a harmonic generator

valve V_2 to $f/n(n-1)$. With the input frequency applied, on switching on the H.T. supply an oscillation of frequency $f/n(n-1)$ is fed back to the balanced centre-taps and modulates the input frequency f , producing sidebands $f + f/n(n-1)$ and $f - f/n(n-1)$. The anode circuit of valve V_1 offers a high impedance to the latter frequency, and the output consists mainly of frequency f/n , which is applied to the grid of V_2 to maintain the output of this valve at $f/n(n-1)$ and also to the input of valve V_3 , which serves as a separator valve. The waveform from V_1 is such that this separation is, in most applications, essential.

While the circuit, when properly aligned, operates satisfactorily, it has a number of disadvantages. It is un-

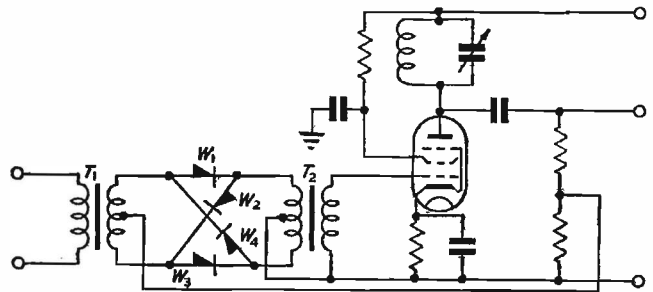

Fig. 1. Balanced-modulator divider

economical in the number of valves used and consequently in the number of components required, and is, of course, bulky in construction. Furthermore, it is difficult to align, and great care must be taken in making adjustments to meet the requirements of good self-starting and complete stability in the absence of the input signal. In practice, a compromise must always be made between these two conflicting requirements.

New Divider

Fig. 3 shows the circuit of the new divider which will, with the use of a single valve, provide satisfactory division ratios ranging from 2:1 to 5:1, or at the cost of a slightly degraded performance, even higher ratios. In addition, it may be used to provide fractional division ratios.

Referring to the drawing, the anode circuit of the valve consists of a transformer, the primary of which is tuned. The secondary of this transformer is connected to one of the diagonals of the bridge formed by rectifiers, W_1 , W_2 , W_3 , and W_4 , and the input terminals to the other diagonal. This arrangement of rectifiers is known as a Cowan modulator and is extensively used in suppressed-carrier communication systems. In such systems the carrier frequency f_c is usually applied to the diagonals a and b of the bridge, and the modulating frequency f to the diagonals c and d . In operation, during one half-cycle

* Engineering Secretariat, British Broadcasting Corporation.

† Patent Application No. 20026/49.

the rectifiers are conducting and practically short-circuit the input frequency f , while during the other half-cycle the rectifiers are non-conducting and have a small shunting effect across the input circuit. In the ideal case the output of the modulator contains sideband components and f , but not the carrier f_c . In suppressed-carrier communication systems considerable effort is made to reduce "carrier leak" and harmonic inter-modulation products. However, when the circuit is used in a divider these components in the output of the modulator are essential. No

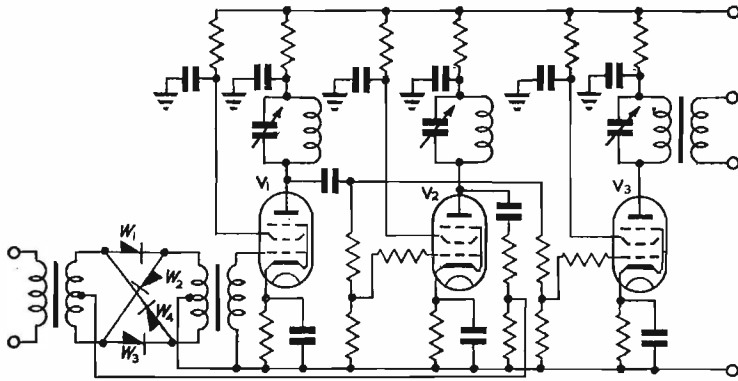

Fig. 2. Divider for ratios greater than 2 : 1

attempt has been made to obtain the optimum operating conditions for the generation of harmonic inter-modulation products, since this would complicate the design without contributing greatly to the performance of the divider. Nevertheless, the balance of the rectifier bridge must be sufficiently accurate to prevent feedback from the anode circuit to the grid circuit of the valve; otherwise, with the correct phase conditions, the divider would behave as an oscillator. This degree of balance is achieved without any special selection of rectifiers.

To set up the divider to produce a division ratio of 2, the transformer primary is tuned to $f/2$, where f is the input frequency. On switching on the H.T. supply a voltage at the frequency $f/2$ is applied to the modulator, and in modulating the input frequency produces sideband frequencies of $(f + f/2)$ and $f/2$. The anode circuit offers a high impedance to voltages of frequency $f/2$, and signals at this frequency are, therefore, available at the output of the divider.

While the arrangement thus described has a definite advantage over the original one-valve type of balanced modulator divider used for division ratios of 2, in that no balanced transformers are required, it has even greater advantages over the type of divider used for division ratios greater than 2. It also has the added attraction that no alteration, except in the value of the capacitor C , is necessary to make the divider produce these greater division ratios, a feature which makes it extremely easy to adjust. For example, when it is desired to line up the divider to produce a division ratio of 3:1, it is only necessary to tune the anode circuit of the valve in Fig. 3 to a frequency $f/3$, where f is the input frequency. When the divider is switched on, a signal at the frequency $f/3$ is fed back to the modulator, which, owing to rectification taking place, generates harmonics of $f/3$. The second harmonic, $2f/3$, modulates the input frequency f to produce output frequencies of $(f + 2f/3)$ and $(f - 2f/3)$. The anode circuit of the valve is tuned to $(f - 2f/3)$, which is the frequency of the signal available at the output of the divider. Other division ratios are produced in a similar manner, and in general if f is the input frequency and n the division ratio, the output frequency will be $f - (n - 1) f/n = f/n$.

In practice it has been found possible to operate with division ratios as great as 8:1, but having regard to the

best operating conditions it is not considered that ratios greater than 5:1 should be used.

The divider, modified as shown in Fig. 4, can also be used to produce fractional division ratios. For example, assuming the input frequency to be f and the normal division ratio of the divider to be n , then there will be present in the cathode circuit of the valve current components of frequencies such as f/n , $2f/n$, and $3f/n$. Referring to Fig. 4, it will be seen that the tuned circuit is arranged in series with the partially undecoupled screen grid of the valve and may be tuned to any of the harmonics of f/n . The output taken from the screen grid, as shown, will contain a component which is a multiple of f/n and is also a fraction of the input frequency. This particular feature has been found useful in divider chains where it is required to convert from one frequency sequence to another.

CONSTRUCTION AND PERFORMANCE

The construction of the divider is extremely simple. It uses a minimum of components, is compact, and without any attempt at miniaturization has enabled divider chains, dividing down from 1,000kc/s to 1,000c/s, to be built in roughly one-third of the space normally required. The bridge rectifiers used in its construction are of the 1mA instrument rectifier copper-oxide variety, and these have been used successfully to cover the frequency range of 50c/s to 1,500kc/s. Other rectifiers could, of course, be used to produce a similar type of modulator. However, this type of rectifier is particularly suitable, for it is small and can be conveniently mounted on a panel or chassis.

The design of the transformer is not critical, and in the higher frequency ranges a Gecalloy bobbin type of construction may be used. It should be designed to provide an impedance step-down of the order of 50,000 to

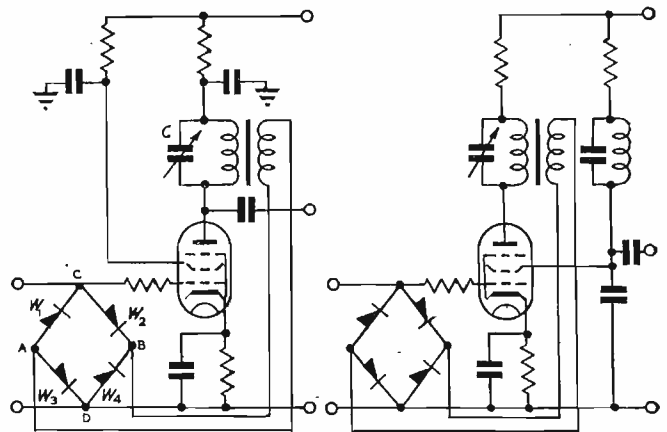

Fig. 3. New single valve divider

Fig. 4. A modification for fractional ratios

600 ohms. A suitable design of transformer can be arranged to cover a fairly wide frequency band, and the only necessary component variation is in the turning capacitor connected across the primary of the transformer. If the divider is to be self-starting and have a good H.T. coefficient, it is desirable that the Q of the transformer primary should be as high as possible.

The values of the tuning capacitor used to tune the primary of the transformer in the anode circuit of the valve are not critical and may be varied ± 10 per cent without the division ratio being affected.

Other good features of the divider are that it is not susceptible to input level variations, and that its output waveform is satisfactory, so that no further separator is

necessary as a rule. In all cases the output may be used to drive subsequent divider stages.

In assessing the performance of a balanced modulator divider in regard to its general stability and self-starting properties it is customary to use the H.T. coefficient as a criterion of performance. When this new divider, set up for a division ratio of 2:1, is tested in this way it is found that it will operate satisfactorily from a normal 300 volts H.T. down to an H.T. supply of 15 volts, and will re-start at this value of H.T. In this respect it compares very favourably with the original type of balanced-modulator

divider. Where the new divider is used to provide greater division ratios than 2:1, it is found that the H.T. supply may be run down from a normal 300 to 100 volts. This figure again compares favourably with a 3-valve balanced-modulator divider adjusted for complete stability.

The divider has been extensively used in the range 50c/s to 1 500kc/s in BBC service and is now part of the standard input of BBC frequency comparison equipment. It has also been used in chain form in a unit designed to provide a 1 000c/s reference tone from the Droitwich 200kc/s carrier.

A Radio-Frequency Micropotentiometer

By M. Lorant

Extremely simple devices which produce R.F. voltages at a very low impedance and at a wide range of frequencies have been conceived and developed recently by the National Bureau of Standards, America. Known as R.F. Micropotentiometers, they provide accurate voltages from 1 to 10^5 microvolts without the use of attenuators at frequencies up to 300Mc/s and above. Thus, convenient standards of low voltages are made available which should greatly reduce equipment and shielding problems encountered in calibration of present-day commercial voltage generators, attenuators, voltmeters, and other radio-frequency equipment.

The micropotentiometers should prove especially useful in measurements of radio receiver sensitivity. Here the large disagreement between various standard voltage generators at high frequencies and low voltage levels has been due to three major causes. First, generator output im-

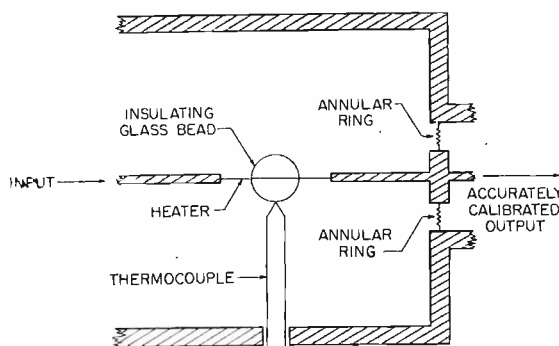

A functional diagram of the R.F. micropotentiometer.

dance and receiver input impedance are not ordinarily known as functions of changing frequencies. Second, extreme care is necessary in using precision voltage-dropping attenuators. Finally, the long-term calibration stability of vacuum tube voltmeters is uncertain. For these reasons, manufacturers of voltage generators have not been able to guarantee the accuracy of their equipment at all frequencies. Development of the micropotentiometers now appears to have removed most of the obstacles to standardization of receiver sensitivity.

The new instruments consist essentially of appropriately housed and mounted current-carrying elements together with means for monitoring the currents they carry. Their electrical constants are simply determined by using known D.C. voltages and currents. The current-carrying elements are annular membrane, either metallic or non-metallic, of

various radii, thicknesses, and electrical resistivities. Monitoring may be accomplished by means of thermocouples, thermoelements, bolometers, stable vacuum tube voltmeters, or other devices whose indications are independent of frequency. Thermoelements have been used in measurements of 1 to 100 000 microvolts at frequencies from zero to 300Mc/s and also for 100 000 microvolt measurements in the region of 1000Mc/s.

These micropotentiometers are the first low-impedance (of the order of milliohms) devices which provide R.F. voltages in the microvolt range and which make these low voltages available without the use of attenuators. The devices are inherently frequency insensitive up to and above 300Mc/s. Extremely low and essentially non-reactive output impedance facilitates their use for checks and references with standard voltage generators. They may be used for direct calibration of percentage-modulation indicators. By means of known voltage ratio, the micropotentiometers may be used to extend the range for checking attenuators

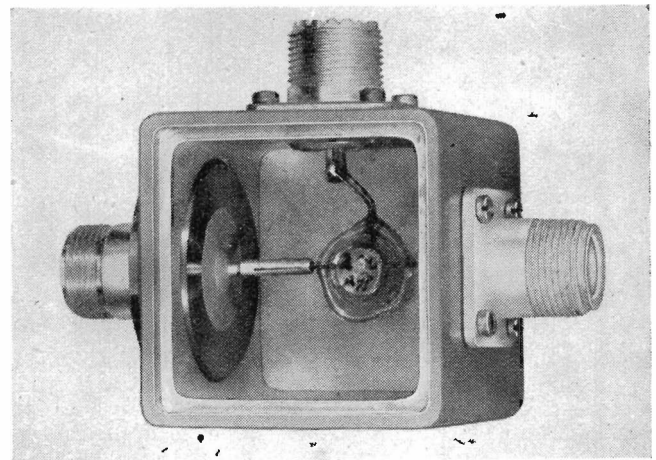

An exposed view of one of the R.F. micropotentiometers.

up to 120db or higher. Simplicity of operation, trouble-free circuits, flexibility, and absence of serious shielding problems make these instruments particularly adaptable to use by personnel of limited training.

In comparing the micropotentiometers with other sources, such as a voltage-measuring thermistor bridge, absolute reproducibility and agreement have been limited only by the relative complexity of the standards of comparison. Verification of the exact frequency and voltage ranges of the micropotentiometers in terms of other independent standards is still in progress at the Bureau, along with other phases of design and application. Probably the greatest single difficulty encountered in this work has been the lack of stable sensitive receivers which can indicate one microvolt (or lower voltages) at 100Mc/s and higher frequencies with accuracies of 10 per cent or better.

Tape Wound Magnetic Cores

By A. Langley Morris,* M.I.E.E.

CORES constructed from stampings or from interleaved strips are not satisfactory when very thin laminations are required, nor when it is desired to make use of the properties of grain oriented silicon iron. Stampings for large cores are wasteful of material, and all conventional interleaved cores are prone to saturation effects at the joints.

Cores wound from a continuous magnetic tape, which do not have these disadvantages, are likely to find increased use in transformers and magnetic amplifiers. Four varieties of these cores are illustrated in Fig. 1.

No tape wound core has a magnetic path wholly through the iron, nor is the flux distribution uniform across the core section. The spiral winding of the tape constitutes an incomplete magnetic turn so that the flux has to cross the inter-laminar space, which unless uniform in thickness, causes local flux concentrations and consequently impaired magnetic characteristics.

The flux density in all cores is greatest in the area

Thus the reluctance of a tape wound toroidal core is almost that of the iron circuit and the benefits of high permeability materials can be fully realized.

The non-uniformity of flux distribution can be expressed as the ratio of maximum flux density to average. If the air path reluctance is neglected, then:

$$\frac{B_{max}}{B_a} = \frac{t}{t+g} \left[\frac{r_2 - r_1}{r_1 \log r_2/r_1} \right] \dots \dots \dots (3)$$

Where B_a = flux density assuming uniform distribution.

Expression (3) does not take account of any change in permeability with flux density. The actual ratio will, therefore, depend upon whether B_a is above or below the point corresponding to maximum permeability and on the rate of change of permeability with flux density.

Rectangular Tape Wound Cores

These are not so easy to construct as the toroidal type

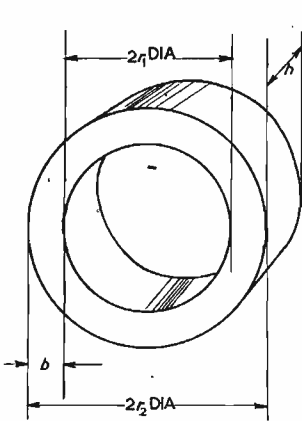

Fig. 1(a) Toroidal tape core

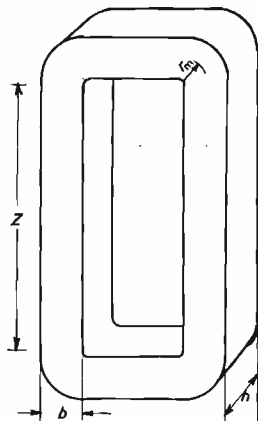

Fig. 1(b) Rectangular tape core with rounded corners

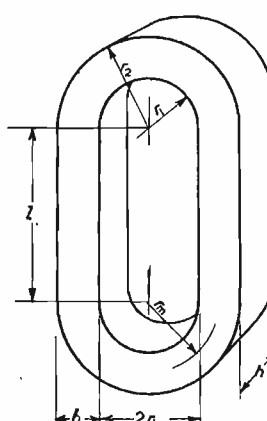

Fig. 1(c) Rectangular tape core with rounded ends

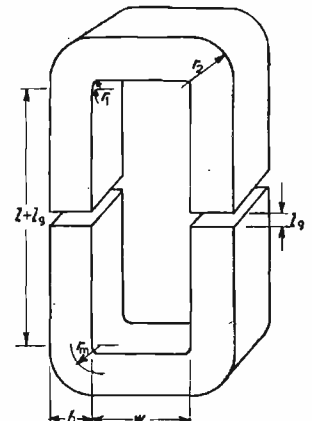

Fig. 1(d) "C" core

adjacent to the window and least at the outer parts, owing to the variation in reluctance. For applications where the flux density of the core is driven into saturation, i.e. for peaking transformers, pulse-actors, and magnetic amplifiers, non-uniformity in flux distribution must receive attention.

Toroidal Cores

It can be verified that the reluctance is given by:

$$S = 1/h \left[\frac{2\pi}{\mu \log r_2/r_1} + \frac{g(t+g)}{2\pi(r_2^2 - r_1^2)} \right] \dots \dots (1)$$

where μ = permeability

g = thickness of interlaminar spacing

t = thickness of tape.

The second term inside the brackets is the air path contribution which can usually be neglected, so that Equation (1) may be written:

$$S = \frac{2\pi r_m}{kh\mu(r_2 - r_1)} \dots \dots \dots (2)$$

k = space factor.

and the interlaminar spacing is less uniform, as a greater tension occurs at the corners during winding. The flux transfer from turn to turn tends to concentrate at the stressed portions where the interlaminar space is reduced. The rounded end core would be expected to have better magnetic characteristics than the rounded corner type, but both would be inferior to the toroidal core.

Assuming uniform interlaminar spacing, the reluctance is approximately:

$$S = 1/A [P_m/\mu + g/P_y] \dots \dots \dots (4)$$

where A = nett core cross section, cm.

P_m = mean path = $2(l + w + \pi/2 \cdot r_m)$

P_y = half mean yoke path = $w + \pi/2 \cdot r_m$

Note that $w = 0$ for the rounded end core.

The air path contribution g/P_y can usually be neglected.

The flux distribution across the core section is not uniform, but to a lesser degree than a toroidal core of equivalent size. The flux density ratio:

$$\frac{B_{max}}{B_a} = \frac{\pi k (r_2 - r_1)}{(l + w + \pi r_m) \log l + w + \pi r_2} \dots \dots \dots (5)$$

* T. R. E. Malvern.

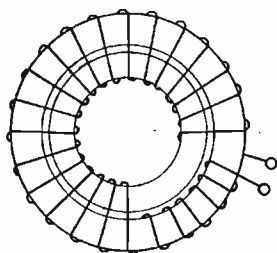

Fig. 2. Series compensated toroidal wound tape core

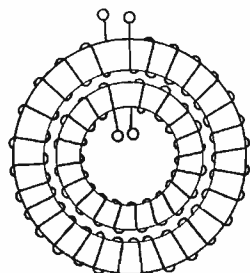

Fig. 3. Parallel compensated toroidal wound tape core

This type of core has a window shape which makes it possible to wind cylindrical windings. A split mandril must be used and rotated *in situ* by a suitable mechanical drive. To avoid a bad space factor the core section can be made in a stepped form by assembling a number of correctly proportioned individual cores.

The rectangular core is an alternative to the toroid, but it has better possibilities for larger sizes of transformers and magnetic amplifiers since cylindrical windings can be used.

The C Core

This is a rectangular core which has been sawn in half so as to enable preformed windings to be used. Careful manufacture is necessary, for the laminations must not short at the cut faces; the cores must butt together with the minimum of air-gap; the gap faces must be kept free from rust; and the cores must be tightly clamped. Noise can be a nuisance and there seems some advantage in cementing the cores with a material such as "Araldite" in addition to the mechanical clamping usually provided.

The magnetic reluctance is greater than for the other two types because of the air-gap at the butting surfaces. Thus the reluctance may be calculated from Equation (4) with an additional term:

$$S' = gs/A \dots\dots\dots (6)$$

where g = total width of air-gaps.

s = fringing factor.

The flux distribution in a C core should be more uniform than in the other types of uncut cores owing to the air-gap, but should the gap faces not be parallel, then serious non-uniformity can occur.

On account of the gap the C core has advantages for applications where the windings carry a polarizing current, i.e., for half-wave rectifier transformers and pulse transformers.

The Improvement of Flux Distribution in Strip Wound Cores

Normally the ratio of B_{max}/B_a given by Equations (3) and (5) should be limited by the core proportions to a value not greater than about 1.2. When the ratio is greater than this amp-turn compensation becomes necessary. The core has to be split into a number of concentric cores with suitable excitation provided for each core. There are three methods of achieving this:

SERIES COMPENSATION

The primary, or exciting winding, is arranged as in Fig. 2 with additional turns wound over the outer cores. If N is the number of turns required for the whole core, then the fraction of N put on an individual core is ΔN where

$$\Delta N \equiv \frac{(P_m - P)N}{P_m} \dots\dots\dots (7)$$

P_m = mean magnetic path of whole core.

P = mean magnetic path of individual core.

Consider a toroidal core 2in. i.d. with 1in. build up, then from Equation (3) $B_{max}/B_a = 1.3$, and compensation is desirable.

The core should be made in two parts, each having a build up of $\frac{1}{2}$ in. with a gap between the cores sufficient to accommodate the wire diameter of the compensating turns—say $\frac{1}{16}$ in. spacing. Then $P_m = \pi \times 3\frac{1}{16}$ in. and $P = \pi \times 3\frac{3}{16}$ in. so that from Equation (7) $\Delta N = 0.184$. Thus 0.916N turns are wound over the composite core with 0.184N turns over the outer core. These extra turns must not be too widely spaced otherwise circulating fluxes will occur across the gap between the two cores.

PARALLEL COMPENSATION

Here each individual core is wound with an exciting winding and the windings connected in parallel to form the primary; see Fig. 3. The flux in each core will be equal; each exciting winding carrying a magnetizing current proportional to the reluctance of its core. The obvious disadvantage of this scheme is the large number of turns required if the primary voltage is high. For the turns have to fulfil the transformer voltage equation with the core area corresponding to that of the individual core.

TERTIARY COMPENSATION

The arrangement is the same as for parallel compensation but the turns are kept to a small number. Equal fluxes will be maintained by the circulating current round the tertiary windings. This current is supplied by the usual primary winding wound over the composite core and its magnitude will depend on the difference in reluctance of the individual cores.

This circulating current is given by:

$$I_2 - I_1 = I_N / N_i \frac{(P_2 - P_1)}{P_m}$$

Where I_N = primary magnetizing current amp turns.

N_i = tertiary turns.

Acknowledgment

The author is indebted to the Chief Scientist, Ministry of Supply for permission to publish this article.

The Home Built Televisor for Wenvoe, Kirk o' Shotts and Holme Moss

Details of the modifications necessary for operating the Electronic Engineering Home Built Televisor on Channels 2 (Holme Moss), 3 (Kirk o' Shotts), and 5 (Wenvoe), are now available.

Since the transmissions on Channels 2, 3 and 5 are similar to that of Channel 4 (Sutton Coldfield), i.e., single-sideband, the Televisors for these Channels are based on "A Home Built Televisor for Sutton Coldfield Reception" (price 4s. 9d. post free), the only differences being in the tuned circuits and the alignment procedure. Full details of these modifications are contained in a four-page leaflet that is now available, price 6d. post free, from:—

Electronic Engineering

Circulation Department
28 ESSEX STREET, STRAND, LONDON, W.C.2

Special Rectifier Circuits

A description of Some New High Voltage Circuits and Consideration of "Centre-tapped" Circuits

by D. B. Corbyn, B.Sc., A.M.I.E.E.

Some novel rectifier circuits are described suitable for producing high voltages but having a better regulation and less ripple voltage than conventional high voltage circuits. The problem of "centre-tapping" rectifier circuits to produce half the normal voltage is also briefly discussed.

THE production of high D.C. voltages from rectifiers is often achieved by the use of the conventional voltage-doubler circuit (Fig. 1(b)) which gives a possible mean output voltage $2\sqrt{2}$ times R.M.S. input voltage. For even higher voltages, voltage triplers, quadruplers or cascade circuits are frequently employed.

All these circuits have a poor voltage regulation, and if heavy currents are required the capacitors become of prohibitive size if anything like the theoretically possible output voltage is to be achieved. Where heavy currents are required then the bridge circuit of Fig. 1(c) is the

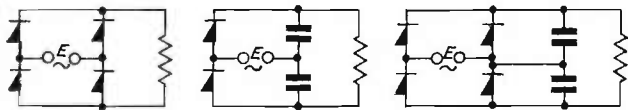

Fig. 1(a). Single-phase bridge rectifier
Fig. 1(b). Voltage-doubler rectifier
Fig. 1(c). New bridge-doubler rectifier circuit

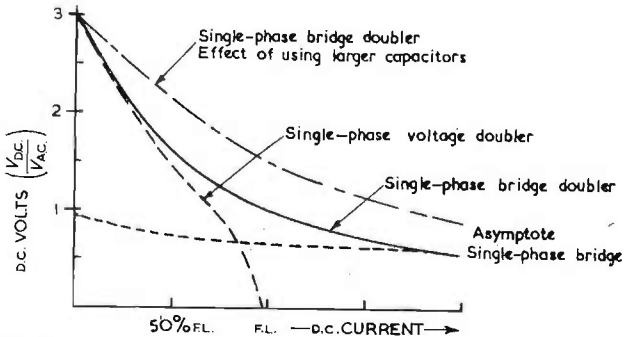

Fig. 2. Comparative regulation curves of various single-phase rectifier arrangements.

commonest but the possible mean output voltage is only about 0.9 times R.M.S. input (A.C.) voltage.

It is possible to combine the two circuits in the manner shown in Fig. 1(c), which can well be named a bridge-doubler circuit. Fig. 2 shows the type of regulation curve exhibited by each of the three circuits discussed. It will be seen that the bridge-doubler circuit has the same voltage output ($2\sqrt{2}E$) as the voltage-doubler at light loads but that it never falls below the output of the bridge circuit at any load.

The overall regulation curve is greatly improved and the circuit would appear to be valuable where heavy overloads have to be carried without undue voltage drop.

The regulation curves have been drawn so that the short-circuit condition of the voltage-doubler is reached at the normal full load rating of the rectifier when used in a bridge circuit. This is far less than the normal amount of capacitance, but is used to exaggerate the differences between various circuits.

Use of Three Phase Circuits

The well known single-phase voltage-doubler and kin-

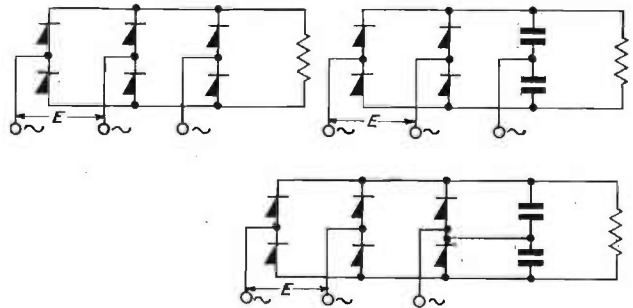

Fig. 3(a). Three-phase bridge rectifiers
Fig. 3(b). Three-phase voltage-doubler rectifier
Fig. 3(c). Three-phase bridge-doubler rectifiers

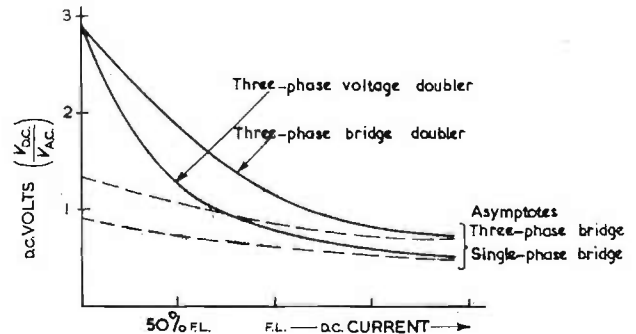

Fig. 4. Comparative regulation curves of various three-phase rectifier arrangements

dred circuits already described all have their three-phase counterparts. Fig. 3(a) is the conventional three-phase bridge rectifier much used for large power outputs and heavy currents. Fig. 3(b) shows a three-phase voltage-doubler which, like the single-phase voltage-doubler, has a mean D.C. output of $2\sqrt{2}E$ volts. On overload, however, it behaves like a single-phase bridge rectifier and thus has

a performance very similar to that of the single-phase bridge-doubler described above. The ripple output is much less than that of the equivalent single-phase circuits.

In order to improve the regulation and increase the current carrying capacity a true three-phase bridge-doubler can be constructed as shown in Fig. 3(c). Comparative regulation curves are shown in Fig. 4 and the three-phase bridge-doubler has an output of $2V(2)E$ volts at light load, but never falls below the output of the three-phase bridge at any load. The regulation curves have been intentionally drawn with rather small capacitors in order to demonstrate better the type of curve.

Output Ripple

The ripple is dependent on load in all the circuits which include capacitors being least (theoretically zero) at zero load and increasing as the load increases.

The table below gives the basic features of the new circuits and also gives the features of the conventional circuits for comparison. The decreased ripple voltage overload in the bridge-doubler circuits should be an advantage in practice since it is an overload that the voltage-doubler circuits are at a disadvantage as an increasing ripple voltage is produced at overload currents at the same time that the smoothing chokes tend to become saturated and less effective.

CIRCUIT	POSSIBLE MEAN D.C. VOLTS *		RIPPLE VOLTS AS PERCENTAGE OF MEAN D.C. VOLTS †			
	O.C.	F.L.	O.C. (per cent)	Main freq. O.C.	F.L. (per cent)	Main freq. F.L.
1 ph. Bridge 1 ph. Volts doubler 1 ph. Bridge doubler	$0.9E$	$0.9E$	48	$2f$	48	$2f$
	$E.2\sqrt{2}$	Any	Nil	$2f$	Any	$2f$
	$E.2\sqrt{2}$	$0.9E$	Nil	$2f$	48	$2f$
3 ph. Bridge 3 ph. Volts doubler 3 ph. Bridge doubler	$1.32E$	$1.32E$	4.3	$6f$	4.3	$6f$
	$E.2\sqrt{2}$	$0.9E$	Nil	$6f$	48	$2f$
	$E.2\sqrt{2}$	$1.32E$	Nil	$6f$	4.3	$6f$

* The voltages given in this column are theoretical and assume a perfect rectifier having zero resistance in the forward (conducting) direction. In practice, the F.L. volts are 10-15 per cent below the O.C. volts, even with the bridge circuits, due to rectifier resistance.

† The ripple figures are given as :-

$$\frac{\text{Total R.M.S. ripple volts}}{\text{Mean D.C. volts}} \times 100 \text{ per cent}$$

Fig. 5(a). Single-phase bridge rectifier with centre-tap

Fig. 5(b). Three-phase bridge rectifier with centre-tap

Transformer usually has an inter-star secondary to prevent D.C. saturation of core when the half-voltage is in use.

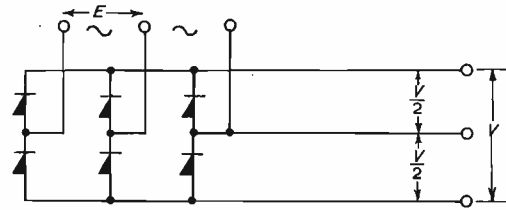
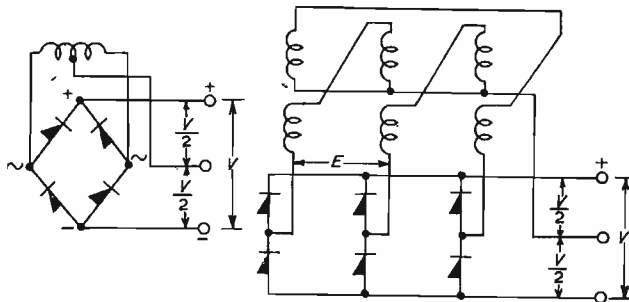

Fig. 6. Emergency method of obtaining half-voltage from three-phase bridge rectifier when supply neutral is not obtainable

Three-wire Outputs and Centre-tapped Rectifiers

Sometimes a three-wire output is desired, such as for a telegraph system, and the two circuits of Fig. 5 show the conventional ways of achieving this for single-phase and three-phase rectifiers respectively.

In the single-phase circuit the full voltage (V) and the "half" voltages both contain 48 per cent of R.M.S. ripple mainly at twice supply frequency. There is no D.C. saturation of the transformer even when only one half of the output is loaded.

In the three-phase centre-tap circuit the full voltage across the outers contains 4.3 per cent R.M.S. ripple mainly at 6 times the supply frequency but the "half voltages" each contain 18 per cent R.M.S. ripple mainly at 3 times the supply frequency. When one half of the output only is loaded, there is a direct current in each of the three-phase lines and it is wise to make the transformer secondary an inter-connected-star winding to prevent saturation of the core by the D.C. component.

None of the circuits containing capacitors, such as the voltage-doubler, can be safely centre-tapped as A.C. may flow through the load via the capacitor and the centre tap departs seriously from the mid-voltage value when only one "half" of the output is loaded.

There is one further way of obtaining a half-voltage from a three-phase bridge rectifier which is shown in Fig. 6. In effect the reverse voltage across one arm of the rectifier is used to supply the load while the load current flows through the other two pairs of rectifier arms.

The ripple voltage is rather high approximately 75 per cent of mean D.C. voltage mainly at supply frequency but the connexion is of use in special cases where no neutral is available and the high percentage ripple is not a serious disadvantage.

Applications

The normal single-phase voltage-doubler circuit is extensively used for radio receiver H.T. supply, and for cable testers and electrostatic precipitators, frequently at 100kV or more with currents of many milliamperes.

The suggested bridge-doubler circuits offer a convenient way of improving regulation and reducing ripple voltage so that cost should often be less than that involved in the more conventional way of increasing capacitor size and/or smoothing.

The single-phase centre-tap circuit (Fig. 5(a)) is often called the "telegraph" circuit and is extensively used as a power supply for three-wire "keyed" telegraph circuits, the commonest nominal voltages being 50 + 50, 80 + 80 and 130 + 130 with loadings up to many amperes.

Both the single- and three-phase centre-tap circuits (Figs. 5(a) and 5(b)) are frequently used for industrial and laboratory power supplies mainly for test purposes at 6 + 6 or 12 + 12 volts and, especially in the case of the three-phase circuit, up to 100 amperes or more.

The circuit of Fig. 6 is merely a curiosity and in all normal cases Fig. 5(b) would be preferred if at all possible.

A Linear Transducer for the Electrical Measurement of Displacement

By M. J. Tucker*, B.Sc.

A simple displacement pick-up is described which works on the principle of a transformer with variable coupling. Over a range of 1cm it is accurate to 0.005cm on a linear scale and gives sufficient output to work a pen recorder without amplification. Outputs up to 1W may be obtained if small errors can be tolerated. Mechanical forces on the moving parts are small.

NUMEROUS transducers for the electrical measurement of displacement have been described. The majority use one of three basic principles: the capacitance of a capacitor may be varied by moving one of its plates relative to the other; the inductance of a coil may be varied by moving a piece of magnetic material; the resistance of a conductor may be varied either by moving a contact along it or by stretching it. Woodcock¹ has given a survey of instruments using these principles, with the exception of the resistance strain gauge. An interesting recent development is the RCA 5734 mechano-electronic transducer in which the current through a triode is varied by moving its anode.

A type of transducer that appears to have been little used is that in which the coupling between two coils is varied by moving one of them relative to the other. The device described below uses this principle and has several desirable features not found together in other types of transducers. In spite of delivering comparatively large power outputs, the forces on the moving parts are small. It is linear over its working range and is stable, so that it is capable of great accuracy. Finally, the device is the acme of simplicity and is cheap and easy to make.

Principle of Operation

The principle of operation is shown in Fig. 1. The primary coil, supplied with A.C., produces an alternating field. The voltage induced in the secondary (or pick-up) coil is proportional to the number of lines threading it and this varies according to its vertical position.

The limbs of the core are good magnetic conductors, and hence the magneto-motive force (or M.M.F.—the magnetic equivalent of an E.M.F.) corresponding to the number of ampere-turns in the coil appears across all parts of the gap. Thus, in positions well inside the gap where the effect of the ends of the limbs is small, the field is uniform and the number of lines of force threaded by

the pick-up coil changes uniformly with displacement. The effect of the ends of the limbs falls off rapidly inside the gap.

The primary coil produces some leakage field which does not pass through the core, and this causes an extra increase in the voltage induced in the pick-up coil when it is very close to the primary. However, this field is small and falls off rapidly above the primary coil so that the errors produced are only just measurable, and there is a considerable range over which a linear characteristic can be produced.

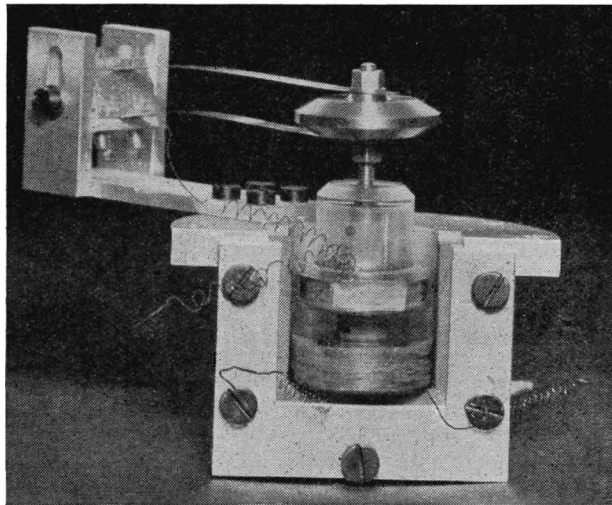

An accelerometer incorporating a transducer of the type described in the article, but with 1 inch square stampings.

[Actual size]

Constructional Details

Fig. 2 gives details of the coil formers and modified stampings.

The core is made of 23 laminations cut from Permalloy B gate stampings, I.S.C. Tech. C. No. 410 of 0.015 inch thickness. These may be cemented together with liquid "Araldite" cement slightly thinned with acetone, or alternatively the centre limb may be riveted and the outer limbs held in a clamp. The resulting core is slightly less than $\frac{1}{8}$ inch thick. Though stallo should have a sufficiently high permeability for the core, Permalloy B was used to give a good

margin of safety. E type stampings could be used, but it is important to have stampings with limbs which are long compared with the distance between them in order to achieve the greatest linear working range.

The coil formers are made from Perspex because this is easy to work and to cement. The primary coil, wound with 1800 turns of 36 s.w.g. "Lewmex" wire, has a D.C. resistance of 57 ohms, an inductance of 0.63 henrys and a Q at 250c/s of about 10 (with no load on the pick-up coil). The pick-up coil is wound with 775 turns of 40 s.w.g. "Lewmex" wire and has a D.C. resistance of 70 ohms. This pick-up coil was designed for use with the detector circuit shown in Fig. 3, but the specification can easily be modified to suit any particular requirement.

Since this article was written a transducer of this type has been made using stampings I.S.C. Tech. C. No. 521 of 0.004 inch thickness, which are 1 inch square and require

* National Institute of Oceanography.

no modification. This transducer is roughly a half-scale reproduction of that described in this article, and has half the working range and a smaller power output (0.5W at 1000 c/s). These stampings appear to be difficult to obtain at present, however.

Performance

The particular purpose for which this pick-up was designed limited the supply frequency to 250c/s, though a higher frequency would be better for the pick-up itself (see below). All the testing has therefore been carried out at 250c/s apart from a few tests to discover the effect of changing the supply frequency.

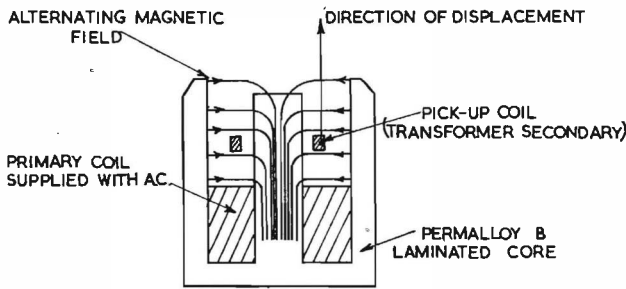

Fig. 1. The Principle of Operation. The voltage induced in the pick-up coil varies with its displacement

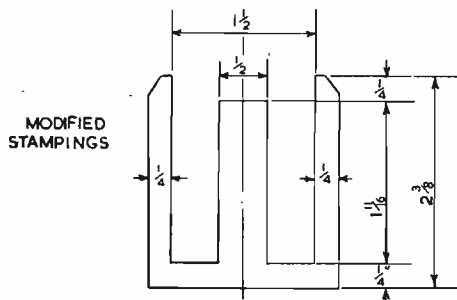
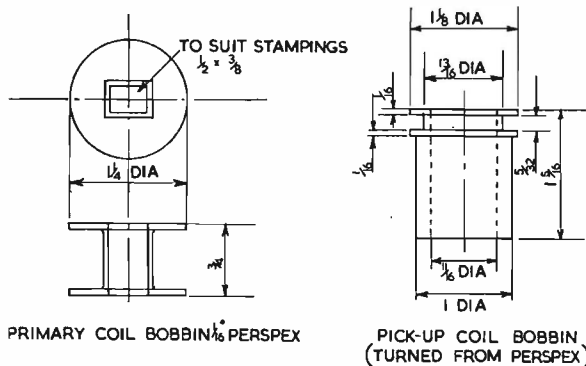

Fig. 2. Dimensions of the Component parts of the Pick-up

Calibration curves are given in Fig. 4. The relation between output and displacement is linear within the accuracy of measurement (equivalent to about 0.005cm) over the 1cm range marked. The departure from linearity is equivalent to less than 0.01cm over the 1.4cm range from 1.0cm to 2.4cm.

Before taking each reading the supply was adjusted to exactly 100 volts, so that the tests apply to a power supply of very low impedance. The degree of regulation required in practice depends on the amount of power being taken from the pick-up coil. If no power is being taken, the impedance of the supply is immaterial; if the rectifier circuit shown in Fig. 3 is used, the output impedance of the supply must be less than 100 ohms. A suitable source of power would be an oscillator with a

cathode-follower output stage connected directly to the primary coil, as owing to the large air-gap there is no fear of saturating the core with the D.C. field. The primary coil must be tuned to the oscillator frequency by means of capacitor connected in parallel. Apart from the effect of variations in load, it is, of course, necessary to stabilize the supply voltage against mains changes to within the order of accuracy required of the pick-up.

Using the rectifier circuit shown in Fig. 3 the output over the working range varies from 1.3mA to 2.7mA, so that there is a considerable unwanted output that can be backed off. If the output is connected to a graphic recorder it is usually possible to offset the mechanical zero sufficiently to make the working range of output current correspond to a reasonable range on the chart. Alternatively, the electrical backing-off circuit shown inside the dotted lines in Fig. 3 brings the zero output position to about the beginning of the working range, and has the advantage over mechanical backing-off of reducing the effect of fluctuations in supply voltage. This electrical backing-off circuit will reduce the slope of the calibration curve slightly owing to its shunting effect on the meter.

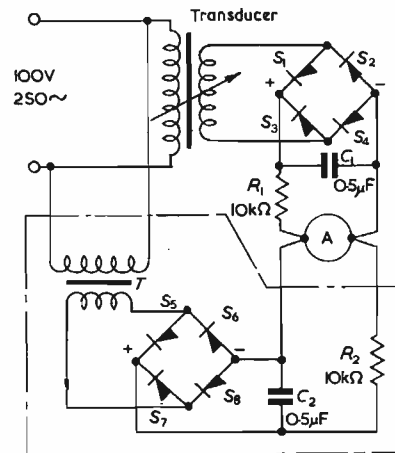

Fig. 3. Rectifier circuit. The circuit inside the dotted line is for backing-off the unwanted output and was disconnected when the calibration curves in Fig. 4 were measured

- S₁₋₈ Sentercel rectifiers type V10/4T
- T Wearite transformer type 208

The output impedance of the device is about 100 ohms at 250c/s and is largely resistive at this frequency, so that the greatest power can be obtained by using a load of 100 ohms. However, this is not advisable for two reasons. Firstly, the output impedance varies from about 100 to 110 ohms over the working range so that the current flowing is not proportional to the intrinsic voltage. Secondly, with this load, up to 1 watt is dissipated in the pick-up coil and this raises its temperature sufficiently to cause a considerable increase in resistance, an effect that is difficult to allow for. If a load resistance of 400 ohms is used, errors due to these causes should not be more than about ±0.015cm (assuming the power supply to have an output impedance of less than 100 ohms—see above) and outputs of up to 1 watt can still be obtained.

The reaction forces on the pick-up coil were measured with the centre of the coil 1.5cm below the tops of the outer limbs of the core. With the output on open circuit of Fig. 3 the force was less than 1 milligram. With the detector circuit of Fig. 3 the force was an attraction of about 30 milligrams, but with C₁ removed the force dropped to about 4 milligrams. With a 400 ohm load there was a repulsion of about 0.45 grams and with a 100 ohm load there was a repulsion of about 2.8 grams. Theoretically a pure resistive load should produce no reaction forces on the coil, but in practice, with low impedance loads the self inductance of the coil causes a repulsive force to

be produced. It is not possible to neutralize this inductance with a capacitance as it varies with the displacement of the coil. With high impedance loads the effect of stray capacitances tends to predominate and small attractive forces are produced.

Supply Frequency

The power efficiency of the device rises as the supply frequency is increased because an increase in the inductive impedance of the primary winding causes the magnetizing current, and hence the copper losses, to decrease. For example, to maintain 100 volts across the primary coil would require about 14 watts at 50c/s (for continuous running not more than 30 volts may be applied at this frequency) whereas 1 watt is required at 250c/s and 0.14 watts at 2000c/s. To offset the decrease in energizing power to some extent the output impedance also rises. Whereas the D.C. resistance of the pick-up coil is 70 ohms, the output impedance is 105 ohms at 250c/s and about 400 ohms at 2000c/s. At 2000c/s the output impedance is largely inductive and varies between 370 and 430 ohms, so that the minimum load resistance for

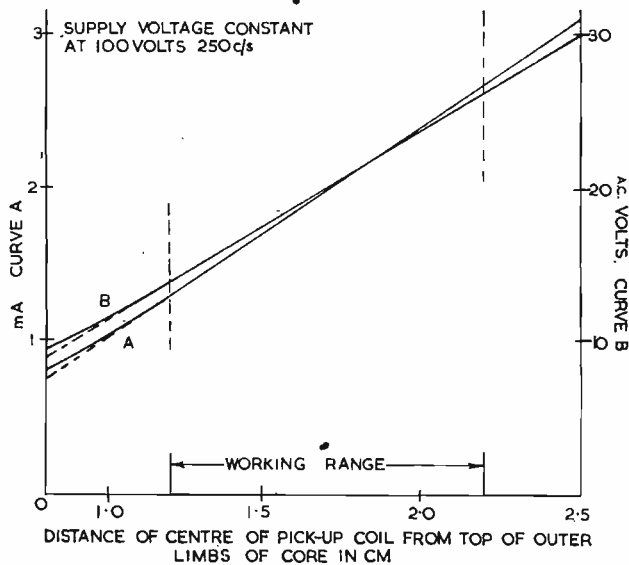

Fig. 4. Calibration curves

Curve A: Current measured with circuit of Fig. 3 with no backing-off (i.e. circuit in dotted line disconnected)

Curve B: A.C. output volts measured with a model H.R.M. Avometer

0.015cm accuracy is about 1500 ohms compared with 400 ohms at 250c/s. The power efficiency at 2000c/s is therefore only about twice that at 250c/s and for most purposes a frequency of between 500 and 1000c/s is probably best.

To avoid the use of a special oscillator it may sometimes be convenient to operate the device from the 6.3 volt 50c/s valve heater supply. A primary coil consisting of 350 turns of 26 s.w.g. "Lewmex" wire would be suitable for this purpose.

To Measure Small Displacements

In order to measure small displacements it is necessary to back-off the steady signal and bring the position of zero output into the working range required. The backing-off circuit shown in Fig. 3 may be used, but the exact balance point then depends to some extent on the characteristics of the rectifiers and on the values of the resistances involved, so that some zero drift would be expected.

A better backing-off system for this purpose is shown in Fig. 5. The unwanted output is balanced as A.C. by

means of a third small fixed coil placed over the centre limb just above the primary and connected in series-opposition to the pick-up coil, a coil of about 350 turns being suitable for use with the pick-up coil specified above. As the position of balance in this system is dependent only on relative mechanical positions the zero drift can be reduced to very small proportions, but it is important to avoid the use of plastics wherever possible as they have large coefficients of thermal expansion. In an instrument using a transducer of this type to measure the displacement of a metal bellows, the zero drift during warming up was equivalent to less than 10^{-4} cm and subsequent displacements could be measured with an accuracy of about 2×10^{-6} cm. In the position of minimum output there is a small residual 90° out-of-phase voltage which is balanced by producing an equal and opposite voltage across a capacitor, leaving only a very small signal consisting of harmonics.

The A.C. output from the transducer may be transformed up and amplified. If the amplifier is tuned to the fundamental frequency, the output at the balance point is negligible and a simple rectifier may be used, it being necessary, of course, to work only on the linear part of the rectifier characteristic. A better but slightly more complicated system is to use a phase-sensitive rectifier² which will enable both positive and negative outputs to be

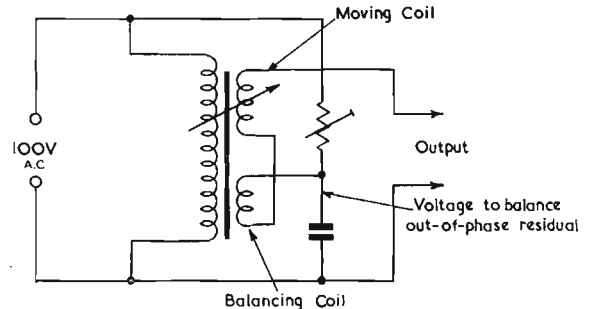

Fig. 5. Arrangement to give a balanced output, allowing the use of amplification to increase the sensitivity

obtained and which may be used with an untuned amplifier.

REFERENCES

1. WOODCOCK, F. J. Some Electrical Methods of Measuring Mechanical Quantities. *Proc. I.E.E.* 97, Pt. I, 136 (1950).
2. TUCKER, M. J. A High Voltage Ring Modulator. *Electronic Engg.* 21, 239 (1949).

VERY - HIGH - FREQUENCY TRANSISTORS*

The Radio Corporation of America announce that several developmental point-contact transistors have been made to oscillate at frequencies well up in the 100-to-200 Mc/s band and one reached a record-high frequency of 225Mc/s. The highest frequency value previously achieved by transistors, according to published reports, has been 50Mc/s.

The transistor, still in the development stage, consists of a speck of germanium crystal and fine contact wires and is no greater in size than a kernel of corn.

Prior to recent R.C.A. experiments, transistors have been regarded as limited to relatively low-frequency applications. The new development promises to extend the use of transistors in high-frequency devices and to new applications in television, F.M. radio, point-to-point radio communication and other electronic equipment for military and civilian use.

* A communication from RCA.

A Timing Circuit

for Controlling Related High Energy Pulses

By K. S. W. Champion,* Ph.D., A.Inst.P., and N. L. Allen,* Ph.D.

As part of a technique for the investigation of high energy gas discharges, an electronic timing circuit has been devised to control the operation of a group of heavier pulse circuits. This device should have wide application in problems where precise control of the sequence of operation of several high energy pulse circuits is required.

Principle of the Timing Circuit

THE circuit described produces sets of three high-voltage triggering pulses with adjustable time separations. The sets of pulses can be obtained either singly or with a definite repetition frequency. The time intervals between the three pulses forming a set can be varied between approximately zero and a maximum overall interval of 3.5msec. The groups of pulses are synchronized to occur at any desired phase of the mains cycle.

The block diagram of the circuit is given in Fig. 1.

valve of the Eccles-Jordan circuit. The particular form of Eccles-Jordan circuit used in this application is shown in Fig. 2. The usual by-pass capacitor between the grid of V_7 and the anode of V_8 (Cf. the circuit of the Loran System¹) had to be omitted for satisfactory operation. This appears to be connected with the low repetition frequency of the trigger pulses. A trigger pulse synchronized to the mains voltage is obtained by differentiating the return transition of this circuit due to the mains pulse after it has received a pulse from the timing circuit.

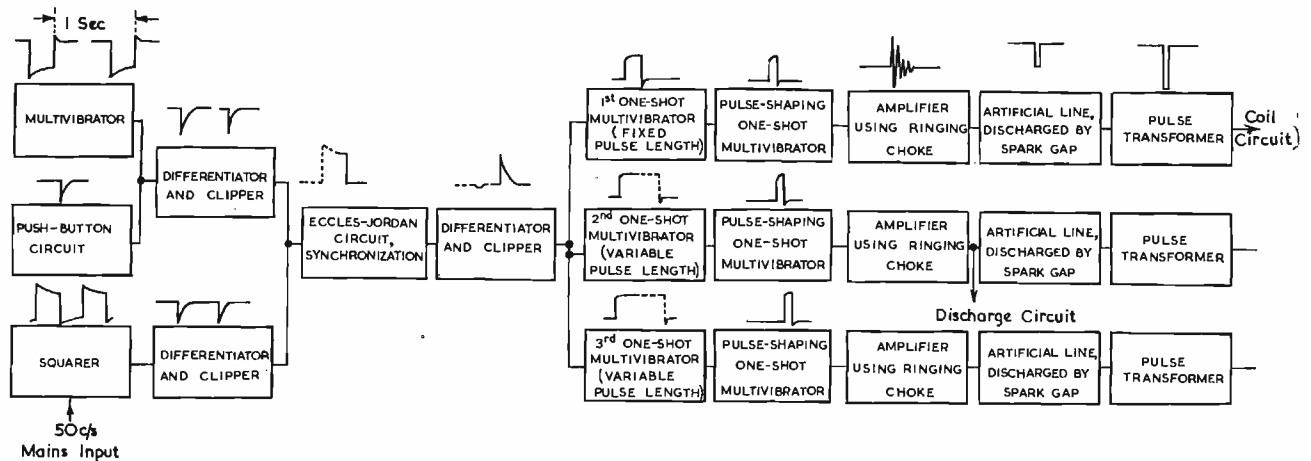

Fig. 1. Block diagram of the timing circuit

The repetition frequency can be controlled either by a multivibrator with a period of approximately one second or by a push-button circuit which produces individual pulses. The low repetition frequency was chosen because of the very large quantities of energy dissipated in the pulses being investigated. An Eccles-Jordan circuit ("flip-flop") is used to achieve the synchronization and one-shot multivibrators of variable pulse length produce the time delays between the three pulses forming a set. The remainder of the circuit is used to form these into high voltage, short duration trigger pulses suitable for triggering ignitrons.

Circuit Details

The detailed timing circuit is shown in Figs. 2 and 3. The output from the multivibrator is connected in parallel with the push-button circuit and the pulses are differentiated. The unwanted positive pulses are removed by clipping and the negative pulses fed to the grid of V_7 , which forms part of the Eccles-Jordan circuit.

Similarly, pulses at 20msec intervals are obtained from the 50c/s mains supply by squaring, differentiating and clipping. These pulses are fed to the grid of V_8 , the other

The phase of the mains at which the pulse occurs can be adjusted by varying the relative impedances of the resistance and capacitance by which the alternating voltage is applied to the grid of V_4 .

The synchronized trigger pulse is applied to a buffer amplifier whose output is used to trigger two multivibrators, each with only one position of stable equilibrium (and hence called "one shot" circuits). The pulse length of one of these is fixed but that of the other is variable. A third one-shot is connected to the common trigger pulse circuit by means of another buffer amplifier. This buffer amplifier is necessary to prevent the trigger pulses locking when the time separation is small. The pulse length of the third one-shot is also variable and extends the range covered by that of the second.

It was found that considerable care was required with the wiring and adjustment to enable small time delays (of the order of microseconds) to be obtained without the pulses locking. However, if a buffer amplifier had been used before each one-shot (instead of the first and second one-shots sharing an amplifier) the adjustment would not have been so critical.

The trailing edges of the one-shot pulses, after differentiation, provide the required set of pulses with adjustable time separations. The circuits for the three pulses after

* The University of Birmingham.

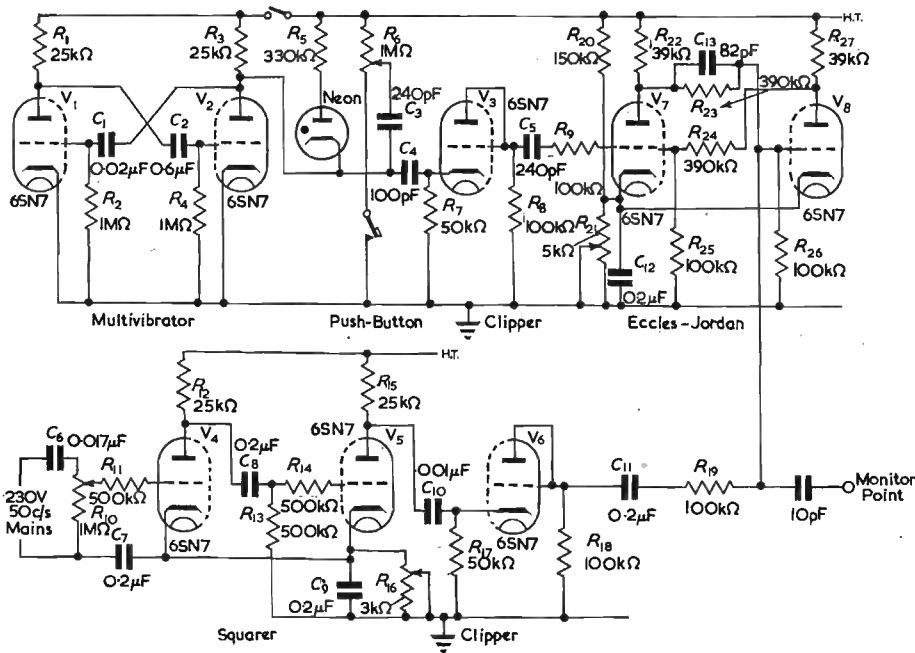
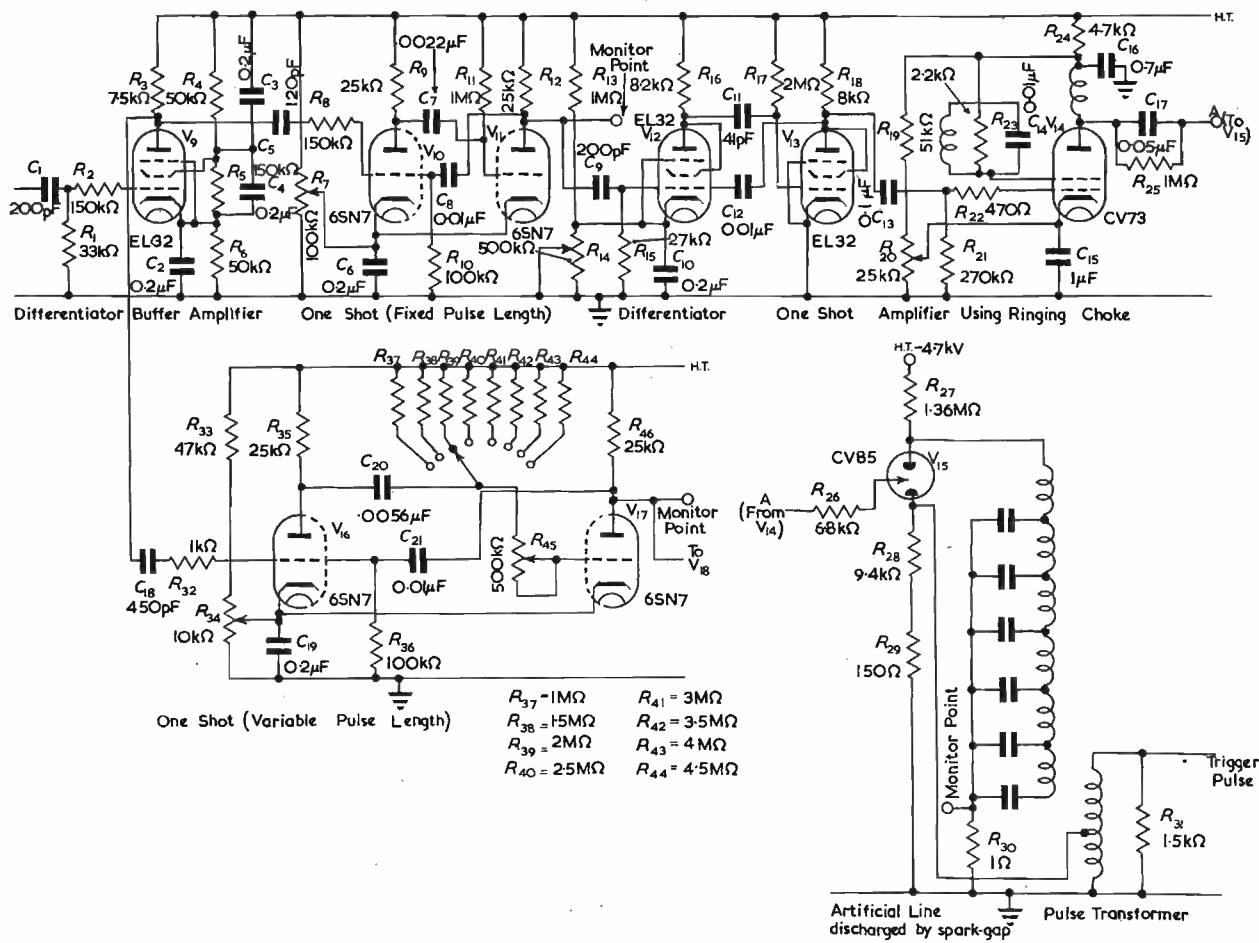

Fig. 2. The timing circuit—section 1

Fig. 3. The timing circuit—section 2
The circuit of V₁₈ to V₂₁ is identical to that of V₁₂ to V₁₅



this stage are identical and so only one will be described. The next stage is another one-shot circuit, of fixed pulse length, to produce a suitably shaped pulse of sufficient magnitude to operate the succeeding stage. The final stages are adapted from part of the circuit of a Service Type 64 modulator. The pulse from the one-shot (approximately 100 volts amplitude) is applied to an amplifier using a ringing choke, whose output is a heavily damped oscillation at 400kc/s, with a maximum amplitude of approximately 3kV. The tuned screen circuit, at a frequency of 25kc/s, assists the production of the high-voltage pulse at the anode. The anode coil has to be well decoupled from the power supply by the resistance-capacitance filter. Otherwise, pulses from this stage reach the first stage and set off further, unwanted, trains of pulses.

The output from V_{14} triggers the pressurized spark-gap V_{15} which discharges an artificial line having a time-constant one microsecond. The discharge current passes through the auto pulse transformer which produces a trigger pulse of amplitude 9kV. This pulse is quite adequate to trigger an ignitron. If a thyratron is to be triggered the output of V_{13} can be used unless the thyratron grid rises to a high potential when the tube fires. In this case a circuit to protect the timing circuit is required and this greatly reduces the effective value of the trigger pulse. Thus, either the output of V_{14} or of the pulse transformer will be required.

Circuit Monitoring

There are three principal monitor points. The first of these is connected to the grid of V_8 via a 10pF capacitor. This point enables the operation of the repetition timing multivibrator, push-button circuit and synchronization to be checked. The 10pF capacitor is necessary to prevent the oscilloscope loading the circuit too heavily and causing the Eccles-Jordan circuit to cease functioning.

The second monitor terminal is connected via a selector switch to the output of the two variable and one fixed pulse-length one-shot circuits. It can thus be used for verifying the operation of the time delays. In addition, these pulses, one positive (corresponding to the beginning of the one-shot pulses) and three negative (one at a fixed

interval of time and the other two at variable intervals) can be used to trigger the single sweep time-base of an oscilloscope on which the pulses of the experiment are displayed. The advantage of the choice of four pulses for triggering the oscilloscope time-base is that by their use any small part of each experimental pulse can be readily brought on to the screen and investigated in detail. With only one trigger pulse it would only be possible to use a relatively slow time-base which permitted the whole pulse to be displayed on the screen, unless additional variable time delay circuits were used.

The final monitor point shows the current pulse flowing through V_{15} (or the other two corresponding valves) and enables the operation of this part of the circuit to be checked.

This timing circuit was designed to control the operation of pulsed magnetic fields produced from capacitor energy storage, as described elsewhere by Champion². The first pulse of the sequence is used to trigger the ignitron which initiates the magnetic field pulse and the succeeding pulses trigger associated equipment. For example, the pulsed magnetic field may be used in cloud-chamber investigations or, as in the present case, in investigations of gas discharges. In the latter case the second trigger pulse initiates the discharge pulse and the third trigger pulse controls equipment used for observations. By means of the variable time delays the relative phases of the pulses can be adjusted at will.

An advantage of the synchronization with the mains is that the magnetic field pulse occurs during the half cycle of the mains in which the capacitor forming the power supply for the field is not being charged, thus avoiding generation of X-rays in the rectifier. Synchronization also eliminates jitter due to ripple from the mains.

Acknowledgment

The authors wish to acknowledge advice given in the above work by Professor J. Sayers.

REFERENCES

- (1) War Report. The Loran System. *Electronics*, p. 110 (Dec., 1945).
- (2) CHAMPION, K. S. W. The Production of Pulsed Magnetic Fields. *Proc. Phys. Soc.* 63B, 795 (1950).

Improved "Bread-board" Construction

An improved method of Bread-board construction has been developed at Metropolitan-Vickers Electrical Co., Ltd., Manchester, for use in their Radar Development Laboratories. The Bread-boards are made from electro-tinned perforated steel sheets, in three sizes which have the

The special tool used for making holes of the required size.

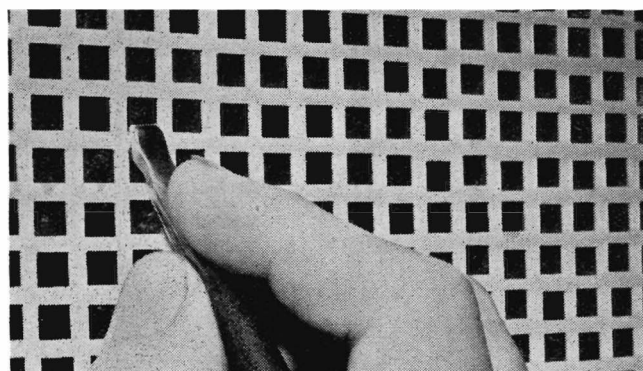

following advantages. Holes of required size can be made quickly and easily, using a special tool. Components, tag-strips, valveholders, etc., can be soldered directly to the chassis. A large part of the wiring can be run on the underside of the chassis, making components more accessible.

With a suitable framework a rack assembly can be built up rapidly. This takes up a comparatively small space, and component changes are easily carried out.

A close-up view of a chassis, illustrating the method of construction

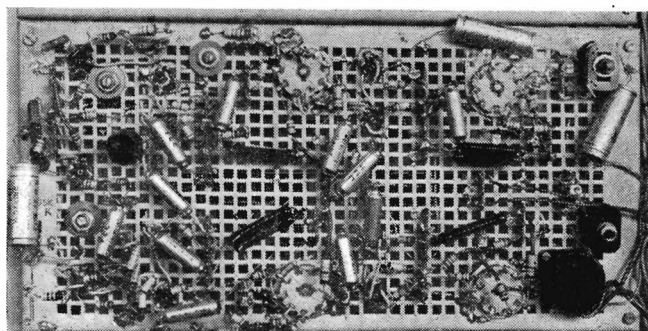

The Resolution of Complex Quantities

By N. H. Crowhurst, A.M.I.E.E.

IN all branches of electronic and electrical engineering, calculations involving the resolution of complex quantities occur. As one example, in the analysis of transformer iron losses, and their subsequent prediction¹, repeated summation of hysteresis and eddy current components of magnetizing current at different frequencies is required. This summation can be made in terms of current components at a given applied voltage to a specific winding; or it may be desirable to treat the losses as components of shunt impedance or admittance.

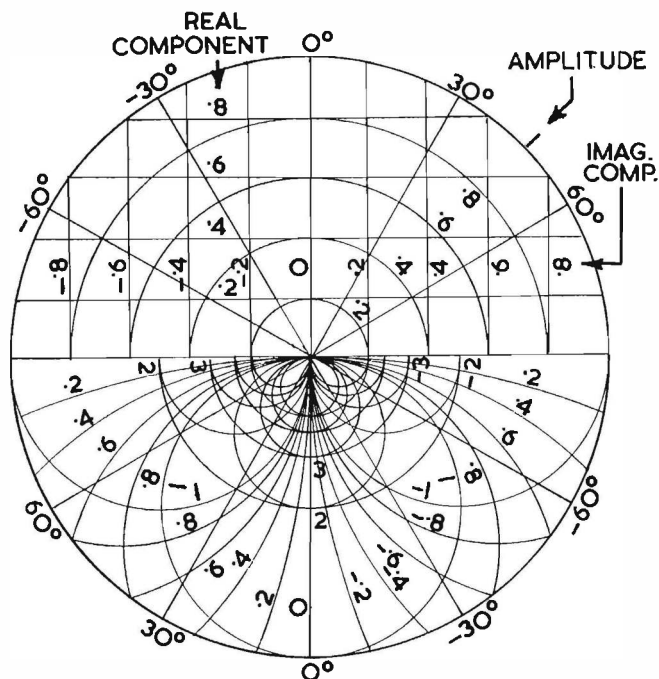

Fig. 1. Simplest form of chart for resolving complex quantities.

Design of Chart

A chart for assisting these calculations can be made in a variety of forms. The most obvious, forming the top half of Fig. 1, is a sort of vector diagram scale, using rectangular co-ordinates for real and imaginary components, and polar co-ordinates for amplitude and phase of the resultant. Linear scales are used, which fact restricts the effective range presentable on one chart. The lower half of Fig. 1 partially overcomes this restriction. The polar co-ordinates again represent amplitude and phase, but amplitude is presented to a reciprocal scale, so the lower half covers values between unity and infinity, while the upper half covers amplitude values between zero and unity. The scales for real and imaginary components on the lower half are no longer rectangular, but take the form of circular rulings, passing through the origin, which in this half represents infinity; those for the real components are centred on the vertical axis, and those for the imaginary components on the horizontal axis.

The disadvantage of this form of presentation, apart from the decrease in accuracy at values either large or

small compared to unity, is the discontinuity occurring at unity amplitude value, where transfer is made from one point on the circumference of the chart to another diametrically opposite. This discontinuity at unity value is overcome by the alternative polar presentation shown at Fig. 2, based on variables different from those for which scales are actually presented. The polar co-ordinates can be regarded as the amplitude and phase of voltage and current along a loss-free transmission line, when the derived scales represent the reflected impedance at any point, in either magnitude and phase, or real and imaginary components². Such scales can be used for resolving other complex quantities not so derived. The scales derived are shown at Fig. 2. Phase rulings are arcs centred on the horizontal centre line, and passing through the infinity and zero points at top and bottom, the boundary circle representing 90°, and the vertical centre line 0°. The real and imaginary component rulings are circles passing through the infinity point, the real component circles centred on the vertical axis, while the arcs for imaginary values are centred on a horizontal axis through the infinity point (tangential to the boundary circle at that point).

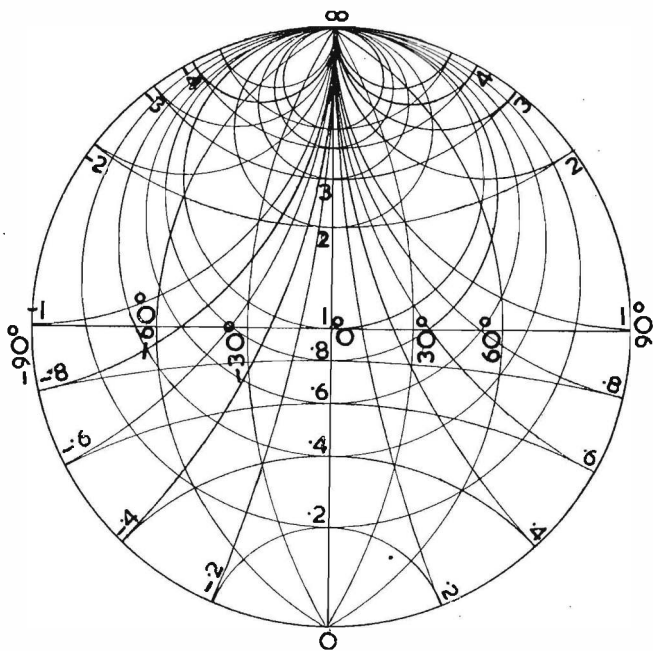

Fig. 2. This derived form avoids the discontinuity of Fig. 1.

But still the useful range of the scales is limited: impedances from zero to infinity are presented, but the scales can only give precision indication of value in the proximity of unity. A chart of the abac variety can be constructed, but each presentation is only useful for a limited range of both amplitude and phase³. For most purposes logarithmic scales are ideal, and the chart here presented uses them. Geometrically it may be regarded as a derivation from Fig. 2: if the right-hand half has its right-hand boundary straightened up, allowing the amplitude rulings to become straight and horizontal, and the other scales adjusted to preserve the correct relationship, the zero and infinity points move to infinity in opposite directions, and the scale becomes logarithmic. The phase scale becomes a linear function of angle. The real and imaginary component rulings take up a log cosine (or log sine) curve.

Use of Chart

The chart has been provided with arbitrary scales for amplitude, covering a range of 10³. The scales marked A are intended for the majority of calculations, such as

COSINE COMPONENT

SINE COMPONENT

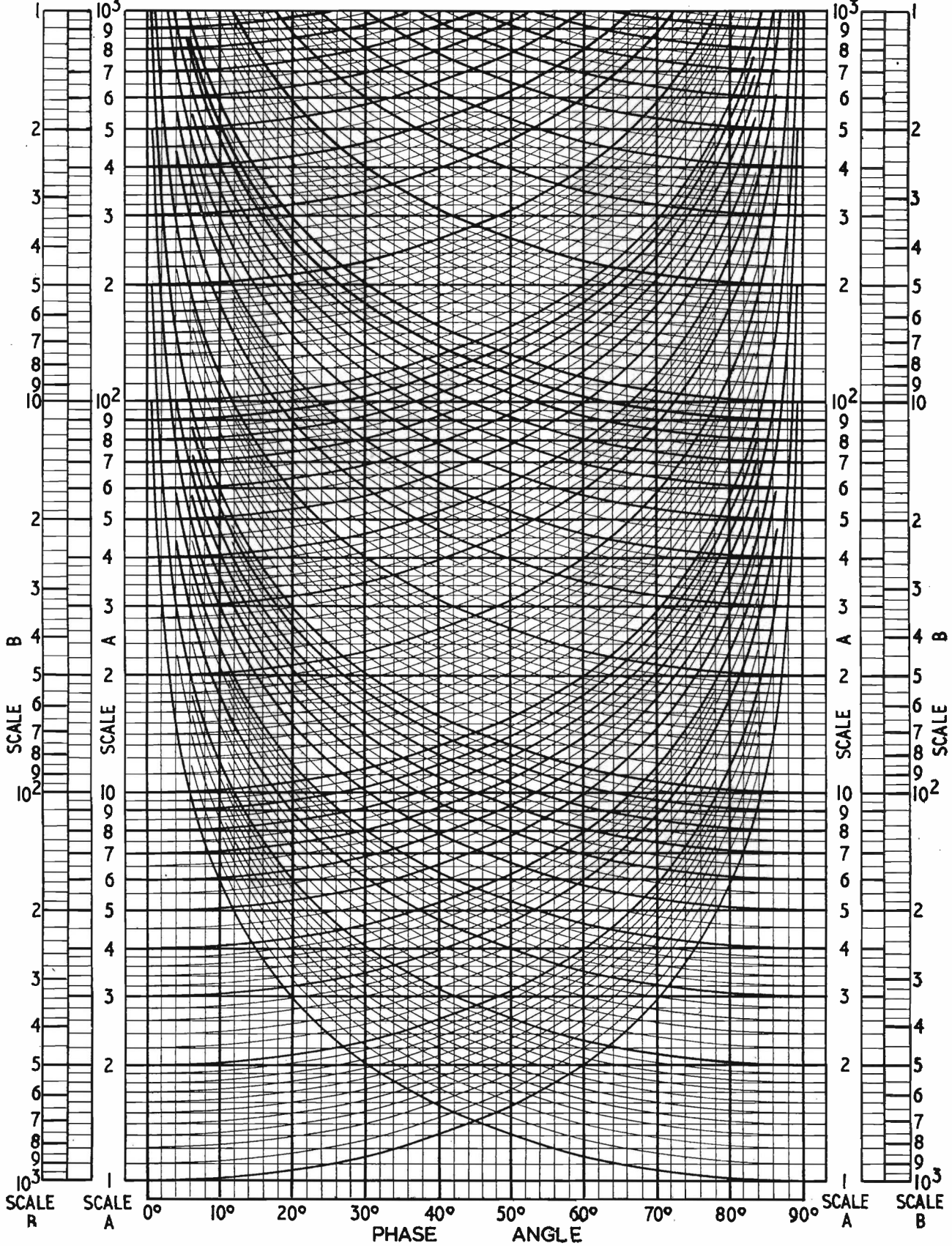

Chart for the resolution of complex quantities

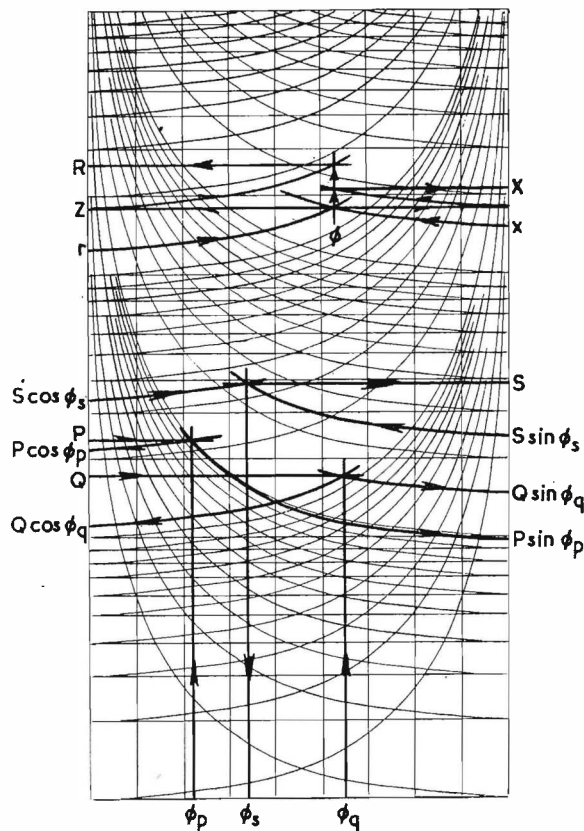
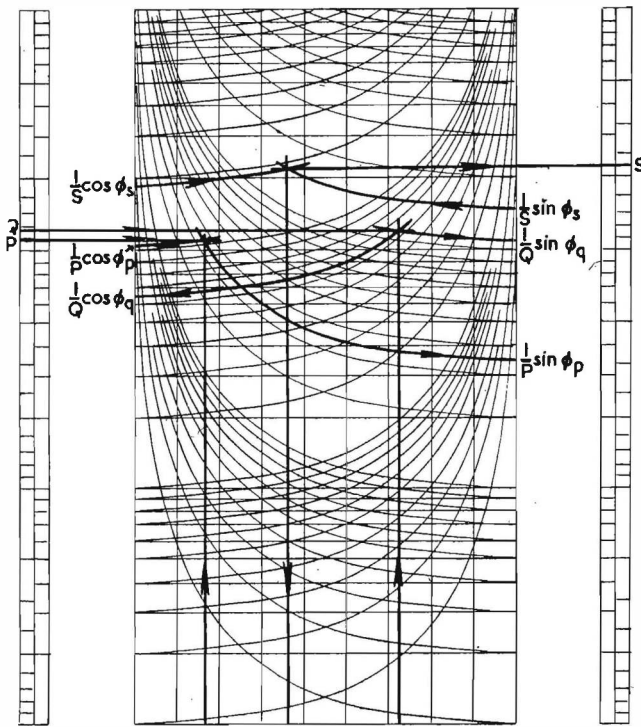

Fig. 3. Illustrating methods of using Chart, A Scales, for finding the sum of two complex quantities, and for equivalent parallel and series combinations.

Fig. 4. Method of using chart, B scales, for finding effective impedance of two impedances in parallel, or admittance of two admittances in series.



$$\frac{1}{S} \cos \phi_s = \frac{1}{P} \cos \phi_p + \frac{1}{Q} \cos \phi_q ; \frac{1}{S} \sin \phi_s = \frac{1}{P} \sin \phi_p + \frac{1}{Q} \sin \phi_q$$

voltages in series, currents in parallel, impedances in series, or admittances in parallel; but sometimes it is desirable to add vectorially impedances in parallel (admittances in series would require the same method), so the scales marked B are provided to facilitate this. Fig. 3 shows use of A scales only, and Fig. 4 the use of the B scales as well. The following examples will illustrate application.

Example 1

A mumetal cored transformer is computed to have a component of magnetizing current due to eddy currents of 0.31mA at 22°, when 10V is applied to one winding. The hysteresis component at the same voltage, is computed to be: 0.7mA, 50.3° at 50c/s; 0.34mA, 56° at 100c/s; 0.2mA, 64.5° at 200c/s; and 0.095mA, 72° at 500c/s.

Using the chart on the eddy current component, the cosine component is given as 0.29mA, and the sine component as 0.115mA. From here the results can be tabulated, using the chart, as follows:

FREQUENCY		50 c/s	100 c/s	200 c/s	500 c/s
Given hysteresis components	Magnitude (mA)	0.7	0.34	0.2	0.095
	Phase-angle	50.3°	56°	64.5°	72°
From chart this resolves to	Cosine comp.	0.45	0.19	0.086	0.029
	Sine comp.	0.53	0.28	0.18	0.09
Adding in the eddy comp. gives a total of	Cosine comp.	0.74	0.48	0.376	0.319
	Sine comp.	0.645	0.395	0.295	0.205
Using the chart again gives	Magnitude (mA)	0.98	0.625	0.48	0.38
	Phase-angle	40.8°	39°	38.5°	33°
Using the B scales to give results as impedances	Z _{hyst} (kΩ)	14.2	29.5	50	105
	Z _{total} (kΩ)	10.2	16	20.8	26.5

The impedance due to eddy currents is 32kΩ. The phase-angles are the same as those given for corresponding currents. In this case the reciprocal B scales have been used to convert calculated values to impedances. If the values to be added vectorially were given initially in the form of impedances in parallel, then the B scales would be used first and last for reciprocal conversion, as illustrated at Fig. 4.

Example 2

Another application of the chart is shown in the top part of Fig. 3. This is the conversion of series components into equivalent shunt components, or *vice versa*. Suppose the inductance of a gapped choke at a certain frequency is found to be equivalent to a resistance of 250Ω in series with a reactance of 1.5kΩ. Using the method shown in Fig. 3, this is equivalent to a parallel combination of 1.55kΩ reactance and 9kΩ resistance. It may be that the measured value of equivalent series resistance is 400Ω, of which the winding D.C. resistance is known to be 150 ohms, in which case the equivalent shunt loss is given as 9kΩ by this calculation; but the equivalent parallel combination, including the effect of winding resistance, would be, using 400Ω for series resistance, 6kΩ.

If the parallel combination is known, and the equivalent series combination is required, the simplest method is to use the B scales in the same way. The foregoing example can be used as a check, working backwards.

REFERENCES

1. CROWHURST, N. H. Transformer Iron Losses. *Electronic Engg.* 23, 396 (1951).
2. WESTCOTT, C. H. Standing Waves and Impedance Circle Diagrams. *Wireless Engineer.* 26, 230 (1949).
3. RYBNER, J. Nomograms of Complex Hyperbolic Functions. (*Jul. Gjellerups Forlag, Copenhagen, 1947*).

Notes from the Industry

Full-time Three-year Courses for Radio Technicians have been organized by the Ministry of Education and will start in September of this year at five centres in London, the Midlands and the North. These courses have been devised to meet the need for technicians who can, on completion of the course, take their places as assistants to qualified research and development engineers.

The entry age will be 16 or 17 years. In the session beginning in September, courses will be held at: Northern Polytechnic, Holloway Road, London; Norwood Technical College, Knight's Hill, West Norwood, London, S.E.27; E.M.I. Institutes, Ltd., 45 Pembridge Square, London; Coventry Technical College, The Butts, Coventry, and Bolton Technical College, Manchester Road, Bolton, Lancs.

While the appropriate examinations of the City and Guilds of London Institute and of the British Institution of Radio Engineers will be taken during the course at all centres, the syllabus, it is stated, will be wider in scope than is required by these bodies and will reflect to some extent the needs of the region. Special attention is to be paid to industrial electronic applications. In most cases successful completion of the course will carry a college diploma.

The courses have the support of the Radio Industry Council, and the various local education authorities concerned may find it possible to offer grants-in-aid in special cases.

Details of the courses are obtainable from the principals of the colleges concerned.

A Technical Training Display is being organized by the Technical Training Committee of the R.I.C. at the Radio Show this year. Its object is to support the various training schemes which have been established to overcome the shortage of technical personnel in the industry.

Demonstrations will be given by the following organizations: Imperial College of Science and Technology, L.C.C. Norwood Technical College, Northampton Polytechnic Institute, E.M.I. Institutes and Marconi College.

A film projector and an information bureau are also included on the stand. A leaflet on careers in the industry has been prepared by the R.I.C. for the occasion.

The Television Society's Transmitter. The Television Society have obtained a Post Office license to transmit television signals under the call sign G3CTS/T, and a transmitter to operate on the sound frequency of 423.5Mc/s and vision frequency of 427Mc/s has been designed. No site for the transmitter is yet available, but the Society has issued its specification in the hope that any other bodies intending to transmit similar television signals in the London area will choose a frequency which will not cause mutual interference.

New Chairman for B.S.I. It was recently announced that the General Council of the British Standards Institution had elected Mr. John Ryan, C.B.E., M.C., as its Chairman to succeed Sir Roger Duncalfe, who had completed his three years term of office.

Mr. Ryan is Vice-Chairman of the Metal Box Co. Ltd., and has been closely concerned with the standardization policies implemented through B.S.I. by the packaging industry. He has been Chairman of the B.S.I. Finance Committee, and served on the General Council and its Executive Committee.

The Rt. Hon. Viscount Waverley, P.C., G.C.B., G.C.S.I., G.C.I.E., F.R.S., was re-elected President of the Institution for the third year. Sir Roger Duncalfe was elected Vice-President.

Johnson, Matthey's South African Company. Johnson, Matthey and Co., Ltd. propose to form a subsidiary company in South Africa under the title of Johnson Matthey and Co. (South Africa), Ltd., with offices in Johannesburg. The initial objectives will be to meet from local production the industrial needs of South Africa and to manufacture the requirements of the jewellery, dental and allied trades.

Furzehill Laboratories Extension. Furzehill Laboratories have now opened a new laboratory and production unit at Cheltenham to manufacture their range of test equipment.

In 1942 the Company became associated with S. Smith and Sons (England) Ltd., and has been responsible for the electronic portion of the Smith Autopilot which is used in the Comet.

RADIO INDUSTRY AWARD FOR TECHNICAL WRITING

First of the Radio Industry Council's Premiums for Technical Writing—to be awarded to authors of technical articles deserving to be commended by the industry—has been won by Mr. J. R. Acton, B.Sc., Grad.Brit. I.R.E., of the Ericsson Research Laboratories, Nottingham.

The award of 25 guineas is made for an article on "The Single-Pulse Dekatron" which was published in "Electronic Engineering" in February 1952. The cheque will be handed to Mr. Acton at a lunch at the Radio Show, Earls Court, on Monday, September 1, in the presence of Mr. A. R. W. Low, M.P., Parliamentary Secretary, Ministry of Supply.

Further awards of R.I.C. Premiums will be announced at the end of the year, the plan being to award up to an average of six a year.

Meetings. The Electro-Physiological Technologists' Association is holding a general meeting at Hurstwood Park Hospital, Haywards Heath, Sussex, on Saturday, September 20, commencing at 10.30 a.m. There will be papers and demonstrations of interest to electrophysiologists and others concerned with the recording of low frequency phenomena. Non-members are welcome at this meeting, and should write to the Honorary Secretary, Mr. G. Johnson, at the above address, for full particulars.

The British Sound Recording Association is having its first meeting of the season at 7 p.m. on September 26, at the Royal Society of Arts, John Adam Street, London, W.C.2, when the Presidential Address will be given by H. Davies, M.Eng., M.I.E.E.

The Society of Instrument Technology is holding a lecture on "The Fundamentals of Flow Measurement" by Dr. W. J. Clarke on September 30, at the Royal Society of Tropical Medicine and Hygiene, Portland Place, London, W.1.

A meeting of the Presentation of Technical Information Discussion Group will be held at University College, Gower Street, London, W.C.1, on September 29, at 6 p.m. A paper entitled "Technical Publications" will be presented by G. Parr.

Mr. P. V. Hunter, C.B.E., Hon.M.I.E.E., recently resigned his post of Deputy Chairman of British Insulated Callender's Cables, Ltd., as he is in his 70th year and is desirous of reducing his commitments. He will, however, continue as a non-executive director and remain on the boards of several of the subsidiary companies.

Mr. E. D. Hart, M.A., A.Inst.P., A.M.I.E.E., has recently joined the Equipment Division of Mullard, Ltd., where, as head of the Technical Department, he is responsible for market surveys, technical publications and other technical commercial activities.

Mr. A. M. Spooner has joined the staff of High-Definition Films, Ltd., for special work in connexion with electronic process shots and artificial scenic devices. Until recently Mr. Spooner was a member of the Designs Department of the BBC.

Midland Silicones, Ltd., recently announced that plant is now being constructed in Britain by Albright and Wilson Ltd., for the manufacture of "Silastomer", a silicone rubber. The material will be manufactured in grades to correspond with the imported Dow Corning "Silastic" products as far as possible.

Change of Address. Messrs. Pennine Radio and Television Ltd., recently announced that the address of their Head Office and Works has changed from 9-11 Southgate, Elland, Yorks to Page Street Works, Back Page Street, Huddersfield.

Advertisement Erratum. On page 13 of the August issue the D.C. input of the Rivlin valve voltmeter was given as 40 megohms. This figure should have been quoted as 20 megohms.

ELECTRONIC EQUIPMENT

A description, compiled from information supplied by the manufacturers, of new components, accessories and test instruments.

Cossor Mark II Marine Radar

(Display Console shown below)

THE Mark II four range Cossor marine radar equipment embodies several changes. The display and main rack consoles have been re-designed to simplify installation problems, while servicing facilities have been improved.

The front panel of the display console is easily detached, allowing the unit to be lifted out and forward on a special seating, and an adjustable cover over the plan position indicator and controls is so designed that it may be depressed downwards out of sight at the back. When not in operation the entire indicator unit is protected by the cover.

The plan position indicator is a 9 in.

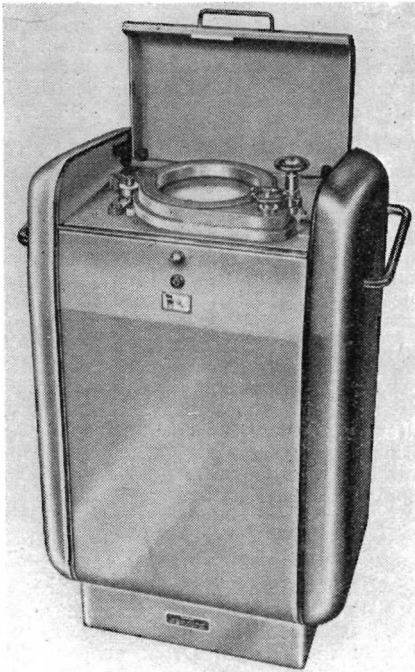

cathode-ray tube. A press button puts the equipment into full operation. An adjustment clarifies the screen of unwanted echoes, and by means of an expanded centre short-range navigation can be undertaken through narrow channels, etc. Bearing readings are by an illuminated cursor rotated by a hand wheel and by a bearing scale calibrated in degrees; four range scales are available: 1.2, 3, 12 and 30 nautical miles. Definition has been improved by the introduction of a variable pulse length of 0.2μsec with the 1.2 and 3 mile range, and 0.6 with the 12 and 30 mile range. The change over from one to the other is automatic, controlled by the position of the range switch.

For testing purposes, a characteristic display is obtained by pressing a button on the display console panels which indicates the overall efficiency of the equipment.

The main rack console contains the main components which operate the equipment: the transmitter/receiver, modulator, lock and power units. These units are contained in racks set one above the other, and the cabinet is air-conditioned by a dryer and blower unit.

Actual servicing on any of these four units is simplified by a bracket servicing tray which fits to the front of the cabinet and allows any one of the units to be pulled forward clear of the rack, plugged in again and tested while the equipment is working. Two automatic switches operate when the door of the main rack is opened: one, running from an independent d.c. supply, lights up the interior of the cabinet while the other disconnects the main a.c. current to the four units. The performance of every valve of importance in the equipment can be accurately checked by means of a built-in meter, switches and jack plugs.

The rotating aerial system consists of three main parts: the reflector, gear box and the echo box. The reflector, which rotates through 360° at approximately 28 R.P.M. in wind speeds up to 80 knots, is fed with v.h.f. energy from the transmitter which it radiates in a narrow beam of about 1½°. The gear box contains a d.c. motor for driving the reflector, gears, slippings and magstrip element, all contained in a watertight compartment. The echo box provides the artificial echo used in testing the equipment.

The motor alternator is designed to convert the ship's d.c. supply to the a.c. voltage necessary for the equipment. The input can be either 110 or 220 volts d.c. and the output is 500c/s a.c. at 180 volts. This unit can be installed in the engine room or other convenient position.

The Mark II has an accuracy range which is better than ±2 per cent of maximum range of scale in use; two small objects with a range difference of 70 yards may be separately distinguished. The accuracy bearing is ±1 per cent at the edge of the display; two small objects at the same range will be separately distinguished if the clearance between them is 3°. The frequency band of working is 9 320-9 500Mc/s (3cm).

Cossor Radar Ltd.,
Highbury Grove,
London, N.5.

Wolsey Co-axial Outlet Box

(Illustrated top right)

DESIGNED for positive clamping and easy fixing of the cable without strain on the inner conductor by the introduction of bends, the new Wolsey co-axial outlet box is made to R.E.C.M.F. specifications. It is of adequate mechanical strength to ensure firm contact pressure and good electrical contact.

The outer contact surfaces are cadmium-plated, and the inner surfaces silver-plated, with dielectric of high-grade

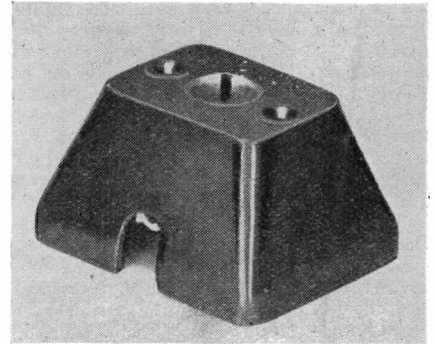

natural polythene ensuring minimum loss. The outside is finished in polished electro-plated oxy-bronze.

The dimensions of the base are 1½ in. by 1½ in., with a depth of ¾ in. Socket parts have standard dimensions so that the outlet box can be used with any standard plug.

Wolsey Television, Ltd.,
75 Gresham Road,
Brixton, London, S.W.9.

Mullard Rectangular C.R.T.

(Illustrated below)

THE new Mullard cathode-ray tube, type MW36-22, is a direct viewing television type with a 14 in. diagonal rectangular screen.

The tube is indirectly heated with a 6.3V heater, and has an external conductive coating, the capacitance of which to the final anode may be used to provide smoothing for the E.H.T. supply. It has magnetic focusing, double magnetic deflection, and incorporates an ion trap which has a magnet field intensity of 59 to 67 gauss.

Typical operating conditions of the C.R.T. are as follows: V_{a2} 10kV, V_{a3} 250V, V_g for cut-off -33 to -72V, and focusing ampere turns approximately 1 000.

Mullard, Ltd.,
Century House,
Shaftesbury Avenue,
London, W.C.2.

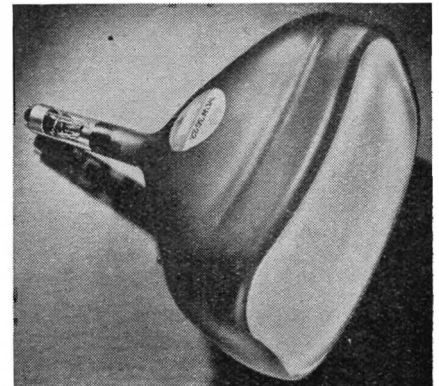

High Speed Recording Tube

(Illustrated right)

THE new 20th Century Electronics C.R.T. is a 6in. precision type with a flat face ground and polished internally and externally. The precision electron gun is similar to that used in the type S6 range of tubes. Three post deflector accelerators are provided permitting the use of a high final accelerator—third anode voltage ratio with the minimum of distortion. With a 3:2 ratio the reduction of deflexion sensitivity is approximately 30 per cent. The maximum voltage rating of the tube is 20kV on the final P.D.A. and 10kV on the third anode. The latter contact is brought out to a side connexion.

Both the X and Y deflexion plates are brought out to side connexions—the Y connexions being situated on the same side of the bulb as the third anode in order to minimize losses at high frequencies. The screen powder normally used is of specially short persistence having a high light output in the blue and ultra violet regions.

Used photographically with fast blue sensitive emulsions the tube is capable of fully resolving transient phenomena occurring at less than 0.001 μ sec intervals.

20th Century Electronics, Ltd.,
Dunbar Works, Dunbar Street,
West Norwood, London, S.E.27.

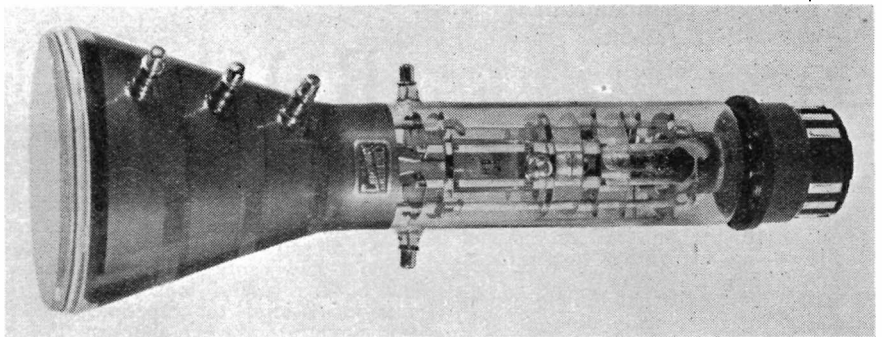

36 contacts are arranged so that the circuit passes through the coupling in the same geometrical formation as in the cable. Each coaxial or balanced twin unit has two contacts, the screen in the former case being isolated from adjacent coaxial screens and from other screens in the cable.

Although the couplers are integrally moulded to the ends of the cable, the aluminium bronze housings can be readily replaced if damaged.

British Insulated Callender's Cables, Ltd.,
Norfolk House, Norfolk Street,
London, W.C.2.

New Mycalex Material

A NEW X-ray absorbent material is being produced by the Mycalex Co., Ltd., which is an extension of this firm's moulding material so that it has the effect of "stopping" X-rays.

Mycalex mouldings are produced so that they are as accurate dimensionally as the mould from which they are made, and so that there is no warping or shrinkage after moulding. Also inserts can be incorporated during moulding.

The material electrically is not subject to carbon formation, arcing or tracking, and has a power factor of the order of 0.0015, with a dielectric strength of approximately 500 volts per mil.

Mycalex Co., Ltd.,
Ashcroft Road,
Cirencester, Glos.

E.M.I. Portable Magnetic Tape Recorder

(Illustrated bottom right)

THE Model L/2 E.M.I. portable battery operated magnetic tape recorder is designed for use in mobile commentating, interview work, etc. The complete recorder measures 14in. by 7in. by 8in., and weighs 14 $\frac{1}{2}$ lb.

The equipment uses normal 5in. diameter spools containing 600ft of standard $\frac{1}{4}$ in. tape, and is available in three versions having operating speeds and playing times as follows: Model L/2A 3 $\frac{1}{4}$ in./sec, 30 minutes playing time; Model L/2B 7 $\frac{1}{2}$ in./sec, 15 minutes playing time, and Model L/2C 15in./sec, 7 $\frac{1}{2}$ minutes playing time.

Separate recording and replay heads and amplifiers are provided to facilitate monitoring from tape during recording and to allow the tape to be replayed on site.

The tape is easily and quickly threaded, and is brought up to the

heads and driving capstan by two guides and the rubber pressure roller, which is latched into position by a lever on the motor-board. The record/replay switch is also on the motor-board, and pre-selects the desired operation. Once these two controls have been set, the case lid is closed and the equipment controlled by the motor "on/off" switch. The control panel carries sockets for crystal microphone and headphones, and, under a hinged flap, the pre-set gain control, loudspeaker jack for replay purposes, and the meter switch enabling motor, H.T., L.T. and bias volts to be checked on the level meter.

The overall performance of the three versions is as follows: the frequency response at 15in./sec is 50 to 10 000c/s (± 2 db), at 7 $\frac{1}{2}$ in./sec 50 to 7 000c/s (± 2 db), and at 3 $\frac{1}{4}$ in./sec 50 to 3 000c/s (± 2 db); the signal to noise ratio is better than 45db at 1 000c/s unweighted when replayed on an E.M.I. studio recorder, and the wow is better than 0.2 per cent at 15in./sec, 0.25 per cent at 7 $\frac{1}{2}$ in./sec and 0.3 per cent at 3 $\frac{1}{4}$ in./sec.

The batteries providing the motor supply give an effective life of 1 $\frac{1}{2}$ hours operation where each 15 minutes of running time is followed by a similar rest period, or of $\frac{1}{2}$ of an hour if run continuously. The H.T. batteries have an operating life of 15 hours. All batteries can be removed without disturbing the recorder mechanism. The L.T. cells are contained in a metal carrier which can be easily refilled or replaced as a unit.

E.M.I. Sales and Service, Ltd.,
Hayes, Middlesex.

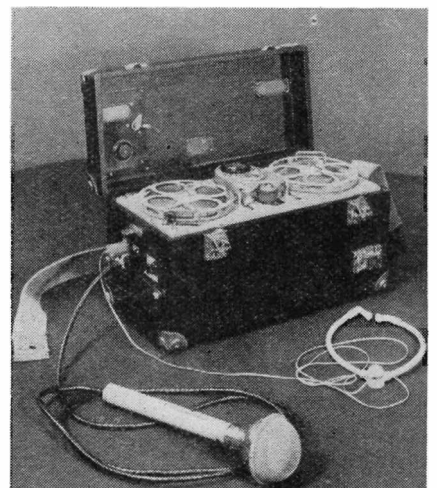

New Television Camera Cable System

THE B.I.C.C. Polypole television camera cable system introduced in 1949 provided for the first time a single-strand cable in unit lengths with integrally moulded-on couplers. The company have now introduced a similar cable to work with television camera designs which have become progressively smaller and require more circuits. The new design is known as Polypole III and is illustrated above together with its predecessor. Compared with the latter the Polypole III coupler is smaller, lighter and more compact, and it provides for up to 36 circuits.

The cables are of small dimensions, due partly to the use of single-strand conductors and to the high accuracy extrusion processes evolved for applying the polythene dielectric. The overall diameter of the latest 36-circuit cable is only 0.82in. This cable consists of a centre of three screened circuits each of which may be coaxial or balanced twin, and three triplets of insulated conductors. The outer layer contains 21 single insulated conductors.

The cables are screened overall and sheathed with P.V.C. or tough rubber. They are light in use, easily handled and kinking is eliminated; they can also be bent in a small radius without injury.

The couplers consist of male and female connectors, enabling unit lengths of cable to be built up as required. The

Electrical Communications Experiments

By H. R. Reed, T. C. G. Wagner and G. F. Corcoran. 458 pp. John Wiley and Sons, Inc., New York, and Chapman and Hall Ltd., London. 1952. Price 54s.

ALTHOUGH the book is called "Electrical Communications Experiments" many of the experiments described are basic electrical experiments. The book is divided into four sections, each section dealing with fifteen experiments. The first section is called "D.C. Fundamentals" and deals with simple experiments such as the calibration of voltmeters, Wheatstone's bridge and Kelvin's bridge. Later in the section more complex experiments are described, e.g., load lines, ballistic galvanometer calibration, *BH* loops and the operation of diode rectifiers. Section two is entitled "A.C. Fundamentals", the first experiment being on the use of the cathode-ray oscillograph. This section describes such experiments as impedance measurement, resonant circuits, A.C. bridges and transmission lines. The third section called "Engineering Electronics" covers experiments on valve characteristics, amplifiers, valve voltmeters, oscillators, thyratrons and time-base circuits. The final section called "Radio Engineering" is concerned with experiments at radio frequencies, such as R.F. impedance measurements, R.F. bridges, coupled circuits, modulation, detectors and tests on radio receivers.

Each experiment is divided into roughly three sections: a theoretical section explaining the theory of the experiment and deriving any formulæ required, an account of the method in which the experiment is to be performed and, finally, a suggested report on the experiment. The theoretical sections are well written and give considerable details concerning the theory of the experiment. There is a feeling that, in some cases, the theoretical section is rather overdone and there is a tendency to go rather too deeply into some subjects. This is particularly so where it is the first time that a student has performed an experiment on this particular subject. For example, on the experiment on *LC* oscillators (there being only one) over 10 pages are devoted to the theory, which deals with oscillators in the rather unusual manner of a valve coupled through a π -type coupling.

The book is American and, unfortunately, all references are to American apparatus. There are a number of experiments based on American commercial instruments, e.g. the General Radio type 650A impedance bridge, type 916A radio frequency bridge, and type 821A twin-tee impedance measuring set. Although the basic experiments may be performed with similar apparatus manufactured in this country (if available in the laboratory), the detailed practical instructions are of little value. In a similar way some of the terms used are American and unfamiliar to engineers in this country.

It is difficult to decide whether the book was intended for students or lecturers. The book is excellent for students at a college where most of the experiments are performed with similar apparatus and in the same way as described in the book, but it is doubtful

whether this set of sixty experiments would fit into many telecommunication courses in this country. If the experiments are performed in a different way the book may confuse rather than help. The book is useful to lecturers as it gives many ideas for experiments, but it is doubtful whether the experiment would be performed exactly as described, owing to the different ideas of various lecturers and the difficulties of suitable apparatus. The book would have been more useful to lecturers if more details had been given concerning some of the apparatus used.

The book is well produced and appears to be free from serious errors. A number of references are given to books for further reading, but all these are published in America.

G. N. PATCHETT

Amplifiers: The Why and How of Good Amplification

By G. A. Briggs and H. H. Garner. 216 pp. 174 illustrations. Wharfedale Wireless Works, March 1952. Price 15s. 6d.

MR. BRIGGS has acquired a wealth of sound commonsense from the viewpoint of a practical man. In his book he achieves an effect almost as informative as a personally conducted tour of an exhibition specially designed to demonstrate his findings, always enlivened with a touch of humour here and there. This new book is no exception. And the quality of production is up to the usual standard.

It should fill a useful gap for the kind of reader to whom the earlier books, "Loudspeakers" and "Sound Reproduction", have appealed, helping him to understand some of the points that often are so hazy. After defining the various factors contributing (or failing to contribute) to amplifier quality, a wide range of aspects of amplifier technique are conversationally discussed. Particular attention has been given to push-pull operation, negative feedback, tone compensation, and input circuits. Quizzes between the authors, and occasional summaries, help the reader to understand some of the more difficult sections. There are many instances in the book illustrating the usefulness of Mr. Briggs' oscillogram response curve display method. Mr. Garner's chief contribution to the book is a new amplifier with associated accessories, two tuners and a pre-amplifier, and Mr. Briggs discusses its development.

In the authors' introductions and conclusion attention is called to the criticisms likely to be levelled at a book of this type—over-simplification, or too much technicality; and the inevitability that some errors of fact or deduction will creep in. On the whole they are to be commended in the extent to which they have minimized these risks, but one or two points should be mentioned.

The B.S.I. deprecated term "fre-

quency distortion" is used in Chapter 1, but in later references ambiguity of meaning is nicely avoided by demonstrating the shape of frequency response curve. Mr. Briggs confesses a weakness in multiplying over ten, which may account for one or two errors in quoting percentages. It is felt that the chapter title "Whistle and Scratch Filters" might well have its last word omitted: it gives a concise discussion on handling whistle and needle scratch, which is quite illuminating, but gives no information on filter design. In dealing with hum from energized speaker units, to check the energizing as a possible source, it is not sufficient merely to disconnect the speech coil, but it should be short-circuited.

To the reviewer, the prize piece of humour is, "We understand that there is no truth in the assumption that people with bats in the belfry can hear ultrasonic frequencies." Of course, other readers may have a different preference—there is plenty of choice. Answering queries from readers seems to be a hobby for Mr. Briggs—Mr. Garner joins him in this offer—so in buying this book the reader also obtains a free service!

N. H. CROWHURST

Principles of Radio

By Keith Henney and Glen A. Richardson. 655 pp. 6th edition. John Wiley and Sons Inc., New York and Chapman and Hall Ltd., London. April 1952. Price 44s.

THE volume under review is a comprehensive, non-mathematical text designed specifically for "those who must learn radio without the help of a teacher." It is a completely revised edition of a work which first appeared in 1929: its senior author (Henney) is well known for his work as Editor-in-Chief of *Electronics*, while his collaborator is Assistant Professor of Electronics, Iowa State College.

The assumption is made that the reader knows nothing of mathematics and science: consequently the opening chapters suffer from the usual malaise of overcrowding and over-simplification. By chapter 7, however, the authors are well into radio theory with a discussion on "Properties of Alternating-Current Circuits." Vector diagrams are freely used and a conscious effort is made to provide practical examples. Chapter 8 deals with resonance, and it is refreshing to find an elementary text using zero phase angle as the criterion of resonance. It is regrettable that precision in this matter should be accompanied by looseness in defining and discussing *Q*. While it is true that engineers will talk colloquially of the *Q* of a coil, it is realized that in fact this property can only be assigned to a resonant circuit. Henney and Richardson state explicitly that "... the term (*Q*) may be applied to a single element such as a coil, with its own associated resistance, or it may be applied to a circuit made up of several impedance elements". They go on to

differentiate between Q at resonance and off resonance, imply that Q varies with frequency only because reactance varies with frequency, and unhappily do not make any mention of voltage magnification. Chapter 9 on "Properties of Coils and Condensers" effectively concludes the section of the book on A.C. theory.

Chapters 10-14 deal with vacuum tubes and include a brief glance at the crystal diode and the transistor. The general treatment is thorough and satisfying and embraces such associated subjects as power supply filters, swinging chokes, vibrations, decibels and modulation. Chapter 15 on "Amplitude Modulated Receiver Systems" deals with a heterogeneous group of subjects, and the main thread of the discussion is taken up again in Chapter 16 on "Oscillators". Chapters 17 and 19 deal with amplitude and frequency modulation respectively, while Chapter 18 discusses "Lines, Antennas and Radiation". The remaining five chapters deal sketchily with a variety of topics including television and radar.

As can be seen, the scope of the book is very wide, and it may well be that it would have been advisable to jettison the introductory chapters which deal with subjects treated in every elementary textbook on electricity and magnetism in order to devote more time to detailed study of radio fundamentals. The high price of this very attractively produced volume is unfortunate: its only advantage over the much less expensive Stationery Office publication is that it is very topical, but this does not compensate for its other weaknesses. The present volume would be a useful adjunct to a group library, but a luxury to a serious student.

K. G. LOCKYER

Facts From Figures

By M. J. Moroney. 472 pp. Penguin Books. 1951. Price 5s.

MR. MORONEY has not spared himself to find examples of everyday interest telling us not only how to deduce facts from figures, but also how to make sure that other people's deductions are not misleading. Towards the middle of the book it becomes a little technical because his main interest is quality control.

Let us list those who can find what they desire in this book. First there are those interested in the jolly diagrams on housing progress, imports, and what happens to income tax or national insurance contributions. Next, those thoughtful enough to try to understand such things as price indices which determine wages, changes in population, whether there is any significance in parallel trends, e.g., the number of accidents to children and the number of playing fields near their homes and so on. Finally technicians and scientists, not always with a large knowledge of higher mathematics, who want to know about averages and fluctuations, quality control and errors. They will find what they want written easily and happily.

There is one criticism which is shared with other more expensive books of a popular type. The size of the pages is such that perhaps eight or more are needed to explain one example, and reference backwards and forwards may make reading rather difficult.

G. J. KYNCH

Colour Cinematography

By Adrian Cornwell-Clyne, M.B.E., F.R.P.S. 780 pp. 3rd edition. Chapman & Hall Ltd. 1951. Price 84s.

THIS new edition of a monumental work will be welcomed by all who are in any way connected with or interested in colour cinematography.

The first chapter deals with the historical background and the second chapter, entitled "The Theoretical Basis", deals in great detail with light sources, trichromatic analysis and colour filters, emulsions, reproduction, projection light sources, screens, the human eye, etc. This chapter alone comprises approximately one-half of the book. Then follow chapters on additive and subtractive processes, colour cameras and beam-splitting systems, and bipack.

The second part of the book comprises chapters on process projection, sound tracks, toning, stereoscopic methods, make-up and colour sensitometry.

The third part discusses colour vision, colour harmony and colour standards.

The book concludes with fourteen appendices of patents and information on the latest methods, and is one of the most valuable parts of the book.

It is difficult to review this book in the normal way. To say that it is a mine of information is an understatement; it is encyclopædic. It is, and will continue to be, the standard source of information on all topics connected with modern pictures in colour.

R. McV. WESTON

The Radio Amateur's Handbook

784 pp., 1202 illustrations. 29th edition. The American Radio Relay League. 1952. Price \$4.

THIS handbook is compiled by the headquarters' staff of the American Radio Relay League, and the new edition has been revised and restyled to bring it up to date.

The first chapter is devoted to the history of American amateur radio, and is followed by three chapters on fundamentals—electrical laws and circuits, vacuum-tube principles and data on high frequency communication.

The H.F. receivers section contains information on single-sideband receiving techniques and a wide variety of constructional material, and that on H.F. transmitters incorporates details of the design and construction of amateur transmitting equipment. Other chapters cover power supply, mobile equipment, keying methods and techniques, transmission lines, antennae and radio-telephony.

U.H.F. and V.H.F. apparatus is covered in five chapters dealing with propagation phenomena, receivers, transmitters, etc.

Audio Handbook No. 2—Feedback

By N. H. Crowhurst, A.M.I.E.E. 64 pp., 40 figs. Norman Price (Publishers) Ltd. 1952. Price 3s. 6d.

THIS handbook follows the previous one in the series that deals with audio amplifiers. It presents the various methods in which feedback, both positive and negative, can be utilized in an essentially practical manner. Charts and abacs are used extensively to minimize and ease the calculations necessary in the design of such circuits.

CHAPMAN & HALL

Out this month DESIGN FOR A BRAIN

by

W. Ross Ashby

M.A., M.D., D.P.M.

Director of Research,
Barnwood House, Gloucester

254 Pages. 70 Figures. 36s. net.

A book of particular interest to electro-physiologists. Readers of this Journal will remember Dr Ashby's provocative article under the same title in the December 1948 issue.

Our Complete Catalogue
has been revised and reprinted.

Please write for:

Section 10

ELECTRICAL ENGINEERING
&
ELECTROTECHNOLOGY

Section 11

ELECTRONICS
(Vacuum Tubes & their Applications)

37 ESSEX STREET, LONDON, W.C.2

The latest
"Electronic Engineering"
monograph

RESISTANCE STRAIN GAUGES

By J. Yarnell, B.Sc., A.Inst.P.

Price 12/6

This book deals in a practical manner with the construction and application of resistance gauges and with the most commonly used circuits and apparatus. The strain-gauge rosette, which is finding ever wider application, is treated comprehensively, and is introduced by a short exposition of the theory of stress and strain in a surface.

Order your copy through
your bookseller or direct from

Electronic Engineering

28 ESSEX STREET, STRAND,
LONDON, W.C.2.

BOOK REVIEWS (Continued)

Television Receiver Practice

By Roy Holland. 80 pp., 64 figs. Norman Price (Publishers) Ltd. 1952. Price 5s.

THIS book, or booklet, is a collection of circuits of the different sections of modern television receivers. Each circuit is described and illustrated. Advantages and disadvantages are also mentioned. In so small a book it is inevitable that the descriptions must be very brief and it is a pity that so much of the text is occupied giving the values of the components in the circuits. They could be marked in the diagrams instead of, or as well as, the usual R_1 , C_1 , L_1 , etc. At approximately a penny per effective page space should not be wasted anywhere.

The diagrams are of a very high standard and most of them show the waveforms at various points. This is a good feature and could well be extended to several other diagrams.

Each of the seven chapters covers one or more sections of a television receiver: power supplies, frequency changers, time-bases, etc., and the various circuits are clearly described by one who is obviously familiar with them. No description of the sound section is given or methods of selecting the R.F. or I.F. and eliminating vision on sound, except very briefly when showing two sound-on-vision traps.

A few errors were noticed. On page 68 a vision interference limiter is shown in which the diode cannot ever conduct, and on page 70 the diodes of a sync separator are likewise always non-conducting. This type of separator has been used with thyratron time-bases, but fed from the cathode of the video stage which provided the initial bias needed to make the separator function. The anode waveforms of the time-base on page 37 are also not typical by any means and do not show the effect of the efficiency diode.

The book is, however, neat and interesting, and should be of help to those who would like to know about modern television circuits.

C. H. BANTHORPE

Electrical Engineer's Reference Book

Edited by E. Molly, M. G. Say and R. C. Walker. 2,196 pp., 2,050 figs., 275 photographs. Sixth edition. George Newnes Ltd. May, 1952. Price £3 3s. 0d.

THE sixth edition of this reference book is arranged in thirty-two sections, and has been enlarged to cover recent developments in electricity generation. It gives particulars of the British Electricity Authority and of the new power stations now under construction, including extensions. The chapter on hydro-electric plants now covers the hydrogen cooled alternator and the schemes of the North of Scotland Hydro-Electric Board.

The first section has been enlarged to include an article on the operational methods for transients, and the second contains new data on power station cabling and gas-turbine power plants. A

survey of street lighting recommendations has been added to section 12.

Other new matter relates to recent developments in geiger tubes, ultrasonics, magnetic amplifiers and the D.C. bias system of remote control.

Elementary Mathematics

By Lewis W. Phillips. 339 pp., 147 figs. Macdonald and Co. (Publishers) Ltd. April, 1952. Price 12s. 6d.

IN this volume the author, who has a wide experience of industry and education, including the teaching of mathematics, sets out to give a simple and interesting treatment of elementary mathematics designed to help both students and teachers in secondary technical schools, evening institutes and polytechnics.

The scope of this book covers the syllabus for the examinations of the Royal Society of Arts and similar examining bodies in elementary mathematics. Those intending to take up National Certificate courses in various technical subjects will find in this book all the necessary preparatory groundwork.

The subject is dealt with in a simple and straight-forward manner, and those who want to study mathematics, but have forgotten what they learnt at school, would find it an excellent basis for revision. There are numerous worked examples in the text, followed by a number of exercises. The correct answers to these are given at the back of the book. There is included also a selection of the R.S.A. examination papers from the period 1944 to 1950.

The Oscilloscope Book

By E. N. Bradley. 87 pp., 44 figs. Norman Price (Publishers) Ltd. Price 5s.

THIS is a somewhat elementary booklet dealing with the construction and use of a simple but reasonably useful cathode-ray oscilloscope. Constructional details are also given for auxiliary equipment such as a wobulator, square-wave generator, etc., and the various applications for which they may be used are adequately described.

The book is obviously directed to the amateur and not the professional, and as such it is quite sound.

Vade Mecum 1952

By P. H. Brans. 416 pp. 9th edition. P. H. Brans Ltd., Amwerp, and Bailey Bros. and Swinfee Ltd., London. 1952. Price 25s.

THE ninth edition of this valve guide has been somewhat simplified in that only transmitting and receiving valves are now listed and all valves are tabulated in alphabetical and numerical order. As a result it is much easier to locate a given valve type and to ascertain the main facts concerning it than was previously the case.

Vade Mecum must be, without doubt, one of the most comprehensive valve guides published anywhere in the world.

PUBLICATIONS RECEIVED

LANCASHIRE DYNAMO HOLDINGS LTD. 1951 DIRECTORS' REPORT AND ACCOUNTS. In the Chairman's speech, Mr. H. W. Bosworth said that the net profit of the Group for the year amounted to £221,713 as compared with £214,755 for the previous year, and increased production and expansion of export trade during the year had been somewhat hampered by Government restrictions and licensing difficulties. Lancashire Dynamo Holdings Ltd., 94, Petty France, London, S.W.1.

THE CORROSION RESISTANCE OF TIN AND TIN ALLOYS by S. C. Britton, M.A., is a book dealing with the use of tin as coatings for the protection of steel and other metals from rusting and corrosion. It is divided into three parts, respectively covering the corrosion of tin itself, its alloys, and coatings of tin and its alloys upon other metals. The book is published by the Tin Research Institute, Fraser Road, Perivale, Greenford, Middx., from whence copies may be obtained, price 3s. 6d. each.

PLASTICS FOR INDUSTRY is a brochure which surveys various methods of manufacturing plastic articles, and it includes a comparative chart to outline the relevant properties of the different types of plastic materials used in industry. Copies are available free from Resinoid and Mica Products Ltd., 28, Queen Anne's Gate, London S.W.1.

FOIL AND PAPER CAPACITORS FOR POWER FACTOR IMPROVEMENT AND CAPACITOR MOTORS is Leaflet CL538 of A. H. Hunt (Capacitors) Ltd., Bendon Valley, Garratt Lane, Wandsworth, London, S.W.18. The catalogue gives technical details of power factor improvement capacitors and standard types for use with electric motors.

MEMORANDUM ON GAMMA-RAY SOURCES FOR RADIOGRAPHY has been prepared by a Committee of the Industrial Radiology Group of the Institute of Physics to provide a brief account on gamma-ray source for radiography, with particular reference to A.E.R.E., Harwell, and the Radiochemical Centre, Amersham. An appendix contains data sheets which summarize much of the available information. Copies of the Memorandum may be obtained from the Institute of Physics, 47, Belgrave Square, London S.W.1., price 3s. 6d.

UNITS AND STANDARDS OF MEASUREMENT EMPLOYED AT THE N.P.L. III—ELECTRICITY is a booklet dealing with current, voltage, resistance, power, energy, inductance, capacitance, frequency etc. It gives an account of the history of the subject, and defines the units employed at the N.P.L. for the measurement of electrical quantities and the standards by means of which these units are determined and preserved. There is also a section on R.F. standards. The booklet is published by Her Majesty's Stationery Office for the D.S.I.R., and is available only from the N.P.L., Teddington, Middx., price 9d., postage 1½d.

LABORATORY SPECIALITIES—CATALOGUE NUMBER 16B-S gives details of the specialized instruments manufactured by Griffin and Tatlock Ltd., for use in laboratories. It includes: balances, fractionating column packings, distillation apparatus, ovens, presses, glass apparatus, etc. Griffin and Tatlock Ltd., Kemble Street, Kingsway, London W.C.2.

R.S.G.B. AMATEUR RADIO CALL BOOK, published in May, 1952, gives a list of call signs of amateur radio operators in the United Kingdom, the Channel Islands and the Irish Republic. It costs 3s. 6d., and may be obtained from the R.S.G.B., New Ruskin House, Little Russell Street, London W.C.1.

MARITIME V.H.F. RADIO-TELEPHONES is a brochure explaining how this type of equipment can serve ships and harbours. It also describes briefly the Pye apparatus used for these installations. Rees Mace Marine Ltd., 11, Hinde Street, Manchester Square, London W.1.

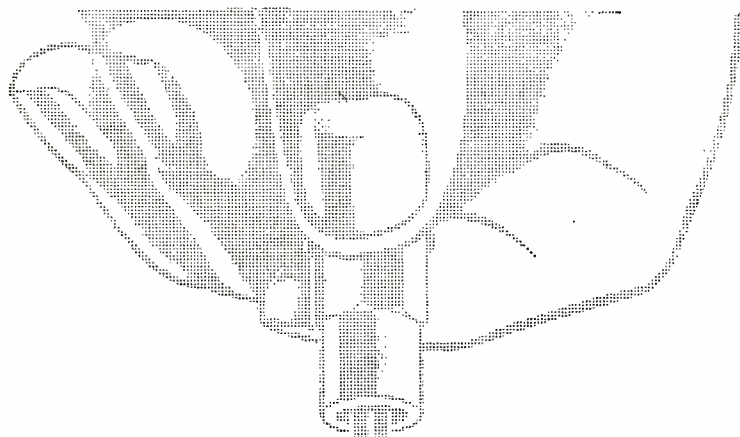

EDISWAN



By adding the Clix range of radio, television and electronic components to its existing list of products The Edison Swan Electric Co., Ltd. is able to offer an improved components service to the radio industry. Future enquiries and orders for these products, and others in the Ediswan range, will be welcomed.

**United
for better
Radio, Television
& Electronic
component
service**

THE EDISON SWAN ELECTRIC COMPANY LIMITED
155 Charing Cross Road, London, W.C.2, and branches

Member of the A.E.I. Group of Companies

ER9

NICKEL CHROME

Fine

RESISTANCE WIRES

Manufactured to customers' specifications in gauges down to 50 s.w.g. and finer if required, "Cromaloy" V Resistance Wires are produced in long lengths to speed output by minimising time-wasting operational changes.

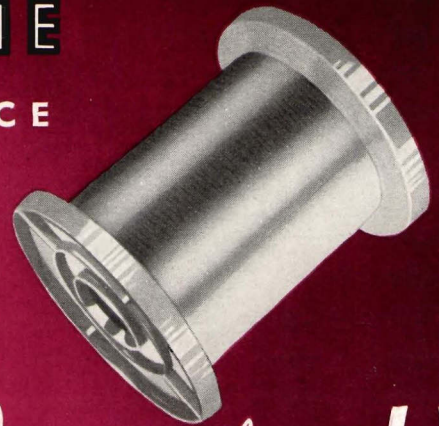

LONG LENGTHS
DOWN TO 50 S.W.G.

Cromaloy V

FOR CONSISTENCY

A. C. SCOTT & CO LTD., CROMALOY HOUSE, CITY ROAD, MANCHESTER

LONDON AGENT: COTSIL LTD., 80 MORTIMER ST., LONDON, W.1. TEL: LANGHAM 1071/2

dm AS 12

CONTROL

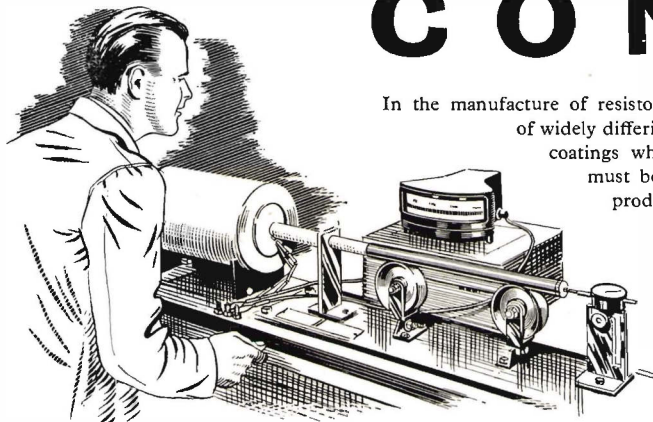

In the manufacture of resistors we consider thermal expansions at high temperatures—of widely differing materials such as ceramics, resistance wires and protective coatings which comprise the system. At high temperatures a balance must be achieved to eliminate any stress/strain relationships in the product at room and at working temperatures. To this end thermal expansions of ceramic cores and protective coatings are accurately measured by means of a Dilatometer. Precise knowledge of this fundamental character ensures maximum reliability and stability and is evidence of our insistence upon 100% efficiency throughout production.

Depending upon the duty of a resistor, special protective coatings are available:

VITREOUS · CEMENT
SILICONE · LACQUER

Full information on the application of ERG Wire Wound Resistors is to be obtained from our London Sales Office: 10 Portman Square, London, W.1. (Welbeck 8114).

Resistors

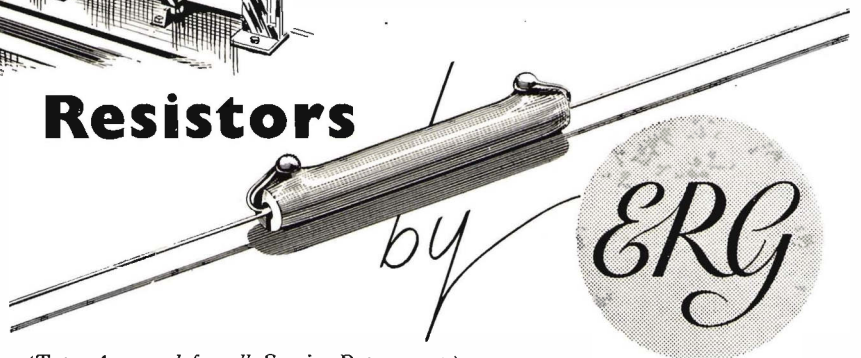

(Type Approved for all Service Departments)

ERG INDUSTRIAL CORPORATION LTD · MATTHEW STREET · DUNSTABLE · BEDS

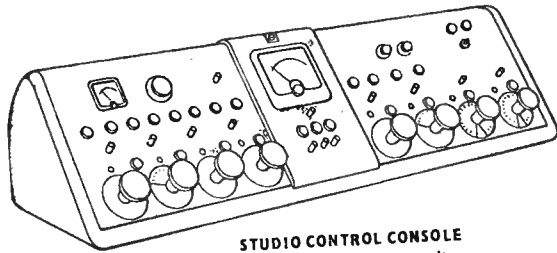

STUDIO CONTROL CONSOLE
for flexible, high-quality control of programmes from two studios.

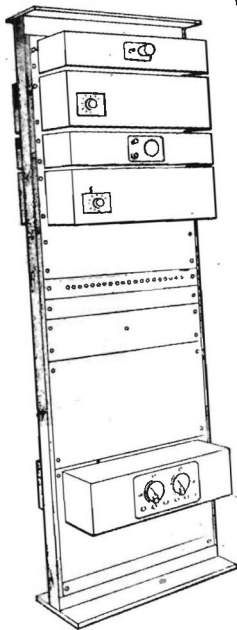

AUTOMATIC MONITOR
for immediate location of sources of distortion in transmissions.

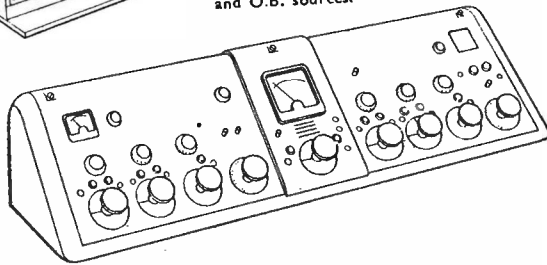

CONTINUITY CONTROL DESK
to provide broadcast continuity from several studios and O.B. sources.

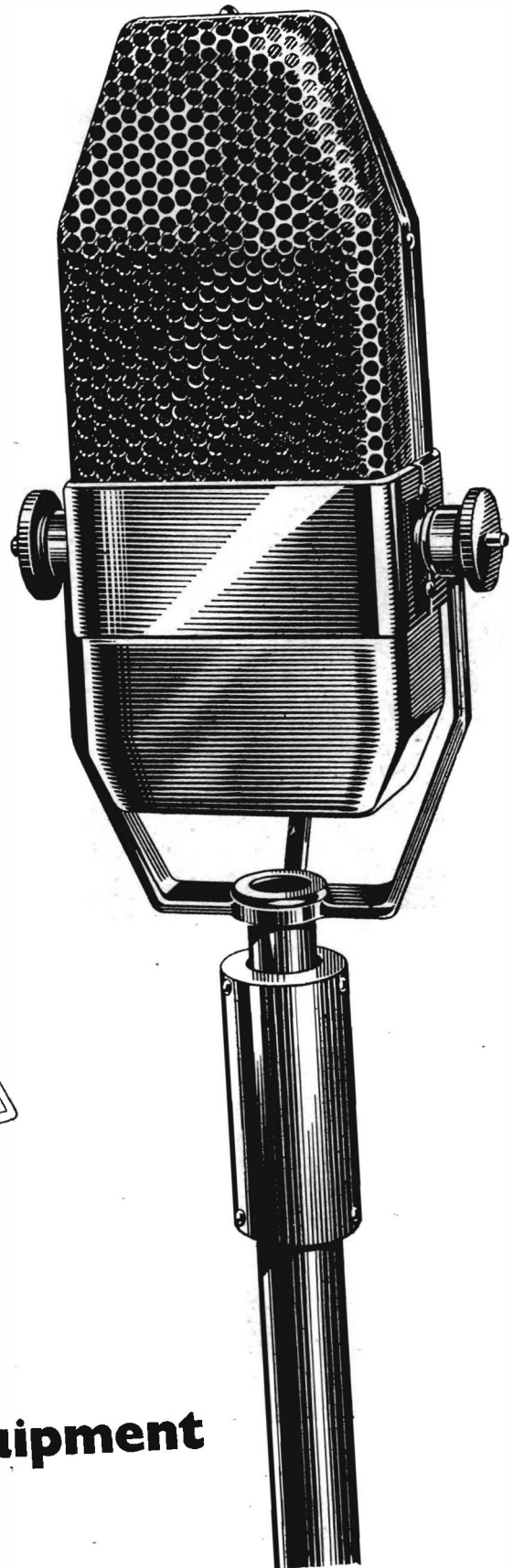

MARCONI

broadcasting equipment

MARCONI'S WIRELESS TELEGRAPH COMPANY LTD · CHELMSFORD · ESSEX

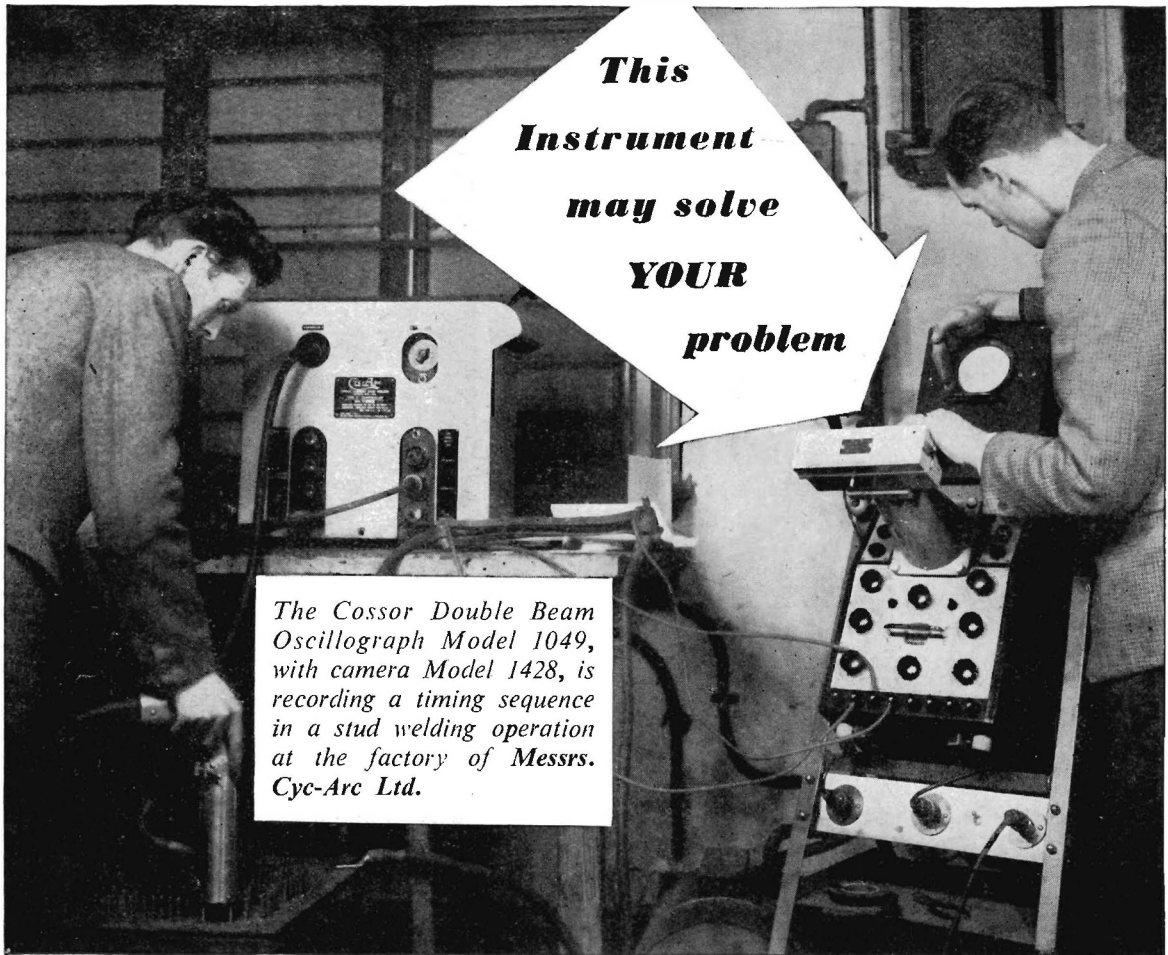

**This
Instrument
may solve
YOUR
problem**

The Cossor Double Beam Oscillograph Model 1049, with camera Model 1428, is recording a timing sequence in a stud welding operation at the factory of Messrs. Cyc-Arc Ltd.

In displaying simultaneously the mutual effect of two related and variable quantities the Cossor Double Beam Oscillograph is solving many of the fundamental problems with which the Research and Development scientist is constantly beset. In addition, workers in every branch of Industry are realising the infinite uses of this instrument in the detection and analysis of faults and the accurate monitoring of manufacturing processes.

The technical advisory staff of the Cossor Instrument Division is always at your service to help with your own particular problem.

In Models 1035 and 1049 the two traces are presented on a flat screen of 90mm. diameter and the amplifiers and time base are so calibrated that measurement of the voltage input as well as the time interval between various significant portions of the oscillogram is made possible. Permanent records of these traces for subsequent analysis may conveniently be made by attachment of the Cossor Model 1428 Camera.

ELECTRONIC **COSSOR** INSTRUMENTS

Please address enquiries:

A. G. COSSOR LTD., INSTRUMENT DIVISION (DEPT. 2), Highbury, London, N.5

Telephone: CANonbury 1234 (30 lines)

C.I.33

★ Use COSSOR VALVES and TUBES ★

Don't be misled by the size!

The brilliant idea of using a castellated insulating track on one aluminised paper strip enabled HUNTS to dispense with the old-fashioned twin windings and produce one of the smallest miniature capacitors on the market. Despite the midget proportions efficiency has actually been increased; the MOLDSEAL casing and the directly soldered end leads give a high degree of strength and protection from moisture and intermittence. The range runs in two sizes shown below

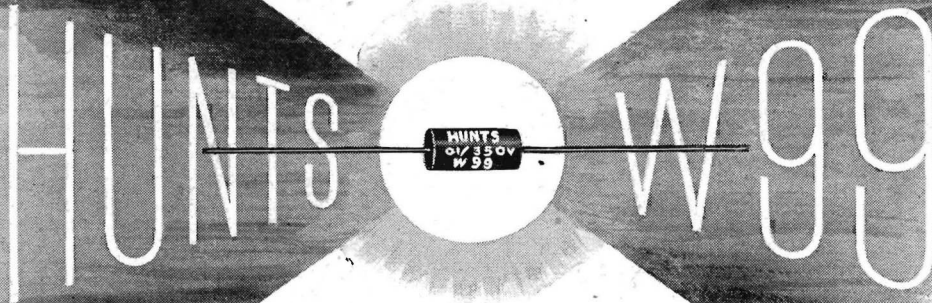

STANDARD RANGE

Wkg. Voltage	Cap. Range μ F	★ Size
150 D.C.	0.004 to 0.01	A
	0.02 to 0.04	B
350 D.C.	0.001 to 0.003	A
	0.004 to 0.01	B
600 D.C.	2.5pF to 0.001	A
	0.002 to 0.004	B
300 A.C.	0.00005 to 0.001	A
	0.002 to 0.004	B

★ A. 3/16" x 7/16" B. 1/4" x 9/16"

REGISTERED

TRADE **HUNTS** MARK
CAPACITORS

A. H. Hunt (Capacitors) Ltd. Wandsworth, London, S.W.18 • BATtersea 3131

Meet us at **STAND No. 56.** The National Radio Show, Earls Court, Aug. 26-Sept. 6

MUIRHEAD MAGSLIP RESOLVER NO. 2

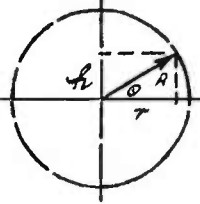

Given R & θ
find h & r

$$h = R \sin \theta$$

$$r = R \cos \theta$$

Change of axes.

$$x' = x \cos \alpha + y \sin \alpha$$

$$y' = y \cos \alpha - x \sin \alpha$$

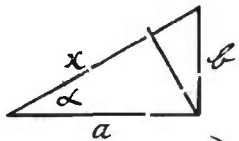
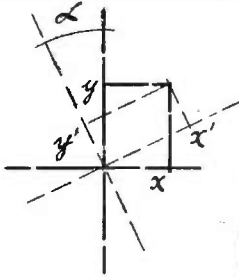

~~$$x = \sqrt{a^2 + b^2}$$~~

$$x = a \cos \alpha + b \sin \alpha$$

Given N & E
determine R & θ

$$R = E \cos \theta + N \sin \theta$$

$$\theta = E \sin \theta + N \cos \theta$$

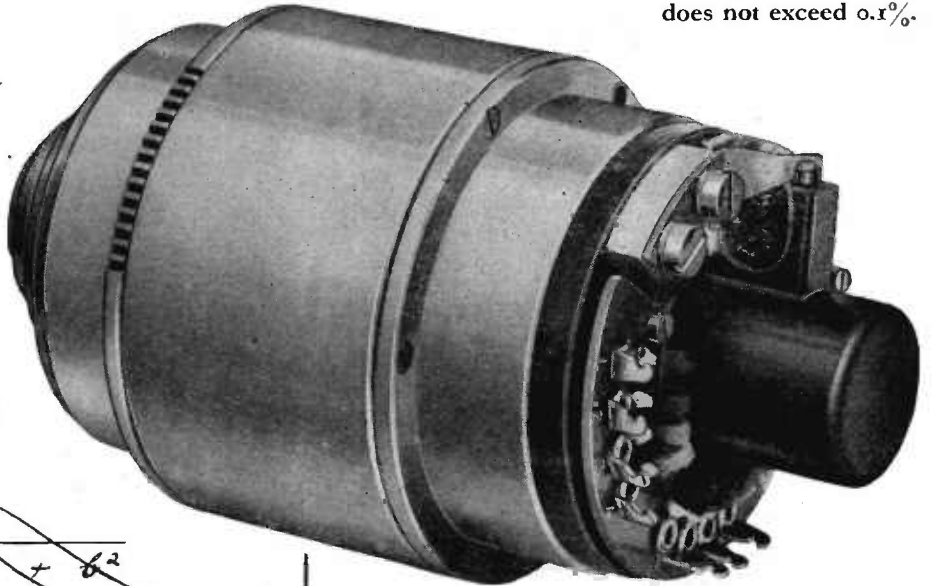
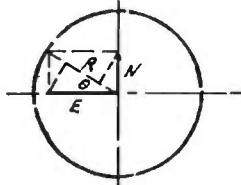

THE RESOLVER No. 2 is a special type of Magslip used for the solution of trigonometrical problems such as the conversion of polar to Cartesian coordinates.

Each stator phase is energized in accordance with an applied computing voltage. No power is taken from this source, energization being obtained by means of an amplifier and a second (feedback) stator winding. The rotor voltages are proportional to the exciting voltages and to the sine and cosine of the angle between the stator and rotor electrical axes. The error does not exceed 0.1%.

POST THIS COUPON

Please send me Bulletin B-690 fully describing
MUIRHEAD MAGSLIP RESOLVERS

NAME _____
MAILING ADDRESS _____

COMPANY _____

POSITION _____

79

MUIRHEAD & CO. LTD., BECKENHAM, KENT, ENGLAND

PRECISION ELECTRICAL INSTRUMENT MAKERS

the finest insurance
against
valve
replacement
costs



In every stage of
the G.P.O. micro-
wave television link
from Manchester to
Kirk o' Shotts...

Standard
VALVES

for dependability
— and long life

Standard Telephones and Cables Limited

Registered Office: Connaught House, Aldwych, London, W.C.2

RADIO DIVISION: Oakleigh Rd., New Southgate, London, N.11

FOR HIGH- FREQUENCY INSULATION-

specify
'FREQUELEX'

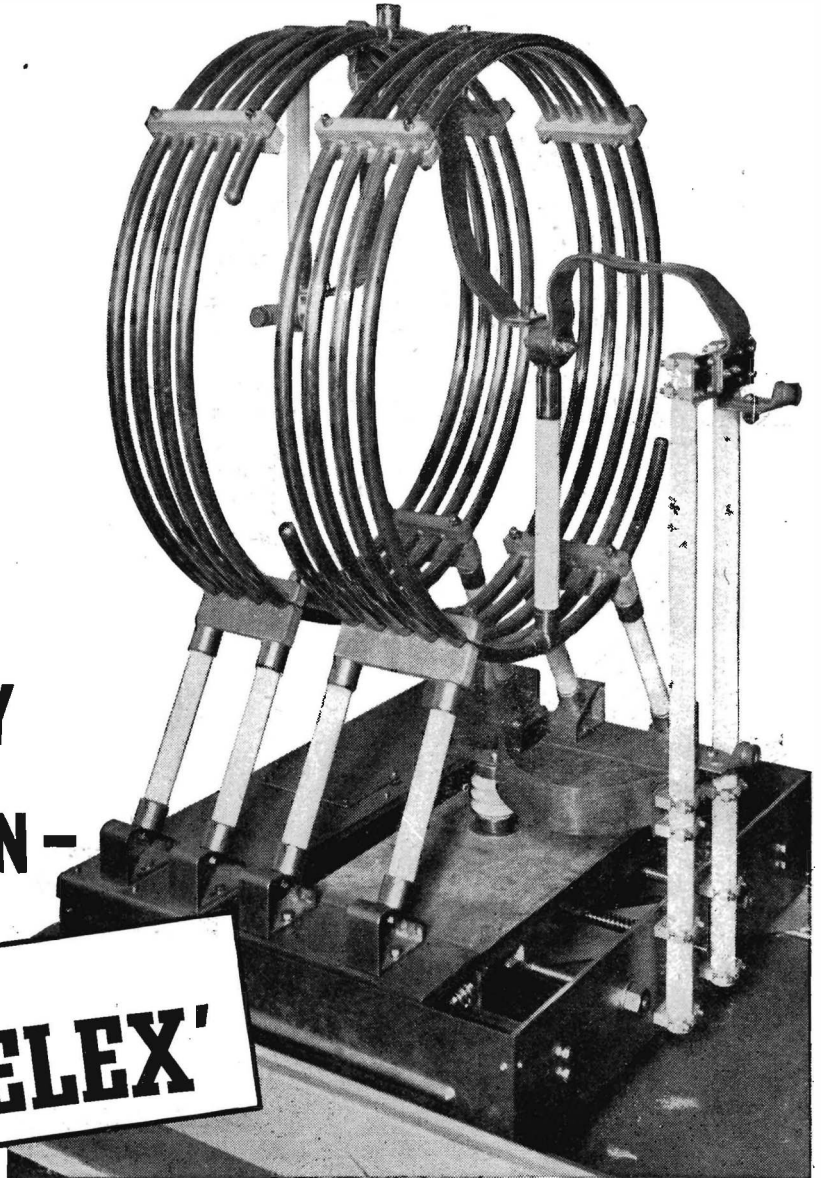

Photograph by permission of the Standard Telephone & Cables Ltd.

The Coupling Coil shown is supported by our "FREQUELEX" Ceramic Rods, and forms part of a 200 KW. Radio Transmitter.

This is only one of many applications where Rods made to close limits are required.

We specialise in the manufacture of Ceramic Rods and Tubes of various sections in several classes of materials over wide dimensional ranges.

The principal materials are:

1. Porcelain for general insulation.
2. Frequelex for High Frequency insulation.
3. Permalax and Templex for Capacitors:

The degree of accuracy depends on the size of the Rod or Tube, but the standard degree of accuracy is outlined in the Inter - Service Component Manufacturers' Council - Panel R Specification embodied in our Catalogue of Radio Frequency Ceramics, copy of which will be sent on request.

Large Rods up to 44" long and 1½" square are used as supports for Tuning Coils, etc.

We shall be pleased to have your enquiries for all sizes of Tubes and Rods. Prompt deliveries can be given for most sizes.



Bullers LOW LOSS CERAMICS

BULLERS' LIMITED, 6 Laurence Pountney Hill, E.C.4. Phone: MANsion House 9971 (3 lines). Grams: 'Bullers, Cannon, London'

MARCONI

offers appointments to

DEVELOPMENT ENGINEERS

PROJECT ENGINEERS

TECHNICAL SALES ENGINEERS

It is a tradition for Marconi's Wireless Telegraph Company Limited, with its unique reputation, to point the way in all branches of avionic research and development.

Today the Company has vacancies for suitably qualified engineers who have experience of airborne and ground based H. F., V. H. F. or U. H. F. communication equipment or navigational aids.

Attractive careers await such men who wish to become: DEVELOPMENT ENGINEERS; PROJECT ENGINEERS; TECHNICAL SALES ENGINEERS.

You are invited to write, giving full personal details and quoting the reference S.A.20 to :—

Central Personnel Services,
MARCONI'S WIRELESS TELEGRAPH COMPANY LTD.
24/30 Gillingham Street, London, S.W.1

Your application will, of course, be treated in strict confidence.

Delco Power for AIRCRAFT

As a contribution to the rearmament programme GENERAL MOTORS LIMITED have made arrangements for DELCO motors for the Aircraft Industry and other special purposes to be manufactured at the FRIGIDAIRE DIVISION.

The Delco range of British-made motors, generators, rotary transformers etc. for aircraft is designed to provide power for a wide variety of ancillary equipment including electronic control gear and radio.

Design approval is held from the Ministry of Supply Director of Instrument Research and Development, for D.C. Aircraft Electric Motors.

Available motors include totally enclosed, fan ventilated flame-proof and immersed types built to meet users' requirements and the relevant M.O.S. specifications. All motors achieve maximum output with minimum weight and many variations of standard designs are regularly manufactured to meet individual demands.

All enquiries for

DELCO AIRCRAFT MOTORS

To FRIGIDAIRE DIVISION OF GENERAL MOTORS LIMITED
STAG LANE · KINGSBURY · LONDON N.W.9 · Colindale 6541

some typical applications . . .

- ★ SERVO DEVICES
- ★ GUN TURRET MECHANISM
- ★ BLOWERS
- ★ DE-ICING EQUIPMENT
- ★ FOLLOWER DEVICES
- ★ HYDRAULIC PUMP DRIVES
- ★ VENTILATING FANS
- ★ CAMERA DRIVES
- ★ FLAP OPERATORS
- ★ RADIATOR SHUTTERS
- ★ BOMB SIGHT
- ★ FUEL PUMPS
- ★ SCANNER DRIVES

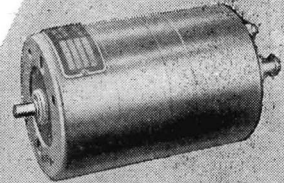

2½" dia. Frame Size Motor
Two Pole—D.C.

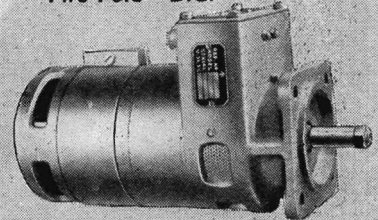

3" dia. Frame Size Motor
Two Pole—D.C.

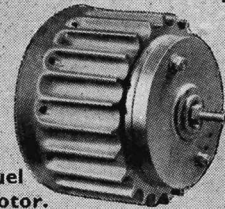

Immersed Fuel
Boost Pump Motor.

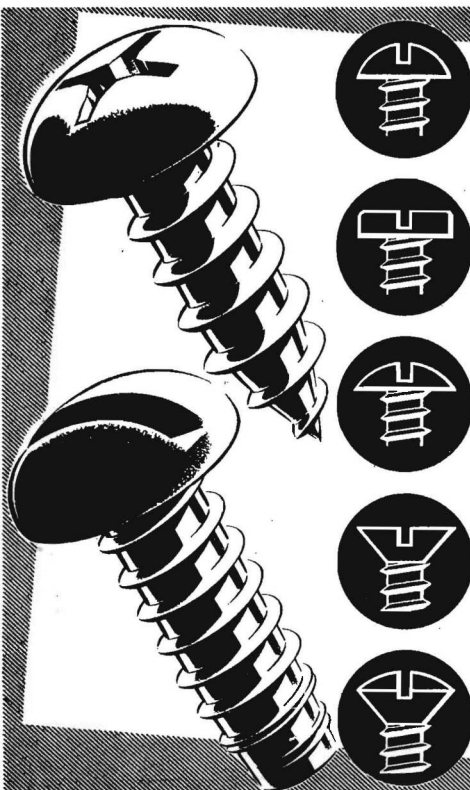

Self-Tapping SCREWS

We manufacture these hardened self-tapping screws which are available on short delivery in all finishes. They can be supplied with Phillips recessed heads as well as with slotted heads, in two types, namely the fully pointed type A, and the blunt pointed type Z.



LINREAD LTD · COX ST · BIRMINGHAM 3

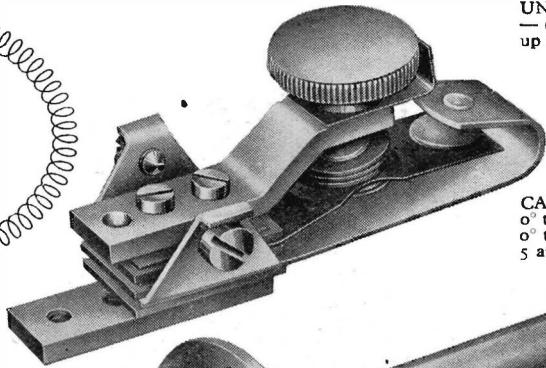
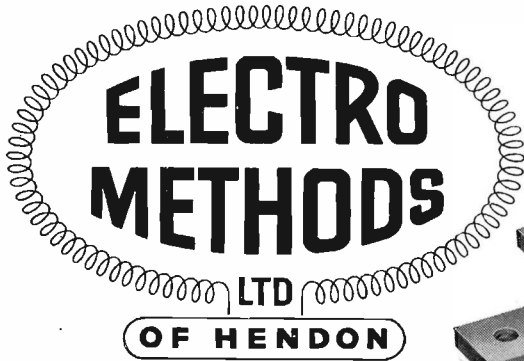

UNIVERSAL Type B
— 60° to 350° C.
up to 2 kW.

CARTRIDGE Type 1B
0° to 200° C.
0° to 400° C.
5 amp. rating, 250 volts

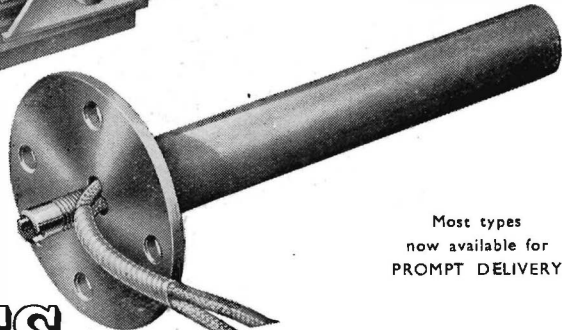

Most types
now available for
PROMPT DELIVERY

—the first name for
precision
THERMOSTATS

Complete technical data of our extensive range of Thermostats will be forwarded on request. The unrivalled experience of our technicians in the field of temperature control is at all times at your service.

ELECTRO METHODS LTD. (Division T1)
220 THE VALE, LONDON, N.W.11. Phone: Gladstone 6611

SPECIALISTS IN THE MANUFACTURE OF THERMOSTATS, RELAYS AND MAGNETIC AMPLIFIERS



Sound travels
better by
VITAVOX



VITAVOX loudspeakers and microphones are designed for specialised application in the extensive field of sound reproduction. Thus the solution to your sound problem is primarily the selection of the right VITAVOX model to meet your specific needs.

The range extends from small hand microphones to two-way loudspeaker systems, and includes instruments to give the highest quality reproduction in all fields.

VITAVOX
LOUDSPEAKERS AND MICROPHONES

VITAVOX LIMITED, Westmoreland Road,
London, N.W.9. Telephone: COLINDALE 8671-3

FOR HIGH FIDELITY RECORDINGS

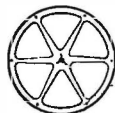

Careful design and rigid control in manufacture, provide the critical listener with a reliable hard-wearing tape that will help to get the very best results from any tape recorder.



MAGNETIC DATA

Coercivity 240-260 Oersteds
 Total Remanent Flux . . . 0.4/0.5 lines $\frac{1}{2}$ in. width
 Uniformity throughout a reel ± 0.5 d.b.

FREQUENCY RANGE

50 c/s to 10 Kc/s at a playing speed of $7\frac{1}{2}$ in./sec.

Medium coercivity gives a high signal output with an extended high-frequency response, whilst still retaining an easy erasure. Signal/noise ratio is high; transfer and distortion are negligible.

PLAYING TIMES (per track)

REELS	$1\frac{1}{2}$ " / SEC	$3\frac{1}{2}$ " / SEC	$7\frac{1}{2}$ " / SEC	15 " / SEC
1200 Ft.	120 Min.	60 Min.	30 Min.	15 Min.
600 Ft.	60 Min.	30 Min.	15 Min.	$7\frac{1}{2}$ Min.
300 Ft.	30 Min.	15 Min.	$7\frac{1}{2}$ Min.	$3\frac{3}{4}$ Min.

If you want advice on tape-recording problems, our entire technical knowledge is at your disposal. Write to :—

MINNESOTA MINING & MANUFACTURING CO. LTD., 167 Strand, London, W.C.2. Telephone: TEMple Bar 6363



MINIRACK OSCILLOGRAPHS

High quality cathode-ray recording instruments

- ★ Single or multi-channel
- ★ Trolley or table mounted
- ★ Visual or recording
- ★ Specialised F.M. and D.C. Amplifiers
- ★ Pick-ups for measuring Pressure, Force, Vibration, Acceleration, etc.

Please write for New Catalogues



ME15 single-channel recorder with built-in camera

SOUTHERN INSTRUMENTS LIMITED

HAWLEY · CAMBERLEY · SURREY

Telephone: Camberley 1883-4.

Telegraphic Address: "Minrak, Camberley, England."

3 WAY MIXER AND PEAK PROGRAMME METER

for recording and large sound installations, etc.

One milliwatt output on 600 ohm line (.775 V) for an input of 30 microvolts on 7.5—30 ohm balanced input.

Output balanced or unbalanced by internal switch. The meter reading is obtained by a valve voltmeter with 1 second time constant, which reads programme level, and responds to transient peaks.

Calibration in 2db steps, to plus 12db and minus 20db referred to zero level. Special low field internal power packs supplies 8 valves including stabilising and selenium rectifier, consumption 23 watts.

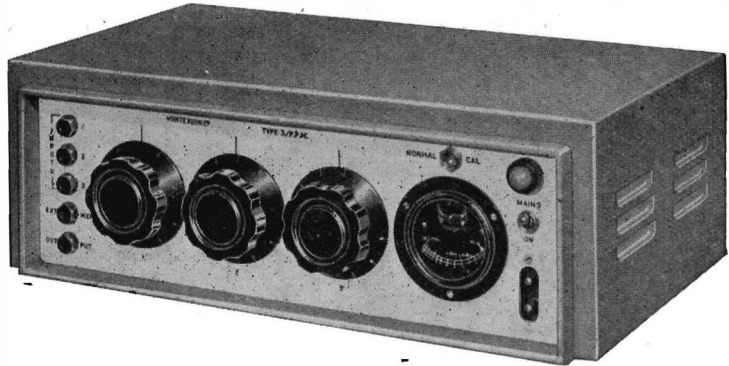

Manufactured by :

VORTEXION LIMITED

257-263, THE BROADWAY, WIMBLEDON, LONDON, S.W.19

Phones : LIBERTY 2814 & 6242-3.

Grams : "VORTEXION, WIMBLE, LONDON"

MIP
Manufacturers of Ammeters, Voltmeters, Ohmmeters, Wattmeters and frequency meters for switchboard or portable use.

**MULTI-RANGE TEST SET
SERIES 100**

The universal testing set for Service Engineers. Sensitivity—10,000 ohms per volt. Strong metal case with carrying handle, complete with leads having detachable bulldog clips and test prods. Size 9 x 5½ x 4 ins.

MEASURING INSTRUMENTS (PULLIN) LTD.
Electrin Works, Winchester St., London, W.3
Tel. : ACO rn 4651/3 & 4995.

RANGES
AC/DC VOLTS : 10, 25, 100, 250, 500, 1,000.
DC MILLIAMPS : 2.5, 10, 25, 100, 500.
AC/DC MICROAMPS : 100 Microamps 10v range.
RESISTANCE RANGES : 0/1 Meg (13,500 ohms mid-scale) 0/10,000 ohms (135 ohms mid-scale).

SEE *and* COMPARE . . .

ALL ON STAND 93

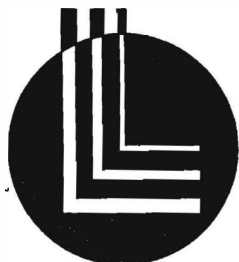

LIVINGSTON LABORATORIES LTD

RETCAR STREET,
DARTMOUTH PARK HILL, LONDON, N.19
Telephone: ARCHWAY 6251/2

. . . the latest examples of test instruments covering the requirements of research organisations, development engineers, factory inspection and test departments, service engineers, and industrial electronics departments.

In addition to the wide range of test instruments normally available, we will be exhibiting for the first time, some entirely new and important instruments incorporating recent developments.

As independent suppliers of most well-known instruments, we can offer completely unbiased advice on the suitability of equipment for your specific purpose. If you are unable to visit the Show, we shall be pleased to send you a résumé of the service we offer, or to welcome you, preferably by appointment, at our laboratories.

Specialists in Instruments for the Communications Industry

Bare & Insulated Resistance Wires

EUREKA (Regd) and **VACROM** (Regd)
CUPRO-NICKEL NICKEL-CHROME



for
INSULATED WIRES

'Eureka' (Regd.) and 'Vacrom' (Regd.) Resistance Wires can be supplied BARE or with STANDARD COVERINGS of cotton, silk, rayon, enamel and glass.

These wires have been used for many years for winding resistances for instruments, control apparatus, etc.

'Eureka' with its low temperature coefficient is always in demand for precision work, while Nickel-Chromes are used where high resistance is required in a limited space.

Full details gladly supplied upon request



for
BARE WIRES

**THE LONDON ELECTRIC WIRE COMPANY
AND SMITHS, LIMITED**
LEYTON, LONDON, E. 10.

VACTITE WIRE COMPANY LTD.
75 ST. SIMON STREET,
SALFORD 3, LANCs.

A Practical Test

A cold advertisement with its printed claims is all very well as an introduction to a product, but how much better a practical test of a manufactured characteristic.

Over 3,000 people passed through our demonstration room at the recent Northern Radio Show held in Manchester. At the end of each demonstration period we received a round of spontaneous applause denoting the obvious pleasure that good quality reproduction can afford to the receptive ear.

It is not often that the general public is given the opportunity of such a demonstration, and indeed seldom that a printed claim can be adequately proved to the entire satisfaction of all concerned.

At this year's 'Radio Earls Court' we of the House of Goodmans once again have the pleasure of presenting for your enjoyment a practical demonstration of our High Fidelity Reproducers.

The reproducers demonstrated will include the well-known Axiom series in modified form and, of recent design, two special high fidelity 8" units—Axiom 101 and 102.

We look forward to the pleasure of your company. Remember—Demonstration Room No. D.7 and Stand 41, Earls Court, August 26 to September 6, 1952.

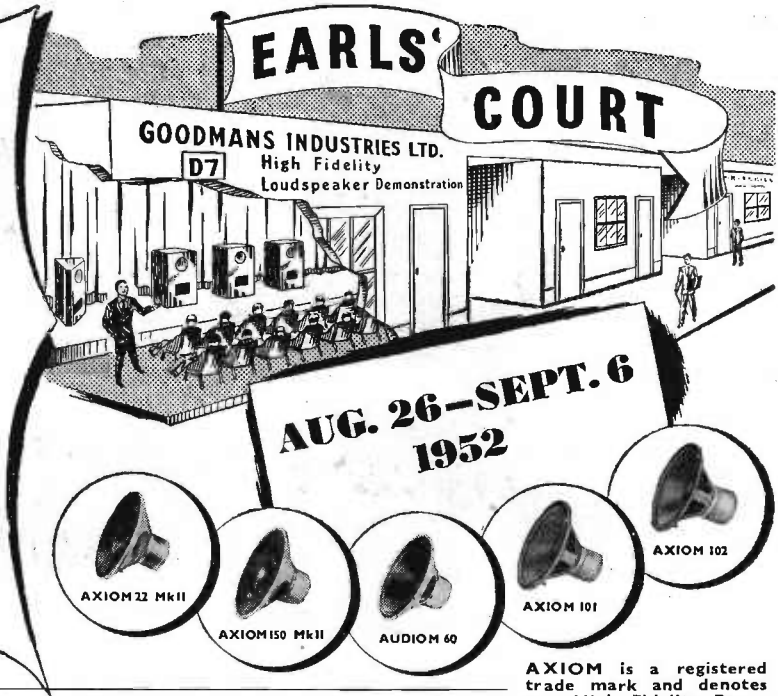

AXIOM 12 Mk II

AXIOM 150 Mk II

AUDIOM 60

AXIOM 101

AXIOM 102



GOODMANS

GOODMANS INDUSTRIES LIMITED

Axiom Works, Wembley, Middlesex

Telephone: WEMbley 1200 (8 lines)

AXIOM is a registered trade mark and denotes our High Fidelity Range of reproducers.

AUDIOM is the registered trade mark that is applied to our good quality commercial reproducers.

GOODMANS is the registered trade mark of all the Company's products

TOROIDAL POTENTIOMETERS 10-1000 WATTS

Ceramic Insulation only—and approved for Tropical conditions. Complete Ceramic Rings for strength. Approved by all Government Departments. Reasonable Delivery.

Also Precision Toroidal-wound Potentiometers (including 360° of winding with up to eight tapping points) and Helical-wound Potentiometers of 3600° of winding. All are available with sealed spindles and glass or ceramic terminal seats.

Specialists in ALL TYPES OF TOROIDAL WINDINGS

P. X. FOX LIMITED
HORSFORTH · YORKSHIRE · ENGLAND
 Telephone: Horsforth 2831
 Telegrams: Toroidal, Leeds

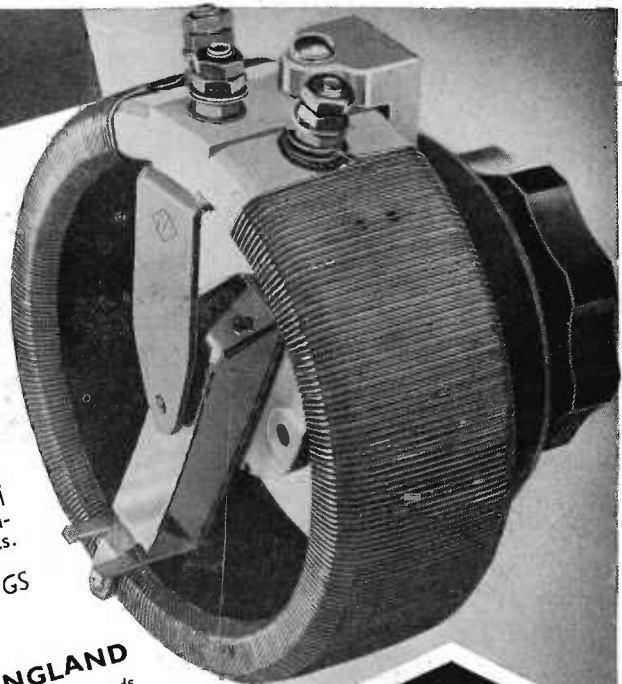

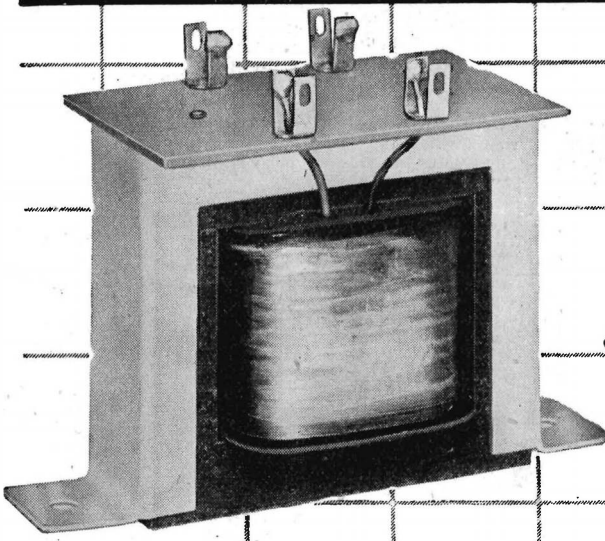

Are you using a transformer this size?



when this size might do the job

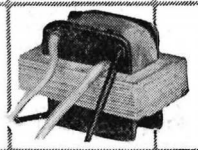

Miniaturization can simplify your production problems. Maybe it can widen your market too, by enabling selling costs to be reduced. If you are interested in Input, Output or Interval Transformers, or L.F. Chokes, between the sizes indicated, write for a copy of our comprehensive Brochure—Free and Post Free. Small or large quantities supplied at competitive prices.

Manufacturers of Miniaturized Electronic Instruments
JOHN BELL & CROYDEN
 117 HIGH STREET, OXFORD
 Telephone: Oxford 48362 & 47072

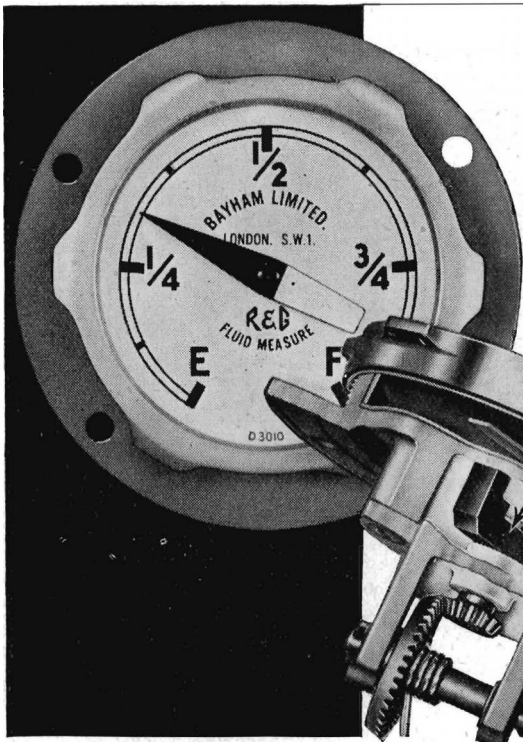

R&G FLUID MEASURES

use **MUREX Sintered Permanent Magnets**

A Murex Sintered Alcomax III Permanent Magnet operates the pointer through the solid body of the contents gauge, ensuring complete isolation of the dial from the liquid. A high degree of magnetic efficiency is required for this application, and as in many other applications, Murex Sintered Magnets continue to give accurate and reliable service.

Photographs by courtesy of Bayham Ltd., (Engineers).

MUREX LIMITED • (Powder Metallurgy Division) • RAINHAM • ESSEX Tel.: Rainham, Essex 3322
 LONDON SALES OFFICE: CENTRAL HOUSE, UPPER WOBURN PLACE, W.C.1. Tel.: EUSon 8265

SULLIVAN PORTABLE GALVANOMETERS

EMPLOYING A NEW
SUSPENDED COIL
PORTABLE GALVANOMETER UNIT

which may be supplied alone or boxed
complete with scale, illumination (with
Mains Transformer) and novel Scale
Magnification

These Galvanometers are also available as

DIRECT READING
MICROAMMETERS
MILLIVOLTMETERS
and OHMMETERS



A compact, sensitive, yet robustly suspended galvanometer has been developed in our laboratories and, having undergone extensive trials, has proved to be extremely reliable for all purposes. All galvanometers are fitted with shock absorbing non-sticking stops, thus overloads of up to 100 times full scale current may be applied without risk of damage to the movement.

Galvanometers covering the ranges	Micro-ammeter 4 ranges	Milli-voltmeter 5 ranges	Ohmmeters covering the ranges
Coil resistances 10 to 500 ohms	(full scale) 0 to 1 μ A	(full scale) 0 to 1 mV	0 to 5,000 ohms
Periods 1.5 to 2 seconds	0 to 10 μ A	0 to 10 mV	0 to 50,000 ohms
30 to 2,400 $m\Omega/\mu$ A	0 to 100 μ A	0 to 100 mV	0 to 0.5 megohms
	0 to 1,000 μ A	0 to 1 V	0 to 50 megohms
	Period 2 seconds	0 to 10 V	
		Period 1 second	

H. W. SULLIVAN LIMITED, LONDON, S.E.15. Tel : New Cross 3225 (P.B.X.)

BALDWIN PROTECTION ELECTROMETER

A robust, portable battery-operated instrument for dosage measurement of x and γ radiation at tolerance level.

The range of the instrument is 200 mr., which is twice the daily tolerance dose.

Ionization chambers supplied for use with the instrument are of the personnel protection type ; any number of these may be used with the one instrument.

Write for details—Leaflet No. 122



BALDWIN INSTRUMENT CO. LTD., DARTFORD, KENT

Dartford 2989 & 2980

Technical Control

Close technical control of production is an all-important factor in the manufacture of Telcon Metals. Accurate tests and measurements are made at various stages in the course of production and the illustrations show two of the many routine examinations conducted in our well-equipped laboratories.

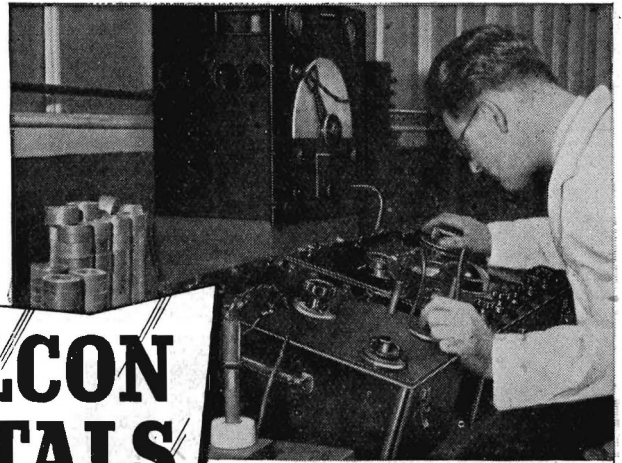

Precision measurement of magnetic characteristics of toroidal Mumetal cores by the Ferrometer.



Routine Factory testing of Mumetal toroidal cores.

TELCON METALS

- MAGNETIC ALLOYS — Mumetal, Radiometal, H.C.R., Rhometal, Permendur, R2799, 36/64, Dust.
- RESISTANCE ALLOYS — Pyromic, Calomic, Telcuman, Telconstan, Telconal.
- SPECIAL ALLOYS — Thermostatic Bimetals 140, 400, 15, Telcoseal, Invar, Beryllium-Copper.



The Telegraph Construction & Maintenance Co. Ltd

Head Office: 22 Old Broad Street, London, E.C.2
Telephone: LONDON WALL 7104

Enquiries to: Telcon Works, Greenwich, London, S.E.10
Telephone: GREENWICH 3291

Some MEN don't seem to understand

the importance of the welfare side from THE WOMAN'S ANGLE. By the simple depression of a lever THE BARRYWALD SANITARY INCINERATOR will automatically and effectively destroy sanitary towels, surgical dressings, documents, etc., solving a vital and major welfare problem in FACTORIES, OFFICES, INSTITUTIONS, etc.

▲ The only Incinerator incorporating our Patented Safety Devices.

The **BARRYWALD**
Safety
Automatic Incinerator

PAT. Nos. : 555062-621085 & CORRESPONDING FOREIGN PATENTS

Supplied to :—

Admiralty, Argosy Radiovision Ltd., Air Ministry, B.E.A., Chloride Batteries Ltd., A.C. Cossor Ltd., Edison Swan Electric Co. Ltd., Metropolitan Police, English Electric Ltd., J. Gerrard & Son, Ltd., G.E.C. Ltd., Post Office Telephones, etc.

**ECONOMICAL
EFFICIENT
FOOLPROOF
INDISPENSABLE**

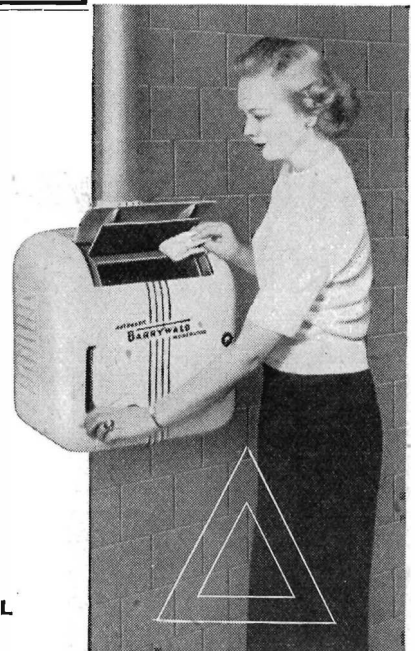

Awarded the Certificate of the Royal Institute of Public Health and Hygiene.

SANIGUARD APPLIANCES Limited
62, LONDON WALL, LONDON, E.C.2.

Telephones: MONARCH 4922-4923

DIVISION OF ALLIED METALS LTD.

STRAIN makes its mark...

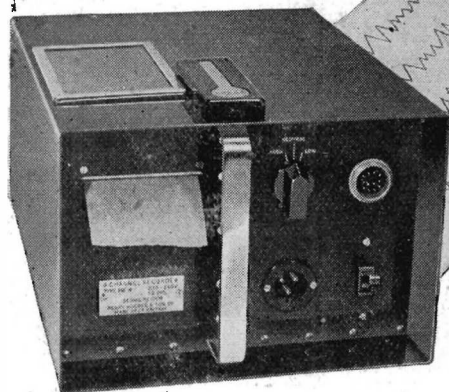

The equipment comprises three Units. The Oscillators and Power Supply Unit, the Bridge and Amplifier Unit, and that shown, the Recording Unit.

KELVIN HUGHES

Four pen dynamic Strain Recorders

Employing four pick-off devices and recording their output simultaneously, the Kelvin Hughes Strain Recorder gives valuable information on the behaviour of a structure or a machine under conditions of dynamic loading. Resistance wire strain gauges, capacitance-change and inductance-change devices such as accelerometer pick-up systems may be used independently in each channel. Sensitivity is such that full-scale deflection for a 200 pF capacity pick-up is given for a change of approximately 1 pF, while with a 2000 ohms resistance gauge, full-scale deflection is obtained for about 0.006% change of resistance. Single channel instruments are also available.



KELVIN HUGHES PRECISION INSTRUMENTS

Why not write for further details?

KELVIN & HUGHES (INDUSTRIAL) LIMITED, 2, CAXTON STREET, LONDON, S.W.1

DAWE distortion factor METER

... for the direct
measurement of total
harmonic content of
audio-frequency
apparatus



Frequency range: 20 c/s to 20 Kc/s fundamental
Distortion range: 0.1 to 50 per cent

now available for immediate delivery!

Technical data from: DAWE INSTRUMENTS LTD., Instrument Division,
130 UXBRIDGE ROAD, HANWELL, LONDON, W.7. EALING 6215

* Visit S.I.M.A. Exhibition and Symposium, 2nd - 5th September, 1952

PHILIPS *present...*

**CATHODE RAY
OSCILLOSCOPE •
GM 5653**

MADE IN HOLLAND

Portable—mains operated

High frequency oscilloscope suitable for pulse work and television.

FEATURES:

- 1 Frequency range of amplifiers 1 c/s to 7 mcs.
- 2 Sensitivity 15 mV/cm.
- 3 Time base frequency 5 c/s to 160 Kcs.
- 4 Internal post acceleration voltage available.
- 5 Built in attenuator, 4 step.
- 6 Probe included.



SPECIAL OFFER

A new booklet "The Oscillograph and its Applications", price 5/-, is now available in limited quantities. This concisely written book is divided into two parts. The first part describes modern oscilloscopes; the second part contains one hundred typical examples of their use. Profusely illustrated, and invaluable to engineers and technical colleges alike. Copies may be obtained from:



PHILIPS ELECTRICAL LTD.

INDUSTRIAL DEPARTMENT

CENTURY HOUSE · SHAFESBURY AVENUE · LONDON · W.C.2.

INDUSTRIAL X-RAY EQUIPMENT · ELECTRONIC APPARATUS · LAMPS AND LIGHTING EQUIPMENT · ARC & RESISTANCE WELDING PLANT & ELECTRODES
MAGNETIC FILTERS · BATTERY CHARGERS AND RECTIFIERS · H.F. HEATING GENERATORS · RADIO & TELEVISION RECEIVERS

(Pl.224)

**EVEN A miniature
DIFFUSION PUMP CAN OFTEN MULTIPLY
THE CAPACITY OF YOUR ROTARY PUMP!**

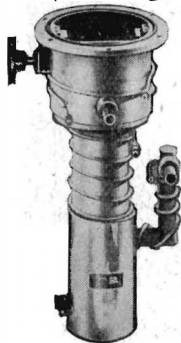

SPECIFICATION
102(1") oil diffusion pump
ULT. VACUUM:
 5×10^{-6} mm.Hg.
SPEED (baffled) 7-3
litres/sec.
SPEED (unbaffled) 9-1
litres/sec.
FLUID CHARGE 10ml.

The addition of an EDWARDS 1 in. oil or mercury inexpensive diffusion pump will provide a vacuum better than 10^{-6} mm. Hg and the unlimited scope of a high vacuum system . . . an invaluable aid where industrial research and pilot experiments are being conducted on a small scale.

Let us know what vacuum equipment you have available and we will gladly advise you on the best combinations and techniques.

for better vacuum service . . .

W. EDWARDS

& CO., (LONDON) LTD., LONDON, S.E.26

Phone: Sydenham 7026 (8 lines) Grams: Edcohivac, Souphone London

ELECTRONIC EQUIPMENT VALVE COOLING

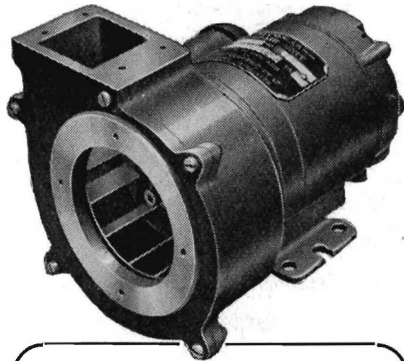

Secomak
MFC

Blower Units are also made in larger sizes, having outputs up to 140 c.f.m. and static water lift up to 32".

Send us particulars of your requirements.

"Secomak" Model 129 Blower Unit, designed specifically for Valve Cooling. Output: 33 c.f.m. free air. Static Water Lift: 0.63". Single phase, permanent capacitor, totally enclosed motor rated at 25 volt/amps for continuous running. Overall dimensions: 6½" × 5½" × 4½".

SERVICE ELECTRIC CO., LTD.

SECOMAK WKS. HONEYPT LANE, STANMORE, MIDDX. Tel: EDmore 5566-7/8/9

**REDUCE YOUR
PRESS TOOL COSTS**

**THE HUNTON UNIVERSAL BOLSTER OUTFIT
FOR SHEET METAL PIERCING AND
BLANKING ON FLY PRESSES**

Bolster Frame with 2 adjustable gauges and insertable steel Holders for Dies ¼ in. to 3½ in. bore diameter.

Two Punch Holders with detachable positive-action Strippers take the complete range of Punches ¼ in. to 3½ in. diameter.

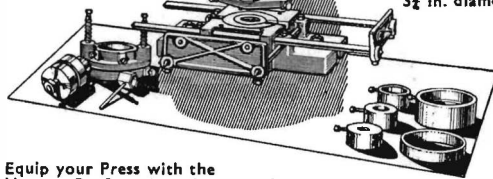

Equip your Press with the Hunton Outfit and use inexpensive standardised Punches and Dies ¼ in. to 3½ in. diameter obtainable from stock—in ½ in. sizes—when you need them. Standardised Tools also available at short notice for Square, Oblong and other shapes, Louvre Forming (up to 8 in. long), Corner Notching, Corner Radiusing, Angle Iron Notching and Piercing, etc. Get the Outfit now—Buy Punches, Dies and tools as you need them

Descriptive brochure and prices on request.

HUNTON LIMITED

Phoenix Works, 114-116, Euston Road, London, N.W.1
Telephone: Euston 1477 Telegrams: Untonexh, London

IF YOU would like
a HOUSE
near PERMANENT EMPLOYMENT
in an INTERESTING JOB
with a GOOD SALARY
and a PENSION SCHEME
at a MODERN FACTORY
in an ATTRACTIVE TOWN
near LONDON
then

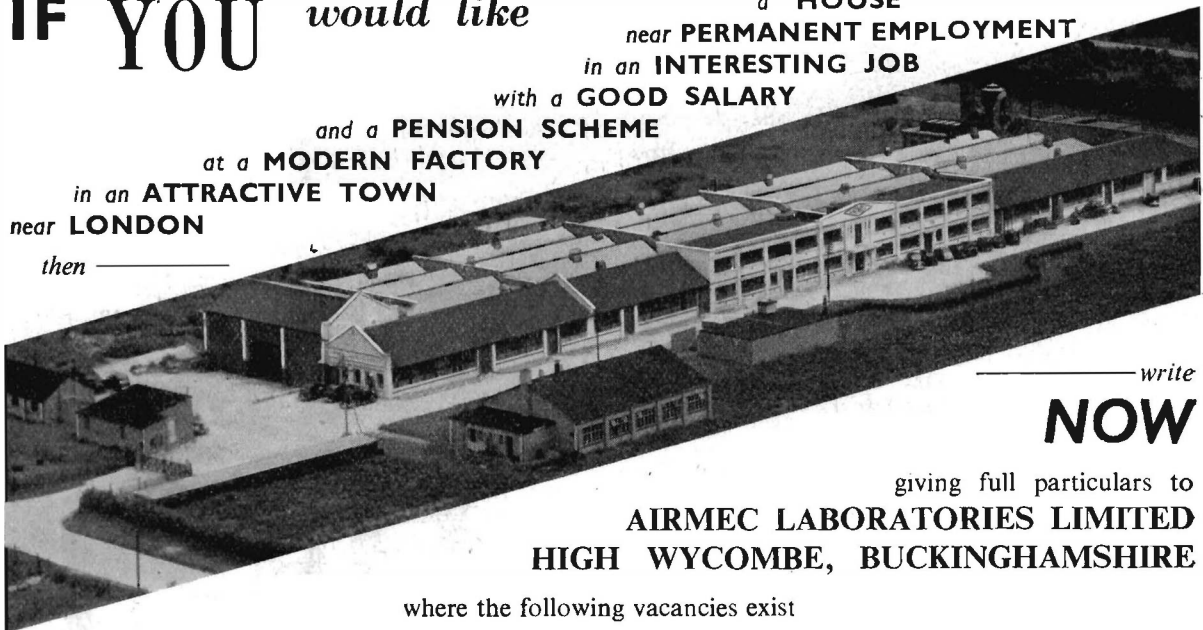

write
NOW

giving full particulars to
AIRMEC LABORATORIES LIMITED
HIGH WYCOMBE, BUCKINGHAMSHIRE

where the following vacancies exist

DRAUGHTSMEN

TOOL DESIGNER DRAUGHTSMEN

TECHNICAL ASSISTANTS

DEVELOPMENT ENGINEERS

PLANNING AND ESTIMATING ENGINEERS

Ordinary National Certificate and experience in Radio or Telephone Industry.

Ordinary National Certificate in Mechanical Engineering and experienced in light to medium Engineering.

National Certificate, etc., and experience of electronic equipment, with a Degree in Electronic subjects, preferably Telecommunications, and at least three years' experience of electronic equipment.

Higher National Certificate Mechanical Engineering with workshop training in light engineering.



Wide clearance

comes to terms

with a close fit!

Don't go together — or do they? In actual fact they DO and Ragosine 'Extreme Viscosity' Lubricants make it possible. Developed during the war, they are now widely used by Instrument Makers for a variety of purposes. For instance, they 'take up the slack' — you can work to wider clearances (an important production factor) yet maintain close, accurate fitting and perfect ease of movement.



*That's one purpose—
there are others too!*

- SEALING COMPOUNDS
- THREAD LUBRICANTS
- PRESSURE TIGHTNESS GREASES

- DAMPING FLUIDS
- All of real interest to YOU!*

Let us send you fully explanatory literature which may open your eyes to the vast possibilities of

RAGOSINE

INSTRUMENT GREASES

RAGOSINE OIL CO. LTD.

MINERVA WORKS, WOODLESFORD, Nr. LEEDS

London Office: Ibox House, Minorities, London, E.C.3

n.d.h

EGEN

first and foremost!

Egen Potentiometers are recognised everywhere for their dependability and are constantly being specified by radio and electronic engineers. A specialised carbon deposition guarantees perfect electrical stability. Note these features:—

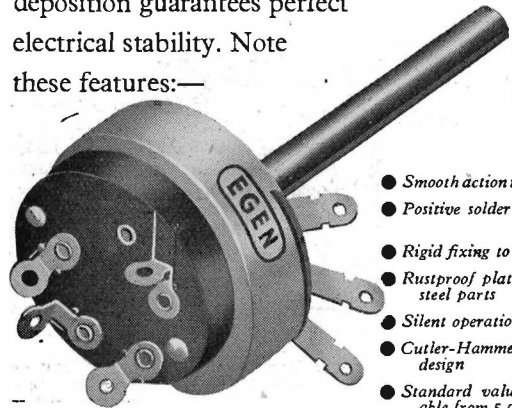

- Smooth action movement
- Positive solder tag location
- Rigid fixing to chassis
- Rustproof plating of all steel parts
- Silent operation
- Cutler-Hammer switch design
- Standard values available from 5,000 ohms. to 2 megohms.

Egen Potentiometers are also available with single pole or double pole switch and without switch. Switches only supplied separately if required.

PRE-SET RESISTORS.

A wire-wound pre-set resistor for panel or chassis mounting: Multi-unit banks available to special order.

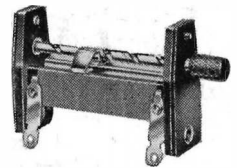

SUB MINIATURE VOLUME CONTROL

For use in Deaf Aids and other miniature electronic apparatus.

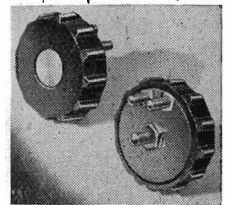

Overall diameter less than 1/2"

Export enquiries welcomed

EGEN

POTENTIOMETERS

EGEN ELECTRIC LTD

Charfleet Industrial Estate, Canvey Island, Essex. 'Phone: Canvey 691 & 2

LAMALAC

INSULATION

SYNTHETIC RESIN LAMINATED MATERIALS

Sheet, Rod and Tube in all dimensions, Bobbins & Coil Formers to any specification

MICA AND MICANITE SHEET AND MANUFACTURED PARTS

MICA & MICANITE SUPPLIES LTD.

BARNBURY SQUARE, LONDON, N.1.

Telephone: NORTH 3032/5 Telegrams: MICASULIM-LONDON

SOLONS FOR ESSENTIAL JOBS!

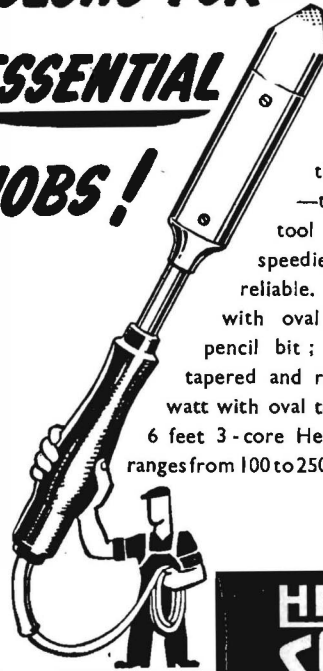

Use SOLONS for the jobs that matter —this modern precision tool makes soldering speedier, simpler and more reliable. 5 models: 65 watt with oval tapered and round pencil bit; 125 watt with oval tapered and round pencil bit; 240 watt with oval tapered bit; each with 6 feet 3-core Henley flexible. Voltage ranges from 100 to 250. Write for folder Y.10

HENLEY SOLON
ELECTRIC
SOLDERING IRONS
FOR INDUSTRIAL USE

W. T. HENLEY'S TELEGRAPH WORKS CO. LTD.
51-53 Hatton Garden, London, E.C.1.

OUR TECHNICIANS WILL WELCOME YOUR PROBLEMS

Dainite

MOULDED RUBBERS

JUST PHONE:
MARKET HARBOROUGH - 2274/5
OR WRITE:

THE HARBORO' RUBBER COMPANY LIMITED
MARKET HARBOROUGH : LEICS.

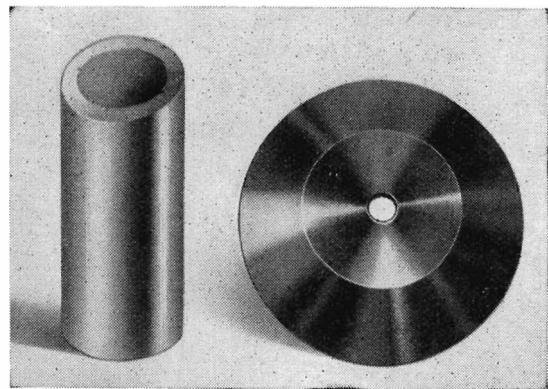

X-RAY TARGETS WITH OR WITHOUT CAST-ON COPPER BODY. ROTATING ANODES.

MOLYBDENUM TUBES AND OTHER MOLYBDENUM COMPONENTS
TUNGSTEN RODS AND THREE-PIECE LEAD WIRES FOR TUNGSTEN TO GLASS SEALS
TUNGSTEN WELDING ELECTRODES FOR INERT GAS ARC WELDING
TUNGSTEN CONTACT RIVETS AND SCREWS



ELECTRO-ALLOYS Ltd.

12, BRUNEL RD., LONDON, W.3.

Makers of TUNGSTEN and MOLYBDENUM Products

They get around!

Made by people with a conscience.

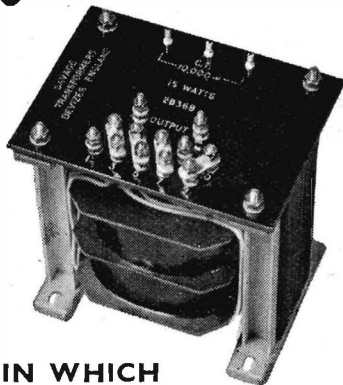

COUNTRIES IN WHICH SAVAGE TRANSFORMERS ARE IN USE

- | | | | |
|-----------|-------------|-----------------|--------------|
| Spain | Iran | Switzerland | Iraq |
| Canada | Ireland | U. of S. Africa | Italy |
| Australia | Jamaica | Belgium | Israel |
| Malaya | Portugal | Egypt | Libya |
| Finland | New Zealand | Gibraltar | Mexico |
| India | Malta | Pakistan | Cyprus |
| China | Rhodesia | Brazil | Argentine |
| U.S.A. | Sweden | San Salvador | Sierre Leone |

TRANSFORMERS
SAVAGE OF DEVIZES
LIMITED

Nursted Road, Devizes, Wilts. Telephone: Devizes 536.

DONOVAN ACCESSORIES — FOR THE ELECTRONIC APPARATUS MANUFACTURER!

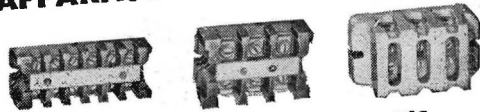

TYPE J.96 TERMINAL BLOCKS
Made in 15, 30 and 60 amp. sizes

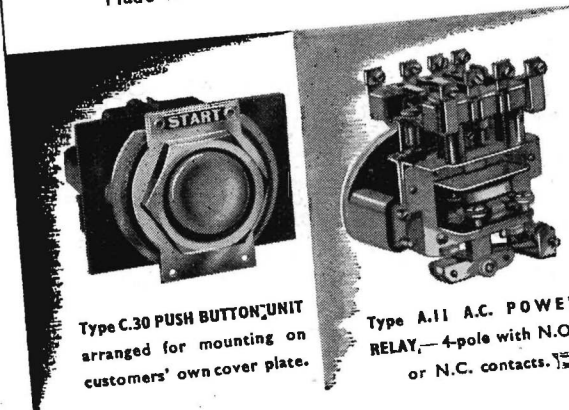

Type C.30 PUSH BUTTON UNIT arranged for mounting on customers' own cover plate.

Type A.11 A.C. POWER RELAY, — 4-pole with N.O. or N.C. contacts.

THE DONOVAN ELECTRICAL CO. LTD.
Safuse Works · Stechford · Birmingham 9

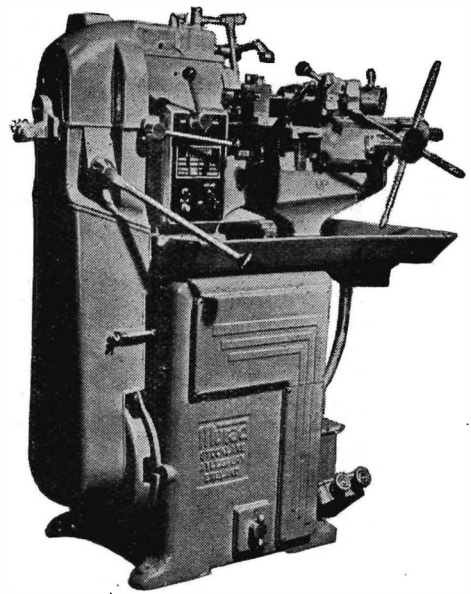

acclaimed in both hemispheres

Murad CAPSTAN LATHE

MURAD DEVELOPMENTS LTD., STOCKLAKE, AYLESBURY, BUCKS.
PHONE: AYLESBURY 790 (4 lines) CABLES: MURADITE, AYLESBURY

Only with CO-AX R.F. CABLES

AIR-SPACED ARTICULATED

Patents Regd. Trade Mark.

LOW WATTEN TYPES.	IMPED OHMS	ATTEN. dB/100ft. of 100 Mc.	LOADING Mc. #10002. 100/ft.	O.D. "	
A 1	74	1.7	0.11	0.36	HIGH POWER FLEXIBLE
A 2	74	1.3	0.24	0.44	
A 34	73	0.6	1.5	0.88	
LOW CAPAC. TYPES.	CAPAC. pF/ft.	IMPED. OHMS	ATTEN. dB/100ft. 100 Mc.	O.D. "	
C 1	7.3	150	2.5	0.36	PHOTOCELL CABLE
PC.1	10.2	132	3.1	0.36	
C.11	6.3	173	3.2	0.36	
C 2	6.3	171	2.15	0.44	VERY LOW CAPACITANCE
C22	5.5	184	2.8	0.44	
C 3	5.4	197	1.9	0.64	
C33	4.8	220	2.4	0.64	
C44	4.1	252	2.1	1.03	

THE LOWEST EVER CAPACITANCE OR ATTENUATION

IMMEDIATE DELIVERIES

SPECIALISTS IN AIR-SPACED ARTICULATED CABLES SINCE 1929

TRANSRADIO LTD.
CONTRACTORS TO H.M. GOVERNMENT
138A CROMWELL ROAD, LONDON, S.W.7
ENGLAND

EARLY DELIVERY

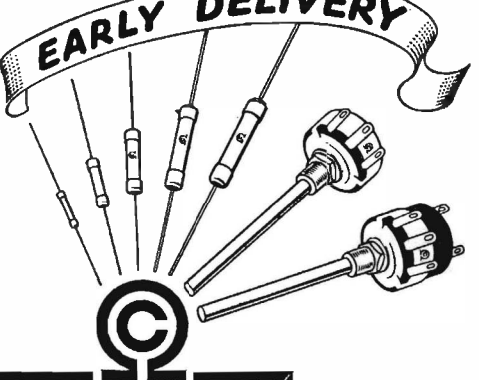

CONSTANTA

HIGH STABILITY RESISTORS
available in ratings from 0.063 up to 2 watts
and with tolerances of $\pm 0.5\%$ $\pm 1\%$ $\pm 2\%$
 $\pm 5\%$ and $\pm 10\%$

CARBON POTENTIOMETERS
Switch and non-switch types, Linear, Pos.
and Neg. Log. Law.

Sole U.K. Concessionaires :-
G. A. STANLEY PALMER A.R.Ae.S.
MAXWELL HOUSE, ARUNDEL STREET, LONDON, W.C.2
TEM. Bar 1610

WILLIAM M. H. **SMALL** LTD.

Phone: Victoria 0223. 2003
Grams: Small, Victoria 0223. 2003
Birmingham

WRIGHT STREET
SMALL HEATH
BIRMINGHAM. 10



WASHERS in all materials
PRESSED NUTS Brass & Steel
PRESSINGS in all Metals,
Bakelite & Fibre.

**Electrolytic
Iron Powder**
'SINTREX'
BRAND

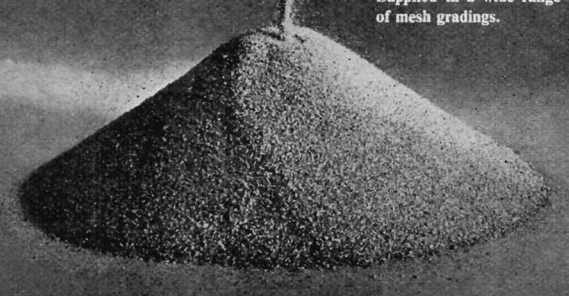

Its exceptional purity
makes it especially suit-
able for electrical and
magnetic applications.
Supplied in a wide range
of mesh gradings.

**GEORGE COHEN
SONS & CO. LTD**

BROADWAY CHAMBERS
TELEPHONE **600**
LONDON - - - W.6
RIVERSIDE 4141

**PRECISION IN CERAMICS
BY BRAY**



Quantity production of small automatically made pieces in
Steatite, Porcelain, and Rutile materials for electric cooking
and heating equipment, and telecommunication apparatus.

BRAY



GEO. BRAY & CO. LTD., Leicester Place, Leeds 2.
Tel.: 20981/8. Grams: "Bray, Leeds 2"

SENSITIVE PANEL MOUNTING METERS

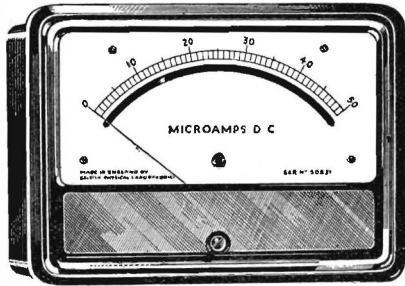

SIZE	2½"	3½"	5"
RANGE	25μA to 50A	10μA to 50A	10μA to 50A

(Prices on application)

S.50 types microammeters are stocked by M.R. Supplies Ltd. at New Oxford Street, W.C.1

All sizes available with MIRROR SCALE
1st Grade Accuracy.

BRITISH PHYSICAL LABORATORIES
HOUSEBOAT WORKS · RADLETT · HERTS
Telephone: RADLETT 5674-5-6

SYNTHETIC RESIN-BONDED

TUBES

FORMERS AND BOBBINS

**Tube
Lamination
LTD.**

DESBOROUGH PARK ROAD,
HIGH WYCOMBE, BUCKS.

Tel. · 1921/2

MOULDINGS

COMPRESSION AND INJECTION

Elco Plastics Ltd

DESBOROUGH PARK RD., HIGH WYCOMBE, BUCKS

A.I.D. APPROVED

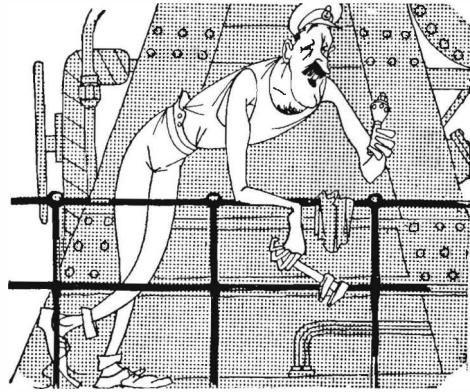

Time and time again you'll find them

Afloat aloft or ashore, you come across "Castle" Components in every phase of engineering. Our Repetition Work in all metals, as well as Machining and Light Assemblies, has won a reputation for always being exactly right. Brochure on request.

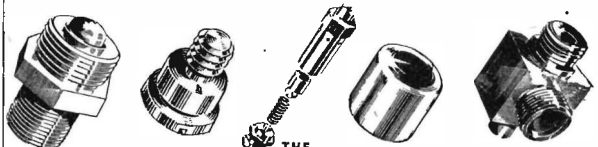

THE
CASTLE ENGINEERING
COMPANY (NOTTINGHAM) LIMITED

HASLAM STREET · CASTLE BOULEVARD · NOTTINGHAM

L 6134B

"Cyldon" Precision Variable CAPACITORS

from MINIATURE TRIMMERS to
HIGH VOLTAGE
TRANSMITTER CAPACITORS

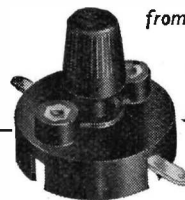

No. 26. Mica

Compression Trimmer

For use in Television circuits. High stability with constant, wide capacity swings and long life at high voltage. Blade resilience not affected by continual setting. Low loss Rockite base and best Mica di-electric give very efficient Power Factor. Location method prevents flash-over from blade movement. Capacities up to 1,000 pF. at 1,500 or 3,000 v. D.C. test and up to 3,000 pF. for 250 v. D.C. test. 1.225" diam. 1¼" high.

Here are shown just two examples from the comprehensive "Cyldon" range. For precision, stability, and long life, "Cyldon" superiority is recognised by all designers and users of electronic equipment.

No. 18/5.

Air Di-electric Trimmer

Of high stability and excellent Power Factor. High but smooth operating torque. Metal parts silver plated. First-grade ceramic base. Single-hole fixing. Split stator and locking versions also available. Max. capacities from 10-30 pF. Base size 1" x ¾"

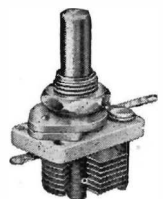

● Full details of the complete "Cyldon" range, and list of Overseas Agents, available from the Manufacturers:

SYDNEY S. BIRD & SONS, LTD. Contractors to Ministry of Supply, Post Office, and other H.M. Government Depts.

CAMBRIDGE ARTERIAL ROAD · ENFIELD · MIDD. Enfield 2071-2

WAYMOUTH GAUGES & INSTRUMENTS LTD.

a subsidiary company of

SMITHS AIRCRAFT INSTRUMENTS LTD.

invite applications for vacancies in their Engineering Department at Godalming.

PROJECT ENGINEER to direct the work of a team engaged on projects covering specialised instruments and electronic equipment. Applicants should possess a University Degree or Higher National Certificate in Electrical Engineering or similar qualifications and have had experience in this type of work. *Ref. E1.*

ASSISTANT ENGINEER for theoretical and experimental work on magnetic amplifiers. Qualifications such as degree in Physics or Electrical Engineering or Higher National Certificate are required. Previous experience in this field of work would be an advantage. *Ref. E2.*

ASSISTANT ENGINEER for theoretical and experimental work on problems of aircraft fuel contents gauging. Qualifications similar to post above are required. *Ref. E3.*

TECHNICAL ASSISTANT to assist in development work on magnetic amplifiers and electrical instruments. For this previous experience is not essential but preferred qualifications would be an Engineering degree or Higher National Certificate in Electrical Engineering. *Ref. E4.*

TECHNICAL WRITER for preparation of installation, maintenance, and overhaul manuals and other publications. Experience of aircraft installations and electrical equipment is essential. Some previous experience in this type of work would be an advantage. *Ref. E5.*

DRAUGHTSMEN, senior and junior, for work on aircraft instruments, magnetic amplifiers and electronic equipment. Minimum qualifications Ordinary National in Mechanical or Electrical Engineering. A knowledge of Inter Service requirements and current design practice is required for the senior post. *Ref. E6.*

INSTALLATION ENGINEER to assist in installation aspects of fuel contents gauges and generally work with other engineers on calibration and field work on similar equipment. Applicants should have a knowledge of aircraft installations and accessories and preferably some previous experience in this type of work. *Ref. E7.*

Applications should be made in writing, quoting the reference of the vacancy, and giving details of qualifications and experience to the Chief Development Engineer, Waymouth Gauges & Instruments Ltd., Station Road, Godalming, Surrey.

Put **HIGH SPEED**
into **SOLDERING** WITH

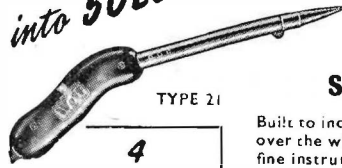

TYPE 21

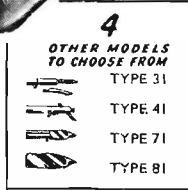

4
OTHER MODELS
TO CHOOSE FROM
TYPE 31
TYPE 41
TYPE 71
TYPE 81

SOLDE RGUNS

Built to increase output and cut costs over the whole field of soldering from fine instrument work to heavy industrial soldering. Only Wolf Solderguns have all these outstanding advantages.

OFF-STRAIGHT EASY-GRIP HANDLE
PERFECT CONTROL • LOW CURRENT CONSUMPTION • MAINTAINS CORRECT HEAT • QUICKER HEAT-UP • LOCALISED HEAT • A MODEL FOR EVERY PURPOSE

HIGH SPEED SOLDERING

Win new efficiency and economy with Wolf Type 51 Soldergun. Its trigger-feed action and perfect balance make it indispensable to all modern assembly.

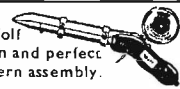

TYPE 22

SOLDERING IRONS

For all who, for special reasons, prefer the conventional straight type handle, identical as regards elements and bits to Wolf Solderguns but with round hard wooden handle with heat deflecting skirt.

TYPE 32

TYPE 42

It pays to Solder with **Wolf**

ELECTRIC SOLDE RGUNS & SOLDERING IRONS

* Obtainable from all high-class stockists and ironmongers

WOLF ELECTRIC TOOLS LTD. PIONEER WORKS HANGER LANE LONDON W.5
TELEPHONE PERIVALE 35314 BRANCHES BIRMINGHAM MANCHESTER LEEDS BRISTOL GLASGOW

Dept. E.E.



18 TOTTENHAM COURT ROAD, LONDON, W.1.

Tel.: MUSeum 2453/4539

Business Hours: Monday-Friday 9—5.30 Saturday 9—1

RELAYS

D.C. COIL RESISTANCE

3,000 TYPES: 1.9Ω to 80,000Ω
600 TYPES: 0.4Ω to 9,200Ω.

ALSO LARGE STOCKS OF DOUBLE & TRIPLEWOUND AND SLUGGED COILS.

CONTACTS

3,000 TYPES: up to 8 sets.
600 TYPES: up to 4 sets.
3,000 TYPES: Make (M), Break (B), in Twin-silver, Twin-platinum, Dome-silver (2 amp.), Tungsten (5 amp.), and Flat-silver (8 amp.). Change-Over (C), in all but Tungsten: Make-Before-Break (K), in Twin-silver and Twin-platinum.

600 TYPES: (M), (B) and (C), in Twin-silver and Twin-platinum.

SPECIAL
High resistance slugged coils (up to 10,000 OHMS with 1" slug) now available.

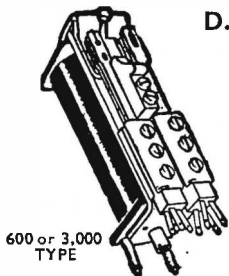

600 or 3,000 TYPE

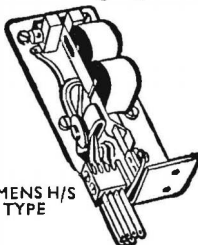

SIEMENS H/S TYPE

Graham Gear Co Ltd

SPURS
SPIRALS
BEVELS
8-100 D.P.

STATION ROAD
BROOKMANS PARK, HERTS.
Tel:- HATFIELD 3130

L. WILKINSON

Wholesale and Export

19, LANSDOWNE ROAD, CROYDON

Phone : CRO 0839

Telegrams : " WILCO " CROYDON

Voltage Regulators. Input 230 volt A.C. 21 amps., output 57.5 Vt. to 228 volts in 16 Steps. With current limiting Reactor. Made by English Electric. £15.

Variac Transformers. Type 80 CO. Input 200/240 v. Output 220 v. 7.5 amps. £7 10s. each.

Crystal Ovens. Type TC9. 6V 15 amps., with Crystal AR3. Frequency 655-7, complete with Unit R817. 55s. Also Crystal Oven, Type I, 10A/13971. 35s.

Portable Electric Blowers. 220/230 volts 220 watts. Completely enclosed, 8 ft. flexible hose and nozzle. 7 yds. C.T.S. flex. Various applications in industry where clear dry air is required. £8 15s.

Wheatstone Bridge. Accuracy 0.01 per cent. Five decades of "Thousands" "Hundreds" "Tens" "Units" "Tenths". Made by H. W. Sullivan, Ltd.

P.O. Standard 6 ft. Racks. For 19 in. panels, heavy channel type. £7 10s. each.

Operators' desks for above Racks, 19 in. by 12 in. 15s. each.

Klaxon Geared Motors. No. IK55B3-W7. 230V. A.C. Split Phase Induction Type, with a torque of 15 lb. in. R.P.M. 175 £10 each.

Battery Chargers. "Westalite." Input 100/250V. A.C. Output 12V. 16 amps. D.C. Fully variable, fused and metered. £15 15s. each, carriage paid.

Battery Charger. Type 42A. Input 230V. A.C. Output 6 or 12V. 4 amps. In black crackle case with fuses, switch and meter. £5 5s., carriage paid.

Signal and Noise Generator. For television frequencies 20/88 Mc/s. in 4 Bands. Crystal controlled. Leaflet available on request. Price £14 10s.

Auto Transformer. 230/115 volts 500 watts 50 cycles, fully shrouded, new. Made by Met.-Vic. £4 10s. each.

Electronic Ignition Tester. Type U.E.D. English Electric, employing an entirely new technique in ignition testing of internal combustion engines. Incorporating cathode ray tube giving a visual trace of the complete ignition cycle enabling the electrical performance of the entire system to be observed whilst the engine is running. Operates on 230 volts A.C., also 6, 12 and 24 volts D.C. Brand new. £35.

Relays. P.O. Type 3000. Built to your requirements. Prompt delivery given.

SINE-COSINE POTENTIOMETERS
MAGSLIP INDICATING SYSTEMS
SERVO MOTORS

IPOTS
SELSYN SYSTEMS
MAGSLIP DIFFERENTIALS
MAGSLIP CONTROL SYSTEMS
MAGSLIP SINE-COSINE RESOLVERS

Selected Government Surplus, in new condition, for Immediate Delivery.

Brochure and Price List from :

SERVOTRONIC SALES

INCORPORATING HOPTON RADIO
I, HOPTON PARADE, HIGH ROAD, STREATHAM,
LONDON, S.W.16

Telephone : Streatham 6165

SUPPLIERS TO UNIVERSITIES, RESEARCH LABORATORIES and
MANUFACTURERS THROUGHOUT THE WORLD

**BRASS, COPPER, BRONZE,
ALUMINIUM, LIGHT ALLOYS**
IN ROD, BAR, SHEET TUBE, STRIP, WIRE

3000 STANDARD STOCK SIZES

H. ROLLET & CO., LTD.

6, CHESHAM PLACE, LONDON, S.W.1.

SLOane 3463

WORKS :

36, ROSEBERY AVENUE, LONDON, E.C.1.

"No Quantity too Small"

also at

Liverpool - Manchester - Birmingham - Leeds

WE TALK YOUR LANGUAGE
when it comes to **TRANSFORMERS**

- ★ designed for standard & special applications.
- ★ built for reliability.
- ★ engineered for trouble-free operation.



TRANSFORMERS BY **Amos of Exeter** A.I.D. APPROVED
AMOS OF EXETER, R.T.S. WORKS, COWICK STREET, EXETER.

FREE

**A VALUABLE
BOOK**

which details the wide range of Engineering and Commercial Courses of modern training offered

by E.M.I. Institutes—the only Postal College which is part of a world-wide Industrial Organisation. Engineering Courses include training for :
City and Guilds Grouped Certificates in Telecommunications ; A.M. Brit. I.R.E. Examination, Radio Amateur's Licence, Radio & Television Servicing Certificates, General Radio and Television Courses, Radar, Sound Recording, etc. Also Courses in all other branches of Engineering.

EMI Institutes

associated with
MARCONIPHONE COLUMBIA HMV

COURSES FROM **£1** PER MONTH

POST NOW

Please send, without obligation the FREE book
E.M.I. Institutes, Dept. 11
43 Grove Park Rd., Chiswick, London, W.4

Name

Address

IC.10E

**'Radiospares'
Quality Parts**

**THE SERVICE ENGINEER'S
FIRST CHOICE**

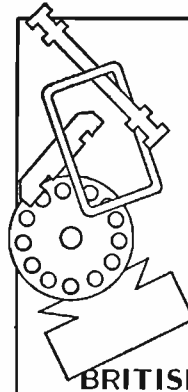

MICA

DISCS
DIAPHRAGMS
ELEMENT STRIPS
CONDENSER PLATES
SPECIAL SHAPES
RAW MICA
WASHERS
etc

BRITISH MICA CO. LTD. - BEDFORD.

ELECTRONIC INSTRUMENTS IN INDUSTRY

COSSOR Oscilloscopes, Cameras, Sweep Generators.

DAWE Stroboscopes, Vibration Meter, Sound Level Meter, A.F. Analyser, Moisture Meters.

ADVANCE Signal Generators, Audio Generators, Constant Voltage Transformers.

AVO Multirange Meters, Electronic Test Meters.

If You Require Further Information Consult:—

A. C. FARNELL, LTD.

Tel. 32958-9

15 PARK PLACE,
LEEDS, 1

Tel. 32958-9

HIGH PURITY GERMANIUM DIOXIDE

(GeO₂)

Manufactured by

ELGAR LABORATORIES

(ELGAR TRADING LTD.)

240 High St., Harlesden,
London, N.W.10, England.

Cables: ELGATRAD, LONDON



RELAYS AND KEY SWITCHES

LARGEST EX-GOVT. STOCK IN GT. BRITAIN

Types 600-3000 Relays — Siemens High Speed
Also A.C. 250 volts 50 cycles

Unselector Switches, Telephone Switchboards, Telephone Components,
Plugs, Jacks, Handsets — Government Contractors.

JACK DAVIS (RELAYS) LTD. (Dept. E.E.)

36 PERCY STREET, LONDON, W.1

Phones: MUSEum 7960, LANgham 4821

“SANOID” FIRST AID

For over fifty years we have studied and supplied the specialised First Aid requirements of Industry. We believe our efforts have been of advantage to those we are privileged to serve, as on many occasions we have been able to meet the particular needs of various industries and conditions.

May we help you? Our wide experience is at your service, and we should be pleased to send you our current catalogue and price list.

A PRODUCT OF

Cuxson Gerrard & Co. Ltd.
OLDBURY BIRMINGHAM

FIRST AID SPECIALISTS

ESTABLISHED 1878

THE LATEST in AIR DIELECTRIC TRIMMERS

Encased in acetate container for extra protection

Width: 16.5 m/m. Length: 22 m/m. Height: 1.5 to 8pF—7.5 m/m. 1.5 to 20pF—10 m/m. 2 to 26pF—11 m/m. 2 to 32pF—12 m/m. Law: Straight line capacity. Power Factor: Less than .001. Insulation: over 2000 megohms. Voltage: 500 D.

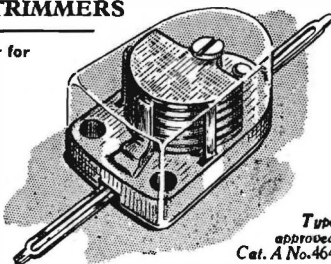

Tube approved
Cat. A No. 464

OXLEY DEVELOPMENTS CO. LTD.

ULVERSTON, NORTH LANCs. TEL: ULVERSTON 3306

TECHNICAL BOOKS

H. K. LEWIS & Co. Ltd., invite inspection of their stock of books on all branches of Radio and Electrical Engineering.

LENDING LIBRARY: Technical and Scientific. Annual Subscription from TWENTY-FIVE SHILLINGS

Prospectus Post Free on Request.

THE LIBRARY CATALOGUE revised to December 1949, containing a classified Index of Authors and Subjects. To subscribers, 17s. 6d. net. To non-subscribers 35s. net. Postage 1s. 3d.

LONDON: **H. K. LEWIS & Co. Ltd.**, 136 Gower St., W.C.1
Telephone: EUSTon 4282 (7 lines)

“SPEARETTE”

MINIATURE



VALVE.

WIRING JIGS

SPEAR ENGINEERING CO. LTD.

TITAN WORKS, WARLINGHAM, SURREY.

Telephone: Upper Warlingham 2774.

POWER Transformers

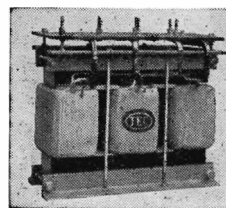

10VA to 100kVA Open, Enclosed, Oil Cooled, D.W. and Auto

For Industrial Engineering, Furnaces, Electronics, Phase Conversion, etc.

THE TRANSFORMER & ELECTRICAL CO. LTD.

Eastern Works, Walthamstow, London, E.17

Phone: KEYstone 5031/2

INDEX TO ADVERTISERS

A.B. Metal Products Ltd.	22	Electronic Engineering Monographs	433	Murad Developments Ltd.	56
Advance Components Ltd.	17	Elgar Trading Ltd.	61	Murex Ltd.	48
Airmec Laboratories Ltd.	27 and 53	E.M.I. Institutes Ltd.	60	Nagard Ltd.	31
Amos of Exeter	60	English Electric Co., Ltd., The	11	Oxley Developments Ltd.	61
Automatic Coil Winder & Equipment Co., Ltd., The	24	Erg Industrial Corporation Ltd.	34	Painton & Co., Ltd.	Cover i
Automatic Telephone & Electric Co., Ltd.	10	Erie Resistor Ltd.	29	Palmer, G. A. S.	57
Baldwin Instrument Co., Ltd.	49	Farnell Ltd., A. C.	61	Philips Electrical Ltd.	52
Bell & Croyden, John	48	Fox Ltd., P. X.	47	Radiospares Ltd.	60
Belling & Lee Ltd.	12	Frigidaire Division of General Motors Ltd.	42	Ragosine Oil Co., Ltd.	54
Bird & Sons Ltd., Sydney, S.	58	Furzehill Laboratories Ltd.	23	Rivlin Instruments	21
Bray & Co., Ltd., George	57	General Electric Co., Ltd., The	13	Rollet & Co., Ltd.	60
British Mica Co., Ltd.	60	Goodmans Industries Ltd.	47	Salford Electrical Instruments Ltd.	25
British Physical Laboratories Ltd.	58	Graham Gear Co., Ltd.	59	Saniguard Appliances Ltd.	50
British Power Transformer Co., Ltd.	14	Harboro' Rubber Co., Ltd., The	55	Sankey & Son Ltd., Joseph	8
Bullers Ltd.	40	Henley's Telegraph Works Co., Ltd., W. T.	55	Savage Transformers Ltd.	56
Burgess Products Co., Ltd.	28	Hunt Ltd., A. H.	37	Scott & Co., Ltd., A. C.	34
Castle Engineering Co. (Nottingham) Ltd., The	58	Hunton Ltd.	53	Service Electric Co., Ltd.	53
Chapman & Hall Ltd.	433	Johnson Matthey & Co., Ltd.	3	Servotronic Sales	60
Cinema-Television Ltd.	15	Kelvin & Hughes Ltd.	51	Small Ltd., William, H.	57
Cohen, Sons & Co., Ltd., George	5	Leland Instruments Ltd.	30	Southern Instruments Ltd.	44
Cole Ltd., E. K.	5	Lewis & Co., Ltd., H. K.	61	Southern Tools Ltd.	62
Cossor Ltd., A. C.	36	Linread Ltd.	42	Spear Engineering Co., Ltd.	61
Cuxson, Gerrard & Co., Ltd.	61	Livingston Laboratories Ltd.	46	Standard Telephones & Cables Ltd.	19 and 39
Davis Supplies Ltd., Alec	59	London Electric Wire Co. & Smiths Ltd.	46	Steatite & Porcelain Products Ltd.	16
Davis (Relays) Ltd., Jack	61	Lyons Ltd., Claude	26	Sullivan Ltd., H. W.	49
Dawe Instruments Ltd.	51	Marconi Instruments Ltd.	18	Telegaph Condenser Co., Ltd., The	Cover iii
Donovan Electrical Co., Ltd.	56	Marconi's Wireless Telegraph Co., Ltd.	35 and 41	Telegaph Construction & Maintenance Co., Ltd.	50
Drayton Regulator & Instrument Co., Ltd.	62	Measuring Instruments (Pullin) Ltd.	45	Transformer & Electrical Co., Ltd., The	61
Edison Swan Electric Co., Ltd., The	Cover ii and 33	Mica & Micanite Supplies Ltd.	55	Transradio Ltd.	56
Edwards & Co. (London) Ltd., W.	52	Minnesota Mining & Manufacturing Co., Ltd.	44	Tufnol Ltd.	9
Egen Electric Co., Ltd.	54	Muirhead & Co., Ltd.	38	Viscose Development Co., Ltd.	20
Elco Plastics Ltd.	58	Mullard Electronic Products Ltd.	7 and 32	Vitavax Ltd.	43
Electro-Alloys Ltd.	55	Mullicore Solders Ltd.	Cover iv	Vortexion Ltd.	45
Electro-Methods Ltd.	43			Waymouth Gauges & Instruments Ltd.	59
				Whiteley Electrical Co., Ltd.	7
				Wilkinson, L.	60
				Wolf Electric Tools Ltd.	59

HIGH PRECISION TOOLMAKING for RADIO VALVE & ELECTRICAL INDUSTRIES

- From simple Gauges—to—Multi-Stage Progression Tools and Special Machines.
- Specialists in the application of Tungsten Carbide for High Speed Production and Wear Resistant Tools.
- Accurate Press Tools for thin materials and Laminations.
- Tungsten Carbide Press Tools for Long Runs.
- Profile Grinding.
- Precision Grinding of Steel, Tungsten Carbide and Ceramics.

SOUTHERN TOOLS LTD.

22/24 UPPER MULGRAVE ROAD,
CHEAM, SURREY.

Vigilant 0074/5



- Combining the properties of:*
1. A compression spring capable of repeated flexing.
 2. A container which can be hermetically sealed.
 3. A packless gland.

HYDRAULICALLY FORMED
BY A PROCESS UNIQUE
IN THIS COUNTRY

FOR Automatic coolant regulation. Movement for pressure change. Packless gland to seal spindle in high vacua. Reservoir to accept liquid expansion. Dashpot or delay device. Barometric measurement or control. Pressurised couplings where vibration or movement is present. Dust seal to prevent ingress of dirt. Pressure reducing valves. Hydraulic transmission. Distance thermostatic control. Low torque flexible coupling. Pressure sealed rocking movement. Pressurised rotating shaft seals. Aircraft pressurised cabin control. Refrigeration expansion valves. Thermostatic Steam Traps. Pressure amplifiers. Differential pressure measurements. Thermostatic operation of louvre or damper.

Write for List No.M.800-1

Drayton METAL BELLOWS

Drayton Regulator and Instrument Co. Ltd., West Drayton, Middlesex

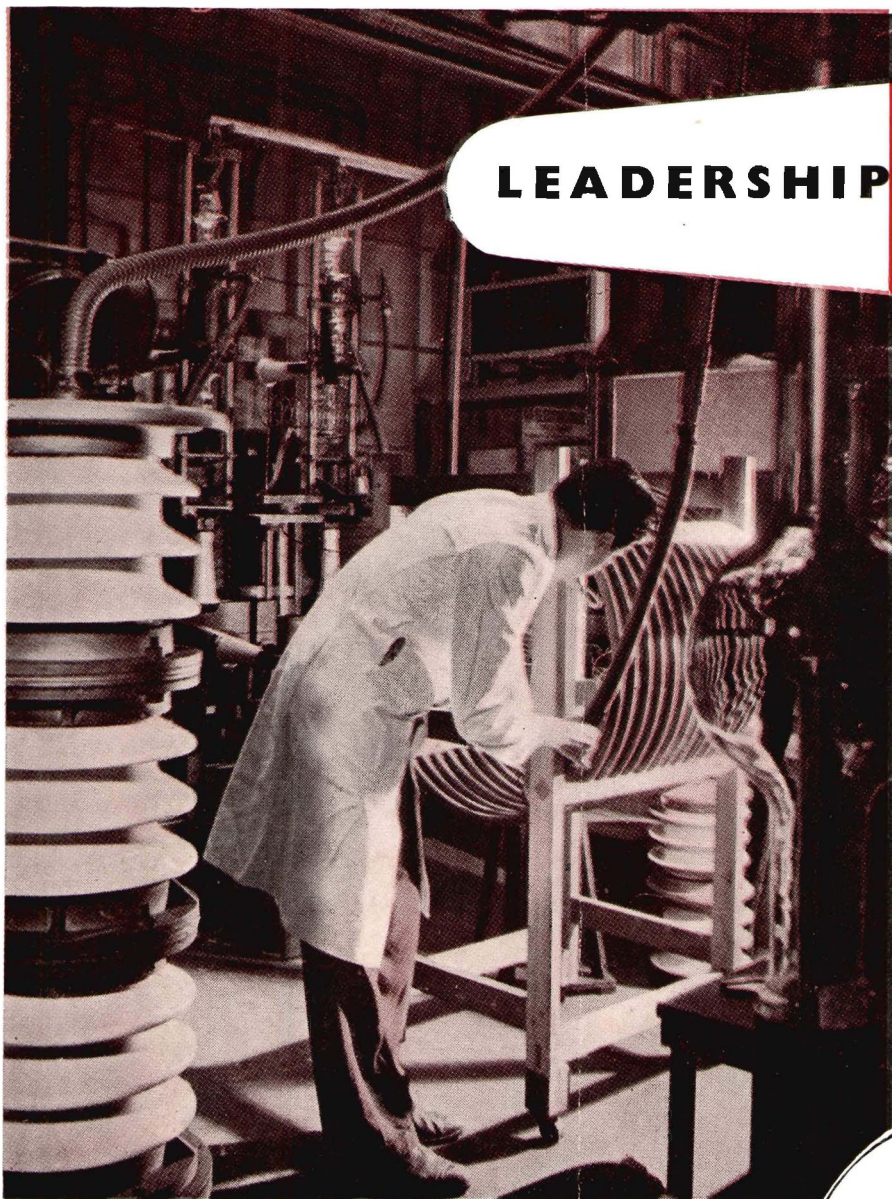

LEADERSHIP

**from
the
inside**



**SEE US AT THE
RADIO SHOW
ON STAND No. 72**



Many know us as manufacturers of vast quantities of small condensers — those ranges in constant demand for electronic needs and electrical appliances. There are also important sections at T.C.C. where giant High Voltage types, as used, for example, in radio transmitters and for industrial power factor correction, are designed and built. This is indeed condenser making on the grand scale, involving specialised knowledge and experience, and demanding skill and precision.

The illustration shows final checking in high-voltage test bay.



*Quest and Test—symbols of
Condenser Perfection*

SPECIALISTS IN CONDENSERS SINCE 1906

THE TELEGRAPH CONDENSER CO. LTD · RADIO DIVISION · LONDON · W.3 · Tel: ACORN 0061 (9 lines)

ERSIN MULTICORE makes Radio Show history-AGAIN



... 10,000 PERFECT JOINTS
IN TELEVISION CAMERA ASSEMBLY
DEMONSTRATION BY PYE OPERATIVES

For the first time at any exhibition, the public saw the intricate assembly of Pye Television Camera units on the Ersin Multicore Stand at Earls Court. Pye chose Ersin Multicore for the 10,000 soldered joints in every camera because it is the only solder containing three cores of exclusive extra-active non-corrosive Ersin Flux, which ensures instantaneous melting, guaranteed flux continuity and complete freedom from "dry" or H.R. joints. Some of the units made at the Radio Show were flown direct to the U.S.A., where Ersin Multicore is already well established as the most reliable and economical solder made.

We will be pleased to send to manufacturers, free of charge, new technical literature and bulk prices. Service engineers, radio and television enthusiasts can obtain size 1 cartons from most radio and electrical shops.

ERSIN LIQUID FLUX SOLDER SLUGS & PELLETS

A non-corrosive, extra-active rosin base liquid flux, for dipping purposes or other soldering processes where it is not convenient to use *Ersin Multicore Solder*. Approved by A.I.D. and G.P.O., and widely used by U.S.A. Electronic Manufacturers. Supplied in 1-gallon and 5-gallon cans. Samples gladly sent without charge to manufacturers on receipt of firm's official order.

Where electronic heating methods are being employed, and in other suitable soldering operations, Ersin or Arax Multicore Solder is available in slug or pellet form, in a wide range of sizes in all standard tin/lead alloys, incorporating Ersin or Arax fluxes. Can be supplied without flux cores. More economical than stamped washers, which are available to special order. Samples of any practicable size gladly sent to manufacturers.



SIZE 1 CARTONS 5/- RETAIL

Catalogue Ref. No.	Alloy Tin/Lead	S.W.G	Approximate length per carton
C 16014	60/40	14	13 feet
C 16018	60/40	18	37 feet
C 14013	40/60	13	13 feet
C 14016	40/60	16	26 feet

MULTICORE SOLDERS LTD., MULTICORE WORKS, MAYLANDS AVENUE, HEMEL HEMPSTEAD, HERTS. BOXMOOR 3636.