

ELECTRONICS AND TELEVISION & SHORT-WAVE WORLD

OCTOBER, 1940

1/6



THE FIRST
TELEVISION
JOURNAL
IN THE
WORLD

HULTON
PRESS LTD.,
43, SHOE LANE,
LONDON, E.C.4.

£8.10

PRINCIPAL CONTENTS

OCTOBER, 1940

	Page
A New Development in D.C. Restoring Circuits	436
Adding Band-spread to Short-wave Receivers	437
Simple methods for improving long-distance reception	
Auditorium Acoustics	438
Problems associated with the distribution of sound in large halls	
Television Radio-relay System	441
Details of a radio network for the distribution of television programmes over wide areas.	
Improved Method of Manufacturing Condensers	444
Measurement of Scanning Speeds of Cathode-ray Tubes	445
News Brevities	447
The Construction and Physical Properties of Gas-filled Triodes	449
The Multivibrator as a Frequency Source	453
A useful method of obtaining a series of frequencies from an oscillator without the use of a tuned circuit.	
RCA Large-screen Television	455
Linear Diode-condenser Valve Voltmeter	457
Theory and design of an A.C. mains-operated thermionic voltmeter	
Recent Developments	461
Reducing Hum by a Bridge-type Feed-back Circuit	463
New Method of Manufacturing Electron Emissive Cathodes	464
Columbia Colour Television	465
First details of an entirely new American system	
Volume Expansion	466
A simple method of employing a modified A.V.C. circuit	
Modern X-ray Associated Apparatus	467

Contributions will be promptly considered: they should be accompanied by a stamped addressed envelope for return in case of non-acceptance.

Manufacturers are invited to send details of new productions for review.

TAYLOR ALL-WAVE SIGNAL GENERATORS

(6.5 to 3,000 metres)

The 4 different models available are further examples of the outstanding design, efficiency and reliability of TAYLOR instruments.

Each model is a fully self-contained unit and provides modulated frequency signals for all types of receiver tests.



TAYLOR ALL-WAVE SIGNAL GENERATOR.

Read this brief specification:—

FREQUENCY RANGE

6 overlapping ranges covering from 46 mc/s to 100 Kc/s. (6.5 to 3,000 metres). Five of these are direct ranges and one harmonic range covers the ultra short band.

MODULATION

A separate valve, oscillating at 400 cycles, is employed to supply internal modulation, and can also supply up to 5 volts to the output jack on the generator. There is a choice of either internal modulation at 400 cycles, or, unmodulated or externally modulated by an external source of audio frequency.

ATTENUATION

Two attenuators provide for coarse and fine adjustments. 0 to 10 microvolts and multiplications of 10, 100, 1,000 and 10,000.

- MODEL 60 A. A.C. mains, 200/250 volts, 50 cycles.
- MODEL 60 U. A.C./D.C. mains, 200/250 volts.
- MODEL 60 L. A.C./D.C. mains, 100/150 volts.
- MODEL 60 B. Battery operated by self-contained H.T. and L.T. Dry Batteries.

All models are supplied complete with instruction book, and all are priced at

£11. 11. 0

Taylor Instruments are British make and all are Guaranteed for six months

DELIVERIES AT PRESENT, EX-STOCK

The Taylor range of instruments includes UNIVERSAL METERS (4 models) £6. 10. 0. to £16. 16. 0. VALVE TESTERS (3 models) £9. 9. 0. to £15. 9. 6. SIGNAL GENERATORS and an OSCILLOSCOPE at £18. 18. 0. Details of any model will be sent on request.

British Made by—

TAYLOR Electrical Instruments Ltd.
419-422 Montrose Avenue,
SLOUGH, Bucks.
Phone: Slough 20061.

Electronics

AND
TELEVISION
AND
SHORT-WAVE WORLD

EDITORIAL, ADVERTISING AND PUBLISHING OFFICES
43, SHOE LANE, LONDON, E.C.4

Editor : H. CORBISHLEY

Telephone : CENTRAL 7400

Subscription Rates; Post Paid to any part of the world—3 months, 5/- ; 6 months, 10/- ; 12 months, 20/-.
month) 1/6 net. Registered for Transmission by Canadian Magazine Post.

Monthly (published 25th of preceding

News and Views

AS might be expected, the present position has seriously affected the circulation of technical literature which has been available from other countries, to say nothing of the reduction in technical books and monographs. Some of the continental publications are still procurable through roundabout channels, but the inevitable restrictions on the subject matter of technical articles have caused many papers on important aspects of electronics to be postponed.

In the book world it is gratifying to note that some publishers are proceeding with their programmes, although on a less ambitious scale. This is all the more encouraging as certain of the technical branches of the services have expressed the wish for technical books and literature to be sent them. There must be many opportunities for the study of the theory of electronics among the technical units in the Army and Air Force and readers would be helping the waiting time to hang less heavily if they would send suitable textbooks to units in their neighbourhood or hand them in at any post office.

We are sure that all our readers will join us in offering sincere condolences to the Council and members of the Television Society whose premises were severely damaged by a bomb which fell in the neighbourhood early in September.

An account of the opening of the Society's headquarters appeared in the August issue for 1939 and since that time the work of establishing and improving the premises has gone steadily on in spite of the severe setback which the War occasioned to television.

The happening is all the more unfortunate in that the Society have for years suffered under the handicap of having no library or meeting room of their own in which members could discuss their problems in an informal atmosphere. The realisation of their wishes was made possible by the generosity of Capt. R. Wilson who has been an enthusiastic experimenter in television from the earliest days and the efforts of many voluntary workers who gave their time to the fitting out of the library premises.

We are pleased to hear that the collection of books on Television, which includes a copy of the earliest known handbook by Mihaly, is undamaged and the

museum specimens have come to no harm. These were stored in the basement at the outbreak of war.

The Lecture Secretary, Mr. G. Parr of 68 Compton Road, N.21, informs us that the library facilities will be restored as soon as repairs have been completed and that members' data service is still available although the opening date of the 1940 session is unavoidably postponed.

We would urge all television enthusiasts to support the Society's efforts to the utmost in anticipation of the restoring of the television service after the war. The Society is unique in that it caters solely for television workers and is the first scientific society to be established in this field. Particulars of membership can be obtained from the Lecture Secretary at the above address.

The L.T. accumulator is one of those components of the modern radio receiver which is taken for granted, and very few users of battery sets take the trouble to enquire into its life or working. A comprehensive paper on the accumulator and its various applications has just appeared in the Journal of the Institution of Electrical Engineers* which can be read with interest by all users of accumulators in electrical apparatus. Of particular interest are the batteries specially designed for use in meteorological balloons which are sent up into the stratosphere to obtain records of weather conditions. The weight and size of these batteries is all-important and the makers have succeeded in producing an H.T. and L.T. unit weighing only 1 lb., giving 16 mA. at 106 v. for over 2 hours. The L.T. drain is .43 amp. at 2.3 v. for the same time.

In the discussion which followed the paper it was mentioned that the number of radio accumulators in use was approximately 3 million!

Recent developments in accumulator design have been in the construction of "dry" accumulators which will solve many problems of providing adequate power supply for output stages in battery sets.

It is to be hoped that the battery receiver of the future will have the tonal quality and output of its mains counterpart.

* "Storage Batteries," by E. C. McKinnon.

Auditorium Acoustics—Cricks

Sources of Reflection

While the use of a cellular horn reduces the importance of reverberant sound so far as the treble is concerned, reflections of sound cannot be avoided, and in fact must not be, otherwise it would be impossible to maintain a fairly even level of sound intensity from front to back of the seating area. The points at which reflection occurs are,

however, of great importance from the point of view of "presence."

Consider the two auditoria shown in Fig. 5. In either case a person seated at the centre of the balcony will receive both direct and reverberant sound from the speakers. In the case of the sketch (a), he will receive direct reflections off the ceiling near the proscenium; the rear wall is acoustically treated, and no reflection is heard from behind; therefore such an auditorium will have a good "presence."

In the case of (b), the ceiling reflection occurs from almost overhead, and if the back wall is untreated, a patron in the centre of the balcony will receive actually more sound from above and behind than from the direction of the screen; consequently the "presence" will be bad. In addition, the domed ceiling will produce a sound focus near the front of the balcony, and if the auditorium is sufficiently large, a certain echo may be noticed towards the front of the house.

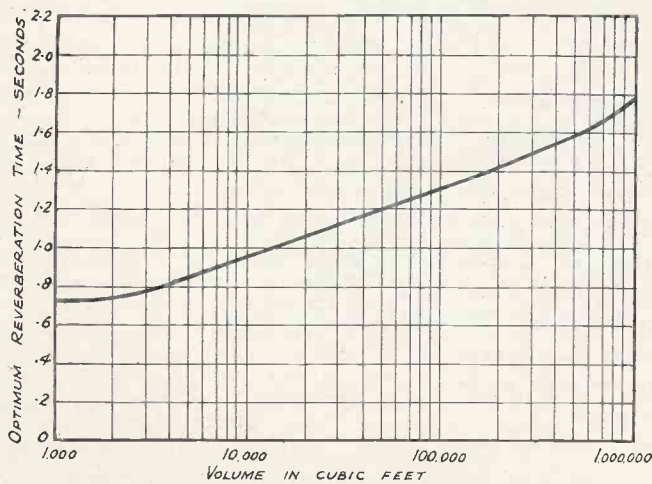

Courtesy "Motion Picture Sound Engineering."

Fig. 4. Recommended reverberation period.

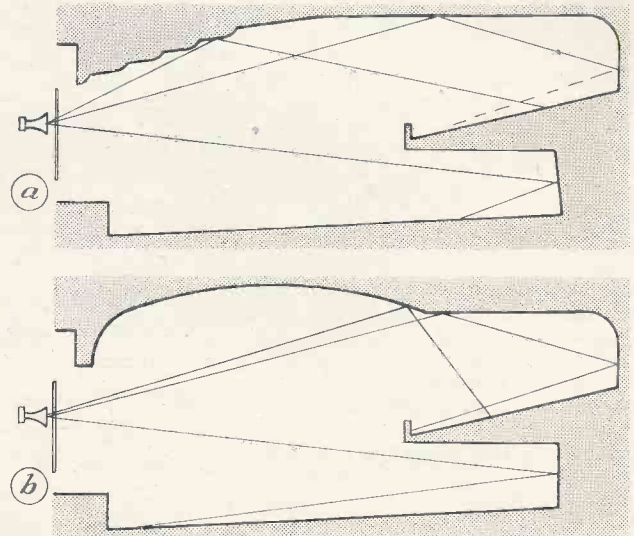

Fig. 5. Good and bad acoustic design.

Heavy Water Rochelle Salt.

THE piezo-electric effect in Rochelle salt has found practical application to some extent in microphones, receivers, gramophone pick-ups and electric filters. A limitation of its use, however, has been the rapid loss of the piezo-electric properties above temperatures of 75° F.

According to the *Bell Laboratory Record*, A. N. Holden, of the Chemical Laboratories, has recently found that Rochelle-salt crystals retain their piezo-electric properties to 95° F. if made with heavy water instead of ordinary water, as first suggested by S. O. Morgan.

The behaviour of Rochelle salt proves to be in almost all respects an electrical counterpart of the magnetic behaviour of iron and other ferromagnetic materials. Below a certain critical temperature a ferromagnetic material has been shown to consist of small domains, each spontaneously magnetised, but the directions of magnetisation of the many domains are so distributed as to produce no net magnetisation.

A Rochelle-salt crystal, similarly, in

its anomalous temperature range, has been shown to consist of small domains polarised in two opposing directions. The process of charging the material in bulk, by an applied electric field, consists largely in reversing the direction of polarisation of these domains.

The much higher internal damping and variation with temperature of the natural frequency of vibration of bars of Rochelle salt make it very unlikely that the material could replace quartz, the other well-known and widely applied piezo-electric substance.

The further extension of the useful temperature range of Rochelle-salt crystals further will broaden their usefulness in fields where they are effective.

Gilbert Wright, American inventor, has just developed a device for changing sound, such as that of a buzz saw, a high wind, or music into spoken English. It is thought that this invention will be particularly useful in the film industry. The sound to be modified comes from a record and is applied to the operator's throat. The operator then speaks and modifies the sound from the record into spoken words.

A new photo-tube which utilises a caesium photo-surface possessing a remarkable sensitivity to the major portion of the spectrum is now being produced by R.C.A. It is claimed that the new cathode surface is ten times as sensitive to daylight as the best previously available surfaces.

WAR-TIME ECONOMY

During the present emergency it is absolutely essential to conserve supplies of paper and facilitate distribution. Readers, therefore, are earnestly requested to ask their newsagents or bookstalls to reserve a copy of this journal for them each month or alternatively place an order for regular delivery.

A TELEVISION RADIO-RELAY SYSTEM

By

F. H. KROGER, BERTRAM TREVOR and J. ERNEST SMITH,
Engineering Department, RCA Communications, Inc., New York, N.Y.*

TO determine the feasibility of relaying television it is necessary to consider the proper aerial heights, aerial aperture dimensions, spacing between relay stations, and power radiated to give the most economical result. These considerations must be based upon available data on ultra-high frequency propagation. There are other factors such as signal fading, unusual interfering noise sources, and aerial efficiency which must be taken into account. Moreover, the particular terrain in question will be a factor in determining the final layout since advantageous use can often be made of elevated points thus permitting lower tower structures.

It is of interest to note that when the aerials of a fixed aperture at each end of a link are at heights sufficient to allow the direct and reflected rays to arrive at the receiving aerial with a phase angle of substantially 120 degrees, the required amplifier power gain is then inversely proportional to the square of the frequency, assuming a constant transmitter power input. This fact indicates that it would be advantageous to operate at as high a frequency as possible; especially, since the higher the frequency, the lower will be the aerial heights necessary to bring the direct and reflected rays together with the 120-degree phase angle at the receiving aerial.

It is felt that 500 megacycles for a carrier frequency would be a suitable starting point even though higher frequencies may offer additional advantages.

Frequency modulation was employed in the work due to its advantages for circuits where multipath phenomena are absent. Furthermore, valves were available which greatly minimize the equipment for producing a frequency-modulated carrier. In addition, frequency modulation permits the use of limiting and class C amplification thus simplifying the problem of maintaining overall circuit linearity.

Recent measurements have shown that car ignition interference is present with about the same field strength on all frequencies between 40 and 450 megacycles. This means that the interfering energy received with aerials of the same

effective height and directivity will be constant with frequency. However, the aerial directivity (power gain) for a given aperture area increases in proportion to the square of the frequency;

This paper deals with some of the problems involved in designing radio networks to interconnect television broadcasting stations and describes some of the methods applied in their solution. As a result of these developments it has now been found feasible to provide radio networks for television programme distribution over wide areas.

hence, a large reduction of received interference at the higher frequencies if the interference is not generated directly in front of the receiving aerial.

No appreciable fading has been ob-

served during the tests of this television relay. A circuit of 30 miles in length operated on 500 megacycles with good optical clearance has shown fading of more than ten decibels to occur rarely and then only for short periods of less than an hour.

Assuming that fading is produced by varying amounts of refraction which results in varying the path-length difference between the direct and reflected rays, then it would be expected that minimum fading would occur when, under average conditions, the path-length difference is half a wavelength. This condition brings the direct reflected rays in phase at the receiving aerial which results in the strongest possible field. Changes of refraction conditions in the atmosphere will alter the phase angle between the two components and will alter the resultant field strength only slightly. The opposite condition occurs when the two components are nearly in phase opposition at the receiving aerial, as in this case a small change in phase angle gives a large change in resultant field.

It is not usually economical to place the aerials at a sufficient height to bring the direct and reflected rays in phase, so that a compromise with aerial heights should give a path-length difference of 1/6th wavelength or 120 degrees. This condition results in a received field equal to that which would be obtained in free space where only the direct ray would be present.

Repeater Amplifier

The maximum gain that can be used is determined by the ratio between the maximum repeater-output power and the noise power appearing at the repeater input. If this ratio is 120 decibels and a signal-to-noise ratio of 50 decibels is desired, then the repeater gain would be 70 decibels.

At the present state of development, the 500-megacycle receivers having an R.F. band of eight megacycles give an equivalent noise-power input of 1.4 times 10^{-12} watts. The signal power required for a 50-decibel signal-to-noise ratio is then 1.4 times 10^{-7} watts. If

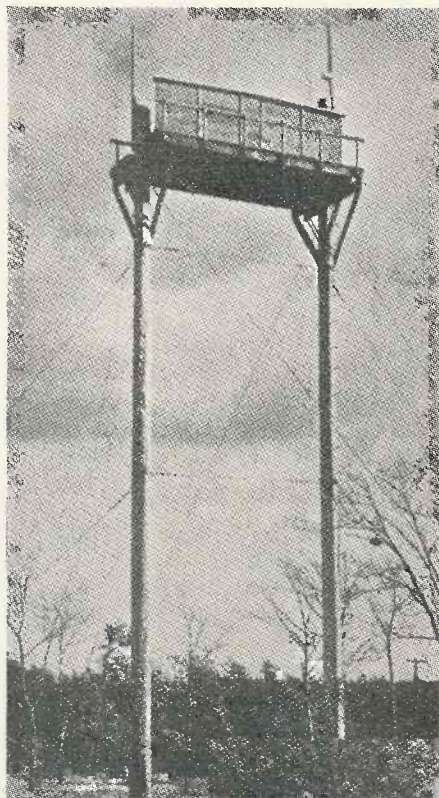

Fig. 1. Riverhead receiving aerial.

* R.C.A. Review, July 1940.

the maximum power output of the repeater amplifier is 1.4 watts, a repeater gain of 10⁷ or 70 decibels is required.

This amplifier must have a flat band-pass of at least eight megacycles. Experience has shown that stable operation can be maintained by converting the 500-megacycle signal to a lower intermediate frequency in the neighbourhood of 100 megacycles where the major portion of the gain is readily realised. An output of about 0.7 watt can be obtained on either the same 500-megacycle carrier frequency or an adjacent frequency by a high level converter. A single stage of amplification is sufficient to raise this power level to about two watts.

The system described used a repeater having an input frequency of 474 megacycles and an output frequency of 460 megacycles.

Relay Stations

The relay system consisted of a terminal station at Hauppauge, a repeater station at Rocky Point, and a terminal at Riverhead, all located on Long Island. The tower and aerial structures at Riverhead are shown in Fig. 1.

A spacing of 15 miles between stations made this circuit 30 miles long. Television signals as broadcast from the Empire State Building on 45.25 megacycles were received at Hauppauge on a receiver whose video output was fed to the 474-megacycle frequency-modulated terminal transmitter. These signals were relayed to Riverhead with good quality, a total distance of 70 miles from New York. The terminal transmitter consisted of a 52.7-megacycle oscillator coupled with a reactance valve which was fed from a video amplifier carrying the picture signal. Following the oscillator, a wide-band tripler stage brought the carrier frequency to 158 megacycles after which a power-amplifier stage served to drive another wide-band tripler stage giving an output frequency of 474 megacycles at a power level of one watt.

A monitor rectifier at the transmitter output gave video signals to allow the output picture to be observed at all times.

The terminal transmitter was coupled to the cylindrical parabolic-reflecting aerial by means of a single 75-ohm coaxial feed line having a loss of one decibel per 100 feet. The parabolic reflector was excited by four folded doublets located along the focal axis. A 100-ft. tower supported the aerial house which was fabricated from 1/4-in. waterproof plywood treated with boiled linseed oil.

The repeater amplifiers and aerials at Rocky Point were housed in another cylindrical plywood structure at the top of a 115-ft. tower. The aerials were similar to the one used at the Hauppauge terminal.

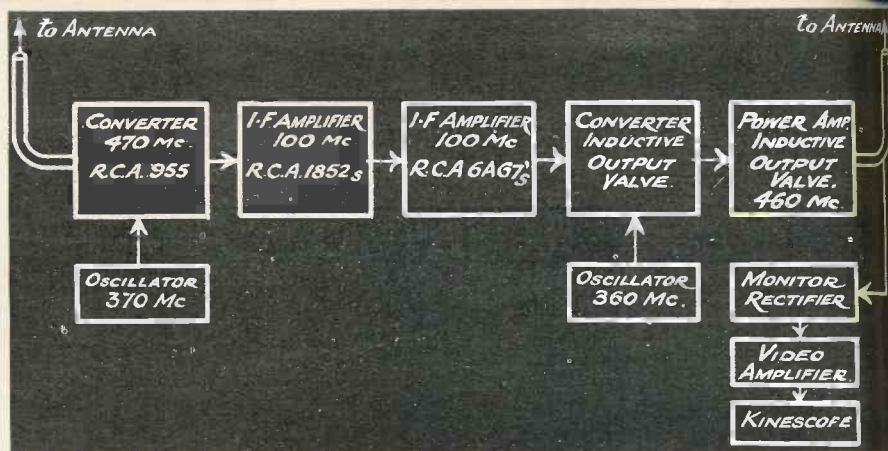

Fig. 2. Schematic diagram of repeater-amplifier.

A schematic diagram of the elements is shown in Fig. 2. The input signal of 474 megacycles was fed to a triode converter, 8 stages of intermediate-frequency amplification, an inductive output valve operated as a high-level converter, followed by an inductive output valve operating as a power amplifier.

The input converter made use of an RCA 955 triode by feeding the signal to the grid and supplying a local oscillator excitation of 374 megacycles to the cathode. The 100-megacycle intermediate frequency was taken from the anode circuit and amplified by six wide-band transformer-coupled stages using RCA 1852 pentodes. Following this were two-wide band stages using RCA 6AG7's which brought the level up to 1 watt.

This level was necessary to drive the inductive output valve as a converter. A local oscillator of 360 megacycles was also supplied to the input of this valve in order to obtain the final output frequency of 460 megacycles at a level of about 0.7 watt.

The final inductive output power amplifier provided sufficient gain to feed 2 watts to the aerial. The overall gain of the repeater amplifier was measured to be 80 decibels under actual operating conditions.

At the Riverhead terminal a cylindrical parabolic aerial situated 70 feet above ground fed the signal to the terminal receiver over a 75-ohm coaxial cable. The receiver used an RCA 955 converter identical to that in the repeater amplifier. Following this, a two-stage 100-megacycle I.F. amplifier using RCA 594 valves gave sufficient gain and selectivity to allow another conversion to 29 megacycles at which frequency the major portion of the gain was obtained with six wide-band transformer-coupled stages of RCA 1852's. A frequency discriminator of the Con-

rad type in combination with an RCA 6H6 diode rectifier delivered push-pull video signals to an amplifier which in turn was connected to the monitor Kinescope. Fig. 3 shows the schematic diagram.

It will be helpful briefly to consider the nature of a television signal and particularly to compare frequency modulation with amplitude modulation for this type of modulating signal.

With amplitude modulation, it is well known that the sidebands are symmetrical about the carrier both as to amplitude and phase no matter how unsymmetrical the positive and negative polarities of the modulating wave may be. It is a curious fact that the first tendency of a student, during his early amplitude-modulation studies is to associate one sideband with one polarity of the modulating wave.

While this tendency is definitely incorrect when applied to amplitude modulation it is not so far wrong when the sideband distribution of the frequency modulated wave is considered. Actually, the amplitude of the sideband components are symmetrical about the carrier in frequency modulation *only when the polarities of the modulating wave have symmetrical waveshapes*. The phase of the sidebands, on the other hand, are never symmetrical about the carrier.

A distinction should be made between A.C. transmission and D.C. transmission of the video signal as applied to a frequency-modulated system. Since the standard video composite signal inherently contains all necessary informa-

Fig. 3. Schematic diagram of terminal-receiver.

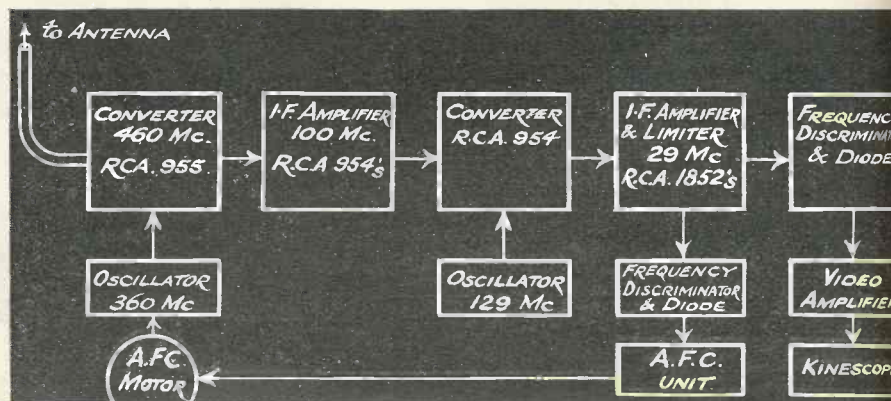

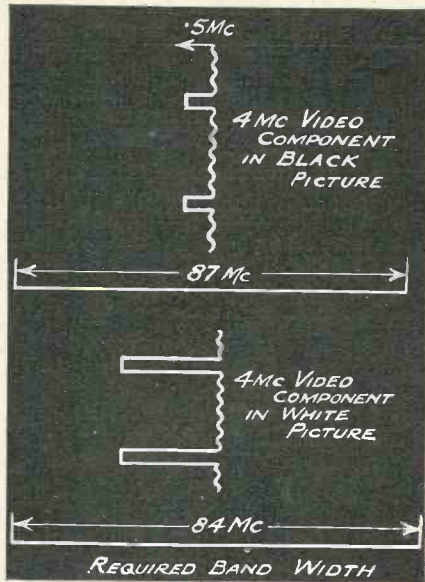

Fig. 4. A.C. frequency modulation (carrier at mid-band.)

tion as to the picture background level (by maintaining a fixed peak amplitude and fixed supersync amplitude), the D.C. component may be restored in the video circuits at the receiving terminal. Insofar as the relay is concerned, the signal to be transmitted may be considered as an A.C. wave only. If this is done the R.F. carrier component will not be shifted when modulation is applied. On the other hand, if the D.C. component is transmitted over the relay, the R.F. carrier component will vary with the picture background and the

frequencies corresponding to the supersync pulses will remain unchanged. Comparison of Figs. 4 and 5 indicates the range of R.F. or I.F. frequency division with respect to the pass band for the two cases.

With the carrier set at midband and employing A.C. transmission with a peak deviation from the carrier of 2 Mc., picture definition of 375 lines was obtained with negligible transients. Synchronising and linearity were entirely satisfactory. The r.m.s. signal-to-noise ratio was 31 db.

To determine if more effective use of the pass band could be obtained with D.C. transmission, the carrier was manually adjusted in steps from the centre towards the edge of the pass band. This was permissible since the D.C. component of the monoscope signal is constant. At each point the video-signal polarity was reversed to compare the transmissions for two extremes of background level. In effect, this test also simulated partial sideband transmission as the carrier approached the edge of the pass band. The opinion of several observers was that the fidelity of transmission remains unchanged until definite sideband clipping of the synchronising pulses resulted in poor synchronisation.

With the carrier shifted towards the edge opposite to the excursions of the supersync pulses, however, it was found that a somewhat larger peak-to-peak frequency deviation could be employed. Because of this and the possible theoretical advantage of maintaining the synchronising pulses in a fixed portion

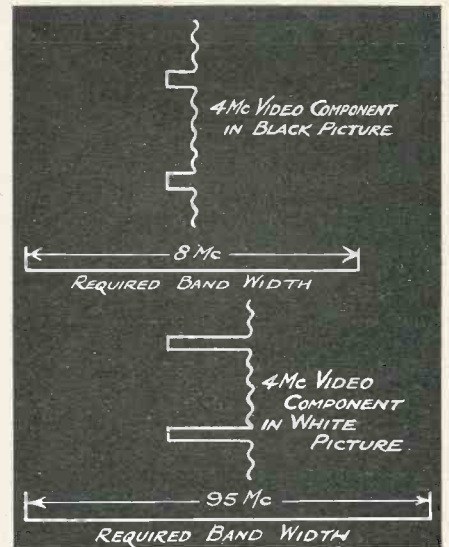

Fig. 5. D.C. frequency modulation (carrier variable).

of the band, automatic D.C. insertion in the frequency modulators may be employed. As a matter of interest, the simultaneous transmission of video and sound on the same carrier was satisfactorily demonstrated in an additional test.

In conclusion, it can be said that radio relaying of television signals in the ultra-high frequency spectrum above 400 Mc. has been successfully accomplished and that a system consisting of radio relays would be technically adequate and feasible for television programme distribution.

The Origin of Electronics

Sir Joseph Thompson's Work

IN August the scientific world lost two of its most distinguished members within a few days of each other—Sir Joseph Thompson and Sir Oliver Lodge. Their names are of particular interest to readers of this journal as they were pioneers in the electron theory and most of our present knowledge of electronics is based on the foundations which were laid by them in the late nineteenth century.

The science of the free electron dates back to the days of Faraday, before the name "electron" had been coined and originated in his research into the conduction of electricity by a gas.

In his Experimental Research (Par. 392) he comments on the fact that while it is difficult to get a spark to pass through a column of gas, when once the discharge is passing the gas becomes conducting and succeeding discharges will follow readily. This phenomenon was also investigated by other workers about 1879 and it was de-

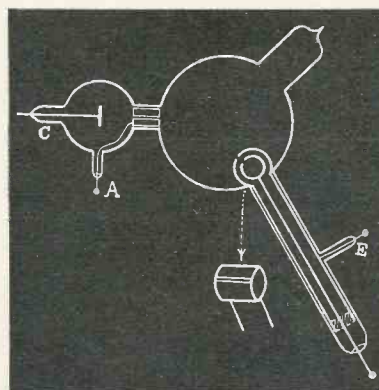

Vacuum tube made by J. J. Thompson to investigate the nature of cathode rays.

monstrated that the presence of the discharge in the gas enabled current to pass through it, not necessarily in the direction of the discharge, with comparative ease.

J. J. Thompson and E. Rutherford (afterwards Lord Rutherford) published an account in 1896 of the effect of X-rays on the conducting properties of gases and found that the rays had a similar effect to that of the spark discharge. At this time the presence of charged ions in the gas was accepted as a basis for the explanation of the phenomena and J. J. Thompson extended his research into the nature of ionisation and the causes producing it.

The first textbook on electronics may fairly be assigned to him and was published about 1898. It is a classic among physics books and although now out of date (and out of print) can still be read with interest and profit. In "The Discharge of Electricity Through Gases" he describes all the phenomena which he and his fellow workers studied at this time and explains how they are correlated. His name will be principally remembered for the work on cathode rays and the quantitative measurements on electrons in motion.

The fact that cathode rays were negatively charged had been demonstrated by Perrin in 1895, but Thompson pointed out that his experiment did not show that the negative charge was in-

(Continued on page 446)

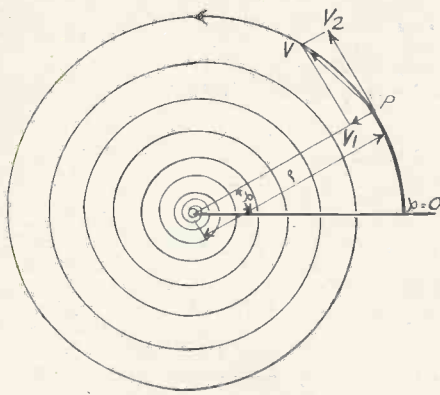

Fig. 1. Logarithmic spiral.

The Measurement of Scanning Speeds of Cathode-ray Tubes

By L. Blok

THE writing speed of the beam of a cathode-ray tube is a most important factor in determining the optimum conditions for photographing transients on the screen.

The blackening of the film or light-sensitive paper depends mainly on the sensitivity of the material and the brightness and size of the spot on the screen. If these factors are fixed and in addition the optical enlargements of the camera arrangement is known, the blackening will then depend on the velocity at which the spot moves.

In order to determine this velocity it is necessary to allow the spot to describe a path on which the velocity changes continuously, while at every point of the path the velocity must be known with sufficient accuracy. It is then possible to determine on the photograph the point where the path of the spot is still sufficiently visible. The velocity at that point is the maximum scanning speed which can be photographed under the given conditions.

A very simple solution of the problem is obtained when the light spot

describes a logarithmic spiral with a constant angular velocity. (See Fig. 1).

The number of turns of the spiral must be so great that an element of the curve may be considered as an element

This article describes a simple method of determining the greatest scanning speed of cathode-ray tubes which can be photographed. The light spot on the screen is allowed to describe a logarithmic spiral, at every point of which the speed can easily be determined. The point of least intensity of the spiral which is still sufficiently visible in the photograph determines the maximum scanning speed required. We are indebted to "Philips Technical Review" for the information provided.

of a circle. To obtain the spiral electrically on the tube, the deflections must have the form of damped oscillations which differ in phase by 90°.

Such a voltage can be obtained in a

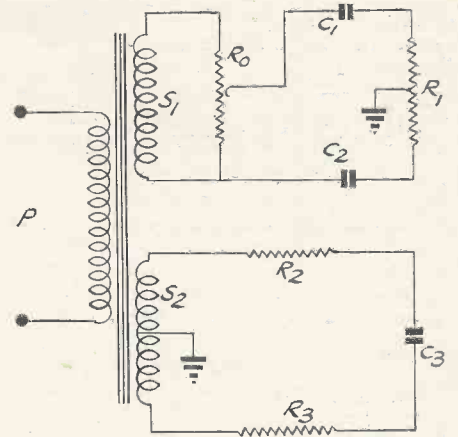

Fig. 2. Transformer with two similar symmetrically loaded secondary windings. The voltages on R_1 and C_2 differ 90° in phase and are symmetrical with respect to earth.

simple manner by giving an LCR circuit an electrical impulse, and allowing it to die out in oscillations of its own frequency according to the well-known equation:—

$$V_t = V_0 e^{-\frac{R}{2L} t} \cos \omega t,$$

where V_0 is the voltage on the circuit due to the impulse at the moment $t=0$, V_t the voltage at the time t , R the series resistance, L the self-inductance of the circuit, $R/2L$ the damping factor and $\omega = 2\pi f$, in which f is the frequency of the circuit itself.

By applying this voltage to the primary winding P of a transformer which has two separate equal secondary windings S_1 and S_2 (Fig. 2) two similar secondary voltages are obtained of the same form as the primary voltage.

In order to obtain the desired phase difference, S_1 is loaded with the resistance R_1 and the condensers C_1 and C_2

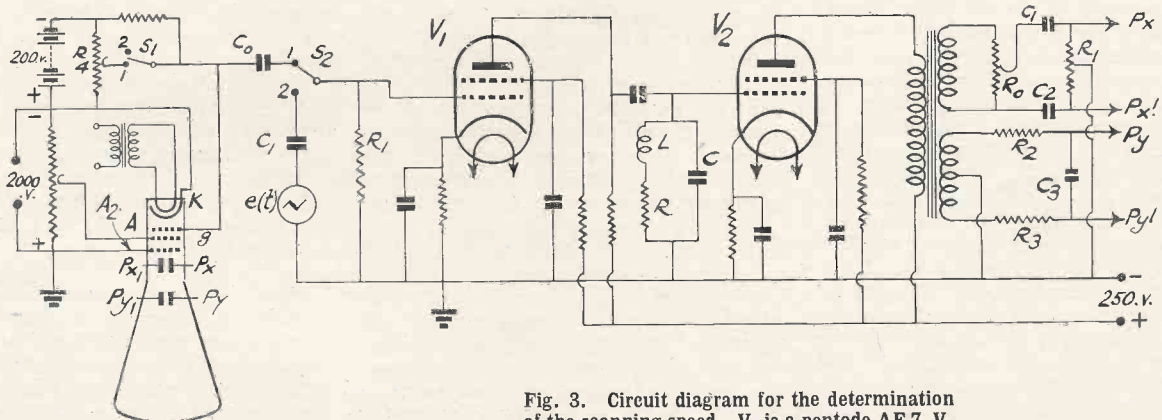

Fig. 3. Circuit diagram for the determination of the scanning speed. V_1 is a pentode AF 7, V_2 a pentode AL5.



and S_2 with R_2 , R_3 and C_3 , which are chosen so large so that:—

$$\frac{1}{\omega C_1} + \frac{1}{\omega C_2} = R_1 \text{ en } R_2 + R_3 = \frac{1}{\omega C_3}$$

while in addition it is provided that:—

$$R_1 = 2R_2 = 2R_3 \text{ and } C_1 = C_2 = 2C_3$$

In this way the voltage V_{R1} on R_1 is made equal to the voltage V_{C3} on C_3 , while both are symmetrical with respect to earth, and, moreover, the phase difference between V_{R1} and V_{C3} is exactly 90° .

With a cathode-ray tube the proportionality factor between voltage and deflection is not the same for both pairs of deflection plates. The spiral obtained will, therefore, be "oval." By applying the voltage V_{R1} which can be regulated with the potentiometer R_0 to the more sensitive plates, this difference may be compensated and the spiral becomes "circular."

Description of the Circuit.—The circuit is shown by Fig. 3. The positive of the high tension supply for the anode voltage is earthed. When the switch S_1 is in position 1, with the help of potentiometer R_4 the voltage of the grid g of the cathode-ray tube can be regulated, and thereby the strength of the electron current. When S_1 is in position 2, g becomes about 200 volts more negative than the cathode k and the current of electrons is thereby suppressed.

With switch S_2 in position 1, on changing S_1 from 2 to 1, the adjusted electron current begins to flow and a voltage impulse occurs on the grid of value V_1 . The oscillating circuit LRC thereby receives an impulse so that on the primary winding of the transformer in the anode circuit of V_2 the desired damped sinusoidal oscillation occurs.

There is a potential of more than 2,000 volts on condenser C_0 which must be constructed accordingly.

For good adjustment of the camera it is desirable that it be focused upon the spiral itself. For this purpose it is also necessary to be able to obtain a permanent image of the spiral on the screen of the cathode-ray tube. To do this, a saw-tooth voltage generator $e(t)$ is connected over the condenser C' by means of switch S_2 in position 2. When

i is the prevailing current and $\dot{i} = V_{R'}/R'$, we may write:—

$$e(t) = \int \frac{V_{R'}}{R'C'} dt + VR, \text{ or, differentiating,}$$

$$\frac{d e(t)}{dt} = \frac{V_{R'}}{R'C'} + \frac{d}{dt} V_{R'}$$

If $C'R'$ is sufficiently small, the first term of the right-hand member of the equation dominates, and we may safely write the voltage derivation in approximation:

$$\frac{d e(t)}{dt} = \frac{V_{R'}}{R'C'}$$

The voltage on R' and therefore supplied to the grid of V_1 is proportional to the derivative of the voltage $e(t)$ with respect to time.

The form of the voltage $e(t)$ as a function of the time is indicated in Fig. 4a, while in Fig. 4b the variation of $V_{R'}$ as a function of t is drawn for sufficiently small values of $C'R'$. The latter figure shows plainly the occurrence of periodic impulses. Each of these impulses causes the spiral to be described once.

In this way a permanent image appears on the screen of the tube. If the time between two impulses is made shorter than that necessary for the almost complete fading of the oscillations of the circuit, the light spot can no longer reach its point of rest. It then does not form a point in the centre, but ends at an arbitrary point on one of the windings. An interesting effect is obtained when the frequency of the impulses is continuously increased. The spiral is then seen to be erased from the centre outwards.

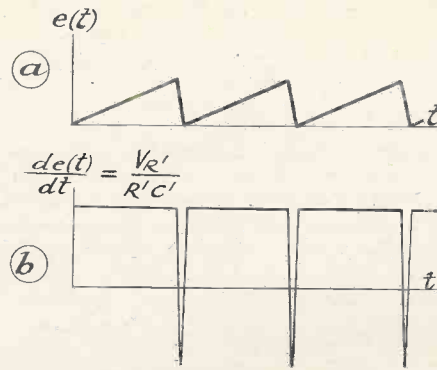

Fig. 4. Form of the sawtooth voltage $e(t)$ and of its derivation de/dt as a function of the time.

R' and C' are correctly chosen, this sawtooth voltage $e(t)$ gives periodic impulses to V_1 , with a frequency depending on the frequency of the sawtooth voltage. For the circuit in which this voltage works the following holds:—

$$e(t) = V_0' + V_{R'}$$

in which V_0' is the voltage on the condenser C' and $V_{R'}$ that on R' .

Upon substituting $V_0' = \int \frac{i}{C'} dt$ where

"The Origin of Electronics"

(Continued from page 443)

separable from the rays, but that it might be an accidental accompaniment.

To settle the point he made up a discharge tube of the type shown on p. 443.

(Proc. Camb. Phil. Soc. 1897) in which the rays from the cathode C were passed into a second chamber containing two co-axial cylinders each having a slit facing the incoming rays. The inner cylinder was connected to an electrometer and the outer to earth. When the rays were emitted from the cathode, by the application of a high potential to the anode A , they passed into the second globe, but did not enter the cylinders as they were out of the "line of fire." The rays were then gradually deflected by a magnet so that they entered the cylinders through the slit, their presence being indicated by the appearance of a luminescent patch at the opening. As soon as they had entered, the electrometer showed a strong negative charge in the inner cylinder, thus proving that the charge

accompanied the rays whatever their path. Thompson says: "It would hardly seem possible to get a more direct proof that a stream of negatively electrified particles is an invariable accompaniment of the cathode rays than the experiment described. When we catch the cathode rays we catch at the same time a charge of negative electricity, and however we may pull the cathode rays about we cannot dissociate them from the negative charge."

Thompson's crowning achievement may be said to be the measurement of the electron—its mass and charge. From the experiment just described he proceeded to the investigation of the exact nature of the negatively electrified particles: were they molecules of gas, or atoms, or some other form of matter? The experiments made by Lenard on the penetration of cathode

rays through metal had shown that the carrier of the charge could not be comparable with ordinary molecules, or aggregations of molecules, and it seemed reasonable to assume a particle smaller than the atom.

To obtain information as to its actual size, the following experiment was performed: Cathode rays produced in one form of vacuum tube were passed into a cylinder similar to that shown in the diagram. A thermo-junction was inserted in the cylinder so that the heat developed by the energy of the rays could be measured.

The electrometer connected to the cylinder, as before, gave a measurement of the electric charge on the particles. The apparatus thus enabled the kinetic energy of the particles to be measured, and hence their mass, and the charge. The ratio of the charge to the mass, denoted by e/m is a constant frequently used in electron engineering, and the value found by more modern methods does not differ greatly from that originally found by Thompson at the end of last century.

Mention of "Electronics and Television & Short-wave World" when corresponding with advertisers will ensure prompt attention.

News Brevities—

Commercial and Technical

THE Federal Communications Commission have now authorised commercial frequency-modulation broadcasting, and decided to allocate the 42 to 50 Kc. channel to this system. This will provide 40 F.M. channels each 200 Kc. wide; 35 will be used for commercial stations and 5 for "non-commercial educational" stations.

* * *

The wavelength of W₂XBS, N.B.C.'s television transmitter is to be altered as a result of the Federal Communications Commission's commercialisation of frequency modulation. This transmitter is at present utilising one of the channels now allotted to frequency modulation and manufacturers are faced with the problem of possible changes in television receivers in the area served by the W₂XBS transmitter.

* * *

Laurens Hammond, whose name is well known in connection with the electronic organ, has been awarded the 1940 medal from the Franklin Institute in Pennsylvania, "in consideration of the inventive skill displayed in the development of the Hammond organ."

* * *

It is estimated that at present approximately 160 television receivers a week are being sold in the New York area of U.S.A.

* * *

High-speed X-ray photography was the subject of a discussion at a meeting of the American Physical Society held on June 21, and shadow photographs taken with an exposure short enough to show a moving bullet while passing through a block of wood were shown. The photographs were taken by using a very brief electrical surge of high voltage and sufficient amperage was obtained by charging a condenser and then discharging it through the X-ray tube. Dr. C. M. Slack and his associates in the Westinghouse Lamp Division were responsible for developing the new X-ray tube.

* * *

The requirements of metals and

alloys for cathodes, anodes and grids are presented in an article entitled "Materials for Vacuum Tube Manufacture" which appeared in *Industrial and Engineering Chemistry* for August, 1940. A brief treatment of the thermionic emission of oxide-coated thoriated-tungsten, and tungsten filaments is also given.

Metals and alloys for use in glass-metal seals are discussed and the function of getters explained. Silicates, sulphides and tungstates are treated in terms of persistence and colour of luminescence when used for fluorescent screens in cathode-ray tubes. Methods of assembly and testing of various equipments are described.

* * *

A new 16-page short-wave station guide which lists several hundred stations throughout the world, together with their frequencies and call letters, has been prepared by the broadcasting division of the General Electric Company (U.S.A.).

The book is being offered gratis to listeners to the company's international stations. The guide also includes operating schedules of stations and a world-wide time map comparing times of the world with Eastern Standard Time. It is printed in English, Spanish and French.

* * *

During air raids subscribers to the Radio Relay System receive a warning through their loudspeakers in their own homes. This is a day and night service which is available to those who are connected to the system. During a recent raid subscribers received the warning four to five minutes before the sirens sounded, thus giving them an extra few minutes to make their preparations.

* * *

A new television station, W₂XWV, will shortly go on the air in New York City. It is being erected by engineers of the Allen B. DuMont Company for the purpose of studying the field strength of televised signals in the New York area. A temporary aerial has already been set up for preliminary tests. The station will operate on 1 Kw, and it is anticipated

that the effective receptive range will be more than 30 miles.

* * *

The reception of frequency modulation transmission from W₉₀XA, the only F.M. station operating west of the Mississippi, is checked in various parts of Wisconsin by means of a test car equipped with receiver and portable aerial.

* * *

The number of applications for frequency modulation stations received at Washington (U.S.A.) now totals 130.

* * *

Details of a National Television Systems Committee organised in America for the purpose of determining basic standards for television transmission, are given in the August, 1940, issue of *Electronics*.

Representatives have been invited from 15 commercial and professional organisations in an endeavour to bring together all the larger television interests so that the differences might be composed and a single set of standards prepared and offered to the Federal Communications Committee for official adoption.

In addition to the main committee, several sub-committees are to be organised and each will deal with an individual aspect of the problem, which has been split up into nine main divisions, viz.: System Analysis, Subjective Aspects, Television Spectra, Transmitter Power, Transmitter Characteristics, Transmitter-receiver Co-ordination, Picture Resolution, Synchronisation and Radiation Polarisation. Each sub-committee will prepare a report at the conclusion of its work, stating both majority and minority opinions; standards formed on the basis of these reports may be approved by the main committee and will then be submitted to the Federal Communications Committee by the Board of Directors of the Radio Manufacturers' Association.

The National Television Systems Committee is sponsored by the R.M.A. and will have the full co-operation of the Federal Communications Committee.

* * *

The head office of Messrs. W. T. Henley's Telegraph Works Co., Ltd., is now at Milton Court, Westcott, Dorking, Surrey; communications for the engineering department, however, should be addressed W. T. Henley's Telegraph Works Co., Ltd., H.O. Engineering Department, Gravesend, Kent.

development!

*new
markets*

*new
prospects*

Write to :—

Advertisement Department,
Electronics & Television,
43/44, Shoe Lane,
London, E.C.4.

NEW FIELDS OF DISCOVERY

and applications of vacuum physics are constantly being made. HAVE **YOU** CONSIDERED HOW YOU CAN BENEFIT? The market is large . . . it includes communication, radio, television, photo-electricity, broadcasting, aircraft and police communication, sound reproduction, vacuum tube applications, optics, electrical measurement, therapy, radiology, electrical manufacture, public address, electrical and wireless technology, Government requirements, etc., etc.

IF YOU MANUFACTURE

Measuring Instruments.	Test Gear.
Vacuum Apparatus.	Radio Receivers.
Insulating Material.	Oscilloscopes.
Coils.	Magnets.
Switches.	Wires.
Condensers.	Small metal parts, etc.
Transformers.	Convertors and Generators.
Valves.	Quartz crystals.
Pickups.	Cold Cathode Tubes.
Rheostats.	Remote Controls.
Electron Tube Parts.	Aerial Equipment.
Speakers.	Recording Equipment.
Electron Tube Equipment.	Plastics.
Electrical Controls.	Broadcast Equipment.
Meters.	Sound Equipment.
Oscillators.	Vibrators or Optical Apparatus.
Relays.	

THERE IS A MARKET

for your products in the electronic field.

ELECTRONICS AND TELEVISION & SHORT-WAVE WORLD

circulates in the research, design and production departments of many of the most important industrial concerns in the country, **It reaches the men that matter**—the men who find it a valuable source of information covering development in the several fields of electronic science. They will be interested to know how **your** products can assist them in research and production.

vibrator becomes stable and the output voltage resolves into definite frequencies.

For best performance, the input should be increased slightly beyond that point. An excessive increase will cause the multivibrator to jump to another frequency. When the crystal oscillator is assuming full control, the variable circuit elements can be changed appreciably without loss of synchronization.

Although not a necessity, it is best practice to employ a resistance-coupled input and output amplifier stage with each multivibrator. The input amplifier serves to de-couple the oscillator and prevents circuit reactions from influencing the frequency. The output amplifier protects the multivibrator in the same manner and also increases the output. Radio-frequency chokes should be connected in series with the grid and anode coupling resistors of the output amplifier to bring about accentuation of the higher harmonics. These are shown in Fig. 3.

Crystal Control of Oscillations

An example of a crystal oscillator is the Bliley type SMC100 unit contain-

ing a specially ground crystal which will oscillate at either 100 kc. or 1,000 kc., and which, in a simple inexpensive circuit, gives dependable accuracy. The circuit and recommended values are given in Fig. 4.

To ensure best performance and accuracy, a correctly designed tank coil (L) is an integral part of the unit. C should be a dual 350 mmfd. tuning condenser. The output at 100 kc. is approximately 1.5 volts r.m.s., and the harmonics will be usable up to the 30th or greater, depending on the sensitivity of the receiving equipment employed.

For greater output and higher harmonics from the secondary standard, one or two untuned amplifier stages should follow the oscillator. These, as shown in Fig. 3, are resistance-coupled amplifiers with R.F. chokes in series with the anode and grid-coupling resistors, and biased to give a distorted output. The R.F. chokes cause the amplifier gain to increase somewhat with frequency thereby accentuating the higher harmonics. Either triode or pentode valves will give the greatest gain and harmonic output. The circuit values are not critical but are best adjusted by trial to give the greatest output at the highest harmonic desired. For increasing the output at any given har-

monic, or harmonics, the anode circuit of the amplifier can be tuned.

An application by the Columbia Broadcasting System for permission to build a new 50,000-watt international short-wave station at Brentwood on Long Island, New York, has been approved by the Federal Communications Commission, and C.B.S. now has full authority to proceed with the construction of two such powerful transmitters.

A permit to increase power and provide for removal of Columbia's present short-wave station, WCBX from Wayne, New Jersey, to Brentwood, 40 miles from New York City was granted a few weeks ago by the F.C.C.

The new plants will be on the property of the Mackay Radio and Telegraph Company and because of the space available (1,200 acres) there will be no physical limitation to the types, number or lengths of aerials to be erected.

The completed stations are destined to be the most modern and complete short-wave units in the United States. They will use a total of 13 frequencies, enabling the stations to operate on the most desirable frequency for any given hour of the day or season of the year in any direction, directed according to known atmospheric conditions along the most desirable transmission paths.

R.C.A. LARGE-SCREEN TELEVISION

THE Radio Corporation of America Laboratories have recently completed an experimental large-screen television receiver which has several novel features, particularly as regards the optical system which is employed.

The model which, it is stated, is an intermediate step in the development of much larger apparatus, projects a picture 6 ft. by 4½ ft. with a brightness comparable to a cinema screen.

The apparatus comprises three units (1) a high-intensity projection tube and optical system; (2) high-tension power supply and (3) the receiver, amplifier and controls; the overall dimensions of all three when assembled are 6 ft. long, 2 ft. wide and 5½ ft. high.

The arrangement of the projection tube and optical system are shown in the illustration. The image end of the projection tube faces to the rear—that is, away from the screen and

This diagram shows the novel optical system of the R.C.A. large-screen television receiver which employs a concave mirror and angular projection lens.

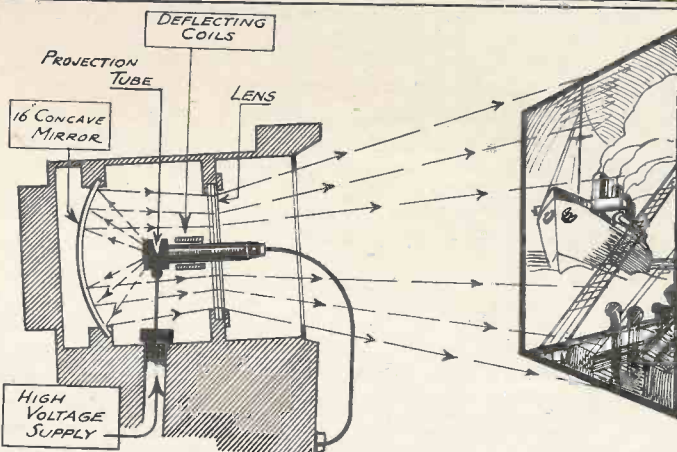

the image, and is thrown upon a concave mirror surface measuring 16 in. in diameter. The mirror collects the light and magnifies the image 22½ times. The image is then reflected back through a lens surrounding the neck of the tube, and projected 20 ft. on to a screen of the beaded type.

The optical system of the unit has an effective numerical aperture of F:0.7, or more than 4 times the speed of the best available projection lenses. This means an increase in screen brightness of more than 4 times.

The new projection tube requires

56,000 volts as compared with the 4,000 to 6,000 volts used by the tube in the ordinary home-type television receiver. The actual size of the image on the face of the projection tube is 2.4 by 3.2 in. The television signals can be fed to the receiver by either the usual aerial system or by a direct wire line from the source of the programme.

It is stated that excellent results have been achieved with this apparatus, but it is not proposed to put it on the market for some considerable time and at all events until the television position in the U.S.A. has been clarified.

Valve Voltmeter

It is hoped that a wide range calibration unit will be described in this Journal in due course wherefrom a voltage range of 10 volts to .0001 can be accurately obtained.

If a suitable A.C. supply is not obtainable then very approximate calibration can be obtained from a D.C. source as shown in Fig. 5, condenser C_1 being short circuited. The equivalent A.C. volts are in peak values, by equal D.C. voltages, so to convert to R.M.S. values it is necessary to multiply the D.C. by 1.414.

Due to the unusual bridge amplifier circuit transient overloading of V_1 does not result in risk of any damage to the meter, for it is so arranged by the bridge values that a change of about 0.8 milliamp is the maximum that can be obtained.

Separate calibration curves for each range have been drawn and except for the first .025 milliamp the curves are nearly straight lines when drawn on linear graph paper.

Components for Valve Voltmeter

CONDENSERS

- 1—.005 mica (C_1) (Dubilier)
- 1—.005 mica (C_2) Dubilier
- 1—24 μ F. 450 working electrolytic (C_3) (T.C.C.).
- 1—4 μ F. paper (C_4) (B.I.).

CHOKE

- 1—30 henries at 50 mA. (Ch.1) (Partridge & Mee, Leicester).

METER

- 1—0.5 milliammeter (Ferranti).

RESISTANCES

- 1—40 megohms (R_1) (Claude Lyons).
- 1—5 megohms (R_2) (Erie)
- 1—2.5 megohms (R_3) (Erie).
- 1—1.5 megohms (R_4) (Erie).
- 1—35 megohm (R_5) (Erie)
- 1—.1 megohm (R_6) (Erie).
- 1—.1 megohm (R_7) (Erie).
- 1—25,000 ohms power resistance (R_8) (Varley).
- 1—5,000 ohms power resistance (R_9) (Varley).
- 1—400 potentiometer (R_{10}) (Igranic).
- 1—10,000 ohms power resistance (R_{11}) (Varley).
- $R_{12}, R_{13}, R_{14}, R_{15}, R_{16}$ — compensation resistances, values dependent on ratios of R_3 - R_7 — overall approximately 75 ohms.
- 1—5,000 ohms power resistance (R_{17}) (Varley).
- 1—100,000 ohms $\frac{1}{2}$ watt (R_{18}) (Erie).

Fig. 5. Method of obtaining approximate calibration from a D.C. source.

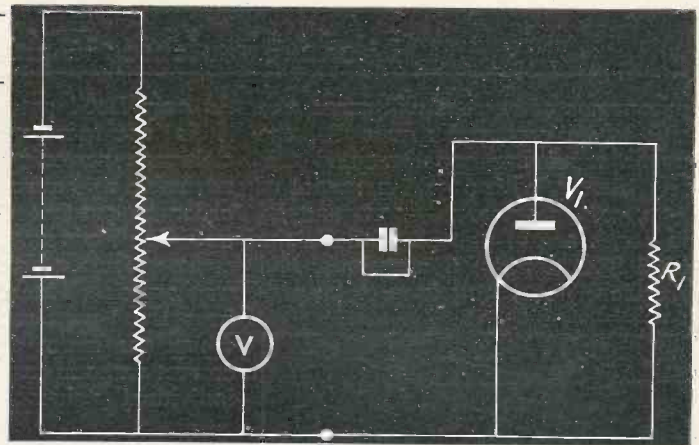

SUNDRIES

- 1—two-pole 5-way switch (Yaxley—Webbs Radio).
- 1—Acorn valve base (Hammarland—Webbs Radio).

TRANSFORMER

- 1—10/0/200/220/240 primary (T_1) (Partridge & Mee, Leicester) secondaries:

250-0-250 v.	50 mA.
2-0-2 v.	2 amp.
2-0-2 v.	1 amp.
6.3 v.	.3 amp.

VALVES

- 1—RCA 955 Acorn (Webbs Radio) (V_1).
- 1—AC.2.HL (V_2) (Mazda).
- 1—UU4 (V_3) (Mazda).
- 1—Neon stabilizer type 4687 (Mullard) (V_4)
- 1—Neon stabilizer type 4687 (Mullard) (V_5).

Baird Television, Ltd. Amalgamation Plan.

A SCHEME for the amalgamation of Baird Television, Ltd., with Cinema Television, Ltd., was the subject of a petition before Mr. Justice Bennett in the Chancery Division on August 27.

Counsel, for Baird Television, said that the company had a share capital of £1,087,500. Its loan capital was £326,406. A Receiver was appointed last November.

The assets of Baird Television, Ltd., it was contended, had a substantial prospective future value if the company's business could be continued and the highly-specialised technical staff retained until television transmission was resumed.

Cinema Television, Ltd., had been formed with a capital of £250,000. By

Mention of "Electronics and Television & Short-wave World" when corresponding with advertisers will ensure prompt attention.

conditional agreement made between Baird Television, Ltd., the trustees of a trust deed dated in April, 1939, and the Gaumont British Picture Corporation, the latter had agreed to pay up in cash the whole of the £30,000 First Debentures to be created by Cinema Television, Ltd. The capital of the latter company was to be increased to £368,250.

It was proposed that the transferee company issue 80,000 redeemable preference shares, of 5s. each credited as fully paid, to unsecured creditors of Baird Television, Ltd.

The petition was adjourned until October 14, Mr. Justice Bennett giving the direction that it was to be advertised to give an opportunity to anyone who wished to oppose it.

Vacuum Pump Oils and Waxes

Formerly, some of the oils and waxes used with condensation vacuum pumps and for vacuum joint sealing, came from Germany.

W. Edwards and Co., of Southwell Road, Loughboro' Junction, London, S.E.5, inform us that they have a full range of oils, greases and waxes available for every purpose in this class.

These include two oils for condensation vacuum pumps, and some specially developed waxes for sealing purposes. One is a black wax which is a special substitute for the German "Picein." This adheres well to glass and metal and is sufficiently yielding at 15° C. to avoid cracking in use. It flows freely at about 80° C.

Another new material is a brown wax which has been specially developed for uses requiring high melting points and great tensile strength.

These oils and waxes are sold under the trade name of "Apiezon," and the company will gladly furnish further information on request.

A RECORD OF PATENTS AND PROGRESS

RECENT DEVELOPMENTS

PATENTEES

Kolster-Brandes, Ltd., and W. A. Beatty :: The M.O. Valve Co., Ltd., and C. W. Cosgrove :: Baird Television Ltd., and C. S. Szegho :: Standard Telephones and Cables Ltd. :: Telefunken Ges fur Drahtlose Telegraphie m.b.h. :: K. Vockenhuber and A. Handler :: H. G. Lubszynski :: Automatic Telephone and Electric Co., Ltd., and A. P. B. Renshaw

Television Brightness Control
(Patent No. 521,873.)

When transmitting a television programme, particularly from a photographic film, it is difficult to apply automatic gain control in such a way that it will maintain in proper perspective those variations in what may be called "background" illumination that are due to changes in the brightness of the scene, or the photographic density of the film. In this connection it must be borne in mind that it is necessary at all times to preserve a reasonable impedance-matching between the various stages of valve amplification.

The problem is tackled, according to the invention, by passing the signals produced by scanning the film to a valve unit which acts as a "brightness-analyser." This averages out the extremes of background illumination, and by confining the signals to certain limits, ensures a more balanced effect at the receiving end. At the same time, a reasonable degree of impedance matching is maintained between the various stages of valve amplification. — Kolster - Brandes, Ltd., and W. A. Beatty.

Shadow Tuning Indicators
(Patent No. 521,983.)

A familiar type of visual tuning-indicator for wireless sets consists of a miniature cathode-ray tube in which the correct tuning point is shown by the contraction of a sector-shaped "shadow" into a thin line. When receiving strong signals, however, there is a tendency for the shadow-control electrode to be overloaded, so that the shadow contracts into a thin line too soon, i.e., before the true tuning point is reached.

According to the invention, this defect is overcome by providing a second shadow-control electrode, which is arranged on the opposite side of the cathode to the first, and is connected to the latter through a high resistance which keeps the two electrodes in

question at different potentials, no matter what the actual strength of the incoming signal may be. The result is that the shadow shrinks gradually right up to point where the circuits are dead in tune.—The M.O. Valve Co., Ltd., and C. W. Cosgrove.

Fluorescent Screens
(Patent No. 522,465.)

It is known that the addition of beryllium allows a higher excitation voltage to be applied to a fluorescent screen, without causing distortion. The reason is that the beryllium enhances the production of secondary electrons, which tend to disperse the charges that normally accumulate on the screen, and so maintain it as a high equilibrium potential. In this way a more brilliant illumination becomes possible.

According to the invention, beryllium hydroxide, with the addition of a small amount of caesium, is used to produce still more satisfactory results on the fluorescent screen.—Baird Television, Ltd., and C. S. Szegho.

Radio Aid to Flying
(Patent No. 522,574.)

Short-wave wireless is used to enable the pilot of an aeroplane to ascertain his height above ground in fog

modulated carrier-wave from an aerial mounted at one end of the wings. The outgoing wave is reflected back to the machine from the ground below, and is received on an aerial mounted at the opposite end of the wing-spread. During its journey down and back, a phase-difference proportional to the distance travelled will be introduced in the reflected wave. This is measured on a phase-meter which is calibrated to show the elevation of the machine directly in feet.

The comparison is made against a wave which is fed directly to the indicator from the transmitter through a wire connection. This "standard" frequency is supplied to one detector, whilst the reflected wave is fed to a second detector, both of the detectors being coupled to the coils of the phase-meter or indicator. The effect of any waves that are picked up by the receiving aerial, direct from the transmitter (without having first reached the ground and been reflected back) is offset by a compensating network connected between the two aerials.—Standard Telephones and Cables, Ltd.

Generating Centimetre Waves
(Patent No. 522,905.)

The figure shows a valve of the

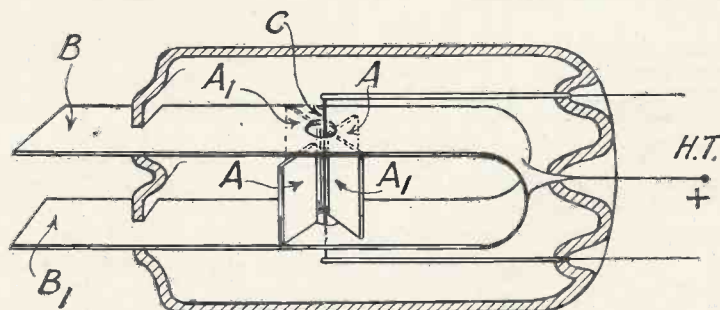

Magnetron valve for generating centimetre waves. Patent No. 522,905.

or during conditions of bad visibility. The machine is fitted with a short-wave transmitter which radiates a magnetron type designed to generate waves of the order of centimetres. The waves are built up along a

The information and illustrations on this page are given with permission of the Controller of H.M. Stationery Office

Lecher-wire resonator, consisting of two strips of metal B, B₁, which pass inside the glass tube and are bent over to make a short-circuited "loop" at one end, near the high-tension supply.

Two pairs of anodes A, A₁ are arranged at right-angles to the resonator, as shown, and edge-on to the heated cathode C, which passes centrally between them. The pair of anodes A, in line with each other, are fastened to the upper limb B of the resonator, so as to leave a gap between their lower ends and the second limb B₁. The other pair of anodes A₁ are similarly secured to the lower limb B, but are separated by a gap from the upper limb B₁.

The electron discharge occurs between the cathode C and the opposed edges of the anodes A, A₁. Under the influence of the field from an external magnetic winding (not shown), oscillations are generated and build-up along the short-circuited section of the Lecher-wire resonator.—*Telefunken ges für drahtlose Telegraphie m.b.h.*

Photo-electric Meters

(Patent No. 522,919.)

In order to make the most of the very small current produced by the action of light on a photo-electric cell for use in a photo-electric exposure meter means are provided for varying the effective magnetic flux across the pole-piece of a meter of the moving

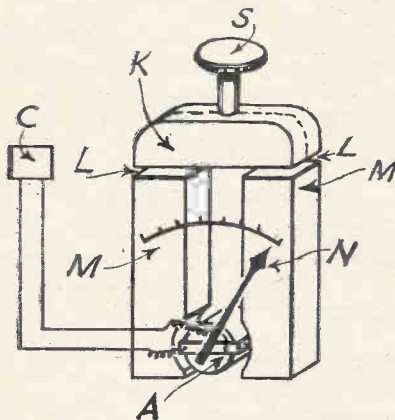

Moving-coil meter with variable magnetic flux. Patent No. 522,919.

coil type. This avoids the effect of any varying resistance in the cell circuit, and also simplifies the insulation of the moving members of the meter.

As shown in the figure, the moving coil or armature A, which carries the indicator needle N, is mounted between the two pole-pieces of the magnet M. The gap between the

limbs of the magnet and an upper yoke K can be varied, so as to adjust the sensitivity of the instrument for different uses, by means of a screw S. A layer L of copper or other non-magnetic substance prevents the yoke from "sticking."

As the output from the photo-electric cell C varies with the incident light, the current passing through the moving coil A will cause the needle N to swing in one direction or the other to an extent depending on its value and the width of the pole gap.—K. Vockenhuber and A. Handler.

Cathode-ray "Switching"

(Patent No. 523,640.)

A number of sensitive-cell units are arranged at the end of a cathode-ray tube in the position usually occupied by the fluorescent screen. The electron beam from the cathode of the tube is then made to fall upon one or other of the cells, as desired, so as to close an associated circuit.

The arrangement provides a selective switch arrangement which can be used, for instance, to call up a given subscriber in an automatic telephone system. The glass part of the cathode-ray tube is plugged into a moulded-rubber or other insulating support so that it can be readily removed and replaced, if necessary, the vacuum inside the glass being maintained by an external air-pump.—*Automatic Telephone and Electric Co., Ltd., and A. P. B. Renshaw.*

Television "Intensifier"

(Patent No. 522,951.)

The effect of a ray of light upon a photo-sensitive cathode is intensified by electronic bombardment in a tube of the shape shown.

The picture to be televised is projected through a lens L on to a photo-electric cathode K, and the electrons so liberated are first attracted towards positively-charged anodes A, and are then swept around the tube by the effect of the magnetic field from an external winding W, until they strike the back of the cathode from which they started.

The front face of the cathode K is coated with a photo-electric substance, whilst the back face is coated with a fluorescent substance which is laid on a thin translucent layer of aluminium. The impact of the electron stream on the back surface produces fluorescent light, which thus serves to liberate more free electrons from the front or photo-sensitive sur-

face, so that a regenerative action sets in and serves to intensify the original effect of the incident light.

The tube is bulged, as shown at the top, to provide a flat window D through which the picture is focused. The coils of the external winding are correspondingly spaced, and this, to-

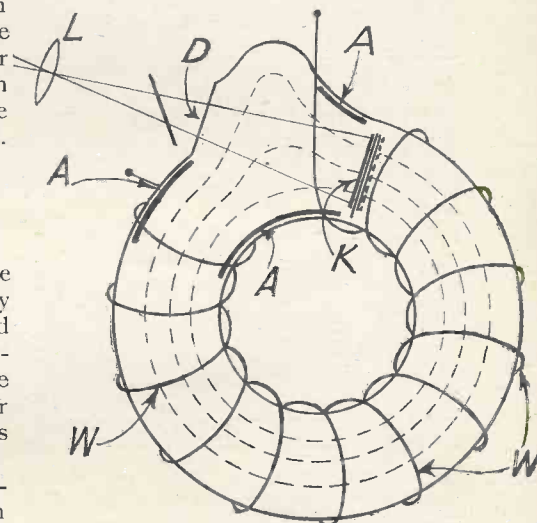

Regenerative television pick-up tube. Patent No. 522,951.

gether with the anodes A, forces the electrons to keep to the dotted line paths, and ensures that the secondary image formed on the back of the cathode K coincides exactly with the original formed on its front face.—H. G. Lubszynski.

A Summary of Other Electronics Patents

(Patent No. 514,650.)

Means for reversing the polarity of the signals in a television system using an intermediate film record.—*Fernseh Akt.*

(Patent No. 517,428.)

Arrangement of the translucent viewing screen in the cabinet of a television receiver.—*Baird Television, Ltd., and L. C. Bentley.*

(Patent No. 515,800.)

Intervalve coupling arrangement giving a substantially uniform response over a wide frequency band, such as is used for television.—*Baird Television, Ltd., and C. E. Maitland.*

(Patent No. 515,801.)

Preventing "tilt and bend" distortion in a television transmitter of the Iconoscope type.—*Baird Television and V. A. Jones.*

ance H to potentiometer M. However, resistance M may generally be of about 2 megohms and about ten times greater than the resistance H. With these elements so proportioned, the capacity of condenser L may be made sufficiently small to produce sufficient unbalance of the bridge at low frequencies to produce the desired degeneration and, at the same time, not materially reduce the desired transmission of low and medium frequency potentials from resistance H to potentiometer M. That is, the reactance of condenser L, when adjusted for desired degeneration with contact Z at the top of the potentiometer M is relatively small as compared to resistance M so that it does not substantially reduce the current produced in the resistance by the potential of resistance H. It is, however, sufficiently large as compared to the resistance H to be effective in unbalancing the bridge with respect to potentials produced by the anode current of V_2 flowing in resistance I and N.

In the diagram the potentiometer M is shown as having its lower portion shunted by the series combination of resistance R_2 and capacity C_2 thereby partially to shunt out the medium and high frequencies for so-called bass compensation. These elements, of course, influence the value of condenser L necessary for desired degeneration with contact Z at the top of the volume control resistance M and if such elements be employed, the value of condenser L must be determined with them included in the circuit.

Of course, the balance of the bridge may, as is sometimes desirable, be so adjusted that when contact Z is at the top of the volume control a regenera-

tive voltage is supplied to the grid, thereby increasing the amplification and sensitivity of the receiver. This may be effected by proper choice of resistance H, M, I and N so that the point of balance falls on potentiometer M slightly below the upper terminal for medium and high frequencies.

Condenser L may be sufficiently small so that this regeneration does not exist for low frequencies, and in fact so, that for such frequencies, the system may even be degenerative when contact Z is at, or near its extreme upper position.

In this way advantage of regeneration may be had to increase the sensitivity of the receiver to middle frequencies such as 400 cycles and high frequencies, and, at the same time, hum and the tendency to produce howl and flutter are reduced by degeneration at low frequencies, all with contact Z at the same position high on the volume control potentiometer.

It will be noticed that condenser H_1 , which is the conventional intermediate frequency by-pass condenser for the diode load resistance H has its lower terminal connected between resistance N and I rather than directly to the lower terminal of resistance H. This is to avoid unbalance of the bridge at high frequencies which would result if this condenser were included in an arm instead of across the diagonal XY as shown.

Resistance I is included in circuit between the cathode and anode of diode J, F, but it is sufficiently small in value so that the unidirectional voltage across it does not objectionably affect the operation of the diode. Ordinarily it may be of the order of 10 ohms.

denum, or thoria may be added to the oxide of molybdenum after reduction, but before consolidation of the metal powder by sintering and mechanical working to the solid state.

The Electrolytic Bath

In practice it has been found that a content of thoria of about 3 per cent. by weight of the molybdenum is satisfactory and that a filament of this thoriated metal may be used, although the percentage of the thoria may be varied considerably. While thoria is to be preferred, equivalents of thoria, for example, one of the group of metals consisting of zirconium, uranium, cerium, titanium, vanadium, yttrium and lanthanum may be used with molybdenum to form a base and the base then chromium plated in a conventional chromium plating bath, the essential constituents of which are chromic acid and a sulphate.

One example of a satisfactory bath is 33 oz. chromic acid, containing at least 95 per cent. chromium oxide (CrO_3) and not more than 0.2 per cent. of SO_4 , and .45 gramme chemically pure sulphuric acid (H_2SO_4) in a gallon of water. The limits of thickness of the chromium plating may be wide, although a very thin plating appears to be entirely satisfactory.

While the current density for plating the chromium on the thoriated metal base may vary between wide limits, for example, from a few hundredths of an ampere to over 1 ampere per square centimetre, a current density of about 1 ampere per square centimetre for a period of one minute seems to produce the most satisfactory results. The resulting chromium plated thoriated wire may then be flashed in hydrogen.

An essential step in the preparation of this cathode is that it should be flashed in ammonia gas. One method used to flash the filament in ammonia is to position within a bell jar the cathode filaments to be treated, and allow liquid ammonia to expand into the gas chamber to expel the air within the jar. The filaments are then heated to temperature of approximately 2,000° K. for a period from thirty seconds to one minute. It is also desirable, though not necessary, to insure stability of emission, to season the filament by operating the electron discharge device containing the filament with normal voltages applied for approximately fifteen minutes in an oscillating circuit.

It is believed that the chromium applied electrolytically when heated with the ammonia gas permits the chromium to alloy with the molybdenum and tungsten more easily, the result being that the chromium cannot be so easily vaporised and deposited on the walls and other parts of the tube to cause the difficulties mentioned before.

(Continued opposite)

A New Method of Manufacturing Electron-emissive Cathodes

SOME difficulty has been experienced in making electron emissive cathodes which are stable and long-lived for use in discharge tubes operating at high-frequencies and high voltages.

Cathodes composed mainly of one of the metals tungsten, molybdenum or tantalum, and having in addition chromium and an oxide of one of the metals thorium, cerium, yttrium and lanthanum have been found to be superior in operation to the well-known pure tungsten, activated thoriated tungsten, and oxide coated nickel cathodes.

However, in some cases under severe operating conditions when operated at high frequencies there is a tendency for the chromium in the cathodes of

the above described type to vaporise and condense on the cold parts of the tube, such as the walls, press and spacers, causing leakage between elements at high voltages. This also results in the reduction of emission from the cathode.

An improved cathode in which the above noted undesirable features are substantially reduced or eliminated, may be prepared as follows:—

A thoriated molybdenum base may be prepared as a ductile metal, or by squirting the finely divided material admixed with a binder. For example, if molybdenum is used, powdered nitrate of thoria may be added to the powdered oxide of molybdenum before the reduction of the oxide of molyb-

Columbia

Colour Television

First Details of an Entirely New System

TELEVISION in full colour for practical broadcasting was demonstrated to a representative of the Federal Communications Commission by the Columbia Broadcasting System on August 29. Dr. Peter C. Goldmark, C.B.S., Chief Television Engineer, has invented and developed the system. The colours, it is stated, are real colours, not just approximations, and they appear to have a greater and more faithful range of shade and vitality than exist to-day even in colour motion pictures. It has been found that the use of colour actually increases the apparent definition of the picture and makes small objects easier

to recognize. This is because contrast between colours is discernible, where contrast between mere shades of grey may be lost to the eye. For instance, taking a picture of a very small red flower against a background of grass both the flower and the grass would appear as shades of grey in black and white television. But in full colour television, the red flower stands out in sharp contrast against the green grass.

The method by which the full colour is produced was described as being inherently simple. The receiver used in the colour demonstration is a standard production model equipped with a simple attachment. The additional cost of the colour attachment, it is said, is comparatively small.

Although the demonstration was described by CBS engineers as a laboratory development, colour motion pictures were actually broadcast from the CBS high power transmitter on the Chrysler Building and successfully received in the CBS laboratories.

This broadcast, which marked the first use of the CBS transmitter for broadcasting actual pictures aside from test patterns, was picked up by a number of individuals who reported having received good black and white pictures; these viewers now know that they were looking at a picture that was being simultaneously viewed in the CBS laboratories as a colour picture.

This demonstrates one of the most unique features of this system which makes possible reception of the picture either in full colour or in black and white. If the receiver is equipped with the colour attachment, it converts the signal into a full colour picture. Without the colour attachment, the same signal produces a black and white picture. The receiver used in the colour demonstration is a standard production model altered to only a minor extent and equipped with the colour attachment. It is hoped that the system will be ready for commercial use by next January. It is pointed out that the possibility of such early commercial realisation was increased because the system requires only one camera at the pick-up point, one transmitter, and a

receiver with only a single cathode-ray tube of conventional design. Heretofore it has been generally thought that colour television would require what amounted to three separate pick-up and receiving channels, each carrying one of the primary colours.

Although the scanning standard employed differ from any of those that have been proposed to the Federal Communications Commission, they produced at the demonstration a black and white picture of 343-line quality. Despite the fact that the colour picture appeared to the eye to have definition superior to that of black and white pictures using a higher number of lines, a still further increase in the number of lines of the colour picture is contemplated, and Dr. Goldmark has already started work on raising the line number to between 400 and 500, at the same time remaining within the usual $4\frac{1}{2}$ megacycle band width. We hope to publish full technical details of the system at an early date.

A New Insulating Process

An entirely new method of pressing insulating material on coils, etc., is described by H. Warren in the July-August issue of *B.T.H. Activities*, which largely overcomes the difficulty of providing intricate moulds necessary under certain circumstances.

The process consists of applying pressure by means of hot steel shot. For example, a coil which requires an insulating covering of synthetic resin treated fabric is covered with the material and then served with india-rubber tape. It is then placed in a strong steel box provided with a plunger forming the lid, the space around the coil being filled with steel shot previously heated to a temperature of, say, 150° C. Pressure is applied to the plunger, and is transmitted by the steel shot in all directions, so that all the surfaces of the coil are pressed. After the requisite period under heat and pressure, the shot is poured out, the coil is extracted, and the rubber tape is removed. The rubber is, of course, employed in order to prevent the shot from adhering to the insulation being pressed.

One particular advantage of this method is that the pressure follows up any irregularities of the surfaces being pressed, hence, if, on production of a number of articles there is some variation of dimensions, the pressing operation will nevertheless ensure that each part will be adequately pressed and moulded—a feature which cannot usually be ensured with rigid moulds.

Apart from the obvious economy of not having to make expensive moulds in which to press articles of which only a few may be wanted, the time required to make the moulds is eliminated, and this feature is often of vital importance in urgent experimental work or repairs.

"Manufacturing Electron - emissive Cathodes."

(Continued from preceding page)

A cathode made in accordance with the above has a normal operating temperature several hundred degrees K. below the normal operating temperature of the conventional activated thoriated tungsten cathode, and in the conventional type of valve operated at the customary anode voltage the same anode current can be obtained from the cathode at its normal operating temperature with only about one-half the energy per unit area that must be used to obtain the same anode current from the conventional activated thoriated tungsten cathode at its normal operating temperature.

When the cathodes are to be used in low voltage valves, for example, under 1,000 volts, to increase the electron emissivity any of the cathodes above described may be coated with the usual electron emitting coating of alkaline oxide, which may be applied in a conventional manner by applying barium and strontium carbonates and converting them into the oxides.

The above cathodes are very efficient emitters and will operate at a comparatively low temperature (1,200° C.) and very high voltages up to approximately 3,000 volts can be used on the anode of a valve, without the cathode suffering any ill effects due to ion bombardment. These last two characteristics make these cathodes particularly suitable for indirectly-heated cathodes in high voltage gas or vacuum valves.

The cathode described is a development reported from the laboratories of the Radio Corporation of America.

Please ask your bookstall or newsagent to reserve a copy of **ELECTRONICS AND TELEVISION & Short-Wave World** each month and avoid disappointment.

OPPORTUNITIES SECTION

BUSINESS :: EQUIPMENT :: EMPLOYMENT :: MISCELLANEOUS

The charge for miscellaneous advertisements on this page is 12 words or less 2/-, and 2d. for every additional word. Single-column inch rate displayed, 12/6. All advertisements must be accompanied by remittance. Cheques and Postal Orders should be made payable to Hulton Press, Ltd., and crossed, and should reach this office, 43, Shoe Lane, London, E.C.4, not later than the 15th of the month previous to date of issue.

"More Electronic Patent Summaries."

(Patent No. 514,807.)

Separating the line and frame synchronising impulses in a television system with interlaced scanning.—*The General Company, Ltd.; E. C. Cherry; G. W. Edwards and B. J. O'Kane.*

(Patent No. 515,302.)

Separating the frame synchronising impulses from the line synchronising impulses and picture signals in a television receiver.—*Pye, Limited; W. Jones and B. J. Edwards.*

(Patent No. 515,947.)

Scanning circuit for a cathode-ray tube having a screen set at an angle to the normal path of the electron stream.—*Baird Television, Ltd., and G. R. Tingley.*

(Patent No. 516,247.)

Television system in which a supersonic wave light-cell is used to compensate for slight inaccuracies in the synchronising signals.—*Scophony, Ltd.; A. F. H. Thomson and A. H. Rosenthal.*

(Patent No. 519,515.)

Phonic motor with a toothed rotor and stator, forming two separate magnetic circuits, for synchronising the scanning impulses in television.—*I. M. K. Syndicate, Ltd.; P. Nagy and D. H. Byron.*

(Patent No. 518,317.)
Arrangement for facilitating the examination of very small objects in an electron microscope.—*Fides Ges. m.b.h.*

(Patent No. 517,839.)

Cathode-ray tube circuit for generating oscillations of saw-tooth form.—*Fernseh.*

(Patent No. 518,574.)

Electron-optical arrangement for focusing a cathode-ray beam and reducing spherical aberration.—*Marconi's Wireless Telegraph Co., Ltd.*

(Patent No. 516,620.)

Method of making cathode-ray screens on which the received pictures are reproduced by incandescence.—*F. J. G. van den Bosch.*

INDEX TO ADVERTISERS

	PAGE
Automatic Coil Winder & Electrical Equipment Co., Ltd.	Cover ii
British Institute of Eng. Technology	Cover iii
British Mechanical Productions, Ltd.	477
British Tungfram Radio Works, Ltd.	474
Candler System Co.	478
Celestion, Ltd.	473
Chlx	477
Du Bois Co., Ltd.	476
Edison Swan Electric Co., Ltd.	434
Electradix Radio	478
Fluxite, Ltd.	Cover ii
Foyles', Ltd.	Cover iii
Galpins	479
General Electric Co., Ltd.	469
Henley's, W. T., Telegraph Works Co., Ltd.	475
Lockwood & Co.	476
Partridge, N.	477
Peto-Scott Co., Ltd.	477
Pitman's	477
Premier Radio Co.	471
Radio Society of Great Britain	480
Radiomart	475
Taylor's Electrical Instruments, Ltd.	433
Technological Institute of Gt. Britain	473
Telegraph Construction Maintenance Co., Ltd.	Cover ii
Television Society, The	480
Vacuum Science Products, Ltd.	476
Ward, Chas. F.	478
Webb's Radio	Cover iv

MISCELLANEOUS

ALL TYPES of Rotary Converters, electric motors, battery chargers, petrol electric generator sets, etc., in stock, new and second-hand.

A.C.-D.C. Conversion Units for Operating D.C. Receivers from A.C. Mains, 100 watts output, £2. 10/-; 150 watts output, £3. 10/-.

WARD, 46, Farringdon St., London, E.C.4. Tel. Holborn 9703.

LOUDSPEAKER repairs, British, American, any make, 24-hour service; moderate prices.—*Sinclair Speakers, Pulteney Terrace, Copenhagen Street, N.1.*

BRITISH VALVES at less than 1/3rd cost. (All Guaranteed.) Battery types: 2v. Double Diode Triode, 2/-; Power, 1/6; Super Power, 1/9; Pentodes 4 and 5-pin, 2/6; Class B, 3/6. Mains types: 4v. AC/HL indirectly heated, 2/6; A.C. Screen-Grid, 3/6; S.G. High Gain, 3/6; S.G. Variable-Mu, 3/6. A.C. D.C. types: K.T.30, 3/6; L.13 Detectors, 1/6; U.30 Rectifiers, Octal, 1/6. All made by well-known British manufacturer. Terms: Cash with order to S.S. (E) Radio Service, 20 Upper Duke Street, Liverpool.

LOUDSPEAKERS

3,000 SPEAKERS P.M. and energised 4" to 14", including several Epoch 18". *Sinclair Speakers, Pulteney Terrace, Copenhagen Street, N.1.*

RADIO MAP AND GLOBE

WEBB'S Radio Map of the World enables you to locate any station heard. Size 40" by 30" 2 colour heavy Art Paper, 4/6d., post 6d. Limited supply on Line, 10/6, post 6d. **WEBB'S** Radio Globe—superb 12" full-colour model. Radio prefixes, zones, etc. Heavy oxydised mount. Post Paid. 27/6.—*Webb's Radio, 14, Soho Street, London, W.1. Phone: Gerrard 2089.*

MORSE EQUIPMENT

FULL RANGE of Transmitting Keys, Practice Sets, Oscillators, Recorders and other Radio Telegraph Apparatus, designed and manufactured by **T. R. McElroy**, World Champion Telegraphist. Absolutely first-class construction.—*Webb's Radio, 14, Soho Street, London, W.1. Phone: Gerrard 2089.*

TUITION

PRACTICAL POSTAL COURSES, radio television, test equipment design, trade-test coaching for R.A.F. post, I.P.R.E. and I.W.T. exams.; booklet free—*Secretary, I.P.R.E., 3, Shirley Rd., London, W.4.*

PATENT AND TRADE MARK AGENTS

GEE & CO., (H. T. P. Gee, Mem. R.S.G.B., etc.). 51-52, Chancery Lane, London, W.C.2. Holborn 4547-8. Handbook free.

MORSE TRAINING

MORSE CODE COURSES. "Book of Facts" Free.—*Candler System Co. (Room 55 B), 121 Kingsway, London, W.C.2.*

WANTED

ALL TYPES of used Radio Sets, Radio & Electrical accessories. Bought for cash. *University Radio, 22 Lisle Street, W.C.2. Phone GER. 4447.*

FOYLES

BOOKSELLERS TO THE WORLD

New and second-hand books on every subject
113-125 Charing Cross Rd., London, W.C.2
Telephone Gerrard 5660 (16 lines)

TELEVISION.

A NEW COURSE OF INSTRUCTION.

We have pleasure in announcing that our new "Television" Course has met with remarkable success. The enormous demand for the Course has shown, beyond any shadow of doubt, that it fills that long-felt need which we anticipated when we went to such trouble and expense in its preparation.

We shall be happy to send full details of this special "Television" Course on request. Particulars are also available of other Courses in all branches of Wireless, Television, Talking Picture Engineering, etc., and of the easiest way in which to prepare for the A.M.I.E.E., A.M.I.W.T., A.M.I.R.E., etc., Examinations.

We teach by correspondence, and guarantee "NO PASS—NO FEE." Our Technical Consultant is Professor A. M. Low.

Send for full particulars to-day. Free and without obligation.

THE BRITISH INSTITUTE OF ENGINEERING TECHNOLOGY
337, SHAKESPEARE HOUSE, 17/19, STRATFORD PLACE
LONDON, W.1.

"Electronics &

Television and

Short-wave

World" will be

sent post paid

to any part of

the world for

twelve months

for 20/-