

Electronic Engineering

A MORGAN BROTHERS PUBLICATION

DECEMBER 1967 3s. 6d.

INTRODUCING THE SCHNEIDER RT *Digitest* (only 9 lb in weight)

**AVERAGE
PRICE
£150**

(Industrial
and Trade
Discounts)

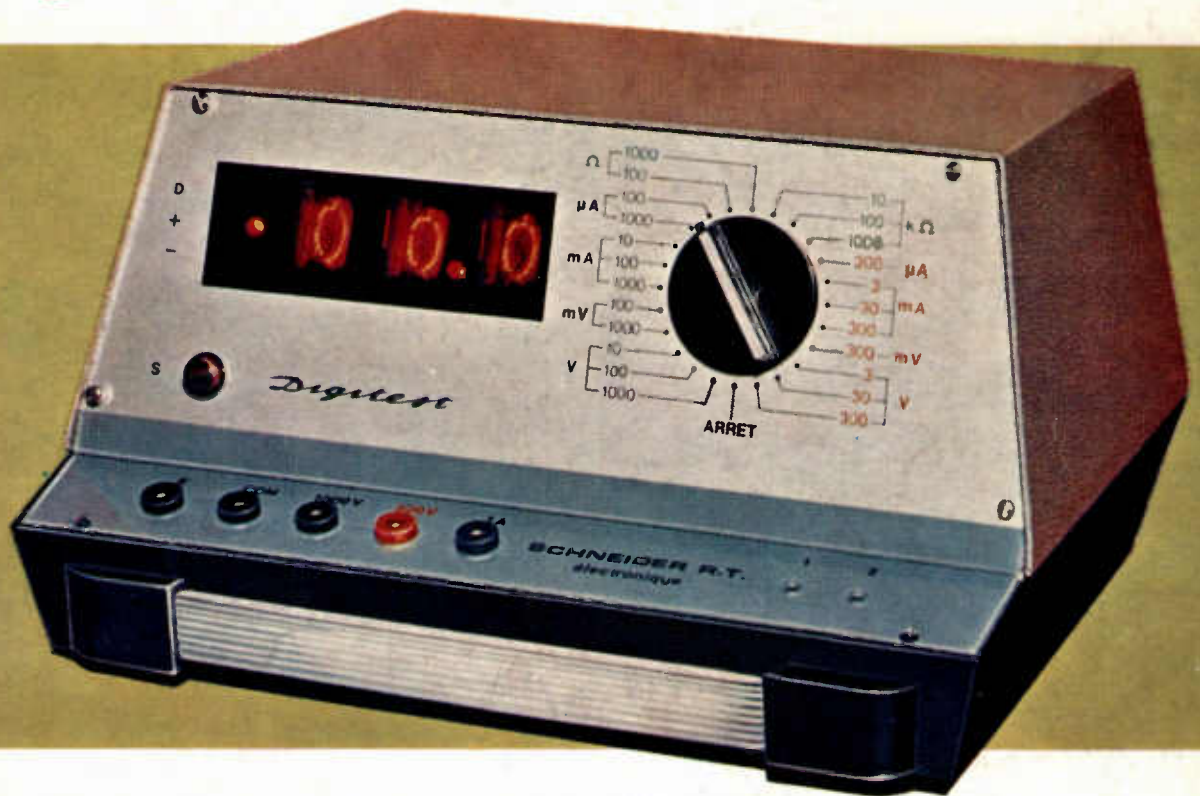

DIGIT DISPLAY MULTIRANGE PORTABLE METER

23 RANGES AC - DC - VOLTS - AMPS - OHMS

HIGH INPUT IMPEDANCE

WITHSTANDS TEN TIMES OVERLOAD *AUTOMATIC POLARITY &*

0.1% RESOLUTION *OVERLOAD INDICATOR*

FOLLOWING MODELS AVAILABLE:

- **SELF-CONTAINED DRY-BATTERY MODEL - P**
- **MAINS-DRIVEN MODEL - S**
- **MAINS OR BATTERY MODEL - SB**

(with NiCd rechargeable cells and built-in charger)

For further information and
specification data contact:

KYNMORE ENGINEERING COMPANY LTD

19 BUCKINGHAM STREET · LONDON · W.C.2

Tel: (01)-839 2371 · Cables: Kynmore · Telex: 24504 (Servopot London)

For more information circle No. 1

It costs



and it's still inexpensive!

With 80 AMPS D.C. output it can do the job of a number of conventional stabilised power supplies. For heavy duty applications, choose a model from the 'POWERFLEX' range.

Type 35 350W (0-35V) £360
Type 75 750W (0-35V) £480
Type 170 1700W (0-65V) £510
Type 260 2600W (0-65V) £570

Full technical details on request from:

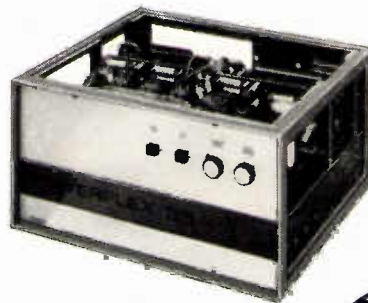

Farnell

INSTRUMENTS LTD, Sandbeck Way, Wetherby, Yorks. Tel: Wetherby 3541/6 lines



Electronic Engineering

Incorporating
 ELECTRONICS, TELEVISION and SHORT WAVE WORLD
 Editor: L. G. POOLE, B.Sc.

CONTENTS

733	Commentary	
734	Delay unit suitable for television-field delay	<i>by D. Howorth and J. G. Ingleton</i>
739	Fast transistorized pulse amplifiers	<i>by D. Ivekovic</i>
744	Binary-decimal encoder using integrated circuits	<i>by K. J. Dean</i>
748	Instantaneous pulse-measuring voltmeter	<i>by N. A. Westman, S. Westerlund and S. T. Berglund</i>
752	Behaviour of a Schmitt-trigger circuit used in conjunction with a current-integrating capacitor	<i>by L. A. W. Kemp, D. O. Bottrill and S. Klevenhagen</i>
756	Timing unit for control of stimulation signals	<i>by K. J. Kapota</i>
759	Train decade counter	<i>by R. P. Ingram</i>
763	Example of digital-to-analogue conversion	<i>by W. Olthoff</i>
766	Voltage-to-frequency conversion	<i>by B. D. Rakovich and S. Tesic</i>
769	Crystal-controlled 164MHz oscillator/quadrupler	<i>by D. Singh and J. Garters</i>
773	Period-quantized encoder for toll-quality p.c.m. systems using a modified monostable multivibrator	<i>by V. K. Agarwal</i>
778	Transistorized high-voltage supplies	<i>by R. E. Crosbie</i>
783	First cable for Cape Town—Lisbon link	
784	New books	790 New equipment
788	Short news items	797 Diary of the month
FRANÇAIS 798	Résumés des principaux articles	
DEUTSCH 799	Zusammenfassung der wichtigsten Beiträge	
90	Classified Advertisements	95 Index to Advertisers

Subscription Rates

Home:
 £2.5s. p.a. (3 yrs. £6.)
 Overseas:
 £9.15s. p.a. (3 yrs. £7.10s.)
 Canada & U.S.A.:
 \$8.00 p.a. (3 yrs. \$22.00)
 Single copy: 3.6d.
 plus 1s. 6d. postage

PUBLISHED MONTHLY on the last Friday of the preceding month by:—

MORGAN BROTHERS (PUBLISHERS) LIMITED

at 28 ESSEX STREET • STRAND • LONDON • WC2 Telephone: 01-353-6565



MEMBER OF THE AUDIT BUREAU OF CIRCULATIONS



MORGAN-GRAMPIAN LIMITED 1967

By how much will FREON* cut the cost of your industrial cleaning? 10%? 50%? 80%?

Because it removes grease and oils without harm to metal, plastic or elastomeric parts, and has high density and low surface tension, FREON is the ideal cleaning solvent.

Du Pont makes over 40 different FREON fluorocarbons—all *tailored* to handle specific needs.

Many companies have reported dramatic savings in labour and solvent costs after using FREON solvents—and they have received the benefit of Du Pont's considerable technical experience in effectively analysing cleaning problems.

Find out how FREON solvents can give you better cleaning at lower cost by completing the coupon and posting it today.

To: Du Pont Company (United Kingdom) Ltd.,
'Freon' and 'Valclene' Products Department,
Du Pont House, Fetter Lane, London, E.C.4.

I am interested in receiving information on the
advantages of using FREON solvents in cleaning

(State application)

Name _____

Position _____

Company _____

Address _____

Enquiries from outside the U.K. and Eire should be addressed to:
Du Pont de Nemours International S.A., 'Freon' and 'Valclene'
Products Department, 81 route de l'Alre, Geneva, Switzerland.

FREON*

SOLVENTS



Better Things for Better
Living
...through Chemistry

* Du Pont's registered trademark

EE/12/67

4 NEW KSM PULSE GENERATORS

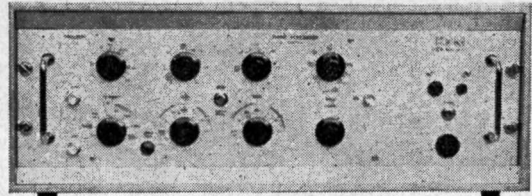

T 14 £185

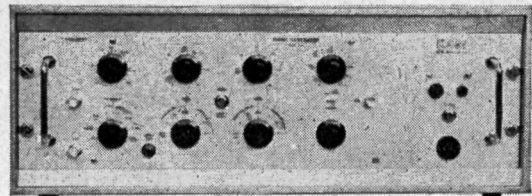

T 15 £330

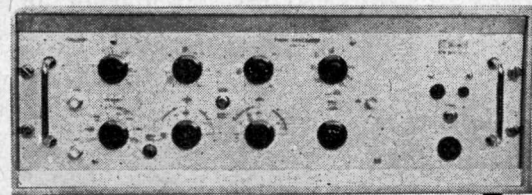

T 16 £235

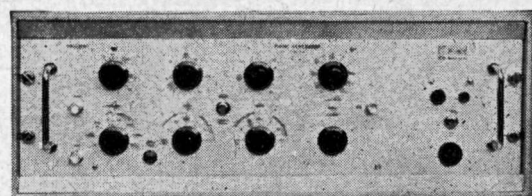

T 17 £380

RISE AND FALL TIME independently variable from 10 ns to 30 ms.

FREQUENCY RANGE from 5HZ to 15MHZ.

OUTPUT AMPLITUDE variable up to 50 V into 50 OHMS
positive or negative from earth.

PULSE WIDTHS 30 ns to 300 ms.

DELAY 30 ns to 300 ms.

DOUBLE PULSE FACILITY UP to 15 MHZ single shot button.
External gating. Triggering or synchronising.

K.S.M. ELECTRONICS LIMITED

Bradmore Works, Bradmore Green, Brookmans Park, Hatfield, Herts.
Tel: Potters Bar 59707.

REED

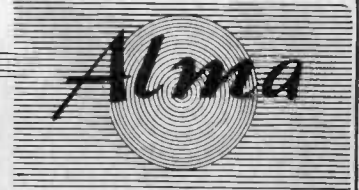

RELAYS REED UNISELECTOR

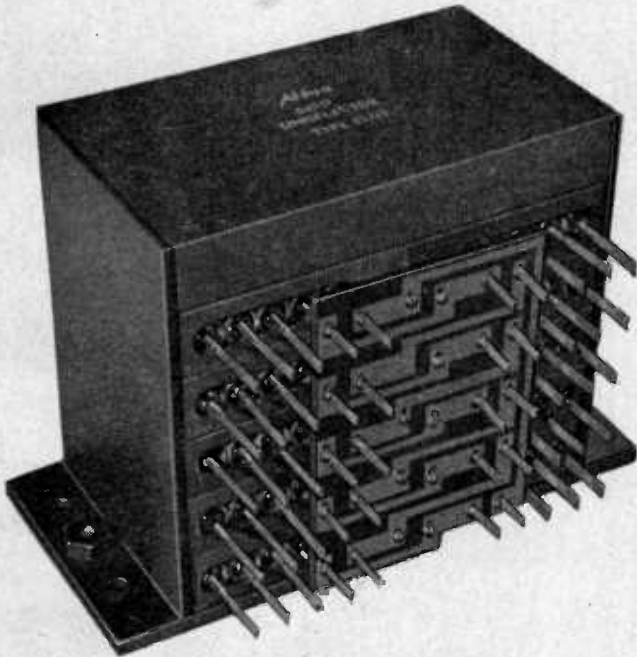

Designed for those special switching applications which are beyond the capabilities of conventional uniselectors and stepping switches. Any number of ways up to 100 can be supplied with up to 6 banks. Reverse operation can be provided and automatic homing to any pre-selected number.

- ★ Higher speed of operation
- ★ Fully sealed contacts—no adjustments or maintenance
- ★ Instantaneous re-set without going through all contacts
- ★ Changeover or normally closed contacts can be supplied if required
- ★ Independent "make" contacts are employed instead of a common wiper circuit
- ★ Low contact resistance

Application notes now available

Written as a result of extensive experience into customer's problems, a number of notes are now available and further notes are in preparation. Ask for a set to-day.

New Miniature Relays

Alma introduce a new range of miniature relays, designed exclusively for printed circuit applications. Combining extreme reliability with compact size, these relays are available in three standard sizes.

TYPE DRPP

Sub-miniature normally open relay of single ended construction



Coil Voltages
6V, 12V or 24V

Coil Power
150 mW average

Contact ratings
Max. Volts 10V
Max. Current 10mA
Max. Power 0.1 Watts

Dimensions
0.5" long
0.25" diameter

TYPE DRPM

Miniature normally open relay



Coil Voltages
6V, 12V or 24V

Coil Power
150 mW average

Contact ratings
Max. Volts 100V
Max. Current 0.25A
Max. Power 3 watts

Dimensions
0.8" long
0.3" wide
0.285" high

TYPE DRPMC

Miniature changeover relay



Coil Voltages
6V, 12V or 24V

Coil Power
150 mW average

Contact ratings
Max. Volts 100V
Max. Current 0.25A
Max. Power 3 Watts

Dimensions
0.8" long
0.3" wide
0.285" high

ONEOFFMANSHIP IN REED RELAYS

Alma have designed nearly 200 reed relays in little over two years. Many—originating as specials—have now been incorporated into our standard range, or have been adapted to form the basis of other specials. So if you have a call for a reed relay quite unlike anything you've heard of before, contact Alma and save time.

ALMA COMPONENTS LIMITED

Park Road · Diss · Norfolk

Telephone: Diss 2287 : Telex: 98162

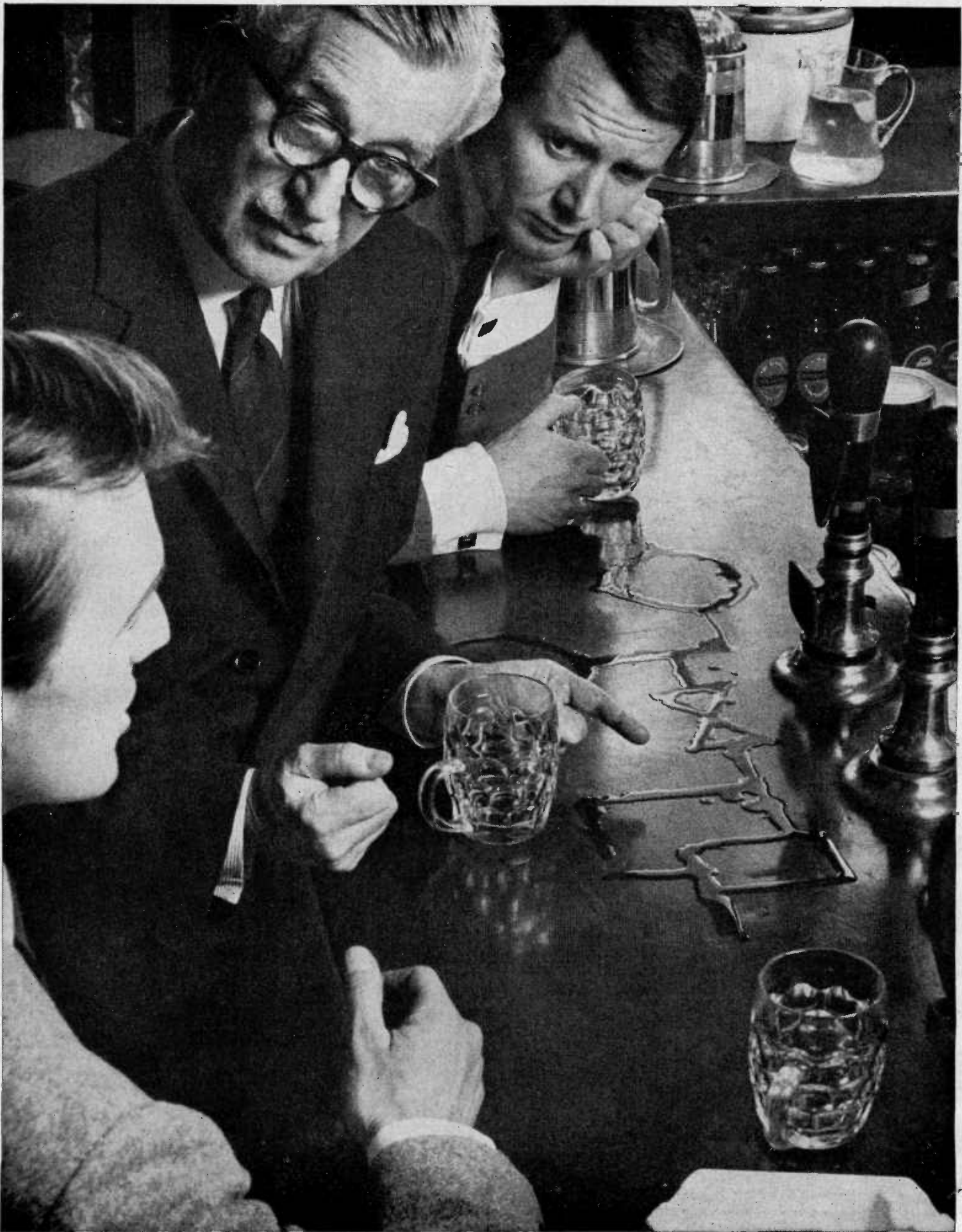



ACROSS INDUSTRY... THEY'RE PREPARING FOR NATURAL GAS

ARE YOU?

Among engineers the talk is of gas from the sea—more and more finds have turned hope into certainty that this new primary fuel is going to provide an enormous stimulus to British industry, changing the economics of production and encouraging expansion. Clean and flexible for delicate processing work—plentiful for large-scale use, natural gas has already proved to be the ideal industrial fuel in other countries. Soon, backed by the research and technical know-how of the Gas Industry, it will make its impact on the industrial scene in Britain. Conversion from town gas is no problem—talk to your Gas Board's Industrial Gas Officer—he'll convince you of your bright new future with High Speed Gas from the North Sea. Ask him for a copy of "Preparing for Natural Gas"—a progress report to industry.

Industry is looking forward to
NATURAL HIGH SPEED GAS 

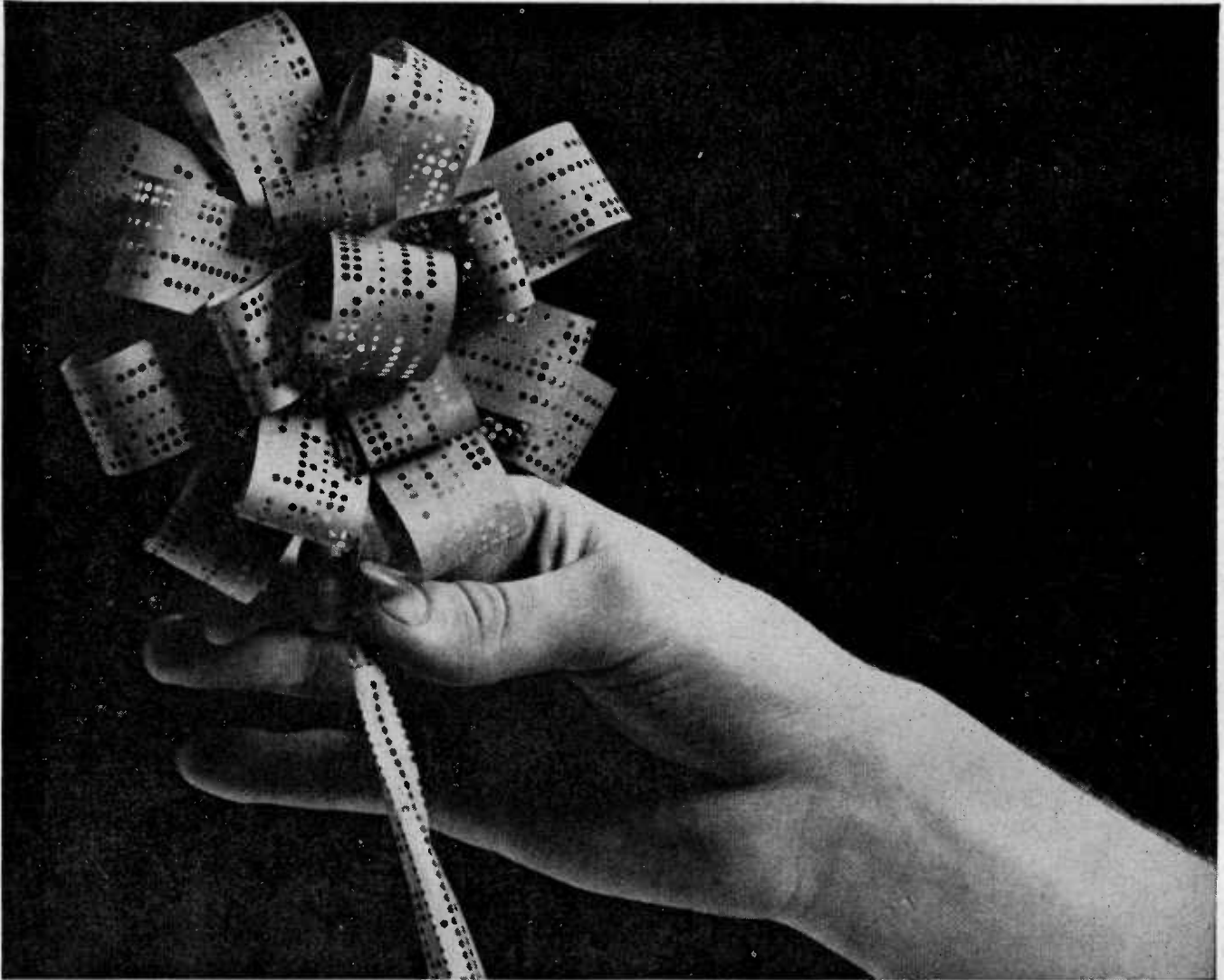

Hall and Kay have green fingers

when it comes to air conditioning for computers

Delicate plants, computers . . . their air conditions must stay within a hairsbreadth of the perfect.

The people to ensure that are the HK Organisation. They draw on many years of specialised experience in the installation of air-conditioning plant for factories, schools, offices, restaurants, cinemas and textile mills — some razor-thin tolerances in the air around *that* industry, too! HK technicians and designers are ready to examine your air-conditioning requirements, and to put forward complete specifications, drawings and estimates for an efficient and economically-running installation.

If atmospheric conditions are a problem, let HK clear the air for you!

AIR CONDITIONING DIVISION

Hall & Kay Limited,
Birch Street, Ashton-U-Lyne
Lancs,
Tel: ASHton 5551 (7 lines)

HEATING DIVISION

Birch St., Ashton-U-Lyne
Tel: ASHton 5481 (3 lines)

ELECTRICAL DIVISION

Electric House,
Birch St., Ashton-U-Lyne,
Tel: ASHton 4252 (3 lines)

Members of the Spark Holdings
Group of Companies

READ ALL ABOUT THE HK 'THREE-IN-ONE' SERVICE

Send for the brochure which describes and illustrates the full extent of the service offered by the HK Organisation in air conditioning, heating and electrical power.

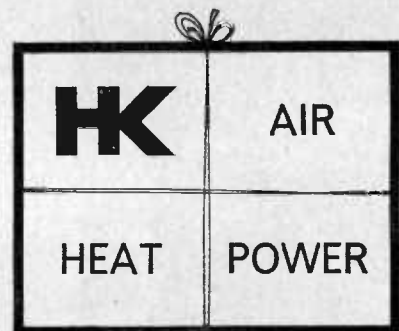

G. 994

HALL & KAY AIR-CONDITIONING, HEATING AND POWER ENGINEERS

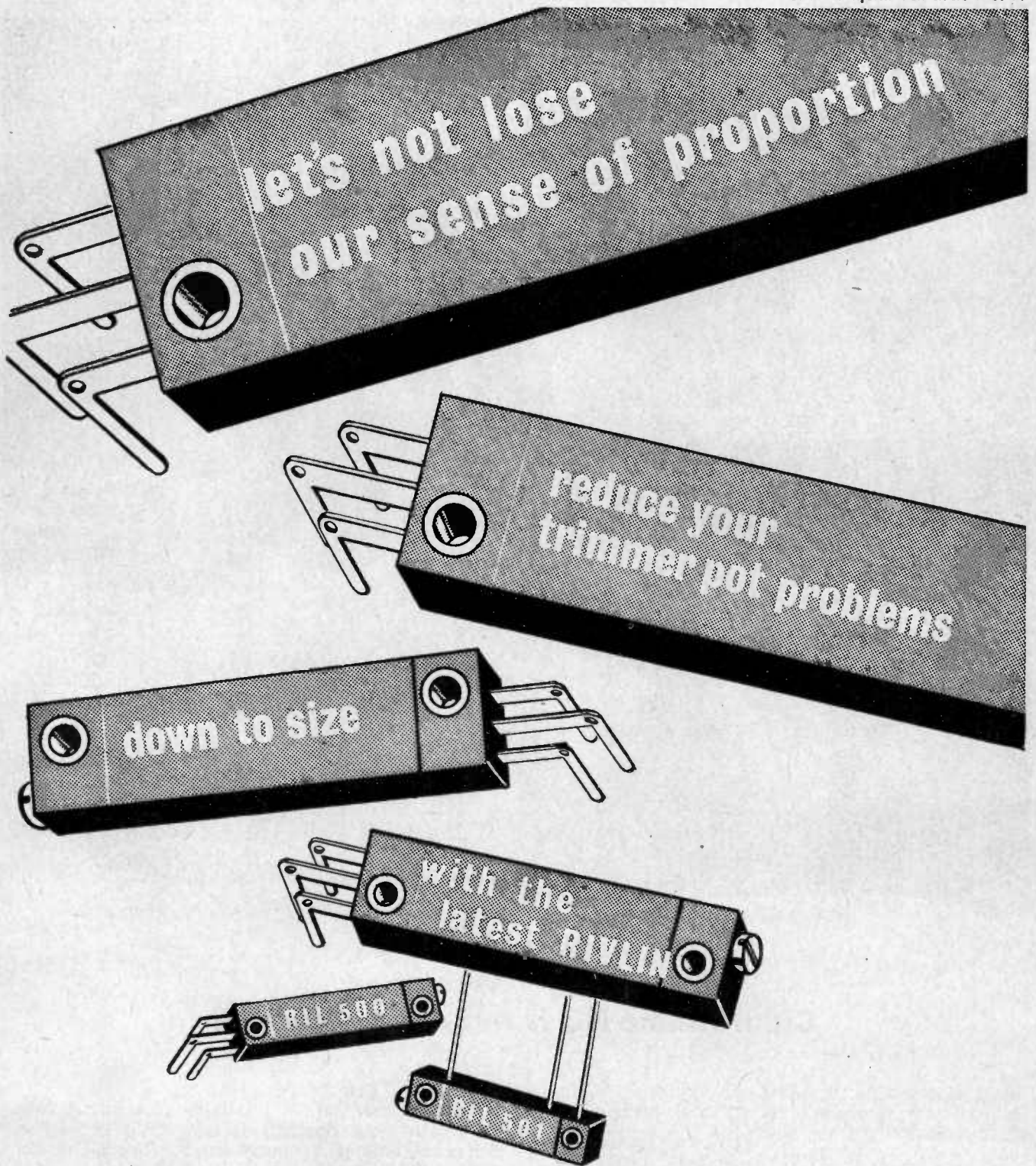

These new rectangular potentiometers incorporate a variable resistor controlled by a multi-turn lead screw with clutch mechanism to prevent overwinding. Reliable operation over long periods is assured, combined with unusually low noise output. The price is realistic and delivery is good. May we send you a sample and detailed specification for evaluation.

"You can rely on Rivlin"

RIVLIN INSTRUMENTS LIMITED.

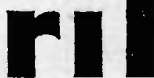

Yorktown Industrial Estate, Doman Road, Camberley, Surrey.

(Camberley 21107/8) London Office: 687 Finchley Road, N.W.2. (Swiss Cottage 3038).

For more information circle No. 12

Photograph by courtesy of Oerlikon Engineering Company Zurich

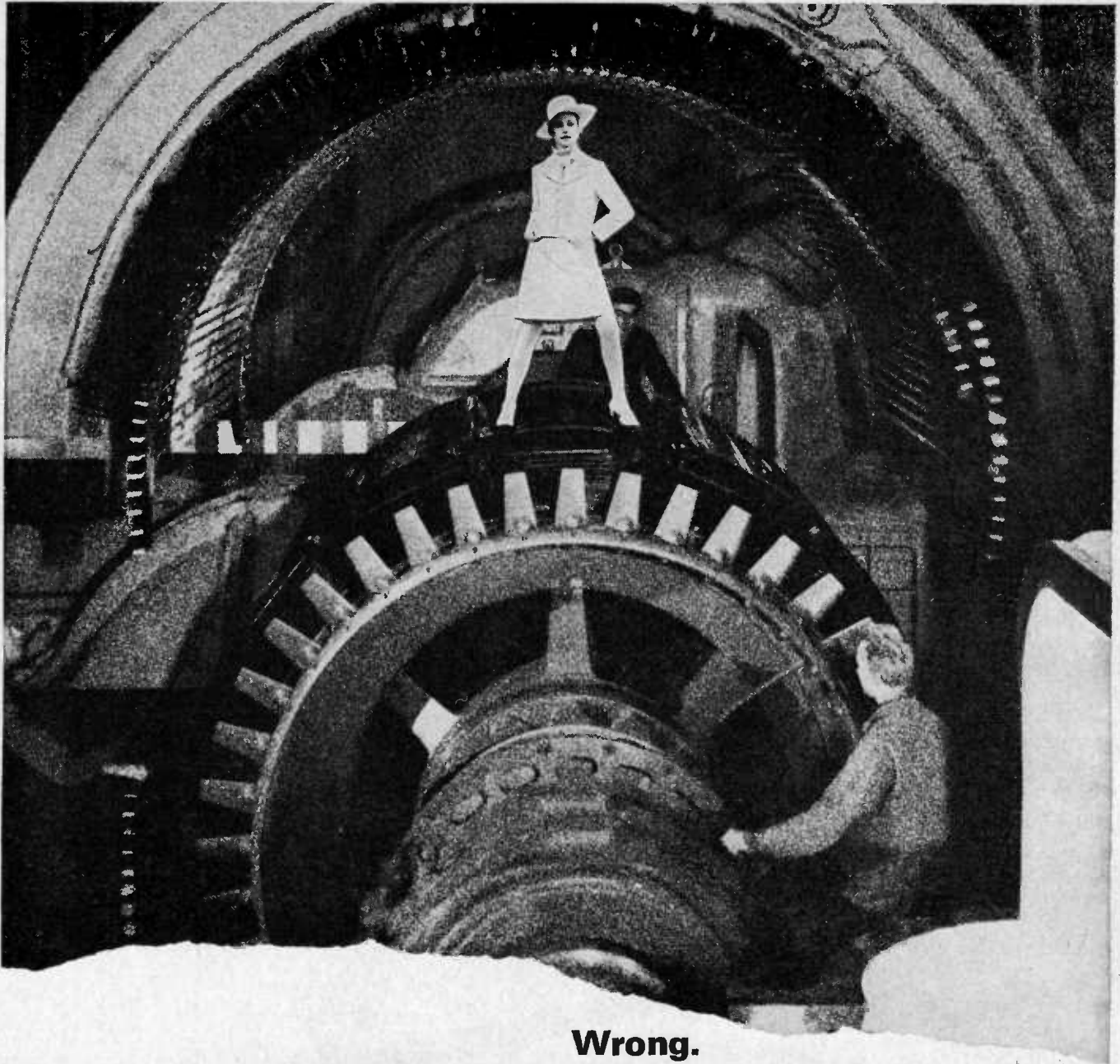

**Wrong.
Chlorothene NU is not a spray cleaner.**

It's a slush, wipe, dip and spray cleaner. About the safest, most versatile, effective and economical industrial solvent you can buy.

For example, Chlorothene* NU has proved so successful for electrical maintenance work—including in-service cleaning of large, dirt-fouled electric motors—that many contractors and maintenance engineers now use it exclusively.

Chlorothene NU demonstrates superior solvency, does no harm to insulating materials, is non-flammable like trichloroethylene, but low in toxicity as well. It has an ideal evaporation rate, can be easily recovered for re-use.

In developing this amazing solvent, Dow (world's largest producer of chlorinated solvents) uncovered many other effective applications, such as production equipment cleaning, parts cleaning and general all-around plant housekeeping.

Perhaps you can discover a few more. The sooner you try it the sooner you'll realize important time and money savings in your cleaning operations. Send for a test sample by writing us, or contact your Dow distributor.

Dow Chemical Europe S.A.
Alfred Escher-Strasse 82, 8027 Zurich, ☎ 051/274192

- Please send detailed information.
- Please send Chlorothene NU sample.
- I would like a demonstration.



Name and Title: _____

Company: _____

Address: _____ 67-209/45

* Trademark of The Dow Chemical Company

Extra Sensory Dawe instruments provide a sixth sense for industry. Accurate, reliable, robust instrumentation for measurement, study or detection of the apparently intangible; instrumentation designed and manufactured with care to advance industrial progress. And our para-normal powers don't end there. They can also be applied to production processes such as cleaning, welding and machining.

EXTENDING YOUR RANGE OF MEASUREMENT

DAWE 900 SERIES DIGITAL INSTRUMENTS

Counters, Timers, Tachometers, Ratio Meters, Frequency Meters and Multiple Function Units all of plug-in modular construction.

ALSO AVAILABLE AS INDIVIDUAL PLUG-IN MODULES

ESD

A SIXTH SENSE CALLED DAWE



Digital Frequency Meter, Counter, Timer Type 901A/6. Frequency range: 1 MHz. Price: £154 (illustrated). Digital Frequency Meter, Counter, Timer Type 920A/4. Price: £113. Three, four or five digit models also available.



Digital Timer Type 960/6. Range: 10 μ s to 10⁴ secs. (Nearly twelve days) with six digits. Price: £142. Three, four or five digit models also available.

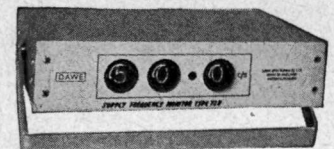

Supply Frequency Monitor Type 728. For continuous monitoring of 50, 60 or 400 Hz supplies. Price: £69.

Write today for full technical details.



DAWE

INSTRUMENTS LIMITED

CONCORD ROAD, WESTERN AVENUE, LONDON, W.3. TEL: 01-992 6751

A member of the *Sims* group of companies

ADCOLA
PRODUCTS LIMITED
(Regd Trade Mark)

SOLDERING
EQUIPMENT

606 Series

**NEW
HIGH EFFICIENCY
TOOLS**

AVAILABLE IN
FOUR TEMPERATURES
FROM 250°C TO 410°C

For Catalogues apply to:

SALES & SERVICE DEPT.,
ADCOLA PRODUCTS LTD.,
ADCOLA HOUSE,
GAUDEN ROAD,
LONDON, S.W.4

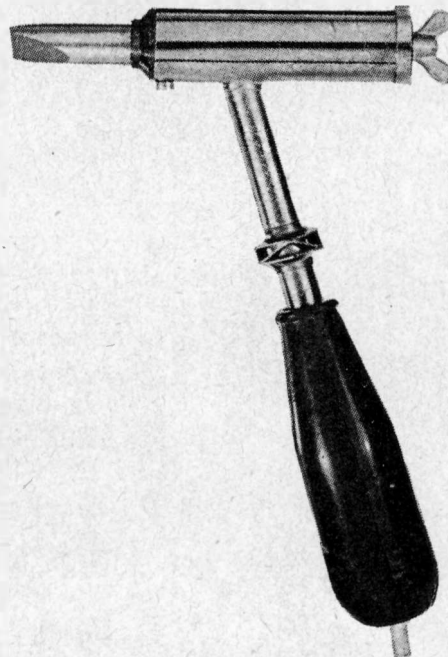

ILLUSTRATED: R 1000 1/4" dia. BIT OFFSET MODEL

Telephone: 01-622 0291/3

Telegrams: SOLJOINT, LONDON, S.W.4

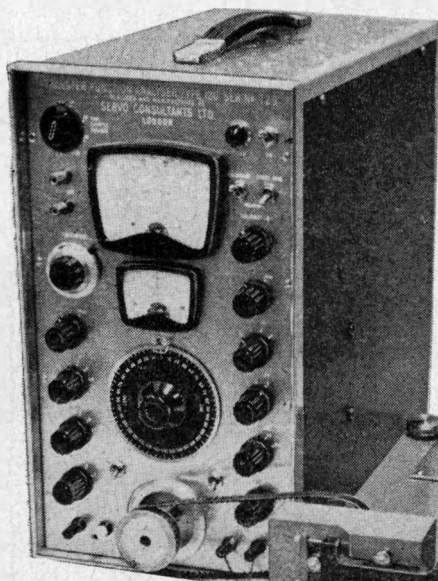

**TRANSFER FUNCTION ANALYSERS
and AUTOMATIC NYQUIST
DIAGRAM PLOTTERS**

*Transfer Function Analyser Type 120 measuring
the transfer function of a demonstration mass-
spring-damping system.*

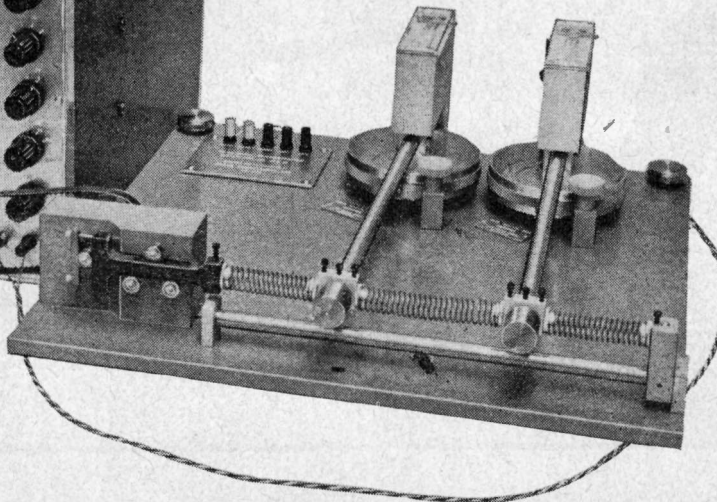

FEATURES:

All Models :

- Direct reading] of phase and amplitude.
- Frequency range 0.2 - 100 Hz.
- D.C. input and output for testing servo systems and networks.
- Modulated carrier for A.C. systems.
- Facilities for direct operation of mechanical input systems.

Plotter Type 105 :

- Automatic Nyquist Plot with adjustable sweep rate.

SERVO CONSULTANTS LIMITED

Sunleigh Road, Alperton, Middlesex

Telephone: 01-902 4464

ten times better than MIL.

the average resistance change
for
British made

Painton Metlohm Type PMF 60 Metal Film Resistors

when measured after 1000 hours at the

MIL-R-10509F

rating of $\frac{1}{8}$ watt at 125°C
(three times the DEF 5115 rating) is

0.05%

(Mil spec limit $\pm 0.5\%$)



Painton & Co. Limited

KINGSTHORPE · NORTHAMPTON

Tel: 34251 (10 lines)

Grams: Ceil, Northampton

Telex 31576

AUSTRALIA Painton (Australia) Pty. Ltd. U.S.A. Painton Inc. ITALY Painton Italiana. SWEDEN Svenska Painton A.B. BENELUX Painton S.A.
GERMANY Painton G.m.b.H.

For more information circle No. 17

EPS

The first totally encapsulated power supplies with a performance comparable to normal stabilised units. EPS units provide DC outputs from unstabilised DC sources without the need for auxiliary rails





the smallest, toughest, humidity-proof power supplies in the world

Output Voltages: 3-8V, 5-30V, 20-60V; preset and selected by a single external resistor.

Output Currents: up to .25A, .5A and up to 5A.

Protection: re-entrant current, any level up to .5A, up to 2A and up to 5A and selected by a single external resistor. The .25A units are not protected.

★NATO code No. 6110-99-924-1162

TYPE NO.	OUTPUT (preset)	CURRENT RATING	COMMON RAIL POLARITY	SIZE	PRICE			
EPS 24	5-30V	.25A	-		1 1/8"	£12		
EPS 25			+		1 1/8"	£14		
EPS 26			-		1 1/8"	£12		
EPS 27	3-8V		+		1 1/8"	£14		
EPS 20	5-30V		.5A		-		1"	£12
EPS 21					+		1"	£14
EPS 22		-		1"	£12			
EPS 23	3-8V	+		1"	£14			
EPS 2★	5-30V	2A		-			1 1/2"	£12
EPS 3				+			1 1/2"	£14
EPS 4			-	1 1/2"		£12		
EPS 5	3-8V		+	1 1/2"		£14		
EPS 6	20-60V		-	1 1/2"		£15		
EPS 7			+	1 1/2"		£15		
EPS 8	5-30V	5A	-		3 1/2"	£18		
EPS 9			+		3 1/2"	£20		
EPS 10			-		3 1/2"	£18		
EPS 11	3-8V		+		3 1/2"	£20		
EPS 12	20-60V		-		3 1/2"	£22		
EPS 13			+		3 1/2"	£22		

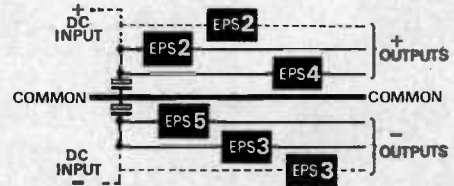
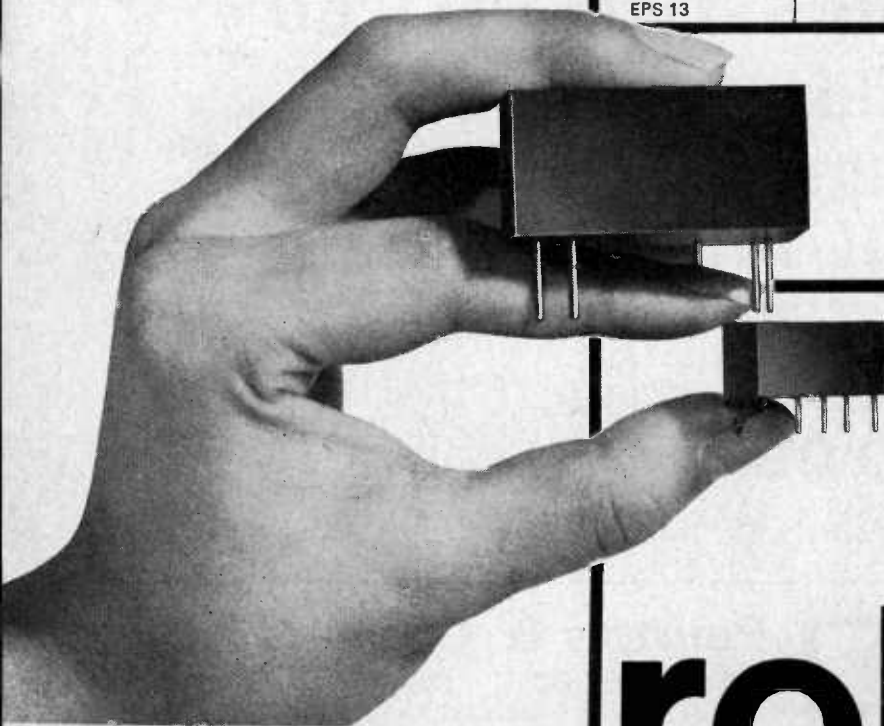

now even smaller!
(less than 1/3 of a cubic inch)

roband

Roband Electronics Limited Charlwood Works Charlwood Surrey Crawley 20172

EPS

SWITCHING REGULATORS

The only one of its kind, the Roband EPS Switching Regulator chops an unregulated voltage at high frequency, averaging the rectangular pulses produced. A high degree of stabilisation against load and mains variation, as well as ripple rejection is obtained through automatic variation of pulse width.

Apart from the obvious advantages of encapsulation, (toughness, humidity-proof, etc.) these switching regulators contain a unique form of internal metal screening which diminishes radiation signals inherent in this type of device.

Advantages over conventional series regulators are:

Dissipation: very low and basically only current dependent.

Efficiency: can be as high as 90%.

Economy: a single unregulated rail will drive as many units as required, even if output voltages differ widely.

Mains Failure: the nature of the circuit permits them to continue operating for mains failure of 1/10 sec. duration.

Programming: the output can be swung over the complete range of voltage, even though the input remains fixed.

EPV

INVERTERS

(square wave)

within a tough, humidity-proof encapsulation, a static inverter of unique design,

smallest in the world

lowest audio noise level

exceptional frequency stability

short circuit protection

efficiency: 85%

regulation: 24v units: 5%
12v units: 10%

TYPE NO.	INPUT VOLTS	OUTPUT VOLTS	CURRENT RATING	COMMON RAIL POLARITY	SIZE	PRICE (Carr. Pd UK)	TYPE No.	INPUT D.C.	A.C.	OUTPUT POWER	FREQUENCY	SIZE	PRICE (Carriage paid UK)
EPS 108	15-50V	6-30V	5A	-	2 1/4"	£29	EPV 50/100	12V	115/230V	100W	50 c.p.s.	3 3/8" x 3 3/8" x 4 1/2"	£37.10.0
EPS 109				+	1 1/2"	£29	EPV 400/100	12V	115/230V	100W	400 c.p.s.	3 3/8" x 3 3/8" x 3 1/2"	£37.10.0
EPS 110	10-40V	3-20V		-	1 1/2"	£29	EPV 50/200	24V	115/230V	200W	50 c.p.s.	4 1/2" x 4 1/2" x 5 1/2"	£50. 0.0
EPS 111				+	4 1/2"	£29	EPV 400/200	24V	115/230V	200W	400 c.p.s.	3 3/8" x 3 3/8" x 4 "	£50. 0.0

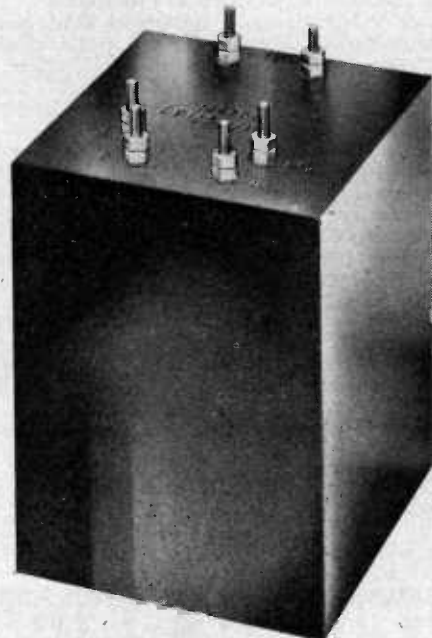
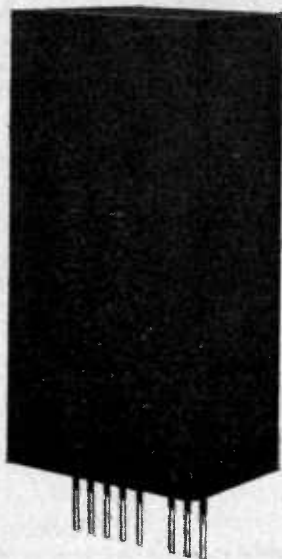

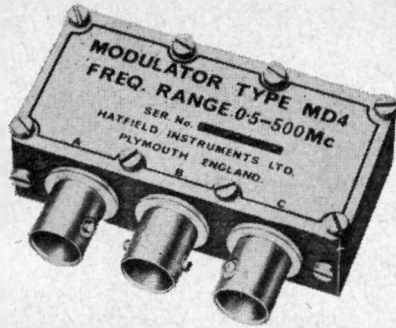

● BETTER PERFORMANCE

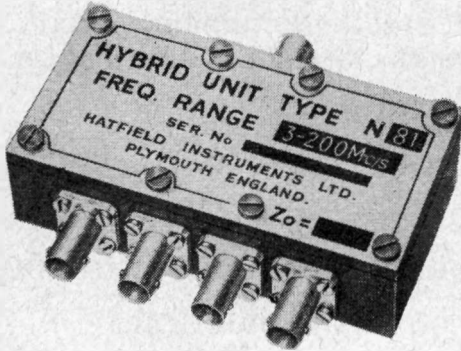

● WIDER RANGE

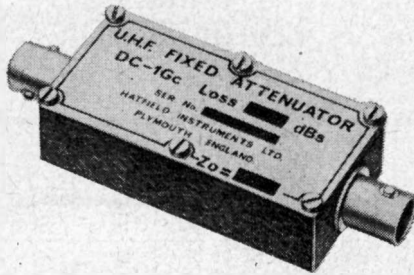

● NEW STYLES

The Hatfield range of Modulators, Fixed Attenuators, Signal Dividers and Hybrids has been re-styled and extended by the new developments illustrated.

The compact V.H.F. Double Balanced Modulator Type MD4 uses "Hot Carrier" Diodes and is capable of very good performance as an amplitude modulator, mixer, phase detector or current controlled V.H.F. Attenuator. Input and output frequency range is 0.5-500 MHz, modulation frequency range DC-500 MHz.

The new Hybrids, Types N81 and N82 are passive couplers having a very wide operational bandwidth. A significant feature of these new types is that all outputs are in phase, making the units particularly suitable for coupling multiple antennae.

Designed as complementary units and to operate over the range DC to 1 GHz the new U.H.F. Fixed Attenuator and Signal Divider will shortly be available. The Signal Divider provides an efficient and inexpensive method of dividing one signal between two outputs, whilst maintaining the minimum of V.S.W.R. and insertion loss. Furthermore, there are no intermodulation products. The Fixed Attenuators are available in standard losses of 1, 3, 6, 10 and 20 dB with a V.S.W.R. not exceeding 1.2 : 1 at GHz.

All the new units are fitted with B.N.C. Connectors. Write now for full specifications.

HATFIELD INSTRUMENTS LTD. Dept. E.E.
BURREINGTON WAY, PLYMOUTH, DEVON.

Telephone: Plymouth (0752) 72773/5 Telegrams: Sigjen, Plymouth

HATFIELD BALUN

67-0020



"LIGHTNING"

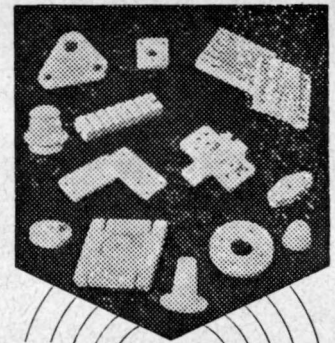

H.F. CERAMICS & FERRITES

- LIGHTNING BRAND HIGH FREQUENCY CERAMICS ANSWER STRICT REQUIREMENTS OF ADVANCED RADIO AND ELECTRONIC TECHNOLOGY:
- (1) LOW LOSS AT HIGH FREQUENCY
 - (2) ABILITY TO WITHSTAND HIGH TEMPERATURE AND HIGH HUMIDITY.
 - (3) HIGH DIELECTRIC STRENGTH, INSULATION RESISTANCE AND MECHANICAL STRENGTH.
 - (4) SMALL COEFFICIENT OF EXPANSION.
 - (5) HIGH STABILITY UNDER VARIOUS CLIMATIC CONDITIONS, UNDER VIBRATION, IMPACT, RADIATION OR CHEMICAL REACTIONS.
 - (6) PRECISION MADE WITHIN CLOSE TOLERANCES.

MADE TO ORDER.

Enquiries and orders are cordially invited.

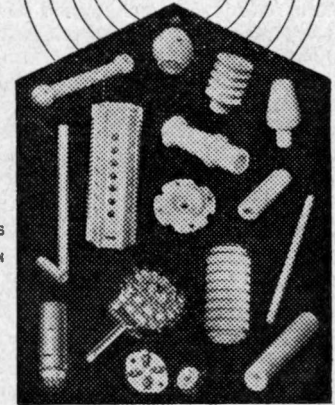

CHINA NATIONAL INSTRUMENTS IMPORT & EXPORT CORP.
SHANGHAI BRANCH

27 Chung Shan Road, E.1, Shanghai. Cable Address: INSTRIMPEX Shanghai

BRAZING NEWS

LOW VAPOUR PRESSURE
OXIDE FREE

WESGO



V.P.O.F.

BRAZING ALLOYS

Western Gold & Platinum Company of California, U.S.A. specialise in the production of these ultra high purity precious metal alloys used for brazing vacuum tube components and other critical high temperature applications—gas turbines—Jet and Rocket Engines. Available as powder, wire, strip and sheet.

Send for further details from the Sole United Kingdom distributors:—

GILBY-BRUNTON LIMITED
SEAMILL, MUSSELBURGH, SCOTLAND

Telephone Musselburgh 2369

famous for TOPHET Resistance Wires

London Office: 47 WHITEHALL, S.W.1

Telephone: Whitehall 6058

Quick, follow that curve.

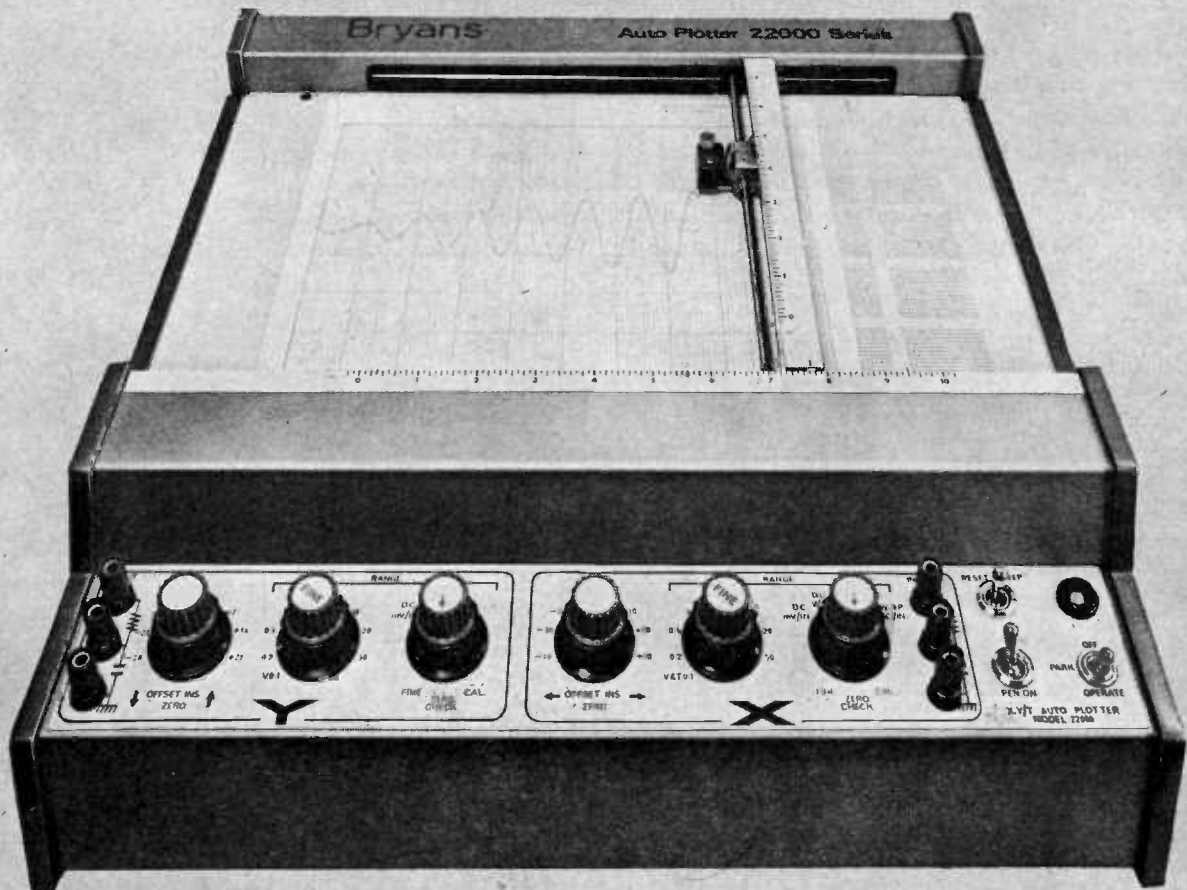

With the world's highest performance plotter
45 in/sec writing speed,
1200 in/sec² acceleration—
you can follow transient or rapidly varying inputs more accurately than with any other.

Bryans 22000 series plotters are simple to operate.

No manual gain control.

No external unit needed for A C conversion.

Neat rear plug-in panel for accessories and computer connections.

Let us demonstrate the 22000 series now.

Bryans Ltd Willow Lane Mitcham Surrey Mitcham 5134

Bryans

A member of Seltronic Group Ltd



NOW A CHOICE OF BRADLEY DVMs

Bradley Digital Voltmeters are compact all solid-state instruments, having an accuracy of 0.1% of reading. They have been designed to ensure high reliability, and ease of operation. They feature high input impedance, isolated input and visual indication of polarity and range. Three models are available.

The 160 measures from 1 mV to 1000 V d.c. in 4 ranges and has manual selection of polarity and range. Price £210.

The 160A in addition has automatic selection of polarity. Price £240.

The 165 measures from 100 μ V to 1000 d.c. in 5 ranges and has automatic selection of polarity. Price £275.



AND A NEW DIGITAL OHMMETER

The model 166 will read resistance from 0.1 ohm to 2 megohms with an accuracy of 0.1%. At £240 it will rapidly pay for itself when used on production lines or in inspection centres, because its clear digital read-out greatly facilitates the repetitive measurement of resistive components.

May we demonstrate these Bradley Instruments, or may we send our latest data sheet? Write or phone 01-450 7811.

BRADLEY INSTRUMENTS

G. & E. BRADLEY LTD.

Electral House, Neasden Lane, London, N.W.10.

90% of planar transistor needs from fifty or so devices—that's Mullard Practical Planar

Choosing the right transistor is simple

Remember, Mullard Practical Planar gives you :

Practical Selection—no need to wade through hundreds of specs. The Mullard Practical Planar Guide leads you straight to the right transistor for your application—selection is almost automatic.

Practical Transistors—all the inherent benefits of planar technology, with the backing of the unique Mullard reputation for quality.

Practical Availability—ex stock delivery every time and assured long-term availability.

Practical Prices—large-scale production of the types that really matter means keener prices than ever before.

If for any reason you are unable to select from the Practical Planar types, the full range of Mullard planar transistors is still available.

But most of the time it will pay you to pick Practical Planar.

Send for your copy of the Mullard Practical Planar Guide *NOW*.

Mullard **PRACTICAL** **PLANAR**

MULLARD LIMITED, INDUSTRIAL ELECTRONICS DIVISION
Mullard House, Torrington Place, London WC1 01-580 6633

For Practical Planar transistors in a hurry, get in touch with your nearest Mullard Industrial Distributor.

TMD 123

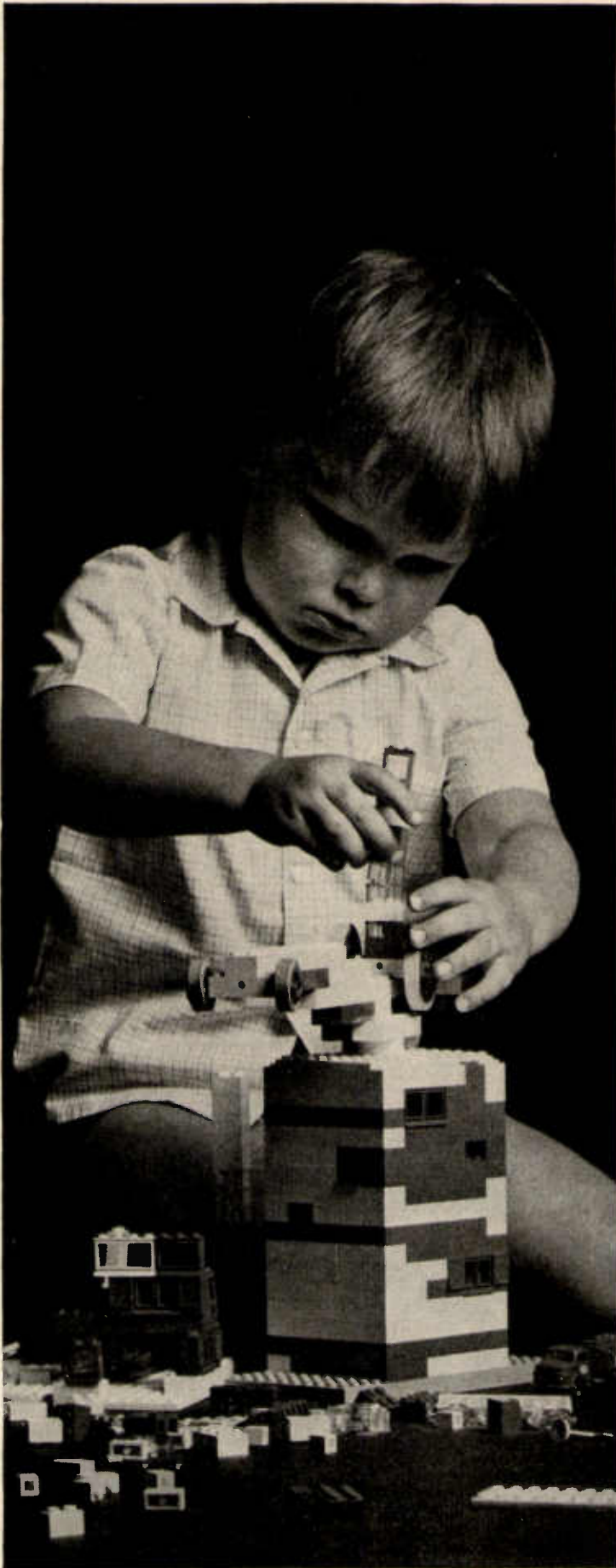

**Some of today's
young engineers are
not yet using our
wire and cable**

but they will . . .

because of their quality.

They'll come to realize that we only use the best materials for construction.

The miniature high-frequency coaxial cables have a high tensile strength centre conductor, copper-clad and silver-plated to give normal conductivity at radio frequencies. Depending on application the dielectric consists of either Grade 0-3 polythene, irradiated polythene or PTFE for high-temperature operation at 250° C.

One of the two types of sub-miniature electric cables available with from two to sixty conductors uses a hard drawn, tinned copper cadmium wire. This development increases the breaking load without impairing the flexibility and facilitates stripping of the insulation.

Switchboard cables for main and local exchanges have conductors of annealed copper wire with high conductivity, evenly coated with pure tin and insulated with a high grade P.V.C. compound. P.V.C. does not support combustion, is resistant to most acids, alkalis and solvents and will not support mould or fungus growth.

This is what we mean by quality.

Write for further details on the rest of our considerable range.

Standard Telephones and Cables Limited,
Rubber and Plastic Cable Division,
Corporation Road, Newport, Mon.
Telephone: Newport 72281. Telex: 49368.

STC

world-wide telecommunications and electronics

the new
SERVISCOPE* S.51B
has over
15,000
backers!

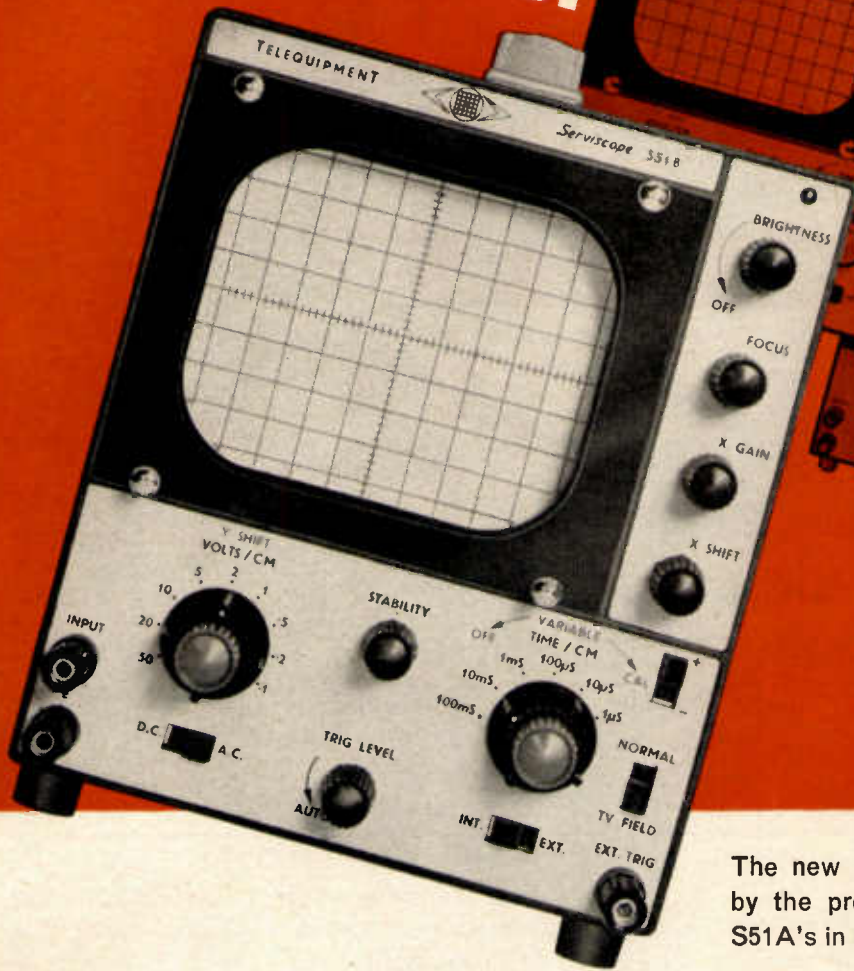

The new improved S51B oscilloscope is backed by the proved performance of well over 15,000 S51A's in use throughout the world.

- More scope — D.C. X-Amplifier standard
 - Only £55 in the U.K.
 - Large 5" screen — Bright trace
 - Small size — low weight
 - DC-3Mc/s — 100mV/cm sensitivity
 - Auto sync and trigger level control
 - Easy to use oscilloscope
 - Ideal for inspection, production control, transistor testing, training, monitoring etc.
 - Specification leaflet ready for you
- RIGHT NOW!** * *Serviscope* is a registered trade mark of *Telequipment Ltd.*



TELEQUIPMENT LIMITED • 313 CHASE ROAD • SOUTHGATE • LONDON N.14 • TELEPHONE: 01-882 1166



means
you're free
to design your
ideal system
without compromise

CCSL (Compatible Current Sinking Logic) is the progressive concept in microcircuits. Now you are free to build your ideal system without the need to compromise within the limitations of specific logic families.

CCSL enables the designer to combine the most important advantages of the $TT\mu L$, $DT\mu L$ and $LPDT\mu L$ families. These families are all 'current sinking', current flows out of the inputs of the driven gates, and into the outputs of the driving gates. All use positive NAND logic and all are

compatible with each other—logically, electrically and mechanically. Let us give you an example: Suppose you want to build a high frequency decade counter. Previously you would have reviewed the merits of each microcircuit family, decided which had the characteristics essential for your system and then agreed to accept the family with the least number of undesirable characteristics. With CCSL you avoid this compromise. You can cross family boundaries using, say, $TT\mu L$ in the first stage, $DT\mu L$ in the second, third and fourth stages



and LPDT μ L in each succeeding stage and thereby satisfy the requirements of your system. But that is not all—all new bipolar complex functions being developed by SGS-Fairchild will be an extension of the CCSL concept. Future modification of equipment designs using CCSL will therefore be relatively simple.

Easy to use loading rules and guides to equipment design together with abridged data, applications and summaries of compatible families are all given in the SGS-Fairchild CCSL Handbook.

WRITE FOR THE CCSL HANDBOOK TODAY



the progressive concept in microcircuits

SGS-Fairchild Limited

Planar House · Walton Street · Aylesbury · Bucks.

Telex: 83245 · Telephone: Aylesbury 5977

SGS-Fairchild SPA-MILAN · SGS-Fairchild GMBH-STUTT GART

SGS-Fairchild SA-PARIS · SGS-Fairchild AB-STOCKHOLM

How far do you go to ensure quality and reliability?

Stop right here!



Morganite Cermet Trimming Potentiometers

These potentiometers have the superior quality and reliability that components for space age electronic equipment must have.

Every component part of a cermet trimmer is subjected to rigorous quality control ensuring built-in reliability.

The high operating temperature of the ceramic and precious metal cermet resistance tracks gives an increased power rating, facilitating miniaturisation and improved high frequency performance. Cermet tracks are not subject to catastrophic failure.

The cermet range includes two linear motion and three rotary type trimmers, with ratings of 0.5W to 1.0W at 70°C and 85°C. The military versions meet the environmental requirements of MIL-R-22097B.

Every cermet is manufactured under controlled atmospheric conditions and extensively tested at each production stage, guaranteeing the highest level of reliability.

Put your trust in cermet.

Send us the coupon and let us tell you more.

Please send me full details of Morganite Cermet Trimming Potentiometers

NAME..... POSITION..... COMPANY.....

ADDRESS.....

Morgan MORGANITE RESISTORS LIMITED

Bede Trading Estate, Jarrow, Co. Durham. Tel: Jarrow (ONE-2) 897771. Telex: 53353



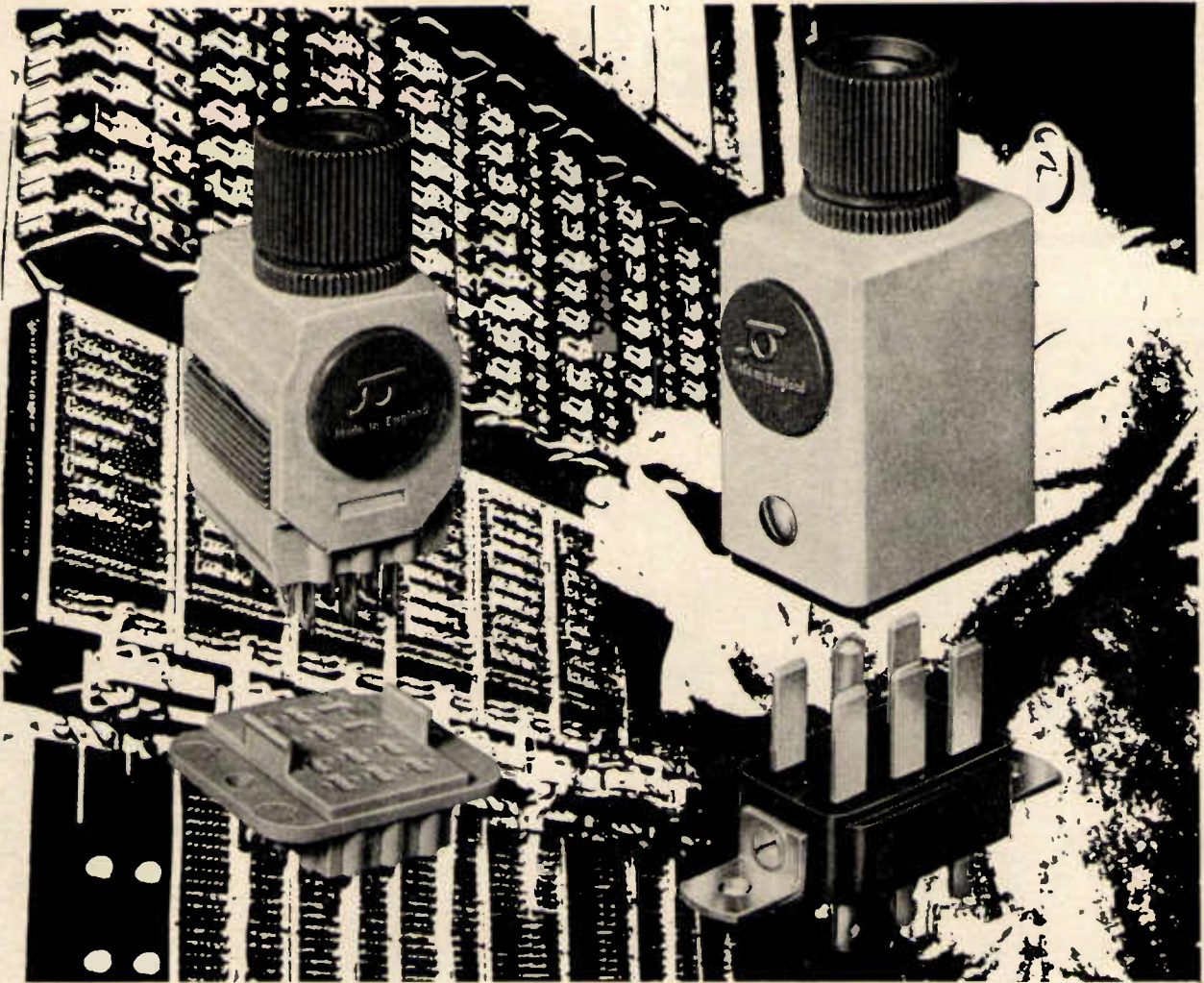

JONES 300 and 400 SERIES Mk. II

The Cannon Jones Mk. II 300 (miniature) and 400 (standard) are basically similar and interchangeable with types produced by Cannon for the last 28 years. Important design improvements have been made:—

JONES 300 SERIES

★ Completely re-designed, it features contemporary styling
★ Requires no tools for assembly ★ Has snap on moulded cover with side or top cable entry ★ Complies with British and European safety requirements ★ Mates with the original Jones Miniature ★ 5 amp current rating.

JONES 400 SERIES

★ Re-designed to include new deep-drawn aluminium can
★ Improved cable clamp and collet arrangement with variety of collet diameters supplied ★ Silver plated contacts ★ Phenolic insulator ★ Entirely interchangeable with the existing Jones Standard Series ★ 15 amp current rating.

For more information please write, requesting "Jones" Catalogue, to Cannon Electric (G.B.) Limited, Lister Road, Basingstoke, Hants. Telephone Basingstoke 3171.

Manufacturing and stocking facilities in Basingstoke and distributor network in British Isles as follows:

- ★ A.W.P. Electronics (Surrey) Ltd., Rowan House, Smallfield Road, Horley, Surrey. Tel. Horley 5481.
- ★ Electronic Services—STC, Edinburgh Way, Harlow, Essex. Tel. Harlow 26811.
- ★ James Scott (Electronic Agencies) Ltd., 90 West Campbell Street, Glasgow, C.2. Tel. CENTral 3866.
- ★ Holiday & Hemmerdinger, Ardwick Green, Manchester, Lancs. Tel. ARDwick 6366.
- ★ S.D.S. (Portsmouth) Ltd., 67/69 Commercial Road, Portsmouth, Hants. Tel. Portsmouth 20465.
- ★ P.S.P. Electronics Ltd., 228 Preston Road, Wembley, Middx. Tel. 01-904 9521.

® Trademark, ITT Cannon Electric.

© 1967 Cannon Electric (G.B.) Limited.



CANNON

I.F. equalization in microwave links.

Display shows dual response of 70 MHz filter. Upper trace is Group Delay, 0.5 nsec/cm, and lower trace shows IF flatness, 0.1 dB/cm. The frequency base is 5 MHz/cm.

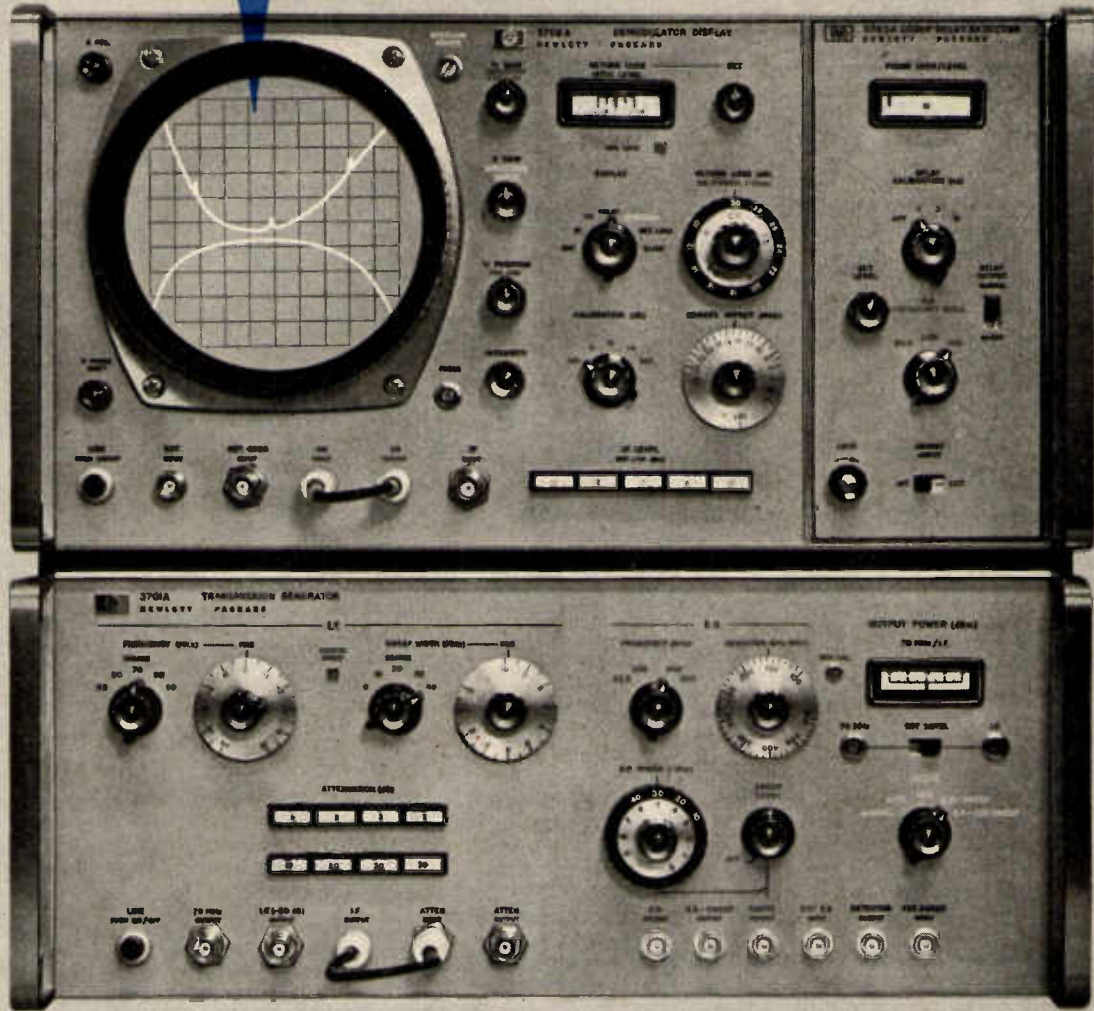

Microwave link analyzer

Make measurements on systems with up to 1800 channels

Group delay to 0.1 nsec.
 IF amplitude response to 0.02 dB.
 Modulator/demodulator linearity to 0.1%.
 Modulator/demodulator sensitivity.
 Spectrum display.
 Return loss to 32 dB with hybrid.
 Perform remote tests through link.
 Obtain slave display with loop back.

Features

Simultaneous display of group delay and amplitude response.
 Flicker free display with 70 Hz sweep rate.
 Swept or fixed IF 45 to 95 MHz.
 Three switch selectable baseband frequencies.
 Calibration of amplitude, group delay and frequency is provided.

Portable — two lightweight units and one plug in.

Reliable all solid state circuitry.
 Full range of accessories provided.

Prices:

3701A Transmission Generator	£ 963
3702A Demodulator Display	£ 1336
3703A Group Delay Detector	£ 256

HEWLETT  PACKARD

Hewlett-Packard Limited
 224 Bath Road, Slough, Buckinghamshire,
 Tel. Slough 28406 and 29486

Headquarters in USA: Palo Alto (Calif.)
 European Headquarters: Geneva (Switzerland)
 European Plants: South Queensferry (Scotland)
 Böblingen (Germany)



SMALL TRANSFORMERS

for electronic applications
with Interservice Qualification Approval

With long experience in the manufacture and supply of small transformers for the Services and Government, English Electric offer a wide range particularly suitable for radio, radar, telecommunications, aircraft and marine transmitters and receivers and other applications where quality, reliability and compactness are essential. Capacity is also available to manufacture in quantity to customers' specifications.

OPEN TYPE 'C' CORE TRANSFORMERS with full interservice qualification approval,
Humidity Class H.1 to DEF. 5214.

Transformers can also be supplied to the less stringent requirement, Humidity Class H.2.

HERMETICALLY SEALED 'C' CORE TRANSFORMERS with full interservice qualification approval.

RESIN CAST 'C' CORE TRANSFORMERS with limited qualification approval.

Send your enquiries, or for technical publications, to:

The English Electric Company Limited, Transformer Sales, East Lancashire Road, Liverpool, 10

Leadership in transformer design

**ENGLISH
ELECTRIC**



TFL 57A

Instrument Rectifiers Now Ex Stock

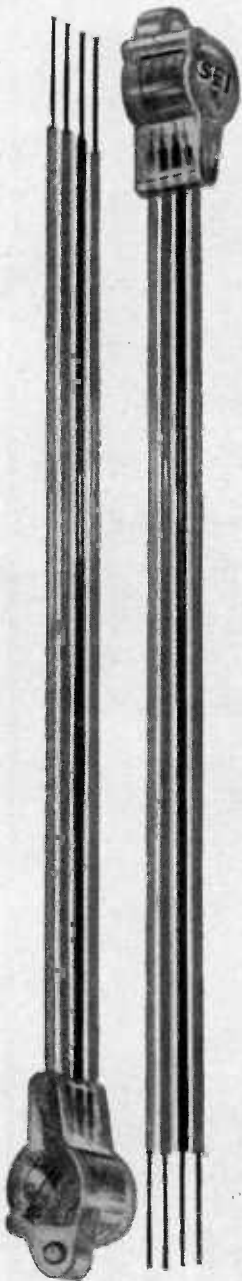

SEI copper oxide instrument rectifiers have been designed to suit almost all types of movement in moving coil instruments.

Type 1mA, a bridge rectifier unit recommended for $100\mu\text{A}$ to 1mA movements.

Type 5mA for 1 to 5mA movements.

Type 10mA for 5 to 10mA movements.

For immediate delivery

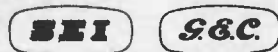
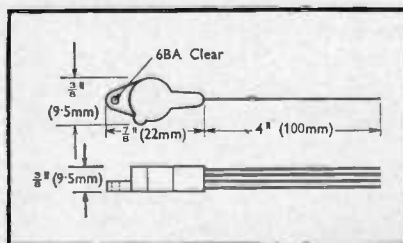

Salford Electrical Instruments Limited
Peel Works, Barton Lane, Eccles, Manchester.
Telephone Eccles 5081. Telex 66711.
London Sales Office: Brook Green,
Hammersmith, W.6. Tel: 01-603 9292.
A Subsidiary of The General Electric
Co. Ltd. of England.

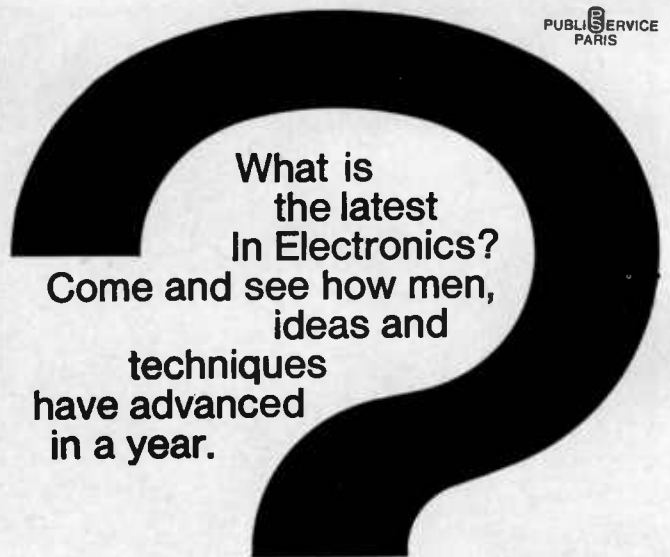

Be present at the

INTERNATIONAL EXHIBITIONS OF ELECTRONIC COMPONENTS AND OF AUDIO-EQUIPMENT

FROM APRIL 1st TO 6th 1968 - PARIS
PORTE DE VERSAILLES



INTERNATIONAL CONFERENCE ON COLOUR TELEVISION

scientific and technical considerations
FROM MARCH 25th TO 29th 1968 - PARIS

Programme and registration conditions on request

S.D.S.A. - RELATIONS EXTERIEURES
16, RUE DE PRESLES - 75 PARIS 15^e - FRANCE

IS YOUR EQUIPMENT WORTH A DIRECTOR?

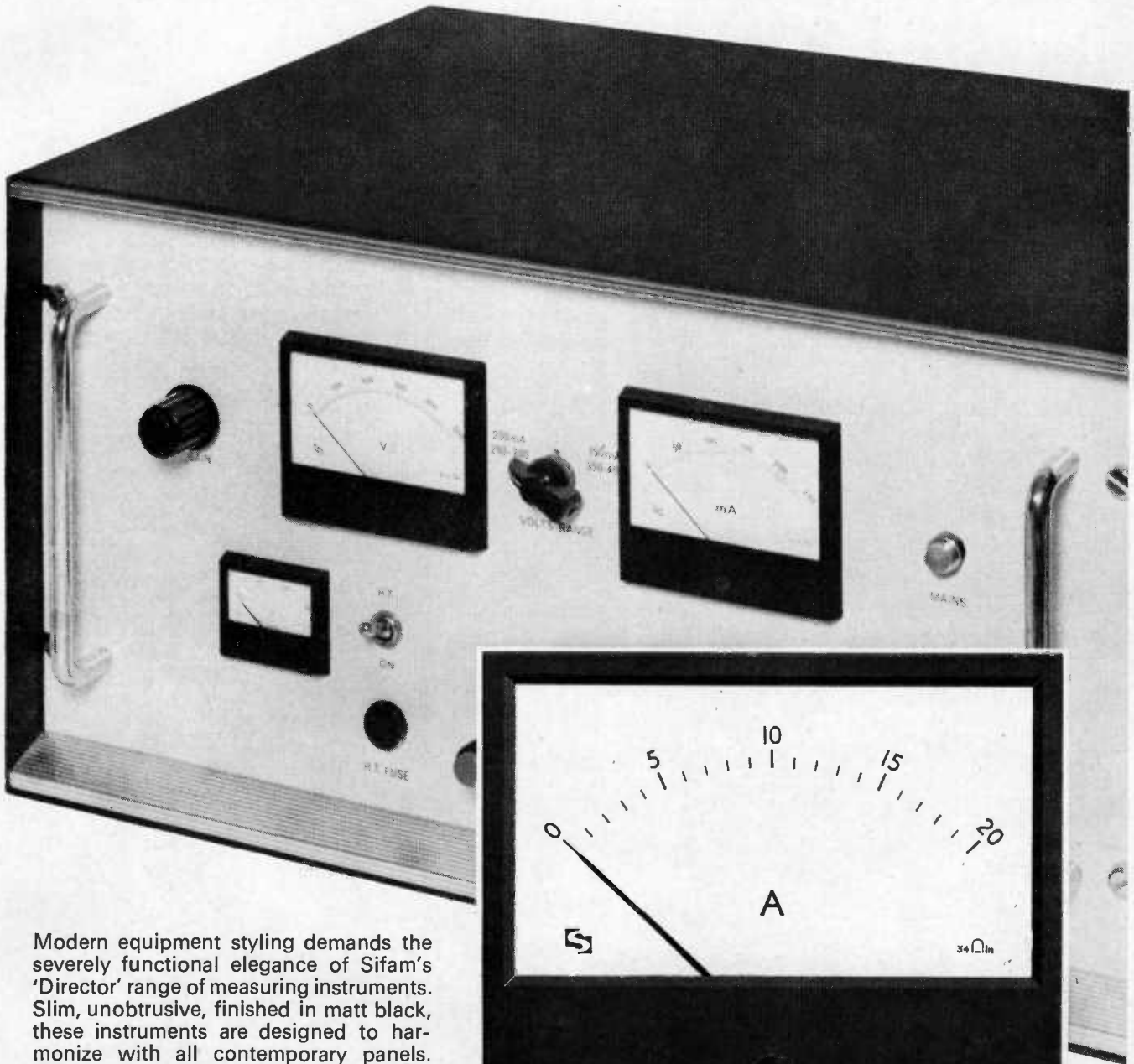

Modern equipment styling demands the severely functional elegance of Sifam's 'Director' range of measuring instruments. Slim, unobtrusive, finished in matt black, these instruments are designed to harmonize with all contemporary panels. They are also supremely practical—readings can be taken easily and accurately. Director instruments are made in five sizes with scale lengths of 1.34in., 2.0in., 2.75in., 3.75in. and 5.0in. The three largest sizes are also available with a taut-band, ligament suspended movement for applications where toughness combined with extra sensitivity is required. Pointers and scales comply with B.S.3693: Part 1: 1964, or to your requirements.

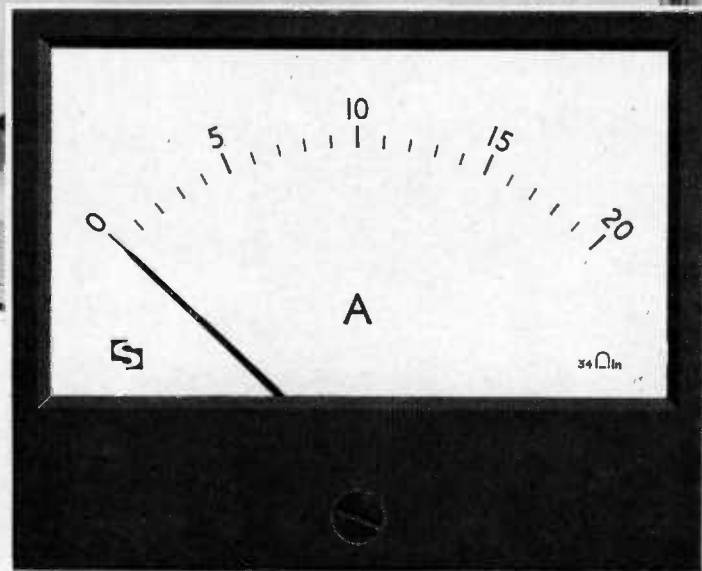

Illustrated actual size is the Director Type 34, with a scale length of 2.75in. (69.8mm).

Director instruments are already installed in equipment manufactured by leading British and overseas organisations. Deliveries can be arranged to suit your production programme. Please write for full details.



SIFAM ELECTRICAL INSTRUMENT COMPANY LIMITED
WOODLAND ROAD TORQUAY DEVON ENGLAND
Telephone: TORQUAY 63822 Telegrams: SIFAM TORQUAY

S156

What price performance like this?

Direct gating at 100 MHz . . . costs just £725 in the Racal 801R Digital Frequency Meter

Like all 800 Series instruments, the 801R, the latest in the line, is custom-designed for specific function, combining excellent sensitivity with high input impedance and exceptional stability. Gate times of 10 mS to 10 seconds and the RACAL patent dynamic readout give operational flexibility – instant follow for fast tuning or resolution of 0.1 Hz. Remote control and BCD output are options of particular value to the Production Engineer. Measuring to 500 MHz (resolving to 1 Hz in just over one second) the 801/802 combination at £995 is value engineering at its best, true RACAL performance.

- Measures 10 Hz to 100 MHz
- 1 M Ω & 15pF input impedance, 10 M Ω with your 'scope probe
- 50 mV sensitivity
- 2 parts in 10⁹ daily stability
- 500 MHz Resolution with fully automatic heterodyne converter 802
- Remote control and BCD output options
- 8-digit latched display

If you need any more convincing, get details and a demonstration by contacting:
Racal Instruments Ltd., Crowthorne, Berkshire, England.
Telephone Crowthorne 5652: Telex 84166

RACAL
800
series



And what does the panel think of this?

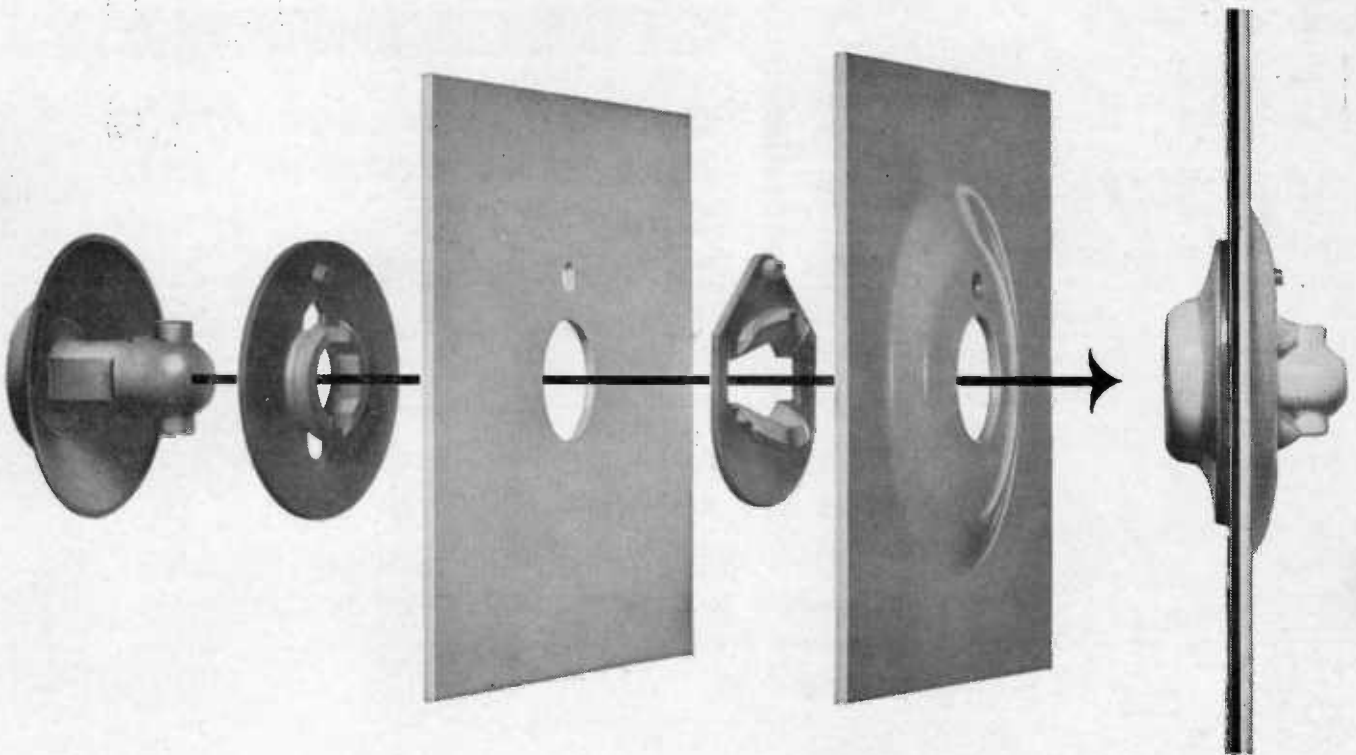

THIS IS ROTOLOK, THE BIGGEST INNOVATION SINCE QUICK-RELEASE FASTENERS WERE FIRST THOUGHT OF. No panel's ever seen anything like it. Rotolok makes it possible with a simple quarter turn in either direction to remove panels and facias and allow immediate access to whatever lies behind. Till now, most quick-release fasteners have been made of metal and have been difficult and time-consuming to assemble. Research and design at GKN led to Rotolok, the fastener which combines constructional simplicity with rapidity of installation. 'Rotolok' made from engineering plastics is easy to fit and requires no tools for assembly. Thumb pressure is sufficient to click the grommet and the cam to their plates. Once in place and locked the unit is absolutely secure. Locking and unlocking is performed with a coin, lever-key, thumb-key or socket wrench. A quarter turn either way and it's secure, another turn and it's released. Rotolok costs approx. 20% less initially than its market rivals and thereafter cuts 'in-place' costs dramatically. Rotolok is the most revolutionary fastener to arrive on the market in years. It has applications in your industry. Ask for a demonstration of it now. We offer a free design and advisory service for all applications. *Contact GKN Screws & Fasteners Limited, Heath Street Division, Automotive and Dynaflo Components, P.O. Box 61, Heath St., Smethwick, Warley, Worcs., Tel: 021-558 1441.*

GKN ROTOLOK QUICK-RELEASE FASTENERS

Patent Pending

GKN—way ahead in fastener design

RL3

For more information circle No. 38

**HAVE
YOU
GOT
YOUR
COPY
YET?**

**A POCKET GUIDE TO
SEMICONDUCTORS**

QUARNDON SEMICON'67

**QUARNDON ELECTRONICS
(SEMICONDUCTORS) LTD.
SLACK LANE · DERBY
Telephone: (0332) 43492/46695
Telex: 37163**

WRITE TODAY
FOR YOUR
COPY: SENT
FREE TO YOUR
BUSINESS
ADDRESS

**CONTAINS 112 PAGES OF TECHNICAL DATA AND PRICES
ON TEXAS INSTRUMENTS: S.G.S. FAIRCHILD:
EMIHUS MICROCOMPONENTS: TRANSISTOR A.G.:
SPRAGUE AND TADIRAN SEMICONDUCTORS**

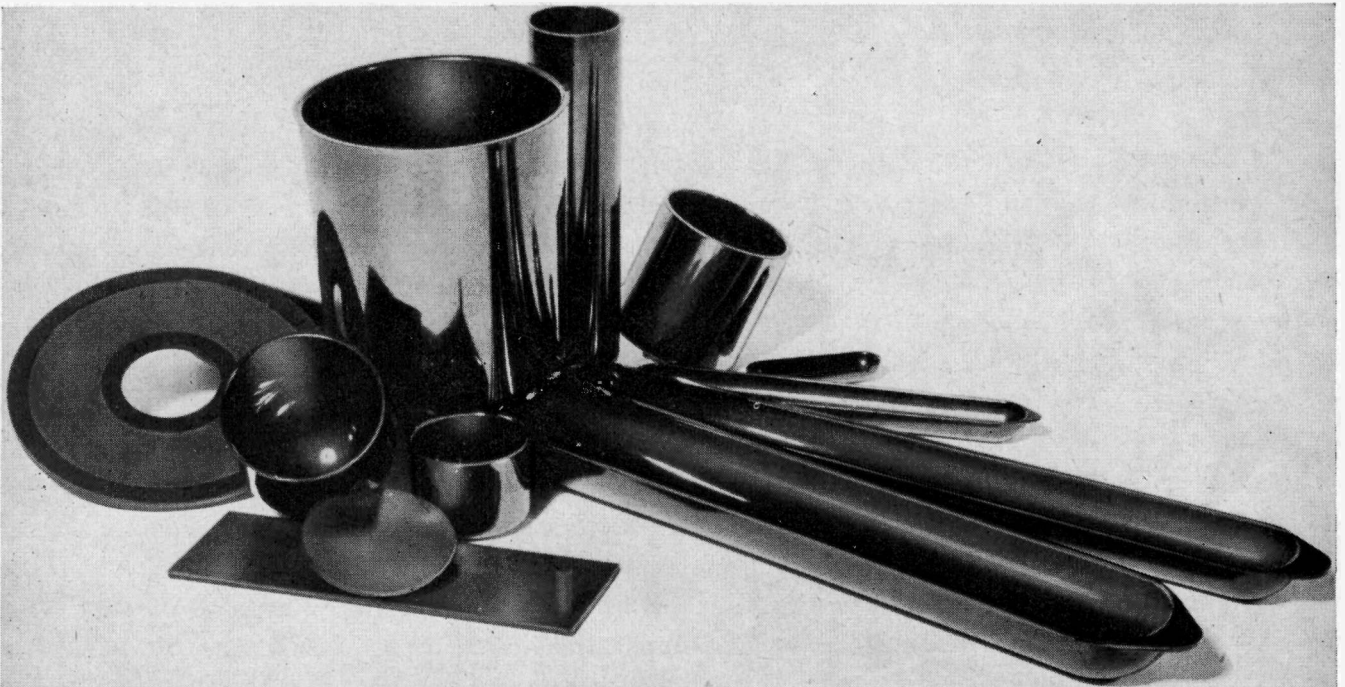

in electronics — Versatile Vitreous Carbon

Vitreous carbon crucibles, boats and plates are being extensively used for the processing of semi-conductor and fluoride laser materials, together with the growth of alkali halide optical crystals, zone refining of metals and wafer supports.

Vitreous Carbons Limited

Evenwood, Bishop Auckland, Co. Durham,
England. Telephone: West Auckland 678

CW 15217

For more information circle No. 39



You're all right 'Jack'

-with **RS** There's no need for you to get stranded for lack of radio and electronic components. We supply them 'by return'. All distress signals to **RS** please!



Radiospares

4/8 MAPLE STREET, LONDON, W.1. ENGLAND · TELEPHONE: 01-387 7232 (8 lines) TELEGRAMS AND CABLES: RADOSPERES, LONDON, W.1.

DECEMBER 1967

31

ELECTRONIC ENGINEERING

Let cathodeon provide you with a megacycle escort

(... anything from 1-140 motorcycles)

We at Cathodeon are very happy to sit back in our swivel chairs and let your orders for crystals drop into the mailbox day after day. It's a great life and doubtless has everything to do with our reputation for a first-class product and reliable delivery. But we know that, on occasion, you would also welcome some assistance in determining the optimum crystal specification for a new or unfamiliar application. That's where you can call on us again! If you're heading into strange territory, chances are Cathodeon have already mapped out the route and we'll gladly provide a megacycle escort to keep you on the right road.

Got the drift? Better 'phone Cathodeon now!—or write to the megacycle factory, Cathodeon Crystals Ltd., Linton, Cambridgeshire. Telephone: Linton 501. Telex: 81212. Cables: 'Quartz' Cambridge.

cathodeon

QUARTZ CRYSTALS • CRYSTAL FILTERS • CRYSTAL OVENS

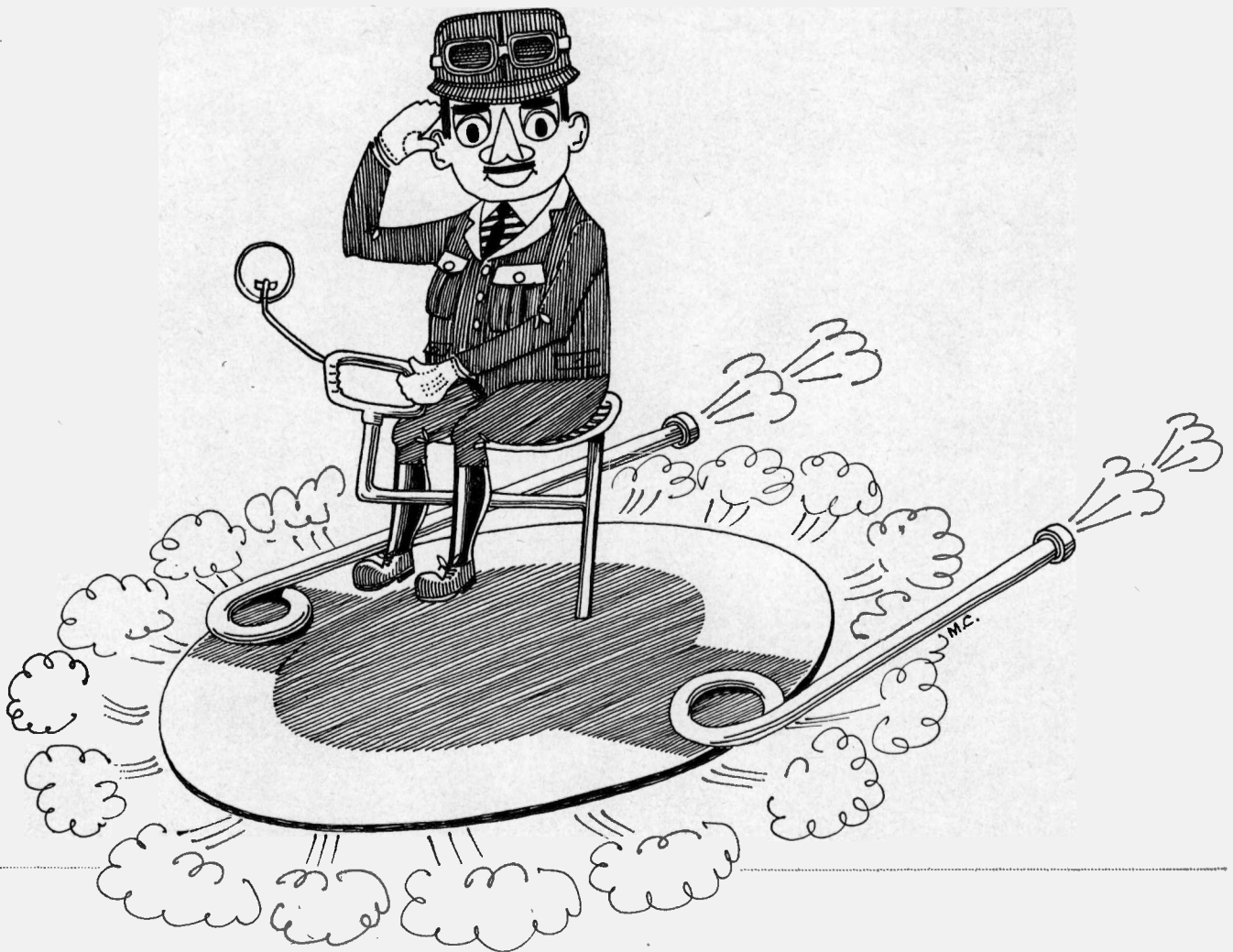

**INCREASE
THE SENSITIVITY OF
YOUR OSCILLOSCOPE,
VOLTMETER
OR
COUNTER**

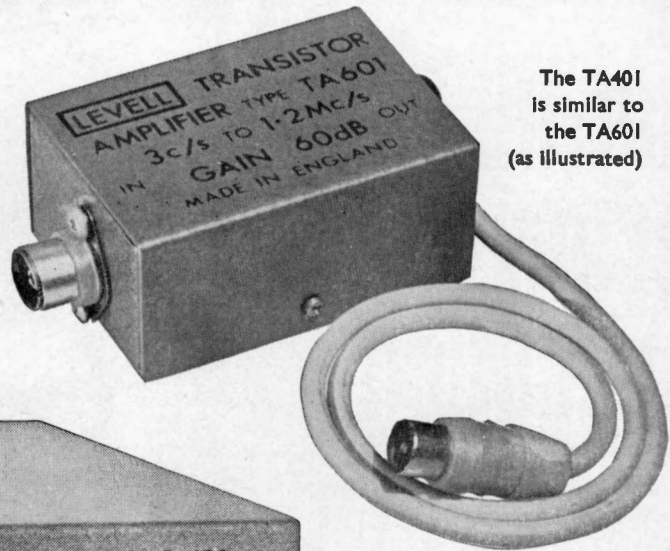

The TA401 is similar to the TA601 (as illustrated)



**TA605
ACTUAL
SIZE**

SPECIFICATIONS

	TYPE TA401	TYPE TA601	TYPE TA605
GAIN	40dB ± 0.1 dB	60dB ± 0.1 dB	20, 30, 40, 50 and 60dB ± 0.2 dB.
BANDWIDTH ± 3 dB	1Hz-3MHz	3Hz-1.2MHz	20-40dB, 1Hz-3MHz; 50dB, 2Hz-2MHz; 60dB, 4Hz-1.5MHz.
BANDWIDTH ± 0.3 dB	4Hz-1MHz	10Hz-300kHz	20-40dB, 4Hz-1MHz; 60dB, 10Hz-300kHz.
INPUT IMPEDANCE	>5M Ω , <40pF from 100Hz to 1MHz	>1M Ω , <50pF from 100Hz to 300kHz	>5M Ω , <40pF from 100Hz to 300kHz.
INPUT NOISE	<15 μ V, zero source; <50 μ V, 100k Ω source	<15 μ V, zero source; <40 μ V, 100k Ω source	As TA401 and TA601 at 40dB and 60dB.
POWER SUPPLY	PP3 battery, life 100 hours		PP9 battery, life 1,000 hours, or A.C. Power Unit.
AVAILABLE OUTPUT	1V up to 1MHz, 300mV at 3MHz, into load of 100k Ω and 50pF		1.5V up to 2MHz, 1V at 3MHz, into 100k Ω and 50pF.
OUTPUT IMPEDANCE	100 Ω in series with 6.4 μ F		
SIZE & WEIGHT	3" \times 1 $\frac{3}{4}$ " \times 1 $\frac{1}{4}$ " 7 oz.		2 $\frac{1}{2}$ " \times 4" \times 5 $\frac{1}{2}$ " 2 $\frac{1}{2}$ lb.
PRICE with Battery and input lead	£17.0.0	£17.0.0	£27.0.0 (Optional A.C. Power Unit £7.10.0 extra).



Fully detailed leaflets are available on our complete range of portable instruments.

LEVELL ELECTRONICS LIMITED

Park Road, High Barnet, Herts. Telephone: 01-449 5028.

For more information circle No. 43

AC plug-ins for any application

Whatever your AC Measurement need the chances are DYMAR fill the bill. ALL Plug - Ins are now available in the New METER UNIT type 70A. THE DYMAR SYSTEM is unique.

DYMAR

**Plug in with Dymar
and be satisfied**



Type 70A/711

Type 705

- For General purpose Wideband use Plug-In type 701
- For True R.M.S. Measurements use Plug-In type 702
- For Low level balanced signals use Plug-In type 705
- For VHF/UHF Millivolts use Plug-In type 711
- For R.F. Power Measurements use Plug-In type 781

For details of these and many other Plug-Ins contact:

DYMAR ELECTRONICS LTD

Rembrandt House • Whippendell Road • Watford • Herts • Telephone: 21297
Broadway/DY 705

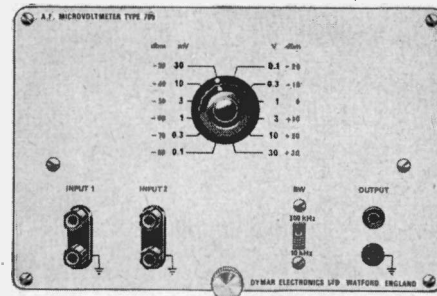

Moririca

A Mark of Quality

**CADMIUM
SULFIDE AND
SELENIDE
PHOTO -
CONDUCTIVE
CELLS**



**MORI PHYSICS & CHEMISTRY
LABORATORY CO., LTD.**

205 Tozuka-machi, Tozuka-ku, Yokohama, Japan
Cable Add: MORIRIKA YOKOHAMA

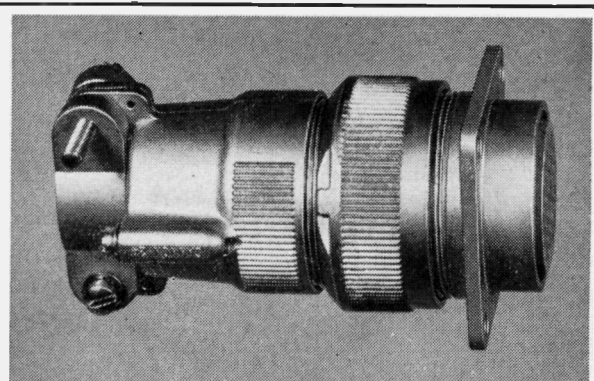

**New high performance CV connectors
for space age applications**

A new series of circular environmental connectors. MIL-C-5015 type configuration employing crimp type contacts with the proven "Little Caesar" rear release contact assembly. Toolled in a wide range of layouts. Operating temperature 55°C to +175°C.

**Cannon Electric
(Great Britain) Ltd.,
Lister Road,
Basingstoke, Hants.
Tel: Basingstoke 3171**



CANNON

For more information circle No. 44

For more information circle No. 45

Now you can design with top quality metal encapsulated FET's and stay within budget... by specifying new Newmarket FET's. Two 'N' Channel Depletion — Junction Gate ranges are now in production:

NKT 0111 Series — Low Capacitance r.f.
NKT 0211 Series — Medium Capacitance af

Get the full facts on new Newmarket FET's for yourself. We'll send data sheets and full details by return. If you haven't seen our new Industrial Products Portfolio, we'll send that too. Simply post the coupon.

Newmarket Transistors
Exning Road, Newmarket, Suffolk. ONE 3 3381
Please send me full details of
Newmarket 'metal can' FET's at plastic prices by return.

name _____ position _____

company _____

address _____

Please tick if you would also like to see a copy of Newmarket Transistors new complete Industrial Products Portfolio.

3



For more information circle No. 47

Best performance under the sun!

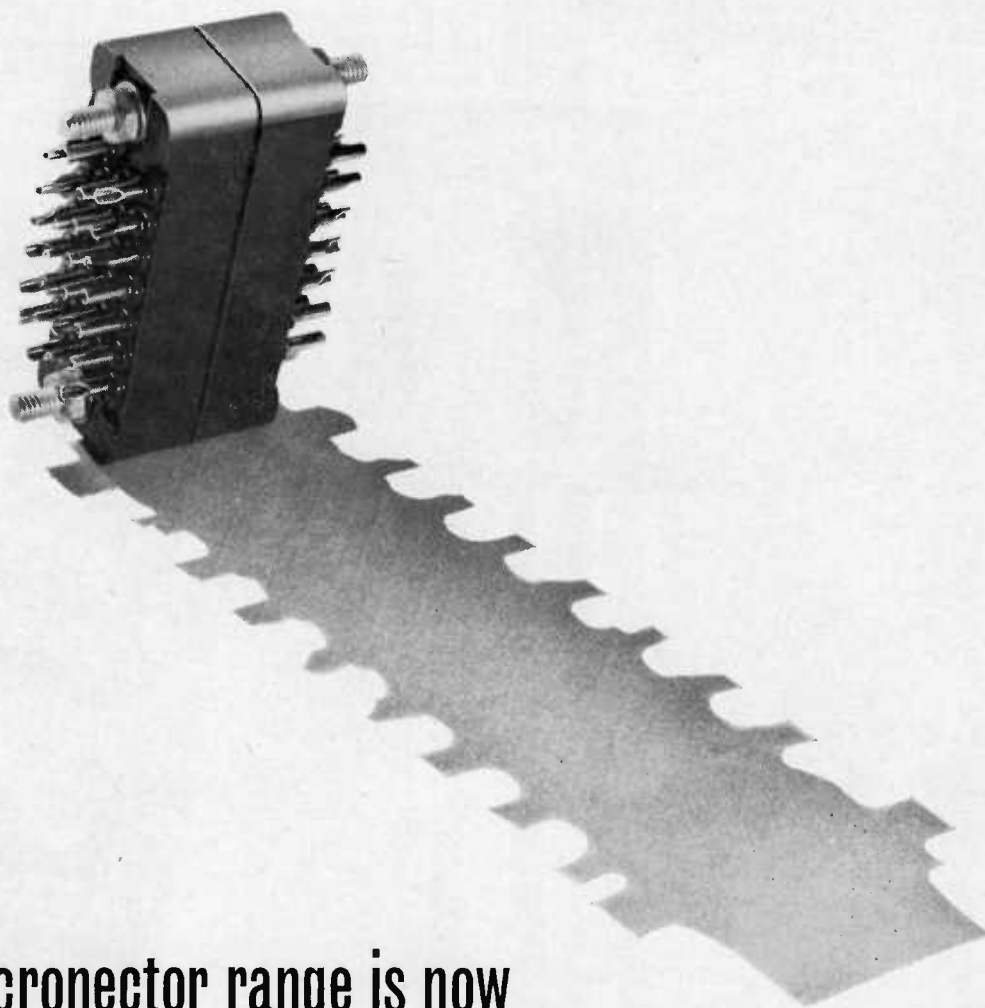

McMurdo Micronector range is now improved with D.A.P.* for tropical efficiency

***DIALLYL PHTHALATE** – the robust plastic material that McMurdo have chosen for the improved **Micronectors**. This is the highest quality material of its type available for tip-top tropical performance because it has really exceptional electrical and mechanical properties and supercedes the moulding formerly made in melamine. For the finest, fool-proof connections under the sun – you've got to take your hat off to McMurdo! Write for full details of the **Micronector** range now!

MCMURDO ELECTRONIC COMPONENTS

Write to: Technical Sales Department,
THE MCMURDO INSTRUMENT COMPANY LTD.,
RODNEY ROAD · FRATTON · PORTSMOUTH
TEL: PORTSMOUTH 35361 · TELEX: 86112

LUGTON & CO. LTD., 209/210 Tottenham Court Road, London W.1. Telephone: Museum 3261
SASCO, P.O. BOX No. 20, Gatwick Road, Crawley, Sussex. Telephone: CRAWLEY 28700 (also Chipping Sodbury 2641. Cumbernauld 25601. Hitchin 2242).
NORWAY. J. M. Feiring, A/S Lilleorvet I, OSLO PERU. Estemag Peruana S.A., P.O. Box 2838, LIMA
PHILIPPINES. C & C Commercial, P.O. Box 2419, MANILA



looking for know-how?*
 analogue computers
 computing modules
 special purpose simulators
 logic tutors

System Computers have it*

Apart from our wide range of analogue computing equipment, we manufacture a comprehensive range of technical and scientific products for use in industry, research and education.

The TAG series of Transistorised Analogue Computers incorporates unique and compact modular patchboard and highly engineered consol systems. Fully solid state transistor computing amplifier and hybrid capability are additional features.

The Analogue Tutor Mk 2 is a low cost instrument specifically designed to give a simple

direct method of teaching analogue techniques.

The Logic Tutor is a teaching aid to the understanding of combinational logic and digital computers.

We produce standard computing modules which can be assembled to provide special purpose simulators or data processing units to your specification.



Write for more information on our products or computing service to

System Computers Limited
 FOSSWAY • NEWCASTLE UPON TYNE 6 • ENGLAND



Where Quality and Performance at the right price are essential... specify WELWYN

56-20 SERIES INDUSTRIAL GRADE POTENTIOMETERS

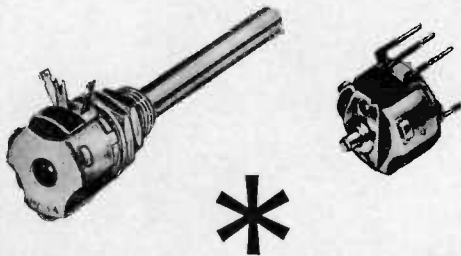

- * SUPERIOR CARBON TRACK ELEMENT
- * ELECTRICAL ENDURANCE < 6%
- * MECHANICAL ENDURANCE < 3%
- * HOP-ON and HOP-OFF < 1%
- * OHMIC RANGE 100Ω to 4.7 MΩ
- * SELECTION TOLERANCE 20%
- * LINEAR, LOG and INVERSE LOG LAWS
- * LOW NOISE
- * COMPLETE RANGE OF SPINDLE & MOUNTING CONFIGURATIONS



WELWYN ELECTRIC LIMITED
BEDLINGTON · NORTHUMBERLAND · ENGLAND

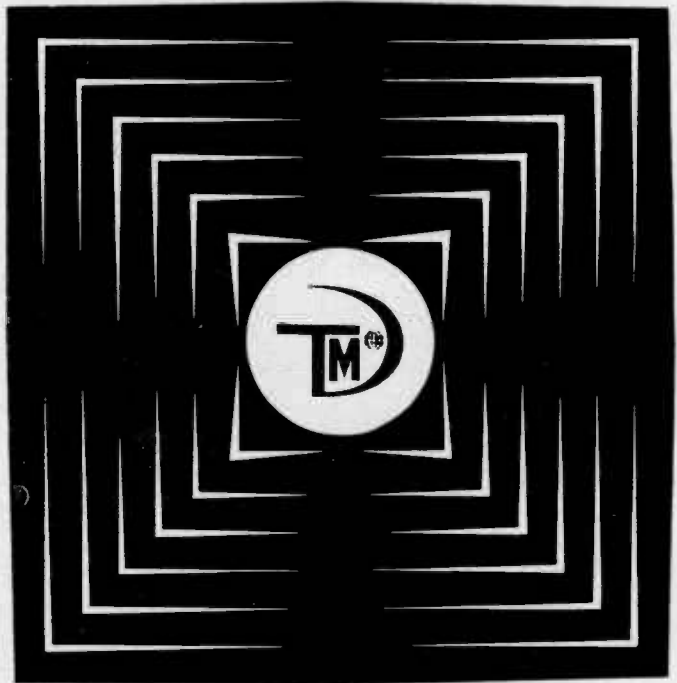

Precision micro-welders from the U.S.S.R.

Electric leads of 0.0010 to 0.10 mm. in diameter can be precision-welded by the Soviet-made micro-welders "CONTACT-1", "CONTACT-2", "CONTACT-3" and "CONTACT-4", featuring top-precision micro-manipulator equipment and extra sharp image binocular microscope. These micro-welders, which can weld in a protective atmosphere if necessary, are indispensable in the fields of industry and science—particularly the semiconductor industry.

"CONTACT" micro-welders can effect contact pressure welding with separate feed of tool and wire, pressure welding with combined feed of tool and wire, pressure welding with electric pulse heating, and ultrasonic welding.

For more information please write to:

V/O **"TECHMASHEXPORT"**
MOSCOW B-330, U.S.S.R.

or to: The Trade Delegation of the U.S.S.R. in the U.K.,
32 Highgate West Hill, London, N.6.

Siemens SN

standard
miniature
plug-in relays

with
2 changeover
4 changeover
or
2 changeover
heavy duty
contacts

are now
30% cheaper
and ex-stock



By standardising on a selected number of relays within the Siemens 154 range, it is now possible to offer these types at greatly reduced prices—over 30% reduction for large quantities. These are the famous Siemens relays with gold-flashed silver contacts and Makrolon covers. Sockets are available with solder tags or printed circuit pins.

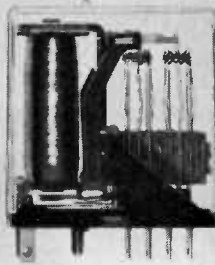

Also within the vast Siemens range of plug-in relays are 56 other combinations of single and twinned silver and gold contacts, and many special purpose relays including the hermetically sealed type V23162, magnetic latching type P, sensitive type L and ac operated type W. The latest addition to this large range is the V23154-N for direct insertion into printed circuits.

Siemens relays satisfy all needs.

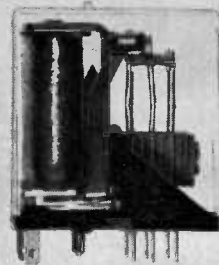

Please send for the latest Siemens SN leaflet and prices.

B & R Relays Ltd
Temple Fields Harlow
Essex Telephone
Harlow 25231-4
Telex 81140
Sole UK agents for
Siemens Relays

B&R

SIEMENS

MARCONI HLTTL

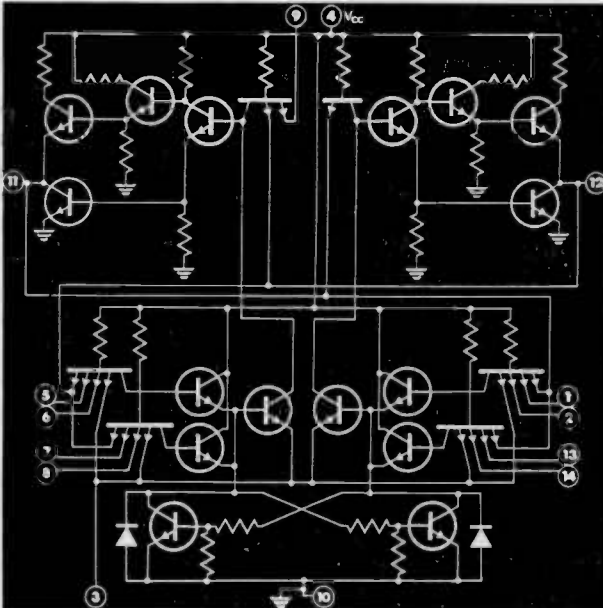

Marconi microelectronics high-level transistor-transistor logic circuits are now available. Typical propagation delays of 10 ns or 6 ns with two fanout versions for both industrial, 0°C to +70°C and military, -55°C to +125°C, temperature ranges.

THE HLTTL RANGE :

- SINGLE AND DUAL GATES
- TRIPLE AND QUAD GATES
- EXPANDABLE GATES
- FLIP FLOPS
- MULTIPLE POWER DRIVERS
- HERMETICALLY SEALED
DUAL IN LINE PACKAGE

IMMEDIATE DELIVERY

GREATER MANUFACTURING CAPACITY

The opening of the new manufacturing plant at Witham enables immediate delivery to be made of a wide range of microelectronic devices manufactured to a stringent specification for specialized applications.

ADVANCED RESEARCH CAPABILITY

Marconi production is backed by Britain's most advanced electronics research and development organization.

THE RANGE OF DEVICES INCLUDES

- | | |
|---|---|
| Diode assemblies, single and multiple. | Tunistsors. High capacitance and wide range of capacitance swing. |
| Transistors. JEDEC registered and specialized single and multiple types. | MOS field effect logic sub-systems. |
| Linear circuits including high-frequency cascode amplifier and multi-purpose 'N' element. | MOS field effect transistor arrays. |
| Varactor diodes for frequency multiplication and micro-wave switching. | Cross ring modulators and bridge rectifiers. |
| | Full range of Micronor II—the fastest DTL available. |

CONFIDENTIAL DESIGN SERVICE

The Marconi Microelectronics Applications Engineering Group offers an experienced confidential design and consultancy service for the application of microelectronics to customer systems and the design of specialized circuits.

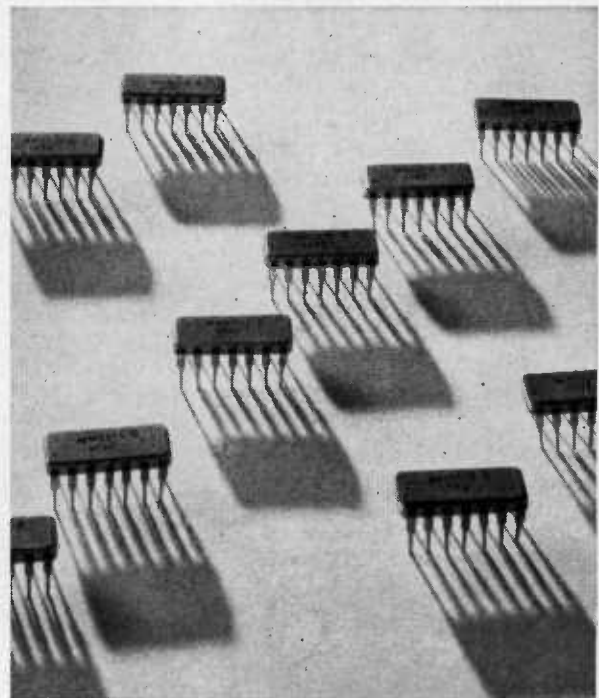

MARCONI MICROELECTRONICS

The Marconi Company Limited, Witham, Essex.
Telephone: Witham 3401 Telex: 99201

AN 'ENGLISH ELECTRIC' COMPANY

LTD/T64

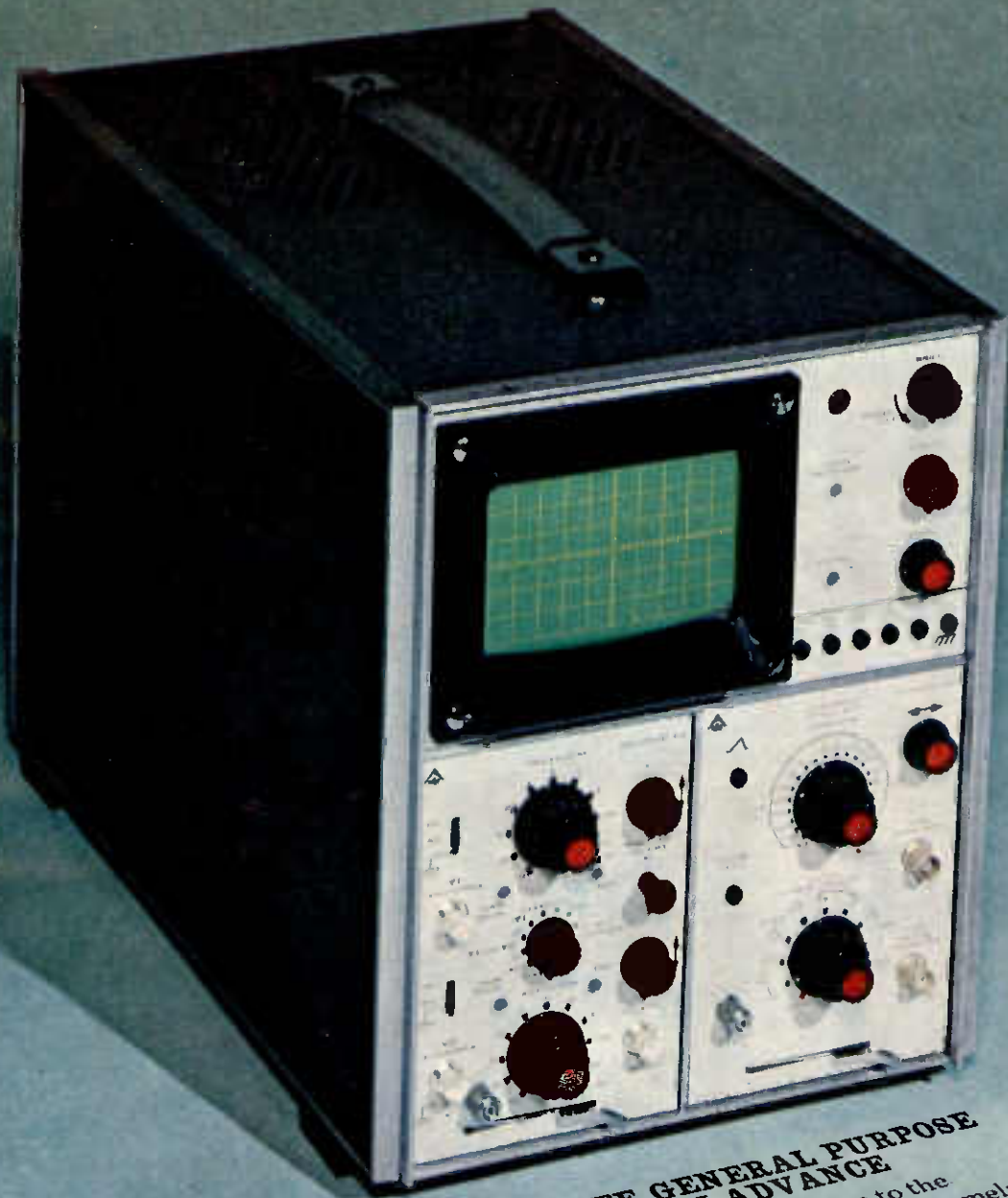

ADVANCE
OS 2000

**SOLID STATE GENERAL PURPOSE
AND NEW FROM ADVANCE**

The OS2000 is the latest addition to the Advance Oscilloscope range. It is extremely versatile with X and Y plug-ins, has a bandwidth of 20MHz at 10mV/cm (or 5MHz at 1mV/cm) dual trace, and many features normally associated with the most expensive oscilloscopes

- Fully operational in 15 seconds
 - 'Volstat' stabilised supplies maintain calibration accuracy
 - 200ns Signal Delay
 - Superb Triggering
- The OS2000 is the finest possible addition to your Instrumentation.

Seeing is believing ● Ask for a demonstration now

- U.K. Prices: £195 Single Trace & Standard Time Base; £230 Dual Trace & Standard Time Base

ADVANCE ELECTRONICS LIMITED
Roebuck Road, Hainault, Ilford, Essex.
Tel: 01-500 1000 Telex: 263785

Coutant

New 'A' Series Power Range

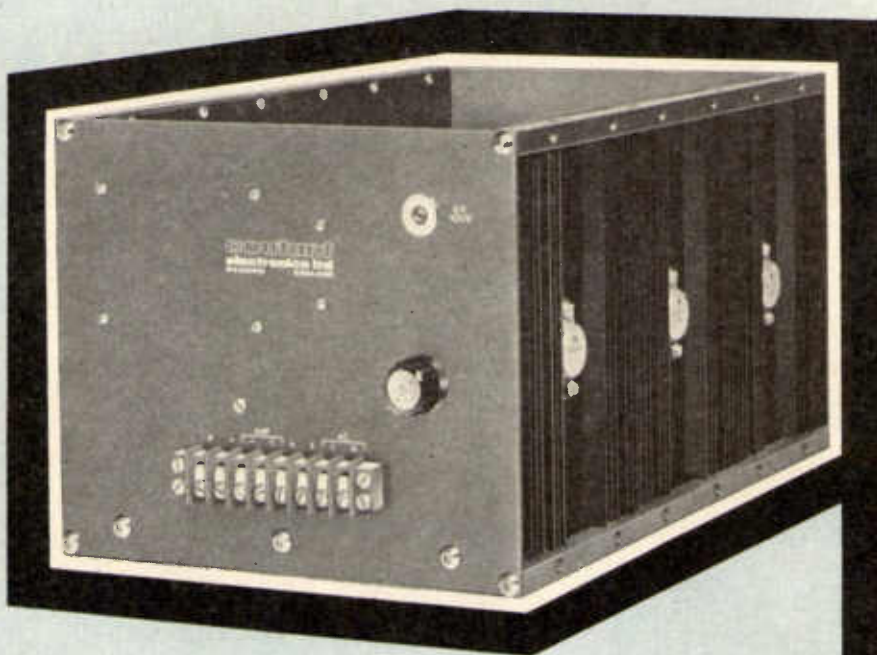

The Reliable Way To Keep Power Costs Down

3 Voltage Ranges.

Current ratings to 50 amps.

Parallel and Series operation.

Single and Twin Output models.

All types of load.

Remote sensing.

Coutant's aim is to give you the right supply at the right price and this new range is designed to do just that. 46 models, with 3 voltage ranges and current ratings sensibly chosen from $\frac{1}{2}$ to 50 amps, allow you to pick the modular units you need without wasting time, power or money. The specification provides top performance without load problems, lock-out worries or high temperature snags, and all units comfortably meet the specified figures—we know because each one is tested. Current sharing, parallel operation is a bonus on all single units and both twin and single units can be worked in series. A call to Reading 55391 is the first step to get acquainted with this new range.

Units are available in a variety of rack mounting assemblies from simple brackets to extending slide fittings. We can provide all your requirements.

Protective covers, instruments cases, indicating lamp switches, meters and screw terminals, are a few of the available extras for most of the "A" Series units.

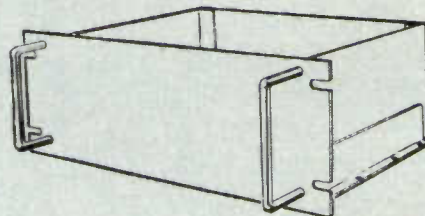

SPECIFICATION

Stabilisation Ratio

Greater than 10,000:1

Output resistance

Less than 1 milliohm for units to 10 amps. Less than 0.2 milliohms for units to 10 amps and above

Output impedance

Less than 0.1 ohm at 100 K c/s

Low frequency ripple and noise

Less than 200 microvolts peak to peak

Ambient temperature range

-10° C to + 65° C

Temperature coefficient

Less than 0.02% /C° (0.005% /C° optional)

Overload protection

Re-entrant characteristic with an initial constant current period of about 200 milliseconds to ensure reliable "switch-on" into non-linear loads. Recovery from overload is automatic.

Input voltage

100 to 125 volts and 200—250 volts 45—400 c/s single phase. Permissible deviation $\pm 10\%$ from nominal.

Output Voltage Adjustment

Voltages are pre-set during the extensive test procedures but the new design allows you to change the voltage easily. A convenient front panel control provides a $\pm 1v$ adjustment at any voltage—low voltage modules have a wider adjustment.

Voltage ranges, current rating's & prices

	Type No.	Current	'A' Voltage	Size Ref.	Price
Single Output	ASA50	0.5 amp	1-7.5V	10	£23
	ASA100	1 amp		10	£24
	ASA200	2 amp		11B	£32
	ASA300	3 amp		11D	£37
	ASA500	5 amp		12	£41
	ASA700	7 amp		13	£53
	ASA1000	10 amp		12	£60
	ASA1500	15 amp		14A	£80
	ASA2000	20 amp		14B	£110
	ASA3000	30 amp		15	£170
Twin Output	ATA5000	50 amp	2×1-7.5V	15	£230
	ATA50	2×0.5 amp		11D	£42
	ATA100	2× 1 amp		11D	£44
	ATA200	2× 2 amp		11D	£58
	ATA300	2× 3 amp		13	£67
	ATA500	2× 5 amp		14A	£74

	Type No.	Current	'B' Voltage	Size Ref.	Price
Single Output	ASB50	0.5 amp	6-15V	10	£24
	ASB100	1 amp		11A	£25
	ASB200	2 amp		11C	£33
	ASB300	3 amp		11D	£38
	ASB500	5 amp		12	£43
	ASB700	7 amp		13	£55
	ASB1000	10 amp		13	£64
	ASB1500	15 amp		14B	£83
	ASB2000	20 amp		14B	£126
	ASB3000	30 amp		15	£180
Twin Output	ATB50	2×0.5 amp	2×6-15V	11D	£43
	ATB100	2× 1 amp		11D	£45
	ATB200	2× 2 amp		12	£59
	ATB300	2× 3 amp		13	£69
	ATB500	2× 5 amp		14A	£78

	Type No.	Current	'C' Voltage	Size Ref.	Price
Single Output	ASC50	0.5 amp	6-30V	10	£25
	ASC100	1 amp		11C	£26
	ASC200	2 amp		11D	£35
	ASC300	3 amp		12	£41
	ASC500	5 amp		13	£54
	ASC700	7 amp		14A	£72
	ASC1000	10 amp		14A	£78
	ASC1500	15 amp		15	£145
	ASC2000	20 amp		15	£170
	ASC3000	30 amp		15	£214
Twin Output	ATC50	2×0.5 amp	2×6-30V	11D	£45
	ATC100	2× 1 amp		11D	£47
	ATC200	2× 2 amp		13	£63
	ATC300	2× 3 amp		14A	£74
	ATC500	2× 5 amp		14A	£98

Size Reference Chart

	HEIGHT	WIDTH	LENGTH
10	3½	3½	7½
11A	5	3½	7½
11B	5	3½	8
11C	5	3½	9½
11D	5	3½	11½
12	5	4½	12½
13	5	6½	11½
14A	6½	8½	12½
14B	6½	8½	16½
15	8½	17½	17½

Call Reading 55391 for full details of this and all the Coutant range.

Coutant electronics Ltd

Electrotech Instruments Division
3 Trafford Road · Reading · Berkshire · England, Tel: Reading 55391

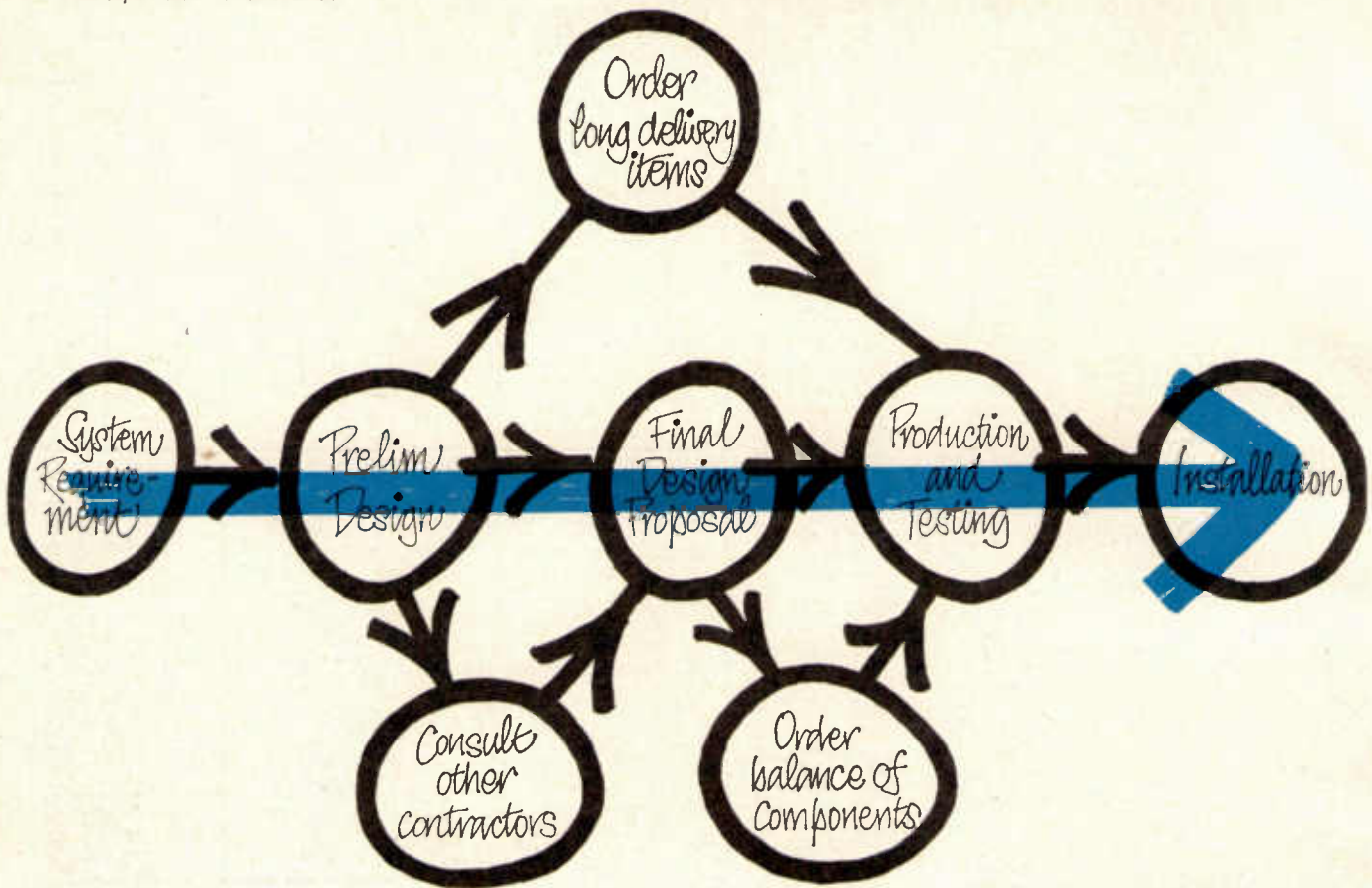

—the critical path to fast systems control

Network Analysis shows you the shortest route to complete systems control— with Vosper Electric. See how the Vosper design, engineering and manufacturing service fits into your future projects; taking a complex problem off your mind and supplying you with complete design, production and installation of process and supervisory control systems. Using highly skilled experts and the finest components drawn from world-wide sources, Vosper Electric is the straightest path to high efficiency, low-cost systems control. Send us your enquiries, or ask for one of our Engineers to call.

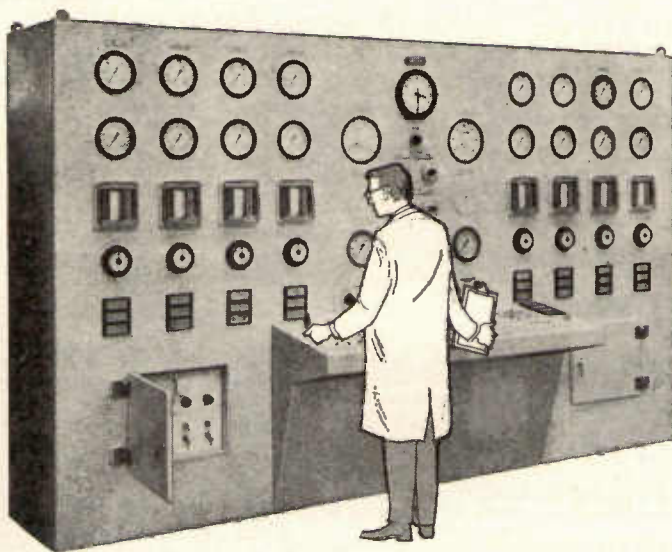

VES-1

Riggs
ADVERTISING LTD

VOSPER ELECTRIC

INDUSTRIAL & MARINE CONTROLS DIVISION
OF THE VOSPER THORNYCROFT GROUP
Castle Trading Estate, Portchester, Fareham, Hampshire
Telephone: Cosham 79481. Telex: 86115

 A SUBSIDIARY OF THE DAVID BROWN CORPORATION LIMITED

150 MHz, 2.4 ns

New performance from probe tip to CRT!

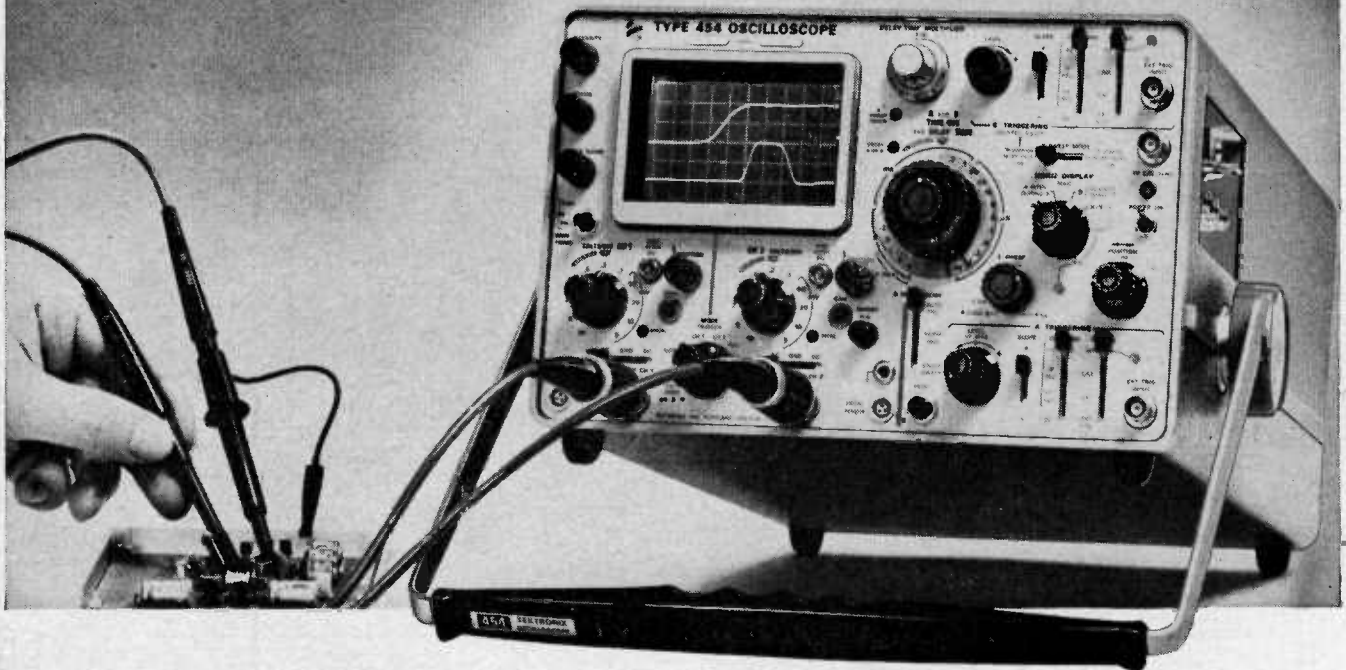

The Tektronix Type 454 is an advanced new portable oscilloscope with DC-to-150 MHz bandwidth and 2.4-ns risetime performance where you use it—at the probe tip. It is designed to solve your measurement needs with a dual-trace, vertical, high-performance triggering, 5-ns/div delayed sweep and solid state design. You also can make 1 mV/div single-trace measurements and 5 mV/div X-Y measurements.

The vertical system provides the following dual-trace performance, either with or without the new miniature P6047 10X Attenuator Probes:

Deflection Factor*	Risetime	Bandwidth
20 mV/div to 10 V/div	2.4 ns	DC to 150 MHz
10 mV/div	3.5 ns	DC to 100 MHz
5 mV/div	5.9 ns	DC to 60 MHz

*Front panel reading. With P6047 deflection factor is 10X panel reading.

The Type 454 can trigger internally to above 150 MHz. Its calibrated sweep range is from 50 ns/div to 5 s/div, extending to 5 ns/div with the X10 magnifier on both the normal and delayed sweeps. The delayed sweep has a calibrated delay range from 1 μ s to 50 seconds.

Type 454 (complete with 2 P6047 and accessories) . . . £1,051 + £215 17s. duty
 Rackmount Type R454 (complete with 2 P6047 and accessories)

£1,089 + £223 13s. 2d. duty

New Type 200-1 Scope-Mobile® Cart £34 + £7 4s. 0d. duty

Pulse fidelity

This double-exposure photograph shows the same 12-ns-wide pulse displayed on the Type 454 (upper display) and on a 7-ns, 50-MHz oscilloscope (lower display). Note the difference in detail of the pulse characteristics displayed on the Type 454 with its 2.4-ns risetime performance.

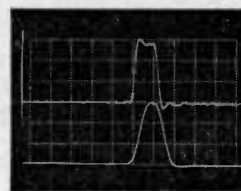

10 ns/div

5 ns/div delayed sweep

The delayed sweep is used to measure individual pulses in digital pulse trains. The Type 454 with its 1 μ s-to-50 s calibrated delay time, 5-ns/div sweep speed and 2.4-ns risetime permits high resolution measurements to be made. Upper trace is 1 μ s/div; lower trace is 5 ns/div.

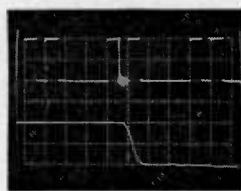

Double Exposure

X-Y

The upper display is a 150-MHz signal that is 50% modulated by a 2kHz signal. The lower display is an X-Y trapezoidal modulation pattern showing the 150-MHz AM signal vertically (Y) and the 2kHz modulation signal horizontally (X). Straight vertical line is the unmodulated carrier. Multiple exposure.

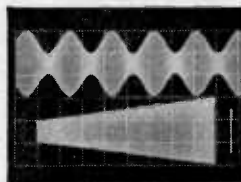

150 MHz AM

For detailed information on any of our products, please fill in reader reply card or write, telephone or telex.



Tektronix U.K. Ltd.

Beaverton House · Station Approach · Harpenden · Herts
 Telephone: Harpenden 61251 · Telex: 25559

For overseas enquiries:

AUSTRALIA: Tektronix Australia Pty. Ltd. 4-14 Foster Street, Sydney, N.S.W.

CANADA: Tektronix Canada Ltd. Montreal, Toronto & Vancouver.

FRANCE: Relations Techniques Intercontinentales, S.A., 134 Avenue de Malakoff, Paris XVI.

SWITZERLAND: Tektronix International A.G., P.O. Box 57, Zug, Switzerland.

REST OF EUROPE AND THE MIDDLE EAST: Tektronix Ltd. P.O. Box 36, St. Peter Port, Guernsey, C.I.

All other territories: Tektronix Inc., P.O. Box 500, Beaverton, Oregon, U.S.A.

Bullers CERAMICS

for the **ELECTRONIC INDUSTRY** (and Electrical Appliance Manufacture)

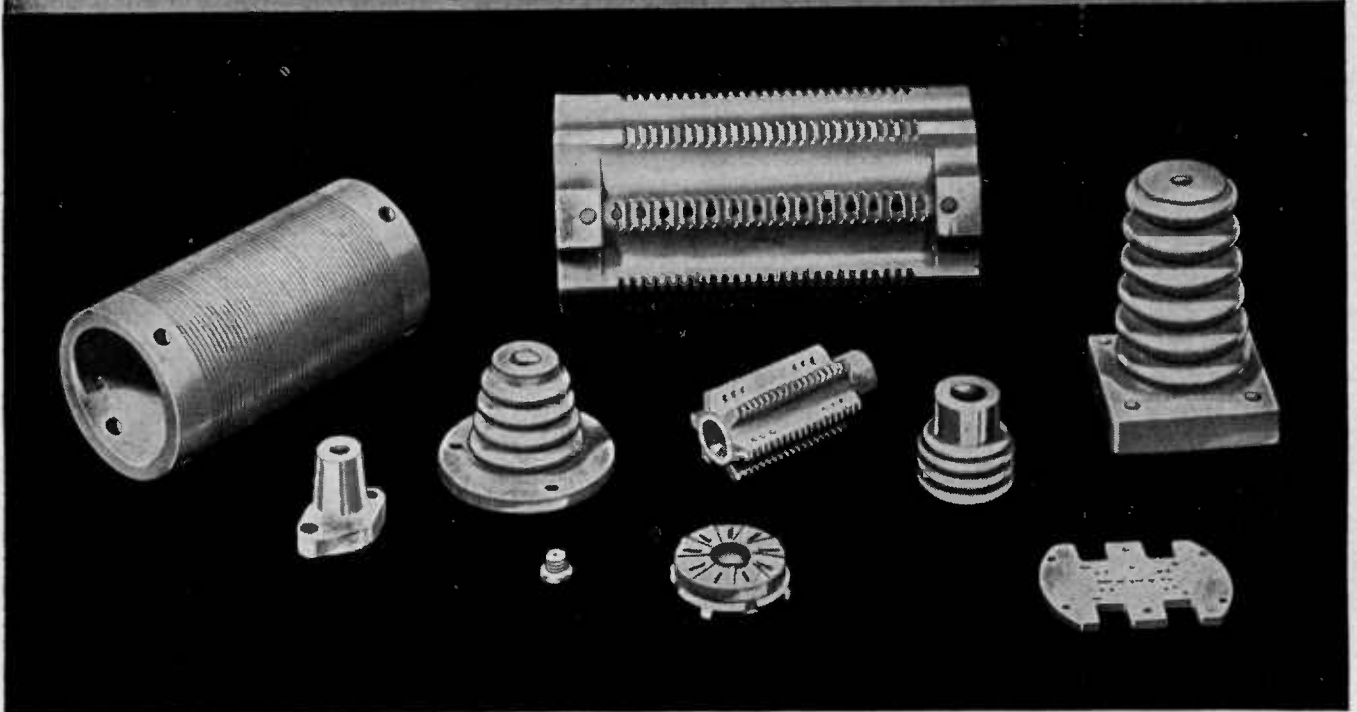

Frequelex—for high frequency insulation.

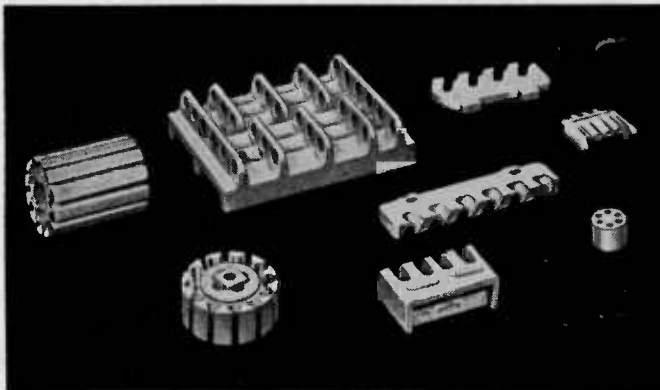

Refractories for high-temperature insulation.

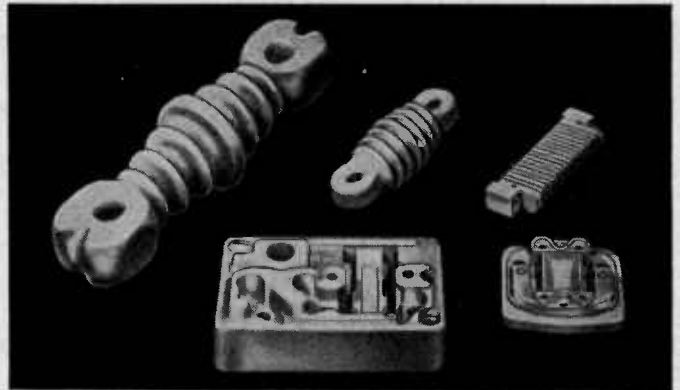

Bullers porcelain for general insulation purposes.

Meticulous care in manufacture, high quality material, with particular attention applied to *dimensional precision and accuracy*, explain the efficiency and ease of assembly when using Bullers die pressed products.
Write today for detailed particulars.

BULLERS LIMITED

Milton. Stoke-on-Trent, Staffs.

Phone: Stoke-on-Trent 54321 (5 lines)

Telegrams & Cables: Bullers, Stoke-on-Trent

London Office: 6 Laurence Pountney Hill, E.C.4.

Phone: MANsion House 9971

ARE YOU KEEPING PHYSICAL DIMENSIONS WELL IN HAND?

This Digital Indicator makes a bright display (up to eleven characters) within a panel area of less than half a square inch.



This is Type M24, the smallest in the K.G.M. range. There are many others described in our catalogue; may we send you a copy to prove that we make the widest range of indicators in the country.

KGM

electronics limited
BARDOLPH RD RICHMOND
Phone: RICHmond 7171 Surrey

TEMPERATURE TEST CHAMBERS

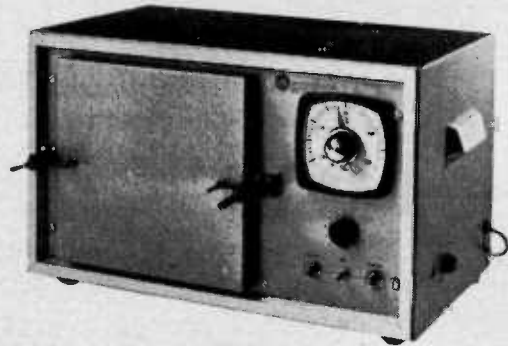

DESIGNED
AND
BUILT IN
GREAT
BRITAIN

MINI K/CO, MK.II MODEL 'A' PORTABLE.

TEMPERATURE RANGE $-70^{\circ}\text{C. to } +200^{\circ}\text{C.}$
CONTROL SENSITIVITY $\pm 0.3^{\circ}\text{C.}$
TEMPERATURE GRADIENT WITHIN CHAMBER $\pm 2^{\circ}\text{C.}$

INTERNAL CHAMBER SIZE

MODEL	A	B	C
	$9\frac{1}{2}'' \times 9'' \times 8\frac{1}{2}''$	$12'' \times 12'' \times 10''$	$15'' \times 10'' \times 9''$

PRICE	£ 174 18 0	£ 248 12 0	£ 308
-------	------------	------------	-------

40 OTHER MODELS AVAILABLE COVERING TEMPERATURE RANGES $-190^{\circ}\text{C. TO } +500^{\circ}\text{C.}$



montford

INSTRUMENTS LIMITED
79 LOTS RD., CHELSEA, LONDON, S.W.10
Telephone: 01-352 2231 (P.B.X.) Telex 264449
Sponsor Member of the Society of Environmental Engineers

PLASTIC
MOULDINGS

FREDERICK W. EVANS LTD.
Plastic Works, Long Acre, Birmingham 7. Tel: East 3071-2

For more information circle No. 60

1N 914 DIFFUSED SILICON COMPUTER DIODE

$V_R = 75\text{V}$, 75mA ave. 225mA peak, 500mA surge,
4pF at $V_R = 0$
 $\text{trr} = 4\text{ns max. (10mA } I_F, 6\text{V } V_R \text{ recover to 1mA)}$
 $\text{trr} = 8\text{ns max. (10mA } I_F, 10\text{mA } I_R \text{ recover to 1mA)}$
Forward Recovery Voltage = 2.5V (50mA pk. sq. wave,
VERY LOW PRICES: $\mu\text{S P.W.,}$
1-99 1/5 10nS rise time,
100 up 11d 5-100 Kc/s rep. rate.)

Large quantities quickly available at even lower prices
—ask us for quotation.

RASTRA Electronics Ltd.,
275/281 King Street, London W 6 Tel: RIVerside 2960

For more information circle No. 61

BEHIND EVERY BRIMAR OSCILLOSCOPE TUBE ...AN UNRIVALLED PERSONALISED SERVICE

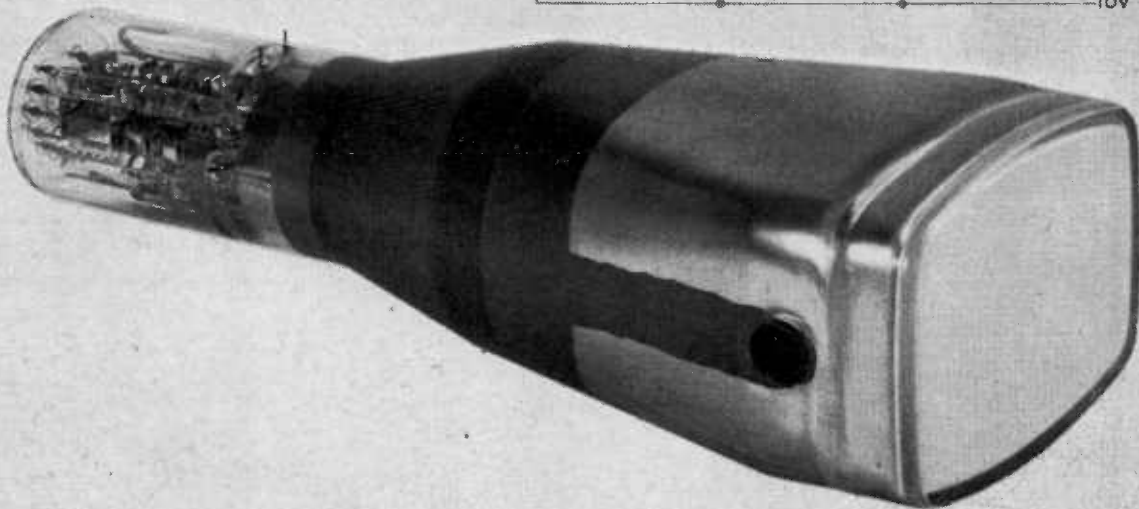

There's a BRIMAR tube to meet the needs of every oscilloscope designer—ranging from general purpose tubes of medium bandwidth to tubes designed specifically for exacting applications requiring features such as short length, wide bandwidth or dual phosphors. Face plates range from 8½" large displays to 1" types for numerical and indicator presentations including the latest 7 x 5 cm rectangular size.

PERSONALISED TECHNICAL SERVICE

Every BRIMAR oscilloscope tube is backed by a first-class technical service and assistance on any type of problem involving it—from special characteristics to circuit design. BRIMAR engineers are always available—contact is on a personal level. Just phone or write.

The BRIMAR D13-51GH is a modern Mesh P.D.A. 6 x 10 cm²-area tube, which gives improved brightness, higher deflection sensitivities and higher ratios of screen to deflector voltage with no shrinkage of raster area. The D13-51GH displays single phenomena up to 30 MHz bandwidth and is suitable for use with transistorised circuits. It needs fewer control voltages than other mesh tubes. Length is only 13¼".

We shall be pleased to let you have full details of the BRIMAR D13-51GH and the rest of the interesting range of BRIMAR industrial cathode ray tubes.



Thorn-A.E.I. Radio Valves & Tubes Ltd.
7 Soho Square, London W1. Telephone: 01-437 5233

TA695B

VAREX

the most complete power supplies ever built

3 Modes Constant voltage, constant current and re-entrant current. The re-entrant mode provides the ultimate in protection of external loads under fault conditions, by dropping to a lower energy state in 3 μ sec.

Mode Identity Automatic visual indication of operating mode, even for fault conditions.

Presetting 3 way output switch for pre-setting voltage and current independently before connection to external load. Continuously variable coarse and fine controls provide 1% incremental accuracy.

Programming/Slaving Remote programming facilities for voltage and current over the entire range. Parallel and series operation, allow twin units to be operated at double voltage or double current.

Outstanding Specification Drift: $\pm 0.005\%$ Long Term Random Variations (Initial 15 mins: $+0.15\%$)

Temperature Coefficient: $0.01\%/^{\circ}\text{C}$

Stabilisation Ratio: 10000:1

Ripple & Noise: $35\mu\text{V RMS}/100\mu\text{V peak to peak}$

Output Resistance: Constant Voltage: $0.5\text{ m}\Omega$ 10 Amp units, rising to $10\text{ m}\Omega$ for 1 amp units

Output Resistance: Constant current: 30K

Output Impedance: $100\text{ m}\Omega$ at 100K c/s

Transient Recovery Time: 3 μ secs.

Max Ambient Temperature: 50°C

Reliability Varex are totally indestructible under short-circuit and overload conditions; this, coupled with all-silicon line-up, C-core class H2 transformers and high temperature electrolytic capacitors, ensure a prolonged trouble-free life.

TYPE	OUTPUT (VOLTS)	CURRENT RATING	OVERALL HEIGHT	OVERALL WIDTH	OVERALL DEPTH	PRICE (CARRIAGE PAID UK)
VAREX 60-1	0-60V	0-1A	5 $\frac{7}{8}$ " (142.9mm)	8 $\frac{7}{8}$ " (225.4mm)	10 $\frac{1}{2}$ "	£75
VAREX 30-2	0-30V	0-2A			(266.7mm)	£75
VAREX 60-5	0-60V	0-5A			15 $\frac{1}{2}$ "	£155
VAREX 30-10	0-30V	0-10A		(387.4mm)	£155	
VAREX TWIN 60-1	2 x 0-60V	2 x 0-1A		12 $\frac{1}{2}$ " (317.5mm)	11 $\frac{7}{8}$ "	£140
VAREX TWIN 30-2	2 x 0-30V	2 x 0-2A			(301.6mm)	£140
VAREX TWIN 60-5	2 x 0-60V	2 x 0-5A			16 $\frac{1}{2}$ "	£285
VAREX TWIN 30-10	2 x 0-30V	2 x 0-10A			(419.1mm)	£285

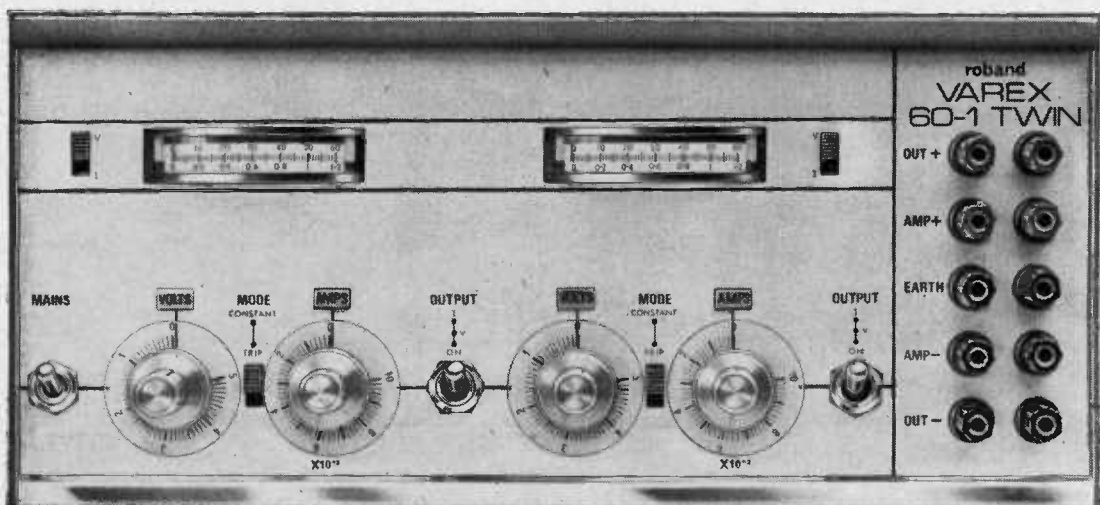

roband

Electronics Limited
Charlwood Works
Charlwood
Horley
Surrey

CRAWLEY 20172

REX

the most sophisticated stabilised power supplies of all

67 series

the economy range

TYPE NO.	OUTPUT VOLTS (pre set)	CURRENT RATING	WIDTH	HEIGHT	DEPTH	PRICES (carriage paid UK)
REX 2L	0-12V	2A	3½"	5"	7½"	£36. 10.
REX 5L	0-12V	5A	4½"		11½"	£48. 15
REX 10L	0-12V	10A	4½"		16½"	£66. 10.
REX 15L	0-12V	15A	8½"		14½"	£84. -
REX 1H	0-30V	1-25A	3½"		7½"	£34. 10.
REX 2-5H	0-30V	2-5A	4½"		9½"	£44. 5.
REX 5H	0-30V	5A	4½"		14½"	£57. 5.
REX 10H	0-30V	10A	8½"		14½"	£84. -
REX 1S	30-50V	1A	3½"		7½"	£37. 15.
REX 2-5S	30-50V	2-5A	4½"		12½"	£55. 15.
REX 5S	30-50V	5A	8½"	12½"	£77. 5.	

TYPE NO.	OUTPUT VOLTS (pre set)	CURRENT RATING	WIDTH	HEIGHT	DEPTH	PRICES (carriage paid UK)
67-1L	0-7V	1A	2½"	5"	8"	£22
67-2L		2A	2½"	5"	8"	£24
67-4L		4A	3½"	5½"	6½"	£33
67-5L		5A	4-7/8"	6½"	9-3/8"	£38
67-10L		10A	4-7/8"	6½"	10½"	£52
67-1A	6-24V	1A	2½"	5"	8"	£22
67-2A		2A	3½"	5½"	6½"	£27
67-5A		5A	4-7/8"	6½"	9½"	£40
67-10A		10A	5½"	6"	12"	£55
67-Twin 1A		6-24V (X2)	1A (X2)	4-7/8"	5½"	6½"
67 Twin 5A	6-24V (X2)	5A (X2)	5½"	8"	12"	£76
67-1H		1A	3½"	5½"	6½"	£27
67-2H	24-40V	2A	4-7/8"	6½"	9-3/8"	£34
67-5H		5A	5½"	6-3/8"	10½"	£50

NEW RANGE 0-7V

NEW RANGE 24-40V

PERFORMANCE Input Voltage: 100-125/200-250 ± 7½%. 48-400 cps. Stability (15% mains variation): 0.01%. Stability (0 to full load): 0.05%. Ambient Temperature: -10°C to +60°C. Temperature Coefficient: 0.01%/°C. Protection: Self-resetting current limiter preset to operate at 110% of maximum current rating. Ripple and noise: 500 microvolts, peak to peak.

PERFORMANCE Input Voltage: 100-125/200-250 ± 7½%. 48-400 cps. Stability (15% mains variation): 0.1%. Stability (0 to full load): 0.2%. Ambient Temperature: -10°C to +60°C. Temperature Coefficient: <0.05%/°C. Protection: Self-resetting current limiter preset to operate at 110% of maximum current rating. Ripple and noise: 2mV RMS.

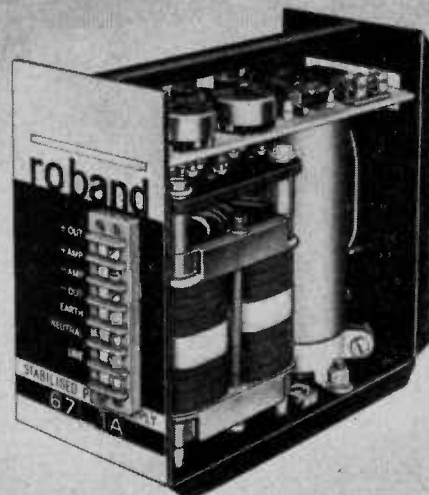
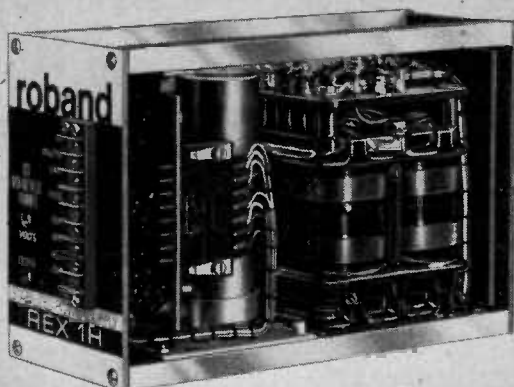

For more information circle No. 65

The *Quality &*
Reliability of **YOUR PRODUCT START** *at your* **SUPPLIER**



BRITISH PRODUCTIVITY
COUNCIL CAMPAIGN

H. ROLLET & Co. LTD.

ALUMINIUM MAGNESIUM BRASS COPPER BRONZE STAINLESS STEEL NYLON ROD TUBE SHEET STRIP WIRE

Only National Independent Stockist - Branches in most Major Cities. Since 1896 - "No Quantity Too Small"



**OFFER A COMPLETE SERVICE
FOR THE DESIGN AND MANUFACTURE OF
ELECTRONIC COMPONENTS AND EQUIPMENT**

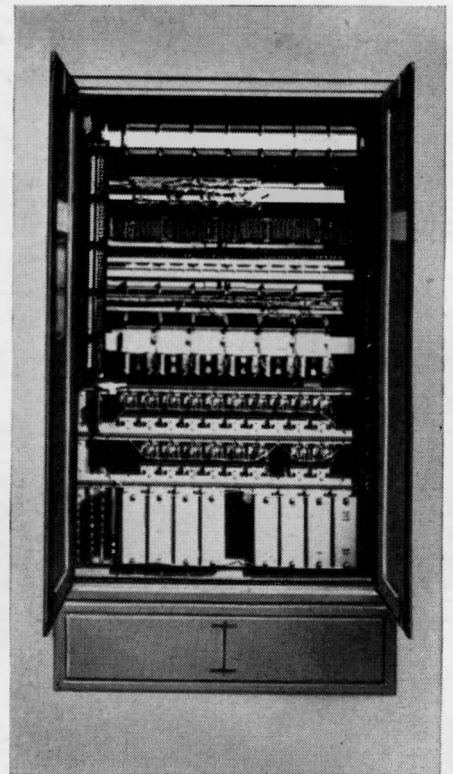
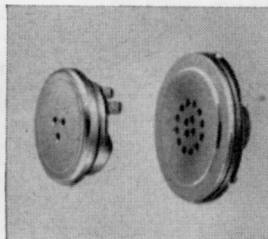
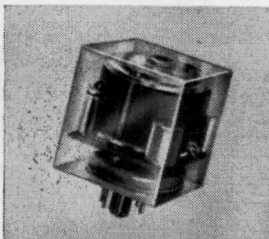
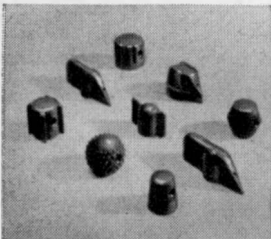

Whiteley Electronic Components are designed and precision-built in the Company's own factories. Every operation is strictly controlled, every part is vigorously inspected and tested. Nothing is left to chance—hence Whiteley's enviable reputation.

WHITELEY ELECTRICAL RADIO CO. LTD.
MANSFIELD • NOTTS • ENGLAND • Tel: MANSFIELD 24762

LONDON OFFICE: 109, KINGSWAY, W.C.2
Telephone: HOLborn 3074

For more information circle No. 66

Electronic DC to AC Inverters

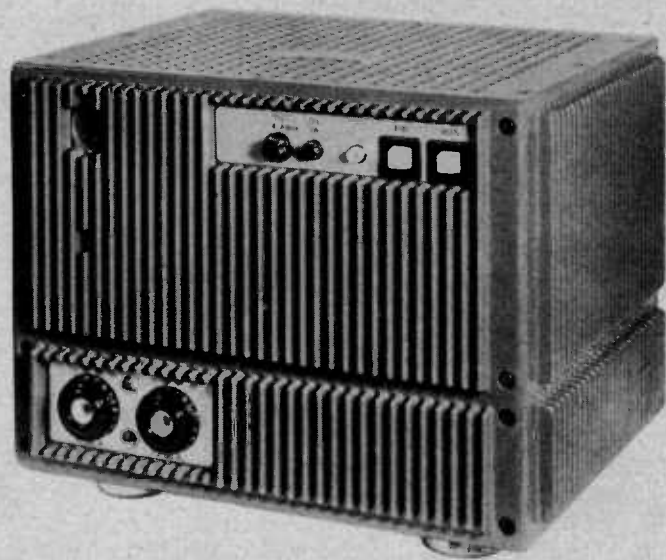

Sorensen DC to AC inverters outdate mechanical choppers and rotary converters. Since semi-conductors are used throughout, the unit is immediately operative.

Sorensen inverters with output power ranges from 125 to 3000 VA are built for input voltages between 12 and 220 V $\pm 15\%$, depending on the output power. The sine-wave output voltage of 220 V (other voltages on request) is stabilized against load and input voltage variations to $\pm 3\%$ or, on special request, to $\pm 1\%$. Distortion factor at full load: $> 5\%$. The output frequency is 50 or 60 Hz, stabilized to $\pm 0,5\%$. As optional equipments to every model are available: input filter, output radio-noise suppression filter as well as an automatic cross-over circuit line-inverter.

Please contact us also for DC power supplies, HV power supplies, AC line regulators.

Sorensen-Ard AG
8045 Zürich Binzstrasse 18
Telefon 051/35 87 24



If you need magnets . . .
permanent magnets,
with special materials,
and special shapes —
like these —

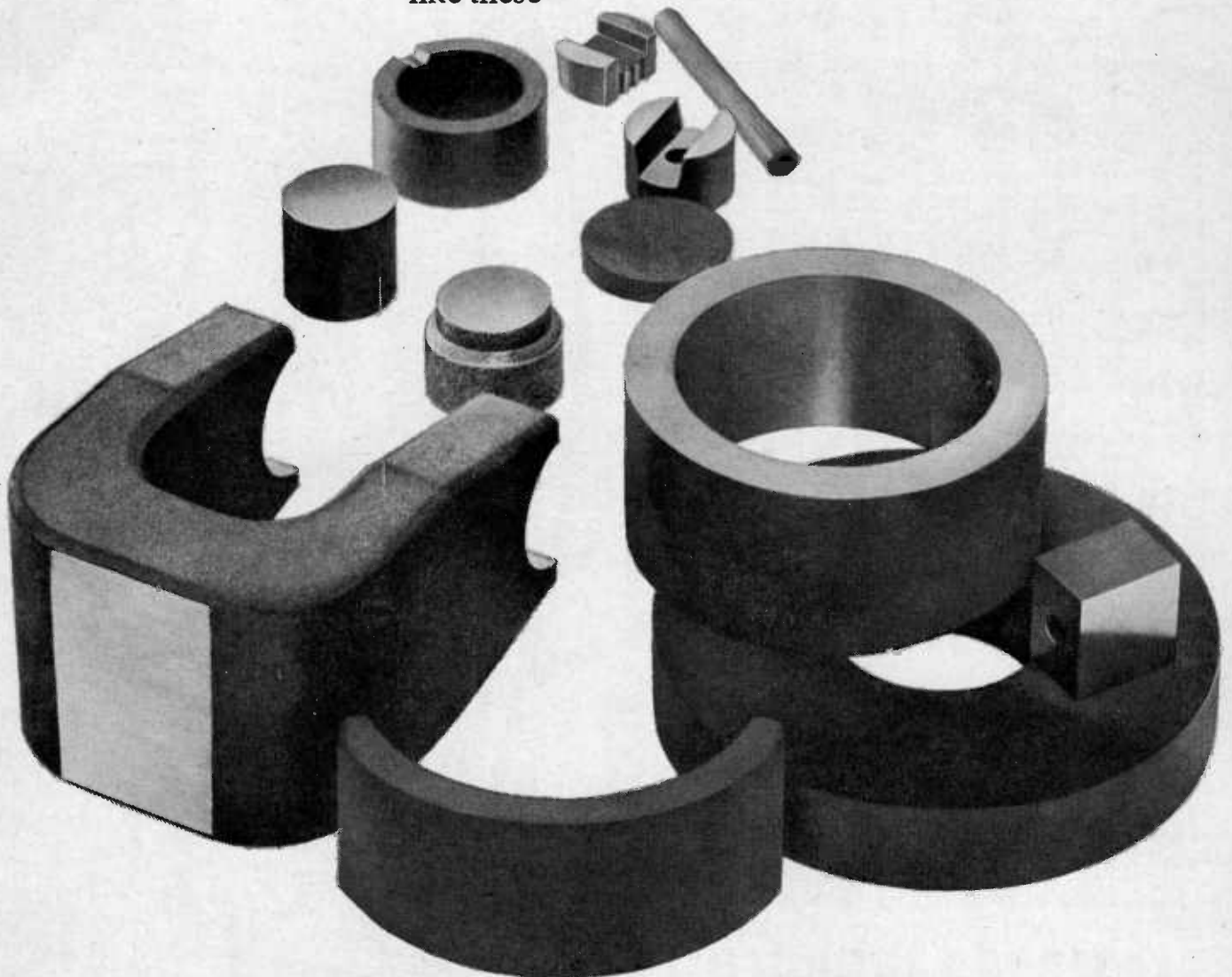

Talk to the specialists — Mullard.
They offer you ceramic or metallic permanent magnets
in large quantities to your specification — quickly.
Mullard materials — Magnadur, Ticonal and Reco —
are household names to magnet users.
For full information send for your copy of the
Mullard Permanent Magnets Book, and a folder of
technical information sheets.
Or discuss your requirements direct with the
Mullard Magnet Group — telephone Southport 86921. Ext. 41

Mullard INDUSTRIAL ELECTRONICS DIVISION,
Mullard Limited, Mullard House, Torrington Place,
London, W.C.1.

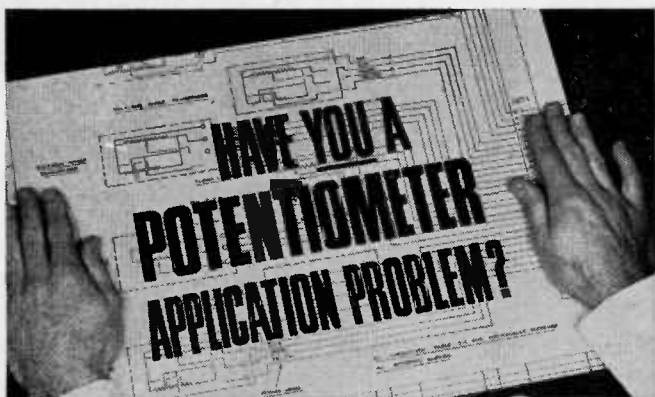

THIS 3-GANG
FULLY ADJUSTABLE
ROTARY
POTENTIOMETER
WAS DESIGNED FOR AN
INDUSTRIAL
ANALOGUE
COMPUTER

Part of this Rotary Potentiometer is multi-tapped and one of the other sections has an internally generated non-linear law.

0.1%
LINEARITY
PG
CUSTOM-BUILT
PRECISION
POTENTIOMETERS

We offer a wide range of robust Rotary and Rectilinear Potentiometers. All are subjected to severe environmental testing to M.O.A. Standards. Rectilinear Potentiometers available stroke lengths 0.25in. to 40in. Tappings to customers' requirements, also sealed or spring-loaded shafts.

ALL MAJOR INDUSTRIES SPECIFY PENNY & GILES RELIABLE CUSTOM-BUILT PRECISION POTENTIOMETERS

OUR CUSTOMERS INCLUDE THE FOLLOWING COMPANIES

ASSOCIATED ELECTRICAL INDUSTRIES LTD. . BRITISH EUROPEAN AIRWAYS . BRITISH OVERSEAS AIRWAYS CORPORATION . DOWTY ROTOL LTD. . ELLIOTT FLIGHT AUTOMATION LTD. . THE ENGLISH ELECTRIC CO., LTD. . THE MARCONI CO., LTD. . ROLLS-ROYCE LTD. . S. SMITH & SONS (ENGLAND) LTD. . VACTRIC CONTROL EQUIPMENT LTD.

ALSO IN GENEVA: CASE 2, 1211 GENEVE 6, SUISSE. SEND FOR SPECIFICATIONS & COLOUR BROCHURES. Dept. EE 13



PENNY & GILES LTD
MUDEFORD · CHRISTCHURCH · HANTS · Tel: Highcliffe 2233/4

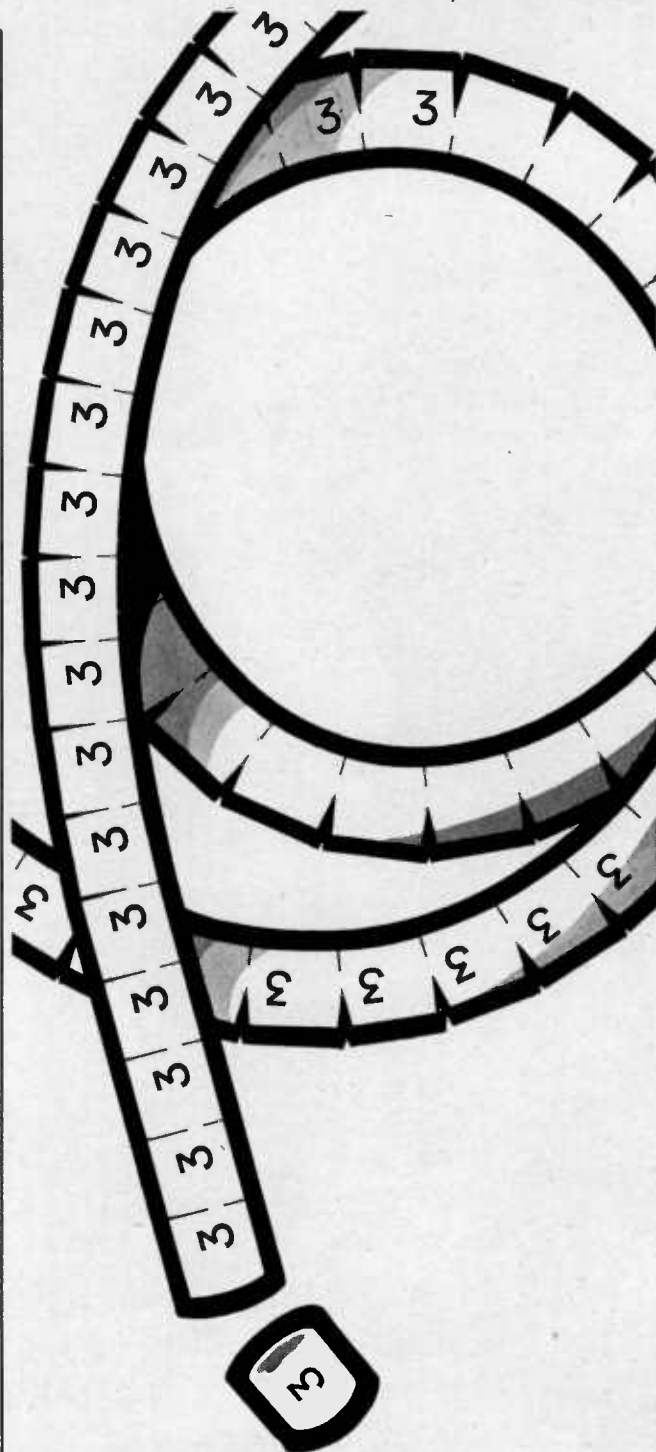

0 type markers

Basic Information: A widely accepted means of identifying cables. The thin wall of the sleeves enables them to be used where space is restricted. Any number can be used according to required code for either left or right hand entry. Available in the form of alligators—no spilling—in sizes 2.0mm to 5.5mm. Numbers are obtainable in International Colour Code, and White. Letters standard Black on White. Send for details and prices to:

Critchley Bros. Ltd., Brimscombe, Stroud, Glos.
Tel. Brimscombe 2451 (5 lines) Telex 43194.

CRITCHLEY
specifically

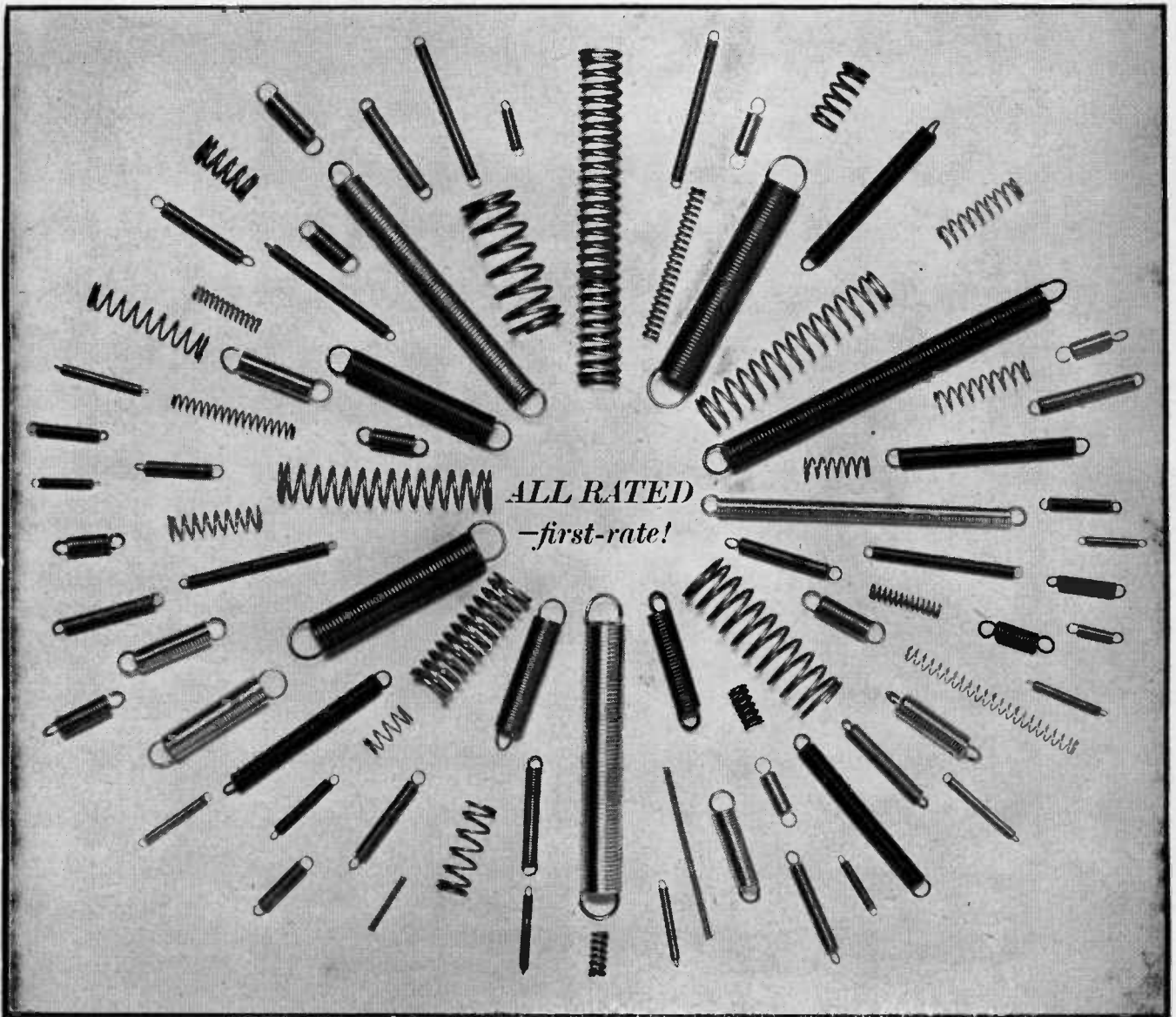

NOW FROM TERRY'S!

A RANGE OF RATED SPRINGS!

COMPRESSION AND EXPANSION!

Terry's brand-new rated range is over 300 springs long. Compression springs from .25" to 6" free length, outside diameters .120" to 1.480". Expansion springs from .75" to 8" free length outside diameters .125" to 1.0". All of guaranteed ratings. All offered in bulk quantities. The prices are competitive and delivery immediate. First-rate news? Then fill in and post off the coupon now, and make certain of having all the figures about Terry's rated springs close at hand. Do it now!

Everything springs from



Please send me my free copy of your Rated Springs catalogue.

NAME _____

POSITION _____

COMPANY _____

ADDRESS _____

P5

POST TO: HERBERT TERRY & SONS LIMITED,
REDDITCH, WORCESTERSHIRE.



what's a little one doing in an advertisement about big Daddy?

You can't beat family pride! So when we decided to show you the 2106 Visicorder, we thought let's bring the little one in as well.

The 1706 was after all the first ever low cost UV recorder, and what a fine picture it makes with its newly added electronic flash timing, grid lines and 5 sets of 8 paper speeds...

But it's the 2106 that's the real big Daddy of Honeywell's oscillograph family. For a heart it has the world's best galvos—range 0 to 13,000 Hz. Its 12 (+ 2 auxiliary) channels, chart speeds up to 300 cm/s and full width electronic time and grid lines add up to a pretty powerful versatility.

... And it's not as expensive as it looks! The 2106 is just one of the Visicorder family about which we'd like to tell you more. We will gladly add your name to the mailing list if you drop a line to Honeywell Controls Limited, Test Instruments, Great West Road, Brentford, Middx. Atlas 9191.

Honeywell

Honeywell International: Sales and service offices in all principal cities of the world. Manufacturing in U.K., U.S.A., Canada, Netherlands, Germany, France, Japan.

For more information circle No. 74

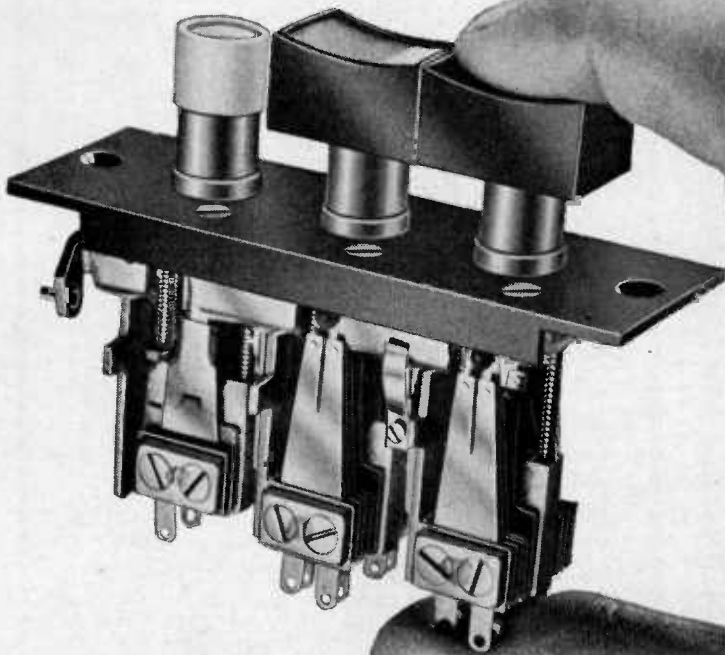

unmistakably Sasse

SASSE
SWITCHES
SWITCH BARS
INDICATORS

(Above) Sasse Luminous
Switch Bar, Type 1170

2 Sasse Miniature Toggle
Switch, Type 203

3 Sasse Indicator for
wide-angle viewing
Type 510

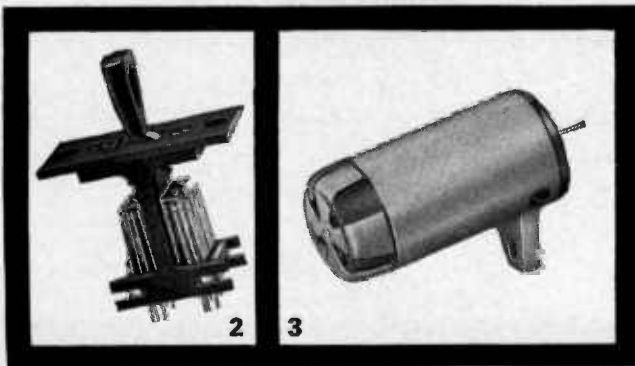

Essential for the control of more sophisticated electronic equipment are components designed and built to standards far higher than those acceptable in conventional commercial applications.

Those high standards are attained, and even exceeded by Sasse control components. In design, in quality of materials, in workmanship, in appearance, and above all, in performance, Sasse components rank high in their field. Sasse switches are of all-metal construction, rugged and built to last.

The Sasse standard range is extensive, covering practically every requirement of electronic designers and engineers. Three typical components are shown here, but there are many others. A complete, dimensioned list will be sent on request to the:

SASSE SWITCH DIVISION
of **THE RADIO RESISTOR CO LTD** **LAB**

PALMERSTON ROAD · WEALDSTONE
HARROW · MIDDLESEX

Telephone: HARrow 6347 · Telex: 25573

LEACH RELAYS

SERIES K AND KH
10 AMP 4PDT RELAY IN A 1" CUBE CASE

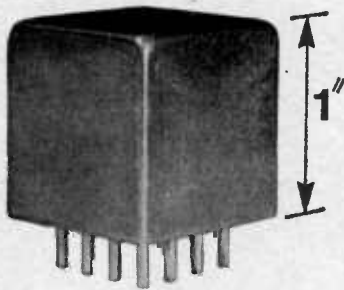

A true subminiature 4-pole relay! Not much bigger than a sugar cube—yet it will switch 10 amp over 100,000 times and will resist shock to 100-500 g's and vibration to 30-50 g's. All-welded can. Polarized. Designed to meet the severest environmental applications in the aircraft and electronics industries. Available in a variety of mounting and terminal styles. Just one of the series of Leach Relays, Time Delays, Power Contactors and High Environmental Tape Recorders, covering the whole range of electronic requirements.

Send for full data and specifications.

FieldTech Ltd

London Airport · Hounslow · Middlesex
Telephone: SKYport 2811

SQUARE ROUND or OBLONG

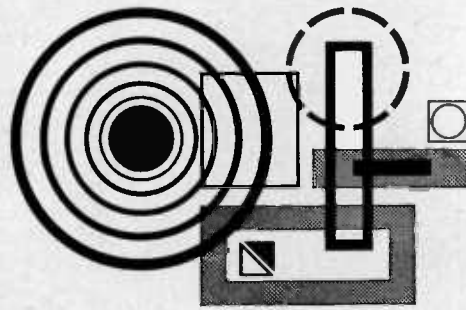

Precision wound from fabric or paper based resin impregnated materials to British Standard Specifications, Enalon manufacture round, square or rectangular tubes with various types of finish to tolerances of .0015". Diameters range from 0.090 ins. to 8 ins. and can be supplied pierced, turned, crimped, machined, slotted, or as required. All tooling produced in their own Tool Room by craftsmen.

For further details, please write or telephone.

ENALON PLASTICS LIMITED

TONBRIDGE, KENT. Tel. OSE. 22. 3343

DIOTESTOR IN-CIRCUIT TRANSISTOR TESTER

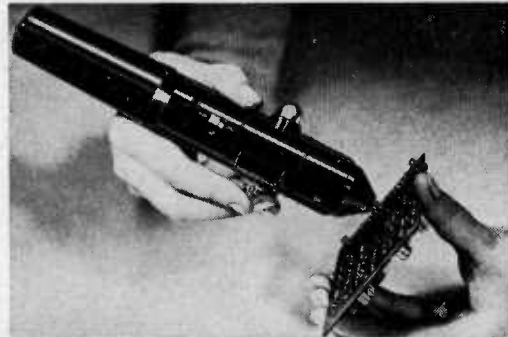

BRITEC LIMITED, 17 Charing Cross Road, London, W.C.2
Tel: 01-930-3070

For more information circle No. 77

Quartz Crystal Units

For
ACCURACY
RELIABILITY
PRICE ECONOMY
you can *DEPEND*
on

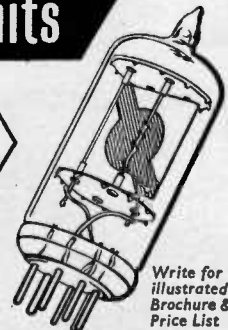

Write for
illustrated
Brochure &
Price List

THE QUARTZ CRYSTAL Company Ltd.

Q.C.C. Works, Wellington Crescent, New Malden, Surrey
Telephones: 01-942 0334 & 2988 Grams & Cables: Quartzco, New Malden

For more information circle No. 78

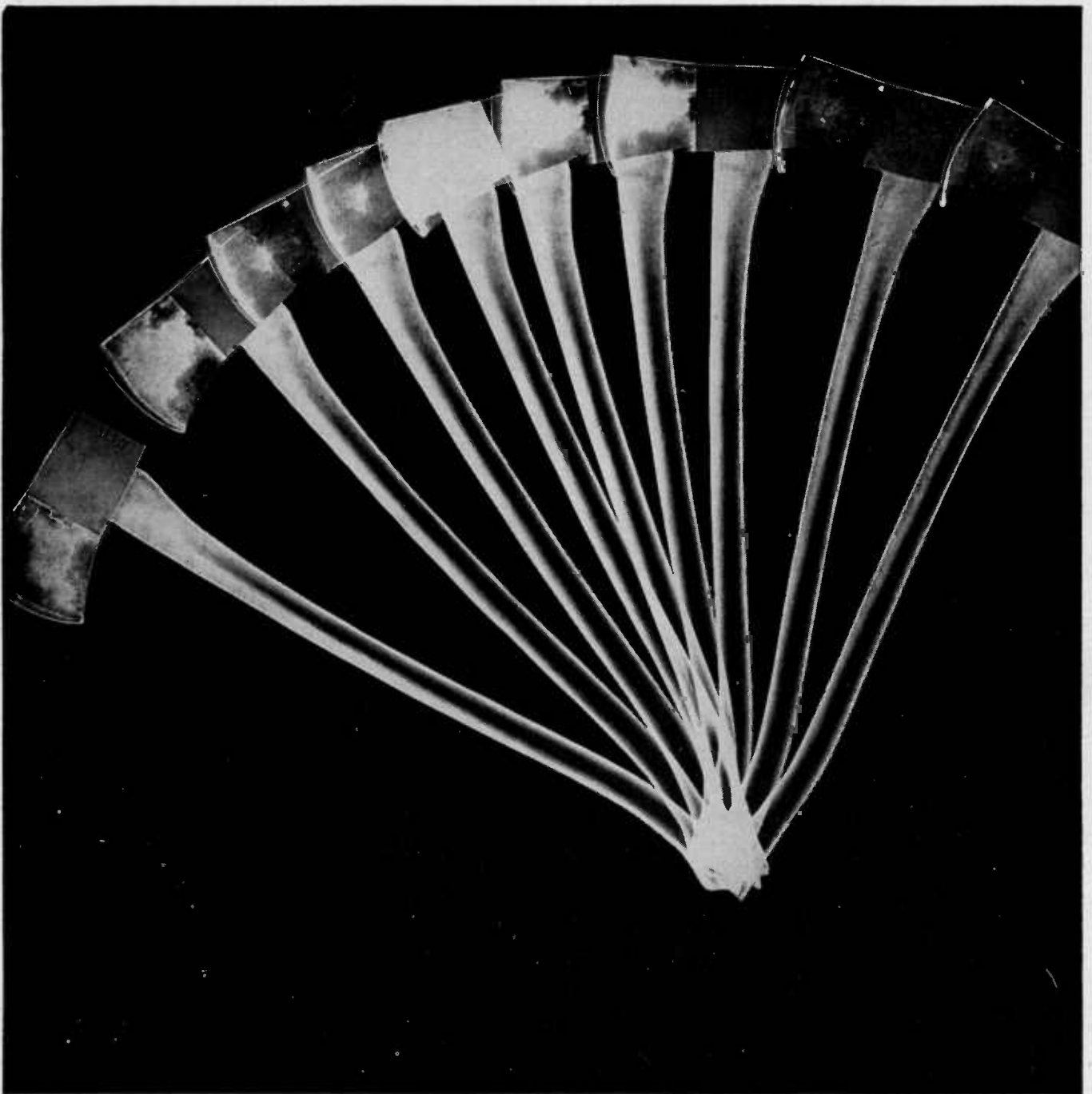

Cheapest way to chop

DC-to AC with an AEI Synchronous Chopper. It fits a standard B9A 9-pin thermionic valve holder, is suitable for feeding both high resistance and transformer-coupled low impedance circuits, its low noise level allows a 1 microvolt signal to be detected. Typical applications are: recording thermo-couple and ionisation chamber outputs; drift correction in analogue computer amplifiers; general instrumentation. Stability is high, operational life is long. Available in two models: CK3 for 50 c/s; CK4 for 100 c/s.

CK3 AND CK4 SYNCHRONOUS CHOPPER

Write to: Power Protection and Meter Department, AEI Switchgear Division, Trafford Park, Manchester 17, or your nearest AEI office.

AEI SWITCHGEAR

ASSOCIATED ELECTRICAL INDUSTRIES LIMITED SWITCHGEAR DIVISION TRAFFORD PARK MANCHESTER 17

SM 302/1

a differential d.c. voltmeter with a difference-

a built-in standard reference cell

Unlike other differential d.c. voltmeters, Marconi Instruments' new TF 2606 has a built-in standard reference cell, avoiding the need to rely on the stability of zener diodes for long-term accuracy. Simply by switching to the standard cell, calibration can be checked *at any time*.

TF 2606 gives typical accuracy of $\pm 0.02\%$ over the full voltage range of 0 to 1100V. Temperature range 10°C and 35°C. Three voltage ranges (11, 110 and 1100V) and five decade dials ensure high discrimination whilst reducing the need for frequent range changing.

Discrimination. Digital measurement discrimination is 0.0005% full scale. Overall discrimination on the 11V range is better than $100\mu\text{V}$.

High Input Resistance. Input resistance below 11V is almost infinite; on other ranges 1M Ω .

Overload Protection. TF 2606 will withstand considerable overranging.

Analogue Output. An analogue output of 75mV full scale is provided for a chart recorder—a separate digital to analogue converter is unnecessary.

At half the cost of a 5-digit d.v.m. of similar performance TF 2606 allows even higher accuracy by reading to 6 significant figures.

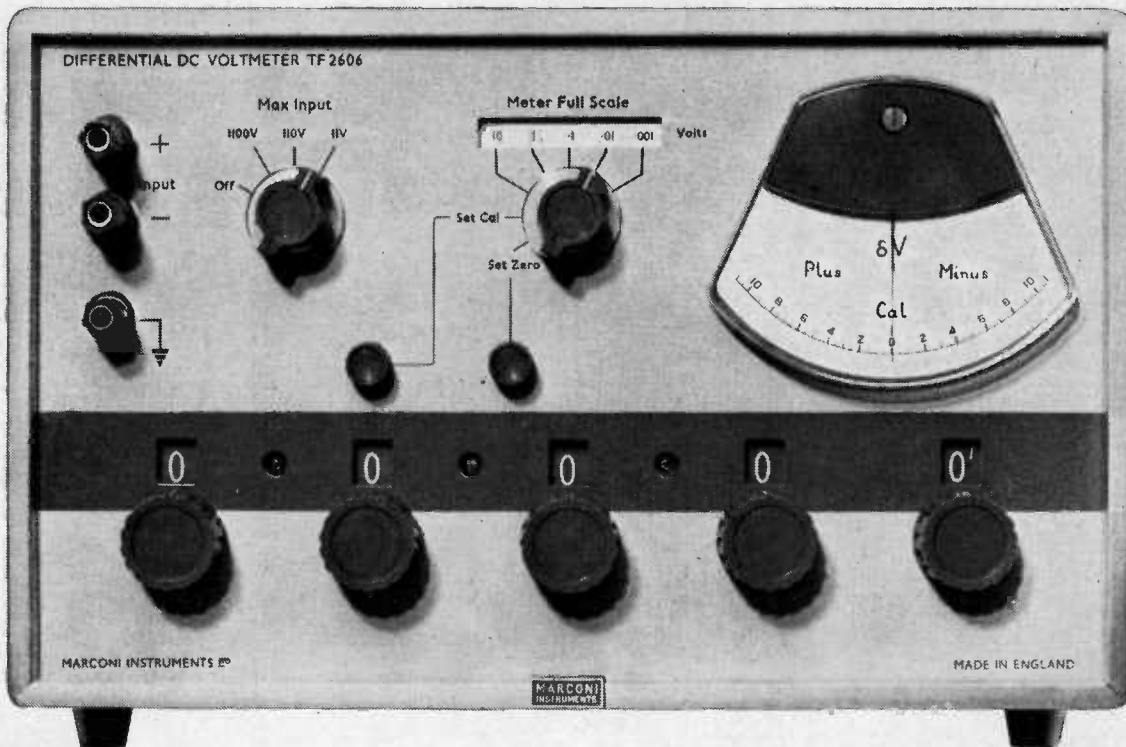

An English Electric Company

Please write for full technical details.

MARCONI INSTRUMENTS LIMITED

Longacres, St. Albans, Herts. Telephone: St. Albans 59292 Telex: 23350

Electronic Engineering

VOL. 39 No. 478.

AS EVERYONE KNOWS, telecommunications affairs in the United Kingdom are in the steady hands of the Post Office, and are very big business, with an annual capital expenditure of £300 million. The near and distant future of this empire was given by J. H. Merriman, in a lucid inaugural address at his accession to the chairmanship of the Electronics Division of the I.E.E. He was understandably a little cautious, but, as he said, the system must be economic, open-ended and versatile so that development can proceed; the pattern now laid down must be seen not to be obsolete before the end of its useful life.

An important consideration in any planning is the very large investment which has been put into local cable networks, and any progress in the service must, of necessity, include the use of these networks. They are in some ways an obstacle to further growth, in that they were laid down when the idea of a 100% 'on-demand' service was not thought necessary or economically feasible. On the other hand, the good bandwidth/noise characteristics of local links are not as yet realised to their full potential, and there is no doubt that further facilities could be provided to take up this potential.

It is noticeable that the evolution of our telecommunications system (and other people's too) is towards p.c.m. A major hitch in the smooth progress is synchronization overall. Obviously, delays in transmission of pulses will occur, and the longer the distance the greater the asynchrony. One must, therefore, expect that small-scale p.c.m. will be the first to be tried, and this is where the Post Office is advancing. Junction circuits between exchanges are in progress of conversion to p.c.m. at the rate of $\frac{1}{4}$ million channel miles per annum, said Merriman, all of them of the order of ten miles in length. A further stage is to be taken next year by setting up an experimental p.c.m.

tandem exchange, comparable with the junction p.c.m. circuits; if several such exchanges are connected in a star configuration, then servo-controlled delay circuits can take care of pulse synchronization. Densely populated areas may quite well be served by a network of star-connected complexes of this sort.

The pressure of all-digitization of the channels must be resisted to some extent until the long-distance multichannel digital lanes and their associated multiplexers (and methods of large-area synchronization) have been developed into economic units. Such influences towards an overall digital system may cause, said Merriman, the evolution of independent special-purpose networks before a complete system is working. This state of affairs might cause, and the thought of it is causing, concern.

The new chairman touched on one most interesting subject—total control of the total network. This really stems from the possibilities of local traffic overloads and the inevitability of the occurrence of faults. Both of these phenomena point to the provision of redundancy or slack in the system, i.e. alternative routing. The more complex a system, the less likely that human operators can cope unaided with overloads or breakdowns. The Post Office is therefore looking at traffic data collection with a view to its use for control and is setting up network co-ordination centres; these will be operated manually in the first instance.

We, as engineers, do not generally view the growth of intricate, almost sentient, organizations like computer-controlled integral telecommunications networks as anything but the logical results of engineering capability. Nevertheless, our Asimovian seventh sense tells us to beware lest the networks themselves originate messages of more import than the time of day.

Delay unit suitable for television-field delay

by D. Howorth, B.Sc.Tech., M.I.E.E., A.M.C.T., and J. G. Ingleton, BBC Research Department

This article describes the design and construction of a 2.5ms delay unit which has been developed as part of a field delay for television applications. A brief description of the ultrasonic delay line used is given, together with a detailed description of the input and output amplifiers and the ancillary circuits necessary to achieve an overall gain of unity and a delay stability of the order of $\pm 2ns$. The design of a suitable network for the equalization of the response/frequency characteristic of the delay line is also described.

(Voir page 798 pour le résumé en français: Zusammenfassung in deutscher Sprache auf Seite 799)

IN the past, ultrasonic delay lines with mercury or fused quartz as the transmission medium have been used to delay television signals by one or two television scanning-line periods^{1,2,3,4}. There are other applications in television engineering, however, which require signals to be delayed by periods of one or two television fields (i.e. by periods of 20ms and 40ms for 50-field systems, and by periods of 16 $\frac{2}{3}$ ms and 33 $\frac{1}{3}$ ms for 60-field systems). The technology of ultrasonic delay lines is not yet sufficiently advanced for single delay lines having delays of this order to be produced with a performance adequate for television purposes. The maximum delay which can be achieved in a single delay line with an adequate performance is approximately 3 to 4ms, and for this magnitude of delay the adequacy of the performance is, at the present time, marginal. One high-quality delay line which is available and which has a performance that permits the cascading of a number of units to form a field-period delay is the 2.5ms delay line type YL2104/09 developed by the Mullard Research Laboratories and manufactured by the M.E.L. Equipment Co. Ltd. This article describes the design and construction of a 2.5ms delay unit based on this delay line, and it was intended to use eight of these units in cascade to produce a 20ms delay suitable for television applications.

2.5ms fused quartz ultrasonic delay-line

The principles of design and operation of fused-quartz ultrasonic delay lines are well documented^{5,6,7}. The YL2104/09, which is shown in Fig. 1, is a double-deck line with a delay of 1.25ms provided by each deck; the ultrasonic signal is transferred from one deck to the other by means of a corner reflector. The transmission-path length for a delay of 1.25ms is in the region of 5m, and, in order to contain this in a fused quartz block of reasonable dimensions, a folded transmission path is used. The fused quartz block is ground into a 15-sided irregular polygon in which the signal is made to undergo 31 reflexions in each deck, as shown in Fig. 1. In order to obtain a good compromise between insertion loss and ultrasonic bandwidth, the delay line uses unbacked Y-cut quartz-crystal transducers which operate in the transverse mode and have a capacitance of approximately 200pF. Unwanted secondary responses of the delay line are kept to a minimum by the removal of sections of the fused-quartz block which are not traversed by the wanted signal but which might be traversed by the unwanted signals, and also by placing ultrasonic absorbing material on the edges of the block where necessary. Cross-talk between the two decks is avoided by cutting away as much material as

possible between them. The details of the performance required from the delay lines are given in Table 1 and the response/frequency characteristics of the eight delay lines intended to be used as a field delay, as measured at their specified operating temperature, are given in Fig. 2.

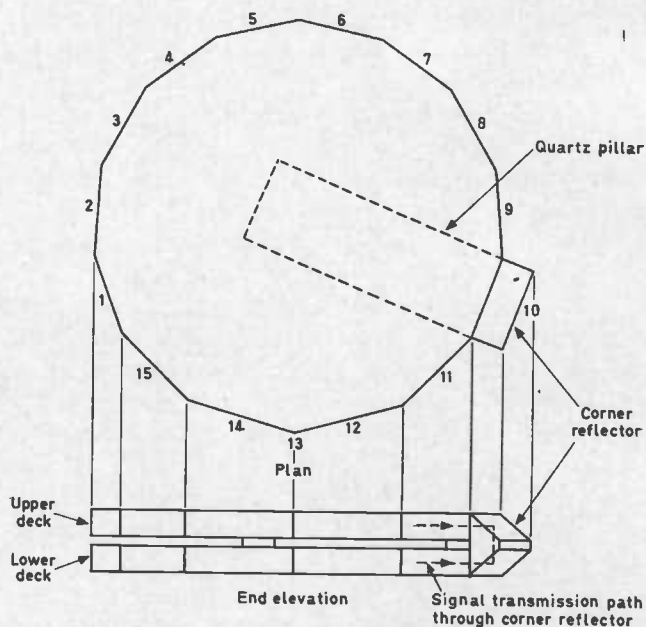
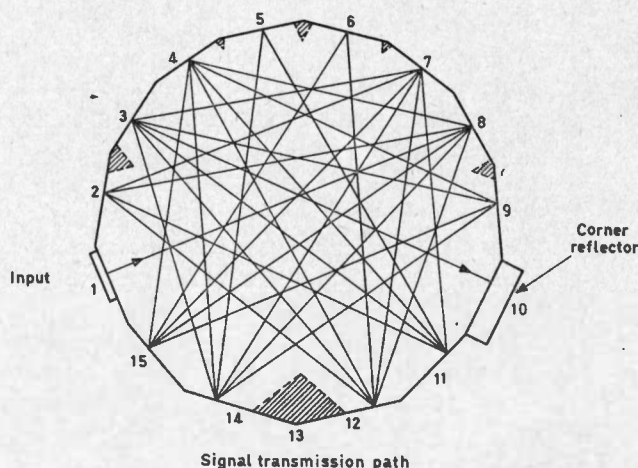

Fig. 1 Signal-transmission path and geometry of the 2.5ms delay line type-YL2104/09

Table 1 Specification of the 2.5ms delay line type-YL2104/09*

Delay	2485 μ s
Tolerance on delay	+0, -3.5 μ s
Band centre frequency	30MHz
Ultrasonic bandwidth†	10MHz between -6dB points
Secondary responses	<1% with respect to the wanted signal
Insertion loss at 30MHz	<40dB using 75 Ω terminations
Operating temperature	343°K
Temperature coefficient of delay	75 \times 10 ⁻⁶ /degK (approximately)
Transducer capacitance	200pF \pm 10%

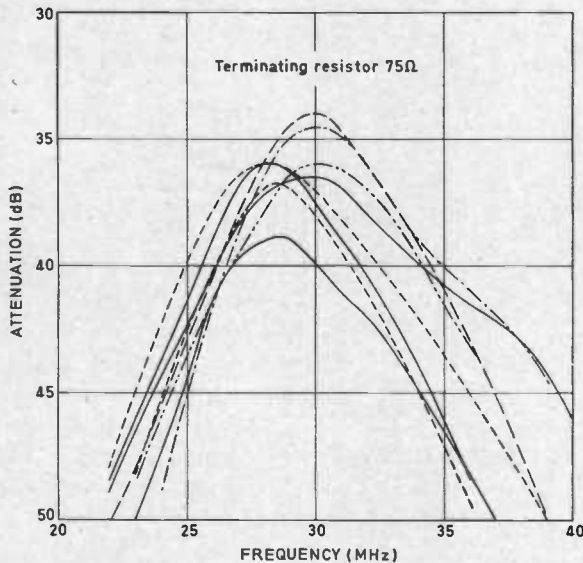

Fig. 2 Response/frequency characteristics of the eight 2.5ms delay lines

Design and construction of a 2.5ms delay unit

The component parts necessary for the construction of a 2.5ms delay unit using an ultrasonic delay line are shown in Fig. 3. The delay line is mounted in a thermally insulated container so that it may be conveniently maintained at its specified operating temperature, and a servocontrol system is provided to keep the operating temperature constant to within the required tolerance limits. The input and output amplifiers are necessary to compensate for the insertion loss of the delay line and the equalizing network is required to equalize the ultrasonic response/frequency characteristic over as wide a frequency range as possible. The design of the amplifiers and the equalizing network must be directed towards obtaining as large a signal as possible (consistent with adequate linearity) across the input transducer, so that the noise factor of the unit is as low as possible.

* These delay lines use a delay medium prepared from naturally occurring quartz; recent developments in the preparation of synthetic fused quartz have made possible the production of delay lines with performance characteristics better than those given.

† The ultrasonic bandwidth includes the effects of all bandwidth limitations in the transducers and fused-quartz transmission medium, but neglects limitations of bandwidth occurring in the electrical circuits associated with the delay line. Factors controlling the ultrasonic bandwidth include the mechanical resonance of the input and output transducers, the variation with frequency of the directivity of the transducers and the variation with frequency of the attenuation of the fused-quartz transmission medium.

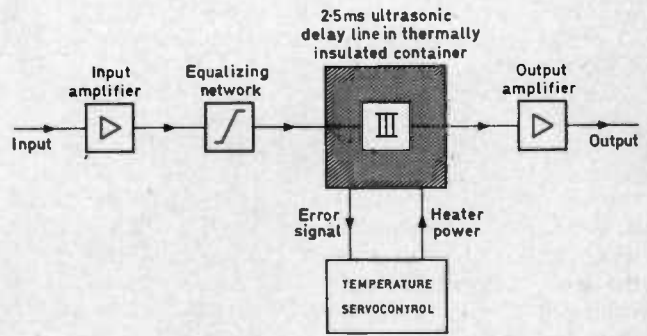

Fig. 3 Block diagram of the 2.5ms delay unit

TEMPERATURE CONTROL OF THE 2.5MS DELAY UNIT

The stability of the delay provided by each 2.5ms delay unit of the eight such units required to provide a field-period delay is approximately \pm 2ns and, in order to achieve this accuracy, the operating temperature must be maintained within \pm 0.01degK of the nominal value. The design of a constant-temperature enclosure with this degree of precision has been described previously⁸.

DESIGN OF THE EQUALIZING NETWORK

The network required to equalize the ultrasonic response/frequency characteristic of the delay line may be placed at any point in the circuit of the unit; but it has been found that the most convenient position is between the input amplifier and the delay line¹. The characteristics of the eight delays to be used in the field delay, which are shown in Fig. 2, are to some extent dissimilar. In order to avoid designing eight separate equalizers, it was decided to employ a common design based on the average charac-

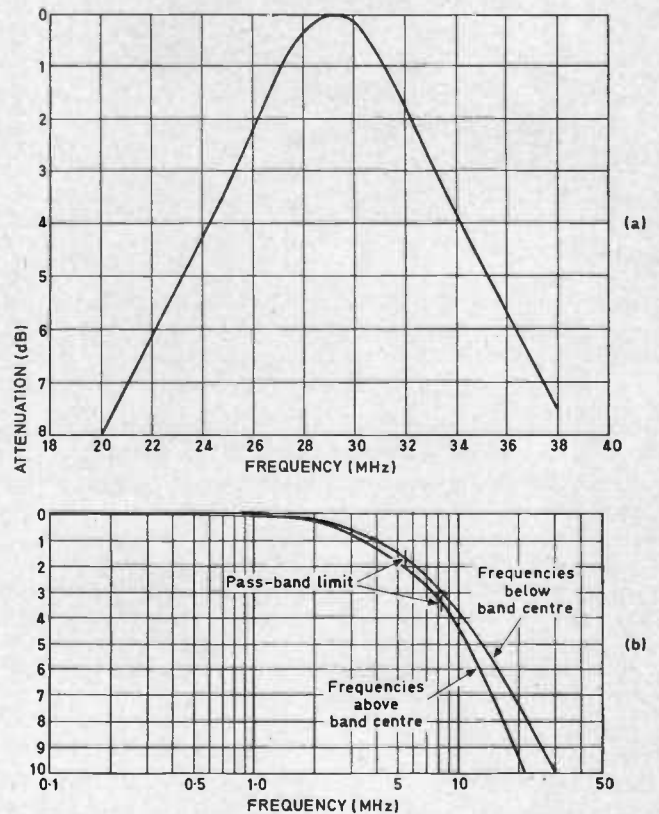

Fig. 4 Average response/frequency characteristic (a) of the eight lines and the equivalent low-pass characteristic (b)

teristic of the eight delay lines, shown in Fig. 4(a), and to adjust each equalizer individually to obtain the best overall response.

In order to calculate the equalizing network for the delay line, it is convenient to transform the bandpass characteristic shown in Fig. 4(a) into the equivalent low-pass characteristic shown in Fig. 4(b). An inspection of the average characteristic given in Fig. 4(a) shows that it is very similar to that of a pair of cascaded tuned circuits which have the same resonant frequency (29MHz) and the same bandwidth†. In this case, the expression for the equivalent low-pass characteristic $|A(f)|$ must be of the form

$$|A(f)| = \frac{1}{1 + (af/10)^2} \dots \dots \dots (1)$$

where f is the frequency in megahertz and the frequency at which the response of the equivalent low-pass characteristic has fallen by 6dB gives $a = 0.8$. The equalization of the low-pass characteristic may be investigated by multiplying equation (1) by a characteristic which has the same form as the modulus of the transfer function of a suitable equalizing network. The input impedance of the transducer is purely capacitive, and therefore the equalizing network must include this capacitance; Fig. 5 shows the circuit diagram of a low-pass network which will be shown

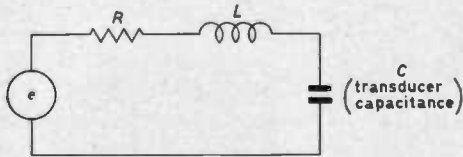

Fig. 5 Equivalent low-pass equalizing network

to be suitable for this purpose. The modulus of the transfer function of this network $|B(f)|$ is of the form

$$|B(f)| = \frac{1}{[1 - (b_1f/10)^2 + (b_2f/10)^4]^{\frac{1}{2}}} \dots \dots \dots (2)$$

The expression for the equalized response, $|E(f)|$, is therefore

$$|E(f)| = |A(f)| \times |B(f)| = \frac{1}{[1 + (2a^2 - b_1)(f/10)^2 + (a^4 - 2a^2b_1^2 + b_2^4)(f/10)^4 + (2a^2b_2^4 - a^4b_1^2)(f/10)^6 + a^4b_2^4(f/10)^8]^{\frac{1}{2}}} \dots \dots \dots (3)$$

In order to achieve a flat response/frequency characteristic in the required passband, investigation shows that equation (3) should have a characteristic which is a close approximation to the Chebyshev type given by

$$|C(f)| = \frac{1}{[1 + 18K(f/10)^2 - 48K(f/10)^4 + 32K(f/10)^6]^{\frac{1}{2}}} \dots \dots \dots (4)$$

where $2K$ is the peak-to-peak magnitude of the permissible ripple.

The coefficients of the denominator of the transfer function of the equalizing network given in expression (2) and the magnitudes of the ripples of the equalized characteristic may be determined by equating the first three coefficients of the denominator of the right-hand side of equation (3) with those of the denominator of the right-hand side of equation (4) and substituting a value of $a = 0.8$. The magnitude of the ripple can be shown to be approximately ± 0.1 dB, and the characteristic of the equalizing network to be

$$|B(f)| = \frac{1}{[1 - 1.118(f/10)^2 + 0.619(f/10)^4]^{\frac{1}{2}}} \dots \dots \dots (5)$$

By comparing equation (5) with the modulus of the transfer function of the circuit shown in Fig. 5, equations may be derived from which the circuit component values of the network can be obtained in terms of the transducer capacitance (200pF). The low-pass network so obtained can then be transformed into the bandpass network shown in Fig. 6. The attenuation/frequency characteristic for this network is given in Fig. 7, together with the average characteristic of the delay lines and the average equalized characteristic. It can be seen that the latter characteristic is substantially flat over a bandwidth of 8MHz; however, because the characteristics of the delay lines are somewhat dissimilar, the equalized characteristics of the units as obtained in practice will differ slightly from that shown.

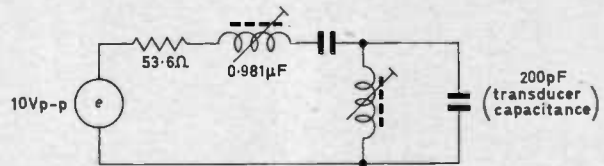

Fig. 6 Bandpass equalizing network

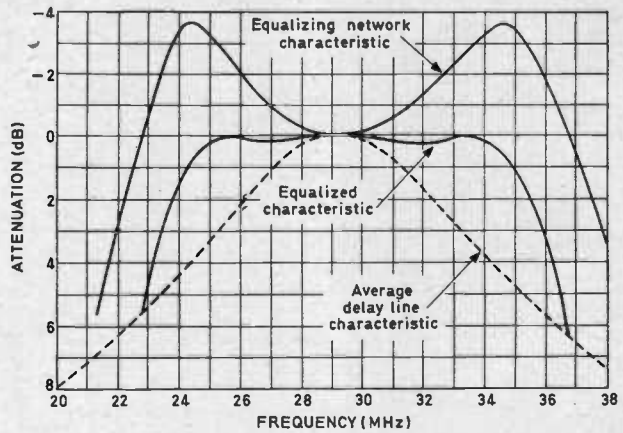

Fig. 7 Response/frequency characteristics of the equalizing network and the equalized response

In order to place the equalizing network as close as possible to the input transducer, the reactive components are assembled on a printed-circuit board which is mounted in a screened compartment in the aluminium casting alongside the transducer*. The input amplifier is designed to have an output impedance which provides the correct resistive component of the network.

INPUT AMPLIFIER

The input amplifier has a gain of 20dB in order to raise the level of the input signal from 1V p-p to 10V p-p. Because a transistor amplifier has an output impedance high compared with that required by the equalizing network, it is convenient to modify the equalizing network so as to be suitable for use with a constant-current source. The circuit of the modified equalizing network is shown in Fig. 8, and it can be seen that the amplitude of the current required is approximately 200mA p-p. A circuit diagram of the complete amplifier (and equalizing network) is given in Fig. 9.

The input signal is passed through a 75Ω attenuating

† This was first pointed out by C. F. Brockelsby, formerly of Mullard Research Laboratories, who had also calculated a similar equalizing network independently.

* These networks were in fact constructed and prealigned to equalize the characteristic given in Fig. 7.

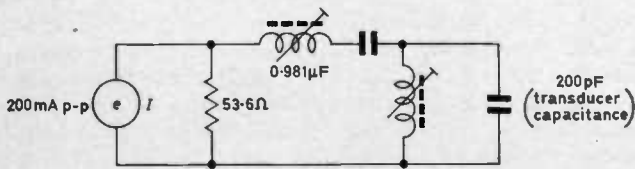

Fig. 8 Bandpass equalizing network modified to suit a constant-current source

network, which is used to adjust the overall gain of the delay unit to be exactly unity. The attenuator is terminated by the 300Ω resistor R_2 across the secondary of the transformer T_1 which has a turns ratio of 1:2. The first stage

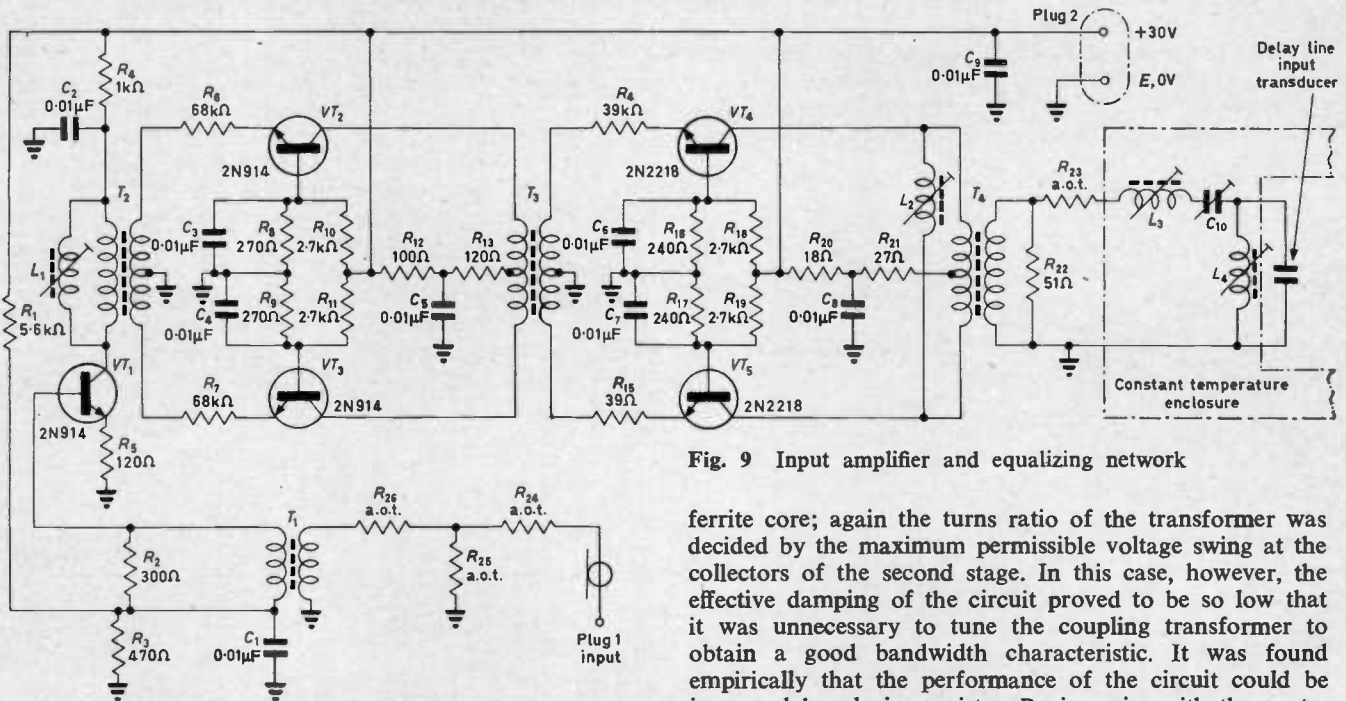

Fig. 9 Input amplifier and equalizing network

of the amplifier VT_1 uses a grounded-emitter configuration in which some current feedback is provided by means of a resistor R_5 in the emitter circuit. The coupling circuit between the collector of the first stage and the input of the push-pull second stage VT_2 and VT_3 is, in effect, a tightly coupled tuned transformer with a centre-tapped secondary; in practice, the construction of such a transformer, with an accurately balanced secondary and the minimum of effective stray capacitance between the windings, is quite critical, and for this reason a transformer T_2 , wound on a small ferrite core, is used together with a tuning inductor L_1 across its primary† The turns ratio of the coupling transformer was determined by the maximum voltage-swing at the collector of the first stage obtainable without significant nonlinear distortion. This method of design was found to give a more than adequate bandwidth in this particular case. The transistors in the push-pull second stage are used in the grounded-base configuration. When driven from a high impedance source as compared with the input resistance of the transistor, the linearity of this type of circuit is excellent; in practice, because the input resistance of each transistor is very low (10 to 20Ω), small resistors are placed in series with the emitters, to make the circuit less dependent on the transistor parameters.

† This technique has the additional advantage of making the amplifier more flexible with regard to changing the gain, centre frequency or bandwidth for use with other delay lines.

2.5ms delay unit suitable for television-field delay —?

The reactive component of the input impedance of the grounded-base amplifier used is inductive and therefore does not narrow the bandwidth of the amplifier. The internal feedback of the transistor is less troublesome than with a grounded-emitter stage which eases the practical construction and alignment of the amplifier. The output current of each transistor differs from the input current only by the current which flows through the base connection; therefore the voltage gain of the amplifier is principally decided by the coupling-transformer ratios.

The output of the second stage is coupled to the input of the push-pull final stage VT_4 and VT_5 by means of another tightly coupled transformer VT_3 wound on a

ferrite core; again the turns ratio of the transformer was decided by the maximum permissible voltage swing at the collectors of the second stage. In this case, however, the effective damping of the circuit proved to be so low that it was unnecessary to tune the coupling transformer to obtain a good bandwidth characteristic. It was found empirically that the performance of the circuit could be improved by placing resistor R_{13} in series with the centre tap of the primary winding of the coupling transformer. This, in effect, reduced the signal current flowing in the centre tap because of unbalance, and caused the electrical centre tap to be different from the physical centre tap so far as the signal was concerned.

The principles of design of the final stage VT_4 and VT_5 follow closely those of the second stage, but use transistors capable of a greater dissipation. The output transformer T_4 is again a transformer wound on a ferrite core, but has an unbalanced secondary winding; in this case a tuning inductor L_4 across the primary was found to be necessary. The terminating resistance R_{22} of the amplifier was made a little less than that required for the equalizing network; so that a small series resistor R_{23} could be included to make small adjustments to the circuit.

The amplifier was constructed on a printed-circuit board which was carefully designed to keep the signal paths as short as possible and to preserve the symmetry of the circuit. All the transistors except VT_1 were fitted with appropriate heat sinks and in the case of the output transistors, where the heat sinks were mounted on the printed circuit, the copper was etched from beneath them so as to preserve the low stray capacity of that stage. It has been found, so far, that, with the types of transistor used in the push-pull stages, it is not necessary to select matched pairs. In the design of the amplifier, it was thought that the fact that the output transformer was tuned would not have an appreciable effect on the performance of the

equalizing network because of its relatively low impedance. In practice, it was found that adjusting the tuning of the output transformer had some effect, in that, over a small range of adjustment, it modified symmetrically the degree of peaking in the equalizer response; it could therefore be used as a fine adjustment of the degree of equalization.

OUTPUT AMPLIFIER

The output signal obtained from an ultrasonic delay line with quartz crystal transducers may be regarded as a constant current from a high-impedance source with a capacitance equal to the transducer capacitance across the output terminals. The insertion loss of the delay line is defined as the ratio of the voltage which this current would develop across a specified terminating impedance to the voltage applied across the input transducer; for the 2.5ms delay line in question, therefore, the output current for a 10V p-p input signal would be approximately 1.33mA p-p.

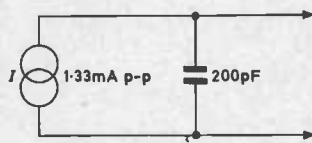

Fig. 10 Equivalent circuit of the delay-line output

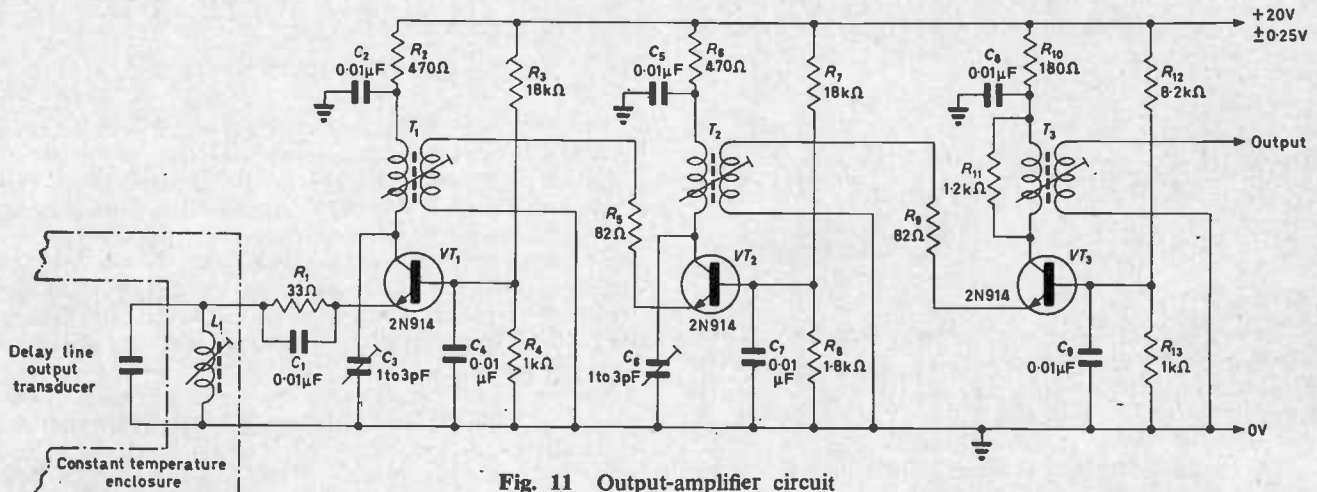

Fig. 11 Output-amplifier circuit

Thus the equivalent circuit of the output of the delay can be represented as shown in Fig. 10. With a current of the order of 1mA p-p, a good signal/noise ratio can easily be obtained, provided that all the current is used effectively. As the output is of interest only over a certain band of frequencies, the transducer capacitance can be tuned by means of a shunt inductor, and an optimum value of shunt resistance chosen to damp the circuit. If the input resistance of the amplifier were lower than the optimum, a useful current gain could be obtained by means of the transformer; in this case, however, the input resistance of a transistor in the grounded-base configuration has approximately the optimum value.

The circuit diagram of the output amplifier is shown in Fig. 11; it consists of three grounded-base stages in cascade which are connected by tightly coupled tuned transformers. The transformers in the collector circuits of the first and second stages VT_1 and VT_2 comprise a stagger-tuned pair. The primary inductances of the transformers are designed to resonate at the stagger-tuning

frequencies and the turns ratios of the transformers are chosen to transform the input resistance of the following stage to the required damping resistance across the tuned circuit; in the design of this type of amplifier, some allowance must be made for the internal feedback of the transistor. The output stage of the amplifier VT_3 is designed to provide a 75Ω output impedance over the whole of the passband. The output obtained from the amplifier for a 1mA p-p input is 1V p-p across 75Ω . The amplifier was constructed on a printed-circuit board carefully designed to keep the signal paths as short as possible and small adjustable capacitors C_3 and C_6 were provided across the collector circuits of VT_1 and VT_3 , in order to compensate for variations in transistor capacitance.

Performance

Because the delay units are intended to be used together as a field delay, precise measurements on individual units have not been made. Measurements have been made of the delay stability and these show that the heating and servocontrol systems are satisfactory. Test measurements have shown that the insertion losses of the delay lines have a spread of 5dB, each unit should therefore have an overall gain lying between 0dB and +5dB; as mentioned, the gain of the input amplifiers can be adjusted to make the overall gain equal to unity. Tests carried out on the feasibility of producing satisfactory overall response/frequency

characteristics using the equalizing networks have shown the latter to be adequate. The measured signal/noise ratio of the prototype unit is greater than 60dB. Experiments have been carried out in which television pictures and waveforms have been recirculated through one unit eight times, thus providing a 20ms delay; the results indicate that the performance of a unit is satisfactory for use as part of a television field delay.

References

- 1 Vertical aperture correction using continuously variable ultrasonic delay lines. BBC Engineering Monograph, 47 (1963)
- 2 A review of television standards conversion. BBC Engineering Monograph, 55 (1964).
- 3 MESSERSCHMID, U.: The generation of contour pictures in television by re-shaping the video signal. *Rundfunktech. Mitt.*, 7, 160-171 (1963)
- 4 BROCKELSBY, C. F., and PALFREMAN, J. S.: Ultrasonic delay lines and their application to television. *Philips Tech. Rev.*, 25, 234-252 (1964)
- 5 ARENBERG, D. L.: Ultrasonic delay lines. *J. Acoust. Soc. America*, 20, 1-26 (1948)
- 6 HAMMOND, V. J.: Quartz delay lines . . . the state of the art. *British Commun. Electronics*, 9, 104-110 (1962)
- 7 BROCKELSBY, C. F., PALFREMAN, J. S., and GIBSON, R. W.: Ultrasonic delay lines. Iliffe (1963)
- 8 Precision temperature-controlled environments for ultrasonic fused-quartz delay lines. *Electronic Engng.* 39, 706-710 (1967)

Fast transistorized pulse amplifiers

by D. Ivekovic, Institute 'Ruder Boskovic', Zagreb, Yugoslavia

In this article, the properties of several transistorized pulse-amplifier-stage configurations connected in cascade are compared. The stages considered are (a) a common-emitter transistor with inductive compensation in the collector circuit, (b) a common-emitter transistor with RC base compensation, inductive collector compensation and an emitter follower as an interstage, and (c) a cascode with both collector and base compensation and with an emitter follower as an interstage. The cascade is supposed to be of identical stages, each having a critically damped response to a step function. The optimum gain for each stage is found; the cascode stage is shown to have the highest optimum gain and a cascade consisting of cascode stages has the shortest risetime for a given gain. According to the results obtained, a 2-cascode-stage amplifier using 2N976 transistors is constructed having a gain of 12 and a risetime of 1.5ns.

(Voir page 798 pour le résumé en français: Zusammenfassung in deutscher Sprache auf Seite 799)

In pulse-amplifier design, there is often a demand for the shortest risetime for a given gain or for the highest gain for a given risetime. To meet such requirements, the relationship between the risetime and the gain of the stages which comprise the cascade has to be known. The relation between an n -stage cascaded-amplifier gain A_K and the gain of each stage is

$$A_K = A_1 A_2 A_3 \dots A_n \dots \dots \dots (1)$$

The cascade risetime T_K in terms of stage risetimes is

$$T_K = \sqrt{T_1^2 + T_2^2 + T_3^2 + \dots + T_n^2} \dots \dots (2)$$

if none of the stage responses to a step function has an overshoot.

The definition of risetime given by Elmore¹ will be used in this article; this is expressed in terms of the circuit parameters by the gain transfer-function pole and zero locations. For an amplifier of a monotonic response, the poles p_1 and zeros z_m being real, the risetime is of the form

$$T_K^2/2\pi = \sum_{l=1}^L 1/p_l^2 - \sum_{m=1}^M 1/z_m^2 \dots \dots \dots (3)$$

In valve amplifiers, the gain/risetime ratio of a stage is a gain-independent constant defining the valve figure of merit. This allows the optimum integral synthesis of the cascade-gain transfer function. In transistorized amplifiers, the ratio A_1/T_1 is a gain-dependent function and an integral gain-transfer-function calculation is rather complex². In the article, cascaded amplifiers of identical stages will be considered. The cascade gain A_K is a function of the single-stage gain A^0 :

$$A_K = A_0^n \dots \dots \dots (4)$$

and the cascade risetime T_K is a function of the single-stage risetime T^0 :

$$T_K = T_0 \sqrt{n} \dots \dots \dots (5)$$

Cascades of various critically damped circuit configurations will be considered. The circuit giving the shortest cascade risetime for a given cascade gain will be determined. Practical results measured for an amplifier realized

using 2N976 transistors, often used in fast pulse amplifiers, will be compared with the given analysis.

Common-emitter stage with inductive compensation in the collector circuit

A common-emitter stage with inductive compensation in the collector circuit connected in a cascade is shown in Fig. 1(a) and its equivalent circuit in Fig. 1(b). The voltage-gain transfer function is of the form

$$A(p) = A_0 \frac{b_1 p + 1}{a_2 p^2 + a_1 p + 1} \dots \dots \dots (6)$$

where $A_0 = A(0)$ is the low-frequency gain

$$A_0 = \frac{\beta_0 R_L}{R_L + r_b + R} \dots \dots \dots (7)$$

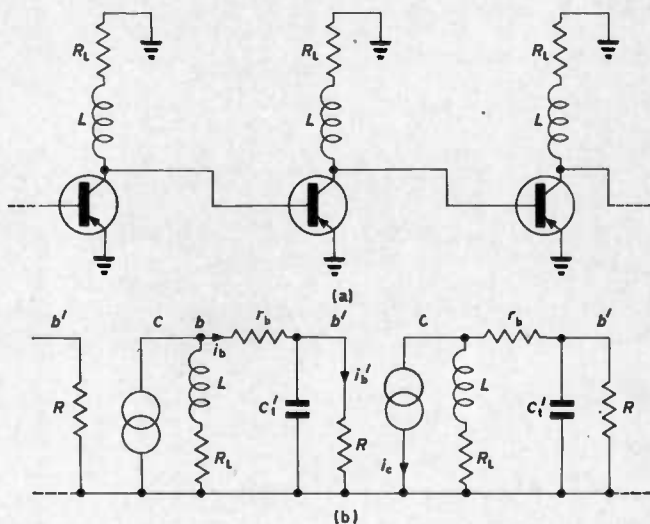

Fig. 1 (a) Common-emitter transistor stage with inductive compensation in the collector circuit connected in a cascade. (b) Equivalent circuit

β_0 is the low-frequency common-emitter current gain, r_b is the base-spreading resistance, R is the emitter resistance r_e multiplied by β_0 , and C_t' is the input capacitance contributed by the diffusion capacitance $C_t = 1/r_{e\omega_t}$ and the Miller-effect capacitance:

$$C_t' = C_t + C_o (R_L/r_e) \dots \dots \dots (8)$$

$\omega_t = 2\pi f_t$ is the common-emitter current-gain bandwidth product and C_o is the collector-base capacitance.

When the transfer function is of the form in equation (6), the Elmore risetime, expressed in terms of the transfer-function coefficients, is

$$T_0^3/2\pi = a_1^3 - b_1^3 - 2a_2 \dots \dots \dots (9)$$

the coefficients for this stage configuration being

$$b_1 = L/R_L \dots \dots \dots (10a)$$

$$a_2 = \frac{RC_t' L}{R_L + r_b + R} \dots \dots \dots (10b)$$

$$a_1 = \frac{Rr_b C_t' (R_L/r_b + 1) + L}{R_L + r_b + R} \dots \dots \dots (10c)$$

For the case when the inductive compensation is not applied, $L = 0$ and the normalized risetime as a function of gain has the form

$$T = \frac{T_0 \omega_t}{\sqrt{2\pi}} = (1 + A_0 r_e / \beta_0 r_b) \left(\frac{\beta_0 r_b}{r_b + \beta_0 r_e} + A_0 r_b C_o \omega_t \right) \dots \dots \dots (11)$$

With inductive compensation in the collector circuit, the stage response to a step function is critically damped if one of the following conditions is fulfilled:

- (i) the pole is real and second-order and closer to the origin of the complex frequency plane than the zero
- (ii) the poles are real and different, the closer of them being cancelled by the zero³.

In valve amplifiers, the second-order pole of the stage with inductive compensation in the anode circuit is always closer to the origin of the complex frequency plane than the zero. In the transistor circuit considered, however, this is not the case until the inequality

$$A_0 \geq \frac{\beta_0 r_e}{2r_b + \beta_0 r_e} \dots \dots \dots (12)$$

which is derived from equations (6), (7) and (10) according to condition (i), is fulfilled. The second-order pole will exist if inductance L is

$$L = L_{1(\text{crit})} = \frac{RC_t' (r_b + R_L)^2}{4(R_L + r_b + R)} \dots \dots \dots (13)$$

The magnitude of the pole is

$$p_{1,2} = -2 \frac{r_b + R_L + R}{C_t' R (r_b + R_L)} \dots \dots \dots (14)$$

and the zero

$$z_1 = -(R_L/L) \dots \dots \dots (15)$$

The normalized risetime T_L of such an inductively compensated stage is shorter than the risetime T of an uncompensated one:

$$T_L = T/y \dots \dots \dots (16)$$

the risetime reduction factor y here being

$$y = y_1 = \frac{4}{\sqrt{[8 - (1 + r_b/R_L)^2]}} \dots \dots \dots (17)$$

If the gain A_0 is less than the value defined by equation (12), the second-order pole will not ensure a critically damped response, since the zero is closer to the origin of the complex frequency plane than the pole. Therefore the zero must be cancelled by the closer pole; i.e. the induct-

ance must be

$$L = L_{2(\text{crit})} = \frac{RC_t' R_L (r_b + R_L)}{R_L + r_b + R} \left(1 - \frac{R_L}{r_b + R_L} \right) \dots \dots (18)$$

For this, the risetime reduction factor is

$$y = y_2 = (1/2) (r_b/R_L + 1) (R_L/r_b + 1) \times \left\{ 1 + \sqrt{1 - \frac{4}{(r_b/R_L + 1) (R_L/r_b + 1)}} \right\} \dots \dots \dots (19)$$

The function $y = y(r_b/R_L)$ is shown in Fig. 2. When R_L approaches infinity, y approaches 1.51, this being the gain-invariant risetime reduction factor for the equivalent valve circuit.

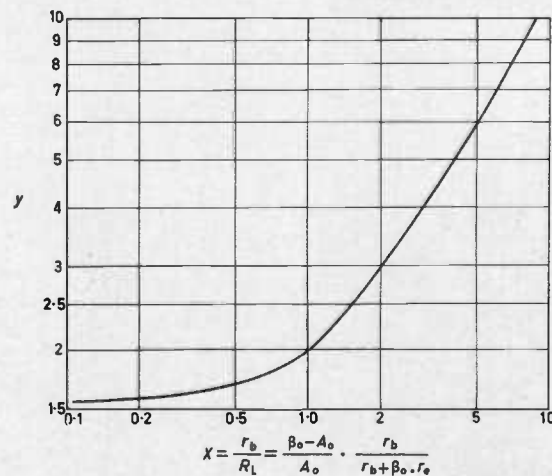

Fig. 2 Risetime reduction factor y as a function of the base-spreading-resistance/collector-load-resistance ratio $y = y(r_b/R_L)$ for the common-emitter inductively compensated collector circuit

Common-emitter stage with collector- and base-circuit compensation and with an emitter follower as an interstage

A common-emitter stage with inductive compensation in the collector circuit and RC compensation in the base circuit connected in cascade, with an emitter follower as an interstage, is shown in Fig. 3(a) and the equivalent circuit in Fig. 3(b). The stage time constant is defined by two partial time constants, these being the base-circuit time constant τ_1 and the collector-circuit time constant τ_2 . Consideration will first be given to τ_1 .

The base-compensating network consists of a parallel combination of a resistor R_B and a capacitor C_B . The base-compensating-network time constant $R_B C_B$ is adjusted so that the base-circuit current response is critically damped; i.e.

$$R_B C_B = \beta_0 r_e C_t' \dots \dots \dots (20)$$

where C_t' is defined by equation (8).

When condition (20) is fulfilled, the common-emitter transistor input impedance consists of a parallel combination of R'' and C_t'' connected in series with r_b ; R'' and C_t'' are given by

$$R'' = \beta_0 r_e + R_B = Q \beta_0 r_e \dots \dots \dots (21)$$

$$\text{and } C_t'' = \frac{C_B C_t'}{C_B + C_t'} = \frac{1}{Q r_{e\omega_t}} (1 + Q A_0 r_e C_o \omega_t) \dots \dots (22)$$

The stage gain is

$$A_0 \approx \frac{R_L}{Q r_e} \dots \dots \dots (23)$$

the emitter-follower output impedance is

$$Z_0 \approx r_e + \frac{r_b + R_L}{\beta_0}$$

and the time constant τ_1 is

$$\tau_1 \approx 1/\omega_t (r_b/r_e + Q A_0/\beta_0 + 1) (1 + Q A_0 r_e C_0 \omega_t) \dots (24)$$

The emitter-follower contribution to the risetime will be assumed to be due to a capacitance connected between the collector of the common-emitter transistor and the ground⁴.

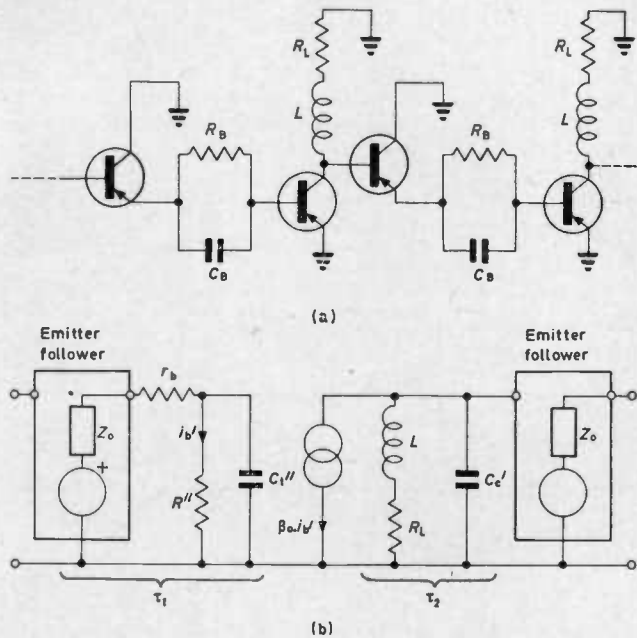

Fig. 3 (a) Common-emitter stage with inductive collector and RC base compensation and with an emitter follower as an interstage when connected in a cascade. (b) Equivalent circuit

The capacitance C_c' in Fig. 3(b) consists of the collector-base capacitance of the common-emitter transistor, the emitter follower and the emitter-follower diffusion capacitance:

$$C_c' = 2C_0 + \frac{1}{Q\beta_0 r_e \omega_t} \dots (25)$$

So the collector-circuit time constant is

$$\tau_2 \approx r_b C_0 [1 + Q A_0 (r_e/r_b)] \left(2 + \frac{1}{Q\beta_0 r_e C_0 \omega_t} \right) \dots (26)$$

As the emitter-follower input capacitances have been extracted, the emitter follower will cause a pole in the stage-gain transfer function of approximately $p \approx -\omega_t$.

The complete stage risetime will be calculated under the following assumptions:

- (i) the base-circuit compensation is adjusted to ensure a critically damped current response in the base circuit, as already mentioned;
- (ii) the collector-circuit inductive compensation is adjusted to ensure a critically damped voltage response for the whole stage, meaning that the response of the collector circuit itself has a certain overshoot.

In the literature, there are diagrams meeting the requirements necessary for the realization of the second assumption⁵.

The complete stage risetime is

$$T_B^2/2\pi = \tau_1^2 + (\tau_2/y)^2 + 1/\omega_t^2 \dots (27)$$

where y' is the collector-circuit risetime reduction factor due to the inductive compensation. According to the configuration of the collector RLC network, y' depends only on the magnitude of the $L/R_L^2 C_c'$ ratio. This dependence is well known from the valve-amplifier technique.

Cascode stage with collector and base compensation and with an emitter follower as an interstage

Cascode connection of identical cascode stages with collector and base compensation, using emitter followers as interstages, is shown in Fig. 4(a), with its equivalent circuit in Fig. 4(b). The criteria for the stage design are the same as formulated the previous section; namely: a critically damped base-circuit current response and a critically damped voltage response of the whole stage, causing a certain overshoot in the voltage response of the collector circuit itself. The values of $R_1'' A_0$, C_c' and τ_2 for this circuit are determined by the relations (21), (23), (25) and (26), respectively.

The input capacitance C_1'' of the cascode circuit will be less than that in the stage circuit previously discussed, owing to the diminished Miller effect:

$$C_1'' = \frac{1}{Q r_e \omega_t} (1 + r_e C_0 \omega_t) \dots (28)$$

and the input time constant is therefore

$$\tau_1 \approx 1/\omega_t (r_b/r_e + Q A_0/\beta_0 + 1) (1 + r_e C_0 \omega_t) \dots (29)$$

Since the common-base transistor output capacitance has been extracted and calculated in C_c' , the common-base transistor itself will cause a pole in the complete-stage transfer function of $p \approx -\omega_t$. The stage risetime is

$$T_B^2/2\pi = \tau_1^2 + (\tau_2/y)^2 + 2/\omega_t^2 \dots (30)$$

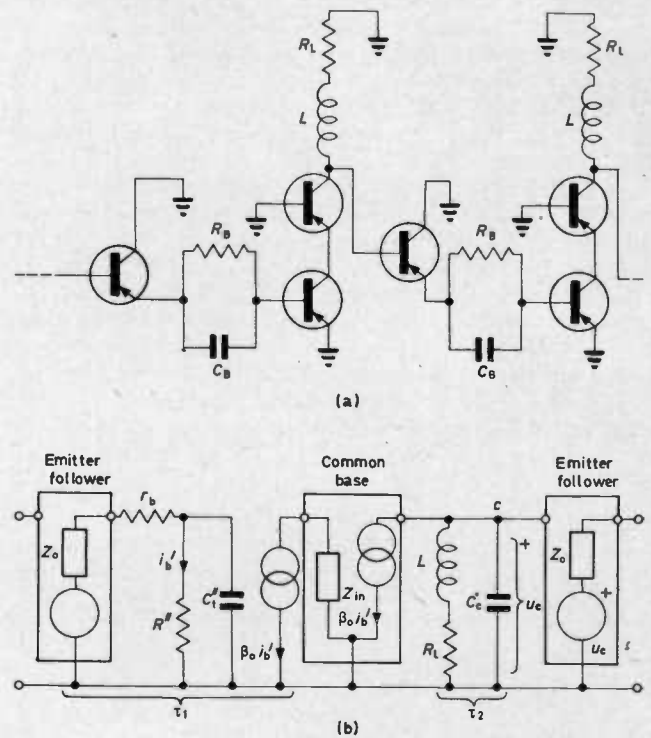

Fig. 4 (a) Cascode circuit with both collector and base compensation and with an emitter follower as an interstage when connected in a cascade. (b) Equivalent circuit

Comparison of cascaded amplifiers

In this section, the properties of the three described stage configurations are compared. Numerical calculations are made for when 2N976 transistors are applied. The d.c. working point is chosen to ensure maximum cutoff frequency $f_t = \omega_t/2\pi$ and a collector-base capacitance C_0 as small as possible. This is accomplished by choosing a high-voltage medium-current working point, the voltage

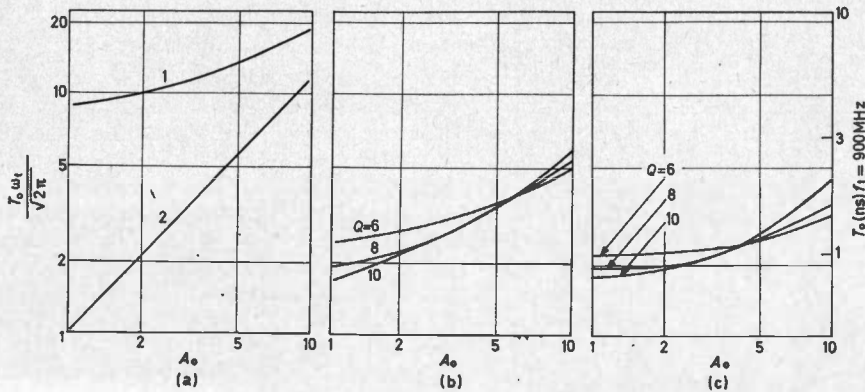

Fig. 5 Diagrams showing the normalized stage risetime $T = T_0 \omega_t / \sqrt{2\pi}$ and the actual stage risetime T_0 for when $f_t = \omega_t / 2\pi = 900\text{MHz}$ as a function of stage gain A_0 calculated for 2N976 transistors

- (a) for a common-emitter stage with both collector and base compensation and with an emitter follower
 - (b) for a cascode stage with both collector and emitter compensation and with an emitter follower
 - (c) for a cascode stage with collector and base compensation and with an emitter follower
- (Q is the base RC compensation coefficient $Q = 1 + R_B / \beta_0 r_0$)

and current being limited by the maximum dissipation. At a collector voltage of 5V and a collector current of 10mA, the 2N976 transistor parameters are $\beta_0 = 110$, $f_t = 900\text{MHz}$, $C_0 = 1.5\text{pF}$ and $r_0 = 25\Omega$.

In Figs. 5(a), (b) and (c), the normalized stage risetime $T = T_0 \omega_t / \sqrt{2\pi}$ depending on the stage gain A_0 is shown. The actual risetime in nanoseconds for when $f_t = 900\text{MHz}$ can be found as well. At higher gains, the base-compensated circuits exhibit an increase in risetime as the base-compensation coefficient Q increases; because, at higher gains, the collector time constant, which increases with Q , is a dominant component in the stage time constant. At lower gains, the base time constant is dominant, and increasing Q decreases the risetime by decreasing the base time constant [Figs. 5(b) and (c)]. The advantage of the cascode stage is apparent at higher gains, owing to the elimination of the Miller effect. At a gain of less than 2, a single-transistor common-emitter stage has the shortest risetime, because the Miller effect is small and there are no additional transistor time constants.

It is of interest to find

- (a) the stage circuit having the highest optimum $A_{0(\text{opt})}$, i.e. the gain ensuring the shortest cascade risetime, and
- (b) the circuit which ensures the shortest cascade risetimes T_K for a given cascade gain A_K .

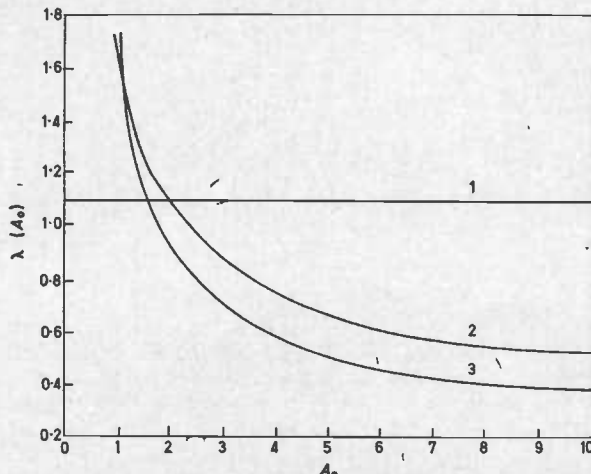

Fig. 6 Stage-risetime/stage-gain ratio as the function of the stage gain A_0 for

- (1) common-emitter stage with an inductive collector compensation
- (2) common-emitter stage with both collector and base compensation and with an emitter follower
- (3) cascode stage with collector and base compensation and with an emitter follower

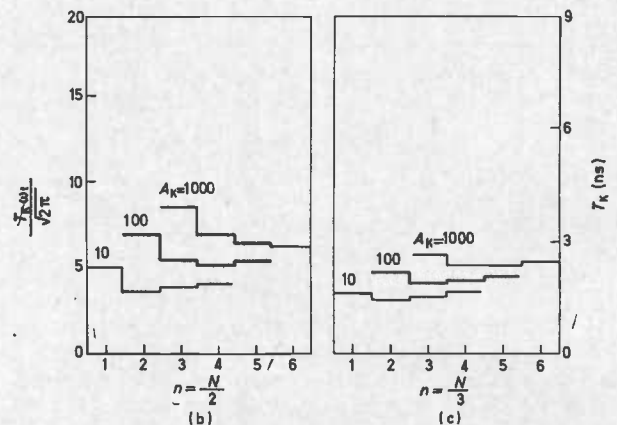
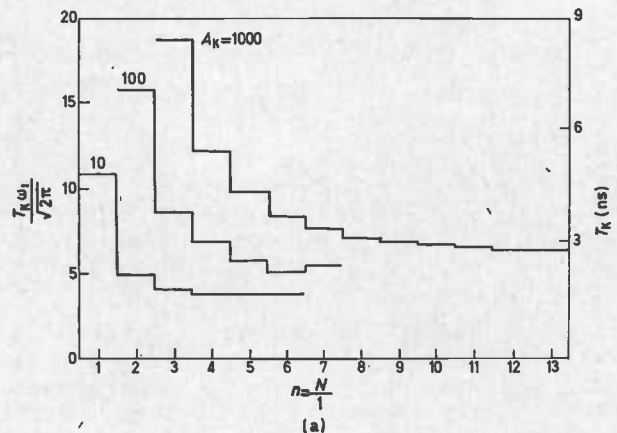

Fig. 7 Normalized n -stage cascade risetime $T_K \omega_t / \sqrt{2\pi}$ as a function of the number of stages n and for several values of cascade gain A_K , for

- (a) common-emitter, inductively compensated collector stage
 - (b) common-emitter stage with both collector and base compensations and with an emitter follower
 - (c) cascode stage with both collector and base compensation and with an emitter follower
- (N is the number of transistors per cascade)

The normalized stage risetime T will be assumed as the produce of the stage gain A_0 and a gain-dependant factor:

$$T = \frac{T_0 \omega_t}{\sqrt{2\pi}} = A_0 \lambda(A_0) \dots \dots \dots (31)$$

Since all stages are identical, from equations (4), (5) and (31), the normalized cascade risetime follows:

$$T_{K(\text{norm})} = \frac{T_K \omega_t}{\sqrt{2\pi}} = A_0 \lambda(A_0) \sqrt{\frac{\ln A_K}{\ln A_0}} \dots \dots \dots (32)$$

Fig. 8 Very-fast-response amplifier constructed according to the given analysis; the amplifier gain is $A = 12$ and the risetime $T \approx 1.5$ ns

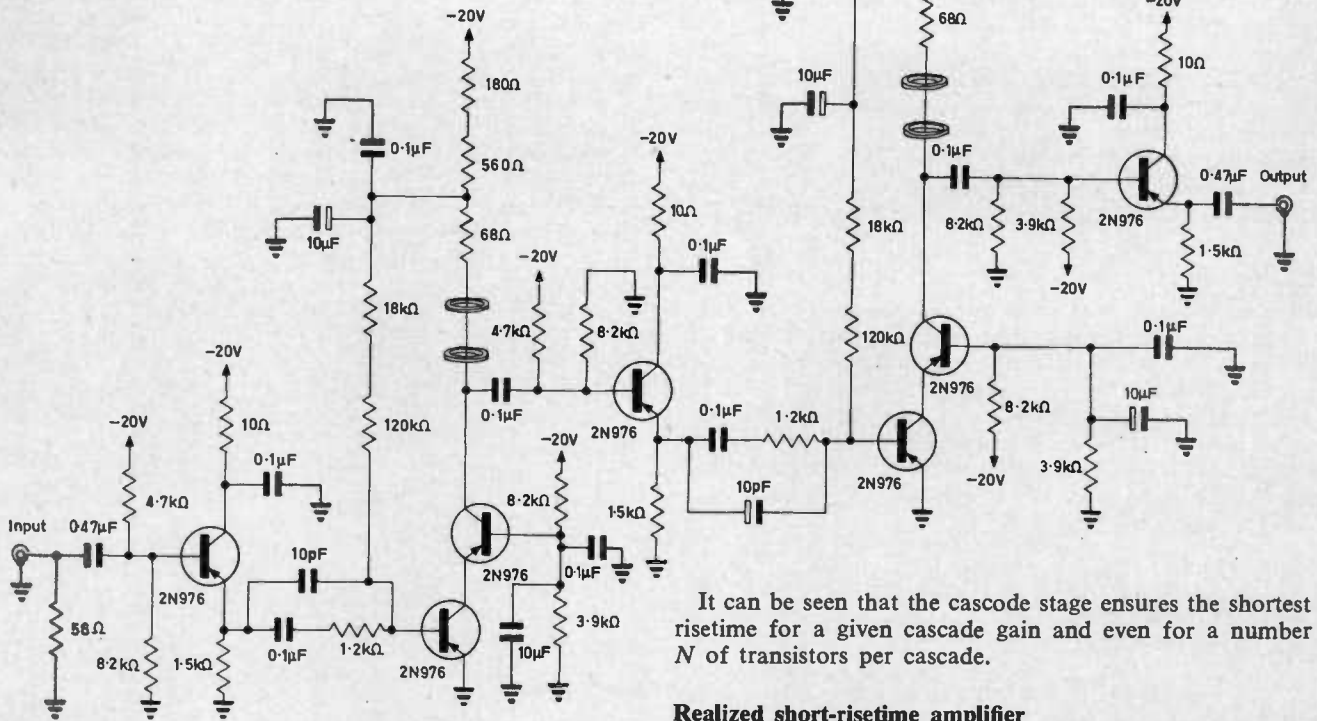

It can be seen that the cascode stage ensures the shortest risetime for a given cascade gain and even for a number N of transistors per cascade.

Realized short-risetime amplifier

Based on the above considerations, a very fast-response amplifier using 2N976 transistors has been constructed; the circuit is given in Fig. 8. The amplifier consists of two identical stages, each consisting of a cascode circuit with inductive compensation in the collector circuit, RC compensation in the base circuit, and an emitter follower as an interstage. There is another emitter follower between the input and the first stage to make the amplifiers insensitive to the generator output impedance. In both stages the d.c. stabilization is accomplished by a negative feedback from the collector to the base. The amplifier gain is $A_K = 12$ and the stage gain is $A_0 = \sqrt{12}$. In Fig. 5(c), the optimum value of Q is about 8. The cascode d.c. working point is determined by the collector voltage $V_0 = 6V$ and the collector current $I_0 = 10mA$ in both transistors. The base current is $I_b = 0.09mA$; the emitter resistance is $27/I_0 = 2.7\Omega$; the collector load resistance R_L is determined by equation (23) and is, for this case, 68Ω . The base resistance R_B is determined by equation (21): $R_B = \beta_0 r_0 (Q - 1) = 110 \times 2.7 (7.5 - 1) \approx 1.8k\Omega$.

Since the Miller effect is practically negligible, the lower transistor input capacitance is approximately $C'_i \approx 1/r_{e\omega}$. According to equation (20), the base-compensating capa-

To find the A_0 ensuring the shortest $T_{K(norm)}$, put $dT_{K(norm)}/dA_0 = 0$, and obtain the differential equation

$$\lambda(A_0) + A_0 \frac{d\lambda(A_0)}{dA_0} - \frac{\lambda(A_0)}{2 \ln A_0} = 0 \dots\dots (33)$$

In Fig. 6, the function $\lambda(A_0)$ is shown for the circuits considered.

For the single-transistor common-emitter stage [curve (1)], $\lambda(A_0)$ is a constant, and equation (33) has a solution known from valve-amplifier design; i.e. $A_0 = \sqrt{e} = 1.65 = A_{0(opt)}$.

For the two base-compensated circuits considered [curves (2) and (3)], the function $\lambda(A_0)$ can be given the form

$$\lambda(A_0) = a/A_0 + b$$

a and b being constants. For this case, equation (33) has the solution

$$A_{0(opt)} = \frac{a}{b(2 \ln A_{0(opt)} - 1)} \dots\dots (34)$$

Since, for the cascode [curve (3)] the coefficients are $a \approx 1.5$ and $b \approx 0.22$, the optimum cascode-stage gain is

$$A_{0(opt)} = 4.1$$

For the common-emitter [curve (2)], the coefficients are $a \approx 1.3$ and $b \approx 0.42$, and the optimum gain for this circuit is

$$A_{0(opt)} = 2.8$$

The number n of cascode stages ensuring the shortest cascade risetime T_K for a given cascade gain A_K has to be found. The normalized cascade risetime is

$$T_{K(norm)} = (a + b \sqrt[n]{A_K}) \sqrt[n]{n} \dots\dots (35)$$

Putting $dT_{K(norm)}/dn = 0$,

$$a/b = (2 \ln \sqrt[n]{A_K} - 1) \sqrt[n]{A_K} \dots\dots (36)$$

and $n_{opt}(A_K)$, for several values of gain A_K ,

$$n(10) = 1.6; n(100) = 3.3; \text{ and } n(1000) = 4.9$$

In Fig. 7, the normalized cascade risetime for the circuits considered is given depending on the number of stages n and for various amounts of cascade gain.

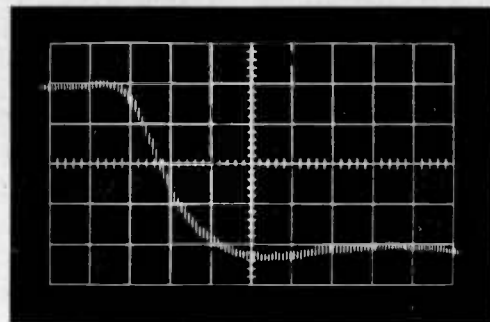

Fig. 9 Amplifier response to a step function recorded on a 0.6ns risetime oscilloscope; the sensitivities are 1ns/division and 1V/division

capacitance $C_B = \beta_0 / r_{be} \omega_c = 110 / (1.8 \times 10^3 \times 2\pi \times 900 \times 10^6) = 10.8 \text{ pF} \approx 10 \text{ pF}$.

The collector inductive compensation is obtained by putting two ferrite toroids of permeability approximately 20 on each collector load resistor. The amplifier response to a step function from a mercury-wetted-contact pulse generator was recorded on a 0.6 ns risetime sampling oscilloscope and shown in Fig. 9. The risetime of the amplifier is approximately $T_r \approx 1.5 \text{ ns}$, and the stage risetime $T_0 = 1.5 / \sqrt{2} \approx 1.1 \text{ ns}$, showing a good accordance with the numerical results obtained [Fig. 5(c)].

Conclusions

In a common-emitter single-transistor stage connected in a cascade of identical stages, the stage risetime reduction factor due to the inductive compensation in the collector circuit decreases as the stage A_0 increases. As A_0 approaches its maximum value β_0 , the risetime reduction factor approaches its minimum value 1.51. At very low values of A_0 (approximately 2 and less), this stage exhibits the fastest response of all three stage circuits considered.

The risetime/gain ratio is a gain-invariant value.

When an emitter follower is used as an interstage, RC compensation can be added in the base circuit and so diminish effectively the input time constant, especially at higher gains. The risetime/gain ratio is proportional to $1/A_0$; the optimum value of gain is $A_{0(\text{opt})} = 2.8$.

The cascode stage with both collector and base compensation and an emitter follower is free of Miller effect. Therefore the risetime/gain ratio diminishes with gain even faster than in the previously considered stage. This stage has an optimum gain of $A_{0(\text{opt})} = 4.1$.

Of all stage circuits considered, the cascade ensures the shortest cascade risetime for a given cascade gain and even for a given number of transistors per cascade.

References

- 1 ELMORE, W. C.: *J. Appl. Phys.* 19, 55 (1948)
- 2 SCOTT, L.: University of California Radiation Laboratory report UCRL-10009 (1961)
- 3 MULLIGAN, J. H.: *Proc. Inst. Radio Engrs.* 37, 516 (1949)
- 4 KOZIKOWSKY, J. L.: *Trans. IEEE, CT-11*, 129 (1964)
- 5 MAMONKIN, J. G.: *Pulse amplifiers*. Gosenergoizdat, Moscow (1958). In Russian
- 6 WILLIAMS, C. W., and NEILER, J. H.: *Trans. IRE, NS-9*, 1 (1962)

Decimal-binary encoder using integrated circuits

by K. J. Dean, M.Sc., F.Inst.P., C.Eng., F.I.E.E., M.I.E.R.E., *Letchworth College of Technology*

The article describes the design of a decimal-binary encoder which is based on the logical control of a shift register. The design has been used with integrated circuits and uses the principle of successive multiplication in the register.

(Voir page 798 pour le résumé en français; Zusammenfassung in deutscher Sprache auf Seite 799)

A RECENT article¹ aroused some interest in the technique which was described for converting a number available in binary code into a binary-decimal code 8421BCD. A comparable problem, which differs in a number of points from that of the converter, is that of converting a number available in 8421BCD into pure binary code. In this case, the BCD number may be derived from a bank of ten pushbuttons, each of which corresponds to a decimal number. When a button is pushed, gates connected to the preset inputs of four bistable elements are controlled to give the corresponding BCD number. The encoder to be described consists of a register comprising groups of four bistable elements or flip-flops. Hence, in this way, a BCD number can be generated and inserted into the encoder. It now remains to convert this number to pure binary code, since this is the form best suited to arithmetic operations.

Principles of operation

Consider the decimal number 243; this may be expressed in BCD form as follows:

1 0 0 1 0 0 0 0 1 1
(2) (4) (3)

In order to convert this to a pure binary number, the 10 digit (4) must be multiplied by 10, the 100 digit (2) must be multiplied by 10^2 , and each of these added to the 1 digit. The method may be extended in this way to cope with higher powers. The 10 digit is therefore passed through a multiplier once and the 100 digit passed through two similar multipliers etc. In each case, the multiplier must multiply by 10.

To multiply a number by 16, a shift to the left of four binary places is required. Thus, to multiply by 10, the number is first shifted four places left (or, what is equivalent to this, it is inserted to the left of an empty 4bit register) and then the product of 6 times the original number is subtracted from it.

The rules for carrying out the complete multiplication are best illustrated by a number of examples. In each case, when the number stored in the four elements which are controlled subsequent to a shift pulse is not less than 5, 3 must be subtracted from it. This subtraction is carried out at the same time as the following shift pulse. This is

the main problem in the design of the code converter. First, the decimal number 43 will be converted to pure binary code:

	K	L	M	N	
0 1 0 0 (4)	0	0	1	1	shift and examine number in <i>KLMN</i>
0 1 0	0	0	0	1	1
0 1	0	0	0	0	shift without modification
0	1	0	0	0	1 1
	0	0	1	0	shift without modification
	0	0	1	0	0 1 1
					subtract 3 and shift
					1 0 1 1
					shift twice and stop
					1 0 1 0 1 1

Result: binary 43

The method can now be extended to deal with three binary digits; the number 243 will be used:

	K	L	M	N	P	Q	R	S	
1 0 (2)	0	1	0	0	0	0	1	1	shift and examine numbers in <i>KLMN</i> and <i>PQRS</i>
1	0	0	1	0	0	0	0	1	1
	1	0	0	1	0	0	0	0	shift without modification
	1	0	0	1	0	0	0	0	1 1
									subtract 3 from <i>KLMN</i> and shift
									0 1 1
									shift without modification
									0 0 1 1
									subtract 3 from <i>PQRS</i> and shift
									1 0 0 1 1
									subtract 3 from <i>PQRS</i> and shift
									0 0 1 1
									1 1 0 0 1 1
									shift twice and stop
									1 1 1 1 0 0 1 1

Result: binary 243

From this second example it will be seen that, after the 10 digit, the method is repetitive; so that a complete

decoder consists of a register of the kind shown in Fig. 1 using the required number of multipliers, one for each decade, into which the BCD number must be inserted in parallel (i.e. not serially) and from which it is serially shunted out. However, the first shift, using the method already described, must take place without modification.

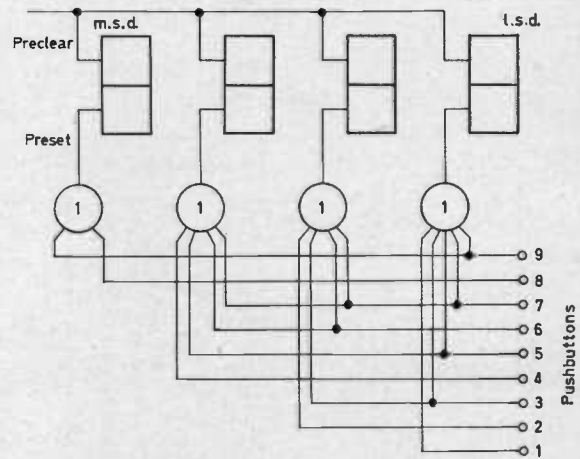

Fig. 1 Shift register controlled by pushbuttons and capable of storing the binary-coded decimal numbers 0-9

The need for this to be taken into account in the design can be removed if the number is inserted into the decoder already displaced through one shift. This is illustrated in the following example of conversion of the number 279 into pure binary code; note that the number has been shifted by one place at the start:

	K	L	M	N	P	Q	R	S	
1 (2)	0	0	1	1	1	1	0	0	1
									subtract 3 from <i>PQRS</i> and shift
									1 1
									subtract 3 from <i>PQRS</i> and <i>KLMN</i> and shift
									1 1 1
									shift without modification
									0 1 1 1
									subtract 3 from <i>PQRS</i> and shift
									1 0 1 1
									1 0 1 1 1
									subtract 3 from <i>PQRS</i> and shift
									0 1 0 1 1 1
									shift out and stop
									1 0 0 0 1 0 1 1 1

Result: binary 279

Design method

Table 1 shows the states which may exist in the register PQRS before a shift pulse; examination of the table will show that there are six possible combinations which can never occur if one considers the results of prior modifications to the register. Also, if the BCD number is placed in the register displaced by one shift, as already described, none of these six immaterial states need be considered further (immaterial states are shown with asterisks).

TABLE 1

States before shifting				States after shifting			
P	Q	R	S	Q	R	S	T
0	0	0	0	0	0	0	0
0	0	0	1	0	0	0	1
0	0	1	0	0	0	1	0
0	0	1	1	0	0	1	1
0	1	0	0	0	1	0	0
0	1	0	1	*			
0	1	1	0	*			
0	1	1	1	*			
1	0	0	0	0	1	0	1
1	0	0	1	0	1	1	0
1	0	1	0	0	1	1	1
1	0	1	1	1	0	0	0
1	1	0	0	1	0	0	1
1	1	0	1	*			
1	1	1	0	*			
1	1	1	1	*			

The design of the shift register can now be carried out using Karnaugh maps to determine the input conditions. This is particularly advantageous here as there are these six immaterial states. It should be noted that, if the reader compares this method with that for a binary-decimal converter, the immaterial states in that case are not identi-

TABLE 2

	PQ	00	01	11	10
RS	00	0	4	12	8
	01	1	*	*	9
	11	3	*	*	11
	10	2	*	*	10

cal with those here. The master map shown in Table 2 can now be drawn up. This gives the location of each of the states in the original register. Immaterial states are marked with an asterisk.

Further maps can only be drawn up when the logic of the bistable elements is precisely known. Since with new designs it is almost certain that integrated circuits will be used, and most integrated-circuit bistable elements are JK flipflops, these will be used in the design. In this case, it will be assumed that the inputs are J and K. It should be noted that, if flipflops are used with inputs \bar{J} and \bar{K} , the required logical inputs can be deduced by negating those which are derived here. Table 3 summarizes the logic for a JK flipflop.

TABLE 3

P	J	K	Q_{n+1}
0	*	*	Q_n
1	0	0	Q_n
1	0	1	0
1	1	0	1
1	1	1	\bar{Q}_n

The steering conditions for the flipflops can now be drawn up from the data given in Table 3. The steering table (Table 4) is most important, since it gives the information which is required to steer the flipflop from one state to another.

TABLE 4

From	To	Necessary conditions	
		J	K
0	0	0	*
0	1	1	*
1	0	*	1
1	1	*	0
†	1	1	0
†	0	0	1

† unknown states

Using the information given in Table 4, it is now possible to complete two Karnaugh maps for each flipflop, one for each input, placing information in the appropriate cells, as indicated by Table 2. In all, eight maps are required; these are given in Table 5.

These results, obtained by looping groups of cells in the usual manner, may be summarized as follows:

$$\begin{aligned}
 Q_J &= PRS & Q_K &= \bar{P} \\
 R_J &= \bar{P}Q + PQ & R_K &= \bar{P} + S \\
 S_J &= R & S_K &= \bar{P}\bar{R} + PR \\
 T_J &= \bar{P}S + \bar{P}\bar{S} & T_K &= \bar{P}\bar{S} + PS
 \end{aligned}$$

TABLE 5

PQ		RS			
		00	01	11	10
00	0	*	*	0	
01	0	*	*	0	
11	0	*	1		
10	0	*	*	0	
		Q_j			
PQ		RS			
		00	01	11	10
00	0	1	0	1	
01	0	*	*	1	
11	*	*	*	*	
10	*	*	*	*	
		Q_k			
PQ		RS			
		00	01	11	10
00	*	*	*	*	
01	*	*	*	*	
11	1	*	*	1	
10	1	*	*	0	
		R_j			
PQ		RS			
		00	01	11	10
00	*	*	*	*	
01	1	*	*	0	
11	0	*	*	1	
10	*	*	*	*	
		R_k			
PQ		RS			
		00	01	11	10
00	0	0	0	0	
01	*	*	*	*	
11	*	*	*	*	
10	1	*	*	1	
		S_j			
PQ		RS			
		00	01	11	10
00	0	0	1	1	
01	1	*	*	0	
11	1	*	*	0	
10	0	*	*	1	
		T_j			
PQ		RS			
		00	01	11	10
00	1	1	0	0	
01	0	*	*	1	
11	0	*	*	1	
10	1	*	*	0	
		T_k			

It now remains to implement this logic to control the flip-flops, as outlined in Fig. 2. In order to convert a number available in binary-decimal code into pure binary code, a number of these encoding groups of four flip-flops and their controlling gates will be required.

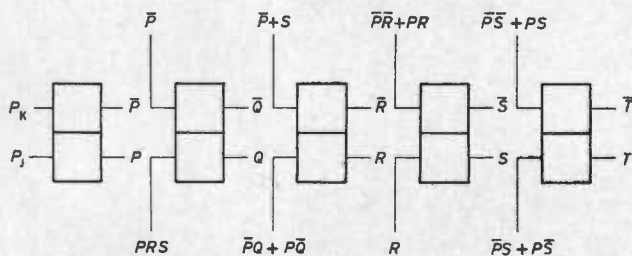

Fig. 2 Logical diagram showing the control of a decimal-binary encoder

Nonintegral numbers

An interesting extension of this method deals with the encoding of nonintegral numbers available in binary-decimal code. Clearly, the integral part of the number can be handled in the way just described; but to encode the part of the number to the right of the binary point, this must be divided successively by 10, instead of multiplying it. This may, of course, lead to recurring results, since the binary equivalents of exact decimal numbers are not always themselves capable of expression other than by recurring binary numbers. Two examples will illustrate this.

(i) Conversion of 0.75 to binary code

	0	1	1	1	0	1	0	1	
		(7)			(5)				
								add 3 to each decade and shift	
.1		0	1	0	1		0	0	0
								add 3 to first decade and shift	
.1 1		0	0	0	0		0	0	
								stop	

Result: binary 0.75

(ii) Conversion of 0.76 to binary code

	0	1	1	1	0	1	1	0		
		(7)			(6)					
								add 3 to each decade and shift		
.1		0	1	0	1		0	0	1	0
								add 3 and shift		
.1 1		0	0	0	0		0	1	0	0
								shift		
.1 1 0		0	0	0	0		1	0	0	0
								add 3 and shift		
.1 1 0 0		0	0	0	1		0	1	1	0
								add 3 and shift		
.1 1 0 0 0		0	0	1	1		0	0	1	0
								shift		
.1 1 0 0 0 0		0	1	1	0		0	1	0	0
								add 3 and shift		
.1 1 0 0 0 0 1		0	0	1	0		1	0	0	0

There are two points to note: the result shows no sign of clearing the registers, and the method involves inserting the digits in parallel into the dividers, whereas the dividers discussed in the earlier article had numbers inserted into them in series.

Acknowledgments

The author wishes to thank those who have discussed with him the methods which have been described for code conversion, particularly F. K. Hanna² and C. P. E. Brown³, also D. O'Dell and S. Money of A. E. W. Gosport, for their most helpful suggestions.

References

- 1 DEAN, K. J.: A binary-decimal converter using integrated circuits, *Electronic Engng.* 38 (Oct. 1966)
- 2 HANNA, F. K.: Correspondence, *ibid.* 39 (March 1967)
- 3 BROWN, C. P. E.: Correspondence, *ibid.* 39 (July 1967)

Instantaneous pulse-measuring voltmeter

by N. A. Westman, *University of Uppsala*,
S. Westerlund, *European Space Research Organisation*
and S. T. Berglund, *University of Lund, Sweden*

A robust and fast instrument has been developed for pulse-voltage measurements. The principle is that of charging a capacitor and reading off the voltage by means of an electrometer amplifier, and the instrument can be operated in the following modes: pulse-height measurements of single events; measurement of maximum amplitude in a time interval; and measurement of pulse voltage at a predetermined time. As described here, the instrument is directly usable for pulse voltages between 0.1 and 5V and pulse lengths up to several seconds, but it can easily be modified for operation in other ranges. The output is displayed on a deflectional instrument; resetting is automatic and readoff times of up to several minutes can be selected. Risetime when the instrument operates in the pulse-height-reading mode is better than 1μs; for instantaneous-value measurement, the accuracy is related to the time derivative of the pulse at the time of locking.

(Voir page 798 pour le résumé en français: Zusammenfassung in deutscher Sprache auf Seite 800)

IN the study of various pulsed-discharge mechanisms in gases, there is often a need to record primary, as well as secondary, voltages, currents and magnetic fields. The usual manner of recording is by means of oscilloscopes; but, if several quantities must be recorded simultaneously, the equipment becomes costly. Furthermore, in some cases it is sufficient to monitor or record just the peak value of a quantity during the discharge; sometimes its value at a predetermined time is preferred. The instrument described here is designed to serve a purpose outlined in the above considerations. First made as a conventional pulse-height-measuring voltmeter, it was later also developed into an instantaneous-value-measuring instrument.

Peak-reading instruments rely mostly on the principle of charging a storage capacitor through a diode by means of a special charging amplifier, and an electrometer amplifier is used to measure the resulting voltage. If leakage currents are sufficiently low, the voltage is memorized

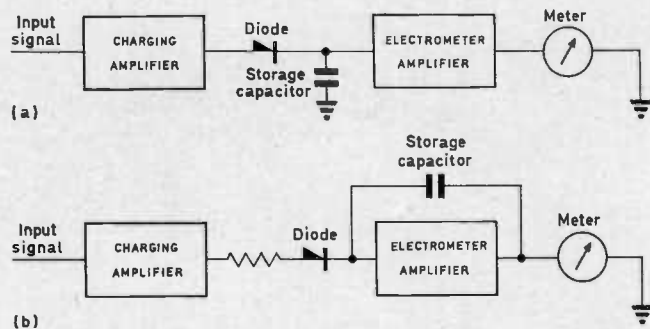

Fig. 1 Schematic diagrams of peak-reading instruments

for a time that is long enough to permit the setting of an indicating meter. A schematic diagram of such an instrument is shown in Fig. 1(a). Another type of circuit

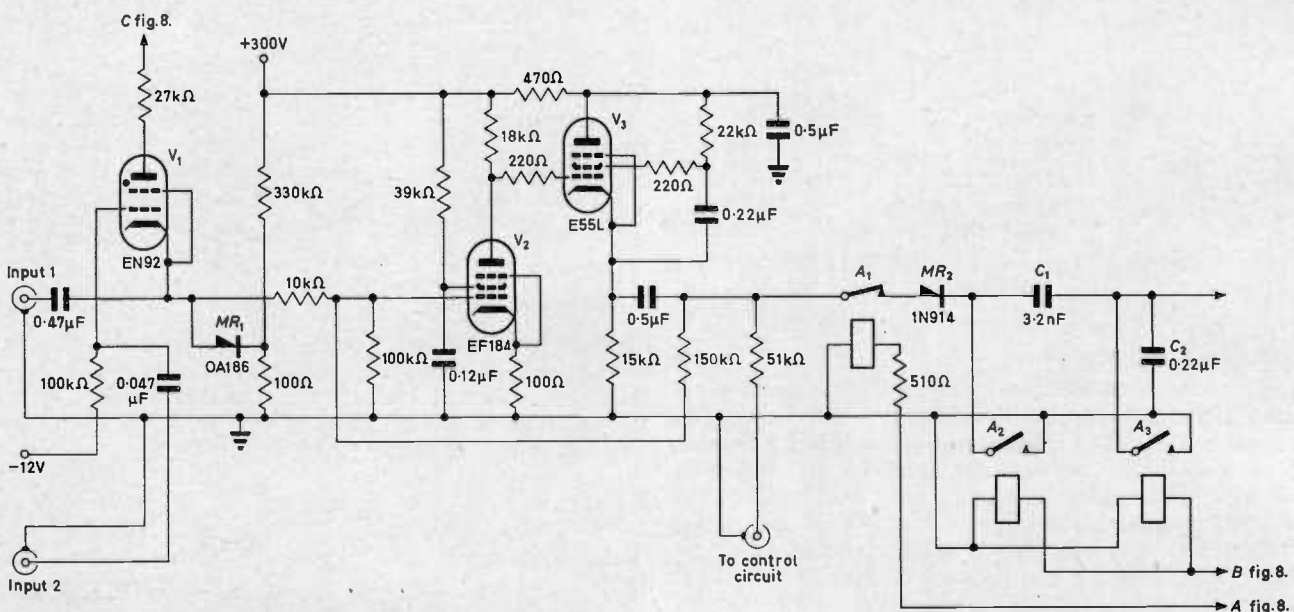

Fig. 2 Charging amplifier for peak-value locking with storage-capacitor circuit and clamping thyatron

is shown in Fig. 1(b); here the electrometer circuit is connected as an operational amplifier with the storage capacitor in the feedback loop. Both circuits have their advantages: a long holding time is more easily achieved with the latter circuit; however, for the recording of fast pulses, large currents are involved in the charging of the storage capacitor, and in the latter circuit these currents must be supplied by both amplifiers, and therefore, for pulses of short risetimes, the circuit in Fig. 1(a) should normally be better suited, and it was chosen by the authors in accordance with this assumption.

Charging amplifier

The device was first constructed as a conventional single-pulse peak-reading voltmeter, having an additional cutoff arrangement whereby the charging of the storage capacitor could be interrupted at a given time. By this means the instantaneous value at a given time during the rising part of a voltage pulse could be locked or memorized and read out. The charging amplifier is shown in Fig. 2. It consists of an amplifying stage V_1 , with the addition of a cathode-follower V_2 , and there is overall shunt feedback around the two stages. The circuit is designed for only positive output pulses which charge the storage capacitor through the diode MR_2 . The pentode E55L was chosen as a cathode follower; since this tube can deliver hundreds of milliamperes without drawing grid current and has a very large transconductance, the circuit can be loaded by a relatively large storage capacitor with retained short risetime and good linearity. A large storage capacitor has the advantage that the leakage current in the diode MR_2 , when it is reverse biased, becomes of lesser significance, and the circuit also becomes less sensitive to pulses through stray capacitances and through stored charge in the diode when the amplifier is cut off for the locking of an instantaneous voltage.

The input signal on input 1 must be negative. The circuit used here is preceded by an electronic integrator for magnetic-field measurements, in which case the correct polarity is chosen by turning the field search coil. For other purposes, a phase-reversing stage may be necessary at the input. Another feature of the instrument is that the storage capacitor is part of a capacitive voltage divider. By this means, the voltage at the output of the charging amplifier and at the input of the electrometer amplifier may be independently chosen for best performance. The former voltage must be large so that the influence of the non-linear element MR_2 can be neglected. The voltage on the

storage capacitor, on the other hand, should be low, since the leakage conductance may increase when the voltage across the capacitor increases; also a low voltage allows for a large capacitance. To summarize: for a given charge, a large RC holding time is more easily achieved with a large capacitance and a low voltage.

The three relay switches in conjunction with the capacitor voltage-divider are reed relays, which are switched on and off either manually or by an automatic circuit to be described later. Before each measurement, the relay RLA_1 is the first closed and then the relays RLA_2 and RLA_3 are momentarily closed to discharge the capacitors C_1 and C_2 . The contact of RLA_1 remains closed during the charging pulse and is then automatically opened after a delay of about 1ms. It has a leakage resistance of the order of $10^{12}\Omega$. In Fig. 3, the charging of the voltage divider when an input pulse of negligible risetime is fed to input 1 (Fig. 2) is shown. The measurement is made before the diode MR_2 . It is the slower pulse with an over-swing

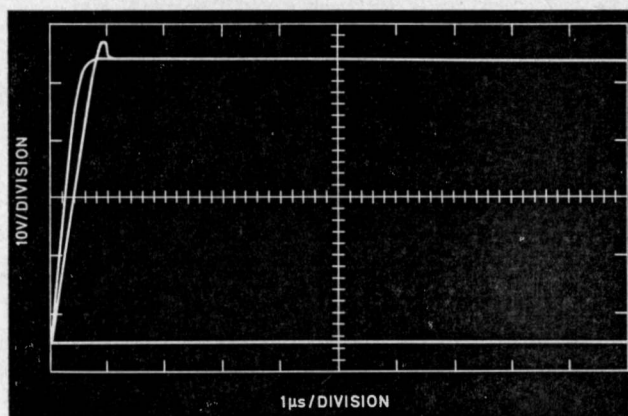

Fig. 3 Oscilloscope traces (redrawn) that show the risetime limit for the charging of the capacitor voltage divider

that represents the charging. The other steeper pulse without over-swing is the voltage from a second input-voltage step of equal magnitude, when the capacitor chain is already charged. There is no change in voltage plateau, which means that a true reading is obtained for a single pulse; the overshoot may depend on an induced voltage in the oscilloscope probe attachments. The charging time, for a voltage of 50V, corresponding to nearly full scale

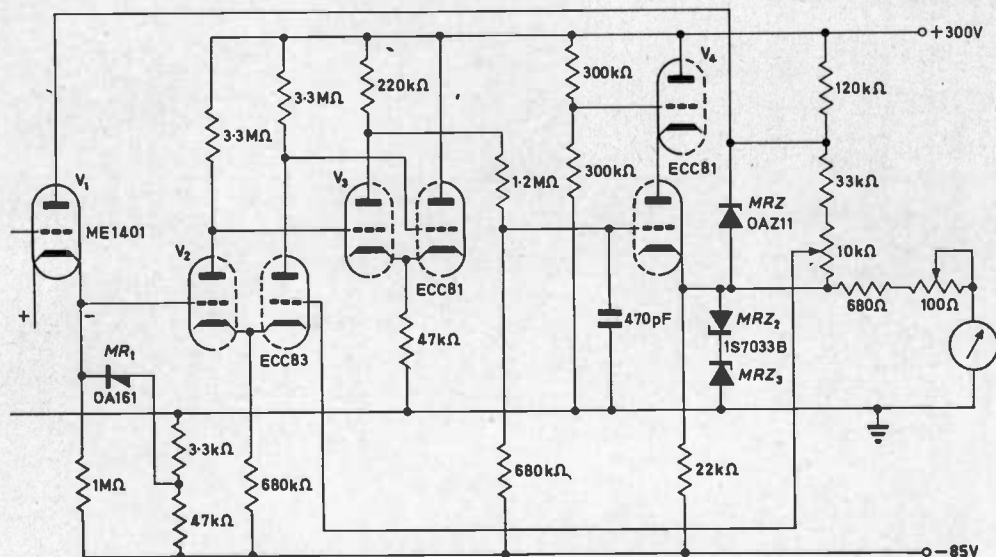

Fig. 4 Memory voltmeter circuit

deflection of the instrument, is seen to be about $1\mu\text{s}$. It is determined by the peak current obtained from the cathode-follower, which is about 200mA .

For the measurement of an instantaneous value of a monotonously rising pulse or maximum amplitude in a selected time interval, it would be sufficient to cut off the cathode-follower V_3 by a negative voltage step at its grid at the correct time. Then the instantaneous value in question would be seen as a peak value at the cathode-follower output and measured in the usual way. However, in the circuit of Fig. 2, the controlling pulse acts directly on the input signal. The thyatron V_1 is normally nonconducting and does not influence the signal; but, if it is triggered by a positive pulse at input 2, it gives a sharp positive pulse in parallel with the input signal, which is thereby replaced by a small positive voltage large enough to cut off the cathode-follower via tube V_2 , and the storage-capacitor voltage is clamped. The accuracy in time is limited mainly by time jitter in the thyatron triggering, which becomes more important when the time derivative of the pulse is high. Therefore the waveform should be known or anticipated for an exact definition of the accuracy.

Memory voltmeter

An electrometer tube V_1 (Fig. 4) is used as a cathode-follower at the input of the memory electrometer amplifier. It is not included in the feedback loop around this amplifier, but high linearity is ascertained by means of a large load resistance. Furthermore, its anode voltage is taken from the amplifier output in such a way, via the Zener diode MRZ_1 , that it approximately follows the input signal. A rectifier diode MR_1 , and two Zener diodes MRZ_2 and MRZ_3 are incorporated in the circuit for the protection of the electrometer tube and the indicating meter. There are two longtail-pair amplifier stages V_2 and V_3 , terminated by a cathode-follower, which is loaded by the indicating in-

strument, a moving-coil 1mA panel meter. The cathode of V_1 is fed from a direct voltage, which is stabilized by a 2-stage Zener-diode circuit; the filament supply for V_2 is also stabilized. The short-term input-voltage drift thereby becomes sufficiently low to be negligible at a full-scale deflexion of about 1V . The loop gain of the amplifier is greater than 1000 and the overall gain about unity; so that the accuracy of the electrometer may be set equal to that of the millimeter. Time constants of several hours are reached, which means that, for a 1% accuracy in the reading of the instrument, several minutes are available. The linearity of the instrument as a peak-pulse-height-measuring instrument is good even down to low voltage, as is seen from Fig. 5, which shows a measurement series of the meter scale reading single pulses as a function of the input pulse height.

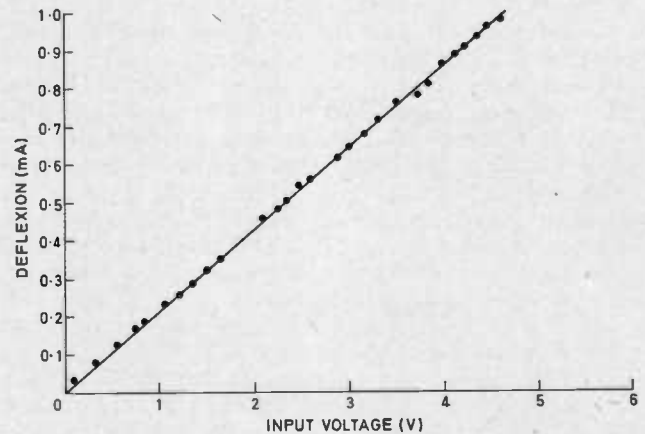

Fig. 5 Measurement of the linearity of the instrument used as a peak-reading voltmeter

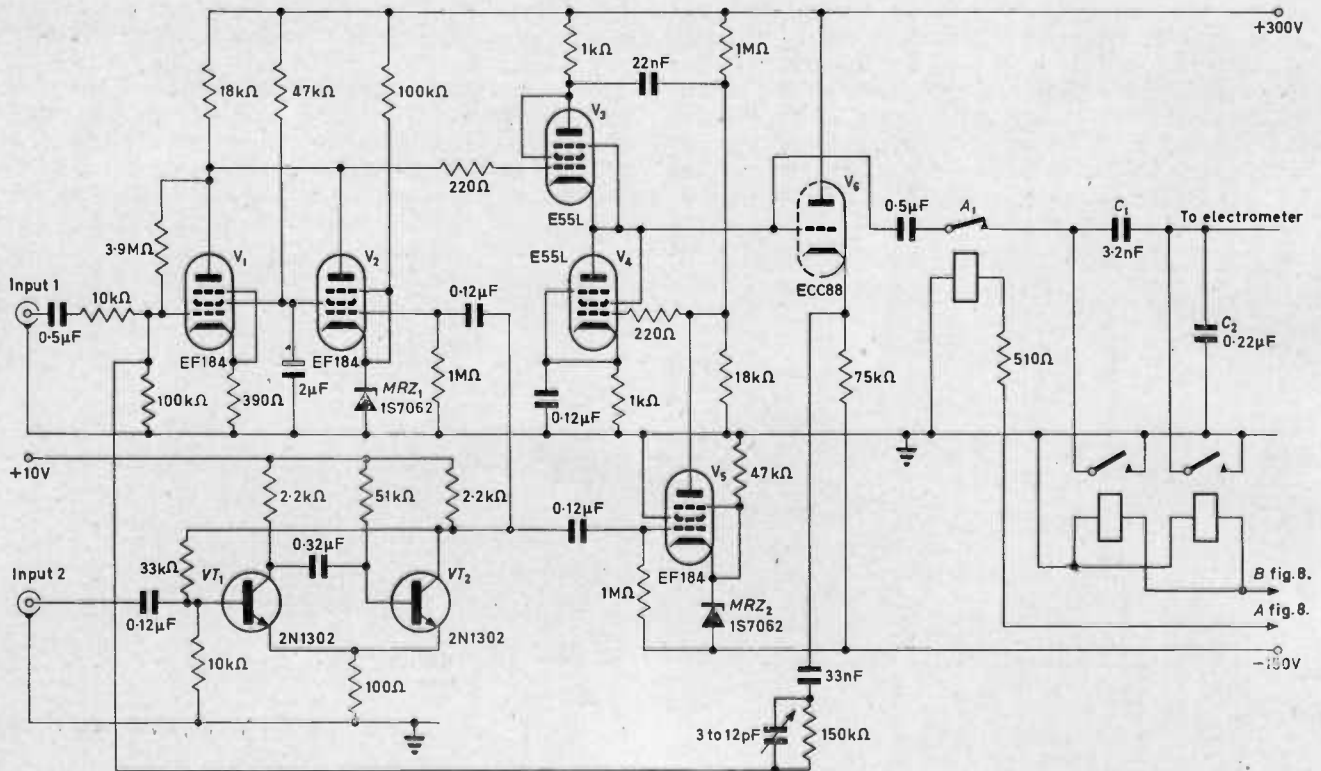

Fig. 6 Charging amplifier for instantaneous-value locking

Instantaneous value-locking amplifier

When the instantaneous value of an arbitrary pulse is to be locked, the charging amplifier becomes more complicated. The circuit is shown in Fig. 6; the simple cathode follower is replaced by a White cathode follower V_3 and V_4 , with two E55L valves. It works in class-AB with a quiescent current of 10mA. However, the peak current may be more than 100mA in either tube. If both tubes can

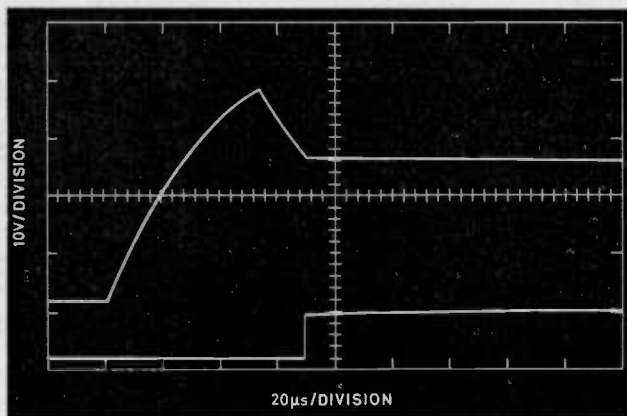

Fig. 7 Oscilloscope traces (redrawn) when the voltage of a pulse is locked at an instant of decreasing value

extra adjustments involving, for instance, different pulse-forming circuitry to the grids of V_2 and V_5 . The cathode follower is cut off for a few milliseconds, during which time the relay RLA_1 opens.

Fig. 7 shows the locking of a voltage after about $67\mu\text{s}$; the time is given by the pulse fed to input 2 (Fig. 6).

Automatic control circuit

The instrument is constructed to allow for two charging and memory circuits of the type described above; so that two signals at a time may be measured. It is also possible to measure the voltage of one event at two different times. There is an automatic control circuit in common for both, which, after each measurement, zero-sets the instruments and closes the relay between the charging and memory circuits; i.e. it makes the instrument ready to receive new pulses. The control circuit is shown in Fig. 8; it consists of a monostable multivibrator for pulse delay V_1 a thyatron V_2 , a 'switching' triode V_3 , and a cold-cathode trigger tube V_4 . When the instrument is at rest and ready to receive pulses, V_2 and V_4 are nonconducting. In Fig. 8, the contacts of the relays RLA_4 and RLA_5 are shown for this condition, and it is seen that thereby the relay RLA_1 of Fig. 2 is closed while the relays RLA_2 and RLA_3 are open. The multivibrator is triggered by a positive pulse, for instance, from one of the charging pulses; and when it goes back to its stable state, after a delay

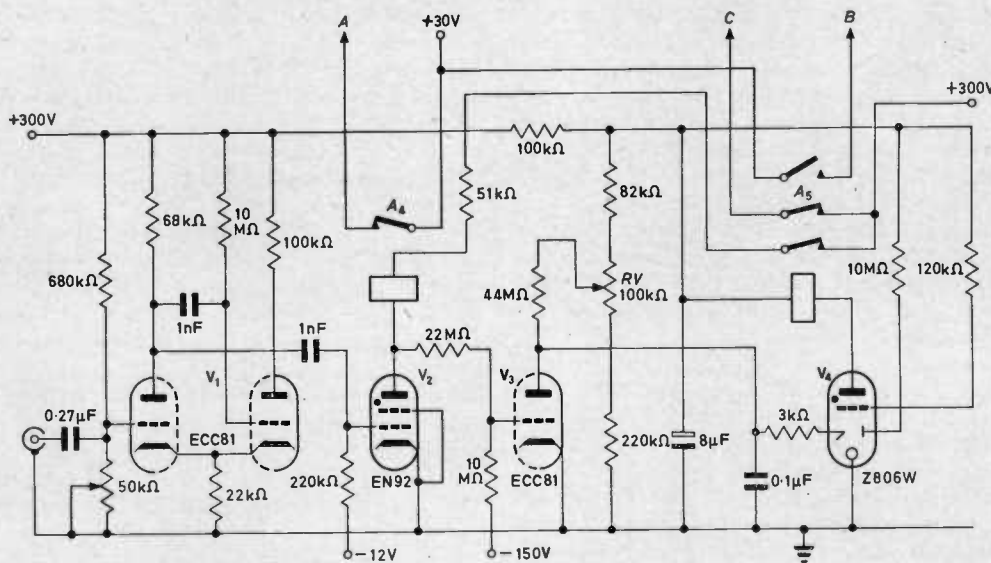

Fig. 8 Control circuit for automatic resetting

be simultaneously cut off, their common output becomes floating, and the leakage current, which may be of either sign, is small enough to be neglected during the time that elapses before the relay RLA_1 opens; the delay is still typically 1ms. There is now, of course, no diode in series with the capacitive voltage divider, c.f. Fig. 2. Negative feedback around the circuit is arranged *via* a cathode-follower V_6 , since no resistive load is allowed at the output. A transistor monostable multivibrator VT_1 and VT_2 , which is triggered by an external pulse at input 2, controls the cutoff. It delivers a positive pulse of short risetime to the pentodes V_2 and V_5 , the anodes of which are d.c.-coupled to the grids of the White cathode follower. However, the tubes of this must be simultaneously cut off if they are both conducting, otherwise an error voltage of positive or negative sign is added to the signal voltage at the output. Good results are obtained with the circuit shown, without

determined by the circuit constants, it triggers the thyatron. When the thyatron anode-voltage goes down, the triode V_3 is cut off, and the voltage on the trigger electrode of V_4 starts rising at a rate that is adjustable by the setting of potentiometer P . The choice of delay in the triggering of V_4 which is thereby provided for, determines the time available to read off the indicating instrument. The thyatron also opens the contact of relay RLA_4 , *via* which RLA_1 of Fig. 2 is also opened. When V_4 triggers, the relays RLA_2 and RLA_3 in Fig. 2 are closed for a moment, during which time the capacitors C_1 and C_2 are discharged. The anode circuits of thyatron V_1 Fig. 2 and thyatron V_2 of the control circuit are simultaneously opened and the thyatron extinguished. The trigger tube is self-extinguishing, and when it has cut off, the instrument is again ready for a measurement. All indicated supply voltages are stabilized by conventional voltage-stabilizing circuits.

Behaviour of a Schmitt-trigger circuit used in conjunction with a current-integrating capacitor

by L. A. W. Kemp, B.Sc., Ph.D., F.Inst.P., National Physical Laboratory (formerly with The London Hospital), and D. O. Bottrill, B.Sc., D.I.C., and S. Klevenhagen, B.Sc., M.Sc., The London Hospital

An analysis is given of the current and voltage conditions obtaining in a Schmitt-trigger circuit whose input signals are provided by the voltage excursions on a capacitor which is charged by an ionization current until the Schmitt-trigger voltage is reached, when the capacitor is rapidly discharged to the reset voltage and the cycle then recommences. Particular attention is given to the theoretical prediction and experimental confirmation of the existence of a minimum ionization current below which the Schmitt will fail to trigger, and a maximum above which the Schmitt will fail to reset, having triggered for the first time only.

(Voir page 798 pour le résumé en français: Zusammenfassung in deutscher Sprache auf Seite 800)

THE Schmitt circuit was first published¹ as a thermionic device, and has found wide application as a voltage discriminator in, for example, pulse-height analysers; but implicit in the usual textbook analysis of the circuit is the assumption that it is fed from a low-impedance signal source. However, Hampshire and Peterson² used equivalent-circuit techniques to investigate the conditions for regenerative switching of a p-n-p Schmitt circuit, in which the input transistor is normally bottomed and where the source impedance is neither very large nor very small.

In the recent design of a digital integrating X-ray dosimeter, a Schmitt circuit has been employed in a situation in which the signal voltage is that produced across a capacitor used to integrate the current from an ionization chamber monitoring an X-ray beam. The limits of the voltage excursions between which the capacitor is alternately charged and discharged are determined by the trigger and reset voltages of the Schmitt circuit. This arrangement does not constitute the normal low impedance signal source, and an analysis of the current and voltage conditions before and after triggering was found to be necessary in order to elucidate fully the behaviour of the circuit. In particular, a theory was required to account for the existence of a minimum ionization current below which the Schmitt fails to trigger, and a maximum above which the Schmitt fails to reset having triggered once only.

The input arrangement and basic Schmitt circuit are shown in Fig. 1. The integrating capacitor C is of the polystyrene (unprotected tubular) type with very high insulation properties and excellent stability, and has a

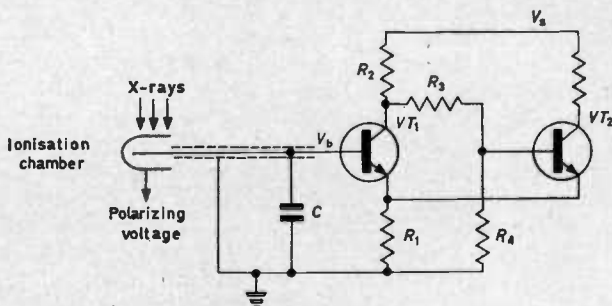

Fig. 1 Input arrangement and basic Schmitt circuit

value of about $0.1\mu\text{F}$ in the circuit studied. VT_1 and VT_2 are Fairchild BFY 77 silicon n-p-n transistors, which have very high current gains at low collector currents and very low leakage current to the base under reverse-bias conditions (typically of the order of 0.1nA). In the untriggered state of the circuit, this leakage current is a negligible fraction of the capacitor charging current, the latter usually being of the order of tenths of a micro-ampere.

It has been found experimentally that, for this circuit, the minimum and maximum current limits, described above, are 18nA and $2.6\mu\text{A}$, respectively. The theory developed to explain these current limits is described below, and excellent agreement exists between the predicted and experimentally determined values.

Theory

Existence of a minimum input current limit

In Fig. 2, curve (a) represents a plot of base current I_b against the base-emitter voltage V_{be} for the input transistor VT_1 , while curve (b) represents the (positive) feedback voltage V_{FB} which appears on the common emitter line

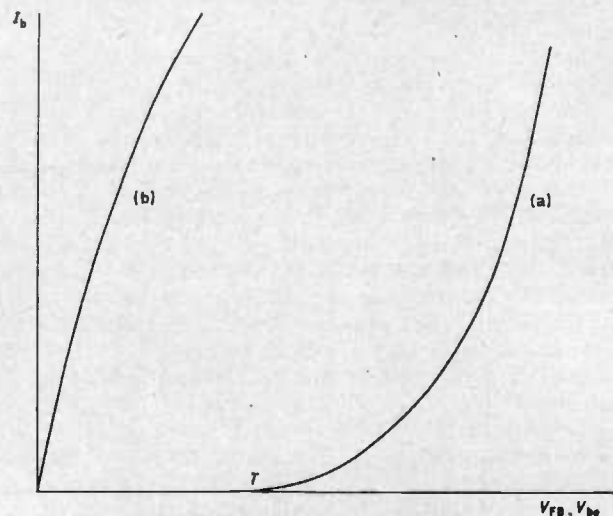

Fig. 2 (a) I_b versus V_{be} (b) I_b versus V_{FB}

for any given base current I_b into VT_1 . It is easily shown that, if the base current of VT_2 is neglected in comparison with the current through R_3 and R_4 , this feedback voltage is given by

$$V_{FB} = \beta I_b \frac{R_2 R_4}{R_2 + R_3 + R_4}$$

as a result of the emitter-follower action of VT_2 . (The effect of VT_1 emitter current in raising the common-emitter line voltage can be ignored in the circuit studied, in which $R_1 \ll R_2$.) Needless to say, curve (b) will have the same shape as a plot of I_b against collector current.

V_{be} (Fig. 2) is, of course, the amount by which the voltage V_b on the capacitor C (Fig. 1) must exceed the common-emitter line voltage in order to produce a base current I_b in VT_1 in the absence of feedback. Since, for any given I_b , the feedback reduces the common-emitter line voltage by an amount V_{FB} , indicated by curve (b), it follows that, to produce the current I_b with feedback present, the net voltage by which V_b must exceed the common-emitter line voltage is given by V_x , the horizontal distance between curves (a) and (b) at the given current level I_b . The variation of V_x with I_b is represented in Fig. 3. It will now be shown that the minimum input (ionization) current I_{min} for which the circuit will trigger is equal to the base current I_b corresponding to the point Y at which V_x just reaches its maximum. This may be indicated in general terms as follows. Suppose that C has charged to a voltage which exceeds the quiescent common-emitter line voltage by the value of V_{be} corresponding to the point T on curve (a). Then VT_1 will be on the threshold of conduction. Further charging of the capacitor increases V_b and hence I_b (the positive feedback present merely resulting in smaller V_b for given I_b than would otherwise have been necessary in the absence of feedback).

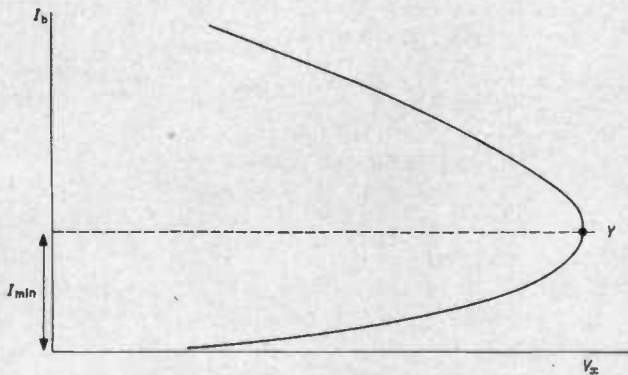

Fig. 3 I_b versus $V_x (= V_{be} - V_{FB})$

Once I_b reaches the value I_Y (Fig. 3), at which V_x is a maximum, inspection of Fig. 3 shows that thereafter an infinitesimal increase in I_b will result in a base current, which, to maintain it, requires a smaller value of V_x than that already obtaining. Current therefore begins to be taken from the capacitor (thus tending to diminish V_x), with I_b increasing very rapidly indeed: the trigger action, and the subsequent discharge of the capacitor to the reset voltage, is thereby initiated.

The process may be treated somewhat more rigorously as follows. If V_b , V_{be} and V_{FB} are the voltages corresponding to the base current I_b obtaining at any time t after the commencement of conduction in VT_1 but before actual triggering occurs, then a further increase ΔI_b in base current in time Δt will change these voltages by amounts of ΔV_b , ΔV_{be} and ΔV_{FB} , where

$$V_b = \left(\frac{I_{in} - I_b}{C} \right) \Delta t = (\Delta V_{be} - \Delta V_{FB}) = \Delta V_x$$

It follows that the rate of change of base current is given, as a function of base current, by

$$\frac{dI_b}{dt} = \left(\frac{I_{in} - I_b}{C} \right) \frac{dI_b}{dV_x} \dots \dots \dots (1)$$

(i) Consider the case where the input current is less than I_{min} . The terms $(I_{in} - I_b)/C$ (which represents the charging of the capacitor) and dI_b/dV_x are depicted as functions of I_b (using suitable ordinates) by curves (b) and (a), respectively, in Fig. 4. The product of these two terms is depicted by curve (d) in Fig. 4 and, as indicated above, represents the rate of change of current flowing into the

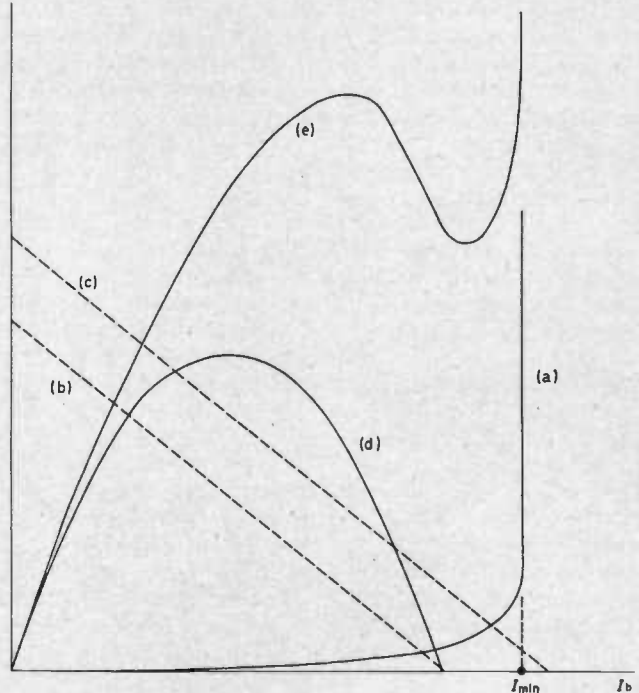

Fig. 4 (a) $\frac{dI_b}{dV_x}$ versus I_b
 (b) $\frac{I_{in} - I_{min}}{C}$ versus I_b for $I_{in} < I_{min}$
 (c) $\frac{I_{in} - I_{min}}{C}$ versus I_b for I_{in} slightly greater than I_{min}
 (d) $\frac{dI_b}{dt}$ versus I_b for $I_{in} < I_{min}$
 (e) $\frac{dI_b}{dt}$ versus I_b for I_{in} slightly greater than I_{min}

base as a function of I_b . The curve initially rises, passes through a maximum, and then falls to zero when all the input current has been diverted into the base ($I_{in} - I_b = 0$) and the charging of the capacitor has ceased. (For dI_b/dV_x , initially small and increasing with I_b , is nevertheless still finite when I_b becomes equal to I_{in} .) No further feedback occurs and the capacitor voltage V_b remains constant, with V_{be} at a value corresponding with a base current equal to I_{in} .

(ii) Consider now the case of $I_{in} = I_{min}$. As the input current is diverted into the base, the rate of charging of the capacitor will again fall towards zero. However, when I_b approaches I_Y (Fig. 3), dI_b/dV_x assumes rapidly increasing values, becoming infinite when the current reaches I_Y . Curve (c), in Fig. 4, represents the term $(I_{in} - I_b)/C$ in equation (1) for an input current slightly in excess of I_Y , and curve (e) represents the corresponding rate of change

of current into the base. The latter curve becomes infinitely steep in the vicinity of $I_b = I_T$. Therefore, if the input current approximates to I_T , the rate of change of current into the base can be increased precipitately if a transient appears on the base to cause I_b to rise, even momentarily, above I_T . It is obvious, therefore, that, for $I_{in} = I_T$, the condition obtaining when the whole of this current is diverted into the base is one of unstable equilibrium, and that this current must exceed to produce positive triggering of the Schmitt trigger.

(iii) Consider finally the case where $I_{in} > I_{min}$. The sequence of events described under case (ii) above is again followed up to the point where $I_b = I_{min}$. Immediately I_b goes beyond this, a condition results in which the value of V_x required to maintain the higher current into the base of VT_1 is less than that already being provided by the capacitor voltage V_b . A regenerative switchover of VT_1 and VT_2 thus occurs as rapidly as the stray inductive and capacitive elements of the circuit permit (of the order of $0.1\mu s$ for the circuit studied), VT_1 bottoming and C discharging through R_1 via the base-emitter junction of VT_1 , until V_b falls (in a few tenths of a millisecond) to the neighbourhood of the reset voltage of the Schmitt trigger. At this point, VT_1 will come out of bottoming and C will now discharge much more slowly as a result of the considerably increased input impedance of VT_1 , now in the active mode. This phase of the discharge lasts, in fact, for about 3ms in the circuit studied, during which time the collector of VT_1 rises steadily as the emitter voltage (and therefore collector current) falls. The base voltage of VT_2 also rises steadily (via the potentiometric action of R_3 and R_4) until VT_2 begins to take current again, when resetting of the Schmitt sets in regeneratively, VT_1 switching off and VT_2 switching fully on. V_b is left at the reset voltage, and the capacitor commences to charge again with the full input current flowing into it.

A trace of the common-emitter line voltage-waveform for the whole of this cycle is shown in Fig. 5.

Existence of a maximum input-current limit

It is now necessary to elucidate the reason for the circuit failing to reset when the input current exceeds a certain value I_{max} . After the first trigger, the capacitor will discharge, as described above, towards the reset voltage through R_1 and the base-emitter junction of the bottomed

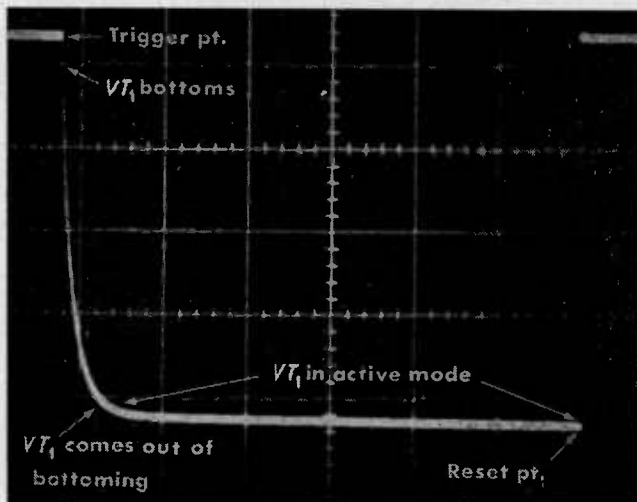

Fig. 5 Oscilloscope trace of the common-emitter line voltage-waveform (scale: 1V/cm; 0.5ms/cm)

VT_1 . As the capacitor voltage falls, the base current of VT_1 will also fall until this has become equal to the input current. No further current can then be taken from the capacitor, and its voltage can, of course, fall no further. Thus, unless the circuit has reset before this condition obtains, it can never do so. Hence there are two circumstances preventing resetting:

- (i) When the base current of VT_1 , having fallen to the level of the input current, is so large that VT_1 is still bottomed, a stable condition results with the collector voltage of VT_1 (and therefore the base voltage of VT_2) below the base voltage of VT_1 . Obviously the Schmitt cannot then reset.
- (ii) When the base current of VT_1 , again having fallen to the level of the input current, is not large enough to retain VT_1 in the bottomed condition but is nevertheless sufficiently large to prevent the voltage of the collector of VT_1 (in the active mode) from rising sufficiently to bring VT_2 into conduction again (via the potentiometric coupling to the VT_2 base), again a stable condition results. This condition, with VT_2 on the threshold of (but not actually) conducting, corresponds to the upper limit of the range of input current for which the circuit will both trigger and reset and provides the basis for the following analysis yielding the value of this upper limit.

Let β be the current gain of VT_1 corresponding to the required base current I_{max} , and V_T the base-emitter voltage of VT_2 when the circuit is on the threshold of resetting, just as described. The common-emitter line voltage = $\beta I_{max} R_1$.

Therefore the base voltage V_{b2} of $VT_2 = \beta I_{max} R_1 + V_T$
 $= I_p R_4$

where I_p is the potentiometer current R_3 and R_4 . But, if V_{c1} is the collector voltage of VT_1 , the base voltage of VT_2 is also given by

$$V_{b2} = V_{c1} \frac{R_4}{R_3 + R_4} = [V_s - (\beta I_{max} + I_p) R_2] \frac{R_4}{R_3 + R_4}$$

where V_s is the supply voltage.

Eliminating I_p from these equations gives

$$\beta I_{max} = \frac{V_s R_4 - V_T (R_2 + R_3 + R_4)}{(R_1 R_2 + R_1 R_3 + R_1 R_4 + R_2 R_4)}$$

In the circuit studied,

$V_s = 29V$; $R_1 = 0.68k\Omega$; $R_2 = 22k\Omega$; $R_3 = 4k\Omega$ and $R_4 = 6.8k\Omega$

Taking V_T from Fig. 7 to be approximately 350mV, a value of $2.7\mu A$ is then obtained for I_{max} , in very good agreement with the experimentally determined value (see below).

Experimental verification of theory

The I_b/V_{be} characteristic for VT_1 and the corresponding collector currents were measured using the circuit in Fig. 6. The base currents were measured by G_1 , a suspended-coil mirror galvanometer having a sensitivity of approximately 5mm/nA at 1m (accurately calibrated beforehand),

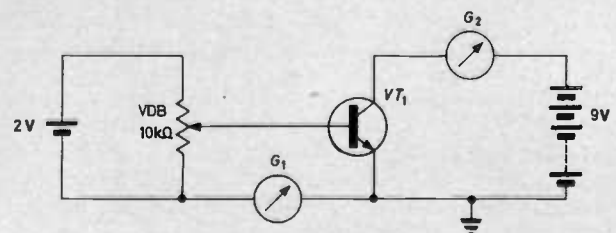

Fig. 6 Measurement of I_b , I_o and V_{be}

while the collector currents were measured by a calibrated galvanometer G_2 .

Apart from the I_b/V_{be} characteristic, the current gain β and feedback voltage V_{FB} were obtained as functions of I_b . V_{be} and V_{FB} (as functions of I_b) are given in Fig. 7, while Fig. 8 gives their difference V_x , also as a function of I_b . It will be seen that the latter curve indicates a maximum value of V_x at an I_b of 18nA, corresponding to I_{min} in the theoretical discussion given above. By obtaining values of dI_b/dV_x from the curve in Fig. 8, the curves in Fig. 9 were obtained, depicting the product

$$\left(\frac{I_{in} - I_b}{C}\right) \frac{dI_b}{dV_x}$$

for values of I_{in} equal to 10, 15, 17, and 19nA. It will be seen that, for $I_{in} = 17nA$, the rate of change of base current falls to zero at $I_b = I_{in}$; whereas, for $I_{in} = 19nA$, i.e. slightly in excess of I_{min} , the rate of change rises precipitately as the base current passes through I_{min} . It is thus clearly shown that, for an input current very nearly equal to I_{min} (18nA), any spurious voltage transient, leading to even a slight increase in I_b , will cause the Schmitt, in this condition of unstable equilibrium, to trigger as described in the discussion above.

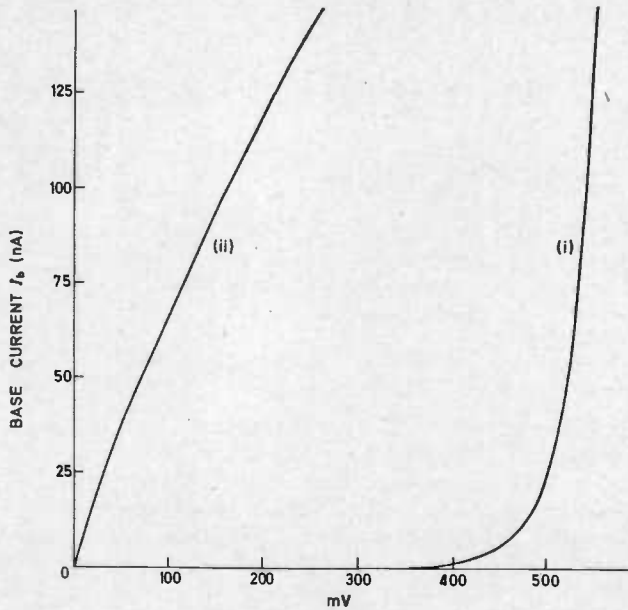

Fig. 7 Experimental curves (i) V_{be} versus I_b (ii) V_{FB} versus I_b

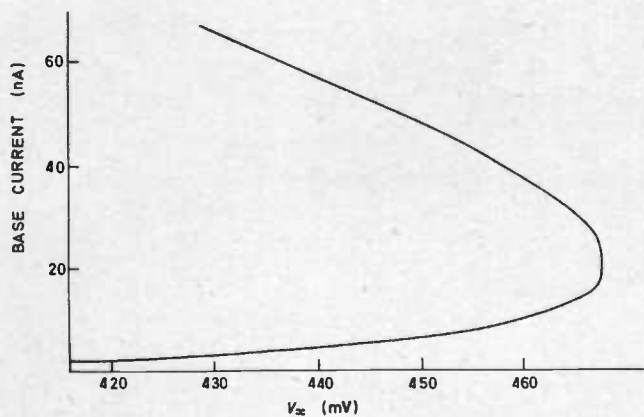
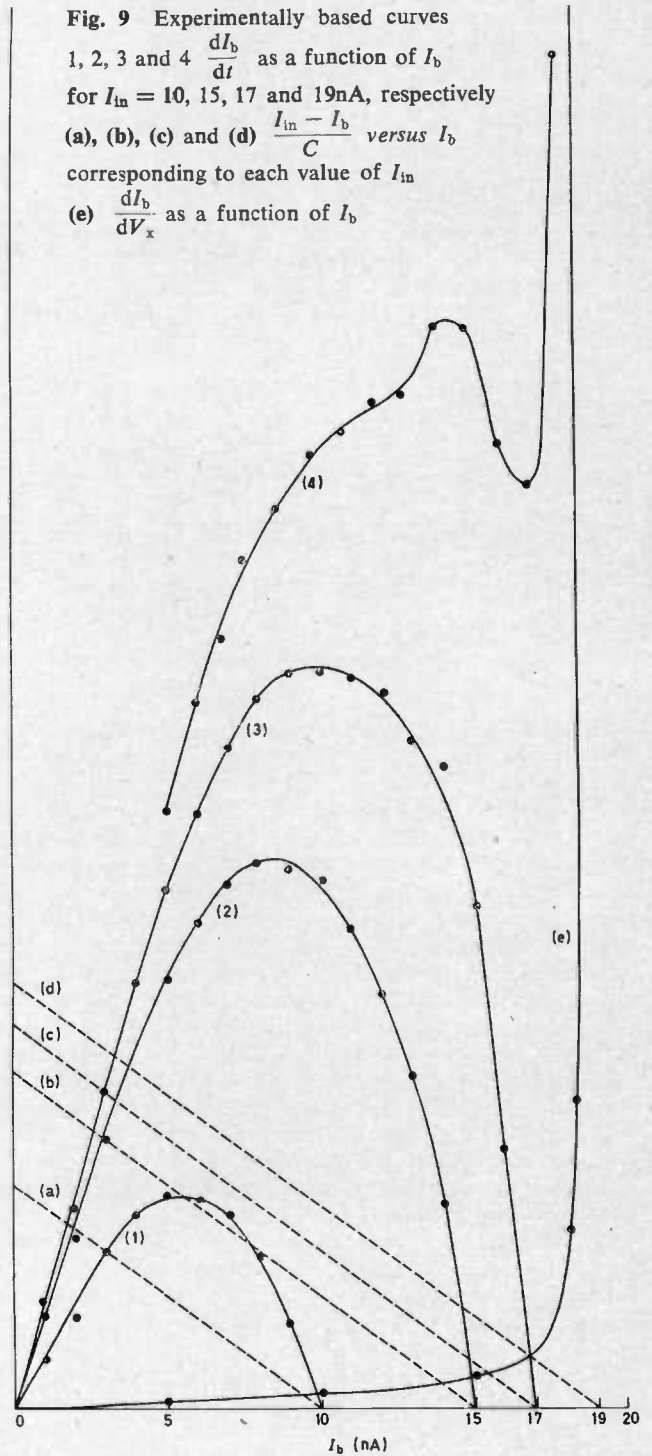

Fig. 8 Experimental curve of V_x versus I_b

The circuit used to determine the minimum current required to trigger the Schmitt is shown in Fig. 10. The voltage-dividing box (VDB) was adjusted very carefully until the galvanometer spot indicating the base current, after having taken up a stable deflexion, required an extremely small increase only in the VDB reading to cause it to deflect very slightly further to a new position which it would occupy for a time of the order of tens of seconds, after which the Schmitt would, in general, trigger spontaneously as a result of a random voltage transient. The base current corresponding to this condition, was found to be 18.0nA, in precise agreement with I_{min} as determined from Fig. 8.

Fig. 9 Experimentally based curves 1, 2, 3 and 4 $\frac{dI_b}{dt}$ as a function of I_b for $I_{in} = 10, 15, 17$ and $19nA$, respectively (a), (b), (c) and (d) $\frac{I_{in} - I_b}{C}$ versus I_b corresponding to each value of I_{in} (e) $\frac{dI_b}{dV_x}$ as a function of I_b



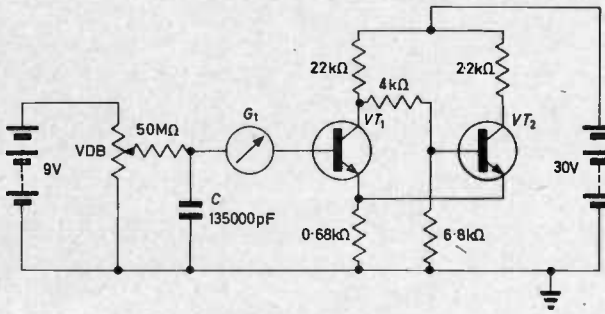

Fig. 10 Determination of I_{min}

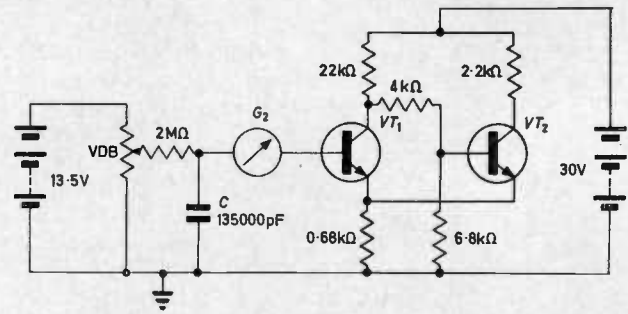

Fig. 11 Determination of I_{max}

The maximum limit to the input current was determined using the circuit in Fig. 11. The Tinsley galvanometer was used to measure the base current, and the VDB was again very carefully adjusted, this time to a setting for which the Schmitt just triggered once, but failed to reset. The value found was $2.6\mu A$, in excellent agreement with the theoretically predicted value of $2.7\mu A$ (see above).

Acknowledgments

The authors wish to thank P. Wilson for his assistance in the experimental work.

References

- 1 SCHMITT, O. H.: *J. Sci. Instrum.* 15, 24 (1938)
- 2 HAMPSHIRE, D. W. H., and PETERSON, D.: *Electronic Engng.* 39, 38 (1967)

Timing unit for control of stimulation signals

by K. J. Kapota, *University of Oxford Institute of Experimental Psychology*

This article describes a general-purpose time-interval generator with a variable duty cycle (range 1 to 100s) for use in experimental psychology and physiology. The instrument utilizes the properties of the unijunction transistor to produce a scale linearity of $\pm 5\%$ over a 10:1 time range.

(Voir page 798 pour le résumé en français: Zusammenfassung in deutscher Sprache auf Seite 800)

RESEARCH in experimental psychology and physiology is expanding rapidly, creating a wide variety of problems to be solved by the electronics engineer¹. On examination, much of the research, although very different phenomena are being investigated, can be supported by instruments consisting of a number of basic circuit modules. A common problem involves the time control of signals (visual or auditory displays or electrical stimulation of the brain) which have to be produced for a given period at a given frequency. Different circuits have been used in the three fields indicated, and a number of transistor designs, particularly for neurophysiological work^{2,3}, have been published. However, most circuits deal with signals operating for less than a second, with intersignal intervals of the order of a few seconds at the most; and in many experiments much longer time intervals are involved. The circuit presented here, for example, was used in controlling stimulation applied to the brain, and the ranges required were 1 to 10 and 10 to 100s.

As the parameters of stimulation and display become increasingly critical, it is desirable to have a design philosophy which improves the flexibility of the equipment needed. Modular construction assists this requirement in general, and separation of the time control from the stimulation source aids this particular design.

The method of generating time-interval pulses normally involves the charging of a capacitor C_t from a fixed voltage V through a resistor R_t . When the voltage across

the capacitor has reached a defined level, it is discharged, marking the end of the time interval. For periods of $10\mu s$ to 1s, common transistor circuits can be used; but difficulties occur in the design of conventional multivibrators when they are used to generate time intervals of more than 1s. The value of R_t is limited by the base current necessary to saturate the transistor in the conducting state. The capacitor leakage current increases with increasing values of C_t and imposes a severe limitation on the maximum working period and time-scale linearity of the circuit. Conventional transistor multivibrators can be improved by various techniques^{4,5}, but these circuits were found unsuitable as variable-period generators. From the many circuits and devices examined, the simplest and most reliable circuits were found to be those using unijunction transistors.

Unijunction transistor astable circuit

The basic characteristics of the unijunction transistor (u.j.t.) have been described in detail over the past few years^{4,6,7,8}. A common u.j.t. astable circuit is shown in Fig. 10. The timing capacitor C_t is charged from V_{bb} through R_t . The voltage across C_t increases until the unijunction emitter E has reached the peak-point voltage V_p . The capacitor is discharged through the emitter, base B_1 and R_1 until the emitter ceases to conduct, and the cycle is repeated. An output pulse with a period defined by R_t , C_t , V_p and V_{bb} is available across R_1 .

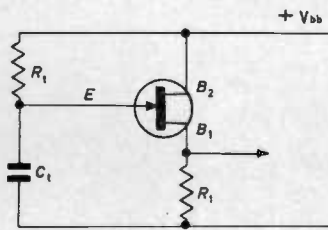

Fig. 1 Common unijunction-transistor astable circuit

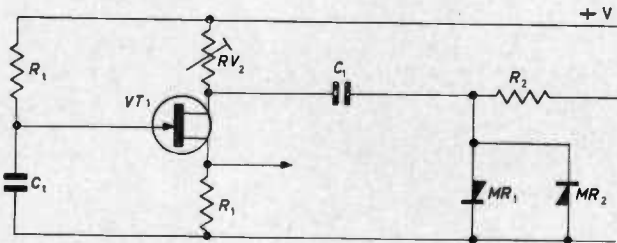

Fig. 2 Circuit with unijunction base B_{11} modulated

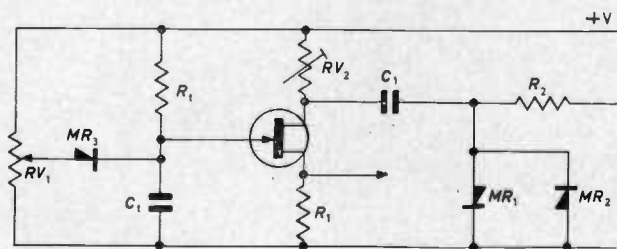

Fig. 3 Alternative method for controlling the period of oscillation

The emitter current I_p required to trigger the unijunction transistor imposes a maximum value on R_t of about $3M\Omega$. With a nonelectrolytic capacitor of $2.2\mu F$, a period of about 5s can be obtained (see Appendix). The value of R_t can be increased to $100M\Omega$ if the unijunction base B_{11} is modulated as shown in Fig. 2. The preset resistor VR_2 provides a degree of control over V_p . The function of the low-voltage 50Hz signal is to reduce the peak-point voltage V_p , thus allowing the u.j.t. to trigger. As the emitter voltage increases with the charging of C_t , the emitter draws negligible current until it reaches V_p . If the value of R_t is too high, the emitter current I_p is not available to trigger the unijunction transistor. The modulation signal reduces V_p below the voltage across C_t , and the capacitor supplies the necessary current to trigger VT_1 . With $R_t = 100M\Omega$ and $C_t = 2.2\mu F$, the pulse period $T = 180s$.

For a variable-period pulse generator, a charging resistor

consisting of a $100M\Omega$ potentiometer is not practical. An alternative method of controlling the period of oscillation is shown in Fig. 3. The voltage across C_t is biased from VR_1 through a low-leakage silicon diode MR_3 . The variable element can now be of reasonable value, and a $10k\Omega$ 10-turn helical potentiometer was used in this design.

Monostable circuit

The monostable circuit is a development of the astable circuit. The unijunction transistor is coupled to a conventional bistable circuit as shown in Fig. 4; the charging of C_t is now controlled by the state of transistor VT_2 . The quiescent state of the bistable circuit is VT_1 OFF and VT_2 ON, which prevents C_t from charging above the voltage set by VR_1 . Provided that this voltage is below the peak point V_p of the unijunction transistor, the circuit will remain in this stable state. A positive trigger pulse at the base of VT_1 causes the bistable to change state, i.e. VT_1 ON and VT_2 OFF. The capacitor C_t is now charged through R_t from V ($R_2 \ll R_t$) until the voltage across C_t has reached V_p , and VT_3 is triggered. The positive output pulse, coupled through MR_4 to the base of VT_2 , triggers the bistable circuit which returns to the initial state VT_1 OFF, VT_2 ON. The diodes MR_4 and MR_5 prevent feedback to the low-impedance trigger sources from the bistable circuit.

Timing control unit

The complete circuit is shown in Fig. 5. The astable circuit drives the monostable stage which controls the ON-OFF state of the emitter-follower/relay circuit. The components are mounted on plug-in printed-circuit boards where possible, to form complete modules. For maximum flexibility, the timing capacitors (an inexpensive polyester $\pm 10\%$ type) are mounted on a separate board.

The calibration of the astable and monostable circuits is identical and can be carried out using a digital timer. The following calibration procedure will ensure scale coverage with the minimum adjustment:

- (i) The dial of the 10-turn potentiometer is adjusted to give equal scale overtravel.
- (ii) With the dial set at 1, the $10k\Omega$ preset resistor is adjusted to give 11.0V at the wiper of the helical potentiometer.
- (iii) The dial is now set to 10, and the $1k\Omega$ resistor is adjusted to obtain the required period.
- (iv) The dial is reset to 1, and the $10k\Omega$ preset adjusted to obtain the period required.
- (v) Stages (iii) and (iv) are repeated until the scale is covered and within the specification.

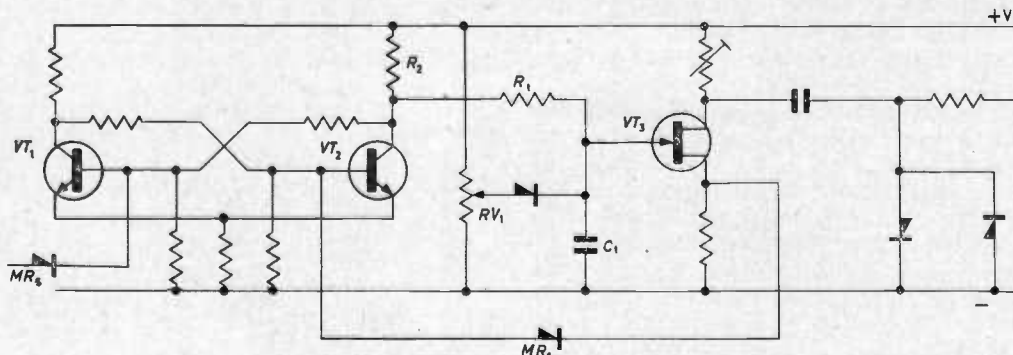

Fig. 4 Unijunction transistor coupled to a conventional bistable circuit

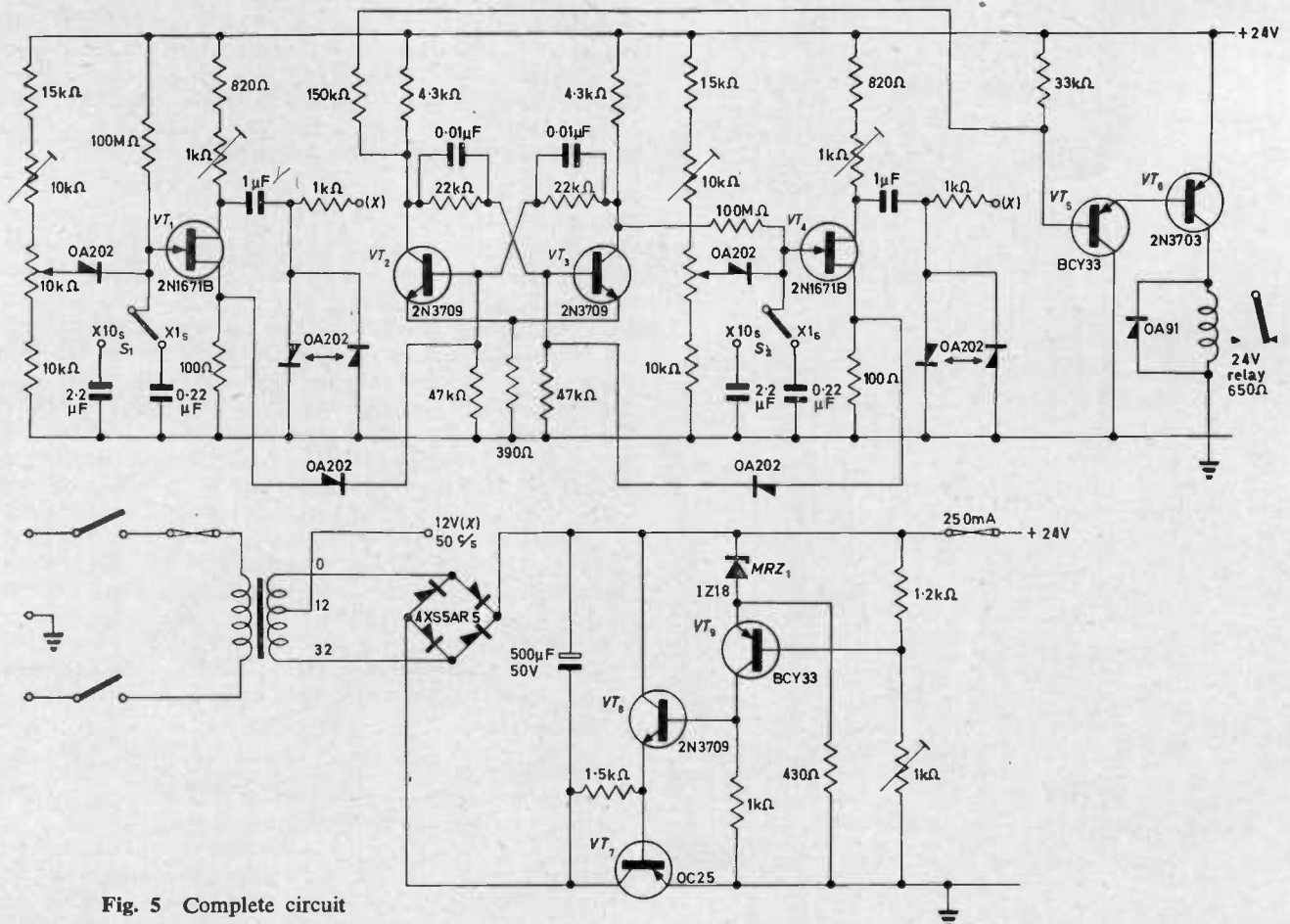

Fig. 5 Complete circuit

If this procedure is followed, the time taken for calibrating the circuits should be about 20min. With the polyester capacitors used (Mullard C281 and C296) range errors were well within specification.

Applications

The timing unit has been used to control the application of sine, square, triangular and sawtooth waveforms, for brain stimulation. Simple audio-amplifier and lamp circuits have also been controlled by the instrument. Using the circuit blocks, a multiple-process system can be built. Two separate monostable and output circuits can be synchronized by triggering them from a single astable circuit. If more than two monostable circuits are used (for programmed displays etc), emitter followers should be included to 'buffer' the output of the astable pulse generator.

Conclusions

The unijunction-transistor circuits described are useful as pulse and delay generators, for periods of more than 1s. Although the present instrument is used for stimulation control, the circuits can control a wide variety of processes. The relay output stage provides a flexible arrangement for research work, and both miniature and reed-type relays have been used in the output circuit. By forming banks of parallel polyester capacitors, time intervals of 500s have been recorded, giving stable results under normal laboratory conditions. The timing circuits do not require particularly well stabilized supply lines, but the potentiometer bias circuits must be fed from a constant-voltage source. The simple stabilized power supply is based on a published design⁹ and is suitable for the present specification. For input-voltage changes of $\pm 10\%$, and

load currents up to 250mA, the output-voltage change is less than 0.1%. The measured time-interval error due to this supply variation is less than 2%.

Acknowledgments

The author wishes to express his thanks to S. Graham for his technical assistance, and to the Director of the Institute of Experimental Psychology for the laboratory facilities provided at Oxford. The work reported here was sponsored in part by the US Air Force Office of Scientific Research under Grant AF EOAR 64-2; financial support was also received from the Science Research Council.

Appendix

A first-order approximation for the oscillation period is

$$T = C_t R_t \log_e \frac{1}{1-z}$$

where z is the intrinsic standoff ratio and defined in terms of the peak-point voltage V_p by the equation

$$V_p = zV_{bb} + V_d$$

The voltage V_d is the forward volt drop across the diode formed by the $E-B_1$ junction.

References

- 1 SIDOWSKI, J. B. (Ed): *Experimental methods and instrumentation in psychology*. McGraw-Hill
- 2 CATTON, W. T., and MOLYNEUX, L. E.: A physiological stimulator using junction transistors, *Electronic Engng.* 32, 301 (1960)
- 3 CATTON, W. T.: A transistorised double-pulse stimulator for use in neurophysiology, *ibid.* 35, 427 (1963)
- 4 PINTO, J. J.: Semiconductor time-delay circuits, *ibid.* 36, 433 (1964)
- 5 TOWERS, T. D.: *Elements of transistor pulse circuits*. Iliffe
- 6 *G.E.C. Transistor Manual*. General Electric Company
- 7 JOYCE and CLARK: *Transistor-circuit analysis*. Addison-Wesley
- 8 HENLY, H. R.: The unijunction transistor, *Wireless World* 70, 3 (1964)
- 9 COLLINS, D. J.: A simple high-performance series stabiliser, *Electronic Engng.* 36, 435 (1964)
- 10 YOUNG, J. F.: Timers using unijunction transistors, *Electronic Engng.* 39, 621 (1967)

Train decade counter

by R. P. Ingram, B.Sc.(Eng.), C.Eng., M.I.E.E.

This article describes the principle, design and use of the train decade counter. Its cost and complexity are compared with that of the binary counter to demonstrate its suitability for industrial use.

(Voir page 798 pour le résumé en français: Zusammenfassung in deutscher Sprache auf Seite 800)

THE train decade counter can be constructed from any form of logic, and consists, in essence, of a shift register containing five stages of flipflop, the output being reverse-connected to the input. The register then forms a ring of flipflops rather like the topological analogue of the Möbius strip. Correspondingly, if a train of 0s is initially set up in each stage of the register and the train is pulsed round with count pulses, as each 0 leaves the last stage of the register it arrives at the first stage transformed into a 1. Thus, after two pulses there are two 1s etc., until after five pulses there are five 1s. The departure of the 1s from the last stage then similarly brings about the entry of 0s at the first stage. The truth table for this counter is shown in Table 1. It can be seen that a train counter of n stages is able to count up to $2n$. The train decade counter therefore requires five stages as compared with the four stages which would be required by the equivalent binary counter.

Table 1 Train-counter truth table

Count pulse	State of stores or flipflops after pulse				
	A	B	C	D	E
0	0	0	0	0	0
1	1	0	0	0	0
2	1	1	0	0	0
3	1	1	1	0	0
4	1	1	1	1	0
5	1	1	1	1	1
6	0	1	1	1	1
7	0	0	1	1	1
8	0	0	0	1	1
9	0	0	0	0	1

Logic elements

The use and cost of the train counter will be considered by comparing its construction with that of the binary counter using integrated logic elements of the type most used in industry at present. These are the NAND gate with positive-going signals and the master-slave JK flipflop.

This particular NAND gate always gives a positive output 1, except when all positive input signals are present, whereupon a 0 is produced at the output. The same NAND gate, when used so that the negative signal is considered as 1, becomes a NOR gate; but, as the positive logic is most favoured, the NAND gate will be used for this investigation. The graphic representation of the NAND gate is shown in Fig. 1.

The form of the master-slave JK flipflop is shown in Fig. 2. Information is made available to the slave store through inputs J and K . Occurrence of the trigger pulse permits acceptance of the input information to the slave store and subsequent isolation of the inputs; so that, as this information is transferred from the slave to the master store, alteration of the JK inputs does not interfere with the transference of the original information.

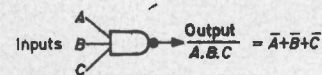

Fig. 1 NAND gate

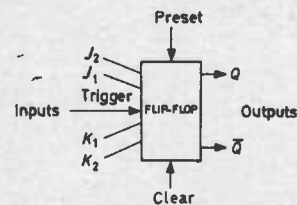

Fig. 2 Master-slave JK flipflop

Using integrated-circuit elements, a dual JK flipflop is a single package containing two flipflop units, each usually having one J input and one K input connection. The single JK flipflop package, however, often has several JK inputs; so that $J = J_1 J_2 J_3$ etc. and $K = K_1 K_2 K_3$ etc. CLEAR and PRESET inputs are available for initially setting the output Q and its inverse \bar{Q} . The truth table for a JK flipflop with no inversion between the J input and Q output is shown in Table 2. At the instant t_n , the J and K columns show the initial setting of these inputs, and after the trigger pulse, at t_{n+1} , the new output setting is indicated in the Q column.

Table 2 Truth table for the JK flipflop used

t_n		t_{n+1}
J	K	Q
0	1	0
1	0	1
0	0	Q_n
1	1	\bar{Q}_n

Unidirectional counter

The connection of a unidirectional train counter using the JK flipflops is shown in Fig. 3. The five stages are directly connected together in a simple repetitive way, without the need for any additional gates. An equivalent

decade of binary counters is shown in Fig. 4; this uses only four JK flipflops, but requires considerably more gating. Its connection is complicated and not repetitive.

It will be noticed that both of these types of counter are synchronous in operation; i.e. as each count impulse occurs, all the stages which are to change state do so at the same instant. This property is inherent in the train counter, but will not be present in the simpler and cheaper

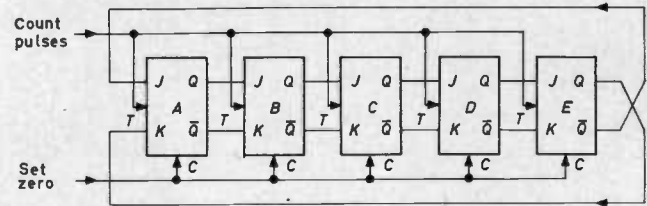

Fig. 3 Unidirectional train counter using five JK flipflops

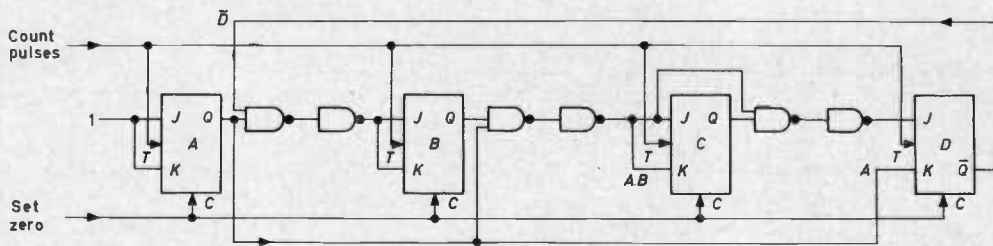

Fig. 4 Unidirectional binary decade counter for synchronous operation

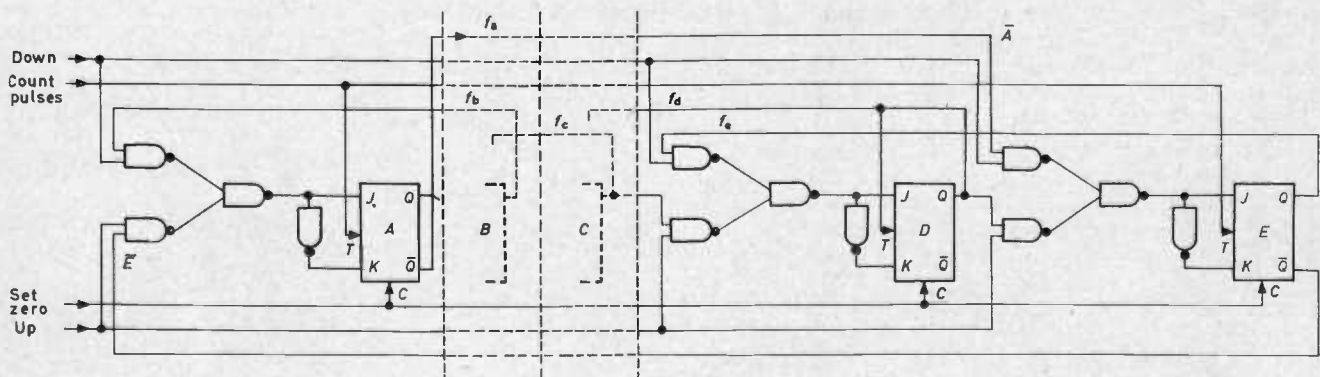

Fig. 5 Bidirectional train counter

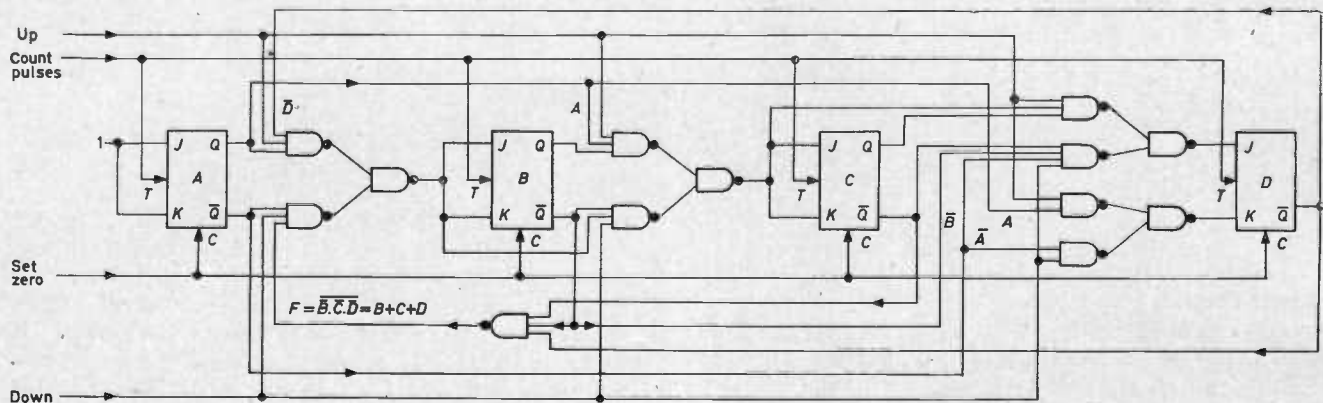

Fig. 6 Bidirectional binary decade counter

ripple-through binary counter. Ripple-through counters can be obtained in the form of one logical package, and are admirably suitable for applications such as frequency division. However, during the time taken for the effects of each input pulse to ripple through the counter, many misleading combinations of states occur, which, if used for numeric comparison, would give a wrong output and possibly put the system into the fault condition. Therefore the ripple-through counter is unsuitable for comparative work and the synchronous counter is to be preferred for general-purpose operation.

Both the counters shown are set to zero by the application of a suitable voltage level which clears all stages to the 0 condition. Other impulse methods of zero setting are used, but they will not be considered in this article.

Bidirectional counter

The connection of a bidirectional train counter is shown in Fig. 5 and its corresponding synchronous binary counterpart in Fig. 6. In each case, the count direction lines must be held with the logical 1 applied to the required direction line only, and the potential of these lines must not be allowed to change during the duration of an actual count pulse. Although many variations in the design of the binary counter are possible, the design shown is considered to be typical from the aspect of minimal gating configuration. The train counter has an attractive symmetry, although it needs a rather high number of gates when using the *JK* flipflops. The binary version uses fewer gates, but suffers from a high internal usage of output connexions, which, as a consequence, are unavailable for external switching. This limitation is further increased by the lower number of output connection points existing. However, the *JK* flipflop is particularly suited to the binary counter, as its unique input mechanism is fully exploited, thus giving economy of design.

Looking ahead

At each *JK* flipflop input of the train counter shown in Fig. 5, there are four NAND gates. The gate which shunts the *JK* input in conjunction with the *JK* flipflop is equivalent to a *D* flipflop, as shown in Fig. 7. The *D*

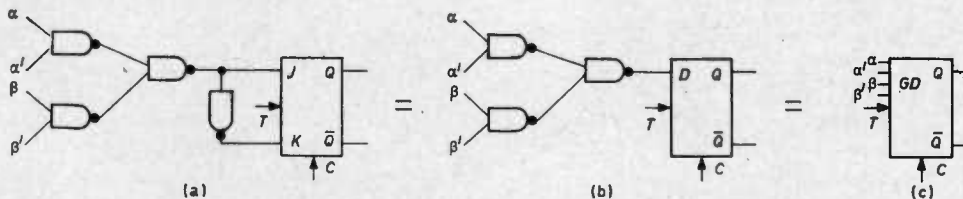

Fig. 7 (a) *JK* flipflop gated for bidirectional train counting (b) Equivalent *D* flipflop (c) Gated-*D* flipflop, where $D = \alpha\alpha' + \beta\beta'$

flipflop operates by transferring the *D*-input to the *Q*-output on application of the trigger pulse. Each *JK* flipflop with its four input gates can therefore be replaced by a *D* flipflop and three input gates. This is not entirely convenient, as a whole decade would require five half-dual-*D* flipflops, and fifteen quarter-quadruple 2-input NAND gates. The most satisfactory solution would be the inclusion of the three gates into a *D* package to form a gated-*D* element. A versatile bidirectional train counter could then be constructed by the simple direct connexion of five of these *GD* flipflops, whereby a considerable saving in complexity and cost could be achieved. The quantity production of this item should be well justified by demand for applications in both counters and shift registers. Most integrated-circuit packages have sufficient connexion leads for the inclusion of a *GD* flipflop.

Decoding

The operation of this counter is that the train of 0s set up initially is pulsed round so that, after five pulses, it appears as a train of 1s, having made a complete rotation around the ring, and after another five pulses it again arrives back as a train of 0s. It may be seen from the truth table (Table 1) that, in any particular count condition, some of the consecutive flipflops will be in one state, and the remainder in the opposite state. The magnitude of the stored number will be dependent on the

Table 3 Gate connexion for decoding decade train counter

AND gate output=1	Number indicated
\overline{AE}	0
$A\overline{B}$	1
$B\overline{C}$	2
$C\overline{D}$	3
$D\overline{E}$	4
AE	5
$B\overline{A}$	6
$C\overline{B}$	7
$D\overline{C}$	8
$E\overline{D}$	9

location, and the direction of the transition between the two states. Table 3 shows that, for each decimal output an AND gate with two inputs connected to the various flipflop *Q* and \overline{Q} outputs is required to detect each relevant transition. A total of ten 2-input gates is necessary for the decoding of one decade of train counter.

Indication of zero occurs when $\overline{AE} = 1$. Using only NAND gates, *A* would be gated with *E* into a 2-input gate, but this gate would need to be followed by another

inverting NAND gate in order to obtain the AND function. If either simple AND gates or NOR gates were available, this last stage of gating would be eliminated. The NOR gate uses the principle $\overline{AE} = \overline{A+E}$ with inputs *A* and *E*. The corresponding binary counter requires a maximum of four inputs to each of its set of ten gates. As there are certain redundant combinations of the four flipflop outputs, it can be shown that, in fact, two 4-input gates, six 3-input gates, and two 2-input gates are required, again followed by inverting gates, if NAND gates are used exclusively.

Number comparisons

Many control systems call for a comparison of the accumulated number in a counter with a preset number, in

order to determine which is the larger. This can be conveniently carried out with the train counter, because of its overlapping pattern of output states. Consider initially one decade of counter, and the preset number available as one line only bearing a 1 from a group of ten. The number comparison can be made for each preset number outlet by AND gating the two counter outputs corresponding to all lower numbers. Should any one of these gates produce an output, the preset number P exceeds the accumulated number T .

Thus, if the counter outputs are labelled t_a, t_b, t_c, t_d, t_e , respectively, and the preset outlets p_0-p_9 , $P > T$ when

$$p_1 t_a t_e + p_2 t_b t_e + p_3 t_c t_e + p_4 t_d t_e + p_5 t_e + p_6 t_a + p_7 t_b + p_8 t_c + p_9 t_d = 1$$

i.e. $P > T$ when

$$t_e(p_1 t_a + p_2 t_b + p_3 t_c + p_4 t_d + p_5 + p_6 + p_7 + p_8 + p_9) + p_6 t_a + p_7 t_b + p_8 t_c + p_9 t_d = 1$$

The latter form will probably lead to a more practical arrangement if interpreted in terms of NAND gates (each with less than eight inputs). This logical arrangement is shown in Fig. 8, and uses 16 NAND gates.

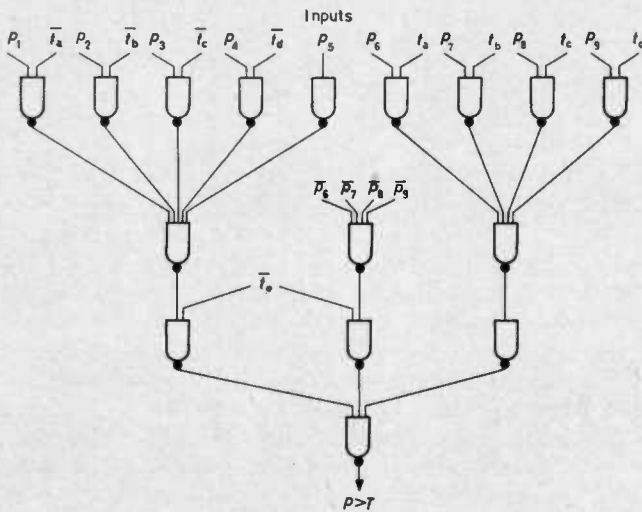

Fig. 8 Gates for comparison of preset decimal number P with train-counter number T

Similarly, for the accumulated number to exceed the preset number, $T > P$ when

$$t_0(p_0 + p_1 + p_2 + p_3 + p_4 + p_5 t_a + p_6 t_b + p_7 t_c + p_8 t_d) + p_0 t_a + p_1 t_b + p_2 t_c + p_3 t_d = 1$$

Thus, for one decade, determination of $P > T$ and $T > P$ can be made and consequently $P = T$ is apparent when both $P > T$ and $T > P$. Once any two conditions are known, the third follows automatically.

The parity condition can be determined separately by

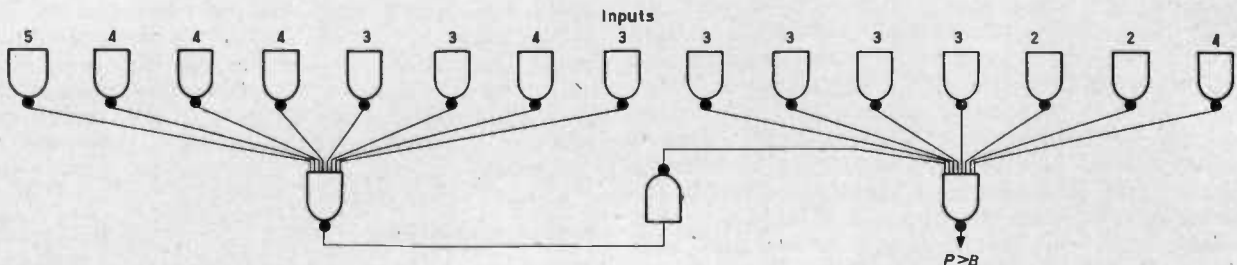

Fig. 9 Gates for comparison of preset decimal number P with binary-counter number B

gating each counter output condition directly with the preset number outputs. This direct determination of parity involves a similar number of gates, with possibly more gate inputs than the greater-than or less-than comparison.

The gating arrangement of a similar numeric comparison using a binary decade counter is shown in Fig. 9. This necessitates the use of 18 NAND gates, mostly with many input connexions, which throw an excessive load on to the binary-counter outlets. Additional gates and regrouping may be necessary in order to reduce the number of input connexions. If the binary number B is represented by b_a, b_b, b_c, b_d , and the preset number P as before, one possible logic comparison relating to Fig. 9 gives $P > B$ when

$$p_1 \bar{b}_a \bar{b}_b \bar{b}_c \bar{b}_d + p_2 \bar{b}_b \bar{b}_c \bar{b}_d + p_3 (\bar{b}_b \bar{b}_c \bar{b}_d + \bar{b}_a \bar{b}_c \bar{b}_d) + p_4 \bar{b}_c \bar{b}_d + p_5 (\bar{b}_c \bar{b}_d + \bar{b}_a \bar{b}_b \bar{b}_d) + p_6 (\bar{b}_c \bar{b}_d + \bar{b}_b \bar{b}_d) + p_7 (\bar{b}_a \bar{b}_d + \bar{b}_b \bar{b}_d + \bar{b}_c \bar{b}_d) + p_8 \bar{b}_b + p_9 (\bar{b}_d + \bar{b}_a \bar{b}_b \bar{b}_c) = 1$$

A similar relationship and comparison holds for $B > P$.

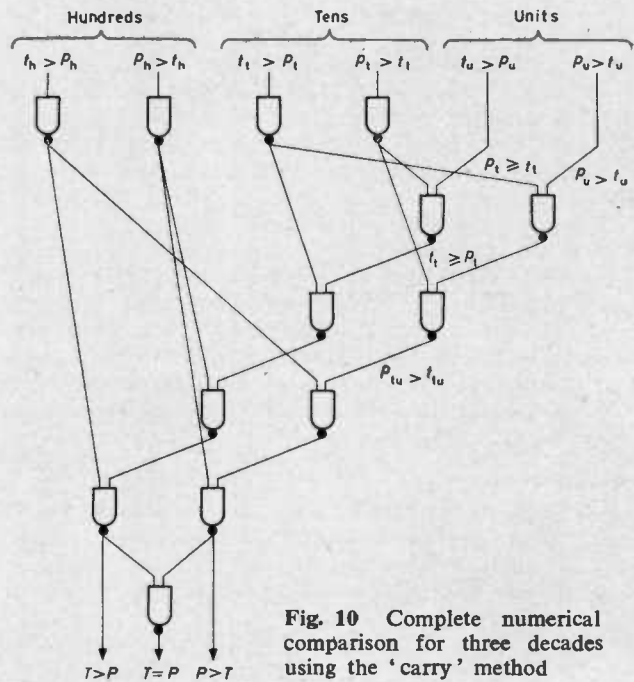

Fig. 10 Complete numerical comparison for three decades using the 'carry' method

For completeness, Fig. 10 is included to show the 'carry' method of number comparison for interconnexions between three decades. This gives an overall indication of $A > B$, $A = B$, $A < B$, and is applicable to any type of counting system.

Conclusions

Using JK flipflops, the unidirectional train counter is cheaper than the binary counter, and its arrangement is

simpler and more repetitive. Decoding is also cheaper and simpler as fewer connections are required. The binary counter with decoding may cost over 20% more than the unidirectional train counter with its decoder. In practice, the form of decoding described is unlikely to be used, as it is more usual to use special AND gates, or lamp driving gates. The relative saving in cost may then show up to an even greater extent with these special gating elements. The bidirectional train counter using JK flipflops is basically slightly dearer than its binary counterpart, but this difference tends to be offset when the cost of decoding is included. When numerical comparisons are involved, the cost of the train equipment becomes significantly lower than that of the binary equipment. Because of the greater external switching capability of the train counter, in conjunction with the lower loading requirements of its processing equipment, the train counter readily allows for the connection of a much greater variety of external equipment without need for substantial signal reinforcement.

It is expected that the development of the gated-D type of flipflop would allow the basic cost of the bidirectional train counter to fall below that of the binary counter, and a standard counter of this form would be sufficiently adaptable to be included into any industrial counting system.

APPENDIX

To give an idea of the relative costs of the different counting and gating methods, average market prices of integrated-circuit elements are used to compute the element

cost of each configuration. Obviously, absolute prices vary considerably between manufacturers, but the figures give a fair indication of the sums involved. The costs of printed boards, connexions etc. are ignored as these are assumed either proportional to element cost or constant.

Estimated average prices

Single 8-input NAND gate £2.9
 Double 4-input NAND gate £3.3
 Treble 3-input NAND gate £4.2
 Quadruple 2-input NAND gate £4.0
 Single JK flipflop £3.8
 Dual JK flipflop £5.6
 Single gated-D flipflop £5.6

Relative circuit costs per decade

Arrangement	Train	Binary
Unidirectional counter	£14	£17.2
Bidirectional counter	£34*	£27.3
Decoder	£20	£23.7
Single-stage number comparison $P > T(B)$	£17.6	£29.7
Unidirectional and decoding	£34	£40.7
Bidirectional and decoding	£54	£51
Bidirectional and complete numerical comparison	£69.2	£86.7

* Using gated-D flipflops, this is reduced to £28

Reference

1 *Silicon Micronor II circuits*, 29, Ferranti handbook (Oct. 1965)

Example of digital-to-analogue conversion

by W. Olthoff, *European Atomic Energy Community, Petten, Netherlands*

A situation requiring the continuous monitoring of small fluctuations in large signals is explained, and a system for providing an analogue output for the lowest two digits of a five-figure voltmeter is described which has an accuracy within 1% of the fourth digit, allowing small fluctuations to cover the full width, instead of a tiny fraction, of a stripchart recording.

(Voir page 799 pour le résumé en français: Zusammenfassung in deutscher Sprache auf Seite 800)

FOR many purposes it is necessary to record small perturbations of large signals, such as high-temperature-thermocouple voltages. As a rule, normal stripchart recorders are not sensitive enough for this purpose; moreover, the zero suppression is not very stable. In certain experiments, it was required to record temperature fluctuations of 1degC in a furnace with a temperature of 1000 degC, using a Pt-PtRh thermocouple; this represents 10µV on a total voltage of about 10mV. To overcome the difficulties of lack of accuracy and sensitivity in stripchart recorders, a digital voltmeter having a resolution of 10µV on the 300mV range was obtained. The instrument has five digits, and is calibrated by means of a built-in standard cell. When temperature recordings are made using this instrument, a digital printer may be connected to it. Dis-

advantages of these printers are that the information is stored in the form of ciphers instead of a curve, the time scale is not always very clear, the recording is not continuous, and it is noisy. If the output of the lowest one or two digits could be made analogue, so that a normal stripchart recorder could be connected, all the disadvantages of a digital printer would be avoided. The fluctuations could be recorded over the full width of the stripchart, and, apart from measuring the total voltage, the digital voltmeter would take over the function of an accurate linear preamplifier with stable zero suppression for the stripchart recorder.

In this report, a system is described which provides the digital voltmeter with an analogue output for the lowest two digits, having an accuracy of 1% of the fourth digit.

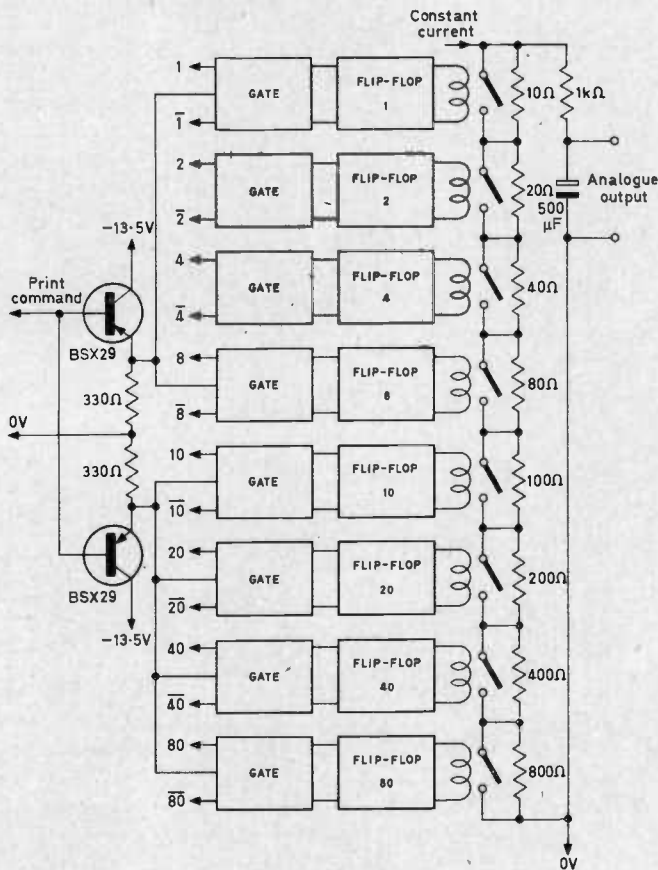

Fig. 1 General assembly

Principle

As in many binary systems, the digital voltmeter used utilizes counting decades, each containing four flipflops, working according to the natural binary code. Each flip-flop has two outputs, one of them giving the ON-OFF information. At adjustable time intervals, all the information is wiped out by resetting all flipflops, and information according to the new situation is stored; this is known as sampling. For continuous measurements, the sampling rate should be as high as possible, for instance 10/s. During sampling, no information is available—an intolerable situation when a continuous recording must be made. So the first step is to provide every flipflop in the decade with a memory flipflop of the r.s. (reset-set) type, carrying the same information as the original counting flipflop but bridging the sampling 'dead' times.

The second step is to use each memory flipflop to control an electromechanical relay which inserts or removes a resistor in a resistor chain. The value of the resistor must correspond to the numerical value assigned to the flipflop (Fig. 1). For instance, the 1—2—4—8 flipflops must control, respectively, resistors of 10, 20, 40 and 80Ω, and for the next higher decade 100, 200, 400 and 800Ω. Thus the total value of the resistor chain corresponds to the value indicated by the lowest two decades. The last step is to now feed the resistor chain from a constant-current supply, to give an analogue signal at the output.

In the described system, a constant current of 1mA was chosen, which gives 10mV over 10Ω, corresponding to 10μV at the input. In this way the gain is 10³. For insensitive recorders, the gain can easily be increased by choosing higher resistors or a higher constant current. The four highest resistors should have a 1% tolerance, while 5% is adequate for the four lowest resistors.

Circuit

First, the available signals at the digital-voltmeter output have to be verified. The levels and pulses shown in Fig. 2 were measured at the 50-way Amphenol output connector. The print-command signal gives a small positive step at the beginning of the sampling period and a large negative impulse immediately after sampling. At the flipflop outputs, a level of -20V means ON and a level of +10V means OFF; the contrary is the case on the inverted outputs. Outputs from these stages must not be loaded. The inverted outputs $\bar{1}$ and $\bar{10}$ were missing, and substituted by outputs from the two lowest decimal points. This was arranged by disconnecting the decimal-point outputs in the digital voltmeter, and connecting them to the flipflops.

Another item is the power supply: on the 50-way connector, 0, +9 and -10V are available; the -10V, however, cannot be loaded further. At the collector of VT_2^* , a level of -13.5V was measured, with a much greater capacity, and this voltage was used instead.

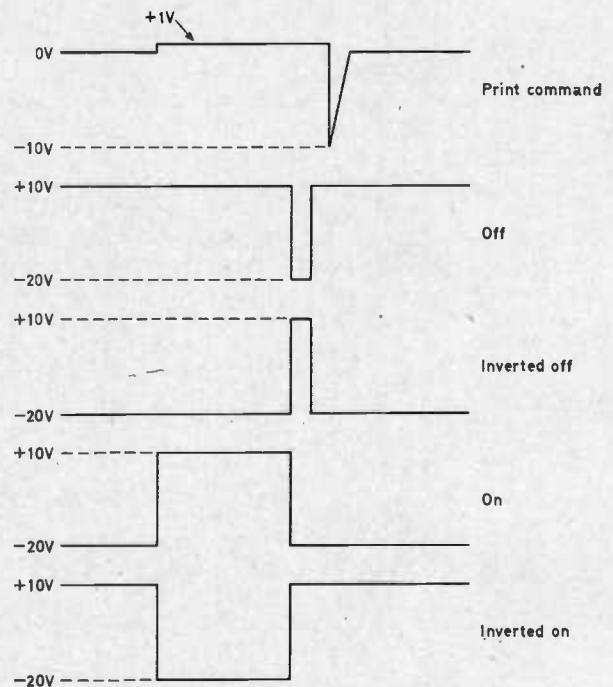

Fig. 2 Sampling: available signals

Fig. 3 shows how the output signals are handled. The print-command signal passes an emitter follower (BSX29), intended to drive a complete decade. Next it is fed into four twin gates, controlled by the outputs of the counter flipflops. Depending on the state of each flipflop,

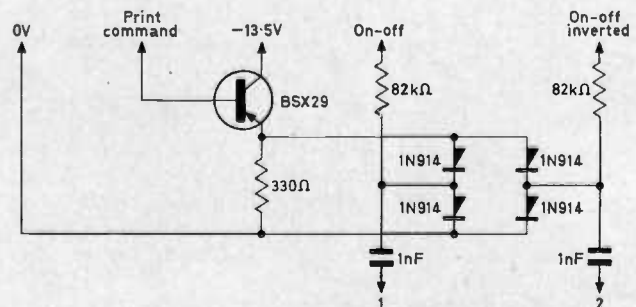

Fig. 3 Print-command driver and gate

* This refers to the instruction manual of the LM1440.2 voltmeter used

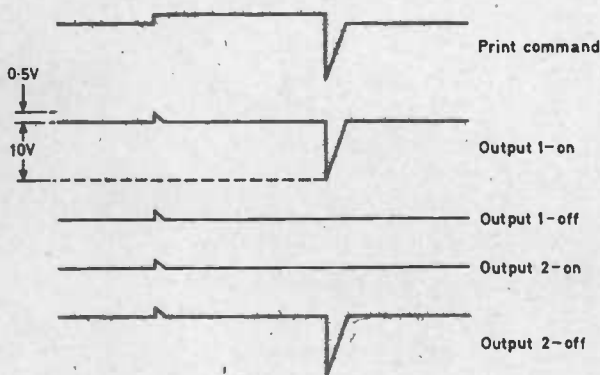

Fig. 4 Gate-output signals

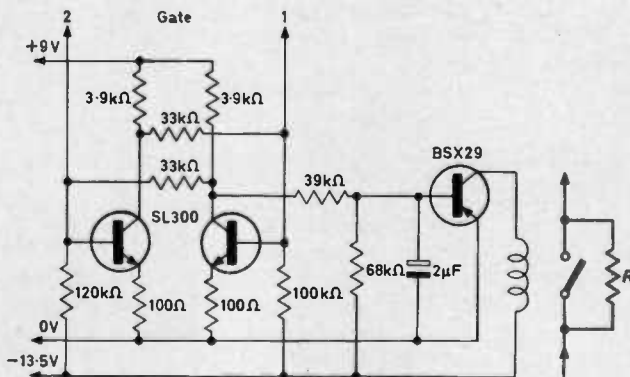

Fig. 5 Flipflop and relay stage

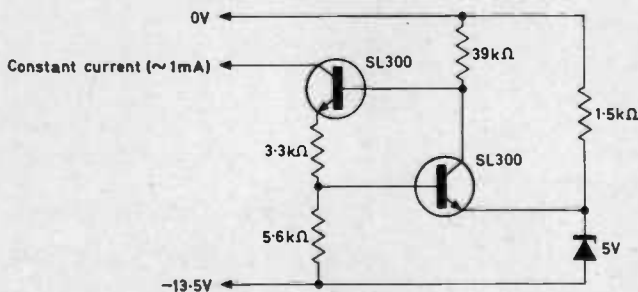

Fig. 6 Constant-current supply

the signal arrives at output 1 or 2 (Fig. 4). Outputs 1 and 2 are used to control a memory flipflop (Fig. 5). The emitter resistors of 100Ω are intended to limit the loading of the gate outputs and to obtain a certain feedback. As the SL300 transistors have a β of approximately 300, the input resistance of each transistor is of the order of $\beta R_e = 30k\Omega$. Together with the coupling resistances of $33k\Omega$, this makes about $15k\Omega$, or about $4k\Omega$ for one decade consisting of four flipflops.

Owing to feedback, the gain is roughly $R_c/R_e = 40$. Moreover, the bias of the conducting transistor is

$$V_{\text{bias}} = -13.5 + \frac{120(13.5 + 9)}{120 + 35 + 3.9} = -13.5 + 17 = +3.5\text{V}$$

(input current neglected) and of the nonconducting transistor,

$$V_{\text{bias}} = -13.5 + \frac{120(13.5 + 1)}{120 + 33} = -13.5 + 11.3 = -2.2\text{V}$$

No speed-up capacitors have been included, so that the flipflop is not too sensitive and random signals do not trigger it. The print-command signal is of the order of 10V, which is more than adequate for triggering.

The memory flipflop must now control a relay. A normal relay is too bulky and requires too much power; and so a dry magnetic reed was chosen, with a 12V coil of $1k\Omega$. The required 12mA is delivered by a driver transistor BSX29, which is in turn controlled by the flipflop through a divider of $39\text{-}68k\Omega$. The $2\mu\text{F}$ capacitor is included to bypass any signal coming directly from the gate.

The component parts are assembled as shown in Fig. 1. A constant current is fed to the resistor chain, while the $1k\Omega$, $500\mu\text{F}$ filter is intended to suppress peaks which are generated during the switching of the reeds. The circuit of the constant-current supply is given in Fig. 6. The voltage drop across the emitter resistor of a transistor is compared with a Zener reference. The difference is amplified and fed back to the base; thus the collector delivers a constant current.

Construction

The LM1440.2 digital voltmeter contains an empty plug-in unit at the rear, on which a 50-way contraconnector has been mounted. In this empty unit there is room for five or six printed-circuit cards of the Veroboard-304 type. It was possible to mount two complete units, each consisting of twin gate, memory flipflop, driver reed and resistor, on one printed-circuit card; four of these print cards are needed [Fig. 7(a)]. The five circuit connectors are mounted on an aluminium plate at the bottom of the plug-in unit, and a connector is mounted at the rear for the analogue output.

Operation

As seen in the circuit, the output voltage fluctuates between zero and -1V , for digital readings between 00 and 99. The output filter with ($1k\Omega$, $500\mu\text{F}$) has a time constant of 0.5s, which would suit most stripchart recorders. To check operation, a triangular waveform was applied to the digital voltmeter, and the analogue output signal recorded.

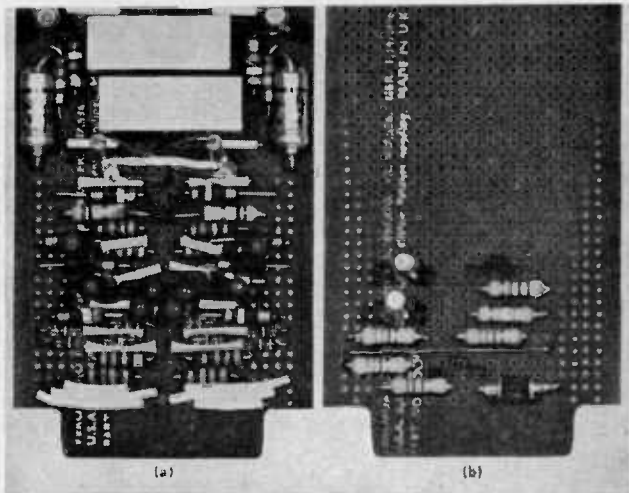

Fig. 7 Printed-circuit cards

- (a) Double flipflop and relay stages
- (b) Constant-current supply

When both the lower decades were read out, linearity appeared perfect, and no steps could be recognized. With only one decade, the steps were relatively larger and discernible. This could be overcome by introducing a larger time constant, at the price of increasing response-time. In practice, however, the steps may be neglected.

Voltage-to-frequency conversion

by B. D. Rakovich, Ph.D., and S. Tesic, *Electrotechnical Faculty, University of Belgrade, Yugoslavia*

Various collector- or emitter-coupled multivibrators used in voltage-to-frequency conversion are compared with the conventional collector-coupled multivibrator. A modified version of the basic multivibrator which uses only one additional transistor and two diodes is described, and it is shown that this circuit has some advantages when high input impedance, linearity of the frequency/control-voltage characteristic and temperature stability are all of importance.

(Voir page 799 pour le résumé en français: Zusammenfassung in deutscher Sprache auf Seite 800)

A NUMBER OF PAPERS have been published dealing with voltage-to-frequency converters based on magnetically coupled or RC-coupled multivibrators; although some very good results have been obtained using inductively coupled multivibrators with square-loop magnetic materials^{1,2,3}, voltage-to-frequency converters derived from collector- or emitter-coupled multivibrators⁴⁻⁹ are more commonly used, as they are more easily designed to prescribed specifications than other circuits, except in some specific applications. In this article, some well known multivibrator modifications are reviewed and their characteristics compared with those of the conventional collector-coupled multivibrator with variable base-bias supply. By adding one transistor in the common base lead, the input impedance of the conventional circuit can be increased without affecting either the linearity or sensitivity of the circuit.

Frequency control of conventional multivibrators

The frequency of oscillation of the free-running collector-coupled multivibrator (Fig. 1) can be varied by changing the voltage V_x to which the base resistors are connected. From the approximate expression for the frequency of oscillation

$$f = \frac{1}{2CR_b \log \left(1 + \frac{V_{\infty}}{V_x} \right)} \dots \dots \dots (1)$$

it can be seen that this simple circuit fails to maintain a linear relationship between the frequency of oscillation and the control voltage V_x . This is because the discharging current of the coupling capacitors is an exponential func-

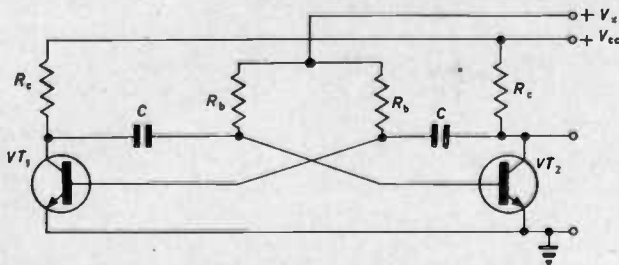

Fig. 1 Collector-coupled multivibrator with variable bias supply

tion of time instead of a constant determined by V_x . However, it has been shown by Hurst and Seal⁶ that the variation of frequency with control voltage can be made practically linear if the smallest value of V_x is higher than $V_{\infty}/2$. Karger and Wening⁸ have presented tables and graphs from which the minimum value of V_x/V_{∞} can be found for a given deviation of incremental slope from the mean slope in the specified frequency range.

In many applications, a high input impedance (looking towards the oscillator input terminals from the control voltage source) is required. Since the input impedance of the symmetrical multivibrator in Fig. 1 is approximately $R_b/2$, a high input impedance cannot be obtained unless an unreasonably high R_b is used. This may impair the working conditions of the transistors, which must be fully saturated when conducting. Another difficulty is that the sensitivity $\Delta f/\Delta V_x$ (defined in Hz/V) decreases rapidly with increasing R_b .

The modification of the basic circuit proposed by Hurst and Seal⁶ shown in Fig. 2 provides a higher input impedance approximately equal to R'_b and maybe in the range 100-200k Ω ; but the sensitivity remains very small, not exceeding tens of hertz for 1V change in the control voltage.

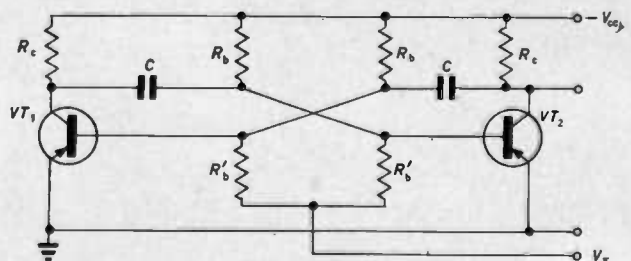

Fig. 2 Multivibrator with trimming frequency-adjustment voltage V_x

Multivibrator with constant-current charge

To obtain a more linear relationship between the operating frequency and the control voltage, Biddlecomb⁴ has substituted constant-current sources for base resistors in the conventional collector-coupled multivibrator, as shown in

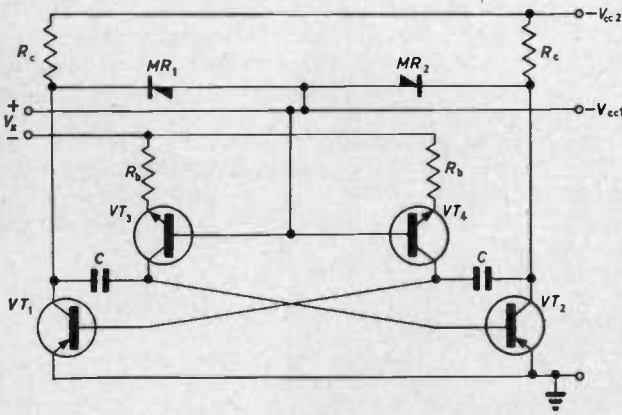

Fig. 3 Collector-coupled multivibrator with constant-current sources

Fig. 3. Subsequently, Shvetskiy, Yuzevich and Taranov¹⁰ have investigated the characteristics of this circuit and found that its temperature stability can be improved by using additional diodes in base and collector circuits. Neglecting the reverse currents of the transistors and the voltage drop across the diode and the saturated transistor, the frequency of oscillation of the symmetrical constant-current-charge multivibrator is approximately

$$f = \frac{\alpha_3}{2CR_b} \frac{V_x - V_{be3}}{V_{ce1}} \approx \frac{I}{2CV_{ce1}} \dots \dots \dots (2)$$

where $I = (V_x - V_{be3})/R_b$

= discharging current of the timing capacitor

$V_{be3} = V_{be4} =$ base emitter voltage of VT_3 and VT_4

and $\alpha_3 = \alpha_4 \approx 1 =$ common-base current gain of VT_3 and VT_4

The dependence of the base-emitter voltage of VT_3 and VT_4 on the voltage V_x constitutes the main cause of the nonlinearity of the frequency/control-voltage characteristic. A nonlinearity smaller than 1% per octave can be achieved¹⁰; the nonlinearity is defined as the departure of the frequency from the best straight line.

The impedance presented to the control-voltage source is relatively small, being approximately equal to $R_b/2$. The sensitivity $\Delta f/\Delta V_x$ depends on the resistors used in the emitter circuits of VT_3 and VT_4 ; but 500-1500Hz/V can be obtained readily. A very useful feature of this circuit is that it can be used both as narrow- and wide-range voltage-controlled oscillator. By appropriate design,

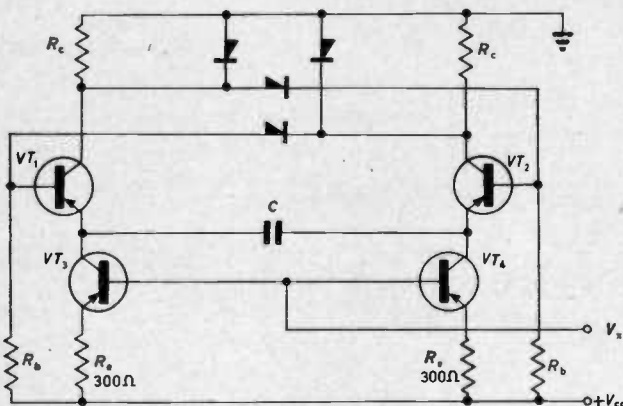

Fig. 4 Emitter-coupled multivibrator with constant-current sources

the frequency operating range can be extended to cover five octaves⁴.

Another circuit, described by Cooper⁵, with constant-current charge and suitable for wide-range operation, is shown in Fig. 4. An emitter-coupled multivibrator is used and the constant-current sources VT_3 and VT_4 are substituted for the transistors in the emitter leads of the basic emitter-coupled multivibrator circuit. The input impedance is approximately $\beta R_b/2$, where β is the current amplification factor in common-emitter connection. However, since R_b must be relatively small to maintain the proper operating conditions for VT_1 and VT_2 , only a moderate input impedance can be obtained. All other characteristics of this circuit are similar to those of the circuit in Fig. 3, except that the linearity of the frequency/control-voltage relationship is slightly inferior.

Finally, a novel converting circuit proposed by Jones⁹ is presented in Fig. 5; the timing networks, in which VT_5 and VT_6 are used instead of the base resistors in the conventional version of the circuit, are connected through the emitter followers VT_3 and VT_4 to the corresponding collectors of the transistors VT_1 and VT_2 . An extremely wide frequency range covering at least ten octaves can be obtained with this circuit, but the linearity and the temperature stability are considerably inferior when compared with those of the other circuits described, unless a rather complex stabilizing network employing several additional transistors is used.

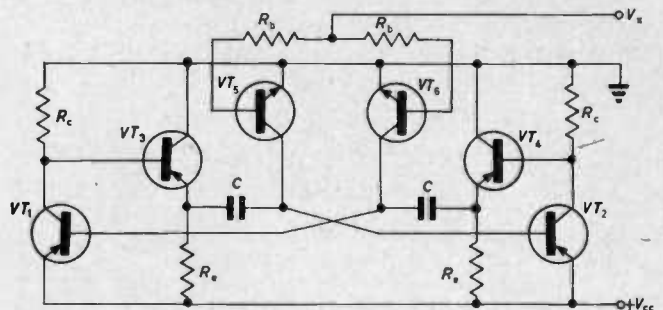

Fig. 5 Converter for wideband operation

High-input-impedance multivibrator

The input impedance of the conventional multivibrator used as a voltage-to-frequency converter can be greatly increased without affecting the sensitivity by connecting VT_3 in the common-base lead, as shown in Fig. 6. The input impedance is approximately $\beta_3 R_b/2$, where β_3 is the common-emitter current gain of VT_3 . The use of diodes MR_1 and MR_2 has been discussed in the literature^{11,12}; they isolate the collector circuits of VT_1 and VT_2 from the corresponding recharging paths of the timing capacitors, thus improving the rectangular waveshapes at the collectors VT_1 and VT_2 . What is more important, however, is that the temperature stability of the circuit is considerably improved by their action.

The discharging current of the timing capacitor is

$$i_d \approx \frac{V_{ce1} + V_x - V_{be1} - V_{ce2} - V_{be3} - V_{D2} + R_b I_{co}}{R_b} e^{-t/CR_b} \dots \dots (3)$$

where $V_{be1}, V_{be3} =$ base-emitter voltages of VT_1 and VT_3 , respectively

$V_{ce2} =$ voltage drop across VT_2

$V_{D2} =$ voltage drop across MR_2

$I_{co} =$ reverse current of transistors

Using the same simplification as that for the constant-current-charge multivibrator, from the equation (3) the

following expression for the frequency of oscillation can be derived:

$$f \approx \frac{1}{2CR_b \log \left(1 + \frac{V_{oc1} - V_{bas}}{V_x} \right)} \dots \dots \dots (4)$$

The emitter current of VT₃, which is equal to the sum of the base current of the conducting transistor and the discharging current of the timing capacitor, is almost constant, and therefore V_{bas} is also constant and does not affect the linearity of frequency/control-voltage relationship. This has been checked experimentally using the circuit model with high-speed silicon planar transistors 2N708 for VT₁, VT₂ and VT₃, and silicon diodes EA828 for MR₁ and MR₂. The other circuit parameters were as follows: R_{c1} = 6.8kΩ; R_{c2} = 1.5kΩ; R_b = 47kΩ; C = 2.2nF; V_{oc1} = -6V; V_{oc2} = 18V.

The oscillation frequency was varied over approximately two octaves, from about 5-19kHz, by varying the control voltage in the range 0-16V. The nonlinearity of the frequency/control-voltage relationship, measured as the percentage deviation of the incremental slope from the slope of the best straight line, was found to be less than 0.5%, and the sensitivity was 862Hz/V. In Table 1, these results are compared with those obtained with the constant-current-charge multivibrator (Fig. 3) using transistors 2N708 for VT₁ and VT₂ and IW8239 for VT₃ and VT₄, the other components corresponding to those in Fig. 6.

The temperature stability was checked over the ambient temperature range 20-60°C and compared with those of the conventional collector-coupled multivibrator (Fig. 1)

Table 1 Voltage-to-frequency conversion

V _x	CIRCUIT IN FIG. 3		CIRCUIT IN FIG. 6	
	f	Δf/ΔV _x	f	Δf/ΔV _x
V	Hz	Hz/V	Hz	Hz/V
0			5000	866
2	4277	816	6732	864
4	5909	820	8520	861
6	7548	823	10242	859
8	9194	826	11960	858
10	10846	828	13676	858
12	12501	829	15391	859
14	14159	830	17109	863
16	15819		18834	

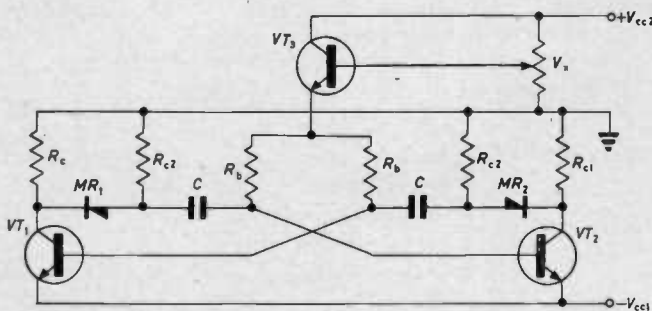

Fig. 6 Multivibrator with high input impedance

and the multivibrator with constant-current sources (Fig. 3). The frequency deviation due to change in ambient temperature depends on V_x, as seen from Fig. 7, in which Δf = φ(V_x) for an ambient-temperature rise of ΔT = 40degC is plotted.

Better results are obtained with higher values of V_x; for V_x > 3V, the frequency deviation of the high-input-impedance circuit in Fig. 6 is less than 1% for ΔT = 40degC. The stabilizing effect of the isolating diodes can be seen by comparing the curves (c) and (d).

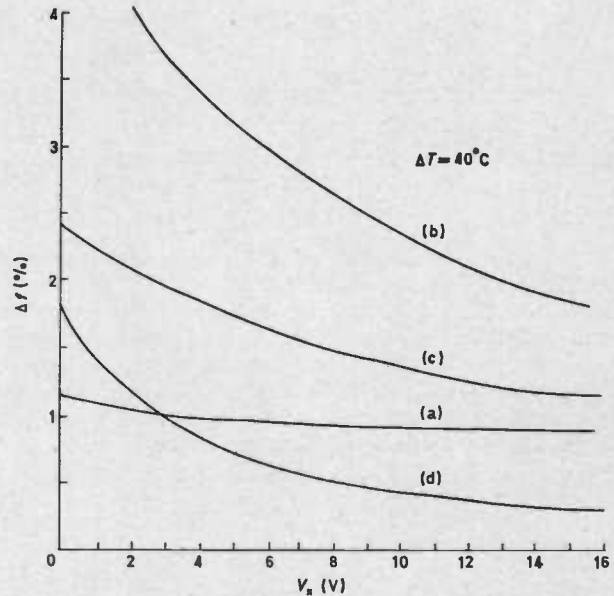

Fig. 7 Temperature deviation as a function of V_x

- (a) Conventional multivibrator
- (b) Multivibrator with constant-current sources
- (c) High-impedance multivibrator with isolating diodes short-circuited
- (d) High-impedance multivibrator with isolating diodes

Conclusions

It has been shown that the linearity of the frequency/voltage relationship of the conventional multivibrator is quite competitive, and that the temperature stability is superior, compared with those with more complex circuits. The use of collector- or emitter-coupled multivibrators with constant-current sources seems justifiable only in applications where a large operating-frequency range extending over two or more octaves (for example in decade oscillators) is required.

References

- 1 STEPHEN, P.: A magnetic core voltage-to-frequency converter, *Trans. IEEE, SET-9*, 12 (1963)
- 2 HEISTERMANN, F.: Spannungs-Frequenz-Umformer für Messzwecke, *AEG-Mitteilungen*, 50, 1/2 (1960)
- 3 SMILJANIC, G.: Operation of a magnetically coupled multivibrator with square B/H loop cores, *Electronic Engng.*, 37, 44 (1965)
- 4 BIDDLECOMB, R. W.: Latest multivibrator improvement linear voltage-to-frequency converter, *Electronics*, 36, 64 (1963)
- 5 COOPER, J. J.: A wide-band voltage controlled square wave generator with linear characteristics, *Electronic Engng.*, 35, 595 (1963)
- 6 HURST, S. L.: Frequency control of astable transistor multivibrator circuits, *Electronic Engng.*, 37, 182 (1965)
- 7 Multivibrator mit weiter Frequenzvariation—Berichte aus der Elektronik, *Elektronik*, 8, 251 (1963)
- 8 KARGER, H., and WENING, G.: Ein Multivibrator für Fernmesszwecke, *Elektronik*, 1, 337 (1966)
- 9 JONES, R. J. P.: A wide frequency range voltage controlled multivibrator, *Electronic Engng.*, 39, 14 (1967)
- 10 SHVETSKIY, B. I., YUZEVIKH, Y. V., and TARANOV, G. V.: Error analysis of the transistor voltage-to-frequency converter, *Kontrolno-izmeritel'naya tekhnika*, 3, 49 (1966) (in Russian)
- 11 ROZNER, F.: Thermistor multivibrator circuits, *Electronic Engng.*, 29, 455 (1957)
- 12 DODGSON, P.: Improved multivibrators, *Electronic Engng.*, 35, 328 (1963)

Crystal-controlled 164 MHz oscillator/quadrupler

by D. Singh, A.M.I.E.E., Mullard Ltd.
and J. Gartens, Mullard Radio Valve Co.

The article describes the design and construction of a crystal-controlled local oscillator giving 13mW at 164MHz. A third-overtone all-glass-mounted 41MHz crystal is used.

(Voir page 799 pour le résumé en français: Zusammenfassung in deutscher Sprache auf Seite 800)

IN 1966, a series of projects was launched to develop circuits using silicon planar transistors in various stages of mobile communications equipment, and assessment of v.h.f. transistor mixers indicated that the first local oscillator should deliver about 13mW into the mixer for the best blocking performance. The design of a crystal-controlled local-oscillator source for this application was initiated.

General design considerations

FREQUENCY STABILITY

The oscillator frequency was chosen 10.7MHz below the frequency of the receiver, which would be required to operate over the band 156-174MHz. The frequency stability of the local oscillator required can be seen by reference to the highest frequency of the band (174MHz). The receiver i.f. bandwidth is 15kHz (-3dB); the maximum modulation frequency is taken as 3kHz. The base-station transmitter-frequency stability is specified in GPO publication W6298 (1959) as $\pm 1\frac{1}{2}$ kHz. The absolute receiver frequency stability is therefore ± 3 kHz, which is 14 parts/ 10^6 . This stability is that required to receive the on-tune signal; the order of stability required to ensure freedom from adjacent channel breakthrough may be rather better, but it depends on the selectivity at i.f. outside of the 15kHz passband. This frequency stability must extend at least over the temperature range -10 to +40°C specified by the GPO. In practice, the supply voltage would vary between 11 and 16V, but Zener stabilization for the local oscillator is assumed.

OUTPUT VOLTAGE

It has been found previously that an output voltage of 800mV in 50 Ω is suitable for the transistor mixer circuit chosen. Increased local-oscillator injection improves blocking performance of transistor mixers*.

CHOICE OF CRYSTAL FREQUENCY

It is considered expensive to use an overtone crystal at 164MHz, compared with the use of a lower-frequency oscillator with frequency multiplication. The two likely choices for starting frequency are in fact such that the 3rd or 4th harmonic is the l.o. frequency. From practical consideration it is considered that 3rd-overtone operation offers improved frequency stability and greater latitude

regarding component layout. It was decided, therefore, to base the design example on a 41MHz oscillator with frequency quadrupling in the same stage, using the 'varactor' effect of the nonlinear collector-base junction.

CHOICE OF OSCILLATOR TRANSISTOR AND CRYSTAL

The Mullard BFY52 transistor was chosen because it has $f_t > 60$ MHz and $C_{ob(min)}$ of 6pF at 160MHz. The dissipation in the crystal when used in its series mode is a direct function of its series resistance at resonance, and while the dissipation must in all cases be less than 2mW to maintain long-term oscillator stability, it is of interest to get this to a minimum; and a crystal with a series resistance of 20 Ω or less is recommended. The unit used for this design was a Mullard QX3000 all-glass-mounted crystal.

CHOICE OF OSCILLATOR CIRCUIT

The choice of circuit was influenced by the following considerations:

- manner of frequency multiplication
- possibility of earthing one crystal terminal.

Frequency multiplication

The following techniques are possible:

- A single oscillator stage followed by transistor quadrupler: it would be difficult to obtain the required output voltage at the 4th harmonic in a single stage, also it would be expected to be noisy and to affect receiver sensitivity by its noise contribution.
- An oscillator stage followed by a varactor multiplier and an amplifier at 164MHz: as varactor diodes cost nearly as much as transistors, the chief objection here is on economic grounds.
- Use of the collector-base junction of the oscillator transistor as a varactor quadrupler itself: in this way only a further simple amplifier stage is needed; this system seems to offer minimum complexity for the required performance.

Channel selection in multichannel receivers involves switching crystals, and stray capacitance exists between switch contacts and earth. If neither crystal terminal is at earth potential, with respect to r.f. in the oscillator layout, frequency stability and loop gain may be affected. If one side of the crystal is earthed and the crystal is used in its series mode, both of these problems are greatly reduced. Both of these points are satisfied in the design presented.

* SINGH, D.: Mullard Central Application Laboratories internal report UB 104

Circuit design

CIRCUIT CONFIGURATION

The basic configuration was of a common-base oscillator and is shown in Fig. 1, omitting the d.c. components. The crystal provides positive feedback at its series resonant frequency from collector to emitter. Fig. 2 shows the same circuit with an added impedance-transforming network at the input to raise the input impedance so that $I_{\text{crystal}}R_{\text{in}}$ is large enough to keep the loop gain greater than 1, simultaneously keeping the crystal current down to the right limit so as not to exceed the crystal dissipation rating of 2mW. Fig. 3 shows the same circuit redrawn so that point X in Fig. 2 is earthed. Fig. 4 is shown with C_1 replaced by a filter which has a capacitive reactance equal to C_1 at 41MHz but which is tuned to pass 164MHz to the output terminal.

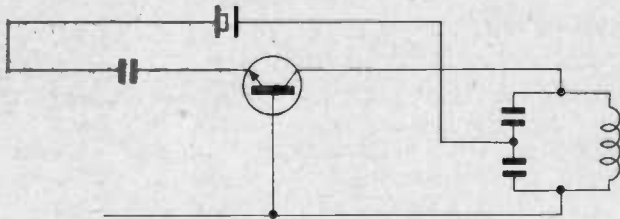

Fig. 1 Basic configuration

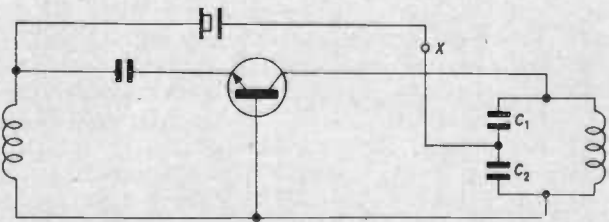

Fig. 2 Circuit of Fig. 1 with impedance-transforming network

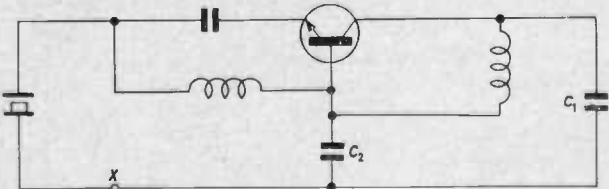

Fig. 3 Circuit of Fig. 2 redrawn with point X earthed

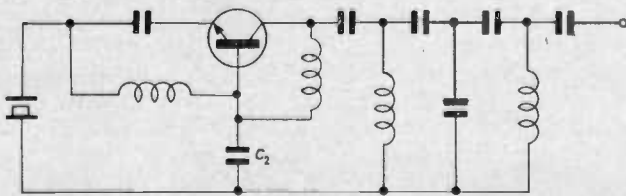

Fig. 4 Circuit of Fig. 3 with C_1 replaced by a filter

CIRCUIT ANALYSIS

Design of the 41MHz oscillator

The output power at 41MHz aimed for was 50mW, and it was assumed that the efficiency of the oscillator would be 50%.

Choice of collector voltage

A Zener-diode stabilized supply of 9.1V was chosen, using a Mullard BZY88 (C9V1) diode. This allowed adequate

stabilization from the 13.8V supply from a 6-cell battery. Allowing about 2V for emitter d.c. stabilization, an available collector-emitter voltage of 7V is possible.

Determination of the collector current

The oscillator output power is given by the expression

$$P_{\text{out}} = P_{\text{d.o.}}\eta - P_x$$

where $P_{\text{d.o.}}$ = total d.c. power input

η = total circuit efficiency

P_x = dissipation in the crystal.

The assumption is made in the above expression that the transistor power gain is much greater than 1, or that the output power into the circuit load is much greater than the power required to maintain oscillation.

If $P_{\text{out}} = 50\text{mW}$

$\eta = 0.5$

$P_x = 2\text{mW}$

(this is the maximum advisable dissipation allowing long-term stability to be maintained)

$$\text{Then } P_{\text{d.o.}} = \frac{50 + 2}{0.5}$$

$$= 104\text{mW}$$

The direct collector current is therefore

$$I_o = 104/7 \approx 15\text{mA}$$

The peak available collector alternating current is therefore 15mA.

Calculation of the collector load R_L'

If the oscillator is to be matched into a load R_L' , the resistance R_L' which should be presented to the collector is given by

$$R_L' = \frac{\text{available collector-emitter voltage}}{\text{peak collector current}}$$

assuming that $V_{\text{ce(sat)}}$ is much lower than the available supply voltage.

$$R_L' \approx 7/15 \times 10^3 = 470\Omega$$

Calculation of the emitter transformer circuit

The input admittance Y_{in} of the BFY52 in a common base circuit is given by

$$Y_{\text{in}} = Y_{\text{ib}} - \frac{Y_{\text{fb}}Y_{\text{rb}}}{Y_{\text{ob}} + Y_L'} \dots \dots \dots (1)$$

If it is assumed that $b_{\text{ob}} + b_L' \ll g_{\text{ob}} + g_L'$

$$\text{then } Y_{\text{in}} = Y_{\text{ib}} - \frac{Y_{\text{fb}}Y_{\text{rb}}}{g_{\text{ob}} + g_L'} \dots \dots \dots (2)$$

Assume that b_{rb} is tuned out by the reactance across the crystal between collector and emitter:

$$\text{then } Y_{\text{in}} = Y_{\text{ib}} - \frac{Y_{\text{fb}} - g_{\text{rb}}}{g_{\text{ob}} + g_L'} \dots \dots \dots (3)$$

The Y-parameters of the four samples of BFY52 were measured at 40MHz. The average values obtained were

$$Y_{\text{ib}} = 64.5 - j47 \text{ mmho}$$

$$Y_{\text{ob}} = 3.65 + j2.35 \text{ mmho}$$

$$Y_{\text{fb}} = -49.3 + j50.3 \text{ mmho}$$

$$Y_{\text{rb}} = -3.07 - j0.78 \text{ mmho}$$

Substituting in equation (3),

$$Y_{\text{in}} = 37.0 - j19.8 \text{ mmho}$$

This corresponds to a series resistance of 21Ω and an inductive reactance of 11.2Ω .

The power gain is the ratio of the modulus of power output to the modulus of power input, or, alternately, the product of the modulus of voltage gain squared and

the ratio of output to input conductance. As power is dissipated only in the resistive portions of the input and load, only conductances need to be considered. The power gain is thus given by the following relationship:

$$\text{power gain} = (V_2/V_1)^2 g_L/g_{in} = \left[\frac{Y_{fb}}{Y_{ob} + Y_L} \right]^2 G_L/G_{in}$$

Using the measured values of Y_{fb} , Y_{ob} and the calculated values of Y_L , G_L and G_{in} ,

$$\text{power gain} = \left[\frac{-49.3 + j50.3}{3.65 + 2} \right]^2 \times 2/27 = 8.35$$

Therefore the power gain is sufficient to justify our original assumption that the power gain is much greater than 1.

As the BFY52 has a large collector-base capacitance which acts as a varactor, the waveform across the crystal has a fairly high harmonic content. It was therefore decided to design the circuit for a crystal dissipation of 1mW, as the power circulating through the crystal at higher harmonics will increase the dissipation slightly. According to the published information of the Mullard all-glass crystals for the chosen frequency, the equivalent series resistance is less than 20Ω. For the design calculations 20Ω was assumed.

For a crystal dissipation of 1mW, the peak crystal current i_x is given by

$$i_x = \sqrt{\frac{2 \times 1.0}{20 \times 10^3}} \text{ A} \\ \approx 10\text{mA}$$

But peak collector current is 15mA; therefore the current ratio to be transformed into the emitter circuit is 10:15 (assuming that the transistor $f_T \gg 40\text{MHz}$), i.e. 1:1.5. Therefore the impedance transformation ratio is approximately 2.25:1.

The reflected emitter input resistance R_p' seen by the crystal is thus 2.25 times the parallel equivalent input resistance R_p , where

$$R_p' = \frac{1}{\text{Re}(Y_{in})}$$

$$\text{Therefore } R_p' = \frac{2.25 \times 10^3}{37} = 61\Omega$$

One can now transform Y_{in} to $1/R_p'$ by using the series-capacitor circuit shown in Fig. 2.

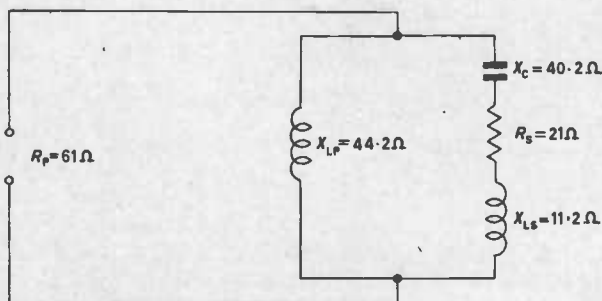

Fig. 5 Series-capacitor circuit

The Q -factor of the transformed circuit, which is called Q' , can be obtained from the following relationship,

$$R_p' = R_s [1 + (Q')^2]$$

where R_s is the equivalent series resistance of Y_{in} , and L_s is the equivalent series reactance of Y_{in} .

$$\text{Therefore } Q' = \sqrt{\frac{61 - 21}{21}} = 1.38$$

$$\text{Also } Q' = \frac{X_c - XL_s}{R_s}$$

where C and L_s are defined by reference to Fig. 5.

$$\text{i.e. } 1.38 = \frac{X_c - 11.2}{21}$$

Thus $X_c = 40.2\Omega$

whence $C_1 \approx 100\text{pF}$ at 41MHz. (in Fig. 6)

$$\text{Then } \omega L_2 = [X_c - L_s] \left[1 + \frac{1}{(Q')^2} \right] \\ = 44.2$$

whence $L_2 \approx 180\text{nH}$ at 41MHz, where L_2 is the parallel inductance needed to resonate the emitter circuit.

Calculation of the collector tank values

The voltage ratio of collector voltage to feedback voltage is calculated as follows,

$$\text{feedback load} = \text{crystal equivalent series resistance} + R_p' \\ = 20 + 61 = 81\Omega$$

Since the peak crystal current is 10mA, the voltage across the feedback load is $\frac{10 \times 80}{10^3} = 800\text{mV}$

The collector circuit transformation for the feedback loop is therefore $N = 7/0.8 = 8.75:1$. Thus

$$X_{L3} = R_L' / Q''$$

where Q'' is the Q -factor of the collector circuit, and X_{L3} is defined by reference to Fig. 6.

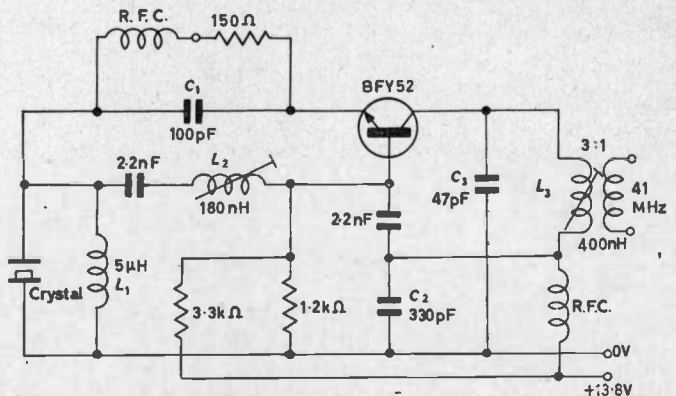

Fig. 6 Complete circuit

Assuming Q'' is 5,

$$X_{L3} = \frac{460}{5} = 92$$

$$= 400\text{nH at 41MHz}$$

The parallel capacitance needed to tune this is therefore approximately 40pF.

$$\text{Therefore } \frac{C_2 + C_3}{C_3} = 8.75:1$$

where C_2 and C_3 are defined by reference to Fig. 6.

$$\text{Also } \frac{C_2 C_3}{C_2 + C_3} \approx 40\text{pF}$$

whence, by substitution,

$$C_2 = 330\text{pF}$$

$$C_3 = 47\text{pF}$$

The complete circuit therefore becomes as shown in Fig. 6. The inductance L_1 tunes out both the crystal-holder capacitance and the transistor b_{rb} . At 41MHz, an adjustable

5 μ H inductance may be used. The coupling coil L_3 was adjusted for a turns ratio of approximately 3:1 to match an R_L' of 470 Ω to an output impedance of 50 Ω . The base bias resistor network is calculated to give a quiescent collector current of 15mA.

FREQUENCY MULTIPLICATION

The majority of harmonic currents flow in a loop composed of the collector-base junction and the capacitive parts of the external circuit between them, mainly the capacitive arm of the collector tuned circuit. Owing to the arrangement of the circuit, these harmonic currents flow from the collector to earth through the 47pF tuning capacitor. So in order to extract the 4th harmonic, it is necessary to replace this capacitor by a network with an equivalent reactance at 41MHz, but which forms a filter at 164MHz; this is shown in Fig. 7. The configuration is so chosen that frequencies below 160MHz and well removed from it (lower harmonics and fundamental) are greatly attenuated.

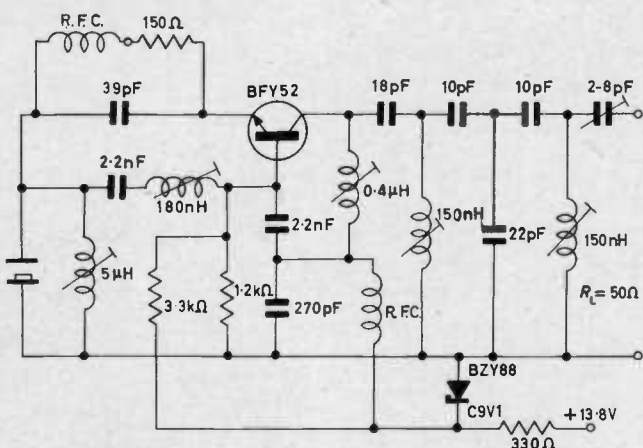

Fig. 7 Circuit altered for extraction of 4th harmonic

Performance

ALIGNMENT

Frequency-selective voltmeters are connected across the crystal and the output to measure 41MHz and 164MHz signals, respectively. First, the collector coil L_3 is adjusted to obtain oscillation. Spurious modes are differentiated by noting the voltage across the crystal; in the correct mode this is a minimum. The 164MHz circuits are tuned for a maximum; insufficient coupling between the 164MHz filter and the following load can result in the whole circuit oscillating at 164MHz, but this is rectified by increasing the value of the 6pF output-coupling capacitor. Successive adjustments are then made to get maximum output at 164MHz with minimum voltage across the crystal at 41MHz. All coils are given a final trim to achieve the same effect. It may be noted here that crystal dissipation is a function of crystal series resonant impedance, and high quality all-glass-mounted crystals with series resistance of 20 Ω or less are recommended.

MEASUREMENT OF EXPERIMENTAL CIRCUIT

A circuit was assembled according to the design of Fig. 6; layout was not found to be critical. Four samples of BFY52 were tried in the circuit and all samples could be satisfactorily tuned. The output of the oscillator was found to be 28mW at 41MHz. The output power of Fig. 7 at 164MHz was found to be 1mW.

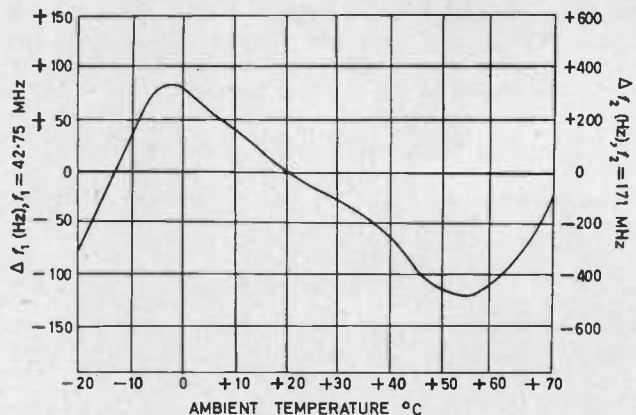

Fig. 8 Variation of output frequency with temperature

The nominal frequency of the oscillator was 41MHz. The variation of output frequency with temperature is shown in Fig. 8. The unregulated supply voltage was varied by about $\pm 5\%$ and negligible variation of oscillator frequency could be detected.

Buffer amplifier

For the original receiver application it was decided to use one stage of amplification at 164MHz to drive the mixer. A simple common-emitter amplifier using BF115 was constructed; the test circuit is shown in Fig. 9.

With this amplification, the output at 164MHz became 13mW, which is considered sufficient for the application.

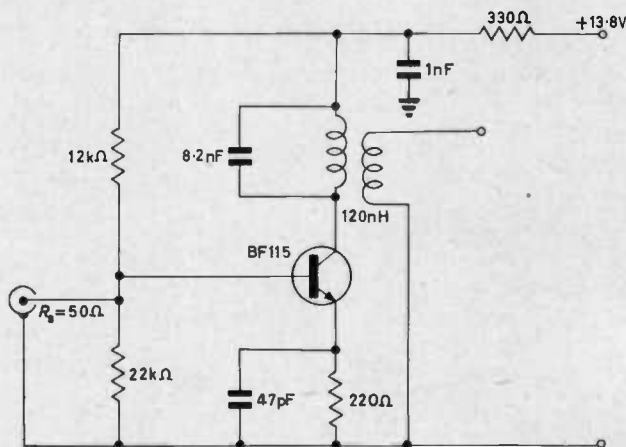

Fig. 9 Common-emitter amplifier

Conclusions

A crystal-controlled oscillator has been designed and constructed using the BFY52 transistor. A third-overtone all-glass-mounted crystal at 41MHz is used and the voltage-variable collector-base capacitance of the oscillator transistor gives direct frequency multiplication to 164MHz. The available output power tuned to 41MHz was 28mW, and tuned to 164MHz was 1mW. With a single-stage buffer amplifier using a BF115 transistor, the available output was 13mW. The total frequency variation of the oscillator over the temperature range -10 to $+70^\circ\text{C}$ was 300Hz. The output and frequency stability make the design suitable as the local oscillator of a v.h.f. mobile communications receiver for 25kHz channel spacing.

Period-quantized encoder for toll-quality p.c.m. systems using a modified monostable multivibrator

by V. K. Agarwal, Page Communications Engineers, Inc., Washington DC, USA

A period-quantized analogue-to-digital convertor is described by which pulse-amplitude-modulated (p.a.m.) samples are encoded into pulse-code-modulated (p.c.m.) characters by being passed through an intermediate step of pulse-duration modulation (p.d.m.). Linear conversion of p.a.m. to p.d.m. is obtained by using a modified monostable multivibrator circuit as combined comparator and linear-sweep generator. The use of integrated circuitry in the logic-design requirements of the high-speed counters AND gates and shift-register store offers not only technical benefits but also suggests a less expensive, reliable and simple encoder for toll-quality p.c.m. systems

(Voir page 799 pour le résumé en français: Zusammenfassung in deutscher Sprache auf Seite 800)

ONE of the most important operations in a p.c.m. system is the conversion of an input signal from analogue to digital form. Basically, this conversion process is achieved by time-sampling the original signal, quantizing the resultant p.a.m. signal in amplitude, and then coding it in a digital form in which each sample is assigned a particular code pattern. The number of bits required for coding determines the number of quantized signal amplitude steps. Although amplitude quantization is widely used, it is possible to quantize in period rather than in amplitude. This article describes a method for encoding p.a.m. samples into p.c.m. characters by incorporating an intermediate step of p.d.m. An encoder based on this principle is designed for encoding a large number of toll-quality channels. In the p.c.m. system,

this involves working with a basic 'channel group' and then multiplexing several encoder outputs'. As each encoder serves only a fraction of total channels in the system, the advantages are simplicity and reduced encoder speed, which, in turn, minimize system-crosstalk problems.

Encoder speed and sensitivity requirements

Assuming that the period-quantized encoder is shared by 12 voice channels (one channel group) and that each channel is sampled 8000 times/second and each sample is encoded into 8 bits (i.e. 256 quantization steps), if the sampling and settling time is less than $2\mu\text{s}$, the duration of each quantization step is $32\text{-}0\text{ns}$, which requires a

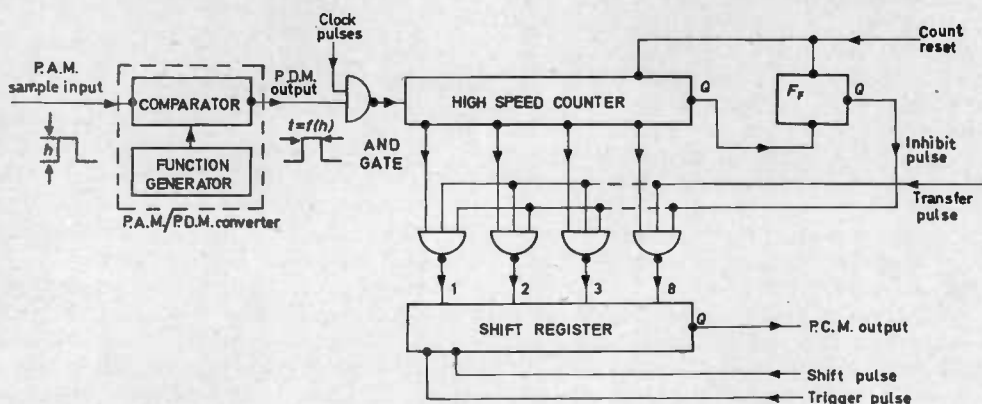

Fig. 1 Block diagram of period-quantized encoder

counter speed of approximately 32MHz for this encoder. Further, assuming a dynamic range of 10V peak-to-peak input signal and a 26dB preferential gain for low-level signals (logarithmic compression characteristic with $\mu = 100$), it can then be seen that the p.a.m.-to-p.d.m. converter must be sensitive enough to respond to a quantization step of at least 2mV. [If q represents quantization-size, $20 \log (10/256)q = 26$].

General description

Fig. 1 illustrates the basic block diagram of the period-quantized encoder. The p.a.m.-to-p.d.m. converter gives an output-pulse duration which is a function of the amplitude h of the p.a.m. sample to be encoded. The duration-modulated pulse opens the AND gate allowing the clock pulse to reach the counter. As the clock runs at a constant frequency, the number of pulses reaching the counter is directly proportional to the duration of the converter output pulse, which, in turn, is related to the p.a.m. sample. If the counter is assumed to be in the zero state just before the beginning of the p.d.m. pulse, the residue left in the counter after the p.d.m. pulse has concluded is the binary sequence representing the p.a.m. sample input. This stored count can then be transferred to the shift register store, where it is read out serially as p.c.m. code.

In the encoder, the two most desirable features are accuracy of digital representation and a large number of quantized steps. The minimum number of quantization steps required is limited by the permissible quantization noise. For toll-quality performance in a p.c.m. transmission system, the number of amplitude-quantized steps should be the maximum possible, and the use of 8-digit coding is recommended. This system also requires instantaneous companding, as it is desirable to have smaller quantization steps for lower speech levels². A stringent linear conversion of p.a.m. to p.d.m. is desirable for the system; consequently, emphasis is placed on the design of an extremely sensitive and simple comparator circuit. The modified monostable-multivibrator circuit described is for linearizing the conversion of an analogue voltage to a time interval. Basically, the monostable multivibrator is used as a comparator for conversion of p.a.m. to p.d.m. It incorporates a linear-sweep voltage generator which utilizes the current source as a voltage-feedback circuit.

Linearizing the conversion of p.a.m. to p.d.m.

The principle involved is to convert the amplitude of the modulating-signal samples obtained by p.a.m. into a time interval. The p.a.m. signal is applied to one input terminal of a comparator circuit, as shown in Fig. 2, and the output of a sawtooth generator is applied to the other terminal. The sawtooth wave commences to rise from zero at the beginning of the sampling period, and, when its instantaneous amplitude exceeds the signal amplitude, the comparator produces a change in voltage at its output. Thus the comparator output is a pulse of voltage which commences at the beginning of the sawtooth wave and ends when the amplitude-modulated input signal is correctly converted into p.d.m.

The modified monostable-multivibrator circuit described embodies both a comparator and a linear sawtooth generator (encircled by the dotted lines of Fig. 1). The basic circuit is a timing-capacitor discharge through a constant-current source, which results in a linearized sweep voltage. Use is made of a linear ramp of voltage as a

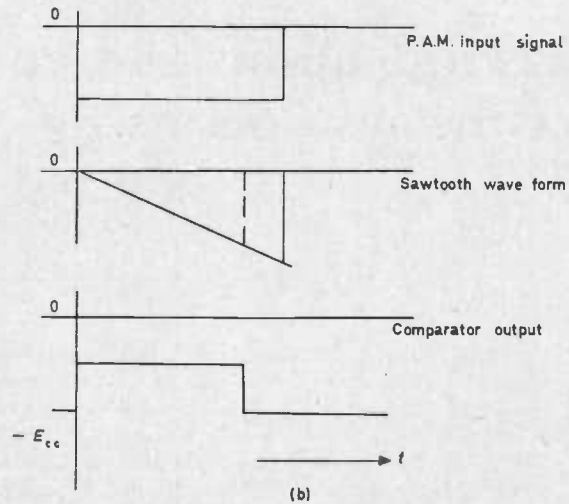
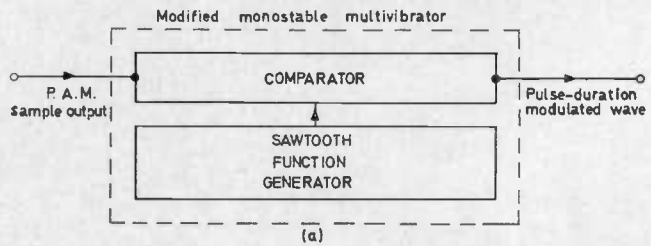

Fig. 2 Method of p.a.m./p.d.m. conversion
(a) Block diagram (b) Waveforms

timing device, where the height is varied while the slope is kept constant. The constant ramp of voltage is stopped, then reset to zero, each time it reaches a voltage value.

In the conventional circuit³ accurate linear voltage sweep is not obtainable, because it would require an impractically large feedback capacitor. To attain more linear sweeps of long duration, the following paragraphs show that the feedback capacitor is replaced by an element consisting of a current source with the required voltage drop. Further, it is shown that the use of a composite amplifier possessing a controlled larger-than-unity gain reduces the nonlinearity of the ramp. A continuously controlled pulse duration over a wide range is obtained because the circuit design is independent of the feedback-circuit capacitor, and the gain of the composite amplifier can be controlled. Despite the increased number of active components (compared with conventional circuits), elimination of a bulky capacitor suggests circuit compatibility with microelectronic-fabrication techniques.

Linear control of pulse duration

Referring to Fig. 3, if V is the initial voltage from which the timing capacitor C starts discharging during the quasistable state, and if the capacitor-discharging current I is maintained constant, $V = 1/C \int I dt$; it follows that duration of the pulse at the collector of VT_2 is given by $T = CV/I$. Resistor R_{L1} is chosen so that VT_1 saturates when conducting. The collector current of VT_1 is made proportional to $(-E_{cc} + V_d)$, where V_d is the emitter d.c. control voltage. The voltage drop $R_{L1}I_{L1}$, and hence the voltage V , is directly proportional to the emitter-control voltage V_d . Thus the duration of the output pulse can be varied linearly by the control voltage applied to the emitter of VT_1 through a low-impedance divider.

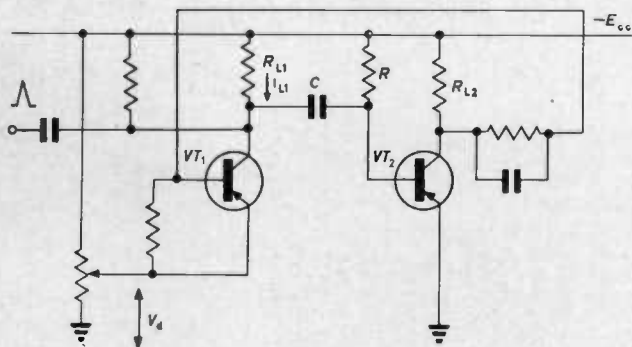

Fig. 3 Basic monostable-multivibrator circuit for control of pulse duration

Continuously controllable pulse duration over a very wide range

ANALYSIS OF CONVENTIONAL CIRCUIT WITH CAPACITIVE FEEDBACK

It is generally known that a bootstrap integrator circuit is one classical method of obtaining a linearly varying voltage where an integrating capacitor C is connected in parallel with the input terminals of an amplifier (Fig. 4). The capacitor C is charged by a nongrounded voltage source (capacitor C_1 of very large capacitance simulates the floating battery, usually $C_1 > 10C$) connected in a positive-feedback path between the amplifier output and input. However, this type of circuit shows a large non-linearity of sawtooth voltage because of both an insufficient C_1/C ratio and shunting of the charging capacitor C by the input resistance of the emitter follower.

In the following, the bootstrap circuit of Fig. 4(a) is analysed with the aid of the equivalent circuit in Fig. 4(b), giving sweep error in terms of sweep duration. In the analysis, it is assumed that the time constant of feedback capacitor C_1 is considerably longer than that of C , and the voltage across C_1 does not change during the voltage-sweep time. Referring to Fig. 5, a positive trigger at the col-

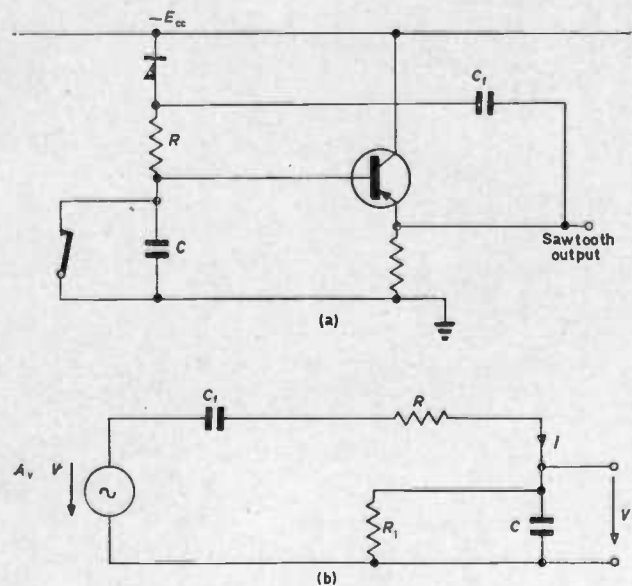

Fig. 4 Bootstrap-integrator circuits
(a) Basic (b) Equivalent

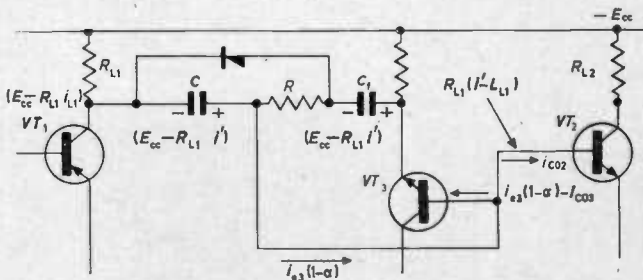

Fig. 5 Circuit to compute discharge-current capacitor C

lector of VT_1 starts a regenerative process which turns VT_1 ON and VT_2 OFF—this is the quasistable state. Termination of the quasistable state occurs soon after the discharging current has decreased to the point where the base current of VT_1 cannot keep it in saturation. At the end of the quasistable state, the voltage at the base of transistor VT_2 is $R_{L1}(i' - i_{L1})$, where i_{L1} and i' are the currents through the resistor R_{L1} in the stable and quasistable states, respectively, of the multivibrator circuit. Also, the discharging current i_L of timing capacitor C is equal to the current through resistor R ; and, if the base current of VT_3 is neglected, this discharge current is given by

$$i' = i_L = i_R = \frac{[2(E_{cc} - R_{L1}i') - (E_{cc} - R_{L1}i_{L1}) + R_{L1}(i' - i_{L1})]}{R} \dots \dots \dots (1)$$

$$= \frac{(E_{cc} - R_{L1}i')}{R}$$

$$= E_{cc}/(R + R_{L1})$$

Analysis of the equivalent circuit yields the following differential equation representing voltage v across timing capacitor C

$$CR \frac{d^2v}{dt^2} + \frac{dv}{dt} (x + y + z) + \frac{v}{C_1R_1} = 0 \dots \dots (2)$$

where $x = R/R_1$, $y = C/C_1$, $z = (1 - A_v)$

The input impedance and voltage amplification of the emitter-follower amplifier are given by R_1 and A_v , respectively. When the switch S is open, at $t = 0$ (transistor VT_1 OFF), voltage $v = R_{L1}(i' - i_{L1})$

$$\text{Let } \frac{x + y + z}{CR} = 2\lambda; \quad \frac{1}{CRC_1R_1} = \delta^2$$

$$\text{Then } \frac{d^2v}{dt^2} + 2\lambda \frac{dv}{dt} + \delta^2 v = 0 \dots \dots \dots (3)$$

The output voltage across the timing capacitor is given by

$$V = \frac{E_1}{(R_{L1} + R)C_1} e^{-\lambda t} \sinh st + R_{L1}(i' - i_{L1}) \dots (4)$$

Approximating,

$$e^{-\lambda t} = 1 - \lambda t + \frac{(\lambda t)^2}{2} - \dots \dots$$

$$\sinh st = st + \frac{(st)^3}{3!} + \dots \dots$$

and $i' = E_1/(R + R_{L1})$

and, since $\lambda t \ll 1$ and $st \ll 1$,

$$V = \frac{E_1 t}{(R_{L1} + R)C} (1 - \lambda t) + R_{L1}(i' - i_{L1}) \dots \dots (5)$$

In the circuit in Fig. 5, there are initial conditions which add an $R_{L1}(i' - i_{L1})$ term to the above expression, but this term does not effect the linearity of V . Here, the term

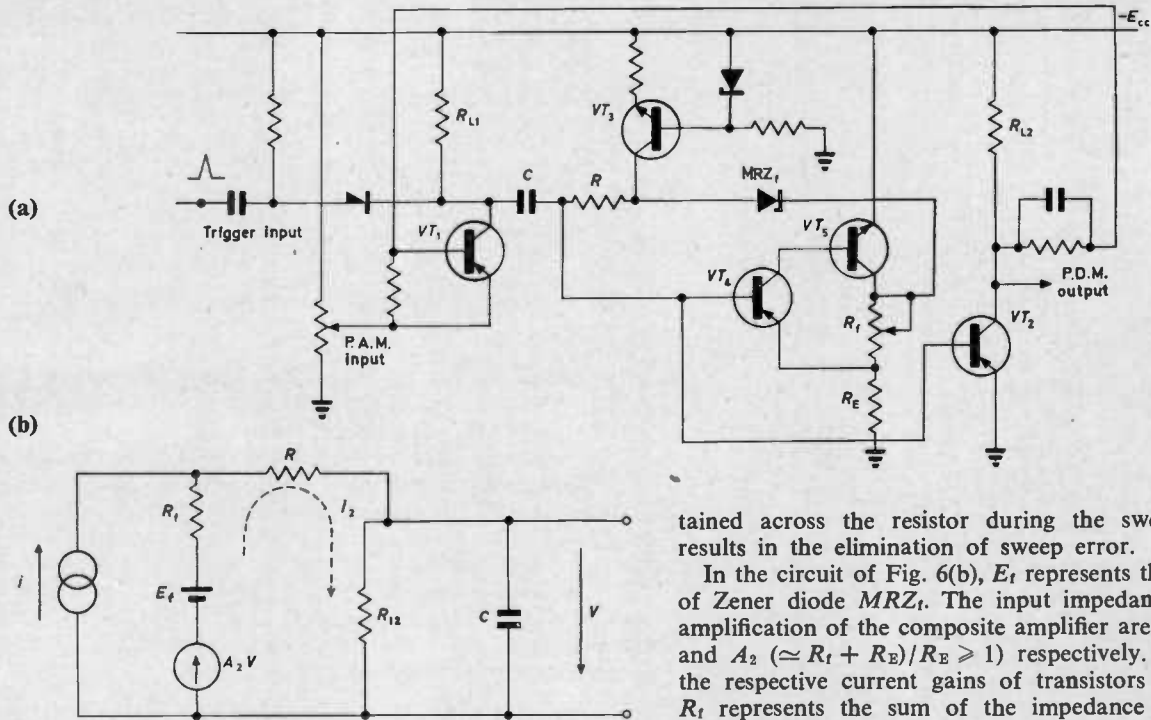

Fig. 6 (a) Circuit of modified monostable multivibrator
 (b) Equivalent discharging circuit of time-constant capacitor

$\lambda t = (x + y + z)t/2CR$ gives the nonlinear distortion error; the expression also shows that this error is less with $C_t > C$ and with $A_v \approx 1$. For example: the nonlinear distortion error for a circuit of this type, with a duration of $8\mu s$ (which corresponds to encoding time), is given as gain = 0.95; $R = 11k\Omega$; $C = 20\ 000pF$; $C_t = 2\mu F$; $R_1 = 220k\Omega$; therefore, percentage nonlinear distortion

$$= \frac{50(x+y+z)t}{CR}$$

$$= \frac{50 \times 8 \times 10^{-6} (1 - 0.95 + 0.01 + 0.05)}{20\ 000 \times 10^{-12} \times 11 \times 10^3}$$

$$= 0.018\%$$

ANALYSIS OF MODIFIED MONOSTABLE MULTIVIBRATOR CIRCUIT

If the feedback capacitor C_t in Fig. 4 is replaced by an element consisting of a current source which maintains a constant voltage in the circuit during the sweep time, the sweep error can be reduced to almost zero. Further, the composite amplifier characteristics, i.e. gain and input impedance, contribute a significant role in controlling the nonlinearity of the sawtooth voltage. Fig. 6(a) illustrates the modified circuit and Fig. 6(b) the equivalent discharging circuit of time-constant capacitor C . It should be noted that the linear sweep is generated during the quasistable state of the multivibrator, when capacitor C discharges through the ON transistor VT_1 . VT_3 , in common-base configuration, operates as a constant-current source. This eliminates the sweep error due to a conventional feedback capacitor and helps to attain a linear sweep. The composite amplifier, consisting of VT_4 and VT_5 , is capable of maintaining the amplifier voltage gain A_2 very close to unity or to larger than unity. The voltage across resistor R is approximately equal to the voltage drop of Zener diode MRZ_1 . If the current through R is constant, the current flow through the diode tends to stabilize the voltage drop. By this method, a constant voltage is main-

tained across the resistor during the sweep time. This results in the elimination of sweep error.

In the circuit of Fig. 6(b), E_t represents the voltage drop of Zener diode MRZ_1 . The input impedance and voltage amplification of the composite amplifier are $R_{12} (\approx \beta_1 \beta_2 R_E)$ and $A_2 (\approx R_f + R_E)/R_E \geq 1$ respectively. β^1 and β_3 are the respective current gains of transistors VT_4 and VT_5 ; R_t represents the sum of the impedance of MRZ_1 and the amplifier output impedance. Referring to Fig. 6(b),

$$-E_t - A_2V = IR_t - i_2R_t \dots \dots \dots (6)$$

$$E_t + A_2V = -IR_t + i_2(R_t + R + R_{12}) - i_3R_{12} \dots \dots (7)$$

$$0 = i_2R_{12} + i_3R_{12} + \frac{1}{C} \int i_3 dt \dots \dots \dots (8)$$

$$V_t = \frac{1}{C} \int i_3 dt \dots \dots \dots (9)$$

This gives,

$$E_t + A_2V + IR_t = i_2(R_t + R + R_{12}) - i_2R_{12} + V_t$$

$$\text{or } i_2 = \frac{E_t + A_2V + IR_t - V}{(R_t + R)}$$

Substituting this in equation (8), and simplifying, gives

$$V + C \frac{dv}{dt} R_{12} = \left[\frac{E_t + A_2V + IR_t - V}{R_t + R} \right] R_{12}$$

$$(R + R_t) R_{12} C \frac{dv}{dt} = R_{12} (IR_t + E_t) +$$

$$V [A_2R_{12} - (R_{12} + R + R_t)]$$

$$\text{or } \frac{R_{12}(R + R_t)}{(R_{12} + R + R_t)} C \frac{dv}{dt} + V = \frac{R_{12}(IR_t + E_t)}{(R_t + R + R_{12})} + \frac{R_{12}A_2V}{(R_t + R + R_{12})}$$

$$\text{or } R \left(1 + \frac{R_t}{R} \right) C \frac{dv}{dt} + V \left[\frac{1 + R + R_t}{R_{12}} \right] = (IR_t + E_t) + A_2V$$

$$\text{or } RC \frac{dv}{dt} - V \left[(A_2 - 1) - \left(\frac{R + R_t}{R_{12}} \right) \right] - (IR_t + E_t) = 0 \text{ (since } R_t \ll R \text{)}$$

The differential equation is then reduced to

$$\frac{dv}{dt} + \frac{(z_2 + x_2)V}{CR} - \frac{(IR_t + E_t)}{CR} = 0 \dots \dots \dots (10)$$

where $z_2 = (1 - A_2)$; $x_2 = R/R_{12}$; and $R \ll R_{12}$

The solution of the above differential equation after simplification is then given by

$$V = \left(\frac{IR_t + E_t}{z_2 + x_2} \right) \left[1 - \exp \left(- \frac{z_2 + x_2}{CR} t \right) \right] \dots (11)$$

The voltage V across capacitor C can then be approximated to the following expression:

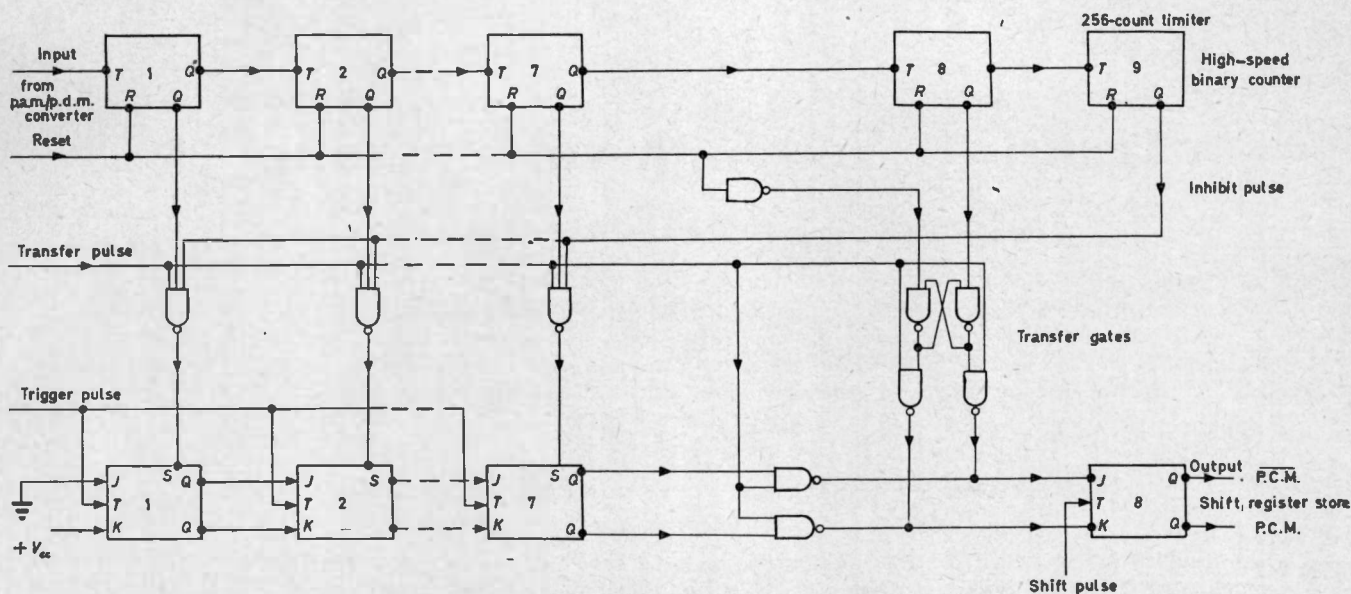

Fig. 7 Encoder logic circuitry

$$V = \frac{IR_t + E_t}{CR} t \left[1 - \left(\frac{z_2 + x_2}{2CR} \right) \right]$$

In the above expression, the nonlinearity factor is dependent only on z_2 and x_2 , both of which are controlled by the amplifier characteristic. This should be compared with the earlier expression, in which the sweep error was dependent on three quantities. Therefore the percentage nonlinearity factor of the sawtooth voltage is clearly reduced by this modification. It can be seen that, in the expression $z_2 = (1 - A_2)$, where the amplification factor A_2 can be controlled to a unity gain or larger-than-unity gain, z_2 can be adjusted as desired, and that this results in a negligible (or zero) nonlinearity factor. For further comparison, consider again an example with a duration of $8\mu s$, as in the earlier case:

$$R = 11k\Omega; C = 20\,000pF; R_{12} = \beta_1\beta_2R_B \approx 2M\Omega$$

$$\text{percentage nonlinearity} = \frac{50(z_2 + x_2)t}{CR} = \frac{50(1 - A_2 + 11/2 \times 10^9)}{20\,000 \times 10^{-12} \times 11 \times 10^3} \%$$

As the gain A_2 can be controlled to unity or larger than unity by adjusting R_t , the numerator can theoretically be reduced to zero, and this results in a negligible nonlinearity factor.

Encoder logic

The period-quantized encoder requires a high-speed digital counter, which, until recently, had been difficult and expensive to design. However, use of integrated circuits in the design make it possible to attain not only system technical benefits but also lower cost and greater reliability. The extreme simplicity of the logic requirements for the period-quantized encoder make it quite attractive for adaption into a practical analogue-to-digital converter. The logic, consisting of a high-speed counter, AND gates and a shift register store is shown in Fig. 7, and is self-explanatory. In the counter circuit, a reset pulse is applied to all flipflops before a new count begins. A 256-count limiter is added to provide an output code of all 1s if the 256 count is exceeded, owing to an input overload. The counter is read into a $2\mu s$ store after a code conversion is complete, and the counter is ready again to accept

new counting pulses. The shift-register store, comprising set/reset flipflops, converts the parallel p.c.m. signal into a serial pulse train.

Conclusion

A period-quantized encoder for toll-quality p.c.m. systems is described, which uses a modified monostable multivibrator as a comparator and linear sweep generator. A continuously controlled linear variation between p.a.m. sample input voltage and output-pulse duration over a very wide range is obtained when the timing capacitor of the monostable multivibrator is discharged through a constant-current source. A further improvement in linearity of the sweep is achieved when a composite amplifier of controlled gain is incorporated in the circuit. Study of the block schematic reveals the simplicity of the proposed system and the ease with which the analogue-to-digital conversion is accomplished. The period-quantized encoder is expected to provide greater accuracy; also, it should offer less complexity per digit when compared with a conventional system, such as a bit-at-a-time encoder (particularly for an 8-(or more)-digit encoder). A high-speed counter (32MHz) is used, which, until recently, had been expensive and difficult to design. Use of integrated circuits such as JK flipflops, RST flipflops, d.t.l. NAND gates etc. in the comparatively simple logic requirements suggests a less expensive and more reliable system.

Acknowledgment

The author wishes to express his appreciation of the contribution, criticisms and encouragement of K. T. Thorsen and F. W. Mills; thanks are also due to M. McLaughlin for making the experimental model.

The work described was carried out while the author was with the Northern Electric Research and Development Laboratories, a subsidiary of the Bell Telephone Company of Canada.

References

- 1 THORSEN, K. T., and MILLS, F. W.: A toll-quality counting-type encoder, *NEREM Conf. Rec.*, 198-199 (Nov. 1966)
- 2 SMITH, B.: Instantaneous commanding of quantized signals, *Bell Syst. Tech. J.*, 653 (May 1957)
- 3 RAKOVICH, B. D.: A linear delay circuit with stabilized pulse duration, *Electronic Engng.*, 35, 112-114 (1963)

Transistorized high-voltage supplies

by R. E. Crosbie, B.Eng., Ph.D., C.Eng., M.I.E.E., University of Salford

One of the more difficult aspects of the transistorization of electronic equipment is in the design of e.h.v. generators; this article discusses the basic problems encountered with such units, including methods of stabilization. The resulting conclusions are applied to the design of three practical units; one of these uses an oscillator believed to be new to the e.h.v. field and which promises wide application to e.h.v. circuits.

(Voir page 799 pour le résumé en français: Zusammenfassung in deutscher Sprache auf Seite 800)

ONE of the areas in which the transition from thermionic valves to transistors is not yet complete and which presents several problems is that of e.h.v. power supplies. Circuits giving voltages of up to about 20kV at currents up to a few milliamperes, and stabilization circuits capable of stability and ripple figures down to about 0.1%, are considered in this article. Among the points to be covered in the preliminary design stages of all such circuits are

- (i) best oscillator frequency
- (ii) oscillator configuration to be used
- (iii) most suitable transistor
- (iv) most suitable rectifier
- (v) rectifier configuration required
- (vi) type of stabilization, if necessary.

In practice, the oscillators are usually made to operate in one of two frequency ranges; these are roughly 1 to 2kHz and 17 to 50kHz, the choice depending on the relative importance of efficiency, smoothing and acoustic noise.

An oscillator can consist of a single self-oscillating stage or a low-power oscillator driving an output stage. The latter method is more flexible but more complex, and is generally recommended only where high power is required; the self-oscillating inverter has been found satisfactory for outputs of up to at least 30W, which covers most applications. Two types of self-oscillating circuit are usually considered in the literature of d.c. converters^{1,2,3}; these are commonly known as the ringing-choke and the transformer-coupled circuits. In the ringing-choke circuit, which is always single-ended, a transistor is used to cut off the current through the primary of the e.h.v. transformer. The resultant swing in the primary voltage is stepped up in the transformer and rectified. The circuit can be designed to limit the peak collector voltage to a suitably safe level. An advantage of this method is that the transformer secondary voltage is not determined solely by the input voltage.

The transformer-coupled circuit takes several forms, depending on the method of timing the transistor switching. Circuits have been described using both push-pull and single-ended configurations, which use transformer saturation^{1,2,4}, β falloff², and CR, LR and LC timing⁴. Another circuit which is useful for lower-voltage supplies is based on a transformer-coupled bistable circuit⁵.

Silicon transistors with a low enough saturation resistance are expensive, and the choice of transistor is usually between various germanium power types, depending on whether high-voltage, current and power rating or high cutoff frequency is more important. The rectifier provides

a choice of silicon, selenium or vacuum rectifiers in half-wave or multiplier circuits. Stabilization may be provided by the use of feedback or shunt or corona stabilisers.

In the following sections these questions are developed further and then applied to the design of three practical units which were designed for radar-display applications; i.e.

- (a) 14kV fixed, 50 μ A stabilized
- (b) 1-10kV variable, 3mA stabilized
- (c) 2kV fixed, 1mA stabilized

General design considerations

The points raised in the last section are now developed in more detail.

OSCILLATOR FREQUENCY

It was stated above that the oscillator frequency usually falls in the ranges 1-2 or 17-50kHz. The main advantage of the lower ranges is that higher efficiency is possible. Transistors operate most efficiently as saturated switches, and this is the preferred mode of operation in d.c. converters. In this way, efficiencies of well over 80% are possible in high-power low-voltage (<1kV) units. Since most of the power loss in the transistors occurs during switching and the switching time is essentially independent of the switching frequency, transistor losses should be roughly proportional to this frequency.

However, squarewave operation is only possible when the transformer resonant frequency is several times the switching frequency, and in practice it is found that, for the high transformer ratios needed in e.h.v. circuits, squarewave operation is not possible in the higher-frequency range (>17kHz). This causes a greater reduction in efficiency than would result from the assumption of losses proportional to frequency. One method of achieving squarewave operation and high frequency is to use a large number of multiplier stages and a reduced transformer ratio; but the gain in efficiency may be more than offset by the increased complexity of the rectifier.

There are two main disadvantages of 1kHz operation. It is evident that, the lower the oscillator frequency, the larger the smoothing capacitor will be for a given requirement; where very low ripple is required the highest possible frequency should be used. Owing to magnetostriction in the transformer core, audiofrequency oscillators produce an audible whistle; this can be annoying to operators of equipment, and is often in itself sufficient reason for selecting a higher frequency.

Radiation from the unit is more likely to cause trouble

in adjacent circuits if a higher frequency is used, but, by careful layout and screening, serious difficulties can usually be avoided.

OSCILLATOR CIRCUIT

The ringing-choke oscillator is only suitable for low-frequency operation, because the resonant frequency of the coil has to be very high compared with the switching frequency. It has poor regulation, since it delivers constant power to the load and it can only be used in a single-ended arrangement. This means that the current taken from the supply has a poor form factor. In its favour, the circuit allows a large step-up of the direct-voltage supply with comparatively low transformer ratios and it is capable of high efficiency.

The various squarewave transformer-coupled circuits mentioned may be used in those cases where the transformer resonant frequency is much greater than the switching frequency. This restriction normally precludes the use of these circuits at very high output voltages (unless a multiplier rectifier is used) and at supersonic frequencies. An arrangement which has been found suitable for these high-voltage high-frequency supplies is a transformer-coupled push-pull circuit operating as a sine-wave oscillator at a frequency determined by the transformer resonance; suitable transformers can be wound with a resonant frequency of about 20kHz. Depending on the output power, efficiencies of up to 55% have been achieved.

A transformer-coupled bistable circuit has been used to produce a 2kV output from a quadrupler-rectifier using solid-state rectifiers. Squarewaves are obtainable at frequencies of, or more than, 30kHz; even at such frequencies, efficiencies of 50% are possible. It is felt that this circuit could be used to give higher output voltages with little loss in efficiency.

TRANSFORMER

One of the most important features of the transformer is its resonant frequency; in order to keep this high it is usually necessary to wavewind the secondary winding in one or more pies, to minimize the winding capacitance. The use of several pies gives lower capacitance but introduces multiple higher-frequency resonances. If only one pie is used, a cleaner waveform is achieved and insulation is easier, because, in multiple-pie windings, the bottom of the last pie is at a high a.c. potential ($1 - 1/n$ times the transformer output). If space conditions dictate a long low secondary winding, several pies may have to be used.

At supersonic frequencies, ferrite U-cores are most suitable, since they have low eddy-current losses. Because they have a low permeability, leakage is high, and care should be taken to ensure good coupling between windings. If there is a high leakage inductance between primary and secondary, voltage transients appear on the collector waveform which can cause damage to the transistors unless special protection is included. Leakage inductance is minimized by winding the secondary on top of the primary and feedback windings.

RECTIFIERS

Two points arise concerning the rectifier circuit, the type of rectifier and the configuration. If a large number of stages are used, vacuum rectifiers are ruled out because of their heater requirements, which are usually provided from separate windings on the transformer. In a few cases, the heater supplies may be derived from a separate oscillator (this is dealt with later). Two types of solid-state rectifier are available—silicon and selenium stacks.

Both are made from a number of cells in series but they have different characteristics.

Miniature selenium stacks are suitable for frequencies up to about 50kHz, but they take up more space than equivalent valves. They pass rather high leakage currents, which increase rapidly with temperature; so that, in applications with high ambient temperatures or low forward currents, voltage derating is often necessary, increasing the size further. Typical figures are 100 μ A maximum leakage at 40°C, with most units well within this limit. Experiments have shown that 20% voltage derating leads to a 3:1 reduction in leakage.

Silicon rectifiers pass a low reverse current, typically 5 μ A at 10kV and 25°C, and can be used over a much wider temperature range than selenium; they are also smaller than selenium stacks, being about the same size as equivalent miniature valves. However, they are not recommended for frequencies above about 3kHz, because of differences in the hole-storage characteristics of the individual junctions. The rectifiers are liable to break down at higher frequencies, because unequal recovery times cause most of the reverse voltage to be applied initially across a few rapidly recovering junctions. Furthermore, high-voltage units are very expensive.

Thermionic rectifiers are cheap, fairly reliable and have very low leakage; they are suitable for operation at high frequencies and are insensitive to ambient-temperature changes. They require heater supplies, and these usually involve extra insulated windings on the transformer; for this reason they are unsuitable when several stages of multiplication are used.

Stabilization

Methods of stabilization can be divided into two types—feedback or shunt. Feedback stabilization is accomplished by comparing a fraction of the output voltage with a stable reference; the error voltage is then amplified and used to modify some parameter of the oscillator, which may be the bias voltage of an oscillator transistor or the voltage drop across a transistor in series with the d.c. supply. Shunt stabilization uses a shunt stabilizer valve or a corona stabilizer to maintain the output voltage constant when the input or output conditions vary.

FEEDBACK STABILIZATION

Feedback stabilization is more difficult with transistors than with valves. Using valves, it is a fairly simple matter to amplify the error voltage in one stage and drive the grid or screen of an oscillator valve. In transistor circuits, considerable current is required from the feedback amplifier, which necessitates a very high current gain. To drive a series transistor, a base-current swing of, say, 10 to 100mA may be needed, depending on the power. The current in the reference resistance chain may be restricted to, say, 100 μ A. Thus a 0.1% change in output voltage would cause a change of 0.1 μ A in the reference current. Even if the whole of this change is fed into the input stage of the amplifier, a minimum current gain of 10^5 to 10^6 is needed. Such an amplifier might easily have a gain of 10 times this in practice, owing to provision of tolerances to allow for transistor-gain spreads. With such high gains, stability and temperature sensitivity present considerable problems. Care must also be taken in the design of the rectifier smoothing circuit. Since the rectifier time constant, which is long, is included in the feedback loop, the high-frequency response of the feedback system is poor. The smoothing capacitor must therefore cope with transient load changes.

An advantage of the feedback method is that a variable output voltage is easily obtained; the method is also more efficient in general than shunt methods, in which the full power is generated continuously.

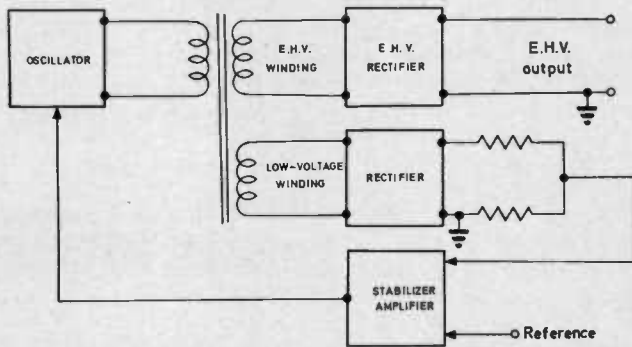

Fig. 1 Stabilization from auxiliary winding

Feedback from an auxiliary output

A variation of the feedback method is to use a feedback amplifier which takes its input from a lower-voltage auxiliary supply (Fig. 1); more current can be made available and a lower-gain amplifier can be used. The degree of stability attained depends largely on the variations in the e.h.v. output current, as the stabilizer controls only the transformer output voltage and does not correct the changes in output current. A 15/kV, 50 μ A unit stabilized from a 200V grid-bias winding, gave a 0.1% change in output for a $\pm 6\%$ change in supply voltage, and a 2% change in e.h.v. output from no load to full-load current. This type of circuit is particularly suitable where the output current is not subject to large changes; it could also be used in conjunction with a shunt stabilizer where maximum performance is required.

SHUNT STABILIZATION

Two types of shunt stabilizer are available: the thermionic-triode stabilizer and the corona tube (Fig. 2).

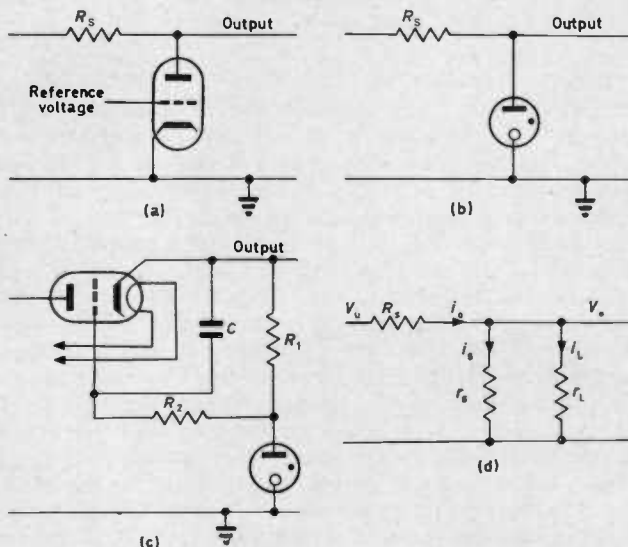

Fig. 2 Shunt stabilization

- (a) Thermionic shunt stabilizer
- (b) Corona stabilizer
- (c) Corona stabilizer with series valve
- (d) Shunt stabilizer equivalent circuit

Thermionic-triode stabilizer (Fig. 2a)

The grid of the stabilizer is connected to a stable reference voltage and the output voltage is largely independent of the unregulated supply voltage. A typical tube (the GEC type-A2637) has a maximum anode voltage of 30kV, maximum current of 1.5mA and an r_a of 4.5M Ω . The main advantages are that the output voltage can be varied by providing a variable grid supply and the tube is comparatively inexpensive; the disadvantages are its large size and the grid-bias and heater requirements.

Corona stabilizers

A corona stabilizer is a gas-filled cold-cathode two-electrode device which provides an essentially constant voltage corona discharge at currents from between 10 and 100 μ A to about 1mA. Tubes can be obtained for voltages from a few hundred volts up to about 30kV. Where a fixed output is required, corona tubes afford the simplest method of stabilization (Fig. 2b). They are more expensive than triode stabilizers and more limited in current, but above about 12kV they are rather large. The output impedance is typically 1M Ω at 15kV. Lower output impedances and higher currents are obtainable if a suitable valve is connected in series (Fig. 2c). The valve must be a high-voltage low-current type preferably with a high amplification factor and modest heater requirements. Some manufacturers of corona tubes produce triodes specifically for this purpose.

The equivalent circuit of a corona stabilizer is shown in Fig. 2d; changes in V_o are caused by four factors:

(i) Changes in r_L

Since $r_L \gg r_s$, the combined resistance of r_L and r_s is nearly constant, and hence i_o is constant. Thus a change in r_L causes an equal and opposite change in i_s . The resulting change in V_o is

$$\delta V_o = +\delta i_s r_s = -\delta i_L r_s$$

(ii) Supply-voltage changes

Experiment confirms that V_u varies linearly with the supply voltage V_{in} over a range of at least $\pm 10\%$ from nominal; i.e.

$$\delta V_u = k \delta V_{in}$$

$$\text{and } \delta V_o = \frac{r_s}{R_s + r_s} \delta V_u$$

Thus for $n\%$ change in V_{in} $\delta V_o = \frac{R_s + r_s}{r_s} n/100 V_u$

(iii) Ambient-temperature changes

If the temperature coefficient is $a\%$ per degC, for an ambient temperature change of δT degC,

$$\delta V_o = a/100 V_o \delta T$$

Self-heating of the tube tends to stabilize this effect giving smaller changes than predicted.

(iv) Ripple

In theory, the corona tube reduces ripple in the ratio $Z_s (R_s = Z_s)$, where Z_s is the impedance of the tube at the ripple frequency (usually slightly higher than r_s). In practice, the ripple voltage is often much higher than expected, owing to oscillator radiation. A capacitor in parallel with the tube reduces the ripple to a fraction $1/(1 + \omega CR_s)$ of the unstabilized ripple.

Practical e.h.v. units

The above principles are now applied to the design of three practical units.

CIRCUIT FOR 14kV FIXED, 50 μ A, STABILIZED

The requirements of fixed output voltage and low current

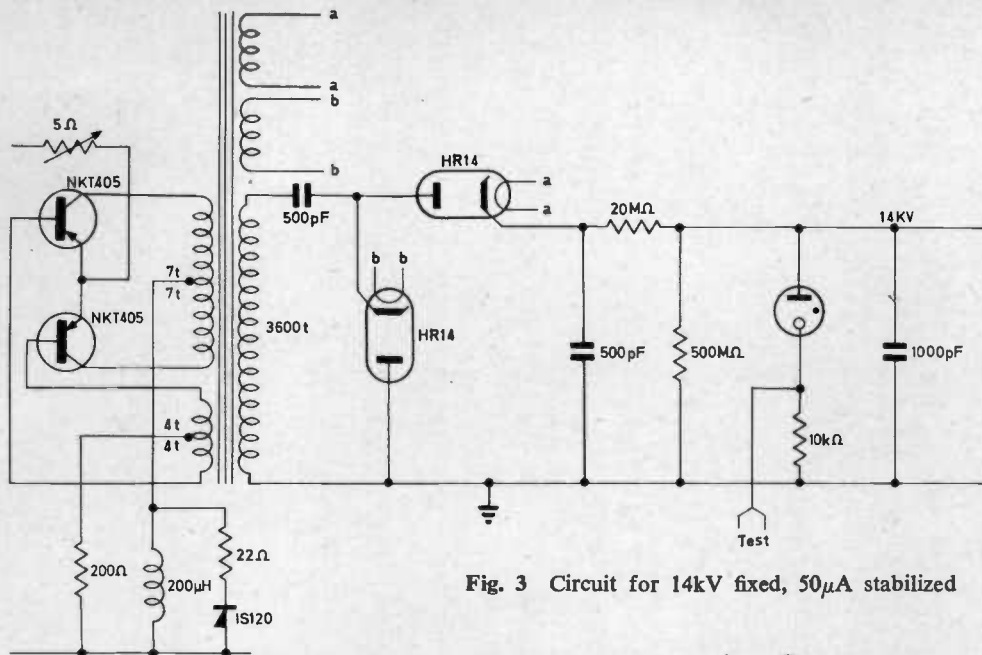

Fig. 3 Circuit for 14kV fixed, 50μA stabilized

suggest the use of corona stabilizers. In the circuit in Fig. 3, the oscillator is a transformer-coupled push-pull circuit with a sinewave output at the transformer resonant frequency (about 20kHz). NKT 405 transistors provide a good compromise between maximum-voltage ratings (60V) and f_a (800kHz). The inductance in the negative supply lead is an important feature of the circuit: maximum efficiency demands that the transistors are bottomed for the whole of their conduction periods and that switching is as rapid as possible; the choke tends to maintain constant total current and it produces a nearly square current waveform in each transistor with more rapid switching. Typical waveforms with and without the choke appear in Fig. 4.

The collector-voltage waveform is approximately half-sinewave. The collector centre-tap waveform is ideally as shown in Fig. 4f, and, since there is no direct voltage across the choke

$$2/\pi V_{\max} = V_{h.t.}$$

r.m.s. voltage between collectors = $\sqrt{2} V_{\max} = \pi/\sqrt{2} V_{h.t.}$
Thus the peak collector voltage is $\pi V_{h.t.}$

Transformer leakage inductance causes spikes on the collector waveform, and catching diodes may be necessary to prevent transistor damage. A voltage-doubler rectifier with thermionic rectifiers was used, as this gave small size, low cost and good high temperature performance. The unstabilized transformer output voltage is 18kV at 200μA maximum. Any stabilized output voltage between about 10 and 16kV is possible with a suitable choice of R_s and corona tube.

The performance of the unit as calculated and confirmed experimentally is as follows:

$R_s=20M\Omega$; $V_u=18kV$; $r_s=1M\Omega$; $a = +.007\%$ per degC

Regulation from zero to full load = 50V

Regulation for $\pm 5\%$ change in supply voltage = $\pm 40V$

Output-voltage change for a change from 0 to 40° = $+40V$

Peak to peak 20kHz ripple = 15V

Setting up of the unit is achieved by setting the test-point voltage to 2V by adjustment of the supply voltage.

CIRCUIT FOR 1-10kV VARIABLE, 3mA, STABILIZED

The output power of the circuit in Fig. 3 can be increased with slight modification to about 10W. Further increase of power requires paralleling of the oscillator transistors;

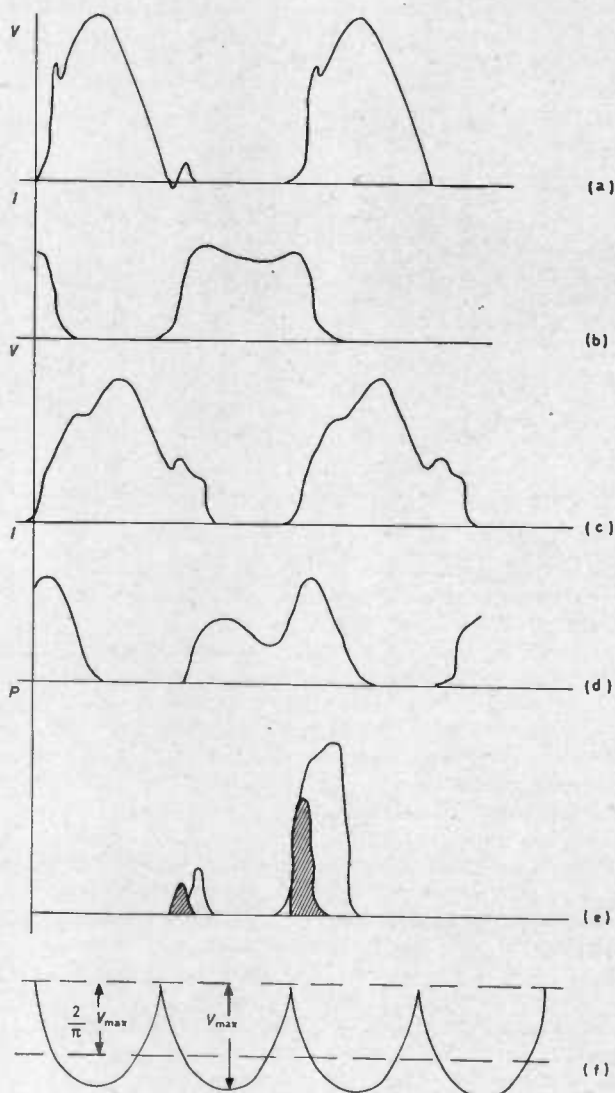

Fig. 4 Transistor waveforms for the circuit in Fig. 3

- (a) Choke input, collector voltage
- (b) Choke input, collector current
- (c) No choke, collector voltage
- (d) No choke, collector current
- (e) Instantaneous collector dissipation (no choke : white; choke input : shaded)
- (f) Collector-winding centre-tap voltage

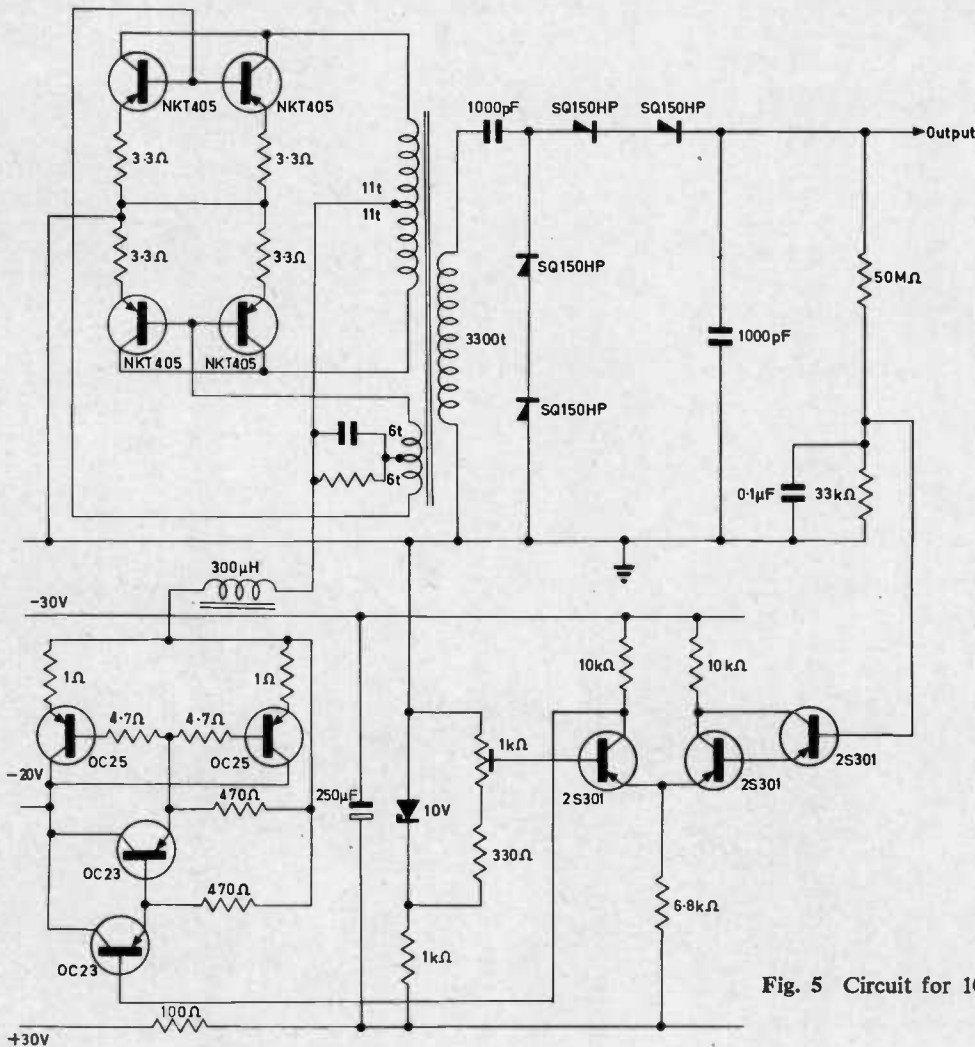

Fig. 5 Circuit for 10kV varying, 3mA stabilized

this technique is used in the circuit shown in Fig. 5. The requirement here is for a 1-10kV variable stabilized supply giving up to 3mA.

Two transistors in parallel are used in each side of the oscillator with equalizing resistors in the emitters; in fact, the circuit operates more efficiently with some emitter resistance. If valve rectifiers are used, a separate oscillator is needed to supply the heaters, because of the variable output voltage. Selenium rectifiers were used in practice, because the ambient temperature was not likely to exceed 30°C. Because of the variable output, corona stabilizers were unsuitable, and so a feedback stabilizer is used. The amplifier current gain required is not excessively high, because a fairly large reference chain current can be spared with the higher output current, while still maintaining a reasonable efficiency. The output from the feedback amplifier drives a series transistor which controls the d.c. supply to the oscillator; a Zener diode is used as reference. Higher-power outputs than 30W can be produced by using more transistors in parallel in both the oscillator and the supply line.

The performance of the unit is as follows:

- Output voltage = 1-10kV, variable
- Output current = 3mA maximum
- Output impedance = 250kΩ
- Regulation ±10% d.c. supply = ±0.5%
- Efficiency = 47%
- Frequency = 20kHz

CIRCUIT FOR 2kV FIXED, 1mA, STABILIZED

In the circuit in Fig. 6, the oscillator is adapted from a circuit described in Reference 5, to which reference

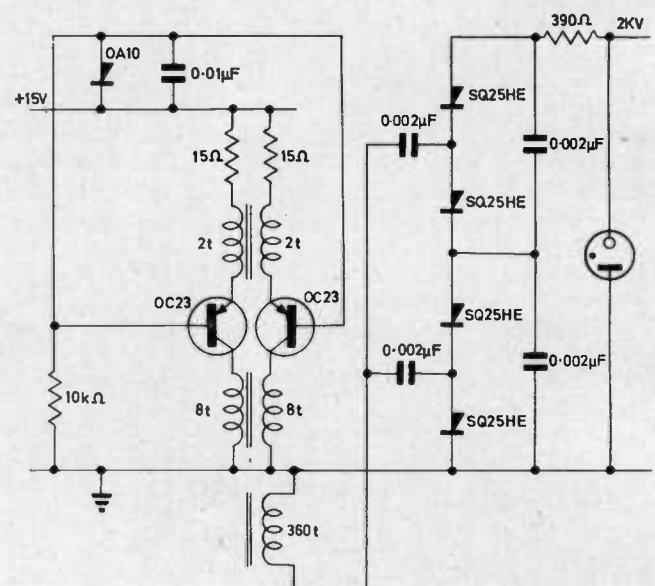

Fig. 6 Circuit for 2kV fixed, 1mA stabilized

should be made for a detailed description of its operation. It is essentially a transformer-coupled bistable circuit operating in grounded-base configuration. The frequency of the squarewave output is given by

$$f = \frac{1}{4L_m \frac{n-1}{n^2(R_o + R_{in})} - 1/R_L}$$

where L_m = inductance of transformer collector winding
 α = grounded-base current gain of the transistor
 n = turns ratio of collector winding to emitter winding
 R_o = emitter series resistance
 R_{in} = input resistance of transistors at peak emitter current
 R_L = resistance presented by load

since $\alpha \approx 1$ and $R_o \gg R_{in}$, f depends on the transformer inductance and turns ratio, the emitter resistance and the load resistance. The peak emitter current, and hence the maximum output power, depends on the value of R_o . The lower R_o is, the greater the power.

To ensure squarewave operation, the transformer resonant frequency is kept high compared with f . In this case, to keep the winding small, a quadrupler rectifier was used to give 2.5kV d.c. OC23 transistors are used with a 15V supply, which gives a peak collector voltage of 30V. The transformer is wound on a 35mm pot core, which gives a very compact construction. Selenium rectifiers and a corona stabilizer provide the 2kV output.

The performance of the unit is as follows:

Output voltage	= 2kV
Output current	= 1mA
Unstabilized output voltage	= 2.5kV
Output impedance	= 50k Ω
Input stabilization ratio	= 10:1
Frequency	= 30kHz
Efficiency	= 50%

The collector-voltage waveform gave good squarewaves with about 5 μ s risetimes. The transformer secondary volt-

age could be considerably increased with little degradation in performance. Tests show that output power could be boosted to give over 10W from a pair of OC23 transistors, with a probable increase in efficiency. In general, the effect of reducing R_o and increasing the power output is to reduce the oscillation frequency.

Conclusions

The design of a transistorized e.h.v. unit requires careful study of the exact requirements. Points of importance are output requirements, oscillation frequency, ambient-temperature range, the degree of stability required and whether a variable or fixed output voltage is to be provided. It has been shown how these considerations affect the final design. In many cases where stabilization is essential, corona stabilizers are most suitable when a fixed output is required. Where a variable output is specified, a feedback amplifier is more practicable. At voltages above a few kilovolts, especially where the oscillator frequency is above the audio range, thermionic rectifiers are still necessary in many applications. The transformer-coupled bistable circuit is a useful new circuit in the e.h.v. field. It is of proven utility for lower voltages and shows promise as a means of efficiency providing higher voltages at moderate power levels and at supersonic frequencies.

Acknowledgments

The author wishes to thank the Director of Research of The Marconi Co. Ltd for permission to publish this article.

References

- 1 The design and operation of transistor d.c. converters, *Mullard Tech. Comm.* 2, 17 (Feb. 1956)
- 2 HOLME, R. A.: D.C.-to-d.c. transistorised converters, S.T.C. Application Report MK/143
- 3 TOWERS, T. D.: Practical design problems in transistor d.c./d.c. converters and d.c./a.c. inverters, *Proc. IEE, Pt. B, Suppl.* 18, 1373 (May 1959)
- 4 New high-power d.c. converter circuits, *Mullard Tech. Comm.* 5, 43 (April 1960)
- 5 The junction transistor push-pull blocking oscillator, *Mullard Tech. Comm.* 5, 48 (June 1961)
- 6 BAXANDALL, J. P.: Transistor sine-wave LC oscillators, *Proc. IEE, Pt. B, Suppl.* 16, 748 (May 1959)

First cable for Cape Town—Lisbon link

During October, 1260 n.m. of deep-sea lightweight submarine telephone cable, with 55 n.m. of armoured shallow-water cable and a total of 149 repeaters and equalizers, were loaded from the STC factory at Southampton into the cable ship *Mercury*, bound for Cape Town. The 5582ton d.w. Cable & Wireles ship, on charter to STC, is carrying out the first lay of cable in a £22M scheme to link South Africa with the continent of Europe. The new link will be capable of carrying 360 simultaneous 2-way telephone conversations; it will have intermediate landing points as Ascension, Cape Verde Island and the Canary Islands, where some channels will interconnect with a cable laid in 1965 to the Spanish mainland, and will terminate at Lisbon, where it will have access to a high-capacity cable to be laid between there and Cornwall—a joint project by the British Post Office and the Portuguese PTT. STC have supplied, or will supply, cable, repeaters and terminal equipment for all these projects. The cable, to be owned and operated by the new South Atlantic Cable Company (Pty) Ltd, will provide a 10-fold increase in channels and much better quality of communication between South Africa and Europe which, at present, relies on high-frequency radio channels. From Cape Town, the *Mercury* will be steaming towards Ascension at speeds up to 8 knots, laying the deep-sea 1in lightweight cable with the repeaters spliced in at 9½ n.m. intervals. She is expected to finish her first lay by mid-December 1967 and will then return to Southampton

for more cable and repeaters. The whole project is due for completion by the end of December 1968.

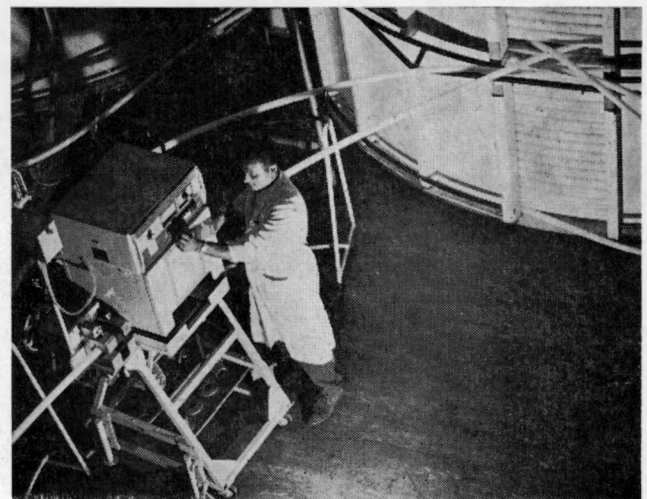

Lengths of cable without the outer copper conductor are joined, the operator inspecting the joints by X-ray

NEW

BOOKS

Basic theory of waveguide junctions and introductory microwave network analysis

By D. M. Kerns and R. W. Beatty. 150 pp. Demy 8vo. Pergamon Press. 1967. Price £1 15s.

This monograph is a valuable addition to the literature on microwave networks. The first part, concerned with the more general and basic aspects of the theory of waveguide junctions, constitutes a relatively rigorous introduction to the impedance, admittance and scattering descriptions of junctions. The second part (nearly 70% of the book), dealing with applications, is valuable, not only in deriving useful formulas from the basic theory, but in effectively illuminating the earlier discussion. This part develops analytical tools which are especially useful in microwave-measurements applications; it introduces fundamental definitions of quantities to be measured, e.g. attenuation and phase-shift. Expressions for power, input reflection coefficient, efficiency, attenuation, mismatch loss and phase shift are obtained in terms of scattering coefficients. Restrictions and limitations placed on scattering coefficients of 2-ports by realizability, reciprocity and losslessness are given. The effect of different characteristic impedances of the waveguide leads is taken into account. Some properties of linear fractional transformations are applied to 2-ports and extensions to multiports are discussed; cascading of 2-ports is treated analytically. An introduction to the theory of 3-ports is given, also descriptions of directional couplers and hybrid tees; the use of signal flow graphs is discussed. Exercises extend and supplement the text, and an appendix contains selected rules and definitions of matrix algebra and other material. This book will be invaluable to all concerned with the design and analysis of microwave networks or with microwave measurements.

F. A. BENSON

The physics of modern electronics

By W. A. Gunther. pp. 337. Constable and Co. Ltd. 1967. Price 18s.

Several years ago this reviewer commented with pleasure about the appearance of a book on the physics of electronics. Since then, several books of that nature have been published, some quite good. It is strange, therefore, that the publishers of this volume should

claim that it is the first of its kind. Nor could it be called a book suitable for students of engineering; at best, it is a popular, if muddled, exposition of not-so-modern physics finding applications in electronics. The treatment is wordy, and what is described as explanation is often just a restatement of observed phenomena full of analogies which do not stand up and digressions into practical, albeit naive, applications. Atomic structure is treated twice (in the first and the last chapter), and each time it is satisfied with the Bohr model without even mentioning that it only works for hydrogen and with some difficulty for one or two other elements. In between, the second chapter covers 'diodes, tubes, photoelectric cells etc.', followed by 'tubes with grids', in which mutual conductance is referred to in Continental fashion as slope, amplification factor does not appear and is replaced by its inverse called grid-penetration factor, and a tetrode is referred to as a 4-pole tube. Next comes gas diodes, including a host of lesser known and better forgotten gas devices; cathode-ray and other tubes, including counting tubes, photomultipliers, television cameras and scintillation counters are all lumped together. There follows a chapter on velocity-modulated tubes, in which the working of a reflex klystron is explained by reference to a Barkhausen-Kurz valve. The remaining chapter is entitled 'Semiconductor elements (transistors)', and, apart from the highly unsatisfactory treatment of $p-n$ junctions and transistors, it covers plasma, m.h.d. generators, piezoelectric effect and even magnetic amplifiers. The author is not helped by bad translation; some sentences simply do not make sense. Terms have been translated without reference to English-language usage ('... not to be connected parallel because of the combustion voltage scatter' refers to parallel operation of cold-cathode diodes). There is also a regrettable lack of uniformity in dealing with units and symbols.

M. H. N. POTOK

The theory of waveguides and cavities

By R. A. Waldron. 120 pp. Demy 8vo. Maclaren & Sons Ltd. 1967. Price £1 12s.

A set of articles originally published in *Electronic Technology* in 1961 forms the basis for this book. These articles dealt

with a general approach to the exact theory of waveguides and cavities, examples of waveguides and discussion of special points and perturbation theory, with applications. A further six chapters in the book complement the original papers, to give an account of the fundamental principles of the theory of guided waves. Most of this material has also been published previously and is merely reprinted here. Waveguide modes are discussed, including the possibility of a unique system of mode nomenclature. The importance of arriving at the correct interpretation of the mode spectrum is pointed out and examples from studies of helix and ferrite-loaded waveguides are given. Surface impedance as a boundary condition is discussed, the basic perturbation formula for a resonant cavity is derived and chapters are devoted to electromagnetic fields in ferrite ellipsoids and resonant-cavity methods of measuring ferrite properties. The book is not intended for the beginner who wishes to learn waveguide theory but as a discussion of basic topics for the reader who is already aware of their existence, with the object of establishing the validity and significance of various concepts. It should interest microwave scientists aiming at expertise in the subject and will provide supplementary reading for a student wishing to widen his understanding of the fuller implications of the theory.

F. A. BENSON

Electron dynamics of diode regions

By C. K. Birdsall and W. B. Bridges. 270 pp. Med. 8vo. Academic Press. 1966.

As the title suggests, this book treats the notion of charged particles in time-varying fields. The authors begin by describing a single-charge analysis based on the one-dimensional planar diode model; in the discussion which follows, Ramo's theorem on induced currents is developed. The simplicity of the model used enabled the authors to treat non-linear theory, but it was pointed out that more realistic models make it necessary to linearize. The second chapter gives a general linear analysis, including the kinetic-power theorem, followed by an application to the space-charge-limited diode, to an idealized multi-grid tube as well as to velocity-jump effects. The ideas developed in this chapter have their roots in the work of Benham and

Llewellyn, in particular, and the authors discuss the relation between the Llewellyn equation and those of Hahn's space-charge-wave theory. The stability of flow is next considered; this requires the development of nonlinear theory. To achieve this, the authors introduce a multiparticle model, which consists of a fluid (the electron stream) divided into a large number of blocks which are, in turn, condensed into sheets. The self-fields of the charges are included in the equations and the simultaneous motion of the sheets is obtained from a computer in a series of computer experiments. The reader is introduced fairly gently to the process by first treating some simplified problems. Two chapters are devoted to treating the theory of gaps—klystron gaps (including multiple gaps) and crossed-field gaps; the magnetron-injection gun is also discussed in the second of these two chapters. The sixth chapter discusses the emission and noise properties of thermionic cathodes and photocathodes, as well as secondary emitters; the chapter closes with a section on partition and induced grid noise. The final chapter is devoted to transit-time effects in semiconductors; the analysis is developed along lines similar to Llewellyn's treatment of the vacuum diode, and is applicable to general diode regions with fairly long transit times. However, the injection mechanism itself is not discussed in any detail. The literary style is relaxed, which makes the work easy to read although in places a more precise statement would have been preferable. Occasionally the authors lapse into rather cumbersome mathematics (usually owing to the choice of notation), but this is completely offset by the practice of leaving some of the steps to the reader as problems—a practice strongly to be recommended, particularly as the authors suggest procedures in the more difficult cases. The book is a useful one (which could be enhanced in value if a future edition contained a fuller description of Eulerian and Lagrangian variables) and possesses a list of references which gives the reader a good picture of the field as it stood in, say, 1965. It is well printed and the figures are clear, also there is an author index as well as a subject index.

R. H. C. NEWTON

Introduction to network analysis

By Ben Zeines. 306 pp. Med. 8vo. Prentice/Hall International. 1967. Price £4 8s.

The author is an instructor at RCA Institutes Inc. and an assistant professor at Hofstra University; he therefore has teaching experience at both industrial and academic institutions. The preface states that 'the analysis and performance of networks, network theorems, and network applications are the major subjects for study by modern technicians, engineers and physicists'. The book consists of 10 chapters: steady-state network analysis; network theorems; the Laplace transformation; resonance;

coupled circuits; electrical-wave filters; band filters; attenuators and equalizers; filter-network synthesis; tuned-voltage amplifiers. These are followed by an appendix, a bibliography and an index. The book contains a great number of numerical examples, which form an integral part of the text. It could be argued that chapters 6 to 10 deal not with network analysis but with network design; given the inclusion of design topics, it would be preferable to see a more modern and less incomplete treatment of image-parameter filters, equalisers and modern insertion-parameter filters. The advances of modern electrical-network engineering are frequently conceived and achieved at a highly theoretical and mathematical level which is not easily accessible to the majority of 'modern technicians, engineers and physicists', for whom the book under review is intended. There is therefore an undoubted need for a variety of textbooks at various levels of theoretical and mathematical sophistication; there is also room, among the many 'orthodox' books on network theory, for experimentation and unusual mixtures of subject matters. There can be no doubt that the author of this book tries, in a novel way, to introduce nonmathematical readers to inherently highly mathematical topics like Laplace transformation and modern insertion-parameter-filter theory. However, the price paid for this—a general looseness of concepts and definitions—is too high and defeats its purpose. As the book has much more the character of a handbook than that of a textbook (most theorems are simply stated—neither derived nor proved), it is particularly unfortunate that the book is marred by a number of misleading or wrong definitions and statements. For example, the definition of 'linear circuit element' on page 1 ('ratio of voltage to current is a constant') is misleading as it does not apply to *instantaneous* currents or voltages in reactive networks. The definition, on page 46, of a 'piecewise continuous function' as 'zero for time less than zero' is wrong. Tables 4.1 and 4.2 have a number of wrong entries (misprints?) and the definition of image impedance on page 139 is wrong. Summarizing, it appears that the main contribution which the book can make is to serve as a useful source of problems (worked examples). In the hands of an experienced and knowledgeable teacher, it may also act as a stimulus for trying out simple approaches to difficult subjects and offering unusual selections and combinations of topics.

W. SARAGA

Einführung in die Schaltalgebra (Introduction to switching algebra)

By H. Bühler. 154 pp. Med. 8vo. Birkhäuser Verlag, Basel, Switzerland. 1967.

This is the fifth volume of Birkhäuser's series of 'Textbooks of electrotechnology'. As one would expect from the publishers, the book is beautifully

produced. One can only judge by the impressions conveyed by the book itself, and in the present case one gets the feeling that the author did not write about his own subject. There is, to begin with, a very clear exposition of the aims and a careful statement of symbols and definitions. This is followed in the next chapter by the fundamental postulates and rules of switching algebra, each case being illustrated by both the relevant relay and logic block diagrams. Circuits comprising a memory element (hold-in contact) as well as the effects of delayed operation and graded response thresholds are introduced. Chapter 3—Analysis and synthesis of switching circuits—then seems to go over the same ground again, although, to be fair, the Karnaugh diagram is introduced here. Chapter 4 is entitled 'Practical examples', and is again subdivided into analysis and synthesis; all this is followed by a list of formulas and an index. The index lists 137 entries referring between them to only 62 of the 134 pages of the text; one page is actually referred to 12 times.

K. L. SELIG

Semiconductor junction devices

By J. Frank Pierce. 164 pp. Demy 8vo. Prentice/Hall International. 1967. Price £2.

In recent years, the field of electronic devices and applications has expanded to such an extent that no single volume could provide basic coverage. The Merrill series is an open-ended textbook at undergraduate level, from which volumes can be selected to meet the requirements of a particular teaching syllabus. This present volume analyses the basic *p-n* junction and then proceeds to examine the various junction devices—tunnel diodes, reference diodes, switching diodes, field-effect transistors, m.o.s. transistors and junction (bipolar) transistors. The final chapter gives rather less detailed attention to the thyristor and integrated circuits, which may well warrant separate volumes later in the series. Provided with plenty of elbow room, the author has organised his material extremely well. The mathematical treatment is comprehensive and easy to follow; in addition, the significance of the results obtained is clarified by worked examples. The author derives equivalent circuits where appropriate, and demonstrates their use in simple circuit applications. The book is not only valuable for its mathematical treatment, however; the author has a very readable style and gives an excellent descriptive account of the devices, which can be followed without much attention to the mathematics.

P. ROBINSON

Focusing of charged particles: Vol. 2

Edited by A. Septier. 471 pp. Med. 8vo. Academic Press, NY. 1967. Price £7 12s.

This book deals with the theoretical and experimental aspects of the problems

involved with focusing and directing beams of charged particles. It is divided into two volumes, with 13 contributory authors in vol. 1, and 14 in vol. 2, both being edited by Albert Septier. Vol. 1 is divided into sections—potential, fields, trajectories and lenses; vol. 2, with which this review is concerned, has three sections—focusing of high-intensity beams, prisms and focusing in particle accelerators. The first section, of 156 pages, has 119 pages devoted to electron beams, and 37 to ion beams. The section on electron beams deals with both the design of electron guns and the various forms of magnetic-beam-focusing systems in common use. The second section, of 130 pages, deals with the deflection of beams of charged particles using electrostatic and magnetic systems. The third section, of 165 pages, has four subsections. The first three deal with optics of electrostatic accelerator tubes and focusing in linear and circular particle accelerators; the fourth section deals with the use of secondary targets when particles other than protons and electrons, which can be accelerated, are required. The treatment throughout would appear to be a well balanced blend of theory and practice, with a good bibliography at the end of each subsection, and can be recommended to both students and workers in the various fields.

P. E. LAMBERT

Fundamentals of silicon-integrated-device technology: Vol. I—Oxidation, Diffusion and Epitaxy

Edited by R. M. Burger and R. P. Donovan. 495 pp. Med. 8vo. Prentice/Hall International. 1967. Price £6.

This book is the first in a series being produced by a group of authors at the Research Triangle Institute, North Carolina. The object of the series is twofold, according to the preface: first to provide the integrated-device engineer with a single source for much of the information that he now acquires from the technical literature, thereby increasing his efficiency; second, to inject more science into integrated-device technology where empiricism is at present prominent. Judged narrowly according to these objectives, the book is not entirely successful. The practical information needed by the integrated-device engineer is already available in a more accessible form in at least one other book; and if the authors have succeeded in shedding the light of science over the darkness of empiricism at all, the effect can hardly be said to be dazzling. This is not to say that the book is valueless, however, but rather that the objectives were too ambitious. Much of the text is a digest of published literature, with a very extensive list of references up to the autumn of 1965, and this could be valuable, especially to a worker new to the field. At times, the authors stray into areas normally regarded as remote from integrated circuits, particularly in the

section on oxides, where considerable attention is given to the properties of commercial glasses. Here and there, a research scientist will find this most stimulating, but it is done at the cost of supplying much information that will ultimately be found irrelevant. The book is printed in facsimile typescript.

P. J. DANIEL

Electrical noise

By R. King. 195 pp. Crown 8vo. Chapman & Hall Ltd. Price £1 15s.

This monograph is intended for post-graduate students of electrical engineering or final-year undergraduates. A mathematical introduction is followed by discussions of thermal noise, noise in vacuum diodes, triodes and pentodes, in semiconductor diodes and triodes and current noise. The author then considers noise in linear networks, amplifiers and detectors and in communications systems. He concludes with a chapter on noise measurement and sources. The book deals primarily with the noise mechanisms in vacuum and semiconductor diodes and triodes, and the circuit techniques for dealing with them. There is very little reference to noise in the microwave region and none to microwave devices. Within these limitations, the book contains an excessive number of errors, particularly in the mathematics, and some sections may be misleading to a newcomer to the field. A rather small number of references to papers and more detailed textbooks are included.

I. SNOWDEN

Statistical communication and detection with special reference to digital data processing of radar and seismic signals

By E. A. Robinson. 362 pp. Med. 8vo. Charles Griffin & Co. Ltd. 1967. Price £4 10s.

This book provides a most absorbing discussion of the use of a digital computer as a data-processing device for processing signals in noise, in the fields of both radar and seismology. The similarities and points of divergence in the two fields are well covered and, although a good grounding in statistical communication theory is necessary to ensure appreciation of the work, a real effort is made to develop a relationship between the mathematical model and the physical system which it represents. The book is divided into five main parts: Part A consists of a descriptive discussion of signal and noise sources in radar and seismology. The first obvious difference in the two fields is that, whereas noise in radar is generally random and uncorrelated, seismic noise is correlated in various degrees in both time and space. Based on the basic concept of the noisy channel, the difference in signal-detection problems is discussed: in radar, the designer chooses his signal for transmission and can shape it to produce optimum signal-detection conditions; in earthquake and

underground - nuclear - explosion seismology, the situation is rather analogous to radio-astronomy, since the seismologist has no control over the source of signals that he receives. However, he does have the opportunity to make experiments in controlled explosions, to find out something of his signal and channel characteristic.

Part B demonstrates once again the application and usefulness of the Fourier transform as a tool for the communication engineer. Relationships between aperture illumination and radiation pattern of antennas and between pulse shape and spectral bandwidth are developed, but there the book only acts as a supplement to standard works in the field.

Part C discusses numerical filtering methods and makes extensive use of the z-transform for the study of correlation techniques. Examples given here of reformulation of conventional analogue treatment of problems into digital terms include elimination of seismic ghost reflections and elimination of water reverberation. The application of deconvolution, or inverse filtering to problems in radar and seismology, with the associated approximation techniques, is given good coverage.

Part D covers digital processing of signals in noise. The first section is standard material on autocorrelation and spectral distribution functions of stochastic signals referred to electrical-noise phenomena and microseismic noise, but again the extension to sampled data techniques and the effect of digital filtering is discussed. In the discussion of detection of signals in noise, the advantage of the matched filter for white noise is related to the radar problem, and comparison is drawn with noise with an arbitrary autocorrelation, of interest in seismic applications. This section is completed by a chapter on signal enhancement and prediction, drawing heavily on such classic contributions as that of Wiener.

Part E deals with certain special topics on multichannel data processing with special reference to velocity filtering for seismic arrays. The basic concept is the notion of filtering in the domain of both temporal and spatial frequency, and at this point the real divergence between radar and seismology is clear. Whereas, in radar, sonar etc., signals and noise propagate with the same velocity, this is not the case in seismology. Here, velocity filtering offers the capability of enhancing the signal/noise ratio significantly without signal-waveform deterioration, since no signal bandwidth is sacrificed.

The book ends with a discussion of adaptive array systems in radar and seismology. Here, again, an important divergence occurs, in that the narrowband h.f. radar signal lends itself to the use of phase-locked-servo techniques. In contrast, the typical seismic-signal spectrum covers three octaves, e.g. 0.01 to 10Hz, and the conclusion is

drawn that a general-purpose digital computer whose programs are adaptive appears to be the most feasible automatic adaptive seismic array system. An extensive bibliography is included and a set of problems without answers follows most chapters. This is hardly a book for the undergraduate, but those specifically interested in the application of digital data processing to signal detection should find it of great value.

R. BARRETT

Mathematical techniques in electronics and engineering analysis

By J. W. Head. 264 pp. Demy 8vo. Hiffe Books Ltd. 1967. 18s.

The purpose of this book is to provide engineers with detailed information on the use of a number of simple mathematical techniques, which will assist in the solution of many of the commoner engineering problems. Simultaneous equations with real coefficients are solved using a method which allows computational checks to be made at intermediate stages in the solution, minimizing the risk of error. The root-locus method for examining the behaviour of algebraic equations is considered in detail, with a number of examples worked through. Lin's iterative process is discussed for improving the approximate values of roots obtained from the root-locus method, and examples are worked of an alternative technique due to Jordan. Pascal's triangle is introduced to give the coefficients of the binomial series, and the convergence of series in general is discussed. The coefficients in a partial-fraction expansion are evaluated. After a section on the basic meaning of differentiation and integration, a number of ways of solving integrals are considered. These include solution by substitution, where a table of useful substitutions is included, solution by parts, by series expansion, and by Simpson's rule. A selection of techniques for simplifying and improving the accuracy of numerical calculations includes quadratic interpolation and least-square methods. Elementary treatments of trigonometry, operational methods and matrixes are followed by a chapter dealing with a method for ensuring the minimum variation of a function. After a discussion of impedance calculation, the last part of the book examines various mathematical methods for determining the stability of a network. The book should prove of interest to a large number of engineers, representing as it does a personal and rather unconventional viewpoint on a number of useful basic mathematical techniques. The emphasis throughout the book is on the use of the techniques and many numerical examples are included in the text. Engineering undergraduates might find it a worthwhile addition to their standard texts.

D. P. HOWSON

Solutions d'exercices du cours élémentaire de mathématiques supérieures: tomes I à III, de J. Quinet, Third edition

By H. Perréaud. 256 pp. Dunod, Paris. 1967. Price 16F.

Detailed answers to the problems set in Quinet's course in higher mathematics.

Wireless World Diary 1968

T. J. & J. Smith and Hiffe Electrical Publications. 1967. Price 6s 6d.

This well-known diary now has 79 pages of information preceding the diary section. It includes valve data, transistor equivalents, a most comprehensive list of addresses of organizations involved in radio and electronics, colour codes, broadcast frequency channels etc. The diary itself has two pages for each week.

Electronic counting: circuits, techniques, devices

Edited by E. J. Kench. 219 pp. Industrial Electronics Division, Mullard Ltd. 1967. Price £1 17s. 6d

Within a small compass the whole range of electronic counting techniques is presented in this book with clarity and illustrated with many circuits, annotated with component values. An explanation of Boole's logic, with Venn diagrams, is followed by a chapter on the basic counting elements, i.e. diode gates, DTL, DCTL gates etc., bistable circuits, and concluding with brief descriptions of thyristors and counting tubes. The need for pulse shaping is defined and shaping circuits are described. Detailed information on active circuits of all kinds then follows, with two chapters on counters using other than the decimal system. The important function of storage is outlined with examples. The penultimate chapter shows how decoding and conversion is carried out and Veitch diagrams are introduced here with their practical use. Finally, a description of numerical indicator tubes is given, showing electrical characteristics and their insertion into circuits.

Safety for industry: a manual for training and practice

By F. L. Creber. 188 pp. The Royal Society for the Prevention of Accidents. 1967. Price £1 10s.

As the author says: '... it would not be practicable to produce a safety manual which would cover all exigencies and eventualities'. This book is intended as a general guide to good safety practice and as a basis for training at any level in accident prevention. Many safety precautions are essentially the application of common sense but a large number involve special knowledge beyond common sense e.g. handling of solvents or gases, and these are emphasized by the author. Not the least useful part of the book is the list for further reading and reference where information on specialized matters is available.

List processing

By J. M. Foster. 54 pp. Macdonald. 1967. Price £1 1s.

List processing is associated with those operations of a computer which have to do with the ordering of sets, e.g. a queue is such an ordered set of entries. The author describes briefly the representation of lists and the operations performed on them. Most of the programming in this book uses, in the main, the Algol language with some modifications, but a chapter is devoted to other special list languages.

Introduction to computational linguistics

By D. G. Hays. 231 pp. Macdonald. 1967. Price £3 10s.

A basic text is presented, primarily for university courses intended for students with no previous experience of the subject. The

first three chapters introduce digital computers and the various methods of internal and external storage. The remainder of the book is concerned with the technique of linguistic data acquisition, dictionary look-up, grammatical strategies etc. The final chapter puts into perspective the aims and means of automatic translation. Full lists of references are included for further reading, many entries being annotated as regards contents.

Safety with cryogenic fluids

By M. G. Zabetakis. 156 pp. Heywood. 1967. Price £3 10s.

One of the 'International Cryogenics Monograph' series under the general editorship of Mendelsohn and Timmerhaus: although the author is American the contents of the book are universally applicable and combine in a short compass all of the physiological, physical and chemical hazards involved in fluids whose critical temperature is below room temperature. A chapter details plant and test-site safety considerations and a particularly useful set of safety data sheets is included for every gas of interest.

Electric power systems

By B. M. Weedy. 307 pp. Wiley. 1967. Price £2 15s.

Many books on this subject tend to describe the components of power systems in detail, without regard to the system as a whole. The author has reversed this procedure and presents a coherent account of the operation and analysis of electric power systems. The point of view taken is that of the final year of a modern first degree course, so that the reader is expected to be more or less familiar with the fundamental principles of electromagnetism, networks and control theory. The author's objective ('to present the power system as a system of interconnected elements which may be represented by models either mathematically or by equivalent electrical circuits') is well carried out and the book is recommended to electronics engineers who wish to have a modern approach to the subject.

Publications received

Logic handbook—flip chip modules

428 pp. Digital Equipment Corporation, 146 Main Street, Maynard, Mass. 01754, USA. 1967.

Small computer handbook

494 pp. Digital Equipment Corporation, 146 Main Street, Maynard, Mass. 01754, USA. 1967.

Semiconductors and integrated circuits

—Part 2
320 pp. Philips Electronic Components and Materials Division. 1967.

Industrial electronics handbook

By R. Kretzmann. 308 pp. Philips Technical Library. 1967. (3rd Edition, 3rd reprint).

The dynamic characteristics of limiters for sound-program circuits

By D. E. L. Shorter, W.I. Manson and D. W. Steffings. 15 pp. British Broadcasting Corporation. 1967. Price 5s.

A survey of the development of television test cards used in the BBC

By G. Hersee. 20 pp. British Broadcasting Corporation. 1967. Price 5s.

Subroutine Heitler

By A. Foderaro. 20 pp. Atomic Energy Research Establishment. 1967. Price 3s. 6d. (from HMSO).

SCAT and SLAB: two computer codes for the computation of thermal neutron-scattering cross-sections

By P. Hutchinson and P. Scholfield. 44 pp. Atomic Energy Research Establishment. 1967. Price 8s. (from HMSO).

SHORT NEWS ITEMS

Medical- and biological-engineering conference

The second Canadian Medical & Biological Engineering Society conference will be held at the King Edward Hotel, Toronto, Canada, on the 9th, 10th and 11th September 1968. The deadline for contributed papers is the 20th May, when 350-word abstracts will be required in triplicate. These should be sent to: Prof. N. F. Moody (Chairman, Papers Committee), Institute of Bio-Medical Electronics, University of Toronto, Ontario, Canada.

US order for TRACE

American Airlines has become the first US domestic carrier to buy the Hawker Siddeley Dynamics TRACE electronic test unit. The order, worth \$250 000, is for equipment to test autopilots on the airline's jet fleet automatically. This TRACE-600 (test-equipment for rapid automatic checkout and evaluation) unit will be the first with built-in capability for producing punched tape suitable for computer analysis of test results. By feeding the punched tape containing the test results into a computer, performance trends for each specific autopilot can be analysed as well as all autopilots on a fleet basis. This will result in better preventive-maintenance programs and improved autopilot designs based on the recorded and analysed data. The unit will be installed at American Airline's maintenance and engineering centre in Tulsa, Oklahoma, in March 1968.

Telex service still expanding

An order to the value of £1 975 750 has been placed by the GPO with Creed & Co. Ltd, the Brighton firm of teleprinter manufacturers. This is the largest single order received in the company's history. The order covers 4800 teleprinters, 2070 tape readers and 165 keyboard tape punches. Most of the equipment will be used in the GPO's rapidly expanding public teleprinter service, Telex. At the end of June of this year, there were 2005 machines connected to the system, compared with 10746 on the 30th June 1963. All of the teleprinters will be manufactured at the Brighton location, and the tape readers and keyboard tape punches at the company's Treforest factory in South Wales.

International conference of engineering organizations

The project to set up a worldwide organization for professional engineers

is now to go ahead. Proposals were first reported a year ago when the initiative was taken by EUSEC. The inaugural meeting will take place in Paris in early March 1968 with the substantial support of UNESCO. The conference will comprise national and international representing engineers of a professional level of technical competence. 61 professional-engineering societies, representing 26 countries, including Czechoslovakia, Hungary and the USSR, have so far expressed a wish to participate in the new organization. International organizations which are joining the conference are FEANI (Fédération Européenne d'Associations Nationales d'Ingenieurs), CEC (Commonwealth Engineering Conference) and UPADI (Union Panamericana de Asociaciones de Ingenieurs). British participation will be both on a national basis and internationally, through membership of FEANI, CEC and ENSEC.

European-satellite solar-generator contract

Ferranti have received an order worth over £300 000 from the MESH consortium to provide solar generators for the ESRO TD1 and TD2 satellites. The ESRO-TD prime contract was awarded to MESH earlier this year and is the fourth ESRO satellite project. The satellites, which are due to be launched in 1969 and 1970, will carry a sun-oriented array of 11 520 silicon solar cells manufactured at Ferranti's Gem Mill factory. The mounting of the cells on the satellite structure will also be carried out by the company at their Wythenshawe laboratories. These solar cells have also been supplied for the ESRO-2 satellite, the second model of which is to be launched shortly, and the first all-British satellite, *Ariel-3*, which was launched on the 5th May and is operating successfully.

Seminar on communication-satellite Earth stations

An international seminar on communication-satellite Earth stations is being organized jointly by the Post Office, the Ministry of Technology and British industry; it will be held from the 20th to 31st May 1968. The first week of the seminar, at the Royal Lancaster Hotel, London, will be allocated to the presentation of papers and the second week to visits to the Post Office Earth station at Goonhilly and to important scientific

establishments engaged on work in the field of satellite communications. The seminar is expected to be of special interest to overseas administrations concerned with the planning, specification, purchasing and operation of Earth stations. It will provide a comprehensive survey of the techniques involved in the planning and operation of Earth stations for civil communications, and will be supported by an exhibition. A number of overseas countries will be invited to participate; observers from British industry and other interested organizations will also be invited.

Ground-to-air communication contract

Standard Telephones & Cables Ltd has received an order from the Ministry of Technology for 100W u.h.f./a.m. transmitters, type-DU.8-D, and general-purpose a.m. receivers, RX.25-series; the order is worth approximately £250 000. The DU.8-D is a crystal-controlled amplitude-modulated u.h.f. transmitter with a nominal output power of 100W. It operates at signal frequencies in the 225-400MHz band, and is primarily intended for ground-to-air communication. The RX.25-series fully transistorized pre-set receivers are specifically designed for unattended operation. Their proven dependability makes them particularly suitable for airfield application, where allotted receiver frequencies function for long periods. Both equipments will be manufactured by the company's Radio Division at New Southgate in North London.

New Zealand contract with Plessey

Important export orders worth £275 000 for the supply of telephone-exchange equipment to the New Zealand Post Office have been placed with the Plessey Telecommunications Group. The major contract, worth over £100 000, calls for the supply of rural automatic-exchange equipment. In addition, Plessey is to manufacture and supply a new 3000-line satellite automatic exchange for Waikiwi and provide an extension to the Levin central automatic exchange.

Visual business communication

Vision is added to sound in a new concept of business communication which may be available for public service in the 1970s. Confravision, the name given to this possible future service, would be available to businessmen who, simply by booking studio time, would be able to

hold meetings and conferences with business colleagues in distant places over intercity closed-circuit-television links. The Post Office will test the likely demand for a future service by inviting representatives of commercial and industrial undertakings at top management level to two experimental work studios in London. This experimental demonstration link accommodates up to five people at each end. One studio is situated at the GPO Engineering Department's headquarters in Gresham Street, and the other is at the GPO Research Station at Dollis Hill, London. The studios will offer Confravision and other allied facilities, such as facsimile transmission and photocopying of documents and sound recordings of the proceedings. Until the precise range of facilities required by potential users is confirmed, speculative charges are in the range of £120 per hour for calls between studios 100 miles apart to £200 per hour at 200 miles.

Conference on noise

The Institute of Physics & The Physical Society announces that its electronics group, in collaboration with the electronics division of the IEE, is arranging a conference on the physical aspects of noise in electronic devices, to be held at the University of Nottingham on the 11th-13th September 1968. Review papers will be presented on the noise aspects of grid-controlled valves at very low frequencies, microwave tubes, measurement techniques, semiconductor devices, flicker $1/f$ and other very-low-frequency noise, oscillators, radiation statistics, lasers, masers and parametric amplifiers, particle detectors and photodetectors. Contributions on these or associated subjects are invited. Summaries (three copies) should be submitted to the Conference Secretary, I. Snowden, The M-O Valve Co. Ltd, Research Laboratories, First Way, Exhibition Grounds, Wembley, Middlesex, no later than the 31st May 1968. Registration details will be available in February/March and can be obtained from the Meetings Officer, The Institute of Physics & The Physical Society, 47 Belgrave Square, London SW1.

World's first wideband submarine telephone cable

The World's first wideband submarine-telephone-cable system went into operation on the 9th October, between Norway and Denmark. The contract was carried out by the all-British company, Submarine Cables Ltd (an AEI company), who designed and manufactured the 80n.m. of cable and 10 submersible transistorized repeaters. The system will provide 480 (4kHz) circuits, but would be capable of handling 640 (3kHz) circuits. The special terminal-station transmission and power-feed equipment was manufactured by AEI Telecommunications Group. The cable was laid by the Post Office cable ship *Monarch* under charter to Submarine Cables Ltd. In the coming months, Submarine Cables

will be supplying 1000n.m. of cable for service in the North Sea, Baltic and English Channel followed by a further 1000n.m. for the Mediterranean and Atlantic, adding to the existing 23 000 miles—a third of the World's total—of submarine telephone cable already supplied by this company.

Solid-state-physics conference

The Institute of Physics & The Physical Society announces that its 5th annual conference on solid-state physics will be held at the University of Manchester Institute of Science and Technology on the 3rd-6th January 1968. The conference will follow the same general pattern as the four preceding annual conferences held in Bristol and Manchester, and will provide an opportunity for workers in all branches of solid-state physics to meet and discuss recent developments. The basic principle of the conference is to provide a forum for the whole range of solid-state physics, to promote a crossfertilization of ideas and techniques from one specialized area to another. The program will be deliberately arranged to encourage specialists to get together for as long a time as possible and meet and exchange views and ideas, rather than planning a series of consecutive specialist meetings within the conference period. In the past, the conferences have been of interest mainly to academic physicists, but it is intended that the 1968 conference should include one or two review papers to be given by invited speakers from industry with a particular bearing on applications. Invitations to speak have been extended to a number of prominent scientists.

Counter order to Venner

An order for 200 counters, believed to be the largest ever placed by the GPO for this type of equipment, has been received by Venner Electronics Ltd. With the addition of telephone-circuit test gear, manufactured to GPO design specifications, the value of the contracts exceeds £40 000. The counters are basically TSA-6636 type, with 6-digit inline readout (including decimal-point display) and full 12.5MHz response. The main feature of the instrument is its versatility, as it also provides for multi-period measurement up to 10^7 cycles, time measurements from $1\mu\text{s}$ to 10^7s (115 days) and full frequency-ratio measurement. The accuracy of the 2MHz oven-controlled crystal is 1 in 10^6 .

British radar success in Russia

British radar equipment is in operation for the first time at the principal Soviet air-traffic-control centre for the Moscow area at Vnokovo Airport. The Marconi/Thomson secondary radar equipment, SECAR, is an advanced and effective civil air-traffic-control aid. It provides both height and identity information to supplement the radar display, allowing air-traffic controllers to evaluate the complete air situation at once, without

the need to question the pilot on the radiotelephone. The equipment was transported to Moscow from Chelmsford, and has been set up there by Marconi engineers. The complete system was first demonstrated to a high-level delegation of Soviet visitors in October. Altitude and identity decoding, in both the active and passive modes, were demonstrated, together with emergency radio-failure decoding and special position-identification decoding.

Radar order for Ekco

Ekco Electronics have won an order from BOAC for airborne weather radar worth over £½M. This is for re-equipping the corporation's 707 fleet with E290 weather radar in place of the earlier version of Ekco radar supplied 10 years ago. The E290 system is based on the wider-pulse techniques pioneered by Ekco, a development which has led to a major change in general weather-radar design. The system incorporates a 30kW, 4 μs , pulse transmitter/receiver combined with a solid-state modulator giving increased range without high power peaks and providing a striking improvement in both performance and reliability.

Submarine cable with highest capacity yet

Standard Telephones & Cables Ltd has been awarded a contract by American Telephone & Telegraph Company worth £4M for the supply of 1350 n.m. of a new-design 1½in submarine cable to be used in a system to link the Caribbean area with the United States. The cable, to be jointly owned by AT&T, ITT, RCA Communications Inc. and Western Union International, will have a higher capacity than any yet in operation and will be able to carry 720 simultaneous 2-way telephone conversations (3kHz channels). It is expected to come into service during the summer of 1968 and will be laid between Jacksonville, Florida, and St. Thomas, Virgin Islands. Also, STC is now building for ITT's Radio Corporation of Puerto Rico a 960-channel microwave system which will link Puerto Rico with St. Thomas. The new communication system will provide high-quality service for the growing business and private traffic between the US mainland, Puerto Rico and the Virgin Islands, as well as areas served via these points, such as the Dominican Republic, Haiti and Venezuela. To produce this new larger-diameter lightweight cable, production facilities at STC's Southampton cable factories have been extensively modified and expanded and production for the USA-Virgin Islands system is already under way. A heavily armoured version of the cable for use at the shallow-water shore ends, to prevent damage by ships' anchors, trawlers etc., will also be made at Southampton. Transistorized repeaters (which will be laid at 10 n.m. intervals) and terminal equipment for the system will be manufactured by the Western Electric Company.

NEW EQUIPMENT

A description, compiled from information supplied by the manufacturers, of new components, accessories and test instruments.

THERMOELECTRIC-GENERATOR MODULES

G. V. Planter Ltd,
Windmill Road, Sunbury-on-Thames, Middlesex

A range of thermoelectric-generator modules designed to provide a steady and reliable electric-power output, with maximum working temperatures of up to 300°C, is introduced by G. V. Planter. The operation is based on the direct conversion of heat, typically derived from isotopic or 'fossil' fuel sources, into electrical energy, exploiting the Seebeck effect. The modules are suitable for applications in which long-term reliable performance is required, for instance in marine and aircraft navigational aids, telecommunication systems,

matched-load conditions at closely controlled hot- and cold-sink temperatures. The modules are supplied with individual test certificates. Typical performance and physical characteristics are: type-TPG/205: maximum hot-sink temperature 300°C; matched load output 750-900mW; open-circuit voltage 3.6V, for a temperature difference of 200°C; internal resistance 2.1Ω (20°C); outside dimensions 0.740 × 0.740 × 220in. Type-TPG/210: maximum hot-sink temperature 300°C; matched load output 400-500mW; open-circuit voltage 3.6V, for a temperature difference of 200°C; internal resistance 3.9Ω (20°C); outside dimensions 0.740 × 0.740 × 0.420in.

For more information circle No. 271

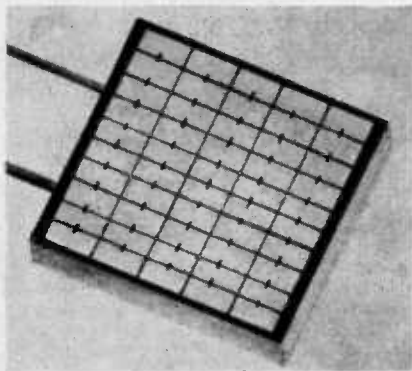

remote weather stations, cathodic-protection units, and for portable power supplies etc. The generators comprise 100 limbs (50 thermoelements) produced from p- and n-type semiconductor alloys based on bismuth telluride. The elements are connected in series electrically, but in parallel thermally, to give 'hot' and 'cold' faces. The establishment of a temperature difference between the faces produces a voltage which depends on the temperature gradient and the matrix configuration. The array is encapsulated to give a monolithic mechanically strong assembly which is capable of operation at elevated temperatures. The faces of the generators are lapped to close tolerances, to permit good thermal contact with the hot and cold sinks. If required, integral Chromel/Alumel thermocouples, the junctions of which are flush with the faces of the array, can be provided. To achieve maximum reliability, the modules are subjected to stringent control during manufacture; each undergoes a series of acceptance tests, including a 15h output-power test under

SUBMINIATURE GLOW LAMPS

AEG (Great Britain) Ltd,
Lonsdale Chambers, 27 Chancery Lane,
London WC2

AEG (Great Britain) Ltd are now marketing, on behalf of Osram GmbH, Munich, two subminiature glow lamps, types-682 and -683. The technical specifications are basically as follows:

voltage: 5V

current consumption: 60mA

base: (type 682) S4s; (type 683) with or without 25mm wire leads

The subminiature glowlamps have been specially developed to minimize the size of components and instruments; e.g. these lamps are ideal for computers, transistor switching and aircraft instrumentation. They are ruggedly built to withstand sudden shock and vibration and can be used in any position.

For more information circle No. 272

PORTABLE V.H.F./U.H.F. CALIBRATOR

Racal Instruments Ltd, Dukes Ride, Crowthorn,
Berkshire

The new v.h.f./u.h.f. calibrator type-850 is the latest addition to the 800-series of Racal instruments. Simple to use, it is light, portable, and may be powered by dry batteries or a.c. power supplies. The calibrator is used to monitor the carrier frequency of small and large transmitting installations in the frequency range 100kHz-500MHz in less than 1min. This instrument will be valuable to the field service engineer for routine tuning, day-

to-day calibration and field maintenance, especially of v.h.f. radiotelephones, allowing checks to be made without removal of the transmitting equipment from its vehicle, and without the use of complex and costly ancillary test equipment. It may also be used for production-line testing and in the r. & d. laboratory for calibration checks. Sampling techniques are employed to eliminate the ambiguities normally associated with beat-frequency oscillators; an audible beat note is generated if the carrier frequency is incorrect, enabling anyone to make fine frequency adjustments by tuning the transmitter to zero beat. The sampling rate is chosen from 12.5, 25 or 50kHz, depending on the channel spacing in the relevant frequencyband, and it is assumed that the

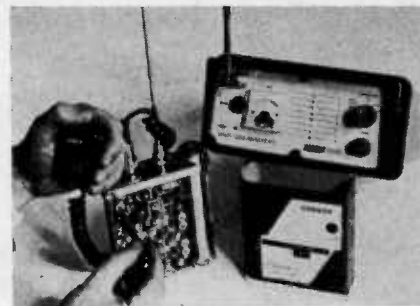

operating frequency is a multiple of one of these frequencies. The inbuilt oscillator attains a stability of 1 part in 10⁶ within 60s and 1 in 10⁷ in 3 min. Silicon solid-state devices are used throughout, mounted on fibreglass printed-circuit boards to give high reliability; the case is moulded from high-impact styrene.

For more information circle No. 273

BACKWARD-WAVE OSCILLATORS

Varian Associates Ltd,
Russell House, Molesey Road, Walton-on-Thames,
Surrey

Six miniaturized voltage-tuned magnetically shielded backward-wave oscillator tubes have been introduced by the Palo Alto Tube Division of Varian for aerospace and test-instrument applications. All of these b.w.o.s are ideal for high-speed wide-frequency-range swept signal sources; together they cover various frequency ranges between 8.0

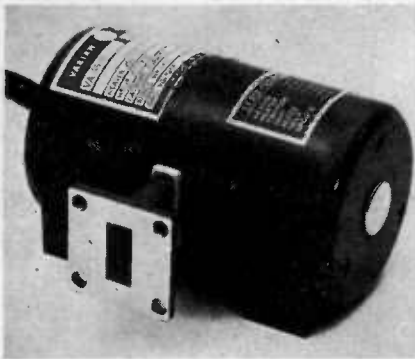

and 26.5 GHz. Each of these tubes exponentially tunes over its entire frequency range without discontinuity, by changing only the helix voltage. A non-intercepting negative-voltage control grid permits amplitude modulation without drawing appreciable current in the modulating circuit. Integral magnetic shielding reduces the stray magnetic field $\frac{1}{2}$ in away from the tube to less than 10Gs. For this reason, the tube appears as a passive ferrous material to any magnetically sensitive device. Operation in contact with ferrous materials or in stray magnetic fields will not usually degrade the tube performance. Magnetic shielding, the sturdy metal-ceramic construction, a small size of less than 5×6 in and a weight of only 4lb make these tubes attractive for space and airborne applications; cooling is by convection, requiring no forced air.

For more information circle No. 274

PRINTED-CIRCUIT EDGE CONNECTOR

AMP Industrial Terminal House, Stanmore, Middlesex
AMP Industrial have introduced the A-MP split-leaf connector, which uses contacts of 2-piece construction. The board-contact section is manufactured from phosphor bronze and is hard-gold-plated; it is bifurcated for contact redundancy and has a spring-roll receptacle to mate with the rear-post portion of the contact. The rear post is phosphor bronze, tin-plated, and is designed to accept Termini-point clips. Additionally, it is suitable for solder, weld or wrap-type wiring. In the event of the board contact becoming damaged in service, it can be removed easily and a new contact inserted without removing the connector or disturbing the rear wiring. Diallylphthalate or glass-filled polycarbonate housings accommodate boards

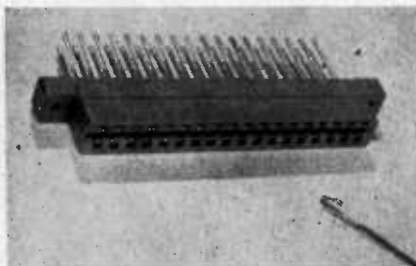

from 0.056 to 0.070in thick. Polarizing of connectors can be achieved by inter-contact keying plugs. The connectors are designed for use with the Termini-point automatic wiring machine for volume production or with one of the range of lightweight handtools for smaller production requirements.

For more information circle No. 275

WASHERS FOR POWER TRANSISTORS

Jermyn Industries,
Vestry Estate, Sevenoaks, Kent

Jermyn Industries introduce a range of hard anodized washers for power transistors and thyristors which offer considerable advantages over mica. They are designed specifically for TO3, TO66,

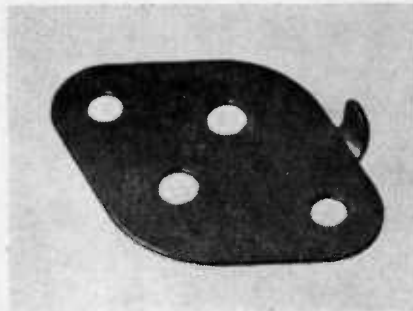

MS3 and stud-mounted GE triacs and thyristors with $\frac{1}{2}$ in U.N.F. studs. Manufactured from high-quality NS4 aluminium, these washers are treated by the Jermyn hard-anodized process, which provides a file-hard finish. The thermal resistance of this finish is five times better than mica and insulation resistance is better than $1000M\Omega$ at 500V. Advantages of hard-anodized washers over mica include: higher power output from the device, reduced circuit costs; hard surface finish not punctured or scratched by chassis burrs, with consequent increase in circuit safety and reliability; mechanically robust, not requiring careful handling like mica, which tends to crack during assembly. These anodized washers are available from stock.

For more information circle No. 276

IMAGE ISOCON TUBES

English Electric Valve Co. Ltd,
Chelmsford, Essex

English Electric Valve is developing two Isocon television-camera tubes and samples are available for experimental evaluation. The P850 is a $4\frac{1}{2}$ in image-Isocon designed for viewing low-intensity X-ray fluoroscopic screens. It has a curved faceplate for use with standard mirror optical systems; if a corrector plate is interposed, a refractive optical system may be used. This tube is used extensively in the image-intensifier equipment manufactured by Marconi. The P880 is a 3in image-Isocon designed for special television purposes at very

low scene illuminations. It can produce good pictures when the photocathode illumination is only 10^{-4} ftcandles; even if the photocathode illumination falls as low as 10^{-6} ftcandles, acceptable pictures can still be produced. Both sizes of Isocon have been developed from the range of image-Orthicons. Each uses a special beam-readout section which reduces the noise in the output signal. In addition, scenes having a very wide range of light-levels can be handled.

For more information circle No. 277

HIGH-SPEED T.T.L. DECADE COUNTER

Mullard Ltd, Torrington Place, London WC1

Latest addition to the Mullard range of t.t.l. integrated circuits is a monolithic high-speed decade counter, type-FJJ141, for use at clock rates up to 10MHz. The circuit can be used in three separate modes to provide a symmetrical divide-by-10 count or to provide either a divide-by-2 or a divide-by-5 count. It consists of four dual-rank master slave flipflops internally connected. Gated direct reset lines are provided to inhibit count inputs and return all outputs to a logical zero or to a BCD count of 9. Outputs of at least 2V are obtained, a level which is more than adequate to drive associated circuits. Power consumption is only 132mW. Normal 14-pin dual-in-line encapsulation is used. Brief data: supply 5V; clock rate (max): 10MHz; fan-out: 10; noise immunity: 0.4V (min), 1V (typ); total dissipation: 132mW; temperature range: 0 to 70°C.

For more information circle No. 278

COMBINED TRANSISTORIZED OSCILLATOR AND MILLIVOLT-METER

Lander Electronics,
24 West Kensington Mansions, London W14

Models-OMS and -OMD by Lander Electronics comprise a fully transistorized oscillator and millivoltmeter covering the audiofrequencies, in a single case measuring $6 \times 5\frac{1}{2} \times 5\frac{1}{2}$ in. Power is supplied by $2 \times$ PP9 batteries which help to make this a compact portable economic instrument. The two models differ only in the meter scaling: model-OMS gives readings in decibels and OMD reads r.m.s. voltage. The meter sensitivity is determined by an 8-position switch giving readings from -60 to +20 dBm (OMS) or 1mV to 10V (OMD). The oscillator is a Wien-bridge feedback network with thermistor control of the output level. Twelve selected frequencies, covering the range 40-16 000 Hz, are selected by a 12-position switch. Oscillator output is continuously variable, with a maximum output of approximately 0.8V r.m.s. The actual output level can be accurately set on the meter. Each half of the unit has its own ON/OFF switch to allow either half to be used separately, thus conserving battery



voltage. Test sockets are provided at the rear for measuring battery voltages. Input and output terminations are via standard 2-way jack sockets.

Oscillator section:

Frequencies: 40, 60, 110, 250, 1k, 3k, 5k, 8k, 10k, 12k, 14k, 16kHz; accuracy: +5%; distortion: less than 1%; power supply: 1×PP9 battery; minimum battery voltage required: 8V; frequency change for a fall in supply of 1V: less than 4%; output impedance: 1kΩ maximum.

Millivoltmeter section:

Meter ranges: (OMS) -50, -40, -30, -20, -10, 0, +10, +20dBm (1mW into 60Ω); (OMD) 3mV, 10mV, 30mV, 100mV, 300mV, 1V, 3V, 10V r.m.s.; meter scaling: (OMS) -10 to +2dB (accurate readings down to -60dBm); (OMD) 0-1V; 0-3V (2 scales: readings down to 1mV); frequency response: +1dB, 20 -100kHz; accuracy: +5%; power supply: 1×PP9 battery; change in reading for a fall in supply of 1V: -½dB; input impedance: 1MΩ.

For more information circle No. 279

NOISE GENERATOR

Claude Lyons Ltd,
Instruments Division, Hoddesdon, Hertfordshire

The Elenco series-624A fixed-frequency noise generator offers a wide selection of fixed-frequency ranges from 10, 20, 50, and 200Hz to upper frequencies of 20, 50, 100, 200, 500 and 600kHz. Output-spectrum uniformities flat within ±0.5, ±1.0, ±2.0 and ±3.0dB are standard, while other frequency ranges and spectral uniformities are readily available. Each series-624A noise generator supplies a Gaussian noise voltage with a precisely controlled white-power frequency spectrum, and a symmetrical nonclipped waveform with true zero mean level. The output level is continuously adjustable from 0 to 3V r.m.s. with a peak-to-r.m.s. capability of



at least 3.5:1. An output voltmeter scaled 0-5V r.m.s. is incorporated. Output impedance is 200Ω ±10%. A step attenuator is incorporated, minimum external load resistance on direct output being 7000. These solid-state instruments provide performance superior to valve-type instruments and have compact dimensions of 5½in height, 8½in width and 11in depth. One or two units can be rack-mounted on a 19 × 5½in panel.

For more information circle No. 280

MECHANICAL FILTERS

G. A. Stanley Palmer Ltd, Island Farm Avenue,
West Molesey Trading Estate, Surrey

An extensive range of mechanical filters made by the Collins Radio Company is now being marketed by G. A. Stanley Palmer Ltd. There are three main types in varying case styles to suit particular applications. These are bandpass (200-500kHz), s.s.b. (250-500kHz), and multiplex sideband (60-108kHz). The filters are made in a multiplicity of bandwidths, and a design service is available for specials. They are electrically and mechanically stable, and resist aging, breakdown and drift, even with extremes of temperature or long and continuous service. Frequency drift is as low as 1.5-2 parts/10⁶ per degC over a -25 to +85°C range, and the filters will operate over a temperature range in excess of -55 to +105°C. Aging tests have shown that cycling between 25 and 90°C for an 8-month period produces a maximum deviation of less than 1 part in 10⁶. A flat-topped frequency response with ripple as low as ±0.25dB has been achieved, and filters have been built with a 60:6dB shape factor as low as 1.2:1. Cases are in some instances as small as ½in³ in volume.

For more information circle No. 281

HIGH-VOLTAGE POWER-SUPPLY RANGE

The Belix Co. Ltd,
47 Victoria Road, Surbiton, Surrey

The Belix HV range of power supplies comprises nine different units based on three sizes of module. Units are supplied set to a particular voltage in the range 0-250V twin, or 0-500V single, at currents between 100 and 700mA. Output voltage may be automatically programmed, or changed manually by the substitution of one component, with a corresponding transformer-tapping change. A linear programmable system can be used down to zero voltage, owing to the fact that the power-supply control amplifier is designed so that its characteristics remain unaltered by a change in output voltage. Each unit has a 20V potentiometer adjustment fitted as standard. All the units in this range will operate in free-standing conditions at up to +55°C ambient, but operation at much higher temperatures can be attained by the use of forced-air cooling. Electronic over-

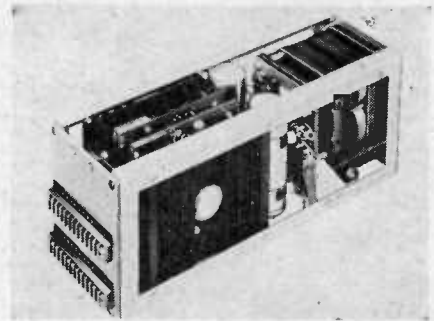

load protection of the re-entrant type is fitted so that the units are self-resetting. The HV range is available for inputs of 100, 110, 120, 200, 220, 240V, and the stability (ratio of change in input voltage to change in output voltage) is greater than 2000:1; weights vary from 8 to 19lb.

For more information circle No. 282

LEAD-THROUGH CAPACITORS

Oxley Developments Co. Ltd,
Priory Park, Ulverston, Lancashire

Oxley Developments have introduced a lead-through capacitor which gives good performance and reliability in the field. The mounting of the components on an earthed chassis provides low-frequency or d.c.-insulated connexion through the chassis, together with an appropriate capacitance to earth. This capacitance helps to prevent the passage of high-frequency energy along the lead-through wire. The component is mounted in a 2BA-clearance hole; the body and nut are 4BA-hexagon nickel. Brief characteristics are as follows: operating-temperature range: -20 to +120°C; tolerances available: -10% +80% and +20%, test voltage: 1600V d.c.; working voltage: 350V d.c. The ranges include 47pF, 470pF and 1000pF. Joint Service Numbers have been allocated to these components.

For more information circle No. 283

CHOPPER AMPLIFIER

Ancom Ltd,
Devonshire Street, Cheltenham, Gloucestershire

Ancom announces an encapsulated chopper amplifier, type-15C-1. It is designed for operation from +15 and -15V supplies, but versions for other commonly used voltages can be provided. Type-15-1 is a noninverting low-drift



NOT AN INTERESTING - LOOKING ADVERT REALLY

JUST 7 NEW NEWS FROM MD

NEW SERVICES NOW OFFERED BY MD

**1 NEW
MD PRINTED CIRCUITS → BUT HIGHER PRECISION**

**2 NEW
MD PLATING → GOLD-PLATING SERVICE**

**3 NEW
MD PLATED-THROUGH HOLES → AVAILABLE SOON**

**4 NEW
MD STEP-AND-REPEAT PRECISION PHOTOGRAPHY**

**5 NEW
MD CHEMICAL MILLING → DOUBLED CAPACITY**

**6 NEW
MD A NEW FACTORY → BEAUTIFUL**

**7 NEW
MD AND A NEW ADDRESS → NOTE IT DOWN**

**MICROPONENT
DEVELOPMENT
LIMITED**

An entirely independent
British Enterprise

**MOVED
TO**

**PRIORY WORKS
39/43 BELMONT ROW,
BIRMINGHAM. 4.
Telephone (021) 359-3556.**

LONG-LIFE, constant voltage during discharge,

rapid recharging, low size/output ratio,

no maintenance, wide temperature tolerances

**HOW
MUCH MORE
DO YOU
ASK**



**OF A
RECHARGEABLE
BATTERY ?**

Capacities from 0.09 to 900 A/hr. Robust electrical and mechanical strength. All these are Voltabloc virtues. Allying their unique sintered plate construction to the high-efficiency nickel-cadmium couple, Voltabloc batteries are today transforming the entire structure of industrial battery technology... setting new performance standards within a physical size smaller than any other rechargeable batteries of equivalent capacity.

From satellites to cordless shavers, aircraft to computers, Voltabloc versatility is little short of extraordinary. Even where

the use of batteries has hitherto been fettered by the sheer bulk of the lead-acid principle or the uneven discharge of primary cells, Voltabloc batteries can provide the vital power. They have been designed and developed by SAFT, our parent company and the world's leading manufacturer of modern nickel-cadmium batteries.

So if you have a requirement for consistent portable power, think Voltabloc first.

Write or telephone for full details of Voltabloc cells and batteries.



VOLTABLOC

SINTERED PLATE NICKEL-CADMIUM BATTERIES

A Voltabloc battery powers the emergency firing system of the world-beating high-velocity 120mm stabilised gun on the British Chieftain 50ton tank.

Noise dosimeter by Epsilon Industries Ltd. uses Voltabloc batteries so that it can operate anywhere without the need for battery replacement.

Concord supersonic airliner will be made safer by its ability to restart its engines in the air with Voltabloc batteries.

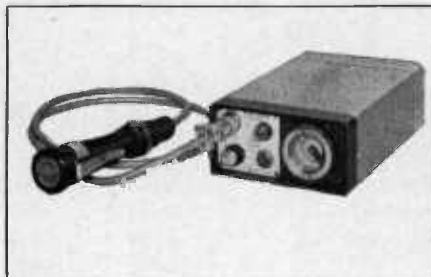

Cadmium Nickel Batteries Ltd Spedant Works, Park Royal Road, London, N.W.10. Tel: 01-965 7424 A subsidiary company of



amplifier designed for instrument applications. It is ideal for use with thermocouples and similar systems where fast response is not a prime requirement. Low noise level and very high input impedance are other features. Gain is adjusted by connecting a resistor between two of its terminals. Typical characteristics are: d.c. open-loop gain: 10^3 ; offset current: 100pA; offset voltage/temperature coefficient: $0.5\mu\text{V}/\text{degC}$ (max); input noise: $0.5\mu\text{V}$ r.m.s.; bandwidth (connected as a $\times 1000$ amplifier): 40Hz; input impedance $500\text{M}\Omega$; size $3\frac{1}{2} \times 1\frac{1}{2} \times \frac{1}{2}$ in.

For more information circle No. 284

TELEGRAPH-SIGNAL GENERATOR

The Plessey Automation Group,
Data Handling Division, Poole, Dorset

Ideal for use as a portable instrument, this fully transistorized telegraph-signal generator is one of the latest products developed by the Data Handling Division of the Plessey Automation Group. Known as the TSG10, the equipment generates a 5-unit signal plus a unit-length start element and a stop element of 1, $1\frac{1}{2}$ or 2 units, selected at any one of three fixed speeds in the range 45 to 75 bauds. Start element or bias distortion can be applied to the output signal in fixed increments of 5% over a 0-50% range. A stable frequency source and digital techniques eliminate calibration and permit simple precise control.

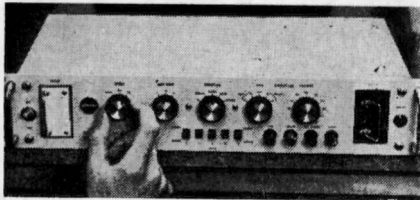

The instrument, being $3\frac{1}{2}$ in (8.9cm) high, 19 in (48.3cm) wide and $9\frac{1}{2}$ in (22.9cm) deep, is designed to mount within a 19 in (48.3cm) international rack and occupies two units ($3\frac{1}{2}$ in, 8.9cm) of rack space. The Carpenter electromechanical relay type 3N1Z is fitted to all standard models. Alternatively, the Plessey TER10 electronic relay is available as a plug-in replacement. The instrument, including the output relay and coder, weighs only 12.5 lb (5.7kg), and can therefore be carried easily by the user, in a specially designed case available as an optional extra.

For more information circle No. 285

TWIN-CONTACT GENERAL-PURPOSE RELAY

Telephone Manufacturing Co., Ltd,
Roper Road, Canterbury, Kent

A twin-contact version of the general purpose relay GPR-300 has been introduced by the Telephone Manufacturing Co. Ltd, a member of the Pye Group. The TMC single-contact relay has proved its reliability in service; however,

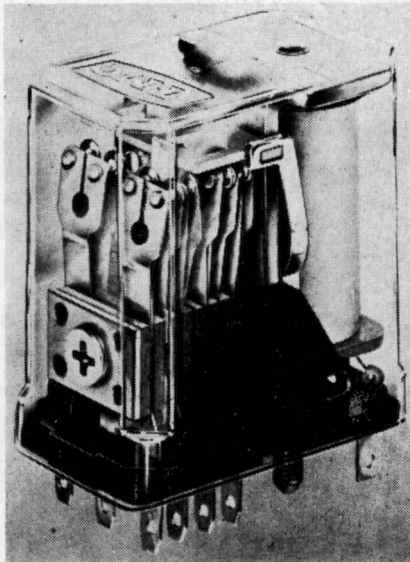

for conditions which are too arduous for the standard relay, and particularly where direct wiring is needed, the GPR twin will be suitable. Greater switching reliability can be obtained by the twin-contact relay, and using phosphor bronze spring blades and large bifurcated contacts, these relays offer high contact forces, giving long life. Technical details are as follows: mechanical life of 10^8 operations; switching capacities up to 110V a.c. or d.c.; complete interchangeability with British and Continental types; coil range up to 110V; wired or printed-circuit sockets; up to four changeover gold-flashed fine-silver contacts; fully bridged mounting frame to eliminate base distortion; temperature range up to 80°C with 60% r.h. (80% r.h. up to 40°C); case (excluding pins) $30 \times 19 \times 20\text{mm}$ or $30 \times 19 \times 30\text{mm}$.

For more information circle No. 286

ELECTRONIC TELEPRINTER

Creed & Co. Ltd, Hollingbury, Brighton, Sussex

An 8-bit electronic dataprinter which prints 96 characters, including upper- and lower-case letters, has been developed by Creed & Co. Ltd. The new machine, known as the Envoy Electronic Dataprinter, operates at up to 10 characters/s, and is designed for online use as a data-communication set, or offline for 8-track tape preparation, interpretation, duplication and editing. The new dataprinter has been designed to meet three main objectives: to improve reliability, provide increased flexibility and simplify and reduce the maintenance requirements. Microminiature integrated-circuit packages have been introduced to replace most of the intricate high-speed mechanisms characteristic of entirely mechanical online printers. By eliminating complex mechanical units such as the clutch and selector, reliability has been significantly increased and maintenance time reduced to a minimum. Altogether, more than 70% of the parts most subject to wear in

mechanical equipment of this type have been replaced by electronics, and the remaining mechanical units handle only comparatively simple functions such as typehead operation and paper transport. Flexibility also has been extended by the use of electronics, which permits the provision of facilities not previously available without the addition of complex mechanical units. One such facility is the 'stunt box'; this can now be provided by the addition of a small plug-in electronics unit which allows the Envoy to sample incoming codes and operate external circuitry when a particular code group is registered. Such a facility could be used to switch in ancillary equipment such as tape punches and readers, to switch on and off the Envoy's own tape units or to switch in only the addressed dataprinters in a multistation network.

For more information circle No. 287

MOTOR TACHOGENERATOR

Moore Reed & Co. Ltd,
Walworth, Andover, Hampshire

Motor generators in a size-10 frame (0.98in diameter) are now available from Moore Reed. In these instruments, which are used in servocontrols for load actuating and system damping, the feedback signal is obtained from a low-inertia precision-built tachogenerator integral

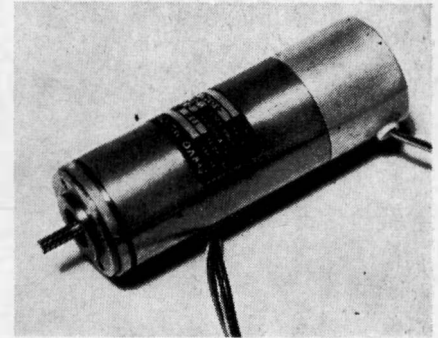

with the drive motor. The instruments are designed to provide a low output impedance of 500Ω and excellent signal/noise ratio, and are suitable for the temperature range -65 to $+110^\circ\text{C}$. Currently available models are suitable for 26V reference phase, 20V centre-tapped control phase and 26V generator excitation, but can be supplied for a range of voltages. The illustration shows the size 10M6 type-10 G4A-101 motor tachogenerator; frame and bearings are of corrosion-resistant steel.

For more information circle No. 288

LOW-NOISE AMPLIFIER

Brookdeal Electronics Ltd,
Myron Place, London SE13

The LA350B low-noise amplifier is the latest addition to the Brookdeal range of low-noise amplifiers and signal-recovery equipments. This is designed to make the latest techniques in low-noise amplification available in a go-



anywhere form. The circuitry is designed to provide a good noise figure at frequencies above 1kHz from a wide range of source impedances: a 3dB or better noise figure is available from an impedance of 1 to 500k Ω . The noise bandwidth can be changed by the use of built-in high-pass and low-pass filters. The maximum gain is 100dB; this can be reduced in 5dB steps by distributed feedback attenuators, in such a way as to maintain a good noise performance throughout the range of 55dB attenuation. The unfiltered bandwidth is 3Hz to 300kHz and nonlinearity is held below 0.1% at all positions of the controls up to the full output level of 2V r.m.s. The circuitry includes the latest Brookdeal low-noise pulse-response circuitry, which ensures excellent linearity with impulsive inputs. The power options are selected by a front-panel switch; these include mains operation (with a wide-range stabilizer), internal battery (with facility to check the voltage level on the output meter) and external battery (with elaborate arrangements to prevent damage from faulty connection). This amplifier is based on an equipment developed for the Ministry of Defence.

For more information circle No. 289

INTEGRATED-CIRCUIT POWER SUPPLY

Westinghouse Electric Corp.,
Molecular Electronics Division, Box 7377,
Elkbridge, Md. 21227

An integrated voltage regulator that contains the monolithic equivalent of one of the most widely-used discrete power-supply circuits is now available from Westinghouse. It provides the same (or better) performance as the discrete circuit it replaces and gives system designers very significant space savings, because it is packaged in a low-profile TO3 case. The WM-110 and WM-330 units can replace most present discrete power-supply regulators, for these inte-

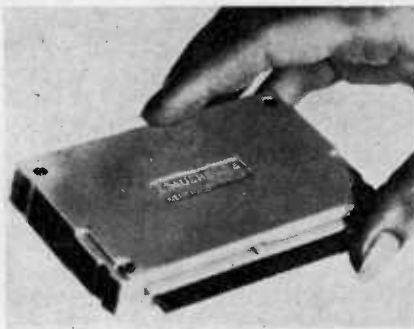

grated circuits can deliver 0.2A outputs at 8 to 48V. They provide 2% or better regulation at 1A. In addition, for the less-frequent power supplies that demand higher current outputs and closer regulation, the WM110 and WM330 units make ideal basic building blocks. The main difference between the WM-110 and WM-330 is that the WM-330 has an additional lead brought out so that external discrete Zener references may be used instead of the internal Zener reference. This allows the WM-330 to be used for outputs less than 8V; d.c. input (unregulated): 10-51V; maximum power dissipation: 25V; thermal impedance: 3.0 (with heat sink).

For more information circle No. 290

P.C.-TYPE BALUN TRANSFORMERS

Cambion Electronic Products Ltd,
Cambion Works, Castleton, Nr. Sheffield

Cambion announces the availability of a range of epoxy-encapsulated balun transformers as standard off-the-shelf items (part numbers 7167 and 7168). Designed specifically for coupling between balanced/unbalanced and unbalanced/balanced networks, the new baluns are described as closely coupled low-loss 1/1, 4/1 and 16/1 impedance-matching broadband r.f. transformers. They provide simple reliable solutions to difficult circuit impedance-matching broadband frequency problems and facilitate coupling from a 2-terminal to a 3-terminal network, or from a 3-terminal return to a 2-terminal network. The balun transformer provides coupling between both balanced/unbalanced and unbalanced/balanced networks over the frequency range 0.07 to 70MHz and impedance ranges of 50-200 Ω , 75-300 Ω , 50-50 Ω and 75-75 Ω . It handles up to 100W of r.f. power; r.f. dissipation rating is 0.7W. The 7168 miniature balun provides 1/1, 2/1, 4/1 and 16/1 impedance ratios over the frequency range 0.1 to 100MHz. The r.f. power-dissipation rating is 0.33W; the 7168 handles up to 5W.

For more information circle No. 291

INTEGRATED-CIRCUIT OPERATIONAL AMPLIFIER

Burr-Brown Research Corporation,
6730 S. Tucson Boulevard, Tucson, Ariz. 85706

Burr-Brown Research Corporation introduces a series of monolithic integrated-circuit operational amplifiers. This new series, called the BBIC Op Amps, overcomes many of the limitations of present commercially available i.c.s. They have dependability, repeatability and uniform performance from unit to unit. The amplifiers may be indefinitely short-circuited to earth without damage and the input is protected up to the supply voltage. Unity-gain stability is assured with virtually any capacitive loading without changing phase compensation or adding a decoupling resistor. Specifications for the eight models include

selection of input-voltage offset drifts of from ± 5 to $\pm 30\mu\text{V}/\text{degC}$ maximum, and maximum offset current drifts of ± 0.2 to $\pm 0.4\text{nA}/\text{deg.C}$. These specifications apply over the full -55 to $+125^\circ\text{C}$ for the four military-temperature-range units, and from -25 to $+85^\circ\text{C}$ for the commercial amplifiers. The c.m.r.r. is typically 100dB for all units and the open-loop gains range between 93 and 100dB. Rated output voltage is $\pm 10\text{V}$ on all units. The output current is $\pm 10\text{mA}$ for the wide-temperature-range units and $\pm 5\text{mA}$ for the commercial amplifiers. The low-noise units are offered with 3 μV peak, and 0.15nA peak, maximum equivalent input noise. All units are supplied in a standard TO99 can (low-profile TO5). Supply voltages from $\pm 9\text{V}$ to $\pm 18\text{V}$ may be used.

For more information circle No. 292

DIGITAL VOLTMETER

Data Research Ltd,
Durban Road, Bognor Regis, Sussex

Data Research have introduced a digital voltmeter, the DR.1350, as the first instrument available in a range of sophisticated digital-measurement equipment. The DR.1350 is an all-solid-state integrating-type 5-range digital voltmeter which incorporates a number of special features normally only available on far more expensive instruments. This is a lightweight and compact instrument, and it includes a carrying handle, which, when used as a stand, allows the instrument to be tilted forwards or backwards for easy viewing in any position the user requires. The DR.1350 is versatile and will answer a need in many environ-

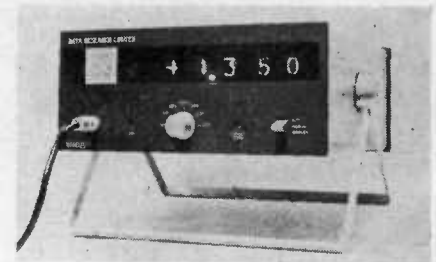

ments, including research laboratories, production testing, process control, and on-site servicing applications. It is 11in wide, 4 $\frac{1}{2}$ in high and 10in deep. It has five ranges: 2kV, 200, 20 and 2V and 200mV; the maximum reading is 1999 on all ranges and the input impedance is $>1000\text{M}\Omega$ on all ranges. The display is by 15mm clarity-view characters, cold-cathode tubes; input required: 115 or 240V a.c. $\pm 15\%$.

For more information circle No. 293

INTEGRATED-CIRCUIT COUNTING UNITS

Ebauches SA., Ch-2001, Newchâtel, Switzerland
The Oscilloquartz Department of Ebauches SA, Switzerland, have developed a new series of easy-to-use plug-in

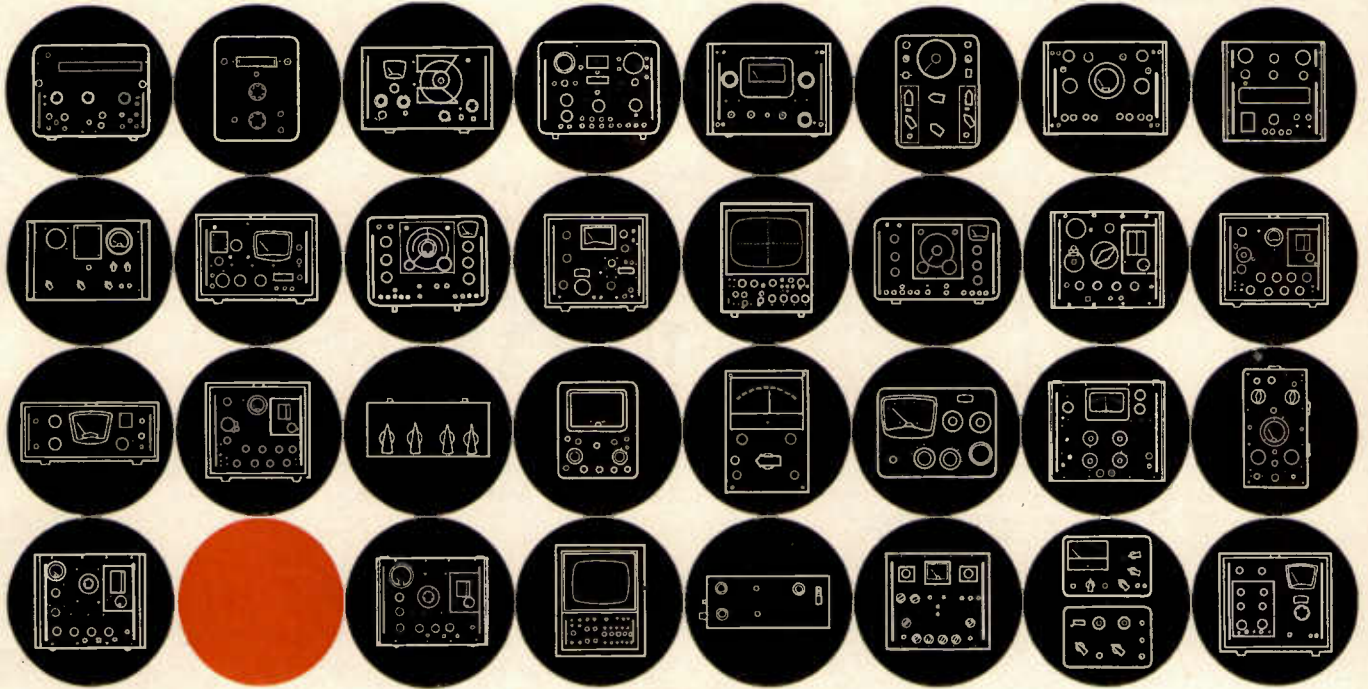

NEW!

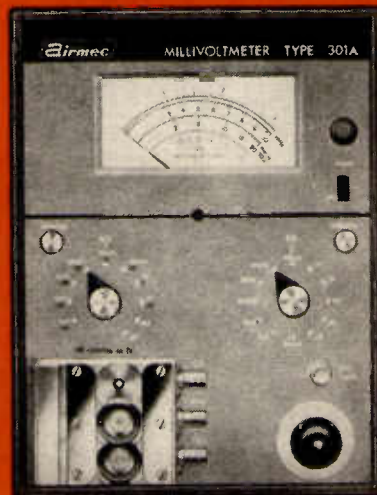

Just one
of the
large range of
thoroughly
reliable
long lasting
laboratory
instruments
by Airmec

AC/DC Millivoltmeter Type 301A

This wide range millivoltmeter enables alternating voltages from $300\mu\text{V}$ to 3V to be measured over the frequency range 100 c/s to 900 Mc/s , and direct voltages from $100\mu\text{V}$ to 10V .

Special features include the provision of a high impedance low capacitance probe and the incorporation of 50Ω and 75Ω terminated T Heads of low VSWR on the front panel. Accurate measurements in 50

and 75 ohm systems can therefore be made without the need for external accessories.

In addition to two voltage scales and a decibel scale the meter has a milliwatt scale to enable power measurements in the micro and milliwatt range to be carried out in an impedance of 50Ω .

The proven circuitry of the Type 301 giving low noise level and high stability has been retained whilst the instrument has been re-designed and restyled in the Airmec new look range of instruments.

Write or phone for full details, Wave Analysers, Phase-Power-Modulation-Volt Meters, Oscilloscopes, Counters, Signal Generators & Standards, Insulation Testers etc.

Airmec

AIRMEC LIMITED
HIGH WYCOMBE BUCKS

Tel: High Wycombe 21201 (10 lines)
Telex: 83243



LABORATORY
INSTRUMENTS
DIVISION

YO·HO·HEAVE·O

THERE'S A CLEVER TOUCH TO THE MANUFACTURE OF LEMO CONNECTORS....

They'll only part company with fingertip pressure - simply and easily, as no amount of sheer brute force can do. Firm-latching Lemo connectors are precision-engineered to take tug-o'-war tactics - and all contact surfaces are gold-plated for minimum resistance. We've got a wide range too, to ensure simple cable assembly and panel mounting of sockets for every application. Post the coupon for full details!

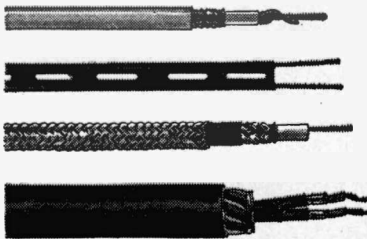
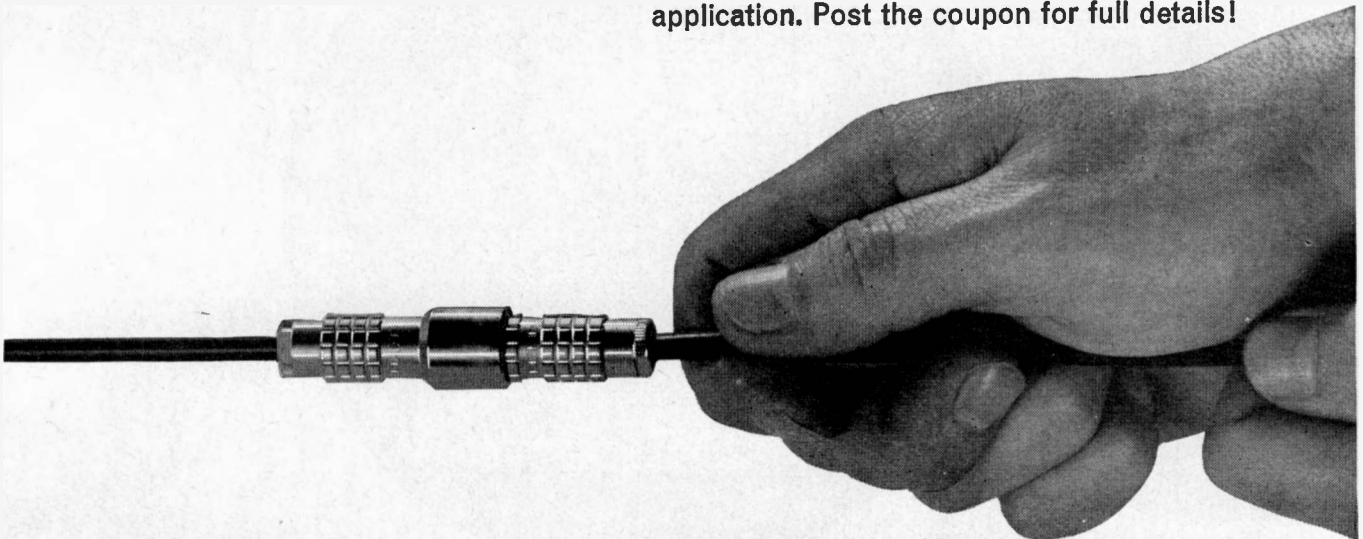

POST THE COUPON FOR NEWS ABOUT NUTEC CABLES TOO!

Nutec offer a complete range of superbly made High-Frequency and Audio Frequency cables to match the high-class connectors. Special types of cables can be made to order with rapid delivery - but a range of Mil. Spec. RG cables is always in stock!

Cables

Tick which you are interested in and post now to:
Nutec Electronics Limited,
Mercantor House,
5 East Street,
Shoreham-by-Sea, Sussex.
Telephone: Shoreham 4498

Connectors

NAME & POSITION

ADDRESS

.....

.....

EE12

counting units intended for industrial applications. A wide field of application is open to this new series of multi-purpose plug-in units: they are well suited to most existing counting or fast-logic problems, such as event counters with digital display, preselection counters, preselection n -dividers etc.; they will also find extensive application in the construction of industrial measuring instruments, i.e. frequency meters, period meters, time-interval counters, revolution counters, pulse generators, reversing counters etc. Most of them are fitted with integrated circuits of t.t.l. technology. They feature faster switching, low power requirements and low sensitivity to transients. They are enclosed in a small ($60 \times 102 \times 16$ mm) plastic case which contains a double-sided printed circuit on which the integrated circuits, as well as a reduced amount of discrete elements for transient protection, are mounted. Ambient temperature: 0 to 70°C; supply voltage: +5V ± 0.25 V; logic level 1: +2.5V $< U < +5$ V; logic level 0: 0V $< U < +0.5$ V.

For more information circle No. 294

DIGITAL PHASE ANALYSER

Burdept Electronics, St. Fidelis Road, Erith, Kent

A solid-state digital phase analyser with numerical display is being launched in Britain by Burdept Electronics (Royston Industries Group) under an agency agreement with GETAI, the Brussels-based research company. Called the GT500, this instrument performs accurate phase measurements over a wide range of frequencies (100Hz to 100kHz) and amplitude levels (1mV to 200V r.m.s.) Burdept Electronics claim that the GT500 can be used for telemetry, servomechanisms, Doppler-effect measurements, phase-modulation measurements, wave analysis, transfer-function analysis, time-base restitution, digital synchronization and vibration analysis. A phase-lock loop is used, which includes a voltage-controlled oscillator at a high frequency and a synchronous digital counter. The numerical expression of the phase is contained in this counter, when the phase of the v.c.o. oscillation is locked in phase on the input wave. The reference channel can be triggered from an external source, or a second phase-lock loop may be used to track the reference-signal input. The instrument incorporates a coherent detector which may be used to acquire automatically both signal and reference.

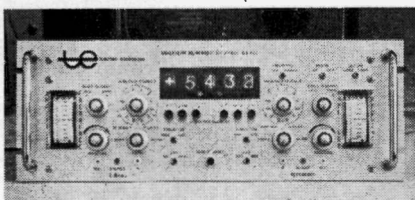

Phase difference may be measured to an accuracy of 1 part in 10^{-4} of the period between 80Hz and 0.8kHz, 1 part in 10^{-3} between 0.8 and 8kHz and 1 part in 10^{-2} between 8 and 80 kHz, over a temperature range of 0-45°C. Input impedance is greater than 1M Ω and capacitance less than 15pF for both channels. A 4-line binary-coded decimal output is provided to drive printers, computers etc. The instrument may be extensively programmed by external means.

For more information circle No. 295

CHOPPER-STABILIZED OPERATIONAL AMPLIFIER

Analog Devices Ltd, 38-40 Fife Road, Kingston-on-Thames, Surrey

Analog Devices model-211 is a low-cost fast-response chopper-stabilized operational amplifier. In contrast with the most advanced differential-amplifier designs, chopper-stabilized operational amplifiers are immune to thermal transients and components aging. Where long-term stability is necessary, the model-211 will perform excellently. Encapsulated in a 3in package, the amplifier is fully protected against overdrive, overloads and short circuits: it will mount directly onto printed-circuit cards. The specification features 1 μ V/degC voltage drift and 3×10^{-12} A/degC current drift over the temperature range -25 to 85°C; 20MHz unity-gain bandwidth; 100V/ μ s slewing rate and full power output to 500kHz. A built-in overload-recovery circuit allows the amplifier to recover from overloads in 200×10^{-9} s. Applications include fast analogue-digital and digital-analogue converters; precise current-to-voltage converters, ultrastable voltage and current sources; active filters, sample-and-hold circuits and high-gain servopre-amplifiers.

For more information circle No. 296

A.F. MILLIVOLTMETER

J. E. Sugden & Co. Ltd, Bradford Road, Cleckheaton, Yorkshire

The Si451 millivoltmeter is the first of a range of laboratory audio test instruments. The instrument is intended for the audio engineer, and many special features for audio applications are incorporated. Such features include a comprehensive set of ranges with 1, 2, 5, 10, 20 and 1, 10, 100, 1000 selectors allowing small incremental range-changing to be effected, which, together with a variable control, permits any point on the scale to be used when making relative measurements. The variable control at its limit positions provides a calibration for sine-wave r.m.s. or peak-to-peak measurements, the latter being especially useful to the development engineer or trouble shooter, as peak-to-peak swings are the defining factor in the operation of a circuit. Indication is by a clear front 3in scale meter with linear calibrations to 1, 2, and 5 units f.s.d, with a

decibel scale where 0dB = 1mW in 600 Ω . The special features do not preclude use for general-purpose applications and some, in fact, enhance such use. Maximum sensitivity is 1mV peak-to-peak (approximately 350 μ V r.m.s.) frequency response is 20Hz-20kHz within 0.5dB total excursion. There is an oscilloscope output of approximately 3V at f.s.d. and power is by batteries, which, together with the insulated feet, prevent hum loops. The front panel and case are functional and yet aesthetically pleasing, and, other than the black enamelled surround, all surfaces are green or light-grey p.v.c.-covered for simple cleaning and scratch resistance. The size is approximately $10 \times 5 \times 7$ in; weight (complete) is 11lb.

For more information circle No. 297

HIGH-STABILITY RESISTANCE-WIRE MATERIAL

Johnson Matthey Metals Ltd, 81 Hatton Garden, London EC1

Johnson Matthey Metals announce the introduction of Stabilohm 133, a new alloy in the Stabilohm range of high-stability resistance-wire materials. Stabilohm 133, a modified nickel-chromium alloy, has been specially developed in the Johnson Matthey research laboratories to have a resistivity of 133 $\mu\Omega$ /cm, approximately 20% higher than that of 80/20 nickel-chromium, and an exceptionally low temperature coefficient of resistance. Two grades are available—standard and premium quality. The latter has a maximum temperature coefficient of $\pm 5 \times 10^{-8}$ /degC over the range -65 to +150°C, and can be supplied as wire down to 0.0006in (0.015mm) in diameter. The standard quality, having a slightly higher temperature coefficient, is available as wire down to 0.009in (0.23mm) in diameter, and is particularly suitable for use in less critical applications where lower cost is vitally important. Both qualities can be supplied as bare wire or with any of the five JMM enamels—Diamel, Trimel, S-Diamel, oleo and polyurethane.

For more information circle No. 298

GALVANOMETER-AMPLIFIER SYSTEM

Claude Lyons Ltd, Instruments Division, Hoddesdon, Hertfordshire

To complement their types-5651 and -5656 multichannel recording oscillographs, Svenska Diamant have introduced the type-4980 d.c.-to-10kHz amplifier system, available in Britain

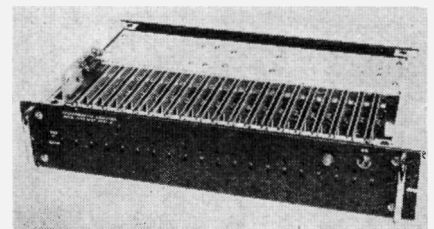

through Claude Lyons Ltd. The 4980 system provides up to 20 operational channels and comprises a chassis incorporating power supplies and test facility and accommodating up to 20 amplifier cards in any combination of the four types of amplifier at present offered. The four amplifier cards available all provide d.c.-to-10kHz response, 35Ω nominal load impedance, and outputs of $\pm 50\text{mA}$ d.c. or peak a.c. at 35Ω load, $\pm 42\text{mA}$ at 50Ω load, and $\pm 23\text{mA}$ at 100Ω load impedance. The 4982 amplifier is a low-gain impedance-matching type with voltage gain from 0.01 to 2.5 and is designed for use with high-impedance transducers with outputs from 0.7 to 200V. The 4983 is a low-noise low-drift amplifier with a gain of 10 to 500, input impedance $10\text{M}\Omega$, input-current offset less than 200nA , drift of $10\mu\text{V}/\text{degC}$ maximum, and noise over 1Hz - 10kHz below $1\mu\text{V}$ at 100Ω source impedance. It is designed for use with thermocouple resistive bridges, strain-gauge transducers and other low- or medium-noise transducers. The type-4984 amplifier card features very high input impedance of more than $10\,000\text{M}\Omega$ and is recommended for use with high-impedance transducers. Gain is 2 to 200, and input-current offset less than 200pA . Both the 4985 and 4984 have diode-protected inputs, maximum input current being $\pm 200\text{mA}$. The type-4985 card is a high-gain differential type; gain is 50 to 2500 and common mode rejection more than 100dB. Maximum input voltage is $\pm 6\text{V}$ and maximum common-mode voltage $\pm 15\text{V}$. Recommended for all grounded or floating transducers or bridges, input impedance is $1\text{M}\Omega$, input-current offset less than 50nA and noise less than $1\mu\text{V}$ at 100Ω source impedance, or $2\mu\text{V}$ for $10\text{k}\Omega$ source impedance. All four amplifiers incorporate 20-turn screw-driver-adjustment gain and balance potentiometers, accessible through the chassis front panel when installed. A d.c./a.c. converter, type 4989 is available as an optional extra to permit operation from 12/24V d.c. input.

For more information circle No. 299

ULTRASONIC WIRE STITCH BONDER

General Micronetics Ltd, Boundary House, Boston Road, London W17
Now available from General Micronetics is model-1400/1401 lead-frame bonder, manufactured by Engineered Machine Builders Inc. of Mountain View, California. This machine is an addition to the existing range of transistor and i.c. wire bonders and is designed to connect aluminium or gold wires of 0.0007 to 0.002in diameter from a semiconductor chip to the lead-frame terminal, in less than 2s per lead. Wire feeding is automatic and the wire is torn off clean at the second bond leaving no tail or burr. The following features are also incorporated in the machine: built-in solid-state ultrasonic

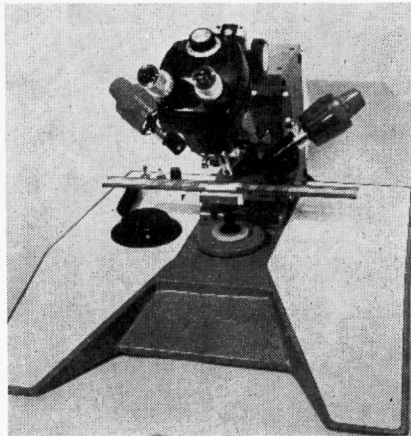

power supply and logic unit with two controllable channels for time and power, 3W into 40Ω over a frequency range of 66 to 78kHz; it is designed to handle lead frames up to 8in long and is capable of rotation over a full 360° around the centre line of the unit being bonded. A special mechanical chuck holds the lead frame rigid while bonding, and automatically advances the next device under the bonding tool. Bausch & Lomb Stereozoom Optics with Nicholas illuminators complete the specification.

For more information circle No. 300

FLIPFLOP TOGGLES AT 120MHz

Motorola Semiconductor Products Inc., York House, Empire Way, Wembley, Middlesex
Designed to meet the requirements of high-frequency counters, frequency synthesizers, and extremely-high-speed registers, a new JK flipflop features a typical toggle frequency of 120MHz. Known as the MC1027P, this newest member of the MECL II integrated-circuit family of high-speed emitter-coupled logic is available from Motorola Semiconductor Products. Basically, the MC1027P is an a.c.-coupled JK flipflop with 4J and 4K inputs as well as direct set and reset inputs. The new unit operates with the same logic levels and is fully compatible with other members of the MECL II series. The significant difference in the MC1027 is speed; the 120MHz toggle frequency of the MC1027P is more than twice as fast as any saturated logic flipflop. Its nearest competitor in operating speed is another MECL II flipflop—the MC1013P—which has an 85MHz typical toggle frequency. The addition of the MC1027P gives the logic designer a capability of dealing effectively with requirements for extra-fast registers and counters in a computer system. For maximum speed, the 120MHz flipflop should be driven by the MC1023P clock driver. This high-performance dual 4-input OR-NOR clock driver provides a 2ns-risetime pulse, with a 2ns propagation delay. In common with all MECL JK flipflops, the a.c.-coupled inputs of the MC1027P are labelled J and K. In

contrast with conventional flipflops, the J and K signify that a high logic state inhibits the input and a negative level 'enables' this input. This approach often simplifies system design.

For more information circle No. 301

POWER-SUPPLY UNITS

D.E.B. Electronics Ltd, Cottonmill Lane, St. Albans, Hertfordshire

A dual-output bench power unit utilizing silicon semiconductors throughout, and designed for ruggedness and reliability, is available from D.E.B. Electronics. Three terminals are provided, the centre terminal being common; these terminals are completely floating, and any one may be earthed to give several modes of operation, e.g. two positive supplies, two negative supplies, or one of each. Each individual rail is continuously variable within the range 5 to 15V, and the maximum current is



500mA. Constant-current protection is employed, and the level at which it operates is continuously variable between 50 and 500mA. The level to which it is set is displayed on the meter. The unit has been designed and manufactured to excellent standards of reliability and workmanship, and by the use of up-to-date techniques and components a very low price has been achieved. For those applications requiring an even lower price, a version is available without metering. Specification:

Input: 190V to 240V a.c. 45-65Hz

Output: (1) 5V to 15V d.c. at 500mA maximum, and (2) both rails continuously variable

Temperature: suitable for operation at full-load ambient temperatures up to 50°C

Regulation: typically 0.22%

Ripple and noise: less than 1mV peak-to-peak, typically $700\mu\text{V}$ peak-to-peak
Stability: typically: upper rail 2000:1, lower rail 600:1.

For more information circle No. 302

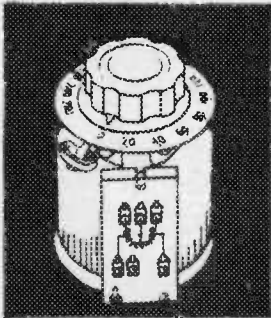
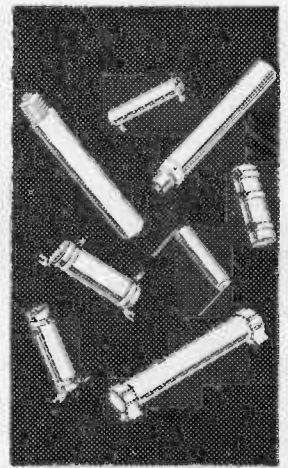
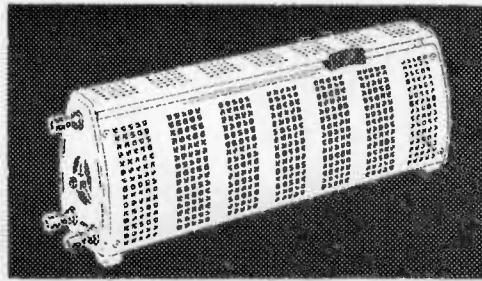
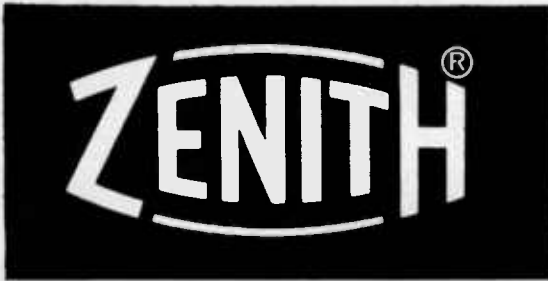

VARIAC[®] Continuously Variable Transformers
Catalogue V64

RHEOSTATS Tubular and Carbon Plate
Compression Type, Catalogue TR8

„
„
„ **“Zenohm”[®]** Rotary Rheostats, Catalogue ZR1

RESISTORS **“Ceramite”[®]** Wire Wound Embedded
Catalogue TG5

„
TRANSFORMERS **“Zenite”[®]** Wire Wound Embedded for low values
Phase Shifting (Catalogue PS4) and Fixed Ratio

**AUTOMATIC
VOLTAGE
REGULATORS**

High Speed, Catalogue HSR1

TEST SETS

Insulation Flash Testing
Catalogue FT3

„ „
Meter Test, single and polyphase
Specifications MT.1113 and MT.1111

„ „
Primary Injection, Specification PI.650819

„ „
Secondary Injection, Specification SI.650820

„ „
Earth Continuity, with Test Fingers to meet the
requirements of BS.3456 Parts A1 and B1,
Specification ES.1001

THYRIAC[®] Solid State Power Controllers

TRANSUCERS Resistance, for control valves,
crane jib angle monitoring,
lock gates, reeling devices, etc.

DIMMERS Tungsten, Fluorescent, manual and automatic

*Details gladly sent on request—please specify the item(s)
in which you are interested.*

“Variacs” are distributed in the United Kingdom and Eire by Claude Lyons Ltd., Hoddesdon, Herts.
and Liverpool

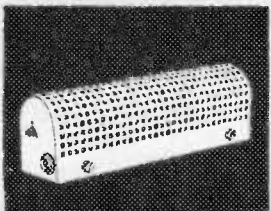
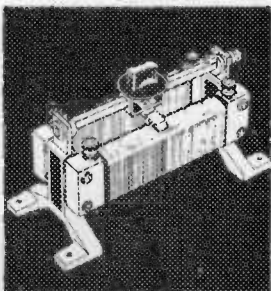
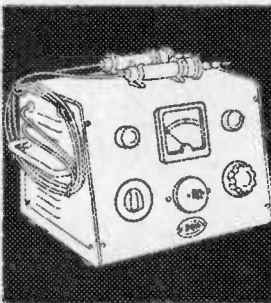
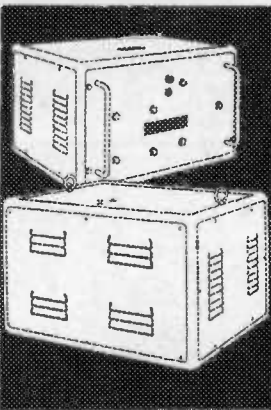
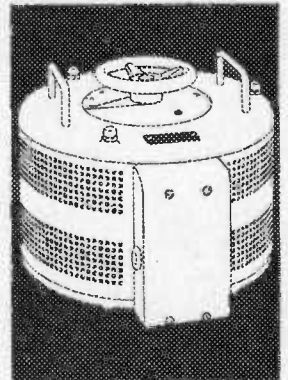
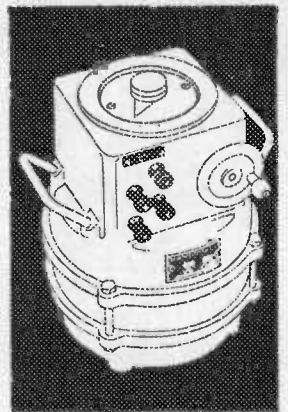
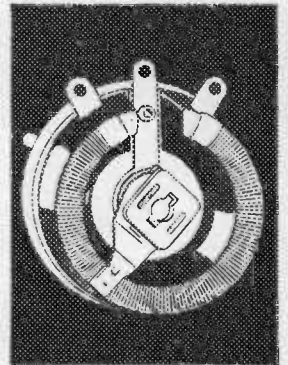

THE ZENITH ELECTRIC CO. LTD.

ZENITH WORKS · VILLIERS ROAD · WILLESDEN GREEN · LONDON N.W.2
Telephone: WILLESDEN 6581/5 Telex: 261778 Telegrams: “VOLTAOHM, LONDON N.W.2”

'100,000 hour tested' Ekco HV Supply Units

Now available to you

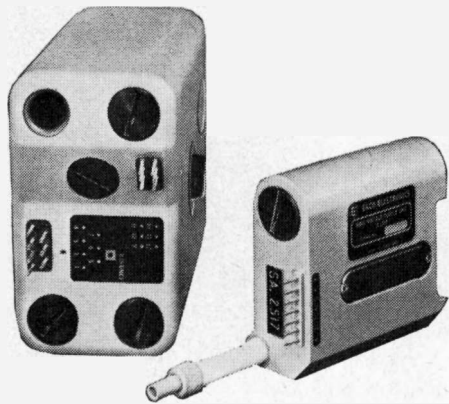

Ekco HV Supply Units are now available for a wide range of applications: head-up displays, airborne and ground radar, military CRT displays; and industrial applications.

Resin encapsulated by specially developed techniques for high stability in a wide range of environments.

Reliability and efficiency proved by hundreds of thousands of hours in service in civil airborne weather radar and military equipments.

Full range of standard types up to 30kV. Special purpose units can be developed to customers' particular requirements.

Contact: Technical Sales, Aviation Division, Ekco Electronics Limited, Southend-on-Sea, Essex. Telephone: 49491 Telex 99167



HIRST ELECTRIC

—the most comprehensive range of British Magnetising Equipment

The HIRST range of Energy Storage and Pulsed Ignitron Magnet Chargers, De-Magnetisers and Setters covers every application and features high reliability and safety, instant charging, identical results with every pulse, high productivity and low power consumption. Whatever your magnetising problems, get in touch with HIRST.



Type MC6A

—a general-purpose magnet-charger for medium to large magnets and enclosed magnet systems. Output variable, 0-830V at 2,760 microfarads or 0-420 V at 11,040 microfarads. Foot-pedal initiation, instantaneous recharging. Full range of fixtures available.

**SEND TODAY FOR THE NEW
MAGNETISING EQUIPMENT CATALOGUE**

HIRST

ELECTRIC INDUSTRIES LTD

MANUFACTURING ELECTRICAL ENGINEERS
GATWICK ROAD, CRAWLEY, SUSSEX. CRAWLEY 25721-5
(formerly Hirst Electronic Ltd.)

SINGLE-PHASE FULL-WAVE-BRIDGE UNITS

Jermyn Industries, Vestry Estate, Sevenoaks,
Kent

The X35FD to X420MD range of bridge units introduced by Jermyn Industries is built with the 1057 heatsink and the General Electric (USA) range of rectifiers type-A44/5. The rectified output is taken directly from the two heatsinks via two solder tags (one heatsink positive, the other negative). The maximum input-voltage ratings are 35, 140, 280 and 420V r.m.s. and the d.c. output

current is 25A continuous at 25°C ambient. The overall size is $4\frac{1}{2} \times 2\frac{1}{2} \times 1\frac{1}{2}$ in. Two pairs of insulated leads give access to the input; the unit may therefore be directly wired into the circuit. The four input leads also provide the facility of operating the two halves of the bridge separately for centre-tapped-transformer application. In this case, the two halves may be of different voltage ratings. The negative heatsink is provided with four 4BA-clearance insulated mounting holes, or four 2BA-clearance uninsulated mounting holes.

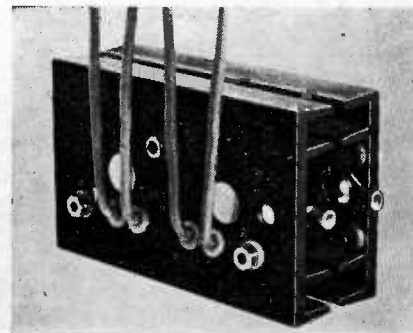

For more information circle No. 303

DIARY OF THE MONTH

4 Electrostatic generation by Dr. P. Secker. I.E.E. At Town Hall, Chester, 6.30 p.m.

4 Engineering of the Independent Television Service by P. A. T. Bevan. I.E.E. At the 'Wig and Gown', Maidstone, 7 p.m.

4 Electronic telephone exchanges by Prof. J. E. Flood. I.E.E./I.E.E. At Queen's Building, Bristol University, 6 p.m.

5 Techniques of hi-fi reproduction. S.I.T. At the College of Further Education, Whitehaven, Cumberland, 7.15 p.m.

5-7 Electrical methods of machining and forming. I.E.E./I.Mech.E./I.Prod.E. conference. At Savoy Place, London WC2.

6 Electricity and electronics in agriculture and horticulture by B. W. Ricks, B. C. Stenning and G. O. Harries. I.E.E. At National College of Agricultural Engineering, Silsoe, Bedfordshire, 7.30 p.m.

6 Chromoscan by J. Hambleton. Society of Electronic and Radio Technicians. At Charles Trevelyan Technical College, Maple Terrace, Newcastle-upon-Tyne, 7.15 p.m.

6 The behaviour of thyristor amplifiers in closed-loop control systems by F. Fallside. I.E.E. At Royal Victoria Hotel, Sheffield, 6.30 p.m.

6 Electronics in the power section by J. S. Ekbery. I.E.E. At S.E.E.B. Offices, Hove, Sussex, 6.30 p.m.

7 Scanning electron microscopy—its use in the evaluation of semiconductor devices and materials by Dr. P. R. Thornton. I.E.E./I.E.R.E. At Lecture Theatre 4, Engineering Laboratories, Trumpington Street, Cambridge, 8 p.m.

7 Higher degrees in industry by E. R. L. Lewis. I.E.E. At University of Aston in Birmingham, 6.15 p.m.

7 Radar measurements on meteor trails by Dr. J. A. Clegg. I.E.R.E. At Farnborough Technical College, 7 p.m.

7 The University of Birmingham instrumentation in the Ariel III satellite by J. H. Wager. I.E.R.E. At Department of Electronic and Electrical Engineering, University of Birmingham, Edgbaston, 7.15 p.m.

7 Electric cars by R. E. Gleadow. I.E.E. At Kingston College of Technology, Kingston-upon-Thames, 6.30 p.m.

8 Automatic testing of electronic devices, components and circuits. I.E.E. colloquium. At Savoy Place, London WC2.

8 Modern design trends in communication receivers by D. Thomas. Society of Electronic and Radio Technicians. At Llandaff Technical College, Western Avenue, Cardiff, 7.30 p.m.

11 Experiences with railway electrification by A. H. Emerson. I.E.E. At Crewe Central College of Further Education, 7 p.m.

12 The evaluation and prediction of equipment reliability by P. Cox, V. J. McMullan and Mrs. D. Crook. I.E.E./I.E.R.E. At London School of Hygiene and Tropical Medicine, Keppel Street, London WC1, 6 p.m.

12 Radio-interference suppression by G. A. Jackson. I.E.E. At E.M.E.B. Social Club, Angel Lane, Northampton, 6.30 p.m.

12 Engineers of the future by Prof. Thring. I.E.E./I.C.E./I.Mech.E. At Liverpool University, 6.30 p.m.

12 Ever decreasing circles (micro-electronics) by R. G. Dixon. I.E.E. At the Ashby Institute, Belfast, 6.30 p.m.

12 The L.T.R. cable tube system by W. H. Lamb. The Institution of Post Office Electrical Engineers. At Savoy Place, London WC2, 5 p.m.

13 Radioastronomy by I. W. Sheffield. I.E.E./I.E.R.E. At Edinburgh University, 7 p.m.

13 Travelling high-field domains in bulk semiconductors and their application as function generators by M. P. Wasse. I.E.E./I.E.R.E. At Welsh College of Advanced Technology, Cardiff, 6.30 p.m.

13 Domain-originated functional integrated circuits by M. P. Wasse. I.E.E./I.E.R.E. At the Welsh College of Advanced Technology, Cardiff, 6.30 p.m.

13 Adaptive astable/monostable circuits in class-D amplifiers by D. C. Smith. I.E.R.E. At Highbury Technical College, Cosham, nr. Portsmouth, 6.30 p.m.

14 The design of a fully-transistorized colour-television receiver by J. W. Russell, S. C. Jones and R. Gray. I.E.R.E./I.E.E./Royal Television Society. At Renold Building, College of Science and Technology, Altrincham Street, Manchester.

14 Integrated circuits by H. Blackburn. I.E.R.E. At Stafford College of Further Education, Tenterbanks, Stafford, 7.15 p.m.

15 Communications by satellite by H. E. Pearson. I.E.E. At Mander College, Bedford, 7 p.m.

18 Testing and approval of electrical appliances by R. Harvey. I.E.E. At Merz Court, University of Newcastle, 6.30 p.m.

19 Logic circuits by R. C. Rippin-gale. Society of Electronic and Radio Technicians. At Mid Herts College of Further Education, The Campus, Welwyn Garden City, Hertfordshire, 7 p.m.

20 Electronically controlled adjustable-speed drives by P. A. Bennett. I.E.R.E. At Percival Whitley College of Further Education, Francis Street, Halifax, 6 p.m.

Résumés des principaux articles

Élément à retard conçu pour le retard de champ de télévision par D. Howorth et J. G. Ingleton

Résumé de l'article
aux pages 733 à 738

Cette étude traite de la conception et de la construction d'un élément à retard de 2,5ms mis au point pour pouvoir être inséré dans un retard de champ de télévision. L'étude comprend une description sommaire de la ligne à retard à ultra-sons utilisée dans ce dispositif, ainsi qu'une analyse détaillée des amplificateurs d'entrée et de sortie et des circuits auxiliaires nécessaires pour obtenir un gain global d'unité et une stabilité de retard de l'ordre de ± 2 ns. La construction d'un réseau approprié pour l'égalisation de la caractéristique de réponse/fréquence de la ligne à retard est aussi décrite.

Amplificateurs d'impulsions transistorisés à action rapide par D. Ivekovic

Résumé de l'article
aux pages 739 à 744

L'auteur compare les propriétés de plusieurs montages d'étages amplificateurs d'impulsions transistorisés et reliés en cascade. Les étages étudiés sont: (a) un transistor à émetteur commun avec compensation inductive dans le circuit collecteur, (b) un transistor à émetteur commun avec base de compensation RC, compensation au collecteur inductive, et un circuit à charge cathodique par transistor faisant fonction d'étage intermédiaire, (c) un cascode avec compensation de base et de collecteur et avec un circuit à charge cathodique par transistor faisant fonction d'étage intermédiaire. Le cascode est censé être composé d'étages identiques dont chacun comporte une réponse atténuée critique à une fonction de plot. Le gain optimum pour chaque étage est établi; l'étage de cascode a le gain optimum le plus élevé et une cascade composée d'étages de cascodes a le temps de montée le plus réduit pour un gain donné. Suivant les résultats obtenus, un amplificateur d'étage à deux cascodes utilisant des transistors 2N976 est construit; son gain est de 12 et son temps de montée de 1,5ns.

Encodeur décimal binaire à circuits intégrés par K. J. Dean

Résumé de l'article
aux pages 744 à 747

L'auteur décrit le dessin d'un encodeur décimal binaire basé sur la commande logique d'un registre de déphasage. Ce dessin a été utilisé avec des circuits intégrés et il applique le principe de la multiplication successive dans le registre.

Voltmètre de mesure instantanée des impulsions par N. A. Westman, S. Westerlund et S. T. Berglund

Résumé de l'article
aux pages 748 à 751

Un instrument robuste et rapide a été mis au point pour la mesure de la tension d'impulsions. Le principe consiste à charger un condensateur et à lire la tension au moyen d'un amplificateur électrométrique. L'instrument peut être utilisé dans les modes suivants: mesure de la hauteur d'impulsion d'événements séparés; mesure de l'amplitude maxima dans un intervalle de temps; mesure de la tension d'impulsions dans un temps prédéterminé. L'instrument peut être employé directement pour des tensions d'impulsions entre 0,1 et 5V et des longueurs d'impulsions de plusieurs secondes mais il peut être facilement modifié pour le fonctionnement dans d'autres gammes. La sortie est affichée sur un instrument à déviation, le réenclenchement est automatique et des temps de lecture de plusieurs minutes peuvent être choisis. Le temps de montée lorsque l'instrument fonctionne dans le mode de lecture de la hauteur d'impulsion est supérieur à μ s; pour la mesure instantanée de la valeur, la précision est fonction du dérivé de temps de l'impulsion au moment du verrouillage.

Comportement du circuit à déclenchement Schmitt utilisé en liaison avec un condensateur à intégration de courant par L. A. W. Kemp, D. O. Bottrill et S. Klevenhagen

Résumé de l'article
aux pages 752 à 756

Cette analyse porte sur les conditions de courant et de tension rencontrées dans un circuit à déclenchement Schmitt dont les signaux d'entrée sont fournis par les excursions de tension sur un condensateur chargé par un courant d'ionisation jusqu'à ce que la tension de déclenchement Schmitt soit atteinte. A ce moment-là, le condensateur est rapidement déchargé dans la tension de réenclenchement et le cycle recommence. Les auteurs considèrent avec minutie la prédiction théorique et la confirmation expérimentale de l'existence d'un courant d'ionisation minimum au-dessus duquel le circuit Schmitt n'effectuera pas de déclenchement et maximum au-dessus duquel le circuit ne se réenclenchera pas, s'étant déclenché pour la première fois seulement.

Élément de minutage pour la commande des signaux de stimulation par K. J. Kapota

Résumé de l'article
aux pages 756 à 758

Il s'agit ici d'un générateur universel à intervalle de temps et à cycle de régime variable (gamme de 1 à 100s) prévu pour la psychologie et la physiologie expérimentales. Cet instrument utilise les propriétés du transistor à unijonction pour produire une linéarité d'échelle de $\pm 5\%$ dans une gamme de 10:1.

Compteur de trains de décades par R. P. Ingram

Résumé de l'article
aux pages 759 à 763

L'auteur traite du principe, de la conception et de l'utilisation du compteur de trains de décades. Son prix et sa complexité sont comparés à ceux du compteur binaire pour mieux montrer les qualités qui le rendent propre à l'usage industriel.

Exemple de conversion numérique-analogique par W. Olthoff

Résumé de l'article
aux pages 763 à 765

Le principe du contrôle continu de faibles fluctuations dans les grands signaux est expliqué par l'auteur qui poursuit cette introduction par la description d'un système fournissant une sortie analogique pour les deux plus petits chiffres d'un voltmètre numérique à 5 chiffres. La précision de ce dernier est de 1% du quatrième chiffre, ce qui permet à des fluctuations réduites de s'étendre sur toute la largeur d'un diagramme d'enregistrement au lieu de n'en couvrir qu'une fraction très réduite.

Oscillateur quadrupleur de 164MHz à commande par cristal par D. Singh et J. Garters

Résumé de l'article
aux pages 769 à 772

Cet article décrit la conception et la construction d'un oscillateur à commande par cristal fournissant 13mW à 164MHz. Un cristal entièrement monté sur verre à troisième harmonique est utilisé et un quadrupleur est incorporé au dispositif pour assurer la fréquence voulue.

Encoder à périodes quantifiées pour les systèmes à caractères modulés par impulsions codées et avec contrôle à distance utilisant un multivibrateur monostable modifié par V. K. Agarwal

Résumé de l'article
aux pages 773 à 777

Cet article décrit un convertisseur analogique-numérique à périodes quantifiées dont les échantillons à modulation d'amplitude par impulsions sont encodés sous forme de caractères à modulation de code par impulsions en les faisant passer à travers un degré intermédiaire de modulation de durée par impulsion. La conversion linéaire de la modulation d'amplitude par impulsions en modulation de durée par impulsions s'effectue en utilisant un circuit multivibrateur monostable modifié comme générateur combiné comparateur et à balayage linéaire. L'emploi de circuits intégrés dans les dessins logiques du compteur à action rapide, les portes ET et les réservoirs d'enregistrement de déphasage, présente non seulement des avantages techniques mais permet également de réaliser un encodeur sûr, simple et moins coûteux pour les systèmes à modulation de code par impulsions et à contrôle à distance.

Blocs d'alimentation transistorisés à haute tension par R. E. Crosbie

Résumé de l'article
aux pages 778 à 783

Un des aspects les plus difficiles de la transistorisation du matériel électronique est la réalisation des générateurs hyperfréquences. Cet article analyse les problèmes de base que posent ces éléments, ainsi que les méthodes de stabilisation. Les conclusions qui en découlent sont appliquées à la réalisation de trois éléments pratiques. L'un de ces éléments utilise un oscillateur constituant une innovation dans le domaine des hyperfréquences et qui devrait trouver de nombreuses applications dans les circuits hyperfréquences.

Zusammenfassung der wichtigsten Beiträge

Eine Laufzeitleitung für die Verzögerung von Fernsehteilbildern von D. Howorth und J. G. Ingleton

Zusammenfassung des
Beitrages auf Seite 733-738

Der Bericht beschreibt Entwurf und Konstruktion einer 2,5-ms-Laufzeitleitung, die als Teil einer Teilbildverzögerung im Fernsehsektor entwickelt wurde. Eine kurze Beschreibung der verwendeten Ultraschall-Laufzeitleitung wird zusammen mit einer eingehenden Beschreibung der Ein- und Ausgangsverstärker sowie der Zusatzschaltungen gegeben, die für die Erzielung des Verstärkungsfaktors 1 und einer Laufzeitkonstanz von ± 2 ns erforderlich sind. Ferner wird der Entwurf eines für die Entzerrung des Frequenzgangs der Laufzeitleitung erforderlichen Netzwerkes gegeben.

Schnellansprechende transistorierte Impulsverstärker von D. Ivekovic

Zusammenfassung des
Beitrages auf Seite 739-744

In diesem Beitrag werden die Eigenschaften mehrerer transistorierter Impulsverstärkerstufen in Kaskadenschaltung miteinander verglichen. Die in Betracht gezogenen Stufen sind (a) eine Emittor-Transistorschaltung mit induktiver Kompensation im Kollektorkreis, (b) eine Emittor-Transistorschaltung mit RC-Basis-Kompensation, induktiver Kollektor-Kompensation sowie einem Emittorfolger zwischen den Stufen, und (c) eine Kaskode mit Kollektor- sowie Basiskompensation und einem Emittorfolger zwischen den Stufen. Die Kaskode soll aus identischen Stufen bestehen; jede dieser Stufen hat eine kritisch gedämpfte Sprungcharakteristik. Die optimale Verstärkung wird für jede Stufe bestimmt. Es wird gezeigt, dass die Kaskodenstufe die höchste optimale Verstärkung hat und dass für eine vorgegebene Verstärkung die Kaskadenschaltung der Kaskodenstufen die kürzeste Anstiegszeit ergibt. Nach den erreichten Ergebnissen hat ein aus zwei Kaskodenstufen mit Transistoren 2N976 bestückter Verstärker eine zwölffache Verstärkung und 1,5 ns Anstiegszeit.

Dezimal-Binärverschlüssler mit integrierten Schaltungen von K. J. Dean

Zusammenfassung des
Beitrages auf Seite 744-747

In diesem Beitrag wird der Entwurf eines Dezimal-Binärverschlüsslers, der auf der logischen Steuerung eines Schieberegisters beruht, beschrieben. Der Entwurf wurde mit integrierten Schaltungen ausgeführt und wendet das Prinzip der aufeinanderfolgenden Multiplikation im Register an.

Unverzögert impulsmessendes Voltmeter von N. A. Westman, S. Westerlund und S. T. Berglund

Zusammenfassung des Beitrages auf Seite 748-751

Ein robustes und schnelles Instrument wurde für das Messen von Impulsspannungen entwickelt. Nach dem Messprinzip wird ein Kondensator geladen und die Spannung mit Hilfe eines Elektrometerverstärkers gemessen. Das Gerät kann in folgenden Betriebsarten eingesetzt werden: Impulshöhenbestimmung von Einzelvorgängen, Messung der Höchstamplitude während eines Zeitintervalls und Messen der Impulsspannung in einem vorgegebenen Zeitpunkt. In der beschriebenen Ausführung kann das Instrument für direktes Messen von Impulsspannungen zwischen 0,1 und 5 V sowie Impulslängen bis zu mehreren Sekunden Dauer Verwendung finden; es lässt sich jedoch ohne Schwierigkeiten für Einsatz mit anderen Bereichen abwandeln. Der Ausgang wird auf einem Ablenkmessgerät angezeigt. Die Rückstellung erfolgt automatisch, und Ablesezeiten bis zu mehreren Minuten können gewählt werden. Bei Betrieb für Impulshöhenbestimmung ist die Anstiegszeit des Instruments für Momentanwertmessungen kürzer als 1 μ s, und die Messunsicherheit hängt mit der zeitlichen Ablenkung des Impulses zur Zeit der Verriegelung zusammen.

Verhalten einer Schmitt-Triggerschaltung bei Anwendung in Verbindung mit einem stromintegrierenden Kondensator

Zusammenfassung des Beitrages auf Seite 752-756

von L. A. W. Kemp, D. O. Bottrill und S. Klevenhagen
In diesem Beitrag wird eine Analyse der Strom- und Spannungszustände in einer Schmitt-Trigger-schaltung gegeben, deren Eingangssignal durch die Spannungsauslenkungen eines Kondensators erzeugt wird. Der Kondensator wird durch einen Ionisationsstrom aufgeladen, bis die Schmitt-Triggerspannung erreicht ist; dann wird der Kondensator schnell auf die Rückstellspannung entladen, und der Zyklus beginnt von vorn. Der theoretischen Voraussage und versuchsweisen Bestätigung eines Mindest-Ionisationsstroms, unter dem die Schmitt-Schaltung nicht triggern wird, und eines Maximums, über dem die Schmitt-Schaltung nach dem ersten Triggern nicht zurückstellen kann, wurde besondere Aufmerksamkeit gewidmet.

Zeitgeber für die Steuerung von Reizsignalen von K. J. Kapota

Zusammenfassung des Beitrages auf Seite 756-758

Der Beitrag beschreibt einen Universal-Zeitintervallgenerator mit regelbarem Tastverhältnis (Bereich 1 . . . 100 s) für Anwendung in der experimentellen Psychologie und Physiologie. Das Gerät nutzt die Eigenschaften der Doppelbasisdiode aus, um eine Skalenlinearität von $\pm 5\%$ über einen Zeitbereich von 10:1 zu erreichen.

Kettendekadenzähler von R. P. Ingram

Zusammenfassung des Beitrages auf Seite 759-763

Der Beitrag beschreibt Prinzip, Entwurf und Anwendung des Kettendekadenzählers. Kosten und Kompliziertheit werden mit denen des Binärzählers verglichen und seine Eignung für industriellen Einsatz nachgewiesen.

Beispiel einer Digital-Analog-Umsetzung von W. Olthoff

Zusammenfassung des Beitrages auf Seite 763-765

Eine Situation, in der die laufende Überwachung kleiner Schwankungen eines grossen Signals erforderlich ist, wird erläutert. Ein beschriebenes System gibt einen analogen Ausgang für die zwei niedrigsten Stellen eines fünfstelligen Digitalvoltmeters und hat eine Fehlergrenze innerhalb 1 Prozent der vierten Ziffer. Es wird dadurch möglich, die kleinen Schwankungen über die ganze Breite eines Streifen-schreibers statt über einen kleinen Bruchteil der Breite aufzuzeichnen.

Quarzgesteuerter 164-MHz-Oszillator-Vervierfacher von D. Singh und J. Garters

Zusammenfassung des Beitrages auf Seite 769-772

Dieser Beitrag beschreibt Entwurf und Konstruktion eines quartzesteuerten Oszillators, der bei 164 MHz 13 mW abgibt. Ein Dritter-Oberton-Quarz in Allglasausführung schwingt bei 41 MHz; ein eingebauter Vervierfacher ergibt die gewünschte Frequenz.

Ein periodenquantisiertes Codiergerät für Nahverkehrs-PCM-Systeme mit einem abgewandelten monostabilen Multivibrator

Zusammenfassung des Beitrages auf Seite 773-777

von V. K. Agarwal
In einem beschriebenen periodenquantisierten Analog-Digitalwandler werden pulsamplitudenmodulierte (PAM) Proben in pulskodemodulierte (PCM) Zeichen verschlüsselt, nachdem sie als Zwischenstufe pulsbreitenmoduliert (PDM) wurden. Lineare Umsetzung von PAM auf PDM wird durch eine abgewandelte, monostabile Multivibratorschaltung erreicht, die als Kombination einer Vergleichseinrichtung und eines linearen Kippgerätes arbeitet. Durch Anwendung integrierter Schaltungen in der Logik des Schnellzählers, den Und-Gattern und Schieberegisterspeichern ergeben sich nicht nur technische Vorteile, und es liegt nahe, dass es sich hier um ein zuverlässiges und einfaches Codiergerät handelt, das bei geringerem Aufwand die für PCM-Nahverkehr erforderliche Qualität aufweist.

Transistorierte Hochspannungsquelle von R. E. Crosbie

Zusammenfassung des Beitrages auf Seite 778-783

Eine der schwierigeren Aufgaben der Transistorisierung elektronischer Ausrüstungen ist der Entwurf von Höchstspannungsgeneratoren. Dieser Beitrag befasst sich mit den Grundproblemen, die in solchen Geräten auftreten, und berücksichtigt auch die Konstanthaltungsmethoden. Die sich daraus ergebenden Rückschlüsse finden beim Entwurf von drei praktischen Geräten Anwendung. In einem dieser Geräte wird ein Oszillator eingesetzt, der im Höchstspannungssektor neu zu sein scheint und für den in Höchstspannungsschaltungen breite Anwendungsmöglichkeiten zu bestehen scheinen.

Another series of improved Signal Generators

3.8-7.6 GHz 7-11 GHz

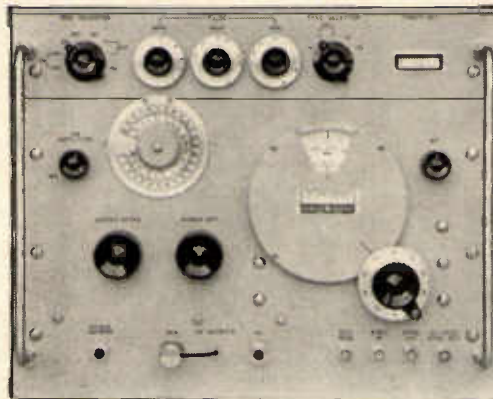

618C Signal Generator

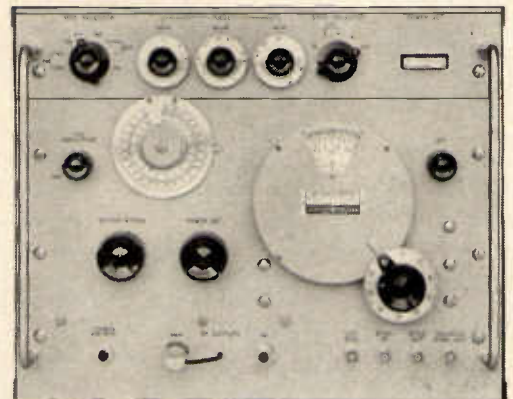

620B Signal Generator

Very low residual FM; cleaner signals mean more accurate measurement results
High level auxiliary rf output; can phase-lock or count frequency
New power monitor without "zero set"; simplified operation
High performance, lighter weight power supplies

These improved signal generators from Hewlett-Packard offer new standards of highly accurate and stable test signals. The new power supplies result in the lower residual FM (10 kHz p-p max.) and decrease the weight of the instruments. The auxiliary rf output allows you to phase-lock the signal-generators with the hp 2650A Oscillator Synchronizer to provide crystal oscillator stability at microwave frequencies. It also can be used with an electronic counter for utmost precision in monitoring frequency.

Ultra-fine tuning capability is assured with the addition of a ΔF frequency vernier control. A new crystal detector type power monitor eliminates zero setting; operation is simplified with less chance for operator error.

Brief specs are listed here. Call your Hewlett-Packard field engineer for complete information.

SPECIFICATIONS hp 618C, 620B Signal Generators

Frequency range: hp 618C, 3.8 to 7.6 GHz; hp 620B, 7 to 11 GHz
Frequency calibration: Direct reading, accuracy better than $\pm 1\%$
Frequency stability: $< 0.006\%/^{\circ}\text{C}$ change in ambient temp.; $< 0.02\%$ change for $\pm 10\%$ line voltage variation
Residual FM: hp 618C, ≤ 8 kHz p-p; hp 620B, ≤ 10 kHz p-p
Calibrated rf output range: 1 mw or 0.224 v to 0.1 μv (0 dbm to -127 dbm) into 50Ω
Output accuracy: Within ± 2 db from -7 dbm to -127 dbm
Auxiliary rf output: Fixed level of at least 0.3 mw
Modulation: Pulse, square wave, FM; internal or external
Weight: Net 63 lbs (29 kg)
Price: hp 618C, hp 620B, £ 884; rack mount add £ 8

 Manufactured in the UK for home and overseas markets



Hewlett-Packard Limited
 224 Bath Road, Slough, Buckinghamshire
 Tel. Slough 28406 and 29486

Headquarters in USA: Palo Alto (Calif.)
 European Headquarters: Geneva (Switzerland)
 European Plants: South Queensferry (Scotland)
 Böblingen (Germany)

The "non-plastic" plastic transistors

So reliable you'd think they were hermetic



We're big enough to realize that with any plastic transistor, you're bound to have questions concerning reliability.

So...long before RCA announced this family of "Hometaxial-Base" silicon power plastic devices (10 transistors with ratings of 36W or 83W), our reliability engineers devised a most rigorous new-product testing program. RCA

subjected hundreds of units to stresses beyond device ratings and the results are so impressive that, frankly, you'd think the transistors were hermetic.

We thought it would be appropriate for you to see our reliability manager's comment on the tests to date.

Here's what he had to say: "...sure we've had failures to our end points. But take a close look at them. Out of 376 units totalling 410,000 device hours at 175°C (versus an actual transistor rating of 150°C) only 3 failed. There were 2 failures from 119 units subjected to 25 temperature cycles of -65°C to 175°C (device rating is 5 cycles of -65°C to 150°C). In all, our actual unit hours on all life tests, including storage, operating, and reverse bias, total over 1,600,000 with a failure rate of 1.7% per 1,000 hours. And if you adjust for the fact that all these tests were essentially at over-stress conditions, the result is an estimated failure rate of less than 0.1% per 1,000 hours."

Why not evaluate the facts behind RCA's "non-plastic" plastic transistors yourself? We documented all of the details in a no-nonsense brochure (HBT-600A) which we'll be glad to send you. Just write to RCA Electronic Components & Devices, International Marketing, Clark, N. J., U.S.A. 07066 or see your local RCA distributor.

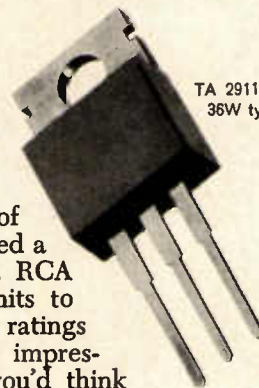

TA 2911
36W type for printed-circuit boards

TA 7155
36W type for TO-66 sockets

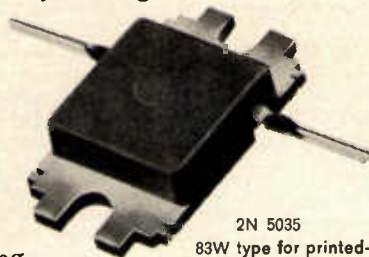
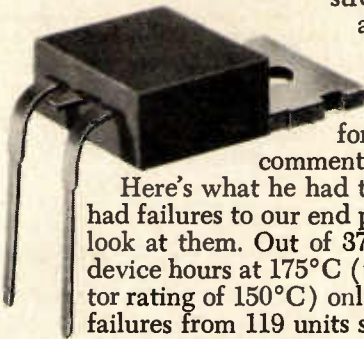

2N 5035
83W type for printed-circuit boards

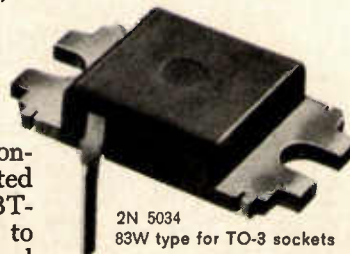

2N 5034
83W type for TO-3 sockets

RCA Electronic Components and Devices



The Most Trusted Name in Electronics

Trademark(s) ®Registered · Marca(s) Registrada(s)

AUTHORIZED DISTRIBUTOR IN GREAT BRITAIN: RCA Great Britain, Ltd., Lincoln Way, Windmill Rd., Sunbury on Thames, Middlesex. **EUROPE, MIDDLE EAST & AFRICA:** RCA International Marketing, S.A., 118 rue du Rhone, Geneva, Switzerland.

Real value-engineering from Weir

For more information circle No. 90

Here's the latest example:
Microreg
All-silicon variable power supply,
0-25V, 0.5A

£24.10.

Compare this specification with much more expensive bench instruments:

- Continuously variable voltage control, 0-25V, 0.2% resolution.
- Ripple and noise < 1mV peak at 25V.
- Worst case transient < 250mV peak at 25V.
- Transient recovery time < 10 μ sec.
- Load regulation < 0.1%, supply regulation < 1mV + 0.03%
- Automatic output current limit; short-circuit proof.
- 2% dual scale output voltmeter/ammeter.
- Negligible turn-on drift
- Stackable case for series or parallel multiple operation.
- Floating output for +ve or -ve working.
- 7½ x 3½ x 6½ ins, 19 x 8 x 16 cm;
- 5 lbs. 2.3 Kg.



Minireg 401/402
0-30V, 0-1.25A, 25W.
Regulation < 0.05%.
Ripple < 200 μ V peak-peak.
£39.10.0/£49.10.0.



Majoreg 440/460 Series
0-60V, 0-1.25A, 40/50W.
Regulation < 0.05%.
Ripple < 200 μ V peak-peak.
From £49.10.0.



DV 500
Digital voltmeter, 1mV-1000V dc.
4 ranges. Neon number display.
Accuracy 0.1%fs, + 0.2% reading.
£99.10.0.



Modureg 361
0-25V, 0-0.25A, 6.25W.
Regulation < 0.1%.
Ripple < 1mV peak-peak.
£21.10.0.



Modureg 351
Rack-mounting version of 361
variable or preset voltage,
5 units in 19" rack width.
£18.10.0. each



Modureg 341
Uncased version for building into
prototypes, instruments, control
systems.
£17.10.0.

WE

Weir Electronics

Weir Electronics Ltd.,
Durban Road Bognor Regis Sussex.

Bognor Regis 3606
Telegrams Electron Bognor Regis



**NO ONE OFFERS A
WIDER RANGE OF
MONITOR TUBES
THAN BRIMAR....**

BRIMAR offers the most comprehensive range of monitor tubes in the country, together with the widest selection of phosphors.

The tubes range in size from 5" to 23". They can be used for television camera viewfinders, studio quality monitors, data displays and closed circuit television – twenty tubes in all! They have been designed to give maximum resolution under high ambient lighting conditions.

A variety of mounting and implosion protection methods, including self protecting bonded glass faces are available from BRIMAR who are Britain's leaders in implosion protection.

Common features include magnetic deflection, electrostatic focus and aluminised screens.

The phosphors. In addition to the standard type for television, a wide selection of others is available offering varying degrees of persistence and colour.

....OR A MORE PERSONALISED SERVICE!

Every BRIMAR tube is backed by a first-class technical service and assistance on any type of problem involving its use in monitors – from special characteristics to circuit design. BRIMAR engineers are always available – contact is on a personal basis. Please telephone or write for full details.



Thorn-A.E.I. Radio Valves & Tubes Ltd.

7 Soho Square, London W1. Telephone: 01-437 5233

TA6959

INTRODUCING THE 'DUALINE' SYSTEM

FOR INDUSTRIAL MEASUREMENT AND CONTROL

Range of Plug-in Cards, Packs and Alternative Housings to Unify Design, Development and Production

Typical applications—
Amplifier and Servo units; Logic control etc. for Industrial, Educational and Scientific purposes

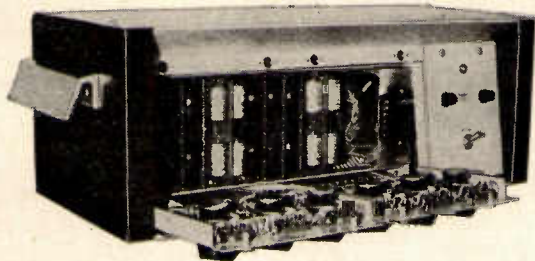

DUACASE—HOUSING for DUAPACK

- Complete access with quick-release fasteners
- Distinctive styling, hinged panels
- Light alloy construction, anodised finish
- Range of standard sizes to suit Duapack
- Competitive prices and good delivery

Shirehall ELECTRONICS LIMITED

STATION YARD · BOROUGH GREEN · SEVENDAKS · KENT · BOROUGH GREEN 2612

99.999+%

Sb

Sn

Pb

Alloys prepared as ingot, wire, rod or foil.

Also available in lump form—antimony and tellurium (lead content less than .001%) for thermo-electric applications.

ASSOCIATED LEAD



MANUFACTURERS LIMITED

Clements House, 14 Gresham Street, London, E.C.2.

Crescent House, Newcastle upon Tyne 1.

Lead Works Lane, Chester.

NIM S by

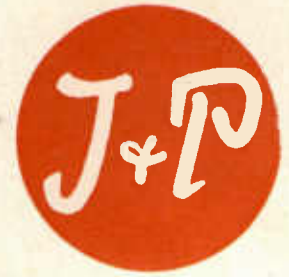

(NUCLEAR INSTRUMENT MODULES: as adopted by U.S. Atomic Energy Commission and conforming to TID-20893 Rev.)

BRITISH SYSTEM AVAILABLE NOW

SCALERS NM130 series

- 6 decades
- 5 megacycles
- Print-out
- Integrated circuits
- Printed wiring
- Small size

NM130: £195 ex works
(binary coded decimal display)

NM135: £295 ex works
(decimal "in line" display)

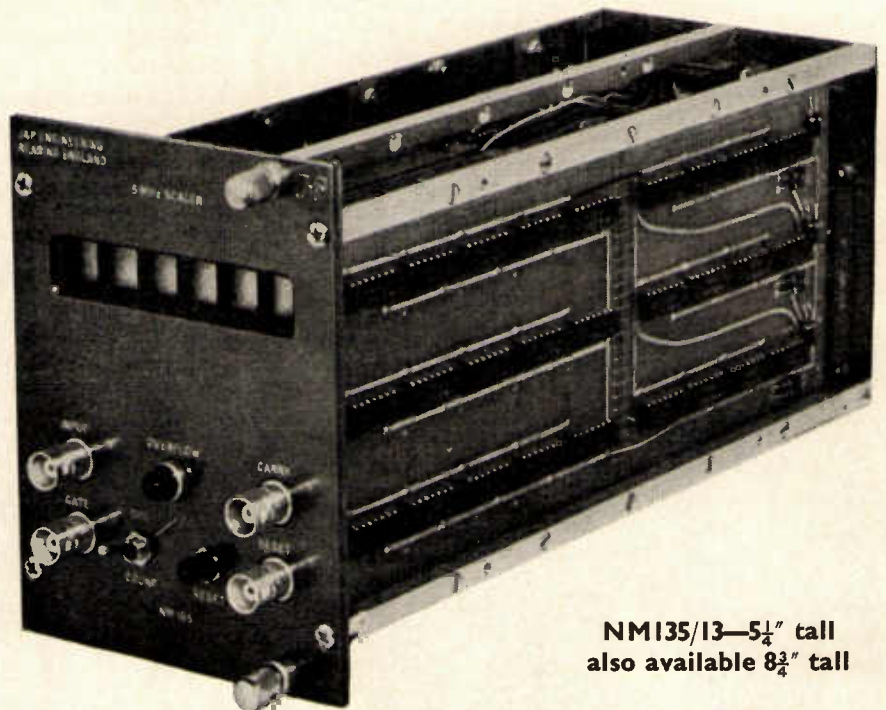

NM135/13—5¼" tall
also available 8¾" tall

The J & P NIM system is a fully interchangeable modular system of electronic instruments, whose dimensions, interconnections, voltage supplies and coupling pulses, are internationally used—giving an entirely new concept in flexibility.

J & P have a complete range of instruments available in both the 8¾" tall and 5¼" tall systems. The J & P 5¼" NIM system is one of the most compact instrument systems available, making the fullest advantage of integrated circuits and micrologic.

J & P Engineering (Reading) Ltd.

PORTMAN HOUSE · CARDIFF ROAD · READING · BERKS · Reading 52227

Another series of improved Signal Generators

3.8-7.6 GHz 7-11 GHz

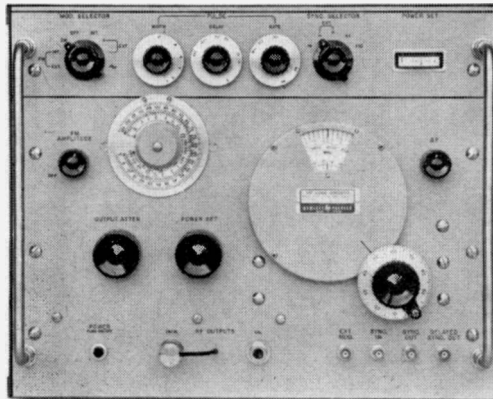

618C Signal Generator

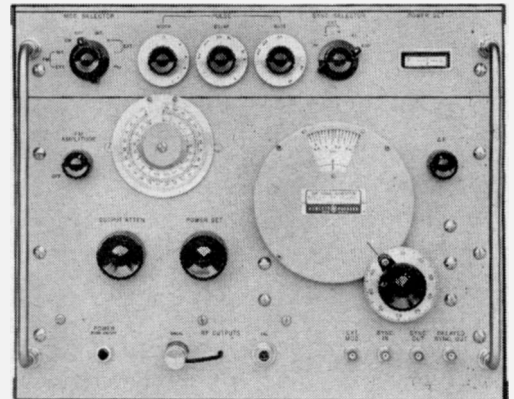

620B Signal Generator

Very low residual FM; cleaner signals mean more accurate measurement results
High level auxiliary rf output; can phase-lock or count frequency
New power monitor without "zero set"; simplified operation
High performance, lighter weight power supplies

These improved signal generators from Hewlett-Packard offer new standards of highly accurate and stable test signals. The new power supplies result in the lower residual FM (10 kHz p-p max.) and decrease the weight of the instruments. The auxiliary rf output allows you to phase-lock the signal-generators with the hp 2650A Oscillator Synchronizer to provide crystal oscillator stability at microwave frequencies. It also can be used with an electronic counter for utmost precision in monitoring frequency.

Ultra-fine tuning capability is assured with the addition of a ΔF frequency vernier control. A new crystal detector type power monitor eliminates zero setting; operation is simplified with less chance for operator error.

Brief specs are listed here. Call your Hewlett-Packard field engineer for complete information.

SPECIFICATIONS hp 618C, 620B Signal Generators

Frequency range: hp 618C, 3.8 to 7.6 GHz; hp 620B, 7 to 11 GHz
Frequency calibration: Direct reading, accuracy better than $\pm 1\%$
Frequency stability: $< 0.006\%/^{\circ}\text{C}$ change in ambient temp.; $< 0.02\%$ change for $\pm 10\%$ line voltage variation
Residual FM: hp 618C, ≤ 8 kHz p-p; hp 620B, ≤ 10 kHz p-p
Calibrated rf output range: 1 mw or 0.224 v to 0.1 μv (0 dbm to -127 dbm) into 50Ω
Output accuracy: Within ± 2 db from -7 dbm to -127 dbm
Auxiliary rf output: Fixed level of at least 0.3 mw
Modulation: Pulse, square wave, FM; internal or external
Weight: Net 63 lbs (29 kg)
Price: hp 618C, hp 620B, £ 884; rack mount add £ 8



Hewlett-Packard Limited
 224 Bath Road, Slough, Buckinghamshire
 Tel. Slough 28406 and 28486

Headquarters in USA: Palo Alto (Calif.)
 European Headquarters: Geneva (Switzerland)
 European Plants: South Queensferry (Scotland)
 Böblingen (Germany)

The "non-plastic" plastic transistors

So reliable you'd think they were hermetic



We're big enough to realize that with any plastic transistor, you're bound to have questions concerning reliability.

So...long before RCA announced this family of "Hometaxial-Base" silicon power plastic devices (10 transistors with ratings of 36W or 83W), our reliability engineers devised a most rigorous new-product testing program. RCA subjected hundreds of units to stresses beyond device ratings

and the results are so impressive that, frankly, you'd think the transistors were hermetic.

We thought it would be appropriate for you to see our reliability manager's comment on the tests to date.

Here's what he had to say: "...sure we've had failures to our end points. But take a close look at them. Out of 376 units totalling 410,000 device hours at 175°C (versus an actual transistor rating of 150°C) only 3 failed. There were 2 failures from 119 units subjected to 25 temperature cycles of -65°C to 175°C (device rating is 5 cycles of -65°C to 150°C). In all, our actual unit hours on all life tests, including storage, operating, and reverse bias, total over 1,600,000 with a failure rate of 1.7% per 1,000 hours. And if you adjust for the fact that all these tests were essentially at over-stress conditions, the result is an estimated failure rate of less than 0.1% per 1,000 hours."

Why not evaluate the facts behind RCA's "non-plastic" plastic transistors yourself? We documented all of the details in a no-nonsense brochure (HBT-600A) which we'll be glad to send you. Just write to RCA Electronic Components & Devices, International Marketing, Clark, N.J., U.S.A. 07066 or see your local RCA distributor.

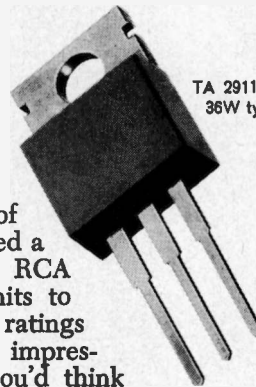

TA 2911
36W type for printed-circuit boards

TA 7155
36W type for TO-86 sockets

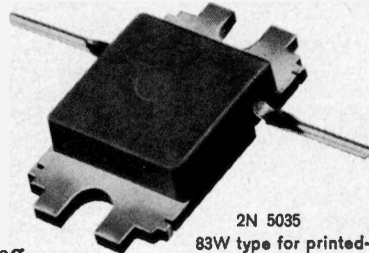

2N 5035
83W type for printed-circuit boards

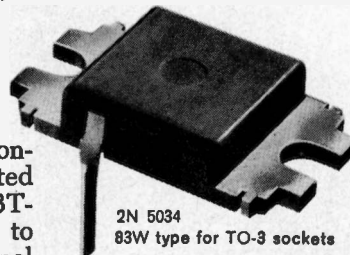

2N 5034
83W type for TO-3 sockets

RCA Electronic Components and Devices



The Most Trusted Name in Electronics

Trademark(s) ©Registered Marca(s) Registrada(s)

AUTHORIZED DISTRIBUTOR IN GREAT BRITAIN: RCA Great Britain, Ltd., Lincoln Way, Windmill Rd., Sunbury on Thames, Middlesex. **EUROPE, MIDDLE EAST & AFRICA:** RCA International Marketing, S.A., 118 rue du Rhone, Geneva, Switzerland.

Real value-engineering from Weir

For more information circle No. 90

Here's the latest example:
Microreg
All-silicon variable power supply.
0-25V, 0.5A

£24.10.

Compare this specification with much more expensive bench instruments:

Continuously variable voltage control, 0-25V, 0.2% resolution.
Ripple and noise < 1mV peak at 25V.
Worst case transient < 250mV peak at 25V.

Transient recovery time < 10 μ sec.

Load regulation < 0.1%, supply regulation < 1mV + 0.03%

Automatic output current limit; short-circuit proof.

2% dual scale output voltmeter/ammeter.

Negligible turn-on drift

Stackable case for series or parallel multiple operation.

Floating output for +ve or -ve working.

7½ x 3½ x 6½ ins, 19 x 8 x 16 cm;

5 lbs. 2.3 Kg.



Minireg 401/402
0-30V, 0-1.25A, 25W.
Regulation < 0.05%.
Ripple < 200 μ V peak-peak.
£39.10.0/£49.10.0.



Majoreg 440/460 Series
0-60V, 0-1.25A, 40/50W.
Regulation < 0.05%.
Ripple < 200 μ V peak-peak.
From £49.10.0.



DV 500
Digital voltmeter, 1mV-1000V dc.
4 ranges. Neon number display.
Accuracy 0.1%fs, + 0.2% reading.
£99.10.0.



Modureg 361
0-25V, 0-0.25A, 6.25W.
Regulation < 0.1%.
Ripple < 1mV peak-peak.
£21.10.0.



Modureg 351
Rack-mounting version of 361
variable or preset voltage,
5 units in 19" rack width.
£18.10.0. each

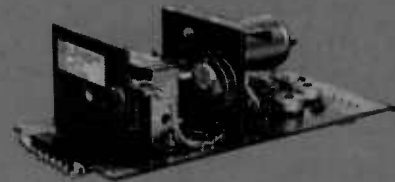

Modureg 341
Uncased version for building into
prototypes, instruments, control
systems.
£17.10.0.

WE

Weir Electronics

Weir Electronics Ltd.,
Durban Road Bognor Regis Sussex.

Bognor Regis 3606
Telegrams Electron Bognor Regis



**NO ONE OFFERS A
WIDER RANGE OF
MONITOR TUBES
THAN BRIMAR**

BRIMAR offers the most comprehensive range of monitor tubes in the country, together with the widest selection of phosphors.

The tubes range in size from 5" to 23". They can be used for television camera viewfinders, studio quality monitors, data displays and closed circuit television – twenty tubes in all! They have been designed to give maximum resolution under high ambient lighting conditions.

A variety of mounting and implosion protection methods, including self protecting bonded glass faces are available from BRIMAR who are Britain's leaders in implosion protection.

Common features include magnetic deflection, electrostatic focus and aluminised screens.

The phosphors. In addition to the standard type for television, a wide selection of others is available offering varying degrees of persistence and colour.

....OR A MORE PERSONALISED SERVICE!

Every BRIMAR tube is backed by a first-class technical service and assistance on any type of problem involving its use in monitors – from special characteristics to circuit design. BRIMAR engineers are always available – contact is on a personal basis. Please telephone or write for full details.



Thorn-A.E.I. Radio Valves & Tubes Ltd.

7 Soho Square, London W1. Telephone: 01-437 5233

TA6959

INTRODUCING THE 'DUALINE' SYSTEM

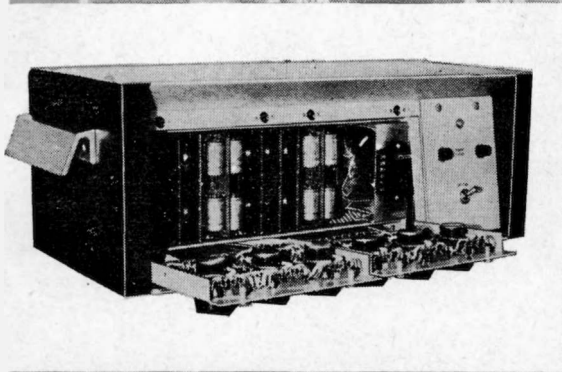

FOR INDUSTRIAL MEASUREMENT AND CONTROL

Range of Plug-in Cards, Packs and Alternative Housings to Unify Design, Development and Production

Typical applications—

Amplifier and Servo units; Logic control etc. for Industrial, Educational and Scientific purposes

DUACASE—HOUSING for DUAPACK

- Complete access with quick-release fasteners
- Distinctive styling, hinged panels
- Light alloy construction, anodised finish
- Range of standard sizes to suit Duapack
- Competitive prices and good delivery

Shirehall ELECTRONICS LIMITED

STATION YARD · BOROUGH GREEN · SEVENOAKS · KENT · BOROUGH GREEN 2612

99.999+%



Alloys prepared as ingot, wire, rod or foil.

Also available in lump form—antimony and tellurium (lead content less than .001%) for thermo-electric applications.

ASSOCIATED LEAD



MANUFACTURERS LIMITED

Clements House, 14 Gresham Street, London, E.C.2.
Crescent House, Newcastle upon Tyne 1.
Lead Works Lane, Chester.

NIMMS by

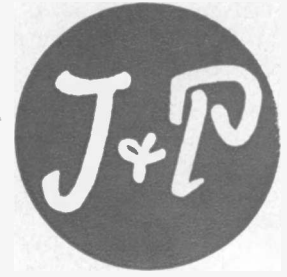

(NUCLEAR INSTRUMENT MODULES: as adopted by U.S. Atomic Energy Commission and conforming to TID-20893 Rev.)

BRITISH SYSTEM AVAILABLE NOW

SCALERS

NM130 series

- 6 decades
- 5 megacycles
- Print-out
- Integrated circuits
- Printed wiring
- Small size

NM130: £195 ex works
(binary coded decimal display)

NM135: £295 ex works
(decimal "in line" display)

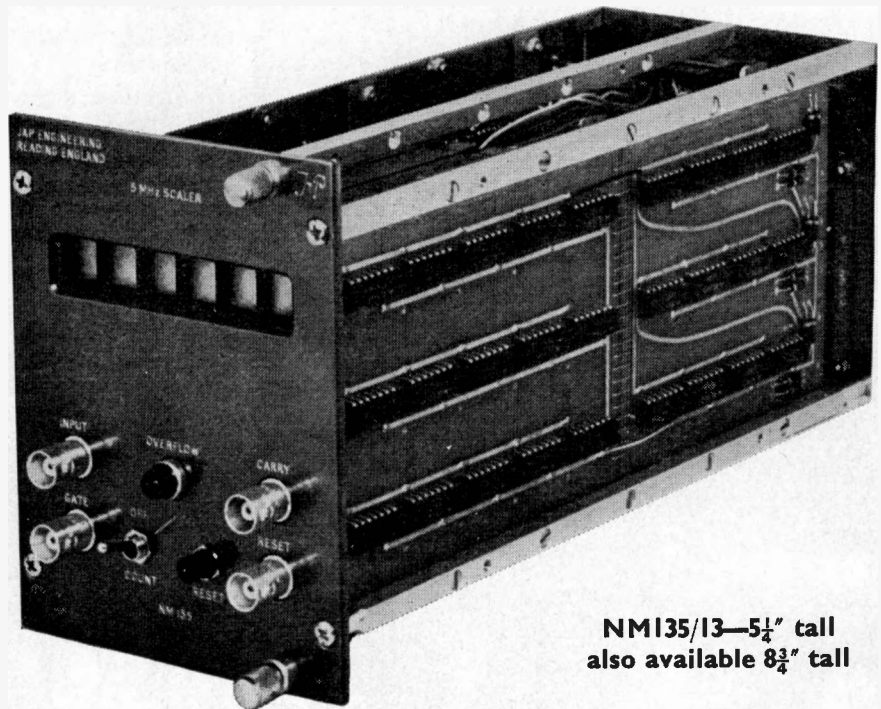

NM135/13—5½" tall
also available 8¾" tall

The J & P NIM system is a fully interchangeable modular system of electronic instruments, whose dimensions, interconnections, voltage supplies and coupling pulses, are internationally used—giving an entirely new concept in flexibility.

J & P have a complete range of instruments available in both the 8¾" tall and 5½" tall systems. The J & P 5½" NIM system is one of the most compact instrument systems available, making the fullest advantage of integrated circuits and micrologic.

J & P Engineering (Reading) Ltd.

PORTMAN HOUSE • CARDIFF ROAD • READING • BERKS • Reading 52227

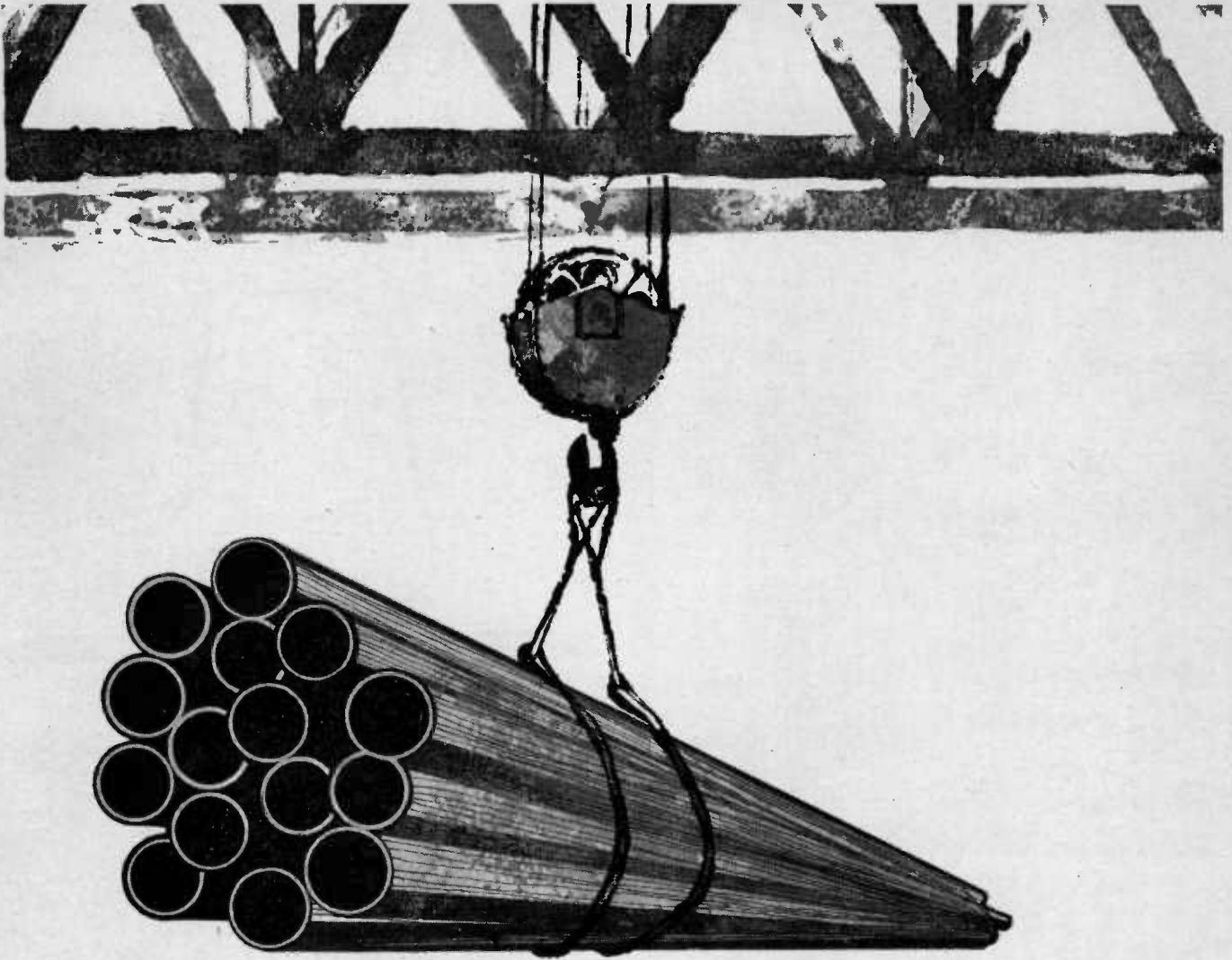

Why Stewarts and Lloyds tubes seam longer

The success of continuous seam welding of tubes at Stewarts & Lloyds has a lot to do with their RF generators. Its reliability has meant trouble-free runs in the production of some of the longest seam welded tubes ever made. Power for these generators comes from 4 English Electric BW194 high power triodes, which are particularly well suited to this application and are part of a whole range of valves developed by EEV for industrial purposes. This industrially orientated range is available in outputs up to 250kW with air, water or vapour cooling. For further technical details and the name of your nearest stockist, write to:

ENGLISH ELECTRIC VALVE COMPANY LIMITED

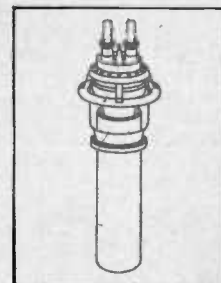

CHELMSFORD, ESSEX. TELEPHONE: 61777

AP290



torovolt variable transformers

Auto-Wound and Double-Wound

Proved by experience, Cressall variable ratio Toroidal transformers provide the most reliable & convenient form of voltage, current or power control. Supplied open or protected: as ganged assemblies or motorised for remote control.

EXAMPLES FROM THE TOROVOLT RANGE

1. Torovolt Model 33Y. An encapsulated auto-wound variable transformer of the smallest size consistent with reliability and long life. Output 0-240v. 0.9A
2. Portable Metered Torovolt. A compact and versatile power or voltage controller ideally suited to laboratory and test bench use. A.C. outputs up to 10A. Alternatively, D.C. outputs through an internal rectifier.
3. The Torovolt double-wound transformer provides smooth variations of output voltage from a secondary winding isolated from the input supply. Outputs from 120VA up to 750VA.
4. The Torovolt auto-wound unit enables smooth adjustments of A.C. voltage to be obtained from zero up to the maximum output voltage. Continuously rated outputs from 0-135v. 2.25A up to 0-270v 30A.
Illustration is of model 76ZT rated at 30A.

A member of the **expamet** Group

THE CRESSALL MANUFACTURING COMPANY LIMITED
CHESTON ROAD • BIRMINGHAM 7 • TELEPHONE: EAST 3571

A new light on 'BARB' INDICATOR LAMPS

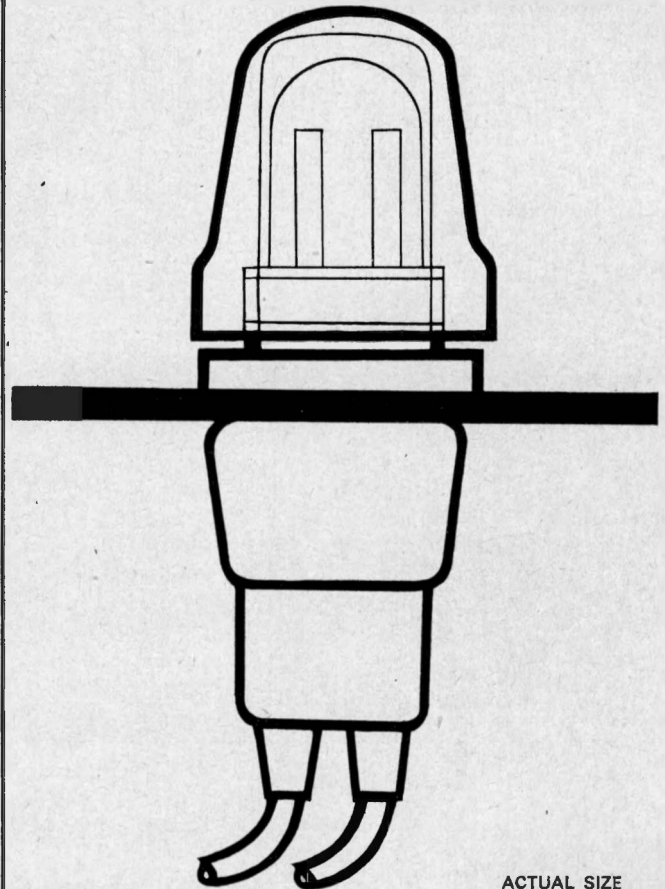

ACTUAL SIZE

The Oxley Subminiature Panel lamp features simple press fit anchorage by means of the proven 'Barb' principle.

The aesthetic lens assembly provides clear visual indication from almost any angle with simple lamp replacement from the front. The indicator has been designed to incorporate and utilise fully the advantage of low consumption Subminiature Incandescent lamps, available in 6 volts, 12 volts and 28 volts. Lens colours (Red, amber, yellow, green, blue, and clear).

A neon version is also available for 250 and 110 volts working.

British and foreign patents, British Patent Number 766862.

See your Electrical Engineering Index for full technical data.

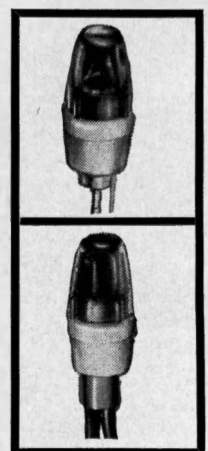

OXLEY®



OXLEY DEVELOPMENTS CO. LTD., ULVERSTON, LANCS.
Tel: Ulverston 2621. Cables: Oxley Ulverston

MARCONI SPECIALIZED COMPONENTS

In this you can have
a quartz crystal



And the oscillator too!

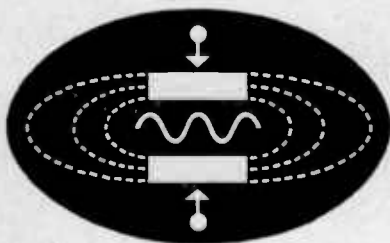

Marconi Specialized Components include a comprehensive range of highly stable oscillators in the range of 1 kHz to 140 MHz, crystal filters, crystal and component ovens, ferrite devices, quartz delay lines, and solid-state high-speed relays.

The Marconi Company Limited, Specialized Components Division, Billericay, Essex. Telephone : Billericay 2654. Telex : 99201

AN 'ENGLISH ELECTRIC' COMPANY

LTD/F70

Who keeps score?

Keeping continuous count of fast-moving items is a job for automation. Faster than other systems and infallibly accurate, Counting Instruments take stock, keep score, check production, aid research, contribute to computerization . . . In all branches of industry, Counting Instruments are taking over.

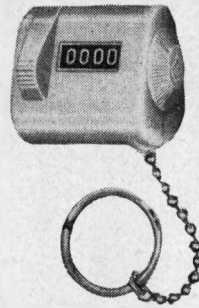

HAND TALLY COUNTERS
A simple four-figure unit operated by finger pressure. Reads up to 9999 and can be reset at any stage.

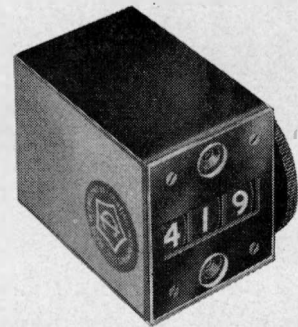

LIGHTWEIGHT ELECTRO-MAGNETIC COUNTERS
Three- or four-figure units built to withstand severe mechanical shocks. Accurate even at 7G.



COUNTING INSTRUMENTS LIMITED

New CAMBION® integrated circuit assemblies...

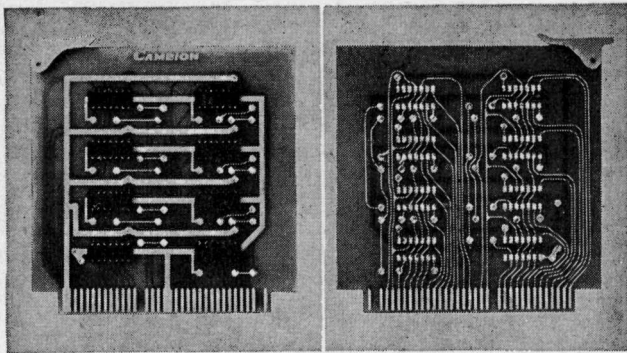

Typical Logic Assembly (4½" x 4½") Shown Front and Back

150 ways to better logic design

Start projects at the systems level. New low cost, highly flexible and universal, CAMBION IC logic assemblies comprise a broad selection of logic functions such as decoders, counters, shift registers, etc. CAMBION DTL (diode transistor logic) integrated circuit logic assemblies are characterized by high speed operation, positive logic levels, low power input, large noise threshold and 70 pin output/input configuration. Send for our latest Fact-pak on CAMBION digital logic assemblies. It's FREE.

Cambion Electronic Products Ltd., Dept., 320, Castleton, Nr. Sheffield. Tel.: Hope 406/407. Telex: 54444

CAMBION®

Standardize on CAMBION. The guaranteed electronic components For more information circle No. 100

aim Pulse Technology

'n' NEW PULSE GENERATORS FROM AIM

We're not quite sure just how many pulse generators we've introduced. It's not that we can't add up, but we find that whenever we bring out more AIM plug-ins someone always comes along with a combination we've never dreamed of.

This time we've added four pulse generating modules to our range and half a dozen basic pulse generators using them.

This time we'll sit back and wait for you to tell us how many pulse generators we've got.

- Clock rates : 0.001Hz to 20MHz
- Widths : 25nSec to 1second
- Delays : 25nSec to 1second
- Rise/fall times : 5nSec to 1second
- 20 volts p-p into 50 ohms
- d c coupled pulse power amplifiers
- d c offset over full output range
- Voltage programmable sweep
- Trigger, sync and gated operation
Double and multiple pulse
- Pulse burst

AIM also manufactures in its modular range: Lock-in amplifiers, phase-lock systems, 1GHz samplers d.c. power amplifiers, automatic Nyquist plotters.

AIM ELECTRONICS LTD, 71-73 FITZROY ST. CAMBRIDGE, Tel: (0223) 62560 For more information circle No. 101



ADD/SUBTRACT ELECTRO-MAGNETIC COUNTERS
Self-contained and precisely engineered; twin escapement mechanisms facilitate adding and subtracting by impulse.



HIGH SPEED, QUICK-RESET ELECTRO-MAGNETIC COUNTERS
Extreme accuracy at fast-counting speeds. Six-figure reading; designed for flush panel mounting.

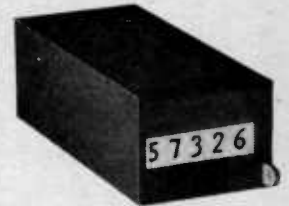

NON-RESETTABLE ELECTRO-MAGNETIC COUNTERS
Small 5- or 6-digit counters with life-expectancy over 100M counts. Frontal area less than 0.92 sq. ins. —ideal for small panels.

Elstree Way, Boreham Wood, Hertfordshire.

Telephone: ELStree 4151

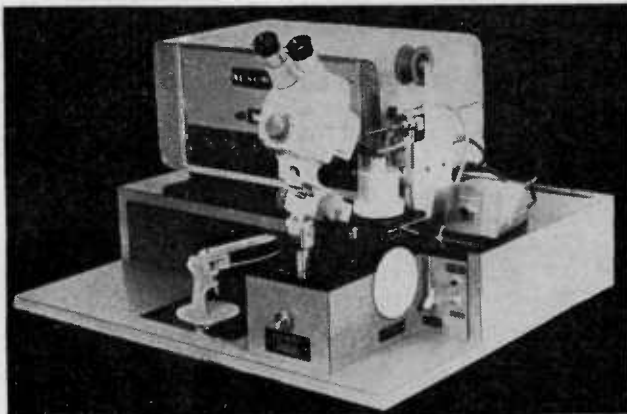

Close-ups of welding tip in position over work-holding chuck. Vacuum chuck above is standard equipment. Mechanical chuck below is optional.

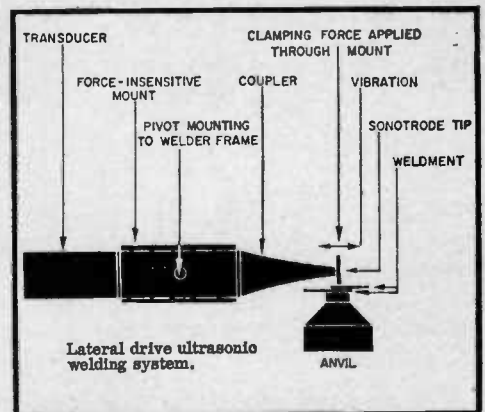

ULTRASONIC MICRO-WIRE BONDING

THE MOST ADVANCED WELDING TECHNIQUE FOR MICROCIRCUITRY

From transistors to integrated microcircuits Ultrasonics is a proved production method for lead-wire bonding in mass production.

Kerry's 20 w. W-260-A-welder combines within the one unit all components of wire feed, work manipulation under welding tip, welder head operation and positioning.

Aluminium and gold wires, ranging in size from 0.0005 inch to 0.010 inch diameter, can be welded to both plain and metallised surfaces of silicon and germanium. Copper, nickel, aluminium, gold wires and ribbons can be welded to aluminium, nickel copper, silver, gold, tantalum, chrome, nichrome, platinum and molybdenum films on various glass and ceramic substrates for micro-miniature circuit applications. Such junctions are free of brittle, high-resistance intermetallic compounds, and are characterized by low noise and low ohmic resistance.

- * NO HEAT
- * NO FLUX
- * NO CLEANING
- * NO PURPLE PLAGUE BY REPLACEMENT BY ALUMINIUM WIRE TO SILICON BONDING.

OTHER KERRY ULTRASONIC WELDING EQUIPMENT

Ultrasonic spot, seam, and ring welding equipment is available in a range of sizes and models from 20 watt to 4,000 watt units.



For literature and demonstration please contact

Leaders in ultrasonics
Wilbury Way, Hitchin, Herts.
Phone: Hitchin 51711

A member of the Kerry Group of manufacturing companies.

**"HEAT
RESISTANT
TO 800°C"**

and a really practical proposition



**COPPER CLAD
POLYIMIDE (H.film*)
the HIGH TEMPERATURE
Di-electric**

No soldering problems. Reasonable costs stabilised at last. This laminate is truly self-extinguishing in its flammability standard and can be subject to soldering temperatures in the range 535°F—550°F.

**Available EX U.K. STOCK from
OSWALD E. BOLL LTD of WOKING**

also COPPER CLAD POLYESTER—the original flexible laminate and glass/epoxy, paper/epoxy and paper/phenolic rigids for the MANUFACTURE of HIGHEST QUALITY Printed Circuits.

The Technical Sales Department is available for consultation on the use of all Multilayer Circuit raw materials.

*Registered name of Du Pont.

**Oswald E. Boll Limited,
4a COMMERCIAL RD., WOKING, SURREY
(Tel. WOKING 61633 and 2018)**

Also at Zurich, Paris, Hamburg, Milan and Brussels

'QUIETLY SUPERIOR'

**FREQUENCY
CONTROL**

for
**communications
equipment**



Providing an extensive range of crystals for frequency control, in all sizes, designed to meet the requirements of the communications equipment designer and manufacturer, Brookes Crystals are available in either hermetically sealed metal cans, or a variety of evacuated glass envelopes.

Write now for detailed literature and price lists.

**BROOKES
CRYSTALS**

**Stand for dependable
frequency control**

**Brookes Crystals (1961) Ltd.
Cornhill, Ilminster, Somerset
Telephone: Ilminster 2271/2.**

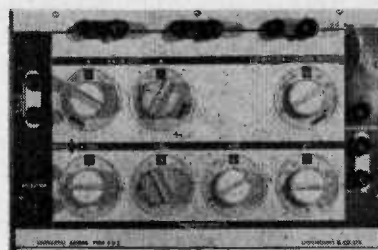

**BASIC
UNIVERSAL
BRIDGE**

(for laboratory and teaching purposes)

For the measurement of L, C and R using your own generator and signal detector.

Wide range of Resistance, Capacitance and Inductance Boxes available, all at very reasonable prices.

LIONMOUNT & CO. LTD.

Bellevue Road, New Southgate, London, N.11, ENGLAND
Tel: (01) 368 7047

For more information circle No. 106

VITALITY



Miniature and Sub-Miniature
Indicator Bulbs in sizes from 4.5mm

Catalogue from
**VITALITY BULBS LTD
MINIATURE LAMP SPECIALISTS**
BEETON'S WAY, BURY ST. EDMUNDS, SUFFOLK. TEL: 2071 STD 0284/2071

For more information circle No. 107

Distortion Measurement

Only 110 mV required

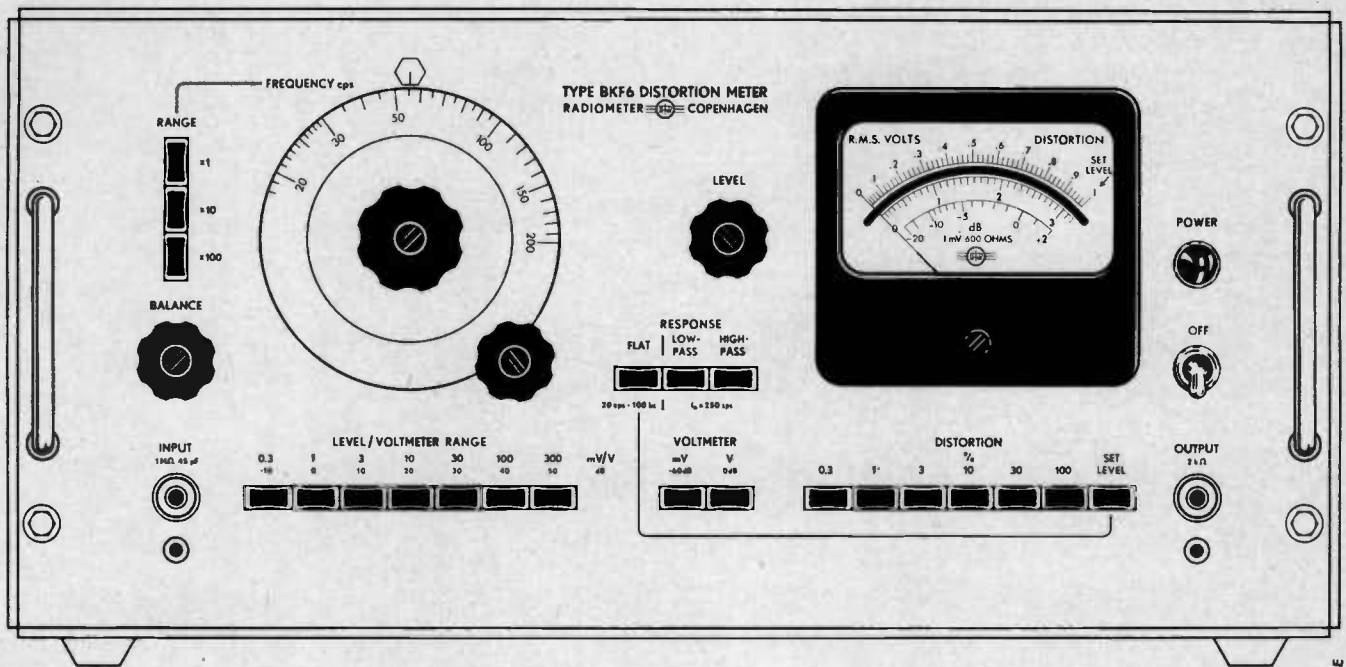

The DISTORTION METER, Type BKF6, is a precision instrument which measures the percentage of distortion. It is also useful as a sensitive voltmeter and as a calibrated amplifier. It features: ▶ High sensitivity during distortion measurements: 110 mV ▶ Constant high input impedance ▶ r. m. s. sensing and reading ▶ Very low hum and noise level ▶ Push button operation ▶ First scale division at 0.01 % distortion.

Frequency Range:

Fundamental Frequency 20 Hz to 20 kHz
 As Voltmeter 20 Hz to 200 kHz
 Distortion Range: 0.3 % to 100 % fs.
 Voltage Range 0.3 mV to 300 V fs.
 Input: 1 MΩ ≠ 45 pF.
 Output: 10 V at full scale deflection, 50 max.

RADIOMETER A/s • EMDRUPVEJ 72 • COPENHAGEN NV • DENMARK

RADIOMETER

COPENHAGEN



We pay our people to work for you—

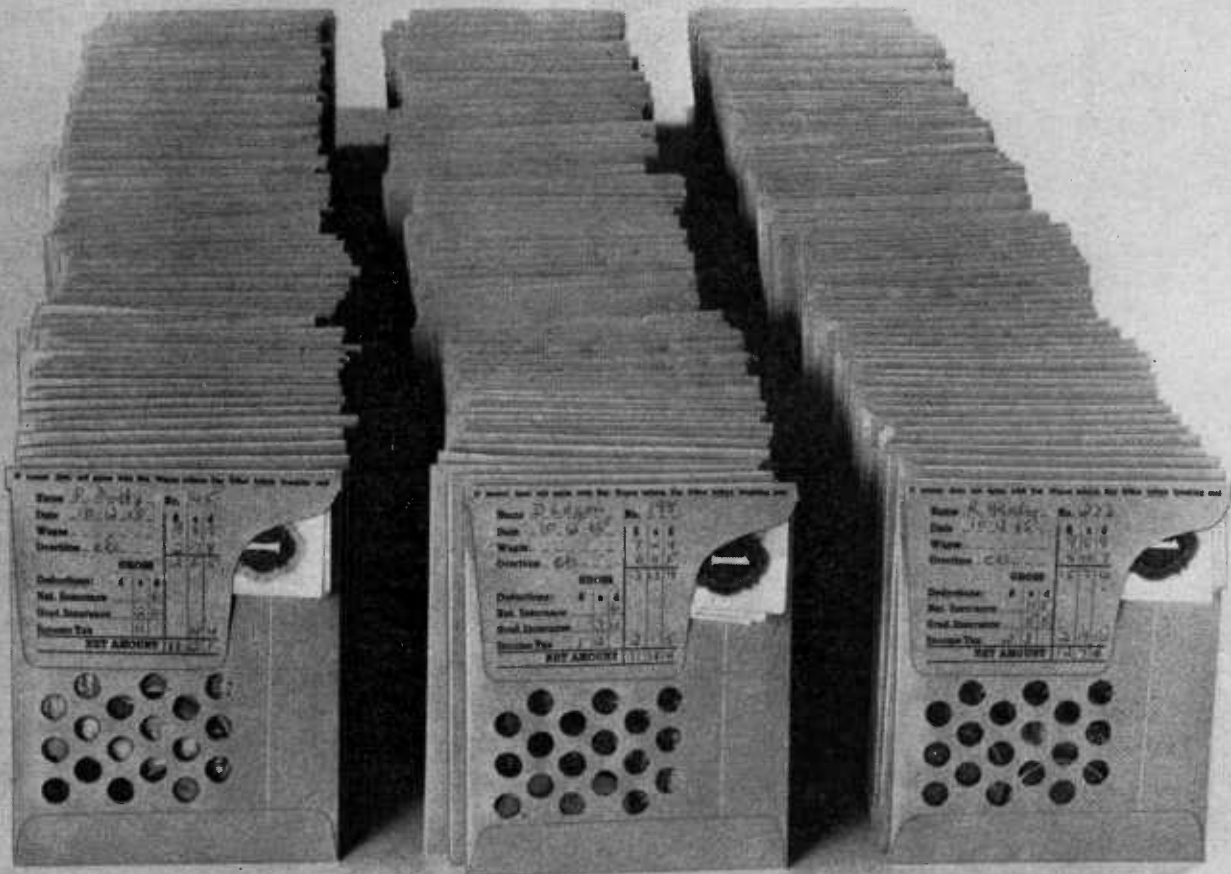

we supply factory and know-how too!

Production problems? Diversification difficulties? Target date doldrums?

Lumber the lot on Broxlea—the *specialist* subcontractors to the British Electronics Industry. (At one time or another, everybody who's anybody in the business has!)

Our factory just outside London has space for your work *now*. It is fully equipped to assemble all kinds of electronic and telecommunications equipment. Particularly wiring, cable-forming and pre-formed wiring systems.

Our own supervisory engineers are fully qualified and highly experienced. If you prefer, however, your own staff can supervise every operation on the spot.

Enough talking. May we *show* you the comprehensive facilities we have to offer? Please 'phone, telegram or write our Managing Director (Mr Leslie Izzard) and arrange a visit at any time that suits you.

BROXLEA

The largest company exclusively engaged in subcontracting
for the Electronics and Communications Industry.

Broxlea Limited (MoA approved) Broxbourne, Herts. Hoddesdon 64455

VARIABLE SPEED DRIVES?

the really
accurate
ones
come from

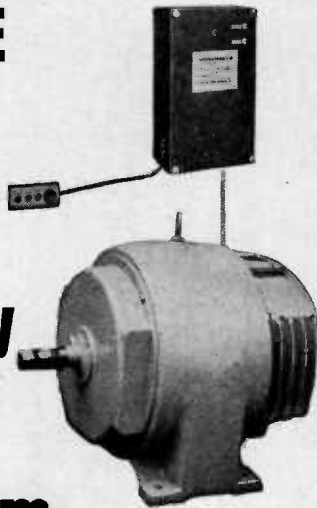

BERCO

↓ to 250 BHP
Local or remote control facilities

Bercotrol Variable Speed Drives give stepless variation of speed held to $\pm 0.25\%$ of top speed at any setting, from no load to full load and with normal supply voltage variations. With this kind of accuracy *Bercotrols* are ideal for providing closely matched speeds in multi-motor drive systems.

Complete drives with motors up to 6.5 h.p. supplied from stock

MOTOMATIC VARIABLE SPEED DRIVES



for all low power applications

A range of unique motor generators and transistorised amplifiers giving the exceptional speed range of 1000:1 with remarkable speed holding characteristics.

for full information on both systems ask for list S/109

Industrial Electronics Division
THE BRITISH ELECTRIC RESISTANCE CO. LTD.,

Queensway, Enfield, Middx.
Tel: 01-804 2411 Telex No. 263194

59B

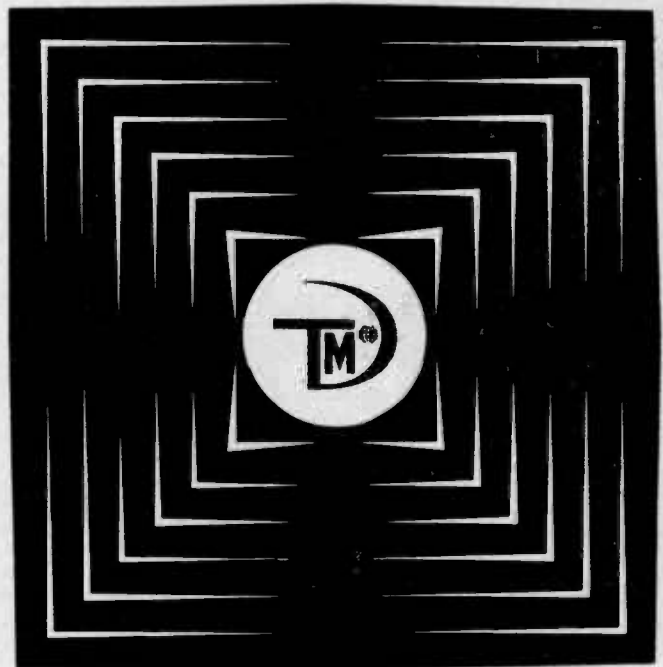

200 TRANSFORMER CORES PER HOUR

can be produced on
RIBBON CORE MAKING
MACHINES

from the U.S.S.R.

60 different types of cores can be produced on this equipment. Of original design, it incorporates the latest technological advances, and its simplicity of readjustment makes it invaluable in the mass production of transformers and chokes.

Slot dimensions, mm - 8-20 × 25-50

Core length, mm - 50-150

Ribbon width, mm - 12.5-50

Please send your enquiries to the sole exporters:

V/O **TECHMASHEXPORT**

MOSFILMOVSKAYA 35
MOSCOW B-330, U.S.S.R.

or to: The Trade Delegation of the U.S.S.R. in the
U.K., 32 Highgate West Hill, London, N.6

TECHMASHEXPORT

Polyester. Wound with polyethylene Terephthalate film, combining the advantages of an extended temperature range with small size. High insulation resistance, excellent stability, close tolerances. Ideal for computers, transistor circuitry, test equipment, filters, timing circuits and for coupling and by-pass capacitors.

Polystyrene. Extremely competitive alternatives to silvered mica capacitors. Suitable for applications where high reliability, high stability, low power factor and negative temperature coefficient are important. For precision timing circuits, electrical storage, pulse networks, precision filters, decade and bridge standards etc.

Plastic Film Capacitors

Polycarbonate. Provide high performance with small size. Low temperature coefficient, low dissipation factor and low dielectric absorption. Used for satellite instrumentation, space flight equipment and numerous other critical applications.

Teflon. Designed for miniature computers and filter networks. High quality capacitors with high insulation resistance and low loss over a wide temperature range.

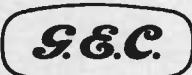

Write for leaflets.

SALFORD ELECTRICAL INSTRUMENTS LIMITED

Peel Works, Barton Lane, Eccles, Manchester. Tel: ECCles 5081. Telex 66711
London Sales Office: Brook Green, Hammersmith, W.6. Tel: 01-603 9292
A Subsidiary of the General Electric Co. Ltd. of England.

High Reliability Instruments

meguro



MAK-659

Dist. meter

—FOR AUDIO LABS AND PRODUCTION—

Measurement Ranges

■ **Distortion** Range: 0.1 to 30%, 5 steps; frequency: 20Hz–200kHz; Input impedance: 600, 10k, 20k ohms; automatic control range: 40dBm or 100X in voltage; fundamental suppression: over 60dB.

■ **Level** Range: –70 to +40dBm, 600 ohms, and –70 to +20dB (0.3mV–10V), 10k and 20k ohms; frequency: 20Hz to 600kHz.

S/N (signal/noise)	Range	Input
	0 to 70dB	–22 to 0dBm
	0 to 90dB	0 to +38dBm

frequency: 20Hz to 60kHz.

● Catalog sheet on request:



MEGURO DENPA SOKKI K.K.

(Meguro Electronic Instrument Co., Ltd.)
No. 5, 1, 2-chome, Chuo-cho, Meguro-ku, Tokyo, Japan
TEL: 711-7191~7 Cables: MEGURODENPA TOKYO

“I resolved that, whenever I heard a rumour about existing automation, I would pack my bags and go and have a look at it”

Thus Dr. David Foster—and a fascinating story he has brought back from his global explorations. He divides his new book “MODERN AUTOMATION” into three parts:—

1. A plain man's guide to cybernetics.
2. Practical examples of automation from various parts of the world.
3. A searching discussion of the economics and politics of automation, past, present and predicted.

MODERN AUTOMATION

by David Foster, Ph.D., M.I.Mech.E., M.I.E.E., M.I.Chem.E.

is vital reading for every engineer, manager or intelligent layman in 1967. Order it from your bookseller price 42s., or have it sent by post for 43s. (post paid) from

MORGAN BROTHERS (Publishers) LTD.
28 ESSEX STREET · STRAND · LONDON · W.C.2

AN ELECTRONIC MAINTENANCE CENTRE IN THE MOUNTAINS?

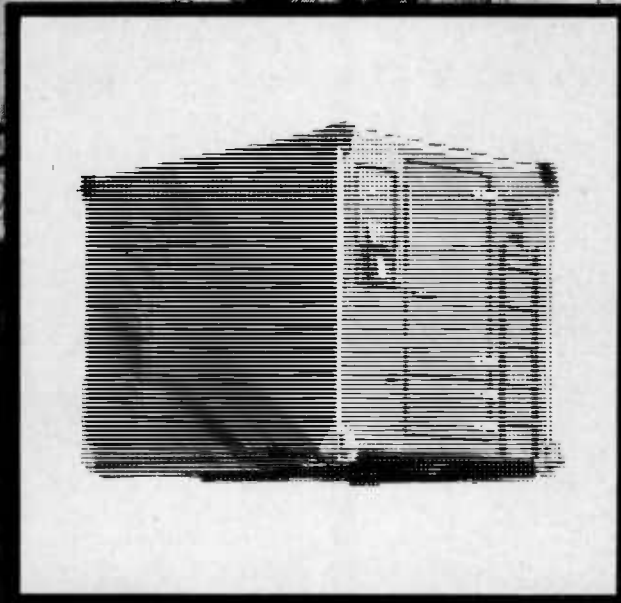

FULLY PROTECTED IN A SHOCK-PROOF FOKKER-CRAIG SHELTER

Even the most sophisticated communication systems can break down. One faulty link in a key relay may result in a wrong decision being taken. Maybe with unfortunate, even disastrous, results. Quick repair is vital - but how to ensure this if the trouble lies in isolated mountains, deserts, swamps...? One effective answer - highly mobile maintenance centres. But effectiveness of such units is linked to the degree of protection they provide for their own equipment. And here there can be no compromise. Such protection must be complete. Fully effective against all hazards - solar radiation, flooding, storms, sub-zero temperatures, magnetic field influences, earth tremors, humidity, fungus... Exactly the sort of protection given by a Fokker-Craig shelter. A unique, compact unit that employs a bonded all-metal sandwich construction with a foamed-in-place core of poly-urethane. Gives it remarkably high insulation properties, light weight - and immense strength, enough to withstand vertical accelerations of $3\frac{1}{2}$ g or sudden shocks, such as a drop of 18". With its payload of 5000 lb. it can be transported by land, sea or air to any difficult trouble-spot and quickly made operational. Qualities found ideal to meet the strict requirements of the NATO Hawk programme. But ask about the many uses for versatile Fokker-Craig shelters. And about the comprehensive Fokker service. Lots of impressive facts you ought to know.



ROYAL NETHERLANDS AIRCRAFT FACTORIES FOKKER · SCHIPHOL · HOLLAND
CABLE ADDRESS: FOKPLANES AMSTERDAM

The most popular COLVERN standard

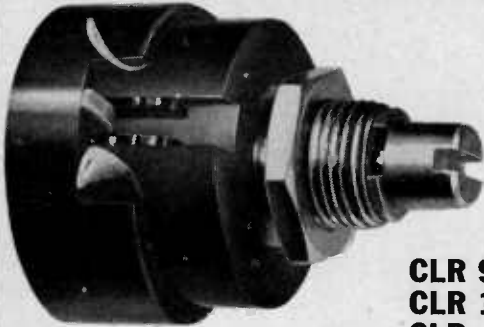

CLR 901C
CLR 1106
CLR 4001

and type approved sealed potentiometers

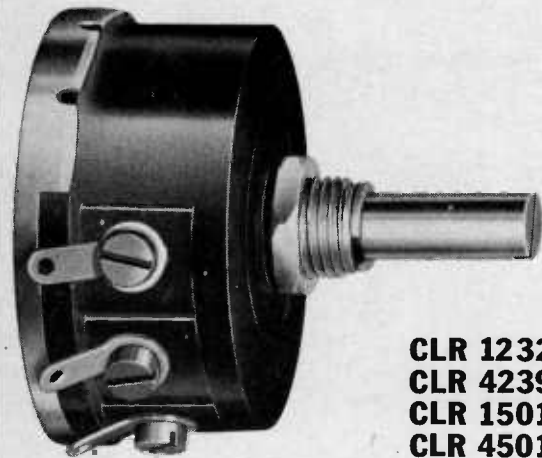

CLR 1232
CLR 4239
CLR 1501
CLR 4501

Are stocked by official distributors

CABLES & COMPONENTS
PARK AVENUE, LONDON, N.W.10.

EDMUNDSONS ELECTRONICS
60-74 MARKET PARADE,
RYE LANE, LONDON, S.E.15.

COLVERN LTD.
SPRING GARDENS, ROMFORD, ESSEX.
Telephone: ROMFORD 62222 Telex: 23984

POTTER & BRUMFIELD

*quality relays
available ex-stock*

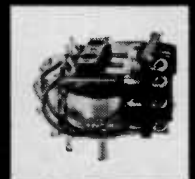
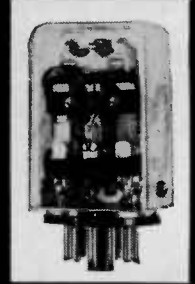

KHP

KA/KAP

	Arrangement	4 PDT	Up to 3 PDT
Contacts	Material	Silver Silver Cadmium Oxide Gold Alloy	Silver Silver Cadmium Oxide
	Rating	3 Amps @ 30 Volt DC or 120 Volt AC	5 or 10 Amps @ 240V
Coil	Voltage	AC to 120 Volt DC to 110 Volt	AC to 240 Volt DC to 110 Volt
	Power @ 25° C	AC: 1.2 VA DC: 0.5 Watts min.	AC: 2.0 VA DC: 100 Mw min. per pole
	Resistance	20,000 Ohms max.	16,500 Ohms max.
Ambient Temperature Range — degrees C	-45 minimum to +70 maximum	AC & DC: -45 minimum AC: +70 maximum DC: +85 maximum	10 million
Mechanical Life (cycles)	AC: 50 million DC: 100 million		
Dimensions	L: 1.281" W: 0.859" H: 1.109" Terminals: .250"	Open: L-1.844" W-1.469" H-1.687" Closed: L-1.581" W-1.438" H-2.281"	

AVAILABLE EX-STOCK FROM

HARDMANS OF ROCHDALE

Hardman & Co. Ltd., Hardale House, Baillie Street,
Rochdale 47411. Telex: 63237

TEXAS INSTRUMENTS LIMITED, SUPPLY DIVISION

12 Wellcroft Road, Slough, Bucks.
Slough (0813) 29481. Telex: 84363
Midland: Hammond House, 2259 Coventry Road, Sheldon.
Birmingham (021) 743-2078. Telex: 338815
Southern: 119 High Street, Southampton.
Southampton (0803) 27267. Telex: 47580
North Western: York House, York Street, Manchester 2.
Manchester (061) 236-8303. Telex: 66478

SASCO: 63 Gatwick Road, Crawley, Sussex.
Crawley 28700

Stover Trading Estate, Yate, Bristol.
Chipping Sodbury 2641. Telex: 44765
Hunting Gate, Wilbury Way, Hitchin, Herts.
Hitchin 2242. Telex: 82283

Factory 13b, Carbrain Industrial Estate, Cumbernauld.
Cumbernauld 25801. Telex: 778104

They're all in our new Stock Catalogue, available
from your distributor or the address below.

And there are 5 other basic types to choose from.



POTTER & BRUMFIELD,

Division of AMF International Ltd.,
Binsey Lane, Oxford. Tel: Oxford 40701



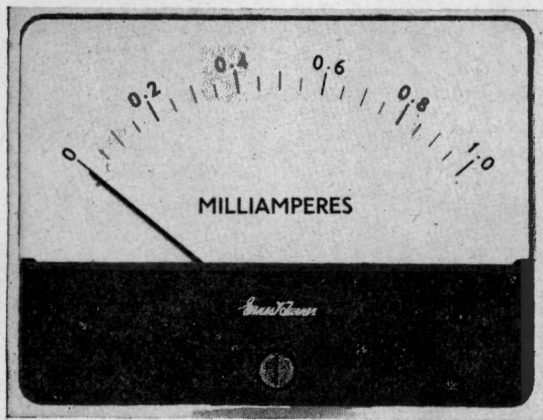

MODEL 645

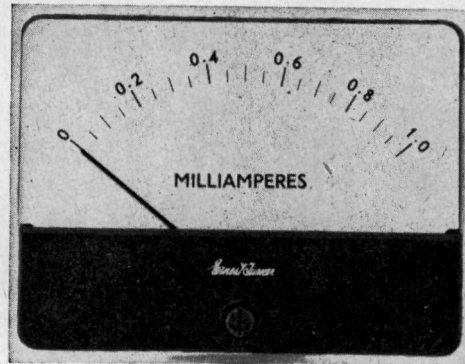

MODEL 644

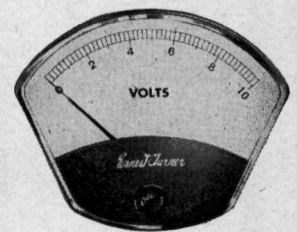

MODEL 403

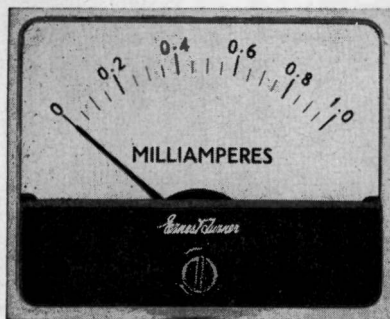

MODEL 643

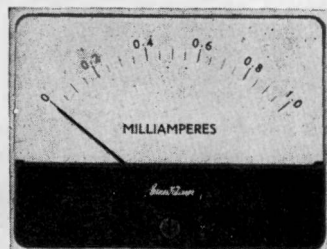

MODEL 6425

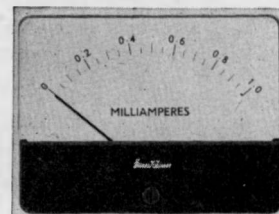

MODEL 642

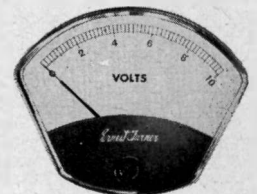

MODEL 402

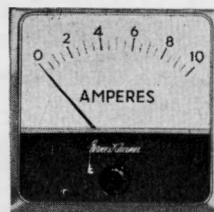

MODEL 641



MODEL 640

CLEARLY...

... Ernest Turner. We have pleasure in presenting the full range of our Clear-Front instruments, they are all illustrated approximately half-size. Two new models have recently been added to the range, they are Models 644 and 6425. The series was designed to meet the demand for a transparent-cased meter of modern design, based on our popular moulded rectangular series. They have the added advantage of shadow-less dials which are admirably suited to multiple and other special scaling. For full details of the range apply for catalogue 86/15.

ERNEST TURNER ELECTRICAL INSTRUMENTS LTD.

CHILTERN WORKS

HIGH WYCOMBE · BUCKS

Tel: 30931-4

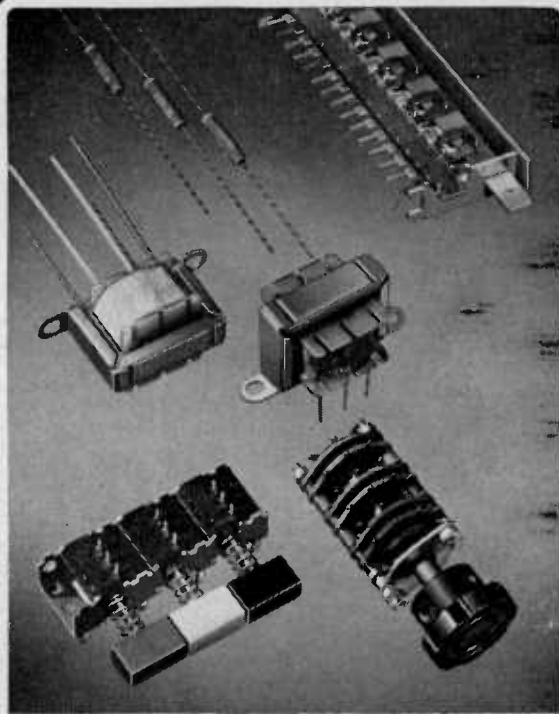

there's a
world of capability in

EMICOMPONENTS

SUB-MINIATURE TRANSFORMERS

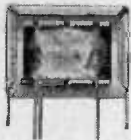

High quality volume production at low price on wire gauges down to 50 S.W.G.
Audio Series -
Max. power up to 500 mW.
Small Power Series -
Max. power up to 12VA, 50 cps.

EMICOMPONENTS are designed by professionals and used in professional applications ranging from rockets to hi-fi. They are used by EMI themselves in the design and development of systems and equipment where no compromise is permissible - in quality performance or value. This is the reason for their constant reliability. The EMICOMPONENTS range includes A.C. and D.C. Motors, PET Capacitors, Miniature Rotary and Illuminated Push Button Switches and Miniature Transformers with outputs up to 20 VA. Send coupon for literature giving performance and dimensional details.



EMI SOUND PRODUCTS LIMITED
COMPONENT DIVISION-HAYES-MIDDX
TELEPHONE: 01-573 3888 - EXT: 667

Please send me details of the following EMICOMPONENTS:

- A.C. & D.C. MOTORS PET CAPACITORS MINIATURE
ROTARY SWITCHES PUSH BUTTON SWITCHES
MINIATURE TRANSFORMERS *Tick appropriate square*

Name _____
Company _____
Address _____
Tel. No. _____

PRINTED CIRCUITS

**QUALITY BOARDS
COMPETITIVE PRICES
GOOD DELIVERY**

Design and prototype service with ample production facilities for small batches or long runs. All usual materials and finishes.

G.P.O. and M.O.A. Approved.

ELECTRONIC ASSEMBLY

Skilled labour for assembly of electronic or electrical equipment backed by machining and fabrication facilities.

S.C.E.E. Limited

Reddicap Trading Estate, Sutton Coldfield
Telephone: 021-354 8048

A **Cressall Expamet** Company

**25W POWER TRANSISTOR WITH A | EX
DIAMETER LESS THAN A PENCIL! | STOCK**

DIAMETER=7 mm HEIGHT=3 mm
The silicon B5000 can dissipate
25W at $T_c=100^\circ C$
and is available in gain selections from
 $h_{FE}=30-75$ to $h_{FE}=150-250$ at 500mA
 $V_{CE0}=35V$ $I_C=3A$ $f_T=2.5$ Mc/s
Prices and data sheets available on request, as is our Short Form Catalogue/Price List.

RASTRA Electronics Ltd.,
275/281 King Street, London, W.6. Tel: RIV 2960

For more information circle No. 121

FARM IMPLEMENT AND MACHINERY REVIEW

Established 1875

A monthly journal for manufacturers and distributors of all types of farm machinery and equipment

Annual Subscription 25/- post free (includes one free copy of Farm Implement Buyers Guide)

Member of the Audit Bureau of Circulations

*For further details about subscriptions or advertising, write to
FARM IMPLEMENT AND MACHINERY REVIEW
28 ESSEX ST · STRAND · LONDON, WC2
Tel: CENTral 6565

MORGAN BROTHERS (Publishers) LIMITED

For more information circle No. 122

Our digital voltmeter costs \$349, and measures Ohms free.



The Fairchild 7050 DVM is a digital rebuttal to analog meters. It measures volts or ohms with a resolution of 1mV or 1 ohm, and with an accuracy of 0.1%. Integrated circuits, dual slope integration, automatic polarity, floating input and display storage are all included as standard. The 7050 weighs less than four pounds and costs U.S. \$349. The tilt stand doubles as a handle and costs \$16 extra. Our data sheet is free.

FAIRCHILD
INSTRUMENTATION

Representative: Aveley Electric Ltd. South Ockendon, Essex, Tel: South Ockendon 3444, TWX: 24120 AVEL OCKENDON

European Headquarters: FAIRCHILD INSTRUMENTATION LTD., Grove House, 551 London Road, Isleworth, Middlesex, England, Tel: 560-0838, TELEX: 24693

Precision Resistors

wire-wound

with alternate sections reversed for low inductance.

compatible resins

for bobbin and encapsulation.

0.01% stability

after 2000 hours, an independent test.

16 types

with axial lead, radial lug or printed circuit connections, many with type-approval, all stable over range -65°C to $+150^{\circ}\text{C}$.

**all this and
quantity deliveries
in six weeks**

prototypes 14 days

Send for full details of
MEC P-type precision wire-wound resistors to
Miniature Electronic
Components Ltd
St. Johns Woking Surrey
Woking 63621

m-e-c

Trimmer Potentiometers
Wire-wound Resistors
Miniature Switches
Elapsed Time Meters



escap®

DC micromotors, low-priced precision products

Escap 26 motors

ø 1.024" (26 mm)

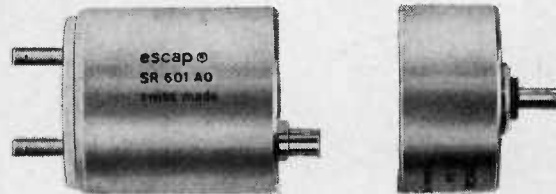

voltages: 1.5 to 9 V
power: up to 420 mW
low current consumption, high efficiency,
long life
with or without built-in centrifugal regulator
wide range of microreducers

New!

Escap 15 motors

ø 0.595" (15 mm)



voltage: maximum 6 V
power: up to 300 mW
low current consumption, high efficiency

Escap® micromotors are manufactured by Portescap, one of the leading companies in the Swiss watch industry.

General distributors:
Reno SA, Micromotors Department
165, rue Numa-Droz
CH-2300 La Chaux-de-Fonds, Switzerland

Sole Distributors for Great Britain:
Trident Electric Ltd.
P.O. Box 47
Reading, Berkshire
England

IEA

Year Book and Buyers Guide

1967



Contains over 700 pages of detailed information on the inter-related fields of instruments, electronics and automation.

Fully reflects the growth and changes in these fields over past year.

Contains four completely new, fully tabulated surveys:

- Electronic voltmeters*
- General purpose analogue computers*
- Microelectronics*
- Process chromatographs*

Is still at the same price—£3 (including postage)

Instruments Electronics Automation Year Book and Buyers Guide

**ORDER
YOUR
COPY
NOW!**

**The Circulation Manager
I.E.A. Year Book and Buyers Guide
28 Essex Street, Strand, London, W.C.2.**

*Please supply,copies of the I.E.A. Year Book and
Buyers Guide at £3 per copy.*

Remittance for £..... is enclosed|will be sent on receipt of invoice.

NAME

ADDRESS

SIGNED DATE

EE

CLASSIFIED ADVERTISEMENTS

RUN-ON AND SEMI-DISPLAYED The charge for these advertisements is 6s. per line of approximately 6 words (Minimum 24s.), for Run-on advertisements. For Semi-displayed advertisements the charge is 72s. per single column inch. Use of Box Number 3s. extra. Copy is required by 14th of the month for insertion in the next issue.

FULLY DISPLAYED (With border rules, larger type faces and blocks if required). The charge is 80s. per single column inch—minimum 3 inches. Eighth page £15 0s. 0d. Quarter page £30 0s. 0d. Half page £57 10s. 0d. Full page £115 0s. 0d. Use of Box Number 3s. Blocks must be supplied mounted. Copy is required by 5th of the month (if proofs are wanted), or by 10th of the month (without proofs) for insertion in next issue.

Advertisements for publication and replies to box numbers should be addressed to:

Classified Advertisement Dept., "Electronic Engineering", 28 Essex Street, Strand, London, W.C.2. 01-353 6565

OFFICIAL APPOINTMENTS

SCOTTISH HOME AND HEALTH DEPARTMENT

PRINCIPAL SCIENTIFIC OFFICER/ SENIOR GRADE ENGINEER

SENIOR SCIENTIFIC OFFICER/ MAIN GRADE ENGINEER

Two posts for men and women in the National Health Service Supplies Branch in Edinburgh. According to qualifications and experience, the successful candidate for one post will be graded Principal Scientific Officer or Senior Grade Engineer. Candidates must normally be aged 35 or over for (a), and at least 26 for (b).

DUTIES: Post (a) to lead a team of professional and technical officers concerned with the supply of equipment to the Scottish Hospital Service; to advise the department on current trends in scientific instrumentation, on the evaluation and performance of new equipment and on research and development; to maintain close liaison with other government departments, universities and other technical institutions; to represent the department on scientific committees.

Post (b) to work to the leader of a team of professional and technical officers concerned with the supply of equipment to the Scottish Hospital Service; and to be particularly concerned with electronic equipment, automation in hospitals, bio-engineering and allied equipment.

QUALIFICATIONS: Normally degree or Dip. Tech. with 1st or 2nd class honours, or equivalent or higher qualification in a relevant branch of science or engineering or in mathematics or corporate membership of I.E.E. or I.E.R.E.; but, a candidate without the prescribed qualifications may be admitted if he can produce evidence of high professional attainment. Candidates must have experience, both of medical equipment and specialist hospital departments, relevant to the duties of the post(s) for which they apply. In addition, for post (a) knowledge of computers and their relationship to medicine would be an advantage; and for post (b) experience with equipment safety standards is desirable, and some knowledge of x-ray equipment would be an advantage.

SALARIES: (a) Principal Scientific Officer £2,250-£3,107; Senior Grade Engineer £2,639-£3,105; (b) Senior Scientific Officer £1,744-£2,155; Main Grade Engineer £1,894-£2,510. Starting salary may be above minimum for all grades. Non-contributory pension. Promotion prospects.

WRITE Establishment Officer, Room 365A, St. Andrew's House, Edinburgh, 1, for application form quoting S/6684/67. Closing date 15th December 1967. W 5771

ST. THOMAS' HOSPITAL

BIOMEDICAL ENGINEERING

A vacancy exists for a SENIOR ASSISTANT in the Medical Electronics Department, concerned with the development of electronics and electromechanical instrumentation techniques in the medical field. Applicants should possess a minimum qualification of a pass degree in electrical engineering, or equivalent, and should have experience in semi-conductor circuit development. Ability to handle mechanical design and construction of prototype devices is essential. Salary in the range £1,365-£1,737 plus £75 per annum London Weighting. Applications to Personnel Officer, St. Thomas' Hospital, London, S.E.1. W 5758

WANSBECK HOSPITAL MANAGEMENT COMMITTEE

SENIOR ELECTRONIC TECHNICIAN

Applications are invited for the above post to carry out duties in the Wansbeck, South East Northumberland, and adjacent Groups of Hospitals throughout Northumberland.

Qualifications should include the H.N.C. (Electronics or Light Current Electrical Engineering), or City & Guilds Telecommunications Engineering Certificate, or of similar academic level.

The person to be appointed should have wide experience in the electronic field including telecommunications, radio frequency transmission and reception, audio frequency systems, domestic and public entertainment, pulse generation, automatic control systems, and electro-medical apparatus. Hospital experience would be an advantage.

The Technician will be based at Stannington, Northumberland, and be responsible to the Group Engineer, Wansbeck H.M.C. for organising a system of routine maintenance covering a wide variety of electronic equipment.

National Health Service Conditions of Service. Salary within the scale £980-£1,300 p.a.

Applications giving full details of age, education, experience, qualifications and present salary, together with the names and addresses of three referees should be sent to the Group Secretary, Wansbeck H.M.C., 12 Stanley Street, Blyth, Northumberland, to arrive by 9th December 1967. W 5759

EAST CUMBERLAND HOSPITAL MANAGEMENT COMMITTEE

SENIOR ELECTRONIC TECHNICIAN

Applications are invited for the above post to carry out duties in the East Cumberland and Garlands Groups of Hospitals.

Qualifications should include the H.N.C. (Electronics or Light Current Electrical Engineering), or City & Guilds Telecommunications Engineering Certificate, or of similar academic level.

The person to be appointed should have wide experience in the electronic field including telecommunications, radio frequency transmission and reception, audio frequency systems, domestic and public entertainment, pulse generation, automatic control systems, and electro-medical apparatus. Hospital experience would be an advantage.

The Technician will be based at Carlisle, and be responsible to the Group Engineer, East Cumberland H.M.C., for organising a system of routine maintenance covering a wide variety of electronic equipment.

National Health Service Conditions of Service. Salary within the scale £980-£1,300 p.a.

Applications, giving full details of age, education, experience, qualifications and present salary, together with the names and addresses of three referees, should be sent to the Group Secretary, East Cumberland H.M.C., Cumberland Infirmary, Carlisle, to arrive by the 9th December 1967. W 5761

ST. BARTHOLOMEW'S HOSPITAL, LONDON, E.C.1.

ELECTRONIC ENGINEER OR PHYSICIST

An ELECTRONIC ENGINEER or PHYSICIST is required to take charge of high voltage machines used for Radiotherapy. These comprise a 15 MeV continuously evacuated electron accelerator and a 6 MeV Linear Accelerator operating basically on solid state units. For the successful applicant there will also be an opportunity to collaborate on research work. Applicants must have a degree. The salary will either be on the scale £855 to £1,658 or £1,833-£2,276 per annum according to qualifications and experience, plus £75 London Weighting. Applications should be sent to the Clerk to the Governors quoting ref. no. ASC/1271. W 5768

POST OFFICE

EXECUTIVE ENGINEERS AND ASSISTANT EXECUTIVE ENGINEERS

Applications are invited for posts as EXECUTIVE ENGINEERS and ASSISTANT EXECUTIVE ENGINEERS in London and provinces for work on the development and design of communications systems and postal service equipment.

QUALIFICATIONS:

Executive Engineers: Degree or Dip. Tech. in Mechanical or Electrical Engineering, or Physics or Applied Physics, or have achieved Corporate Membership of the I.E.E., I.Mech.E., or I.E.R.E. Final year students may apply.

Assistant Executive Engineers: G.C.E. (or equivalent) pass in English language, and one of the following: H.N.D. in Electrical or Mechanical Engineering or Applied Physics; a pass in (or exemption from) Parts 1, 2 and 3 of the examinations of I.E.E., or I.Mech.E.; a pass in (or exemption from) Sections A and B of the I.E.R.E. examinations; a pass in (or exemption from) Parts 1 and 2 of the examination of the Council of Engineering Institutions, in subjects acceptable to one of the Institutions named above.

SALARIES (national): *Executive Engineer:* £878 (at 21)-£1,565 (at 34 or over)-£1,871; will become £906-£1,677-£1,884 on 1st January 1968.

Assistant Executive Engineer: £734 (at 18 or under)-£1,097 (at 25 or over)-£1,631.

Salaries increased for officers serving in London. Non-contributory pension. Promotion prospects.

AGE: *Executive Engineer:* At least 21 and under 35 on 31st December 1967. Some extensions for service in H.M. Forces or Overseas Civil Service. *Assistant Executive Engineer:* At least 17½ and under 27 on 31st December 1967.

Applications for both posts from well qualified older candidates will be considered.

APPLICATION FORMS from Civil Service Commission, 23 Savile Row, London, W.1, quoting S/353. W 5764

ST. GEORGE'S HOSPITAL

HYDE PARK CORNER, LONDON, S.W.1.

A Senior Medical Electronics Technician Grade III and a student are required in the Physics Department of St. George's Hospital, either at Hyde Park Corner, S.W.1. or Tooting, S.W.17. The person appointed will be engaged in work dealing with isotopes, scanning, pacemakers and other bio-medical engineering applications. Applications with names of two referees to Hospital Secretary, St. George's Hospital, Hyde Park Corner, London, S.W.1. W 8753

BOARD OF TRADE (CIVIL AVIATION)

RADIO AND ELECTRONIC ENGINEERS

Qualified engineers required as Assistant Signals Officers in the field of Civil Aviation for the provision and installation of advanced electronic equipment—including the latest type of radar, telecommunications, navigational aids, etc.

QUALIFICATIONS: Degree with 1st or 2nd class honours in Electrical Engineering or Physics, or have passed all examinations for M.I.E.E., A.M.I.E.R.E. or A.F.R.Ae.S.

AGE: 23 and normally under 35 on 31st December 1967 (extension for Forces and Overseas Civil Service).

SALARY (Inner London): On the scale £1,040-£1,985 (will become £1,110-£2,052 on 1st January 1968) depending on age and qualifications. Good prospects of promotion.

Pensionable appointments. **APPLICATION FORMS** from Civil Service Commission, Savile Row, London, W.1., quoting S/85/A.S.O. W 5763

THE NATIONAL INSTITUTE OF AGRICULTURAL ENGINEERING

TECHNICIAN

The N.I.A.E. has a vacancy for the following post in the grade of TW 11.

Instrumentation Department.

Experienced TECHNICIAN required to assist in the planning and execution of development work involving electronics and electro-mechanical devices. Qualifications: O.N.C. or preferably H.N.C. in Electronics Engineering.

Salary scale: £1,228-£1,402 p.a. to be increased retrospectively on 1.1.68 to £1,283-£1,490 p.a.

FIVE DAY WEEK, SUPERANNUATION, CANTEEN.

Transport from Bedford, Amptill and Flitwick areas.

Application forms from: The Secretary, N.I.A.E., Wrest Park, Silsoe, Bedford. Ref. ED/67/10.

W 5760.

SITUATIONS VACANT

DEVELOPMENT ENGINEER

for rapidly expanding Company
in Slough

Interesting work on new development machine tool control in numerical and other fields including servo design.

Write to EE/730 c/o Hanway House,
Clark's Place, London, E.C.2.

W 8752

ELECTRONIC INFORMATION

A few vacancies exist in various parts of the country for Electronic Engineers, specialising in particular fields (for example, large radar systems, computer interface equipment, airborne radar etc.), to analyse specifications and circuit information and to prepare comprehensive system publications as part of the logistics operation. Applicants will be offered appropriate engineering salaries for particular experience, supported by recognised qualifications and an interest in the presentation of information.

Apply Box No. W 8756, c/o ELECTRONIC ENGINEERING, stating field of experience and preferred location.

DEVELOPMENT ENGINEER, electro-medical instruments. Interesting opportunity for a young engineer with talent and initiative. Minimum degree or H.N.C. and two years experience of analogue transistor circuits. Physics or instrument technology background preferred. Small progressive company expanding into new factory. Write to Chief Engineer, R. G. Wakeling & Co. Ltd., Holly Road, Twickenham, Middlesex, giving qualifications, personal details and experience. W 5768

SITUATIONS WANTED

PROMPT PAYMENT AND COLLECTION of manufacturers surplus Electronic Equipment and Components. Turn your tied up capital into cash and save wasted space. Contact Electronic Brokers Ltd., 8, Broadfields Avenue, Edgware, Middlesex. Tel: 01-958 9842. W 8755

EDUCATIONAL

EDUCATION FOR THE ENGINEERING MISSION

Reference this recent IEEE lecture, advertiser desires correspondence with members interested in principle of continued (adult) learning opportunities within the sphere of work and in the deeper roots of motivation for same. Pneumatic and Electronic Control Systems Holdings, 91a Grosvenor Road, Westminster, London, S.W.1. W 5762

SITUATIONS VACANT CONTINUED

WELLWORTHY

A founder member of the Associated Engineering Group, is the foremost manufacturer of Diesel Engine Piston Equipment in the world, and employs 5,000 people in six factories in the South of England—and offer the following career opportunities, at their modern, up to date Research and Development Laboratories in Lymington.

ELECTRONICS ENGINEERS

Preference given to those with previous experience in the field of General Electronics, Instrumentation, Strain Gauge Applications, and Application of Electronics to engine tests.

Academic qualifications would be H.N.C. or equivalent, applicants with lesser qualifications (O.N.C.) are invited to reply for the posts of Assistant Electronics Engineers. Preferable age group for above appointments—up to 40 years.

If you are interested in any of the above opportunities please write to:—

Employment Manager,
Wellworthy Limited,
LYMINGTON, Hampshire.

W 5757

AGENCIES

SWISS COMPANY

seeks agent or agents to introduce their hard-metal precision tools to the British market. Technical knowledge of precision engineering is required.

Reply to:

DIRECTION D'UNIVERSO S.A.

Avenue Léopold-Robert 82, 2300 La Chaux-de-Fonds (Suisse).

W 8754

BOX NUMBER REPLIES SHOULD BE ADDRESSED AS FOLLOWS:

BOX NO.....,

ELECTRONIC ENGINEERING

28 ESSEX STREET, STRAND,
LONDON, W.C.2

BUSINESS OPPORTUNITIES

SITTINGBOURNE, KENT.—Light Industrial Building—Owners will let up to 9,000 sq. ft. to small and expansion-minded concern in the Assembly & Repair business at a nominal rental. They will consider giving financial assistance in respect of the purchase of additional trade plant and equipment. Apply Box No. W 8747 c/o ELECTRONIC ENGINEERING.

PATENTS

THE PROPRIETORS of British Patent No. 818413 for "Improvements in and relating to the Construction of Leading-in Connections for Glow Discharge Vessels" desire to enter into negotiations with a firm or firms for the sale of the patent, or for the grant of licences thereunder. Further particulars may be obtained from Marks & Clerk, 57/58 Lincoln's Inn Fields, London, W.C.2. W 8750

CAPACITY AVAILABLE

FAST SERVICE FROM ELECTRICOLE, "THE ELECTRONICS FACTORY". PROTOTYPE AND PRODUCTION WIRING, ASSEMBLY, AND COIL WINDING. AMPLE FACILITIES FOR QUANTITY PRODUCTION. 2-14 SHORTLANDS, HAMMERSMITH, W.6. TEL: 01-748-9924. W 379

PORTLAND ELECTRONICS LIMITED, sub-contractors to the Ministry, Electronic, and Telecommunication Industry have facilities available for prototype and production wiring. We also offer design facilities, test and inspection function to A.I.D./E.I.D./M.O.A. standards and complete test functions. For your immediate requirements telephone 061 338 3768. **PORTLAND ELECTRONICS LIMITED DESIGNERS AND MANUFACTURERS OF SCIENTIFIC INSTRUMENTS, STALYBRIDGE, CHESHIRE.** W 5769

B.P.A. ELECTRONICS can undertake immediately, short or long-term contracts for: Electronic and Electro-Mechanical assembly and wiring, Coil winding (including toroidal), cable forming, vacuum impregnation and encapsulation, printed circuit board manufacture including layout and preparation of artwork. Inspection to A.I.D. or A.R.B. if required. **BOULTON PAUL AIRCRAFT LIMITED, WOLVERHAMPTON.** Tel: Fordhouses 3191. W 5770

SERVICE

PRINTED CIRCUITS

from your circuit diagrams
Prototypes supplied in 24 hours
also

**P. C. Board Wiring
Coil Winding
Transformer
Winding**

to your requirements

A. & E. Instrumentation Ltd.
13 High Street,
Harefield, Middlesex.
Telephone: Harefield 2356
Telex: 263914 Autocontrol Ldn

W380

OUTSTANDING OPPORTUNITIES FOR ABOVE AVERAGE DESIGN & DEVELOPMENT ENGINEERS

To Earn Not Less Than £2,500 p.a.

Qualified Engineers are urgently required to work in the Home Counties and Provinces, with experience in one or more of the following fields:

- (1) ANALOGUE AND DIGITAL EQUIPMENTS
- (2) MICROWAVE AND COMMUNICATIONS
- (3) RADAR AND NAVIGATIONAL AIDS
- (4) INSTRUMENTATION

This is a first class opportunity to work on exciting projects at exceptional salary levels.

STRAND TECHNICAL CONTRACTORS LTD.

Norman House, 105-109 Strand, W.C.2. 01-836 5557 Please quote: EE/1 W 8748

A CAREER IN SELLING with SOLARTRON

Measure yourself for a Sales Engineering position with one of the world's foremost electronic instrumentation companies.

THE QUALITIES WE NEED

Mark yourself out of 10

- 1. A strong desire to sell
- 2. An engaging personality
- 3. Enthusiasm
- 4. Age 25-35 years
- 5. B.Sc., Grad.I.E.E., I.E.R.E., H.N.C., or equivalent
- 6. Broad practical engineering experience
- 7. Interest in measurement
- 8. Ambition
- 9. Clean driving licence
- 10. Resident Hants or Dorset area

TOTAL

How did you make out? A score of 85 or over and you could be on the way to a top sales executives chair. No previous selling experience? Don't worry, our training sees to all that.

Applications to:

**Dr. M. Race, Personnel Manager,
The Solartron Electronic
Group Ltd.,
Farnborough, Hants.**

W 5765

BOROUGH POLYTECHNIC

Borough Road, London, S.E.1.

The Borough Polytechnic, situated in Southwark, has been nominated as one of the colleges in London that will be designated a "Polytechnic" under the terms of the 1966 White Paper. Large building extensions, now well advanced, will completely rehouse the Department of Electrical and Electronic Engineering.

Applications are invited for the following posts:—

A PRINCIPAL LECTURER and A SENIOR LECTURER in ELECTRONIC ENGINEERING

Applicants should hold a good honours degree in Electrical Engineering or in Physics and should be corporate members of an appropriate professional institution. They should have had relevant industrial or research experience and preferably teaching experience.

Whilst applications will be considered from candidates specialising in any branch of electronic engineering, it is particularly hoped to make one appointment in **Radio Communications** (Ref E.11) and the other in **Digital Systems** (Ref E.12).

Candidates with superior qualifications and experience will be considered for the **Principal Lectureship**, which is a post of considerable responsibility, both academically and administratively.

Present Salary Scales (currently under review) are:—

Principal Lecturer: £2,450 p.a. to £2,670 p.a.

Senior Lecturer: £2,210 p.a. to £2,450 p.a.

It is hoped that the persons appointed to these posts will engage in research work, for which opportunities and facilities can be made available.

Further particulars and application forms may be obtained from the Clerk to the Governing Body, with whom applications should be lodged before 31st December, 1967.

W 5766

TECHNICAL AUTHORS

For the steadily expanding Ekco Aviation Division

The work involves the preparation of overhaul and maintenance manuals, to various civil and military specifications, on a number of interesting projects, including the most advanced airborne weather radar in the world.

The essential qualifications are a sound knowledge of electronic fundamentals, and the ability to think logically and write accurately. Preference will be given to applicants familiar with current work in solid-state radar or some closely related field.

High standards are expected; high salaries and secure employment under excellent conditions are offered in return. The Company's premises are situated in very pleasant surroundings in a seaside area.

Write or 'phone for appointment:

**Personnel Manager, Ekco Electronics Ltd.,
Southend-on-Sea, Essex**

Southend 49491

W 8749

It's no problem

to get suitably qualified technical
men through the pages of

Electronic Engineering

the technical journal

read by qualified men such as yourself

Contact : Classified Department
ELECTRONIC ENGINEERING
28 Essex Street, Strand, London, W.C.2
or 01-353 6565

Printed Wiring Connectors Series 635 & 864

DELIVERIES FROM STOCK

SERIES 635

- Low cost with high reliability
- Terminations for soldering or wire wrap
- Can be cut to size—up to 35 contact positions single or double sided
- 0.2 contact centres for $\frac{1}{16}$ " board mating
- Various styles of fixing feet when used in racking system

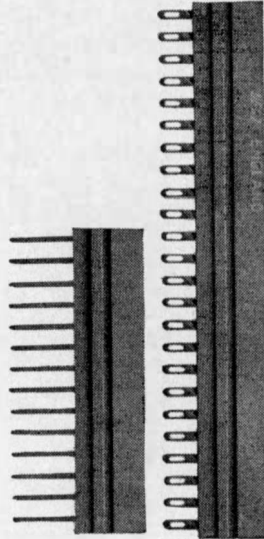

SERIES 864

- 0.200" contact pitch wire wrap connector
- "Bellows" form contacts gold flash or heavy gold plated
- Contact/termination assemblies can be easily removed and replaced
- 8, 16, 24, and 32 contact positions single or double sided standard, other sizes supplied on special request

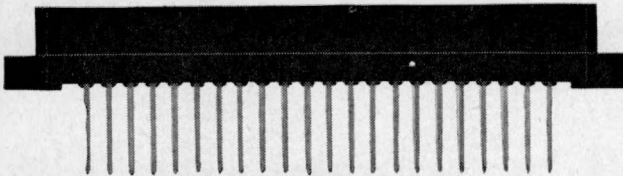

UECL Component information No. 5

UECL offer unbeatable value in component service and reliability. UECL precision built connectors are designed and manufactured to satisfy *your* requirements.

Write for the new, short handy-reference catalogue (fully illustrated) — gladly sent on request. Please quote EE40A. **A New Reader?**—then ask for the complete catalogue which gives full details of the entire range of UECL precision components.

419 Bridport Road, Greenford,
Middlesex, England.
Tel: WAXlow 5721-7
Grams: Connector
Greenford Telex: 263136



Ultra Electronics (Components) Limited

YOU WANT PARTS URGENTLY

—almost immediately!

So what do you do?

You reach for the 'phone and dial ONO 239 8072, if it is anything made by the United-Carr Group. You will be surprised how soon you'll get what you want.

Your immediate needs are our business

We exist to supply the small user quickly with *standard* parts made by these Companies and carry large stocks of their fasteners and clips and a wide range of Radio, Electronic and Electrical components. We're geared to speedy handling and dispatch.

But you will need our latest catalogue

For quick and accurate ordering you should keep our comprehensive catalogue by you. This useful reference book gives full details of the wide range of parts we stock—nearly everything of the kind you are likely to require.

Even though not ordering anything immediately, you should write now for this useful publication and so be ready to handle rush jobs whenever they arise.

United-Carr Supplies Ltd., Frederick Road, Stapleford, Notts.,
Sandlacre 8072 STD ONO 239 8072



WIDE-BAND TRANSFORMERS AND BALUNS FOR COMMUNICATIONS ANTENNA MATCHING

**SPECIALISTS IN r.f. TRANSFORMER
DESIGN FROM 5 W TO 10 KW**

HYBRID TRANSFORMERS
PASSIVE MULTI-COUPPLERS
PULSE TRANSFORMERS
NOTCH FILTERS
CROSS-OVER FILTERS

R. H. MINNS BALUNS LTD.

LOWER MILL,
KINGSTON ROAD,
EWELL, SURREY

01-394 0499

INDEX TO ADVERTISERS

A

A.E.I. (Manchester) Ltd.	59
A.I.M. Electronics Ltd.	76
Adcola Products Ltd.	10
Advance Electronics Ltd.	41
Airmec Ltd.	63
Allied Electronics Ltd.	96
Alma Components Ltd.	3
Associated Lead Manufacturers Ltd.	71

B

B. & R. Relays Ltd.	39
Belling & Lee Ltd.	Cover iii
Boll, Oswald E., Ltd.	78
Bradley, G. & E. Ltd.	16
Britec Ltd.	58
British Electric Resistance Co.	81
Brookes Crystals (1961) Ltd.	78
Broxlea Ltd.	80
Bryans Ltd.	15
Bullers Ltd.	45

C

Cadmium Nickel Batteries Ltd.	62
Cambion Electronic Products Ltd.	76
Cannon Electric (G.B.) Ltd.	23, 34
Carter Gears Ltd.	95
Cathodeon Crystals Ltd.	32
China National Instruments Import & Export Corp.	14
Colvern Ltd.	84
Counting Instruments Ltd.	76, 77
Count Electronics Ltd.	42, 43
Cressall Manufacturing Co. Ltd.	74
Critchley Brothers Ltd.	54

D

Dawe Instruments Ltd.	9
Dow Chemical Co. (U.K.) Ltd.	8
Du Pont De Nemours International S.A.	2
Dymar Electronics Ltd.	34

E

E.M.I. Sound Products Ltd.	86
Ecko Electronics Ltd.	66
Enalon Plastics Ltd.	58
English Electric Co. Ltd.	25
English Electric Valve Co. Ltd.	73
Evans, Frederick W., Ltd.	46

F

Fairchild Instrumentation Ltd.	87
Farnell Instruments Ltd.	Cover ii
Fieldtech Ltd.	58

G

G.K.N. Screws & Fasteners Ltd.	29
Gas Council	4, 5
General Test Instruments Ltd.	Cover iv
Gilby-Brunton Ltd.	14

H

Hall & Kay Ltd.	6
Hatfield Instruments Ltd.	14
Hewlett Packard SA Geneva	24, 67
Hirst Electric Industries Ltd.	66
Honeywell Controls Ltd.	56

I

I.E.A. Year Book & Buyers Guide	89
---	----

J

J. & P. Engineering (Reading) Ltd.	72
--	----

K

K.G.M. Electronics Ltd.	46
K.S.M. Electronics Ltd.	2
Kerry's (Ultrasonics) Ltd.	77
Kynmore Engineering Co. Ltd.	Cover i

L

Levell Electronics Ltd.	33
Lionmount & Co. Ltd.	78

STEPLESSLY VARIABLE OVER A 27/1 SPEED RANGE ON FULL LOAD



Reliable, positive hydraulic
variable speed transmissions
from $\frac{1}{2}$ H.P. up to 40 H.P.

Write for further details, quoting reference: 1667

CARTER GEARS LIMITED.

makers of Hydraulic Infinitely Variable Speed Gears.
BRADFORD 3, YORKSHIRE, ENGLAND.

For more information circle No. 130

INDEX TO ADVERTISERS (continued from previous page)

M

Marconi Co. Ltd.	40, 75
Marconi Instruments Ltd.	60
Meguro Electronic Instruments Co. Ltd.	82
McMurdo Instrument Co. Ltd.	36
Micropont Development Ltd.	61
Miniature Electronic Components Ltd.	88
Minns Baluns, R. H., Ltd.	94
Montford Instruments Ltd.	46
Morganite Resistors Ltd.	22
Mori Physics & Chemical Laboratory Co. Ltd.	34
Mullard Ltd.	17, 53

N

Newmarket Transistors Ltd.	35
Nutec Electronics Ltd.	64

O

Oxley Developments Co. Ltd.	74
-------------------------------------	----

P

Painton & Co. Ltd.	11
Penny & Giles Ltd.	54
Portescap S.A.	88
Potter & Brumfield	84

Q

Quarndon Electronics Ltd.	30
Quartz Crystal Co. Ltd.	58

R

Racal Instruments Ltd.	28
Radio Corporation of America	68
Radio Resistor Co. Ltd.	57
Radiometer A/S	79
Radiospares Ltd.	31
Rastra Electronics Ltd.	46, 86
Rivlin Instruments Ltd.	7
Roband Electronics Ltd.	12, 13, 48, 49
Rollett, H., & Co. Ltd.	50
Royal Netherlands Aircraft Factories Fokker	83

S

S.C.E.E. Ltd.	86
S.D.S.A. Salon International des Composants Electroniques	26
S.G.S. Fairchild Ltd.	20, 21
Salford Electrical Instruments Ltd.	26, 82
Servo Consultants Ltd.	10
Shirehall Electronics Ltd.	71
Sifam Electrical Instruments Co. Ltd.	27
Sorensen-Ard A.G.	51
Standard Telephones & Cables Ltd.	18
System Computers Ltd.	37

T

Tektronix U.K. Ltd.	52
Tequipment Ltd.	19
Terry, Herbert, & Sons Ltd.	55
Thorn-A.E.I. Radio Valves & Tubes Ltd.	47, 70
Turner, Ernest, Electrical Instruments Ltd.	85

U

Ultra Electronics (Components) Ltd.	94
United-Carr Supplies Ltd.	94

V

Vitality Bulbs Ltd.	78
Vitreous Carbons Ltd.	30
Vneshtorgreklama (USSR)	38, 81
Vosper Thornycroft Group (Vosper Electric)	44

W

Weir Electronics Ltd.	69
Welwyn Electric Ltd.	38
Whiteley Electrical Radio Co. Ltd.	50

Z

Zenith Electric Co. Ltd.	65
----------------------------------	----

MEGOHM METER



Type 2565
For MAXIMUM reliability

The modern method of measuring insulation in workshop, laboratory and on location.

- No skill required: Just press keys and read Megohms.
- Widely used in schools, factories, Laboratories, Colleges, Government Establishments.
- Standard Model reads 20M to 50,000M @ 250-1000 volts; Lower and Higher Resistance & Voltage Ranges to Order.
- Mains Operated: Stabilised Voltage: Will read insulation Resistance of Capacitors.
- Proven Circuitry. Gives years of trouble-free Service.
- Easily Portable. Weight 14½lb. Dimensions 12½x8½x9 inches. Steel Case.
- Alternatively available in Polished Teak Case with Lid and Carrying Handle.

Write or phone for full details to

ALLIED ELECTRONICS LTD Telephone 01-874 1856

28 UPPER RICHMOND ROAD, LONDON, S.W.15

For more information circle No. 131

Electronic Engineering

INDEX TO VOLUME 39, 1967

MORGAN-GRAMPIAN LIMITED
28 ESSEX STREET · STRAND · LONDON · W.C.2.

INDEX

JANUARY TO DECEMBER 1967

	Page		Page
A			
Aerials, the design and adjustment of m.f. broadcasting, by P. Knight	6	Digest of literature on dielectrics, Vol. 29	331
Amplifier, A 50 to 500MHz broadband transistor, by A. E. Hilling	352	Directory of electronic circuits	119
Amplifiers, analysis of feedback, by G. J. Pridham	436	Economic computation and economic cybernetics studies and research	265
Amplifiers combining bipolar and field-effect transistors, by W. Gosling	478	Eddy currents	331
Amplifiers, design of low level d.c. chopper, by S. K. Bhola and R. H. Murphy	318	Einführung in die Anwendung kontaktloser Schaltelemente (introduction to the applications of contactless switching elements)	520
Amplifier design, v.h.f. solid-state power, by T. Spencer	72	Einführung in die Schaltalgebra (introduction to switching algebra)	785
Amplifier (s.d.a.) for nuclear reactors, new shutdown, by I. G. Morris (Part 1)	485	Einfluss von Hochfrequenzüberlagerungen bei Stosspannungen auf das Durchschlagverhalten von Luft unter Atmosphärendruck bei verschiedenen Elektrodenanordnungen	718
(Part 2)	553	Electric power systems	787
Analogue multiplier, a simple high speed, by J. P. Wilson	11	Electrical and electronic trader's year book 1967	331
Analysier for use in human electromyography, an, by P. Fitch	240	Electrical conduction mechanisms in thin insulating films	189
Antenna, backfire meander-line, by S. C. Loh and J. Jacobsen	575	Electrical noise	786
Antenna, X-band omnidirectional double-slot-array, by T. Takeshima	617	Electrical properties and applications of thin films	717
Array of slots on the surface of a cylinder, directivity of, by J. Ricardi	578	Electromagnetic shock waves	188
Automation for the Tyne tunnel	309	Electron dynamics of diode regions	784
Averager, electromechanical running, by K. C. Ng and K. K. Murthy	169	Electronic automatic control devices	329
Averaging of heart-rate responses in rats following electrical brain stimulation, by W. J. Mundle	686	Electronic circuit analysis: volume 2—active networks	461
Aviation, electronics in	322	Electronic communications	395
		Electronic computers made simple	395
		Electronic counting: circuits, techniques devices	787
		Electronic digital systems	48
		Electronic engineering	118
		Electronic inverters	395
		Electronic laboratory instrument practice	331
		Electronics and nucleonics dictionary	119
		Electronic sensing devices	265
		Electronics from theory into practice	331
		Electronic testing	520
		Electronic weighing and process control	518
		Elementary electronics	651
		Elements of energy conversion	652
		Engineering electronics	520
		Engineering science at the university	189
		Fluctuations of stationary and non-stationary electron currents	785
		Focusing of charged particles, Vol. 1	119
		Fourth state of matter	518
		Fundamental electronics	331
		Fundamentals of digital machine computing	651
		Fundamentals of electronics	786
		Fundamentals of silicon-integrated-device technology, Vol. 1	719
		Gas-lasers	395
		Generalized electric machines	719
		Handbook of basic transistor circuits and measurements	719
		Handbook of electronic instruments and measurement techniques	719
		High-frequency communication	331
		History of the house of Siemens, Vol. I and II, 1914-45	265
		Impedanzuntersuchungen an dielektrischen Flachantennen (study of the impedance of dielectric plane aerials)	520
		Instruments, electronics, automation year book and buyers' guide	395
		Integrated circuits	265
		Introducere In Cibernetica Sistemelor Discrete (introduction to discrete systems cybernetics)	787
		Introduction to computational linguistics	519
		Introduction to cybernetics	265
		Introduction to dynamic programming	785
		Introduction to network analysis	119
		Introduction to vector analysis for radio and electronic engineers	189
		Ionization avalanches and breakdown	119
		Laplace transforms for electronic engineers	650
		Laplace transform theory and electrical transients	650
		Laser light	264
		Laser receivers	650
		Lasers	461
		Les machines electriques en automatique appliquee	652
		Linear sequential circuits: analysis, synthesis and applications	787
		List processing	331
		Lithium-drifted germanium detectors—proceedings of panel, Vienna, 6-10 June 1966	49
		Longitudinal space-charge waves	718
		Low-noise electronics	520
		Machine translation	395
		Magnetism and magnetic materials 1966 digest	518
		Magnetism in solids	787
		Mathematical techniques in electronics and engineering analysis	331
		Mathematics for radio and electronics technicians	49
		Measuring methods and devices in electronics	331
		Membranes—technology and economics	650
		Microelectronics	330
		Microwave breakdown in gases	330
		Microwave valves	520
		Modelle und Ersatzschaltungen von Halbleiterdioden (models and equivalent circuits of semiconductor diodes)	331
			520
B			
Binary-coded-decimal circuit with gated feedback, an asynchronous, by S. L. Hurst	25		
Bus services with computer checking of time-tables, planning a v.h.f., f.m. radio system for, by T. K. Tawfiq	224		
BOOK REVIEWS	48, 118, 188, 264, 330, 394, 460, 518, 650, 717, 784		
Advanced electronic techniques: proceedings of the second Oxford electronics lecture course	520		
Advances in microwaves, volume 1	519		
Volume 2	717		
American microelectronics data	119		
Analysis and synthesis of tunnel diode circuits	330		
Analysis of discrete physical systems	394		
Antenna theory and design, volume II, second edition	460		
Anthology of Philips research 1891-1966	265		
Automatic control systems explained	189		
Automation and instrumentation	395		
Basic automatic control theory	264		
Basic electrical engineering: circuits, electronics, machines, control	719		
Basic electricity for electronic engineers	395		
Basic mathematics for electronics	395		
Basic television: part 1	719		
Basic theory of waveguide junctions and introductory microwave network analysis	784		
BBC handbook, 1967	265		
Beitrage zur Analyse des dynamischen Verhaltens von Regelkreisen (papers relating to the analysis of the dynamic behaviour of control circuits)	331		
Challenge of the computer utility	189		
Circuit design for audio	717		
Communication system engineering handbook	719		
Comparative study of programming languages	49		
Computer programming for science and engineering	49		
Design and construction of electronic equipment	265		
Dictionary of electronics	330		
Dictionary of electro-technology, German-English	330		
Differential and difference equations	394		

	Page
Music, physics and engineering	718
Nachrichtentechnik—eine einführende Darstellung	461
Nachrichtenübertragung	460
Negative absolute temperatures	119
Optical properties of solids	331
Partial differential equations	331
Particle accelerators	395
Phase-lock techniques	119
Phasor diagrams	49
Physical fields	265
Physical laboratory handbook	49
Physical principles of magnetism	49
Physics of modern electronics	784
Plastic insulating materials	119
Principles of linear circuits	118
Proceedings of IFIP congress, 1965, New York City, May 24-29, Vol. 2	331
Programmierung von Datenverarbeitungsanlagen (programming of data information)	395
Progress in nuclear energy series: IX—analytical chemistry, volume 7	49
Publications of the National Bureau of Standards	719
Radio amateur's handbook	520
Radio and electronics components: vol. 1—fixed resistors	520
Radio relay systems	119
RCA receiving tube manual	331
Regulations for the electrical equipment of buildings	49
Reports on progress in physics, parts I and II	331
Safety for industry	787
Safety with cryogenic fluids	787
Semiconductor circuits: worked examples	265
Semiconductor devices	189
Semiconductor junction devices	785
Sequential-circuit synthesis: state assignment aspects	118
Short wave listening	49
Signale und Systeme (signals and systems)	394
Silicon and germanium power rectifier technology	49
Simple approach to electronic computers	331
Solutions d'exercices du cours élémentaire de mathématiques supérieures, tomes I à III de J. Quinet	787
Statistical communication and detection	786
Strahlungskopplung von Wendelantennen (radiation coupling of helical aerials)	265
System analysis by digital computer	188
Technical drawing	520
Techniques of pulse-code modulation in communication networks	652
Tehnika Frequentelor Foarte Inalte (v.h.f. techniques)	265
Telefonie La Mare Distanta (Long Distance Telephony)	265
Teleurope	119
Théorie et pratique des circuits à transistors	48
Theory and application of active devices	329
Theory of waveguides and cavities	784
Transduktorschaltungen (transductor circuits)	189
Transformers for electronic circuits	460
Transistor circuit, design and analysis	118
Transistor physics	264
Transistors for audiofrequency	520
Transistor specification and substitution handbook	265
Ultrasonic machining of intractable materials	265
Untersuchungen an dielektrischen Stielstrahlern über den Einfluss der Strahlungskopplung auf deren Fusspunktsimpedanz (the influence of the radiation coupling on the base impedance of dielectric rod radiators)	329
Untersuchungen über ebene Beugungsprobleme elektromagnetischer Wellen für rechtwinkligkeilförmige Gebiete (plane diffraction problems of electromagnetic waves in right-angled, wedge-shaped areas)	329
Wireless World diary 1968	787
Worked examples in modern physics, vol. I and II	520
Zur Frage der Verhütung von Kollisionen in der Binnenschifffahrt (aspects of collision prevention on inland waterways)	265

C

Cable for Cape Town-Lisbon submarine link, first	783
Calculus, open-limit, by C. G. Mayo and J. W. Head	696
Checking equipment for aircraft, automatic	243
Circuit synthesis, approach to applied, by R. H. Dadd	668
Circuits incorporating new coupling-loop configurations, all magnetic, by D. J. Morris	412
COMMENTARIES .. 1, 71, 141, 211, 279, 345, 411, 535, 599, 667,	477
Compensating networks, a note on a.c., by D. R. Wilson	316
Cone of confusion, simulation of, by S. Dalal	78
Control for overhead travelling crane, radio	418
Conversion, example of digital-to-analogue, by W. Olthoff	763
Conversion, voltage-to-frequency, by B. D. Rakovich and S. Tesic	766
Converter, accurate current-to-frequency, by J. Korytkowski	568
Convertor, accurate triangle-sine, by G. Klein and H. Hagenbeuk	700
Convertor for low frequencies, accurate a.c.-d.c., by R. W. Gellie and A. G. Klein	484
Convertors using linear ramps, time-amplitude and amplitude-time, by C. Riddle—Part 1	600
Part 2	711
Counter, a rapidly reversible 700kHz digital decade, by J. F. Brandwijk and P. H. Sydenham	298
Counter, train decade, by R. P. Ingram	759
Counter, transistorized 100MHz binary, by R. J. Hood	642
Current-driven source-follower, the parameters of the, by P. F. Ridler	290
Current-measuring transistor circuits, logarithmic, by K. Sæ Højberg	20

D

Data logger scaler and alarm limit comparator, a, by R. J. S. Ruckman	177
Data service, an automation instrument	249
DATA SHEETS AND CATALOGUES	532, 662, 729
Decade boxes with binary output, by D. P. Franklin	152
Dekatron selectors with low-cost transistors, coupling, by J. F. Young	323
Delay lines, precision temperature-controlled environments for ultrasonic fused-quartz, by D. Howorth, C. R. Caine and L. T. E. Ward	706
Delay unit suitable for television-field delay, by D. Howorth and J. G. Ingleton	734
Detector for power measurements, a square-law, by J. F. Golding	82
Digital-analogue convertor with reciprocal read-out, a simple, by L. Davison and R. Wilson	381
Digital coding equipment for recording field strength measurements, by D. G. Beadle and D. E. Susans	233
Domain originated functional integrated circuits	183
Drive circuits for a piezo-electrically driven mechanical vibrator, two terminal, by T. J. Stevenson	222

E

Electroluminescent panels for display of complex systems	435
Electrometer circuit, a junction transistor, by T. K. Cowell	362
Electronic sketch-pad	545
Esaki diode pair, comparator-hold circuit using the facing-coupled, by Y. Murata	356
Eurocontrol experimental centre, the	166
Extraction of signals from noise using digital techniques, by A. B. E. Ellis	546
ELECTRONIC EQUIPMENT	50, 120, 190, 266, 332, 396, 465, 524, 589, 656, 723, 790
Accelerometer	592, 659
Adders, integrated circuit	399
Amplifier, buffer	190
Amplifier, carrier frequency	338
Amplifier, chopper	792
Amplifier, chopper-stabilized operational	795
Amplifier, d.c.-coupled wideband power	658
Amplifier, differential operational	474
Amplifier, f.e.t.-input operational	727
Amplifier, integrated medium-power	659
Amplifier, integrated-circuit operational	794
Amplifier, low-drift high-speed operational	660
Amplifier, low-noise	793
Amplifier, operational	468
Amplifier, oscilloscope differential	194
Amplifier, plug-in differential	531
Amplifier, servo	270
Amplifiers, solid-state charge	726
Amplifier, transistorized charge	473
Amplifier, unity-gain	529
Analysers, high-frequency wave	465
Analysers, inductor	400
Analysers, servo	269
Attenuator, u.h.f. switched	333
Automatic gauging equipment	335
Balun transformer	794
Boards, circuit-development	656
Bridge and amplifier, d.c.	123
Bridge, automatic	473
Bridge, radio-frequency	659
Bridge supply and indicator, d.c.	402
Bridge units, single-phase full-wave	797
Cables, television-relay	528
Calibrator, portable v.h.f./u.h.f.	790
Camera, closed circuit television	470
Camera, new	524
Camera-viewfinder tube	655
Capacitance box	333
Capacitance boxes, decade	659
Capacitor box, binary	268
Capacitors, etched tantalum foil	729
Capacitors for printed-circuit boards	658
Capacitors, glass-dielectric trimmer	782
Capacitors, lead-through	782
Capacitors, miniature monolithic ceramic	724
Capacitor, miniature p.t.f.e. tubular	724
Capacitors, paper/polyester	55
Capacitors, polycarbonate	31
Capacitors, polyester-film	724
Capacitors, quartz trimmer	402
Capacitors, variable	336
Cathode-ray tubes, instrument	590
Clock, digital	193
Comparator, visual inspection	470
Computer, general purpose	334
Connector, mark 4 crimp	473
Connectors, board-to-board	726
Connectors, printed circuit edge	334, 656, 791
Controller, analogue	593
Controls, modular plug-in	402
Control system, logic	472
Converters, analogue/digital and digital/analogue	466
Converters, static	591
Cooling unit	194
Co-ordinate marking-out tables	401
Copper, gold inlaid beryllium	726
Counter, batch	266, 337
Counter, high speed t.t.l. decade	791
Counter, pre-set	269
Counter, 12.5MHz	400
Counters, digital	123, 336
Counter converters	727

	Page		Page
Counting units, integrated circuit	794	Oscilloscope, solid state	50
C.R.T. for multiple displays, small	472	Oscilloscope system, digital	526
Crystal units, glass	267	Oscilloscope tube, short	468
Data acquisition system	401	Oscilloscopes, 12.4GHz sampling	467
Datalink equipment	339	Pencil-follower ancillary equipment	53
Delay line	54	Phase analyser, digital	795
Delay line, broadband variable	468	Photocells, resistive	595
Delay line modules	338	Photosensitive semiconductors	661
Delay lines, multiple tapped	530	Plug and socket, multi-pole	53
Delay line, wire	728	Plugs and terminals, screwless	268
Detector, leak	339	Potentiometers	194
Detector, null	398, 655	Potentiometer, d.c.	267
Detector, vehicle	332	Potentiometer, miniature	50, 190, 471, 528
Digital d.c. voltmeter	51	Potentiometer, moulded-track	527
Diode assemblies, multiple	195	Potentiometer, preset	594
Diodes, electroluminescent	396	Potentiometers, plastic-film elements for precision	727
Diodes, encapsulated silicon	466	Potentiometer slave unit	120
Diode, high-power silicon	592	Potentiometers, subminiature	52, 472
Diodes, v.h.f. tuner	469	Potentiometers, trimmer	400, 403
Diodes, zener	724	Potentiometer, wirewound	191, 339
Discriminator, differential	467	Power modules, compact i/c	529
Display, microminiature in-line digital	472	Powermeter, plug-in r.f.	727
Distortion meter, peak-reading	465	Power packs	591
E.H.T., compact packaged	655	Power supplies	193, 397, 525, 660
E.H.T. supply	194	Power supplies, encapsulated stabilized	593
Electro-encephalograph, portable	466	Power supplies and voltage references, modular	526
Electronic-circuit kits	528	Power supplies, high-current d.c. stabilized	468
Encapsulant, silicone	531	Power supplies, high-voltage	792
Encoder, digital	396	Power supplies, stabilized	269, 338
Encoders, binary coded decimal	398	Power supply, compact h.v.	529
Environmental test chamber	466	Power supply, d.c.	337
F.E.T., n-channel	660	Power supply, dual	121
F.E.T. operational amplifier	591	Power supply, integrated-circuit	794
F.E.T. test set	121	Power supply, isolated	332
Filter, Coaxial bandpass	725	Power supply units	471, 796
Filter, module, tunable	531	Power unit, miniature	266
Filters, mechanical	191, 792	Pre-amplifier, high resolution	190
Flipflop toggles at 120MHz	796	Preselector, tracking	591
Flowmeters, blood	334	Probe, high-voltage	525
Frequency comparator	659	Programming boards	122
Frequency divider, microwave	271	Pump, gradient	398
Frequency doubler/phase shifter	725	Pumps, molecular sieve sorption	52
Frequency standard	530	Ratiometer	402
Fuse, thermal	532	Receiver, broadcast	724
Galvanometer-amplifier system	795	Recorder, automatic dewpoint	123
Galvanometer amplifier, 7-channel	594	Recorder, miniature potentiometric	524
Galvanometer, input-attenuator module	473	Recorder, multi-channel	122
Gauge, Pirani-Penning	337	Recorders, multi-point	121
Gauge, vacuum	195	Recorder, ultra-violet	399
Generators, function	729	Recording belts, magnetic	592
Generator, microwave signal	53	Rectifiers, miniature h.v. silicon	656
Generator, noise	792	Rectifiers, power	725
Generator, PAL pattern	266	Rectifiers, silicon	723
Generator, pulse	338	Regulator module, plug-in series	529
Generator, sub-standard frequency	267	Relay, fixed- or adjustable-time-delay	661
Generator, telegraph-signal	793	Relay, heavy duty	192
Glow lamps, subminiature	790	Relay, miniature	269, 273, 401, 526
HV-supply units	656	Relays, reed	399
Indicators, electroluminescent numerical	339	Relay, solid-state	526
Indicator, magnetic bearing	51	Relay, twin-contact general purpose	793
Indicator, miniature neon	594	Reperforator, printing	271
Indicator, transistorized	396	Resin adhesive/sealant, epoxy	661
Inductance bridge, transistorized	590	Resistance box	272
Infra-red source diodes	592	Resistance bridge	530
Instrumentation modules	528	Resistance standards, calibration	661
Inverter	333	Resistance wire, high-stability	795
Instruments, true r.m.s.	123	Resistor modules, miniature	338
Klystrons, m-band reflex	530	Resistors, carbon-film	193
Lamp, miniature indicator	273	Resistors, microminiature	54, 474
Laser equipment	54	Resistors, positive temperature coefficient	193
Lasers, gas	527	Resistors, precision variable	125
Lasers, r.f. excited gas	272	Resistor unit, switched	524
Limiters, high power v.h.f.	398	Scaler, reversible	470
Logic modules, plug-in	590	Scales, decimal digital	192
Magnetron, Ku-band pulse	728	Servopotentiometer, precision	724
Magnetron for linear accelerations	469	Shielding boxes, r.f.	52
Matrix board for computer memory	473	Signal-converter series	657
Meter, microwave peak-power	727	Single-trace unit for increased sensitivity	590
Meter, microwave	594	Sound-level calibrator	595
Meter unit	595	Sound-level meter	657
Microcircuit compositions, thick-film	191	Source, d.c. millivolt	468
Microphones, high intensity	659	Source/detector, r.f.	55
Microswitch, thin	589	Strain bridge, direct reading	121
Microvoltmeter for signals in noise	661	Strain gauge power supply and bridge balance unit	272
Microvoltage, miniaturized equipment	336	Strippers, thermal wire	530
Millivoltmeter, v.h.f.	728	Suppressors, solid-state transient	658
Mixers, double-balanced	474	Switch, microwave	124, 334
Mixer, X-band	725	Switch, multi-port coaxial	335
Modular control package	595	Switch, subminiature coaxial	471
Modulator, solid-state	790	Switch, subminiature sealed press	596
Modules, thermo-electric generator	471	Switches and relay units, magnetic reed	590
Monitors, transistorized CCTV	55	Switches, dry reed push-button and key	122
Monitor, film resistance	123	Switches, rotary water	191
Monitors, current	400	Switching modules, static	270
Motor, microminiature	54	Switching units, static	51
Motor, miniature synchronous	55	Synthesizer, u.h.f. variable-frequency	465
Motor protection units	337	Tabulator key	591
Multi-meter	596	Tachogenerator, motor	793
Multimeter, digital	474	Tachometer, digital	266, 473
Multiplier, analogue	527	Tape, heads, instrumentation	272
Multiplier, d.c.	529	Tape shuttle unit	190
Multivibrator, monolithic	331	Tape testing equipment	120
Network-analyser system	333	Tape winder, paper	271
Noise measuring equipment, microwave	403	Telemetering system	793
Numerical indicator tubes	532	Teletypewriter, electronic	728
Oscillator control, microwave sweep	124	Television measuring instruments	728
Oscillator, Gunn effect	401	Temperature-test chamber	595
Oscillator, micro	469	Temperature transducer, subminiature	525
Oscillator, miniature h.f.	335	Tester, f.e.t.	332
Oscillators, miniature stabilized	593	Test machine, new mark II multicore solderability	471
Oscillator, swept	727	Test set, semiconductor	657
Oscillator, temperature-compensated crystal	335	Test system, semiconductor go/no-go	469
Oscillator, test	525	Tetrodes, power	526
Oscillator, transistor	401	Tetrode, u.h.f.	472
Oscillator, transistor decade	791	Thermoelectric modules	397
Oscillator and millivoltmeter, combined transistorized	790	Thermocouple potentiometer	594
Oscillators, backward-wave	268	Thermometer, electronic	660
Oscillograph, recording	528	Trace reader	53
Oscilloscope, sampling			

	Page
Tracer, programmable semiconductor curve	470
Transceiver, transistorized vehicle	527
Transducers, absolute pressure	191
Transducer, capacitive movement	592
Transducer, proximity vibration	50
Transducer, torque	54
Transformers, micro-miniature	400
Transformers, ring current	336
Transistor holder, press-fit	267
Transistor lead preforming tool	268
Transistor, plastic-overlay	723
Transistor, silicon integrated chopper	474
Transmission test equipment	726
Transmitter receiver, s.s.b.	120
Transvertors	399
Trimmers, miniature	723
Tube, high-contrast storage	531
Tubes, image Isocon	791
Tuning unit, microwave	589
T.W.T. supply, low power	466
Ultrasonic hardness tester	124
Varactor, step-recovery	723
Variable-capacitor boxes	726
Vibration monitoring system	192
Voltmeter, a.f. milli-	795
Voltmeter, differential	125, 589, 658
Voltmeter, digital	122, 403, 794
Voltmeter, new 7in-scale low-cost valve	472
Voltmeter, versatile a.c.-d.c.	657
Washers for power transistors	791
Waveguide frequency meter	660
Welding tools, miniature	267
Wire bonder, ultrasonic	270, 796
Wire stripper, self-adjusting	725
Yarn clearer	397

E

Encoder for full-quality p.c.m. system using a modified monostable multivibrator, period-quantized, by V. K. Agarwal	773
Encoder using integrated circuits, binary-decimal, by K. J. Dean	744

F

Feedback pair, simplified design of the, by J. C. S. Richards	97
Filter circuit for tuned amplifiers and sinusoidal oscillators, a second-order active, by E. A. Faulkner and Viscount Downe	287
Filters, loading effects in two-section RC, by J. F. Young	23
Filter with independent control over the pole and zero locations, a simple active, by W. Farrer	219
Flight simulator for America	176
Flight simulator, the Belfast	171
FRENCH .. 57, 127, 197, 275, 341, 407, 475, 533, 665, 731, 798	
Frequency divider using micrologic elements, by S. Jannazzo and G. Rustichelli	419
Frequency synthesizer, an electronically swept, by E. Kantarizis	442

G

Gate, high-speed linear, by E. A. Faulkner and J. B. Grimbleby	565
Generator, a 10MHz, 1A, 50V pulse, by R. W. Atsford and R. E. Hayes	507
Generator, digitizing-pulse, by S. C. Acharyya	503
Generator, linear-staircase, by M. Cadwallader	682
Generators for use in electrophysiology, constant voltage double-pulse, by A. F. Lewis	252
Generators, random and pseudorandom number, by M. Davio	558
GERMAN .. 64, 134, 204, 276, 342, 408, 476, 534, 666, 732, 799	
Goonhilly to be extended	218

H

Hall-effect measuring system for large direct and alternating currents, by D. J. Lloyd and C. W. Taylor	452
High-voltage supplies, transistorized, by R. E. Crosbie	778

I

Impulse testing of dynamic systems using cross-correlation techniques, by F. Jones	310
Information theory and data transmission, simplified, by A. E. Cawkell—Part 1	212
Part 2	302
Input/output equipment for the Argus computer, new	112
Inverter, firing an adjustable-frequency three-phase, by R. L. V. de Lima Mendes	41
Inverter for mains operated equipment, a stable 50Hz, by W. T. Maloney	374

K

Kidney machine, an automatic	40
--------------------------------------	----

Page

L

Laser radiation, continuously tunable	699
Learning situation, demonstration model for a simple, by P. C. Van Soest	629
Lens for television displays, new electromagnetic	428
LETTERS TO THE EDITOR .. 186, 262, 391, 458, 516, 586, 648, 715	

Binary to decimal convertor, a	186
Bridge circuit with high selectivity, improved RC	649
Cascode circuit using complementary transistors, a modified	262, 393
Converter, binary-to-decimal	649, 716
Corotrons	393
Counter, binary-quinary decade	517
D.C. follower, augmented	262
Decade counter, binary-quinary	716
Electrometer circuit, a junction transistor	648
Films, electrical resistance of evaporated nichrome	516
Giro handling equipment	187
Interference in thyristor controllers, suppression of radio	516
Nucleonic instrument design, economy and reliability	263
Null networks and frequency stability of null network oscillators	186
Oscillators, frequency stability in	649
Oscillator, negative-resistance transistorized	715
Peak-reading circuit, precision	648
Phase inversion in an overloaded amplifier	263
Recorder integrator using a unijunction transistor, simple	648
Solid-state multiplier, a simple	187
Stabilizing output of Wien bridge	392
Voltage reference source, a novel	391
Zener-diode alternatives	715
Low-voltage ring-of-two reference, by P. Williams	676

M

Measurement of Parameters of semiconductor devices, by G. May	483
MEETINGS THIS MONTH .. 56, 126, 196, 274, 340, 663, 730, 797	
Memory element, solid-state h.l.t.t.l. 16-bit, by Anh Nguyen-huu and R. H. Murphy	581
Microcircuits, large-scale integration of	704
Microelectronics, new concept in	704
Modulation, combination leading and trailing edge variable slope pulse, by O. E. Kruse, D. L. Lewis and J. K. Jackson	174
Modulator, analysis of the capacitance error of a m.i.s.f.e.t. chopper, by J. Dostal	640
Modulators, large-deviation phase and frequency, by D. J. Comer	495
Monostable, a high duty cycle high stability, by R. C. French	372
Motors with electronic speed control, small brushless d.c.	99
Motor vehicles, electronic equipment for, by G. N. Patchett	228
Multiplication using logarithmic diodes, high frequency, by R. P. Ingram	110
Multivibrator, a wide frequency range voltage controlled, by R. J. P. Jones	14
Multivibrator with very small mark/space ratio, by S. Tesic	671

N

Negative-impedance-convertor circuits, large-signal characteristics and stability criteria of, by A. C. Davies	536
Noise analysis of feedback amplifiers, by P. J. Finnegan	612
Noise margins in binary electrological systems, by E. L. Jones	142
Non-linearity by analogue simulation, determination of, by G. W. Holbrook and J. S. Collins	172
Nucleonic instrument design, economy and reliability in, by B. Shepherd	100

O

Oscillator/quadrupler, crystal-controlled 164MHz, by D. Singh and J. Garters	769
Oscillators, distortion in RC bridge feedback, by V. B. Mehta	582
Oscillators for radio frequencies, some novel RC, by R. S. Sidorowicz—Part 1	498
Part 2	560

P

Phase-sensitive detector and its application to a resolved components voltmeter, a current-switching, by J. G. Lacy	148
Powermeter, thermistor, by S. M. Bozic and J. R. Whitbread	637
Power supply design, some approaches to photomultiplier, by R. Barlow and J. Watson	90
Power supply for 3kV, 60mA, stabilized, by G. Klein and C. W. Bodenhausen	609

	Page
Power supply using controlled avalanche rectifiers, a mains stabilized high voltage, by R. W. J. Barker	161
Proportional plus rate information on a c.r.t. in the form of two pointers, a means of displaying, by M. R. Green and K. Lord	376
Product-assessment laboratories, the Plessey	439
PUBLICATIONS RECEIVED 340, 662, 719	787
Pulse amplifiers, fast transistorized, by D. Ivekovic	739
Pulse circuit for long delays, a, by B. Jovicic	424
Pulse-length-modulation systems, characteristics of asynchronous and bipolar, by P. D. Sharma	691
R	
Radio and space research field station at Chilbolton	447
Receivers, dynamic measurements on narrow-band, by J. F. Golding	448
Receiver, transistorized colour television	585
Recorder integrator using a unijunction transistor, a simple, by A. R. Atkins	440
Recorder system, a simple frequency-modulation tape, by W. Tempest and M. E. Bryan	87
Recording of mechanical position, a convertor for automatic, by U. Kracht	250
Redundancy in digital systems, by F. A. Inskip	244
Regulation of line level in long carrier links, automatic, by J. Korn	429
S	
Satellite communications terminal for the Royal Navy	19
Satellite in America, UK-3	45
Satellite launcher, a small British	301
Scaler design consideration, series-connected tunnel-diode, by Z. C. Tan and J. B. Earnshaw	624
Scanning electrical information channels	325
Schmitt trigger circuit, an analysis of the action of a, by D. W. H. Hampshire and D. Petersen	38
Schmitt trigger circuit used in conjunction with a current-integrating capacitor, behaviour of a, by L. A. Kemp, D. O. Bottrill and S. Klevenhagen	752
SHORT NEWS ITEMS 46, 115, 184, 259, 326, 404, 462, 521, 587, 653, 720, 788	
Slippage of asynchronous motors, a digital instrument for measuring the, by V. Bohm, V. Popescu and T. Teitel	106
Solar noise as a means of providing accurate vertical polar diagrams for radars, by M. J. B. Scanlan— Part 1	280
Part 2	367
Speed transients using optical gratings, measurement of, by D. K. Ewing	2
Stimulator, a dual channel, by J. W. Hinshelwood and A. G. Seabridge	16
St. Thomas's Hospital intensive-care monitoring system	506
Stub-matching by scattering-matrix methods, analysis of, by J. N. Saha	571
Switches for computer mode control, analogue, by N. W. Bellamy and S. R. Styler	512
T	
Tchebycheff directional couplers, the design and manufacture of waveguide, by K. E. Hancock	292
Telecommunication system for light aircraft, combined Telemetry system, short-range shock-measuring, by J. Morrison	451
Telephone exchanges, electronic	542
Television camera, a new photoconductive	96
Television in the BBC Engineering Division	86
Television, London educational	647
Television outside broadcast, first colour	286
Television picture tube, a new colour	494
Temperature control, application of a <i>pnpn</i> switch to, by A. Lupic and B. Kovak	387
Thermistor, a diamond	28
Thermistors, calculation of V-I curves for n.t.c., by M. R. McCann—Part 1	33
Part 2	346
Thermistor thermometer, sensitive, by J. C. S. Richards	426
Thin and thick film circuits	674
Timers using unijunction transistors, by J. F. Young	621
Timing unit for control of stimulation signals, by K. J. Kapota	756
Tracer providing calibrated axes, voltage/current-characteristic, by Min Wei Li and G. Hoffmann de Visme	644
Transistor calculations, unified, by D. W. W. Rogers	30
Transistor parameters and their influence on amplifier risetime, by D. Ivekovic	680

	Page
Transmission lines, strip, by J. Swift	490
Transmission lines with matched loads, analysis of repeated systems of, by J. N. Saha	632
Triangular-wave generator with large frequency sweep, an accurate, by G. Klein and H. Hagenbeuk	388
Twin-T filter design having an adjustable centre frequency, by K. G. Beauchamp	384

V

Voice-operated watch, a, by K. J. Kapota	114
Voltage reference source, a novel, by T. P. Dawson and G. C. Taylor	113
Voltmeter, instantaneous pulse-measuring, by N. A. Westman, S. Westerlund and S. T. Berglund	748

W

Wattmeter for magnetic loss measurement, a thermocouple, by J. K. Choudhury, R. K. Mondal and S. N. Bhattacharyya	34
---	----

AUTHORS

A

Acharyya, S. C., Digitizing-pulse generator	503
Agarwal, V. K., Period-quantized encoder for toll-quality p.c.m. system using a modified monostable multi-vibrator	773
Alsford, R. W. (with R. E. Hayes), A 10MHz, 1A, 50V pulse generator	507
Atkins, A. R., A simple recorder integrator using a unijunction transistor	440

B

Barker, R. W. J., A mains stabilized high voltage power supply using controlled avalanche rectifiers	161
Barlow, R. (with J. Watson), Some approaches to photomultiplier power supply design	90
Beadle, D. G. (with D. E. Susans), Digital coding equipment for recording field strength measurements	233
Beauchamp, K. G., A twin-T filter design having an adjustable centre frequency	384
Bellamy, N. W. (with S. R. Styler), Analogue switches for computer mode control	512
Bhattacharyya, S. N. (with J. K. Choudhury and R. K. Mondal), A thermocouple wattmeter for magnetic loss measurement	34
Bhola, S. K. (with R. H. Murphy), Design of low level d.c. chopper amplifiers	318
Bodenhausen, C. W. (with G. Klein), Stabilized power supply for 3kV, 60mA	609
Bohm, V. (with V. Popescu and T. Teitel), A digital instrument for measuring the slippage of asynchronous motors	106
Bozic, S. M. (with J. R. Whitbread), Thermistor powermeter	637
Brandwijk, J. F. (with P. H. Sydenham), A rapidly reversible 700kHz digital decade counter	298
Bryan, M. E. (with W. Tempest), A simple frequency-modulation tape recorder	87

C

Cadwallader, M., Linear-staircase generator	682
Cawkell, A. E., Simplified information theory and data transmission (Part 1)	212
(Part 2)	302
Choudhury, J. K. (with R. K. Mondal and S. N. Bhattacharyya), A thermocouple wattmeter for magnetic loss measurement	34
Collins, J. S. (with G. W. Holbrook), Determination of non-linearity by analogue simulation	172
Comer, D. J., Large-deviation phase and frequency modulators	495
Cowell, T. K., A junction transistor electrometer circuit	362
Crosbie, R. E., Transistorized high-voltage supplies	778

D

Dadd, R. H., Approach to applied circuit synthesis	668
Dalal, S., Simulation of cone of confusion	78
Davies, A. C., Large-signal characteristics and stability criteria of negative-impedance-converter circuits	536
Davio, M., Random and pseudorandom number generators	558
Davison, L. (with R. Wilson), A simple digital-analogue converter with reciprocal read-out	381
Dawson, T. P. (with G. C. Taylor), A novel voltage reference source	113

	Page		Page
Dean, K. J., Binary-decimal encoder using integrated circuits	744	Jacobsen, J. (with S. C. Loh), Backfire meander-line antenna	575
Dostal, J., Analysis of the capacitance error of a m.i.s.f.e.t. chopper modulator	640	Jannazzo, S. (with G. Rustichelli), Frequency divider using micrologic elements	419
Downe, Viscount (with E. A. Faulkner), A second-order active filter circuit for tuned amplifiers and sinusoidal oscillators	287	Jones, E. L., 'Noise margins' in binary electrological systems	142
E			
Earnshaw, J. B. (with Z. C. Tan), Series-connected tunnel-diode scaler design consideration	624	Jones, F., Impulse testing of dynamic systems using cross-correlation techniques	310
Ellis, A. B. E., Extraction of signals from noise using digital techniques	546	Jones, R. J. P., A wide frequency range voltage controlled multivibrator	14
Ewing, D. K., Measurement of speed transients using optical gratings	2	Jovicic, B., A pulse circuit for long delays	424
F			
Farrer, W., A simple active filter	219	K	
Faulkner, E. A. (with Viscount Downe), A second-order active filter circuit for tuned amplifiers and sinusoidal oscillators	287	Kantarizis, E., An electronically swept frequency synthesizer	442
Faulkner, E. A. (with J. E. Grumbleby), High-speed linear gate	565	Kapota, K. J., A voice operated watch	114
Finnegan, P. J., Noise analysis of feedback amplifiers	612	Kapota, K. J., Timing unit for control of stimulation signals	756
Fitch, P., An analyser for use in human electromyography	240	Kemp, L. A. W. (with D. O. Bottrill and S. Klevenhagen), Behaviour of a Schmitt trigger circuit used in conjunction with a current-integrating capacitor	752
Franklin, D. P., Decade boxes with binary output	154	Klein, A. G. (with R. W. Gellie), Accurate a.c.-d.c. convertor for low frequencies	484
French, R. C., A high duty cycle stability monostable	372	Klein, G. (with C. W. Bodenhausen), Stabilized power supply for 3kV, 60mA	609
G			
Gellie, R. W. (with A. G. Klein), Accurate a.c.-d.c. convertor for low frequencies	484	Klein, G. (with H. Hagenbeuk), An accurate triangular-wave generator with large frequency sweep	388
Golding, J. F., A square-law detector of power measurement	82	Klein, G. (with H. Hagenbeuk), Accurate triangle-sine convertor	700
Golding, J. F., Dynamic measurements on narrow-band receivers	448	Knight, P., The design and adjustment of m.f. broadcasting aerials	6
Gosling, W., Amplifiers combining bipolar and field-effect transistors	478	Korn, J., Automatic regulation of line level in long carrier links	429
Green, M. R. (with K. Lord), A means of displaying proportional plus rate information on a c.r.t. in the form of two pointers	376	Korytkowski, J., Accurate current-to-frequency convertor	568
Grumbleby, J. E. (with E. A. Faulkner), High-speed linear gate	565	Kovac, B. (with A. Lupic), Application of a pnpn switch to temperature control	28
H			
Hagenbeuk, H. (with G. Klein), An accurate triangular-wave generator with large frequency sweep	388	Kracht, U., A convertor for automatic recording of mechanical position	250
Hampshire, D. W. H. (with D. Petersen), An analysis of the section of a Schmitt trigger circuit	38	Kruse, O. E. (with D. L. Lewis and J. K. Jackson), Combination leading and trailing edge variable slope	174
Hancock, K. E., The design and manufacture of waveguide Tchebycheff directional couplers	292	L	
Hayes, R. E. (with R. W. Alsford), A 10MHz, 1A, 50V pulse generator	507	Lacy, J. G., A current-switching phase-sensitive detector and its application to a resolved components voltmeter	148
Hilling, A. E., A 50 to 500MHz broadband transistor amplifier	352	Lewis, A. F., Constant voltage double pulse generators for use in electrophysiology	252
Hinshelwood, J. W. (with A. G. Seabridge), A dual channel stimulator	16	Lewis, D. L. (with O. E. Kruse and J. K. Jackson), Combination leading and trailing edge variable slope	174
Hoffmann de Visme, G. (with Min Wei Li), Voltage/current-characteristic tracer providing calibrated axes	644	Li, Min Wei (with G. Hoffmann de Visme), Voltage/current-characteristic tracer providing calibrated axes	644
Højberg, K. Sjøe, Logarithmic current-measuring transistor circuits	20	Lloyd, D. J. (with C. W. Taylor), A Hall-effect measuring system for large direct and alternating currents	452
Holbrook, G. W. (with J. S. Collins), Determination of non-linearity by analogue simulation	172	Loh, S. C. (with J. Jacobsen), Backfire meander-line antenna	575
Hood, R. J., Transistorized 100MHz binary counter	642	Lord, K. (with M. R. Green), A means of displaying proportional plus rate information on a c.r.t. in the form of two pointers	376
Howorth, D. (with J. G. Ingleton), Delay unit suitable for television-field delay	734	Lupic, A. (with B. Kovac), Application of a pnpn switch to temperature control	28
Howorth, D. (with C. R. Caine and L. T. E. Ward), Precision temperature-controlled environments for ultrasonic fused quartz delay lines	706	M	
Hurst, S. L., An asynchronous binary-coded-decimal circuit with gated feedback	25	Maloney, W. T., A stable 50Hz inverter for mains operated equipment	374
I			
Ingram, R. P., High frequency multiplication using logarithmic diodes	110	May, G., Measurement of parameters of semiconductor devices	483
Ingram, R. P., Train decade counter	759	Mayo, C. G. (with J. W. Head), Open limit calculus	696
Inskip, F. A., Redundancy in digital systems	244	McCann, M. R., Calculation of V-I curves for N.T.C. thermistors (Part 1)	346
Ivekovic, D., Fast transistorized pulse amplifiers	739	McCann, M. R., Calculation of V-I curves for N.T.C. thermistors (Part 2)	426
Ivekovic, D., Transistor parameters and their influence on amplifier risetime	680	Mehta, V. B., Distortion in RC bridge feedback oscillators	582
J			
Jackson, J. K. (with O. E. Kruse and D. L. Lewis), Combination leading edge and trailing edge variable slope	174	Mendes, R. L. V. de Lima, Firing an adjustable-frequency three-phase inverter	41
		Mondal, R. K. (with J. K. Choudhury and S. N. Bhattacharyya), A thermocouple wattmeter for magnetic loss measurement)	34
		Morris, D. J., All-magnetic circuits incorporating new coupling-loop configurations	412
		Morris, I. G., New shutdown amplifier (s.d.a.) for nuclear reactors (Part 1)	485
		Morris, I. G., New shutdown amplifier (s.d.a.) for nuclear reactors (Part 2)	553
		Morrison, J., Short-range shock-measuring telemetry system	542

	Page		Page
Mundle, W. J., Averaging of heart-rate responses in rats following electrical brain stimulation	686	Sharma, P. D., Characteristics of asynchronous and bipolar pulse-length modulation systems	691
Murata, Y., Comparator-hold circuit using the facing-coupled Esaki diode pair	356	Shepherd, B., Economy and reliability in nucleonic instrument design	100
Murphy, R. H. (with S. K. Bholra), Design of low level d.c. chopper amplifiers	318	Sidorowicz, R. S., Some novel RC oscillators for radio frequencies (Part 1)	498
Murphy, R. H. (with Anh Nguyen-huu), Solid-state h.l.t.t.l. 16-bit memory element	604	(Part 2)	560
Murthy, K. K. (with K. C. Ng), An electromechanical running average	169	Singh, D. (with J. Garters), Crystal-controlled 164MHz oscillator/quadrupler	769
N			
Ng, K. C. (with K. K. Murthy), An electromechanical running average	169	van Soest, P. C., Demonstration model for a simple learning situation	629
Nguyen-huu, Anh (with R. H. Murphy), Solid-state h.l.t.t.l. 16-bit memory element	604	Spencer, T., V.H.F. solid-state power amplifier design ..	72
O			
Olthoff, W., Example of digital-to-analogue conversion	763	Stevenson, T. J., Two terminal drive circuits for piezo-electrically driven mechanical vibrator	222
P			
Patchett, G. N., Electronic equipment for motor vehicles	228	Styler, S. R. (with N. W. Bellamy), Analogue switches for computer mode control	512
Peterson, D. (with D. W. H. Hampshire), An analysis of the action of a Schmitt trigger circuit	38	Susans, D. E. (with D. G. Beadle), Digital coding equipment for recording field strength measurements ..	233
Popescu, V. (with V. Bohm and T. Teital), A digital instrument for measuring the slippage of asynchronous motors	106	Swift, J., Strip transmission lines	490
Pridham, G. J., Analysis of feedback amplifiers	436	Sydenham, P. H. (with J. F. Brandwijk), A rapidly reversible 700kHz digital decade counter	298
R			
Rakovich, B. D. (with S. Tesic), Voltage-to-frequency conversion	766	T	
Ricardi, J., Directivity of an array of slots on the surface of a cylinder	578	Takehima, T., X-band omnidirectional double-slot-array antenna	617
Richards, J. C. S., Sensitive thermistor thermometer ..	674	Tan, Z. C. (with J. B. Earnshaw), Series-connected tunnel-diode scaler design consideration	624
Richards, J. C. S., Simplified design of the feedback pair	97	Tawfiq, T. K., Planning a v.h.f., f.m. radio system for bus services	224
Ridler, P. F., The parameters of the current-driven source-follower	290	Taylor, C. W. (with D. J. Lloyd), A Hall-effect measuring system for large direct and alternating currents	452
Riddle, C., Time-amplitude and amplitude-time convertors using linear ramps (Part 1)	600	Taylor, G. C. (with T. P. Dawson), A novel voltage reference source	113
(Part 2)	711	Teital, T. (with V. Bohm and P. Popescu), A digital instrument for measuring the slippage of asynchronous motors	106
Rogers, D. W. W., Unified transistor calculations	30	Tempest, W. (with M. E. Bryan), A simple frequency-modulation tape recorder	87
Ruckman, R. J. S., A data logger scaler and alarm limit comparator	177	Tesic, S., Multivibrator with very small mark/space ratio	671
Rustichelli, G. (with S. Jannazzo), Frequency divider using micrologic elements	419	W	
S			
Saha, J. N., Analysis of stub-matching by scattering-matrix methods	571	Watson, J. (with R. Barlow), Some approaches to photo-multiplier power supply design	90
Saha, J. N., Analysis of repeated systems of transmission lines with matched loads	632	Westman, N. A. (with S. Westerlund and S. T. Berglund), Instantaneous pulse-measuring voltmeter	748
Scanlan, M. J. B., Solar noise as a means of providing accurate vertical polar diagrams for radars (Part 1) (Part 2)	280 367	Whitbread, J. R. (with S. M. Bozic), Thermistor power-meter	637
Seabridge, A. G. (with J. W. Hinshelwood), A dual channel stimulator	16	Williams, P., Low-voltage ring-of-two reference	676
		Wilson, D. R., A note on a.c. compensating networks	316
		Wilson, J. P., A simple high-speed analogue multiplier	11
		Wilson, R. (with L. Davison), A simple digital-analogue convertor with reciprocal read-out	381
		Y	
		Young, J. F., Loading effects in two-section RC filters ..	23
		Young, J. F., Coupling Dekatron selectors with low-cost transistors	323
		Young, J. F., Timers using unijunction transistors	621

© MORGAN-GRAMPIAN LIMITED 1967

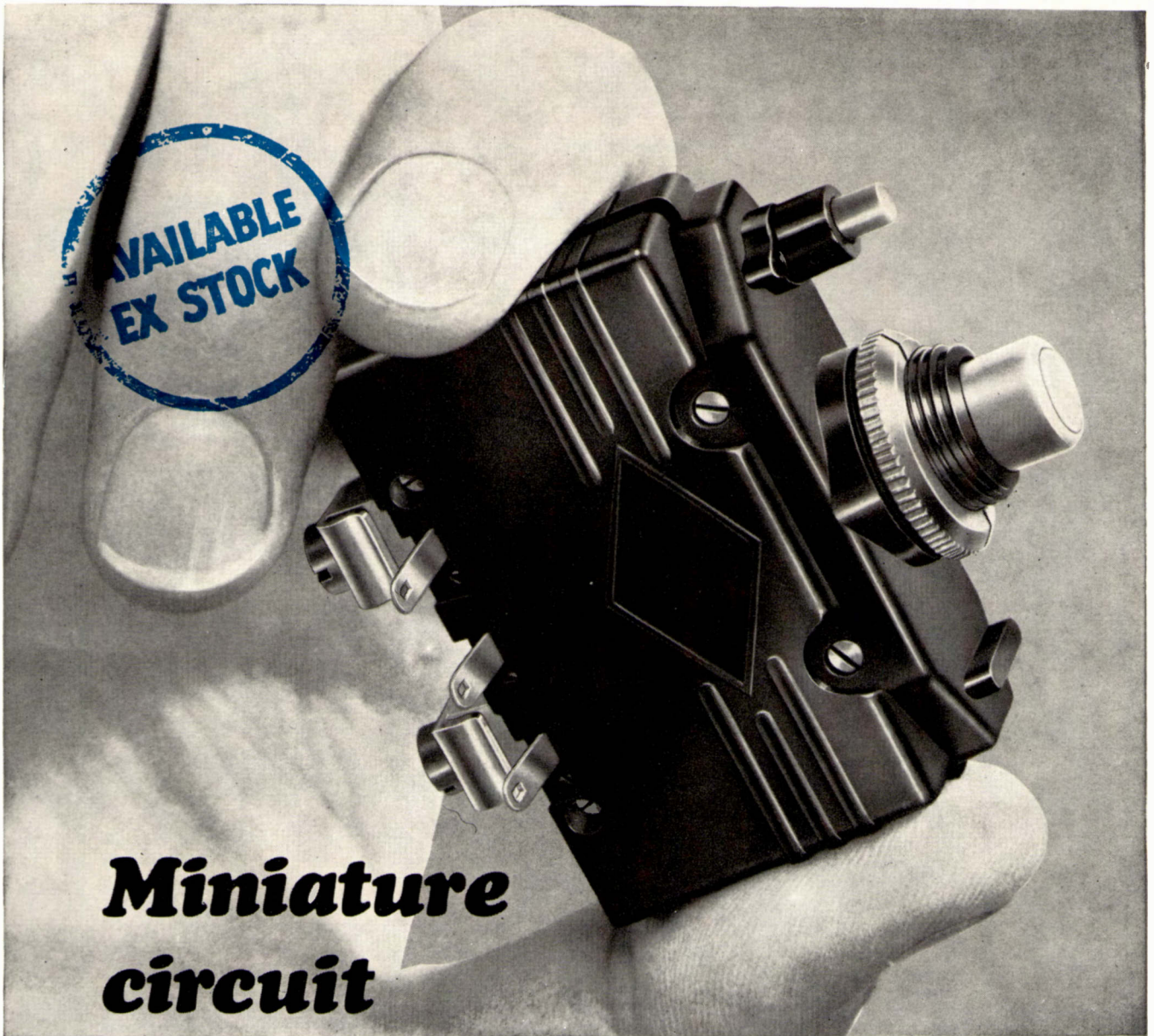

**Miniature
circuit
breakers
with **BIG**
Advantages**

The Belling-Lee "Securex" Miniature Circuit Breaker is a precision unit which provides protection, switching plus a clear indication of the circuit condition. Two basic types are available, thermal or thermal-magnetic. Available in many ratings from 300 mA to 15 A.

*FOR FULL SPECIFICATIONS RING ENF 5393
OR WRITE FOR DATA SHEETS E17-E20.*

BELLING-LEE

COMPONENTS

connecting research to industry

BELLING & LEE LIMITED, GREAT CAMBRIDGE ROAD, ENFIELD, MIDDLESEX

Telephone : 01-363 5393 Telex : 263265

For more information circle No. 4

VIDAR

DATA ACQUISITION SYSTEMS



F.M. MULTIPLEX SYSTEMS

DIGITAL DATA LOGGING SYSTEMS

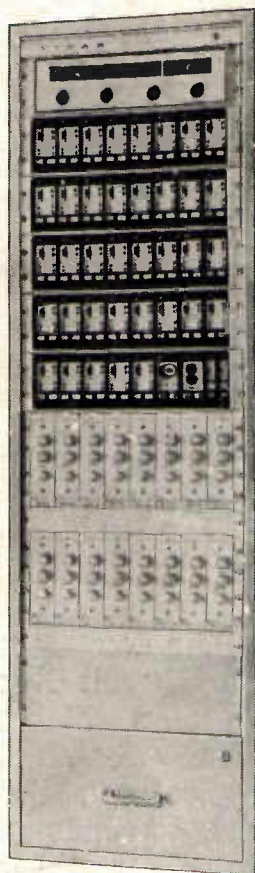

VIDAR VI-TEL *

Up to 240 2 KH/z bandwidth signals can be recorded on a 1.5 MHz tape recorder. Low level differential input with 5 mV sensitivity (for 40% deviation). Common mode voltage 250v D.C. .0025% Linearity.

* Reg'd Trade Mark



VIDAR D-DAS *

Low level, high speed systems (up to 50 channels per sec with 0.1% resolution) 6 digit integrating voltmeter 10 mV F.S.D. with 300% over-range makes use of expensive amplifiers unnecessary. C.M.R.R. 140db with 1000Ω unbalance. Systems with computing facilities also available.

Sole U.K. Agents

GENERAL TEST INSTRUMENTS LTD

GLOUCESTER TRADING ESTATE, HUCCLECOTE, GLOUCESTER
Gloucester 67154