

# Electronic Engineering

INCORPORATING ELECTRONICS, TELEVISION AND SHORT WAVE WORLD

## PRINCIPAL CONTENTS

High Vacuum Gauges — Part 2

Photo-Mechanical Oscillators

L.F. Amplification — Part 3

Electronic Temperature Control

Cathode-Ray Tube Traces — Part 2 (Cont.)

**2/- JAN., 1945**

# DECADE OSCILLATOR

## Type D-105-A "... as easy to use as a resistance box"

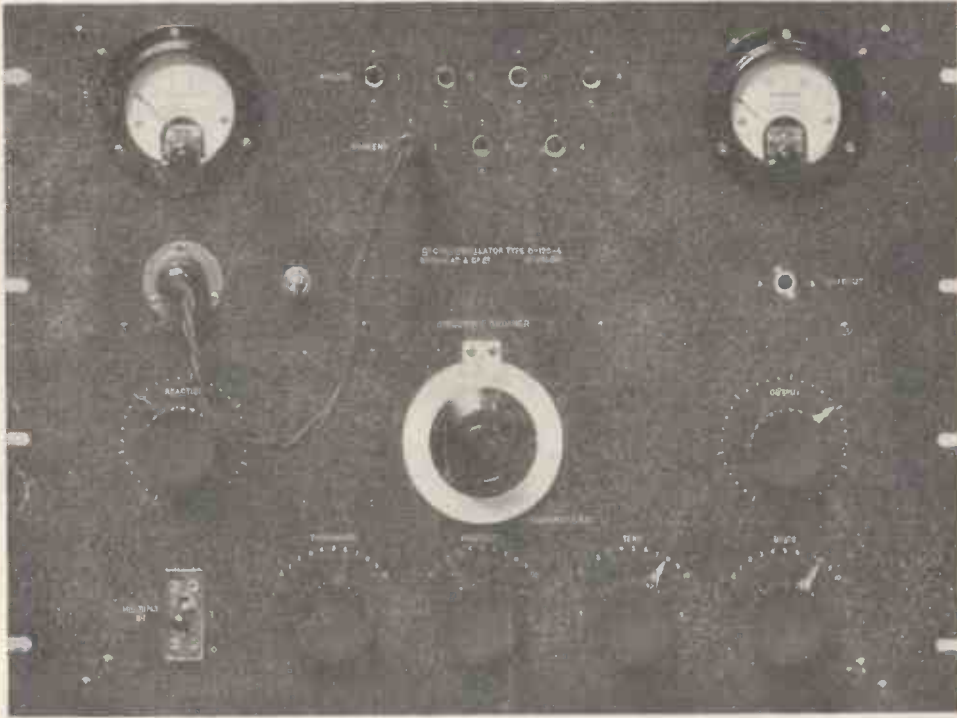

The **MUIRHEAD-WIGAN DECADE OSCILLATOR** Type D-105-A, illustrated, is an instrument of outstanding performance embodying something entirely new in oscillator design.

**FREQUENCY IS DIRECT READING TO PRECISION ACCURACY ON FOUR DECADES.** There are no troublesome calibration charts to refer to or engraved scales to adjust.

For full particulars of this and other Decade Oscillators, write for Bulletins B-320-A, B-321-A and B-528-A.

**MUIRHEAD & CO. LTD., ELMERS END,  
BECKENHAM, KENT**

Telephone: Beckenham 0041-0042

### Specification :

#### FREQUENCY

1 c.p.s. to 111.1 Kc/s on two ranges :—  
1 c.p.s. to 11.11 Kc/s by 1 c.p.s. steps.  
10 c.p.s. to 111.1 Kc/s by 10 c.p.s. steps.

#### ACCURACY

$\pm 0.2\%$  or 2 c.p.s. over the entire frequency range.

#### OUTPUT 2 watts maximum.

#### HARMONIC CONTENT

2% at 2 watts : 1.25% or less below  
1 watt.

#### POWER SUPPLY 200 to 250 v. 50 c.p.s.

# MUIRHEAD

FOR OVER 60 YEARS DESIGNERS AND MAKERS OF PRECISION INSTRUMENTS

C.R.C.31

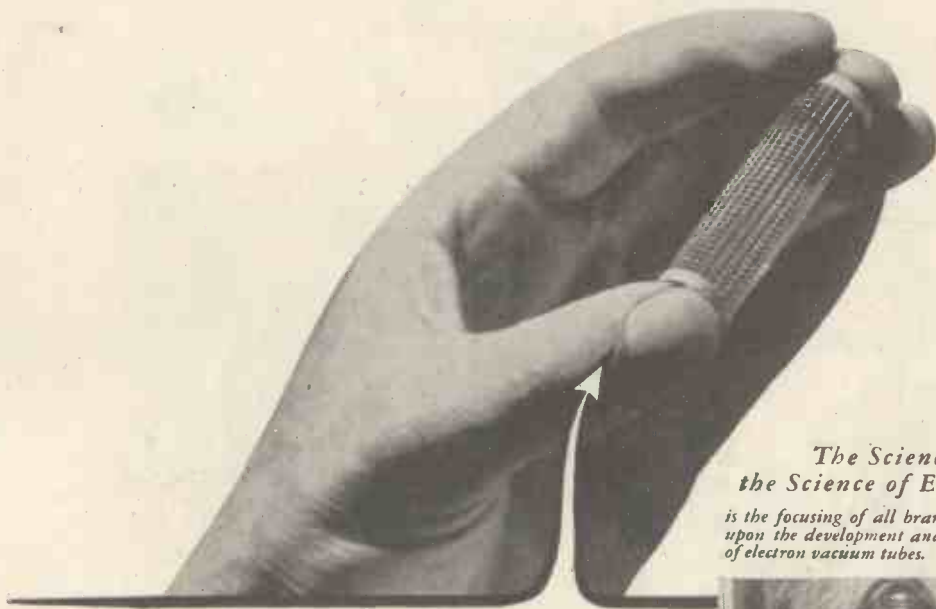

*The Science Behind  
the Science of Electronics*

*is the focusing of all branches of science upon the development and improvement of electron vacuum tubes.*

# Eimac "X" Grid

*Solves grid emission problem!*

Grid emission, with the resulting instability of operation, parasitic oscillations and prematurely burned out filaments, has become a thing of the past. The new Eimac "X" grid will not emit electrons even when operated at incandescent heat.

The solution to the problem of grid emission lifts a great barrier which has long stood in the path of electron vacuum valve development and the progress of electronics. Eimac Engineers in developing the "X" grid have made a real contribution . . . and a very important one . . . toward the development of new and more efficient vacuum valves. It is such heads-up Engineering that has made Eimac valves first choice of leading electronic engineers throughout the world . . . and maintained them in that position year after year.



**THERMO-DYNAMICS**... Vacuum furnaces heat materials to exceedingly high temperatures.



**CHEMISTRY**... Experimentation with metallic components and preparation of chemical compounds.



**POWDER METALLURGY**... Compounding special alloys.



Follow the leaders to

**ELECTRONIC  
TELESIS**

*The layman's handbook of Electronics will be sent you upon request without cost or obligation.*

**Eimac**  
REG. U. S. PAT. OFF.  
**VALVES**

**EITEL-McCULLOUGH, INC.**, 874 San Mateo Avenue, **SAN BRUNO, CALIF.**  
Plants located at: San Bruno, California and Salt Lake City, Utah

Exports Agents: **FRAZAR & HANSEN**, 301 Clay St., San Francisco 11, Calif., U. S. A.

# TUCKER EYELETS



# AND TAGS

GEO. TUCKER EYELET CO. LTD.

WALSALL ROAD, BIRMINGHAM, 22

Phone: BIRchfields 5024

# Constant Voltage



## TRANSFORMERS

LINE VOLTAGE VARIATIONS OF  
 $\pm 15\%$  REDUCED TO  $\pm 1\%$

TYPICAL SPECIFICATION

Input Voltage	... 190-260 v. 50 c.p.s.
Output Voltage	... 230 v. $\pm 1\%$
Max. load	... 150 watts
Input power factor	over 90%

Prices on application. Write for details

## ADVANCE COMPONENTS LTD.

BACK RD., SHERNHALL ST., WALTHAMSTOW, E17. PHONE: WARKWOOD 43663

# MINIATURE or MIDGET

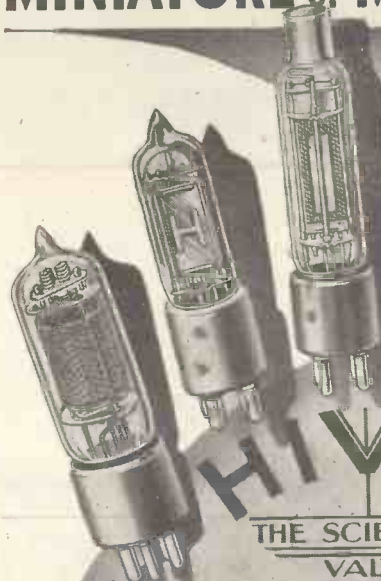

We specialise  
in their  
manufacture.

# HIVAC

THE SCIENTIFIC  
VALVE

Originators,  
designers & manufacturers of Midget Valves

HIVAC LIMITED, Greenhill Crescent, Harrow on the Hill, Middx. Phone: HARROW 0895

# Miniature I.F. Transformers

DESIGNED FOR MAXIMUM GAIN AND SELECTIVITY IN THE SMALLEST DIMENSIONS

The coils are contained in enclosed pot-type iron dust cores, tuning adjustments being obtained by means of adjustable iron dust centre cores.

Fixed tuning condensers are contained inside the screening can.

Units are made with a number of variations in windings and coupling coefficients for certain circuit conditions, but five Standard types are recommended for general use.

*Wartime restrictions prevent our accepting orders other than those covered by priority numbers*

The illustration shows the actual size of the Unit which is provided with one hole fixing, the terminal wires being fed through Insulated bushings which, in turn, prevent movement of the transformer when mounted in position.

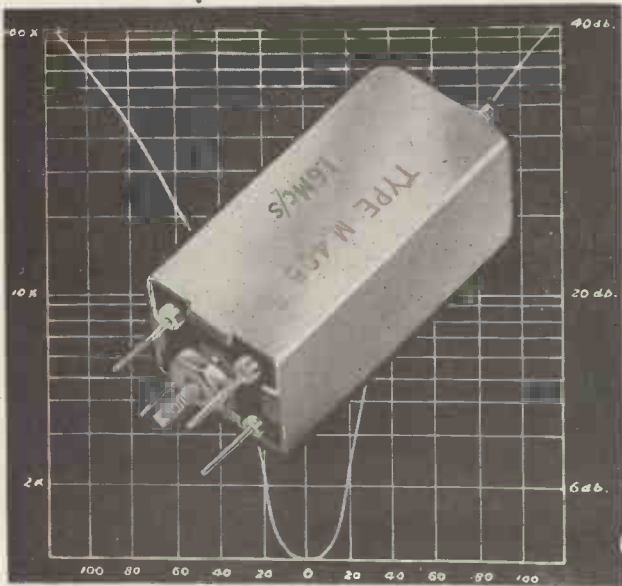

**WRIGHT & WEAIRE LTD.**  
HIGH ROAD, TOTTENHAM, N.17.

Telephone : TOTtenham 3847-8-9.

## For Peak Performance *with High Voltages*



*The Pioneers of Low-Loss Ceramics*

U.I.C. Fixed Ceramic Pot and Plate Condensers have been primarily developed for use in transmitter circuits. Made only from the highest grade raw materials and subjected to the most rigorous mechanical and electrical inspection, their performance especially with H.F. loads and high voltages is unsurpassed. TYPE APPROVED. Full details on request.



**CERAMIC**  
*High-Voltage*  
**CONDENSERS**

UNITED INSULATOR CO. LTD., 12-22 LAYSTALL ST. LONDON, E.C.1.  
Tel. TERminus 7383 (5 lines) Grams: Calanel, Smith, London



ELECTRO-MEDICAL EQUIPMENT

DRAWING OFFICE EQUIPMENT

SPECTROGRAPH ANALYSIS EQUIPMENT

H.F. ELECTRIC FURNACES

Interference created by above is suppressed by H.F. mains filters and screened rooms.  
We supply screened rooms of any dimensions and H.F. mains filters 15 and 300 amperes maximum loadings.

AERIAL SYSTEMS DESIGNED & INSTALLED

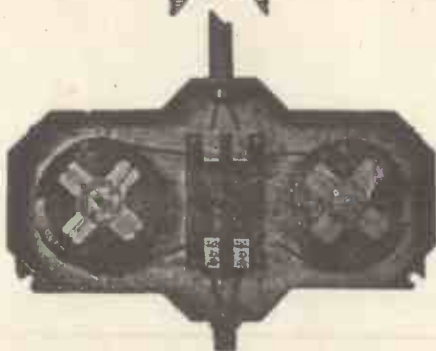

A Typical H.F. Filter.

**BELLING & LEE LTD**  
CAMBRIDGE ARTERIAL ROAD, ENFIELD, MIDD

GA

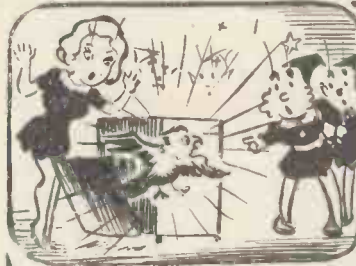

**THE "FLUXITE QUINS" AT WORK**

"Our Wireless needs FLUXITE, that's clear, Those noises it makes are darn queer; Just hark at it now, That's bad language, I vow,"  
"You're right" exclaimed OO. "Look what's here."

For all **SOLDERING** work—you need **FLUXITE**—the paste flux—with which even dirty metals are soldered and "tinned." For the jointing of lead—without solder; and the "running" of white metal bearings—without "tinning" the bearing.

It is suitable for **ALL METALS**—excepting **ALUMINIUM**—and can be used with safety on **ELECTRICAL** and other sensitive apparatus.

With Fluxite joints can be "wiped" successfully, that are impossible by any other method

Used for over 30 years in Government Works, and by leading Engineers and Manufacturers, OF ALL **IRONMONGERS**—IN TINS—8d., 1/4 and 2/8. Ask to see the **FLUXITE SMALL SPACE SOLDERING SET**—compact but substantial—complete with full instructions, 7/6.



The "Fluxite Gun" puts Fluxite where you want it by simple pressure.  
Price 1/6, filled 2/6.

**ALL MECHANICS WILL HAVE**

**FLUXITE**

**IT SIMPLIFIES ALL SOLDERING**

Write for Leaflets on **CASE HARDENING STEEL** and **TEMPERING TOOLS** with **FLUXITE** also on "WIPED JOINTS." Price 1d. each.

**FLUXITE LTD. (Dept. T.V.) Bermondsey St., London, S.E.1**



**BEAT FREQUENCY OSCILLATORS**

**LELAND INSTRUMENTS LTD**

—for priority requirements only, at present. Write for particulars stating frequency range required.

21, JOHN STREET, BEDFORD ROW, LONDON W.C.1  
TELEPHONE: CHANCERY 8768

# LONG LIFE, HIGH EFFICIENCY AND A SIMPLE CIRCUIT

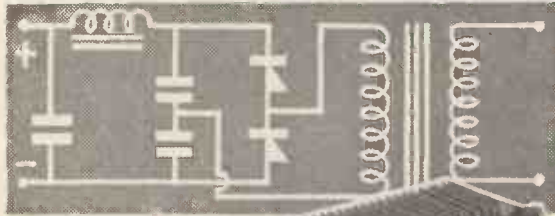

A metal rectifier in the voltage doubler circuit provides full wave rectification with a transformer secondary voltage less than the voltage of the output from the rectifier. Further, no filament winding is required and the transformer is simpler and less costly.

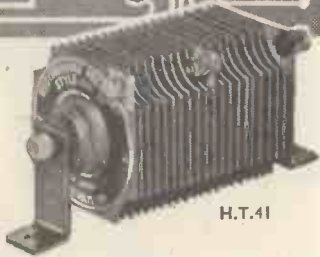

H.T.41



## METAL RECTIFIERS

WESTINGHOUSE BRAKE & SIGNAL CO. LTD.  
Pew Hill House, Chippenham, Wilts.

# TRANSFORMERS

We make Transformers of many types up to 10kVA for industrial purposes. Supplied to all branches of the Services and built and tested under conditions as gruelling as those prevailing in operational areas, they represent the last word in reliability.

Send us your enquiries; we may be able to help YOU. You can rely on Woden Equipment.



# WODEN

TRANSFORMER CO. LTD.

MOXLEY ROAD-BILSTON-STAFFS. Telephone: Bilston 48350

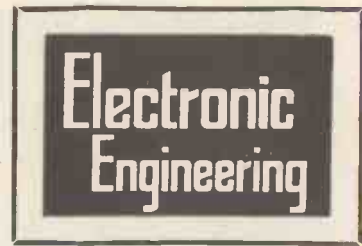

JANUARY, 1945

Volume XVII.

No. 203.

# CONTENTS

	PAGE
Editorial—More Training ... ..	315
Finishing Tinplate by H.F. Treatment ...	316
A Rotating-Anode X-Ray Generator Part 2 ... ..	317
High Vacuum Gauges—Part 2 ... ..	322
Low Frequency Photo-Mechanical Oscillators ... ..	326
Cathode-Ray Tube Traces—Part 2 ...	329
Low Frequency Amplification—Part 3 ...	335
An Electronic Potentiometer Pyrometer	340
“Lighthouse” Tubes ... ..	344
Frequency Compensated Delay Network	345
January Meetings ... ..	346
Abstracts of Electronic Literature ...	348
Book Review ... ..	350

**CONDITIONS OF SALE**—This periodical is sold subject to the following conditions, namely, that it shall not without the written consent of the publishers first given, be lent, re-sold, hired out or otherwise disposed of by way of Trade except at the full retail price of 2/- and that it shall not be lent, re-sold, hired out or otherwise disposed of in a mutilated condition or in any unauthorised cover by way of Trade, or affixed to or as part of any publication or advertising, literary or pictorial matter whatsoever.



## *... as the wave of a hand*

People are apt to take it for granted that all mechanism must make some kind of a noise.

Yet consider the complexity of the mechanism in a human hand, and its extraordinary adaptability to different tasks, from playing the piano to lifting heavy loads. Nevertheless it is silent; why?

Because Nature—in whose footsteps we humbly follow—does not use metal-to-metal joints with clearances, but welds muscle on to bone, providing an ideal construction, flexible, yet without backlash.

Here at Metalastik we are constantly engaged in the design and manufacture of devices which, made of metal parts welded to rubber, are used to permit or restrict movement, or to damp vibrations of various kinds. We can use natural or synthetic rubber, our rubber-to-metal weld can be used with various metals, and we know exactly how to design in metal and rubber to meet any desired conditions.

*Our services are at your disposal.*

*Metalastik Ltd., Leicester.*

# **METALASTIK**



PROPRIETORS :

HULTON PRESS, LTD.

# Electronic Engineering

EDITOR

G. PARR.

EDITORIAL, ADVERTISING AND PUBLISHING OFFICES, 43-44, SHOE LANE, LONDON, E.C.4

TELEPHONE :

CENTRAL 7400

Monthly (published last day of preceding month) 2/- net. Subscription Rates : Post Paid to any part of the World— 6 months, 13/- ; 12 months, 26/- . Registered for Transmission by Canadian Magazine Post.

TELEGRAMS :

HULTONPRES, LUD LONDON.

## More Training

THE training of students for the electronic and radio profession has been referred to several times on this page and no apology is made for returning to the subject again.

This time the theme is the Selection and Training of Personnel for Industry, on which a discussion was opened by Major F. A. FREETH, F.R.S., at the Institute of Physics on December 2nd.

The address was notable, not so much for any new theories of training put forward, but for the wide variety of aspects of training on which he touched and the stimulating way in which the remarks were given.

He recognised that in the selection of scientific staff, the common criteria were a first or second class honours degree with one or two years' research, but insisted that a degree should be regarded as only a step in the research worker's career. General knowledge and the ability to speak and write good English were equally important, and the people of the best general education were most likely to be successful and, above all, to last longer.

Particular mention was made of the laboratory technician, and the suggestion was made that a new assessment was required of the degrees of skill in various branches of science. The technical schools might recognise, by the issue of "master" certificates, the attainment of a certain skill in the performance of mechanical work or craftsmanship which is vital to Industry.

About research: The conditions of research in industry are very different from those in Universities where the relationship of master and pupil holds. The ideal research director should be a colleague rather than a master, and "the director

who is a little Führer is apt to leave a trail of devastation behind him during the course of years, and a new brood of horrid little Führers to follow in his footsteps."

An excellent piece of advice as a cure for staleness in ideas was given by Major Freeth to a friend. He took him to a library and opened at random one of the leading scientific journals of the early part of the century, saying "Turn over the pages for a bit." In Major Freeth's words, "My advice to anyone who feels off colour is to dip at random into some famous well of knowledge. He will be surprised at what he will fish up, and the relief it will give him."

Stress was laid on the importance of broadening one's outlook by wide reading and visiting conferences and other centres. "Everyone should be taught to use a library: some people are like ferrets, others have no idea."

These extracts do not do justice to the address as a whole, and it is hoped that it will be available for publication in full. Both employers and staff will find something to think over.

To all readers of this Journal the Editorial Staff send Best Wishes for a Happy and Prosperous 1945.

## Finishing Tinplate by H.F. Treatment

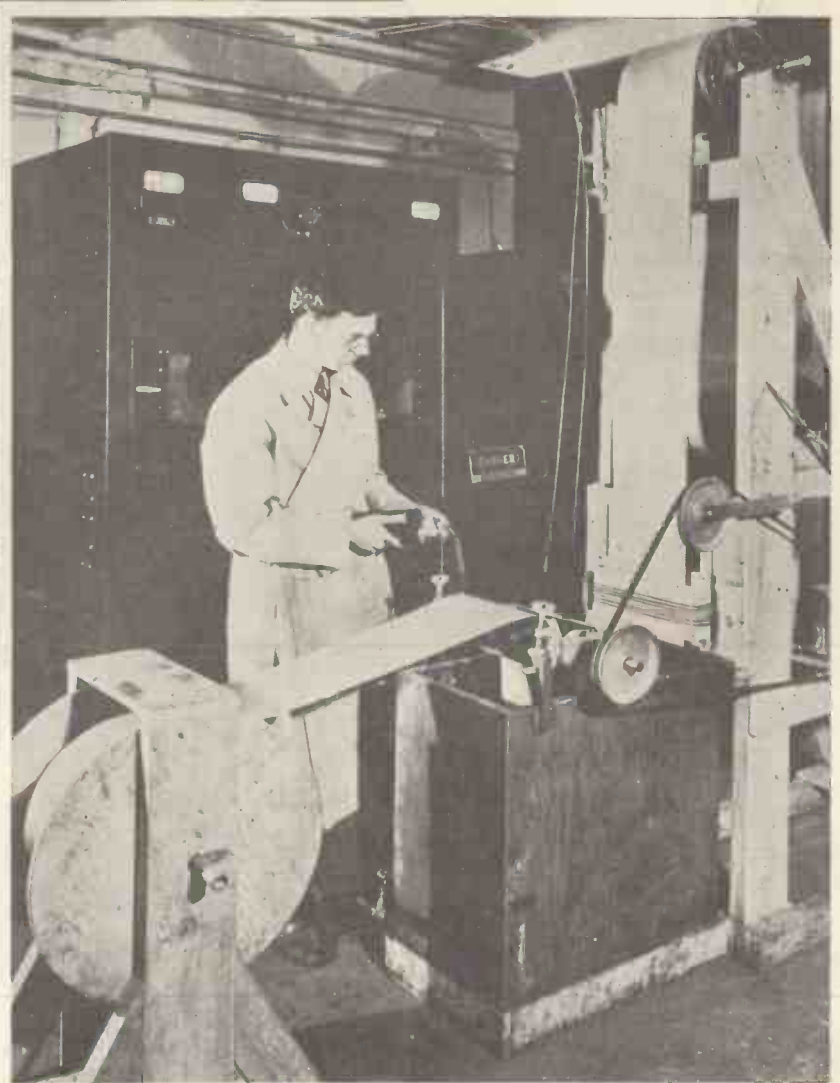
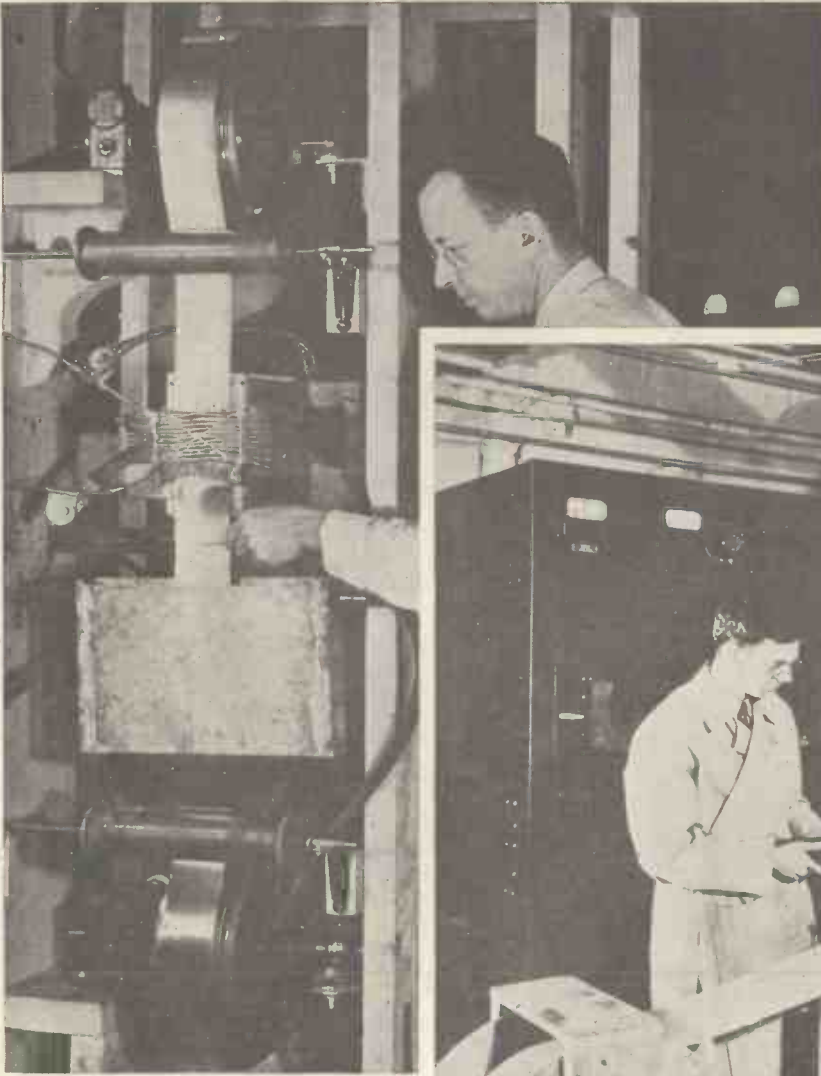

*(Photographs - Michael Lorant)*

The smooth corrosion-resisting finish on tinplate is usually obtained by treating it in hot oil or gas furnaces. By the use of H.F. heating, Westinghouse (U.S.A.) have reduced the processing time to one-tenth that formerly required. The upper photograph shows tinplate strip passing through a 200 kc/s. oscillator coil and thence into a cooling water tank. This process was referred to in an abstract in the June issue.

# A Rotating-Anode X-Ray Generator

## Part II.—Electrical, Theory and Performance

by IAN MacARTHUR, M.A., Ph.D.\*

### Electrical (Figs. 10 & 11)

#### (a) General

**T**HE H.T. to the X-ray tube is supplied by a 10 kVA centre-tapped transformer. Two valves give biphasc rectification. Tube and valve filament currents are supplied by step-down transformers. The X-ray target is earthed, and the centre-tapping of the H.T. transformer is earthed through a milliammeter and D.C. relay.

#### (b) Safeguards

The following devices safeguard equipment and operator. i. A Watt governor (Fig. 6), which switches off the H.T. by a relay if the speed of rotation of the target falls below a certain (arbitrarily selected) value, is attached to the mercury cup. It consists of a split brass cylinder insulated by mica sheet from the mercury cup and flanged to take a conducting metal contact strip. Two metal arms are pivoted about horizontal axes at the top of the cylinder on opposite sides, one a dummy for dynamical balance. As the target rotates, a small arc attached to the upper end of the other arm tends to make contact with the cup to complete the circuit. The critical speed, at present set at 440 r.p.m., is controlled by a spring and movable bob. ii. A water cut-out of a simple pressure-vane type on the effluent pipe from the target is in the same circuit as the governor, and operates if the cooling supply falls below a selected value. iii. To avoid target deterioration through accidental surges of tube current due to outgassing, leaks, etc., a D.C. relay is set to switch off H.T. and tube filament circuits above pre-arranged values of tube current. iv. The door of the cage surrounding the H.T. equipment is fitted with a switch to break the H.T. circuit if opened. v. Operation of the H.T. circuit is indicated by warning lamp. vi. A slotted control rod (Fig. 1) ensures that switches are made and broken in safe sequence.

#### (c) Primary Circuits† (Fig. 10).

Current from 50 c/s. A.C. supply mains at 200 V passes through an oil

\* I.W.S. Research Fellow, Department of Textile Physics, University of Leeds.

† Recently slightly modified in detail.

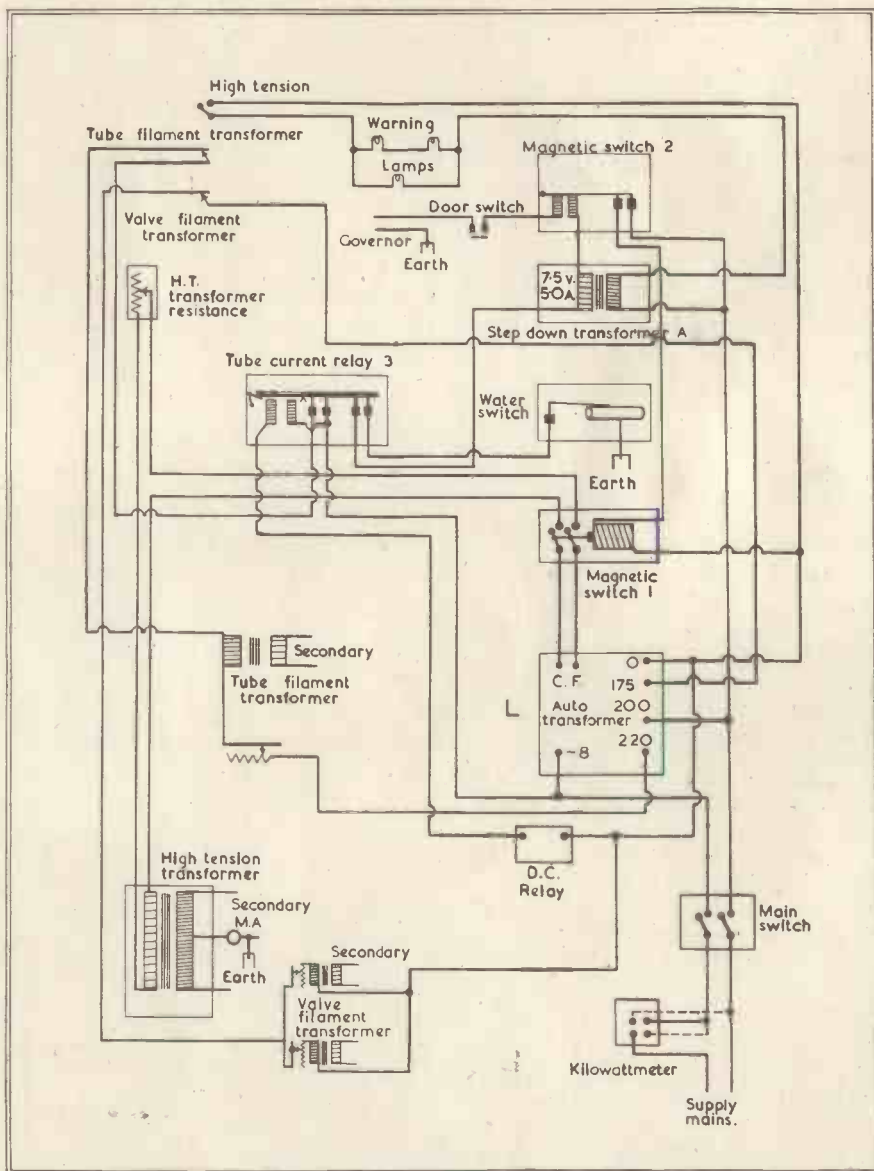

Fig. 10. Primary Circuits.

circuit-breaker main switch complete with no-volt and overload release coils, through a kilowattmeter to a 10 kVA auto-transformer (L). Suitable tappings supply the primary circuits for valve filament, tube filament, and H.T. transformers. In addition to a D.C. relay, three solenoid-actuated

relays, viz., magnetic switches (1), (2), and a tube current relay (3), provide safeguards. In (2) and (3), connexion is by prong and mercury cups, normally open in (2) and closed in (3). The mercury cups in (2) form a circuit with the solenoid of (1) and the 0 and 200 V terminals of L. One

pair in (3) are in series with cage door switch, governor, and water switch; the other pair are in circuit with tube filament transformer primary and switch, control rheostat, and -8 and 220 V terminals of L. The solenoid in (3) is in series with the trip contacts of the D.C. relay through the -8 and 0 V terminals of L. The primary circuit (P) of the H.T. transformer is closed by switch (1) for whose operation the mercury cups of (2) must be connected. As is clear from the above and Fig. 10, this occurs if, and only if, main, tube filament and H.T. switches, cage door, governor contacts, water switch, and connexion between the cups of (3) are all closed. When too great a current passes through the X-ray tube, the trip contacts of the D.C. relay close to operate (3), breaking the tube filament and H.T. circuits, the latter, through (2), breaking the solenoid current of (1), therefore circuit (P) also. (3) is re-made by hand. Finely-stepped voltage is supplied to (P), which contains a heavy 20-40 A  $10\Omega$  starting resistance, using the coarse and fine (C, F) tapping series.

#### (d) Secondary Circuits

(Fig. 11).

The voltages supplied by the step-down transformers for valve and tube filament currents are 25 and 15 V respectively. Transformer A permits external safeguards to be at  $\sim 8$  V. The secondary terminals of the 10 kVA., 150 kVp. H.T. transformer are connected through resistances each to the cathode of a Philips Metalix rectifying valve (Type M160,† 150 kVp/500 mA). The valves are normally run with filament tension and current of 12.6 V and 8.0 A respectively, to carry 200 mA. The valve anodes are linked by a brass rod and through resistances  $R_1$  and  $R_2$  to the H.T. terminal of the X-ray tube.  $R_1$  consists of 7 20,000 $\Omega$  B.E.R. Co. units in series to carry 100 mA.  $R_2$  consists of 4 carbon resistances of 150,000 $\Omega$  each, 2 in series, 2 in parallel, to carry  $\sim 20$  mA. These suppress tube surges that might cause destructive arcing between cathode and target.  $R_2$  is shunted after degassing up to 10 mA. at 30 kV.

Tube current is measured by a milliammeter in series with the D.C. relay between the centre-tapping MA, of the H.T. secondary and earth. Tube voltage is measured by the current through a 12 M $\Omega$  oil-immersed spag-

hetti wire resistance  $R_3$  connected to the H.T. terminal of the X-ray tube and earthed through a milliammeter. An instrument panel (Fig. 2) carries wattmeter and tube voltage and current milliammeters in addition to the D.C. relay and H.T. warning lamp.

#### Operative Technique

The rotary pump is switched on and the Audco tap opened later. With the discharge tube black hard, the condensation pumps with cooling water are switched on and solid CO<sub>2</sub> charges periodically maintained. Working vacuum should be attained inside 20 minutes. All water flows are then adjusted, the target rotated, and valve and tube filament currents switched on. Tube filament current and primary voltage to H.T. transformer are adjusted to yield the desired tube current and H.T. voltage. Relays are checked. H.T. is switched on and off with the starting resistance in. Closing down routine follows the inverse order. Cooling of the condensation pumps, aided by fan, need not be complete before air is admitted up to the Audco tap by needle valve in the P<sub>2</sub>O<sub>5</sub> trap, on switching off the rotary pump. Degassing is advisable on renewing a filament or after long disuse. This is done by electrical clean-up with  $R_3$  in the circuit, the voltage being brought up to  $\sim 30$  kV. and maintained as tube current is

gradually increased.  $R_2$  is later short-circuited. Care and maintenance consists chiefly in cleaning and adjusting contacts, oiling bearings, and sealing occasional leaks. The greatest care with the latter is well repaid in trouble-free operation and extended filament life. Normally, when sealed by the Audco tap, the tube remains black hard for days on end.

#### Theory

Moving anodes to avoid target disintegration are not new. Breton<sup>35</sup> and Pohl<sup>36</sup> described early models, and Stintzing<sup>37</sup> applied the principle in emission X-ray spectrum analysis. Their systematic development is due largely to Dr. Bouwers and his associates of the Philips X-ray Research Laboratory (medical and industrial radiography), and to Dr. A. Müller, Royal Institution (crystal analysis). Several installations embodying various principles are now in use, and some general surveys are available.<sup>37</sup> In addition to the fundamental problem of focusing powerful electron beams, essential non-engineering features behind design of moving-anode generators are form and composition of anode, shape of focus, specific load, load, heat and temperature distribution in focal area.

The theory of the permissible input in X-ray tubes has been discussed mainly by Bouwers<sup>38,39</sup> and Abbott<sup>39</sup> for "flash" radiography, and by Müller,<sup>40,21b</sup> De Graaf and Oosterkamp,<sup>41</sup> and DuMond *et al.*<sup>42</sup> for continuous output. The former problem is the simpler. For exposures ( $t$ ) < 0.1 sec., the focus surface temperature ( $T$ )  $\propto \sqrt{t}$  for a stationary target. For a tungsten target and  $t$  0.05 sec., 300 w is the maximum specific input (mWs = max. energy/unit time/unit area). For a target moving  $\phi^2$   $\times$  width of focus in time  $t$ , mWs for the same  $T$  and  $t$  as for a stationary target increases almost  $\phi$  times. In 0.05 sec., a "Rotalix" tube will stand mWs of 2.4 kW., an 8-fold increase. mWs is a maximum for a non-pulsating load. By designed loading and special cooling methods,<sup>36b</sup> radiograph exposures are possible in microseconds.<sup>43</sup> Similarly, with copper anodes, diffraction X-radiograms can be taken in a few secs.<sup>44</sup> Line foci are more efficient than spot foci of equal area.

For continuous output, Müller has treated the case of water-cooled stationary and moving copper targets of varying thickness for both spot and line foci. Assuming a uniform energy

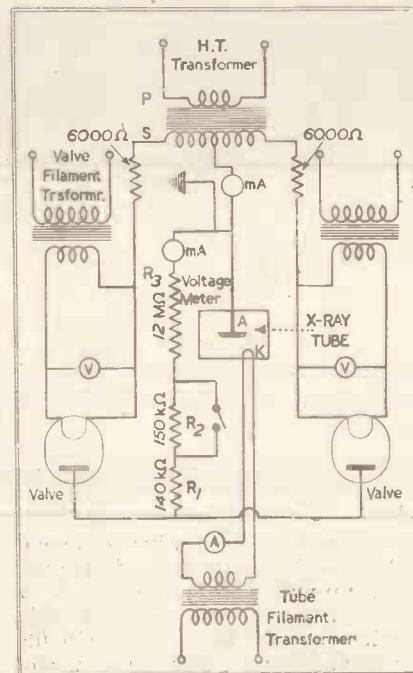

Fig. 11. Secondary Circuits.

† Recently replaced by 28001/MV.

distribution over the focal spot, and a sufficiently large target to permit simplifying boundary conditions, he takes comprehensive account of the heat flow in evaluating the input to maintain a steady limiting surface temperature, which cannot be  $>$ , and in practice lies well below, the M.P. Large specific inputs  $W_s$  are favoured by a high ratio of focal spot dimensions ( $r, a, b$ ) to target thickness ( $l$ ), but safety factor and cooling difficulties preclude small target thicknesses in practice. For  $l \sim 3$  mm,  $mW$  on spot ( $r=0.05$  cm.), and line ( $a=0.5, b=0.05$  cm) foci are  $\sim 0.8$  and  $3.5$  kw., respectively. In general, with certain restrictions,

$$mW^{(stat)} = 4.25 (T - T_0) \cdot k \cdot r \dots (1)$$

$$mW^{(rot)} = 4.04 (T - T_0) \cdot k \cdot r \cdot \sqrt{v \cdot r \cdot \rho \cdot c / k} \dots (2)$$

Line focus

$$mW^{(stat)} = 4.25 (T - T_0) \cdot k \cdot \lambda(a, b) \dots (3)$$

$$mW^{(rot)} = 4.04 (T - T_0) \cdot k \cdot a \cdot \sqrt{v \cdot b \cdot \rho \cdot c / k} \dots (4)$$

or better, taking account of re-entrant path on a finite rotor,

$$mW^{(rot)} = \frac{4.04 (T - T_0) \cdot k \cdot a \cdot \sqrt{v \cdot b \cdot \rho \cdot c / k}}{\left[ 1 + \frac{2a}{\pi^2 R} \cdot (1 + \log_e \frac{4R}{a}) \cdot \sqrt{v \cdot b \cdot \rho \cdot c / k} \right]} \dots (4')$$

- where  $mW$  = limiting input (watts),
- $T$  = limiting temperature (e.g., M.P.) of surface ( $^{\circ}C.$ ),
- $T_0$  = temperature of cooling metal-water interface ( $^{\circ}C.$ ),
- $r, b, a$  = respectively radius, semi-width, semi-length of spot and line foci (cms.),
- $k$  = thermal conductivity of target material (watts/cm. $^{\circ}C.$ ),
- $\rho$  = density of target material (gm./cm. $^3$ ),
- $c$  = specific heat of target material (watt. sec./gm. $^{\circ}C.$ ),
- $v$  = relative velocity of focal spot (cm./sec.),
- $R$  = radius of path of focal spot on target,
- $\lambda(a, b) = \lim_{n \rightarrow \infty} A_n = \lim_{n \rightarrow \infty} B_n$  where
- $A_n \equiv (A_{n-1} + B_{n-1})/2, B_n \equiv \sqrt{A_{n-1} \cdot B_{n-1}}$  for  $n=1, 2, \dots, \infty$ ;  $A_0 \equiv a, B_0 \equiv b$ .

Inserting the values for copper,  $mW^{(rot)}/mW^{(stat)}$  for spot focus is approximately equal to  $\sqrt{v \cdot r}$ . For conditions of focus (a),  $r=0.043$  cm.,

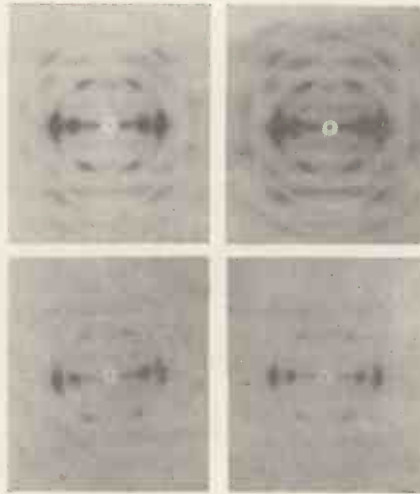

Fig. 12. Ramie. Exposures 7.5, 15, 30, 60 sec. D 2 cm., CuK $\alpha$ ,  $\frac{1}{2}$  mm., slit. (Reduced to 0.8 linear).

$R=8.4$  cm., target speed = 620 r.p.m.;  $\sqrt{v \cdot r}=4.8$ . For our radially set line focus (c),  $a=0.375$  cm.,  $b=0.03$  cm.,

further by foreshortening and other factors; clearly,  $mW_s$  decreases though  $mW$  increases with increasing area of a given type of focus (stationary or rotating target); e.g., for a spot focus,  $r=0.005$  cm., Cu stationary target,  $mW_s=2.4$  kw/mm $^2$ . Note that  $mW \propto \sqrt{v}$ . Taking  $T=300, T_0=20$ , and using (2) and (4)' respectively,  $mW$  for foci (a) and (c) respectively are found, at 620 r.p.m., to be 907, 5,520 watt; i.e., at 30 kV., the safe limiting tube currents are respectively 30, 184 mA.

Possibly Müller's safe estimate is conservative at lower speeds, though Fournier *et al.*<sup>40</sup> using the low speed of 1 r.p.s. hold it in accord. Certainly the earlier formula (4), later modified to (4)', exaggerates the safe limit at really high speeds; for extrapolating towards  $\infty$  the ratio exceeds that of (total path swept out)/(focal area). This upper limit is found correct by Du Mond *et al.*<sup>42</sup> Dealing with large focal areas, they take into account the fact of oscillatory heating cycles by re-entrant path (Müller, on due consideration, finds this negligible for sharp foci), but treat the heat flow as 1-dimensional only, giving a large safety factor from the standpoint of design, for low  $r/l$  ratios.

An excellent treatment for circular and infinite line foci on a stationary anode has been given by De Graaf and Oosterkamp,<sup>41</sup> with special reference to a well-known Philips model. Taking  $T_0=0$ , they find

$$\frac{\pi k T}{mW l} = 2 \frac{b}{l} \log \frac{4l}{\pi e b} \left[ 1 + \frac{b^2}{2l} \right] + 8 \tan^{-1} \frac{b}{2l} \dots (5)$$

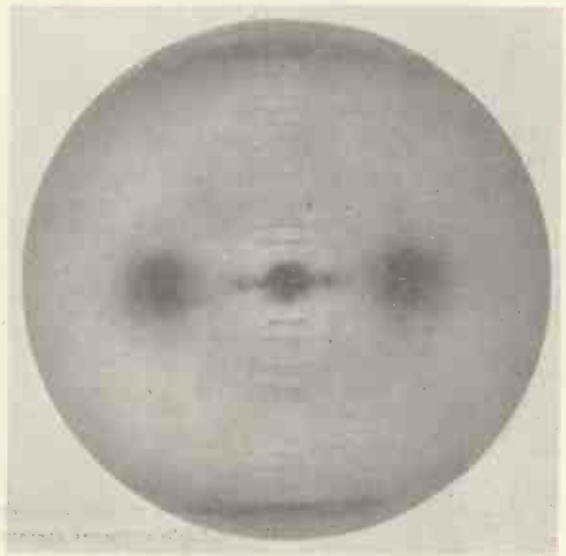

Fig. 14. Fibre X-radiogram of African Porcupine Quill Tip. Plane plate, D 9.8 cm.; CuK $\alpha$  rays: dried, P $_2$ O $_5$  + Vacuum.

whence  $mW = 80 \text{ w/mm}^2$ . For limiting cases of  $b/l \gg \ll 1$ , the temperature gradient at the cooled wall is determined and, for the latter case, the temperature distribution in the focal spot. The curve of the latter may be flattened out by preferential peripheral loading, but this has its dangers. As the optimum  $l$  is that giving the maximum permissible focus temperature with the cooling water just failing to boil,  $l$  and water flow are clearly related. 2-3 mm. for  $l$  is an optimum, taking mechanical safety into account. As shown by Nieukerke,<sup>45</sup> increased efficiency, especially for higher speeds of cooling water, is attainable by suitably shaped anodes. In practice, replacing an infinite sheet by a rotor of finite radius affects  $mW$  slightly, and then only for increasing  $l$ .

While data for existing rotating-anode generators<sup>21, 20</sup> tend to bear out computation, other factors are of practical relevance. The optimum focus depends on the use envisaged; the lesser safety factor with high  $W$ s may be outweighed by economic fac-

tors; a thin target favours high  $W$ s, so far as conditioned by  $T$ , but  $mW_s^{(rot)}/mW_s^{(stat)}$  increases with  $l$ , though  $mW_s^{(rot)}$  itself does not; energy in a focus is never uniform, and may develop "hot spots" with filament wear; cooling efficiency is vital and may fall off through interfacial gaseous layers or "furring" —in the present model, the internal shellacing necessitated by the porous upper casing is an undesirable feature; quite apart from impurity lowering the target M.P., this temperature limit is too high; the cracking induced on the focal path occurs at lower temperatures (a 300° C. safe limit for copper is suggested<sup>21, 20</sup>) and may be an inevitable accompaniment of steep and oscillating temperature gradients with induced crystallographic grain strain and disruption;<sup>46</sup> finally, with merely biphasic rectification, power inputs are higher than quoted for not inconsiderable times, so that a "hunger-and-burst" periodicity occurs (in the present model normally at approximately 10 cm. path intervals); indeed, it may

even be advantageous to avoid synchronism with the speed of the target itself.

**Performance**

The table opposite lists, with some comparable figures, typical performance of the present model with its three focusing systems. When running near their respective  $mW$ s, and for 0.5 mm. pinhole slits, the relative speeds are  $(c) \gg (b) > (a)$ . The speed of (a) with its finely foreshortened beam is practically the same as that of the F-G-M tube, X-radiograms of satisfactory definition and intensity being taken (D 3 cm., 0.5 mm. slit) for rubber, silk, jute, hair, mica, asbestos, quill, etc., in approximately 5 minutes at 16-30 ma., 30 kV. Above 40 ma., the target grooves. That  $mW$ s at  $\sim 1.8 \text{ kw/mm}^2$  is rather lower than practically theoretical values obtained elsewhere,<sup>19, 21</sup> is doubtless due to less efficient cooling. System (c), with its projected focal area of  $0.75 \times 0.6 \text{ mm.}$ , is admirable for general purposes. Fig. 12 (ramie) shows its performance for speed. Definition (e.g., single

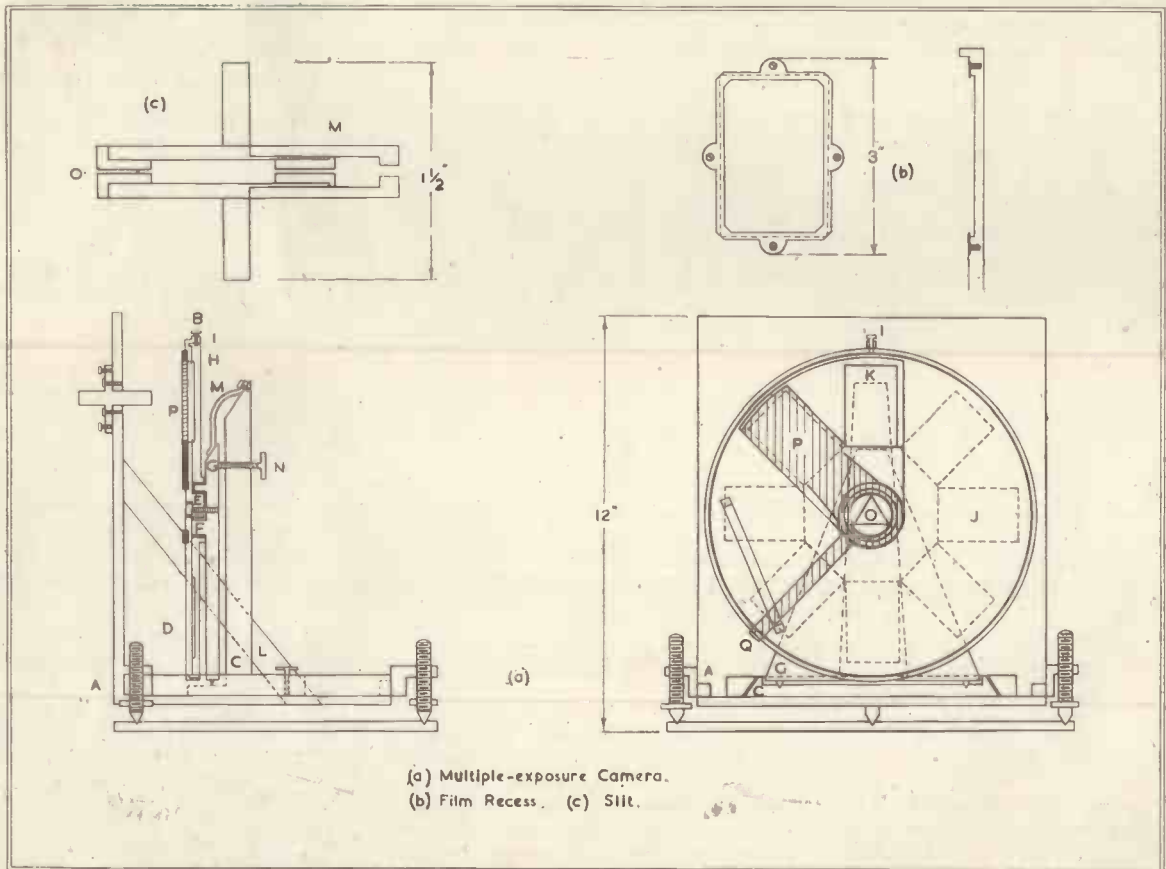

(a) Multiple-exposure Camera. (b) Film Recess. (c) Slit.

Fig. 13. Multiple-exposure camera, as used for component X-radiograms of Fig. 12.

Comparative Performance Table

Source	Normal Running			Focus	Focal Area mm <sup>2</sup>	Ws kw/mm <sup>2</sup>	Speed rpm	Remarks
	mA	kV	kW					
Hosemann	150	10	1.5	Line	2 × 20 = 40	0.038	osctn.	Al target
"	220	10	2.2	do.		(0.082)	120	do.
DuMond	105	287	30	Patch	79	0.38	gyrator	
Müller (a)	150	30	4.5	Line	1 × 10 = 10	0.45	2000	
" (b)			50	Line	1.2 × 30 = 30.60	0.83	do.	Fe target
						-1.67		
Beck	250	40	10.0	Line	1 × 15 = 15	0.67	1200	
"	250	25	6.3	do.		0.42	1800	
F-G-M (a)	60	30	1.8	Spot	0.75	2.4	60	
	80	28	2.2	do.	1.0	2.2	60	target marks
(b)	250	40	10.0	Line	1 × 8 = 8	1.25	180	
Fournier	600						180	1 sec. flash only
Astbury (a)	30*	30	0.9	Spot	0.63	1.43	533	slight marks
	24*	30	0.72	do.		1.14	...	
(b)	70*	30	2.1	Line	.8 × 3.5 = 2.8	0.7	...	slight marks
(c)	70*	30	2.1	do.	.6 × 7.5 = 4.5	0.47	620	◀mWs
Rotalix	200—	30		Line	2 × 7.5 = 15	2.0	1200	0.05 sec. flash
	400							Cu—W target

\* A discrepancy between the expected emissivity of the Ta wire used in the filament, the heating effect on R<sub>1</sub> and R<sub>2</sub>, the excessive power loss compared with that recorded as passing through the generator, and the apparent lack of closer approach to theoretical mWs was examined recently. By thermal and other measurements, it was shown that the real input was double that being recorded. A check showed this due to a millimeter mis-setting, now rectified. The currents quoted earlier<sup>47</sup> should therefore be doubled.

crystal work) is also excellent. Fig. 14 shows the precision and detail securable<sup>48</sup> even for a moderately well organised natural fibre (keratin, protein of porcupine quill) using really fine slits and longer exposures.

Future Developments

The high-power moving-anode X-ray generator is now in marked demand in science and industry generally. There is ample scope for novel design. Little attention has been given to the gas type; with the hot filament type, the electronics, e.g., by electron microscope methods, would repay study, and it seems probable that grid control and magnetic focusing of beams from a sturdy filament will be a future trend; the present movements, seals, vacuum controls, drive, and cooling methods are by no means exhaustive. With the characteristic features of our own model retained, improved workshop facilities, the experience of usage, and the expanding needs of fundamental fibre-structural research have focused attention on detail improvements embodied in Model 3, now

under test. Of more robust engineering and precision construction, this model incorporates forced jet cooling immediately at the focal spot, absence of rotating water-joint, thrust vice ball-races, increased rotational speed with even less vibration and friction, a fixed mercury cup of lower capacity, more powerful pumping equipment with semi-automatic control, simpler assembly and dismantling—in particular, the target is removable without disturbing the Hg+oil seal. With much of the assembly, erection and test, Dr. C. J. Brown (of I.C.I., Ltd.) has given valued assistance. Model 3 should prove more flexible in use, and a report on its performance will be presented in due course.

Acknowledgments

The writer's warmest thanks are again due to Dr. W. T. Astbury, F.R.S., for his genial direction of this and kindred work, carried out under the joint auspices of the International Wool Secretariat and University Authorities, in the Textile Physics Research Laboratories, University of Leeds.

REFERENCES

PART I

- Hess, Z. Krist., 97, 107, (1937).
- Scemann, Ann. Physik, 6, 1, (1930).
- Frevel, Rev. Sci. Instr., 8, 475, (1937).
- George, Nature, 136, 180, (1935).
- Stephen and Barnes, Nature, 136, 793, (1935); 137, 532, (1936).
- Brentano, Nature, 136, 988, (1935).
- Fankuchen, Nature, 139, 193, (1937).
- Johann, Z. f. Physik, 69, 185, (1931).
- Cauchois, C.R., 194, 362, 1470, (1932); J. de Phys., 3, 320, (1932); 4, 61, (1933).
- Johansson, Z. f. Physik, 82, 507, (1933).
- Watson, Rev. Sci. Instr., 8, 480, (1937).
- Günther, C.R., 204, 1115, (1937); Ann. de Phys., 12, 161, (1939).
- C. S. Smith, Rev. Sci. Instr., 12, 312, (1941).
- DuMond and Kirkpatrick, Rev. Sci. Instr., 1, 88, (1930). Kirkpatrick, Rev. Sci. Instr., 12, 552, (1941).
- Jentzsch and Nähring, Z. f. techn. Phys., 12, 185, (1931). Nähring, Z. f. techn. Phys., 15, 151, (1934).
- Bowers, Physica, 10, 125, (1930); Fortsch. a. d. Geb. d. Röntgenstr., 48, 232, (1933).
- DuMond and Youtz, Rev. Sci. Instr., 8, 291, (1937).
- Hosemann, Z. f. techn. Phys., 20, 203, (1939).
- Fournier Gondet and Mathieu, J. de Phys., 8, 171, (1937).
- Stintzing, Phys. Z., 27, 844, (1926); Metallw., 17, 761, (1938).
- Müller and Clay, P. Phys. Soc., 46, 703, (1934). J. Inst. El. Eng., 84, 261, (1939).
- Beck, Physikal. Z., 40, 474, (1939).
- Linnitzki and Gorski, Techn. Phys. U.S.S.R., 3, 220, (1936).
- Astbury and Preston, Nature, 133, 460, (1934).
- Bowers, Br. J. Radiol., 5, 311, (1932); Strahlenther., 38, 157, (1930).
- Eisenstein, Rev. Sci. Instr., 13, 208, (1942).
- Machlett, J. Appl. Phys., 13, 398, (1942).
- Dershem, Rev. Sci. Instr., 7, 86, (1936). Stephenson and Sylvester, Rev. Sci. Instr., 12, 448, (1941).
- Bowers, Physica, 2, 145, (1935).
- Knoll, et al, Z. f. Phys., 96, 612, (1935). Dosse and Knoll, Arch. f. Elektrotechn., 29, 729, (1935). Dosse, Z. f. techn. Phys., 17, 121, (1936).
- Danilow, Techn. Phys. U.S.S.R., 2, 444, (1935).
- Ruhemann, Techn. Phys., U.S.S.R., 5, 206, (1938).
- McCue, Rev. Sci. Instr., 14, 389, (1943).
- Beese, Rev. Sci. Instr., 8, 258, (1937).

PART II

- Breton, "Les Rayons Cathodiques et Rayons X," Rev. Sci. et Ind., (1890).
- Pohl, Exhibit, Internat. Congr., Stockholm.
- Gross and Attlee, Am. J. Roentgenol., 276 (1939). Pilon, Soc. Fr. Electr. Bull., 10, 31, (1940). Carson, Radiology, 37, 338, (1941).
- Bowers, Z. f. techn. Phys., 8, 271, (1927).
- Abbott, J. Appl. Physics, 13, 384, (1942).
- Müller, P. R. Soc., A 117, 30, (1927); 125, 507 (1929); 132 646, (1931).
- De Graaf and Oosterkamp, J. Sci. Instr., 15, 293, (1938).
- DuMond, Watson and Hicks, Rev. Sci. Instr., 6, 183, (1935).
- Oosterkamp, Phil. Techn. Rev., 5, 22, (1940).
- Fournier, Soc. Fr. Electr. Bull., 9, 531, (1939). cf. also Fig. 12.
- Nieukerke, Physica, 6, 721, (1939).
- Brech, J. Sci. Instr., 18, 101, (1941).
- Inaug. Mtg., X-Ray Analysis Group, Inst. of Phys, Manchester, Oct. (1943).
- MacArthur, Nature, 152, 38, (1943).

# High Vacuum Gauges

By M. PIRANI, Dr.Phil., F.Inst.P., F.S.G.T., and R. NEUMANN, Dipl.Ing.

## Part II.

FOR the quantitative measurement of low pressure the following properties of the substances concerned may be used: (a) weight, (b) elasticity, (c) heat conductivity, (d) ionisation, (e) disordered or partially ordered molecular movements of the gas.

### (a) Weight

The chief representative is the McLeod gauge first proposed in 1874. It is based on a direct application of Boyle's law. Fig. 8 shows its original shape and the following is an abstract of McLeod's description:—<sup>26</sup>

"The tube (a) communicates with the Sprengel and with the apparatus to be exhausted, (b) is a siphon barometer with a tube about 5 mm. in diameter; the principal parts of the measuring apparatus consist of (c), a globe of about 48 cm.<sup>3</sup> capacity with the volume tube at the top, and (d) the pressure tube; these two are exactly of the same diameter to avoid error from capillarity. The tube at the bottom of the globe is ground into a funnel-shaped portion at the top of the wide tube (e); and to the side of the latter the pressure tube (d) is joined. The volume-tube at the top of the globe is graduated in millimetres from above downwards, the lowest division in this particular apparatus being 45; the pressure tube (d) is also graduated in millimetres, the (0) being placed at the level of the 45th division on the volume tube. A ball and socket joint connects the bottom of (c) with a vertical tube (f) about 800 mm. long which is connected at its lower extremity by means of a flexible tube with the mercury reservoir (g); a stop cock (h) permits the regulation of the flow of mercury into the apparatus."

The principle of the gauge consists in separating a certain volume of gas and compressing it by mercury to a certain other volume and then measuring the difference of the mercury level in a closed capillary and a capillary connected to the apparatus to be exhausted. Some continental writers call this "Arago's method." In fact, Arago and Dulong used a similar principle about 115 years ago in their investigations on steam pressure." Their report was ordered by

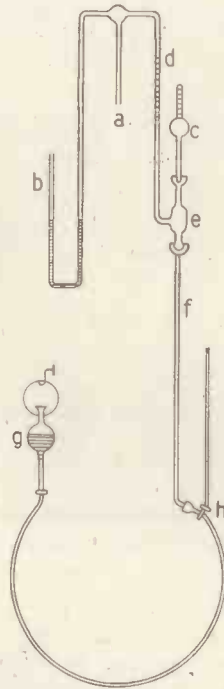

Fig. 8. Original McLeod gauge.

the French Académie des Sciences for furnishing to the French Government the foundations for legislature concerning safety measures for preventing boiler explosions. As a by-product experiments for investigating the validity of Boyle's law could be carried out at considerably higher pressures than before. As a mercury column of 75 to 80 ft. was required the experiments were carried out in an unused bell tower of the old church of St. Genevieve in the Collège Royal of Henri IV. The tube for the mercury column consisted of 13 lengths of 2 m. each of crystal glass 5 mm. inside, 15 mm. outside diameter. To relieve the bottom parts of the tube from the pressure exerted by the upper parts each length of tube was separately balanced by counter weights. The mercury levels inside this tube and a closed manometer tube and the volume of the air compressed in the latter were measured.

McLeod's improvements of the method used by Arago consisted in the use of a globe of a given volume

beneath the "volume tube" or closed capillary and in the convenient method of raising the mercury by lifting the reservoir connected with the gauge proper by a flexible tube.

The ratio between the volume of the globe and the volume of that part of the closed capillary which, when the mercury has been raised, contains the compressed gas determines the measuring range of the gauge.

If a quantity of gas of volume  $V$  and pressure  $p$  is compressed at constant temperature to the smaller volume  $v$  the pressure  $P$  is according to Boyle's law determined by the equation

$$Vp = vP$$

Two different methods are used for reading a McLeod gauge.

If  $C_x$  is the distance between the top of the closed capillary and the mercury level,  $C_y$  the difference between this level and the mercury level in the open capillary (Fig. 9),  $k$  the volume of 1 mm. of one of the capillaries we have

$$v = kC_x \quad P = C_y$$

$$p = \frac{vP}{V} = \frac{kC_x C_y}{V} = k_1 C_x C_y$$

With the first method the mercury column is lifted until the level in the open capillary flushes with the top of the closed capillary so that

$$C_y = C_x$$

and

$$p = k_1 C_x^2$$

The pressure is therefore read on a quadratic scale starting from the top of the closed capillary.

With the second method  $C_x$  is kept constant and we have

$$p = k_2 C_y$$

so that  $p$  may read on a linear scale on the open capillary.

The above explains also why the closed capillary is called "volume tube" and the open capillary "pressure tube."

For very exact measurements it used to be necessary to determine exactly the volumes of the globe and of the capillary at its different heights as it was not possible to draw the capillaries so that they have



exactly the same diameter throughout. With modern instruments the manufacturer guarantees the equality of the diameters of the closed capillary and the pressure tube. Also the shape of the meniscus and its difference for upwards and downwards movement of the mercury must be taken into account.<sup>28,29</sup> Besides, it is necessary to clean the mercury and the glass parts of the instruments very thoroughly.<sup>30</sup>

While the principle of the McLeod gauge remained the same since its invention various modifications have been proposed for its improvement. A few of them may be mentioned. In order to obtain a rapid equalisation of pressure between the vacuum to be measured and the gauge the tube connecting the two is made with a large diameter and the pressure capillary having the same diameter as the closed capillary is branched from this tube as shown in Fig. 9.

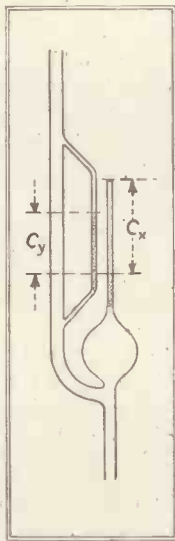

Fig. 9. Head of McLeod gauge.

According to C. H. Gimingham<sup>31</sup> the volume tube carries at its top a short piece of carefully calibrated thermometer tubing. For lower exhaustions the air is compressed into the wider portion of the volume tube, for higher exhaustions into the thermometer tube. Two pressure tubes with diameter corresponding to that of volume tube and thermometer tube respectively are provided. Also more than two different diameters have been proposed.

More recent types of the McLeod gauge specially aim at dispensing with the flexible tubing of the original

design. This is important since the rubber which is used for this flexible part tends to age and then allows air to enter the gauge and the vacuum system and also contaminates the mercury. The gauge becomes dirty and the readings inaccurate. Figs. 10 and 11 show the rubberless gauge of W. Edwards & Co., Ltd., in which besides large parts of the apparatus are made of stainless steel. This design is due to O. Seitz. (Swiss Patent 87,996.)

No grease is required for a smooth operation of the telescopic tubes. A felt packing at the upper opening of the mercury reservoir is sufficient for preventing the mercury from creeping along the outside of the smaller stainless steel tube. Figs. 12 and 13 show the principle of the bench type of Edwards, in which a two-way top allows the raising and lowering of the mercury by connecting the mercury reservoir either to the open air or to a rough vacuum supply. This latter improvement is analogous to that proposed 1865 by Poggendorff and T. R. Robinson for Geissler's vacuum pump.<sup>32</sup>

To reduce the necessary amount of mercury and the time of measurement

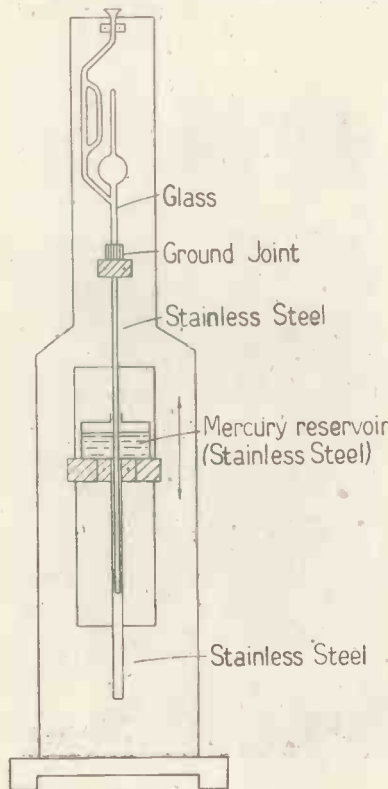

Fig. 10. Rubberless McLeod gauge.

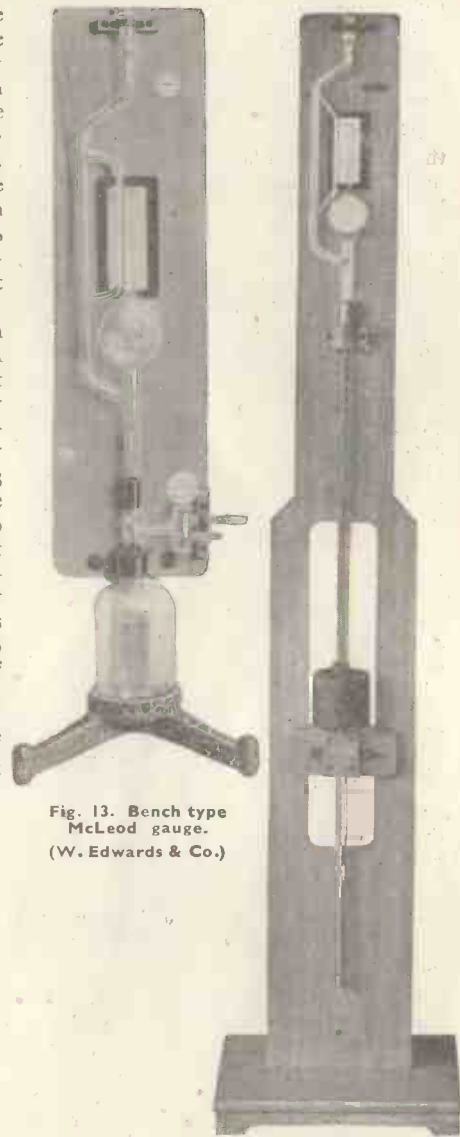

Fig. 13. Bench type McLeod gauge. (W. Edwards & Co.)

Fig. 11. Rubberless McLeod gauge. (W. Edwards & Co.)

Stintzing proposed the use of a displacing body introduced into the measuring space (German Patent 384,423). Another proposal by Stintzing tends to extend the range of measurement by arranging at the top of the volume tube a discharge tube. He claims that by this means a vacuum of  $10^{-8}$  mm. Hg. may be measured (German Patent 391,973).

A modification quite frequently used on account of its small size and its portability is Edwards "Vacustat" based on an invention of M. Brunner<sup>33</sup> and consisting of a container and tubing rotatably arranged with its

direct reading scale on a metal stand (Fig. 14). A somewhat similar design was proposed by Gaede (Vacuscope).<sup>34</sup> Their range lies, however, only between 10 and  $10^{-3}$  mm. Hg.

Also a displacing body dipping into the mercury but actuated electromagnetically was proposed by M. Schenkel (German Patent 412,409). A robust instrument based on this principle was recently developed by Messrs. Tills and Potts, Birkenhead. It also uses another principle according to which, by arranging an overflow in the pressure tube, only the Hg level in the capillary needs to be read (Weintraub, German Patent 457,016). By these means a compact, accurate and reliable instrument is obtained avoiding the use of a barometric column of liquid, a rough vacuum supply, tilting or other inconveniences. The gauge is made largely of metal and has easily interchangeable gauge glasses so that, for instance, pressures between  $10^{-3}$  and 4 mm. Hg are read on a gauge glass of  $3/32''$  bore, whilst with a gauge glass of  $5/32''$  bore pressures between  $10^{-2}$  and 11 mm. Hg may be read. The instrument is manufactured by J. W. Tills & Co., Ltd., Wallasey, and sold by the General Engineering Co. (Radcliffe), Ltd. Principal use of this gauge is made in dielectric impregnating plants.\*

If the results of measurements with the McLeod gauge should prove to be not sufficiently reproducible there may be several causes:—

(1) Temperature not constant. This cause is not frequently met with as a change in temperature of, say,  $14^{\circ}$  C. causes an error of 5 per cent., and it is quite unusual that so large changes of temperature occur if measurements are compared.

(2) Mercury or containers soiled. As was stated before, both require a thorough cleaning before starting work and occasionally in the course of the operation. The cleaning of the mercury is best done by leading a current of air through it and then filtering it. Distillation *in vacuo* is recommended for obtaining cleanest mercury. The cleaning of the glass container is first done with nitric acid for removing organic substances, then with ammonia for removing

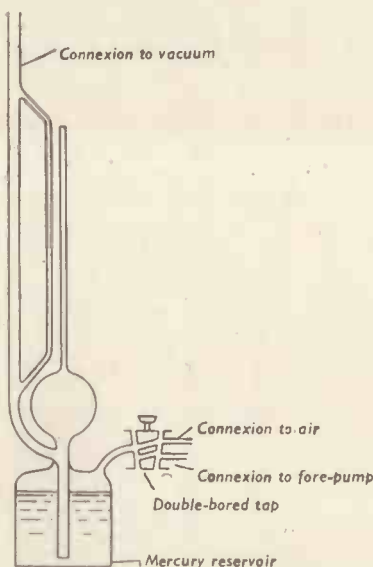

Fig. 12. Bench type McLeod gauge.

alkalis and some of the fats or greases, then with distilled water and finally with alcohol to remove the rest of the fats. A subsequent treatment with ether is not recommended as it usually contains some fats and thus contaminates the glass again. Preferable is a soap solution and boiling water and a subsequent heating

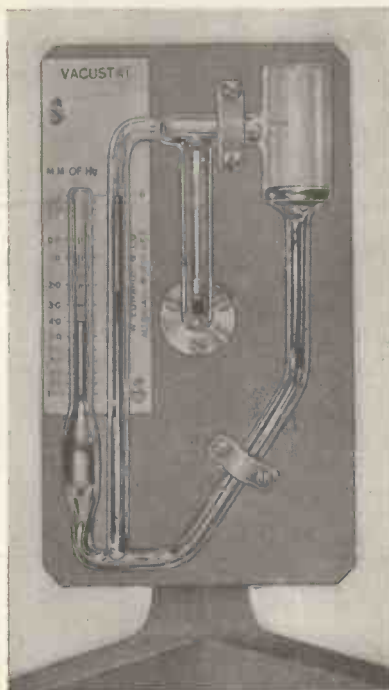

Fig. 14. The "Vacustat."  
(W. Edwards & Co.)

for removing traces of water. If this heating process is not possible washing with chromosulphuric acid is recommended.

If after heating and evacuating a small quantity of vapour or of another gas of, say,  $10^{-4}$  to  $10^{-5}$  mm. pressure is admitted to the vessel it will disappear immediately as it is immediately adsorbed by the glass walls. As Dr. B. P. Dudding put it in the introduction to the discussion of the Electronics Group of the Institute of Physics, June 10, 1944: "After baking to the highest possible temperature *in vacuo*, your glass wall is a most powerful pump in your circuit."

(3) Small leaks in some parts of the vacuum system. A convenient method for detecting leaks is illustrated in Fig. 15. A wire electrode is introduced in the vacuum system and a wire provided with a piece of cotton wool soaked in alcohol is applied on the outside where the leak is suspected. High frequency is applied to the two electrodes and the leak is easily located as a white pencil of light emerges from it extending to the fixed electrode. The discharge stops as soon as the outer electrode is removed as the pump draws the gases away. In case of an emergency leaks may be sealed with apiezon wax or a solution of ethyl cellulose in toluene (m.p. about  $150^{\circ}$  C.) may be used for the purpose, although this cannot be recommended as a proper measure.

Of course, these considerations refer not only to measurements made with the McLeod gauge but also to vacuum systems in general.

Many investigations have been made for testing the accuracy of measurements made with the McLeod gauge. Only one of them shall be mentioned here as it was based on an instrument also using the weight principle. The instrument was proposed by Prof. Paschen, Erlangen, and the investigations were carried out by F. Hering, who was also responsible for its actual design (1906). The instrument compares the mercury levels of a Tomicelli vacuum and the vacuum to be measured by a micrometer screw allowing of an accuracy of exact measurement down to  $10^{-3}$  mm. Hg, while vacua of  $10^{-4}$  mm. Hg may easily be estimated. For determining the exact levels platinum points making contact with the mercury surface are used. The moment of contact is indicated by a galvanometer.<sup>35</sup>

\* We have to thank Messrs. Tills and Potts for drawing our attention to the fact that in dielectric impregnating plants, much smaller pressures than those given in Table 2, line 5, are used. In fact, those figures were not meant to apply to this kind of work. But we realise that as this is a very important application it should be mentioned separately.

On a similar principle work the manometers of Lord Rayleigh (1901)<sup>30</sup> and the "optical lever gauge" of S. E. Shrader and H. M. Ryder (1919).<sup>37</sup> With these instruments the mercury levels are compared by a light beam and mirror arrangement. They measure total pressure and not only partial pressure as the McLeod gauge does and can, therefore, rank in the files of absolute manometers.

As the vapour pressure of mercury is of the order of  $10^{-6}$  mm. Hg at room temperature in measuring higher vacua the freezing out of the vapour by means of a liquid air trap is recommended for exact measurements. If all precautions are taken the range of the McLeod is of the order of  $10^{-6}$  mm. Hg (Knudsen)<sup>38</sup> or even  $5 \times 10^{-6}$  (Simon).<sup>39</sup> The capillary should not be smaller than 1 mm. diam. as otherwise impurities impair the exactness of measurement. The final volume should not be smaller than 2 mm.<sup>3</sup> and the length of the mercury column corresponding to this volume not smaller than 5 mm. Some people use the "sticking" of the mercury in the capillary which is observed by a slow lifting and lowering of the column as a yardstick for a very good vacuum, probably under  $10^{-6}$  mm. Hg. But this sticking effect is probably due to a gas layer adsorbed in the upper part of the capillary. The layer is very thin with very low pressures so that surface forces of the glass wall are able to retain the mercury surface. Actually, if before measurement the gas skin is removed by heating the effect starts at higher pressures. Therefore this criterion is not believed to be a very reliable one.<sup>40</sup>

As the McLeod gauge is based on the validity of Boyle's law as a matter of principle it should only be used with perfect gases. For imperfect gases the following relation

$$\frac{p_0 V_0}{p_1 V_1} = 1 + \lambda \text{ may be used,}$$

$p_0$  being a very low pressure and  $p_1$  atmospheric pressure. For  $\lambda$  Farkas and Melville give the following values:—<sup>41</sup>

CO <sub>2</sub>	0.07
C <sub>2</sub> H <sub>2</sub>	
C <sub>2</sub> H <sub>4</sub>	
C <sub>2</sub> H <sub>6</sub>	
N <sub>2</sub> O	
SO <sub>2</sub>	0.0234
NH <sub>3</sub>	0.015
PH <sub>3</sub>	1600.0

M. Francis—dealing mainly with the sorption effects of the walls—gives a detailed account of the use of

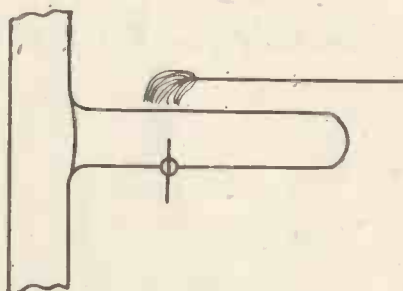

Fig. 15. Detection of leaks.

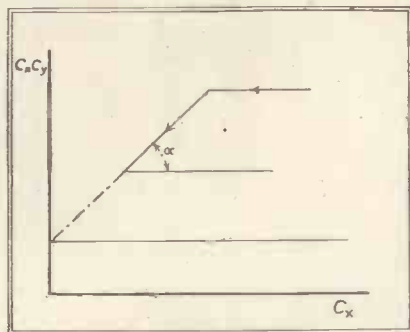

Fig. 16 Method for determining vapour pressure.

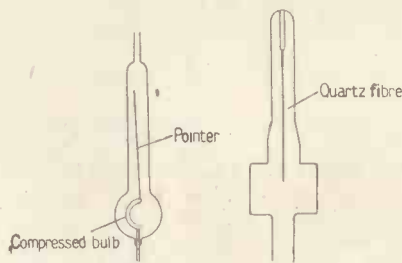

Fig. 17. Bourdon type gauge.

Fig. 18. Quartz fibre gauge.

the McLeod gauge with non-permanent gases.<sup>42</sup>

It is even possible to use the McLeod gauge for establishing the presence of condensable vapours. The method was communicated to us by a mutual friend who has asked us not to disclose his name. The method is based on the second method mentioned above of reading a McLeod gauge.  $C_x$  (see Fig. 9) is the length of the capillary section into which the gas and vapour is compressed and  $C_y$  the length of the mercury column indicating the pressure. Omitting proportionality factors we have

$$C_x = v = \frac{a}{p_x} \text{ (for a permanent gas)}$$

where  $a$  is a constant and  $p_x$  the pressure of the permanent gas. Calling

the vapour pressure of the saturated vapour  $p_0$  we have

$$C_y = p_x + p_0$$

If we now plot the product  $C_x \times C_y$  as ordinate against  $C_x$  as abscissa (Fig. 16) we obtain a straight line parallel to the abscissa if no condensable vapour is present or if the compression is so low that no condensation takes place. As soon as with higher compression a condensation starts the sloping line

$C_y \times C_x = C_x \times p_x + C_x \times p_0$  will be obtained which is of the form  $y = a + bx$

with  $b = \tan \alpha$ , which angle  $\alpha$  indicates the magnitude of the saturation pressure. Extrapolation to  $C_x = 0$  gives the gas pressure as indicated in the drawing.

(b) Elasticity

Gauges based on elasticity either measure the distortion of a solid body under the pressure applied or they determine the time necessary for damping the oscillations of a vibrating fibre. This time will depend on pressure and on the properties of the gas.

The first-named principle underlies the well-known Bourdon-type manometer used for higher pressures. Modifications of this manometer to make it applicable for measuring higher vacua were first made as early as 1906 by Ladenburg and Lehmann.<sup>43</sup> Fig. 17 shows a modification of this type of gauge which is in quite extensive use to-day, although suitable for higher pressures only (0.1—1 mm. Hg.<sup>44</sup>). A flattened bulb mounted inside a glass envelope carries a long pointer which allows of observing the magnified movements of the bulb and usually by means of a microscope with an eye-piece scale. Also mirror reading has been applied to this type of gauge. In another modification the distortions of a long quartz spiral are measured either directly or with mirror reading.

The second principle is used in the quartz fibre manometer first proposed by Haber and Kerschbaum.<sup>45</sup> As a predecessor of this gauge the one described by Sutherland should be mentioned which is based on the principle used by Maxwell and by Kundt and Warburg for determining the viscosity of gases from the logarithmic decrement of the oscillations of glass plates suspended on a torsional wire opposite fixed glass plates. Haber and Kerschbaum's manometer is much simpler. It is shown in Fig. 18. Langmuir had

# Low Frequency Photo-

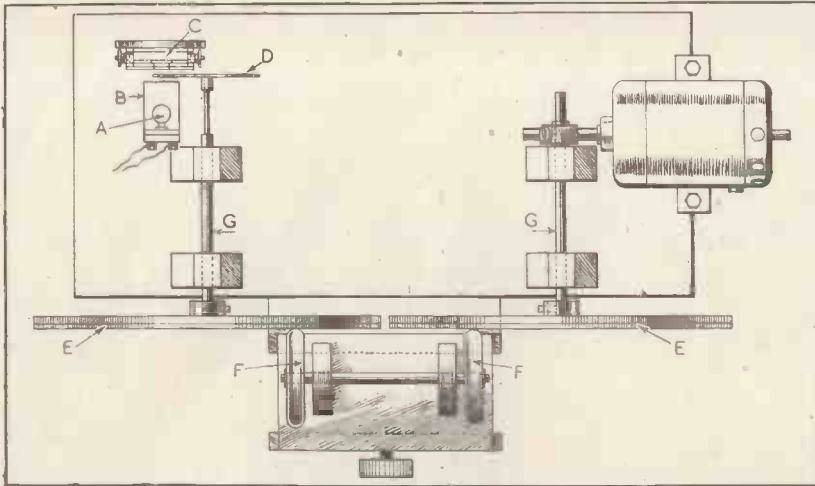
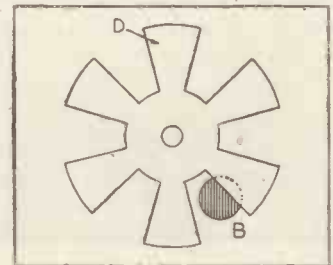
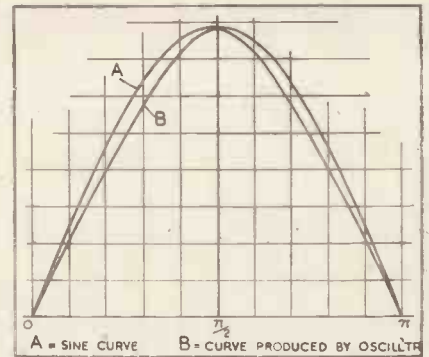

Fig. 1 (top right). Curve produced by the oscillator of Fig. 2, showing departure from sine wave-form.

Fig. 2 (above). Form of simple photo-mechanical oscillator using a sector disk and variable speed drive.

Fig. 3 (lower right). Sector disk and aperture.



## High Vacuum Gauges (continued)

observed in 1913 that a vibrating wire enclosed in an evacuated bulb takes quite a considerable time (115 minutes) in order to reach its half-time value. In the quartz fibre manometer use is made of this observation. The quartz fibre of 0.1-0.4 mm. diam. and about 10 mm. length is suspended in a suitably-shaped container. The oscillations may be started from outside either by simply shaking the container or by a magnet acting on a piece of iron contained in a glass pivot movable in sockets inside the container. The time in which the oscillations are damped to half their initial amplitude is given by the relation.

$$t = b / (\phi M - a)$$

where  $\phi$  is the pressure,  $M$  the mol. wt. of the gas,  $a$  a constant depending on the elasticity of the fibre and on temperature,  $b$  a constant depending on the thickness of the fibre.

A. S. Coolidge proposed a bifilar arrangement of the vibrating system. By this means the system is forced to vibrate in a plane while in the original design the formation of Lissajous figures impaired the exactness of the measurement.<sup>46</sup>

As was shown by G. Wetterer<sup>47</sup> the

sensitiveness of this arrangement at low pressures may be materially improved by attaching a quartz calotte of a few  $\mu$  thickness to the two quartz fibres where they are fused together. He also gives measured and calculated pressure-time characteristics in double logarithmic scale both for instruments with and without the damping calotte. Instead of using quartz fibre a quartz strip may be used. The properties of such a manometer applicable for pressures between  $2 \times 10^{-2}$  and  $5 \times 10^{-4}$  are given by Brüche in his Danzig thesis.<sup>48</sup>

In another modification proposed by King<sup>49</sup> two crossed silica fibres are used, the vertical one being extended between two fixed points, the horizontal one carrying at its ends small fused spheres which reflect light from a lamp through a lens and prism to a photographic plate.

The quartz fibre manometer is sometimes called a friction manometer or a viscosity gauge as the viscosity of the surrounding gas influences the damping effect. As was shown by Kundt and Warburg<sup>50</sup> viscosity depends on pressure only if the free path of the molecules becomes comparable with the dimensions of the apparatus. Therefore, an upper

pressure limit exists for this kind of gauge.

The lower pressure limit is reached when the density of the molecules is so small that no friction effects can be discerned any more.

### References

- 26 McLeod, *Phil. Mag.*, 68, 110, 1874.
- 27 Arago and Dulong, *Ann. de Chim. and de Phys.*, 43, 74, 1930.
- 28 Ref. 4, pp. 69-71.
- 29 Ref. 6, p. 126.
- 30 Ref. 1, p. 88, ref. 4, p. 65, ref. 10, pp. 23-24, 192-194.
- 31 Gimmingham, *J. Soc. Chem. Ind.*, 3, 83, 1884.
- 32 Poggenorff, *Pogg. Ann. Phys.*, 125, 151, 1865.
- 33 Robinson, *Phil. Mag.*, IV 28, 235, 1864.
- 34 Brunner, *Helv. chim. acta*, 13, 915, 1930.
- 35 Ref. 10, p. 61.
- 36 Hering, *Ann. d. Phys.*, 21, 319, 1906.
- 37 Lord Rayleigh, *Phil. Trans.*, A 190, 205, 1901.
- 38 Shrader and Ryder, *Phys. Rev.*, 13, 321, 1919.
- 39 Knudsen, *Ann. d. Phys.*, 28, 75, 1909.
- 40 Simon, *Z. techn. Phys.*, 5, 221, 1924.
- 41 Ref. 5, p. 150.
- 42 Ref. 11, p. 76.
- 43 Francis, *Trans. Far. Soc.*, 31, 1325, 1935.
- 44 Ladenburg and Lehmann, *Verh. Dtsch. Phys. Ges.*, 8, 20, 1906.
- 45 Ref. 11, Fig. 56.
- 46 Haber and Kerschbaum, *Z. Elektrochem.*, 20, 296, 1914.
- 47 A. S. Coolidge, *J. Am. Chem. Soc.*, 45, 1637, 1923.
- 48 Wetterer, *Z. techn. Phys.*, 20, 281, 1939.
- 49 Brüche, *Ann. d. Phys.*, 79, 695, 1926.
- 50 King, *Proc. Phys. Soc.*, 38, 80, 1925.
- 51 Kundt and Warburg, *Poggend. Ann. Phys.*, 155, 337 and 525, 1875.

(To be continued.)

# Mechanical Oscillators

By G. R. BALDOCK, B.Sc.,

and W. GREY WALTER, M.A.\*

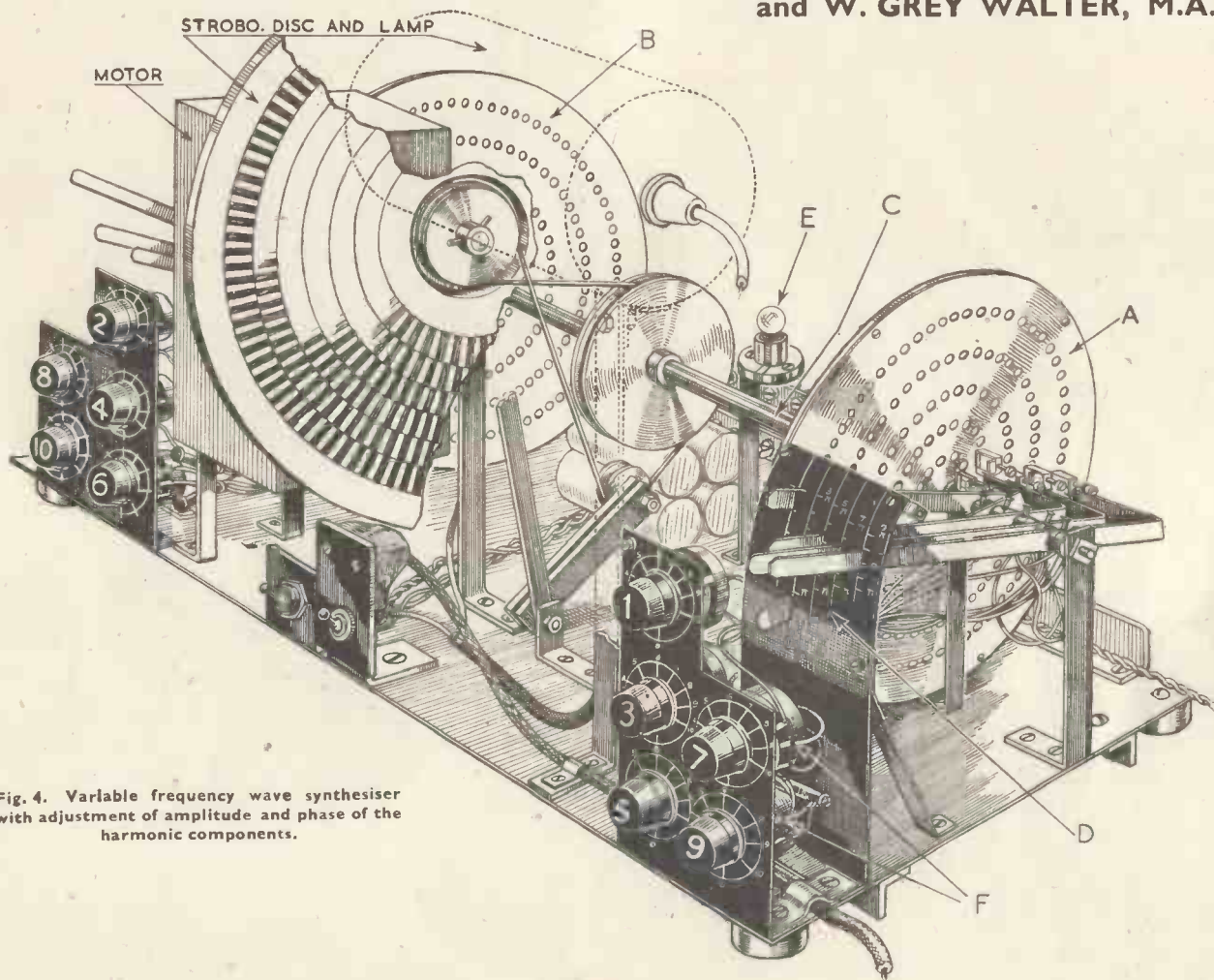

Fig. 4. Variable frequency wave synthesiser with adjustment of amplitude and phase of the harmonic components.

LOW frequency oscillations of constant waveform and good frequency stability can be produced by a variety of RC-coupled feed-back circuits. Greater simplicity and ease of control can be achieved by means of a photo-mechanical generator,<sup>1</sup> and this method is of particular value when frequencies below 10 c/s. are required. In this range the photo-oscillator has the following advantages over the electronic type:—

(1) The amplitude is independent of the frequency.

(2) The frequency can be accurately set by a stroboscopic method.

A waveform containing about 5 per cent. of odd harmonics is obtained by the movement of a straight shadow across a circular aperture. (Fig. 1, Curve B.) An oscillator constructed on this principle is represented diagrammatically in Fig. 2.

A beam of light is produced by means of a small bulb A mounted inside a metal cylinder B, opposite which is a circular aperture with a selenium cell C behind it. Between the aperture and the light is a disk D cut as shown in Fig. 3, so that

the width of each sector is equal to the width of each cut out sector, and to the diameter of the aperture. It is driven on a spindle connected to a variable-speed device consisting of two large disks E coupled by a pair of tyred pulleys F, whose positions can be adjusted to give a speed range of 100:1. The spindle G is driven by a geared down 1/32 H.P. induction motor.

With a 1-watt bulb, the maximum output is 5 mV. and the oscillator is designed to run from 1 c/s. to 100 c/s.

\* Burden Neurological Institute.

### Continuous Waveform Generator

The oscillator described above can be adapted to produce continuous oscillations of any desired waveform by the following means.

The sectored disk is replaced by a drum of about 10 inches diameter, with narrow slits parallel to its axis cut at equal intervals round its circumference. The light source is placed inside the drum near the axis, and a selenium cell is mounted close to the periphery, so that the slits scan the cell as the drum rotates. (The EEL size 37×50 mm. was found to be convenient.)<sup>2</sup> In the cell mounting there is a curved slot into which can be inserted a mask consisting of a variable width tracing of the wave to be reproduced. This is made either on film or in the form of a metal cut-out. A much purer sine wave is obtained by this method. The generator is useful for obtaining the Fourier analysis of a given waveform. A mask of the same shape is inserted into the slot, the machine is run at a suitable speed, and the output is fed into a low frequency analyser.

This system is particularly useful in dealing with aperiodic complex waveforms, as it can convert a section of record into a continuous periodic function, a process which would be exceedingly difficult to carry out with valve circuits.

### Wave Synthesiser

In investigations on biological oscillations it has been found that not only the relative amplitudes, but also the phase relations of the different harmonics in the waveform, are significant. As a wave analyser cannot indicate the phase relations they have to be determined by a graphical method.<sup>3</sup> To avoid laborious arithmetic, a multiple oscillator has been constructed to produce any waveform containing no harmonics higher than the tenth, the amplitudes and phases relative to the fundamental being adjustable to any desired values. To obtain the phase analysis of a given waveform the amplitudes are set according to the analysis, and the phases are adjusted until a waveform similar to the original is produced. The scale readings then give the approximate values of the phase angles.

The synthesiser consists essentially of two disks A and B (Fig. 4) fixed on a spindle C. In each disk are drilled five rings of holes, A giving the fundamental and 3rd, 5th, 7th

and 9th harmonics, and B the 2nd, 4th, 6th, 8th and 10th. The ring producing the *n*th harmonic contains 6*n* holes, its radius being such that each hole, and the space between each

hole, subtends an angle  $\frac{\pi}{6n}$  at the centre of rotation. Opposite each ring a selenium cell is mounted, with an aperture of the shape shown in Fig. 5, the angle between the sides of the aperture being also  $\frac{\pi}{6n}$ . This

produces the waveform of Fig. 1. The cells are fixed to levers which can rotate about an axis in line with the spindle C and the ends of the levers are movable across scales D calibrated in radians for phase setting. The light source is a small bulb E placed so as to give a fairly even illumination of all the cells, whose outputs are equalised by loading them with suitable resistances. Potentiometers F are connected across the cells, so that the relative amplitudes can be altered at will, and the outputs from these are connected in series to the output terminals.



Fig. 5.

Thus any p.d. of the form  $\sum_{n=1}^{10} a_n \sin(2\pi nft + \alpha_n)$  can be produced, where *f* is the fundamental frequency.

The spindle C is driven by a belt from a variable-speed gramophone motor to which is fitted a stroboscopic disk providing a series of accurate frequency standards. The lines are made clearer by using a neon lamp as 100-cycle illumination. As the output at each frequency is only  $\frac{1}{2}$  mV., it is necessary to screen the motor with a mumetal box. The frequency of the fundamental is variable between  $\frac{1}{2}$  c/s. and 4 c/s.

The oscillator has been useful in checking the resonance points of the reeds of the low frequency analyser<sup>4</sup> recently described and also for demonstration purposes.

The advantage of a mechanical over an electrical system lies in its simplicity, as the design of a circuit to produce ten harmonics with controllable phase relations would be

extremely complicated and the ganging of the resonance circuits would be difficult to adjust, if the frequency is to be variable.

A seven channel electronic synthesiser, covering a range from 50 to 20,000 c/s. has recently been described.<sup>5</sup> It has the advantage that the seven frequencies are not necessarily harmonically related, so that fractional multiples of the fundamental can be obtained. To work this instrument, seven separate RC oscillators must be available as well as the synthesiser, and these will not run well with the conventional amplifiers at infra-sonic frequencies. The very slow speed of the photo-mechanical generator has been found of value, not only for mimicking electro-biological waveforms, but also for instructional purposes, since the deliberate tracing-out of a complex waveform by a recording pen seems somewhat less puzzling to a student than a standing wave on an oscillograph screen.

### Typical Results

The waveforms shown on p. 333 were produced by feeding the output of the wave synthesiser described into an amplifier and recording on an ink-writing oscillograph. The amplitudes of the harmonics present are expressed as percentages of the amplitude of the fundamental, and their phase angles,  $\alpha_2, \alpha_3$ , etc., are referred to the equation

$$y = a_1 \sin \omega t + a_2 \sin (2\omega t + \alpha_2) + a^3 \sin (3\omega t + \alpha_3) + \dots \text{ etc.}$$

The waves are not to be regarded as accurate graphs of the above function, but as a guide to the type of curves to be expected with such mixtures of harmonics. Variations from the true curves are due to small inaccuracies in the drilling of the holes in the disks.

### REFERENCES.

- 1 "Measuring Frequency Characteristics with the Photo-Audio Generator," W. Schaffer and Lubszynski, *Proc. I.R.E.*, Vol. 19 (1931), p. 1242.
- 2 "Some Measurements on Selenium Photo-Cells," G. A. Veszi, *Electronic Engineering*, May, 1943, p. 505.
- 3 "Mathematics Applied to Electrical Engineering," p. 300 (Warren and Russell).
- 4 "An Automatic Low Frequency Analyser," W. Grey Walter, *Electronic Engineering*, June, 1943, p. 9.
- 5 "Harmonic Synthesiser for Demonstrating and Studying Complex Waveforms," J. M. Somerville, *Jour. Sci. Inst.*, Vol. 21, (1944), R. 174.

# Cathode-Ray Tube Traces

## A Series to Illustrate Cathode-Ray Tube Technique

### Part II.—Straight Line Time Bases (continued)

By HILARY MOSS, Ph.D., A.M.I.E.E.

#### Time Bases Employing Discontinuous Waves

IN the last issue we treated the simplest form of time base—an oscillator producing a continuous sine wave of which only the centre section is used. In high frequency work where it is so easy to produce harmonically related frequencies, and thus obtain perfect synchronising between the time base and the phenomenon under investigation, this form of time base is often of the very greatest value. In many types of laboratory work, the possibility of thus obtaining perfect synchronising is much more important than securing a high degree of time linearity in the trace. The main drawback to this type of time base lies in the fact that the flyback necessarily occupies the same time as the used forward stroke. The flyback is usually not wanted for recording, and is often a nuisance, so that even disregarding all linearity questions, the occupancy cannot exceed 50 per cent. This fact has led to the more general use of time base waveforms in which the flyback is much more rapid than the forward stroke, so that the wave is discontinuous. (Photo No. 82.)

Fig. 4 shows the essential elements in this most general class of time bases. It should be noted that the charging circuit producing the used forward stroke operates continuously even throughout the flyback period when the trigger is conducting. The latter is arranged to have negligible resistance when it has struck, so that the effect of the continuously operating charging circuit of relatively high resistance is negligible during the flyback.

We shall now discuss briefly a few aspects of the components forming Fig. 4.

#### The Charging Mechanism

(a) *Exponential Time Bases.*—This is the simplest case in which the condenser is charged through a linear resistor. Referring to Fig. 5,\* if  $E_m$  is the constant line voltage suddenly applied across the series condenser/resistance circuit at time  $t=0$ , then the voltage  $e$  across the condenser at

Fig. 4. Fundamental circuit of discontinuous time base.

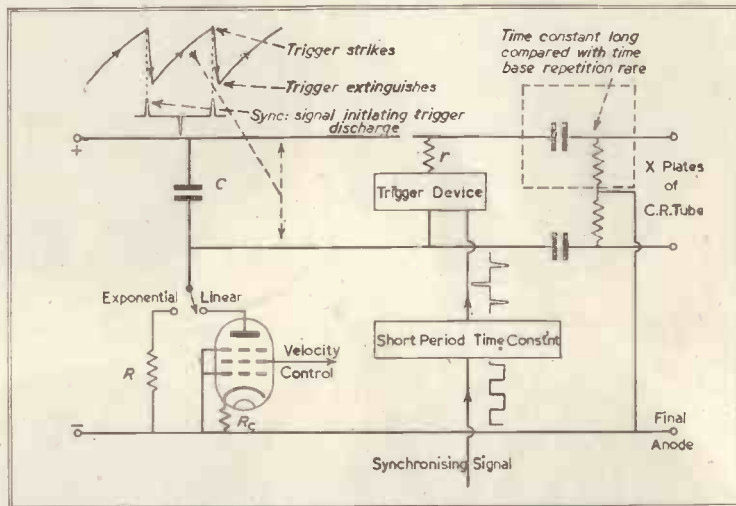

any subsequent time  $t$  is given by the familiar form

$$e_c = E_m(1 - \exp -t/CR) \dots (32)*$$

The voltage across the resistance at any time  $t$  must be the difference between  $E_m$  and  $e_c$ , and is thus

$$e_r = E_m \exp -t/CR \dots (33)$$

The curves (32) and (33) are mirror images in the line  $e = E_m/2$ . Their general shape is indicated in Fig. 5. Note that from (32) and (33)

$$\frac{d(e_c)}{dt} = \frac{d(e_r)}{dt} = \frac{E_m}{CR} \exp -t/CR \dots (34)$$

so that the *moduli* of the slopes of the waves from condenser and resistance are the same.

Reasoning in precisely the same way as for the sinusoidal time base wave we can easily obtain expressions for the linearity and displacement errors. The reader should verify that on the postulate that the time base condenser voltage falls to zero after the trigger has operated (not strictly true but a reasonably accurate assumption):—

fractional linearity error =  $(1 - \exp -t/CR) = e/E_m \dots (35)$

fractional displacement error =  $\frac{E_m}{e} \cdot \ln(1 - e/E_m) - 1 \dots (36)*$

The inset diagrams on Fig. 5

should make the derivation of these expressions very simple. The latter figure also plots them against  $e/E_m$ , the fraction of the line voltage used before the trigger operates. Note that for a given useful fraction of the line voltage employed, the errors in linearity and displacement are considerably larger than for cut sinusoidal bases.

(b) *"Linear" Time Bases.*—Consider the condenser  $C$  in Fig. 4 being charged by a current of instantaneous value  $i$ , and let the potential difference across its terminals be  $v$  when its charge content is  $q$ . Then

$$q = C \cdot v \dots (37)$$

by definition and  $dq/dt = i = C \cdot dv/dt$  by (37) ... (38)

Now  $dv/dt$  is the rate of increase of voltage, which is thus shown by (38) to be constant if  $i$ , the charging current, is also constant. Hence the problem of producing a linear timing wave is that of producing a device which has a constant current characteristic. Note, incidentally, that (38) shows that the departure from linearity† is directly measured by the deviations of the charging current from constancy.

The commonest constant current

† Linearity, that is, of the voltage wave appearing across the time base condenser  $C$  when the latter is isolated from the loading effect of the deflector plates.

\* p. 332.

\* Note notation  $\exp \phi \equiv e^\phi$ ,  $\ln \phi \equiv \log_e \phi$ .

# Patterns relating to

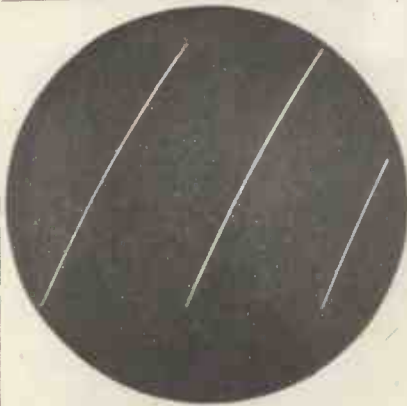

82  
Typical discontinuous time base wave.

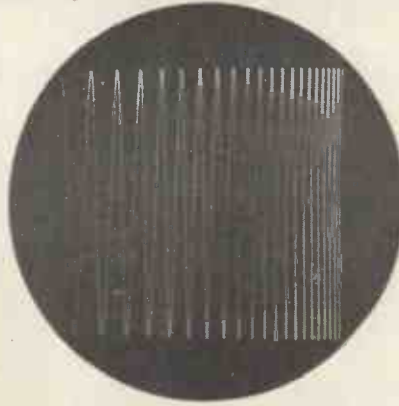

83  
Impure 50 c/s sine wave displayed on exponential time base. High speed flyback

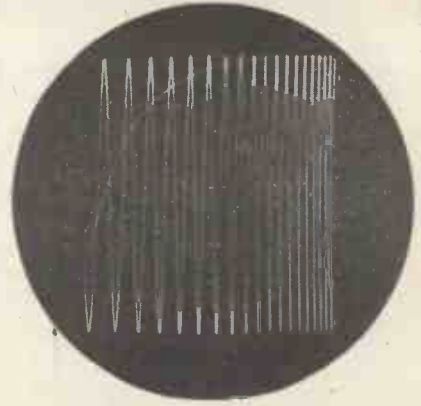

84  
As 83 but flyback slowed by limiting resistance of higher value. Resistance  $r$  (Fig. 4).

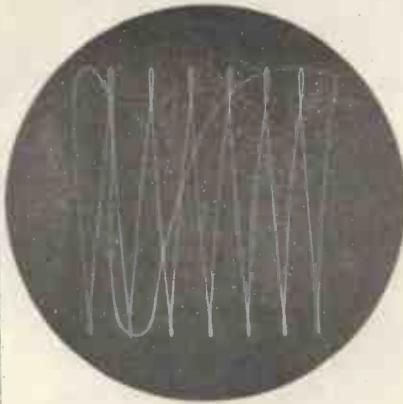

85  
Impure 50 c/s sine wave displayed on velocity modulated time base. Velocity modulation due to poor smoothing on H.T. supply to T.B.

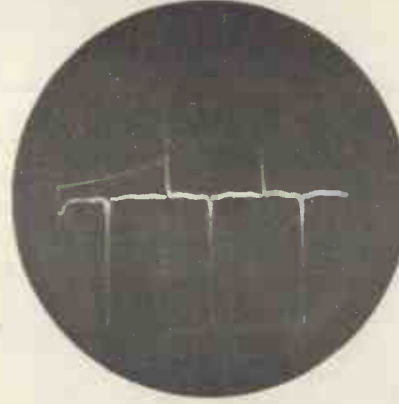

86  
Appropriate shape for synchronising signal: steep wavefront and short duration so that sync. pulse is over by the time flyback has finished.

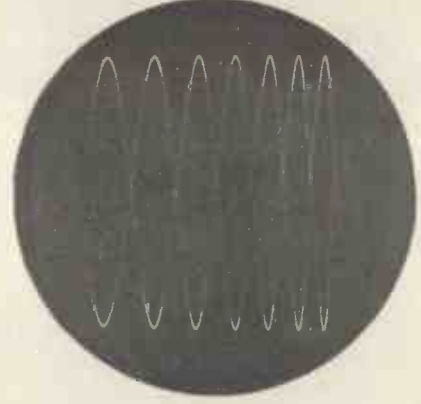

87  
Non-integral ratio between sine wave frequency and T.B. repetition rate (3.5 to 1).

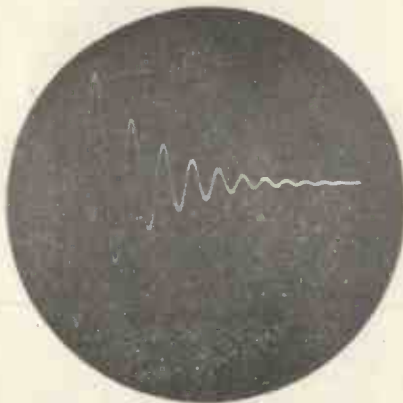

88  
Calibration wave for T.B. produced by impulse excitation of damped oscillatory circuit by flyback pulse.

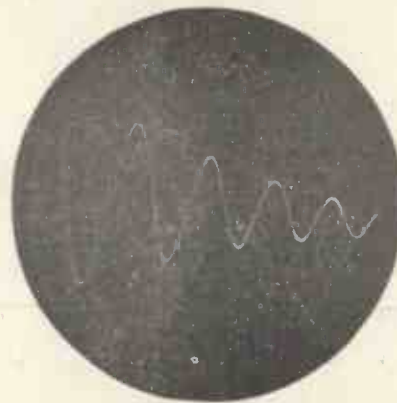

89  
As 88, but with circuit of lower decrement.

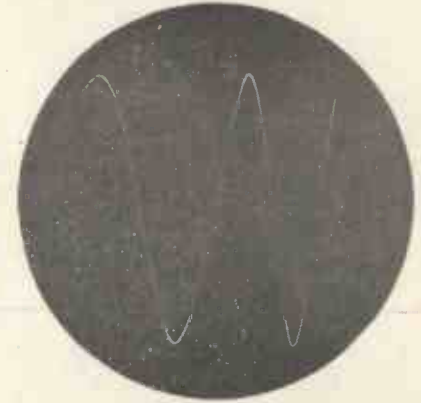

90  
Impure 50 c/s sine wave displayed on "linear" base showing very bad linearity due to operation of pentode on "knee" of anode current characteristic.



# Straight-line Time Bases

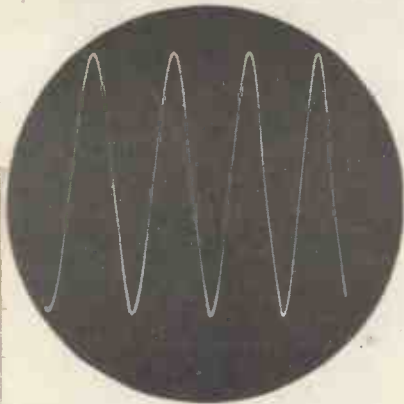

91

As 90, but with pentode operating on correct part of characteristic.

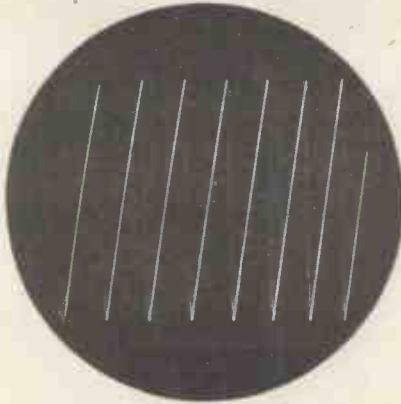

92

Substantially linear wave displayed on linear time base. Linearity of latter improved by insertion of cathode bias feedback resistor  $R_c$  (Fig. 4).

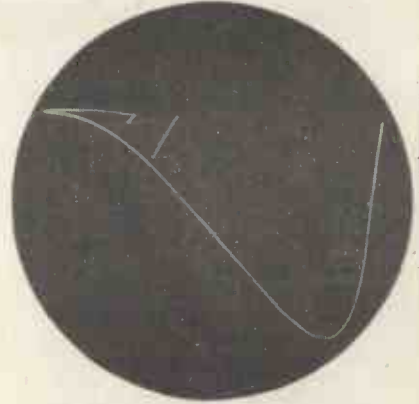

93

Illustrating broken up flyback due to excessive sync. signal amplitude.



94

Further examples of broken up flyback.

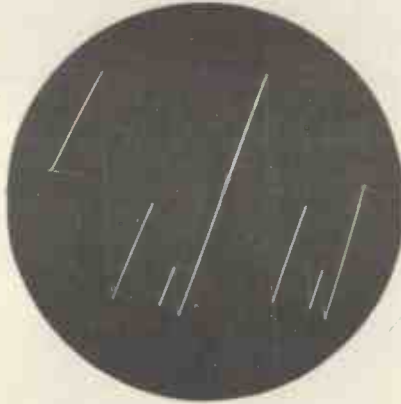

95

Further examples of broken up flyback.

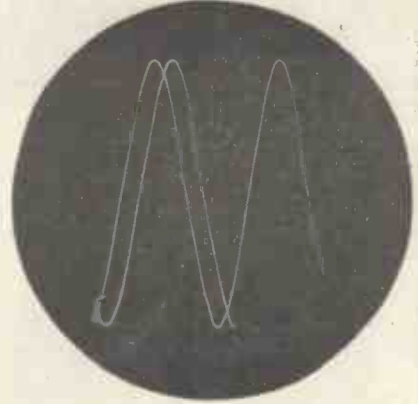

96

Illustrating trigger firing on different sync. pulses on successive sweeps.

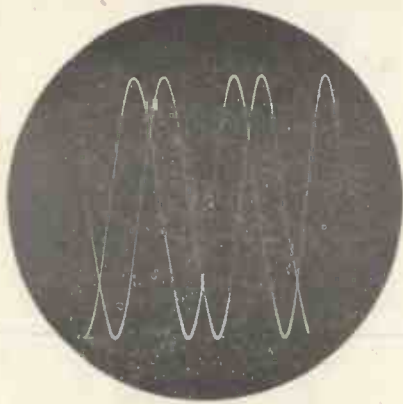

97

Another example similar to 96.

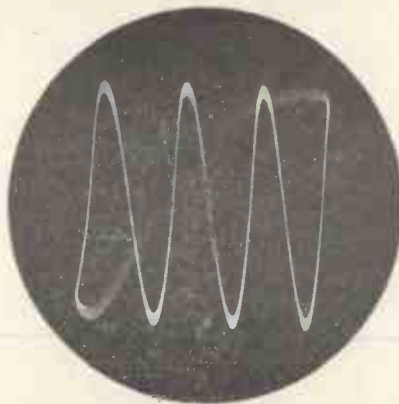

98

Radio frequency sine wave display thickened by 50 c/s mains interference. Repetition rate of T.B. about 24,000 per sec.

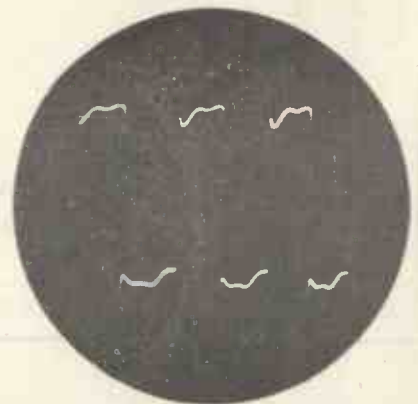

99

Square wave displayed on a linear base. Severe 50 c/s interference. Latter occurs at the same point in successive traces due to locking of base repetition rate to mains frequency.

device is a pentode. The latter has the property that over quite wide ranges the anode current is nearly independent of the anode voltage. Fig. 6 shows typical characteristics for a Cossor MS/Pen illustrating this point. The actual value of the anode current is dependent on the screen and control grid voltages. In use the control grid is often operated at zero voltage, and the anode current varied by alteration of the screen voltage. This varies the charging rate of the condenser and thus varies the "velocity" of the time base sweep.

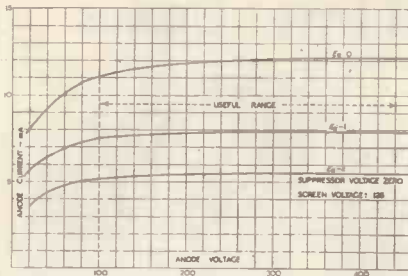

Fig. 6. Typical Pentode Characteristic.

Examination of the curves of Fig. 6 and some of the photos will show that the linearity obtainable from this simple pentode charging circuit is far from perfect. To obtain best results the control grid and screen voltages must be correctly chosen so as to work on the most constant current part of the anode current characteristic.

A considerable improvement in linearity† can be obtained by including a resistance in the cathode line of the pentode as indicated in Fig. 4. Photo No. 92. This acts as a negative feedback device which tends to hold the current constant.

It is important to appreciate that to obtain a high degree of linearity it is in general essential to isolate the time base condenser from the tube deflector plates by a valve. A cathode follower having a very high input impedance is an appropriate arrangement. Such isolation is necessary because the plate load of the cathode-ray tube must be partly resistive (each plate must have a D.C. path back to anode), and it is a fundamental postulate of equation (38) that the device being charged up is a pure condenser without losses.

**The Flyback Mechanism**

Two general types are in common use: (a) gas-filled triodes or "thyatron," and (b) hard valve trigger circuits as in the famous "Puckle" time base. Space does not permit a discussion of these here.

The speed at which these devices discharge the condenser is limited largely by the maximum permissible current through the valves employed. This can be controlled by the insertion of suitable series resistances. (Photos Nos. 83 and 84.) At sweep repetition rates up to several thousand per second, the flyback can generally be made so fast that the return trace does not interfere at all with the forward stroke, and no grid pulsing for flyback suppression is necessary.

**Synchronisation of Discontinuous Wave Time Bases**

This is almost always brought about by injecting into the trigger circuit a correctly timed pulse which initiates the flyback. A steady pattern demands precision of timing, and as the injection of too large a synchronising signal usually distorts the flyback (Photos 93, 94, 95), a synchronising wave of steep wave-front is very desirable (Photo 86).

Since precise synchronising requires a pulse at the end of each charging cycle, it is fundamental that the synchronising pulse must not have a lower frequency than the time base cycle. The pulse frequency can be higher than the time base cyclic rate, but it is inadvisable to have too many pulses per cycle, as in that event any slight cyclic irregularity in their am-

plitude may cause the flyback to start on the wrong pulse. (Photos 96 and 97.)

**Calibration of Time Bases**

A very convenient method is to use the sharp pulse of the flyback to shock excite a tuned circuit connected across the "Y" plates. The calibration then depends only on the properties of a passive circuit which can be made very stable. (See photos 88 and 89.)

**Locking of Time-Base Repetition Speeds to Supply Mains Frequency**

This is a most important principle of wide application in almost all branches of oscillography. Even when the greatest care is taken it is difficult to prevent the electron beam in the C.R. tube from having a small cyclic displacement at the supply mains frequency. In these circumstances, unless the time base repetition rate is equal to mains frequency (or submultiple thereof) successive traces will not coincide, and the resultant pattern will be blurred. (Photo 98.) By locking the repetition rate to the mains, this blurring may be avoided, but it must be observed that this does not remove the distortion (Photo 99) but merely fixes it at the same place in successive traces. This might conceal its presence and it is advisable, therefore, to unlock the time base when checking for interference.

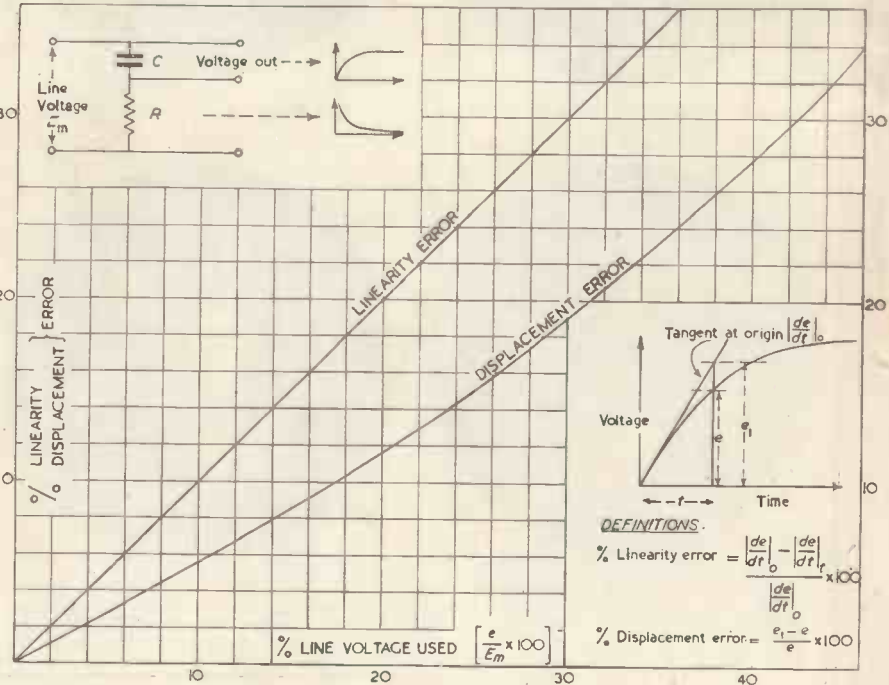
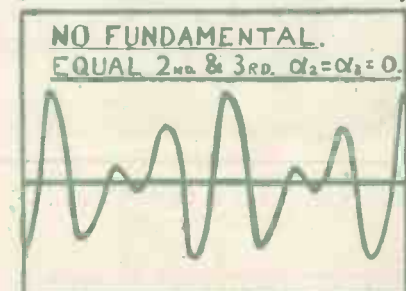
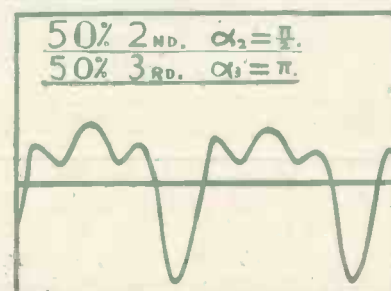
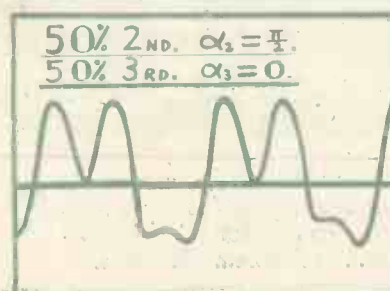
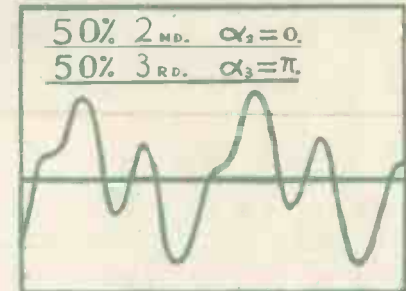
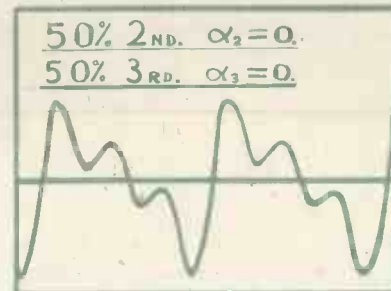
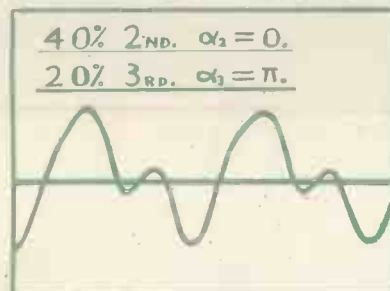
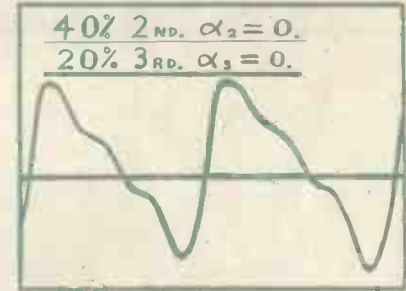
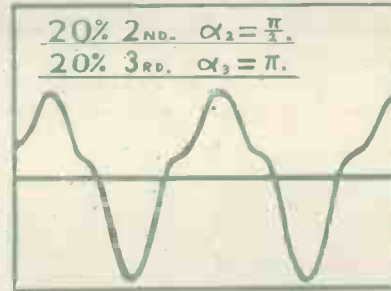
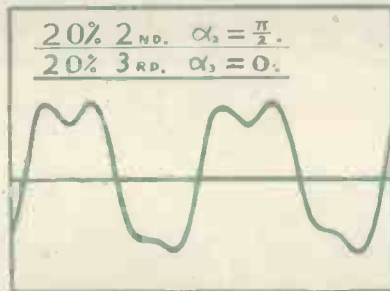
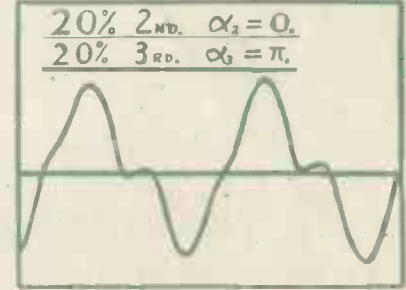
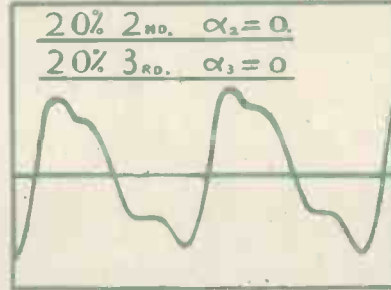
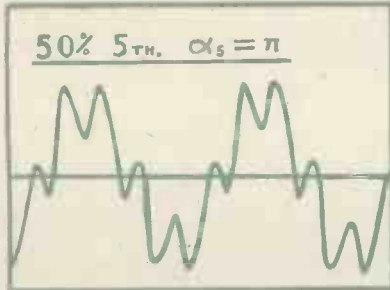
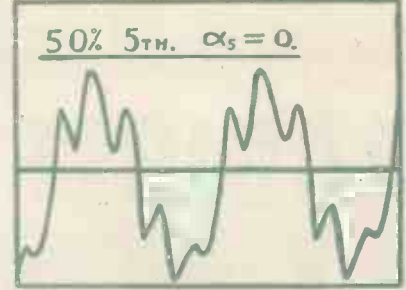
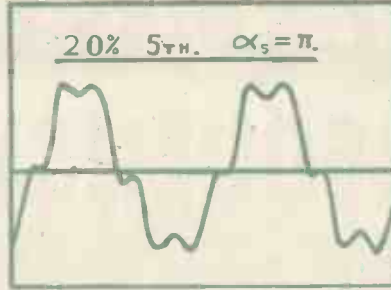
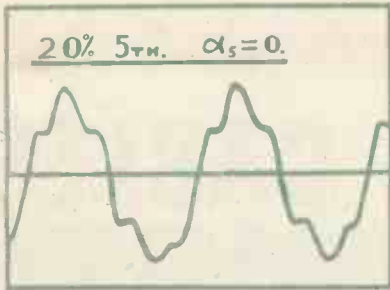

Fig. 5. Exponential Time Base.

### Typical Waveforms produced by the Wave Synthesiser



# Callender

## RADIO FREQUENCY CABLES



Our radio frequency cables are playing an important part in the control of operational aircraft. We are specialists in the manufacture of all types of low loss and low capacity cables for use at high frequencies. Our research and technical services are available in connection with high frequency cable problems relating to radar, electronics, television and telecommunications.

**CALLENDER'S CABLE & CONSTRUCTION CO. LTD., HAMILTON HOUSE, VICTORIA EMBANKMENT, LONDON, E.C.4**

*All over the World*

# Low Frequency Amplification

## Part III. Frequency Response for Low and High Frequencies

By K. R. STURLEY, Ph.D., M.I.E.E.

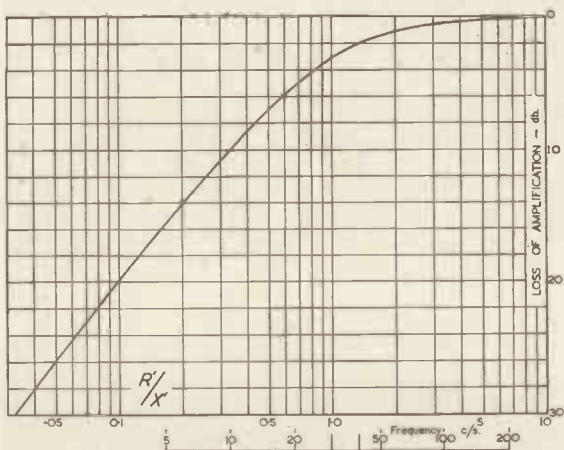

Fig. 19 (left).  
Attenuation distortion—loss of amplification at low frequencies.

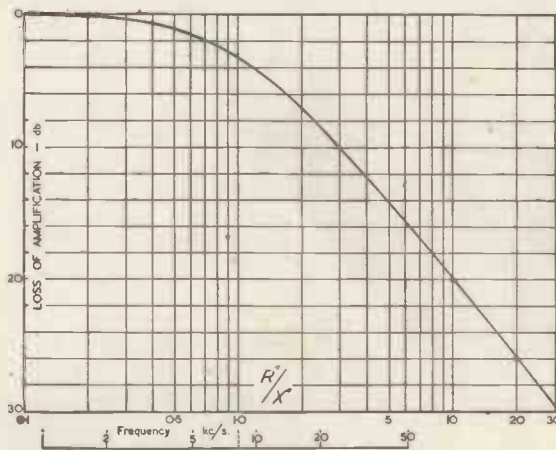

Fig. 20 (right).  
Loss of amplification at high frequencies.

FROM the two expressions 9 and 10 given in the previous article, we can plot two frequency response or attenuation distortion curves, one of low frequency loss  $(-10 \log_{10} [1 + (\frac{X''}{R'})^2])$  db against  $\frac{R'}{X'}$  and the other of high frequency loss  $(-10 \log_{10} [1 + (\frac{R''}{X''})^2])$  db against  $\frac{R''}{X''}$  as shown in Figs. 19 and 20.

These curves are made of general application by using a logarithmic horizontal scale for  $\frac{R'}{X'}$  and  $\frac{R''}{X''}$ . Since the two ratios are proportional to frequency we can convert to frequency response by positioning a similar logarithmic scale marked in frequency underneath the ratio scales so that  $f_{10} = \frac{1}{2\pi C_c R'}$  c/s. registers against  $\frac{R'}{X'} = 1$ , and  $f_{10} = \frac{1}{2\pi C_s R''}$  c/s. against  $\frac{R''}{X''} = 1$ . The complete frequency response is obtained by joining the low and high frequency responses from Figs. 19 and 20. If the two responses produce appreciable

loss in each others pass ranges the total loss is the sum of the losses at each frequency due to the low and high frequency responses. This also means that the amplification at the medium frequencies in the centre of the pass-range is less than that given by expression 4b in the previous article (December), viz.,  $\frac{\mu R_o'}{R_a + R_o'}$ .

### Phase Distortion

Phase distortion can be estimated by plotting phase angle displacement curves of output voltage relative to input against  $\frac{R'}{X'}$  and  $\frac{R''}{X''}$  as shown in Figs. 21 and 22. The phase angle displacement is the phase angle component of expression 6a.

$$\frac{A_1}{A_m} = \frac{1}{1 - j \frac{X'}{R'}}$$

viz.,  $\phi_1 = \tan^{-1}(\frac{X'}{R'})$ , and of expres-

$$\text{tion (8a) } (\frac{A_h}{A_m} = \frac{1}{1 + j \frac{R''}{X''}}), \text{ viz,}$$

$\phi_h = \tan^{-1}(-\frac{R''}{X''})$ . A positive sign

for  $\phi$  indicates that the output voltage component frequency leads upon the input voltage component, and a negative sign means that the output lags behind the input component.

Phase angle displacement can be converted to time advance (positive sign for  $\phi$ ) or time delay (negative sign for  $\phi$ ) in microseconds by noting that time advance or delay  $\phi^{\circ} \times 10^8$

$$= \frac{360^{\circ} \times f}{\phi^{\circ} \times 10^8} \text{ microseconds} \dots\dots\dots (11)$$

where  $\phi$  = phase angle displacement and  $f$  = frequency in c/s.

Curves of general application are obtained by plotting time advance or delay against  $\frac{R'}{X'}$  and  $\frac{R''}{X''}$ , all to logarithmic scales as shown in Figs. 23 and 24. The frequency at  $\frac{R'}{X'} = 1$

and  $\frac{R''}{X''} = 1$  is taken as 1 c/s. in calculating time delay; at  $\frac{R'}{X'} = 10 = \frac{R''}{X''}$

it is, of course, assumed to be 10 c/s. To apply the curves to a particular set of component values, the frequency scales are located against the  $\frac{R'}{X'}$  and  $\frac{R''}{X''}$  scales as shown and an identical logarithmic time advance or

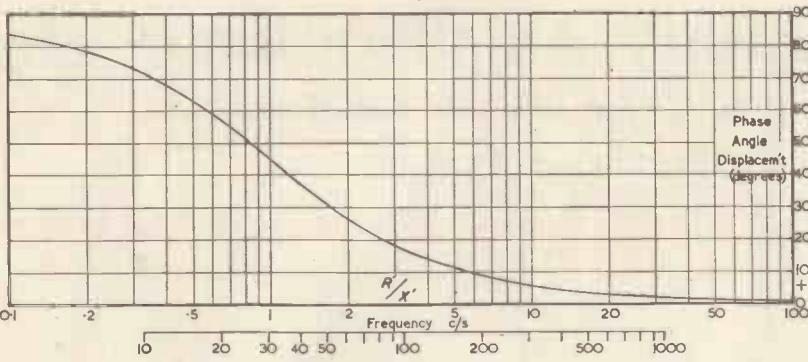

Fig. 21 (left).

Phase angle displacement curve for the low frequency range.

delay scale is located so that 125,000 microseconds, divided by the frequency  $\frac{R'}{X'}$  corresponding to  $\frac{R'}{X'}$  (30.6 c/s.) or  $\frac{R''}{X''}$  (8,260 c/s.) equals 1, is registered against 125,000 microseconds. on the original scale. Thus, at 50 and 100 c/s., there are time advances of 1,720 and 472 microseconds. respectively, and at 5,000 and 10,000 c/s. time delays of 17.2 and 14.2 microseconds. for the component values selected.

For zero phase distortion the time advance or delay experienced by each frequency component as it passes through the amplifier must be constant, which means that the phase angle displacement must be directly proportional to frequency. This is not possible at the low frequency end of the pass range because  $\phi$  is inversely proportional to frequency, and the time advance increases rapidly as frequency is decreased. The time error is very much greater at the low frequency end than at the high frequency end, and phase distortion is much more serious than attenuation distortion when visual indicating apparatus is employed. The only method of counteracting this distortion is to select coupling component values (particularly of  $C_c$ ) such that the time advance at the lowest frequency it is desired to accept is as small as possible. Special circuits can be used to correct phase distortion and these will be discussed in a subsequent article.

Since the time delay at the high frequency end increases with increase of frequency a time delay error curve of general application may be constructed by plotting the difference between 159,000 microseconds. (the time delay approached in Fig. 24 as  $f$  is decreased) and the curve in Fig. 24 against  $\frac{R''}{X''}$ , both to a logarithmic

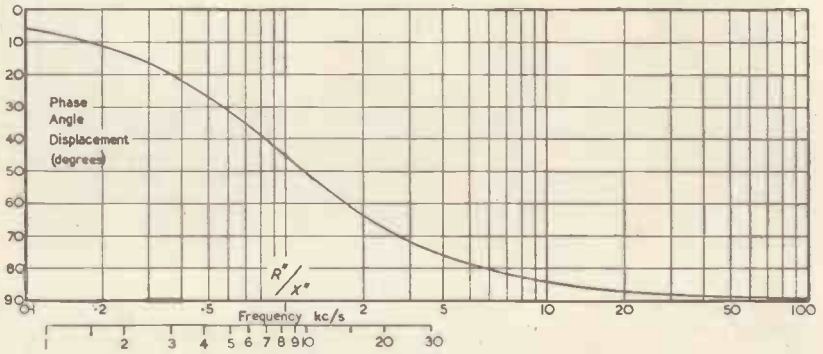

Fig. 22 (below).

Phase angle displacement curve for the high frequency range.

scale. Fig. 25 shows this result, the time error representing an advance because the component is insufficiently delayed. The actual time error is obtained by locating a logarithmic time scale such that  $\frac{34,000}{f_{bo}}$  microseconds, registers with 34,000 microseconds. on the original scale where  $f_{bo}$  is the frequency corresponding to  $\frac{R''}{X''} = 1$ . Taking again the component values listed above, the time error scale is registered at  $\frac{34,000}{8,260} = 4.11$  microseconds., and the errors at 5,000 and 10,000 c/s. are read as 1.95 and 5.3 microseconds. respectively. Because phase angle displacement is inversely proportional to frequency at low frequencies, a similar curve to Fig. 25 cannot be constructed for this range.

Inspection of the attenuation (Fig. 19) and time advance curve (Fig. 23) shows that increase of  $R'$  decreases attenuation and phase distortion at the low frequency end of the band, but increase of  $R''$  increases both forms of distortion at the high frequency end. Now increase of  $R_a$  increases both  $R'$  and  $R''$ , so that a tetrode valve will tend to produce less distortion at low frequencies

and more at high frequencies than a triode for given values of  $R_o$ ,  $R_g$ ,  $C_c$  and  $C_s$ . As far as anode circuit distortion is concerned the tetrode is superior to the triode as an amplifier of low frequencies, but it must be remembered that the screen circuit can introduce appreciable attenuation and phase distortion at low frequencies.

Maximum amplification (obtained in the middle range of frequencies) is calculated from 4b, and it is most conveniently expressed in terms of the amplification factor of the valve as

$$\frac{A_m}{\mu} = \frac{1}{1 + \frac{R_o}{R_o'}} \quad \dots \dots \dots 12$$

Plotting 12 against  $\frac{R_o'}{R_a}$  (Fig. 26)

shows that it increases as  $R_o'$  increases, but the rate of increase becomes small when  $R_o'$  exceeds  $5R_a$ . A point to be noted is that  $\mu$  is not necessarily itself independent of  $R_o'$  but is actually affected by variation of the  $R_o$  component of  $R_o'$ . This is made clear by reference to the triode  $I_a E_a$  characteristics of Fig. 13; as  $R_o$  is increased the load line AB is carried into the curved lower part of the characteristics (see line AB') where  $\mu$  decreases and  $R_a$  increases.

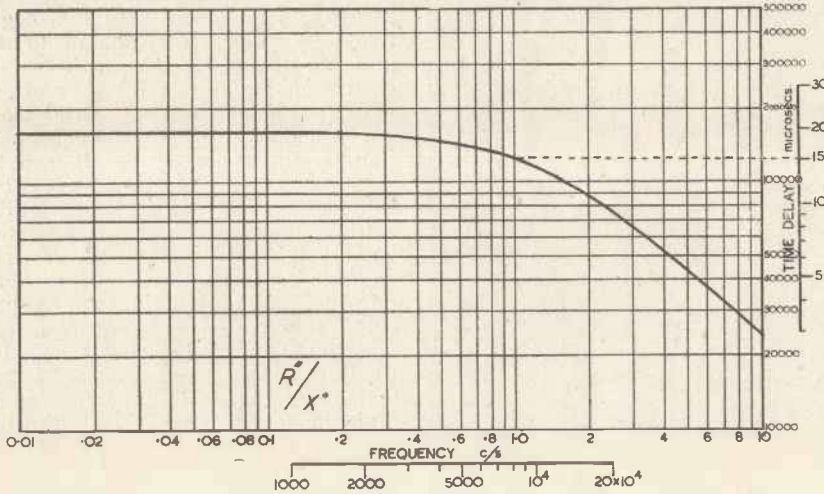

Fig. 24 (left). Time delay curve for the high frequency range.

Fig. 23 (below). Time advance curves for the low frequency range.

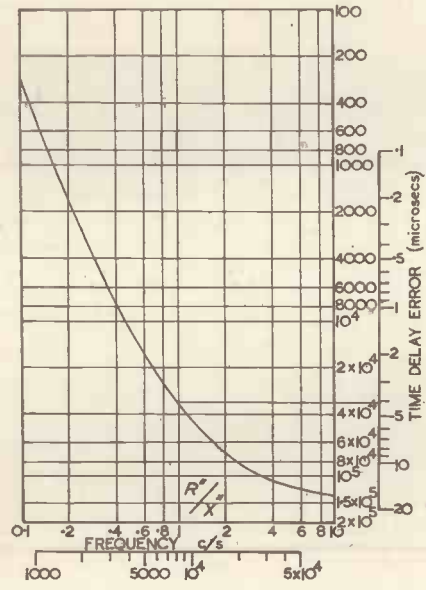
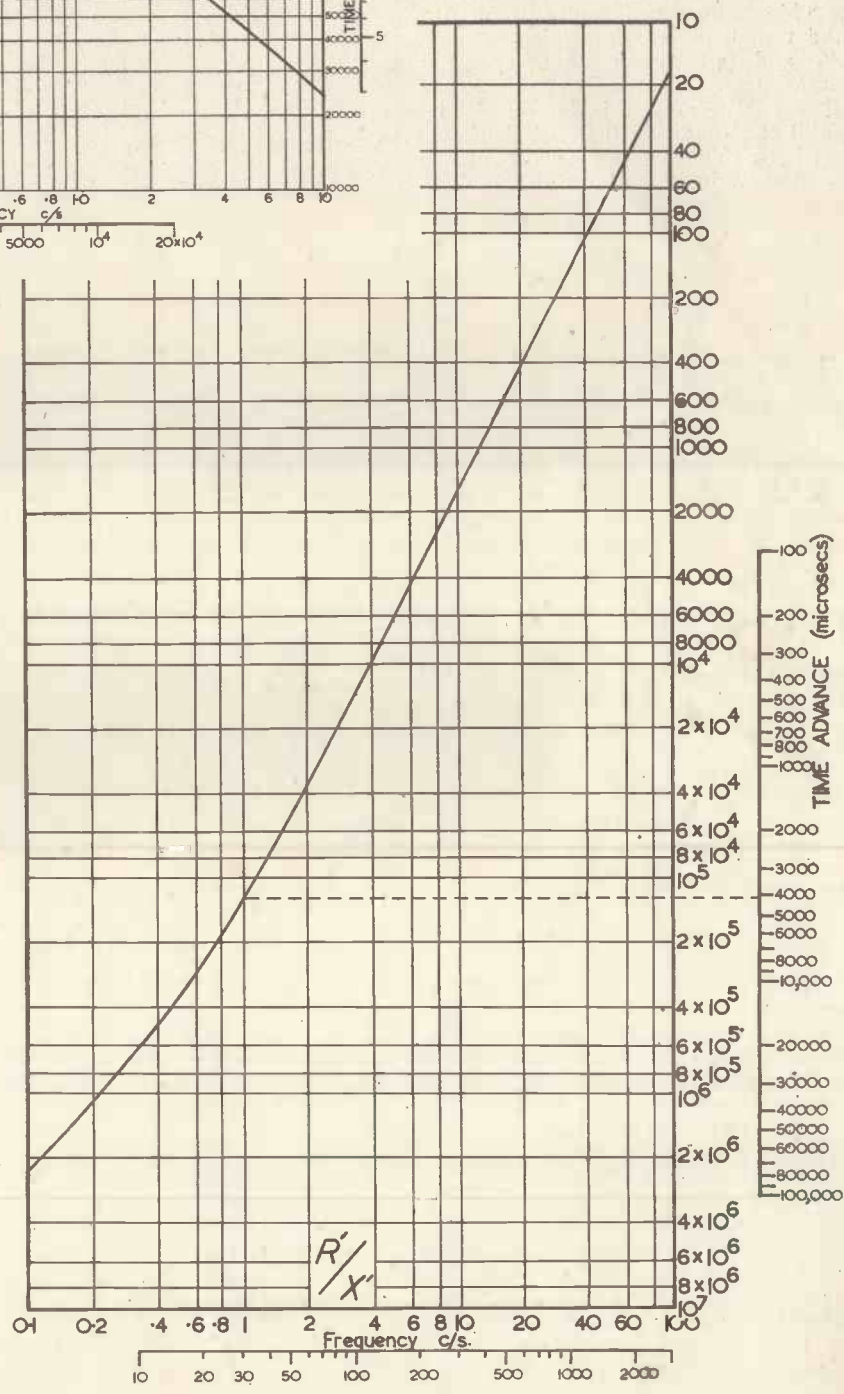

Fig. 25. Time delay error curve for the high frequency range.

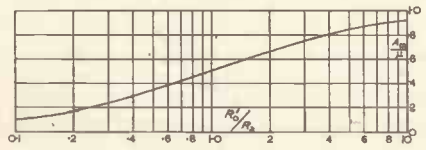

Fig. 26. Ratio of actual to maximum amplification for different values of  $\frac{R_0}{R_a}$

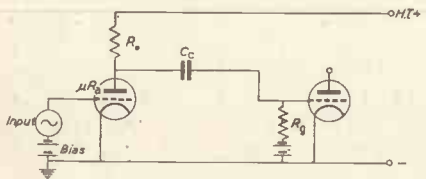

Fig. 27. A circuit for a low frequency amplifier

On this account it is inadvisable to make  $R_o$  much greater than  $3R_a$ .

An alternative expression for maximum amplification may be derived by replacing  $\mu$  by  $g_m R_a$ .

$$A_m = \frac{g_m R_a R_o'}{R_a + R_o'} \dots\dots\dots 13a$$

=  $g_m \times$  parallel combination of  $R_a$ ,  $R_o$  and  $R_g$ .

This expression is more useful for the tetrode valve, for which  $g_m$  and  $R_a$  and not  $\mu$ , are the important parameters. Generally,  $R_a$  is large (> 0.5 M $\Omega$ ) and it is impossible to fulfil the condition that  $R_o'$  shall exceed  $R_a$ . The maximum value of  $R_o'$  is limited by the shape of the  $I_a E_a$  characteristics and/or by the stray capacitance and permissible distortion at high frequencies. When it is much less than  $R_a$ , expression 13a becomes

$$A_m = g_m R_o' \dots\dots\dots 13b$$

**The Effect of the Grid Leak of the Succeeding Valve on Overall Performance**

So far we have considered the effect of the anode load impedance upon the various types of distortion, regarding the valve as a constant voltage A.C. generator. Since, however, the D.C. and A.C. load resistances are never equal, (the former

is  $R_o$  and the latter  $R_o' = \frac{R_o R_g}{R_o + R_g}$ ) this

method of analysis is not strictly correct and, though for most practical purposes it is satisfactory, the influence of  $R_g$  has an important bearing on design procedure. For the middle range of frequencies the reactance of the coupling capacitance  $C_c$  in Fig. 27 is very small in comparison with  $R_g$ , so that the A.C. load on the valve is represented by a

resistance  $R_o' = \frac{R_o R_g}{R_o + R_g}$  which is less

than  $R_o$ . Referring to the  $I_a E_a$  characteristic curves for a triode (it is also true of a tetrode valve) shown in Fig. 28, we must represent this condition by two lines. The first AB, corresponding to the D.C. load resistance  $R_o$ , starts from an anode voltage equal to the H.T. voltage, while the second CD is the A.C. load line corresponding to  $R_o'$ .

The point K, the intersection between AB and CD, coincides with the intersection of AB with the appropriate grid bias curve as long as the applied A.C. grid voltage is small. Two effects may be

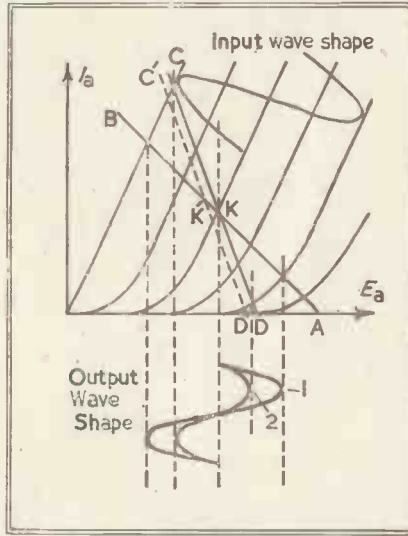

Fig. 28. The effect of the grid leak of the succeeding stage upon load performance.

noted: (1) the output voltage is reduced (compare the voltage waves 1 and 2 in Fig. 28) and (2) harmonic distortion tends to be increased. For a triode valve the reduction in output voltage will not be large if  $R_o'$  exceeds  $3R_a$  (see Fig. 26). There is a greater reduction in output voltage in the case of the tetrode valve because  $R_o$  is usually less than  $R_a$ , so that changes of  $R_o'$  will have greater influence on overall amplification. The reduction in amplification is, however, much less important than the fact that the bottom end of the line CD enters the cramped part of the  $I_a E_a$  curves, and harmonic distortion is increased with large input voltages. The resultant flattening of the lower part of the anode current wave causes rectification, which increases the D.C. current in  $R_o$ . The line CD changes its intersection point as shown by the line C'D' and the intersection point K'. In order to reduce harmonic distortion to a minimum the ratio of A.C. to D.C. load resistance ( $R_o'/R_o$ ) should be as near unity as possible, i.e.,  $R_g$  should have the highest possible value.

**Grid emission**

The maximum value of  $R_g$  is limited by the danger of causing "softness" to develop in the succeeding valve. A valve is said to be soft when it loses its vacuum, due most often to release of gases originally absorbed in the metal of the electrodes or by the getter. It may be caused by reverse grid current (in a direction

such as to make the grid less negative) due to grid emission or to the presence of positive ions in the valve. Grid emission is usually a result of volatilisation of active material from the cathode followed by its condensation on the cooler grid. It can be reduced by preventing excessive cathode temperatures (the L.T. voltage should not exceed the rated value) and by maintaining the grid and anode at as low a temperature as possible. A high grid temperature encourages emission from any active material deposited upon the grid. Cooling fins are often connected to the top of the grid support wires of high anode current valves. Positive ion current is due to the collection of positively charged atoms of residual gas, from which electrons have been released by collision with the cathode stream of primary electrons. Some gas atoms are always present even in the highest practically realisable vacuum, and positive ion formation is therefore almost inevitable. The effect of grid emission and positive ion current may be cumulative if a high value of  $R_g$  is employed. The positive bias produced by the reverse grid current increases anode current, and raises the temperature of the anode causing it to release absorbed gases, which form more positive ions. At the same time the anode temperature increases due to increased anode current and this raises the grid temperature, which results in greater grid emission. The effect is cumulative and a high grid leak may very rapidly cause softening of the valve. The tendency for this reverse grid current is greatest in high anode current valves, and the grid leak of an output valve may have to be limited to 0.1 M $\Omega$ . For a voltage amplifier valve a resistance from 1 to 2 M $\Omega$  is permissible. Since it is inadvisable to make the ratio of A.C. to D.C. load resistance ( $R_o'/R_o$ ) much less than 0.8, a voltage amplifier stage before a large power output valve must not be designed with a high D.C. load resistance.

In most types of low frequency amplifiers cathode self-bias and anode decoupling are employed for each stage. The latter is a wise precaution to adopt in a single-stage amplifier and is essential in a multi-stage amplifier if motor boating is to be avoided. Both circuits tend to modify the low frequency response and in the next article we can consider how they affect attenuation distortion.

(To be continued.)





# PAINTON VITREOUS RESISTANCES

From the time of its incorporation Painton & Company has concentrated on the manufacture and supply of electrical components of the grade required by transmission engineers in equipments designed for telephone administrations, broadcasting companies, etc. We will gladly send you particulars:

**PAINTON & CO LTD  
NORTHAMPTON**

**VARNISHED ART SILK**  
0.5 to 10 M.M.

**VARNISHED COTTON**  
0.5 to 35 M.M. TO A.M. SPECFN.

**ROLLED SILK**  
0.5 to 10 M.M. TO A.M. SPECFN.

**DELAFLEX  
SLEEVIINGS**

"DELAFLEX" CAN ALSO BE SUPPLIED  
WITH METAL SCREENING IF DESIRED

**De La Rue Insulation Limited**  
IMPERIAL HOUSE • 84 REGENT STREET • LONDON W1 • TEL REGENT 2901

# An Electronic Potentiometer Pyrometer

By

James J. Fraser \*

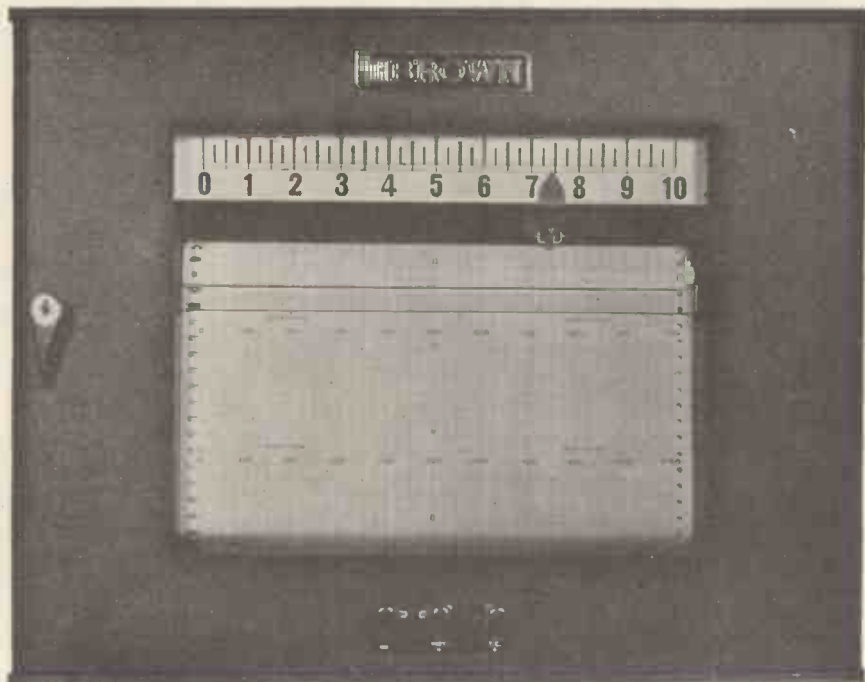

Fig. 1. Front view of the Honeywell-Brown Pyrometer indicator and recorder.

**A** POTENTIOMETER Pyrometer may be defined as an electrical instrument which measures temperature by balancing the electromotive force (emf) generated by the thermocouple against a known voltage from a battery. The known voltage is varied by movement of a contactor along a slide wire across which the battery voltage is impressed. The position of balance is reached when the two opposing voltages are equal and no current flows in the balancing circuit. Since the emf of the thermocouple has a definite value for such temperature, the position of the contactor along the slide wire can be calibrated to read directly in temperature.

The method of operating the conventional potentiometer pyrometer has been to determine the condition of unbalanced voltage in the circuit by a galvanometer. Deflection of the galvo pointer is amplified *mechanically* and the position of the slide wire contactor is periodically shifted to the point of balance by a motor-driven system of levers, pawls and gears.

The operating principle of the Electronic "Continuous Balance" Potentiometer Pyrometer utilises the same "null-balance" measuring circuit, but differs basically from conventional systems because its balancing

operation is continuous and not periodic. The galvanometer and its associated mechanisms are replaced by a "Continuous Balance" unit. This unit *electrically* amplifies the unbalanced voltage in the measuring circuit to provide the energy necessary to operate a rebalancing motor which repositions the slide wire contactor and the recording pen and/or indicator. By this means not only is continuous balance achieved but also increased measuring sensitivity is gained and fewer moving parts are required.

To secure the electrical amplification of the unbalanced D.C. Voltage in the measuring system, the "Continuous Balance" unit first converts the D.C. unbalance into an alternating voltage. This alternating voltage is then amplified in voltage and power by the electronic system to a value which can be used to drive a reversible balancing motor. A schematic diagram illustrating the overall system is shown in Fig. 2.

#### Conversion

The conversion of any unbalanced D.C. voltage to an alternating voltage of proportional magnitude is accomplished by a "converter" and a specially designed input transformer. The alternative voltage thus created is timed with the A.C. supply voltage in such a way as to identify

whether the thermocouple emf is above or below the point of balance and consequently to give the proper direction of rotation to the balancing motor. The two units which accomplish the conversion and timing are shown inside the dotted rectangle of Fig. 2.

The "converter" is essentially a flat metal reed oscillating between two contacts connected to the opposite ends of the primary winding on the input transformer. The unbalanced D.C. voltage is impressed across the converter and the centre tap of the primary winding on the input transformer. Thus, as the vibrating reed moves from one contact to the other, any unbalanced D.C. voltage will cause direct current to flow first in one direction through one-half of the primary winding, then in the opposite direction through the other half of the primary winding. This action generates an alternating flux in the input transformer core which in turn induces an alternating voltage on the transformer secondary. The action of the converter is related to the A.C. supply voltage by the "energising coil" which is excited by the A.C. line voltage through a step-down transformer. The reed is polarised by a permanent magnet and is therefore actuated by the energising coil

\* Honeywell-Brown Ltd.

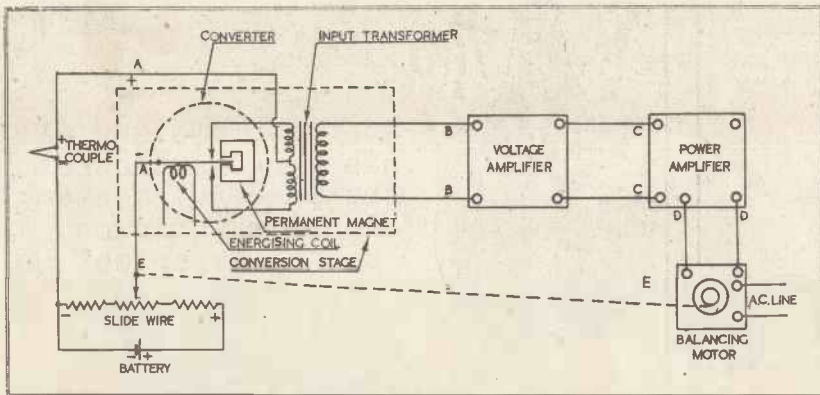

Fig. 2. Schematic diagram of the "Continuous Balance" system.

to oscillate in synchronism with the A.C. supply voltage. The direct current following in each half of the transformer primary winding will therefore create 50-cycle alternating voltage in the transformer secondary.

The entire rebalancing action of the "Continuous Balance" system is based upon the timing relationship between the alternating voltage formed by the converter and the A.C. supply voltage wave; this timing depends upon the direction of unbalance in the potentiometer circuit. For example, when the measured temperature rises above the temperature at which the potentiometer is in balance, the emf of the thermocouple will cause a difference in potential across AA in Fig. 2 having a polarity as shown. For this condition the converter will induce in the input transformer secondary a voltage in phase with the supply voltage. If, on the other hand, the temperature falls below the temperature at which the potentiometer circuit is in balance the polarity across AA will be reversed, and the voltage input to the voltage amplifier will be 180 degrees out of phase with the A.C. supply voltage.

**Voltage Amplification**

The alternating signal voltage from the input transformer is passed through three stages of voltage amplification. Two twin triode tubes with high amplification factors are used to accomplish this. The first tube contains the first two stages, and the second tube contains the third stage. The remaining triode section of the second tube is used as a rectifier to supply direct current potentials to the plates of the other three sections with the source of power obtained from a special transformer. A variable "sensitivity control" located between the second and third

stages of voltage amplification permits operating adjustment of the balancing system.

**Power Amplification**

Two duo-triode tubes of low amplification factors are used in the power amplification and feeding into one receiving the output of the last stage of voltage amplification winding of the balancing motor. The two tubes are identical and connected in parallel to divide the power load. To simplify the explanation, operation of the power amplifier will be described on the basis of a single twin triode tube. The second twin triode, being connected in parallel to the first, merely duplicates its action and does not change the principle of operation. The two sections of the one tube are therefore represented on the schematic circuit shown in Fig. 3 as two individual triodes designated as 1 and 2. The plate voltage of

tube 1 is supplied from A.C. supply voltage through winding No. 1 of the power transformer, and plate voltage of tube 2, through winding No. 2; by this means the plate voltages on the tubes are made alternatively positive and negative in frequency with the A.C. supply voltage. The significance of this will be evident from the following discussion. If it is assumed that the polarities in transformer windings 1 and 2 are as marked on the diagram for the positive half-cycle of line voltage, tube 1 will have a positive plate voltage and tube 2 a negative plate voltage during this period, and only tube 1 can conduct plate current because a tube only conducts when its plate is positive with respect to the cathode. The existence and magnitude of a plate current in tube 1, however, depends upon the potential of the grid during this half-cycle period.

During the negative half-cycle of line voltage, the polarities in transformer windings 1 and 2 are reversed, impressing a positive potential on the plate of tube 2 and permitting only it to conduct plate current during the negative half-cycle of line voltage. Here again, however, the existence and magnitude of a plate current depends upon the potential of the grid during this half-cycle period.

Now consider the quantitative effect of the grid on the plate current as governed by the input signal from the voltage amplifier. There are three cases to discuss, namely: Case 1, when the input signal to the grids is in phase with the line voltage; case 2, when the input signal to the

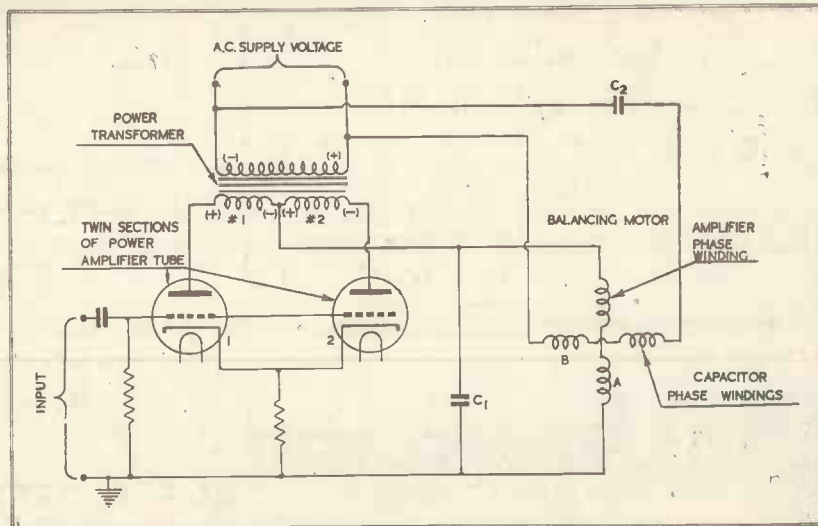
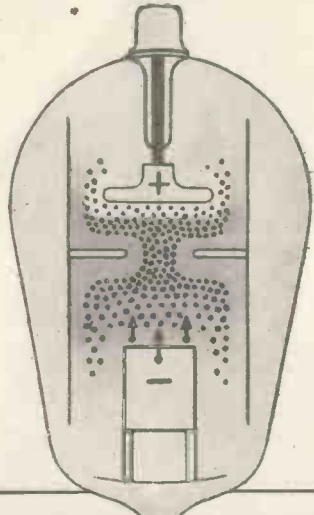

Fig. 3. Simplified diagram of power amplifier stage and connexions to balancing motor.



# RESEARCH



## ELECTRONIC CONTROL

BTH Research has carried out pioneer work in all branches of electronic science and has been responsible for many of the major technical developments and applications

# BTH RUGBY

THE BRITISH THOMSON-HOUSTON COMPANY LIMITED, RUGBY, ENGLAND



A3456 N



## TWO SPOTS OF DIRT-

Just as Tojo and all his gang have upset the peaceful system in this world so can an imperfect transformer gum up the works of any electrical system.

A mere few specks of dust in the wrong place can make you wonder if you're going silly.



It's a good thing to remember that every Parmeko transformer is "pressure impregnated". What does all that mean? Well, to revert to the vernacular, it means there's no muck in it now nor never.

**PARMEKO LTD.**  
**LEICESTER**  
*Makers of Transformers*

Transformers are the very heart of electronic equipment and no equipment can be more efficient than its transformers . . . you should make a point either of consulting our research department or specifying Parmeko on your orders.



I am the c.g.s. unit of energy—you'll find me in every radio circuit.

## ERG

ERG is the trademark that will identify our products of quality—small parts for big jobs.

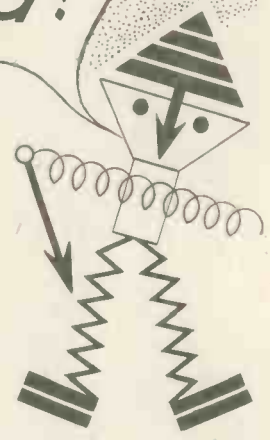

**ERG RESISTORS LTD.**  
1021a, FINCHLEY ROAD  
LONDON, N.W.11  
Phone : Speedwell 6967



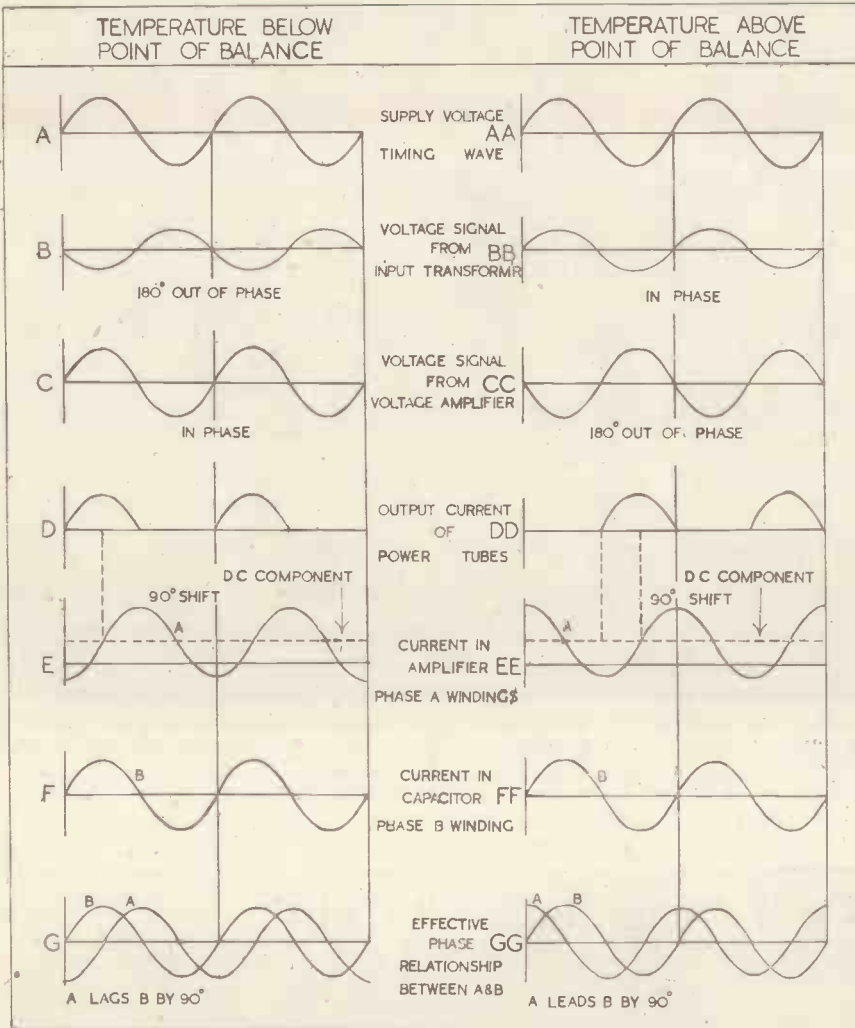

Fig. 6. Curves showing the derivation of phase relationship between A and B windings.

grids is 180 degrees out of phase, and case 3, when there is no input signal to the grids.

Case 1: With an in phase signal to the power tube grids, the grids will be positive for the positive half-cycle of line voltage, and vice versa, as shown in Fig. 4(B). Tube 1 is conducting on the positive half-cycle of the line voltage and will deliver a relatively large plate current because its grid is made more positive; this current is shown in Fig. 4(D). On the negative half-cycle of line voltage tube 2 tends to conduct because its plate potential is positive, but the grid being made more negative nullifies this effect, with the result that no plate current flows during this period (see Fig. 4(DD)). Inasmuch as any plate current from either tube flows through the same circuit to the drive winding A of the balancing

motor, the output from the power tubes in this case will be a pulsating current as shown in Fig. 4(E).

Case 2: When the input signal is 180 degrees out of phase with the line voltage, the controlling effect of the grid for each half-cycle of the supply voltage is reversed, with the result that a relatively large plate current will flow from tube 2 and no plate current will flow from tube 1. It will be noted, therefore, that in effect the drive current to the balancing motor in this case has been shifted 180 degrees in phase from that in Case 1.

Case 3: If the instrument is in balance, there is no input signal to the power tube grids because there is no unbalanced D.C. voltage. Therefore, the grid potential on tubes 1 and 2 is constant at some negative value determined by the grid balance, causing the plate current in both

tubes to be equal on each of their half-cycle periods of operation.

**Balancing Motor Operation**

The current output from the power amplifier is connected to the balancing motor which functions to convert the amplified unbalance of the potentiometer circuit into mechanical motion. This motion is not only used to move the slide wire contactor to a new position of balance, but also to actuate the indicating, recording and controlling components of the system.

The motor used in the "Continuous Balance" potentiometer is a two-phase reversible induction type.

Fig. 5(A) shows the windings of the stator poles, phase B being connected to the A.C. supply through a capacitor and phase A to the output of the amplifier (see Fig. 3).

In Fig. 5(B) the instantaneous values of the currents in the two windings are shown, the effect of the capacitor being to produce a 90 degree phase difference between the currents in A and B.

In Fig. 5(C) the instantaneous direction of the magnetic field is shown corresponding to the four instants of time marked in Fig. 5(B). It will be seen that the creation of a rotating field by the stator currents causes the rotor to move in a direction which is determined by the lag or lead of phase A on phase B.

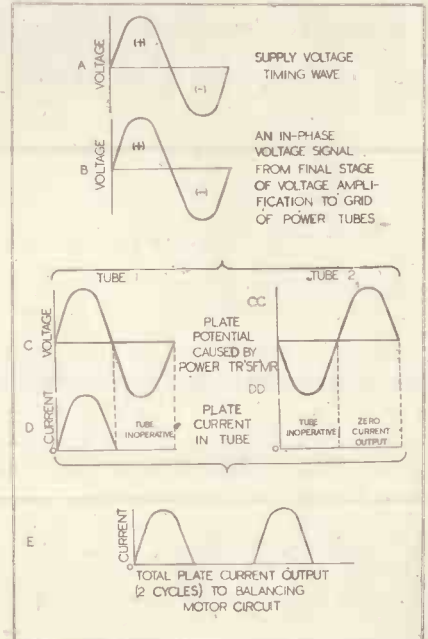

Fig. 4. Showing effect of phase relationship on the power output stage and the current in the balancing motor circuit.

Fig. 6 illustrates by a series of curves how either condition of unbalance creates a current in the amplifier phase winding A and how this current is phase-related to the current in the capacitor phase winding B to cause the proper rotation of the balancing motor.

The curves of Fig. 6(D) and (DD) show the pulsating current output of the power tubes for the two conditions of unbalance. The curves of Figs. 6(E) and (EE) show the current in the amplifier (phase A) windings which results from the power tube current.

If now the curves of the current in the amplifier phase winding are superimposed on those of the current in the capacitor (phase B) windings, the phase relationship between the two is evident as shown on the curves of Figs. 6(G) and (GG).

It will be noted on these curves that the curves as given in Figs. 6(E) and (EE) have been dropped down and shown as an alternating current with the same zero base line used for the supply current. This is

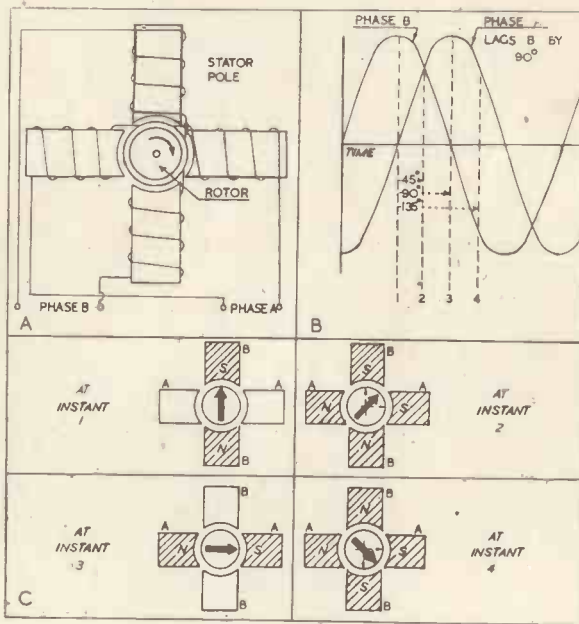

Fig. 5. The rotating field produced by the main supply and amplifier currents.

justified for purposes of explanation inasmuch as the D.C. component of this current shown by the dotted lines in Figs. 6(E) and (EE) produces no driving force in the balancing motor. A comparison of Figs. 6(G) and (GG)

will indicate that for one condition of unbalance, the current in the amplifier (phase A) winding lags the current in the capacitor (phase B) winding by 90 electrical degrees, and for the other condition of unbalance phase A current leads phase B current by 90 electrical degrees.

For a condition of balance in the potentiometer, the current output from the power amplifier is composed of two equal pulses for each cycle of the supply voltage, tending to drive the balancing motor one direction on one half-cycle and the opposite direction on the other half-cycle and resulting in no motion of the motor.

The reader will readily appreciate, after a study of this operating principle, that the Brown "Continuous Balance" pyrometer brings to the instrument field many

advantages in pyrometry hitherto unheard of. The most important of these advantages are: (a) simplicity, (b) stability of calibration, (c) greater accuracy, (d) ruggedness, (e) sensitivity, and (f) speed of operation.

## The G.E. Co.'s "Lighthouse" Tubes

A new development in disk-seal construction is the range of Megatrons, or "lighthouse" tubes, produced by the G.E. of America. As shown in the illustration, these tubes are constructed with the electrodes in parallel planes, giving very low anode-cathode capacitance and high permanence of characteristics.

The tubes are made in both transmitting and receiving types, and the following tentative data have been released:—

### GL-599

High vacuum diode for use at U.H.F. Filament 6.3 v., 0.75 amp. Octal base. Anode-cathode capacitance 2.45  $\mu\text{F}$ . Max.  $I_a$ , 30 mA.

### GL-446 A and B

Triodes designed for use as oscillators, amplifiers, or converters at U.H.F., the 446B operating at higher frequencies. The filament rating is 6.3 v., 0.75 amp. The transconductance is 4,500 micromhos and the  $\mu$  is 45. Inter-electrode capacitances: Grid-cathode 2.2; grid-anode 1.6; anode-cathode

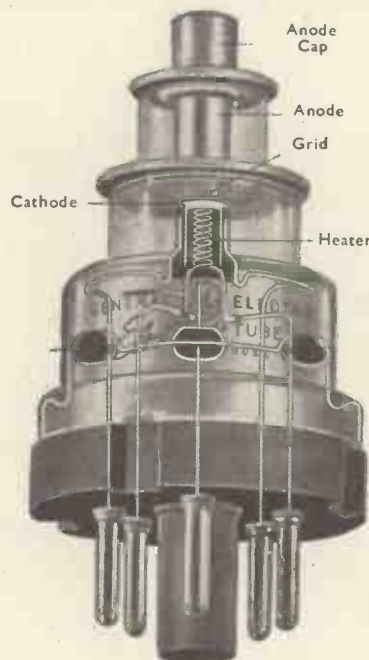

0.02  $\mu\text{F}$ .; anode dissipation 3.75 W.; anode current 15 mA. at 250 volts. Max.  $I_a$  20 mA.

When used as an oscillator, the maximum anode voltage is 400 and the maximum anode current 20 mA. The recommended grid leak is 10,000 to 20,000 ohms.

### GL-2C44

High vacuum triode for use as amplifier or converter at higher radio frequencies. Heater voltage and current as before. Inter-electrode capacitances: Grid-anode 2.0; grid-cathode 2.7; anode-cathode 0.1  $\mu\text{F}$ .; grid transconductance 7,000; anode dissipation 5 W. at 250 v.; 13 W. at 500 v.

Typical operating conditions:—

Anode voltage, 250.

Anode current, 25 mA.

Cathode bias, 100 ohms.

When the valve is operated at maximum ratings a heat-conducting connector is recommended for the anode to keep the temperature within 150-175° C.

## Frequency-Compensated Delay Network

If a delay network is to be of any use for delaying pulse signals, it is necessary that it should delay a pure sine wave signal for a time which is independent of the signal frequency.

The delay time per section produced by a network consisting of  $m$ -derived low pass sections is  $t$  where:—

$$t = \frac{2m}{\omega_0} \times \frac{1}{\left[ 1 - (1 - m^2) \left( \frac{\omega^2}{\omega_0^2} \right) \right] \sqrt{1 - \left( \frac{\omega^2}{\omega_0^2} \right)}}$$

where  $\omega = 2\pi f$ ,  $\omega_0 = 2\pi f_0$

$f$  is the signal frequency

$f_0$  is the network cut-off frequency.

From the formula for  $t$  it can be seen that if  $m=1.22$  and  $0 < f < \frac{1}{2}f_0$ , the delay time is very nearly independent of frequency. A delay network built up of sections having  $m=1.22$  is therefore of use for delaying pulse signals.

It can also be seen that, if  $m > 1.22$ ,  $t$ , in the main, decreases with frequency, whereas, if  $m < 1.22$ ,  $t$  increases with frequency. Furthermore, the rate of increase or decrease in  $t$  with frequency becomes greater the more  $m$  diverges from 1.22.

As is well known, a  $m$ -derived delay network can be constructed as shown theoretically in Fig. 1b.

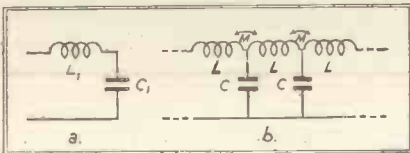

If Fig. 1a be the parent half section,  $C = 2mC_1$ ,

$$\frac{M}{L} = \frac{1 - m^2}{2(1 + m^2)} \quad L = \left( \frac{1 + m^2}{m} \right) L_1$$

It can be seen that, if  $m=1.22$ ,  $M/L = 0.1$ .

Two coils placed close together on a rod in such a manner as to be series aiding have, in general, a value of  $M/L$  much in excess of 0.1. As a value of  $M/L > 0.1$ , corresponds to

a value of  $m > 1.22$ ,  $\frac{dt}{d\omega}$  is consider-

ably negative. If, however, the coils are series opposing  $M/L < 0$ , and

$m < 1.22$ ,  $\frac{dt}{d\omega}$  is then considerably

positive.

It can be seen that, if a network consisting of close coupled series aiding coils is put in series with one consisting of close coupled series op-

posing coils, the negative  $\frac{dt}{d\omega}$  of the

one will tend to compensate for the

positive  $\frac{dt}{d\omega}$  of the other. In fact, if

$$n_1 \frac{dt_1}{d\omega} + n_2 \frac{dt_2}{d\omega} = 0$$

where  $n_1$  and  $n_2$  are the respective numbers of sections in the two parts of the delay network.

Since  $\frac{dt_1}{d\omega}$  and  $\frac{dt_2}{d\omega}$  are not inde-

pendent of  $\omega$  the compensation is not complete, but it can be made very good.

Both parts of the delay network should be of the same characteristic impedance, and of the same  $\omega$ . Both parts of the delay network would normally be mounted on the same rod, the first coil of one being in close proximity to the last one of the other. The section at which the junction takes place has to be specially designed, since it will have an  $M/L$  which is neither that of the high  $m$  filter nor that of the low  $m$  filter.

The fact that the coils are placed in close proximity, and not by several times their width as has to be the case for  $M/L = 0.1$  means that much space is saved since the overall network is, for a given number of sections, much shorter.

It will be appreciated that, if desired, more than one kind of  $m$ -derived section may be used and that by choice of suitable sections any input impedance frequency characteristic, or output frequency characteristic, can be obtained. Further, several different kinds of  $m$ -derived sections may be used alternatively in bunches of one or more sections.

—Communication from E.M.I. Laboratories. 10.11.44.

# VACTITE

## Wires & Tapes

RESISTANCE WIRES TO THE FINEST SIZES

- MOLYBDENUM
- VAC-STEEL
- PLATINUM SHEATHED
- GAS-FREE NICKEL
- WIRES, TAPES, BARS, MESH AND VALVE PARTS

# VACTITE WIRE

CO., LTD.

19 QUEEN ANNE'S GATE,  
WESTMINSTER, S.W.1.

Telephone: WHITEHALL 2552.

# JANUARY MEETINGS

NOTE.—In general, visitors are admitted to the meetings of scientific bodies on the invitation of a member, or on application in writing to the Organising Secretary at the address given. In certain cases (marked \*) tickets may also be obtained on application to the Editorial offices of this Journal.

## Institution of Electrical Engineers

### London Section

All meetings of the London Section will be held at The Institution of Electrical Engineers, Savoy Place, Victoria Embankment, London, W.C.2.

### Radio Section

Date: January 16. Time: 5.30 p.m.  
Discussion on:

"Frequency Allocation for Long-Distance Communication Channels."

Opened by:

R. L. Smith-Rose, D.Sc., Ph.D.

Date: January 24. Time: 5.30 p.m.  
Lecture:

"Television Broadcasting Practice in America," 1927-1944.

By:

D. G. Fink (Office of the U.S. Secretary for War, on leave of absence from the staff of ELECTRONICS).

Read by:

Dr. D. B. Langmuir.

Note: This is a joint meeting with the Television Society.

### Informal Meeting

Date: January 22. Time: 5.30 p.m.  
Discussion on:

"Applications of Electricity to Water Supply."

Opened by:

J. F. Shipley, M.I.E.E.

The Secretary:

The Institution of Electrical Engineers, Savoy Place, Victoria Embankment, W.C.2.

### Student's Section

Date: January 15. Time: 7 p.m.  
Lecture:

"Insulating Varnishes."

By:

W. P. Walters, B.Sc.

Date: January 6. Time: 2.30 p.m.  
Visit to:

The Odeon Theatre, Leicester Square, London, W.C.2.

Date: January 20. Time: 2.30 p.m.  
Visit to:

Museum Automatic Telephone Exchange, Howland Street.

Section Secretary:

R. G. Stefanelli, 19 Effingham Lodge, Surbiton Crescent, Kingston, Surrey.

## The Television Society \*

All meetings will be held at The Institution of Electrical Engineers, Savoy Place, W.C.2.

Date: January 2. Time: 6 p.m.

Lecture:

"Separating Sound from Vision."

By:

K. R. Sturley, Ph.D., M.I.E.E.

Date: January 24. Time: 5.30 p.m.

Lecture:

"Television Broadcasting Practice in America," 1927-1944.

Read by:

Dr. D. B. Langmuir.

Note: This is a joint meeting with the Radio Section of the I.E.E., by kind invitation of the Committee.

Lecture Secretary:

G. Parr, 43 Shoe Lane, London, E.C.4.

General Secretary:

O. S. Puckle, 8 Mill Ridge, Edgware, Middlesex.

## The Royal Photographic Society

### Kinematograph Section

Date: January 20. Time: 3 p.m.

Held at:

16 Princes Gate, London, S.W.7.

Lecture:

"The Future of Television in the Kinema."

By:

G. Parr, A.M.I.E.E.

Secretary:

J. Dudley Johnston, 16 Princes Gate, London, S.W.7.

## British Kinematograph Society

All meetings will be held at the Gaumont-British Theatre, Film House, Wardour Street, W.1.

Date: January 3. Time: 6 p.m.

Lecture:

"The Electron Microscope."

By:

G. Parr, A.M.I.E.E.

Date: January 24. Time: 6 p.m.

Lecture:

Newman Memorial Lecture.

By:

Arthur Pereira, F.R.P.S.

Note: This is a joint meeting with the Royal Photographic Society (Kinematograph Section).

Organising Secretary:

R. H. Cricks, Dean House, 2 Dean Street, London, W.1.

## The Association for Scientific Photography \*

Date: January 27. Time: 2.30 p.m.

Held at:

The Caxton Hall, Westminster.

Lecture:

"Light for Photography."

Electric Discharge Lamps for Photography.

By:

H. K. Bourne, M.Sc., M.I.E.E., A.R.P.S.

The Secretary:

Association for Scientific Photography, 34 Twyford Avenue, Fortis Green, London, N.2.

## Institute of Physics

### Electronics Group

Date: January 27. Time: 2.30 p.m.

Held at:

Physics Department, the University, Manchester.

Lecture:

"Reactions in the Electric Discharge."

By:

Dr. R. W. Lunt.

Note: This is a joint meeting with the Manchester and District branch of the Institute of Physics.

Group Secretary:

A. J. Maddock, M.Sc., F.Inst.P., Messrs. Standard Telephones and Cables, Ltd., Oakleigh Road, London, N.11.

## Brit. I.R.E.

### N.E. Section

Date: January 17. Time: 6 p.m.

Held at:

Neville Hall, Newcastle-upon-Tyne.

Lecture:

"Pulse Modulation."

By:

W. A. Beatty, M.Brit.I.R.E.

### Midland Section

Date: January 24. Time: 6 p.m.

Held at:

University of Birmingham, Edmond Street, Birmingham.

Lecture:

"Wave Guides."

By:

T. H. Turney, Ph.D.

Secretary:

G. D. Clifford, 9 Bedford Square, London, W.C.1.



# ELECTRICAL CONTACTS

## IN PRECIOUS METALS OR PRECIOUS METAL ALLOYS

JMC electrical contacts are in demand for war service in all types of electrical equipment in all theatres of war, but we endeavour to maintain our advisory service to customers and give the benefit of our wide experience in the application of precious metals and their alloys to all kinds of contact requirements.

SILVER. PLATINUM SILVER-COPPER  
GOLD. GOLD-SILVER PLATINUM-IRIDIUM  
PLATINUM-GOLD-SILVER PLATINUM-RUTHENIUM  
AND OTHER ALLOYS  
PALLADIUM-SILVER  
PALLADIUM-COPPER

*Enquiries should be headed "Contact Enquiry"  
and addressed to Head Office.*

**JOHNSON, MATTHEY & CO.**  
LIMITED.

73/83, HATTON GARDEN,  
LONDON, E.C.1

Users of electrical contacts who do not possess a copy of our earlier reference booklet No. 112, are invited to apply for a copy of the abbreviated war-time edition illustrated reference No. 114



# VISION

Now each must plan his future; let past achievement stimulate to greater effort in times to come.

For us, this means many things: bringing the boon of Rediffusion service to thousands of homes; contributing Radio Heating to industrial progress; building Radio Transmitters for world-wide links—and always, the freshness of vision which commands leadership.

## REDIFFUSION LTD

A SUBSIDIARY OF BROADCAST RELAY SERVICE LIMITED



Designers and manufacturers of Radio Communication and Industrial Electronic Equipment

VICTORIA STATION HOUSE • VICTORIA STREET • LONDON • S.W.1 (PHONE VICTORIA 8831)

# ABSTRACTS OF ELECTRONIC LITERATURE

## MEASUREMENT

### Improved Cathode-Ray Curve Tracer (A. H. B. Walker)

The very great flexibility of the normal cathode-ray tube is never more fully demonstrated than when it is used to plot the complete dynamic characteristics of some non-linear variable. Both axes can be plotted on the screen simultaneously with the required curve by the addition of a standard vibrator unit to the curve-tracing circuit. The vibrator is driven by energising a driving coil from a low voltage source of d.c. in series with a resistance. One very pleasing feature of the system is that the axes are always drawn with a length just sufficient for the curve being examined.

—*Wireless World*, Sept., 1944, p. 266.\*

### Apparatus for the Determination of Dispersion at Supersonic Frequencies (L. N. Liebermann)

Variation of the velocity of sound with frequency yields useful information on the rate of transfer of translational energy to molecular vibrational energy. Variations have been measured by a method which allows the direct observation of small velocity changes. The apparatus permits comparison of the phases at various frequencies in two gases, one being a non-dispersive gas. If the phases are measured in the two gases at positions which correspond to equal numbers of wavelengths from the source, then  $\Delta\psi/\psi = \Delta V/V$  where  $\Delta\psi$  is the phase difference in the two gases and  $V$  is the velocity in the dispersive gas. A 90-kilocycle quartz bar is excited at its fundamental and upper harmonics to produce the various frequencies. The sound is received by an L-cut Rochelle salt microphone and the phase determined by a 360° electrostatic phase shifter accurate to  $\pm 3^\circ$ .  $\psi$  was 3.600° (10 wavelengths) at the fundamental.  $V$  is taken from the literature. Five frequencies between 90 and 450 kilocycles were used; these differed by approximately 90 kilocycles. Insufficient amplifier gain at higher frequencies prevented extension of this range. Measurements on the dispersion of CO<sub>2</sub> at atmospheric pressure are in agreement with previous values.

—*Bulletin of the American Physical Society*, April 28, 1944.

### The use of Wire-wound Electrical-Resistance Strain Gauges (S. F. Dorey)

In its modern form, the wire-wound electrical-resistance strain gauge consists of a coil of exceedingly fine wire, about 0.001 in. in diameter, wound on a flat former and bonded under heat and pressure between layers of resin-impregnated paper. Changes of strain in the material are communicated to the gauge wire through the medium of an adhesive and, within wide limits, a given change of strain results in a proportional change of gauge resistance. As a typical example of the application of the gauge, the measurement of strains on a test box having panels representing those in the combustion chamber of a Scotch boiler is discussed.

—*Shipbuilder*, Sept., 1944, p. 328.\*

### A Four-Tube Counter Decade (J. T. Potter)

A simple electronic counter decade is described which can form the basic unit for counters for a wide variety of applications. The counter decade utilises Eccles-Jordan trigger circuits in the binary progression 1-2-4-8, and incorporates two feed-back capacitors which give forced resetting at the count of ten so as to retain the normal decimal system. The operation of the trigger circuit and counter decade is described and applications of the unit as a welding timer, an interval timer, a frequency divider, a radiation counter and an electronic calculator and for selector applications, etc., are discussed.

—*Electronics*, June, 1944, p. 110.

## THERMIONIC DEVICES

### A Closed Cell for Electron Microscopy (I. M. Abrams and J. W. McBain)

A very simple closed chamber for electron microscopy has been devised. The plastic windows interfere very little with electron examination and easily withstand a difference of one atmosphere pressure between the inside of the cell and the remainder of the microscope. Some limitations of electron microscopy in examining specimens in liquid or attempting to observe ordinary Brownian movement have been emphasised. Particles in free Brownian movement necessarily elude observation.

—*Jour. App. Phys.*, Aug., 1944, p. 607.\*

### Energy Conversion in Electronic Devices (D. Gabor)

An electronic oscillator is a "machine" for the conversion of d.c. power into a.c. power with electrons as the moving parts. By means of the Maxwell-Poynting theory the conversion process can be localised and analysed into the elementary contributions of the volume elements. Integral relations for the whole valve can be expressed in various forms of which the following lends itself best to physical interpretation: The power consists of three parts. The first is the "collector power" determined entirely by the potentials and currents of the electron collectors. The second is the "transit power" produced by the changes of space potential during the flight of the electrons. The third power component is due to electric fields induced by alternating currents.

All methods of producing alternating electron currents can be reduced to emission, transit time, or deflection modulation.

A threefold division is also adopted for the sources of the electromagnetic field. Space charges and their complementary surface charges play no part in the power conversion. An exhaustive classification of all power-producing processes under nine headings is obtained, and is applied to a few special examples.

—*Jour. I.E.E.*, vol. 91 (pt. 3), p. 128.

### Electronics, Past and Future

This article is a broad survey of electronics and its many applications. Electric power was, in its early days, applied for one main purpose, namely, the production of light, and three lines of electronic development originated in the arc, the discharge and the incandescent filament lamp. Of the development in electronic apparatus the following examples are selected for special comment: (a) the grid-controlled mercury-arc rectifier; (b) the inverter; (c) the ignition; (d) the magic eye. An enumeration of the applications of electronic devices concludes the article.

—*Engr.*, 15/9/1944, p. 210.\*

\* Abstracts supplied by the courtesy of Metropolitan Vickers Electrical Co. Ltd., Trafford Park, Manchester

AN  
ANNOUNCEMENT  
BY  
HOOVER LIMITED

During the war, the manufacture of the Hoover, the World's Best Cleaner, has of course, temporarily ceased.

Instead, the whole of our resources, very considerably extended, have been devoted to the manufacture of many types of electrical machines, produced in very large quantities, including Rotary Transformers.

For obvious reasons we are not able to give full details of the wide range of these products, but it can be said they have fulfilled a large variety of purposes. The experience thus gained during the war will be at the disposal of all demanding precision engineering both for post-war Home and Export Trade.

**HOOVER**  
Limited

*Manufacturers of the World's Best Cleaner*

PERIVALE · GREENFORD · MIDDLESEX



*Manufacturers of  
the famous*

**DAIK  
SWITCH**

*The only switch with*

**FLOATING & DOUBLE  
ROTOR & CONTACT**

Available in a wide range of circuit combinations for radio, television and other applications.

**BRITISH N.S.F. CO. LTD.**  
KEIGHLEY, YORKS

Phone: Keighley 4221/4 Grams: Enesef, Keighley

GA

*Cyldon*

**VARIABLE CAPACITORS**

Ranging from Miniature Air Trimmers to Transmitting Capacitors operating up to 15 KV, covering all applications including VHF, etc.

We are probably producing or developing just the capacitor you are requiring!

**SYDNEY S. BIRD & SONS LTD.**  
CAMBRIDGE ARTERIAL ROAD, ENFIELD.

## BOOK REVIEW: "Plastics for Production" By Paul L. Smith (Chapman & Hall). 12/6 net.

MR. SMITH has reviewed the application of plastics in many fields. He has approached the subject in a critical fashion which is to be commended, in contradistinction to the fulsome eulogies which the word "Plastics" seems to evoke from so many writers. The book should be useful to the production engineer who is considering the use of plastics and whose knowledge of them is scanty. There are, for example, some useful notes upon the economies of mouldings. Simplification has been achieved by the omission of chemical considerations, but one rather wonders whether this has perhaps been overdone, particularly concerning the important question of plasticisers which are only mentioned casually in the text. The main emphasis lies on the physical properties of the various thermo-plastic and thermo-setting plastics and the important consideration of the effects of service conditions upon those properties. This information has been extracted largely from the literature and is presented piecemeal from various sources. There is no objection to this but such information would be more readily as-

simulated if a consistent system of units was employed. One finds, for example, power factors given as percentages or as  $\tan \delta$ , thermal properties in both F.P.S. and C.G.S. units and Brinell Hardness figures given without reference to load or ball diameter. There are errors such as compressive strengths quoted as "tons" without reference to the area concerned.

The chapter "Plastics for Insulation" should be of particular interest to readers of this journal. Emphasis is laid here upon thermo-setting resins, with which Mr. Smith is presumably most familiar. Thermo-plastics have but scanty mention. Polystyrene and polyethylene are certainly mentioned, although the latter is ignored in a paragraph on high fre-

quency insulation, while there is little indication of the important rôle which is being played by the polyvinyl chloride compounds as cable insulants. The relevant information on these materials can be found at other places in the book; perhaps this scattering of information is inevitable in a book which attempts to cover such a wide field, but such presentation does detract from its value.

Certain errors are present, which should be corrected. Thus reference is made to the *casting* of sheets, rods and tubes of polystyrene!; ethyl cellulose is stated to be stable to light and a reference to polyvinylidene chloride tubing as being used "instead of rubber" is perhaps ambiguous. Some misprints are present; presumably these are more prevalent under wartime conditions. The most striking, perhaps, is the reference in the preface to "*obtuse* technical and mathematical data." Is this merely a misprint for "obscure," or is it a secretly heart-felt opinion of the author's obtruding from the subconscious as a judgment upon his fellow technicians?

H. A. N.

Books reviewed on this page  
or advertised in this Journal,  
can be obtained from

H. K. LEWIS & Co. Ltd.  
136 Gower Street, W.C.1

If not in stock, they will be obtained  
from the Publishers when available

# CASE

by

## IMHOF'S

ESTABLISHED 1845

THE HALLMARK OF A GOOD INSTRUMENT



If you are inclined to the view that your instruments deserve a case that is better built and of more attractive and functional design, or you build equipment that needs precision sheet metal work, you will be interested to have this catalogue. A penny stamp and the request on your business letterhead will bring it you.

ALFRED IMHOF LTD. 112-116 NEW OXFORD STREET, LONDON, W.C.1. MUSEUM 5944

# 5 mmf/ft

NEW LOW LEVELS in capacity  
and attenuation of CO-AX Cables  
mean new possibilities in electronic  
equipment design both for the  
war effort and for the post-war  
electronic age.

Write for characteristics

## BASICALLY BETTER AIR-SPACED

# CO-AX<sup>®</sup> LOW LOSS CABLES

TRANSRADIO LTD. 16 THE HIGHWAY · BEACONSFIELD · 6-BUCKS.

*You already know we make -*

RADIO SLEEVINGS  
INSULATING TUBING  
COVERED WIRES  
AND CABLES

*— now potential users of High Frequency Equipment should write for particulars of 'Tenaplast' Co-axial Cable*

**TENAPLAST**  
LIMITED  
ENGINEERS IN PLASTICS  
7 PARK LANE · LONDON · W.1

*War to the*  
**NIFE**



SERVING THE COUNTRY WITH ITS *Life*

NIFE All-Steel Alkaline Batteries are now in use wherever the Services require — **MAXIMUM RELIABILITY.** After the War, they will be available for peace-time radio requirements.

**ALL STEEL ALKALINE BATTERIES**

NIFE BATTERIES LTD. · HUNT END · REDDITCH · WORCESTERSHIRE

**T**HE Model 7 Universal AvoMeter is the world's most widely used combination electrical measuring instrument. It provides 50 ranges of readings and is guaranteed accurate to B.S. first-grade limits on D.C. and A.C. from 25 to 100 cycles. It is self-contained, compact and portable, simple to operate, and almost impossible to damage electrically. It is protected by an automatic cut-out against damage through severe overload, and is provided with automatic compensation for variations in ambient temperature.

Orders can now only be accepted which bear a Government Contract Number and Priority Rating

Sole Proprietors and Manufacturers : **AUTOMATIC COIL WINDER & ELECTRICAL EQUIPMENT Co. Ltd.,** Winder House, Douglas Street, London, S.W.1  
Telephone : VICTORIA 3404/8.



Regd. Trade Mark  
**MEANS ACCURACY**

**ONE INSTRUMENT**

- measures :—
- Current, A.C. and D.C. (0 to 10 amps.)
  - Voltage, A.C. and D.C. (0 to 1000 v.)
  - Resistance (up to 40 megohms)
  - Capacity (10 to 20 mfd.)
  - Audio-frequency Power Output (0 to 4 watts)
  - Decibels (— 10 Db. to + 15 Db.)

The AvoMeter is one of a useful range of "Avo" electrical testing instruments which are maintaining on active service and in industry the "Avo" reputation for an unexcelled standard of accuracy and dependability—in fact, a standard by which other instruments are judged.

## SHELL TYPE CERAMIC INTERNATIONAL VALVE HOLDER

HIGH Ω  
LOW INTER-ELECTRODE CAPACITY  
HIGH INSULATION  
INTERCHANGEABLE  
TYPE APPROVED

For Technical Data:  
**OXLEY DEVELOPMENTS Co., Ltd.**  
ULVERSTON, LANCs.  
Tel: 486

You'll remember

# DALY

for

## ELECTROLYTIC CONDENSERS

Condenser Specialists for over 20 years

Daly (Condensers) Ltd.,  
West Lodge Works, The Green, Ealing, W.5.  
Telephone: Ealing 4841

# FOYLES

BOOKSELLERS TO THE WORLD  
Nearly 3,000,000 new and Second-hand Books on  
Engineering and other subjects.  
Books Bought.

119-125 Charing Cross Road, London, W.C.2  
Tel: Gerrard 5660 (16 lines). Open 9-6 Inc. Sat.

## TRANSFORMERS

to customers' specifica-  
tions or in accordance  
with standard list.



### W. BRYAN SAVAGE LTD.

Westminster Road, London, N.W.9. Calldate 7131

## LONDEX for RELAYS

We manufacture a  
wide range of Relays  
for A.C. and D.C.



Relay MC (D.C. only)

Relay FL

Ask for Leaflet SPN/EO

## LONDEX LTD

MANUFACTURERS OF RELAYS  
207 ANERLEY ROAD, LONDON, S.E.20  
PHONE: STOLHAM 9230/6

### CLASSIFIED ANNOUNCEMENTS.

The charge for miscellaneous advertisements on this page is 12 words or less 4/- and 4d. for every additional word. Box numbers count as four words, plus 1/- extra for replies. Remittance should accompany advertisement. Cheques and P.O.'s payable to Hulton Press Ltd., 43 Shoe Lane, E.C.4. Press date—15th month for following issue.

#### FOR SALE

**IN STOCK**, Rectifiers, Accumulator Chargers, Rotary Converters, P.A. Amplifiers, Mikes, Mains Transformers, Speakers of most types, Test Meters, etc., Special Transformers quoted for.—University Radio, Ltd., 238, Euston Road, London, N.W.1. Ger. 4447.

**ELECTRONIC MUSIC.** Experimenter offers organ reeds (steel), pick-up magnets, amplifier, etc. S.A.E. for details. Box 707, "Electronic Engineering."

#### LOUDSPEAKERS

**LOUDSPEAKERS**—We carry on. Sinclair Speakers, 12, Pembroke Street, N.1.  
**LOUDSPEAKER** repairs, British, American, any make, moderate prices.—Sinclair Speakers, 12, Pembroke Street, N.1.

#### MISCELLANEOUS

**WE WILL BUY at your price** used radios, amplifiers, converters, test meters, motors, pick-ups, speakers, etc., radio and electrical accessories. Write, phone or call, University Radio Ltd., 238, Euston Road, London, N.W.1. Ger. 4447.

**WEBB'S** Radio Map of the World enables you to locate any station heard. Size 40' by 30' 2 colour heavy Art Paper, 4/6, post 6d. Limited supply on Linea, 10/6, post 6d.—Webb's Radio, 14, Soho Street, London, W.1 Phone: GERrard 2089.

**MORSE Practice Equipment** for Class-room or Individual Tuition. Keys, Audio Oscillators for both battery or main operation. Webb's Radio, 14, Soho Street, London, W.1 Phone: GERrard 2089.

**BERRY'S (SHORT WAVE) LTD.**, carry, in addition to the usual radio parts, a most complete range of **RADIO AND ELECTRONIC EQUIPMENT**, including C.R. Tubes, 2½ in., £3 6s. 0d.; 4½ in., £6 1s. 0d.; Meters, 0/5 ma, 5/8. 6d.; 0/1, 7/5s. 6d. Meico 5w. Amplifier, £16 10s. 0d. Rothermel Crystal Mikehead, £4 15s. 0d.; Pickups, 7/3s. 6d., 7/8s. 9d. Ceramic S.W. Variables: .0001, 4s. 6d.; .00016, 4s. 9d.; 15 mmf., 3s. 6d.; 25 mmf., 3s. 9d.; 40 mmf., 4s. 6d.; 75 mmf., midget, 6s. Precision 4 in. S.M. Dial, 9/1 with driving head and vernier, 3/5s. S.M. Drive, 8/1 with station-named dial escutcheon and glass, 8s. 6d. "P" Coils, 2s. 3d., 2s. 6d. I.F.'s, 7s. 6d. Metal Cabinets with hinged lid, panel and chassis, 3/9s. 6d., 6/3s. Jacks and Plugs, 2s. 6d. each. S.W. H.F. Chokes, 2s. 6d. All-wave 2.5 ma., 3s. 6d. Toggle and Rotary Switches, Ceramic Valve-bases, Stand-offs, Feed Throughs, Formers, Radio Manuals. Send rd. stamp for full list "E" to 25, High Holborn, London, W.C.1. (Tel.: Holborn 6231).

**THE TECHNICA CAMERA CO.**, 21, William IV Street, consulting photographic engineers to H.M. Government Departments, undertake the solving of photographic engineering problems.

**ENGINEERS** have capacity for design and development work on radio and television and all types of test gear. Post-war designs. Drawings supplied. Box 709, "Electronic Engineering."

**WE OFFER** cash for good modern Communication and all-wave Receivers.—A.C.S. Radio, 44, Widmore Road, Bromley.

#### SITUATIONS VACANT

**ELECTRONIC ENGINEER**, French, Austrian, Czech, etc., required for research work. Priority job with peace-time prospects. Box No. 691, "Electronic Engineering."

**CHIEF INSPECTOR** required by firm engaged on war work in S.W.5. Write giving full particulars to Box 704, "Electronic Engineering."

**CHIEF-OF-TEST** required by firm engaged on war work in S.W.5. Must have sound knowledge of production testing of H.F. and U.H.F. equipment. Write giving full particulars to Box 705, "Electronic Engineering."

**HEAD FOREMAN** for Instrument Section required by firm engaged on war work in S.W.5. Write giving full particulars to Box No. 706, "Electronic Engineering."

**CHIEF ENGINEER** required by firm engaged on war work in S.W.5. Write giving full particulars to Box No. 703, "Electronic Engineering."

## Into Battle with... FELT

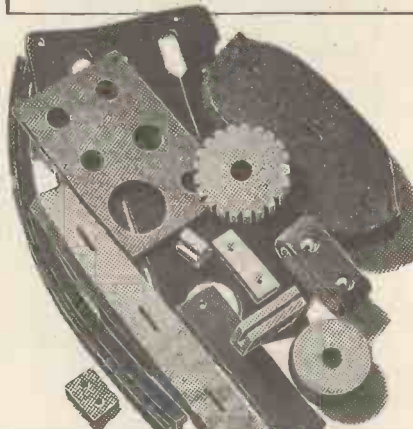

Woolen & Hair Felts, Cloths, Furnishing, Mechanical, Surgical, Washers, Strips and Gaskets. Gas Meter Washers. Felt Cut and Turned. Waterproofing.

## STERLING TEXTILE INDUSTRIES LTD

STERLING WORKS, ALEXANDRA ROAD, PONDERS END  
MIDDLESEX  
HOWARD 2214-5, 1755  
STEREX, ENFIELD

### Classified Announcements (Contd.)

**RADIO DEVELOPMENT ENGINEERS** required for the Laboratory of large electrical engineering works in the N.W.—B.Sc. (Hons.) Physics or Chemistry, or equivalent standard—age 25 to 30. Salary according to age, qualifications and experience—from £375 to £600 per annum.

Applicants should write quoting A.736KA to the Ministry of Labour and National Service, Central Register, Room 5/17, Sardinia Street, Kingsway, London, W.C.2 for the necessary forms which should be returned completed on or before January 11, 1945.

**SALES ENGINEER** required by well established firm contemplating manufacture of television receivers, high-quality radio receivers and scientific apparatus of an electronic nature. Applicant will be expected to be capable of preparing a complete sales policy and organisation, and should have an all round experience and good connections in the radio trade. In reply, give availability, experience and technical qualifications Box 710, "Electronic Engineering."

**PRODUCTION ENGINEER** required with technical qualifications and engineering experience in television and radio field. Applicants should be capable of planning and organising a complete lay-out for receiver assembly and of supervising production. Reply stating availability, experience and qualifications. Box 711, "Electronic Engineering."

**APPLICATIONS ARE INVITED** by a well-established firm in London area, from first-class radio engineers with qualifications and experience capable of assuming responsibility for the production designing of television and high quality radio receivers. Box 712, "Electronic Engineering."

**WANTED.** Communications (radio) Technical Writer to prepare detailed technical publications from brief particulars, using own technical judgment, practical experience and imagination. Must be able to cover all aspects from installation to maintenance, bring out essential points of technical interest, and evolve representative descriptions covering equipments differing in detail. Equipments up to 200 kilowatts involved. Write stating age, experience and salary required to Box 1334, A.K. Advtg., 212a, Shaftesbury Avenue, London, W.C.2.

#### SITUATION WANTED

**PHYSICIST**, 33, Ph.D., 2 years X-ray, 9 years radio, all branches, at present not fully utilising qualifications, ready immediately take charge section electronic instrument design or similar post, willing travel Continent. £750 p.a. Box 708, "Electronic Engineering."

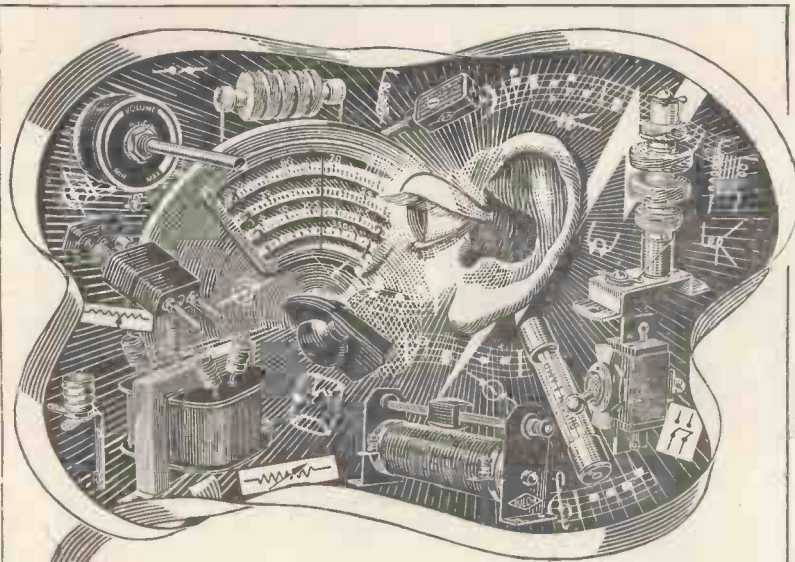

## The World of Tomorrow.

**J**UST as the Reliability and Ingenuity of BULGIN Radio Products have been proved in the stress of War, so in the World of Tomorrow Industry can safely trust us with their Component Problems and Requirements.

The Return of Peace will find us ready to ease a large part of your production difficulties. Our Technique, with a back-ground of 21 years of experience solely devoted to the Manufacture of Essential Components, will safeguard your trade-mark.

*"The Choice of Critics"*



Regd. Trade Mark

**A. F. BULGIN & COMPANY LTD.,**  
Radio and Electrical Component Manufacturers,  
**BYE PASS RD., BARKING, Essex.**

Tel.: RIPPLEway 3474 (5 lines)

## From Atoms to Stars

MARTIN DAVIDSON, D.Sc., F.R.A.S.

An important new book on the popular subject of atomic physics and astronomy. Written primarily for the amateur scientist and the intelligent layman. The most recent discoveries and theories are lucidly explained, with a sprinkling of mathematics for those who like figures as well as facts and reasoning as well as conclusions.

Fully illustrated 15/-

## Worked Examples in Electrotechnology

W.T.PRATT, B.Sc., A.C.G.I., D.I.C., A.M.I.E.E.

This collection of over 200 worked examples in Electrotechnology will be of considerable assistance to students.

**HUTCHINSON'S**  
Scientific & Technical Publications  
47 PRINGES GATE, LONDON S.W.7

## TRANSFORMERS & COILS

to specification

MANUFACTURED or REWOUND

**STANLEY CATTELL, LTD.**

9-11, East Street, TORQUAY, DEVON

Phone Torquay 2162

## LAMINATIONS & SCREENS RADIOMETAL · PERMALLOY SILICON ALLOYS

Electrical Sound & Television Patents Ltd.

12 PEMBROKE ST., N.1

## TESTOSCOPE

Indispensable to Radio Service Engineers. Makes 20 tests. Interesting Booklet on request. From all wholesalers or direct. Send for Leaflet L24

**RUNBAKEN · MANCHESTER · I**

## AFTER THE WAR !

The advance in Radio Technique after the war will offer unlimited opportunities of high pay and secure posts for those Radio Engineers who have had the foresight to become technically qualified. How you can do this quickly and easily in your spare time is fully explained in our unique handbook.

Full details are given of A.M.I.E.E., A.M.Brit. I.R.E., City and Guilds Exams. and particulars of up-to-date courses in Wireless Engineering, Radio Servicing, Short Waves, TELEVISION, Mathematics, etc., etc.

Prepare for to-morrow's opportunities and post-war competition by sending for your copy of this very informative 112-page guide NOW—FREE.

**British Institute of Engineering Technology**  
(Dept. 337a) 17, Stratford Place, London, W.1

12 Browning



ALWAYS ON DUTY

EDDYSTONE

358X COMMUNICATION RECEIVER



THE RECEIVER MAY BE INSPECTED  
between 9 a.m and 4 p.m (Saturdays 9 a.m to 12 noon)

30 Page Booklet available at 2/6 Post Free.



LONDON AGENTS:

**WEBB'S** Radio

14, SOHO ST. LONDON, W.1.

Phone: GERvard 2089

MANUFACTURED BY:

**STRATTON & CO. LTD., EDDYSTONE WORKS, BIRMINGHAM**

Phone: PRIORY 2231

Cables: "STRATNOID" BIRMINGHAM