

Electronic Engineering

INCORPORATING ELECTRONICS, TELEVISION AND SHORT WAVE WORLD

PRINCIPAL CONTENTS

Lightning

Glass Bases for Radio Valves

The Mechanism of Leaky Grid Detection

Cathode Ray Tube Traces — 3

A Resistance Capacity Oscillator

2/- AUG. 1944

Final Test



THE finished valve is finally subjected to extremely rigid tests to ensure the high quality and long life associated with Brimar Products.

BRIMAR
(BVA)
VALVES

STANDARD TELEPHONES AND CABLES LIMITED, FOOTSGRAY, SIDCUP.

The fact that goods made of raw materials in short supply owing to war conditions are advertised in this magazine should not be taken as an indication that they are necessarily available for export.

Going one better
IN COMMUNICATIONS



To-day, wherever Bullers Low Loss Ceramics are used, reception is clearer and better than ever before.

Made in Three Principal Materials:

Years of research in Bullers Laboratories have developed these materials to such a high level of efficiency that Dielectric Loss is virtually eliminated. Bullers Ceramics are now playing a vital part in maintaining communications under all conditions.

FREQUELEX. An insulating Material of Low Dielectric Loss. For Coil Formers, Aerial Insulators Valve Holders, etc.

PERMALEX. A High Permittivity Material. For the construction of Condensers of the smallest possible dimensions.

TEMPLEX. A Condenser material of medium permittivity. For the construction of Condensers having a constant capacity at all temperatures.

BULLERS LIMITED
 THE HALL, OATLANDS DRIVE, WEYBRIDGE, SURREY
 Telephone: Walton-on-Thames 2451
 Manchester Office: 196 Deansgate, Manchester

Bullers

LOW LOSS CERAMICS



**ELECTRONIC
DEVICES**
*for
Science &
Industry*

G.E.C.
CATHODE RAY
TUBES ETC

Osram
Valves

Osram
PHOTO CELLS



The G.E.C. is foremost in the design, production and supply of radio valves and electronic devices as being essential links in the national effort to secure a speedy victory.

Thermionic Valves, Cathode Ray Tubes and associated Electronic Devices will inevitably become increasingly necessary in post-war application to scientific development in all spheres of electrical engineering and industry.

Here are just a few examples :—

- Navigation Aids
- Oscilloscopes for Industrial and Scientific Research
- Valve Control Devices and Electronic Switches.
- Loud Speaking announcements and Alarm Systems.
- High Frequency Heating.
- Instruments of all kinds.

HIGH PERFORMANCE

Long years of patient training and practice are behind every Dubilier volume control and variable resistor. There is no substitute for these years of experience which ensure that uniformly high performance for which all Dubilier products are world famous.

Illustration shows
Volume Controls.



DUBILIER

CONDENSER CO. (1925) LTD.





one in a thousand

Ten years ago we introduced the first British-made low-loss ceramic. To-day the range of Frequentite components covers more than a thousand pieces of every shape and size. With such a store of manufacturing experience we are able to offer advice backed by practical knowledge on your insulation problem. Please consult us before you finalize your design.



STEATITE & PORCELAIN PRODUCTS LTD.

Head Office: Stourport-on-Severn, Worcs.

Telephone: Stourport 111.

Telegrams: Steatite, Stourport.

S.P.26

LONG LIFE, HIGH EFFICIENCY AND A SIMPLE CIRCUIT

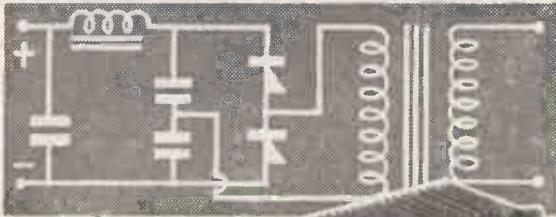

A metal rectifier in the voltage doubler circuit provides full wave rectification with a transformer secondary voltage less than the voltage of the output from the rectifier. Further, no filament winding is required and the transformer is simpler and less costly.

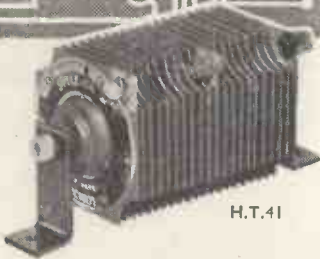

H.T.41



METAL RECTIFIERS

WESTINGHOUSE BRAKE & SIGNAL CO. LTD.
Pew Hill House, Chippenham, Wilts.

SOLEON INDUSTRIAL ELECTRIC APPLIANCES

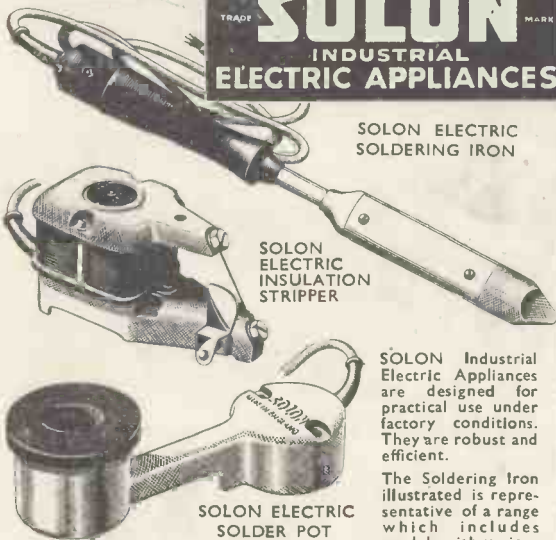

SOLEON ELECTRIC SOLDERING IRON

SOLEON ELECTRIC INSULATION STRIPPER

SOLEON ELECTRIC SOLDER POT

SOLEON Industrial Electric Appliances are designed for practical use under factory conditions. They are robust and efficient.

The Soldering Iron illustrated is representative of a range which includes models with various

types of bits suitable for a wide variety of jobs.

The Insulation Stripper provides a quick method of severing the insulation neatly without damaging the conductor, by means of an electrically heated wire.

The Solder Pot maintains $\frac{1}{2}$ lb. solder at working temperature.

Please write for Folder Y9.

W. T. HENLEY'S TELEGRAPH WORKS CO., LTD.
MILTON COURT, WESCOTT, DORKING, SURREY

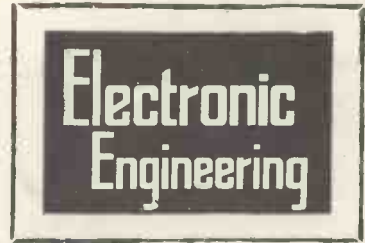

AUGUST, 1944

Volume XVII.

No. 198.

CONTENTS

	PAGE
Editorial—Mathematics	95
Lightning	96
Glass Bases for Radio Valves	101
A Note on the Phase-Splitting Amplifier Circuit	103
The Mechanism of Leaky Grid Detection	104
Cathode-Ray Tube Traces	109
An Analysis of a Direct Current Galvanometer Amplifier	114
A Resistance-Capacity Oscillator	118
Electronics in Post-War Industries	120
Research and the Future of the Radio Industry	121
Focused Supersonic Waves in Biological Experiments	122
Correspondence	124
Abstracts of Electronic Literature	128
Book Reviews	130

CONDITIONS OF SALE—This periodical is sold subject to the following conditions, namely, that it shall not without the written consent of the publishers first given, be lent, re-sold, hired out or otherwise disposed of by way of Trade except at the full retail price of 2/- and that it shall not be lent, re-sold, hired out or otherwise disposed of in a mutilated condition or in any unauthorised cover by way of Trade, or affixed to or as part of any publication or advertising, literary or pictorial matter whatsoever.

*Over twenty years of
experience and research
are behind the advanced
technique of today...*



MULLARD
THE MASTER VALVE
A Valve for Every Purpose

DOMESTIC · COMMERCIAL · INDUSTRIAL · SCIENTIFIC · MEDICAL · EXPERIMENTAL

THE MULLARD WIRELESS SERVICE CO. LTD., CENTURY HOUSE, SHAFTESBURY AVENUE, LONDON, W.C.2. (77 rev.)

PROPRIETORS :

HULTON PRESS, LTD.

Electronic Engineering

EDITOR:

G. PARR.

EDITORIAL, ADVERTISING AND PUBLISHING OFFICES, 43-44, SHOE LANE, LONDON, E.C.4

TELEPHONE:
CENTRAL 7400

Monthly (published last day of preceding month) 2/- net. Subscription Rates :
Post Paid to any part of the World—
3 months, 6/6 ; 6 months, 13/- ; 12 months, 26/- . Registered for Transmission by Canadian Magazine Post.

TELEGRAMS
HULTONPRES, LUD
LONDON.

Mathematics

ON this page a year ago we referred to a report which had been issued by the Institute of Physics on the training of Physicists, which mentioned that some modification in the present method of teaching mathematics to prospective physicists was desirable.

A Committee composed of members of the Institute and the Mathematical Association has now issued a separate Report on "The Teaching of Mathematics to Physicists," which embodies their recommendations for the teaching of mathematics to physicists in training at universities.

Several of the remarks in the report are well worth quoting in view of the interest which is being taken at present in the post-war training of students for research and the close relation between physics and electronics.

It is recognised that the physicist will be studying mathematics mainly for the purpose of applying it to his own particular problems. "In the past, much of the time allotted to Applied Mathematics has been spent in the solution of problems in which the interest has resided mainly in the ingenuity of the mathematics . . . however admirable these may be in the training of the professional mathematician, they are out of place

with the physicist, and may be omitted, not only without loss, but with actual benefit."

The Committee are of the opinion that the mathematical requirements of the average student of physics cannot be fully satisfied by a selection from among the courses normally provided for students of mathematics, and recommend that a special course for physics students is instituted.

The minimum requirements of a student who intends to qualify as a fully-trained physicist are covered by "Schedule A," intended to be covered in two years, taking one-third of the student's time.

Schedule B, covered in a further year, is for students who specialise in

physics during a 3-4 years' course, and Schedule C is for advanced students and will not normally form part of an undergraduate course.

The standard of knowledge required for starting on Schedule A is the Higher School Certificate.

Details of the schedules are given in full in the Report, and it is emphasised that they have been drawn up with a view to giving the physics student a general view of the content of mathematics and a knowledge of what mathematical techniques are available, together with the types of investigation for which each is suitable.

In other words, mathematics is introduced to the physics student as a useful tool (to use a detestable and overworked word) and its application to the solution of physical problems is the main aim of the new syllabus.

Teachers in Universities and Technical Colleges would be well advised to study the booklet, which will give them suggestions for pruning or amending their courses to suit the more practical needs of the coming post-war graduates.

Postscript: "A student whose mathematical ceiling is really unduly low would probably be well advised to transfer his interest from physics to some other branch of science."

Index to Vol. XVI.

A full cross-referenced index for Volume XVI of *Electronic Engineering* is now available, price 6d., post free.

Applications should be addressed to the Circulation Dept., Hulton Press, 43 Shoe Lane, E.C. 4., and be accompanied by a P.O. or stamps to the value of 6d.

Important

Subscribers who have their copies of the journal sent direct from the Circulation Dept. need not apply separately for the Index, which will be sent in due course.



Stationary photograph of a lightning discharge in California.
(Photo by Jackson Welch).

THE accumulation of knowledge concerning the lightning discharge has greatly increased during recent years and, although much still remains unknown, we now possess a reasonably clear picture of the mechanism of development of the discharge, together with a large amount of data relating to the currents and quantities of electricity involved. Many of the investigations have been stimulated by the natural desire for an understanding of the discharge process, and there has been an additional incentive in that lightning is a problem of considerable practical importance to the electrical engineer on account of the annual damage which it causes to transmission lines and associated apparatus. Progress has also been facilitated by the development of new instruments capable of recording high-speed transient phenomena, such as the cathode-ray oscillograph.

While a considerable amount of the research on lightning has been carried out by electrical engineers, who require to determine the magnitude and time-variation of the currents produced in order to estimate the degree of protection necessary for distribution networks, the lightning discharge is itself a phenomenon of considerable interest in its relation to the whole problem of atmospheric electricity. Many studies

have been made by meteorologists and physicists with regard to the generation of electric charge in the thundercloud, the development of the lightning discharge, and the electrostatic field changes at the earth and in the atmosphere during fine-weather and stormy conditions. The radiated fields which occur during the discharge have also been investigated and are found to be of sufficient intensity to form one of the main causes of radio-atmospherics.

The number of lightning discharges which occur annually over the earth's surface is probably much greater than is generally realised in this country, where lightning is a relatively infrequent occurrence. It is estimated that a total of 44,000 thunderstorms occur each day, and that these give rise to 100 lightning discharges per second. The average charge lowered to earth by each discharge is about 20 coulombs, so that the equivalent continuous current is about 2,000 amps. The voltage gradient between the thundercloud and earth is several hundred volts per cm., so that, for a thundercloud height of 2 km., the average power which is continuously expended as a result of lightning is some 10^8 kilowatts.

The Electrification of the Thundercloud

The generation of this large amount of power is effected by thermodynamical

Lightning

By J. M. MEEK,*

D.Eng., F.Inst.P., A.M.I.E.E.

cal forces, which culminate in the formation of the thundercloud. A principal feature of the latter, which is generally in the form of a cumulonimbus cloud, is the presence of strong upward air-currents, and it is considered that the interaction of these currents with water-drops, and ice-crystals, is the main factor in the electrification of the thundercloud.

Recent measurements by Sir George Simpson and his associates have supplied useful evidence concerning the distribution of electric charge in thunderclouds. Free balloons carrying various forms of recording apparatus were released at intervals during storms. In this manner continuous records have been obtained of the variations of electric gradient and temperature in the atmosphere, both beneath and within the thundercloud. The measurements indicate that the cloud base is usually negatively charged and that a positive charge predominates in the upper regions of the cloud, though a localised positive charge is also frequently observed to be present in the cloud base. The magnitude of the electric gradient is not more than about 100 volts per cm.

The temperature in the cloud base is generally above freezing point, and precipitation is in the form of water-drops. In the upper portions of the cloud it is found that the temperature falls to values as low as -20 degrees centigrade, so that ice-crystals, and not water-drops, will be present.

Simpson has suggested that the electrification of the thundercloud takes place as a result of two processes, depending on the presence of water-drops or ice-crystals. In the former case, the proposed mechanism is based on the experimental observations of the breaking of water-drops in an air-blast, when a positive charge is

*Metropolitan Vickers Electrical Co. Ltd.

developed on the broken drops while the air becomes negatively charged. The interaction of raindrops with rapidly rising air-currents, which are a known feature of thunderclouds, can then cause a separation of electric charge in the lower portion of the cloud. The alternative process, relating to ice-crystals, was first suggested by Simpson in connexion with the electrification of the atmosphere during blizzards in the polar regions. The impacts of ice-crystals are considered to result in the ice becoming negatively charged and the air positively charged. Such a mechanism explains the charge distribution observed in the upper regions of the cloud.

Various other suggestions, notably that of Professor C. T. R. Wilson, have been put forward to explain the mechanism of cloud electrification. Wilson considered a water-drop in the fine-weather field, which is normally about 1 volt per cm. in such a direction that the drop is polarised with a negative charge on its upper surface, and a positive charge on its lower surface. Large drops falling through the cloud will then attract negative ions which are rising in the external field, and, if the water-drops fall at a speed greater than that of positive ions in the external field, no positive ions will become attached to the drops. In this manner large drops carry negative charges to the lower regions of the cloud, while the upper regions become positively charged. The possibility of such a mechanism has been demonstrated experimentally.

When the voltage gradients which have been created in the region of the thundercloud are sufficiently great, the separated charges may be neutralised by the development of lightning dis-

charges. Although the number of discharges which take place within the thundercloud itself, is larger than the number which occur between cloud and ground, the latter are of most direct interest and will be considered in this article.

Photographic Studies of the Lightning Discharge

The development of the lightning discharge has been studied by a number of investigators with the rotating-film or rotating-lens camera, which was originally devised by Sir Charles Boys some fifty years ago. In such a camera, there is a relative movement of film and lens, so that any portion of the discharge which becomes luminous

earlier than another portion is distinguished by distortion of the photographed image, as illustrated diagrammatically in Fig. 1. The speed of development of the discharge can be determined from a knowledge of the relative speed of rotation of lens and film.

The first successful photographs of lightning, taken with a rotating-lens type of camera, were obtained by Schonland in South Africa during 1933. Subsequently, a number of investigations have been carried out, with the result that we now possess a fairly clear picture of the progress of the luminous discharge channel between cloud and ground, as will now be described.

Analysis of the rotating camera photographs show that the lightning discharge is preceded by what Schonland has termed "leader strokes." The discharge to open country is initiated at the cloud by a streamer which travels rapidly towards the ground, but which is extinguished before it has covered more than a fraction of the total distance. Some 50 microseconds later a second streamer follows down the track of the first streamer and elongates the channel by about 10 metres, and the process continues until the ionised channel reaches the ground, as shown schematically on the left-hand side of Fig. 2. This series of streamers, known as the "stepped leader" stroke, has a mean effective speed of about 2×10^7 cm. per sec. from cloud to ground, but the speed of the individual steps is of the order of 10^9 cm. per sec. This mechanism occurs in some 65 per cent. of the discharges observed by Schonland, and in the remaining discharges the stepped leader mechanism is that indicated in Fig. 6, where the speed

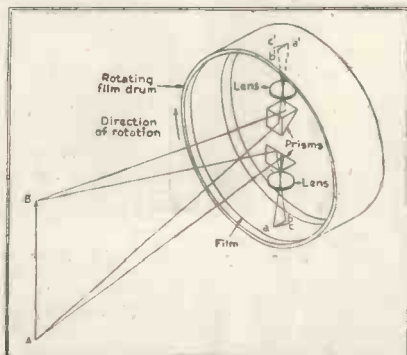

Fig. 1 (a). Schematic diagram to illustrate the operation of a rotating-film type of camera, as used by McEachron.

(Reproduced from the Journal of the Franklin Institute)

Fig. 1 (b right). Photograph of a multiple-stroke lightning discharge as observed with a rotating-lens camera, in which two lenses are rotated at the ends of a diameter of a circle, so that two photos. of each stroke are obtained. The sequence of the strokes is indicated by the letters a-h. Dart leader strokes can be clearly distinguished for the strokes b and d. A "still" photograph of the discharge, marked 8, is mounted in the centre of the rotating-lens photograph.

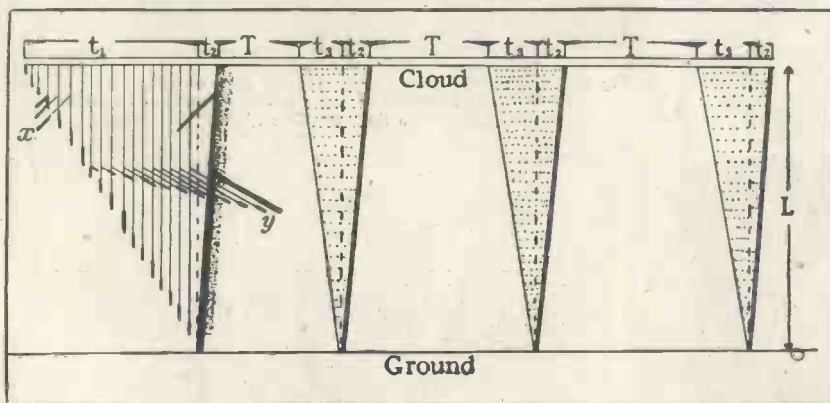
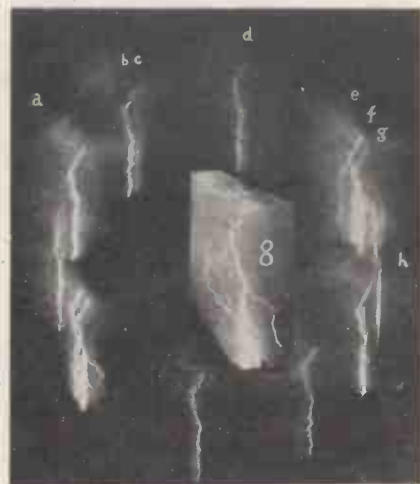

Fig. 2. Representation of the development of a branched discharge along a vertical path from cloud to ground, with a stepped leader preceding the first stroke and dart leaders preceding the three subsequent strokes. The average values of the quantities indicated on the diagram are: $t_1 = 0.01$ sec. $t_2 = 0.00004$ sec. $t_3 = 0.001$ sec. $T = 0.03$ sec. $L = 2$ km.

(Reproduced from the Proceedings of the Royal Society)



and intensity of the leader stroke as it approaches ground are considerably reduced below those obtaining in the initial stages of the development.

As soon as the stepped leader stroke reaches ground the main stroke, or return stroke, travels up the preionised channel from ground to cloud at a speed of nearly 10^{10} cm. per sec. Branches of the discharge, which are traced out by the leader stroke are retraced by the return stroke. A photograph of a stepped leader stroke and the subsequent return stroke is given in Fig. 3.

After the extinction of the first main stroke there may be a pause of several hundredths of a second, when a second

leader and return stroke may occur. The leaders to the second and subsequent strokes usually travel in a single flight from cloud to ground at a speed of about 2×10^9 cm. per sec., as shown in Fig. 2, and have been termed "dart" leaders. The second and subsequent strokes rarely show branching and follow the original main channel in detail. The total number of strokes in a discharge is not usually greater than six, though as many as thirty have been observed, while the whole discharge may have a duration of as long as 1 second.

The above-described mechanism of development refers to discharges to open country, and some modification

is required in the description of discharges to high buildings. McEachron studied lightning discharges striking the Empire State Building, which is 1,250 ft. in height, and found that the discharge is usually initiated at the top of the building in the form of a leader stroke which develops upwards in a stepped manner towards the cloud, as indicated in Fig. 4. The characteristics of this stepped leader stroke are closely similar to those found for the discharge in open country, except that the direction of travel is reversed. But when the stepped leader stroke reaches the cloud there is no return stroke, in the accepted sense, but a continuing current discharge is ob-

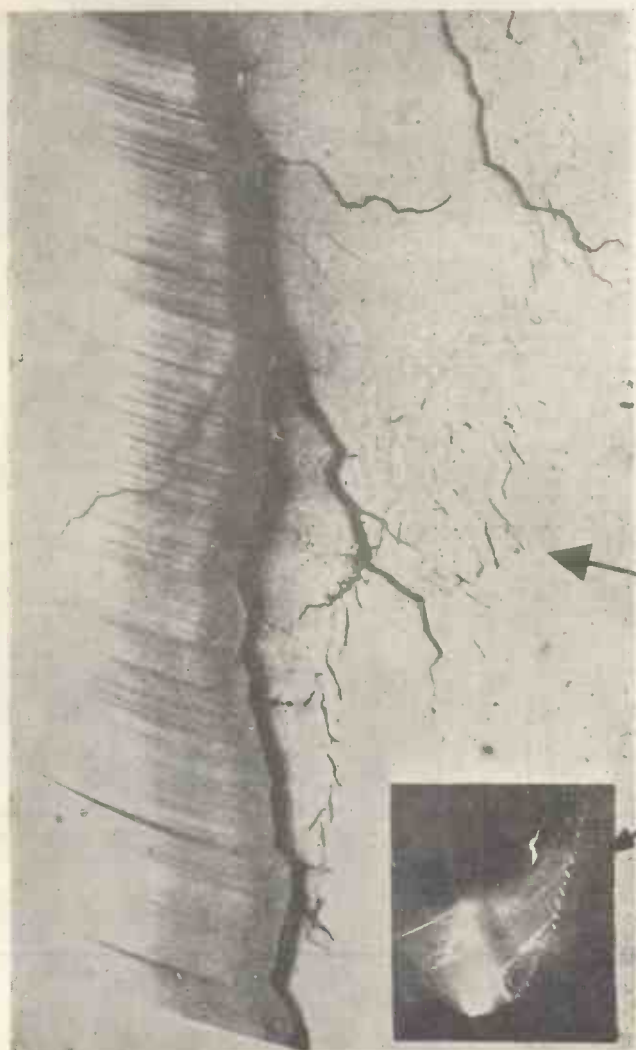
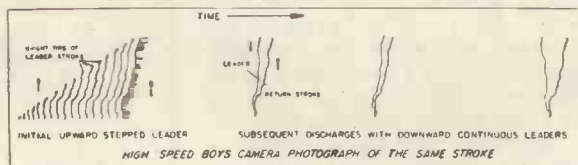

Fig. 3. Photograph of the development of two separate stepped-leader strokes as recorded with a rotating-lens type of camera the direction of lens movement is indicated by the arrows.
(Reproduced from the Proceedings of the Royal Society)



CLOUD TO TALL CONDUCTING STRUCTURE

Fig. 4. Representation of the development of a four-stroke discharge between a high building and a cloud.

(Reproduced from the Journal of the Franklin Institute)



STILL CAMERA PHOTOGRAPH OF STROKE

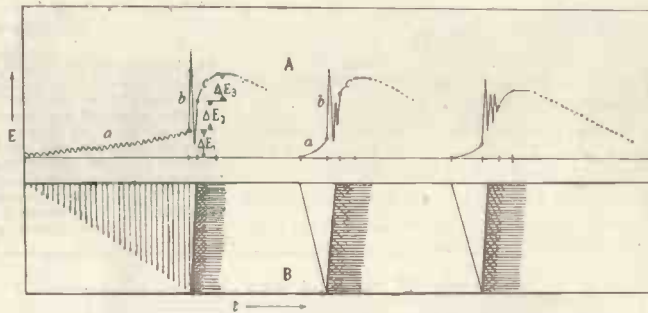

Fig. 5. Electric field change at the ground close to a lightning discharge, as observed in about 65 per cent. of Schonland's records.
(Reproduced from the Proceedings of the Royal Society)

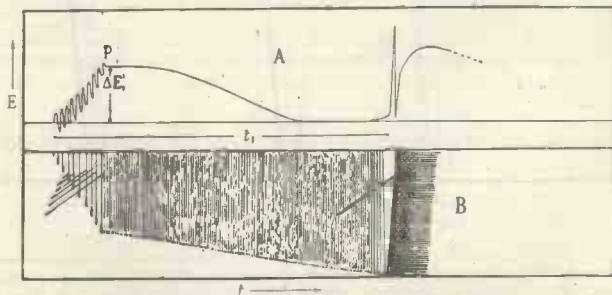

Fig. 6. Less frequently observed field change, applicable to about 35 per cent. of the discharges recorded by Schonland.

(Reproduced from the Proceedings of the Royal Society)

served. The subsequent strokes of the discharge are found to be preceded by dart leaders, which develop from the cloud to the building.

Field Changes and Atmospherics

The photographic investigation of lightning indicates the general process of development of the discharge, but does not yield values for the magnitudes of the currents involved. Direct measurements of these currents are not readily obtainable, on account of the random nature of lightning, and only a few records are usually obtained each year by a single recording equipment. It is, therefore, necessary to maintain a large number of recording equipments, which may be connected to transmission lines and other objects liable to be struck by lightning, in order to obtain sufficient records for a statistical survey to be made. However, much valuable information concerning the discharge currents, and their variation with time, may be determined indirectly, by observations of the electric field changes produced by lightning.

The field change is measured with an aerial, whose output is amplified and transferred to the plates of a cathode-ray oscillograph. In Schonland's experiments the oscillogram is photographed with a moving-film camera, in which the film is carried on the circumference of a rotating drum, with an axial traverse, so that the records are displaced in a spiral manner. The film movement is used to provide the time-scale, and the normal time-sweep plates are both connected to earth, so that, in the absence of a field change, there is a stationary spot on the oscillograph screen. In order to prevent fogging of the film, the spot brilliance is maintained at a low value until the occurrence of the transient to be recorded. An increase of spot brilliance is then effected by the use of a trigger unit which is operated by the electric pulses produced by the stepped leader stroke, and in this way a complete record of the main wave-form is ensured.

The variations of electric field, at the ground near the discharge, and associated with the two types of discharges usually observed by Schonland are shown in Figs. 5 and 6. Three main changes of field take place, as was first shown by Appleton and Chapman, who identified the A portion with the stepped leader stroke, the B portion with the return stroke, and the C portion with the continuation of the discharge current after the return stroke has reached the cloud. The



Artificial lightning (a one million volt flash). Taken at the Research Lab. of Metropolitan Vickers Electrical Co. Ltd.

frequency of the pulses on the A portion preceding the initial stroke of the discharge is found to correspond with that of the individual steps of the stepped leader mechanism; such re-current pulses do not occur on the A portions preceding subsequent strokes of the discharge when step-free dart leaders are present.

A study of the field-change records enables some quantitative calculations to be made concerning the total electric moment destroyed during the discharge. The electric field strength on the earth's surface at a distance r from the discharge, where r is large compared with the channel height, can be determined by consideration of the electric moment M caused by the charge distribution in the cloud and in the discharge channel, together with the electrical image below the earth's surface, and is given by

$$E = \frac{1}{r^3} \left(M \right) + \frac{1}{cr^2} \left(\frac{dM}{dt} \right) + \frac{1}{c^2 r} \left(\frac{d^2 M}{dt^2} \right) \quad (1)$$

where c is the velocity of light and the quantities in the brackets are the retarded values at time $(t - \frac{r}{c})$. The

first term represents the electrostatic field due to the dipole, while the remaining two terms are radiated fields dependent on the rate of change of electric moment. If the distance of the discharge from the recording aerial is known, the electric moment involved in the discharge may be determined by analysis of the field change record.

The electrostatic field, which varies inversely with r^3 , diminishes rapidly with increasing distance from the discharge, and at distances greater than about 20 miles, the first two terms of equation (1) become negligible compared with the third term. The radiated field expressed by the latter is greatest on the occurrence of the current surge in the return stroke of a discharge, but the sudden changes of electric moment caused by the stepped development of the initial leader stroke are also responsible for radiated fields which are clearly detectable at considerable distances.

The electric field changes recorded several hundred miles from the discharge are found to be complicated by pulses introduced by successive reflexions of the original radiated wave between the ionosphere and earth. Typical trains of pulses, as recorded by Schonland at different distances from the discharge, are shown in Fig. 7. The

initial pulse G represents the ground wave, which is propagated directly to the recording station, and is usually of a simple character, with a duration corresponding to the duration of the return stroke of a lightning discharge. The radiated field caused by the stepped leader stroke is small compared with that produced by the return stroke, and the presence of the former is only weakly discernible in the records of Fig. 7. The successive pulses S_1, S_2, S_3 , etc., represent the waves which have undergone one or more reflexions at the ionosphere. With increasing distance from the discharge the time-intervals between the successive pulses diminish until eventually the pulses merge and the original character of the ground pulse is lost.

Appleton, Watson-Watt, and their associates, in their studies of atmospherics by day, generally observed a highly damped train of about five oscillations. Further investigations, by Schonland and others, show that a much greater number of oscillations occurs in the wave-form of atmospherics at night, and as many as 40 have been detected. This lower attenuation of atmospherics at night is understandable on account of diurnal changes in the characteristics of the ionosphere, which forms a sharply defined reflecting layer at night, whereas, the layer is more diffuse during the day, and greater absorption of the radiated wave takes place.

A determination of the height of the ionosphere may be made by analysis of the atmospheric wave-forms. The time-interval t_n between the arrival of the ground wave and the n th sky pulse, which has undergone n reflexions at the ionosphere, is given by

$$ct_n = \sqrt{4n^2h^2 + d^2} \left(1 + \frac{h}{r}\right) - d \dots (2)$$

where c is the velocity of light, h is the height of the reflecting layer, d is the distance between the discharge and the recording station, and r is the earth's radius. The value of h may then be determined by consideration of expression (2) in conjunction with the analysis of a single train of pulses, and is found to be about 90 km. at night and about 60 km. by day, in close agreement with the measurements of other observers.

Direct Measurements of Lightning Currents

It is not possible to describe at all fully in this article the many investigations which have been made, by oscillographic and other methods, of the voltages produced on transmission lines as a result of lightning, and only

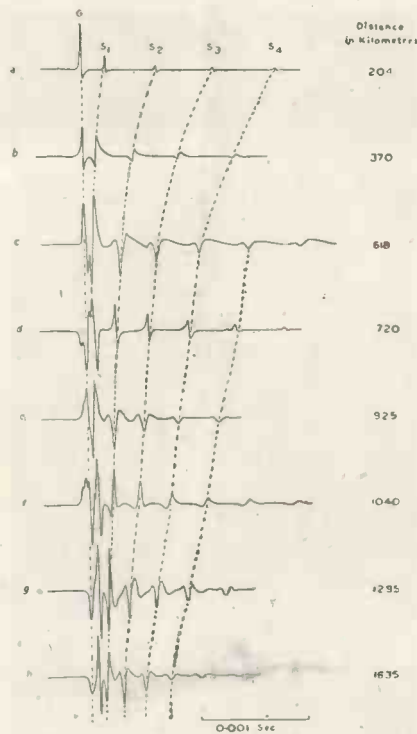

Fig. 7. Typical trains of pulses as observed in electric field change measurements at large distances from lightning discharges, and influenced by successive reflexions from the ionosphere.

(Reproduced from the Proceedings of the Royal Society)

a brief summary of some of the methods and results will be given. Transmission lines may be struck directly by lightning or, alternatively, a discharge may strike a supporting tower and raise the potential of the latter to a value dependent on the product of the tower footing resistance and the lightning current through the tower, which may be sufficient to cause flash-over from the tower to the line. Appreciable induced voltages may also be produced by nearby lightning discharges to ground.

The cost and care required to maintain a large number of oscillographic recording units preclude their extensive application to lightning measurements, and various alternative methods of recording have been devised. One method makes use of an instrument known as a klydonograph, which consists essentially of a point electrode resting on a photographic film, behind which is a plate electrode. On the occurrence of a voltage surge between the electrodes a discharge pattern, or Lichtenberg figure, is produced on the film, and the size and appearance of the pattern gives a record of the magnitude and polarity of the applied voltage. A further method, which is now widely used,

depends for its operation on the magnetic field produced by the lightning current in its passage to earth. Magnetic links consisting of several laminations of magnetic material, with high retentivity and about 2 inches long, are supported on the transmission-tower legs. In the event of a current surge through the tower the links become magnetised and measurement of the degree of magnetisation enables the magnitude or the current to be determined from calibration curves.

The use of magnetic links has also been extended, in an instrument called a fulchronograph, to give a record of the variation of current with time. The links are mounted around the circumference of a rotating wheel, in such a way that they pass between two coils carrying the current surge. The magnitude of the current at any particular time is recorded by the residual flux which it produces in the magnetic link which happens to be between the coils at that time, and measurement of the magnetisation of the various links enables a graph relating current with time to be drawn. Calibration of the fulchronograph in the laboratory show that the results obtained compare favourably with oscillographic records, and its relative simplicity as compared with the cathode-ray oscillograph make it a more suitable instrument for use in large numbers for lightning investigations.

Some of the difficulties inherent in the uncontrolled nature of lightning are overcome by observations of discharges to high buildings, which tend to be struck more frequently by lightning than surrounding low objects. In McEachron's studies of discharges to the Empire State Building, in New York, a number of oscillographic measurements of the total lightning discharge current have been made, and a few of these have been synchronised with the rotating-camera photographs earlier described. However, the different character of the discharge process, in that the discharge is preceded by an upward-developing leader stroke, makes it necessary for a certain discretion to be used in the direct application of the results to the case of discharges to ground, or to relatively low objects.

As a result of the various measurements of lightning currents by the above, and other methods, the following general conclusions have been made. Practically all the lightning discharges convey negative charge from cloud to

(Concluded on p. 123)

Glass Bases for Radio Valves

By M. A. ROWE



Glass base with pins in position.
By Courtesy of the G.E.C.

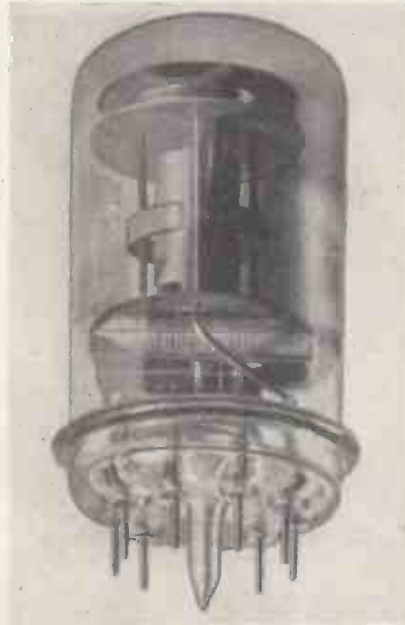

Finished valve sealed on to the base.
By Courtesy of the G.E.C.



Small glass 'button' bases ready for mounting

BEFORE the war the use of higher frequencies for radio communication and, in particular, the advent of television, made desirable the shortening of the distance between the electrode structure and the socket in radio valves. This led to the production of the so-called all-glass or ring seal valve. The numerous operational advantages of this construction were quickly appreciated by the Services and, in consequence, it was necessary to establish manufacture in this country on a grand scale. It is proposed to limit this article to notes on a few of the production problems involved and how some of them have been solved.

Fundamentally, the finished component consists of a glass disk or button, with the pins or electrode wires sealed in. The parts of these pins which remain external in the finished valve become, of course, the actual legs for making contact with the socket, they must be therefore reasonably firm in order to keep their alignment. In the Mullard EF50 and the American Loctal range this is admirably achieved by using a lead glass pressing in which are sealed chrome iron alloy straight-through pins. It is interesting that two distinct techniques have been evolved to obtain the result.

The first method consists of making a glass pressing with the requisite holes formed in. This is then placed in a suitable mould with the finished

wires assembled and the whole reheated and re-pressed. The second method entails a single operation. A portion of hot glass, called a gather, is made to drop into a mould in which the loose pins have previously been assembled. The top half of the mould is then pressed down causing the molten glass to flow round sealing the pins, thus taking its final shape from the mould. The exhaust tube in the case of the first method is generally sealed on at the same time as the pins are sealed, whereas in the second method, it is usual to make a separate operation after the bases have been made and annealed. An ingenious automatic machine developed by the Mitchell Glass Co., for the G.E.C., is illustrated. It has eight heads arranged on a rotary table. This is coupled to a timer which actuates the glass feeder so that as each gather is cut off by the shears, a fresh mould is timed to catch it.

Rectangular funnels are provided to collect the chrome iron pins which have to be automatically fed into the moulds. This machine makes 40 complete bases per minute so that the pin feeding mechanism has to handle 360 pins in the same time. A close-up photograph shows the

bottom half of the mould turning over to receive the pins. The gather weighs 9 grams, and when properly adjusted, the feeder is capable of delivering them with a weight variation of only 3 per cent. The mould design is such that this small variation can be taken care of without causing excessive strain and chisles.

The alternative method of construction simplifies the glass problem very much as a simple disk is pressed out with lobes arranged where the holes will be required; the extremities are then ground off leaving the holes straight through. The third operation consists of re-heating and sealing-in of pins by re-pressing.

An interesting development has now taken place in connexion with the miniature valve button stem. The original method used in American midget valve construction consists of using two small cut lengths of tubing arranged one inside the other, the pins being assembled between the two. The whole assembly, which is held in two half-dies, is then heated up and the dies brought together to press the glass up to the desired shape. The disadvantage of this construction is the length of time taken. Recently patents have been taken out on machines that have been designed to overcome the difficulty; one machine produces buttons to a desired weight between 1.2 and 1.5 grams with holes already in, without the necessity of a grinding operation. A second machine seals in the wires. Due to the very

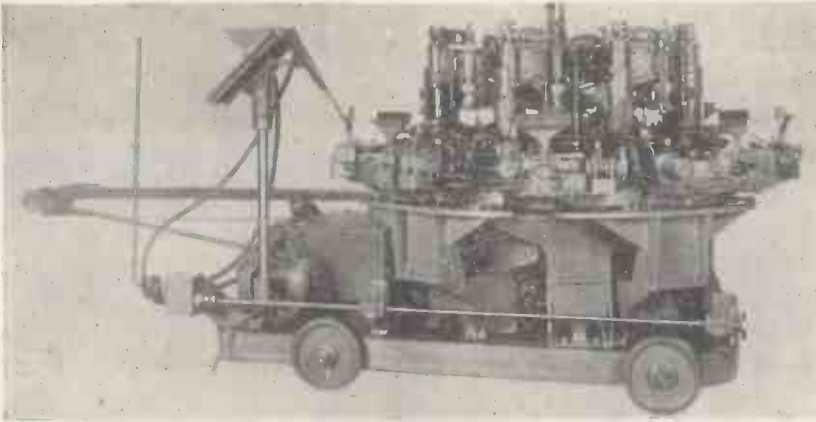
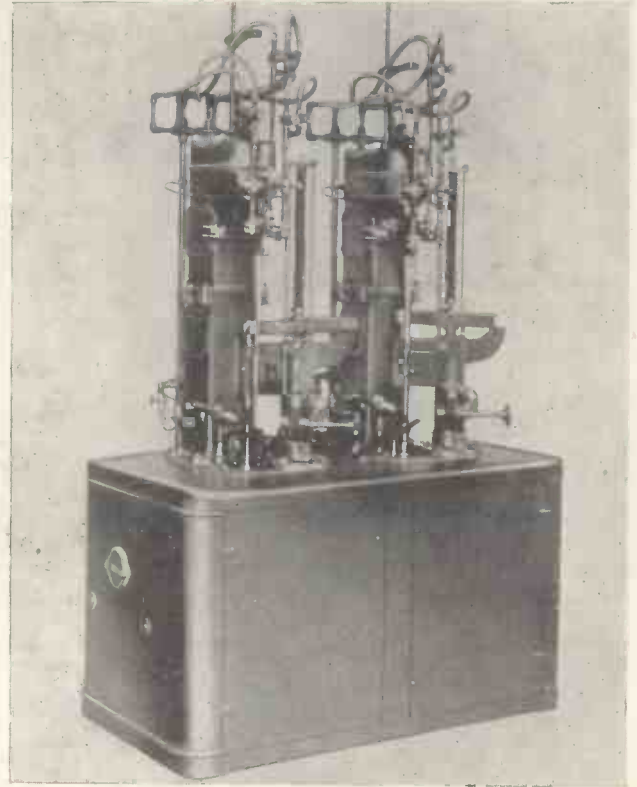
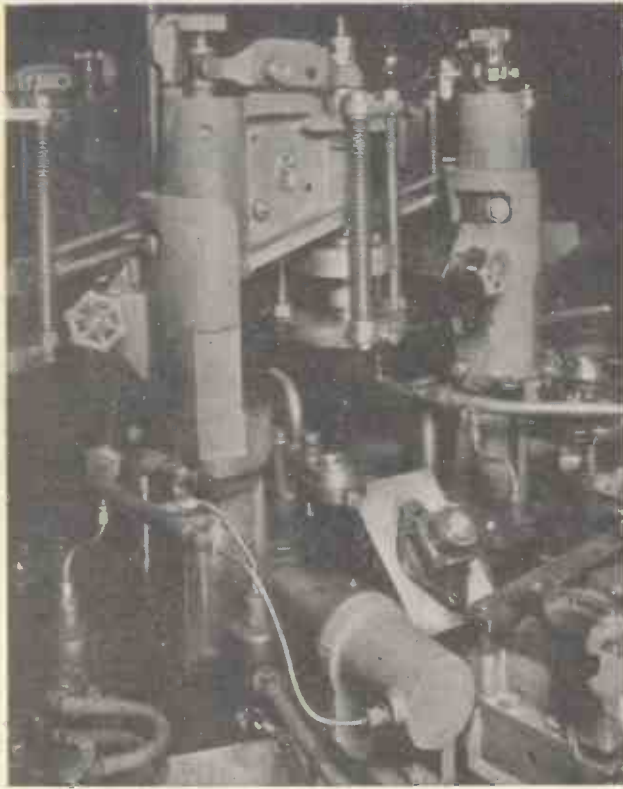

Fig. 1. Mitchell 6-head automatic 9-pin base machine showing pin feeding mechanism. (Mitchell Glass Co. Ltd.)

Fig. 2. Close-up of 8-head machine, showing the mould ready to receive the pins.

Fig. 3. (below) Twin-head machine for making button bases.



small weight involved the normal glass feeder and tank surface were out of the question so that a new method had to be worked out to produce a tiny gather.

The designers have solved this difficulty by using a similar chucking mechanism to that used on a normal hot-cut flare machine, but in place of the wheel and mandrel cutting device, a small sized version of a normal pair of glass cutting shears is used. In practice this has been found to give excellent results and so long as the machine is carefully set up

the weight variation is very small. Both rod and tubing have been tried and experience shows that thick walled tubing gives the best results.

The next problem was to make the holes in the button, and it was felt that the desirability of doing without a grinding operation was great enough to warrant considerable experiment and thought being expended in seeking a solution. The mould is made in such a way that the pin mandrels which are to form the holes in the glass, are continuously moving while the pressing is taking place. This, of course,

obviates the sticking which would otherwise take place and a clean parallel hole results. The speed of production is entirely controlled by the heating time required to make the gather. Lead glass necessarily introduces a certain amount of difficulty, and restricts the fierceness of the flames that can be used, and carefully balanced air or oxygen must be arranged in order to prevent reduction of the lead in the glass.

One unit head is capable of making 200/250 per hour. The photograph shows the latest machine arranged

with two heads on a common table. The box bed contains driving motor, reduction gear, cam shafts, etc., making it completely self-contained. Both heads work off the one motor but are provided with separate cams. The two heads are therefore set to run out of phase to reduce the internal stress in the machine. The tubing is fed in at the top and steadied by a rod seen cut short in the illustration. The top overhanging casting contains the chucking mechanism and measuring device. Immediately underneath are the shears and three burners. The funnel that catches the gather is mounted on the press head which is automatically swung over to the pressing position immediately the gather has dropped into the mould below.

Having made the button, the next problem is sealing the electrode wires in. It would appear from results of various trials and experiments that a greater number of advantages can be obtained by carrying out the operation in a horizontal plane. A form of radiant preheating is essential and will prevent any tendency of the glass to fly when subjected subsequently to fierce flames during the sealing operation. Fig. 4 illustrates a single-head bench machine which has proved very successful for small scale production.

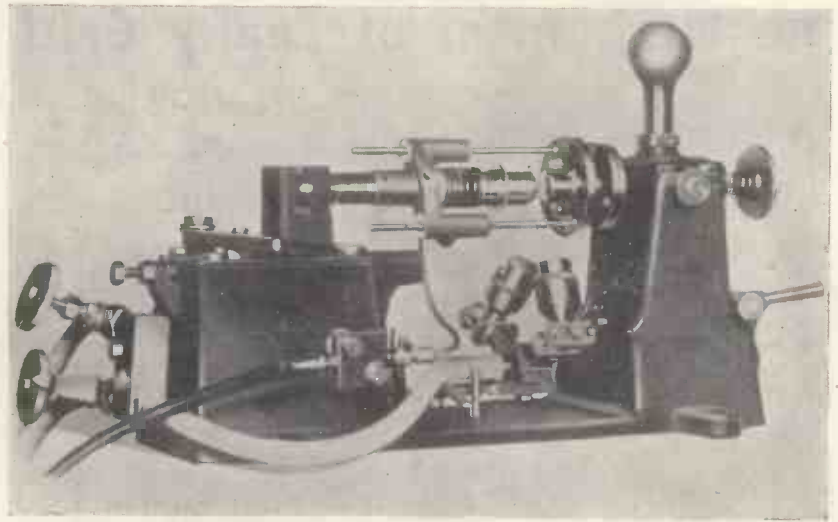

Experimental single head bench machine for miniature valve base pin sealing.

The mandrel is made so that it may be hinged up vertically, as it was thought that loading in this position might be simpler than horizontally. Experience has shown, however, that this may not be necessary and the multi-head machine now under construction will probably be arranged with horizontal rotating heads. The mandrels will be removable to facilitate

inserting the wires and feeding the buttons. Pressing up will be done automatically after which the finished bases will be ejected and conveyed directly to the annealer.

The writer wishes to acknowledge with thanks the permission given by the Osram-G.E.C. and the Mitchell Glass Co. to use certain information incorporated in these notes.

A Note on the Phase-Splitting Amplifier Circuit

by E. K. M. BIRD

Following on various articles dealing with the Schmitt phase-splitting amplifier circuit, no doubt many readers will be incorporating it in amplifiers.

The accompanying diagrams of two versions of the circuit show that the grids of both the valves are actually connected to the tapping points of potentiometers to which are applied the voltage drop in the common cathode resistor R_4 . The potentiometers consist of R_2 and C_2 , R_3 , C_1 in the case of V_1 , and R_5 and C_3 in the V_2 side.

The voltage across R_4 is of the order of 70 and of this not more than, say, $1/250$ th, must appear across R_5 , because such voltage is added to the standing bias developed by R_5 .

With R_5 at the usual value of 2 megohms, this means that C_3 in the right-hand side must have an insulation resistance of not less than 500 megohms, and the resistances of C_3 , R_1 and C_1 on the "input" side must

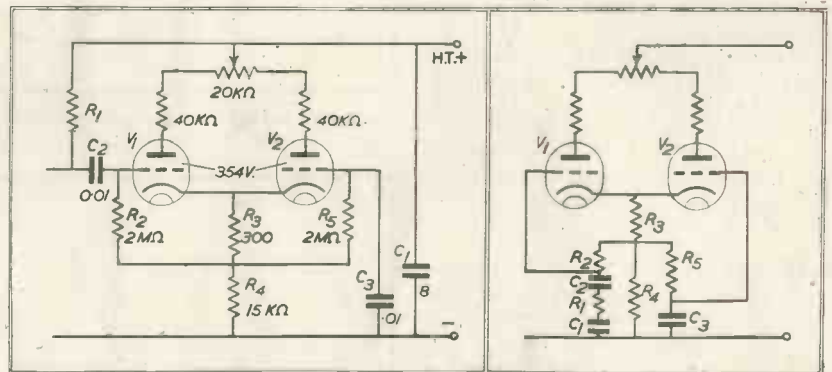

also total this amount. In other words C_2 and C_3 must both be of unusually high quality.

In a practical case the bias on V_1 was so high that the signal was rectified, and it would seem advisable to modify the circuit values somewhat. R_4 may be reduced a little without upsetting the balance, and R_2 and R_5

may also be reduced as long as the rest of the circuit values are adjusted to suit. If both these measures are taken and good mica condensers are used for C_2 and C_3 , a satisfactory compromise should be possible, though a limitation in the possible results from the circuit would seem to be inevitable.

The Mechanism of Leaky Grid Detection—Part I

By S. W. AMOS, B.Sc.(Hons.)

INTRODUCTION.—At one time the leaky grid detector (which is alternatively known as the grid-leak or cumulative grid detector), the basic circuit of which is given in Fig. 1, was very popular and it is still used to-day in the simpler types of receiver. The precise mechanism of operation of this type of detector is rather complex and although it is true to say, as many of the elementary text-books do, that it behaves as a diode detector combined with a triode amplifier, the fact that the triode is directly coupled and uses the steady potential developed across the diode load resistance as grid bias, makes the operation more complicated than this simple explanation suggests. In this article the author makes no claim to have produced an exhaustive analysis of the subject; the paper is intended as a contribution towards the literature on leaky-grid detectors and to throw some light on the choice of operating conditions to obtain optimum performance. The first part of the article will contain a qualitative account of the mechanism of the process and the later part, more quantitative, is based on some experimental data obtained by the author and will deal in some detail with the amount of second harmonic distortion introduced by the detector.

The connexions to the grid and cathode of a leaky grid detector are precisely the same as those to the anode and cathode of a shunt-fed diode detector, but it is important to realise in the case of the triode that the grid circuit conditions are influenced by those in the anode circuit. Generally speaking if a triode is taking a certain value of grid current with the anode disconnected from the H.T. supply, then reconnection of the anode will result in a reduction in the value of the grid current though the value of the grid-cathode impedance,

$i.e., \frac{\delta E_g}{\delta I_g}$ remains unaltered. This is

illustrated in Fig. 2, in which the dotted line represents the grid-cathode characteristic with no potential on the anode and the full line shows the effect of a normal positive potential on this electrode. A point worth noting in this respect is that variations in the numerical value of the H.T. supply to the anode have a

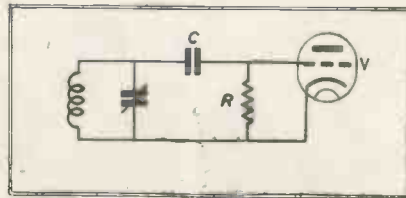

Fig. 1. Basic circuit of grid leak detector.

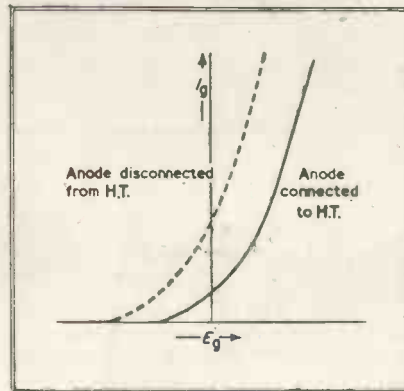

Fig. 2. Effect of anode potential on grid current.

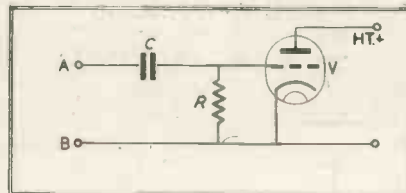

Fig. 3. To explain operation of the detector.

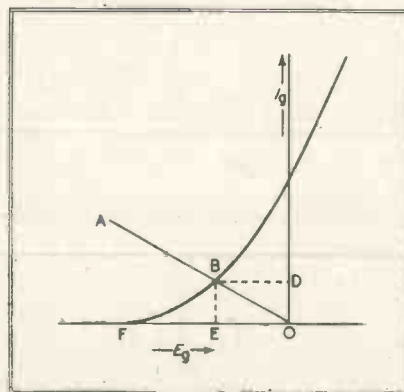

Fig. 4. Diagram for obtaining value of grid current from grid characteristic and load line.

very small and generally negligible effect on the grid current, provided that the anode potential is not so low as to approach that of the grid. In the experimental work carried out for this analysis the effect of changes of anode circuit conditions never affected the grid current by more than 5 per cent. This is very convenient for it means that the E_g-I_g characteristic (the full line of Fig. 2) applies irrespective of the value of the H.T. supply to the anode and it is likewise independent of the value of the anode coupling resistance.

Even in the absence of an input signal a certain grid current flows and the grid therefore takes up a certain definite negative potential with respect to the cathode, and the value of this negative potential decides the value of the anode current. The value of the grid current can be obtained from the E_g-I_g curve for the value as shown in Fig. 4. OA is the load line for the value of grid leak used (*i.e.*, $\cot \theta = R$) and B is its intersection with the characteristic curve. OD represents the grid current flowing in the absence of a signal and OE represents the grid potential.

If the slope of the load line OA is varied (by altering the value of R) then the values of OD and OE both change. This has been used as a method of deriving grid bias potentials, for it is clear from Fig. 4 that it is possible to obtain any value of steady negative potential desired, provided it is less than OF, by using the correct value of grid leak. This method has been chiefly employed in battery sets, though for valves with directly-heated filaments the value of the filament voltage also enters into grid bias considerations in a manner to be explained later.

Having thus established the E_g-I_g characteristic which obtains in practice we can now consider the operation of the detector. Suppose in Fig. 3, that an alternating voltage of constant amplitude is applied across AB. If the valve V represents a detector then a typical value for the frequency of this applied AC is 1,000 kc/s. and typical values for C and R are 100 $\mu\mu\text{F}$. and 250,000 ohms respectively. The reactance of C at 1,000 kc/s. is 1,592 ohms, which is negligible compared with the value

of R . When the grid of V is driven positive the grid-cathode path is conductive and grid current flows through R , the potential difference developed across it being such that the grid is made negative with respect to the cathode. Some grid current flows, as just explained, even at those instants when the input voltage is zero; in fact, as shown in Fig. 2, a small negative potential is necessary to suppress grid current completely, but for most of each negative half cycle of the input voltage, if the amplitude is several volts, the valve is non-conductive so that the periodic pulses of grid current take the form shown in Fig. 5.

The applied alternating voltage is superposed, of course, on the steady grid bias developed in the absence of a grid signal by the flow of grid current through the grid leak. This is indicated in Fig. 5, in which OA is, as before, the load line for the value of grid leak used and OB represents the "no-signal" grid bias. As soon as the input signal is applied the value of the grid bias changes as a consequence of the increased grid current. This is also shown in Fig. 5. Suppose, for example, we wish to find the value of grid bias developed by an alternating input of a certain amplitude. In Fig. 5 DE represents to scale the chosen amplitude and it is drawn parallel to the axis of potential so that D lies on OA and E on the $E_g - I_g$ characteristic. The pulses of grid current have the waveform shown, their maximum value being EF . Such a current, in flowing through R develops a potential of peak value OG as indicated.

The waveform of the potential difference developed across the grid leak clearly tends to have the same shape as that of the grid current but the presence of the grid condenser C modifies it considerably for this charges up on the peaks of the pulses and discharges in the troughs and so tends to smooth the pulsating voltage into a steady potential. The discharge of a condenser obeys the law:—

$$q = q_0 e^{-\frac{t}{RC}}$$

where q = value of the charge at any instant t after the discharge and q_0 = initial charge.

Now the time interval between any two successive peaks in the pulsating PD developed across R is a millionth of a second and in this time the charge on the plates of the condenser

has fallen to a value given by the equation:—

$$\frac{q}{q_0} = e^{-\frac{I}{250,000 \times 100 \times 10^{-12} \times 10^6}}$$

in which R has been put equal to 250,000 ohms and C equal to 100 μF . From this

$$\frac{q}{q_0} = e^{-.04}$$

so that

$$\log_e \frac{q}{q_0} = -.04$$

and so finally

$$\frac{q}{q_0} = .961$$

In the time taken for one complete cycle therefore the charge on the condenser has fallen to .961 of its initial value. This means the actual waveform of the potential difference across R is as given by the full line in Fig. 6. The dotted lines indicate the pulsating nature of the origin of this potential and the rate at which the condenser discharges has been deliberately exaggerated. In practice the voltage across R is much steadier than is suggested in Fig. 6, as may easily be imagined from the result of the above calculation. The value of this steady potential developed across R , which we will represent throughout this paper by E_g' , depends on the value of R in a manner which will be quantitatively discussed later, but it is very nearly equal to the peak value of the A.C. input to the de-

tor, and so has the effect of biasing back the triode amplifier to an extent approximately equal to the peak value of the A.C. input.

Referring back to Fig. 3, let us now consider what happens to the anode current I_a of the valve V when the steady alternating voltage is applied between A and B . The relationship between the grid potential, E_g , and the anode current I_a of a triode valve may be represented by the usual dynamic characteristic shown in Fig. 7. For a given valve the shape of the curve is fixed once the value of the H.T. supply and the magnitude of the anode coupling resistance R_a are decided. The slope of the curve at $E_g = 0$ is, in fact, given by $\mu/(R_a + R_g)$ where μ is the amplification factor and R_g the value of the anode impedance of the valve. Now the steady potential E_g' developed across R acts as the grid bias for the triode amplifier section of the detector and the sinusoidal impulses of the A.C. supply swing the grid potential above and below this value as shown in Fig. 7. Now if the peak value of the A.C. input is large enough the steady bias developed across R may very well be outside the grid base completely: on the other hand, if the input is small then the full extent of the grid swing may be accommodated within the grid base, as shown in Fig. 7. The valve in Fig. 7 is working under class A conditions and the variations in anode current are a fairly faithful copy of the A.C. input and the amount of harmonic distortion introduced is no

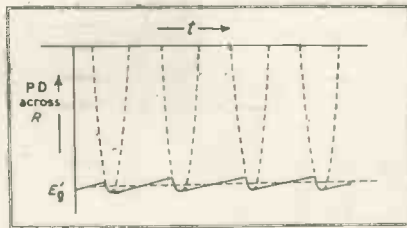

Fig. 5 (below). Grid current under signal conditions, showing change of grid bias.

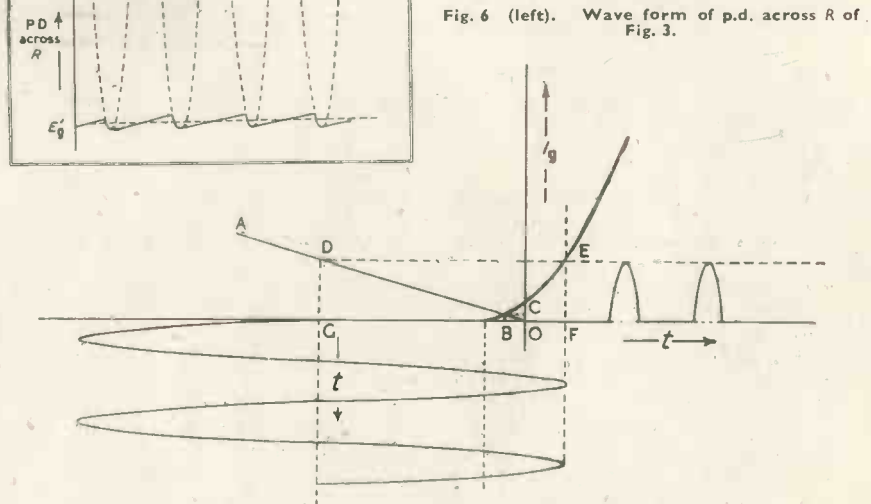

Fig. 6 (left). Wave form of p.d. across R of Fig. 3.

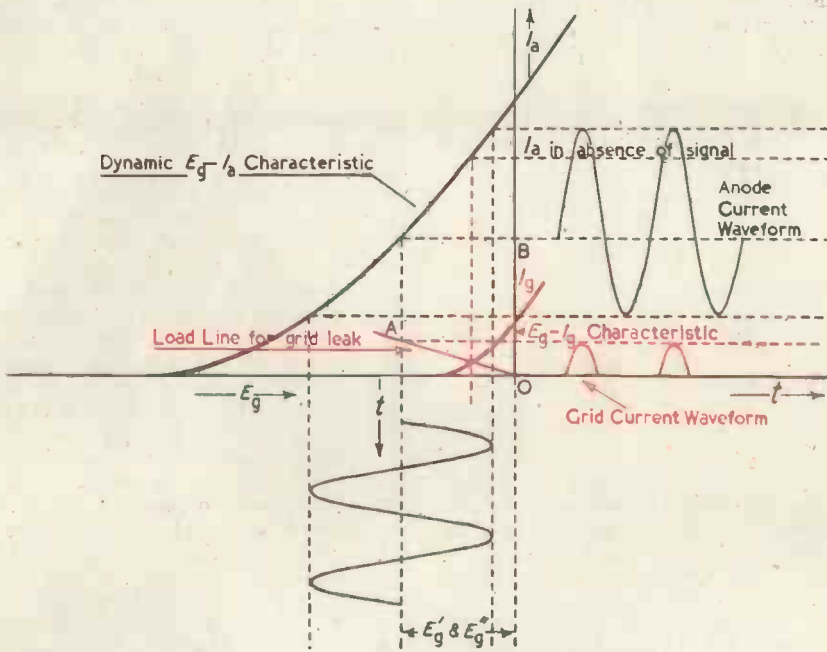

Fig. 7. Leaky grid detector with small unmodulated RF signal applied to grid.

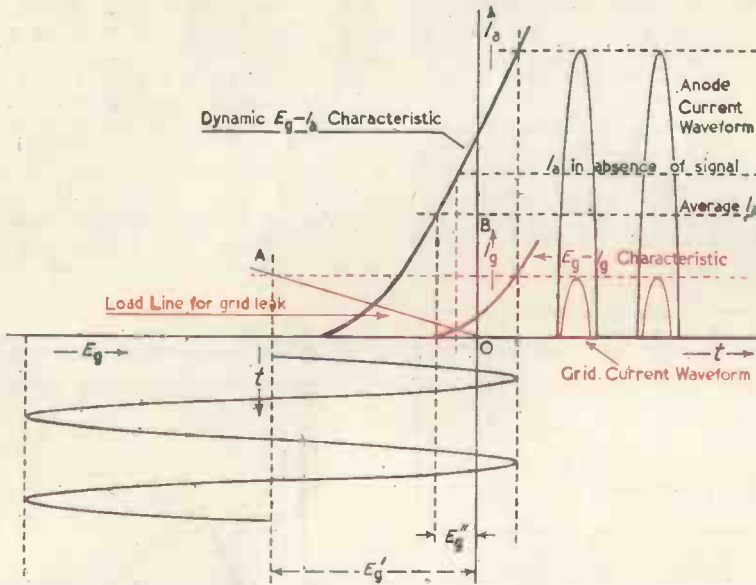

Fig. 8. Leaky grid detector with large value of unmodulated RF applied to the grid.

greater than is normally encountered in triode class A amplifiers. The mean anode current indicated by OB in Fig. 7 is the same value that would flow if the valve were given a steady bias, say, from a cell, of value equal to the grid bias developed across R. Consider now Fig. 8, in which the A.C. input is great enough to give the valve a grid bias many times greater than its cut-off value. The

valve is now clearly operating under class C conditions and the anode current flows during a fraction of each input cycle. The anode current has therefore a pulsating nature and its waveform is somewhat similar to that of the grid current. This series of impulses may be regarded as being equivalent to a steady current of value OB. Now the steady potential E_g' is, as explained earlier, approxi-

mately equal to the amplitude of the alternating input voltage to the detector, so that it immediately follows that E_g' will intersect the dynamic $I_a - E_g$ characteristic for inputs whose amplitude is less than the value of the grid base of the triode as in Fig. 7, and E_g' will lie completely outside the grid base, i.e., beyond cut-off, for inputs with an amplitude greater than the grid base. For such large inputs the detector behaves as a class C amplifier as shown in Fig. 8. As before the average anode current is indicated by OB. Now these steady anode currents of value OB in Figs. 7 and 8 could have been produced in each case by a steady grid potential of value E_g'' . This has been indicated in Figs. 7 and 8 and it will be referred to in the subsequent text as the "equivalent grid voltage" or "equivalent grid signal." We may define the grid voltage equivalent to a given alternating voltage input as that value of steady bias which applied to the grid of the valve produces, with the same values of anode load and H.T. voltage, a steady anode current equal to the mean value given by the alternating voltage. It is clear that while E_g' may theoretically have any value between zero and infinity, being approximately equal to the peak voltage of the applied alternating signal the equivalent values of E_g'' will always lie within the grid base since the valve always takes some anode current no matter what the value of the applied alternating voltage. For small alternating inputs of amplitude less than half the grid base, E_g' and E_g'' will be equal but for very large inputs E_g'' will be very much less than E_g' and becomes in fact asymptotic to a value approximately equal to half the grid base. The exact relationship between E_g' and E_g'' will be discussed in Part II. The essential difference between a leaky grid detector and a diode detector followed by a triode AF amplifier is that in the former it is the variations in the value of E_g'' which constitute the signal applied to the triode whereas in the latter the AF signal is formed by the changes in the value of E_g' .

Modulated Waveforms.—Now suppose a modulated alternating voltage is applied to AB in Fig. 3. Its amplitude is varying, and the grid bias E_g' of the triode amplifier is varying in sympathy with the modulation waveform so that the positive peaks of the alternating input voltage just

drive the grid sufficiently positive for the grid current to provide the necessary grid bias in flowing through R . The voltage input to the grid of the triode amplifier thus takes the form shown in Fig. 9. In Fig. 9 a small RF signal, shallowly modulated, is indicated and its greatest amplitude is within the grid base of the triode amplifier. The anode current is seen to be a faithful copy of the applied grid voltage and is its mean value and is therefore a true replica of the modulation waveform. In these conditions the amount of distortion introduced is as small as is normally associated with triodes operating under class A conditions. As a consequence of the modulated RF signal lying entirely within the grid base of the valve at every instant of time the effective grid signal E_g'' is equal to the potential E_g' developed across R . It should be noticed that an increase in input signal brings about a fall in anode current. This is quite the opposite to what occurs in an anode bend detector.

Consider now Fig. 10, which illustrates the conditions obtaining when a modulated RF signal of large amplitude is applied to the detector. The amplitude of the unmodulated carrier has been made about double the grid base and very deep modulation by a sinusoidal waveform is indicated. For most of each cycle of the modulating signal the valve is now biased beyond the cut-off value of anode current and is thus operating under class C conditions. The anode current is pulsating therefore so that the effective grid voltage is less than the value of the grid bias as explained above. Once during each cycle of the modulating signal, however, the amplitude of the RF carrier approaches zero so that the instantaneous value of the grid bias E_g' similarly approaches zero. At and near these instants of time the detector is operating under class A conditions as for Fig. 9, so that the detection and amplification are substantially distortionless and $E_g' = E_g''$ as shown in Fig. 10. If, therefore, a leaky grid detector is given a very large modulated RF signal the amplification given by the triode is greater for one half of each cycle of the modulation frequency (when $E_g' = E_g''$) than for the other half (when $E_g'' \ll E_g'$). This is another way of expressing a severe amount of second harmonic distortion. The mutilation of the modulation waveform is obvious in Fig. 10. The distortion so introduced varies with the modulation depth.

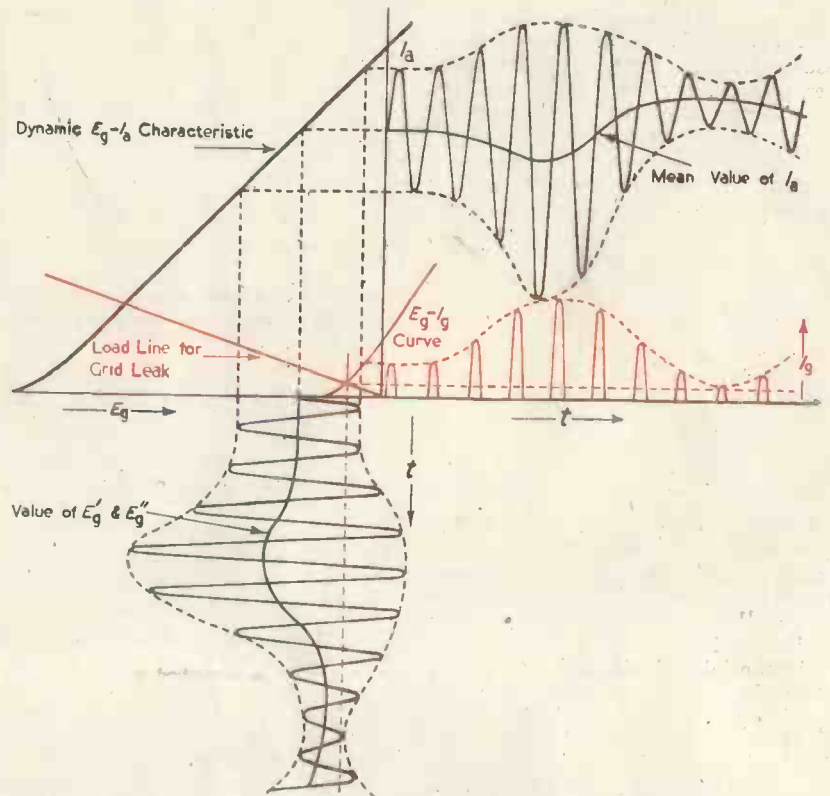

Fig. 9. Leaky grid detector with small slightly modulated RF signal.

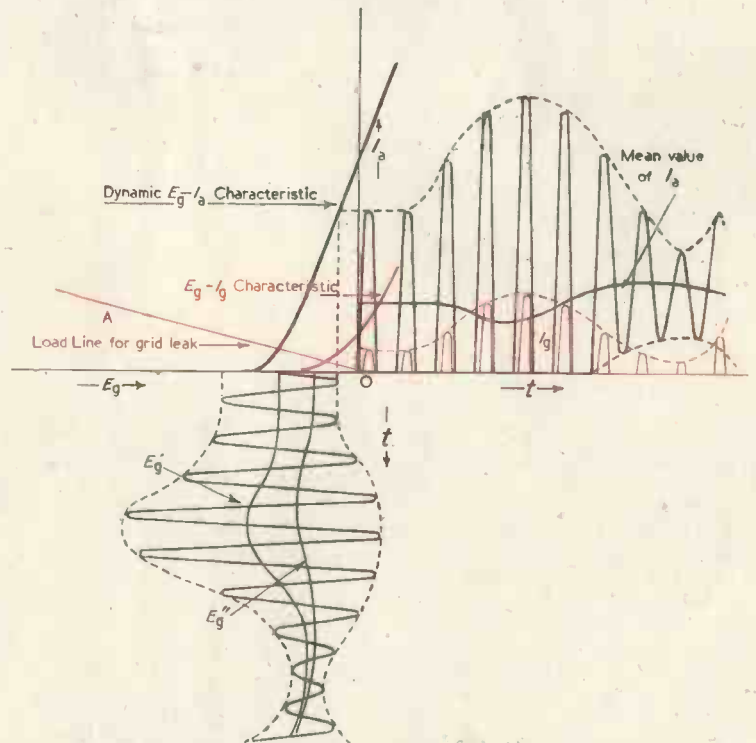

Fig. 10. Leaky grid detector with large value of modulated RF applied to grid.

Operating Conditions for Minimum Distortion.—To obtain distortionless results from a leaky grid detector, then, we can say from Fig. 9 that the maximum peak-to-peak value of the modulated RF signal should not exceed the grid base. In other words, the peak value of the unmodulated carrier should not exceed one quarter the grid base. For a given valve the grid base can be increased by increasing the H.T. supply voltage, and if the anode load is a resistance by replacing it by a choke or transformer. If it is desired to demodulate a large signal then to obtain a large grid base a valve with a low amplification factor (such as an A.C./P.1) and an adequate H.T. voltage should be used. The leaky grid detector operating under such conditions as these is usually known as a power grid detector.

Leaky Grid Detectors in Battery Receivers—Although it has not been specifically stated the preceding text applies strictly only to valves with equipotential cathodes and it has been assumed throughout that the grid leak is returned to the cathode. Since the potential of the filament in a directly-heated valve varies along the filament the operation of the detector will depend to some extent on the end of the filament to which the grid leak is returned. It is an essential condition for a valve to be a successful leaky grid detector that grid current should flow in the absence of a grid signal. Suppose that grid current does not flow until the grid is appreciably positive with respect to the cathode. This occurs with directly heated valves such as those used for leaky grid detection in battery sets, in which the grid leak is returned to the negative side of the filament, and the $E_g - I_g$ characteristic has the appearance given in Fig. 11. OA does not now meet the curve and grid current does not flow until the grid has a positive potential given by OB. If therefore a modulated R.F. signal is applied to the valve, the peak value of which is less than OB then no grid current will flow and no bias will be produced across R. All that happens is that the grid potential fluctuates in sympathy with the applied signal about its mean value of zero volts and the anode current will vary in a similar manner. The mean anode current, however, will be steady as the $E_g - I_g$ characteristic is usually very straight near $E_g = 0$ and so practically no detection results. Any A.F. signals that are produced in the anode circuit under these con-

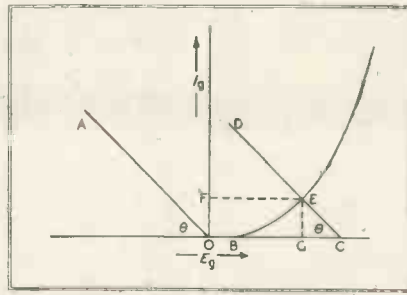

Fig. 11. Grid current characteristic for directly heated valve.

ditions are due to the slight non-linearity of the $E_g - I_g$ curve. In order to induce grid current to flow it is necessary to bias the valve positively by, say, returning the grid leak to the positive side of the filament. The grid current so produced is then given by OF in Fig. 11. CD is parallel to the load line OA ($\cot \theta = R$) and OC represents the potential difference across the filament.

Conditions Influencing the Choice of Values for C and R

(1) In order that the value of E_g' shall approach closely the peak value of the alternating voltage input to the detector the charge on the condenser C should leak away slowly through R, so slowly, in fact, that the fall in the potential on the plates of C in the time taken for one complete cycle of the RF input should be small, say, less than 5 per cent. of the initial value. For a 5 per cent. fall in potential:—

$$\frac{q}{q_0} = .95$$

$$\text{and } -\log_e \frac{q}{q_0} = -\log_e .95 = -.0513$$

Since, as shown earlier,

$$\log_e \frac{q}{q_0} = -t/RC$$

then $t/RC = .0513$

Now for one cycle, $t = 1/f$

$$\text{Therefore } CR = \frac{1}{.0513f} = \frac{19.5}{f}$$

Putting $f = 1,000$ kc/s. (10^6) we have:—

$$CR = \frac{19.5}{10^6} = 1.95 \times 10^{-5}$$

If $C = 100 \mu\text{F}$, therefore, R is given by:—

$$R = \frac{1.95 \times 10^{-5}}{100 \times 10^{-12}} = 1.95 \times 10^5 = 195,000 \text{ ohms.}$$

R then should be at least 195,000 ohms and preferably greater.

The first condition is hence that CR shall not be less than $\frac{19.5}{f}$ where f is the carrier frequency.

(2) C and R are effectively in parallel, and since they are connected between grid and cathode of the amplifier section of the detector they will have an effect on the A.F. fidelity of the arrangement, tending to cause a loss of high notes. At low audio frequencies the reactance of C is generally very much greater than R. At 50 c/s., for example, the reactance of a condenser of 100 μF . capacitance is about 32 megohms, so that the impedance of the network may be taken as equal to R, but at high audio frequencies the shunting effect of C is appreciable (at 10,000 c/s., for example, the reactance of the same condenser is 159,000 ohms) and must be allowed for. The impedance of the network at high audio frequencies is given by:—

$$Z = \frac{\frac{1}{j\omega C} \times R}{\frac{1}{j\omega C} + R} = \frac{R}{1 + j\omega CR}$$

i.e., it has been reduced in the ratio $\frac{1}{1 + j\omega CR}$

This may be taken as an estimate of the loss of high notes and it may be conveniently written in decibel notation thus:—

$$\text{High note loss} = 20 \log_{10}(1 + j\omega CR) = 20 \log_{10} \sqrt{1 + \omega^2 C^2 R^2} = 10 \log_{10} (1 + \omega^2 C^2 R^2)$$

Suppose $C = 300 \mu\text{F}$. and $R = 2$ megohms (values commonly advocated some years ago) the loss at 10,000 c/s. given by this combination is:—

$$10 \log_{10} (1 + 4\pi^2 \times 10^8 \times 300^2 \times 10^{-24} \times 4 \times 10^{12}) = 10 \log_{10} 1423 = 31.5 \text{ db.}$$

Suppose we decide to restrict the loss at 10,000 c/s. to 3 db.

This occurs when the reactance of C is numerically equal to R.

$$\therefore \omega CR = 1$$

$$\therefore CR = \frac{1}{\omega} = \frac{1}{2\pi f} = \frac{1}{6.284 \times 10^4} = 1.591 \times 10^{-5}$$

$$\text{If } C = 100 \mu\text{F} \text{ then } R = \frac{1.591 \times 10^{-5}}{10^{-10}} = 159,000 \text{ ohms.}$$

(Continued on page 116.)

Cathode-Ray Tube Traces

A Series to Illustrate Cathode-Ray Tube Technique

Part I.—Lissajous Figures (continued)

By HILARY MOSS, Ph.D., A.M.I.E.E.

IN the first two articles we dealt with the true Lissajous figures, defined by the equations

$$x = A \sin m\theta$$

$$y = B \sin (n\theta + a)$$

treating separately the two distinct cases: (a) where n/m is integral, and (b) where n/m is non-integral. By analogy, the term "complex Lissajous figure" has been applied to the much more complex system.

$$x = \sum A_k \sin (m_k \theta + \beta_k)$$

$$y = \sum B_k \sin (n_k \theta + \alpha_k) \quad (1)$$

and we shall now treat a few of the properties of these loci, passing lightly over the question as to how far the nomenclature is justified.

Case 3.

Complex Lissajous Figures

The general properties of (1) are exceedingly complex, and any attempt to give a far-reaching analysis of such features as intersection loci, etc., is quite unprofitable. All that will be attempted is to give a broad outline. In practice each system is best treated as a special case.

Period of the System

The loci defined by (1) are always closed curves, which are traversed once while θ goes through 2π radians.

Boundary of the System

For all values of the phase angles α_k, β_k , the figure must lie wholly within the rectangle defined by

$$x = \sum |A_k|, \quad y = \sum |B_k|$$

Symmetry Considerations

The analysis of (1) can be assisted by some interesting theorems on symmetry. A figure is said to be

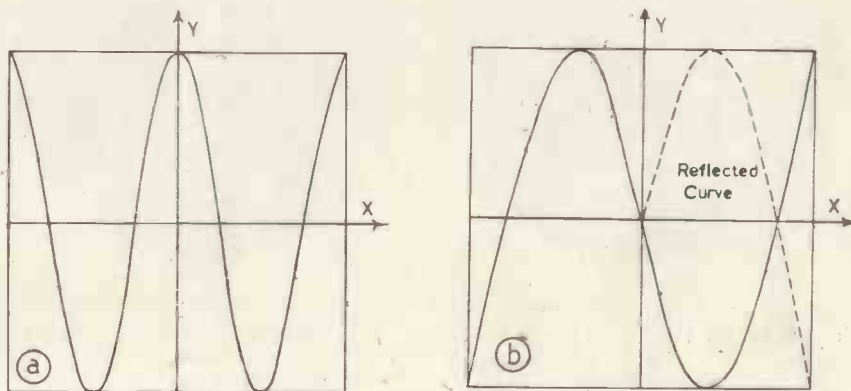

Fig. 4. Illustrated simple and reflected symmetry.

symmetrical about an axis, if a line drawn at right angles to that axis cuts the figure in an even number of points (zero is an even number) which can be grouped into pairs spaced equally on either side of the axis. Fig. 4(a) for instance, is symmetrical about the vertical (Y) axis. This is the highest form of symmetry about an axis.

An important lower class of symmetry is that involving a reflexion in an axis. Fig. 4(b) for instance, is not symmetrical as it stands about the vertical (Y) axis, but becomes so if that portion of the figure to either side

of the vertical axis is reflected across the horizontal axis. We shall now prove that where this type of reflected symmetry exists, it must be reciprocal for a pair of rectangular axes, i.e., in the above case the figure becomes symmetrical about the horizontal axis for a reflexion in half the vertical axis.

Consider the rectangular coordinate axes shown in Fig. 5. P and Q are two points on any curve having the reflected symmetry property discussed above, i.e., when Q is reflected in the X axis to form Q', then P and Q' are symmetrical about the Y axis. Then PT must equal TQ'. Hence Q' is the image of P in the Y axis and since Q'N = NQ as Q' is the image of Q by hypothesis, the reflexion of P in the axis has made the figure symmetrical about the X axis. Hence reflexion symmetry is reciprocal.

We shall now prove that if the harmonic terms applied to one axis are all even in frequency, while the terms applied to the other axis are all odd in frequency, that the figure traced by the system (1) is symmetrical about the axis of the even harmonic terms.

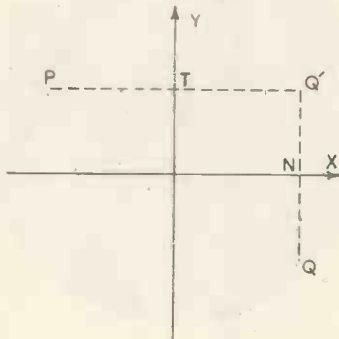

Fig. 5. Proof of the reciprocity theorem.

Complex Lissajous Figures

$$x = A_5 \sin (5\theta + \beta_5)$$

$$y = B_2 \sin 2\theta$$

$$x = A_3 \sin (3\theta + \beta_3)$$

$$y = B_2 \sin 2\theta$$

Resultant (see text)

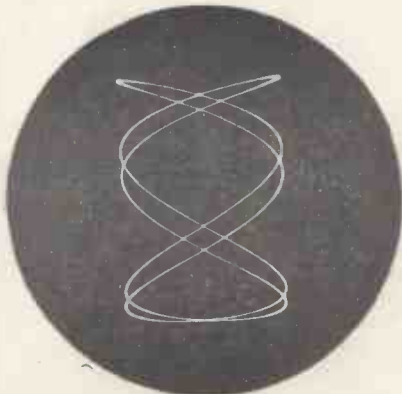

37

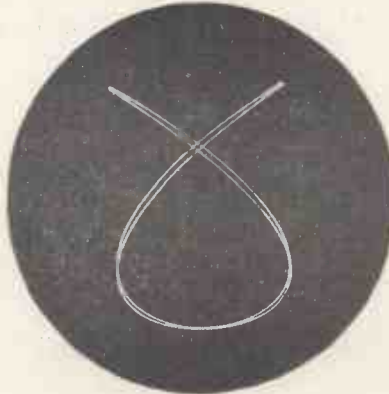

38

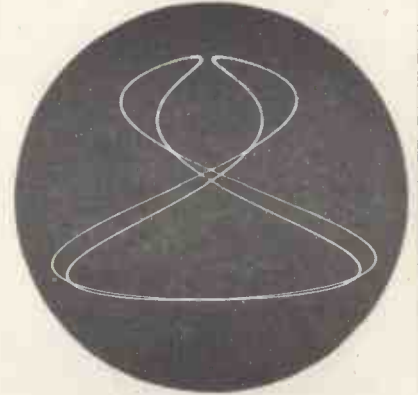

39

$$x = A_5 \sin (5\theta + \beta_5)$$

$$y = B_2 \sin 2\theta$$

$$x = A_3 \sin (3\theta + \beta_3)$$

$$y = B_2 \sin 2\theta$$

Resultant (see text)

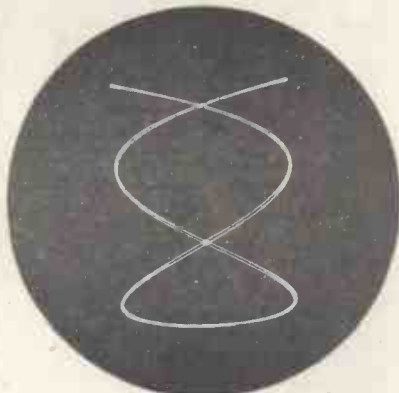

40

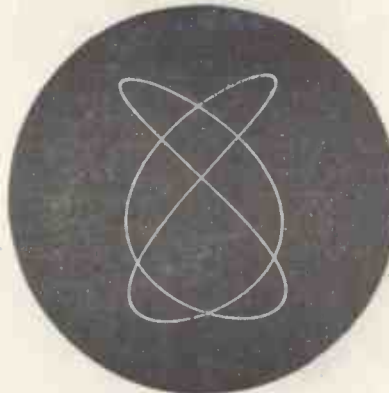

41

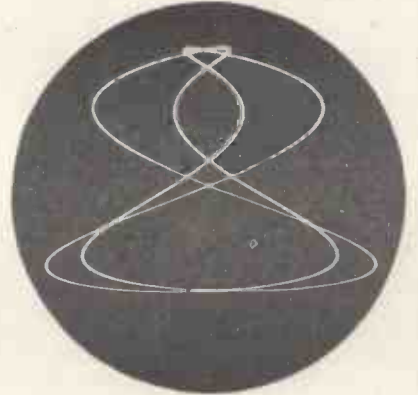

42

$$x = A_5 \sin (5\theta + \beta_5)$$

$$y = B_2 \sin 2\theta$$

$$x = A_3 \sin (3\theta + \beta_3)$$

$$y = B_2 \sin 2\theta$$

Resultant (see text)

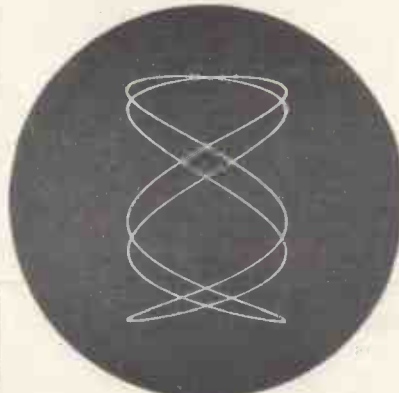

43

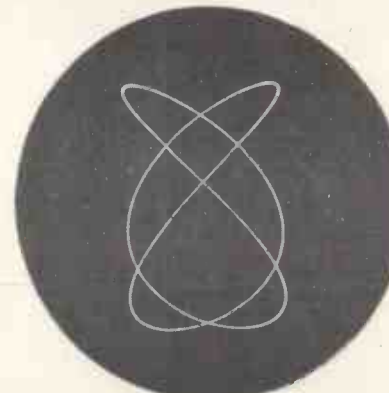

44

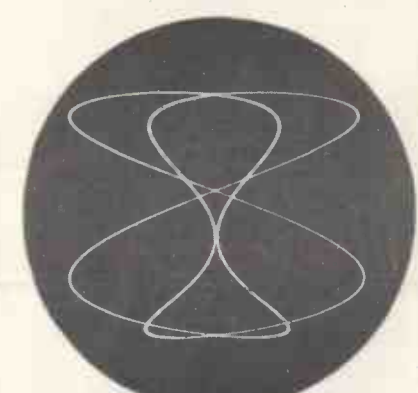

45

Complex Lissajous Figures

$x = A_3 \sin (5\theta + \beta_3)$ $y = B_1 \sin 4\theta$
 (special case, see previous article)

$x = A_3 \sin (3\theta + \beta_3)$ $y = B_4 \sin 4\theta$
 (special case, see previous article)

Resultant (see text)

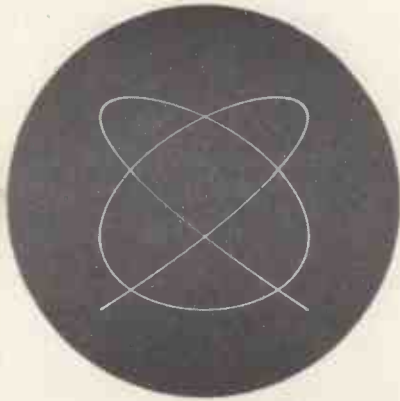

46

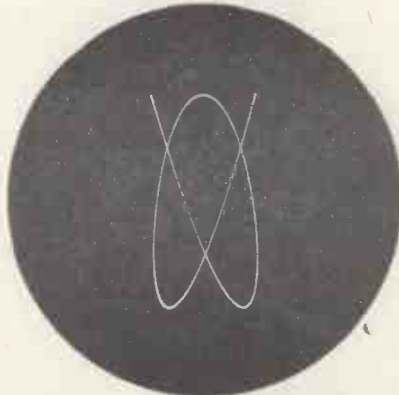

47

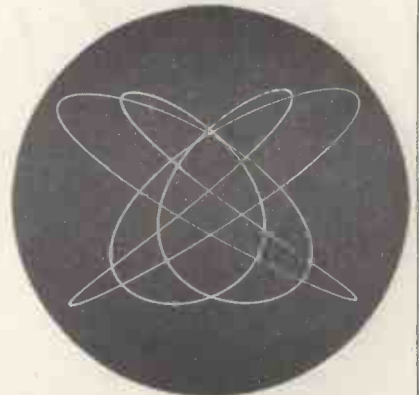

48

$x = A_1 \sin \theta$ $y = B_5 \sin (5\theta + \alpha_5)$

Reflected Symmetry
 $x = A_1 \sin \theta$ $y = B_3 \sin (3\theta + \alpha_3)$

Resultant (see text)

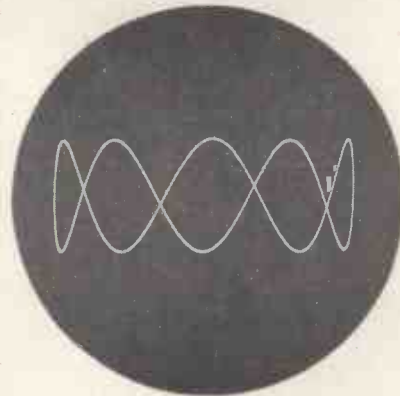

49

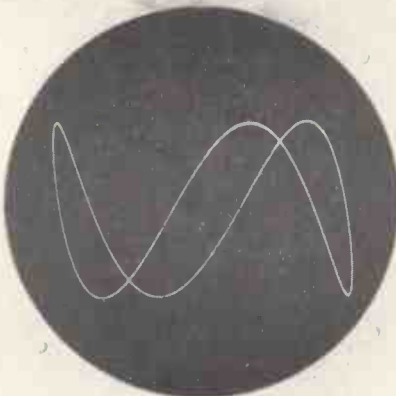

50

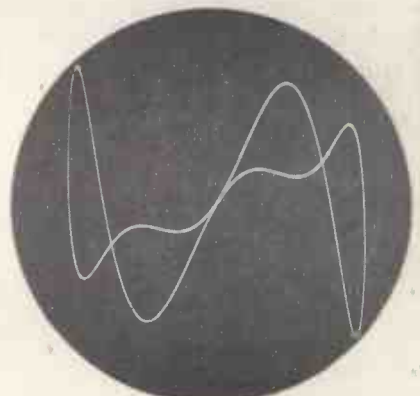

51

$x = A_4 \sin (4\theta + \beta_4)$ $y = B_2 \sin 2\theta$

No Symmetry
 $x = A_3 \sin (3\theta + \beta_3)$ $y = B_2 \sin 2\theta$

Resultant (see text)

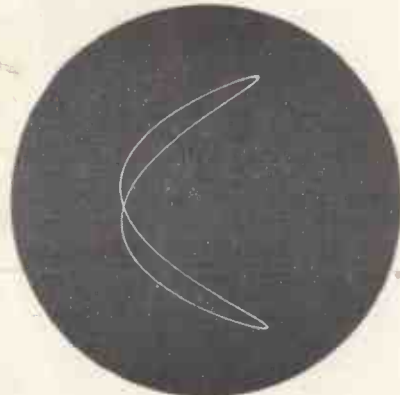

52

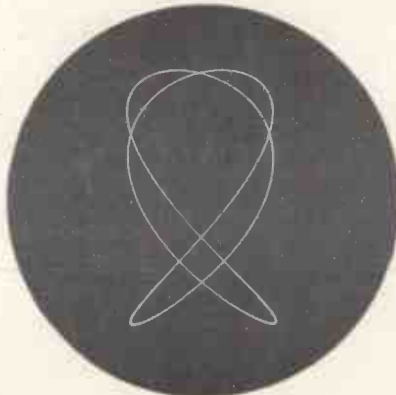

53

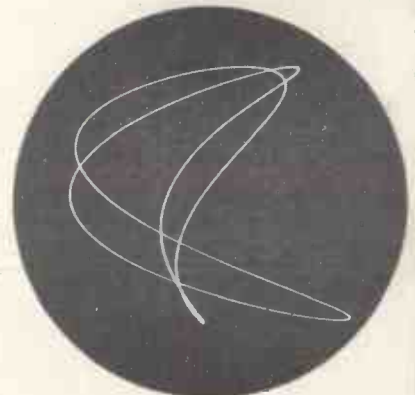

54

The system (1) is now

$$x = A_1 \sin(\theta + \beta_1) + A_3 \sin(3\theta + \beta_3) + \dots$$

$$y = B_2 \sin(2\theta + \alpha_2) + B_4 \sin(4\theta + \alpha_4) + \dots \quad (18)$$

Consider the new value of the "x" component when θ has advanced by π radians. It will be from (18)

$$x' = A_1 \sin(\theta + \pi + \beta_1)$$

$$+ A_3 \sin((3\theta + 3\pi + \beta_3) + \dots$$

and since

$$\sin \Phi = -\sin \{ \Phi + (2K + 1)\pi \}$$

where K is any integer it follows that

$$x' = -x$$

so that the x displacement is numerically as before but of opposite sign, *i.e.*, the two values of x are equally spaced on either side of the "Y" axis. Now consider the new value of y for the increase of π in the value of θ . It will be from (18).

$$y = B_2 \sin(2\theta + 2\pi + \alpha_2)$$

$$+ B_4 \sin(4\theta + 4\pi + \alpha_4) + \dots$$

and since

$$\sin \Phi = (\sin \Phi + 2\pi K)$$

it follows that

$$y' = y$$

so that the value of y is entirely unchanged. Hence the curve possesses pairs of points at equal distance from the "X" axis, equally spaced from, but on opposite sides of, the "Y" axis. Hence the curve must be symmetrical about the "Y" axis, *i.e.*, the axis containing the *even* harmonics.

Reflected Symmetry

We shall now prove that if the oscillations on both axes contain only *odd* harmonics, then the curve must possess reflected symmetry. This can be deduced very easily from the previous reasoning. Again, considering two values of θ differing by π , these must correspond to equal but opposite values of x as already proved. But since the "Y" axis now contains only odd harmonics, the corresponding values of y are also equal but *opposite*. Hence reflexion of one half of the curve must create symmetry about an axis.

As a corollary we note that if either component axis contains a mixture of odd and even harmonics then the figure cannot possess symmetry of any sort.

Again, we note that *both* oscillations cannot contain only *even* har-

monics, since it is postulated that the expansions of m_k and n_k in (1) do not contain any common factor. If they do, then this factor is divided out—an operation which in no way affects the properties of the system, and which must result in the appearance of at least one odd value of θ in the expressions.

Photos Nos. 37-48 inclusive illustrate the symmetry about an axis containing only even harmonics, when the other axis contains only odd harmonics. In each row, the two left-hand figures are the component oscillations, and the right-hand figure the resultant. Note that this is always perfectly symmetrical about the "Y" axis. The three rows on the left-hand page correspond to different phases in the component oscillations, and give some idea of how these can affect the resultant curve.

Photos No. 49-51 illustrate reflected symmetry, where both oscillations contain only *odd* harmonics. Photos 52-54 inclusive illustrate the case where one of the component oscillations contains a mixture of odd and even harmonics. In this case the resultant figure has no form of symmetry.

The technique for the production of the figures was similar to that outlined in the first article (Fig. 2). The latter circuit was merely modified to provide an additional harmonic channel so as to give the double harmonic term in the "Y" axis. This double term was so obtained simply by series connexion of the two outputs.

The photographic technique was similar to that so far employed except for the use of Ilford recording paper type FP1 in place of film. If anything the paper seems to give more satisfactory results as it is less liable to marking from dust, etc., during the drying after processing.

Formation of the Resultant Curve from the Component Oscillations

It is important to appreciate that the shape of the resultant curve is not

uniquely defined by the shape of its components. Suppose these are defined by

$$x_1 = A_1 \sin(l\theta + \beta) \quad (19a)$$

$$x_2 = A_k \sin(k\theta + \gamma) \quad (19b)$$

with a common "y" displacement of

$$y = B_n \sin n\theta \quad (19c)$$

Provided that $l/n, k/n$ are non-integral, or $n = 1$, there will be $2n$ numerically distinct values of β associated with each simple Lissajous figure defined by (19a) and (19c). Similarly there will be $2n$ distinct values of γ associated with each simple Lissajous figure defined by (19b) and (19c). (This peculiar property of the simple Lissajous figure with non-integral frequency ratio was discussed in article No. 2). Hence there will be $4n^2$ possible resultant curves for each pair of component curves. However, since a reversal in the direction of rotation of the spot round *both* component curves can only reverse the direction of rotation of the spot round the resultant, without altering its shape, it follows that there are only half this number (*i.e.*, $2n^2$) possible shapes to the resultant figure. Furthermore, if the direction of spot rotation round each of the component curves is known, there will be only n possible values of phase angle associated with each component figure, and thus n^2 possible shapes to the resultant curve. The table below generalises these results.

We thus see that unless $n = 1$ (*i.e.*, unless the common axis frequency is that of the fundamental), it is still not possible to construct a unique resultant figure given the shape of the component curves, even though the direction of spot rotation round these curves is known. To eliminate this final uncertainty, some form of pulse common to all the component curves must be introduced, so that the common points are defined. Some examples of the use of this pulse will be given in the next article.

Order of harmonic in single term on common axis	Total No. of harmonic terms on compound axis	Total possible No. of resultant figures different in shape or direction of spot rotation	Total possible No. of resultant figures different in shape	Total possible No. of resultant figures when direction of rotation of spot in all component figures is known
n	t	$(2n)^t$	$\frac{1}{2}(2n)^t$	n^t



ADVERTISEMENT OF THE TELEGRAPH CONDENSER CO., LTD.

GA

An Analysis of a D. C. Galvanometer Amplifier

By D. I. LAWSON, M.Sc.*

Introduction

THIS amplifier is suitable for amplifying the small current flowing in a galvanometer circuit so that if necessary a recorder may be operated. It has been shown¹ that if a fraction of the amplified current is fed back in opposition to the main current in the galvanometer circuit, its effect will be apparently to increase the stiffness of the galvanometer suspension, thus increasing the speed at which recordings may be made. The present analysis was necessitated by the construction of an amplifier similar to that described by McAlister Matheson & Sweeney² and used in a recording infra-red spectrometer. A somewhat simplified circuit omitting zero adjusting controls is shown in Fig. 1.

The small e.m.f. to be measured is connected at the terminals T and this causes a current to flow through the galvanometer G. The image of the aperture A which normally illuminates the photocells P₁ and P₂ equally will be deflected as the mirror moves, and the potential applied to the grid of the valve V will consequently vary. This will cause the current flowing through R₁ to change, and since the point B is held at a fixed potential above C by the neon stabiliser S₂, the change in current in R₁ will cause the current in R₂ to vary. This change in current will be dependent on the original current flowing in the galvanometer circuit, which may therefore be measured in terms of the current in R₂. A fraction of the current flowing in R₂ may be introduced into the galvanometer circuit through the feedback connexion R₃, R₄. If the feedback is negative, the response time of the galvanometer is decreased although sensitivity of the apparatus is reduced. In the same way the sensitivity may be increased by positive feedback at the cost of increasing the response time.

Circuit Analysis

(a) Galvanometer and Photocells

If the deflection sensitivity of the galvanometer is α cm/amp., then if

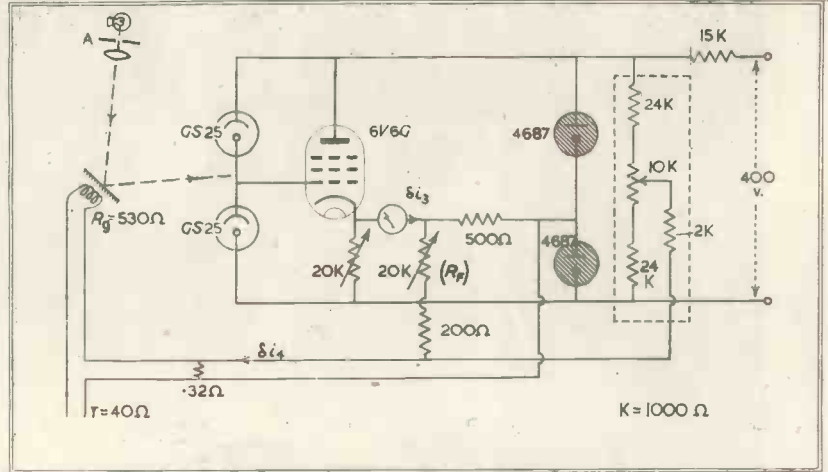

Fig. 4. Complete circuit of amplifier and galvanometer.

a current δI amps. is flowing in the galvanometer circuit, the image of A will be deflected through a distance $\alpha \delta I$ cm. If the current sensitivity of each photo sensitive surface is i amps/lux cm² and the intensity of illumination of the image is L lux, the initial current through each photocell will be $Laix$ amps., since an area ax sq. cms. will be illuminated (Fig. 2). The currents through P₁ and P₂ will increase and decrease respectively by an amount $Laix\delta I$ amps., due to the current δI flowing in the galvanometer circuit and if E is the potential difference across both photocells, the grid potential of the valve V will

$$\text{change by } \frac{\delta a/E}{x^2} \text{ volts.}^\dagger$$

It is interesting to note that this potential is independent both of the sensitivity of the photocell and the intensity of illumination of the image, but that it is inversely proportional to the width x of the strip of light falling on both cells in the rest position.

(b) The Valve Amplifier

If g is the mutual conductance of the valve shown in the circuit Fig. 3, we may write

$$i_1 = eg$$

$$e_1 = (i_1 + i_2) R_1$$

$$e = e + e_1$$

$$V - e_1 = i_2 R_2$$

Solving for i_1 in terms of V , R_1 , R_2 , e and g , we have

$$i_1 = \frac{V(1+gR_1) - egR_1}{R_1 + R_2 + gR_1R_2} \dots\dots (1)$$

The following approximate values serve to show the magnitudes involved

$$R_1 = 5,000\Omega$$

$$R_2 = 200\Omega$$

$$g = .007 \text{ amp/volts}$$

$$\text{Thus } R_1g \gg 1 \quad R_1 \gg R_2$$

† See Appendix I

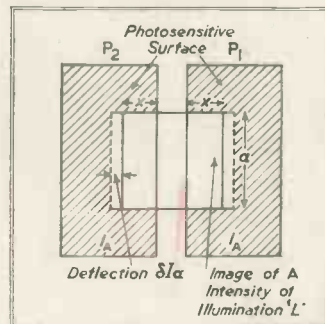

Fig. 2. Illumination of photo-sensitive surface.

* Research Laboratory, Pye Limited.

Equation (1) therefore simplifies to

$$i_2 = \frac{V - e}{R_2 + 1/g}$$

and thus the change in i_2 is given by

$$\delta i_2 = - \frac{\delta e}{R_2 + 1/g}$$

Now the change in grid potential

δe is known to be $\frac{E a \delta I}{2 x}$ and hence

$$\delta i_2 = - \frac{E a \delta I}{2 x (R_2 + 1/g)}$$

The current magnification is

$$\gamma = \frac{\delta I}{\delta i_2} = \frac{2 x (R_2 + 1/g)}{E a}$$

Taking $E = 200$ V, $x = 0.5$ cm.
 $a = 11.2 \times 10^6$ cm/amp.
 $(R_2 + 1/g) = 340 \Omega$
 We have $\gamma = 6.6 \times 10^8$.

(c) Feedback

If we assume that a fraction β of the output current* is fed back into the galvanometer circuit we may recalculate the gain as follows. Due to the presence of feedback, the change in output current will have a different value, say δi_3 . The current in the galvanometer circuit will be $(\delta I + \beta \delta i_3)$ where β assumes positive or negative values according as the feedback is positive or negative. We may write

$$\delta i_3 = \gamma (\delta I + \beta \delta i_3)$$

$$\text{Gain} = \frac{\delta I}{\delta i_3} = \frac{\gamma}{1 - \gamma \beta}$$

If the feedback is positive and $\beta = 1/\gamma$ the system will be unstable since the gain becomes infinite, but using values of β less than this will result in a further increase in the gain of the system.

If the feedback is negative we have

$$\text{Gain} = \frac{\delta I}{\delta i_3} = \frac{\gamma}{1 + \gamma \beta}$$

and if $\gamma \beta \gg 1$ we have the gain of the system equal to $1/\beta$. This will mean that the instrument will be independent of variations in circuit parameters.

(d) The Galvanometer Circuit

The current fed back into the galvanometer circuit will be

$$\beta \delta i_3 \text{ or } \frac{\gamma \beta \delta I}{1 \pm \gamma \beta}$$

In the case of negative feedback this approaches the value of the primary current for values of $\gamma \beta \gg 1$.

The equation of motion of a gal-

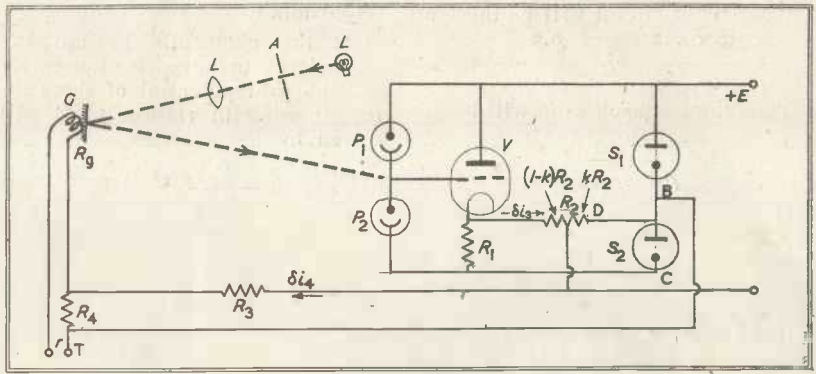

Fig. 1. Simplified circuit diagram of amplifier.

vanometer suspension system, through which a current δI is passing may be written

$$K \ddot{\theta} + \left(b + \frac{G^2}{\tau + R_g} \right) \dot{\theta} + C\theta = G\delta I \dots (2)$$

the suspension.

$b \dot{\theta}$ is the retarding moment due to where K is the moment of inertia of air damping.

G the deflecting moment for unit current.

C the restoring moment of the suspension for unit angle of deflection.

τ is the internal resistance of the E.M.F. to be measured.

R_g is the galvanometer resistance.

The term $\frac{G^2}{\tau + R_g} \dot{\theta}$ is the damping

due to currents induced in the galvanometer circuit by the motion of the coil in the magnetic field.

In the steady state case we have

$$C\theta = G\delta I \quad (\ddot{\theta} = \dot{\theta} = 0)$$

Now if feedback is employed δI is replaced by $\delta I \pm \beta \delta i_3$ or $\delta I \left(\frac{\gamma \beta}{1 \pm \gamma \beta} \right)$

The deflection will be reduced or increased $\left(\frac{1}{1 \pm \gamma \beta} \right)$ times. We

might regard this as being due to a change in the stiffness of the suspension since the feedback depends on the deflection of the beam rather than the current in the galvanometer circuit. If the feedback is negative the new stiffness of the suspension C' will be related to C by

$$C' = (1 + \gamma \beta) C \sim \gamma \beta C$$

or if the feedback is positive

$$C' = (1 - \gamma \beta) C$$

The period of oscillation τ of the suspension $\tau = 2\pi \sqrt{\frac{K}{C}}$ will therefore

be reduced $\sqrt{\gamma \beta}$ times when negative feedback is employed.

Details of Practical Circuit

The circuit of a galvanometer amplifier we have used is shown in Fig. 4. The network shown inside the dotted line is used to feed a small steady current into the galvanometer circuit in order to facilitate centring the beam of light between the photocells.

The feedback may be varied by which is in series with the resistance adjusting rheostat R . If δi_3 is the current flowing between the cathode of the valve and the centre connexion of the stabilising tubes the current δi_4 flowing into the galvanometer circuit shunted by 0.32 ohms will be approximately

$$\delta i_4 = \frac{500}{R_v + 700 \cdot 32} \delta i_3$$

A fraction $\frac{500}{530 + 40}$ of δi_3 will be re-introduced into the galvanometer circuit.

The current re-introduced into the

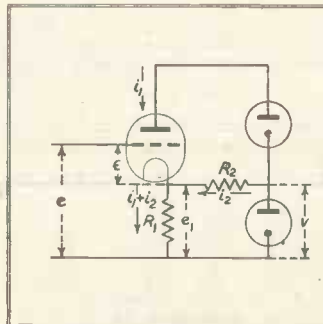

Fig. 3. Valve amplifier.

* See Appendix 2.

galvanometer circuit will be therefore

$$\frac{530 \times 0.32}{(R_F + 700)570} \delta i_3 = \frac{0.3}{R_F + 700} \delta i_3$$

Thus the feedback ratio will be

$$\beta = \frac{0.30}{R_F + 700}$$

If the feedback ratio is so large that $\gamma\beta \gg 1$, the gain is $1/\beta$. We have found it advantageous to use the apparatus in this condition to decrease the period of the galvanometer. The following table shows the agreement between calculated and measured gain.

R _x	β	Gain (1/β)	Gain (measured)
1,000 ohms	1.76 × 10 ⁻⁴	5,700	5,750
1,700 "	1.25 × 10 ⁻⁴	8,000	8,100
4,300 "	6 × 10 ⁻⁵	17,000	16,300
6,000 "	4.5 × 10 ⁻⁵	22,000	22,600
10,000 "	2.8 × 10 ⁻⁵	37,000	36,500

The gain of the system without feedback using a galvanometer having a sensitivity of $a = 4.0 \times 10^6$ cms/amp was found to be 450,000.

The gain may be calculated in this case from

$$\gamma = \frac{E}{2x} \frac{a}{(R_2 + 1/g)}$$

If

$$E = 200V.$$

$$R_2 = 500 \text{ ohms.}$$

$$g = 4 \times 10^{-3} \text{ amps/volt.}$$

$$x \sim 1 \text{ cm.}$$

the calculated gain is 530,000.

Conclusion

(1) It has been shown that the gain of the galvanometer amplifier is independent of the photocell characteristics if a cathode follower output stage is used. The current gain is given by:

$$\gamma = \frac{Ea}{2x(R_2 + 1/g)}$$

(2) If a fraction (β) of the output is reintroduced into the galvanometer circuit the gain is altered by a factor

$\frac{1}{1 \pm \gamma\beta}$ when β is positive or negative according to the sign of the feedback.

(3) The apparent effect of feedback is to change the stiffness (i.e., restoring couple for unit deflection) of the suspension by a factor (1 ± γβ) the positive sign referring to negative feedback.

It is hoped that these notes will be of use to other workers in this field.

The author wishes to express his indebtedness to Messrs. Pye Ltd. for permission to publish this note.

Appendix I

If the photocells P₁ and P₂ are considered to have resistances r₁ and r₂, the grid potential of the valve V measured with respect to C will be given by

$$E \frac{r_2}{r_1 + r_2}$$

If the deflection of the galvanometer spot changes the equivalent resistances of the photocells P₁ and P₂ to (r₁ - δr₁) and (r₂ + δr₂) respectively the new grid potential will be

$$E \frac{r_2 + \delta r_2}{(r_1 + r_2 - \delta r_1 + \delta r_2)}$$

so that the change in potential becomes

$$E \left\{ \frac{r_2 + \delta r_2}{r_1 + r_2 - \delta r_1 + \delta r_2} - \frac{r_2}{r_1 + r_2} \right\}$$

$\frac{\delta r}{r}$ if we put r₁ = r₂ = r.

If the photocell is connected to a constant voltage source, we have

$\frac{\delta r}{r} = \frac{\delta i'}{i'}$ where i' is the current taken by the photocells in the undeflected position.

δi' is the change of current in each cell corresponding to the deflection of the galvanometer.

$$\frac{E \delta i'}{2 i'} = \frac{E L_a a i \delta l}{L_a x i} = \frac{E a \delta l}{2 x}$$

Appendix 2

Since R₃ ≫ R₂ and R₄ is very small compared with the resistance of the galvanometer circuit, we see on referring to Fig. 1

$$i_1 \sim \frac{kR_2 i_3}{R_3}$$

Feedback current in galvanometer circuit = $\frac{R_4}{R_3 + R_4} i_1$

Where R₃ = galvanometer resistance
r = internal resistance of E.M.F. applied at terminals T.

$$\text{Feedback current in galvanometer circuit} = \frac{kR_2 R_4}{R_3 R_4 + r R_4} i_3$$

$$\text{or } \beta = \frac{kR_2}{R_3 + r}$$

REFERENCES

1 A. V. Hill, Proc. Physiol. Soc. 92 (1938) 43.
2 McAlister, Matheson & Sweeney, Rev. Sc. Inst. 12 (1941) 314.

The Mechanism of Leaky Grid Detection

(Continued from page 108.)

R should therefore not be greater than 159,000 ohms with this value of condenser or the loss at 10,000 c/s. will exceed 3 db. The second condition is thus that CR must not exceed 1/2πf if the loss at f c/s. per second is to be less than 3 db. and this condition is in direct contradiction to the first, and the only solution which satisfies both is for R to equal 1/2πf. If C is made 100 μμF. then R = 159,000 ohms. and the relationship between C and R is clearly a reciprocal one. If C = 500 μμF. then R must be 31,400 ohms. for conditions (1) and (2) to be obeyed.

(3) In order to decide which of the infinite number of possible values of C and R to use in practice we must consider the damping imposed by a leaky grid detector on the tuned circuit which precedes it. This is approximately equivalent to placing a resistance of value R/2 across the circuit. This is the damping due to the detector section only; there is additional damping due to Miller effect and the magnitude of this depends on the magnitude and nature, i.e., phase angle of the anode load. Damping due to this cause may be even greater than that due to the first mentioned source. Such damping is a good thing in that it reduces any side-band cutting occurring in the tuned circuit but is bad in that it impairs the selectivity and amplification of the circuit. Damping may be reduced by the use of reaction but care should be taken in its use otherwise excessive side-band cutting may result. If R is made large then damping from this source can be minimised.

(4) A large value of R necessarily entails, however, a small value of C and if C is made very much less than about 100 μμF. its reactance at the carrier frequency becomes appreciable compared with the value of the impedance of the grid-cathode path of the valve and so losses result.

In practice, therefore, the values of C and R most commonly used have tended to become stabilised at C = 100 μμF. and R = 250,000 ohms. This combination gives a loss of 5 db. at 10,000 c/s. and the charge on C falls to 96 per cent. of its initial value (as shown earlier) for a carrier frequency of 1,000 kc/s. Damping is not serious and at this carrier frequency the reactance of C is about 25 per cent. of the grid cathode impedance of an average triode.

(To be concluded.)

Made to
measure

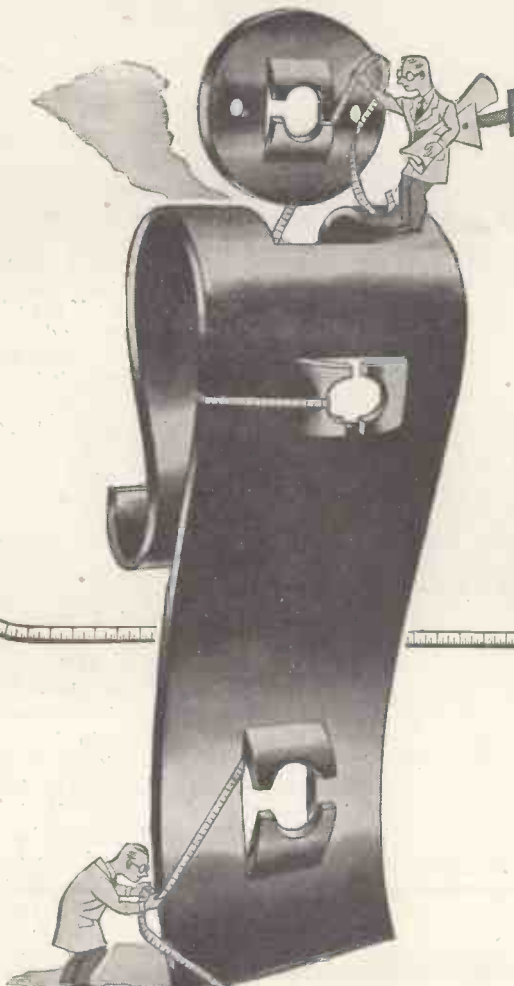

The standard Spire nut is only one form, and the most elementary form at that, of fixing by the Spire method. There are already over 300 special Spire designs, each of which has been "made to measure," for some particular job. In most of them no separate nut or washer is needed. The Spire fixing is part of the component itself. It is pretty safe to say that Spire can simplify *most* assembly jobs. Send us along any ordinary assembly-parts or drawings. We'll see if we can't cut out some of the bits and pieces and reduce the operational time by designing a Spire assembly. No charge for this. If it works we'll get your order. If it doesn't we'll tell you so and there's no harm done.

THAT'S Fixed THAT! NP 1506.

Aircraft manufacturers and coachwork builders employing stressed skin construction are saving time and money and material by the use of this simple Spire fixing. It serves to hold the tack bolts in position until riveting of skin sections has been completed. It is quicker to use than the usual square pressed nut and is easily removed for further use when its 'holding job' is done.



Spire

* A BETTER way of fixing

Simmonds Aerocessories Limited · Great West Road · London · A Company of the Simmonds Group

A Resistance-Capacity Oscillator

By S. S. WEST, M.B.E.*

RESISTANCE capacity oscillators appear to be the vogue. The literature has recently dealt with several variations on this theme. The possibilities of the 2-valve common cathode arrangement when suitably changed in concept to be applicable to a selective regenerative circuit appear however, thus far to have been overlooked.

One form of this circuit arrangement, a convenient one to employ for purposes of description is depicted in Fig. 1. In this form it is a change-over switch with two stable positions. Similarly, it is a "switch" if the resistance R is removed provided that the bias on the grids of the valves is asymmetrical though in this latter case some of the advantages which the arrangement possesses as a "switch" are lost. If the resistance R is absent and the bias conditions for V_2 and V_6 are similar the circuit behaves in very much the same way as a conventional multi-vibrator having one D.C. coupling.

Briefly, the action is as follows. A slight random disturbance in value of the grid potential of valve V_2 , assuming for the sake of example that this disturbance is in a negative sense, will produce an amplified positive signal on the anode of this valve. This positive signal is applied to the grid of valve V_6 through the R.C. network C_4 and R_5 increasing the current through this valve and in consequence the potential drop across resistance R_3 will increase; that is, the cathode of valve V_2 becomes more positive. This is equivalent to rendering the potential of the grid of valve V_2 still further negative which in turn sends its anode more positive and so on. Obviously, this action is cumulative and continues until no further change in potential across the resistance R_1 is possible since the H.T. voltage is finite. The anode current in the valve V_2 is now cut off whereas the valve V_6 is passing a heavy current, but it is apparent that the R.C. network C_4 and R_5 will not maintain this condition since the static bias for both valves is equivalent. The charge on condenser C_4 leaks away taking the

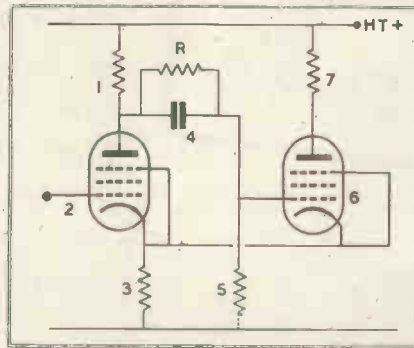

Fig. 1. 2-Valve circuit with common cathode resistor.

potential of the grid of valve V_6 in a quasi-exponential manner towards the negative pole of the H.T. Accordingly, the current through the valve V_6 falls, causing the potential drop across the resistance R_3 to reduce. The foregoing description for one half cycle of the operation then repeats in a converse sense.

It has perhaps been noted that in describing this operation the potential changes occurring across the cathode resistance have been sequentially referred to one valve only. Actually, of course, the true potential change across this resistance is the difference potential due to the action of the two valves. However, this is no difficulty if it is remembered that one of these potentials is proportional to the amplified anode signal of one valve whereas the other is the degeneration potential change which will be smaller than the initiating signal at all times. This arrangement then will oscillate in a manner analogous

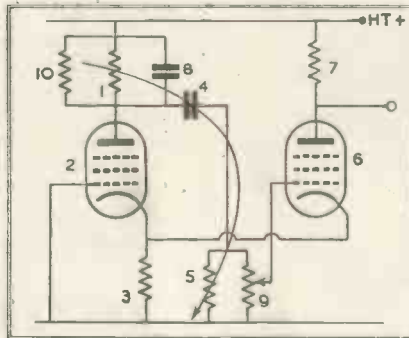

Fig. 2. Circuit of Fig. 1 with phase correct-ing network.

to that of the conventional multi-vibrator, the oscillations attaining an amplitude such that the various losses restrict the regenerative gain so that for the system μ becomes unity. Since there is both anode and grid limiting taking place the wave shape will be distorted; therefore, to obtain sinusoidal oscillations it will be necessary to have the amount of regeneration under control. This is readily achieved in a variety of ways, e.g., resistances R_1 , R_2 and R_3 can be adjustable to particular values, and either the condenser C_4 or the grid connexion of the valve V_6 can be tapped into a suitable point of the resistances R_1 and R_2 respectively. The latter alternatives are preferable because there is then no change in the static operating conditions for the valves when the controls are adjusted. It will be seen later, however, that such a change if small, can be tolerable if other advantages can be secured at the same time.

When the circuit is operated so that the correct regeneration conditions (i.e., $\mu = 1$) are a function of the circuit losses, the fundamental frequency of oscillation is primarily determined by the CR product of components C_4 and R_5 , i.e., the time taken for condenser C_4 to discharge through resistance R_5 governs the change-over cycle. However, if a gain control between the valves is employed the oscillatory conditions are fundamentally affected. Consideration now shows that if it is assumed that there is no possibility of phase shifting in the H.T. source, and that the circuit is exactly as shown by Fig. 1, then there is no particular reason why oscillations should be produced because the R.C. network C_4 and R_5 produces a phase lead at all frequencies so that the feedback cannot be in the correct sense for positive regeneration. However, this circuit omits components which are unavoidably present, namely, the interelectrode capacity of the valves and stray capacitances present in the circuit. In particular, it is convenient to consider the capacities which are in shunt with the resistance R_5 and to assume that they are the only ones present. This combination of R_5 and the stray capacities will at one frequency provide a phase lag equal to

the lead due to the network C_4 and R_5 . It is at this frequency, the frequency for which there is no virtual phase shift between the anode of the valve V_1 and grid of the valve V_2 , that the system will oscillate.

It has been remarked that the R.C. coupling between the valves introduces a phase shift so that if the frequency of oscillation is to be under control a further network must be introduced whose phase characteristic as a function of frequency is equal and opposite to that of the coupling network.

The circuit diagram Fig. 2 depicts an arrangement which fulfils these conditions. It is seen that the only additions which have been made are a condenser C_3 across the resistance R_1 , a potentiometer R_6 in shunt with the resistance R_5 to facilitate adjustment of the oscillatory condition and a compensating resistance R_{10} which is a simple way to ensure that the ratio of R_1 to R_5 is maintained as the frequency is changed. These latter resistances can be ganged together to permit variation of frequency but it is necessary before accepting such an arrangement to examine in more detail its general suitability.

For the sake of clarity in the following it is assumed $R_1 = R_5 = R$ and $C_3 = C_4 = C$. The impedance of the shunt network composed of R_1 and C_3 is given by the equation

$$Z_1 = \frac{X_c^2 R - jX_c R^2}{X_c^2 + R^2}$$

from which the phase angle

$$\phi = \tan^{-1} \frac{R}{X_c} = \tan^{-1} \omega CR,$$

that is the voltage lags the current across Z by an angle ϕ whose tangent is equal to ωCR .

The impedance of the series network comprised by C_4 and R_5 is $Z_2 = R - jX_c$. The voltage " e " across R_5 with respect to the voltage across Z_2 (assumed unity) is given by

$$e = \frac{R}{R - jX_c} = \frac{R^2 + jX_c R}{R^2 + X_c^2}$$

the phase angle

$$\phi = \tan^{-1} \frac{X_c}{R} = \tan^{-1} \frac{1}{\omega CR}$$

We have then two networks (1) a shunt circuit retarding the phase, and (2) a series circuit whose output terminals are such as to provide a

phase lead with respect to the input. The requirements for oscillation are that the phase angle ϕ due to the composite network shall be zero, that

$$1 - \omega CR = 0.$$

Equating it is seen that $\omega CR = 1$ and $f = \frac{1}{2\pi CR}$

It is apparent then that the frequency is inversely proportional to either C or R . That is, if either the two resistances or two condensers are ganged the frequency of oscillation can be readily varied, the frequency being doubled for $R/2$ or $C/2$ and so on. Unfortunately this arrangement is not satisfactory in practice for it can be shown that the attenuation ratio of the network connected in this manner varies with frequency. This is inconvenient because it is necessary to readjust the oscillatory conditions for each new frequency setting. However, a simple rearrangement provides a solution.

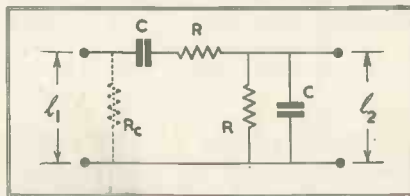

Fig. 3. Shunt and series R-C network.

The ratio of e_2/e_1 for the network of Fig. 3 is given by the equation

$$\frac{e_2}{e_1} = \frac{R/(1+j\omega CR)}{(R/(1+j\omega CR)) + R + \frac{j\omega C}{j\omega C}} = \frac{1}{j\omega CR/(1+j\omega CR) - (\omega CR)^2}$$

It has been shown that frequency is inversely proportional to either C or R and examination of this equation under these conditions shows that the ratio e_2/e_1 is a constant, for any change in C.R. values produces a reciprocal change in frequency. It is to be noted, however, that the equation for the impedance of the circuit

$$Z = R - jX_c + \frac{X_c R}{X_c + jR}$$

is consequently the impedance will vary with frequency.

A suitable arrangement for a variable frequency oscillator whose design is based on these circuits is given by Fig. 4.

The valves V_1 and V_2 comprise the oscillator, the resistances R_5 and R_6 and condensers C_1 and C_2 the frequency selection network. Either the condensers or the resistances can be ganged to provide the control. In the former case, which is in general preferable because it is a simpler matter to obtain a 2-gang condenser whose ratio of capacities is more accurately maintained, it will be necessary to screen the condenser, for the stator will be common to the grid of the valve V_2 . In practice, if a wide frequency range is to be covered it is preferable to employ a band selection scheme. For example, it is convenient to switch the resistances, or to switch in condensers by means of two gang switches so that the frequency can be varied coarsely in, say, 10/1 steps, fine control over this ratio being provided by the variable control.

If a standard commercial 2-gang condenser is to be employed it is as well to check initially the ratio of

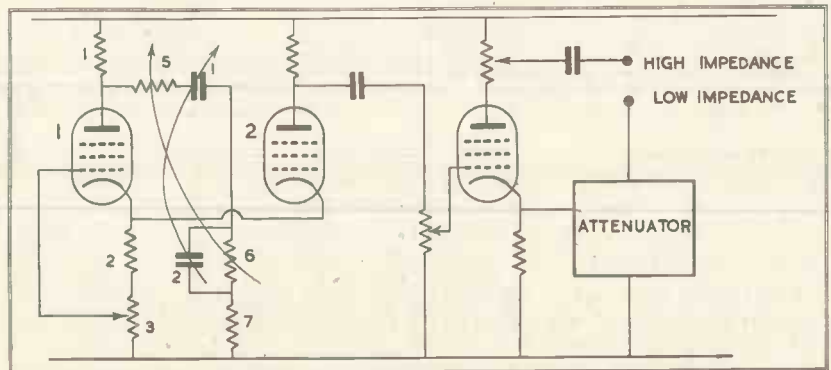

Fig. 4. Circuit of R-C oscillator based on previous circuit.

minimum to maximum capacity. Most condensers cover only a range of the order from 7 to 9 to 1.

Examination of the circuit diagram fig. 4 shows that the oscillator section varies somewhat from the arrangement of Fig. 2. The changes are, firstly, that the oscillator control is in a different form. It can be shown that the performance of a R.C. oscillator is governed completely by the nature of the amplifier. That is to say that, since the "Q" of the R.C. feedback network is unity, the virtual "Q" of the circuit will be a function of the amplifier design.

To ensure a "good" amplifier it helps considerably to incorporate negative feedback.

Fortunately, the circuit is very amenable to the inclusion of a negative feedback arrangement, this being achieved by the simple expedient of returning the grid of the valve 1 to a portion of the common cathode resistance $R_2 + R_3$. Since R_3 can be small compared with R_2 , the small D.C. change in the bias value for the valve V_1 , occurring with adjustment of the degree of feedback does not warrant incurring the complication of a R.C. filter between the slider of R_3 and the grid of the valve.

It is seen that this arrangement will permit the degree of feedback to be easily adjusted so that the correct oscillatory conditions are readily securable.

One other change has been made. Since the analysis of the network of Fig. 3 disregarded the presence of R_2 and since this resistance will have some influence on the performance it is desirable to compensate for its effect. There are various ways of achieving this, the simplest being to include a fixed resistance R_7 as shown in the circuit of Fig. 4. If resistances R_5 and R_6 and condensers C_1 and C_2 are equal in value at all times it can be shown that the value of resistance R_7 should be half the value of that for resistance R_1 .

An output buffer valve is a worthwhile inclusion. The arrangement shown is so straightforward as to need no further description.

In conclusion, it is pointed out that the circuit arrangement of Fig. 4 is equally suitable as a selective amplifier and is capable of quite a good performance as such.

Electronics in Post-War Industries

From a report on Post-War Development issued by the British Institution of Radio Engineers.

TO industry generally, radio engineering has been synonymous with entertainment and, prior to 1939, the application of electronic principles in the industrial field was, save for the most elementary purposes, confined almost entirely to the radio and light electrical engineering industries. That this was so, was not because the equipments in use were unreliable or demanded the constant attention of skilled engineers, but because industry generally had not appreciated or had not even been made aware of the versatility of this new branch of engineering.

A large number of applications of electronic devices has been made during war-time in the field of electrical machines and industrial process control. Such devices include voltage regulators, speed and process controllers, motor controllers and welding timers, as well as equipment for the detection and control of radiant energy, the control of heat in resistance welding and the control of temperature in resistive and inductive heating. These devices can be set to operate within precise limits and give indication aurally, visually or mechanically when certain limits are exceeded; the limits can be established in terms of colour, shade or density, time or speed, rotation or vibration, temperature or humidity, physical size or shape, continuity or interruption of flow, silence or noise, compression or expansion or even changes in the chemical or metallurgical composition of a body.

Such devices are not the laboratory day-dreams of the electronic engineer or physicist, they are accomplished facts, already used by the more enlightened manufacturers.

The chemical industry, to whom quality control and inspection is of paramount importance, has many such electronic devices in routine production use. To the industrial chemist one of the most important factors to be controlled is hydrogen-ion concentration, the degree of which affects such diverse processes as the preparation of photographic emulsions, the manufacture of jams and jellies, the refining of sugar, the colour brilliance of pigments and the sterilisation of food. By means of electronic equipments this control can now be effected by unskilled operators or, if necessary, it can be made entirely automatic.

With equipment incorporating a simple cathode ray tube, such as is used for resonance indication on modern radio receivers, it is possible for an operator with comparatively little experience accurately to titrate turbid or coloured liquids such as are often met with in the chemical industry. Previously this operation was subject to considerable personal error when performed by skilled operators.

In the control of such products as paints, dyes, inks, glues, beer, etc., it is necessary to compare continually the shade of colour of the product with previous standards. With the older visual methods there was always the danger of personal errors when so matching colours, and optical fatigue was a serious factor when routine matching was necessary.

With the electronic colorimeter employing balanced photoelectric cells, the sources of error and fatigue have been completely eliminated, and such devices are in constant use. Operated by unskilled personnel they differentiate shade to limits beyond the capabilities of the human eye.

The inspection of "live" high-speed photographic film for flaws, blemishes, etc., on the emulsion hitherto presented a considerable problem due to the low intensity of light permissible for such inspection. Electronic methods provide a complete answer.

Electronic applications are also possible in many branches of mechanical engineering. Electronic micro-meters, comparators and gauges are now available to measure dimensions to an accuracy of one hundred-thousandth of an inch. Such devices are not delicate laboratory instruments requiring skilled handling but are sturdy and robust, designed to be used by relatively unskilled personnel under shop conditions. Suitably adapted, they can be used to measure the ellipticity and straightness of bore of gun and rifle barrels, cylinder bores, etc.

Although the applications described enter into almost every branch of industry they touch but the fringe of possible developments. As the diversity of devices at present in use become more widely known, still further applications must follow and, with the release of the results of war-time research, new and as yet unexplored fields will be revealed.

Research and the Future of the Radio Industry

By O. S. PUCKLE,
M.I.E.E.

IT is a fact that, prior to the war, very little real research work was carried out by the radio industry in this country. Nearly all the work done in the (so-called) research departments was more in the nature of development than research. Those firms which had American contacts often based their development work upon research which had been carried out in America and those firms which had no American connexions were, to a certain extent, left behind in the race, although they could sometimes make up for this difference by copying or developing ideas which were published in American technical journals or by having close connexions with the primary English and Scottish Universities. No one will deny the ability of British scientists or decry the results which they have produced, but much more can be done if the necessary money and facilities are provided and much more must be done if the Empire is to regain the position it held fifty years ago. During the War, except in its early stages, very little actual research work has been performed outside the orbit of the Government Research Departments. However, the small amount of research which was carried out in the industrial firms during this early War period was probably a great deal more than in a similar period during peace time.

We have in this country two research organisations which are national in character and which deal with electrical engineering matters. These are the National Physical Laboratory, which is controlled by the Government, and the Electrical Research Association which is controlled by a body whose members are appointed by a number of the larger electrical engineering companies. Neither of these organisations, however, deal exclusively with radio engineering and the tremendous growth of this industry throughout the Empire during the last decade, together with the importance of regaining world radio markets, makes it essential that such a body should immediately be formed. This body should function for the whole Empire and should collaborate with similar bodies in foreign countries and with research organisations in other branches of industry both within and without the Empire.

To bring about this result, each company in the radio industry should contribute a fixed percentage of its annual income towards the upkeep of a radio research organisation and a further fixed minimum percentage towards the upkeep of its own research department. This radio research organisation should act as a central clearing house for the dissemination of information from abroad and of its own work to all its subscribers and they, in turn, should furnish the radio research organisation with reports on all their research work for general circulation. The question as to whether such a national radio research organisation should carry out research work itself is one upon which opinion is divided but I feel that it should do so. Complete and willing co-operation along these lines will soon produce very beneficial results from a national, an Empire and an individual company point of view, by avoiding too much duplication of effort. For example, in the development of a radically improved television system, which will shortly be necessary, the radio research organisation could apportion the research work amongst its member firms and so achieve more rapid results. This does not mean that all over-lapping of work should be avoided. On the contrary, it is probable that no piece of research should be carried out in less than two locations since it is advisable to foster competition and, furthermore, it will provide the advantage of the pursuit of a solution to each problem by two, usually different, routes. In this way, it is likely that more elegant solutions will be achieved.

So far as the engineering industry is concerned, the rapid solution of complex engineering problems together with their realisation as meritorious and practical commercial systems is the only achievement which will enable this Empire to regain its lost status in world trade. The regaining of this status is essential since, otherwise, we cannot absorb all the trained personnel who are at present in the Services, neither can we retain and improve our standard of living and that of the world at large. If the various industries fail to do this the results will be likely to lead to world depression and unrest and possibly even to another disastrous war.

For the above reasons, and somewhat in the manner described above, it is essential that much more in the way of research work shall be carried out by individual radio firms.

It is pertinent to inquire at this juncture: What is the rôle which industry should play in the social organisation of the world? It used to be considered that industry is solely a means of providing profits for shareholders, but everyone now concedes that it has, in addition, a much more beneficial and noble part to play. This rôle may be itemised (not in order of importance) as follows:—

(a) Provision of a high standard of living and financial security in sickness and old age for its employees together with reasonable prospects for advancement.

(b) Manufacture of goods or supply of services which are of benefit to mankind as distinct from those for which a sale can be found. This implies high quality and lasting value.

(c) The improvement of the standard of living of mankind.

(d) The training and education of its employees in both a general and a technical sense by providing and/or arranging the necessary facilities. This involves close collaboration with the universities and technical and other colleges.

(e) Provision of adequate research facilities and collaboration with other research organisations.

(f) Permission for the exercise of full freedom of expression for its employees subject, of course, to loyalty to the employer.

It is evident that industry has a very important part to play in the development of Society and I believe that it will rise to the occasion. I believe, also, that in some respects the proverb "It is more blessed to give than to receive" might be written "It is more profitable to give than to receive." It is axiomatic (though the fact has not always been appreciated) that the higher the mental capacity and the standard of living of all classes of society the greater will be the general prosperity including that of industrial shareholders. Increased research and educational facilities can help materially towards this end.

Focused Supersonic Waves in Biological Experiments

By J. G. LYON, R. L. ZWEMER, A. J. CHICK and A. E. MILLER

The biological effects of supersonic waves were first investigated by Ward & Loomis in 1926. In this article, reproduced from the *Journal of General Physiology*, (Vol. 26 No. 2), the authors describe a circuit for producing focused waves for biological experimental work

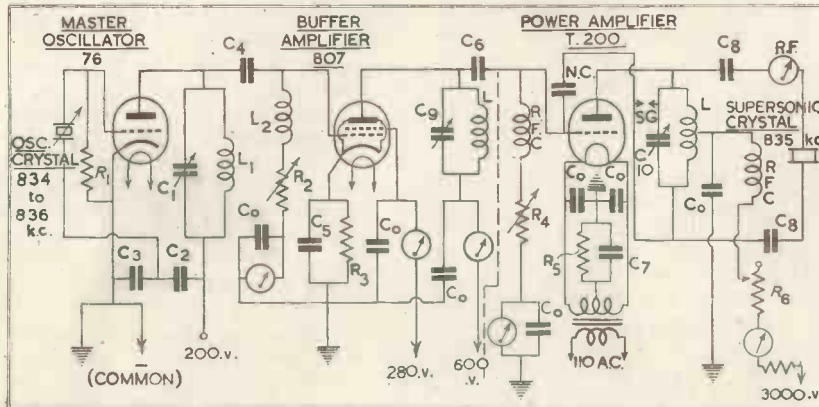

ULTRASONIC, or supersonic waves as they are sometimes called, are mechanical vibrations in solid, liquid, or gaseous mediums lying above the range of human hearing. They have been produced mechanically and electrically, utilising magnetostriction and piezoelectric effects. The latter method is the only one which is adapted to the generation of ultrasound at frequencies above 500 kc/s., which is the range most often used in biological work. It consists of passing a high frequency electric current through a quartz plate, so that the latter expands and contracts in resonance, with the alterations of the current passing through it, and emits ultrasound waves of a corresponding frequency.

The biological effects of supersonic waves were first thoroughly studied by Wood and Loomis¹ in 1926-27 at Tuxedo Park, New Jersey. They observed its stimulating and lethal effects on unicellular organisms, tissues, small fish, and animals. Since then, a host of subsequent investigators have expanded our knowledge regarding the thermal, chemical and photochemical effects of ultrasound. Its dispersing power, its ability to produce stable emulsions between immiscible fluids such as mercury and water, and its stimulating and destructive effects on virus, bacteria, potato shoots, and animal tissues *in vitro* and *in vivo* have also been studied.

To date, all biological and neurological applications of supersonic

waves have utilised plane waves, proceeding in parallel paths from the flat surface of the quartz crystal generator, and no attempt has been made to increase their local intensity by bringing them to a focus. However, some years ago, this possibility was suggested by the late Dr. James Chiles of the University of Virginia.

Purposes of the Present Investigation

We have attempted to apply biologically the physical discovery of Grutzmacher² (1935) that very short ultrasonic waves can be focused by giving a concave curvature to the surface of the vibrating quartz plate, constituting the source of radiation. Thus, he was able to concentrate approximately 150 times as much ultrasonic energy at the focal spot as could be found at a similar spot close to the vibrating plate.

The chief aim of the present study has been to project such a focused beam of supersonic waves into fresh tissue blocks and into the tissues and organs of living animals, so as to produce a maximum of change deep at the spot of focus with a minimum of change in the intervening tissues traversed by the beam before it reaches the focus.

The Radio Frequency Power Generator

The oscillating electrical potential across the opposite faces of the X-cut concave quartz crystal, ground to a natural frequency of 835 kc., is supplied by what amounts, in principle, to a small $\frac{1}{2}$ kw. radio transmitter, such as is used for code signalling.

The apparatus is so constructed that

the bottom shelf holds the power source, the middle shelf houses the master control crystal oscillator and the first amplifier buffer stage. The output of the latter is conducted by means of a special cable through the inner shelf shielding to the top unit—the power amplifier. The entire set-up is shielded and carefully grounded to prevent radio interference, for safety against high voltage, and to prevent inter-stage feed back. Special features of each of the above stages will be taken up in turn.

The power supply is a filament heating power and anode voltage source. The design used is that of a full wave mercury vapour rectifier circuit (type 866) with choke input filter. Although not entirely necessary, a filter adds to the stability of output voltage and helps to solve the radio interference problem, of which this set-up has given no signs. The rectifier operates on A.C. mains, and has a maximum output of 6,000 volts D.C.

The master crystal control oscillator (Fig. 1) utilises an ordinary receiver type triode (type 56 or 76, depending on the filament heater voltage available). This is loosely coupled with the grid of the tube in the buffer stage.

The buffer stage utilises the RCA 807, a beam-power tube with high power sensitivity. This provides the grid driving power necessary for Class C operation of the power amplifier T-200 tube on the top shelf.

The radio-frequency voltage to the ultrasonic crystal is controlled by varying the D.C. voltage to the anode of the power amplifier tube. This is accomplished by a voltage dropping variable resistor (Fig. 1, R₆). To prevent initial transient voltages, while turning on the circuit, from becoming excessive, the best procedure was to put all this resistance in the circuit before turning on the T-200 plate voltage. Then the resistance may be decreased until any predetermined radio-frequency ammeter reading (R.F.) is reached. A spark gap (S.G.) is included across the tuned output circuit to take transient voltages that might otherwise injure the crystal. For long tube life, resistor

R_6 must be at maximum when the crystal or other load is not coupled to the power amplifier; otherwise the available power for this efficiently adjusted stage may have to be dissipated entirely in the anode of the tube.

Resistor R_5 acts as a "safety-valve" to limit the current to the anode, which if overloaded too often, may result in the tube current becoming erratic due to gases given off from overheated parts. As the power amplifier draws more and more current, the voltage drop across R_5 automatically increases, to put a higher negative voltage on the grid of the T-200 tube.

Resistors R_2 and R_4 are adjusted with peak load for the maximum radio-frequency current to the supersonic crystal.

In the R.F. output circuit, fixed condensers, C_3 , bypass the alternating current, but isolate the supersonic crystal in its container from the high-voltage direct current on the anode of the power amplifier tube. Not only do these condensers provide safety for the operator, but they also help to neutralise the inductance of the long leads to the supersonic crystal.

The chief feature of the foregoing design is the use of a quartz crystal as a master oscillator instead of an inductance and capacity in the first grid circuit. The final ultrasound generating crystal is ground to match this oscillator crystal, so that the entire unit may be tuned to resonance and neutralised once and for all. "Fishing" for the supersonic crystal frequency is unnecessary. A vernier adjustment, built into the master oscillator crystal holder, allows a very slight frequency shift (834-836 kc/s.) so that it is possible to set it at exact resonance with the driven ultrasound crystal (835 kc/s.). This gives a maximum power transfer which, together with the accurate and stable means of tuning, accounts in part for the high supersonic output obtained with the relatively low radio-frequency power available.

REFERENCES

- Wood, R. W. & Loomis, A. The Physical and Biological Effects of High Frequency Sound-Waves of Great Intensity. *Phil. Mag.*, 1927, 4, 417.
- Grutzmacher, L. Piezoelektrischer Kristall nut Ultraschallkonvergenz. *Z. Phys.*, 1935, 96, 342.
- Bergman, L., Ultrasonics and Their Scientific & Technical Applications, Inc., London, Chapman & Hall, Ltd., 1938 translated by Hatfield, H. S., from Ultraschall, VDI-Verlag, Berlin.
- Harvey, E. N., Biological Aspects of Ultrasonic Waves. A General Survey, *Biol. Bull.*, 1930, 59, 306.
- Harvey, E. N., The Effect of High Frequency Sound Waves on Cells and Tissues, *Am. J. Physiol.*, 1929, 90, 379.

No component values are given in the original. Ed.

Lightning—Concluded from p. 100

ground, though in a few instances, a positive charge is lowered during the latter part of the discharge. The number of component strokes of a discharge may be as high as thirty, but usually only two or three are observed, with an average of about 30 milliseconds between the strokes. The crest magnitude of the discharge current is generally of the order of 20,000 amps., and only occasionally exceeds 100,000 amps. These higher currents persist for only short times and usually decay to half-value in less than 40 microseconds, but lower currents of about 1,000 amps. may continue for several milliseconds, and it is during this latter period that the greater proportion of cloud charge is lowered to the ground. The quantity of charge involved ranges from low values up to 100 coulombs, with an average value of about 20 coulombs.

Conclusion

An adequate description of the lightning discharge can clearly not be given in an article of this length, and the author has only been able to present the current knowledge of the subject in a very brief manner. No mention has been made of the many laboratory experiments designed to reproduce lightning characteristics, with high voltage and high-current surge generators, and which have contributed to a better understanding of the discharge mechanism, the effects produced by lightning, and the development of protective apparatus.

The reader will find that comprehensive surveys of the literature are given in the general references quoted below.

The author is indebted to Dr. A. P. M. Fleming, Director and Manager of the Research and Education Departments, Metropolitan-Vickers Electrical Co. Ltd., for permission to publish this article.

REFERENCES

GENERAL

- "Thunderstorms and Their Electrical Effects," B. F. J. Schonland, *Proc. Phys. Soc.*, 55, 445, 1943.
 "The Lightning Discharge," C. E. R. Bruce and R. H. Golde, *J.I.E.E.*, 88, 487, 1941.
 "Lightning," B. L. Goodlet, *J.I.E.E.*, 81, 1937.
 "Lightning Phenomena," C. F. Wagner and G. D. McCann, *Trans. A.I.E.E.*, 60, 1943.
 G. Simpson and F. J. Scrase, *Proc. Roy. Soc. A.*, 161, 309, 1937.
 G. Simpson and G. D. Robinson, *Proc. Roy. Soc. A.*, 177, 281, 1941.

PHOTOGRAPHY OF LIGHTNING

- B. F. J. Schonland and others, *Proc. Roy. Soc. A.*, 143, 654, 1934; 152, 545, 1935; 162, 175, 1937; 164, 132, 1938.
 K. B. McEachron, *J. Franklin Inst.*, 227, 1939.
 FIELD CHANGES AND ATMOSPHERICS
 E. V. Appleton and F. W. Chapman, *Proc. Roy. Soc. A.*, 158, 1, 1937.
 R. A. Watson-Watt, J. F. Herd and F. E. Lutkin, *Proc. Roy. Soc. A.*, 162, 267, 1937.
 F. E. Lutkin, *Proc. Roy. Soc. A.*, 171, 285, 1939.
 F. W. Chapman, *Proc. Phys. Soc.*, 51, 876, 1939.
 B. F. J. Schonland and others, *Proc. Roy. Soc. A.*, 166, 56, 1938; 176, 180, 1940.
 T. H. Laby and others, *Proc. Roy. Soc. A.*, 174, 145, 1940.

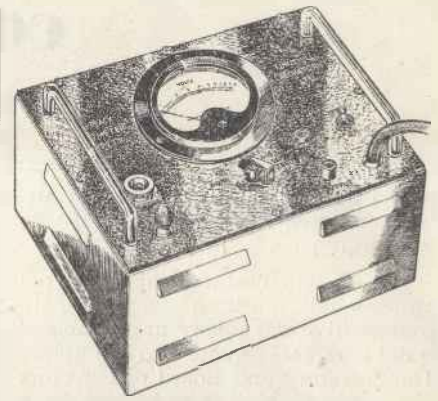

FEEDBACK VOLTMETER, TYPE 378

FIVE VOLTAGE RANGES

1mV	—	10mV
10mV	—	100mV
100mV	—	1V
1 V	—	10V
10 V	—	100V

Four inch meter, graduated logarithmically to 1/10 FSD.

Constant reading accuracy of $\pm 5\%$ from 1/10th FSD to FSD.

Frequency Range. 50 c/s to 250 kc/s.

Input Impedance. 2 megohms.

Input connection. Concentric screened socket.

Stability. Negative feedback and internal stabilising render sensitivity and meter zero setting substantially independent of mains variations and normal valve ageing.

Amplifier. The instrument may also be used as a general purpose amplifier with a gain of about 500.

Mains Supply 200-250v. 50 c/s. 20 watts.

Size. Panel 8" x 10 $\frac{1}{2}$ " Depth 7"

Price: £75

FURZEHILL
 LABORATORIES LTD.
 BOREHAM WOOD
 HERTS
 TELEPHONE . ELSTREE 1137

CORRESPONDENCE

DISCUSSION ON ELECTRONIC MUSIC

SIR,—I would like to make a few points on different paragraphs in Mr. Lewer's article, for which I hope he will forgive me.

The author's statement that the professional musician is "strongly conservative and abhorrent of change" is not correct—I quote two examples: The Secretary and Board of Directors of one of our leading orchestras have discussed plans to purchase recording apparatus in peacetime, fully realising the advantages of this for rehearsal, etc. Furthermore, my uncle, Sir Thomas Beecham, was one of the first to purchase a Hammond Organ in this country, but the generally held opinion of the Hammond is that it fails musically where the pipe organ excels, although it has many undoubted advantages.

Under the heading of "Electronic v. Acoustic" one gathers that Mr. Lewer has probably never heard a concert orchestra with less than 5 per cent. harmonic distortion; when he does, and if he appreciates it, there is no doubt he will modify his views. The electric gramophone superseded the acoustic version because it was better and easier to listen to and cheaper for the result. In this the "electronic profession" did the musical world a great kindness, for which they have been plentifully rewarded in the sale of records.

Today, we have certain instruments, a certain "law" which governs the construction and form of music; these are ever progressing: compare Palestrina with Handel, and Handel with Delius and Arnold Bax;—musicians progress too! Yet today, with many first class orchestras and good music being played all over the country the masses do not properly appreciate music although there is a gradual trend towards it, especially in the last few years. Seeing that this situation exists what possible advantage can there be in producing new sounds with "screeching" oscillating valves and the like? Years of work have gone into perfecting the clarinet and oboe. Musical expression can be executed to the full on these and we cannot even copy these two instruments electronically with any accuracy. The Hammond Organ fails in this respect musically, and whilst musicians will

say this, they will admit that it is an ideal substitute where space and economy and not music are the main considerations.

The same applies to the Electronic Piano. Years of work and research have been involved to produce pianos like the Steinway and the Bluthner, etc.; why are these better than other makes? To the scientist they may appear the same, but to the pianist there is a vast difference and also to his "appreciative" audience. The pianist can tell you which is the best by playing them. He prefers one because the instrument responds to him, he experiences that feeling he strives for: the same feeling of emotion which comes with the appreciation of music.

The Electronic Engineer cannot yet reproduce the piano to that extent but he must, if he is to assist, consult the musician on what is required, or better still, be a musician himself!

There can be no future in Electronic Music unless we, of the "Electronic profession," as Mr. Lewer puts it, are prepared to assist and descend from the throne upon which we imagine ourselves, and consult musicians. We assisted with the gramophone, sound transmission, films, electronic organs particularly; but there is still room for improvement—we cannot attempt perfect reproduction of symphony orchestras. I consider it a mistake to try to find substitutes for musical instruments before we can copy them or before we have the ability to produce sounds as beautiful.

In conclusion, Scientific Research and progress will always be a necessity to mankind physically but music and culture have been and always will be "spiritual" or aesthetic requirements. Let us try to assist them rather than change them.

Yours etc.,

J. BEECHAM.

Mr. Lewer Replies

SIR,—The examples which Mr. Beecham quotes to show that musicians are not conservative but welcome new developments do not, in my opinion, disprove the generalisation which I ventured to make in my article. It should have been clear from the

context that I was referring to the reluctance on the part of musicians to accept *instrumental* innovations. Mr. Beecham's reference to the progress of musical *form* from Palestrina to Arnold Bax is interesting and cannot be refuted, but it is irrelevant. The fact remains that there has been no outstanding improvement in acoustic musical instruments for several generations.

Perhaps Mr. Beecham is not aware of the numerous technical papers which have been published on the physics of musical instruments, notably in the *Journal of the Acoustical Society of America* and in the *Philosophical Magazine*, but he need have no fear that scientists are lacking in their appreciation of music either subjectively or objectively. The piano in particular has been studied in great detail, and in many respects the scientist knows more about the various tonal qualities of an instrument than the musician himself.

The goal of electronic music, for Mr. Beecham, appears to be the ability to copy the tone of existing instruments, but surely this is unnecessary. Did the brass attempt to copy the tones of the woodwind? The fact that the tones are different does not mean that they are bad. Neither does it mean, of course, that they are good. Whether they are good or bad depends on the intrinsic acoustic qualities of the new instrument and also on the musical education of the public. The beauty resides in the mind of the hearer—not in the mechanism of the instrument.

I can assure Mr. Beecham that as a clarinet player in an orchestra for several years I have a sympathetic ear for the "cultured" forms of musical expression, and my approach to the problem of electronic music is therefore not wholly scientific.

Yours faithfully,

S. K. LEWER.

Electronic Organs

SIR,—Whilst thanking Mr. Lewer for his interesting article in your June issue, I feel that in his anxiety to forward the claims of Electronics, he does scant justice to the instruments

Would you expect a cup to bounce?

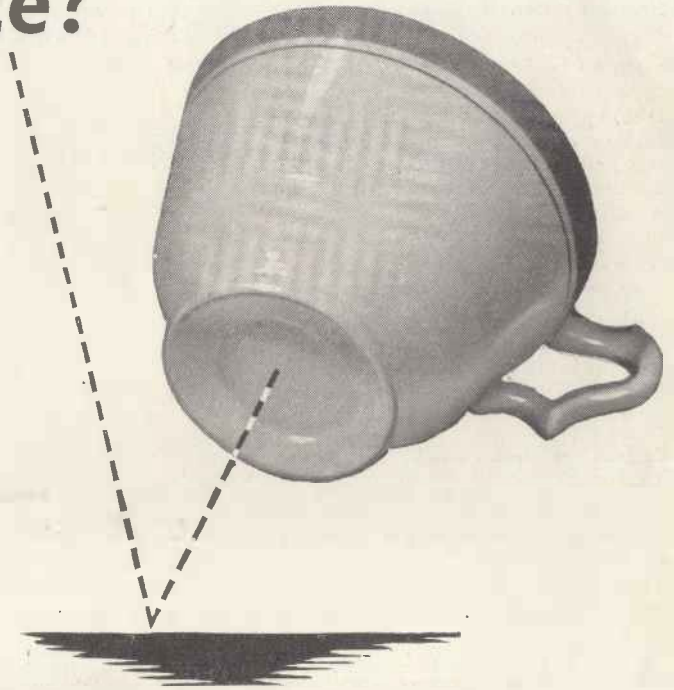

MOST people are surprised or indignant when a Plastics article fails to stand up to a heavy blow. Some plastics *are* brittle and are not intended for such rough usage. If you really want an article that will bounce, the Plastics Industry will be able to supply it after the war. Plastics can be endowed with a variety of properties to suit a vast number of uses. As an example, Bakelite moulding powder X 199 incorporating a fabric filler will produce mouldings possessing an impact strength as high as 1.5 foot pounds and a cross breaking strength of 14,000 lb. per square

inch. Of course, such material is not made into cups but has its special uses in industry where a high degree of mechanical strength is essential. The Bakelite Laminated range includes materials so tough that in certain circumstances they can be used with advantage instead of steel, bronze and other metals.

Choose the correct material for the job and Plastics will not let you down. The technical staff of Bakelite Ltd. can give you invaluable help in this direction.

TREFOIL
BAKELITE  **PLASTICS**

REGD. TRADE MARKS

Pioneers in the Plastics World

BAKELITE LIMITED, 18 GROSVENOR GARDENS, LONDON, S.W.1

CORRESPONDENCE

DISCUSSION ON ELECTRONIC MUSIC (contd.)

which it is hoped to replace in the future by new methods.

In particular, his views on the Organ seem to be influenced by the Cinema type of instrument rather than the true organ. This latter, in its best form, is not only unique in tonal effect, but it bears no resemblance to a "one man band," and any orchestral colours which are included in its scheme are but useful adjuncts to provide increased variety of effect.

Mr. Lewer speaks of the diapason as if this were the only tone peculiar to the organ. This is not so. Even if it were, it is still far too complex a colour to produce as yet in all its splendour by electronic means. But, when one goes further and contemplates the production of a really well developed mixture and reed ensemble, the difficulty of providing anything comparable by electronic means becomes more apparent.

With regard to your correspondent's criticism of Organ Builders' attempts to imitate orchestral instruments, I think he must have been unfortunate in his experience of such stops. I have personal knowledge of many Oboes, Clarinets, French Horns and Orchestral Flutes which are extremely characteristic of their orchestral prototypes, much more so than any electronic set-up I have yet heard.

Now lest the above remarks should give the impression that I am a pipe organ die-hard, let me say that I have been most keenly interested in the production and possibilities of a British Electronic Organ for the past 15 years, and I am convinced that these instruments have a definite place in the sphere of music. It is by no means necessary for them to be designed so that a new technique is essential for their proper use, and a number of Electronic Organs, with standard control in every detail, are in service, giving very satisfactory results. But we must not fall into the error of mistaking mere power of effect for quality, neither, in the present state of electronic progress must we expect the tonal results obtainable to be so outstanding as to render obsolete their extremely artistic and impressive predecessors. For, in the first place (and unfortunately) the Electronic Organ began by being a cheap substitute for

the organ; secondly, the many harmonics present in the tone of even a single diapason, gamba or reed pipe, are not yet faithfully reproducible by any amplifier, or loud-speaker equipment, and, lastly, until a generator of sufficient scope is available to permit the delicate harmonic synthesis needed for close imitation, the chief use of electronic tone production will be for instruments in which relatively undeveloped tones are acceptable, or, in the case of organs, buildings where space for an adequate orthodox installation cannot be arranged.

Yours faithfully,

FOR THE JOHN COMPTON ORGAN
COMPANY LTD.,

J. I. TAYLOR,
Technical Director.

Mr. Bourn Joins In

SIR,—I read with interest Mr. Lewer's article dealing with the future of Electronic Music.

It is easy for most people with the requisite electrical and musical knowledge to produce a machine on which it is possible to play tunes. Whether such machines fall into the category of musical toys or musical instruments depends on whether or not the instrument is suitable for the performance of serious music. For certain classes of "music," the noise produced by a saw (amplified or not), or even a comb and paper, may be quite adequate, and even result in large sales. Such devices could not be employed by the serious musician, and it is with regard to the class of instrument which can be said to contribute to serious music—that an important point arises, to which Mr. Lewer makes no reference, and it applies particularly to the organ, and in a lesser degree, to the piano.

When an organ is purchased, the make is chosen chiefly by reason of the tonal properties with which it is endowed by the skill of the builders. It has a particular character or personality due largely to the final treatment, regulation, etc. With proper maintenance, this personality will be preserved for a very long period. If an electronic instrument is to compete in this important respect, it must be stable tonally, and must not be at the mercy of ageing components,

such as valves, resistors, etc. It should also be possible at any future date by making elementary checks, as, say, with a voltmeter, to ascertain that all the tonal requirements are being met, and that any renewals that have to be made can be applied without upsetting the tonal adjustments.

I cannot agree that organ nomenclature is so very fanciful, particularly in the examples given by your correspondent. There are many shades of reed tone (as with other families), just as there are shades of colour. Red, for instance, may range from Salmon Pink to Light Cherry, Vermilion, etc., and these names to an artist have a definite meaning. They could, of course, be labelled Red No. 1, No. 2, and so on, as they would appear in an ironmonger's paint list. In like manner, names such as Trumpet, Trombone, Tuba, Tuba Horn, etc., to a musician also have a definite meaning, and would convey much more at a glance than would Red No. 1, etc. A Viola da Gamba is a stringy toned stop, and is named after the instrument (as in most other cases) it most closely resembles, which seems to me to be fair enough. There are undoubtedly a good many names which are redundant and which should be dispensed with, but the existing terminology appears to be quite satisfactory to the majority of musicians.

The creation of the tonal ensemble in an organ requires great experience, skill and artistry. To my mind, therefore, it is undesirable that means of upsetting the final regulation should be available (at least for public use) to the organist, as dire results of amateur attempts at synthesis are already well known, to the detriment of electronic instruments.

It may be of interest to note that electronic sections have been regularly incorporated with pipe organs by at least one British firm since 1933, and in some cases organists of no mean repute have been unable to distinguish the electronic tone from that of normal pipes. The first British all-electric organ was demonstrated in 1935, and a number of examples were built prior to the War.

Yours faithfully,

L. E. A. BOURN,
The John Compton Organ Co.

LOW LOSS



The Highland Laddie seems to object to any loss, but even an insulation engineer likes to keep his losses as low as possible. So when a low loss machinable material is required which will stand up to 400°C he naturally turns to MYCALEX.

Power Factor (1 meg & over) .002	Tensile Strength (lbs./sq. in.) 5,800
Permittivity 6.7	Water Absorption... NIL.
Electric Strength (volts/mil) 550	Plastic Yield ...450°C.

Send for illustrated brochure.

MYCALEX COMPANY LIMITED • CIRENCESTER • GLOS.

SK45



It's always there!

Do not jeopardise production by taking the risk that the core of flux may be missing from the solder-wire you use. Be safe. Use Multicore 3-Core Solder. You will have, always, three cores of Ersin Flux—the fastest-action, non-corrosive, safety flux which makes "dry" or "H.R." joints impossible. Multicore is approved by A.I.D. and G.P.O. If you are engaged upon Government contracts write for technical information and samples.



ERSIN MULTICORE

The Solder Wire with 3 Cores of Non-Corrosive Ersin Flux

MULTICORE SOLDERS LTD. COMMONWEALTH HOUSE, NEW OXFORD ST., LONDON, W.C.1. Tel: CHAncery 5171/2

ABSTRACTS OF ELECTRONIC LITERATURE

RADIO

Some Aspects of Radio Reception at U.H.F. (E. W. Herold)

At U.H.F. the fluctuation noise of tubes and circuits in the receiver is sufficiently greater than antenna noise and other forms of interference to limit the reception of weak signals. Signal-to-noise ratio is often one of the chief problems in reception at U.H.F. The bandwidth of the receiver is also of great importance, both for the determination of the maximum speed at which intelligence can be received and for the determination of the total noise which will be encountered. Circuit and noise bandwidth are not always the same and are distinctly separated in the analyses. Finally, selectivity is a third important aspect of ultra-high-frequency reception.

It is shown that the receiving antenna "captures" an amount of the transmitted power which, at a given wavelength, depends only on the directivity. Thus, receiving-antenna design is chiefly concerned with directivity, which determines the maximum signal-to-noise ratio and with bandwidth, or Q , which determines the useful frequency range. The Q of the half-wave dipole is determined by its surge impedance which in turn depends on the ratio of diameter to length of the conductors. The antenna Q is low even for small diameters and is lowered even further by the receiver load. Coupling the antenna to the receiver requires low-loss transmission lines and proper impedance matching. The amount of reflexion at line-coupling elements or at insulating beads can easily be calculated and formulas are given for cases in which the non-uniform sections are short compared with the wavelength. The losses due to such reflexions rise with frequency and may be appreciable even for rather small beads, if isolated.

The selectivity of superheterodyne receivers is largely obtained in the intermediate-frequency stages. However, the receiver input circuits, prior to the mixer stage, determine the image response. It is found that the image-to-signal ratio depends on the ratio of the input-circuit bandwidth to intermediate frequency. Thus, high intermediate frequencies are desir-

able. The design of resonant-line input circuits between the antenna and the tube to obtain any desired band-widths can be carried out by use of lumped-circuit equivalents. This procedure is simplified since distributed losses in the line circuits can often be neglected in comparison with the lumped loss introduced by connexion of a tube. If a bandwidth is too narrow, the Q can be lowered by coupling the antenna tighter. If the bandwidth is too wide, the Q can be raised by coupling the tube more loosely to the circuit.

An Appendix gives useful data for transmission-line circuits including their equivalents in the form of lumped L and C circuits.

—*Proc. I.R.E.*, Aug, 1943.

Enemy Aircraft Radio Equipment (C. P. Edwards)

The object of the paper is to describe the most widely used radio-communication installations and aids to navigation found in German military aircraft, with brief mention of Italian and Japanese practice. Since it is impossible in the space available to give full descriptions of the equipment, detailed attention is given only to points of particular technical interest. The items to be described perform roughly the same functions as their counterparts in British and American aircraft, but the practice with regard to methods of construction and installation is vastly different.

The paper does not set out to compare German and British practice item by item, but it may be stated generally that, except in the case of fighter equipment, in which British practice is unquestionably superior, no outstanding advantage can be credited to either side.

The equipment is described under the following headings:—

- (1) Bomber general-purpose equipment, including intercommunication system and power supply.
- (2) Direction-finding and beam approach.
- (3) Fighter and single-engined dive-bomber equipment.
- (4) Pilots' radio-telephone sets, or "command" sets.
- (5) Italian and Japanese equipment.
- (6) Installation practice; materials, construction and components.

—*Jour. I.E.E.*, Vol. 91, Part III. No. 14, June, 1944, p. 44.

INDUSTRY

High-Frequency Heating (D. W. Brown)

In this article the author provides a simple, yet comprehensive study of the theory of high frequency heating. He deals with both eddy current and capacity current methods, but emphasis is laid more on the latter because the article refers chiefly to the heating of thermoplastic resins. The various methods of producing the H.F. currents are surveyed, together with the apparatus and operational technique involved. The author concludes with a review of the various applications of this form of heating in a wide variety of fields.

—*Plastics*, May, 1944, p. 218.*

Electronic Heating Design Chart (C. V. Fields)

This article mainly comprises a chart type of ready-reckoner for the use of designers of induction heating and dielectric heating apparatus, to facilitate determination of circuit parameters. The use of the chart is fully explained by means of two skeleton charts and special examples; among the factors that can be determined by the chart are reactance, frequency, capacitance, kVA., current and voltage.

—*Electronics*, April, 1944, p. 143.*

Fabricating Wood Aircraft "Skins" (J. P. Taylor)

Radio-frequency heating is extensively used in the production of flat laminated stock. It is also coming into favour for the fabrication of curved spars and other parts of the structural type. This article discusses experimental manufacture of thin coverings such as those that constitute wing and fuselage surfaces.

—*Electronics*, Vol. 17, No. 4 (1944) p. 102.

Work Coils for H.F. Heating

It is indicated that the winding of the work coils which transfer radio-frequency energy from high frequency equipment to the object being heated is generally governed by past experience. Examples of such coils, made by engineers at Lepel High Frequency Laboratories, New York, are presented to serve as guides in winding coils for similar applications.

—*Electronics*, Oct., 1943, p. 112.*

* Supplied by the courtesy of Metropolitan-Vickers Electrical Co. Ltd., Trafford Park, Manchester.

Our specialised function

Engineering practice today demands an ever-increasing range of small electric motors and electro mechanical apparatus of new and non-standard patterns. In addition to producing special designs in quantity at competitive prices, we are interested in your experimental needs. As soon as they are released from the claims of war production our research and design laboratory together with our manufacturing resources will be at your disposal.

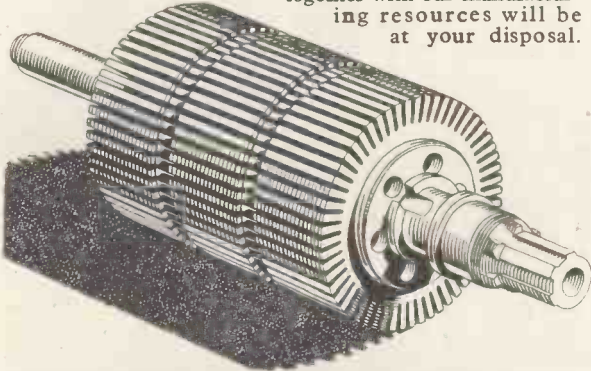

Write for particulars of any special type of apparatus that interests you: we will forward details and literature when available.

SMALL ELECTRIC MOTORS LTD.



BECKENHAM, KENT
A subsidiary of
BROADCAST RELAY SERVICE LIMITED



TENAPLAS Electrical Insulation

TENAPLAS LTD., 7 PARK LANE, LONDON, W.1



STATIC TWO-DIMENSIONAL visual delineation of any recurrent law.

RELATIVE TIMING OF EVENTS and other comparative measurements with extreme accuracy.

PHOTOGRAPHIC RECORDING of transient phenomena.

SIMULTANEOUS INDICATION of two variables on a common time axis

INDUSTRIAL INDICATING and TESTING afford increasing scope for the Cathode Ray Tube as the only device with the above inherent features, of which the last is unique in the Cossor DOUBLE BEAM Tube.

The Model 339 Cossor Oscillograph thus equipped is invaluable on all problems of research, production or operational testing, when the effect examined is applied as a voltage. When recurrent the traces are studied visually and when transient are recorded photographically, using Model 427 camera.

A. C. COSSOR Ltd.,

INSTRUMENT DEPT.

Cossor House, Highbury Grove, London, N.5

Phone: CANonbury 1234 (33 lines).

Grams: Amplifiers Phone London.

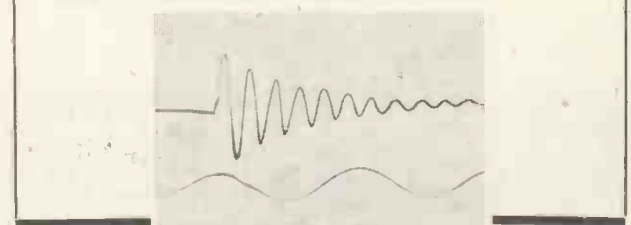

BOOK REVIEWS

Elements of Radio

By A. M. & W. Marcus. 672 pp. 504 figs. (Allen & Unwin 27s. 6d. net).

The authors have, after many years teaching experience, come to the conclusion that the best approach to the study of radio is through the conventional receiver and not by commencing "with a mass of laws and principles."

This conclusion is carried into effect in this book, which is divided into two sections. The first deals with wave-motion, the tuner, reproducer, and other components of the receiver, and the second covers the principles—D.C. and magnetism, A.C., inductance, valve theory, and transmitters.

In some cases this may sound as though the authors are putting the cart before the horse, but the treatment has been very well thought out and there is very little taken for granted in the elementary descriptions in the first part. One of the difficulties in this method of arrangement is to avoid the use of the words "see on."

Whether other teachers of radio will agree with this method of presentation

remains to be seen, but there is a lot to be said for interesting the student in the practice from the start, rather than leading him along the conventional road of first principles first.

The arrangement and typography of the book are excellent, and the few minor errors will be allowed for by the teacher and unnoticed by the student. Each chapter is prefaced with fundamental questions which the authors set out to answer, and at the end of the chapter is a glossary of terms and summary. An appendix gives a series of experimental demonstrations with the usual tables of data and symbols.

Altogether, a book to be recommended as a welcome change from the average run of textbooks.

G.P.

Electrotherapy

E. B. Clayton 265 pp. 85 figs. (Baillière, Tindall & Cox, 10s. 6d. net).

Though primarily intended for students working for the electrotherapy exam. of the Chartered Society of Physiotherapy there is much in it to interest the engineer interested in applications of electricity to medicine. He will of course be familiar with the contents of the first six chapters, which deal with electrical theory, but after this follows a description of the adaptation of d.c., a.c., and induction coil currents to medical treatment with notes on the technique.

Diathermy is not included, and this is the subject of a separate book by the same author. The book is of particular use in introducing the electronic engineer to the technical terms in use in this application of electricity—some of them will certainly surprise him.

**Books reviewed on this page
or advertised in this Journal,
can be obtained from**

H. K. LEWIS & Co. Ltd.

136 Gower Street, W.C.1

*If not in stock, they will be obtained
from the Publishers when available*

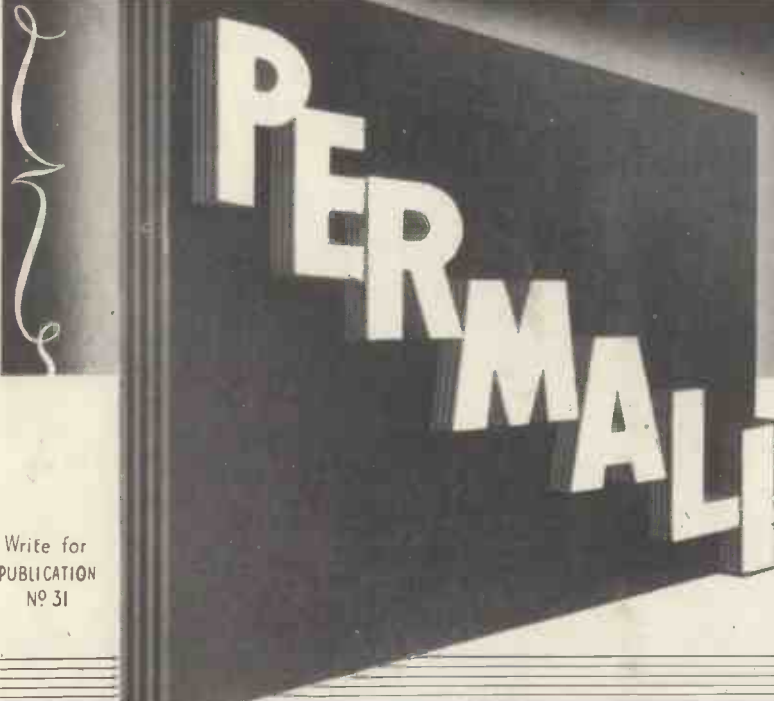

Write for
PUBLICATION
No 31

LAMINATED
Electrical
INSULATION

to

DCD WT
1000

Telephone
GLOUCESTER
4941.

THE NEW INSULATION CO. LTD. BRISTOL RD. GLOUCESTER.
LONDON OFFICE WINDSOR HOUSE, 46 VICTORIA ST. S.W.1 TEL: ABBEY 6494

Telegrams
'NICO
GLOUCESTER

MELTON
METALLURGICAL
LABORATORIES LTD.

Liquid Silver

Platinum & Gold Solutions

For Metallising Mica Ceramic Quartz etc.

Low Melting Point Solder and Non - Corrosive Liquid Flux (A.I.D. Approved)

IPSWICH ROAD TRADING ESTATE SLOUGH, BUCKS. 'Phone : Slough 20992

Agents for Australia :
A. S. HARRISON & CO. PTY. LTD.
 85 CLARENCE STREET, SYDNEY



Well made of steel, double ridged for strength. Teeth on three sides of lower jaw give firm grip and good contact. Opens 1½".

Wingard products are always equal to the job they have to do. For our own sakes—as well as yours—they bear our name, because the reputation of the maker is, in the last analysis the best guarantee of the product.



CHURCH ROAD · HENDON · LONDON · N.W.4

PITMAN

THERMIONIC VALVE CIRCUITS

By Emrys Williams. This book incorporates the theory of the operation and design of thermionic valve circuits, and constitutes a convenient textbook dealing exclusively with the subject, suitable for universities, technical colleges, and electrical engineers trained in the days before the development of the valve.

Second Edition. 12s. 6d. net.

MODERN RADIO COMMUNICATION

By J. H. Reyner, B.Sc.(Hons.), A.C.G.I., D.I.C., A.M.I.E.E., M.Inst.R.E. A manual of modern theory and practice, covering the syllabus of the City and Guilds Examinations, suitable for candidates for the P.M.G. Certificate.

In two volumes.

Vol. I. Eighth Edition. 7s. 6d. net.

Vol. II. Fourth Edition. 7s. 6d. net.

Parker Street, Kingsway, W.C.2

BOOKS

RELIABILITY



Earnings and savings go into the British Banks. Experience has given the people confidence that this service will never let them down . . .

In the same way you can depend on

TRIX

QUALITY SOUND EQUIPMENT
 THE TRIX ELECTRICAL CO. LTD.

1-5 MAPLE PLACE
 LONDON, W.1

Telephone: Museum 5817

Reliability is the most important factor with Sound Equipment too—you can take Trix for granted in this respect. For the present, supplies are restricted to priority orders.



Let him keep 'em! We've got all the medals we want in the knowledge that we are doing our level best for the war effort. We look forward to our reward in renewing our friendly relations with the radio trade as soon as circumstances permit. Meanwhile, the benefit of our long experience in the production of precision wire-wound resistances is at your disposal for vital war equipment.

RELIANCE

Manufacturing Co. (Southwark) Ltd.
 Sutherland Rd., Higham Hill,
 Walthamstow, E.17.
 Telephone—Larkwood 3245

It is with deep regret that we have to announce the death of Dr. Norman Partridge, founder and senior partner of our firm.

The valuable technical contributions he made to the industry will not, however, be lost, as the business will be continued by his co-partner and close collaborator, Mr. A. L. Bacchus, who for many years has managed both the business and production of the firm.

The high quality and normal technical standard always associated with Partridge Products will be fully maintained and there will be no variation in our service or attention to detail.

N. Partridge

Transformer Manufacturers
 76-78, PETTY FRANCE, LONDON,
 S.W.1. Telephone: ABBey 2244

GALPINS ELECTRICAL STORES

"Fairview" London Road, Wrotham, Kent.

TERMS: Cash with order. No C.O.D.

Regret no Orders can be accepted from Eire or Northern Ireland.

ELECTRIC LIGHT CHECK METERS, well-known makers, first-class condition, electrically guaranteed, for A.C. mains 200/250 volts 50 cy. 1 phase 5 amp. load, 10/- each.

AMPLIFIER COMPONENTS from dismantled American 10 Watt Amplifiers, all metal case and compound filled, Input Transformers, 15/-; Inter-stage, 7/6; Push pull input, 10/-; Push pull output, 10/-; Push pull output, 20/-; Power Transformers, 12/6 and 25/-; Capacitor Packs, 10/- and 20/-; Rectifiers, 12/6; Audio filters, 7/6.

MOVING COIL AND M.I. METERS.

MASSIVE GUNMETAL WINCH for use with 1/16 in. solid steel wire, worm and wheel, complete with long handle, weight 50 lbs. Price £3, carriage paid.

METER MOVEMENTS for recalibration, moving coil, 4in. scale, deflection not known. Price 20/-.

MOVING COIL, ammeter reading 0-350 amps, 6 in. dia., switchboard type, complete with shunt. Price 70/-.

ROTARY CONVERTOR, input 48 v. D.C., output 75 v. at 75 M/A. A.C. could also be used as 50 v. motor or would generate, 30/-.

ROTARY CONVERTOR, D.C. to D.C., input 48 volts D.C., output 2,500 v. at 1 K.W., constant rating, as new, £10.

TAPE MACHINE, fitted KLAXON 220 v. D.C. motor, geared drive, rheostat control. 18 ohms. relay, complete with tape reel and tape, as new, £7 10s.

H.T. TRANSFORMER in case size 10 x 7 x 6 ins. (no oil) 20V. to 10,000V. centre tapped, output 2 1/2 K.V.A. at 500 cycles. Intermittent rating. £8.

FOR FULL DETAILS OF ABOVE AND OTHER GOODS, SEND FOR LIST, 2/6.

THE POLYTECHNIC, REGENT ST., W.1 SCHOOL OF ENGINEERING

Head of School: PHILIP KEMP,
M.Sc.Tech., M.I.E.E., A.I.Mech.E.

RADIO ENGINEERING. A FULL-TIME DAY COURSE in telecommunications, extending over a period of three years, preparing for the National Diploma and other examinations and for the radio and telephone industries.

School re-opens on 18th September, 1944.

EVENING CLASSES in these subjects commence on 25th September. Enrolment from 18th to 20th September, 6 to 8 p.m.

Further particulars may be obtained on application to the Director of Education.

TESTOSCOPE

Indispensable to Radio Service Engineers. Makes 20 tests. Interesting Booklet on request. From all wholesalers or direct. Send for Leaflet L24

RUNBAKEN · MANCHESTER · I

LAMINATIONS & SCREENS RADIOMETAL · PERMALLOY SILICON ALLOYS

Electrical Sound & Television Patents Ltd.
12 PEMBROKE ST., N.1

CLASSIFIED ANNOUNCEMENTS.

The charge for miscellaneous advertisements on this page is 12 words or less 4/- and 4d. for every additional word. Box numbers (4 words) plus 1/- extra. Remittance should accompany advertisement. Cheques and P.O.'s payable to Hulton Press Ltd., 43 Shoe Lane, E.C.4. Press date—15th month for following issue.

FOR SALE

IN STOCK, Rectifiers, Accumulator Chargers, Rotary Converters, P.A. Amplifiers, Mikes, Mains Transformers, Speakers of most types, Test Meters, etc., Special Transformers quoted for.—University Radio, Ltd., 238, Euston Road, London, N.W.1. Ger. 4447.

LOUDSPEAKERS

LOUDSPEAKERS—We carry on: Sinclair Speakers, 170, Copenhagen Street, N.1.

LOUDSPEAKER repairs, British, American, any make, moderate prices.—Sinclair Speakers, 170, Copenhagen Street, N.1.

MISCELLANEOUS

WE WILL BUY at your price used radios, amplifiers, converters, test meters, motors, pick-ups, speakers, etc., radio and electrical accessories. Write, phone or call, University Radio Ltd., 238, Euston Road, London, N.W.1. Ger. 4447.

WEBB'S Radio Map of the World enables you to locate any station heard. Size 40" by 30" 2 colour heavy Art Paper, 4/6, post 6d. Limited supply on Linen, 10/6, post 6d.—Webb's Radio, 14, Soho Street, London, W.1 Phone: GERrard 2089.

MORSE Practice Equipment for Class-room or Individual Tuition. Keys, Audio Oscillators for both battery or main operation. Webb's Radio, 14, Soho Street, London, W.1 Phone: GERrard 2089.

RADIO ELECTRIC PATENTS. Well known London Radio Component manufacturers are open to consider Patents or Designs for post-war period. Write: Progress, c/o Alfred Bates and Son, Ltd., 130, Fleet Street, London, E.C.4.

ADVERTISERS wish to secure services of small progressive firm desirous to expand business and having facilities for manufacturing radio equipment, and preferably also high-frequency laboratory equipment. The services to consist in the manufacture on a considerable scale, and in the development where necessary of special apparatus in which advertisers are interested. Advertisers desire to acquire financial interest in firm or in special branch of it. Apply Box No. 682, "Electronic Engineering."

SITUATIONS VACANT

A.M.I.E.E., City and Guilds, etc., on "NO PASS-NO FEE" terms. Over 95% Successes. For full details of modern courses in all branches of Electrical Technology send for our 112-page handbook—FREE and post-free. B.I.E.T., (Dept. 337B), 17 Stratford Place, London, W.1.

REPRESENTATIVE required by London firm of Radio Component manufacturers. Splendid post-war opportunity. Connection not essential but one acquainted with the purchasing departments of the leading radio set manufacturers preferred. Write: "Representative," c/o Alfred Bates and Son, Ltd., 130, Fleet Street, E.C.4.

SPECIAL radio development engineer required with all round experience and special qualifications in U.H.F., C.R.T., circuit and presentation work; essential work with excellent post-war prospects. Applications, which will be treated in confidence, should state fully technical training and particulars of positions held, together with salary required to Box No. 684, "Electronic Engineering."

MECHANICAL design superintendent required with engineering experience in design and development work in the light engineering and radio field; salary from £600 to £800 per annum according to experience; good post-war prospects. Please write in confidence stating full details of training and experience to Box No. 685, "Electronic Engineering."

WANTED

WE OFFER cash for good modern Communication and all-wave Receivers.—A.C.S. Radio, 44, Widmore Road, Bromley.

WANTED URGENTLY by research worker, copies "Electronic Engineering," January, February, March, June, July, August, October, all 1943. State prices. Box No. 686, "Electronic Engineering."

SYNCHRONOUS MOTORS

"SANGAMO"

200-250 Volts A.C. 50 c. Self Starting fitted Reduction Gears, Ideal movements for Time Switches, Electric Clocks, etc. Rotor speed 200 r.p.m. Final Speed 1 rev.—12 minutes approx. Consumption 2 1/2 watts. Size 2 1/2 x 2 1/2 x 1 1/2. 22/6 As above but Enclosed Pattern, Consumption 3 watts, 25/-

MERCURY BREAK TRIP SWITCHES. 15-20 Amps., enclosed Bakelite on metal saddles. 2, 1/10 by 7/10. Terminal block, etc., 6/6 each.

WIREWOUND NON-INDUCTIVE RESISTANCES. Ideal for Meter Shunts, Resistance Boxes, etc. 2 1/2 per cent. accuracy, wound on Bakelite bobbins 1/2 x 1/2 in. One of each of the following ratings 25, 50, 100, 200, 400, 600, 1,000 and 2,000 Ohms., 5/6 per lot. Postage paid. Large quantities available.

ELECTRO MAGNETS. 200-250 volts A.C. Resistance 320 ohms. 1 1/2 x 1 1/2 ins., 3/6 each.

REV. COUNTERS. Ex Meters, drum type, 0-999, Automatic reset to zero on completion, 3/6 each.

PROJECTION LENSES. 1 in. Focus, Ideal for 9.5 or 16 m.m. Films, Sound-heads, etc. Oxidised mounts, 1 1/2 in. long, 3/8 in. diameter, 5/- each. TERMS—CASH WITH ORDER.

H. FRANKS

SCIENTIFIC STORES,

58, NEW OXFORD STREET, W.C.1.

Phone: MUSEum 9594

Large selection of differential reduction gears, meters, relays, etc., for Callers only.

Bargains in Radio, Electrical and Scientific Apparatus.

30-PAGE CATALOGUE No. E.E. 6d. POST FREE

ELECTRADIX RADIOS,

214, Queenstown Rd., Battersea, London, S.W.8

AFTER THE WAR!

The advance in Radio Technique after the war will offer unlimited opportunities of high pay and secure posts for those Radio Engineers who have had the foresight to become technically qualified. How you can do this quickly and easily in your spare time is fully explained in our unique handbook.

Full details are given of A.M.I.E.E., A.M.Brit I.R.E., City and Guilds Exams, and particulars of up-to-date courses in Wireless Engineering, Radio Servicing, Short Waves, TELEVISION, Mathematics, etc., etc.

Prepare for to-morrow's opportunities and post-war competition by sending for your copy of this very informative 112-page guide NOW—FREE.

British Institute of Engineering Technology
(Dept. 337a) 17, Stratford Place, London, W.1

FOYLES

BOOKSELLERS TO THE WORLD
Nearly 3,000,000 new and Second-hand Books on Engineering and other subjects.

Books Bought.

119-125 Charing Cross Road, London, W.C.2
Tele: Gerrard 5660 (16 lines). Open 9-6 Inc. Sat.

ERNST B. WESTMAN LTD.

39 LOMBARD STREET, LONDON, E.C.3

Represent

THE FOOTE MINERAL COMPANY

PHILADELPHIA, PA., U.S.A.

who manufacture and develop powdered

METALS, FERRO-ALLOYS, &c.

Also DUCTILE ZIRCONIUM METAL



SILVERED MICA CONDENSERS



*Overshadow
all others in
quality and
performance*

Incessant progress in methods of manufacture and research linked with the most thorough mechanical and electrical inspection, are reasons for the outstanding superiority of U.I.C. Silvered Mica Condensers. Available in all standardized sizes. Suitable for tropical and arctic conditions. Type approved.

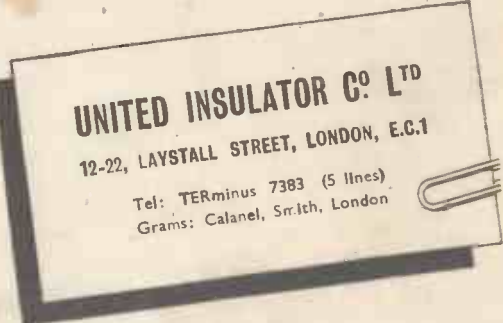

THE PIONEERS OF LOW LOSS CERAMICS

A TAYLOR FAMILY

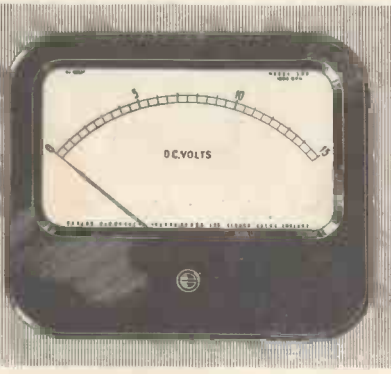

- MODEL 500
5" scale.
Size 6 1/4" x 5 1/4"
- MODEL 400
4" scale
Size 4 3/8" x 4 3/8"
- MODEL 350
3 1/2" Instrument type.
Flush or Pro-
jecting.

These moving coil instruments are very soundly constructed, and are accurate and dependable in use. A very large number of ranges are available in moving coil, Rectifier and Thermocouple type instruments. Model 400 and 500 instruments are also available with illuminated dials. All models are supplied in black moulded insulated cases, and Alnico magnets and stainless iron polepieces and cores are used.

We also manufacture several other sizes of moving coil instruments with scales of 2" and up.



Send your enquiries to
TAYLOR ELECTRICAL INSTRUMENTS, LTD.,
419-424 Montrose Avenue, Slough, Bucks.
Telephones: Slough 21391 (4 lines). 'Grams: " Taylins, Slough."



TELCON CABLES

for
**HIGH
FREQUENCY
TRANSMISSION
and RECEPTION**

Full particulars of all Telcon Products from
**THE TELEGRAPH CONSTRUCTION
& MAINTENANCE CO. LTD.**
Head Office: 22, Old Broad Street, London, E.C.2
Telephone: London Wall 3141



WEBB'S

Are looking into the future at the shape of things to come...

MEANWHILE all 'hands' are engaged on priority orders for equipment of importance to the war. As stockists and distributors of Eddystone Products, one outstanding instrument we are selling and servicing today is the highly practical and reliable **EDDYSTONE 358X RECEIVER**, which can be examined at our London Showrooms.

London's leading
Radio & Television
Specialists

Write or call whatever
your requirements.
Intelligent & helpful
service guaranteed.

Telephone:-
GERRARD
2089



Frequency
Range 31,000 to
40Kc/s. Sensi-
tivity (above
1,500 Kc/s) —
3 microvolts.
Full circuit and
performance
details from 30
page instruct-
ional book—2/6
post free.

WEBB'S Radio

14, SOHO STREET, OXFORD STREET, LONDON, W. 1.

HOURS:- 9 a.m. till 6 p.m. for OFFICIAL business. SHOP HOURS:- 10 a.m. to 4 p.m. (Sat. 10 a.m. to 12 noon)