

# Electronic Engineering

INCORPORATING ELECTRONICS, TELEVISION AND SHORT WAVE WORLD

## PRINCIPAL CONTENTS

A New Frequency Analyser

The Tapped Coil Aerial Coupling

Nikola Tesla. 1857 — 1943

Data Sheet. — The Cathode Follower (contd.)

The Synchronisation of Oscillators. — Part 3

**2½ JUNE, 1943**

# Heater coating

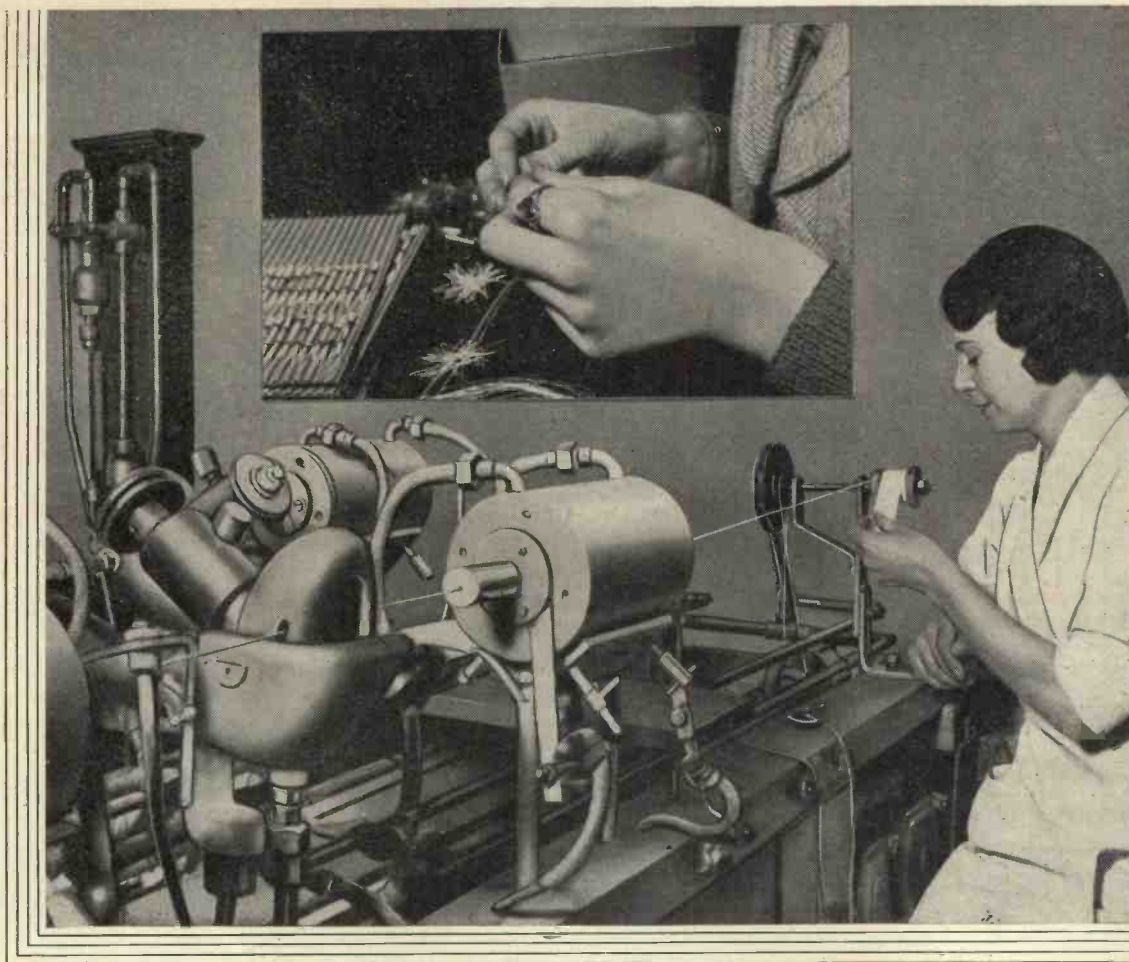

**H**HEATER COATING is a highly specialised process vitally concerned with the life of the valve, the greatest care being taken with this and all processes to ensure the longevity associated with Brimar Valves.

**BRIMAR**  
**BVA**  
**VALVES**

STANDARD TELEPHONES AND CABLES LIMITED, FOOTSCRAY, SIDCUP.

The fact that goods made of raw materials in short supply owing to war conditions are advertised in this magazine should not be taken as an indication that they are necessarily available for export.



**T H E R E   I S   N O   S U B S T I T U T E  
F O R  
E N G I N E E R I N G   E X P E R I E N C E**



*And this is obviously a matter of extent, intensity and time.*

Take Electrical condensers for instance—simple in conception maybe—but demanding infinite experience and skill, to satisfy the exacting operating conditions of modern requirements. The fulfilment of these has meant the whole time occupation of highly skilled specialists, working at high pressure, in this way to earn, along with their countrymen in other spheres, the right of survival.

What a wealth of experience and technical excellence will be available to all, when happier times arrive ; and nowhere more than in Dubilier Condensers.

**DUBILIER**  
CONDENSER CO. (1925) LTD.





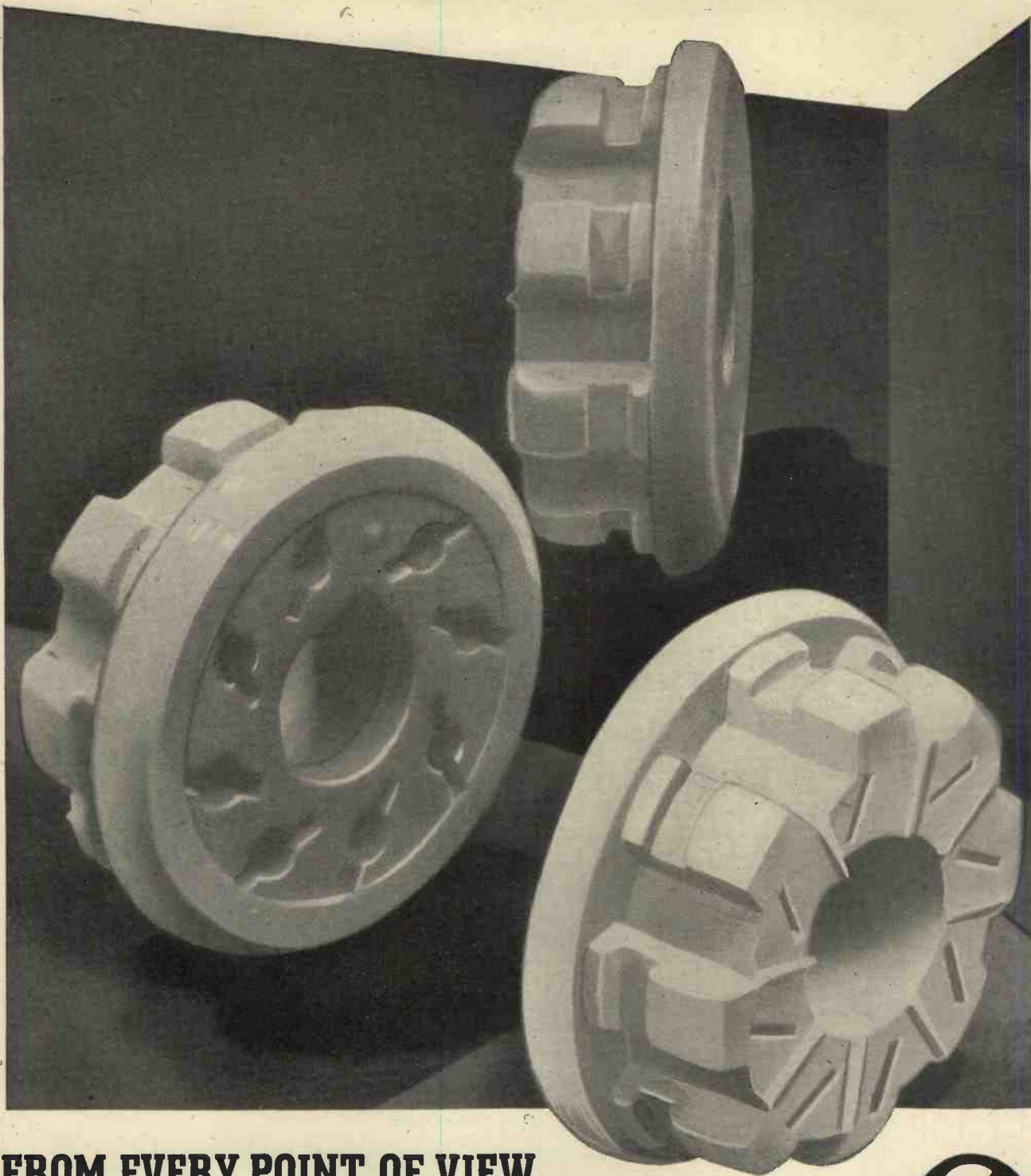

## FROM EVERY POINT OF VIEW

Frequentite is the most suitable material for all high frequency applications. Ten years ago we introduced the first British-made low loss ceramic, and consultation with us before finalising the design of new components is a wise precaution.



# STEATITE & PORCELAIN PRODUCTS LTD.

Head Office: Stourport-on-Severn, Worcester.

Telephone: Stourport 111.

Telegrams: Steatain, Stourport.

SP 20

*Value proven  
by long service*

# **Osram Valves**

MADE IN  
ENGLAND

*for*

INDUSTRIAL APPLICATIONS

•

ELECTRO MEDICAL  
EQUIPMENT

•

THERMIONIC INSTRUMENTS  
and TEST GEAR

•

VITAL COMMUNICATIONS  
and WARNING SYSTEMS  
ETC.

THE GENERAL ELECTRIC CO. LTD.  
Magnet House, Kingsway, London, W.C.2



# GE CALLOY

## RADIO CORES

### MAIN ADVANTAGES

- Greater magnification.
- Higher selectivity.
- Small size
- Reduced costs.
- Robust construction.
- Simple adjustment.
- Non-rusting.

**SALFORD ELECTRICAL INSTRUMENTS LTD.**

PEEL WORKS, SALFORD, 3. Telephones : BLAckfriars 6688 (6 lines). Telegrams and Cables : "Sparkless, Manchester"  
 PROPRIETORS: THE GENERAL ELECTRIC Co. Ltd., OF ENGLAND

*The NEW*

## — "HYPERLOY" —

### TRANSFORMERS AND CHOKES

A range of high-performance, space-saving Components designed to meet the exacting requirements of modern Electronic and Communications equipments.

- Small in size.
- Weighing only 2 ozs.
- Meeting the most rigid Tropical Specification.
- Easily mounted in any position.
- Manufactured in a variety of windings to meet many diverse applications.

## WRIGHT & WEAIRE LTD.

HIGH ROAD, TOTTENHAM, N.17

Telephone: TOTtenham 3847-8-9



**SPECTRUM ANALYSIS OF GASES**

The exact composition of materials used in the manufacture of **WESTINGHOUSE METAL RECTIFIERS**

is determined by analysis of the spectrum, and recorded by spectrograms photographed by the apparatus shown. The gas discharge method of excitation is being used in this instance.



Though Westinghouse Rectifiers are unfortunately in short supply, the groundwork of research and experiment is laying the foundation of the advanced Rectifiers of tomorrow. May the day soon dawn when these Rectifiers once more will be available for all uses.

*Westinghouse Rectifiers*

WESTINGHOUSE BRAKE & SIGNAL Co., Ltd., Pew Hill House, Chippenham, Wilts.

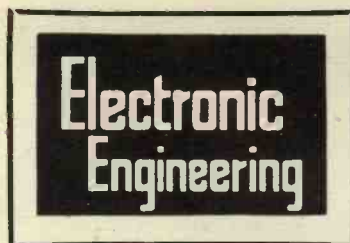

JUNE, 1943

Volume XVI.

No. 184.

**CONTENTS**

	PAGE
Editorial—Training .....	7
An Automatic Low Frequency Analyser .....	9
A High Voltage R.F. Voltmeter .....	13
The Tapped Coil Aerial Coupling .....	14
Nikola Tesla .....	17
Data Sheet Supplement—The Cathode Follower .....	21
Synchronisation of Oscillators—Part III .....	26
June Meetings .....	30
Wave Analysis Part III (concluded) .....	31
Book Reviews .....	38
Abstracts .....	40
Notes from the Industry.....	42

*Precisely!*



*for accurate testing it must be*

**TAYLOR METERS**

Write for complete details to:  
**TAYLOR ELECTRICAL INSTRUMENTS, Ltd, MONTROSE AV. SLOUGH, BUCKS.**  
 Telephone: Slough 21381 (4 lines).

**CONDITIONS OF SALE**—This periodical is sold subject to the following conditions, namely, that it shall not without the written consent of the publishers first given, be lent, re-sold, hired out or otherwise disposed of by way of Trade except at the full retail price of 2/- and that it shall not be lent, re-sold, hired out or otherwise disposed of in a mutilated condition or in any unauthorised cover by way of Trade, or affixed to or as part of any publication or advertising, literary or pictorial matter whatsoever.



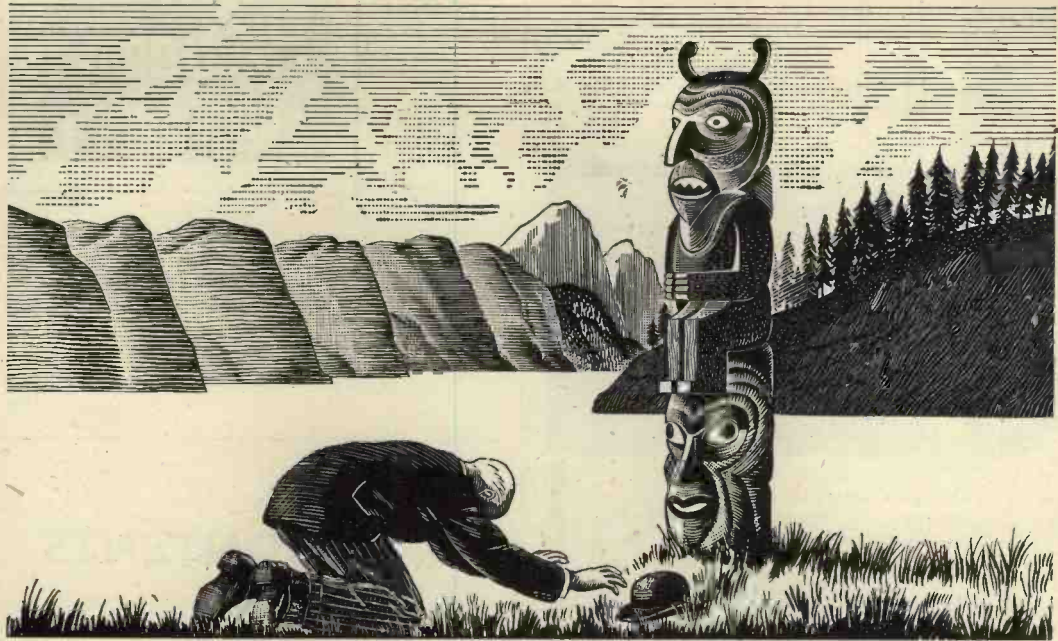

## Taboo

**P**RODUCTION has its psychological as well as its physical problems, for some of us are by nature unduly impressed by the orthodox.

As greater inroads are made into the country's resources of labour and materials, improvements in technique will alone remain for further exploitation.

In this spirit the Simmonds Organization wrestles with convention. Its products are born of an imaginative approach to the problems of the hour and evidence abounds that they are effecting great national savings in time, labour and materials.

It is well that the AEROCESSORY came to challenge genuflection.

# S I M M O N D S

*The Creative Impulse in*

**AERONAUTICAL, INDUSTRIAL & MARINE**

*Construction*

THE SIMMONDS NUT • PINNACLE NUT • SPIRE NUT  
SIMMONDS GAUGES, INSTRUMENTS AND CONTROLS  
FRAM OIL & ENGINE CLEANER

SIMMONDS AEROCESSORIES LTD.  
GREAT WEST ROAD, LONDON

A COMPANY OF THE SIMMONDS GROUP

LONDON, MELBOURNE, PARIS, NEW YORK.



PROPRIETORS :

HULTON PRESS LTD.,

# Electronic Engineering

EDITOR:

G. PARR.

EDITORIAL, ADVERTISING AND PUBLISHING OFFICES, 43-44, SHOE LANE, LONDON, E.C.4

TELEPHONE:  
CENTRAL 7400

Monthly (published last day of preceding month) 2/- net. Subscription Rates: Post Paid to any part of the World—3 months, 6/6; 6 months, 13/-; 12 months, 26/-. Registered for Transmission by Canadian Magazine Post.

TELEGRAMS:  
HULTONPRES LUD  
LONDON.

## Training

**T**WO memoranda have recently been issued on the training of students for science, engineering and other subjects. The first, issued by the Ministry of Labour, is headed "Further Education and the Training Scheme," and outlines the arrangements made for assisting suitably qualified men and women, on demobilisation, to take up further education beyond the secondary school standard.

"His Majesty's Government recognise the importance of securing to the country after the war the service and influence of those highly trained in the humane studies. . . . and of ensuring an adequate supply of men and women equipped to fill the higher posts in industry, commerce, and the professions."

Actually, science is not mentioned by name, but as it is undoubtedly a profession, connected with industry, and normally humane, it is presumably covered.

The scheme is primarily intended for Service students and a condition of eligibility is full-time service during the war in work of national importance which has caused the interruption or diversion of a career. Refresher courses are also provided for older men.

Successful applicants will be awarded grants enabling them to take a full course of training in the

desired profession (subject to approval by the authority).

A leaflet containing all the information at present available about the scheme is obtainable (Reference P.L.120/1943) and any applications for assistance for those who have already been discharged from war service should be addressed to the Appointments Dept., Ministry of Labour, Sardinia Street, London, W.C.2. Callers are not welcomed.

The second memorandum is one issued by the Education Sub-committee of the I.E.E. and concerns itself among other things with the measures that will lead to improvement in the status of craftsmen and apprentices.

It is recommended that part-time day release for both general and technical study should be made compulsory, and this should not be less than a day a week. The present scheme for Higher National Certificates should be continued and developed and should form an integral part of student apprenticeship.

Regarding the syllabuses of the ordinary National Certificate course in electrical engineering, the report says: "Attention given to general physics is on the whole deficient, while the elementary consideration of electronic devices—now of such importance in most branches of electrical engineering—has not yet penetrated into many courses.

The report also has a word to say about the teaching profession. "The teacher's preoccupation with teaching the use of existing things must necessarily tend to make his subject static and immersed in detail rather than vital and with a wide perspective. . . (P. G. Wodehouse has a better phrase in "the big, broad, flexible outlook.")

Great benefit would result if teachers were required to spend two or more years in industry before being allowed to commence their teaching work.

It is recommended that so far as teachers in the technical institutions are concerned that the hours of teaching be limited so that they may have a better opportunity of keeping in touch with the progress of their own professional interests. (But, what's wrong with the holidays?)

A last important point: "Their remuneration should be such as to encourage transfer to the teaching profession from more senior posts in the industry itself."

The whole report is interesting reading and bears evidence of careful thought by practical members of the industry. Readers who take the trouble to go through it carefully will find much that they agree with and will utter the usual phrase "Something ought to be done about it."

## Records taken by the Frequency Analyser

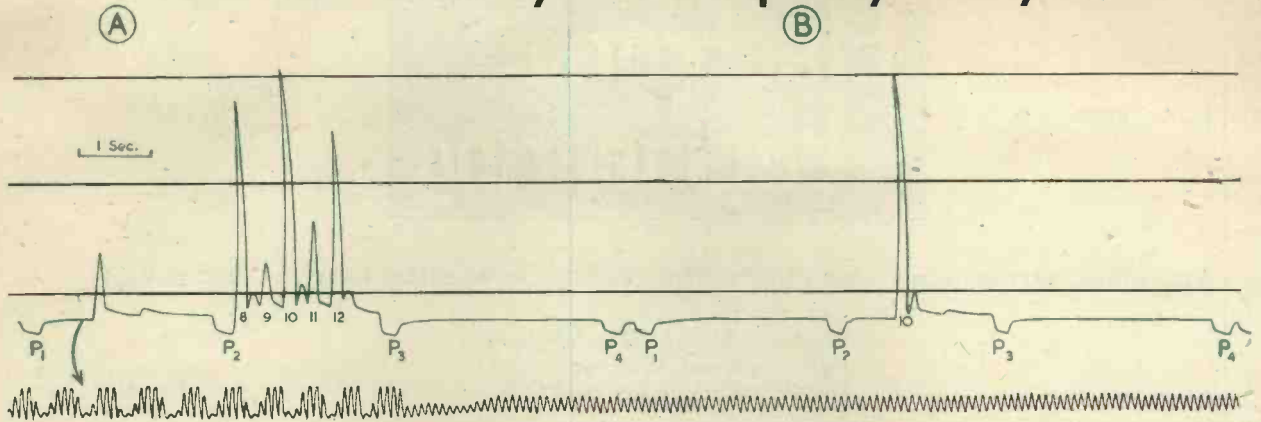

Fig. 6. (a) Analysis of 10 c/s rhythm from a photo-oscillator modulated manually at about 2 c/s showing sidebands at 8 and 12 c/s. The small hump at 2 c/s is due to rectification during modulation.  
 (b) A steady 10 c/s rhythm from the photo-oscillator.

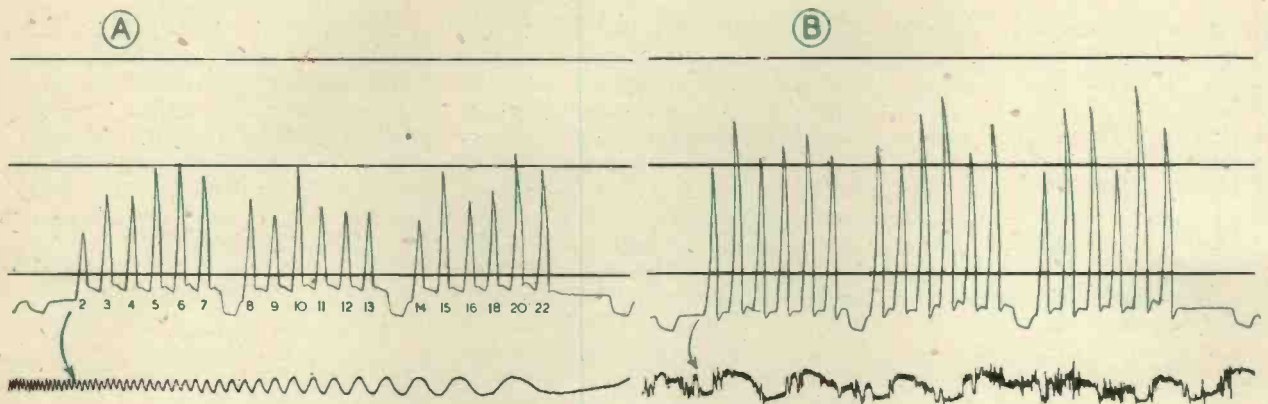

Fig. 7. Analysis of (a) sliding frequency (0 to 25 c/c).  
 (b) Noise containing the same band of frequencies.

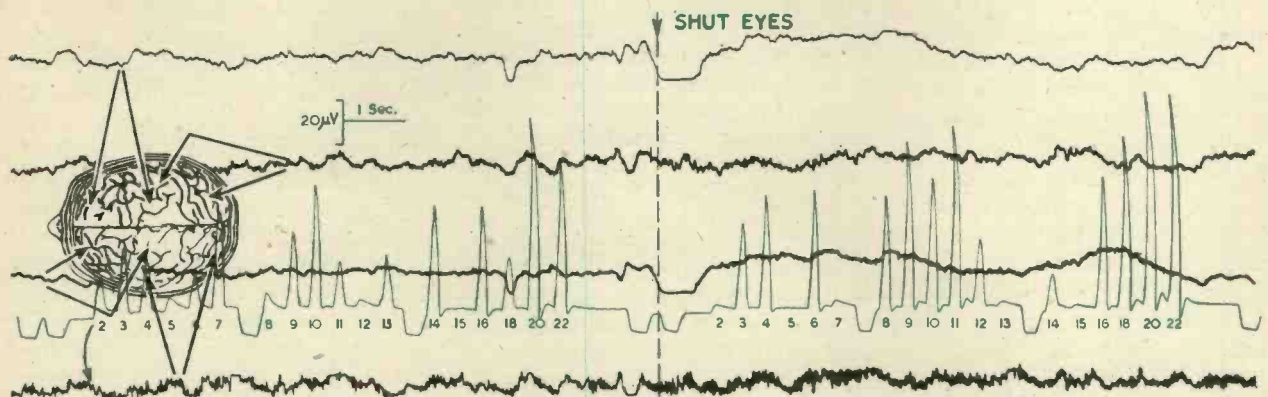
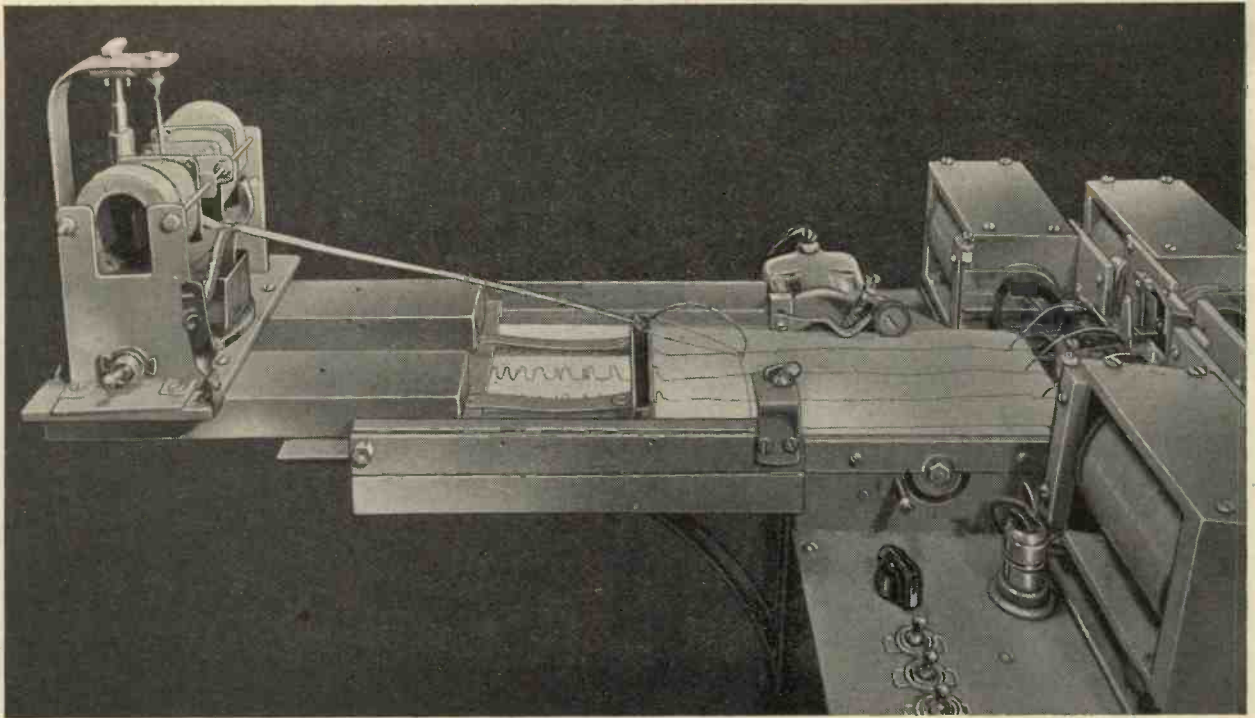

Fig. 8. Analysis of electroencephalogram from a neurasthenic patient. The record is not strikingly abnormal but analysis shows that the components are not random. Note the harmonic at 20 c/s of the smaller 10 c/s "alpha rhythm" and the effect of closing the eyes.





## An Automatic Low Frequency Analyser

By W. GREY WALTER, M.A.\*

A new apparatus for analysing and recording the components of a complex low-frequency wave-form. Although developed primarily for electroencephalographic research it can be adapted to the investigation of audio-frequency or vibration phenomena.

**I**N a recent paper before the Institution of Electrical Engineers (reprinted in this journal)<sup>1</sup> an account was given of the recording and amplifying methods used in electro-biology with particular reference to the electrical activity of the human brain. From the electrical records, or encephalograms (abbreviated to EEG) shown in this paper it can be seen how complex and irregular are the electrical oscillations produced by highly organised living tissue.

These irregularities and complexities are not merely intriguing—they have a very real and important association with both normal mental processes and with serious clinical abnormalities such as brain tumours, epilepsy, and mental disorder.

With well designed apparatus the records are continuous graphs of voltage against time on linear co-ordinates. The frequencies seen by inspec-

tion are from less than one c/s to about 25 c/s, and there are also transients of many types. All the frequencies or "rhythms" are subject to deep and irregular modulation of amplitude phase and frequency. Usually there is a dominant rhythm; in normal subjects this lies between 8 and 13 c/s, in pathological cases it is usually lower and occasionally higher. Most of the rhythms show signs of impurity suggesting the presence of harmonics. A very good imitation of an electrical brain rhythm can be made by scribbling an irregularly modulated sine wave on a piece of paper. The resemblance is not a coincidence—the irregularities have a cause similar to that responsible for the EEG variations; fluctuations in the excitability of the nervous system.

For some years investigators were content to interpret their records by inspection, although several have made attempts at some sort of analytical or quantitative procedure.

Some have applied mathematical analysis of the Fourier type or its adaptations such as Bernstein's (Livanov and Petrova 1938)<sup>2</sup> or Rohracher.<sup>3</sup> Others have used tuned recorders or filter circuits as frequency selectors (Drohocki 1938),<sup>4</sup> Davis and others,<sup>5</sup> and Walter.<sup>1</sup> Of these attempts none has given really satisfactory results. Mathematical and graphical methods are far too tedious to use on a long record (EEG records are often 100 metres long) and selection of a short strip is often misleading. Frequency selection without an integration or summation process can show fluctuations from moment to moment, but gives almost as complex a record as the original; even more so if twenty tuned recorders are used. The only really ingenious method, designed specially for the job is that of Grass<sup>6</sup> already referred to in this journal.<sup>7</sup> This method, which resembles that of Sacia<sup>8</sup> in converting a

\* The Burden Neurological Institute, Bristol.

The photograph above shows the recording pen of the analyser mounted on the left of a standard Grass pen writer and spaced so that the analysis is given over the appropriate section of the record.

non-repetitive curve into a repetitive one by splicing the record into a continuous loop, has the disadvantage that a special variable-width or variable-density film record must be taken. Therefore a film record must be run concurrently with the direct recorders, or a decision must be made beforehand as to whether or not a record is likely to turn out interesting. Further, the analysis is not available until the film has been processed and run through the analyser.

One fact proved by any analysis, however achieved, is that the records of electrical brain activity contain far more than meets the eye. The eye is, in fact, singularly unsuited to the task of frequency analysis, particularly when both frequency and amplitude modulation are present. The ear is better adapted, and when trained can recognise the presence of harmonics as well as detect changes in frequency in a sound of varying amplitude. This is the justification of the "Encephalophone" devised by Beevers and Fürth,<sup>9</sup> but in this method the absence of an analysed record makes comparison of results impossible unless a separate record is made of the sonic transform.

Inadequate though these methods are, the results obtained with them suggested that if an automatic analyser could be constructed so as to compromise between speed and resolution—the two incompatibles—entirely new fields might be opened. The preliminary specification was drawn up as follows:

1. The spectrum must be traced on the original record, so that the features of both could be directly correlated.
2. The frequencies covered must be between one and 25 c/s.
3. The time taken for analysis must not be longer than 10 secs., since this time is about the longest for which the record is likely to remain at all constant.
4. Resolution must be of the order of 0.5 c/s at the lower frequencies and about 1 c/s at the higher.
5. The machine must be capable of continuous working whenever a record is taken and must not involve a high recording cost.
6. The first cost must be within the reach of centres engaged on EEG work, since the true value of the apparatus depends upon the width of its application.

This specification is much the same as would be required for an audio-frequency analyser except of course for the frequency range to be covered, and the form of the biological potentials

is similar to those in Bourne's Class (c), the non-recurrent continuous.<sup>10</sup> Of the methods developed for this type of work in the audible range several are described by Bourne.<sup>10</sup> The only one which could conveniently be adapted for EEG potentials is the Acoustic Spectrometer of Hickman<sup>11</sup> which uses a bank of tuned reeds as frequency discriminators or splitters. In Hickman's method each reed bears a mirror which reflects a beam of light on to a screen, so that vibration of the reed produces a line of light. The several lines are proportional to the amplitude of the reeds and the spectrum is visible as a histogram. These deflections could be instantaneously photographed, but in a rapidly varying waveform this would be misleading. In such systems with highly selective frequency splitters the build-up and die-away time is considerable so that the amplitude at any one moment depends not only upon the waveform at that moment, but on the events during the preceding moments during which the vibrating element has been building up or dying away. A better method of registration would be to expose a slow plate to the whole spectrum for a longish period, so that lines of varying lengths and densities would be developed according to the amount of vibration of each reed during the exposure period. This has the drawback of introducing a third dimension, density, in addition to frequency and amplitude. It also shares with several other methods the flaw of delay between recording and analysis. There is no doubt, however, that a tuned reed is the simplest form of frequency splitter, particularly for very low frequencies. Below 10 c/s an inductance-capacity tuned circuit becomes either very bulky indeed or very unselective, and the alternative, employed by Scott<sup>12</sup> is to use a frequency selective resistance capacity network of the parallel-T or Wien type in the feedback circuit of an amplifier with negative feedback. This implies a valve or valves for each frequency, together with supply circuits, and though perfectly feasible is expensive and no more efficient or elegant than the reeds. It should be clear that to satisfy the above specification it is much simpler to provide a multiplicity of resonators than to attempt to scan the whole compass of frequencies with a single one of variable tuning. It was therefore decided to use reeds as frequency splitters.

The next problem was to provide a storage register which would collect from each reed during the whole of the analysis epoch of about 10 secs. an indication of the number and amplitude of vibrations which it had experienced. This indication must not take

any appreciable energy from the reed, since if a reed has to do any work it will be damped and less selective. The handiest form of indication is, of course, a change in potential, and the matter resolves itself into the problem of making the reed vibrations build up a potential difference. The most satisfactory method of doing this is to fit each reed with a small shutter, which in the position of rest cuts off from a vacuum photo-cell the light from a steady source. In series with the photo-cell are a source of e.m.f. and a condenser. When the reed is at rest the photo-cell is dark and the condenser acquires no charge, but when the reed is set into vibration light is admitted to the cell. If the optical arrangements are correct, the intensity of light, and therefore the conductance of the photo-cell, is directly proportional to the amplitude of reed-vibration. If the condenser capacity, the maximum illumination, and analysis epoch are all correctly chosen, only the straighter portion of the condenser charging curve will be used and the condenser will therefore acquire a charge proportional approximately to the amplitude and number of the reed vibrations during the analysis epoch. This charge can be applied to the grid of a power-valve driving a recording pen, and this pen will give a deflection, the height of which will indicate the energy at the reed frequency during the epoch.

Before describing the scanning and writing mechanisms more clearly alternative storage systems must be considered.

This arrangement using a vacuum photocell has been tried and comes up fully to expectations. With 150 volts from a rectifier as a charging e.m.f. and a 1 $\mu$ F. condenser for storage, a charge of about 60 volts is acquired in a 9 sec. epoch when the reed is kept at full amplitude, using a 24 watt car bulb as the light source with no lens. In this period the charging curve scarcely departs from a straight line, and the relationship between amplitude, number of vibrations and potential reached is satisfactory. The only drawback of the method is its expense, since at least 20 reeds are required for EEG analysis, and this means a considerable outlay on photocells. A simpler method has been tried and has already given good results, despite its limitations.

Instead of a shutter, each reed is provided with a fine steel contact wire W which in the position of rest is just out of contact with a mercury cup. (Fig. 1). When the reed vibrates the contact is made and broken at each oscillation. In series with this contact is a 4 megohm resistance, a source of e.m.f. and a 1 $\mu$ F. condenser. (Fig. 4.)



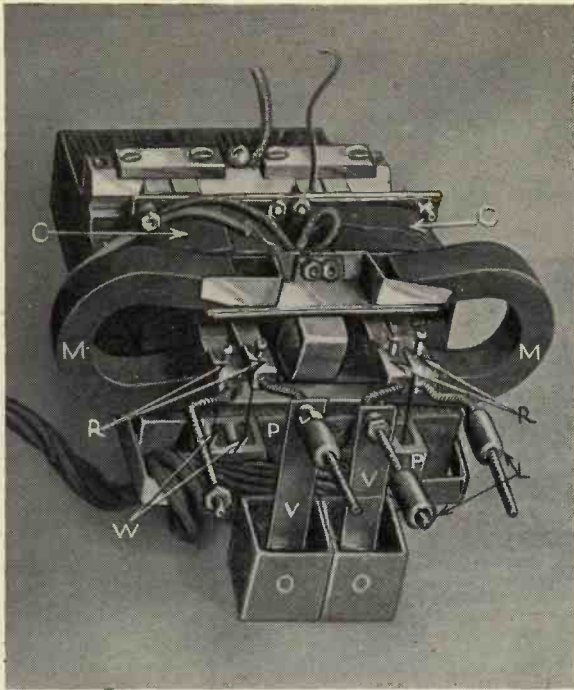

Fig. 1. Photograph of four of the frequency-splitting reeds. (7, 5, 4 and 6 c/s.) C, driving coils; M, magnets; R, reeds; W, contact wires; P, Perspex mercury cups; L, lead tuning weights; O, oil dash pots; V, vanes.

As in the photocell arrangement, the condenser acquires no charge unless the reed vibrates. When the reed vibrates more than the distance between its contact and the mercury, the condenser charges to a potential depending upon the number of vibrations and their amplitude. The relation between amplitude of vibration and duration of contact is not, of course, anything like linear. The effect of this is seen most clearly when the reed is kept in constant vibration for the whole of one epoch, and the amplitude is changed, but constant during the whole of the next epoch. In this case the reed can execute only exactly the same number of vibrations as are in the oscillation driving it, supposing the two to be in resonance, and a change in amplitude of the input can be signalled only as a change in amplitude of the reed vibration. The relation between amplitude and deflection of the analysing writer in these conditions is shown in Fig. 5. This non-linearity is not as serious in practice as might appear, since continuous oscillations are unusual in EEG records, and when they appear, variations in their amplitude are not of very great quantitative importance and are easily detected by inspection. When the rhythms occur in bursts, that is when the oscillation is deeply modulated or even intermittent, the situation is not so unfavourable since the reed will go on vibrating after the oscillation has died down and the number of vibrations will be greater with higher amplitudes. (Fig. 5). In order

to compensate to some extent for the curvature of these relationships, the power valve is biased down to the lower bend so that the sensitivity of the writing circuits increases with larger amplitudes where the other curves become flattened.

It is more important that each reed should have the same sensitivity and transformation ratio than that the transform should be precisely accurate; this is achieved by careful adjustment of the contact-mercury distances

for each reed. As will be seen from the figure, the reeds are of the inductor type, giving a wide linear amplitude. The coils for all the reeds are in series across the anodes of two PP5/400 power valves in paraphase, so that the sensitivity of each one can be separately adjusted with shunts or series resistances. The resistances of the coils are 300 ohms, and for economy in space and outlay each coil drives two reeds except at the lowest frequencies. Adjacent reeds are two cycles apart to reduce intercoupling, and the frequencies to which they are tuned are: 2 3 4 5 6 7 8 9 10 11 12 13 14 15 16 18 20 22 c/s. More by luck than adjustment the Q and damping factors have turned out suitably except at the lowest frequencies which require oil damping. The Q is about 30 which means that the response is about 70 per cent. down at 5 per cent. off tune. This appears to give adequate coverage of the bands.

Scanning of the condensers is by a motor-driven rotary switch of the telephone pattern. (Fig. 2). This is arranged so that the 180° of the contacts is covered in 9 secs. A second bank of condensers, one for each reed, is provided so that while one bank is being scanned by the rotary switch the other bank is in the reed charging circuit. When the scanning is complete after 9 secs., a change-over switch, driven from the same motor as the rotary switch, brings the second bank of condensers out of the charging circuit and they are then scanned while the first is connected to the charging circuit. In this way an analysis can be made every 9 secs. instead of every other 9 secs. The

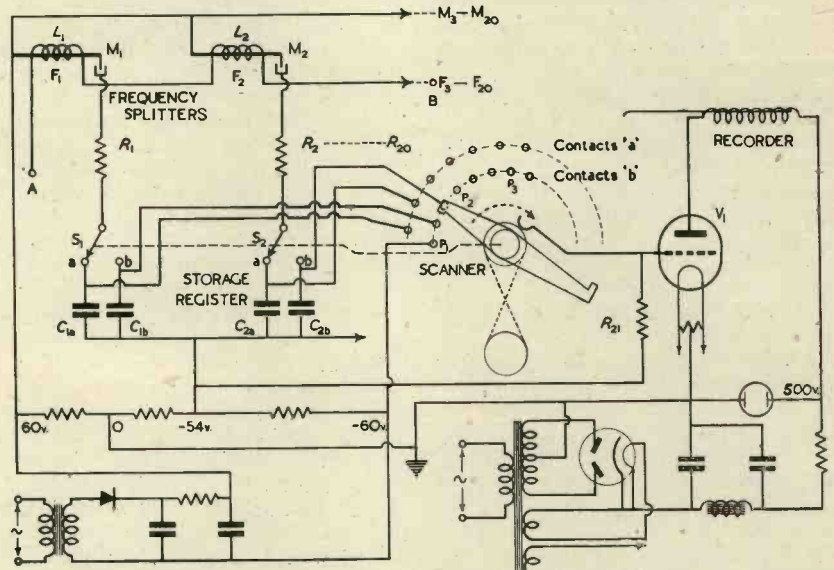

Fig. 4. Circuit diagram of the analyser showing two of the splitting and storing circuits. A and B are the output terminals from the main amplifier. S<sub>1</sub> etc.: Changeover switch contacts R<sub>1</sub>R<sub>20</sub>: 4 Meg. C<sub>1a</sub>, C<sub>1b</sub> etc.: 1.0 μF. L<sub>1</sub>, L<sub>2</sub>: driving coils for reeds, F<sub>1</sub>, F<sub>2</sub>: reeds; M<sub>1</sub>, M<sub>2</sub> etc.: Mercury contacts. Contacts P<sub>1</sub>, P<sub>2</sub> etc. provide negative pulses to mark start and finish of each epoch and divide the frequency bands.

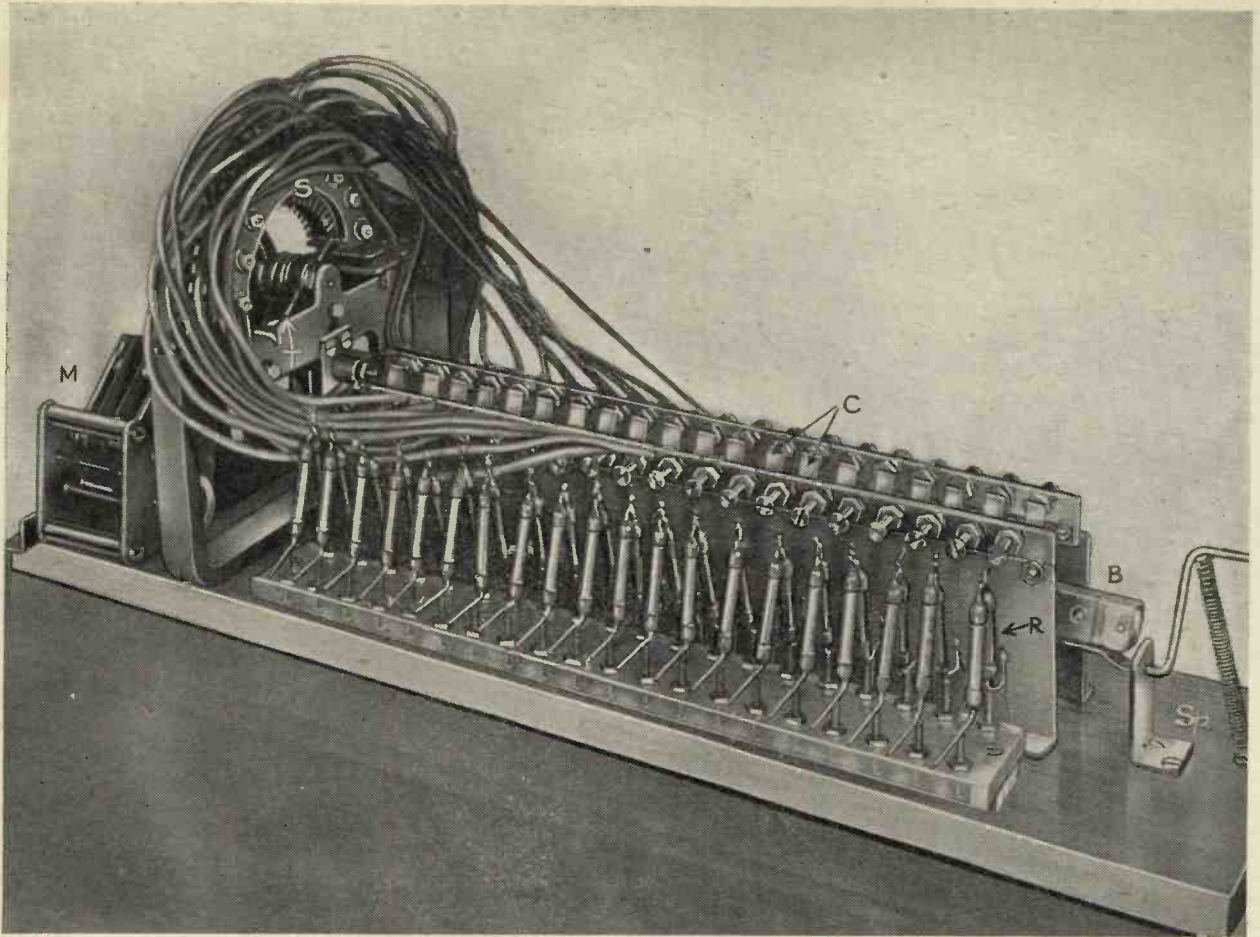

Fig. 2. Photograph of the Rotary Scanning Switch, (partly wired). M, driving motor, S, switch contacts, T, trip lever to throw change-over switch. C, contacts, R, charging resistances. B, bar of 20 pole change-over switch. Sp, Spring to give toggle action to B.

two scanning contacts are connected to the grid of the power valve, which has a leak of a value such that the condensers are completely discharged during the half second of each contact. This ensures that no residual charge remains in the condensers after each scanning epoch.

As already mentioned, the power valve is heavily overbiased from a separate circuit in order to compensate for the non-linearity of the charging circuit characteristic. In the anode is the driving coil of a balanced inductor writing oscillograph, Fig. 3. The writing arm of this is 31 cm. long and writes over an arc of 8 cm. Since the analysis epoch is 9 sec. and the change-over takes 1 sec., the analyzing pen is placed so that it writes on the paper of the direct record 10 secs. later, that is, 15 cm. further along the paper, since the usual recording speed with this apparatus is 1.5 cm. per sec. In this way the analysis is traced directly over the record to which it applies. The EEG apparatus used has four channels, and a 2-pole, 4-way

switch enables any of the four channels to be analysed at will.

The analysis, or spectrum, is traced as a series of brief deflections, which, in the original records are in red ink to distinguish them from the direct records, which are in blue. This gives the effect of a histogram or line spectrum, the frequency base being provided by the movement of the paper, much as in Freystedt's method<sup>19</sup> which employs a cathode-ray oscillograph as the recorder. In the reproductions shown the spectrum is printed in green.

Before discussing the results obtained with this apparatus, some mention should be made of its limitations. The resolution is such that a steady frequency exactly halfway between two of the reed-frequencies will be recorded as a sub-maximal deflection of the two nearest reeds, and a similar record would be given by an oscillation containing equal amounts of energy at the two frequencies. The possibility of this ambiguity could be reduced by giving the reeds a band-

pass characteristic, easily done by having two reeds coupled much as two tuned circuits are coupled to form a band-pass filter. At higher frequencies, the same effect could be obtained by tuning the reed driving coil. For any given problem the simplest solution is to provide a sufficient number of reeds to cover the compass and close enough together in frequency to correspond to the degree of frequency stability of the phenomena to be studied. For EEG work the present arrangement is satisfactory because the rhythms usually vary in frequency by about half a cycle and such variation does not seem to have any deep significance. It is generally agreed that a variation of 10 per cent. in the normal alpha rhythm is common and certainly without any pathological implication. Two features of the method greatly assist interpretation; the superposition of the spectrum on the original record and the repetition of the analysis every ten seconds. For the average routine record more than 100 analyses are made and from the



consistency of the spectrum and its variation from channel to channel and in different conditions any ambiguity can be quickly resolved.

As is well-known, the resolution of such a device depends upon the selectivity of the frequency splitters; a high selectivity implies a long build-up time and die-away time, and this limits the shortness of the epoch and the speed of the analysis. It is inevitable therefore, that particularly at the lowest frequencies, a vibration begun at the end of one epoch will persist into the next even when it is initiated by a brief wave-train or transient. The energy in the phenomenon will therefore appear partly in one analysis and partly in the next, although the phenomenon itself occurred wholly in the first epoch. Here again inspection of the record usually clears up the matter, and except when the event occurs only once during the whole record the distribution evens out over the 100 or so epochs. In the course of several months continuous use these drawbacks have not been found serious.

From the constructional and maintenance standpoint, there is no doubt that the photocell method of integration is more satisfactory than the mercury cup and high resistance. This method is also much more flexible and should not be troublesome even at audible frequencies. The reeds have

Referring to the two colour records on page 8: the deflections are numbered with the frequencies which they represent. P1, P2, P3 and P4 are negative pulses provided by contacts on the scanning switch. P1 indicates the start of an epoch, P2 divides the slow band from the normal alpha band between 7 and 8 c/s. P3 divides the normal alpha from the higher frequencies, P4 indicates the end of the epoch.

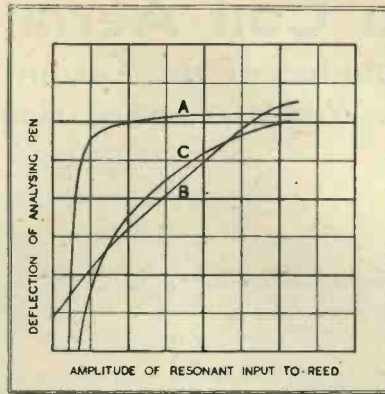

Fig. 5. Curves showing relation of amplifier input and analyser response. Curve A shows relation between amplitude of input at a resonant frequency and deflection of analysing pen when the oscillation lasts throughout the epoch. Curve B shows the same when a photo-cell is used instead of the mercury contact, and high resistance. Curve C shows the same for the mercury-resistance system when pulses of varying amplitude but constant short duration are analysed. This curve is more relevant to EEG records than curve A.

not been found to go off tune, but it is, of course, essential in the mercury type to keep the contacts clean and properly adjusted.

Results

The figures illustrate some of the performance characteristics of the apparatus. In Fig. 6 the appearance of sidebands with amplitude modulation is contrasted with the single line spectrum of a steady frequency. In Fig. 7

put is compared with that of a random noise. This "noise" is infra-sonic, of course, and as far as the range 2-22 c/s is concerned is "white," that is it contains components at all frequencies. These records illustrate clearly that the process of analysis is not reversible—the phase relations of the various components are not indicated by the analyser. Fig. 8 is an EEG from a neurasthenic patient and shows how a complex record is resolved. In this case the dominant frequency is the 2nd harmonic of the very small alpha rhythm, which the analysis shows to be slightly but definitely augmented by closing the eyes. Such a record is practically meaningless on direct inspection without analysis.

In a later article it is hoped to present some further results obtained with the method and to discuss its future possibilities

(This apparatus is provisionally patented.—Ed.)

REFERENCES

- 1 Parr and Walter, *Electronic Engineering*, XV 456, 1943, XV 519, 1943.
- 2 Livanov and Petrova, *Med. Experimentale (Ukraine)* II, 31, 1938.
- 3 Rohrer, *Physiolog. Archiv*, 238, 535, 1937.
- 4 Drolowski, *Comptes Rendus Soc. Biol.*, CXXIX, 889, 1938.
- 5 Davis, Loomis, Harvey and Hobart, *J. Neurophysiol.*, I, 24, 1938.
- 6 Grass and Gibbs, *J. Neurophysiol.*, I, 521, 1938.
- 7 Dawson, *Electronic Engineering*, XV, 34, 1942.
- 8 Sacia, *J. Optical Soc. Amer.*, IX, 487, 1942.
- 9 Beevers and Fürth, *Electronic Engineering*, XV, 419
- 10 Bourne, *Electronic Engineering*, XV, 149, 1942.
- 11 Bourne, *Electronic Engineering*, XV, 472, 1943.
- 12 Hickman, *J. Acoust. Soc. Amer.*, 6, 2, 109, 1934.
- 13 Scott, Referred to by Bourne (3). See 10
- 14 Freystedt, *Zeit. f. Tech. Physik.*, XVI, 533, 1935.

## A High Voltage R. F. Voltmeter

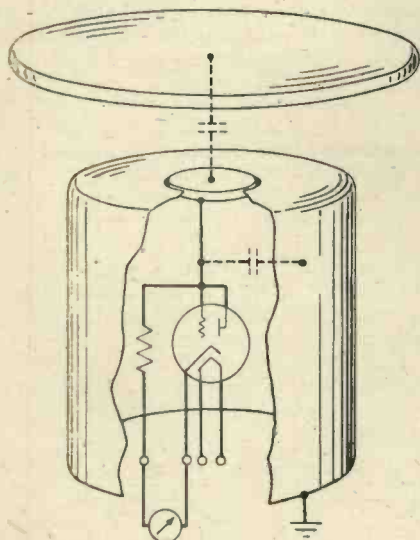

Arrangement of Voltmeter and circuit.

Measurement of the high voltages encountered in radio circuits requires a potential divider because measuring instruments cannot take the full differences of potential. One method is to connect a large and a small capacitance in series across the voltage and measure the drop across the larger capacitance. This drop can be made small by using a large ratio of capacitances, since the voltages of two condensers in series divide inversely as their capacitances.

In the radio-frequency voltmeter shown here the top plate, which is about 3 inches in diameter, and the small metal disk concentric below it, form one capacitance. Distributed capacitance between this disk and earth provide a much larger series capacitance whose potential can be conveniently measured. A valve rectifies the potential and a milliammeter in the valve circuit indicates the full voltage.

With this arrangement voltages up to 10,000 volts with frequencies up to 50 megacycles can be measured.

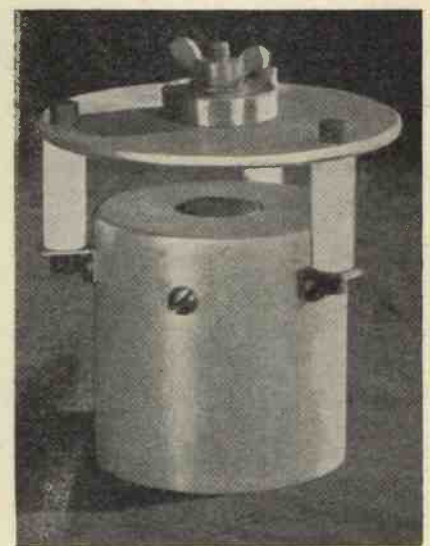

Exterior View of Voltmeter.

*Bell Lab. Record*, Vol. 21, No. 5 (1943), page 126.

# The Tapped Coil Aerial Coupling

## The Performance of the Circuit Analysed

By S. W. AMOS, B.Sc., (Hons.)

THE following is an analysis of the circuit shown in Fig. 1, which is often used for coupling an aerial to the first tuned circuit of a receiver. Expressions will be derived showing how the performance of such an aerial coupling varies with the position of the tapping point. We shall be concerned only with the medium wave-band, 550-1,500 kc/s.,  $L$  having the standard value of 157  $\mu$ H and  $C$  having a maximum capacity of 500  $\mu$ F. The tapping point divides the tuned coil into two parts with inductances represented by  $l_1$  and  $l_2$ , the mutual inductance between these parts being  $M$ . We have immediately that

$$L = l_1 + l_2 + 2M.$$

For the purpose of this analysis the aerial-earth system is represented by a condenser  $c$  in series with a resistance  $r$  so that the electrical equivalent of Fig. 1 is as given in Fig. 2. In this  $V_1$  represents the modulated R.F. signal induced in the aerial-earth system,  $R_1$  and  $R_2$  being the R.F. losses in  $l_1$  and  $l_2$  respectively.  $V_2$  is the R.F. input to the grid of the first valve in the receiver.

There are three properties of any aerial coupling circuit which need to be investigated before we can pass judgment on its performance. These are:—

- (a) the voltage magnification of the circuit. This is taken as the value of  $V_2/V_1$  in Fig. 2.
- (b) the selectivity of the circuit. We will define this as the ratio of effective  $Q$  of the tuning inductance when the aerial is connected, to its maximum  $Q$  (i.e., when the aerial is disconnected). We have thus:—

$$\text{selectivity} = \frac{\text{effective } Q}{\text{maximum } Q} = \frac{L\omega}{R_s} \cdot \frac{R_s}{R_1 + R_2}$$

where  $R_A$  = additional R.F. loss due to the aerial and  $R_s = R_1 + R_2$ .

- (c) the effect on the tuning of the presence of the aerial connexion. It has often been said that the effect of the aerial is to add, in parallel with  $C$ , a capacity  $\Delta C$  given by:—

$$\Delta C = \frac{n^2}{N^2} \cdot C$$

where  $n$  is the number of turns in  $l_2$  and  $N$  the total number of turns in the tuning inductance.

Fig. 1. (right). The tapped-coil aerial coupling circuit and Fig. 2 (left) its electrical equivalent.

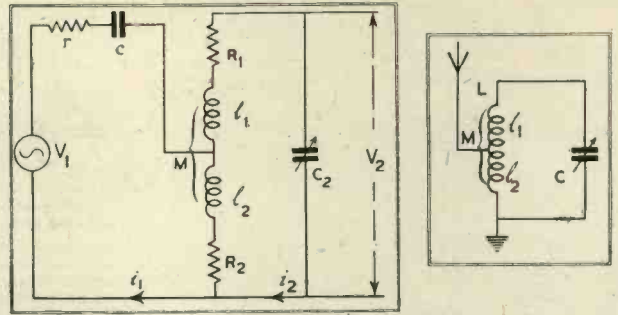

### Voltage Magnification of the Circuit

Applying Kirchhoff's laws in Fig. 2 we have:—

$$V_1 = i_1 Z_1 - (j\omega M' + R_2) i_2$$

where:—

$$M' = M + l_2$$

$$Z_1 = R_p + jX_p$$

$$R_p = r + R_s$$

$$\text{and } X_p = L\omega - 1/\omega C \quad (1)$$

and:—

$$0 = i_2 Z_2 - (j\omega M' + R_2) i_1$$

where:—

$$Z_2 = R_s + jX_s$$

$$R_s = R_1 + R_2$$

$$X_s = L\omega - 1/\omega C \quad \dots (2)$$

From (2):—

$$i_1 = \frac{i_2 Z_2}{j\omega M' + R_2}$$

Substituting in (1) for  $i_1$ :—

$$V_1 = \frac{i_2 Z_2}{Z_1} - (j\omega M' + R_2) i_2$$

which gives:—

$$\frac{V_1}{Z_2} = \frac{i_2}{Z_1} \left[ \frac{Z_2}{Z_1} - (j\omega M' + R_2) \right]$$

Now  $V_2 = \frac{i_2}{j\omega C}$  so that:—

Voltage magnification of circuit

$$\frac{V_2}{V_1} = \frac{j\omega M' + R_2}{Z_2 - \frac{(j\omega M' + R_2)^2}{Z_1}}$$

In practical circuits  $R_2$  is usually negligible compared with  $j\omega M'$  so that:—

$$\frac{V_2}{V_1} = \frac{M'/CZ_1}{Z_2 - \frac{(j\omega M' + R_2)^2}{Z_1}}$$

Let  $A + jB = Z_2 - \frac{(j\omega M' + R_2)^2}{Z_1}$

Then:—

$$\frac{A + jB}{(j\omega M' + R_2)^2} = \frac{R_s + jX_s}{Z_1^2} \quad (3)$$

$$\frac{V_2}{V_1} = \frac{M'}{Z_1 C(A + jB)} \quad \dots (4)$$

Equating real parts in (3) we have:—

$$A = R_s - \frac{Z_1^2}{\omega^2 M'^2 R_p + 2\omega M' R_2 X_p}$$

$$= R_s + \frac{Z_1^2}{\omega^2 M'^2 R_p + 2\omega M' R_2 X_p}$$

(as  $R_2 \ll \omega M'$ )

$$= R_s + R_x + R_y \quad \dots (5)$$

where  $R_x = \frac{Z_1^2}{\omega^2 M'^2 R_p}$  and  $R_y = \frac{Z_1^2}{2\omega M' R_2 X_p}$

Now  $R_p \ll X_p$  so that  $Z_1 \ll X_p$ ; in which case:—

$$R_y = \frac{2\omega M' R_2}{Z_1}$$

Reverting now to expression (4) for the voltage step-up of the circuit, we can see that this is a maximum when the reactive term in the denominator vanishes. This occurs when the circuit is tuned to resonate at the frequency of the applied signal. At this frequency  $B = 0$  and the gain of the circuit is given by:—

$$\frac{V_2}{V_1} = \frac{M'}{Z_1 C(R_s + R_x + R_y)}$$

**Selectivity of the Circuit**  
We have already seen that:—

$$\text{selectivity} = \frac{R_s}{R_1 + R_2}$$

and we can now see from expression (5) that the R.F. loss associated with the connexion of the aerial to the tapping point is equivalent to two additional series resistances  $R_x$  and  $R_y$  introduced into the circuit. Hence:—

$$R_A = R_x + R_y$$

and the selectivity is given by:—

$$\text{selectivity} = \frac{R_s}{R_s + R_A} = \frac{R_s}{R_s + \frac{M'^2 \omega^2 R_p}{Z_1^2} + \frac{2M' \omega R_2}{Z_1}}$$



**Effect of Aerial Coupling on Tuning**

If we equate the imaginary parts in (3) we have:—

$$B = X_s - \frac{(j\omega M' + R_2)^2}{X_p}$$

$$\frac{0}{X_s} - \frac{M'^2 \omega^2}{X_p} \quad (\text{as } R_2 \ll \omega M')$$

As  $X_p = l_2 \omega - 1/\omega C$ ,  $X_s = L\omega - 1/\omega C$   
and  $M' = M + l_2$ :—

$$(M + l_2)^2 \omega^2 = (L\omega - 1/\omega C)(l_2 \omega - 1/\omega C)$$

$$\therefore M^2 \omega^2 + 2Ml_2 \omega^2 + l_2^2 \omega^2 = Ll_2 \omega^2 - \frac{1}{\omega^2 C} - \frac{L}{C} - \frac{1}{C}$$

Putting  $L = l_1 + l_2 + 2M$  and remembering that  $M = k\sqrt{l_1 l_2}$  where  $k$  is the coefficient of coupling between the two parts of the tuning coil we have:—

$$(k^2 - 1)l_1 l_2 \omega^2 = \frac{1}{\omega^2 C} - \frac{l_2}{C} - \frac{L}{C}$$

which gives:—

$$C = \frac{1}{\omega^2 L} \frac{1 - \omega^2 c l_2}{1 - \frac{c l_1 l_2 \omega^2 (1 - k^2)}{L}}$$

from which it can be seen that  $C = 0$  when  $1 - \omega^2 c l_2 = 0$ , i.e., the highest frequency obtainable with this aerial circuit is given by:  $\omega = 1/\sqrt{c l_2}$ . This expression neglects the stray capacities such as the self-capacity of the tuning coil and the minimum capacity of the tuning condenser which, in practice, prevent this value of  $\omega$  being actually realised. If the aerial is not coupled to the coil at all then  $C = 1/\omega^2 L$  so that the effect of the addition of the aerial is effectively to add a capacity  $\Delta C$  in parallel with the existing tuning condenser where:—

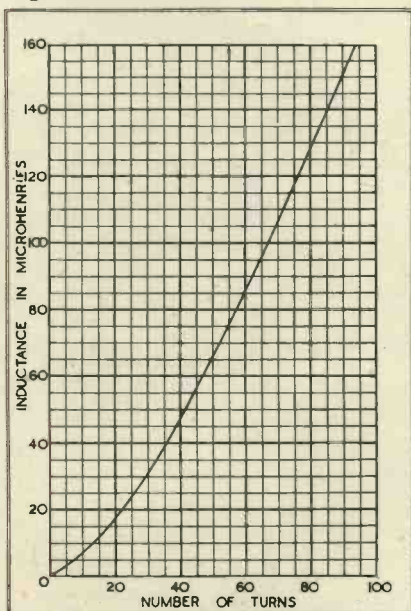

Fig. 4. Inductance curve drawn for single-layer solenoids, 1 in. in diameter, wound with No. 36. D.S.C. wire.

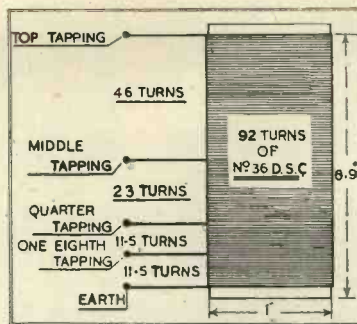

Fig. 3. Winding details and position of tapping points used in the experimental work.

$$\Delta C = \frac{1}{\omega^2 L} \left[ \frac{1 - \omega^2 c l_2}{1 - \frac{c l_1 l_2 \omega^2 (1 - k^2)}{L}} \right]$$

We have thus the following three fundamental formulæ which between them describe completely the performance of this aerial coupling circuit:—

Voltage amplification =  $\frac{M'}{CZ_1(R_s + R_x + R_y)}$

where  $C = \frac{1}{\omega^2 L} - \Delta C$ ,  $R_s$

Selectivity =  $\frac{1}{R_s + R_x + R_y}$

Reflected capacity,

$$\Delta C = \frac{1}{\omega^2 L} \left[ \frac{1 - \omega^2 c l_2}{1 - \frac{c l_1 l_2 \omega^2 (1 - k^2)}{L}} \right]$$

**Calculation of M and k**

To test the validity of the above expressions, experiments were carried out on an inductance, the dimensions of which are given in Fig. 3. Its inductance is 157 μH and the various tapping points used in the experimental work are as indicated in the figure. The three tapping points used included one-half, one quarter and one eighth of the total number of turns and will be referred to, in the subsequent text, as the "middle," "quarter" and "one-eighth" tapings respectively. The various values of inductance required in the formulæ were calculated from Reyner's formula:

$$L = \frac{.2n^2 D^2}{3.5D + 8l} \mu H,$$

where  $n$  = total number of turns in the winding under consideration,  $D$  = diameter of the winding in inches,  $l$  = length of the winding in inches.  $M$  may be calculated from Fig. 4, which is a graph of inductance plotted against number of turns for the coil in question. As  $L = 157 \mu H = l_1 + l_2 + 2M$ , then:—

$$M = \frac{1}{2}[157 - (l_1 + l_2)] \mu H \quad \dots (6)$$

Consider the quarter tapping. From Fig. 4 the inductance of the two parts of the coil are clearly 20 and 105 μH. Substitution of these values in (6) gives  $M$  as 15.5 μH. The value of  $k$  may be obtained from the relationship:—

$$k = M/\sqrt{l_1 l_2}$$

For the tapping point under consideration  $k$  is clearly given by:—

$$k = \frac{15.5}{\sqrt{20 \times 105}} = .33.$$

The variation of  $M$  and  $k$  with the position of the tapping point is illustrated in Fig. 5. The constancy of  $k$  over quite wide variations in the position of the tapping point is noteworthy.

**Measurement of  $R_s$ .**

Accurate calculation of the effective R.F. resistance of an inductance at a given frequency is impossible: it is best obtained by measurement, and for this experiment it was derived by measurement of  $Q$  at various frequencies.  $R_s$  is then given by  $L\omega/Q$ . The values obtained are given in Table 1. As shown in this table the frequencies used were those for which  $\omega$  has integral values, for these simplify subsequent calculations. This completes our knowledge about the inductance. In the experimental work the dummy aerial used consisted of a condenser of 225 μμF capacity (nominally 200 μμF) and a resistor of 25 ohms in series. We now have sufficient information to calculate the gain, selectivity and reflected capacity at any value of  $\omega$  for any tapping point. This has been done and the results for gain, selectivity and reflected capacity are given in the curves of Figs. 6, 7 and 8 respectively. Fig. 7 also includes a curve illustrating the variation of  $Q$  with frequency. The projection of the curves on the axis of frequency indicates the frequency range covered. The agreement between measured and calculated re-

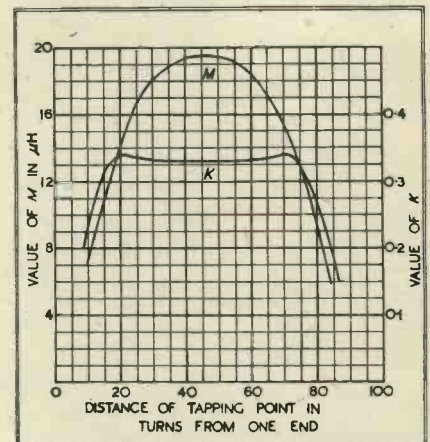

Fig. 5. Variation of M and K with position of tapping point for coil illustrated in Fig. 3.

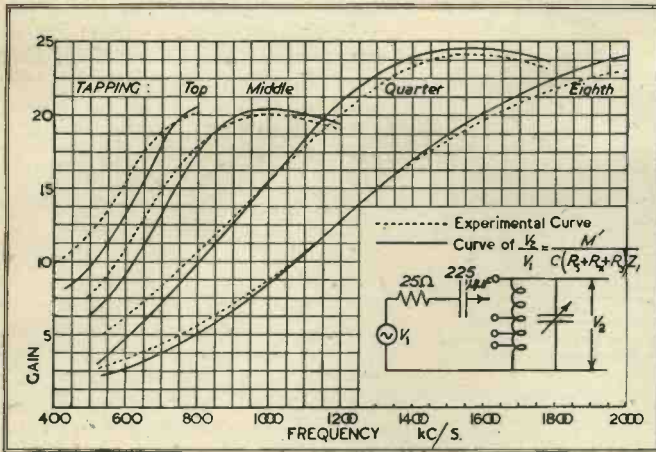

Fig. 6 (above). Gain of the coil illustrated in Fig. 3 using dummy aerial shown and various tapping points

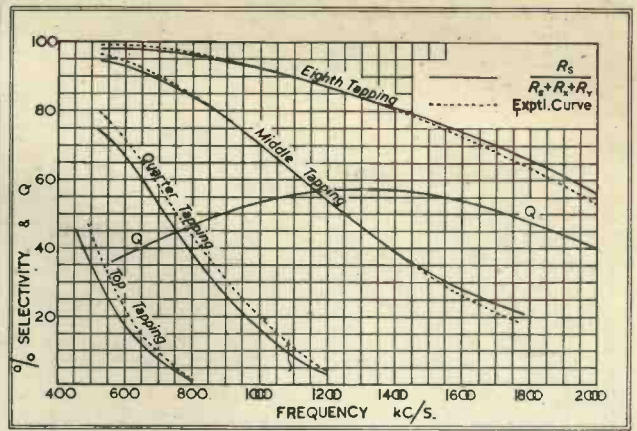

Fig. 7 (top right). Variation with frequency of selectivity of coil of Fig. 3.

sults is as good as the method of making some of the measurements permits. In Fig. 8 the lines parallel to the axis of frequency are the reflected capacities calculated from the simple formula:  $-\Delta C = \frac{n^2}{N^2} \cdot C$ . The agreement with experiment is fair and this formula could justifiably be used where extreme accuracy is not wanted.

**Best Tapping Point**

This is best determined from Fig. 9 which shows the percentage of maximum selectivity and voltage gain obtained with the coil for various tapping points. The maximum possible voltage amplification given by the coil at any frequency is equal to the value of  $Q/2$  at that frequency and this can only be achieved when the aerial circuit is accurately matched to the impedance of the tuned circuit. The curves were obtained entirely by interpolation from Figs. 6 and 7. It is at once obvious that it is the frequency range which is going to decide the best tapping point. For example if this coil were required to work at a frequency of 650 kc/s. only, then the middle tapping point will, from Fig. 9 give 60 per cent. of the maximum possible selectivity and the same percentage of the maximum possible gain—quite a good compromise. Similarly at approximately 1,600 kc/s., the one-eighth tapping gives 70 per cent. of the maximum of both qualities, but if the entire medium waveband is wanted—and this is our usual desire—we are immediately limited to tapping points lower than two-fifths for all others above this cut the high frequency end of the waveband. With the coil in question the best compromise is given by the quarter tapping for which the gain varies from 20 per cent. at 550 kc/s. to 85 per cent. at 1,500 kc/s. and the selectivity varies from 90 per cent. at 550 kc/s. to 30 per cent. at 1,500 kc/s. If selectivity is deemed more important

Fig. 8 (right). Variation of reflected capacity,  $\Delta C$ , with frequency for coil of Fig. 3.

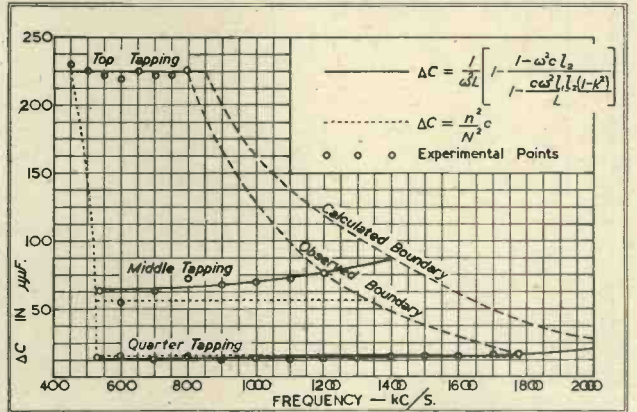

than gain—as it often is—then it would be preferable to use the one-eighth tapping for which the selectivity does not fall appreciably below 80 per cent. of the maximum at any medium wave frequency. In con-

clusion the author hopes that this article will help to throw some light on the mathematics of a commonly used circuit, and will aid the construction of coils to give a particular performance.

TABLE I

W (x10 <sup>6</sup> )	3	4	5	6	7	8	9	10	11	12	13
f (kc/s)	477	637	796	955	1114	1274	1434	1592	1757	1910	2068
Q	32	40	46.8	51.3	54.5	56.2	55.3	52.6	49	44	36.7
R <sub>s</sub> (Ω)	14.72	15.70	16.78	18.36	20.16	22.35	25.55	29.85	35.25	42.82	55.60

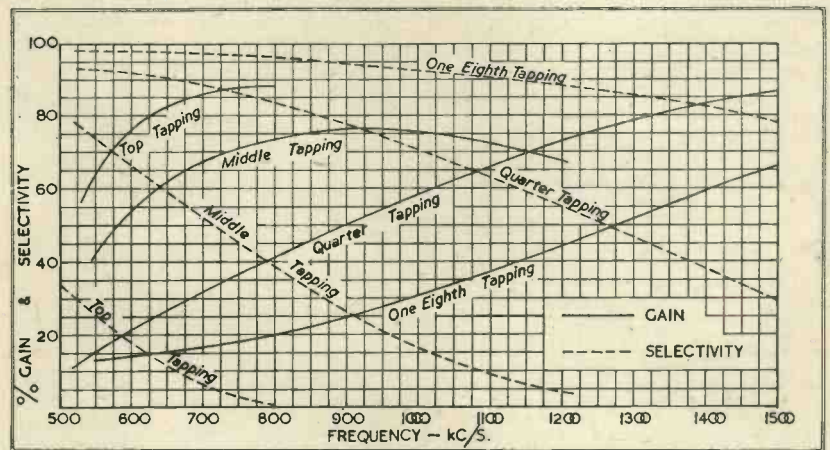
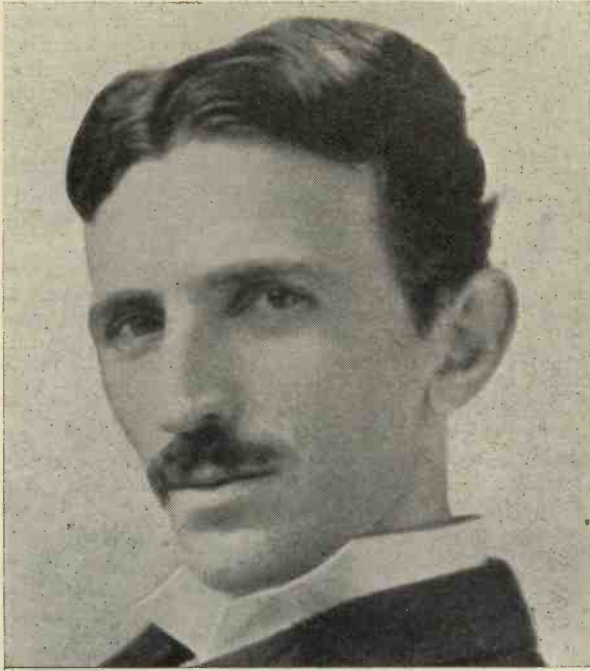

Fig. 9. Variation of gain and selectivity of coil of Fig. 3, with frequency for determination of optimum tapping point.



# Nikola Tesla, 1857-1943

By R. P. HOWGRAVE-GRAHAM, M.I.E.E.



The author of this article made a close study of Tesla's experiments in high frequency discharges and was in correspondence with him over a period, besides demonstrating the effects to numerous scientific audiences in this country.

**T**HERE has always been something very attractive in the personality of Nikola Tesla, and in attempting to estimate his work the element of remoteness on this side of the Atlantic has had its compensation in our greater detachment from the storms of criticism and controversy which swept across his life and have left their records in the technical press of the United States.

Tesla was born in 1857 at Smiljan. His father, a priest of the Greek Church, moved to Gospic near the Croatian coast where Tesla was first educated.

The experimental daring of the later man was typified when his attempt at aerial navigation with an old umbrella resulted in a bad fall which laid him up for six weeks.

Later on he went to the Higher Real School at Cartstatt in Croatia where he graduated in three years instead of the normal four. At the Gratz Polytechnic in Austria where he prepared for a professorship in Mathematics and Physics he saw and used a Gramme dynamo and this implanted in his mind the determination to abolish commutators and brushes which seemed to him to be major defects. Changing his plans, he took up engineering and with a view to the

great importance of foreign languages studied at Budapest and Prague and became an accomplished linguist.

Hard necessity presently forced him into an engineering post in the Government telegraph system at five dollars a week so he presently decided that it was necessary to make a lucrative invention.

The first appearance of the telephone in Hungary engaged him in the invention of improvements, but he was restless and ambitious, and in 1881 went to Paris, where he joined a large electrical power company. All this time his mind was actively searching out new lines and fresh outlets and the next year found him staking everything on departure for America, where he felt there was larger scope. He was soon at work with Edison, and was active in the improvement of arc lighting. A great step was the foundation of the Tesla Electric Company of New York in 1887, for in the following year he evolved his polyphase motors which fulfilled his old quest for commutatorless brushless machines.

Mr. Walter Baily, of Hampstead, had produced an elementary two-phase rotating-field motor with a small disk armature by using a D.C. supply and revolving commutator; then Prof.

Galileo Ferraris, of Turin, in 1887 made the same fundamental invention in a vitally new form; he used an ordinary A.C. supply with resistance-inductance split-phase windings and adjuncts. Ferraris thought this invention unimportant and wanted to give it to the world freely, but was persuaded to allow the Westinghouse Company to take out patents and received an insignificant financial gift.

In 1887 the company, to the chagrin of Ferraris, sponsored Tesla's patents though they were not issued until 1888. These showed his prolific inventiveness and untiring energy and there is little doubt that his discovery was independent, though his early machines were mostly synchronous motors operated by a rotational instead of a constant-axis alternating field; his most important claim was probably the use of the rotating field for bringing synchronous motors up to running speed. The patents were attacked over and over again in the American courts, but always emerged triumphant until their expiry in 1905. His large machines had efficiencies as high as 95 per cent.

As a designer of electrical machinery, Tesla showed outstanding originality not only in the development of induction motors, but in pioneer inventions of homopolar generators and high-frequency alternators. The latter he produced with characteristic persistence, overcoming successive unexpected difficulties with great ingenuity. Describing the inexperienced beginner's natural procedure in designing the alternators he says: "He will then get the satisfaction of having produced an apparatus which is fit to accompany a thoroughly Wagnerian opera. It may besides possess the virtue of converting mechanical energy into heat in a nearly perfect manner."

These alternators produced most interesting results and he obtained frequencies up to 30,000 c/s, eliminating noise and excessive loss.

In the "Electrical Review of New York" 1898 appeared a striking and little-noticed article on electric lighting by fluorescence, called by him "phosphorescence." This contained remarkable photographs taken by the light of an evacuated fluorescent bulb and at this early date shows the characteristics of ultra-violet photography, an interesting example being Tesla's

own hand in which the finest structural texture of the skin is evident in spite of the coarseness of the half-tone block-screen.

The following prediction is striking: "The photographer will be made entirely independent of daylight—at any hour of night or day."

The production of high frequency mechanical oscillators—really reciprocatory high frequency dynamos called forth extraordinary ingenuity and resource in overcoming difficulties. However, their success, like that of high-frequency alternators, subsequently ceased to matter when the Poulsen arc came into use to be supplanted in turn by the valve.

Any attempt to summarise effectively Tesla's total effort and achievement would be a formidable task, even if the grain were winnowed from the chaff, for Prof. Eccles\* tells us that he took out about 700 patents, mostly before he was 50 years old.

\* *Nature*, February 13, 1943, p. 189.

In 1891 the whole world was startled by a lecture on A.C. currents at very high frequencies and potentials, delivered before the American I.E.E. and the invitations which soon went out from Europe resulted in its repetition for the British I.E.E. and the Royal Institution in 1892. He always showed deep admiration for the great British physicists and the lecture opened with a glowing tribute to Sir William Crookes and passed on to an almost excited resumé of the rapidly expanding achievements of alternating current working; it exhibits, like all his writings, a mind carried away by ever fresh wonder and delight at new phenomena and glowing with imaginative conceptions of future possibilities.

My own youthful joys are recalled by Tesla's boy-like delight shown in the following passage which I have a little abbreviated:—

"In all these experiments which are so very very interesting, ever since the greatest experimenter who

lectured in this hall discovered its principle we have had a steady companion, an appliance familiar to everyone, a plaything once, a thing of momentous importance now—the induction coil. From the ablest among you, I dare say, down to the inexperienced student, we all have passed many delightful hours experimenting with it. We have watched its play, and thought and pondered over the beautiful phenomena which it disclosed to our ravished eyes."

He then described the fascinating series of experiments with what is now always known as the Tesla coil or transformer.

Most readers must have seen the peculiar brush discharges of such a coil if only on a small scale and may appreciate my comparison of the workings of Tesla's mind with these luminous, ramified threads of ionised activity, for each new result produced by him subdivided in fresh ideas of ever widening inference, conjecture and experiment.

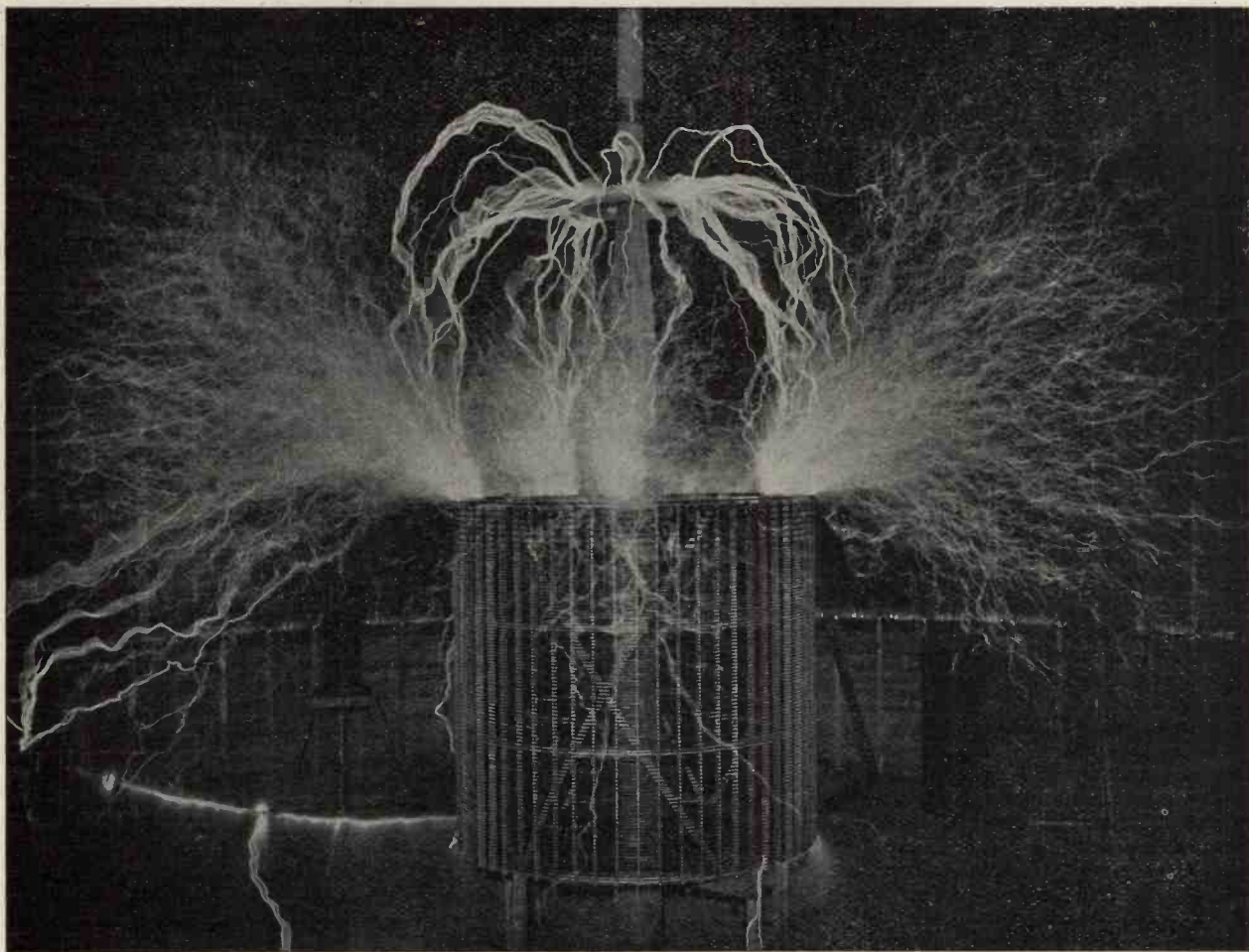

Combustion of atmospheric nitrogen by the discharge of an electrical oscillator giving twelve million volts and alternating 100,000 times per second. The flame-like discharge shown in the photograph measured 65 feet across. (Tesla's description).



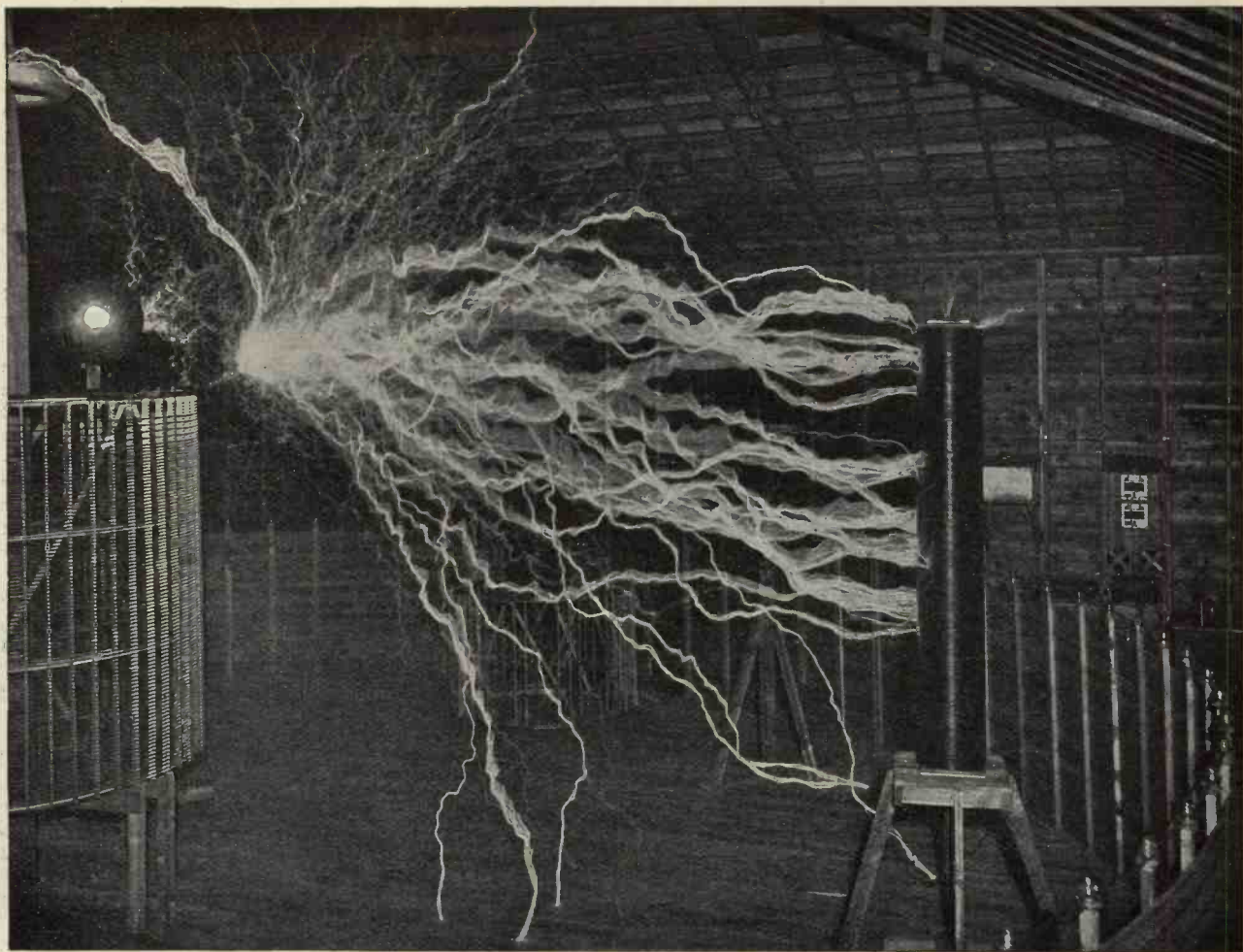

"The discharge escapes with a deafening noise, striking an unconnected coil 22 feet away."

Eager delight in the sheer physical beauty spurred him on as did the romantic physical basis of it all and the harmony, one might almost say the counterpoint, of its relations to the rapidly developing physics which followed on the work of Maxwell, Kelvin and Hertz.

In all this Tesla was half artist and some effort is needed in these latter days to realise the thrill of wonder and awe experienced by him in producing newly, on a spectacular scale, the extraordinary phenomena of high frequency discharges which are now so familiar.

It is quite impossible to describe the almost interminable series of experiments and observations on brush discharges, "streamers," the excitation of rarefied gases, the fluorescence and also the incandescence of substances under high frequency bombardment, the exaggerations and the unexpected peculiarities of inductive, and self-inductive action and the remarkable effects of capacitance at widely dif-

ferent high frequencies and potentials with numerous other most striking phenomena involving vast expense and labour.

Probably the best account of this wealth of work is in "The Inventions, Researches and Writings of Nikola Tesla," by Martin, 1894, but after that date there came sufficient to occupy another volume.

I cannot help thinking that in a laboratory endowed for the repetition and extension of Tesla's described and suggested experiments, where such are amenable to modern valve-operation there might be startling and important results.

The *Electrical Review of New York* 1899 contains an article with very fine photographs and opens with a reference to the disastrous fire which destroyed his laboratory in 1895. After speaking of the crippling delay and his efforts to resume the threads Tesla continues: "Ideas come through happy inspiration, apparently

without much exertion, but it is the working out of the many harassing details and putting into a presentable form which consumes time and energy."

Then follows characteristic banter directed at the sensation-mongers among the journalists, especially those who had enlarged upon his proposals for the wireless control of ships. He speaks of "my invention enabling me to move and explode torpedo boats by will power, and my efforts to annihilate the entire British Navy." It was about this time that an English newspaper (the reader will guess which!) said that Mr. Nicholas Testa (sic) proposed to transmit "millions of horse-power" from Niagara, utilising the well-known fact that a conductor at low temperatures conducts with small loss "by laying it in a trough of liquid hydrogen at the bottom of the sea"!

The 1899 article shows a photograph of Tesla taken by the light, claimed to be of 1500 candle-power, emitted



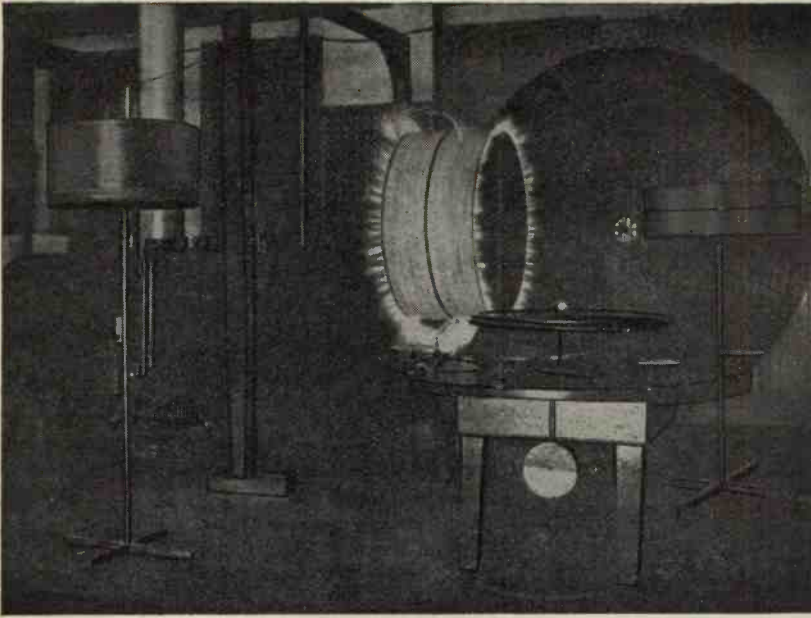

A disconnected resonance coil in response, while surrounding untuned coils are quiescent. P.D. is claimed to be more than 500,000 volts.

by a globe held in his hand and receiving energy across space from an oscillator-coil of only four turns. There are other similar illustrations. A beautiful photograph shows a disconnected resonating coil with discharges streaming from the edges while neighbouring untuned coils are quiescent. In another a blazing torrent of discharges comes from one terminal of a much larger oscillator, the illuminated space being 18 ft. across.

In 1903 Tesla directed his laboratory staff to send me two of the actual half-tone copper blocks used for some of his articles and I have kept them carefully ever since. I believe they have never been published in England until the present day when his recent death seems to make their appearance in *Electronic Engineering* very appropriate.

The Tesla coil concerned consisted of a primary coil wound right round the whole laboratory with a concentric secondary inside it. The frequency was 100,000; the P.D. was estimated at  $1.2 \times 10^6$  volts (though that may be questioned) and the discharge in the photograph measured 65 feet across. In the second picture the discharge, which made a deafening noise, strikes a coil 22 feet away and is described as causing combination of the nitrogen and oxygen in the air in large quantities. I believe it is a fact that when this oscillator was first set in operation he was inundated with wrathful letters from people in houses up to some hundreds of yards away, who, when warming their nether parts

against their radiators after dinner, received long and calorific sparks thereto.

With my own small coil I once or twice started fires before I improved the control, and once this occurred in a distant room on another floor. Tesla's most grandiose and imaginative scheme envisaged the transmission of energy over the whole earth, at least for signalling, and he hoped for the performance of useful work by setting the whole globe in electrical oscillation.

His wireless receivers had shown widely spaced nodes and antinodes of potential as thunderstorms moved over the earth's surface and he conceived the idea of energising the whole globe with zonal stationary waves resulting from reflexion at the antipodes by the agency of a huge and high earth-connected power-oscillator. Was this utterly wild? Who would have believed in a prediction of the effect of the great volcanic explosion at Krakatoa in 1883 when a gigantic acoustic wave traversed the spherical atmospheric shell round the earth making seven double journeys at intervals of eighteen hours, being reflected each time at the antipodes and causing zonal depressions in all the barometers as it passed with a velocity approximating to that of ordinary sound?

Experiments on a gigantic scale were made and greater ones planned. Tesla says that his huge oscillator on Long Island emitted streamers 100 ft. high and made the building appear

on fire, while the roar of the discharge was audible at 10 miles distance.

This scheme became almost an obsession and was probably what he referred to in a letter to me dated 1903 in which he says "I am hopeful to show at a time not distant that much greater wonders can be performed by the use of the methods and apparatus which it has been my good fortune to evolve."

Two more utterances may be quoted which are of particular interest in light of present-day developments:

"There is no doubt that with the enormous potentials obtainable by the use of very high frequencies and oil insulation, luminous discharges might be passed through many miles of rarefied air and that by thus directing the energy of many hundreds or thousands of horsepower motors or lamps might be operated at considerable distances from stationary sources."

Again: "To whatever results investigations of this kind may lead, their chief interest lies for the present in the possibilities they offer for the production of an efficient illuminating device.

"In no branch of the electrical industry is an advance more desired than in the manufacture of light. Every thinker when considering the barbarous methods employed, the deplorable losses incurred in our best systems of electric light production, must have asked himself 'what is likely to be the light of the future?' Is it to be incandescent solid, as in the present lamp, or an incandescent gas?—a phosphorescent body, or something like a burner, but incomparably more efficient?"

Dr. Eccles in his article in *Nature* sums up Tesla's considerable achievements in radio engineering and concludes thus: "Throughout his long life of eighty-five years, Tesla seldom directed attention to his own successes, never wrote up again his old work and rarely claimed priority though continually pirated. Such reserve is especially striking in a mind so rich in creative thought, so competent in practical achievement."

I hope I have corrected the too-common conception of Tesla as a mere showman. In so far as he was wildly visionary and extravagantly imaginative he showed the rather attractive defects of his wonderful and intriguing qualities. I consider him a bold, daring genius whose contribution to science was very real. Not all his dreams were realised, but that is the universal fate of the artist-poet whether or not he is also a scientist. (*The author will deal with other aspects of Tesla's work in a later article.*—Ed.)



# The Cathode Follower

## Part III (a) Noise Performance

The first part of this series, which dealt with performance at lower frequencies, appeared in the issue for December 1942. A more extended treatment, suitable for higher frequencies, appeared in February 1943, and the equations given below follow serially from this instalment.

### Normal Amplifier

THE signal to noise ratio of a valve is one of the most important criteria determining its suitability for use in the first stage of an amplifier. A great deal has been written on the subject in connexion with valves used in normal amplifier circuits both with triode and pentode connexions, but little attention has been paid in the technical literature to the performance of the cathode follower circuit.

The generalised solution for any cathode load circuit is very complex and will not be attempted here. The case where the phase shift in the cathode load circuit is small for the noise components within the pass-band allows for a reasonably simple solution and this is given below.

Due to Thermal Agitation a noise voltage  $E_T$  is developed across the terminals of a resistance  $R$  and the mean square value of this voltage is given by

$$\overline{E_T^2} = 5.5 \times 10^{-23} TR\Delta f \text{ volts}^2 \quad (88)$$

where  $T$  is the temperature of the resistance in degrees Kelvin and  $(\Delta f)$  the equivalent overall pass-band (see Data Sheet No. 19 for further details). The value of the resistance  $R$  is expressed in ohms. If we make  $T = 291^\circ \text{K}$  or  $18^\circ \text{C}$  then

$$\overline{E_T^2} = 1.6 \times 10^{-20} (R\Delta f) \text{ volt}^2 \quad (89)$$

It is sometimes more convenient to visualise the noise voltage  $\overline{E_T^2}$  as produced by a noise current  $I_T^2$  flowing from a constant current generator into the resistance  $R$ . The noise current  $\overline{E_T^2}/R^2$  is then

$$I_T^2 = \frac{1.6 \times 10^{-20} (\Delta f)}{R} \text{ amps}^2 \quad (90)$$

In Data Sheet No. 20 it was shown that the noise current  $I_n^2$  flowing through the anode circuit of a valve was related to the mean anode current  $I_a$  by the expression.

$$I_n^2 = 3.16 \times 10^{-19} I_a (\Delta f) F^2 \text{ amps}^2 \quad (91)$$

where  $F$  is a factor depending on space charge and ratio of screen to anode current, and this can be referred to the input grid circuit of the valve as a noise voltage given by

$$[E_n^2]_a = \frac{I_n^2}{g_a^2} \dots \quad (92)$$

where  $g_a$  is the anode current mutual conductance. The noise voltage at the grid is most conveniently expressed in terms of a resistance which at room temperature produces an equal amount of noise voltage; its value is obtained by equating (89) and (92). This resistance known as the Equivalent Noise Resistance  $[R]_{eq}$  is independent of band width and can be directly compared with additional noise voltages due to the resistance of the tuned circuit, aerial or any other resistance in the grid circuit.\*

Triode Connected Amplifier: 6AC7  $\approx 200$  ohms. S.P.41  $\approx 300$  ohms.

Grid Injected Pentode Frequency Changer: 6AC7  $\approx 3,000$  ohms.

If in the anode circuit of our amplifier we now include a coupling resistance (or tuned circuit) of value  $R_d$ , the mean noise squared voltage produced by this resistance can be referred to the grid circuit by dividing it by the (stage gain).<sup>2</sup> (See Fig. 1). In the following discussion it is convenient to express all the mean noise squared voltages in terms of Noise Resistances. Thus the total mean squared noise voltage referred to the grid can be written in the form

$$[E_n^2]_a = \left\{ [R]_{eq} + \frac{R_d}{g_a^2 R_d^2} + [R_2]_{eq} \left( \frac{R_a + R_d}{g_a R_d R_a} \right)^2 \right\} K \quad (94)$$

where  $K = 1.6 \times 10^{-20} \Delta f$  (95)  
 $R_a$  is the anode A.C. resistance and the temperature is  $18^\circ \text{C}$ .

The term  $\frac{R_d}{g_a^2 R_d^2}$  therefore represents the noise resistance of the anode coupling referred to the grid input circuit while the last term is the equivalent Noise Resistance of the second valve referred to the grid of the first valve. The r.m.s. noise voltage is therefore proportional to the square root of the total noise resistance in the grid input circuit.

When the input circuit resistance is negligible the total noise resistance is:  $[R_n]_{eq}$  and is equal to the sum of the resistances inside the brackets of Eq. (94).

### Cathode Follower

If as before we first examine for simplicity the case of a single cathode follower stage (see Fig. 2) and let  $I_{no}$  represent the r.m.s. noise current component in the cathode current with  $R_c = 0$  and  $I_{nc}$  the new r.m.s. noise current when  $R_c$  is given a finite value, then

$$I_{nc} = I_{no} - I_{nc} g_c R_c$$

and 
$$\overline{I_{nc}^2} = \frac{\overline{I_{no}^2}}{(1 + g_c R_c)^2} \dots \quad (96)$$

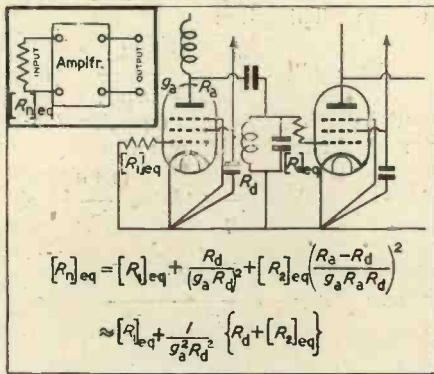

Fig. 1.

$$[R]_{eq} \approx 20 \frac{I_a}{g_a^2} F^2 \text{ ohms} \quad (93)$$

with pentodes having  $I_a/I_n = \frac{1}{4}$ ,  $F^2$  is of the order of  $\frac{1}{4}$ , with triodes  $F^2$  is of the order of  $1/10$  to  $1/20$ . As typical values we can take the following resistances:

Pentode Connected Amplifier: R.C.A. 6AC7/1,852  $\approx 700$  ohms. S.P.41 800 ohms. E.F.50  $\approx 1,400$  ohms.

\* The reason for this is that the resultant mean noise squared voltage, produced by the summation of the outputs of several independent noise sources having random characteristics, is equal to the sum of the mean squared noise voltages. It is therefore equal to the noise produced by a resistance of a value equal to the sum of the resistances in the grid circuit.

where  $g$  is the cathode current mutual conductance.

To transfer this in the form of a noise voltage in the input grid circuit we divide as before by the square of the operating mutual conductance, so that

$$[E_i^2]_n = \frac{I_{ao}^2 (1 + gR_c)^2}{(1 + gR_c)^2 g^2} = \frac{I_{ao}^2}{g^2} \dots (97)$$

Hence a triode valve used in a cathode follower circuit has exactly the same noise voltage in the input circuit and the same equivalent noise resistance as when used in a normal amplifier circuit since  $g_a = g$ .

To transfer the Thermal Agitation noise of the resistance  $R_c$  to the grid circuit, we have a mean square noise current

$$I_T^2 = \frac{1.6 \times 10^{-20} \Delta f}{R_c} \dots (98)$$

flowing in the parallel combination of  $R_c$  and a resistance equal to  $1/g$ . The thermal noise voltage across  $R_c$  is therefore equal to

$$E_T^2 = \left[ \frac{R_c}{(1 + gR_c)^2} \right] K \dots (99)$$

and transferring this to the input circuit by dividing by the square of the gain gives

$$[E_i^2] = \left[ \frac{R_c}{g^2 R_c^2} \right] K \dots (100)$$

where the terms in the square brackets of equations (99) and (100) represent the noise resistances in the cathode and input circuit respectively.

A similar process was used for deriving equation (94) where the noise resistance of the anode coupling at the anode is equal to

$$R_d \left( \frac{R_a}{R_a + R_d} \right)^2$$

Considering next a complete stage including the following valve, with a tapped tuned circuit acting as a matching transformer between the two valves (see Fig. 3) the gain between the two grids is given by

$$\frac{e_3}{e_1} = \frac{gR_d N}{N^2 + gR_d} \dots (101)$$

where the transformer ratio  $N = e_3/e_2$ . By differentiating (101) with respect to  $N$  we obtain the condition for maximum gain and load matching which occurs when  $N^2 = gR_d$  and

$$(e_3/e_1)_{max} = \frac{1}{2} \sqrt{gR_d} \dots (102)$$

This value of  $N$  does not usually give the highest signal to noise ratio. In Fig. (3)  $(R_1)_{eq}$  and  $(R_2)_{eq}$  represent the Equivalent Noise Resistances of the first and second valve respectively.

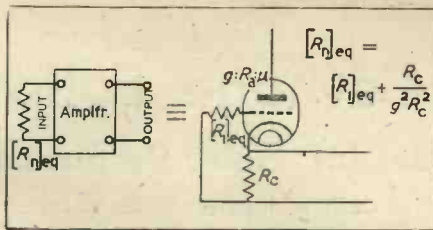

Fig. 2. Equivalent noise resistance of single Cathode Follower stage.

Transferring  $R_d$  and  $(R_2)_{eq}$  to the cathode circuit we have

$$[E_c^2]_n = \left\{ \frac{R_d N^2}{(N^2 + gR_d)^2} + \frac{(R_2)_{eq}}{N^2} \right\} K \dots (103)$$

and the noise referred to the input circuit is

$$[E_i^2]_n = \left\{ (R_1)_{eq} + \frac{R_d N^2}{g^2 R_d^2} + (R_2)_{eq} \left[ \frac{N^2 + gR_d}{gR_d N} \right]^2 \right\} K \dots (104)$$

if we make  $N^2 = gR_d$ , i.e., the condition for maximum gain, then

$$[E_i^2]_n = \left\{ (R_1)_{eq} + \frac{1}{g} + \frac{4}{gR_d} (R_2)_{eq} \right\} K \dots (105)$$

To make the total noise resistance a minimum in equation (104) we differentiate the expression in the brackets with respect to  $N$  and equate to zero. This gives

$$N^2 = gR_d \sqrt{\frac{(R_2)_{eq}}{R_d + (R_2)_{eq}}} \dots (106)$$

and inserting this into equation (104) we obtain the minimum noise

$$[E_i^2]_n = \left\{ (R_1)_{eq} + \frac{a}{g} + (R_2)_{eq} \frac{(1+a)^2}{gR_d a} \right\} K \dots (107)$$

$$\text{where } a = \sqrt{\frac{(R_2)_{eq}}{R_d + (R_2)_{eq}}} \dots (108)$$

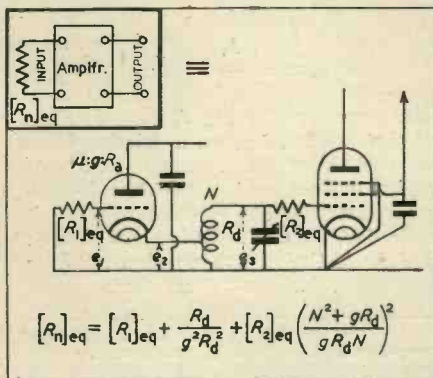

Fig. 3. Complete Cathode Follower stage including the following valve, with tuned circuit coupling.

The optimum value of  $N$  given by equation (106) is always lower than that for maximum gain, though it tends to the same value when  $R_d \ll (R_2)_{eq}$ . The noise resistance however decreases as  $R_d$  is made large compared with  $(R_2)_{eq}$ , and some consideration must therefore be given to the maximum usable value of  $R_d$ . When sideband attenuation is not important  $R_d$  should be made as high as possible, and its value will be mainly limited by the input resistance of the second valve and general losses.

If, however, it is required to amplify over a given frequency band with limited attenuation, then for a given tuning capacity we are limited in the maximum working dynamic resistance of the tuned circuit which can be used.

Let the dynamic resistance of the circuit be  $R_{do}$  when the mutual conductance of the cathode follower has been reduced to zero, and  $R_{dw}$  under normal operating conditions. Then

$$\frac{R_{do} N^2}{gR_{do} + N^2} = R_{dw} \dots (109)$$

and

$$N^2 = \frac{gR_{do} R_{dw}}{R_{do} - R_{dw}} \dots (110)$$

Inserting this value into equation (104) we obtain

$$[E_i^2]_n = \left\{ (R_1)_{eq} + \frac{1}{g} \left( \frac{R_{dw}}{R_{do}} \right) \cdot \frac{1}{1 - \frac{R_{dw}}{R_{do}}} + (R_2)_{eq} \left[ \frac{1}{gR_{dw} \left( 1 - \frac{R_{dw}}{R_{do}} \right)} \right]^2 \right\} K \dots (111)$$

Having settled the value of  $R_{dw}$  from band-width considerations,  $R_{do}$  should be made as high as possible in order to reduce the noise and  $N^2$  is then adjusted to satisfy equation (110). By combining equation (101) and (110) we obtain the gain

$$\frac{e_3}{e_1} = \sqrt{gR_{dw} \left( 1 - \frac{R_{dw}}{R_{do}} \right)} \dots (112)$$

the condition for optimum gain and matching (regardless of band-width considerations see equation (102)) makes  $R_{do} = 2R_{dw}$ .

From equations (111) (112) and (102) it will be seen that for a fixed band-width provided  $R_{do}$  can be made greater than  $2R_{dw}$  the optimum matching condition not only gives an inferior noise performance, but also a lower gain.



**Performance Comparison**

It is instructive to compare numerically the performance of alternative cathode follower adjustments with a straight forward amplifier circuit. Suppose  $R_{aw}$  has to be made 1,500 ohms and  $R_{do}$  cannot be made greater than 5,000, then if we take the S.P.41 under the operating conditions of Table 2, Section (b) and assuming an equivalent noise resistance of 300Ω as a triode and 800Ω as a pentode, we have :—

*Optimum Matching.*  $R_{do} = 3,000\Omega$ .

From (102) and (105):

$$\frac{e_3}{e_1} = 2.81 \text{ and}$$

$$[R_n]_{eq} = 300 + 95 + 101.5 = 496 \text{ ohms}$$

*Minimum Noise.*  $R_{do} = 5,000\Omega$   $\frac{R_{aw}}{R_{do}} = .3$

From (111) and (112):

$$\frac{e_3}{e_1} = 3.32$$

$$[R_o]_{eq} = 300 + 40.7 + 72.3 = 413 \text{ ohms.}$$

With the particular values chosen the noise resistance obtained from (107) regardless of band-width considerations is only reduced to 412 ohms.

*Ordinary Pentode Amplifier.*  $R_{do} = R_{aw} = 1,500\Omega$ .

$$\frac{e_3}{e_1} = 12.6$$

from (94)

$$[(R_n)]_{eq} = 800 + 9.6 + 5 = 815 \text{ ohms.}$$

From the above examples it will be seen that the improved noise performance of the cathode follower circuit is entirely due to the better noise performance of a triode connexion as compared with the pentode. The noise

of the succeeding stage contributes materially to the overall noise performance of the cathode follower. In fact if for any reason  $R_{do}$  has to be made low, the noise performance of the cathode may become inferior to that of the normal pentode amplifier.

When considering the overall noise performance of a receiver, the step up of the aerial tuned circuit must be included. The best overall performance will be obtained when the dynamic resistance of the aerial tuned circuit is large compared with the total noise resistance at the first valve. The cathode follower with its lower input capacity and higher input resistance allows the dynamic resistance of the aerial tuned circuit to be increased and thus enables a further improvement in signal to noise ratio to be obtained. In the above discussion the question of induced grid noise has been omitted for simplicity.

**(b) Amplifier Circuits**

THESE are two main types of cathode follower circuit connexions that may be employed and the most suitable type depends entirely on performance requirements. The two alternative arrangements are shown in Figs. 4a and 4b from which it will be seen that the difference between them is that in Fig. 4b a pentode is employed with the screening grid decoupled to cathode.

It has been shown (see equations (38) (39) (80) and (82)) that provided  $R_g$  is very large,  $\mu \gg \gamma$  and  $\rho_o^2(1 + C_{gc}/C_c) = \omega^2 R_c(C_{gc} + C_c)$  is small the input capacity of the cathode follower circuit shown in Fig. 4a is given approximately by

$$C_1 \approx C_{gs} + \frac{C_{gc}}{1 + gR_c} \dots (39)$$

From (39) it will be seen that however large we make  $gR_c$  the input capacity cannot be reduced below the value of  $C_{gs}$ .

If it is important to reduce the input capacity to its lowest possible value then a screened pentode connected as shown in Fig. 4b should be employed. The grid to anode capacity is now negligible usually less than 0.01  $\mu\mu\text{F}$ , and the grid to screen grid capacity  $C_{g1g2}$  and the grid to suppressor grid capacity  $C_{g1g3}$  have now to be added to  $C_{gc}$  as these electrodes are returned to cathode (the reactance of the screen decoupling condenser is as-

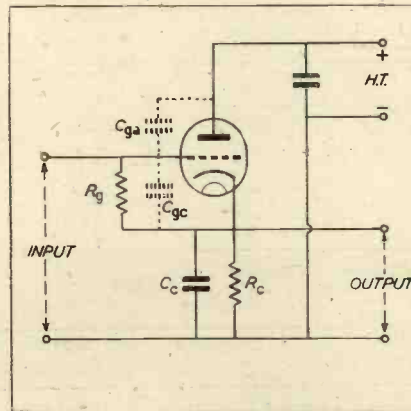

Fig. 4a

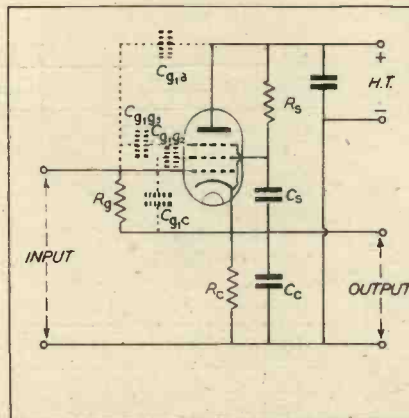

Fig. 4b

sumed negligible). The input capacity is now given by

$$C_1 \approx \frac{C_{g1c} + C_{g1g2} + C_{g1g3}}{1 + gR_c} + C_{g1a} \dots (113)$$

from which it will be seen that by making  $gR_c$  sufficiently large the input capacity can be made very small. In the case of metallised or canned valves it may not be always possible to connect the metallising to the cathode, and when the metallising is connected to chassis the grid to metallising capacity will have to be added to the anode to grid capacity in the above equation. (114).

In Table 1 are given the individual electrode capacities of two well known high slope television screened pentodes, the Mullard E.F.50 and Mazda S.P.41. These figures which were obtained on individual valves illustrate the order of magnitudes involved, and may not agree exactly with the manufacturers average values.

To these figures, which were taken with the valves cold, must be added the increment in the control grid capacity when the cathode is heated and that due to the space charge.\* The manufacturers published values for these capacities for a cathode current of 13 mA are given in Table 1—while the mutual conductance for the

\* See "Gain Control of R.F. Amplifiers" C. E. Lockhart, E.T. & S.W.W. Aug. 1940.

same cathode current with both pentode and triode connexions are given in Table 2. Unfortunately, no information is available as to the relative magnitudes of the grid to cathode and grid to screen components of the space charge capacity. For the purpose of the following examples the grid to screen component will be assumed equal to one-third of the total space charge increment in capacity.

With the above assumptions we can now illustrate the improvement in input capacity obtainable with the pentode connexion of Fig. 4b. This is shown in Table 2 where the input capacity of the S.P.41 and EF50 are given both for the normal pentode amplifier connexion and the pentode and triode connected cathode follower.

Whether the improvement in input capacity is worth while will depend

increases rapidly as the ratio of screen current to anode current increases. With a screen current to anode current ratio of the order of 25 per cent. the equivalent noise resistance with the pentode connexion is some 2½ times greater than with the triode connexion. When the noise of a succeeding amplifier is considered the effect is even greater. (See section on Noise Performance).

(d) Cathode followers are often employed to isolate several receivers operating on the same aerial or alternatively to reduce the magnitude of the frequency changer oscillator output appearing on the aerial. In both cases the coupling capacity is equal to the effective grid cathode capacity, and this is greater in the case of the pentode connexion. (See Table 2).

### Cathode Follower as Driver

In the previous section the use of the pentode connexion was discussed in the first stage of an amplifier where noise performance is very important. The cathode follower is, however, also extensively used as a driver for an output stage that requires to be driven into the positive region of its grid current characteristic. Such output stages, when taking appreciable grid currents, must be driven from a very low impedance source in order to ensure a low harmonic content. As the frequency is increased the design and construction of a suitable transformer with sufficiently low leakage inductance becomes more difficult and this applies particularly to television type waveforms. The low output impedance provided by the cathode follower offers an ideal solution to the problem. If we let  $V_o$  be the peak output required from the driver ( $V_a$ )<sub>min</sub> the minimum value of the anode-cathode voltage of the driver and  $V_{HT}$  the voltage of the H.T. supply, then

$$V_o = V_{HT} - (V_a)_{min}$$

The larger the grid current of the output stage the higher must be the cathode current available for any value of ( $V_a$ )<sub>min</sub>. With triodes the value of ( $V_a$ )<sub>min</sub> for high cathode currents can only be reduced by taking the grid of the driver positive, which is not usually desirable. By the use of the pentode connexion with a high time constant for  $C_s R_s$ , the screen voltage will remain sensibly constant, and provided a pentode or tetrode with a low "knee" voltage is employed a larger output voltage for a given H.T. supply voltage can be obtained than in the case of an equivalent triode.

TABLE 1

Input	SP41	EF50
Control Grid to Cathode ... ..	5.5	3.5
" " Screen Grid... ..	3.5	2.5
" " Suppressor Grid ... ..	0.1	≤0.1
" " Anode ... ..	0.005	0.003
" " Heater ... ..	≤0.1	≤0.1
" " Shield ... ..	—	0.7
" " Metallising ... ..	1.7	1.2
Increase in grid Capacity due to heating ... ..	0.4*	0.2*
Increase In grid Capacity due to space charge. ( $\Delta C_{g1}$ )	3.8	2.0
Output		
Cathode to Anode ... ..	0.75	≤0.1
" " Screen Grid ... ..	0.9	0.1
" " Suppressor Grid ... ..	0.3	≤0.1
" " Shield ... ..	—	0.8
" " Metallising... ..	3.0	1.0
" " Heater ... ..	8.0	3.0

\* Metallising or can connected to chassis. All capacity values in  $\mu\mu\text{F}$ .

to a large extent on what other capacity is present across the input circuit.

Unless it is essential to keep the input capacity at a minimum value, the triode connected cathode follower should always be employed as the pentode connexion reduces the standard of performance due to the following causes :—

(a) Due to the screen decoupling resistance  $R_s$  being effectively in parallel with  $R_c$  as far as the cathode load impedance is concerned, the maximum obtainable value for this load is limited.

(b) Due to the A.C. component of the screen current not flowing through the cathode load circuit, the effective mutual conductance for a given cathode current is reduced by some 20-25 per cent.

(c) With the pentode connexion the signal to noise ratio will be reduced. The equivalent noise resistance in-

TABLE 2

		Cathode Follower Pentode Connexion	Cathode Follower Triode Connexion	Normal Pentode Amplifier
MAZDA S.P.41 $V_a = V_s = 200$ $I_c = 13$ mA	Input Capacity with $R_c = 100\omega$	—	10.65	15.0
	$R_c = 1,000\omega$	3.1	7.25	—
	$R_c = 10,000\omega$	1.86	6.6	—
	Coupling Capacity	13.3	8.5	0.005
	Mutual Conductance mA/V	8.4	10.5	8.4
MULLARD EF.50 $V_a = V_s = 250$ $I_c = 13$ mA	Input Capacity with $R_c = 100\omega$	—	7.45	10.1
	$R_c = 1,000\omega$	6.6	4.9	—
	$R_c = 10,000\omega$	2.4	4.4	—
	Coupling Capacity	8.9	5.8	0.003
	Mutual Conductance mA/V	6.5	8.45	6.5



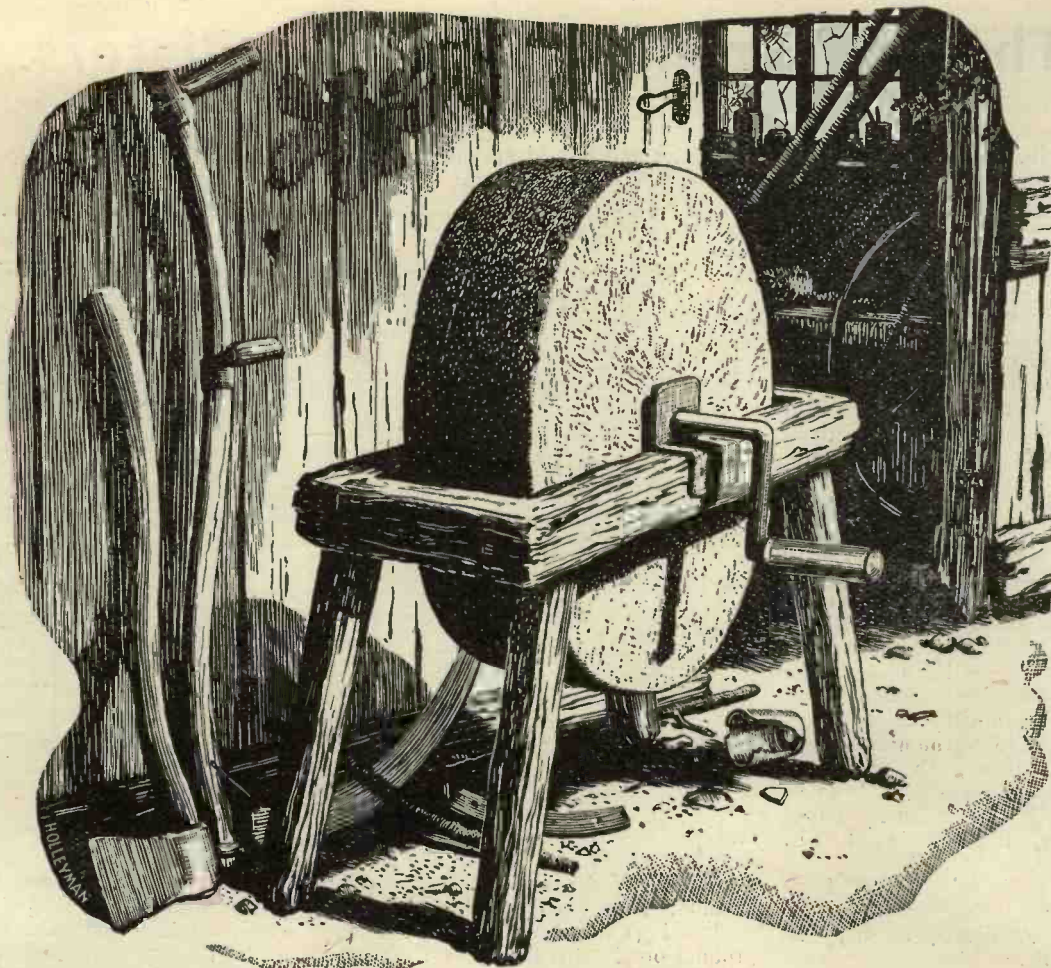

## *Grindstones and Milestones*

The old grindstone outside the village smithy served its purpose well, but many highly specialised industries demand grinding wheels of tougher metal and greater variety.

Many of the grinding wheels in the factories of to-day are artificial stones, made in many grades and sizes, and they are essential machines in a variety of industries.

The millions of tiny particles which go to make these grinding wheels have to be bonded together with something that will always hold, whatever else disintegrates. That 'something' which holds the particles together is Bakelite Synthetic Resin Cement . . . yet another example of the many industrial uses of Bakelite Plastics—another milestone in modern chemical-industrial achievement.

BAKELITE LIMITED, 18 GROSVENOR GARDENS, LONDON, S.W.1

TREFOIL

**BAKELITE**  **PLASTICS**

REGD. TRADE MARKS

*Pioneers in the Plastics World*

# The Synchronisation of Oscillators

By D. G. TUCKER, B.Sc. (Eng.), A.M.I.E.E. \*

Part III. Synchronisation to Harmonics and Sub-Harmonics ; Other Methods of Synchronisation.

## I. Synchronisation to Harmonics, i.e., Frequency Division

IT is well-known that relaxation oscillators can be readily synchronised to harmonic frequencies, and the process is in common use in the time-base circuits of oscillographs, in chains of multivibrators, etc. This was discussed at the beginning of Part I, and several references were given there to some of the adequate literature on the subject.

Feedback and other "sine-wave" oscillators can also be locked directly to harmonic frequencies, but not so readily as relaxation oscillators. The process is closely connected with the harmonic production in the oscillator itself, and in this respect the relaxation oscillator has the advantage. The distortion in a feedback oscillator is a rather variable quantity, and so makes synchronisation to harmonics unreliable. In consequence, the process is very rarely used. Some analysis of the problem is given in a paper on frequency dividers by R. L. Fortescue.<sup>1</sup>

However, synchronisation of feedback oscillators to harmonics can be effected by indirect means, as described below.

### I.1. Indirect Method

This method has been much used in the synchronisation of carrier telephone systems, where in the standard multi-channel system a pilot tone of 60 kc/s is transmitted to line from the frequency-control station and used at other stations to synchronise a 4 kc/s local master oscillator. In general the process is as follows: If  $f$  is the frequency required from the oscillator to be locked, and  $nf$  is the control frequency, then the latter is modulated with the  $(n-1)$ th harmonic of the oscillator output, and the resulting difference tone is injected as a normal

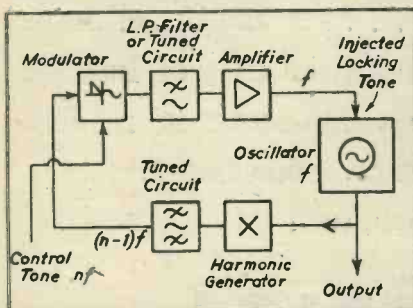
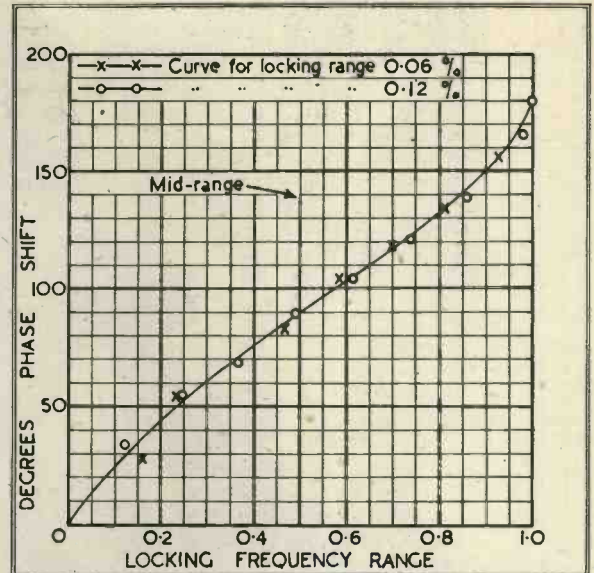

Fig. 1. Indirect Synchronisation to a Harmonic

\* P.O. Research Station.

Fig. 2. Phase Characteristics of 15th harmonic of oscillator in the scheme of Fig. 1. ( $n=15$ )



locking signal into the oscillator. Let the natural frequency of the oscillator be  $f + \Delta$ ; then the  $(n-1)$ th harmonic is  $(n-1)f + (n-1)\Delta$ . On modulating this with  $nf$ , the difference product obtained is  $f - (n-1)\Delta$ . If this is injected into the oscillator, whose natural frequency is still  $f + \Delta$ , it will evidently tend to reduce  $\Delta$  (since the sign of the error is opposite in the two frequencies) and as it does so the effect becomes stronger, so that finally  $\Delta$  becomes zero, and the oscillator is synchronised stably at a frequency  $f$ . The scheme is shown in block schematic form in Fig. 1. The detailed design is quite straightforward; the voltage of tone to be injected into the oscillator is found, in practice, to be the same as would be required if it were a constant frequency  $f$  instead of  $f - (n-1)\Delta$ .

This system of synchronisation gives a very good suppression of unwanted signals present in the control tone. No detailed tests have been made of single-tone suppression, but tests of "flutter" effect on telephone systems have been published elsewhere,<sup>2</sup> and show remarkable results.

It is important that the incoming control tone is modulated with the  $(n-1)$ th harmonic of the oscillator and not with the  $(n+1)$ th harmonic. If the latter is used, the difference frequency is  $(n+1)(f + \Delta) - nf$  which is  $f + (n+1)\Delta$ . If this is injected into the oscillator of frequency

$f + \Delta$ , it will obviously tend to increase the error, and a state of instability will be reached which is similar to the well-known "squegging."

The question of the phase characteristic of this synchronised oscillator system is of importance. It is evident that the phase relation between the output of the oscillator and the locking signal injected into the oscillator can vary from  $-90^\circ$  to  $+90^\circ$  over the locking range, just as in any other locked oscillator. But the phase relation that matters is that between the synchronising tone  $nf$  and the output of the oscillator. Consider a phase-change of  $\phi$  at the output of the oscillator; the phase-change at the output of the frequency multiplier is therefore  $(n-1)\phi$ . After modulation with the unchanged control tone, the phase-change on the injected tone is  $-(n-1)\phi$ , the sign being reversed as it is the difference frequency which is selected and the original phase-change occurred on the lower of the two frequencies being modulated together. Thus a phase-change of  $n\phi$  between injected locking tone and oscillator output corresponds to a change of only  $\phi$  at the output relative to the control tone  $nf$ . Since  $n\phi$  can vary over a range of  $180^\circ$ , then  $\phi$  can vary only  $180^\circ/n$  or  $\pm 90^\circ/n$ .

Some phase measurements were made on a system as described, in which  $n = 15$ . The phase variation of the output of the 15th harmonic of the



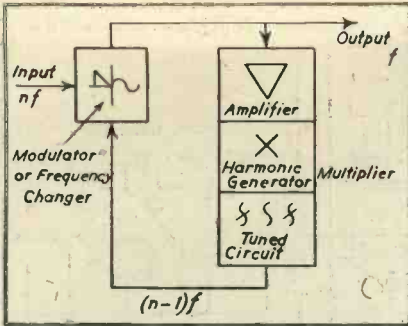

Fig. 3. Frequency-divider without free oscillator

oscillator was recorded over the locking frequency-range. Fig. 2 shows the results; in the frequency scale the overall locking range is taken as unity in order that the presentation may be free of the actual frequency range, of which the results are theoretically independent. The curve shows the variation for the 15th harmonic to be 180° overall, which corresponds to 12° at the oscillator output. This agrees, therefore, with the theoretical explanation above. The variation is seen to be symmetrical about the middle-point. However, the characteristic is not necessarily symmetrical; lack of symmetry is a common feature in synchronising problems (see Part 1, para. 6).

1.2. A Frequency-Divider not Capable of Free Oscillation

A disadvantage of all the types of frequency divider referred to above is that they involve oscillators capable of free oscillation. Thus, there are two dangers (a) they may pull out of lock and so give a beat-note or (b) the control tone may fail and leave the oscillator generating an inaccurate frequency. Moreover, the phase variations which occur may be inconvenient. It would from many points of view be advantageous to have a frequency divider in which the production of an output frequency is dependent on the presence of the input frequency, and which cannot drift into a "pull-out" condition.

This condition can be fulfilled by a circuit which is really a logical development of that described in paragraph 1.1 above, obtained by omitting the locked oscillator. In its simplest form the new circuit is as indicated in Fig. 3. The whole circuit is conveniently considered as consisting of two main portions, the frequency changer and the frequency multiplier. The general principle of operation is as follows: If the ratio of division is  $n$  and the required output frequency is  $f$ , then the frequency multiplier is designed to give the  $(n-1)$ th harmonic of  $f$ . This is then modulated with the input frequency  $nf$ , giving the required output frequency  $f$ , and

in addition  $(2n-1)f$ , which is readily eliminated, however. One obvious requirement for continued production of  $f$  is that the loop gain shall be slightly greater than unity at the required frequency, with a non-linear characteristic, just as in the case of a feedback oscillator. This is conveniently arranged in design as in the example shown in Fig. 4, by considering the input/output characteristics of the frequency changer and multiplier units separately. The example chosen is of a 750 to 150 c/s divider in which the multiplier produces, and selects the 4th harmonic of 150 c/s. It will be seen that the curves intersect at two points; this is more or less inevitable, since harmonic generators are not efficient at low input levels. Therefore, for an output frequency to be produced, the circuit must be disturbed artificially to bring the circuit voltages above those represented by intersection A. Above this point there is a gain round the loop circuit, so that the voltages build up until intersection B is reached, where the loop gain is zero. This is the stable working point.

It is not necessary to make any special provision for making the loop phase shift zero or  $2n\pi$  at the required frequency. The loop phase shift will automatically adjust itself when operation commences, because of the multiplication of phase in the

multiplier and the change of sign in the frequency changer. For example, if  $\phi$  represents the phase of  $f$  with respect to the input frequency  $nf$ , and if the phase shifts in the multiplier and frequency changer are  $\theta_1$  and  $\theta_2$  with respect to their output frequencies, then

$$\text{Phase at output of multiplier} = (n-1)\phi + \theta_1$$

Phase at output of frequency changer

$$= -(n-1)\phi - \theta_1 + \theta_2$$

and since this phase has already been defined as  $\phi$ ,

$$\phi = -(n-1)\phi - \theta_1 + \theta_2$$

$$\theta_2 - \theta_1$$

$$\text{or } \phi = \frac{\theta_2 - \theta_1}{n}$$

and therefore changes in  $\theta_1$  or  $\theta_2$ , which may occur with amplitude changes affect only the relative phases of the input and output frequencies, but will not otherwise affect the operation.

It is probably fairly evident now that the circuit is effectively a locked oscillator, but with the important properties that (a) if the input frequency fails there is no longer any output, and (b) the phase relation between output and input frequencies is fixed only by the nominally constant phase shifts in the networks of which the circuit is composed.

The amount of selectivity required

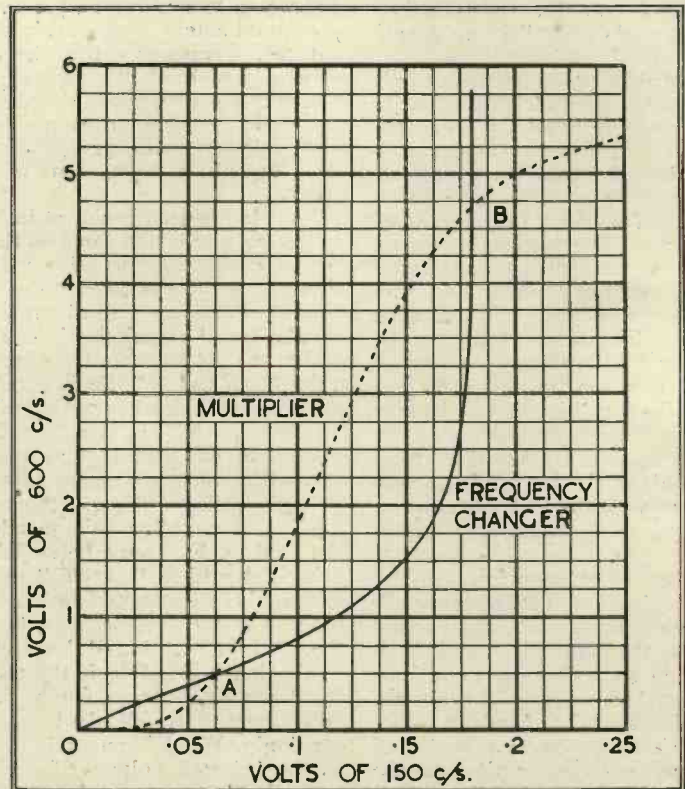

Fig. 4. Loop characteristic of 750 to 150 c/s divider (voltage of 750 c/s=0.7 volt.)







advantages of direct injection are (a) control by a small motor driving a tuning condenser on the oscillator, and (b) electrical control of frequency, using a valve as a variable circuit element. Both these methods can be used practically to eliminate the interference caused by unwanted signals present in the control signal (as will be discussed in Part 4), and both can be made to give no immediate change of frequency on failure of the control tone. To offset these advantages, there is a considerably more complicated circuit to design, construct and maintain, and in method (a) there is the additional disadvantage of no control whatsoever of phase variations.

3.1. Control by Motor

The scheme is briefly as follows: The synchronising tone is caused to beat with the output of the oscillator, and the beat frequency is arranged (by means of a phase-splitting circuit) to create a rotating field around a permanently magnetised rotor, which is coupled by gearing to the fine tuning air-condenser on the oscillator. The rotor turns in such a direction that the beat frequency is reduced, and finally a condition is reached in which the oscillator frequency is the same as that of the syn-

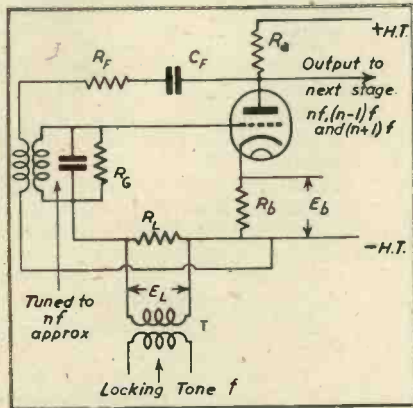

Fig. 6. Oscillator locked to sub-harmonic ( $R_L$  and  $E_L$  should read  $R_{syn}$  and  $E_{syn}$  respectively.)

chronising tone, and the rotor remains stationary until a change of frequency of the oscillator once more produces a rotating field. The motor can have a large mechanical inertia, and so can eliminate the effects of unwanted signals—it will respond only to the steady frequency approximately the same as the natural frequency of the oscillator. If the synchronising tone fails, the oscillator continues at the frequency at which it was last controlled—there is no sudden jump as in the case of an oscillator locked by injection. Owing to the slowness of the motor in following

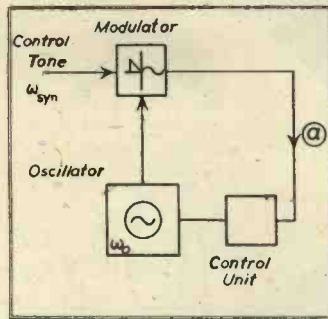

Fig. 7. Electrical control of frequency

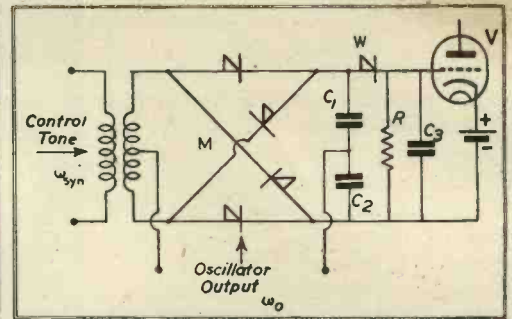

Fig. 8. Modulator and Part of Control unit for Fig. 7

and correcting errors of frequency, and owing also to backlash in the gearing, large errors of phase can arise, with no limit such as exists ( $\pm 90^\circ$ ) in the injection method. The system has been applied to a recent design of carrier telephone equipment.<sup>6</sup>

3.2. Electrical Control

Fig. 7 shows a block schematic of this system. The control tone has an angular frequency  $\omega_{syn}$  and the oscillator has an angular frequency at any instant of  $\omega_0$ . The output of the oscillator and the control tone are modulated together and the addition frequency removed by means of a filter or a shunt-connected condenser. The current in the output of the modulator unit, i.e., in path (a), is now

$$k \sin [(\omega_0 - \omega_{syn})t + \theta]$$

where  $k$  is a constant,  $\theta$  is the initial phase of  $\omega_0$  relative to  $\omega_{syn}$  at time  $t = 0$ . Now the control unit consists of some circuit that controls the frequency of the oscillator to an extent dependent on the current in the control path (a). Suppose, for simplicity, that the oscillator frequency varies directly as the current in (a). Let the oscillator frequency be  $\omega_N$  when the control is removed.

Then  $\omega_0 = K \sin [(\omega_0 - \omega_{syn})t + \theta] + \omega_N$  where  $K$  is a new constant.

The only stable condition is therefore

$$\omega_0 = \omega_{syn}$$

Any other solution gives  $\omega_0$  varying with time.

Therefore if this stable condition can be achieved, synchronisation is effected. Actually, the circuit as described will not automatically cause synchronisation to occur; it is necessary first to adjust the oscillator frequency until  $\omega_0 = \omega_{syn}$ . After this, however, we evidently obtain the relationship (from the equation above, when  $\omega_0 = \omega_{syn}$ ).

$$\omega_{syn} - \omega_N = K \sin \theta$$

and the current in the control path be-

comes dependent on the phase angle  $\theta$  between the oscillator output and the control tone. Thus, if the oscillator frequency now tends to change, the control current changes and readjusts the frequency. The important properties of this circuit are therefore:

(a) "Pull-in" is not automatically effected; but once synchronised, the oscillator will remain synchronised over the range of the control unit.

(b) The phase relationship between the oscillator output and the control tone is strictly controlled, and thus large phase errors cannot accumulate as they do in the motor control system.

The control unit can function in three ways: (a) the control current is applied to the grid of a valve so as to determine its anode impedance. This impedance is then used as part of the oscillator feedback resistance, and can in this way exert a small control of frequency, by means of the amplitude changes it can produce. These act chiefly on the inductance if it is iron-cored, but the changed distortion in the valve also influences the frequency.

(b) The control current is applied to a valve so as to change its input capacitance ("Miller" effect), which can be connected in parallel with the tuning capacitance of the oscillator, and so control the frequency.

(c) The control current is used as in (a) to determine the resistance of a valve, which is incorporated in one of the tuning resistances of an RC-tuned oscillator; this method gives a very wide range of frequency control.

The inability of the simple scheme described to "pull-in" when a frequency difference exists is a serious disadvantage. It can be overcome by using the circuit of Fig. 8 for the control unit. M is a ring modulator, with the switching tone fed through condensers  $C_1$  and  $C_2$  on the output side. W is a rectifier working into the resistance-capacity circuit,  $R_3, C$ . When  $\omega_0 = \omega_{syn}$ , only direct current is produced by the modulator, and W acts only as a resistance. The grid

potential of valve V is determined by the phase relation between  $\omega_0$  and  $\omega_{syn}$  and has control of the frequency as described above. When  $\omega_0$  and  $\omega_{syn}$  are different, however, the output of M consists of the sum and difference frequencies,  $\omega_0 + \omega_{syn}$  and  $\omega_0 - \omega_{syn}$ . The former is more or less eliminated if the condensers  $C_1$  and  $C_2$  have a sufficiently large capacitance, leaving only  $\omega_0 - \omega_{syn}$  to be rectified by W.

If  $C_3$  is not too large, the steady potential difference between grid and cathode will vary with the frequency  $\omega_0 - \omega_{syn}$ . Thus the valve V can change the oscillator frequency in accordance with this potential difference in such a direction as to reduce  $\omega_0 - \omega_{syn}$ , eventually making this difference zero, and bringing the circuit to the first condition described. This pull-in property can be made effective over as large a range of frequency as the control valve can deal with.

#### BIBLIOGRAPHY

1. R. L. Fortescue, "Quasi-Stable Frequency Dividing Circuits," *J.I.E.E.*, June, 1939, p. 693.
2. D. G. Tucker, "Carrier Frequency Synchronisation," *P.O.E.E.J.*, July, 1940, p. 75.
3. D. G. Tucker and H. J. Marchant, "Frequency Division without Free Oscillation," *P.O.E.E.J.*, July, 1942 p. 62.
4. R. L. Miller, "Fractional-frequency Generators utilizing Regenerative Modulation," *Proc.I.R.E.*, July, 1939, p. 446
5. D. G. Tucker, "The Generation of Groups of Harmonics," *Electronic Engineering*, Nov., 1942, p. 232.
6. F. J. D. Taylor, "Carrier System No. 7," *P.O.E.E.J.*, Oct., 1941, p. 101.

#### Advice to Learners

"There's one thing about this radio business that sort of gripes the old timers. Nobody expects to start shooting a 75, a 37, a machine gun or even a pistol until he's been taught a lot. But when it comes to a radio set—that's different, and any healthy American over 18 (and not dead drunk) is, for some reason or other, supposed to be able to walk up to the near side of a radio set, look it squarely in the eye, rapidly twist all the knobs in a different direction, stick a couple of plugs inside and, presto—it talks both ways. But the above is pretty near 100 per cent. baloney, and don't let it fool you."

—From a U.S. Signal Corps Instruction pamphlet.



### AT THE MOMENT

Our entire productive capacity is engaged one hundred per cent. providing "the tools to finish the job"—and we are getting on nicely—Until this is accomplished we must grin and bear it, and look forward to the day when our Potentiometers will again be available for normal trade purposes—Roll on the Day!

## RELIANCE

Manufacturing Co. (Southwark) Ltd.  
Sutherland Road, Higham Hill,  
Walthamstow. E. 17,  
Telephone—Larkwood 3245

Wartime installations show more conclusively than ever that

you can

trust

# TRIX

Quality SOUND Equipment

To Priority Order Only



To priority order only.

30 watt Amplifier  
Model T633

There are TRIX Amplifiers from 5-500 watts.  
Send for details.

**TRIX ELECTRICAL CO. LTD., 65, Bolsover St., London, W.1.**  
Phone EUS 5471/2  
Grams: Trixradio, Wesdo, London.

## June Meetings

### Institution of Electrical Engineers Student's Section

A visit has been arranged for June 5 to Messrs. W. T. Henley's Telegraph Works Co., Ltd. Details may be obtained from the Secretary, 9 Cranley Road, Ilford, Essex.

### Institute of Physics

The Summer Meeting of the London Branch of the Institute of Physics will be held jointly with the London Mathematical Society on Saturday, July 3, 1943, in the rooms of the Royal Society, Burlington House, Piccadilly, London, W.1, commencing at 2.0 p.m., and will take the form of a Conference on "The Applications of Mathematics to Physics."

Papers will be presented as follows:—

1. "Matrices in Practical Mathematics," by Dr. A. C. Aitken, F.R.S. (University of Edinburgh).
2. "Computational Methods and Mathematical Tables," by Dr. L. J. Comrie.
3. "Mathematical Solutions by Models," by Mr. H. L. Blackburne (Messrs. Merz & McLellan, Consulting Engineers).
4. "Applications of Elementary Mathematical Processes — with Special Reference to Circuit Theory," by Dr. S. Whitehead (The British Electrical and Allied Industries Research Association).

Opportunity will be given for discussion on each paper. A break will be made for tea. Visitors will be welcome without formality.

### Brit. I.R.E.

There will be a meeting of the North-Eastern Section on Friday, June 4, at Rutherford College, Newcastle-on-Tyne, when Mr. L. C. Pocock, M.Sc. (Messrs. Standard Telephones and Cables) will read a paper on Microphones and Receivers. The meeting will commence at p.m. This paper was read before the London Branch on April 30.

### The Association for Scientific Photography

A meeting of the Association for Scientific Photography will be held on Saturday, June 5, 1943, at 4 p.m., in the Lecture Theatre of the Royal Institution, 21 Albemarle Street, London, W.1. The meeting is open to all persons interested in the application of photography to scientific work, and particulars of the association can be obtained from the Hon. Secretary, Mr. R. McV. Weston, "Houndwood," Farley, Salisbury, Wilts.



# Wave Analysis

## Part III—Analysis of Periodic Wave-Forms (Concluded)

By K. BOURNE\*

### Heterodyne Methods

The heterodyne method covers the broad field of what is often known as "Search-tone" analysis. The apparatus may be very simple or very complex, and in general the method is extremely flexible. While no rigid demarcation is possible, there are two fairly distinct groups: that in which the "Search-tone" is set to approximate to the frequency of the component to be measured, and that in which the heterodyne tone changes the frequency of the selected component to that of a fixed frequency selective element, at which frequency the component is amplified and filtered as required. In essentials, the two divisions are the same—the waveform is modulated by another, reasonably harmonic-free, oscillation: the sum or difference product of the modulating tone with the selected component is filtered, amplified if necessary, and measured on the indicating instrument. Thus the basic requirements are search-tone, modulator, selector and indicator, and these will be considered in turn.

The heterodyning oscillator will not be considered in detail. If a very low second-frequency is chosen, the oscillator may need to be a beat-frequency type to conveniently cover a wide range: one of the advantages of a high selector frequency is that a small percentage change of frequency in the oscillator covers a wide range of analysis-frequency (e.g., for a second-frequency of 50 Kc/s., an oscillator range of 40-50 Kc/s. or 50-60 Kc/s., depending upon which sideband is used, will cover a band of 0-10 Kc/s.). Such an oscillator, even if of very simple and straightforward design and construction, can by virtue of the small frequency ratio over which it has to work give a constant output with low harmonic content: but evidently as the second-frequency goes up, the frequency stability required in the heterodyning oscillator rises in proportion. The design of oscillators has been dealt with too fully and too often for there to be any purpose in repeating the details or giving many references: certain general articles may be referred to,<sup>13 14 15</sup> and the subject is considered in most of the references to search-tone analysers given.

Almost all conceivable non-linear

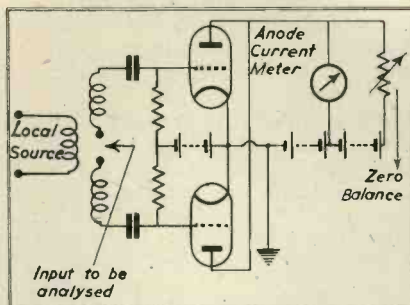

Fig. 9. Valve Voltmeter Analyser.

circuits have been pressed into service as modulators. In particular, meters have been widely used: a non-linear meter is almost a complete analyser in itself, combining modulator, selector and indicator, needing only an oscillator to provide a set-up for harmonic measurement. The meters used for the purpose have been in general of the dynamometer or valve-voltmeter type: an electrometer has also been used.<sup>16 17</sup> Dynamometer instruments have been used for harmonic analysis since the beginning of the century, and much work has been done to determine the conditions for accuracy in their use. The instantaneous torque on the movement (to which the deflection is proportional) is given by  $k i_1 i_2$  where  $k$  is a meter constant and  $i_1 i_2$  the instantaneous currents in the moving and fixed coils. If now  $i_1$  is a search tone given by  $i_1 = I_1 \sin \omega_1 t$  and  $i_2 = I_2 \sin \omega_2 t$  the movement torque will be  $k I_1 I_2 / 2 [\cos (\omega_1 - \omega_2) t - \cos (\omega_1 + \omega_2) t]$ . The term of frequency  $\omega_1 + \omega_2 / 2\pi$  will in all normal cases be beyond the maximum frequency at which the meter will vibrate, and if  $\omega_1 \approx \omega_2$ , the meter needle will oscillate at a frequency  $\omega_2 - \omega_1 / 2\pi$  with an amplitude of  $k I_1 I_2 / 2$  either side of zero. If  $k$  is found (e.g., from a D.C. calibration) it is seen that a knowledge of  $\omega_1$  and  $I_1$  will determine the value of  $I_2$  and  $\omega_2$  (the values  $I_1$  and  $I_2$  given above are peak and must be divided by  $\sqrt{2}$  if r.m.s. values are required). From this it is seen that if  $i_2$  consists of a number of terms of different frequencies  $\omega_3, \omega_4$ , etc., the torque will be found by summing a number of terms of frequencies  $\omega_1 \pm \omega_2 / 2\pi$ ,  $\omega_1 \pm \omega_3 / 2\pi$ , etc., which will only have an effect on the meter when their frequencies are very low, i.e., when  $\omega_1 \approx \omega_2$  or  $\omega_1 \approx \omega_3$ , etc. Thus the meter

acts as a modulator and low-pass filter, and by reason of its considerable inertia, possesses great inherent selectivity. This selectivity may be too great in some cases, needing impracticably high frequency stability in either source or search-tone: in this case a meter with less inertia is required, and may be a suspended or string electrometer (see the discussion appended to Cockcroft, Coe, Tyacke and Walker's paper<sup>17</sup> and reference quoted above).<sup>18</sup> The conditions for accuracy with a dynamometer instrument are considered at length by Cockcroft, Coe, Tyack and Walker.<sup>11</sup> (See also reference<sup>18</sup>). In particular it is shown that second order products due to harmonics from the auxiliary oscillator are of small importance in most practical cases. If currents other than the very low frequency difference tones had no effect on the reading, the sensitivity of the method (given sufficient pre-amplification) would be limited only by the ability of the instrument to stand the large instantaneous torque values concerned, and to dissipate the heat produced by the considerable power involved: however, the inevitable slight variation of the meter constant over the range will cause rectification of the higher-frequency terms and give a false deflection (that is, the meter will not be a perfect multiplying modulator, and a unidirectional component, and possibly unwanted modulation products will be produced). The method will give good results on harmonics of the order of 1 per cent., but is not suitable for high frequencies, due to the inductance of the dynamometer coils. In this respect, the electrometer would be very much better, assuming its capacitance were kept reasonably low.

The valve-voltmeters used have been of the square-law anode bend type. A valve working under this condition has a characteristic which is given approximately by

$$i_a = ae + be^2 \quad \text{where}$$

$i_a$  is the anode current  $e$  is the voltage applied to the control grid: and if a wave-form  $E_0 \cos \theta_0 + \sum E_n \cos \theta_n$ , is applied, where  $E_0 \cos \theta_0$  is the variable search tone and  $\sum E_n \cos \theta_n$  is the waveform to be analysed,  $i_a = a(E_0 \cos \theta_0 + \sum E_n \cos \theta_n) + b(E_0 \cos \theta_0 + \sum E_n \cos \theta_n)^2$ . Due to the inertia of the anode-current meter, only the D.C. component and any very low-frequency terms will be

\* Post Office Research Station.

indicated. If the expression for  $i_a$  is expanded, then besides the D.C. component and high-frequency terms, there are a number of different terms in the product  $2bE_o \cos \theta_o \Sigma E_n \cos \theta_n$   $b(\Sigma E_n \cos \theta_n)^2$  which can produce low frequencies. The second of these cannot produce low-frequency terms if it is a harmonic series, but if it contains random frequencies, it may give fixed beats (*i.e.*, of frequency independent of the search-tone frequency). These beats are thus easily recognised by their constant frequency, but will normally render the method difficult or useless: thus it cannot be used for non-harmonic wave-forms in general (though in the majority of cases it is quite satisfactory, the chance of unwanted beats occurring being very small). The product term given above will be the sum of terms of the form  $2bE_o E_n \cos \theta_o \cos \theta_n = bE_o E_n [\cos(\theta_o + \theta_n) + \cos(\theta_o - \theta_n)]$  and thus if  $\theta_o$  is made nearly equal to  $\theta_n$ , the anode current meter will indicate a current swing given by the low-frequency component  $bE_o E_n \cos(\theta_o - \theta_n)$ , *i.e.*, with a half-swing amplitude of  $bE_o E_n$

and although the magnitude of the coefficients  $c, d$ , etc., fall rapidly as the degree of the terms increases, the third order coefficient at least is by no means negligible. A portion of the valve characteristic can be found quite accurately quadratic, but if the amplitude of the applied voltages is such as to swing beyond the limits, the accuracy falls rapidly: the sensitivity of the meter cannot be increased indefinitely to enable the applied voltages to be kept low, since it is then prohibitively difficult to keep the residual current balance steady. A considerable gain is achieved by using a matched pair of valves, as in Greenwood's<sup>20</sup> development of the original method (Fig. 9) since in this case the third order term will be cancelled out and the extent of the quadratic characteristic considerably extended. This method can enable estimates to be made of harmonics of the order of .1 per cent., as compared with about 1 per cent. when a single valve is used.

The attempt to combine so many functions naturally leads to lower

is to replace the valves with metal-rectifiers, as shown in Fig. 10b; this circuit is usually worked as a switching modulator, *i.e.*, the local oscillation is at a considerably higher level than the tone to be analysed, and thus alone controls the resistance of the rectifiers, so that they are conductive and non-conductive on alternate half-cycles. A more fully developed form of this modulator is the "ring" modulator shown in its usual form in Fig. 11 (refer to references quoted above,<sup>23, 24</sup> for detailed theory). From the two forms in which the modulator is drawn, it is seen that it is balanced against both inputs, and is usually finally adjusted to eliminate the local oscillation by feeding this into one transformer via a low resistance potentiometer (*see* Fig. 11b) a capacitance balance being added if very complete elimination is desired (a differential condenser across the transformer is the simplest method). With such a modulator the main modulation products are of the form  $(2n-1)C+V$  where  $C$  is the local frequency,  $V$  the input frequency and  $n$  an integer: those of the form  $C+nV$  can be reduced to very low proportions by working the modulator at a low input level, and the complex products  $mC+nV$  where  $m$  and  $n$  are integers greater than one are of too low a level to give trouble. By using a comparatively high frequency selective element, unwanted products which might give false indications will fall well beyond the frequency of the selector: if  $C$  is considerably higher than  $V$  (*i.e.*, many times  $V$ ) it will matter little which sideband is chosen, but the lower sideband is best, as this gives a higher value of  $C$  for a given selector frequency. There is no possibility of placing  $C+nV$  products outside the band, since these are of the same

(again it must be noted that the values thus obtained will be peak). Thus any component of the wave-form can be detected by beating with the local oscillator and its value found from the amplitude of the beat. There will be also, besides this current swing, a D.C. component (this is, of course, what is normally required and utilised in a valve voltmeter). This can be balanced out, and thus will not affect the sensitivity of the method; it need not even be balanced out to any great degree of accuracy, since the amplitude of the swing is given by the difference of the extreme meter readings.

This method was proposed by Suits<sup>19</sup> and has the advantage over the dynamometer instrument of consuming only a negligible amount of power, and of having a very wide frequency range. Its chief limitation is that a valve characteristic is not accurately quadratic: the anode current is given by

$$i_a = ae + be^2 + ce^3 + de^4 \dots$$

accuracy and less flexibility than is possible when the functions of modulator, selector and indicator are separated. Thus, the anode-bend modulator, normally in its balanced form (Carson<sup>21</sup> or Heising<sup>22</sup> modulator) is widely used, though it is being superseded by rectifier modulators.<sup>23, 24</sup> The principle of the Carson or Heising modulator is shown in Fig. 10a, and is seen to be very similar to Greenwood's valve-voltmeter circuit. It is usually worked as a square-law modulator, and being balanced eliminates or greatly reduces the strength of third-order components, as well as balancing out one of the inputs. The local oscillation is usually applied between the input transformer centre-point and earth, and if the circuit were completely balanced, would not appear in the output. Residual unbalance can be corrected by the balancing circuit shown dotted, or by equivalent means.

A natural development of the circuit

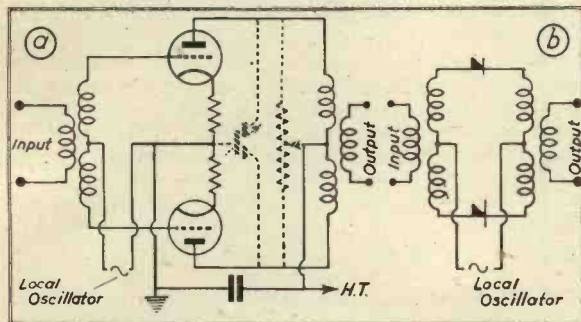

Fig. 10. (a) Carson Modulator. (b) Rectifier Modulator.

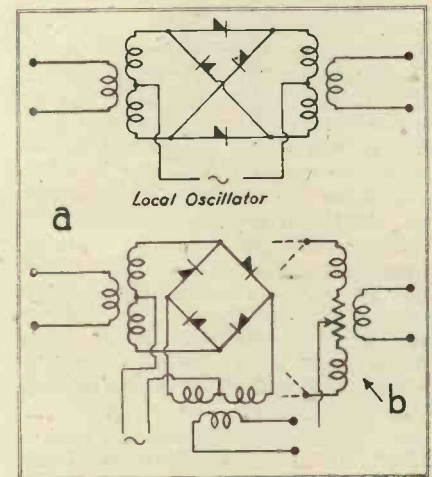

Fig. 11. Ring Modulator.



form as the harmonics which it is desired to measure; they must evidently be eliminated as completely as possible, which can be done by using a low input level. The same necessity holds for the Carson type of modulator, which is even more susceptible to overloading. Caruthers<sup>23</sup> gives figures to show that for an input level of 30 db. below 1mW. to a modulator with an oscillator input of 0.75v., the  $C + nV$  products will be of the order of 80 db. or more below the wanted output: this is fairly satisfactory, and it is evident that the input level can be made still lower if necessary without getting down to resistance noise (though trouble may be found with mains interference picked up by the transformers if the level be made too low).

There has been an increasing tendency to resort to the rectifier modulator described above, though the Carson type has been widely used. Many other types have been employed where requirements were not very onerous. The single valve modulators of anode-bend or multi-grid type have been used for the sake of simplicity and general convenience: their

pose of the heterodyne principle is to get increased selectivity, this is a primary requisite. The use of low selector frequencies is attended by considerable disadvantages in the operation of the modulator, but a low-pass filter as selector offers a ready means of obtaining very high selectivity. Preferably the filter should cut off below 50 c/s. to avoid mains pick-up (and to allow the frequency range to extend to a low frequency). Alternatively, if for use at high frequencies only (*i.e.*, above about 2 Kc/s.), a band-pass filter or several tuned circuits resonating in the audio-frequency band can be used; there is then the minor disadvantage of two tuning positions. Although the low-pass filter form of analyser has been widely used, it is not in general so satisfactory as the use of a high selector frequency (30-50 Kc/s. is usual for an analyser covering the audio band). The magnetostriction<sup>31</sup> and electro-mechanical<sup>32, 33</sup> resonators, widely used before the introduction of crystal filters, have been largely replaced by quartz resonators, preferably used in the form of narrow-band filters.<sup>35, 36</sup> A crystal filter selector gives a flat-top

Moore and Curtis<sup>33</sup> is shown in schematic form in Fig. 12; the modulator was of the Carson type, giving a suppression of some 60 db. against interfering products, and the selector frequency was made approximately 11 Kc/s., the audio band covered being 0.5 Kc/s. The selector was a centre-clamped steel rod, vibrating longitudinally, using telephone receivers as drive and pick-up elements: it had an equivalent "Q" of about 15,000. With this high value, the resonance was extremely sharp and tuning could not have been easy, but the selectivity was good, the response being some 40 db. down at  $\pm 40$  c/s. off tune. An instrument on a similar principle, used as part of a noise meter, was described by Osborn and Oplinger<sup>31</sup> considerably later; they used a balanced rectifier modulator, followed by a mechanical filter in many ways similar to that of Moore and Curtis, but using a brass rod with drive and pick-up coils attached. The utmost selectivity was not desired: 20 db. at about  $\pm 45$  c/s. from resonance was obtained with comparatively thin rod ( $\frac{1}{4}$  in. brass as against  $\frac{1}{2}$  in. steel of Moore and Curtis); this resonator was

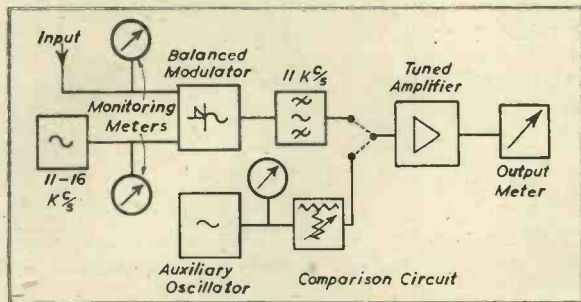
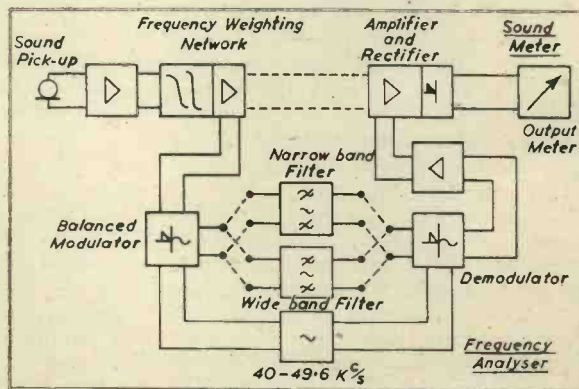

Fig. 12. Heterodyne Analyser of Moore and Curtis.

Fig. 13 (right). Sound Meter and Analyser of Castner.



general theory is considered by Strutt and others (Strutt includes a large bibliography in his paper;<sup>25</sup> a magnetic modulator is used by Barrow);<sup>27, 28</sup> and in order to obtain a very large degree of selection together with excellent square law characteristics, thermal modulators either in bridge form<sup>29</sup> or using a saturated diode with the input and search frequencies supplying the heating current for the diode filament<sup>30</sup> (a lamp bulb and photocell has also been used.)<sup>30</sup> These thermal methods are, of course, only suitable for those analysers in which the search tone is adjusted almost to coincidence with the component to be measured. After the modulator, the modulated wave-form is applied to the selector, which competes with the modulator as the key-stone of the whole apparatus. Since the main pur-

characteristic with a very high attenuation beyond the cut-off frequencies, as opposed to the inconveniently sharply-peaked resonance curve of a high "Q" magnetostriction or single quartz "Crystal gate" resonator.

The problem of the forms of indicator best adapted to recording and non-recording instruments has already been considered: it now remains to see how the design of suitable analysers has been dealt with in practice. The heterodyne analyser was foreshadowed with the development of the superheterodyne radio receiver, to which it is closely analogous: and the Bell Laboratories in 1927 published details of two instruments which can be considered as prototypes of two main forms of analyser.

The first of these, described by

followed by a tuned transformer to increase the selectivity at some distance from resonance. It is usually necessary to supplement magnetostriction, electro-mechanical and piezo-electric resonators with further tuned circuits, since these special devices may freely pass frequencies at some distance from their resonant point. The upper frequency limit was again fairly low (5,200 c/s.) and the selector frequency 6,800 c/s.

Meanwhile the quartz crystal was developed as a selective element, and in 1933 an analyser was produced<sup>37</sup> incorporating two crystals in a "Crystal gate" circuit. A Carson modulator was used, interfering products being some 70 db. below the wanted signal; the two crystals were operated at "Q" values of 20,000 and 5,000. The selectivity was some 60 db. at  $\pm 80$  c/s.

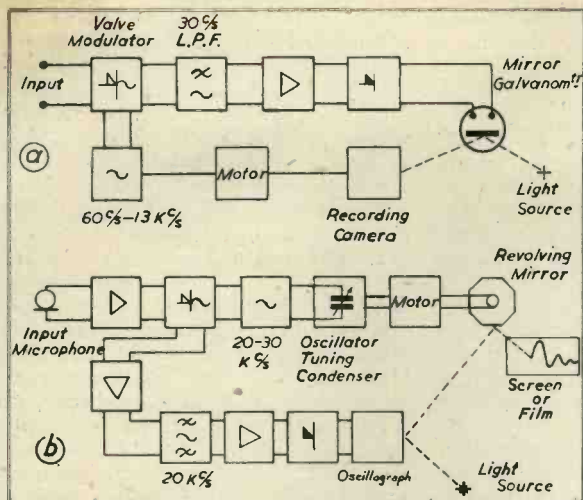

Fig. 14. (a) Grutzmacher's Recording Analyser. (b) Schuck's Recording Analyser.

off resonance. The range extended to 15 Kc/s., the oscillator varying from 35 Kc/s. to 50 Kc/s. (the crystal frequency). This instrument was widely used and was further developed some years later,<sup>38</sup> the chief alterations being the use of three three-electrode crystals to give a "flat-top" characteristic, of width about  $\pm 1.5$  c/s., with 60 db. suppression  $\pm 35$  c/s. from resonance; a linear meter in place of a square law indicator; and a phase-splitting valve to feed the Carson modulator in place of a transformer (an input transformer unless carefully shielded is very likely to pick up mains hum). In the meantime, Castner<sup>39</sup> in 1935 described an instrument having several novel features. (See Fig. 13). It was designed as part of a sound meter, and used wide (500 c/s.) and narrow band (22 c/s.) quartz filters operating around 40 Kc/s.: the 22 c/s. filter had some 50 db suppression at 100 c/s. off tune. The analyser incorporated a balanced rectifier modulator and demodulator, the demodulation of the component after selection allowing the same amplifiers and meter to be used as when the equipment was employed as a non-selective noise-meter: this method also allows aural observation, and measurement of very low frequencies. Normally such measurements are complicated by the local oscillator frequency passing the selector: in this case, any such frequency will only give a D.C. component when demodulated. Another recent design<sup>40</sup> covering 20 c/s.–15 Kc/s., uses a balanced rectifier modulator, fed by a cathode-coupled valve: the two stage crystal circuit gives a  $\pm 2$  c/s. flat top, and suppres-

sion greater than 40 db. at 30 c/s. off tune.

The second wave analyser from the Bell Laboratories in 1927, described by Landeen<sup>42</sup> was for use at higher frequencies (3 Kc/s.–50 Kc/s.) and had a selector frequency of 800 c/s. Using several tuned circuits, the response obtained was greater than 50 db. down at 250 c/s. off tune, which was ample for the intended purpose and could readily have been increased. A Carson modulator was used, and intermodulation tones were at least 85 db. down: this excellent figure was obtained by the aid of two preselector circuits before the modulator. The possibility of using ganged preselector circuits is a considerable advantage possessed by this type of analyser when employed at fairly high frequencies, as the preselection may amply compensate for the inferior modulation characteristics produced by the use of a low second frequency. Such an analyser is to all intents and purposes similar to a high grade communications receiver, and such a receiver makes an excellent analyser. For analysers covering the audio-frequency band, a low-frequency selector is not very satisfactory. They have been used for recording instruments where speed was not essential and high selectivity desired, and in one or two specialised cases,<sup>27, 29, 30</sup> where extreme selectivity was desired: it is possible to separate components less than 1 c/s. apart by such means. Double modulation has also been used to obtain extra selectivity.<sup>42</sup>

A third general type is the recording analyser, where the audio-frequency range is desired to be covered as quickly as possible. As emphasised in Part II, speed is inevitably lowered

as resolution increases, but exact relationships have not yet been fully worked out. Figs. 14a, 14b and 14c show three of the successful arrangements employed, those of Grutzmacher,<sup>43</sup> Schuck,<sup>44</sup> and Hall<sup>45</sup> respectively. The first of these uses a low-pass filter of 30 c/s. cut-off and covers a range of 0–13 Kc/s.; the speed is comparatively slow, due to the high resolution; the use of an indicator scale tending to square-law renders the accuracy and sensitivity very low. A later development is the "Sound Prism" of Schuck, which uses a high selector frequency (20 Kc/s.) and covers the frequency range (several are provided, 0–5 Kc/s. and 2–10 Kc/s. being the most used) in about 1/10 second, with a resolution of 200 c/s. Still later is the analyser of Hall, who uses two 20 Kc/s. magnetostriction resonators, with a response 50 db. down at 100 c/s. off resonance. This high selectivity has meant the sacrifice

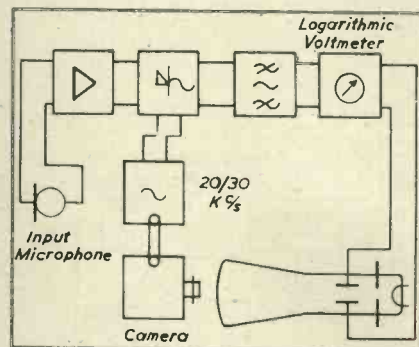
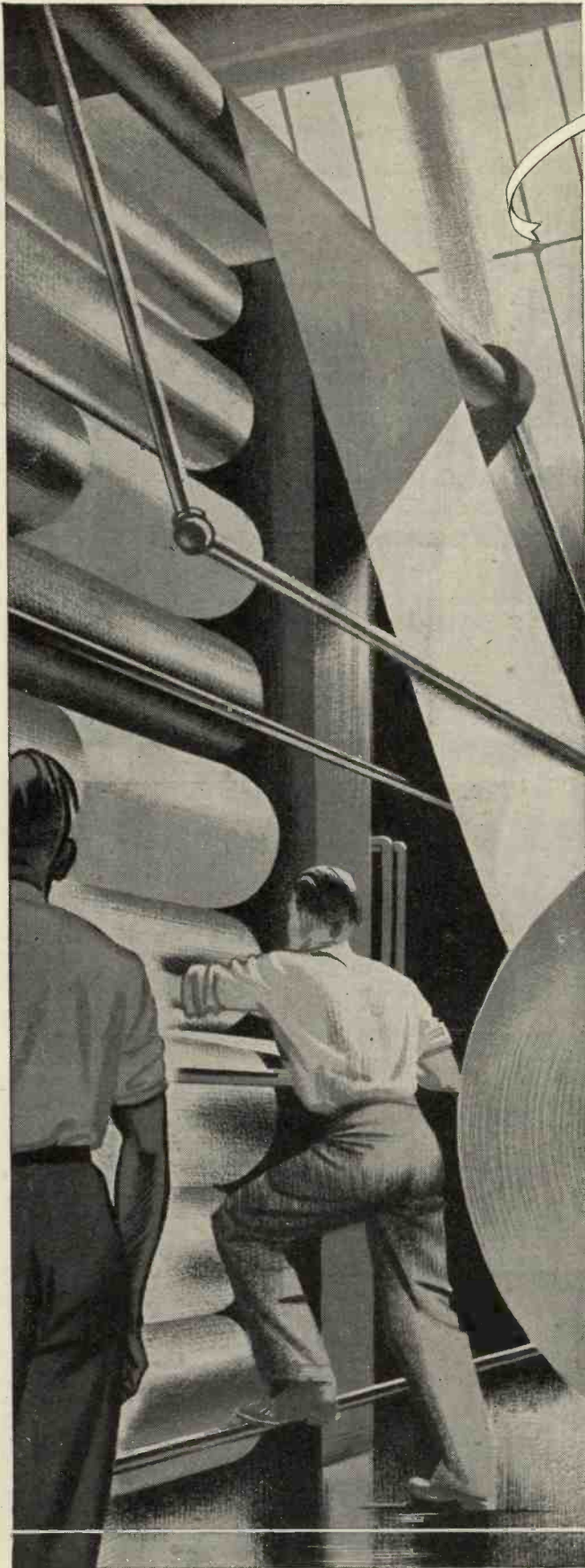

Fig. 14. (c) Hall's Recording Analyser using C.R. Tube.

of speed, the range 50 c/s.–10 Kc/s. being covered in 4 seconds. All these analysers use Carson modulators. The three references above all give discussions of the relation of analysing speed to resolution, and the problem has also been dealt with by Kupfmüller,<sup>43</sup> Salinger,<sup>47</sup> Lewis,<sup>48</sup> and Feldtkeller and Wilde<sup>49</sup> It has been stated that the speed of the heterodyne type analyser is inversely proportional to the square of the resolution, and Salinger using a Fourier Integral method, obtains the criterion  $\gamma = F^2/16$  where  $\gamma$  is the speed in c/sec.<sup>2</sup> and  $F$  the cut-off frequency of a low-pass filter used in a heterodyne analyser (*i.e.*,  $F$  is half the band-width); he also states that this applies to the case where a band-pass filter is used at higher-frequencies. Experimentally, Schuck has found that using a number of loosely-coupled tuned circuits,  $\gamma \approx 64F^2$  is more suitable; he considers





# Valves and Paper

Paper is manufactured in the reel, and for many purposes it remains in reel form until it is finally printed and cut—as, for example, in the production of printed labels and wrappers. This method calls for a very high degree of accuracy in the final operation of cutting the paper to size, since even the slightest error in timing when the reel is fed to the cutter means that the printed design will be out of register.

This is another typical instance where the Thermionic Valve can solve the problems of industry. By means of valves and light-sensitive cells in a suitably designed control system, the printed design itself can be used to regulate the speed of the paper through the rollers and determine its exact position under the cutters. This ensures a degree of precision unobtainable by mechanical methods; the accuracy is not affected even by a variation in the size of the design due to expansion or contraction of the paper.

## MULLARD

THE MASTER VALVE

*A Valve for Every Purpose*



DOMESTIC • COMMERCIAL • INDUSTRIAL  
SCIENTIFIC • MEDICAL • EXPERIMENTAL

the form of the selector will influence the result apart from its transmission characteristic: this seems very unlikely from general principles. Lewis using operational calculus, and contour integration with a graphical method to evaluate the integral obtained, has obtained interesting curves for single resonant circuits, but was unable to generalise his results: Feldtkeller and Wilde give an approximate graphical method of general application for a single resonant circuit, and allowing a certain amount of shift of the resonant point, a speed of 6 seconds per Kc/s. per  $\pm 10$  c/s. band-width is allowable, i.e.,  $\gamma = 16.7F$  and speed is inversely proportional to the resolution. And there the matter rests: it is known that a shift and a blunting of resonance occurs and secondary maxima appear above resonance if the frequency passes too swiftly through the natural frequency of the selector and simple cases have been evaluated; the effects have been observed experi-

mentally on several occasions (see for example Schuck and Hall, l.c.). Unfortunately a single resonant circuit is not of much use for analysis purposes, and a general solution for a given form of frequency response appears to be lacking: and if found, would most likely be too difficult in the evaluation for practical application. Experiments to determine the maximum usable speed will thus continue to hold the field for the present.

### III. Other Methods of Analysis

There are one or two methods which are of interest and are mentioned to complete the survey. The stroboscopic method of de Nemes<sup>50</sup> uses a stroboscope disk with concentric rings of black and white segments, the numbers of segments in adjacent rings rising in integral multiples of the smallest number. The disk is driven synchronously with the fundamental of the applied wave-form, and illuminated proportionately to the wave-form amplitude: the dark and light shad-

ing appearing on the rings gives an indication of the harmonic content. Accurate measurement is not possible, but a direct indication of the phase position of the harmonics is given.

An accurate method for the measurement of amplitude and phase of odd harmonics of power frequencies is described by Gall,<sup>51</sup> and a somewhat similar device by Gates.<sup>52</sup> His method uses a synchronously driven disk with a varying number of contacts, so that the indicating meter is connected to the supply  $n$  times per cycle where  $n$  is the order of the harmonic concerned. By suitably proportioning the contacts, the maximum obtained when the contact is moved around the disk will indicate to a considerable degree of accuracy the harmonic amplitude. The conditions for accuracy and the design of the disk are discussed by Gates (l.c.). Contact trouble prevents the use of this device at audio frequencies, but for power frequencies it has the considerable advantage of substantial immunity from variations of frequency.

## BIBLIOGRAPHY

- 1 Morgan, *J.I.E.E.*, 71, 431, p. 819 (November, 1932).
- 2 Churcher and King, *J.I.E.E.*, 68, p. 97 (1930).
- 3 Wegel and Moore, *B.S.T.J.*, 3, p. 299 (1924) or *Trans. A.I.E.E.*, 43, p. 457 (1924).
- 4 Delsasso, *J.A.S.A.*, 3, 1, p. 167 (July, 1931).
- 5 Piddington, *P.I.R.E.*, 24, 4, p. 591 (April, 1938).
- 6 Barnard, *Elect. Comm.*, 16, 2, p. 158 (October, 1937).
- 7 Scott, *P.I.R.E.*, 26, 2, p. 226 (February, 1938).
- 8 McCurdy and Blye, *Trans. A.I.E.E.*, 48, 4, p. 1167 (October, 1929).
- 9 Ballantine, *Electronics*, 2, p. 472 (1931).
- 10 Ryall, *Inst. P.O.E.E.*, Printed paper No. 155 (1934).
- 11 Payne and Story, *W.E.*, 12, 146, p. 588 (November, 1935).
- 12 Hunt, *R.S.I.*, 4, p. 672 (1933).
- 13 Groszkowski, *P.I.R.E.*, 21, 7, p. 958 (July, 1933).
- 14 Llewellyn, *P.I.R.E.*, 19, 12, p. 2063 (December, 1931) or *B.S.T.J.*, 9, p. 67 (January, 1932) or *Bell Monograph*, B.640.
- 15 Dow, *P.I.R.E.*, 19, 12, p. 2095 (December, 1931).
- 16 Grutzmacher, *Z.f.t.P.* 10, 11, p. 572 (1929).
- 17 Cockcroft, Coe, Tyacke and Walker, *J.I.E.E.*, 63, 337, p. 69 (1925).
- 18 Nicholson and Perkins, *P.I.R.E.*, 20, p. 734 (April, 1932).
- 19 Suits, *P.I.R.E.*, 18, 1, p. 178 (January, 1930).
- 20 Greenwood, *W.E.*, 9, 105, p. 310 (June, 1932).
- 21 Carson, *P.I.R.E.*, 7, p. 187 (1919).
- 22 Heising, *P.I.R.E.*, 13, p. 291 (1925).
- 23 Caruthers, *B.S.T.J.*, 18, 2, p. 315 (April, 1939).
- 24 Petersen and Hussey, *B.S.T.J.*, 18, 1, p. 32 (January, 1939).
- 25 Weymann, *Hochf. t. u. Elektikus*, 49, 6, p. 181 (June, 1937).
- 26 Strutt, *P.I.R.E.*, 22, 8, p. 981 (August, 1934).
- 27 Barrow, *Ann. d. Physik*, 11, p. 147 (1931).
- 28 Barrow, *P.I.R.E.*, 20, p. 1626 (October, 1932).
- 29 Ernsthansen, *Arch. f. Elektrotech.*, 31, 5, p. 299 (May 18, 1937).
- 30 Diebitsch and Zuhrt, *E.N.T.*, 9, p. 295 (August, 1932).
- 31 Hall, *P.I.R.E.*, 21, p. 1328 (1933).
- 32 Marvin, *J.A.I.E.E.*, 50, p. 349 (May, 1931).
- 33 Moore and Curtis, *B.S.T.J.*, 6, p. 217 (1927), *Bell Monograph* B.253.
- 34 Osborn and Oplinger, *J.A.S.A.*, 5, 1, p. 39 (July, 1933).
- 35 Mason, *B.S.T.J.*, 16, p. 423 (October, 1937).
- 36 Mason and Sykes, *B.S.T.J.*, 19, p. 221 (April, 1940).
- 37 Arguimbau *Gen. Rad. Expt.* 8, 1-2 (June-July, 1933).
- 38 Arguimbau *Gen. Rad. Expt.* 13, 7 (December, 1938).
- 39 Castner, *Bell Lab. Record*, 13, p. 267 (May, 1935).
- 40 Marconi-Ekco Inst. Co., Ltd., *J.S.I.*, 17, 3, p. 70 (March, 1940).
- 41 Landeen, *B.S.T.J.*, 6, p. 230 (1927).
- 42 Eisner, *Hochf. t. u. Elektikus*, 42, 2, p. 53 (August, 1933).
- 43 Grutzmacher, *E.N.T.*, 4, 12, p. 533 (December, 1927) and *Z. f. t. P.*, 10, 11, p. 570 (November, 1929).
- 44 Schuck, *P.I.R.E.*, 22, p. 1295 (November, 1934).
- 45 Hall, *J.A.S.A.*, 7, 2, p. 102 (October, 1935).
- 46 K pfm ller, *E.N.T.*, 1, p. 146 (November, 1924) and *E.N.T.*, 5, p. 18 (January, 1928).
- 47 Salinger, *E.N.T.*, 6, 8, p. 293 (August, 1929).
- 48 Lewis, *Trans. A.S.Mech.E.*, 54, p. 253 (1932).
- 49 Feldtkeller and Wilde, *T.F.T.*, 30, 12, p. 347 (December, 1941), also Feldtkeller, *T.F.T.*, 29, 12, p. 353 (December 1940).
- 50 de Nemes, *Phil. Mag.*, 18, p. 303 (1934).
- 51 Gall, *J.S.I.*, 9, 12, p. 262 (August, 1932).
- 52 Gates, *J.S.I.*, 9, 12, p. 380 (December, 1932).

In the above, *B.S.T.J.* is the *Bell System Technical Journal*, *P.I.R.E.* is the *Proceedings of the Institute of Radio Engineers*, *J.A.S.A.* is the *Journal of the Acoustical Society of America*, *W.E.* is the *Wireless Engineer*, *J.S.I.* is the *Journal of Scientific Instruments*, *R.S.I.* is the *Review of Scientific Instruments*, others are standard or self-explanatory.



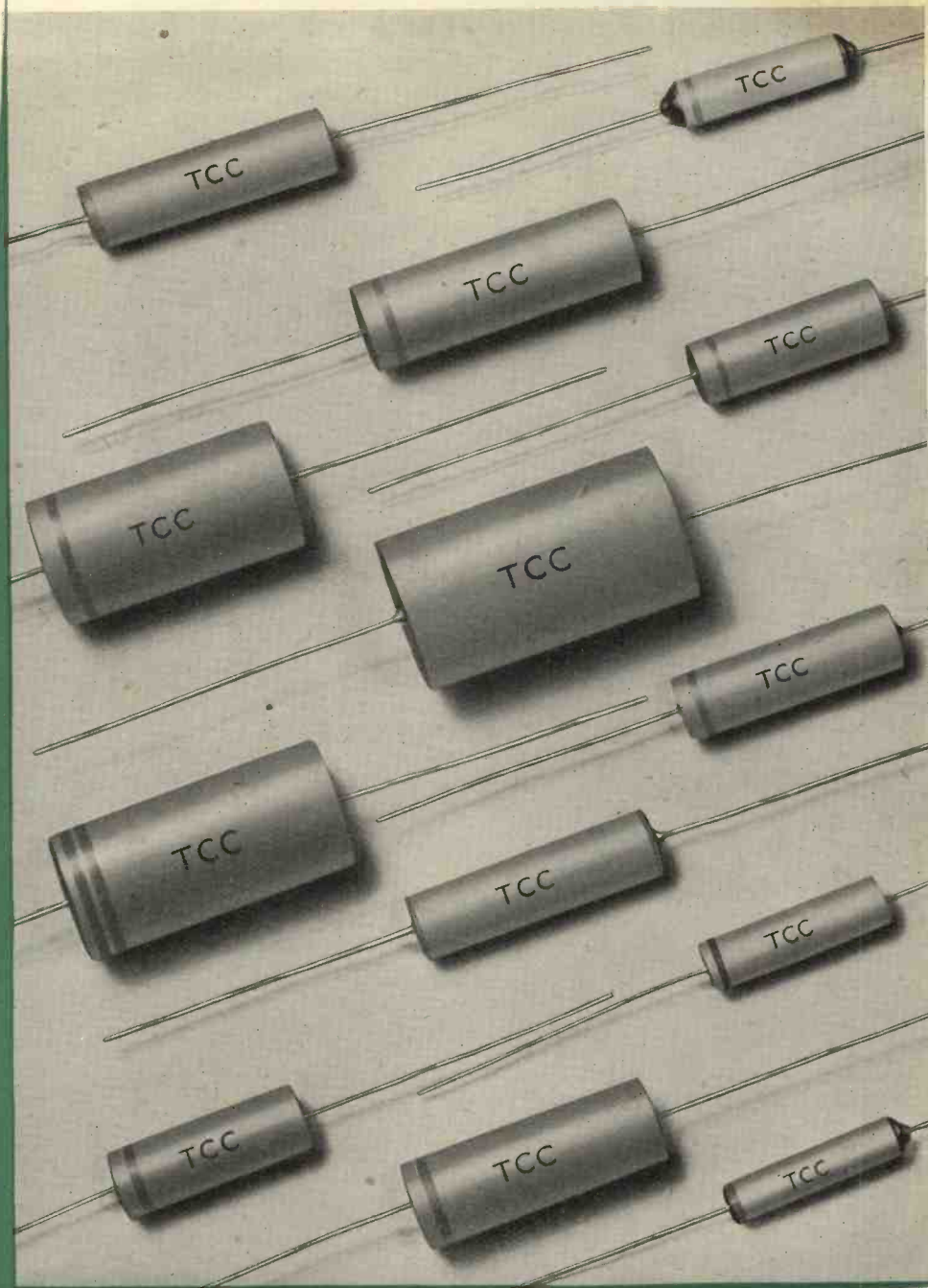

# TCC

**PRE-EMINENT IN PEACE  
INDISPENSABLE IN WAR**

# BOOK REVIEWS

## High Frequency Thermionic Tubes.

First Edition, A. F. Harvey, 235 pp. 99 figs. (Chapman & Hall, 18s. nett.)

Dr. Harvey is to be congratulated in that he is the first in the field with a work in the English language on the experimental aspects of electron inertia at high radio frequencies.

Comparatively little theory is included, however, and it might with some be a point of criticism that what theory is given is just too brief to be convincing. An introduction covering tube characteristics and performance at low frequencies is followed by 36 pages on the influence of frequency on tube properties such as input and output impedance, mutual conductance, and feedback impedance. Measurements of active losses and changes in input capacitance, following Strutt, are described, and the importance of minimising lead inductance (page 43) is well brought out in some photographs of tubes for working at frequencies up to 1,700 Mc/s. Retarding field generators are given only 24 pages of text, and as positive ion tubes come in for special consideration (the relative sluggishness of the Cs ions employed being a factor making for effective operation at much lower frequencies) the treatment of this section is inevitably incomplete.

Justification for the brevity is to be found in the greatly increased space devoted to the magnetron tube (104 pages) in which the mechanism for returning the electrons in front of the anode is now a magnetic field applied with its lines of force substantially aligned with the filament. It is, however, difficult to believe that the "comparatively simple electrode structure makes the application of theory easier," for although we have no grid to contend with, the motions are now far from radial, and, as Dr. Moullin says in a foreword to the work, "there is some violent conflict between the problem of the real magnetron and the problem of mechanics which it appears to present."

The concluding chapter (43 pages) deals with Klystron (velocity modulated) tubes and related topics. The account of Wave Guides and Hour Radiators suffers somewhat from a certain brevity (doubtless imposed on several aspects of the book by wartime restrictions of paper, etc.). This is, however, largely mitigated by an exhaustive list of references to this fascinating field.

Minor criticisms, such as occasional misspelt authors' names, wrong numbers quoted for diagrams in text, are not detailed here, as they do not seriously impair the work. On page 3 "differentiation" should presumably read "integration." A more serious criticism is the almost complete absence of tube and circuit noise as a factor influencing the performance. Moreover, nowhere does the author substantiate his claims for special suitability of the BK and magnetron tubes described, if not on the power-frequency chart of page 189, and it seems that in view of the greater frequency range covered by triodes used in the normal connexion, unprejudiced consideration of this chart leads one to infer, as some have consistently maintained, that to try and "utilise" electron inertia at high frequencies is to meet with results less satisfactory than those obtained by designing triodes for minimum electron inertial effects to work in the normal connexion.

No one engaged in high frequency developments, should be without this book, which summarises a difficult and sometimes controversial subject in a masterly fashion. W.E.B.

## A Course in Radio Fundamentals

George Grammer. (The American Radio Relay League, Inc., West Hartford, Conn. 104 pages, including assignments, examination questions and answers. 107 illustrations. Price, 50 cents U.S.)

The material of this book was originally prepared in response to the demand for a course of study covering those fundamentals upon which practical radio communication is built. Appearing first as a series of articles in *QST*, so great was the enthusiasm with which it was received that the complete series is now published under one cover.

The course is equally valuable for use in connexion with home study and as a classroom guide for the teaching profession. For home students it serves to replace the teacher,

giving detailed experimental exercises and procedure as well as supplementary explanatory material where needed, in addition to providing an accurate gauge of progress through the probing examination questions accompanying each assignment. For instructors it is a completely synthesised course outline, of particular value to those who find themselves in the new field of radio technician training without the benefit of a planned course or time for thorough preparation.

The text on which the course is based is "The Radio Amateur's Handbook," long recognised as outstanding in the radio training field. Either the 1942 or 1943 standard editions or the widely-used "Defence Edition" may be used.

## The Cathode Ray Tube and its Applications

G. Parr. 180 pp. 80 figs. (Chapman and Hall, 13s. 6d.) 2nd Edition

This book is intended to give the newcomer to the subject an insight into the science and art of oscillography and it should help very materially in increasing his interest and in leading him to delve further into a fascinating subject. To this end, the author has added what must be almost a record bibliography of 738 items. This bibliography is a very full one, but its value would be increased considerably if, in a future edition, the titles of the papers could be given. The bibliography is, in fact, divided into sections covering the different aspects of oscillography, but, even so, the further subdivisions which the actual titles would supply should prove invaluable.

The book covers the cathode-ray tube and its operation and performance, time bases, measurements and indications applicable to radio and industrial problems, television, etc. As the author points out, he had to rush the revision due to circumstances beyond his control and the second edition is, therefore, not so complete as he would have wished. It is suggested that a new edition should be limited to expanding the present subject matter and to correcting those errors and loose statements which have still survived from the first edition.

There are in the radio branches of the Services many who in peace-time worked in spheres very remote from radio, and to these, in particular, the book will prove of very great value.

O.S.P.

Books reviewed on this page  
or advertised in this Journal,  
can be obtained from

**H. K. LEWIS & Co. Ltd.**

136 Gower Street, W.C.1

If not in stock, they will be obtained  
from the Publishers when available



# MYCALEX

(REGD. TRADE MARK)

## INSULATION

Heat resisting up to 400° Centigrade.  
 Excellent electrical qualities.  
 Impervious to weather conditions.

*Mouldings with Metal Inserts*

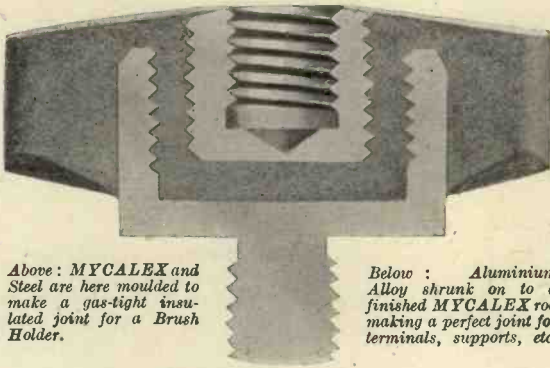

*Above: MYCALEX and Steel are here moulded to make a gas-tight insulated joint for a Brush Holder.*

*Below: Aluminium Alloy shrunk on to a finished MYCALEX rod making a perfect joint for terminals, supports, etc.*

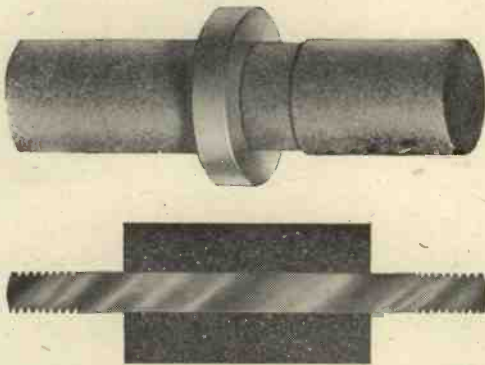

*In this piece, a copper insert has become an integral part of the whole through close adherence to the MYCALEX surround.*

### MYCALEX

*Cut pieces delivered from stock*

Stock sizes of MYCALEX can be dispatched within three days.

Price List with sizes will be sent on application.

MYCALEX LTD., CIRENCESTER, GLOS.



# TELCON CABLES

for  
**HIGH FREQUENCY TRANSMISSION and RECEPTION**

Full particulars of all Telcon Products from:  
**THE TELEGRAPH CONSTRUCTION & MAINTENANCE CO. LTD.**  
 Head Office: 22, Old Broad Street, London, E.C.2  
 Telephone: London Wall 3141

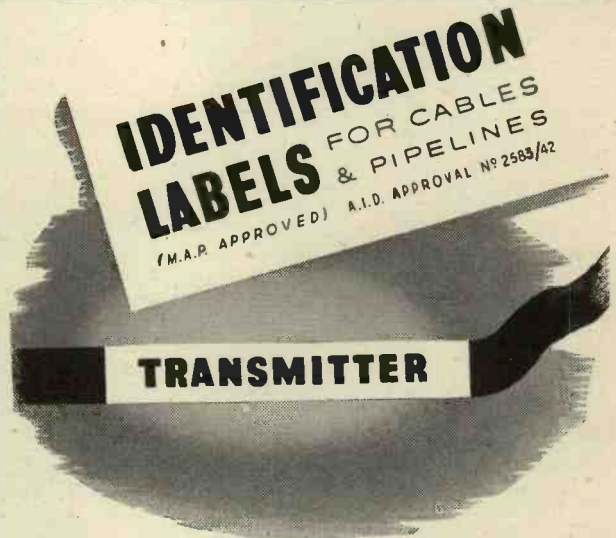

Indelibly printed on white or coloured fabric for use in conjunction with transparent adhesive tape.

● Guaranteed 2/3 day delivery service.

## P.P. PAYNE & SONS LTD

HAYDN ROAD NOTTINGHAM Phone: 64335  
 BUSH HOUSE LONDON Phone: TEMple Bar 6356

# ABSTRACTS OF ELECTRONIC LITERATURE

## TELEVISION

### Automatic Frequency and Phase Control of Synchronisation in Television Receivers

(K. R. Wendt, and G. L. Fredendall)

This paper describes a synchronising means at the receiver that employs a new principle in the field of synchronisation. The principle is automatic frequency and phase control of the saw-tooth scanning voltages. In such a system, synchronisation depends on the average of many regularly recurring synchronising pulses. Noise has insufficient energy at the scanning frequencies to effect control through the direct-current link from which all but relatively long-time variations are filtered out.

Experimental receivers, in which automatic phase and frequency control of the scanning oscillators has been incorporated, have operated with high immunity to noise. The degree of immunity is of a different order of magnitude from that found in conventional synchronising systems.

Noise cannot affect horizontal resolution or interlacing. An intrinsic property of the new system is perfect interlacing. The return line in an automatic-frequency-controlled system may start before synchronisation.

Consideration of this new development indicates that its use would result in several improvements in television service: (1) when severe conditions occur, an improved picture is obtainable at points within the present service area; (2) under such noise conditions, the useful service area is extended; (3) the maximum resolution permitted by a television channel is realisable at locations having low field strengths. It is expected that these improved results will be attained without increase in the cost of the television receiver.

—*Proc. I.R.E.*, Vol. 31, No. 1, Jan., 1943, page 7.

## MEASUREMENT

### Audio Frequency Schering Bridge

(J. W. Snelson)

A description is given of equipment suitable for testing specimens having a capacitance from 20-6,000 microfarads and power factor ( $\tan \delta$ ) less than 0.008. The bridge itself is used in conjunction with a Wagner earth device and a valve oscillator giving either 800 c/s or 1,600 c/s at approximately 100 volts. Details are given of the use of the box and the evaluation of the readings taken.

—*M.V. Gas.* April, 1943, pages 175-8.\*

## CIRCUITS

### Steady State Currents of Electrical Networks

(D. L. Waidelech)

It is shown that the methods of operational circuit analysis may be extended to give the steady state current, not only in the well-known Fourier series form, but also in the form of the sum function of this Fourier series.

This sum function is very useful in determining the wave form of the current. Three methods of obtaining the steady state current are given along with their restrictions, and these methods involve a real integral, a finite series and a complex integral. An example of these methods is also given.

—*Jour. App. Physics*, Vol. 13, No. 11 (1942), page 706.

### The Half-Wave Voltage Doubling Rectifier Circuit

(D. L. Waidelech and C. H. Gleason)

An analysis of the half wave voltage doubling rectifier circuit is made with the main assumption that the tube drop is zero while conducting. The performance characteristics of the circuit as predicted by the analysis are presented together with experimental verifications of several of these characteristics.

Operating conditions for which polarised electrolytic condensers may be used and the currents to be expected on short circuit are discussed. The performance characteristics calculated from the analysis are presented as curves suitable for use in the prediction of the performance of an assembled circuit, and in the design of this doubler to meet specified operating conditions.

A comparison is made of the performance characteristics of the half-wave and full-wave voltage doublers.

—*Proc. I.R.E.*, Vol. 30, No. 12 (1942), page 535.

## INDUSTRY

### Radiographic Inspection Technique Applied to Special Welding Problems

(D. M. McCutcheon)

The application of the million-volt X-ray beam to the detection of under-surface flaws is shown to be nearly independent of section thickness, an indirect beam being used for thin sections. The X-ray inspection of repair welds in aluminium aircraft cylinder heads is described. The development of a technique which will insure resolution on the X-ray film of the smallest important defect is considered.—*Weld. J.*, Jan., 1943, p. 16.\*

## RADIO

### Microphones and Receivers

(L. C. Pocock)

Deals with performance with special reference to speech communication. Smaller or more efficient microphones will become possible as magnetic materials improve. It is stated that stereophonic transmission over two channels limited to 5,000 c/s is to be preferred to single channel reproduction up to 15,000 c/s, so that development of stereophonic reproduction may be expected as giving better performance for a given wavelength occupancy.

Speech power for reception, receiver and microphone characteristics are discussed at length.

—*Jour. Brit. I.R.E.* (To be published.)

## ELECTRON OPTICS

### Simplified Electron Microscopy

(C. H. Bachman)

The principles of the electron microscope and its construction are given. The advantages of an electrostatic lens with the negative electrode tied to the cathode potential over the electromagnetic type which requires very accurate voltage-current regulation are explained. Details are given of the latest G.E.C. microscope which uses three electrostatic lenses, the condenser lens having been eliminated, and external photography.

—*Electronics*, Vol. 16, No. 2 (1943), page 78.\*

### Electron Microscopy

(V. K. Zworykin)

The essential parts of an electron microscope are outlined and details given of the latest R.C.A. model. This stands 7 ft. high and occupies 5 sq. ft. of floor space. All the power is derived from 110 V. a.c.; radio frequencies are employed for the generation of the high voltage and three electromagnetic lenses are included. The use of the microscope in the examination of powders is illustrated. The investigation of opaque surfaces, using either a plastic replica of the surface or a scanning electron microscope, is described. Details are given of a simple and compact microscope for making routine observations. It is 16 in. long and has a fixed magnification of 5,000 at a stabilised operating voltage of 30 kV.

—*Electronics*, Vol. 16, No. 1 (1943), page 64.

\* Supplied by the courtesy of Metropolitan-Vickers Electrical Co. Ltd., Trafford Park, Manchester.



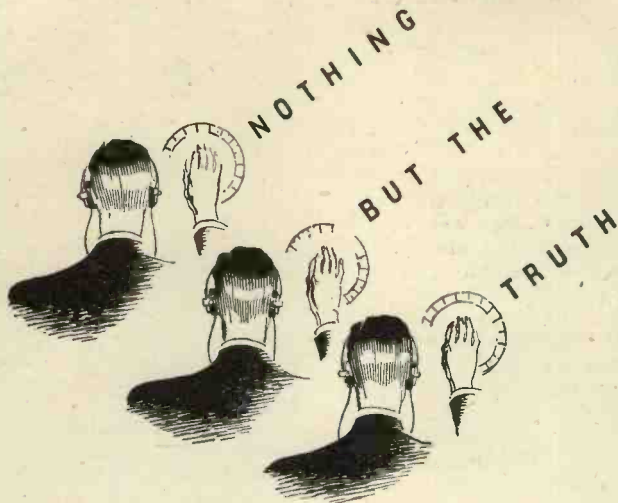

An electrical instrument may embody every assembled component necessary for an accurate measuring device. But it will remain ineffective for its purpose until its own individual performance has been checked and proved and calibrated. It is on the test bench that it finds itself; the inquisitor will be content with nothing less than the truth.

The testing of every measurement device produced by Marconi Instruments—and there are 60 of them in production—is as uncompromising as is every phase in its design and production. For these are instruments made for the measurement of very fine limits of performance. They apply the experience of a lifetime to the demands of a new technical age. In every requirement of to-day they live up to the traditions of accuracy and resource that have belonged for nearly half a century to the name Marconi.

# MARCONI Instruments Ltd

ST. ALBANS · HERTS · TELEPHONE 4323

## HEAT...



... in the heat of the desert or the jungle, the cold of winter or high altitudes, SILVERED MICA CONDENSERS have to do their job and maintain their stability.

TYPE APPROVED.

## ... COLD



**UNITED INSULATOR CO LTD**

12-20 LAYSTALL STREET, LONDON, E.C.1

Phone: TERminus 7383

Grams: Calanel, Phone, London

*The  
Pioneers  
of low-loss  
Ceramics*

## NOTES FROM THE INDUSTRY

### X-Ray Analysis in Industry

SOME important developments in the methods and technique of examining the behaviour of solids by X-Ray diffraction methods were announced at the Institute of Physics' second Conference on X-Ray Analysis in Industry, which was held in Cambridge on April 9 and 10 last.

The conference, over which Sir Lawrence Bragg presided, was attended by over 200 persons. The physicists, chemists, metallurgists and engineers who were present came from many different industries and Government establishments as well as from academic institutions, thus demonstrating the growing field of application of this method of analysis.

Photographs, models and apparatus were exhibited in the adjoining Crystallographic Laboratory.

The organising committee of the conference was requested to seek the sanction of the Board of the Institute of Physics for the formation of a new group under its auspices so that the work of these first two conferences might be continued.

Further particulars will be issued in due course. The secretary of the conference is Dr. H. Lang, of the Insti-

tute of Physics, The University, Reading.

### Radio Industries Club

At the twelfth annual general meeting of the Radio Industries Club, held at the Connaught Rooms, London, on April 20, Sir Noel Ashbridge, M.I.E.E., Controller of Engineering of the B.B.C., was elected president for 1942-3 in succession to Col. V. Z. de Ferranti. Well over 100 members were present, there being no guests on this occasion.

During the luncheon which preceded the meeting, a ballot was held to elect five members to fill vacancies on the committee, this resulting in the following new elections: Guy R. Fountain (Tannoy Products), A. J. P. Hytch (British Broadcasting Corporation) and J. H. Williams (A. C. Cossor, Ltd.). In addition, A. G. Beaver (Sun Electrical Co., Ltd.) and W. E. Miller (*Wireless and Electrical Trader*) were re-elected.

### W. T. Henley's

A new London office and store have been opened by W. T. Henley's Telegraph Works at 51-53 Hatton Garden, E.C.1. (Phone CHAncery 6822). The office and store at Demby House,

Wembley, is now closed, and the Advertising Dept. has moved from Westerham to the London office.

### Leather V-Section Ropes

The Benson Vee Leather Co., of Longside Lane, Bradford, announce the introduction of a range of leather V-ropes to overcome the growing scarcity of rubber ropes. The standard sections are:  $1\frac{1}{2}$  in.  $\times$   $\frac{3}{4}$  in.;  $\frac{7}{8}$  in.  $\times$   $\frac{5}{8}$  in.;  $\frac{3}{4}$  in.  $\times$   $\frac{7}{16}$  in.;  $\frac{1}{2}$  in.  $\times$   $\frac{1}{16}$  in.;  $\frac{3}{8}$  in.  $\times$   $\frac{3}{32}$  in.; the first dimension being the width and the second the depth. The mechanical properties of these ropes are in every respect comparable with the finest rubber ropes. Advice and data are available on request.

### B.S.I. Publications

Among the recent publications of the British Standards Institute are the following:

Glossary of Electrical Terms, Part 4 (Section 5): Transmission and Distribution. 2s. post free.

B.S. 1062. Code of Practice for Planning Electrical Wiring Installations. 1s. post free.

B.S. 1114. Wartime Finish of Machinery and Plant. 1s. post free. All obtainable from the B.S.I., 28 Victoria Street, S.W.1.

# PERMALL

ELECTRICAL  
INSULATION  
to DCD WT 1000

The NEW INSULATION CO., LTD.

Telephone:  
Glos. 4419.  
Write for publication  
No. 31.

BRISTOL ROAD, GLOUCESTER  
London Office: 40, BROADWAY, S.W.1.

Telegrams:  
"Nico, Gloucester."  
Telephone:  
ABBey 6494.



**Rotary Cutting, Grinding,  
Filing and Polishing - use  
Morrisflex**

MORRISFLEX Flexible Shaft Equipment is in increasing demand in the Radio and Electrical Industries. Various attachments are available, and a wide range of REX Rotary Files and Cutters, for cutting, grinding, filing and polishing both non-ferrous alloys and ferrous metals. MORREX Rotary Wire Brushes are supplied for buffing and cleaning metal, also MORRISFLEX Rotary Rasps for wood-working. MORRISFLEX Machines are available in overhead suspension, bench and floor types.

*Write for fullest details.*

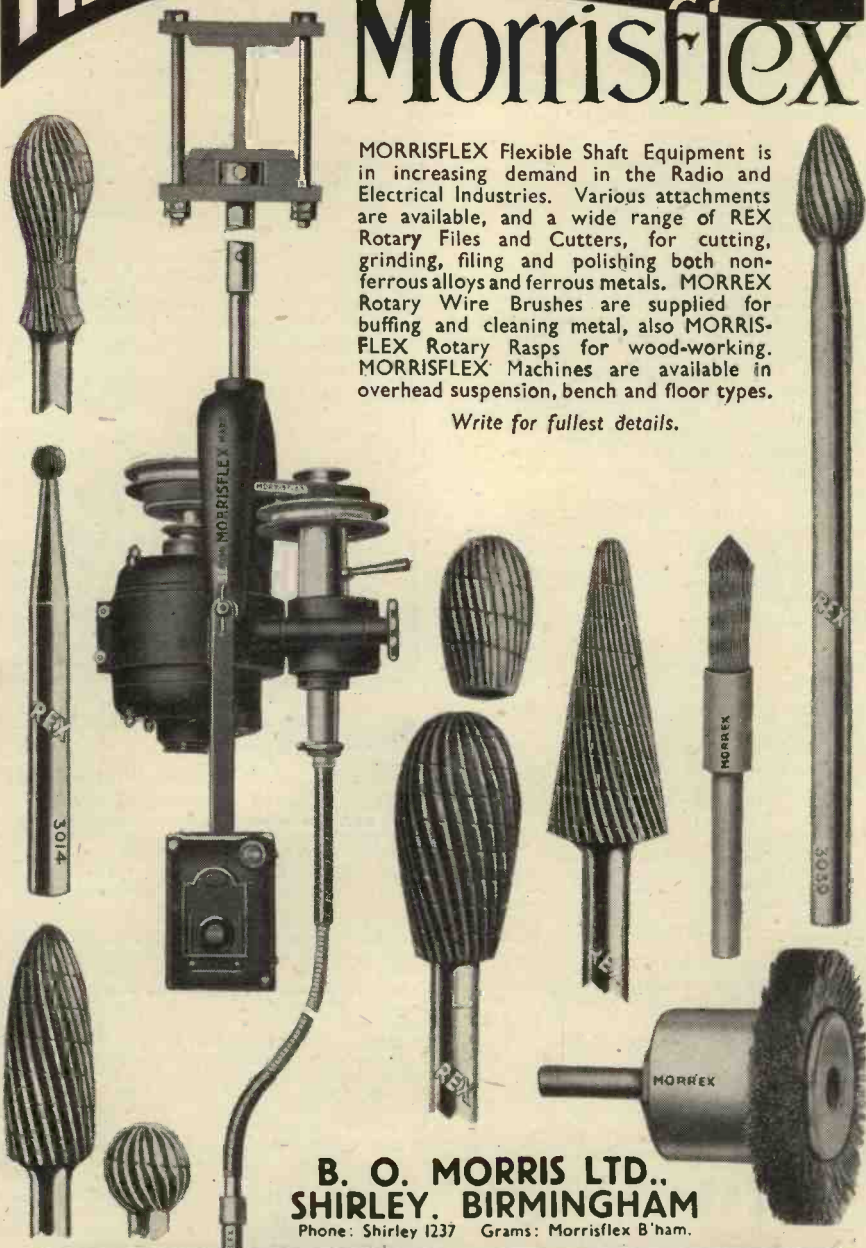

**B. O. MORRIS LTD.,  
SHIRLEY, BIRMINGHAM**  
Phone: Shirley 1237 Grams: Morrisflex B'ham.

*Announcement*

We manufacture Low Loss Ceramic Parts at least as good as any on the market but we regret that we are at present unable to accept orders for these as our production of these materials is already being used for work of national importance

**LOW-LOSS  
CERAMICS**

*by*

**TAYLOR**

**TUNNICLIFF  
& CO., LTD.**

*Head Office: Eastwood, Hanley, Staffs. London: 85, Strandham Hill, S.W.2. Factories at Hanley, Stone and Longton, Staffs. Telephone: Tulse Hill 5265-6 and Stoke-on-Trent 5272-4.*

**Morrisflex**  
**Flexible Shaft Equipment**



★ **RADIO BOOKS** ★**RADIO RECEIVER  
CIRCUITS HANDBOOK**

Containing practical notes on the Operation of Basic Modern Circuits. By E. M. Squire. A useful guide to circuits for members of the radio industry, and radio amateurs. By dealing with the receivers in stages the author has achieved the utmost clarity and conciseness. The text is liberally illustrated with circuit drawings and other diagrams. 5s. net.

**SHORT WAVE RADIO**

By J. H. Reyner, B.Sc.(Hons.), etc. This book deals with the developments and progress in the field of short wave radio telegraphy, giving comprehensive data and practical methods of application. Has been quoted as being "one of the finest short-wave treatises available." 10s. 6d. net.

**ACCUMULATOR, CHARGING,  
MAINTENANCE AND REPAIR**

By W. S. Ibbetson, B.Sc., A.M.I.E.E., M.I.Mar.E. Intended for the use of all interested in the charging and upkeep of accumulators for wireless work, electric vehicles, motor cars and cycles, country house lighting and emergency plants. Seventh Edition. 6s. net.

**PITMAN'S FOR RADIO BOOKS**

There are over thirty books on all branches of radio on our List. Write or call for our Technical Catalogue; you'll find in it all the books you might require.

39, PARKER STREET, KINGSWAY, W.C.2

★ **PITMANS** ★**ELECTRADIX BARGAINS**

Switches and Plug  
Sockets on Ebonite  
Panel Case  
Mahogany



P.O. BRIDGE RES.  
Box. to 8,000 ohms by  
10 ohm steps.

Stand Scales for Spot use. £2 10s. Wheatstone Bridges and 142M Resistance boxes quoted for. A number of ex. W.D. Wheatstone Bridges, less coils, cheap. Circuit testing G.P.O. Vertical Galvos, 35/- Mag. Ringer and A.C. Bell, 25/-.

**CHARGERS.** We can supply at short notice and with preference on Priority orders, valve and metal rectifiers from 2 volts, ½ amp to 8 volts, 32 amps. Stamp for List, or specify requirements.

**PANEL SWITCH AND OTHER RHEOSTATS**  
Aetna 0 to 1 ohm and "off"; 3 amps, 6 volts. Uses: dimmers charge sub-circuit regulators, mode and test control, etc. 1-hole fixing and extra bracket for rack. Hollow knob takes min bulb to glow on circuit. New U.S.A. 2/6, worth 5/-. Fixed wire-wound resistors or range extenders, 8 ohm enclosed type, 1/6. Strip wire-wound 6 and 30 ohm dual, 1/9. Stip ditto, 250 ohms, 2/-. Big rheostats 40 amp ironclad type, grid resistance with heavy 10 stud step switch, drops 220 volt mains to 50 volts, 40 amps, size 33 x 16 x 14 ins., £5 10s. 0d. 110 volt ditto, 16 x 14 x 16 ins., only £2 10s 0d.

**LIGHT RAY CELLS.** Selenium Bridge, in bakelite case. Raycraft Model, 21/-. Electro-cell, self generating, light meter type, 35/-. Raycraft Ray Set, with relay, 42/-. Relay enclosed 10,000 ohm tele-type, 22/6. For other Relays see special leaflet, 2d.

NOTE OUR new address. Visit our Showrooms.

**ELECTRADIX RADIOS**214, QUEENSTOWN ROAD, BATTERSEA, S.W.8.  
137 Bus passes door. Phone: Macaulay 2159.**Classified Announcements**

The charge for miscellaneous advertisements on this page is 12 words or less 3/-, and 3d. for every additional word. Single-column inch rate displayed, £1. All advertisements must be accompanied by remittance. Cheques and Postal Orders should be made payable to Hulton Press, Ltd., and crossed, and should reach this office, 43, Shoe Lane, London, E.C.4, not later than the 15th of the month previous to date of issue.

**CAPACITY AVAILABLE**

**ELECTRICAL and Mechanical Engineers** have available capacity for the production of thermionic amplifiers, sound equipment, and small electro-mechanical apparatus. Essential work only. "Electronic Engineering," Box 658.

**FOR SALE**

**IN STOCK, Rectifiers, Accumulator Chargers, Rotary Converters, P.A. Amplifiers, Mikes, Mains Transformers, Speakers of most types, Test Meters, etc., Special Transformers** quoted for.—University Radio, Ltd., 238, Euston Road, London, N.W.1. Ger. 4447.

**LITERATURE**

**7,000 MEMBERS** of the Scientific Book Club believe that Knowledge is Power. Are you a member? Particulars from 121, Charing Cross Road, London, W.C.2.

**LOUDSPEAKERS**

**3,000 SPEAKERS P.M.** and energised 4" to 14" including several Epoch 18". Sinclair Speakers 170, Copenhagen Street, N.1.

**LOUDSPEAKER repairs, British, American, any make, 24-hour service; moderate prices.**—Sinclair Speakers, 170, Copenhagen Street, N.1.

**MISCELLANEOUS**

**WE WILL BUY at your price** used radios, amplifiers, converters, test meters, motors, pick-ups, speakers, etc., radio and electrical accessories. Write, phone or call, University Radio Ltd., 238, Euston Road, London, N.W.1. Ger. 4447.

**WEBB'S Radio Map of the World** enables you to locate any station heard. Size 40" by 30" 2 colour heavy Art Paper, 4/6, post 6d. Limited supply on Linen, 10/6, post 6d.—Webb's Radio, 14, Soho Street, London, W.1. Phone: GERRARD 2089.

**FULL range of Transmitting Keys, practice sets and other equipment for Morse training.**—Webb's Radio, 14, Soho Street, London, W.1. Phone: GERRARD 2089.

**ENGINEERS** capable of producing electronic equipment to specimen and instructions offered interesting new line. Suitable for small firm or radio expert. Some capacity immediately required. "Electronic Engineering," Box 657.

**RUBERY OWEN MESSIER LTD.** of Warrington, Lancs, manufacturers of undercarriages and other aircraft equipment have announced to the Trade that they will henceforth carry on business in the name of Messier Aircraft Equipment Ltd. The Board of Directors and Management remain unchanged.

**WANTED**

**WE OFFER cash for good modern Communication and all-wave Receivers.**—A.C.S. Radio, 44, Widmore Road, Bromley.

**HANK BUSHES** and screws to your specifications (Repetition Work). Quick deliveries. D.T.Co., "Electronic Engineering," Box No. 654.

**WANTED to purchase, April, 1941 "Electronics"** Wiltshire, 138, The Mall, Preston Hill, Kenton, Middx.

**ELECTRIC VEHICLE WANTED.** Car or Utility. Particulars, price, where seen, BM/RLPV, London, W.C.1.

**RADIO VALVE manufacturing facilities** wanted by London Research firm. "Electronic Engineering," Box 659.

**SITUATIONS VACANT**

**A.M.I.E.E., City and Guilds, etc., on "NO PASS-NO FEE" terms.** Over 95% Successes. For full details of modern courses in all branches of Electrical Technology send for our 112-page handbook—FREE. B.I.E.T., (Dept. 337B), 17 Stratford Place, London, W.1.

**FOYLES**

★ BOOKSELLERS TO THE WORLD ★

New and Second-hand Books on Engineering and every other subject.

Books Bought.

119-125 Charing Cross Road, London, W.C.2

Tele: Gerrard 5660 (16 lines). Open 9-6 Inc. Sat.

**Ode****Partridge**

No. 23

**TRULY RURAL**

The Agricultural Minister  
Asks all to volunteer  
To help the hard-pressed farmer  
To grow more food this year.

Four bob a day is all I pay  
For bed, three meals and tent,  
But ground sheet, blankets, mattress too  
Are loaned me free of rent.

Among the things I have to take  
Ere starting to dig roots,  
Are towels, mug, a cake of soap,  
Old clothes and good stout boots.

A wisp of straw between my teeth,  
Knife, fork and spoon in hand,  
A couple of plates, a pillow slip,  
I'm ready for the land.

For one whole week my Bardic chair  
I leave, with greatest joy,  
And for a modest bob an hour  
O'i'll be a Varmer's Boy.

**N. Partridge**

Ph.D. B.Sc., M. Brit. I.R.E., M.I.E.E.

Makers of Transformers and Chokes  
King's Bldgs., Dean Stanley St.,  
LONDON S.W.1

Telephone: VICTORIA 5035

**GALPINS ELECTRICAL  
STORES**

"Fairview" London Road, Wrotham, Kent.

**PLEASE NOTE CHANGE OF ADDRESS**

This business is now transferred permanently to the above address where all mail orders will receive strict personal attention.

TERMS: Cash with order. No C.O.D.

(Eire and Northern Ireland orders cannot be accepted.)

**HEADPHONES, 120 ohm, Secondhand, complete** with headband and cords, in perfect working order. Price 7/6 per pair, post free.

**INSTRUMENT METAL RECTIFIERS, by famous** makers, 10 M/A full load working. Price 15/- each, post free.

**TUNGSTEN CONTACTS, 3/16 in. dia., a pair** mounted on spring blades also two high quality pure silver contacts, 3/16 in. dia., also on spring blades, fit for heavy duty, new and unused, there is enough base to remove for other work. Price the set of four Contacts, 5/-, post free.

**POST OFFICE RELAYS, Small type high resistance,** twin blade, very low milliamperes operation, as new Price 7/6 each, post free.

**ELECTRIC LIGHT CHECK METERS, well-known** makers, first-class condition, electrically guaranteed, for A.C. mains 200/250 volts 50-cy. 1 phase 5 amp. load 10/- each; 10 amp. load, 12/6, carriage 1/-.

**I.K.W. FIRE ELEMENTS, mounted, size** 16 x 1½ x 1 ins., for 220 volts A.C. or D.C., as new 6/-, post free.

**½ WATT WIRE END RESISTANCES, new and** unused, assorted sizes (our assortment), 6/6 per doz., post free.

**VOLTMETERS, 2½ in. dia., panel mounting, moving** coil, range 0-120 volts, F.S.D., very low, modern makers by famous makers. Price, 32/6 post free.

**AMMETERS, description as above, range 0.1** amps., Price, 25/- post free.

**KLAXON MOTORS, for 220 volts D.C., shunt** wound, ball bearing, fitted reduction gear giving speed of 700 r.p.m. High-grade job. Condition as new. Price, 50/- carriage paid.

**D.C. MOTORS, shunt wound, ball bearing, ½ h.p.,** high grade. Condition as new. Can be offered for 110 volts or 220 volts as required. Price either voltage, 40/- carriage paid.





**T**HE Model 7 Universal Avo-Meter is the world's most widely used combination electrical measuring instrument. It provides 46 ranges of readings and is guaranteed accurate to B.S. first grade limits on D.C. and A.C. from 25 to 100 cycles. It is self-contained, compact and portable, simple to operate and almost impossible to damage electrically. It is protected by an automatic cut-out against damage through severe overload, and is provided with automatic compensation for variations in ambient temperature.

The AvoMeter is one of a useful range of "Avo" electrical testing instruments which are maintaining on active service and in industry the "Avo" reputation for an unexcelled standard of accuracy and dependability—in fact, a standard by which other instruments are judged.

*Some delay in delivery of Trade Orders is inevitable, but we shall continue to do our best to fulfil your requirements as promptly as possible.*

Sole Proprietors and Manufacturers :

**AUTOMATIC COIL WINDER & ELECTRICAL EQUIPMENT Co., Ltd.,** Winder House, Douglas Street, London, S.W.1. Phone : Victoria 3404/7.



**"UNO"**  
DRAWING INKS  
are suitable for  
every drawing  
office use.

**A. WEST & PARTNERS, LTD.** 36 BROADWAY, WESTMINSTER, S.W.1

*Precision Presswork*

**CLARKES (Redditch) LTD.**  
SINEW WORKS  
**REDDITCH**  
TEL. 100 ENGLAND ESTAB. 1920

ON A.I.D. APPROVED LIST

**"AFTER THE WAR" TELEVISION**

With the coming of Peace, and backed by the Technical advances that have resulted from the war years, **TELEVISION** will again spring to life and offer opportunities, as never before, *to the trained man.*

Now is the time to prepare for this new "market." Our Home-study "**Television**" Course is comprehensive, up-to-date and suitable both for the amateur and experienced Radio Engineer.

We definitely guarantee  
**"SATISFACTION—OR REFUND OF FEE"**

You are advised to send for details of this special Television Course immediately, to investigate its possibilities. Details will also gladly be sent of A.M.I.E.E. and A.M.Brit.I.R.E., Examinations and other courses in all branches of **WIRELESS ENGINEERING**, including particulars of our special **SHORT WAVE** and **RADIO SERVICING COURSES** which are in such demand—Free.

**BRITISH INSTITUTE OF ENGINEERING TECHNOLOGY**  
Principal : Prof. A. M. Low.  
7, Shakespeare House, 17/19, Stratford Place, London, W.1



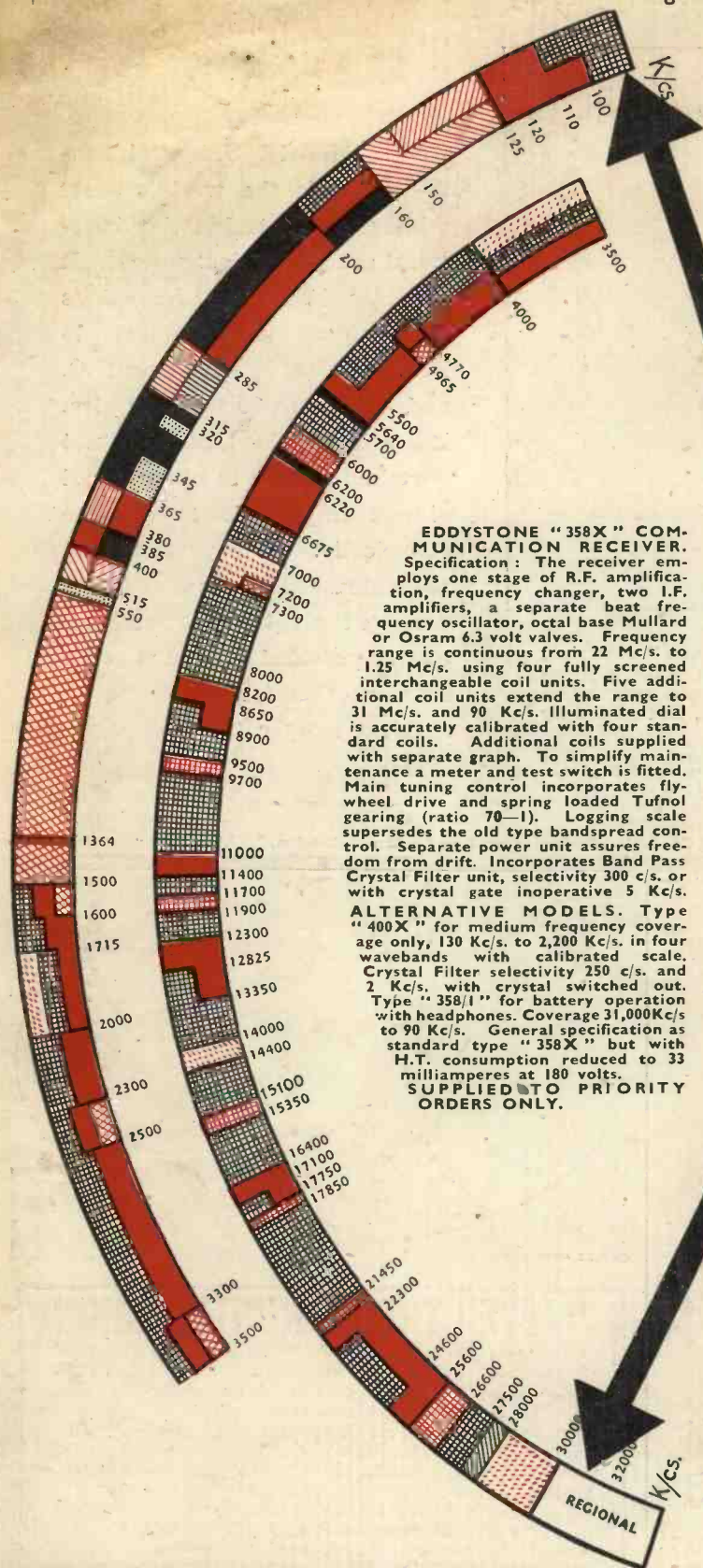

**EDDYSTONE "358X" COMMUNICATION RECEIVER.**  
 Specification: The receiver employs one stage of R.F. amplification, frequency changer, two I.F. amplifiers, a separate beat frequency oscillator, octal base Mullard or Osram 6.3 volt valves. Frequency range is continuous from 22 Mc/s. to 1.25 Mc/s. using four fully screened interchangeable coil units. Five additional coil units extend the range to 31 Mc/s. and 90 Kc/s. Illuminated dial is accurately calibrated with four standard coils. Additional coils supplied with separate graph. To simplify maintenance a meter and test switch is fitted. Main tuning control incorporates fly-wheel drive and spring loaded Tufnol gearing (ratio 70-1). Logging scale supersedes the old type bandspread control. Separate power unit assures freedom from drift. Incorporates Band Pass Crystal Filter unit, selectivity 300 c/s. or with crystal gate inoperative 5 Kc/s.

**ALTERNATIVE MODELS.** Type "400X" for medium frequency coverage only, 130 Kc/s. to 2,200 Kc/s. in four wavebands with calibrated scale. Crystal Filter selectivity 250 c/s. and 2 Kc/s. with crystal switched out. Type "358/1" for battery operation with headphones. Coverage 31,000Kc/s to 90 Kc/s. General specification as standard type "358X" but with H.T. consumption reduced to 33 milliamperes at 180 volts.

**SUPPLIED TO PRIORITY ORDERS ONLY.**



# EDDYSTONE

## "358X"

### Communication Receiver

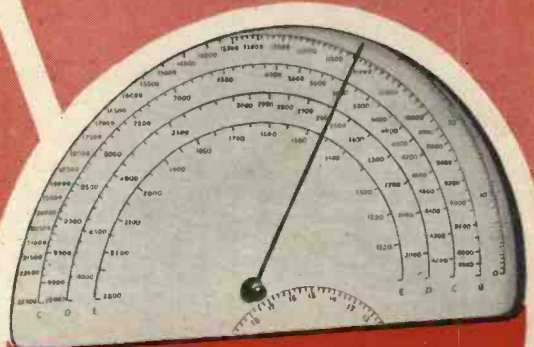

**WIDE FREQUENCY RANGE**

In these days of ever changing frequency allocation the Eddystone "358X" meets all emergencies with a coverage from 31Mc/s to 90Kc/s.

# WEBB'S RADIO

## THE SHORT-WAVE SPECIALISTS

The receiver may be inspected at  
**14, SOHO STREET, LONDON, W.1.**  
 Between 10 a.m. and 4 p.m. (Sats. 10 a.m. to 12 noon.)  
 Telephone: GERRARD 2089.

- AERO-NAUTICAL
- FIXED
- AERO-RADIO BEACONS
- RADIO SOUNDING
- GOVERNMENT
- MARITIME MOBILE
- COASTAL MOBILE
- MARITIME RADIO BEACONS
- International Broadcast
- BROADCAST
- MARITIME DIRECTION FINDING
- AMATEUR
- MOBILE