



Electronic Engineering



INCORPORATING ELECTRONICS, TELEVISION AND SHORT WAVE WORLD

PRINCIPAL CONTENTS



Data Sheet: Inductance Compensated R.C.C. Amplifiers
The Design of Wide Band V.F. Amplifiers
A New Frequency Generator
Review of Progress in Electronics, Pt. III
Lapping and Testing Quartz Crystals
Preparation of Sound Film Track

1/6^D JUNE 1941

For H.M. Services

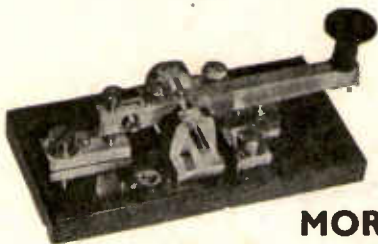

MORSE KEYS

There is a great interest in equipment for training operators, particularly for Service requirements. Although supplies are limited, Webb's are making every endeavour to reserve supplies for members of the Forces, Schools, etc. Below are details of some of the lines which can be delivered speedily but numerous other lines are generally available.

Model A. A bar type key of the popular "Post Office" type specially designed for initial training. Finish, nickel-plate on wood base with heavy terminals at 8/-.
 Model B. Heavy-duty bar type key as illustrated. Lacquered brass, heavy contacts on polished wood base at 10/6.
 Model C. Post Office type bar key with micrometer adjustments capable of withstanding hard work at 17/6.
 McElroy Semi-automatic "Bug" key Standard heavy-duty model at 43/-.

McELROY AUTOMATIC TRANSMITTER

This is a machine consisting of photocell, the ray to which is broken by printed tape. The output from the cell is amplified and triggers a sensitive relay, making the instrument capable of keying at any speed from 5 to 50 words per minute. It should be used in conjunction with an audio oscillator as illustrated. Price of Mac Auto complete with one tape (approximately 2,000 words), £9 4s. Tape Puller for feeding the above, £3 17s. 6d.



HEADPHONES

Webb's have available a special lightweight headphone manufactured for training purposes by S. G. Brown solely for Webb's at 17/6 a pair. All other popular headphones are available from stock including the FAMOUS BROWN'S "A" ADJUSTABLE REED at 57/6.

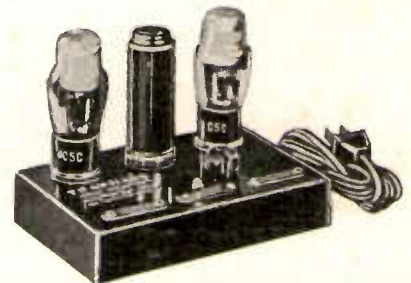

AUDIO OSCILLATOR

Audio Oscillator suitable for feeding one to ten pairs of headphones complete with line cord for 230-volt A.C. mains giving 1,000 cycle note, complete with valves, 45/-.

HEAVY-DUTY "SCHOOLS" MODEL AUDIO OSCILLATOR, giving outputs to feed 20 or 50 pairs of telephones or alternatively several loudspeakers, is now available at £7 10s. 0d.



WORLD-WIDE INFORMATION

WEBB'S RADIO

14, SOHO ST., OXFORD ST., LONDON, W.1.

OPEN 9.0 a.m. TO 6.0 p.m. SATS. 1 O'CLOCK

TELEPHONE : GERRARD 2089



TELCON CABLES

for
HIGH FREQUENCY TRANSMISSION and RECEPTION

Full particulars of all Telcon Products from:
THE TELEGRAPH CONSTRUCTION & MAINTENANCE CO. LTD.
Head Office: 22, Old Broad Street, London, E.C.2
Telephone: London Wall 3141
Temporary Address: Blackstone, Redhill, Surrey
Redhill 1056

THE "FLUXITE QUINS" AT WORK

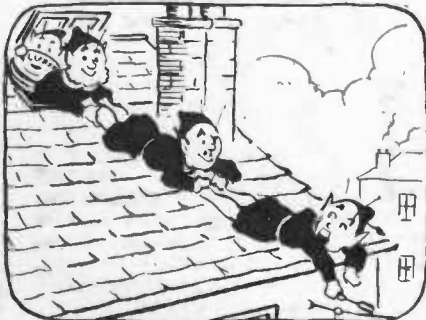

*Cried OI, from the gutter "Hold Tight!
Till I've soldered this aerial right I can see now quite plain Why it's broken again Pass me down, lads, the tin of FLUXITE!"*

See that FLUXITE is always by you—in the house—garage—workshop—wherever speedy soldering is needed. Used for 30 years in government works and by leading engineers and manufacturers. Of Ironmongers—in tins, 4d., 8d., 1/4 and 2/8. Ask to see the FLUXITE SMALL-SPACE SOLDERING SET—compact but substantial—complete with full instructions, 7/6. Write for Free Book on the art of "soft" soldering and ask for Leaflet on CASE-HARDENING STEEL and TEMPERING TOOLS with FLUXITE.

To CYCLISTS! Your wheels will NOT keep round and true unless the spokes are tied with fine wire at the crossings and SOLDERED. This makes a much stronger wheel. It's simple—with FLUXITE—but IMPORTANT.

THE FLUXITE GUN puts FLUXITE where you want it by a simple pressure. Price 1/6, or filled 2/6.

FLUXITE LTD. (DEPT. T.V.),
BERMONDSEY ST., S.E.1.

ALL MECHANICS WILL HAVE

FLUXITE

IT SIMPLIFIES ALL SOLDERING

TAYLOR ALL-WAVE SIGNAL GENERATORS

(6.5 to 3,000 metres)

Each of the four different models available is a fully self-contained unit and provides modulated frequency signals for tests on all types of receivers.



TAYLOR ALL-WAVE SIGNAL GENERATOR.

Important features to note.

FREQUENCY RANGE

6 overlapping ranges covering from 46 Mc. to 100 kc. (6.5 to 3,000 metres).

MODULATION

A separate valve, oscillating at 400 cycles, is employed to supply internal modulation, and can also supply up to 5 volts to the output jack on the generator. There is a choice of either internal modulation at 400 cycles, or unmodulated, or externally modulated by an external source of audio frequency.

ATTENUATION

Two attenuators provide for coarse and fine adjustments. 0 to 10 microvolts and multiplications of 10, 100, 1,000 and 10,000.

FOUR MODELS AVAILABLE

MODEL 60.A.—A.C. mains, 200/250 volts, 40/100 cycles.

MODEL 60.U.—A.C./D.C. mains, 200/250 volts.

MODEL 60.L.—A.C./D.C. mains, 100/150 volts.

MODEL 60.B.—Battery operated. Complete with self-contained Batteries.

All models are supplied complete with screened output lead and instruction book. The price for either model is

£12.12.0

(No purchase tax payable)

Fully descriptive Brochure of Taylor British Made Signal Generators, Universal Multi-Range Meters, Oscilloscope and Valve Testers will be sent on request.

BRITISH MADE. GUARANTEED 6 MONTHS

TAYLOR

Electrical Instruments Ltd.
419-422 Montrose Avenue,
SLOUGH, Bucks.
Phone: Slough 21381.

33kV 10mA. D.C. PRESSURE TESTING EQUIPMENT



Voltage Regulator.



Step-up Transformer.



Rectifier.



Reservoir Condenser.

The Westinghouse Metal Rectifier is particularly suitable for providing the D.C. potential necessary for cable testing and fault location. It is robust and needs no attention, maintenance or renewals. Its bulk is relatively small, and it forms a light compact and portable equipment strong enough to stand up to rough usage, shocks and vibrations without damage. It is very simple to use, overloads are permissible, and the cable discharges rapidly.

Westinghouse METAL RECTIFIERS

Write for full details to Dept. E. & T.
Westinghouse Brake & Signal Co. Ltd.,
Pew Hill House, Chippenham, Wilts.

TROUBLE- TRACKING SIMPLIFIED

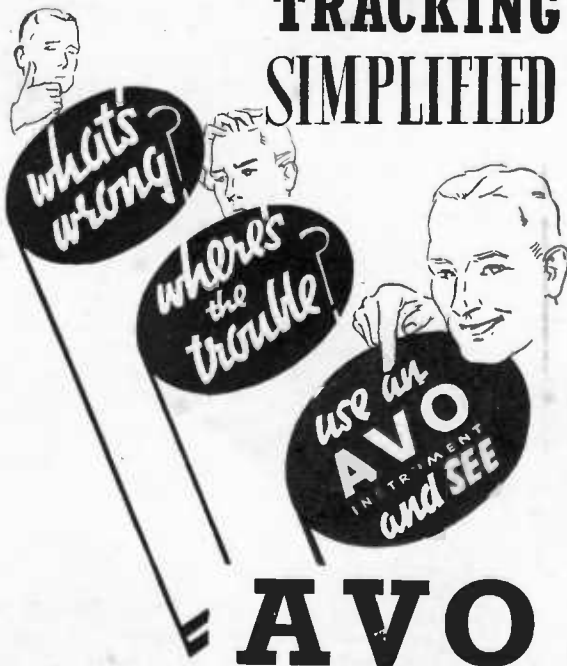

AVO
Regd. Trade Mark
ELECTRICAL MEASURING
INSTRUMENTS

● The Universal AvoMinor and the D.C. AvoMinor put within the reach of the serious amateur a means of rapid precision testing of an accuracy unobtainable with other instruments in their class. Their simplicity and versatility make short work of all the normal trouble tracking problems. They are worthy members of a range of "AVO" Instruments renowned for their high standard of workmanship and efficiency.

THE UNIVERSAL AVOMINOR

ELECTRICAL MEASURING INSTRUMENT

22 Ranges of Direct Readings

D.C. Volts	A.C. Volts	D.C. Milliamps
0- 75 milli-volts	0- 5 volts	0- 2.5 milli-amps
0- 5 volts	0-25 "	0- 5 "
0- 25 "	0-100 "	0- 25 "
0-100 "	0-250 "	0-100 "
0-250 "	0-500 "	0-500 "
0-500 "		

RESISTANCE

0- 20,000 ohms	0- 2 megohms
0-100,000 "	0- 5 "
0-500,000 "	0-10 "

THE D.C. AVOMINOR

ELECTRICAL MEASURING INSTRUMENT

13 Meters in ONE

Current milliamps	Voltage volts	Resistance ohms
0- 6	0- 6	0- 10,000
0- 30	0- 12	0- 60,000
0-120	0-120	0-1,200,000
	0-240	megohms
	0-300	0-3
	0-800	

In spite of greatly increased production, most of our output of "AVO" Instruments is being taken by the Services. Delay in delivery of Trade orders is consequently inevitable, but we shall continue to do our best to fulfil your requirements as promptly as possible.

● Write for fully descriptive pamphlets and current prices.



THE UNIVERSAL AVOMINOR



BRITISH
MADE

THE D.C. AVOMINOR

Sole Proprietors and Manufacturers:

AUTOMATIC COIL WINDER & ELECTRICAL EQUIPMENT Co. Ltd., Winder House, Douglas Street, London, S.W.1.

Phone: Victoria 3404/7

Monthly (published 25th of preceding month) 1/6 net. Subscription Rates : Post Paid to any part of the World— 3 months, 5/- ; 6 months, 10/- ; 12 months, 20/-. Registered for Transmission by Canadian Magazine Post.

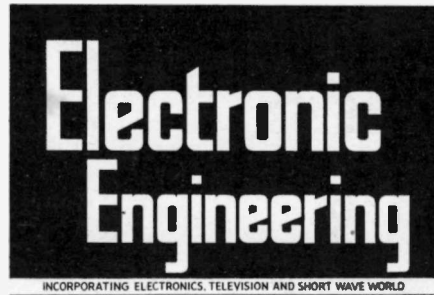

PROPRIETORS :
HULTON PRESS LTD.,
Editor : **G. PARR.**

TELEPHONE :
CENTRAL 7400

TELEGRAMS :
HULTONPRES LUD,
LONDON

EDITORIAL, ADVERTISING AND PUBLISHING OFFICES, 43-44, SHOE LANE, LONDON, E.C.4

CONTENTS

	PAGE		PAGE
A Progressive Policy—Editorial	245	Mercury Column Aerial (abstract)	270
The Muirhead-Wigan Decade Oscillator	246	Patents Record	272
Mechanical Adjustment for U.S.W. Oscillator	248	Negative Feedback Tone Control	278
Review of Progress in Electronics, III.	249	A Focusing Coil Support	279
Cutting and Lapping Quartz Plates	252	Abstracts of Electronic Literature	280
Preparation of Sound Film Track	255	Novel Seamed Cathode Sleeve	283
Design of Wide Band V.F. Amplifiers	258	Concentric Line Circuit for U.H.F.	284
Data Sheets I, II and III	263	Latent Period in Muscle Response (abstract)	288
A Distribution System for All-Wave Signals	268		

15w. AC & 12-VOLT DC AMPLIFIER

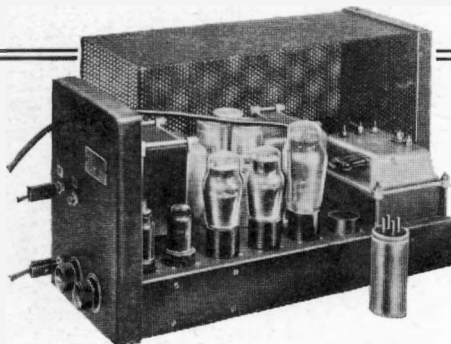

TYPE CP20

Prices : Plus 20% War Increase

AC and 12-volt CHASSIS with valves, etc. **£12 12 0**

AC only CHASSIS with valves, etc. .. **£8 18 6**

Gauze Case for either chassis 12/6 extra.

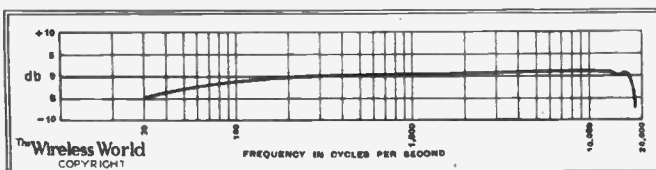

Any response curve supplied to order
Prompt deliveries on Priority AI Contracts

THIS small Portable Amplifier operating either from AC mains or 12-volt battery, was tested by "THE WIRELESS WORLD," October 1st, 1937, and has proved so popular that at Customers' demand it remains unaltered except that the output has been increased to 17.2 watts and the battery consumption lowered to 6 amperes. Read what "The Wireless World" said,—

"During tests an output of 14.7 watts was obtained without any trace of distortion so that the rating of 15 watts is quite justified. The measured response shows an upper limit of 18,000 c-s and a lower of 30 c-s. Its performance is exceptionally good. Another outstanding feature is its exceptionally low hum level when AC operated even without an earth connection. In order to obtain the maximum undistorted output, an input to the microphone jack of 0.037 volt was required. The two independent volume controls enable one to adjust the gain of the amplifier for the same power output from both sources, as well as superimpose one on the other, or fade out one and bring the other up to full volume. The secondary of the output transformer is tapped for loud speakers or line impedances of 4, 7.8 and 15 ohms."

VORTEXION LTD.

257, The Broadway, Wimbledon, S.W.19

Phone : LIBerty 2814

TONE UP YOUR SET WITH MAZDA

The
MOST FAMOUS
SET MAKERS

Fit
MAZDA
RADIO
VALVES

Mazda Radio Valves are manufactured in Gl. Britain for the British Thomson-Houston Co. Ltd., London & Rugby and distributed by

THE EDISON SWAN ELECTRIC CO. LTD.  155 CHARING CROSS RD., LONDON, W.C.2

For full particulars write to Technical Service Department

Electronic Engineering

A Progressive Policy

AS announced in last month's issue of **ELECTRONICS AND TELEVISION**, the title of this Journal has been altered to one which will indicate more clearly its widening scope and the trend of its editorial policy.

Twelve months ago, Hulton Press, Ltd., acquired **ELECTRONICS AND TELEVISION**, foreseeing the demand that would arise from an authoritative publication covering the whole field of electronic engineering and they have lost little time in putting their plans for the future into effect, in spite of the difficult times through which we are passing.

In its new form, this Journal will provide the whole industry, research engineer, factory engineer and student alike with a medium for interchanging ideas and learning the progress which is being made in all parts of the world.

Original technical articles by specialists in a particular branch of electronics will appear regularly, and the features which have already proved useful to industrial engineers—patent abstracts, reviews of books and instruments, and novel circuits—will be retained and enlarged.

Commencing with this issue we publish the first of a series of Data Sheets for the use of design engineers engaged on special amplifier work

The New Editor of "Electronic Engineering"

Mr. G. Parr, who has been appointed Editor of "Electronic Engineering," has been intimately associated with the electrical and radio industry for over twenty years, and is well known to readers of "Electronics & Television" as a writer and lecturer on radio subjects.

Mr. Parr completed his training as an electrical engineer at Finsbury Technical College during the last war, and after a brief interlude in the Wireless Branch of the Royal Navy rejoined the College Staff as lecturer and demonstrator in Electrical Engineering.

On the closing of the College he was engaged as Radio Valve Engineer by the Edison Swan Electric Co., and subsequently as head of the Technical Service section of the Radio Division he has been actively concerned in the various applications of electronics to industrial uses.

He was one of the first in this country to demonstrate the use and versatility of the cathode ray tube as a measuring instrument, and published one of the first books on the tube and its circuits.

As Hon. Lecture Secretary of the Television Society he has devoted much of his spare time to furthering the interests of television amateurs and was largely responsible for the organisation of their present headquarters.

Mr. Parr brings to his new appointment a practical appreciation of the difficulties and problems of the radio and allied industries, and Hulton Press, Ltd., hope that under his direction this Journal will contribute largely to their solution.

and short wave research. These are bound in a convenient position for detaching without mutilation of the journal and can be assembled in a separate cover to form a valuable design manual.

To those readers who fear that their interest in radio and television in particular will no longer be catered for, we would point out that these subjects still remain the most important branch of electronic engineering and will continue to receive extensive treatment.

Without the vast amount of research which has been done in both radio and television the wider application of electronics to industry and national requirements of the present day would not have been possible, and the radio engineer is still the pioneer in new methods of controlling the electron.

We believe, however, that the greatest expansion in the future will be in the use of thermionic devices in the industrial re-organisation after the war, and we are setting out to encourage this expansion now.

We are sure that manufacturers and research workers will appreciate the confidence that we have in the future, and will support our endeavour to provide the industry with an up-to-date and informative journal.

A New Frequency Generator

The Muirhead-Wigan Decade Oscillator

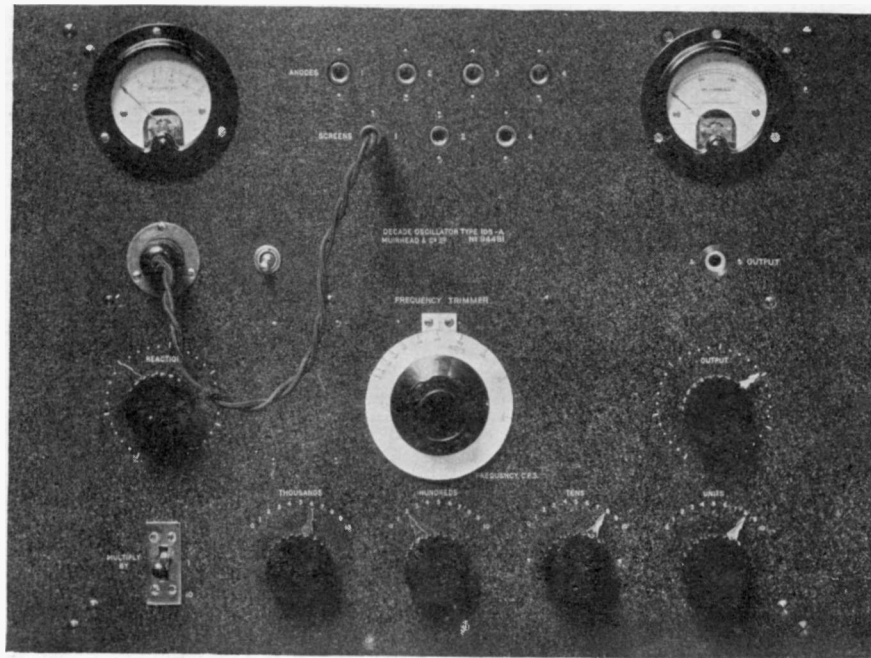

Range :
1 c. p. s.
to 100 Kc/s.

Patented

MESSRS. MUIRHEAD & CO., LTD., have recently produced an oscillator which has a number of novel features. The most striking of these is that the frequency generated is read off directly from step-by-step decade dials in the same manner as an ordinary decade resistance box. With the four decades provided, frequencies from 1-10,000 c.p.s. may be set up in steps of 1 c.p.s. and from 10 Kc/s to 100 Kc/s in steps of 10 c.p.s.

The oscillator utilises resistance-capacity tuning and it is claimed that this together with the direct reading decade arrangement (which is only practicable with this form of tuning) has enabled an oscillator to be produced in which high reading accuracy and stability are coupled with wide frequency range. Stable L-C oscillators of wide frequency range are, of course, common, but not with a direct reading dial. Heterodyne oscillators seldom exhibit very high stability at low frequencies and, unless considerable mechanical in-

genuity is exercised in expanding the scale, they cannot be read very accurately.

The frequency selective network used in the Muirhead-Wigan Oscillator is shown in Fig. 1 in which A consists of a resistance R_1 in series with a capacitance C_1 and B consists of a resistance R_2 in parallel with a capacitance C_2 . If now, a source of alternating voltage is applied to terminals 1 and 2, then at one and only one frequency the voltage appearing across terminals 3 and 4 will be in phase with the input voltage. The frequency at which this condition of zero phase shift through the network occurs, is given by the

$$\text{expression } f_0 = \frac{1}{2\pi\sqrt{R_1R_2C_1C_2}} \text{ and}$$

this is also the frequency at which minimum attenuation through the network occurs. In Fig. 2 such a network is shown connected between the output and input of an amplifier possessing no appreciable internal phase-shift. The phase shifting network is arranged to form a positive feedback path having a minimum attenuation at the frequency f_0 and consequently maximum gain in the amplifier will occur at this frequency, thereby providing the amplifier with highly selective properties. If now,

the gain is increased by other means until the gain of the amplifier exceeds the power loss in the network the system will oscillate at the frequency for zero phase-shift.

A particular application of resistance capacity tuning has made possible the Decade Oscillator to be described. The principle of reciprocal tuning (a brief description of which is given here) is due to E. R. Wigan, of the Signals Experimental Establishment, Woolwich. In the phase-shifting network of Fig. 1, let C_1 and C_2 be fixed and R_1 and R_2 simultaneously variable. Then if the two latter are varied in the same ratio, the attenuation of the network at the frequency of oscillation will remain constant while the frequency varies

in proportion to $\frac{1}{\sqrt{R_1R_2}}$ or $\frac{K}{R}$ where K is a constant depending on the ratio of R_1 to R_2 .

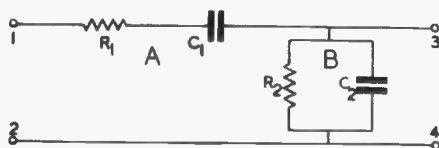

Fig. 1.

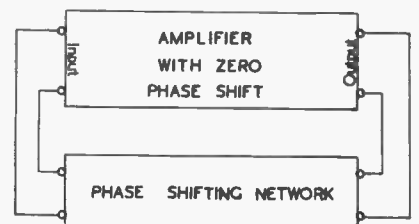

Fig. 2.

It is convenient to consider the case in which $C_1 = C_2 = C$ and $R_1 = R_2 = R$.

Then $f_o = \frac{1}{2\pi RC}$ or $\frac{K}{R}$, the value of C being a fixed quantity.

Clearly if R_1 and R_2 are arranged to read as conductances and have a common control reading on a dial, then the frequency generated will be proportional to that dial reading.

In the Muirhead-Wigan Decade Oscillator type D-105-A it has been arranged to vary the quantity $1/R$ according to a decade law. Four decades of frequency are provided giving $\times 1$, $\times 10$, $\times 100$, and $\times 1,000$ c.p.s. The procedure for obtaining, say, 1,234 c.p.s. is simply to set the thousands dial to 1, the hundreds dial to 2, and the tens and units dials to 3 and 4 respectively: just as one would set a four-dial resistance box to 1,234 ohms. No reference to calibration charts is necessary and the accuracy of the frequency so obtained is of a very high order throughout the frequency range. In addition to being a simple method of setting the frequency, the decade principle provides a means of adding or subtracting accurately known increments of frequency; a feature of great value in testing filters and other apparatus having non-linear frequency characteristics. Furthermore, the interpolation accuracy over, say, a thousand cycle band is very considerably higher than the overall accuracy of the oscillator.

The circuit diagram is shown in

Fig. 3 where V_1 , V_2 and V_3 comprise the oscillator amplifier followed by an output amplifier, V_4 and V_5 . The phase-shifting network consists of R_1 , C_1 , R_2 and C_2 . In this phase-shifting network R_1 always equals R_2 and both are simultaneously variable by means of the decade dials. Similarly $C_1 = C_2$; and either one of two values for this quantity may be selected by means of a key switch. The operation of this switch provides two ranges of frequency: 1 c.p.s. to 11,110 c.p.s. and 10 c.p.s. to 111,100 c.p.s. Resistance capacity coupling is employed between all stages of the amplifier, and negative feedback is introduced into both amplifiers generally to improve the characteristics and stability with thermionic variations. The alternating output voltage from the oscillating amplifier is fed to the grid of V_4 which is in turn R.-C. coupled to the output pentode V_5 . Output control is effected by varying the degree of negative feedback from V_5 to V_4 by means of a continuously variable wire wound resistor controlled by a knob on the front of the panel. This method of control has the very desirable property of reducing the overall noise level with reduction in output.

Two output circuits are provided: 8,000 ohms choke-capacity coupled and a resistance-capacity output for use below 10 c.p.s. Using the latter, good waveform is obtainable down to 1 c.p.s., as it is a feature of the oscillator amplifier that the harmonic content is small and constant at all frequencies.

The characteristics of this amplifier, employing negative feedback, are such that on the lower frequency range, the decade frequency law holds to $\pm 0.2\%$ or ± 2 c.p.s., whichever is the greater from 1 c.p.s. to 11.11 Kc/s. Above 20 Kc/s on range 2, the internal phase-shift of the amplifier and impurities in the resistive and reactive elements in the network combine to increase the frequency error, and in order to limit this to $\pm 0.2\%$ it is necessary to employ a correcting device in the form of two small variable air condensers across C_1 and C_2 , of such values that frequency corrections of the order of 2% may be effected. These trimmers are operated from a common control knob provided with a pointer and scale engraved in frequency. A sufficient number of points is calibrated so that when the decade frequency dials are adjusted and the trimmer set to the frequency nearest to that indicated by the dials, the output frequency is correct to $\pm 0.2\%$.

A further trimming condenser is connected across C_2 in the phase shifting network, the function of which is to provide a frequency correction for changes in ambient temperature. This condenser is not calibrated and is provided with a screw-driver adjustment.

The oscillator is completely mains-operated, and voltage stabilisers are included in the A.C. supply circuit and in the main H.T. lead following the rectifier valve. The A.C. voltage stabiliser is not included in the oscil-

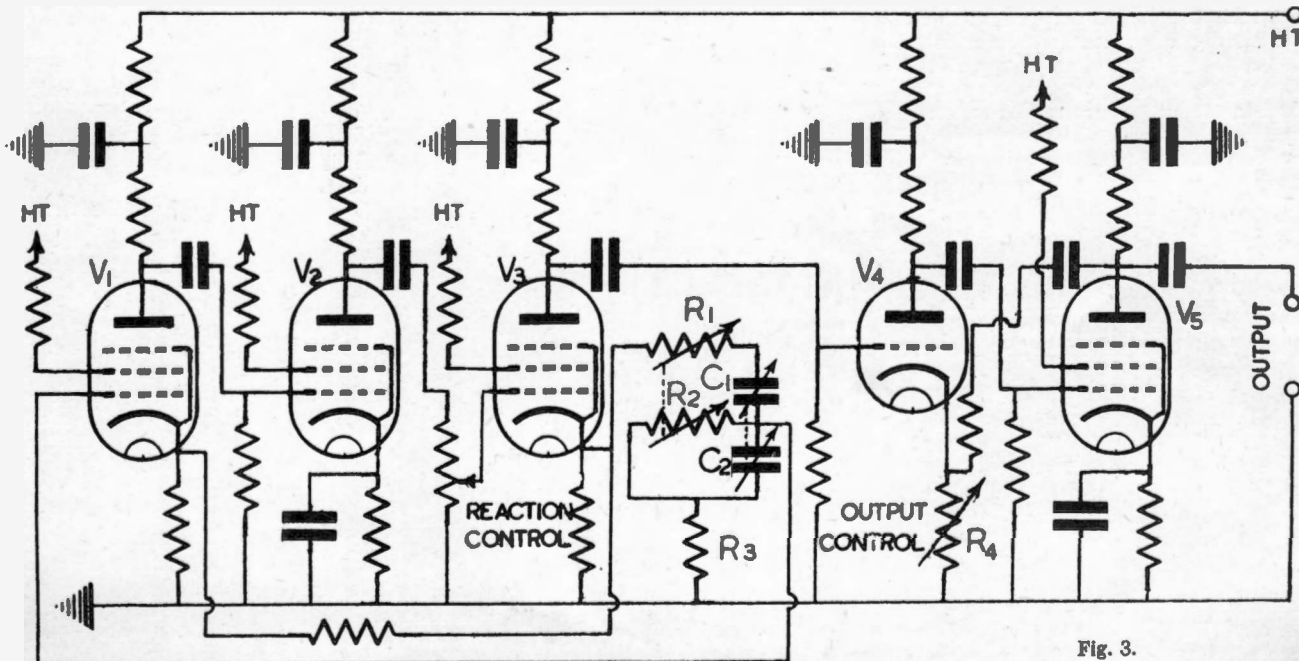

Fig. 3.

lator but mounted on a separate panel which may be mounted on the rack beneath the oscillator. The photograph illustrates the layout of the controls and the general appearance of the instrument, and Fig. 4 shows one of the decade switch units. The following is a brief specification of overall performance:—

Frequency Selection.

On the low range the frequency is direct reading on four decade dials in steps of 1 c/s. On the high range the smallest step is 10 c/s and use must be made of the calibrated trimmer as a secondary adjustment above 20 Kc/s.

Frequency Range.

Two ranges selected by a range switch: 1 c.p.s. to 11,110 c.p.s. in 1 c.p.s. steps and 10 c.p.s. to 111.1 Kc/s in steps of 10 c.p.s.

Frequency Accuracy.

Low frequency range: from 1 c.p.s. to 11,110 c.p.s. $\pm 0.2\%$ or ± 2 c.p.s., whichever is the greater.

High range: $\pm 0.2\%$ from 10 Kc/s to 11.1 Kc/s with proper use of the frequency trimmer. Changes in A.C. supply voltage introduce a further frequency error which does not ex-

ceed 0.05% for $\pm 10\%$ voltage variation.

Frequency Stability.

After an initial warming-up period the hourly stability is better than 0.01%.

Power Output and Harmonic Content

The maximum power output is 2 watts into 8,000 ohms load for 2% total harmonic; below 1 watt the total harmonic content does not exceed 1.25% above 20 c.p.s.

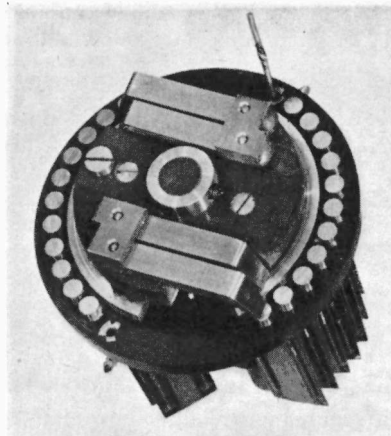

Fig. 4.

Power Supply.

200 to 250 volts A.C.

Summary

The Muirhead-Wigan Decade Oscillator combines the high accuracy of the inductance-capacity tuned circuit oscillator with the speed of adjustment of the heterodyne type. It is particularly useful for the investigation of non-linear frequency characteristics where it is often necessary to make a large number of measurements in a minimum of time, and for this work it has an accuracy superior to the heterodyne oscillator. Perhaps the most useful feature is the very high accuracy with which it conforms to the decade law over a limited frequency band. Under these conditions the operation is delightfully simple, it being necessary only to adjust the frequency decades having first set the other controls at one of the frequencies on the range. Although considerable stress has been laid on the specialised features of this oscillator it finds a wide application as a precision instrument in general laboratory practice.

A Convenient Mechanical Adjustment for a U.S.W. Resonant-line Oscillator

THE use of tuned circuits consisting of concentric lines is becoming increasingly popular in ultra short-wave work, and the Radio Corporation of America Laboratories have developed the following practical method of adjustment for valve oscillators incorporating this type of resonant circuit.

The inner conductor A and the outer conductor B of a $\lambda/4$ low-loss line are connected together by a metallic end plate C. The free end of A is attached to a corrugated metal bellows D linked to an Invar rod E in order to avoid variations of length with temperature, any slight adjustment necessary here being made by means of the knob F. The oscillator valve, say, a 955 Acorn type triode, is supported at one end of a sliding copper tube G located midway between the inner and outer line conductors. The anode and grid are each connected by means of sliding flexible spring contacts H to metal plates J, which are in turn mounted on

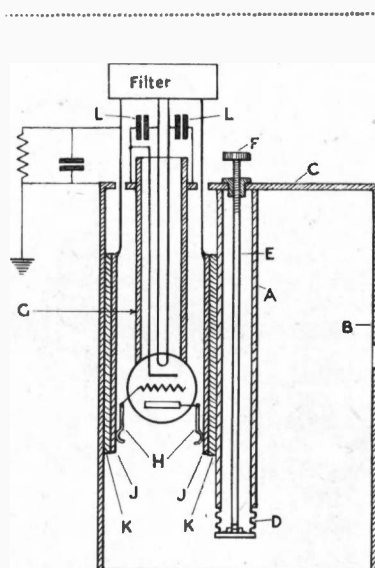

the line conductors A, B and insulated by spacers K: the cathode is earthed to the end plate, while the filament leads are by-passed to earth for high-frequency currents through condensers L. Suitable operating potentials are applied to the anode and grid via the plates J.

By means of this arrangement the length, and hence the inductance, of anode and grid leads is kept to a minimum.

When the tube is slid along so as to bring the valve connexions near the end plate C, the frequency stability is a maximum, but the load on the valve is also a maximum, and may be sufficient to prevent oscillation. Hence, the required adjustment is a compromise between reliable valve performance and maximum frequency stability. R.C.A. have obtained successful results with this arrangement up to frequencies of about 300 megacycles/sec.

Review of Progress in Electronics

III. Photoconductivity

By G. WINDRED, A.M.I.E.E.

"For over 50 years the new element (selenium) remained little but a chemical curiosity. It was found that its atom weighed 79.2 times as much as the hydrogen atom, that it melted at 217° C. and boiled at 690°; that it occurred in several "allotropic" modifications, the lightest of which weighed 4.3 times its own bulk of water; that it was insoluble in water, but dissolved readily in acetone, aniline, and other organic liquids; that it was allied to sulphur a non-metal, on the one hand, and to tellurium, a metal, on the other, being itself practically non-metallic . . ." E. E. Fournier D'Albe, "The Moon-Element: an Introduction to the Wonders of Selenium," London, 1924.

THE element selenium (Se) was discovered by J. J. Berzelius as an impurity in sulphuric acid in 1817. The physical and chemical properties of the substance in its various forms soon became well known,¹ but it was not until 1873 that its curious electrical properties were observed. On February 4 of that year, Willoughby Smith addressed to Latimer Clark, Vice-President of the Society of Telegraph Engineers (now the Institution of Electrical Engineers) a letter² describing the experiments carried out by himself and his assistant, May, in the course of which it was noticed that the electrical resistance of selenium underwent changes in accordance with variations of illumination. When exposed to bright sunlight, the conductivity of some sticks of crystalline selenium which were being used as resistors was much greater than when the sunlight was obscured.

This discovery resulted in a great deal of attention being given to selenium and its possibilities of useful application in practice. Some idea of the extent of this work may be gathered from the fact that a bibliography³ of the subject prepared by the New York Public Library up to the year 1925 included references to no fewer than 1,536 items of literature and 138 selected patents.

The phenomenon of photo-conductivity, as represented by the variation in electrical resistance of a substance with variation in illumination, is exhibited by a wide variety of materials and also by some liquids. Most applications of the effect make use of selenium, owing to its marked properties in this respect. Physical data concerning selenium are given in Table I. It should be pointed out in this connexion that the utmost caution is necessary in the use of data on selenium given in the usual physical tables. Some tables, including even the famous Smithsonian, give values of various properties without specifying

the particular form of selenium to which they correspond.

It is instructive to compare the values of resistivity in Table I* with that of copper, which may be taken as 1.7×10^{-6} in ohm. cm. units. The figure of 7×10^4 for crystalline selenium given by Fournier D'Albe represents about 4×10^{10} , or forty thousand million times the figure for copper. This is evidently a value measured in the light, whereas the dark value quoted in the table for a sample of unspecified form represents a ratio of some 10^{22} and is representative more of an insulator than a semi-conductor.

In the present article our attention is confined to selenium. For a discussion of photo-conductivity effects in other substances and liquids the reader is referred to Chapter VIII of the treatise by Hughes and Du Bridge.⁴

General Theory

The observed effect of light on selenium may be explained readily on the basis of modern physics, which regards a beam of light as a shower of corpuscles or quanta; the energy of each of these entities, known as photons, being determined by the wavelength and frequency of the light, in accordance with Planck's hypothesis. According to this view we may suppose that the energy represented by the incidence of photons comprising a beam of light directed on to selenium may so disturb the surface atomic structure that some of the bound electrons are removed from their normal atomic orbits and added to the normal number of free electrons which exist under conditions of darkness and which determine the dark-conductivity of the material. This is a reasonable explanation of the increase in conductivity caused by illumination.

It is reasonable to suppose that the number of free electrons produced in this way with light of a given wavelength will be proportional to the light intensity. The production of each free electron will also naturally result in the creation of a residual positive ion. It must be supposed that the recombination of electrons and ions is continually taking place in the material while it is illuminated, and it is evident that under these conditions a steady value of conductivity is reached only when the rate of production of ions and electrons is equal to their rate of recombination.

On the basis of this theory, Fournier D'Albe⁵ was able to produce a satisfactory mathematical analysis, on the following general lines: If E is the energy of the incident light beam, as determined by its intensity for a given wavelength, then the number of electrons (and ions) produced in unit time will be given by aE , where a is a suitable constant. If it be assumed that the rate of recombination is proportional to the square of the number of electrons present, then the number recombining in unit time is bN^2 , where N is the number present and b is another constant. It follows that the increase in the number of electrons present in unit time is

$$\frac{dN}{dt} = aE - bN^2 \quad \dots (1)$$

In the steady state, when the rate of production is equalled by the rate of recombination, the differential in equation (1) is zero, and

$$\begin{aligned} aE &= bN^2 \\ \text{so that } N^2 &= aE/b, \\ \text{and } N &= K\sqrt{E}, \quad \dots (2) \\ \text{where } K &= \sqrt{a/b}. \end{aligned}$$

Since N , the number of electrons present, is a measure of the conductance, we have reached the important result that the conductance is proportional to the square root of the light intensity.

* page 270.

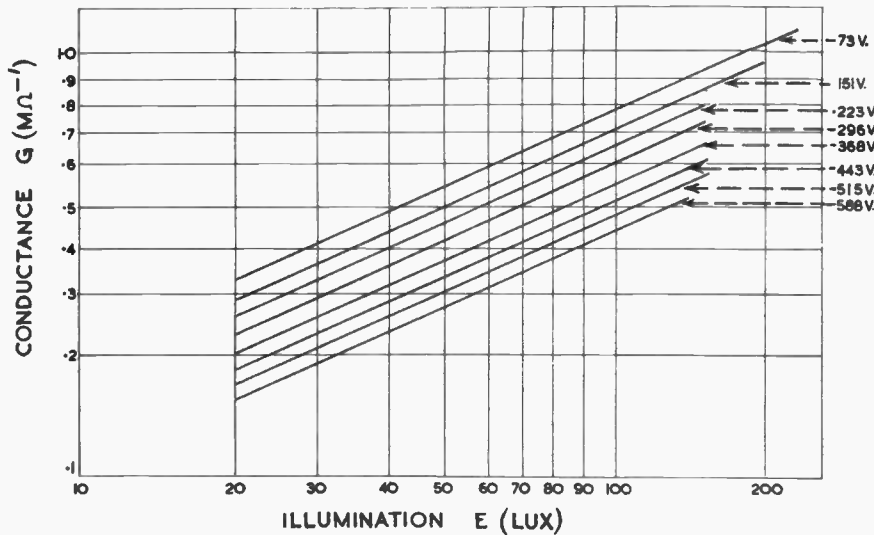

Fig. 1. Change of conductance of selenium with illumination.

(Courtesy Radiovisor Parent Ltd.)

It may be noted here that equation (2) is of the form

$$N = kE^x,$$

so that if the change of conductance G is represented as the difference between the light and dark conductances, G_1 and G_0 respectively, then

$$G = G_1 - G_0 = kE^x,$$

where k and x are constants of the material. The relationship between G and $\log E$, representing the change of conductance with change of illumination for light of a given wavelength, is seen to be a linear one. It is well represented by the curves in Fig. 1, obtained from measurements on commercial selenium bridges. From the equal slope of the curves it is seen that the value of x remains fairly constant. The value of k is seen to be dependent upon the voltage and inversely proportional thereto.

It may be doubted whether the simple theory we have outlined is truly representative of all the phenomena taking place in selenium. Recent work on the subject has shown that it is necessary to recognise the existence of a primary photo-electric effect and resulting secondary effects of considerable complexity which are not yet fully understood. It has been pointed out by Hughes and Du Bridge⁴ that "in many cases, of which selenium is an excellent example, the superposed secondary effects are so much greater than the fundamental primary photo-electric effect that they completely obscure it." The important work of separating the effects was carried out in the course of lengthy researches by Gudden and Polh⁶. It was shown by Fleschig⁷ that within the experimental limit of 10^{-4} sec. the primary photo-electric current commenced simultaneously with illumination by blue light. The measurements with infra-red illumination were subject to a larger experimental error, and showed that the response was simul-

taneous within 10^{-1} sec. The secondary effects are comparatively slow, and place a somewhat drastic limit upon the frequency response of selenium.

As long ago as 1900, Himstedt⁸ made the important discovery that the photo-conductive action of selenium was also produced by X-rays, and observed more than 50 per cent. reduction of resistance by this means. He suggested the use of the effect as a means of comparing the intensity of different sources of radiation, and also mentioned the possibility, for which he found no direct evidence, that the effect might be attributed to illumination of the selenium by fluorescence or phosphorescence caused by the incident radiation.

Photo-conductive Bridges

There is some confusion of nomenclature referring to photo-conductive devices, which are referred to both as cells and bridges. It may be admitted that reference to cells may introduce confusion with those of the Becquerel type, and for this reason alone the term bridge seems preferable. This term also describes more accurately the construction of most devices of the kind, in which the photo-conductive material (usually selenium) bridges a gap between two electrode structures. The change of resistance between the electrodes under the effects of changing illumination may be utilised in a variety of ways to produce an electrical response governed by these changes.

Early types of bridge were inconsistent in their behaviour, and subject to sudden failure. A wide variety of forms appeared at different times, embodying various principles of manufacture, and it became very evident that one of the most important considerations in the manufacture of efficient types was the development, with long experience, of a satisfactory technique. A certain amount of secrecy has surrounded most

industrial processes, although some information is available. Interesting particulars are given in the books by Hughes and Du Bridge,⁴ and Barnard,⁹ and in a paper by Phillips.¹⁰

Henney¹¹ mentions a construction in which two enamelled wires are wound side by side on a glass sheet or other insulating plate. The enamel is scraped off one surface and selenium painted on, after which the unit is heat-treated. It is stated that in the FJ-31 Selenium Tube (American G.E.) the selenium surface is formed entirely in a vacuum by a process similar to that used in vaporising metals in thin films on the bulbs of radio valves. A dry inert gas is admitted during the annealing process and is retained in the tube. The dark resistance of the FJ-31 is stated to be about 6 megohms. When illuminated, the resistance may drop as low as 0.75 megohm, corresponding to a resistance change of 8:1. It is claimed for other bridges of American manufacture (Clark Instrument Company) that a resistance change of 25:1 may be obtained with a dark resistance of about 25 megohms.

A typical modern cell of British manufacture is shown in Fig. 2. In this type the electrodes are formed by two thin metal grids with projecting teeth fused on to a thin glass plate. The teeth of the respective grids are interspaced without causing electrical contact or producing a high capacity. Molten selenium is applied to the surface and then thermally treated to obtain the required crystalline structure. The thickness of the selenium film is normally only a few hundredths of a millimeter, so as to eliminate as far as possible the shunting effect of any in-

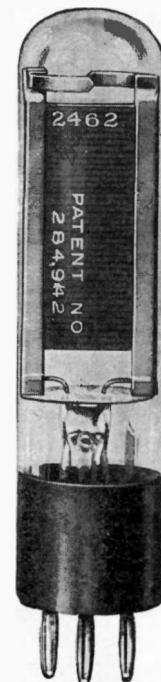

Fig. 2. Modern selenium bridge.

(Courtesy Radiovisor Parent Ltd.)

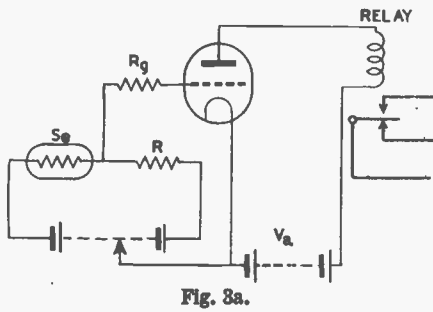

Fig. 3a.

tioned at all, in the majority of textbooks.

Some typical circuits are shown in Fig. 3. In diagram (a) the bridge Se is connected in series with a suitable resistance across a D.C. source; the voltage drop across each branch with respect to the cathode of the triode being determined by the position of the tapping represented by the arrow. Variations in resistance of the bridge under the effects of illumination cause a variation of grid potential which is utilised to control anode current flow so as to operate the relay. A modified form of this circuit is shown at (b), making use of two bridges, Se 1 and Se 2. Light falling on Se 1 reduces the resistance of this branch and causes an increase of anode current for operation of the relay. The anode current is reduced by light falling on Se 2, so that alternative methods of operation are possible. An advantage of this circuit is that the effects of changing temperature are largely neutralised owing to the equal but opposing effects in the respective bridges. An A.C. circuit generally similar to the arrangement in diagram (a) is shown at (c). With regard to operation at high frequencies, the selenium bridge is severely limited by its speed of response, but acoustic applications are possible with suitable circuits, as shown for example in diagram (d). In this case the variation of voltage across a resistance and inductance branch carrying the bridge current

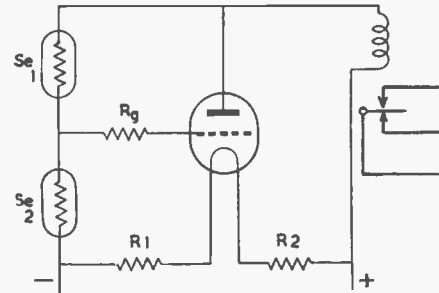

Fig. 3b.

active material. The glass bulb is evacuated and then filled with an inert gas. Bridges of this type are made in different grades, according to the intended application, and have dark resistances ranging between 0.5 and 20 megohms.

Applications

Most of the early work on selenium bridges was purely experimental; the chief object being to determine the electrical properties under various conditions of operation. Ordinary measuring instruments are sufficient for this purpose, but when it is desired to make a bridge perform useful work, such as the operation of a relay, it becomes necessary in most cases to amplify the current changes resulting from changes in illumination. The subject of amplification in relation to photo-conductive bridges is a somewhat neglected one, and is inadequately dealt with, if men-

is passed to the grid of the first amplifier stage. By this means the high frequencies are suitably emphasised.

Conclusion

In this article we have outlined very briefly the salient points of development in photo-conductivity. In the interests of completeness, several items of literature dealing specifically with the subject have been included in the Bibliography (items 12 to 20 inclusive), which is believed to be reasonably complete.

BIBLIOGRAPHY

- 1 Cf., for example, Sir H. E. Roscoe and C. Schorlemmer, "A Treatise on Chemistry," 5th ed., London, 1920 vol. I, p. 467.
- 2 W. Smith and May, *Journ. Soc. Telegr. Eng.*, 2, 1873, p. 31.
- 3 M. F. Doty, "Selenium: A List of References, 1817-1925," New York Public Library, 1927.
- 4 A. L. Hughes and L. A. Du Bridge, "Photo-electric Phenomena," New York (Mc-Graw-Hill), 1932.
- 5 E. E. Fournier D'Albe, *Proc. Roy. Soc., A*, 89, 1913, p. 75.
- 6 B. Gudden and R. Pohl, *Zeits. f. Phys.*, 6, 1921, p. 248; 7, 1921, p. 69; 16, 1923, p. 170; 17, 1923, p. 331; 31, 1925, p. 651; 37, 1926, p. 881.
- 7 W. Fleschig, *Zeits. f. Phys.*, 33, 1928, p. 372.
- 8 F. Himstedt, *Phys. Zeits.*, 1, 1900, p. 476.
- 9 G. P. Barnard, "The Selenium Cell," London, 1930.
- 10 C. E. S. Phillips, paper on "The Manufacture of Selenium Cells" in the volume of collected papers "Photo-Electric Cells and their Applications," London (Phys. Soc.), 1930.

(Continued on page 256)

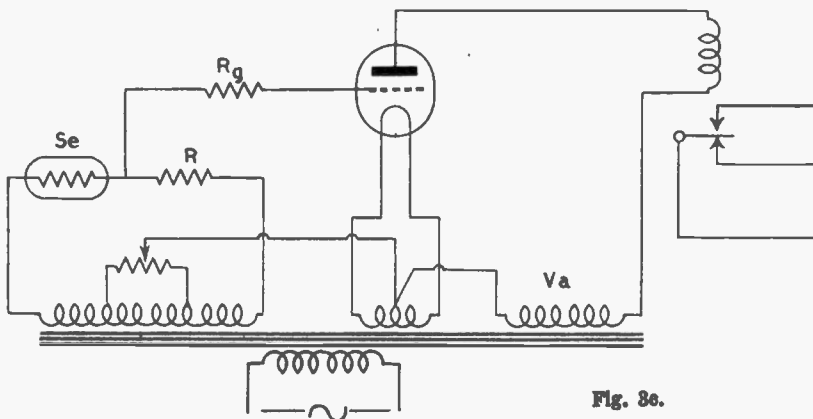

Fig. 3c.

Figs. a, b, c, d. Typical amplifier circuits for use with selenium bridges.

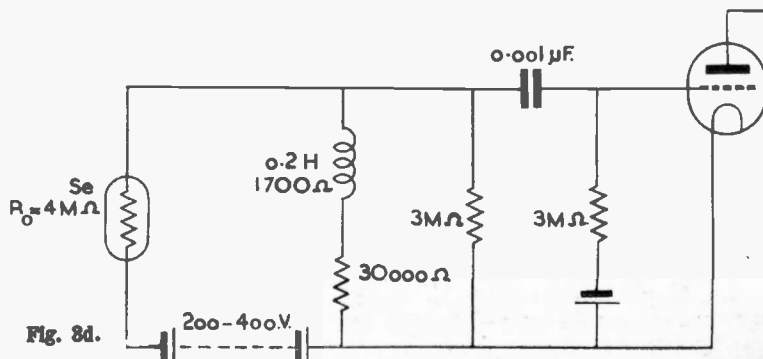

Fig. 3d.

The Preparation of Piezo-electric Quartz Plates

Technique of Cutting, Lapping and Frequency Measurement

By F. BUTLER, B.Sc.

THE previous section of this article was concerned with the design of a quartz crystal cutting and lapping machine, and the present contribution deals with actual cutting and finishing operations on the crystal blanks. This subject is so wide and complex that it is only possible to select a few of its aspects for detailed treatment. It is unfortunate that even when quartz is obtained from the most reliable sources, large portions of each natural crystal are useless for piezo-electric purposes. Much of the elaborate equipment used by commercial concerns is employed to detect faults at an early stage in the cutting operations, and so prevent waste of valuable time in finishing processes on a blank which will eventually prove to be useless. High accuracy in setting up and cutting is required in the production of plates of low frequency-temperature coefficient, and this in turn needs expensive and complicated equipment for quantity production. When only small-scale production is contemplated the problem is much simplified, and it is easier to cut a plate, lap it approximately to size and test it in an actual circuit than it is to conduct an elaborate series of tests which in any case need the plate in a semi-finished condition. Simple test apparatus will be described for detecting optical twinning and reference must be made for details of more decisive electrical and chemical (etching) tests to the bibliography given at the end of the first instalment.

Modes of Vibration of Quartz Crystals

Any elastic solid may perform longitudinal, shear, torsional and transverse vibrations. Only the first two are of importance in quartz oscillator applications. Longitudinal vibrations cause a plate to exhibit alternating changes in length, breadth or thickness, and thus there are three fundamental modes of vibration, one along each of these directions. Each mode is accompanied by an infinite range of harmonics, and the frequency is calculable from a formula of the type:—

$$f = \frac{1}{2l} \sqrt{\frac{E}{d}}$$

in which f = vibration frequency.
 l = length in direction of vibration.
 E = elasticity modulus.
 d = density.

The variables on the right-hand side are affected by temperature and, moreover, have different values in different directions in the crystal. It is possible to choose some particular cutting angle which so plays off the various effects against each other that the final frequency is independent of temperature over a wide range. This is not possible for high-frequency plates using longitudinal vibrations, such as are performed by X-cut crystals. Instead, shear vibrations are employed. The high-frequency shear mode of vibration of a plate is one in which the major surfaces of the plate slide backwards and forwards in opposite directions and yet remain parallel. These vibrations occur in Y-cut plates,

completely removed. It is, however, possible to choose a cutting direction which minimizes this effect.

To summarize, then, we are left with three useful cutting systems:—

1. X-cut, in which longitudinal vibrations are performed. Both high- and low-frequency modes are generated, the temperature coefficients of frequency being respectively of the order of -20 and -3 parts per million per degree Centigrade. Only the low-frequency mode of these crystals will be utilized, e.g., in 50 kc/s or 100 kc/s bars.

2. A.T.-cut, in which high-frequency shear vibrations are employed, and for which the temperature coefficient of frequency is almost zero. The undesired modes of variation are only weakly excited, and generally give no trouble. Slight edge-grinding removes this tendency.

3. A.C.-cut, in which zero coupling with unwanted vibration modes is obtained. A low-temperature coefficient of frequency is also secured at the same time, usually about $+10$ parts per million per degree Centigrade.

The first two are of the greatest practical importance.

Other cuts have been devised having desirable properties, but of little interest in the present connexion, and they will not be described.

Fig. 1 shows how the cutting is performed. The natural crystal is first cut into hexagonal prisms, the ends perpendicular to the optic axis. X-cut bars are produced by cutting perpendicular to the prism sides and ends, making the major surfaces of the bar parallel to the optic axis. The vibrations of the bar are along its length, the frequency and size being related by the expression: Length (mm.) \times frequency (kc/s) = 2,750.

Thus a 50 kc/s standard has a length of 55 millimetres, and in this way the approximate dimensions of a crystal to operate at any desired frequency may be obtained.

The A.T.-cut plate may best be described by considering a Y-cut plate to be rotated until its major faces make an angle of 35° with the optic axis, or until these faces intersect the end surfaces of the prism at 55° .

The procedure in producing X-cut bars

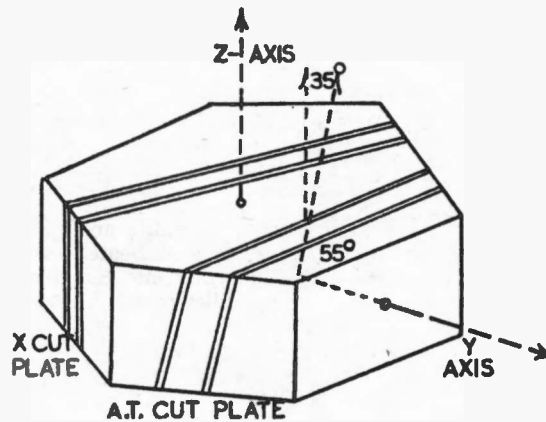

Fig. 1. Illustrating types of cut.

and in all high-frequency plates other than the X-cut type. Plates vibrating in the shear mode may use contact holders, while X-cut crystals are preferably operated with an air gap or with metal electrodes deposited on the major surfaces.

When a solid is vibrating in one main direction it suffers changes of length in the two perpendicular directions, and these are of the same frequency as the main vibration. It may happen that some harmonic of the longitudinal mode coincides in frequency with the fundamental or with some other harmonic of a vibration in an unwanted direction. Pronounced coupling of this type gives erratic results with Y-cut plates which therefore are no longer used. Wide variations in temperature coefficient of frequency and actual jumps in frequency due to changes in temperature are always observed with Y-cut crystals. The worst effects may sometimes be reduced by edge-grinding, but are seldom

is so simple that no further reference is required. Instead, attention will be focused on the production of high-frequency A.T.-cut plates. The approximate thickness required may be calculated from the relation:

Length (mm.) \times frequency (kc/s)=1,650.

A plate of 3 Mc/s has thus a thickness of 0.55 millimetre.

To avoid possible mistakes over the orientation of the A.T. plate, it should be stated that the direction of rotation of the plate should be towards parallelism with one of the minor apex faces of the terminating pyramid on the natural crystal. This face actually makes an angle of $38^{\circ} 13'$ with the optic axis.

Cutting Procedure

The first operation is to cut off the base of the natural crystal perpendicular to the optic axis. Growth lines will usually be observed round the prism faces, and these enable the crystal to be set up with fair accuracy, since they are perpendicular to the Z-axis. The crystal is bolted down to the tapped work plate, using clamps or dogs as for irregular work on a lathe faceplate or boring table. Care must be taken to avoid cracking the brittle crystal. The accuracy of setting may be checked by

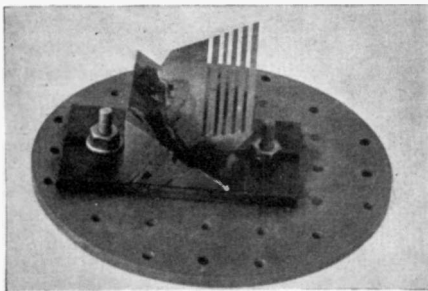

Fig. 2. Fixture used in production of A.T. cut plates.

constructing triangular metal setsquares of various sizes, having angles as nearly as possible 90° , $51^{\circ} 47'$ and $38^{\circ} 13'$ respectively, and on slipping a square of suitable size against the end pyramid face the angle between this and the work-plate should be $38^{\circ} 13'$. Cutting should then be commenced, the work being fed steadily against the rotating saw, the whole being flooded continuously by paraffin brushed liberally on the working edge. Provided the work is rigidly bolted down, very rapid cutting may be secured. A crystal of 3 square inches cross section has been cut through in six minutes using a diamond-loaded bakelite cutting wheel. The one disadvantage of these wheels, apart from their extreme fragility and high price, is some lack of accuracy because it seems impossible to manufacture a perfectly flat disc.

The next operation is to true the base

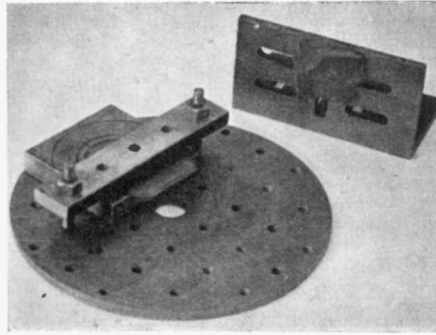

Fig. 3. (Left) cutting edges of quartz plates. (Right) use of slotted angle plate in crystal cutting.

of the cut crystal by lapping with carborundum powder and water until it is perpendicular to the optic axis. A bevel gauge is set to $51^{\circ} 47'$ and when the correct stage has been reached all the pyramid faces will fit closely against the arm of the gauge. The accuracy of the finished plates depends entirely on this adjustment, which should be done with extreme care, as the trued face is used as a reference plane for all other settings. One of the greatest problems in dealing with crystals is to devise some form of universal fixture which will hold all types and sizes for the cutting operation. Plaster of Paris chucks are used by the G.P.O., with ceresine wax for holding semi-finished plates and bars. All the work described in the present article has been done using solid shellac cement. The shellac flakes are softened by heat and the pre-heated quartz crystals pressed firmly into the cement, leaving a strong fillet round the base of the crystal. Properly performed, this operation fixes the crystal so firmly that it can only be removed by heating. Before cutting, the security of fixing must be tested, for the slightest movement during sawing will cause a breakage of the cutting wheel at a cost of over $\pounds 10$. Extreme cold should be avoided, as the shellac is very brittle under these conditions.

Fig. 2 shows a special fixture used in the production of A.T. plates. A slotted mild-steel plate carries a steel angle block, giving a mounting face at 35° to the horizontal. When the crystal is set up with its trued end on this surface, then the desired 35° cuts will be made by a vertical saw. Some examples of cutting are shown.

Plates of any desired thickness are made by slacking the holding-down bolts and moving the fixture as required. When the crystal has been sliced into hexagonal plates, these must be trimmed square along the edges. Fig. 3 shows the set-up for this operation. The crystal blanks are mounted on a steel block, held down by a clamping bar (with some resilient packing interposed), and the edges cut true as required. A far better way for thin crystals is to assemble a batch under molten ceresine

wax, being careful to exclude air, and to true the whole assembly at one operation. The edges of a thin and fragile crystal are best trued by waxing it to a piece of plate-glass, and placing on top another thin glass slip to guide the entering edge of the saw, both glass and quartz being cut together.

Fig. 3 also shows how thin crystal plates may be cut from odd irregular pieces of quartz, using a small slotted angle plate to which they are cemented.

Optical Examination of Quartz Blocks

There is little object in making elaborate tests on small A.T.-cut plates before cutting, since so little time is involved in this operation, and it is simpler to try them, after rough lapping, in an actual circuit. Before producing a large low-frequency bar, however, it is worth while to conduct a rough test of the suitability of the raw material. This is done using the properties of polarized light with the apparatus shown in Fig. 4, the construction of which is obvious from the photograph. This polariscope consists of a lower reflector made of plain unsilvered glass. A horizontal beam of light falling on this is polarized when the angle of the plate is about 33° to the vertical. The quartz block to be examined rests on the middle table, having a circular hole for light transmission. The emergent light from the quartz block is analysed by a pile of six thin glass slips 3 in. by 1 in. in size.

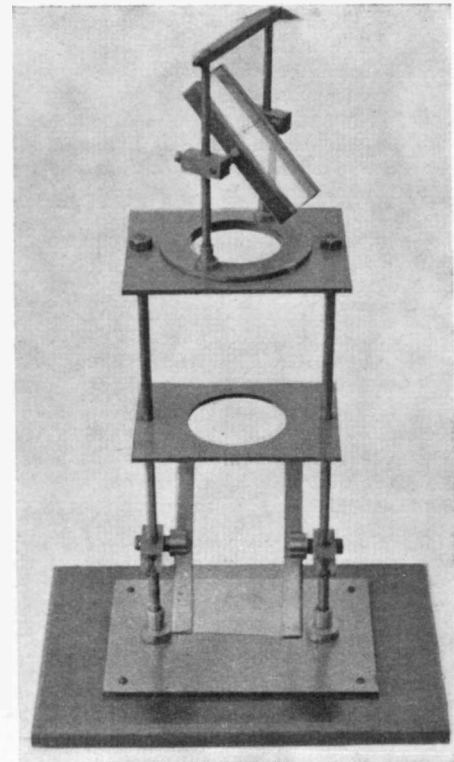

Fig. 4. Simple polariscope for detection of optical twinning.

Optically twinned portions show up as brilliantly coloured patches when examined through the pile of plates. These portions are useless piezo-electrically. The best viewing angle is with the axes of rotation of polarizer and analyser perpendicular, and with both sets of plates at 33° to the vertical. Diffused white light is best for examination purposes. Blocks are prepared for testing by making two cuts perpendicular to the optic axis, the prism ends being roughly polished and rendered transparent by brushing over with paraffin oil or by putting glass slips above and below the quartz, the contact surfaces all being coated with paraffin.

Lapping Processes

When the blanks are delivered from the cutting machine, there remains the grinding operation whereby the frequency is raised to the desired value. This is a highly skilled procedure which is impossible to describe, and in which success is obtained only after long practice. Probably the best account ever given is that by C. F. Booth in the *Post Office Electrical Engineers' Journal* references to which have already been made. The first rough work is done on the rotary cast-iron lap, the set-up being as shown in Fig. 1 of the first part of this article. The finishing operations are carried out on fixed, close-grained cast-iron laps.

Starting with a paste of No. 150 grade carborundum powder and water, lapping is commenced with large circular sweeps, heavy pressure while grinding alternating with light pressure to enable fresh abrasive to come under the quartz blank. A second lapping follows on another plate, using No. 600 abrasive. Micrometer measurements are taken from time to time, and parallelism secured by using most pressure on the parts of greatest thickness. To assist in this, the thinnest part is marked 0, and pencilled on the plate surface are figures like 1, 2, 2, 3, giving the amount to be lapped off to bring the whole plate parallel. In spite of the greatest care, the corners will show thinner than the centre, but if the plate is thin and flexible the pressure of a finger-end in the centre is sometimes enough to level off the surfaces. Failing this, a small piece of scrap quartz or glass can be used for localized grinding of the plate surfaces. A very accurately ground surface plate is required for the final truing operation, using the finest abrasive. In this way it is possible to produce surfaces parallel to almost any desired accuracy. With a vernier micrometer reading ten-thousands, one-half of a division may be estimated, though extreme skill and care are required in this operation. During all these operations the frequency is slowly rising, and we have now to measure this frequency, and then to re-

move the last traces of crystal while keeping the plate parallel, avoiding double frequencies and maintaining the highest piezo-electric activity. Except for standard frequency bars or plates, an exact specified frequency is not always required, though the actual frequency must be accurately measured. It is emphasized that in the case of standards of frequency the final adjustments

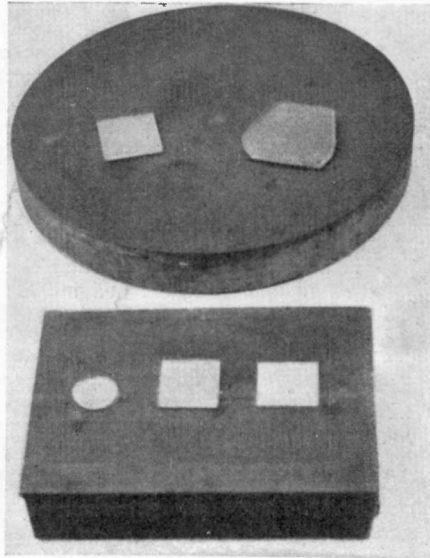

Fig. 5. Cast iron lapping plates showing crystal blanks.

must be made with the crystal in its proper holder and with its actual operating circuit. Fig. 5 shows the circular lap for preliminary operations, and the rectangular surface plate for finishing purposes. Various crystal blanks are also shown in different stages of production. Circular plates are produced by the use of a thin rotating copper tube fed with carborundum paste, the technique being similar to glass drilling.

Preliminary Testing of Crystal Plates

Before the final allocated frequency is approached the crystal should be tested in an actual circuit. A simple triode "Miller" oscillator circuit is set up, using good components. The tuned circuit should cover the expected range

with a small condenser setting. The crystal holder may consist of two stainless steel plates, ground flat on a surface grinder, not lapped, and of approximately the same size as the crystal. A 50,000-ohm grid leak is used, and a 0-100 microammeter registers the grid current. A milliammeter of suitable range is included in the H.T. feed circuit. A crystal may be said to be satisfactory if the anode and grid currents show no abrupt discontinuities as the anode tuning control or crystal temperature are varied (except, of course, when the condenser setting is advanced until oscillations cease). It should be possible to reduce the standing anode current to approximately one-tenth by proper setting of the anode tuning condenser, which gives some indication of the crystal activity. A better indication is rapid starting of oscillation on closing the H.T. circuit.

Crystal Holders

These may be classified broadly as contact-type and air-gap holders. The latter should be used for X-cut bars, the former being suitable for A.T. plates.

Fig. 6 shows typical examples. The central photograph shows a 50-kc/s bar with its associated grid-leak resistance. The holder consists essentially of two stainless steel electrodes separated by ceramic spacers. There is a 1-1,000-inch air-gap left above the bar. The lower electrode is very heavy, and of high thermal inertia. The top is as small as convenient to minimize the electrostatic capacitance. Brass claws attached to the lower electrode prevent appreciable side play of the quartz bar, but do not actually touch it. The whole is mounted on a thick ebonite base, and a 5-megohm grid leak fitted in parallel with the holder. This crystal was adjusted by beating its fourth harmonic against the B.B.C. Droitwich transmitter on 200 kc/s. It was easily possible to adjust the crystal oscillator anode tuned circuit so that one beat was observed in five minutes, though this precision was not held on shaking the crystal in its holder or on changing the valve or supply voltages. This crystal has been used in measurements of the frequencies of other crystals produced subse-

(Continued on page 281)

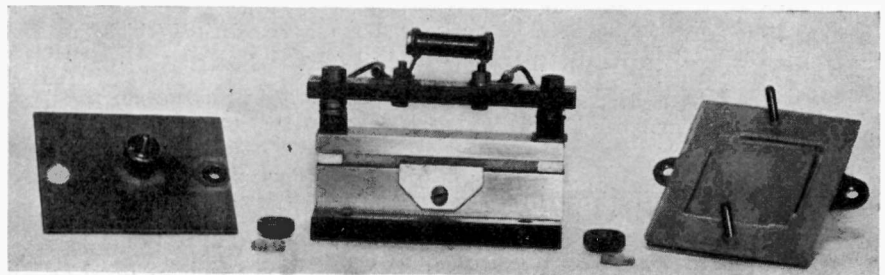

Fig. 6. Quartz crystal holders for bars and plates.

The Preparation of Sound Film Track

By
R. HOWARD CRICKS, F.R.P.S.

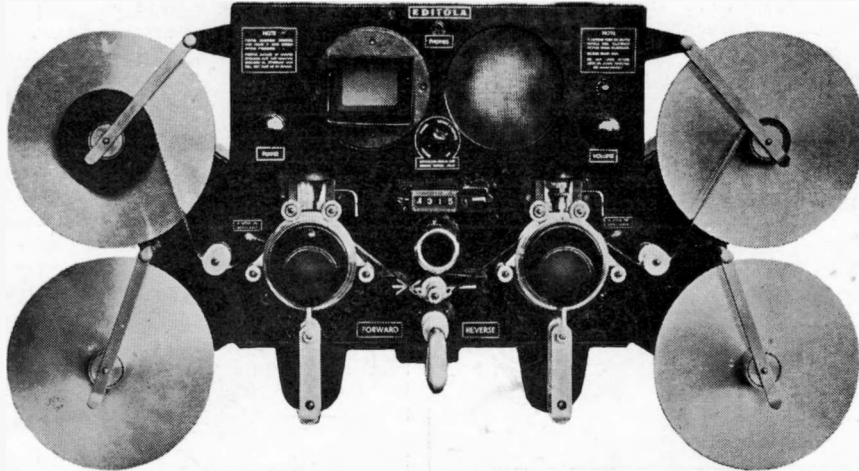

Fig. 1. "Editola" film editing machine. The picture is scanned on the left-hand drum, and is reproduced on the small screen above it. The sound is scanned on the right-hand drum, above which is the loud-speaker. Separate films or a married print can be run, in the former case provision being made for synchronising. [Courtesy of Studio Film Laboratories, Ltd.]

THE first requirement in the production of a film sound track is editing in conjunction with the picture. Generally, the picture is first cut and joined in the various scenes and sequences, as indicated by the script, or as modified by the director or editor and then the sound track is cut to match, and, of course, accurately synchronised.

Synchronising is carried out on a Moviola, or similar device, in which picture and sound are reproduced simultaneously from separate films. A synchronous point is found in the picture and sound films, which may be the sound of the clapper-board which is sounded at the commencement of each take, or it may consist of matching lip movements with sounds. Once a synchronous point is found, it is generally marked on both films by means of a china pencil; thereafter the picture and any number of sound films can be kept in synchronism by feeding them over a

number of sprockets carried on the same shaft, on what is known as a synchronous rewriter.

Another essential piece of editing equipment is a double-film projector, in which provision is made for running separate picture and sound films, or a married print as desired. But the film editor makes use of many expedients other than the mere joining of various sections of track. The bulk of sound track footage exemplifies some indirect method of achieving a desired result. Most of these methods fall within three categories: pre-synchronising, post-synchronising, and re-recording.

Pre-synchronising

The supreme example of the first is the sound cartoon film. The method employed in practically every modern cartoon film consists in first recording the whole of the sound track, and editing it; then a detailed scenario is drawn up, carefully matched to the

track, and precisely timed as to seconds and frames (the film editor's multiplication table runs, of course, 16 frames equal one foot, 24 frames equal one second).

The thousands of drawings representing individual scenes and movements are drawn, the actions, and particularly the lip movements carefully synchronised with the scenario. When picture and sound are married, the illusion is produced of the cartoon characters actually speaking.¹

Although the scenarist works with an editing machine, he has to be capable, in order to produce exact synchronism, of reading the various sounds in the track. He attains the art of recognising the modulation corresponding to a particular sound, some of which are illustrated in Fig. 2. As will be seen, the vowel sounds have initial, central and final phases; the first and last may be confused with consonantal sounds, which, however, have more clearly defined oscillograms².

The same method of pre-synchronising is frequently used with living actors or actresses. Where a singer is required to move about a large set while singing a song, the track is generally recorded in advance, and is then played back in the studio, the singer mouthing the words before the camera in time with the reproduced sound.

Another reason for using this system is the vanity of stars, who wish to avoid showing the facial contortions necessitated by the effort of producing the top notes. Often, however, it can be detected in the finished film by a certain lack of perspective and reality; the volume fails to change as the singer moves about, and the reverberation

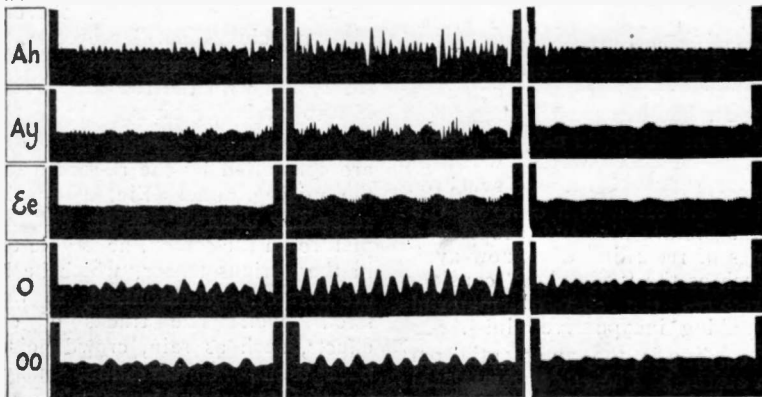

Fig. 2. Waveforms of vowel sounds.

remains unaltered. Synchronism may also be at fault.

It can safely be reckoned that any scene showing a couple dancing and conversing, or singing in a moving vehicle, has been pre-synchronised. In such a case, the music would be first recorded; the conversation or singing would also be separately recorded. With the music played back at a low level, and speech at a higher level, the artistes are photographed dancing, close-ups are taken of them mouthing the words that are being reproduced; no sound is, of course, recorded at the time. Then the music track and the

remarkably proficient in finding English words having a sufficiently close lip-movement to match a close-up of a French-speaking actor. The increased number of syllables in French seems to present no difficulty, since many are slurred over in speech; a greater difficulty is the Teutonic guttural.

Different dubbers use different devices for timing their new track. The dubbing actor for instance may watch the script projected like a running sign below the picture, so facilitating synchronism; but generally, repeated rehearsal is thought the best way for securing naturalness of intonation.³

and the proportion of incidental noise, must be suitably varied. Sound recorded at an unsuitable level can be corrected, in order to save the cinema projectionist the necessity of continually altering his fader. The frequency characteristics of a recording can be modified; to give an extreme instance, the distortion of a voice on the telephone can be produced.

Re-recording Equipment

The essential of re-recording is that the various tracks, and possibly a disc,

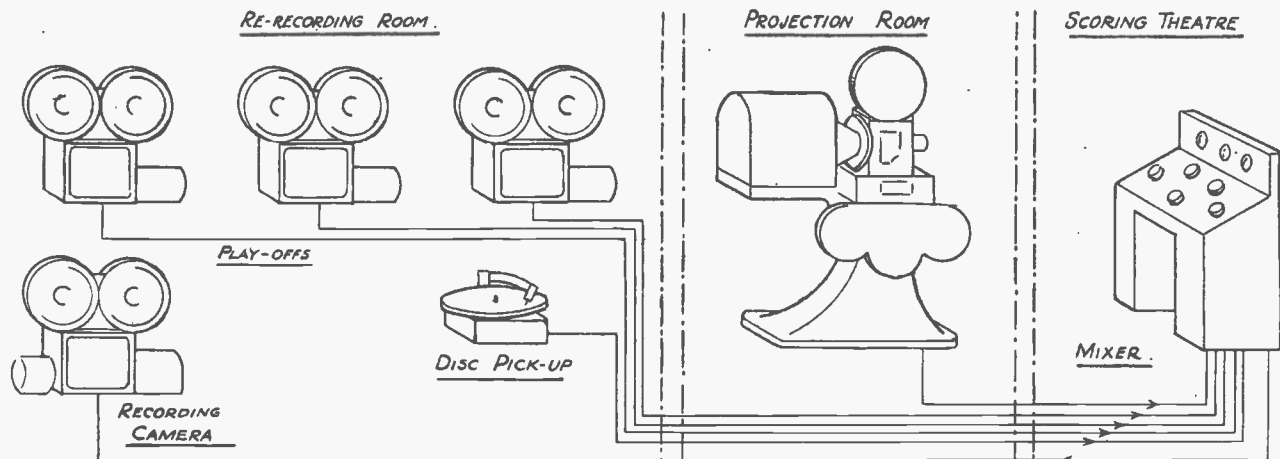

Fig. 3. Diagram of re-recording channel.

dialogue track are mixed together, generally with some degree of volume control to suit the movement seen in the picture.

Post-Synchronising

Post-synchronising is obviously the reverse process. The picture is shot first, then the sound fitted to it. Frequently this expedient may enable a film shot silent to appear as a talkie, and may therefore avoid the necessity of taking expensive and delicate equipment to uncivilised parts of the world. In the early days of sound, it saved from the junk-heap many silent films, which the public saw as talkies. News-reels shot silent can have a commentary and any necessary effects, such as gunfire, added in the editing department.

Another application is known as dubbing, which is used in making versions of a film in a different language (note the different application of the word to its meaning in gramophone recording). This is a highly intricate business, though at its best it can give remarkably realistic results.

The essential is, of course, that the foreign-language script should correspond in number of syllables, lip-movement, and accentuation, with the original recording. Actually, a close correspondence is necessary only in the case of close-ups, and dubbers become

Re-recording and Mixing

Re-recording is probably the most widely used process of all. Practically every film, not excluding news reels, makes use of it. By its aid background music can be added to a dialogue track, the clap of thunder can be taken from the library and added weeks after the artiste has registered alarm; the commentary of a news reel can be recorded above the natural sound recorded with the original negative, or subsequently added from the library.

The modern conception of re-recording includes, however, many other applications. Push-pull tracks are being increasingly employed in the studio, but they must be re-recorded to a standard track for release prints. Certain effects may have been shot on discs; this is a method often used when sound can be "shot wild," to use the general expression—in other words, when the effects are recorded without synchronism with, and often at a different time from, the picture film (the use of various types of recording discs now available, such as the "Simplat," considerably reduces the cost of materials when making inexpensive films).

Re-recording is, too, an essential part of film editing. The editor may decide to cut in a long-shot in the middle of a close-up; the volume of the track,

be run in synchronism with the recording negative and generally with the picture film, which is projected so that the re-recordist can time the various effects. Fig. 3 shows schematically a complete re-recording channel.

The three sound tracks (there may, of course, be more) are run together on three sound heads, driven by synchronous motors or by mechanical coupling from the one motor; alternatively, they may be run on a multi-way play-off, which ensures their running together in correct synchronism and, thanks to a massive flywheel, at a perfectly constant speed. The play-offs are driven by means of a synchronous or interlock motor (or motors) which ensure synchronism with the double-film or "clover-leaf" projector, which runs either a mute film or a sound print, and with the recorder. Provision is also made for discs.

The outputs from the various tracks are controlled by the re-recordist from the mixing panel (Fig. 4) in the re-recording theatre. As he watches the picture on the screen, he is able to fade in the various tracks, which he knows are correctly synchronised, at the desired level. The tracks of certain effects, such as rain, crowd noises, or background conversation, may be joined into endless loops, which can be faded in as desired.⁴

Ground Noise in Re-recording

In the early days of sound, one of the great defects of re-recording was the increase in ground noise. It was the introduction of noise reduction systems that provided a sufficient improvement for re-recording to become practicable.

While it might be thought that the noise of the original tracks and the re-recorded tracks would add together, so increasing the ground noise appreciably (and correspondingly decreasing the volume range) actually, they add together according to the r.m.s. rule; in other words, if n_1, n_2, \dots are the ground noise of the component originals, which are reproduced at relative intensities of r_1, r_2, \dots the relative intensity of the final ground noise N will be given by:—

$$N = \sqrt{[(n_1 r_1)^2 + (n_2 r_2)^2 + \dots + N^2]}$$

Thus the resultant ground noise is in practice little greater than that of the noisiest of the component tracks.

Background Suppression

One of the most aggravating things, whether in broadcasting or the sound film, is background music or noise which renders speech unintelligible. Broadcast commentators frequently make use of a manual control, to fade down a distant microphone when the commentary is interpolated. A much superior arrangement, because it can be made to work almost instantaneously, is automatic background suppression.

The basic principle of such a system is that the volume of sound effects or music is varied automatically and simultaneously, in accordance with the dialogue level. The volume of the background is reduced as the dialogue occurs, the extent of the reduction being in proportion to the level of the dialogue. Besides improving the intelligibility of speech, it avoids overshooting on the track.

The basis of background suppression is a variable-gain amplifier, the gain of which is controlled by the level of the speech. A controllable proportion of the speech current is fed into a valve which through a potentiometer varies the gain of a variable- μ valve; adjustment of this potentiometer varies the amount of control. A delay circuit prevents any alteration of level so abrupt as to be noticeable. The degree of reduction of background is limited by means of a resistance which limits the maximum value of rectified current.

Apart from the improved clarity of speech, such a circuit has an important psychological effect. Because the level of background is normally fairly high, and the speech when it is superimposed is still intelligible, the illusion is obtained of selective listening, such as is customary in real life, but which is not actually possible in a monaural system.*

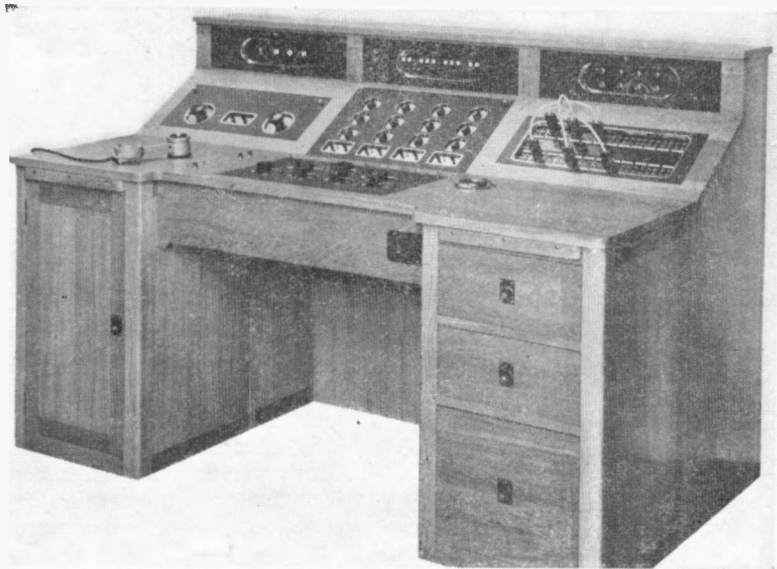

Fig. 4. Re-recording mixer panel; left are circuit switches; top centre volume control neons, and below them frequency and volume controls for each microphone; right is the patching panel, permitting flexibility of connections.

[Courtesy RCA Photophone Ltd.]

By means of these various processes previously discussed, it will be clear that as many tricks are possible with the sound track as with the picture. A track may be modified in loudness or frequency characteristics; whether it is produced before, during, or after the picture film, it may be accurately synchronised to the picture; effects not present in the original recording may be added; tracks recorded on different occasions may be reproduced consecutively and without apparent interruption.

But there is one trick which the recordist has not yet learnt: he cannot yet alter the duration of a sound without altering its pitch, or conversely, he cannot alter its pitch without altering its duration. Thus, if the editor wishes so many bars of already recorded music to match a given picture sequence, he must cut the latter to suit the music track; he cannot speed up or slow down the music without altering the pitch and character of it.

Some years ago a French mathematician set himself to overcome this difficulty by the application of mathematical principles, which, even though they are so far impracticable, are of sufficient interest to bear repetition.

By the use of trigonometrical formulae he demonstrated that by modifying a recorder, or by over-printing negative and positive tracks of a given frequency, the fundamental could be raised or lowered by octaves, twelfths, double-octaves, or other intervals, or conversely that the footage could be correspondingly decreased or increased while maintaining the pitch constant.

Thus to lower the fundamental sine-wave:

$$y = \sin \omega t$$

by one octave, i.e.,

$$y = \sin (2\omega t)$$

he makes use of the equation:

$$\sin^2 \omega t = \frac{1}{2} - \frac{1}{2} \cos (2\omega t)$$

The function $\sin^2 \omega t$ is obtained by the combination of area and density recording; if both the swing of an oscillograph mirror and simultaneously the intensity of the recording light are proportional to the strength of the rectified signal (rectification being needed because the square of $-\sin \omega t$ is necessarily positive) the resultant impression naturally will have the effect of squaring the original signal. Similar methods are suggested to produce the curves corresponding to $\sin (3\omega t)$ and other multiples up to $1 - \cos (10\omega t)$, masks of varying mathematical curves being employed to produce the various powers.

Unfortunately, notwithstanding the ingenuity of this method, it was very soon pointed out that it could only relate to one frequency at a time, and it was never explained how the normal track, comprising a large number of simultaneously recorded frequencies, could be so handled, even in the simplest case of a single note, when such frequencies consist of a Fourier series.*

The only possible solution to this difficulty appears to be the Western Electric "Vocoder," described recently in this journal.† If the claims made for it are justified, it seems that it would be possible to feed in music in one key, and it could emerge transposed to another key. It remains to be seen whether such an application of this wonderful device would be possible.

Synthetic Sound

Finally, reference should be made to a particularly interesting development,

(Continued on page 281)

The Design of Wide-band Video Frequency Amplifiers

Part I. High-Frequency Correction by Series Inductance

By C. E. LOCKHART

THE first circuit to be treated is the most popular and widely used method of counteracting the loss of amplification at higher frequencies in R.C.C. amplifiers, by the use of series inductance compensation. The circuit in question is illustrated diagrammatically in Fig. 1a which shows a two-stage resistance capacity coupled amplifier with the compensating inductance L connected in series with the anode load resistance R, while Fig. 1b shows the equivalent circuit. In these circuits C_w represents the working input capacity of the following stage, while C_o is the anode-earth capacity of the amplifier. In the equivalent circuit C_T is equal to the total capacity across the anode circuit (C_T = C_w + C_o) and for the purpose of this article it will be assumed to include any stray capacities, such as wiring strays, that may be present.

It will be seen that with the inductance omitted the capacity C_T shunts the anode resistance R at high frequencies with a consequent loss of gain.

For simplicity the following assumptions which are justified in practice will be made:

1. R_a >> R and R_a >> |Z| i.e., that the amplifier valves are pentodes or tetrodes so that their anode A.C. resistance R_a is very large compared with the anode load R or |Z| (see on).

2. R_g >> R so that the shunting effect of the grid leak can be neglected.

3. That the anode-grid capacity C_{ga} of the amplifying valves is sufficiently small for its effect to be neglected.

The stage gain at any frequency is

$$A = g \cdot \frac{R_a \cdot Z}{R_a + Z} = g |Z| \quad \dots (1)$$

where |Z| is the absolute value of the anode impedance at any given frequency and g is the mutual conductance of the valve. At medium-low frequencies where the shunting action of C_T and the series effect of L are negligible |Z| = R and A = g R ... (2)

If we, therefore, express the relative gain at any frequency as the ratio of the gain at that frequency to the gain at medium-low frequencies, then

$$\text{Relative gain} = \frac{|Z|}{R} \quad \dots (3)$$

which is only a function of the circuit constants. Working in decibels we have:

The theoretical side of wide-band video frequency amplification has been treated to a considerable extent during the last few years and it is the object of this series of articles to provide the design engineer and research worker with complete data by means of which, with the minimum of labour, the performance of a given amplifier may be predicted or an amplifier designed to fulfil a given specification.

$$\text{Relative gain in dB} = 20 \log \frac{|Z|}{R} \quad (4)$$

$$\text{Now } \frac{Z}{R} = \frac{1}{R} \left[\frac{R + j\omega L}{(1 - \omega^2 LC_T) + j\omega C_T R} \right] \quad (5)$$

in order to bring the expression into a form more suitable for numerical computation we use the parameters

$$K = \frac{L}{C_T R^2} \text{ and either } f_0 = \frac{1}{2\pi\sqrt{LC_T}} \text{ or}$$

$$f_0 = \frac{1}{2\pi C_T R}$$

The case of $f_0 = \frac{1}{2\pi\sqrt{LC_T}}$ was briefly

dealt with in an article on "The Figure of Merit of H.F. Valves,"* but suffers from the disadvantage that it is not possible to directly compute from it the response of an uncompensated stage (L = 0). In this article we shall therefore use the second method which gives the following expression:

$$\frac{|Z|}{R} = \frac{\sqrt{1 + \left(\frac{f}{f_0}\right)^2} \left\{ 1 + K \left[\left(\frac{f}{f_0}\right)^2 K - 1 \right] \right\}}{\left(\frac{f}{f_0}\right)^2 + \left[\left(\frac{f}{f_0}\right)^2 K - 1 \right]} \quad \dots (6)$$

where $K = L/(C_T R^2)$, $f_0 = 1/2\pi C_T R$ (i.e., the frequency at which $\omega C_T R = 1$), f = the frequency at which it is desired

to compute the value of $\frac{|Z|}{R}$ and $f/f_0 = 2\pi f C_T R = \omega C_T R$.

The relative gain expression (6) expressed in dB has been plotted on Data Sheet No. 1, for values of K = 0, 0.2,

* ELECTRONICS AND TELEVISION, March 1941, p. 106.

0.32, 0.4, 0.5, 0.6, 0.8, 1.0 and 2.0 and (f/f₀) between 0 and 2.5 which covers all normal requirements of both British and American Television Standards.

It can be shown that expression (6) has a most constant value for varying values of (f/f₀), i.e., gives the flattest frequency response, when K = 0.414.

Phase Distortion

When considering the amplification of transients and pulse-like signals that are encountered in television reception and transmission, it is not sufficient to provide a reasonably level response in order to reproduce the original impulse faithfully, but it is necessary in addition to reduce phase distortion to a minimum.

An impulse signal consists of a large number of harmonically related voltages, the amplitudes and phase angles of which are suitably related to provide on summation the desired shape of impulse.

Thus in the case of the rectangular pulse shown in Fig. 2 the only reason that we get the very sharp rise at point

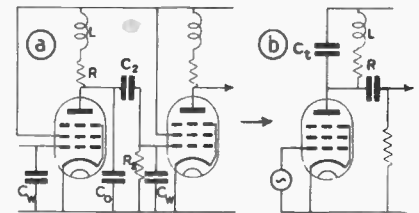

aa' is that at this instant all the component sine waves forming the resulting pulse are going through their zero-amplitude point together and are all rising in amplitude. Similarly at the point b b' they are all going through their zero-amplitude point together and are about to fall further in amplitude.

If the phase relation of the component sine waves is upset for any reason, so that they do not all pass through zero amplitude at the same instant or that at that point they are not all about to rise or fall together, then the sharpness of the pulse will be destroyed and the flat top to the pulse is no longer obtained.

From the above it will be seen that in order to pass an impulse without distortion it is essential that all its component frequencies should take an equal

amount of time to get through the amplifier chain. The absolute value of time, whether in minutes or fractions of a micro-second, is immaterial as long as the transit time through the amplifier is equal for all the component frequencies of the impulse.

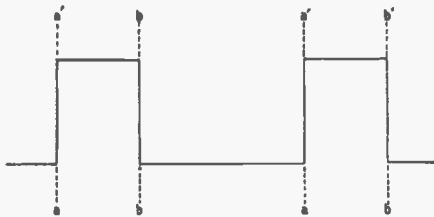

Fig. 2.

In normal electric circuit theory it is customary to denote at any given frequency an impedance with a phase angle ϕ by the symbols $|Z| \angle +\phi$ or $|Z| \angle -\phi$ (according to whether ϕ is positive or negative) where ϕ is given by the expression

$$\tan \phi = \frac{\pm X}{R} \quad \dots (7)$$

and X is the reactive component and R the resistive component of the circuit impedance. When the reactive component is inductive X and ϕ are positive and current lags behind the voltage across the impedance, while when the reactive component is capacitive X and ϕ are negative and the current leads the voltage across the circuit.

For any given applied frequency 'f' it will take $1/f$ seconds for the voltage or current to complete a cycle so that if ϕ is expressed in radians the current will to the grid reaching its maximum reach its maximum

$$\frac{\pm \phi \text{ radians}}{2\pi f} = \frac{\pm \phi \text{ radians}}{\omega} \text{ seconds}$$

after the voltage has reached its maximum. If ϕ is expressed in degrees the time is

$$\frac{\pm \phi^\circ}{360^\circ \cdot f} \text{ seconds}$$

Now in the case of a single stage amplifier we are concerned in the time difference between the voltage applied to the grid reaching its maximum and the voltage across the anode load reaching its maximum. With $R_a \gg R$ the anode current will be in phase with the grid to cathode voltage and therefore an inductive anode impedance $|Z| \angle +\phi$ will result in the output voltage leading the grid voltage and a capacitive anode impedance $|Z| \angle -\phi$ in the output voltage lagging the applied grid voltage. The

time delay of the amplifier therefore becomes

$$\text{time delay } t = - \left(\frac{\pm \phi \text{ radians}}{2\pi f} \right) \text{ seconds} \quad (8)$$

or

$$= - \left(\frac{\pm \phi^\circ}{360^\circ f} \right) \text{ seconds} \quad (9)$$

— a negative time delay being interpreted as a time advance, *i.e.*, with a recurrent phenomenon the anode voltage leads the applied grid voltage.

When dealing with an amplifier consisting of several stages we add the relative gains of the individual stages expressed in dB. to obtain the overall amplitude frequency response, and the overall time delay of the amplifier is also obtained by adding the time delays of the individual stages. In the case of the resulting phase shift of an amplifier, we add the phase angles of each stage and allow for the fact that a 180° phase reversal occurs at each stage.

In an amplifier consisting of "n" similar stages having a phase shift due to the circuit constants of $\pm \phi$ per stage at a frequency f, the resulting total phase shift ϕ_T of the complete amplifier becomes

$$\phi_T = \left[\pm n \phi - \frac{1 - (-1)^n}{2} \pi \right] \text{ radians} \quad (10)$$

or

$$\phi_T = \left[\pm n \phi - \frac{1 - (-1)^n}{2} p\pi \right] \text{ radians} \quad (11)$$

where p is the harmonic order of frequency. p is unity for the fundamental component of the pulse frequency and 2 for the second harmonic, etc.

The resulting total time delay 't' for the amplifier is then

$$t' = - \left[\pm \frac{\phi}{\omega} - \text{constant} \right] \text{ seconds} \quad (12)$$

The second term in equations (10) and (11) represents the 180° phase shift inherent in each amplifier stage and due consideration will show that this cannot alter the shape of the pulse, provided each component frequency is shifted 180° or appropriate multiples of 180° .

The first term can, however introduce distortion and it is essential to keep the value of

$$\frac{n \phi}{\omega} \quad (13)$$

constant at all frequencies if all the individual component waves of the applied pulse are to take an equal time to go through the amplifier. This last requirement can be met either by having $\phi = 0$ at all frequencies or, alternatively, by arranging for the value of ϕ to vary directly with frequency, passing through zero or a multiple of π at zero frequency.

The first alternative is unobtainable with the circuit under discussion; the second can, however, be reasonably satisfied over a limited range of frequencies.

In terms of the parameters previously chosen

$$\phi = \tan^{-1} \left\{ f/f_0 \left[(K-1) - (f/f_0)^2 K^2 \right] \right\} \quad (14)$$

which for the special case of $L = 0$ $K = 0$ simplifies to

$$\phi = - \tan^{-1} (f/f_0) \quad \dots (15)$$

Equation (14) has been plotted in a series of curves in Fig. 3 over the same range of the parameters K and (f/f_0) as

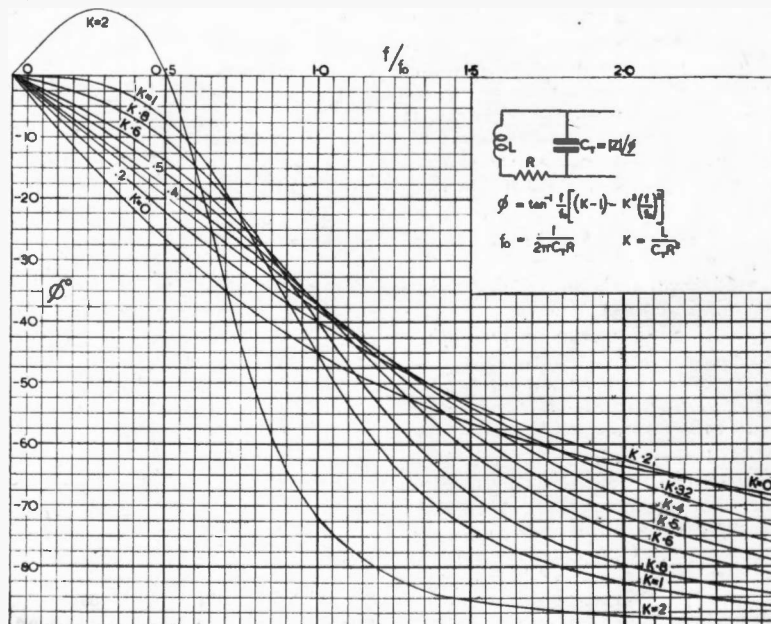

Fig. 3.

the amplitude curves previously described. It can be shown that a value of $K = 0.32$ gives the most linear relation of ϕ versus (f/f_0) and, therefore, gives a minimum of phase distortion.

In the calculation of the effect of phase distortion on the shape of the resulting pulse, it is usually more convenient to deal in time delays rather than phase angles. As has been shown in equation (12) the portion of the time delay which can introduce distortion is

$$t = - \left[\frac{\pm \phi^0}{360^0 2\pi f} \right] \text{ seconds, and}$$

converting this to the present parameter (f/f_0) ,

$$f_0 t = - \left[\frac{\pm \phi^0}{360^0 2\pi (f/f_0)} \right]$$

This is plotted on Data Sheet No. 2 over the same range of the parameters K and (f/f_0) as the previous curves.

Calculations of Response Curves

In order to illustrate the practical use of Data Sheets 1 and 2, a typical calculation of an amplitude frequency response and time delay curve is given.

Consider the case of an uncompensated amplifier with two pentodes coupled by an anode load of 4,000 ohms. Let $C_0 = 5 \mu\mu\text{F}$, $C_w = 10 \mu\mu\text{F}$ and allowing, say, $5 \mu\mu\text{F}$ for wiring and component strays $C = 20 \mu\mu\text{F}$. The product CR is, therefore, equal to $4 \times 10^3 \times 20 \times 10^{-12} =$

$$0.08 \times 10^{-8} \text{ secs. } f_0 = \frac{1}{2\pi CR} = 1.99 \times 10^8 \text{ cycles and } L = 0 \text{ therefore } K = 0.$$

First convert the applied frequency given in column 1 of Table I to the form (f/f_0) by dividing by 1.99×10^8 and then read off the attenuation on Data Sheet 1 on the curve labelled $K = 0$. These readings have been tabulated in column 3 of table I. Next the value of $(f_0 t)$ is read off the curve labelled $K = 0$ of Data Sheet 2. These figures are tabulated in column (4). By dividing the values of $f_0 t$ by 1.99×10^8 we obtain the time delay from the grid of the first stage to the grid of the second stage excluding the 180^0 phase reversal. This time delay has been tabulated in microseconds in column (5).

If the procedure described above is repeated for a range of values of the product CR a family of curves is obtained, from which the performance for any intermediate value of R can be obtained by interpolation.

These calculations have been carried out for values of K equal to 0, 0.32 and 0.4, the most likely values to be employed in practice, and for CR values of 0.04, 0.08, 0.1, 0.12 and 0.14 microseconds, and the resulting curves are shown in Figs. 4, 5 and 6 respectively. It will be seen that $K = 0.4$ gives the

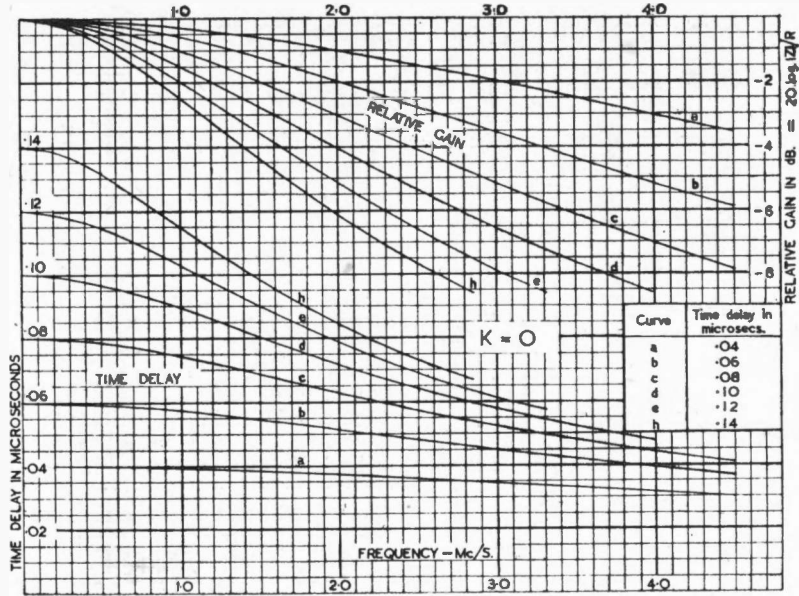

Fig. 4.

flattest frequency response curves, while $K = 0.32$ the most constant time delay.

Choice of Circuit Constants

As was pointed out in the article previously referred to, the Figure of Merit of an amplifier is proportional to the product of the frequency band passed and the amplification. If we arbitrarily define the cut-off frequency f_0 of the amplifier as the frequency at which the gain has dropped 1 dB. below the gain at medium-low frequencies without exceeding ± 1 dB, within the pass band, then the Figure of Merit will be only a fraction of the value of K employed.

On Data Sheet 3, Chart 1, the value of the product $C_T R$ required to produce an attendance of -1 dB. has

been plotted against f for values of $K = 0, 0.2, 0.32, 0.4, 0.5$ and 0.6 . With K values of above 0.6 the gain exceeds $+1$ dB. over a portion of the pass band.

It will be seen from these curves that the larger the value of K the greater is the $C_T R$ product that may be employed for a desired value of f_0 , so that with a given value of C_T the value of R (and therefore the available gain) can be increased by employing large values for K .

Fig. 7 illustrates the improvement in gain that may be obtained for a given value of f_0 by increasing the value of K above zero. In addition a curve is given which shows the improvement in the value of (f/f_0) available for a given value of $C_T R$ and gain. By doubling the ordinates of the (f_0/f_0) scale (f_0/f_0) becomes unity for $K = 0$ to a sufficient degree of accuracy, and the scale will

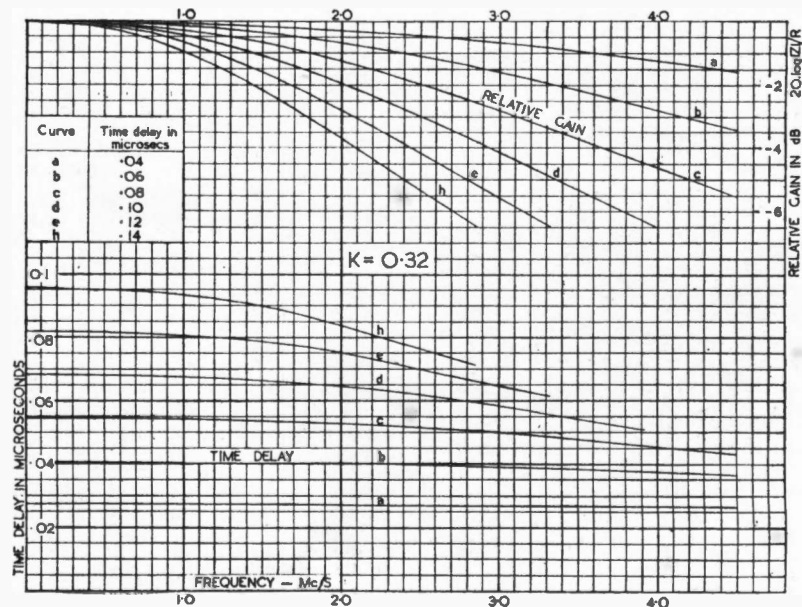

Fig. 5.

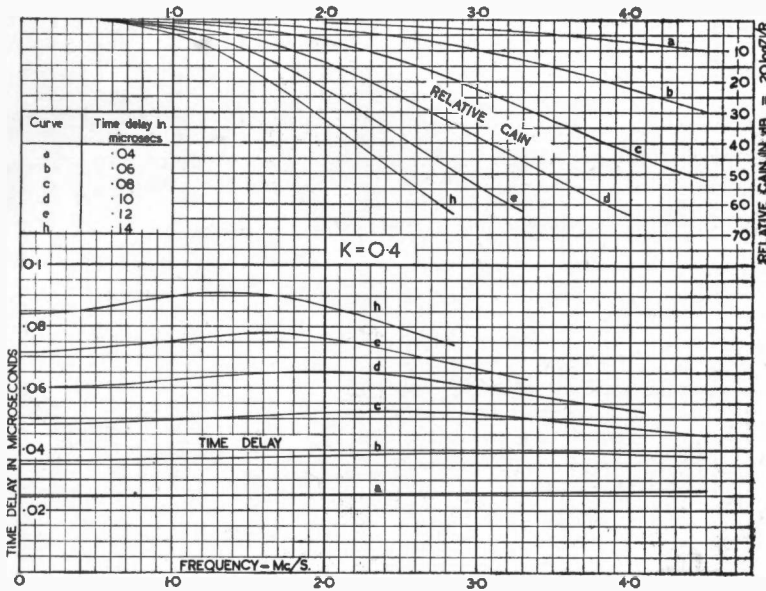

Fig. 6.

The choice of the value of K to be employed, therefore, will depend on the particular application.

In the case of television receivers employing one video stage following the diode detector, the use of too high a stage gain is disadvantageous in the case of the British system. This is due to the high gain resulting in a small carrier being applied to the detector diode and this in turn reduces the effective modulation percentage of the synchronising pulse due to the curvature of the diode output characteristic. A reasonably high anode load is, however, required, in order to obtain a sufficient output to modulate the C.R. tube.

In addition, due to the large number of tuned circuits used in television receivers the time delay characteristic of the grid of the video valve may follow any shape according to the characteristics of the tuned circuits employed, so that the most suitable value of K will depend on individual cases. The writer in fact knows some commercial television receivers that have successfully employed an uncompensated video stage without excessive loss of gain and, what is still more important, output.

In general a value of K = 0.4 gives a satisfactory general compromise be-

(Continued on last page of Data Sheet)

then read directly the improvement in band width available by increasing K above zero. For example by increasing K from zero to 0.4 the band width f_0 may be increased $2\frac{1}{2}$ times for a fixed gain, or alternatively the gain may be increased $2\frac{1}{2}$ times (+7 dB.) for a fixed band width.

quency response and time delay variation can be obtained for all values of K between 0 and 0.5, provided only a very small number of stages is cascaded and the overall gain is sacrificed.

The only object of H.F. compensation is to obtain the maximum possible gain for a given performance specification.

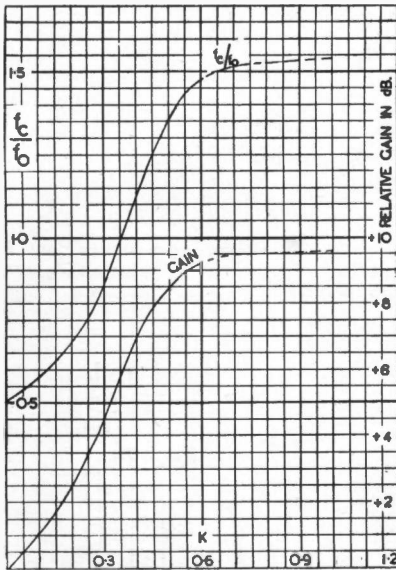

Fig. 7.

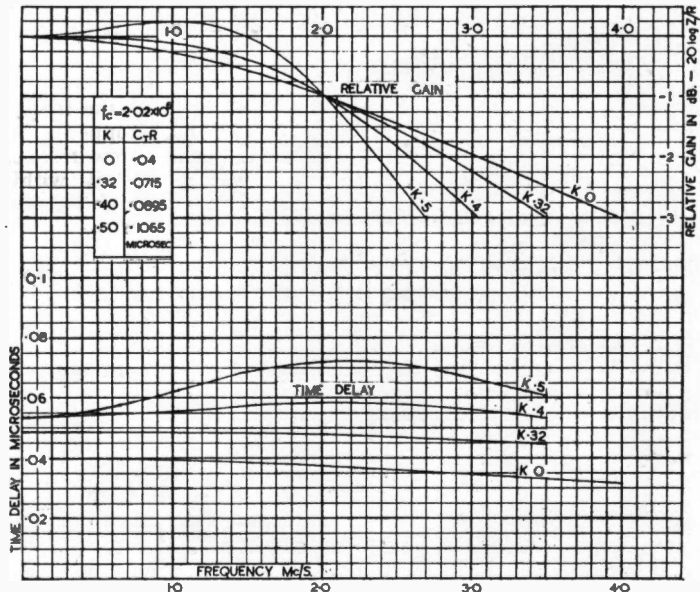

Fig. 8.

If a very level response and constant time delay is not of paramount importance, a value of K of 0.5 may be advantageously employed; higher values of K, however, do not provide any further improvement. Fig. 8 illustrates the relative frequency response and time delay performance for a value of f_0 of just over 2 megacycles for K = 0, 0.32, 0.4 and 0.5. Up to 2 megacycles, the frequency response curve of K = 0.32 was too close to the K=0 curve to be drawn for reproduction.

From the above discussion it will be clear that a reasonable amplitude-fre-

Applied Frequency, f cycles/sec.	f/f_0	Attenuation in Db.	$f_0 t$	Time delay, t in microseconds
-------------------------------------	---------	-----------------------	---------	----------------------------------

0	0	0	0.159	0.0799
0.5×10^6	0.251	-0.28	0.1558	0.0782
1.0×10^6	0.502	-0.99	0.147	0.0739
1.5×10^6	0.754	-1.95	0.1367	0.0688
2.0×10^6	1.005	-3.0	0.125	0.0628
2.5×10^6	1.255	-4.05	0.1138	0.0571
3.0×10^6	1.507	-5.18	0.104	0.0523
3.5×10^6	1.758	-6.15	0.0955	0.048
4.0×10^6	2.01	-7.0	0.0875	0.044
4.5×10^6	2.26	-7.87	0.0815	0.0409

Specimen calculation of the frequency response and time delay of an amplifier having R=4,000 ohms. $C_T=20 \mu\mu F$ K=0. $f_0=1.99 \times 10^6$ cycles.

Introducing the DECADE OSCILLATOR!

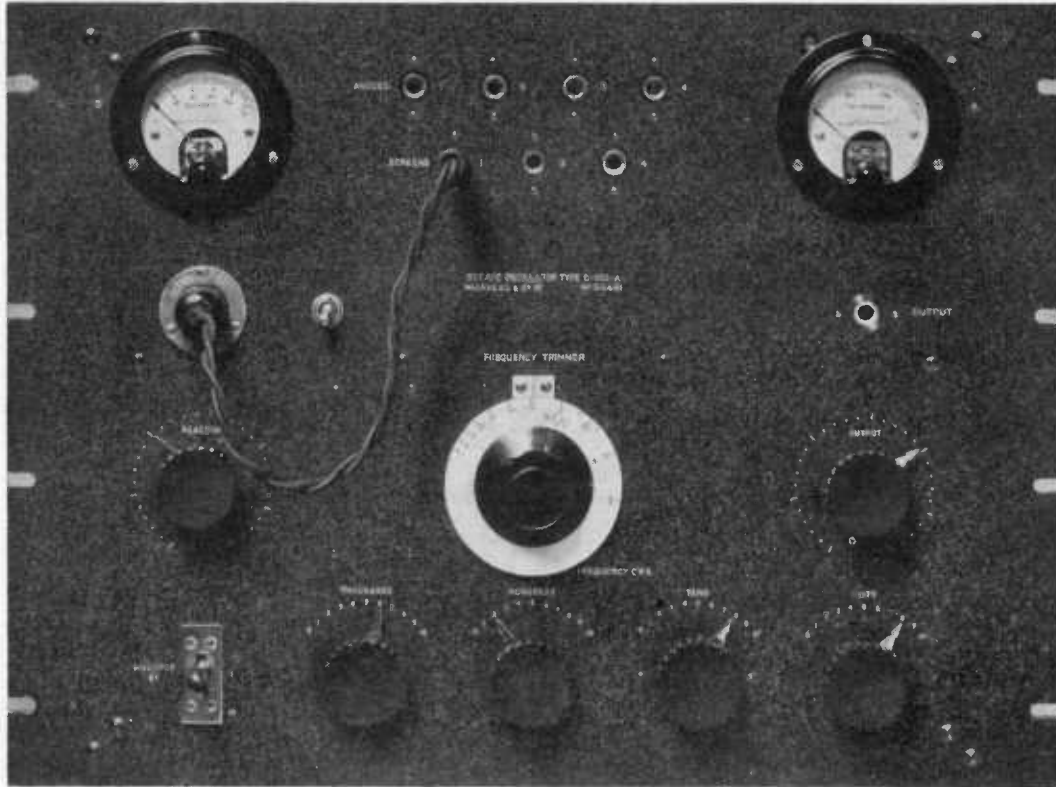

The MUIRHEAD - WIGAN DECADE OSCILLATOR Type D-105-A illustrated, is an instrument of outstanding performance embodying something entirely new in oscillator design.

FREQUENCY IS DIRECT READING TO PRECISION ACCURACY ON FOUR DECADES.

There are no troublesome calibration charts to refer to or engraved scales to adjust.

*"It's as easy to use as
a resistance box"*

For full particulars of this and other Decade Oscillators, write for Bulletins B-320-A, B-321-A and B-528-A.

MUIRHEAD & COMPANY LIMITED,
ELMERS END, BECKENHAM, KENT.
Telephone: Beckenham 0041-0042.

Specification

FREQUENCY

1 c.p.s. to 111.1 Kc/s. on two ranges :—
1 c.p.s. to 11.11 Kc/s. by 1 c.p.s. steps.
10 c.p.s. to 111.1 Kc/s. by 10 c.p.s. steps.

ACCURACY

+ 0.2 per cent. or 2 c.p.s. over the entire frequency range.

OUTPUT

2 watts maximum.

HARMONIC CONTENT

2 per cent. at 2 watts : 1.25 per cent. or less below 1 watt.

POWER SUPPLY

200 to 250 v. 50 c.p.s.

MUIRHEAD

FOR OVER 60 YEARS DESIGNERS AND MAKERS OF PRECISION INSTRUMENTS

DATA SHEETS I, II and III

On the High-Frequency Performance of Inductance Compensated R.C.C. Amplifiers

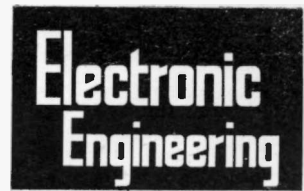

The data sheets included with this issue of ELECTRONIC ENGINEERING are the first of a series which have been specially prepared for design engineers and research laboratories and will deal with subjects of importance at the present time.

The series will be completed by the addition of standard sheets of general data in order that the whole may provide a useful design manual in a compact form.

A common failing in the majority of data sheets which have appeared from time to time is that the reproduction is not made with regard to the dimensions of the co-ordinate lines.

The principal requirement of any graphical representation is that it shall be possible to interpolate readings with a reasonable degree of accuracy and, when uniform scales are used, this is met by making the co-ordinates of standard linear dimensions. In the data sheets overleaf a unit of 5 mm. per division has been chosen, making it possible to interpolate readings by means of a rule, subject to the unavoidable limitations of reproduction and paper shrinkage.

IN an article in this issue the H.F. performance of Inductance Compensated Resistance Capacity Coupled Amplifiers is fully considered and it is the purpose of these notes to provide in a condensed form most useful for reference instructions on the use of the attached Data Sheets for the calculation of the H.F. performance of wide band video amplifiers.

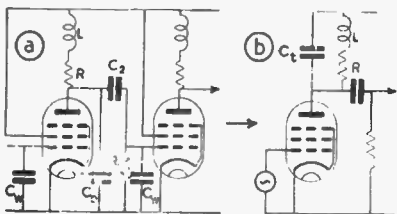

Fig. 1 illustrates the general type of circuit considered together with its equivalent circuit where C_T represents the total capacity across the anode coupling circuit R , L , and should include the stray capacities due to wiring and components such as coupling condensers, valve holders, etc.

Consider the case of the compensated circuit used as the anode coupling device (such as a pentode or a tetrode) when the amplification available will be directly proportional to the value of $|Z|$. The relative gain can be expressed as the ratio of the gain available at any frequency to that available at medium low frequency. Expressed in dB:

$$\text{Relative gain in dB.} = 20 \log |Z|/R. = 20 \log_{10} X$$

$$\sqrt{1 + (f/f_0)^2 \{1 + K [(f/f_0)^2 K - 1]\}^2}$$

$$\frac{(f/f_0)^2 + [(f/f_0)^2 K - 1]^2}{1 + (f/f_0)^2 \{1 + K [(f/f_0)^2 K - 1]\}^2}$$

A value of $K = 0.414$ gives the most constant gain or amplitude versus frequency response.

As a criterion of performance the cut-off frequency f_0 can be taken as that which gives an attenuation of -1 dB.

The impedance of any frequency may be completely expressed by:

$$|Z| \phi = \frac{X_1}{R_1} \tan^{-1} \frac{X_1}{R_1}$$

where X_1 is the reactive component and

SYMBOLS

R = resistance in ohms of the anode coupling circuit to medium low frequencies (this includes the resistance of L , but not of any decoupling circuit by-passed by a reasonably large capacity.)

L = Compensating series inductance in henries.

C_T = total capacity across anode coupling circuit in farads.

$$K = \frac{L}{CR^2}$$

$f_0 = \frac{1}{2\pi C_T R}$ i.e., frequency in cycles/sec. at which $\omega_0 CR = 1$

f_0 = the highest frequency at which attenuation is 1 dB. without the gain exceeding ± 1 dB. within the pass band

f = applied frequency in cycles/sec.

$|Z| = \sqrt{X_1^2 + R_1^2}$ = absolute value of anode circuit impedance in ohms.

$\pm \phi = \tan^{-1} \frac{X}{R_1}$ = phase angle of Z . ϕ is positive when the reactive component X of Z is inductive and ϕ is negative when it is capacitive.

$t = - \left[\frac{\pm \phi}{2\pi f} \right]$ = time delay in seconds. A negative time delay is interpreted as a time advance.

R_1 the resistive component of the impedance $|Z|$.

$$\phi = \tan^{-1} \left\{ \frac{f}{f_0} \left[(K - 1) - \left(\frac{f}{f_0} \right)^2 K \right] \right\}$$

The amount of time by which the voltage across the anode circuit lags on the applied grid voltage is expressed as the Time Delay t . For convenience of plotting this is expressed as:

$$t_0 t = - \left[\frac{\pm \phi}{2\pi (f/f_0)} \right] \text{ if } \phi \text{ is in radians}$$

$$= - \left[\frac{\pm \phi^\circ}{360 f/f_0} \right] \text{ if } \phi \text{ is in degrees.}$$

The most constant time delay is given by $K = 0.32$.

To clarify the use of the curves a typical calculation follows:

It is required to design an anode coupling circuit for a pentode to provide an attenuation of -1 dB. at 2 megacycles/sec. with $K = 0.4$ and $C_T = 20 \mu\mu\text{F}$. Gain, phase angle and time delay versus frequency characteristics as well as the value of L and R are to be determined.

1. Value of $C_T R$ and R .

Chart I Data Sheet 3 gives curves of the $C_T R$ value required against f_0 and from it $f_0 = 2 \times 10^6$ c/sec. $C_T R = 0.09 \times 10^{-6}$ and therefore $R = 4500$ ohms.

2. Value of L .

Chart III Data Sheet 3 gives curves of the value of the series inductance required with $K = 0.4$ for various values of $C_T R$ and C_T . From this for $C_T = 20 \mu\mu\text{F}$. $C_T R = 0.09 \times 10^{-6}$ and $L = 162 \mu\text{H}$.

TABLE

Frequency f in Mc/sec.	f/f_0	Relative gain in dB.	$f_0 t$	t in μS .	ϕ in degrees.
0.1	0.0565	0	0.0955	0.054	-1.95°
0.5	0.2825	-0.02	0.0967	0.546	-9.85°
1.0	0.565	-0.12	0.0993	0.0561	-20.2°
1.5	0.848	-0.4	0.1023	0.0579	-31.3°
2.0	1.13	-1.0	0.104	0.0588	-42.3°
2.5	1.41	-1.88	0.1032	0.0584	-52.4°
3.0	1.695	-2.57	0.1	0.0565	-61°
3.5	1.975	-4.12	0.095	0.0537	-67.5°
4.0	2.26	-5.3	0.0892	0.0504	-72.5°
4.32	2.5	-6.28	0.0845	0.0478	-76°

Data Sheets Nos. IV and V in the July issue will cover The Characteristic Impedance of Transmission Lines

The design of these charts is copyright by Hulton Press Ltd., and must not be reproduced without the permission of the publishers.

$\frac{|Z|}{R}$ CHARACTERISTICS OF A PARALLEL TUNED CIRCUIT

Relative Gain of Inductance compensated R-C. Coupled Amplifier = $20 \log \frac{|Z|}{R}$.

$$20 \log \frac{\sqrt{1 + \left(\frac{f}{f_0}\right)^2 \left\{1 + K \left(\left(\frac{f}{f_0}\right)^2 K - 1\right)\right\}^2}}{\left(\frac{f}{f_0}\right)^2 + \left(\left(\frac{f}{f_0}\right)^2 K - 1\right)^2} \text{ dB.}$$

f = Applied frequency - c.p.s. dB.

$$K = \frac{L}{C_T R^2} \quad f_0 = \frac{1}{2\pi C_T R}$$

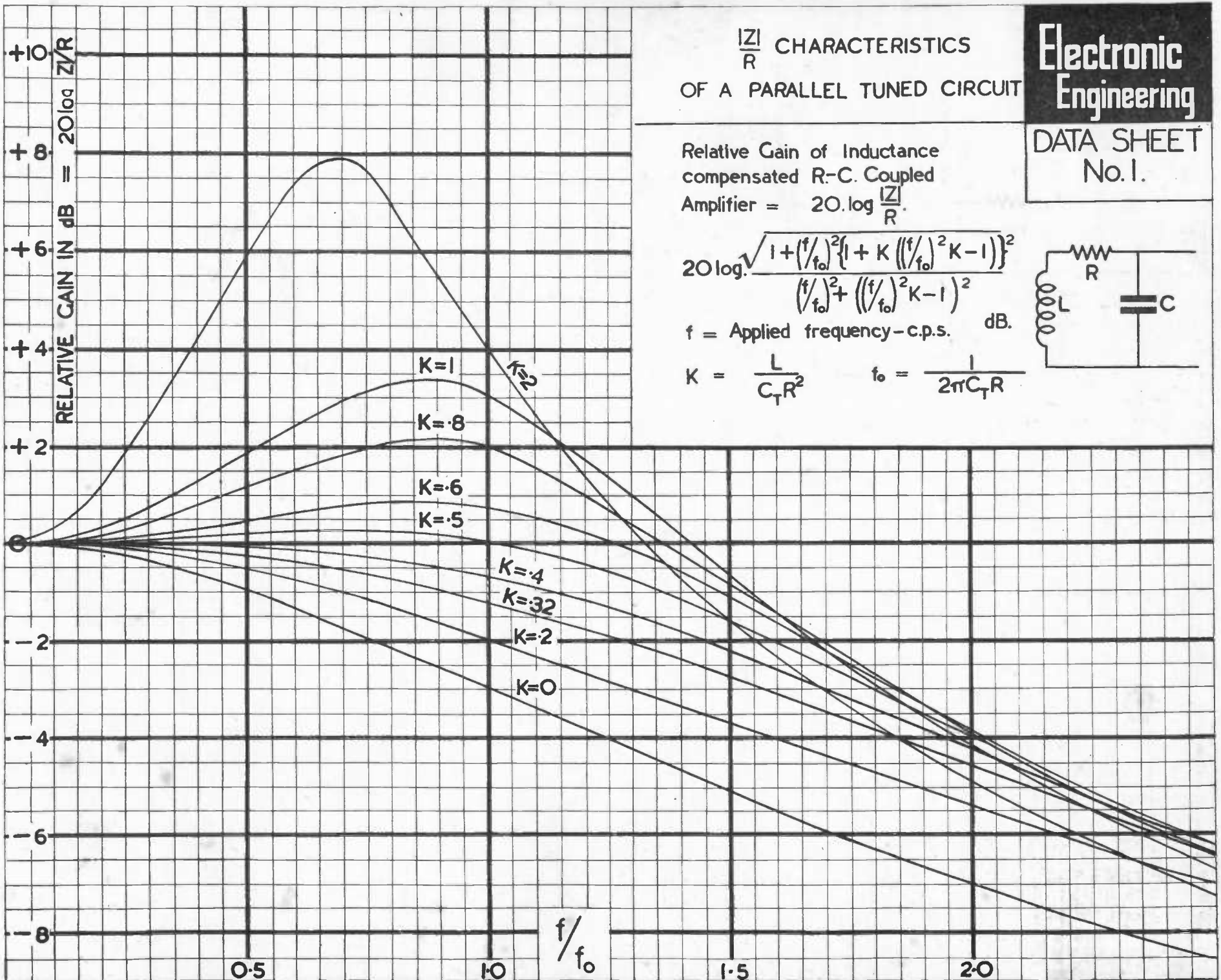
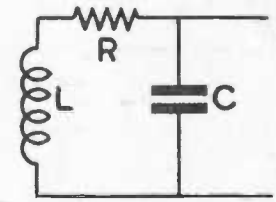

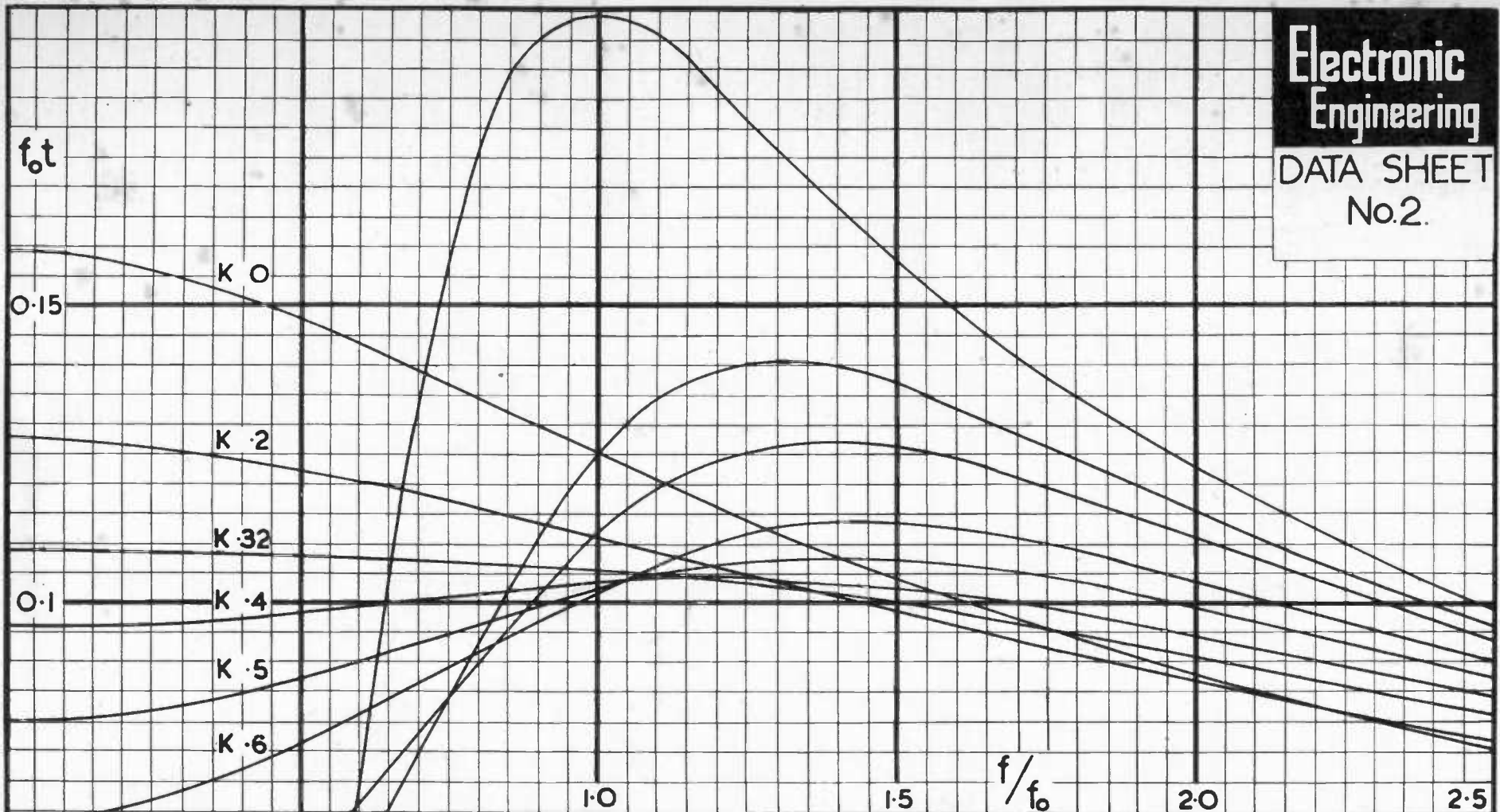

TIME DELAY CHARACTERISTICS OF A PARALLEL TUNED CIRCUIT

$$\phi = \tan^{-1} \left\{ \left(K - 1 \right) - \left(\frac{f}{f_0} \right)^2 K^2 \right\} = \text{Phase angle of Impedance } |Z|$$

f = Applied frequency - c.p.s.

$$f_0 = \frac{1}{2\pi C_T R} \quad K = \frac{L}{C_T R^2}$$

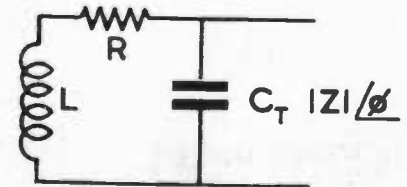

$$t = \text{Time delay in secs.} = -\frac{\pm \phi^\circ}{360^\circ} \cdot f = -\frac{\pm \phi}{2\pi f} \text{ radians}$$

The Design of Wide-band Video Frequency Amplifiers

(Continued from page 260)

tween amplitude frequency and time delay characteristics. With a larger number of cascaded stages a lower value tending towards $K = 0.32$ will be required in order to maintain a sufficiently constant time delay characteristic.

In a television receiver where the video valve follows the diode rectifier a ripple voltage at signal frequency will be applied to the grid of the video valve in addition to the modulation frequency. For values of K greater than, say, 0.3 the factor $K (f/f_0)^2 \gg 1$ even for frequencies of the order of those employed for the I.F. (13 Mc). Under these conditions the relative gain equation

$$\frac{|Z|}{R} = f_0/f.$$

The value of series inductance required is given by the expression

$$\text{Chart I} \quad L = K C_T R^2 = K \frac{(C_T R)^2}{C_T}$$

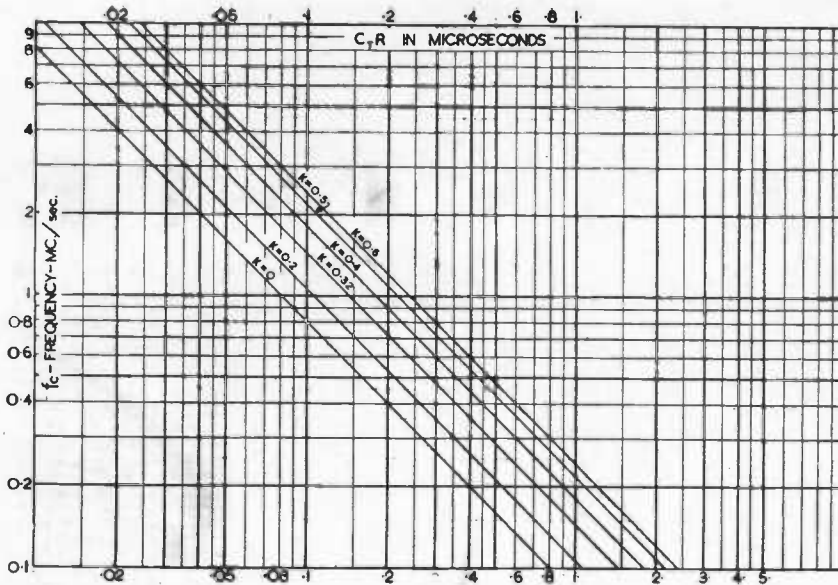

3. Relative gain v. frequency characteristics.

For this, first convert the (f/f_0) scale of Data Sheet I into an absolute frequency scale by multiplying by $f_0 =$

$$\frac{1}{1} = 1.77 \times 10^6. \text{ This con. } 6.28 \times 0.09^{-2}$$

version is carried out in columns 1 and 2 of the attached table. Then read off the relative gain from the curve $K=0.4$. This relative gain is tabulated in column 3.

4. Time delay v. frequency characteristic.

To obtain this read off the value of f_{0t} from the curve $K=0.4$ on Data Sheet II and then divide this value of f_{0t} by $f_0 = 1.77 \times 10^6$ to obtain the time delay t . The values of f_{0t} and t so obtained have been tabulated in columns 4 and 5 respectively.

5. Phase angle-frequency characteristic.

To obtain the phase angle of Z in degrees multiply the value of f_{0t} in column 4 by $-360 (f/f_0)$ and to obtain the phase angle in radians multiply f_{0t} by $-2\pi (f/f_0)$. The phase angle ϕ in degrees is tabulated in column 6.

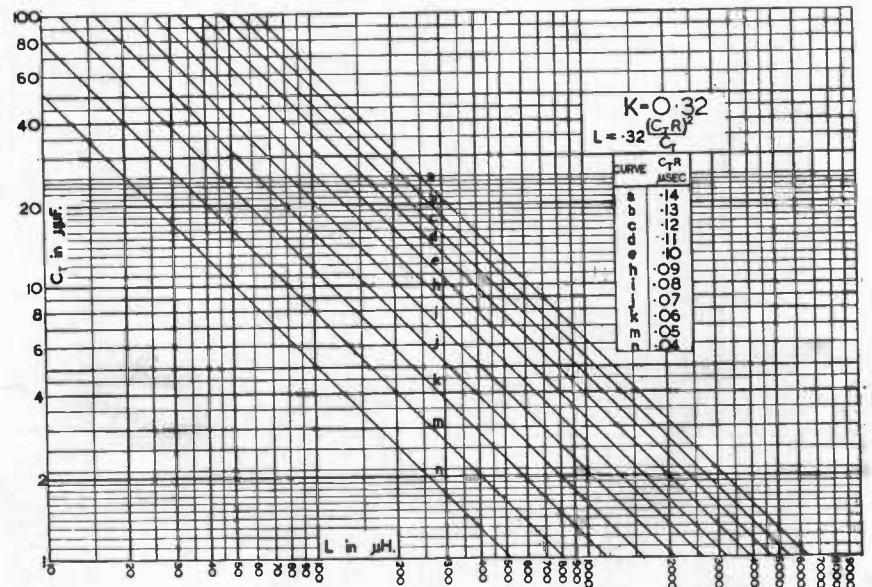

Chart II

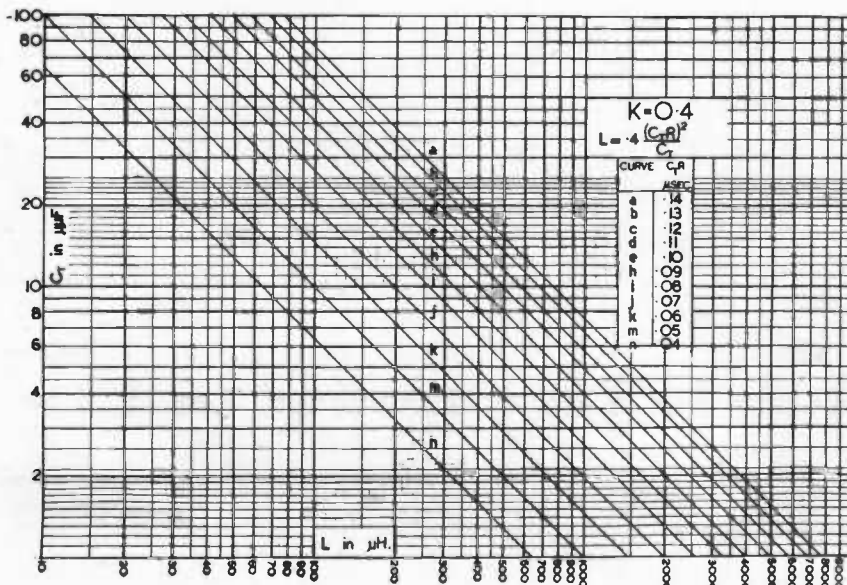

Chart III

This expression has been plotted on charts 2 and 3 on this page for $K = 0.32$ and $K = 0.4$ against C_T for various values of $C_T R$ between 0.04×10^{-6} and 0.14×10^{-6} .

To illustrate the use of these charts, take for example the case where it is required to design a coupling circuit which has an attenuation of -1 dB. at 2 megacycles with $K = 0.4$, the value of C_T being $20 \mu\text{F}$ as before. From Chart I we see that a $C_T R$ product of 0.09×10^{-6} may be obtained which gives $R = 4,500$ ohms. From Chart III we obtain $L = 162 \mu\text{H}$.

Care should be taken to wind the inductance L to have a minimum amount of self capacity so that its natural resonance frequency is as high as possible, or it may produce spurious signals due to shock excitation. From this point of view it is also beneficial to wind the inductance with fine resistance wire, and by distributing part of the resistance R in the inductance, damp this circuit.

FREQUENTITE

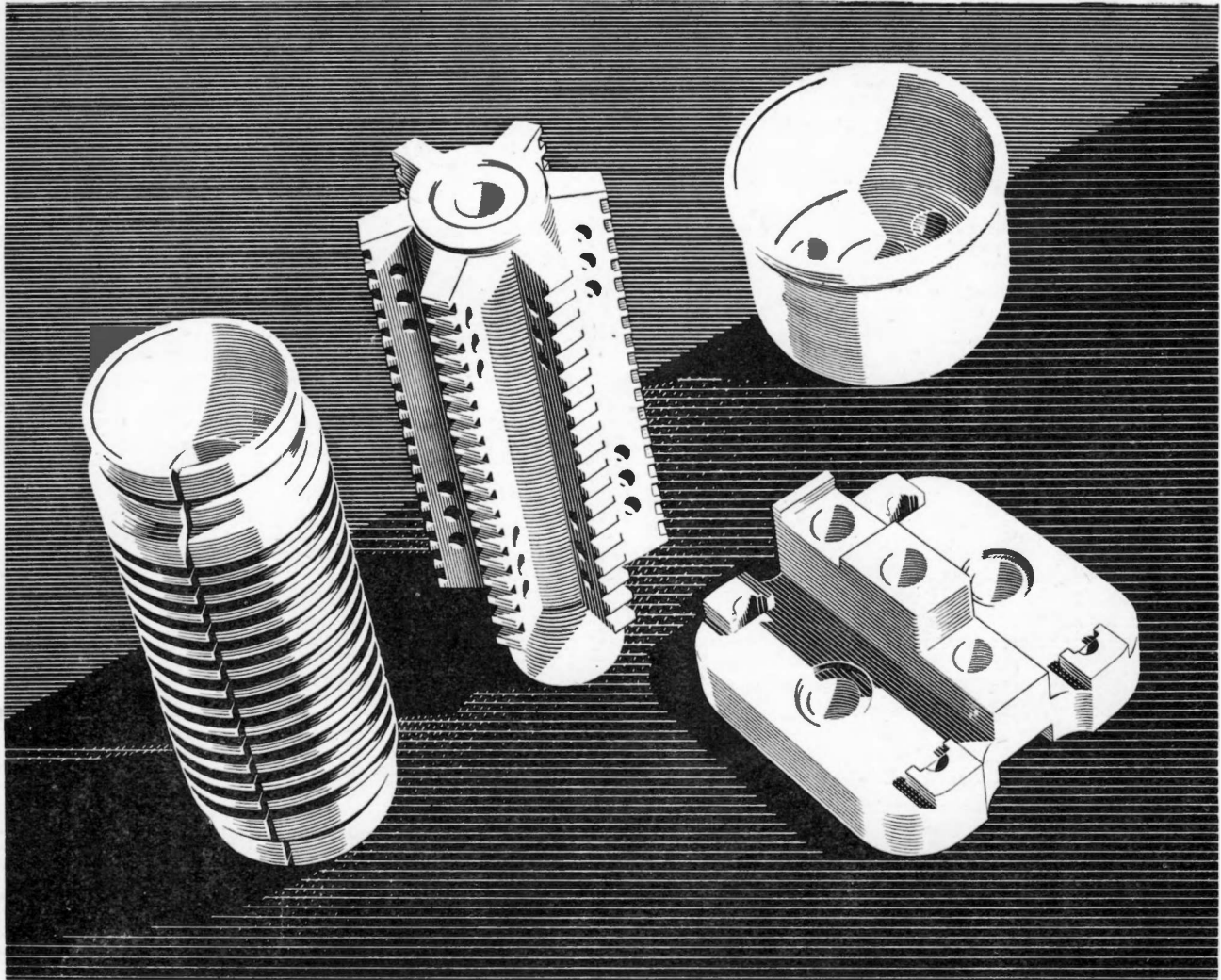

THE PIONEER BRITISH-MADE LOW LOSS CERAMIC

THE OUTSTANDING properties of Frequentite — Low Loss and High Mechanical Strength — led to a demand which even before the war severely taxed our productive capacity. The needs of the fighting services have inevitably led to restriction in supplies for general industry, *but we can now meet all requirements promptly.*

Extensions to our plant, the employment of specialised new equipment, and progressive improvements in our manufacturing technique made during the past seven years, now enable manufacturers to obtain bulk supplies of the most intricate designs. Please write for Catalogue No. S.P.10.

STEATITE & PORCELAIN PRODUCTS LTD.

Head Office and Works :

Telephone: STOURPORT 111.

STOURPORT-ON-SEVERN, WORCS. *Telegrams:* STEATAIN, STOURPORT.

A Distribution System Suitable for All-Wave H.F. Signals, including Television Frequencies

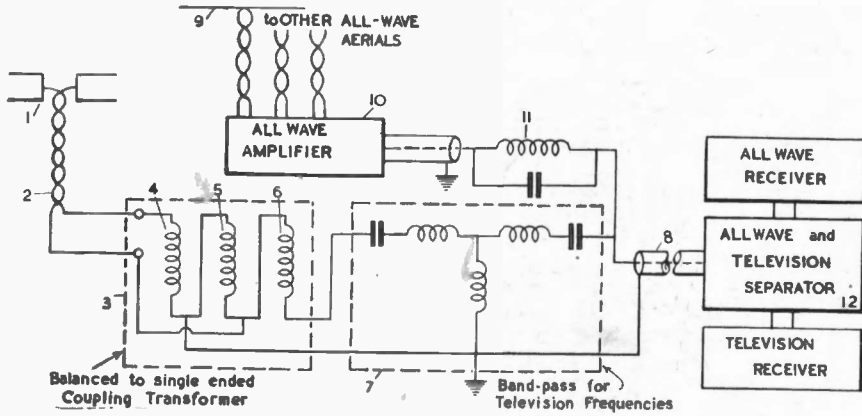

Although the separator shown in Fig. 2 is capable of giving good results, much better discrimination between the high and low frequencies is provided by that shown in Fig. 3. In this unit a band-pass filter 15 is substituted for the U.F. transformer 13. It comprises a T-section, the series arms 16, 17 being series-resonant in the television band, while the shunt arm 18 is series-resonant at the I.F. to suppress interference at that frequency. If the television receiver is provided with balanced input terminals a transformer is used to couple the filter 15 to the receiver. The low-frequency channel is identical to that shown in Fig. 2.

In Fig. 1 the transmission line 8 carries both high- and low-frequency

It has become customary in blocks of flats to provide a communal aerial system for the tenants, but, with the inception of television, greater difficulties than before have arisen in providing a satisfactory signal input to the various receivers located remotely from the aerial system. A new distribution system has been developed by the R.C.A. Laboratories to meet this situation, and particulars are given below.

A typical system may be such as for operating over a low-frequency band, including either the normal broadcast band, or the latter and a short-wave band extending to 18 or 20 Mc., and a high-frequency band including television frequencies between 44 and 56 Mc.

Fig. 1 shows a television aerial 1 coupled by a balanced line 2 to a special input transformer 3 having three coils 4, 5, 6 interwound on a common former in series-aiding relation with high mutual coupling between them to give minimum transformation loss, the line being connected across the first and second coils. This transformer is necessary to enable the balanced line to be connected to an unbalanced line, such as the concentric line 8. The output from transformer 3 is taken from across coils 5, 6 to the concentric distribution line 8, via filter 7 which passes the U.H.F. television band, but prevents feedback of signals from the "all-wave" amplifier 10 via the television aerial. Reception of other than television frequencies is provided for by aerial 9 connected through amplifier 10 and a wave-trap 11, to the common line 8. The wave-trap is tuned to the centre of the television band, and serves to prevent the loss of U.H.F. signals through the all-wave amplifier.

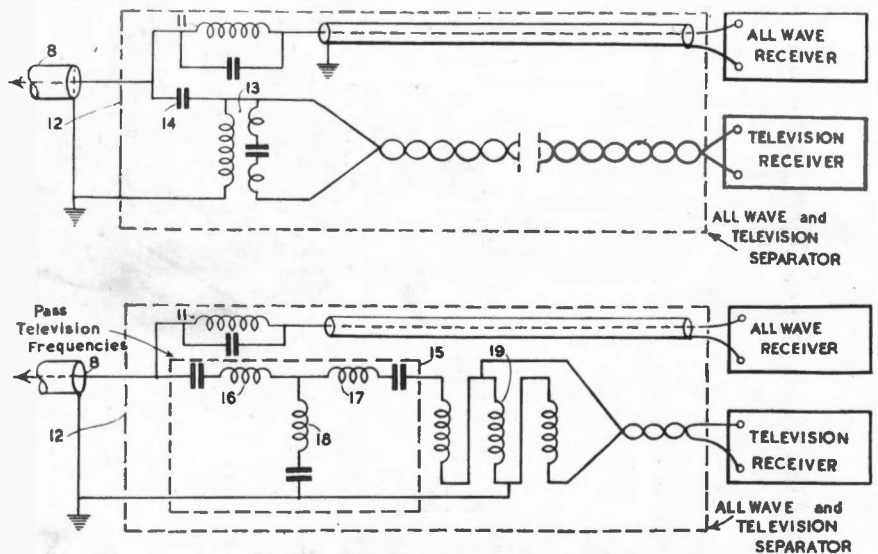

Fig. 1 (above). A typical distribution system. Figs. 2 & 3 Details of Separator (12).

The concentric line 8 conducts both the television frequency and the lower frequencies to a simple unit, where they are separated and passed on to the respective receivers. The unit 12, shown in detail in Fig. 2, comprises two channels, of which one, for the higher frequencies, includes a high-frequency transformer 13 coupled to the concentric line 8 by a small condenser 14, which presents a substantial impedance to the lower frequencies. The television receiver is connected to the high-frequency transformer secondary. The low-frequency channel connecting the line 8 to the all-wave receiver includes a wave-trap 11, identical with the one shown in Fig. 1, which blocks the television or high-frequency signals from the all-wave receiver.

currents, and if this line is a long one the high-frequency currents are attenuated to a much greater extent than the low-frequency currents. This can be corrected by the provision of amplification for the high-frequency signals as shown in Fig. 4. The low-frequency signals by-pass the amplifier via the band pass filter 19, but the high-frequency signals pass through a further amplifier. This amplifier incorporates input, output and intervalve couplings 20, 21, 22, each consisting of a T-section filter. The arms 23, 24 of these filters correspond to the primary, while arms 24, 25 correspond to the secondary of the customary transformer, whose mutual inductance is replaced in the present instance by the common branch 24. The input capacity 26 prevents the

*Serving
the
National
Interest-*



**Osram
Valves**

MADE IN ENGLAND

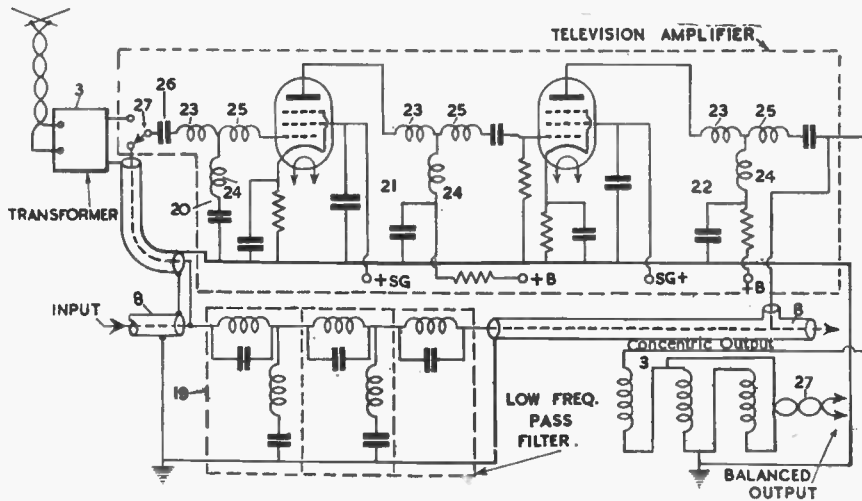

Fig. 4. H.F. Amplifier and (Fig. 5.) its response.

low frequencies from entering the amplifier. The frequency characteristic of this amplifier is shown in Fig. 5. The switch 27 in the position shown connects the amplifier input directly to the concentric line 8; its other position enables the television amplifier to derive its input from a separate aerial.

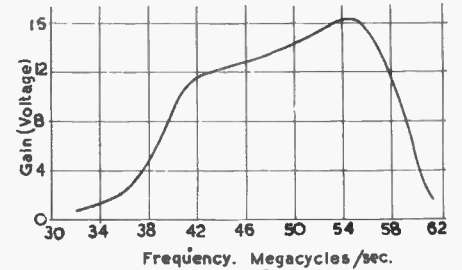

Fig. 5.

Review of Progress in Electronics

(Continued from page 251)

- 11 K. Henney, "Electron Tubes in Industry," New York (McGraw-Hill), 1934, Chapter V.
- 12 E. Ruhmer, "Das Selen und seine Bedeutung für die Elektrotechnik" (Selenium and its uses in Electrical Science), Berlin, 1902.
- 13 M. A. W. Sperling, "Beiträge zur Kenntnis der Selenzellen" (Introduction to Theory of Selenium Cells), Giessen (O. Kindt), 1908.
- 14 K. H. Moeller, "Ueber eine Verwendung der Selenzelle zur Tageslichtmessung" (An application of the selenium cell to daylight measurement), Kiel (Ludtke u. Martens), 1909.
- 15 W. Jaenichen, "Lichtmessungen mit Selen" (Light measurements with selenium), Berlin (Nikolasse), 1914.
- 16 C. Ries, "Das Selen" (Selenium), München (Huber), 1918.
- 17 T. W. Benson, "Selenium Cells: Construction, Care and Use," New York, 1919.
- 18 S. Wein, "Selenium Cells and How They are Made," New York, 1919.
- 19 G. A. Boutry, "Phénomènes Photo-électriques et Leurs Applications" (5 volumes), Paris (Hermann), 1936. Vol. III—Photoconductivity.
- 20 N. F. Mott and R. W. Gurney, "Electronic Processes in Ionic Crystals," Oxford, 1940.

TABLE I.—PROPERTIES OF SELENIUM

Property	Unit of Measurement	Kind of Se.	Value	Authority*
Atomic weight	—	—	79.2	[1, 2, 3
Density	g./cm ³	red amorphous	4.26	1
		red crystalline	4.28	1
		grey crystalline	4.47	1
		liquid	4.80	1
			4.27	3
Melting point	° C.	—	217	1, 3
			220	2
Boiling point	° C.	—	690	1, 3
			688	2
Specific heat	Cal/g./° C. (norm. temp.)	crystalline	0.084	1, 3
	(16.5° C.)	amorphous	0.095	1, 3
	(20.5° C.)	not specified	0.075	2
	(29.5° C.)	"	0.077	2
	(38° C.)	"	0.085	2
		"	0.131	2
Latent heat	Cal./g. (217° C.)	—	13	2
Resistivity	Ohms/cm ³	crystalline	9 × 10 ⁴	1
		not specified		
		(in dark)	2 × 10 ¹⁶	3
Linear expansion	per ° C.	crystalline	4.9 × 10 ⁻⁵	1
	(0° C.)	vitreous	3.7 × 10 ⁻⁵	1
	(0-100° C.)	not specified	4.39 × 10 ⁻⁵	2
		"	6.6 × 10 ⁻⁵	2
		"	(mean)	
	(40° C.)	"	3.68 × 10 ⁻⁵	3

*1. E. E. Fournier D'Albe. 2. Smithsonian Physical Tables. 3. Kaye and Laby.

A Mercury Column Aerial

THE use of a mercury column as an adjustable aerial is suggested by S. A. Peterson* for demonstrating the effects of aerial length on resonance. The mercury is contained in a glass tube connected to a reservoir by rubber tubing. By altering the angle of inclination of the glass tube to the horizontal the length of the column can be varied. Contact with the mercury is made by the conventional platinum seal through the side of the tube.

The high resistivity of the mercury column causes certain effects when used as a radiating element, notably in broadening the resonance peak. The field strength at the best adjustment of aerial is, however, the same for both mercury and copper.

Doublets can be constructed using both separate or common reservoirs, a common connexion being fed by means of a "delta match." Capacity coupling can be made by collars fastened round the outside of the tubing.

It is not recommended that tubing of less diameter than 1/4 in. be used, owing to the tendency of the column to break up with the smaller sizes. Results in practice have been very promising, and the adjustable aerial is particularly recommended for class instruction work.

*Radio, May, 1941.

Care of Condensers

The R.M.A. point out that there is a risk of deterioration in electrolytic condensers if left idle for long periods, and recommend that unused receivers should be switched on for at least five minutes every six months to maintain the dielectric film on the plates. The condensers should be watched for any abnormal symptoms during this "forming" period.

CERAMIC TRIMMER CONDENSERS

for Service & the Services

Special Features include :

- Simple design and small size.
- Low power factor.
- Perfect mechanical and electrical stability.
- Negligible or negative temperature co-efficient.
- Unaffected by humidity.
- Linear capacity law.
- Capable of fine adjustment.

Send for interesting Technical Brochure.
CONTRACTORS TO GOVERNMENT DEPTS.
ON A.I.D. APPROVED LIST.

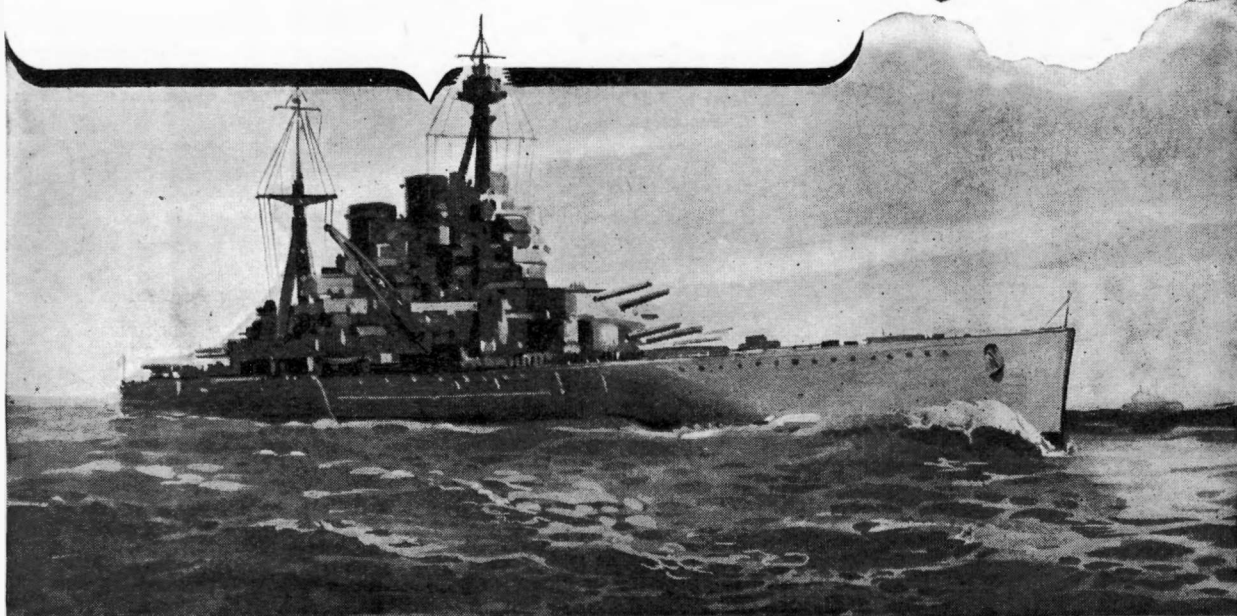
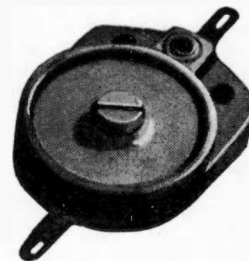
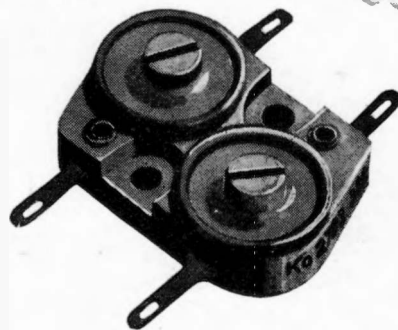

UNITED INSULATOR CO LTD

The Pioneers of Low Loss Ceramics

12-16 LAYSTALL STREET, LONDON, E.C.1

Tel: TERMINUS 4118-9

Grams: CALANEL SMITH, LONDON

PATENTS RECORD

Television

Projection System.
Receiver Gain Control.
Colour Television Scanning.
Saw Tooth Generators.
Interference Suppression.

Electronics

Electron Multiplier.
Electron Microscope.

Electro-Medicine

H.F. Treatment.

The information and illustrations on this page are given with permission of the Controller of H.M. Stationery Office. Complete copies of the Specifications can be obtained from the Patents Office, price 1/-.

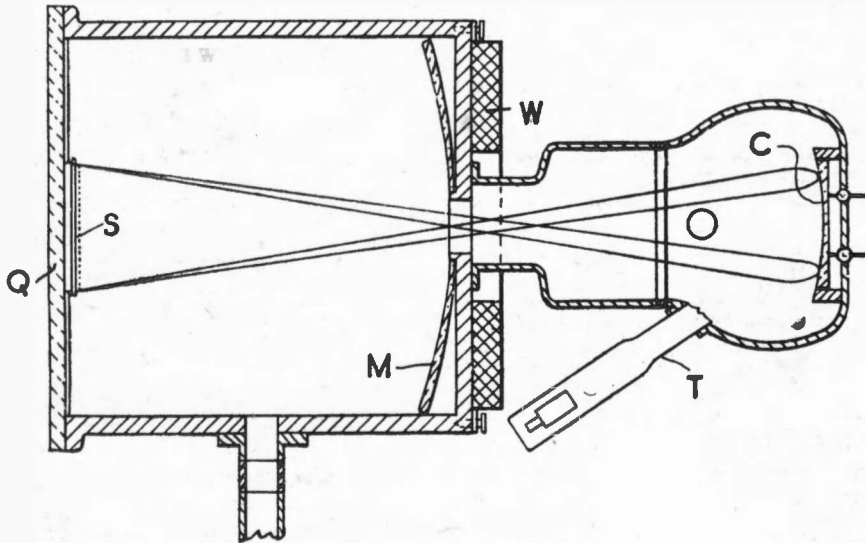

Large-scale Television

(No. 531,760.)

The figure shows an arrangement for projecting television pictures of a size suitable for use in cinema theatres. The method involves the production of an incandescent image of the picture, which is then magnified to the required size by optical means. An important feature is the use of a "mosaic" cathode at an intermediate stage of the process.

The incoming signals are first applied to a cathode-ray tube T in the ordinary way, the modulated electron-stream of this tube being used to scan the mosaic surface of a secondary cathode C. The latter is composed of an "emitting" surface of Barium, uniformly sprinkled with discrete particles of insulating material, so that it may be described as the "inverse" of the ordinary mosaic screen.

Electrons emitted from the cathode, as it is scanned, are focused by a winding W on to a reproducing screen S. This is placed in the centre of a quartz plate Q forming the end of the projection chamber. The screen S is initially heated to a temperature such that the impact of the stream of electrons causes the picture to appear by incandescence. The glowing image is then reflected by the curved mirror M out through the quartz plate Q on to the distant viewing-screen which may be of standard cinema-theatre size.—*Marconi's Wire-*

less Telegraph Co., Ltd., and L. M. Myers.

Gain-control for Television Receivers

(No. 531,653.)

There are obvious difficulties on applying the usual methods of A.V.C., as used for ordinary sound broadcasting, to a television receiver. Looking ahead to the time when the short-wave band may possibly be occupied by a number of different television programmes, the inventors disclose means for automatically adjusting the receiving set to the different conditions required, say, when changing over from a nearby television transmitter to a more distant one. They assume that when a selection of such programmes becomes possible, the process of changing over from one to another will follow the present broadcast practice of push-button tuning. Accordingly, they propose to link the station-selecting button with switches which automatically cut in or out volume-control resistances of an appropriate value in order to ensure the necessary variation in gain control as between strong and weak signals.

Although the method is admittedly not so elastic as ordinary A.V.C., it appears to provide a satisfactory alternative for television signals.—*The General Electric Co., Ltd., and T. R. Cowley.*

High Frequency Treatment

(No. 523,502.)

High-frequency oscillations are frequently used for curvative purposes in medicine, for the sterilisation or dissection of materials and to initiate or control reactions. When frequencies of the order 30 to 300 Mc. are employed in a "lumped" inductance and capacity circuit, it is difficult to prevent radiation which, apart from representing so much loss, is also a source of interference with broadcast reception. As an alternative, the high-frequency energy can be generated and concentrated by a radiator so placed relatively to a reflector that an intense field is built up between the two. This can be controlled so as to minimise external or useless radiation, and to focus the energy mainly upon the object to be heated.

The object of the invention is to simplify the focusing arrangements of such a system. As shown in the drawing, high-frequency oscillations are fed along a transmission line T to a dipole aerial A, which is enclosed in a box or casing of copper, or other highly-conducting material, with sides of the dimensions shown in terms of the working wavelength. The position of the dipole is adjusted by sliding the transmission line to and fro until reflection sets up a stationary-wave system as shown by the dotted-line curves, the dipole being situated at one of the loops. The object S to be treated is then placed on an insulated platform P at the other loop, where it will be subjected to a uniform electric field.—*The General Electric Co., Ltd.*

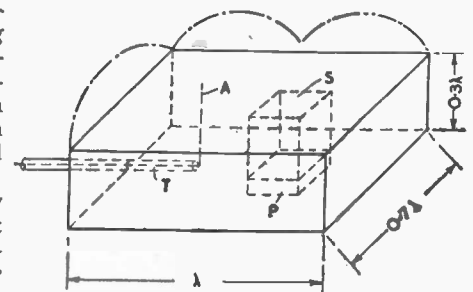

(Continued on page 274)



PREPARE NOW TO EMPLOY MORE & MORE WOMEN



"Look constantly to women for your new recruits; they are excellently suited to many types of work. Hundreds of thousands must enter war production this year and every factory must play its part."

This is Point No. 3 of the Ministry of Labour's "4-POINT PLAN TO INCREASE WAR PRODUCTION" addressed to management.

THE OTHER 3 POINTS IN THE PLAN ARE:—

POINT No. 1. Skilled men are needed for the really skilled jobs. Be sure that each of your men is employed up to the very limit of his skill. Combat skilled labour shortage by breaking down processes wherever you can, and by training up your workpeople, both men and women, to jobs of greater skill.

POINT No. 2. Training Schemes must be developed to the greatest possible extent. Take in more new workers for training on the job in your own works. Remember that the Government will help you with semi-skilled men and women trained under official schemes.

POINT No. 4. Efficient Personnel Management is essential. Remember that you must secure the whole-hearted co-operation of your workpeople. Look closely to their welfare. Many of them may be new to industry; be patient and help them all you can during the first difficult weeks. A little foresight will reduce your labour turnover.

HERE ARE JUST A FEW TYPES OF ENGINEERING WORK WHICH WOMEN ARE NOW DOING IN WAR FACTORIES

1. Operating Heald Internal Grinders, on which the sleeve valves of aero engines are internally ground to a tolerance of $\frac{2}{1000}$ ths of an inch. Operating thread grinding machines to similar limits.
2. Pneumatic riveting of main spars of aircraft and de Bergue riveting of exhaust manifolds.
3. Welding steel fabricated plate in thicknesses of $\frac{1}{2}$ in. to $1\frac{1}{2}$ in.
4. Boring tubes 17 in. to 20 in. diameter, up to 48 in. long on special machines.
5. Working heavy machine tools on all operations—except roughing—in production of 25 lb. shells.
6. Operating on 16 ft. long gun barrel boring lathes and large surface grinding machines.
7. Milling gun parts to limits of $\frac{1}{1000}$ th of an inch—and grinding them to limits of $\frac{1}{100}$ th of $\frac{1}{1000}$ th of an inch on Brown & Sharpe machines.
8. Grinding on fine instrument work, including pivoting and external grinding; gear hobbing on Mikron machines.
9. Working on radial drilling machines up to 6 ft. 6 ins. where they do their own setting up and use no jigs.
10. Optical grinding and polishing to extremely fine limits.
11. Capstan setting, internal and external grinding, grinding screw gauges and inspecting them.

REMEMBER! if you have not yet received your copy of "THE EMPLOYMENT OF WOMEN . . . SUGGESTIONS TO EMPLOYERS" instruct your secretary to write for one to-day, asking for pamphlet 87/1941 to the Manager of the nearest office of the Ministry of Labour and National Service.

MOBILISE FOR



Patents Record

(Continued from page 272)

Suppressing Interference

(No. 531,724.)

One known method of reducing the effect of disturbances due to the ignition system of motor cars, upon a television receiver, is to separate-out from the sound channel any interference "peak" that has an amplitude greater than the maximum desired level of sound, and to use it to "block" one of the subsequent amplifiers in the set, so as to prevent the disturbance from reaching the loudspeaker. Since it is frequently necessary, in practice, to alter the gain of the sound channel, and since any such alteration necessarily involves a corresponding readjustment of the level at which the peaks of interference are brought into action, this method is not a very convenient one.

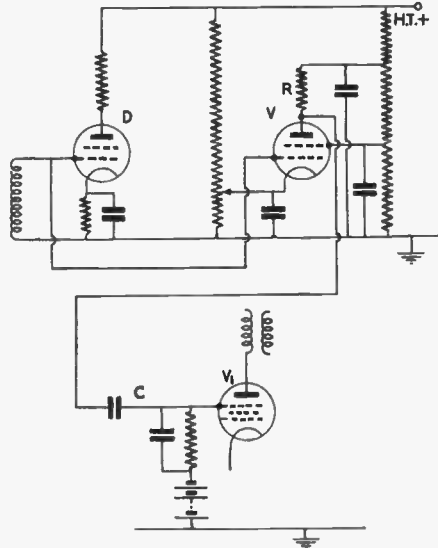

On the other hand, it is very seldom necessary to adjust the gain of the vision signals, and the inventors accordingly propose to transfer the "control" of the peak-suppressing means to a point in the vision channel. Incidentally, the "control" is then effective on both channels.

As shown in the figure, the vision signals are applied simultaneously to the grids of the anode-bend detector D and to a "control" valve V, which is normally biased to cut-off. The effect of a peak disturbance is to make V conductive, and the corresponding voltage impulse set up across the load resistance R is applied through a condenser C to "block" an amplifier V₁ in the intermediate-frequency stage of the sound channel. Preferably a delay network is included in the coupling between the valves V and V₁.—*The General Electric Co., Ltd., and B. J. Okane.*

Saw-tooth Oscillation-generators

(No. 532,110.)

The oscillation-generator in the time-base circuit of a television receiver usually includes a condenser which is slowly charged through a high resistance to a predetermined voltage and then rapidly discharged by a gas-filled tube or other form of electronic "switch." The high-voltage charging-source is closely associated with the circuit as described, so that any sudden fluctuation in the supply is liable to be transferred and to give rise to a resulting distortion of the desired waveform.

In order to prevent this, it is proposed to isolate or divorce the discharge circuit from the primary voltage supply in the following way. The pulse generator is coupled to the grid of a valve which is normally biased to cut-off until a pulse comes along. It is then rendered conductive, and during this interval allows a condenser in its output circuit to be charged from the H.T. source through a high resistance. The condenser then discharges to produce a saw-tooth voltage in the ordinary way, except that between pulses the H.T. supply is disconnected from the output condenser, because the valve during this time is non-conductive.—*A. A. Thornton (Philco Radio and Television Corporation).*

Electron Microscopes

(No. 532,340.)

The objects to be examined are placed in a number of borings made at right angles to the axis of an optically-ground bar. The bar is guided in a sleeve so as to bring successive objects into view, both bar and sleeve being secured outside the microscope by a suitable packing.

The arrangement avoids the necessity for using grease as a sealing agent, and also permits the objects to be kept at any desired temperature, a point of considerable importance when delicate organic preparations are concerned. Heating or cooling fluid is applied through other borings made parallel to the main axis of the bar, so that the vacuum remains unaffected. Electric heating wires may be used instead of a fluid.—*F. Krause.*

(Patent No. 528,105.)

Scanning system designed to prevent or minimize the production of colour "fringes" when transmitting television pictures in natural colours.—*The General Electric Co., Ltd., and L. C. Jesty.*

(Patent No. 527,980.)

Reduction in the risk of H.T. voltage leakage by mounting the anode at the end of a glass support.

Electron Multipliers

(No. 532,082.)

Secondary-emission amplifiers range from the comparatively simple single-stage multiplier to the complex multi-stage type capable of giving enormous amplification. The invention relates to a two-stage tube as representing a convenient compromise, which is simple to make and effective in use.

The indirectly-heated cathode is at the centre of the tube and is associated with control and accelerating electrodes, so arranged as to divide the total cathode emission into two equal streams which are focused in diametrically opposite directions. Each stream is split into two diverging halves by a biased wire running parallel with the cathode, and one of the targets, together with the output electrode, are arranged in the space left between the two diverging half-streams.

These strike against the first target (which is placed near the wall of the tube) and are reflected back so as to converge on the first-mentioned target, the multiplied stream being finally collected by the anode or output electrode. The positively-directed part of the original cathode stream is similarly treated by a second set of electrodes symmetrical with those already described.—*The M-O Valve Co., Ltd., and G. W. Warren.*

(Continued on page 276)

ESSENTIAL BOOKS

MODERN RADIO COMMUNICATION

By J. H. Reynier, B.Sc. (Hons.), A.C.G.I. A comprehensive guide to modern radio theory and practice. A particularly valuable introduction for prospective recruits for Signals branches of the Services. Deals fully with every point and explains fundamentals in the clearest possible manner. There is no more popular or successful book. 2 vols. 7s. 6d. net each. The author has succeeded admirably.—*Electronics.*

RADIO RECEIVER SERVICING AND MAINTENANCE

By E. J. G. Lewis. *Wireless World* says: "The book is so practical, so replete in facts, and so well arranged that the reader will gain the necessary knowledge to work in a logical manner."—It shows the service engineer what to do and just how to do it. 8s. 6d. net.

RADIO RECEIVER CIRCUITS HANDBOOK

By E. M. Squire. A useful guide to circuits for members of the radio industry and radio amateurs. It deals with the receiver in stages, and combines general theory with practical information. 4s. 6d. net.

INTRODUCING RADIO RECEIVER SERVICING

By E. M. Squire. One of the best books available on this subject. Invaluable to students, radio service engineers, testers and dealers, enabling all to attain a working knowledge of the subject in a minimum of time, and without laboriously studying unnecessary theoretical frills. 6s. net.

RADIO AND TELECOMMUNICATIONS ENGINEER'S DESIGN MANUAL

By R. E. Blakey, D.Sc. A concise and practical manual dealing with the basic design principles of radio components and radio test gear. 15s. net. "Invaluable to all radio experimenters and many radio designers and service engineers."—*Electrical Engineer.*

from Booksellers or from Pitman's
39, Parker Street, Kingsway, W.C.2

GET THEM FROM
PITMAN'S

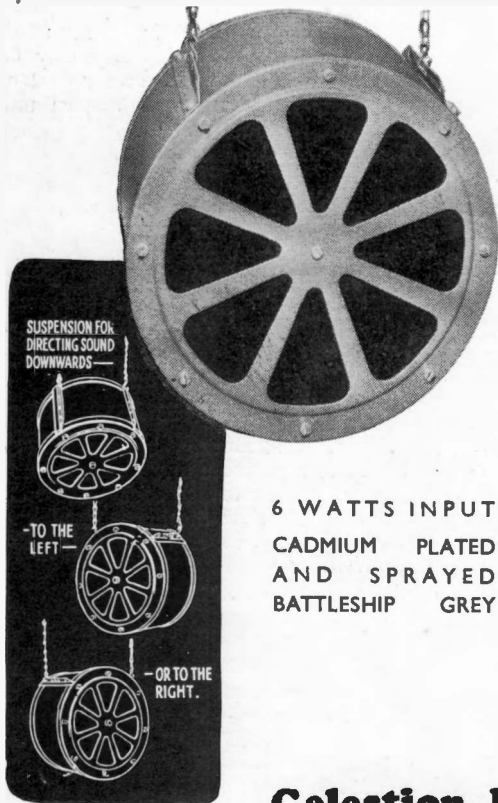

6 WATTS INPUT
 CADMIUM PLATED
 AND SPRAYED
 BATTLESHIP GREY

Address your staff through a

CELESTION LOUDSPEAKER

—with a volume sufficient to overcome local noise.

The same speaker will carry music to your staff—true music, not just a volume of sound.

The Celestion method of suspension enables the sound to be directed wherever you want it.

Celestion Limited, Kingston-on-Thames, Surrey
 Acoustical Engineers Telephone : KINGston 5656-7-8

THE DIAGRAMS IN THIS JOURNAL ARE LETTERED WITH

“UNO”



STENCILS

FOR LEGIBILITY & NEATNESS

A. WEST & PARTNERS, LTD.
 36, Broadway,
 WESTMINSTER

SPEED



with the
**“ADVANCE”
 PRESS
 BUTTON
 SIGNAL
 Generator**

Ideal for rapid measurements

SPECIAL FEATURES: Colpitts Oscillator followed by R.F. amplifier. Input to attenuator controlled by valve voltmeter. Frequency modulation and attenuator reaction on frequency negligible.
FREQUENCY RANGE: 100 kc/s. to 25 Mc/s. in twelve fixed steps as desired.
R.F. OUTPUT: 1 μ V. to 100 mV.
MODULATION: Fixed at 30% at 400 cycles.

PRICE
£35
 NETT

Write for full details to:—

ADVANCE COMPONENTS LTD.,
 Back Rd., Shernhall St., Walthamstow, London, E 17
 Telephone: Larkwood 4366-7

CLASSIFIED SUMMARY OF ELECTRONIC PATENTS

Television

Reception

(Patent No. 530,115.)

Frequency-changing valve or modulator circuit, particularly for separating-out different television programmes.—*Kolster-Brandes Ltd., D. S. B. Shannon, and P. K. Chatterjea.*

(Patent No. 531,306.)

The use of a colloidal solution of a clay-like material for making a birefringent screen for a television receiver.—*Scophony, Ltd., and A. H. Rosenthal.*

(Patent No. 531,828.)

Method of preparing an oxidised aluminium plate as a sensitive mosaic screen with high secondary emission for use in television.—*Baird Television, Ltd., and P. W. Willans.*

Scanning

(Patent No. 531,712.)

Time-base unit for a television system using double-interlaced scanning.—*Hazeltine Corporation.*

(Patent No. 531,159.)

Means for transmitting simultaneously over the same radio link or line-wire a number of different picture signals.—*The General Electric Company, Ltd., and D. C. Espley.*

Sync. Circuits

(Patent No. 529,790.)

Single-valve circuit, with a secondary-emission electrode, for handling both sets of synchronising impulses in television.—*Kolster-Brandes Ltd., and C. N. Smith.*

(Patent No. 530,227.)

Method of controlling and initiating at precisely related intervals the synchronising impulses used for interlaced scanning systems.—*Hazeltine Corporation.*

Thermionic Devices & Circuits

Secondary Emission Tubes

(Patent No. 529,837.)

Double-beam method of improving the efficiency of a secondary-emission discharge-tube.—*Kolster-Brandes Ltd., D. S. B. Shannon, and O. K. Chatterjea.*

(Patent No. 531,219.)

Method of using an electron multiplier for modulation and for reducing undesirable stray couplings with the carrier-wave source.—*The General Electric Co., Ltd., and D. C. Espley.*

(Patent No. 531,558.)

Electron-multiplier in which the collector anode is perforated in line with apertures in the secondary cathode.—*F. J. G. van den Bosch and Vacuum-Science Products, Ltd.*

Discharge Tubes

(Patent No. 529,964.)

Use of an electric discharge tube with a variable internal resistance for controlling the effective reactance of an associated circuit.—*Philips Lamps Ltd.*

(Patent No. 530,107.)

Arc-discharge valve circuit for establishing a coincidence in frequency between two A.C. sources, or for controlling their frequency with respect to a standard frequency.—*The British Thomson-Houston Co., Ltd.*

(Patent No. 532,675.)

Variable-impedance switch for controlling the illumination of a bank of electric discharge tubes.—*Franco-British Electrical Co., Ltd., and A. H. Brackensee.*

(Patent No. 532,633.)

Signal distributing system of the stop-start type including normally non-conducting channels each of which include electronic discharge devices.—*International Business Machines Corporation.*

C. R. Tubes

(Patent No. 530,138.)

Cathode-ray tube with means for producing a conical dispersion of the electron stream.—*Marconi's Wireless Telegraph Co., Ltd.*

Industrial Applications

(Patent No. 533,026.)

Photo-electric "reading" apparatus for use with the perforated records used, say, for compiling statistics.—*Deutsche Hollerith Maschinen Ges. mbh.*

(Patent No. 530,105.)

Electronic control circuit for the current-supply in "spot," seam or line welding processes.—*The British Thomson-Houston Co., Ltd.*



BRITISH MADE PHOTO CELLS

Barrier layer photo voltaic cells suitable for all types of light measurement—photometers, exposure meters, comparators, colour matchers, reflection, refraction, and density measurement, light switches, counters, and burglar alarms.

Special cells with very low capacity for sound film work, film gramophones and other acoustic purposes, also push-pull cells.

SPECIAL CELLS MADE TO ORDER.



O-16/43

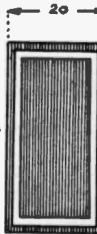

O-20/40



O-16/37X



O-13/20D

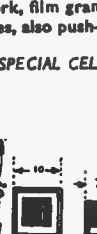

S-10

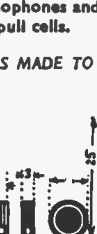

R-7



R-25

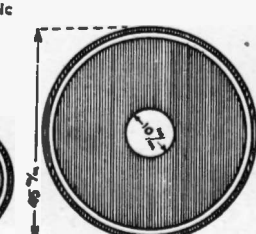

R-45/10X

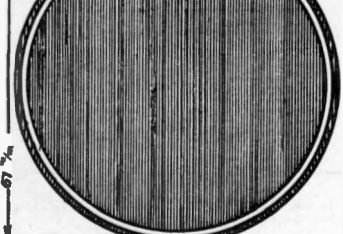

TYPE-R-67

Some standard sizes of photo elements. Characteristics and prices on application.

ELECTRO PHYSICAL LABORATORIES

(RENNY & WENDER) LTD.
50, BRAMPTON GROVE, LONDON, N.W. 4. Hendon 2103

INTEREST IN TELEVISION IS NOT DEAD!

The war may have temporarily checked the development of television in this country, but the interest of hundreds of amateurs has not waned. If you are one of those who wish to keep in touch with television developments and meet fellow enthusiasts, the *Television Society* offers you every facility.

The work is still being actively carried on at the new headquarters at 17, Featherstone Buildings, W.C.2, where a library and data collection has been installed, and a museum of historic specimens is in course of arrangement.

If you are interested in keeping television "on the map" and helping the work forward, write for particulars of membership to the Hon. General Secretary:

MR. J. J. DENTON,
17, Anerley Station Road,
London, S.E.20

THE TELEVISION SOCIETY

(Founded 1927)

President: Sir AMBROSE FLEMING, M.A., D.Sc., F.R.S.

Universal Electrical Co.

221, CITY ROAD, LONDON, E.C.1

Telephone: CLERK 7030

1/25 H.P. Universal motors with reduction gear final drive, 240 R.P.M. A.C./D.C. 230 volts. 85/- each.
Westinghouse Charger. 200/250 A.C. 6-8 volts at 32 amps £12. 10. 0.
Westinghouse Charger 200/250 A.C. 6-8 volts at 15 amps £10. 0. 0.
All Types of American Valves In Stock.
Sliding resistances, 400 and 800 ohms, 7/6 each.
Rack type Westinghouse Rectifier. 110 v. or 230 v. 50 c. 1 PH. 50 v. .75 amps. 75/-
Centrifugal Pump Unit and Motor, complete £3 15. 0 each.
D.C. Electric Drill up to 1/2 in., 200/240 37/6.
Stirrup pumps 16/6 each.
Photo Electric Cells 15/- each
"Ferranti" Line Transformers, new 6/- each.
"Foster" Double wound Transformers:
110 to 230 volts 500 watts, 50/- 110 to 230 volts 3,000 watts 130/-
110 to 230 volts 1,000 watts, 80/- 110 to 230 volts 5,000 watts 190/-
110 to 230 volts 2,000 watts 100/-
Transformers 110 to 230 volts A.C. input, 12 volts output for shelter lighting:
40 watts 15/- each. 75 watts 17/6 each. 100 watts 22/6 each.
All Types of Rotary Converters sold and purchased.

"AFTER THE WAR" TELEVISION

With the coming of Peace, and backed by the Technical advances that have resulted from the war years, TELEVISION will again spring to life and offer opportunities, as never before, to the trained man.

Now is the time to prepare for this new "market." Our Home-study "Television" Course is comprehensive, up-to-date and suitable both for the amateur and experienced Radio Engineer.

We definitely guarantee

"SATISFACTION—OR REFUND OF FEE"

You are advised to send for details of this special Television Course immediately to investigate its possibilities. Details will also be sent of A.M.I.E.E. and A.M.Brit.I.R.E. Examinations and other courses in all branches of Wireless Engineering. Our literature is quite free.

BRITISH INSTITUTE OF ENGINEERING TECHNOLOGY
Principal: Prof. A. M. Low.
337, Shakespeare House, 17/19, Stratford Place, London, W.1.

ELECTROMAGNETIC THEORY

By J. A. STRATTON

Associate Professor of Physics, Massachusetts Institute of Technology

615 pages, 9x6, 116 Text-Figures, 42/- net

(International Series in Physics)

THIS advanced text and reference book on electromagnetic theory is designed for readers possessing a general knowledge of the experimental and theoretical aspects of the subject as well as an adequate mathematical preparation. Postulating Maxwell's equations at the outset, the emphasis is everywhere on the dynamic rather than the static field. A mathematical formulation of the general theory in the first chapter is followed by a comprehensive investigation of energy and stress relations. The properties of static fields are discussed in Chapters III and IV, and the remainder of the book is devoted to the propagation of plane, cylindrical and spherical waves, the theory of radiation, and concludes with a study of representative boundary-value problems.

Contents

Preface
The Field Equations
Stress and Energy
The Electrostatic Field
The Magnetostatic Field
Plane Waves in Unbounded, Isotropic Media

Cylindrical Waves
Spherical Waves
Radiation
Boundary-Value Problems
Appendices
Index

APPLIED X-RAYS

By GEORGE L. CLARK

Professor of Chemistry, University of Illinois

Third Edition.

674 pages, 9x6, 342 illustrations. 42/- net

(International Series in Physics)

HERE is an entirely new and revised treatment of physical, chemical, medical and industrial applications of X-radiation, clearly illustrated by actual representative examples. It is the only book, in any language, which covers the entire science of X-rays, making possible an interesting integration of physics, chemistry, crystallography, genetics, biology, medicine, and industries of every kind.

What X-rays are, how they may be used, what results they produce, why they can be applied to actual problems, and how industry is using them, are the practical questions which receive complete answers in this book.

Noteworthy are the chapters on the measurement of intensity; the measurement of quality; photochemistry; a complete survey of the biological effects of X-rays; the structures of minerals, soils, clays, ceramics and cements; culminating in the chapter on polymers, natural and synthetic materials (such as plastics, Nylon, synthetic rubber, polyvinyl derivatives, etc.) with giant molecules.

McGRAW-HILL PUBLISHING COMPANY LTD.
Aldwych House London, W.C.2

Negative Feedback Tone Control Circuits

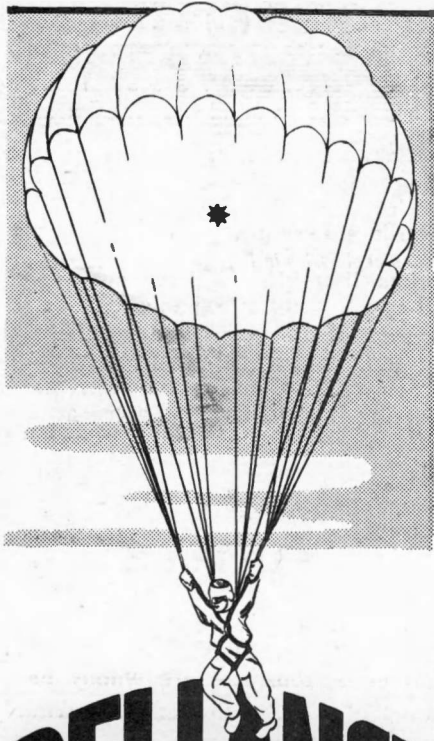

RELIANCE POTENTIOMETERS

"On duty for the duration"

... a doubtful component at this* point is false economy ... similarly wherever control of variable resistance is required it pays to consult RELIANCE.

It has been the object of this Company to produce controls of a high degree of reliability and efficiency achieved through twenty years experience in the manufacture of components. On A.I.D. list. Contractors to the Air Ministry, Ministry of Supply, Admiralty, Post Office, etc.

RELIANCE
MANUFACTURING CO (SOUTH WARK) LTD

Sutherland Road, Higham Hill,
Walthamstow, E.17

Telephone No. : LARKSwood 3245

Fig. 1,

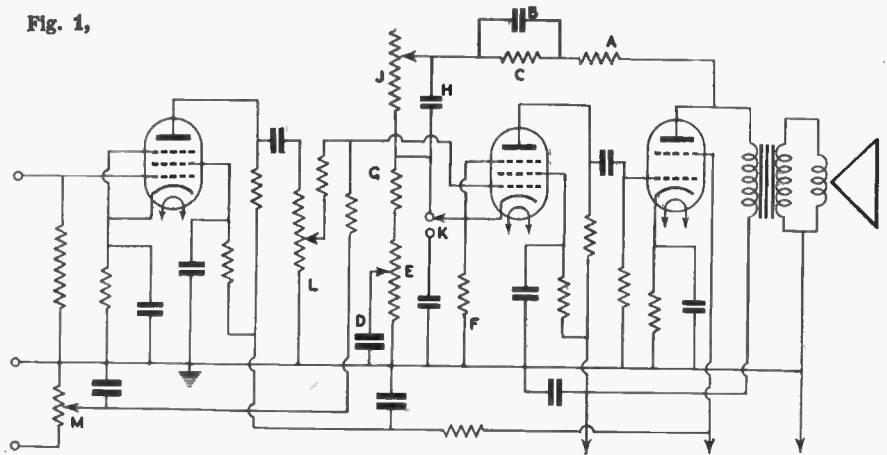

TONE control circuits operating through the agency of negative feedback have advantages, and the arrangements illustrated in the accompanying diagrams have been found useful by R.C.A. engineers.

Fig. 1 shows a circuit providing variable bass-boost and treble attenuation, the control being applied to the second valve of a three-stage audio frequency amplifier by means of a feedback circuit connected between the output of the final valve and the cathode of the second valve. The details of the control are briefly as follows: The fixed resistance A limits the amount of feedback current and also prevents loading of the output circuit. The capacity B shunted across the series resistance C provides additional feedback at the treble end of the audio frequency range, with consequent reduction in the gain of the amplifier, the ratio of impedance of B to resistance of C being chosen so as to achieve a desired limit of treble attenuation.

The value of capacity D is chosen so that when it is shunted across the whole of resistance E, the treble attenuation due to B is eliminated. Limiting resistance G is included to prevent the treble response rising above a desired level. This arrangement of the variable control at the earthed end of the feedback circuit enables the control elements to be located according to convenience, without undue worry about shielding. The bass is controlled by means of capacity H shunted variably across resistance J, the limit of variation being again determined by the ratio between impedance of H and resistance of J.

When tone control is not required the whole of the feedback circuit may be cut out by adjusting the switch K to the alternative setting shown. The gain of the arrangement may be controlled from the signal feed and bias potentiometers L and M respectively.

Fig. 2 shows a variant which provides, in addition, treble boost and bass attenuation: this is done quite simply

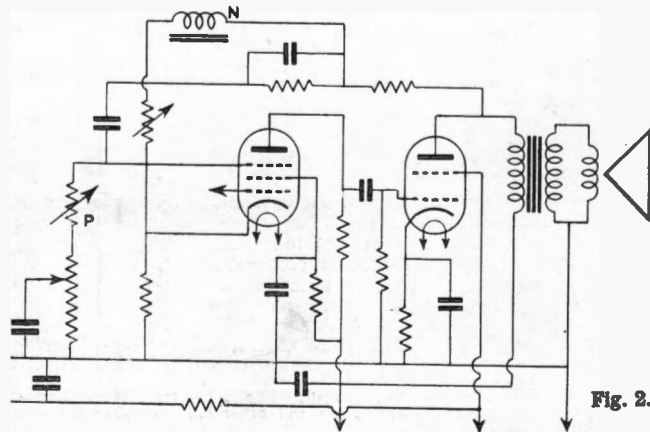

Fig. 2.

Variation of the treble end, if desired, is provided by shunting the capacity D across a variable fraction of resistance E, thus by-passing the feedback energy at the treble end round the

by including in the bass control section of the feedback circuit a choke N of suitable value, and replacing the limiting resistance G of the treble control by a variable resistance P.

Focusing Coil Support

WITH magnetically focused C.R. tubes it is desirable to provide the coil support with adjusting means so that the coil may be accurately positioned to obtain correct focusing.

A coil support provided with a suitable adjusting arrangement is shown in the illustrations. In Fig. 1 (a) is the focusing coil having a free rim (c); (b) are shaped bolts which engage the rim (c), and are screwed into the assembly supporting body (d). Bolts having suitably shaped heads are illustrated in Fig. 2 (e), (f) and (g).

By turning two of the bolts, the coil can be tilted about any axis vertical to the tube axis, whereas by turning all three bolts simultaneously an adjustment of the coil in height can be effected. The bolts can be turned, e.g.,

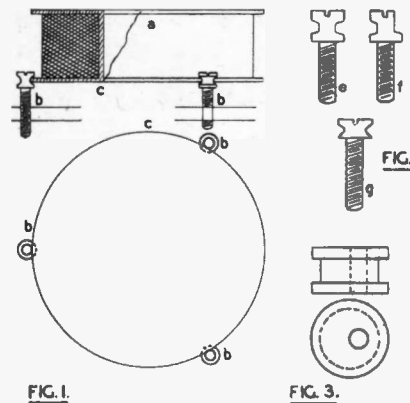

by a screw-driver or by a flexible extension if a control from a remote point is desired. Very often the provision of a small tilting adjustment is sufficient to arrive at an optimum focus. If the lateral degrees of freedom are desired as well, the bolts are inserted in the supporting body by means of the bushes shown in Fig. 3. By turning the bushes in a concerted manner the coil can be shifted laterally up to double the amount of the eccentricity of their bores. The bushes can also be used to take up an inaccuracy of the diameter of the coil rim or the holes supporting the bushes.

If the rim forms a complete circle, one of the bolts is preferably a bolt shaped as in Fig. 2 (f). The coil is then inserted while the cut portion faces the coil, and is locked into the support by giving the bolt half a turn.

The rim might form an integral part of the coil as shown in Fig. 1, or it might be specially provided for the support. In this case only three sections to engage the bolts need to be provided, and the coil can be locked to the support by giving it a slight turn while inserting it.

—E.M.I., Ltd.

COMMUNICATIONS DEPEND....

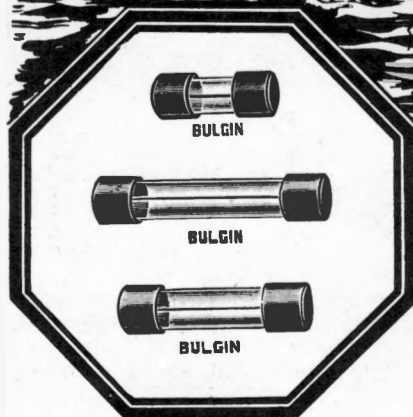
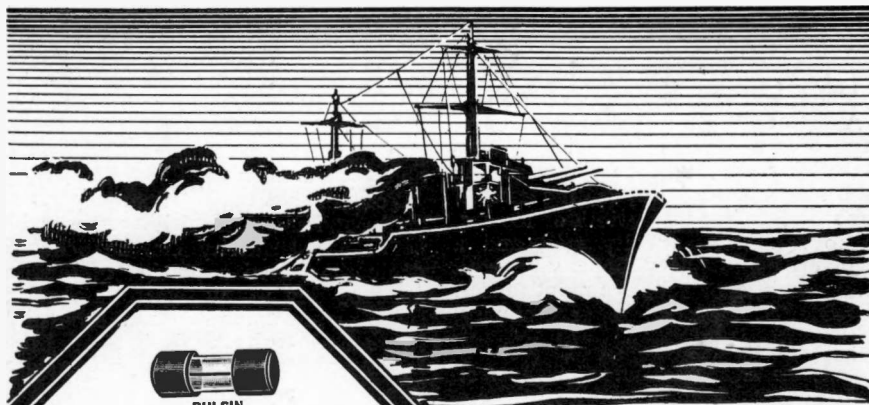

ON SMALL PARTS....

In countless instances quite intricate pieces of apparatus are wholly dependent on the proved reputation and reliability of their component parts.

All products from the House of Bulgin are pre-eminent for superior design and workmanship, and every article bearing our Trade Mark has to pass exacting and exhaustive tests during the course of its production.

That is why every manufacturer of national importance incorporates Bulgin Components.

The Choice of Critics

BULGIN FOR FUSES

The finest Radio and small Electrical Glass-enclosed Fuses in the world. The comprehensive range, from 60 MA. to 25 A., covers every requirement. Accurate and uniform in characteristics and made to British Standard Specification No. 646, R.M.A.—, and R.C.M.F.—Specification. Absolutely fireproof and safe, sure in action upon 50-75% overload. It is better to be safe than sorry!

Let us send you

Our 80-pp. Radio Service Manual: fully illustrated, 280 circuits and diagrams. Over 25,000 copies sold. 1/3 post free.

ALWAYS DEPEND ON -

BULGIN

REGISTERED • TRADE • MARK

A. F. BULGIN & CO. LTD., BY-PASS RD., BARKING, ESSEX

Tel. Rippleway 3474 (4 lines)

ABSTRACTS OF ELECTRONIC LITERATURE

Television and C.R. Tubes

Hard Valve Pulse Sharpening Circuit (R. D. Huntoon and L. J. Strohmeyer)

A circuit using all hard tubes and giving output pulses of either sign essentially the same in form as the inter-stage pulses in a scaling circuit. Input pulses having a width of 100 sec. to 10 sec. work equally well and a change of bias permits operation with either positive or negative input pulses.—*Rev. Sci. Inst.* 12, p. 35, January, 1941.

Deflection and Impedance of Electron Beams at High Frequencies in the Presence of a Magnetic Field (L. Malter)

A theoretical study was made of the behaviour of an electron beam moving between a pair of plates across which is impressed a high-frequency signal, the entire structure being immersed in a constant magnetic field parallel to the plane of the plates.

The beam experiences an oscillatory deflection with components parallel and perpendicular to the plane of the plates. The amplitude of the deflection is dependent upon the transit time through the region between the plates and upon the strength of the magnetic field. The maximum values occur at low-frequencies and zero magnetic field.

The beam results in the impedance between the plates becoming complex. Since the resistive portion of this impedance goes through zero and negative values, there exists the possibility of generation of sustained oscillations in an external circuit.

For certain combinations of transit angle and magnetic field, considerable deflection sensitivity can be achieved while the resistive portion of the impedance due to the electron beam is small or negative. Thus, the possibility exists for the design of high-frequency amplifier tubes with negligible loading.

The same general conclusions are arrived at when the velocity components of the electron beam at the point of exit from the region between the pair of plates is considered. Deflection-type amplifier tubes can be designed which depend for their operation either upon deflecting an electron beam or giving the beam a velocity component normal to its original direction of the motion.—*R.C.A. Review*, Vol. 5, No. 4, p. 439.

Thermionic Tubes

* V.D.E. Rules for Mercury Vapour Apparatus

Draft modifications are published of para. 14 and Table I of V.D.E. c555/1936, Rules for Mercury Vapour

Apparatus. This paragraph and table concern the connexion groups and systems of connexion of mercury vapour rectifier transformers.—*E.T.Z.*, May 2, 1940, p. 398.*

Circuits

U.H.F. Oscillations in a Demountable Valve with Plane Electrodes (W. A. Leysdon)

A symmetrical double cathode, double positive grid arrangement is claimed to show distinct advantages over the Barkhausen-Kurz connexion in oscillation-generating power. An examination of the results shows definite relationships between applied voltage, electrode distances and wavelength of the u.h.f. oscillations generated. It is possible that the recorded results could be explained by a modification of the Benham-Müller theory which predicts ranges of negative conductance for a diode to which u.h.f. potentials are applied.—*Proc. Phys. Soc.* 53, p. 141, March, 1941.

Measurements

* Photo-Electric Humidity Measurement (C. Strobel)

The author describes a new photo-electric method of measuring the dew
(Continued on page 282)

MODERN MERCURY SWITCHES

with TIME DELAY FEATURES
will solve many of your problems

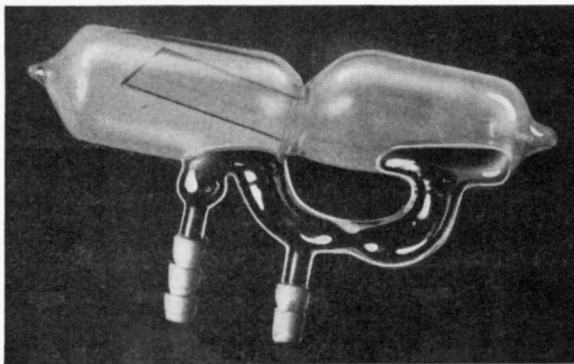

Experienced workers, efficient plant, personal supervision—ensure quality.

WE ALSO SUPPLY SUITABLE RELAYS

I. A. C. LTD.

88 CHASE ROAD, NORTH ACTON, N.W.10
PHONE : WILLESDEN 7281.

Make sure of your copy regularly . . .

SUBSCRIPTION RATES

All over the world
12 Months . . . 20/-
6 Months . . . 10/-

All subscriptions are payable in advance. Cheques and Postal Orders should be made payable to "Electronic Engineering"

To avoid disappointment you should place an order with your newsagent to deliver this journal each month or fill in this coupon and send your subscription direct to us.

The Circulation Manager ELECTRONIC ENGINEERING,
43-44 Shoe Lane, London, E.C.4

Please supply ELECTRONIC ENGINEERING for.....months

for which I enclose Cheque value
Postal Order

NAME.....

ADDRESS

The Preparation of Piezo-electric Quartz Plates

(Continued from page 254)

quently. The method of comparing the frequencies employed the technique described in the General Radio Company's Bulletin on Frequency Measurement (see also the article on this subject by R. S. Roberts in the May 1941 issue of this Journal).

The other device shown in the photograph is a much simpler but inferior type of air-gap holder consisting of two metal plates separated by a low-loss spacer in which is cut a cavity large enough to take the crystal without constraint. The principal disadvantages are:—

1. High electrostatic capacitance (the insulating spacer is virtually a dielectric short-circuit in parallel with the crystal).
2. High temperature-coefficient of frequency (far more serious than that of the crystal).

A better type, built on the same general lines, has insulating plates above and below the crystal recessed to take spring-loaded metal plates which are held in contact with the quartz crystal. This avoids the variable air-gap effect, and is better suited for use in semi-portable equipment. The general question of holders is too large to be discussed in detail, and the interested reader is referred to the bibliography already given (Section 3), in which modern holders are illustrated. The cutting machine already described may be used in the production of fused quartz, pyrex glass or ceramic insulators for use in high-grade holders, or in the production of quartz prisms for optical work.

The subject of quartz oscillator circuits is one on which much work is being done. In particular there is at last considerable interest in circuits which operate the crystal at its series resonance frequency and which are thus only affected to a secondary extent by the crystal holder and valve input capacities. Other modern circuits swamp this capacity by a large parallel tuning capacity and thus render small variations of little importance. It is time that many of these circuits were brought into general use, and it is hoped that with the production of high-grade crystals the performance of oscillator circuits will be such as to employ the crystals to the best advantage.

Please mention

**ELECTRONIC
ENGINEERING**

when replying to advertisers

The Preparation of Sound Film Track

(Continued from page 257)

which so far has been chiefly of academic interest: the production of synthetic sounds.

The oscillograms of Fig. 2 indicate that a person skilled in reading a track could devise a phonetic "alphabet," and could thus actually draw sounds which have previously had no actual existence. Such a method is quite feasible, but it has the objection of being an extremely tedious process. It has been developed with some success by a Russian sound expert, who produced the track of a cartoon film in this fashion, introducing tones corresponding to no known musical instrument.

In this country, it has on occasion been employed on a small scale with the object of replacing the track of words deleted by the censor. For instance, it has been necessary to change the name of a character in a film, and therefore whenever the name was mentioned a section of hand-drawn track was inserted, the drawings being, of course, designed to suit the intonation and timbre of the speaker.

A modification of this system which might have wide possibilities is the production of a composite track by superimposing photographically in the desired proportion (*i.e.*, with suitably balanced exposures) a number of fundamental tones which are themselves hand-drawn. It is in fact a photographic equivalent to the principle of the modern electronic organ, and could well be employed for many unusual effects.

REFERENCES.

1. *J. Soc. Mot. Pic. Eng.*, Aug. 1938, p. 144.
2. *Bianco e Nero*, Apr. 1940, p. 3.
3. *J. Soc. Mot. Pic. Eng.*, Jan. 1940, p. 43.
4. *Technique Ciné.*, July 1936, p. 699; Aug. 1936, p. 715.
5. *Kine. Weekly*, Oct. 27, 1938, p. 39.
6. *J. Soc. Mot. Pic. Eng.*, Sept. 1937, p. 286.
7. *J. Soc. Mot. Pic. Eng.*, July 1935, p. 79.
8. *Ideal Kinema*, Mar. 1935, p. 49.
9. *Electronics & Television*, July 1940, p. 307.
10. *Technique Ciné.*, Dec. 1935, p. 547; Feb. 1936, p. 564; Mar. 1936, p. 591.
11. *Philips Technical Review*, June 1939, p. 167.

New G.E.C. Loudspeakers

The General Electric Co. have designed several new types of loudspeakers at present available for installations of national service. There are two types with normal handling capacities of 6 or 10 watts for outdoor use, and one specially designed for mobile use which is of small dimensions and has an output of 4 watts. For internal address requirements there are speakers handling 4 or 6 watts fitted in service grey cabinets, and in places where the noise level is low a junior "omni-diffusion" type is recommended.

Details are given in Leaflet No. 25 available on request from the General Electric Co., Ltd., Magnet House, Kingsway, London, W.C.2.



WHILE the present emergency has necessitated increased output of certain of our products, recent extensions enable us to maintain that individual service on which our business was built up.

For thirteen years we have specialised in the application of electronics to industry and our accumulated resources and unparalleled experience are at your disposal.

Let us know your problem.

Oscillographs, Amplifiers,
Oscillators, Frequency
Standards, Pressure Recorders,
Vibration Analysers, Speed
Measuring Equipment, Clock
Timers, etc., etc.

FIL
FURZEHILL
LABORATORIES LTD.
BOREHAM WOOD
HERTS
TELEPHONE • ELSTREE 1138



ALL - POWER Transformers Ltd.

It would be difficult to enumerate the various types of winding and components which we produce.

Sufficient to say—We specialise in the manufacture of Mains Transformers and Chokes of every type and size. Supplied in quantities or singly; We are willing also, to co-operate in the production of any proposition put to us, within our scope, to execute, with care and promptitude.

Write us for particulars :

8a Gladstone Road, Wimbledon, S.W.19

*Phone : L1Berty 3303

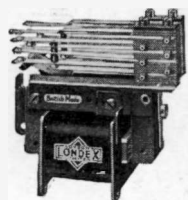

Multiple Contact Relay LF.

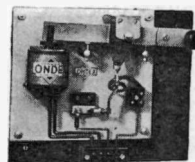

High Sensitive Relay, H.S.

RELAYS

For A.C. and D.C.

2V.A. coil consumption, from 2-600 volts, tested to 2000 volts. Time lag relays, High Sensitive Relays, Synchronous Process Timers, and complete Control Plants.

Ask for leaflet SPN/EO,

LONDEX

LTD.

Electrical Remote Control Engineers & Manufacturers
Anerley Works, 207 Anerley Rd., London, S.E.20
*Phone : Sydenham 6258/9

Please mention
ELECTRONIC ENGINEERING
when replying to advertisers



TRIX QUALITY
for RELIABILITY **AMPLIFIERS**

The TRIX Electrical Co. Ltd., 65 Bolsover St., London, W.1

Abstracts of Electronic Literature

(Continued from page 280)

point, and permitting of exact measurement of the humidity in air and other gasses within the temperature range of -10 to $+250^{\circ}$ C. He also gives an electric connexion which, without the use of vapour pressure of psychrometer charts, makes possible direct and linear indication of the relative humidity as a percentage on an electrical pointer instrument or recording apparatus.—*E.T.Z.*, June 6, 1940, p. 515.*

Electrometer Tube for Laboratory and Industrial Use

(L. Sutherlin and R. H. Cherry)

This tube is suitable for detection and measurement of direct currents greater than 10^{-16} A and can be used to detect and measure potentials in high-resistance circuits to 0.1 mV or better.—*Trans. Electrochem. Soc.*, 78 p. 11, 1940.*

Industry

* Communication Installations near Traction Installations Fed by Mercury Vapour Rectifiers

These draft guiding instructions by V.D.E. concern measures to prevent interference of neighbouring communication installations by traction installations fed by mercury vapour rectifiers. They cover: definitions; measures to be taken against interference; general measures to be adopted in the case of new installations; special measures required for example where a telephone line and a contact wire or supply line come within a prescribed distance of each other.—*E.T.Z.*, May 9, 1940, p. 422.*

Ceramic Insulating Materials (Thurnauer)

The author reviews the various ceramic materials used for insulation in electric circuits, their composition, methods of manufacture and characteristics. Among the materials mentioned is "Mycalex," which is composed of ground mica and lead borate glass, and for which excellent high temperature and frequency characteristics are claimed. A recent development is a ceramic material known as "Alsifilm," which can be made into flexible sheets of about 0.002 to 0.003 in. thickness, and which, it is stated, can be used in place of mica.—*Electrical Engineer*, November, 1940. p. 451.*

60 kVA Half-cycle Bench Mounting Spot Welder

For delicate work which cannot be spot-welded on conventional machines, Metropolitan-Vickers Electrical Company have developed special equipment, and a brief description of its operation is given in this article. By employing a weld period not exceeding half a cycle, high power can be used with a minimum of heat dissipation, the timing being controlled by means of a metal ignition valve.—*Engineering*, February 14, 1941.*

New Dialling Tone for "No Such Number"

(Krom)

Bell Telephone Laboratories have developed a new siren-like tone to indicate that a subscriber has dialled a non-existent number. A frequency varying between 200 and 400 c.p.s. is produced by a relaxation oscillator, of which the grid potential is varied by 0.5 volt every half second. The output is amplified to a higher level than the normal "number engaged" tone to warn the subscriber immediately.—*Bell Laboratories Record*, April, 1941, p. 254.

Electronics in Petroleum Research

Penther & Pompeo, of the Shell Development Co., U.S.A., report several novel applications of valves to precise measurement in petroleum research, including the measurement of potential with current flow of less than 10^{-12} amp., the study of lubrication by continuous resistance measurement and the measurement of polish on metal surfaces to within a few millionths of an inch.—*Electronics*, April, 1941, p. 20.

Theory

Dielectric Loss in Thin Films of Insulating Liquids (Garton)

This paper describes theoretical and experimental work on the dielectric loss of films of insulating liquids so thin that the motion of ions under an alternating field is limited by the boundaries of the film. Films of this thickness normally occur in porous impregnated insulation and lead to a dielectric loss angle which varies greatly with the applied stress.—*Jour. I.E.E.*, March 1941.

Discharges in Insulation under Alternating Current Stresses (Austen, Whitehead)

The nature of internal discharges in actual insulation and also on model circuits exposed to alternating voltages is studied by means of a special oscillographic bridge equipment. A theory of the occurrence of these discharges is developed and shown to agree with the oscillographic observations; examples are given of the various different kinds of phenomena which may occur.—*Jour. I.E.E.*, March, 1941.

Frequency Modulation (S. W. Seeley)

This paper, which contains generalised theory of the principal characteristics of frequency-modulation systems, is purposely made broad in its attack in order to achieve simplicity of presentation of fundamentals. Detailed treatment of specific problems associated with this type of modulation is given in the articles listed in the bibliography.—*R.C.A. Review*, Vol. 5, No. 4, p. 468.

* Abstracts are supplied by the courtesy of the Research Department, Metropolitan Vickers Electrical Company, Limited.

Novel Seamed I.H. Cathode Sleeve

CATHODE sleeves usually of nickel comprise either the drawn seamless tube or the seamed type tube made by rolling metal blanks into a cylinder and joining the edge along the side of the cylinder. Neither type of sleeve has all of the features necessary for high strength and low cost. The seamed tubing, for example, has a bulky seam along one side and bows and buckles when heated and cooled over a wide range of temperatures, apparently because of the asymmetrical distribution of metal in the sleeve. Further, if the seamed sleeve is made with an intergral connecting tab at one end, the blank must be cut with a considerable waste of material. The seamless tubing has the disadvantage that it cannot be made with an integral tab, and is difficult to emboss to form the beaded stops for holding the sleeve in its insulating spacers.

The following description and illustrations show a new method for the high-speed manufacture of seamed I.H.C. sleeves, which has recently been developed in the Laboratories of the Radio Corporation of America.

In Fig. 1 of the illustrations the cathode sleeve comprises two semi-cylindrical pieces of metal 6 and 7 joined along their longitudinal edges. The edge portions or flanges 8 and 10 of semi-cylindrical piece 6 and the edge portions 9 and 11 of piece 7 are formed outwardly from the barrel of the cathode as shown in Fig. 2 and are fixedly joined together to form a rigid metal cylinder. The joined edge portions of the cylinder are folded against the side of the cylinder and serve as reinforcing ridges along the two seams on opposite sides of the sleeve. The registering edge portions of the semi-cylindrical pieces may be joined as by welding, or by a lock seam.

One of the seams is terminated short of the ends of the cylinder so that ends 12 of the flanges on the outer surface of the cylinder conveniently serve as stops which abut against the top and bottom insulators when mounted in a valve. A cathode tab 26 is provided at one end of the sleeve out of alignment with the seam and shoulder 12.

This improved double seam cathode sleeve with integral tab and mica stops

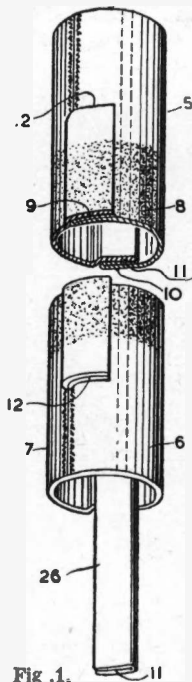

Fig. 1.

Each cylinder with its two welding seams is finally removed from the strip by shearing knives 21 and 22 tapered at their ends to incline the welding seams from their normal stand-up position. Each cylinder is finally carried between forming blocks 23 and 24 on mandrel 25 and the two seams pressed down. The forming surfaces of the blocks 23 and 24 or mandrel 25 must be longitudinally recessed to receive the three layers of metal along each seam. It is apparent that the metal in either seam can be pressed to the inside or to the outside of the cylinder. In the particular machine shown, mandrel 25 is provided with a recess diametrically opposite a recess in forming die 23.

It is desirable to increase the electrical resistance between the two strips 13 and 14 where they are pressed together by the welding electrodes, so that less welding current is necessary for the weld. Indentations or beads may be pressed in strip 13 so that only

is made on automatic machines with simple reciprocating forming dies. The dies of one machine for shaping the two semi-cylindrical pieces from strip metal and for welding their edge portions is shown in Fig. 2 where the ends of the sleeves and the sides of the various forming dies is shown.

Two strips of metal 13 and 14 are fed from right to left over a stationary arbor 15. Two welding electrodes 16 and 17 first press the strips together between the first arbor 15 and a second arbor 15a, drawing and stretching the strips around the

arbors, and welding them together. As the material is indexed to the left, each cylinder comes into registry with recessed forming dies 18 and 19, which support the cylinders as unwanted portions of the metal are cut away. One cutting die is shown at 20.

(Continued on page 288)

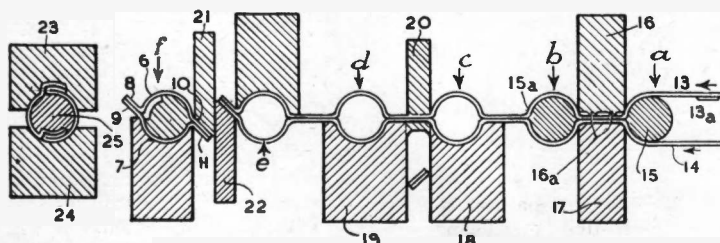

Fig. 2. Diagram of forming processes.



If your work is for the Government and you are experiencing difficulty in obtaining transformers from your usual source, please get into touch with us.

We can still give prompt deliveries providing your order quotes the number of the Government contract for which the goods are required. The latter is essential.



King's Bldg., Dean Stanley St., London, S.W.1.

Phone: VICTORIA 5035

WARD AC/DC ROTARY CONVERTERS

for operating P.A. amplifiers, Radio Receivers, etc.

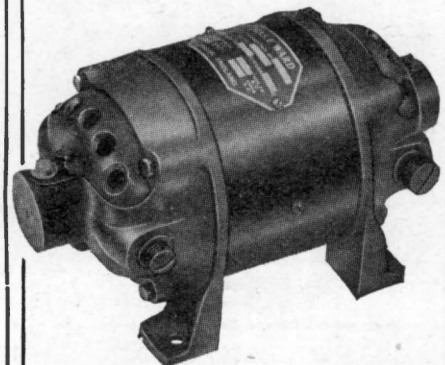

WE ALSO MANUFACTURE

DC/DC ROTARY TRANSFORMERS, SMALL ALTERNATORS, SMALL DC MOTORS, H.T. GENERATORS, MAINS TRANSFORMERS up to 10 k.v.a., PETROL ELECTRIC generator sets up to 50 k.v.a. BATTERY CHARGERS for private and industrial use, and are fully equipped for general small engineering work.

Full details of any of the above upon request. Export enquiries invited.

CHAS. F. WARD,
46, FARRINGTON ST., LONDON, E.C.4
Telephone: Holborn 9703. Works: Hackney, E.9.

Concentric Line Circuits for Ultra-high Frequency

The purpose of this article is to point out briefly the advantages of concentric line circuits, the types and materials that may be used and how practical arrangements can be set up and used in U.H.F. equipment.

BEFORE discussing the characteristics of concentric line circuits it will be useful to outline what it is desired to improve by their use. In a receiver it is essential to keep the noise

the inductance (the Q), so that a high signal voltage may be built up. This must be done in conjunction with using the auto-transformer method of frequency. Whereas a value of Q for

long is ample, while one of 6 in. long could be used quite effectively. For circuits where it is necessary to keep the impedance high, the ratio of the tube diameters may be made much in excess of the usual 3.6:1, or roughly 4:1, which gives maximum Q . Incidentally, as the ratio is increased the line is shortened (keeping the same capacity for resonating the line to the required frequency). Thus the natural choice for an oscillator would be 3.6:1 or thereabouts, while for a "gain" application two or three times this ratio can be used. It is not, therefore, at all essential to use very long lines, or even round ones. One example of a square outer conductor is an old copper I.F. transformer can.

Copper is one of the best metals for the purpose, the resistivity of various types of aluminium and duralumin being around two to three times as great. There is also no reason why different metals should not be used for inner and outer conductors. A good idea is to use a $\frac{1}{4}$ in. outside-diameter copper pipe for the inner line, and bend and solder a piece of thick copper sheet to the required outer diameter, unless the exact requirements are readily obtainable.

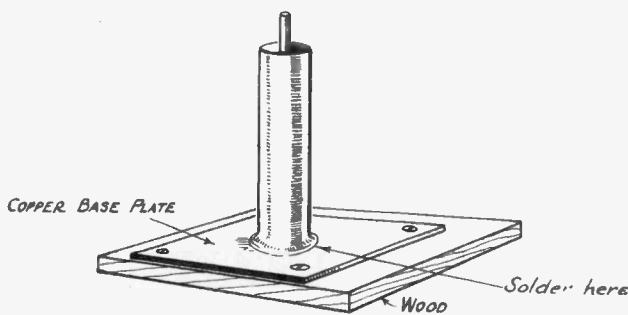

Fig. 1. Mounting the vertical concentric line.

generated by the first stage as low as possible as this "set noise" is amplified, along with the signal, by the following stages of the receiver. Therefore it is important that the maximum gain (consistent with good stability) be obtained in the first stages in order that the received signal when weak, may be

increasing the voltage amplification of the valve itself.

Contrary to a coil, the Q of a concentric line inductance *increases* with a concentric line of fixed length, at 100 Mc, may easily be 4,000 to 5,000 and rapidly increase with frequency, a coil and condenser would not be able to reach more than around 5 per cent. of this value. Also, as has already been noted, with a coil, Q would *decrease* as the frequency was raised. It should not be forgotten, however, that although it is possible to have a high Q , it may easily be reduced drastically if the valve connected across it acts as a relatively low resistance; but even in extreme cases it would be much better than a coil.

The merits of "long-lines" for circuit elements have long been lauded, but the concentric line has an important advantage in that it is a completely screened system. With "long-lines" it is usually found necessary to screen separate stages of any particular apparatus to prevent pick-up or radiation (which increases alarmingly as the rods are spaced wider apart); with concentric lines this is quite unnecessary.

Types and Materials

Concentric lines may be built quite short, as short thick lines have a higher Q than long thin ones (although it is, of course, necessary to use more capacity). At 60 Mc. a line of 15 to 20 in.

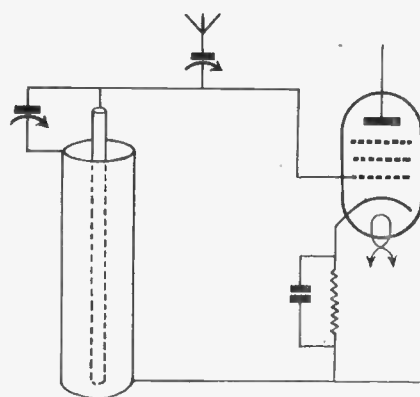

Fig. 2. The simplest way of using concentric lines (for an R.F. amplifier) but not recommended for obtaining the full advantage of coaxial circuits.

able to compete with the internal noise. In a R.F. amplifier, therefore, it is necessary to design the input (grid) circuit and output (anode) circuit for high impedance and a high ratio of the reactance to the effective series resistance of

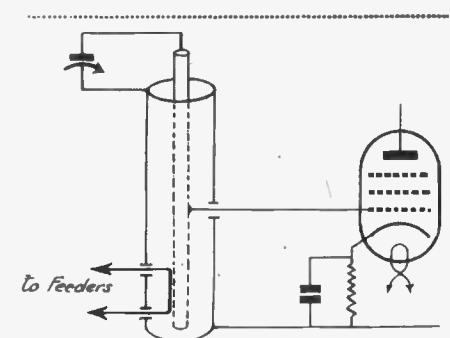

Fig. 3. In this circuit the grid has been tapped half-way up the line, increasing the selectivity. The antenna loop is a piece of wire (insulated from the outer conductor) running close to and parallel to the inner conductor near the cold end. This corresponds to a link at the "cold end" of a coil.

The Construction and Application of Concentric Lines

Having decided on outer and inner conductors, the question arises how can they best be mounted. This depends
(Continued on page 287)

PREMIER RADIO

PLEASE NOTE—ALL KITS ARE NOW SUBJECT TO PURCHASE TAX. THIS IS INCLUDED IN THE PRICE.

PREMIER SMOOTHING CHOKES

Type	Current	Henrys	Res	Prices
C 40/500	40 MA	20-34 H	500 ohms	6/-
C 60/180	60 MA	8 H	180 ohms	6/-
C 60/400	60 MA	25-34 H	400 ohms	8/8
C 60/500	60 MA	18-30 H	500 ohms	8/8
C 100/400	100 MA	20-34 H	400 ohms	10/8
C 150/185	150 MA	20-34 H	185 ohms	15/4
C 200/145	200 MA	20-34 H	145 ohms	18/-
C 250/120	250 MA	25 H	120 ohms	20/-

Premier Pick-ups.

Heads (Will fit any tone-arm) ...	8/9
Premier Pick-ups with Volume Control Tone Arm ...	17/6

ANOTHER SPECIAL OFFER.

Rothermel Brush Piezo Crystal Pick-ups. Standard, S.B. Model with arm ...	34/9
De Luxe Pick-up Head (Will fit any tone-arm) ...	34/9

PREMIER 1941 HIGH FIDELITY AMPLIFIER KITS

Each Kit is complete with ready drilled chassis, selected components, specially matched valves and full diagrams and instructions.

	Kit of Parts with Valves	Completely Wired and Tested
4-watt A.C. Amplifier	£2 14 0	£3 11 6
6-watt A.C.	£6 16 6	£7 13 6
8-10-watt A.C./D.C.	£7 9 0	£7 9 0
15-watt A.C.	£7 18 9	£9 8 0

Black Crackle Steel Cabinet 17/6 extra.

MAINS TRANSFORMERS

Wire-ends. All L.T. Windings Centre-Tapped

SP. 250	250-0-250 v. 60 m.a. 4 v. 1-2 a, 4 v., 2-3 a., 4 v. 2-3 a.	13/4
SP. 300	300-0-300 v. 60 m.a., 4 v. 2-3 a, 4 v., 2-3 a., 4 v. 2-3 a.	13/4
SP. 301	300-300 v. 150 m.a. 4 v. 2-3a, 4 v. 2-3a., 4 v. 1a, 4 v. 1a	17/4
SP. 350A	350-350 v. 100 m.a. 5 v. 2a (not C.T.), 6.3 v. 2-3 a.	16/-
SP. 350B	350-350 v. 100 m.a. 4 v. 2-3a, 4 v. 2-3a, 4 v. 2-3a.	16/-
SP. 351	350-350 v. 150 m.a. 4 v. 1-2a, 4 v. 2-3a, 4 v. 3-4.	17/4
SP. 351A	350-350-150 m.a. 4 v 3 a, 4 v. 2-3 a., 4 v. 1 a, 4 v. 1 a.	22/-
SP. 352	350-350 v. 150 m.a. 5 v. 2a, 6.3 v. 2a, 6.3 v. 2a.	18/-

Auto Transformers. Step up or down. 100-125 v. to 200, 230 or 250 v. A.C., 60 watts, 11/4; 125 watts 15/-; 250 watts, 22/-.

L.T. Transformers, all C.T.			
4 v. 2-3 a.	... 11/4	6.3 v. 2-3 a.	... 11/4
2.5 v. 5 a.	... 11/4	7.5 v. 3 a.	... 11/4
5 v. 2-3 a.	... 11/4	12 v. 3-4 a.	... 18/-
Push-Pull Driver Transformers, ... 6/6			
Universal Output Transformers. 11 Ratios Single or Push-Pull ... 6/6			

MATCHMAKER UNIVERSAL OUTPUT TRANSFORMERS

Will match any output valves to any speaker impedance.

11 ratios from 13 : 1 to 80 : 1, 5-7 watts, 16/10.
10-15 watts, 21/10. 20-30 watts, 36/10.
Paxolin Valve Holders, chassis mounting, 4 or 5 pin, 4d. each. 7 pin, 4d. each.

PREMIER MICROPHONES

Transverse Current Mike. High grade large output unit. Response 45-7,500 cycles. Low hiss level, 23/-.

ALL ENQUIRIES MUST BE ACCOMPANIED BY 2d. STAMP.

"LEARNING MORSE"

Premier Morse Practice Key on Bakelite Base and Brass Movement	3/3
General Purpose Morse Key	5/10
Bakelite Buzzers	2/-
3 Henry Chokes	7/6
Complete Kit of Parts for Valve Oscillator as described in W.W. "Learning Morse"	25/-

NEW PREMIER S.W. A.C. RECEIVER

In response to many requests we have now produced an A.C. version of the popular Premier Short Wave SG3 Kit. Circuit : Pentode H.F. Stage, Pentode Detector, Beam Power Output, and F.W. Rectifier. 200-250 v. A.C. Operation. Built-in Power Pack. Hum-free operation. For use with Phones or P.M. Speaker.

Complete Kit of Parts with drilled chassis, all components. Plug-in Coils covering 13-170 metres, 4 valves and full instructions **£6-14-6**

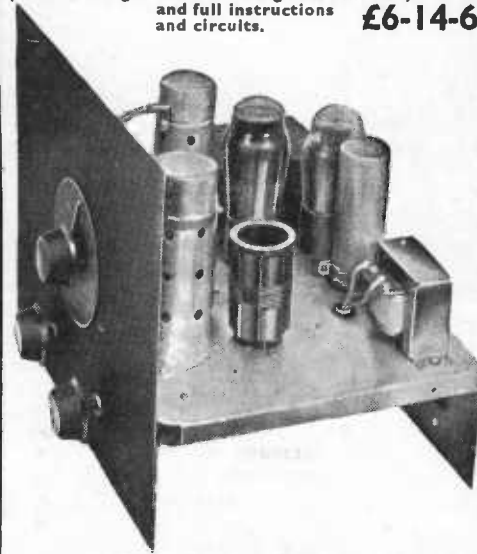

Battery Version also available Kit £4 15 4 Extra Coils 9-15, 200-2000m. also available

★ "The Wireless World" said they were "very much impressed" ★
See full Test Report pp. 492-3 December issue
Send for full details

PREMIER BATTERY CHARGERS for A.C. MAINS

Westinghouse Rectification complete and ready for use

To Charge : 6 volts at 1 amp. 26/ 2 volts at 1/2 amp. 13/4 12 volts at 1 amp. 28/ 6 volts at 1/2 amp. 22/- 6 volts at 2 amps. 43/6

MOVING COIL SPEAKERS

All complete with transformer. Rola 6 1/2 in., 15/-; 10 in. P.M.s, 22/6; Goodman 8 in. P.M.s, 20/-.

ENERGISED MODELS

Plessey 8 in., 175 ohm field, 7/6; 10 in. B.T.H. 1,600 ohm field, less transformer, 11/6.

Moving Coil Mike. Permanent magnet model requiring no energising. Response 90-5,200 cycles. Output .25 volt average. Excellent reproduction of speech and music. 49/-.

PREMIER SHORT-WAVE KITS for OVERSEAS NEWS

Incorporating the Premier 3-Band S.W. Coils 11-86 Metres without coil changing. Each Kit is complete with all components, diagrams and 2-volt valves. 3-Band S.W., 1-Valve Kit, 18/-; 3-Band S.W. 2-Valve Kit, 27/6.

DE LUXE S.W. KITS

Complete Kit, including all Valves, coils, wiring diagrams and lucid instructions for building and working. Each Kit supplied with a steel Chassis, Panel and plug-in coils to tune from 13 to 170 metres.

1 Valve Short-Wave Receiver or Adaptor Kit	24/6
1 Valve Short-Wave Superhet Converter Kit	28/-
2 Valve Short-Wave Receiver Kit	35/6

SHORT-WAVE CONDENSERS

Trolital insulation. Certified superior to ceramic. All-brass construction. Easily ganged

15 m.mfd.	... 2/4	100 m.mfd.	... 3/-
25 m.mfd.	... 2/6	160 m.mfd.	... 3/7
40 m.mfd.	... 2/6	250 m.mfd.	... 4/-

SHORT-WAVE GEAR

Short-Wave Coils, 4- and 6-pin types, 13-26, 22-47, 41-94, 78-170 metres, 2/- each, with circuit. Premier 3-Band S.W. Coil, 11-25, 19-43, 38-86 metres. Suitable any type circuit, 2/11.

4-pin or 6-pin Coil Formers. Plain or Threaded, 1/2 each.

Bakelite Dielectric Variable Condensers. .0005 mf. Suitable Tuning or Reaction, 1/6 each.

Short-Wave H.F. Chokes. 10-100 m., 10 1/2 d. each. High grade Pie-Wound U.S.A. type, 2/- each.

Lissen Dual Range Screened Coils. Medium and Long Waves, 2/9 each.

PREMIER REPLACEMENT VALVES

4 volt A.C. 5-pin Types, A.C./H.L., A.C./L, A.C./P., A.C.H.P., A.C.V.H.P., A.C./V.M. All 5/6 each.

Premier I.F. Trans., 450-470 k/cs., Air cores. With or without Top Grid connection. 5/-.

Flexible Couplers. 1/2-in. bore. 11d. each.

Valve Screens for International and U.S.A. types, 1/2 each.

Jacks. Single or Closed Circuit. 1/9.

Electric Soldering Irons, 200-250 volts, 5/10. Super Model 11/9.

Potentiometers, all resistances, 2/4 each; with switch, 3/3.

Beehive Stand-offs, 2 1/2 in., 7d. each.

Mains Noise Suppressors, comprising double wound Choke and Conds., 6/6 each.

Microphone Cable, weatherproof. Shielded and Rubber covered, 1/- yard.

ELECTROLYTIC CONDENSERS.

Cardboard cases. 500 v. working, 4 mfd. and 8 mfd., 2/- each, 8+8, 4/-, 4+4 2/11, 4+4+1 3/9, 4+4+4 4/3, 16+8 4/11, 16+16 6/-, 25 mfd. 25 volt, 1/6, 50 mfd. 12 volt, 1/6, 15 mfd. 100 volts, 1/3, 4 mfd. 500 volt, 4/8. .1+1 Mains Buffer, 1/2

Microphone Transformers. Suitable for all mikes. Tapped primaries, A, 20 and 40 : 1; B, 30 and 60 : 1; C, 50 and 100 : 1. 6/6 each.

Microphone Stands. Floor Type, 32/6.

All orders under 5/- 6d. post extra.

PREMIER RADIO CO.

ALL POST ORDERS to: JUBILEE WORKS, 167, LOWER CLAPTON ROAD, LONDON, E.5 (Amherst 4723).

CALLERS to: Jubilee Works, or 169, Fleet Street, E.C.4 (Central 2833), or 50, High Street, Clapham, S.W.4 (Macaulay 2381).

ATTENTION! TELEVISION PURCHASE

Chassis, Components,
C.R. Tubes,
etc.

NEVER before has such an opportunity occurred. We have just completed the purchase of the stock of the pioneer Television manufacturer. All stock unused as taken direct from Warehouse and Factory. Chassis, C.R. Tubes, Speakers, Cabinets, Amplifier units, Components and accessories of every description. Enquiries invited from public and trade. To be cleared at ridiculous prices. Inspection invited. Here are only a few items.

BELOW COST

POWER PACK and AMPLIFIER CHASSIS

Size 16 $\frac{1}{2}$ in. x 13 $\frac{1}{2}$ in. x 4in. First class examples of how scientific instruments should be built. Planned as the main unit for Television receivers costing many pounds. Includes heavy mains transformer 350-0-350, 120 m.a. with 4 4-volt 5 amp. tapplings. High voltage transformer for supplying C.R. Tube. Various condensers including 16 x 16 mfd. 550 volt working, 1-16 mfd. 450 volt working, 50 x 50 x 2 mfd. B.I. Electrolytics, etc., etc. Pentode output transformer; chokes; resistors; trimmers; bias electrolytics; mica and tubular condensers; short-wave coils, etc., etc. The quality of the workmanship and components is of the highest class. New and unused as received from the actual manufacturer's warehouse. 67/6. Also a slightly smaller chassis fulfilling the same functions but made for a different model, 62/6.

C.R. TUBES

Included in the consignment are 8in., 10in. and 14in. approx. magnetic type only of Cathode Ray Tubes. Brand new in original cartons or mounted on new chassis. Send us your requirements and we will quote by return. C.R. Tubes not available to-day through ordinary channels. Will clear at low prices. Collection by buyer.

VISION UNITS

To fit on above Time Base. Consists of 3 Mullard T.S.E.4 and 1 Mazda D1 Valves. Approximately 25 resistors ranging from 75-75,000 ohms, and about 30 condensers of various values, together with Rejector, Grid and various Band Pass Coils, also approximately 10 chokes of various descriptions and W6 Westector. All completely wired and carefully screened in metal box. Unused as received direct from the manufacturers. 40/- each. (Complete circuit and service manual available, price 6d. each.)

40/-

MAINS TRANSFORMERS

We have handled many thousands of mains transformers, but truly these are one of the best jobs we have seen. Originally made for Television Power Packs where accuracy and robustness is essential. Weight 12 lb., size 5 $\frac{1}{2}$ in. x 4 $\frac{1}{2}$ in. overall. 350-0-350 volts, 120 m.a. Four tapplings each giving 4 volt 5 amps. Brand new and unused. 25/- each.

25/-

TIME BASE CHASSIS

For 8in. Cathode Ray Tube. Well-made cadmium-plated chassis, size 17in. x 14 $\frac{1}{2}$ in. x 2in., containing approximately thirteen fixed resistors ranging from 15,000 ohms to 1 megohm, five variable resistors, 2,000 to 20,000 ohms, approximately 14 various tubular and electrolytic condensers, also sundry focus and scanning coils and chokes. Price 30/- each. (Complete circuit and service manual available, price 6d. each.)

30/-

TUBE SUPPLY UNITS

For high voltage 16/18in. Tubes. Approx. 6,000 volts output. Includes B.I. 1 x 1 mfd. 7,000 volt d.c. test condensers with porcelain insulators, transformer and rectifying valve, all shielded in metal case. Again, Brand new, 45/- (B.I. condenser supplied separately at 20/- and the transformer at 10/6.)

45/-

LONDON CENTRAL RADIO STORES

23, LISLE STREET, LONDON, W.C. 2
GERRARD 2969

You are invited

to apply for details of membership in the Radio Society of Great Britain.

Membership is open to those who are genuinely interested in the science of radio communication, and who are engaged in experimental or research work.

Since the outbreak of hostilities many hundreds of additional members have joined the Society, thereby helping to create a strong and virile organisation which will be in position to negotiate with the authorities for the early restoration of amateur facilities.

The T. & R. Bulletin

This is now completing its 16th year of continuous monthly publication, and it provides members with the latest technical information. In addition, special features such as "Khaki and Blue," enable members in and out of the Services to maintain contact with one another.

PRINCIPAL CONTENTS OF MAY ISSUE

"AN EFFICIENT RECEIVING INSTALLATION"
"MATHEMATICS FOR THE RADIO AMATEUR"
"A FIELD OPERATOR'S VADE MECUM"
"CONSTRUCTING A SEMI-AUTOMATIC KEY"
COSMIC DATA, DISTRICT NOTES, EMPIRE NEWS,
HAM HOSPITALITY, ACTIVE SERVICE LIST.

A copy of the current issue, together with details of reduced war-time subscriptions, will be sent to any address in Great Britain, the British Empire or the U.S.A. on receipt of P.O. for 1/-, or its equivalent.

MEMO.—Have you purchased your copy of The Amateur Radio Handbook? 328 pages, 300 illustrations. (Price 4/- post free).

All communications to The Secretary-Editor—

RADIO SOCIETY OF GREAT BRITAIN, 16, Ashridge Gardens, London, N.13

Telephone: Palmers Green 3255. Office Hours: 9.30. a.m. - 5.30 p.m.
Saturdays: 9.30 a.m. - 12.30 p.m.

Great Possibilities for

TECHNICALLY QUALIFIED ENGINEERS KEY MEN IN WARTIME AND AFTERWARDS

The finest posts and the majority of posts in this war are technical and when the war is over, the immense increase in technique and mechanisation created for war purposes will be applied to reconstruction and commerce. An age of great possibilities for qualified engineers is here. Study at home with The T.I.G.B. and take a Recognised Engineering Qualification such as A.F.R.Ae.S., A.M.I. Mech.E., A.M.I.E.E., etc. in which examinations T.I.G.B. Students have gained 25 FIRST PLACES and hundreds of passes. Write now for "The Engineer's Guide to Success"—200 Courses—covering all branches—Aeronautical, Tele-communication, Mechanical, Electrical, Chemical, etc. etc.

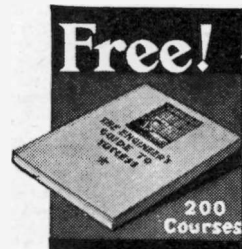

THE TECHNOLOGICAL INSTITUTE OF GREAT BRITAIN
160, Temple Bar House, London, E.C.4.

LOUDSPEAKER & TRANSFORMER SERVICE

(BRITISH AND AMERICAN)

TRANSFORMERS DESIGNED AND REPAIRED.

NEW SPEAKERS 3" to 18" P.M. and MAINS
ENERGISED.

SPEAKERS OF ALL KINDS FROM 10/6.

SINCLAIR SPEAKERS

PULTENEY TERRACE, COPENHAGEN ST., TER 4355
LONDON, N.1.

Concentric Line Circuits for Ultra-high Frequency

(Continued from page 284)

largely upon the rest of the circuit; whether the line is to be tapped at some point or not. If it is to be bolted down to the chassis the closed end may be blocked up in any convenient way, with copper sheet cut to the correct shape and soldered in position. When the pipe is to be vertical the arrangement shown in the drawing, Fig. 1, is usually adopted. The base piece is made from sheet copper which is screwed to the wooden base, the pipes are then soldered to the sheet.

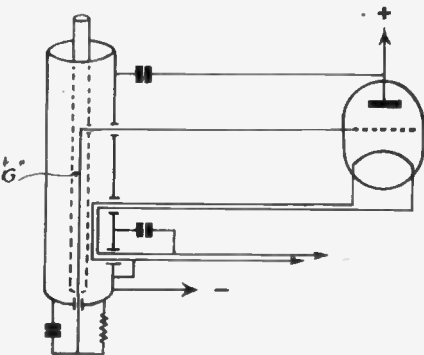

Fig. 4. Cathode-above ground oscillator for directly heated valve.

With regard to tapping the line, instances of this occur in a cathode-above-ground oscillator, or an R.F.

amplifier with the plate tapped half way down the line, increasing the available signal output from the stage. Moreover, the selectivity can be increased by tapping the grid of the amplifier down the line.

Any type of U.H.F. receiver may be greatly improved by the substitution of concentric lines, whether it is a simple super-regenerator or a superhet. Best results will be obtained if the above remarks about impedance, tapping points, etc., for the different uses are kept in mind.

Tracking in a superhet may be accomplished in many ways; the usual padder and trimmer method may be used as in normal practice. Different line lengths can be selected, and arranged to track exactly at two points (the difference of which is equal to the I.F. used) in the desired tuning range. Different pipe ratios for oscillator and mixer can also be arranged to track well; in this last case the lining up is done in the middle of the band and is found to keep very close throughout. It is well to remember that the shorter the line and the lower the I.F. used, the easier will be the tracking.

Fig. 4 shows the familiar cathode above-ground oscillator for a directly heated valve. The grid wire, G, may be taken either through a hole in the inner conductor and out at

the bottom, or led down close to the inner conductor and out through a hole in the copper plate at the bottom. This arrangement is to allow the grid condenser and leak to be placed at the cold end of the inductance as is frequently done in transmitting practice. The filament wires should not be coupled so closely to the inner conductor as the grid: a tuned circuit may be placed in the anode of the valve, as in the usual so-called "electron-coupled" oscillator. Fig. 5

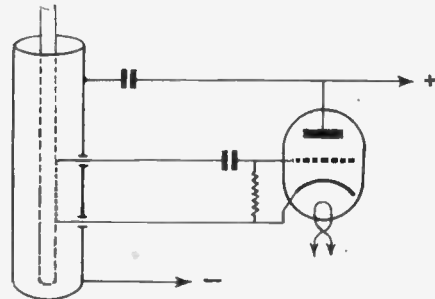

Fig. 5. The same arrangement for an indirectly heated valve.

illustrates the same arrangement for an indirectly-heated valve, the only difference being that the grid condenser has been shown in an alternative position.

It is, of course, possible to use a coaxial tuned circuit in the grid, and a coil in the anode, but the stability of the arrangement is likely to suffer.

GALPINS ELECTRICAL STORES

TERMS: Cash with Order or C.O.D. Charges extra

Owing to war circumstances this business is now transferred to

21, William St., Slough, Bucks.

Phone: SLOUGH 20855

ALL GOODS SENT ON THREE DAYS APPROVAL AGAINST CASH

ELECTRIC LIGHT CHECK METERS, small, late type, well-known makers, in good condition, electrically guaranteed for 200/250 volts 50 cy. 1 phase A.C. mains. 5 amp. type 6/-; 10 amp. 7/6; 20 amp., 9/- each. Post 1/- on all types.

D.C. ELECTRIC LIGHT CHECK METERS, 200/250 volts 5 and 10 amps., 5/6 each, post 1/- (in new condition)

REGULATORS, STARTERS AND LARGE DIMMER RESISTANCES. Stud Switch-arm type. State wants.

SWITCHBOARD VOLT AND AMPMETERS MOVING COIL AND MOVING IRON. All first-class makers. Please state requirements.

EX R.A.F. GALVANIC ACCUMULATOR TANKS, 5x5x8in., new and unused, 3/6 each, post 1/-

EX R.A.F. SWITCH PANEL, with case (new), fitted 6 small knife switches, leads, cord and cleats, complete in wood case, 2/6 each, post 6d.

HIGH-VOLTAGE TRANSFORMERS, useful for all test work, or television. Input 200/240 volts, output 5,000 and 7,000 volts, 7/6 each, post 1/-

VOLTAGE CHANGING TRANSFORMERS (Auto Wound), 100/110 to 200/240 v. or vice versa, fully guaranteed, 1,000 watts, 80/-; 2,500 watts, 110/-.

DUG-OUT LAMPS. Ex R.A.F. solid brass construction, glass dome complete with 12 volt bulb, (any bulb can be fitted), wall fitting 3/- each, post 6d. Ditto wing type, r s new 2/6, post 6d.

DUG-OUT LAMPS. Ex R.A.F. Porthole type or can be bracket fitted. Glass dome three colour fitting, white, red or green, solid brass construction, 6in. dia., complete with bulb, any size bulb can be fitted. Price 3/- post 6d.

ROTARY CONVERTOR, D.C. to D.C., 110 volts input to output of 600 volts at 150 m.a., 65/- carriage paid.

‡ **H.P. 110 V. D.C. MOTOR**, as new, ball bearing totally enclosed, 30/- carriage forward.

EX R.A.F. AUTOMATIC CHARGING CUT-OUTS AND VOLTAGE REGULATORS to suit any dynamo up to 20 volts at 15 amps, fully adjustable, wiring instructions complete in metal case, 3/6, post 9d.

DYNAMOS, all-shunt wound and fully guaranteed, 50/75 V.—15 A., 86/10/-; carriage forward.

GUNMETAL PULLEYS, 7-in. dia. to take 1-in. dia. rope, complete with rope guard and hook. 7/6 each, postage 1/-.

FLOOD LIGHTS, 12 in. dia., multi mirror type with 5 in. dia. Mangin mirror centre any bulb can be fitted. 15/-, carriage paid.

110 V. BULBS, 150 C.P. Ediswan screw fitting, half-watt gas filled, 2/6 each post free, or 25/- per doz.

HOT WIRE AMPMETER, 5 in. dia., reading 0-2 amps, 15/- post free.

POST OFFICE MORSE KEYS, standard pattern, solid brass construction, in first-class condition. 15/- post free.

PRESS-BUTTON UNITS, 8-way, 7x6x1 1/2, fitted capacitors, condensers, etc., for 3-gang tuning. Price 5/6 post free.

LARGE TRANSFORMER, double wound, primary 230 volts input, output 300-0-300 v., capacity 3 kw. Price £3 10s. 0s. carriage forward.

TELEPHONE MAGNETOS or hand calling generators, 3 and 4 magnet type, unboxed, in good working order. Price 7/6 post free.

8-WAY Press-Button switches fitted paxolin terminal strip. 2/6 each post free.

X-RAY TRANSFORMER, capacity 2 kW., oil filled, output 70,000 volts, complete with auto transformer to suit any A.C. mains working from 100 to 250 volts 50 cycle single phase. Price £15 carriage forward.

ROTARY CONVERTER D.C. to A.C., input 220 v. 9 amps.; output 85 volts, 50 cycle, single or 3 phase, in perfect working order. One foot broken off (missing). Price £12 10s. 0s. carriage forward.

H.T. 8 METAL RECTIFIERS, secondhand, but in perfect condition, 7/6 post free.

MILLIAMPMETERS, by Turner, moving coil, 2 in. dia range 0-30 M/A or 0-150 M/A, price 25/- each, post free.

DYNAMO, maker "Crompton," shunt wound, very solid construction, output 220 volts 10 amps., 4 pole, speed 1,750 R.P.M., and pulley. Price £8 10s. 0d. carriage forward.

P.A. SPEAKER CABINETS, not polished, size 22 in. by 18 in. by 13 in., to take 14 in. dia. cone, the whole made of 1/2 in. thick plywood. Price 20/- carriage 2/6; Ditto, in Rexine, slightly soiled, 17/6, carriage 2/6.

Novel Seamed I.H. Cathode Sleeve

(Continued from page 283)

the beads contact strip 14 when welding current starts. Pressure of the electrodes force the two strips together as the beads melt.

Alternatively, two parallel ridges 16a shown in Fig. 2, may be machined in the face of welded electrode 16 so that the welded current may be concentrated along two lines parallel to the cylinders.

The edge portions or flanges 8, 9, 10 and 11 of the two semi-cylindrical pieces 6 and 7 of the sleeve may be joined by lock seams 1 as shown in Figs. 3 and 4. One flange on each piece is made with flaps such as 8a and 11a so that it may be folded over the registering flanges to clinch the two semi-cylindrical pieces together. This clinched standing stem may then be folded against the side of the cylinder and the material of the two seams pressed either to the inside or to the outside of the cylinder as in the sleeve of Fig. 1. The seam on one side of the cylinder may be cut off short of the ends of the cylinder to provide mica stops and two of the four layers in the other seam continued beyond the end of the cylinder to make a tab.

When the stock for the sleeves is of sheet metal about .002 inch in thickness it is preferable to make the tab of

two thicknesses of folded metal from one edge of one of the semi-cylindrical pieces, although one, three or four of the

flanges of the seam could be extended for the tab.

The finished cathode comprises a sleeve with reinforcing seams along opposite sides, and these seams materially strengthen the sleeve and prevent bowing or buckling when heated to high temperatures. The symmetry of the metal in the cylinder is believed to contribute in the strength of the sleeve.

New R.C.A. Laboratories

It has been announced that the Radio Corporation of America are to build new laboratories at Princeton, New Jersey. They will be the headquarters for all research and development work of the R.C.A. and for its patent and licensing activities.

The Vice-President in charge will be O. S. Schairer.

Please mention
ELECTRONIC ENGINEERING
when replying to advertisers.

Latent Period in Muscle Response — Measured by the C.R. Tube

THE determination of short time intervals by the interruption of a mains frequency trace on the screen of a cathode-ray tube has been applied by A. Sandow (N.Y. University Biology Department) to the measurement of the latent period in the mechanical response of frog muscle.*

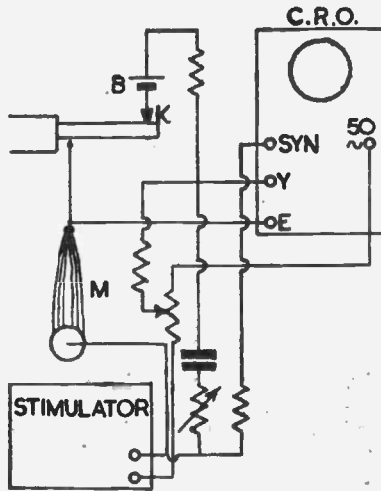

The circuit is shown in outline in the diagram. The output of a variable frequency stimulator is applied to the muscle M and to the vertical plates of the tube through an amplifier.

The time base is set for single sweep and the synchronising terminal is connected to the stimulator so that a fraction of the potential is sufficient to trip the sweep. The start of the beam is within 0.1 millisecond of the application of the stimulus. A 50 c.p.s. mains potential is also applied to the vertical plates so that the traversal under normal conditions traces two or three cycles of the mains voltage.

When the muscle contracts, however, the contact K is broken, and the input condenser of the amplifier, normally charged by the battery B, is suddenly discharged through the grid resistance of the first stage and the resulting impulse sends the beam off the screen.

The latent period corresponds to the proportion of the 50 c.p.s. wave which appears on the screen, and this can be photographed in the usual way.

* "Du Mont Oscillographer," Mar. 1941.

CLASSIFIED ANNOUNCEMENTS

SCALE OF CHARGES

The charge for miscellaneous advertisements on this page is 12 words or less 2/-, and 2d. for every additional word. Single-column inch rate displayed, 12/6. All advertisements must be accompanied by remittance. Cheques and Postal Orders should be made payable to Hulton Press, Ltd., and crossed, and should reach this office, 43, Shoe Lane, London, E.C.4, not later than the 15th of the month previous to date of issue.

MISCELLANEOUS

ALL TYPES of Rotary Converters, electric motors, battery chargers, petrol electric generator sets, etc., in stock, new and second-hand.

A.C.-D.C. Conversion Units for Operating D.C. Receivers from A.C. Mains, 100 watts output, £2. 10; 150 watts output, £3. 10.

WARD, 37, White Post Lane, Hackney Wick, E.9.

LOUDSPEAKER repairs, British, American, any make, 24-hour service; moderate prices.—Sinclair Speakers, Pulteney Terrace, Copenhagen Street, N.1.

SHORT-WAVE EQUIPMENT

G5NI for Short Wave Equipment; largest stocks in the country; communication receivers; National distributors; American and British Valves, etc. 48, Holloway Head, Birmingham.

PICK-UPS

MOVING COIL PICK-UPS. "Coil" and Voigt stockists. Quality Amplifiers. HOLIDAY, HEMMERDINGER LTD., 74, HARDMAN STREET, MANCHESTER 3.

LOUDSPEAKERS

3,000 SPEAKERS P.M. and energised 4" to 14", including several Epoch 18". Sinclair Speakers, Pulteney Terrace, Copenhagen Street, N.1.

RADIO MAP AND GLOBE

WEBB'S Radio Map of the World enables you to locate any station heard. Size 40" by 30" 2 colour heavy Art Paper, 4/6d., post 6d. Limited supply on Linen, 10/6, post 6d. WEBB'S Radio Globe—superb 12" full-colour model. Radio prefixes, zones, etc. Heavy oxidised mount. Post Paid. 2/7/6.—Webb's Radio, 14, Soho Street, London, W.1. Phone: Gerrard 2089.

MORSE EQUIPMENT

FULL range of Transmitting Keys, practice sets and other equipment for Morse training.—Webb's Radio, 14, Soho Street, London, W.1. Phone: GERard 2089.

TUITION

WIRELESS. Students of both sexes trained for important War-time Radio Appointments, also for peace time careers in all branches of Radio & Television. Boarders accepted. Low inclusive fees. College in ideal peaceful surroundings. Prospectus Free. Wireless College, Colwyn Bay.

PRACTICAL POSTAL COURSES, radio television, test equipment design, trade-test coaching for R.A.F. post, I.P.R.E. and I.W.T. exams.; booklet free—Secretary, I.P.R.E., Bush House, Walton Avenue, Heuley-on-Thames.

MORSE TRAINING

FREE. "Book of Facts," tells you all about The Candler System of Code-training. Courses for Beginners and Operators.—Write: Candler System Co. (55B) 121, Kingsway, London, W.C.2.

WANTED

ALL TYPES of used Radio Sets, Radio and Electrical accessories. Bought for cash. University Radio, 22 Lisle Street, W.C.2. Phone: GER. 4447.

COMMERCIAL DEVELOPMENT

THE OWNER of Patent No. 482835 is desirous of arranging by way of licence or otherwise on reasonable terms for the commercial development in Great Britain of this invention, which concerns IMPROVEMENTS IN OR RELATING TO TELEVISION PLANT.—For particulars address ELKINGTON AND FIFE, 20 to 28, Holborn, London, E.C.1.

"LESDIX" EMERGENCY LIGHTING

Emergency Electric Lighting for Shelters, Headquarters, homes and factories.

Have your own Petrol-Electric Lighting and Charging Plant.

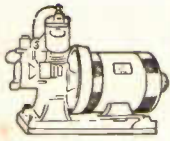

500-watt, single cyl. 2-stroke, water-cooled, self-oiling Stuart-Turner engine; mag. Ign. coupled to 50/70 volts, 10 amps., shunt dynamo, 1,000 r.p.m. Fuel and Water Tanks. These are £45 sets ready for immediate delivery. Price **£17 10 0**

150-watt engine on similar lines, but coupled to 25/30 volts, 6 amps., dynamo. **£13 10 0**

As we have had to move our London Office, and stores are somewhat disorganised, we are unable to receive callers, but can deal with all post orders and enquiries for the above Lists up to No. 51 are obsolete. NEW List ready shortly.

LESLIE DIXON CO.

225 UPPER THAMES ST., LONDON, E.C.4.

Varley

Quality Components

- I.F. TRANSFORMERS
- WIRE WOUND RESISTANCES
- L.F. CHOKES & TRANSFORMERS
- MAINS TRANSFORMERS
- DELAY SWITCHES

Varley (Prop. Oliver Pell Control Ltd.)
Cambridge Row Woolwich, S.E.18

TELEVISION:

Concise Postal Course of Instruction for Radio Engineers

Apply—

BRITISH RADIO ENGINEERING COLLEGE

179, CLAPHAM ROAD, LONDON, S.W. 1

(Do not delay. Be conversant with subject now and prepared for business after the War.)

Please mention ELECTRONIC ENGINEERING when replying to advertisers

INDEX TO ADVERTISERS

	PAGE
A.S.C. Radio ... Ltd.	Cover III
Advance Components, Ltd.	275
All-Power Transformers, Ltd.	282
Automatic Coil Winder and Electrical Equipment Co., Ltd.	242
British Institute of Eng. Technology	277
Sulgin, A. F., & Co., Ltd.	279
Celestion, Ltd.	275
Columbia Records	Cover III
Du Bois Co., Ltd.	Cover III
Edison Swan Electric Co., Ltd.	244
Electro Physical Laboratories	276
Fluxite, Ltd.	241
Foyles' Ltd.	Cover III
Furzehill Laboratories, Ltd.	281
Galpins	287
General Electric Co., Ltd.	269
I.A.C., Ltd.	280
Leslie Dixon Co.	Cover III
Lockwood & Co.	Cover III
London Central Radio Stores	286
London, Ltd.	282
McGraw-Hill Publishing Co., Ltd.	277
Ministry of Labour	273
Muirhead & Co., Ltd.	262
Partridge, N.	283, Cover III
Pitman's	274
Premier Radio Co.	285
Radio Society of Great Britain	286
Reliance Manufacturing Co. (Southwark), Ltd.	278
Savage, W. Bryan, Ltd.	Cover III
Sinclair Speakers	286
Steatite and Porcelain Products, Ltd.	267
Taylor's Electrical Instruments, Ltd.	241
Technological Institute of Great Britain	286
Telegraph Construction and Maintenance Co., Ltd.	241
Television Society, The	277
Trix Electrical Co., Ltd.	282
United Insulator Co., Ltd.	271
Universal Electrical Co.	277
Varley	Cover III
Vortexion, Ltd.	243
Ward, Chas. F.	283
Webb's Radio	Cover II, IV
West, A., & Partners, Ltd.	275
Westinghouse Brake and Signal Co., Ltd.	242

A.C.S. RADIO — offers

McMurdo Silver, 1940, 15-17 Olympic Auto-radiogram, new, pre-war list price 72 Gns.
Scott All-wave Auto-radiogram, with Capehart Record changer, magnificent cabinet, perfect order, little used ... £120 0 0
1939 Midwest, in standard modern console, as new ... £20 0 0
Hammarlund Super Pro, SP 110, 15-560 metres, with power pack, as new £59 0 0
Cellophone Radiogram, 13-2,000 metres, photo-electric ribbon type gramo. Dem. soiled. Cost 55 Gns. ... £37 10 0
Ekco Model CS11, Push Button Console, 13-2,000 metres, New, at pre-tax price £17 17 0
Murphy, Model A. 90, new, at pre-tax price £11 10 0
Defiant, 1939/40, 6 v. Table Receiver, dem. soiled ... £15 15 0
American General Electric Radioforte Console, 7 valves, push button, 200/550 metres, Beamscope aerial. Cost 68 Gns. New condition ... £27 10 0
Eddystone Special, 15-87 metres, three bands, separate speaker and power pack. As new ... £17 10 0
Crosley, 1938/9, Radiogram, Queen Anne period cabinet, 10 valves, 13-2,000 metres. Perfect order ... £16 16 0

Ex-Bromley. Carriage and Packing extra. Inspection and collection invited.

A.C.S. RADIO

44, Widmore Road, Bromley, Kent.
Phone and Grams: RAVensbourne 0156. Open to 6 p.m. except Wed., 1 p.m.

TRANSFORMERS

to customers' specifications or in accordance with standard list.

W. BRYAN SAVAGE LTD.

Westmoreland Road, London, N.W.9. Colindale 7131



CASES

In WOOD, METAL and REXINE for RADIO and RADIO INSTRUMENTS

Details of Radio Cases for the Home will be forwarded on receipt of 2½d. In stamps.

LOCKWOOD & CO. (Dept. E.)
65, LOWLANDS ROAD, HARROW, MIDDLESEX

*Phone: BYRON 1818

FOYLES

★ BOOKSELLERS TO THE WORLD ★
New and secondhand Books on every subject.
Join The Scientific Book Club!
113-125 Charing Cross Road, London, W.C.2
Telephone: Gerrard 5660 (16 lines)

Air Ministry Approved. List No. B 980555/59
Contractors to the General Post Office, Etc.

CORED-SOLDERS

Manufactured by THE DU BOIS Co., Ltd.
15, Britannia St. London, W.C. 1.
Terminus 4624

QUICK COURSE IN MORSE

by R.A.F. Signallers

on COLUMBIA Records

A complete new course of instruction in Morse Code made with the co-operation of R.A.F. Signallers. From the Alphabet to Fast Transmission with varying degrees of typical jamming. Invaluable to those about to join the Fighting Forces, A.T.C., or Merchant Service.

What an advantage to enter, already proficient in this important part of the training! Start now — ask your local dealer about these records — today!

4 Records DB 1995-98 12/- (+ 2/8d. Tax)
Booklet of Instruction included

INCREASED PRODUCTION FACILITIES

Arrangements have now been completed whereby our pre-war delivery rate of Special Transformers (per return in the case of small quantities and large quantities correspondingly prompt) has again been achieved. This special service is strictly reserved for Urgent Government Work and the Government Contract number for which the goods are required must be quoted when ordering.

N. PARTRIDGE, BSc., A.M.I.E.E.

King's Buildings, Dean Stanley Street, London, S.W.1.
Telephone: VICTORIA 5035.

CONDITIONS OF SALE AND SUPPLY.—This periodical is sold subject to the following conditions, namely, that it shall not without the written consent of the publishers first given, be lent, re-sold, hired out or otherwise disposed of by way of Trade except at the full retail price of 1/6 and that it shall not be lent, re-sold, hired out or otherwise disposed of in a mutilated condition or in any unauthorised cover by way of Trade; or affixed to or as part of any publication or advertising, literary or pictorial matter whatsoever.



EDDYSTONE 358

A LANDMARK IN COMMUNICATION RECEIVER DESIGN

Like the famous lighthouse the Eddystone Model "358" is British to the core . . . in physical design it is solid and workmanlike . . . built to withstand continuous hard wear. Our designers have incorporated every advanced detail to assure that the performance be more than equal to the many exacting tasks which it is being required to undertake by all departments of H.M. Forces.

SPECIFICATION

The receiver employs one stage of R.F. amplification, frequency changer, two I.F. amplifiers, a separate beat frequency oscillator, octal base Mullard or Osram 6.3 volt valves. Frequency range is continuous from 22 m/cs. to 1.25 m/cs. using four fully screened interchangeable coil units. Five additional coil units extend the range to 31 m/cs. and 90 k/cs. The large illuminated dial is accurately calibrated with the four standard coils and additional coils are supplied with separate graph. High and low impedance head phone jacks are provided.

PRICES
AND COMPLETE
SPECIFICATIONS
ON REQUEST

TO SIMPLIFY MAINTENANCE a metre and test switch is fitted to check emission of each valve. Main tuning control incorporates fly wheel drive and spring loaded Tufnol gearing (ratio 70-1). To facilitate re-tuning to any given position a logging scale is incorporated. This supersedes the old type band spread control.

SEPARATE POWER UNIT is provided to assure freedom from drift and over heating of the R.F. and I.F. stages.

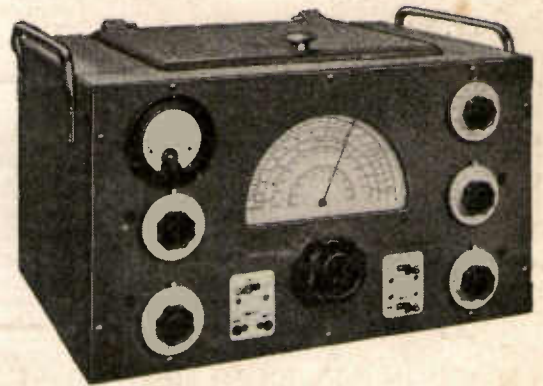

SPECIAL MODELS OF THE "358" AND "400" INCORPORATING BAND PASS CRYSTAL FILTER UNITS ARE AVAILABLE.

Medium Frequency Model "400"

To meet the demand from His Majesty's Forces for a highly sensitive receiver to cover only medium frequencies the model "400" has been developed. In general design it is similar to the "358" but is provided with four coils only covering frequency range from 130 k/cs. to 2,200 k/cs. The entire frequency range is accurately calibrated on the main illuminated dial and a separate logging scale, as in the "358" is provided.

Dual Ratio Loud Speaker.

A robust 7-inch cone unit permanent type speaker supplied with dual ratio transformer input impedances, 600 ohms and 7,000 ohms, is designed to match the welded steel, grey crackle finish receiver cabinet.

WEBB'S RADIO

14, SOHO ST., OXFORD ST., LONDON, W.1.

OPEN 9.0 a.m. TO 6.0 p.m. SATS. 1 O'CLOCK

TELEPHONE : GERRARD 2089

