

TELEVISION
October, 1932

TELEVISION A SEA-LION

TELEVISION

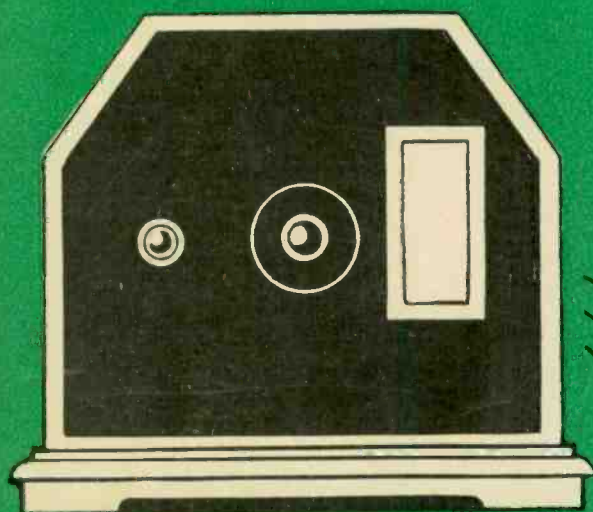

OCTOBER, 1932

How to Construct
a Mirror-Drum

The B.B.C. Programmes:
Prizes for Readers

Reports from
Germany and U.S.A.

Television in an Aeroplane

Vol. 5

No. 56

1
NET.

THE FIRST TELEVISION JOURNAL IN THE WORLD

LEWCOS LEADS IN RADIO COMPONENTS

Every part made by Lewcos is a speciality in the strictest sense of the term: the most advanced in design and most accurate in manufacture.

Stocks of Lewcos Components of every description are held by all first-class radio dealers.

Write to Radio Publicity Dept. T for descriptive leaflets of the components you require.

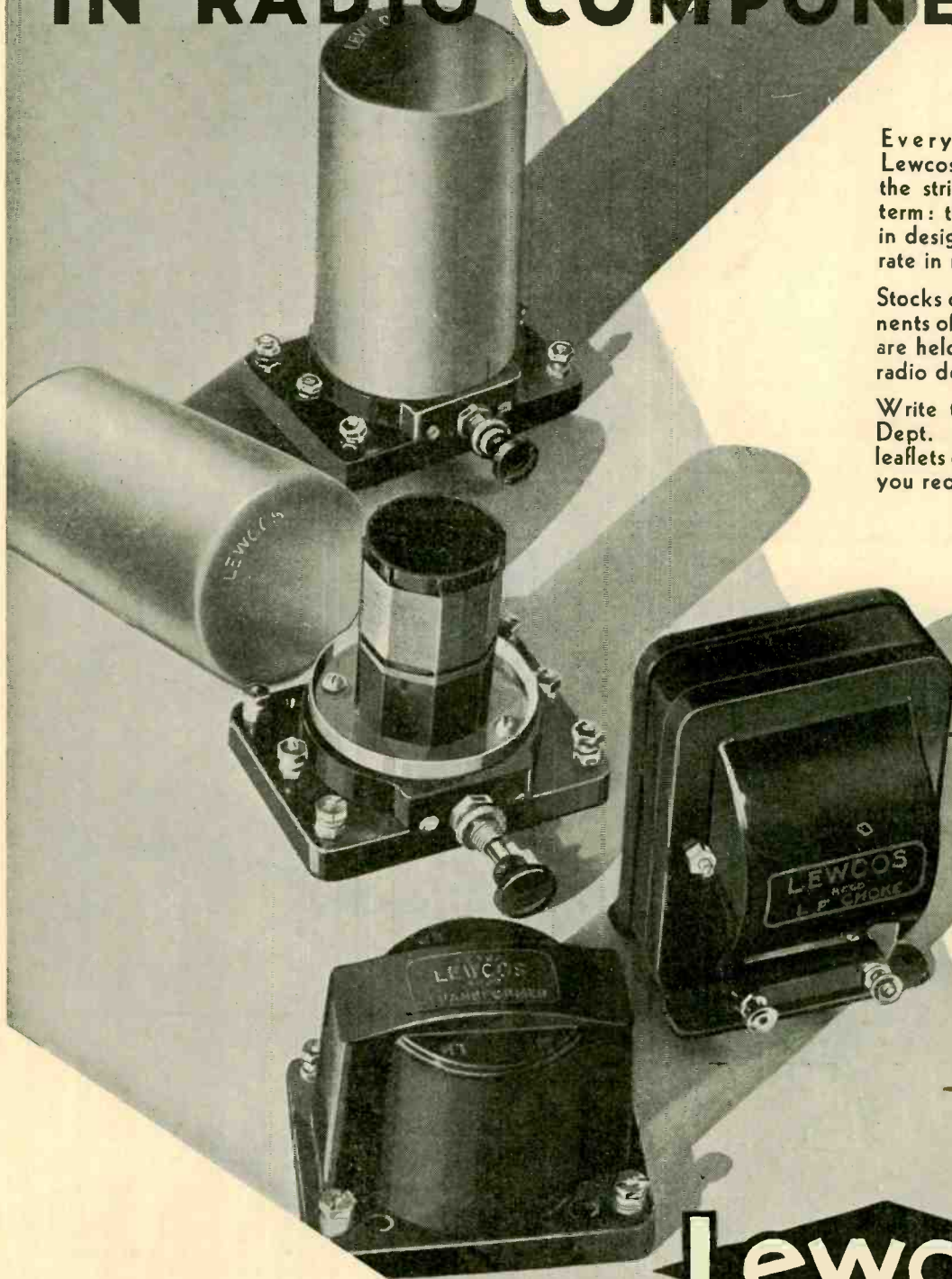

Lewcos
REC'D

LEWCOS RADIO PRODUCTS FOR BETTER RECEPTION

THE LONDON ELECTRIC WIRE COMPANY AND SMITHS LIMITED, CHURCH ROAD, LEYTON, LONDON, E.10

MORE "MERVYN" Components

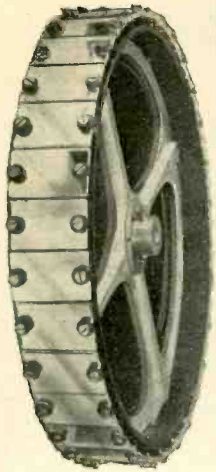

The MERVYN MIRROR DRUM

Designed for the projection of the B.B.C. television transmissions with a 3-7 picture ratio.

Price 5 guineas

A MERVYN SCANNING DISC

Made from 30 gauge aluminium with 30 square holes 3-7 ratio and brass bushed. Standard bush sizes 1/4" to 3/8" other sizes slightly extra.

Price 12/6

The MERVYN MAINS TRANSFORMER

Specially made to supply the voltages for the "Visionette" receiver. Fitted with marked terminals.

Price 35 -

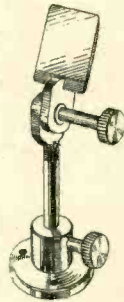

ADJUSTABLE DIAPHRAGM

This is most essential in obtaining the correct size square spot on the projection screen. Made in brass.

Price 6/-

UNIVERSAL ANGLE MIRROR STAND

Is the most satisfactory way of directing the light ray to the mirror drum.

Price (complete with patent plate mirror) 7/6

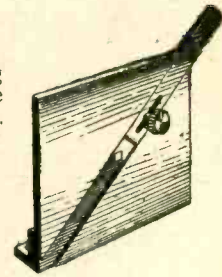

SCREEN

Of fine ground glass giving excellent illumination, 10" x 6"

Price 2/6

Pure Nitro Benzene for Kerr Cells 1/- per bottle
We are also suppliers of Nicol prisms, Lenses, Radio and electrical equipment.

All orders £1 or over carriage free. Send orders and enquiries to :

The MERVYN SOUND and VISION CO., LTD.

60, CRAVEN PARK ROAD, HARLESDEN, N.W.10

Telephone : Hol. 6332.



The only
TRANSFORMER
that is good
enough for
TELEVISION

Type AF5. Price 30/-
Ratio 1/3.5. Inductance 265/75 Henrys

Every Ferranti Transformer is guaranteed to give a performance within 5% of the published curve, AND within 5% of every other Ferranti Transformer of the same type. Ferranti are the only transformers so guaranteed.

FERRANTI TRANSFORMERS

FERRANTI Ltd., HOLLINWOOD, LANCs.

London—Bush House, Aldwych, W.C.2.

A Selection of
WIRELESS, TELEPHONY &
ELECTRICAL ENGINEERING
BOOKS

RADIO ENGINEERING

J. H. REYNER, B.Sc., A.C.G.I.

VOL. III. of the ELECTRICAL ENGINEERS' DATA BOOKS, prepared under the editorship of E. B. WEDMORE, M.I.E.E., Director of the British Electrical and Allied Industries Research Association.

SYNOPSIS.—Radio Calculations and Measurements—Tuning and Radiation—Thermionic Valves—Radio Transmitters—Radio Receiving Apparatus—Design of Masts and Aerials—Telegraphy—Telephony—Miscellaneous Tables.

484 pages, 314 illustrations, 111 tables.

Net 7s.

ELECTRICAL INSULATING MATERIALS

H. WARREN, M.I.E.E., A.M.I.A.E.

Chief of the Engineering Laboratory, British Thomson-Houston Co. THIS book deals comprehensively with all the important Insulations used in the construction of electrical apparatus.

SYNOPSIS OF CONTENTS.—Natural Mineral Insulations—Mica—Mica Products—Asbestos—Slate and Marble—Basalt—Vitrified Insulations—Porcelain—Stoneware—Steatite—Quartz—Glass—Enamels—Moulded Composite Insulations—Sheet, Rod and Tube Insulations—Wood—Paper—Press-board—Fibre, etc.—Varnishes—Enamels—Paints—Cements—Filling Compounds and Mineral Oils—Treated Sheet Insulations—Sleevings, etc.—Wire Coverings.

516 pages. 158 illustrations, 103 tables.

Net 42s.

AN OUTLINE on AUTOMATIC TELEPHONY

WILLIAM AITKEN, M.I.E.E., A.Am.I.E.E.

Demy 8vo. With 42 diagrams.

Net 2s. 6d.

PRACTICAL TELEVISION

E. T. LARNER.

IN this book the early history and development of the attempts to transmit sight by radio are collected and discussed, with descriptions of all the principal apparatus. Mr. J. L. Baird has written a foreword to the book.

Demy 8vo. Fully illustrated.

Net 10s. 6d.

RADIO—BEAM AND BROADCAST

A. H. MORSE, A.M.I.E.E., Mem.I.R.E. (N.Y.)

A CRITICAL and constructive commentary on the actual development of wireless telegraphy and telephony.

Demy 8vo. Illustrated.

6s.

SMALL ELECTRIC GENERATING SETS

W. WILSON, M.Sc., B.E., M.I.E.E.

INTRODUCTION.—General Types of Internal Combustion Engine Sets—The Electric Circuit—The Secondary Battery—The Dynamo—Original Type of House Lighting Equipment—Automatic Features in Modern Plants—Starting the Engine—Reverse-Current Cut-outs—Regulation of Current during Charge—Cessation of Charge—External Power Supply during Charge—Automatic Starting and Signalling—Switchboards, Meters and Accessories—Engines, Belts and Couplings—Non-Automatic Sets—Semi-Automatic Sets—Fully-Automatic Sets—Consumption and Cost—Installation, Wiring and Management—Suitable Types of Load—Conclusion.

60 illustrations. 161 pages.

Net 18s.

A complete Catalogue will be sent upon application to:

ERNEST BENN LIMITED

**Bouverie House, Fleet St.,
London - - - E.C.4**

STYLE
H.T.9
METAL
RECTIFIER

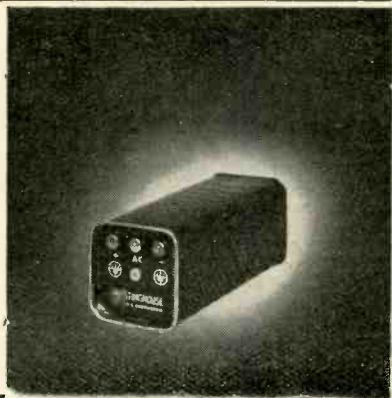

OUTPUT
300v.
60m.A
PRICE
21/-

"MEET THE NEEDS ADMIRABLY"

Mr. H. J. Barton Chapple, Wh.Sch., B.Sc., Technical Editor of "Television" uses and recommends

WESTINGHOUSE METAL RECTIFIERS

and says:—

"On the rectifier side, particular attention must be drawn to the metal rectifiers of Westinghouse. It is interesting to see that they are KEEPING PACE WITH THE TREND OF MODERN RECEIVER DESIGN, which demands higher and higher voltages, and the new models meet the needs admirably for television enthusiasts."

Write for full details, prices and circuits to:—

The Westinghouse Brake & Saxby Signal Co., Ltd.
82, York Road, King's Cross, London, N.1.

TELEVISION AT ● ITS BEST

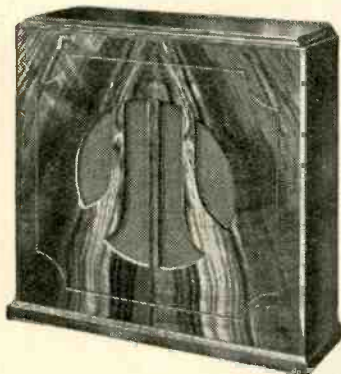

Here is one of the new Celestion models, the PPM, 69, a very sensitive speaker that has a remarkable brilliant tonal response. Housed in a cabinet of handsome design and including universal transformer Price £4. 5. 0 Oak. £4. 10. Mahogany and Walnut.

For the complete enjoyment of Television, music and speech must be reproduced with a life-like fidelity that defies all efforts to distinguish it from the original. Only by using a speaker that has proved its ability can you be certain of getting these results—such a speaker will be found in Celestion's range of PPM Speakers that give a quality of tone and sensitivity never before attained. For price and size there is a speaker to meet your requirements in the Celestion range—ask your local dealer to demonstrate.

CELESTION

The Very Soul of Music

LOUD-SPEAKERS

CELESTION LTD, London Road, Kingston-on-Thames.
London Showrooms: 106 Victoria Street, S. W. 1.

TELEVISION for October, 1932

TRANSFORMERS

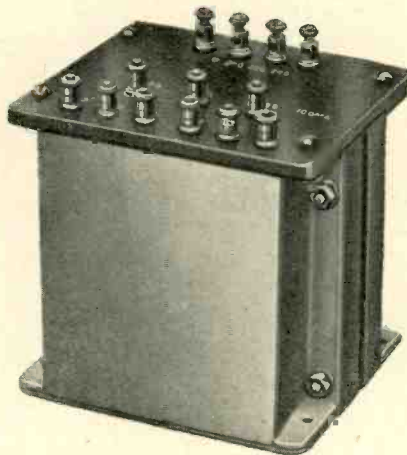

During the last 25 years we have
made over

100,000 TRANSFORMERS

ranging from 5 watts to 1,000 kilowatts output. We are equipped for the speedy manufacture of SPECIAL TRANSFORMERS OF ALL TYPES, and our Engineers are at your service for the design of TRANSFORMERS TO SUIT YOUR REQUIREMENTS.

FOSTER

ENGINEERING CO., LTD.,

Established 1903.

Apex Works, Wimbledon, London, S.W.19.

Telephone: Liberty 2211.

Smooth H.T. Supply is essential for TELEVISION!

The high efficiency and dependability of "M.-L." Power Plant assures users of smooth H.T. from any convenient current supply.

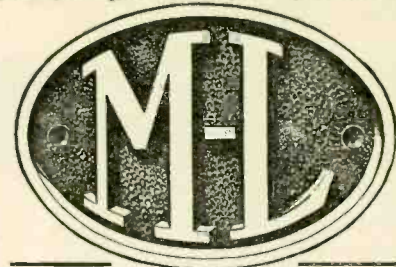

**RADIO & TELEVISION
POWER PLANT**

EXTENSIVELY USED BY
BAIRD TELEVISION CO.

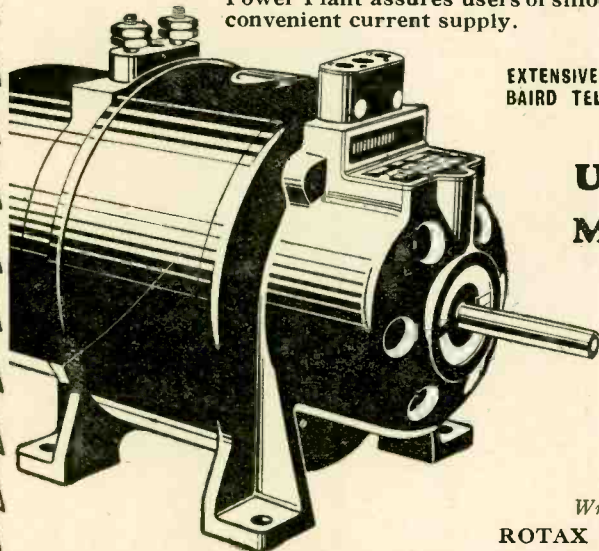

Used and Recommended by Mr. H. J. BARTON CHAPPLE

Wh. Sch., B.Sc. (Hons.),
(Technical Editor of "TELEVISION")

FOR

★ The operation of an A.C. MAINS DRIVEN TELEVISOR from D.C. MAINS or an L.T. BATTERY,
OR

★ The supply of H.T. Current of 100, 150 or 200 m.a. at 400v., 500v., or 600v. D.C. from D.C. mains or a 12v. accumulator

Write for an interesting descriptive Technical Booklet:

ROTAX LTD., RADIO DEPT. 13, WILLESDEN, N.W.10

BARCELONA
MOSCOW
JOHANNESBURG
MADRID
Etc., Etc.

Just a few of the many stations that can be received with your set when fitted with an Ealex Short Wave Converter.

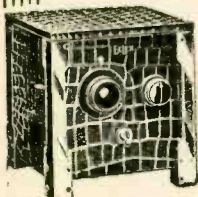

Write for list No. DD1

J. J. EASTICK & SONS
Ealex House
118, Bunhill Row,
London, E.C.1.

*Phone:—
Metropolitan 0314/5/6

70 EXTRA STATIONS!

With your present set you can increase your range of programmes by over 60 or 70 stations. Just put the Ealex Short-Wave Converter in front of your set and connect the Aerial and Earth terminals—no alterations necessary—and you will then get stations on the 16-60 metre band. Additional coils for the 60-120 metre and 140-190 metre bands can be supplied for 5/- extra.

One valve model 60/- (with valve).

All mains model (without valve) 65/-.

2 valve model (without valves) 85/-.

COLVERN—T.D. COIL

AN UP-TO-DATE COIL WITH UP-TO-DATE FEATURES

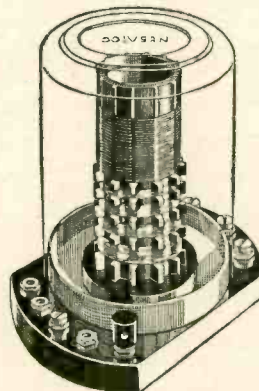

**TYPE
TD
PRICE
8/6**

Type TD, an entirely new Colvern Coil, designed to give super selectivity on both long and broadcast wave bands.

The coil is completely screened, giving a very neat appearance, and incorporates tapped aerial coupling and reaction, while the four alternative aerial tappings are arranged as sockets with a wander plug.

The first two tappings give aerial couplings similar to those normally employed, but with greatly increased selectivity.

Nos. 4 and 5 give a high degree of selectivity with weak aerial coupling—suitable for use in a "swamp" area.

A most important feature of this coil is that there is no break through on the long wave band from B.B.C. stations.

COLVERN LIMITED

MAWNEYS ROAD - ROMFORD, - ESSEX

Telegrams :
Benbroish Fleet
London

TELEVISION

Telephone :
City 0244
(10 lines)

Proprietors : BENN BROTHERS LTD.

Established 1880

Editorial, Advertisement and Publishing Offices :

Bouverie House, Fleet Street, London, E.C.4

(Closed on Saturdays)

SUBSCRIPTION RATES
13/6 PER ANNUM, POST FREE.
6/9 SIX MONTHS, POST FREE.
AMERICAN RATES
\$4.50 PER ANNUM, POST FREE.
\$2.25 SIX MONTHS, POST FREE.

MS. AND OTHER MATERIAL
FOR EDITORIAL CONSIDERATION
SHOULD BE ACCOMPANIED BY A
STAMPED ADDRESSED ENVELOPE,
AND SHOULD PREFERABLY BE
TYPEWRITTEN.

Contents October 1932

	PAGE
NOTES OF THE MONTH	279
THE B.B.C. PROGRAMMES : SPECIAL REVIEW	280
REPORTS FROM READERS	283
BRITISH ASSOCIATION AT YORK : MARCONI DEMONSTRATION	285
POINTS FROM THE PRESS	287
IS THE SCANNING DISC OBSOLETE ?	290
HOW TO CONSTRUCT A MIRROR DRUM	292
NEWS FROM ABROAD : UNITED STATES AND GERMANY	294
RETAINING THE HIGHER FREQUENCIES	296
" NEWS " BY TELEVISION : THE BAIRD PROCESS	298
A BEAT-FREQUENCY OSCILLATOR	300
THE ENTHUSIAST SEES IT THROUGH	302
FROM MY NOTEBOOK	306
LETTERS TO THE EDITOR	309
SUBMARINE TELEVISION	310
REPORTS ON APPARATUS TESTED	311
OUR FREE INQUIRY SERVICE	312

Index to Advertisements

Baird Television Ltd.	278	Lambert, H.	iii
Benn, Ltd., Ernest	274	Leaman, L.	ii
Celestion Ltd.	275	London Electric Wire Co. & Smiths Ltd.	ii
Classified Television Dealers	iv	Mervyn Sound & Vision Co. Ltd.	273
Colvern Ltd.	276	Miscellaneous Announcements	iii
Dossett Studio	iii	Rotax Ltd.	276
Eastick, J. J. & Sons.	276	Salter, J.	iii
Ferranti Ltd.	273	The Westinghouse Brake & Saxby Signal Co. Ltd.	275
Foster Engineering Co., Ltd.	275		

Praised by the Press

The most important advantage of the new instrument is that the image is reproduced on a screen 9 in. high by 4 in. broad, so that it can be seen by a room full of people. In the older model, in which the image was produced in a lens, not more than four people could see it at any one time.—*The Times*.

Improvements on the former television apparatus include:

An image which can be seen by a roomful of people simultaneously, instead of by only three or four persons.

Sufficient brightness of the image to make it visible in a room electrically lit, so that it is not necessary to put the room in darkness.

Compactness of the apparatus.
—*The Daily Telegraph*.

A new home "Televisor" receiver gave results of a quality and brilliance considerably in advance of any form of television I have seen.—*News-Chronicle*.

Television has arrived!

This is no wild statement, for yesterday I saw a practical and convincing demonstration of moving images on a screen that can be seen from any angle by any number of people.
—*Daily Mirror*.

The quality of the black and white image is very much better than the reddish picture produced by previous "Televisor" receivers. These preliminaries were followed by a cartoonist, who did some quick-action cartoons on large sheets of paper in view of the audience. Here again the results were remarkably clear.
—*Amateur Wireless*.

The image can be viewed without putting the room in total darkness. The new machine measures, when closed, 1 ft. 6 in. in length by 8 in. wide and 13 in. high. From the distance at which we viewed it the image appeared quite clear, the undesirable line effect not being noticeable.—*Electrician*.

Probably the most convincing television demonstration yet given in this country was staged by the Baird Television Company at their headquarters in Long Acre, London, W.C.2, on Thursday, June 30th, when *The Wireless World* was able to witness the new home "Televisor" receiver in action. Although the actual transmission was carried out on a short line between two rooms, it was obvious that if comparable results could be obtained by wireless the new instrument could guarantee genuine entertainment value.

—*Wireless World*.

We were considerably impressed by the "Televisor" receiver, the images being clear, and of the real entertainment value. The usual flicker does not seem to be quite so noticeable, while the up and down "float" of the image is slight. A great improvement lies in the fact that the "line" effect obtained with the old scanning disc model is entirely absent.

Programmes can now be seen in comfort by

a number of people at a time, and in black and white. . . . When we apply the acid test as to whether we ourselves would, at least for the time being, be satisfied with the results, the answer is in the affirmative.

—*Wireless and Gramophone Trader*.

The new Baird model is a remarkably fine piece of work.
—*To-Day's Cinema*.

I feel convinced that a real step forward has been made with the new apparatus.—*Wireless Magazine*.

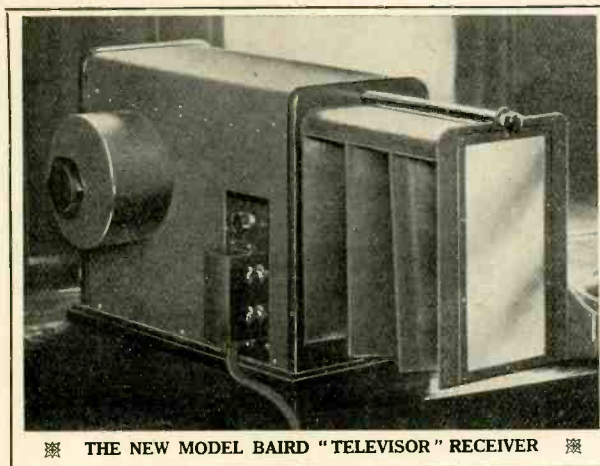

THE NEW MODEL BAIRD "TELEVISOR" RECEIVER

THE LATEST!

"TELEVISION TO-DAY AND TO-MORROW"

by Sydney A. Moseley and H. J. Barton-Chapple

TELEVISION'S BOOK OF REFERENCE

The new edition of this book is a veritable mine of information. It gives the only authoritative details of television as represented by the Baird process. Theory and practice combined in non-technical language suitable for the amateur.

PRICE 7/6 Postage 6d. extra.

Order now from

TELEVISION PRESS LTD., 133, LONG ACRE, W.C.2.

ADVT. OF

BAIRD TELEVISION, LTD.

133, LONG ACRE, LONDON, W.C.2.

Phone
Temple Bar
5401.

TELEVISION

The First Television Journal in the World

Publishers : BENN BROTHERS, LTD. *Technical Editor* : H. J. BARTON CHAPPLE, WH. SCH., B. SC

Offices : BOUVERIE HOUSE, FLEET STREET, LONDON, E.C.4

VOL. V. No. 56]

OCTOBER 1932

[IS. NET

Notes of the Month

THOSE of us who predicted that a big public was waiting for television, once broadcasts could be given at regular hours, have been amply justified in this view during the past month. The interest in television is already so great that it is difficult to realize that the B.B.C. transmissions began as recently as August 22. Every day brings us a fresh batch of Press cuttings showing not only that television is the most lively "news" of the moment, but also that the radio critics are beginning to look-in as a matter of course to this latest addition to the programmes. At the outset the B.B.C. was careful to explain that television was "feeling its way;" the programmes are still experimental, but the first few weeks have made it quite clear that television has come to stay at Broadcasting House and steady improvement is now assured.

* * * * *

Our special correspondent "Spectator" makes the interesting suggestion that a "surprise item" should be included every week. This was, of course, a regular feature of the early radio programmes, and while television is still at the elastic stage a similar item should be possible. We have already seen a great airman, and once or twice a month it would be appropriate to televise people or objects on which public is focussed at the moment. The Sunday evening appeal on behalf of charity would provide another opportunity for televising distinguished people, while at the same time enabling lookers to use their vision sets at an earlier hour than is available on week-days.

* * * * *

Critics of television are fond of stating that people do not want to look at the orchestra to enjoy wireless music. In the ordinary way they do not; but in listening to a great pianist or 'cellist there is a distinct advantage in seeing the

artist as well. Anyone who watches Kreisler is impressed with his quiet and very modest manner, which is so much in keeping with the superb quality of his performance. Music cannot be entirely divorced from its interpreter. This is particularly true of singing, and a correspondent confesses that when his vision receiver went wrong one evening in the middle of a programme, the singer failed to appeal any longer. "Having seen and heard her, hearing alone failed to satisfy," he writes. "That feeling of deprivation—a sense of missing something—is going to make many converts now that programmes are broadcast on four nights a week."

* * * * *

The ideal word to correspond with "listener" has still to be found. A good suggestion is "watcher," but it generally implies a special or unusual effort, such as setting watch for a rare bird—or a burglar! Television will gradually become a normal part of radio entertainment and a word is wanted that will do for all time. Another reader suggests "teleshower," but this again is not ordinary enough for general use. We understand that the broadcasting authorities are inclined to favour "looker," as it corresponds with the verb at present most commonly used in connection with television.

* * * * *

We are glad to draw attention to the first autumn meeting of the Television Society, which will be held at University College, on October 12, at 7 p.m. A description of the television apparatus shown at the Berlin Radio Exhibition will be given by Mr. E. H. Traub. The lecture will be of special interest to those who read the account of the Exhibition in our September issue, in which the new daylight television equipment was described. Further particulars may be obtained from the honorary secretary, Mr. J. J. Denton, 25, Lisburne Road, London, N.W.3.

Last Month's Programmes

By "Spectator"

"THERE is more genuine variety in the regular television sessions than in the rest of the programmes put together," writes a radio critic of a London evening journal, in a gush of wrath engendered by the absence of contrast in B.B.C. programmes. Although inspired by irritation, an obvious truth underlies his remark. Television is two-dimensional entertainment and when a programme builder can appeal to the eye as well as the ear, his range of choice is at once extended. Conjurors, dancers, cartoonists, jugglers and animal acts all find a place and greater variety follows.

Now that the first month is past, the B.B.C.'s work for television can be assessed and all the evidence points to the conclusion that the broadcasters are seriously attempting to popularise the new science. Ingenuity and enthusiasm are at work and a high standard of artistic performance has been achieved.

Jim Mollison

Lingering doubts of the sincerity of the B.B.C.'s intentions for television were dispelled by the announcement that Jim Mollison would not broadcast until the late hour of 11.0 p.m., when he would also be televised. Millions must have been kept from their beds in order that this national figure might be seen by the few as well as heard by the many. They retire early in Glasgow, Mollison's birthplace, and it needed courage on the part of the B.B.C. to keep them waiting till 11.0.

From this point, it was clear that the B.B.C. meant business and the variety and quality of its programmes have since shown that it is determined to explore every possibility of the art.

In the direction and production of the programmes, Sir John Reith is well served by Messrs. Gielgud and Robb. Much that is new has been added to drama and light entertainment since Val Gielgud was appointed Productions Director three and a-half years ago. Always ready to experiment with new ideas, he has never been reluctant to discard methods that have failed in practice. To produce television programmes successfully a man must be conscious of the present limitations of the medium and must believe implicitly in a future for the art. While not overlooking the facts of the situation, Eustace Robb is continually looking ahead to the time when larger images will be presented with greater

definition and a wider range of movement. With Val Gielgud directing and Eustace Robb producing, development will be rapid.

A blue lamp was used in the projector for the first time when Jim Mollison and Amy Johnson came to the studio. Jim declined to make up; but thought that Amy would like to look her best. Despite fame and scorching publicity, Amy Johnson retains a soft, restful charm, and though she photographs badly, she televises well. She wore a black dress with white facings—colours that are always recommended for the televisor on account of the need for contrast. Her Northern accent gives homeliness to an undistinguished voice and her "Come on, Jim" and wistful smile must have melted many hearts as she drew her husband into the picture. Unaffected pride and simple pleasure were clearly reflected in her face by the check-receiver in the projection room, while her husband stood phlegmatic and unruffled beside her in the flickering beam of light.

There is a Napoleonic quality about Jim Mollison. Short and square, but not heavily built, with hair parted low one side and draped over the forehead at the other, immobile features and a steady stare. The illusion would have been complete had he followed directions and placed his arm across his chest to cover his shirt-front. He spoke fluently, unperturbedly, and without a note, for five minutes.

"Afternoon Dress Essential"

A new technique is developing in the twilight of Studio BB and details of dress count for a lot. The gleam of starched linen presents a problem and heroes of the future may find their invitations marked "Afternoon dress essential." Hours have been spent in dressing ventriloquists' dolls, and black paint for Joe Young's tops that spun before a white screen was only chosen after elaborate tests. For the ex "Yo-Yo" champion a cinematographic effect was employed. The top was first shown as a large blob in the foreground of the picture. It then retreated slowly, taking shape gradually as it came into focus before the sheet.

A cat found by the producer in a mews near Rutland Gate, figured in the programme the day after the capture of "Jemima," a wild cat left behind in Portland Place by workmen employed in building Broadcasting House. "Jemima" had

meowed its way to fame by interrupting a concert given in the National programme one Sunday evening and had only been secured after a hot chase by a squad of twelve men in a basement corridor at the B.B.C. building. This impersonation of "Jemima" introduced an element of surprise that is welcome in any programme and showed that those responsible for the transmissions are alive to the value of topicality as a stimulus to interest. The cat's performance came as a fitting climax to days of publicity that had served to make the public feline-conscious.

Now that this incident has demonstrated the utility of surprise, the television producer should consider including each week an item having a novelty appeal. For many months the "Surprise Item" was a regular feature of the main programmes. It was dropped after an exhaustive test because of the difficulty in obtaining highly topical material at a fixed time each week. This difficulty would not occur with the television period because programmes are as yet elastic, which is in itself a virtue. In many cases artists are not engaged until a few days before their appearance and so it would be possible to bring any person or object to the televisor at short notice without dislocation of long-standing engagements.

There is no reason why the subject once or twice a month should not be the individual or thing upon which public attention is focussed for the time being. It could not always be a Mollison; but these are early days and the taste of "lookers" is not yet exacting. The experiment would be worth trying. For instance, some months ago an appeal was made to secure the Portland Vase for this country. The Vase was a piece of rare value and beauty that few of the public had seen. An exhibition by means of television with an explanation by an expert would have made the Vase

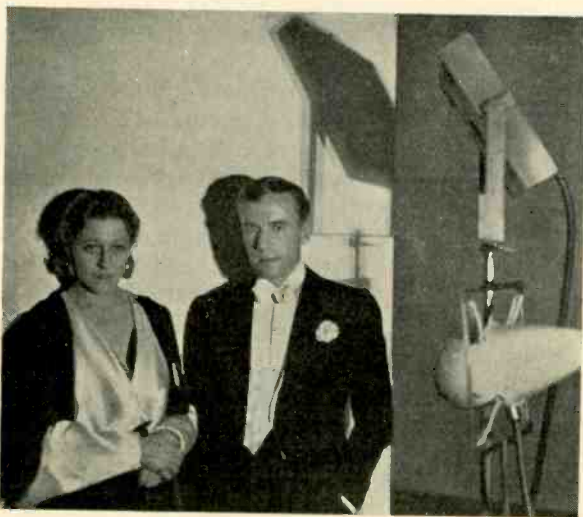

Jim Mollison declined to make up but thought that Amy would like to look her best. She televises well.

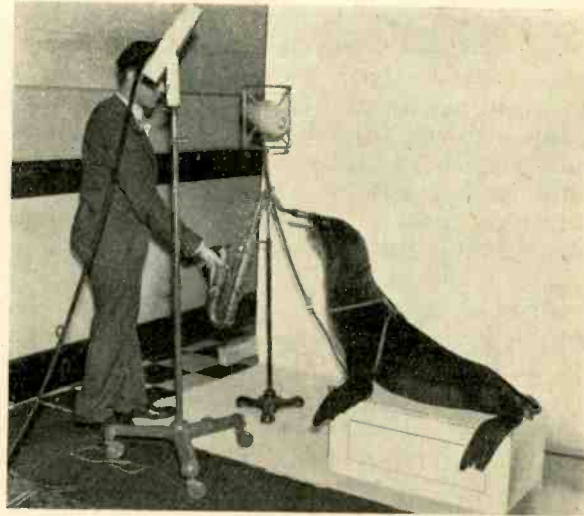

"Pal," the sea-lion, gave an impeccable performance. He was not rehearsed owing to a temperamental objection.

more widely known and would have helped to swell the fund.

It has not been possible for me to be present in the studio for every transmission; and on several evenings I have sat at home looking and listening. One evening, half-way through the programme, as the result of a temporary defect, I was deprived of my "vision." Betty Bolton was singing. Her numbers were good; she has a snappy style and her turns in ordinary programmes have frequently given pleasure. But that night, when I could no longer see her, the act failed to appeal. I was irritated and gave up listening, though I am sure she was in her usual good form. Having seen and heard her, hearing alone failed to satisfy. That feeling of deprivation—a sense of missing something—is going to make many converts now that programmes are broadcast on four nights a week.

For the early transmissions from Broadcasting House, it was natural that the B.B.C. should call upon artists with experience of television conditions. Cyril Smith, the accompanist, who worked so hard in Long Acre, is still heard, though rarely seen. Pioneers of earlier days who are now seen in the programmes include Betty Bolton, soubrette and brunette; Betty Astell of the fair hair and pretty voice; and John Rorke, who always gets a laugh from me with his "Up I came with my little lot."

The "effects" people put in some good work for Max Templeton's shadow-show. Max makes that mouse positively live, and the screech as he tweaks its nose is as near to the real thing as any effect that I have heard. The shadow is obtained by placing the artist in front of the projector and the light casts his shadow upon the "extended" or distant white screen that is used for full figure work. The photo-electric

cells are placed behind the artist and thus pick up only his shadow from the screen. Silhouettes of Fred Douglas, used with telling effect for his coon songs, were projected by the same method.

Louie Freear has been engaged for a vaudeville programme following her television debut. This veteran artist is one of Eustace Robb's greatest successes. Her funny face, comic figure and hearty patter makes an irresistible combination. Of all her songs, I choose as best "Sit back, hold tight, Mary's going to sing." It is no criticism of Louie Freear to say that she cannot be so good without television to accentuate her talents. It is a moot point whether she is well-advised to undertake a broadcast without "vision." Gillie Potter, like Sir Harry Lauder, gets his effect with his voice; but George Robey needs to be seen. And, B.B.C., now that television is here, why should we not be allowed to have this artist?

A classical night towards the end of September catered for an audience that had not previously been touched by television programmes, and the inclusion of Adila Fachiri marked a step forward. This great concert artist gave the superb performance that music lovers expect of her. She was quite untroubled by the wavering light in the semi-darkness. Let us have Suggia next. By the way, to face up to the glare of the projector, is not nearly so disconcerting as it appears. No artist, however temperamental, need be unnerved. Laurie Devine prefers it to a spotlight. A clever dancer, this, and so versatile that onlookers could have more and not tire of it.

I have never been able to decide whether I preferred Peggy Cochrane to sing, fiddle, or play the piano, but she made it easier for me when she sang to her own accompaniment on the violin for the first time. "Oo, that kiss" and "Gosh, Darn" were sung by Jane Carr, but I forgave her because she looked so charming. This young star of the screen and radio likes televising and asked whether she could come and sing again. She will.

Blondes or Brunettes?

Jane Carr is very fair, of course, but Eustace Robb was non-committal when asked whether the televisor preferred blondes or brunettes. It does not matter, but features should be well-defined. Make-up helps. Willy Clarkson says it must be heavy, and dark blue paint is used. Smears on the sides of the nose lighten that feature when it is too heavy. No professional dresser is employed at the B.B.C. and artists often bring their friends and relations to help. Large dressing rooms decorated in black and red by Raymond McGrath, are situated across the passage from Studio BB. Who would have guessed that the

head-dresses worn by Ray Wallace for her imitation of Vesta Victoria and Marie Lloyd were made on the spot from black and white paper? For her next appearance she is making a "Connie Ediss" hat from a hat shape and ostrich feathers.

Ralph Coram is another good mimic. I thought his make-up as Albert Chevalier better than for Charles Coburn, though he certainly sang "The Man who Broke the Bank at Monte Carlo" in Charley's own but evidently not imitable way.

A Gala Evening

The Japanese night was a gala evening and five Japs squatting in black and white costumes on straw mats and squawking presented an unforgettable picture. Nothing of Wuriu's dance, "The Spirit of the Snowy Heron," was lost on the check receiver; Kendo, that is, fencing with poles, obviously better suited to the medium, had greater definition than the ju-jitsu performance. Altogether an entertaining and amusing evening, worth repeating.

Gambarelli, who was the first artist to broadcast from the Jenkins television studio in New York, knew her business and how to dress for it. Robert Algar was right to bring his rough-haired terrier, which added colour to his song, "The Gay Highway."

For a moment I feared that Max and Harry Nesbitt would falter in their song when a full-throated "woof-woof" startled everyone in the studio during their act. It was Pal, the sea-lion, expressing gratitude for his safe delivery from the lift outside. He gave an impeccable performance, much to his credit, for he was not rehearsed owing to a temperamental objection. After each effort he was rewarded by herrings thrown by Mrs. Dixon, and later breathed fishily and affectionately upon the announcer, who recoiled instantly.

Now for a word of criticism. Something has got to be done about that piano. The majority of turns have a piano accompaniment and the continual rum-tum-tum of this single instrument becomes monotonous. Occasionally an accordion and a saxophone have been heard, and once or twice drumbeats have marked the rhythm of a dance. More variety is necessary here. Ever since those good American artists, Fairchild and Lindholm, popularised the use of two pianos, several years ago, two instruments have generally been played for supporting light studio entertainment. Listeners have grown accustomed to the heavier tone and must be irritated now, as I am, by the tinkling of one piano, and surely, for outstanding programmes a quintet or small saxophone or tango orchestra might be

employed. The size of studio BB limits any musical combination to five or six, now that screens, photo-electric cells and other gear must be accommodated. The period of reverberation of the studio is 0.85 seconds, which renders it suitable acoustically for octets and dance bands. Let us hear them.

In case it should be argued that expense prohibits the employment of such musicians, it may be recalled that musical combinations of a high order play from time to time in the Children's Hour which is able to engage performers who are already at the studios for shows that precede or follow the children's period. In the same way members of orchestras in the evening programme could be recruited for the television transmissions. Many would be willing to stay on for half-an-hour for a reasonable fee. It may be said that these artists are not always suitable for visual transmission. But who would deny that such romantic figures as Val Rosing and Gershom Parkington would be acceptable? It is neither necessary nor practicable to transmit the image of the whole band.

Screens and other apparatus inseparable at present from an eye-and-ear transmission complicate the task of securing a good acoustical balance, especially when an artist moves from a close-up to extended vision, but practice has overcome an unevenness that was audible at first. The arrangements are not ideal for controlling the sound transmission which is handled by an engineer in the control room remote from the studio. This engineer has no facility for looking and is expected to control the volume of sound without a vision receiver in which to see what is happening in the studio. Sometimes he must be puzzled as sounds fade away without apparent reason. These are early days, finesse will be added later, and defects will be overcome.



The ju-jitsu experts who took part in a recent television performance from Broadcasting House.



Nothing of Wuriu's Dance, "The Spirit of the Snowy Heron," was lost on the vision receiver. An entertainment worth repeating.

As with the main programmes, so with television, the B.B.C. is working much in the dark and it would like to hear from listeners and lookers how they react to the programmes. Indulgence is not asked, and criticisms, if constructive, will be welcomed. The first month's programmes have set a reasonably high standard and lookers may rely upon the B.B.C. to improve upon it as time goes by. Making allowance for the embarrassment caused by the accommodation and the necessarily brief preparation, the result can only be described as a triumph of ingenuity by one who has watched the patient work and painstaking care of detail of a staff that has been tested to the point of exasperation by new and difficult conditions of work.

Reports from Readers.

Reports that the new B.B.C. television programmes are being received satisfactorily have reached the editor from readers in various parts of the country, including Essex, Cheshire, Northumberland, Warwickshire, Hertfordshire, and also from the Continent. Some of these letters are given below and on other pages, and the report from Paris reproduced in our "Enthusiast" columns is of special interest.

This Month's Prize

A free subscription will be given every month to the reader who sends the most interesting comments on the programmes, and the prize for September is awarded to Mr. D. R. Parsons, of "Cartref," Shenstone Court Drive, near Tichfield, for the following letter:—

"The transmissions are definitely a big

improvement on the old Baird transmissions from Long Acre, due no doubt to the long experience with which the B.B.C. producers have had in giving entertainment. The means of presentation, both in the 'giant shadow effect' seen before the artist appears and the way the televising apparatus follows the performers about together with the novel idea of making the artists come on and bow at the conclusion of the half hour, makes the television broadcast of definite entertainment value which is, after all, what is desired by the general public. Although fading is experienced some nights here in the Midlands, on good nights it is obvious that there is much more detail in the images than previously. Ghost images on two occasions have been very predominant, up to six images being seen, one behind the other.

The Sea-Lion

"The artists have been excellent and particular mention must be made of our old friend Rupert Harvey, the cartoonist, also Max Templeton for his marvellous shadow graphs which are excellent for televising. The best evening's entertainment so far was on September 2, for two outstanding reasons. Firstly, the idea of showing Max and Harry Nesbitt playing their ukeleles, one behind the other, was excellent and made the best of the oblong 7 x 3 ratio; secondly, the televising of Dixon and his Pal was the most outstanding turn I have seen. To see his wonderful sea-lion clapping hands and balancing a ball on his nose while roaming about the floor of the studio was a sight not to be missed. But the yo-yo player, Joe Young, was, in my opinion, not a suitable subject for televising as there is not a lot of amusement in watching two outstretched hands and two small black objects! Incidentally, the black and white check floor of the studio comes through excellently."

Other readers share Mr. Parsons' view that the performing seal was one of the most attractive items so far televised from Broadcasting House. Mr. T. Payne, of North Gosforth, Newcastle, writes:—

"The novel nature of this programme was greatly appreciated. The performing seal was seen very well indeed doing its various tricks, such as playing an instrument, applauding itself and balancing the ball. The two comedians also came through very clearly, the stout one seated and the other standing behind him. Their collars and ties were very distinct.

"Recent transmissions have been somewhat spoilt by atmospheric disturbances, morse signals and interference from the Leipzig and Moravska-Ostrava stations, but thanks to a marked diminution in atmospherics on September 26, the

classical concert that evening was excellently received.

"The programme opened with a harpist, and the two colours of the harp post stood out most prominently throughout the entire transmission. Whilst the harpist was playing, the picture remained perfectly steady and needed no alteration for synchronising. The movement of the player's left hand was very distinct. Miss Adela Fachiri, playing a violin, was also excellently seen. She appeared to be wearing a rather large ring on the third finger of the bow hand. The violin was very clear, apparently its colour was light yellow, which contrasted very well against the black finger board and tail piece.

"The lady dancer who followed came through particularly well in her second number, in which she did a large amount of posing and reclining on the floor. The finish of this act, with the lady lying on the floor and the Chopin musical accompaniment made a very effective picture.

"The lady singing two Old English songs was very distinct. She was wearing a close-fitting dress and what appeared to be a wrist watch or bracelet, and her necklace could also be seen."

A suggestion for improving the effect of full-length scenes is made by Mr. H. Awcock, of 296, Essex Road, N.1, who reports:

"The vision from London is on the whole all that can be desired, but I think still better results would be obtained if, in the extended view, the artists were to keep a pace or two nearer the projector and try not to run off the picture. The close-ups are really good; one can even see the pupils of the eyes of the performers. "Nigger" turns are not quite the right stuff for the screen as all the detail of the features is blotted out.

"We have in the past enjoyed watching several plays. Can these be put over again, with a picture puzzle or a film now and again? Dance bands we have seen and can do without as they are not animated enough. Sketch artists are very interesting so long as the artist's shadow is not thrown across the picture in the making; the interest lies in seeing it grow. Last, I think we need a black spot or screen to watch while changing over to let us know we are still there."

Future Programmes

Further reviews of the B.B.C. broadcasts will be published in the next issue of TELEVISION. Television programmes are broadcast every week on Monday, Tuesday, Wednesday and Friday from 11 to 11.30 p.m. Vision is transmitted from Brookman's Park on 261.3 metres, and the accompanying sound is transmitted from Daventry on 398.9 metres.

British Association at York

Demonstration of Marconi Apparatus

THE Marconi "news" transmitter, described recently in TELEVISION, and other television apparatus was demonstrated for the first time during the meeting of the British Association at York last month. Television images were transmitted by wireless from the Marconi Works, Chelmsford, to St. Peter's School, York, a distance of 180 miles. The wireless demonstration took the form of sending verbal messages from characters printed on a moving tape, which was passed through the transmitter at Chelmsford at speeds corresponding to 60 words per minute and upwards, the words being read like a moving sign on a ground glass screen in the receiver at York. Demonstrations illustrating the complete process were also given to several groups of scientists at St. Peter's School.

Three different types of television receivers installed at York were inspected with particular interest. These were the television "news" receiver with its ground glass screen 25 inches by 3 inches for the reception of printed messages, the television "broadcast" receiver giving a moving picture on a screen 8 inches by 8 inches, and the television "projector" receiver which is capable of throwing a moving picture on to a white screen four feet square. The following information issued by the Marconi Company describes these instruments in detail.

The television signals were received at York on 750 metres by means of a simple type of radio receiver designed to have a very broad frequency response curve. The receiver consists of one stage of high frequency magnification, anode bend detection and one stage of low frequency amplification. The output from this receiver was taken to a power amplifier for use on the 15-line

tape scan "news" receiver. This gives a picture on a ground glass screen 25 in. x 3 in. A sodium tube of the dumbbell type is mounted close to an aperture, the modulated light being projected on to the screen by means of a mirror wheel, driven by a synchronous motor and giving a horizontal scan. The speed of the mirror wheel is 1,200 r.p.m. and gives 20 pictures per second.

Synchronism is effected by a synchronising amplifier A.C. mains operated and consisting of two valves with large power output. This amplifier is connected so as to follow the second stage in the television signal amplifier.

The 50-line "broadcast" receiver gives a picture on a ground glass screen 8 ins. x 8 ins. A similar sodium tube is used as on the 15 line receiver, the light is projected on to the screen by means of a mirror wheel driven by a synchronous motor and giving a horizontal scan. The speed of the mirror wheel is 900 r.p.m. and gives 15 pictures per second. Synchronism is effected by the same amplifier as is used for the Television "News" Receiver.

The 50-line "projection" receiver gives a picture on a white screen 4 ft. x 4 ft. The light source is an arc modulated from a Kerr Cell

and is projected on to the screen by a mirror wheel driven by a synchronous motor giving a horizontal scan. The speed of the mirror wheel is 900 r.p.m. and gives 15 pictures per second. Synchronism for this motor is effected by another synchronising amplifier similar to that used for the sodium receiver, and is connected to follow the second stage in the amplifier modulating the Kerr Cell.

The "News" 15-line transmitter, which was in operation at Chelmsford, is designed to modulate any high class radio transmitter in such a way

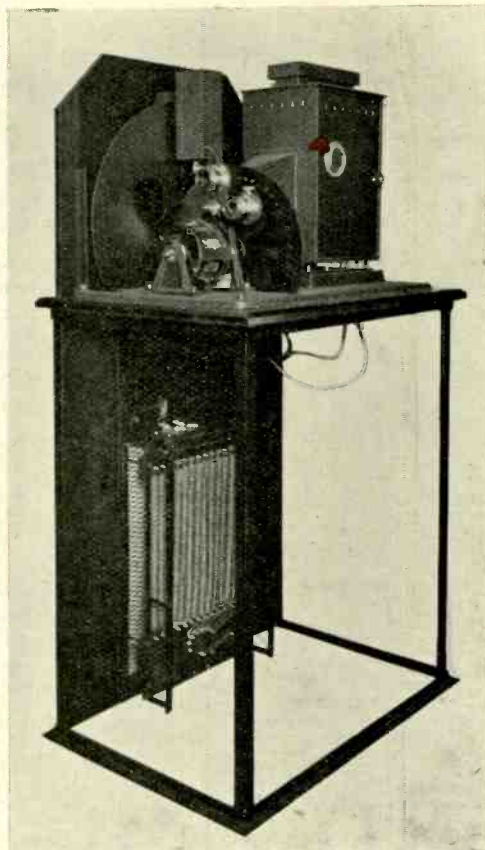

Scanning device for the Marconi 50-line "Broadcast" television transmitter.

that images of characters printed on a semi-transparent tape can be received by a suitable receiver. This equipment was fully described in the July issue of TELEVISION.

The television "Broadcast" 50-line transmitter which was in operation at York, has been designed to enable television pictures of moderately good definition to be transmitted at the rate of 15 per second from any high-class transmitter.

Four Circuits

In addition to the scanning apparatus, photoelectric cell, and amplifier system, circuits are provided (a) for maintaining the motor driving disc at a constant speed; (b) for generating synchronising impulses which are passed to the receiver and there synchronise the receiver motor with the transmitter motor; (c) for "monitoring" the transmitted picture, i.e. checking the type of picture being transmitted; and (d) for control purposes.

The scanning machine comprises two Nipkow discs, motors for driving the discs, two projection lenses and an arc lamp. The transmitting disc proper is constructed of thin aluminium sheet which is punched with 50 square holes .45 mm in size. These holes or apertures are arranged round the disc in the form of a spiral and are spaced at 7.2° apart, each hole differing from the preceding one in radius to the centre of the disc by exactly its own width.

The disc is driven directly from an $\frac{1}{8}$ h.p. synchronous motor which is driven from a D.C. supply of 100 volts and maintained at a constant speed by a separate A.C. supply. At right angles to the transmitting disc is a second disc which is used for the purpose of "monitoring" the transmitted picture. This is driven by a second motor which is kept in strict synchronism with the motor driving the transmitting disc.

The arc lamp is "hand fed" and is equipped with a hemispherical reflecting mirror. It is situated directly behind the disc and projects a beam of light on to the top vertical centre of the disc, forming an illuminated area sufficient to embrace 22.5 mm. square corresponding to a 7.2° arc which forms one picture. The holes in the disc pass through this illuminated area and the light passing through the holes is thrown on a screen through one of the two lenses, the apertures in the disc being focussed on to the subject which is placed in front of the screen and in the light beam. Alternative lenses are provided for use when scanning a full length figure or when a close up of a head is being transmitted. The "full length" lens has a focus of $3\frac{1}{2}$ ins. with F.2.75. The "close up" lens has a focus of 2 ins. with F. 1.8. The lenses are mounted on arms and are selected by a simple swing-over

device. A movable frame is fixed between the disc and the lens for the purpose of adjusting the length of traverse of the light spot so that the end of one scan is immediately followed by the beginning of another.

The monitor disc is larger in size than the transmitter disc, the aperture dimension being .75 mm. This being used for the purpose of check reception, is equipped with a neon tube having a flat plate some 4 cm. square which is placed behind the disc and vertically above the disc spindle. This plate, when luminous, lights up an area of the disc corresponding to one picture area. A viewing lens and holder is mounted in front of the disc for the purpose of magnifying the image and cutting out extraneous light.

The line amplifier is a simple resistance capacity coupled unit employing 5 valves, 4 of which are in cascade, the last two being paralleled off, one to the line output transformer and the other to the monitoring amplifier. This amplifier has a substantially straight line frequency characteristic from 50 to 18,000 cycles, the normal fall-in level at 9,000 cycles of a resistance capacity coupled amplifier being extended by the use of an air-core choke in series with the anode of the first valve. Gain control is supplied for the amplifier as a whole and for the monitoring valve separately.

The monitoring amplifier is used for the purpose of checking the radiated picture against the line picture. The line signal is tapped in the line amplifier and is magnified through three resistance capacity coupled stages to the output valve which is choke coupled to the neon tube behind the monitoring disc. The amplifier also contains a radio frequency circuit consisting of a band pass filter and anode bend rectifier. A simple switch cuts off the line signal from the first valve grid and connects it to the detector output, by which means the line or radio signal may be observed in the monitor neon tube.

Tests with Australia

Tests which have been in progress for some time between this country and Australia, have been carried out between the Marconi Company's own experimental station G2BS at Chelmsford and the Sydney station of Amalgamated Wireless (Australasia) Ltd. The B.B.C. Imperial Broadcasting Station G5SW, which is also situated at Chelmsford, has not been concerned with these tests. The Marconi Company's station G2BS is a beam station, and for the television experiments has had its signals directly projected towards the Sydney station, while G5SW is a short-wave non-directional broadcasting transmitter.

Points from the Press

Critics Look to the Future

THE Press throughout the country is following the progress of television with interest. The leading daily papers continue to devote much space to recent developments, and the radio correspondents are mostly enthusiastic. Mr. Harold Watkins, of the *Daily Mail*, looks forward to seeing television repeat the history of broadcasting—expanding in interest every year. Television, he writes, is earning a larger show of general wireless interest. “Now that there is a television studio at Broadcasting House and the television programme arrangements are in the B.B.C.’s own hands, it has assumed a much greater importance. Because there is no separate television receiving licence, no one can accurately estimate the number of looker-in there are to-day, but there are sufficient to form a handsome nucleus for the millions of to-morrow.”

“Everyone admits the possibilities of television’s future, but at present it is being held back by at least three factors: the need for still better television receivers; the lack of an adequate and sufficiently cheap supply of the latest types so far developed; and the necessarily short periods when wavelength can be spared by the B.B.C. for television programmes. As for the first, research is going on in more laboratories and workshops in the country than most people suspect. I have heard rumours of new systems that are being developed and are almost ready to see the light of day, and impending improvements in existing systems.

Probable Developments

“So far as the provision of the new sets is concerned, I am told on good authority that a number of firms here are working on the production of a receiver which will embody the necessary double radio receiver as well as the vision apparatus. At least one firm had expected to exhibit such a set at the recent exhibition, but was not able to complete it in time. Programmes will be available when there is sufficient demand for them. The B.B.C. has adopted television officially and is watching its development with the greatest interest.

“At present television is rather a luxury for the few, as the apparatus, compared with a simple wireless receiver, is necessarily rather expensive. On the other hand, one should bear

in mind that only ten or twelve years ago the most elementary crystal set—crude receiver as it was—cost from £5 to £10.”

The wireless talk relayed from a submarine tank off the Bahamas by Dr. William Beebe leads the *Sunday Times* to foresee the day when events of this kind will be seen as well as heard by radio. In a leading article entitled “Adventurers All?” this newspaper asks what will be the effect of this development on mankind.

From the Depths of the Sea

“From down in the depths the marine explorers bring back awesome and glowing tales which directly touch the imagination of all of us—luminous sea-monsters, and creatures for which names have not yet been found, steering mysterious courses through the inky waters, carrying their own illumination with them. Not only so, but while they were engaged in their perilous experiment the explorers maintained contact with the surface, and broadcast to millions of men and women sitting by their firesides the sights which their eyes were the first among human kind to behold. Soon, with television, every man will be able to be his own explorer, to scale Everest, to tear a way through untrodden jungle, to penetrate the Black heart of the sea, with all the thrill and none of the danger and fatigue. Will it inspire the human race to be more adventurous—or will it make us intolerably lazy?”

Under the title of “Television Nearing its Triumph,” the *News of the World* comments on a proposal of some of the West-end sporting clubs to televise greyhound racing. “The scheme is based on the progress that has been made in television since the experimental and successful broadcast of this year’s Derby, and now the engineers are confident that the spectacle of greyhound racing by television can be accomplished without difficulty. The sporting clubs have quickly realised the possibilities of this scientific success. The clubs are already equipped with totalisators and tape machines. Only one essential is missing—the thrill of seeing the races run. Television is going to supply the spectacle.”

A television expert stated in an interview with this newspaper: “The process of transmitting a greyhound race by television to a screen in a



POTENTIALITIES OF TELEVISION.

Voice. "DOCTOR I DON'T FEEL WELL AND I'D LIKE TO SHOW YOU MY TONGUE. LOOK!"

(Reproduced by permission of the proprietors of "Punch.")

West-end club is not impossible; in fact, it is a development of the early future. Transmitters, which resemble a portable cine-camera in appearance, could be installed at various points on a greyhound track, and the races recorded on the receiver at the other end. The method would be to lay a land line from the track, and by a series of ultra-short waves transmit the picture to the screen. The fact that greyhound racing takes place in a small space would facilitate reproduction of a complete picture of any event from start to finish, and watchers of the screen would see quite clearly how the dogs ran."

There can be no doubt, says the Bournemouth *Times and Directory*, that many more people are interested in television than was the case a year or two ago. And this, despite the fact that many of the technical wireless papers have done their best to discourage this interest.

"Buying a television apparatus is not a task which one would undertake light-heartedly and consequently those who own such apparatus take good care that they know what they are getting before they put down their money. Therefore, I can see no justification for the statements that listeners have bought television sets expecting great things and have been disappointed. The elaborate arrangements which have been made

by at least one big London firm for showing apparatus under working conditions makes it most unlikely."

There is clearly a keen interest in television in the North of England, and enthusiasts are anxious to know more about "this new and fascinating science." The wireless correspondent of the *Daily Dispatch*, Manchester, suggests that the B.B.C. should arrange a talk, "to give listeners some idea of what is expected from the experiments now being carried on." Northern listeners are quite entitled to ask, he says, how long it is going to be before they are put on the same footing as their fellows in the South of England. What is being done about the tests conducted some time ago with a view to sending out vision broadcasts from Moorside Edge? Does the B.B.C. intend eventually to extend its broadcasts to the Midland, Scottish, and Welsh Regional stations, or is London to have the monopoly of television reception?

"Having gone so far as to take entire charge of the television programmes, the B.B.C. ought, I think, to explain something about its future plans and projects in connection with this important branch of radio science. The subject is one of considerable importance, now that a proportion of licence money is being spent on artists

to take part in the broadcasts, and if the B.B.C. would take listeners more into their confidence on the subject it would materially stimulate interest in the many sides of television. Incidentally it would be beneficial to the manufacturers who are engaged in the production of the receiving instruments to know where they stand. A well-balanced statement about the possibilities and limitations of vision broadcasts would do something to place the new science on a sound footing."

In Full Stride

Discussing "Television in Full Stride," a correspondent of the *Manchester City News* describes the reception of the B.B.C. transmissions as "so astonishingly good" that he expects "a revolution in the radio world within a year." Nobody, he says, will be content simply to listen if he can see as well, "and see so clearly, so minutely and so amusingly."

A television transmission "as clear as an ordinary talkie" has been received in Ireland, according to the *Dublin Evening Mail*.

Commenting on the televising of Mr. Mollison, the *Northern Echo* says that "the fact that this important feature of the programme was entrusted to the television experiment seems to indicate a much greater faith in the system. "There seems little doubt that the events and people included in this section of the programme will become more interesting and more ambitious." Mr. Mollison was also heard "clearly and distinctly" by the *Western Mail* correspondent, and both the broadcast and the television transmission were regarded as "completely successful."

Television enthusiasts in the West of England are anxious for local transmissions from the Plymouth station. The *Western Evening Herald* describes the fact that there are only a few television sets in Plymouth as "an amazing situation in view of the intrigue and fascination of this embryonic science. It must have the support of local transmissions of the programmes



The sea-lion at Broadcasting House, as seen by the well-known artist Mr. Arthur Watts. (By courtesy of the *Radio Times*).

received from London." This is confirmed by Mr. W. H. Axworthy, of Messrs. Axworthy & Co., Ltd., radio dealers. "It is high time the Plymouth station started to relay the television broadcasts from London," he said. "Television is an accomplished fact. There is nothing wrong with the Baird system. We are able to receive on our televisors in Plymouth the programmes broadcast at night from London with fair success. But if they were relayed through Plymouth there would be no difficulty at all."

Referring to the televising of the sea lion and other animals which have already performed in Broadcasting House, the *Nursery World* comments that these are the "very thing for children for whose entertainment television promises at least as much entertainments as the wireless and the telephone. There are rumours that an elephant is shortly to be "televised," but no well brought up child will be able to enjoy this special treat, as the television programme does not begin until 11 p.m. Could not the B.B.C. consider the extension of the Children's Hour to televising? There is every argument for initiating the younger generation as early as possible into the latest marvel of science."

Television "A Commonplace"

Sir Emsley Carr spoke of the future of television in his presidential address to the Institute of Journalists. A few years hence, he said, television would be as commonplace both for news and pictures, and speeding up in mechanical production would be followed by a further development in world-wide news. Several newspapers also make interesting forecasts regarding the future. The prophecy that within two years everybody who owns a wireless set will have a television receiver as well was made to the *Glasgow Herald* by a prominent pioneer in television development.

A well-informed article in *Reality* states that the immediate future depends upon the initiative of the wireless trade, which has so far been slow to realise the possibilities of television. "Although British manufacturers have a way of being just a little behind public demand, fortunately when they do get going with a new product it is always a first-class job. The B.B.C. are now giving full support to the programme side of television, and there is no doubt that a fortune is waiting for the firm which first markets a good cheap receiver.

"Before very long we are likely to see yet another big development in the wireless industry, and while affording a fascinating hobby for the public, television will provide further employment for hundreds of British workmen."

Is the Scanning Disc Obsolete?

By H. J. Barton Chapple, *Wh.Sch., B.Sc., A.M.I.E.E.*

“OFF with the old and on with the new” would seem to be the motto of many readers. At least that is the impression gathered from the many questions asked at Radiolympia, and also from letters to the editor. I refer particularly to the question of whether the scanning disc is to be displaced by the mirror drum in the television receiving apparatus.

Undoubtedly this somewhat new aspect has been brought to life by the recent demonstration of the latest Baird “Televisor” receiver. In this apparatus the image is built up, not by a spirally perforated disc scanning a neon lamp whose glow intensity varies continuously in sympathy with the incoming television signals, but through the medium of a mirror drum projecting on to a screen a beam of light whose intensity is controlled by the newly developed Baird grid cell.

On the surface I suppose it is quite a natural order of things to imagine that the time is ripe for an immediate change as far as the receiving end of television is concerned. But it is one thing for a large company with vast television experience, large resources and ample opportunities for experimenting to make any change, but quite another matter for the amateur with his limited knowledge, small resources and few experimental opportunities to imagine that he is going to do likewise in one fell swoop and get equivalent results.

There are, however, many experimenters anxious to try out every new development as it comes along and for their benefit I propose to devote two or three articles to mirror-drum apparatus, the first of which appears on page 292.

As I am anxious to make this discussion as complete as possible we may well ask ourselves a simple question right at the outset—Why do we scan? A little while ago I remember reading a most interesting short article published in *Television News of America*

which dealt with this identical problem. It pointed out that ever since the days of the first scanning disc invented by the German Nipkow we have been taught that we cannot transmit images electrically at a distance unless some form of scanning device is employed. The article went on to explain that the telephone receiver or loud-speaker needs no scanning device, while the camera reproduces on a photographic plate instantaneously the true scene to which it is exposed.

The same is true of the ordinary mirror and even the eye, although in the case of the latter there are at the back of the retina countless “rods or cones” each of which is connected separately with a nerve. Nature’s television system, however, does not go through the process of consecutively breaking up the scene in a manner analogous to present day scanning but does the work as a whole.

The writer finally expressed the view that no doubt at some future date the image will be transmitted as a whole and while this ideal is a nice one to cherish and it is easy to prognosticate, we have got to face the facts as we know them to-day and exploit our present knowledge to the full in order to make the most of the fascinating hobby.

At the transmitting end the apparatus which actually converts the different grades of light and shade into corresponding terms of electrical current for transmission purposes is the one or more photo-electric cells. Now a moment’s thought should be sufficient to demonstrate the impossibility of one or more photo-electric cells converting an entire scene or image into terms of electrical current variations.

There are far too many differing light values spread over the area within its compass, and the effect would be to give an average light value response which obviously is useless for our purpose.

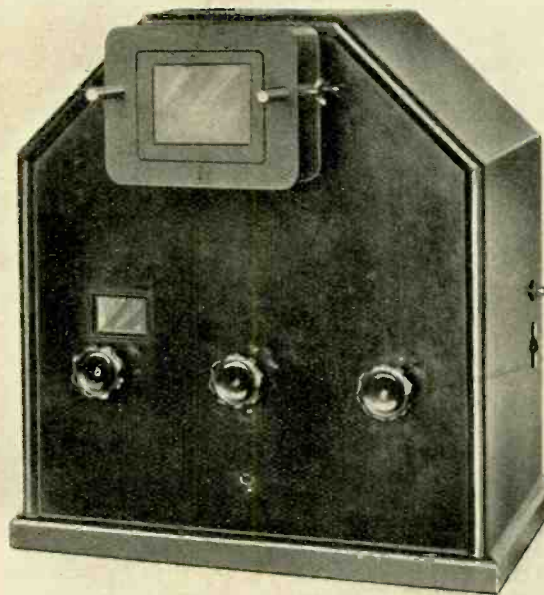

A projection receiver made by Fernseh, A.-G., using a 60-hole disc and one of the recently developed lamps.

In consequence we have to analyse our subject or scene to be televised into a large number of elemental areas. These areas will each possess a definite reflected light value when illuminated by the travelling light spot and the cell is then capable of responding to each small light value in turn without any time lag.

This process is continued, spot by spot and strip by strip, until the whole of the area has been disembodied into values of light and shade and corresponding light values until one complete picture conversion takes place. The whole process is repeated without a break several times per second and the resultant signal is transmitted by wire or wireless after amplification.

Having detected and still further amplified these signals at the receiving end, it is necessary now more or less to reverse the process of disintegration used at the transmitting end. That is to say we must reassemble all the differing light values into their correct position and thus out of this mosaic pattern produce an intelligent and clearly recognisable image of adequate brilliancy. This apparently simple problem has taken several years to reach a stage where results of real value from the technical and entertainment angle can be secured by the amateur.

Putting on one side the question of synchronisation, since this does not enter into the present discussion we require two essential components for this purpose. One is a source of light whose intensity can be made to follow faithfully the converted variations of the transmitting end and secondly some form of scanning device which will give the optical effect of re-assembly on a lens or screen.

Very many schemes have been tried and as far as the amateur is concerned undoubtedly the simplest and cheapest combination is a disc with a series of holes perforated as a single turn spiral, working in conjunction or more strictly revolving in front of a neon lamp. The critics of television, eager to discount a science which, in many cases, they have only studied superficially, have seized on this combination in an endeavour to show that such a method cannot of itself give results

comparable in any way with the home cinema.

To those critics I would say that they have either been misinformed (for often their remarks are based on mere hearsay) or they have not taken the trouble to examine results which of themselves would be direct refutation of their comments. With a plain straightforward disc, having holes punched in accurately, I have seen images obtained both from a film or the actual subject which have revealed a wealth of detail. The images have been comparable in quality in the case of the film with that obtained by a picture of direct projection of the same size.

If I am asked why apparatus of this nature is not in the hands of the general public, I can only say that the reason is wrapped up in the vehicle normally

used for transmitting the images namely, the ether. The avariciousness of the authorities controlling sound broadcasting has left few available frequency channels for television transmissions of this very high standard and quality except on the ultra-short waves.

To get back to our problem, however, one of the difficulties associated with disc working, especially when more than thirty holes are used, is the light source. The glow on the plate of an ordinary flat type neon lamp is somewhat lacking in intrinsic brilliancy when judged from the resultant image point of view, if used with a disc of moderate dimensions, having quite minute holes.

In the August issue of TELEVISION (page 211) a description was given of a sodium lamp which has been developed by Fernseh A-G., the company sponsoring Baird television in Germany. According to the latest information the images obtained in conjunction with this new lamp are so bright that even with a 120 line scan they can be viewed in an undarkened room. Furthermore, it is possible to project images through the holes of a 60 line disc on to a front screen and not view them through a lens. The results then are claimed to be superior to those previously secured with a mirror drum and crater neon operating under similar conditions.

Surely this is sufficient answer to those who remark that the scanning disc is obsolete.

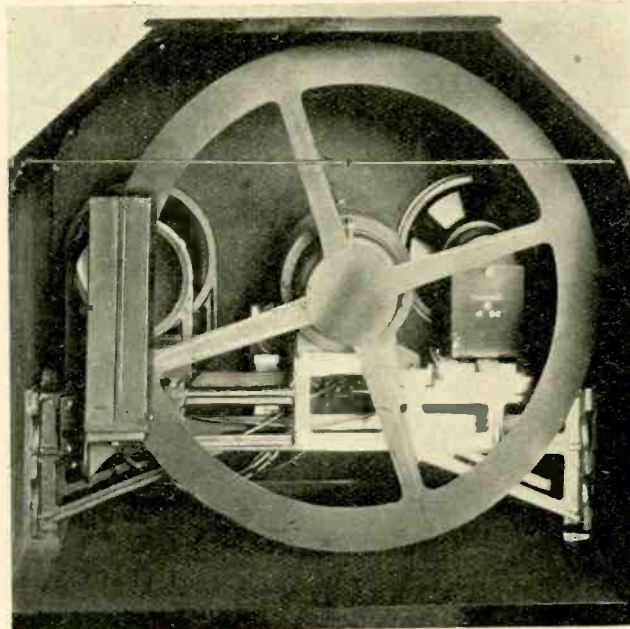

Internal view from the back of the old model "dual" Baird "Televisor." A loudspeaker is included, and can be seen on right.

Constructing a Mirror Drum

The First Stage.

By H. J. Barton Chapple.

A MIRROR drum which gives a *perfect* scanning field is a very expensive item and even one which does not reach this high standard of efficiency is not cheap to make. There are, however, many amateurs who are keen to make a start on this work.

First of all, then, a word as to how the drum functions, for many readers have written to ask me for this information. In a disc the holes are positioned radially and circumferentially, so that strips of light, each one touching its neighbour, are exposed as the disc revolves. Except in the latest type of disc and lamp (referred to on

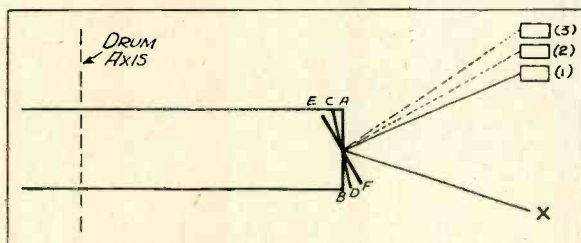

Fig. 1. How the mirrors function.

page 291) no question of projection arises. How then can we place our mirrors so that they reflect light from a suitable source and build up a light area of strips?

This is a little difficult to show diagrammatically but reference to Fig. 1 will help matters. Suppose we have a point source of light X which throws a beam of light on to a mirror A.B. With ordinary laws of light the angle of reflection equals the angle of incidence and we shall then have a small area of light (1) thrown on to a fixed screen. (To simplify the diagram the spot area is turned round through 90 degrees into the plane of the paper.) If the mirror was turned round the drum axis it would cause the spot to trace out a strip of light.

Now suppose the next mirror is inclined slightly on the drum edge surface, so that it seats itself with reference to the drum axis as mirror C.D. The resultant reflected light spot is now (2) and drum movement about its axis will create a light strip immediately next to that which has been traced out by (1). This process can be continued right round the drum edge, until one complete strip area has been traced out. With each revolution the effect is repeated but it will be appreciated that the difference in the inclinations of the mirrors one with the other

is very small indeed, and any slight inaccuracy will be magnified in the resultant light field area.

It is seen therefore that the work involved in construction is of a precision nature and calls for both skill and patience on the part of the home constructor if a good drum is to materialise. We come now to methods of construction of which several can be employed and which I shall deal with in turn; but for this article I shall content myself with what is perhaps one of the simplest from the amateur's point of view.

Referring to Fig. 2, we have a disc of metal of diameter A.B., the metal being of such a character that it can be bent or pressed easily, such as commercial aluminium or brass. "Teeth" of length DB. are cut round the outer edge of this disc, the thickness of the disc, by the way, being a matter of personal choice, but 1/16th inch is very satisfactory.

The angular spacing between similar edges of each tooth is 12 degrees for a thirty mirrored drum, and the width EF. of each tooth should be about one third of the total arc E.G. Exact dimensions will depend so much upon the final size of the drum required by the constructor, that I shall content myself at this juncture with giving

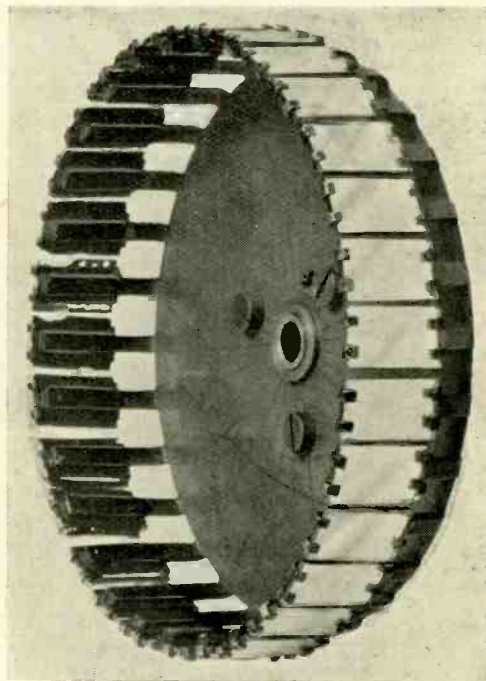

Photograph of the completed drum with mirrors in position.

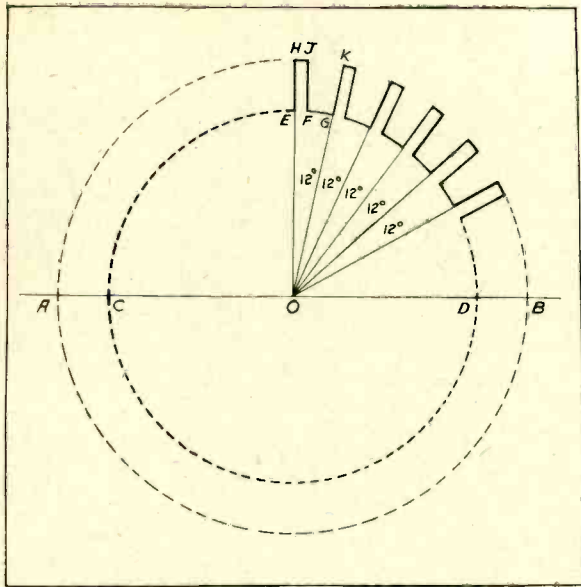

Fig. 2. How to cut the "teeth" in the disc.

sizes for a drum whose ultimate outside diameter is nearly four inches. For larger sizes the constructor can increase the dimensions by simple proportion. The sizes are as follows:—

$$C.D. = 3\frac{5}{8} \text{ inches}$$

$$E.H. = 1 \text{ inch}$$

$$E.F. = \frac{1}{8} \text{ ,,}$$

$$E.G. = \frac{3}{8} \text{ ,,}$$

Thickness of metal (not shown) $1/16$ th inch.

(The sizes of EF. and EG. are not exact but obviously the two lengths will be settled automatically by the diameter CD. and the twelve degree separation between adjacent radii.)

Having obtained a circular metal blank $5\frac{5}{8}$ th inches in diameter, first of all mark off carefully with an accurate protractor the thirty radii sub-

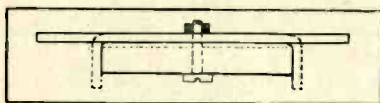

Fig. 3. The "teeth" are bent through an angle of 90 degrees.

tending an angle of 12 degrees at the centre O. A machine dividing head is ideal for this work if the reader possesses one.

Now scribe the circle of diameter CD., namely $3\frac{5}{8}$ inches and mark off the distance EF. so that EF is one third EG. Draw the line FJ. parallel to EH. for each individual "tooth" and then proceed to cut or file away the thirty sections corresponding to the area FJKG. Keep strictly to the scribed lines on the metal disc, so as not to weaken in any way the separate teeth similar to EFJH.

Next obtain a solid metal disc exactly $3\frac{5}{8}$ inch

in diameter, drill a small hole through the centre and a hole the same size in the toothed disc and bolt the two together, as indicated in Fig. 3. Grip this combination in a vice and carefully tap or bend over each tooth so that it is turned through an angle of 90 degrees and lies parallel to the bolt. Remove the solid metal disc and the result of this handiwork will resemble the rough sketch in Fig. 4.

The direction in which this design is leading should now be clear to the reader and an examination of the accompanying photograph will settle this. The spokes, as I have called them, are really arms, on each of which is accommodated a small mirror held in brass clips, the back of each clip being soldered to the arm.

The clip can take one of many forms: that shown in Fig. 5a is quite simple, $1/32$ nd inch

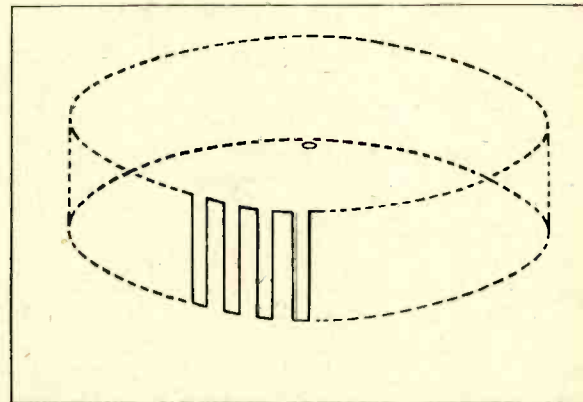

Fig. 4. Sketch of drum before the mirrors are fitted.

brass being employed. Each one of these clips should be soldered to one of the drum arms, so that the "final edge" of the clip projects about $1/16$ th inch beyond the arm edge, as shown in Fig 5b. The mirror size which can be conveniently accommodated in these clips is $5/8$ inch long and $3/8$ inch wide and $3/64$ th inch thick.

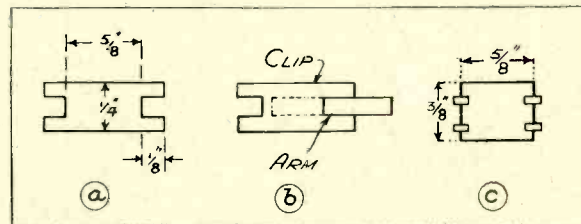

Fig. 5. Three stages in fixing the mirrors.

Fig. 5c shows the method of holding the mirror in place by bending the clip ends over, but this part of the construction, together with the method of setting the mirrors, will be dealt with next month.

(To be continued).

News from Abroad

From our Own Correspondents

The United States

AN unusual demonstration of a new type of cathode-ray television receiver was recently given on an airliner of the Western Air Express Company. The demonstration took place over Los Angeles, California. Mounted in the forward end of the passenger compartment was a radio receiver cabinet with a glass screen, about 8 inches across, near the upper edge. Behind this screen was a cathode-ray tube, and in the cabinet was the television reception equipment. Current was supplied to the receiver from a special generator mounted in the plane. The system used in this demonstration is a development of Harry R. Lubcke, and the signals were sent from the Don Lee Television station at Los Angeles. An automatic synchronisation system was employed so that the receiver could be freed from the requirements of operation on the same power line as the transmitter. An 80 line picture was transmitted 15 times per second, on a frequency of 44,500 kilocycles or $6\frac{3}{4}$ metres.

According to reports, the image received was quite plain, it being possible to note details of the dress on a young lady, a motion picture of whom was used at the transmitter as the subject to be televised. The windows in the fuselage of the plane had, of course, to be curtained in order to make the image visible to the audience.

There is a possibility of using television to transmit to plane pilots such useful information as weather maps, and thus add one more factor of safety to flying. Of course, pilots now have weather reports sent to them by radio telephone, but a clear, constantly amended map would undoubtedly be more satisfactory, besides leaving the phone channel clear for other traffic.

Wide Range

In the September issue of TELEVISION we gave some extracts from the *New York Times*, showing the wide range of reception that is now being obtained by television enthusiasts here. Further letters received by the Columbia Broadcasting Company indicate that their television programmes have been picked up successfully in New England. They travel in all directions in much the same way as musical broadcasts. "Congratulations on the excellent visual programmes we are receiving from your station," said a spectator in Middlebury, Vt., in writing to W2XAB.

"Reception is very dependable and the signal strength is quite sufficient for good quality; in fact, of the six television stations I receive regularly, yours gives the greatest detail. I have especially enjoyed seeing the dancer and the boxing bouts. For reception at this distance I find that it is much better to have the actress dressed in white or light clothes for far-from television vision."

This correspondent adds that the background should be given attention. "Passing shadows of persons not in the field of vision are extremely annoying and confusing. May I suggest that your announcements be made by visual card as far as possible? Interruption of the regular signal throws off the automatic synchronisation in most cases."

In this connection it is reported that scenic backgrounds are now used at the Columbia television station, with the result that lookers-in obtain the illusion of a full stage. These had to be designed with care. Heavy outlines of simple designs in black and white show up the best. Ordinary scenery with its delicate shadings is useless with television in its present state, but adaptation of black and white designs made out of proportion give amazing results. So perfectly did one scene come through that it caused considerable comment among observers when it was put on the air for the first time.

It was a skyline view of New York, showing the buildings silhouetted in black against a white sky. Immediately following the test seven telephone



This Cathode-ray receiver was successfully demonstrated to passengers in an air-liner flying over Los Angeles.



Large crowds visited the television exhibit at the Milan Radio Exhibition held in Italy last month.

callers inquired if W2XAB was actually scanning from the roof of the building, which incidentally, overlooks a similar skyline. It is found that the illusion produced by television often makes the simplest things appear strikingly lifelike, despite the fact that they are mere pieces of cardboard on which rough sketches have been made.

Cartoons drawn in front of the Columbia transmitter in New York have been picked out of the air at Fairmont, W. Va.

Occasionally the pictures are very clear by the time they arrive in Michigan, but some difficulty is experienced in fading. It is reported that more power is needed to send the faces from New York into that area with good signal strength in the daytime. The sunlight curtails the images that travel on certain wavelengths in much the same way that it shortens the range of broadcasting stations.

Discussing the problems of television with the *New York Times*, Mr. William Schudt, director of the W2XAB station, said that television "Still has its limitations, and plenty of them. For example, we are limited in pictorial presentations to three people. We cannot show full-length pictures with sufficient signal power to register properly in the home receiver.

"We plan programmes for the limits of present television. Boxing is presented in a miniature ring. Contestants are cautioned to stay in focus of the flying spot lest they disappear off to an unseen corner of the television screen. Dick Madeo, who has presented many of the fistic

exhibitions, has learned to box in circles always within the focus of the light ray. The engineers likewise have adjusted their scanning apparatus so that it may be adjusted rapidly to follow the fighters in a limited space around the ring."

Germany

In last month's issue of TELEVISION, I referred to the mirror screw shown by the Tekade Company at the Berlin Radio Exhibition. I have since heard from a reliable source that the first patent on the mirror screw was issued to a Mr. D. B. Gardner by the United States of America Patent Office on April 8, 1930. Mr. Gardner applied for the patent on September 17, 1928. This patent is earlier than the Okoloscany-Tekade application, but I understand that a number of similar patents have been applied for in different quarters. All these matters will have to be cleared up the moment television becomes a commercial business in Germany.

There is very little progress to report at the moment. All those occupied with television research here in Berlin went on holiday immediately after the exhibition and are not expected back until the end of September.

Regular daily transmissions of films have been taken up in Berlin on the 7 metre wave with 4 Kw in the aerial. The transmissions take place from 10-11 a.m. daily, with 90 lines and 25 frames a second. Compared with the B.B.C. transmissions in England, the results are naturally far superior in picture quality, as there is no flicker and there is much more detail. The B.B.C. images, with their 30 lines and 12½ frames a second (where 16 frames are the very least for a flickerless picture) are very good indeed, but I must say that the steady 90 line German picture did produce an "Ah!" from my television-tried eyes, on first seeing it after leaving London. Of course, the B.B.C. have a public service and the Germans are still waiting for the development of the new ultra short-wave channel before starting.

The 30 line Witzleben transmissions will probably be discontinued very shortly, but the 30 line 12½ frame transmissions from the Königswusthausen station will be continued for the benefit of amateurs throughout the country.

The Brussels No. 1 station has recently been testing with an older type of German television transmitter supplied by Radio-Vitus. I understand that these tests are only for the information of the engineers, and will probably be discontinued, but they afford further evidence of the widespread interest that television is now arousing in other parts of the Continent.

Retaining Higher Frequencies

II.—Frequency Correction

By E. G. Bowen, M.Sc.

IN the first part of this article it was shown how band pass filters obviate the loss of higher frequencies which occurs in simple tuning circuits. But the band pass filters involve the use of matched coils and ganged condensers in circuits which must be carefully balanced if they are to be successful. Another simpler solution of the problem would be welcome, and quite recently a new method has appeared which gives promise of replacing the rather cumbersome band pass filter of to-day. It is frequency correction—which allows a loss of high frequency in the tuning circuits and compensates for it in the low frequency stages.

The Stenode

Perhaps the first example of frequency correction is found in the "Stenode" receiver invented by Dr. Robinson. The receiver uses as its "tuning circuit" an oscillating quartz crystal which has an extremely narrow resonance curve, and as we saw in Part I, a narrow resonance curve causes a loss of the higher audio frequencies. After being received the signals are

method of reception is a super-heterodyne method, and between the cost of the quartz crystal and the large number of valves necessary the method is rather too ambitious for the ordinary amateur.

Stenodes are now being made which do not require a quartz crystal. Instead, extreme selectivity is obtained by careful design of the transformers in the intermediate frequency amplifiers. Tone correction is then carried out in the low frequency amplifier as before.

Still more recently receivers have been designed with ordinary tuning circuits which have been made very selective by the fullest application of reaction. Such a receiver need only consist of a detector followed by sufficient low frequency amplifying valves to bring the signals up to the required strength. One of these amplifying valves of course is used to compensate for the high frequency losses which occur in the tuning circuit.

Now we are interested, not in attaining extreme selectivity but in methods of frequency correction whereby the serious losses occurring in even the

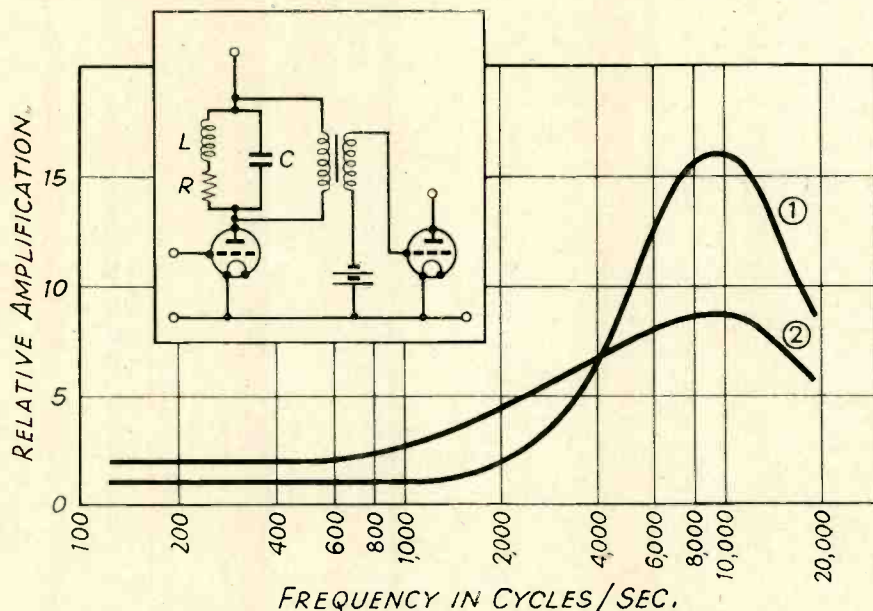

Fig. 6. Frequency correction by means of a parallel resonance circuit across the primary of a transformer.

rectified and amplified in the usual way, but included among the low frequency stages is one which boosts up the higher frequencies and restores them to their correct level. Unfortunately the use of the oscillating crystal requires that the

simplest tuning circuits can be corrected. Fig. 1, in the first part of this article, is a typical resonance curve of a simple tuning circuit to which reaction has been applied.

Examination showed that a side-band fre-

quency of 5,000 cycles a second is cut down to a third of its true strength, while a frequency of 10,000 cycles is cut down to about a sixth. Compensation for these losses would mean that a

giving one of the low frequency stages a rising characteristic, designing it so that high audio frequencies are amplified many more times than low frequencies.

Fig. 8. Correction by means of a plain inductance.

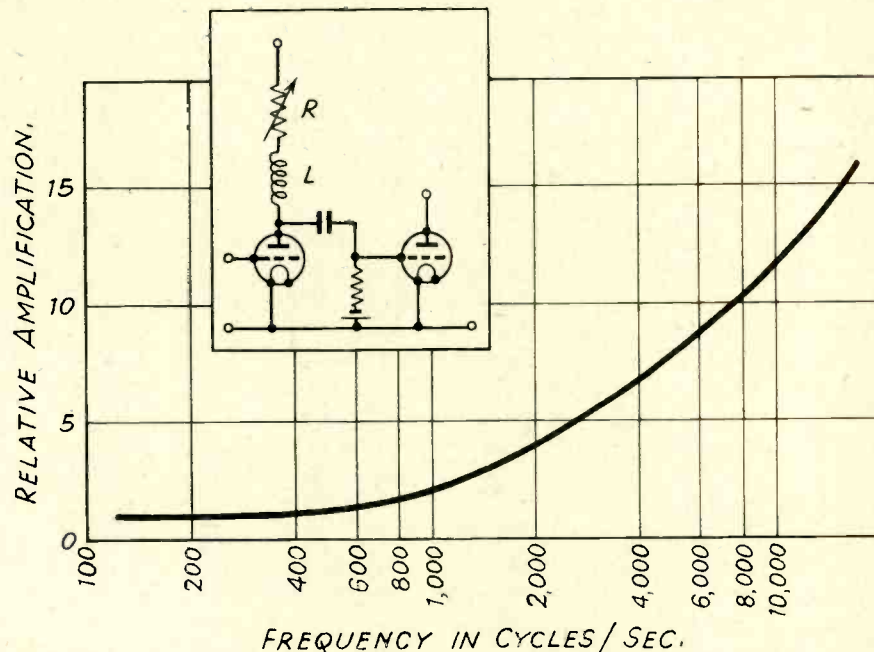

frequency of 5,000 cycles should be amplified three times as much as a low frequency of say a 100 cycles, and similarly a frequency of 10,000 cycles amplified six times as much as any low frequency. Such correction is carried out by

In a transformer coupled amplifier, frequency correction is carried out by connecting a parallel resonance circuit consisting of an inductance L , a resistance R and a condenser C , across the primary of a transformer in one of the low frequency stages as in Fig. 6. If the inductance and capacity of this parallel circuit have a resonance frequency of 10,000 cycles, then the amplification curve of the arrangement would be as shown. Greatest amplification always occurs at the resonance frequency, but the exact shape of the curve depends on the resistance R . The lower frequencies up to 1,000 cycles are not amplified to any great extent, but higher frequencies up to 10,000 cycles receive greater and greater degrees of amplification. Above 10,000 cycles there is a cut off with little amplification of still higher frequencies.

But transformer coupling does not always give the best results in an amplifier used for television reception and it is therefore advisable to consider methods of correction in a resistance capacity coupled amplifier which has been found suitable for television reception.

Resistance Coupling

In the case of Fig. 7 the resonance circuit is connected in series with the anode resistance R_A which must have a considerably smaller value than usual. The coupling condenser and grid leak have standard values, while the inductance

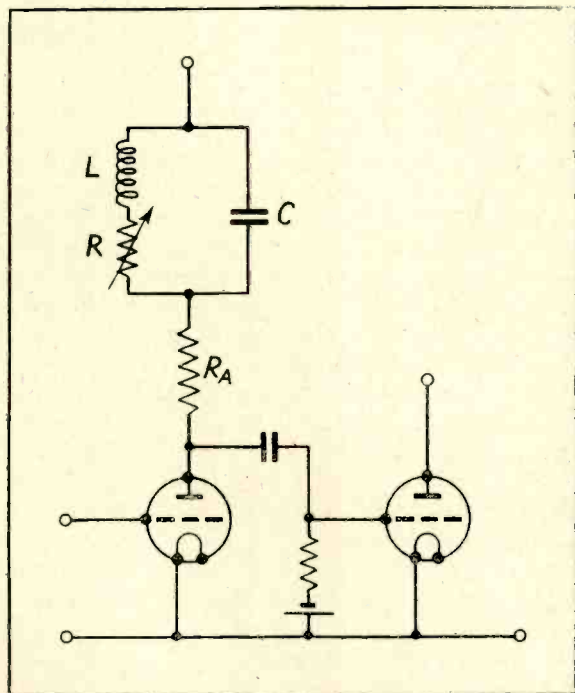

Fig. 7. Frequency correction in a resistance capacity coupled amplifier with a parallel resonance circuit.

L and capacity C of the resonance circuit are chosen to have a resonance frequency in the neighbourhood of 10,000 cycles. Convenient combinations of coil and condenser are: 0.3 henry and 0.0008 mfd., 0.2 henry and 0.001 mfd. and 0.1 henry and 0.002 mfd. Any of these will give maximum amplification in the neighbourhood of 10,000 cycles as in Fig. 6, but again the exact shape of the curve is governed by the resistance R in series with the inductance L.

This resistance may conveniently be made variable from 0 to 1,000 ohms. When it is small, there is little amplification of low frequencies and great amplification of the higher frequencies as in curve 1, Fig. 6. But as R is increased, there is greater amplification of low frequencies and rather less amplification of high frequencies than before. This is illustrated in curve 2, and it can be seen that by a suitable adjustment of the variable resistance R, the amount of frequency correction can be varied and made to compensate partially for the losses occurring on the tuning circuits of any particular receiver.

A simpler method of frequency correction uses a plain inductance with a resistance in the anode circuit as in Fig. 8. The coupling condenser and grid leak again have their usual values, and the inductance L may be one of the 0.3 henry air-

core chokes now available for purposes of frequency correction. The resistance R should be variable from 0 to 5,000 ohms so that the amount of frequency correction can be varied to suit the tuning circuits used before the amplifier.

Included in Fig. 8 is a typical amplification curve obtained with this form of coupling. It will be observed that amplification goes on increasing up to and above 10,000 cycles, the actual position of resonance being well above this frequency. The coil forms a resonance circuit with its own self capacity, and since this capacity is small, the resonance frequency is well up above 10,000 cycles.

We have seen that ordinary tuning circuits cause a serious loss of higher audio frequencies and that at present there are two methods of overcoming it. The first method, the use of band pass filters, prevents losses in the earlier stages of a receiver. The second, frequency correction, allows this loss to take place but compensates for it later.

Each method involves some additional complication. The band pass filter needs accurately matched coils and ganged condensers, while frequency correction means a additional stage of compensated low frequency amplification.

“News” by Television

The Baird Process

READERS of TELEVISION may remember that as far back as November, 1930, a description was given of the apparatus employed by the Baird Company to transmit what was popularly called Television Screen News. Before April, 1930, hand worked apparatus was in use, but early in that month an electrical device was introduced which functioned most satisfactorily and it is not too much to say that it made a most instructive and interesting addition to the daily programme.

Those “looking-in” used the images of the words passing across the screen to help them in gauging the efficiency of the wireless sets they were employing, shadow effects, ghost images, distortion and so on being very apparent with the moving black letters on a white background.

Even in those early days, however, the idea of presenting news by television was not new for in the year 1927 Mr. J. L. Baird was not only working on the idea but took out several patents covering details of the apparatus. Furthermore, he made a combination of the three

From a Correspondent

Greek words “tele,” “logos” and “skopos” and coined the rather unwieldy word “Telelogoscopy” which is literally “seeing writing at a distance,” in order to represent the process.

Although for this adjunct to the normal daily broadcast service the ordinary Baird spotlight system with a track or belt moved slowly through a part of the scan was employed, in August 1929 a specialised form of the same equipment was developed.

This was adapted to scan or explore *only* the actual tape in rectilinear strips and not a relatively large area of which the printed words formed only a part. The tape was simply a paper tape of the tape machine kind with typewritten characters on it. One of the accompanying illustrations shows a typewriting machine built specially for this purpose. The large roll of white tape runs freely in a shallow cylindrical casing on the top right-hand corner of the machine and this tape is fed out on the left with the usual intermittent feed associated with a typewriter.

To transmit this printed script a scheme similar to that shown in pictorial form in the accompanying diagram was used. For the purposes of explanation this diagram should be used in conjunction with the second illustration, which is a photograph of the essential parts of the original apparatus laid out in such a fashion that their function can be appreciated quite readily.

Scanning the Type

The tape from the typewriting machine is looped and then passes into a framework having a long rectangular slot. The rate of feed through the slot is maintained at any given value according to requirements, the tape loop compensating for the typewriter's intermittent feed.

In order to scan the long narrow tape so that the scanned area exactly fits the tape and enable rectilinear scanning to be used (the former requirement ensures full use of the available transmission channel being made) the following scheme was employed.

A source of light has its resultant beam condensed by a lens on to a right angled prism conveniently mounted inside a hollow drum. The beam of light was in this way bent at right angles and made to cover a definite rectangular area (shown by dotted lines inside the drum in the pictorial sketch). The drum had a spiral of holes pierced through the side—an apertured drum scanner is the name given to the device—and by revolving the drum at a constant speed each hole passed vertically across the light area.

Each pencil of light emerging from the drum was focussed on to the moving tape by means of a suitable lens and one or more photo-electric cells carefully positioned picked up the light reflected from the printed strip and converted this

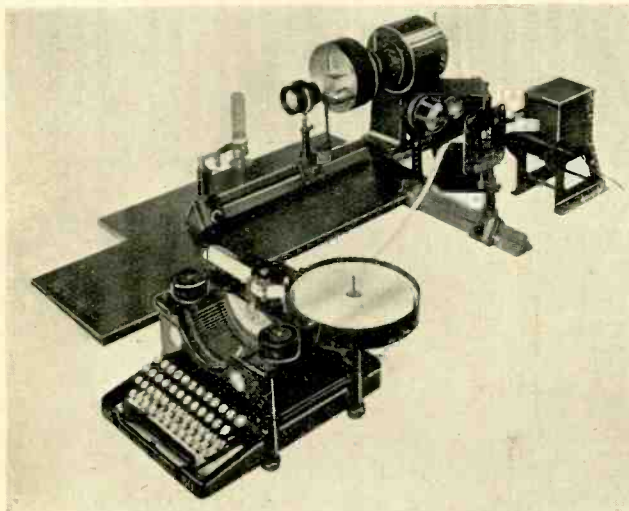

The Baird apparatus for transmitting news by television.

to proportional current variations in the conventional television fashion.

Note particularly that the scanning area (long horizontally and narrow vertically) conforms exactly to the size of the portion of the tape

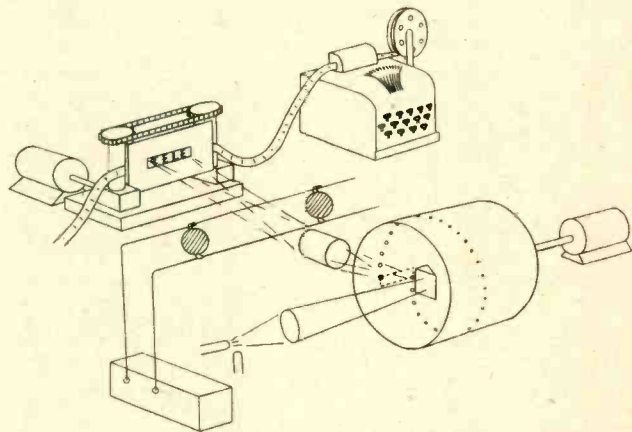

Diagram showing in pictorial form how the lettered type is scanned and becomes a television signal.

exactly in the field at any time. In addition it is interesting to point out that with the particular type of layout described there is not as much curvature of the scanning lines as there would be with a disc.

Excellent results were obtained with the experimental receiver employed in testing out this "news by television" by wireless. A sixty hole disc is used and the neon lamp plate is a long rectangle to give the effect required. On page 270 of last month's issue was shown a disc marked out for this long narrow scanning area, the minute holes being just visible.

The whole apparatus was developed and constructed primarily for transmitting unorthodox characters such as Siamese, Japanese, Chinese or printed matter by radio when fading makes morse transmission difficult as a service and the ordinary Creed undulator is useless. As a matter of fact one model was actually made up for Prince Purachatra for use in Siam but the negotiations were never concluded.

Permanent Signals

When it is found necessary to record the signals permanently a receiver of the kind shown in British patent No. 324904 could be used in which tape chemically prepared passes through sets of contacts connected in scanning sequence to the output of an amplifier.

From the foregoing it will be gathered that the televising of printed matter forms a rapid means of communication and is also very much simpler than the transmission of actual objects as there is no graded light and shade to worry about but merely black and white contrasts.

A Beat-Frequency Oscillator

By Robert Desmond

LAST month (page 254) the general description and construction of a simple beat-frequency oscillator was considered, and we will now assume that the components are assembled and the necessary wiring completed. The first thing to decide on is the type of valves to be used. The writer employs three Osram L610 valves for the V_1 , V_2 and V_4 positions and a Mullard PM5B for V_3 (see diagram on page 254 in last month's issue). Any make of valve with similar impedance and amplification factor may be used, either in the 2, 4 or 6-volt range.

Having decided on the valves, the high tension supply should next be considered. Two hundred volts is suggested so that after allowing for the voltage drop across the various resistances, about 120 volts will be available on the anodes of the valves. In the previous issue no mention was made of values of R_3 and C_7 . On inspection of the circuit diagram it will be seen that the H.T. supply to V_1 and V_2 is via R_3 , which serves as a voltage reducer, and if the valves take a current of the order of 4 milliamperes, R_3 should be 10,000 ohms, while the value of C_7 is 1 mfd. The valves V_1 and V_2 are biased rather less than normal, V_3 for anode bend rectification and V_4 as a L.F. amplifier.

After checking the wiring and making quite sure that everything is in order, place the biscuit tin cover screens in position, and with a pair of headphones across the output, we are ready for

ments the beat note has already been heard in the headphones. The coarse-tuning condenser should be varied from maximum to minimum, and if everything is in order, the familiar chirp of what is termed oscillation when tuning a radio receiver will be heard. More than likely there will be at least three sets of chirps of which one will stand out stronger in signal strength and clearer in tone. With this chirp try and obtain the silent point, but do not be disappointed if you find it impossible even to get within some hundred cycles of silence. First make sure that whatever note you finally tune down to is obtained by increasing the capacity from the silent point, which means that the variable frequency is lower than the fixed one.

Next slowly adjust the neutrodyne condenser and it will be observed that the note changes to a higher or lower pitch as the capacity is either increased or decreased, while increasing the value of the condenser controlled by the slow motion dial will cause an increase of pitch. Having passed these tests the apparatus must now be calibrated.

Calibration up to 4,096 cycles is carried out with the aid of a piano and will first be described. First switch on the oscillator for about ten minutes to let it settle down. Set the slow-motion dial to 10 and leave the coarse tuning condenser as in the first test. Now strike the lowest B of the piano which will give a note of 30 cycles as will be seen from the frequency

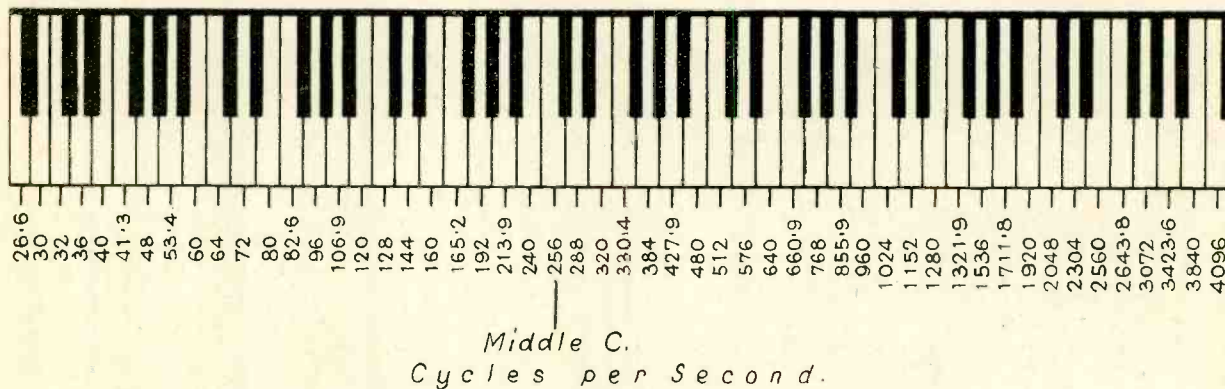

A diagram of the frequency chart of the piano keyboard, as described in this article.

the first tests. First turn the hairline of the slow-motion condenser to the setting 10 on the 100 degree scale and the neutrodyne condenser to half its value. No doubt in making these adjust-

chart of the piano keyboard reproduced in diagrammatic form. Try with the aid of the neutrodyne condenser to get the beat note in tune with that of the piano. If the two notes can be

brought into step leave the oscillator alone for some minutes to see if the oscillator note remains constant. If satisfactory, play the notes of the piano up to such a point in the treble that the

reliable enough. The output of the beat note is of the order of 1.1 volts and is practically constant over the whole range. A change of valves and also the H.T. and L. T. values will alter

* * *
A circuit diagram
for testing the
amplifier.
* * *

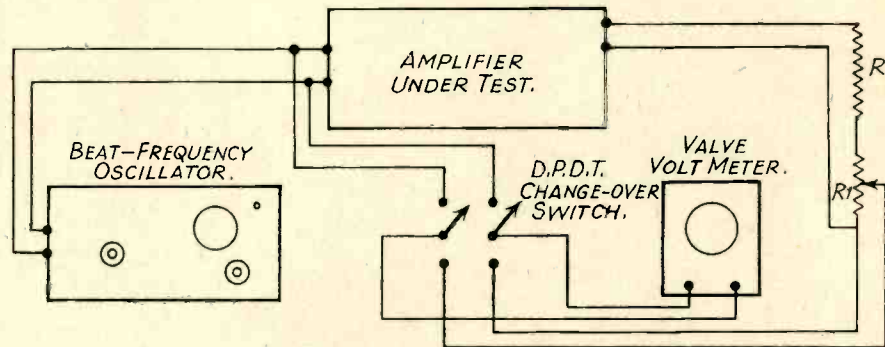

slow-motion tuning condenser reads 90 degrees leaving the other condensers unaltered. It is possible, according to the value of C_2 , that the top note of the piano is reached before the 90 mark or vice versa. If we assume that the highest C but one is reached, that is to say a note of 2,048 cycles, at 90 we will have a set of readings from which a calibration graph can be prepared. Should, however, the beat note go down as low as the lowest B, or be inclined to waver, a higher note must be chosen as the lowest frequency.

The second set of readings is started by resetting the slow-motion dial to 10 and raising the beat note to the same pitch as the highest note of the first set of readings by the aid of the neutrodyne condenser only. Unfortunately there is only an octave before the topmost note of the piano is reached and from 4,096 to 10,000 cycles the procedure is not quite so easy. The method that will now have to be employed is to raise the oscillator note an octave above the lower notes in the piano. For example top G's octave is 6,144 cycles, but even by this method we can only obtain a frequency of 8,192 cycles, and to reach up to a note of 10,000 cycles we must tune the oscillator note to a second octave of a lower note, such as top E, whose fundamental frequency is 2,560, first octave above 5,120 and second octave 10,240.

The Higher Frequencies

Here a word of warning must be given. If the constructor lacks what is termed a good "ear," it will be necessary to enlist the aid of a musical friend when calibrating the higher frequencies.

In the apparatus described two sets of readings were sufficient to cover a 40-10,000 cycle range. The first and last 10 divisions of the slow-motion dial were not used in the calibration as with the condenser incorporated it was not considered

the calibration to a small degree and therefore should be kept constant. The amount of harmonics in the output signal will be of the order of 10 per cent.

Characteristic of an L.F. Amplifier

To use the oscillator to test the characteristic of an L.F. amplifier the procedure is as follows. Connect the output of the oscillator to the input of the amplifier under test (see diagram) and connect in parallel two outers of a D.P.D.T. switch the centre points of which are connected to the input of a valve voltmeter, as described in TELEVISION for March and April, 1931. Across the output terminals of the amplifier connect the resistances R and R_1 . The value of R should be similar to the normal load on the output valve while R_1 is a 400 ohms potentiometer.

The centre of the potentiometer and the bottom side are connected to the lower points of the D.P.D.T. switch as in the diagram so that by changing over the switch the voltmeter is either on the input or output of the amplifier. Set the oscillator signal to some convenient level on the valve voltmeter, then switch over to the output and starting with the slider of the potentiometer at the bottom gradually bring it up till some convenient voltage is read on the valve voltmeter.

Now starting at the lowest frequency, keeping the input volts constant, increase the frequency at the same time noting the output volts at every change of frequency, the results of which should be duly plotted. The oscillator has many uses including the modulation of an H.F. oscillator when used for adjusting band pass circuits and the testing of the response of loud speakers. In conclusion it may be said with confidence that it is a piece of apparatus that is well worth constructing by the serious experimenter and is by no means so tedious to make and calibrate as the written description might make it appear.



“The Enthusiast Sees it Through”

THE opening of the television transmissions from Broadcasting House has rekindled the enthusiasm of those of our practical readers who for a period were unable to make any experiments owing to the absence of signals. Furthermore, the fact that these transmissions now occur at night instead of in the morning has added enormously to the number of potential “spectators.” Our post bag confirms this, and we should like to take this opportunity at the beginning of the winter months to invite all those who are experimenting to write and tell us of their work, supplementing their remarks with diagrams and photographs wherever possible.

Reception in Paris

News from abroad is always welcome in this series as it proves completely (often to the confusion of sceptics) that while certain difficulties do exist in long distance television reception, as in ordinary wireless sound reception, it is possible to obtain definite results of quite a high standard. This is borne out by a letter just received from a previous enthusiastic contributor to this series, namely M. R. Aschen of 18, Rue Victor Duruy, Paris XV.

He mentions how French television amateurs (and there are many of them) have welcomed with enthusiasm the new transmissions by the B.B.C. and in sending along a theoretical diagram of the wireless receiver employed, and two photographs of his actual vision apparatus he says:—

“Since August 22 the French television amateurs have welcomed with enthusiasm the English transmissions on the 261 m. The quality

of these transmissions has been greatly superior to those of the year before and the programmes are very varied. On some evenings it is just like a cinema, notably the transmission of August 24, which was received under the most favourable conditions. The seal with its master also had an enormous success, as has been confirmed by other observers in Paris. Thus we see great progress on all sides!

“The long wave 251 m. comes through very well at night and can be received easily with a “Super” 5-valve. In France we recommend the superheterodynes, which also use good “low frequency” transformers on a high frequency. Our latest models work on 400 kilocycles. A receiver

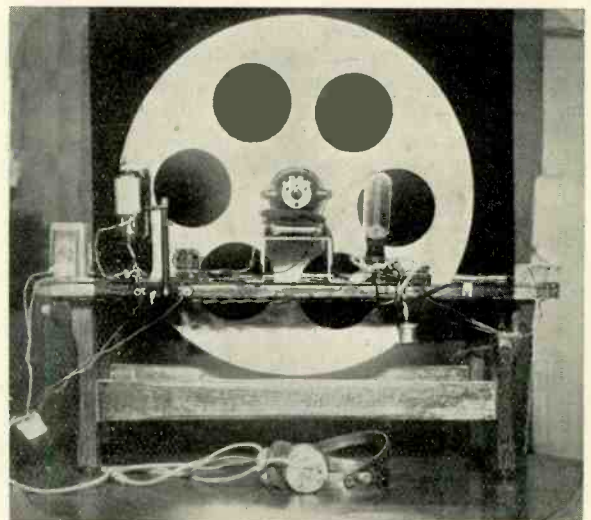

A view of M. Aschen's vision receiver.

with two stages of intermediate and one stage of low frequency gives images which are clean and luminous while the stability is remarkable. The synchronisation leaves room for improvement,

apparatus (the construction of which started over a year ago), was attached to the radio set. To relate in detail the numerous experiments undertaken in search of means for driving the disc

* * *
Theoretical diagram of the television receiver used in France.

Its construction is described as remarkably simple, and it provides excellent reception of the transmissions from England.

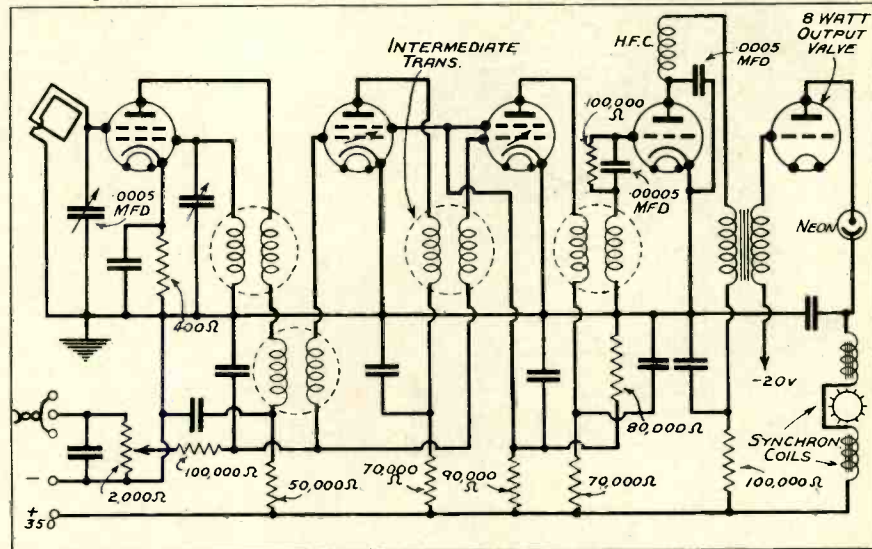

because "fading" is very troublesome and easily upsets the synchroniser. The local oscillator on 375 cycles per second becomes indispensable, but it seems to me that the speed varies at the transmission end and often exceeds 375 cycles/sec, that is to say 7/0 turns per minute, which obliges me to synchronise by turning the apparatus more east. The fading on some evenings is so troublesome that one often sees two images separate up to the half of one image. This separation permits one to calculate easily the height of the Heaviside layer without any special instrument. Here you have a very exact method of measuring.

"Attached is a sketch of the receiver in use now which gives excellent results and which is especially remarkable for the great simplicity of its construction. We hope that it will serve us for some time yet for the reception of the excellent transmissions from England."

Working Under Difficulties

In these admittedly strenuous times it is encouraging to find anyone who does his best to meet the situation with a stout heart. Although faced with difficulties Mr. A. W. Eastlake, of 42, Fairview Road, Stamford Hill, N.15 has done his best to overcome them without incurring undue expense. His total expenditure has only been a matter of a few shillings, but he has surprised all his friends by making the apparatus work. We therefore take this opportunity of wishing Mr. Eastlake a bright future and trust that he will soon be able to continue his experiments with renewed confidence. He says:—

"On the evening of August 22, a television

would prove a laborious undertaking. I will, therefore, content myself by stating that the attempted utilisation of the sewing machine, gramophone and manual power were only a few of the likely sources explored, none of which were found suitable, so during a spell when money was scarce and time plentiful, I decided to try my hand at making an electric motor. The material used was a piece of gas pipe for the yoke, "case binding strip" for laminations, the armature spindle being brought to shape and size with a file and emery paper, a lamp was procured and lens boxes, disc and baseboard were then made. On obtaining an accumulator from a car breaker for a few shillings, the motor was tested and found to be not sufficiently powerful to rotate a 20 in. disc, even when lightened, so a 12 in. disc was made. By the time everything was in running order, however, I was busy in other directions and the evening transmissions had been discontinued, so all was stowed away, and became well coated with dust till Monday evening, August 22. At 11 o'clock the gas was turned out, the set switched on, and the motor started up. Things were not entirely successful, for the motor vibrated a lot due to the armature spindle being eccentric, and after ten minutes running the brushes were found to grind on the commutator, both having become burnt.

"A friend who has an interest in the weird and wonderful contraption, as well as myself, had that evening only fleeting glimpses of silhouetted pictures, but no amount of fine rheostat adjustment could hold it for more than a second; those glimpses have, however, justified the expenditure of seven shillings, and the many hours of work

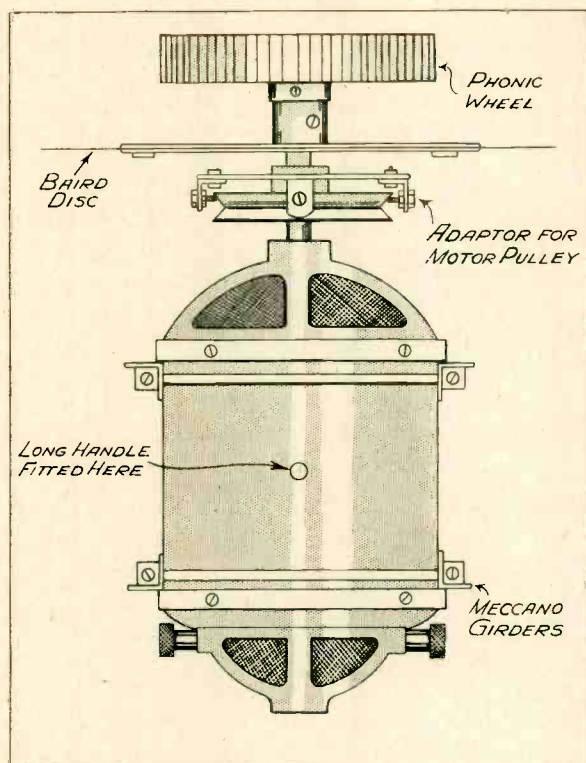

Fig. 1. Details of the framing device and pulley adaptor described by Mr. Owers.

entailed in the construction, and have surprised everybody around me by the fact of it working. Unfortunately things will have to remain as they are for the present, as the prospects of another enforced holiday is imminent, which makes the purchase of a commercially made motor out of the question. A current of 4.5 milliamps at 120 volts was used to actuate the neon lamp, the total set consumption being 7 milliamps, while the current taken by motor was 2.5 amps. at 6 volts."

Excellent Results

Mr. Joseph Owers, of 130 Praed Street, Paddington, W.2., has lost no time in getting his apparatus working and according to his own words has been rewarded with excellent results. His keenness is reflected in his willingness to help others to do likewise, and undoubtedly readers will welcome the contribution he has sent to this series.

"Some months ago I gave details of my first attempts at television reception. Since then I have constructed vision apparatus which, although fully enclosed, has a case so arranged that its removal is a matter of minutes, thus making it easy to carry out any adjustments or experiments. The photographs of the complete receiver shows that apparatus of this type can be quite as unobtrusive as a modern radio receiver.

There are several features that I am sure will interest readers of TELEVISION, especially those who are thinking of constructing apparatus for the reception of the evening transmissions.

"In Figs. 1 and 2 it will be seen that the motor is held between four Meccano girder strips, the tension is adjusted by moving the collars on the tie rods, "framing" being carried out by rotating the motor body by means of the long handle. Of course, this scheme is only possible when a motor with a perfectly rounded body is used, otherwise the toothed wheel will foul the pole pieces whenever "framing" is attempted.

"The pulley adaptor is constructed from a Meccano wheel having four radial slots, the boss is removed and replaced by a length of $\frac{1}{4}$ in. rod, which is bolted into position, to take the Baird disc and synchronising wheel. Four small corner brackets are loosely bolted to the Meccano wheel slots, being free to slide therein. The adaptor is then fastened over the pulley by bolts passed through the corner brackets. Centring is obtained by running the motor slowly, and lightly tapping the wheel until the spindle runs perfectly true, then the bolts are finally tightened up. I have explained this in detail because there are so many motors suitable for television work which have pulleys immovably fixed to their spindles and this adaptor provides an easy way

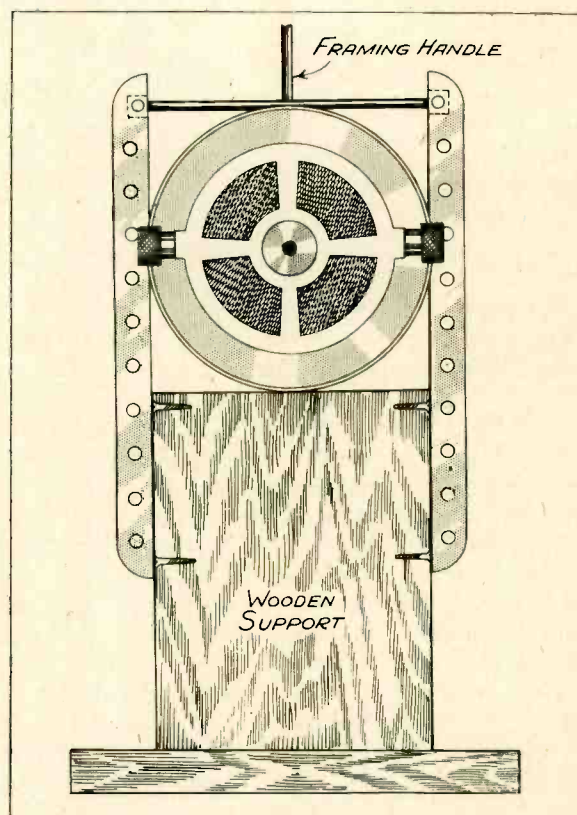
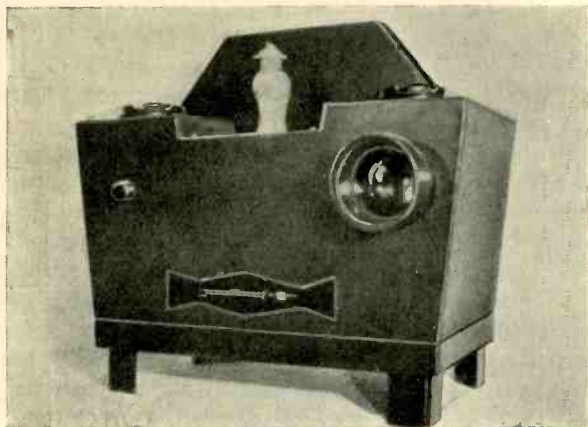

Fig. 2. Front view of the motor assembly.

out of the difficulty of fitting an extension for the disc. If care is taken over the final tightening of the bolts, there is no possibility of slip



Front view of the casework.

occurring. My disc is running as true now as when first fitted.

"Meccano strip makes an excellent stand for the lens assembly, as will be seen in the photograph of the chassis; the assembly is a sliding fit on the two uprights, and can be instantly removed for lens cleaning. The rigidly supported synchronising coils can be seen in the background.

"The casework is composed of plywood, covered with brown leather cloth, and it is made in three sections. When assembled the case is very firm and provides complete enclosure. The slot seen in the front is for the motor resistance.

"I am getting excellent results from the Broadcasting House transmissions, definition being greatly improved. One has so much more chance to carry out experiments on these new evening transmissions."

An Ambitious Reader

Although busy on other matters our readers always manage to find time to fit in their television work. Mr. F. Plymen, of "St. Aubin," 7, The Fairway, North Wembley, is a case in point and although he has only just returned from a holiday he has already sampled the new transmissions. He contemplates some very interesting work for the coming winter months, as readers will see from his own letter:—

"I regret that since writing to you last January I have not been able to devote much time to television.

"I am, of course, very pleased with the new transmissions but so far I have only been able to look in to two of them as I have been away on my summer holiday. These two transmissions were reasonably successful. Images were very powerful but owing to slight incorrect matching between the neon and the high voltage

pentode a certain amount of distortion is present.

"However, I can soon get over this difficulty. My new motor is very successful. It is a 110 volt A.C. model and works through a resistance from 230 volts A.C. mains. As it is 1/10 h.p. it runs very well, having plenty of power to spare. During the winter I intend to improve my apparatus further. I am going to fix up the synchronising gear and mount the whole in a cabinet. If possible I intend to carry out some experiments with the mirror drum receiver. Also I want to improve my wireless set, to extend its range to receive the Berlin transmissions and probably to make it work on ultra-short wavelengths to tune in the 7 metre transmissions."

Still Going Strong!

Some interesting comments on the reception of the television programmes are made by Mr. H. Awcock, of 296, Essex Road, London, who writes:—

"I first took an active interest in television with the publication of your first issue, and when searching the ether one night I picked up a transmission of the play, 'Box and Cox,' by Messrs. Baird. I decided to make up the receiving side of the simple vision set which was described in No. 1. I received very crude pictures as a result of my efforts, but these were enough to make me go further. In the October, 1930, issue Mr. W. J. Richardson described a 'Wireless Vision Receiver,' and as I am still getting perfect

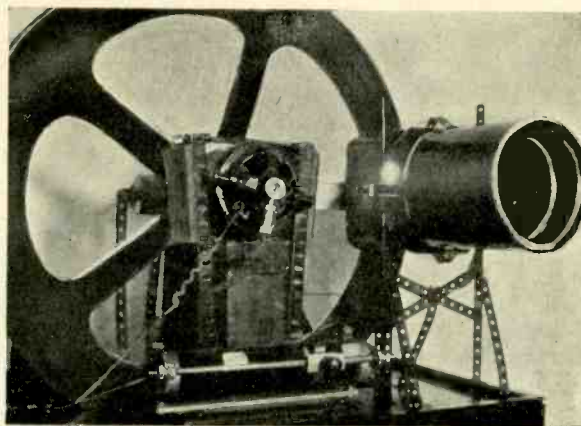

Another view of the receiver constructed by Mr. Owers.

results from this set, I think room should be found in a future issue for a reprint of this article; perhaps Mr. Richardson could even increase the range a little.

"The sound side of the new programmes is not very good. The Midland regional has completely faded out on several occasions and left us with a dumb show for perhaps a minute at a time. Would it not be possible to exchange wavelengths with the London Regional and run the show from Brookman's Park?"

From My Notebook

By the Technical Editor

The B.B.C. Transmissions

The high standard of the original television transmissions has been very thoroughly maintained by the B.B.C. and the department concerned is deserving of praise for its painstaking efforts to give as much originality as possible. No doubt many readers were thrilled at being able to see James Mollison and his wife after his tumultuous welcome in London. This was not the first time that they both had faced the "moving spot light," as during Derby week they participated in the transmissions taking place by line between the Baird Company's studios at Long Acre and the Metropole Cinema, Victoria. After this transmission I had a very long talk with them and as pioneers in another science, namely long distance aviation, they only too readily appreciated the difficulties which have to be overcome in the admittedly young science of television.

Then we have had on our home "screen" the performing sea lion, a marvellous act with a splendid subject for the transmitter to follow, while Miss Louie Freear, who took part in the first television transmission from Broadcasting House, has rendered some more of her famous songs in her inimitable manner. Two other artists who came over well were Harry Hemsley with child impersonations and cartoons, and Red Fred, "the little marvel on the wheel" who did trick riding and balancing on a single wheel bicycle.

Substitutes for "Looker-in"

I have been very interested in the many suggestions put forward for a word that would adequately describe the action of an individual watching television reception and be a substitute for "looker-in" which is felt to be clumsy. A very long time ago I suggested the word "televisioner," while about a year or so ago *Television News* of America ran a competition on exactly the same problem and the first prize was awarded to "visualist."

In about the middle of 1930 TELEVISION made a fruitless attempt to find a really euphonious word and this brought forth an interesting comment from "The Broadcaster" in the *Radio Times*. He said: When broadcasting began those who listened to it became known as "listeners-in," a not very fortunate term, which was obviously chosen to mark the difference

between a man with the simple use of his ears and one who applied them to listening to wireless. The term may have come from America, where the expression to "listen in on" or eavesdrop on a telephone conversation has long been current. Feeling that "listener-in" was not the happiest of terms, several publications, including our honourable selves, invited the public to invent one neater and more expressive. Alternatives were mooted by the hundred. Wireless enthusiasts ran a grave risk of becoming known as "auditors," "radiards," "etherphiles," "harkers," "radiofans," and so on—but, once the fuss died down, the "listeners-in" had become the "listener," and that was that. To-day, though still teething, television is experiencing the same growing-pains, as witnessed by a correspondence in recent issues of our contemporary, TELEVISION. An objection raised to the term "looker-in" has brought into being a number of alternatives: "Scanner," "gazer," "observer," and so on. They all stress the visual side of the invention, disregarding the aural. "Looker-in" is ugly; "looker" worse. Someone will have to invent a portmanteau word which is both neat and inclusive.

As the question is again being discussed in TELEVISION, it is interesting to recall these earlier suggestions at the present time.

Another U.S. Station?

An application for a new experimental visual broadcasting station which would make tests in transmitting images in colour, was recommended for granting in an Examiner's report made public recently by the Federal Radio Commission. The applicants, the Sparks-Withington Co., Jackson, Mich., propose to carry on a series of experiments between a television station and an experimental station which will broadcast sound signals simultaneously with the visual images. It was stated at the hearings on the case that engineers of the company claim to have developed a method of scanning by which images are transmitted by wire, using only half the usual frequency band width required for visual broadcasts.

In the report, it is pointed out that the station, if erected, will be a laboratory for experiments which probably would "result in a substantial contribution to the development of the visual broadcasting art." Chief among these experi-

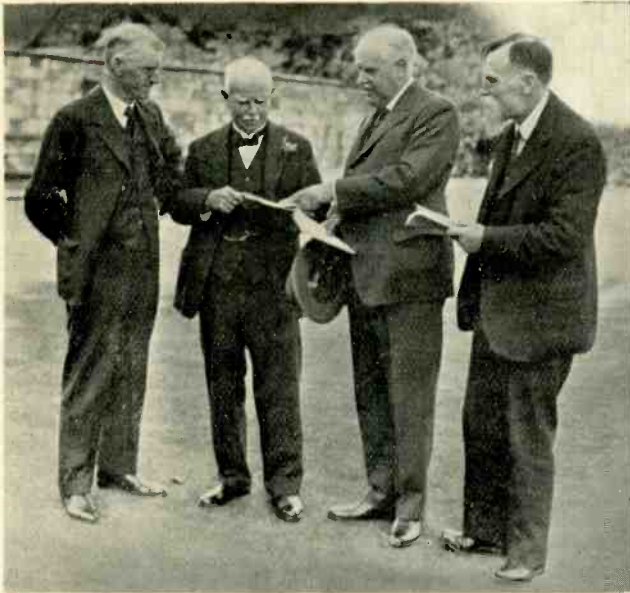

Professor Boswell, Sir Alfred Ewing, Sir Josiah Stamp and Professor Myers at York, where a Demonstration of television was given to the British Association.

ments is one in which it is proposed to transmit visual images in colour, by a method using a prism filter.

Broadcast Critics' Circle

Just over a year ago the Broadcast Critics' Circle was formed under the chairmanship of Mr. Sydney A. Moseley. This organisation has made a united effort through the columns of the daily and weekly press to guide the B.B.C. as to the real needs of the public and the work has been singularly successful. That the B.B.C. themselves appreciate what is being done was reflected in two luncheons given by Mr. Gladstone Murray of the B.B.C. to the Circle. I was present on both occasions and at the first the Circle members were introduced to the Director of Programmes and his colleagues and the subsequent discussion enabled both sides to air their views in a very pleasant manner. It was learned, for example, that only a very small percentage of those artists who apply for auditions are successful in passing the "mike" test and this adds considerably to the difficulty of building up suitable programmes.

At the second luncheon the new Director of Talks expounded on the arrangements which have been made for this most criticised section of the B.B.C. programmes. One interesting item which appealed to me arose out of the announcement that Mr. Vernon Bartlett's broadcasts from European capitals during the coming months will give him an opportunity of speaking in an entirely different way from his previous broadcasts, which have, for the most part, taken place

from a studio in London. In his new venture he will speak surrounded by the influences of the places he is actually visiting, and his viewpoint for that reason is likely to be somewhat different from what it would be if he waited until he returned to London. These broadcasts will mark an entirely new departure in the series of talks.

Reverting to the question of these "round table" lunches which have been productive of a much better understanding between the B.B.C. and its critics, it occurs to me that the time is just ripe for a "television luncheon." With television making its debut under complete B.B.C. auspices, why not clear the air at once and let the Corporation extol on the policy it intends to follow, and then take advantage of the suggestions which are sure to be made?

Model Engineers

The fourteenth model engineer exhibition held at the beginning of September proved of outstanding interest to old and young. My good friend, Mr. Percival Marshall of the *Model Engineer* is to be congratulated on his wonderful efforts. There were working model railways, steam and sailing ships, aeroplanes and locomotive and engineering models of every description. The infinite patience which must have been used in the construction of these pieces of apparatus is a credit to the amateurs, while the workmanship was in many cases on a par with the pukka professional job.

Experimental Radio Engineering

Some years ago it was my intention to write a book dealing with the teaching of radio principles in the laboratory, the matter to be essentially descriptions of experiments which could be conducted by students to emphasise the principles involved in the performance of radio apparatus. Unfortunately a sudden change in the sphere of my activities made me abandon the idea and I now find that J. H. Morecroft's book entitled "Experimental Radio Engineering" (published by Chapman and Hall at 21s. 6d.) meets this long felt need.

The author is to be congratulated on the painstaking care he has given to a thorough consideration of each of the fifty-one experiments described. The book is well produced, having 250 explanatory diagrams, so that the experimenter can hardly make a mistake. I have thoroughly enjoyed delving into its pages and with every experiment the object and analysis is carefully described while at the front of the book there are thirty odd pages of introduction, giving explicit information on principles and the pitfalls to avoid in experimenting. Altogether this is a first class book which every radio experi-

menter and student is strongly advised to acquire.

Sight and Sound on One Wave

From enquiries which have reached me it would appear that the article published in last month's issue of TELEVISION was not quite clear to some readers. First of all it should be noted that the information given concerned activities in America and second the statement was made that the *conventional* 100 kilocycle wide band was used.

There is absolutely no such side band latitude in this country except on the ultra-short waves, and on the medium waveband now being used by the B.B.C. for television transmissions it represents the ether space taken up by eleven broadcasting stations. With a sufficiently large side-band three or four distinct types of signals can be sent on one wavelength. Another point to bear in mind is that sight and sound superimposed on one carrier occupy a greater side band than is the case if two separate channels are employed.

To cover the wide band of 100 kilocycles the frequency response curve of the wireless receiver has to be sensibly flat over the whole range, whereas normal receiver practice is to have a flat curve up to about 9 kilocycles. No doubt in the near future this side band question will be settled on terms more favourable to television and when it is television progress will be more rapid.

A New Radio Factory

It is always a pleasure to record progress, especially when it is well merited and I was, therefore, delighted to form one of a party which visited the new works of Belling & Lee, Ltd. My good friend, Mr. E. M. Lee is a director of this company formed ten years ago and from its inception the specialisation has been in the manufacture of terminals, wander-plugs, in fact, anything that bears a relation to radio connections.

The new building covers 22,000 square feet of floor space and has been constructed with a view to obtain flexibility so that new developments and new ideas can be put into practice with the minimum delay or disorganisation. Partitions have been kept to the absolute minimum, and are so constructed that they can be moved to another position very quickly. The whole factory is ready to be expanded at any moment by building further bays on to the south side and then removing the temporary south wall as soon as the new bays are ready for occupation.

The machinery consists mainly of high-speed automatic lathes and is capable of turning out almost any shaped part in either metal or insula-

tion material. The principal materials worked are brass and "casein rod," this latter being made from milk by first extracting the pure casein, which is rather like cheese, and then dyeing it and adding suitable fillers, and hardening with formaldehyde to produce the very attractively coloured substance from which so many small wireless parts are made. Many parts have to be polished, which is done mainly by automatic methods, and a dust extracting plant prevents dust getting in the air from these machines. Metal parts are mostly sent to the nickel-plating department, where they are first freed from all dirt and grease by means of the latest chemical processes including a degreasing plant, which uses the chemical trichlorethylene in the form of vapour for removing the last traces of oil.

The press section includes a special type of press, which Belling & Lee have developed for producing the permanent lettering on their terminals, plugs, etc. From the press work we proceeded to the hand assembly and finished inspection. In one corner of the assembly department some exceedingly fine wire was being handled in the production of Radio Fuses. This wire is so fine that it melts before the filament of a valve could be damaged in the event of any fault in the receiver. Some of the wire is only one-twentieth of the thickness of a human hair, and it takes some months of training before the operators are able to handle it safely and speedily.

Altogether it was a most interesting visit and afforded ample proof that a real industry has been built round the "bits and pieces" of radio.



A front view of the new factory of Belling & Lee, Ltd.

Letters to the Editor

HAS TELEVISION ARRIVED?

To the Editor of TELEVISION.

SIR.—I have followed with much interest the controversy as to whether television in the home is really an accomplished fact, and I feel, as an early supporter of television, that I really must write this letter, particularly as I was the author of the article referred to in *World Radio*.

In the first case, the writer of the article published in *Popular Wireless* is, like myself, a member of the Institution of Electrical Engineers, the motto of which is "To promote the general advancement of Electrical and Telegraphic Service and its Applications" and he should therefore be the last person to write articles which hinder the advancement of television. Does he imagine that television has not arrived in the home, when hundreds of television enthusiasts saw the Derby in the Midlands at the same time as the actual event? We must admit that there was room for improvement, but it was definitely of entertainment value.

Anyone who looked-in last Friday night and saw Rupert Harvey again, will have marvelled at the improvements noted since the old experimental transmissions in the morning. Or take the case of the girl dancer who followed him and did some of the most wonderful acrobatic dancing I have ever seen—is not that of entertainment value? I should be the last person to say that some big improvement is not necessary before television is in every home. What is needed in television is a valve to replace the crystal detector and to continue the analogy, were not crystal sets used in every home before a valve set was installed?

The truth is that such biased articles do more to prevent the advancement of television than anything else, and it is therefore pleasant to see the enthusiasm with which the technical press have welcomed the new Baird home receiver which will, it seems to me, revolutionise television in this country. What every enthusiast wants to do is to give practical demonstrations of television, for after all "seeing is believing"! If such a movement could spread over the country the people would become "television-minded," because I find that all who have seen the images are astonished at what they are able to see.

Yours faithfully,

D. R. PARSONS.

"Cartref,"

Shenstone Court Drive,
Nr. Lichfield.

A NEW SYSTEM?

To the Editor of TELEVISION.

SIR,—In your issue of December, 1930, you published a letter of mine dealing with a new method of light modulation. After some thought I have been able to devise what I imagine to be a possibility for a new system of television. My assumptions might be wrong—nevertheless, they may interest your readers. The method is as follows:

Supposing you take the pencil rays of light from the object to be televised and convert them into sound waves of different frequencies, the

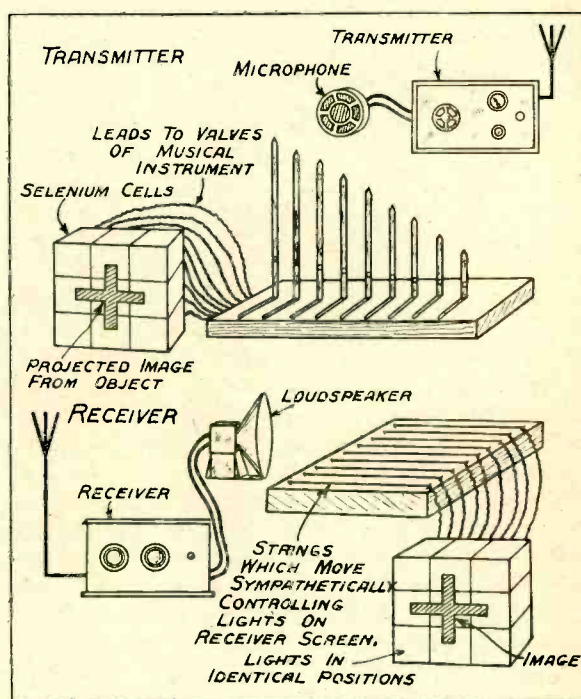

intensity of each note being directly proportional to the intensity of the image rays. This could be done by using a honeycomb of selenium cells to control the valves of a reed instrument—each note being represented by a cell at a certain point on the transmitting screen. The result would be a chord (or probably a discord) of notes—always of the same frequency, but varying in intensity.

This chord is picked up by a microphone, amplified and sent over the ether. At the receiving end the process is reversed. The sound is reproduced by a speaker, and each note is separated from the other by using apparatus having strings of identical pitch with the notes of the transmitting apparatus. (This is possible when you consider the principle of sympathetic

vibration). The result now is that you have the strings vibrating in sympathy with the amount of light and shade in the image honeycomb.

The next step is to convert these vibrations into separate light spots—varying in intensity with the amplitude of vibration (I think this could be done)—and finally by projecting each spot on to a screen, the light for each note being in a corresponding position to the cells and notes at the transmitting end.

I realise that in many ways this is extremely complicated and that many flaws are likely to crop up—one is the time lag of sympathetic vibration.

I have found it easier to visualise this system using sound waves—I should think there is an electric magnetic parallel. Anyway it does away with scanning and might be worth investigating.

Yours faithfully,
W. P. OWEN.

37, Hollingbourne Road,
Herne Hill, S.E.24.

A TELEVISION CLUB

To the Editor of TELEVISION.

SIR,—I notice in the current issue of TELEVISION an article by your special correspondent, headed "Television at Radiolympia," in which he mentions that the question, "Why cannot we experimenters meet each other" was frequently asked by visitors to the exhibition. The reply given was that they should band together in local societies, or form television groups in radio societies which already exist in many parts of the country. It may interest your newer readers to know that it has been suggested that a small local Club should be formed in the South-Eastern district, preferably in the neighbourhood of Norwood, Dulwich or Peckham, for scientific research, especially television.

Applications should be made to Mr. E. Bates, 95, Upper Tulse Hill, S.E., or to myself. A meeting would be convened to discuss the formation of a Club.

Yours faithfully,
ARTHUR H. BIRD.

Radio Experimental Station G.6A.Q.,
35, Bellwood Road,
Waverley Park, S.E.15.

Popular Wireless reports that the new branch of the Clapham research station is being kept busy with tests of gear for television and the Empire transmissions. The short-wave receivers have now been built and the engineers are working on special checking apparatus for the television transmissions.

Submarine Television

A new television apparatus, "to assist in deep sea exploration," has been invented by Dr. Hans Hartman, a pioneer in oceanography, and is described by Dr. Alfred Gradenwitz in the *Wireless Constructor*. The explorers are seated in a darkened cabin on board the ship from which the submarine television camera, attached to an electric cable, is lowered into the sea. On the screen of an ordinary receiver, it is possible to see the television image transmitted through the cable from the depth of the ocean.

As soon as anything of particular interest appears on the screen a pressure upon a contact button will bring the cinema camera into action, thus recording upon the film all that is passing. "Aided by television, the human eye will be able to plunge into the farthest depths, otherwise inaccessible to man. Hartman's television camera is likely to show what creatures, never allowed to rise to the light of day, are the inhabitants of these infinite lightless spaces."

Dr. Hartman has already, with the aid of his special diving apparatus, been able to dive to great depths and to discover in the Mediterranean extensive submarine ruins of some prehistoric city which he is inclined to connect with the mythical Atlantis, and which he expects further to explore with his television camera. Any improvement in television will, of course, readily be applied to the submarine television camera.

From Talkies to Television

According to the film critic of the *Leicester Evening Mail*, preparations for the time when the televised film or play will become the rule have reached an advanced stage. "A cinema television set has been constructed at a Leicester factory, and will be marketed when the time is ripe for the change-over from talkies to television."

The factory is that of Messrs. A. E. Morrison and Sons, Gartree Street, Leicester, where the Morrison Sound Equipment is manufactured. Recently they have put on the market a new standard talkie apparatus which includes a new system of amplification. This system, which has been designed by Mr. A. E. Morrison and his son, Mr. A. C. Morrison, has been constructed with a view to the change-over from talkies, and will meet the requirements of both television and talkies.

Mr. A. C. Morrison, who is responsible for the electrical side of the business, told this newspaper that it was only a question of time before televised pictures would completely replace talking pictures.

Reports on Apparatus Tested

The Technical Editor of TELEVISION will be pleased to receive apparatus, components, etc., from manufacturers for test and if found suitable, for review in these columns.

A New Pick-up

Some time ago we reviewed in these columns the model W5 pick-up made by Celestion, Ltd. This has now been discontinued and in its place the W8 model has been introduced. Unless the pick-up used in any radiogram is of high quality the resulting reproduction will be of very poor calibre. We were therefore glad of the opportunity of trying out the new Celestion model and can assure readers that it embodies the features which are essential for good reproduction from gramophone records.

Reckoned over the whole range, its voltage output averages from 1 to $1\frac{1}{2}$ volts, quite satisfactory from the sensitivity point of view, and it exhibited remarkable freedom from any unpleasant resonant peaks. There was a good low note response, a feature which will commend itself to those who are keen on retaining base reproduction.

As far as mechanical features are concerned, the design allows the head to be rotated through an angle of 180 degrees while there is an ingenious arrangement for quick needle changing. It has a frictionless spring bearing between the tone arm and the supporting standard and this allows the pick-up to be moved in almost any direction without friction being introduced. It can be gathered therefore that the instrument is a most attractive proposition, and for the sum of 35s. is supplied complete with a drilling template and rest pillar.

An Osram Kit Set

The Osram Thirty-three Music Magnet Kit Set comprises a self-contained 3-valve receiver complete with loud speaker housed in a bakelite cabinet in which ample space is provided for a standard H.T. battery, a G.B. battery, and an L.T. accumulator. The completed set is most compact and has a very good finish.

The simplicity with which this self-contained kit set can be assembled is one of the most remarkable points about it. It actually involves the wiring up of three units which, in themselves, comprise a number of components already connected up. Apart from this there are only about a dozen wires to be connected, and these do not entail soldering—the bugbear of most amateur constructors, and the instruction chart gives very complete details which prevent the amateur from going wrong.

The metal chassis is built up as an entirely separate item, and the tuning stages are adequately screened giving complete stability. The circuit employs two S21 screen-grid metallised battery valves in the H.F. and detector stages, and this combination has been found to conduce to a high degree of sensitivity and selectivity. The advantage of a screen-grid detector lies in the fact that it allows a high stage gain with a minimum damping of the preceding tuned circuit. The output valve is resistance-capacity-transformer coupled to the detector.

Three Controls

The three controls are situated in the centre of the front panel below the speaker fret. The middle of the three knobs controls the dual gang condenser in the usual manner, the dial aperture figuring above. The tuning is very simple as the scale is calibrated in wavelengths. The wavelengths covered are approximately 210-535 metres on the medium band and 1,000-2,000 on the long band, and this is adequate for most purposes.

A second knob actuates the range switch. This has two well-defined positions and is very positive in its action. A third knob serves for volume control. This control simultaneously affects both the aerial input and reaction. It is graded and on test was found to give a very smooth and satisfactory variation of volume. The battery "on and off" switch is situated at the rear of the instrument, and is easily accessible.

Facilities are furnished for the connection of a gramophone pick-up. The pick-up is given a two-stage output, so that ample volume is available for all normal purposes. The use of the pick-up does not entail the disconnection of the aerial, but it was found that the aerial tuning knob and the radio volume control need to be set at their minimum positions for most effective results. The loud speaker incorporated in the set is a new design on the moving iron principle and drives a floating cone, and the resulting reproduction was of quite good quality.

The set is designed to operate from a standard 100 volt H.T. battery, and the space allotted within the cabinet is adequate not only to accommodate this, but also a G.B. battery and a 2-volt accumulator. It was noticed that the space is even sufficient for the inclusion of an H.T. mains power unit in lieu of an H.T. Battery. By such an arrangement all auxiliary wiring or components outside the cabinet are dispensed with.

To protect the valves a fuse is incorporated at the back.

The set worked immediately it was connected up and the handling of the controls was mastered in a few minutes. Although tested near the Brookman's Park twin stations selectivity was of quite a high order and in normal situations at least twelve to eighteen stations should be tuned in with ample strength for listening to in comfort. When it is remembered that the price of this set is nine guineas, ex batteries and accumulator, we say unhesitatingly that it is remarkable value for the money. Our only criticism is that we should have preferred a moving coil speaker but, of course, this would have added to the price of the set.

Ealex Short Wave Adaptor

We learn from Messrs. J. J. Eastick & Sons that they have introduced one or two new models of their original short wave convertors. In the illustration on this page will be seen an interior

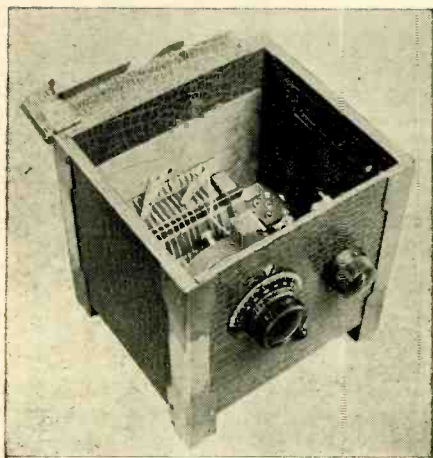

Interior view of the battery type short-wave converter.

view of the battery type model and readers are referred to page 114 of our May, 1930 issue for a very comprehensive report of this most efficient piece of apparatus.

Undoubtedly, this addition to any wireless set covering the medium and long wavebands will open up a new vista which in the majority of cases has been closed to the listener. The additional apparatus is simple to connect and work and merits serious consideration from our readers.

Belling-Lee "Scrufuse"

The importance of including fuses in any form of wireless receiver has been stressed in this journal so need not be gone into again. Now, in spite of the general absence of standard ratings there are many who still show a partiality towards the employment of lamp fuses, forgetting that there is a risk of including an ordinary lamp

bulb instead of one designed specially for fuse purposes.

The new Scrufuse of Messrs. Belling and Lee is an attempt to meet this case and should be welcomed by those who desire replacements for their screw-type holder. This fuse has many advantages among which can be mentioned its greater strength than the lamp fuse while the length of the fuse path is greater. Furthermore, it lends itself readily to the colour coding which is now becoming standard practice with fuse makers and can be marked easily with its rated value.

We have tested several samples of these new products—they are available in five different ratings from 60 mA to 750 mA—and found them remarkably well made. They carry their rated current continuously and blow almost instantly at approximately 50 per cent. overload. This is altogether a very good product, well up to Belling-Lee's high standard, and all the ratings are one price, namely 6d. each.

Free Enquiry Service

May we draw the attention of new readers to our free inquiry service. Every experimenter in taking up television is faced at some time or another with a technical problem on which advice is required. In view of the increasing interest in this science and the need for making technical information widely available, TELEVISION has arranged to answer questions without charge. Inquiries should be stated as concisely as possible and written on one side of the paper only, and *must be accompanied by the coupon* which appears on another page. The Editor cannot at the moment undertake to supply circuit diagrams, blue prints, etc., in this free service, but will welcome inquiries on every aspect of television.

Autumn Lectures.

Mr. J. J. Denton, hon. secretary of the Television Society, will give a course of lectures on television, illustrated by experiments and demonstrations, at the Borough Polytechnic, Borough Road, London, S.E.1, on Thursdays from 8 to 9.30 p.m. commencing on October 6. Students may enrol on any evening after 6.30 p.m. This course of lectures will be followed by 12 lectures on Television at Morley College, on Fridays from 7.30 to 9.30 p.m., commencing on January 5, 1933. The lecturer will deal with the principles involved in early experiments and in the most recent developments of television; the development of sound and sight signals by electrical means; scanning devices, types of transmitters and receivers and other aspects of the subject.

MISCELLANEOUS ANNOUNCEMENTS

Readers wishing to sell secondhand apparatus and components, books, etc., are invited to make use of this advertisement section at the rate of 3d. per word (minimum, 36 words).

Announcements should be written on one side of the paper only, and accompanied by a postal order made payable to Benn Brothers, Ltd.

BALLBEARING Electric Motors, extra long spindle ideal for synchroniser, high grade absolutely best value 35/-. Motor variable fixed resistance 7/6, Knob adjusters 2/6, Phonic wheel 4/-, Poles, yoke, assembly 15/-, Square hole Scanning Disc 12/6, Synchronisers, framing controls, Neons, Lenses, everything for television, lowest prices.

Secondhand Bargains, Motors reconditioned 13/6, double ended 18/6, Mains transformers (425 h.t. for Vissionette 21/-), eliminators chokes condensers etc. send requirements. Seen by appointment—A.C.R. 47, Gerrard Street, Piccadilly.

THE owner of BRITISH PATENTS numbers 364231 and 364232 offers licenses for short periods without charge to substantial firms wishing to experiment. The patents concern *spiral mirrors* and *spiral mirror drums* for scanning.—Apply E. WOTTON, SOLICITOR, RAMSGATE.

MIRROR Drums, Component parts for Home Construction. Scanning Discs, Motors, etc.—JOHN SALTER (Established 1896) Experimental and Radio Engineer, 13, Featherstone Buildings, High Holborn, London, W.C.1. Telephone—Chancery 7408.

A. DOSSETT, Commercial Artist and Draughtsman for all technical diagrams illustrations and layouts—HAZLITT HOUSE Southampton Buildings Chancery Lane London Holborn 8638.

RADIO Vision Receptors (Television). Parts for Experimenters supplied by JOHN SALTER (Established 1896), Experimental and Radio Engineer, 13 Featherstone Buildings, High Holborn, London, W.C.1. Telephone—Chancery 7408.

L. LEAMAN
97, NORTHFIELD AVENUE
WEST EALING, LONDON, W.13
For Radio and Television
DEMONSTRATIONS DURING TELEVISION TRANSMISSIONS
Baird Components Supplied
PHONE: EALING 5394 (MEMBER, TELEVISION SOCIETY)

BOROUGH POLYTECHNIC
BOROUGH ROAD, LONDON, S.E.1.
(Elephant and Castle)

A course of LECTURES on
TELEVISION

(Illustrated by Experiments and Demonstrations)
will be given on THURSDAYS, 8-9.30 p.m.
commencing 6th October, 1932, by

J. J. DENTON, A.M.I.E.E. (Hon. Sec. Television Society)

* Students may enrol on any evening after 6.30 p.m. Fee for Student residing in the administrative County of London. 2! s.

“ THE ELECTRICIAN ”

The oldest Weekly Illustrated Journal of Electrical Engineering, Industry, Science and Finance

Established 1861 Price 6d. weekly

WILL KEEP YOU FULLY INFORMED

of the progress of this great science
in all its aspects, including radio.

Write for a specimen copy to the Publisher,
BOUVERIE HOUSE, FLEET STREET, LONDON, E.C.4

- LAYOUTS.
- ARRANGEMENTS.
- MODERN IDEAS.
- BLUE PRINTS.
- ELECTRICAL DESIGNS.
- RADIO DIAGRAMS.
- TELEVISION INVENTIONS.

**D
R
A
W
I
N
G
S**

Lambert.
8, COUNTY ROAD,
THORNTON HEATH,
SURREY.

“ TELEVISION ”
COUPON
FOR FREE INQUIRY SERVICE

Name

Address

Enclose with this coupon a stamped addressed envelope.
Readers writing from abroad should use the Universal Stamp Coupon, obtainable from most post offices.

October, 1932

11-6 X-10-6

THE FOLLOWING DEALERS ARE WILLING TO DEMONSTRATE TELEVISION

"TELEVISORS" • KIT SETS • COMPONENTS

AMERSFOORT (HOLLAND)
 BAGSHOT
 BEDFORD
 BEDWORTH
 BEXLEY HEATH
 BICESTER
 BIRMINGHAM
 BIRMINGHAM
 BISHOPS STORTFORD
 BOURNEMOUTH
 BRACKNELL
 BRAINTREE
 BRIDGEND
 BURTON-ON-TRENT
 CAERPHILLY
 CHALVEY
 CHESTERFIELD
 CHIPPERFIELD
 COLCHESTER
 COULSDON
 COVENTRY
 COVENTRY
 DARLINGTON
 DEAL
 DEWSBURY
 DOVER
 EASTBOURNE
 EASTBOURNE
 ERDINGTON
 FELIXSTOWE
 FOLKESTONE
 GERRARDS CROSS
 GODALMING
 GRAYS (ESSEX)
 KIRKCALDY
 LEIGHTON BUZZARD
 LLANDUDNO

WILLEN VAN LOON
 LINDFIELDS GARAGE
 JEAKINGS & SON
 T. H. RUSSELL
 J. SPENCER (LONDON) LTD.
 LAMBOURNE BROS.
 C. WEBB LTD.
 SHANNON & CAPENER
 H. R. MOORE LTD.
 J. E. BEALE LTD.
 DRAKE & MOUNT LTD.
 COX'S GARAGE
 WRIGHT & ASHWORTH
 RADIO & CY-KAR MART
 L. PRITCHARD
 J. D. HALLIDAY
 G. KENNINGTON (CHESTERFIELD) LTD.
 A. C. GEORGE
 SHROSBURY & BAKEWELL CO. LTD.
 THE "VIC" WIRELESS STORES
 MAX. A. BUCH
 PARKER'S RADIO SERVICES
 C. SHARP
 G. CLOUT
 BICKERS LTD.
 DOVER RADIO STORES
 A. BODKIN & CO., LTD.
 OWEN H. RELLY
 STANLEY'S RADIO
 L. E. PULFORD
 BOBBY & CO., LTD.
 R. F. CHIPPS
 H. J. CHALLEN
 GRAYS WIRELESS CO. (H. W. FRANKLIN)
 GIBB & WATSON
 GRIFFIN BROS.
 EVANS & EVANS

Stationstraat 32B
 Surrey
 Mill Street
 Tram Terminus, Coventry Rd.
 127 The Broadway
 47 Market Square
 41 Carrs Lane
 13 Aston Road North
 Northgate End
 Hants
 Berks
 Rayne Road
 Kings Bldgs., Adair Street
 Cross Street
 73 Princes Avenue
 Nr. Slough
 Victor Lane
 The Common
 73 Crouch Street
 21 Chipstead Valley Road
 143 Lower Ford Street
 3 Holyhead Road
 321 North Street
 Electrical Engrs.
 The Galleries
 4 Townwall Street
 11 Cornfield Road
 "Gavinwood," Willingdon
 191 High Street
 141 Hamilton Road
 48 Sandgate Road
 6 Oak End Way
 12 Church Street
 Clarence Road
 270 High Street
 11 High Street
 29 Mostyn Ave., Craig y-Don

LONDON :

BATTERSEA
 BAYSWATER
 BRIXTON
 BROMLEY
 CLAPHAM COMMON
 CRICKLEWOOD BROADWAY
 EALING
 EALING (WEST)
 EARLSFIELD
 EAST BARNET
 EDGWARE
 EDGWARE
 FULHAM PALACE ROAD
 HAMMERSMITH
 HOLLOWAY
 HOUNSLOW
 KINGSTON
 KNIGHTSBRIDGE
 KNIGHTSBRIDGE
 MUSWELL HILL
 NEW BOND STREET
 OXFORD STREET
 PECKHAM
 PIMLICO
 WEST NORWOOD
 WIGMORE STREET, W.
 WOOD GREEN
 LUTON
 NEWCASTLE
 NEW MALDEN (SURREY)
 NORWICH
 PERRY BAR
 PLYMOUTH
 RAMSGATE
 RAMSGATE
 ROCHDALE
 ROCHESTER
 SLOUGH
 STAINES
 TONBRIDGE
 WALLINGTON
 WALLINGTON
 WEST BYFLEET
 WEST DRAYTON
 WITLEY (SURREY)
 WORTHING

F. F. KELLY
 HOPE, NORMAN & CO.
 QUIN & ANTENS
 UNIVERSAL ENGINEERS
 DEMPSEY & CO
 HARDEN & CO.
 KEEN WIRELESS CO.
 L. LEAMAN
 H. HOLIER & SONS
 EAST BARNET WIRELESS STORES
 A. ALDERTON
 J. F. WISSON
 "ECONOMIC"
 W. H. OATES
 JONES BROS. (HOLLOWAY) LTD.
 SANDERS ELECTRIC & RADIO SUPPLIES
 BENTALLS LTD.
 BROMPTON RADIO CO.
 HARRODS LTD.
 VICTOR RADIO SERVICES
 KEITH PROWSE LTD.
 SELFRIDGE & CO., LTD.
 HAVIL RADIO
 F. DOVE & SONS
 E. SHELDRICK
 WIGMORE RADIO SERVICE
 DISTRICT SUPPLIES LTD.
 R. J. STEARN & CO.
 PAYNE & HORNSBY LTD.
 ACORN SERVICE STATION LTD.
 E. A. PRIEST & CO.
 WELLINGTON RADIO & ELECTRICAL DEPOT
 W. H. ANWORTHY & CO.
 J. CARMAN
 E. COVENEY & SONS
 BANNISTER & FITTON
 A. F. SMITH & SONS, LTD.
 G. CASE & SONS
 V. & D. KEALE
 A. T. LANGTON
 W. BELDING
 BULLOUGH BROS.
 A. LONG
 SPRATLEY BROS.
 G. WOOTON
 E. LAMB

5 Park Road
 85 Westbourne Grove
 Brixton Road
 1 Chatterton Road
 69 South Side
 99 Cricklewood Broadway
 1 Dare Road
 97 Northfield Avenue
 422 Garratt Lane
 8 Park Parade
 8 Bank Parade, High Street
 2 Cheapside, Deans Lane
 24 Fulham Palace Road
 195 Hammersmith Road
 Holloway Road
 119 Staines Road
 Surrey
 20 Brompton Arcade
 S.W.
 8 Firs Parade
 159 New Bond Street
 W.7
 30 High Street
 77 Pimlico Road
 493 Norwood Road
 36/38 Wignore Street
 43 High Road
 7 Manchester Street
 7 St. Andrew's Buildings
 Kingston By-pass Road
 28 St. George's Road
 303 Birchfield Road
 106 Tavistock Road
 65 King Street
 20 Belle Vue Road
 27 Milnrow Road
 215 High Street
 2, Grove Parade, High Street
 Kingston Road
 High Street
 9 The Parade, 320 Stafford Rd.
 34E Woodcote Road
 1 Byfleet Corner
 Station Road
 Northfields
 Franklin Road, Durrington

● GIVE YOUR LOCAL DEALER A CALL TODAY ●