

TELEVISION

**IMPORTANT
DEVELOPMENTS
PENDING**

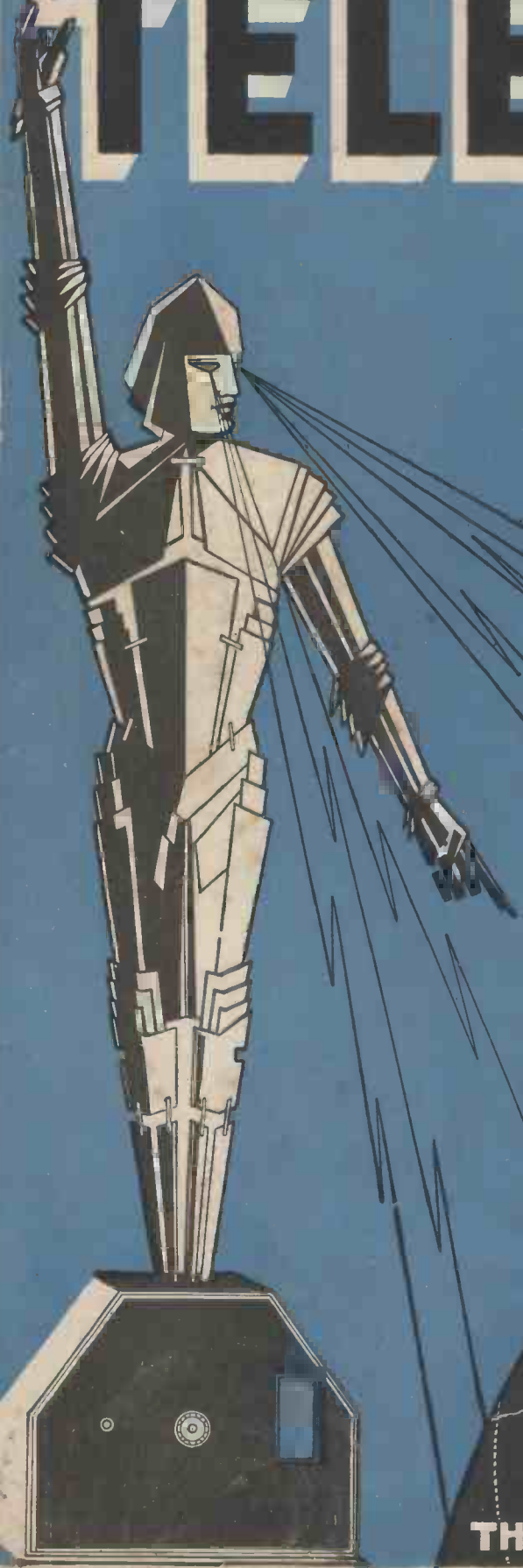

THE WORLD'S FIRST TELEVISION JOURNAL.

EMINENTLY
SUITABLE
XMAS GIFTS

BOUND VOLUMES
of
"TELEVISION"

HANDSOMELY BOUND IN
RICH BROWN IMITATION
LEATHER, MOROCCO
FINISH, LETTERED IN
GOLD ON FRONT AND
SPINE, COMPLETE WITH
INDEX.

HANDSOME PERMANENT RECORDS
OF THE WORLD'S FIRST
TELEVISION JOURNAL.

VOLS. 1, 2, & 3 **12'6** EACH
POST FREE

BINDING CASES
for
"TELEVISION"

AVAILABLE FOR THOSE
WHO WISH TO HAVE
THEIR OWN COPIES
BOUND. IN BROWN
CLOTH, LETTERED IN
GOLD ON FRONT AND
SPINE, WITH INDEX.

BOUND VOLUMES ARE PREFER-
ABLE TO LOOSE, WORN COPIES.

EACH **4'6** POST
FREE
*Indexes (only) for Vols. 1, 2, & 3, 6d. each,
postage 2d.*

TELEVISION PRESS, LTD,
505, CECIL CHAMBERS, STRAND, W.C.2

TEMPLE BAR 8169

TELEVISION

TELEVISION PRESS, LTD.

Editorial, Advertisement and Publishing Offices:
505, CECIL CHAMBERS, STRAND, LONDON, W.C.2
Telephone: TEMPLE BAR 8169

33921

SUBSCRIPTION RATES
13/6 PER ANNUM, POST FREE.
6/9 SIX MONTHS, POST FREE.
AMERICAN RATE:
\$4.50 PER ANNUM, POST FREE.
\$2.25 SIX MONTHS, POST FREE.

MSS. AND OTHER MATERIAL FOR EDITORIAL CONSIDERATION SHOULD BE ACCOMPANIED BY A STAMPED ADDRESSED ENVELOPE, AND SHOULD BE TYPEWRITTEN.

PRINCIPAL CONTENTS

	PAGE
THIS MONTH'S CAUSERIE	By Sydney A. Moseley 371
FAIR PLAY FOR TELEVISION	By Garry Allighan 373
ON THE NATURE OF LIGHT, PART II	By Sir Ambrose Fleming 374
INTRODUCING THE NEW TELE-RADIO RECEIVER, PART III	By H. J. Barton Chapple 376
OUR LATEST COMPETITION.	379
A BROADCAST TALK	By J. L. Baird 380
FROM MY NOTEBOOK	By H. J. Barton Chapple 385
A GIANT AMONG VALVES	388
"TELEVISION'S" QUERY CORNER	390
THE AMATEUR "VOLOHMETER"	By William J. Richardson 391
WORKSHOP HINTS	By Thos. W. Collier 395
A TRIBUTE TO EDISON	By Leslie P. Dudley 397
THE ENTHUSIAST SEES IT THROUGH	398
TRADE NOTES OF THE MONTH AND APPARATUS TESTED	402
LETTERS TO THE EDITOR	406

INDEX TO ADVERTISERS

	PAGE
"Armchair Science"	403
Baird Television Ltd.	iii (Cover)
Bapty, S. Lee	393
Bound Volumes	ii (Cover)
"Discovery"	405
Dossett, A.	408
Dubilier Condenser Co. (1925) Ltd.	387
"Irish Radio News"	407
Leaman, L.	389
Mullard Wireless Service Co., Ltd.	370
Oates, W. H.	375
"Psychology Foundation, S.A."	401
Salter, J.	408
"Television To-day and To-morrow"	iv (Cover)

ORDER FORM

CUT THIS OUT AND HAND IT TO YOUR NEWSAGENT.

To Mr., Newsagent,

Address

Please deliver to me at the address given below a copy of **TELEVISION** for January, and monthly thereafter until countermanded.

Name

Address

Mullard

THE · MASTER · VALVE

The Mullard 2-volt range, already supreme in performance, now includes the P.M.202, a super-power valve specially designed to economise in low-tension current consumption. With its low filament consumption of only 0.2 amp.—no more than that of an ordinary power valve—it gives large volume and high quality reproduction. It is thus particularly suitable for use in the output stage of portables and small battery operated sets. Take advantage of the efficiency, and fit one in your receiver to-day.

Price **13/6**

P M · · 2 0 2



**SUPER
POWER
OUTPUT**

MADE IN ENGLAND

Advert. The Mullard Wireless Service Co., Ltd., Mullard House, Charing Cross Road, London, W.C.2

Arks.

TELEVISION



THE OFFICIAL ORGAN OF THE TELEVISION SOCIETY

SYDNEY A. MOSELEY, *Managing Editor.*

Consultants { H. J. BARTON CHAPPLE, Wh.Sch.,
B.Sc.(Hons.), A.C.G.I., D.I.C., A.M.I.E.E.
C. TIERNEY, D.Sc., F.R.M.S.
W. J. JARRARD, B.Sc., A.R.C.S., A.I.C.

VOL. IV] DECEMBER 1931 [No. 46

THIS MONTH'S CAUSERIE

OUR first pleasing duty this month is to offer our congratulations to John Baird on his marriage in New York to Miss Margaret Albu. I always thought there were no flies on Mr. Baird, and this is borne out by his excellent choice and also by the extraordinarily efficient manner in which he kept this romance secret.

* * * * *

There are movements on foot which, at the time of writing, I cannot disclose, although there is every prospect of an announcement in the public press. If things turn out as I hope, they will crown the long and arduous work which I have regarded as peculiarly my own. At the same time there are prospects of important development in regard to the American rights of the British Company. The British Company did not enter America in the manner reported by the New York Press; they were simply invited by a number of people who thought that, in the interests of science and commerce, the Baird Company should take part in television in America. Therefore it was a friendly co-operation, which I am glad to say is developing very favourably. The result, I justly hope and anticipate, should have an excellent bearing on the situation in America. More I cannot say for the moment.

* * * * *

The position with the B.B.C. is also better than it

has been, although I must apologise to the number of listeners who complain that since television entered the programme the B.B.C. has been unable to announce the transmissions sufficiently far in advance. This is not the B.B.C.'s fault, any more than it is the fault of the Baird Company. The arrangements to go into programme time were suddenly decided upon and, since the B.B.C.'s time-table is made up well in advance, it was not possible to announce the special programmes. I think you will find that all this will right itself before long.

* * * * *

The new Postmaster-General is a dark horse, but I hope he will win the race. I am also hoping that he will take as keen an interest in the development of television as did his predecessors. All the Postmasters-General so far, with the exception of Major Attlee, took the opportunity of visiting the Baird studios and seeing exactly what was going on. Major Attlee was probably too busy, and I understand he looked in for a moment at the "Televisor" at the Post Office, but I take leave to say that the receiver at the Post Office, like the receiver at Savoy Hill, does not give the best results because of local interference. I think Major Attlee will regret that he missed the golden opportunity of seeing television in its home during his term of office.

*Entire Contents of this Journal copyright in the U.S.A., 1931, by Television Press, Ltd.
Foreign Translation Rights Reserved.*

The competitions which this magazine held in co-operation with the Baird Company proved so successful in the past that it is rather regrettable that there have not been more of them. The one which was held on Thursday, November 12th, during the morning transmission of television, was arranged suddenly, so that there was no time to announce it in the last issue of TELEVISION. However, announcements were duly made through the microphone and a very fine response was obtained.

I think that a good deal of interest was aroused and useful information derived from these experiments, and I understand now the Baird Company may arrange for more of them. Readers, therefore,



Mr. Baird with the daylight transmitter used to televise the parade of horses and finish of the Derby and which has now left for America.

should listen to the announcements made in the course of the morning transmissions.

America, as I have pointed out again and again, has shown more imagination and understanding of the television situation than most people in this country, and I wish to place on record that I think big developments within the next six months will more than justify all I have written on this point. At the same time it is exceedingly interesting to note that, after Mr. Baird's investigations in New York and after conferences with scientists on the spot, he cabled over for the daylight transmitter, with which he made history when he televised the last Derby. America has achieved much in the way of television, but apparently this was one of the few things that Baird could claim as an undisputed advantage.

This is to acknowledge the considerable help the London Press is giving these days to television. When there is news to print about television, it is printed. At the same time I find I have got into hot water through criticising the activities of Mr. Rothafel, the American entertainment magnate who came over to this country and was fêted by the very people who are calling out "British endeavour." Mr. "Roxy" certainly did not come over on behalf of British interests. He naturally came over on behalf of the big American organisation of which he is a prime factor. It is a mystery, too, about his reference to television. My criticism in this respect has been challenged by one of his publicity representatives. All I can say is, while I admire the energy and enterprise of "Roxy," I am going to keep my eye on him, and I advise all British manufacturers and all who are sincere in their protestations of "British first" to do likewise.

* * * * *

In surveying the field of activities of the British Company one must not forget France. I understand that developments in Paris shortly will be of great interest to those who have followed the efforts of the London firm to stake out claims all over the world.

* * * * *

Readers will rejoice in the occasional contributions to this magazine by the veteran and pioneer, Sir Ambrose Fleming. Sir Ambrose these days lives on the coast and naturally is not so active as one would like; at the same time I have pleasure in informing readers that he will continue to contribute occasional articles to the TELEVISION Magazine.

* * * * *

As regards Mr. Baird, his illness and marriage have held up the article promised by him. At the same time the typical speech delivered by him in the broadcast address in New York will be read with interest if not amusement by our readers.

* * * * *

I desire to call attention to the article by Mr. Garry Allighan, the publicity representative of the Radio Manufacturers' Association. I recommend it particularly to the members of the Association, who rely on their representative for obtaining the right news.

He points out that there is the danger of the British public being swept off its feet, by the talk of television, into American arms. In warning public opinion against this manœuvre, Mr. Allighan states quite definitely that the general feeling respecting the science is that if television is to come to this country it must come the British way and via a British system.

Sydney A. Mosley

Fair Play for Television

B.B.C. SHOULD SUPPORT BRITISH INVENTORS FIRST

MR. GARRY ALLIGHAN, in *The Yorkshire Weekly Post Illustrated* of November 7th, writes:

What does "Roxy's" visit mean?

There is a danger of the British public being swept off its feet, by talk of television, into American arms. It is my duty to warn public opinion against what is a very insidious manoeuvring of popular interest to the benefit of a big American entertainment factor. I will explain the present situation in detail.

Some days ago I was with two hundred other journalists and leaders of the entertainment industry invited to a lunch given in honour of Samuel Rothafel, known familiarly as "Roxy," the entertainment king of America. He was accompanied by various highly paid executives of the Radio Corporation of America and other branches of the mammoth international electrical trust which has thrown its octopus arms around the entertainment of the whole world.

I asked "Roxy" what was the object of the lunch—a most expensive function at the Carlton Hotel—and he replied, "We want to tell you all about Radio City which we are building."

"Radio City"

Radio City, it appears, is a huge building in New York which will be occupied by the Radio Corporation of America who control the talking film equipment, the National Broadcasting Company, the biggest radio distributors on that continent, and Radio Pictures Limited, producers of some of the finest films that have been shown in this country.

I told "Roxy" frankly that I could not see why the people of Britain should be interested in the building of a large entertainment edifice in New York, and asked him why he should expect us to be concerned in that matter.

He replied: "Because from Radio City will be broadcast radio programmes and televised programmes for reception in this country."

In this way did "Roxy," if I may use the term, blow the gaff. I can elaborate with details. Radio Corporation of America possesses the only possible competitive alternative to the Baird system of television. At this moment in the U.S.A. there are five million television sets ready to be imported into this country so that British owners can receive American television programmes.

American Plot

Behind this plot there are certain negotiations with the B.B.C. which are certainly very innocent or very

sinister. At this lunch I was speaking to the chief engineer of the National Broadcasting Company of America, and he told me that they were intending to broadcast American programmes through the B.B.C. services in this country.

He explained that only the best American programmes would be so broadcast in Great Britain,



An artist's conception of Radio City as it will look from the air.

and as the best programmes were sponsored by American advertisers, the B.B.C. would, if the plans matured, broadcast to British listeners programmes sponsored by American advertisers and containing American advertising material.

It is significant to note that on the day following the lunch "Roxy" and the other delegates from R.C.A. and N.B.C. visited Savoy Hill and took lunch with the chiefs of the B.B.C.

(Continued on page 404)

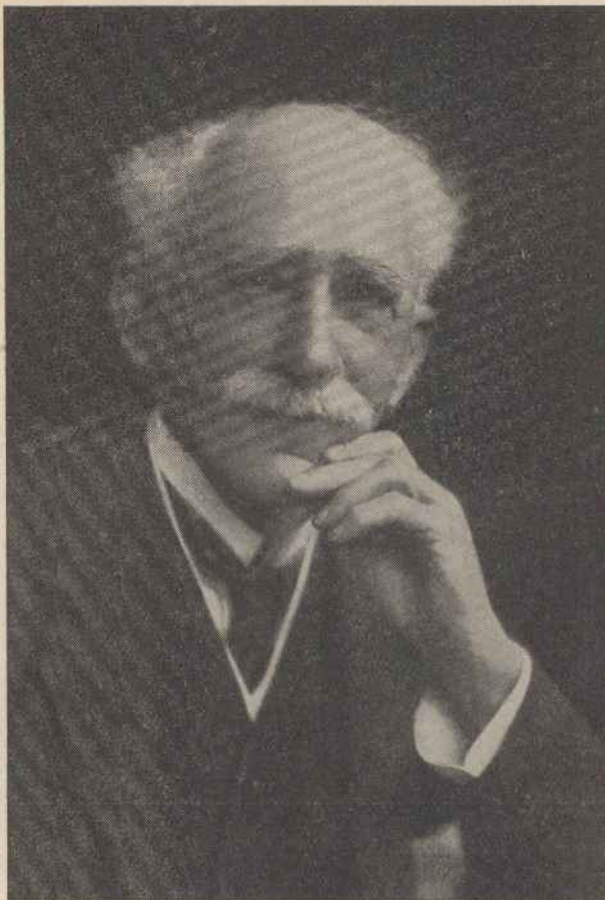

*Our distinguished contributor
Sir Ambrose Fleming, D.Sc., F.R.S.*

(PART 2)

THERE is a close relation between the energy e of a photon and the frequency n of the kind of light with which it is associated expressed by the law $e = nh$, where h is called Planck's constant and has the value $6.55/10^{27}$ nearly from the German physicist who first called attention to it.

This yellow light has a frequency of about 5×10^{14} and hence the yellow photon has an energy of $32.5/10^{13}$ or $3\frac{1}{4}$ billiergs. The violet photon has about twice the energy of the red photon. But the energy of the X-ray photon may be 25,000, as great as that of a yellow photon, and this is the reason why the exposure of the human body to X-radiation for any length of time is so extremely dangerous. The powerful X-ray photons destroy the human skin or epidermis when they are hurled upon it.

The question then arises, What is a photon? All photons travel through empty space with the same velocity, viz.: 300,000 kilometres per second, or nearly 186,000 miles per second. Moreover, a photon always moves from one place to another by the path which involves the shortest possible time of passage, no matter how much it may be reflected or retracted on its journey.

Then again a photon has a certain mass or weight

On the Nature of Light

By

Sir Ambrose Fleming,
D.Sc., F.R.S.

which is obtained by dividing its energy by the square of the velocity of light. Hence if e is the photon energy in ergs then $e/9 \times 10^{20}$ is the mass in grams. Thus if the yellow photon has an energy as shown of $3\frac{1}{4}$ billiergs its mass in grams is $3.61/10^{23}$. We can then tell how many photons there are in a space of 1 centimetre cube filled with bright yellow light.

It can be shown that very bright sunlight expends against a black surface of 1 sq. cm. area on which it falls about 1,350,000 ergs per second, and since all this energy is contained in a column of light 3×10^{10} centimetres long and 1 sq. cm. in section, the energy in 1 centimetre cube of space filled with bright light is about $45/10^6$ ergs or 45 millionths of an erg. But we have seen that the energy of a yellow photon is about $3\frac{1}{4}$ billiergs or $3\frac{1}{4}/10^{12}$ erg. Hence in a centimetre cube filled with bright sunlight there must be about 14 million photons. These photons are to be thought of as distributed about the volume but to be moving forward with the velocity of 300,000 kilometres per second.

In addition then to the photons, we must think of a beam of light as consisting of a train of electromagnetic waves and the photons as distributed along the wave so that the maximum density of the photons agrees in locality with the maxima of electric and magnetic force in the wave.

The true wave conveys very little energy. The energy is located in the photons, which are, so to speak, carried forward with the wave crests. Just as particles of iron in a magnetic field tend to accumulate in places where the field is strongest, so the photons seem to congregate at the antinodes of the

electromagnetic wave where the electric and magnetic forces are strongest and are carried forward with the wave crests.

This, then, accounts in a simple manner for the phenomena of interference. If two rays of light originating in one source pass by two paths, differing in length by an odd number of half wavelengths to one and the same point they annihilate each other. There are then at that point no photons, because there is no electric and magnetic force. On the other hand, if the waves conspire to increase the amplitude, then the photons increase at that place also. The photons are so swept forward by the waves and always exist at those places where the wave amplitude is greatest, and do not exist at all where there is no amplitude.

Going a little farther we can mention certain interesting relatives between matter and light.

We know that matter or chemical atoms are built up of smaller particles or atoms of electricity called protons and electrons. An atom of hydrogen gas consists of 1 proton and 1 electron. The proton has about 1,840 times the weight of an electron.

Now an atom of tungsten, the metal used for the filaments of electric lamps, weighs 184 times as much as the atom of hydrogen.

Hence as regards weights or masses we have the following relatives. An atom of negative electricity or an electron weighs $9/10^{28}$ of a gram. An atom of hydrogen weighs 1,840 times as much as an electron. An atom of tungsten weighs 184 times the atom of hydrogen or 338,540 times as much as an electron. But we have seen that a photon of yellow light weighs only about $1/300,000$ th part of that of an electron.

Hence a light photon is as much less in mass than an electron as an electron is less than an atom of tungsten.

The question then arises whether protons and electrons which are the constituents of matter may not themselves be built up of light photons or of some smaller elements. We know from astronomical arguments that the matter of which the sun and stars are composed is melting away into radiation to supply the light and heat they emit. Our sun loses 240 million tons of its mass every minute to supply its light and heat, and the same or more for the stars.

Only a very, very small fraction of all this radiation is caught and used on planets and other stars, and the rest all voyage intermittently through space. We may ask, what becomes of all this energy? Is it possible these wandering photons are built up again in some far distant place into new matter in the form of protons and electrons? If the material universe is melting away with light, is it possible that light can condense again into matter? Sir James Jeans in his book *The Mysterious Universe* has given an answer in the negative to this suggestion, because, as he points out, such a re-formation of matter from energy would contradict the second law of thermodynamics. But this second law is only true for us because we cannot handle individual atoms; we can only deal with averages of enormous numbers.

In the preceding paragraphs we have written of the light photons as if they had a continuous existence and were propagated bodily through space just as we conceive electrons to move.

But there are strong arguments for thinking that the photons do not move from place to place as photons; that is, as little packets of energy or light quanta as they are called.

The relation of atoms to radiation is such that when an atom emits radiation it always does so in an exact integer number of photons or quanta. When an atom absorbs radiation it always takes in, if at all, a single photon or quantum. If the energy of that photon is not sufficient to ionise the atom the atom will not take in any of it. If it is more than sufficient, then the atom uses the surplus to give greater velocity to the emitted electron but not to emit more electrons.

The phenomena of diffraction and interference compel us to admit that light travels from place to place as waves or undulations and the phenomena of polarised light also compel us to admit that these undulations are of such a nature that the vector which changes or oscillates is in a direction at right angles to the line of propagation. Again the energy distribution must be continuous over the wave front. Nevertheless, when atoms give out or take in radiation they do it in whole mouthfuls at a time, all or not at all.

It is as if persons were pouring water into a lake always in whole bucketsful at a time at one place and others at some other place were taking water out always in whole bucketsful. The water would not flow through the lake in bucketsful distinct from the rest of the water.

Any theory of light to be valid must therefore take account of this peculiarity of the atomic appetite for radiation.

Whilst maintaining the classical explanation of diffraction, interference, and polarisation, it must explain how this energy is given out or taken in by atoms in whole quanta if at all. Also it must explain how an atom can draw out this quantum from a wave so feeble in energy that there is not a whole quantum in an area of the wave front equal to the area of the atom.

Much therefore remains to be discovered before we can say we understand the true nature of that familiar thing, a Ray of Light.

W. H. OATES

COMPLETE TELEVISION SERVICE

Our Depot affords unique facilities to those interested in Television. Our own transmitting apparatus enables us to give callers demonstrations upon request.

DEMONSTRATIONS

BETWEEN 9 A.M. AND 6 P.M.

THE BAIRD "TELEVISOR," ALSO HOME CONSTRUCTOR'S "TELEVISOR" KITS, SUPPLIED FROM STOCK.

Only genuine Baird components are supplied by us. We have a full range available of parts and accessories.

195, HAMMERSMITH ROAD,
LONDON, W.6. RIV. 3342.



Introducing the New Tele-Radio Receiver

(PART 3)

DESIGNED AND DESCRIBED BY
H. J. Barton Chapple,
Wh.Sch., B.Sc. (Hons.), A.C.G.I.,
D.I.C., A.M.I.E.E.

HAVING disposed of the vision apparatus itself, it behoves us now to examine the various alternative methods which are open for adoption as far as the vision wireless receiver is concerned. Several correspondents have written to me on the matter since I first introduced the series, and it is certainly not going to be an easy matter to satisfy all tastes.

A Reasonable Plea

Quite justifiably it has been pointed out that anyone with a good-quality wireless receiver normally

slightly. Whereas it was my original intention to feed both receivers from one high-powered eliminator, I feel that perhaps the largest majority will be served if I build the two receivers as almost separate entities. Whether or not the speech set is required can then be left to the individual to decide, and in no way will it really affect the final course, except that two separate eliminators will be made up with separate functions instead of one large one with a dual function.

Looked at from another point of view this may be the more economical plan, for whereas provision would have had to be made in the form of an anti-



⊗ ⊗ ⊗

Interval coupling is an item of extreme importance which has to be considered carefully when designing a wireless receiver. Certain of the components needed are illustrated, and only those of the highest grade must be utilised.

⊗ ⊗ ⊗

in use in the home for the reception of sound will not feel disposed to build another one of a similar character to include in a large cabinet. The reasonableness of this plea has made me alter my plans

official load on the large eliminator to take the place of the vision set which obviously has only a limited use because of the paucity of the television transmissions, each eliminator can be designed to give its

maximum efficiency and be used at will. I shall make it possible for either set to feed the loud speaker, so that comparative tests can then be made by the constructor.

R.C. versus Transformer

So much for that side of our question; now let me deal with another. My remarks concerning the superiority of resistance-capacity coupling over any other form when judged from the really best-quality standpoint has involved me in several arguments with protagonists of other forms of coupling, mainly transformer. For example, one of Messrs. Fer-

LS5A type, while the milliammeter is what is called the three-way type, having three distinct ranges of 0/12, 0/12, and 0/120 milliamperes. The valves V_1 and V_2 are of the MHL4 type.

Phase Change

In the course of the discussions that have centred round this R.C. versus transformer ideal (it has been raging now since the first day that wireless experimenters began dabbling in the science) the question of phase change was naturally raised. This has an important bearing on the quality of the resultant television image, and on the face of it would appear to be one of those things which

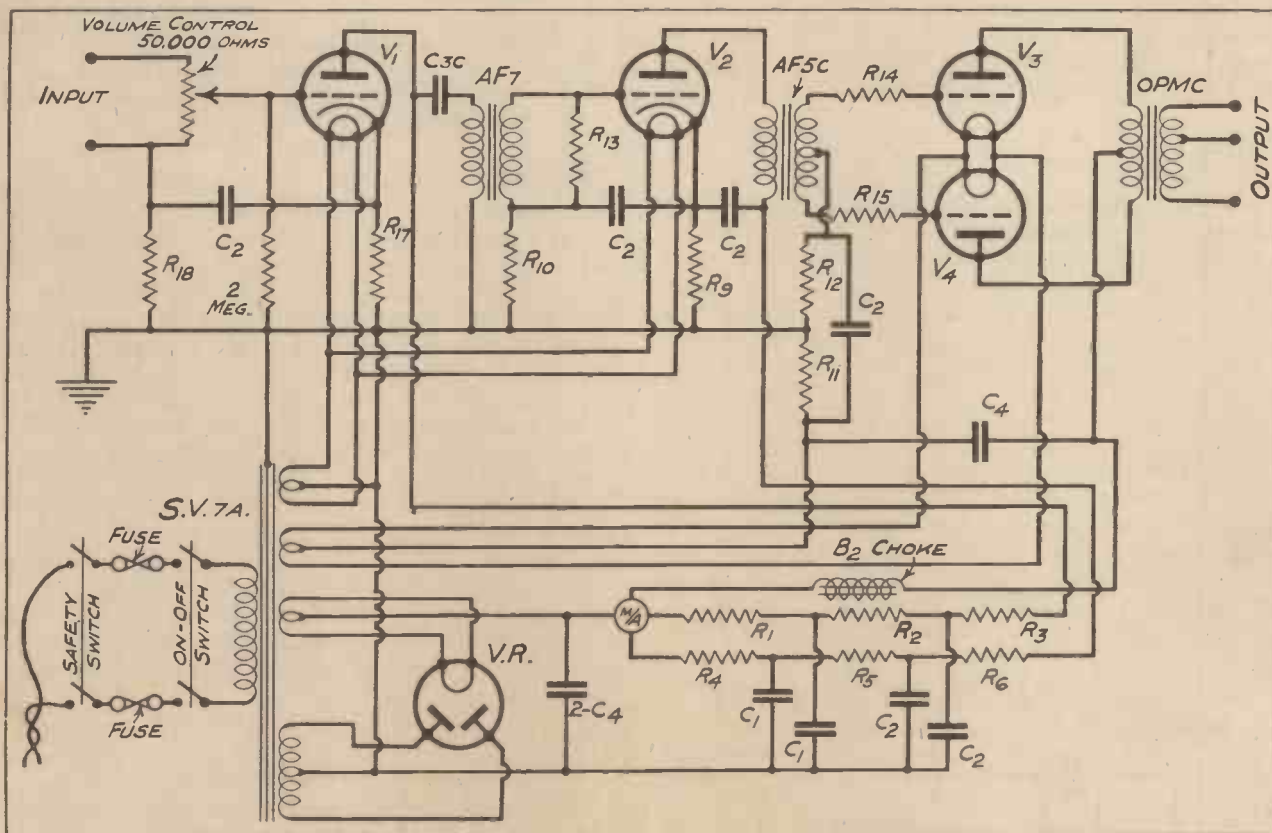

Fig. 1.—The circuit diagram of a really first-class A.C. mains amplifier, complete with H.T. feed and special decoupling devices. The output valves are in push-pull and the frequency characteristic of the whole amplifier is of the highest order.

ranti's experts has, both in conversation and subsequently by correspondence, brought all his guns to bear upon me to prove that my remarks were not strictly correct.

Readers may have noticed that on Messrs. Ferranti's stand at the recent radio exhibition at Olympia was a very fine A.C. mains amplifier, which I learned had been so designed that when complete with its rather elaborate decoupling devices gave a straight line characteristic up to 9,000 cycles. While full data is not yet available owing to one or two minor changes which are being made, Fig. 1 gives the main essentials, and I am sure that readers will be interested in examining this diagram. The two last valves working together in push-pull are of the

would make television absolutely impossible.

This, of course, is not the case, and the same point occurs in connection with musical reproduction. For example, in an orchestra it is impossible for every instrument to be played precisely in phase with every other instrument due to the human element, and it is suggested that the phase differences produced by the characteristics of the transformers are minute compared with this. Again it has been stated that it is impossible to discern the difference between the note produced from a violin when the bow is moved upwards and then suddenly reversed, although, in this case, the note produced while of the same frequency and amplitude is actually 180 degrees out of phase.

Overloading

It should also be borne in mind that even in a resistance-capacity coupled amplifier phase changes do take place, and it would appear that these can be avoided only by doing away with the coupling condensers, and this presents considerable difficulties from the practical point of view. One of the main troubles, of course, is bound up in endeavouring to obtain an R.C. amplifier that does not overload (or any amplifier for that matter), and it is well recognised that the R.C. amplifier distorts far more dreadfully when overloaded even momentarily than is the case with the transformer-coupled amplifier.

I mention all these points to assure readers that if we are out for the very best results every avenue must be explored with meticulous care, and I am doing everything that I can to make this investigation a thorough one.

Detection

Another correspondent very kindly reminded me of the new development in power-grid detection which was described by Mr. F. R. Colebrook in the *Wireless World* in June last. It was pointed out in the article that as far as the grid circuit is concerned very large signal voltages can be rectified without distortion by the grid detector, but there are limitations due to curvature in the anode characteristic.

It is found therefore that the single-valve power-grid detector requires a high anode voltage before linear results are possible, and to avoid this, as well as to provide certain additional advantages, the author suggested the simple expedient of dividing the functions of rectification and amplification, and allocating each to a separate valve.

In Fig. 2 is shown a method of connecting the anode of the rectifier valve when reaction is not required, while Fig. 3 shows the complete circuit of the dual-valve detector with provision for reaction.

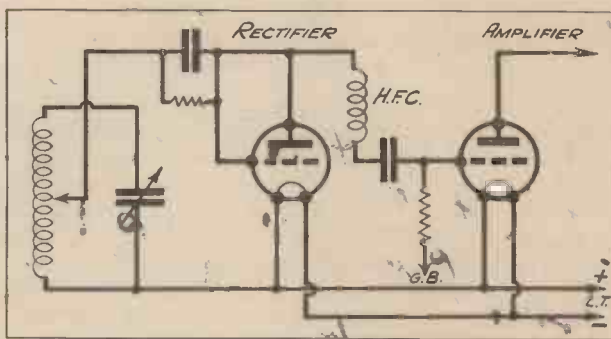

Fig. 2.—When reaction is not required the anode of the rectifier valve can be connected in this manner.

Mr. Colebrook points out that apart from the introduction of the additional valve no other requirements are imposed on the remainder of the set, which can be of quite conventional design. Moreover, normal decoupling resistances can be used in the rectifier stage since the anode voltage conditions

are much less stringent than in the original power-grid rectification circuit.

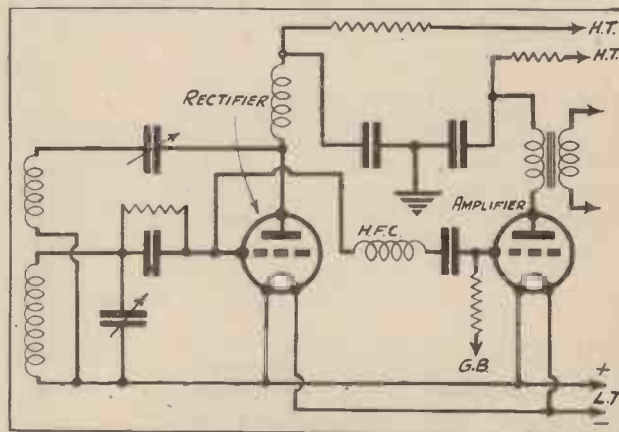

Fig. 3.—Modifications introduced to provide for reaction.

A Loss of Brilliance

Reverting once more to the question of high-frequency amplification with which I dealt briefly in the first article of this series, we must not forget the distortion introduced in the high-frequency stage or stages. The figure of 8,000 cycles each side of the resonant tune position is the figure frequently quoted as being desirable for having almost the same degree of amplification as the "tuned" frequency. If we have a low-resistance resonant circuit, then the resultant resonant curve is sharp and there is a serious loss of the higher notes, and "brilliance" from the musical standpoint or intimate detail from the television angle is lost.

A circuit having a comparatively high resistance will reintroduce this brilliancy by flattening the resonance curve, but we are faced immediately with another factor brought about by modern conditions of high-powered broadcasting, namely interference or lack of selectivity.

Apparent Incompatibility

This apparent incompatibility between selectivity and absence of distortion is a very acute one, and is now being tackled by radio designers. One method which is gaining popularity is the employment of band-pass filters in the high-frequency side. In some sets where reaction is used the manufacturer has offered a partial solution by giving both negative and positive reaction.

The former condition is brought into play when receiving moderately strong stations not requiring great amplification, for in this way the effective resistance is increased and high-note loss reduced. By reverting to the latter condition, selectivity is improved by effective resistance reduction and amplification is normal. These points have an important bearing in a wireless set to be used for receiving television signals, which can be resolved in the vision apparatus as an image of the highest quality, and continuous experiment must be made to achieve the ideal condition.

Our Latest Competition

ON Thursday, November 12th, during the course of the television broadcast by the Baird Company from their studio at Long Acre, a competition formed part of the programme as had been announced on three of the days prior to this event.

The competition took the form of a simple story, which was read out slowly by the announcer, there being fifteen missing links in this story. In the "Televisor" competitors were able to watch exactly all the actions of the two artists participating, and were able to note the movements conforming to the text.

The story is printed below, and it will be seen that instead of being complete, fifteen of the actions are omitted, and these were definitely portrayed by the artists and broadcast by television.

Every competitor was asked to note exactly these fifteen distinct actions, and describe them in their own words so as to make the story complete. They were then asked to write down the numbers against the clues as they were read out, and send in a list to 505 Cecil Chambers, giving these separate items.

A large number of entries was received, but unfortunately several of the competitors failed to comply with the very simple rules which were laid down and, in consequence, were automatically disqualified. Amongst the remainder we found one competitor who successfully wrote down a list giving these missing links in their exact order and exact description. We have much pleasure, therefore, in congratulating Mr. C. C. Buckle, of 64c Mattock Lane, West Ealing, W.13, on his remarkable effort. He has been forwarded a copy of *Television To-day and To-morrow*, and we trust the study of its pages will enable him to improve still further his knowledge of the subject.

The Story

"We are taking you to see a certain young lady who shall remain anonymous. When we see her she is sitting in a chair before the fire, busily *Clue No. 1*, which pastime she seems to enjoy. Suddenly we see her rise, cross the room and *Clue No. 2*, which occupies her for several seconds, during which she is smiling to herself. She then *Clue No. 3*, and tidies the room.

"Apparently a bell rings, for she rises and a young man enters. She seems pleased to see him, and is more delighted when he gives her *Clue No. 4*, which he promised her some weeks before. He is then seen to *Clue No. 5* which she *Clue No. 6*.

"Being the perfect hostess, she offers him *Clue No. 7*, and rings for the maid, who enters and is given an order.

"They talk together, gesticulating, and are evidently in deep argument. Suddenly they seem to disagree, for he rises and paces up and down.

"In the meantime the maid enters with *Clue No. 8*, which are put on the table, and the maid retires.

"A little ashamed of having quarrelled with her guest, and desiring to give an impression of nonchalance, she walks across the room to a mirror and *Clue No. 9*, after which she *Clue No. 10*, and finally sits down in a happier frame of mind. Meanwhile her visitor is comforting himself with *Clue No. 11*, and his hostess follows suit.

"He then appears to have a sudden thought, for he glances at his watch, and searches for *Clue No. 12*, into which she *Clue No. 13*. On bidding each other good-bye they are seen to *Clue No. 14*, and he takes his departure.

"The young lady moves towards her chair, sits down, and is again seen busily *Clue No. 15*."

Solution of Competition

- | | | |
|----------|-----|-----------------------------|
| Clue No. | 1. | sewing. |
| " " | 2. | lift receiver of telephone. |
| " " | 3. | puts telephone down. |
| " " | 4. | a book. |
| " " | 5. | remove his coat. |
| " " | 6. | takes from him. |
| " " | 7. | a chair. |
| " " | 8. | two cups and saucers. |
| " " | 9. | powders her nose. |
| " " | 10. | combs her hair. |
| " " | 11. | drinking. |
| " " | 12. | his coat. |
| " " | 13. | helps him. |
| " " | 14. | kiss. |
| " " | 15. | sewing. |

IMPORTANT NOTICE TO READERS

WITH the increasing interest which is being manifested in television developments and the growing numbers of amateurs who are conducting definite experiments in the science, we have had a very large number of queries sent in from readers who are seeking advice.

We are, therefore, inaugurating a query service for the benefit of these readers. Will they note that we shall be pleased to give advice on their problems, provided these are set out carefully and neatly on one side of the paper?

There will be a nominal charge of one shilling for this service, the number of queries to be answered for this sum not to exceed one. We cannot, however, undertake to supply blue prints, circuit diagrams, etc., in this service.

If there is space in the magazine, we shall include one or two selected queries in our Editorial columns, so that others can reap the benefit of our advice.

A Broadcast Talk by John Logie Baird

GIVEN ON SUNDAY, OCTOBER 18th, 1931, FROM STATIONS W.M.C.A. AND
W.P.C.H., NEW YORK.

LADIES AND GENTLEMEN,
It is a very great pleasure and privilege to address you by the invitation of Station W.M.C.A., which has asked me to give a short talk on my impressions of New York, and to say a few words about my work on television.

Before doing so, however, may I pause for a very brief moment to say that in the death early this morning of Thomas A. Edison the world at large lost a great benefactor and one of the greatest pioneers of electrical science. Almost every branch

Well, my first impression of New York was associated with the bagpipes, for the United Scottish Clans very kindly arranged a reception for me on the pier, with a complete pipe band and a police escort. On landing from the boat we drove through the streets of New York to the hotel. I was positively thrilled by the overpowering magnitude of the buildings. In Europe a ten-story building is considered exceptionally high, in fact, a skyscraper, whereas in New York there do not appear to be any buildings less than twenty or thirty stories, and



⊗ ⊗ ⊗ ⊗ ⊗

Mr. Baird's original apparatus, to which he makes reference in the course of his broadcast talk, is now housed in the Science Museum at South Kensington. It was made from nothing more substantial than soap boxes, biscuit tins, sealing wax, etc., with a disc cut out of cardboard.

⊗ ⊗ ⊗ ⊗ ⊗

of scientific research was enriched by his contributions. In many parts of the world Mr. Edison was considered the greatest living American. I know that already Great Britain is mourning with you the passing of a magnificent personality and a master mind of modern science.

one building I have been in runs up to a hundred and two stories.

Apart from the buildings, the whole atmosphere of New York is very different from that of Europe. It is an atmosphere of go-ahead vigour, welcoming novelty and enterprise. The people here are all out

for progress, whereas in Europe we are inclined to look with distrust and suspicion upon anything new. In the last few days I have had an opportunity to look into the position of television on this side of



The birthplace of True Television—22, Frith Street, Soho, London.

the Atlantic, and I am truly amazed at the immense amount of public interest and the remarkably good work which has been done. This new branch of science is having a warm welcome, and every encouragement is being given to it, not only by the public but by the broadcasting authorities throughout the country, in strong contrast to the lack of interest and, in some cases, obstructionist attitude of the broadcasting authorities of Europe.

As an example of the acceptance of television in this country, the plans of this well-known station from which I am speaking to go ahead immediately with an up-to-date broadcasting television programme, and to use all means in their power to further the science and bring its benefits as quickly as possible to the public at large, are extremely encouraging.

Our Company is installing the necessary television transmitting apparatus, and we hope, in a very short time, to be sending out from this station regular television programmes similar to those which we are now sending out in London, but with this

difference, that through W.M.C.A. we shall have a very much longer time available. You are no doubt aware that this station has a sole concession for broadcasting Madison Square boxing matches, and it is hoped in a very short time to add to the word description of the fight by transmitting scenes of the actual fight itself. In addition, arrangements are being made for broadcasting outstanding theatrical events, such as opening nights of Broadway productions. This will be done with apparatus similar to that which we are using in England for broadcasting scenes such as the Derby horse-race as we did in June last.

I know you are all very much interested in what is being done in Europe in television, and perhaps you would like to hear some of my own early personal experiences.

In 1925 television was regarded as something of a myth. No true television had ever been shown—only crude shadows. At that time I was working very intensively in a small attic laboratory in the Soho district of London. Things were very black;



Miss Dora Selvey photographed with Mr. Baird on the occasion when her image was televised to the "Berengaria" in mid-Atlantic, and recognised on board by her fiancé, Mr. S. W. Brown, the liner's chief wireless operator.

my cash resources were almost exhausted, and as, day after day, success seemed as far away as ever, I began to wonder if general opinion was not, after all, correct, and television was in truth a myth. But

one day, it was in fact the fifth Friday in October 1925, I experienced the one great thrill which research work has brought me. The dummy's head which I used for experimental purposes suddenly showed up on the screen, not as a mere smudge of black and white, but as a real image with details and with gradations of light and shade. I was vastly excited and ran downstairs to obtain a living object. The first person to appear was the office boy from the floor below, a youth named William Taynton, and he, rather reluctantly, consented to submit himself to the experiment. I placed him before the transmitter and went into the next room to see what the screen would show. The screen was entirely blank, and no effort of tuning would produce any result. Puzzled, and very disappointed, I went back to the transmitter, and there the cause of the failure became at once evident. The boy, scared by the intense white light, had backed away from the transmitter. In the excitement of the moment I gave him half a crown (then worth 60 cents), and this time he kept his head in the right position. Going again into the next room, I saw his head on the screen quite clearly. It is curious to consider that the first person in the world to be seen by television should have required a bribe to accept that distinction.

From this moment I knew that success was assured, and on January 27th, 1926, I invited the

the general public, as it was given considerable publicity in the Press.

From then on the cash shortage ceased, and I was able to make apparatus out of more substantial and suitable materials than soap boxes, biscuit tins, etc. The first transmitting apparatus, for example, had a disc made of cardboard, and the lamp which supplied the illumination was a motor-cycle bulb enclosed in a perforated biscuit tin. The subject for all these preliminary tests was a dilapidated ventriloquist's dummy, and the whole of this conglomeration now rests in the Science Museum in London.

In these preliminary experiments very bright lights were used, and while listening to the complaints of the sitters who were dazzled and blinded by the brilliant illumination, the idea occurred to me to use invisible rays instead of light. This proved by no means an easy matter. I first of all tried the ultra-violet light, and several of the staff nearly lost their eyesight due to the blinding effect of the rays. The next effort was to use the rays at the other end of the spectrum—the so-called infra-red rays, and after some trouble the experiment met with success, and I was able, towards the end of 1926, to demonstrate again to the Royal Institution the transmission of a person sitting in total darkness. This phenomenon I christened "Noctovision" or "seeing in the dark," and it was subsequently shown at the British Association of Science when people sitting

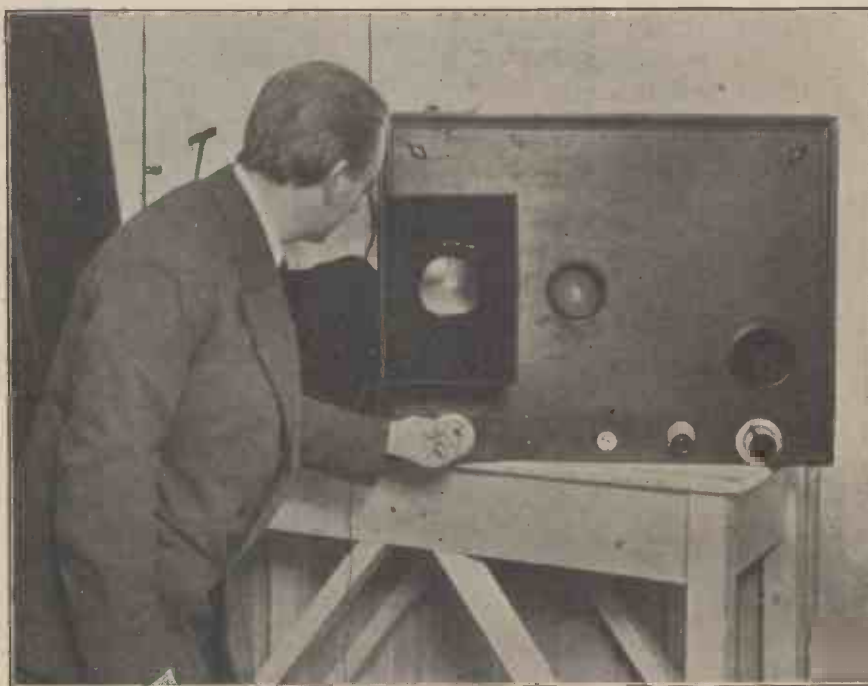

Mr. J. L. Baird "looking-in" on the screen of the identical "Televisor" which was used in the trans-Atlantic and mid-Atlantic experiments.

Royal Institution, which, as you probably know, is one of the leading scientific bodies of the world, to a demonstration. Over forty leading scientists turned up, and the little laboratory and the stairs leading to it were packed with some of the most distinguished scientists of Europe. The demonstration was a great success, and excited immense interest, not only in the world of science but among

in total darkness at Leeds were transmitted by telephone line to London, approximately two hundred miles distant.

An interesting little episode occurred in connection with the first experiments of broadcasting by noctovision. One of the young lady members of our staff was used as a subject. During the noctovision tests, I was looking in at a check receiver and saw

the young lady quite clearly moving her head this way and that, and then I was greatly surprised to see the head of one of the engineers also suddenly appear on the screen. He bent forward and kissed the young lady. I mentioned the matter the next

the transmission to the *Berengaria* in mid-ocean, where the chief wireless operator of the ship was able to see the image of his fiancée in Long Acre, London.

Television is now broadcast regularly through the

⊕ ⊕

In June 1931, the parade and finish of the horses in the world-renowned Derby was broadcast by television for the first time in the history of the science.

⊕ ⊕

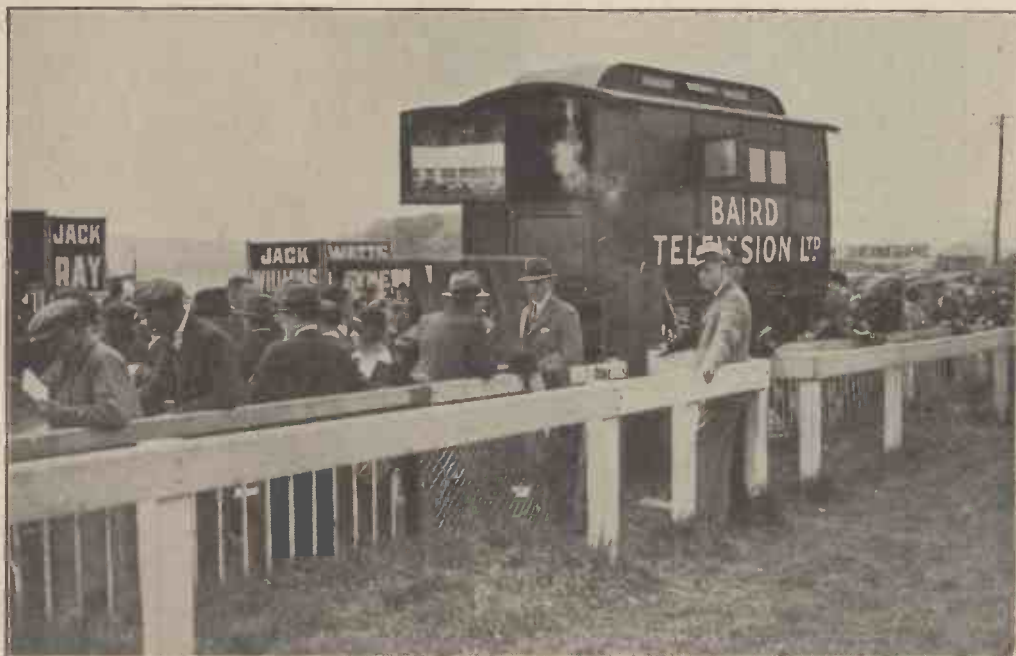

day and she indignantly denied it, but the engineer admitted that the temptation of the dark room and the good-looking young lady had been too much for him.

The next development of consequence was the



The present model Baird "Televisor," which can be compared with an earlier type shown on the preceding page.

transmission of television images across the Atlantic on February 8th and 9th, 1928. On February 9th, 1928, using a short-wave station situated at Coulsdon, a suburb of London, images were successfully transmitted to Hartsdale, a suburb of New York. This was followed almost immediately by

British Broadcasting Corporation, and our programmes include such things as small plays, boxing matches, and ju-jitsu demonstrations, and last June we broadcast the finish of the great British horse-race, the Derby, which takes place on the Epsom Downs race-course about twenty miles from London. We had a portable daylight transmitter placed opposite the winning post. From there television images were sent by telephone lines to the British Broadcasting Corporation wireless transmitter, and broadcast over the British Isles, so that owners of "Televisors" were able, while seated in their homes, to look in and watch the horses flash past the winning-post. This created an immense amount of interest, and we received many appreciative letters.

I will conclude now by saying that television is only in its infancy and big developments are pending. The television images which have been seen by the general public are no criterion of what has been achieved in the laboratories. Our work now is to simplify and cheapen our present laboratory apparatus, so that it can be made available to the man in the street. The problem of television is solved. What remains to be done is entirely a matter of technical and commercial development.

Throughout the world the highest scientific thought is being devoted to television. Vast strides have been made, and will be made, in this new art. I myself look forward to seeing, in the not far distant future, television theatres supersede the talkies, and the home "Televisor" become as common as the home radio is to-day.



The Television Society

THE SECOND MEETING, HELD ON
WEDNESDAY, NOVEMBER 11th

ON Wednesday, November 11th, at 7 p.m., the Physics Lecture-room of University College, Gower Street, W.C.2, was well filled with members, who enjoyed a most successful evening devoted to cathode-ray methods of television.

Mr. W. G. W. Mitchell, B.Sc. (Lecture Secretary), who took the chair in the absence of Dr. Tierney, announced that Dr. Zworykin's paper was postponed to the January meeting, when a second evening would be devoted to the same subject.

The evening was opened by Professor MacGregor Morris (Professor of Electrical Engineering, East London College), who was most painstaking both in the demonstrations given and in the exposition of the foundational facts involved in the development of suitable conditions for the production of a focused and rapidly moving "jet" of controlled electrons that may luminously produce a television image on the phosphorescent screen of the cathode-ray tube connected to the output of the receiving amplifier.

By the aid of special tubes, features of the discharge at differing atmospheric pressures between sixty-six thousandths and five millionths of an atmosphere were shown. Thus at low exhaust the discharge followed a sinuous tract, then developed the Faraday dark space, and next striæ, and at high exhaust produced the cathode ray, whose effects were plainly seen by the fluorescence of the glass walls of the tube.

By aid of a long Braun tube and the most recent models of the cathode-ray oscillograph, Professor Morris exhibited and discussed the varying characteristics due to the type of tube, giving data by the aid of diagrams and the black board, and explaining the theories of the focused ray.

A vote of thanks proposed by Ronald Poole, Esq., B.Sc., and seconded by Wm. C. Keay, Esq. (Treasurer), was heartily endorsed by the audience. The second part of the evening's programme consisted of the following series of papers, which were read by Mr. Mitchell and will be fully published in the journal of the Society:

"The Cathode-ray Tube Method of Television,"

by Manfred von Ardenne (Berlin). Summary of paper: Quality of the picture obtained. Cathode-ray transmitter or mechanical transmitter. The experimental apparatus. Reception from a mechanical transmitter. Results.

"The German Post Office Cathode-ray Television System," by E. H. Traub (Student Member). Summary: The function of the German Post Office and its attitude towards television. General description of the system. The control of the cathode ray. The generation of the synchronising impulses and their separation. The saw-tooth wave generators for the receiver. The "short" circuit and the actual television circuit. The "Telehor" Cathode-ray Tube. Conclusion.

"A Vacuum Photo-cell Type of Transmitter," by C. E. Roberts (Student Member).

The first paper was read by E. H. Traub. In this, technical details were given of cathode-ray methods exhibited at the German Wireless Exhibition last August, as well as methods developed at the German Post Office.

The paper by M. von Ardenne was illustrated by a photograph of a television image by cathode rays and other illustrations.

The last paper, contributed by C. E. Roberts, was illustrated by lantern slides, and described a vacuum photo-electric cathode-ray tube operated externally by magnets. Here the optical image of the television transmitter is transformed into an electrical image by the aid of rapidly moving cathode rays, which scan photo-electric cells after passing through a small aperture.

These photo-electric cells transmit the television signals to the external amplifying circuits.

These papers will be published in the journal of the Society, and copies will be sent free to all Fellows and Associates whose subscriptions are paid. Student Members can obtain the issue at half the published price. Inquiries for these, and for particulars of membership of the Society, should be addressed to Joint-Secretaries, Television Society, 4 Duke Street, Adelphi, London, W.C.2.

PLEASE MENTION TELEVISION WHEN REPLYING TO ADVERTISERS

From My Notebook

By *H. J. Barton Chapple*,
Wh.Sch., B.Sc.(Hons.), A.C.G.I.,
D.I.C., A.M.I.E.E.



Double-grid Valves

THE development, or rather the revival, of the double-grid valve is one of the features of this season's radio. This type of valve achieved a certain measure of popularity many years ago, when it was employed chiefly as a detector or low-frequency amplifier working at a low anode voltage, but radio technique had not, at that time, developed sufficiently far for the possibilities of a double-grid valve to be fully exploited, and the type fell into disuse.

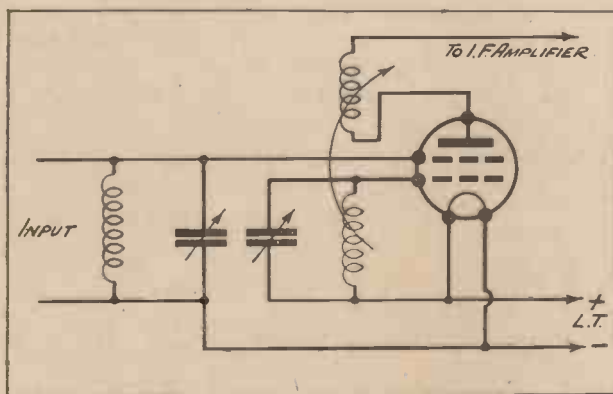

One method of connecting up the double-grid valve is for the outer grid to function as the control grid, while the oscillator coil and condenser is joined between the auxiliary grid and L.T. +.

To-day, however, the double-grid valve has come into its own, and is being employed in many super-heterodyne receivers, as well as finding application in deaf aids and other apparatus where, owing to restriction of bulk and weight, the size of any H.T. batteries must be kept at a minimum.

One example of this valve is the Mullard type PM1DG, and in construction this double-grid valve follows the general design of the triodes in the two-volt PM series, but, of course, there is a second grid. The filament, anode, and outer grid are connected to the usual four pins in the base, while the inner grid is connected to a side terminal. The filament is rated to consume 0.1 ampere on 2.0 volts.

There are two ways in which the double-grid valve may be employed in a super-heterodyne receiver :

(a) as a "mixer" valve in conjunction with a separate local oscillator ; and

(b) as a combined oscillator-detector.

In the first method it is usual to employ the inner grid as control grid, the other grid being interconnected to the grid of the local oscillator.

In the oscillator-detector arrangement the outer grid is used as control grid, and is connected to the aerial circuit, while the oscillator coil with its associated condenser is connected between the auxiliary grid and L.T. positive, as indicated in the accompanying diagram.

The valve can also be used as a low-frequency amplifier, with low anode voltages of the order of 20 volts. A bias of $1\frac{1}{2}$ to 3 volts negative should be

With the auxiliary grid at a potential of 20 volts positive the curves shown are the static characteristics of the Mullard PM1DG.

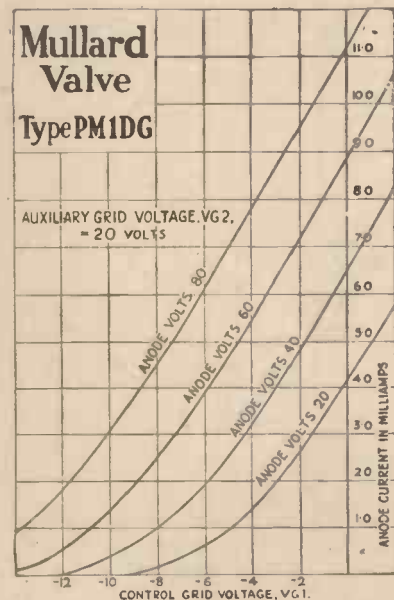

applied to the control (outer) grid, and a positive voltage of about 20 volts on the inner grid.

Another interesting application of this valve is in wavemeters where use can be made of its negative resistance characteristics to produce oscillations in

a resonant circuit. In this arrangement the outer grid is connected via a 1 megohm leak to the L.T. negative, and via a 0.0003 mfd. condenser to the inner grid. The anode is connected to L.T. positive, while the circuit which it is required to oscillate is connected between the inner grid and H.T. positive, which may be from 9 to 20 volts.

This arrangement possesses a marked advantage over a triode oscillator, in that no taps or other retro-action arrangements are required on the coil.

The "Edison Effect"

The recent demise of Edison has no doubt brought to the fore the effect which is now generally associated with his name. Unfortunately the phenomenon is often misunderstood, and a few words of explanation are therefore opportune.

In the very early forms of carbon filament lamps a disintegration of the carbon particles from the filament itself caused a very bad blackening on the inside of the bulb. Due to the unevenness of the filament cross section, it was found that at one point there was a greater resistance than at others, and in consequence more heat was developed there. Since the carbon particles were in a highly incandescent state, some of them were "boiled off" and left the filament surface in straight lines, to be deposited on the glass and darken the interior. Now, it will be quite apparent that a certain section of the glass would be shielded by one side of the filament, and a streak appeared on the glass, giving the effect of a silhouette of that piece of filament (see accompanying diagram).

A Lamp to Prize

Professor Fleming (now Sir Ambrose Fleming) carried out some interesting experiments in which he shielded the negative leg of the filament with a

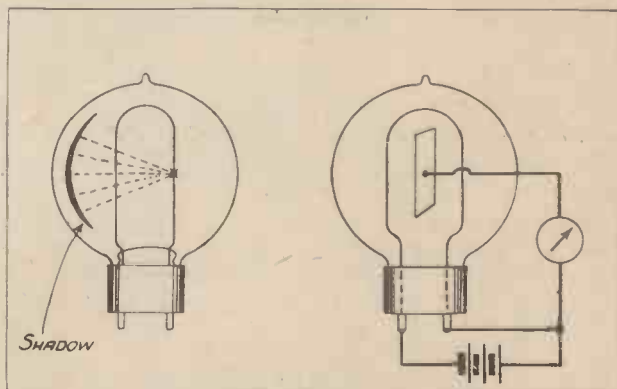

Illustrating the molecular shadow produced by the "Edison effect" and indicating also how Fleming carried out his experiments leading to the development of the valve.

metal plate, and this enabled him to prove quite conclusively that there was an actual stream of negatively electrified particles passing from the negative leg to the metal plate. The meter—a sensitive one—was connected up as in the diagram, and these effects were really the forerunner of the

Fleming valve, father of the present-day thermionic valve.

I have in my possession a Royal Ediswan lamp which I prize rather highly. It was installed in its bayonet socket for actual use as far back as 1911, and the lamp in question shows clearly this phenomenon of the molecular shadow. There is a very pronounced circular marking, this particular shape being due to the shape of the filament inside the bulb.

Transmissions from Witzleben

More than once in these columns I have drawn the attention of readers to the television transmissions which take place from the Witzleben station,

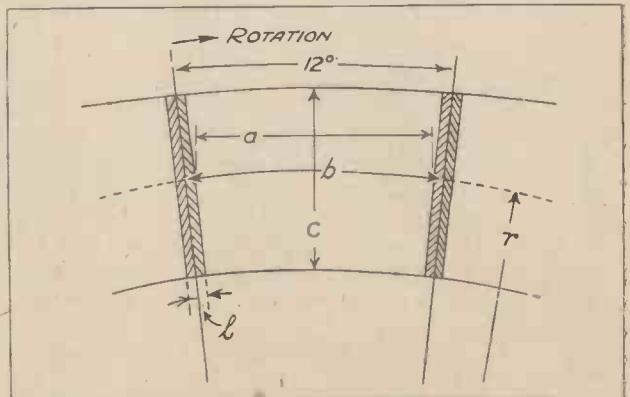

Certain relationships are established in these pages to enable readers to adjust their discs for looking-in at the Witzleben transmissions.

and which on many occasions have been received and watched by enthusiasts. Now, while the Baird transmissions are based on vertical scanning in an anti-clockwise direction, the German transmissions are designed for horizontal scanning in a clockwise direction. The images received in this country are therefore turned through 90 degrees as well as being reversed. Furthermore, since the English picture ratio is 7 to 3 and the German ratio 4 to 3, the resultant images as seen in this country will appear distorted.

For the benefit of those experimenters who desire to look in at the Witzleben transmissions, the data given below should prove useful. It will enable them to make the required adjustments, and if desired build up a disc to conform to this continental standard.

Disc Details

First of all you should notice that although the rotation of the scanning disc is in the reverse direction to the Baird standard, the scanning of the images is such that the apertures of the receiving disc, as seen by the observer, traverse the field of the image, beginning from the left at the top line and finishing at the right below. In other words, strip movement is from outside to inside just the same as in this country. Referring to the accompanying diagram, another point to notice is that there is a definite mask off of one hole at each side

of the picture in order to provide a synchronising signal. The true image ratio is therefore $\frac{a}{c} = \frac{40}{30} = \frac{4}{3}$, but the total mean breadth is really equivalent to 42 holes, this corresponding to the dimension b .

We have therefore the following data from which to make any calculations:

Total number of light strips in one image = 30.

If l is width of one aperture (square) then height of picture $c = 30 l$.

The image frame $\frac{c}{a} = \frac{4}{3}$.

Width $b = a + 2 l$.

The average radius $r = \frac{30b}{2\pi}$.

Hence $b = \frac{2\pi r}{30} = 42 l$.

If the mean radius of the disc is known, then it is quite a simple matter to calculate the other quantities from the equations which have been derived above.



While making the voyage to America on the "Aquitania," Mr. Baird met the world-renowned H. G. Wells, and the two are seen together on one of the liner decks.

Transmission Times

According to the latest information the experimental television transmissions from Witzleben, working on a frequency of 716 kiloHertz (418 metres) and a power of 1.7 kW. are as follows:

Mondays, Tuesdays, and Thursdays 8 to 9 a.m., and Friday midnight to 1 a.m.

Then we have Königswusterhausen broadcasting with a power of 35 kW. on a frequency of 183.5 kiloHertz (1,635 metres) at the following times:

Thursday 12.45 to 1.45 a.m.

Saturday 8 to 9 a.m.

In the case of Witzleben different experimental films alternating with television proper form the subjects, while with the long-wave station films only are broadcast. In both cases it should be noted that the times have already been converted to the Greenwich Mean Time standard.

NOW...

DUBILIER

CONDENSERS

at a price to suit everybody



This entirely new range of Types 665 and 670 Condensers has been introduced in addition to our well-known 610 and 620 Mica Condensers, and are sold at prices within the reach of all. These new models are specially designed for use where high efficiency, compactness, and light weight are essential, and are built up to a standard—not down to a price.

PRICES:

TYPE 665

.0001, .0002, .0003 mfd. ... 6d. each
.0005 mfd. ... 9d. each

TYPE 670

.0001, .0002, .0003 mfd. ... 1/- each
.0005, .001, .002 mfd. ... 1/3 each
.005 and .006 mfd. ... 1/6 each
Types 610 and 620, prices from 1/8 to 3/- each

DUBILIER CONDENSER CO.
(1925) LTD.

Ducon Works, Victoria Rd., N. Acton,
LONDON, W.3



The transatlantic telephone control panel at the Rugby Station.

FEW branches of electrical science have made such rapid progress as that of wireless communication, and in this rapid advance, involving the closely inter-related efforts of many of the world's leading scientists, the thermionic valve has played an exceedingly important part.

This apparatus, originally invented in 1904 by Dr. J. A. Fleming (now Sir J. A. Fleming), in the form of the two-electrode valve, and improved by Dr. Lee De Forest in 1907 by the introduction of the grid or third electrode, and subsequently developed by investigators throughout the world, now forms the heart of every modern system of wireless communication.

Construction Difficulties

Our great broadcasting systems, the transatlantic telephone, the beam stations which keep us in close touch with our Empire overseas—all these have as their basis the discovery and evolution of the thermionic valve.

Yet in spite of these rapid advances, the wireless engineer has been very restricted in his efforts economically and efficiently to increase the power at his disposal, by the fact that the valve in its commercial form has up to the present necessarily been constructed in the form of a highly evacuated glass or silica bulb into which are sealed the electrodes necessary for its operation.

The difficulties of construction and operation of this type of valve increased as greater and greater outputs were required. Cooling, deterioration of the vacuum, and the great expense of replacement when the valve failed—all had presented difficult problems.

For many years the ideal of a valve whose vacuum would not become poorer with age, in which the great difficulty of sealing off the electrodes under vacuum in the process of manufacture would be avoided, and in which the filament could be replaced or other repairs executed, and the valve rapidly and easily again placed in operation, has been the object of much investigation.

A Giant Amongst Valves

Oil Distillates

Continuously evacuated valves have previously been operated successfully under laboratory conditions, the vacuum being maintained by means of the mercury vapour pump. This process, however, was rendered commercially impracticable by the fact that the mercury vapour, due to its high vapour pressure, prevented the necessary degree of vacuum from being maintained unless recourse was had to the expensive and unwieldy process of cooling with liquid air.

The discovery leading to this achievement emanated from the Research Laboratories of the Metropolitan-Vickers Electrical Company, wherein some three years ago experiments in no way connected with

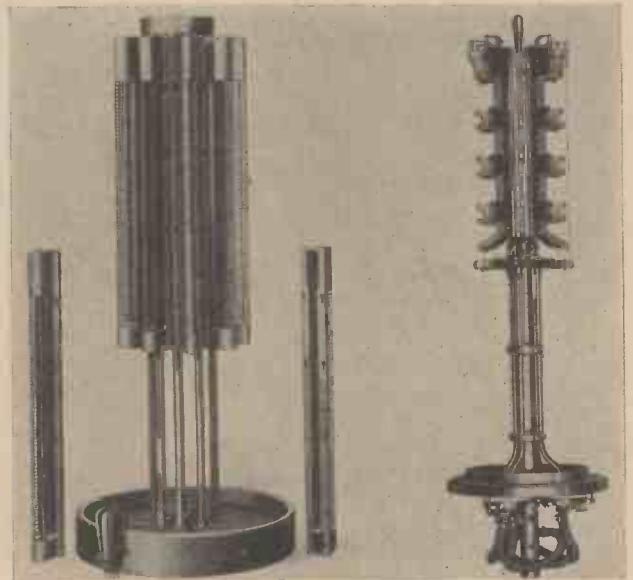

The grid assembly is shown on the left and the filament assembly on the right. The filament current is 500 amps.

wireless communication or thermionic valves, and indeed not expected to be of any industrial consequence, led to the production of oil distillates having remarkable properties.

They could be boiled at a fairly low pressure without decomposition, and yet at room temperature their rate of evaporation was so small that they could be placed inside a wireless valve without impairing the vacuum.

It was quickly realised that here was the ideal liquid to replace the mercury of the vapour pump, as, due to its low volatility, cooling could now be effected with water and the cumbersome and expensive liquid-air process eliminated.

facilitate demounting and assembly. Its filament current is approximately 500 amperes, or about 5,000 times that of a receiving valve, and its filament emission 160 amperes representing an almost inconceivable electron flow of 300,000,000,000,000,000

⊕ ⊕ ⊕

A bank of high-power amplifying valves at Rugby. Sir Ambrose Fleming's original invention of the thermionic valve made these possible to-day.

⊕ ⊕ ⊕

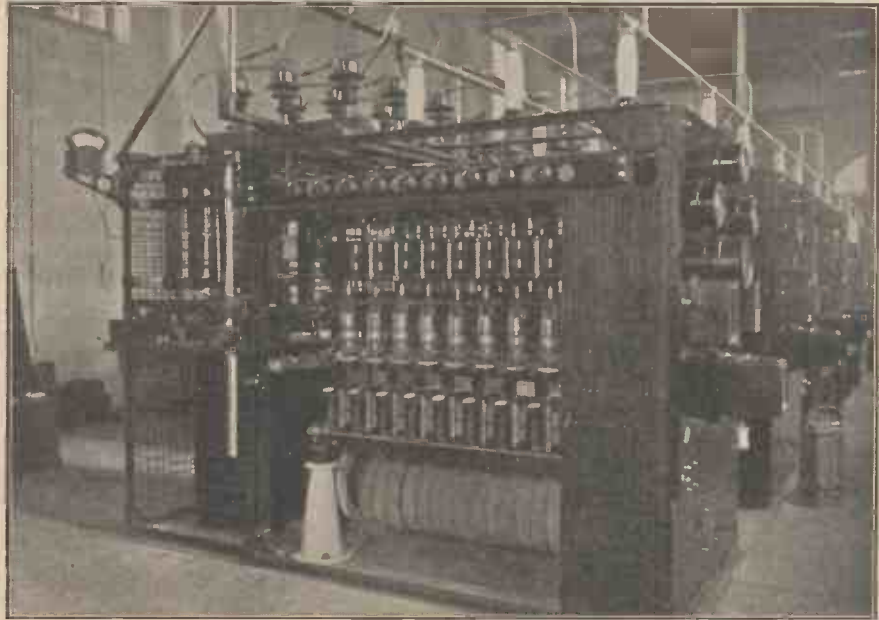

In 1930 a valve designed for an input of approximately 25 kilowatts was constructed, incorporating the new development, and proved so satisfactory in actual continuous service at the Rugby wireless station, that the G.P.O. ordered a 500-kilowatt valve.

(three hundred thousand billion) electrons per second, and is capable of operating the main transmitter at Rugby.

No glass is used in its construction, but a robust combination of steel, porcelain, and copper, the most common materials utilised in the manufacture of electrical equipment. As a result of the continuous evacuation, and in sharp contrast with valves of the permanently sealed type, this new valve improves with age, any gas evolved during its operation being rapidly removed by the pumps. Thus an exceedingly high vacuum is maintained even at the highest power inputs. The pumps, with the exception of a simple type of primary extractor, have no moving parts, and mechanical trouble is therefore a very remote possibility.

Finally the valve is completely demountable. In the event of filament or other repairs being necessary, it may be rapidly taken to pieces, the repairs executed with ordinary engineering tools, and the whole re-assembled and placed back into operation in the course of a few hours.

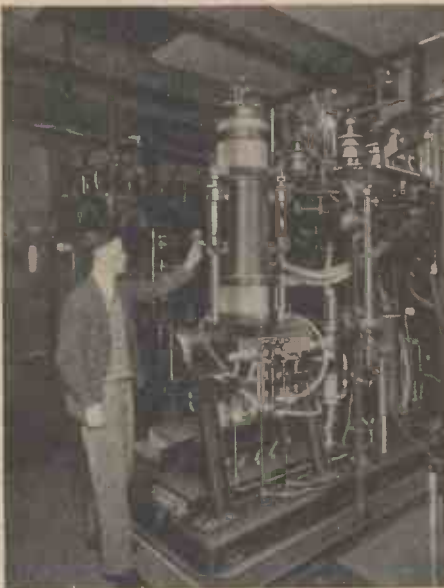

⊕ ⊕ ⊕

The 500 kW. valve during installation at the Rugby Wireless Station. A receiving valve is being held up for comparison purposes.

⊕ ⊕ ⊕

Physical Characteristics

Physically this huge new valve stands 10 ft. high and is 14 in. in diameter. Complete it weighs over a ton and is built on a welded-steel bedplate 8 ft. long by 3 ft. wide. Its water-cooled steel anode weighs 3 cwt., and is equipped with hydraulic jacks to

L. LEAMAN
97, NORTHFIELD AVENUE
WEST EALING, LONDON, W.13

For Radio and Television

DEMONSTRATIONS
 DURING TELEVISION TRANSMISSIONS

Baird Components Supplied

PHONE: EALING 5394 (MEMBER, TELEVISION SOCIETY)



QUERY:

Having recently been bitten by the "television bug" (and hard), I wondered whether you would be so good as to put me right on one or two matters on which I am somewhat at sea, and thus help me to get started on the construction of my first television set. I have only seen one or two recent issues of TELEVISION, and these do not contain the information I require. My points of difficulty are as follows:

- (1) Will a G.E.C. Osglim lamp give recognisable results—just to kick off with?
- (2) I have a 3-valve S.G. commercially-built set (very powerful). I presume this will be suitable? It is an alternating-current all-mains set.
- (3) Do I merely connect the neon in place of the loud speaker?
- (4) The loud speaker is a moving coil, having four connections to the set. The leads are connected to plugs, two being red and two black. To which two do I connect the neon?
- (5) Is it necessary to control the milliamperes fed to the neon by a resistance, and if so, what value resistance is required?
- (6) Which is the issue of TELEVISION that described how to make a jig for marking out the scanning disc?
- (7) Has the making of a synchroniser been described in any issue of TELEVISION?
- (8) Could a motor-cycle magneto be converted into a mains-driven motor?

Possibly, if you can give me the date of an issue of TELEVISION which has described the construction of a complete television set, I might find the answers to most of the above queries therein.

R. F. S.

REPLY:

You certainly have compiled a very interesting series of queries and we will do our best to answer these for you.

- (1) The G.E.C. Osglim lamp will give you recognisable results with your image, and some experimenters prefer to remove the resistance

Television's Query Corner

element contained in the lamp base. For details dealing with the removal of this resistance element from an Osglim lamp may we refer you to the TELEVISION Magazine of March 1931, page 20.

- (2) A commercial set, provided it gives you adequate signal strength in the output stage, is suitable for television purposes, but, in order to secure the best results, this receiver must be of the highest quality and preferably mains-driven, as in your case. Under certain circumstances it is necessary to use an output power unit, and for this information we refer you to the "Tele-Power" Unit described on page 260 of the September 1931 issue of our magazine.
- (3) The question of the connection of the neon lamp to the receiving circuit, although a very simple matter, depends primarily upon the voltage you have available in the output circuit of the last valve. If you have a voltage of about 350 volts, then the neon can be connected directly in the plate circuit; if, however, your voltage is of the order of 200 to 250 volts, then it is necessary either to choke or transformer feed the neon lamp as explained in the TELEVISION Magazine of January 1931, page 436.
- (4) Since you have four connections from the set to the moving-coil loud speaker, we can only assume that two of these leads are for energising the field of the magnet of the speaker. You will have to ascertain on site which pair of leads feed the field and which pair of leads feed the coil. Obviously the pair of leads you will require for television purposes are those which normally feed the coil of the speaker.
- (5) It is generally advisable to control the milliamperes fed to the neon by means of a resistance. It is impossible to state the value of this resistance until it is known what current in milliamperes your neon is to take, and also what "spare voltage" this resistance has to absorb.
- (6) The construction of a disc for television purposes has been described in the July 1929, December 1929, and January 1930 issues of our journal, and we would recommend these for your attention.
- (7) The construction of synchronising apparatus has been dealt with in previous issues of our journal, and, in addition, please note that there will be details furnished in the next

(Continued on page 401)

The Amateur "Volohmeter"

By William J. Richardson

THE amateur experimenter who takes a pride in his handiwork (and show me the one worthy of his name who does not) realises only too well that he must not work in the dark. These remarks are applicable specially to television, for being a new science the work conducted falls mainly within the pioneering category. Measurements of every kind are therefore very necessary if the pitfalls are to be avoided. Several ingenious test-bench sets have been described in this journal on various occasions, and to supplement these the "Volohmeter" has been designed.

Main Functions

Stated simply, its main functions are the measurement of L.T. voltages, H.T. voltages, and resistance. The whole apparatus is quite compact, as will be gathered by examining the photographic illustration on this page, while the cost entailed is very moderate when its full performance is realised. Fig. 1 shows you the theoretical circuit which was finally devised in order to carry out these measurements in a simple manner.

The meter M is an accurate moving-coil milliammeter, 0 to 1 mA. range. Now, the principle on which a voltmeter works is simply Ohm's Law—the current flowing through a circuit is given by dividing the voltage by the resistance. Our milliammeter will measure the current, so if we add the resistance *in series* with the meter we can obtain the

voltage ranges desired. To drive one milliampere through 10,000 ohms 10 volts are required. Actually an allowance should be made for the resistance of the meter, which in the case of the Ferranti instrument employed is 73 ohms, but the error introduced by neglecting it is less than 1 per cent., so the resistance R_2 of Fig. 1 is therefore 10,000 ohms. Merely multiply all the meter readings by 10 when measuring an unknown voltage across the terminals — and L.T. +, and this gives you volts.



The completed "Volohmeter" is neat and very simple to use, measuring resistances and covering two ranges of voltages.

Accuracy

Working on exactly the same reasoning, if the switch S_1 is placed in its lower position a resistance R_2 of 200,000 ohms is introduced between the terminals — and H.T. +. A voltage range of 0/200 volts is thereby secured, and the meter readings must be multiplied by a factor of 200 to give you volts. Since on both these ranges the voltage measurements are based on 1,000 ohms per volt, the "Volohmeter" is excellent for use in conjunction with eliminators. Too often are erroneous results obtained

by measuring eliminator volts with a low-resistance instrument, but in this case a high degree of accuracy is assured.

The resistances R_1 and R_2 were supplied specially by the Watmel Wireless Co., Ltd., and are guaranteed to be their rated value, and, when ordering, the constructor should make that stipulation.

Resistance

We now come to the question of resistance measurements. Our switch S_1 is changed over to the top position, and this introduces a variable resistance R_1 of 250 ohms maximum value as a shunt

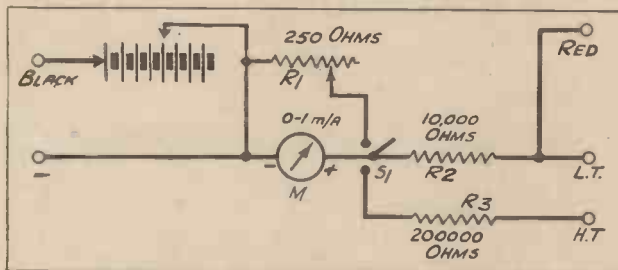

Fig. 1.—The theoretical diagram of the amateur "Volohmeter" is very simple to understand.

across the meter. If we consider the circuit between the terminals marked red and black, we have a battery whose function is to force current through the meter M , the resistance R_2 , and any external resistance that may be connected externally across the terminals.

For the purposes of our measurement the true value of the total current does not matter, provided that during the period taken for any measurement the current does not vary. The shunt R_1 has been included to adjust the "zero" of the meter. If the terminals are short-circuited we should, strictly speaking, require just over 10 volts to force one milliamper through the resistance R_2 and the meter

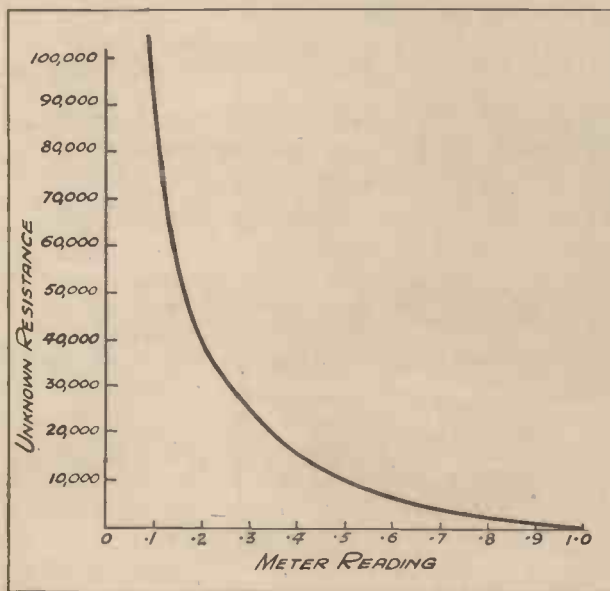

Fig. 2.—To enable resistances to be measured a graph must be plotted according to the table in the adjoining column.

M alone. Allowance must be made for battery variation, however, and the shunt is therefore added so that these variations can be compensated.

If we short-circuit the red and black terminals and arrange for the voltage to be any value between 10 and 18 (two 9-volt G.B. batteries are specified),

then R_1 can be altered so that the meter reads exactly its full scale deflection of 1 mA. If now any resistance replaces the short-circuit the current will drop and thus give us a measure of the resistance in ohms.

A Table and Graph

For example, since the resistance always in circuit is 10,000 ohms (the small resistance of the meter and R_1 can be neglected as they are small in comparison), if we insert another 10,000 ohms between the red and black terminals the current will be halved.

By Ohm's Law $I = \frac{E}{R}$. But the value of E is constant for any one measurement when the "short-circuit" adjustment has been made, therefore the product of resistance and current is a constant.

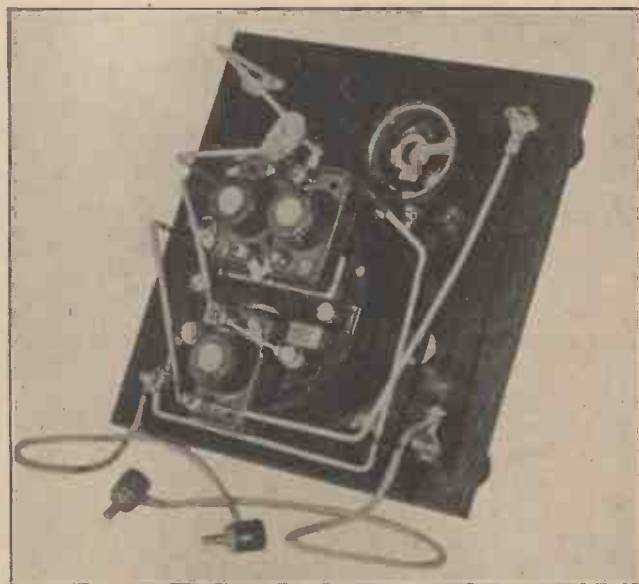

Three fixed resistances are mounted on a small piece of wood and held under the strap fixing the meter to the panel.

Thus if the current is half, the total resistance is doubled, if the current is a quarter of the maximum, the resistance is quadrupled, and so on. In this way we obtain the following table by allowing for the known 10,000-ohm resistance in circuit:

Meter Reading.	Total Resistance.	Resistance whose value is to be measured.
·1	100,000	90,000
·2	50,000	40,000
·3	33,333	23,333
·4	25,000	15,000
·5	20,000	10,000
·6	16,666	6,666
·7	14,285	4,285
·8	12,500	2,500
·9	11,111	1,111
1·0	10,000	0

A curve can then be plotted with unknown resistance and meter reading as co-ordinates, and the curve is as shown in Fig. 2. Resistance values are

read off directly, the apparatus functioning as an ohm-meter.

Components required

Having appreciated the value of the "Voloh-meter" and the ease with which measurements can be made, let us turn to constructional details. First of all the list of components used in apparatus:

One ebonite panel, 6 in. by 6 in. by $\frac{1}{4}$ in. (Peto-Scott & Co., Ltd.).

One sloping desk-type oak cabinet to take above panel (Peto-Scott & Co., Ltd.).

One 0 to 1 mA. moving-coil milliammeter (without fuse) (Ferranti, Ltd.).

Three wire-wound resistances, one 10,000 ohms and two 100,000 ohms. (Watmel Wireless Co., Ltd.).

One variable Colverstat, type M.T., 250 ohms resistance (Colvern, Ltd.).

One anti-capacity switch, rotary type, miniature pattern, with knob and window (Wright & Weaire, Ltd.).

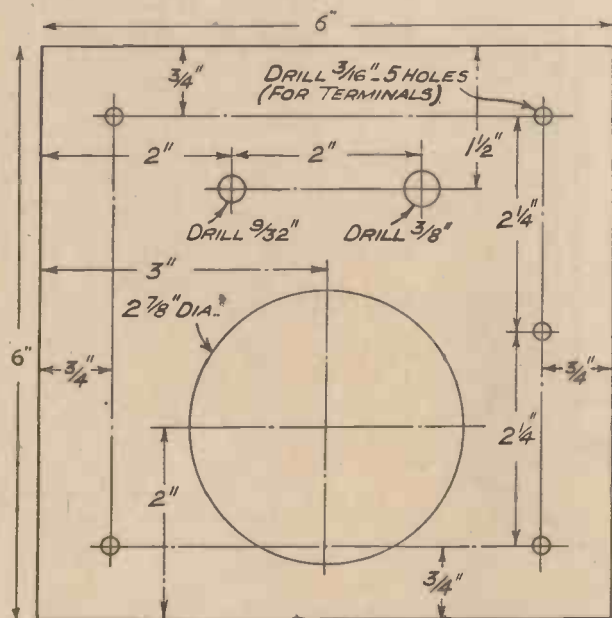

Fig. 3.—Mark out the small panel in accordance with these dimensions.

Five insulated terminals, type B (H.T. +, L.T. +, -, Red, and Black) (Belling & Lee, Ltd.).

Four wander plugs and two spade tags (Belling & Lee, Ltd.).

Two testing prods (J. J. Eastick & Sons).

Two 9-volt G.B. batteries, length of flex, and Glazite for wiring.

Panel Assembly

First of all mark off carefully the hole centres in the small panel according to the dimensioned diagram of Fig. 3, drill the holes and then see that the panel fits snugly into the sloping-desk cabinet. Then mount in place the terminals, switch, and variable resistance (note particularly that this component has

no "off" position) as shown in the accompanying illustrations and wiring diagram of Fig. 4.

To mount the fixed resistances in position you



Use this illustration to help you visualise the wiring runs of each short lead.

will require a thin piece of wood (three-ply is admirable) $1\frac{1}{4}$ in. by $1\frac{1}{4}$ in., and this must be slipped under the strap normally holding the meter in place.

MOTOR STAND

Complete with pinion, spindle and knob as specified by Mr. H. J. Barton Chapple in the last issue for the Tele-Radio Receiver.

5/- Postage 9d.

S. LEE BAPTY

60, CRAVEN PARK ROAD, N.W.10

WILLESDEN 7084

SCANNING DISCS

STANDARD - 20 $\frac{1}{2}$ -INCH
ALUMINIUM - 30-HOLE
BRASS-BUSHED

12/6

When ordering, please remit sufficient to cover postage; also please state size of motor spindle.

TRADE ENQUIRIES WELCOMED

Screw down the resistances in the manner indicated, and then grip the wood to the meter back (and incidentally hold the meter rigid) by screwing home the two screws provided with the instrument. If your wood strip is a little too thick just include a little packing on each side where the strip feet should touch the back of the panel.

together by a short length of flex having plugs at each end, place them in the bottom of the cabinet and insert the pair of plugs on the instrument into sockets which give, say, a voltage of 12.

For resistance measurements move the switch knob over to the left and short-circuit the red and black terminals. Then adjust the variable resistance

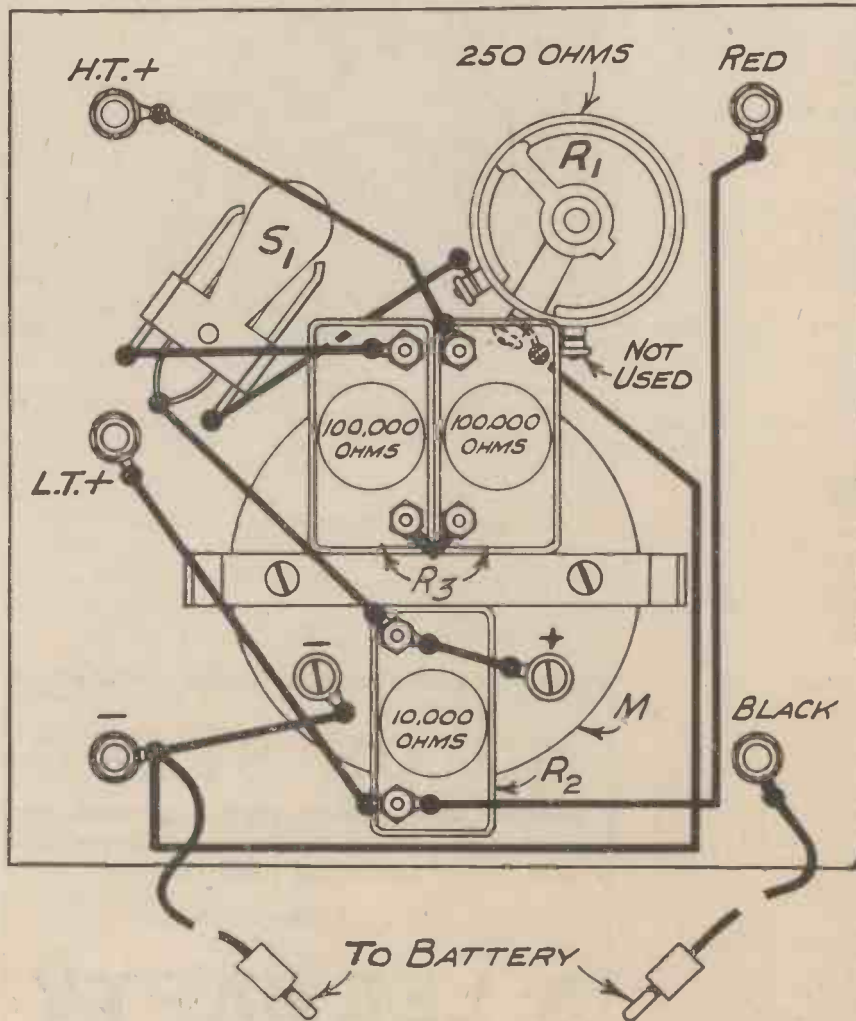

Fig. 4.—The constructor will experience no difficulty in completing the wiring of his "Volohmeter." Only a few short lengths of Glazite are necessary for the rigid connections and two short lengths of flex as indicated. See that each joint is properly soldered.

Wiring

All is now in readiness for the small amount of wiring. Use Fig. 4 and two of the photographs to guide you for this, keeping the wires short and rigid (Glazite is particularly useful for this), and making sure that none of the soldered joints are of the high-resistance character. A good clean hot iron, soldering tags well tinned, and the minimum of Fluxite or resin will help you here. The two flex leads terminating in wander plugs join on to the terminals marked black and —, while the testing prods are connected to the twin flex having the spade tags at the opposite ends.

Working Instructions

We are now in a position to put the "Volohmeter" to use. Link the two 9-volt G.B. batteries

until full-scale deflection is given on the meter for this condition. Then with the aid of the testing prods any unknown resistance between the range of zero and 100,000 ohms can be found by noting the meter needle position and reading off the value direct from the graph. In plotting your graph use a sheet of large paper and draw in the curve very carefully to ensure accuracy.

To measure voltages between 0 and 10 volts connect the unknown source between the terminals — and L.T. + by means of the testing prods and multiply the meter reading by ten, having first set the switch in its mid position. Similarly for voltages up to 200 join between — and H.T. +, and multiply the meter reading by 200 when the switch is over to the right. This switch is supplied with a knob and "window," and you should mark the ivoryine

(Continued on page 405)

Workshop Hints

By *Thos. W. Collier*

IN the last issue of this magazine I gave a list of tools, some of which were marked off as being more useful to commence with, especially if one has to keep cost in consideration. You will have noticed that the vice appeared as the most expensive item on the list, but it is an investment you will not regret.

Files and How to Use Them

If you have not already purchased the files listed, here is a selection which will meet most of your requirements.

	<i>Approx. cost</i>
	<i>s. d.</i>
*One 6-in. Flat Second Cut	7
One 6-in. Flat Smooth	8
One 6-in. Round Second Cut	6
*One 6-in. Half-round Second Cut	7
One 6-in. Square Smooth	6
*One 4-in. Flat Dead Smooth	9
Six small File Handles	1 0
	4 7

Those marked with an asterisk will be found of more immediate use. Do not use any file without first fitting a handle. To fit a handle correctly, heat the tag end of the file sufficiently to burn the wood to the shape of the tag before hammering on, and thus prevent split handles. With care these files will last for years; do not use them on ebonite, and do not file down to the hardened jaws of the vice.

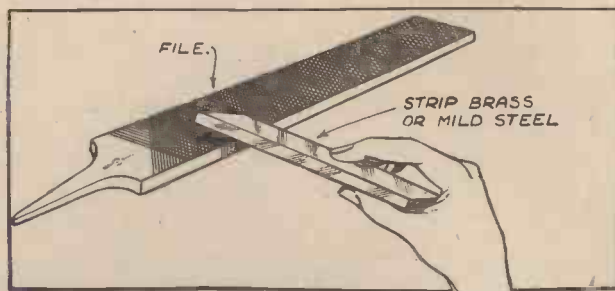

Fig. 1.—When a file has to be “cleaned” use a piece of strip brass or mild steel in this way.

When cleaning becomes necessary (you will find the teeth clog frequently) do not use a “file card” or scratch brush, but employ a piece of strip brass or mild steel as illustrated in Fig. 1, and this will not injure the file in any way.



When working on very soft metals such as aluminium, it is a good plan to coat the file lightly with chalk—ordinary chalk will do—and so prevent clogging or the making of scores or deep scratches, which are difficult to remove.

If you are not accustomed to using a file, the following hint will help you—Use both hands and keep the file flat.

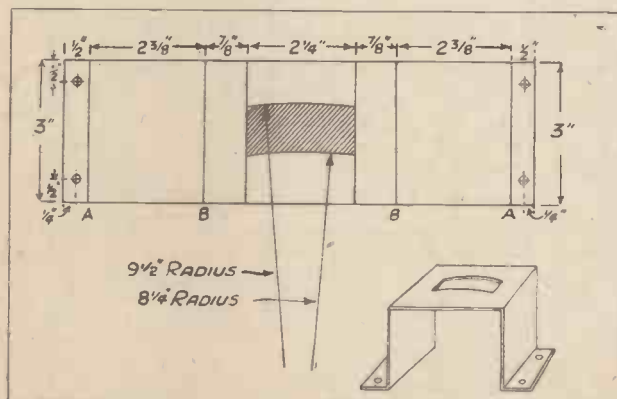

Fig. 2.—Drill out the four fixing holes and cut the shaped aperture before bending on lines A and B.

The Process of Filing

We will now go through the action of filing step by step. First place a piece of metal in the vice, the top face level with the jaws and just above them. Now hold the file flat on the face of the metal with a slight pressure on the fingers of the *left hand* only. Next push the file forward with the *right hand*, allowing the left hand to go forward with it and still keeping the pressure on the fingers; we have now made our first cutting stroke (a file only cuts on the forward stroke). Now bring the file back with both hands, relieving the pressure on the fingers just sufficiently to keep it flat on the work. Repeat these strokes, and you will soon find both hands working together quite freely.

A Lens Mount

A lens mount is an item which you will need if you are constructing your own vision receiver. It is an easily made piece of apparatus, and is designed to accommodate the two lenses, which can be purchased separately from the Baird Company.

This mount consists of a wooden structure carrying both lenses and a mask for framing the picture.

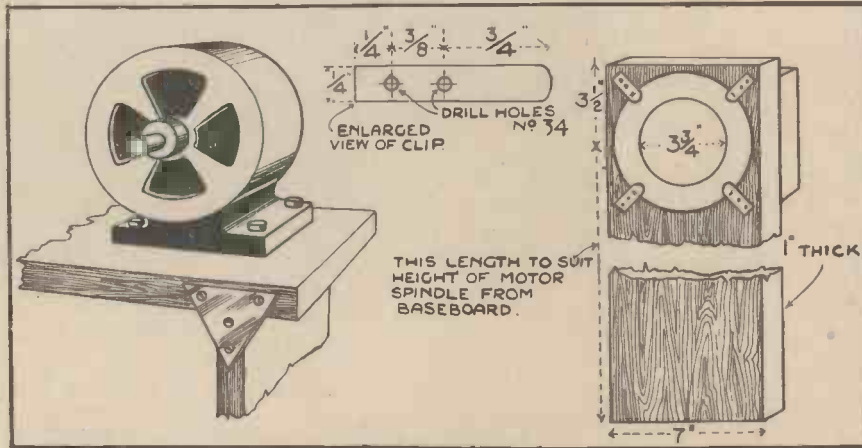

Fig. 3.—A front view of the lens mount with a 6-in. dia. lens in position. The disc motor is included to show how the correct wood length is obtained by reference to the height of motor spindle from baseboard.

First obtain a piece of wood of suitable length, 7 in. wide by 1 in. thick (the length will be the distance from the baseboard to the centre of the motor spindle plus $3\frac{1}{2}$ in.) (see Fig. 3). Mark a line down the centre of the wood and another at right angles to it $3\frac{1}{2}$ in. from the top. This should be done on both sides. Now set your dividers or compasses and mark out on one side two circles, one $3\frac{3}{4}$ in. dia. and the other 6 in. dia.; turn the wood over and mark two more circles, one $3\frac{3}{4}$ in. dia. and the other 4 in. dia. On this same side mark off two additional lines across the width of the wood, $2\frac{1}{2}$ in. each side of and parallel with the horizontal centre line. These are for locating the mask centrally. Next cut out the inner circle $3\frac{3}{4}$ in. dia.—this can be done with a fret-saw or pad-saw—trim up the hole with the half-round file, and finish

about 12 in. by $\frac{1}{2}$ in. by $\frac{1}{4}$ in. and drilling 3 holes down the centre as shown in Fig. 4, use the smallest drill you have. All you need now are two nails, drive them first in holes Nos. 1 and 2, then move No. 2 to 3. No. 1, of course, is the central point and is not moved. Having marked out the radial lines, you must now cut out that section (an easy matter with a penknife), trim the aperture with a smooth file, bend at A and B to form an arch as shown and screw in position.

The job is now completed and should be given a coat of dead black paint. The lens mount can be held in position on the baseboard by means of angle brackets, the construction of which was described last month.

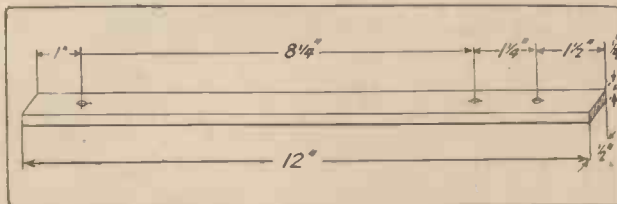

Fig. 4.—For extempore trammels drill a wood strip according to the dimensions above.

with glass paper. Now make the 8 clips as shown, using aluminium about $\frac{1}{8}$ in. thick, or brass about $\frac{3}{8}$ in. thick.

Making the Mask

Place the large lens central with the 6-in. circle, bend 4 clips to fit snugly on the convex face of the

BOOK REVIEW

Television, by E. H. Felix, published by the McGraw-Hill Publishing Company, Limited, at 12s. 6d., is devoted mainly to methods and uses. Although the writer claims to deal with existing television systems, the basic processes involved, standards of performance, and limitations which have a bearing on the attainment of commercial performance standards, he confines his remarks almost entirely to American schemes, and fails to appreciate what has been done in England and the European continent.

Generalities applicable to all television systems are, however, described quite well, such as, for example, the chapters devoted to scanning the field of view, the detail requirements of television reproduction, and the eye as an instrument of television. The possible commercial application of television to the advertiser is also dealt with.

A Tribute to Edison

ON October 18th of the present year the world's most prolific inventor was lost to mankind with the death of Thomas Alva Edison.

That none but the barest details of the work of this remarkable man can be given in a brief account will be appreciated when it is realised that, during his lifetime, Edison was granted more than fourteen hundred patents.

He was born on February 11th, 1847, in Milan, Erie County, Ohio. On account of the poorness of his parents, Edison had no schooling beyond that which he received from his mother, and, at the age of twelve, was put to selling newspapers for a living. His heart, however, was set on things mechanical, and, when an opportunity presented itself, he persuaded a stationmaster to teach him operative telegraphy. An apt pupil, it was not long before Edison became proficient enough to secure an appointment on the line. It was while in this position that he produced his first invention. This consisted of an automatic device which would cause his telegraph instrument to send a signal indicating that he was awake at his post, even though he might be asleep in his cabin. In view of the severe reprimanding which young Edison received for his ingenuity on this occasion, it is humorous to note that he was destined to become known, in later days, as "the man who could do without sleep!"

After some years as a telegraph operator, Edison invented an automatic recorder. In the year 1868 he devised a method of duplex telegraphy, this invention being the precursor of the multiplex systems now in common use.

In 1869 Edison, still extremely poor, went to New York in search of a better job. This he eventually secured in the office of the Law Gold Reporting Company. Shortly afterwards he received £8,000 as his share of the invention of an improved stock printer. With this money he established his laboratory and factory in Newark, New Jersey, where he carried out his early experiments in electricity, before removing ultimately to West Orange.

Of the enormous number of his inventions, Edison claimed that the only one upon which he stumbled by accident was the phonograph, the rest being the result of careful experiment and observation. It was not his habit to work on a single device at a time; he possessed the remarkable ability to develop perhaps a score of ideas almost simultaneously.

The telephone with which we are all so familiar to-day, owes its commercial practicability to Edison's invention of the carbon microphone. An important development of this was the microtaximeter, an instrument which Edison invented, working on the same principle as the carbon microphone, but used for the detection of small variations in temperature. During the total eclipse of 1878, the microtaximeter

was successfully employed to demonstrate the presence of heat in the sun's corona.

Shortly after his invention of the phonograph, Edison produced an apparatus known as the aerophone, this being an instrument for the amplification of sound waves without distortion.

No less important than his discoveries in the field of acoustics were his researches in the science of electricity. It was Edison who superseded the arc by the incandescent electric lamp. In his first experiments the filament, which was exposed to the air, consisted of a fine platinum wire heated to incandescence by means of a battery. But with this method Edison found the rate of oxidation to be excessive. Therefore he replaced the platinum filament by one of carbon sealed into an evacuated glass bulb. From that moment onwards the development of electric lighting was rapid.

Some time later Edison produced the kinematograph, a device for the exhibition of animated photographs. Although crude, this invention may be said to represent the foundation-stone of all our modern luxury cinemas.

During the years of the war, Edison invented a vast number of marvellous devices which were used by the fighting forces. Among these, mention must be made of the apparatus which he evolved to enable a ship to turn rapidly in her own length; an instrument for detecting submarines by means of sound waves; cloud shells, and also a method of locating hidden enemy guns by sound ranging.

From the point of view of the radio or television experimenter, Edison's most interesting work was, perhaps, his investigation of the phenomenon known to-day as the "Edison effect." This phenomenon consists of the blackening of the inside surface of an incandescent electric lamp bulb during use. Edison's researches into the cause of the blackening led to the development of the thermionic valve, for he found that emission of electrons from the filament was the cause of the phenomenon. Further experiments of his, coupled with those of Fleming, led to the important discovery that a positively charged sheath placed round the filament would attract the electrons to it, this being of course the basic principle of the two-electrode valve.

It is a sad coincidence that Edison's death should have occurred during the same year as the centenary of Faraday's discovery of electro-magnetic induction. However, this fact should serve to couple together, for all time, the names of these two great scientists. As Sir Hugo Hirst, Chairman of the General Electric Company, said: "Faraday's inventions laid the technical and scientific foundations for the electrical industry of to-day, but Edison's genius was the match that set aglow the present electrical age."

LESLIE P. DUDLEY.

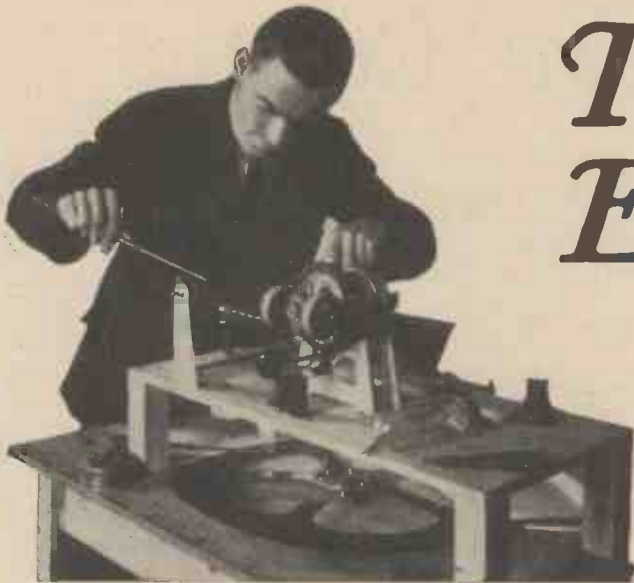

The Enthusiast Sees it Through

THE present day is a "red-letter" day for all those enthusiastic and unflagging amateurs who have lately supported an uncertain cause with all the generous wholeheartedness of the pioneer.

Television is being acclaimed by the outside world. No longer will keen experimenters be regarded with the indulgent awe of those people who sceptically—and often ignorantly—refused to treat the new science with the respect it all along deserved. And now its deserts may become commands, and the services of those who can demonstrate to the public that which is constantly engaging their attention will be at a premium.

This in itself should be sufficient thanks for those who have kept in touch with all movements in this direction. Their justification is now complete, and this should further encourage them to continue along the same lines, so that in the future, when television is a household word, they will be able to make the proud boast, "I was in at the beginning."

Send in your reports to this magazine and continue to inspire its readers to support you with their own efforts.

Rebuilding his Vision Apparatus

Mr. J. W. Piggott, of 129 Gorsefield Road, Birkenhead, Cheshire, has now entirely rebuilt his vision apparatus, and modelled it on the lines of the Baird "Televisor." As readers will see, Mr. Piggott has gone to a great deal of trouble in order to make his apparatus function successfully, and, according to him, his results are encouraging. He says:

"The vision apparatus has been entirely rebuilt, this time on the lines of a Baird instrument, the chief difference being the rather unusual output arrangements.

"This circuit is the only one which has given any synchronising effect worth having, as both the power valve and the neon get their full voltage, unlike the previous series arrangement.

"As the diagram shows, the neon is now choke fed, via a 2-mfd. condenser, the choke in the anode circuit being the synchronising coils themselves.

"The neon is struck from the mains, the current passing through a 0 to 500,000 ohm resistance (of the cheap carbon variety!), and the secondary winding of a Ford ignition coil, which acts as a smoothing choke.

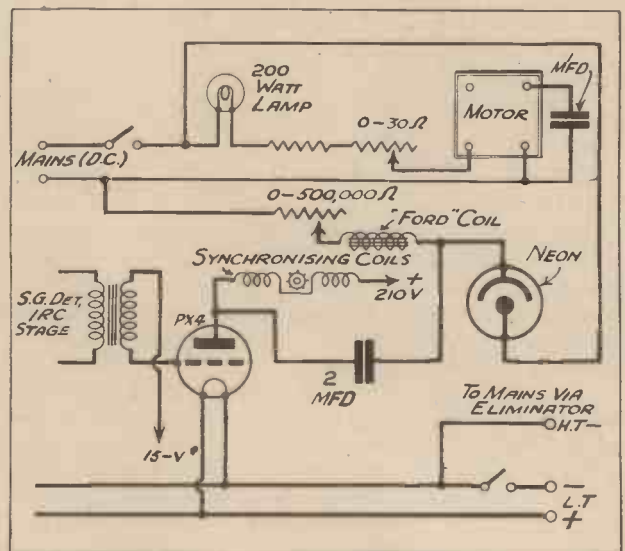

By wiring up his output circuit in the manner shown above Mr. Piggott secures full voltage on both the neon and power valve.

"The neon is new, being of the letter 'I' type (Osglim) minus its resistance. It is almost entirely silvered, except for a 4 by 6 cm. aperture, frosted, in front of the plate.

"The frosting was carried out by rubbing the surface of the lamp with emery paper lubricated with turpentine.

"The motor circuit is also shown: the motor is in

series with a 200-watt lamp, a 40-ohm fixed resistance, and a 0 to 30-ohm filament resistance. A 1-mfd. condenser, connected between a commutator and one of the motor leads, removes every chance of interference with the receiving set.

"A friction control (the knob on the right-hand side of the motor actuates this) is very useful in speed adjustment.

"The results are encouraging; a year's experimenting has brought a small measure of synchronism and, at times, some very fine pictures. I even obtained a picture of sorts, certainly sideways and moving, from Berlin the other night. However, I am eagerly awaiting the North Regional Television, which they told me about at the Baird Stand, Olympia."

to run my neon lamp and output valve in series with about 500 volts H.T. supply, but unfortunately, as I have only a beehive neon lamp (with resistance removed), I have been obliged to use some rather old-fashioned output valves, as the P625 valve which is normally used in the set is only rated to pass 24 milliamperes, and I do not wish to run this at the 40 milliamperes necessary to give a good illumination with this type of neon lamp. These valves have proved rather unsatisfactory, and better results can be obtained with the P625 and only 24 milliamperes.

"Of course the brilliancy of the lamp is considerably reduced by the paper (grease-proof paper which has been oiled), which is mounted in front of it to obliterate the image of the beehive. I am able

Several alterations have been made to Mr. Orchard's original receiver. The following details have been supplied.

- $R_1 = 60,000$
- $R_2 = 40,000$
- $R_3 = 65,000$
- $R_4 = 5,000$
- $R_5 = 25,000$
- $R_6 = 10,000$
- $R_7 = 10,000$
- $C_1, C_2 = .0005$
- $C_3, C_4, C_5, C_6 = 2.0$
- $C_7, C_8 = 1.0$
- $C_9 = .001$
- $C_{10} = .0003$
- $C_{11} = .0001$

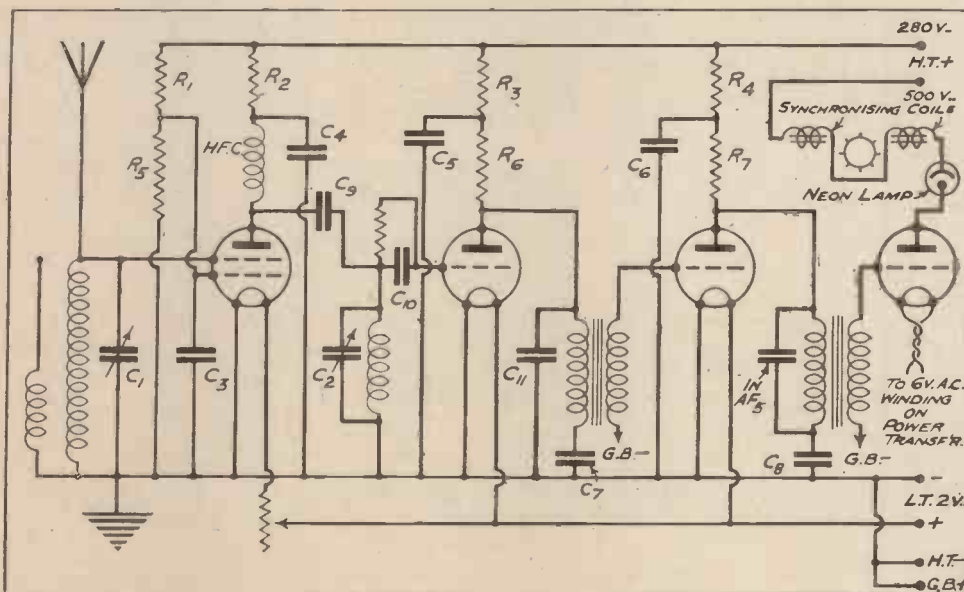

Work on Synchronising

Although Mr. D. F. Orchard, of 118 Devonshire Avenue, Portsmouth, Hants, has been experiencing a certain amount of trouble with his valves, it appears that he has been highly successful in fitting up automatic synchronising to work in conjunction with his vision apparatus.

He has been good enough to send along details of this, and readers will be interested to learn how he carried out these experiments.

Mr. Orchard is one of our long-standing enthusiasts, and we are sure that with the winter months we shall be able to look forward to further interesting results from the work that he is carrying out. He says:

"I am sorry I have not been able to send you any account of my television results before, but I have only recently been able to renew my experiments. As far as the picture is concerned results have been rather disappointing, but I am pleased to say that the synchronising gear which I have just fitted up is highly successful. I have been trying

as yet to obtain far better images with the choke-feed method which was in use when I wrote to you last. The toothed wheel for synchronising was made out of iron sheet which had been kept at a dull red heat for about two days. Although the finished product was far from accurate from a television point of view, it works very satisfactorily, and the picture can be held absolutely stationary for long periods.

"The wheel, although true on the lathe, was unfortunately far from such when mounted on the motor shaft, and final adjustments were made by filing down each tooth the required amount. This was a very long job, but the results have justified it. A piece of 1 in. by 1/2 in. iron was bent to a U shape to complete the magnetic circuit, this, however, unfortunately had to be fixed, so the scanning disc has to be moved slightly round the spindle when the synchronising line comes in the middle of the picture.

"As you will see from the circuit diagram enclosed, several alterations have been made to the receiver circuit since I last wrote to you. I can highly recommend the parallel-feed method of con-

necting the transformer; it greatly improves high note response and stability. I am hoping soon to try out power-grid detection, and thereby hope to improve results, as the detector is slightly overloaded at present.

"The use of a variable resistance in the S.G. filament lead for volume control does not appear to introduce distortion at this distance from Brookman's Park.

"Wishing TELEVISION every success."

A Weymouth Effort

Although our reader, Mr. Gordon A. Spencer, of 8 Kempton Road, Weymouth, describes his television experiments as "humble," we feel that all the more praise is due to him for overcoming two rather large drawbacks, namely expense and inadequate current supply.

The painstaking work carried out by Mr. Spencer reflects great credit upon his ingenuity, and he describes the work, in his own words, as a "sweet memory."

We take this opportunity of wishing him more strength to his arm in his new Scottish home, where,

commutator. The armature needed rewinding, I did it; the magnetic polepiece needed remagnetising, I did that, etc.—in fact, I was really tired of wire turning and magnet stroking. This motor when loaded up with 8 volts gave about 600 revolutions per minute. Desperately I picked up another magnet to stroke the poles while in action, and similar poles touched—swish—and she jumped another 500 revolutions to the tune of a noise like the historical 'Tin Lizzie' in a thunderstorm.

"The disc used was of the conventional 30-hole, 20½-in. type, made in skeleton fashion of Bristol Board, and when fixed on the motor spindle it brought the speed down to about 800 revolutions. In series with the motor and supply was a rheostat to get the correct speed.

"The neon was an Osglim screw-base 230-volt lamp with series resistance removed. Behind this was an old concave mirror, which served to throw an image on the small ground gelatine screen. This screen was shielded by a Bristol Board tunnel blacked with boot polish.

"I have in use a straight-three receiver, det. and 2 L.F., both transformer coupled, a bigger set meaning more H.T. current which, considering my de-

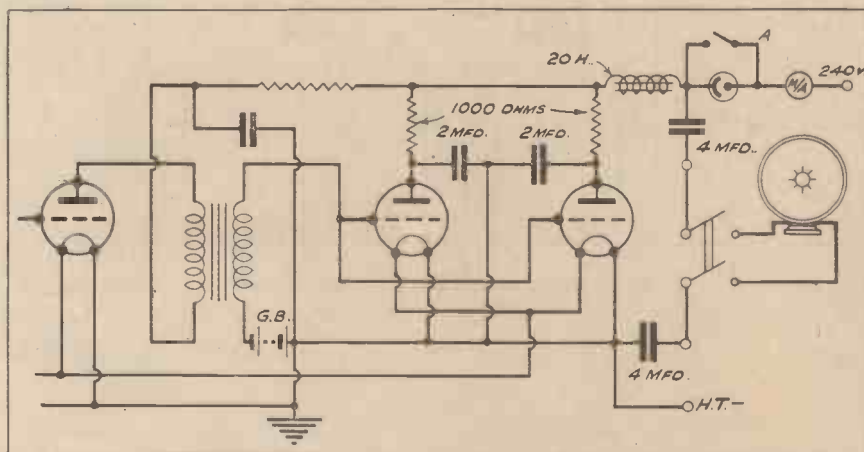

Mr. Gordon A. Spencer carried out some very interesting experiments in television reception. Although for the time being only "a sweet memory," Mr. Spencer has given us details of his apparatus and we can look forward to further information when he is installed in his new home.

we understand, electric mains will be available. In the course of his letter he says:

"I am enclosing details of my very humble television experiments in the hope that perhaps others may realise that good results can be obtained under the two biggest drawbacks, viz. expense and lack of current supply. My second reason for writing is to show you that Weymouth is not entirely behind the times, although I have looked for local 'Tele-men' in vain in the district.

"I have been a regular reader of TELEVISION for some time now, and about four months ago I decided to try some experiments. I resurrected a very ancient motor of the 4-volt type, complete with 2-pole armature, permanent magnet polepiece, and brass

pendence on dry batteries, is not possible—at least, for any length of time. I had decided, however, that a 'splash' in H.T. could be made, so I broke the bank over four new 60-volt triple-capacity H.T. batteries. The aerial on which I work is 50 ft. high and out in the open, so that the signal handed to the detector is very large compared with the usual three.

"On the great day, I tuned in and connected up the neon in the plate circuit of the last valve. It flashed away while I struggled with the synchronising gear. 'At last,' I said as queer lines, blobs and flashes covered the screen. Beyond very faint shadows of images, however, nothing was forthcoming. The signal strength, so I presumed, was too low, and therefore I set about to hook up a rough circuit of odds and ends.

PLEASE MENTION TELEVISION WHEN REPLYING TO ADVERTISERS

"I have plenty of spare components, and with these I evolved a 5-stage set, with plug-in coils: S.G., det. (anode-bend), 2 R.C., and transformer coupled fourth stage to two P2's in parallel.

"This circuit after a little adjustment proved very satisfactory, and I spent many half hours trying to receive complete transmissions. Unfortunately my motor was taking 3 ampères at 8 volts, so that my small accumulators were behaving very erratically under such ill-treatment, resulting in a widely varying speed.

"Very soon the H.T.'s, under a discharge of 40 mA, turned up their toes, and I was forced back to the old det. and 2 L.F. life with just a memory left. But what a memory—so sweet!

"You may be surprised at the elaborate anti-moto devices in a 'hook up' as shown, but the last-stage had to be decoupled to drop the voltage from 240 to 180. I fitted the shorting switch so that the speaker could be used to check purity and tuning together with the milliammeter.

"I have done no more in the matter since that, and the apparatus has been 'unshipped,' for in a short while I shall be moving with my parents to join the Scottish readers in Greenock. There I have visions of mains, mains with a big M, and already circuits are being evolved. As soon as I am in a position to give you details of my work I shall be pleased to do so, for I appreciate the co-operative effort that must be made by us all to further the advance of television."

Television's Query Corner

(Concluded from page 390)

issue. For further information we would refer you to our January and February 1930 issues.

- (8) We regret that we have no information available as to the conversion of a motor-cycle magneto into a mains-driven motor. If, however, you were thinking of using this for driving the disc of the vision apparatus, we do not recommend the policy, as one of the prime essentials for television receiving apparatus is the employment of a reasonable quality constant-speed motor, the normal running speed being 750 r.p.m., this being necessary in order to synchronise with the transmitter.

We can supply any of the back copies mentioned at a cost of 6d. per copy, plus postage.

No doubt you will find, in addition, considerable useful information to help you in your work in the series of articles which we are now publishing on the "Tele-Radio" Receiver, by Mr. H. J. Barton Chapple, but in any case, from the information we have given you, we feel sure that this will be sufficient to set you on the road, and we wish you every success in your efforts to receive the television signals now being broadcast by the Baird Company through the medium of the B.B.C. transmitter at Brookman's Park.

Reveals Secret of Personal Influence

Simple Method that Anyone Can Use to Develop the Powers of Personal Magnetism, Memory, Concentration, Will-Power and to correct Undesirable Habits through the wonder-science of Suggestion. 80-page Book Fully Describing this Unique Method and a Psycho-Analysis Character Delineation FREE to all who write at once.

"The wonderful power of Personal Influence, Magnetism, Fascination, Mind-Control, call it what you will, can surely be acquired by everyone no matter how unattractive or unsuccessful," says Mr. Elmer E. Knowles, author of the new book entitled: "The Key to the Development of the Inner Forces." The book lays bare many astounding facts concerning the practices of the Eastern Yoghis and explains a unique system for the Development of Personal Magnetism,

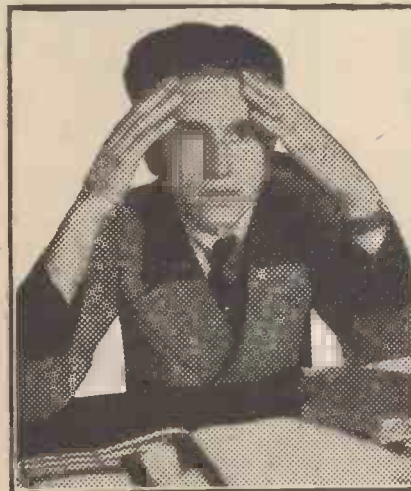

Mr. Martin Goldhardt.

Hypnotic and Telepathic powers, Memory, Concentration, Will-Power and the correction of undesirable habits through the wonder power of Suggestion.

Mr. Martin Goldhardt writes: "My own success with the Knowles System justifies my belief that it does more for the advancement of people than any other existing method." The book, which is being distributed broadcast free of charge, is full of photographic reproductions showing how these unseen forces are being used all over the world, and how thousands upon thousands have developed powers which they little dreamed they possessed. The free distribution of 10,000 copies is being conducted by a large Brussels Institution, and a copy will be sent post free to anyone interested.

In addition to supplying the book free, each person who writes at once will also receive a psycho-analysis character delineation of from 400 to 500 words as prepared by Prof. Knowles. If you wish a copy of Prof. Knowles' book and a Character Delineation, simply copy the following verse in your own handwriting:

"I want power of mind,
Force and strength in my look,
Please read my character,
And send me your book."

Also send your full name and address plainly printed (state whether Mr., Mrs. or Miss), and address your letter to: "PSYCHOLOGY FOUNDATION, S.A." (Dept. 569), No. 18, rue de Londres, Brussels, Belgium. If you wish you may enclose 4d. (stamps of your own country) to pay postage, etc. Be sure to put sufficient postage on your letter. Postage to Belgium is 2½d.



TRADE NOTES OF THE MONTH

REPORTS ON APPARATUS TESTED

A New Osram 2-volt Pentode Valve

TO complete the range of highly efficient 2-volt valves fitted with the new "Wembley" filament; the General Electric Company, Limited, has now released a 2-volt pentode valve, and we have just completed tests on a sample.

The utilisation of the "Wembley" filament has enabled a very high degree of mutual conductance to be obtained, while at the same time adequate electrode clearances are still maintained so as to ensure rigidity and freedom from electrode contact.

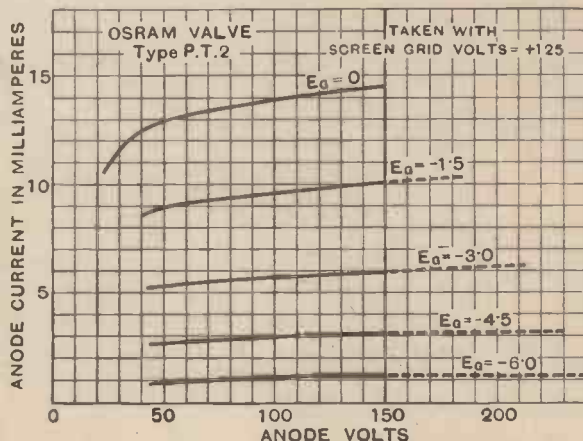

Static characteristic curves of the Osram pentode valve reviewed on this page.

One of the chief characteristics of the Osram PT2 which we noted, is large power output combined with a very low H.T. current consumption. We learn that the valve has been designed particularly with a view to minimum drain on the H.T. battery, as it was realised that the type would be applicable

to portable sets, where the problem of the demand on the H.T. battery is of prime importance. In spite of the reasonable H.T. current—we measured approximately 3 milliamperes at 100 volts and 5 milliamperes at 120 volts—the undistorted A.C. output of the Osram PT2 is remarkable. It is desirable, however, to shunt the loud speaker or output circuit by a resistance of about 20,000 ohms in order to avoid distortion.

The valve base is of the standard 5-pin variety fitted with solid pins, and when used in the last stage of portable sets with a battery voltage of from 100 to 120 volts, a grid bias of approximately 3 volts was found suitable. If the PT2 is employed in sets operating from an H.T. battery eliminator, the H.T. voltage can be increased to 150 with advantage in power output, and ample undistorted volume is obtained with a grid bias of only $4\frac{1}{2}$ volts.

The noted characteristics of the Osram PT2 are as follow:

Filament Volts	2.0 max.
Filament Current	0.2 amp.
Anode Volts	150 max.
Screen-grid Volts	150 max.
Mutual Conductance	2.5 mA/volts
(Measured at Anode Volts 100, Screen Volts 100, Grid Volts Zero.)	

The price is 20s.

A very useful wireless station indicator has been produced by the G.E.C. This is of a dual character, giving the wavelengths of a selection of well-received stations on 200 to 1,875 metres and, in addition, by rotating a second disc one is able to see the recommended Osram valves for each stage in a wireless receiving set. This is a very helpful device, and we understand from the G.E.C. that they will be pleased to furnish a copy to any of our

readers who write to them direct at Magnet House, Kingsway, W.C.2, mentioning TELEVISION.

Mullard 3 Kit Receiver

In designing their new three-valve receiver, which is known as Type 1932, the Mullard Wireless Service Co. have attempted, with success, to provide the very highest possible performance which can be obtained from that very popular valve combination of screened-grid H.F. amplifier, detector, and pentode output valve. The success of the circuit as a whole results from the combined efficiency of every part of the equipment.

In the first place the coil assembly deserves particular mention. Special coils designed for this set are of the solenoid type and are accurately matched, a point which greatly facilitates the ganged tuning which is another feature of the set. There are, of course, two sets of coils, one in the aerial circuit and one forming the tuned-grid circuit of the detector valve, and each set consists of two coils, one for long and one for medium waves. The arrangement of these coils is such that the two short-wave coils



The completed Mullard 3 Kit Receiver has a first-class appearance and backs this up with a remarkably good performance.

are set at right angles to each other; similarly the two long-wave coils are at right angles with each other, and, in addition, each short-wave coil is at right angles to its associated long-wave coil. Apart, therefore, from the very efficient screening between the aerial and H.F. inter-valve tuned circuits, the possibility of interaction between the coils is reduced to the lowest possible value.

Separate trimmers are provided for each half of the gang condenser, the trimmer on the aerial tuning condenser being used, however, as a series aerial condenser for the adjustment of selectivity, while the second trimmer is used for matching purposes.

For the rest of the circuit, the method of detection is the usual leaky-grid arrangement; coupling between the detector and output stage is by transformer, and it is worth noting that a 0.25 megohm grid leak is used as an H.F. stopper between the transformer secondary and the grid of the pentode.

We found the actual construction of this set a very simple problem, as all the components are bolted down by screws and nuts, provided with the kit, on to a metal base in which holes, the correct distance apart, are ready drilled. The complete receiver is shown in an illustration, and it will be gathered

ONE SHILLING — MONTHLY

ARMCHAIR SCIENCE

A POPULAR ILLUSTRATED
MAGAZINE FOR THE
AVERAGE MAN &
WOMAN

YOU will enjoy reading this popular, brightly illustrated magazine dealing with curious and interesting discoveries and events throughout the world. Each month there is interest and instruction for every member of the family.

"Profitable and delightful reading."—*Alnwick City Gazette.*

"Well worth a monthly shilling."—*Derbyshire Advertiser.*

"Full of good things, fully and attractively illustrated."—*Northants Evening Telegraph.*

"Deserves a front place. Every copy sold will find a permanent reader."—*National Newsagent.*

- ★ Send 3d. in Stamps for
- ★ Free Specimen Copy to
- ★ address below

DECEMBER SPECIAL ISSUE NOW ON SALE

ARMCHAIR SCIENCE LTD.
SUBSCRIPTION DEPT.
56 Victoria St., LONDON, S.W.1

from this that it looks a very workmanlike piece of apparatus. Very complete working instructions are furnished together with the constructional chart, and with the aid of these any listener, however inexperienced, should be able to construct and operate this receiver without the slightest difficulty. In operation the receiver justified its early promise, and we were able to log very easily and rapidly a dozen broadcasting stations from at home and abroad.

Selectivity was quite adequate under the conditions of the test but, of course, it should always be borne in mind that selectivity adjustments should be made to be just adequate to meet the conditions of environment. If the set is made too selective, a slight decrease in volume of weak and to some extent all stations will result.

The constructor will find himself at home with the controls in a very short space of time, and when used in conjunction with a good-quality loud speaker the reproduction is of the highest order. When one remembers that the kit of essential components and



The well-known reinforced diaphragm and a strong housing externally characterises the Celestion R.P.M.12 loud-speaker unit. The unit put up a remarkable performance under test.

valves is priced at £6 10s. and the same kit with the addition of a first-class walnut cabinet is priced at £7 2s. 6d., the acquisition of this receiver is a proposition which we can recommend to our readers wholeheartedly. It conforms to all modern requirements, and appears to be made not to a price but to a performance.

Celestion Permanent-magnet Moving-coil Loud Speaker

The Celestion R.P.M.12 loud-speaker unit, which we have just tested, is similar in make up to that of the R.P.M.8 model, the test report of which appeared in our September issue. That is to say, the diaphragm is of the well-known Celestion reinforced type, while the whole of the permanent magnet is enclosed in a very strong housing to prevent dirt and swarf from entering the magnet gap.

The speech coil impedance is rated at 7 ohms, and we employed one of the suitably tapped transformers which are supplied with these speakers. Our tests showed that this model gave amazingly clear and realistic reproduction. It is very efficiently designed, with a full and clear tone and a not too over-emphasised bass. The response over the usual frequency range showed an almost complete

absence of resonance peaks, and the volume obtained from this speaker is sufficient for a small hall without overloading. Sensitivity was excellent, and we can say quite definitely that it is one of the best permanent-magnet speakers we have so far tested.

A careful study of the chart supplied, giving the best output transformer ratios, should be made before connecting the speaker to the wireless receiver. The price of the speaker unit alone is £6, and the transformer to use in conjunction with same is a further £1. Readers desiring a high-quality moving-coil loud speaker can turn to this Celestion model with every confidence.

Fair Play for Television

(Concluded from page 373)

Making the Choice

The position then reveals itself thus: Television is certain to come into the realm of practical entertainment in from three to five years' time.

There are two alternative systems available at the moment—the British system, known as Baird, and the R.C.A. system from America. British listeners are justified in asking the B.B.C. why they are tinkering with the American system and why they are not giving adequate support to the British system. I was present recently at Savoy Hill when the first televised programme was broadcast from there to British listeners.

In my opinion this was a scandal. No proper facilities had been provided for televising programmes, but a portable equipment had to be carted over from the Baird headquarters, and in a haphazard manner the artists were televised. I can state that at the new broadcasting house now being completed in Langham Place there are twenty broadcasting studios, but not one equipped for television purposes.

Fair Play

Is the B.B.C. treating the British system fairly? Is it their proposal to hand over British listeners to American television interests? Are American advertising programmes to be broadcast on British wavelengths?

These are but a few of the questions which we have a right to ask. I know that there are men who write sketches and plays for B.B.C. broadcasting who are anxious to get into the good books of "Roxy," so as to write plays and sketches for American broadcasting and television purposes. They need to be told that their private ambitions do not constitute sufficient justification for handing over British wavelengths to American advertisers and American television manufacturers. I make use of this column to state to the B.B.C. the general feeling respecting this subject: If television is to come to this country, it must come the British way and via a British system.

The Amateur "Volohmeter"

(Concluded from page 394)

strip in this way. Switch knob on left, R (for resistance), switch knob in mid position, L.T. (for 0 to 10 volts), and switch knob on right, H.T. (for 0 to 200 volts).

By the intelligent use of this compact and inexpensive test instrument readers can assure themselves that their wireless receivers and vision apparatus are working at full efficiency. When carrying out the resistance measurements a current of less than one milliampere is flowing through the circuit under test, and thus there is little fear of any damage being caused to the most delicate of apparatus. Anode resistances, inductance coils (including transformer windings and low-frequency chokes), potential dividers, and synchronising coils are but a few of the items that frequently demand checking up, and, in addition, one can see instantly if there is an open circuit. In the case of the latter no needle deflection will take place, and having located an offending component in this way, it can be repaired or replaced.

Do not forget to renew the batteries after the "Volohmeter" has been in use about a year, and within that period slight adjustments in the wander-plug position may be necessary, although there is a good voltage reserve from the two 9-volt batteries in series.

Coming to the voltage side of the instrument, it is important to realise that even with the most perfect set the final result depends essentially on three variable quantities, namely filament, plate, and grid voltages. These are of fundamental importance, for valve replacements can be avoided by seeing that the maker's ratings are adhered to rigidly.

Incorrect grid bias, besides causing distortion, sets up a heavy drain on the H.T. source. If you are dependent upon batteries, remember that the life of these is measured in so many milliampere hours. You can only secure the most economical results, and therefore the longest life from the battery, by reducing its output to the lowest limit consistent with the signal strength desired. This can be done by the correct adjustment of the filament, plate, and grid voltages by means of the "Volohmeter." The two ranges should be quite adequate for this purpose, but if the reader desires to extend the H.T. readings beyond the 200 volts, he has merely to add a 100,000-ohm fixed resistance in series for each 100 volts addition to the scale. These resistances can be included in series with the terminals externally, or, if preferred, mounted inside the small cabinet in a convenient position.

Of course, similar remarks apply to the 10-volt scale, a further 10,000-ohm fixed resistance being necessary for each 10-volt scale increase, but here you must be careful not to upset the arrangements made for resistance measurements.

Bearing in mind all these factors, I am sure readers will agree quite readily that the test instrument described is one which will find many uses on the test bench, in the service-room, and in the home.



DISCOVERY

FOUNDED 1920

for everyone interested in

SCIENCE

NEVER TOO TECHNICAL
NEVER TOO POPULAR

BUT

AUTHENTIC ARTICLES
BY LEADING EXPERTS

THE CONTENTS OF THE December Number

include the following:

SCIENCE AND HUMAN EXPERIENCE

By Sir Arthur Eddington

THE NEW ELEMENT

By A. S. Russell

A CHANCELLOR'S DEFENCE

By R. B. Mowat

400 YEARS OF MEXICAN ART

By René d'Harnoncourt

THE RÔLE OF THE CINEMA IN SCIENCE

By R. Neil Chrystal

PRICE . . 1/- MONTHLY

ANNUAL SUBSCRIPTION 12/6

SEND FOR FREE SPECIMEN COPY
NOW TO

THE MANAGER, "DISCOVERY,"

Bouverie House, Fleet Street,

LONDON, E.C.4

LETTERS TO THE EDITOR

The Editor does not hold himself responsible for the opinions of his correspondents. Correspondence should be addressed to the Editor, TELEVISION, 505, Cecil Chambers, Strand, W.C.2, and must be accompanied by the writer's name and address.

INTERESTING, ENTERTAINING, AND AMUSING

To the Editor of TELEVISION

DEAR SIR,—You no doubt will be greatly interested to hear that the first television broadcast from a B.B.C. studio, viz. that of Jack Payne and his Band, was received most excellently at my home in the North of England.

The picture and music combined to make what was really and truly nothing more or less than a talking picture in the home.

I was able to entertain four friends, as well as myself, to a most interesting, entertaining, and amusing twenty minutes.

I am certain that this broadcast of last evening marks the advent of a new wireless era, which will be the combination of music and pictures in the home, and I am looking forward to seeing and hearing many more entertainments of a like nature.

Yours faithfully,

T. PAYNE.

7 ST. ANDREW'S BUILDINGS,
GALLOWGATE,
NEWCASTLE-ON-TYNE.

October 16th, 1931.

MORE JUVENILE RECORDS

To the Editor of TELEVISION

DEAR SIR,—Perhaps you would like the enclosed cuttings as an indication of the activities in Ports-

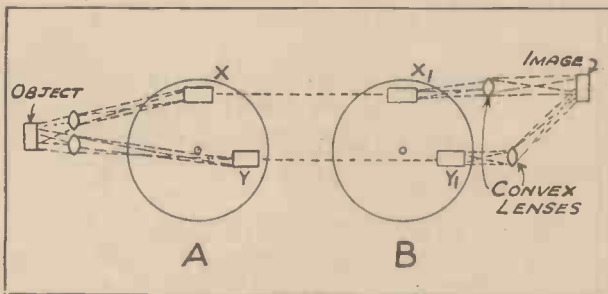

A suggestion for a two-line television transmission made by Mr. Land in the correspondence columns.

mouth. Television is being received very well here. (Publically I mean.) At the lecture referred to there were about 300 or 400 people present.

By the way, one of your correspondents refers to a possible record in regard to his daughter aged fifteen tuning-in the Baird "Televisor." May I say that one of my boys, aged six years, can connect up the Baird instrument to the Baird A.C. Receiver, tune-in, frame, and hold the picture perfectly for the half hour (irrespective of the idiosyncrasies of the transmitter!). This he does frequently. On one occasion when I had arranged a "show" for some local doctors, he "did" the lot himself with ease.

Looking forward to the new TELEVISION with interest.

Yours faithfully,

ALBERT PARSONS
(F.R.A., F.T.S.).

THE MUNICIPAL COLLEGE,
PORTSMOUTH.

October 20th, 1931.

ANOTHER SCANNING SUGGESTION

To the Editor of TELEVISION

DEAR SIR,—Since writing my last letter it has occurred to me that the idea which I put forward will prove to be exceedingly complicated in practice, and I believe that a simpler method of combined scanning is more likely to be fruitful of results. I am of the opinion, however, that a combined system of scanning is the only mechanical way out of the difficulty, and that the simple method of using one spiral disc is but the mere principle, which should somehow be enlarged upon. Mr. Baird, being a genius of outstanding merit, is more likely to improve upon the existing systems than anyone else, but still, I know all progressive sciences are glad of suggestions, however "far-fetched," so long as they contain the mere germs of possibility.

I have just thought of what results could be obtained by having a two-line television transmission in the following manner.

A is a system of transmission, having a spiral disc, scanning an object horizontally at X, and the same object focused at Y vertically. At both X and Y the image being scanned is focused on to a photoelectric cell. The impulses received on the cell by the horizontal scansion at X are sent down a circuit to the receiving end B, where the impulses are made to light the neon lamp at X₁, and a horizontal scansion, similar to X, is carried out by the disc.

At Y , the same is done, only vertical scanning of the object is done at Y , and vertical replacement of the image at Y_1 .

Thus a horizontal and a vertical scansion is obtained, by focusing lenses, of the same object, which



⊙ ⊙ ⊙

Mr. T. Payne, of Newcastle, explains in his letter that when he received the Witzleben television transmissions the word PAUSE came through his "Televiser" in the fashion illustrated.

⊙ ⊙ ⊙

scansions are superimposed again by lenses at the receiving end B .

Unfortunately I am afraid two separate circuits are necessary for this experiment, but the result should mean considerable increase of detail.

I hope I have not caused you too much trouble in stating my facts, but I know all ideas are welcome.

Yours faithfully,
 GEORGE E. LAND.

61 KING STREET,
 HODTHORPE,
 NR. MANSFIELD,
 NOTTS.

October 7th, 1931.

CHECKING DISC HOLES

To the Editor of TELEVISION

DEAR SIR,—Having been a regular reader of your excellent magazine TELEVISION since No. 1, I cannot help noticing the number of articles on making scanning discs, although the authors of them rarely give a means of checking the finished disc for accuracy. The following idea occurred to me in consequence. By using as a screen a piece of sensitised paper, such as "Slogas," with the sensitive side facing the disc, and an ordinary light (gas or electric) instead of a neon lamp, if the disc is turned by hand so that every hole in it traverses the paper, on developing the paper a record is obtained of any faults in the cutting, and by filing and covering the almost perfect disc should result. As the materials cost about 9d., I think the trouble is well worth while, and may



THIS
 SAMPLE

COPY

F R E E

From experience we find those interested in Television to be THE real Radio ENTHUSIASTS. Everyone who is enthusiastic will naturally be interested in IRISH RADIO NEWS, and accordingly, if you drop us a line with your name and address, we will gladly send you a specimen copy FREE.

Irish Broadcasting is particularly interesting to those who are really keen on Radio. Hear Sponsored Programmes within the British Isles.

Edited by JAMES KITCHEN, A.M.I.R.E.
 PUBLISHED EVERY FRIDAY

Regular Contents include:
 OFFICIAL IRISH AND B.B.C.
 PROGRAMMES FOR THE WEEK
 "BROAD TUNING," by A.Z. (Gossip)
 HINTS FOR CONSTRUCTORS
 GRAMOPHONE NOTES
 NORTHERN IRELAND NEWS
 Special Articles, News, Photos, Etc.

Why Not Become a Subscriber?

One Year, Post Free . . . 7s. 6d.
 Six Months, Post Free . . . 3s. 9d.

Irish Radio News

Editorial and Publishing Offices:
 179 PEARSE STREET, DUBLIN
 Phone: DUBLIN 43236

ENGLISH BRANCH:
 RICHMOND HOUSE
 NORTHBROOK ROAD, LONDON, S.E.13
 Phone: LEE GREEN 1059

save nasty words over a streaky picture. I trust that somebody may find this tip useful. I have not tried this scheme myself, as unfortunately I do not possess a "Tevisor," although I may try to obtain one before the winter is out.

Wishing all the best to TELEVISION and the British system.

Yours faithfully,
G. PRIDE.

7 PURVES ROAD,
KENSAL RISE,
N.W.10.
November 9th, 1931.

FROM BERLIN TO NEWCASTLE

To the Editor of TELEVISION

DEAR SIR,—It may interest some of your readers to learn that I had some fairly good television results from Witzleben (Berlin) last evening.

At several periods during the transmission I had the word "pause," very sharp and distinct, across the picture. It was received in the form as per sketch enclosed.

When the picture was at its best, I saw a man apparently doing physical culture exercises. I also had a picture of what appeared to be two men either boxing or wrestling.

The transmission finished at 12 midnight.

Yours faithfully,
T. PAYNE.

7 ST. ANDREW'S BUILDINGS,
GALLOWGATE,
NEWCASTLE-UPON-TYNE.
November 7th, 1931.

NEW DISC IDEAS

To the Editor of TELEVISION

DEAR SIR,—In considering the disc suggested by your correspondent Mr. Land, it would be interesting to know how many holes it ought to have.

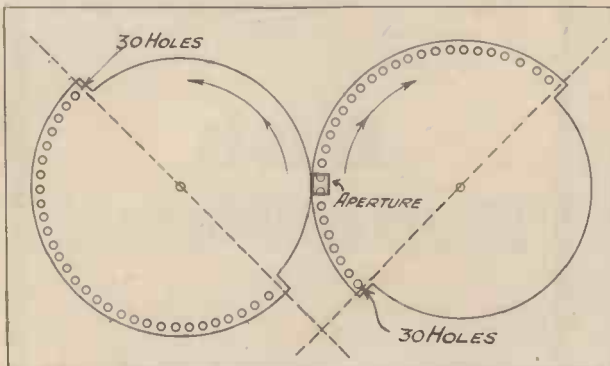

A.—Alternate scanning by discs running in opposite directions.

If it is a 60 (double 30) hole disc and if the speed is 375 r.p.m., giving $12\frac{1}{2}$ double-scanned pictures per second, then each individual strip would contain just

half the detail of a standard Baird strip, the top frequency being constant.

If this detail is increased to equal the Baird strip detail, then the speed would have to be halved—

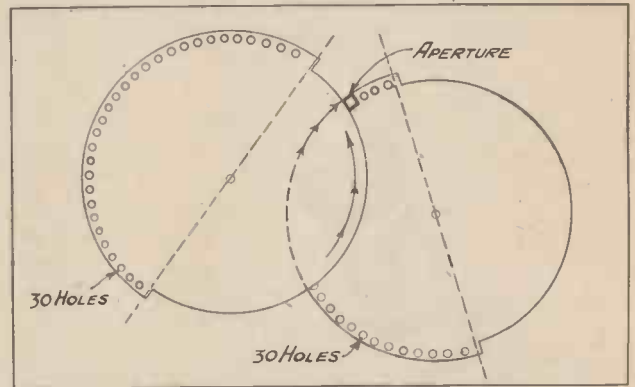

B.—Combined horizontal and vertical scanning as suggested by Mr. Carmichael.

reduced to $6\frac{1}{4}$ pictures per second: rather too slow, I think.

An optical system would be required for superimposition at the receiver, as he suggests. One would also be needed for the transmitter, unless the distance between the apertures is small compared with the breadth of the subject scanned. Also, long thin articles such as violin bows would be distorted if pointed at the scanning mechanism.

Any advantage to be gained from alternate scanning by groups of strips curved in opposite directions might be secured by having two 30-hole discs, as in A, coupled by a pair of accurate spiral gears made of some rubber composition. If these both revolved at 375 r.p.m., i.e. $12\frac{1}{2}$ pictures per second, then the strips scanned through the aperture indicated would each give the same detail as Baird strips, the top frequency being constant. The advantage might lie in the fact that the strip divisions are intercrossed, but only at the top and bottom.

Combined horizontal and vertical scanning might be advantageous in that it would abolish the sharp cut-off between adjacent strips. This might be carried out by using similar discs coupled by gears and set as in B. No extra optical system would be needed in either case.

Yours faithfully,
P. F. CARMICHAEL.

CLADDOCH, GARTOCHARN,
DUMBARTONSHIRE.
November 11th, 1931.

PARTS for experimenters. Scanning Discs, 12/6; Baseboards with slot and four feet, 12/-; Viewing Lenses, per pair, 13/-; Motors, 35/-; Phonic Wheels, 3/6. JOHN SALTER (Established 1896), Featherstone Buildings, High Holborn, London, W.C.1.

A. DOSSETT, Commercial Artist and Draughtsman for all technical diagrams, illustrations and layouts.—HAZLITT HOUSE, Southampton Buildings, Chancery Lane, London. Holborn 8638.

The list of live dealers who are demonstrating **BAIRD TELEVISION** gets bigger every week!

ASHFORD (KENT)
BAGSHOT
BEACONSFIELD
BEXLEY HEATH
BICESTER
BIRMINGHAM
BIRMINGHAM
BISHOPS STORTFORD
BOURNEMOUTH
BRACKNELL
BRIDGEND
BRIXTON
BURNHAM
CHALVEY
CHELMSFORD
CHERTSEY
CHESTERFIELD
COLCHESTER
COULSDON
COVENTRY
DARLINGTON
DEAL
DOVER
ERITH (KENT)
FARNHAM
GERRARDS CROSS
GODALMING
GRAYS (ESSEX)
HORLEY
KIRKCALDY
KNEBWORTH
LEIGHTON BUZZARD

C. HAYWARD & SONS
LINDFIELDS GARAGE
BEACONSFIELD MOTOR CO. LTD.
J. SPENCER (LONDON) LTD.
LAMBOURNE BROS.
C. WEBB LTD.
SHANNON & CAPENER
H. R. MOORE LTD.
J. E. BEALE LTD.
DRAKE & MOUNT LTD.
WRIGHT & ASHWORTH
QUIN & XTENS
TIMMS & ALDRIDGE
J. D. HALLIDAY
LONDON RADIO CO.
RADIOGRAM STORES
G. KENNINGTON (CHESTERFIELD) LTD.
SHROSBURY & BAKWELL CO. LTD.
THE "VIC" WIRELESS STORES
MAX. A. BUCH
C. SHARP
G. CLOUT
DOVER RADIO STORES
CREFFIELD ELECTRICAL SUPPLIES
WILEYS
R. F. CHIPPS
H. J. CHALLEN
GRAYS WIRELESS CO. (H. W. FRANKLIN)
S. A. COUTTS
GIBB & WATSON
E. S. HEAP
GRIFFIN BROS.

20/42 New Street
Surrey
68 London End
127 The Broadway
47 Market Square
41 Carrs Lane
13 Aston Road North
Northgate End
Hants
Berks
Kings Bldgs., Adair Street
Brixton Road
Bucks
Nr. Slough
209 Moulsham Street
87 Guildford Street
Victor Lane
73 Crouch Street
21 Chipstead Valley Road
143 Lower Ford Street
321 North Street
Electrical Engrs.
4 Townwall Street
90 High Street
Downing Street
6 Oak End Way
12 Church Street
Clarence Road
Victoria Road
270 High Street
London Road
11 High Street

LONDON :

BROMLEY
CROYDON
EALING
EALING (WEST)
EARLSFIELD
EAST DULWICH
EAST DULWICH
EDGWARE
EDMONTON
ENFIELD
FULHAM PALACE ROAD
HAMMERSMITH
HARROW (NORTH)
HENDON
HOLLOWAY
ISLEWORTH
KINGSTON
LEE
NEW BOND STREET
OXFORD STREET
PALMERS GREEN
PIMLICO
THORNTON HEATH
TOTTENHAM
WALWORTH
WEMBLEY
WEST NORWOOD
WOOD GREEN
MIDHURST
NEWCASTLE
NEW MALDEN (SURREY)
NORWICH
PLYMOUTH
RAMSGATE
REDHILL
ROCHDALE
SLOUGH
SOUTHALL
STAINES
TONBRIDGE
UXBRIDGE
WALTON ON THAMES
WATFORD
WELLING
WEST BYFLEET
WEST DRAYTON
WEYBRIDGE
WINDSOR
WOKING
WORTHING

UNIVERSAL ENGINEERS
KENNARDS
KEEN WIRELESS CO.
L. LEAMAN
H. HOLLIER & SONS
R. MANSEL JONES
RAND & BARKER
J. F. WISSON
E. J. HERAUD
HOWARDS LTD.
"ECONOMIC"
W. H. OATES
BATTERY SERVICE CO.
S. G. THAINE
JONES BROS. (HOLLOWAY) LTD.
S. R. WEBB
BENTALLS LTD.
A. BEDFORD & SONS
KEITH PROWSE LTD.
SELFRIDGE & CO. LTD.
PALMERS GREEN RADIO SERVICES
F. DOVE & SONS
D. L. KING & CO.
B. HOGBEN, A.M.INST.B.E.
GAS LIGHT FITTINGS LTD.
MELODY HOUSE (J. C. MILLS)
E. SHELDRICK
DISTRICT SUPPLIES LTD.
V. DALE
PAYNE & HORNSBY LTD.
ACORN SERVICE STATION LTD.
E. A. PRIEST & CO.
W. H. AXWORTHY & CO.
J. CARMAN
ROBERTS & SONS
BANNISTER & FITTON
G. CASE & SONS
LAYTON & CO.
V. & D. KEALE
A. T. LANGTON
WILLIS & SONS
H. N. BULLEY
L. J. IVE
WELLING RADIO STORES
A. LONG
SPRATLEY BROS.
E. W. FARROW
S. A. SURPLICE
C. F. ROYSTON & CO.
E. LAMB

1 Chatterton Road
High Street
1 Dare Road
97 Northfield Avenue
422 Garratt Lane
40 Lordship Lane
Melbourne Grove
2 Cheapside, Deans Lane
78 Fore Street
31 Church Street
24 Fulham Palace Road
195 Hammersmith Road
47 St. Annes Road
192 Brent Street
Holloway Road
191 Twickenham Road
Surrey
11 High Road
159 New Bond Street
W.I.
15 Melbourne Park, N.13
77 Pimlico Road
20 High Street
272 High Road, N.15
322 Walworth Road
56a Ealing Road
493 Norwood Road
43 High Road
North Street
7 St. Andrew's Buildings
Kingston By-pass Road
28 St. George's Road
106 Tavistock Road
65 King Street
72 Station Road
27 Milnrow Road
2 Grove Parade, High Street
10 South Road
Kingston Road
High Street
278 High Street
18 High Street
7 Clarendon Corner
3 The Parade
1 Byfleet Corner
Station Road
42 High Street
27/29 Sheet Street
Guildford Street
Franklin Road, Durrington

Advt. of Baird Television, Ltd., 133 Long Acre, London, W.C.2.

THE GIFT PROBLEM SOLVED

NON-TECHNICAL FRIENDS

WILL BE GLAD TO POSSESS A BOOK WHICH DEALS, IN NON-TECHNICAL LANGUAGE, WITH A SUBJECT IN WHICH THEY ARE BOUND TO BE INTERESTED IN THE NEAR FUTURE

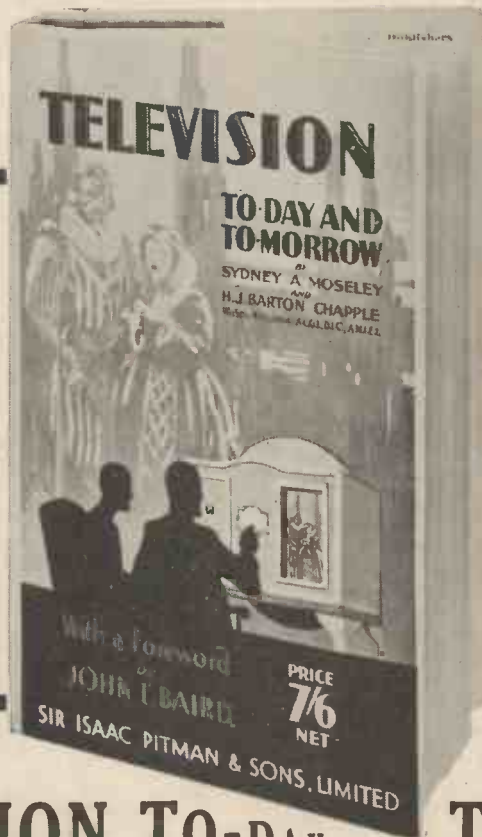

FELLOW EXPERIMENTERS

WILL BE GRATEFUL FOR AN AUTHORITATIVE BOOK WHICH WILL GIVE THEM THE UTMOST ASSISTANCE IN THEIR EXPERIMENTS AND RESEARCH

"TELEVISION TO-DAY AND TO-MORROW"

(SECOND EDITION)

By SYDNEY A. MOSELEY and H. J. BARTON CHAPPLE, B.Sc.(Hons.), A.M.I.E.E.

All the big developments which have occurred in the Television World since this book was first printed are fully described in the New Edition. Every advance of the science is dealt with. The Second Edition is a veritable mine of the latest information.

"DAILY NEWS"

"Many secrets of the apparatus used are revealed in detail for the first time in this book, together with full technical information about the system, put in simple language specially for the wireless amateur."

"ELECTRICAL TIMES"

"This book is of very considerable general interest. It sets out very clearly the outstanding developments and achievements in the evolution of television broadcasting."

"YORKSHIRE POST"

"The book is neither dull nor formidable for the non-technical reader; in addition to the diagrams, this book is excellently illustrated by almost fifty photographic plates."

PRICE

7/6

POSTAGE SIXPENCE EXTRA

"NOTTS GUARDIAN"

"The authors have kept in mind the fact that many persons interested in wireless have no very deep knowledge of electrical matters, and have written a book which the amateur will readily understand."

"ABERDEEN PRESS AND JOURNAL"

"The subject of television is dealt with in an admirable and non-technical manner, and we are led through essentially intricate phases to a clear appreciation of what has been done, what takes place, and the possibilities for the future."

"ELECTRICAL REVIEW"

"The illustrations are good, well-chosen and interesting, while the diagrams and sketches are numerous and clear. It is well worth careful perusal by anyone interested in this entertaining subject."

ORDER NOW FROM

TELEVISION PRESS, LTD.

505, CECIL CHAMBERS, STRAND, W.C.2

Telephone: TEMPLE BAR 8169