

FOR THE  
RADIO LISTENER

# short wave magazine

May 1992 £1.75 ISSN 0037 - 4261

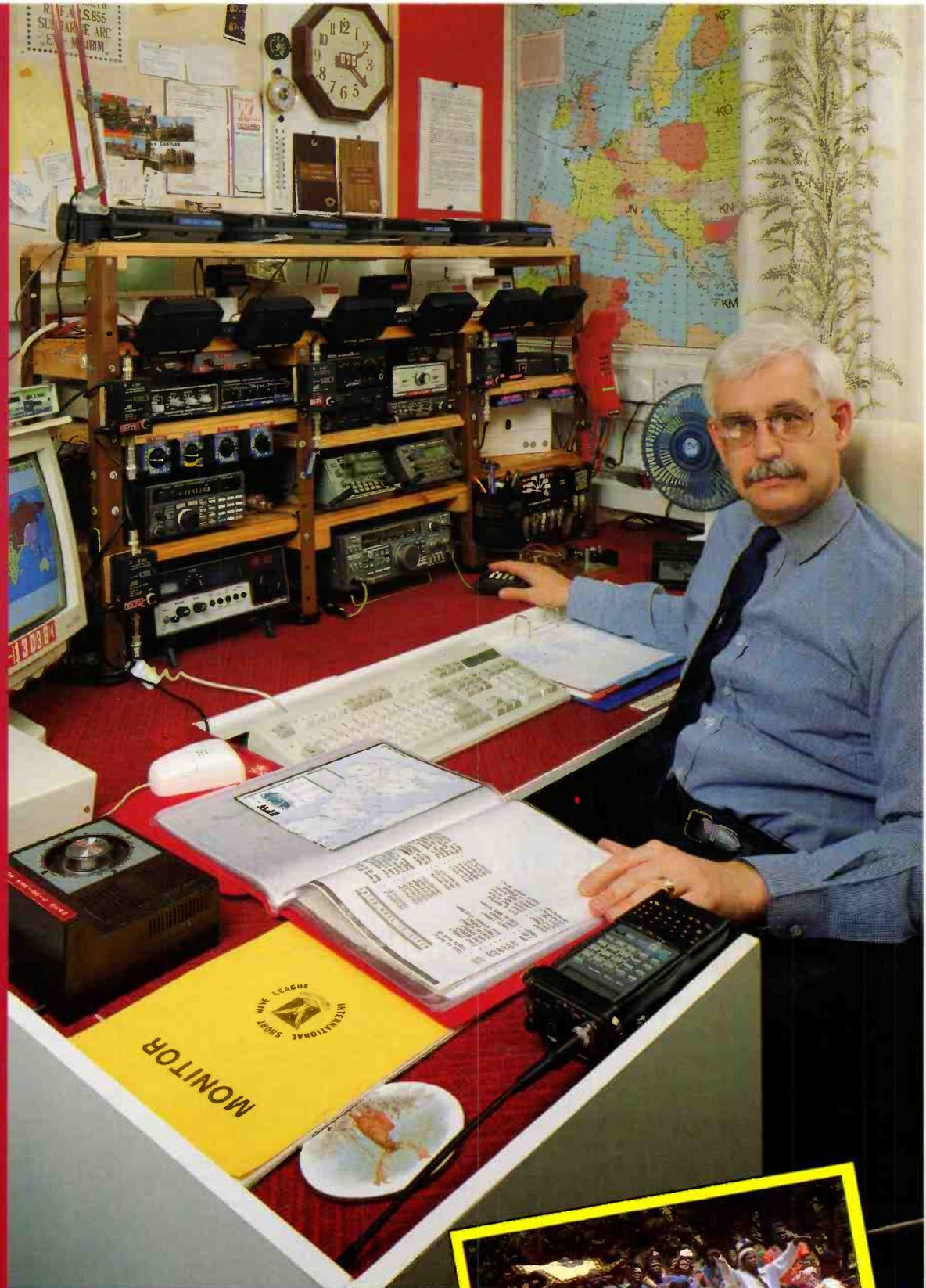

## AMATEUR RADIO RECEIVING STATION G-13038

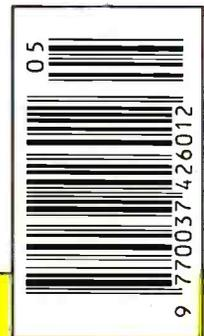

**Regular Features**  
Airband, Scanning,  
Junior Listeners, SSB  
Utility Listening,  
Propagation and  
Broadcast Enthusiasts

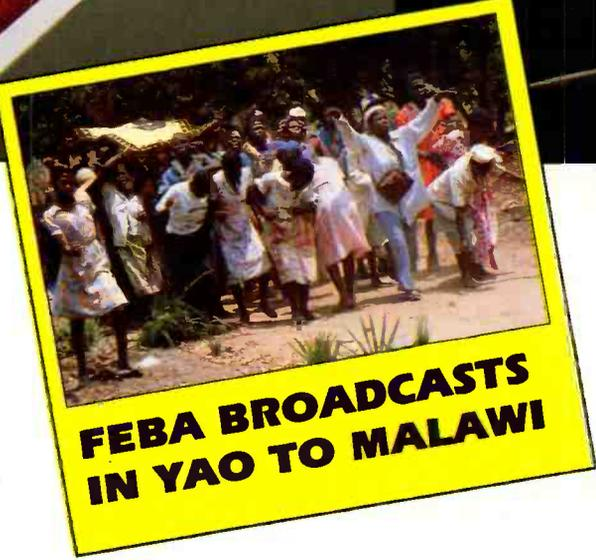

**FEBA BROADCASTS  
IN YAO TO MALAWI**

**RELIGIOUS BROADCAST SPECIAL**

# The Ultimate in Mobile Scanners

1,000 Channel Wideband Scanner

Frequency Range: 500kHz – 600MHz  
800 MHz – 1300 MHz

Receiving Modes: AM – FM – Wideband FM

Search Steps 5kHz to 995kHz

Selectable 10dB Attenuator

Tape Recorder Output Socket

Automatic Tape Recorder Switching Circuit

Keypad or Rotary Tune Controls

Switchable Audio Squelch

All Metal Case For Improved EMC Compatibility



AVAILABLE FROM YOUR LOCAL DEALER  
OR DIRECT FROM

**NEVADA COMMUNICATIONS**  
189 LONDON ROAD, NORTH END,  
PORTSMOUTH PO2 9AE

USE YOUR CREDIT CARD FOR SAME  
DAY DESPATCH

**ORDER HOTLINE**  
(0705) 662145

**£279**



**— Wideband Scanning Receiver MS 1000 —**

**VOL. 50 ISSUE 5 MAY 1992  
ON SALE APRIL 23**

(Next Issue on sale MAY 28)

**EDITOR: Dick Ganderton, C. Eng., MIEE, G8V FH**  
**ART EDITOR: Steve Hunt**  
**NEWS & FEATURES: Elaine Richards G4LFM**

**EDITORIAL**

**Enefco House, The Quay,  
Poole, Dorset BH15 1PP**

**TEL: (0202) 678558**

**FAX: (0202) 666244**

**CREDIT CARD ORDERS: (0202) 665524**

*(Out of hours service by answering machine)*

**ADVERTISEMENT DEPARTMENT**

**ADVERTISEMENT MANAGER**

**Roger Hall G4TNT**

**TEL: 071-731 6222**

**FAX: 071-384 1031**

**ADVERTISEMENT PRODUCTION (Poole)**

**Marcia Brogan**

**TEL: (0202) 676033**

**FAX: (0202) 666244**

© PW PUBLISHING LTD. 1992.

Copyright in all drawings, photographs and articles published in *Short Wave Magazine* is fully protected and reproduction or imitation in whole or in part is expressly forbidden. All reasonable precautions are taken by *Short Wave Magazine* to ensure that the advice and data given to our readers is reliable. We cannot however guarantee it and we cannot accept legal responsibility for it. Prices are those current as we go to press. *Short Wave Magazine* is published monthly for \$45 per year by PW Publishing Ltd., Enefco House, The Quay, Poole Dorset BH15 1PP. Second class postage paid at Middlesex, NJ. Postmaster: send address changes to C & C Mailers International, 40 Foxhall, Middlesex, NJ 08846.

# contents

- 10** ICS FAX-2 Review  
*Mike Richards*
- 15** Peter G. Rayer G-13038
- 18** A Novel 3.5MHz Receiver with Reaction - Part 1  
*Ian Hickman*
- 25** An IF Output - the Easy Way  
*John Wells*
- 27** Retuning hi-fi Headphones for Short Wave Listening  
*Richard Q. Marris*
- 30** Special Book Offer - *Ferrell's Confidential Frequency List*
- 31** Religious Broadcasters - an Overview  
*Andrew Steele*
- 27** Broadcasting The Gospel  
*Dick Ganderton*
- 34** World by 2000  
*FEBA Radio Interview*
- 31** Sony ICF-SW77 World Band Receiver Review  
*Peter Shore*

## RELIGIOUS BROADCASTERS

### REGULARS

**Cover:**

The story behind our main cover picture this month is told on page 15.

The inset picture shows the 'people of the dance' - the Yao Muslims from Malawi and was kindly supplied by FEBA Radio to go with our Religious Broadcasters feature.

FEBA Radio's Programming Director Tony Ford is interviewed by Trevor Barnes on page 39.



- |                           |                          |
|---------------------------|--------------------------|
| 53 Airband                | 63 Long Medium & Short   |
| 48 Amateur Bands Round-up | 67 Watching Brief        |
| 44 Bandscan N. America    | 6 News                   |
| 74 Book Service           | 44 Airband               |
| 59 Decode                 | 43 PCB Service           |
| 49 DXTV Round-up          | 67 RadioLine             |
| 2 Editorial               | 4 Rallies                |
| 25 First Aid              | 47 Satellite TV News     |
| 4 Grassroots              | 54 Scanning              |
| 56 Info in Orbit          | 2 Services               |
| 76 Index to Advertisers   | 43 SSB Utility Listening |
| 5 Junior Listener         | 77 SWM Subscribers' Club |
| 2 Letters                 | 77 Trading Post          |
| 12 Listen With Grandad    |                          |

...GOOD LISTENING

**BOOK SPECIAL OFFER  
COUPON SWM MAY 1992**

**TRADING POST  
COUPON SWM MAY 1992**

# editorial

## SWM SERVICES

### Subscriptions

Subscriptions are available at £21 per annum to UK addresses £23 in Europe and £25 overseas. Subscription copies are despatched by Accelerated Surface Post outside Europe. Airmail rates for overseas subscriptions can be quoted on request. Joint subscriptions to both *Short Wave Magazine* and *Practical Wireless* are available at £34 (UK) £37 (Europe) and £39 (rest of world).

### Components for SWM Projects

In general all components used in constructing SWM projects are available from a variety of component suppliers. Where special, or difficult to obtain, components are specified, a supplier will be quoted in the article.

The printed circuit boards for SWM projects are available from the SWM PCB Service.

### Back Numbers and Binders

Limited stocks of most issues of SWM for the past five years are available at £1.80 each including P&P to addresses at home and overseas (by surface mail).

Binders, each taking one volume of the new style SWM, are available price £5.50 plus £1 P&P for one binder, £2 P&P for two or more, UK or overseas. Please state the year and volume number for which the binder is required. Prices include VAT where appropriate.

Orders for p.c.b.s, back numbers, binders and items from our Book Service should be sent to **PW Publishing Ltd., FREEPOST, Post Sales Department, Enefco House, The Quay, Poole, Dorset BH15 1PP**, with details of your credit card or a cheque or postal order payable to PW Publishing Ltd. Cheques with overseas orders must be drawn on a London Clearing Bank and in sterling.

Credit card orders (Access, Mastercard, Eurocard or Visa) are also welcome by telephone to Poole (0202) 665524. An answering machine will accept your order out of office hours.

The choice of Religious Broadcasters as the special subject this month, was made, not because of any pious beliefs on my part, but rather because these stations are very popular with short wave listeners throughout the world. They broadcast on regular schedules with recognisable programmes, so it is relatively easy to listen to them. Their programmes, particularly those aimed at the DXer, can also be very interesting. Obviously it is not possible to mention every single religious broadcaster and station in the space allocated in this issue. The omission of any station does not imply that they do not merit the attentions of readers or that they are in some way beyond the pale. So far the choice of special subjects seems to have been popular with you, the readers and we have more lined up during the rest of this year.



G8V FH

# letters

### Dear Sir

Being a reader of Short Wave Magazine for a great number of years (I have copies going back to 1963 priced 2/9), I have noticed quite a few changes in the style of your magazine over that period.

However, I must congratulate you on February's edition, the colour and format. The airband special was of particular interest to me as I live between two airports. By the way, I am 63 years old and my first non-commercial reception was in 1954, Cullercoates Radio on a Bush receiver.

My present station is a Trio R2000 with a Global a.t.u. and random wire, I also have a Realistic scanner. Your magazine suites all interests in s.w.l.

**John Devine  
Co. Durham**

### Dear Sir

As an active member of Radio Polonia's DX Club, I am writing to bring the following to your attention.

In connection with your feature on this station on page 6 of December 1991 issue of SWM. I sent them a photocopy. On two separate DX Club programmes they have referred to this and said how pleased and grateful they are to *Short Wave Magazine* for this write up, and they have wondered who sent you the information.

On Monday January 13, this station changed its name from Radio Polonia to Polish Radio, Warsaw and also altered the schedule:

0630-0730 9.525, 7.270 & 6.135MHz  
1600-1700 11.840 & 9.525MHz  
2000-2100 9.525, 7.270 & 7.145MHz  
2200-2300 7.270, 6.135, 5.955 & 1.503MHz

Also in view of the piece about Radio Prague Monitor Club on page 5 - 'Junior Listener' - of the December issue, I wonder if Jon Jones might be interested in mentioning Polish Radio, Warsaw DX Club, new members very welcome, ten reception reports to join, attractive QSL cards, free schedules and DX diploma awards.

I would like to take this opportunity of thanking you for the very interesting and informative *Short Wave Magazine* each month.

**Sheila Hughes  
Morden**

*Jon Jones would be pleased to hear from any readers who belong to radio station DX Clubs as this is a good way for younger readers to start their broadcasting hobby. Details to the address on page 5 please.*  
- Ed.

### Dear Sir

At least two of the recently released hostages have praised the positive effect of BBC overseas radio services during their captivity but from time to time governments of all political hues are tempted to threaten the continuous of such broadcasts on the grounds of money saving. It is only when there is a war or a cold war that broadcasts in the language of the 'hostile' country are stepped up, and there have even been examples of axed foreign language services on the grounds that the people of friendly nations don't need any cultivating and that they ought to be listening in English anyway.

The hostages' positive opinions of the BBC should perhaps be used by DXers and s.w.l.s world-wide as the basis for a QSL - and letter-writing - campaign to support and encourage broadcasts from the stations which they listen to in the languages they want. Many UK s.w.l.s will be able to confirm, for example, that even when a non-British station simply announces its title in English and other languages between its call signs, a very positive bond with listeners speaking that language is formed. This must be even more so for listeners in smaller world language groups, so this is really not a question of huge expense so much as a desire to reach out more widely and to avoid using radio as war propaganda by keeping tension down beforehand - a policy which short wave radio is a very attractive and cost-effective option.

**Edward Turnbull  
Northumberland**

# letters

## Dear Sir

Recently, it was the 10th anniversary of the Argentinian invasion of the Falkland Islands, which took place on 2 April 1982.

In the many books that have subsequently dealt with that historic event, several state that with the words, "we have lots of new friends", Port Stanley's telex operator broke the news to a stunned and disbelieving Britain. At least one of those books reproduces a photostat of that teleprinter exchange and shows the time of that message to have been 4pm BST on 2 April 1982.

I am wondering if this was indeed the first confirmation from the Falklands that the invasion had actually taken place. Whilst I was recently in Port Stanley, I learned that an amateur radio operator may have been even earlier with the news. Unfortunately, I was not there long enough to pursue the matter further. Perhaps a reader may have received the transmission, and may even have a tape recording of that historic signal.

In view of the coming anniversary, it would be interesting to be able to set the record straight. How, and precisely at what time, did news of the invasion first reach the UK from the Falklands?

**Peter Cox, Plymouth**

## Dear Sir

I am almost sure to be the first DXers from Russia submitting a letter the *SWM*. June 1991 copy was the first in my life accidentally received from my friend, Arma Aksland, living in Colorado Springs (USA). While reading your magazine I realised that I am doomed to stay an endless beginner in radio monitoring. Though I was a professional radioman during my army service.

DXing is a rare hobby in our country because, for the first, we have a lack of good receivers available here, and for another, having a shortage of information sources. In fact, from your magazine, from the only copy of it I received much more information about 'Tropical Short Wave' stations, for example, than I could gather by myself for a year period!

Because of these reasons, there is not even a small DX club in our city (Kazan), though its population is a little less than 1.5 million. Taking an opportunity of getting familiar with *Short Wave Magazine* I would like very much to start post communications with DXers in England and all over the world. I am 25, my name is Dmitri Souslov. I am sure to answer all of your letters in English. Here is my address:

Russia (Pocqua) 420080

Kazan - 80

PO Box 96

**Dmitri Souslov, Kazan**

## Dear Sir

Over the last few months I have read with interest the letters dealing with the receiving or otherwise of QSL cards from amateurs.

When I first started collecting these many years ago, I seem to recall it was done on a one for one basis, all very friendly. I bought some specially printed cards from *PW*, (1979 as shown here), and used the call books to send one of these direct to the amateur as a short wave listener.

Using the bureau took far too long, one could die of old age waiting for a return card

by that method. By using the mail I could collect foreign stamps as well. Sometimes I got a card back, sometimes I did not, usually I did. Even as an s.w.l., my cards were favourably received.

Why should amateurs expect a listener to send IRCs, addressed envelopes, begging letters, etc., which would all add to the cost, over a pound I should imagine with postage from this end, to operators who are not interested today in getting reports from short wave listeners anyway.

**Cliff Stapleton  
Torquay**

## Dear Sir

Being mainly a broadcast band listener, I was unsure about visiting the London Amateur Radio & Computer Show on Saturday March 7. However, I am very pleased that I did. Rather than catering solely for licensed amateurs and computer buffs, there was much of interest to short wave listeners and indeed for any kind of radio enthusiast.

Apart from a wide selection of new and second-hand receivers, I saw several suitable a.t.u.s, antennas, kits and lots of bits. There was a good range of useful books and magazines, with some very tempting special offers, particularly on the *SWM/PW* stand!

My desire for an extension speaker was easily satisfied as there were plenty to choose from, some at discontinued prices. In fact, the three halls were filled with stands offering an amazing variety of items, from antenna masts to Zener diodes. I was even able to buy a Mothers' Day card!

So whether you are interested in amateur radio, broadcast bands, utilities, scanning or even CB, these shows are well worth visiting.

**Keith Mellor, Cheltenham**

## Dear Sir

Since playing with a strange radio called an Eddystone at work, I couldn't believe the stations that were coming in. Anyway, I was looking in *W.H.* Smith one day and came across *Short Wave Magazine* and I thought, what a good magazine this is. It really is an

IF YOU HAVE ANY  
POINTS OF VIEW THAT  
YOU WANT TO AIR  
PLEASE WRITE TO THE  
EDITOR. IF YOUR LETTER  
IS USED YOU WILL  
RECEIVE A £5 VOUCHER  
TO SPEND ON ANY *SWM*  
SERVICE.

The Editor reserves the right to shorten any letters for publication but will try not to alter their sense. Letters must be original and not have been submitted to other magazines. The views expressed in letters published in this magazine are not necessarily those of *Short Wave Magazine*.

outstanding read. From reading your magazine I have purchased a Sony SW7600 radio and it is smashing. This is the first time I have come across anything like *Short Wave Magazine*. The magazine and the short wave listening is incredible.

I now look forward to reading you magazine and s.w.l.ing for many years to come.

**David Crookes  
Plymouth**

## Dear Sir

Congratulations on a fine December issue. I must report to you my reception, in mid-October at 2015UTC on approximately 13.75MHz (my Phillips D1875 won't allow a greater degree of accuracy), in the 22m band, of what your 'SSB Utility Listening' author Peter Rouse calls the 'number stations'.

My SINPO on the 'numbers station' was 35533. I can not confirm hearing a male voice, I received a female voice, speaking English, reading a string of 3 to 5 character numeric strings. Sometimes there was only one number spoken.

During the course of reception of the 'numbers station' that I observed for 20 minutes I received no station identification and heard only a female voice. Please note that my reception report was received on a.m. not s.s.b.

Extrapolating the issue in my mind it would reasonably appear that someone is attempting to place at least one format of broadcast on the air and may be operating a low power (<50kW) transmitter in the Midlands or in Scotland.

I hope my report helps in the 'number station' mystery. Please let me know.

**Bruce Graham, Argyll**

# grassroots

## rallies

\* Short Wave Magazine & Practical Wireless in attendance \*

**May 3:** The National Vintage Communications Fair will be held at the NEC. It's a one-day event for specialist collectors and others interested in buying and selling vintage radios, telephones, televisions, jukeboxes, gramophones, records and other related mechanical-music items, ancient or modern.

**May 4:** Dartmoor RC Rally will be held at St Paul's Church Hall, Yelverton. Doors open at 10.30am. Free parking, usual traders, refreshments, Bring & Buy. **George Spray. Tel: (0822) 853885.**

**May 10:** The 8th Yeovil QRP Convention will be held at the Preston Centre, Monks Dale, Yeovil. Doors open at 9am with admission £1.50 including a lucky draw programme. 10.15am - Chordal Hop to VK, 11.30am - An 80m Construction Project, 2pm - HF Antennas to Match Your Garden, 3.15am - Watch the Birdies. The convention closes at 5pm.

**May 17:** The annual Parkanaur Amateur Radio Rally will be held in the Silverwood Hotel, Lurgan, Co. Armagh. The rally will be open from 12 noon. Proceeds from the rally go to the Stanley Eakins Memorial Fund. **Jim Lappin. Tel: (0762) 851179.**

**May 17:** The 35th Northern Mobile Rally will take place in the Flower Show Hall at the Great Yorkshire Showground, Harrogate, north Yorkshire. The Showground opens 10am, doors open 10.45am. Talk-in on S22, Bring & Buy, bar and cafeteria. Free parking and loads of stands. Entry and parking off Wetherby to Harrogate Road. Separate arrangements for disabled visitors off Hookstone Wood Road. **Mike. Tel: (0423) 564353/507653.**

**May 24:** The 16th Annual East Suffolk Wireless Revival will be held at the Maidenhall Sports Centre, Maidenhall Approach, Ipswich. Doors open at 10am. There will be a massive Bring & Buy, car boot sale, antenna measurements and all the usual traders. **Syd Mason. Tel: (0473) 748515.**

**\*May 30/31:** RSGB National Rally at NEC Birmingham. The RSGB's annual showpiece. Almost every major retailer/supplier in attendance, plus all the specialist amateur radio groups will be there too. Note that the date has been changed from that published before so as not to coincide with the Dayton Ohio event in the USA. Free parking is provided with a shuttle bus to the front of Hall 7.

**Acton, Brentford & Chiswick RC:** 3rd Tuesdays, 7.30pm. May 19 - My Feedline Tunes My Antenna by G3IGM. Paul Truitt G4WQO. 071-938 2561.

**Barnsley & DARC:** Mondays, 7.15pm. Darton Hotel, Station Road, Darton, Barnsley. April 27 - Getting Started on Satellites by G4JJ, May 4 - Open Talk on 1992 Rally, 11th - The RSGB by G4EJP, 18th - Amateur Radio Observation Service by G3STG, 25th - The Novice Licence by G0NMJ. Ernie G4LUE. (0226) 716339.

**Bromley & DARS:** 3rd Tuesdays, 7.30pm. The Victory Social Club, Kechill Gardens, Hayes. May 19 - Talk by Ian Daniels. Geoffrey Milne. 081-462 2689.

**Conwy Valley RC:** 1st Thursdays, 7.15pm. The Studio, Penrhos Road, Colwyn Bay, Clwyd. May 7 - Talk by Dr David Last, 14th - Visit to Pentir National Power Switching Station. Merfyn Jones GW4NNL, 72b Princes Drive, Colwyn Bay, Clwyd. (0492) 530725.

**Derby & DARS:** Wednesdays, 7.30pm. 119 Green Lane, Derby. April 29 - Cheese & Wine Party, May 6 - Junk Sale, 13th - 144MHz DF Practice, All-estree Park, Derby. Richard Buckley. Ambergate 852475.

**Dronfield & DARC:** 1st & 4th Mondays, 7.30pm. Room 3, Gladys Buxton School, Dakhill Road, Dronfield. Other Mondays, socials at the Fleur-de-Lys, Main Road, Unstone. May 4 - No Meeting, 18th - Fox Hunt. Piers Oldham. Tel: (0246) 290444.

**Edgware & DRS:** 8pm. Watling Community Centre, 145 Orange Hill Road, Burnt Oak. May 14 - Advances in RF Power Semiconductors by G3SGC, 28th - Constructors Contest & NFD Briefing. Hank Kay G0FAB. (081-205 1023).

**Hoddesdon RC:** 1st & 3rd Thursdays, 8pm. Conservative Club (side entrance), Rye Road, Hoddesdon. April 30 & May 14 - Social, 28th - EMC by G3ZKE. Roy G4UNL. 081-804 5643.

**Lincoln SWC:** Wednesdays, 8pm. City Engineers Club, Waterside South, Lincoln. April 29, May 5 & 20th - Activity Night, 10th - Telecom Trail, Donnington On Bain, 13th - AGM, 24th - Fox Hunt. Patrick G00SO, QTHR.

**Mansfield ARS:** 1st Thursdays, 8pm. The Polish Catholic Club, off Windmill Lane, Woodhouse Road, Mansfield. May 7 - AGM. Mary G0NZ. (0623) 755288.

**Midland ARS:** 3rd Tuesdays, 7.30pm. Headquarters Unit 22, 60 Regent Place, Birmingham B1 3NJ. April 27 - Computer Night, May 25 - Computer Night, 29th - Atari Night. John Crane G0LAI. 021-628 7632 (evenings).

**Norfolk ARC:** Wednesdays, 7.30pm. The Norfolk Dumpling, The Livestock Market, Harford, Norfolk. April 29 - First HF NFD Briefing, May 6 - REAL Radio, 13th - GB3NB Repeater AGM, 20th - Project JUNO, What Happened by G0KRU, 27th - Final HF NFD Briefing. Jack Simpson G3NJQ. (0603) 747992.

**North Ferriby United ARS:** Fridays, 8pm. North Ferriby United Football Social Club, Church Road, North Ferriby. May 1 - Way Ahead Meeting by G4VKK, 8th - QFE or QFH - What Are They Talking About by G4VKK, 29th - Surplus Equipment Sale. Frank Lee. (0482) 650410.

**ARC of Nottingham:** Thursdays, 7.30pm. Sherwood Community Centre, Mansfield Road, Nottingham. April 30 - Electromagnetic Compatibility by G8SOZ, May 7 - Discussion on Summer Fox Hunts, 14th - Talk by Regional Liaison Officer, 21st - 144MHz Foxhunt & WAB Activity, 28th - RAYNET by G3YUT. Rex Beastall. (0602) 733740.

**Preston ARS:** Alternate Thursdays. The Lonsdale Sports & Social Club, Fulwood Hall Lane, Fulwood. April 30 - Windmill Land by Mr Dunkerley, May 14 - Pageant of Lancaster Priory by Mrs Tomlinson, 28th - Prep Night for HF NFD. Eric Eastwood G1WCCQ. (0772) 686708.

**RSGB City of Bristol Group:** 1st Mondays, 7pm. The Small Lecture Theatre, Queens Building, University of Bristol, University Walk, Bristol. April 27 - RSGB Morse Testing System by G3ZJH, May 18 - 1st British Amateur Radio Operation From Uzbekistan (U18), 25th - Picnic at Ashton Court at 2pm. Dave Coxon G0GHM. (0275) 855123.

**South Bristol ARC:** Wednesdays. Whitchurch Folkhouse Assoc, Bridge Farm House, East Dundry Rd, Whitchurch. April 29 - Mystery Subject by G3OUK, May 6 - 40m Evening, 13th - Exhibition of Your Own Hobbies, 20th - The Talking Brick by G4YZR, 27th - Signwriting for the Rally. Len Baker. Whitchurch 832222.

**Southgate ARC:** 2nd & 4th Thursdays. Winchmore Hill Cricket Club Pavilion, Firs Lane, Winchmore Hill, London N21. May 14 - Early Radar, part 2 by Stan Woods. Brian Shelton G0MEE. 081-360 2453.

**South Notts ARC:** Fridays, 7pm. Highbank Community Centre or Fairham Community College, Farnborough Road, Clifton Estate, Nottingham. May 1 - Open Forum, 8th & 22nd - Construction (Fairham College), 15th - OSCAR & FUJI Videos, 29th - On Air. Ray G7ENK. (0602) 841940.

**Stockport RS:** 2nd & 4th Wednesdays, 7.45pm. Room 14, Dialstone Centre, Lisburne Lane, Offerton, Stockport. May 13 - Computers As Was/Today by P. Stanley, 27th - Photographic Tips by G4RLD. John Verity G4ECI. 061-439 3831.

**Stratford upon Avon & DARS:** 7.30pm. The Home Guard Club, Main Road, Tiddington, Stratford-upon-Avon. May 11 - Computers in Amateur Radio by G4OIL. A. Beasley G0CXJ. 060-882495.

**Three Counties RC:** Alternate Wednesdays, 7.30pm. The Railway Hotel, Liphook, Hants. May 6 - British Nuclear Fuels Ltd, Their Operations & The Environment, 20th - UoSAT, The Management & Equipment Needed To Run The Ground Station. Dave G4VCC.

**Tor ARA:** Tuesdays, 7.30pm. Either Ernest Bailey Community Centre, New Street, Matlock or Duke of Wellington, Chesterfield Road, Matlock. May 7 - Buffet & Get-together at Duke of Wellington. Vince Shirley. (0773) 826747.

**Torbay ARS:** Fridays, 7.30pm. ECC Social Club, Highweek, Newton Abbot. May 22 - Junk Sale. Walt G3HTX. (0803) 526762.

**West of Scotland ARS:** Fridays, 8pm. Scout Shop, 21 Elmbank Street, Glasgow. May 8 - WAB, 25 Years On! by GM4FDM, 22nd - AGM. K. Fox. Jack Hood. (0698) 350926.

**Wimbledon & DARS:** 2nd & last Fridays, 7.30pm. St Andrews Church Hall, Herbert Road, SW19. May 8 - General Activity Evening, 29th - Cable TV by G3DPW. Chris Frost. 081-397 0427.

### Club Secretaries:

Send all details of your club's up-and-coming events to;  
'Grassroots',  
Lorna Mower  
Short Wave Magazine, Enefco House,  
The Quay, Poole, Dorset BH15 1PP

# junior listener

## Young Amateur of the Year

If you're under 18 and interested in radio, then perhaps you qualify for the title of Young Amateur of the Year. You need to be either:

- involved in d.i.y. amateur radio construction
- operate radios concerned with community radio (e.g. emergency communications networks)
- encourage other to become interested or
- be involved in school projects.

The closing date for entries is 31 July 1992 and you must be under 18 at that time.

Again this year, the award is being sponsored by the RSGB and The Radiocommunications Agency. The winner collects a cash prize, an RSGB amateur radio log book and a visit to the Agency's Radio Monitoring Station at Baldock, Hertfordshire.

All applications or nominations for the award must be sent to: Young Amateur of the Year Award 1992, **Radio Society of Great Britain, Lambda House, Cranbourne Road, Potters Bar, Herts EN6 3JE.**

Best of luck if you decide to have a go.

## New Scouts Badge

I'm sure most of you have heard of the Scout movement, many may belong. But there is a new and interesting Badge you can try for called The Scouts Radio Technicians Badge, which has been sponsored by Adam Leisure Group plc.

The idea of the badge is to introduce Scouts to radio technology. Over a period of six

weeks, Scouts build radio equipment and learn how to communicate with it. In the photo you can see the six Northampton Scouts who were first to gain the new Badge with their leader and the headquarters technology adviser.

If any of you obtain the new badge, drop me a line with some details of the project you completed, I'm sure others would be interested to know. That applies to Guides and Brownies doing their Communicator Badge too.

## More Young Engineers Needed

I've heard some interesting news from the DTI regarding young people wishing to become engineers and scientists. They want to encourage more of the brightest and best young people to choose careers in science and engineering. Peter Lilley (he's the Trade & Industry Secretary - well he was at the time I wrote this, the General Election is still three weeks away!) launched a series of videos as part of 'Innovation Wealth from Science & Engineering'. A complicated way of saying that they want to encourage science and engineering among school-children!

The videos use real examples to demonstrate how scientific ideas are turned into commercial technology in areas such as telecommunications, biotechnology and the environment.

The video series forms a part of a full programme that includes a series of local events bringing together schools and industry. So hopefully you may be seeing these videos at school soon and if you think that science and technology is

something you'd like to go into for a career, TELL YOUR TEACHER. You'll be surprised how much they'll encourage you.

## Historic Radio

An exhibition that might interest you is one on HMS *Warrior 1860* in the



Jon Jones  
PO Box 59  
Fishponds  
Bristol BS16 4LH



HM Naval base at Portsmouth. Between June 20 and 28, there will be an exhibition of Historic Radio equipment circa 1890-1939. Whilst you're there you can always go and visit all the other historic sights in Portsmouth and make it a really good day out. If any of you go, don't forget to tell me about it.

## Transformers

I came across the photograph above from Circuit, advertising their toroidal mains transformers and wondered how I could work such a brilliant photo into the column! Well, we've never discussed transformers, so here goes.

So, just what does a transformer do? Rather than get involved with lots of technicalities, I'll try and stick to simple language. The main feature of a transformer is its ability to change the impedance of a.c. power. Many transformers also have the characteristic of passing a.c. power but not d.c. What do I mean when I talk about impedance changes? If we go back to basics all electrical sources consist of two key parameters - voltage and current. It's the ratio between these two that defines the impedance. The formula is Impedance in Ohms( $\Omega$ ) = Volts(V)/Amps(A). At this point I ought to add a warning that this is a very simplified view and the calculation of impedance in real circuits is somewhat more complex.

Let's now look at a simple transformer and its effect on signals

passing through it. A simple transformer would consist of a magnetic core and two windings called the primary and secondary. For the sake of this example we'll assume that the secondary has twice as many turns as the primary. Let's see what happens if we connect an a.c. power source of 100V at 1A. From this we can calculate that the impedance of the power source is 100/1 or 100 $\Omega$ . Because the secondary has double the turns of the primary, the voltage is stepped-up to twice its original value, i.e. 200V. But what happens to the available current? If the current available remained the same we would have effectively made a power gain which can't be right. The answer is that the current is halved to 0.5A. All is reasonably straightforward so far, but what happens to the impedance? Let's work it out - we know the secondary voltage is 200V and the current is 0.5A. Using the formula I gave earlier, the secondary impedance becomes 200/0.5 = 400 $\Omega$ . The important point to note is that although the primary to secondary turns ratio is 1:2 the impedance ratio is the turns ratio squared.

We have demonstrated three important parameters of a typical transformer which are.

- 1: The voltage is changed in direct proportion to the turns ratio.
- 2: The current is changed by the inverse of the turns ratio.
- 3: The impedance changes by the square of the turns ratio.





## SRI on Astra

On March 19, Swiss Radio International started round-the-clock transmissions to the entire European continent on the Astra 1A satellite using a sub-carrier of the Swiss Teleclub (7.2MHz). Now all SRI programmes can be heard under the best reception conditions from Finland to Morocco and Britain to Moscow.

For the moment, only a few individual listeners have access to this service. It's designed primarily for radio stations, resort hotels, embassies and consulates. Up to now, numerous European radio stations, notably in France, Spain and Italy, have received SRI programmes by line or through their cassette service.

Now, with the installation of a parabolic antenna of between 400 and 1200mm, you can receive information, documentary and music programmes from Switzerland at any time of day or night. These SRI programmes are already heard in Switzerland on the cable radio network and digital radio. Now they can be also received in Switzerland via Astra satellite free of charge.

SRI programmes on Astra include about five hours of broadcasts in English and French respectively, three hours in German and Italian, one and a half hours in Spanish and 45 minutes in Arabic. Added to this are music programmes produced by SRI itself or in collaboration with other stations.

At the moment, SRI programmes on Astra are primarily conceived as a special service, but in the coming months they will gradually be developed into a fully-fledged European-wide broadcasting outlet. With this aim, they are counting a lot on synergy within the Swiss Broadcasting Corporation and co-operation within Europe.

## Open Day

Waters & Stanton will be holding their annual open day on Sunday May 10 from 10am to 5pm. Last year was so successful they are aiming for something even bigger this year. There will be free food and free drink for every one plus a prize draw. Those needing talk-in should initially call G0PEP on 145.5MHz.

They will be offering some fantastic bargain and clearance lines on a wide variety of amateur radio equipment covering two floors of their premises.

**Waters & Stanton Electronics, 22 main Road, Hockley, Essex SS5 4QS. Tel: (0702) 206835.**

## Stolen

Stolen from the Siskin stand at the Blackpool rally on March 15 was a Fairmate HP2000E scanner. The serial number was 19429. It was unboxed, without instructions and accessories. If you can help Siskin trace this equipment, contact them:

**Siskin Electronics, 2 South Street, Hythe, Southampton SO4 6EB. Tel: (0703) 207155.**

## New from Grundig

The Satellit 700 is similar in design to the popular Satellit 500, with even more to offer the short wave listener. Features include f.m., m.w., l.w. and 1.6-30MHz s.w. coverage, automatic station search or manual tuning, direct frequency input, 64 memory positions featuring 8 alternative frequencies each, RDS and built-in b.f.o.

It also has a data monitor with indication of frequency, waveband, memory position, metre band, stereo, field strength, battery check, station name (8 digits), RDS, external antenna, mode, etc. You can program the station names for your favourite stations.

The radio costs £349.99 from your local Grundig stockist.



## DX TV News

Despite the monopoly of the Austrian air waves that the ORF enjoys, several 'pirate operators' successfully provide radio entertainment from neighbouring countries within the v.h.f. f.m. band 88-108MHz. About 6 transmitters operate currently amongst these being C-D International from Bratislava (Slovakia); MM2 - Moribor (Slovenia); Radio Zirog - Brenner (Italy); Antenne Austria - Sopron (Hungary). The pirate operators are hoping that independent radio may be legalised in Austria during 1992, which will allow them to go 'inland' onto Austrian soil.

The ORF however are expanding their own FM radio services with Big City Radio in Vienna, and the Blue Danube Radio service which operates in English in main towns such as Vienna, Fraz, Linz, Innsbruck and Salzburg is being re-launched as Euradio running 18 hours a day and expanding into a 4th national network. The 'pirates' suspect this will remove all free f.m. channels and effectively block the pirates aspirations as well!

With the on-going changes in Russia (or CIS, Commonwealth of Independent States) so the radio/TV service administration have also changed. The Russian State Television now operates as 'Ostankino', after the main TV production centre and transmitting base in Moscow. Ostankino will continue to be state financed during 1992 but from next year it is hoped that it will become a privatised commercial operation with a 50% public share ownership. The Central TV First Channel will be passed to the CIS with each state having programme input allocations (as will happen with the Central Radio). The 2nd channel will be 'for Russia', the 3rd for Moscow and the 4th channel for education. Ostankino will continue to provide programme and technical services for the TV channels both Moscow and time shifted for the several time zones across the Soviet land mass.

My Gib contact advises that TVE Spain are now using NICAM for stereo enhancement on certain programmes but when a foreign language film is shown one track remains as the original language whilst the other track is used for a Spanish dubbed sound track which TVE call 'Dual' transmission.

Australian TVDXer Robert Copeman advises that the two Ch. A0 TV transmitters (46.25MHz nominal vision carrier) which have been received during appropriate F2 layer conditions recently are: RTQ-0 (formerly DDQ-0) located at Toowoomba, Queensland running 150kW at 46.171MHz carrier; and AMBN-0 (ABC) located at Wagga, New South Wales running 100kW e.r.p. at 46.240MHz. (Note the actual vision carrier offset can be received on a scanner and measured, thus confirming transmitter being received. During February 1992 a UK DXer received 3 separate New Zealand TV Ch. 1 transmissions by measuring the incoming vision carrier and noting the offset relative to the 45.25MHz nominal carrier).

**Roger Bunney.**



# Aerial Systems for serious listeners

## Look to Lowe

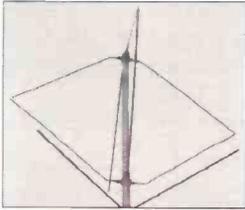

### DX-One Electronic Antenna

£249 inc VAT

The World Radio TV Handbook said of the DX-One "... the best of its type available anywhere in the world." It has a frequency range of 50kHz - 50MHz (\*3dB) and 10kHz - 75MHz (\*6dB); it is both horizontally and vertically polarised, so low-angle (DX) signals suffer less selective fading. The output level from the antenna is adjustable in steps from +6dB to -40dB for optimum matching. The extremely high intercept point (+66dBm 2nd order, +40dBm 3rd order) and a very low noise figure (12.8 dB) ensure optimum performance. The indoor unit contains a mains power supply, a step-wise attenuator and a very effective medium wave suppression filter. It also has two receiver outputs for feeding two receivers without mutual interference.

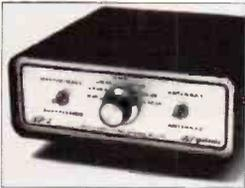

### SP-2 Antenna Splitter

£152 inc VAT

A growing number of radio enthusiasts have two receivers, but no space for two separate antennas. The SP-2 is the answer for connecting two receivers to one antenna (be it active or passive). The SP-2 offers a very high degree of isolation between the two receivers (<30 dB). The SP-2 ensures that, within the frequency range of 50kHz - 50MHz, no unwanted mutual interference, heterodynes or signal loss will occur as a result of connecting a second receiver.

With a single receiver, the SP-2 offers a precision step-attenuator (0 - 40 dB) which helps to reduce receiver inter-modulation. Included is a very effective switchable medium wave suppression filter.

For those with space for a second antenna (e.g. one horizontal, one vertical), the SP-2 offers a simple way to switch between the two for comparison purposes.



### Magnetic Longwire Balun

£36 inc VAT

This balun has been described in the trade press as the "most revolutionary development for shortwave listeners in the last 25 years". Quite a claim! But this antenna device does solve one of the most severe problems associated with random long wires; the input cable. An MLB allows you to use highly screened co-axial cable between the antenna and receiver WITHOUT energy loss due to impedance mismatch. Computers, light-dimmers, televisions, and fluorescent lights no longer cause interference

problems. We recommend RG58/u 50ohm co-axial cable.

The MLB has been designed so that a very short length of antenna wire can be used and still be perfectly matched to the 50ohm antenna input of the receiver. Even an antenna of just 12.5 metres (41 feet) provides good results from 100kHz - 40MHz without the need for an antenna tuner. Static build-up on the antenna is allowed to leak away to earth potential - excellent for protecting receivers with FET front end circuitry. Static noise levels on long, medium, and the tropical short wave bands of 60 & 90 metres are considerably lower. The MLB is easy to mount on existing longwire or "T" antennas.

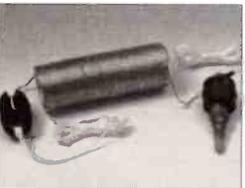

### MLB Antenna: Mark I

£56 inc VAT

A complete passive wire antenna with a built-in MLB, the MLB Antenna: Mark I has excellent performance on long, medium, and short waves. It is 12.5 metres in length and can be mounted vertically or horizontally. Frequency range 100kHz - 40MHz.

The MLB Antenna: Mark I offers all the advantages of the Magnetic Longwire Balun like: coaxial feeder, broadband performance without an antenna tuner and static decoupling. Heavy duty and completely water-proof, it comes complete with nylon support cord, heavy-duty insulator, high-quality plastic covered antenna wire, PL 259 connector and a water-tight rubber sleeve to cover co-axial/MLB connection.

### MLB Antenna: Mark II

£67 inc VAT

Similar to the Mark I, but 20 metres long. The MLB Antenna: Mark II offers improved performance at medium and long wave frequencies, although the high frequency performance above 30MHz is reduced.

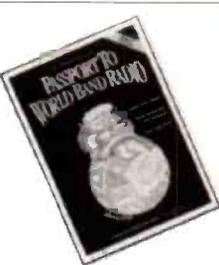

### THE LISTENERS' BOOK OF THE YEAR GETS EVEN BETTER

The new 1992 issue of 'Passport to World Band Radio' is now with us and it's even better than before. The 200 pages have risen to almost 400 and every section carries the unmistakable authority of the world's best short wave companion.

Broadcasts are listed as before; not only in frequency order but also by language, country of origin AND the times of broadcasts. There are no less than 56 pages of receiver reviews, including the latest NRD-535 and Drake R-8, together with news, views and general information.

If you own a short wave radio, you MUST have the 'Passport' by its side. The price last year was £12.95; we have kept the price the same this year at £12.95 (plus £1.55 p&p.). Send off today.



# LOWE ELECTRONICS LIMITED

Chesterfield Road, Matlock, Derbyshire DE4 5LE Telephone: 0629 580800 Fax: 0629 580020

# For the very best in Communications Receivers Look to Lowe

## Communications Receivers from KENWOOD

### R-2000

- 150kHz - 30MHz  
118MHz - 174MHz (optional)
- LSB, USB, CW, AM, FM
- Digital VFO with excellent stability
- Dual 24hr quartz clocks
- 10 memories (tunable by VFO)
- Memory/band scans
- 3 built-in IF filters
- Quality audio with 4in. speaker
- 375mm(W) x 115mm(H) x 210mm(D)
- Optional accessories
- On demonstration at all Lowe Regional Centres

R-2000 £549 inc VAT



### R-5000

- 100kHz - 30MHz  
108MHz - 174MHz (optional)
- USB, LSB, CW, AM, FM & FSK
- 10Hz step Dual Digital VFOs
- Superb Interference Reduction
- 100 memories with full data storage
- Dual 24-hour quartz clocks
- Keyboard frequency selection
- RS-232C interface for use with 'CONTROL' software

R-5000 . . . £925.00 inc VAT

## The NRD-535 General Coverage Receiver

Latest in the line of NRD receivers, the NRD-535 is a triumph for JRC and represents a true step forward in features, performance and facilities for the dedicated listening enthusiast.

The smooth tuning is the first thing you notice and JRC has developed a direct digital synthesiser (DDS) system which tunes in 1Hz steps. The accuracy and stability are of laboratory standard. There is of course the front panel keypad for swift frequency setting.

All mode reception covers AM, USB, LSB, CW, FM, RTTY and even FAX with IF filter bandwidths to suit the modes.

For winking out the weak stations, the NRD-535 excels. Pass band shift enables you to slide the IF filter around the signal so as to eliminate the adjacent signal and a totally new notch system gives tunable rejection with a 40dB notch depth. There is also an optional Bandwidth Control board.

For the keen broadcast DXer, there is also an optional plug-in ECSS board for locking on to an incoming AM signal and then picking off either sideband.



There are 200 memory channels, each of which stores, frequency, mode, bandwidth, attenuator and AGC settings, comprehensive frequency sweep facilities and no less than 16 different functions which can be programmed from the front panel by the user.

For the advanced user, the NRD-535 is fitted with a RS-232C interface for 28 computer controlled receiver functions. Available for demon-

stration at Matlock and the regional centres .

- |                               |                |
|-------------------------------|----------------|
| NRD-535 HF Receiver . . . . . | £1,195 inc VAT |
| CMF-78 ECSS option . . . . .  | £229 inc VAT   |
| CFL-243 BWC option . . . . .  | £359 inc VAT   |

**LARGE STOCKS ready for shipment NOW!**  
Telephone us today for delivery tomorrow.  
Mail order welcomed at all our centres



BOURNEMOUTH: 27 Gillam Road, Northbourne Tel: 0202 577760

BRISTOL: 6 Ferry Steps Ind Estate Tel: 0272 771770 CAMBRIDGE: 162 High St, Chesterton Tel: 0223 311230 CUMBERNAULD:

Cumbernauld Airport Foyer Tel: 0236 721004 LONDON (HEATHROW): 6 Cherwell Close, Langley Tel: 0753 545255

LONDON (MIDDXX): 223/225 Field End Rd, Eastcote Tel: 081-429 3256 NEWCASTLE: Newcastle Intn'l Airport Tel: 0661 860418

Short Wave Magazine, May 1992



*If you're in the market for a self contained FAX decoder, the new ICS FAX-2 could fit the bill. Mike Richards takes a look at this latest release from ICS Electronics Ltd.*

# ICS FAX-2

The first point to note about the FAX-2 is that this is no amateur toy, but a professional unit designed to be used at sea. You can see from the photograph that the styling is quite different to that used for many of the other products from ICS Electronics. In addition to receiving and printing FAX charts, the FAX-2 can be used for standard RTTY and FEC transmissions. Having whetted your appetite, let's move on to take a detailed look at the FAX-2.

### Overview

As the FAX-2 has been designed primarily for use on-board ship, weather-proofing and ruggedness is critical. The FAX-2 features a purpose-built die-cast aluminium case to protect the electronics from the hostile marine environment. To minimise control problems the FAX-2 uses a very effective eight-button membrane unit. This controls all the user settable options and provides good protection from a salt atmosphere. These buttons also had a very positive action.

The only area where extreme care needed to be taken was the paper loading door on the front panel. Despite all this protection it's important to note that the FAX-2 must be mounted in a dry area.

Moving on to the external connections, these were all accessed via a fifteen-pin connector on the rear panel. A plug for this connector was supplied with the FAX-2 and connections to the plug were made via screw terminals. This proved to be a very flexible connection system that was rather better than a multitude of different sockets for the various functions.

The power demands of the FAX-2 had been very well thought out with a voltage range of 8-34V d.c. This enable standard 12 or 24V supplies to be used without any alteration to straps or switches. The power consumption was also very modest at 0.01W when at power down standby and 2.5W with power on. The peak current demand was 4A and that was only achieved during printing.

For FAX, RTTY and FEC

reception, an external receiver is required. This needs to be a good quality communications receiver or marine h.f. transceiver. The FAX-2 requires an audio signal and can either accept a signal from the external speaker connection or the auxiliary output. To make this operation as simple as possible, a lead fitted with a standard 3.5mm jack was provided.

One of the plus points about the FAX-2, was that it was able to simultaneously receive Navtex and Marine Page transmissions. This was achieved by connecting optional external receivers to the rear panel.

The handbook for the FAX-2 was presented in spiral bound A4 format with about 50 pages. The manual was very well set out covering all the key operational features in simple language. There was also good use of diagrams to explain the display and inter-connection detail. This was supplemented by some useful reference sections that included a frequency list and examples of FAX charts.

### Smart Keypad

The front panel keypad that controls the operation of the FAX-2 is well worth spending some time on. ICS have clearly put a lot of thought into developing a simple to

operate system of control for the FAX-2. The result is that FAX, Navtex, RTTY, FEC and Marine Page can all be controlled by an eight button keypad. When you consider that timer operation is included, this is quite a feat.

The key pad is set out in two rows, and its the top row that controls the main functions. These keys are marked as up arrow, down arrow, left arrow and right arrow. The up and down arrows are used to scroll through the various modes. are shown on the well light liquid crystal display. Once the required mode has been selected, the right arrow is used to select the parameter while the other keys alter the parameter setting. Once the selection is complete the new parameters can be stored by pressing the left arrow button. So you can see that most of the features are in fact controlled by just four buttons. The secret, of course, is in the use of a well thought out menu system.

The lower set of four buttons are used to control miscellaneous features i.e. power on/off, start/stop, dimmer and paper feed.

### FAX Reception

Although the FAX-2 features RTTY and FEC modes, I suspect that the prime reason for choosing this unit would

be its FAX reception. This mode was also one of the simplest to use.

Once the FAX mode had been selected, the FAX-2 automatically put itself in to standby mode. All that remains is to tune the receiver to a suitable FAX frequency. Anyone who's tried FAX reception will know that accurate tuning is critical for good quality results. The FAX-2 features a very effective tuning indicator to help with the tuning. This indicator takes the form of a simple spectrum analyser type display within the I.c.d. unit. This results in pair of bars that move across the display as the tuning is altered. The optimum tuning point is when the two bars straddle the centre point.

When set to the FAX standby mode, the FAX-2 is ready for fully automatic reception. The software is able to detect the standard range of start and stop tones and automatically sets the Index Of Co-operation (IOC) drum speed. This is great for maritime operation as once a station has been tuned in you can continue with other tasks and let the FAX-2 get on with the business of FAX reception.

One of the other special attractions of the FAX-2 is its built-in printer. This was a thermal unit that produced very good quality charts. I've included a few examples in this review. Perhaps the only snag was its small print size due to a paper width of 111mm. ICS have considered this and you have the option to print the chart in two strips one after the other. These two strip can then be glued together, so giving a chart with twice the normal width. They even supplied a tube of Pritt Stick! This option was particularly useful when receiving some of the more complex charts. As a further refinement, you could choose only the left, right or centre parts of the image. With all these modes the printing doesn't start until the whole image has been received. For occasions where you want to observe the chart as it arrives, you could choose to print line by line as it's received.

The modes available for automatic reception were IOCs of 288 or 576 and drum speeds of 60, 90, 120 and 240 r.p.m. This covers all the common



FAX standards.

When selecting a FAX station to receive it's useful to be able to start a print part way through a transmission. By doing this you can quickly check that the signal quality is good enough. This function is provided on the FAX-2 by pressing the S (start) button on the front panel while in standby mode - printing then starts line by line. One other parameter that can be set is the polarity of the received signal. This performs basically the same function as changing from upper to lower sideband.

### Navtex

The FAX-2 featured two methods of receiving the vital Navtex information system. The first was to use the main receiver in much the same way as with FAX reception. All you had to do was tune to 518kHz and fine tune using the tuning display. One of the features of the Navtex system is that all the transmissions are coded to indicate the transmitting station and the message type. By using the arrow buttons on the front panel you could set the FAX-2 to selectively receive these messages and stations.

For a more sophisticated system, the optional ICS external FAX receiver can be used. With this connected, the FAX-2 can resolve FAX and Navtex simultaneously. This adds considerably to the power and versatility of the FAX-2. By using this system the sailor can be sure that vital navigation messages are received, regardless of what the main receiver is being used for.

### Marine Page

The FAX-2 supports the Marine Page experimental service being operated by BT.

The service is designed to enable paging messages to be sent to any ship in UK waters. The system employs a variant of FEC that includes a Selcal. The FAX-2 provides this support in much the same way as with Navtex using an external receiver. This results in the same advantages, i.e. the message is received even during FAX reception.

### RTTY Reception

The FAX-2 includes the facility to receive standard RTTY transmissions. This can be very useful for plain language weather reports and news from press stations.

All the standard modes were supported i.e., 45, 50, 75 and 100 baud. There was no requirement to set the shift separately and the FAX-2 was able to handle shifts from 170Hz up with no problems. However, it's worth noting that the narrower the shift, the more critical the tuning becomes. In addition to being able to reverse the polarity of the signal, the FAX-2 included an Unshift-on-space facility. One of the weaknesses of RTTY as a communications system is the way in which a shift character has to be sent to switch between figures and letters. Under good conditions this is not a problem, However, if the signal suffers interference you may well find that the received text turns to gibberish! The Unshift-on-space facility on the FAX-2 goes a long way towards overcoming this problem.

The final reception mode included in the FAX-2 is FEC. This is virtually identical to the Navtex system except that it's used for general communications. Probably the most common usage is the transmission of traffic lists from coastal stations.

### Sophisticated Timer

With FAX charts taking so long to transmit a good timer is a very useful accessory. The FAX-2 features a built-in timer with a host of powerful features designed to make life easy. The timer includes six user settable programmes that can be repeated every day. This means you can automatically pull out your favourite charts every day. Included in the programming options is the facility to set the operating period, receive mode and receive parameters. With these features you can also set the type of print-out to ensure that you get the best from each transmission.

As if all this wasn't enough, Icom users could take advantage of a further enhancement. If your Icom is fitted with the RS-232 serial interface you could program the timer to set the mode and frequency of your receiver! This enables fully automatic reception of charts and messages from a range of stations.

### Built-in Printer

As I've already mentioned the FAX-2 includes a built-in thermal printer. In order to make maximum use of the printer ICS have made it available for use by external devices. The connection is made via the rear panel and the printer accepts data at 1200 baud. To ensure compatibility with other systems the printer width is user programmable between 40 and 80 columns.

### In Use

Setting-up the FAX-2 proved to be very simple thanks to the clear menu driven display. One of the most critical areas for automatic FAX reception is the reliability of the start and stop tone detection. The FAX-2 turned in excellent performance in this area and was able to pull out the appropriate tones even in very noisy conditions. The only occasions where it missed a tone the interference was so bad that the image wasn't worth receiving anyway!

When I first saw the size of the printer I was concerned about the readability of the

resultant image. My fears proved unfounded as the definition of the thermal printer is excellent and perfectly readable with normal eye sight. The only time I did have problems was when receiving four panel charts. However, the solution was to print these charts in two halves.

All the other modes worked just as successfully with no problems at all.

The FAX-2 currently costs £750.00 plus VAT, with the optional external Navtex receiver costing £175.00 plus VAT.

My thanks to **ICS Electronics Ltd., Unit V, Rudford Industrial Estate, Ford, Arundel West Sussex BN18 0BD. Tel: (0903) 731101** for the loan of the review model.

## Specification

Reception Modes:	Facsimile Navtex RTTY FEC BT Marine Page
FAX Modes:	Auto, 60, 90, 120 and 240 r.p.m. Auto, 576 and 288 IOC
Navtex:	Conforms to CCIR 540-1
Print Modes:	Normal Double size (both halves) Double size (left half) Double size (right half) Double size (centre portion) 40 or 80 column text 6 programmes/day plus external frequency control
Timer:	
Temperature Range:	0 - 40°C
Power:	8 - 34V d.c. <0.01W standby (off) <2.5W standby (on) 1A average, 4A peak while printing
Mounting:	Shelf or Panel mount
Weight:	3kg



## Conclusion

The FAX-2 has certainly been very well thought out and provides a wide range of features designed to simplify the reception process. Key features for the mariner are the fully automatic reception plus the ability to simultaneously receive Navtex messages. The construction of the FAX-2 is also worthy of note and well up to the standard required for maritime operation.

The FAX-2 is clearly designed for use in a marine environment, but I'm sure it will also appeal to some short wave listeners.

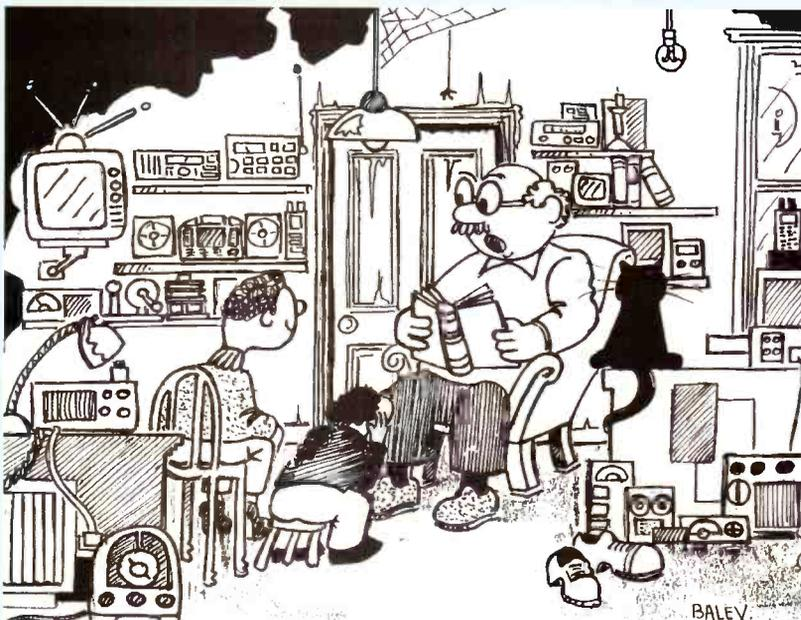

## Listen With Grandad

By Leon Balen and David Leverett

Enjoy the antics of our newest addition to the Short Wave Magazine staff. 'Grandad' and his family will be appearing regularly from now on.

Do you relate to any of the situations the old chap gets into? If so then why don't you let the Editor know, there must be loads of strange and funny experiences you could share with our readers. £5 SWM Gift Vouchers for any published.

*Once upon a time there were three programmes: Light, Home and Third...then along came Radio Luxembourg....*

# South Midlands Communications Ltd.

Southampton (0703) 255111 Leeds (0532) 350606 Chesterfield (0246) 453340  
Birmingham 021-327 1497 Axminster (0297) 34918

## LISTEN OUT

## with SMC SONY at SMC

YAESU  
JRC  
AOR  
SONY  
ICOM  
KENWOOD  
DRAKE  
FAIRMATE  
BEARCAT  
LOWE  
YUPITERU



The **FRG9600**, a premium scanning receiver covering 60-905MHz, SSB, CW, AM & FM modes. 99 memories. 5, 10, 12.5, 25 & 100kHz scanning steps. Keyboard frequency entry. Optional converters to extend range from 0.15-30MHz and 800-1300MHz

Yaesu's serious about giving you better ways to tune in to the world around you. And whether it's for local action or world-wide DX, you'll find our HF/VHF/UHF receivers are the superior match for all your listening needs. When you want more from your receivers, just look to Yaesu. We take your listening seriously.



### NRD535 from JRC

The new NRD535 epitomises the very best in communications receiver design. This high technology product is based on the abundant technical experience gained by JRC in the professional communications receivers field. This means that the NRD535 is arguably one of the best receivers available to meet the discerning listeners needs. Brief specifications are as follows. Frequency coverage: 0.1-30MHz; Operating modes: CW, SSB (LSB & USB), AM, FM, FSK & RTTY; Supply voltage: 240V A.C. or 13.8V D.C. ECSS, BWC & RTTY units available as options.

The **FRG8800** HF communications receiver. A better way to listen to the world. Continuous coverage from 0.15-30MHz optional module for VHF coverage from 118 to 174MHz. SSB, CW, AM & FM modes. Direct frequency entry keyboard.



JRC NRD535



DRAKE R8E

### DRAKE R8E

Now available from SMC the new DRAKE R8E communications receiver. These receivers utilise the very latest in technology to meet the demanding requirements of today's listeners. Conveniently located front panel controls allow for rapid operator programming and ease of use. The R8E receiver covers 0.15-30MHz and with the optional VHF converter will also cover 35-55MHz and 108-174MHz. The large clear LCD display gives the operator full information about the current receiver status.

A COMPREHENSIVE RANGE OF RECEIVERS AVAILABLE AT MOST BRANCHES



SMC are pleased to be able to offer the SONY range of Multiband Receivers. They feature all the latest technology allowing unequalled coverage of both broadcast and shortwave bands, yet remaining both compact and easy to use. All the models illustrated cover VHF broadcast. SW

broadcast, and some models cover other bands as well. The very latest model available from SONY is the ICF-SW77. This receiver covers LW, MW, SW and FM stereo broadcast bands and has SSB reception on the SW bands. A comprehensive keypad and LCD display give easy control over the massive array of features available. Other SONY products available include the minuscule ICF-SW1, the versatile ICF-SW7600, the popular ICF-2001D and for airband enthusiasts the AIR7 and ICF-PRO80.



### AOR AOR AOR

SMC are pleased to be able to offer a large number of models from the very comprehensive AOR range which includes both hand portables and mobiles/base stations.

All the receivers are built to the highest possible specification yet remain very competitively priced. Often the leaders in the field, the AOR range is proving very popular amongst both professional and non professional users.

The top of the range model must be the AR3000 which covers 100kHz-2036MHz without any gaps. The mid range model is the AR2800 which is a convenient unit for mobile or base operation and covers 500kHz-600MHz and 800-1300MHz. Last but not least is the AR2000 which is an extremely flexible handheld scanner covering 500kHz-1300MHz.

Why not contact us today for more details of the AOR range.



### OTHER MAKES AND MODELS



The Bearcat 200XLT is the cream of the Bearcat handheld scanner range. With 200 memory channels and simple operation these are proving very popular. Frequency coverage 66-88, 118-174, 406-512 and 806-956MHz.



The compact HX850E is a basic scanner with a few memories. Ideally, suitable for a novice in the scanner market. AM/FM modes and a frequency coverage of 60-89, 118-136, 140-174 and 406-495MHz.



- Free Finance on selected items, subject to status. Details available on request.
- Up to £1000 instant credit, a quotation in writing is available on request, subject to status.
- Yaesu Distributor Warranty, 12 months parts and labour.
- Carriage charged on all items as indicated or by quotation.
- Prices and availability subject to change without prior notice.
- Same day despatch wherever possible.

Southampton (0703) 255111  
SMC HQ, School Close  
Chandlers Ford Ind. Est.  
Eastleigh  
Hants SO5 3BY  
9am-5pm Mon-Fri  
9am-1pm Sat

Leeds (0532) 350606  
SMC Northern  
Nowell Lane Ind. Est.  
Nowell Lane  
Leeds LS9 6JE  
9am-5.30pm Mon-Fri  
9am-1pm Sat

Chesterfield (0246) 453340  
SMC Midlands  
102 High Street  
New Whittington  
Chesterfield  
9.30am-5.30pm  
Tues-Sat

Birmingham 021-327 1497  
SMC Birmingham  
504 Alum Rock Road  
Alum Rock  
Birmingham B8 3HX  
9am-5pm Tues-Fri  
9am-4pm Sat

Axminster (0297) 34918  
Reg Ward & Co. Ltd  
1 Western Parade  
West Street  
Axminster  
Devon EX13 5NY  
9am-5.20pm Tues-Sat

# KW

## COMMUNICATIONS

Chatham Road, Sandling  
Nr Maidstone, Kent ME14 3AY

Telephone: 0622 692773  
Fax: 0622 764614



Instant credit available  
Mail/telephone order by cheque  
or credit card (E & OE)

KW Communications is back in business! After a brief "rest" and under new ownership and management that understands the needs of the listener, KW will be offering the shortwave listener and scanning enthusiast a wider range of equipment and accessories, carefully hand picked to ensure quality and value for money. Whatever your interests are, be it chasing tropical DX on the shortwave broadcast bands or checking the progress of Concorde over the Atlantic, we have the receiver for you - from the fabulous new Lowe HF150 to the truly superb JRC NRD-535. We also stock an enormous range of scanning receivers for monitoring air band, marine, amateur radio and other local VHF and UHF frequencies. We've got hand held, mobile and base station scanners from Signal's R537S airband receiver to the sophisticated Icom R7100. We stock a wide range of accessories including antennas, preamps, books and frequency guides and of course our experience to help you get the best from your equipment. Call in and see the widest range of equipment in the largest shortwave centre in the south east.



### DON'T FORGET

We also have a range of pre used equipment - all fully warranted - and we'll be happy to take your receiver or scanner in part exchange. Simple, speedy mail order - ring for details

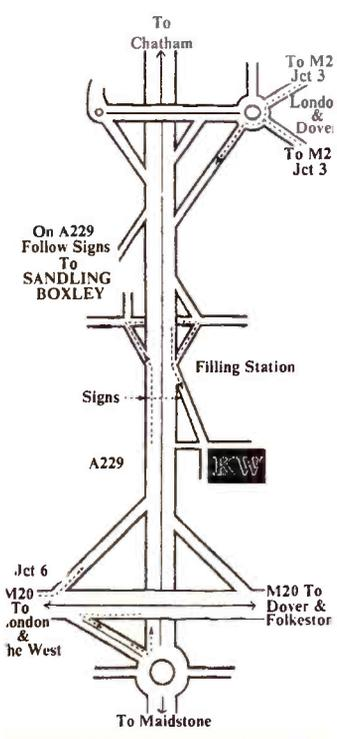

### SCANNING RECEIVERS

- ALINCO**  
DJX1 New! .....£269.00
- ICOM**  
R1 Micro size scanner.....£369.00  
R100 Excellent mobile.....£510.00  
R7100E .....£1120.00  
R9000E .....£4080.00
- AOR**  
AR3000A New improved.....£765.00  
AR2002 Old favourite .....£395.00  
AR2800 .....£395.00  
AR2500 Ask about software!.....£419.00  
AR2000 .....£269.00  
AR1500 Handheld inc. SSB!.....£299.00
- SIGNAL**  
R537S Tuneable airband RX.....£59.95  
R550 40 ch airband.....£129.00  
R535 VHF, UHF airband.....£254.00
- WIN**  
WIN108 Free binoculars!.....£179.00
- YUPITERU**  
MVT7000 Great handheld .....£289.00  
VT125UK Airband scanner.....£179.00
- FAIRMATE**  
HP2000 Same spec AR2000 .....£259.00

- SONY**  
AIR7 Airband, AM/FM PSB....£229.00
- YAESU**  
FRG9600 Old faithful with SSB....£520.00

### ACCESSORIES

- NEW FROM MALDOL**  
"ACTION HUNTER" series of wide band set top and mobile antennas to suit most scanners. Also TX on ham and cellphone! Call for details.
- JIM M75 Scanner preamp .....£69.95  
JIM PSU101 Base stand/charger.....£29.95  
D505 Active mobile ant .....£69.95  
D707 Active base ant .....£99.95  
D130N Wide band discone.....£81.00  
REVCONE Low cost discone.....£39.95  
Headphones .....from £9.95  
TCM 84V Voice activated recorder.....£34.95  
Magnetic longwire balun .....£36.00  
AT1000 SWL ATU .....£79.00

Plus all the books, frequency guides, connectors, insulators, aerial wire and coax to compliment your equipment.

### SHORTWAVE RECEIVERS

- KENWOOD**  
R2000 .....£549.00  
R5000 .....£895.00
- ICOM**  
R72E .....£659.00  
R71E .....£875.00
- YAESU**  
FRG8800 .....£649.00
- SONY**  
SW1E .....£149.95  
SW7600 .....£149.95  
2001D .....£279.95  
SW77E .....£339.95
- JRC**  
NRD535 .....£1099.00
- LOWE**  
HF150 .....£329.00  
HF225 .....£429.00

**OPENING HOURS:**  
**MONDAY-SATURDAY**  
**9.30am-6pm**  
**(MON open 10am, SAT close 5pm)**

Cover Picture Story

# Peter G Rayer G-13038

*This month's cover picture is interesting as it shows the receiving station of one of Short Wave Magazine's regular readers, Peter G Rayer.*

**P**eter Rayer's interest in radio started in 1963, when he joined the Wootton Bassett Air Training Corps and started to learn the Morse code under the watchful eye of Dick Rugg (G2BRR). The Radio Room had the R1154/1155 aircraft radios and the exotic Eddystone 358, which could be used, under very close supervision, to hear all the strange noises of short-wave radio.

Peter continued this interest throughout his subsequent service in the Royal Air Force and was licensed in 1970/71 as MP4BIM whilst stationed at Muharraq in Bahrain. He was also active with the callsigns MP4BB and MP4BS (the JAOTA Station).

Like many of the older short-wave listeners, Peter can read Morse at speeds in excess of 25 w.p.m., but has no interest in transmitting himself. He prefers to spend up to 70 hours a week listening on all the amateur frequencies. He is best known for his reports on h.f. RTTY, and sends out about 3000 QSL cards each year!

Peter is active with many of the UK radio organisations and is currently a Council

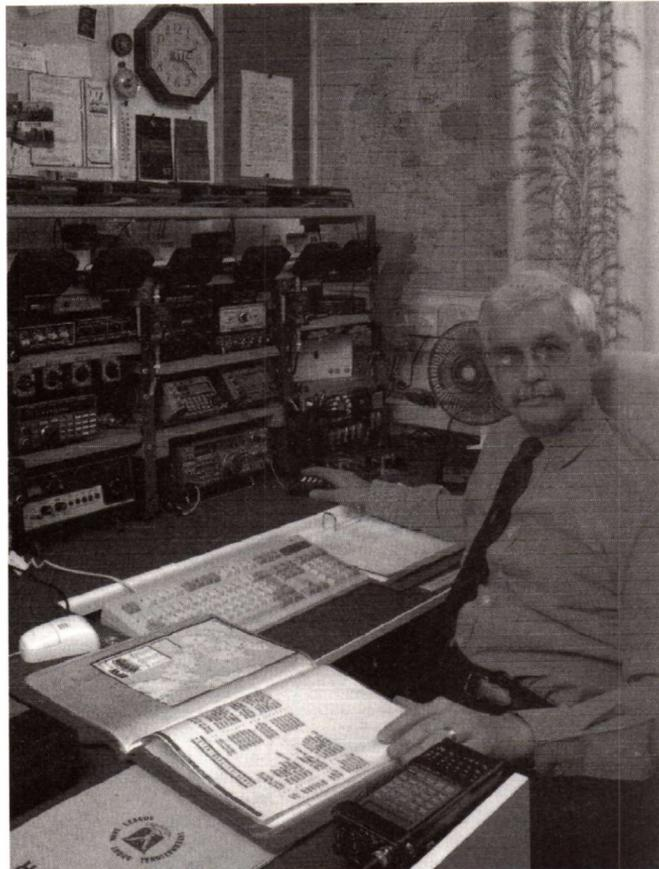

Member and World Treasurer of the International Short Wave League. Although partially disabled himself, he is often seen helping the Bournemouth Radio Amateurs Invalid and Blind Club at their various functions. He was pleased to become a member of the Radio Amateur Old Timers Association in June 1991.

### Radios

The main radios in the picture are: The Kenwood R-5000 used for general h.f. listening and linked to a PC-286 via a Kantronics Kam, the antennas are Datong AD-370 N-S and AD-270 E-W. A Kenwood R-2000 is linked to an Atari 520stfm via his second KAM for amateur FAX, etc. The

antenna in this instance is another Datong AD-370 N-S.

A Yaesu FRG-9600 is linked to both Kams to monitor the packet DX clusters, so that any DX window can be spotted. The antenna is a Dressler ARA-500.

Peter uses a Lowe HF-225 to listen to the short wave broadcast bands, although he is not a broadcast band DXer. The antenna used for this is a Dressler ARA-30.

### VHF and UHF Listening

The v.h.f./u.h.f. listening is done via various antennas, linked to an AOR AR-3000 and the AOR AR-3000A. All the sets have squelch-controlled tape backup, using Sony TCM-818 tape recorders.

An interesting point regarding Receiving Station G-13038 is that all the antennas, including the v.h.f. and 1296MHz beams, are internally situated in the roofspace of his house, only about 6 metres above ground level and just 33 metres above sea level. ■

Dear Newsagent,  
please reserve / deliver my monthly  
copy of SHORT WAVE MAGAZINE

Distributed by Seymour

NAME .....  
ADDRESS .....  
.....  
.....  
Signed .....

**Be sure of getting your copy of SWM each month. Place this regular order form with your newsagent... today**

**If you can't see SWM on the bookshelf at your local outlet, please call the Editorial Office in Poole and we will talk to our distributors to find out why!**

# NEVADA EVERYTHING

## YUPITERU

### MVT 7000 HANDHELD

PROBABLY THE UK'S MOST POPULAR HANDHELD SCANNER!

- ★ Receives 8 to 1300 MHz (at reduced sensitivity)
  - ★ 200 Memory channels
  - ★ Rotary or keypad freq. control
  - ★ AM/FM/NFM
  - ★ Large display with signal strength meter
- EACH SET IS SUPPLIED COMPLETE WITH:-  
Full set of high power NiCads, AC charger, DC power lead and carry strap ..... **£289**



### MVT 8000 MOBILE/BASE

This new model is the mobile version of the popular MVT 7000 Handheld above.

- ★ Receives 8 to 1300MHz (at reduced sensitivity)
- THIS RADIO IS ESPECIALLY SENSITIVE AT UHF FREQS. Set is supplied with mains power unit ..... **£299**

### MVT 6000 MOBILE/BASE

An economy version of the new MVT 8000 above - housed in the same case.

- ★ Receives 25-550MHz, 800-1300MHz
  - ★ 100 Memory channels
- SPECIAL PRICE ..... £CALL**

## AIRBAND RADIOS

This month we are pleased to introduce THE WORLDS FIRST DEDICATED CIVIL/MILITARY AIRBAND RECEIVER, THE VT225.

A powerful pocket scanner that leaves the competition standing. - A super sensitive set designed for optimum performance on the Civil/Military Airbands.

- ★ Receives 108-142 MHz Civil Airband
  - ★ 222-391MHz Military Airband
  - ★ 149.5-160MHz Marine Band
  - ★ 100 Memory channels
  - ★ AM/FM on VHF
  - ★ Priority channel function
- EACH SET IS SUPPLIED COMPLETE WITH:- NiCads, earphone, carrying strap and mains charger ..... **£229**



### VT-125 UK CIVIL AIRBAND RECEIVER

Using the same technology as the VT-225, this set covers the full Civil Airband - hearing distant signals that are inaudible on some other scanners.

- ★ Covers 108-142MHz
  - ★ 30 Direct entry memories
  - ★ Search steps 25, 50, 100kHz
- SUPPLIED COMPLETE WITH NICADS AND UK CHARGER ..... **£149**

## FAIRMATE

### HP2000

STILL ONE OF THE MOST POPULAR HANDHELD SCANNERS ON THE MARKET.

Over the last year the HP2000 has outsold almost all other models.

- ★ Continuous coverage from 500kHz to 1300MHz
- ★ 1000 channels of memory
- ★ Keypad or rotary control
- ★ AM, FM and WIDE FM modes
- ★ Search steps from 5 to 99.5kHz



### EVERY SET COMES COMPLETE WITH:-

Full set of high power NiCads, 2 antennas, carrying case, earphone, DC cable, belt clip and strap, UK charger ..... **£269**

### MS1000 BASE/MOBILE SCANNER

MOBILE VERSION OF THE HP2000 HANDHELD BUT WITH SEVERAL ADDITIONS:-

- ★ Switchable audio squelch
- ★ Tape recorder output socket
- ★ Automatic - signal operated tape recorder switching
- ★ All metal case for improved EMC compatibility
- ★ Receives:- 500kHz - 600MHz 805 - 1300MHz. Supplied with mains power supply. .... **£279**



## AOR SCANNERS

### AR1500 HANDHELD

Covers 500kHz to 1300MHz receiving NFM, WFM, AM, and SSB (using a BFO) ..... **£POA**

### AR2002 BASE/MOBILE

Receives 25 - 550MHz, 800 - 1300MHz, AM, FM, WFM Super-sensitive receiver ..... **£399**

### AR2500 BASE/MOBILE

Receives 5-550MHz, 800-1300MHz AM, NBFM, WFM. 1984 Memory Channels, Fast 36 CH/SEC Scan. Resolves SSB with BFO control ..... **£399**

### AR2800

★ Receives 500kHz - 600MHz, 800 - 1300MHz AM, FM, WFM. SSB capability with BFO.

★ 1000 Memory ..... **£395**

### HIGH POWER NICADS

700 mAh long life (1.2V Pen Cells) ..... **£1.90**

### STANDARD NICADS

500 mAh ..... **£1.25**

## SCANNERS

### ALINCO DJ-X1

HANDHELD SCANNER

- ★ Covers 500kHz to 130MHz
  - ★ 100 Memories
  - ★ AM/FM/WFM
  - ★ 3 Scanning speeds
- PLEASE NOTE:-  
ALINCO DO NOT INCLUDE BATTERIES AND CHARGER AT THIS PRICE. .... **£269**

### ALINCO ACCESSORIES

Set 6 high power NiCads ..... £11.40  
UK Charger ..... £17.95  
Alinco EPP16N NiCad Pack ..... £29.95  
Alinco EDC25 Drop-in Charger ..... £18.95  
Alinco ESC15 Battery Case ..... £10.95  
Alinco Soft Case ..... £9.95

### BEARCAT 200XLT

200XLT HANDHELD SCANNER

Still one of the easiest to use, and the most reliable scanners on the market, easy to program, sensitive receiver.

- ★ 200 Memories
- ★ 66-88, 118-174, 406-512, 806-956MHz
- ★ UK Charger/NiCad Pack supplied ..... **£229**

### BEARCAT 760XLT

A mobile/desktop version of the 200XLT above but with 100 memories. Supplied complete with mains adapter ..... **£235**

## NEW FROM SONY

### SW55 MULTIBAND RADIO

Complete with hard case and all accessories, antenna, earphones, mains adaptor. Probably the very best from Sony. This radio is a real winner, with dual conversion receiver and a host of features:-

- ★ 150-30MHz
- ★ 76-108MHz
- ★ AM/FM/SSB
- ★ 125 memories
- ★ Digital world time clock/alarm
- ★ World map display
- ★ Four way tuning system - 125 memory presets, Manual tuning, Auto scan, 10 key direct tuning

Now in stock for immediate shipment at just ..... **£249**

## SONY

As a Sony Shortwave Centre we stock the complete range of Sony Shortwave products - here is a selection of the popular models.

### ICF2001D

A full coverage shortwave, VHF, and airband radio (150kHz to 136MHz). Receives AM, FM, and SSB ..... **£299**

### SW77

One of the new additions to the Sony range, the SW77 covers 150kHz to 30MHz plus 76-108MHz. With a rotary tuning dial, 125 scan memories, reception of AM, FM, USB, LSB, CW, tape record facility, this is a superb all rounder ..... **£349**

### SW800

A pocket size VHF and Shortwave radio, covers 76-108MHz, 3.7 - 17.9MHz Shortwave. With 60 memories and credit card style facility for programming ..... **£99.99**

### SW1E

Pocket shortwave plus VHF radio supplied with headphones, case and shortwave guide. This model won't hurt your pocket! ..... **£149**

### SW7600

One of Sony's most popular VHF and Shortwave radios, 76-108MHz FM, 150kHz - 30MHz Shortwave receives AM, FM, SSB ..... Well Rated! ..... **£149**

### AIR 7

Very popular, sensitive Airband handheld radio - lovely audio quality & large easy to use key board ..... **£229**

### PRO 80

Combined Shortwave VHF handheld. Complete with add on converter for UHF Airband. This model comes also with the usual Handy Frequency Guide Booklet. Excellent S/Wave Results ..... **£299**

### AN1

An external active antenna with built-in pre-amp, covers 150kHz - 30MHz. Fully portable with easy to mount fixing brackets ..... **£57.95**

### AN3

Active antenna for Aircraft and VHF reception, suitable for Sony Air 7 and others ..... **£54**

### AR3000A NEW MULTIMODE SCANNER £765

AOR's top of the range model now improved.

- ★ Receives 100kHz - 2036MHz. Modes:- USB, LSB, CW, AM, FM, WFM.
- ★ Computer control is also available via the RS232 socket. Software for IBM PCs & clones is also available.

**INTRODUCTORY OFFER**  
SUPPLIED WITH FREE WIDEBAND DISCONE WORTH £49.95

Note: This is a UK version from AOR and not a foreign grey import.



SEND IN £2 FOR OUR NEW 72 PAGE COLOUR CATALOGUE (INCLUDES A £2 VOUCHER)

USE YOUR CREDIT CARDS FOR SAME DAY DESPATCH



# ING FOR THE RADIO ENTHUSIAST

## HUGE STOCKS - FAST DELIVERY - PERSONAL SERVICE

NEVADA COMMUNICATIONS, 189 LONDON ROAD, PORTSMOUTH PO2 9AE

TELEPHONE HOTLINE: (0705) 662145 FAX: (0705) 690626

### SCANNER ACCESSORIES

#### LOW NOISE PRE-AMPLIFIERS

These new pre-amplifiers are a must for the scanner enthusiast and will allow reception of signals that were inaudible without them.

#### MODEL M75

For base and handheld scanners

- ★ 25-2100MHz
- ★ Low noise GaAs FET
- ★ Selectable filters for optimum performance
- ★ Variable gain/attenuation control



£69.95

#### MODEL M100

Same specification as the M75 above but with full RF switching. May be used with transceivers of up to 5 watts RF output Ideal for the latest TwinBanders

£79.95

#### TWO-WAY REMOTE MASTHEAD SWITCH

Uses one coax feeder to the masthead and remotely switches between 2 antennas with this unit. Very low loss up to 1.3GHz. Uses Greenpar N type connectors

£44.95

#### JIM PSU101 MK IV

A combined desk stand and power supply/charger for handheld scanners. Suitable for most popular models. Special versions now available please call for more details

£29.50

#### JIM BHA3

Desktop stand for handheld scanners

£9.95

#### JIM CH-A4

Mobile holder for use with handheld scanners in the car

£6.95

### SCANNING ANTENNAS

#### NEVADA SCANMASTER (500 kHz - 1500MHz)

New high quality wide band receiving antenna uses fibre glass/stainless steel, with 4 small radials. 'N' type connector. Length 1.1 metres

£39.95

#### WB1300 DISCONE (25-1300MHz)

Stainless steel top of the range 'N' type connector. Complete with short mounting pole and clamps

£49.95

#### MICRO-SCAN (180-1300MHz)

New low cost ground plane antenna

£12.00

#### SKYBAND (25-1300MHz)

Stainless steel economy wideband Discone

£24.00

#### WB500 (50-500MHz)

Mobile scanner antenna on a magmount complete with cable

£27.95

#### LOG PERIODIC BEAM (105 - 1300MHz)

20-element wideband beam - can be used for transmit on VHF/UHF amateur bands. 12dB fwd. gain. .... £135.00

#### DIAMOND D707 (500kHz - 1500MHz)

A base antenna with 20dB pre-amp 3.5ft long fibreglass with mounting kit. Requires 12V DC supply. .... £99.00

#### DIAMOND D505 (500kHz - 1500MHz)

Mobile version of the D707 superb antenna. .... £69.00

#### TELESCOPIC SCANNER ANTENNA

(BNC) ..... £5.75

#### RUBBER DUCK SCANNER ANTENNA

VHF/UHF (BNC) ..... £11.95

### ICOM

ICOM We carry a varied selection of the Icom range of Amateur radio products including all of their latest models. However should you want something which is not in stock PAUL can get most things within 24 hours! (subject to availability). Icom have been known over the years for their Quality and Performance, here is just a small selection of their vast range!

#### IC R7100

Covers 25 - 2000MHz. Includes 900 memory channels with all mode capability. Five diferent scan options and an automatic record facility, what more you ask? Full brochure available. .... £ CALL

#### IC R72

Covers 100kHz to 30MHz on the HF Bands and offers all mode reception (FM, with the optional board) Easy to use and ideally suited to the new comer. A full 99 memory channels with scan facility and a 10dB pre-amp fitted as standard. .... £ CALL

#### IC R1

Icom's most popular pocket-sized wideband scanner Frequency from 150kHz to 1300MHz with 100 programmable memories. AM, FM and WFM Modes. Sleep timer and clock facility Optional NiCads, carry cases, and fast chargers are available. NEW LOW PRICE ..... £359

#### IC R100

Mobile or base extra wideband scanning receiver covering 500kHz to 1.8GHz with 100 memory channels and receives AM, FM & WFM Modes ..... £499

### KENWOOD

#### R2000 RECEIVER

A good 'Middle of The Road' Receiver giving general coverage receive from 150kHz to 30MHz. Built in clock and timer facility. Ten user programmable memories Optional VHF Converter (Secondhand models usually available) ..... £ CALL

#### R5000 RECEIVER

Based on the receive section of the TS440S HF Transceiver bath in looks and design this model covers 100kHz to 30MHz all mode, 100 memories and facility for optional filtering. RECOMMENDED ..... £ CALL

### SHORTWAVE RECEIVERS

#### LOWE HF-225

Receiver (30kHz - 30MHz) Optional extras inc FM/AM detector, Nicads, Speaker, Case & Active Ant. .... £439.00

#### LOWE HF-150

Receiver Economy model but with an excellent set of 'EARS'. LCD display. Portable or Mains Power ... £329.00

#### NRD-535

Japanese top of the range general coverage receiver, 0.1 - 30MHz Lots of Options available ..... £1115

#### DRAKE R8E

New American top class receiver, 100kHz - 30MHz, supplied with all filters as standard. Really outstanding - see recent reviews £965



#### DRAKE R8 VHF CONVERTER

(35 - 55MHz) (108 - 174MHz) £195

#### GRUNDIG SATELLIT 500

A full coverage receiver with 42 memories, receives LW, MW, FM and SW bands ..... £299

#### SANGEAN ATS803A

Full short wave coverage portable receiver with FM stereo. 14 memory channels, 12 shortwave broadcast bands ..... £109.95

#### PHILLIPS D1875

Shortwave receiver covering all the major shortwave broadcast bands SPECIAL PRICE ..... £49.95

#### STEEPLETONE SAB9EP

A complete Airband pack comes with Airband Radio, Headphones & intro book. .... £29.95

### STEEPLETONE MRB7

Multi-band Radio. This radio will appeal to both Aircraft Enthusiasts and the Marine Monitors. The multi-band 'jumbo' radio has almost everything you need to monitor these bands. LW, MW, & SW plus the Marine and Aircraft Bands. .... Good Starter! ..... £69.95



### TRADING POST

CASH, CASH, cash, got a 'RIG' want a scanner? give PAUL a ring for p/x details or as a 'Buy-in'.

- Yaesu FR101 Receiver c/w Ext. Spkr Horn Bands only, Exc. Cond ..... £275.00
- Mars2 'Hipster' Receiver 150kHz-520MHz all-mode, Boxed V.G.C. .... £215.00
- Trio R1000 S/W Receiver. Digital Display with timer V. Clean. .... £350.00
- Trio R2000 Rx. Good middle of the road receiver, Avg. Cond. .... £450.00
- Icom R72 Gen. Cov. RX almost new still U/Glee. Bargain. .... £500.00
- Yaesu FRG7 Good old Faithful Receiver. .... Still Going! ..... £175.00
- Realistic Pro37 200 Channel H/Held Scanner, As new. .... £175.00
- Sony Air7 Handheld Airband Receiver, offers around. .... £185.00
- Nevada M51000 Base/Mobile Scanner, Exc. Cond. G/Teo ..... £215.00
- Regency 7000 Base/Mobile Scanner, V. Sensitive Radio. .... £215.00
- Fairmate HP2000 'The ultimate' in handheld scanners full 1000 memories, v.g.c. but tiny box. .... £215.00
- AOR AR3000A The best base station scanner money can buy All mode 150kHz - 2.1GHz Ex-demo model ..... £699.00
- Yupiteru MYT-7000 c/w PSU101 supply/stand. Avg. cond G/Teed fully tested model ..... £220.00
- Alinco DJ X1 The latest model in excellent condition with box and all manuals incl. Frequency book, G/Teed ..... £225.00

WHY NOT UPGRADE YOUR OLD R7000 FOR THE TOP OF THE RANGE R9000! IN LIMITED QUANTITY WE CAN OFFER SPECIAL P/X DEALS, CALL PAUL FOR ALL THE INFO...

### BOOKS...BOOKS...BOOKS...BOOKS

- Shortwave Confidential Frequency List. Lists 0-30MHz Freqs. .... £8.95
- VHF/UHF Frequency Guide A real must for serious users ..... £5.95
- Marine Frequency Guide Near the coast? Ideal book ..... £4.95
- VHF/UHF Airband Guide At last, now back in print ..... £6.95
- Scanners 2 by Peter Rouse, Both books full of good info. .... £8.95
- Scanners 3rd Edition ..... £10.95
- Short Wave Communications. Renowned contributor to the popular Short Wave Magazine ..... £8.95
- Air Traffic Radio 1991 (updated for '92) ..... £3.95
- Sounds Easy Guide to Britain's Radio Stations ..... £2.95
- Flight Routings Guide Book ..... £4.95

### Directory of Military Aviation Communications.

Space Shuttle operations, War games, in-flight refuelings, interception of Soviet BEAR Recon-Bombers, Military Airshows, secret coded transmissions, these are only a taste of what's in store in this publication. Frequency, Locations & some maps for Europe & North Africa are included for reference ..... £17.95

# A Novel 3.5MHz Receiver with Reaction

## Part 1

Ian Hickman

In the early days of radio, or of 'wireless' as it was universally known, stations were few in number and of relatively low power by current standards. For cheapness, receivers were usually entirely passive, only the rich being able to afford a costly and power-hungry set with one or more bright emitter valves. The favoured receiver for the man in the street was a crystal set and this was usually fed by 100 feet (30m) of 'aerial wire' strung from gutter or chimney level to the apple tree at the end of the garden, or some other support, aided by an efficient earth that needed watering in dry weather. The only power available to produce an audible output was the received r.f. energy itself, and most of the energy was in the carrier at that. Even at the comparatively rare instants of 100% modulation, the useful information power in an amplitude modulated wave is only equal to one half of the carrier power or one third of the total power. Thus listening was confined to headphones, unless one lived very near the transmitter. The crystal detector, usually galena - an ore containing lead sulphide, was an inefficient detector compared to a modern diode. But even so it imposed rather heavy damping on the tuned circuit, giving crystal sets a reputation for poor selectivity. As an increasing number of more powerful stations came on the air, the limitations of the crystal set became painfully obvious.

The development of the dull emitter triode, with its 2V filament drawing only a fraction of the current consumed by the 6V filament of a bright emitter valve, brought wireless sets with better sensitivity and selectivity within the reach of

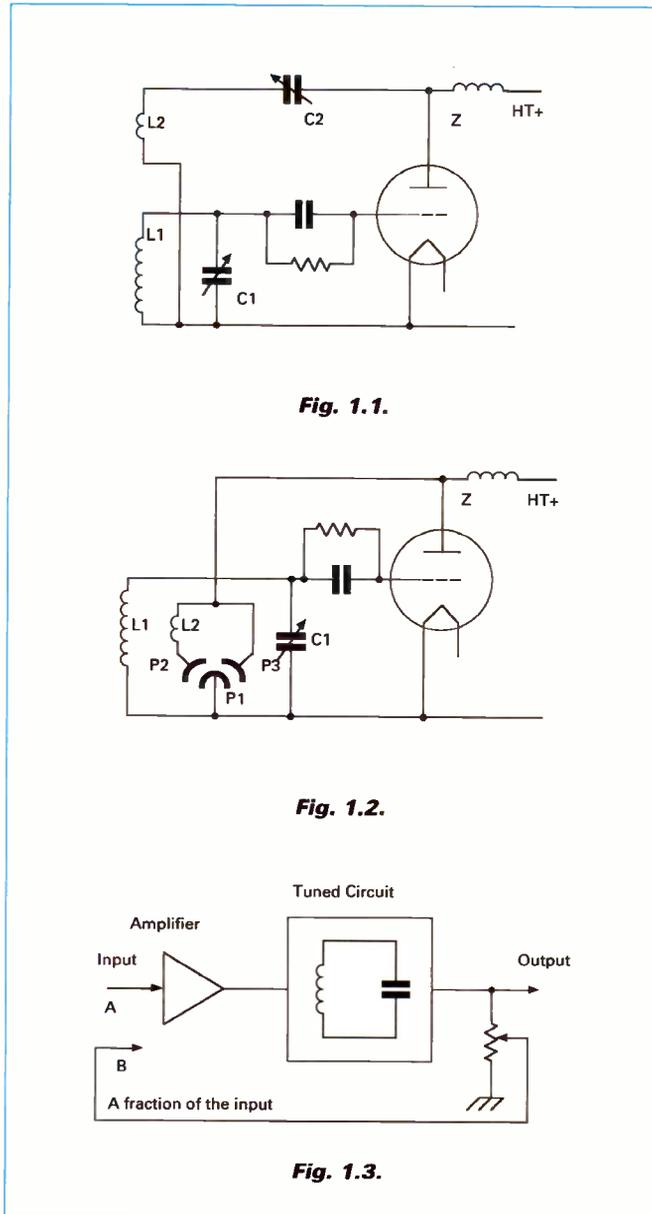

Fig. 1.1.

Fig. 1.2.

Fig. 1.3.

many for the first time. The improved sensitivity enabled more stations, including foreign ones such as the popular Radio Normandy, to be received, whilst the improved selectivity enabled one to hear the wanted station without hearing a station on an adjacent frequency in the background at the same time. But the greatly improved selectivity and sensitivity were

not just due to the reduced loading of the triode's grid on the tuned circuit and its modest degree of amplification respectively. The key to the improvement was reaction, also known as regeneration and, in America, as 'tickling'. The application of reaction simply involves the feedback from the output of the amplifier triode of some of the amplified rf signal to the

input, where it further reinforces the weak incoming signal. Typical circuits were as in Fig. 1.1, a very popular simple cheap arrangement, and Fig. 1.2 where the more expensive differential reaction condenser was claimed to give smoother control and reduced 'hand capacity' effect; this was often a problem in sets with a Bakelite or plywood front panel. I don't know who first thought of the brilliantly effective idea of reaction, but it must surely have been in use long before the appearance of the dull emitter valve. Its use continued long after their departure as well, being incorporated in many small t.r.f. mains table radio sets which were popular till well after the Second World War. It was also occasionally used to increase the gain and selectivity of the i.f. stage of a superhet communications receiver and even to do away with the i.f. stage altogether, as in the 'Sobelette' small mains medium and long wave table radio, which had a frequency changer and i.f. transformer feeding directly into a leaky grid detector with a fixed degree of reaction.

Extremely effective as reaction was when properly applied, it was over-sold by some writers of the period, one self-styled expert explaining that it could increase the stage's gain to the wanted signal 'right up to infinity'! But I certainly found it of enormous use as a lad when building sets using 2V battery valves with components handed down to me by good folk who had bought an 'all mains set'. I also incorporated it in a near-lethal mains set I later built using three pensioned-off American UX-based valves and sundry salvaged linecords thrown out by the local radio repair man. The set was about 5.5 x 5.5 x 6.5in high, just large

*For the man in the street, a simple crystal set with as much 'aerial wire' as possible down the garden was the usual means of listening to early wireless stations - valves were too costly. For this project, Ian Hickman has delved into his past and come up with an interesting design for a single band receiver with the mystical 'reaction' to improve both sensitivity and selectivity.*

enough to use a Goodmans 5in round loudspeaker, and the line-up was a 77 r.f. pentode as leaky grid detector with reaction, a 43 output pentode and a 25Z3 rectifier. It was before the days of ferrite rod antennas, but the set gave good loudspeaker volume reception on all the local stations, and many foreign ones after dark, on a home made 600mm telescopic antenna. Many years later I incorporated reaction in a transistorised three-waveband receiver (Ref. 1) with excellent results. But although the general principle is plausible enough, in all that time I never came across a convincing explanation of exactly how reaction improves reception. Some time ago therefore I set out to explore the arrangement more thoroughly, using the design of an 3.5MHz (80m) receiver as the vehicle for the investigation. The result was a receiver of surprising performance, which will be described shortly. Firstly however, I hope you will find it interesting to read about the results of my experiments and deliberations concerning reaction, and how it can be so effective in some cases and so disappointing in others.

### How the Circuit Developed

To begin with, we need to look at the operation of an r.f. oscillator - a tuned amplifier with feedback from its output to the input. **Fig. 1.3** shows an amplifier fed with a small external input A and complete with an arrangement to bleed off a portion B of the output, ready to be fed back to the input. If the portion B is exactly equal in amplitude to the input signal A, and moreover is exactly in phase with it, then (if we were nimble enough to do it

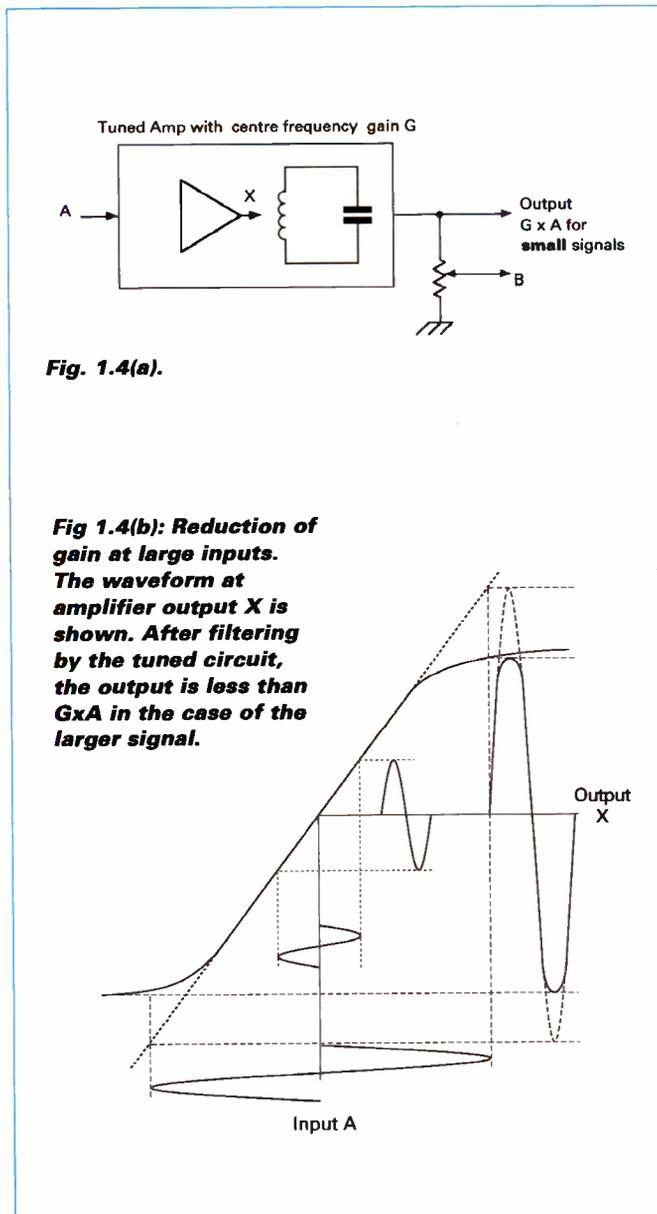

instantaneously) we could substitute the feedback signal B for the external input A. The circuit would simply carry on exactly as before for evermore, the amplitude of the output neither increasing nor decreasing - after all why should it, since the amplifier sees exactly the same input as previously? Of course, in the practical world of engineering, as distinct from the

abstractions of mathematics, two physical quantities are never exactly equal, or if they were, they won't remain so indefinitely, so in practice when B is substituted for A, the oscillations will either die away or build up until they can't get any larger.

Let's look at this second possibility in more detail. **Fig. 1.4** shows a tuned amplifier which is nice and linear for

small amplitude signals, but which limits symmetrically as the input increases. For small inputs the output is simply G times as large, G being the gain of the amplifier. For larger signals, the peaks of the input run into the non-linear region, resulting in clipping of the waveform as shown. The resultant waveform is no longer a pure sinewave, harmonic distortion is introduced. However, assuming that the tuned circuit comes after the amplifier as shown and that it operates at a reasonably high Q, only the fundamental frequency component will appear at the output: moreover, due to the limiting, its amplitude will be less than G times the input - the effective gain has fallen as the input amplitude increased beyond the amplifier's linear signal handling range. The signal B (which we will assume is in phase with the input A if the latter is exactly on tune with the amplifier's tuned circuit) will likewise no longer increase in proportion to the input as the output signal increases beyond the linear range, and this is what stabilises the amplitude of an oscillator's output.

The gain from A to B is called the loop gain and if it exceeds unity at the frequency where B is in phase with A, then the circuit will start to oscillate when B is connected to A. **Fig. 5** shows various possible ways in which the loop gain at the fundamental frequency can vary with input amplitude. A characteristic such as (d) is ideal for a high stability oscillator such as the v.c.o. of a synthesiser, or the local oscillator of a superhet receiver. The very rapid change of loop gain with amplitude in the region where the loop gain is unity will result in a very stable amplitude of oscillation - low

# Deals of the decade

Ten years...that's how long we've been supplying you

Stockists of DIAWA - VIBROPLEX - ICOM

## DEWSBURY ELECTRONICS

176 LOWER HIGH STREET

WEST MIDLANDS



Tel: (0384) 390063/371

## EASY READER DM-1000

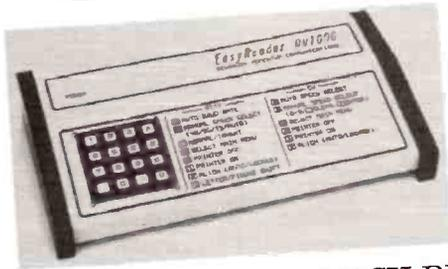

Introducing the all new 'EASY READER DM-1000' RTTY/CW DECODER.  
In our opinion "the most simple to use decoder ever seen".

- RTTY BAUDOT 45/50/75 BAUD
- CW SPEED 2-99 WPM
- RTTY ASCII 110 AND 200 BAUD
- AUTOMATIC OR MANUAL SPEED SELECTION
- STATUS LINE ON SCREEN GIVING MODE, SPEED IN USE AND PRINTER ON/OFF
- OUTPUT TO VIDEO MONITOR AND PRINTER (CENTRONICS/PARALLEL)
- OPTIONS: UHF TV OUTPUT RS-232 OUTPUT
- FEC FOR NAVTEX ETC. NO COMPUTER REQUIRED. SEE REVIEW IN SWM APRIL, 1992

Price: £199.95 inc VAT P&P £5.00

SAE for full details

## UNIVERSAL RADIO INC. UNIVERSAL M-900

A compact easy to use decoder for Baudot, RTTY, Sitor A and B, Morse Code and FAX. Output is to video monitor and parallel printer port. Baudot speeds are 45, 50 and 74 Baud, FAX speeds are 60, 120 and 240 LPM, 288 or 576 IOC. Advanced features include UOS, OPI, squelch, automatic or manual FAX. Video is 40 or 80 character, 18 or 22 lines, 50 or 60Hz refresh. FAX output to screen. FEC-A-96 Baud, FEC-A 144 Baud, FEC-A 192 Baud. NO COMPUTER REQUIRED.



**Requires:** 12 VDC at 800 mA  
**Dimensions:** 9" wide x 3.75" high x 13.25" deep  
**Weight:** 2.5kg

Price: £590.00 inc VAT P&P £10.00

SAE for full details

# Trade at Dewsbury

with quality goods and service...here's to another ten!

- YAESU - KENWOOD - JRC - WAVECOM

**ELECTRONICS,**  
**100 MARKET STREET, STOURBRIDGE,**  
**WYANDS DY8 1TG**

**01228 Fax: (0384) 371228**



## WAVECOM W-4010 VERSIONS 4&5

Professional grade high performance decoder/analyser, easy to use and at an affordable price. Decodes up to 27 commercial codes including Packet and FAX. Both serial and centronics output, as well as output to composite video monitor. Powered from 13.8 volt supply (option).

### Dimensions:

7.75" wide x 3.25" high x 10" deep

Can be supplied in Standard 19" rack together with Video Screen and integral power supply. **NO COMPUTER REQUIRED.**

SAE for details. Reviewed in Practical Wireless August, 1990.



## UNIVERSAL M-7000 DECODER

Advanced decoder which will decode up to 17 different RTTY codes, including Packet and FAX. Outputs to printer and to composite video monitor. FAX to both screen and printer.

Features real time clock output for scope, needs **NO COMPUTER** for operation. However external computer may be used for controlling M-7000 if required.



**Dimensions:** 16.4" wide x 3.5" high x 12.75" deep  
**Weight:** 9lbs

Mains powered 120 (230 volts). Supplied with extremely well written user manual plus a second Getting Started manual for new RTTY listeners.

**Price: £1030.00 inc VAT P&P £10.00**

SAE for full details

**Fig. 1.5:**  
Reproduced from  
*Analogue Electronics*,  
Ian Hickman, Heineman  
Newnes 1990 with  
permission from the  
publishers.

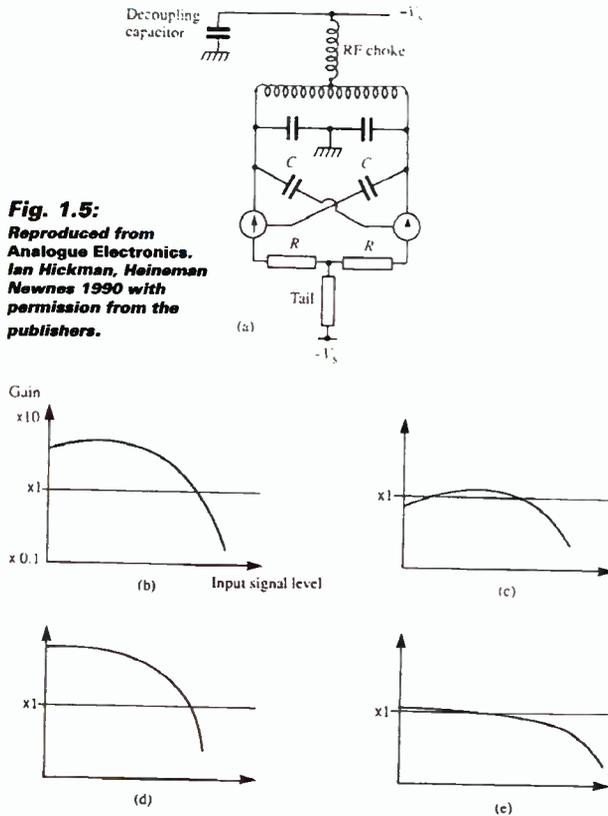

amplitude of a.m. noise sidebands. This is typical of the Vakar type of oscillator in (a) - where the active devices could be transistors, f.e.t.s or valves - when the resistors R are zero or low in value. And if the operating Q of the tank circuit is very high then the magnitude of the phase noise sidebands will also be very low. Characteristic (b) is commonly encountered and adequate, but inferior to (d), whilst one sometimes comes across an infuriating oscillator with a characteristic such as (c). This oscillator sometimes starts and sometimes doesn't, depending upon whether the switch-on transient shock excites the tuned circuit to ring with an amplitude at which the loop gain exceeds unity: if so, then the amplitude rapidly builds up to the higher of the two unity gain points.

Characteristic (e) would be very unsuitable for a high stability oscillator; the very gradual change in gain with amplitude around the unity gain point would result in poor amplitude stability, rendering the oscillator's amplitude very susceptible to outside influences such as hum on the supply rails etc. However, it is just what is wanted for a receiver using reaction, since the amplitude of oscillation is exceedingly susceptible to influence by r.f. energy at the frequency of the tuned circuit, coupled in from an external source, via an antenna.

Having reached this conclusion, I designed a tuned

r.f. amplifier stage which had only a modest gain but which was very linear. Tests showed that its amplitude of oscillation, when the feedback was adjusted so that the loop gain just barely exceeded unity, was indeed very sensitive to external r.f. signals and this is the basis of the remarkable performance of the final version of the receiver described below, the block diagram of which is shown in Fig. 1.6.

Unlike the leaky grid detectors with reaction shown in Figs. 1.1 & 1.2, the reaction is applied around an r.f. stage, which is coupled to a separate detector. The detector output passes through a single pole lowpass filter and then through a 35dB amplification stage. It then passes through two two-pole lowpass filter stages which, with the earlier single pole stage, form a 5-pole elliptic lowpass filter. This passes

audio frequencies up to 3kHz but provides 57dB of attenuation at 4.5kHz and all higher frequencies. This provides additional selectivity at audio, to augment the high selectivity at r.f. provided by the use of reaction. The signal is then routed to an output stage providing a further 35dB amplification, either direct or via a tunable audio frequency filter for use with c.w. signals. This state- variable narrow bandpass filter can be tuned over the range 350Hz to 3kHz approx. and provides a further 22dB of attenuation at frequencies one octave above and below the tuned frequency and beyond.

**In Part 2 we will deal with the final circuit diagram and start construction of this interesting receiver.**

Reference 1. The PW Imp 3 - Waveband Receiver, Ian Hickman, *Practical Wireless*, May 1979, pages 40 - 46.

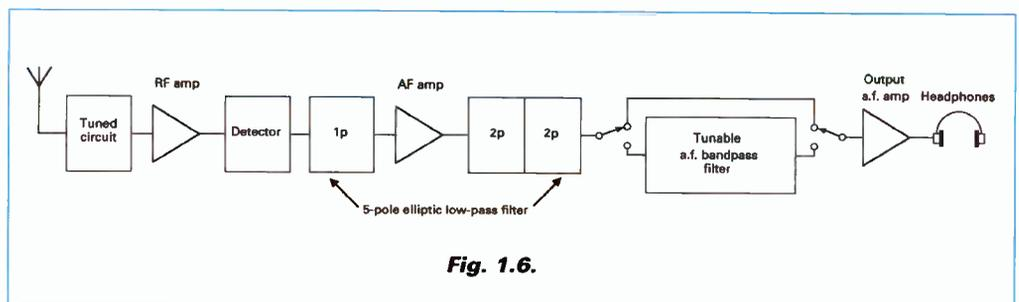

## Abbreviations

a.m. amplitude modulation  
c.w. continuous wave (Morse)  
dB decibels  
f.e.t. field effect transistor  
Hz hertz  
i.f. intermediate frequency  
kHz kilohertz  
m metres

MHz megahertz  
mm millimetres  
Q the 'goodness' of a circuit  
r.f. radio frequency  
t.r.f. tuned radio frequency  
V volts  
v.c.o. voltage controlled oscillator

megahertz  
millimetres  
the 'goodness' of a circuit  
radio frequency  
tuned radio frequency  
volts  
voltage controlled oscillator

**PAY A VISIT TO**

**SUPER**

# HAMSTORES

**AVAILABLE AT SUPER HAMSTORES THIS MONTH;  
A FULL RANGE OF WIDEBAND, HF, VHF, UHF, BASE-STATION,  
MOBILE & HANDPORTABLE RECEIVERS.**

**Whatever your requirements we will help you make the right choice.**

**WIDEBAND RECEIVERS**

R9000.....100kHz - 2GHz All Mode .....	£4080.00
R100.....100kHz - 1856MHz AM/FM .....	£ 510.00
R1.....100kHz - 1300MHz AM/FM .....	£ 349.00
AR3000A.....100kHz - 2036MHz All mode .....	£ 765.00
AR2000.....500kHz - 1300MHz AM/FM .....	£ 269.00
MVT7000 ....8MHz - 1300MHz AM/FM .....	£ 289.00
DJX1 .....500kHz - 1300MHz AM/FM .....	£ 269.00

**HF RECEIVERS**

R5000.....100kHz - 30MHz All mode (VHF OPT) .....	£ 925.00
R71.....100kHz - 30MHz All mode (FM OPT) .....	£ 875.00
R72.....30kHz - 30MHz All mode (FM OPT) .....	£ 659.00

**HF RECEIVERS CONTD.**

R2000.....150kHz - 30MHz All mode (VHF OPT) .....	£ 549.00
HF225.....30kHz - 30MHz All mode (FM OPT) .....	£ 429.00
HF150.....30kHz - 30MHz SSB/AM/CW .....	£ 329.00

**VHF/UHF RECEIVERS**

R7000.....25MHz - 2GHz All mode .....	£1012.00
R7100.....25MHz - 2GHz All mode .....	£1100.00
FRG9600 ....60MHz - 905MHz All mode .....	£ 520.00

**AIRBAND RECEIVERS**

WIN108 .....108MHz - 142.975MHz AM .....	£ 178.00
MVT125 .....108MHz - 142.00MHz AM .....	£ 169.00

In addition, HAMSTORES stock a wide range of new transceivers plus a large selection of second-hand and ex-demo gear including; BARENCO, DIAMOND, COMET, SONY, AOR, LOWE, DRAE, CUSHCRAFT, AKD, KANGA KITS, MFJ, DEECOMM, CDR, ALLGON, TOYO, AEA, MET, ICOM, YAESU, KENWOOD, ALINCO, JRC ETC. Watch this space for more news,

**73's, Chris G8GKC, Gordon G3LEQ and John G8VIQ.**

**Opening times for both stores: 09:00 - 17:00 Tuesdays to Saturdays**

## HERNE BAY

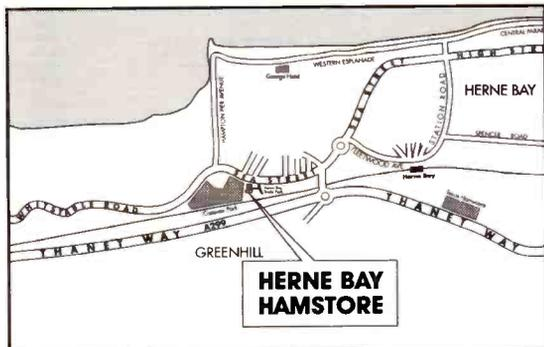

Payment by Access, Visa and Switch. Part-exchanges welcome, finance can easily be arranged (subject to status). Interest free credit is available on selected new ICOM products.

If you cannot visit an ICOM HAMSTORE in person we operate an efficient, computer-based Mail order service. Stock items normally despatched within 24Hrs.



Unit 8, Herne Bay West Industrial Estate,  
Sea Street, Herne Bay, Kent CT6 8LD  
Telephone: (0227) 741555, Fax: (0227) 741742

## BIRMINGHAM

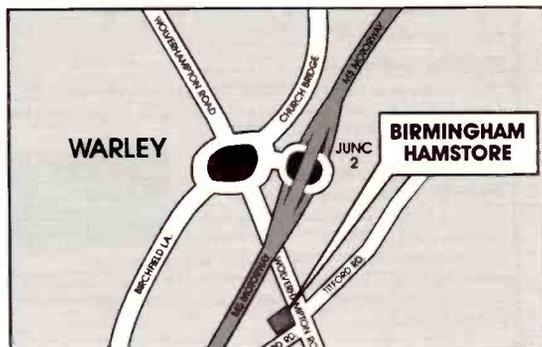

International House, 963 Wolverhampton Rd.  
Oldbury, West Midlands B69 4RJ  
Telephone: 021 552 0073, Fax: 021 552 0051

## GUIDE TO UTILITY STATIONS 1992

10th edition • 534 pages • £26 or DEM 70  
7500 new coastal and fixed station frequencies!

Our bestseller covers the complete frequency range between 0 and 30 MHz. We are the very first to publish *all* new maritime frequencies world-wide in use since the gigantic global frequency transfer in July 1991! Latest military and political events such as the impacts of the Gulf War and of the recent and current revolutions in Eastern Europe are covered exclusively by our UTILITY GUIDE. Sophisticated operating methods and regular overseas monitoring missions (1991 for months in India, Malaysia, Mauritius, Reunion, Surinam and Venezuela) complete this unique book.

The completely revised new edition includes a frequency list with 19136 frequencies, and a call sign list with 3514 call signs. Up-to-date schedules of FAX meteo stations and RTTY press services are listed both alphabetically and chronologically. Abbreviations, addresses, codes, definitions, explanations, frequency band plans, international regulations, modulation types, NAVTEX schedules, Q and Z codes, station classes, telex codes, etc. - this reference book lists everything. Thus, it is the ideal addition to the World Radio TV Handbook for the "special" stations on SW!

Further publications available are *Guide to Facsimile Stations*, *Radio-teletype Code Manual* (11th editions) and *Air and Meteo Code Manual* (new 12th edition). We have published our international radio books for 23 years. They are in daily use with equipment manufacturers, monitoring services, radio amateurs, shortwave listeners and telecommunication administrations worldwide. Please ask for our free catalogue, including recommendations from all over the world. For a recent *Shortwave Magazine* book review see Ian Chard in issue 2/91. All manuals are published in the handy 17 x 24 cm format, and of course written in English.

Do you want to get the **total information** immediately? For the special price of £88/DEM 245 (you save £15/DEM 40) you will receive all our manuals and supplements (altogether more than 1700 pages!) plus our **Cassette Tape Recording of Modulation Types**.

Our prices include airmail postage to everywhere in the world. Payment can be by £ or DEM cheque, cash, International Money Order, or post giro (account Stuttgart 2093 75-709).

Dealer inquiries welcome - discount rates on request.

Please mail your order to:

### KLINGENFUSS PUBLICATIONS

Hagenloher Str. 14, D-7400 Tuebingen, Germany  
Tel. +49 7071 62830

# SKYVIEW

## SYNOP

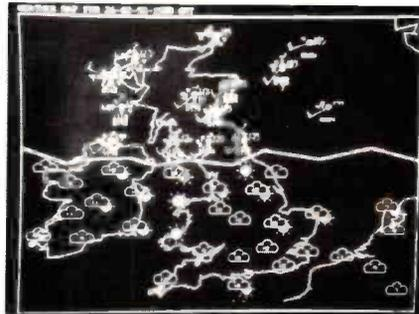

**£99.00** INC VAT

### NEW CONCEPT IN WEATHER IMAGING

- Includes full RTTY/NAVTEX System & Hardware interface.
- Plot detailed Weather Maps.
- Uses RTTY met data.
- Supports VGA, EGA.
- Pictorial and Synop plot facilities.



NEW



## SATFAX



**£199.00** INC VAT

### NEW INTERGRATED SAT/FAX SYSTEM

- Modes FAX, METEOSAT, NOAA (APT)
- Timetable - Automatic Switching.
- Supports VGA, EGA, CGA, + HERC.
- 640 x 800 Resolution, 16 Grey Scales.
- Includes S/ware & H/ware interface.

SKYVIEW SYSTEMS LTD. Skyview House,  
Coekaynes, Abresford, Essex. CO7 8BZ.

Sales: 0206 823185 / FAX: 0206 825328

Technical Sales: 0205 359658

## ENTERPRISE RADIO APPLICATIONS ALTD.

5 Clarendon Court  
Winwick Quay  
Warrington  
WA2 8QP  
Tel: (0925) 573118

### MK.II MICROREADER

The easiest way to receive CW, RTTY, AMTOR, SITOR and NAVTEX without all the fuss of computers. Just plug into your speaker socket and switch on. The Microreader automatically decodes both amateur and commercial stations

displaying the received text on its own LCD screen. The Microreader also incorporates a MORSE TUTOR facility that allows you to check both your receiving and sending performance. £170.00.

### BP34 AUDIO FILTER

Someone once said that this filter is too good for amateur radio use. We, along with hundreds of BP34 users would disagree. The BP34 combines ease of use with a degree of performance not found in any other filter. Exceptionally sharp cut off and guaranteed 80dB stopband attenuation make this filter a must for the more serious user. £109.50.

UPGRADE KIT  
FOR SITOR/  
AMTOR/NAVTEX  
version 4.1 many other  
improvements  
£20.00

### RS232 DISPLAY

Don't tie up your computer while monitoring. This new unit will display, store and print messages sent via the RS232 output from the MICROREADER or PACKET TNC.

Text is stored in memory and at the same time displayed on the large 160 character backlit screen. A unique scrolling facility allows you at any time to scroll back and forth through over fifty screens of text messages while still receiving data. The display incorporates a PARALLEL PORT that allows printing of all or selected sections of text at the touch of a button. £185.00.



All products are guaranteed for two years  
and all prices include VAT  
and postage and packing.



## An IF output - the easy way

Now that single sideband, reduced carrier broadcast transmissions have started, some owners of valved receivers may be wondering how to tap off some i.f. signal for a phase-lock detector. John Wells offers a solution in this short article.

**T**here can't be a simpler way of tapping off some i.f. signal than that shown in **Fig. 1**. The last (or only) i.f. amplifier will usually have a cathode resistor and capacitor as shown in **(a)**. All that is needed is to disconnect the earthy end of the capacitor and insert a 47Ω resistor in series as shown in **(b)**. In some receivers the cathode capacitor is part of a multiple block, in which case it can simply be disconnected and another capacitor of the same value fitted at the valve socket. The output is taken by a length of coaxial cable to a socket, which could be fitted at the rear of the receiver, or anywhere else if required. The socket can be mounted on a bracket attached by an existing screw to avoid the need to drill holes in the chassis. The only precaution needed is to keep the cable away from the other i.f. stages, since the braid, even on good quality cable, is leaky

enough to cause unwanted coupling. This modification has no noticeable effect on either i.f. gain or alignment, whether shorted, open, or correctly terminated. In the case of my

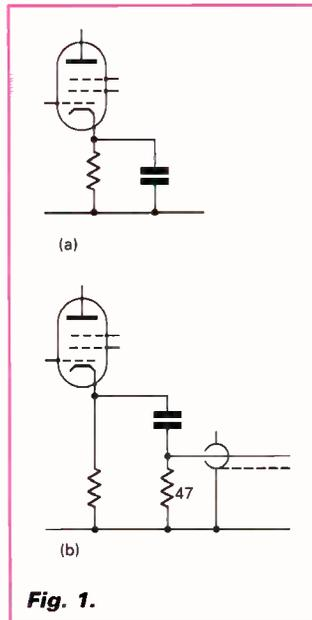

**Fig. 1.**

AR88 it provides about 10-20mV of signal - ample for an outboard phase-lock detector.

The output can also be used as an input - for example to insert a high level b.f.o. signal for s.s.b. if one is not provided - don't forget to turn off the a.g.c. - or for a modulated signal generator to test the detector and audio stages.

### Moral

The moral here is not to forget the cathodes when considering 'add-ons'. An S-meter can be connected in the earthy end of the cathode resistor of any a.g.c.-controlled stage. If the local

oscillator is of the type with an earthed cathode, a small resistor here will give an output to a frequency counter, although some small re-alignment may be required. If the b.f.o. has an earthed cathode, then a small resistor, transistor, or both in parallel can be inserted in the cathode lead, and fed with a 'sniff' of i.f. signal, to give an injection-locked oscillator to feed the more exotic of detector. All of these suggestions are cheap to carry out, and make no serious alterations to the receiver wiring - so they can easily be removed if required at a later date if you want to sell the set. ■

### Abbreviations

a.g.c.	automatic gain control
b.f.o.	beat frequency oscillator
i.f.	intermediate frequency
mV	millivolts
s.s.b.	single sideband
Ω	ohms

## First Aid

As a newcomer to this fascinating hobby, I have just acquired a second-hand communications receiver - namely a SMC-73, mainly for u.s.b. listening particularly to aircraft.

Having hastily connected a temporary makeshift antenna, a 7m wire hanging from the bedroom window to a tree, I can received good quality signals of conversations between aircraft and ground controllers on New York Oceanic at around 8.95MHz.

I wonder if anyone could enlighten me with regards to the origin and age of this receiver.

**Richard Foster, 25 Bodmin Close, Scunthorpe, South Humberside DN17 1TW.**

I own a Realistic PRO 2021 scanner. I would be grateful if anyone knows of a way of having 'switchable a.m.'. Now you only have a.m. for the airband, this can be tiresome.

**G.P. Jones, 74 Joseph Luckman Road, Bedworth, Warwickshire CV12 8BQ.**

I am looking for a manual for the Prinzsound R999 solid-state 26 8-band radio. I will pay any costs, etc. **I.N. Solly, 32 The Centre, Newington, Ramsgate, Kent CT12 6LE. Tel: (0843) 595574.**



# ASK ELECTRONICS LTD



248 Tottenham Court Road, London, W1P 9AD Tel: 071-637-0353/0590 Fax: 071-637-2690

## SONY

ICF-SW1E .....£134.95



**ULTRA-COMPACT SHORTWAVE RADIO WITH PLL SYNTHESIZER CIRCUITRY**

FM/LW/MW/SW reception • PLL synthesized circuitry • FM stereo • Continuous AM frequency coverage • 4 way tuning: 10 memory presets, auto scan, manual tuning, 10 key direct tuning • Programmable timer • Sleep function • Digital clock and alarm • LCD display with light function • Dual conversion system • 2 step tone control • Key protection • Record out socket • Supplied with stereo earphones, shortwave guide and compact aerial • Power: 2xAA size battery.

ICF-SW800.....£94.95

ICF-SW1S KIT.....£195

ICF-SW20.....£59

AN-1 ANTENNA.....£49



SONY SPECIALISTS 071-637-03531 071-637-0590 Fax: 637-2690

### SONY ICF-SW55 "SUPERADIO"

- World time zones • SSB
- Full digital p/sets
- Multiband

**£249 only**

### YOUR SONY SPECIALIST

Full Worldwide Guarantees from SONY! CALL THE SONY SPECIALISTS 071-637-0353/0590!! Mail Orders Welcome. 071-637-0590/0353 Fast - Efficient - Convenient. To your doorstep!!



ICF-SW7600.....£134.95

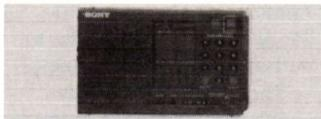

**HIGH PERFORMANCE PORTABLE RECEIVER WITH PLL SYNTHESIZER CIRCUITRY AND CONTINUOUS AM FREQUENCY COVERAGE**

LW/MW/FM/SW/SSB reception • PLL synthesized circuitry • FM stereo • Continuous AM frequency coverage • 4 way tuning: 10 memory presets, auto scan, manual tuning, 10 key direct tuning • Sleep function • Digital clock • Programmable timer • 2 step tone control • Antenna input socket • Headphone socket • Key protection • LCD display • Dual conversion system • Supplied with compact antenna, stereo earphones and AC power adaptor • Power: 4xAA size battery.

ICF-PRO80 Air/marine band scanner .....£275

ICF-AIR7.....£229

WA-8800 Full SW M-band stereo cassette recorder.....£199

CR-V21 world band receiver - fox printout, RTTY weather rec.....£2699

### SONY CAR "DISCMAN" Full range

D808K.....£229

D802K.....£189

D800K.....£169

D202.....£145

## ROBERTS

R727 5 bands - FM/MW/SW/LW/SW1-4.....£79.95

R747 3 bands.....£92.95

RF-M3 Tiny.....£59.95

RP-26 FM/MW/LW.....£81.95

RP-14 Cassette radio 4 FMs.....£60.95

RC-30 Mono cassette radio.....£51.95

### AWARD WINNERS

**071-637-0353/0590**

#### AN AWARD WINNING MASTERPIECE

ICF-2001D Kit.....£319.95 ONLY  
Finest all-round pro-receiver in the business.

FM/LW/MW/AIR multi-band reception • 32 station preset memory • Synchronous detector circuit • PLL quartz-locked synthesiser circuit digital/analogue tuning • 2-way scan tuning (memory, broadcast, define) • 2-position tone control • Direct metre band access • 4-event programmable time • AM attenuator SSB reception • External antenna for AM, FM and AIR band • 288x159x52mm (w/h/d) 1.7kg. 2001 DSYSTEM-ICF-2001D with active antenna AN-1 in one complete package.

NEW ICF-SW77 Similar specification to 2001D but with jog-shuttle dial tuning for accuracy.....£329



D33.....£119

DT66.....£189

D350.....£250

D99.....£189

DZ555.....£325

"Flagship machine"

WC's equaliser memories

## GRUNDIG

SATELLIT 650.....£459.00

SATELLIT 500.....£275.00

SATELLIT Cosmopolit.....£91.90

YACHT BOY 220.....£56.99

YACHT BOY 230.....£73.00

CONCERT BOY 225.....£36.70

PLEASE MAKE ALL CHEQUES PAYABLE TO ASK ELECTRONICS AT:

248-250 TOTTENHAM COURT ROAD, LONDON, W1P 9AD, UK

## PHILIPS

D2345

• Portable Radio • LW/MW/FM/2 x SW • Fine Tuning Control • Mains/battery supply.....£24.95

### D1875

• Compact 12-band Portable Radio • LW/MW/FM/9 shortwave • Large tuning control • Tuning LED indicator • Telescopic and ferritecore aerial • DC supply connection • Earphone connection • Wrist strap • Attractive pouch.....£49.95

## DAT

digital audio tape

Sony TCD3.....£425

Casio DA7.....£575

Casio DA100.....£389

• All electrical digital world receiver • LW/MW/FM/13 x SW • Continuous tuning over total AM band • Direct keyboard tuning • 9 station memory • Variable pitch BFO for CW/SSB reception • Touch panel switching • LCD frequency display • Mains/battery supply

STILL ONLY!  
**£119.95**  
BEST BUY!!

**PHILIPS**  
D2935 RADIO

**CALL NOW FOR IMMEDIATE DESPATCH! MAIL ORDER LINES 071-637-0590/0353!!**



PROFESSIONAL W/BAND RECEIVERS.....£2699

**WORLD BAND RECEIVER WITH MULTIBAND/SATELLITE RECEPTION AND RTTY/WEATHER FAX PRINTOUT**

FM/LW/SW/SAT reception • Reception and print out of weather fax and RTTY weather satellite information with optional AN-P1200 aerial • Built-in printer • Triple loop PLL synthesized circuitry • 5 way tuning: 421 memory presets, scan tuning (auto, define and memory), spectrum analysed tuning (using graphical display of signal strength), manual tuning with jog dial, 10 key direct tuning • Continuous waveband coverage AM 9.29999-99.99999 KHz, FM 87.5 - 108 MHz, SAT 137.62/141.12 MHz • Synchronised detection system • Auto memory input for easy automatic storage of up to 10 stations • Priority reception • 8 Programme/1 week timer • TCXO (Temperature Compensated Crystal Oscillator) for ultimate stability of the reception frequency • Active search system • Memory list • Sleep function • Cassette player / computer interface for data storage and other uses • Built-in high resolution thermal printer using 110mm paper with horizontal resolution of 860 dots • Printer with enlargement capability • Dual power supply - AC adaptor/rechargeable battery pack • External active antenna • AF filter • Digital quartz clock • Large LCD display with contrast control • Squelch control • Key protection • AM attenuator, dual conversion system • RF gain control • Record out • External aerial sockets • Supplied with AC adaptor, Rechargeable battery pack, battery charger, active antenna with bracket and cable kit, dust cover, printer paper, shortwave guide, fax guide and operation table • Power: NP22.

MULTI-BAND RADIOS/SCANNERS/TRANCEIVERS

## LONDON'S PREMIER COMMUNICATION EQUIPMENT BARGAIN CENTRE

**071-637-0590/0353**

"FULL RANGE KENWOOD COMMUNICATIONS EQUIPMENT"

# Retuning hi-fi Headphones for Short Wave Listening

**S**hort wave listeners, as well as transmitting amateurs, need to be able to receive a.m., s.s.b. or c.w. signals. Each is different in terms of bandwidth! While our headphones should ideally produce the maximum intelligibility and sensitivity in each mode, this must be with minimum interference. *Telecommunications* (W. Fraser 1957) tells us that, "telephony is, by international recommendation, made sensibly uniform over the range 300-3400Hz". This is sometimes known as 'speech of commercial quality'. In other words, with this frequency range we will get maximum speech intelligibility - surely this is what we need.

The *Radio Designers Handbook* by F. Langford-Smith reproduces the following interesting table for Speech:

## FREQUENCY RANGES FOR SPEECH

Application	Articulation (%)	Freq range (Hz)
High fidelity reproduction	98	62 - 8000
Good fidelity	98	150 - 7000
Fair fidelity (public address)	96	200 - 5000
Restricted bass* unbalanced	96	500 - 5000**
Restricted bass & treble*	95	500 - 4000**
Very restricted*	90	500 - 3000**
Telephone		300 - 3400**

\*for noisy locations    \*\* response may be peaked

*The selection of headphones is possibly one of the more haphazard areas of amateur radio communications. Small fortunes are spent on the purchase of communications receivers and transceiver, but often an exotic pair of hi-fi headphones is plugged into the receiver. You may be lucky, but the performance of the expensive RX will most likely be degraded by using totally unsuitable phones. Richard Q. Marris offers some simple, yet practical, solutions.*

similar good quality bipolar magnetic phones, will appreciate their excellence.

Alas, they are now somewhat difficult to find; though there is, on the junk market, US Army Signal Corps phones 'R-14' by Radio Speakers Inc. They can be purchased sometimes for pennies, 'non-working', which usually means that the cord is defective or missing. The cord is easily replaceable, with twin loudspeaker wire. A pair of such phones is excellent for a.m. and s.s.b. communications speech; though the headband is a little like a vice! Put some pressure, externally, on the diaphragm, with a wafer of paper, thus reducing the gap with the bipolar magnets and, bingo, you can peak it quite sharply for c.w. reception only. This does take a little trial and error, plus patience! And there we have the basis of more efficient headphone reception by retuning. Try retuning hi-fi, or other, phones for the required mode whether a.m., s.s.b. or c.w. - a.m. is included as it is used by h.f. broadcast stations, and some amateur stations on Top Band.

The modern, lower cost, hi-fi phones usually consist of a dynamic, or Mylar, sound unit (yes - there are other types!) built into an earcup fastened to the headband. The front is often cemented onto the cup and fitted with ear cushions. The front, or inner, surface is widely vented to provide wide frequency sound to the ear; and the earcup rear is usually decoratively vented to improve the base frequencies.

The frequency response, of these phones, depends on the type and efficiency of the in-built sound unit; the size of the earcup which forms a sound chamber; and the front and rear venting. This is an over simplification, as there are other factors which do not concern retuning the phones.

Several pairs of low cost hi-fi phones have been experimentally retuned at this QTH, and two typical examples will be discussed:

However for hi-fi reproduction of MUSIC he suggests the extremes of 30Hz -20kHz. Of course we are looking for a much narrower bandwidth for c.w. reception.

With modern day hi-fi phones we have, in fact, frequency ranges anything between 15Hz and 30kHz, which are ideal for f.m. and stereo entertainment reception - but - use them with a communications RX, and we will probably encounter wide band interference/noise, for a narrow band requirement, with resultant low audible sensitivity, and a lack of 'crispness' with s.s.b. and c.w.

Those lucky enthusiasts who have a good pair of S.G. Brown, Teleonics (USA), or

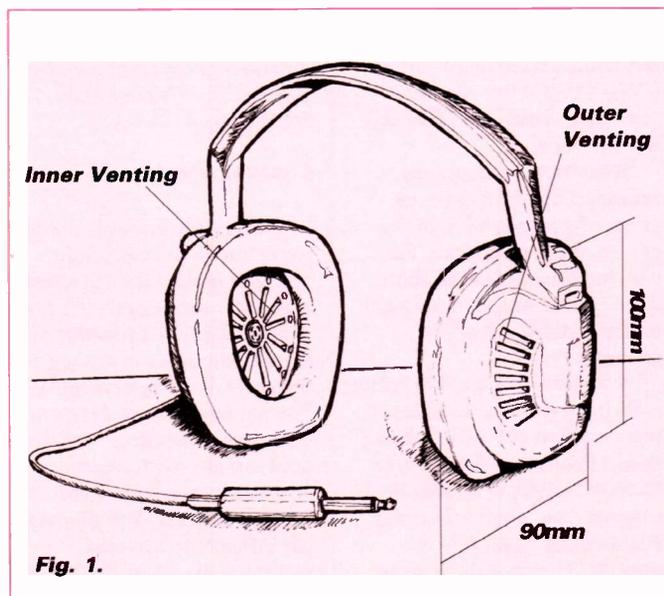

# Project

- 1: A large Mylar insert type
- 2: A light-weight dynamic type.

Before commencing experimental retuning, the following points should be noted:

1: Fit a mono plug in place of the existing stereo plug

2: Use the phones, unmodified, for an hour or more, around the bands, on a.m., s.s.b. and c.w. to get the 'feel' of them.

3: Check equality of sound level between both earpieces. If different, it may be the earpieces which are different, or your ears!

4: Modify one earpiece, step by step, referring the new performance to the original on the unmodified earpiece. A simple shaped soft pad can be cut to block off either earpiece, as required.

5: Step by step modifications should not be made irreversible.

6: The modifications can only be undertaken by ear; without an artificial ear and associated equipment, which would cost far more than the RX!

## Experiment No. 1

For this experiment a large Mono Educational Headset (Soundlab 600 MST Mono) was purchased (illustrated). A Mylar insert is used. The quoted frequency response is 40Hz - 15kHz. The quoted impedance is 600Ω, though, in practice, it seemed to make little difference whether they are used on the 8 or 600Ω audio RX outputs! A suspicion exists that these phones also appear in another disguise and type number, for hi-fi stereo reception. This was born out by replacing the mono plug with a stereo plug, which produced a quite good hi-fi performance. The sensitivity was judged as rather low.

Fig. 1 shows the inner and outer venting.

The modified end result was required for c.w. reception, but, for future reference, a record was kept of modifications for a.m., s.s.b. and c.w. The steps taken were:

1: Pieces of black pvc insulating tape were shaped to seal off the outer radial venting slots. Comparing the results with the unmodified

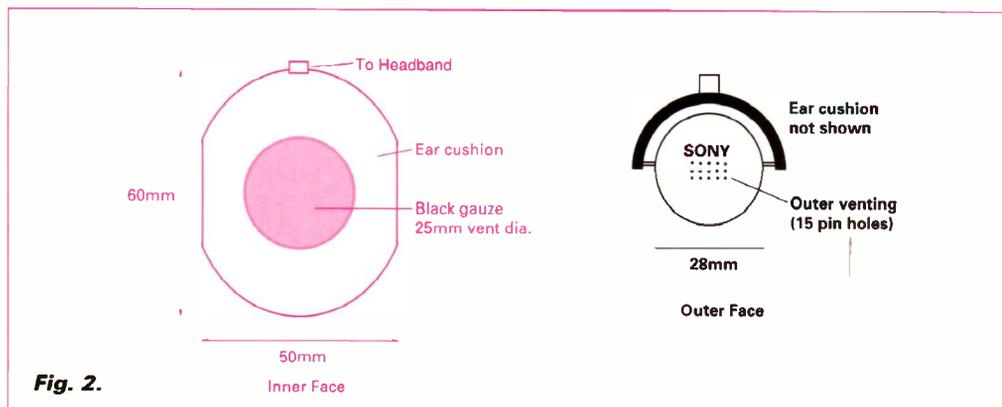

Fig. 2.

earpiece showed that a considerable amount of bass had been removed. A small amount of mains hum was introduced into the RX, but could only be heard on the unmodified earpiece. Furthermore there was an apparent increase in sensitivity when the outer vents were sealed.

2: The inner venting consists of a central hole (approx: 3mm diameter); surrounded by a circle of four small slots, which are again surrounded by a pattern of larger radial slots and holes. See Fig. 1.

The larger radial slots were sealed off with pvc tape and again effectively considerably reduced the audio bandwidth. Sealing off two of the inner slots (out of four) in addition, produced an earpiece which seemed best for h.f. broadcast a.m. station reception. The sensitivity of the earpiece also showed an increase.

3: The remaining two of the inner circle of four slots, were now sealed off, just leaving the centre hole unmodified. This seemed the best for s.s.b. reception.

4: For c.w. a peak of around 800Hz was required, and the centre 3mm diameter hole was gradually reduced, in size, to pin hole size. This was achieved with small pieces of pierced stiff card, held in place, with double sided sticky tape. The difference between the modified, and unmodified, earpieces was very noticeable. The bandwidth was greatly reduced, and the sensitivity was up, but this and selectivity were still lower than required. The unmodified earpiece was modified in a similar way, and the results sounded better when using both ears, but still not up to the requirements for c.w. reception.

## Experiment No 2

For this experiment a pair of more expensive, small, light-weight Sony MDR-CD5 dynamic stereo headphones were used. These weigh in at around 85g and are comfortable and excellent for hi-fi reception. They were much more sensitive than the previous phones. A mono plug was then fitted with the earpieces in series.

From Fig. 2 it will be seen that the rear venting consists of three rows of five-pin holes in a rectangular pattern.

The inner venting is just a very thin black piece of fabric gauze, covering the sound unit, surrounded by the ear cushions.

Modifications for retuning were remarkably simple:

1: On one earpiece the outer venting was sealed off with a piece of white pvc tape. There was an immediate reduction in low frequency response, with apparent increase in audible sensitivity.

2: To seal off the inner venting, several pieces of stiff card (beer mats!) discs were cut using a 10p piece as a template. These discs can be slipped under the ear cushions, which are stuck to the earpiece.

New front venting was arranged by trying various sizes, of a single hole, in the centre of the card discs. For c.w. the final hole was about 1mm diameter, 2mm for s.s.b. and about 4mm for a.m. speech.

3: The overall audible result was, in all modes, superior to the modified 600MST headset. When the other earpiece had been modified, in an identical manner, the result was quite excellent as a pair of c.w. phones. The card discs were then replaced with glass fibre

board drilled discs (1mm hole for c.w.) with further performance improvements, and fully justified the effort.

## Conclusions

The step by step experiments, described, could form the guidelines for other experimenters to try retuning hi-fi and other headphones for a selected mode. The outer venting should always be sealed off first, followed by reducing the inner venting to small dimensions, which can only be found by trial and error experiments. The results with some phones should be excellent and others poor. The initial price, of the hi-fi phones, seems to have no bearing on the results.

It should be stressed that individual modifications, to headphones, will differ from type to type; and from person to person, due to differences in initial performance and individual hearing response. For example, experiments with several types of headphones seems to indicate that better retuning results can be obtained with the smaller light-weight dynamic phones, such as the Sony MDR-CD5.

## Lowest Cost

Amazingly enough, a final experiment, in this series, with the lowest cost/smallest size hi-fi headphones (£3.45!) produced really excellent c.w. results, though the sealing of the outer venting was tricky. The sensitivity and selectivity was very acceptable; and the light-weight made them comfortable to wear over longish periods. The phones were Realistic Nova-34, weighing in at 57g and were obtained from Tandy. ■

# Link Electronics

## THE REALISTIC SPECIALISTS

★ ★ SPRING SALE ★ ★

### PRO-2006

With hyperscan – 400 memories  
AM/FM 25-520, 760-1300MHz, 240V A.C./12V D.C.  
★ only £299.95 ★ List price £329.95 ★

### PRO-2022

68-88, 108-136 (AM), 136-174, 380-512, 806-960MHz  
200 memories, 240V A.C./12V D.C.  
★ only £179.95 ★ List price £199.95 ★

### PRO-9200

68-88, 108-136 (AM) 136-174 406-512MHz, 16 memories  
240V A.C./12V D.C.  
★ only £119.95 ★ List price £129.95 ★

### PRO-2025

Superb compact mobile – 16 memories  
68-88, 136-174, 406-512MHz  
★ only £89.95 ★ List price £99.95 ★

### PRO-35

Hand-held – 100 memories  
68-88, 108-137 (AM), 137-174, 380-512MHz  
★ only £159.95 ★ List price £179.95 ★

### PRO-37

Hand-held – 200 memories  
68-88, 108-137 (AM), 137-174, 380-512, 806-960MHz  
★ only £199.95 ★ List price £229.95 ★

All scanners include FREE p&p in the UK. 12 months warranty

## Link Electronics

G0CVZ

(Authorised Tandy dealer)

G6YTI

228 Lincoln Road, Peterborough PE1 2NE

(0733-345731) SAE for leaflet.

Phone for latest on second-hand bargains



# MARTIN LYNCH

G4HKS

THE AMATEUR RADIO EXCHANGE CENTRE

286 Northfield Avenue, Ealing, London W5 4UB. Tel: 081 566 1120 Fax: 081 566 1207

ANNOUNCING  
THE NEW ICOM  
ICR-7100HF



FROM CHRIS PARNELL, THE SKILLED  
DEVELOPMENT ENGINEER WHO  
ORIGINATED THE ICOM ICR-7000HF,  
MARTIN LYNCH CAN NOW OFFER THE  
NEW ICR-7100HF.

After months of specialist engineering, I can now offer the receiver with a frequency range of 50KHz to 2000MHz. By pressing the original dimmer button on the front panel, the ICR-7100 transforms into a high performance HF receiver in addition to its VHF/UHF capabilities. You do not have to guess at the display like other attempts at the modification. 14.200.00MHz reads as displayed. Employing a modified version of the ICR-7000HF module, Icom UK have approved the installation so you have total peace of mind.

AT ONLY £1120 INCLUDING VAT,  
THE NEW ICR-7100HF IS AVAILABLE FROM  
STOCK.

PART EXCHANGE WELCOME.  
**081-566 1120**

DEALER AND OVERSEAS  
ENQUIRIES WELCOME

BUYING  
OR SELLING...  
DIAL  
081-566 1120  
NOW!

ALINCO

YAESU

KENWOOD

ICOM

AOR

STANDARD

Authorised Dealer

Martin Lynch is a Licensed Credit Broker.  
Full written details upon request. Typical APR 32.9%

**PHONE 081-566 1120**

For fast mail order Tel: 081-566 1120.  
Please add £10.50 for 48 hour delivery.  
SHOP OPENING HOURS: Tuesday - Saturday 10 - 6pm.  
24 hour Sales HOT LINE 0860 339 339 (after hours only.)  
FAX order line open 24 hours.

## SSE HIGH QUALITY ACCESSORIES

THE CHARGER & SCANNER SPECIALISTS

## FOR SCANNING MONITOR RECEIVERS

Jim PSU-101

1. **JIM PSU-101 MkIV.** A high quality UK manufactured fully regulated 220-240V AC power supply with RADIO BASE HOLDER combined. For use with FAIRMATE HP-100E/200E/2000/1000AB. AOR-1000/2000. YUPITERU MVT-5000/7000/125, VT225. REALISTIC PRO-35/38. ICOM-R1. UNIDEN UBC50XL. BC55XLT. UBC70XLT. ALINCO DJ-X1. UBC100XLT. New unique features include 2 DC output sockets one for radio and the other for accessories. A bracket for BNC socket for antenna connection. Separate DC leads included. **PRICE £29.95.**



2. **JIM BH-A3.** Universal base stand for handheld scanners-transceivers etc. convenient, safe support of radio. Adjustable front stop. Heavy duty chromed base. Bracket for BNC socket for base antenna connection. **PRICE £9.95.**

3. **JIM CH-A4.** Car mounting holder for handheld scanners- transceivers with BELT CLIP support. Safe and convenient use of scanner etc. in car, truck, boat etc. **PRICE £7.00.**

4. **JIM BC-4H.** Unique FAST Universal 4 hour + 14 hour Ni-cad charger. "auto-switch-off" timer (no more guessing). Ideal Fairmate, AOR, Yupiteru etc. Leads + 4 sizes of AA holders supplied. **PRICE £19.50.**

5. **JIM SM-A1** High quality S meter for scanners CB. **PRICE £26.95.**

Payment by postal order or cheque. Prices include postage

Further information on SSE products, send A4 SAE to:

## SOLID STATE ELECTRONICS (UK)

6 The Orchard, Bassett Green Village,  
Southampton SO2 3NA  
Tel: (0703) 769598

NEW  
PSU-101 MK IV

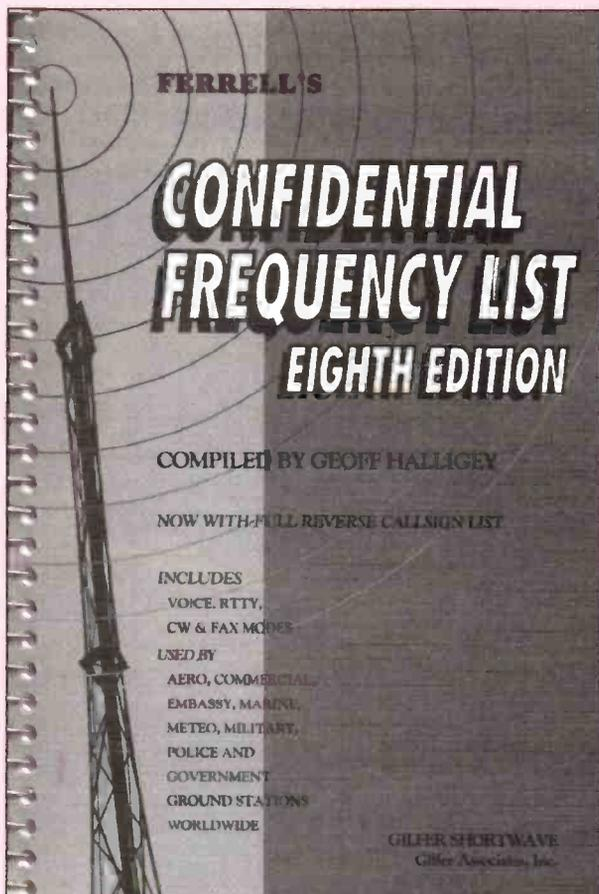

**Save £4**

**Special Offer Price**  
**UK £14.95 post free**  
**Overseas £15.95 inc surface post.**

*Normal SWM Book Service Price £18.95 inc P&P*

# SPECIAL OFFER

## Ferrell's Confidential Frequency List - Eighth Edition

Compiled by Geoff Halligey

The Eighth Edition of the popular *Ferrell's Confidential Frequency List* has been extensively revised to take account of the many changes that have taken place in the last few years. Many of these changes result from the recent political events that have so dramatically changed the maps of Eastern Europe and the former Soviet Union. There has also been a big change round in the marine frequency allocations. Ferrell's has also changed its format dramatically to ensure that it keeps up with events and to meet the demands of its users.

The most noticeable change has been to the overall presentation, switching from the original perfect bound, soft-covered book to a much easier to use spiral bound format that allows any of the 544 pages to lay flat open on the desk or be turned under to present a single page to view.

Complete coverage of the h.f. spectrum from 1.605 to 28.000MHz is now provided with only broadcast, amateur bands and unidentifiable c.w. stations, using irregular or no call signs at all, left out. A reverse frequency listing is also now provided showing every known frequency against each call sign.

This is a book that the listener cannot afford to be without and our Special Offer will enable you to get your copy, not only early, but at an advantageous price.

### HOW TO ORDER

Complete **both** coupons, in **ink**, giving your **name and address clearly in block capitals**. Coupon (2) will be used as the address label to despatch your antenna to you. Send the coupons, with your cheque, to: SWM Special Offer (May), FREEPOST, Enefco House, The Quay, Poole, Dorset BH15 1PP.

If you wish to pay by credit card (Access, Mastercard, Eurocard or Visa only), please fill in your card details and sign the coupon where indicated.

(1)

**To: Short Wave Magazine Special Offer (May), FREEPOST, Enefco House, The Quay, Poole, Dorset BH15 1PP**

**Please send me .....Ferrell's Confidential Frequency List(s) @ £14.95 each post free.**

Name.....

Address.....

Postcode.....

I enclose cheque/PO (Payable to PW Publishing Ltd) £.....

Charge to my Access/Visa Card the amount of £.....

Card No.

Valid from.....to.....

Signature.....

(2)

Name.....

Address.....

Postcode.....

If you do not want to cut your copy of *SWM*, you **must** send the Book Special Offer flash from the foot of the Contents Page of this issue.

**Offer closes 30 June 1992.**  
 PW Publishing Ltd., Poole, Dorset  
 (Reg. No. 1980539, England)

# Religious Broadcasters- an Overview

1931 was an auspicious year in the world of international broadcasting! It was then that missionary broadcaster HCJB began transmissions in Spanish and English from the South American republic of Ecuador. But, in fact, HCJB's small start had been preceded by religious broadcasters in a number of other countries including Ireland and, of course, the United States.

In fact, religious broadcasting is as old as radio. Not surprising really when you realise that Christians have been communicating for centuries.

However, when HCJB's founders first fired up their tiny transmitter and called the parent organisation the World Radio Missionary Fellowship they could hardly have imagined how things would develop from then on. Today, hundreds of stations exist around the world which have, as their main objective, the communication of the Christian gospel. The way each one approaches that task varies enormously but the aim is similar.

Although HCJB may have been the first of the major international Christian broadcasters it is by no means the biggest. Today, organisations like Trans World Radio and Far East Broadcasting Company have more stations to their name than the pioneers.

Trans World Radio now transmits from seven sites around the world. Unlike some of the other organisation, TWR rents much of its air time from other broadcasters, although it owns its stations on Bonaire in the Netherlands Antilles (in the Caribbean), Guam in the Pacific and in Swaziland. The Scandinavian based IBRA Radio have also taken the decision to rent transmitter time - sometimes from the other Christian broadcasters and sometimes from stations such as Radio Trans Europe in Portugal and Radio Mediterran in Malta.

## Sharing Resources

It would probably be true to say that the various Protestant Christian broadcasters have broadly focused their activities in specific regions and there is an increasing emphasis on sharing resources so that duplication of service is avoided. Increasingly, too, the missionary stations are focusing their efforts and attention of what might be considered to be minority

languages. In the past ten years some 40 new language services have been added to the combined schedules of the stations in languages such as Uzbek, Azeri and Georgian. Other languages are being actively planned.

## Technical Developments

The fact that the stations are broadly religious in their activities doesn't mean that they are technological backwaters. HCJB, for example, operates a research and development team which designs and builds new transmitters for both the h.f. and v.h.f. bands. These developments are made available to their partner organisations.

SIM's Radio ELWA in Monrovia, Liberia, went back on the air in January using an HCJB-designed and built portable f.m. transmitter. Its signals can be heard within a 50 mile radius around Monrovia.

ELWA was a powerful gospel voice in West Africa when it was caught in the crossfire of Liberia's civil war in August 1990; the international transmission site was levelled. SIM officials decided to replace the station using HCJB's portable f.m. transmitter, which is small enough to fit in a suitcase.

The broadcasters have also been active in investigating the use of satellite delivery techniques.

As the end of the Millennium approaches the international christian broadcasters are adjusting their approach to the task of broadcasting so that the new techniques and the latest technology are used with the aim of sharing the message of God's love world wide.

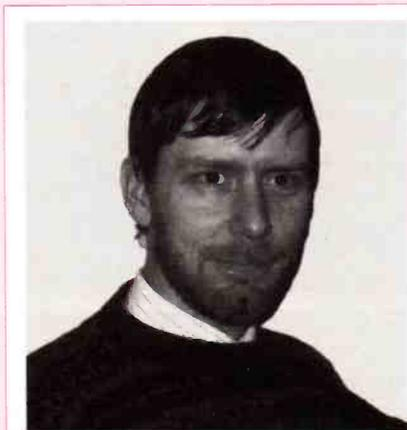

**Andrew Steele has many years of experience with HCJB, both in Ecuador and as the Executive Director of HCJB-UK in Bradford. He is also Chairman of the Evangelical Missionary Radio Committee. Here he gives us a brief overview of what religious broadcasting is about.**

# Religious Broadcasters

# Waters & Stanton Electronics

UK's largest stockist of specialist receivers



**MVT-5000 scanner £229**  
25-550MHz & 800-1300MHz AM/FM

The MVT-5000 is a superb budget priced scanner with amazing sensitivity added to which it is very simple to use. The only gap in its range is the TV broadcast band and if you can live with 100 memories it offers incredible value! Hundreds are in use, many by professional users and like all Yupiteru equipment it has proved to have unsurpassed reliability. Available from stock with our 12 month parts and labour warranty.

**SONY SW-7600 £149**  
200kHz-30MHz + FM BROADCAST SSB/CW/AM  
Includes free AC supply aerial and case!

The classic portable for those on the move who want to keep in touch with the world broadcasts. In addition it gives good reception of SSB and is a travellers joy! All our stocks are genuine UK Sony.



**Lowee HF-150 £329**  
USB/LSB/CW/AM (sync) 30kHz-30MHz 12vDC/230V AC



The HF-150 receiver is a high performance short wave receiver that we can

recommend for those on a budget. Make no mistake, this receiver really does perform. Give us a call for more information.

**SONY ICF-2001D £289**  
150kHz-30MHz + FM + airband USB/LSB/CW/AM (sync)  
Includes free universal AC adaptor

If you want a truly portable communications receiver that performs as well as base station models yet fits into the domestic scene, look no further. At £399 it would be good value. At £289 it's an absolute bargain.

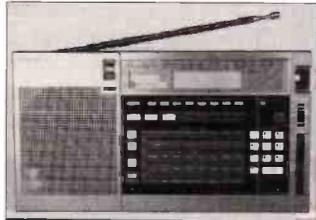

**SONY ICF SW77 £349**  
150kHz-30MHz + stereo FM AM/SSB/CW

The SW-77 is the latest short wave portable from Sony. It integrates computer technology to provide a programmable data base of station names in its memory bank. Also included are 5 different timers and 162 preset stations. Fabulous!



**Free Coffee!**  
**Free Advice!**  
**Free Quotes!**

OK, so we're not giving away any earth shattering freebies! What we are giving you is good, honest before and after sales service with all the help you could ever wish for. Now you might claim that old "Joe Bloggs Shack" is quoting you a better price, so why come to Waters and Stanton. The fact is that several "Joe Bloggs Shacks" went down the "Swanee" in 1991. (No it's not a pub!) Some still shouting their bargain prices as they went. Is that the kind of dealer you really want to risk doing business with? So next time you see any super bargains remember, somebody has to lose. Make sure it's not you! For nearly twenty years we've been selling radio communications equipment at sensible prices. Prices that enable us to still be there when things go wrong. That doesn't mean we're expensive, it simply means we give you a good deal. And you can't ask for better than that. So give us a ring or pay us a visit today; tomorrow; or even next year. We'll still be around!

**YUPITERU VT-225 £229**  
Military & Civil Airband Monitor

The VT-225 is the new exciting monitor from Yupiteru. It covers the full VHF and UHF airbands with a sensitivity that leaves its competitors standing! This dedicated receiver is surely going to become the reference from which all others will be judged. Our stocks are direct from the factory with English handbooks and of course an officially backed factory warranty. Phone or write today for the full information on the new "industry standard" receiver.



**YUPITERU MVT-7000 £289**  
1MHz-1300MHz FM/AM/WBFM  
Includes ni-cad pack and charger

The Yupiteru MVT-7000 is the very latest scanning receiver to leave the factory, being a complete update of the MVT-5000. Its sensitivity is unsurpassed and its logical controls and beautiful design make it one of the smartest and slimmest scanners around. Our professional customers love it and you will too when you try it. Fully featured it has 200 memories, extensive scanning features, is fully programmable and even has an adjustable contrast control on the LCD. To try it is to buy it, so be warned!



**NEW!**

**VT-225**  
VHF/UHF airband monitor AM/FM 108-142/222-291MHz. Superb sensitivity, 100 memories - Phone! (see above)



**AR-1500 £299**  
2MHz-1300MHz FM/AM/SSB/CW

Yes it's true, a hand held scanner that gives you SSB and CW reception. We are hoping to have supplies available by March of this self contained all mode receiver. New from AOR, this promises to be the most comprehensive scanner yet. If you want full details, phone or write for the full specification. And remember as the UK's largest stockist of receivers, we can offer you the kind of back-up service that such an advanced product needs.

Retail and Mail Order: 22 Main Road, Hockley, Essex SS5 4QS. Tel: (0702) 206835/204965 Fax: (0702) 205843  
Retail Only: 12 North Street, Hornchurch, Essex. Tel: (04024) 44765  
VISA & ACCESS MAIL ORDER. 24 Hour Answerphone. Open 6 Days a Week 9am-5.30pm  
Rail: Liverpool St./Hockley or District Line/Hornchurch

# ALINCO's

## "Professional Grade" Scanner DJ-X1. 500kHz-1.3GHz

**"A Scanner of Unrivalled Performance"**

### Specification:

Modes: AM/Narrow FM/Wide FM  
Steps: 5, 9, 10, 12.5, 20, 25, 30, 50, 100kHz  
Antenna: 50Ω BNC  
Supply: 6-15V DC (Internal 9V AA)  
24mA (Battery save.)  
Dimensions: 110 x 53 x 37mm  
Weight: 370g  
Configuration: AM/FM Triple conversion  
Sensitivity: NBFM -8dB (12dB SINAD)  
AM -2dB (10dB S/N)  
Memories: 100 in banks.

UK "Gold Seal" Warranty  
Now With Every Unit  
Look for the sign on the box!

Up until now most handheld scanners have been large and cumbersome with low grade plastic cases using technology that has been around for several years. The arrival of the ALINCO DJ-X1 has changed all that. This brand new receiver is ruggedly built, compact, and above all, ultra sensitive. ALINCO are the first major manufacturer of communications equipment to produce a new generation of scanning receiver. All of a sudden its competitors seem drab, old fashioned and lacking in sparkle and performance.

The new exciting DJ-X1 should be available now at your local dealer. Try it out for yourself, experience the superior design and performance. Compare it with "yesterday's" models and find out just how far advanced the new ALINCO scanner is! But just to whet your appetite, here's a few of its features:

★ 3 scanning speeds ★ 3 scanning modes ★ 100 memories in 3 banks ★ Auto memory loading ★ Priority channel ★ Dual rate battery saver ★ Large battery pack ★ Rotary frequency control ★ Illuminated key pad ★ Auto illumination mode ★ Dual antennas ★ 5 programmable bands ★ Widest range of frequency steps ★ Super front end sensitivity ★ Memory lockout ★ Mode scanning ★ Auto power off ★ Wide range of battery packs ★ Wide range of accessories ★ Intelligent mode programme ★ Rapid tuning rates of 1MHz/10MHz.

\*Each unit now comes with the UK Gold Seal Warranty. Look for the sign on the box!



### ALINCO STOCKISTS:

AVON: G4TJB (0934) 512757 : Uppington Tele-Radio Ltd (0272) 557732 : Amdat (0272) 699352  
BUCKINGHAMSHIRE: Photo Acoustics Ltd (0908) 610625 CAMBRIDGESHIRE: Link Electronics (0733) 346770  
CHESHIRE: CB37 Communications (0270) 588440 : Flightdeck Ltd 061-499 9350 CORNWALL:  
RV Heming Ltd (0637) 872191 : Marine Instruments (0326) 312414 COUNTY DURHAM: Border  
Communications 091-4109 6969 DORSET: Poole Logic (0202) 683093 EIRE: Intronic 010-35321 631007:  
Long Comms 010 3537337152 ESSEX: Waters & Stanton (0702) 206835 : Selectronics (0268) 691481  
HAMPSHIRE: Famborough Communications (0252) 518009 : Siskin Electronics (0703) 207155 : Nevada  
Communications (0705) 662145 HERTS: Potters Bar Radio 0707 49456 ISLE OF MAN: Audio & Domestic  
Spares (0624) 815889 LANCASHIRE: Holdings Amateur Electronics (0254) 59595 : Stewarts Radio (0253)  
21163 LONDON (CENTRAL): Pali-Fones 071-436 0022 : Lee Electronics 071- 723 5521 : Ask Electronics  
071-637 0590 : Ramsons 071-724 2373 LONDON (EAST): Dressler Communications 081-558 0854 : Waters  
& Stanton (04024) 44765 LONDON (NORTH): Radio Shack 071-624 7174 LONDON (WEST): Martin Lynch 081-566 1120 MERSEYSIDE: Amateur Radio Comms (09252)  
29881 NORFOLK: Eastern Communications (0692) 650077 : DP Hobbs Ltd (0603) 615786 NORTH HUMBERSIDE: Heatherlite Communications (0964) 550921  
NORTHERN IRELAND (LONDONDERRY): Omnicomm (0504) 48295 NORTHERN IRELAND: Tyrone Electronics (0662) 242043 NOTTINGHAMSHIRE: RAS  
Nottingham (0602) 280267 SCOTLAND: Jaycee Electronics Ltd (0592) 756962 SURREY: Syon Trading (0372) 372587 SUSSEX: BREDHURST ELECTRONICS (0444)  
400786 TYNE & WEAR: Alytronic 091-2761002 WALES: TMP Electronics (0244) 549563 : Electromart (0792) 842135 WEST MIDLANDS: Aviation Hobby Centre 021-  
782 6560 : Hwards Home Stores Ltd 021 354 2083 : Dewsbury Electronics (0384) 390063 WEST YORKSHIRE: Fish Communications (0484) 420774  
WORCESTERSHIRE: Johnson Sound Services (0905) 25740 : SRP Trading (0562) 730672 YORKSHIRE: Air Supply (0532) 50981.

# £249.95

**UK Distributors: Waters & Stanton Electronics**  
22 Main Road, Hockley, Essex Tel: (0702) 206835

**The religious broadcast stations offer the listener a wide variety of programmes in a wide range of different languages. Although their primary aim is to spread the Gospel as widely as possible throughout the world, they also offer programmes aimed specifically at the DXer. Here Dick Ganderton looks at some of these stations.**

**Radio Vatican's transmitting centre at Santa Maria di Galeria. The statue of the Archangel Gabriel with the appropriately shaped antenna pylon supporting some of the station's antennas.**

## Broadcasting The Gospel

The oldest religious broadcasters have been on the air for just over sixty years. Marconi himself was asked by Pope Pius XI to build a radio station within the then new Vatican State as far back as 1929. The station was inaugurated in 1931 with a speech, by the Pope, in Latin that was heard all over the world. One of the first programmes broadcast was a scientific news programme, again in Latin, about the Pontifical Academy of Sciences! In 1939 new studios were set up in the Palazzina Leone XIII, originally the Vatican Observatory and the ceremony and incorporation of Pope Pius XII broadcast, in nine languages. Throughout World War II **Vatican Radio** remained an important source of information.

By the end of the war it was decided that more powerful transmitters and antennas were required and in October 1957 the new station at Santa Maria di Galeria, 30km north of Rome, was inaugurated. By 1958 Vatican Radio was broadcasting some 20 hours a day in 32 different languages. Now this has risen to 48 hours daily in 34 languages, requiring a staff of over 400 people.

Marconi's original transmitter for the Vatican was located in a little building, which is still in use, on the top of the Vatican hill. The Santa Maria di Galeria site is some ten times the size of the entire Vatican State and for short wave broadcasting has two 500kW Telefunken transmitters feeding into two rotating antennas. One of these is 76m high and 85m in diameter while the other is 106 by 87m, turning on rails. There are also two ASEA Brown Boveri 250kW automatic transmitters and five 100kW transmitters feeding into 25 fixed horizontal curtain antennas. There are also medium wave transmitters on the same site.

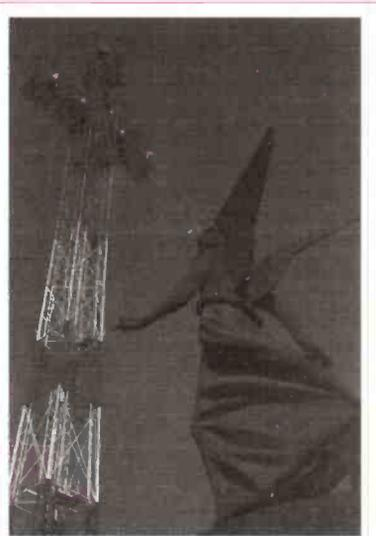

### Way of Life

Also tracing its origins back to 1931 is **La Voz de los Andes** otherwise **HCJB** broadcasting from Quito, Ecuador. HCJB is not just a radio station, it is a way of life for the Ecuadorians, running hospitals, operating mobile medical clinics and flying missionaries, nurses and doctors into the Amazon jungle.

I covered HCJB in a series of articles written after we returned from the Short Wave Magazine/ HCJB DXpedition to Ecuador last year. Technically, the radio operation is fascinating and highly efficient and organised. The sheer scale of the short wave antennas sited high up in the Andes is awe inspiring, the organisation needed to produce the current programming output in so many different languages mind-blowing and the dedication of the English Language Department to short wave radio amazing.

HCJB is one of the religious broadcasters who really appreciate the DXer. Send them a genuine report, with IRCs, of course, and not only will you get back a QSL card, but if your report contains something of interest about yourself then you are likely to hear Ken MacHarg reading it out on his *Soludas Amigos* programme! John Beck runs a weekly programme, *Ham Radio Today*, aimed at the radio amateur while Rich MacVicar host the weekly *DX Partyline* programme.

HCJB is also one of the pioneering short wave broadcast stations experimenting with s.s.b. transmissions. Try listening on 21.455 and 25.950MHz u.s.b. if your set has s.s.b. capabilities. If not then you can still receive it as they inject some 30% of the carrier for this very purpose.

### QSL Cards and Newsletters

QSL cards from the religious broadcasters are often of technical interest and show various aspects of their installations. Antenna farms are a favourite subject, probably because not only are the locations spectacular, but the amount of metal and wire up in the sky is amazing as well. I suppose that these huge antenna arrays are like a modern technological cathedral of the airwaves! The QSL cards are also a way of showing the broadcasters' sponsors something of what they are doing with their donations.

As well as QSL cards many of the stations publish regular newsletters and magazines. *Monitor Month* is a Newsletter about *The Christian Science Monitor* and carries news items and short articles

# Religious Broadcasters

about the activities of the *World Service of The Christian Science Monitor* and *The Herald of Christian Science*. For example, in the September 91 edition there was an interesting article about how American schools are using short wave broadcasts such as the *World Service of The Christian Science Monitor* to enhance their lessons. *World Service of The Christian Science Monitor* broadcasts news Monday through Friday transmitted from **WCSN**, **WSHB** and **KHBI**.

HCJB is another broadcaster running a club for DXers. Membership of these clubs is not free, but is not very expensive either. If you are interested then I suggest that you write to the station concerned, asking for information on membership. Equally, you should not expect to receive the various goodies offered, such as QSL cards, badges, stickers and pennants for nothing. The cost of running a short wave station such as HCJB is very expensive and is carried by donations and volunteer activity. The very least you can do is send a couple of IRCs for the postage. You can also obtain copies of the current broadcasting schedules by writing. It is essential that you have the current schedules as these change during the year and, although reference books such as *World Radio Television Handbook* give you a wealth of information they can only give you the schedules available at the time of publication. *WRTH* does offer a regular update service, but there is nothing like the genuine schedule from the station itself. Don't get me wrong, you should have your own up-to-date copy of *WRTH* by your logbook, but supplement it with information from as many sources as you possibly can.

## Partnership

Several of the religious broadcasters work together in partnerships so as to share the high cost of developing the technology needed to continue with their work. For instance **HCJB** works closely with **FEBC**, **FEBA Radio** and **SIM (Radio ELWA)**. HCJB has its own design and development centre in the USA that designs and builds its own high power short wave transmitters as well as v.h.f. f.m. ones. It is the latter that they have recently used to get Radio Elwa back on the air after the civil war in Liberia.

Another well-known partnership is that of **Trans World Radio**. Trans World radio operates high-power, short wave transmitters from Monte Carlo, Cypress, Swaziland, Sri Lanka, Guam and Bonaire. These transmitters carry programmes on behalf of a variety of religious broadcasters. **Evangeliums-Rundfunk**, an international organisation consisting of **ERF Germany** (Wetzlar), **ERF Austria** (Vienna) and **ERF Switzerland** (Zurich), is one of these partners. Others in Europe are **ICM** in Italy, **Mecovan** in Spain, **The Messengers** in Finland, **Norea Radio** in Denmark, **Radio Evangile** in France, **Trans World Radio** in Holland and **Trans World Radio** in the UK.

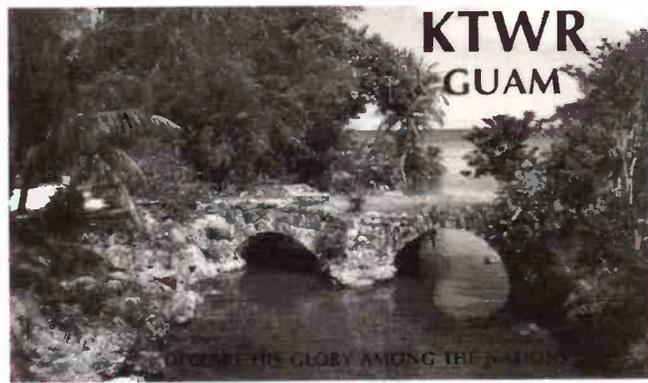

Another broadcaster that doesn't own its own transmitters is **IBRA Radio**, based in Sweden. IBRA buys its airtime on about 80 transmitters of all types around the world. On short wave it uses **Radio Trans Europe** in Portugal, **Radio Mediterane** on Malta, **FEBA** on the Seychelles and **FEBC** in the Philippines and broadcasts in 60 languages to about 100 countries.

## America

The United States has a large number of religious broadcasters. In fact, it is probably true to say that a large proportion of the world's evangelical stations are in some way connected with the various churches in the USA, be it personel, technology or simply funding. Although many of the stations are sited outside the US, there are still some interesting ones that can be heard in Europe broadcasting their message from various parts of the States. One of the best known is probably **WYFR**, otherwise known as **Family Radio**, based in Oakland, California, but with their transmitter sited at Okeechobee, Florida and a relay via Taiwan. **KNLS** is the callsign of the station operated at Anchor point, Alaska by **World Christian Broadcasting**. It beams its broadcasts towards Asia, but it can be heard in Europe, as well as the rest of the world. KNLS tries to express their message without preaching or begging and they are fully financed by donations from individuals and churches who are interested in reaching out to others

*The old Spanish Bridge, Southern Guam. Transworld Radio Station KTWR is on Guam.*

*Irio Fantini's painting in the Marconi Conference Room at Palazzo Pio shows the Popes who have broadcast over Radio Vatican.*



 **RADIOVATICANA**

**QSL**

# Religious Broadcasters

The new f.m. antenna in the Vatican Gardens.

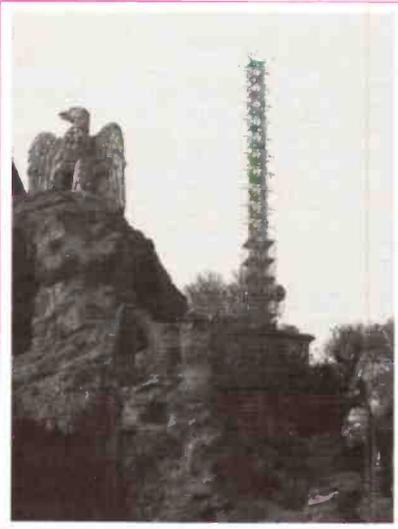

around the world with their message. The station receives mail from all over the world.

Of course, there are also hundreds of local stations, both a.m. and f.m., in the US, which you would not expect to hear over this side of the Atlantic except under exceptional conditions. **Back to the Bible** operates a wide network of such

stations as well as using short wave transmitters around the world such as TWR in Monte Carlo, KTWG on Guam, FEBC on Manila, and HCJB in Quito, Ecuador amongst others.

## WACRAL

Not strictly a religious broadcaster, **WACRAL** - the **World Association of Christian Radio Amateurs and Listeners**, was formed by a Methodist minister, the late Rev. Arthur Shepherd G3NGF, in 1957. The main aim of WACRAL is to promote Christian friendship and fellowship world-wide through amateur radio. Membership is spread around the world and all members receive a quarterly newsletter. I heard that, as I was preparing this article they had enrolled member number 1000. You do not need to be a licensed radio amateur to join WACRAL, although you do need a Christian commitment and an interest in the hobby, including, of course, short wave listening. Many members specialise in receiving and listening to the many Christian broadcast stations active around the world, some of which I have mentioned in this article. Others may be found by looking in *WRTH*.

## Addresses

**Back to the Bible:** Bawtry Hall, South Parade, Bawtry, Doncaster DN10 6JH. or Box 82808, Lincoln, NE 68501 USA.

**Evangeliums-Rundfunk:** PO Box 1444, W-6330, Wetzlar, Germany.

**FEBA Radio:** Ivy Arch Road, Worthing, West Sussex BN14 8BX.

**HCJB:** La Voz de los Andes, HCJB, Cassila 691, Quito, Ecuador, S. America.

**HCJB:-UK:** 131 Grattan Road, Bradford, W. Yorkshire BD1 2HS.

**IBRA Radio:** 105 36 Stockholm, Sweden.

**International Lutheran Laymen's League:** 2185 Hampton Avenue, St. Louis, Mo 63139-2983 USA.

**KNLS:** PO Box 473, Anchor Point, Alaska 99556.

**SIM (Radio ELWA):** PO Box 192, Monrovia, Liberia.

**Trans World Radio:** PO Box 2020, NL-1200 CA, Hilversum, Netherlands.

**Vatican Radio:** Vatican City.

**WACRAL:** Garth Martin, General Secretary, 88 Tennyson Road, Cheltenham GL51 7DB.

**World Association for Christian Communication:** 37 Kennington Lane, London SE11 5QY.

**World Christian Broadcasting:** 3303 North Third Street, Suite H, Abilene, Texas 79603 USA.

**World Service of The Christian Science Monitor:** PO Box 860, Boston, Massachusetts 02123 USA.

**WYFR:** Family Radio, Oakland, California 94621 USA.

## THE AVIATION HOBBY CENTRE



1st FLOOR, MAIN TERMINAL BUILDING,  
BIRMINGHAM INTERNATIONAL AIRPORT  
BIRMINGHAM B26 3QJ  
Telephone: 021 782 2112 or 021 782 6560

OPEN 7 DAYS A WEEK (including bank holidays)

Why not pay us a visit and watch the aeroplanes at the same time. We have two shops, one on the first floor by Mag-Lev (have a free ride to BR station and back) and one in the airport's viewing gallery (viewing gallery open everyday - admission 30p).

Airband radios from £9.95 and scanners from £149 plus a variable selection of good secondhand and part exchange models.

We stock radios by Fairmate, Jupiter, Icom, Steeplestone, Textet etc., models and prices to suit you.

Come and see the finest range of books on aircraft and associated subjects there is; by publishers such as Ian Allan, Airlife, Putnam, PSL, Haynes, MCP and many more. Air maps, frequency charts, books on ATC, even books on how to fly a Cessna or a Jumbo Jet, we stock 'em all. Books for the student pilot and PPL, checklists, flight cases, current topo charts always in stock, nav-flight computers and much more. We also stock aviation postcards, posters and badges (callers only). Can't visit? Then send £1 for our mail order catalogue or telephone us on:

**021 782 2112 or Fax: 021 782 6423**

We accept all major credit cards and cheques with bankers card number (up to £500 for personal callers with I.D.)

ALSO: Why not take advantage of our **SPECIAL OFFER:-**  
Our most popular multi-band radio with a 'rubber duck' aerial -  
Airband - FM - PSB, batteries included,  
12 months guarantee - **£24.95 POST FREE!**

## GAREX ELECTRONICS

### WIDEBAND SCANNERS

All major brands available, with the all-important service back-up. AOR; BLACK JAGUAR, JIL; REVCO; ICOM; YUPITERU. Also good stock of secondhand sets. Ask for list.  
"SCANMASTER" Scanner Controller: versions for AOR2002, REGENCY MX8000, ICOM ICR7000, YAESU FRG9600. Built-in software expands the scanner to over 700 memories, with automatic logging and a host of features. Operates with a dumb terminal or any computer in terminal mode. **£153.25**

### WIDEBAND ANTENNAS

"REVCON" premium quality British VHF/UHF Discone (guaranteed free from exaggerated advertising claims!) SO239 connector **£37.75**  
N-type connector for improved UHF performance **£39.80**  
Optional vertical whip feature for experimenters.  
"RADAC" nest of dipoles: imitated but not equalled. Guaranteed Tx capability over customer specified 6 bands in the range 27-470MHz. with excellent wideband Rx performance.  
SO239 conn: **£86.85** N-type: **£88.89**  
Special VHF/UHF Airband RADAC: 108-136MHz and 220-400MHz **£80.75**  
Top quality cable and connectors also available.

### WIDEBAND PRE AMPLIFIERS

NEW GAREX GA-4 SERIES: 20MHz - 1GHz instrument grade amplifiers precision stripline construction for exceptional stability: 13dB gain at 1GHz with filter to reduce HF breakthrough problems.  
GA-4MN Inline Masthead Amplifier COMPLETE with stripline DC supply unit, requires 12v DC at 30mA, N connectors **£49.50**  
GA-4MS, as above, but PL/SO connectors, (reduced performance) **£48.50**  
"Local-use" versions, small die-cast box package, for 12v DC operation.  
GA-4B (BNC sockets): **£35.75**. GA-4S (SO239): **£35.75**. GA-4N (N sockets): **£39.85**.  
Mains adaptor for use with any of the above preamps: **£8.95**  
DC Supply Block: a precision stripline device for powering masthead amplifiers via the co-ax, suitable for 20MHz - 2GHz with VSWR better than 1.3:1, insertion loss less than 0.5dB, N sockets **£25.35**  
Also with SO239 sockets (reduced performance) **£25.35**

### MOBILE ANTENNAS

REVCO super Mag-mount + 5/8 for 2m **£35.75**  
Mag-mount + 4.5dB for 70cm **£36.75**  
Body-mount 1/2" or 3/8" hole (state which) + 5/8 for 2m **£20.35**  
3/8" hole mount + 70cm colinear (4.5dB) **£20.35**  
Mag-mount with 3dB 900MHz whip: improve the performance of your cell-phone or 900MHz scanner; in the car or on the office filing cabinet. **£35.75**  
REVCO unbeatable glassmounts, with tuned matching units for peak efficiency: 2m or 70cm: standard model: **£40.95**. Deluxe hinged whip models: **£47.95**. All with 4m feeder. Plugs on request.

Write, phone or fax for lists. Regular lines, components and bargains for callers. Open 10am - 5pm Mon - Fri (occasional Sats).

ALL PRICES INCLUDE UK CARRIAGE AND VAT AT 17.5%



**GAREX ELECTRONICS**



STATION YARD, SOUTH BRENT, SOUTH DEVON TQ10 9AL  
Phone: (0364) 72770 Fax: (0364) 72007

# practical Wireless

## M · O · R · S · E - W · E · E · K · E · N · D

Worried about the Morse test? Are you all 'keyed up' about Morse? Does the prospect of getting an 'A' licence 'bug' you? Do you want to put that final 'polish' on your 'keying'? And do you then want to have the opportunity to take your test, while you're enjoying a 'short break' weekend holiday?

If so, why don't you put your name down for the *Practical Wireless Morse Weekend*? For around the £160 mark, we're planning to provide meals and accommodation in a good quality, comfortable Hotel. The weekend will start on the Friday evening, and finish after lunch on the Sunday. You will have the opportunity to have some Morse tuition, before you take the Morse test itself. You'll also have the chance to see and try all the latest aids for c.w. working in amateur radio, meet the experts, other 'key' enthusiasts and have fun at the same time.

### OTHER ATTRACTIONS

Originally planned for the late spring, we're now

looking at a weekend in September. There will be other attractions for friends and family members not joining in with the amateur radio events. Don't forget that we're very close to the delights of the New Forest, the Hampshire and Dorset sea-side resorts and some delightful 'Stately Home' attractions. With that in mind, we plan to organise some coach trips so that the weekend will have something for everyone.

### EXCELLENT COMMUNICATIONS

Communications to this part of the UK are excellent. We've got superb train services from the north and Scotland and even abroad if need be! If you're interested, please send a fully refundable deposit of £25 per person to:

**PW Morse Weekend, Enefco House, The Quay, Poole, Dorset BH15 1PP. Tel: (0202) 678558.**

Alternatively, if you want to hear more about the Morse Weekend, why not call Rob Mannion G3XFD to talk about it? (Between 3 and 4pm please!)

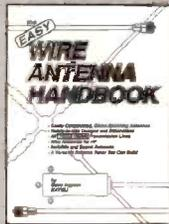

**The Easy Wire Antenna Handbook**  
by Dave Ingram K4TWJ

What's the least expensive and most effective way to equip your new transceiver, QRP rig or classic transmitter and receiver setup for world wide radio communications? Use a homemade wire antenna naturally! This book is dedicated to fulfilling that exact purpose, and it's chocked full of ready-to-use designs and dimensions on both "basic" and "gain" antennas. There is information on hidden and disguised antennas, tuner and baluns, SWR meters, noise bridges, converting any antenna's dimensions to your favourite HF band and more - much more!

Whether you are anxious to join the action on a recently acquired band, seeking a better radiator for your favourite HF band, or getting ready to put your very first signal on the air this book is your guiding source of information. Its contents are "user orientated" rather than technical, it features large diagrams and easy to read text.

£6.95 plus £1 post - overseas £2.50

Write or phone for our free catalogue

**AXDON BOOKS**

Ref: SWM92, 32 Atholl Street, Perth PH1 5NP, Scotland UK  
Sales line 0738 30707



**The RTTY Listener**  
edited by Fred Osterman

A compilation of the RTTY Listener Newsletters issues 1-25 this book is primarily aimed at owners of the Info-Tech M-606 frequency division multiplex demodulator, and later models such as M-6000, M-800 fax converter and the universal radio M-7000. It is full of information on where to look for signals and how to connect your equipment.

The book also includes details on: • Baudot • TDM (Moore) ARQ M-2 • ARQ-E and ARQ-E3 • Packet • Sitor A/B • FDM (VFT) • Facsimile (FAX) • Morse code • ASCII • Bit inversion. This book is a must for the serious RTTY listener.

£16.95 plus £1.75 post - overseas £3.25

**WACRAL**

The World Association of Christian Radio  
Amateurs and Listeners

Invite fellow Christians to join them

**Annual Conference - Newsletter  
'nets' - Awards etc.**

Details from: Derek Chivers, G3XNX  
51 Alma Road, Brixham, TQ5 8QR

Christian Friendship and Fellowship World-wide

*"Word's 25th Anniversary Year will see the release of new albums from Adrian Snell, Iona, Marilyn Baker - the introduction of the "Praise-Him" series, a special 25th Anniversary series, more from the "Adventures in Odyssey", and, in September - the launch of the NCV Youth Bible.*



**Word (UK) Ltd**

9 Holdom Avenue, Bletchley, Milton Keynes, MK11QR  
Tel: 0908 648440  
Fax: 0908 648592

**REDDITCH Sony Centre**

**ICF SW77 £349.99**

TOP SPECIFICATION MULTI-BAND RECEIVER WITH PLL SYNTHESIZER CIRCUITRY, STATION NAME TUNING AND CONTINUOUS AM FREQUENCY COVERAGE.

FM stereo/LW/MW/SW/SSB reception • PLL synthesized circuitry • Continuous AM frequency coverage with 50Hz step tuning • 4 way tuning: 162 memory presets, manual tuning, auto scan, 10 key direct tuning • Station name display of 100 stations • Station call for rapid access to 162 frequency memories • Fully rewritable memories • Broadcast time display • World time display • Synchronised detection system • Dual clock with timer • Antenna input socket • Sleep function • LCD display • Dual conversion system • Headphone Socket • Tape line out socket • Key protection • Stand • Supplied with compact antenna, stereo earphones, AC power adaptor, carrying belt and shortwave guide

Power: 4 x C size battery, 240V AC with adaptor (supplied).



**SPECIALIST AIR BAND**

FOR SPECIALIST USERS, Sony provides a choice of ruggedly-constructed receivers that deliver a truly impressive array of professional features. These two high-specification air-band models incorporate multi-way tuning, squelch control, PLL synthesized circuitry, and reception of PSB (Public Service Band) broadcasts, extending their versatility to allow monitoring of fire service, forestry, marine, highway and weather reports.

**AIR 7 - £249.99 inc VAT**  
HANDHELD MULTIBAND RECEIVER WITH 6-WAY TUNING AND CONTINUOUS WAVEBAND COVERAGE INCLUDING AIR BAND

FM/AM/AIR/PSB Reception • PLL Synthesized Circuitry • Continuous AM Frequency Coverage • 6-Way Tuning: 40 Memory Presets, Auto Scan, Memory Scan, Priority Tuning, Manual tuning, 10 Key Direct Tuning • Wideband Coverage • Squelch Control (Auto and Manual) • Key Protection • LCD Display with Light Function • Dual Conversion System • Record Out Socket • 4-Way Power Supply • Supplied with Helical Aerial, Shortwave Guide, Battery Holder, Earphone and Shoulder Strap • Power: 4xAA size battery • 6VDC • 240VAC with Adaptor (Optional).

PLEASE ADD £5 P&P per order



**ICF PRO80 - £299.99 inc VAT**  
HIGH-SPECIFICATION HANDHELD MULTIBAND RECEIVER WITH FREQUENCY CONVERTOR, 8-WAY TUNING AND CONTINUOUS WAVEBAND COVERAGE INCLUDING AIR BAND

FM/FM Narrow/AM Wide/AM Narrow/VHF/AIR/PSB/UHF Reception • PLL Synthesized Circuitry • Continuous AM Frequency Coverage • 8-Way Tuning: 40 Memory Presets, Memory Scan, Define Scan, Auto Scan, Programme Memory Scan, Priority Tuning, Manual tuning, 10 Key Direct Tuning • Wideband Coverage • Squelch Control (Auto and Manual) • Key Protection • 3 Mode Scan • 2-Step Tone Control • 40 Station Random Memory Presets over 4 Memory Pages • AM/SSB Fine Tuning • LCD Display with Light Function • Dual Conversion System • Record Out Socket • Supplied with Shortwave Guide, PRO80 Frequency Converter, Telescopic Aerial, Earphone, Shoulder Strap, Carrying Case, Aerial Holder and Aerial Plug Adaptor • Power: 4xAA size battery • 6VDC • 240VAC with Adaptor (Optional).



**OBA Electronics Ltd**

58 Evesham Walk, Kingfisher Centre,  
Redditch, Worcestershire B97 4AH

Telephone: 0527 65005

Fax: 0527 595096

# World by 2000

'World by 2000' is the name given to an ambitious project that was initiated by the presidents of the major international christian broadcasting organisations back in 1985.

Its aim is to add to existing foreign language services, so that by the year 2000, every country in the world can be made aware of the gospel message.

FEBA Radio, broadcasting from the Seychelles, answered the call and over the past few years has added 11 new languages to its radio output.

In the current round, three more have just made their way on to the schedules and FEBA's Programming Director, Tony Ford, has been telling Trevor Barnes about the specific problems of introducing Hindko broadcasts to the people of northern Pakistan.

*Tony Ford*

Hindko is probably one of the easy ones at least to get the first step going because there is a group called Team working in Pakistan. An American based mission organisation, they've had a medical worker in the area where Hindko is spoken for many years. So we've had contacts with and they had people who were able to get this medical radio programme on the air for us, as well as the general magazine programme that looks at Hindko culture and so on.

*Trevor Barnes*

When you talk about a language, of course, you're not just talking about it in isolation, it is intimately bound up to a particular culture. How do you begin to get foreign ideas like Christian ethics, the Biblical story, Christian values across to a totally different culture?

*Tony Ford*

The first thing is to find people from that culture. This is one of the peculiarities of FEBA radio that we have a policy of wanting to use people who are born to that language, it's their mother tongue. Therefore, they bring a lot of their culture. The difference between the culture in these areas where we've been broadcasting to and the Bible is far less than you might imagine. The Bible is agricultural, it talks about very simple life styles and very often that matches much more the lifestyle of the people we're broadcasting to than our own lifestyles here in the West. It's when you get to the theological meaning behind the Bible Stories that there are differences especially if you're broadcasting into an area with its own religion already.

*Trevor Barnes*

Now this, of course, is the situation in **Azeri**, one of the other new languages you're introducing. Now you're talking about 17 million people in Northern Iraq, another seven million people in Azerbaijan itself. There must have been particular difficulties introducing this (a) at a time of civil and political unrest and (b) in an area which contains, presumably, the most committed Muslim population anywhere on earth?

*Tony Ford*

The solution with **Azeri** broadcasting is like others where we're broadcasting to strongly Islamic regions where it would be very difficult for any Christian activity to take place there. We're actually using an **Azeri** by birth, now living in the West who has become a Christian. So that, yes, making the programmes is one thing, but actually holding an audience is another and making the programme relevant to the people in that part of the world is a continuing challenge day by day.

*Trevor Barnes*

Do you meet any official Islamic opposition along by the way?

*Tony Ford*

No. I think I'm fairly sure in saying that. We're always aware of the tension between certain elements in Islamic life and Christianity, but officially, no. We've never had any official opposition.

*Trevor Barnes*

Moving next to the final language you're introducing in this current round, namely Yao, being broadcast to the unevangelised of Malawi. In this case you presumably have to have more than just a language programme? The wireless won't do things - I mean if people find it uninteresting or unpenetrable they merely switch off. Presumably you have to have people on the ground, back-up teams and so forth?

*Tony Ford*

Yes, and our broadcasting is a very good example because groups in Malawi that are involved in this radio project are quite wide. We've got denominational groups, as well as Bible Society and various mission groups in different parts of the world. As well as Malawi and Evangelistic groups we have people on the ground going and talking to people in the market places and so on. So we are all aware of one another's activities and we're planning together. We have the Bible Society, for example, printing scripture portions and literature, which will help the radio programmes and then the people in the market places would be talking about the radio programmes. Radio plays a particular part - to use an agricultural metaphor, softening up the ground and then sowing the seed - and other people then come along and nurture and tend and working together we sow fruit for the gospel.

Further information about FEBA Radio can be obtained by sending an s.a.e. to:

FEBA Radio, Ivy Arch Road, Worthing, West Sussex BN14 8BX.

**FEBA Radio broadcast the Christian Message from their transmitters in the Seychelles. The interview reproduced on this page was made for broadcasting by local radio stations in the UK. In it, Trevor Barnes discusses various aspects of broadcasting Christian programmes to a Muslim area with FEBA's Programming Director, Tony Ford. The introductory notes are taken from FEBA Radio's 'Cue Sheet' which accompanied the tape from which the interview was transcribed. Unfortunately, you cannot hear some parts of the broadcast - such as the suggested back announcement and a schoolgirl from Hazara in Northern Pakistan singing Psalm 19 in Hindko!**

# Religious Broadcasters

# Sony ICF-SW77 World



**The Japanese Sony Corporation is the world's largest manufacturer of portable short wave radio receivers and has recently updated the top end of its range with two new sophisticated sets. The SW77 is described as having the most advanced technology in world band receivers. Peter Shore has tried the new set and tells us what it offers to the short wave listener.**

**A**s market leader in world band radios the Sony Corporation invests a tremendous amount of research and development into new models. The new SW77 is the result of many years work and follows the successful ICF-2001D (or 2010 in North America) which has been the top of the Sony range since 1985.

One of the aims of the Sony engineers has been to make short wave listening easier for people who are neither dedicated DXers nor enthusiasts. This has been achieved to a great extent by allowing 162 frequencies to be stored in the receiver along with a six-digit station identification. This does away with need to remember a large number of frequencies used by different stations and will prove a boon for travellers as well as for occasional listeners to the short wave bands. We'll look at the memory facilities in greater detail shortly.

The new receiver is a similar size to its predecessor (276 x 172.5 x 46.5mm) but more attractively styled with the square edges of the 2001D giving way to curves and

corners. It runs on four large 'C' size batteries or a 6V d.c. supply using the adaptor which is included with the set.

### Principle Facilities

In the UK version the SW77 offers coverage from 150kHz through to 29.999MHz continuously together with v.h.f. f.m. from 76.0 to 108.0MHz and stereo listening is possible through headphones. Unlike its predecessor air band is not covered. Single sideband reception on a.m. is available with switchable upper and lower sideband switches and wide and narrow filters are also selectable during a.m. reception. The synchronous detection mode first offered by Sony on the 2001D has been enhanced and is included in the SW77 - of which more later. The loudspeaker takes up the left hand third of the front of the set with the main controls and the digital displays on the right hand side. One of these two liquid crystal displays provides visual operating data and another a clock and multi-function timing device. Both

the displays have backlighting for night-time use as well as adjustable contrast. On the left hand panel are the sockets for connecting an external antenna, headphones, line out to a recorder or amplifier and an external power supply. On the right hand panel are the usual volume and tone controls: volume is adjusted by a slide control and separate bass and treble knobs allow tone adjustment. On top of the set in a pop-up panel is a world time slide device giving speedy time conversions from local time to UTC or to another time zone. The receiver has a sleep function and a sophisticated timer and alarm to provide automatic switch on and off as well as offering remote recording possibilities.

### Operating the Receiver

At first glance the receiver looks rather complicated, and indeed for all but the main functions it is necessary to read the comprehensive handbook which runs to some 34 pages. The set is powered up by means of a push button switch which can be locked off to prevent accidental switch-on in transit. The last tuned station is selected and the frequency is displayed on the larger of the two displays in either kilohertz for long, medium or short wave or in megahertz for f.m. frequencies. A vertical signal meter calibrated in ten units gives an indication of the received signal strength and in practice offers a reasonably accurate indication. Frequencies can be entered direct using the numeric keypad: to call up WCSN using 13.615MHz for example, select a.m. and then enter 1 3 6 1 5 followed by EXE for execute and the frequency is immediately selected. Should an invalid frequency be entered (outside the set's coverage for example) TRY AGAIN is flashed across the display panel. Frequencies on the f.m. band such as 102.2MHz do not need the decimal point entered so the entry order is FM and then 1 0 2 2 followed by EXE. The

# Wide Band Receiver

reception mode is indicated in the display panel - whether WIDE, NARROW, USB, LSB, SYNCH U or SYNCH L. For manual tuning the rotary tuning knob - or jogger, as it has been christened by Sony - is used. This is on the front panel and is therefore turned on its surface and not, as is more usual, on the edge of the knob. The SW77 has adjustable tuning rates down as far as 50Hz on a.m. frequencies although the digital frequency display only shows frequencies to 100Hz. A FAST/SLOW button allows tuning steps to be increased to 1kHz to enable rapid tuning across the bands. Unlike the 2001D, if fast tuning is selected the frequency step automatically assumes a round 0 or 5kHz instead of, say, 15.515.6kHz. Tuning steps in f.m. mode are 50kHz. The tuning knob (or jogger) can be locked or alternatively all the operating keys can be disabled using the KEY PROTECT button. Scanning is available but on short wave it is only possible to scan within the limits of the broadcast bands in 5 kHz steps and once the upper limit is reached, the set bleeps and starts scanning again from the lowest frequency in the band.

The most significant feature of the SW77 as far as tuning is concerned is the provision of pre-programmed memories. Some 82 of the 162 memories have been pre-programmed into pages with frequencies and names of the major international broadcasters, from the BBC to Radio Luxembourg to Radio Australia. Each of the 20 pages of the electronic memory is divided into five sub-sections assigned to different stations. Each sub-section holds ten different frequencies. In addition to storing the frequency the times of operation of each channel have been recorded and provided that the set's main clock has been correctly set to Greenwich Mean Time (or UTC) an indicator on the l.c.d. shows whether the channel is ON AIR. When frequencies or times of operation change it is

possible to write new data to the memories. Whilst most of the pre-programmed frequencies are accurate, some stations have received short shrift from Tokyo: Radio Beijing for example benefits from just one pre-programmed frequency. There are also two 'quick pages' which can be used for most often listened to stations - those which broadcast news regularly, perhaps, or programmes of a particular interest - and one timer page used for memorising stations to turn the radio on and off at particular times. The number of memories should be sufficient for even the most ardent listener and the provision of factory-programmed frequencies and the easy to read digital display is of particular help to people who do not listen regularly to short wave broadcasters.

A feature first introduced by Sony on the 2001D and included in the SW77 is synchronous detection. This should reduce distortion or fading of broadcast features. A pure carrier is generated in the synchronous detector circuit and mixed with the received signal to compensate for attenuations in the signal caused by fading, reducing distortion. If interference is caused by stations on adjacent channels, the circuitry chooses the sideband clear of adjacent channel interference allowing

improved reception. On the sample used for this test, the synchronous detector performed reasonably well, reducing distortion or interference, but when the detector locks, much of the bass of the audio signal is removed leaving somewhat watery and unpleasant audio. This is something which needs to be considered by Sony's engineers. Sensitivity and selectivity can be altered on the receiver: a wide and narrow filter switch and a three position control offers DX, NORMAL or LOCAL sensitivity.

## Performance

The SW77 offers average performance and certainly the model tested placed alongside other Sony receivers including a five year old 7600DA and a 2001D did not seem to perform significantly better. Indeed, sensitivity was not as good as the two older sets. Test measurements with the filter set to WIDE suggest that sensitivity ranges from around -90 to -78dBm for 15dB signal to noise ratio which suggests only average sensitivity. Selectivity rates somewhat better, though, with 38dB down at 5kHz and > 70dB down at 10kHz. Image rejection is good at around 73dB. Overall, performance was disappointing and did not offer any real improvement

over the SW77's predecessors. Battery consumption is high at 172mA and means that a set of alkaline batteries will last for a little over 20 hours. It is therefore cheaper to use the mains adaptor supplied with the set.

## Conclusions

The new ICF-SW77 is a well thought out short wave receiver and one which is designed to make listening as simple as possible for the man in the street as well as appealing to DXers and enthusiasts. The large number of memories makes tuning easy and the sophisticated timer and remote record connection are very useful. It takes time to master all the set's facilities and the operating instructions are not as easy to follow as perhaps they might be. A separate chart is included with the instruction book showing what frequencies have been pre-programmed in the factory. The pre-programming differs according to the market the set is to be sold in, so beware if purchasing from a 'grey market' dealer who may have bought his stocks in the Far East, as frequencies beamed to that region are likely to be programmed into the set! Audio quality is good and stereo reception is offered through headphones on f.m.

The operating controls are easy to use, with each button having a positive action, but there is no raised 'blip' on the 5 button on the numeric keypad which may cause difficulty to visually handicapped users of the set. There appear to be some teething troubles with the SW77 at present, such as the appalling audio when synchronous detection is selected. It may be worth postponing a purchase for a few months until a new batch of sets comes onto the market. However, its detractions are far outweighed by the plus points in terms of value for money, although prospective purchasers must be prepared to pay some £330 for this new Sony receiver.

## Abbreviations

a.m.	amplitude modulation
d.c.	direct current
dB	decibels
dBm	decibels reference one millivolt
DXer	listener who looks for 'long distance' stations
f.m.	frequency modulation
Hz	hertz
kHz	kilohertz
l.c.d.	liquid crystal display
MHz	megahertz
mm	millimetres
UTC	Universal Co-ordinated Time (=GMT)
V	volts
v.h.f.	very high frequency

# propagation

by Ron Ham  
Faraday, Greyfriars, Storrington, West Sussex RH20 4HE

This month, pride of place goes to the beacon section of this column in memory of **Alan Taylor** who died on January 9. Alan was well known for the important work he did to promote, and encourage, the use of radio beacons for the study of propagation.

For the past 20 years, he was the Co-ordinator of the International Beacon Project for the International Amateur Radio Union (IARU Region 1). Although he will be sadly missed, his work will live on each time a radio enthusiast checks a band by first listening for the signals from the worldwide network of beacons that he helped to provide. We extend our deepest sympathy to Alan's family and his multitude of friends.

## Propagation Beacons

I know that Alan appreciated the dedicated work of the beacon monitoring team, **Gordon Foote** (Didcot), **Henry Hatfield** (Sevenoaks), **Ted Owen** (Maldon), **Fred Pallant** (Storrington), **Ted Waring** (Bristol), **Ern Warwick** (Plymouth) and **Ford White** (Portland). Each month their combined logs enable me to produce the regular monthly chart, Fig. 1, which readers around the world can compare with their own findings.

Apart from providing information about the condition of the 28MHz band at a given time, the importance of these observations is shown again this time by highlighting the almost total radio-blackout on February 9. Auroral warnings were also transmitted by the German beacon DK0WCY on 10.144MHz and heard by Gordon Foote on February 2 & 10.

## Solar

Because the sun has so much influence over the ionosphere, and consequently the paths of terrestrial radio signals, the cause of any abnormal behaviour is often found in the reports from our solar observers. For instance, in

January, **Ron Livesey** (Edinburgh), using a 2.5in refractor and 4in projection screen, located 5 active areas on the sun's disc on days 4, 5, 7, 9, 22, 25 & 26, 6 on the 11th, 12th & 28th and 7 on the 10th & 31st. After several days of fog and overcast skies, **Ford White** saw two very large sunspots on the disc on February 26, **Ted Waring** counted 28 sunspots on the 7th and 31 on the 24th, **Richard Gosnell** (Swindon) reported, "one very large sunspot near edge", at 1600 on the 8th and **Tony Hopwood** (Upton On Severn) noted solar flares on the 1st & 27th.

You can see the giant sunspot group observed by **Patrick Moore** at his observatory in Selsey at 0940 on February 16 in Fig. 2.

## Auroral

Streams of particles, ejected by the sun, often cause an aurora to manifest in the earth's polar atmosphere. Briefly, an aurora is a region of random ionisation that conveniently has a strange effect on the tone of radio signals reflected from it. Because of this, wireless operators know of its existence, during the hours of daylight, when it can't be seen anyway, or when the night sky is overcast. However, a visible aurora, depending on the amount of solar activity, displays many colourful forms and is truly a magnificent sight.

My main source of such information is **Ron Livesey**, the auroral co-ordinator for the British Astronomical Association who received reports of 'glows' overnight on January 1, 3, 4, 7 & 8, 'quiet arc or band' on the 13th, 'ray

bundles' on the 11th, 29th & 30th and 'active, moving, pulsating' on the 3rd, 13th & 26th, from observers mainly in Scotland and aboard the Ocean Weather Ship *Cumulus*. **Doug Smillie** (Wishaw) told Ron that he heard weak auroral reflected radio signals on the 144MHz band on the 8th, 29th & 30th and **Tony Hopwood** logged these, tone-A, signals on February 1, 2, 3, 26 & 29.

## Magnetic

The various magnetometers used by **Tony Hopwood**, **Ron Livesey**, **Karl Lewis** (Saltash), **David Pettitt** (Carlisle) and **Doug Smillie**, between them, recorded some magnetic activity on January 1, 3-5, 10-16 & 26-30. **Tony** also reports disturbed conditions on February 1, 4, 27 & 28 and magnetic storms on the 2nd, 3rd & 26th. While the storm was in progress on the 2nd, **Tony** observed an auroral glow behind the cloud to the north between 2230 and 2300.

## Ionospheric

Maximum Useable Frequencies (m.u.f.), which vary with the time of year, are being studied by **Richard Gosnell** who uses the upper h.f. and lower v.h.f. bands. He monitors the Eastern European Citizen's Band (33-43MHz) and the Ch. R1 (49.75MHz) vision frequency to assess the morning conditions. **Richard** heard the pulses on 49.75MHz around 0815 on February

1, 8 & 16, echoes from DW (25.740MHz) at 1340 on the 8th & 1220 on the 15th, signals from the USA on 33.9MHz during the early evenings of the 12th, 13th, 15th, 19th, 22nd, 28th & 29th. He also heard multiple-echoes from Radio Norway (25.730MHz) at 0830 on the 15th.

**Fred Pallant** found the 28MHz band 'quiet' on the 9th, 20th & 21st and reports, 'not a single W or VE beacon all day', on the 25th. Beacons are super indicators because their tiny transmitters are on the air, 24 hours a day, every day and their signals are subject to any change in ionospheric conditions.

## Tropospheric

The slightly rounded atmospheric pressure readings for the period January 26 to February 25, recorded at my home in Sussex, can be seen in my 'DX Television' column elsewhere in this issue. While **George Garden** (Edinburgh) was DXing with his car-radio, high on Cairn O' Mounth, on February 29, he received weak test-transmissions from a new station, Classic FM, operating in the Edinburgh area on 101.6MHz. **Andrew Jackson** reports hearing a new station, Linx FM, broadcasting mainly to Lincolnshire and South Humberside on 102.2MHz. It is well worth looking for DX in Band II throughout the forthcoming Sporadic-E season (May to September) and at anytime during a tropospheric opening.

Fig. 1.

Beacon	January											February																			
	26	27	28	29	30	31	1	2	3	4	5	6	7	8	9	10	11	12	13	14	15	16	17	18	19	20	21	22	23	24	25
DF0AAB	X	X	X	X	X	X					X	X	X	X	X	X	X	X	X	X	X	X	X	X	X	X	X	X	X	X	X
DK0TEN	X																														
DL0IGI	X	X	X	X	X	X	X	X	X	X	X	X	X	X	X	X	X	X	X	X	X	X	X	X	X	X	X	X	X	X	
EA3JA	X	X	X	X	X	X	X	X	X	X	X	X	X	X	X	X	X	X	X	X	X	X	X	X	X	X	X	X	X	X	
HG5GEW	X	X	X	X	X	X	X	X	X	X	X	X	X	X	X	X	X	X	X	X	X	X	X	X	X	X	X	X	X	X	
IY4M	X	X	X	X	X	X	X	X	X	X	X	X	X	X	X	X	X	X	X	X	X	X	X	X	X	X	X	X	X	X	
KC4DPC	X	X	X	X	X	X	X	X	X	X	X	X	X	X	X	X	X	X	X	X	X	X	X	X	X	X	X	X	X	X	
KD4EC	X	X	X	X	X	X	X	X	X	X	X	X	X	X	X	X	X	X	X	X	X	X	X	X	X	X	X	X	X	X	
KF4MS	X	X	X	X	X	X	X	X	X	X	X	X	X	X	X	X	X	X	X	X	X	X	X	X	X	X	X	X	X	X	
KJ4X	X	X	X	X	X	X	X	X	X	X	X	X	X	X	X	X	X	X	X	X	X	X	X	X	X	X	X	X	X	X	
KW7Y	X	X	X	X	X	X	X	X	X	X	X	X	X	X	X	X	X	X	X	X	X	X	X	X	X	X	X	X	X	X	
LA5TEN	X	X	X	X	X	X	X	X	X	X	X	X	X	X	X	X	X	X	X	X	X	X	X	X	X	X	X	X	X	X	
NX20	X	X	X	X	X	X	X	X	X	X	X	X	X	X	X	X	X	X	X	X	X	X	X	X	X	X	X	X	X	X	
N2JNT	X	X	X	X	X	X	X	X	X	X	X	X	X	X	X	X	X	X	X	X	X	X	X	X	X	X	X	X	X	X	
N4MW	X	X	X	X	X	X	X	X	X	X	X	X	X	X	X	X	X	X	X	X	X	X	X	X	X	X	X	X	X	X	
OK0EG	X	X	X	X	X	X	X	X	X	X	X	X	X	X	X	X	X	X	X	X	X	X	X	X	X	X	X	X	X	X	
OH2TEN	X	X	X	X	X	X	X	X	X	X	X	X	X	X	X	X	X	X	X	X	X	X	X	X	X	X	X	X	X	X	
PT8AA	X	X	X	X	X	X	X	X	X	X	X	X	X	X	X	X	X	X	X	X	X	X	X	X	X	X	X	X	X	X	
PY2AMI	X	X	X	X	X	X	X	X	X	X	X	X	X	X	X	X	X	X	X	X	X	X	X	X	X	X	X	X	X	X	
SK5TEN	X	X	X	X	X	X	X	X	X	X	X	X	X	X	X	X	X	X	X	X	X	X	X	X	X	X	X	X	X	X	
VE1MUF	X	X	X	X	X	X	X	X	X	X	X	X	X	X	X	X	X	X	X	X	X	X	X	X	X	X	X	X	X	X	
VE2HOT	X	X	X	X	X	X	X	X	X	X	X	X	X	X	X	X	X	X	X	X	X	X	X	X	X	X	X	X	X	X	
VE3TEN	X	X	X	X	X	X	X	X	X	X	X	X	X	X	X	X	X	X	X	X	X	X	X	X	X	X	X	X	X	X	
VK2RSY	X	X	X	X	X	X	X	X	X	X	X	X	X	X	X	X	X	X	X	X	X	X	X	X	X	X	X	X	X	X	
VK5WI	X	X	X	X	X	X	X	X	X	X	X	X	X	X	X	X	X	X	X	X	X	X	X	X	X	X	X	X	X	X	
VK6RWA	X	X	X	X	X	X	X	X	X	X	X	X	X	X	X	X	X	X	X	X	X	X	X	X	X	X	X	X	X	X	
VK8VF	X	X	X	X	X	X	X	X	X	X	X	X	X	X	X	X	X	X	X	X	X	X	X	X	X	X	X	X	X	X	
WA4DJS	X	X	X	X	X	X	X	X	X	X	X	X	X	X	X	X	X	X	X	X	X	X	X	X	X	X	X	X	X	X	
WA6APQ	X	X	X	X	X	X	X	X	X	X	X	X	X	X	X	X	X	X	X	X	X	X	X	X	X	X	X	X	X	X	
WB4JHS	X	X	X	X	X	X	X	X	X	X	X	X	X	X	X	X	X	X	X	X	X	X	X	X	X	X	X	X	X	X	
WC8E	X	X	X	X	X	X	X	X	X	X	X	X	X	X	X	X	X	X	X	X	X	X	X	X	X	X	X	X	X	X	
WJ9Z	X	X	X	X	X	X	X	X	X	X	X	X	X	X	X	X	X	X	X	X	X	X	X	X	X	X	X	X	X	X	
W3VD	X	X	X	X	X	X	X	X	X	X	X	X	X	X	X	X	X	X	X	X	X	X	X	X	X	X	X	X	X	X	
W7JPI	X	X	X	X	X	X	X	X	X	X	X	X	X	X	X	X	X	X	X	X	X	X	X	X	X	X	X	X	X	X	
W8UR	X	X	X	X	X	X	X	X	X	X	X	X	X	X	X	X	X	X	X	X	X	X	X	X	X	X	X	X	X	X	
W9UX0	X	X	X	X	X	X	X	X	X	X	X	X	X	X	X	X	X	X	X	X	X	X	X	X	X	X	X	X	X	X	
Y02X	X	X	X	X	X	X	X	X	X	X	X	X	X	X	X	X	X	X	X	X	X	X	X	X	X	X	X	X	X	X	
ZS1LA	X	X	X	X	X	X	X	X	X	X	X	X	X	X	X	X	X	X	X	X	X	X	X	X	X	X	X	X	X	X	
ZS5VHF	X	X	X	X	X	X	X	X	X	X	X	X	X	X	X	X	X	X	X	X	X	X	X	X	X	X	X	X	X	X	
ZS6PW	X	X	X	X	X	X	X	X	X	X	X	X	X	X	X	X	X	X	X	X	X	X	X	X	X	X	X	X	X	X	
ZZ1ANB	X	X	X	X	X	X	X	X	X	X	X	X	X	X	X	X	X	X	X	X	X	X	X	X	X	X	X	X	X	X	
5B4CY	X	X	X	X	X	X	X	X	X	X	X	X	X	X	X	X	X	X	X	X	X	X	X	X	X	X	X	X	X	X	

Fig. 2.

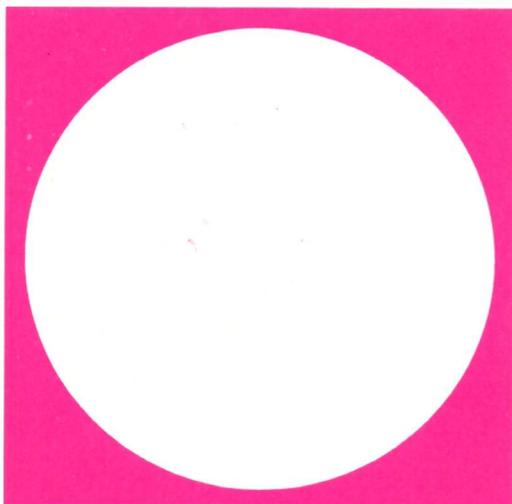

# ssb utility listening

Graham Tanner, 42 David Close, Harlington, Middlesex UB3 5EA.

A few months ago **Keith Elgin** mentioned the intriguing Mystic Star network, used by the 89thAW (the USAF VIP transport unit) for world-wide h.f. communications. I also hear a lot of these transmissions and have some additional information, which I have gathered over the years from various sources. This is also supplemented by another extensive letter from **Paul H** of Newbury, and various letters from several other readers.

The 'Mystic Star' network was set up in 1963 at the request of President Kennedy for use by the President, other VIPs and high ranking officers. Its purpose is to maintain contact between those people and the White House in Washington DC, and it is run under the authority of the National Communications System and operated by the White House Communications Agency. All the USAF GCCS stations and SAC 'Giant Talk' stations world-wide act in support of the network. Anyone wishing to use the network usually makes an initial contact with 'Andrews VIP' (callsign 'Andy'), via a phone patch, using one of the published USAF GCCS h.f. (or SAC 'Giant Talk') frequencies. The ground station will then usually tell them to QSY to a 'channel', for example '118 upper'. The 'upper' refers to u.s.b., they sometimes use a 'lower' channel, for example '460 lower'. Both the aircraft and 'Andy' will QSY to the frequency that corresponds with the channel and they will immediately continue communications either in plain voice or 'in the green' using voice scrambling equipment.

## Scrambled!

Obviously, the plain voice transmissions are easy to copy if you know where they have QSYed, but understanding the nature of the scrambled transmissions is a different matter. The exact method of encoding and decoding is a closely-guarded secret, it's doubtful that even the aircraft crews know exactly how it works. What can be determined from the signals monitored so far is that the whole set-up appears to be based upon a simplex system, i.e., only one radio transmits at any one time. The scrambled signals are quite difficult to explain, they sound

like a high-pitched bubbling voice which doesn't quite make sense. At the start of each 'over', there is a 1 second (approx.) high-frequency timing tone which allows both the transmitter and receiver at either end of the link to synchronise with each other; the tone is immediately followed by the scrambled 'voice'; it is sometimes followed by another two-second tone to indicate the end of the 'over'. The synchronisation is necessary so that the decoding equipment attached to the receiver can un-scramble the coded 'voice' in the right order to make it intelligible again at the receiving end.

Occasionally you will hear the radio operators mention which kind of cryptographic equipment in use, such as 'KY-3', 'VP-100' and 'KY-75'; the latter is also known as 'Parkhill'. I remember a conversation with a crew-member of a C-20B Gulfstream III aircraft a few years ago; he said that they just entered the channel number given by 'Andy', and the comms equipment did the tuning of the radio and a.t.u. One disadvantage with this set-up is that every time the channel and frequency pairings change, somebody has to re-enter all the new pairings into each aircraft and set of equipment. Another source claims that not all the channels are paired to h.f.; some may be paired with u.h.f. satellite frequencies. The frequencies are not only used for voice contacts, they can also be used RTTY (or a similar system) and other computer communications.

There are many frequencies in the Mystic Star network, and only relatively few are known; confirmed channel/frequency tie-ups are quite rare (see the list in the January column, and later). Although there are a possible 999 channel and frequency pairings, many of the frequencies have more than one channel number. The channel number given by 'Andy' indicates which particular frequency and transmitting site are being used for the contact, and when you combine the channel/transmitter site or channel/frequency or frequency/transmitter site, then you are into the realms of classified material. Over the past six months I have heard many contacts between SAM aircraft and 'Andy', but I have never managed to find their

transmissions amongst the published frequencies. During the past 6 months 'Andrews' has frequently used 6.683MHz, and this is known to be both channel 529 and channel 118. Another recent tie-up was heard by Paul H in Newbury during late January, when 'SAM 683' was heard working 'Andy' on 11.159MHz and mentioned they were using channel 954. Keith Elgin has provided some more frequencies to try when listening to the network, and offers the following:

6.810	6.883	8.993	11.059	11.180
11.210	11.228	11.266	13.247	15.048
18.003	18.057	20.016		

Not all the Mystic Star communications are scrambled, on 9/11 **Keith Elgin** heard SAM 29000 on its way from Amsterdam to the USA; many phonepatches were made from the aircraft by military personnel to their families and much of the conversation was about being on board Air Force 1 with the President!

Note that the US Drug Enforcement Agency (DEA) and US Navy are also users of similar voice encryption systems, so some of the frequencies noted by me may be DEA frequencies. The DEA system was shown to good effect in the BBC-1 series *DEA* last autumn, in the episodes that dealt with DEA operations in Bolivia. For the record, the 89thAW are based at Andrews AFB just outside Washington DC, and they have the following aircraft:

**2 x Boeing 747-200 (VC-25A)**  
serials 28000, 29000

**10 x Gulfstream III (C-20B/C)**  
serials 50049, 50050, 60200 - 60207

**9 x Boeing 707 (C-135B/C-137B/C)**  
serials 24126, 24127, 24130, 86970 - 86972, 56973, 56974, 26000, 27000

**3 x DC-9 (C-9C)**  
serials 31681 - 31683

These usually use either their full serial, or just the 'last three', as part of their callsigns. The VC-25As are the new 'Air Force 1/2' replacing the C-137B's 26000 and 27000; whichever aircraft carries the President uses the

'Air Force 1' callsign. The DC-9 aircraft are used for short range trips and are very rarely heard on h.f., however one (31683/SAM 683) visited Europe during late November '91, and again during late January '92.

## Kcabdeef!

In the February magazine I mentioned some new receivers, and asked if anyone had any comments on them. A letter from **David R** in Kent mentions the problems that he had with a new Sony SW-77. After a few days use some of the memories became unusable, so the unit was returned to the shop. It was replaced without question, even though the assistant admitted his lack of knowledge of the particular model. The replacement worked fine for a few days, and then started to suffer the same problem as the first. This unit was also returned to the shop, and has now been sent off to Sony for repair. Other than the memory problem, David says that the set performed very well, particularly on s.s.b. Fortunately David was dealing with a reputable manufacturer and dealer, so is quite likely to get a 'working radio' eventually. This is quite a new model of radio, so maybe the type has to have a while to 'settle down'. The moral is: buy from a reputable dealer.

**Mike Powell** in London mentions that his new Lowe HF-150 is a great improvement on his previous Phillips D-2935. Using either a Sony active antenna or 12m long wire, he reports that he can now hear many more stations that the Phillips just didn't hear. (Thanks for the list Mike).

**Paul W** in Cumbria comments on the USCG notes, also in the February magazine. Back in August '91 he heard 'Rescue 1500' (an HC-130 Hercules aircraft) on a rescue operation working with 'CommSta Boston'. He wrote to the crew of the aircraft and received a computer printout of their mission. Later on, he received a letter and phone-call from the aircraft radio operator while the aircraft was on a short tour of Europe and the UK, and he was invited up to Prestwick to visit the crew and the aircraft. How's that for a 'SSB Utility' QSL!

Printed circuit boards for SWM constructional projects are now available from the SWM PCB Service. The boards are made in 1.5mm glass-fibre and are fully tinned and drilled. All prices quoted in the table include Post and Packing and VAT for UK orders.

Orders and remittances should be sent to: **PW Publishing Ltd, FREEPOST, Eneco House, The Quay, Poole, Dorset BH151PP**, marking your envelope **SWM PCB Service**. Cheques should be crossed and made payable to PW Publishing Ltd.

When ordering please state the Article Title as well as the Board Number. Please print your name and address clearly in block capitals and do not enclose any other correspondence with your order. You may telephone your order using Access or Visa. A telephone answering machine will accept your order outside office hours.

**Please allow 28 days for delivery. Only the p.c.b.s listed here are available.**

## SHORT WAVE MAGAZINE PCB SERVICE



Telephone orders: (0202) 665524

Board	Title of Article	Issue	Price £
SR008	Experimental VHF Receiver	Jun 91	5.81
SR007	VLF Receiver	Dec 90	5.24
SR006	Medium Wave AM Radio	Nov 90	3.34
SR005	R210 Converter	July/August	6.87
SR004	PRO-2004 Modifications	Oct 89	6.63
SR003	HF to VHF Converter	Aug 89	5.22
SR002	Weather Satellite Reception	Jun 88	3.88

## NORTH AMERICA

Gerry Dexter

**A**s always seems to be the case, there's a lot to catch up on in the way of short wave news from the Western Hemisphere. An unending parade of new stations, plans for new stations, new facilities, new programming and so on keeps marching past.

### Eternal Word

Around October we should be noting the initial tests of station WEWN - the short wave voice of the Eternal Word Network, which is installing a station near Birmingham, Alabama. When fully completed it will use four 500kW transmitters. Regular programming is expected to start by Christmas and all four Continental Electronics transmitters are expected to be functional by March 1993. Eternal Word is a Catholic organisation that has its own cable TV network.

The producers of the *Prayerline* programme on WWCR short wave, mentioned last time, have gotten the go-ahead from the US Federal Communications Commission to construct a short wave station. It's expected the station will use WJCR as its call (it already owns WJCR-FM, 90.1MHz). Plans are to convert two 50kW a.m. band transmitters for use on short wave, either separately or in combination. The station will be located at Millerstown, Kentucky, about 50 miles slightly south-west of Louisville.

### Radio Miami

The FCC has given go-ahead-and-build approval to yet another station - Radio Miami International, which will operate a 50kW station beaming mostly to the Caribbean area from Miami, Florida. The completion deadline is 18 May 1993, but a spokesman for the station says they expect to be on the air well before that date. Radio Miami International currently airs its own programmes via WRNO, New Orleans. Most of RMI's programming is and will continue to be in Spanish but they expect to have an English segment on WRNO by now - scheduled for 0430 daily on 7.465MHz. Radio Miami International may be contacted at 8500 SW 8th Street, Suite 252, Miami, Florida 33144, USA.

The same organisation owns Radio Copan International in Honduras which, as of this writing, had not yet started regular broadcasting. At least one test broadcast has been aired, however, so perhaps we can expect to hear signals from this one soon. The station will use 9.950 and 15.670MHz with 1kW.

### High Adventure Update

The long-expected High Adventure Ministries station intended largely to beam to mainland China has, after two false starts, finally settles on a location. It will be built on the Pacific island of Palau. I don't have any kind of an on-the-air target date yet, however.

### Clandestines go Legitimate

Political changes and peace agreements have brought two former anti-government, secret broadcasters in Central America into the ranks of legitimate operations. A number of years ago Radio Miskito was an anti-Sandinista station purporting to speak for the Miskito indians. It was off the air during the last several years of the Contra war but has now returned - or at least a station using the same name has. North American DXers began hearing the station a couple of months ago on 4.560MHz but it has since appeared on 5.560MHz (and announces a frequency of 5.970MHz). It is heard around 1100 and again from 0300 to 0600 broadcasting from Puerto Cabezas.

Radio Venceremos, the main clandestine station of the Farabundo Marti National Liberation Front, is now a legal broadcaster - and even tries to sell advertising time! Though its sister station, Radio Farabundo Marti, is apparently using f.m. only, Venceremos continues to be heard on short wave, usually around 0200, operating around 6.700MHz.

Oddly, through all the years of civil war in El Salvador, the government station, Radio Nacional, was on short wave only once or twice and then only for a few days each time, whereas the opposition station were almost continuously active over a period of several years.

**The radio ship that never was. Adventure Ministries 'China' station was to broadcast from this ship. Now it will be the island of Palau.**

**Spanish National Radio should fill in a few of the blanks in their coverage area when their powerful relay goes on the air from Costa Rica.**

Speaking of clandestine stations, the anti-Castro station La Voz de la Federacion Mundial de Expresos a Politico de Cubanos, which transmitted on 7.080 a few times last year and was subsequently located and closed down by the FCC has now returned. It has been heard on a limited schedule - seemingly Fridays only, from 0130-0145 on 7.417MHz with an anti-Castro speech in Spanish and many station identification announcements.

### Colombia

Radio Nacional de Colombia has begun an English language DX programme *Colombia DX*, airing Saturdays from 2300-0000. The show is hosted by Juan Carlos Pardo and Jaime Molina and may be contacted at PO Box 94321, Bogota. Announced frequencies are 11.825 and 17.865MHz. The latter is not heard here and the former is actually 11.8225MHz.

A fairly new Colombian station is La Voz de Guainia, located in Puerto Inirida, in north-west Colombia near the Venezuelan and Brazilian borders. The station uses 1kW on 3.500MHz and is heard well some mornings around 1000. Another new station, perhaps unlicensed, is Radio Catolica on 3.580MHz. Its location is unknown.

### Ecuador

There are two fairly new stations here, too. Radio Cumando is sometimes heard on 3.3505MHz at around 0930. Radio Tucuban, though to be in or near the town of Onya, is reported on 4.212MHz.

HCJB's DX Party Line programme now has a special 'phone number that you can call and leave DX tips for use on the show. The number (touch tone 'phones only) is 593-2-433-603, preceded by your international dial code. Once you've dialled that number, wait for another dial tone, then punch 489 and you have 90 seconds to leave your message. You can also send FAX messages via 5930204470263.

### Want to Buy a Short Wave Station?

If you happen to have a spare million dollars and have always had the desire to own your own short wave station the government of Chile will happily sell you its facility, once used by its Voice of Chile international service. The complex consists of seven 100kW transmitters, an equal number of antennas and three power plants. You couldn't build a similar facility for anything close to that price today.

### More from Central America

Listen for stronger signals from Radio For Peace International before long. Work continues on the installation of

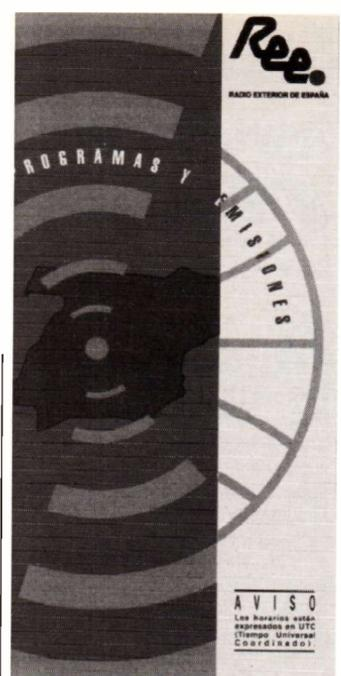

two new 30kW transmitters (the current units are just 500W and 1kW). When active, the new transmitters will use 7.375MHz a.m. and 21.465MHz upper sideband.

The Dominican Republic religious broadcaster Radio Amanecer, 6.025MHz, is now carrying an hour of English, at 0300 to 0400.

Radio Rica, in Nicaragua, on 4.920MHz currently uses 1kW but it expects to increase that to 19kW in the near future. The station currently operates from 1300-1500 and 0100 to 0500 and has sent out some very nice verifications in response to listeners reports.

Watch for the new Costa Rica relay of Spanish National Radio to take to the air before too much longer.

Radio Havana Cuba has begun using the 22m band, with a transmitter on 13.700MHz, that runs from 0200 to 0430.

### RCI QSLs

Radio Canada International may be only a shell of its former self, but their cumbersome QSL policy has taken a definite turn for the better. QSLs from RCI are now handled by the well-known Canadian International DX Club, which should mean a happy end to waiting for the once-a-year blank QSL to come with your programme schedule, filling it out yourself, sending it back and waiting for it to be signed and returned. You still send your reports to RCI (at PO Box 6000, Montreal, PQ H3C 3A8, Canada). RCI sends them on to CIDX.

### WWV Info

The US government standard frequency and time stations WWV, WWVH and WWVB are known around the world. Many, though, don't know of the many types of information WWV broadcasts through the course of an hour. Now the stations have issued a new 27-page booklet detailing the services available. You can obtain a copy by writing to NIST, Mail Station 847, 325 Broadway, Boulder, Colorado 80303, USA and asking for a copy of Special Publications 432.

I'll have more news from the Americas in three months' time. Until then, good listening!

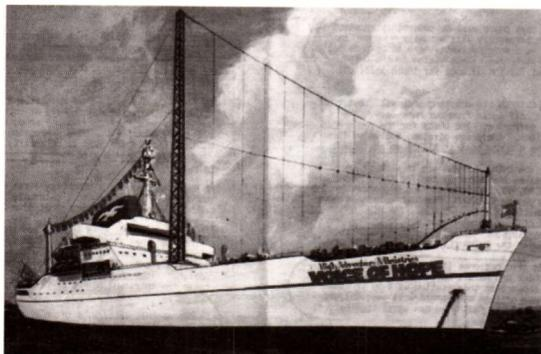

# Computer aided listening

The **NEW AR3000A** receiver is an evolutionary step onward from the highly acclaimed AR3000 and many major improvements have been implemented at the request of enthusiasts. The tuning control is now 'free running' to provide a smooth feel for SSB/CW, x10 buttons have been added to make step size faster and more convenient. All information is contained on a larger LCD with an improved viewing angle instead of a separate LED status indication. The RS232 facility has a switch on the rear panel to enable / disable operation. Memory reset functions are available from the front panel. The re-writing of microprocessor firmware using an even more efficient language has further increased scan and search speeds.

Your listening horizons are truly extended with receive coverage from 100 kHz all the way up to 2036 MHz without any gaps in the range. The AR3000A offers a high level of performance and versatility from long wave through shortwave, VHF and onward to the upper reaches of UHF.

Not only will the AR3000A cover this extremely wide range, it will allow listening on any mode: NFM, WFM, AM, USB, LSB and CW. Tuning rates are selectable from an ultra-fine 50 Hz step for SSB and CW, right the way up to 995 kHz steps for the TV bands and Band-2.

**ACEPAC-3A** is a new and exclusively developed multi-function IBM-PC based program to further increase the flexibility of the AR3000A and AR3000 receivers. No additional hardware is required other than an AR3000A, IBM-PC compatible computer and a standard serial lead.

The software package is designed to run in conjunction with the AR3000A which is an extremely versatile start-of-the-art receiver featuring all mode reception with coverage from 100 kHz to 2036 MHz without gaps. An RS232C port is provided ready for connection to any 'reasonably priced' PC compatible computer using a standard serial cable, the software runs under DOS.

ACEPAC-3A is menu driven for ease of operation and has basic on screen help at the touch of a button, a comprehensive printed operating manual is also supplied as part of the ACEPAC-3A package. Two disks are supplied, one 3.5 inch 720 kB format and the other 5.25 inch 360 kB. Of course you may install one copy onto the hard drive of your computer.

Default settings ensure you can 'get up and go' with the minimum of fuss or delay, these defaults may be changed any time to tailor the exact configuration to suit your needs. When called, ACEPAC-3A checks the serial port connection for the presence of an AR3000A, if the connection is not established ACEPAC-3A enters emulation mode so that you may still familiarise yourself with the software.

Providing you have the appropriate computer hardware, the ACEPAC-3A display is in colour except for the sweep facility (spectrum analysis type graph). For this function you need a graphics card such as CGA, EGA or VGA although Hercules will be supported in all other respects if required. There are two types of display available for the sweep facility (graph-line or dot) and three types of scanning in this mode. You can program start and end frequency, mode, attenuator setting and step size.

Band activity can be monitored both as sweep display and as an 'X' axis table format with squelch opening percentage recorded for each frequency. This is useful to indicate 'how active' the frequencies are in the programmed search range. In addition to the graphic display, ACEPAC-3A can produce a detailed numerical list from the graphical information which may be printed on an Epson compatible printer.

**AORSC - Spectrum Coordinator** is a powerful program for the IBM-PC compatible computer which allows the user to control the AR3000A, AR3000 or AR2500 receivers using the serial port of the computer. Many facilities are offered allowing a high performance radio monitoring system to be put together very simply. The AR3000A supports the 'games port' (if fitted in the computer) to further increase search and scan speed.

A text display is used to present information to the user about the operation of the software. The status of the receiver and software is displayed on the computer monitor above a list of the memory channel contents. The bottom line of the screen contains a menu providing options for the main facilities of the software.

The computer's keyboard may be used to select the frequency and mode of the receiver using dual VFOs. It is possible to switch instantaneously between the two VFOs with a single key press. A fixed VFO offset may be entered into the system and the VFOs locked together using the 'tracking' facility so that the offset is maintained while tuning across the spectrum.

It is possible by using the PBS, to automatically locate signals and place their frequencies in the top 500 memory channels of the software. In addition, channel occupancy can be calculated optionally from preset PBSs so the level of spectrum usage for a band of frequencies can be measured. Similar statistics can be calculated from memory scan with output directed to a printer or disk file.

The Single Frequency Watch (SFW) facility allows statistics about signal activity on a single frequency to be calculated over a period of time. Regular reports on the density of traffic on the frequency can be output to a printer or disk file. This facility allows the number of transmissions per hour to be calculated together with the amount of activity expressed as a percentage of the total time per reporting period. The frequency of reports may be determined by the user.

A list of up to 100 unwanted frequencies can be built up for rejection during scanning operations. It is possible to individually 'tag' memory channels so that a Morse character 'A' is sent through the PC's speaker to alert the user to the presence of activity on a memory channel while memory scanning.

Offset Simplex Reconstruction (OSR) allows both sides of a simplex transmission that are on different frequencies to be recovered by switching intelligently between the two VFOs of the system.

A comprehensive listeners logbook is incorporated allowing the activity of stations to be manually recorded on disk. Print outs of logbook information can be produced and sent to your printer if connected. It is possible to add logbook entries while scanning using a single key press.

Various conversion routines are provided that allow memories, logbook information and the reject frequency list to be output to disk in text format. This allows the data to be imported into an external data base (not supplied) where it can be modified to the user's requirement. The altered data can then be imported back into AORSC so that it can be used with the software.

A comprehensive printed operating manual is supplied as part of the AORSC package, pages of help information may also be read from disk for display on the computer screen while the software is being used. Two disks are supplied, one 3.5 inch 720 kB format and the other 5.25 inch 360 kB. Of course you may install one copy onto the hard drive of your computer. The computer requires a minimum of two floppy disk drives or one floppy disk drive and a hard drive.



Please send a large S.S.A.E. (34p)  
for further details.

**AR3000A Receiver £765.00 inc. VAT**  
**ACEPAC3-A Computer software £119.00 inc. VAT**  
**AORSC Computer software £75.00 inc. VAT**  
**DA3000 discone aerial £69.00 inc. VAT**  
**WA5000 wide band aerial £150.00 inc. VAT**  
**CR400 tapc recording lead £9.99 inc. VAT**

**AOR™ AOR (UK) Ltd.**

**Room 2, Adam Bede High Tech Centre,  
Derby Road, Wirksworth, Derby. DE4 4BG.**

**Tel: 0629 - 825926 Fax: 0629 - 825927**

A subsidiary of AOR Ltd Japan

E&OE

If you are unable to obtain supplies of AOR products from your local dealer,  
you may order directly - we have a fast mail order service.



TWO-WAY RADIO ● AMATEUR RADIO ● AUDIO VISUAL ● SALES & SERVICE  
58 High Street, Newport Pagnell, Bucks MK16 8AQ. Tel: (0908) 610625 FAX: (0908) 216373



# ALINCO's "Professional Grade" Scanner DJ-X1. 500kHz-1.3GHz

"A Scanner of Unrivalled Performance"

**Specification:**

Modes: AM/Narrow FM/Wide FM  
Steps: 5, 9, 10, 12.5, 20, 25, 30, 50, 100kHz  
Antenna: 50Ω BNC  
Supply: 6-15V DC (Internal 9V AA)  
24mA (Battery save.)  
Dimensions: 110 x 53 x 37mm  
Weight: 370g  
Configuration: AM/FM Triple conversion  
Sensitivity: NBFM 8dB (12dB SINAD)  
AM -2dB (10dB S/N)  
Memories: 100 in banks.

**STOP PRESS!!!**  
"Swellingly far better than its obvious rivals"  
says Japanese magazine review

**£269**

Up until now most handheld scanners have been large and cumbersome with low grade plastic cases using technology that has been around for several years. The arrival of the ALINCO DJ-X1 has changed all that. This brand new receiver is ruggedly built, compact, and above all, ultra sensitive. ALINCO are the first major manufacturer of communications equipment to produce a new generation of scanning receiver. All of a sudden its competitors seem drab, old fashioned and lacking in sparkle and performance.

The new exciting DJ-X1 should be available now at your local dealer. Try it out for yourself, experience the superior design and performance. Compare it with "yesterday's" models and find out just how far advanced the new ALINCO scanner is! But just to wet your appetite, here's a few of its features:

- ★ 3 scanning speeds ★ 3 scanning modes ★ 100 memories in 3 banks ★ Auto memory loading ★ Priority channel ★ Dual rate battery saver ★ Large battery pack ★ Rotary frequency control ★ Illuminated key pad ★ Auto illumination mode ★ Dual antennas ★ 5 programmable bands ★ Widest range of frequency steps ★ Super front end sensitivity ★ Memory lockout ★ Mode scanning ★ Auto power off ★ Wide range of battery packs ★ Wide range of accessories ★ Intelligent mode programme ★ Rapid tuning rates of 1MHz/10MHz.

\*Each unit now comes with the UK Gold Seal Warranty. Look for the sign on the box!



From the longest of long wave to the top limits of the short wave spectrum, the HF-150, is designed to give you everything you needed in a real radio receiver. There has quite literally never before been a receiver like the HF-150, because only now have technology and engineering been combined in such an effective package. This is innovation at its very best.

Listening to radio can mean many things, news and current affairs from around the world, ships at sea; aircraft wending their lonely way across the oceans of the sky; sounds of conflict; sounds of peace; drama, real or staged; entertainment; crisis; they are all at your fingertips with a good radio receiver. This is the arena where the HF-150 operates; and operates equally well at home by your fireside or travelling with you wherever you may be.

The HF-150 is designed to be a survivor. No flimsy boxes here; just solid hard alloy casings, metal panels, and machined parts, right down to the silky smooth tuning control and carefully crafted carrying handle supports. This level of

mechanical strength carries the bonus feature of ensuring excellent stability and shock proofing. Take the HF-150 anywhere – it will handle more beatings than you can.

Its performance in electrical terms is impressive, and the specification comprehensive. Tuning range is all the way from 30kHz to 30MHz, with variable tuning rate according to the speed of rotation of the main tuning knob. For large frequency shifts, a single press on the "FAST" button gives tuning in 100kHz steps; a second press returning you to the normal ultra fine tuning rate. Reception modes are Upper Sideband (USB), Lower Sideband (LSB), CW, and AM, but also included is an all new phase locked AM system which allows selection of either synchronous upper or synchronous lower sideband AND synchronous double sideband. This is the ultimate arrangement for coaxing the best from poor short wave broadcasts, and can virtually eliminate the effects of selective fading.

**£329 including VAT**

### ANTENNAS AND PRE-AMPS

#### AA2 ACTIVE ANTENNA for 150kHz to 30MHz

The HOWES AA2 is the active antenna to use for general coverage HF reception. Broad-band performance that does not tail off at the higher frequencies. The neat, compact answer for those with limited space. Holiday use, mobile operation etc. Two selectable gain settings. Local or coax powering (12 to 14V) IP3 +38dBm. Easy to build and much liked by customers!

**AA2 Kit: £8.50**

#### AA4 ACTIVE ANTENNA FOR SCANNERS

The HOWES AA4 gives full coverage from 25 to 1300MHz in a neat compact package. The antenna is only just over 16 inches long, and is designed to be the answer to spacability problems for home or portable operation. A low noise microwave IC is used as the active element. This "high tech" approach gives good performance with a low parts count, making construction straightforward. Reviewed in the November '90 Short Wave Magazine. Excellent performance in a small space!

**AA4 Kit: £19.80**

**New from AOR**



The NEW AR3000A is an evolutionary step onward from the highly acclaimed AR3000 and many major improvements have been implemented at the request of enthusiasts. The AR3000A still covers an extraordinarily wide range from 100kHz-2036MHz without gaps and offers ALL MODES: AM, NFM, WFM, USB, LSB & CW. The LCD is larger and the viewing angle has been changed to further improve visibility. SCAN and SEARCH speed has been greatly increased and new programmable DELAY, PAUSE and PRIORITY facilities have been added. The rotary tuning control is free running to increase user friendliness for SSB/CW listening. Memory clear and microprocessor reset are now available from the front panel.

**£765 inc VAT**

### OUR BEST SELLING BOOKS

**SHORT WAVE LISTENERS CONFIDENTIAL FREQUENCY LIST Bill Laver.** Covering the services and transmission modes that can be heard on the bands between 1.635 and 29.7MHz New 1991 Ed. .... **£8.95**

**THE COMPLETE VHF/UHF FREQUENCY GUIDE 1991 Edition** This book gives details of frequencies from 26-2250MHz with no gaps and who uses what. Recently updated, there are chapters on equipment requirements as well as antennas, etc. .... **£5.95**

**THE SECRET OF LEARNING MORSE CODE Mark Francis** Designed to make you proficient in Morse code in the shortest possible time, this book points out many of the pitfalls that beset the student. .... **£4.95**

**MARINE UK RADIO FREQUENCY GUIDE Bill Laver** A complete guide to the UK s.w. and v.h.f. marine radio networks. Useful information, frequency listings and the World Marine Coastal Phone Stations. .... **£4.95**

**HF OCEANIC AIRBAND COMMUNICATIONS 3rd Edition Bill Laver** HF aircraft channels by frequency and band, main ground radio stations, European R/T networks and North Atlantic control frequencies. .... **£3.95**

**THE POCKET GUIDE TO RITTY & FAX STATIONS Bill Laver** Just updated. Invaluable to all data users, information includes Embassies News Media, Military Marine aircraft etc. .... **£3.95**

P&P £1 EACH BOOK.

### MORE BEST SELLING RECEIVERS

ICOM IC-R1 100kHz-1300MHz handheld.....	£349
ADR-2000 500kHz-1300MHz Hand-held NO GAPS .....	£269
R2000 Kenwood super short wave receiver.....	£549
R5000 Kenwood top range super sensitive receiver.....	£925
FRG8800 Yaesu short wave receiver.....	£649
ICR71E Icom super top performer.....	£875
ICR72E Icom's budget short wave receiver.....	£659
HF225 LOWE Budget price - superb performance.....	£425

FREE DELIVERY - ANY RECEIVER

### The NEW MVT-7000 1MHz-1300MHz



- AM-NBFM-WBFM
- Multiplesteps
- Better than 0.5µV
- 200 Memories
- Rotary Dial
- S-meter
- Fast Scan Speed
- Lockout/Priority
- NiCads
- Charger/AC PSU
- 12V Lead

**£289**

### AR2000

Hand-held wide band scanning receiver. Improved specification. The coverage is 500kHz - 1300MHz with no gaps. Modes are AM, FM (narrow) and FM (wide). The AR2000 features 1000 memories for spot frequencies and 10 search banks. The receiver is powered from its supplied internal nicad batteries but these may be removed and dry batteries substituted to allow extended operation in the field. The AR2000 may also be charged and powered from the car cigar lighter socket using the supplied lead. Also supplied as standard are the DA900 wide band aerial, soft case with strap and AC charger.

R.R.P including VAT **£269** (p&p £5).



**AUTHORISED AGENTS FOR KENWOOD, ICOM, YAESU & ALINCO. FULL SERVICE FACILITIES AVAILABLE**

SPEND UP TO £1,200 INSTANTLY WITH A PHOTO ACOUSTICS LTD. CREDIT CHARGE CARD

PART EXCHANGE WELCOME, ASK FOR KERRY G6IZF OR ANDY G4YOW

RETAIL SHOWROOM OPEN MONDAY - FRIDAY 9.30 - 5.30, Saturday 9.30 - 4.30

Goods normally despatched within 24 hours. Please allow 7 banking days for cheque clearance. Prices correct at time of going to press - E&OE



PHOTO ACOUSTICS

Roger Bunney, 33 Cherville Street,  
Romsey, Hants SO51 8FB

**T**he Winter Olympic Games produced a flurry of activity on many satellites during the period up to February 23 when the games closed. The French Telecom 2a bird temporarily slotted at 3°E worked full time on most transponders (I counted 9 one day though another enthusiast made 12 sightings!) carrying various skiing, bob sleigh and related wintery activities from the remote event sites to the main switching centre at Moutiers. Outgoing feeds to Europe and were carried on several Eutelsat birds in Ku band with international circuits onwards in C Band via Intelsat, etc. Interesting that the Alpine location uplinks into Moutiers used PAL, SECAM and NTSC depending on event originator and eventual destination of the pictures. The Telecom 2a signals were extremely strong. At the time of writing only the occasional carrier is downlinked from Telecom 2a for test purposes, imminently the satellite will be moved to join her sister craft at 8°W. Incidentally if you were puzzled by the 'ORTA 92' caption that often was seen in recent weeks, it stands for Olympic Radio and Television Organisation 1992.

## What's Happening

It looks as if Intelsat VA F15 has now been slotted in at 18°W to replace the inclined orbit VA F6, signals on the various Italian cable feeds improved and stabilised during February, however in the past few days (2nd week March) a single caption announced that the Fininvest Group were using a new satellite at 63°E and detailing programmes, frequencies, polarities, etc. Intelsat VA F11 resides at 63°E. Gareth Foster (near Twickenham) has found the above commented cable feeds with strong signals downlinking into Europe on this bird.

A new one to me was the caption over the Learning/Discovery Channel Intelsat VI F4 27°W at 11.175GHz indicating 'Sun Interference Today' on March 4. I have read of C Band (4GHz) problems when the sun passes directly behind the LNB and the dish receives solar radiation causing interference but never at 11GHz Ku band. This problem tends to occur during the Equinoxes.

An interesting outside broadcast (Feb.18) was being linked back to the Rome studio for RAI from a fishing port, pictures suggested that off-shore a fishing vessel had sunk, a diving barge above was carrying divers and an underwater camera, pictures revealed the boat sitting upright on the seabed, the lack of incrustation suggested a recent sinking. The off-shore pictures were terrestrially linked back to the main OB site on the crowded quayside and suffered deep fading from time to time. Eutelsat II F2 10°E was used for this satellite fed OB on 11.10GHz vertical.

Keith Watkins from Cornwall rang in great excitement to tell of HDTV tests being carried over Eutelsat II F3 16°E on February 23. Keith is using a modified BSB receiver to receive the D2 MAC transmissions which are in the clear. Incidentally the satellite supply firm Trac are selling modified BSB receivers that will enable DMAC and D2MAC signals to be resolved via this tuner. (Trac Satellite Systems on (0642) 452555)

## Orbital News

Canal Plus are again in controversy over their projected Telecom 2a services, CP had intended to operate in SECAM encrypted Nagravision but the French government pushing for adoption of D2MAC and Eurocrypt.

Meanwhile Filmnet are gradually changing transmissions and intend going down the MAC path + Eurocrypt during 1992. Scandinavian cable Succekanalen however have gained the sole Scandinavian rights for Eurocrypt and Filmnet reacted by transmitting in D2MAC in the clear over Astra. Succekanalen transmit D2MAC Eurocrypt and as a result Filmnet were seen free by all D2MAC satellite viewers in Scandinavia, hopefully the free sampler of Filmnet would then gain subscribers when F'net eventually scrambles. The Filmnet service over Eutelsat II F1 13 East will be D2MAC/Eurocrypt which is their Benelux service.

Euronews, the EBU/Eurovision news service now being established at Lyons for on-air early 1993 will run 5 minute newscasts throughout the day and with longer 20/30 minute offerings at night, including current affairs programmes of about 20 minutes. Initially clear PAL will be used with differing languages on appropriate audio sub-carriers though eventually consideration must be given to a future D2MAC service. Total equipment budget is around £5million. Euronews will have no studio other than a voice-over booth operation, programme format will be simple and relying on electronic production to maintain continuity of contribution flow.

## Around The Globe

Star TV that transmits from AsiaSat has to source some 44 000 hours of TV programming annually to fill its 5 transponders. Thoughts are to provide a Hindu language service to serve Asia, the specialised Mandarin service for Taiwan has proved extremely popular. Odd to relate that the Hong Kong based service is forbidden to offer a service into the HK colony itself at present.

Compression Labs, an American company now researching digital video compression is currently working on the projected Music TV Channel to squeeze the future MTV-1, MTV-2 and

The Fininvest Group advising cable operators of changes to downlink transmissions.



Test card from the new German cable channel.

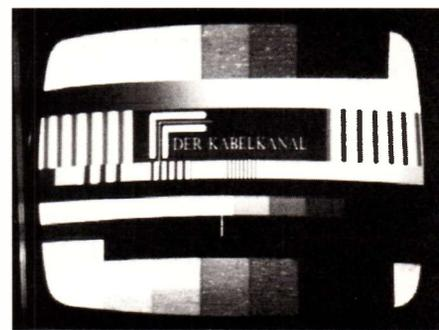

MTV-3 channels into a single TV transponder. A standard NTSC 6MHz channel has already been squeezed into a 2MHz bandwidth thus 3 channels can be fitted into a standard 6MHz channel. Known as a 'Spectrum Saver' it uses 'a Discrete Cosine Transform-based (DCT) algorithm' and enables use of smaller aerials than a conventional analogue TV system (it says in the report!).

North of the border, the Canadian Satellite Communications (Cancom) group is seeking her own C Band satellite to transmit from 1995 hopefully in a Telesat Canada slot at 115°W. The Canadian government currently controls all satellite activity and Cancoms attempt if successful would make it the first privately owned Canadian satellite group.

## More News

The Unicom Satellite Corporation have obtained agreement with Tonga to operate two C and Ku band satellites from mid 1994 and 1995 respectively, one slotted over the Pacific and the other over Asia. Meanwhile the nearby Friendly Islands are proving less than friendly since their satellite allocations overlap that of Tonga - discussions continue. Singapore is to allow a PAY TV subscription service, operated by the SBC and available from the Summer 92. Other than SBC, international broadcasters such as CNN and BBC World TV that are satellite carried will be available on a PAY basis.

Cartoon fans will rejoice in knowing that Tom and Jerry, Flintstones, Yogi Bear, etc., are part of a large package of cartoons from the Hanna Barbera library that Turner Broad-

casting (Turner of CNN fame) have purchased to start a 24 hour cartoon service. Initially available in the USA it's possible that the satellite service will be extended to Europe in due course.

The Republic of Yemen are to inaugurate 2 domestic satellite networks to help with unification between the North and South Yemen, providing business and domestic communications via Arabsat.

In early March Ariane successfully launched and orbited the Japanese Superbird B-1 and Arabsat 1C satellites - one of 1C's transponders has already been leased by CNN for its news programmes.

## Finally...

Finally from Nicholas Earley, our Australian contact a pile of news cuttings have arrived, and picking a few items out - the Australian government is to lift the PAY-TV moratorium from October 1st 1992 and will then allow PAY TV to start, currently the working of foreign PAY TV operations are being studied. AUSSAT B2 which flies early '93 will probably carry up to 6 PAY TV channels and at present licence applications are being advertised. State broadcaster ABC is also involving itself in PAY TV with its own company 'ABC Pay Television'. Sri Lankan Shan Wickremesinghe is to start a satellite TV service later in '92 (August is quoted) which will footprint both the island and Eastern India using standard PAL and a programme format of popular films, music and general entertainment. His initial investment is 50 million Rupees and is seeking Japanese involvement.

# amateur bands round-up

Paul Essery GW3KFE, PO Box 4, Newtown, Powys SY16 1ZZ

**F**irst we turn to **Matt Spencer** (Redhill), who tried every band other than 10MHz; On 1.8MHz I6FLD, UA6LTJ, UB4IDB, UB5VCR and Y08R0P were booked in, while 3.5MHz yielded EA8TH, KP4IF, NP4AT, OY1HJ, OY4AH, PY6KY, SV5TS, VS6MW, UF6FAL, UF6FXC, ZD8JL, ZF8AA, 9K2HF, East Coast Ws, KC9GJ, WB9Z & VE1-2. On 7MHz the scalps included CU2DX (St Miguel Is), H18A, N3BFB, PS7KM, PT7ZK, UA6DFF, YV4ARB & YV5MRR; a flip of the switch to 14MHz for CI3JPP, K4GSO, P43LJP, V00XC for a 'special' & 9K2HF. Melilla by way of EA9TL was noted on 18MHz along with 5V7DP, 7X5VRK, K11ED & WS4I. 21MHz again featured Melilla, this time by way of EA9IB, as well as 9K2RA, K6DIZ, W8ZET & W8IEN. On 24MHz Matt found A92BE, XE1/DK6LV, 5U7M, W1, W9, VO2 & VC3XN. Finally 28MHz were the list included A61AC, EA9IP again, H18A, OG9NDD, P2JHB, PY2ZHS, TI2CF, TI2IX, 9H1DE, 9H6CM, 9K2TC, WA1HMZ/P7 in Arizona, all W call areas, including WEOD in S. Dakota, W1HTV/VOA, 5V0VOA, WA9VIV & V31KX/VOA, all on a 'VOA net', plus VE1-2.

## Congratulations

Nice to hear again from **Harold Wood**, who noted: 3.7MHz 4J4GC; 14MHz IV3SUS & VO1TU; on 24MHz A61AD, Z21HJ, TU2YH; & on 10m VE3IMO, VO1KK, VE2FSC, VE3PWJ, VY2SS, AG1J, A22AA, N8AYC, N8RPA, T77C, ZC4HH & ZA1FD. All were logged with a Philips 2935 and a random wire fed by way of an a.t.u.

When he was listening before, says **Simon Griggs** (Chelmsford), he took four years to hear 69 countries; but since he came back in October last, he has already noted 71 countries! A couple of OKs on Top Band, W2HCW on 80m, EA9UL, EA8GP, an SV & VP2EY were landed on 7MHz & on 14MHz we note V44KG, VK6EWM, 9K2GS, ZS2Y, JA2DWA, VK3AQW, NR7V, SV0VOA, VU2JJ, UF6FHM, TA5C, A71CH, 9K2JH/NLD, 4X1FQ, 9K2HF, JA9AA, 9K2RA/NLD, 9K2JH/NLD, 8P9DX, V21AK, 4S7WP, 4S7TP, CN8NS, YV3CRA, C6A/G4AML, 6Y5DA, J39CO, HR1KAS, 9Y4SF, 8P6AH/KP4, TA3D, 9Y4UNO, CO2GB & UD6GF. As to mode, Simon seems to split almost evenly between c.w. and telephony - congratulations. On to 21MHz, where Simon logged ZD8LII, TK5CW, EA9VKK; concluding with 28MHz where he received KC4KZA, ST0VD, EA8FG, TA3D, HZ1AB, 9K2LX, EA8/G0KPPW, UA9YMF, JA9CNP, VC1PMD, YL3HA, KC4EAY, TU2XZ, UL8AG, UA9YH, SV9ANH, JA7OWD, 9H4CM, PS8RW, 9K2TC and the usual smaller fry.

## Events

The UK Six-Metre Group have a Summer Sporadic-E Contest on June 6. Between 0000UTC & 2400 on June 6,



log all you can on this band. To log a cross-band contact between a 6m station and one in a country which doesn't have 50MHz privileges is acceptable, otherwise stick to 50MHz. QSOs within your own continent are to be OUTSIDE the DX window of 50.110 to 50.130MHz. Note the following: Callsigns, RS(T), membership number if given and Maidenhead Locator. One point per contact, plus one extra if the station is a member of UKSMG. Multiplier is the total number of countries heard plus the total number of Squares heard (one contact may count for both a country and a square multiplier).

Logs go to Maureen Wright, GGW8ZCP, 6 Cwm Eithin, Wrexham Clwyd, LL12 8JY, to be postmarked no later than July 8.

## Nantucket Activity

A group comprising W1/G4DZC, KC1YR, KA1USL & N1BRM will be active from Nantucket Island (IOTA NA 46) during the weekend May 29-31. Activity will be mainly on the h.f. bands (including the WARC allocations), but if interest is shown they may try 50 & 144MHz.

**Vince Cutajar** is in M'Scala, Malta and is a specialist on 18 & 24MHz; on 24MHz he mentions V27A, FS/JE2HCJ, UI8QU, VP2EST, CP1FQ, XE1ENK as late as 2300UTC, HKQ/HK5JPS on San Andres Is, VK9XN on Christmas Island, 9M2AX, 7Q7XX, CO8LY & YX0AI for Aves Island. Turning to 18MHz we find K6SMF, VP5/KF8OY, FS/JE2HCJ, ZL2AAG, AC8W/AH0 (Saipan), IS0FPD, CO8LY, YV3AZC, J8/G0GFX, 4U11TU, FK8GK & YX0AI.

## More Letters

**Gerald Bramwell** in Swinton had his listening confined to the late evenings, 2200 onwards. On the other hand, Gerald makes the best of it by also checking the c.w. end. Hence on Top Band, he found OK1DWS, OK3TZW & G3LPN on the key, plus A92BE, RA9SII, YL1XX, LY1BYK, YL2GVD, LY1EA, various European Russians and a comprehensive collection covering most European countries. On 3.5MHz c.w. we note UB5GRG, UZ1AWT, LY1CX,

UA2FG, OZ1GRS, OH8JN, HA8FM & EA1FBU; the sideband signals included NR1Q, W1FCQ, KC1KQ, K8UR, K3DV, VE1PZ, K2FV, UF7FXC, UJ8JMM, lots of Europeans, VS6WV, 9V1XQ, 9K2HF, A92BE, JA4DC, 9K2SV, YX0AI (Aves Is), OD5/LA4GHA, FM5DN, FG5FC, JA1JRK, TA3W & EA8AMT. 7MHz didn't give much in the way of WVE, with only VE3GAS, but in addition we find UA6WIA, UV6HSQ, UO5OPE, UF6VR, EA8BZF, ZF8AA, EA8BTA, TI2HQ, DL2DG/P/YV5 and Europeans on s.s.b. plus the c.w. from G3RTE, PA3CCM, 4N3QQ, PA3JFV, EA6ZY & DK7NL. Turning to 14MHz I note 8Q7DV, 4S7EF, YB8HX, TU2XG, VK7YV, EA8ZX, 4X4DD, VK3CKH, VU6SPD/MM, 9K2HF/NFD, HK4IQX, HK6QQK, JT11G, OD5MM, VK6PY, EA8BUI, VP2EHF, ZD8SA, VK2RB, YS1EJ, 8R1UN, PP5ZAS, plus some 39 W and VE stations, including a W6 and c.w. from N3AD, K1ST, KR2R, K8AZ & AA2Z. 18MHz was good to W/VE also, including VE7IM, XJ1TX and various East Coast stations, all on sideband, while EA6ZY re-appeared for a c.w. copy. YV3AZC, PT7BZ, YX0AI, ZF2ND, PY4OY, W2KW/KV4, VP8CGQ, ZP5CF, 4X4MS and Europeans made up the tally. On 21MHz half the tally of Ws were logged on c.w., while the DX included JA5BSQ, JJ7ENI, PY3BD, PY2AIZ, CO7JC, ZS1JH, HK6ISX, EA8AKN, TI2VVJ, KP4/WZ7B, EA8NB, EA8BUG, HC6R, CE1BCX, PT7WA, PT2VD, PT700, YN9B, PY2VA & ZF8AA. 24MHz saw mainly Ws, plus EA7ZM, EA9IB, 7Q7MM & 4X4MS plus Europeans, while 28MHz yielded VE2OC, W9CZI,

QSL card given to *Practical Wireless* editor, Rob Mannion G3XFD, at Dayton in 1991.

K10D, AA0DJ, W9RT, K1RAW all on sideband, plus f.m. from N1CHG, N1KJF, W4LEZ G00HJ, G4ZPZ and s.s.b. from J37AE & TA5L plus Europeans. This last listing is a hint to those who listen late that a spin of the dial to 28MHz isn't always pointless - the band is sometimes open quite late.

**Angie Sitton** (Stevenage) didn't manage to listen on Top band this time at all, but she did manage some of the other bands. The c.w. leg of the ARRL DX Contest yielded c.w. from all W call areas except W6, plus VE3, UF6 & Europeans, while 21MHz gave Europeans plus lots of Yanks during the contest. and on 14MHz NK2U, WA6BJB, N9SW, W9AND/4, WG3U, UL2ATB, VE1CH, 5A7LB (QSL via the Bureau) and Europeans. 7MHz gave Angie PY1CB, WA1FXB, VP2V/W2GUP, A92DQ & UA9JJX, while on 3.5MHz UL7JW, UA9CM & W1DX heard at 0020 UTC, during the big Aurora event.

## Halcyon Years

Now we turn to **Mike Birch**, who recalls those halcyon years back in the 'fifties, when he had a succession of Eddystone receivers and HROs; some of the calls from those days Mike remembers better than the current DX on 10MHz. I was particularly interested to see a mention of MD5D0 from the Canal Zone, who became a friend while we both lived in Stevenage in the early-to-mid sixties. CR6AI & YI2AM are two others Mike mentioned from whom I received cards.

## Conclusion

How about a Set Listening Period, covering any amateur band over the weekend May 2-3, using any such simple gear and your normal skywires? If we say G3 is one prefix, GW3 another, GM3 a third, you should be able to find 150 prefixes in a weekend if conditions are at all reasonable. List 'em and send the list with your normal report.

That's our lot for this time. The deadline for next time is to arrive at the address at the head of the column, by May 6, June 5, July 10 respectively.

# dxtv round-up

Ron Ham, Faraday, Greyfriars, Storrington,  
West Sussex RH20 4HE

**Y**ou can never be entirely certain what will happen, wrote **Clive Grey** (West Kirby) in his DXTV report. Those are very true words Clive, especially this month when we take a look at the high number of disturbances, in February, in the upper 'F2' region of the ionosphere and talk more about the tropospheric openings in January and February. The former provided some interesting DX in Band I (40-68MHz) and the latter produced good colour pictures, from Europe and Scandinavia, for long periods in Bands III (175-230MHz), IV (471-608MHz) and V (615-820MHz).

## Band I

"Here's February's log with Dubai and Iran putting in a daily appearance on Ch. E2 (48.25MHz) via 'F2' propagation around lunchtime", said **Simon Hamer** (New Radnor) at the end of the month. In addition he saw weak, fluttering and fading video from New Zealand on Ch. 1 (45.25MHz) at 0800 on the 8th and Australia on Ch. A0 (46.17MHz), China on Chs. C1 & C2 (49.75 & 57.75MHz) and Malaysia, Thailand and possibly Zimbabwe, on Ch. E2, on the 12th.

Although **David Glenday** (Arbroath) identified pages from the Koran among the F2 signals that he received on Ch. E2 on the 19th, there was no hope of identity while similar events were in progress around noon on the 20th & 23rd. **Carl Bowen** (Strelley) reports an F2 opening with activity, at varying strengths, on the 7th, 8th, 15th, 16th, 22nd & 23rd around Chs. E2, R1 (49.75MHz) & R2 (59.25MHz). Although he could not make any positive identifications on these days, Carl managed to make out an Asian announcer on the 8th, a programme with a lot of skiing on the

16th, an Arabic broadcast which looked like Dubai (UAE) on the 22nd and a 'smeary ghosting signal' from the Far East, possibly Malaysia, on the 23rd.

"Plenty of F2", wrote **Bob Brooks** (Great Sutton) who logged such events almost daily from February 5 to 24. From the multitude of distorted pictures, on Ch. E2, he saw an announcer, sub-titles and a caption early on the 11th, a 'crescent and star' logo at 1020 on the 17th and 1355 on the 18th, a 'chess board' pattern at 1235 and Arabic captions at 1340 on the 20th. At midday on the 7th, **Andrew Jackson** (Birkenhead) received a test-card from Iran Television, on Ch. E2, which he identified by, "the large white digital clock in the lower left hand corner". He saw an athletics programme at 1400 on the 8th, unidentifiable pictures on Chs. E2, R1 and possibly A0 at 0925 the 11th. Between 0955 and 1130 on the 22nd, Andrew noted, without identity, pictures on Ch. R1 and caught glimpses of a quiz show with Arabic writing, a children's piece and a test-card with that large white digital clock again on Ch. E2. He also heard what sounded like South American and Arabic voices below Ch. E2 on the 8th.

## Sporadic-E

Simon Hamer and Bob Brooks logged test-patterns from Iceland (RUV) on Ch. E4 (62.25MHz) on February 20, the Norwegian regional Steigen, on Ch. E2, on the 20th and Denmark (DR DANMARK) on Ch. E3 (55.25MHz) on the 24th respectively. During the month, **Russ Burke** (Northampton) received test-cards from the Norwegian regionals Bagan and Melhus and identifications from Italy (RAI-UNO) and Spain (TVE1).

## Picture Archives

Satellite TV enthusiast, **Peter De Jong** (Leiden, Holland) received a test-card from Spain, **Fig. 1** and a British Aerospace logo, **Fig. 2**, via Eutelsat I F4, last October 29 & 30 respectively as well as captions from Holland (**Fig. 3**) and Croatian TV (**Fig. 4**) via Eutelsat II F2 around 1600 last December 8.

## Weather

The slightly rounded atmospheric pressure readings for the period January 26 to February 25, **Fig. 13**, were taken daily, at noon and midnight, from the Short and Mason barograph installed at my home in Sussex. Apart from days 11 to 14, the pressure remained high, above 30.0in (1015mb) and often around 30.5in (1032mb), for several days at a time.

From past experience none of us were surprised to see a number of tropospheric openings when the barometer fluctuated toward the upper end of its range. **George Garden** (Edinburgh) found it 'perishingly cold' while he was DXing, high up, on Cairn 'O Mounth on February 29. Back down south, I noted frosts, sometimes down to 22 and 25°F in the early hours on days 1, 2, 8, 17, 19 & 20. The month was generally dry with only 1.94in of rain and most of that fell between the 11th and 15th inclusive.

When you look at **Fig. 5**, don't think that I have discovered a new type of vertical Yagi, in fact, it was frozen fog on the twigs of a young tree on the South Downs. The fog was so dense that I had to use a flash when I took that picture, around 1500 on the 2nd. The majority of trees and hedges along

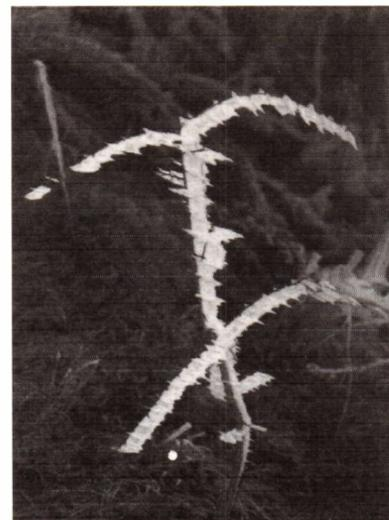

**Fig. 5: A new Yagi?**

the Downs were in the same state which can only be described as one of nature's spectaculars that I was privileged to see.

Peter De Jong is equipped to receive weather satellite pictures and **Fig. 6**, which he copied at 0726 on the 8th, shows a large amount of cloud to the west and north of the UK.

## Tropospheric

"What a weekend the 31/1 - 1/2 was!", remarked **John Woodcock** (Basingstoke) who used his TC-930F receiver to give him positive image pictures from French stations and his D100 converter to copy test-cards from Belgium (RTBF1) and Holland (PTT-NED1) in Band III. He logged pictures from France again during the afternoon of the 8th.

"The atmospheric pressure stood at 1040mb here", wrote **Clive Grey** (West Kirby) about January 29 when he received unusually strong pictures, in colour, with Teletext from Ireland's RTE1 & 2 on Chs. 40 & 46 in the u.h.f. band, adding, "Pictures were so good



**Fig. 1: Spain.**



**Fig. 2: BAe logo.**

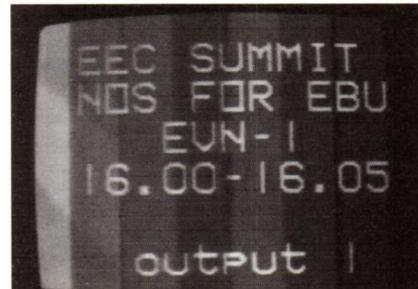

**Fig. 3: Holland.**



**Fig. 4: Croatia TV.**

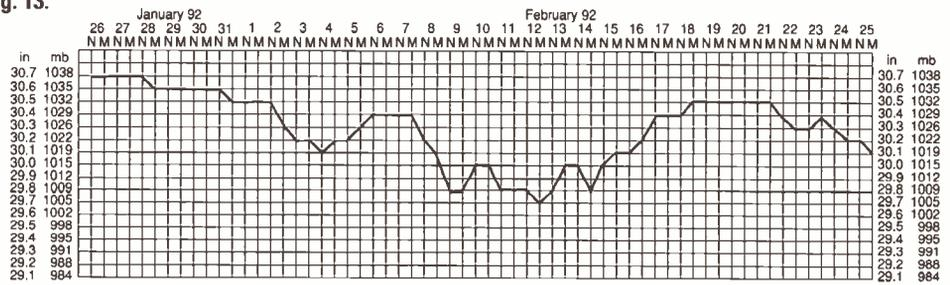

**Fig. 6: Weather picture.**



**Fig. 7: Germany.**

Fig. 13.



that we watched for a full half hour a housewives' cookery programme starting at 2000 on RTE1 with only slight fading". Clive also found the benefit of a directional antenna especially during the following evening when signals from RTE were rather poor and Sutton Coldfield came up when he rotated his beam. Also at that time he logged Yorkshire TV, from Emley Moor on Ch. 47. Clive checked the band again from 1930 on the 31st and found BBC North and Yorkshire TV from Emley Moor and watched the news from BBC Leeds at 2125. "As the high pressure centre shifted East signals seemed to come from the East more than the West", said Clive, who is a very entertaining period for the DXer.

At 1645 on the 30th, **Tony McDonald** (Derby), using a domestic u.h.f. set with a 10-element antenna, received strong colour pictures from the UK transmitters at Belmont (Yorkshire TV), Crystal Palace (Thames TV), Ridge Hill (Central TV) and Anglia TV from Sandy Heath, Sunbury and Tacolneston. Although weak he logged TVS from Hannington and at 2035 added Belgium (TELE21). At 0820 on the 31st, Tony found all the Anglia transmitters and the Dutch Nederland 3 on three channels. During the evening, from 1745, he saw the idents 'TELE21' from Belgium, 'WEST3' and 'ZDF' from Germany and 'TROS T2' possibly from Holland. Like John Woodcock, Tony also found the u.h.f. band open on February 8, when he logged stations from Belgium, France and Holland.

"A good tropospheric opening was the agenda for the end of January," wrote Carl Bowen on February 17. On the 26th & 27th, he reports that French television (A2, FR3 & TDF) had estab-

lished themselves for long periods of time, on the u.h.f. band as CANAL+ had done on Band III.

Carl spent most of the evening of the 30th watching Sport Studio from Holland (NED3) and on the 31st and while the opening declined on February 1, he added Holland (NED1) on Ch. E4 in Band I, Belgium (BRT1 and RTBF) on Ch. E8 in Band III. On February 1, Clive logged Belgium and Holland in Band III.

**Mike and Wendy Evans** (Buckhurst Hill) emptied their camera after the event and sent along photographs of the idents that they received from Germany Hessen 3, Fig 7, on Ch. 37, MDR Fernsehen, Fig. 8, on Ch. 34, Wieringermeer, Fig. 9, on Ch. 39 and Holland Nederland 2, Fig. 10, on Ch. 45.

Simon Hamer received strong pictures from France in Bands III, IV and V during the evening of February 24 and weaker signals from Denmark (DR and TV2), Germany (ARD1 and MDR3) and Sweden SVT1&2) in those bands on the 25th.

Andrew Jackson took advantage of the opening on the 8th when he logged pictures in Band III from Belgium (BRT1 and RTBF1) and France (CANAL+) and Belgium (RTBF TELE21, France (Antene2) and Holland (NOS3) on the u.h.f. bands. Periodically, Russ Burke found tropo conditions so good

that he stopped taking photographs and committed Bands III, IV and V signals to his video recorder for later analysis. He found Germany's ARD and ZDF and Holland's PTT NED 1 & 3 most prominent as shown by a couple of Dutch captions, Figs. 11 and 12 that he logged.

While checking for maximum useable frequencies (m.u.f.) during the early winter months of 1992, **Richard Gosnell** (Swindon) received Band III signals from Belgium, France and Ireland on January 12, France and Ireland on the 14th and 18th, Germany and Ireland on the 15th, Ireland on the 25th and 28th and Belgium, France and Holland on the 31st. In February he logged Belgium, France, Germany and Ireland on the 1st, Ireland on the 2nd and 7th, France and Ireland on the 8th, France on the 15th, 16th and 29th and France and Ireland on the 23rd. David

Glenday received u.h.f. pictures from Belgium (BRT1&2), Germany (WDR1 and ZDF) and Holland (NED1, 2 & 3) throughout the evening of the 8th.

## SSTV

In addition to an amusing demo caption, Fig. 14, **John Scott** (Glasgow) copied slow-scan television pictures during February, around 14.230MHz, from stations in France, Poland, Russia, Spain and Wales Fig. 15. David Glenday recently installed a couple of long wire antennas to feed his SSTV receiver and reports that the, "performance has improved dramatically and computer noise is greatly reduced". He also suggests that by passing those faded screen-dumps through a photocopier "with the contrast cranked up a little bit soon rejuvenates the prints".

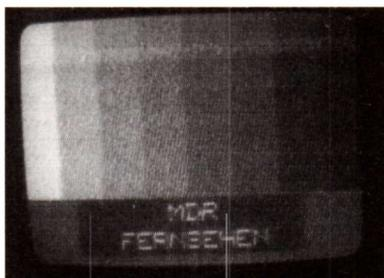

Fig. 8: MDR.

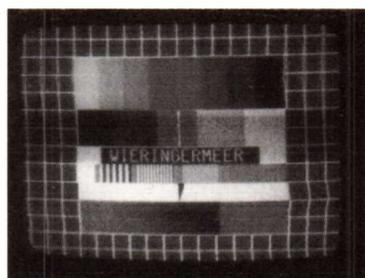

Fig. 9: Wieringermeer.

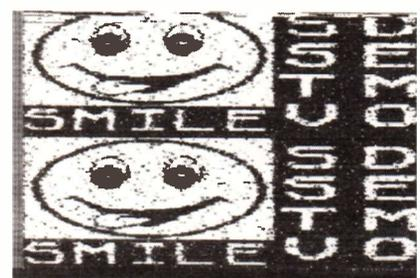

Fig. 14: SSTV.

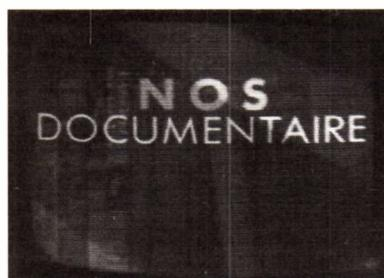

Fig. 10: Holland.



Fig. 11: Netherlands.



Fig. 15: SSTV.

# The only strings attached -



## When buying from Martin Lynch...

OK so I'll admit - there are strings attached when you buy from Martin Lynch. But I don't think you'll complain. New or Secondhand - the "MONEY BACK GUARANTEE" applies. If the equipment is not as described, you can have your money back! No Quibble, no arguments. Nobody offers this kind of deal. Either visiting the shop or Mail Order, the rule still applies. You can't lose.

As an INDEPENDENT RETAILER I can continue to offer you unrivalled personal service. Backed up by the Authorised U.K. Distributors, you have total piece of mind. Phone today for your requirements, or call in at



Graeme G4XOF    Martin G4HKS    Val G4WIS    Bryan

the shop in West London. I'm easy to find - just across the road from NORTHFIELDS UNDERGROUND on the Piccadilly line, (closest Ham Store to Heathrow by Tube) - only a few minutes from the M4/M1/M25.

### AOR

AR1500 NEW the only handy scanner with factory fit SSB ..... £289.00  
 AR2000 the favourite 5-13000MHz ..... £259.00  
 AR2500 for computer control, base scanner ..... £395.00  
 AR2800 best all round base/mobile, includes SSB ..... £375.00  
 AR3000A NEW - the latest version - unbeatable price ..... £ PHONE  
 ACEPAC 3 computer control for 3000 ..... £119.00

### YUPI TERU

VT150 NEW - latest 142-170MHz handie ..... £159.00  
 VT125 the best airband handie scanner ..... £148.00  
 MVT7000 the favourite all band handie ..... £279.00

### LATEST EQUIPMENT IN STOCK!

**ALINCO**  
 DJ-X1E the smartest miniature pocket scanner ..... £259.00

**ICOM**  
 ICR1 still the world's smallest scanner ..... £329.00  
 ICR100 the best mobile scanner ..... £499.00  
 ICR71E excellent HF RX, many used examples ..... £ PHONE  
 ICR72E economy version of above ..... £589.00  
 ICR7000 still available as new ..... £699.00  
 ICR7100HF 50kHz-2000MHz ..... see our other advert  
 ICR9000 special deals on the world's best receiver

### KENWOOD

R2000 general coverage SW RX ..... £529.00  
 R5000 Kenwood's top RX, special deals ..... £ PHONE

### LOWE

HF-150 NEW - latest portable/base HF receiver ..... £329.00  
 HF-225 the best of British receivers ..... £429.00

### DRAKE

R8E 150kHz-30MHz. In stock and on display ..... £965.00

### JRC

NRD 535 commercial build and performance ..... £1095.00

73 MARTIN G4HKS

**MARTIN LYNCH**

G4HKS

THE AMATEUR RADIO EXCHANGE CENTRE



286 Northfield Avenue, Ealing, London W5 4UB. Tel: 081 566 1120. Fax (24 hr): 081 566 1207

**Tel: 081 566 1120 • SALES • SERVICE • MAIL ORDER**

Please add £10.50 for 48 hr delivery.  
 SHOP OPENING HOURS: Tuesday - Saturday 10am-6pm.  
 24 Hour Sales HOT LINE 0860 339339 (after hours only).

Martin Lynch is a licensed Credit Broker - full written details on request. Typical APR 36.8%

THE U.K.'S MULTI-BRAND AUTHORISED STOCKIST!

## THE KITS WITH ALL THE BITS!

Guaranteed complete to the last nut!

### COMPACT 80m CW QRP Tx/Rx

OTR3 Kit - £87.50 P&P £3.00 Ready Built - £140.00  
 ★ Stable VFO ★ Sidetone ★ Audio Filter  
 ★ Requires 12/14 VDC ★ Very detailed  
 Instructions ★ Black steel case  
 ★ Printed panel

40m & TOP BAND VERSIONS  
 ALSO AVAILABLE

### ANTENNA TUNING UNITS

TU1 Kit - £41.25 Ready Built - £57.50  
 TU2 Kit - £51.00 Ready Built - £72.00  
 P&P £3.00

★ Large dia. coil ★ High grade capacitor ★ Built in balun ★ Circuits to match  
 your antenna ★ Up to 30 Watts of CW ★ TU2 has sensitive QRP/SWR meter  
 ★ TU1 is ideal for SWL

### QRP SWR METER

★ Specially designed for QRP ★ HF 1-30MHz  
 ★ Can be set down to 1/2 watt for FSD

★ Ideal for milliwatting ★ Low insertion loss 0.2dB  
 TUA1 Kit - complete with case & meter £18.00 P&P £1.00

### CARLTON (Receiver)

#### 80-40-20m Dc Rx

★ Receives USB, LSB and CW ★ Very sensitive  
 and selective ★ Simple modular construction  
 ★ 12-14 volt battery operated ★ Printed fascia  
 Kit complete with case - £69.50 P&P £3.00

### PSU 15 REGULATED

#### POWER SUPPLY

★ Ready built ★ Mains input ★ 13.8V @ 1.5A  
 output ★ Ideal for DTR3 & 'Carlton' ★ Fully  
 protected

Supplied ready built - £52.00 P&P £4.00

Send SAE for brochure or call Alan G4DVW on 0602 382509

## LAKE ELECTRONICS

7 Middleton Close, Nuthall, Nottingham NG16 1BX  
 (callers by appointment only)



Amateur Radio  
 Communications Ltd



NEW FOR 1992

## ONE STOP SHOPPING AT LAST!

WE ARE PLEASED TO ANNOUNCE THAT  
 THE FINAL PIECE OF THE JIGSAW  
 WENT INTO PLACE ON 2nd MARCH,  
 WHEN WE BECAME THE ONLY  
 APPROVED KENWOOD DEALER FOR  
 THE NORTHWEST & NORTH WALES

It's been a long time coming but now *anything* you  
 require in ham radio equipment is available at 38  
 BRIDGE STREET. What more could anyone ask for?  
 We offer a service second to none, a friendly atmosphere,  
 expert advice, excellent back-up (by one of the top  
 engineers in the country, Frank), plus the usual  
 humorous banter from Peter and Richard and even  
 more important a cup of MY coffee or tea. 73 Elaine

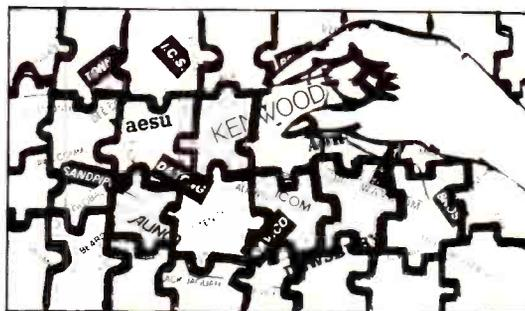

We will be exhibiting at the NEC Show this year, so why  
 not pay us a visit on STAND A23, where not only will we  
 have an extensive display of new equipment but also a  
 large range of second hand and commission goods, all  
 thoroughly checked out by our engineers before being  
 despatched for NEC and each with its own engineer's  
 report.

ARC IS A LICENSED  
 CREDIT BROKER

INSTANT FINANCE AVAILABLE  
 SUBJECT TO STATUS

ALWAYS A LARGE SELECTION  
 OF COMMISSION AND  
 SECONDHAND ITEMS IN STOCK

Please send a S.A.E. for  
 details on new or used  
 equipment required.

MAIL ORDERS RECEIVED  
 BEFORE 3 O'CLOCK SAME  
 DAY DESPATCH  
 PROVIDING EX STOCK.

STAND  
 A23  
 RSGB  
 '92



Amateur Radio  
 Communications,  
 38 Bridge Street,  
 Earlestown,  
 Newton-le-Willows,  
 Merseyside  
 WA12 9BA.

TEL: (0925) 229881  
 FAX: (0925) 229882

OPEN TUES-SAT  
 10-5PM

1 MILE FROM J23, M6 AND  
 4 1/2 MILES OFF J9, M62

OUR AIM IS 100%  
 SATISFACTION

## AERIAL TECHNIQUES



### STAG CTV-9400 PAL/SECAM MULTI-STANDARD COLOUR TV

- 10" Picture tube
- PAL/SECAM compatibility, together  
 with 5.5, 6.0 and 6.5MHz automatic  
 sound switching, enables this set to  
 be used in FRANCE, UK, Western  
 Europe and the Middle East.
- 12V DC or 220/240V AC operation  
 from mains or battery.
- 32 Programme storage tuning.
- Full function remote control.

PRICE £329 + £10  
 overnight delivery  
 by insured courier  
 (Inclusive of VAT)

- Features on screen graphics showing the various modes.
- Interactive 2 digit LED display.
- Built-in Peritel/Scart socket allows connection of a variety of other AV  
 equipment.
- Built-in whip aerial. • 75ohm aerial input at the rear.
- Covers band 1, 3 & UHF plus all cable channels.
- Compact dimensions: Height 255mm (10.03in); Width 266mm  
 (10.4in); Depth 323mm (12.6in); Weight 8.7kg.

We stock a large range of equipment for all types of aerial and satellite  
 installation, all detailed in our 29 page Catalogue at 75p, send for your  
 copy today. We also have available Multi-standard TV's and Video  
 recorders for all systems. PAL, SECAM & NTSC. Most makes of Satellite  
 equipment carried, together with decoders for Canal Plus, RAI UNO, RAI  
 DUE. PAL/D2-MAC satellite receivers now in stock, also SECAM to PAL  
 transcoders (SAE for details).

Special Offer!! Uniden UST-92 D2-MAC to PAL decoder with built-in  
 Eurocrypt card reader £399.00+VAT

Access, Visa and American Express  
 Mail and Telephone orders welcome  
 (24 hour service)



11 KENT ROAD, PARKSTONE, POOLE, DORSET BH12 2EH  
 TEL: 0202 738232 FAX: 0202 716951

# airband

Godfrey Manning G4GLM  
c/o The Godfrey Manning Aircraft Museum,  
63 The Drive, Edgware, Middlesex HA8 8PS

**A**s I'm often asked about my Museum, another mention here would be a good idea. Visits are by prior appointment. Individuals or groups of no more than four are accepted. This can be arranged by 'phoning 081-958 5113, preferably timing your call between 1800-2200 local on a weekday. It comes as a surprise to many that admission is free, since I run the Museum as a hobby and not as a commercial venture. In these days of distorted values many people are suspicious that anything offered for free has no worth. Here at least is one place where old-fashioned standards still apply. All you are asked to contribute is your genuine interest and enthusiasm.

## Help!

How can **A.W. Guy's** receiver (March, Cambridgeshire) pick up signals on the wrong frequency? This is called a spurious response and there are various ways in which it can happen. One explanation could be that the signal is an image (second channel), being twice the i.f. away from the frequency to which the set is tuned. You don't give your i.f., Mr. Guy, but many receivers use 10.7MHz. However, this doesn't help much as  $2 \times 10.7$  subtracted from 105.3 doesn't come out anywhere useful. Also, you thought the spurious signal was a.m. and your receiver is designed for f.m. only, thus suggesting the spurious signal to be getting straight in to the receiver at some other place and possibly overloading one of the circuits. The effect isn't harmful, just annoying. It is quite understandable, but hard to explain any further without a lot more detail of the inner workings of your set.

What approval is needed before an aircraft can land in the various categories of weather minima? **Fran Kelk** (Nottingham) is wondering about this. Transport aircraft can couple the autopilot to the i.l.s. and thereby fly an automatic approach. Once close to the ground, it may be necessary for the human pilot to take over. Cat I means that, by the time 200ft from the ground has been reached (the decision height) cloud and visibility are good enough to enable a visual landing to be completed. A simple aircraft fitted with just one autopilot can handle this case.

Moving on to worsening weather, Cat II conditions don't enable you to see the runway until you're down to 100ft. A more sophisticated airborne fit is required so as to fly accurately enough not to hit the ground and the minimum is regarded as a pair of autopilots cross-checking each other. If there is disagreement between them, you don't know which is correct.

Cat III requires fully automatic landing, including flare and possibly roll-out. Triplicated systems were the first technique for these conditions - if one autopilot was in error, the re-

maining two would out-vote it. Nowadays two pairs of autopilots may be fitted. Above all, no aircraft is approved for passenger operations in low-visibility conditions until the manufacturer has demonstrated its reliability to the airworthiness authority in the state of registration (in the UK, this will be the CAA).

Fran also asks about the 'Seagull' callsign; it belongs to Transport International Aerien. More callsigns are wanted by Des Reed (Malton). 'Air Force One', the President's aircraft, and 'Air Force Two' (Vice-President) are almost household words in the United States. Either might carry the suffix 'Heavy' indicating an aircraft such as the B.747 which produces prolonged wake turbulence. Also, Des is right that 'QNF' ('Weather Watching', P11, April 1991 *SWM*) is a misprint and QNH is intended. Local barometric pressure would be QFE.

**Chris Brenton** (Plymouth) regards himself as more of an "armchair air traffic controller" than a 'plane spotter. So, Chris, this column is for you and thanks for writing me your first letter! Chris contributes some more newsworthy callsigns: Aeroflot 1001 (President's flight) and Air India 001 (Head of State).

Let me help **R. Keary** (Wythenshawe) who's confused about aerodrome identification letters. These are not radio callsigns, but are for administrative purposes. Unfortunately there are two separate systems in operation. The International Air Transport Association (IATA) is a commercial club to which airlines belong. You'll see their three letter codes on the tags attached to checked-in baggage. Examples are HAM (Hamburg), JER (Jersey), LEI (Almeria) and LGW (London Gatwick). So, as you see, not all codes are obvious because there just aren't enough combinations of three letters to go round.

The International Civil Aviation Organisation (ICAO), based in Canada, is an official world-wide regulatory body. Its designations are four-letter and are even more obscure. They typically appear on flight plans. The first two letters are for the country (EG being the United Kingdom) and the remaining letter pair is for the aerodrome within the country. So we have EDDH (Hamburg), EGJJ (Jersey), LEAM (Almeria) and EGKK (London Gatwick). A full listing of both sets of codes is in the *En Route Supplement* for the appropriate part of the world and obtainable by post from Aerad Customer Services, Building 254, PO Box 10, London (Heathrow) Airport, Hounslow, Middlesex TW6 2JA. Tel: 081-562 0795.

## Your Experiences

**Mrs. B.** (I.o.M.) can now fly the A320 whenever she likes - as long as it remains on her Amiga computer. Airbus



Military Dakota Variant at North Weald. (Godfrey Manning).

A320 seems good value with excellent graphics and the need to really plan your flight in advance. It's unreal that it got less than top marks in a magazine review. The reviewer was hoping for a simpler arcade game and instead got something approaching a real flight simulator for just £29.99! I don't see any comments on the speed and smoothness of the response which is normally where such simulations are deficient when run on hobby computers. The software, by Thalion, comes complete with radio navigation charts! Mrs. B. is clearly a 'total aviation person' but still acknowledges having much to learn. Well, we can all say that about ourselves - let's share information through this column and that way my education will be improved too!

The flight simulation demonstration at the London Amateur Radio Show in March was definitely smooth and responsive. It put you in charge of a radio-controlled model aeroplane or helicopter. Unlike real flying where you see the world from the cockpit window, aero modellers watch their aircraft from a distance. This gives a feeling that the controls are operating in the reverse sense when the machine is flying towards you!

## Museum Pieces

Thanks **Ted Crease** (Bradford) for unearthing a teleprinter copy of Sheila Scott's record attempt flight plan from about 1968. The Single Comanche's route from Luqa, Malta, to London is listed on the plan. The callsign given is G-ATOM (actually a Cherokee) which I'm sure is a misprint for G-AT0Y. Hope you make it to the Museum soon, Ted. Most visits are weekdays (including evenings) at present, but do let me know your possible weekends and I might be able to oblige.

**V. Prier** (Colyton) found a two-pointer instrument that sounds like an old i.l.s. indicator. Turn and slip is less likely owing to the perpendicular (rather than collinear) disposition of the two pointers. I'd be grateful to take up your offer to send it to my Museum, and if you do so then I will happily refund your postage costs.

**Martin Gerrard GW60KC** (Broughton) doesn't quite understand everything in this column and so, as I often remark, do please write in and demand an explanation! If readers don't write in, I assume that everybody understands everything - can that really be possible? Living close to Hawarden Aerodrome, Martin often

hears the 'beautiful, distinctive sound' of the restored Mosquito. Despite reverting to wood at a time when the trend was towards all-metal construction, the Mossie was a success and could be knocked out in large numbers by skilled piano and furniture manufacturers during the war. With luck, the restored example will appear on this year's display circuit.

## Follow-Ups

**Peter Nicholson** (Huddersfield) also enjoys the overflights observed by Chris Haigh RS94162 (same town) and reported in March. Peter has seen traffic for 24 at Manchester arriving at high altitude. Airliners are limited in their rate of descent and travel many track miles in the process of losing height. In this case, they can't just join the i.l.s. but instead fly a dog-leg whilst losing height. The aircraft seen by Chris might have been descending as well as flying a triangle. This routing is also sometimes needed to increase separation between aircraft in the inbound stream. I've noticed a similar technique used for arrivals from the south when 23 is the landing runway at Heathrow.

Although the idea of a pleasure flight had to be cancelled through lack of support, thus disappointing **Simon Whitelock** (Portsmouth), **Bob Ramshaw** (Northampton) and **Nick Dalton** (Kenilworth), Nick points out Air Atlantique's classic DC-3 trips from Coventry. As well as flights to view Cowes Week and the Tall Ships Race, there are round trips to enable you to visit various airshows without getting caught in traffic jams. Call Kerry or Val initially on (0203) 307566.

## Frequency and Operational News

The 2/92 *GASIL* from the CAA introduces a new n.d.b. (RDL, 343kHz) at Redhill. With low power, this beacon should be reliable over a 10nm range and is intended for finding the airfield at the end of a flight. It is not powerful enough for en-route navigation.

Local knowledge from **Pat Martindale** (Bridlington) tells us that Leconfield has moved frequency to 123.05MHz, same as Linley Hill, now that both airfields are operating in such proximity. The Sea Kings at Leconfield are Rescue 128 and 129.

CONTINUED ON PAGE 55

Alan Gardener  
PO Box 1000, Eastleigh, Hants SO5 5HB.

**A**s you will have seen in the March issue of *SWM*, Dick Ganderton and I finally managed to choose a winner for the AOR AR2000 competition that appeared in last November's magazine.

This was rather an unusual type of competition in that it required the entrants to suggest enhancements to scanning receivers which could improve their operation or add new features. In order to widen the scope of the competition the entries could be in any form, the only stipulation being that they should just be on one side of an A4 sheet of paper.

Having set the competition I must say that I wondered just what sort of response we would get. I needn't have worried. Just under a hundred entries were received, which was very gratifying, especially considering that the competition didn't just involve 'selecting the correct answer'.

When I met Dick to judge the competition I was amazed at just how much effort had been put into all the entries, some of them were works of art! The judging itself was not easy and it took several hours to gradually reduce the pile down to the final few. We decided that the eventual winner had to be selected from the group which had suggested entirely new ideas, and the final winner was the person we thought had combined the most original new ideas in his entry. My congratulations to **Mr N Evans** of Salisbury who won the AR2000, and the two runners up **C.F. Tearne** of Oxford and **Robin Nixon** of Beckenham who both received copies of *Short Wave Communication* by Peter Rouse.

I am now in the process of collating all the information into a more concise form before passing it on to Richard Hillier of AOR (UK) Ltd., who was good enough to donate the prize. As well as the more innovative suggestions which formed a large proportion of the entries there were many simple ideas which could easily be implemented and which would help to improve the general ease of operation. I hope that some of these ideas will be considered by AOR for inclusion in new models.

Finally I would like to thank all the readers who took the time and trouble to enter the competition and helped to make it such a success.

## BC200XL/PRO-35 AM Modifications

Although a modification to provide manually switched a.m. reception on this receiver was included in the February 1990 column, **P. Mohammed** of Liverpool has passed on an easier way of achieving it. This simply involves identifying two tracks on the printed circuit board and connecting a sub-miniature toggle switch between them (See Fig. 1). He has modified both BC200s and PRO-35s in this way without experiencing any problems. I know

that many people were put off the original modification because it involved identifying and cutting a very fine track on the printed circuit board, however, the new method makes this part much easier - my thanks to Mr Mohammed for this information. The only remaining question is where to fit the switch without having to drill too many holes in the case - has anyone found a neat solution to this problem?

## Utility Monitoring

Mr Mohammed also asks if he could use his Tandy PRO-2006 for receiving and decoding shortwave utility stations by adding an external h.f. converter, the purpose of which is to convert signals in the range 0-30MHz up to a higher frequency band which can be received on a scanner. Although it is possible to receive utility stations in this way, I would not recommend it, mainly because of the difficulties involved in resolving the special types of transmissions used by such stations with a receiver not equipped for s.s.b. reception.

Most h.f. utility stations use some form of frequency shift keying to transmit a binary representation of the original text, picture or information. In order to recover this information the receiver needs to be fitted with a carrier re-insertion oscillator or b.f.o. This is usually a standard item in a shortwave receiver, but is only fitted to some scanners that have the ability to receive s.s.b. signals.

You can add a b.f.o. to a scanner, but an additional problem may be the i.f. filter bandwidth which is likely to be too wide for satisfactory s.s.b. reception. Even if you could overcome these problems by extensive modifications you may still find that the frequency stability of the combined scanner, h.f. converter and b.f.o. circuit is not good enough for prolonged periods of monitoring without the need to keep re-tuning the receiver.

The best option may be to consider buying a cheap short wave receiver such as the Matsui MR4099 or Sangean ATS-803, many of which are available second-hand. These are perfectly good designs for the price and will give much better results than those obtainable with a scanner/converter set-up.

One final suggestion if you have a short wave receiver that is capable of s.s.b. reception at 455kHz or 10.7MHz, is to use the scanner as a converter. In this way you can resolve s.s.b. signals on the v.h.f. amateur bands by tuning the scanner to the actual receive frequency and the short wave receiver to the scanner i.f. Any fine tuning can be performed by adjusting the short wave receiver. The only tricky part is obtaining an i.f. signal from the scanner. With a PRO-2006 this can be obtained in two different ways. A 455kHz output can be obtained in the a.m. mode from

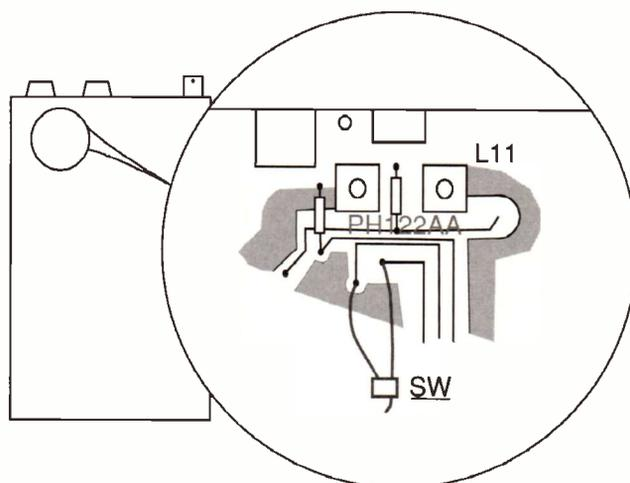

Fig. 1.

the junction of T5 and C157, or with w.b.f.m. selected, a 10.7MHz output can be obtained from the junction of T3 and R250. Both sets of components are located near the middle of the linear p.c.b. As a precaution the signal should be taken from the circuit board via a screened lead with a 1k $\Omega$  resistor and 100nF capacitor in series mounted at the board end in order to prevent any loading of the scanner circuits.

I have mentioned converters before, so if you would like a more detailed explanation try and take a look at the July 1988 column which explained the technique in more detail.

## Splitting Signals

**Don Jackson** of Essex has written with a question which highlights several different problems that can occur when splitting signals from an antenna to feed different receivers or locations. Don has an antenna mounted on a pole at the bottom of his garden, he then feeds the signal to the house with a 25m length of coaxial cable via two 'T' connections, one to feed the signal to the garden shed the other to provide a feed to his conservatory. He is mainly interested in airband monitoring and has recently changed his antenna from a dipole to a 'Slim Jim'. This has not made much difference and he wonders if I can suggest any improvements to the system.

Let's start with the antenna, in some respects a dipole may be more suitable for airband reception than a 'Slim Jim'. This is because the 'Slim Jim' is designed to give more gain by having a lower angle of radiation, that is to say it concentrates its gain towards the horizon rather than up towards the sky. A low angle of radiation is ideal for terrestrial communications but it may produce poor results when the signals are originating from aircraft. However, a 'Slim Jim' may be more suitable if you

are just interested in improving the reception of ground based air traffic control stations.

The next problem is the way in which Don has split the signal to provide feeds to several different locations. By connecting lengths of coaxial cable in circuit with 'T' connectors, what he has effectively done is produce a notch filter. This will severely attenuate signal levels at many different frequencies. The principle of such a filter was explained in the December 1990 column, but it is sufficient to say that when a length of coaxial cable is connected in parallel with the signal path it produces a notch at odd resonant multiples of the cable length. So in this example if Don has his receiver connected to the antenna feed in his shed, the 25m length of cable feeding the house will act a notch filter with a repetition frequency of approximately 2MHz. So when he tunes across the aircraft band he will get a dramatic reduction in received strengths at intervals of 2MHz.

The solution to this problem is to either use a low-loss TV antenna splitter of the type sold by Maplin or Tandy or to loop the coaxial cable feed to the house via the shed and conservatory with an in-line plug and socket. The scanner can then be connected in circuit wherever it is required. The big advantage in using this method is that there is no signal loss, unlike the splitter method where up to half of the incoming signal may be lost.

Don is also concerned about protection against lightning - this is particularly important if you tend to leave your scanner connected to an external antenna for any length of time. Although we don't have too many lightning storms in this country it is quite surprising just how much of a static charge can build up on an external antenna. With the increasing sophistication of

modern receivers it is a good idea to consider some form of simple precautions before you are faced with expensive repair bills.

The first step should be to bond the braid of the coaxial cable to a good earth point before it enters any property. This is best achieved at the base of the mast by means of a large earth spike driven into the ground. A short thick lead or braid then needs to be connected to the outer of the coaxial cable. One way to do this to use a coaxial 'T' connector to join the cable. The earth lead is then hard soldered to the outer of an old coaxial connector which is attached to the spare port of the 'tee' connector. This will provide some protection but does not provide a static discharge path for the inner of the cable. This can be done in several ways. The first is to choose an antenna with a d.c. ground connection. A folded dipole or 'Slim Jim' antenna should already provide a d.c. path between the inner and outer of the coaxial cable, but other antennas such as discons may not. A quick check with a multimeter on its resistance range will tell you if your antenna has a d.c. static discharge path, if it doesn't then you may have to provide one. Connecting an r.f. choke between the inner and outer of the cable is one solution. This

can be made by winding several turns of enamelled wire through a ferrite bead, the two ends of the wire being connected in circuit at a suitable point. If the choke is fitted inside a coaxial connector it can be connected into a 'T' junction as described previously. If you want to spend more money you can obtain special lightning protection devices which fit in-line with the coaxial cable and provide a discharge path for static before it can build up to a dangerous level, although these tend to be more suitable for use with larger antennae such as those designed for the short wave bands.

I hope that these suggestions will be of use to you Don, and I will be interested to hear the results of your experiments.

### Low Band VHF

Several readers have now written in with their comments on the 38.65MHz mystery signals heard by **Tim Anderson**, which I mentioned in the March column. The general consensus is that they are likely to be the Pakistani Police force who have also been monitored on 38.675, 38.725 and 38.75MHz.

February brought a whole bunch of very strong signals from North Ameri-

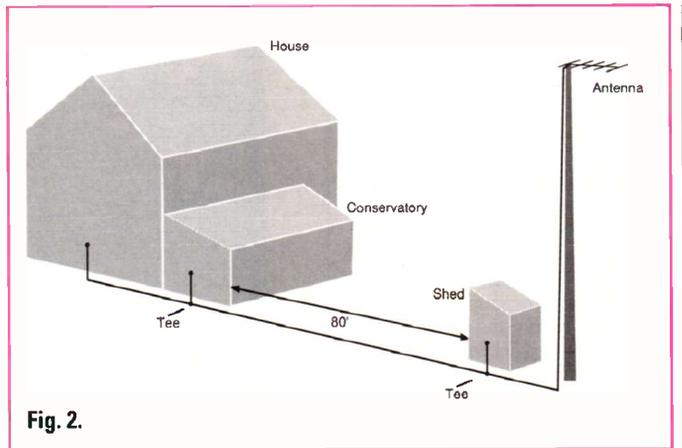

Fig. 2.

can ambulance services around 33.8, 33.86 and 33.9MHz and several Spanish speaking South American paging systems around 32.960MHz.

Towards the end of February I was amazed at the number of pulsed meteor scatter communication systems I could hear, many of which were fading up and down in strength during the course of the monitoring period. Signals were logged on 32.505, 32.55, 35.575, 35.605, 36.63, 36.65, 36.7, 36.75, 36.89, 37.7, 37.75, 37.8, 38.8, 38.845, 40.925, 42.99, 45.02, 45.04, 45.09, 45.135,

45.16, 46.065, 46.14, 46.185, 47.115, 47.14, 47.165, 47.185, 47.235, 47.255 and 47.375MHz.

One other interesting signal logged by a reader was a repetitive message stating that it was a feed for British Satellite Broadcasting, this was heard on 48.08MHz. That's all for this month, I would be interested in receiving more of your low band v.h.f. loggings particularly the more unusual ones, so why not drop me a line.

Until next month. Good listening.

### Airband 53 ➔

A cheap source of frequency information comes from **David Fairbotham** (Flightdeck, The Airband Shop, 192 Wilmslow Road, Heald Green, Cheadle, Cheshire SK8 3BH. Tel: 061-499 9350). Two A5 format booklets have been produced, each available from The Airband Shop for £1.40 inclusive of UK postage. First is *Airways*, a list of the frequencies used for controlling traffic on UK airways ordered by airway number (starting with A1, finishing at W2, and then listing the lower airspace advisory routes). In this respect, the book replicates information found in the official en route supplements but is much cheaper. Also included in the 16 pages plus cover is a list of beacons and reporting points. This is useful if you're trying to locate a reporting point when only its name is known; a great help to my readers. It's a pity that just one further list is missing, and perhaps David could add it to the next edition. A list of beacons ordered by callsign would be helpful; entering the list would yield the name which could then be looked up in the existing beacon section to find full details.

The other book (*World Airport Frequencies*) lists principal frequen-

cies at major airports around the world and, at 12 pages plus cover, would fit into any traveller's baggage. The UK is excluded and only major terminals are covered. Remember that this is a compact guide - you could carry the full official supplement with you, but it would add considerably to your limited baggage allowance!

A list of reporting points would help **H.A. May** (Haslemere) discover where ORTAC is. It's a reporting point in the Channel, south-west of the Isle of Wight, at N50°0' W002°0.3' on airway R41. When crossing this imaginary point, pilots only make a report to air traffic control if they were previously requested to do so. The name is unfortunate since it sounds too much like VORTAC, a general term applied to any v.o.r. and TACAN combination.

Mr. May asks about the ICF-2001D. I'm sure a dedicated scanner would give better results on v.h.f. Some time ago many readers wrote in experiencing problems with this receiver, so why not look at the new additions to the Sony range? If choosing a scanner, ensure that direct frequency entry is easy. Some scanners only permit listening to frequencies that are already

in memory, making it inconvenient to tune into a spot frequency at will. Hope these suggestions help; sorry, no direct replies are possible but all answers appear in this column.

Despite advance planning, the arrivals at the PFA Rally at Wroughton last year did seem more chaotic than previous events at Cranfield and I'm not sure why. It must have caused consternation amongst many of the participants. **Richard Gosnell G4MUF** (Swindon) suggests that incoming traffic should be coordinated onto final approach in order of their arrival times overhead the hold. The controller could

actually ask for aircraft to reply only if they arrived prior to a certain time, and thus process the queue methodically. Very sensible, Richard, so please suggest this direct to the PFA at Shoreham (0273) 461616.

Due to lack of space a comprehensive review by **Tom Wylie** (Strathclyde) of Scottish overflights has with regret been held over until next time.

The next three deadlines (for topical information) are May 8, June 5 & July 9. All correspondence to 'Airband,' c/o **The Godfrey Manning Aircraft Museum, 63 The Drive, Edgware, Middlesex HA8 8PS**.

### Abbreviations

a.m.	amplitude modulation
B.	Boeing
CAA	Civil Aviation Authority
Cat	Category
DC	Douglas Commercial
f.m.	frequency modulation
ft	feet
GASIL	General Aviation Safety Information Leaflet
i.f.	intermediate frequency
i.l.s.	instrument landing system
kHz	kilohertz

MHz	megahertz
n.d.b.	non-directional beacon
nm	nautical miles
QFE	altimeter pressure setting, reads zero at aerodrome elevation
QNH	altimeter pressure setting, reads height above sea level
TACAN	TACTical Air Navigation
v.h.f.	very high frequency
v.o.r.	very high frequency omnidirectional radio range

Lawrence Harris

5 Burnham Park Road, Peverell, Plymouth, Devon PL3 5QB

There haven't been any recent dramas amongst the WXSAT group but one or two interesting events have occurred. METEORS 2-20 and 2-19 exchanged operations in early February; this was expected because 2-20 was approaching the terminator (the boundary between night and day), at which time I suspect the solar panels are not being efficiently illuminated. To my surprise (even if nobody else's) METEOR 3-4 has continued in normal operations throughout its passage across the terminator.

For those recent recruits to monitoring the Russian METEOR satellites, a study of their orbits shows that, unlike the sun-synchronous NOAA wxsats, the METEORS constantly change their orbital planes. These slowly move towards the next (or previous) terminator, whether morning or evening. For several days at the terminator they are not well illuminated by the sun, and so their power systems may be put under a strain. Consequently the Russians usually swop from one METEOR to another.

### MAGION 3

In mid-February, while METEOR 2-19 was coming south-bound from over the North Pole, there was a strange effect, during the morning pass, on its 137.85MHz signal. At first I suspected a problem with the transmitter. The following pass was perfect, but then the next days saw a repeat performance with the early pass. I checked out some recent launches and found one satellite - MAGION 3 which was simultaneously passing over the UK. By checking each time MAGION 3 coincided with METEOR 2-19 the interference was obvious. When MAGION had drifted away some days later, 2-19 was then alright. Two satellites on 137.85MHz!

### METEOSAT 3

This geostationary WXSAT presently at 50°W is easily heard from the UK, but a recent press announcement from the Information Division of EUMETSAT states that it will be drifted further along the Clarke belt to about longitude 100°W. This is to help the Americans who are not yet able to replace GOES-west. I am not sure of the date of this move but suspect that it may not be until 1993.

### METEOSAT 4

During mid February, imaging of our side of the earth was done by METEOSAT 5 but the picture data was transmitted by number 4. Possibly as a result of this, the 'country outlines' (added by the ground computer) were often displaced. Peter de Jong of Leiden in Holland is a regular monitor of METEOSAT and he reported the

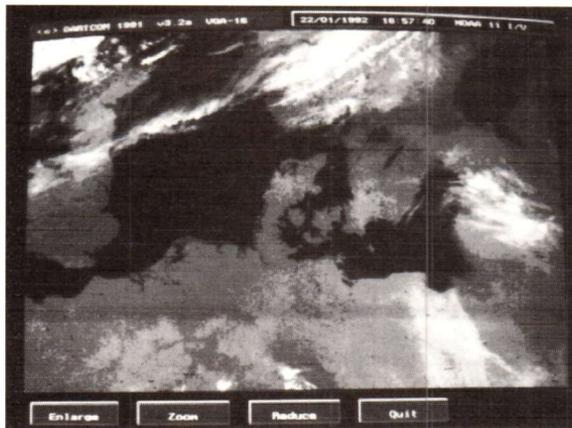

Fig. 1: Denmark and region, NOAA 11 from Matt Taylor.

faulty east edge image seen on the O3 and E3 formats (infra-red and water vapour). Peter tells me that he is refraining from upgrading his METEOSAT system because 'of the plans for digital WEFAX and a.p.t.'. I have received recent information from EUMETSAT which advises that some meteorological transmissions will be encrypted (coded) but these are not our WEFAX ones. Similarly, the digital transmissions should remain un-encrypted. I am trusting that they won't be coded because I have just ordered a PDUS (Primary Data User System)! Mind you, Peter only lives along the road from EUMETSAT so I hope that he will keep me up-to-date with any new plans!

### FENGYUN 1-2

This Chinese polar orbiting WXSAT ceased normal a.p.t. broadcasts several months ago, but occasionally my scanner stops on 137.80MHz (FENGYUN'S frequency) and a carrier was heard intermittently. After checking one or two orbits it could be positively confirmed. I haven't seen, or had any reports of a.p.t. from anyone.

### Letters

A large number of letters continue to request Kepler elements, as well as posing some interesting problems, and in some cases passing on helpful comments for this column. Michael Wood of Deal in Kent has a Spectrum 128 computer and asked about the possibility of using it for WXSAT reception. The smaller computers such as the BBC, Amstrad and Spectrum have had programs written for them to decode WXSAT signals. In each case an interface is needed - that is, some hardware to convert the audio output from the receiver into a computer-compatible signal. For the Spectrum, the only supplier of which I am aware is Technical Software who advertise in SWM. I reviewed their APT-1 module about a year ago. James Booth of

Portsmouth uses the Maplin receiver and decoder plus his Amstrad 464 computer for picture production. He says that good pictures can be obtained with a lot of practice, and is wondering about buying the Maplin METEOSAT antenna and built-in pre-amp. I have seen their advertisement and I wrote to them over a year ago requesting more information.

### Cirkit Receiver

Tony Branton G8VUS of Malvern Link recently purchased the Cirkit receiver kit and uses it in conjunction with a Tonna 10-element beam which, Tony comments, greatly reduces the local 'pager' break-through. I wondered whether Tony might need to track the satellites with such a directional beam, but he doesn't mention doing so. He is now working on improvements to his other equipment. For people new to WXSAT monitoring, the 'pager' interference referred to is the use of frequencies very close to 'our' weather satellite band of 137 - 137.9MHz. The WXSATs transmit using powers of around 5W. The authorities allocated a number of frequencies, including one inside the WXSAT band (!) to transmitters that are used to trigger personal paging units. Their output power is enormous and so we have seen severe interference on normal WXSAT receivers. Some manufacturers have gone to considerable efforts to make their receivers resistant to this (and other) interference.

Gerard Melia of Stockport also uses a Cirkit receiver feeding his Amstrad 2086 which runs PCGOES, and reports that he hasn't suffered from paging interference. P Grant of Crewe requested a copy of the Shuttle Kepler elements that I have available for readers of this column, and he points out that there is a shareware program for the PC (personal computer) called STSORBIT which can use this information. I haven't seen the program but presumably it is dedicated to shuttle

tracking.

Ken Reece G8UYB has recently bought a PC in addition to his Amiga 500 which runs Amigasat and tells me that he is now also running Prosat2. A number of correspondents are now operating two separate systems! John Hancock of Coventry also uses Amigasat, and told me that he had some problems with his framestore. The Remote Imaging Group (RIG) have made boards available for the framestore, but the components do need to be purchased and mounted separately. Even with expert help, it was some four months or so before I got mine working - it is a major project.

### Pre-amp?

Another welcome recruit to the world of WXSATs is John Knox of Wimborne who has worked in the field of terrestrial communications for many years. He is currently using a home-made crossed dipole and Yaesu FRG-8800 receiver to hear the satellites, but proposes to buy the Timestep Proscan receiver, a 137MHz pre-amp and Prosat2 software to run on an Amstrad 2086. John wonders whether this combination of equipment is OK. If John is receiving good, clear signals from his crossed dipole then he should not need to buy a pre-amp. Generally speaking, if you use up to 20m of good quality cable (e.g., UR47, UR67 or H100) then your receiver should be sensitive enough to hear signals without fitting a pre-amp. The computer should be suitable, particularly if it has a VGA (or better) screen. Do check equipment compatibility with the manufacturer before purchase though.

Roger Ray of Telford is proposing to upgrade his 100% Maplin equipment and asks me whether I have any experience of the Proscan receiver (previously mentioned). I haven't seen the receiver myself though I believe that I might be reviewing it this year. I understand that it is immune to pager interference, but again this needs to be checked with the supplier.

### Manoeuvres

B Berman of Burton-on-Trent sent me an interesting note saying that NOAA 12 appeared to have slowed early in December while METEOR 3-4 and 2-20 speeded up. Looking back at my log book I had 'flu' at that time but logged METEOR 2-19 as being the operational METEOR as well as 3-4. It is worth pointing out that the METEORS can manoeuvre to some extent because they are fitted with propulsion units. In order to spot this you need to either check the times as he did, or plot the mean motion (or similar parameter) using the Kepler elements. I did this a year or two back and was quite surprised to see how one could spot the manoeuvre dates. The NOAA 12 ob-

# THE TIME IS RIGHT

Buy a Junghans Radio Controlled Clock today and you will always know that the time is right. On March 29th when British Summer Time began how many of your other clocks automatically changed to show the correct time? Here are just a few of the many styles available.

Digital alarm clock - black or white.....	£46.50
Wood mantel clock in walnut or cherry.....	£165.00
Wood mantel clock in light or dark oak.....	£125.00
Solid brass case carriage clock.....	£149.00
Digital wrist watch still available.....	from £164.00
Analogue radio controlled wrist watch.....	from £355.00
Mantel clock available in white, black and grey.....	£67.50
Large white 32cm dia wall clock.....	£67.50
Coloured kitchen wall clocks 22cm dia peaches, vegetables or chickens motif.....	£69.00
Walnut or oak case wall clock 27.6cm.....	£129.00
Walnut, oak or cherry wood square cased.....	£117.00

★★★  
Any Junghans clock will make an ideal gift for all occasions.

Send a SAE for our full list of Junghans Radio Controlled Clocks and Watches.

★★★

## ★★ NOW IN STOCK - ALINCO DJ-X1 - only £269 ★★

This new "Professional Grade" scanner is compact, ruggedly built and very sensitive. It features 3 scanning speeds, 3 scanning modes, and 100 memories in 3 banks. Frequency control from the keyboard or the rotary frequency control. A wide range of accessories are available.

• Coverage: 500kHz - 1.3GHz • AM/narrow FM/wide FM • Size: 100 x 53 x 37mm • Weight: 370g •

AMDAT stocks a wide selection of radio equipment and accessories at our Bristol shop. We display the latest digital receiving equipment and provide professional advice on its use. New and used radio equipment available for ICOM YAESU AOR ALINCO.

**Wide range of books and magazines available.**  
**Computers and accessories in stock**

Prices subject to change. Prices shown include VAT. Carriage extra

# AMDAT

4 Northville Road, Northville  
Bristol, BS7 0RG  
0272 699352



GOLD SEAL  
BP GARAGE

NORTH WALSHAM RD

B1150

EDWARDS RD

SHOP OPEN  
MON-SAT 9.30-5.30

# THE SHORT WAVE

CENTRE  
NORWICH



## Do you need a scanner or receiver ? Do you need amateur radio equipment ?

"Kenwood, Icom, Yaesu, Alinco, Yupiter, Aor etc"  
**But most of all do you need equipment serviced?**  
We have up to date test equipment, fully equipped workshop for all types of radio equipment.

Second Hand Equipment Available, Part Exchange Welcome.

**TEL: OR FAX: 0603 788281**

Prop: P. Gunther G4XBT, 95 Colindeep Lane, Sprowston, Norwich, Norfolk NR7 8EQ. VAT No. 595 1239 21

**NEW SHOP OPEN NOW!**  
**"PHONE US NOW FOR BEST PRICES"**

servation might be an error in the Kepler elements - I'm not sure.

From Caterham in Surrey came a letter from **Ray Howgego G4DTC** who has recently acquired weather satellite receiving equipment and says he is both 'thoroughly addicted' to it, and finds it 'compulsive'! He is using a Multiplex 386SX Genius computer fitted with a 105Mb hard disk which is rapidly filling up with picture files! He uses PCGOES software, but with an Icom R7000 receiver and a discone! The Icom is used with a 250kHz bandwidth setting (ugh!) which, as Ray says, is far from ideal! For optimum WXSAT use it is essential to use a dedicated WXSAT receiver which will have a bandwidth of about 50kHz. Ray also monitors the h.f. and v.l.f. bands and tells me that his most stunning images are those from GOES relayed by the USN station at Norfolk, Virginia on 10865, 16410 and 20015kHz. Ray has also monitored 'poorer quality images' from Prague Meteo on 111.8kHz at 30 minutes past the hour. I have been wondering which FAX stations re-broadcast GOES pictures so many thanks to Ray for this information.

**M Hellier** writes from Long Sutton in Somerset to say that he has had difficulties receiving satellites using his Realistic Pro37 scanner and discone. The problem could well be the lack of gain. I have a discone and the Pro-2004 scanner, but I had to fit a wide-band pre-amp to the discone before I could hear any satellites. The discone must be mounted as high as possible and so I suspend mine in the loft because the chimney already has two antennas fitted to it. It is worth noting again that the Pro37 scanner is

not designed for WXSAT use, although you will hear them - like the Icom mentioned previously.

### TBUS Information

**Ian Chard** of Brighton has monitored Bracknell transmissions on 4.487MHz at 2045UTC and sent me a printout of the predictions data for NOAA 11. This is the same data that is broadcast by GOES2, but it is a little easier to receive Bracknell! The data includes updates on the status of each NOAA.

### Kepler Elements

A print-out of the latest elements (and/or future shuttle elements) is available for one s.a.e. All known weather satellites are included, together with their transmission frequencies if operating. This data is supplied courtesy of NASA. Data is normally posted within 48 hours; any delays are due to postal delays in my receiving new elements.



**Fig. 2: METEOSAT 4 water-vapour image (E1) from Pete Beardmore**

you will notice that at one node it crosses the equator while going north (ascending!) and the other node crosses while going south (descending). We always use the ascending node for Kepler elements. Next month we'll continue with these parameters.

### Global Positioning System

Some readers have asked for more information on the satellites used in the Global Positioning System (GPS). This is a satellite-based radio positioning and navigation system which is not yet fully operational. Using 1575.42 and 1227.6MHz, it will consist of 21 satellites grouped in six different orbital planes, with some spares. These orbits have periods of 12 hours and are inclined at 55 to the equator, so their average height will be 20 200km. This means that at least four will always be visible to the user at any given time. Each satellite transmits on both frequencies, but only the first may be accessed by civilian users. The telemetry contains information on the satellite clock, navigation and system data. Military users will be able to achieve an accuracy of within 30m but civilian users will 'only' obtain about 200m, due to the lower efficiency of the civilian system. The satellites carry atomic clocks for accuracy. If anyone requires more information on software for navigation they can contact Andy Hancock of PC Maritime Ltd in Plymouth; Tel (0752)-550341.

### Frequencies

NOAAS 9, 11 a.p.t. on 137.62MHz  
 NOAAS 10, 12 on 137.50MHz  
 NOAA beacons on 136.77 and 137.77MHz  
 METEOR 2-19 or 2-20 on 137.85MHz  
 METEOR 3-4 on 137.30MHz  
 OKEAN 3 on 137.40MHz (not heard recently)  
 FENGYUN 1-2 sometimes a carrier on 137.80MHz

### Books

A letter from **Roger Ray** of Telford mentions some interesting books on satellites: *The Illustrated History of NASA and Images of Earth*. He tells me that the first has some good photographs of early Tiros and similar satellites and they both have excellent pictures of earth from space. I hope to complete my own epistle on weather satellites shortly.

### Beginners - Kepler Elements Part 2

As mentioned last month, many readers have asked for an explanation of Kepler elements - those parameters which enable computer programs to predict the position of a satellite at a future time. This month we continue, with RAAN!

**RAAN - Right Ascension of Ascending Node:** With a name like that one can understand a reluctance to learn about satellite orbits! If you have an interest in astronomy you will know that astronomers describe the position of objects (stars or planets) in the sky using two parameters (apart from the date) - declination (which is the angular height of the object above or below the celestial equator) - and right ascension (RA). This RA is actually a simple measurement. It is the angle (measured eastwards) between a place in the sky called 'the First Point of Aries' and the object. As the earth rotates on its axis each day, the stars appear to move once around the sky. The sun appears to move in front of these stars, and so to define a 'starting place', the position occupied by the sun at the start of spring is called the vernal equinox, and defines RA = 0. It was once in the constellation of Aries, but because of the changes in the direction of earth's polar axis, (called precession) this 'First Point' has actually moved, but we still use that position on the celestial sphere to mark the origin of Right Ascension. It can be measured in either hours (using 24 hours equals 360) or simply degrees.

### Nodes?

If you draw a diagram showing the satellite's orbit at an angle of perhaps 82 to the equator (METEORS have this inclination), you will realise that this orbit can be drawn in an infinite number of positions - anywhere around the earth. Now join a line between the two places where the orbit crosses (intersects) the equator and we have two positions - called the nodes. We are getting closer! Thinking about the satellite's movement along this orbit,

### Abbreviations

AOS	Acquisition of signal
a.p.t.	automatic picture transmission
AVHRR	Advanced Very High Resolution Radiometer
BBS	Bulletin board service
CGA	Colour Graphics Adapter
DOS	Disc Operating System
EMS	Expanded (or extended) memory
ESA	European Space Agency
GOES	Geostationary Operational Environmental Satellite
GOMS	Geostationary Operational Meteorological Satellite
h.r.p.t.	high resolution picture transmission
LOS	Loss of signal
NASA	National Aeronautics and Space Administration
PDUS	Primary Data User Station
VGA	Video Graphics Array

Mike Richards G4WNC  
200 Christchurch Road, Ringwood, Hants BH24 3AS.

**P**aul Charlton of Ilford has written asking if there is anything he can do to improve the stability of his receiver. He currently uses a Yaesu FRG-7700 receiver with decoding software from Grosvenor Software (G4BMK). Before looking at the solutions, let's look at the root cause. The first point to appreciate is that temperature variations are the prime cause of frequency drift. This is because as the temperature rises so components in the receiver tend to expand. It's this physical change that causes the frequency to change. Although receiver designers go to great lengths to minimise the drift, perfection has yet to be achieved. With most modern receivers having synthesiser control, the overall stability is usually defined by a crystal controlled reference oscillator. One way to improve the performance of your receiver is to see if the manufacturers can supply an external frequency standard. These normally comprise a crystal oscillator housed in a temperature controlled oven. They tend to be expensive, but often provide a tenfold improvement in stability.

Before you rush out to buy an external standard, there's a few points you can check. Remembering that temperature is the key component, you need to ensure that your receiver is kept away from any draughts. Ideally your operating area should be maintained at a constant temperature. This applies before you start operating, as well as during.

Another important point is to ensure that the receiver is well ventilated. If you restrict the air flow around the receiver you'll find that the internal temperature takes longer to settle. This will both increase drift and may even shorten the life of the receiver.

If any readers have experienced drift problems and found cures, I'd be very interested to hear the details.

**Tim Strickland** of St Leonards on Sea asks for details of the Marine Page system that operates on 441kHz. All I know at the moment is that it's an experimental paging system operated by British Telecom. As far as I'm aware the transmission mode is an FEC variant, but I don't have any further details. If anyone can help, I'd be pleased to hear.

It's always gratifying to get letters from satisfied customers and it seems **Les Gibson** of Bristol is well pleased. Les wrote to me some months ago enclosing a tape and asking if the recorded signal was that of Offenbach. I was able to confirm this and give him some advice on a suitable decoding system. Just to prove that he succeeded, Les sent me a few photographs of Meteosat images. You should see a sample or two of his results in the column.

**Peter Court** of Birmingham is thinking of supplementing his v.h.f. equipment with a Lowe HF-225 (an

excellent choice). He'd like to use this for RTTY, c.w. and FAX reception. The problem he has is in deciding which of the many decoding systems to use with his BBC B or Atari STE computer. It's very difficult for me to make a clear recommendation as there are so many variables. Basically you get what you pay for. The best advice I can offer is try before you buy and radio rallies are one of the best places to do this.

**Patrick Scott** of Fulham has written to tell how pleased he is with the latest firmware for his ERA Micro-reader. The latest version (4.1) adds ARQ and FEC modes to the Micro-reader's range of modes. The upgrade costs £20.00 but, having seen an early copy, I can assure you it's well worth it.

Patrick also has a question - he wants to know if anyone produces a decoding system that will handle Teletext signals. At the moment he can receive the signals using his Yaesu FRG-9600 but would like to store and display the Teletext on his IBM compatible PC. If anyone can help, please drop me a line.

## RTTY Datacard

I've just received a sample of an ingenious decoding aid from Tiare Publications in the US. One of the most common problems facing the newcomer is that of how to recognise the different signal types. If you're using one of the simpler decoding systems it doesn't take too long to try out the available options. However, if you're using one of the sophisticated packages with lots of options, selecting the right mode can be very difficult.

It's in this latter case that the new RTTY Datacard comes into its own. The card is supplied a double sided A4 sheet encapsulated in a plastics cover. In order to use the card you will need a decoder that can measure both the baud rate and shift of the incoming signal. The main part of the Datacard comprises a table known as the Yarbrough Matrix Tuning Table. This table cross references the baud rate and shift to make a guess at the mode. Although this may sound rather crude, it's precisely what any experienced monitor does almost without thinking. The main advantage it gives is a reasonable starting point for further analysis. By way of an example, a signal with a shift of 425Hz (medium on the matrix) and a baud rate of 75 is shown as Baudot. This is a very reasonable assumption that I'm sure would be right in most cases. As I'm sure you can imagine, it's not all as simple as that. The worst case was 192 baud with a medium shift where seven likely modes were listed. Despite this coarseness the guidance given appeared to be sound.

Although the matrix was clearly the main component of the data card the second side contained a lot of

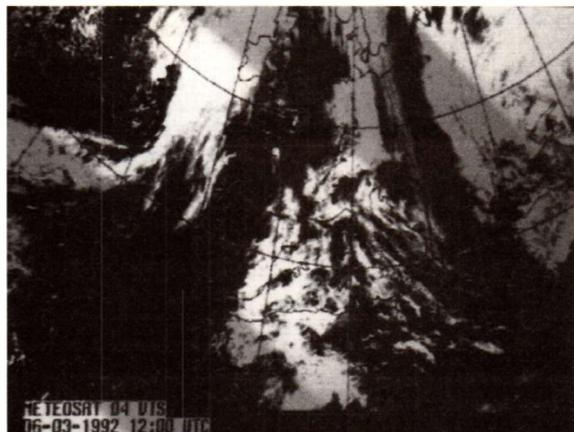

Meteosat image from Les Gibson.

useful information to help guide the listener to the correct mode.

The market for this card is really limited to those using sophisticated decoders such as the Universal M-7000, M-1000, Wavecom 4010 and Hoka Code-3. Despite these limitations, I thought the card was very useful and has found a place in my shack.

For those of you who'd like one they are available direct from **Tiare Publications, PO Box 493, Lake Geneva, WI 53147, USA. Tel: (414) 248-4845.** The price is a modest \$6.00 plus \$1.00 post and packing. If you prefer to order by credit card, they accept Visa and Mastercard.

## Atari FAX

Atari users will no doubt be pleased to hear that there is some new FAX software available. The new program is designed to be used with a Kantronics TNC and an Atari ST/STE with at least 1MB of RAM (2MB preferred). Running the program with the Kantronics TNC enables h.f. FAX images to be displayed and saved to disk. When saving an image you have a choice of two formats. The most versatile of these is GEM.IMG as these can be easily exported to other graphics packages. The great advantage being that a noisy image can be cleaned-up and generally enhanced. The program also allows screen sized snapshots to be saved in DEGAS format. You can also perform several image manipulation functions such rotation and zooming.

For more information contact **C.J.R. Strevens (G4ZHT), 11 Kenley Rd, London SW19 3JJ. Tel: 081-540 1973** (evenings).

## Pan Pals?

**Bernard Harratt** of Pontefract has prompted me to bring up the subject of pen pals. This is perhaps a bit of a corny title but the suggestion is that readers may like to communicate with others that use similar equipment. This strikes me as a very good idea as the complexities of decoding mean that each of the various systems seem to have their own range of associated problems. Talking to other users is often a very good way of finding the solution. You can also swap hints and tips for improving the results or just making life easier. What I would also like to see is perhaps the occasional letter from those involved to see just how successful the scheme is.

So to get down to some practicalities, I'll start with Bernard. He currently runs a Spectrum 48K+, Spectrum Plus Three, Yaesu FRG-7 receiver, Trio 9R-59DS receiver and a Star LC-10 printer. He also has a Kempton Eprinter interface that he would like to connect to the Spectrum - any help would be appreciated. If you could help or would just like to share ideas, Bernard's address is: 49 Northfield St., South Kirkby, Pontefract, W. Yorks WF9 3NG.

If anyone else would like to make contact with other like minded listeners please drop me a line. If you'd rather I didn't print your name and address I'm quite happy to handle the initial contact through me. Don't forget to give as much detail as possible on your equipment and interests when writing.

## Unshift-on-Space

Although I've made general reference to this this facility while explaining various RTTY modes, I think some more detail is in order.

The prompt for this feature was a letter from **Paul Charlton** of Ilford. Paul asked why he has problems with numbers being printed as letters when receiving frequency lists. To gain a full understanding we need to return to some basics of how a RTTY signal is constructed. Regular readers will no doubt have heard of the International Telegraph Alphabet No. 2 or ITA2. This is simply a table that shows the code used to represent the various characters that we want to send. If we look at a computer based system the computer uses this table to work out what code to generate when a key is pressed. All very simple but there's one fly in the ointment. This is due to there being only five elements available for each character. Just to remind you of the binary counting system you can see that with a five unit code there are only 32 possible combinations.

Decimal Value:	16	8	4	2	1
Binary Value:	1	1	1	1	1

With twenty-six letters in the alphabet plus ten digits and punctuation you can see that this is not enough. The solution to the problem was to give each of the thirty-two combinations two meanings. These two sets of codes are called Letters and Figures so you can guess how they're used! To make the system practical two of the codes

FAX chart received by Alan Jarvis using PC HF FAX.

had to be used to switch between letters and figures. These two codes are known as letter and figure shift characters. The addition of these codes means that we end up with a total of sixty codes available for letters, numbers and punctuation. This is clearly more than enough but, create another problem. The snag is that the figure and letter shift characters become extremely important. With any of the other characters bursts of interference only corrupts single characters. However, if a shift character is lost or an additional shift inserted, the following text turns into gibberish. This is one of the major failings of the ITA2 as an encoding system. From a commercial point of view the solution has been to design new robust codes that not only reduce the chance of error but enable error correction to take place. Perhaps the most common example of this is the CCIR 476-4 alphabet used by the SITOR ARQ systems.

Despite the seemingly bleak picture I've painted, there are several ways that significant improvements can be made.

One system adopted by some press and telegraph agencies was to only use the letters character set and completely ignore the figure set. The problem, of course, is that you have to spell out punctuation and figures. This is the reason why so many telegrams included the word STOP at the end of each sentence. The advantage with this technique was that it significantly reduced the error rate on important commercial messages.

### Simpler Solution

A simpler solution came with the advent of computer based decoding systems in the form of Unshift-on-Space. This is a simple system that forces a return to letter shift after every space character. The theory is simple - numbers within a message are normally followed by a space then letters. By forcing the return to letters, the facility can greatly reduce the number of errored characters received. However, as it is a compromise, it can't be used all the time. A classic example of this is the coded weather stations that have become popular with many readers. These stations send their data in five digit blocks with a separating space. If you try to receive this with the Unshift-on-space enabled, the numbers will be printed as letters. You can also hit problems when receiving station schedules. The solution is simply to switch-off the unshift-on-space.

If you get caught out and end up with some vital message corrupted, do not despair. You can quite easily convert between letters and numbers or vice versa.

Just to make life easy for you, at the top of the next column is a conversion chart that I prepared earlier!

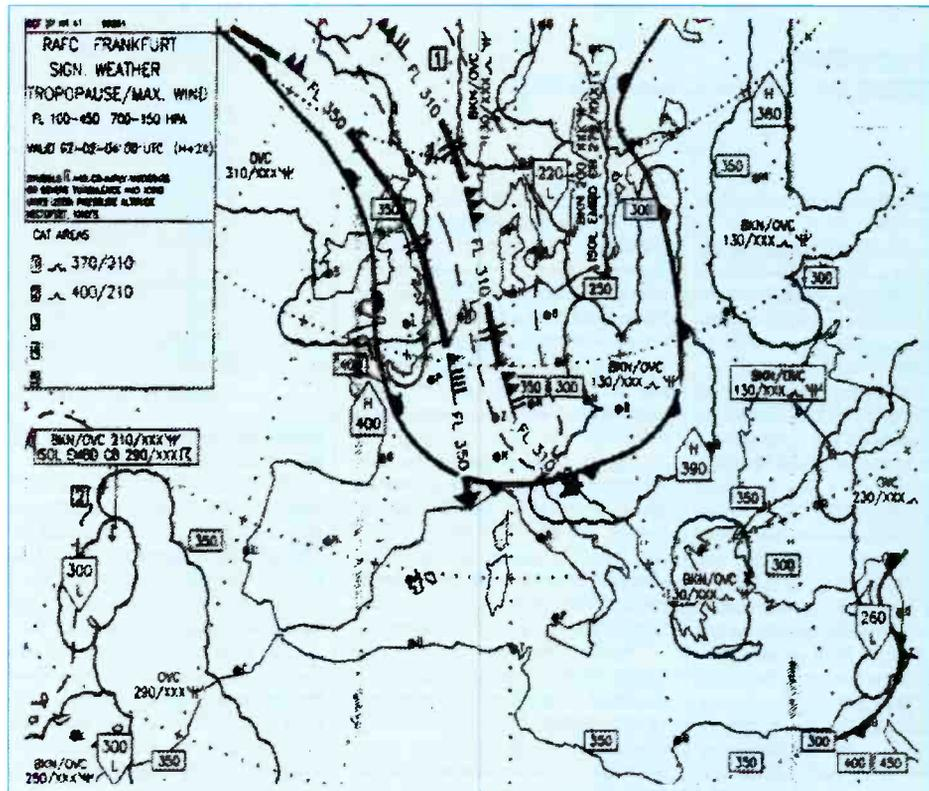

Letters	Figures
A	-
B	?
C	:
D	\$
E	3
F	!
G	&
H	#
I	8
J	^
K	(
L	)
M	.
N	/
O	9
P	0
Q	1
R	4
S	'
T	5
U	7
V	=
W	2
X	/
Y	6
Z	+
<	<
≡	≡
letter shift	figure shift
space	space

To illustrate the use of the chart let's suppose we'd received the following corrupt frequency ABMUTO. By cross referencing between the letters and figures columns this can be converted to 12.759. The process can of course be used in reverse to convert from numbers to letters.

### FAX Printing

Several people have written to me asking how they can improve the print quality from their FAX decoding packages. The problem stems from the fact

that many of the computer based FAX programs are optimised for viewing on a computer screen. This often results in a significant quality loss when the result is directed to the printer. As mentioned in last month's Decode, the most versatile packages are those that allow the image to be stored in a standard format such as PCX. If you have this option, you'll find that some of the graphics packages have excellent print utilities.

For those that use the Hoka Code-3 program, I'll repeat the tip I gave some months ago. To get the best printer output you need to run INSCODE3 and change the screentype to CGA. When in the FAX module you then need to set the screen IOC to 176. Although this is a rather cumbersome fix, the results are well worth it.

To help those who have yet to find a solution, I'd very much like to hear from readers who are getting good printouts. Please send full details of both the FAX and graphics packages involved. I'd also like to see some examples of good quality FAX images.

### Frequency List

Now on to the list for this month which has been compiled from the following readers: **Ted Rickett, Day Watson, Ken Whayman, Jan Nieuwenhuis** and Paul Charlton.

If you'd like a copy of my full list, just send three first or second class stamps to the address at the head of the column.

This month's list follows the normal format, i.e. Frequency, mode, speed, shift, callsign, time and notes.

2.6185MHz, FAX, 120, 576, GFE25, 1900, Bracknell Met  
3.332MHz, AUTOSPEC, 68.5, 85, -, 2337, Ocean Nomad oil rig

4.002MHz, RTTY, 50, 425, YRR2, 2000, Bucharest Met  
4.215MHz, ARQ, 100, 170, -, 1939, Oostend Radio  
4.272MHz, ARQ, 100, 170, NMN, -, US Coastguard  
4.307MHz, FAX, 120, 576, -, 2000, Unid WX  
4.583MHz, RTTY, 100, 850, DDK2, 2356, Hamburg Met  
4.777MHz, FAX, 120, 576, IMB51, 1900, Rome Met  
6.316MHz, ARQ, 100, 170, NMN, -, US Coastguard  
6.446MHz, FAX, 120, 576, GYA, 1930, Northwood  
7.8925MHz, FEC, 100, 170, SPW, 1446, Warsaw radio  
8.154MHz, RTTY, 50, 240, MKD, 0028, RAF Akrotiri  
8.377MHz, ARQ, 100, 170, V7AA, 1909, MS Pan Maple  
9.3415MHz, RTTY, 50, 340, FDY, 0832, FAF Orleans  
10.1499MHz, RTTY, 75, 250, SUA246, Mena Cairo press  
10.536MHz, RTTY, 75, 800, CFH, 1935, CF Halifax  
11.080MHz, RTTY, 50, 600, YKP28, 1846, SANA Damascus  
11.133MHz, RTTY, 50, 400, BZG41, 1530, Beijing press  
12.186MHz, RTTY, 50, 400, -, 1741, JANA Tripoli  
12.735MHz, c.w., -, -, URL, 1847, Sevastopol (Ukraine)  
13.9965MHz, RTTY, 50, 400, STK, 0010, Khartoum air  
14.932MHz, RTTY, 50, 850, -, 1522, Spanish press  
16.0296MHz, FAX, 120, 576, NPN, US Navy Guam  
16.8195MHz, ARQ, 100, 170, NMN, -, US Coastguard  
19.8216MHz, ARQ, 100, 170, -, 1831, UN Geneva  
22.0068MHz, TWINPLEX, 100, -, -, 1432, MFA Islamabad

**ICS**

# FIRST FOR PERFORMANCE, VERSATILITY ... AND VALUE

ICS pioneered computerised amateur data reception in the UK. Our experience and expertise are second to none. Today we have the finest range of data and facsimile receiving equipment available and we pride ourselves on its superior performance, reliability and excellent value for money.

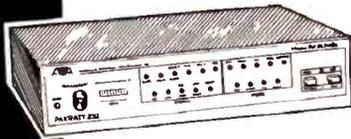
**PK-232**

**PK-232 MBX  
Multi-Mode  
Terminal Unit  
£339.95**

The most popular terminal unit ...ever. Receive and transmit Fax, RTTY, Amtor, Sitor, CW, ASCII, Morse, Navtex and Packet on your IBM-PC. Unique Signal Identification and Acquisition (SIAM) mode plus the best HF demodulator there is. Very easy to use. Supplied complete with all cables and software.

## **MET-2 Satellite Receive System £939.95**

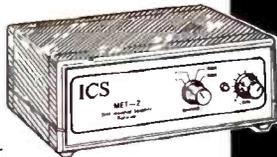
**MET-2**

Receive Meteostat weather satellite pictures live on your own PC. New, very advanced version with super VGA support, 3D display effect, 100 frame animation, NOAA option with gridding and much more... Exceptional value for money.

**ICS-FAX II**

**ICS-FAX II  
£129.95**

Displays superb weather fax images on an IBM-PC. Also includes Navtex, RTTY and FEC as standard. Cheaper and easier to use than similar products. Connects to any HF SSB receiver. 9 to 25 pin interface adaptor included. Colour Upgrade £49.95.

## **SONY ICF-SW55 Communication Receiver £249.99**

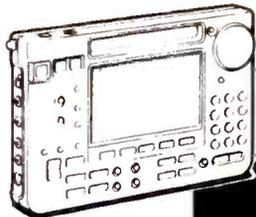
**ICF-SW55**

Perfect for use with ICS-FAX II. Displays station name and up to 5 channels for each station. 150KHz to 30MHz plus FM stereo. USB, LSB, AM. 50Hz tuning resolution. 125 memories.

Prices include VAT at 17.5%. Add £6.00 Postage & Packing. Please contact us for free catalogue and price list.

Our products are available direct and from dealers throughout Europe. Callers by appointment.



ICS Electronics Ltd. Unit V,  
Rudford Industrial Estate, Arundel,  
West Sussex BN18 0BD  
Tel: (0903) 731101 Fax: (0903) 731105

**ICS**

# Cirkit TESTING



## **TM SERIES MULTIMETERS D-MM Good Value!**

The TM series of low cost meters, with 3½ digit LCDs, full overload protection, strong ABS case and packed with features. Supplied with test leads, battery and manual.

**NOW  
EVEN BETTER  
VALUE!**

TM 5315	DC current (10A) continuity and diode test	56-05315	£19.99
TM 5365	Capacitance and frequency (200kHz) ranges	56-05365	£36.50
TM 5375	Frequency range (20MHz) and HFE test	56-05375	£36.95
TM 115	AC & DC current (10A), HFE and continuity test	56-00115	£32.50
TM 135	Capacitance and temp. ranges (inc. probe)	56-00135	£45.95
TM 175	Frequency (15MHz), capacitance ranges with HFE, diode, continuity and LED test.	56-00175	£53.60
TM8020	3¾ digit display, frequency (4MHz), capacitance (40µF), AC + DC current to 20A	56-08020	£54.76
TM8030	3¾ digit display, frequency (4MHz), temperature (inc. probe), AC + DC current to 20A	56-18030	£59.96
7705	Capacitance meter, 1pF to 20,000µF	56-07705	£39.82

## **BLACK STAR**

Top quality, UK made, frequency counters and generators.



Jupiter 2010	2MHz function generator plus 20MHz freq. counter	56-12010	£233.00
Orion	PAL TV pattern generator	56-01600	£269.00
1410	Video Monitor Tester	56-01410	£527.00
Meteor 100	100MHz counter	56-00100	£128.08
Meteor 600	600MHz counter	56-00600	£158.63
Meteor 1000	1000MHz counter	56-01000	£209.15
Apollo 100	100MHz counter/timer	56-10100	£381.88
Nova 2400	2.4GHz counter	56-02000	£351.33
Jupiter 500	500kHz function generator	56-00500	£129.25
Jupiter 2000	2MHz function generator	56-02001	£175.05

## **HAMEG 'SCOPES**



All Hameg scopes are supplied with two x 10 probes, mains lead, manual and 2 year warranty.

**EUROPE'S  
BEST SELLING  
'SCOPE**

HM203-7	Dual channel, 20MHz	56-52037	£397.15
HM205-3	Digital storage, 20MHz sampling	56-52053	£716.75
HM604	Dual channel, 60MHz	56-56040	£716.75
HM1005	Triple channel, 100MHz	56-01005	£930.60

Full details of all the above are included in our comprehensive catalogue, £1.70 (Inc. P&P).

All the above are currently in stock and available for immediate delivery. Standard P&P £1.20, next day delivery £4.60.

All prices include VAT (at 17.5%)

**Cirkit**

**Cirkit Distribution Ltd.**  
Park Lane, Broxbourne, Herts EN10 7NQ.  
Telephone (0992) 444111.

# Weather Satellites

Timestep have been producing inexpensive weather satellite equipment for 7 years. Following our success in both the UK and North American education market, we are now bringing our expertise to the amateur satellite user. All of our equipment is designed, built and fully supported in Britain, by Timestep engineers.

Lawrence Harris uses Timestep equipment for his column in Short Wave Magazine. Les Currington who received the first Chinese Feng Yun image and presented it to Chinese Diplomats, also uses Timestep equipment.

## PCSAT III

This innovative package will receive NOAA, METEOR, OKEAN, FENG YUN, METEOSAT, GOES and GMS. All images are received automatically on any PC with CGA, EGA, VGA or SVGA display.

Zoom, Pan, Contrast Stretch, False Colour, and Laser Print are just some of the features this system offers. Extensive filtering and a precision A-D are used on an internal PC Half Card, for superior image quality.

Animation from Meteosat is no mere gimmick! The atmosphere is a fluid in constant motion. Follow the dynamic progress of storms and cloud cover, on up to 100 full frames continuously animated images!

The really important feature is the ability to display in 800 pixels 600 lines and 256 colours, all at the same time. Some other systems will display 256 colours but only in far less resolution. Nearly all VGA and SVGA graphic cards are supported.

Full Satellite Resolution is received and stored by the system in a massive 512Kb file. This enables the stunning image quality and image processing.

Only £199.00 inc VAT & postage  
Upgrade for £99.00 and your PC GOES in exchange.

## Meteosat Receivers

Meteosat Yagi	£124.95
Meteosat Preamplifier	£92.00
20m Meteosat cable	£16.00
Meteosat receiver	£199.00
PCSAT III cable	£9.95
PCSAT III system	£199.00

Complete Meteosat system as above only £640.00 inc.

## Polar Systems

We produce a professional scanning receiver for NOAA, METEOR, OKEAN and FENG YUN; and low cost antenna systems. INSTANT TRACK is the ultimate Polar tracking program for up to 200 satellites at £24.95 inc.

## Computers

We can supply PCs to any specification at really good prices. Call us if you need details or if you want to purchase a complete "turnkey" solution.

**Call or write for a full catalogue.**

**Timestep Weather Systems**  
Wickhambrook Newmarket  
CB8 8QA England  
Tel 0440 820040 Fax 0440 820281

# RADIO SHACK



## AR3000A

The latest full coverage receiver/scanner covering all frequencies from 100 kHz to 2036 MHz. Available from stock **£765.00**

## SCANNERS FROM RADIO SHACK

AR-950	Base/mobile scanner .....	£199.95
AR-2000	Series II 0.5-1300MHz, 1000 memories .....	£269.00
AR-1500	NEW - as above, with SSB .....	£299.00
AR-2002	25-550 & 800-1300MHz .....	£399.00
AR-2500	Base/Mobile 5-550 & 800-1300 MHz RS232 .....	£419.00
AR-2800	Base/Mobile 0.5-600 & 800-1300MHz .....	£395.00

### ALL AOR PRODUCTS STOCKED

PRO-38	10 Channel handy scanner .....	£79.95
PRO-2022	200 Channel search & scan .....	£199.95
PRO-2024	60 Channel search & scan ) .....	£99.95
PRO-37	200 Channel SPECIAL PRICE UNTIL JANUARY 31 ...	£169.95
PRO-2006	400 Channel 25-560 & 720-1300 MHz .....	£329.95
IC-R-1	Icom's min.100kHz-1300 MHz 100 Ch. scanner .....	£369.00
IC-R-100	High performance base/mobile .....	£485.00
IC-R7100	25-2000MHz high performance receiver/scanner ..	£1120.00
BJ MK3	Black Jaguar .....	£179.00
DJ-X1	Alinco's latest .....	£269.00
UBC-200XL	200 Channel Handy Bearcat .....	£229.00
MVT-6000	Jupiter base/mobile station .....	£249.00
MVT-7000	Latest hand-held Jupiter .....	£279.00
HP-200E	From Fairmate 1000 memories .....	£269.00
MS-1000	Nevada Base receiver .....	£279.00
R-535	Signal Airband Receiver .....	£199.00



## DRAKE R8 RECEIVER £965.00

HF-225	Low high performance compact receiver .....	£429.00
R-2000	Kenwood's HF receiver, 10 memories .....	£549.00
VC-10	VHF convertor for above .....	£165.00
R-5000	Kenwood's De-luxe HF set .....	£895.00
VC-20	VHF convertor of R5000 .....	£170.00
FRG-8800	Yaesu HF Receiver .....	£649.00
FRV-8800	VHF convertor for above .....	£100.00
NRD-535	JRC-HF receiver .....	£970.00
IC-R71E	Icom HF receiver .....	£875.00
IC-R72E	Latest set, mains with internal battery pack .....	£589.00
IC-9000	The ultimate radio .....	£4080.00

Carriage free in U.K. Call us for our tax free export prices.

We will be pleased to quote you for anything you require in the communications and computer field. We are pleased to hear from you and see you. We aim to give you the attention you deserve, so please call before you come along.

73s Terry Edwards G3STS

## RADIO SHACK LTD

188 Broadhurst Gardens, LONDON NW6 3AY



(Just around the corner from West Hampstead Station on the Jubilee Line)



Tel: 071-624 7174 Fax: 071- 328 5066

# long medium & short

Brian Oddy G3FEX, Three Corners, Merryfield Way, Storrington, West Sussex RH20 4NS

**N**ote: l.w. & m.w. frequencies in kHz; s.w. in MHz; Time in UTC (=GMT). Unless stated, logs compiled during the four week period ending February 29.

Following reception of transatlantic l.w. signals from Europe in December and January, Alan Roberts (Quebec) continued to search during February, but conditions were unfavourable. In the seemingly endless noise, Alan detected an occasional weak carrier on European broadcast frequencies, but was unable to resolve the modulation.

Since the permanent closure of Sweden's oldest transmitter in Motala on 189kHz, Philip Rambaut (Macclesfield) has been able to receive the 10kW signals from Caltanissetta, Italy. Seldom reported, this may well be one to add your Dx list!

Whilst 250m a.s.l. overlooking Donegal, N.Ireland Sid Morris (Rowley Regis) looked for transatlantic signals with a Sangean ATS 803A portable plus telescopic whip. The first became audible on 960kHz at 0150 and was CFFX in Kingston, ON. This was soon followed by CJYQ in St. John's, NF on 930 and VOXM, also in St. John's, on 590. At 0215 he listened to WOGL in Philadelphia, NJ on 1210. He logged two of the many stations in New York, WINS on 1010 and WOR on 750, before switching off at 0250.

Surprisingly, exactly the same stations were noted by Jim Willett in Grimsby! However, he also listened later and heard WOSO in San Juan, Puerto Rico on 1030, R.Anguilla, The Valley, Anguilla 1505 and the Caribbean beacon, Anguilla 1610, all rated SIO222.

Last month Tim Bucknall (Congleton) reported hearing speech and music from a station on 930kHz, which he suspected was CJYQ. Since then he has checked that frequency often and he has now established that the signal does originate from CJYQ. At 2340 he logged it as 11221.

Good reception of N.Africa signals was noted by George Millmore in Wootton, IOW. After dark he rated the sky wave signal from Ain Beida, Algeria 531 as SIO333; Sidi Bennour, Morocco 540 as SIO222; Les Trembles, Algeria 549 as SIO444; Gafsa, Tunisia 585 as SIO333; Djedaida, Tunisia 630 as SIO333; Alger, Algeria 891 as SIO333; also Alger, Algeria 981 as SIO333.

English news bulletins from Croatian Radio via Zadar (1200kW) on 1134kHz have attracted Michael Williams in Redhill. They start soon after 2200 and last for about 8 minutes. Michael says the announcers do not give a programme or frequency guide - just 'Hello' and 'Goodbye'. He rates the sky wave signal as SIO333.

Further to the closure of the m.w. outlets of some local radio stations, Simon Hamer (New Radnor) has told me that 819kHz, used by the Hereford outlet of BBC Hereford and Worcester, will be allocated to Heads Of Valleys (S.Wales). Also 756kHz, used by the Shrewsbury outlet of BBC R.Shropshire, will go to R.Maldwyn (Powys). Could you please let me know if any changes are expected in your area?

Despite the continuing high level of solar activity, h.f. conditions have been good, strong signals from many areas have reached here. Nevertheless, many broadcasters will alter their schedules at the end of March to allow for seasonal changes. No doubt some will move their operating frequencies by a few kilohertz, but this usually results in co-channel interference and tends to be counter-productive.

### Listeners:-

- (A) Jana Arunachalam, Thumrait, Oman.
- (B) Tim Bucknall, Congleton.
- (C) P. Guruprasad, Madikwe, S.Africa.
- (D) Sheila Hughes, Morden.
- (E) Rhoderick Illman, Oxted.
- (F) Eddie McKeown, Co.Dowd.
- (G) George Millmore, Wootton I.O.W.
- (H) Sid Morris, Rowley Regis.
- (I) Sid Morris, while in Donegal.
- (J) Don Phillips, Bridlington.
- (K) Peter Pollard, Rugby.
- (L) Hugh Quinn, Co.Kildare.
- (M) Tom Smyth, Co.Fermanagh.
- (N) Phil Townsend, E.London.
- (O) Jim Willett, Grimsby.
- (P) Michael Williams, Redhill.

## Medium Wave Chart

Freq kHz	Station	Country	Power kW	Listener
520	Hof-Saale	Germany	0.2	F*,G*
531	Ain Beida	Algeria	600	D,G*,O*
531	Leipzig	Germany	100	F*,G*,H*,L*
531	Oviedo	Spain	10	B*,F*,G*
540	BRT-2 Wavre	Belgium	150/50	F*,G,H*,L*,N*
540	Ga-Rankuwa	B. Thatswana	50	C
540	Sidi Bennour	Morocco	600	G*
549	Les Trembles	Algeria	600	F*,G*
549	DLF Bayreuth	Germany	200	F*,G*,H*,L*
558	Espoo	Finland	100	F*
558	Valencia	Spain	20	F*,G*
567	Berlin	Germany	100	F*,G*
567	RTE-1	Ireland (S)	500	G*,H,I
567	RNE-5 Marbella	Spain	10	F*
576	Muhlacker	Germany	500	F*
576	Stuttgart	Germany	500	F*,G*,H*,L*
576	Radio Matro	S.Africa	100	C
585	FIP Paris	France	8	F*
585	RNE-1 Madrid	Spain	200	D,F*,G*,H*,L*
585	Gafsa	Tunisia	350	G*
594	Frankfurt	Germany	1000/400	F*,G*,H*,L*
594	Muge	Portugal	100	F*,G*,L*
594	Izhevsk	Russia	100	B*
603	Lyon	France	300	F*,G
603	Sevilla	Spain	20	B*,G*
603	BBC-R4	UK	2	F*,L
612	Kiel	Germany	10	F*
612	RTE-2 Athlone	Ireland (S)	100	G*,H,I
621	RTBF-1 Wavre	Belgium	80	G*,H,J,L*,N*
621	VOA	Botswana	50	C*
621	Barcelona	Spain	10	B*,F*
630	Vigra	Norway	100	F*,L*
630	Tunis-Djedaida	Tunisia	600	F*,G*
639	Praha	Czech	1500	F*
639	La Coruna	Spain	100	F*,G*,H*,L*
648	Orapa	Botswana	50	C*
648	P. de Mallorca	Spain	10	F*,G*
648	BBC Orfordness	UK	500	D,F*,G,H,I,L,N*
657	Burg	Germany	250	F*
657	RCE-2 Madrid	Spain	20	F*,G*
657	Sadiyat	UAE	50	A
657	BBC-R.Wales	UK	2	H*,I,L
666	B'densees der	Germany	300/180	F*,H*,L*,N*
666	Lisboa	Portugal	135	G*
666	Barcelona	Spain	20	F*
675	Marseille	France	600	F*,H*
675	Hilversum-3	Holland	120	F*,G*,L*,N*
684	RNE-1 Sevilla	Spain	250	F*,G*,L*
694	Beograd	Yugoslavia	2000	F*,G*,N*
694	Berlin	Germany	250	F*
693	BBC-R5	UK	150	H*,L
702	Aachen/F.burg	Germany	5	F*,G*,L*
702	Monte Carlo	Monaco	300	F*
702	Ga-Rankuwa	S.Africa	100	C
702	Zamora	Spain	5	B*,G*
711	Rennes 1	France	300	F*,G*,H*,L*,N*
711	Laayoune	Morocco	600	O*
720	Langenberg	Germany	200	G*
720	BBC-R4	Ireland (N)	10	I,L
720	Norte	Portugal	100	F*
720	BBC-R4 Lots Rd	London UK	0.5	G
729	RTE-1 Cork	Ireland (S)	10	F*,G*,L*
729	Oviedo	Spain	50	F*,G*,L*
738	Paris	France	4	F*,G
738	RNE-1	Spain	250	F*,G*,L*
747	Hilversum-2	Holland	400	F*,G*,H*,L*,N*
747	Gobabis	Namibia	100	C
747	R.Cadena	Spain	10	F*
756	Brunswick	Germany	800/200	F*,G*,N*
756	BBC-R4	UK	2	G*,L
765	Sottens	Switzerland	500	F*,G*,H*,L*
774	BBC-R4	Ireland (N)	1	F*,L
774	RNE-1	Spain	60	F*,G*,L*
783	Burg	Germany	1000	F*,G*,L*
783	R.Porto	Portugal	100	F*
792	Limoges	France	300	F*,G
792	Sevilla	Spain	20	F*,G*,L*
801	M'chen-Ism'ing	Germany	300	F*,G*
810	SER Madrid	Spain	20	F*
810	BBC-Scot.	UK	100	H
810	BBC-Scot.	UK	100	F*,G*,I,L,M
819	Bordeaux	France	20	F*,G*
828	Hanover	Germany	100/5	F*
837	Nancy	France	200	F*,L*,N*
837	R.Popular	Spain	10	D*,F*,G*
846	Rome	Italy	540	F*,G*,L*,N*
855	Berlin	Germany	100	F*
855	Murcia	Spain	125	F*,G*,L*
864	Paris	France	300	E*,F*,G,H*,L*,N*
873	AFN via F'kfurt	Germany	150	D*,F*,G*,H*,L*,N*
873	R.Ulster	UK	1	F*,L
882	BBC-Wales	UK	100	F*,G*,H,L,N*
891	Algiers	Algeria	600/300	D,F*,G*,H*,L*
891	Hulsberg	Holland	20	D,F*,G*,N*
900	Milan	Italy	600	F*,G*,L*
909	BBC-R5	UK	140	H,I
918	R.Intercont.	Spain	20	F*,G*,L*
927	BRT-1	Belgium	300	F*,G*,I,L*,N*
936	Bremen	Germany	100	F*,G*,L*,N*
936	Venezia	Italy	20	B*
936	Lerida	Spain	2	B*
945	Toulouse	France	300	F*,G*,L*
945	Rostov-na-D'u	Russia	300	L*
954	RCE Madrid	Spain	20	F*,G*,L*
954	R.Swaziland	Swaziland	50	C*
963	Sofia	Bulgaria	150	F*
963	Pori	Finland	600	D*,F*,G*,H*,J*,L*,N*

Freq kHz	Station	Country	Power kW	Listener
963	Paris	France	8	G
963	Tir Chonail	Ireland (S)	10	L
972	R.Botswana	Botswana	50	C
972	Hamburg	Germany	300	F*,G*,H*,L*,N*
972	M'n'le dLemos	Spain	2	B*
981	Alger	Algeria	600/300	G*,H*
990	Berlin	Germany	300	F*,L*
990	SER R.Bilbao	Spain	10	D*,F*
990	BBC-Twynn	UK	1	L
990	R.Popular	Spain	20	F*
1008	Hilversum-5	Holland	400	F*,G*,H*,N*
1017	Rheinsender	Germany	600	F*,G*,L*,N*
1028	Graz-Dobl	Austria	100	F*
1035	Prog.3 Lisbon	Portugal	120	F*,G*
1044	Dresden	Germany	250	D*,F*,L*
1044	Sobaa-Aioum	Morocco	300	D*
1044	San Sebastian	Spain	10	D*,L*
1053	COPE Zaragoza	Spain	10	B*,F*
1053	BBC-R1	UK	150	H,I
1062	Kalundborg	Denmark	250	F*,G*,L*,N*
1071	Brest	France	20	F*,G*,L*
1080	Katowice	Poland	1500	F*
1089	BBC-R1	UK	150	H,I
1089	R.Bop	S.Africa	100	C*
1089	RNE-5	Spain	10	F*
1107	AFN via Munich	Germany	40	B*,E*,F*
1107	RNE-5	Spain	2	F*
1118	SER-Pontevedra	Spain	2	F*
1125	La Louviere	Belgium	20	F*,G
1125	RNE 5	Spain	10	F*,G*
1125	BBC	UK	1	H
1134	Zadar	Yugoslavia	1200	F*,G*,H*,N*,P*
1143	AFN	Germany	100	F*,E*,F*,H*
1143	Kalinigrad	Russia	150	F*
1161	Stara Zagora	Bulgaria	500	F*
1161	Strasb'g (F.Int)	France	200	L*
1179	SER Murcia	Spain	5	B*,F*
1179	Santiago	Spain	10	B*,F*
1179	Solvesborg	Sweden	600	F*,G*,H*,J*,L*,N*
1188	Kuurne	Belgium	5	F*,G
1188	Al-Hiswah	Yemen	400	A
1197	VOA via Munich	Germany	300	F*,H*
1197	Lancer's Gap	Lesotho	100	C
1206	Bordeaux	France	100	F*,G*,L*
1215	COPE Castellon	Spain	2	B*,F*
1224	Vidin	Bulgaria	500	F*
1233	Melnic	Czech	400	F*
1242	Marseille	France	150	L*
1251	Huisberg	Netherlands	10	F*,L*
1260	VOA via Rhodes	Greece	500	F*
1260	Valencia	Spain	20	F*,G*
1269	Neumunster	Germany	600	F*,G*,H*,L*
1278	Strasbourg	France	300	F*
1278	RTE-2	Ireland (S)	10	H*,I
1287	Litomyls/Liblice	Czech	300/200	F*,G*,L*
1296	San Sebastian	Spain	5	F*,G*
1296	BBC Orfordness	UK	500	F*
1305	Rzeszow	Poland	100	F*
1305	Oranse (RNE5)	Spain	5	D*,F*
1314	Kvitsoy	Norway	1200	D*,F*,G*,H*,L*,N*
1323	BBC Zyyi	Cyprus	50	A
1323	R.Moscow	Germany	150	D*,F*,H*
1332	Rome	Italy	300	D*,E*,L*,N*
1341	BBC-Ulster	Ireland (N)	100	D*,G*,H*,I,L
1341	SER Tarrasa	Spain	2	D*
1350	Nancy/Nice	France	100	D*,F*,G*,H*,L*
1350	VOA via?	?	?/A	
1359	Berlin	Germany	250/100	F*,F*
1368	Manx Radioe	DOM	200	F,I,L,M
1377	Lille	France	300	B*,D*,F*,G,H*,L*
1377	Sandlane	Swaziland	50	C
1377	Ukraine	USSR	50	B*
1386	Kaliningrad	Russia	500	F*,G*,H*,L*
1395	R.Tirana	Albania	1000	D*,F*,G*,H*,J*,L*
1404	Brest	France	20	F*,G*,L*
1413	RCE Zaragoza	Spain	20	F*,G*,L*
1422	Heusweiler	Germany	1200/600	F*,G*,H*,L*
1422	Riyadh	Saudi Arabia	20	A
1431	Dresden	Germany	250	F*
1467	TWR M. Carlo	Monaco	1000/400	D*,F*,H*,K*,L*
1476	Wien-Bisamb'g	Austria	000	F*,G*,H*,L*
1485	AFN	Germany	1	B*
1485	SER	Spain	2	B*
1494	Clerm't-Ferrand	France	20	G*,L*
1494	St.Petersburg	Russia	1000	F*
1503	Stargard	Poland	300	F*,G*,L*
1512	BRT Wolvtertem	Belgium	600	D*,E*,F*,G,H*,J*,L*
1521	Kosice	Czech	600	F*
1530	Vatican R. Rome	Italy	150/450	D*,F*,G*,L*
1539	Mainflingen	Germany	700	F*,G*,L*
1548	Trinc'lee(DW)	Sri Lanka	600	A
1557	Nice	France	300	F*,L*
1566	Sarnen	Switzerland	300	F*,L*
1575	Burg	Germany	250	F*,G*,H*,L*
1593	Langenberg	Germany	400/800	F*,G*,H*,L*
1602	Bautzen	Germany	1	B*,G*
1602	SER R.Cartag'a	Spain	2	B*
1611	Vatican R. Rome	Italy	5	B*,F*

Note: Entries marked \* were logged during darkness. All other entries were logged during daylight or at dawn/dusk.

# long medium & short

## Local Radio Chart

Most days 25MHz (11m) broadcasts have reached their targets well, but outside those areas reception has often been poor or non-existent. A few months ago Alan Roberts could receive almost all of the 11m broadcasts in Quebec, often at good strength, but since then he has observed a gradual deterioration and only three could be heard during February, R. Denmark via RNI 25.730 (Dato S. Am 1130-1155) 35333 at 1140; DW via Julich 25.740 (Ger to E. Asia 1200-1355), 45444 at 1325; also RFI via Issoudun 25.820 (Fr to E. Africa 0700-1550), 25322 at 1455.

Most 11m broadcasts can be heard in here via back scatter, but reception is often marred by flutter fading and echoes. Seldom mentioned is the church service broadcast on Sunday mornings by R. Netherlands via Flevo. This is on two frequencies: 25.940 (Du to Asia? 1030-1125) SIO444 at 1100 by **John Stevens** in Largs; also 25.970 (Du to C/W. Africa 1030-1125) SIO354 at 1050 by **Kenneth Buck** in Edinburgh.

In the 21MHz (13m) band very good reception of R. Australia's Darwin broadcasts has been noted in the UK around noon. They are beamed to S. Asia and the M. East on 21.720 (Eng 1100-1430) and often peak 54444, as noted by **Ron Damp** in Worthing. Earlier, their signals to Asia via Carnarvon on 21.775 (Eng 0100-0900) have been reaching here. At best they were SIO433 at 0830 by **Cyril Kellam** in Sheffield.

Also heard in the morning were R. Japan via Moyabi 21.575 (Eng, Jap to Europe, M. East 0700-0830) 44434 at 0700 by **Philip Lee** in Huntingdon; Voice of the UAE in Abu Dhabi 21.735 (Ar to Europe 0600-0900) 44333 at 0853 by **Ron Galliers** in N. London; R. Portugal via S. Gabriel 21.700 (Portto Africa 1000-1200) 54454 at 1000 by **A. Henry** in Eastbourne; AIR via Aligarh 21.735 (Eng to NE. Asia 1000-1100, Th to Thailand 1115-1200) heard at 1000 by **Don Philips** in Bridlington and SIO434 at 1145 by **John Coulter** in Winchester; BRT Brussels 21.815 (Eng to Africa 1000-1025) 34333 at 1000 by **Sheila Hughes** in Morden; R. Pakistan, Islamabad 21.520 (Eng to Europe 1100-1120) 54344 at 1105 by **Chris Shorten** in Norwich; Voice of the UAE in Abu Dhabi 21.510 (Ar to M. East 1200-1500) SIO333 at 1215 (Eng to C. Am 1230-1300) 54544 at 1240 by **Darren Beasley** in Bridgwater; UAE R. Dubai 21.605 (Eng to Europe 1300-1400) 45354 at 1300 by **Eddie McKeown** in Co. Down; SRI via Schwarzenburg 21.695 (Eng to Asia, Pacific 1330-1400) SIO323 at 1331 by **Julian Wood** in Elgin.

Later, RAI, Rome 21.690 (It to Africa 1410-1730, Sun only) was 45554 at 1442 by **David Edmondson** in Wallsend; R. Sweden via Horby 21.500 (Sw, Fr, Sp, Eng to USA 1430-1600) 54444 at 1544 by **Gordon Milton** in Emsworth; BBC via Ascension Is 21.660 (Eng to Africa 0900-1830) heard at 1600 by **Bernard Curtis**

Freq kHz	Station	ILR BBC	e.m.r.p (kW)	Listener
558	R. Solway	B	2.00	A,G,J
603	Invicta Snd(Coast)	I	0.10	H,L*,M
630	R. Bedfordshire	B	0.20	C*,H,I,L*,M
630	R. Cornwall	B	2.00	H,M
657	R. Clwyd	B	2.00	H,I,J,M
657	R. Cornwall	B	0.50	H
666	Devon Air R.	I	0.34	G*,H,M
666	R. York	B	0.80	M
729	BBC Essex	B	0.20	H,L*,M
756	R. Cumbria	B	1.00	G,J
765	BBC Essex	B	0.50	G*,H,L*,M
774	R. Kent	B	0.70	H,L*,M
774	Severn Sound (3CR)	I	0.14	H,I,M
792	Chiltern R.	I	0.27	H,I*,M
801	R. Devon	B	2.00	G*,H,M
828	Chiltern Radio	I	0.20	L*,M
828	R. WM	B	0.20	I
828	2CR	I	0.27	H,M
837	R. Furness	B	1.00	A
837	R. Leicester	B	0.49	D*,H,I,M
855	R. Devon	B	1.00	H
855	R. Lancashire	B	1.50	G,J
855	R. Norfolk	B	1.50	M
873	R. Norfolk	B	0.30	D,H,M
936	GWR (Brunel R.)	I	0.18	H,I*,M
945	R. Trent (GEM-AM)	I	0.20	G*,H,I,M
954	Devon Air R.	I	0.32	H,M
954	R. Wyvern	I	0.16	C,I,M
990	WABC (Nice & Easy)	I	0.09	I,M
990	R. Aberdeen	B	1.00	G
990	R. Devon	B	1.00	H,M
999	R. Solent	B	1.00	D,E,H,M
999	R. Trent (GEM-AM)	I	0.25	M
999	Red Rose R.	I	0.80	A,G,J
1017	WABC Shrewsbury	I	0.70	H,I,M
1026	Downtown R.	I	1.70	J
1026	R. Cambridgeshire	B	0.50	D,E,M
1026	R. Jersey	B	1.00	D,E,H,M
1035	R. Kent	B	0.50	H,L*,M
1035	West Sound	I	0.32	G
1116	R. Derby	B	1.20	I,M
1116	R. Guernsey	B	0.50	H,M
1152	BRMB (Xtra-AM)	I	3.00	I
1152	LBC (L. Talkback R)	I	23.50	D*,H,M
1152	Piccadilly R.	I	1.50	A,J
1152	R. Broadland	I	0.83	G*,M
1161	GWR (Brunel R.)	I	0.16	C*,G*,I*,M
1161	R. Bedfordshire	B	0.10	M
1161	R. Sussex	B	1.00	H,M

Freq kHz	Station	ILR BBC	e.m.r.p (kW)	Listener
1170	Ocean Sd.(SCR)	I	0.12	H,M
1170	R. Orwell	I	0.28	M
1170	Signal R.	I	0.20	A,I
1242	Invicta Snd(Coast)	I	0.32	I*,M
1242	Isle of Wight R.	I	0.50	A*,G*,H,M
1251	Saxon R.	I	0.76	A*,G*,M
1260	GWR (Brunel R.)	I	1.60	G*,H,M
1260	Leicester (GEM-AM)	I	0.25	I,M
1305	Red Dragon (Touch)	I	0.20	D,H,M
1323	R. Bristol (Som.Snd)	B	0.63	C*,G*,I*,M
1323	S'thern Sound(SCR)	I	0.50	D,G*,H,M
1332	Hereward R.P'boro	I	0.60	I*,M
1332	Wiltshire Sound	B	0.30	D,G*,H,M
1359	Essex R. (Breeze)	I	0.28	E,L*,M
1359	Mercia Snd(Xtra-AM)	I	0.27	I
1359	R. Solent	B	0.85	B*,H,M
1368	R. Lincolnshire	B	2.00	M
1368	R. Sussex	B	0.50	D,H,M
1368	Wiltshire Sound	B	0.10	G*,H
1413	Sunrise R.	I	0.125	H,M
1431	Essex R. (Breeze)	I	0.35	A*,G*,I,L*,M
1431	Radio 210	I	0.14	H,M
1449	R. Peterboro/Cambis	B	0.15	H,I,M
1458	GLR	B	50.00	C*,F*,H,J*,M
1458	GMR	B	5.00	J
1458	R. Cumbria	B	0.50	G
1458	R. Devon	B	2.00	F*,H,M
1458	Radio WM	B	5.00	C*,I
1476	C'ty Snd(1st Gold)	I	0.50	A,C,G*,H,M
1485	R. Merseyside	B	1.20	G,I,J,K,M
1485	R. Sussex	B	1.00	H,M
1503	R. Stoke-on-Trent	B	1.00	C,G*,H,I,J*,M
1521	R. Mercury	I	0.64	H,M
1530	Pennine R. (C. Gold)	I	0.74	G*,H,J
1530	R. Essex	B	0.15	H,M
1530	R. Wyvern	I	0.52	H,I,J
1548	Capital R. (Gold)	I	97.50	H,J*,M
1548	R. Bristol	B	5.00	G*,H,J,K*,M
1548	R. Forth (Max AM)	I	2.20	I*
1557	Chiltern R.(Gold)	I	0.76	G*,I,J
1557	Ocean Sound (SCR)	I	0.50	H,M
1557	Tending R.(Mellow)	I	?	M
1584	Gatwick	I	0.10	H
1584	R. Nottingham	B	1.00	G*,J*,M
1584	R. Shropshire	B	0.50	I
1584	R. Tay	I	0.21	J
1602	R. Kent	B	0.25	G*,H,I,M

Note: Entries marked \* were logged during darkness. All other entries were logged during daylight or at dawn/dusk

### Listeners:

- A: Tim Bucknall, Congleton.
- B: David Crookes, Plymouth.
- C: Francis Hearne, N. Bristol.
- D: Sheila Hughes, Morden.
- E: Rhoderick Illman, Oxted.
- F: Cyril Kellam, Sheffield.
- G: Eddie McKeown, Co. Down.
- H: George Millmore, Wootton, IOW.
- I: Sid Morris, Rowley Regis.
- J: Hugh Quinn, Co. Kildare.
- K: Tom Smyth, Co. Fermanagh.
- L: Phil Townsend, E. London.
- M: John Wells, East Grinstead.

### Listeners:-

- A: Kenneth Buck, Edinburgh.
- B: Tim Bucknall, Congleton.
- C: Sheila Hughes, Morden.
- D: Eddie McKeown, Co. Down.
- E: George Millmore, Wootton, IOW.
- F: Sid Morris, Rowley Regis.
- G: Fred Pallant, Storrington.
- H: Don Phillips, Bridlington.
- I: Philip Rambaut, Macclesfield.
- J: Phil Townsend, E. London.
- K: Ted Walden-Vincent, Gt Yarmouth.
- L: John Wells, East Grinstead.

in Stalbridge and 44445 at 1705 by **Jana Arunachalam** in Thumrait, Oman; VOA via Tangier 21.625 (Eng to Africa 1600-2200) SIO333 at 1626 by **Ted Walden-Vincent** in Gt. Yarmouth; R. Austria Int. via Moosbrunn 21.490 (Eng to Africa 1530-1600) SIO544 at 1630 by **Bryan Kimber** in Hereford; WCSN, Maine 21.640 (Eng to Africa, M. East 1600-2000) SIO544 at 1630 in Rowley Regis and 55344 at 1900 by **P. Guruprasad** in Madikwe, S. Africa; HCJB, Ecuador 21.455 (u.s.b. + p.c. 24hrs) SIO333 at 1704 by **Bill Clark** in Rotherham; R. Netherlands via Bonaire 21.685 (Eng to C. Africa 1830-1925) 45544 at 1850 by **Chris Haigh** in Huddersfield; WYFR, Florida 21.615 (Eng to Europe, Africa 1900-2000) SIO455 at 1920 in Edinburgh; also 21.525 (Eng to Europe, Africa 2000-2200) 53333 at 2115 by **Charles Beanland** in Gibraltar.

Good 17MHz (16m) DX reception has been noted. During the early morning the signals from R. New Zealand Int. via Rangataiki on 17.770 (Eng to Pacific areas 2130-0800) have often reached here. Signal ratings ranged from 55545 at 0559 in Norwich to SIO211 at 0720 in Macclesfield. R. Australia's Darwin broadcast to SE. Asia on 17.750 (Eng 0000-0400) has also been received here. In Wallsend it was 24532 at 0054.

Some signals in this band are intended for Europe. Those noted came from the Voice of Israel, Jerusalem 17.545 (Eng 1100-1130, also to USA) 53455 at 1100 in Eastbourne; R. Pakistan, Islamabad 17.902 (Eng 1100-1120) 55544

## Long Wave Chart

Freq kHz	Station	Country	Power (kW)	Listener
153	Donebach	Germany	500	A,B,C,D,E,F*,G,H*,K,L*
153	Brasov	Romania	1200	A,D*,L*
162	Allouis	France	2000	A,B,C,D,E,F*,G*,K,L*
171	Kaliningrad	Russia	1000	A,B,D,E,F*,G*,J*,L*
171	Medi 1-Nador	Morocco	2000	G*
171	Moscow	Russia	500	C
177	Oranienburg	Germany	750	A,B,O*,F*,L*
183	Saarouis	Germany	2000	A,B,C,D,E,F,G,J*,L*
189	Caltanissetta	Italy	10	I
198	BBC Droitwich	UK	500	B,C,D,E,F*,J*,L*
198	BBC Westerglen	UK	50	A,B,D
207	Munich	Germany	500	A,B,C,D,E,F*,G*,K,L*
207	Azilah	Morocco	800	L*
216	RMC Roumoules	S. France	1400	A,B,C*,D,E,F*,G,I,J*,K,L*
216	Oslo	Norway	200	A,B*,C*,D*,I,L*
225	Konstantinow	Poland	2000	A,B,D,E,F*,G*,J*,L*
234	Junglinster	Luxembourg	2000	A,B,C*,D,E,F,G,J*
234	St. Petersburg	Russia	1000	A,B,D*
243	Kalundborg	Denmark	300	A,B,C*,E*,F*,G,J*,L*
252	Tipaza	Algeria	1500	A,B,C*,E*,G*,J*,L*
252	Laiti	Finland	200	A
252	Atlantic 252	S. Ireland	500	A,B,C*,D,E,F,G,H,J*,L*
261	Burg	Germany	200	B,E,G,L*
261	Moscow	Russia	2000	A,B,D*,F*,G*,L*
270	Topolna	Czech	1500	A,B*,C,D,E,F,G,L*
270	Orenburg	USSR	15	B
279	Minsk	Byelorussia	500	A,B*,D*,E*,F*,G,L*

Note: Entries marked \* were logged during darkness. All other entries were logged during daylight or at dawn/dusk

at 1117 in Bridgwater; RCI via Sackville 17.820 (Eng 1700-1729) SIO555 at 1725 in Edinburgh; HCJB, Ecuador 17.790 (Eng 1900-2000) 33333 at 1956 in N. London; RCI via Sackville 17.875 (Eng 2000-2059) 43433 at 2006 by **Rhoderick Illman** in Oxted; RHC Havana 17.705 (Eng 1900-2100, also to M. East, Africa) 34223 at 2012 in Co. Down; WYFR, FL 17.750 (Eng 2000-2200, also to Africa) SIO444 at 2000 in Winchester; WWCR, USA 17.525 (Eng 1600-2200) 55544 at 2010 by **John Nash** in Brighton.

Many are beamed to other areas.

Among them are R. Romania Int, Bucharest 17.805 (Eng to Pacific areas 0645-0715) SIO333 at 0700 by **Francis Heame** in N. Bristol; R. Prague, Czech 17.725 (Eng to Asia, Pacific areas 0730-0800) 23222 at 0730 in Morden; R. Japan via Yamata 17.810 (Eng to SE. Asia 0700-0800) 34333 at 0740 in Norwich; also 17.890 (Eng to Oceania 0700-0800) 33433 at 0715 in Huntingdon; Voice of Greece, Athens 17.525 (Gr, Eng to Australia 0800-0850) SIO434 at 0840 in Sheffield; AIR via Delhi 17.387 (Eng to Australia, NZ 1000-1100) heard in Bridlington;

# long medium & short

## Tropical Bands

KHBI, N.Mariana Is 17.555 (Eng to NE.Asia, Russia 0800-1200) SIO433 at 1120 in Hereford; Africa No.1, Gabon 17.630 (Fr, Eng to W.Africa 0700-1600) SIO333 at 1520 in Grimsby; R.Nederlands via Talata Volon 17.580 (Du to S.Asia 1530-1625) SIO222 at 1530 in Macclesfield; R.Pakistan, Islamabad 17.555 (Eng to MEast 1600-1630) 43443 at 1600 in Oman; RTM Tanger, Morocco 17.595 (Fr, Eng to M.East, N.Africa 1400-1700) SIO544 at 1605 in Rowley Regis; BBC via Ascension Is 17.860 (Eng to C/W.Africa 1600-1745) SIO333 at 1700 in Rotherham; also 17.880 (Eng to S.Africa 1745-2030) 44343 at 1842 in S.Africa; RCI via Sackville 17.820 (Eng to Africa 1800-1859, Sat/Sun only) 34444 at 1843 in Huddersfield; R.Nederlands via Bonaire 17.605 (Eng to W.Africa 1830-1925) SIO333 at 1910 in Elgin; VOA via Greenville 17.640 (Fr to W.Africa 2100-2200) 54444 at 2127 in Gibraltar.

UK listeners have also noted good **15MHz (19m)** DX reception. Strong signals from R.Australia have often reached the UK during their Darwin transmission to C.Asia on 15.170 (Eng, Chin 0900-1400). They were logged in Macclesfield as SIO444 at 1250. Earlier, their Shepparton transmission to S.Pacific areas may be heard 15.240 (Eng 0000-0930). It was 24442 at 1030 in Wallsend. During the evening R.New Zealand's signals to Pacific areas have been received here on 15.120 (Eng 1845-2130 Sun-Fri), but they have often been marred by co-channel interference from 2000. At best they were 54444 at 1915 in Norwich.

A number of broadcasts to outside Europe were logged: UAE R.Dubai 15.435 (Ar, Eng to Far East 0415-0600) 43444 at 0535 in Oman; R.Japan via Yamata 15.270 (Eng to Oceania 0900-1000) 54444 at 0947 by **Richard Radford-Reynolds** in Guildford; RTL Luxembourg 15.350 (Eng, Fr to E.USA 24hrs) 44444 at 1025 in Eastbourne; R.Tashkent, Uzbek 15.470 (Eng, Ur, Hi to S.Asia 1200-1500) 33443 at 1200 in Bridlington; LJB Tripoli, Libya 15.235 (Ar to W.Africa 1115-1315) SIO333 at 1245 by **Antonio de Abreu Teixeira** in Evesham; R.Romania Int, Bucharest 15.250 (Eng to Asia 1500-1530) SIO544 at 1515 in Rowley Regis; Voice of Vietnam, Hanoi 15.010 (Eng to Africa 1600-1630) 44444 at 1608 in Emsworth; R.Nederlands via Talata Volon 15.570 (Eng to E.Africa 1630-1725) 44444 at 1630 in Morden; Africa No.1, Gabon 15.475 (Fr to W.Africa 1600-2000) 45233 at 1615 in S.Africa and SIO433 at 1742 in Rotherham; RSA, S.Africa 15.160 (Eng to Africa 1600-1800) 53433 at 1745 in Worthing; BBC via Daventry or Woofferton 15.070 (Eng to N/C.Africa 0500-2115) 44434 at 1758 by **Ken Milne** in Basingstoke; RCI via Sackville 15.260 (Fr to Africa 1830-1859) 35244 at 1840 in Huddersfield; R.Norway Int, Oslo 15.220 (Eng to C/W.Africa 1900-2000, Sat/Sun only) SIO434 at 1900 by **Tom Smyth** in Co.Fermanagh; R.Yugoslavia, Belgrade

Freq MHz	Station	Country	UTC	DXer
2.310	ABC Alice Springs	Australia	1710	H,J,Z
2.325	ABC Tennant Cr'k	Australia	1940	H,J,Q
2.485	ABC Katherine	Australia	1710	H,S
2.495	R.Madagascar	Madagascar	2210	Z
2.560	Xinjiang	China	0015	H,Q
3.210	R.Mozambique	Mozambique	2005	Z
3.215	R.Orange	S.Africa	1810	K,Q,R,S,V,Z
3.230	R.Nepal	Kathmandu	2110	Z
3.240	TWR	Swaziland	2040	V
3.255	AIR Shillong	India	1720	Z
3.255	BBC via Maseru	Lesotho	1925	K,Q,S,V,Z
3.270	SWABC 1	Namibia	2020	Z
3.275	AIR Srinagar	India	1645	Z
3.290	SWABC 2	Namibia	2120	K,Z
3.295	Raykiavik	Iceland	2138	O,D,S,Z
3.300	R.Cultural	Guatemala	0055	J,Z
3.315	AIR Bhopal	India	2307	J,Q,V,Z
3.315	SLBS Freetown	Sierra Leone	2000	H,R,V
3.325	FRCN Lagos	Nigeria	1930	R,V,Z
3.355	R.Nac.Luanda	Angola	1935	Z
3.355	R.Botswana	Gaborone	2105	K,Z
3.355	AIR Kurseong	India	1650	Q
3.365	R.Rebelle, L. Julia	Cuba	0100	J,O,Q
3.365	AIR New Delhi	India	1654	Q
3.365	IBC Radio 2	Ghana	2100	C,H,J,N,D,P,R,V,Z
3.380	R.Malawi	Malawi	1720	Z
3.385	RFD Cayenne	Guiana	0553	O
3.395	ZBC Gweru	Zimbabwe	2205	Z
3.777	VOIRI Tehran	Iran	0120	Z
3.905	AIR Delhi	India	1630	H
3.915	BBC Kranji	Singapore	1620	F,H,K,O,Q,Z
3.930	R.Capital	Transkei	2310	Z
3.955	BBC	England	2000	O,H,D,P,S,Y
3.960	PBS Xinjiang	China	0232	H
3.960	RFE/RL Munich	W.Germany	2000	O,H,O
3.965	RFI Paris	France	2020	D,H,M,O,P,T,Y
3.970	RFE Munich	W.Germany	0000	D,H,O
3.975	BBC Skelton	England	0544	O
3.980	VOA Munich	W.Germany	2005	D,M,O,P,T,W
3.985	R.Beijing, China	via Berne	2200	L,N,D,W
3.985	SRI Berne	Switzerland	2000	D,M,N,O,P,S
3.995	DW Cologne	W.Germany	1930	O,H,J,O,P,T
4.005	RRI Padang	Indonesia	1700	H
4.010	R.Frunze 1	USSR	0010	O,V
4.055	R.Moskva 1	Russia	2011	O
4.485	R.Moskva (Ufa)	Russia	0000	G,H,J
4.500	Xinjiang	China	2315	H,O
4.520	R.Moskva 2	USSR	0152	O
4.600	R.Baghdad	Iraq	1805	H,M,O,S,V
4.635	R.Dushanbe	Tadzhikistan	1800	H,J,O,S
4.735	Xinjiang	China	0015	H,J,O,S,V
4.740	Moscow	Russia	1630	O,S
4.740	R.Afghanistan	via Russia	1505	H,V
4.750	R.Bertouria	Cameroon	1911	R,Z
4.765	Brazzaville	PR Congo	1900	C,H,M,O,P,Q,R,V,Z
4.770	FRCN Kaduna	Nigeria	1910	C,H,J,N,D,P,R,S,V,Z
4.775	Kabul City Service	Afghanistan	1915	R,Z
4.775	R.Gabon, Libreville	Gabon	2010	Z
4.775	RRI Jakarta	Indonesia	1730	V
4.780	RTD	Djibouti	1927	Z
4.783	RTM Bamako	Mali	0600	Z
4.790	Azad Kashmir R.	Pakistan	0100	S,Z
4.795	R.Douala	Cameroon	1915	O,R
4.795	R.Moscow	Ukraine	2000	C,O,E,H,M,O,P,R,S,X
4.800	AIR Hyderabad	India	1715	P
4.805	R.Nac.Amazonas	Brazil	2230	H
4.810	R.Orion, Jo'burg	S.Africa	2130	H,S,Z
4.810	R.Yerevan	Armenia	2110	C,M,O,P,R
4.815	R.diff TV Burkina	Ouegad'gou	2200	C
4.820	R.Moskva 4	USSR	2115	C,H,P
4.825	R.Moscow	Siberia	2009	C,H,J,R
4.825	Ashkhabad	Turkmenia	2006	R
4.825	Kharkov	Ukraine	2200	S
4.825	R.Kiev	Ukraine	0110	M,O
4.830	Gaborone	Botswana	1950	H,K,Z
4.830	R.Tachira	Venezuela	2310	G
4.832	R.Rejoj	Costa Rica	0603	I,J,M
4.835	RTM Bamako	Mali	2010	B,C,H,I,M,O,P,R,V
4.845	R.Nacional Manaus	Brazil	0125	Z

15.140 (Eng to S.Africa 1930-2000) 45444 at 1951 by **Darran Taplin** in Brenchley; KTBN, USA 15.590 (Eng to USA 1500-0100) 35343 at 2015 in Brighton; R.Damascus, Syria 15.095 (Eng to USA 2110-2210) 43333 at 2121 in Oxted; VOA via Selebi-Pickwe 15.445 (Eng to M.East, N.Africa 2200-0000) SIO222 at 2230 in N.Bristol; BBC via Ascension Is 15.260 (Eng to S.America 2000-0330) 33333 at 0007 by **Robin Harvey** in Bourne; BBC via Cyprus 15.310 (Eng to M.East, W.Asia 0030-0300), heard at 0030 in Stalbridge; AIR via Aligarh 15.110 (Eng to SE.Asia 2315-0115) 43343 at 0110 in Co.Down.

A few of those intended for European listeners were also noted: Voice of Turkey, Ankara 15.325 (Tur 1000-

1700) SIO333 at 1630 in Gt.Yarmouth; Voice of Vietnam, Hanoi 15.010 (Eng, Fr 1800-2000), heard at 1830 by **David Crookes** in Plymouth and SIO211 at 1855 in Canada; RNB Brasilia, Brazil 15.265 (Eng, Ger 1800-2100) 43443 at 1850 in Bridgwater; WSHB, USA 15.665 (Eng 1800-2200, also to USA) 44433 at 1915 in Huntingdon; WWCR, USA 15.690 (Eng 1200-0000) SIO444 at 2010 in Winchester; SLBC, Sri Lanka 15.120 (Sin, Eng 2000-2130) 32232 at 2029 in N.London; R.Kuwait, Sulaiyah 15.505 (Ar 1800-0000, also to N.Africa) SIO555 at 2000 in Edinburgh; HCJB, Ecuador 15.270 (Eng 2130-2200) SIO444 at 2130 in Hereford; WINB, USA 15.145 (Eng 2247-2345) noted as 'quite good' at 2314 by **Peter Pollard** in Rugby.

Freq MHz	Station	Country	UTC	DXer
4.845	RTM Kuala Lumpur	Malaysia	1415	A
4.845	ORTM Nouakchott	Mauritania	2000	C,H,O,R,V
4.850	R.Yaounde	Cameroon	1955	C,O,P,R
4.850	AIR Kohima	India	2009	R
4.850	R.Tashkent 2	Uzbekistan	0110	O,Q
4.860	AIR New Delhi	India	1642	H,OR
4.860	R.Moscow	Russia	1930	C,O,H,O,S
4.865	PBS Lanzhou	China	2155	C,G,H,O,R
4.865	V of Cinaruco	Colombia	0100	H
4.870	R.Bangladesh	Bangladesh	1610	Z
4.870	R.Cotonou	Benin	2105	C,G,H,J,M,O,P,R,V
4.870	R.Rio Amazonas	Ecuador	0245	G
4.870	SLBC Colombo	Sri Lanka	1615	A
4.875	Super R.Roraima	Brazil	0112	H,Q
4.885	R.Clube do Para	Brazil	0052	G,Q,Z
4.885	R.Difusora Acreana	Brazil	0310	G
4.885	Voice of Kenya	Kenya	1825	P,R
4.890	RFI Paris	via Gabon	0700	M,O
4.890	ORTS Dakar	Senegal	2039	J,D,R,Z
4.895	Voz del Rio Arauca	Colombia	0055	H,Q
4.895	R.Moscow (Kalinin)	Russia	1917	M,OR
4.900	V. of the Strait 2	China	2315	C
4.900	V de la Rev.Conakry	Guinea	1650	H,R
4.905	R.Nat.N'djamena	Chad	1955	C,H,O,R,V
4.910	Tennant Creek	Australia	2135	H
4.910	R.Zambia, Lusaka	Zambia	1806	K,R
4.915	R.Anhanguera	Brazil	2240	H
4.915	R.Nac.Macapa	Brazil	2240	H
4.915	Armon's d'Caqueta	Colombia	2310	H
4.915	R.Ghana, Accra	Ghana	2000	C,H,O,P,R,V
4.915	Voice of Kenya	Kenya	1943	O,R
4.915	R.Cora, Lima	Peru	0350	Z
4.920	AIR Madras	India	1635	H,K
4.930	R.Moscow	Russia	1700	C,H,D,P,R
4.935	Voice of Kenya	Kenya	1730	H,K,N,R,X,Z
4.940	R.Kiev 2	Ukraine	1705	C,D,H,M,O,P,Q,R
4.940	R.Continental	Venezuela	0600	Z
4.950	R.Baku	Azerb'dzhan	1830	C,H,M,O,Q,R,V
4.960	AIR New Delhi	India	0030	H,M,O,V
4.970	R.Rumbos, Caracas	Venezuela	0058	Q,Z
4.975	R.Uganda, Kampala	Uganda	1830	H,N,R,X
4.975	R.Oushanbe	Tadzhikistan	0035	H,M,O
4.980	Ecos del Torbes	Venezuela	2325	H,O,P,Z
4.985	R.Brazil Central	Brazil	0000	H,S
4.990	AIR via Madras	India	0005	O,V
4.990	FRCN Lagos	Nigeria	2000	C,H,M,N,O,P,R,V
5.005	R.Nacional, Bata	Eq.Guinea	2005	P
5.005	R.Nepal	Nepal	1700	H,O,S,Z
5.010	R.Garoua	Cameroon	2208	H,O,R
5.010	SBC Singapore	Singapore	1400	A,S,Z
5.015	R.Moskva	USSR	2140	M,O
5.020	ORTN Niamey	Niger	0045	H
5.020	SLBC	Sri-Lanka	1510	A
5.025	R.Parakou	Benin	2010	H,M,O,P,R
5.025	BBS Thimpu	Bhutan	1420	A
5.025	R.Rebelle, Habana	Cuba	0215	Z
5.035	R.Alma Ata	Kazakhstan	2005	C,O,P
5.040	Vos del Upano, Macas	Ecuador	0025	H
5.040	R.Thiisi 1	Georgia	2000	R,V
5.045	R.Cultura do Para	Brazil	0555	H,M,Z
5.047	R.Togo, Lome	Togo	2034	C,R,S
5.050	GFBC Nanning	China	2141	R
5.052	SBC R-1	Singapore	1330	A
5.055	Faro del Caribe	Costa Rica	0220	Z
5.055	RFO Cayenne	Fr. Guiana	0220	M,O
5.060	PBS Xinjiang	China	2330	M,O,S,V
5.065	R.Candip, Bunia	Zaire	1930	O,Z
5.085	R.Pakistan, Karachi	Pakistan	0000	H,S
5.258	RRI Sibolga	Indonesia	1430	Q
5.260	R.Alma Ata 2	Kazakhstan	2125	C,H,O,Q
5.290	R.Moskva 1	Siberia	2330	H,S
5.320	R.Beijing	China	2130	S,U
5.800	PBS Xinjiang	China	0000	S

### DXers:

- (A) Jana Arunachalam, Thumrait, Oman.
- (B) Charles Beanland, Gibraltar.
- (C) Darren Beasley, Bridgwater.
- (D) Kenneth Buck, Edinburgh.
- (E) Bill Clark, Rotherham.
- (F) Bernard Curtis, Stalbridge.
- (G) Antonio De Abreu-Teixeira, Evesham.
- (H) Chris Edwards, Inverurie.
- (I) David Edwardson, Wallsend.
- (J) Ron Galliers, N.London.
- (K) P.Suruprasad, Madikwe, S.Africa.
- (L) A.G. Henry, Eastbourne.
- (M) Sheila Hughes, Morden.
- (N) Philip Lee, Huntingdon.
- (O) Eddie McKeown, Co.Down.
- (P) Sid Morris, Rowley Regis.
- (Q) John Nash, Brighton.
- (R) Fred Pallant, Storrington.
- (S) Don Phillips, Bridlington.
- (T) Peter Pollard, Rugby.
- (U) Alan Roberts, Quebec, Canada.
- (V) John Sargeant, Bolton.
- (W) Chris Shorten, Norwich.
- (X) Darran Taplin, Brenchley.
- (Y) Ted Walden-Vincent, Gt.Yarmouth.
- (Z) Jim Willett, Grimsby.

# long medium & short

Good **13MHz (22m)** reception from many areas has been evident. The occupants include DW via Julich 13.610 (Eng to W. Africa 0600-0650) 54344 at 0645 in Norwich; SRI via Sottens 13.685 (Eng to Pacific areas 1000-1030) 44444 at 1011 in Co. Down; R. Austria Int via Moosbrunn 13.730 (Ger, Fr, Eng, Sp to Europe 0400-1700), noted as 'very good' at 1545 in Rugby; R. Pakistan, Islamabad 13.665 (Eng to M. East 1600-1630) 23443 at 1600 in Bridlington; UAE R. Dubai 13.675 (Ar, Eng to Europe 0615-2100) SIO555 at 1630 in Edinburgh; KSDA (AWR) Agat, Guam 13.720 (Eng to S. Asia, E. Africa 1700-1900, Sat/Sun only) 33433 at 1715 in Huntingdon; R. Australia via Carnarvon 13.755 (Eng to S. Asia 1430-2100) 44445 at 1500 in Oman and 54444 at 1730 in Worthing; KHBI, N. Mariana Is 13.625 (Eng to M. East, SE. Asia, Oceania 1800-2000) SIO222 at 1845 in Grimsby; ISBS, Iceland 13.855 (Ic to Europe 1855-1930) SIO444 at 1910 in Winchester; WHRI, USA 13.760 (Eng to Europe, Canada 1700-0000) 44433 at 2018 in Basingstoke; RCI via Sackville 13.650 (Eng to Europe 2000-2059) SIO534 at 2040 in Rowley Regis; WCSN, MN 13.770 (Eng to Europe, M. East, Africa 2000-0000) 34444 at 2115 in Oxted; R. Netherlands via Flevo 13.700 (Eng to W. Africa 2030-2125) SIO444 at 2120 in Largs; R. Australia via Darwin 13.605 (Chin, Eng to C. Asia 2300-0100) SIO333 at 2306 in Rotherham.

The **11MHz (25m)** band carries many programmes for European listeners. Some originate from REE Arganda, Spain 11.790 (Sp 0700-1600) 43433 at 0837 in N. London; R. Pakistan, Islamabad 11.570 (Eng, Ur 1700-1900) SIO444 at 1720 in Edinburgh; ISBS, Iceland 11.402 (Ic 1855-1930) SIO333 in Winchester; R. Finland via Pori 11.755 (Eng 1930-2000, also to M. East, Africa) 44444 at 1935 in Emsworth; AIR via Aligarh 11.620 (Hi, Eng 1845-2230) 54444 at 2045 in Basingstoke; R. Damascus, Syria 12.085 (Eng 2005-2105) 34533 at 2105 in Huntingdon; Voice of Turkey, Ankara 11.710 (Eng 2300-0000, also to M. East) SIO444 at 2315 in Hereford; R. Japan via Moyabi 11.735 (Jap, Eng 2200-0000) 55444 at 2310 in Worthing; VVWCR 12.160 (Eng 2200-0100) 33232 at 0001 in Bourne.

There are numerous broadcasts to other areas throughout the day. Among those noted were TWR Bonaire, Ned. Antilles 11.815 (Eng to E. USA, Caribbean area 1055-1330) 24444 at 1057 in Guildford; KSDA, Guam 11.980 (Chin, Jap, Eng to C/E. Asia 0900-1700) 34333 at 1434 in Brighton; R. Kuwait, Sulaiyah 11.990 (Ar to M. East, N. Africa) SIO423 at 1707 in Macclesfield; Vatican R, Italy 11.625 (Eng to Africa 1730-1800) SIO222 at 1736 in Elgin; KCBI, TX 11.735 (Eng to Canada?) 12322 at 1835 in Huddersfield; Voice of Greece, Athens 11.645 (Gr, Eng to S. Africa 1800-1850) 54444 at 1845 in Bridgewater; R. Australia via

Carnarvon 12.000 (Eng to S. Asia 1430-2100) 33433 at 1905 in Brenchley; R. Baghdad, Iraq 11.740 (Ar to Europe?) heard during the evening by Roy Patrick in Derby; King of Hope, Lebanon 11.530 (Eng to M. East 2000-2200) SIO322 at 2112 in Rotherham and SIO222 at 2155 in Canada; R. Nacional da Amazonia, Brazil 11.780 (Port 0800-2200) SIO333 at 2150 in Largs; R. Diff Nacional, Bogata 11.822 (Sp 0930-0500) 34334 at 2300 in Bridlington; R. Sofia, Bulgaria 11.870 (Eng to Latin Am 2245-0100), noted as 'very good' at 2315 in Rugby; RCI via Sackville 11.940 (Eng to Latin Am 2300-2329) SIO333 at 2315 in N. Bristol; R. Globo, Rio de Janeiro 11.805 (Port 0900-0300) SIO333 at 2345 in Evesham; BBC via Ascension Is 11.750 (Eng to S. Am 2200-0330) 'fair' at 0030 in Stalbridge; RHC, Cuba 11.950 (Eng to USA 0000-0600) 32233 at 0200 in Morden.

Good reception of R. New Zealand's **9MHz (31m)** broadcasts to Pacific areas has been noted here. In Basingstoke their 100kW transmission from Rangitaiki, N. Island on 9.700 (Eng 0800-1205) peaked 44444 at 0859, but deteriorated to 34423 by 0930. Potent

signals from R. Australia via Carnarvon on 9.860 (Eng to S. Asia 1400-2100) have also reached here. At 2030 they were 53343 in Norwich. They have also been received well in Oman, rating 44444 at 1610. The ABC domestic service from Brisbane on 9.660 was SIO333 at 1930 in New Radnor.

Some of the numerous 31m broadcasts to Europe stem from SRI via Lenk 9.535 (Fr, Ger, It, Eng 0600-2050) 54555 at 0750 in Bourne; Croatia R, Zagreb 9.830 (News in Eng) 35553 at 0807 in Wallsend; VOIRI, Iran 9.022 (Eng 1900-2000) 33333 at 2000 in Emsworth; R. Beijing, China 9.920 (Eng 2000-2200) 44444 at 2130 in Morden; Voice of Turkey, Ankara 9.445 (Eng 2100-2200) 44444 at 2140 in Brenchley; WMLK Bethal 9.465 (Eng 1700-2200) SIO444 at 2145 in Sheffield; AIR via Delhi 9.950 (Hi, Eng 1945-2230) 53333 at 2230 in Gibraltar; VOFC via Okeechobee 9.852 (Eng 2200-2300) 33333 at 2246 in N. London.

The **7MHz (41m)** logs included QBS Doha, Qatar 7.160 (Ar to M. East 1700-2130) SIO333 at 1840 in Hereford; AIR via Aligarh 7.412 (Eng to Europe 1845-1945) 54544 at 1850 in Bridgewater; Voice

## Transatlantic DX Chart

Freq kHz	Station	Location	Time (UTC)	DXer
<b>USA</b>				
710	WOR	New York	0120	B,C
1010	WINS	New York	0210	B,C
1210	WGLL	Philadelphia	0215	B,C
<b>Canada</b>				
590	VOCM	St. John's, NF	0115	B,C
930	CJYQ	St. John's, NF	2340	A,B,C
960	CFFX	Kingston, ON	0150	B,C
<b>C. America &amp; Caribbean</b>				
1030	WASO	P. Rico	0540	C
1505	R. Anguilla	Anguilla	0310	C
1610	Caribbean B'con	Anguilla	0245	C

DXers:-

- (A) Tim Bucknall, Congleton.  
 (B) Sid Morris, while near Donegal.  
 (C) Jim Willett, Grimsby.

of Nigeria, Ikorodu 7.255 (Ha, Swa, Fr, Eng to W. Africa 0455-2300) 33222 at 1944 in Gibraltar; Voice of the UAE in Abu Dhabi 7.215 (Eng to USA 2200-0000) noted as good at 2307 in Rugby.

In the **6MHz (49m)** band CFRX, Canada 6.070 (Eng 24hrs) was SIO222 at 0700 in New Radnor; CKZN, NF 6.160 (Eng 0930-0500) SIO333 at 2330 in Grimsby; R. Caracol, Colombia 6.150 (Sp 24hrs) SIO333 at 0325 in Evesham.

## Station Addresses

BBC Radio Furness, Hartington Street, Barrow-in-Furness, Cumbria LA14 5FH.

ILR Great North Radio, Radio House, Long Rigg, Swallow, Newcastle-Upon-Tyne NE99 1BB.

Namibian Broadcasting Corp., PO Box 321, Windhoek 9000, Namibia, South West Africa.

Radio Dif. Nacional, Ave. El Dorado, Bogota DE, Colombia, South America.

Radio CFRA, 150 Isabella St, Ottawa, ON, K1S 5A3, Canada.

Radio WPEN, Bala Cynwyd, PA 19004, USA.

## Equipment Used

Jana Arunachalam, Thumrait, Oman: Panasonic RF-B45 or Sony ICF-7600DS + 6m wire.  
 Charles Beanland, Gibraltar: Sangean ATS-803 + a.t.u. + r.w. or Howes AA2.  
 Darren Beasley, Bridgewater: Philips D2935 + Hexagon loop or a.t.u. + 10m wire.  
 Kenneth Buck, Edinburgh: Lowe HF-225 + r.w. in loft or screened loop.  
 Tim Bucknall, Congleton: Sony ICF-2001D + AN-1.  
 Bill Clark, Rotherham: Sony ICF-SW7600 + built-in whip.  
 John Coulter, Winchester: Yaesu FRG-7 + r.w.  
 David Crookes, Plymouth: Sony SW-7600 + built-in whip.  
 Bernard Curtis, Stalbridge: Trio JR 500S + r.w. or Fairmate 2000 scanner.  
 Ron Damp, Worthing: Racal RA17 + 30m inverted V dipole.  
 Antonio De Abreu-Teixeira, Evesham: Sony ICF-2001D + 9.5m wire.  
 Chris Edwards, Inverurie: Yaesu FRG-7700 + FRT-7700 + 40m wire.  
 David Edwardson, Wallsend: Trio R600 + inverted V trap dipole.  
 Ron Galliers, London: Philips D2935 + a.t.u. + 30m wire.  
 P.R. Guruprasad, Madikwe, S. Africa: Sony ICF-7600DA + built-in whip.  
 Chris Haigh, Huddersfield: Lowe HF-225 + Lowe W-225 or 20m wire.  
 Simon Hamer, New Radnor: Lafayette HE30 + a.t.u. + 9m or 22m wire or Grundig S1400 or Sony ICF-2001D + loop.  
 Robin Harvey, Bourne: Matsui MR-4099 + s.w. loop.  
 Francis Hearne, N. Bristol: Sharp WQT370 + r.w.  
 A. G. Henry, Eastbourne: Sangean ATS-803A + built-in whip.  
 Sheila Hughes, Morden: Sony ICF-7600DS; Panasonic DR48 + 15m wire.  
 Rhoderick Illman, Oxted: Kenwood R5000 + 17m wire.  
 Cyril Kellam, Sheffield: Sony ICF-7600DS + AN-1 or 25m wire.  
 Bryan Kimber, Hereford: Zenith R7000 or Realistic SX190 + 25m wire.  
 Philip Lee, Huntingdon: Sony ICF-SW77 + AN-1.  
 Eddie McKeown, Co. Down: Tatung TMR 7602.  
 George Millmore, Wootton, IOW: Tatung TMR 7602 + loop or Racal RA17L + v.l.f. converter + loop.  
 Ken Milne, Basingstoke: Matsui MR-4099 + 6m wire.  
 Gordon Milton, Emsworth: Sony ICF-2001D.  
 Sid Morris, Rowley Regis: Kenwood R5000 + 31m wire or Sangean ATS 803A.  
 John Nash, Brighton: Kenwood R5000 + Datong AD370 or Lowe Balun + r.w.  
 Fred Pallant, Storrington: Trio R2000 + r.w. in loft.  
 Roy Patrick, Derby: Lowe HF-125 + 22m wire.  
 Don Phillips, Bridlington: Yaesu FRG-8800 + a.t.u. + 15m wire.  
 Peter Pollard, Rugby: Sony ICF-2001D + AN-1.  
 Hugh Quinn, Co. Kildare: Lowe HF-225 + FRT-7700 + 25m wire in loft.  
 Richard Radford-Reynolds, Guildford: Sangean ATS-803A + 6m wire.  
 Philip Rambaut, Macclesfield: Int. Marine Radio R.700M + r.w.  
 Alan Roberts, Quebec, Canada: Lowe HF-225 + 31m, 19m or 11m dipole.  
 John Sargeant, Bolton: Lowe HF-225 + 20m wire.  
 Chris Shorten, Norwich: Matsui MR-4099 + 10m wire.  
 Tom Smyth, Co. Fermanagh: Morphy Richards R191 + built-in whip.  
 John Stevens, Largs: Hammarlund HQ 180 or Icom R-70 + r.w.  
 Darran Taplin, Brenchley: Yaesu FRG-7700 + FRT-7700 or FRT-7720 + 30m wire.  
 Phil Townsend, London: Pye Venturer portable.  
 Ted Walden-Vincent, Gt. Yarmouth: Grundig Satellit 1400L + r.w.  
 John Wells, E. Grinstead: RCA AR88D + Loop, also l.w. converter.  
 Jim Willett, Grimsby: RCA AR77 + 4m loop or Trio 9R-59DS + a.t.u. + X dipole.  
 Michael Williams, Redhill: Sony CFS-2011 cassette radio  
 Julian Wood, Elgin: Kenwood R2000 + Yaesu FRT-7700 a.t.u. + 6m wire.

# watching brief

Andy Emmerson G8PTH  
71 Falcutt Way, Northampton NN2 8PH

**T**his time we consider the future of amateur television. That's if it has one. If you think that's a strange thing for me to say, read on.

One of the clearest trends of the amateur radio hobby in general is its growing complexity and the move to commercial equipment. You have only to look at the sophistication of radio bulletin boards, techniques like AMTOR or some of the newer modes of colour slow-scan television. Amateurs, too, are exploiting all manner of highly technical surplus gear to achieve high-tech solutions on pocket money budgets, and while this may not be self-training in the art of wireless telegraphy, I think it can be argued that this is in the 'ham' spirit. I know some of the old-timers don't call this amateur radio as they knew it, and even I get suspicious when I see a shack that consists entirely of expensive commercial equipment. But let's leave that argument for another time.

## Changing ATV

What is clear is that amateur radio - and amateur television - is changing. ATV has hitched a ride aboard the American space shuttle and it is only a matter of time before ATV sympathisers in industry give ATV a transponder or two on board the growing number of satellites in the sky. Again in the States, Henry Ruh KB9FO is petitioning the Federal Communications Commission to relax the rule on 'prohibited transmissions', specifically music.

Henry would like the authorities to change the rules on music to permit non-commercial transmission of educational films on ATV which may contain incidental music. And whereas music is absolutely taboo, should not a musician be allowed to demonstrate a new MIDI device he or she has built over the air without risking losing his or her licence?

Inevitably, then, ATV is changing, but will licence relaxations and the

possibility of continental-wide coverage courtesy of a satellite-borne TV repeater make ATV more interesting? There are those who think not, which means 'serious' ATVers have some problems to solve.

First listen to Bill WA6ITF. I think he sums up the problem most succinctly.

"Long ago, back when I was still a W2, I had a short-lived interest in ATV. I built a station out of some old RCA land mobile gear, home-brewed a converter and put 46-elements on my seven-storey apartment house. Then I spent three glorious weeks being bored totally stiff! After seeing 'Paul's Dog' for the 44th time and 'Mike's slides of Borneo' for the 70th time, I disconnected it all and packed it away in WA2INM's basement, where it probably sits rusting and rotting to this day.

"If ATV is ever to succeed and become even one tenth as popular as f.m. or s.s.b., then it has to offer something more than Fred and Joe sitting in their shorts, drinking a Coor's and looking at one another. With the relatively low cost of good quality home video gear and a lot of imagination, the programming content of ATV could become something that would make people want to stay in ATV - not just pass through it.

## Professional ATV

"There are two sides to television, the technical and the creative. Currently the vast majority of ATVers are technocrats - they give no thought whatever to the content of the communications they are transmitting. It is r.f. purely for the sake of transmitting r.f. and nothing more.

"What professional broadcasting has and ATV desperately needs is a corps of creative talent. We need hams who are willing to be writers, producers, directors and on-camera talent to go out, dream up some truly innovative programming ideas and carry these ideas to a logical conclusion.



Here's a simple idea for an on-screen ident that's different from the others: a clock, your callsign, monitoring frequency and your phone number!

"Suffice to say that ATV can be made interesting to a lot more hams if it offers a bit more than Pete's parakeet and Mary's sewing box. Until it does, I am afraid that I and a lot of others will watch satellite TV instead."

Strong words, but would you disagree? And now here's Hans HB9SVW from Switzerland adding his thoughts on the malaise and disappointment of the ATV mode, as he puts it.

## Few Restrictions

"We hams are in an unusually liberal situation. If we read about some new technology we can try it out straightaway - on the air! No exams, no certificate of competence, no type approval necessary. What would other radio users give for this privilege?!"

"Well, so far so good. But what do we do with this technical knowledge we have gained? And this is where the connection with ATV comes in, though it's really a stab in the back!"

"We ATVers have very few restrictions. There are limitations on the content of our transmissions but this still leaves countless themes from which we can all profit within the definition of amateur radio and self-education, namely the study of tech-

nology and its applications. But do we use it?

"After a brief period being active on packet, I have seen how considerable the interest is in collecting useful data. The system is highly functional and I have access to databases and hook-ups throughout Europe and via short wave, the whole world.

"But this information is silent and only in black and white. With a bit more technology and time I can transmit moving colour pictures. And then it amazes me to reflect that television is the most powerful medium in the world: just think how it is used for politics, informing and advertising. What's more, it has taken over from the printed word in books and newspapers as the prime medium for information.

"Only radio amateurs, who have advanced television facilities at their disposal, would give up an interactive, real-time sound and vision medium and go back to the written word. We used to talk about casting pearls before swine..."

Well said, Hans. Who can argue with that? So why do ATVers shoot themselves in the foot? Who is going to change all this? Or should we pack up our ATV gear and admit defeat now? Write in with your views. A stamp won't cost you much and your view is vital!

## THE UP-TO-DATE NEWS & INFORMATION SERVICE FOR THE LISTENING ENTHUSIAST

RADIO LINE

0891 654676

UPDATED EVERY SATURDAY

RADIO LINE

Calls charged at 36p per minute cheap rate,  
48p per minute at all other times.

# C.M.HOWES COMMUNICATIONS

Mail Order to: **Eydon, Daventry,  
Northants NN11 6PT**  
Tel: 0327 60178



## EASY TO BUILD KITS!

Building your own equipment is not only interesting and fun, but enables you to build up your station facilities without having to spend a fortune. You could update an older receiver with our new DFD4 Digital Read-out, or build yourself an excellent little rig for holiday and portable use. All our amateur band receivers have matching transmitter kits, so you can start with a simple receiver and build up your station in easy stages.



Novice kits housed in optional "hardware packs"

### DFD4 ADD-ON DIGITAL READ-OUT

The HOWES DFD4 enables you to add modern digital read-out accuracy to analogue type receivers and transceivers. The 100Hz resolution will enable you to find stations accurately - be on the right frequency ready to catch those brief messages that you would otherwise miss whilst tuning randomly. The DFD4 can accommodate any IF frequency offset, and VFOs that tune normally or "backwards". We have designed this kit to be as versatile as possible. Why not give me a ring to discuss its use with your radio?

DFD4 Kit: **£39-90**

Assembled PCB modules: **£59-90**

### ASL5 DUAL BANDWIDTH FILTER

Add extra selectivity to your receiver with the HOWES ASL5. The dual filters provide a narrow (300Hz) CW filter and sharper roll-off than crystal filters on SSB or other speech modes. A great addition to reduce noise and interference with all the popular general coverage receivers. No mods are required to the set, the ASL5 connects in-line with the external speaker or headphone socket.

ASL5 Kit: **£15-90**

Assembled PCB Module: **£24-60**

### DXR10 10, 12 & 15M SSB/CW RECEIVER

The HOWES DXR10 is a super little receiver. It can receive signals from amateurs on three DX (long distance) bands, and makes an ideal receiver for those who would like to take up amateur radio with the new Novice Licence. Matching transmitter kits are available to convert it into a transceiver for 10 and 15M to give World-wide SSB and CW contacts.

DXR10 Kit: **£26-60**

Assembled PCB module: **£39-90**

### SOME OTHER ACCESSORY KITS

	Kit	Assembled
AA2	HF Active Antenna 150kHz to 30MHz.	£8-50 £12-90
AA4	25-1300MHz Active Antenna for scanners	£19-80 £26-80
CBA2	Buffer to connect DFD5 to our receivers	£5-90 £9-50
CSL4	Additional SSB/CW filtering for our receivers	£10-50 £17-40
CTU30	HF Bands ATU for RX or 30W on TX	£31-50 £38-40
CV100	HF Converter for VHF Scanners	£26-50 £37-90
DCS2	"S Meter" for our receiver kits	£9-20 £13-80
DFD5	Digital Readout for use with our receivers	£41-50 £64-50
SPA4	Wide-band Receiver Pre-amp 4-1300MHz	£14-90 £20-90
ST2	Morse Practice/Side-tone Oscillator	£8-90 £14-30
SWB30	SWR/Power Indicator & load	£12-90 £18-50

PLEASE ADD £1-20 P&P for kits or £3-00 for hardware.

### ANTENNA INTERFACE

CA30M Hardware Pack plus  
CTU30, SWB30 & ST2 Kits.  
CA30M: **£28-90**



HOWES KITS are produced by a professional RF design and manufacturing company. They contain good quality printed circuit boards with screen printed parts locations, full clear instructions and all board mounted components. Sales and technical advice are available by phone during office hours. Please send an SAE for our free catalogue or specific product data sheets. Normally all items are in stock and delivery is within seven days.

72 & 73 from Dave G4KQH, Technical Manager.

# Bredhurst electronics



BREDHURST ELECTRONICS LTD.  
High Street, Handcross, W. Sussex RH17 6BW  
Tel: (0444) 400786. 400124  
Fax: (0444) 400604

SITUATED AT THE SOUTHERN END OF THE M23 - EASY ACCESS TO M25 AND SOUTH LONDON

## AERIAL ACCESSORIES

		P&P
50m 16SWG H/Drawn Copper Wire	£12.95	£3.00
Small ceramic egg insulators	.65	.25
'T' piece polyprop dipole centre	2.40	.25
Deluxe dipole centre, 259 socket	9.35	2.00
Self-amalgamating tape	4.35	1.00
300 R slotted feeder, per metre	.58	.10
450 R slotted feeder, per metre	.50	.10
URM67 50R low loss coax, per metre	.95	.25
URM76 50R coax, per metre	.40	.10

## SPIRO ANTENNA PRODUCTS

PB1	1:1 Balun 2kW P.E.P.	17.95	2.00
LC160	160 mtr antenna shortener (pair)	24.95	2.50
LC80	80 mtr antenna shortener (pair)	23.95	2.50
T15	21MHz traps 1kW (pair)	39.90	2.50
T20	14MHz traps 1kW (pair)	39.90	2.50
T40	7MHz traps 1kW (pair)	41.90	2.50
T80	3.5MHz traps 1kW (pair)	41.90	2.50

## PALOMAR

RX-100 noise bridge	69.95	2.50
P-405 receiver pre-amplifier	129.95	2.50
PF-300 scf audio filter	139.95	2.50
PB 50-W balun, 1:1, 1.5:1, 2:1, 3:1, 4:1, 5:1, 6:1, 7.5:1, 9:1, 12:1, 16:1	26.95	2.50

## SONY



### ICF SW77

Top specification multi-band receiver with PLL synthesizer circuitry, station name tuning and continuous AM frequency coverage

ICF SW77	349.99
ICF 2001D	299.99
AIR 7	249.99
WA 8800	229.99
ICF SW1E	149.99
ICF SW7600	149.99
ICF 7600DA	129.99
ICF SW800	99.99
ICF 7601E	89.99
ICF SW20	69.99

## RECEIVERS

<b>AOR</b>	
AR3000A	765.00
AR2800	395.00
AR2500	419.00
AR2002	399.00
AR2000	269.00
<b>ICOM</b>	
ICR7100	1120.00
ICR100	510.00
ICR72E	659.00
ICR71	875.00
ICR1	349.00
<b>KENWOOD</b>	
R5000	925.00
R2000	329.00
<b>LOWE</b>	
HF225	429.00
HF150	329.00
<b>JRC</b>	
NRD535	1095.00
<b>YAESU</b>	
FRG8800	665.00
FRG9600M	559.00

Phone for prices on Kenwood Icom Yaesu transceivers, and our wide range of accessories

**BREDHURST ELECTRONICS LTD, HIGH STREET, HANDCROSS, WEST SUSSEX RH17 6BW**  
Open Monday-Friday 9am-5.30pm Saturday 9.30am-4.30pm

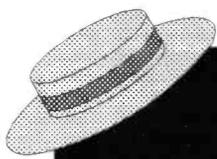

# When it comes to SONY Look to Lowe



ICF-SW1E

ICF-SW7600

ICF-2001D

AIR-7

## ICF-SW1E

Amazing is the only word to describe this ultra-compact radio. Measuring less than 5" x 3" x 1", yet packed with features and performance of a full-size portable, it covers long wave, medium wave and ALL of the short wave spectrum from 150kHz to 30MHz. It even covers FM stereo using the supplied earphones. You get keypad frequency entry, manual tuning and scan tuning for easy operation; whilst clear LCD digital readout (5kHz on SW) ensures accurate tuning. To keep your favourite stations, ten memories are provided and other features include dial lamp, Local/DX attenuator, keyboard lock, tone control and record output jack. To complete this total package there is even a built-in digital clock and alarm. A host of accessories including aerial, carrying case, manuals and others.

List price: £172 **Low price: £149**

## ICF-SW7600

This new SONY portable is a microprocessor controlled general coverage receiver with many advanced features packed into its 7.5" x 4.75" x 1.25" case. Direct access tuning from a clear keypad, manual tuning with UP/DOWN keys, 150kHz to 30MHz coverage plus FM broadcast (FM in stereo through supplied earphones), AM/FM/SSB modes, ten memory channels, auto scanning, tilt stand, keypad lock, 24 hour digital clock with timer and full facilities for tape recording.

List price: £172 **Low price: £149**

## ICF-2001D

Top of the SONY range and a firm favourite. I use one myself at home. The 2001D is a full-feature portable receiver giving you coverage from 150kHz to 30MHz with USB/LSB/AM modes, 116Mhz to 136MHz for the airband enthusiast and full coverage of the VHF FM broadcast band. Dual PLL frequency synthesis ensures accuracy and stability and the readout on short wave is to 100Hz. Features include keypad frequency access on all bands plus manual tuning control, built-in ferrite bar for LW & MW plus whip for SW and VHF, 12/24 hour clock and timer, wide/narrow IF filters, SONY synchronous AM detector with selectable sidebands, 32 channel memory with direct keypad access and memory scanning. Every possible feature is provided. The 2001D comes complete with many useful accessories.

List price: £345 **Low price: £279**

## AIR-7

An unusual airband portable and truly showing the SONY individual approach to design. The AIR-7 is easy to use and the audio quality is excellent; not only on airband but on broadcasts as well since it covers the 108-136MHz airband, the FM broadcast band, the VHF high band from 144-174MHz and, believe it or not, the LW/MW and low SW bands from 150-2194kHz. Ten memory channels, memory scan, keypad lock and priority channel. A truly comprehensive package. Complete with accessories. List price: £287 **Low price: £229**



SONY has brought Short Wave Radio operating convenience to new dimensions with the new ICF-SW77 through the exclusive combination of quick access tuning, synchronous detection, pre-set station tuning, auto scan and more!

## ICF-SW77

Try it at any of our centres!

### Features:

- AM & SSB (LW, MW, SW) FM Stereo reception
- Synchronous detection for less fading/interference
- Keypad entry/manual tuning rate 50Hz/1kHz
- Auto Scan Tuning
- Up to 20 Memory 'pages' with 5 stations on each
- World Time Clock System
- Full brochure on request

### Specifications:

- Frequencies:**
- FM 76.5-108MHz
  - LW/MW/SW 150kHz-30MHz
- Antennas:**
- Telescoping SW/FM
  - Ferrite Bar LW/MW
- Size:**
- 274mm x 165mm x 46mm
- List price: £389  
**Low Price: £329**

**LOWE ELECTRONICS LTD**

Chesterfield Road, Matlock, Derbyshire DE4 5LE  
Tel: 0629 580800 Fax: 0629 580020

\*Bournemouth (Closed Mondays): 0202 577760 Bristol: 0272 771770 Cambridge: 0223 311230

Cumbernauld: 0236 721004 London (Heathrow): 0753 545255 London (Middlesex): 081-429 3256 Newcastle: 0661 860418

**Professional WEATHER MONITORING at low cost**

**FEATURES (depending on model)**

- WIND DIRECTION
- WIND SPEED
- GUST ALARM
- GUST SPEED
- RAINFALL
- SUNSHINE
- OUTSIDE TEMPERATURE
- MIN-MAX TEMPERATURE
- RELATIVE HUMIDITY
- BAROMETRIC PRESSURE
- WOODEN CABINET
- MAINS & 12-24V DC

★ ★ All main readings at a glance ★ ★

SEND FOR COLOUR BROCHURE  
Prices from only **£179** inc. VAT



**R&D ELECTRONICS, UNIT 19, THE ST JOHN WORKSHOPS, MARGATE KENT CT9 1TE. TEL: (0843) 221622**

## RADIO AMATEURS EXAM? PASS FIRST TIME!

**Before you enrol check the benefits of RRC'S unique Home Tuition Service**

RRC has helped thousands of students to success in their examinations with this unique system of postal tuition, one which guides you, step-by-step, to qualify in the shortest possible time. Only The Rapid Results College offers you all these advantages:

<input checked="" type="checkbox"/> A qualified personal tutor	<input checked="" type="checkbox"/> Free advice before you enrol
<input checked="" type="checkbox"/> Study material prepared by specialists	<input checked="" type="checkbox"/> Telephone Helpline
<input checked="" type="checkbox"/> Completely self-contained courses	<input checked="" type="checkbox"/> Free 'How to Study' Guide
<input checked="" type="checkbox"/> Handy pocket-size booklets	<input checked="" type="checkbox"/> Instalment Plan
<input checked="" type="checkbox"/> Personal study programme	<input checked="" type="checkbox"/> Free Postage on course material
<input checked="" type="checkbox"/> Regular marked tests	<input checked="" type="checkbox"/> Worldwide Airmail Service
<input checked="" type="checkbox"/> Courses regularly updated	<input checked="" type="checkbox"/> Extra tuition free if you don't pass first time
<input checked="" type="checkbox"/> 48 hour despatch	

---

**POST COUPON TODAY FOR FREE RADIO AMATEURS PROSPECTUS**  
Please send me my prospectus as quickly as possible.

Mr/Mrs/Miss/Ms \_\_\_\_\_

Address \_\_\_\_\_

Postcode \_\_\_\_\_



**The Rapid Results College**  
Dept. JV122, Tuition House, London SW19 4DS. FREE ADVICE: 081 947 7272 (9am-5pm)  
PROSPECTUS: 081 946 1102 (24 hour Recordacall Service quoting Dept. No. above).





Used amateur radio equipment bought, sold and exchanged – receivers a speciality – mail order no problem. Send SAE for lists.

Phone Dave on 0206 564134.  
Anytime. Callers by appointment.

**G4TNY Amateur Radio**  
PO BOX 1790, COLCHESTER CO2 8TY

**G2VF LOOP ANTENNAS WITH ATU FOR HF HAM BAND TRANSMISSION** (SWR One to One 40, 15 and 10 One Point Five to One 80 and 20) **AND SWLs LONG AND MEDIUM WAVE FOR BCLs.** Loops 21 inches square or triangle. No special skills required. Circuits, Parts Lists sources of supply assembly data. HIGH FREQUENCY LOOP 80 to 10 Metres £5. LONG AND MEDIUM WAVE LOOP FOR BCLs £3. LONG MEDIUM SHORT WAVE LOOP 1500 to 10 METRES FOR BCL SWL £8. SHORT WAVE ATU LOOP OR LONG WIRE £4. PRE AMP LW MW S WAVE £2 PHOTOCOPY HRO MANUAL £4. MW LOOP WITH PRE AMP ATU £3. PRE AMP FOR G2VF HF LOOP OR ATU £4. SHORT WAVE ATU BUILT-IN PRE AMP FOR LOOP OR LONG WIRE £7. SAE details. All projects D.I.Y. METAL DETECTOR £2. **F. G. Rylands, 39 Parkside Avenue, Millbrook, Southampton SO1 9AF. Tel: (0703) 775064.**



**D A T O N G**

E L E C T R O N I C S L I M I T E D

Clayton Wood Close  
West Park  
Leeds LS16 6QE  
Tel: 0532 744822  
Fax: 0532 742872

**For products you can rely upon  
to give amazing results**

For information on **Active Antennas, RF Amplifiers, Converters, Audio Filters, the Morse Tutor and Speech Processors** send or telephone for a free catalogue and selective data sheets as required.

All our products are designed and made in Britain.  
Orders can be despatched within 48 hours subject to availability.



 — VISA AND ACCESS WELCOME — 



# SRP 'SPECIALS'

## WANTED

### Shortwave Receivers and Scanners!

## CASH PAID

## NEW!

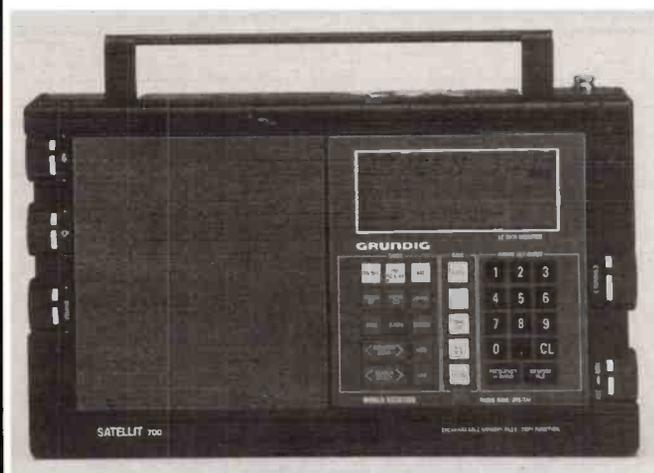

**Now in stock £349**

World receiver with microcomputer-controlled PLL frequency synthesizer tuning. DATA Monitor. RDS - Radio Data System. Indication of station name in the display. 64 station memory positions with 8 alternative frequencies (included). ROM chart. Direct frequency input. Last station memory. Copy function. Storecompare mode. Memory scan. LCD quartz timer clock with 2 time zones.

## SANGEAN ATS 803A

(Direct key-in world receiver with quartz alarm clock timer)

**unable BFO SSB/CW!**

### Specifications and features

★ 150-29.999 continuous tuning with no gaps. Phase locked loop-double conversion Superheterodyne ★ Full shortwave/AM/SSB 150-29999kHz no gaps! + FM87.5-108 mono/stereo ★ Five tuning functions: Direct press button frequency input auto scanning, manual scanning memory recall and manual tuning knob ★ Built-in clock and alarm. Radio turns on automatically at preset time and frequency. ★ Large digital frequency display. ★ Fourteen memories - nine memory channels for your favourite station frequencies. Last setting of mode and waveband stored in five memories. ★ Direct press-button access to all 12 shortwave broadcast bands. ★ Two power sources - battery or AC mains adaptor. ★ General coverage of all AM bands in LW/MW/SW (dedicated broadcast band coverage on all versions), plus of course the FM band for quality sound broadcasts in headphone stereo. ★ SLEEP function turns the radio on or off after an adjustable time of 10-90 minutes. ★ Separate BASS and TREBLE controls for maximum listening pleasure. ★ External antenna jack for better reception. ★ Adjustable RF GAIN control to prevent overloading when listening close to other strong stations or if there is interference. ★ New improved wide/narrow filter (6/2.7kHz) ★ BFO control (Beat Frequency Oscillator) enables reception of SSB/USB/LSWB (single side band) and CW (Morse Code) transmissions. ★ Illuminated display to facilitate night-time use. ★ Designed for both portable and desk top use. ★ Five dot LED signal strength indicator.



DIMENSIONS: 29.2cmx16.0cm (11.5inx6.3inx2.36in).  
OUTPUT: 1200mW (10%THD) WEIGHT: 1.7kg (3.75lbs) without batteries. Wide/narrow filter switch.

**£109.95 + £5 check, test and p&p.**

## SKY SCAN

### Desk Top Antenna Model Desk 1300

Built and designed for use with scanners. Coverage: 25 to 1300MHz. Total height - 36ins - 9ins at widest point. Comes complete with 4 metres of RG58 coax cable and BNC connector fitted. Ideal indoor - high performance antenna and can also be used as a car antenna when your car is static. REMEMBER YOUR SCANNER IS ONLY AS GOOD AS YOUR ANTENNA SYSTEM!

**£49.00 + £3.00 p&p**

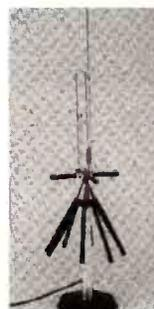

## SKY SCAN V1300 Antenna

Most discons only have horizontal elements and this is the reason that they are not ideal for use with a scanner. Most of the transmissions that you are likely to receive on your scanner are transmitted from vertically mounted antennas. The Sky Scan V1300 discon has both vertical and horizontal elements for maximum reception. The V1300 is constructed from best quality stainless steel and aluminium and comes complete with mounting pole. Designed and built for use with scanners.

**£49.95 + £3.00 p&p**



## SKY SCAN Magmount MKII

For improved performance, wide band reception, 25 to 1300MHz. Comes complete with protective rubber base, 4m RG.58 coax cable and BNC connector. Built and designed for use with scanners.

**£24.95 + £3.00 p&p**



## SAMLEX®

Regulated 13-8V DC power supply  
WITH SHORT CIRCUIT PROTECTION



Model  
RPS1210-  
10-14 amp.  
£49.95 +  
£5.00 p&p



Model  
RPS1215-  
15-20 amp.  
£69.95 +  
£5.00 p&p

## S.R.P. TRADING

Manufacturers and distributors of communications equipment  
Unit 20, Nash Works, Forge Lane, Belbroughton, Near Stourbridge, Worcestershire.

Telephone: (0562) 730672 Fax: (0562) 731002

Showroom opening times: Monday - Friday 9.00 - 5.30pm Saturday 9.00 - 1.00pm. Callers welcome.



# Many Radio Amateurs and SWLs are puzzled. Just what are all those strange signals you can hear but not identify on the Short Wave Bands? A few of them such as CW, RTTY, Packet and Amtor you'll know – but what about the many other signals?

**HOKA ELECTRONICS HAVE THE ANSWER!** There are some well-known CW/RTTY decoders with limited facilities and high prices, complete with expensive PROMS for upgrading etc., but then there is CODE3 from Hoka Electronics! It's up to you to make the choice – but it will be easy once you know more about Code3. Code3 works on any IBM-compatible computer with MS-DOS 2.0 or later and having at least 640k of RAM. The Code3 hardware includes a digital FSK Converter unit with built-in 230V AC power supply and RS232 cable, ready to use. You'll also get the best software ever made to decode all kinds of data transmissions. Code3 is the most sophisticated decoder available and the best news of all is that it only costs **£299!**

- Morse – Manual/Auto speed follow. On screen WPM indicator
- RTTY /Baudot/Murray/ITA2/CCITT2 plus all bit inversions
- Sitor – CCIR 625/476-4, ARQ, SBRS/CBRS FEC, NAVTEX etc
- AX25 packet with selective call sign monitoring, 300 Baud
- Facsimile, all RPM/IOC (up to 16 shades at 1024 x 768 pixels)
- Autospec – Mk's I and II with all known interleaves
- DUP-ARQ Artrac – 125 Baud Simplex ARQ
- Twinplex – 100 Baud F78C Simplex ARQ
- ASCII – CCITT 5, variable character lengths/parity
- ARQ6-90/98 – 200 Baud Simplex ARQ
- SI-ARQ/ARQ-S – ARQ1000 simplex
- SWED-ARQ/ARQ-SWE – CCIR 518 variant
- ARQ-E/ARQ1000 Duplex
- ARQ-N – ARQ1000 Duplex variant
- ARQ-E3 – CCIR 519 variant
- POL-ARQ – 100 baud Duplex ARQ
- TDM242/ARQ-M2/4-242 CCIR 242 with 1/2/4 channels
- TDM342/ARQ-M2/4 CCIR 342-2 with 1/2/4 channels
- FEC-A – FEC100A/FEC101
- FEC-S – FEC1000 Simplex
- Press DPA – 300 Baud ASCII F78C
- Sports Info. – 300 Baud ASCII F78C
- Hellsreiber – Synch./Asynch.
- Sitor RAW – (Normal Sitor but without synchronisation)
- ARQ6-70
- Baudot F78BN

All the above modes are pre-set with the most commonly seen baudrate setting and number of channels which can be easily changed at will whilst decoding. Multi-channel systems display ALL channels on screen *at the same time*. Split screen with one window continually displaying channel control signal status e.g. idle Alphas/Beta/RQ's etc, along with all system parameter settings e.g. unshift on space, *Shift on Space*, multiple carriage returns inhibit, auto receiver drift compensation, printer on, system sub-mode. Any transmitted error correction information is used to minimise received errors. Baudot and Sitor both react correctly to third shift signals (e.g. Cyrillic) to generate ungarbled text unlike some other decoders which get 'stuck' in figures mode!

**Six options are currently available extra to the above specification as follows:** 1) Oscilloscope. Displays frequency against time. Split screen storage/real time. Great for tuning and analysis. £29. 2) Piccolo Mk 6. British multi-tone system that only we can decode with a PC! £59. 3) Ascii Storage – Save to disc any decoded ascii text for later processing. £29. 4) Coquelet – French multi-tone system, again only on offer from Hoka! £59. 5) 4 Special ARQ and FEC systems i.e.. TORG-10/11, ROU-FEC/RUM-FEC, HC-ARQ (ICRC) and HNG-FEC. £69. 6) Auto-classification – Why not let the PC tell YOU what the keying system is?! £59.

## NEW VERSION 4.00 JUST RELEASED – Now with improved user interface and even more features!

*Please add £5 to the above prices for carriage by fully insured First Class Postal delivery (default method).*

Call or write for our comprehensive information leaflet – there is just not enough room here to tell you everything about Code3!

Professional users – please ask about our new CODE30 DSP unit available soon! (Piccolo down to -12dB S/N!!) Prices start from £1250.

# HOKA ELECTRONICS (UK)

26 Bury Road, Shillington, Hitchin, Herts. SG5 3NY  
Phone (0462) 711600 or Fax (0462) 711769



## NEW

### FAX and WEATHER SATELLITES

Full resolution charts and greyscale pictures from any SPECTRUM computer to a dot matrix printer. Basic system £40 plus interface for FAX £40 or WX SATS £59.

### APT-1 WEATHER SATELLITE MODULE

Enables all weather satellite signals to be displayed on any FAX system. Plugs into RX-8 system direct. £59 or £39 if ordered with RX-8.

### RX-8 8-MODE RECEIVE

Every possible feature and performance to receive FAX, HF & VHF PACKET, COLOUR SSTV, RTTY, CW, AMTOR, UoSAT and ASCII on any BBC computer. Reviews Oct. 89 Ham Radio Today and July 91 Rad Comm. Complete system of EPROM, interface, instructions, leads and demo cassette £259.

### RX-4 RTTY CW SSTV AMTOR RECEIVE

Performance, features and ease of use make this still a best seller. Needs TIF1 interface. BBC, CBM64 tape £25, disk £27. VIC20 tape £25. SPECTRUM tape £40, + 3 disk £42 inc adaptor board (needs TIF1 also) or software-only version £25. TIF1 INTERFACE has 4-pole filtering and computer noise isolation for excellent HF and VHF performance. Kit £30, ready-made, boxed with all connections £40. Available only with software.

Also MORSE TUTOR £8, LOGBOOK £8, RAE MATHS £8 for BBC, CBM64, VIC20 and SPECTRUM. BBC LOCATOR with UK, Europe, World maps £10. Disk £2 extra for all. Lots of information available about everything, please ask. Prices include VAT and p&p by return.



**technical software** (SWM)  
Fron, Upper Llandwrog, Caernarfon LL54 7RF  
Tel: (0286) 881886



## THE VINTAGE WIRELESS BOOK LISTING

Published regularly containing 100s of out-of-print, old and collectable wireless, TV and amateur radio books/magazines etc. Send four first class stamps for next issue or £2.50 for next four issues.

**WANTED: Pre 1960 Wireless, amateur radio and TV books and magazines.**

### NEW PUBLICATIONS:

**The Government Surplus Wireless Equipment Handbook.** – Facsimile reprint. Gives detailed information and circuit diagrams plus photos for British and American receivers, transmitters and test equipment etc. Large format. Incorporated is a surplus/commercial cross referenced valve and transistor guide. Price **£13.75** including postage.

**U.S.A. RADIO SURPLUS CONVERSION HANDBOOK** – Facsimile reprint. Includes data, circuits and conversion details for most American transmitters and receivers including the command series and BC348, BC221 etc. Illustrated with over 300 large format pages. **£16.95** including postage.

**THE AUTHORISED BIOGRAPHY OF SIR BERNARD LOVELL** – By Dudley Saward. The man responsible for Jodrell Bank. Contains detailed chapters on the development of wartime radar including H2S and various centimetric equipment. 320 large format pages. A must for those interested in radar and radio astronomy. Many illustrations. A big book brand new. **£8.75 + £1.95 p&p. Telephone orders accepted.**



**CHEVET BOOKS (Dept SW)**

157 Dickson Road, BLACKPOOL FY1 2EU Tel: (0253) 751858.



# RAMS IV

## MULTIMODE Rx PROGRAM FOR YOUR SPECTRUM

- RTTY** 5 Baud rates
- AMTOR** (SITOR)
- MORSE** To 250 wpm or more
- SSTV** ✓ Large picture and multi speed

**All this with generous**

**QSO Review and picture store £25.00**

RMS III users upgrade for £12.50

Send large SAE (33p stamp) for details of all our products.

# J.B.P. ELECTRONICS LTD.

Unit 45, Meadowmill Estate, Dixon Street,  
Kidderminster DY10 1HH Tel: (0562) 753893



# ALAN HOOKER

**SLIMLINE** ■ Allows you to safely mount your hand-held or mobile radio where you can see the controls...

**HEAVY DUTY** ■ Mounts any single flat surface. Adaptable to any vehicle or station use.

Construction made of high quality aluminium.

THE **'RIG SAVER'**

APPROVED DEALER FOR

KENWOOD ICOM YAESU AOR

42 Nether Hall Road, Doncaster, South Yorkshire, DN1 2PZ  
Telephone: Doncaster (0302) 325690



FREE WITH ANY NEW VHF/UHF HANDHELD OR SCANNER

# MODULATIONS COMMUNICATIONS

62 Wootton Road, Abingdon, Oxon. Tel: & Fax: (0235) 521400

**FAIRMATE HP2000**  
As the UK distributor for Fairmate we are constantly working with them to update and produce new features and models.

- Continuous freq. Coverage from 100kHz to 1300MHz
- 1000 Channels of memory
- Keypad or rotary control
- AM, FM and wide FM modes
- Search steps from 5kHz to 995kHz

Every set comes complete with - Full set of high power n-cads, 2 antennas, carrying case, earphone. DC

**£329.95**

**MVT 7000 Handheld**  
The latest in a family of three!

- Frequency coverage from 8 to 1300MHz (100kHz-1300MHz at reduced sensitivity)
- 200 Memory channels
- Rotary or keypad frequency control
- AM/FM narrow and wide FM modes
- Large easy read display with signal meter.

Every set comes complete with - Full set of high power n-cads, telescopic antenna, 240Vac mains charger, DC power lead and carry strap.

**£289**

**400 Channel with Hyper Scan**

- Hyper Scan doubles the scanning speed - 13 or 26 channels per second
- Covers 25-520, 760-1300MHz

**Realistic PRO-2006** - Features ten 40-channel memory banks; a 10 channel monitor bank for temporary storage, plus search and favourite channel priority functions. Sound squelch control prevents lock-ups on unmodulated carriers. Back-lit LCD display with dimmer. AM, FM, narrow and FM-wide modes. Jacks: Tape out, 3.5mm headphones, external DC power and BNC aerial input. Memory back-up requires 9v battery. Measures 76x222x209mm. Mains operation (or 12 VDC cord, extra).

20-9145 ..... **£329.95**

ALSO CB RADIO STOCKISTS

NEVADA Tandy AUTHORISED DEALERS

Part exchange welcome/Mail order  
Call John G1FEK or Val G1HQB

# AIR SUPPLY

83B HIGH STREET, YEADON, LEEDS LS19 7TA. Tel: (0532) 509581  
Shop just two minutes from Leeds Bradford Airport.

## AIR TRAFFIC CONTROLLERS

On hand to help you towards an interesting and rewarding pastime. Specialists in **AIR BAND RADIOS AND SCANNERS**. Hand held, mobile or base - AOR, Signal, Black Jaguar, Yupiteru, Icom, Uniden, Sony, Nevada: HF receivers from Sony, Icom, Lowe, Yaesu, Kenwood: wide range of accessories, aerials, plus CAA publications, maps, books, models from IMC, Wooster, Schabak, photos, souvenir products from British Airways and British Midland Airways. Large range of pilots products. Agents for Transair, AFE and Airtour. Plus lots more.

*If you would like our info pack send large SAE and stamps to value of 50p.*

Shop hours: 1000-1330: 1430-1700 (hours do vary) CLOSED WEDNESDAY

# PLEASE MENTION SHORTWAVE MAGAZINE when replying to advertisements

**FOR SALE:** 4CX250B Eimac/ITT, ex-equipment but fully tested at high power - £30 plus VAT, post paid each. Discounts for 10 or more pieces.

**FOR SALE:** 4CX350A Eimac, ex-equipment but unused appearance, fully tested at high power - £60 plus VAT, post paid each. Discounts for 10 or more pieces.

**WANTED VALVES:** KT66, KT77, KT88, PX4, PX25 valve collections, klystrons, magnetrons, transistors. *Please post us list of what you have. Quick replies, cash waiting.*

**BILLINGTON EXPORT**, Unit F2 Oakendene Industrial Estate, Near Horsham, RH13 8AZ.  
Callers by appointment only. Tel: (0403) 865105 FAX: (0403) 865106.  
Minimum order £50 + VAT. (UK/export).

# PC HF FAX 6.0

**RECEIVE and TRANSMIT FAX IMAGES**

This latest version of PC HF FAX not only enables you to receive weather charts, rebroadcast satellite pictures, amateur and press transmissions on your PC computer but also has the ability to transmit your own fax messages.

**NEW FEATURES INCLUDE:**

- 230 page manual with worldwide fax frequency and schedule list.
- Integrated online fax broadcast schedules with multiple search fields.
- Support for Super VGA displays as well as Hercules, CGA, EGA, VGA, LCD.
- Standard capture resolution 640-800 with 16 grey levels, with VGA, and EMS memory images are saved at 1280x800 with 256 grey levels.
- True colour press and satellite rebroadcast images in EGA, VGA and SVGA.
- Printer support for 14" wide printers plus Epson compatible colour printers.
- File compression, image cropping, Digital noise reduction, Pixel photometry, and Contrast control.
- Import of ASCII text files for conversion and transmission as fax files.

Installation is simple, both the demodulator and modulator plug into the serial port of the PC and are powered by the computer.

Upgrade for existing PC HF FAX users £39.95 p&p £1.50  
**£116.33 inc VAT p&p £3.25**  
Optional Transmit Modulator £59.80

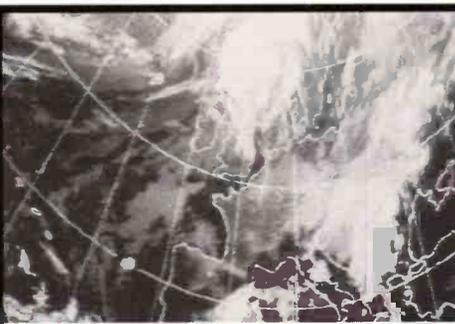

All items come complete with a comprehensive manual, tutorial audio cassette and demodulator. They will work on any PC compatible computer from 8088 to 486 and notebooks. The demodulator plugs into the serial port of the PC and requires audio from a radio receiver. Suitable dedicated receivers and aerials are also available.

**Call today for full details and brochures**

## COMAR ELECTRONICS

UNIT 10, SAMUEL WHITES ESTATE,  
MEDINA ROAD, COWES,  
ISLE OF WIGHT, PO31 7LP

Tel: 0983 200308 Fax: 0983 280402

# PC GOES/WEFAX

**PC GOES/WEFAX enables you to receiver both FAX and SATELLITE images on your PC computer**

In FAX mode it will display weather charts, rebroadcast satellite images, press and amateur transmissions. In SATELLITE mode it will capture images from both METEOSAT and all Polar orbiting satellites. Some of its many advanced features are:

- Image resolution: 640x800x16 standard, 1280x800x256 with VGA and 1MB EMS
- Super VGA support
- Display in black/white, monochrome grey scale, blue/grey
- Colour or user programmable colour
- supports all known FAX and satellite transmission modes
- Start, stop, phasing tone recognition and tuning oscilloscope
- Latitude and longitude gridding on Polar orbiting images
- Interactive thermal infra red analysis
- Polar orbiting prediction program
- Multiframe animation
- Image brightness
- Contrast
- Reversal and rotation control.

**Price only £199 inc VAT p&p £3.25**

## PC SWL 3.0

**PC SWL is a complete package allowing decoding of data sent over radio**

*This new version contains the following facilities:*

- RTTY baudot 45, 50, 75 and 100, or user selectable rate • ASCII 75, 110, 150, and 300, or user selectable rate • FEC/ARQ including AMTOR/SITOR 75 and 100 baud
- MORSE CODE with automatic or manual speed control
- NAVTEX marine weather and navigational information
- RAW HEX for manual decoding
- Improved automatic signal analysis
- Integrated shortwave station log, to enable search, sort and store stations
- New drop down menus, integration with PC HF FAX.

Upgrade for existing PC SWL users £39.95 p&p £1.50  
**£99 inc VAT p&p £3.25**  
Order PC SWL and PC HF FAX together for only £178 p&p £3.25

# SWM BOOK SERVICE



0202 665524

The books listed have been selected as being of special interest to our readers. They are supplied from our editorial address direct to your door. Some titles are overseas in origin.

## HOW TO ORDER

**POST AND PACKING; add £1.00 for one book, £2.00 for two or more books, orders over £40 post and packing free,** (overseas readers add £1.75 for one book, £3.50 for two or more for surface mail postage) and send a postal order, cheque or international money with your order (quoting book titles and quantities) to **PW Publishing Limited, FREEPOST, Enefco House, The Quay, Poole, Dorset BH15 1PP.** Please make your cheques payable to Short Wave Magazine, payment by Access, Mastercard, Eurocard or Visa also accepted on telephone orders to Poole (0202) 665524. Books are normally despatched by return of post but please allow 28 days for delivery. Prices correct at time of going to press. Please note: all payments must be made in Sterling.

O/P = Out of print, O/S = Out of stock.

### LISTENING GUIDES

**FERRILL'S CONFIDENTIAL FREQUENCY LIST**  
Compiled by Geoff Halligey The band 4-28MHz covered in great depth. Who's using what frequency and mode, what's that call sign? These are some of the answers this book will help you find. A very comprehensive book. 390 pages. O/S

**SOUNDS EASY (1991 EDITION)**  
Compiled by Ken Davies A complete guide to the numerous local radio stations throughout the UK. If you do a lot of travelling this book is invaluable. Itemised by areas, it makes finding you kind of sounds easy. 52 pages. £2.95

**AIR TRAFFIC RADIO**  
Ken Davies Frequencies and abbreviations used in air traffic control throughout the UK. Where to listen for tower, ground and radar control in civilian and other airports. It also includes a small section on off-shore oil related use. 64 pages. £3.95

**INTERNATIONAL RADIO STATIONS GUIDE (BP255)**  
New revision by Peter Shore As in 'Broadcast Roundup', his column in PW, Peter Shore has laid this book out in world areas. There are sections covering English language transmissions, programmes for DXers and s.w.l.s. Along with sections on Europe and medium wave and UK f.m. stations. 286 pages. £5.95

**AIR BAND RADIO HANDBOOK (3rd Edition)**  
David J. Smith Listen to conversations between aircraft and ground control. The author, an air traffic controller, explains more about this listening hobby. 174 pages. £7.50

**DIAL SEARCH**  
George Wilcox The listener's check list and guide to European broadcasting. Covers m.w., l.w., v.h.f. and s.w., including two special maps. 54 pages. £3.95

**FLIGHT ROUTINGS 1991**  
T.T. Williams Identifies the flights of airlines, schedule, charter, cargo and mail, to and from the UK and Eire and overflights between Europe and America. 104 pages. £5.25

**GUIDE TO BROADCASTING STATIONS**  
20th Edition 1989/90. Philip Darrington Frequency and station data, receivers, antennas, Latin American DXing, reporting, computers in radio, etc. 240 pages. £10.95

**GUIDE TO FACSIMILE STATIONS 11th Edition**  
Joerg Klingenfuss This manual is the basic reference book for everyone interested in FAX. Frequency, call sign, station name, ITU country/geographical symbol, technical parameters of the emission are all listed. All frequencies have been measured to the nearest 100Hz. 408 pages. £16.00

**GUIDE TO FORMER UTILITY TRANSMISSIONS**  
3rd Edition. Joerg Klingenfuss Built on continuous monitoring of the radio spectrum from the sixties until the recent past. A useful summary of the former activities of utility stations providing information for the classification and identification of radio signals. 126 pages. £8.00

**GUIDE TO UTILITY STATIONS**  
9th Edition. Joerg Klingenfuss This book covers the complete short wave range from 3 to 30MHz together with the adjacent frequency bands from 0 to 150kHz and from 1.6 to 3MHz. It includes details on all types of utility stations including FAX and RTTY. There are 19136 entries in the frequency list and 3514 in the

alphabetical call sign list plus press services and meteorological stations. 502 pages. £21.00

**HF OCEANIC AIRBAND COMMUNICATIONS**  
3rd Edition. Bill Laver HF aircraft channels by frequency and band, main ground radio stations, European R/T networks and North Atlantic control frequencies. 31 pages. £3.95

**MARINE UK RADIO FREQUENCY GUIDE**  
Bill Laver A complete guide to the UK s.w. and v.h.f. marine radio networks. Useful information, frequency listings and the World Marine Coastal Phone Stations. 62 pages. £4.95

**NEWNES SHORT WAVE LISTENING HANDBOOK**  
Joe Pritchard G1UQW A technical guide for all short wave listeners. Covers construction and use of sets for the s.w.l. who wants to explore the bands up to 30MHz. 288 pages. £14.95

**RADIO LISTENER'S GUIDE 1992**  
Clive Woodyear This is the fourth edition of the essential radio listener's guide. Simple-to-use maps and charts show the frequencies for all the radio stations in the UK. When travelling or at home, the guide gives you all the frequencies you'll ever need. 56 pages. £2.95

**THE COMPLETE VHF/UHF FREQUENCY GUIDE**  
1991 Edition. This book gives details of frequencies from 26-2250MHz with no gaps and who uses what. Recently updated, there are chapters on equipment requirements as well as antennas, etc. 88 pages. £5.95

**THE INTERNATIONAL VHF FM GUIDE**  
7th Edition. Julian Baldwin G3UHK and Kris Partridge G8AUV The latest edition of this useful book gives concise details of repeaters and beacons worldwide plus coverage maps and further information on UK repeaters. 79 pages. £2.85

**THE POCKET GUIDE TO RTTY AND FAX STATIONS**  
Bill Laver A handy reference book listing RTTY and FAX stations, together with modes and other essential information. The listing is in ascending frequency order, from 1.6 to 27.1MHz. 60 pages. £3.95

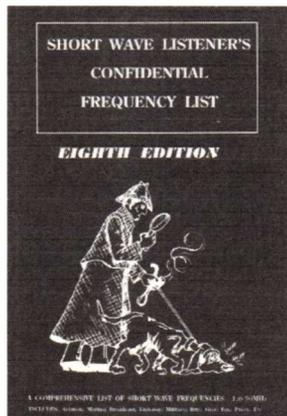

**SHORT WAVE LISTENERS CONFIDENTIAL FREQUENCY LIST**  
Bill Laver Covering the services and transmission modes that can be heard on the bands between 1.635 and 29.7MHz. £8.95

**VHF/UHF AIRBAND FREQUENCY GUIDE**  
Fourth Edition A complete guide to the airband frequencies, civil and military, including how to receive these signals, the frequencies and services, VOLMET and much more about the interesting subject of airband radio. 124 pages. £6.95

**WORLD RADIO TV HANDBOOK 1992**  
Country-by-country listings of l.w., m.w. & s.w. broadcast and TV stations. Receiver test reports. English language broadcasts. The s.w.l.'s 'bible'. 576 pages. £18.95

### ANTENNAS (AERIALS)

**ALL ABOUT CUBICAL QUAD ANTENNAS**  
William I. Orr W6SAI and Stuart D. Cowan W2LX The quad antenna came into being, and popularity, over 50 years ago. This book shows you how to design build and 'feed' this versatile antenna. If you just want to build one then, there are ready-to-go designs for bands between 7 and 50MHz. 122 pages. £6.75

**THE ANTENNA EXPERIMENTER'S GUIDE**  
Peter Dodd G3LDO Although written for Radio Amateurs this book will be of interest to anyone who enjoys experimenting with antennas. You only need a very basic knowledge of radio & electronics to get the most from this book. 207 pages. £8.90

**AN INTRODUCTORY TO ANTENNA THEORY (BP198)**  
H. C. Wright This book deals with the basic concepts relevant to receiving and transmitting antennas. Lots of diagrams reduce the amount of mathematics involved. 86 pages. £2.95

**ANTENNA IMPEDANCE MATCHING**  
Wilfred N. Caron Proper impedance matching of an antenna to a transmission line is of concern to antenna engineers and to every radio amateur. A properly matched antenna as the termination for a line minimises feed-line losses. Power can be fed to such a line without the need for a matching network at the line input. There is no mystique involved in designing even the most complex multi-element networks for broadband coverage. Logical step-by-step procedure is followed in this book to help the radio amateur with this task. 192 pages. £11.95

**HF ANTENNA COLLECTION (RSGB)**  
Edited by Erwin David G4LQJ This book contains a collection of useful and interesting h.f. antenna articles, first published in *Radio Communication* magazine between 1968 and 1989, along with other useful information for the antenna builder. 133 pages. £9.50

**BEAM ANTENNA HANDBOOK (USA)**  
W. I. Orr W6SAI & S. D. Cowan W2LX Design, construction, adjustment and installation of h.f. beam antennas. 198 pages. £7.50

**NOVICE ANTENNA NOTEBOOK**  
Doug DeMaw W1FB Another book from the pen of W1FB, this time offering "new ideas for beginning hams". All the drawings are large and clear and each chapter ends with a glossary of terms. 130 pages. £6.95

**SIMPLE, LOW-COST WIRE ANTENNAS FOR RADIO AMATEURS (USA)**  
W. I. Orr W6SAI & S. D. Cowan W2LX Efficient antennas for Top Band to 2m, including "invisible" antennas for difficult station locations. 191 pages. £7.50

**THE ARRL ANTENNA BOOK (USA) 16th Edition**  
A station is only as effective as its antenna system. This book covers propagation, practical construction details of almost every type of antenna, test equipment and formulas and programs for beam heading calculations. £14.50

**THE ARRL ANTENNA COMPENDIUM (USA) Volume One**  
Fascinating and hitherto unpublished material. Among the topics discussed are quads and loops, log periodic arrays, beam and multi-band antennas, verticals and reduced size antennas. 175 pages. £9.50

**THE ARRL ANTENNA COMPENDIUM (USA) Volume Two**  
Because antennas are a topic of great interest among radio amateurs, ARRL HQ continues to receive many more papers on the subject than can possibly be published in *QST*. Those papers are collected in this volume. 208 pages. £9.50

**THE RADIO AMATEUR ANTENNA HANDBOOK**  
William I. Orr W6SAI & Stuart D. Cowan W2LX Yagi, quad, quagi, l-p. vertical, horizontal and "sloper" antennas are all covered. Also towers, grounds and rotators. 190 pages. £6.75

**W1FB'S ANTENNA NOTEBOOK**  
Doug DeMaw W1FB This book provides lots of designs, in simple and easy to read terms, for simple wire and tubing antennas. All drawings are large and clear making construction much easier. 124 pages. £6.95

**WIRES & WAVES**  
Collected Antenna Articles from PW 1980-1984 Antenna and propagation theory, including NBS Yagi design data. Practical designs for antennas from medium waves to microwaves, plus accessories such as a.t.u.s. s.w.r. and power meters and a noise bridge. Dealing with TVI. 160 pages. £3.00

**YAGI ANTENNA DESIGN**  
Dr James L. Lawson W2ZPV This book is a polished and expanded version of a series of articles first published in *Ham Radio* following on from a series of lectures by the author, who was well-known as the expert on Yagi design. Includes practical designs. 210 pages. £10.95

**25 SIMPLE AMATEUR BAND AERIALS (BP125)**  
E. M. Noll How to build 25 simple and inexpensive aerials, from a simple dipole through beam and triangle designs to a mini-rhombic. Dimensions for specific spot frequencies including the WARC bands. 80 pages. £1.95

**25 SIMPLE INDOOR AND WINDOW AERIALS (BP136)**  
E. M. Noll Designs for people who live in flats or have no gardens, etc., giving surprisingly good results considering their limited dimensions. 64 pages. £1.75

**25 SIMPLE SHORT WAVE BROADCAST BAND AERIALS (BP132)**  
E. M. Noll Designs for 25 different aerials, from a simple dipole through helical designs to a multi-band umbrella. 80 pages. £1.95

**25 SIMPLE TROPICAL AND MW BAND AERIALS (BP145)**  
E. M. Noll Simple and inexpensive aerials for the broadcast bands from medium wave to 49m. 64 pages. £1.75

### DATA REFERENCE

**DIGITAL IC EQUIVALENTS AND PIN CONNECTIONS (BP140)**

#### A. Michaels

Equivalents and pin connections of a popular selection of European, American and Japanese digital i.c.s. 256 pages. £5.95.

#### INTERNATIONAL TRANSISTOR EQUIVALENTS GUIDE (BP95)

##### A. Michaels

Possible substitutes for a popular selection of European, American and Japanese transistors. 320 pages. £3.95

#### NEWNES AUDIO & HI-FI ENGINEER'S POCKET BOOK

##### Vivian Capel

This is a concise collection of practical and relevant data for anyone working on sound systems. The topics covered include microphones, gramophones, CDs to name a few. 190 pages. Hardback £10.95

#### NEWNES COMPUTER ENGINEER'S POCKET BOOK

This is an invaluable compendium of facts, figures, circuits and data and is indispensable to the designer, student, service engineer and all those interested in computer and microprocessor systems. 203 pages. Hardback £10.95

#### NEWNES ELECTRONICS POCKET BOOK

##### 5th Edition

Presenting all aspects of electronics in a readable and largely non-mathematical form for both the enthusiast and the professional engineer. 315 pages. Hardback £10.95

#### NEWNES RADIO AMATEUR AND LISTENER'S POCKET BOOK

##### Steve Money G3FZX

This book is a collection of useful and intriguing data for the traditional and modern amateur as well as the s.w.l. Topics such as AMTOR, packet radio, SSTV, computer communications and maritime communications are all covered. 160 pages. £10.95

#### NEWNES RADIO AND ELECTRONICS ENGINEER'S POCKET BOOK

##### 18th Edition. Keith Brindley

Useful data covering math, abbreviations, codes, symbols, frequency bands/allocations, UK broadcasting stations, semi-conductors, components, etc. 325 pages. Hardback £9.95

#### POWER SELECTOR GUIDE (BP235)

##### J. C. J. Van de Ven

This guide has the information on all kinds of power devices in useful categories (other than the usual alpha numeric sort) such as voltage and power properties making selection of replacements easier. 160 pages. £4.95

## THEORY

#### FURTHER PRACTICAL ELECTRONICS CALCULATIONS AND FORMULAE (BP144)

##### F.A. Wilson

Contains sections about electrical basics, electrostatics, electromagnetism, mathematics, signal processing and generation, amplifiers, noise distortion and reliability. On the radio front there are sections about e.m., waves, spectrum matters, receivers, antennas and transmission line calculations. Finally, general formulae and conversion factors are given, with a short history of electronics. 450 pages. £4.95

#### REFLECTIONS Transmission Lines & Antennas

M. Walter Maxwell W2DU This will help dispel the half-truths and outright myths that many people believe are true about transmission lines, standing waves, antenna matching, reflected power and antenna tuners. 323 pages. £14.50

#### A BEGINNERS GUIDE TO MODERN ELECTRONIC COMPONENTS (BP285)

##### R.A. Penfold

This book covers a wide range of modern components. The basic functions of the components are described, but this is not a book on electronic theory and does not assume the reader has an in-depth knowledge of electronics. It is concerned with practical aspects such as colour codes, deciphering code numbers and the suitability. 164 pages. £3.95

#### AUDIO (Elements of electronics - book 6)

##### F. A. Wilson

This book studies sound and hearing, and examines the operation of microphones, loudspeakers, amplifiers, oscillators, and both disk and magnetic recording. Intended to give the reader a good understanding of the subject without getting involved in the more complicated theory and mathematics. 320 pages. £3.95

#### EVERYDAY ELECTRONICS DATA BOOK

##### Mike Tooley BA

This book is an invaluable source of information of

everyday relevance in the world of electronics. It contains not only sections which deal with the essential theory of electronic circuits, but it also deal with a wide range of practical electronic applications. 250 pages. £8.95

#### FILTER HANDBOOK A practical design guide

##### Stefan Niewiadomski

A practical book, describing the design process as applied to filters of all types. Includes practical examples and BASIC programs. 195 pages. £25.00

#### FROM ATOMS TO AMPERES

##### F.A. Wilson

Explains in simple terms the absolute fundamentals behind electricity and electronics. 244 pages. £3.50

#### PRACTICAL ELECTRONICS CALCULATIONS AND FORMULAE (BP53)

##### F. A. Wilson

This has been written as a workshop manual for the electronics enthusiast. There is a strong practical bias and higher mathematics have been avoided where possible. 249 pages. £3.95

#### SOLID STATE DESIGN FOR THE RADIO AMATEUR

##### Les Hayward W7Z01 and Doug DeMaw W1FB

Back in print by popular demand! A revised and corrected edition of this useful reference book covering all aspects of solid-state design. 256 pages. £10.95

#### THE ARRL ELECTRONICS DATA BOOK

##### Doug DeMaw W1FB

Back by popular demand, completely revised and expanded, this is a handy reference book for the r.f. designer, technician, amateur and experimenter. 260 pages. £8.95

#### TRANSMISSION LINE TRANSFORMERS

##### Jerry Sevick W2FMI

This is the second edition of this book, which covers a most intriguing and confusing area of the hobby. It should enable anyone with a modicum of skill to make a balun, etc. 270 pages. £13.50

## AMATEUR RADIO

#### AN INTRODUCTION TO RADIO WAVE PROPAGATION (BP293)

##### J.G. LEE

How does the sun and sunspots affect the propagation of the radio waves which are the basis of our hobby? They affect the ionosphere, but differing frequencies are treated differently. Find out how to use charts to predict frequencies that will be the most profitable. What effect will noise have on the signal? Find out with this book. 116 pages. £3.95

#### AN INTRODUCTION TO VHF/UHF FOR RADIO AMATEURS (BP281)

I.D. Poole An excellent book to go with the new Novice or full callsign. Nine chapters and an appendix deal with all aspects and frequencies from 50 to 1300MHz. 96 pages. £3.50

#### W1FB'S DESIGN NOTEBOOK

Doug DeMaw W1FB This book is aimed at the non-technical amateur who wants to build simple projects and obtain a basic understanding of amateur electronics. 195 pages £8.50

#### QRP CLASSICS

Edited by Bob Schetgen KU7G Operating QRP is fun. This book increases the enjoyment by showing you how to build items that you can be proud of. They can hold their own against the 'Kenyaecom' rig, and come much cheaper too. Extracts from QST and the ARRL handbook, superbly packed in. 274 pages. £9.95

#### W1FB'S HELP FOR NEW HAMS

Doug DeMaw W1FB This book covers everything from getting acquainted with new equipment to constructing antennas, station layout, interference and operating problems to on-the-air conduct and procedures. 155 pages. £6.95

#### ALL ABOUT VHF AMATEUR RADIO (USA)

##### W. I. Orr W6SAI

VHF/UHF propagation, including moonbounce and satellites, equipment and antennas. 172 pages. £9.50.

#### AMATEUR RADIO CALL BOOK (RSGB) 1991/92 Edition

Now incorporates a 122-page section of useful information for amateur radio enthusiasts. 429 pages. £7.20

#### AMATEUR RADIO SATELLITES the first 25 years

##### Arthur C. Gee G2UK

This souvenir publication is mainly a pictorial account of the pattern of developments which have occurred over the last 25 years in amateur radio satellite operations. 34 pages. £2.25

#### AN INTRODUCTION TO AMATEUR COMMUNICATIONS SATELLITES BP290

##### A. Pickard

This book describes several currently available systems, their connection to an appropriate computer and how they can be operated with suitable software. 102 pages. £3.95

#### AN INTRODUCTION TO AMATEUR RADIO (BP257)

##### I. D. Poole

This book gives the newcomer a comprehensive and easy to understand guide through amateur radio. Topics include operating procedures, jargon, propagation and setting up a station. 150 pages. £3.50

#### HINTS AND KINKS FOR THE RADIO AMATEUR

##### Edited by Charles L. Hutchinson and David Newkirk

A collection of practical ideas gleaned from the pages of QST magazine. 152 pages. £4.95

#### HOW TO PASS THE RADIO AMATEURS' EXAMINATION (RSGB)

##### Clive Smith G4FZH and George Benbow G3HB

The background to multiple choice exams and how to study for them with sample RAE papers for practice plus maths revision. 88 pages. £6.70

#### PASSPORT TO AMATEUR RADIO

##### Reprinted from PW1981-1982

The famous series by GW3JGA, used by thousands of successful RAE candidates in their studies. Plus other useful articles for RAE students. 96 pages. £1.50

#### PRACTICAL GUIDE TO PACKET OPERATION IN THE UK

##### Mike Mansfield G6AWD

Completely revised and updated, this book introduces the concept of packet to the beginner. Problem areas are discussed and suggestions made for solutions to minimise them. Deals with the technical aspects of packet taking the reader through setting up and provides a comprehensive guide to essential reference material. The helpfiles are the latest the author has managed to obtain and there is a reproduction of the UK Packet Map 141pages. £7.95

#### RADIO AMATEUR CALLBOOK INTERNATIONAL LISTINGS 1992 70th Edition

The only publication listing licensed radio amateurs throughout the world. Also includes DXCC Countries list, standard time chart, beacon lists and much more. Over 1400 pages. £19.50

#### RADIO AMATEUR CALLBOOK NORTH AMERICAN LISTINGS 1992 70th Edition

Listings of US amateurs (including Hawaii). Also contains standard time chart, census of amateur licences of the world, world-wide QSL bureau and much more. Over 1400 pages. £19.50

#### RADIO AMATEUR'S GUIDE TO RADIO WAVE PROPAGATION

##### (HF Bands). F. C. Judd G2BCX

The how and why of the mechanism and variations of propagation in the h.f. bands. 144 pages. £15.00

#### THE ARRL HANDBOOK FOR RADIO AMATEURS 1992

The 1992 edition of this extremely useful reference book contains much new material. Packed with information, it's one of the most useful books available for the modern radio amateur. Approx 1000 pages. £16.95

#### THE ARRL OPERATING MANUAL

Another very useful ARRL book. Although written for the American amateur, this book will also be of use and interest to the UK amateur. 684 pages £12.95

#### THE ARRL SATELLITE ANTHOLOGY

The best from the Amateur Satellite News column and articles out of 31 issues of QST have been gathered together in this book. The latest information on OSCARs 9 through 13 as well as the RS satellites is included. Operation on Phase 3 satellites (OSCAR 10 and 13) is covered in detail. 97 pages. £5.95

#### THE ARRL UHF/MICROWAVE EXPERIMENTER'S MANUAL

##### Various Authors

A truly excellent manual for the keen microwave enthusiast and for the budding 'microwaver'. With contributions from over 20 specialist authors. Chapters covering techniques, theory, projects, methods and mathematics. 446 pages £14.50

#### THE COMPLETE DX'ER

##### Bob Locher W3KNI

Now back in print, this book covers equipment and operating techniques for the DX chaser, from beginner to advanced. 187 pages £7.95

#### THE RADIO AMATEUR'S QUESTIONS & ANSWER REFERENCE MANUAL 4th Edition.

##### R. E. G. Petri G8CCJ

This book has been compiled especially for students of the City and Guilds of London Institute RAE. It is structured with carefully selected multiple choice questions, to progress with any recognised course of instruction, although it is not intended as a text book. 280 pages. £7.95

#### THE RAE MANUAL (RSGB)

##### G.L. Benbow G3HB

The latest edition of the standard aid to studying for the Radio Amateurs' Examination. Updated to cover the latest revisions to the syllabus. 132 pages £6.70

#### YOUR GATEWAY TO PACKET RADIO

##### Stan Horzepa W1ALOU

What is packet radio good for and what uses does it have for the 'average' amateur? What are protocols? where, why, when? Lots of the most asked questions are answered in this useful book. It includes details of networking and space communications using packet. 276 pages. £8.95

**This is only a small selection of our Book Service selected as being of particular interest to SWM readers. See last month's issue for further titles. Our sister publication, Practical Wireless, carries titles for the radio amateur.**



#### SHORT WAVE COMMUNICATIONS

##### Peter Rouse GU1DKD

A new book from the word-processor of this best-selling author. Covers a very wide area and so provides an ideal introduction to the hobby of radio communications. International frequency listings for aviation, marine, military, space launches, search and rescue, etc. Chapters on basic radio propagation, how to work your radio and what the controls do, antennas and band plans. 187 pages. £8.95

# ALYNTRONICS

129 CHILLINGHAM ROAD, HEATON,  
NEWCASTLE-UPON-TYNE NE6 5XL TEL: 091-2761002

THE ONLY AUTHORISED DEALER IN THE NORTH-EAST FOR

## ICOM & YAESU

WE ALSO STOCK MANY OTHER ITEMS OF EQUIPMENT FROM  
MFJ ★ BUTTERNUT ★ CUSHCRAFT TONNA ★ DIAMOND ★ AOR  
BEARCAT ★ FAIRMATE ★ JUPITER ★ LOWE ★ TEAM  
MIDLAND ★ NEVADA ★ CTE ★ WELZ  
★ REVEX ★ BOOKS & MAPS ★



LICENSED CREDIT BROKER



OPEN 10am - 5.45pm TUES - FRI 10am - 4.45pm SAT

### THE UK SCANNING DIRECTORY

"OVER 5,000  
SPOT FREQUENCIES"

### THE UK SCANNING DIRECTORY

Here is the book that every scanner owner has been waiting for! It fills in the parts that other books leave blank. Lists over 5000 spot UK frequencies nationwide from 30MHz to 1GHz, gives the band plan, covers public utilities, security, telephone, military and lots more.

Price **£14.95** incl. UK postage.  
Overseas post add £2 for ECC and seairmail or £5 airmail.

### AUDIO GUIDE TO THE SOUNDS OF SHORTWAVE

This tape contains over 30 of the most commonly heard transmission sounds on the shortwave bands. They include RTTY, CW, SITOR FAX, encryption systems, etc., which will help the listener to identify the various transmissions. It is indispensable for new shortwave listeners and will serve as a reference guide to the older ones.

Price **£8.25** incl. UK postage. Overseas post add £1 airmail worldwide.

## INTERPRODUCTS

**S52, 8 Abbot Street, Perth PH2 0EB, Scotland**  
Tel & Fax: **0738-441199**



**NEW**

## SCANNER OWNERS

Listen in when you are 'out' with the amazing AUTO-VOX

Connect to any receiver with a squelch control and the AUTO-VOX will automatically switch your tape recorder on and off as signals are detected. A MUST for all scanner owners.

*Return to a neatly compressed tape of all the action*

The AUTO-VOX may be fitted directly into larger scanners or recorders, taking its power from the rig itself, or housed separately in the free project box supplied. Supplied as a kit with all parts and instructions or ready built and tested.

**KIT £12.50 AUTO-VOX BUILT £25.00**

**Turbo-Charge your scanner with a little help from RADIO RESEARCH**

**AR 1000/2000 - FAIRMATE HP100/200** - Full coverage modification. 0.5-1300MHz.

Upgrades your rig with NO GAPS - Why pay more? .....**£5.00**

**Customising Packs for REALISTIC PRO-2004, 2005, 2006 & 2022.**

Full of useful mods for your set. (State pack required) .....**£5.00**

**S-Meter Driver for REALISTIC PRO-2004, 2005, 2006** .....**£17.50**

**400 Channel Upgrade for REALISTIC PRO-2004 with Super-Scan rate** .....**£5.00**

*Send a SAE for full details and prices of all our scanner upgrades*

**RADIO RESEARCH (SWM) 3 Pasture Close, Whitmore, Staffs. ST5 5DQ**

## IBM PC SOFTWARE

RTTY, AMTOR, CW (Tx and Rx) **BY G4BMK**

SSTV, FAX, Audio Analyser (RX only). See review PW June 1990 Page 66. A high performance multimode program for IBM PC compatibles, £80 complete. Any mix of modes to your choice - send SAE for details and prices.

### ATARI ST

RTTY, AMTOR, CW and Analyser for Atari ST/STE works with hi-res or medium res display, £49. Printed manual £5. Use with ST5 Versaterm etc, or our matching built T.U. \$56.

State callsign, if any, and disk size with order. Add £1 P&P.

## GROSVENOR SOFTWARE (SWM)

**2 Beacon Close, SEAFORD, East Sussex,  
BN25 2JZ. Tel: (0323) 893378**



### Computer control of Your Radio with SCANCAT

- \* One program controls all radios
- \* Unlimited frequency disk files
- \* Create your own presets
- \* Scan between any frequencies in any increment
- \* Create databases of popular frequencies
- \* Load Memories
- \* Kenwood R-5000 and others
- \* Yaesu FRC-9600 and others
- \* JRC NRD-525
- \* AOR-3000 with Spectrum Analysis
- \* Icom's R-71, R-72, R-7000 (most others)

Requires PC compatible with 1 serial port - Interface for Radio.

Once you use SCANCAT with your radio you will never use your radio again without SCANCAT!

**J & J Enterprises - 4001 Parkway Dr. Bossier City, LA, USA 71112**

PH. 318-631-3081 (1400-2100 GMT) or FAX 318-631-3082

**\$49.95**  
plus \$5.00 post  
FREE INFO  
DEMO \$5.00 plus  
\$2.50 post  
Visa - Mastercard -  
AmEx or Money Order

### YORKSHIRE

### KENWOOD

**Alan Hooker Radio Communications YAESU**

42 Netherhall Road, Doncaster.

Tel: (0302) 325690 Open: Mon-Sat 10-5pm

Closed Thursdays.

### ICOM

& most  
Scanners

## Index to Advertisers

Aerial Techniques .....	52	Dressler .....	78	Nevada .....	16, 17, cover ii
Air Supply .....	73	ERA .....	24	OBA Electronics (Sony Centre) .....	38
Alan Hooker .....	73, 76	F G Rylands .....	70	Photo Acoustics .....	46
Alyntronic .....	76	Flight Deck .....	78	Practical Wireless .....	37
Amateur Radio Communications .....	52	G4TNY Amateur Radio .....	70	R & D Electronics .....	70
Amdat .....	57	Garex Electronics .....	37	Radio Research .....	76
AOR (UK) Limited .....	45	Grosvenor Software .....	76	Radio Shack .....	62
ARE Communications .....	79	Hoka Electronics .....	72	Rapid Results College .....	70
ASK Electronics .....	26	Icom .....	23, cover iii	Short Wave Centre, The .....	57
Aviation Hobby Centre .....	37	ICS Electronics .....	61	Sigma Euro Comm .....	78
Axdon Books .....	38	Interproducts .....	76	Sky View .....	24
Billington Export .....	73	J & J Enterprises .....	76	SMC .....	13
Bredhurst Electronics .....	68	J & P Electronics .....	72	Solid State Electronics .....	29
Chevet Books .....	72	Javiation .....	79	SRP Trading .....	71
Cirkit .....	61	Klingenfuss .....	24	Technical Software .....	72
CM Howes .....	68	KW Communications .....	14	Timestep .....	62
CM Leisure .....	78	Lake Electronics .....	52	WACRAL .....	38
Colomor (Electronics) .....	78	Link Electronics .....	29	Waters and Stanton .....	32, 33
Comar Electronics .....	73	Lowe Electronics .....	8, 9, 69, cover iv	Word (UK) .....	38
Datong .....	70	Martin Lynch .....	51, 29		
Dewsbury Electronics .....	20, 21	Modulations Comms .....	73		

PUBLISHED on the fourth Thursday of each month by PW Publishing Ltd., Enefco House, The Quay, Poole, Dorset BH15 1PP. Printed in England by Southernprint (Web Offset), Factory Road, Upton Industrial Estate, Poole, Dorset BH16 5SN. Tel: (0202) 622226. Distributed by Seymour, Windsor House, 1270 London Road, Norbury, London SW16 4DH. Tel: 061-679 1899, Fax: 061-679 8907, Telex: 881245. Sole Agents for Australia and New Zealand - Gordon and Gotch (Asia) Ltd.; South Africa - Central News Agency Ltd. Subscriptions INLAND £21, EUROPE £23, OVERSEAS (by ASP) £25, payable to SHORT WAVE MAGAZINE, Subscription Department, PW Publishing Ltd., Enefco House, The Quay, Poole, Dorset BH15 1PP. SHORT WAVE MAGAZINE is sold subject to the following conditions, namely that it shall not without the written consent of the publishers first having been given, be lent, re-sold, hired out or otherwise disposed of by way of trade at more than the recommended selling price shown on the cover and that it shall not be lent, re-sold, hired out or otherwise disposed of in a mutilated condition or in any unauthorised cover by way of Trade, or affixed to or as part of any publication or advertising, literary or pictorial matter whatsoever.

# trading post

Fill in the order form on page 72 in **BLOCK CAPITALS** - up to a maximum of 30 words plus 12 words for your address - and send it, together with your payment of £2.35, to Trading Post, *Short Wave Magazine*, Enefco House, The Quay, Poole, Dorset BH15 1PP. If you do not wish to cut your copy of *SWM*, or do not wish to use the order form provided, you must still send the corner flash or your subscription number as proof of purchase of the magazine. Advertisements from traders, apparent traders or for equipment which it is illegal to possess, use or which cannot be licensed in the UK will not be accepted.

**FOR SALE** video transfer, 8mm films, slides, photos, titles plus sound track onto VHS. Send s.a.e. for details or Tel: (0670) 481076. Sw-n-y-Nant, Drefach, Llambthor, Dyfed SA40 9YB.

**FOR SALE** Superstar 360 multi-mode with Zetagi 100W mains linear, good working order, other bits, £150. WANTED C64 disk drive. Tel: (0428) 683189.

**FOR SALE** NRD-525 receiver, boxed, with manual, £600. Datong FLZ filter, also boxed, £60. John. Tel: (0661) 852501 Northumberland.

**WANTED** working British Mk123 TX RX with accessories. Tel: (0366) 500867 evenings, Norfolk.

**FOR SALE** Shack clearance. World Radios: Sony CRF330K, £495. Zenith, £80. Normandee like Sony ICF-7600DS, £60. Alba 9 waveband portable pocket type, £10. All in mint condition. Tel: (0462) 441867.

**FOR SALE** AOR1000, 12 months old, hand-held scanner complete with discrete antenna and books, mint and boxed. New satellite forces sale, £195. Tel: (0633) 893769 Gwent.

**FOR SALE** Racal RA17 with manual, £50, buyer collects. Datong ASP automatic r.f. speech processor including external supply, £40. Tel: 051-260 8893 evenings.

**FOR SALE** PK-232 MBX multi-mode terminal unit with E-mail, Morse, RTTY, packet, AMTOR, FAX, Navtex, mail boxes, latest PC-Packratt 2, unused due to business, boxed in mint condition, £250. Ken Watmough G3WXB. Tel: (0323) 20059 Eastbourne.

**FOR SALE** Sony 7600DS receiver 153kHz-29.995MHz

(s.s.b./a.m.) plus 76-108MHz (f.m.), scanning memories, etc., £100. Aiwa HS-J40 recording personal stereo; Dolby play-back, auto-reverse digital tuner, etc., 4 months old, £80. Tel: (0273) 503958 Brighton.

**WANTED** Realistic PRO2001, PRO21 and Regency Touch K500 or other Regency Touch with u.h.f. Letters only please. J. Bidgood, 27 Ashdown Close, Hittingbury, Eastleigh, Hants SO5 1QF.

**FOR SALE** Icom ICR1 boxed, extras include mains p.s.u., charger, cigar lighter attachment, battery pack, battery case, plus Raycom modification, £325. Tel: (0425) 470767 Ringwood.

**WANTED** Service manual with circuit and parts list for Telequipment oscilloscope 720. Beg, borrow for copying against deposit, or buy. All expenses paid. R.F.C. Owen. Tel: (0293) 520172 ext 242 office hours only, Crawley.

**FOR SALE** AEA Pakratt PK232MBX multi-mode terminal unit, c/w manual and all documentation, driver programs for either BBC or IBM PC included, £250 post paid. G3RDG QTHR. Tel: 081-455 8831.

**FOR SALE** mostly WWII collectable items, HROMX, HR0ST, R109, WS38 complete, WS19 MkII, 'D' w/ meter, 10 calibrator, TCS12 TX/RX complete, R1155, radar items, marine RX 60kHz/30MHz (boxed), etc. Cain G3DVF. 18 Oaky Balks, Alnwick, Northumberland NE66 2QE. Tel: (0665) 602487.

**FOR SALE** Bearcat DX-1000HF receiver 10kHz-30MHz u.s.b./l.s.b., c.w., a.m., f.m., digital display, 10 memories, manual separate, switchable i.f.s., first-class performer. Will deliver reasonable distance. £250 o.n.o. Tel: (0695) 22573 after 6pm.

**FOR SALE** Racal RA17L very good condition, £150 o.n.o. Can deliver to 30 miles. Norman. Tel: 081-319 3157.

**FOR SALE** Maplin XG93B audio generator, under half price, £42. Advance E2 r.f. generator 100kHz-100MHz, £24. Marconi r.f. voltmeter, £14. Other test gear, early valve books and manuals, part exchange considered. Meek. 32 Stopples Lane, Hordle, Lymington, Hants SO41 0JA. Tel: (0425) 610669.

**FOR SALE** Yaesu FRG-8800, FRV-8800 converter, FRA-7700 active antenna built-in amplifier, boxed, £450. Last and best Grundig 3400PRO mint condition, £230. Satellite 600PRO like new, 60 memories, pre-selector, £200. Eddystone 940 excellent condition, overhaul, £150. Phillips D2999 world band, almost new, excellent performance, boxed, £150. Tel: 081-571 5759 London.

**FOR SALE** Tektronix GR and HP test equipment, send for sales list. A-Comm Electronics. 7198 South Quince Street, Englewood, Colorado 80112, USA.

**FOR SALE** Bearcat 50XL scanner (pristine condition) spare 144MHz whip, charger, 8 cadmium cells, carrying case, instructions, boxed, £50. Tel: 091-526 7902 Tyne & Wear.

**FOR SALE** Yaesu FRG-8800 fitted with FRV-8800 v.h.f. unit, f.m. wide unit, FRT-7700 a.t.u., FRA-7700 active antenna, LF5 low pass filter, Datong ANF auto notch filter and Datong FL2 audio filter. All manuals included, service manual, boxes, etc., £700 complete. Tel: (0403) 731113 Horsham West Sussex.

**FOR SALE** Kenwood VC10 converter, mint condition, £75. Tel: (0480) 453228.

**FOR SALE** Midland 77-805 UK CB including NiCads, £50. Skyscan desk top 1300 antenna 25-1300MHz, £35. Comprehensive RAE correspondence and revision material, £28. Items boxed, as new, (o.n.o. considered). Tel: (0392) 73714 after 6pm, Exeter, Devon.

**FOR SALE** Yaesu FRG-9600 60-950MHz plus SEM h.f. converter, £400. Also Sony ICF PR080 receiver, 150kHz-223MHz, £190. Psion organiser model CM, £45. All mint condition and with manuals. Tel: (0382) 641743 Dundee.

**WANTED** Yaesu FR400DX radio, retired, reasonable price appreciated. E. Rowe. Tel: 051-648 3031.

**FOR SALE** Panasonic radio cassette recorder, v.g.c., excellent performer, twin speakers, analogue tuning, 9V. f.m., l.w., m.w., s.w., RX4922L, £60. M. Allen, 636 Wordsworth Ave, Parson Cross, Sheffield S5, South Yorks S59JH.

**WANTED** Yaesu FRG-7000 general coverage communications receiver, 250kHz-30.075MHz, all modes in good working order, reasonable price. E.J. Mayes, 3 Radford Street, Manton, Worksop, Notts S80 2NH.

**WANTED** manual (or copy) for National HRO 'Sixty' receiver to buy or borrow. Michael Ryan, 91 Ard-Na-Greeine, Clonmel, Co Tipperary, Eire. Tel: 052-24356 anytime.

**FOR SALE** AR900UK hand-held scanner with airband 108-136, 137-174, 220-280, 300-380, 406-470, 830-950MHz, memory, 100 channels, has squelch, ear-

**More Trading Post on Page 80**

## SWM SUBSCRIBERS' CLUB

*If you have a subscription then you will know all about the Short Wave Magazine Subscribers' Club. If you don't then read on. Membership is free and automatic for all subscribers to this magazine and is our way of saying thank you to all those who have had faith to pay for it 'up front'. Each month there are Special Offers and occasional competitions with some really useful prizes to be won.*

**This month we are offering SWM Subscribers' Club Members a copy of the Short Wave Magazine Radio Information Cassette - 1.**

*The SWM Radio Information Cassette - 1 was produced to enable listeners to identify the various strange sounds that can be heard on short wave and v.h.f. and u.h.f. radio. Side A has tracks with amateur space and satellite working, 50MHz, the more esoteric 144MHz modes such as meteor burst, aurora, sporadic E & moonbounce. Side B has samples of the different data modes - Morse, Baudot, RTTY, AMTOR, FAX and packet.*

**As a member of the SWM Subscribers' Club you can buy your copy of the SWM Radio Information Cassette for just £3.00 inc. P & P.**

**This offer closes on 31 May 1992.**

**Be sure of your copy every month and qualify for the Subscribers' Club as well. Special offers and discounts normally available to all members, including those abroad.**

Please indicate the type of subscription required:

**SHORT WAVE MAGAZINE 1 YEAR**

- £21.00 (UK)
- £23.00 (Europe)
- £25.00 (Rest of World)

**PRACTICAL WIRELESS 1YEAR**

- £19.00 (UK)
- £21.00 (Europe)
- £22.00 (Rest of World)

**SPECIAL JOINT SUBSCRIPTION 1 YEAR ONLY**

- £34.00 (UK)
- £37.00 (Europe)
- £39.00 (Rest of World)

Prices current at April 1992

Subscription to commence with issue dated.....

**Please send me a copy of the Short Wave Magazine Radio Information Cassette - 1 at the special SWM Subscribers' Club price of £3.00 inc. P & P.**

**To: PW Publishing Ltd., FREEPOST, Subscriptions Dept., Enefco House, The Quay, Poole, Dorset BH15 1PP**

Name.....

Address.....

.....

I enclose cheque/PO (Payable to PW Publishing Ltd) £.....

Charge to my Access/Visa Card the amount of £.....

Card No.

Valid from ..... to .....

Signature.....

**Credit Card Orders can be taken on (0202) 665524.**

If you do not want to deface your *SWM* a photocopy of this coupon will be accepted.

# dressler

## COMMUNICATIONS LIMITED

191 Francis Road, Leyton, LONDON E10 6NQ

Tel: 081-558 0854/558 1415

Fax: 081-558 1298

Telex: 8953809

24 hour hotline ansaphone

Open: Monday-Friday 9.00am - 5.30pm

Saturday 9.30am - 4.30pm

**ICR1**  
£325



**ICR72**  
+ARA60  
£699



**ICR71**  
+ARA60  
£875



**ICR7000**  
Few only  
£1000  
inc ARA1500



**ICR7100 inc HF or ARA1500 £1120**

### PRE-OWNED UNITS

FRG9600 x 2 .....each £375  
ICR7000HF .....£750  
ICR71 .....£675  
LOWE 225 + accessories .....£425  
FRG7700 .....£295  
AOR2001 .....£199  
MX8000 .....£275

### YAESU

FRG8800 HF receiver .....£585



FRG9600 50-950MHz .....£499

### ALINCO

DJX-1 .....£259

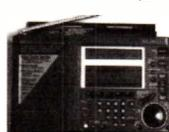

### SONY

SW77 only

**£349**

### YAESU

ICOM

### KENWOOD

STANDARD

### KENWOOD

R5000inc ARA60 .....£925  
R2000.....£ PHONE  
LOWE 225 .....£429  
LOWE 150 .....£329



### JRC

NRD535D+ECSS+BWC+1kHz  
filter inc. ARA60 .....£1699  
NRD535 only .....£975  
NRD535 inc ARA60 .....£1095



### AOR

**PHONE FOR SPECIAL PACKAGE DEALS**

### YUPITERU

MVT7000.....£279

## DRESSLER ACTIVE ANTENNAS

**ARA60 ACTIVE ANTENNA**  
50kHz - 60MHz with limited performance up to 100MHz

**ARA1500 50MHz -1500MHz**  
Frequency Gain  
50-1000 11.5dB  
100 - 1500 11.0dB  
**£163.00 - 'N' connection**

## SHORTWAVE ACTIVE ANTENNA

940mm High 64mm diameter complete with cable + PSU and interface **£163**

Now fully tuneable interface. Intercept point + 21dBm typical.

## SHINWA SR001

Remote control full feature receiver. Still only

**£299!**

Phone for latest prices and offers



Prices correct at time of going to press. Please phone for latest quote. Or contact your local agent any time on the following numbers: Terry (Biggleswade, Beds.) 0767 316 431. Stuart (Bromley, Kent) 081-313 9186.

## SIGMA EURO-COMM

Importers of Communication Equipment  
Manufacturers of Antennas & Accessories  
AMATEUR - SCANNERS - ANTENNAS - CB



### AOR2000

500kHz-1300MHz  
£249

• Free SE700 Discone •

also available

AOR3000A -  
AOR2800 - AOR2500  
'PHONE FOR A GREAT DEAL!'

Now available

### YUPITERU MVT7000

Hand held  
1MHz-1300MHz  
FM/AM/WBFM  
£269 with FREE SE700



FREE with all Scanners sold via Mail Order - DISCONE ANTENNA



### SIGMA SE1300

20-1300 MHz Receive  
Transmit 50, 144, 430,  
900, 1200 MHz input  
power rating: 200 watts  
input impedance: 50 ohms.  
£49.00 + p&p



### SIGMA SE700

70-700 MHz Receive  
Transmit 70-500 MHz  
Max power on transmit  
500 watts impedance  
50 ohms.  
£22.00 + p&p

Mail Order: Cheques and P.O. made payable to Sigma Euro-Comm.

TRADE ENQUIRIES WELCOME

After 6pm and Weekends 021 705 3441 and 0922 414836

Sigma Euro-Comm, Unit 14, 272 Montgomery St., Birmingham Enterprise Units, Sparkbrook, Birmingham B11 1DS. Tele/Fax: 021 766 8146



## FLIGHTDECK THE AIRBAND SHOP

192 Wilmslow Rd., Heald Green, Cheadle, Cheshire SK8 3BH  
Telephone: 061-499 9350 Fax: 061-499 9349

## ALL THE ENTHUSIAST NEEDS

Main Stockists of receivers by:

SONY, ICOM, LOWE, KENWOOD AOR, YUPITERU, UNIDEN, SIGNAL, WIN, FAIRMATE.

Comprehensive range of accessories, aerials, books, aero-charts etc.

PX welcome, finance available (subject to status).

Open: Monday to Saturday 9.30 a.m. - 5.30 p.m.

We are located on the A34 (Wilmslow Road), 2 miles South from the M63 Junction 10, just 3 miles from Manchester International Airport

Send 50p for illustrated catalogue from dept. SWM4

## ANORAK MONTHLY

Is a new monthly publication featuring news of Radio Caroline, Satellite Radio, Local Radio, Short Wave, International Radio and more.

For the latest issue send 50p plus a SAE (or £1.00 plus two SAE's for two issues) to

CM LEISURE SALES, DEPT. SW, P.O. BOX 46, ROMFORD RM11 2QE

(our preferred method of payment is a coin taped to a piece of card, stamps or blank postal orders).

## ELECTRONICS VALVES & TRANSISTORS

Phone for a most courteous quotation  
**081-743 0899**

We are one of the largest stockists of valves etc. in the U.K.

COLOMOR (ELECTRONICS) LTD.

170 GOLDHAWK ROAD  
LONDON W12 8HJ

# JAVIATION

THE VHF/UHF AIRBAND SPECIALISTS

## AT LAST

Our new combined VHF/UHF frequency listing running to over 100 pages is now available. The new publication is in the same format as our previous individual lists and is updated with the same regularity. Not only have we *joined* both lists together but added some extra information as well.

Compiled by enthusiasts for enthusiasts (sorry about the cliché!) – The best available or so we would like to think.

VHF/UHF Frequency Listing:



**£6.50**  
+ £1p&p

## AR-2000

In stock, £269.00 supplied with FREE leather carry case worth £14.99

## MVT-7000

Excellent performance, easy to use, supplied with all accessories – £289.00

## ICOM IC-R1

The smallest hand-held available. Special offer until end of March – £330.00

## AOR AR-2500

We have a small number of units available at a special price of £399.00 including IBM PC software

Carlton Works, Carlton Street, BRADFORD, West Yorkshire, BD7 1DA  
Telephone: 0274-732146 Facsimile: 0274-722627

# ARE

COMMUNICATIONS '92  
"The shop with the smile"

6 Royal Parade Hanger Lane, Ealing London W5A 1ET  
Tel: 081-997 4476 Fax: 081-991 2585

OPEN MONDAY-FRIDAY 9.30-5.30 SATURDAY 9.30-3pm EASY PARKING AT THE REAR OF THE SHOP

**NOW REVITALISED!**

ARE are pleased to announce that we have re-opened under new management and with what is the widest range of equipment ever offered from a single store in London. Not only do we offer our very popular Icom modifications but we also keep an extensive range of other receivers available, plus a good range of secondhand equipment with realistic prices.

REMEMBER, we are only a phone call away for good, honest, friendly advice, a brochure you may need or just a chat. Give us a call now or pop in and see us and you'll see why.

73's – Alan and Jez.

Authorised agents for:

AOR SONY YAESU JRC DRAKE ALINCO LOWE ICOM YUPITERU KENWOOD

### ICR100-SSB



Wideband base/mobile receiver with SSB. 100kHz–1856MHz

– IN STOCK –

SSB kits also available separately

### ICR7100-HF



Icom's base receiver with continuous coverage. 200kHz–2000MHz.

Phone now for details

HF kits also available separately for ICR7100 and ICR7000

### ICR1-SSB



The smallest pocket scanner available with SSB.

100kHz–1300MHz or convert your existing ICR1

PHONE NOW

ASK FOR DETAILS

Part exchange and equipment purchases welcomed! Credit facilities available subject to status. APR from 37.8%. Located next to Hanger Lane Tube Station (Central Line) and on the junction of the A406 & A40. DON'T DELAY PHONE TODAY on 081-997-4476



# PORTABLE PERFECTION



## IC-R100 Mobile/Base Receiver. ▲

On the road or at home the IC-R100 is the ideal solution to receiving stations in the 500kHz - 1800MHz frequency range.

For listening convenience a 24-hour system clock with timer functions, 100 memory channels, direct keypad entry and handy scan functions are featured.

- AM, FM and FM-wide modes.
- 10 programmed scan ranges.
- Priority scan.
- Memory scan.
- Auto memory write scan.
- AFC function.
- Variety of tuning steps.
- Built-in preamp and attenuator.
- 150(W)x50(H)x181(D)mm.

## IC-R1 Handheld Receiver. ▲

Tune into the world around you on the IC-R1, one of the smallest receivers ever made. With continuous coverage from 2MHz - 1300MHz, AM, FM and FM-wide reception right into the palm of your hand.

- Ultra compact size.
- 100 memory channels.
- Direct keyboard entry.
- 10 programmed scan ranges.
- Auto power saver.
- 24-hour system clock with timer functions.
- Advanced scan functions.
- Built-in S-meter.
- Built-in nicad batteries.
- 49(W)x102(H)x 35(D)mm.

Shown here are the two smallest receivers in the ICOM range, designed to complement the larger base stations. Whatever your requirement the answer is ICOM, so good to receive.

For further information about ICOM products and the location of your nearest authorised dealer please contact:  
Icom (UK) Ltd. Dept SW Sea Street Herne Bay Kent CT6 8LD  
Telephone: 0227 741741 (24hr). Fax: 0227 741742.



# ICOM

# KENWOOD



## IN COMMAND

### Kenwood's New FM Dual Bander Sets the Pace

One glance at ergonomic design of Kenwood's TH-78E is enough to tell you that this is far from an ordinary handheld transceiver. You're looking at the smallest dual bander in the world, packed with the finest communications technology: built-in DTSS and paging functions, alphanumeric memory and message paging, dual-frequency receive (including VHF+VHF & UHF+UHF) and double-band scan. Plus much more. Compact and confident, the TH-78E is truly going places.

■ Built-in DTSS & paging functions ■ Alphanumeric memory function (max. 6 characters) ■ Alphanumeric message paging (max. 6 characters) ■ Dual-frequency receive ■ Dual encoder ■ Full-duplex cross-band operation ■ ABC (automatic band change) ■ Double-band scan ■ 50 non-volatile memory channels expandable to 250 channels with optional memory module ME-1 ■ 4-position output power control (High/Mid/Low/Economy low) ■ CTCSS operation with TSU-7 tone decoder (opt.) ■ Sliding keypad cover ■ Auto power-off ■ Auto battery saver ■ 10-minute transmission time-out timer (TOT) ■ 2m automatic repeater offset

### FM DUAL BANDER TH-78E

Distributed in the UK  
by

## LOWE ELECTRONICS LIMITED

Chesterfield Road, Matlock, Derbyshire DE4 5LE  
Tel: 0629 580800 Fax: 0629 580020

