

The
SHORT WAVE
Magazine

2/-

VOL. XII

APRIL, 1954

NUMBER 2

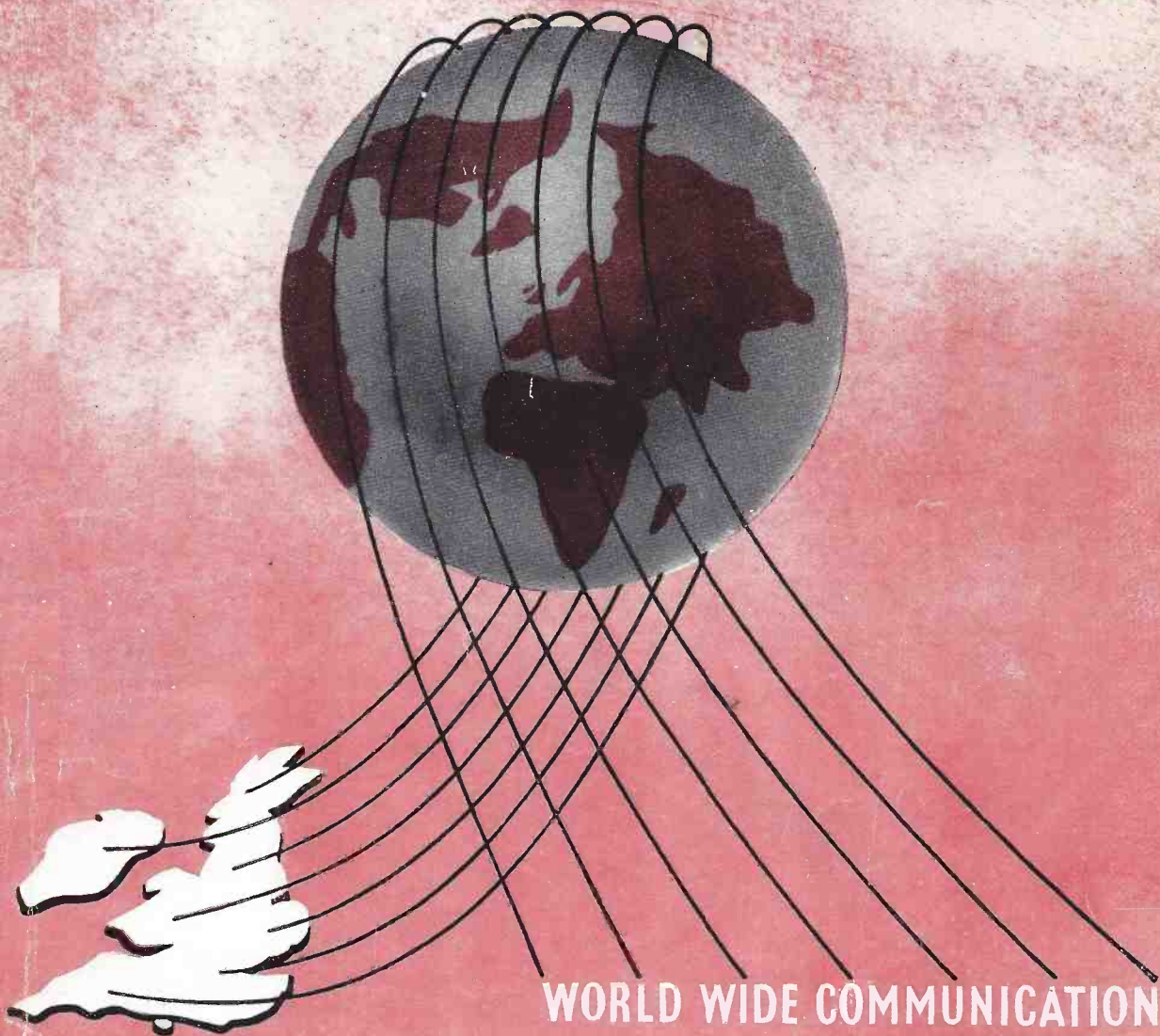

WORLD WIDE COMMUNICATION

H. WHITAKER G3SJ**10 YORKSHIRE STREET, BURNLEY Phone 4924***We are pleased to announce***A COMPLETE NEW RANGE OF CRYSTALS MADE TO EXCEPTIONALLY FINE TOLERANCES IN A WIDE VARIETY OF BASES**

We will be pleased to quote for early delivery of all types of cuts, to your own specified temperature co-efficients. In addition a new range of gold-plated crystals are also available with fundamental frequencies up to 21,400 kc/s in AT and BT cuts with zero temperature co-efficients. All are precision machine lapped, and acid etched to final frequency. Artificial ageing ensures stability of frequency, and activity is such that the EPR is as good or better than Services specification for the frequency.

CRYSTALS : 1,000 kc/s Bliley, Valpey or Somerset, standard $\frac{3}{8}$ in. pin spacing, **20/-** ; 1,000 kc/s octal based for BC221, **30/-** ; Top band to your own specified frequency, $\frac{3}{8}$ in. British or $\frac{3}{8}$ in. U.S.A. fitting, **20/-** ; Top band U.S.A., 3-pin (Collins), **22/6** ; Top band, your old crystals reground and etched to the new allocation, 1,800/2,000 kc/s at approximately **7/6** per crystal ; New frequency allocation for light craft and coastal services, all frequencies available, 2,104/2,527 kc/s, including distress frequencies, 2,182 kc/s $\frac{3}{8}$ in. British, **20/-** ; ditto 3-pin, U.S.A., **22/6** also available in FT243 $\frac{1}{2}$ in. pin spacing to special order only at **17/6**.

AMATEUR BANDS : 3.5 Mc/s to 8,100 kc/s inclusive, FT243 $\frac{1}{2}$ in. or $\frac{3}{8}$ in. British, **15/-** each, plus

or minus 1 kc/s of your own specified frequency ; for spot frequencies add **2/6** ; also available, octal based at **22/6** to special order only ; 8,100 kc/s to 10,000 kc/s, including 9 Mc/s model control band, $\frac{1}{2}$ in. or $\frac{3}{8}$ in. pin spacing, **17/6** ; I.F. ranges, Weston FT241 $\frac{1}{2}$ in. pin spacing, 450, 465 kc/s, etc. Full range available at **12/6**. Enquiries invited for s.s.b. construction based on all i.f. ranges. We undertake the calibration and certifying of any crystal at nominal charges. Regrinding service. Your own crystal to your own specified frequencies depending on shift, approximately **7/6**. All normal orders are usually despatched within 48 hours of receipt. Regrind service is approximately 7 days. In addition we can supply practically all spare parts for almost any make of crystal ; Contact Plates, Lands, Springs, etc.

This month's bargains

Morsekey : Air Ministry type D. Ref. No. 10A/773. The Elite of Services keys. A really fine instrument capable of exceptionally high speeds. Completely enclosed in bakelite case size 7" x 3 $\frac{1}{2}$ " x 2 $\frac{1}{2}$ ". Iridium silver contacts, cushioned, given away at **8/6** each, post free.

VALVEHOLDERS : 807 ceramic to clear **9/-** per dozen. 1625 type (7-pin American) ceramic **10/-** per doz. All brand new boxed.

STATION LOG BOOKS : 300 pages on quality cream laid paper, stout heavy cover, sample leaves on request. Post free **18/-**.

CONNOISSEUR : Standard light weight pick ups. Complete with input transformer. Brand new and boxed. List price **£4/10/5**, inc. tax. Post Free **£1/6/10**. Available in quantity for export, less tax.



An inexpensive yet precision instrument designed especially to meet the exacting needs of the modern service engineer and laboratory technician. With six frequency ranges covering 50 Kc/s to 80 Mc/s, its accuracy is better than $\pm 1\%$ of the scale reading.

50 Kc/s—150 Kc/s	1.5 Mc/s—5.5 Mc/s
150 Kc/s—500 Kc/s	5.5 Mc/s—20 Mc/s
500 Kc/s—1.5 Mc/s	20 Mc/s—80 Mc/s

Scale sub-divisions provide more than adequate discrimination for use in television circuits. Note the starred features below, which combine to maintain a minimum signal of less than $1\mu\text{V}$ up to 20 Mc/s and less than $3\mu\text{V}$ between 20 Mc/s and 80 Mc/s.

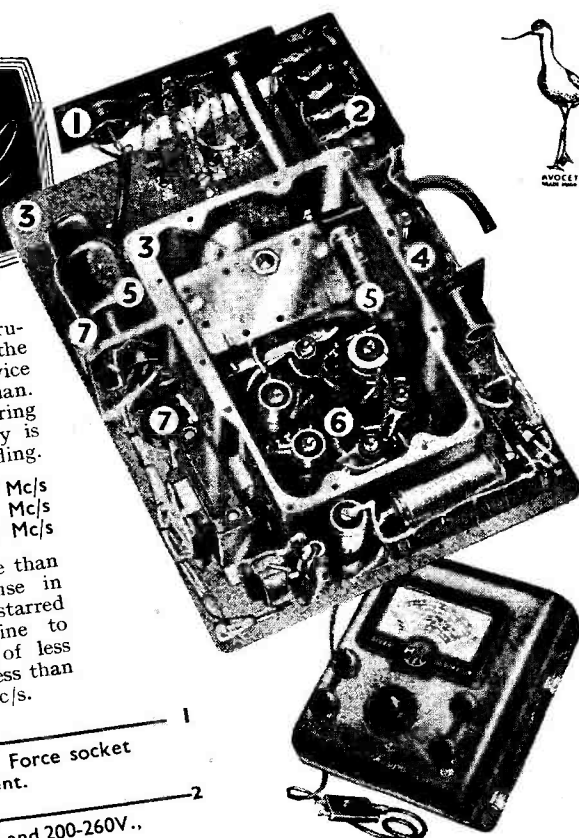

★ **OUTPUT** ————— 1
Coaxial socket for attenuated output. Force socket located totally within H.F. compartment.

★ **MAINS TRANSFORMER** ————— 2
Marked tagboard for inputs of 100-130V. and 200-260V., A.C. 50/60 c/s.

★ **CAST ALUMINIUM H.F. COMPARTMENT & CHASSIS** ————— 3
Large number of fixing holes for H.F. compartment cover ensures excellent electrical bonding and good screening.

★ **FUSE** ————— 4
Easily accessible when replacement is necessary.

★ **VALVES** ————— 5
Standard types run at a rating to ensure long life.

★ **TURRET COIL SWITCHING** ————— 6
Standard "AVO" practice.

★ **ATTENUATOR SYSTEM** ————— 7
Employs close tolerance, high stability midget carbon resistors, low reactance rotary potentiometer modified for H.F. operation with carefully designed screening.

Other features include:—

★ **ILLUMINATED SPOT RANGE SELECTOR**
Gives rapid identification of operational band with intensified lighting round precise frequency. Fine hair line gives close discrimination, particularly on high frequencies.

★ **STOPS**
Separate stops prevent turning of dial with respect to condenser.

★ **MAINS FILTER SYSTEM**
This is screened from main electrical assembly.

★ **BUSHING PLATES**
Provide additional rigidity for rotary controls.

★ **SLOW MOTION DRIVE**
Substantially free from backlash.

MAINS MODEL 100-130V. and 200-260V. A.C. 50-60 c/s. ... £30
or BATTERY MODEL

Sole Proprietors and Manufacturers:—

THE AUTOMATIC COIL WINDER & ELECTRICAL EQUIPMENT CO., LTD.
WINDER HOUSE · DOUGLAS STREET · LONDON · S.W.1 · TELEPHONE VICTOR 4045

FREE

**POST THE COUPON TODAY FOR
OUR BROCHURE ON THE LATEST
METHODS OF HOME TRAINING
FOR OVER 150 CAREERS AND
HOBBIES**

NEW!
EXPERIMENTAL
OUTFITS NOW
AVAILABLE

**COURSES
FROM £1
PER MONTH**

EMI

INSTITUTES
*The only Postal College
which is part of a
world-wide Industrial
Organisation.*

P.M.G. Certificates, City and Guilds
Grouped Certificates in Telecommu-
nications; A.M.Brit.I.R.E. Exam-
ination, Radio Amateur's Licence,
Radio and Television Servicing
Certificates, General Radio and
Television Courses, Radar, Sound
Recording, etc. Also Courses in
all other branches of Engineering.

POST TODAY

Send without obligation your FREE
book, E.M.I. INSTITUTES, Dept. 14K,
43 Grove Park Road, W.4.

NAME

ADDRESS

ICI8

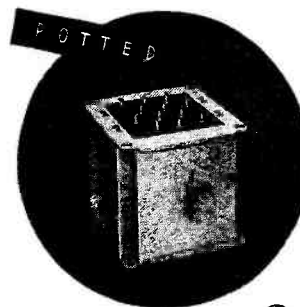

A wide range of capacities
and types for both trans-
formers and chokes. Absolute
reliability owing to vacuum
impregnation and special
compound filling. Suitable for
exacting industrial and clima-
tic conditions. Neat and clean
appearance in equipment.

TRANSFORMERS

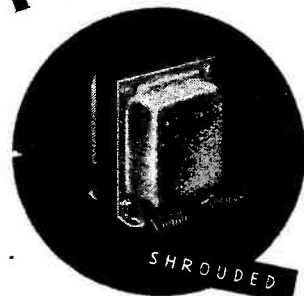

Woden shrouded
transformers have been developed
to give a competitive pro-
duct combined with a first-
class engineering job. Finest
quality materials used
throughout; vacuum drying
and vacuum/pressure im-
pregnation, rigidly tested.
A popular, highly competitive
line.

WODEN TRANSFORMER CO., LTD.
MOXLEY ROAD . BILSTON . STAFFS
Tel : BILSTON 41959

SM/W 2098



Still Available . . .

R.C.A. Transmitters ET.4336 and ET.4332

Complete with Speech Amplifiers MI 11220. Wilcox Gay V.F.O. and Crystal Multiplier
and all tubes.

Normal frequency coverage of the ET.4336 is 2-20 Mc/s. A special modified version
covering 900 Kcs.-2000 Kcs. is available.

HALLICRAFTER BC.610. Complete with Speech Amplifier, BC.614E, Aerial Tuning
Unit BC.939A, all Tuning Units, Tubes and Coils.

Large Stocks of spares available for RCA, BC.610 Transmitters.

Marine Ship to Shore Radio Telephone Equipment.

RECEIVERS AVAILABLE. RCA, AR88 LF and AR88 D, Hallicrafter SX.28, S.27 and National H.R.O.
Frequency Meter BC.221 Modulated and Unmodulated available from stock.

McELROY-ADAMS Manufacturing Group Ltd.

(Sole concessionaires U.K. for Hallicrafter Communication Equipment)

46 GREYHOUND ROAD, LONDON, W.6

Cables : Hallicraft, London.

Phone : Fulham 1138/9.

EDDYSTONE

MODEL '840'

AC/DC COMMUNICATIONS RECEIVER

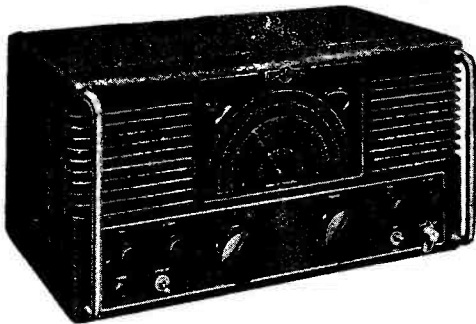

The New Model "840", illustrated above, possesses full Communication facilities and operates from either A.C. or D.C. mains 100/110 and 220/250 volts.

- Seven valve superheterodyne with R.F. stage.
- Frequency coverage 30 Mc/s. to 480 kc/s.
- Gear driven tuning with 140/1 reduction.
- Mechanical bandspread. Accurate re-setting.
- B.F.O. and noise limiter.
- Internal loud-speaker. Headphones jack.
- Robust diecast construction. Rustproofed steel case.
- Suitable for tropical service.
- Weight 30 lbs. Size 16½" × 10½" × 8½" high.

List Price (in U.K.) £45

Exempt from Purchase Tax

PLEASE WRITE FOR FULL SPECIFICATION TO THE MANUFACTURERS:

STRATTON & CO. LTD., EDDYSTONE WORKS, BIRMINGHAM, 31



Switch on to

Solons save time, reduce costs. Solon soldering is always clean, reliable and simple. Five models, in voltage range 100-250; each with 6 feet Henley flexible. 65 watt; oval tapered or round pencil bits. 125 watt; oval tapered or round pencil bits. 240 watt; oval tapered bit.



WRITE FOR FOLDER Y.10



W.T. HENLEY'S TELEGRAPH WORKS
 COMPANY LIMITED
 51-53 HATTON GARDEN, LONDON, E.C.1

DRIVE

Using a chain of 4 E.F.80 valves at only 220 volts H.T. the following grid currents into an 807 (15 K grid leak) can easily be obtained:—

3.5 Mc/s 3.0 mA. 14.0 Mc/s 4.0 mA.
 7.0 Mc/s 4.0 mA. 21.0 Mc/s 2.2 mA.
 28.0 Mc/s 3.5 mA.

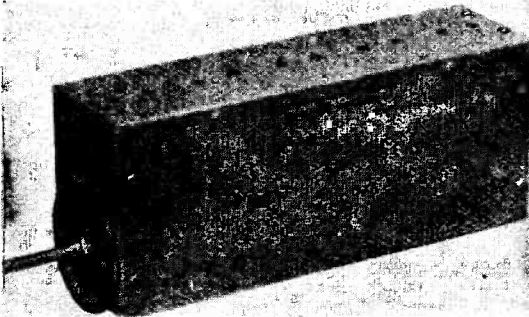

NOW AVAILABLE FOR IMMEDIATE DELIVERY

Any V.F.O. + the *Labgear* W/B Multiplier = 10, 15, 20, 40 & 80m. at the turn of a switch. Price £4 · 10 · 0 direct from:

Labgear (Cambridge) Ltd.

WILLOW PLACE, CAMBRIDGE.

Tel. 2494—2 lines.

NEW! EXPERIMENTAL OUTFITS

LEARN THE PRACTICAL WAY

Specially prepared sets of radio parts with which we teach you, in your own home, the working of fundamental electronic circuits and bring you easily to the point when you can construct and service radio sets. Whether you are a student for an examination; starting a new hobby; intent upon a career in industry; or running your own business—these Practical Courses are intended for YOU—and may be yours at very moderate cost.

EASY TERMS FROM £1 A MONTH

With these outfits, which you receive upon enrolment, you are instructed how to build Electronic Circuits (Amplifiers, Oscillators, Power Units, etc.) leading to complete Radio and Television Receiver Testing and Servicing.

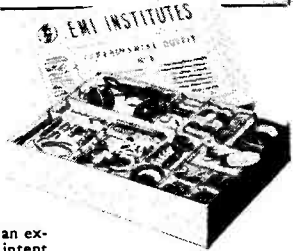

RADIO and Advanced TELEVISION

Other Courses with equipment include: MECHANICS, ELECTRICITY, CHEMISTRY, PHOTOGRAPHY, CARPENTRY. Also Draughtsmanship, Commercial Art, Amateur S.W. Radio, Languages, etc.

POST THIS COUPON TODAY

Please send me your FREE book on Practical Courses:
 To: E.M.I. INSTITUTES, Dept. 14X, 43 Grove Park Rd., Chiswick, London, W.4.

NAME.....
 ADDRESS.....

1C23

E.M.I. INSTITUTES

The only Postal College which is part of a world-wide industrial organisation.

WANTED—AT ONCE!! EQUIPMENT AS LISTED BELOW

SEND US DETAILS NOW

BRITISH TEST GEAR

Marconi, Muirhead, Salford, Sullivan, R.G.D., Furzehill, etc.
 Bridges, Audio Oscillators, Wattmeters, Signal Generators type, TF144G, TF390F, TF390G, 30, 31, 53, 54, 56, 57, 101, etc.

EQUIPMENT URGENTLY REQUIRED

Signal Generators type 101, 54 and 53.
 Sweep Generator type 709B by R.C.A.
 Receiver type R89/ARN.5.
 Receivers type AR.88D.
 Test Set type TS.67/ARN.5.
 Klystrons and valves type 723 A/B, CV. 52, RL.18 and 813.

U.S.A. TEST GEAR

General Radio, Measurements Corporation, Boonton, Dumont, R.C.A., Ferris, etc.
 Test Sets type TS3, TS12, TS13, TS33, TS35, TS56, TS69, TS148, TS174, TS175, TSX-4SE, BC221, 605B, etc.

WE CAN PAY MORE FOR YOUR EQUIPMENT

WE ARE NOT AGENTS

Send for list of our special requirements.

★ WE ALSO REQUIRE MANUALS FOR AMERICAN TEST EQUIPMENT. TELL US WHAT YOU HAVE.

ELM ELECTRIC CO.

175, UXBRIDGE ROAD, LONDON, W.7.

Telephone: EALing 0779 & 9857

BROOKES Crystals

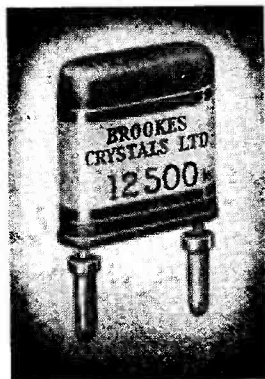

**mean
DEPENDABLE
frequency
control**

Illustrated left is a Type M Crystal Unit from a range covering 8 Mc/s to 17 Mc/s.

- Frequency 12,500 kc/s.
- Hermetically sealed metal can.
- Frequency tolerance $\pm 0.01\%$ of nominal at 20°C., or better for special applications.

ALL Brookes Crystals are made to exacting standards and close tolerances. They are available with a variety of bases and in a wide range of frequencies. There is a Brookes Crystal to suit your purpose—let us have your enquiry now.



Brookes Crystals Ltd.,

Suppliers to Ministry of Supply, Home Office, BBC, etc.

EARLSWOOD ST., GREENWICH, S.E.10

Telephone: GREENWICH 1828.

Grams: Xtals Green London. Cables: Xtals London

LYONS RADIO

LIMITED

3, Goldhawk Rd., Shepherds Bush, London W.12

Dept. MS.

Telephone: SHEPHERDS BUSH 1729

INDICATOR UNITS, TYPE 6. These units contain a cathode ray tube, type VCR97, 4-VR91's, 3-VR54's, high voltage condensers, resistors, pots, etc., etc. In good, used condition, with valves and C.R.T. tested to ensure in good order. PRICE 65/—, carriage 6/6. We can supply a manual "Radio Instruments and their Construction," which contains scope construction details using VCR97. PRICE 2/6, or separately 2/9.

A.C. METERS, M.I. Types. 0/30 Ammeters, flush panel mounting, 5 1/2 in. dia., PRICE 25/—, 0/15 Ammeters, panel mounting projection type, 4 in. dia., PRICE 25/—, Voltmeters. Calibrated 90-170v., flush panel mounting, 5 1/2 in. dia., PRICE 17/6.

EXTENSION SPEAKERS. Standard low impedance 6 1/2 in. moving coil speakers, fitted in attractive cabinet with polished walnut finish. Approx. size 9 x 8 1/2 x 4 in. Brand new condition. PRICE 35/—, Cabinet only 16/6.

TRANSFORMERS. Primary 230v. 50cps., A.C. mains. Secondary 40v. at 2A. Size approx. 6 x 5 x 5 in. PRICE 12/6, post 2/6.

METAL MINE DETECTOR UNITS. This detector gives warning of the presence of metal objects in water, timber or underground, etc., and there are probably many applications for which this equipment can be used in addition to its original one. Electricity, Water and Gas Co.'s Surveyors and Post Office Depts., are amongst those we have so far supplied. The equipment is complete in strong wood transit case, the principal items being an A.F. amplifier employing 3 valves, type ARP12(VP23) mounted, with battery space, in metal case 11 x 11 x 4 1/2 in., search coils, control box pole front and rear sections, high resistance headphones, etc. Power requirements are 60-90v. H.T. battery and 4-1.5v. cells (not included but can be supplied as an extra). Condition is as new and unused with instruction data included. PRICE £3/12/6, carriage 10/6.

2mf. HIGH VOLTAGE CONDENSERS. Working 5,000v. D.C. Test 10,000v. D.C. Overall size 14 x 9 x 6 in. Made by Duublier. PRICE 15/—, carriage 5/—.

BARGAINS BULLETIN of "Selected Surplus" now available. Please send stamps.

SKELETON SLOT FOR TWO METRES

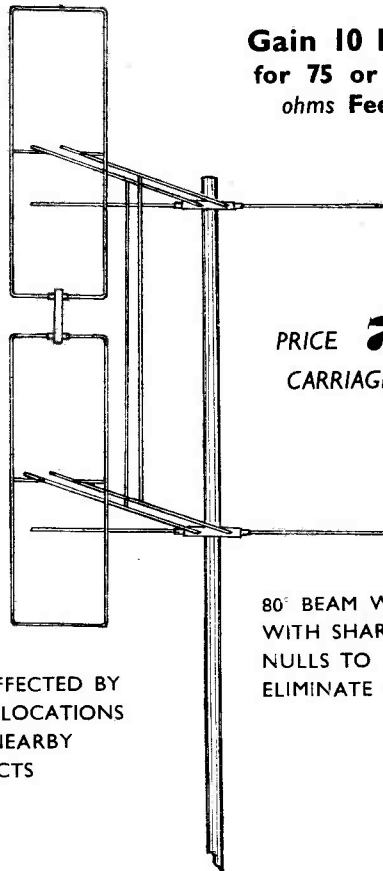

**Gain 10 D.B.
for 75 or 300
ohms Feed**

**PRICE 75/-
CARRIAGE PAID**

**80° BEAM WIDTH
WITH SHARP SIDE
NULLS TO
ELIMINATE QRM**

**UNAFFECTED BY
BAD LOCATIONS
OR NEARBY
OBJECTS**

**PROFESSIONALLY BUILT FOR THE
AMATEUR ENTIRELY FROM DURALUMIN
WITH NO DISSIMILAR METALS TO CORRODE**

CASH WITH ORDER TO:-

Communications Division

J-Beam Aerials Ltd.

CLEVELAND WORKS,

WEEDON RD., INDUSTRIAL ESTATE,
NORTHAMPTON - - Telephone: 1791



Pointers for Designers

AND CONSTRUCTORS
NUMBER THIRTEEN



Z719 — R.F. SHARP CUT-OFF PENTODE

The Z719 is a B9A based sharp cut-off R.F. pentode of all glass construction, having a high input impedance at radio frequencies. Two separate cathode connections are provided. It has a mutual conductance of 7.4 m A/V coupled with low inter-electrode capacitances.

The valve is suitable for use as a signal frequency and I.F. amplifier in F.M. and television receivers, and as a video amplifier. It also performs well as an oscillator and sync. separator.

The 6.3V, 0.3A heater may be used for either series or parallel connected heater systems.

Write for data on the Z719 to:
Osram Valve and Electronics Department.

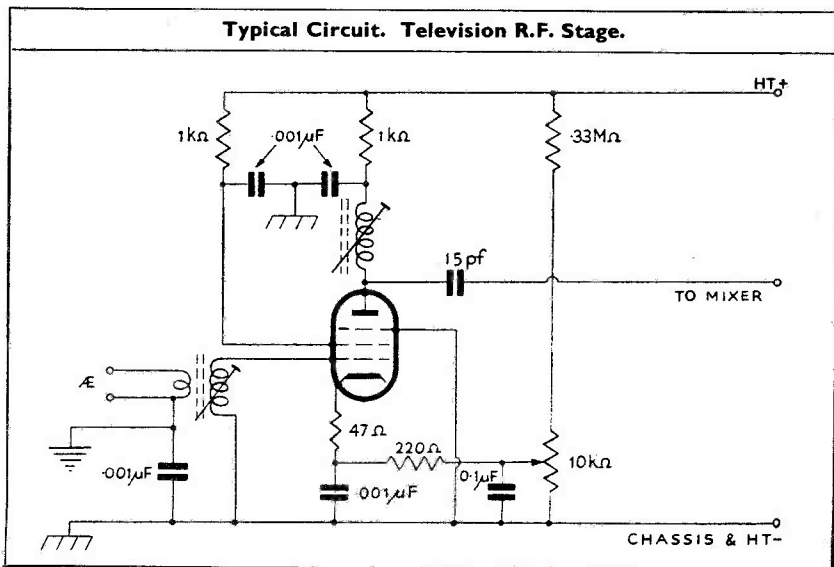

**INDEX TO
ADVERTISERS**

	PAGE
Adcola	126
Altham Radio	127
Anglin, J. T.	126
Automatic Coil	65
Brookes Crystals, Ltd.	69
Brown, S. G.	123
Candler System	125
Clydesdale Supply Co., Ltd.	125
Eddystone	67
Elm Electric	68
E.M.I.	66 & 68
Foyle	126
G.E.C.	70
Gilfillan	128
Harris, H.	124
Henley's	67
Henry's	cover iv
Home Radio	128
J-Beam Aerials, Ltd.	69
Labgear	68
Lyons Radio	69
McElroy Adams	66
Pullin (M.I.)	124
Rollett, H.	128
Samson's Surplus Stores	122
Service Radio Spares	128
S.W.M. Publications Dept.	cover iii
Small Advertisements	123-128
Smith, H. L.	123
Southern Radio	122
Universal Elec.	122
Venner	72
Waterloo Radio	126
Whitaker	cover ii
Woden	66
World Radio Handbook	128
Young	72

SHORT WAVE MAGAZINE

VOL XII

APRIL 1954

No. 128

CONTENTS

	Page
Editorial	73
Making Your Own Transistors, <i>by J. M. Osborne, M.A. (Oxon.) (G3HMO)</i>	74
Aerials and Common Sense, Part I, <i>by The Old Timer</i>	82
Simple VFO-PA for 160 Metres, <i>by J. Booth (G3DMP)</i>	86
DX Commentary, <i>by L. H. Thomas, M.B.E. (G6QB)</i>	89
Personal Touch in TVI, <i>by N. P. Spooner (G2NS)</i>	95
Letters to the Editor	97
Oscillator Injection at VHF, <i>by H. E. Smith (G6UH)</i>	100
VHF Bands, <i>by A. J. Devon</i>	102
VHF Weather Report, <i>by A. H. Hooper (G3EGB)</i>	108
Two-Band VHF Receiver, Part II, <i>by R. F. Weston (G2BVW)</i>	111
New QTH's	116
Random Jottings, <i>by The Old Timer</i>	117
The Other Man's Station — G3FUR	118
The Month with The Clubs — From Reports	119

Managing Editor : AUSTIN FORSYTH, O.B.E. (G6FO)

Advertisement Manager : P. H. FALKNER

Assistant Editor : L. H. THOMAS, M.B.E. (G6QB)

Published the Friday following the first Wednesday each month at 55 Victoria Street, London, S.W.1.
Telephone : Abbey 5341/2

Annual Subscription : Home and Overseas 24s. post paid.

Copyright Reserved throughout the World.

AUTHORS' MSS

Articles submitted for Editorial consideration must be typed double-spaced with wide margins on one side only of quarto or foolscap sheets, with diagrams shown separately. Photographs should be clearly identified on the back. Payment is made for all material used, and it is a condition of acceptance that full copyright passes to the Short Wave Magazine Ltd. on publication.

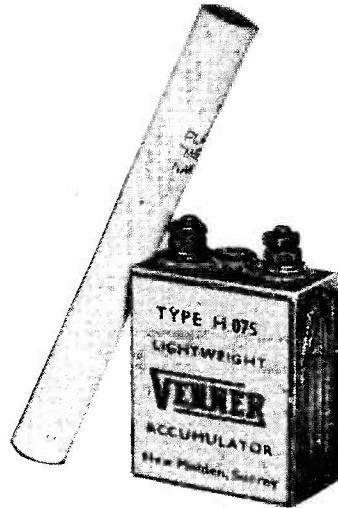

The SMALLEST and lightest re-chargeable accumulator

Full details of this amazing accumulator will be sent FREE. Ask for Brochure SW/A.

VENNER ACCUMULATORS LTD KINGSTON BY-PASS · NEW MALDEN · SURREY

Tel. MALden 2442

Associated Companies: VENNER LIMITED

VENNER ELECTRONICS LIMITED



G2AK THIS MONTH'S BARGAINS G2AK

NOISE LIMITERS. Plug-in type, no re-wiring required. 3 positions. Brand new in cartons. 15/- each. Post and packing 1/-.

METERS. 0-9A Hot Wire, 2" Flush 0-4A Thermo, 20/0/20 amps. 5/-, 0-350 mA Thermo, 0-2A Thermo, 7/6, 0-100, mA 2½" Flush, 12/6. 0-5 mA, square 2", Flush, 10/-, 0-1 mA, 2" square, 20/-, 2" square 0-10A DC, 7/6, 0-50 mA 7/6 each.

RACK MOUNTING PANELS. Black crackle finish, 19" x 5½", 7", 8½" or 10½" at 5/9, 6/6, 7/6, 9/- respectively. Postage and packing 1/6.

COPPER WIRE. 14G. H/D. 140 feet 15/-, 70ft. 7/6. Post and Packing 2/-. Other lengths pro-rata.

TWIN FEEDER. Special offer, 300 ohm flat twin, 150 watt rating. (Minimum 20 yards), 6d. yard, post free. Similar K25.

V.H.F. FANS. THE BUY OF THE YEAR. Air spaced 150 ohm. Coaxial Cable, 20 yard coils, £1 each (Normal price 3/11 per ft.). VERY LIMITED QUANTITY.

GERMANIUM DIODES. B.T.H., 2/-, G.E.C., 2/6 each.

STREAMLINED BUG KEYS by famous manufacturer. Listed over £4. OUR PRICE 45/- only.

HEADPHONES. Low resistance type CLR No.3 9/6, DLR No.2 13/6, high resistance CHR Mark 2 17/6 and the most sensitive of all DHR No.5B 18/6 per pair. P. and P. 1/- per pair.

HIGH NOTE BUZZERS for practice, 5/-, Straight Keys, brand new, all metal, crackle finish, 5/-, Small round Buzzers, 2/-.

SPECIAL TRANSFORMER OFFER. Pri. 115, 210, 240v. Sec. 260/260v. 100 mA, 6.3v. 3A., 6.3v. 1A. (for 6 x 5 rectifier). Universal mounting. Limited quantity, 17/6 each. Post free.

SHADED POLE MOTORS. For Tape Recorders or Gram. Units, with voltage tapping plate 200/250 volts. 3-hole fixing. Our price 12/6 each or 21/- pair. Post and packing on either, 1/6.

A.R. 88 VALVE KIT. 14 valves, £5/10/0.

A.R. 88 CABINETS. Limited quantity. Complete with side channels and base, £4/15/- each. Postage and packing, 7/6. Suitable also for Table Toppers.

A.R. 88 ESCUTCIONS, 22/6. "D" Type, I.F.S., 12/6 each.

R.F. CHOKES. Pie wound, 1.25 mH., 100 mA., receiver type, 9d. each, or 7/6 per dozen; 250 mA., transmitter type, 1/- each, 10/- per dozen.

THIS MONTH'S SPECIAL: MULTI METER, BASIC UNIT. 400 micro amp F.S.D. Scaled, 8 ranges AC/DC volts, HI and LO ohms, complete with rectifier. Made by Triplett U.S.A. Size: 5½" x 2½".
ONLY 32/6 post free.

SPECIAL VALVE OFFER. Kit of 4 midget 1.4v. valves, 1 each 15S, 1R5, 1T4 and 1S4, 30/- or 8/6 each, separately. Most other 1.4v. types also available at 8/6.

SPECIAL VALVE OFFER. 8012, 12/6 each. 6L6G, 10/6, 813 70/-, 829 80/-, 866a 17/6 each or 30/- a pair. 807 10/- each or 17/6 a pair, 913a 45/-.

Please Print Your Name and Address.

MAIL ORDERS TO:—
102 Holloway Head, Birmingham Midland 3254

ALL CALLERS TO:—
110 Dale End, Birmingham.

Central 1635

CHAS. H. YOUNG, G2AK

The
SHORT-WAVE
Magazine

E D I T O R I A L

Interference

It is no use quarrelling with one's neighbours about TVI. Even if he does not always know it, in the last resort the viewer can compel any local amateur—irrespective of the legitimacy of his operations—to close down, at least temporarily. A situation of this kind should never be allowed to arise, as it can lead to all sorts of trouble. It is far better, as suggested by a contributor in this issue, to enlist viewers' interest and sympathy. When viewers come to understand that TVI can be directly traceable to bad design on the part of the manufacturer—which is not the fault either of the dealer, the purchaser or the licensed amateur—then the industry, by the public reaction, will revise its design standards. This, in any case, it will have to do since, quite apart from any question of amateur transmitter interference, so much of the apparatus now being sold to the public and so many TV receiver designs are mutually antagonistic in the electrical sense. In most districts, there are licensed amateurs who are not only keen and active, but also personally influential locally. They can do a great deal to indoctrinate dealers and inform viewers as to where the truth lies in the case of, for instance, a TV receiver with a 14 mc IF.

*Austin Fobell
G8FO.*

Making Your Own Transistors

MATERIALS—SELECTION OF CRYSTALS—METHODS OF PROCESSING—MOUNTING—MEASUREMENTS—AND A TRANSISTOR TEST SET

J. M. OSBORNE, M.A. (Oxon.) (G3HMO)

In this second article, our contributor shows how point-type Transistors can be home-constructed on the amateur workbench. The process, while being essentially simple and requiring the minimum of materials, is also of great experimental interest because it involves not only electricity, but a little physics and chemistry as well. This certainly does not mean "formulae and laboratory facilities," but merely the ability to follow clear instructions and using, for the most part, materials obtainable from the local chemist. The heart of the home-constructed transistor is the germanium diode, which is cheap and readily available. It can truly be said that for the total outlay of a few shillings, transistors can be produced by the average amateur with the usual bench facilities, if he is prepared to be patient, careful and not to be put off by initial failures. The results already obtained by G3HMO with the 160-metre transistor equipment described in the March issue of SHORT WAVE MAGAZINE were with transistors made by himself at home using exactly the process as set out here. The whole subject of transistors and the techniques surrounding their application on our HF bands opens up an entirely new field of amateur interest — and it is also worth noting that at the present stage of development anything in the way of a transistor-transmitter is necessarily ultra-QRP.—Editor.

IN the March issue of *Short Wave Magazine* the writer described a simple 160-metre transmitter using a home-made transistor. Now follow details of the method of making the transistor itself, together with some notes on transistor construction and theory.

The materials and tools needed are:

- (1). A few inches of Phosphor Bronze Wire, 36 or 38 SWG (6 to 8 thou.).
- (2). A supply of tinned copper wire about 18 SWG.
- (3). 25 gm of caustic potash (KOH) in 150 cc of distilled water.
(see precautionary notes in text).
- (4). A Germanium Diode having a **high reverse resistance** (greater than $\frac{1}{2}$ -megohm).
- (5). Perspex sheet, about $1\frac{1}{4}$ " x $\frac{3}{4}$ " x $\frac{1}{4}$ ".
- (6). A strong magnifying glass.
- (7). A pair of fine tweezers.
- (8). 8 BA drill, tap and grub screws.

The procedure is divided into four sections: Making the whiskers, obtaining the crystal, mounting and adjusting these components, and finally processing and testing.

Making the Whiskers. Two similar whiskers are used, but it is worth making at least half-a-dozen at a time. About half-in-inch of the phosphor bronze wire is soldered to a six inch length of the tinned copper. The phosphor bronze wire is then bent into the shape of

Fig. 1. A pair of fine tweezers is the best tool for the job. The shape is not critical and is solely to enable the whisker to act as a spring and press firmly against the crystal.

The whisker is pointed electrolytically, the process being the reverse of electroplating. The end of the whisker is eaten away as the current passes until only a point is left on the end. The pointing solution is made by dissolving 25 grammes of Caustic Potash (chemical formula KOH) in 150 cubic centimetres of distilled water. Any chemist will make up the solution for about one shilling. Technical or "commercial quality" caustic potash is satisfactory. *Neither the solid caustic potash nor the solution should on any account be allowed to touch the skin.* Always have plenty of water handy to rinse off any solution which may accidentally touch or splash the hands.

Some of the solution is poured into a shallow glass dish to a depth of about $\frac{3}{8}$ of an inch. A piece of copper gauze or a spiral of bare copper wire (*see photograph*) is laid at the bottom of the dish with a lead coming out. This is then connected up in the circuit shown in Fig. 2 with the potentiometer, battery, meter and whisker to be pointed. The whisker is immersed to a depth of $\frac{1}{8}$ of an inch and the current adjusted by the potentiometer to 15 mA. The exact current is not critical and should be increased for thicker wires to keep

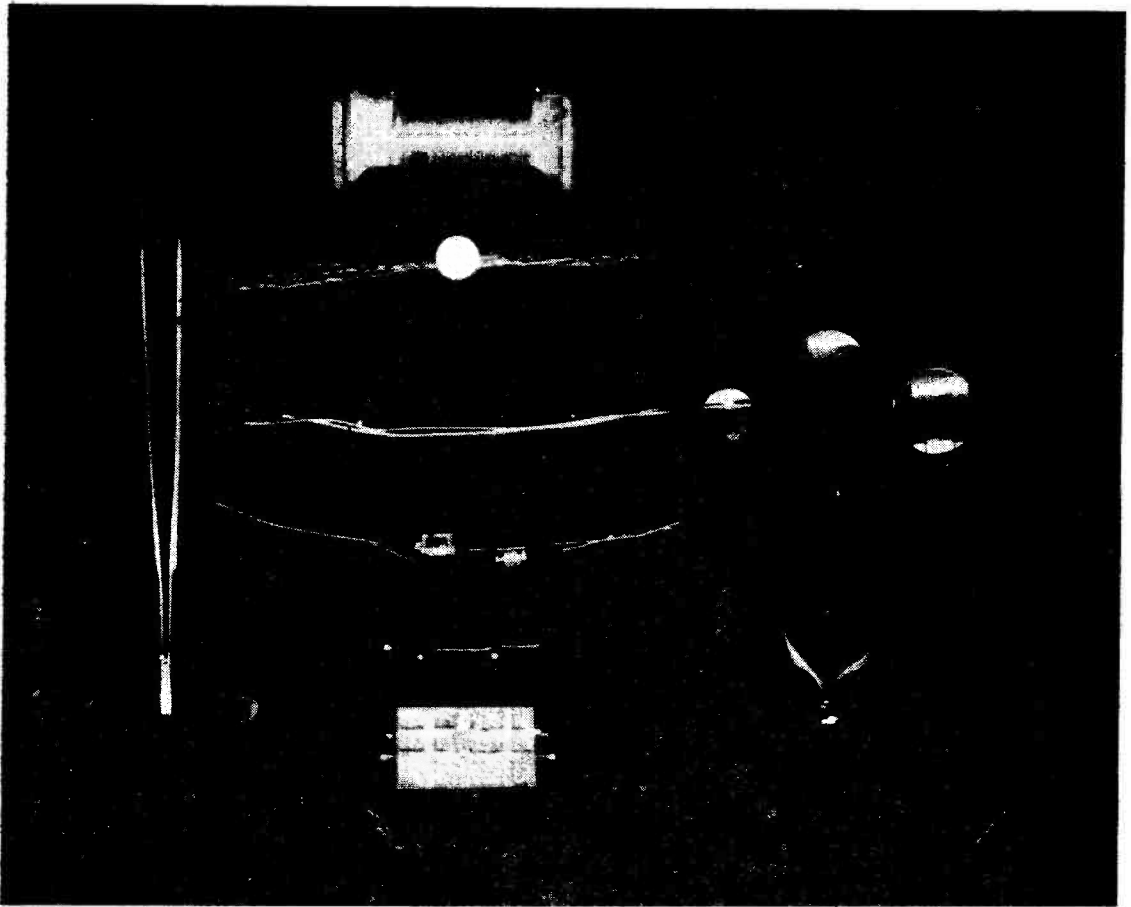

Materials and tools used in making a transistor on the bench. From top to bottom : 18g. tinned copper, bundle of phosphor-bronze wires, whiskers before and after bending, two types of germanium diode readily obtainable, a mounted crystal after removal from a diode assembly, and a perspex mounting block. Also necessary are tweezers and a magnifying glass.

the time of forming reasonable. The current will fluctuate as little bubbles are formed round the whisker. After twenty minutes or so all the immersed wire will be eaten away: the circuit should then be broken and the meter reading will fall to zero. On removal of the whisker, first rinse it in water and then examine with the magnifying glass. It should be pointed and have the same sort of shape as a pencil after it has been sharpened with a pencil sharpener. Long thin points are useless as they are blunted by the least pressure on the point.

In order to get the points close together eventually it is advisable to flatten slightly the shoulder of the wire above the point, taking care not to damage the point. The writer finds the simplest method is to squeeze the wire in a micrometer screw gauge! However, such

treatment of a screw gauge, if one is available, is not to be recommended. Alternatively the wire may be placed between two flat pieces of metal, free from sharp edges, and squeezed in a vice or beaten with a hammer.

Having made about six whiskers they may be stored by sticking the tinned copper into a cork and putting the cork into a bottle. This protects the points. Finally, pour the pointing solution back into its bottle, rinse the glass dish and gauze thoroughly under a tap and put away until needed again.

Obtaining the Germanium. The germanium crystal is the heart of a transistor, just as the cathode is in a valve. The germanium used should have a high degree of purity so that the effect of subsequent processing will not be marred by the presence of impurities. Most of the germanium diodes on the market have a

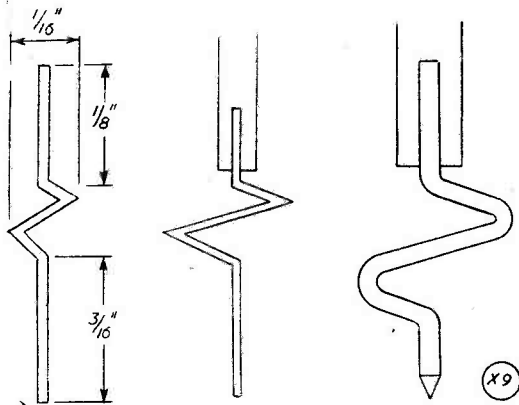

Fig. 1. This diagram shows the approximate dimensions of the phosphor-bronze whisker used in the home-made transistor and its appearance before and after pointing.

considerable n type impurity (see later "Transistor Theory"). However, a few samples will be found of reverse resistance which is in the region of a megohm, indicating a high order of purity. These are the ones that make good transistors. This is the only source of suitable germanium readily available and is used for the home-made transistor. A good selection can be obtained for a few shillings.

A further advantage of using ordinary diodes as the source of germanium is that the crystal is ready mounted in a holder, either by a special soldering technique or by fixing in Woods Metal (a low melting point alloy). It may also have a connecting wire already attached.

The reverse resistance as read on the ohms range of a multimeter should be greater than $\frac{1}{2}$ -megohm (the internal cell of the meter should not exceed ten volts). Alternatively, with -10 volts applied to the diode the current through it should be metered. The current should not exceed 50 μ A and should preferably be less than 10 μ A.

The method of getting the crystal out of its sealing depends on the method of manufacture of the diode. In *all* cases it is a matter of combining brute force and cunning! The perspex-and-glass type is sawn in half with a small hacksaw and the perspex is then chipped away

CAUSTIC POTASH

This is a dangerous substance which, even in solution, is capable of severely burning the skin and damaging clothing. It should not be splashed about, and a jug of water should be kept at hand in case of accidents.

from the main body by further sawing and prising with a screwdriver. The glass of the metal-to-glass seal can be fractured by clamping in a small vice and tightening until the glass breaks. This process is repeated from different angles until the crystal and connecting wire are free from the original sealing materials.

In the all-glass constructed diodes a file is used to make a mark all the way round the centre when it will be found easy to break the diode in two by "tapping with a blunt instrument." The vice technique is then used as before to break away the glass round the seal.

In the type with metal caps, the glass is filed round the middle and the diode broken in two as before. The crystal is mounted on a small brass cylinder held in the body of the cap by a grub screw in the side. Using suitably shaped tools, the brass cylinder may be pressed out in a vice. (See *Wireless World*, January, 1954.) The brass cylinder is then soldered at the bottom to a lead of 18 SWG tinned copper using the minimum of heat.

Mounting. The requirements of the holder are that it should enable the two whiskers and the crystal to be mounted securely with the whiskers pressing firmly on to the crystal with no relative movement between them, and yet

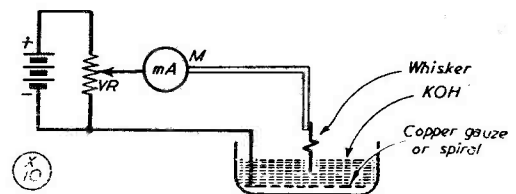

Fig. 2. Circuit for pointing the phosphor-bronze whisker by electrolytic action, using a caustic potash solution. The set-up for carrying out this part of the work is shown in the photograph on the opposite page.

allow the position and pressure of the whiskers to be adjusted. Further, the whiskers should be nearly vertical to avoid slipping of the points over the fairly hard, smooth surface of the crystal.

The method to be described here was evolved after much trial and error. It has two disadvantages: First, it does not take maximum advantage of the potential miniaturisation of these devices. Secondly, the finished article cannot readily be sealed, should this be desired. It is, however, ideal for experimentation as it meets all the main requirements and yet enables the whiskers and crystal to be changed easily and fixes them so securely that generally the

lead wires may be bent and soldered without harm to the transistor.

A piece of $\frac{1}{4}$ " sheet perspex $1\frac{1}{4}$ " x $\frac{3}{4}$ " is cut, drilled and tapped as shown in Fig. 3, and the three components mounted as shown in Fig. 4. With the whiskers initially beside the crystal, the grub screws are fixed tightly. The 18 SWG wire is found to have the ideal elastic properties, having a certain amount of spring which enables the whiskers to be raised and lowered and yet is soft enough to be easily bent to a new position. Watching with the magnifying glass, each whisker is raised, the copper twisted slightly and the whisker lowered gently (trying to avoid blunting the point) on to the crystal. The springiness of the whisker rather than the support wire determines the pressure on the point.

It is useful to have a resistance meter connected between whisker and base while doing this. If the contact is good it will have a forward resistance of 250 to 500 ohms and a reverse resistance in excess of 200,000 ohms. The two points should touch the crystal *very close together*, preferably within one thousandth of an inch, although good results have been achieved with spacing up to five *thou*. In

Table of Values

Circuits, Figs. 2, 5 and 6

Fig. 2.	Dry battery	44 volts.
	Potentiometer	5,000 ohms.
	Meter	0-25 mA range.
Fig. 5.	Switch	SPDT.
	Condenser	0.1 to 1 μ F (see text).
	Meter	0-60 volt range.
	Potentiometer	0.1 megohm.
	HT	90-150 HT battery.
Fig. 6.	VR1 = 5,000 ohms	HT1, HT2 = 150 volt HT battery
	VR2, VR3 = 100,000 ohms	C1 = .005 μ F
	M1, M2 = 0-5 mA meter	C2 = .01 μ F
	M3 = 0-60 and 0-300 volt ranges of multimeter	C3 = 0.1 μ F
		C4 = 0.25 μ F
		C5 = 1 μ F

practice, of course, what this means is "as close as possible without touching." Considerable patience and dexterity are needed at this stage.

The embryo transistor is now connected in the test circuit described on p. 12 of the March issue of *Short Wave Magazine*, and α measured. It should have a value of a quarter or so. Should it have a value now or at any other stage of about unity (one), a short circuit between collector and emitter should be suspected. Provided some control of the collector current is obtained by varying the emitter



Equipment and set-up for pointing the whiskers—see Fig. 2 for circuit. Also shown are flasks of caustic potash solution (KOH) and distilled water. The test tube is used for storing whiskers to protect the points after processing. In the foreground is the pan in which the points are formed by electrolytic action, as described in the text.

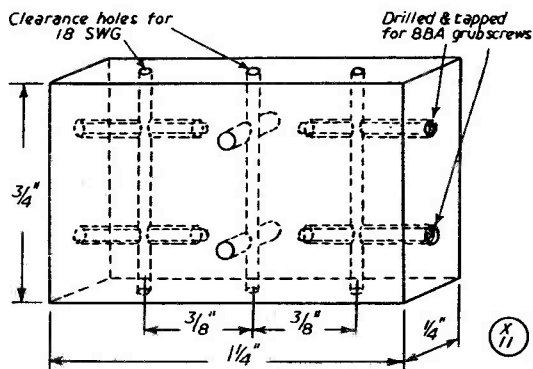

Fig. 3. Dimensions of a convenient perspex block, suitable for mounting the finished germanium triode and holding the electrodes in place. Other methods of doing this will suggest themselves to the ingenious constructor.

current the next stage should be tried. If not, further manipulation of the points, relative to each other and possibly to the crystal, is needed.

Processing. The collector is now "flashed" by discharging a condenser through it and the base. This apparently drives some phosphorous into the crystal which, together with the intense local heating, modifies considerably the electrical characteristics of the germanium.

The circuit for doing this is given in Fig. 5. A condenser of from $0.1 \mu\text{F}$ to $1 \mu\text{F}$ is charged to 10 or 20 volts and discharged through the collector by means of an SPDT switch. (There is considerable room here for experiment in the capacity of condenser and the voltage used.) The reverse resistance of the collector should now be measured and will probably have dropped to 10 or 20 thousand ohms. If it is much higher repeat the flashing process. If it is below 5,000 ohms, move the points to a new position on the crystal and start again! Assuming a value near the limits mentioned measure

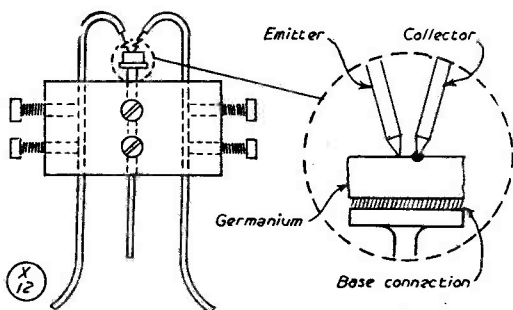

Fig. 4. The transistor as finally mounted on the perspex block, with an enlarged view of the disposition of the electrodes. One of the secrets of success is to get the two points, emitter and collector, as close together physically as is possible.

the current amplification, α , which should now have risen to between $1\frac{1}{2}$ and 4 times. Further manipulation of the emitter is permissible, but should the collector be disturbed it will have to be reflashed. Failure to get amplification may be because of local impurities in the germanium or the use of an unsuitable crystal. The aim should be to produce as high an amplification as possible consistent with a not-too-low reverse resistance.

Whether or not the transistor will work depends on the crystal more than anything else. If the crystal is not suitable, absolutely nothing can be done about it. On the other hand, a crystal which is satisfactory may not produce

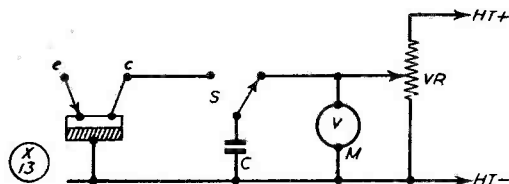

Fig. 5. The collector is processed by discharging the condenser C through it, as explained in the text. The condenser is charged from a battery source by means of the switch S which, when thrown, discharges through the collector. This is all that the processing amounts to, but there is scope for experiment in the degree of processing by using different values of condenser and charging voltage.

results first time, so do not be discouraged too easily. The usefulness of the finished article will depend to a greater or lesser extent on the following:

- The degree of purity of the germanium at the actual point of contact of the whiskers.
- The firmness and sharpness of the contacts. This affects the forward conductance and may influence the processing.
- The spacing between the points of contact. This influences both gain and frequency cut-off.
- The material of the collector whisker. This should contain an element from Group V of the periodic table, such as phosphorous — hence the use of phosphor bronze wire.
- The suitability of the electrical processing. This makes or mars the transistor decisively and is a matter of experience (and luck!).

Notes on Construction

So far only one method of construction has been described, but at each stage there are many different methods which could have been used. A few notes, comments and suggestions related

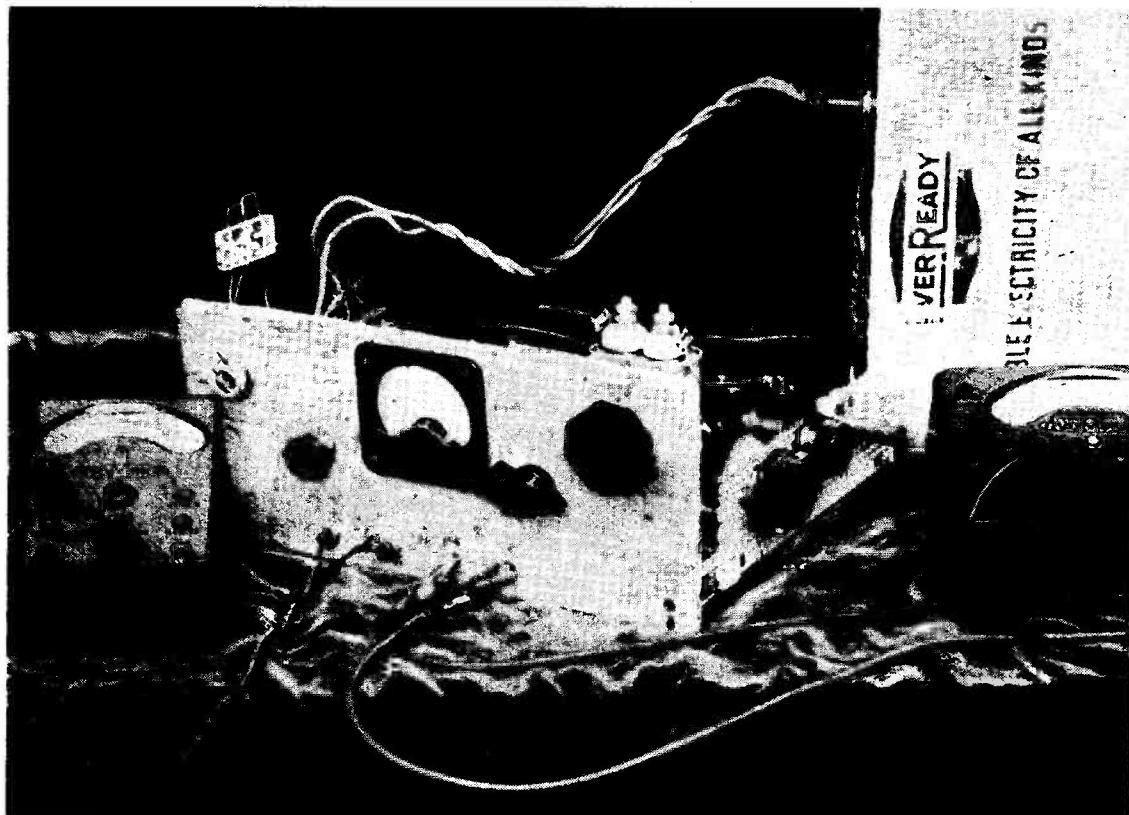

Front view of the rough-up Transistor Test Set described by G3HMO, of which the circuit appears in Fig. 6. It forms a very useful piece of ancillary equipment for the transistor enthusiast, enabling germanium triodes to be checked quickly for alpha and new transistors to be processed for immediate checking. Such a Test Set could be built up very neatly on a small panel and chassis, or into a metal box.

to construction and processing are included.

Whiskers. It has been found that whiskers can be pointed on a fine grindstone driven by a portable drill. It is not so easy or satisfactory as the electrolytic method, but takes less time.

The emitter whisker, unlike the collector, need not be of phosphor bronze and fine tungsten wire of one or two *thou* diameter makes a very good whisker. It is more manageable and can be placed closer to the collector by virtue of its smaller diameter. Tungsten *cannot* be soldered, and the wire should be bound to the support wire with 32 SWG bare copper. The joint is then secured by running solder over the whole. Pointing is similar but requires less current and less time. However, the pointing solution should be double strength (25 gm caustic potash to 75 cc of distilled water) and contain a pinch of cuprous chloride.

Mounting and Sealing. Lead wires and screws can be driven into perspex if heated

with a soldering iron. This provides a method of making the mounting block for those who are without the necessary tap and drills. It also suggests an alternative form of construction in which the wires and crystal are secured to the perspex without screws. The lead wires should have a short length of wire bound round and soldered to give the perspex something to bite on when it cools.

Experiments are proceeding with a cold-setting resin called "Araldite," made by Aero Research, Ltd., of Duxford, Cambridge, with which to seal the finished transistor. It is hoped eventually that this will enable a smaller and more permanent transistor to be made.

Processing. In the circuit of Fig. 5 a smaller condenser charged to a higher voltage and discharged in the reverse direction also gives good results. In this case the battery leads in Fig. 5 are reversed and the voltages of 100 to 200 are used, with condensers ranging from .001 to 0.1 μ F. Successive discharge of condensers

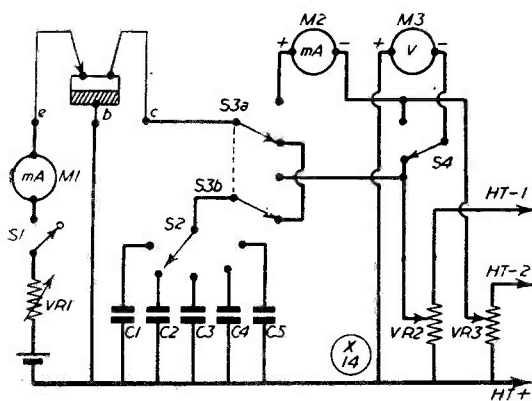

Fig. 6. Circuit for the combined Transistor Processor and Test Set which, for the experimenter, will be found as useful a piece of equipment as the GDO; the switching selects the circuit functions.

starting with the smallest charged to the lower potential and working up to larger capacities and higher voltages also gives a degree of control and enables the process to be stopped at the optimum point.

Transistor Theory

Electrons and Holes. Solids may be divided into three classes according to their resistivity. Those whose resistivity is in excess of 10^7 ohm-cm, in which the electrons are tightly bound to the parent atom, are called insulators. Those whose resistivity is below 10^{-3} , in which certain electrons (free electrons) are comparatively free to move about the body of the solid, are called conductors. The third class, in which resistivity falls half-way between these values are called semi-conductors.

Germanium is a semi-conductor, the electrical characteristics of which can be modified substantially by the presence of a few foreign atoms in the crystal lattice. If these impurity atoms have one more electron than germanium in the outermost orbit, it becomes *n* (negative) type, or one less, *p* (positive) type germanium. In the latter type the missing electron forms, in effect, a positive charge or "hole" available for conduction in the same way as an electron in the other type.

An electron falling into such a hole leaves a hole behind, into which another electron may fall. This is equivalent to a positive charge moving in the reverse direction. Germanium with characteristics similar to that containing *p* type impurities can be formed thermally, presumably by some distortion of the crystal lattice. A junction of the two types behaves as a rectifier allowing a current to

flow easily in one direction and acting as a high impedance in the reverse direction. A metal point contact (the whisker) on the surface of *n* type germanium behaves in a similar way apparently by forming *p* type in the locality of the point, although the mechanism is not clearly understood.

Transistor Action. Removing electrons (or "injecting holes") via the emitter allows electrons to flow more easily through the collector, if they are close enough together. Further, if we modify the germanium in the locality of the collector by electric shock treatment, we get the remarkable effect that a change in current, or rate of flow of electrons, through the emitter produces a greater change through the collector, i.e., a current amplification is obtained. This amplification (which may be two or three times) is difficult to explain, but is probably related to the difference in mobilities of holes and electrons and the formation of *p* and *n* types in thin layers immediately below the collector.

This is, of course, the point-type transistor and we are now hearing more of other types namely, the *n-p-n* and *p-n-p* junction transistors. In these a single crystal of germanium, having *n* properties at the ends and *p* in the middle (or *vice-versa*), is used. The ends correspond to the collector and emitter, and the centre to the base. The junction type transistor is more efficient, although it cannot have an *alpha* greater than one. Its manufacture is more complex, but it can be designed to have particular characteristics. It has very limited frequency response and finds its application in low frequency uses only.

COMBINED PROCESSER AND TEST SET for HOME-MADE TRANSISTORS

This little device is as useful to the constructor of transistors as a GDO is to the constructor of valve transmitters. It fulfils in the one unit two functions:

(a) The *alpha* of a transistor and the output impedance can be measured immediately. The input impedance can also be estimated.

(b) A condenser can be selected, charged to a predetermined voltage and flashed across the collector. Its effect on the transistor can then be determined from (a).

The Circuit

In the circuit diagram, Fig. 6, the switch S3 is normally in the "up" position and connects the collector to a conventional test circuit of milliammeter, voltmeter and variable HT. To

avoid tying up meters unnecessarily, meter terminals are brought out to the front panel. The emitter is connected to an internal $1\frac{1}{2}$ -volt cell through a variable resistance VR1, a built-in 0-5 mA meter and switch S1. This enables the emitter to be switched and the current varied. An estimation of the input impedance can be made from the setting of VR1 for a given current. It could be calibrated by substituting known resistors for the transistor across the emitter-base terminals and marking the setting of VR1 for a fixed current.

At the same time any condenser selected by S2 is charged to a voltage determined by the potentiometer VR2 if HT1 is connected. This voltage may be read by switching the voltmeter from the other circuit by S4.

On depressing the key of S3 the collector is disconnected from the test circuit and the condenser is disconnected from the charging circuit and discharged through the collector.

On releasing the key the effect on the collector impedance may be observed immediately and a quick check of *alpha* made by switching S1 to a preset current in the emitter. The change in collector current can be observed, keeping the voltage constant by adjusting VR3. The charging (HT1) and collector (HT2) supplies are *via* separate terminals, but these can be strapped unless positive flashing is required. To do this a separate battery is needed and the charging HT polarity is reversed. In this case the voltmeter must also be reversed on operating S4. When the set is used for testing only, and not processing, HT1 is not connected.

Construction

In the writer's case the components are mostly stripped from "government surplus" and are assembled on an old breadboard chassis. Layout is not critical and should be arranged for convenience. In particular, the three terminals for the transistor should be easily accessible. The photograph in conjunction with the circuit diagram will make the whole idea self-explanatory. The values used were chosen because they were available and considerable variations are permissible. The condensers should be tested to be free from leaks.

The whole thing can be knocked up in two hours and will save a great deal of time for anyone who is taking up home-made transistors seriously. Its chief value is in allowing immediate assessment of the effect of processing on the transistor. As this is very much a

matter of trial and error, the saving of time is a very real factor.

The author wishes to express his thanks to Mr. E. S. Parke, of The Laboratories, Stowe School, for the photographs accompanying these articles.

TRANSISTOR TOPICS

Readers who are obtaining results with Transistors, either in reception or transmission, on any frequency above 1800 kc are specially requested to let us have notes with circuitry for further articles on the subject, to appear under this heading.

We are particularly interested in hearing from those who, following the articles by G3HMO, succeed in obtaining results from home-made transistors as described by him.

As there are now a number of transistor transmitters on the air, we are instituting a new Achievement Table — "Transistor Contact Record" — based on power-range rating, which is calculated as in the following example :

A 20 milliwatt Collector input is 1/50th of a watt. Contact over a range of 50 miles with this input represents a power-range rating of 2,500 miles per watt.

Claims should give date, time, frequency, collector input, call-sign of station worked, and distance. If both sides of the QSO are with a transistor transmitter and both are using transistor receivers, then the power-range rating, as calculated above, can be doubled. If either side of the QSO involves the use of valve equipment, transmitter or receiver, then the rating is calculated one-way, as in the example. Later, the general principle will be extended to "Counties Worked" and the DX field on all bands upon which Transistor working becomes possible.

Editor.

CARDS IN THE BOX

Cards are held for the operators listed below, for whom we have no forwarding addresses. They can be obtained on receipt of a stamped addressed envelope, with name and call-sign, which must be sent to: BCM/QSL, London, W.C.1. The cards will be despatched on the next fortnightly G clearance. If publication of the call-sign/address in "New QTH's" and in the *Radio Amateur Call Book* is also desired, that should be requested at the same time.

G2ADB, 2FAL, 3BDI, 3DHE, 3EGU,
3HAU, 3ICR, 3IIG, 3IDJ, 3JFL, 3JGL,
3JHF, 3JHZ, 3JIV, 3JJ, 3JNO, 3JNU,
3JPQ, 5BS, G15HZ, GM3IC, 3IGX.

Aerials and Common Sense

PRACTICAL APPROACH AT THE AVERAGE LOCATION

THE OLD TIMER

In this short series of articles, it is intended to attempt to find the answers for those who have to cope with the aerial problem from the practical point of view. That is to say, while we can all get a sound theoretical answer out of the books, what if our wire can only be 36 feet long, or just hooked up to the chimney stack at one end and the garden fence at the other? Can transmitting aerials be expected to give results under the far-from-ideal conditions which actually exist at so many amateur stations? It is hoped that those with just such problems on the communication bands will find these articles give them the guidance and advice that they need.—Editor.

ONE point on which most enlightened amateurs are agreed is the vital importance of the aerial system. They say so at club meetings, they say so on the air, and they constantly re-affirm it among themselves on every possible occasion. How strange, then, to find such a lack of knowledge of the subject in unexpected places.

It seems to be *practical* knowledge, or perhaps just plain commonsense that is lacking: and please don't think we are indulging in gibes at the expense of those who make the mistakes. Our only reaction to some of the strange opinions that one hears bandied about is a genuine desire to help. So we propose to try and put over some "Aerial Common-Sense" (hereinafter known as ACS) for the benefit of those who are willing to admit that there is room for it!

Theory and Practice

Strangely enough, the subject of aerials is one in which theory and practice *do* follow each other very closely. One can learn all the theory, up to a very advanced stage, from the text-books. Starting with feeder-lines, working through "Why does a dipole radiate?" and ending up with some of the more abstruse directional types, it is a fascinating pursuit throughout. But the amateur has to have an essentially practical outlook on these things,

and much of the text-book knowledge (although he *must* acquire it) is not likely to be of great practical assistance to him.

It is nice to know how a rhombic aerial works, or how a Sterba curtain of 32 elements compares with a collinear array two miles long—but it is not of much help to the amateur whose back-garden is just about 60 ft. in length! What *he* wants to know is how to make the best of a 14-mc dipole, or a ground-plane, or a bent wire "wrapped round the garden" for his peculiar requirements. And amateurs' requirements *are* peculiar, make no mistake! It may be necessary to work on six different bands, with a preference for certain directions on certain bands only; the vertical angle of radiation on the DX bands must be considered; the positioning of the aerial with regard to the shack itself can be vital. All sorts of complications keep intruding, in a manner quite unknown to the text-books. In the world conjured up by the latter, one finds someone who wants to communicate with one part of the world on one frequency, and therefore starts with an open field on top of a hill and erects two large masts or towers at strategic points. Free-space polar diagrams are displayed; ground reflection effects assessed. And all the time the amateur is reading this, he is worrying about his garden fence, the neighbour's TV aerial, his own telephone wires and the fact that the feeders have somehow got to reach the shack (on the right side of it to go through the window!).

Fundamentals

First of all, clearly, he must be right with the fundamentals; and then he must be able to do some lucid thinking and make some decisions for himself. Fundamentals will be left to the standard text-books—if we started on them here, we should be embarking on a series of articles that would run for two years.

Likewise we are not going in for detailed measurements, but bear in mind that the electrical length of an aerial is slightly shorter than the physical length, and, for convenience, use this formula (the only one you need worry about) for a half-wave aerial:

$$\text{Length in feet} = \frac{468}{f. (\text{mc})}$$

Or, better still, don't worry about the formula at all, but bear in mind that 67 ft. is a half-wave for some spot at the LF end of the 40-metre band, and 33 ft. 6 ins. is a half-wave for the lower end of Twenty.

Planning

Now is the time to consider the whole situation. What bands do you wish to work on, what kind of DX would please you most, and how much room have you got?

If your garden runs North and South and is only 34 ft. long, then you need not waste much energy in deep thought; but if it is longer than that and offers a choice of direction, then some cerebration is necessary.

You can look up the horizontal polar diagrams of the various lengths of aerial in any text-book. For the moment, remember that a half-wave will radiate best at right-angles to its length (although, as you will see from its "doughnut" pattern, it is pretty good all round, the only really poor directions being directly off the ends). A full-wave, and also one twice as long (four half-waves) will radiate, roughly, on the four diagonals—the four directions at 45 degrees to its axis.

Now any Great Circle Map will show you that, from the U.K., considerable DX is available to anyone whose aerial system covers what we will call "the four diagonals" well. In other words, the broad areas to the NE, NW, SW and SE contain most of the amateur stations in the world. If you are badly off for radiation due East and West you may miss some of those Caribbean and Central American countries, likewise a few parts of the East Indies and India. But the main "DX-bearing areas" lie in, or near, the four diagonal areas. Fig. 1 shows this in simplified form, and shows numbered "sectors" for future reference.

If you settle for fairly good coverage of these areas, the answer is simple. Either two half-waves or four half-waves may be used, and there will not be much difference whether they run North-South, or East-West. Remember, too, that two half-waves on one band will be four half-waves on another, with the polar diagram not very greatly changed (actually the main lobes are at 54° to the aerial in the first case, and 36° in the other, but they are broad enough to cover the 45° direction both ways).

So we arrive at the first fact—that an aerial either 67 or 134 ft. long, running either East-West or North-South, is not to be sneezed at. If it is 67 ft. long it will give you dipole coverage (nearly all-round) on Forty, "diagonal" coverage on Twenty, and an almost similar pattern on Ten. On Fifteen you will still have the diagonal coverage, plus a nice minor lobe at right-angles to the plane of the aerial.

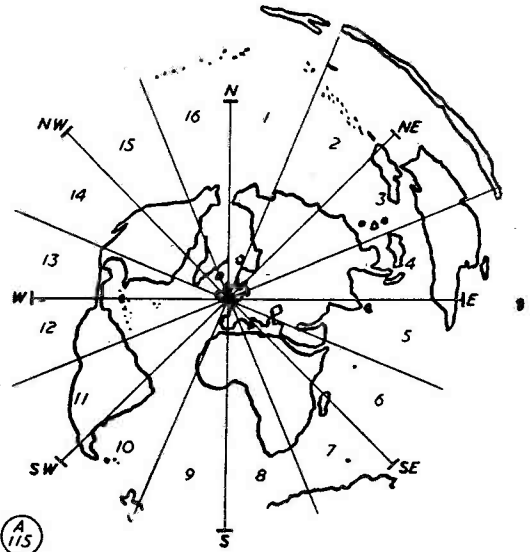

Fig. 1. Outline great circle map to show sectors of coverage referred to in the Table, Fig. 2, using the aerial arrangements discussed in the text.

Fig. 2 gives a rough idea of what may be expected from such aerials on the various bands. It applies to an East-West wire, and the North-South one will be very little different except that it will radiate slightly better to the East and West on Forty and Fifteen, but not quite so well to the North and South. On Twenty there will be very little difference.

Longer Wires

As we make our wire longer, so do the main lobes swing round more and more towards the plane of the wire itself. So if we consider the 134 ft. wire we shall have something that begins to exhibit real "long-wire" tendencies, at any rate on Fifteen and Ten. This means that we are approaching the stage where devotees of these HF bands are well advised to try and *point* their aerial at the directions that they most want to work. The 134 ft. wire will work all round (dipole fashion) on Eighty, will have the diagonal pattern on Forty and Twenty, but on Fifteen and Ten the lobes will be getting round towards the plane of the aerial. Thus a 134 ft. wire, aligned East and West, will be very good for North and South America on the one hand, Asia, Australia and Central and South-East Africa on the other . . . on Forty and Twenty. But on Ten it will be best for Central America, the Southern U.S.A. and the Northern countries of South America, and, the other way, India, Ceylon and the East Indies, with Western Australia coming into the picture.

Making the Decision

From the foregoing you will realise that there is no such thing as an all-band aerial giving all-round coverage! But it really appears that the nearest you can get to such a thing is a 134 ft. wire, which, although its coverage varies over the different bands, does end up by getting everywhere on one band or another. A wire twice this length is a luxury not possible to many; it is very desirable for Top Band DX, but becomes very directional on the higher frequencies.

So decide, with regard to (a) Space and (b) Direction available, whether you will erect 67 ft. or 134 ft. You will be influenced, in this, by the degree of interest that you take in the 80-metre band. If you are not a devotee, then it may well be that 67 ft. suits your purposes even better than 134 ft. Having decided which it is to be, you must next settle on the method of feeding the aerial—and this is where so many otherwise intelligent people seem to come apart!

Quite recently, on the air, we have heard the following two statements: "I am using a folded dipole fed with 72-ohm co-ax, but it doesn't seem to draw properly" . . . and "The aerial is an 80-metre dipole and I can't make it load the PA on Twenty." (No marks awarded for finding the deliberate mistake.)

The first point to be made is this: That some feeder systems will turn your aerial into an essentially one-band affair; others will allow you to use it on all bands; and one, at least, will materially alter its optimum directions from your original plan.

Feeding a Dipole

We will first see what can be done to a simple half-wave aerial. Fig. 3 shows three different methods of feeding it. The first (a) uses 72-ohm co-ax feed at the centre. This makes everything very simple; if the co-ax is fed from a single-turn link coupled to the PA tank circuit, it will be almost perfectly matched and there will be no trouble with standing-waves or radiation from the feeder. *But* there is a disadvantage—as there always is with anything that looks simple. *Your dipole is now essentially a one-band aerial.*

If it is a 67-ft. length, you are virtually tied to Forty; you may "strap the feeders" at the bottom end and feed it as best you can on the other bands, but it will be a hybrid all the time. The feeder length will affect the polar diagram, the feeders will radiate, and woe betide any nearby TV sets or even BC receivers. Definitely not to be recommended, this!

The second arrangement (b) is also centred, this time with 600-ohm open-wire feeders, which must be tuned at the bottom end. Since the impedance at the centre of a dipole is of the order of 72 ohms, the mismatch between feeder and aerial will cause a standing-wave to appear on the feeder (as, of course, it does on all tuned feeders). This will mean that at a point a quarter-wave down the feeders you will find a high-impedance point (probably some thousands of ohms), but another quarter-wave further on they will again look like 72 ohms.

Still talking in terms of a 67-ft. aerial and Forty, this implies that if your feeders are anywhere near 33 ft. long they will present a high impedance to the transmitter and, in the old parlance which we do not much like, they will have to be "voltage fed." We prefer to think of the situation in terms of impedance, and to realise that they will need a high-impedance tuned circuit across them. If, however, the feeders are 67 ft. long or thereabouts, you can feed them just as you fed the 72-ohm co-ax. They will look, at the bottom end, like a low impedance which can be met by coupling a single-turn link tightly to the tank circuit.

The system is no longer bound to one band; on Twenty the 67-ft. top will now look like *two* dipoles, their inside ends (high impedance) being connected to the two sides of the 600-ohm line. So now we have a high impedance junction between feeders and aerial; half a wavelength down the feeders the condition will be repeated. Thus it matters not whether the feeder length is 33 ft. (half-wave) or 67 ft. (two half-waves). The feed, at the bottom, is still of the high-impedance, or, if you prefer it, "voltage" variety. You will get the low-impedance feed condition at the bottom by

AERIAL COVERAGE TABLE

Band	134 ft. E/W	67 ft. E/W
	SECTORS	SECTORS
80	1-3, 6-11, 14-16	—
40	2-3, 6-7, 10-11, 14-15	1-3, 6-11, 14-16
20	2-3, 6-7, 10-11, 14-15	2-3, 6-7, 10-11, 14-15
15	all-round (maxima in 3, 6, 11, 14)	all-round (maxima in 2, 7, 10, 15)
10	maxima in 4-5, 12-13	2-3, 6-7, 10-11, 14-15

Fig. 2. The coverage indicated by this table is approximate only, and refers to maximum radiation, not implying that sectors unmentioned are not covered. The sectors to which the table refers are shown in Fig. 1.

making the feeder length either 17 ft. or 51 ft. (quarter-wave or three-quarters).

But we shall *not* now get the "diagonal" radiation pattern associated with a full-wave aerial. Your 67-ft. top would behave like a full-wave on Twenty if it were in one piece, but it has now been broken in the middle and made into two dipoles, which are *in phase* with each other (if they were joined together at the centre they would be *out of phase*). The polar diagram of two dipoles in phase has been described as "like that of a dipole, but more so"—which is probably the best way of expressing it. Radiation at right-angles to the aerial is greater; off the ends it is less.

Even on Fifteen Metres the polar diagram remains very similar, because now each half of the top is three-quarter waves long; each half consists of a complete dipole and the half of another one. The total effect is of two

always bearing in mind that the optimum loading of the PA must also be watched. In the language beloved of the amateur, if the thing "draws" properly, then the RF is most likely going where it should—up the feeder. But we shall have more to say about aerial tuning units in a later instalment.

Windom Feed

There remains the third method of feed (c)—the single wire connected off-centre, also known as the "Windom." This can be very useful in some circumstances, but is fraught with snags. In theory, if a very good earth connection is used, a point on the aerial can be found at which the single wire feeder will match properly and will carry no standing waves. Radiation from it will therefore be slight. But if the match is not a good one, the feeder will become part of the radiating system, which means that

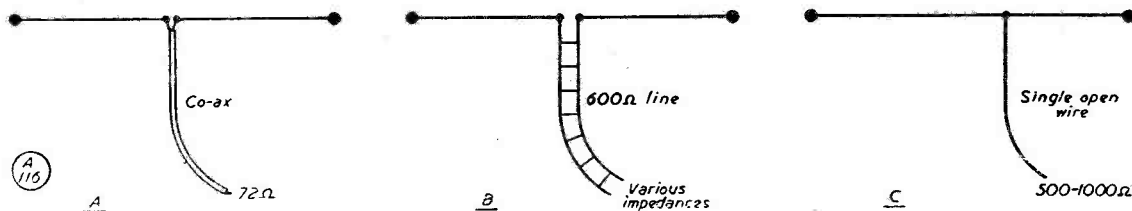

Fig. 3. Three aerial arrangements discussed in the text, with their merits and disadvantages. These are simple systems, but it is not only the beginner who may not be sure how they can be used for the best results.

dipoles in phase with each other (the outer ones) and another (the centre one, where the feeders fit) out of phase with them. So no very sharp pattern results, and the system has quite good all-round radiation.

Again, now, we have a low-impedance feed at the centre; so low-impedance points will again be found on the feeders, now 22 ft. and 44 ft. and 66 ft. from the top—multiples of a half-wave on the new band.

Whatever the length of your feeder, you have definitely got a three-band aerial; but on each band you will have to sort things out at the bottom and confront the feeders with a different impedance from the transmitter. This is only another way of saying that you must have a flexible tuned circuit which can assume a variety of impedances at different frequencies, by the use of varying L/C ratios and, if necessary, taps on the coil.

The average amateur is not equipped for measuring impedances, but he can quite easily insert a couple of RF ammeters in the feeders, and tune up, with various kinds of tuned circuit, until he gets the maximum current into them.

some feeder lengths will be easy to cope with at the bottom end, while others will not. Further, with a radiating vertical feeder which comes right down to the transmitter, TVI troubles will again arise.

Many people have found the Windom a very fascinating aerial, largely, in our opinion, *because* the feeder has been radiating. Only in this condition could it give results materially different from those of a dipole; the radiating feeder has added a vertical characteristic which has possibly put a signal into places not covered by a proper horizontal dipole!

A postscript to the Windom: it is *not* really a multi-band aerial, and the optimum point along the top for feeder matching can only be achieved for one band. There is, however, the possibility of using a feeder wire of a smaller gauge than the aerial wire. The so-called "VSIAA" version used a feeder of 18 or 20 gauge, attached to an aerial of 12 gauge, the point of tapping being exactly one-third of the way along the aerial. This was supposed to make it possible to work on 80, 40 and 20

(or 40, 20 and 10 metres) with the same aerial.

Nowadays, however, this type has lost its popularity, chiefly on account of TVI troubles caused by a radiating feeder, and is not really recommended, especially for the beginner.

End-Fed

There remains a different type—the long wire which comes right to the shack and is fed from the aerial tuning coil itself. This is only justifiable in the case of a very long wire, and with aerials of 270 feet (consisting, perhaps, of some 240 feet on the top and a 30-ft. down lead) can be very successful. The end of an exact half-wave aerial presents quite a high impedance, and is unsuitable for bringing into the shack and coupling to a transmitter; but if the wire is made too long or too short by

several feet one can bring about a state of affairs in which the wire looks, to the transmitter, like 500 or 1000 ohms, and it is then amenable to feeding from a tapping on the aerial coupling coil.

On Twenty a wire of this length is eight half-waves long, and it matters little if one of these half-waves is somewhat maltreated by being taken straight into the transmitter. Again, though, we have the danger of vertical radiation (if the end half-wave or so happens to be vertical) with consequent TVI troubles.

In the next instalment it is proposed to go into more detail concerning the method of feed, with particular reference to what happens at the bottom end of the feeders, and also to concern ourselves with methods of connecting feeders at the *end* of the radiator, instead of the centre.

Simple VFO-PA for 160 Metres

HIGH STABILITY DRIVER CIRCUIT

J. BOOTH (G3DMP)

This article will be of considerable interest to those wanting a self-contained 160-metre transmitter for phone and CW working. The author has found that by using swamp capacities on the grid side of the VFO larger than those normally advocated, it is possible to attain a very good degree of stability while getting enough drive output for 10-watt working.—Editor.

FROM time to time there have appeared in the pages of *Short Wave Magazine* circuits of various types of VFO, each having its own claim to distinction. The writer noticed that invariably they call for a stabilized source of HT and none of them seemed really simple to construct. It was felt that a VFO was a requirement, and yet it had to be easy to build—the parts to be available from the “junk box” — and when built it would be expected to retain its efficiency and stability for a long time. Much thought was given to the subject, particularly as regards not only generating an oscillation but maintaining that oscillation on a fixed frequency. The first

problem was drift and several circuits were tried, but rejected. When working another station a very careful check was kept on that station's frequency and the drift from it. It was noticed that Clapp circuits *did* drift, and in one particular case it was necessary to follow the drift in order to read the transmission! Each time he switched on his frequency was exactly 1862 kc, but he drifted HF quite a lot and at the end of his “over” he was still drifting.

Well, obviously, this was not good enough, so we asked ourselves what caused the drift. It was noticed that in every case a large C/L ratio was advised so that the valve capacity was a very low percentage of the total capacity—the valve capacity being variable and causing the drift—and obviously the lower that percentage was the less drift there would be, so a start was made. It was decided that the Top Band would be best to work on, as a very slight change of frequency could be noticed, and a coil was accordingly wound. With a .0001 μ F variable condenser to tune it and an unstabilized source of HT the drift was checked. Being unsatisfactory—as expected—the coil was reduced and the capacity increased and the results noted. Eventually a point was reached where the frequency remained fairly constant and was thought to be good enough to let loose on the air—but when it was keyed, it was decided that further improvements were necessary.

Eventual Result

The final design was satisfactory in all

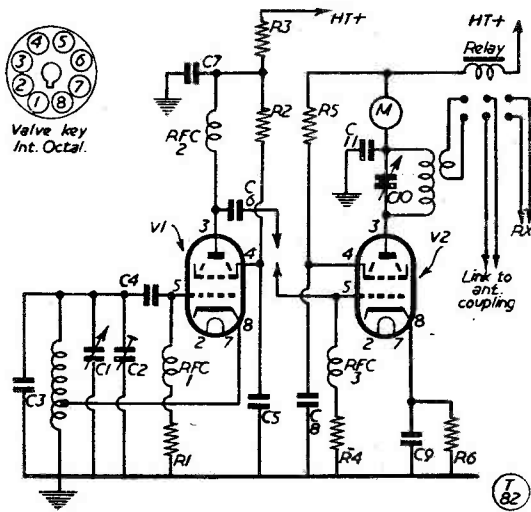

Fig. 1. Circuit of the VFO (V1) and the PA (V2) sections of G3DMP's 160-metre transmitter, using a large swamp capacity at C3 to obtain high oscillator stability.

respects, was very stable and could be keyed in either screen or HT line without any clicks being reported by the locals—even without a filter. The circuit is given in Fig. 1. During a contact with a distant station a schedule was made for the purpose of checking the stability claimed. We worked cross band 160/80 and at a given time the transmitter using the VFO was switched on at the mains. Allowing about half a minute for the heaters to warm up the other station was called and the first transmission was continued for ten minutes. The report received was that no drift whatever was noticed at his end between the start and finish of the transmission. This was repeated at a later date with his crystal filter in and the same report obtained. So it was decided that this was something like the result we were after.

Results on the Air

The original was passed on to G3FTV of Wakefield, for checking. He worked nearly 40 counties and 7 countries on Top Band and his worst result was a slight chirp reported by one station only. This, please note, was with the VFO alone and an unstabilized power pack with condenser input. Since then a PA has been added and the report now is always either T9 or T9x (see Fig. 1). Having gone so far with it we decided to go on phone and added a modulator (Fig. 2). The results were quite good, but the signal was not fully modulated. This was put down to the fact that an ex-W.D.

(C.4102-1) transformer was in use for modulation purposes, so a 6L6 was put in the final of the amplifier and then the reports were much better.

Having this equipment built in bits and pieces, the next thing was to make it look presentable, and so a standard rack mounting chassis was obtained and the VFO-PA, modulator and power pack were set out upon it. The aerial in use is about 100 ft. long and the PA is link-coupled to it through about 20 yards of twin flex (not the best method!) but the only one available for the first test. In the link coupling the relay is fitted and changes from Rx to Tx on the press of the switch. It will be noted that neither the PA nor modulator can be switched on unless the VFO is up. Also the VFO can be set spot-on to any frequency within its range without a signal being radiated.

Coil Value

A keen local SWL built a copy of the VFO and reported that even changing the valve from 6V6 to 6F6 and then to 6L6 made no difference to the calibration. He took his copy to a friend in the Midlands who tried it and was astonished at the stability, though the latter said "What, only 10 turns for 160!" The coil is 10 turns wound on a 1½" ribbed former (16.tpi) and the cathode tap is exactly 3 turns from the earth end. This was found to be optimum position for output and stability. The coil was made and fixed in position as follows: The two ends of the former were cut off and about half-an-inch from one end two holes were drilled to anchor the wire in—leaving about 3 inches spare for the connection. At exactly 3 turns a loop was made by turning

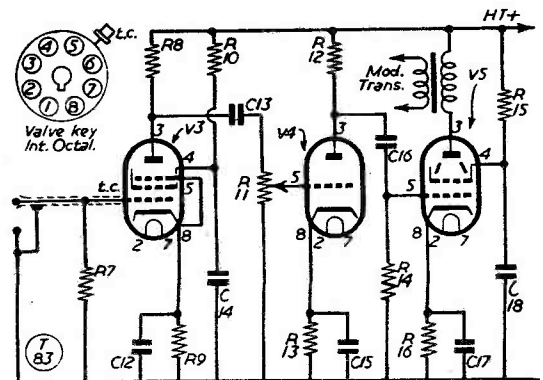

Fig. 2. Speech amplifier section of G3DMP's Top Band transmitter assembly. It is built as a single unit integral with the VFO-PA section. Values are given in the table over.

DX COMMENTARY

L. H. THOMAS, M.B.E. (G6QB)

THE month's conditions have, as usual, produced a wide variety of comments from readers. Also, as usual, however, the distribution of their letters over the various bands leaves no doubt about the real state of the ionosphere, and once again the Top Band emerges as an easy winner. We have, in fact, received more letters concerning Top-Band doings than for all the other bands together.

At the same time, we feel bound to throw out a hint that the apparently bad state of the DX bands is possibly due just as much to inactivity as to poor conditions. This inactivity business is cumulative (we were going to say that it had a "snowball" effect, but we mean precisely the reverse of that!) People listen on a Monday, hear very little on the band, so don't bother to investigate on Tuesday. By Wednesday they are convinced that it would be waste of time even to fire up the rig on the band; so others, listening, hear even fewer signals than conditions would justify—and they go away and do the same thing.

If you want proof of this effect, note the way in which all sorts of unusual DX will turn up during a Contest, however shocking the condition of the band may appear to be. Little did we think that we should ever write, or even hint at, an appeal for more CQ calls—but we do really feel that a few more calls "on spec" might reveal that the band isn't quite as dead as it seems. Practising what we preach (in *this* instance!) we have been surprised to find a very dull band (Twenty at about 0900 GMT) disorganizing a KR6, a JA and a



ZS6Q

CALLS HEARD, WORKED AND QSL'd

DU, all apparently springing up from nowhere in response to a short "CQ DX."

However, the Top-Band section of the mail-bag is bursting at the seams, so we really must clear that one first.

Top Band DX

The last sessions of the Trans-Atlantics were again beset by very poor conditions from our point of view, although the W's and VE's found plenty to interest them. We will not say too much about the organised tests, because the next issue will see the complete summary of this season's event.

Interesting DX on the band (to say the least of it) included KV4AA, 4AQ and 4BB, KP4KD and 4UE, KZ5DE, KH6IJ and 6MG, VP7NM, VP9BDA and 9BF, and ZL3RB. All of these were worked by various W's. VP4LZ also showed up several times, and VE1EA worked him for his first South American contact.

CN2AO made a wonderful job of representing the African Con-

tinental, and incidentally worked more than 30 G's and roughly the same number of W's.

KP4KD worked G6BQ for his first G, and also raised GD3UB and EI9J. The latter QSO made it *six* bands worked between those two stations. EI9J, incidentally, had a remarkable variety of DX contacts outside W and VE: they included CN2AO, KV4AA and 4BB, KP4KD, VP7NM and VP4LZ. We believe that he is the only European station to have worked South America, and duly congratulate him on that last contact, which happened on March 14.

There is no doubt that the path shifted southwards this year, and that although conditions on several mornings were quite hopeless for U.S.A. and Canada, they were good for the West Indies and South America. Unfortunately the activity from those areas was so slight, compared with that from the States, that the general impression remained that of bad conditions. But EI9J went to considerable trouble over these

tests—including the acquisition of another receiver and the carrying out of considerable mods. to it, and he was certainly well rewarded.

Several law-abiding G stations complain that the arrival of exotic prefixes made some of the excitable types see red. Thereafter they called at the wrong times, on the DX station's frequency, on spec., and so on—in short, the law of the jungle prevailed, but nobody got anything.

R. H. Jeakings (Luton), who heard VP4LZ at 0550 on March 14, comments on this behaviour and thinks that more worth-while QSO's would have taken place if some G stations had listened more instead of just calling and calling. VP4LZ was working WIBB (they were almost on the same frequency), and then WIBB moved down to another crystal. After that, the G's took over and VP4LZ was never heard again. A sad story—and not by any means a new one

G2HKU is even more outspoken, and says that VP7NM and KP4KD were on 1879 and 1822 kc, each with a pack of baying hounds calling them at *zero-beat*. He wonders why some of the top DX men should go in to work the DX that our organised tests have got together and then ignore all the rules. He adds that the results they produced amounted to *nil*, whereas one G who stayed inside the suggested band limits was rewarded with a QSO. Trouble is, this *zero-beat* racket usually wipes out the DX station and even the law-abiders can't find him any more.

Cross-Band Working

A surprising amount of cross-band activity (160-80 metres) is being reported these days. SM's, DL's and PA's are all being worked in this way. G3HYJ (Norwich) raised DL7AH, PAØUL and SM6ACO, all three being on or around 3520 kc and listening around 1820 kc. 'HYJ thinks he could easily manage *daylight* cross-band contacts with PA and ON; the work mentioned above was all at about 2300 GMT.

G3CO (London, S.E.14) worked SM7AKG by the same means (3520 kc at 2345). G3HIW (Ilford) mentions hearing SM6ACO on 1820 kc calling CQ G—looks as though the SM must have a pretty potent (and keyed) VFO! G5LH (Horbury) worked OH3PP on March 5 (both stations on Top Band), and the OH said that he had a special licence, but gave no details of how long it was in force. Working cross-band, G5LH raised DL9RKA, south of Munich.

G2HKU (Sheerness) mentions that DL7AH wants cross-band QSO's; he listens around 1820 kc and will reply on or near 3520 kc most nights after 2200 GMT. (Seems these two spots must be getting quite congested now!)

G5JP (Hawkinge) appeals on behalf of the chaps on the 80-metre band on these occasions. On completing a cross-band QSO, he says, the G should do his best to keep the European in the picture; too often he is left with a receiver on 160 and a transmitter on 80 and no one to help him. Until the cross-band habit is more widely known, G5JP suggests that G stations should accept it as a kind of responsibility to find another contact for the European before letting him go.

Incidentally, 'JP reports working UB5CF on 80 metres (G5BJ also worked him); they then got him to fire up on 1820 kc. QRN, unfortunately, beat the attempt both at cross-band and at a direct QSO. UB5CF said "QSL *via* Box 52, Odessa." Final note—SM1BVQ is cross-banding from Visby, Gottland—an island in the Baltic.

GC3EML (Jersey) suggests that some organised Cross-Band tests, possibly in the autumn, might be interesting and worth while.

Some Expeditions

County-chasers should make a date with their rigs over the Easter holiday, as we are promised the following activity: G3GMN, 3EUK, 3JMY and 3IYW will be getting together to operate GW3GMN/P in *Carmarthen, Cardigan and Pembroke*. G5PP also promises to do his stuff, and will be joining forces with G3IWF for the purpose; they will operate two stations, and GW3IWF/P and GW5PP/P will be on the air from *Radnor, Montgomery and Brecon*. These two stations will operate on a rota, so that each of these three Counties will be active for two nights out of three. Activity will be mostly from 1700 until midnight, and as the two stations will be close

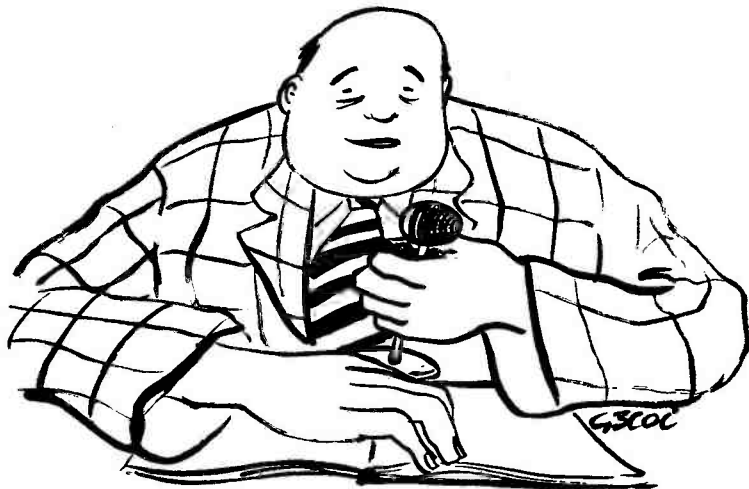

" Eventually, old man, we intend to miniaturise here "

together (physically) they will probably operate at opposite ends of the band.

GM3IGW (Alloa) says he may be leaving GM-land for good, and possibly at short notice. He would like, before doing so, to operate from Selkirk or Peebles under his /A licence, and wants to hear from any SWL in those counties. IGW will provide the transmitter, if the SWL will provide the receiver and a "piece of wire."

Other Top-Band News

GM3IGW says that when he leaves, Clackmannan will still be represented by GM3JNW (Alloa), who is getting under way and very keen. G2HKU mentions QSO's with GC3EBK (Guernsey), G13JEX (Antrim), GM3HRZ (Moray) and others such as OK's and HB9T.

GM2CAS (Aberdeen) has made WABC, including all English counties except Cambridge and Suffolk. He intends going portable in conjunction with GM3HLQ, and they will eventually put Nairn and Inverness on the map.

G3IOX (Birkenhead) is another WABC claimant—using a 66-ft. aerial with a 45-ft. top and a

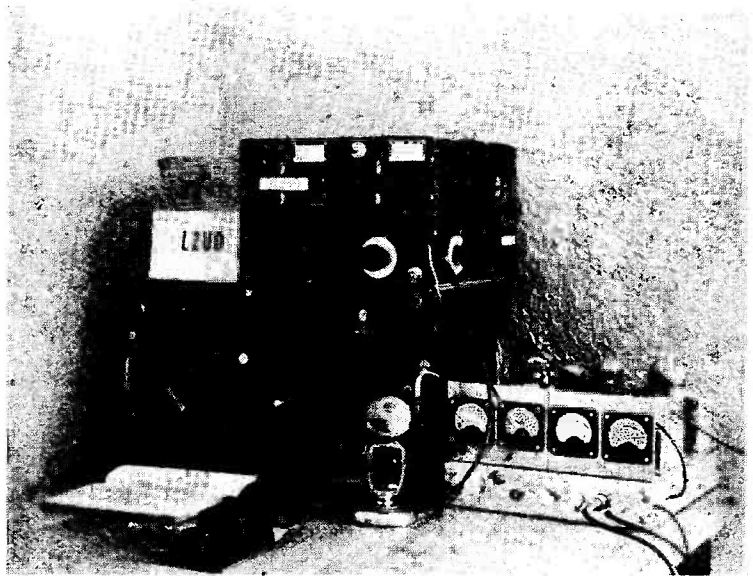

DL2VD of Aachen is ON4AC of Nieuwpoort, being a Belgian licensed under the British DL2 administration. The transmitter runs EF80 Clapp VFO, on 875 kc, into EF80-6K7, into 6AG7-807 PA with 25w. input on 3.5 and 7 mc; for phone, the 807 is plate-screen modulated with a pair of 6V6's, and the aerial is a long-wire, with a BC-342 receiver. DL2VD is always on the look-out for G contacts.

height of only 20 ft. He has also had contacts with OH, OK and DL2—nice work!

G3CFG (Leicester) has moved his QTH, and was amazed to raise GM3JDR (Caithness) on twenty feet of wire slung out of the window. He wants more MDT's (*Magazine* Daylight Tests)—and his wish will be gratified in due course. G13HFT (Belfast) worked GW3CPU (Cardigan) for a new one, making him 81 all round.

G3HIS (Ashbourne) raised ZC4JA on February 28, but can't get across to W-land. He wonders whether we would consider a "WABC/2" award—for doing the whole thing a second time with different stations. We think not, on the whole.

GM3OM (Larbert) mentions GM3JFG (Ross) and GM6JH (West Lothian), and he has now cleaned up Wales except for Merioneth.

G3IOR (Norwich) has a half-wave aerial, 60-ft. up in the clear, but can't raise W's. He gets 599's all round Europe (cross-band included) and good reports from CN2AO and ZC4JA—but still

nothing doing across the pond. So he has now put up a reflector, which brings the W's in at wonderful strength; he even reports hearing W6NDI at 559! Of course, it's too late to worry about it now for this season, but later in the year his luck will probably change.

GM3EFS (Dumbarton) mentions GC3EBK and 3HFE—both in Guernsey—and GM6JH (West Lothian). They have put his score up to 85 worked, 83 confirmed. G3CO mentions GM3FGQ in Stranraer (Wigtown), who will be there for some months.

The DX on Twenty

And so to the real DX bands, starting with Twenty, still the most popular and most useful of them all. A small manifestation in the expedition line showed up, when EA9DE and EA9DF shook the band from Rio de Oro. But EA9DD had previously made such a good job of his trip that there was relatively little panic for these two.

Mornings have been poor, on the whole, and evenings fair to moderate. Early in March the

Short Wave Magazine DX CERTIFICATES

The following have been awarded since the publication of the last list, in the February issue:

WFE	
No. 15	VK3YS (Box Hill, Victoria)
WNA CA	
No. 65	CM9AA (Havana)
66	OZ2PA (Copenhagen)
WABC	
No. 53	G3CO (London, S.E.14)
54	G3ABG (Cannock)
55	GM2CAS (Aberdeen)
56	G2DVD (Sliffold)
57	G3IOX (Birkenhead)
58	G3CFG (Leicester)
FBA	
No. 30	G2BOZ (Kidderminster)
31	G3DO (Sutton Coldfield)
32	KP4KD (San Juan, P.R.)
33	DL1YA (Munich)
34	DL3RK (Kaufbeuren)
35	G8KU (Scarborough)

General conditions for claiming MAGAZINE DX AWARDS and CERTIFICATES appeared on p. 419 of the September, 1953, issue.

conditions seemed very good for Africa; this is mentioned by G3CMH (Yeovil), who heard FB8BC, FR7ZA, five ZD4's, VQ5, VQ8, four ZS3's and ZS8D. On phone 'CMH worked EA9DE, KA2BS (0955), OD5AJ, OX3GA, VS2DV (1550), XZ2KN (1500), ZS3BC, 3A2AH and 3V8AS. Got-aways were CR5SP, KA2IM and 3LR, MP4ABW and ZD9AB. The latter is using the gear of the former ZD9AA, who has now left.

G5BZ (Croydon) has not been very active, but raised MP4BBL, VP2AD and EA9DE, all on CW, and MP4QAH on phone. G3DO (Sutton Coldfield) raised EA9DE on phone, and found conditions good most evenings between 1745 and 1930 GMT. He has just received his WAE (Phone), which is only the second issued to a G.

G3FKM (Birmingham) put up a ground-plane for Twenty and promptly raised DU7SV, KR6AA, EL2P and 2X, MP4BBE and 4BBL, EA9DE and 9DF, VP4LZ, VP6LN, VP8AJ, HS1D and other nice ones—these on CW. Phone work brought in HR1AA, EA9DE, YV5AB and M1B. He also heard LB8YB, using 5 watts of phone.

G3TR (Southampton) is back on the air after months of inactivity and rebuilding. Phone QSO's include EQ3AL (0845), VQ8AL and 8AR, HS1WR, EA9DE, MP4 (Bahrain and Qatar), FB8, VU, VS1, ZS3 and more. He has found South Africans very consistent in the evenings. Some amusement was caused by a pirate with a strong foreign accent, calling himself ZL2BT one morning and VP6FO the next! A few well-chosen remarks from G3TR caused a hurried QRT on both occasions.

Nice ones for G3GWT (Hull) were HS1D (1400), VK1AC, VP2, VP4, VQ5 and W4ASZ/KL7. G3IOR mentions contacts with KV4, MP4, HZ, JA, VP9, EA9, FQ8, VK, W6 and the like—all on CW, although he has now got phone going.

G2DPY (Shoreham) mentions only EA9DE, apart from "the usual stuff."

Forty-Metre Doings

There's no doubt the DX is

there on Forty—if you can find it. One of the consistent diggers is YU1AD (Belgrade), who has raised five brand-new ones in the shape of VP8AK and 8AX, LB8YB, VP2MD and VP3YG. Other doings included twenty W6's via the long path, FB8BJ, dozens of ZS, VK and ZL. And Mirko adds that he has been called by KL7, KR6 and KX6 in the afternoons, but couldn't read them through the fierce QRM.

G2DPY collected EL2X (0600), HC1FG (0835) and YV1AD (0700). G3IOR offers EA9, KV4, TI2PZ, TF5SW and sundry VP9, KP4, LU, ZL, W and the like. He would like to know more about SFX3ZB, calling CQ DX on Forty!

G3GWT struck a bad patch on Twenty, transferred to Forty and promptly raised VP8AW and 8AX, CR6, ZD4, ZE3, ZS, VQ4, PY, LU and the like, and quite enjoyed his stay.

DL7AA (Berlin) now has the magnificent score of 154 worked on the band! His latest were FB8XX, 15LV, HS1D, VP3YG, VS1FE, KG6AAY and CR9AF.

GM3IGW worked MF2 and LZ for two new ones, and heard EL2X, OQ5GU and VQ2GW on CW, CN2AD and ZB2A on phone.

Eighty-Metre DX

It is well known that the 80-metre DX types are rather reticent about their achievements—they don't want the whole thing turning bad on them, and who can blame them? But this month we have a few words from G2DPY on his recent doings up on this band. Some early rising produced results in the shape of EL2X, KV4AA, KZ5IL, TF5TF, OX3AY, ZB1BF and 23 ZL's. All this, by the way, with 25-30 watts and an aerial which is not too clever for Eighty. VP9BDA and XE1MA were also heard on the band.

A new one for DL7AA was VS9AS at 2100 GMT. YU1AD, also a devotee of Eighty, worked SV0SP, VP9BF and HZ1AZ, giving him a score of 76 on Eighty metres.

Fifteen-Metre Stalwarts

Just a few faithful supporters

cling to this band, and do surprisingly well. One of the staunchest is G3HCU (Chiddingfold), who has now raised 77 countries on phone. New ones this month has been 4S7YL, HB9CV, HZ1HZ, IS1CYZ, ZD1SW; other contacts have included CR6, VK6, VS1, VQ2, VQ4, Y1, ZE, ZS, ZS3 and ZS9. And yes—*we did say 21 mc!* 'HCU says conditions are not so bad, and there is even some activity on week-days with VQ4 and ZS.

G3TR, another phone man, has collected EA9DE, EL2X, ET, VK, VS1, ZS9 and lots of VQ's and ZS's. G3CMH, also on phone, worked EA9DE, PY's and 5A2CO. He has found activity confined to week-ends, and mostly Africans at that. The band is generally closed

TOP BAND COUNTIES LADDER (Starting Jan. 1, 1952)

Station	Confirmed	Worked
GM3IGW	86	87
GM3OM	83	85
GM3EFS	83	85
G5LH	82	82
G6VC	82	82
G13HFT	81	81
G16YW	81	81
G3HIS	77	80
G3ELZ	77	78
G2NJ	77	77
G3HIW	69	77
G2YS	66	75
G3CO	66	68
G3IVH	66	68
G8TS	64	69
G3HTI	63	68
G2AYG	63	64
G3BRL	62	63
G5JM	61	77
G2DVD	61	63
G3IOX	60	70
G3CFG	60	62
G3LP	60	60
G3HYJ	59	65
G3JEQ	54	65
G3DO	54	58
G3ITY	44	54
G2HKU	41	46
G8VG	38	51
G5FA	37	52

by 1700, although sometimes it is open for South America later than that.

G5BZ brought his band total up to 96 with EL2X and VP7NM on CW, EA9DE on phone. He also raised KZ5IL again. G8TS (Farnham) was another who raised EA9DE on phone.

News from Overseas

DL2UO (Uetersen, 'BAOR) is ex-VS6CK, and asks us to say that he will be operating by now on 80, 40 and 20 CW.

G3HVB (Cheltenham) has now become VS6CU, but has to run a year on 25 watts CW only. He wants his old Cheltenham friends to look for him on 14 and 21 mc.

YU1GM (Belgrade) is W4GMP, ex-W8RYJ, and is the first foreigner to be granted the privilege of a licence in Yugo-Slavia. He will be using a Viking II and probably a BC-348 with converter. A 12-element Sterba will be used on Twenty, with W8JK arrays on other bands and possibly a V-beam as well. He hopes to work many G's during his stay, and informs us that he is *not* connected with the MARS set-up in any way.

ZD6BX will be coming on the air shortly, and is no stranger to working G's from afar off, being ex-VS1BX. He will be using 100 watts and promises some operation on Forty and Eighty.

No Change

No change in positions, and only three changes in scores have been reported this month for the Five-Band DX table, which is therefore being held over until next month. We should like to see a lot of new entries for it, too.

General Patter

DL7AA would very much like to get in touch with ex-HZ1KE, from whom he still wants a 10-metre QSL!

G3HYJ tells us that ZD4BN should by now be in South Africa, after which he is moving to Rhodesia and hopes to come on 14 and 21 mc.

G2DPY passes on, from VS9AS, a queer message from LUØMA, stating that the "first Argentine expedition to the Himalayas is



“. . . . And at the handle here, is Bert”

assembled in Pokhara.” Whether this means that any signals heard from LUØMA will, in fact, be coming from VU or such-like parts we do not yet know. But it's a call worth noting.

Yet another world-wide DX Contest is with us. The LABRE (Brazil) announces that the “LABRE Contest” will in future take place each year during the first two week-ends in September—CW the first week-end and phone the second. Six-figure numbers consisting of RST and a serial number (or, for phone, five figures consisting of RS and a serial number) will be exchanged. Serial numbers will start at 001 in all cases.

Contacts between stations in different countries, outside the American continent, count one point; contacts between stations within the American continent will count two points; and between stations within the American continent and any other stations in the world, three points.

Two multipliers— for each American area country worked on each band, and for each Brazilian call area (PY 1 to 9) worked on each band.

For those interested, we have a few copies of the rules in full, which we will be pleased to forward on receipt of a stamped addressed envelope. Countries in the American area, numbering 57 in all, extend from Alaska right down to Antarctica—so it looks like being quite a busy and

interesting affair, if September conditions make it worth while.

No FBA Change

Our tentative suggestion, made last month and ever-so-slightly with tongue in cheek, that the Four-Band Award was now too easy and might be scrapped, has produced a few indignant replies. They add up to a pretty logical argument against any change, so, whatever we may produce in the way of a Five-Band or Six-Band Award, the old FBA will remain relax, chaps!

Ethics Again

An amateur who has stuck to Eighty for the past five years recently made an excursion on to the DX bands, and felt the urge to see how things went. After failing completely to add any new ones to his previous list of countries worked, he gave it up, but spent a lot of time listening “to see how it is done these days.” The impressions he gained, while not strictly accurate, are quite illuminating and not at all flattering to the DX fraternity.

His chief grouses concern too-slow sending, too-long CQ calls, zero-beating, cutting-in on QSO's, QSY-ing with the power on, calling CQ DX without listening . . . in fact, all the same old bogeys. It just goes to show that some people never learn. We have all got rather hardened to the pests that make life difficult, but expose an old-timer to them after a long

21 mc MARATHON

(Starting July 1, 1952)

STATION	COUNTRIES
VQ4RF	103
G5BZ	96
G3GUM	91
DL7AA	90
G2WW	85
G4ZU	85
G2BW	82
G3HCU (Phone)	77
G2BJY	77
DL2RO	75
G2YS	74
G6QB	73
G2VD	70
G3DO	68
ZS2AT	66
G3TR (Phone)	64
G3CMH	62
G3FXB	57
G6QX	56
ZE3JO	55
G8OJ	53
G8KP	50
VK2AWU	47
G2DPY	38
GM2DBX (Phone)	32
G5FA	31
G3WP	26
GW3CKB	19
G8VG	18
G2DHV	11
4S7XG	11

absence, and you get a really strong reaction—which we certainly did in this case!

As against this, we have another letter (from another amateur personally known to the first one) which says that the writer would back a *good* DX-man against any of the rag-chewers for general operating ability and “know-how.” He says that most of the consistent DX workers these days operate at about 18 w.p.m. and not with the old 5 w.p.m. DX-roll. And he pleads for a tolerant attitude, adding that he doesn’t even *mentally* curse when someone starts calling CQ on top of the DX being worked—the CQ-er probably doesn’t even know it is there, and where is the poor beginner or plodder to go if everyone hounds him around all the time? In short, he puts the onus for working the DX on the operating ability of the man working it—through all sorts and conditions of QRM, QRN, BF-and-BI, Lids, Spivs and Whatnots.

On the whole, we agree with him, but would like to add “How do some of the inexperienced ones ever improve their technique if someone doesn’t lecture them occasionally?” We have done our fair share of that in the past, and will continue to do so—but never to the extent of “Get off my frequency” or “Leave my DX alone.” Certainly some people have more than their fair share of nuisance-value, and our all-time No. 1 Pet Aversion is certainly the chap who never even suspects the existence of a signal weaker than about S5, who CQ’s and CQ’s, working locals rather than strain his atrophied ears to

find that bit of DX that he seems to want so badly—and, of course, trampling lots of weak DX down in the process. To him we say the largest of “Gerchers”—but there’s nothing we can *do* about it.

ZS2AT (East London) says his particular peeve is the man who can’t wait until the end of a transmission to break in, but must do it while you are busy copying. And he points out that ST2UU and others have only to adopt the “QLH” or “QHL” technique to save themselves a lot of bother; once the gang spread out, you can always choose the “outside ones”—which will make them spread out still more.

DX Strays

FO8AJ was supposed to be operating from Clipperton Island round about March 26-29 we hope he did, and we hope you worked him. TI9AB’s expedition has been postponed, possibly until next year. Two permanent settlers in rare spots are CEØAD and EA9DF.

Any VQ8 call is interesting, but one of them may shortly be on from Tromelin Islet—a new one. HK1AI, formerly HK1GP, is on San Andres Island—also possibly a new one.

That just about completes the April homily, and may we remind you that copy for the May issue is required by **first post on Wednesday, April 14**—on account of the Easter break which follows almost immediately. Address it all to DX Commentary, *Short Wave Magazine*, 55 Victoria Street, London, S.W.1. Until next time, 73 and BCNU.

INDEX — VOLUME XI

Some readers have remarked that the printing of our current Index as a folder, rather than as a 6-page leaflet, is inconvenient for binding. We suggest that this should not matter if the Index is kept as a loose insert, as originally intended, rather than being bound in. It might just be added that, as the Index is an expensive supplement distributed *free* with every copy of the first issue of a new Volume, it is necessary to produce it as economically as is reasonably possible!

CONTINENTAL HOLIDAY PLAN

We are asked by G2DUV and G6MN to announce that they are arranging a fortnight’s holiday party on the Continent, commencing on July 24. Amateurs and their ladies, YL’s or XYL’s, who would like to join are asked to get in touch immediately with Eric Martin, G6MN, Castlemount, Worksop, Notts. Depending on its numbers, an organised party can secure advantageous travel and hotel rates, which all helps to make the holiday money go further.

PERSONAL TOUCH IN TVI

THE NEIGHBOURLY APPROACH

N. P. SPOONER (G2NS)

MUCH excellent information upon the suppression of unauthorised radiation has already appeared in *SHORT WAVE MAGAZINE*, and the purpose, therefore, of the present article is not to attempt to add to such knowledge, but to suggest how readers may best ascertain whether their immediate neighbourhood is TVI-proof or not. "That's easy. You just wait for the P.O. van to call with the complaints," some may say. The original simplicity of this inter-war procedure has, however, been confounded by the advent of TV; gone beyond recall are the days when the gay radiation of key-thumps, parasitics and harmonics would be detected only by a stray BCL or two. The arrival of the van could be still further delayed by keeping off phone and (foxily) relying on the fact that few of the neighbours would recognise CW.

But without having to hear speech or read Morse, viewers can nowadays actually see what is being done to their screens, and the whereabouts of an interference-suspect is much more accurately and rapidly pin-pointed.

Confucius, in a personal QSO, is logged as having once said: "What emerges from a single mouth promptly enters a hundred ears," and an amateur's aerial system certainly prompts gossip to travel faster over a garden fence than by any grape-vine, bush-telegraph or hill-top signal-fire.

It is here in an intimate circle round the amateur site itself than the vexed heart of the interference problem will be found, because even when the effects of harmonic radiation or of swamping have been overcome (as they usually can be) the amateur is still at the mercy of any TV receiver designer who chooses to pirate frequencies allotted by international agreement and the P.M.G. to amateur transmitters. Perhaps this is thought by the receiver designers to be the actual meaning of a "shared band"? The new Post Office policy, to come into force in October 1954 will change a permanent close-down on the interfering frequencies into an embargo lasting only four weeks from the date on which the cause of the trouble (IF choice or image response) is notified to the complainant by the Post Office—but it should be remembered that a radius, peacefully TVI-proof at any given moment, can, within a few hours, again become prone to interference if another of its residents newly acquires an offending receiver. From the amateur's point of view, the trouble can be never-ending. Good, clean signals from an authorised amateur, emitted on a licensed frequency and free of harmonics in any TV channel, can still spoil a

peaceful scene. One may well ask how such an occurrence becomes possible.

Original Sin

It is traceable to the day when, instead of getting together and agreeing on a single standardised intermediate frequency of, say, 34 mc, each TV manufacturer chose to rush off on a separate path. This has produced at least 60 different prototypes, each with a 14 mc IF—and not to be outdone by the antics of its rivals, one firm in particular has even evolved a comic-opera, man-made interference policy of selling John Bull a TV receiver with one hand while, with the other, it sells Mrs. J. B. an unsuppressed hair-dryer!

Slaying the Dragon

What concerns us, as serious amateurs embroiled in all this buffoonery, is that apart from what may or may not later rear its ugly head, a fiery beast has arisen and must be faced. It is not the fault of either retailer or purchaser; neither the one, being unaware of all local amateur addresses, nor the other, being non-technical, can reject the receiver as a trouble-maker until too late. TVI is undoubtedly the most aggressive thing that has ever hit the radio amateur, and the density of life in built-up areas makes direct meetings between licensee and complainant not only unavoidable but also extremely necessary if peace is to be maintained. Personal contacts afford the chance to learn what type of receiver one will have to contend with, and they also present the opportunity of demonstrating the desire for good-neighbourliness. Such approaches dispel suspicion, stifle recrimination and allow a simple explanation to be given of the various sources of local unsuppressed electrical interference that can affect viewer and amateur alike. No reader need ever fear that bearding the lion, so to speak, in this manner is "asking for trouble"—it is the manufacturer who pre-ordains this in most cases. It will usually be found that the viewer warms readily at the discovery that the experimenting amateur is not a public enemy after all, but a reasonable, law-abiding citizen desirous of peace and good relations all round, so that he, too, may be left undisturbed.

Message of Goodwill

The procedure to be described was carried out recently by the writer when setting-up a fringe area /A station 90 miles from the nearest TV transmitter. From the new site itself a dozen or more tilted four-element arrays could be seen, but across the road were two within 50 and 90 feet respectively. Some two or three weeks before moving-in the following letter was sent to the two owners, whose names were obtained from the local directory:

"TELEVISION INTERFERENCE"

"For over 20 years the writer of this letter has been licensed by the Postmaster General to operate an amateur short-wave wireless transmitter

at various addresses in the neighbourhood. Since television started no complaints have been received directly from neighbours or through the licensing authorities that my Morse or telephony transmissions have ever interfered with local television reception. I am hoping that this happy state of affairs continues and that no unwanted signs of my activities appear on your TV screen after I have moved-in opposite. As a viewer, you may have discovered that innumerable sources of still-unrepressed local electrical interference spoil your picture and that the TVI (Television Interference) question may become increasingly vexed as more TV receivers and household electrical gadgets come on the market. As a transmitting amateur, my own short-wave reception suffers from the same sources as your TV, and it may surprise you to learn that some TV receivers can cause severe interference not only to other TV receivers, but also to nearby broadcast and short-wave receivers. Each district provides its own particular TVI problems, and after I have complied with the terms of my licence and have fully suppressed the radiation of harmonics from my apparatus (which is periodically inspected by the Post Office engineers) I am still at the mercy of any TV receiver designer who chooses to tune certain internal parts of the receiver to a wavelength allotted by international agreement and the Postmaster-General to amateur transmitters. The owner of the receiver, the amateur and the Post Office investigator are thus faced with a receiver that naturally accepts the nearby amateur transmissions in preference to those from the television station—a depressing situation brought about entirely by the manufacturer. In view of the complexity of the TVI problem and the fact that complainants themselves may be severe offenders in causing interference to others, you will, I think, agree with me that, in finding a solution, the patient co-operation of all concerned is necessary. If I operate my transmitter when you are viewing a current programme, and any sign of interference from me is visible, every step can then be taken by me to take a cure. This, of course, would not involve you in any expense and your TV receiver would not be touched internally in any way. If, on the other hand, you would like to deal directly with the licensing authorities instead of with me personally, you have only to fill in and post off the accompanying Interference Complaint form. A Post Office engineer will then act as neutral go-between and arrange for exactly the same test transmissions to be made by me as I have already outlined. I should like to take this opportunity of thanking you for reading this necessarily long description of modern conditions and for any consideration you may care to give to the points I have raised. With your permission, I will call later to ascertain the maker's name and the model description or number of your set."

TVI Drill

As can be seen, Mrs. A. and Mr. B. were thus given ample time in which to consider the position, compare notes and brief their reception committees. When the time came for a personal call a cordial reception was given by both, the former expressing the hope that her TV receiver would not interfere with the writer's SX28, and the latter remarking that he now recognised passing cars on his screen and a certain neighbour's unrepressed electric drill; but it was news to him that an amateur transmitter could, perhaps, cause interference. The makers' names and model numbers were obtained during this meeting, published details confirming that Mrs. A's set had a 16 mc IF. The same evening, while she was viewing the current programme, the transmitter was operated on 3.5, 7 and 14 mc in turn and, as was expected, no trace whatever of interference was visible. Band-switching, re-tuning and crossing the road to enquire the effect took little more than 10 minutes in all because, with TV, results are obtained immediately the key closes.

With Mr. B. unfortunately, matters proved very different, as he had been saddled with a pre-amplifier and a 14 mc IF in addition to a 42 mc image frequency for sound! It was, therefore, some considerable consolation to find during the tests that no interference was caused by the 3.5 or 7 mc transmissions and that the explanatory letter had fully paved the way for the 14 mc situation.

Mr. B was all for heaving bricks forthwith at the manufacturer: "That's what I call complete disregard of the market!" he exclaimed; "the maker does what he pleases and the customer can take it or leave it. It's the couldn't-care-less attitude of modern times and an affront to the people who supply the butter for his bread. I wouldn't be in business long myself if I carried on like that." The reduction of transmitter power, the insertion of a high-pass filter and the addition of a receiver mains filter all materially assisted in reducing the interference, but still did not clear it to the satisfaction of either party.

Strategic Withdrawal

Much more could have been attempted were it not for the fact that tampering with a receiver still under guarantee is not permissible and that, in any case, existing P.O. regulations require fringe-area amateurs to cease whatever interference their operations may cause. In the case under consideration, no hardship is suffered by the writer in being kept off 14 mc for four hours in every 24. Mr. B., at business during the day, looks-in at a time when the 14 mc band is not exactly "bursting with DX," and this thought, together with any others that may have been aroused by this article, may encourage readers to strive for *personal contacts always*, so that a better understanding by all concerned in the TVI problem may be lastingly established. Keep your harmonics at home, keep an anti-swamp filter handy in case of need, and trust that the nearest offending TV receiver will be found miles away!

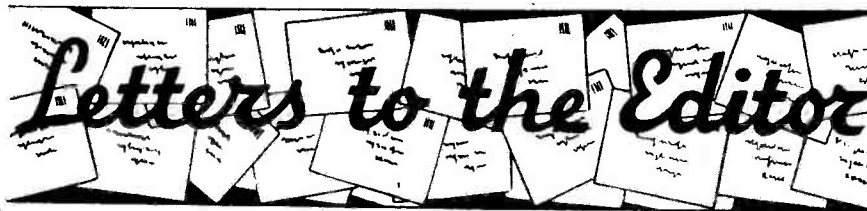

Letters to the Editor

Letters published are those which seem to us to be of general interest, but should not be read as necessarily being in accordance with our own views on the subject. We welcome readers' comments.

TRANSISTORS

SIR,—You are to be complimented on the article "Transmission with Transistors" in the March issue; it is the best as yet published on the subject, and sets a high standard in technical journalism. Nowhere does the author say "... it can be shown that ..." or "... it is obvious that ..." He shows and explains everything. Congratulations to G3HMO, and it is to be hoped that he will appear again in your pages.

A. Parsons, G4XB/G6PU, 19 Woodfield Avenue, Farlington, Cosham, Hants.

SIR, — With reference to G3HMO's article in the March issue, you may be interested in my attempt at making a transistor. I used a 5-pin valve holder as mount, with the crystal held in solder to the centre pin; two electrodes, as emitter and collector, were made by soldering ordinary pins, bent to be springy, to the filament legs of the valve holder; these electrodes were applied to the germanium, and the whole assembly wired into circuit by soldering leads to the valve holder pins. So far, medium-wave reception has been possible.

L. J. Weaver, Louise Cottage, Dunton, Laindon, Essex.

SSB RECEPTION

SIR,—I cannot agree that reception is a problem in SSB working. I do not use anything else but a standard communications receiver in the CW position, i.e., in my own case an Eddystone 750. Additionally, I never switch the BFO off now and use the receiver in this way to take one side of a normal A3 (phone) double-side-band transmission. I am abso-

lutely convinced that, by using this method of exalted carrier reception, the intelligibility of all phone transmissions is increased under QRM conditions. I have, of course, tried front end injection of a separate carrier from a BC-221, but have never found it any advantage.

E. A. Dedman, G2NH, 75 Woodlands Avenue, New Malden, Surrey.

"TWO-BAND VHF RECEIVER"

SIR,—I have recently made some measurements using various front ends in my VHF receiver now being described. The best noise figure obtainable on the 29 mc section, V4-V6 in the block diagram on p.37 of the March issue, is about 8 dB. In view of some work done recently by G3BKQ, it became evident that better figures should be achieved with a cascade arrangement. This is of the CQ "Wallman" type, and is built on the same size chassis as the 29 mc section described in my article, being made interchangeable with it. Using a 6AK5 as a neutralised triode for V4, a 6J6 g.g.t. as V5, and a 6AK5 as triode mixer for V6, the best obtainable noise figure becomes 1.3 dB. As regards the two-metre section of the receiver (Fig. 2, p.38), this gives 3.5-4.5 dB when properly neutralised. The variation that occurs from time to time with a unit of this type is probably due to the form of construction of the 6J6 itself. In the 430 mc front end (Fig. 3, p.38, March) it has been possible to test 12 different valves, 446A's and 2C40's, for V1; the best gives a noise figure of 3.5 dB and the worst 18 dB! These valves all appeared perfect on

characteristics. When using the crystal frequency changer alone, also in the circuit of Fig. 3, the best silicon crystal found out of a selection of 18 gives a noise figure of 5 dB; the majority varied between 6 and 10 dB. All figures quoted in this letter are relative values.

R. F. Weston, G2BVW, 1 Church Lane, Rearsby, Leics.

YOUNGER GENERATION

SIR,—With regard to your suggestion on p.683 of the January issue, I think it would be a good idea if you also allowed non-transmitting SWL's to join the proposed club; there cannot be a lot of amateurs under the age of 17, but there must be a number of enthusiasts who intend to become licensed in the future. In any case, can you give the addresses of some of the "Younger Operators," as it would be interesting to exchange ideas?

R. Ellams, East Bank, Doric Avenue, Bradley Lane, Frodsham, via Warrington, Lancs.

SIR,—I would be interested in joining a Young Operators' Club. I am 15½ and was issued my licence on November 24, 1953. I operate on the Top Band, using the rig of my father, G3DIR. I also run a VFO-BA-PA CW transmitter on 80 metres, with 24 watts input. I have had no real DX yet, but I have worked most of the Continent. The School Radio Club hopes to get a station going in order to gain more recruits.

D. Buckland, G3JKM, 21 The Leas, Baldock, Herts.

SIR,—I read of your proposal to form a Young Operators' Club. Although I am not licensed, but only an SWL, I would like to join the listener section if it should be

possible to form one. I am 15 years old and I listen on the DX bands.

J. Eden, Brook House, Fordham, Ely, Cambs.

Our original idea was, certainly, that the Y.O. Club should be confined to licensed junior operators. As there are not more than half-a-dozen of the latter on the air at the moment, we suggest that those interested should correspond with one another until a few more Y.O.'s are licensed.—*Editor.*

PROBLEM OF TVI

SIR.—A friend of mine had a case of TVI. He called in the GPO, who checked with their TV test set on the desk next to his transmitter, with the TV aerial in the same room. There was no interference whatsoever. This established the fact that the transmitter was free from harmonics in the TV band involved. The GPO informed the complainant that the amateur was not to blame, and that it was up to the makers to put the matter right; this the makers agreed to do, as their TV receiver had its IF in the 14 mc amateur band! But the owner of the set refused to allow the modification, and complained to the P.M.G. My friend then had a letter from the GPO to the effect that he must "cease using the frequency which caused the interference." Taking the matter further, my friend consulted a solicitor, and the upshot of it was that the GPO has agreed that after September 30 amateurs, while always being expected to suppress all harmonics outside their authorised bands, will not, subject to certain provisos, be held responsible for TVI where the TV receiver IF falls in an amateur band.

E. L. Bartlett, 23 Driffield Street, Moss Side, Manchester 4.

It is the case outlined above which is understood to have resulted in the new GPO policy, recently announced, in regard to amateur TVI. This is that until 30 September, '54, amateurs are expected to close down if they

cause TVI, or clear the interference, irrespective of how it may be caused. After the due date, if it is not a fringe area and the TVI can be proved to be due to a receiver design fault, the amateur will be allowed to operate again one month from the date on which the owner of the TV receiver is informed that his set is the cause of the trouble. It should be noted that this ruling does not in any event apply in fringe areas, and in general the GPO policy is that it is for amateurs to overcome TVI. At the same time, set manufacturers will in future be expected to avoid circuits which let in signals on authorised amateur frequencies.—*Editor.*

THE WNACA CERTIFICATE

GENTLEMEN,—There is doubt in the States and Canada as to whether we are eligible for your WNACA award. Whereas I fully realize that this particular certificate would not be too difficult for us to obtain, it would make a very nice addition to the others we have. I wonder if you would be good enough to advise me if I can submit the necessary QSL cards for the WNACA certificate? May I take this opportunity of congratulating you on your part in helping to make this hobby of ours more interesting and worth while. As a former SCM for ARRL here in Michigan, I have been exposed to the more serious side of Amateur Radio—and, believe me, we appreciate your efforts.

N. C. MacPhail, W8DLZ, 1340 Giddings Avenue SE, Grand Rapids, Michigan, U.S.A.

It was, of course, never the intention that our WNACA Award should be open to amateurs on the North American Continent itself, and we feel that the majority of K/KN/VE/W operators would agree with us. We have had a few claims from them, but in such cases we have explained that this particular Award is not for those operators in Canada and the U.S.A.—*Editor.*

CONTEST CONGESTION

SIR.—The figures given in your March Editorial are most interesting and enlightening. It appears that the total number of entrants for contests and ladders, even when doubled, amounts to less than one per cent. of your circulation. This figure gives rise to the thought whether it is really fair for this small minority to make such a mess of the DX bands during numerous week-ends. While your own contests amount to only a few week-ends a year, the total number of contests which take place succeed in occupying a considerable number of week-ends in the year when, to all intents and purposes, the non-contest operator has to abandon his hobby completely. As you say, nobody need enter unless he wants to, but if the entire band (or bands—there are usually several) in which he is interested is occupied with the contest, he has little chance of having a pleasant QSO. Would it not be possible to arrange for contests to take place in a portion of each band only? This would leave part of the band available for the majority who do not wish to take part. I agree that this would increase the QRM for those who enter the contest—but they seem to enjoy that! I appreciate that it is only at week-ends that the problem arises, but then it is only at these times that most amateurs can operate. Obviously, it would require international co-operation to achieve such an arrangement, but I thought that if you organised your own contests on this basis, others might follow suit. It would be a real demonstration of the Ham Spirit if the vociferous minority were to make this gesture to the vast majority.

E. M. Wagner, G3BID, 5 Ferncroft Avenue, London, N.W.3.

Many readers will be in sympathy with the views put forward by G3BID. But let it be made quite clear that we ourselves organise only one annual event—the Club contest, MCC—which takes place over two week-ends and on one band only, 160 metres, at that. The Trans-Atlantic Tests are not competitive and, in any

case, are also confined to 1.8 mc in the early hours of a few Sunday mornings. The ladders, by which is meant our Achievement Tables, are likewise not competitive in the sense of our correspondent's complaint, and they can have no bearing on week-end contest congestion. The only way in which a long succession of contest week-ends can be avoided is by I.A.R.U. action through its own member-societies, each of which is fully entitled to organise what events it likes. It is this that is the cause of the congestion.—*Editor.*

SOME READER OPINIONS

SIR,—I enclose cheque for my subscription, which is now in its 9th year. Looking back, it has been good value for money. Looking forward, when are you going to run a correspondence column? The letters you receive cannot all be unpublishable abuse.

K. Mallett, G2AXU, 23 Bexley Lane, Sidcup, Kent.

... A fine publication, doing a good job. Would like to see you take up very strongly the matter of the encroachment of commercial stations on the amateur bands ...

N. G. Sanders, Chineside, Carbis Bay, St. Ives, Cornwall.

... Your technical articles suit me. I am principally interested in short wave listening and would like it if you could include some articles of SWL interest ...

W. R. Cooper, 36 Irwin Avenue, Belfast, N. Ireland.

... I prefer short articles on VHF and UHF with more details of VHF stations, aerial systems and snags that have been encountered and overcome in obtaining good VHF results ...

J. R. Wordsworth, G3JGJ, Boringdon House, Plympton, S. Devon.

... Of recent months you have given too many pages to VHF. I haven't the slightest interest in VHF. TVI rigs are too frequent also. DX Commentary, The Other Man's Station and the articles on Russian Amateur Radio are good. I used to look forward to each month's edition, but now the Magazine has little interest for

me. I would like to see a lot of articles cut out, also less about modifications to commercial receivers. How about some lighter, non-technical reading? ...

S. R. Long, G8NI, Station Cinema, R.A.F., Newton, Notts.

... Obviously, some months the Magazine has more for me than others, but the fact remains that I've never dared to throw away a copy, and now have about six years' issues waiting to be bound. I am always thumbing through them ...

J. Wightman, G3DLO, St. Norber, The Broadway, Sandhurst, Berks.

... Give us a wider range, including cathode ray and television and circuits directly associated with the picture tube. I find your articles cater for the absolute beginner and mathematics are glossed over. When buying a magazine, I do not expect readily to understand its contents. I buy it in order to further my knowledge ...

J. T. Spokes, G3BSV, 8 Woodview, Grays, Essex.

... I would like to say that I have derived great enjoyment from the Magazine since you re-started publication after the war. It is certain that information you have published cannot, in many cases, be found elsewhere ...

B. G. Dodd, G3BSC, 230 College Road, Erdington, Birmingham, 23.

... One person I should like to see back is GIBF, also more cartoons. Amateur Radio is, after all, a hobby and should not be allowed to become too serious. I always appreciate the humour in the Magazine ...

J. A. Theobald, G3EQM, The Flat, Standard Motor Co., Ltd., Park Royal Road, London, N.W.10.

... Cut DX Commentary a bit and give us more theoretical articles, less constructional. You are not technical enough ...

J. D. Cameron, GM3BEA, 89 Muir Street, Larkhall, Lanarkshire.

... Your articles suit all tastes and usually there is something of interest for every type of amateur. I have been a reader for some years and have always thought the Magazine excellent value for money ...

J. Lees, 5 Hicks Street, London, S.E.8.

... Not enough practical information has ever been published on beam aerials, design, adjustment, use of stubs and correct matching arrangements. The aerial is surely the most important of all! My preference is for VHF technical notes, NBFM and PM methods, and TVI ...

B. C. Oddy, G3FEX, Bonigen, Maudlyn Close, Steyning, Sussex.

... I would like to see more articles on new radio and electronic development, like the Transistor series. However, being an experimenter without a call-sign, I realise that the Magazine is not specifically designed for me ...

D. P. Bussens, Roselands, Valley Road, West Bridgford, Notts.

... I do not think you cater for the absolute beginner, but, taken all round, I find the Magazine a very interesting publication ...

E. Smith, G3BPO, 79 Union Street, Ashton-under-Lyne, Lancs.

... I consider that the articles are very satisfactory, but I think there is rather too much space given over to VHF. I would like to see a few more cartoons, but otherwise I have nothing but praise for a very excellent magazine ...

J. W. Bull, 5A2CA, No. 5 Forces Broadcasting Service, Benghazi, MELF, 6.

... Not much wrong with the Magazine. Must be a difficult job ...

W. Robertson, GM6RI, Schoolhouse, Tannadice, by Forfar, Angus.

... Reckon the Magazine is doing a good job ...

W. G. Johnson, G2BJY, 23 Lynton Avenue, West Bromwich, Staffs.

... If anything, your articles are insufficiently technical, but on the whole the Magazine maintains an excellent balance between theory and practice. DX Commentary and VHF Bands might contain more details of equipment used ...

P. H. Haycock, 54 Egerton Road, Chorlton-cum-Hardy, Manchester, 21.

We shall continue to do our best in the interests of all our readers!—Editor.

Oscillator Injection at VHF

OBTAINING EFFICIENT MIXING

H. E. SMITH (G6UH)

One of the most exacting requirements for the efficient operation of a 144 mc converter is that the mixer stage be given oscillator voltage at the correct level for converting the weakest possible signal. Just how weak the signal must be, before it is lost in the noise, will depend largely upon the efficiency of the RF stage or stages. After that, weak-signal detection depends upon the operation of the mixer. Indifferent performance is more often than not due to over-injection from the oscillator, and is a very common fault in amateur built converters. In this article, our contributor goes into the question of controlling oscillator injection voltage.—Editor.

FOUR types of mixer valve are in common use for 145 mc—the 6AK5, EC91, ECC91 and 12AT7. All require different values of oscillator voltage for optimum weak signal mixing, and it has been found in practice that two valves of the same type will differ in their requirements, due to a slight difference in characteristic.

While valve manufacturers are usually quite helpful in many ways, the information regarding actual values of oscillator voltage for VHF mixing is somewhat sketchy. Even if such detailed information was available the average amateur would find it difficult to make measurements unless he had access to an accurate valve voltmeter. The only real clue we have relates to the 12AT7, for which the manufacturers quote that for efficient mixing the oscillator injection voltage should be "just less than that which causes grid current to flow." How much is "just less"? and how are we going to measure it? The answer is, of course, that we cannot.

The best that one can do, as a rule, is to follow the design data given with a VHF converter article, using the components specified, and hope for the best. The fact that his layout may be different, an older type valve is being used, or different components, is often completely overlooked by the constructor. The average converter, once built, has very little

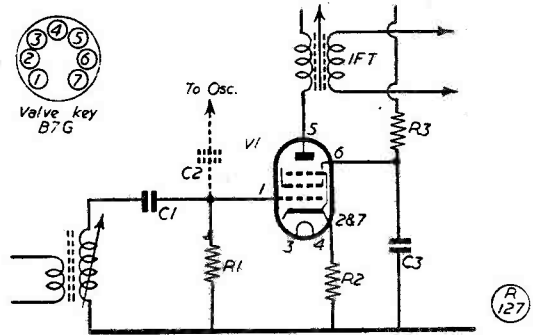

Fig. 1. A typical 6AK5 mixer. Values are: C1, 50 $\mu\mu\text{F}$; C2, 2-3 $\mu\mu\text{F}$; C3, .005 μF ; R1, 1 megohm; R2, 100 ohms; R3, 47,000 ohms.

flexibility, and the more modifications one puts in the more untidy and inefficient the job becomes, until it is finally put aside as being "not worth while."

Let us see how a little more care in attending to the question of oscillator injection voltage may make 50 to 100% difference in the performance of a converter.

The 6AK5 Mixer

Fig. 1 shows a typical 6AK5 mixer circuit. This is usually coupled, via a 2 or 3 $\mu\mu\text{F}$ condenser (dotted in) to an oscillator of the Colpitts type (Fig. 2). The only real control obtainable is by taking the oscillator feed from either the anode (max.) or the grid (min.) of the oscillator valve.

As the 6AK5 requires only a microscopic amount of injection for weak signal detection, this method is quite wrong. Not only is the

Fig. 2. (L) A Colpitts oscillator for an SEO converter, using an EC91 for V1. X and Y are maximum and minimum voltage points respectively, and values could be: R1, R2, 10,000 ohms; C1, 20 $\mu\mu\text{F}$.

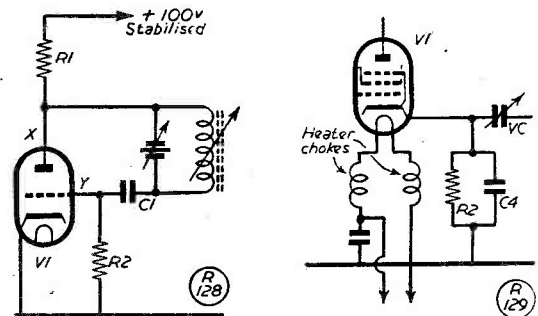

Fig. 3. (R) The circuit of Fig. 1 modified, with the variable capacity VC a 50 $\mu\mu\text{F}$ air-spaced trimmer fitted with an insulated extension to the front panel. C4 is 25 $\mu\mu\text{F}$ and, as shown by-passed heater chokes are advisable.

THE VHF Dinner Meeting at Cheltenham on March 13 heralded, very fittingly, the first opening of the VHF season, and this feature begins to take on its normal appearance again, after three months in the doldrums as far as VHF DX is concerned.

The first workable EDX reported this year—workable, that is, in the sense of coverage over the greater part of the country, as distinct from the fleeting-opportunity contacts between South Coast stations and the nearer Europeans, which are often possible—was during the period March 16-18. It was not an extensive opening, nor was there a great deal of EDX worked, but, on the other hand, there were not a lot of stations on, either over here or on the Continent, as many VHF operators are only just emerging from their winter hibernation.

At any rate, DL, ON and PA stations were getting into the Lancashire area on March 17-18, and on the evening of the 17th our East Coast stations were putting strong signals over to the Continent. For good EDX, G3100 (Oswestry) worked ON4BZ (Brussels) and was hearing DJ1DC (Solingen), also PA0FC and PA0NL, likewise on the 17th; at this period PA0FC was strong with G3EPW (Bury, Lancs.). GM3EGW (Dunfermline) got down certainly as far as the South Midlands in the early evening of March 17, and later on G5BD was acting as link between ON4BZ/GM3EGW—without any luck in getting them together, as far as we know. However, GM3EGW worked G8OU (Ashstead, Sy.) and heard G5MA at 339; another good QSO was with G2FJR (Sutton Bridge), who also worked ON4BZ at RS-59+ both ways.

So, as can be seen, the going was pretty good, and what it comes to is that the peak period was the late evening of March 17. Of course, by the following weekend the buzz had got around that there had been an opening, and there was quite a lot of activity on Sunday 21st. GC2FZC (St. Peter Port, Guernsey) made a

VHF BANDS

A. J. DEVON

Improvement in Conditions—

EDX Workable, March 16-18—

The Cheltenham VHF Meeting—

Easter DX Outings—

Notes on Seventycems—

Station Reports & The Tables—

welcome appearance that evening, working G5TZ/A for his first-ever QSO on Two, and hearing several other stations at useful distances—see "Activity Report."

It will be noticed that met. man G3EGB's data in this issue shows very good agreement with conditions as actually experienced. In the foregoing notes, we have mentioned only the highlights; there were, of course, many good GDX contacts over the period, and all the evidence of increasing activity.

The Cheltenham Meeting

This duly took place on the evening of March 13 and, by all accounts, was regarded as a great success by the 70 or so VHF men present, many of whom had made long journeys to be there. Among these were EI2W (Dublin), G2HQ/G3MY (Sheffield), G5BD (Mablethorpe), G3CCH (Scunthorpe), G5TZ (Isle of Wight), G3WW (Cams.), as well as contingents from South Wales, the Midlands, the Northampton area and Shropshire.

G6FO, Editor of *Short Wave Magazine*, was in the chair for this occasion, while G2AJ with G3FRY were responsible for all the local arrangements. The general opinion was that these were most excellent, as regards not only the meal and the accommodation, but also the thoughtful embellishments, like menu cards large enough for circuit diagrams and neat call-sign lapel tabs, lettered ready for everybody. With these and the usual "identification parade" round the tables, there was no difficulty about recognition and many VHF QSO's and schedules were sealed by first personal contacts.

A goodly array of VHF equipment was on show, much of it brought along by distant visitors, who have the thanks of the organisers for their part in making the meeting such a success.

All those present would probably agree that the highlight of the evening was the very able talk given by G2HCG (Northampton) on "Skeleton Slots," a subject on which he is an acknowledged authority. He had brought with him a two-metre slot section, and in the course of his talk gave all details as to design, construction, matching methods, gain, back-to-front ratio and coverage arc, many of these points being brought out in the discussion that followed his talk. With the actual two-metre assembly there for close examination, many of those present seized the opportunity of making measurements and taking copious notes, with the advice and assistance of G2HCG and G3IAI. We gather that more than a few VHF operators will be trying a skeleton slot array in the immediate future.

The roll of call-signs registered at this very successful meeting reads as follows: EI2W, G2AJ, 2AK, 2ATK, 2BVW, 2HCG, 2HF, 2HQ, 3ABA, 3APY, 3BKQ, 3CCH, 3CKX, 3COJ, 3COZ, 3CUZ, 3CVK, 3DKZ, 3EII, 3ENY, 3FKY, 3FRY, 3GHO, 3HAZ, 3HEK, 3ENS, 3HSD, 3IAI, 3IER, 3IOO, 3IZI, 3JGY, 3JKZ, 3MY, 3NL, 3WW, 4GR, 4SA, 5BD, 5BM, 5LJ, 5MA, 5ML, 5QI, 5RP, 5RZ, 5TZ, 6FK, 6FO,

TWO METRES

ALL-TIME COUNTRIES WORKED LIST

Starting Figure, 14
From Fixed QTH Only

Worked	Station
64	G6NB
63	G5YV
61	G3BLP (630), G3BW
60	E12W (194)
59	G3EHY
57	G2OI (349)
56	G8SB
55	GW5MQ
54	G2HIF (200)
53	G2AJ (519), G2HDZ (416), G3WW, G4CI, G4SA
52	G2NH, G3GHO
51	G5BD, G5BM
50	G3ABA, G3FAN, G5DS (510), G6XX (238)
49	G3IOO
48	G5MA
47	G5WP
46	G2FJR, G4HT (476), G5BY, G5ML (280), G6YU (205)
45	G2XC, G6XM (356)
44	G3BK, G3CCH, G3HAZ (262)
43	G3BA, G3COJ, G4RO, G5DF
42	G2AHP (428), G3GSE (424)
41	G2FQP, G3DMU, G6CI (184)
40	G3CGQ, G5JU, G8KL, G8OU
39	G2IQ, G3GBO (434), G3HBW, G3VM, G8DA, G8IL (325)
38	G2FCL (234), G3APY, G3BNC
37	G2DDD, G2FNW, G2FZU (180), G6TA (277)
36	G2HOP, G3CXD, G6CB (312), G8IP
35	G2DYD, G3FZL, G3HCU (224), G3HWJ
34	G3BKQ, G3WS (153), G8IC
32	G2FVD, G5MR (196), G8VR, G8OY
31	G3HXO, G5RP
30	G3DO (185), G3GOP (208), G3FRY, G5NF, GW8UH
29	G3AGS, G3AKU, G3BJQ, G3FL (194)
28	G8DL, GM3BDA
27	G3DAH, G3FIH, G3ISA (160), G6GR
26	G2CZS (100), G2DCI, G3AEP, G3CFR (125), G3SM (211), G3IER, G4MR (189), G8VN
25	G3FYY, G5SK
24	G3FD, G3FXG, G3FXR, GM3EGW
23	G3CWW (260), G3DLU, G3IUD, G4LX, G5PY, G6PJ, GM3DIQ
22	G3AGR (135), G3ASG (150), G3BPM, G3HIL
21	G2AOL (110), G3IWI, G6XY
20	G3EYV, G3HSD, G3IRA, G3YH
19	G3FEF (118), G3GCX, G5LQ (176)
17	G3JMA
16	G3FRE, GC2CNC
15	G3IWA
14	G2DHV, G3GYY

Note: Figures in brackets after call are number of different stations worked on Two Metres. Starting figure for this classification, 100 stations worked. QSL cards are not required to verify for entry into this Table. On working 14C or more, a list showing stations and countries should be sent, and thereafter added to as more countries are worked.

SEVENTY-CENTIMETRE STATIONS — Eleventh List

CALL	LOCATION	FREQ. (mc)	EQUIPMENT
DL3FM	Mulheim-Ruhr	434.2	Tripler, 32-ele stack, SEO Rx
E12W	Dublin	432.54	Tripler, 16-ele stack, (? Rx)
G2BFT	Solihull	433.17	Tripler, 16-ele stack, (? Rx)
G2BVW	Leicester	432.60	Straight PA, 5-ele Yagi, Special Rx
G2CNT	Cambridge Airport	435.2	Tripler, CC Rx, 12-ele stack
G2DCI	Sutton Coldfield	433.05	832 Tripler, G2DD C'vtrr, 20-ele stack
G2DDD	Littlehampton	435.6	Tripler, 16-ele stack, CC Rx
G2DHV	Lewisham	434.97	Tripler, CC Rx, 16-ele stack
G2DVD	Slinfold, Sussex	434.58	Tripler, G2DD C'vtrr., 16-ele stack
G2FCL	Shipleigh, Yorks.	433.134	Tripler 15E, G2DD C'vtrr., 6-ele Yagi
G2FKZ	London	435.95	<i>no details</i>
G2FNW	Melton Mowbray	?	Tripler, 5-ele Yagi (? Rx)
G2HCG	Northampton	434.00	<i>no details</i>
G2HDY	London, S.W.15	435.50	Tripler, CC Rx, 6-ele Yagi
G2HDZ	Pinner, Middx.	435.17	Straight PA, SEO Rx, 20-ele stack
G2MV	Kenley, Surrey	435.22	<i>no details</i>
G2RD	Wallington, Surrey	435.57	<i>no details</i>
G2WJ	Great Canfield, Essex	436.00	Straight PA, CC Rx, 16-ele stack
G2XV	Cambridge	435.10	Tripler, CC Rx, 12-ele stack
G3ABA	Coventry	?	Tripler, 16-ele stack (? Rx)
G3AEO	Denton, M'cr.	433.13	Tripler, 4/4/4, CC Rx
G3AYT	Hyde, Ches.	433.13	Tripler, City Slicker, CC Rx
G3BKQ	Blaby, Leics.	434.05	Tripler, 48-ele stack, CC Rx
G3CGQ	Luton, Beds.	434.10	<i>no details</i>
G3DA	Liverpool	432.6	Tripler, 6-ele Yagi, CC Rx
G3EOH	Enfield, Middx.	436.03	Tripler, G2DD C'vtrr., 12-ele stack
G3EUP	Swindon, Wilts.	433.9	Tripler, 3 stk'd dipoles, CC Rx
G3FAN	Isle of Wight	435.80	<i>no details</i>
G3FFC	Leicester	?	Tripler, 16-ele stack (? Rx)
G3FIJ	Colchester	435.18	Tripler, SEO Rx, 5-ele Yagi
G3FP	Sidcup, Kent	436.04	<i>no details</i>
G3FZL	Dulwich, S.E.22	435.24	Doubler, CC Rx, 12-ele stack
G3GDR	Watford, Herts.	435.39	<i>no details</i>
G3GOP	Southampton	435.00	<i>no details</i>
G3GZM	Tenbury Wells, Worcs.	?	Tripler, 16-ele stack (? Rx)
G3HAZ	Northfield, Birmingham	433.59	Tripler, CC Rx, 4/4 Yagi
G3HBW	Wembley, Middx.	434.61	Tripler, 12-ele stack, CC Rx
G3HHY	Solihull, Warks.	433.93	Straight PA, 21-valve Rx, 4-ele Yagi
G3HTY	Kidderminster, Worcs.	?	Tripler (? beam array and Rx)
G3IAI	Northampton	433.80	<i>no details</i>
G3ILI	London, S.E.22	434.97	Tripler, 6-turn Helix, R.1294 mod.
G3IOO	Oswestry, Salop.	432.54	Tripler, 16-ele stack, CC Rx
G3IOR	Hellesdon, Norwich	?	Tripler, SEO Rx, 4-ele Yagi
G3IRA	Swindon, Wilts.	436.05	Tripler, SEO Rx, 8 d'ples stk'd
G3IRW	Hoddesdon, Herts.	434.43	Tripler, 2RF CC, 32-ele mesh reflector
G3IUD	Wilmslow, Ches.	432.41	Tripler, CC C'vtrr., 6-ele Yagi
G3IRV	Kirk Langley, Derbys.	433.78	Tripler, Rx various, 16-ele stack
G3JGY	Malvern, Worcs.	436.00	Tripler, SEO Rx, 12-ele stack
G3JZQ	Waltham Cross, Herts.	435.9	6/6PA, SEO Rx, 4-ele Yagi
G3MI	Chesham, Bucks.	434.13	832 Tripler, CC Rx, 10-ele stack
G4AP	Swindon, Wilts.	436.50	Tripler, CC Rx, 3 stk'd D'ples
G4CG	Wimbledon, London.	435.07	CV53 PA, CC Rx, 9-ele Yagi
G4OT	Maldon, Essex	435.240	Tripler, G2DD C'vtrr., 4/4 Yagi
G4OU	Sheerness, Kent	432.414	Tripler, Superhet, 3-ele Yagi
G4RO	St. Albans, Herts.	434.16	Tripler, 16-ele stack, CC Rx
G5CD	Hendon	435.66	<i>no details</i>
G5DS	Surbiton, Surrey	435.61	Tripler, G2DD C'vtrr., 16-ele stack
G5DT	Purley, Surrey	436.02	<i>no details</i>
G5YV	Leeds	432.85	QQVO3-20 Tripler, G2FKZ C'vtrr., 48-ele Stack
G6CW	Nottingham	?	<i>no details</i>
G6NF	Shirley, Surrey	435.47	Straight PA, 5-ele Yagi, SEO Rx, ASB8 cavities
G6RH	Bexley, Kent	434.7	Tripler, 16-ele stack, ASB8 C'vtrr.
G6YP	London, S.E.5	435.75	<i>no details</i>
G6YU	Coventry	434.10	Tripler CC Rx, 16-ele stack
G6ZP	Malvern, Worcs.	435.78	Tripler, SEO Rx, Corner reflector
G8OY	Birmingham	?	Tripler, 24-ele stack (? Rx)
G8SK	Enfield, Middx.	433.15	Tripler, G2DD C'vtrr., 8 1/2-waves stk'd
G8VR	London, S.E.22	435.0	Tripler, SEO Rx, 12-ele stack
GM6WL	Glasgow, W.I.	?	P/P CV53 PA, CC Rx, 20-ele stack
GW2ADZ	Llanymynech, Mont.	432.84	Doubler SEO Rx, 32-ele stack
GW5MQ	Mold, Flints.	432.58	Tripler, 3-ele Yagi (? Rx)
ON4UV	Fayt-lez-Mange, Nr. Charleroi	434.7	Straight PA, CC Rx, 32-ele beam

This list is incomplete as regards some stations known to be equipped for the 70-centimetre band. All 430 mc operators are asked to forward details for inclusion in this Table, under the headings given.

TWO METRES

COUNTRIES WORKED

Starting Figure, 8

- 15 G4MW (DL, EI, F, G, GC, GD, GI, GM, GW, HB, LA, ON, OZ, PA, SM),
G6NB (DL, EI, F, G, GC, GD, GI, GM, GW, HB, LA, ON, OZ, PA, SM).
- 14 G3GHO, G5YV, ON4BZ
- 13 G3BLP, G3CCH, G5BD, G6XX
- 12 G2HDC, G2HIF, G3WW, G6LI, G6RH.
- 11 G2AJ, G2XV, G3ABA, G3IOO, G5UD.
- 10 EI2W, G2FOP, G3BK, G3EHY, G3GHI, G3HAZ, G4RO, G4SA, G5DS, G5MA, G8IC, GW5MQ.
- 9 G2AHP, G3BNC, G3FAN, G3FIJ, G6XM, PA0FB.
- 8 G2XC, G3GBO, G3GSE, G3HCU, G3VM, G3WS, G5BM, G5BY, G5ML, G5MR, G8SB, GM3EGW

6SN, 6WF, 6ZP, 6ZQ, 8FF, 8KL, 8ML, 8PX, 8SB, 8SC, 8SR, GW3EJM, 5BI, 8UH.

Several of those who came for the meeting stayed the week-end in Cheltenham, and there was a good deal of station-visiting on the Saturday and Sunday, with the locals dispensing hospitality in the true amateur fashion.

The Tabular Matter

The Tables are brought in again this month, with your A.J.D.'s devout hope that all movements claimed during the last three months are properly recorded. We would ask that all VHF operators keep us informed of their results, so that these Tables—which are not intended to be in any way competitive—remain an accurate reflection of collective progress; there must be many more operators who qualify for Annual Counties, for instance.

Calls heard and worked, or the "Activity Report," is of direct interest to nearly everybody, and we would be very glad if, whenever you write in to this feature, you include a list of calls heard and worked; it keeps everyone in touch with what is going on, notifies the appearance of new stations, and is of particular value and interest to beginners on both VHF bands—we say "both,"

TWO-METRE ACTIVITY REPORT

(Lists of stations heard and worked are requested for this section, set out in the form shown below, with callsigns in alphabetical and numerical order).

- G2FJR, Sutton Bridge, Lincs. *WORKED*: G2DJM, 2DUS, 2FCL, 2FNW, 2HOP, 3ARX, 3CCP, 3CKQ, 3COP, 3DO, 3DOV, 3EEL, 3EPW, 3FAN, 3FUW, 3GCX, 3GFV, 3GHS, 3GJZ, 3HT, 4SA, 5TZ/A, 5BC, 5BD, 5UD, 5YV, 6OU, 6YU, GM3EGW, GW2ADZ, ON4BZ.
- HEARD*: G3FKJ, 3HTY, 3HWJ, 5MA. (February 22 to March 18).
- GC2FZC, Guernsey, C.I. *HEARD*: G3AUS, 3GVF, 3JHM, 4SA, 5NF, 5TZ/A, 8OU. (Evening March 21).
- G3IER, Cheltenham, Glos. *WORKED*: G2ATK, 3ASC, 3BVU, 3CKX, 3DO, 3EYI, 3EPW, 3FRY, 3HAZ, 3IOO, 3MA, 3NL, 4SA, 5BD, 5BM, 5JU, 5ML/P, 6NB, 6WF, 6VX, 8ML, GW3GWA. *HEARD*: G2BMZ, 3CCP, 3CVK, 3ENY/A, 3FAN, 3FIH, 3FUM, 3IRA, 3JGY, 3TZ/A, 8KL, GW2ADZ.
- G3EPW, Bury, Lincs. *WORKED*: EI2W, G2AK, 2AKR, 2ATK, 2BNZ, 2COP, 2CVD, 2CZS, 2DUS, 2FJR, 2FZN, 2HGR, 2WJ, 2XV, 3A0O, 3AOS, 3WA, 3BKQ, 3CUZ, 3DO, 3DQO, 3FKY, 3GB, 3GHO, 3GXT, 3HYH, 3IER, 3IOO, 3IPH, 3IPH/A, 3ISW, 3IVF, 3IWJ, 3IXE, 3WW, 4SA, 5BM, 5MA, 6NB, 6MI, 6QT, 6RH, 6WF, 8SB, GW3GWA. *HEARD*: ON4BZ, 4HC, PA0FC, ONL. (February 16 to March 18).
- SWL, Bridgend, Glam. *HEARD*: G3HSD, 4SA, 5FF, 5TZ/A, 6NB, 8OU, GW2ACW, 2FRB, 3EHN, 3EJM/A, 8SU, 8UH. (During February-March).
- G2CZS, Chelmsford, Essex. *WORKED*: G2AHP, 2A1W, 2DJM, 2FJR, 2FZU, 2UJ, 3BK, 3CCP, 3DOV, 3EPW, 3GJZ, 3HSM, 3HT, 4CW, 4HQ, 4PV, 5BD, 5MA, 5TZ/A, 6UH, 6YP. *HEARD*: G2DOM, 2HCG, 2KF, 3GHO, 5YV, 6FO, 6LL, GW2ADZ, PA0FC. (February 8 to March 21).

70-Centimetre Band Only

G3BKQ, Blaby, Leics.

WORKED: G2ASF, 2ATK, 2BFT, 2BVW, 2DCI, 2DD, 2DDD, 2FKZ, 2FNW, 2HCG, 2HDU/P, 2HDZ, 2RD, 2WJ, 2XV, 3ABA, 3A0O, 3APY, 3APY/P, 3FAN, 3FD, 3FFC, 3FP, 3FUL, 3FZL, 3GDR, 3GZM, 3GZM/P, 3HAZ, 3HBW, 3HTY, 3IAI, 3IOO, 3IVF, 3JGY, 4AP, 4RO, 5CD, 5DT, 5SK, 6CW, 6NF, 6YP, 6YU, 8KL, 8KZ, 8QY, 8QY/P, GW2ADZ, 5MQ, ON4UV, PE1PL. (Total of 430 mc stations worked during year January 1st to December 31st, 1953).

because we would like to see more lists covering 430 mc operation.

This month's Activity Report, though very short, is interesting, and we would draw particular attention to G3BKQ's 70-centimetre list.

New Seventycem Table

Acting on the suggestion by G2XV, this month sees the start of a new Seventycem All-Time Counties Table, which it is hoped will be supported by all 430 mc operators. During the coming



At the VHF Dinner Meeting at Cheltenham on March 13, G5MA (right) received from EI2W (left) the I.VHF.S. cup in recognition of his outstanding /P work during the last two years; he is the first G holder of the trophy. At centre in this photograph is Austin Forsyth, G6FO, Managing Editor of "Short Wave Magazine."



Of the total attendance of 70 at the Cheltenham VHF meeting on March 13, twenty-two were members of the VHF Century Club. Callsigns in this group include (front row): G2HIF, G5BD (sleeve), G5BM, G3IOO, G4SA, G3ABA, G5RP. At extreme right is G8PX, with G3APY on his right, and G3HAZ. Behind G4SA are G5ML (in glasses), and EL2W. G3WW is immediately behind G3IOO. G5MA is behind and between G2HIF and G5BD, and behind him is GW8UH (in glasses).

(Photographs, Gloucestershire Echo.)

season there will assuredly be great developments on the 70-centimetre band, and it will be very important to maintain accurate records of progress and achievement. We can only do this if we get the information, and in this respect the co-operation of all 430 mc practitioners is earnestly requested.

The Table, as shown here, is only the beginning—there must be many of the 70-odd stations known to be equipped for the 430 mc band which qualify to fill some of the gaps. The starting figure is thought to be reasonable, and is based upon the fact that only two operators claim less than four counties worked. We hope to see this Table grow as the months roll by, and look forward to many more claims for next month.

Some 70-Centimetre Results

It will be agreed by everybody who knows anything about the 430 mc band that G3BKQ (Blaby, Leics.)—who at the moment is way out in front in the new Table

—is one of its outstanding exponents; he has exceptionally fine equipment (which we hope shortly to be describing in *Short Wave Magazine*), and his results over the past year, to which attention has already been drawn, show what can be done in the way of DX working on the 70-centimetre band. During 1953, he worked no less than 52 different stations in four countries, and it can be said that G3BKQ is a reliable contact for anybody using reasonable gear and there when conditions are right. As we know, G3BKQ has been progressively improving his equipment over a long period, and now stands in the same relation to the 430 mc band as do operators like G5YV and G6NB to two metres. For 430 mc, the beam at G3BKQ is a 48-element array, and his CC converter has the exceptionally low noise figure of 1 dB at 435 mc; receivers to the same design are being used by G2HCG, G3HAZ, G3IOO and G6YU.

Good work on 70 cm is also being done by Nat of G3IOO, who

has now worked 8 counties and 3 countries from Oswestry, and is also constantly improving his gear.

Other 430 mc stations to mention this time are G2HDY (London, S.W.15), who has two useful converters for the band and will be regularly active; G3IRW (Hoddesdon, Herts.), who is very anxious for contacts in Cambridge and East Anglia, in which direction he puts out CQ's nightly at 1900-1910, using a beam consisting of 32 driven elements with wire-mesh reflector; and G3JZQ (Waltham Cross), who is equipped for local work and has a new converter on the way.

Over in Malvern, G3JGY and G6ZP are very much on their own as far as 430 mc is concerned, but they are there every evening 1900-2300 working one another and listening round; they would much appreciate some attention from the London area, and G3JGY reports that he is on 70 cm every Sunday morning 1000-1230 calling CQ on a beam-heading for London. G3BKQ/G3HAZ are often heard in QSO,

and are asked to look Malvern way—but no doubt this was arranged at the Cheltenham meeting, at which all mentioned were present.

Still on the 430 mc band, but in quite another connection, we have a report from G3GDR (Watford) on his reception of amateur TV from G2WJ/T, some 30 miles distant at Great Canfield, Essex. (Their results were first reported in this space in our September 1953 issue). With more power at G2WJ/T, G3GDR has been getting much better pictures, and, to prove it, sends a

photograph of the screen of his receiver; this shows good definition and contrast. The G3GDR receiver is a coaxial line mixer with a GEX-66 diode, SEO using a CV82, and a cascade head amplifier; the aerial is a 16-ele stack with mesh reflector, and viewing is on a commercial TV receiver. G2WJ/T says that he would be pleased to radiate a TV signal for anyone who cares to make up a converter, and is, of course, always glad to have reports on his TV transmissions.

Easter DX Outings

Bob of G5MA starts his season's /P touring with another trip to Pembrokeshire during the Easter holiday—so look out for GW5MA/P on the two-metre band. You see his photograph here on the Cheltenham occasion, when EI2W presented the I.VHF.S. cup in recognition of the large contribution made by G5MA on these /P excursions.

Also for Easter Monday, April 19, the French have organised the "R.E.F. VHF Rally," when everyone who can do so is asked to be out on high ground from 0800 to 2359 GMT, using the VHF bands; for our French colleagues, these are 72, 144, 430 and 1200 mc, and it is understood that there will be activity on all these bands, which should make it a very interesting day if conditions are reasonable and the weather fine enough to encourage portable working.

We would be glad to have detailed reports on results obtained with the French stations (including reports from SWL's), for collating and sending forward to the R.E.F. organisers. There are not many G's who can operate on 1200 mc or receive on 72 mc, so anything logged on these bands would be of particular interest.

News from Correspondents

G8VN (Rugby) raised G6FO (Buckingham) for the 100th station worked on the indoor beam in use at G8VN; other stations heard or worked have been G2AHP, G3CKQ, G3IOO, G3WS, G5MA, G6RH and GW2ADZ, with '6RH in Bexley, Kent, often a very good

SEVENTY CENTIMETRES

ALL-TIME COUNTIES WORKED

Starting Figure, 4

Worked	Station
22	G3BKQ
13	G2XV
8	G3IOO
5	G3JRW
4	G2HDY

On working four Counties or more on the 70-centimetre band, a list showing stations and counties should be sent in for this Table, and thereafter new counties worked notified as they accrue.

signal when his beam is not headed on Rugby.

G2CZS (Chelmsford) has a new aerial up—a "Lazy H" with $\frac{1}{4}$ -wave spaced reflectors and fed with 150-ohm line, stub matched. This is giving very encouraging results, and G2CZS finds he can now work stations not usually heard on the old arrangement. A 1900 GMT schedule is kept with G3GJZ (Newmarket) every evening except Wednesday, and even this comparatively short 40-mile path is sometimes difficult, with deep QSB.

G3IER (Cheltenham) found four new counties waiting for him when he pushed the beam up a bit higher, but was unable to receive DJ1BC in the shadow of the Cotswolds when the latter was being called from Oswestry on March 17.

G5MR (Hythe, Kent), with a good outlook to the South, raised F9TV (Liancourt) for the latter's first contact on two metres—he is on 144.95 mc with VFO control. Also worked was G3BKQ, and G6FO has been heard at G5MR. GC2FZC (Guernsey) hopes to be on regularly now that he has broken the ice on two metres with G5TZ/A, who is, of course, a very strong and reliable signal in the Channel Islands. GC2CNC (Jersey) confirms this; he has a new 4-over-4 which seems to be working well and is thinking of calling in on the Southampton net at 1900 on Sundays; GC2CNC would be glad if G3JGJ (Plympton, S. Devon) could get in touch with him.

TWO METRES

COUNTIES WORKED SINCE
SEPTEMBER 1, 1953

Starting Figure, 14

Worked	Station
46	G5YV
43	G3GHO, G4SA
42	G6XX
40	G3IOO
39	G3WW, G5MA
35	G3EPW
34	G2DVD, G2FJR
32	G2AHP, G5BM, G5DS
31	G2XV
30	G5ML
29	G3DO
27	G2DDD, G3CUZ
26	G2FCL, G3IRA
25	G3WS
23	G2CZS, G2HDZ
22	G3FYY
21	G3JFR, G4RO
20	G8VN
19	G3FUW, G5MR, G6TA
15	G2AOL
14	G3FIJ, G3IER

Note: This Annual Counties Worked Table opened on September 1st, 1953 and will run for the twelve months to August 31, 1954. All operators who work 14 or more Counties on Two Metres are eligible for entry in the Table. The first list sent should give stations worked for the counties claimed; thereafter, additions claimed need show only stations worked for each county as they accrue. QSL cards are not required for entry in this table.

EI2W (Dublin) was at the GM VHF meeting in Glasgow on March 24—which we hope to report in the next issue—and is now ready to commence operations with his fixed beam for Scandinavian working. Henry has a magnificent site for this and has gone to great trouble to ensure success when an opening materialises; the beam is carried on 40-ft. poles and, by means of a rope-and-pulley arrangement, can be easily raised or lowered in the vertical plane. Thus, it can be tuned on the nose within reach before being hoisted to its operational height.

And talking of magnificent sites, it should be recorded that Bill, G6NB of Brill, Bucks., is now installed at the new QTH (only a short distance from the old one) and, if anything, is putting out an even more paralysing signal than before; at any rate, he is now in the clear in *all* directions! For a long time he has served as a very useful "local signal generator" for both G5RZ (Leighton Buzzard) and G6FO; at 15 miles, G6NB produces a stronger beat in the receiver than the intermediate stage of the G6FO transmitter.

G3WW (Wimblington, Cambs.) put in a comprehensive report on the March opening, when he had many good GD_X contacts and was receiving strong signals from ON and PA; and he puts himself right by explaining that since March 4 he has *not* been on the Top Band!

G3EPW (Bury, Lancs.) was there for the opening of March 17/18, when conditions were good

for the Continentals in that area; and he advances in Annual Counties. G2FJR (Sutton Bridge) still wants a lot of QSL's which are outstanding and notifies his new frequency as 144.55; he is on every evening from 1830, for Lincs.

G3DLU (Compton Bassett, Wilts.) now has a 16-element stack between two 80-ft. masts and a new converter involving four RF stages—he says that "first tests show a distinct improvement"! The converter is two CV66 g.g.t. stages into a 6AK5/6J6 cascade, 6J6 mixer, and two 955's as oscillator-multiplier; all RF circuits are tunable, and peak nicely, and cutting out the first RF stage *does* result in a drop in signal strength. G3JGJ (Plympton, S. Devon) has a 16-element stack at 55 feet; and on top of this another 16-ele job for 430 mc, for which band he is also equipped; the only stations heard on Two in the last couple of months have been G2BMZ and G3AUS, both of Torquay.

G3HBZ (Feltham) pokes a finger at your A.J.D. by asking how we came to be listening to G3WW and G5ML on the Top Band! Well, the fact is, actually it was like this — well, let's pass on to the next subject, shall we !

VHFCC Elections

Some interesting claims were received for the three most recent issues of the VHF Century Club Certificate, which go to: G3WS, Chelmsford, No. 165; G3CCH, Scunthorpe, No. 166; and PAØFB, The Hague, No. 167.

The G3WS claim showed no less than 58 cards in respect of the old 5-metre band, with six European QSL's on two metres. G3CCH's cards were all for QSO's on the 144 mc band, with 14 Europeans. PAØFB showed cards from nine different countries worked on two metres, made up of eight DL's, three F's, 34 G's, two GW's, 10 ON's, two OZ's, 43 PA's, and LA8RB and SM7BE.

70-Centimetre Contest

Owing to the press of events and the activities scheduled over the next couple of months, further consideration of this is being deferred. It now appears that it would be better to hold such a contest later in the year, rather than at the beginning of the season.

Reports for May

That seems to be it for this month; we look forward to improving conditions and an enlarging mail as the months go on; as in previous years, all VHF operators are asked to keep us informed of their results and activities, and it should here be mentioned that we are always interested in hearing from, or of, new stations opening on the VHF bands. Please address all your VHF news, views and claims to: A. J. Devon, "VHF Bands," *Short Wave Magazine*, 55 Victoria Street, London, S.W.1, to reach us by **April 20 certain** — that is the day immediately after Easter, during which so many operators will be diligently searching the bands. Good hunting, and with you again on May 7.

COVENTRY CORPORATION ON VHF

For the efficient and economical control of their repair and maintenance fleet, Coventry Corporation has decided to operate certain vehicles over a VHF link, with the city engineer's department as headquarters. The project is being developed in co-operation with the General Electric Co., Ltd., and a tower wagon used by the public lighting department has already been equipped with two-way VHF apparatus. This is another practical example of the wide field for the development of commercial mobile radio. In that connection, the Mobile Radio Users' Association is at present in conflict with the P.M.G. in regard to the allocation of frequencies in Band III (174-216 mc). Now earmarked for the Independent

Television Authority, frequencies in this band have up till now been allotted for the mobile radio services.

A. E. GROOM, G2QX

We very much regret to have to record the death, on February 24, at Luton, of old-timer Albert Edward Groom, G2QX, at the age of 63. He was a keen and active operator right up to the end, and readers will remember seeing a photograph of him in his station on p.733 of our February 1953 issue.

VHF WEATHER REPORT

PERIOD FEBRUARY 12 TO
MARCH 19
HOW HB9IV WORKED 11FA

A. H. HOOPER (G3EGB)

The first VHF openings of this season—even if they have been somewhat limited—have occurred during the period ending with this report. It will be seen that G3EGB correctly deduced the good spell actually experienced during the evenings of March 16-18. It is hoped that the new form of presentation of this feature will increase its value for those VHF operators taking a serious interest in the mechanism of VHF propagation. It is always very difficult to show meteorological data in a really palatable form for those who have little knowledge of meteorology. Readers who follow this piece will perhaps agree that G3EGB has now succeeded in finding an interesting, as well as a convincing, way of presenting his evidence.—

EDITOR.

A LATE start for VHF DX this year, with poor conditions continuing until mid-March, when openings to the E, NE and NW developed. An anticyclone, which drifted from the Arctic to Russia and then westward over Sweden, to lie centred over the Shetlands, was responsible. In spite of low temperatures, the reflecting layer that developed appeared strong enough for EDX working. After last year's experiences, it was strange to find DX possible in cold air of Continental origin. The system gradually collapsed and gave way to a milder airstream from the south.

As we have seen, the longer DX paths are achieved by "reflection" from discontinuities in the vertical gradient of radio refractive index, especially when these extend over considerable areas. From the results of radio soundings reported to the *Daily Aerological Record* of the Meteorological Office, London, the presence of such reflecting layers has been deduced. Table I gives the result, and shows for various directions from south-eastern England those occasions when openings by this means are thought to have developed during this last period. An idea of the far limit of each opening is given—by country prefix where possible or by a simple code. (See footnote, Table I). Particularly good occasions are printed in heavy type and are underlined. The table has been contracted during dead periods. We can see, for example, that a few scattered openings of limited value appeared on the evening of March 14, to be followed by improving conditions.

Fig. 1 shows the assessment for the evening of March 16. The pecked lines are where the layer was weak or uncertain, and it is on this basis that the path to LA, open for the previous evening, has been omitted. The southward shift of the low-lying

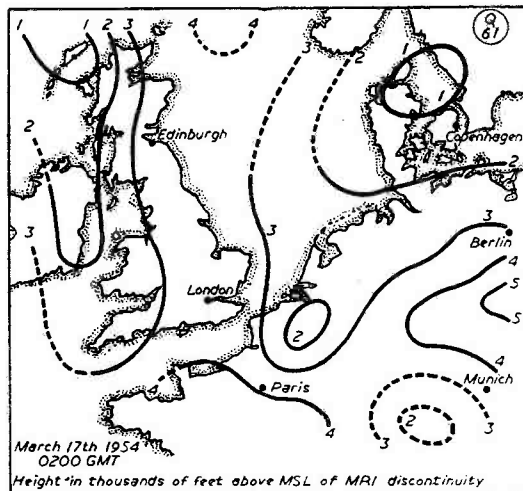

Fig. 1. The reflecting layer which developed for the first EDX spell this year is shown above. From the meteorological point of view, it was of a different type from those experienced last year. The level of activity was not high enough for full advantage to be taken of this opening, but it is noteworthy that Europeans were heard in the north of England and GM3EGW was getting through to the South London area.

patch shown over the Kattegat, which caused this, extended the opening to SM instead. The elongated patch lying from North to South in the West suggests that yet another Lands End - John o' Groats record, VHF DX, was possible! Despite the fact that identification over the North Sea was uncertain, it seems likely that the layer was below 4000 feet over an extensive area.

We have seen that quiet evenings with pronounced radiation cooling are of value in extending inland paths. The effect was beginning to develop towards the end of the period on the one or two clear nights that occurred. The first line of Table I shows those evenings when significant radiation occurred. The figures show the time when the resulting progressive improvement is thought to have reached a maximum. It was not until March 11 that a marked case occurred. Where the terminating time is after midnight, it is entered under the preceding evening.

We found last year that EDX occurred only with MSL barometric pressures in excess of 1019 mb. In the States 1017 mb. has been suggested. Although pressure alone has been an inadequate guide to conditions, the graph is being continued for the time being to see how things work out. Fig. 2 is for the present period, and a pecked line shows the compromise figure of 1018 millibars. Pressure was greater than this for the DX spell, but was also greater over two earlier periods.

DX Spells ?

In an analysis of the results for last year and earlier (*Short Wave Magazine*, February 1954, p.750)

Date	FEBRUARY							MARCH														
	11-14	15	16	17	18	19	20	21	22	23	24-09	10	11	12	13	14	15	16	17	18	19	
Radiation over Bedfordshire, GMT										06		24	24									
NE			OZ									LA	OZ	OZ	OZ		LA	OZ	SM	OZ		
E		PA	WD					PA					WD	WD	PA	ED	ED	ED	WD			
SE								ON							DL	ON		OE		ON		
S									47								48	48	48			48
SW								GC									GC	GC	GC			
NW		L															I,M	I,M	I,M	I,M		

Discontinuities aloft, from S.E. England to countries indicated.

The possibilities for EDX and GDX from February 11 to March 19. Especially good dates are shown in bold type and are underlined. Country prefixes show approximate direction and distances from S.E. England to which good conditions are thought to have extended.

Table 1

- Notes:—(1) Conditions listed are for the evenings of the dates shown.
- (2) Figures in the first line are the times when inland super-refraction had reached its peak.
- (3) Country prefixes indicate the approximate limit of good conditions.
- (4) Subdivisions of distance have been necessary, thus: ED = eastern DL, WD = western DL, L = Lancashire, I = GI, and M = GM. (Sometimes paths to I and M are open together).
- (5) For the southern path degrees of latitude are given.
- (6) Paris is about 49° and Marseilles about 43°N. Particularly marked discontinuities are in heavy type and have been underlined.

the author showed how, over the last five years, certain dates had brought more VHF DX than others. In the manner of Buchan's Cold Spells, the most favoured dates were light-heartedly labelled DX spells. The first of these, March 2. ±5 days is over now and, as we—and Buchan earlier—found, the vagaries of British weather do not lend themselves to this kind of treatment! What of the closely following dead spell of March 13 ±5? The "late arrival" of this year's first DX spell transgressed that one, too!

In actual fact, things looked favourably set up on February 28 with a large anticyclone out in the Atlantic. Instead of the hoped-for drift E or NEwards, it started to move away southwards two days later, and so our unsettled weather continued.

HB9PQ Research

As foreshadowed last month, HB9PQ has kindly sent details of VHF working across the Alps to Italy. It appears that at 1145 GMT on 2 July, 1950. HB1BB informed HB9IV that he had been working 11FA. '9IV then searched over a wide southern arc without result until 1300, when the Italian was suddenly heard at good strength. The Italian end of this QSO could not be heard by '1BB, and attempts by both Swiss stations for a second QSO a few minutes later were unsuccessful. HB9PQ concludes that the inclination of the reflecting layer was fluctuating, being suitable first for one Swiss station and later the other, but never right for both together. He goes on to explain that the forced ascent of a stream of air over a barrier lying across its path—the Foehn effect—results in a series of temperature inversions extending right up to the stratosphere. Fig. 3 gives an idea of the result and suggests possible radio paths from Mount Pilatus. It is thought that only the lowest layer is strong enough to be significant. The additional layer at about 5000 feet on the northern slopes appears when the Foehn wind is strong, and in extreme cases can

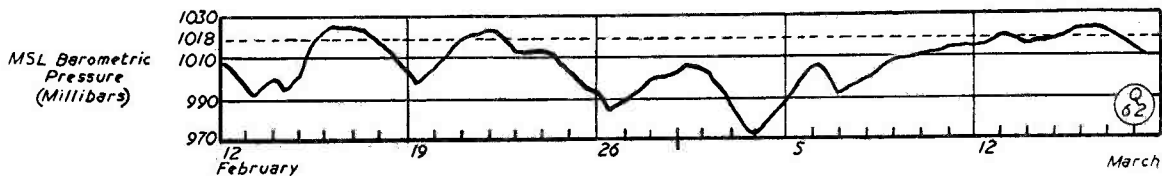

have further layers beneath. The most favourable times are Spring and Autumn. To work over the Alps from the U.K., we need the mountain layers linking up with an RRI discontinuity over the rest

Fig. 2. It has been shown that if there is a critical value for barometric pressure in terms of EDX, that value is 1018 millibars. This graph shows that during the period there were three occasions when it was over 1018 mb — but only one of them coincided with DX conditions, on March 17.

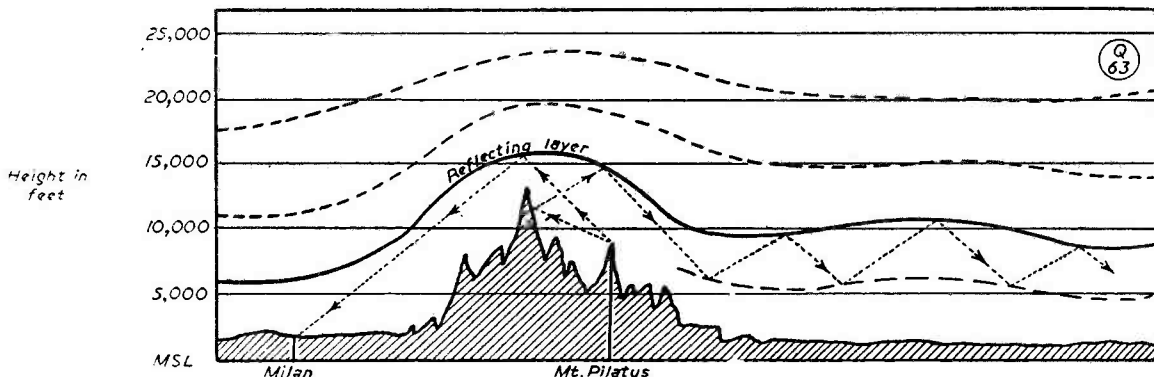

of the path. A special case of Foehn situation, with anticyclones both north and south of the Alps, offers the best chance for us, and these are most likely to develop in the Autumn. Finally, HB9PQ explains that forecasting the onset of Foehn situations is a problem that has long exercised Swiss meteorologists and it is not yet fully solved; he thinks that opportunities that develop for trans-Alp working are very short-lived compared with the effects of reflecting layers elsewhere in Europe, but hopes we do not have to wait as long for an Italian QSO as HB9IV had to wait for G!

During last December the charts of RRI discontinuities prepared daily by the writer showed a layer along the northern slopes of the Alps, which, with fluctuations, persisted for over two weeks. The first news of HB9PQ's work suggested that these may have arisen as a Foehn effect, and the charts were

Fig. 3. The contact HB9IV-I1FA, though it took place some time ago, is of considerable interest because it was over the barrier of the Alps. This sketch shows how, in what is known meteorologically as a "Foehn situation," such a contact becomes possible. For Italy to be workable from the U.K. on Two Metres, this condition would have to occur simultaneously with an opening such as we had on November 22 last — see map on p. 693 January "Short Wave Magazine."

sent to him for scrutiny. It transpired that they were so caused and that there was, in fact, a good measure of agreement in the day-to-day Foehn fluctuations and the height and distribution of the layers. It seems, therefore, that even though chances of G/I working are very small indeed, we can detect the possible chances. HB9PQ hopes to be on Eighty for next Autumn and would be willing to notify the onset of Foehn conditions.

Permission of the Director, Meteorological Office, to make use of information gained from the publications referred to is gratefully acknowledged.

USEFUL CATALOGUE

For the price of a stamp, readers can obtain from Lyons Radio, Ltd., 3 Goldhawk Road, Shepherds Bush, London, W.12, the latest copy of their "Bargains Bulletin of Selected Surplus." Some of the items listed include the 11-valve VHF receiver R.1132A (100-125 mc) available in new, unused condition at 79s. 6d., or used and untested (Grade 3 condition) at only 37s. 6d.; R.1155's, in new condition, at £10 17s. 6d.; RF Units, Types 26 and 27, at 39s. 6d.; and a wide range of other "surplus" gear, parts and experimenter's parcels.

NEW G.E.C. VALVES

The LZ319 is a triode-pentode frequency changer for operation in receiving equipment at frequencies higher than 200 mc, and the B319 is a cascade RF amplifier for the same frequency range. Other new types in the G.E.C. list are the N709, an audio output pentode on a B9A base, and the N349, a line time-base pentode which will stand a peak anode voltage of 10kV. In addition to the GET-1 point-contact transistor, a junction transistor is now available and was shown at the R.E.C.M.F. Exhibition for the first time.

Two-Band VHF Receiver

TWO-METRE AND
70-CENTIMETRE RECEPTION
WITH COMMON IF/AF
AMPLIFIER

PART II

R. F. WESTON (G2BVW)

The first part of this article, in our March issue, dealt with general design considerations and choice of crystal frequencies for the oscillator-multiplier chain. Circuits were given for this and two possible VHF front ends.—Editor.

WHEN the actual line-up of the oscillator-multiplier stages was considered (see section V16-V20, p. 37, March) it was felt that because of the use of re-ground crystals (which might not be quite as active as new ones) and possible further modifications involving the use of other crystal frequencies, it was advisable to use a crystal oscillator on fundamental frequency and not a Squier or other harmonic or overtone oscillator.

For the multiplier stages it was decided that no attempt would be made to multiply more than three times in any one stage. This policy is believed to be a good one as, firstly, it ensures reasonable stability, secondly, a fair degree of flexibility, *i.e.*, it is easy to alter from 2 times to 3 times or *vice versa* to suit experimental requirements, and thirdly, different types of frequency changer need different amounts of injection to obtain optimum working conditions. This third point means that a good supply of RF should be available for injection for it is easy to decrease power output, but often impossible to increase it without exceeding valve ratings.

The valve line-up finally decided on for 115 mc output was 6F12 or Z77 CO followed by two EL91 triplers and $\frac{1}{2}$ -6J6 as a doubler. This arrangement can give up to 1 watt of RF at 115 mc with just over 200v. on the anodes. For the 406 mc output the same valve line-up was chosen followed by the second half of the 6J6 and a final RL18 doubler, this sequence operating with the first EL91 as a tripler followed by the remainder as doublers, five valves in all. This may seem extravagant, but

it has proved extremely useful on numerous occasions.

With the multiplier stages decided on it was a simple matter to combine them, switching crystals, padding condensers and anode supplies as required. The two outputs are taken off the appropriate tuned circuits. Further provision can and has been made in the switching arrangements to use the first four valves as a 1 watt 145 mc exciter, so doing away with all the multiplier stages in the transmitter itself. What it comes to is that five valves can provide local oscillator injection for two metres and 70 centimetres, with a 1-watt drive on 145 mcs. The arrangement is practical, reasonably easy to build, and it works well. The number of valves could of course be reduced on any final design.

As previously explained, the possible output of the multiplier stages has been kept high and when testing out different frequency changer stages it has been found best to include in the HT supply to the multipliers a 20,000 ohm variable resistance so that optimum injection can be ascertained; this can later be removed, measured and replaced with a suitable fixed resistor. Present consumption is 28 mA at 165 volts when receiving on 70 centimetres, and 18 mA at 150 volts when receiving on two metres.

When a crystal multiplier sequence of this type is used, it is essential to screen adequately all components and to by-pass all HT supplies to ensure a minimum of spurious responses, which can occur for the most unpredictable reasons! Completely enclosing the crystal section seems to be fairly effective.

The oscillator-multiplier unit is quite conventional in its circuitry. The switching of condensers and/or coils in the various circuits is done with wafer switches, all driven by an extension shaft and flexible coupling from the front panel. In order that HT supplies can be switched to different front ends an extra wafer is included near the front panel. An additional wafer for switching the IF outputs of different front ends is fitted immediately under the first 29 mc 6AK5, being driven by a mechanical link to the crystal multiplier chain switch.

Construction

It will be seen from the circuit diagram and photographs that normal coil and condenser circuits are used up to 203 mc, while the anode of the RL18 is tuned to 406 mc by a quarter-wave coax line. Circuits above 115 mc are

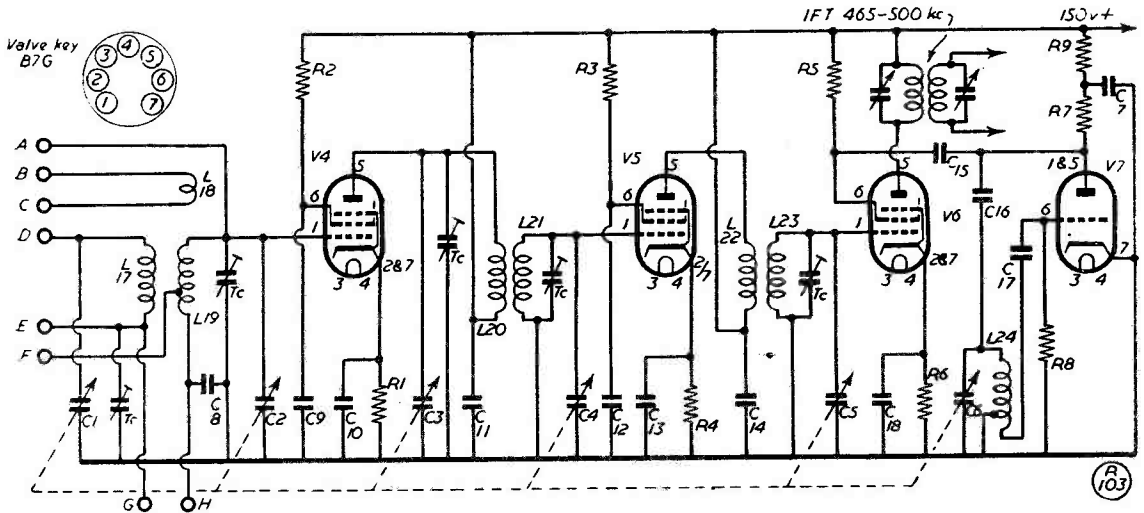

Fig. 5. The 29 mc IF section in the G2BVW VHF receiver. It actually tunes 24-34 mc for coverage on both VHF bands, and all values are given in the table. Coupling V4-V5 and V5-V6 can be as shown, with L20, L21 both tuned, or as L22, L23 with "single tuning"; alternatively, capacity coupling can be used. Pin connections to the left of the drawing are: A, high impedance input to grid V4; BC, link for external converter or aerial; DE, high impedance input; F, tapped coupling; GH, meter connections for crystal current check; TC, 15 μF trimmers; if L17 is not in use it should be disconnected and the trimmer across L19 brought out as a panel control.

not switched. The RL18 anode line is made of $\frac{3}{8}$ " i.d. $\frac{1}{2}$ " o.d. brass tube slotted $\frac{1}{8}$ " wide to within $\frac{1}{2}$ " of each end of its 5" length. A piece of $\frac{1}{8}$ " dia. brass rod is used as the centre conductor; it is held by a brass plug at one end of the tube and a micalex bush at the other. A $\frac{3}{8}$ " long brass collar is used to vary the effective length of the line. It is made to be a slide fit inside the brass tube and is locked by a 6 BA bolt and nut fitting through the

Table of Values

Fig. 5. The 29 mc IF Section

C1, C2,	C17 = 250 μF
C3, C4,	R1, R4 = 220 ohms
C5, C6 = 25 μF max per section	R2, R3 = 15,000 ohms.
	R5 = 22,000 ohms.
	R6 = 330 ohms.
C8, C9,	R7 = 10,000 ohms.
C10, C11,	R8 = 100,000 ohms.
C12, C13,	R9 = 4,700 ohms.
C14, C18,	
C19 = 0.001 μF	V4, V5,
C15 = 20 μF	V6 = 6AK5,
C16 = 500 μF	V7 = 6CA.

COIL TABLE

TWO-METRE CONVERTER (Fig. 2, p. 38, March)

- L1 2t 20 S.W.G.
- L2 8t 20 S.W.G. space approx. $\frac{3}{16}$ " to tune
- L3 9t 20 S.W.G. " " " " "
- L4 4t 20 S.W.G. " " " " "
- L5 4t 20 S.W.G. " " " " "
- L6 2t 20 S.W.G.

OSCILLATOR-MULTIPLIER CHAIN (Fig. 4, p. 39, March)

- L7 30t 28 S.W.G. silk covered close wound for 6 to 9 mc.
- L8 10t 22 S.W.G. " " " " " 18 to 28 mc.
- L9 8t 16 S.W.G. space $\frac{3}{16}$ " " " " 47 to 62 mc.
- L10 4t 16 S.W.G. space $\frac{3}{16}$ " " " " " " "
- L11 2t 20 S.W.G. insulated link
- L12 4t 16 S.W.G. as L10
- L13 2t 20 S.W.G. as L11
- L14 4t 16 S.W.G. as L10
- L15 2t 16 S.W.G. space wire dia.
- L16 2t 16 S.W.G. " " " " "

29 mc IF SECTION (Fig. 5)

- L17 7t $\frac{1}{16}$ " 26 S.W.G. silk covered. Close wound. Dust core
- L18 2t $\frac{1}{16}$ " 20 S.W.G. Earthy end of L19
- L19 7t $\frac{1}{16}$ " 26 S.W.G. as L17 and spaced $\frac{1}{16}$ " from L17
- L20 7t $\frac{1}{16}$ " 26 S.W.G. } wound and spaced as L17 and L19
- L21 7t $\frac{1}{16}$ " 26 S.W.G. }
- L22 3t $\frac{1}{16}$ " 26 S.W.G. Silk covered close wound spaced $\frac{1}{16}$ " from L23
- L23 7t $\frac{1}{16}$ " 26 S.W.G. as L17
- L24 9t $\frac{1}{16}$ " 26 S.W.G. Silk covered close wound, dust core, tap at 2t.

(Note : All coil sizes are inside diameters, i.d.)

slot. Output can be taken off at any point by a small phosphor bronze clip and coax cable.

All coils on the multiplier stages are wound on television type coil formers, without dust-iron cores. The individual numbers of turns of wire are given in the accompanying table and should act as a guide even if different frequency multiplication arrangements are adopted. The switched tuning condensers are of the variable ceramic type; some have been mounted on top of the chassis where they are easily accessible, but they can be placed in any convenient position providing consideration is given to lead length and the possible pick-up in RF circuits of harmonic radiation from them. Above 116 mc two variable condensers are necessary, and two Philips concentric trimmers have been used. It will be seen that in the first half of the 6J6 the coils are switched as well as the condensers. This was done to avoid RF input to the 144 mc FC stage while receiving on 435 mc, or using the oscillator chain as an exciter.

(b) The 29 mc Tunable IF.

This part of the receiver is made up as a sub-assembly, in which form it can be accurately lined up before mounting on the receiver chassis.

The small 2½" x 1¼" x 6½" chassis was made from one piece of 18g. aluminium; it is large enough to hold all components with the exception of the tuning condenser which is mounted on a strip of insulating materials. The two twin-gang condensers (ex-Type 27 RF Units) are split statored on each section to give a total tuning range of from 24 to 34 mc. One half of each section is used to tune each stage with one half-section for the oscillator. Trimming is accomplished on each stage by the use of 7 to 45 µµF ceramic trimmers mounted on the top of the small chassis. The coils used were taken, as explained earlier, from an ex-WD altimeter and are dust-cored. The alignment of the unit is very easy if carried out in the normal way; in fact, the writer used a BC221 and an 1155 fitted with an S-meter as the 500 kc output channel and indicator. The con-

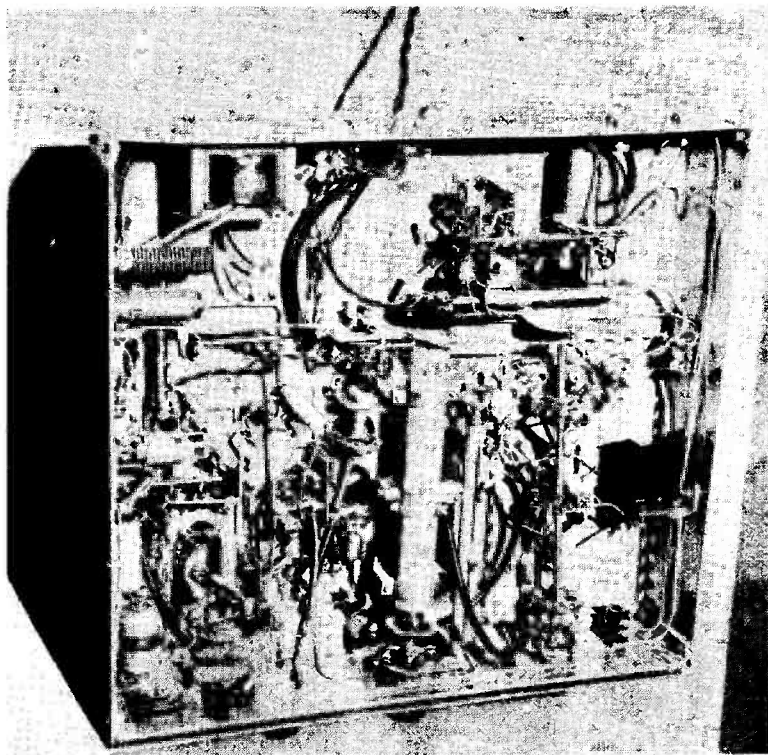

General arrangement underneath the VHF receiver. The tubular assembly in the lower centre is the 70-centimetre mixer; the circuit for this is as Fig. 3 on p. 38 of the March issue.

densers were trimmed for 32 mc and the coils for 26 mc. The 6C4 oscillator valve was chosen in preference to a 9002 because it gave slightly less frequency drift, which is in any case quite good. AVC can, if desired, be fed to the second 6AK5 and to the FC, but in the case of the writer this was not found necessary.

It will be seen from the circuit that a low impedance input link has been fitted to the unit so that the receiver can be used on the 28 mc band or on other bands with external converters. Because various bands are switched into the grid of the first 6AK5 it is essential to provide a front panel trimmer of about 15 µµF. The overall performance of the unit is extremely good and is noticeably better in signal-to-noise ratio than the AR88 station

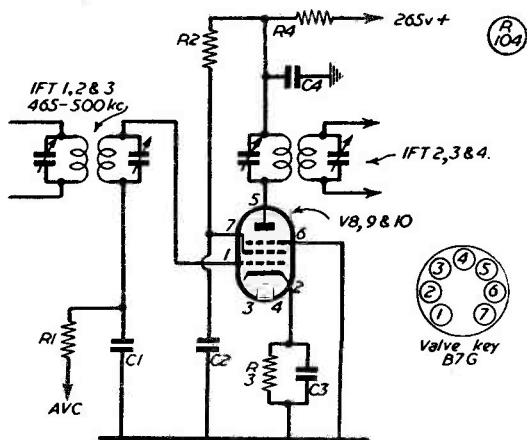

Fig. 6. The 465/500 kc IF stages for the VHF receiver. There are actually three such, V8-V10 in the block diagram on p. 37 of the March issue, all circuits being as shown here for V8.

Table of Values

Fig. 6. The 465-500 kc IF stages

R1 = 470,000 ohms.	C2, C3,
R2 = 15,000 ohms.	C4 = 0.05 µF.
R3 = To suit valves used.	V8, V9,
R4 = 10,000 ohms	V10 = 6F12, Z77, EF91,
C1 = .001 µF.	etc.

Table of Values

Fig. 7. Power supply circuit

R1 = 3,000 ohms., 10 watt.	MR = 500v, 10mA.
R2 = 68,000 ohms, 5 watt.	C1, C2, C3 = 8 μF.
R3 = 20,000 ohms.	C4, C5 = 1 μF.
R4 = 7,500 ohms.	C6 = 50 μF, 50 v. wkg.
L1 = 10H, 90mA.	V21 = 6X5.
T1 = Secondaries : 265-0-265v, 6.3v	V22 = VR150/30.
	V23 = any 70/85 v, 5 mA stabiliser valve.

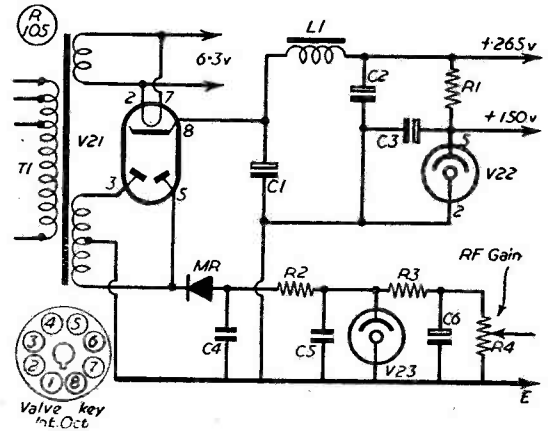

Fig. 7. Power supply arrangements for the receiver, with stabilised outputs for sections as required. V22 is a VR150/30 and V23 a 70-85v. 5 mA stabiliser.

receiver on 28 mc. It would make quite a good converter for use with the BC-348 or 1155 series of receivers.

The slow motion reduction drive to the condenser assembly presented quite a problem which was overcome by using part of the gear drive from an ex-WD Selsyn unit (included with the aerial selsyns when they were purchased) and a small 9-1 ball bearing reduction gear. Total ratio is in the order of 75-1. A 3" dia. by 1" wide flywheel was fitted to the hand tuning control. The tuning dial was made of 1/32" thick celluloid on to which was stuck with amyl-acetate a piece of thin drawing paper. Calibrations can be marked on the drawing paper in Indian ink and the scale can be illuminated from the rear. The scale is viewed through a 2½" square bakelite meter opening exactly similar to the S-meter.

The above brief description of the tuning system has been given for it was thought that while some amateurs may like to purchase one of the excellent units now on the market, others would perhaps like to construct their own from say suitably chosen and spring-loaded gears, such as "Meccano."

(c) *The Second IF Section.* This is again quite conventional; the three IF valves Z77's,

6F12's, or EF91's, are all run with AVC, and if normal screening precautions are taken no instability should be present. The IF transformers used were purchased as 465 kc miniatures, but were obviously intended for use with valves with a much higher inter-electrode capacity than 6F12's with a result that 500 kc has had to be used for the IF. This does not matter, of course, but has been mentioned in case anyone should meet the same trouble. Alignment of the IF's can again be carried out in the normal way and the bandwidth adjusted to suit requirements.

(d) *The AVC, Detector and Noise Limiter.* Two 6D2's have been used for these purposes. No originality is claimed for the circuit, as it is virtually a copy of the AR88 arrangement

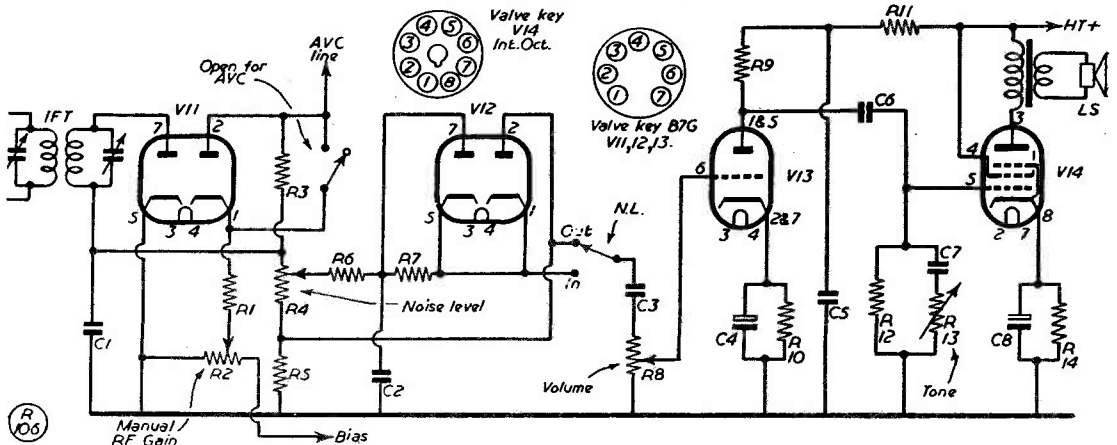

Fig. 8. Circuit of the AVC, noise limiter and audio section of the receiver, for which all values are given in the table.

and very good ; any simpler arrangement could be used and would undoubtedly work well.

(e) Signal Strength Meter and IF Gain Control. Because of the comparatively low anode current consumption of the IF stages the S-meter can be connected in series with the cathode connection to two or more valves working with AVC. This common connection can be quite effective if suitable decoupling and bypassing is used. The values given in the circuit diagram are quite satisfactory. With the cathode current of three valves available it is possible to use a 5 mA meter with a 50 ohms variable shunt. A more sensitive meter is suitable and will perhaps be found advantageous, for it can be switched to read FC crystal current. For the IF gain control about 20 volts negative is required ; this has been obtained by a small metal rectifier connected to the secondary of the HT transformer ; its output is capacity-resistance smoothed and stabilised with a 5 mA neon voltage stabiliser. It was found impracticable to use a resistor in the negative HT lead to obtain the required voltage, for when switching from band to band the HT loading varies considerably affecting the IF gain control to a degree that makes it virtually useless.

(f) BFO and Audio. For the BFO a 6F12 has been used, but again almost any suitable valve and circuit combination will do provided that it is sufficiently stable.

Audio output is taken from a 6F6 driven by a 9002 which is provided with a top-cut tone control. There are no special points about this part of the circuit except perhaps to say that the top cut control has been found very useful.

(g) Power Supply. The chief requirement of this part of the receiver is that it should have reasonable regulation to cope with varying loads without too much voltage fluctuation. The regulated part of the supply has been used for feeding the entire 29 mc IF section, the BFO and some front ends that have been tried.

Table of Values

Fig. 8. AVC, NL and Audio section

R1 = 0.4 megohms.	R13 = 25,000 ohms.
R2 = 7,500 ohms.	R14 = 330 ohms.
R3 = 2.2 megohms.	C1 = 180 μ F.
R4 = 66,000 ohms.	C2, C6 = 0.1 μ F.
R5 = 33,000 ohms.	C3 = 0.02 μ F.
R6 = 680,000 ohms.	C4, C8 = 25 μ F.
R7, R12 = 470,000 ohms.	C5 = 0.5 μ F.
R8 = 2 megohms.	C7 = 0.01 μ F.
R9 = 250,000 ohms.	V11, V12 = 6D2.
R10 = 1,000 ohms.	V13 = 9002.
R11 = 100,000 ohms.	V14 = 6K6.

Possible "Front Ends"

To obtain the maximum benefit from the receiver under present-day conditions of flux with regard to VHF converter design, the physical layout of components and the mechanical construction of the receiver as a whole must allow easy access to converter components and easy removal of converters. A further requirement is that the FC stages of any converter used must be as close as possible to the first tunable IF stage in order to keep coupling losses and stray pick-up down to a minimum. These facts are mentioned here because they can affect the possible layout of any converter that it is thought may be used.

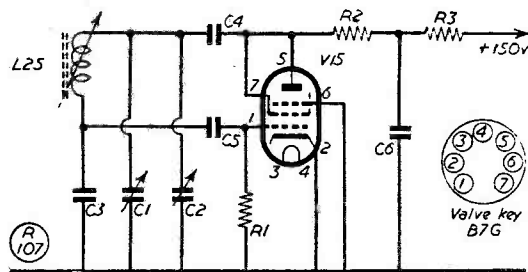

Fig. 9. BFO circuit for the VHF receiver ; this is V15 in the block schematic of Fig. 1 on p. 37, March. The inductance L25 is one half of a standard IF transformer, with the other half disconnected and left open-circuit. Any fixed capacity across L25 is also disconnected and replaced by a trimmer ; the beat adjustment is by a 25 μ F variable C2, brought out as a panel control.

Table of Values

Fig. 9. BFO circuit for receiver

C1, C2 = Tuning.	R1, R2 = 100,000 ohms.
C3 = 0.002 μ F.	R3 = 47,000 ohms.
C4, C5 = 50 μ F.	V15 = 6F12, Z77, EF91, etc.
C = 0.05 μ F.	

Three types of converters have so far been tried on 145 mc. One consisted of a 446A RF stage followed by a 446A FC stage. On the original of this converter it became apparent that several modifications would have to be made in order to increase the "Q" of two of the tuned circuits. The "Q" was very low because of the particular type of construction employed and it was decided to rebuild at some future date when more time is available. The theoretical possibilities of this converter are, in the opinion of the writer, fairly good.

The 446 effort was replaced by a 6J6 neutralised RF stage feeding a frequency changer which has been modified several times using a second 6J6, a 9002 with injection on the cathode and a 6AK5 with various types of injection.

(To be Concluded)

NEW QTH'S

This space is available for the publication of the addresses of all holders of new U.K. call signs, as issued, or changes of address of transmitters already licensed. All addresses published here are reprinted in the quarterly issue of the "RADIO AMATEUR CALL BOOK" in preparation. QTH's are inserted as they are received, up to the limit of the space allowance each month. Please write clearly and address on a separate slip to QTH Section.

- DL2UO**, Cpl. A. Tugwell (*ex-V56CK*), 755 Signals Unit, R.A.F. Station, Uetersen, 2nd T.A.F., B.A.O.R.3.
- DL2UY**, Cpl. K. Smethurst (*G3GPE, ex-Y11X/MP4BAD*), OMC Flight, 2 Group (U) Signals, R.A.F. Station, Sundersn, 2nd T.A.F., B.A.O.R.39.
- EI2X**, M. Beazley, 6 Cartron, Sligo, Co. Sligo.
- G3DMP**, J. Booth, Flat No. 1, 136 Westgate, Wakefield, Yorkshire.
- G3JAQ**, P. J. Mayes, 23 Wensleydale Road, Leigh, Lancs.
- G3JBT**, J. Irlam, 23 Freeman Road, Gravesend, Kent.
- G3JCL**, C. Lawson, 8 Woodcote Green, Wallington, Surrey.
- G3JEP**, Rev. J. E. Penney, Wisborough Green Vicarage, Billingshurst, Sussex. (*Tel.: Wisborough Green 339*).
- G3JGO/A**, B. Priestley, c/o 69 Rockley Road, Sheffield, 6, Yorkshire.
- G3JHA**, J. Holt, 23 Brookfield Avenue, Sunny Hill, Derby.
- G3JIL**, H. A. Johnson, 17 Williams Avenue, Wyke Regis, Weymouth, Dorset.
- GD3JU**, M. R. Thompson, 146 Ballabrooie Drive, Douglas.
- GM3JKC**, C. Cooper, 674 Gallowgate, Glasgow.
- G3JLF**, L. Beevers, 59 Reed Street, Marsh, Huddersfield (*Tel.: Huddersfield 4391*).
- G3JLO**, J. M. Bell, 10 Northumberland Road, Southsea, Hants.
- G3JLR**, F. R. Wilds, 15 Neville Grove, Almondbury, Huddersfield, Yorkshire.
- G3JLX**, R. W. Dawson, 6 Farndon Avenue, Hazel Grove, Cheshire.
- G3JMU**, L. Taylor, 121 London Road North, Lowestoft, Suffolk. (*Tel.: Lowestoft 119*).
- G3JMX**, P. Hayward, 58 Edgerton Road, Lowestoft, Suffolk.
- GM3JNE**, G. R. Brooks, 4 Newarthill Road, Carfin, nr. Motherwell, Lanarkshire.
- G3JOX**, A. B. Greaves, 21 Methley Drive, Leeds, 7, Yorkshire.
- G13JOZ**, J. E. Williamson, 7 Ebrington Terrace, Londonderry.
- G3JPB**, C. H. Noden, Brownhills Manor, Market Drayton, Shropshire. (*Tel.: Market Drayton 3394*).
- G3JPJ**, J. G. Peerless, 37 Maitland Street, Liverpool, 8, Lancs.
- G3JPN**, P. West, c/o 45 Arden Road, Aston, Birmingham, 6.
- G3JQC**, G. W. Hawksworth, 12 Powell Street, Heckmondwike, Yorkshire.
- G3JQE**, A. Wormald, B.Sc., 30 Moorland Drive, Thornbury, Bradford, Yorkshire. (*Tel.: Bradford 65471*).
- G3JQG**, T. Seatter, 41 The Hundred, Eastleigh, Hants.

CHANGE OF ADDRESS

- EI5X**, W. Rothwell, 71 Kinvara Park, Navan Road, Dublin.
- G2ATD**, R. Hill, 5 Sussex Road, North Heath, Erith, Kent.
- GW2BCH**, J. P. O'Brien, 18 Colwyn Avenue, Rhos-on-Sea, Denbighshire.
- G2HKJ**, A. R. Knight, 80 Oakroyd Avenue, Potters Bar, Middlesex.
- G3AVD**, R. Harden, 15 Queens-thorpe Road, Sydenham, London, S.E.26.
- G3BOD**, C. D. Jones, 25 Chetwynd Road, Wolverhampton, Staffs.
- G3DAO**, P. B. R. Cutler, The Flat, 32a High Street, Beaconsfield, Bucks.
- G3DCJ**, J. E. Wootton, Treeve Moor House, Lands End, Cornwall.
- GD3DEF**, B. J. Gealer (*ex-G3DEF*), 1 Selborne Road, Douglas.
- G3DUZ**, B. Froggatt, 119 Compton Avenue, Spottborough Road, Doncaster, Yorkshire.
- G3EEZ**, A. Wakeman, 1 Kendal Close, Aldersley Estate, Tettenhall, Staffs.
- G3EJD**, D. G. Duff, 104 Broughton Road, South Shields, Co. Durham.
- G3EWE**, A. P. Carrington, Nepeta, Stringers Common, Guildford, Surrey.
- G3FUT**, F. J. Hawke, No. 1 St. Michaels, Courtenay Road, Newton Abbot, Devon.
- GW3FWH**, S. G. Stephen, 5 Bridge Street, Llandaff, Cardiff.
- G3GHN**, Clifton Amateur Radio Society, c/o 28 Canadian Avenue, Catford, London, S.E.6.
- G3GOZ**, P. M. Elton, 82 Kenilworth Crescent, Enfield, Middlesex.
- G3GRK**, C. R. E. Ayley, 31 Morland Road, Croydon, Surrey.
- G3HGD**, V. S. Best, 44 Barnes Avenue, Bradford Road, Wakefield, Yorkshire.
- G3IDZ**, Aircraft Apprentices Hobbies (Radio) Club, c/o The Officer i/c Officers' Mess, R.A.F. Station, Locking, Weston-super-Mare, Somerset.
- G3IND**, D. H. Boyles, 59 Capel Road, Forest Gate, London, E.7.
- G3IVH**, E. J. Younge, c/o Y.M.C.A., St. Giles' Street, Norwich, Norfolk.
- G3IXF**, G. A. Palliser, 43 Ridgeway, East Field, Scarborough, Yorkshire.
- G13JCD**, G. Graham, 24 Lawnbrooke Drive, Lisburn, Co. Antrim.
- G3JQC**, W. H. Morris, 7 Valley Drive, Barrow-in-Furness, Lancs.
- G3JDD**, R. G. R. Dobson, 69 Grainger Park Road, Newcastle-on-Tyne, 4.
- G5LS**, H. G. Effemey, Assoc.I.E.E., 1 Meadway Gardens, Ruislip, Middlesex. (*Tel.: RUI 4344*).

CERTAIN connoisseurs of science fiction inform us that they laughed heartily over our clumsy efforts last month. Concerning our suggestions for a "Worked All Heavenly Bodies" Certificate, they ask, with a certain *hauteur*, whether we really imagine radio to be the communication medium throughout the universe? Then they weigh in with an airy assumption that *telepathy* would, of course, be the sole means whereby contact could be maintained between the galaxies. While not disputing the advantages of telepathy over telegraphy, we remain unconvinced and curious. What frequencies do we telepathise on? What form does QRM take? At what speed do the waves travel? We want to know more. If they travel at the mere speed of light, they are useless—generations will have died before they reach their target. If they travel instantaneously, we foresee considerable difficulties there, too—in the manner of those of the young lady who left home at the speed of light, and arrived home the previous night.

OUTMODED

However one looks at this science-fiction business (and it certainly *is* a business these days), there is no doubt that imaginative powers have not waned since the days of Jules Verne and H. G. Wells. Every "modern" device is seen to be completely useless and out-of-date; our most fearsome hydrogen bomb would hardly shave a single hair off the face of the universe, and our pitiable little radio just about resembles the short-range communication between two adjacent ants in a vast colony of those important insects. In short, man is a most ingenious creature in his own fruitful imagination, but when it comes to doing things in a big way, he requires several millions of years to evolve the simplest modifications! Instead of complacently contemplating the "enormous strides" made by radio in fifty years, we should be ashamed at the thought of how primitive, how almost useless our



communications are, after all these aeons!

EXPERIMENTATION

It seems to be only in the realms of transistors and centimetres that any pioneering work is being done by amateurs these days. There is plenty to be done in these spheres, as we all know, but the *incentive* seems slight. In the old days, when we were successively pushed off 1000 metres and 440 metres, and had to explore the fearsome "short waves" of 200 metres and below, there was a reward at every turn. Each new wavelength conquered seemed to bring more spectacular results than its predecessor. Long-distance communication was being opened up, month by month. Had we the same spur to our efforts now, where might we not be on VHF? In the present state of the art, it does seem that VHF ranges will always be somewhat limited unless we can make use of artificial aids—such as satellites flown off into space and kept at the right place to act as reflectors. But we realise that even this is a risky thing to say, and that we might well have dropped a huge brick thirty years ago by proving that ten metres would never be useful for long-range work.

ADVANCED KNOWLEDGE

The chief attraction of VHF work is, indeed, its difficulty, and of the transistor, its originality. It offers an outlet to the amateur

whose intellect is capable of more than mere copying of circuits and operation of a transmitter. It even offers possible rewards for that rare bird, the original thinker. And the VHF addicts will back us up heartily if we say that any sort of success on those frequencies requires more skill than it does on the "DX bands." As a friend of ours put it recently (and poetically), "VHF is VFB—without Know-How it's NBG!" But we still seem to be held up at every turn by the mere *physical* difficulties. Just as 30,000 metres is useless to us (as amateurs) because we couldn't put up a big enough aerial, so, it seems, 1 millimetre may also be very difficult because we can't make one small enough. The first fumbling efforts at 10-centimetre radar ran into trouble because the dipoles were so small and used to burn out; so they scrapped the dipoles and used wave-guides. What do we scrap next?

CONTINENTAL COCKTAIL

Sparing one paragraph for the mundane matter of our bands as they are today, we should like to reaffirm that we are truly amazed at some of the signals emanating from the continent of Europe. They come straight from the early 'twenties, but awaken exasperation rather than nostalgia. Every day one can hear a "thing" with a huge chirp *and* keyclicks *and* drift *and* a nearly raw AC note on the end of it all. Such a noise can only come from a Hartley oscillator built on a cardboard chassis and supplied by chemically-rectified AC with the wrong solution in the rectifiers—or how else is it done? Strangely enough, these things have one point in their favour—they do invariably drift. So if one of them sits on the other end of your contact, it won't be for long . . . he is off on his way to mess up someone else! On telephony we hear comparable noises, surely produced by self-excited oscillators using absorption modulation with a carbon microphone. Oh, the Good Old Days!

The Other Man's Station

G3FUR

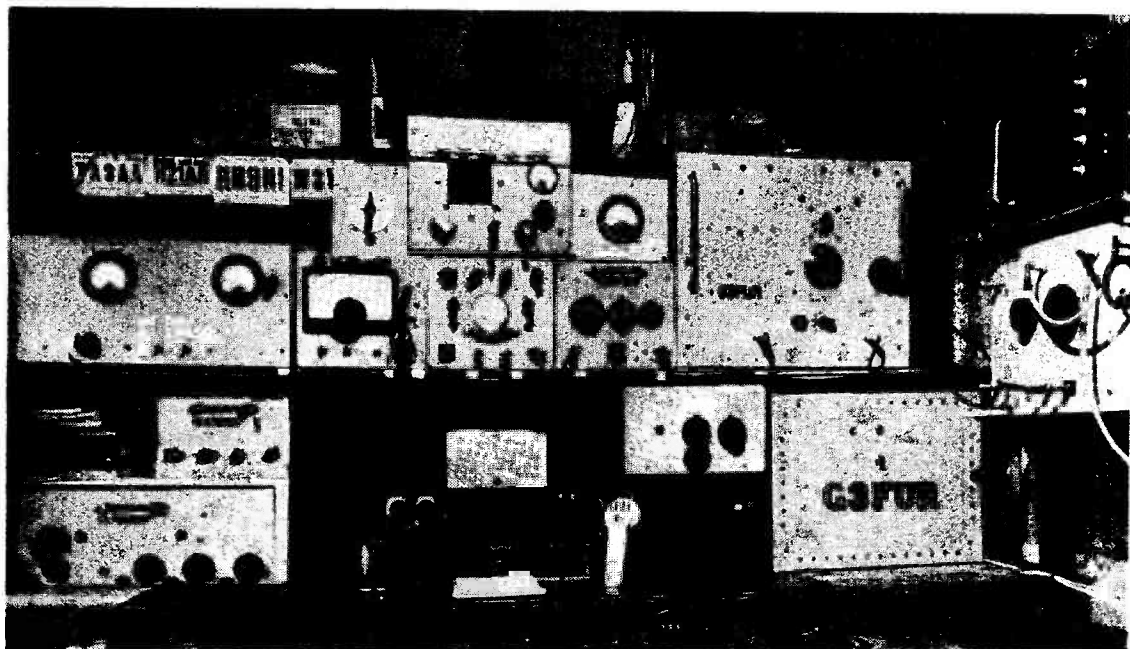

UNTIL September 1951, the subject of our story this time—F. K. Parker, G3FUR, 122 Empingham Road, Stamford, Lincs.—operated VS6CB in Hong Kong.

The photograph above shows his layout as it is at present. The main transmitter is a five-band job, operated mainly on Eighty and Twenty, the basic arrangement being VFO-Wide Band Exciter-PA. The VFO, with built-in crystal calibrator, is a 1.8 mc Clapp, the Exciter uses triode-connected EF50's with an 807 amplifier, and the PA is an 813.

On the audio side, the main modulator is a pair of 807's in AB2, preceded by a triple-channel speech amplifier; this is for a gramophone section for record playing and quality check, and is also used for two microphones run together, one for bass response and the other for top; the gain of each section of the amplifier is independently controlled and mixed into the modulator. An oscilloscope is in continuous use for monitoring and modulation control. Frequency checking is by means of a home-built, GPO approved, heterodyne wavemeter. For reception, G3FUR runs an Eddystone S.640, used with a single-stage 6F13 preselector on 20, 15 and 10 metres.

All units are inter-connected where necessary by shielded or coaxial cable, all power leads are taken

to a main control panel which carries the relays and feeds out power to the various units, and the transmitter itself is fully shielded and suppressed for TVI; its RF output is taken through a low-pass filter to the aerial coupling unit. All power packs incorporate delay switching and overload protection. Including power supplies and the ancillary equipment, the station uses some 60 valves in 24 separate units.

Looking at the photograph, the following is the general layout arrangement: *Bench Level*: Speech Amplifier, Preselector - Receiver C/O, S.640, Frequency Meter, Control Unit. *Above Bench Level*: Preselector, Log Books, Key. *Transmitter Section*: Main Modulator, VFO, Monitor 'scope, Exciter, 813 PA, Phone Monitor, speaker and meters.

The station is operated both on phone and CW, with either an electronic or a straight key, Normally, centre-fed aerials of 132 feet, 66 feet or 33 feet are used, carried on 45-foot sectional wooden masts. While DX is not of particular interest at G3FUR, in the course of time 110C have been worked in 33Z. An excellent record and a very nice station which, with the exception of the receiver and electronic key, has been designed and built throughout by its owner.

THE MONTH WITH THE CLUBS

By "Club Secretary"

(Dead-line for Next Issue : APRIL 14)

WHAT is a *Club-Room*? We have often wondered what sort of picture the expression would conjure up in the mind of someone who had never visited a Radio Club or Society. The strange thing is that, whatever he imagined, he would probably be right—in terms of some particular Club. For we do live in a strange variety of places.

From the Club in a very small town, with perhaps 15 members all told, right up to the highly-organised, old-established institution which can muster 60 to 80 and think nothing of it, we meet in every conceivable kind of place.

Happy is the Club with a room which it can really call its *own*; and how important it is for the welfare of any Club to acquire one. For until one has a safe place which can be locked up between meetings, it is not practicable to run a Club station, or even to provide the simplest of workshop facilities for members. Sooner or later all Clubs come down to this search for someone's unused back-room, garage, workshop or anything with four walls!

Meanwhile, all salutations to the small gatherings in the ante-rooms of fish-and-chip shops; the rooms above cafes and sweet-shops; the back-rooms in Public Libraries that are unused on Thursday evenings—and all the rest, right up to the fortunate lessees of rooms in municipal buildings, science labs. and the like. We will examine a few of them herewith.

The Eagle Inn, Gloucester Road, is the meeting-place at *Brighton*, where the Club meets every Tuesday at 7.30 p.m. Talks on "Radio Mathematics" are under way, Morse classes are running, and the Club Tx performs on Top Band and Eighty.

Harrow meets every Fridays at the Science Lab., Roxeth Manor Secondary School, and "full house" is the usual state of affairs. At the April meetings the accent will be on VHF; the lectures on Basic Theory are proving very popular.

The popular subject of Transistors was covered by G3CCA up at *Leicester*, where they meet at the Holly Bush Hotel, Belgrave Gate. Further details, including a demonstration, will be given on April 12.

The "shack" of *Nottingham University* at Beeston, has been re-organised, and two self-contained stations stand side by side—one for VHF and one for LF bands. They can be operated simultaneously. Although an "internal" society, they will be pleased to welcome visitors at the Club-Room, 74 Broadgate, Beeston, but would like prior notice.

The venue for *Portsmouth* is the Signal Club Room. Royal Marine Barracks, Eastney, but at the March business meeting the matter of acquiring their own premises is coming up—with a view to opening *every evening*. Recent events have been a lecture on the Decca Navigator, and a visit to the Portsmouth G.P.O. main exchange.

Ravensbourne meets in the Science Room, Durham Hill School, Downham, Kent, and membership totals 54. On May 8 they will be staging an exhibition of home-constructed equipment, and the Club Tx, G3HEV, will be active. Normal meetings are on Wednesdays at 8 p.m.

Slade, which meets at Church House, High Street, Erdington, is now setting up a shack to house G3JBN—on the headquarters premises. Visitors are always welcome on alternate Fridays.

Meetings of the *Southend* Club take place in Room L, Queens Road Laboratories, Municipal College, where members have been enjoying a series of talks on Aerials and Wave Guides, by Mr. W. A. Smith, B.Sc.

In *York* they meet at the Club-Room in Fetter Lane, facing the rear of the Queens Hotel, and interest and activity run at a high level. The Club call, G3HWW, has now appeared on VHF for the first time, and the fare offered at the regular Wednesday meetings has been interesting and varied.

The Social Side

Several annual dinners and Hamfests have been reported this month. *Coventry* celebrated on March 5, under the chairmanship of G5ML, with officers present from the Midland and Slade societies. *Stockport* celebrated in March too, with some 80 people at the gathering.

At *Derby* the Annual Dinner and Social attracted an attendance of 58, and G5YY presented a Silver Cup to be known as the G5YY Trophy. This is to be awarded to the winner of a competitive event each year. G3FGY is the first holder.

Lincoln announces a County Hamfest for Sunday, May 23. Assembly is at Lincoln Technical College at 1.30 p.m. Tickets, price 7s. 6d. from G4BU, 116 Portland Street, Lincoln.

On April 24 the *Southend* Hamfest takes place at the London Hotel (corner of Tylers Avenue and High Street).

Worthing is holding an Annual Dinner, but unfortunately this took place before publication; the

notice of this event arrived just too late for inclusion last month. We hope they had a happy evening on March 24.

Lectures

Talks of unusual interest are always being reported by Clubs up and down the country. Secretaries who are scratching their heads for new subjects might take note! For instance, **Clifton** (London S.E.) heard a talk by G6LX on his recent visit to Monaco, where he operated 3A2AY. **Lancaster** had a talk and demonstration on an electronic organ by G2CGQ.

Torbay had an interesting talk by G4RJ on the aerial system used by the Dartmouth Group for NFD and other field day events, and also had an impromptu address by VQ4AY — the son of one of their members.

Yeovil have been testing out a transistor transmitter built by one of their SWL members, and have been making contacts up to 90 miles on it, using the 80-metre band.

Film strips have been used by **Salisbury**, and their final film show is booked for the next meeting, on April 13. On May 11 they will have an evening D/F trial, in the vicinity of the Club Headquarters.

Newcomer

The **Marconi** (Basildon) Amateur Radio Club has just been formed for members of Marconi's Wireless Telegraph Co. at Basildon, Essex, and there are already



Stand organised by the Grafton Radio Society, when they had G3AFT in operation at the recent Islington Handicrafts Exhibition. In this photograph are: G2CJN (standing, extreme right), G2DUP, G3AFC, G3JLA and G8PL.

35 members on the roll. Premises are urgently required for meetings, which take place, at present, in the factory. See panel for Secretary's name and address.

Clubs with no Meetings

The "**British Two-Call Club**" is open to all British subjects who have held calls in two or more "amateur radio" countries. The annual subscription is 2s. 6d., which brings a quarterly newsletter. The 1954 President is DL2RO, and membership is now 124, in sixteen countries.

The former "**QRP Research Society**" is now renamed the **QRP Society**. Their "QRP," a roneo'd compilation, is circulated to members, and the Secretary will be glad to forward full details to all who may be interested.

News in Brief

LEEDS: Meetings on April 21 (visit to Skelton Grange Power Station — assemble at the station 7 p.m.); April 28, Talk on Disc Recording.

LEICESTER: A D/F Field Day has been organised for Sunday, May 16.

NEATH & PORT TALBOT: On May 12 (7.30 p.m. at Royal Dock Hotel, Briton Ferry) there will be a talk by GW3ZV on the subject of VHF.

SOUTH MANCHESTER: On April 9, talk on Radio-Active Materials; April 23, Transmitter and Receiver Testing; May 7, Tuned Line Oscillators.

SPEN VALLEY: On April 21,

NAMES AND ADDRESSES OF SECRETARIES REPORTING IN THIS ISSUE

BRIGHTON: T. J. Huggett, 15 Waverley Crescent, Brighton 6.
BRITISH TWO-CALL CLUB: G. V. Haylock, G2DHV, 63 Lewisham Hill, London, S.E.13.

CLIFTON: C. H. Bullivant, G3DIC, 25 St. Fillans Road, London, S.E.6.

COVENTRY: K. Lines, G3FOH, 142 Shorncliffe Road, Coventry.

DERBY: F. C. Ward, G2CVV, 5 Uplands Road, Littleover, Derby.

EDINBURGH: D. B. R. Black, 16 Edina Place, Edinburgh.

HARROW: S. C. J. Phillips, 131 Belmont Road, Harrow Weald, Middx.

LANCASTER: A. O. Ellefsen, G3FJO, 10 Seymour Avenue, Heysham.

LEEDS: B. A. Payne, 454 Kirkstall Road, Leeds 4.

LEICESTER: W. N. Wibberley, 21 Pauline Avenue, Belgrave, Leicester.

LINCOLN: G. C. Newby, G3EBH, 18 Birchill, Fiskerton, Lincoln.

MARCONI (BASILDON): E. F. Slea, c/o Marconi's Sports and Social Club, Basildon, Essex.

NEATH and PORT TALBOT: H. G. Hughes, GW4CG/A, 3 Hill Top, Stylewen Villas, Baglan Road, Port Talbot, Nottingham.

NOTTINGHAM UNIVERSITY: J. Cragg, Radio Society, Union Room, The University, Nottingham.

PORTSMOUTH: L. Rooms, G8BU, 51 Locksway Road, Milton, Portsmouth.

QRP SOCIETY: J. Whitehead, 92 Rydens Avenue, Walton-on-Thames, Surrey.

RAVENSBOURNE: J. H. F. Wilshaw, 4 Station Road, Bromley, Kent.

SALISBURY: H. G. Fletcher, 171 Castle Road, Salisbury.

SLADE: C. N. Smart, 110 Woolmore Road, Birmingham 23.

SOUTHEND: J. H. Barrance, M.B.E., G3BUJ, 49 Swanage Road, Southend-on-Sea.

SOUTH MANCHESTER: M. Barnsley, G3HZM, 17 Cross Street, Bradford, Manchester 11.

SPEN VALLEY: N. Pride, 100 Raikes Lane, Birstall, Leeds.

STOCKPORT: G. R. Phillips, G3FYE, 7 Germans Buildings, Buxton Road, Stockport.

TORBAY: L. D. Webber, G3GDW, 43 Lime Tree Walk, Newton Abbot.

WEST LANCS.: S. Turner, Balfie Street, Seaforth, Liverpool 21.

WORTHING: R. Chidzey, 33 Bruce Avenue, West Worthing.

YEOVIL: D. L. McLean, 9 Cedar Grove, Yeovil.

YORK: G. Nottingham, G3DTA, 51 Carr Lane, Acomb, York.

talk on Transmitter Design ; May 5, Colour Television, by Dr. G. N. Patchett, at Bradford Technical College.

STOCKPORT : Meetings now held at Blossoms Hotel, Buxton Road. Next dates are April 14 and 28.

TORBAY : Regular meetings on the third Saturday. On April 17, members are asked to bring along anything they want to sell, to help out with the expenses of the society.

WEST LANCS : Meetings every Tuesday at 8 p.m. over Gordon's Sweet Shop, St. Johns Road, Waterloo. YORK : On April 14, "Know Your Ads." (Competition) ; April 21, Open Night ; April 28, talk and demonstration on A Battery Portable Station.

COVENTRY : On April 12, "Home Construction —

Deadline for next month's reports :

First post on Wednesday, April 14,
addressed "Club Secretary,"

Short Wave Magazine,

55 Victoria Street, London, S.W.1.

a Top Band Tx," by G2FTK. On April 26, section II of the same, by G3HDB.

EDINBURGH : Meetings are held every Wednesday in the Club-Room at 16 Bothwell Street, off Easter Road.

MULTICORE WIRE STRIPPER AND CUTTER

The well-known firm of solder manufacturers, who do a world-wide business in their products, are now marketing an extremely useful and practical little tool known as the "Bib Wire Stripper and Cutter." It is a three-in-one tool which will strip insulation from all the usual thicknesses of wire, cut wires cleanly, and also split extruded flex, like the narrow plastic-covered wires in general use. For stripping, the Cutter is adjustable over a wide range of wire thicknesses ; if correctly set, which is a simple matter of an eccentric disc with a set-screw, it is impossible to cut the wire when stripping the insulation. Multicore Bib Strippers are nickel-plated, individually packed, and costing but 3s. 6d., are an essential for the tool kit. If not obtainable locally, order from Multicore Solders, Ltd., Multicore Works, Maylands Avenue, Hemel Hempstead, Herts. Retail traders can obtain the Bib Stripper in cartons of one dozen at 28s. each, either direct or through the usual factors.

CORRECTION — "INDUCTANCE MEASUREMENTS SIMPLIFIED"

G3HAL, the author of this article in our March issue, writes that, by an error in his original draft, the expression opposite (2) . . . (1) in the appendix on p.21 became transposed, and that the 7th line of text, also in the appendix, should read " . . . and the frequency with the addition of . . . "

E.D.R. "OZ-CCA" CONTEST

During the week-end May 1-2, our Danish *confreeres* will be running their "OZ Cross Country Award" Contest. Those wishing to join in this should call "CQ OZ CCA de G—" on any band except 1.7 mc. A participating Danish station will reply in the usual way, adding a letter which indicates his *amt* or Danish district. Each QSO on any band (except two metres) counts one point, and the object of competing operators outside Denmark is to work as many OZ's in as many *amts* as possible. The final score is the total points multiplied by the sum of the number of different districts worked on each band used. There are 25 different *amts* or districts, and if 12 were worked on 3.5 mc, 8 on 7 mc and 16 on 14 mc, the multiplier would be 36 ; if in this example 23 stations were worked on 3.5, 14 on 7 and

30 on 14 mc, the points gained would be 67, and the final score $67 \times 36 = 2,412$ points. For the purposes of this contest, during the period 2100 GMT on May 1st to 2100 GMT on May 2, the same station may not be worked more than once on any one band (but can be worked to score on another band). Phone or CW can be used (but not CW/Phone), and completed contacts will be those where reports are exchanged in the form RST579002 (or RSM in the case of a phone QSO), the second group being the serial number of the QSO starting from 001 ; the OZ station's *amt* letter must also be correctly logged. Logs from participating stations outside Denmark must be post-marked not later than June 1st, addressed: E.D.R., P.O. Box 335, Aalborg, Denmark. Awards will be made to the leading stations in each country taking part in the contest.

CRYSTALS FOR VHF

At the recent R.E.C.M.F. Exhibition, Standard Telephones and Cables, Ltd., showed a wide range of quartz crystals, available in hermetically sealed cans or evacuated glass envelopes. What are known as "overtone" crystals can now be supplied for frequencies up to 55 mc, and production is in hand of crystals that will give output at frequencies as high as 200 mc. This brings nearer the day when we can obtain direct transmitter control at VHF, not only simplifying the design of the transmitter itself, but also eliminating those multiplier stages which are the cause of so much TVI. These STC crystals oscillate in the third, fifth or higher overtone mode and can be used to advantage in overtone oscillator circuits, with which considerable development work is now going on in commercial VHF circles.

INSIGNIA AWARD IN TECHNOLOGY

The City & Guilds of London Institute (Department of Technology) announces that one of their Annual Awards has been conferred upon Ernest Harris Jolley, M.I.E.E., for his work in Telecommunications. Mr. Jolley is a staff engineer in the G.P.O., which he joined as a youth-in-training, and reached his present rank in 1947 ; he is well known in international telecommunications circles as chairman of one of the commissions of the International Telegraph Consultative Committee.

URGENTLY REQUIRED . . .

BRITISH TEST GEAR

U.S.A. TEST GEAR

PULSE ANALYSERS

RECEIVERS

TRANSMITTERS

V.H.F. GEAR

British Test Gear. "AVO," Marconi, Cossor, Salford, Furzehill, Double Beam Scopes, Universal Bridges, Audio Oscillators, Wattmeters, Output Meters, TF 144G, TF 390G. Signal Generators, etc.

U.S.A. Test Gear. Types: TS174, TS175, TS13, TS62, TS56, TS35, TS47, TS69, TS12, TS67 and 1-208, TS33, TS3, TS36, TS45, TS148, TS587/U, UN/URM7, AN/PRM1, TSX-4SE Bendix BC221, LM10, LM7, and any equipment made by General Radio, Ferris, Dumont or Radiation Labs., etc.

SPECIALY WANTED: VHF and micro-wave equipment, Receivers R54/APR4 and Tuning Units 16, 17, 18 and 19. APR5, APR1. Klystrons 723/AB, 2K33, 707A and B, 7K39, 2K40, 2K41, 2K42, CV52, TR3555: Indicator Unit R65 APN9. We will give top price for complete equipment or units. Any 3 cm Signal generators or Spectrum Analysers.

ANY QUANTITY BOUGHT.

We guarantee to pay the Top Prices in this Country

Pulse Analysers. AN/APA6, AN/APA11, AN/APA-6A.

Receivers. RCA, AR88, AR77E: Hammarlund HQ 120, HQ 129X; G.E.C. BRT 400; Hallicrafters SX28, S27, S27C, S27CA, a.c./d.c. 538, SX24, SX42, SX43: RME and other late types: USA BC342, 348, 312: Collins 75A. ARN5, BC733D. British, R1294 and R1359.

Transmitters. BC610, AN/ART 13, ET4336, or parts of ARCI, ARC3. **Required.**—Cables, remote control unit and parts for Collins TCS equipment.

UNIVERSAL ELECTRONICS

Our only address:

27 LISLE STREET, LEICESTER SQ., LONDON, W.C.2

Shop hours, 9.30 a.m. to 6 p.m. Thursdays 9.30 a.m. to 1 p.m.

Write, Call or Telephone — GERard 6410 (Day), MEAdway 3145 (Night)

SAMSONS SURPLUS STORES

BRAND NEW. U.S.A. Sola Constant Voltage TRANSFORMERS. Prim 95-190v. to 125-250, 2,000 watts. Approx. weight 150 lb. Callers only. £27/10/-.

AMAZING OFFER! First time on Surplus Market. **MINIATURE ACCUMULATORS** made by the Willard Battery Co. 36v. 0.2 A.H. Size 3 3/8 in. x 1 1/2 in. x 7/8 in., weight 5 1/2 oz., 5/- each, p.p. 6d. 6v. 1.2 A.H. Size 3 3/8 in. x 1 1/2 in. x 7/8 in., weight 4 1/2 oz., 7/6 each, p.p. 6d. The above accumulators are easily fitted with a hypodermic syringe, which we can supply at 4/9, p.p. 6d., complete with one needle.

BRAND NEW Exide 10v. 5 A.H. GLASS ACCUMULATORS, 8/6, p.p. 1/6.

BRAND NEW Commando PVC TELEPHONE CABLE. 1,000 yard Drums, 15/-, p.p. 2/-. D.3 Single Telephone Cable, 1 mile drums, 57/6, carr. 5/-.

BRAND NEW TYPE 24 RF UNITS. 20-30 Mc/s, 15/-, p.p. 1/6. Type 25 in very good condition, 40-50 Mc/s, 15/-, p.p. 1/6. 6U5G Magic Eye Tuning Indicator, 5/-, p.p. 6d. 7C5, 13D1, 7H7, 9003, all at 5/- each, p.p. 6d.

Admiralty Sound Powered **HAND SETS,** 17/6, p.p. D.5 Field Telephones, complete with hand set and single head-phone, 49/6, carr. 4/-.

12in. Copper Plated **AERIAL RODS.** Fit in type. Fifty for 7/6, p.p. 9d.

169/171 EDGWARE ROAD

LONDON, W.2. Tel: PAD. 7851

125 Tottenham Court Road, W.1. Tel: EUS. 4982

All orders and enquiries to our Edgware Rd. branch please. Open All Day Saturday at the Edgware Road Branch.

Southern Radio's Wireless Bargains

TELESONIC 4-Valve Battery Portable. Complete with Hivac Valves. In metal carrying case. Simply converted to Personal Portable. £2, including conversion Sheet.

TRANSMITTER RECEIVERS. Type "38" Mk. II. BRAND NEW, complete with 5 Valves, Headphones, Aerial and Throat Microphones. £4/15/- per set. Less Batteries.

Type "18" Mk. III. Complete with all valves but less Batteries and attachments. **READY FOR USE. £7/17/6, carriage paid.**

ONE HUNDRED ONLY, Type "38" Mk. II TRANSMITTERS. Used but complete with all valves and contained in usual Carrying Case. Ready for use. **LESS ATTACHMENTS** 30/- per set

RECEIVERS R109, 8 Valves. Vibrator Pack for 6 volts. In Metal Case with built-in Speaker. 1.8 to 8.5 Mc/s. **NEW. £7 carriage paid.**

CRYSTAL MONITORS TYPE 2. NEW IN TRANSIT CASE. Less Crystals 8/-

BOMBSIGHT COMPUTERS, Ex-R.A.F. NEW. Contains GYRO, MOTORS, REV. COUNTERS, GEAR WHEELS, etc., etc. Ideal for MODEL MAKERS, EXPERIMENTERS, etc. £3/5/- each, plus 10/- carriage.

LUFBRA HOLE CUTTERS. Adjustable 1/2 to 3/4 in. Improved high-speed type. 6/6, for Metal, Plastic, Wood, etc., use. **RESISTANCES. 100 Assorted Useful Values, wire-ended** 12/6 per 100

CONDENSERS. 100 Assorted Values, Mica and Tubular, etc. 15/- per 100

PLASTIC CASES, 1 1/4 in. x 10 1/2 in. Transparent. Ideal for Maps, Photos, Display, etc. 5/6

STAR IDENTIFIERS, Type 1 A-N. Covers both Hemispheres. In case 5/6

WESTECTORS, WX6 and W112. 1/- each

CONTACTOR TIME SWITCHES. Complete in sound-proof case. Two-impulses per sec. Thermostatic control. 11/6

REMOTE CONTACTORS, for use with above. 7/6

MORSE TAPPERS, Ex-Government. 3/6

Heavy Duty types. 8/6
Complete Morse Practice Sets with Buzzers. 6/9

ALL LINES PREVIOUSLY ADVERTISED STILL AVAILABLE
Full List of RADIO BOOKS. 2/6d.

SOUTHERN RADIO SUPPLY LTD.,
11, LITTLE NEWPORT STREET, LONDON, W.C.2
GERard 6653.

BC221

£28 paid for these units in good condition if offered before end April. Box No. 1376.

SMALL ADVERTISEMENTS

9d. per word, minimum charge 12/-. No series discount; all charges payable with order. Insertions of radio interest only accepted. Add 25% for Bold Face (Heavy Type). No responsibility accepted for errors. Replies to Box Numbers should be addressed to The Short Wave Magazine, 55 Victoria Street, S.W.1.

OFFICIAL APPOINTMENTS

TECHNICAL INSTRUCTOR (Broadcasting) required by the **NIGERIAN GOVERNMENT** on contract for two tours of 12-15 months. Possibilities of permanency. Salary, etc., according to experience in scale £1,170, rising to £1,269 a year. Outfit allowance £60. Free passages for officer and wife and assistance towards cost of children's passages or grant up to £150 annually for their maintenance in this country. Liberal leave on full salary. Candidates should have had instructional experience at the B.B.C., and must have reached Grade C. minus, or above.—Write to the Crown Agents, 4 Millbank, London, S.W.1. State age, name in block letters, full qualifications and experience, and quote M2C/30305/SQ.

TECHNICAL ASSISTANTS required by the **NIGERIA GOVERNMENT BROADCASTING DEPARTMENT** for one tour of 18/24 months, with option of appointment (a) On agreement with prospect of permanency, with salary, etc., according to experience, in scale £750, rising to £1,035 a year; or (b) On agreement on temporary terms, with salary, etc., in scale £807, rising to £1,115 a year, plus gratuity of up to £150 a year. Outfit allowance £60. Free passages for officer and wife. Assistance towards cost of children's passages or grant of up to £150 annually for maintenance in U.K. Liberal leave on full salary. Candidates should have good experience in the engineering division of the B.B.C. Those selected will be required to undertake operational duties relating to the control and maintenance of radio equipment at Radio Distribution Studios and to assist in the general technical duties.—Write to the Crown Agents, 4 Millbank, London, S.W.1. State age, name in block letters, full qualifications, and experience, and quote M2C/30188/SQ.

SITUATIONS VACANT

DEVELOPMENT ENGINEER required for Amateur Radio products. Excellent prospects for a sound, practical man with drive and initiative. Cambridge area.—Send full details, including salary desired, to Box 1393, Short Wave Magazine, Ltd., 55 Victoria Street, London, S.W.1.

KEEN SHEET METAL WORKERS required for Radio and Instrument Case Manufacture. Improvers also considered.—Apply Philpott's Metal Works Ltd., Chapman Street, Loughborough, Leics.

TRADE

QSL's and LOGS by MINERVA. The best there are.—Samples from Minerva Press, 48 Queen's Road, Brentwood, Essex.

QUANTITY 832-Type Valves wanted urgently.—Write **PYPE-HAYES RADIO**, 606 KINGSBURY ROAD, BIRMINGHAM 24. (ERD. 4942).

Unsurpassed for
QUALITY
REPRODUCTION

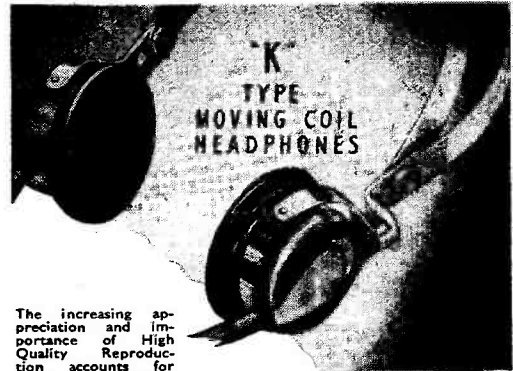
S. G. Brown

The increasing appreciation and importance of High Quality Reproduction accounts for S. G. Brown Type "K" headphones being used in Laboratories, Sound Studios for acoustic research, monitoring, DX work, etc. D.C. Resistance: 47 ohms. Impedance: 52 ohms at 1,000 c/s.

Full details of the wide range of S. G. Brown Headphones for specific purposes are available in Brochure "S"—sent on request.

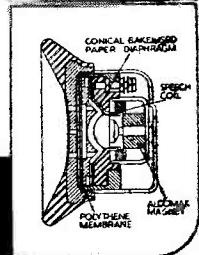
**S. G. Brown Ltd.**

SHAKESPEARE ST., WATFORD, HERTS.
Telephone. Watford 7241.

(12)

INTERESTED IN F.M.?

Smith's
of
EDGWARE ROAD

Component Specialists since Broadcasting started.

Can supply all the parts for the

Amos & Johnstone

F. M. FEEDER UNIT

Send 2/- for "W.W." Booklet, Price List, and Schematic Wiring and Layout Drawing. Also for details of their New Mailing List Scheme.

H. L. SMITH & CO. LTD.

287/289 Edgware Road, London, W.2.

Tel.: Paddington 5891

Hours 9 till 6 (Thursday, 1 o'clock)

Near Edgware Road Stations, Metropolitan and Bakerloo.

AMATEUR EQUIPMENT

AERIAL MASTS. U.S.A. 9ft. Steel one piece solid, tapered whip, 10/-; 20ft. 7 section BC610 whip, 30/-; American 35ft. steel sectional mast 1½" dia., 80/-; 11ft. Plymold sections 4" dia., 20/-; 14ft. Super Pine Poles, 10/-; U.S.A. 20ft. Tripod Base Aluminium Masts, £9; 36ft. Steel Sectional Masts 2½" to 2" dia., £4/10/-; Tylon 10ft. Lattice Sections, 12" wide triangular, £6.

TRANSMITTING TRANSFORMERS. All primaries 200/250v. 50 cycles and Woden make. (A) 4480, 2240, 2000 CT. at 300 m/a. 10 x 9 x 8.62 lbs. 95/-; (B) 640v. 200 m/a., 4v. 6a., 4v. 3a., 4v. 3a. 6 x 6 x 6 22 lbs. 65/-; (C) 8v. 13a., 4v. 6a., 4v. 4a., 4v. 3a., 4v. 3a. all CT. 7 x 7 x 6, 19 lbs., 45/-; (D) 145v. 6a., 4.5v. 2.5a., 4.5v., 2a., 4.5v. 2a. all CT. 5 x 5 x 5 12 lbs., 40/-; (E) 1,500v. 400 m/a. 7 x 6 x 6 22 lbs., 55/-; (F) Four at 4v. 3a., 6v. 3a., 175v. 60 m/a. all CT. 6 x 6 x 4 10 lbs., 30/-; (G) 15v. 6a., 4.5v. 2.5a., 4.5v. 2.5a. all CT. 5 x 5 x 5 10 lbs., 30/-.

TRANSMITTING VALVES. VU-29, 25/-; VT-26C, 17/-; DET-12, 20/-; GU-50, 10/-; AL-63, 12/6; 4212E, 45/-.

CODE GEAR. McElroy Morse Recorders, 95/-; Tape Pullers, 80/-; Page Electronic Keyers, £25; Marconi UG-6 undulators, £18; J-45 Keys, 3/6.

WANTED: TECHNICAL MANUALS, INSTRUCTION BOOKS OF ANY AMERICAN OR BRITISH SERVICES EQUIPMENT.

H. HARRIS, ORGANFORD, DORSET

Lytchett Minster 212

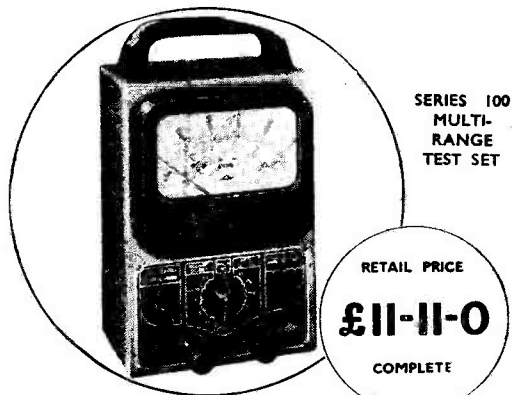

SERIES 100
MULTI-
RANGE
TEST SET

RETAIL PRICE

£11-11-0

COMPLETE

An inexpensive Test Set with 21 basic ranges

The Pullin Series 100 Multi-Range Test Set is an inexpensive piece of equipment invaluable to radio and electronic engineers. It is a compact, portable instrument with a total of 21 basic self contained ranges which provide adequate facilities for the measurement of A.C. voltage, D.C. voltage and current, and resistance. All voltage measurements are at 10,000 Ohms per volt.



PULLIN

PORTABLE TESTING SETS
INDUSTRIAL SWITCHBOARD
INSTRUMENTS
LABORATORY INSTRUMENTS
DYNAMOMETER TEST SETS

MEASURING INSTRUMENTS (PULLIN) LTD

Electrin Works, Winchester Street, Acton, London, W.3.

Phone: ACOrn 4651-4995.

SMALL ADVERTISEMENTS, TRADE—continued

VALVES: Types 813, 832 and 723 A/B, wanted urgently; high prices paid.—Write: Pype-Hayes Radio, 606 Kingsbury Road, Birmingham 24. (Erdington 4942).

WANTED: ALTHAM RADIO CO. pay highest prices in the trade for all American equipment, including test sets, transmitters, receivers, etc.—Jersey House, Jersey Street, Manchester 4. (Tel.: Central 7834-5-6).

WANTED: TUNING UNITS TN17, TN18, TN19 for R54/APR4. £50 each offered.—Box 1383, Short Wave Magazine, Ltd., 55 Victoria Street, London, S.W.1.

VALVES (over 3,000 in stock): 2D21, EC91, 12AU7, 6BR7, 6CH6, 6BW6, 6SN7, 9/-; EL91, 6F33, 12AT7, EY91, 7/-; EF91, 6J6, 12AX7, 6/6; 6AL5, 6C4, EAC91, EF92, 5/6; 829B, £3; 6AK5, 7/6.—Skillman, Franchise Street, Weymouth.

45% PAID for new boxed 813's. Other new surplus valves purchased.—Details to Box 1385, Short Wave Magazine, Ltd., 55 Victoria Street, London, S.W.1.

QSL CARDS AND LOG BOOKS. APPROVED G.P.O. SAMPLES FREE. — ATKINSON BROS., PRINTERS, ELLAND, YORKS.

WANTED: BC610 Hallicrafters, RCA ET4336 Transmitters; SX28's, AR88's receivers and spare parts for above. Best prices.—P.C.A. Radio, Beavor Lane, Hammersmith, W.6 (RIV. 8006).

WANTED: RCA Speech Amplifiers, type MI-11220 J or K, and aerial tuning units BC939A.—Offers, stating quantity and price, to P.C.A. Radio, Beavor Lane, Hammersmith, W.6. (RIV. 8006).

SCR-522, as new, £15; Collins TCS12 receiver, £15; No. 18 Tx/Rx, 45/-; C & P, 10/-; 38 sets, 27/6 (p. & p. 2/-). Send for complete lists.—Electrosurg, Edmund Street, Exeter.

READERS' ADVERTISEMENTS

3d. per word, min. charge 5/-, payable with order. Box Numbers 1/6 extra. Replies to Box Numbers should be addressed to The Short Wave Magazine, 55 Victoria Street, S.W.1.

SERVICE SHEETS REQUIRED, for Technical Library: Pre-war domestic receivers, ALL MAKES AND MODELS, especially PHILIPS V5A, V7U, 470A, 575A, 650A, 660A, 727U; MULLARD MUS2, MUS6, MAS12, MAS15, MAS24, MUS24.—Details, and price required, to: Watts, 62 Belmore Road, Thorpe, Norwich.

RECORD that QSO. Tape Recorder in veneered cabinet, two R/P amps., D104 mike, tape, £18. Marconi Transceiver CNY1, with manual and spare receiver, £16; CR100, with manual, £20; TBY-8 Transceiver, 20/80 mc. offers? BC684A Tx, BC683A Rx, 27/39 mc. with ten crystals, offers? Class-D converted AC, £5.—Box No. 1378, Short Wave Magazine, Ltd., 55 Victoria Street, London, S.W.1.

WANTED: Manual for CR100 Receiver. Any offers for the following: One 5U4G, two VR100, one 6J7, one 6V6, four EF39's, one EBC33, one ECH35.—Boland, 14 Somers Road, Southsea, Portsmouth.

URGENTLY required: RK28's, ATP100 or 4069A Pentodes. Also PV75 or ATP35, as used in No. 12 set. Antenna Tuning Unit G also required, as used with 33 set.—EI2S, Airfield, Bishopstown, Cork, Ireland.

SMALL ADVERTISEMENTS, READERS—continued

READER offers for disposal following magazines: 16 copies *CQ*, 11 copies *QST*, 30 copies *Short Wave Magazine*, 33 copies *R.S.G.B. Bulletin*, which he will be pleased to pass on free of charge to any club or individual.—Box 1395, Short Wave Magazine, Ltd., 55 Victoria Street, London, S.W.1.

GRUNDIG RECORDER, hardly used, £55; B28 Receiver, 60 kc-30 mc, overhauled and re-aligned, perfect, £25. Can be delivered London area.—Collin, 32 High Street, Wickford, Essex.

RECEIVER R1355, in original case, unused. Ideal for 2 metres or conversion TV, £2 10s. 0d. **R**ECEIVER 1155 converted 6V6 output, communication receiver for 80, 40 and 20, £5. **I**NDICATOR UNIT TYPE 6A, unused, £4. **L**IFEBOAT Tx in wooden transit case, £2. **V**ALRADIO Vibrator Unit, 220 DC to 220 AC, 300 watts, 50 and 75 cycles output, TV or radio, £6 10s. 0d. **T**WO CANADIAN No. 58 Walkie-Talkie Sets; 2 complete stations, mikes, phones, aerials, battery container, vibrator, power pack, etc., £9 15s. 0d. **T**RANSMITTER, Top Band and 80, 1625 PA in case, 10 x 9 x 18 deep, self-contained power pack, ideal VFO driver for large rig or low-power Tx, jack for plate-and-screen modulation, £7. Meico M/C microphone, transformer and pedestal, £2 2s. 0d. **B**.R.S. Ribbon Mike with special input transformer, £5 10s. 0d. 1196 Tx/Rx, complete in wooden transit case, £2 10s. 0d. Duplicator, quarto size, roller type, in wooden case, £2.—For all above items, apply to: K. Rogers, G3AIU, 21 Links Road, Epsom. (*Epsom 9945*).

FOR EXCHANGE: Two Vortexion HT Transformers, 500-0-500 volts. **W**ANTED: 1224A Receiver in good condition.—Box 1380, Short Wave Magazine, Ltd., 55 Victoria Street, London, S.W.1.

AMATEUR, commencing National Service, has Communication Rx, BC1147A, for sale; range 1.5-30 mc, input 115v. AC; perfect condition with 500-watt auto transformer; 230/115v. AC, polished case and manual, price £30.—Forsyth, No. 2 Officers' Mess, R.A.F. Feltwell, Norfolk.

URGENTLY WANTED: **M**ANUALS OR **I**NSTRUCTION BOOKS, **D**ATA, **E**T.C., ON **A**MERICAN OR **B**RITISH **A**RMY, **N**AVY OR **A**IR **F**ORCE **R**ADIO AND **E**LECTRICAL **E**QUIPMENT.—**H**ARRIS, 93 WARDOURSTREET, W.1. (*TEL.: GERRARD 2504*).

ALL AS NEW and for 230 AC: D.S.T. 100 Mk. III, with manual; CR100 and Eddystone S504, also Eddystone 740 with S-meter and speaker; S.27 Hallicrafters.—Offers or exchanges to Sutcliffe, 69 Cleckheaton Road, Odsal, Bradford, Yorks. (*Phone: Low Moor 1494*).

SECTIONAL TABLE TOP, general purpose 50-watt relay-controlled transmitter, VFO or crystal; 25-watt modulator, speech amplifier, crystal mic and stand, four power packs; four Labgear PA coils; plug-in WBC's; aerial coupling unit; four new spare valves; as January *Short Wave Magazine*, page 674; £20 or offer, plus carriage. 100/1000 kc two-stage crystal calibrator, no p/pack, 50/-; BC455 Rx, complete, £2; junk box, 10/-; Top Band three-stage transmitter, no p/pack, 50/-; brand-new valves: 866's, 10/- each; 807's, 5/- each; 6L6M's, 7/- each. All plus post or carriage.—Letters to: Benstead, c/o 13 Shady Grove, Alsager, Stoke-on-Trent.

SALE: *Short Wave Magazines*, April 1949-January 1950, March-October 1950, March 1951-February 1952; 6d. each, 12/- complete.—SWL, Dovedale, Birmingham Road, Warwick.

SWL's—Here is a proved and

speedy way to *Pass the*

G.P.O. MORSE CODE TEST

for securing your Amateur Licence

Enrol for the **Candler SPECIAL SHORT COURSE** which includes all essential Morse Code training to enable the average student to be successful. The fee is reasonable too.

★ **WRITE now for the**

CANDLER "BOOK OF FACTS"

stating which course you are interested in

- (1) **Special Short Course** for G.P.O. Morse Code test for Amateur Transmitting Licence.
- (2) **Candler Junior Course** for Beginners.
- (3) **Candler Advanced Course** for Operators who desire to increase their speeds and accuracy.

Terms: Cash or low monthly payments.

THE CANDLER SYSTEM CO.

(Dept. 55SW),

52b ABINGDON ROAD, LONDON, W.8

Candler System Company, Denver, Colorado, U.S.A.

CLYDESDALE *Prices Slashed*

I.F.F. RECEIVER R3109, Ref.: 10DB/506. Contains Motor Generator input 24v., 1.8A D.C. Output 480v., .04A. D.C., with a gearbox operating a switching mechanism to detune the receiver at time intervals. Plus: 4/VR65A (SP41), 2/VR92 (EA50), 2/CV6 (Det. 20) valves, etc. Metal case, dim.: 12" x 12" x 8". Weight 24 lbs.

ASK FOR SM/H961A **19/6** Each. CARRIAGE PAID

RECEIVER 6A
Channel checking unit working on 49-100 metres. Contains 5/VR91 (EF50), 1/GK8, 1/VR55 (EBC33), 1/VR53 (EF39) valves. Thermal switch breaking at 85 degrees F. etc., etc. In metal case 8½" x 7" x 10".

ASK FOR SM/H477A **29/6** Each. CARRIAGE 2/6 EXTRA

AERIAL SYSTEM TYPE 62
U.H.F. Antenna on streamlined moulding with VR92 (EA50) untuned detector stage. Overall dim.: 13" x 4½" x 2½". Antenna 22.5 cm.

ASK FOR SM/H496 **3/6** Each. POST 9d. EXTRA

WIRELESS REMOTE CONTROL UNIT D
N. 2, Mk. 2, ZA.20491. Wooden box 7½" x 6½" x 5½", with hinged lid, containing three relays, one make, 500 ohms.; one make, 20 ohms.; and H.D. double coil type 1,750 ohms. coil makes, 200 ohms. coil breaks. Plus QMB switch and eight brass terminals.

ASK FOR SM/H803 **7/11** Each. POST PAID

EX-R.A.F. V.H.F. CONTROL PANEL TYPE 3A
Input 24v. D.C. Intercom. Control, contains 3 induction coils, type 21A. 3 retardation coils, type 39A; 6 relays; type 26A tuning hand generator; type 25 twin bell set; plus plugger key switches, key switches, panel indicator lamps, etc., etc. Panel finished grey with handles. Unit dim.: 19" x 11" x 9".

ASK FOR SM/E945 **21/-** Each. CARRIAGE PAID

POWER UNIT TYPE 266, in Transit Case
Input 80v. 1.5K cps. A.C. Outputs HT 120v. D.C., bias 3 and 9v. LT 2v. Smoothed and stabilized. Complete with 5U4G valve, VS110 stabilizer, 12v. 1A metal rectifier, etc., etc. In attractive metal case with handles. Dim.: 11" x 9½" x 7½".

ASK FOR SM/E870 **22/6** Each. CARRIAGE PAID

Order direct from:

Tel.: South 2706/9

CLYDESDALE SUPPLY
CO., LTD.
2 BRIDGE STREET, GLASGOW, C.5

WATERLOO RADIO

(Waterloo Bridge Roundabout)

35 TENISON WAY, LONDON, S.E.1.

RINGING CHOKES to supply 2.5 kv. EHT using EF50 valve, 12/6, or with EY51 rectifier and selected EF50 valve **42/6 CHARGER TRANSFORMERS.** Input 200-250v. AC to charge 6 or 12 volts at 1.5 amps, 12/6; 3 Amps, 21/6; 6 Amps, 29/6, post 2/-. **BRIDGE RECTIFIERS** suitable for use with above transformers. 2 amps, 11/3; 3 amp, 12/6; 4 amp, 15/-; 6 amps, 23/6, post 1/4. 10 amps, 30/-, post 1/8. **HALF WAVE, 125v, AC.** input, RM1, 60mA, 3/9; RM2, 120mA, 4/3; DRM2B, 10/9; RM3 125 mA, 5/3; RM4 250v, 275mA, for TV, 15/6, Post 6d. **E.H.T. PENCIL RECTIFIERS.** K3/40 3.2kv, 7/6; K3/100 8kv, 14/8; K3/160, 12.8kv, 21/6. **VALVES.** 6AM6, 6CH6, 6BA6, 6BE6, 12BE6, 6C6, 6BW6, 3A4, 1U5, 6AL5, W77, 6BJ6, 50C5, 19AQ5, 1S5, 6BS7, 6N7gt, 6BH6, 7/6 each; 6k8gt, 12k8gt, 1R5, VR150/30, 9/6.

ADCOLA (Regd. Trade Mark) SOLDERING INSTRUMENTS



Reg. Design No. 860302
British, U.S. and Foreign Patents

Supplied for all volt ranges from 6/7v-230/250v. Meets every requirement for radio assembly, maintenance, telecommunications, etc. High Temperature. Quick Heating. Low Consumption. Light Weight.

3/16in.	Dia.	Bit Standard Model
1/4in.	Dia.	Bit Standard Model
3/16in.	Dia.	Detachable Bit Type

Sole Manufacturers: **ADCOLA PRODUCTS LTD.**

Sales Offices and Works: **Cranmer Court, Clapham High Street, London, S.W.4.** (MACaulay 4272.)

G4GZ'S BARGAINS

VALVES: 2X2, 3D6, 954, 955, 956, AC6Pen, 6J7G, OZ4, VS10A, VU120, 6J5GT, 15D2, 12J5GT, EF92, W77, 4/6. 6AG5, 6C4, 6U5G Y63, 6K7GT, 1LN5GT, 6AL5, EB91, 6F8, 5/6. EF91, Z77, 6AM6, EC52, EF54, EF50, 12BE6, 3A4, 2A3, KTW73, KTZ73, EF5, EF6, EF8, EL2, EK2, X73M, 6/-, EL91, 6AM5, 6X5GT, 6V6G, 6F6G, 6J6, 6G6, 6/6. 6J7M, EL32, 6K6G, 7/-, 12A6M, 1629, 1625, 7C5, 6AK5, 3V4, 1R5, 1S5, 1T4, X66, VR150/30, 6F7, 6L7GT, 6SN7GT, 6CH6, 7/6. 6V6GT, 6F6M, 6Q7GT, EL35, 8/-, 5Z4G, 7S7, 6K8G, 12SQ7GT, 50L6GT, 1V4/350, CBL1, 9/-, 6SQ7M, CV286, 7A3 (PenA4), 6L6G, 6L6M, K766, 10/-, 6K8M, 866A, 12/6. 5CP1, 20/-, 100TH, 45/-, 250TH, 100/-, 829, 55/-, 829B, 70/-, 832, 811, 35/-, 35T, HK24G, TZ40, 808, 30/-, 805, 37/6. 430CA(834), 20/-, VT127A, 50/-.

FEW ONLY LANE TAPE DECKS, 3 Motor, Mk. 3, £12/10/-, plus 10/- carriage.
NEW BOXED M.I. METERS, 3 1/2in. rd., fl. mtg. (2 1/2in. dial), 0-15v. A.C. cal. at 50 cps., 10/- each.
ALL GOODS DESPATCHED BY RETURN. Please add post/packing.

J. T. ANGLIN

160, CLEETHORPE ROAD, GRIMSBY, LINCS. Tel. 56315.

THE WORLD'S GREATEST BOOKSHOP

FOYLES

FOR BOOKS

Huge range of new, secondhand and rare Books on Radio and Allied subjects.

Foyles have departments for Music, Records, Handicraft materials and Stationery.

Subscriptions taken for British, American and Continental radio magazines.

119-125 CHARING CROSS RD., LONDON, W.C.2

Gerrard 5660 (16 lines) ▼ Open 9-6 (inc. Sats.)

Nearest Station: Tottenham Court Road

SMALL ADVERTISEMENTS, READERS—continued

RME69 FOR SALE, complete with matching speaker and instruction manual; good condition. Delivered free within 50 miles Coventry. Price £27 10s. 0d.—Dewhurst, Oaklands, Warwick Road, Kenilworth.

WANTED: BC348 Rx, must be in reasonably good condition.—N. Emery, Box 3233, Nairobi, Kenya.

WANTED: Petrol AC Generator, 110- or 230-volt, single phase, 50 cycles, 350-watt or near; ONAN or similar.—146, Main Street, Larbert.

HALLICRAFTER S38 AC/DC, good condition; buyer collects. West London. Offers?—Box 1394, Short Wave Magazine, Ltd., 55 Victoria Street, London, S.W.1.

RADIO VISION HAMBANDER with speaker and preselector; 1953 model; as new; £29. BC342N, 13 mc to 1.5 mc; 110v. AC supply; black crackle; good working order; £18.—S. Hyde, Chalcraft, Compton Down, Winchester.

HRO JUNIOR with power pack, speaker, coil box, complete with 4 coils, 30 mc to 1.7 mc, and rack; civilian model; colour grey; condition as new; £32 10s. 0d. AR77E, 31 mc to 0.54 mc; excellent working order, nice condition; £25.—N. Lowe, Middle Brook Street, Winchester.

EXCHANGE T.1154 Tx in case, brand-new, for good El-Bug, or sell £4 10s. 0d. Eddystone battery ham band two, complete; ideal for beginner; £2.—Box 1391, Short Wave Magazine, Ltd., 55 Victoria Street, London, S.W.1.

EDDYSTONE 640, good condition, £20 o.n.o. Straight swap for B2 complete.—Mildren, 7 Lower Bore Street, Bodmin.

SALE: S.504, very good order, recently re-aligned, S with S-meter, xtal, etc.; also R.103A, 1.7-7.5 mc, built-in p/pack for AC mains and 6v. DC (new condition), £37 the two, or £27 10s. 0d. and £10 10s. 0d. each, both carriage paid.—Box 1392, Short Wave Magazine, Ltd., 55 Victoria Street, London, S.W.1.

MAGNETIC Recording Heads, twin track. Wearite, slightly used, 50/- each (two only)—W. Hersch, 12 Oakhill Road, S.W.15.

AR 77E FOR SALE, £16; T1403 Tx, CO/BFR/PA (837). 15w. Phone, 40w. CW, 160/80/40 metres; only requires p/pack; £6. Both bargains.—G3BHT, Hove To, Sandy Lane, Hightown, Nr. Liverpool. (Tel.: Hightown 182).

HALLICRAFTER S20, perfect, £25; R107, good condition, £8; buyer collects South London. **WANTED:** TU Units, any condition but front panel must be OK; Command Transmitter.—Box 1382, Short Wave Magazine, Ltd., 55 Victoria Street, London, S.W.1.

NEW, unused Wearite Model "A" Tape Deck, twin track, osc. coil, one reel tape, £25.—I. A. Duck, 97 Belgrave Road, Ilford, Essex.

WANTED: Good HF Receiver, tuning to 30 mc. in exchange for components, valves, etc.; cash adjustment to £10.—Box 1381, Short Wave Magazine, Ltd., 55 Victoria Street, London, S.W.1.

FOR SALE: R1116 Receiver in working order; needs slight attention; price £5. Buyer collects.—Apply J. Price, 148 Church Gate, Cheshunt, Herts.

WANTED: R107; must be first-class condition. State your price. Will probably collect.—16 Coniston Road, Reddish, Stockport.

WANTED: Copy Proc. I.R.E. dated November 1952; full price, plus postage, offered for clean copy.—Box 1387, Short Wave Magazine, Ltd., 55 Victoria Street, London, S.W.1.

SMALL ADVERTISEMENTS, READERS—*continued*

WANTED: Any *QST*'s before November 1923; *Radio*, June 1933 to December 1935; *R/9*, September 1932 to March 1935; *CQ*, January, March, April, June, November, December 1945. Most *Amateur Radio*, many *Break-In*, any *Xtal*. Lists on request (postage refunded).—G3IDG, 95 Ramsden Road, London, S.W.12.

R1155 with built in power pack and 6V6 output stage; fitted in communication cabinet. Also loudspeaker, £7 10s. 0d. New Walkie-Talkie Cdn., No. 58, complete with spare valves, etc., £7 10s. 0d.—13 Edna Street, Battersea.

MARCONI B36 Receiver, almost new, 900 kc to 21.5 mc; two RF, three IF, coil turret; nine new valves, circuit; £10. Garrard 778 RPM, Gram Unit, perfect, £2. Both carriage extra.—Box 1384 Short Wave Magazine, Ltd., 55 Victoria Street, London, S.W.1.

G3FVF, gone QRT. must sell: BC342N (mint) with auto transformer, 80m. 28-watt Phone/CW rack Tx (slight attention); 50-watt modulator with two 500v. and 120v. p/packs; 1154F (new) with HT p/pack. Woden UM3, 10-watt 80m. CW/Tx. Valves: 813 (new), 832 (new), 807's, etc. Other bits and pieces. £35 as one lot (buyer collects).—94 Kingston Avenue, Bedford, Feltham, Middlesex.

EDDYSTONE 750, £40; six-foot rack, 30/-; BC348, £13; Labgear Crystal Calibrator, £7; 500v. p/pack, £5; Taylor 71A meter, £10; two-metre converter, two RF xtal, £6; Transmitter EF91-EL91-QVO4/7-832, £6; Transformers, books, —Write requirements: Southcliff, Highwood Road, Parkstone, Dorset.

BC348; professional conversion; internal power supply; new valves, etc.; £14.—GW8NP, 19 Penhill Road, Cardiff.

R1155N; built-in 200/240 AC, p/pack, S-meter, etc.; £20. 813's, 40/-; Ball Mike S.T.C., 4021C, 70/-; set HRO valves, UX type, 40/- set; Woden trans., 500-0-500, 150 mA, 6.3 at 4-amp., 5v. at 2-amp., choke to match, 50/-; prop pitch motor, £4; heater trans. for pair 813's, 15/-.—GM3AXO, 10 Sweetbank Drive, Markinch, Fife.

£45 OFFERED for AR88, provided in excellent condition.—Box 1386, Short Wave Magazine, Ltd., 55 Victoria Street, London, S.W.1.

GDO 1.5-30 mc. £2; 3 Wearite Midget, 460 kc, IFT's, 15/-; PL68 and jack, 1/- Meters: 1mA 2½", 0.5 mA 1½", 7/6; 40v. 2½", 5/-; 200 mA 2½", 10/-. Valves, at 10/-: 6CH6 (2), 5763 (4); at 5/-: 6J6 (2), 12AU7 (4), 12AX7; at 4/-: Z77 (3), W77 (2), N78 (2), IR5, U78, N17, CV287 (2); at 3/-: 9003 (5), 9002 (2), 6C4 (3), CG1C (3), 9006, EB91 (2). *QST*, various 1947-1953, 1/6 each.—Box 1388, Short Wave Magazine, Ltd., 55 Victoria Street, London, S.W.1.

LABGEAR Wide-band Coupler Unit, new and unused, £3 10s. 0d.; also p'ug-in W/B couplers 80-40-20-10, unused, £2 the set.—J. H. Caldwell, G8US, 9 Chanters Road, Bideford, Devon.

SELL or EXCHANGE: New R1155, R1132 Rx's; used R1155 Rx and amplifier, p/pack, LS; Type No. 3 power unit; No. 18 Rx, new and used; mains (4v.) and battery valves; LS units. Numerous *Wireless World*, *Practical Wireless*. **WANTED:** 20m. QRO Tx, phone and/or CW, Top Band Tx; 103A Rx; W.H.Y.? Cash adjustment if necessary. Private enquirer. All letters answered.—Box 1390, Short Wave Magazine, Ltd., 55 Victoria Street, London, S.W.1.

WE PAY TOP PRICES

FOR
AMERICAN SURPLUS
ELECTRONIC EQUIPMENT

Any Quantity or Condition

LOOK AT THESE EXAMPLES

For equipment in good condition

Receiver R54/APR4, complete	£200
Transmitter ET4336	£110
Scanner RC94	£100
Test Set TS13	£100
Frequency Meter TS175/U	£80
Frequency Meter BC221	£26
Receiver BC348R	£25
Receiver R89/ARN5	£25
Control Box 23270	£5
Klystron 723A/B	£3

We pay similar remarkable prices for

Receivers. R111/APR5, R5/ARN7, AR88D, R65/APN9, BC1033, R15/APN3, R19/TRC1, R15/CPN2, BC348.

Transmitters. CPN2, T11/APN3, ART13, TDE.

Transceivers. ARC1, ARC3, SCR522, TCS, BC800, RT1/APN2.

Indicators. ID17/APN3, ID18/CPN2, BC1151, BC1152, I-81A, I-82A.

Test Sets. Any unit with prefix "TS" and IE19, BC638, I-208.

Modulators. BC1091, BC1142, CM3.

Synchroniser. BC1148.

Power Units. RA34, RA42, RA59, RA62, RA88, RA90, MG149, PE98, PE158, DM28, PUI6.

Tuning Units. TN17, TN18, TN19, TN54, TU57, TU58, TU59.

Control Gear. BC1150, BC1145, JB91, JB95, JB98, JB102, C45, ARC1.

Antenna Gear. BC223A, RC94, AS27, AT4, AN104.

Mountings. FT237, FT247, FT154.

And almost every American made unit even if not mentioned above.

Phone us immediately, transfer charge.

Deal with the firm that has been established for twenty-five years and which is by far the largest buyer of Ham Equipment.

ALTHAM RADIO CO.

JERSEY HOUSE, JERSEY STREET

MANCHESTER 4

Telephone: Central 7834/5/6

SMALL ADVERTISEMENTS, READERS—continued

R107 with manual, £10. Collins Communications Receiver, 3-12 mc, internal power pack, £4.—Sidwell, 7 Abbottsfield Cott., Ware, Herts.

FOR SALE: Eddystone Bug, 37/6; 1880 kc xtal, Brookes, with certificate, £1.—G. H. Coulter, Freen Court, Whitfield, Dover.

SALE: HRO with p/pack, rack mounting, 8 coils, 2 bandspread; condition is as I would buy; excellent; £32. Prefer buyer view, Manchester area.—Box 1389, Short Wave Magazine, Ltd., 55 Victoria Street, London, S.W.1.

B2 WANTED, complete. Going VQ4. All correspondence answered. — Webster, 51 Castlebar Road, London, W.5.

R1155 in perfect order; fitted with internal p/pack and output stage; grey finish, fully aligned; bargain, £7 (carriage paid). Money refunded if not satisfied.—D. Thomas, 6 Coronation Road, Tetbury, Glos.

MOTORISE THAT BEAM; suitable 14 to 420 mc; as used by leading VHF operators; 24-volt series-wound reversing motor, 5-stage gearing, electromagnetic brake; 37/6, carriage paid.—J. B. Armstrong, G3EJR, 40 The Oval, Mirehouse, Whitehaven.

SALE: Ex-Army Tx, 12 Set, 25 watts RT/MCW/CW, £15; two WS38 walkie-talkies, £5 for both; one WS48 American walkie-talkie, £10; complete with battery packs converted for civilian use, mikes, phones, spare valves. All good working order. Delivered North of England.—Box 1396, Short Wave Magazine, Ltd., 55 Victoria Street, London, W.1.

SALE: AR88D; excellent condition and appearance; Webbs' internal RF modification, handbook, calibration graphs, speaker, phones; £85. Also R1155 with power pack and 2 Webbs' pre-selector units with separate power pack, £12.—D. Berry, 6 Rosary Gardens, London, S.W.7.

WILL exchange new 829 for modulation transformer, UM1 or UM2.—Jordan, 43 Tulloch Road, Perth, Scotland.

HAMBANDER (working), £7 o.n.o., or exchange for 28 and 21 mc converter with p/pack.—Smith, 74 Stenhouse Street, Cowdenbeath, Fife.

BARGAIN SALE: CR100 COMMUNICATIONS R RECEIVER. SPLENDID ORDER. FIRST £20. BRAND-NEW TRUVOX TAPE DECK; COST £23; FIRST £18.—369 GLASGOW ROAD, WISHAW, LANARKSHIRE.

SALE: R1116 Sets, £6; R109, 90/-; and R1224A, 75/-; both altered to cover all medium, trawler and short-wave bands.—Matheson, 14 Simpson Road, Aberdeen.

HOME RADIO OF MITCHAM

offer a by return service for all

EDDYSTONE COMPONENTS

Have you seen The new 14" rack equipment?
The range of F.M. i.f. transformers?
The new vernier slow motion dial?

The full range described and illustrated in the new EDDYSTONE catalogue price 1/3, post paid.

HOME RADIO

187, LONDON ROAD, MITCHAM, SURREY. MIT. 3282.

"If Eddystone's make it — we stock it"

BRASS, COPPER, BRONZE, ALUMINIUM, LIGHT ALLOYS IN ROD, BAR, SHEET, TUBE, STRIP, WIRE**3000 STANDARD STOCK SIZES****H. ROLLET & CO., LTD.**

6, CHESHAM PLACE, LONDON S.W.1.

SLOane 3463

Works at 36 ROSEBERY AVENUE, LONDON, E.C.1.

Branches at LIVERPOOL, MANCHESTER, BIRMINGHAM, LEEDS

"No Quantity too Small"

TAKE ADVANTAGE OF THESE PRICES

GUARANTEED VALVES at 2/-, 954; 5/-, 1625; 6/6, 9003, 12A6, 12SK7, 6B8G, 6G6G; 7/6, 807, 12SA7; 8/6, 12SQ7; 25/-, 803, 805.

MORSE KEYS. Totally enclosed A.M. Type, perfect at 2/- each.
HEADSETS. Super U.S.A. H.R. type P.16, with long lead and Jack Plug at 12/6 set.

MAGSLIPS. Hunter 3in. at 6/6 each.

TELEPHONE HANDSETS. 'D' Mk. V. Complete with Handset, ready for use at 37/6 each. £3/10/- per pair.

CABLE P.V.C. Slightly sub-standard 1/1.044in. Single, at 6/6 per 100 yards.

POST AND PACKING EXTRA

R. GILFILLAN & CO., LTD.

7 HIGH STREET, WORTHING, SUSSEX

'Phone: Worthing 8719.

Codes: Bentley's 2nd.

Cables: 'GIL WORTHING'

SPECIAL OFFER

NEW G.E.C. 7-watt, V.H.F. Mobile Tx/Rx, 80.9, 81.1, 81.3 Mc/s. Complete with 12v. Rotary Power Unit each	£30 0 0
Eddystone "640" Receivers, perfect each	£22 0 0
C.R. 100 by Marconi, perfect	£28 10 0
D.S.T. 100 Receivers, 30 Mc/s-50 Kc/s	£30 0 0
H.R.O. Senior, 5 coils, AC/PP	£37 10 0
Several AR.88D, AR.88LF, S.38, S.27, 5X.28, and B.C.221 in stock.	

ALL IN PERFECT ORDER.

YOUR ENQUIRIES WELCOMED.

SERVICE RADIO SPARES

4 LISLE STREET, W.C.2. Gerrard 1734.

Just published

The New Edition

WORLD RADIO HANDBOOK

A new extended and improved edition — the eighth — is now ready. In its preface highly recommended by the UNITED NATIONS and UNESCO.

The new edition of WRH is the best ever published, containing a lot of new short wave stations, with all medium-wave and television stations.

WRH opens a new world for you and is the only complete guide to the short wave services of the world.

LISTEN TO THE WORLD WITH THE NEW EDITION OF WORLD RADIO HANDBOOK

Extended and Improved

Published by O. Lund-Johansen

Price: 9s.

136 pages.

A VALUABLE TECHNICAL HANDBOOK

AT A BARGAIN PRICE ! SPECIAL OFFER 15s. (Reduced from 25/-)

RADIO HANDBOOK - Twelfth Edition

- Comprehensive 300 page radio constructor's Manual. Fully illustrated with excellent photographs and circuit diagrams. Covering
- Receivers — Exciters and QRP Transmitters — SSB and FM Equipment — PA Units for all Amateur Bands — Mobile Gear — Speech
- Amplifiers and Modulators — Power Supply Units — VHF Apparatus — Transmitter Construction — Test Gear — Aerial Design — 20 pages
- on TVI and BCI. Stiff covers.

(This Edition will be unobtainable after present stock is cleared).

Price 15s. Postage 1s.

OTHER PUBLICATIONS FOR IMMEDIATE DELIVERY

	Post Free		Post Free
RADIO HANDBOOK 13th Edition	49/6	SURPLUS CONVERSION MANUAL Vol. 1	21/5
ANTENNA HANDBOOK	11/7	Vol. 2	21/5
HINTS AND KINKS	11/5	THE RADIO AMATEUR'S LICENCE MANUAL	4/10
HOW TO LISTEN TO THE WORLD	1/11	HOW TO BECOME A RADIO AMATEUR	4/10
HAM'S INTERPRETER	5/-	LEARNING THE RADIO TELEGRAPH CODE	2/8
POST-WAR COMMUNICATION RECEIVER MANUAL		WORLD RADIO VALVE HANDBOOK	11/10
Vol. 1	28/6	RADIO TUBE FUNDAMENTALS.	8/4
Vol. 2	28/6	RADIO AND TV HINTS	8/5
A COURSE IN RADIO FUNDAMENTALS	4/10	RADIO AMATEUR CALL BOOK (Complete Edition)	27/-
WORLD RADIO HANDBOOK 1954 Edition	9/-	(Foreign Section)	10/-
ANTENNA MANUAL	28/-	RADIO AMATEURS' MOBILE HANDBOOK	17/6
RADIO AMATEUR HANDBOOK 1954 Edition	31/-		

MAGAZINES BY SUBSCRIPTION

	One Year
Radio Electronics	33/-
Popular Mechanics	32/-
Radio Electronic Engineering Service	56/-
F.M. and Television	24/-
Electronics	32/-
Popular Science	160/-
Proc. I.R.E.	32/-
RCA Review	152/-
Tele-Tech	20/-
Television	40/-
Television Engineering	48/-
CQ	32/-
Audio Engineering	29/-
Radio and Television News.	29/-
QST	36/-
	36/-

SHORT WAVE MAGAZINE

(PUBLICATIONS DEPARTMENT)

55 VICTORIA STREET · LONDON · S.W.1 · ABBEY 5341

HENRY'S

5 HARROW ROAD, LONDON, W.2

Telephone: PADDINGTON 1008/9 and 0401

SEND POSTAGE FOR NEW 1954 COMPREHENSIVE 28-PAGE CATALOGUE

SHOP HOURS:

Mon.-Sat. 9-6.

Thurs. 1 p.m.

INDICATOR UNIT TYPE SLCS

This unit is ideal for conversion for a 'Scope Unit or basis for Midget Television. It contains C/R Tube type ACR10 (VCR193A) complete with holder and cradle, also earthing clip. 1-VR66, 2-VR65, 24 mfd. 550 v. wkg. condenser potentiometers and a varied assortment of resistors and condensers. These Units are in new condition and packed in wooden transit cases. The C/R Tube will be tested before despatch. Dimensions: 8 1/2 in. x 6 1/2 in. x 1 1/2 in., 45/-.

VOLTMETERS

15 v. (50 c.) A.C.M.I. 2 1/2 in. flush panel mounting ...	10/-
20 v. M.C. 2 in. square panel mounting ...	7/6
150 v. M.C. 2 1/2 in. flush panel mounting ...	10/-
3,000 v. M.C. 2 1/2 in. flush panel mounting ...	21/-

MILLIAMMETERS

500 Microamp M.C. 2 in. round panel mounting ...	15/-
1 mA M.C. 2 in. square ...	17/6
1 mA. M.C. 2 1/2 in. flush panel mounting ...	22/6
5 mA. M.C. 2 in. square panel mounting ...	7/6
10 mA. M.C. 2 1/2 in. flush panel mounting ...	10/-
30 mA. M.C. 2 in. round panel mounting ...	7/6
30 mA. M.C. 2 1/2 in. flush panel mounting ...	10/-
50 mA. M.C. 2 in. square panel mounting ...	7/6
150 mA. M.C. 2 in. square ...	7/6
200 mA. M.C. 2 1/2 in. flush panel mounting ...	10/-
300 mA. M.C. 2 1/2 in. flush panel mounting ...	10/-
500 mA. M.C. 2 1/2 in. flush panel mounting ...	12/6

AMP-METERS

1 amp. T.C. 2 1/2 Projection ...	6/-
3 amp. T.C. 2 in. square panel mounting ...	6/-
6 amp. T.C. 2 1/2 in. flush mounting ...	7/6
20 amp. M.I. 2 1/2 in. round ...	10/-
15 amp. M.I. (50 c.) Projection ...	35/-
30 amp. M.C. 2 in. square panel mounting ...	7/6
300 volts 50 cy. A.C. 5 in. dial projection type ...	50/-

M.C. = Moving Coil. M.I. = Moving Iron. T.C. = Thermo-Coupled. All Meters are Brand New and in original cartons.

62A INDICATOR UNIT

Complete with VCR97 or 517C, 12-EF50, 4-SP61, 3-EA50, 2-EB34. Built on double-deck chassis. Absolute new condition. 99/6. Carr. 7/6. Or less Tube, 69/6. Carr. 7/6.

Over 20,000 American K.B.V.A. Valves in stock at minimum prices.

INDICATOR UNIT TYPE 182A

Unit contains VCR517 Cathode Ray 6 in. tube, complete with Mu-metal screen, 3 EF50, 4 SP61 and 1 5U4C valves, 9 wire-wound volume controls and quantity of resistors and condensers. Suitable either for basis of television (full picture guaranteed) or Oscilloscope. Offered BRAND NEW (less relay) in original packing cases at 67/6. Plus 7/6 carr.

T.V. PRE-AMPLIFIER FOR LONDON AND BIRMINGHAM

Complete with 6AM6. Ready to plug into your set, 27/6. P.P. 2/6.

PYE 45 MC/S. STRIP. TYPE 3583 UNITS

Size 1 1/2 in. x 8 in. x 2 in. Complete with 45 Mc/s. Pye Strip, 12 valves, 10 EF50, EB34 and EA50, volume controls and hosts of Resistors and Condensers. Sound and vision can be incorporated on this chassis with minimum space. New condition. Modification data supplied. Price £5 Carriage paid.

No. 38 "WALKIE TALKIE" TRANS-RECEIVER

Complete with Throat Mike, phones. Junction Box and Aerial Rods in canvas bag. Freq. range 7.4 to 9 Mc/s. Range approx. 5 miles. All units are as new and tested before despatch. £4/10/-.

6 WATT AMPLIFIER (UNDISTORTED)

Manufactured by Farmako and Sound Sales for Admiralty. Contains 4 valves, PX25, MS/PEN, AC/HL, MU14. Output Matching and 3Ω and 15Ω, 100/250v. A.C. COMPLETE IN STEEL GREY AMPLIFIER CASE WITH CRYSTAL HAND MICROPHONE, £12/10/- Call for Demonstration

R.F. OSCILLATOR UNIT

6-18 kV., including rectifier winding, 25/-

WANTED

813, 723A/B, 931A & EXTALS, Any quantity

MORSE PRACTICE KIT

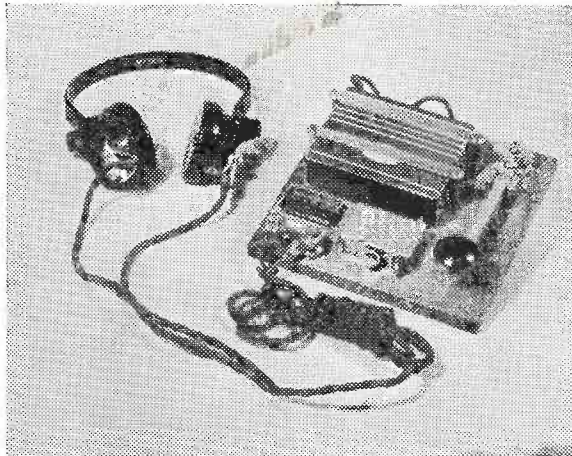

Beautifully balanced Key mounted with audible note buzzer, battery, and phone terminals on hardwood panel, 6 1/2 x 6 1/2 x 1/2 in., plus pair of Headphones. Could be used by two persons, one coding and keying the message, the other de-coding and recording. BRAND NEW. 15/- complete. Post paid. Or less Battery and Headphones, 6/-, post paid. Two kits could be used to send and receive messages in a similar manner.

SPECIAL OFFER!

Our TAPE-DECK AMPLIFIER AND POWER UNIT (List £16/16/-) and TRUVOX TAPE-DECK MARK III (List £23/2/-).

£36.0.0

CONSOLE CABINETS NOW AVAILABLE.

R.F. UNITS

Type 24
20-30 Mc/s.
Switched Tuning.
With 3-SP61
15/- EACH
BRAND NEW.

Type 25
40-50 Mc/s.
Switched Tuning.
With 3-SP61.
19/6 EACH
BRAND NEW.

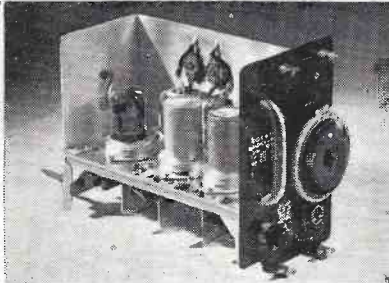

R.F. UNITS

Type 26
50-65 Mc/s.
Variable Tuning.
2-VR136
1-VR137
45/- EACH
BRAND NEW.

New but slightly soiled.
RF 24 12/6
RF 25 15/-
RF 26 35/-

PHOTO CELLS CMG25. Brand-new 25/-

CATHODE RAY TUBES

VCR139A. 2 1/2 in. C/R Tube. Brand new in original cartons (carr. free) ... £1 15 0
VCR97. Guaranteed full T/V picture (carr. 2/-) ... £2 0 0
VCR517 or 517C. Guaranteed full T/V picture ... £1 15 0
VCR138 ... £1 10 0
3BP1, with shield suitable for T/V or 'scope (carr. 1/6) ... £1 5 0
MU-METAL SCREENS for VCR97 or 517. P.P. 1/6 ... 10 0
6 in. ENLARGER for VCR97 or 517. P.P. 1/6 ... 17 6

RECORDING TAPE G.E.C.

600ft. Reels ... 10/-
1,200ft. Reels ... 17/6
BUY NOW - UNREPEATABLE BARGAIN.

ROTARY POWER UNIT Type 104
Input 12v. Output 230 volts 65 mA. and 6.3 volts 2.5 amps. Fully filtered and smoothed and noise suppressed. Ideal for car radio, etc. BRAND NEW ONLY 15/- (postage, etc., 2/6). ALSO 24 v. type 15/-.

PLEASE ADD POSTAGE. ARTICLES UP TO 10/-, 1/-, £1, 1/6, £2, 2/-.