

of the

1/6

SHORT WAVE LISTENER AND TELEVISION REVIEW



DEVOTED TO
SHORT WAVE RADIO RECEPTION
AND AMATEUR TELEVISION

SEPTEMBER 1950
VOLUME 4 · NUMBER 10

PREMIER RADIO

MORRIS AND CO. (RADIO) LTD.,

All Post Orders To: **JUBILEE WORKS, 167 LOWER CLAPTON RD.**
LONDON E.5. (Amherst 4723, 2763, 3111)

152 & 153 FLEET STREET (Central 2833)

207 EDGWARE ROAD, W.2 (Ambassador 4033)
(OPEN UNTIL 6 p.m. SATURDAYS)

**PREMIER
TELEVISOR KITS**
FOR LONDON AND BIRMINGHAM
USING 9" OR 12" MAGNETIC C.R. TUBES

£19.19.0 including all parts, valves and loud-
(Car., etc., 15/-) speaker, but excluding C.R. TUBE

The Vision Receiver, 4 R.F. stages (EF54s), Diode Detector and Noise Limiter (6H6) Video valve (EF54). Complete Kit with valves, £3/16/0. Carriage 2/6.

The Sound Receiver, 3 R.F. stages (6SH7s), Double Diode Triode (6Q7), which acts as Detector and L.F. Amplifier, Noise Limiter (EA50), output valve (6V6). Complete Kit with valves, £3/10/-. Carriage 2/6.

The Time Bases, blocking oscillators on Line (6SH7 and 807) and Frame (VR137 and 6V6). E.H.T. from Line Output Transformer, 10in. P.M. Speaker, Sync. separators 6H6 and 6V6.

Complete Kit with valves, £8/15/6. Carriage 5/-.

The Power Supply, double wound transformer isolating the receiver from the mains. Rectifier 5U4G.

Complete Kit with valves, £4/16/6. Carriage 5/-.

The following Sensitivity figures prove that the Premier Televisor Kit is capable of reception at greater distances than any other Standard Commercial Kit or Receiver whether T.R.F. or Superhet.

VISION RECEIVER

Sensitivity: 25 μ v for 15v peak to peak measured at the Anode of the Video Valve.

Sound Rejection: Better than 40 db.

Adjacent Sound Rejection: Midland Model. Better than 50 db.

SOUND RECEIVER

Sensitivity: 20 μ v.

Vision Rejection: Better than 50 db.

CONSTRUCTION BOOK 3/-.

PREMIER MIDGET RADIO KITS

Re-designed, easier than ever to assemble. These kits are now supplied with point to point wiring diagrams, all parts are supplied including attractive plastic cabinet 12" x 5" x 6", loudspeaker, valves, etc. Illuminated glass dial with new wave lengths. 190-540, 1,000-2,000 metres. For use on 200-250v mains. 6K7, 6SH7, and CV1510 beam power output valves in the A.C. and 6K7, 6SH7 and 12A6 valves in the A.C./D.C. model, both use metal rectifiers.

Please state if A.C. or A.C./D.C. is required.

Complete kit, £4/19/6, including Purchase Tax.

PREMIER 3-BAND MIDGET SUPERHET KIT

Re-designed to receive the short, medium, and long wavebands, 16-50, 194-540, 1000-2,000, with point to point wiring diagrams. A.C. valve line up, 6K8, 6K7, 6Q7 and CV1510 beam power output. A.C./D.C. is the same excepting the output valve which is 12A6. Please state which is required. Metal rectifiers are used in both models, and they are for use on 200-250v mains. Complete with cabinet as illustrated, loudspeaker, valves and all parts.

£6/19/6, including Purchase Tax.

We are now supplying
**NEW LONG RANGE TELEVISOR
KITS (ELECTROSTATIC TUBE)**

For the London or Birmingham frequencies at the same price as the standard kit

— £17/17/0 —

Five Easy to Assemble Kits are supplied:

Vision Receiver with valves, carriage 2/6 . . . £3/13/6

Sound Receiver with valves, carriage 2/6 . . . £2/14/6

Time Base, with valves, carriage 2/6 . . . £2/ 7/6

Power Supply Unit, with valves, carriage 5/- . . . £6/3/0

Tube Assembly, carriage and packing 2/6 . . . £2/18/6

This unit includes the VCR97 Tube, Tube Fittings and Socket and a 6in. PM Moving Coil Speaker with closed field for Television.

The Instruction Book costs 2/6, but is credited if a Kit for the complete Televisor is purchased.

Any of these Kits may be purchased separately; in fact, any single part can be supplied. A complete priced list of all parts will be found in the Instruction Book.

20 Valves are used, the coils are all wound and every part is tested. All you need to build a complete Television Receiver are a screwdriver, a pair of pliers, a soldering iron and the ability to read a theoretical diagram.

WORKING MODELS CAN BE SEEN DURING TRANSMITTING HOURS AT OUR FLEET STREET AND EDGWARE ROAD BRANCHES.

VALVES. We have large stocks of new boxed valves at very low prices. All exempt from Purchase Tax 11C6, 1LD5, 1LN5, 1S4, 1S5, 1N5, 1T4, 3A4, 3D6, 5U4, 5Y4G, 5Z4, 6AC7, 6AG7, 6C5, 6F8, 6J5, 6J7G, 6K7, 6K8, 6N7, 6Q7, 6SA7, 6SJ7, 6SK7, 6SC7, 6SL7, 6SN7, 6U5, 6V6, 717A, 12A6, 9003, 9005, VR55 (EBC33), VT52 (EL32), VR56 (EF36), VR57 (EK32), VR116, VR136 (EF54), VR137 (E52), CV66 (RL37), CV1120 (SU2150A), CV1137 (RL16), CV1068 (AW4), CV189 (U19), CV2941 (EL50), VU39, 807, HYVAC XY, HYVAC XW, KT61, KT61, U50, 6F6, AW4, 4060A, all 6/6. 6H6, 6SH7, 7193, VR78 (D1), all 2/6. VR54 (EB24), VR65 (SP61), VR92 (EA50), VR95 (954), VT121 (955), CV649 (956), CV102 (Xtal Diode), 1626, all 3/6. 6X5, HL23, RL18, VU111, VU133, VU134, CV6, CV73 (11E3), CV1189 (AC6 Pen), CV659 (1625), CV639 (843), (NS2, DQP, BL63 (CV1102), 1616, CV67 (klystron), U17 (CV1113), PT25H (CV1046), all 5/-, 1Q5, 1C5, 6C4, 6J6, 6AB7 6SQ7, 6SG7, all 6/6. 2X2, U74, CV1262 (GU1), CV1141 (GDT4B), GU50 (CV1072), VT30 (CV1030), VR91 (EF50), all 7/6. 5V4, 6B8G, 25Y5, 25Z6, 2050, VT127 (Pen 46), CV1075 (KT66) (matched pairs, 18/6), all 8/6. 6L6, P27/500 (PX25), 705A, 832, CV662 (8012), DE75, all 10/-. 803, 10/-, 805, 10/-, 931A, 30/-, CV186, 40/-, CV19 (EHTT), 60/-, 861, 60/-, 838, 15/-, CV15 (EL266), 40/-, HY114B (CV3505), 15/-, MR300/E (CV3558), 15/-, E1232 (CV92), 20/-.

C.R. TUBES

VCR517E, 20/-; VCR522, 15/-; ACR8, 15/-.

OUR NEW SUMMER CATALOGUE NOW READY—PRICE 6d.

THE SHORT WAVE LISTENER AND TELEVISION REVIEW

VOLUME 4

SEPTEMBER 1950

NUMBER 46

Conducted by the Staff of
The Short Wave Magazine.

EDITORIAL

Published on the third Thursday
in each month by the Short
Wave Magazine, Ltd., 53 Vic-
toria Street, London, S.W.1.
(ABBey 2384.)

Single copy, 1s. 6d. Annual
Subscription (12 issues) 16s.
post free.

The British Short Wave League
is associated with the *Short Wave
Listener & Television Review.*
Inclusive BSWL membership
17s. 6d. (Half-year 9s.)

All editorial and advertising
matter should be addressed to
*The Short Wave Listener &
Television Review*, 53 Victoria
Street, London, S.W.1.

Payment at good rates is offered
for articles of short wave listener
interest.

CONTENTS

SEPTEMBER 1950

Editorial	321
Modifying the TR9 Receiver	322
R.1355 for Television Reception	325
Television for Begin- ners, Part V	332
Broadcast Station List Revision 46·87·49·50 metres	335
Have You Heard?	336
BSWL Review (<i>Members Only</i>) facing pp.	340-341
Calls Heard	344
"Pse QSL"	347
The VHF End	348
1·7 mc on the R.1155	351
DX Broadcast	353

Review

IN the last four years, there is no subject of SWL interest that has not been touched upon in this space, and some of them more than once. While there may be those who consider that these discussions add up to no more than a lot of time and space wasted, the fact remains that they have, in their various ways, not gone entirely unheeded—they have borne fruit.

The general standard of SWL reporting shows steady improvement; there is much more SWL interest in the VHF bands; Club activity has increased considerably; and there is a much wider appreciation of the opportunities (and obligations) of the SWL in the world of Amateur Radio. There is also a keen desire to know more about the practical side of Amateur Radio, as regards both operation and techniques.

As we have so often said, the SWL of today is in most cases the amateur transmitter of tomorrow. The two states follow one another so naturally where the SWL interest is originally in the amateur bands.

We are already doing much for the TV enthusiast in the pages of *Short Wave Listener and Television Review*. We propose shortly to run, in addition, a new series of articles on the general theme, "How to Become an Amateur Transmitter." Watch for these articles—they will be good and will teach a great deal.

Modifying the TR9 Receiver

FOR AMATEUR BAND USE

by F. W. HATTEMORE

THIS ex-R.A.F. receiver is at present readily available on the surplus market for a few shillings, and at such a price is well worth modifying for station use as an auxiliary receiver.

The TR9 is the receiver unit (R1120) of a battery-operated transmitter-receiver designed for R/T use in aircraft. Although the original design is of the early 1930's, this equipment was standard in aircraft during a considerable part of the recent war. The receiver is a six-valve *straight*, with 2 RF stages, detector, and 3 AF amplifiers. As designed, frequency coverage is 4300 to 6600 kc. A 2-volt L.T. supply and 120/150-volt H.T. battery are required. Bias is obtained from an internal battery of 4.5 volts.

As the receiver stands no aerial tuning circuit is incorporated as this was common to that in the transmitter unit PA. The two tuning controls on the front panel are those of the first and second RF tuned anode circuits. Regeneration was provided by variable

capacity coupling between these two tuned circuits. The volume control was external to the unit, remotely operated, and consisted of a 50,000-ohm potentiometer in the screen circuit. A ganged bandspread condenser unit in parallel with the main tuning condensers was used for fine adjustment.

As the set is bought, it is not of very much use, but if the modifications suggested are carried out, it will be found that the two tuned RF stages give this receiver a very good sensitivity, a reasonable degree of selectivity, a good signal-to-noise ratio, and the amount of available gain on the AF side is considerable.

Modification Procedure

The modifications carried out on the author's receiver were as follows: Fitting of tuned input circuit, alteration of the RF tuning circuits and regeneration, fitting of internal RF gain control, telephone jack, loudspeaker, and on/off switch. As modified the receiver gives a good account of itself on all the HF amateur bands, and stability really is excellent, due to the very complete screening of the RF units.

The completed receiver was housed in the original steel case, and in the portion formerly occupied by the transmitter was fitted an aluminium panel carrying the loudspeaker, volume control, switch, and jack for telephones. The complete circuit diagram is shown of the TR9 receiver before modification.

The Coils

The first job is to remove the old tuning coils, as these are to be replaced by plug-in type inductances. This may prove a little tricky owing to the fact that a deposit of resinous matter is added as a seal to the locking nuts holding the coils and their screening cans in position. This is best first loosened by applying a hot soldering iron. Having removed these coils, sockets should be mounted in their place to take the new plug-in coils, which may be either of the 4- or 6-pin type or of the new Eddystone midget series. Immediately adjacent to the 1st RF anode coil is a space on the chassis suitable for mounting the holder for the aerial tuning coil. Each of these coils must be screened from the other, and in the author's case separate screening cans were mounted upside down on the chassis, and the necessary clearance hole cut away to allow the

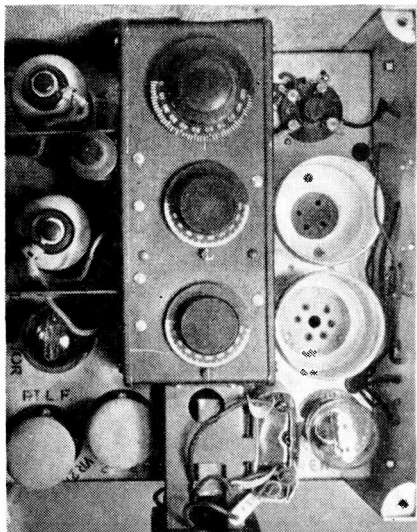

Top chassis view showing location of tuning elements in the receiver section of the TR9.

coil holders to be put in. This can be clearly seen from the photographs.

In the central compartment of the chassis, adjacent to the two tuning condensers, is a space ready provided, into which can be fitted the aerial circuit tuning condenser. This should be, to match the others, of .00025 μ F capacity. In the top cover plate of the receiver, the position over the tuning coils was cut away as shown in the photograph and hinged. This allows easy access to change coils for different wave bands.

The regeneration condenser is removed entirely and its connections taken out.

RF Stage Changes

Before wiring up the RF circuit, remove R3, the RFC in series, and R4, C2. These will be found under the chassis immediately behind V1. In the interests of reasonable selectivity the anode RF circuits are not wired up as originally but arranged for loose coupling as shown in the modified circuit.

Slight changes are made in the detector anode circuit, the load resistor is reduced to 100,000 ohms from 500,000 ohms and the filtering arrangements are rewired as shown in the circuit. Regeneration is now provided by the more orthodox method used in present-day TRF receivers, control being obtained by a potentiometer and pre-set trimmer.

Other Details

The remainder of the AF circuit needs no alteration; an additional refinement might be the fitting of an AF gain control.

The leads to the power supplies are brought

TABLE OF VALUES

Fig. 1. The TR9 Receiver Circuit, Unmodified.

Condensers	
1. 50 μ F	15. 20 μ F
2. 0.1 μ F	16. 230 μ F
3. J	17. .01 μ F
4. } 0.5 μ F	18. 100 μ F
5. J	19. 0.5 μ F
6. 230 μ F	20. } .001 μ F
7. 48 μ F	21. } .001 μ F
8. 20 μ F	22. 50 μ F
9. .01 μ F	23. .5 μ F
10. 10 μ F	24. } .001 μ F
11. 300 μ F	25. } .001 μ F
12. 0.5 μ F	26. 0.5 μ F
13. 0.5 μ F	27. 2 μ F
14. 48 μ F	28. .01 μ F
Resistors	
1. 50,000 ohms	11. 250,000 ohms
2. 20,000 ohms	12. 20,000 ohms
3. 10,000 ohms	13. 500,000 ohms
4. 500,000 ohms	14. 250,000 ohms
5. 1.5 ohms	15. 2 megohms
6. 20,000 ohms	16. 1 megohm
7. 1 megohm	17. 20,000 ohms
8. 1.5 ohms	18. 50,000 ohms
9. 20,000 ohms	19. 200,000 ohms
10. 2,000 ohms	20. 1 megohm
	21. 1 megohm

- V1 } VR18
- V2 } SG215
- V3 } PM2HL or
- V4 } EQUIV
- V5 } VR21
- V6 = VR22, PM2A or equiv.

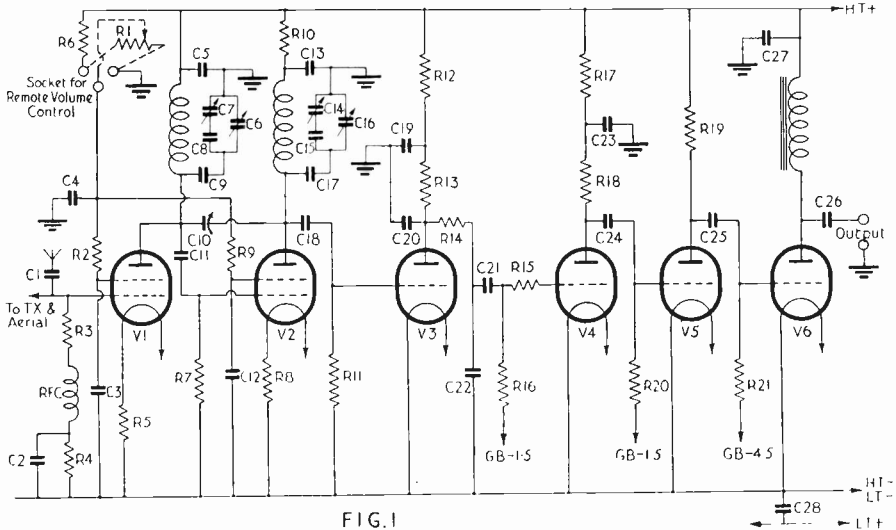

FIG. 1

Fig. 1. Full circuit of the receiver section of the TR9, before modification. This unit was designed for aircraft operation, and was arranged to provide modulation for the associated transmitter as well as speech inter-communication for the crew members. Most TR9 equipments were operated when airborne on a fixed frequency of 6440 kc.

out from contacts on the side of the receiver. Each one is labeled, but HT supply to RF and AF portions will need joining together, as originally these were separated since the AF stages were used as sub-modulator for the transmitter and for provision of aircraft inter-communication.

The decoupling arrangements in the receiver will be found to be quite adequate, even if a

TABLE OF VALUES

Fig. 2. The TR9 After Modification.

- C1 = 50 $\mu\mu\text{F}$
- C2 = 20 $\mu\mu\text{F}$
- C3 = 48 $\mu\mu\text{F}$
- C4 = .00023 μF
- C5 = 0.5 μF
- C6 = 0.5 μF
- C7 = 0.5 μF
- C8 = 20 $\mu\mu\text{F}$
- C9 = 48 $\mu\mu\text{F}$
- C10 = .00023 μF
- C11 = 0.5 μF
- C12 = .00025 μF
- C13 = 0.5 μF
- C14 = 20 $\mu\mu\text{F}$
- C15 = 48 $\mu\mu\text{F}$
- C16 = .00023 μF
- C17 = .0001 μF
- C18 = 0.5 μF
- C19 = .001 μF
- C20 = .001 μF
- R1, R5, R7 = 20,000 ohms
- R2, R8 = 2,000 ohms
- R3, R4 = 1.5 ohms
- R6 = 50,000 ohms
- R9 = 20,000 ohms
- R10 = 100,000 ohms
- R11 = 50,000 ohms
- R12 = 20,000 ohms
- R13 = 250,000 ohms
- R14 = 2 megohms
- R15 = 1 megohm
- V1 = VR18 (SG215)
- V2 = VR18 (SG215)
- V3 = VR27 (PM2HL)

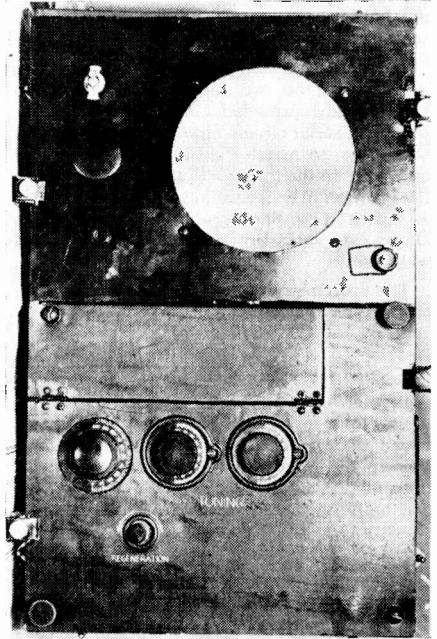

External view of finished receiver in original case, as modified in the manner described in the article.

mains unit is used for HT supply, as is the case in the writer's station.

Testing

Having completed the suggested modification and connected up power supplies, the

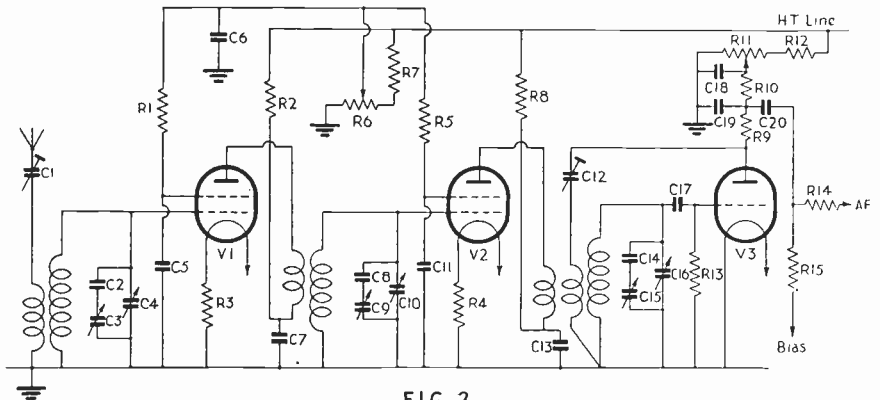

FIG. 2

Fig. 2. The circuit modifications suggested by our contributor to adapt the TR9 receiver for amateur band operation.

appropriate set of similar coils for the required waveband should be inserted, and the receiver is handled as a normal regenerative TRF. No instability at all should be found, and sensitivity of a high order should be noticed, which can be varied by adjustment of the RF screen potentiometer. The detector feedback trimmer is adjusted to enable the detector to oscillate with the control potentiometer advanced almost fully clockwise. In spite of the fact that there are three tuning condensers to adjust, no difficulty should be experienced as the RF tuning is not excessively sharp.

In use, ample gain is obtained for loud-speaker operation, but should telephones be used a jack can be wired to cut out the speaker when phones are plugged in. Results obtained at this QTH have been excellent, and on the broadcast bands good loudspeaker results are obtained using only a few feet of wire on the floor as an aerial. Even with this length of aerial, local amateurs on 160 metres come in sufficiently strongly to overload the output

stage. So the "gain" is ample.

Some Final Points

The current consumption of the receiver is 1.15 amps at 2 volts for the filaments and 18 mA HT at 120 volts.

In conclusion it might be stated that this receiver functions just as well on the medium and long wave broadcast bands, providing the correct range coils are plugged in, and so serves ideally as a stand-by general coverage receiver.

Other modifications such as provision of auto-bias suggest themselves but this is easily carried out from a straightforward application of Ohm's Law. Finally, the TR9 was issued as several models but those encountered are mainly TR9D (R1120). All receivers are basically the same. In the F-model, the AF portion was not used as sub-modulator, this function being fulfilled by the A1134. In the TR11 model, frequency range was 3000 kc-4300 kc, otherwise all receivers are identical.

R.1355 for Television Reception

DETAILED MODIFICATION TREATMENT

By W. N. STEVENS (G3AKA) and L. E. HOWES (G3AYA)

MANY readers have requested details for modifying the R1355 unit for reception of the vision channel. This is still undoubtedly one of the most popular of the surplus TV conversion propositions, due mainly to the sensitivity of the modified unit and the comparative simplicity in conversion. (Another attraction is, of course, the low price of the units!)

Though certain details have already appeared in print regarding this unit, it is felt that what is now required is really detailed and exhaustive treatment of the various modifications needed to convert this IF amplifier strip into an efficient TV vision receiver.

First of all, a brief description of the unmodified unit, the circuit diagram of which is shown in Fig. 1. The first five stages are IF amplifiers (valves V1-V5) of the VR65 (SP61) variety. These are followed by V6 which is a diode, VR92 (EA50), acting as second detector. (The first detector is as in the RF unit, *i.e.* the frequency changer stage). V7 is a VR65 (SP61) operating as the video amplifier, and V8 (also a VR65) is a cathode follower stage to feed the output of the receiver to the Indicator Unit 62

(or 62A), which, with the RF units (25, 26, etc.) formed the complete equipment for the airborne apparatus ARI 5083 (alternatively known as Gee Mark II). The output of the modified R1355 is, of course, fed to the time base unit for television reception.

The grid circuit of V1 includes L1 and C1 which comprise part of the band-pass coupling between the mixer stage and IF amplifier; this resonates at 7.7 mc. The remainder of the IF tuned circuits (L2, 3, 4, 5, 6) are peaked at 7.5 mc and the overall response curve of the complete amplifier unit peaks at 7.5 mc. The bandwidth is plus-and-minus 0.6 mc for 6 dB down, measured from the first IF amplifier grid.

V1 and V2 are provided with variable bias through the resistors R2, R4, R5, R10 and R57 and the potentiometer which is contained in the associated Indicator Unit. The next three stages (V3, V4 and V5) have a special back-bias circuit incorporated to enable the signals as reproduced on the Indicator CRT screen to be read through severe interference—such as jamming. On the panel a four-position switch is fitted marked N, X, Y and Z; this is the "anti-jamming" switch, installed to enable

circuit elements to be varied to counteract various types of jamming. Positions X, Y and Z are the anti-jamming positions and are of no interest to the TV enthusiast, but position N (for "normal") switches out the anti-jamming components and the three stages function as ordinary IF amplifiers.

The power supply incorporated in the unit is unfortunately not suitable for our domestic mains supply, since it is designed to operate from 80 volts AC input at 2,000 c.p.s. It consists of two transformers, two chokes (which are also unsuitable in view of their very low inductance), three valves and associated smoothing components. A VR65 is used to provide a source of stabilised HT to the Indicator Unit via the 6-pin W plug on the front panel (unstabilised HT supply is fed to the 1355 receiver and RF unit); a VU71 (5U4G) is used as an HT rectifier in a normal full wave circuit; a VU120 (SU2150A) is an

EHT rectifier in a conventional half-wave circuit. The complete assembly also contains the RF units, about which more later.

The necessary modifications to the R1355 unit can be classified as follows :

- (1) Removal of existing power pack and substitution of new supply.
- (2) Fitting a contrast control.
- (3) Removal of anti-jamming switch.
- (4) Modification of anti-jamming stages.
- (5) Modification of detector and video amplifier stages.
- (6) Modifying cathode follower stage.

Power Supply

Since the existing power supply is quite unsuitable, the complete section must be removed from the unit (see layout sketch, Fig. 2). First, remove all the above-chassis components such as valves, transformers and chokes. This will leave miscellaneous components and leads to deal with below chassis; these should all be taken out including those going to the Jones plug at the rear of the RF

Fig. 1. Circuit diagram complete, unmodified, of the R.1355 IF amplifier.

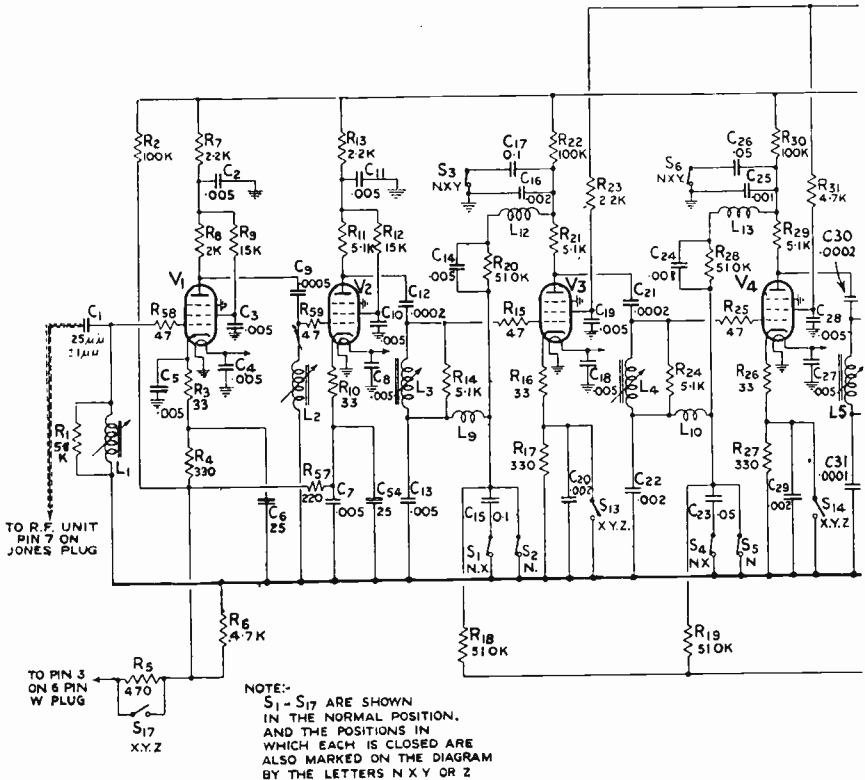

unit compartment and also to the four large terminals between the IF section and the power pack. Next job is to fit a standard 50-cycle power supply and this can be conveniently installed in the space left by removing the existing power pack. Fig. 3 shows a circuit which will meet the requirements for the R1355 and the RF Unit.

The power supply is a convenient full-wave arrangement which gives two separate outputs of HT—one for the R1355 and the other for the RF unit used (e.g. RF25 for London or RF26 for Sutton Coldfield). Note that the centre tap of the transformer HT winding is taken direct to chassis and *not* to the lead marked "to negative rail supply on power pack" shown on Fig. 1 (lower right-hand side of circuit). This lead is already wired to one of the four large terminals previously mentioned and was originally supplied with a voltage of approximately 150-250 volts negative for anti-jamming purposes only; the connection to this terminal is *completely ignored*. (This is emphasised owing to the fact that it is known that in the past, numerous constructors have

taken this connection to the transformer centre tap, expecting the HT circuit to be completed via the various high value resistors in the R1355).

Since the centre tap and one side of the heater supply is taken direct to chassis, it only remains to connect up the "live" heater lead and the two HT positive outputs. The LT line is taken to pin 12 of the Jones plug at the rear of the RF Unit compartment (see Fig. 4A) and also to one of the four large terminals (see Fig. 4D). The main, i.e. highest, HT line is also taken to one of these terminals. The lower HT line goes direct to pin 10 on the Jones plug.

In removing the original power supplies certain leads will have been disconnected, which are now required. These are connections to terminals 7 and 8 on the Jones plug (terminals 10 and 12 have been rewired for LT and HT leads); pin 8 is taken direct to chassis (being LT and HT negative returns) and pin 7 is joined to the inner conductor of the long co-axial pipe which originates at the

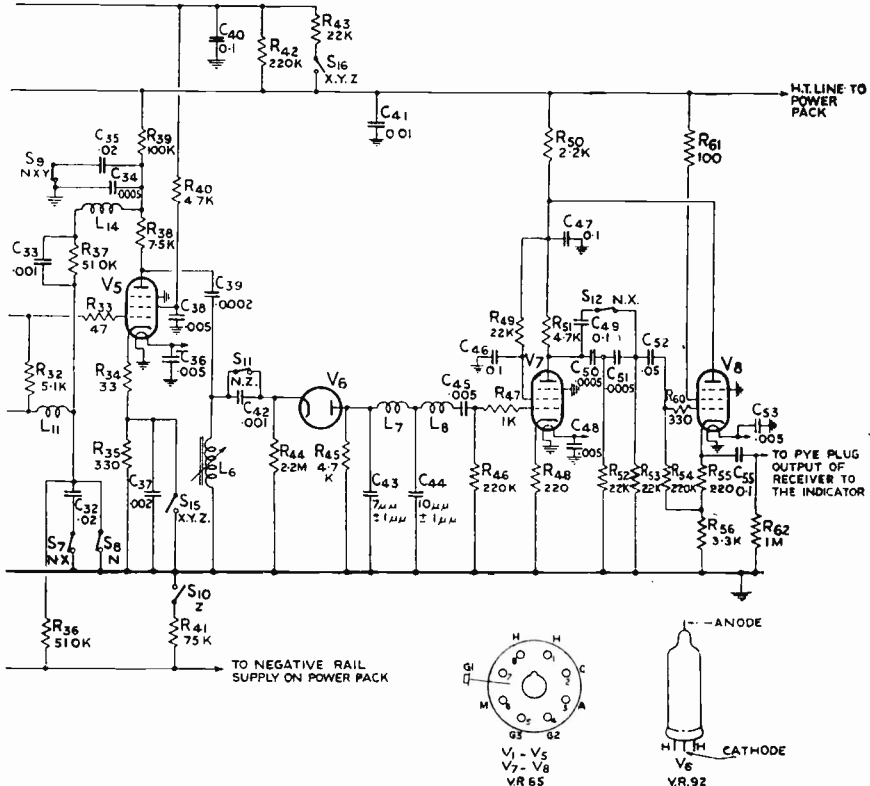

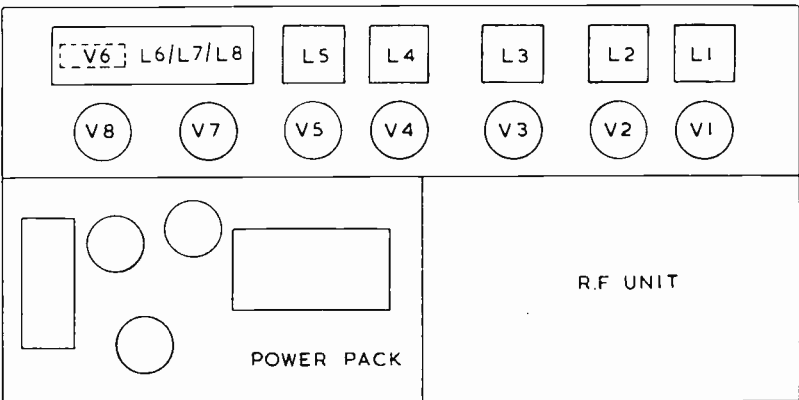

Fig. 2. Layout sketch showing positioning of main components above chassis.

front end of the R1355 section and terminates adjacent to the Jones plug.

Contrast Control

For television reception it is, of course, necessary to provide some means of adjusting the level of the modulation applied to the cathode ray tube. Therefore, a "contrast" or gain control is fitted. This takes the form of a 5,000 ohm potentiometer (3-watt) inserted in the cathode circuits of V1 and V2 (see Fig. 6). One end of the track and the slider are grounded and the free end taken to the live end of resistor R6. In the sketch R5 is shown in dotted outline; this is due to the fact that it is removed when the anti-jamming stages are modified. Fig. 6 is the modified section of the circuit as shown in the lower left-hand corner of Fig. 1.

The lead described as going to "pin 3" may be ignored, but if the potentiometer is fitted to the front panel (which is an advantage) it should be noted that this lead is simply a continuation of the lead from the live end of R6.

Anti-Jamming Switch

First set this control to position "N" and

leave it there. To remove the switch, all leads connected to it will have to be taken off and this, to say the least, is rather a tricky operation. To do the job correctly a continuity tester (or a simple ohm-meter) is really necessary in order that where a circuit is "carried through" the switch the broken leads can be rejoined so that the circuit will function similarly to when the switch was in position "N." Leads terminating at the switch can be traced back to source and completely removed.

By reference to Fig. 1, it can be seen how the switch operates in its various positions. For instance, the connection across R5: This

TABLE OF VALUES

Fig. 3. R1355 Modifications, Power Pack.

- T1 = Secondaries: 300-0-300v at 80 mA; 5v at 2 A; 6.3v at 8 A
- V1 = 5Y3 or similar
- L1 = 10 Henry at 80 mA
- C1 = 16 μ F, 350v DC wkg.
- C2 = 8 μ F, 450v DC wkg.
- C3 = 8 μ F, 350v DC wkg.
- C4 = 0.001 μ F, mica
- R1 = 2 200 ohms 2 watt

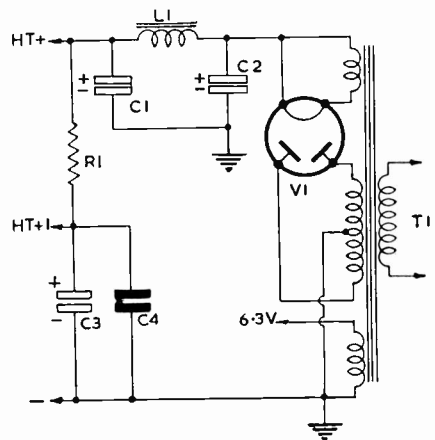

Fig. 3. Circuit of suggested power pack for the R.1355.

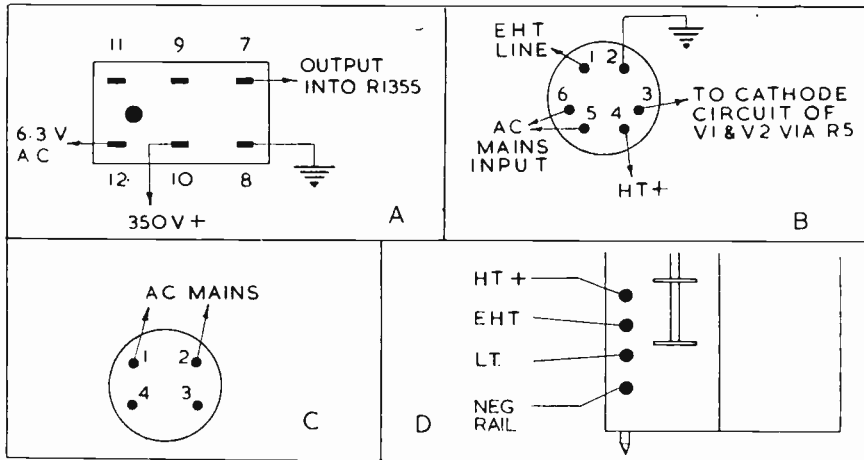

Fig. 4. Detail of connections to various terminal strips. (A) To Jones socket at rear of the RF unit. (B) Connections to 6-pin W-plug on front panel. (C) To 4-pin W-plug on front panel. (D) To the four large feed-through terminals situated between power pack and receiver section. (Note position of the Yaxley switch running parallel.)

has the switch positions X, Y and Z marked by the side of it (S17 refers to the switch contacts). This means that in these positions the switch will be closed and that it will be open on position "N"; so that in the latter position the component R5 will be *in circuit*.

An easy reference is the fact that in Fig. 1 all switch positions are shown when the amplifier is working in the normal (or "N") position of the switch. All points where components are short-circuited by actual closed switch positions in Fig. 1 (such as S1, S2, etc.), and by permanent connections in the modification procedure, may be removed and *vice versa*.

As previously stated, the complete removal of all non-utility components is an extremely tedious task. Since the receiver will work satisfactorily with the switch in position "N" and all anti-jamming components remaining, many constructors will feel that the extra effort is hardly worth while. All we can say is that this decision must lie with the individual!

Anti-Jamming Stages

In these stages there are certain components which contribute nothing to the efficiency of the unit when used as a TV vision receiver. In fact, by carrying out the modifications suggested a very definite improvement in performance may be expected.

First, R5 is removed and bridged, thus making the circuit as shown in Fig. 6. With the switch in position "N" the grid return circuits of V3, V4 and V5 are taken to chassis

via contact S2, S5 and S8 respectively and it will be apparent that a host of components will become redundant. A point worth noting is that L12, L13 and L14 and their respective condenser/resistor components on the earthy side (*i.e.* C14 and R20 with L12) also contribute nothing to performance when on position "N." These may or may not be removed, according to the whims of personal taste.

However, improved efficiency can be obtained by altering the values of R22, R30 and R39. Remove these components and replace by new resistors of 4,700 ohms, quarter-watt rating. The next components to be dealt with are the screen grid feed resistors of V3, V4 and V5; these are re-wired so that the screen-grid feed is similar to that used in V1 and V2 stages.

The "hot" end of R23 is broken and the resistor is taken to the junction of R21 and R22. Similarly with V4 and V5 stages; R31 is taken to the junction of R29 and R30; R40 is taken to the junction of R38 and R39. This will make C40, R42 and R43 unnecessary and they may be removed.

Detector, Video Amplifier and Cathode Follower Stages

The modified V6, V7 and V8 stages are shown in Fig. 5. It is first necessary to remove and bridge C45 (which is contained in the large IF compartment at the rear of the chassis). This makes a DC coupling between the V6

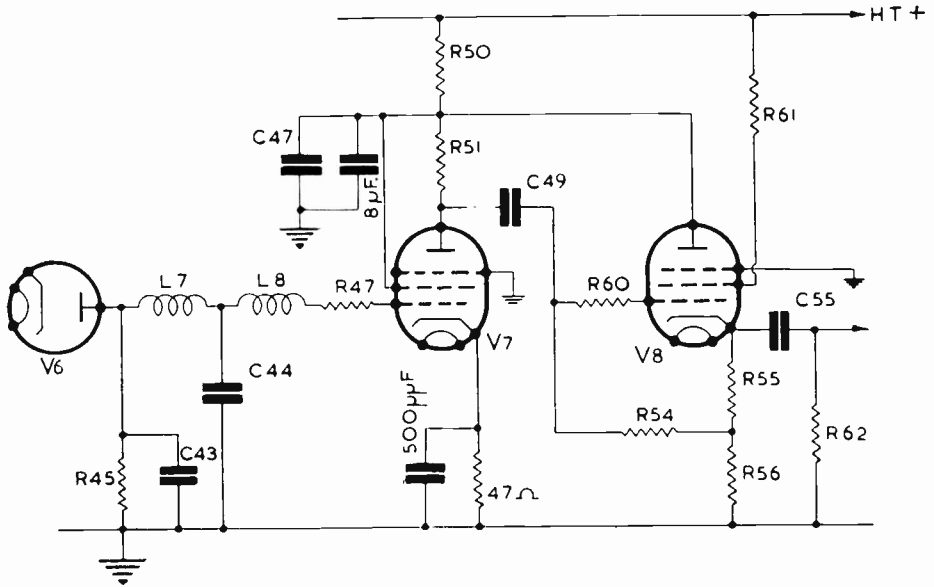

Fig. 5. Circuitry round the V6, V7 and V8 stages as modified. Note the three additional items.

and V7 stages. Also removed is the V7 grid leak R46, thus making R45 the grid leak for both the diode load and the V7 stage.

In the V7 cathode circuit, remove R48 and replace by a new resistor of 47 ohms (quarter-watt). This should then be paralleled by a 500 μ F mica condenser. In the screen-grid circuit, remove R49 and C46 and take the screen grid to the junction of R50 and R51 as shown in the diagram. Since extra decoupling is required now that there is a 100 c.p.s. ripple component on the HT line (in place of the original 4,000 c.p.s.) it is necessary to increase the value of C47; the simplest method of accomplishing this is to parallel C47 with a 8 μ F condenser. The working voltage should be 350 DC.

Turning to the cathode follower stage, the coupling between V7 and V8 demands revision. First of all remove C50, C51, C52, R52 and R53, thus making C49 the coupling condenser as shown in the modified circuit. It will be seen that the S12 contact of the anti-jamming switch is in the closed position, but this can be totally ignored; the leads going to these contacts are removed.

R62 may be retained or removed; it will depend entirely on whether a suitable resistor is contained at the input of the time base unit to be employed.

General Notes

The output waveform from the modified unit gives a negative-going sync pulse and positive-going picture modulation. This is in the correct phase for application to the cathode ray tube grid. The sync pulses will, of course, have to be separated from the picture modulation before application to the time bases by the sync separator and the constructor is advised to take note of the required sync polarity for the type of time base used. Another point to note is that, due to the AC couplings, it will be necessary to provide DC restoration of the picture waveform at the CRT grid.

For constructors desirous of checking the 1F unit, either in the case of breakdowns or

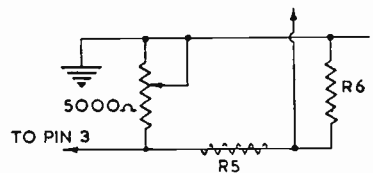

Fig. 6. Showing the fitting of the contrast control. Resistor R5 is in dotted outline because it is removed during modification (see text).

to check efficiency, a table of operating voltages is appended. It should be noted that the voltages given are only approximate and should be used simply as a general guide, because they may vary as much as 25 per cent. from one receiver to another. Also, the figures are for the *modified* units; it can then be checked after the new power pack has been fitted and when the general modifications have been carried out.

LICENCE ITEM

By the end of June last, there were 12½ million BC licences in issue, of which no less than 406,000 were in respect of TV receivers. These are big figures, and show steady expansion, especially on the TV side. You have yours, of course!

SUTTON COLDFIELD DX

GC2AWT (Jersey, C.I.) reports that he is now getting excellent sound and vision reception of the Sutton Coldfield station, on a home-built televisor; having regard not only to the distance but also the much higher frequency than that in use for the A.P. transmission, this is very interesting. Several readers have good reception from S.C. along the South Coast of England.

The voltage readings assume that the HT line voltage to the IF unit is 350 volts and to the RF unit 300 volts, and with an RF25 unit in position. The receiver gain is set at minimum.

V1	Anode 340v	Screen Grid 310v	Cathode bias 5v
V2	Anode 340v	Screen Grid 310v	Cathode bias 5v
V3/4/5	Anode 280v	Screen Grid 280v	Cathode bias 5v
V7	Anode 180v	Screen Grid 280v	Cathode bias 0.5
V8	Anode 280v	Screen Grid 340v	Cathode bias 27v

LEAGUE CERTIFICATES

The current issue of the *BSWL Review*, accompanying this month's *Short Wave Listener and Television Review*, announces the new range of Achievement Certificates open for award to members of the British Short Wave League who can qualify for them. There are no less than five of these Certificates—Heard All Zones (HAZ), The Hundred Country Club (HCC), Heard British Empire (HBE), VHF Counties Heard (VHF CH) and North American Call Areas (NACA). These certificates are available, like the *BSWL Review* itself, only to League members. The qualifying standards, though high, are within reach of all competent SWL's, and certificates are issued only against proofs of reception in the form of either QSL cards or verifying letters.

Come to SMITH'S of EDGWARE ROAD THE FRIENDLY SHOP FOR ALL RADIO COMPONENTS

We stock everything the constructor needs—our 25 years' experience of handling radio parts and accessories enables us to select the best of the regular lines and the more useful items from the surplus market in:

Loudspeakers and Phones	Valves and CR Tubes
Transformers and Chokes	Cabinets and Cases
Meters and Test Equipment	Capacitors and Resistors
Pickups and Turntables	Coils and Formers
Switches and Dials	Plugs and Sockets
Metalwork and Bakelite	Aerials and Insulators
Books and Tools	Motors and Generators
Valve Holders and Cans	Wires and Cables
Metal Rectifiers	Panel Lights and Fuses
Sleeving, Nuts and Bolts, Tags, Clips, Grommets and all other bits and pieces.	

NOTHING TOO LARGE—NOTHING TOO SMALL!
Everything you need under one roof—at keenest possible prices

No general catalogue is issued owing to constantly varying stocks and prices, but we shall be pleased to quote you. Lists are available for the following lines, in which we specialise, and can thoroughly recommend:—

1. The increasingly popular "Electro-Voice" range of Transformers and Chokes. "As good as the best—yet cost little more than the cheapest."
2. The "G.L.G." 16-gauge Aluminium Chassis. "For the man who takes a pride in his rig."
3. "K-A Products" Television Aerials. "A real engineering job."

H. L. SMITH & Co. Ltd.
287/9 Edgware Rd., London, W.2

Telephone: Paddington 5891

Hours 9 till 6 (Thursday, 1 o'clock)

Near Edgware Road stations, Metropolitan and Bakerloo

P. M. G. CERTIFICATE

NEXT EXAM—MAY '51

PREPARE NOW by taking our special POSTAL COURSE. Many former students testify that our tuition was invaluable in ensuring their success in previous examinations.

A former Student writes:

"I have pleasure in being able to advise you that due to the excellence of your postal course, "Radio for the Amateur", I passed the City and Guilds Examination in this subject last May without any undue difficulty".

Full details of this and other courses in FREE BOOKLET from:—

E.M.I. INSTITUTES, Dept. 51

10, Pembridge Square, Notting Hill Gate,
London, W.2. Telephone: BAYswater 5131/2

L.T.O

Television for Beginners

AN OUTLINE OF THE SYSTEM

CARRIER MODULATION—TV CARRIER COMPOSITION—BAND WIDTH

PART V

By W. N. STEVENS (G3AKA) and L. E. HOWES (G3AYA)

HAVING discussed the general outline of the system, the cathode ray tube, how a raster is produced and how the tube is modulated, it now becomes necessary to examine the composite television waveform in order to appreciate the functioning of the various receiver stages.

The vision signal differs from what is normally associated with the transmission of sound and it is divided into two sections—the actual picture modulation and the sync pulses. The former is impressed from 30-100 per cent. of the carrier level (see Fig. 15), the lower limit representing Black and the upper limit White; between these limits the various gradations (greys, or halftones) are found. The sync pulses, inserted to obtain synchronisation of the receiver time bases with the transmitting sequence, are contained from 30 per cent. to zero carrier level and this region (being below the black line) is termed as being “blacker than black”—hence under viewing conditions the sync pulses do not appear as a visible trace on the CRT screen.

Fig. 15 shows the make-up of the waveform, and the reader should note the relative times allocated to the various component parts. It will be noticed that at the beginning and end of each line there is a period of black (known as the front and back pedestals). These are inserted in order to provide more positive synchronisation; for instance, without them should there be a peak white picture element at the end or beginning of a line it would be virtually impossible for the amplitude of the carrier to rise from zero to 100 per cent. instantaneously, with the result that due to the time required for this rapid rise the “white” would appear as grey. The back pedestal also allows time; for a fall from 100 per cent. to zero carrier amplitude could not occur quickly enough to provide the requisite rectangular pulse.

Fig. 16 depicts various stages in the television signal from transmitter to receiver. Example (a) shows an unmodulated RF carrier wave, as encountered in ordinary sound broadcasting in which the carrier amplitude “idles”

at a certain value and upon which the superimposed sound modulation varies the amplitude of the carrier equally above and below this value. In television, however, the RF carrier idles at 30 per cent. amplitude, coinciding with the black level; the picture modulation will produce an increase in carrier amplitude from the nominal 30 per cent. (black) level to the full 100 per cent. (peak white) and the sync pulses will reduce the carrier from 30 per cent. down to zero. Sketch (b) shows a hypothetical example of a modulated TV carrier wave.

Demodulation

Going a step farther, example (c) depicts the state of the signal after demodulation. It will be seen that the RF carrier wave has been “lost” and that only one side of the demodulated signal remains. It will also be noted that the DC component has been retained, i.e. the picture modulation is of a positive character whereas the sync pulses are negative with respect to the zero line (black). Therefore, the two main components of the signal (picture modulation and sync pulses) each have a DC form, which is the necessary condition, and the average level of the signal is passed on to the CRT and synchronising circuits.

Should, however, the signal (after demodulation) be subjected to an AC coupling (i.e. passed through a condenser) it will lose its DC characteristic and become in effect an AC waveform, floating about either side of a zero line midway between the area enclosing the picture modulation (see Fig. 16d). Should this condition arise, it will become necessary to restore the DC component and this is easily accomplished by the insertion of a DC restorer, either in the form of a small diode, or where the circuit is so arranged that the grid and cathode of the following stage bring about DC restoration.

Although the BBC system is described as being of 405-line definition, only 377 of these lines are used for picture modulation. The reason for this is that at the end of every odd and even frame 14 lines are suppressed in order to insert frame and line sync pulses; the

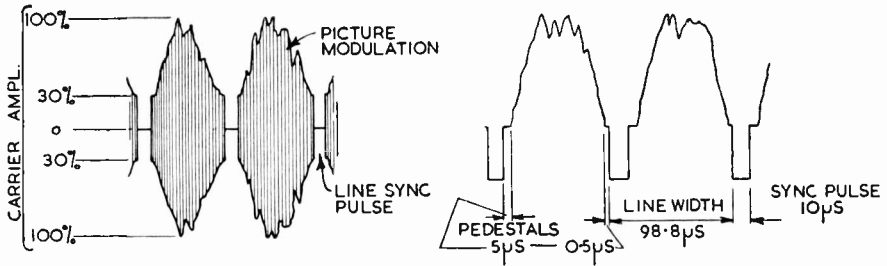

Fig. 15. Sketch showing TV carrier waveform as radiated. In the second sketch (having only one side-band for clarity) are given the various waveform components with respect to time.

procedure is shown in Fig. 17. At the end of the even frame the picture modulation stops at line 405 and is blacked out for a period of time equal to 14 lines. First, eight frame sync pulses are inserted (which take the space of four lines) and these are followed by ten blacked out lines separated by line sync pulses. At Line 15 the odd frame commences and this continues to Line 203½, where the frame sync pulses start another black-out period of 14 lines; and the process is repeated. It should be noted that the frame pulses are broader than the line pulses and are of 40 microsecond duration (as compared to the 10 microseconds of the line pulse). This difference in pulse duration is necessary in order to facilitate separation of the frame and line pulses for application to their respective time bases.

Composition of the TV Carrier

In ordinary sound broadcasting where an RF carrier wave is modulated by an audio signal the carrier ceases to have a single frequency; it will have a band of frequencies (or bandwidth) depending on the frequency of modulation. For example, if a carrier wave of 5,000 kc is modulated by a 1,000 c.p.s. (1 kc) audio signal, the bandwidth will extend from 5,000—1 kc to 5,000+1 kc, or in other words 4,999 to 5,001 kc. The bandwidth is, therefore, 2 kc. In actual practice audio signals of up to around 14,000 c.p.s. (or 14 kc) have to be accommodated which would demand a band-

width of some 28 kc. But owing to the restrictions in frequency space in the broadcasting spectrum the bandwidth of stations is held down to 9 kc (or 10 kc in the U.S.A.).

The TV vision signal, however, requires a bandwidth not in terms of cycles or even kilocycles but in the order of *megacycles*. The sync pulses contained in the television waveform are of a square-wave nature, thereby having a high harmonic content; these harmonics must also be accepted if a faithful reproduction of the square wave is required. These sync pulses and also the picture waveform are contained in the television signal and their combined bandwidth requirements must be met. In actual practice harmonics up to the tenth must be accepted in order to provide adequate resolution.

For calculation purposes the television picture is divided into "picture elements," each of which is equal to the thickness of one line. Since there are 377 "working" lines, a square picture would give us 377 × 377 elements. But the aspect ratio of BBC television is 4 : 3; that is, the width is in the ratio of 4 : 3 against the depth. Therefore the number of elements is 377 × 377 × 4/3 which equals 142,129 × 4/3 or 189,505. It can be seen, therefore, that the greatest number of elements into which the picture will resolve is obtained by calculating how many objects equivalent to the spot size can be fitted into one complete frame. (over)

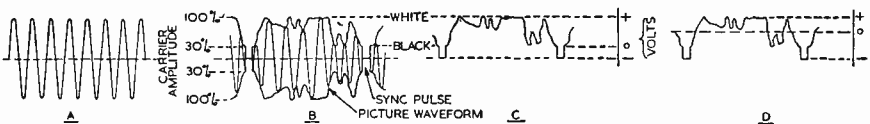

Fig. 16. Various stages in the vision signal as radiated. (A) The unmodulated carrier. (B) Carrier modulated by composite vision signal. (C) Vision signal after demodulation, showing DC characteristic and absence of original carrier. (D) Vision signal after it has been passed through an AC coupling, showing how the picture signal alternates round a mean potential.

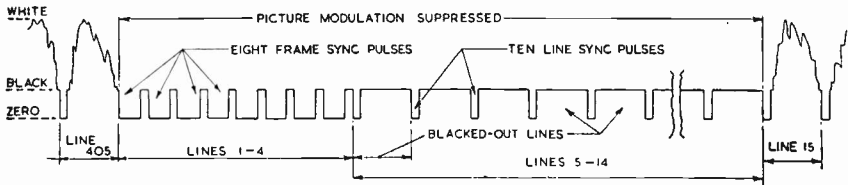

Fig. 17. Showing what happens at the end of an "even frame" when the vision modulation is suppressed for 14 lines in order to accommodate the frame and synchronising pulses. The same method is used at the end of the odd frames; these pulses will start after line 203½ and the picture modulation at line 216½.

Band-Width

Since there are 25 complete pictures each second, the number of picture elements per second is equal to $189,505 \times 25$, or 4,737,625. Without going into elaborate detail, it can be proved that one picture element is only equal to one half cycle and therefore the total number of cycles per second involved is equal to 4,737,625 divided by 2, or 2,368,812. To reduce this to workable figures, it means that the bandwidth of the modulation frequencies is plus and minus 2.4 mc, or 4.8 mc overall. This is the reason why the TV signal is radiated on VHF bands since it would be impossible to accommodate such a bandwidth on normal broadcasting channels.

The diagram of Fig. 18 shows the relative positions of the Alexandra Palace sound and vision carriers and their respective bandwidth requirements. Although the VHF's make possible the use of wide-sideband transmissions, as the number of stations increase there may come a time when even the VHF region will become congested. In order to reduce this, the BBC have adopted the use of single-sideband transmission (as in the case of

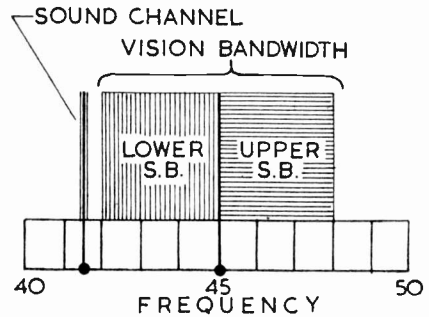

Fig. 18. The "relative positions" of the Alexandra Palace sound and vision channels and the width of their respective sidebands.

Sutton Coldfield and subsequent stations) for the vision channel. In this system one sideband is partially suppressed, usually the lower one.

(To be continued.)

DELIVERY FROM STOCK

No Waiting—By Return Post

NEW RADIOCRAFT "DX-2" RX

Superb new kit, price only 78/6. A.C. operated 2v, using EF50's and latest miniature Eddystone Coils.

NEW "GLOBE-KING" 0-V-0 RX

Acclaimed one of the finest single valve receivers yet! Ideal for beginner or miniature enthusiast. A precision kit, complete with valve, coils, etc., for only 49/6. 2½d. stamp brings illustrated catalogue.

JOHNSONS (RADIO) MACCLESFIELD

MORSE CODE Training



There are Candler Morse Code Courses for

BEGINNERS AND OPERATORS

Send for this Free "BOOK OF FACTS" It gives full details concerning all Courses.

THE CANDLER SYSTEM CO.

(Dept. S.L.) 121 Kingsway, London, W.C.2
Candler System Co., Denver, Colorado, U.S.A.

Read the Short Wave Listener regularly—it will keep you in touch

SHORT WAVE BROADCAST STATIONS

Revision 46-87-49-50 Metres

Giving Frequency, Wavelength, Callsign and Location

These lists appear each month, covering the 11-128 metre section of the wave band within which all the short wave broadcasting services of the world operate. For economy of space, this band is dealt with in five sections, a list of active stations in one of the sections being given in full every month. Such revision is necessary due to constant changes of frequency, callsign and operating schedules. All stations appearing in our lists are normally receivable in this country and are under regular observation.

Fre- quency	Wave- Length	Callsign	Location	Fre- quency	Wave- Length	Callsign	Location
6401	46-87	TGQA	Quezaltenango.	6154	48-75	CS2WD	Lisbon.
6390	46-95	HI9B	Santiago, D.R.	6152	48-76	CE615	Santiago, Chile.
6388	46-96	HC1SE	Quito, Ecuador.	6150	48-78	CKRO	Winnipeg.
6385	46-99		Managua, Nicaragua.			TIRH	San Jose, Costa Rica.
6374	47-07	CS2MA	Lisbon.			YSPD	San Salvador.
6360	47-17	CSX	Lisbon.			VLR2	Lyndhurst, Victoria.
6350	47-24	HRP1 OAX4H	San Pedro Sula. Lima,-Peru.			GRW	London.
6345	47-28	HEI2	Berne.	6145	48-82	HIDE	Cabimas, Venezuela.
6334	47-36	TGTA	Guatemala City.	6140	48-86	RW97	Medellin, Colombia.
6333	47-37	OAX6E	Arequipa, Peru.			DYH2	Moscow.
6325	47-43	TGNA	Guatemala City.			XEDP	Cebu, Philippine Is.
6322	47-45	COCW	Havana, Cuba.				Mexico City.
6321	47-46		Baden-Baden.			FBS	Belgrade.
6307	47-57	YNAS	Managua, Nicaragua.	6138	48-88	HOQQ	Malta.
6301	47-61	YSCP CP23	San Salvador. Tarija, Bolivia.	6135	48-90	CE613 HC2SB	Panama City. Punta Arenas, Chile.
6295	47-66	OTM1	Leopoldville.				Guayaquil, Ecuador.
6294	47-66	TGLA	Guatemala City.				Limasol, Cyprus.
6276	47-80	ZPA1	Asuncion.	6131	48-93	COCD	Havana, Cuba.
6275	47-81	YSR	San Salvador.	6130	48-94	LKJ	Tromso, Norway.
6270	47-84	HJWO	Bogoto, Colombia.			CHNX	Halifax, Nova Scotia.
6256	47-96	YSUA TGRA	San Salvador. Guatemala City.			VLX RW96	Perth, W. Australia. Moscow.
6247	48-03		Budapest, Hungary.	6125	48-98	GWA	London.
6235	48-12	HRD2	La Ceiba, Honduras.	6124	48-99	HRQ	San Pedro Sula.
6230	48-15	TGJA	Guatemala City.	6122	49-00	HP5H	Panama City.
			Venezia Julia.	6122	49-00		Omdurman, Sudan.
			Jammu, Kashmir	6120	49-02	OIX1	Helsingfors, Finland.
6223	48-21	CE622	Santiago, Chile.			LRX1	Buenos Aires.
6220	48-23	OAX4M	Miraflores, Peru.			XEUZ	Mexico City.
			Guatemala City	6115	49-06	HI1Z	Trujillo, D.R.
6215	48-25	SP13	Warsaw, Poland.	6110	49-10	GSL	London.
6213	48-29	HC1AC	Quito, Ecuador.				Tangier.
6204	48-35	YVQC	Bolivar.	6105	49-14	ZYN6	Fortaleza, Brazil.
			Bucharest.	6103	49-16	HJFB	Manizales, Columbia.
6200	48-39	ZYC7 HJCT HOB	Rio de Janeiro. Bogota, Colombia Panama City.	6100	49-18	HJFK TGOA	Pereira, Colombia. Guatemala City.
			Paris.			DYH3	Cebu, Philippine Is.
6195	48-43	GRN	London.	6095	49-22	YUA ZYB7	Belgrade, Yugoslavia. Sao Paulo, Brazil.
6190	48-47	VUD7	Delhi, India.	6090	49-26	TGLB GWM CKOB CBFW VLI2	Mazatenango. London. Sackville, Canada. Vercheres, Canada. Sydney, New S. Wales. Tabriz, Iran. Luxembourg. Moscow.
6188	48-48	TGX1	Guatemala City.	6087	49-28	LRV1	Buenos Aires.
6187	48-49	HIL	Trujillo, D.R.	6085	49-30	ZYK2	Pernambuco, Brazil.
6185	48-53	LLI HC1TR XECC	Oslo, Norway. Ibarra, Ecuador. Puebla, Mexico.				Rome, Italy.
6180	48-54	GRO TIBD	London. San Jose, C. Rica.	6082	49-32		Umtali, S. Rhodesia.
6177	48-56	XEXA	Athens, Greece.	6080	49-34	WLW01 CKFX HI1X	Cincinnati, Ohio. Vancouver, Canada. Trujillo, D.R.
6175	48-58	YSHQ	Mexico City.				Munich, Germany.
6170	48-62	YDB3 DUH2 HJKJ CXA21	San Salvador. Djakarta. Manila, P.I. Bogota, Colombia, Montedideo.	6077	49-36	HI1G	Vladivostok, USSR.
			Munich, Germany.	6075	49-38	APL1 CXA3	Trujillo, D.R. Lahore, Pakistan.
6168	48-64	HI9T	Puerto, Plata, D.R.				Montevideo, Uruguay.
6165	48-66	HER3 4VCM HJWD TILS	Berne. Port-au-Prince. Bogota, Colombia. San Jose, C. Rica.	6070	49-42	GRR CFRX HJEX RW138	Colombo, Ceylon. London. Toronto, Ontario. Cali, Colombia.
6160	48-70	CHAC CBRX	Saigon, Indochina. Sackville, Canada. Vancouver.	6067	49-44	EA9AH	Moscow.
			Munich, Germany.	6065	49-46	SBO	Tetuan, S. Morocco.
			Moscow.			LSR1	Stockholm, Sweden.
6156	48-73		Vienna, Austria.	6062	49-49		Buenos Aires.
6155	48-74	EQB CXA13	Teheran, Iran. Montevideo.	6060	49-50	HORT FIQA	Karachi, Pakistan. Balboa, Panama. Tananarive, Madagascar. Tangier.

Have you heard?

MONTH by month the DX bands seem to hit a new low. No one could claim that July or the early part of August were particularly exciting, although the redeeming feature was that the DX was still there, if one took the trouble to hunt for it. The CW men naturally fared better than the phone enthusiasts.

The SLP's at the end of July showed pretty well what can be expected on twenty-metre phone between 1700-1800 GMT, which was probably one of the best times of the day. Here is a little analysis of the DX heard by those who sent in lists for them. On the 28th it consisted of AR8, EA6, EK, FA, LU, MF2, OA, OQ, VO, VS1, 2 and 6, VU, ZD4 and 4X. The 29th was a little better and gave us AR8, CM, CN, DU, EA8, FA, FT4, KG6, OQ, OX, VO, VQ3 and 4, VS1, 2 and 7, ZD2 and 4, ZE and 4X.

None of it very thrilling, was it? But we should be round the corner by the end of August and maybe we shall have quite a good DX season when the short-skippers begin to quieten down.

There were one or two "plums" about for the CW men, notably FP8AC, KC6WC and 3A1A. Yes, the latter was all right, and was DL4ND operating from Monaco—with permission. It seems that in future any station hailing from Monaco will use the "3A" prefix and not the CZ affair which was so discredited by a pirate last year.

NEWS OF THE MONTH

J. L. Hall (Croydon) mentions the Monaco episode and also outlines two interesting new ones, of which we know nothing more, as yet. First, certain PY's are talking about an expedition to the Trinidad Islands—about 900 miles ENE of Rio de Janeiro, and not in any way connected with VP4. Also DL4VG is said to be going to Ifni (North West Africa) from which he hopes to operate for about two weeks.

J. L. Hall adds a footnote to F. N. Baskerville's comment, last month, on Banka (or Bangka) Island. He says that this island is near Sumatra, not Java, and that F. N. B. must

be confusing it with the town of Bangkalan, on the island of Madoera, which is only a few minutes from Soerabaya. J. L. H. has visited them both, and my atlas certainly confirms his statement.

R. S. Stott (Upminster), who still keeps his place at the head of the Four-Band Table by a very handsome margin, says he is looking forward to the excellent conditions which are bound to prevail on 3·5 and 7 mc this winter. On 7 mc, just recently, he has logged KP4, KZ5, W6, HC and ZL—all on CW—plus Cubans on phone. R. S. S. asks whether anyone has the gen on MD9AA. I have not heard this station, but understand that he was operating from Yemen, which would of course make another nice new one for everybody.

K. Parvin (Thornton Heath) sent in a claim last month for Zones Heard which would have put him third in the Phone Only section of the June Contest. But I am sorry to say it did not reach us till this feature had gone in to the printers. He has found 28 mc worse than at any time during the last 18 months. On 14 mc K. P. logged SUI1MR, sundry OA phones, and EQ3FM, FF8JC, HR2RF, YS1MS, ZP2AC and also KG6, LK7, ZD1, 2 and 4; he replies to the query about UAØFR's Zone by telling us that it is No. 19. Finally, he would like to know whether anyone has ever heard a PY9 on phone?

TEN-METRE ACTIVITY

Having broached the subject of ten metres in the last paragraph, I have run through the few Calls Heard lists for the band and unearthed the following prefixes which have been logged during July:—AR8, CE, CR4, CR7, CS3 (CT2), CX, EA8, FA, HC, KP4, KZ5, LU, MD2, MI3, OQ, PY, ST, TI, VP6, VQ2 and 4, ZD1, 2 and 4, ZE, ZS, ZS3 and 3V. Seeing that all these were on phone, and that the list didn't include the many short-skip Europeans coming in, it shows that 28 mc is well worth watching, even when in the doldrums.

For H. M. Graham (Harefield) it held very little attraction, and he describes July as a "14 mc month." He found most of the evening

AMATEUR BAND COMMENTARY by the DX Scribe



G3UZ, Enfield, Middlesex, was first licensed in 1938, and started with a 6L6 CO on 7 mc. The present rig is 6V6-6L6 807, used with a B2 receiver fitted with band spread. Aerial is a half-wave dipole for Forty.

DX was South American, but occasionally East Africa rolled in, and there were several VE8's. No Central Americans, which is unusual. H. M. G. was intrigued to hear ISIEHM calling XU8SB. Someone lists an XU in Calls Heard—can it be that there is an occasional Chinese station using that prefix again? (Of course the "C" for China was quite unofficial, all "C" stations being Canadian.)

P. H. Strudwick (London, N.W.11) found 28 mc improving towards the end of the month, his best loggings being CR4AC, CR7IV, HC1KX, KZ5GM, TI2SA and ZS3D—to say nothing of ten OQ5's. On 14 mc he heard CZ3AM, who strikes me as a pretty good bet for a phoney. On 7 mc P. H. S. logged HK3ZA and HP1LL, both on phone.

Another "14 mc only" report comes from R. G. Brooker (London, S.E.24), who found that on some days one could hear every kind of DX that one could wish for, and then on others there was nothing but short skip.

CONTESTS AND SUCHLIKE

R. W. Finch's suggestion (last month) about turning the SLP's into a form of contest has brought forth further ideas from G. Moses (Crewe). He says that five SWL friends have been "privately" doing this very thing with the SLP's all this year and feels that with so many keen DX-chasers as we have, you would soon find the performance ladder clogged, at the top, by about a dozen diehards with only a point or so between them. He would like to

see SLP listeners divided up on a *regional* basis, competing in terms for about nine months and then making entrants for the "finals" during the last three months. Out of all this there would undoubtedly emerge a "DX Champ" for the year, who would be well worthy of a medal.

There is a lot in this, but I feel that we are not out to find such a "DX Champ," so much as to give everyone a little competitive activity and lots of fun. The Four-Band Table, for instance, is not there for the glorification of the Top Three, but to show all the humbler scorers where they stand with relation to the more expert listeners and to each other.

G. M. suggests, too, that the position in the table should not be decided either by the number of countries or the number of "points," as at present, but by a Quality Factor possibly evolved by dividing Points by Countries. Thanks, G. M., for your various ideas, all of which will make me think for a bit.

G. Howell (Swaffham) asks for the best time of day to listen for Asia, PK's, VK's and the Pacific Islands. Well, at this time of year, the answer is "When you hear them!" But in a month or two the VK's should be there every morning; at present Asia is there most afternoons. The Pacific Islands are so widely dispersed that they come in at all sorts of different times. Those near Australia and New Zealand are only there in the mornings, but parts like Okinawa, Iwojima and the KG6

islands are usually best in the early afternoons.

MORE ABOUT TEN

F. Pilkington (Colwyn Bay) heard either KC4HZ or KG4HZ on the band, and wonders which it was. Personally, I should say KP was most probably the prefix. . . . D. G. Martin (Cheltenham) heard ZD2JHP and ZE2KA. . . . D. K. Cocking (Farnborough) found the accent strongly on PY, VQ4 and OQ5 plus a whisper from LU and, of course, lots of Europeans.

J. W. Cave (Parkstone) sends another of his interesting charts showing the relative strength of ten-metre signals from different parts of the world. During July, North America and Oceania show as blank spaces; Central America averages out at S4, Asia at S3 and Africa at S6, compared with S6, S6 and S7 respectively for the month of May. He says the band was certainly much worse than in July 1949.

The two most consistent for A. M. Norden (London, N.W.11) were ZD2JHP and VP6HM, although he also logged VP3, CP and HK. . . . L. Corder (Hadleigh) picked up 8 new ones on short skip, the best of which was SP5PZK. . . . J. P. Warren (Croydon) also made hay with the Europeans, and added CE3BZ.

All the other regular chasers content themselves with general remarks about the band, mostly to the effect that the occasional South American or African was the only thing alive! If the States start coming through by the end of August (as they have done in the last four years) we shall know that the band may be fairly good throughout the winter.

TOP BAND COMMENTS

From the bottom to the top—and the first item of news is that the *Short Wave Magazine* will be running a series of Transatlantic Tests in the peak period early next year. All the G stations will be fully briefed, and the North Americans will co-operate to the utmost. Listeners, naturally, will have their part to play, so—Watch This Space, as they say. Meanwhile, here are the dates: January 14 and 28; February 11 and 25; March 11. The times, 0500-0800 GMT.

We should have quite a record number of W's and VE's getting across this time, so start brushing up your Top Band Technique right away, so that you can enjoy the thrills to the full.

M. G. Whitaker (Halifax) has heard PAØGA on the band; so far as I know, the PA's are not allowed to use it—so where did he come from? F. A. Herridge (London, S.W.12) mentions PAØZQ—so maybe there has been a change over there. F. A. H. estimates that 31 countries have been reported on the band since the war. He also brings up

that old one about Monmouthshire! Yes—stations in that county using the "GW" prefix count as another country but also as another English county. Crazy, isn't it? Interesting locals logged by F. A. Herridge were G3EBG/A, working from a hospital bed with a B2 and ten feet of wire on the floor as an aerial; G2XG/A working from a fete at Chingford; G8SK/A working from a car, using the car aerial, and audible at 40 miles on phone; and G300/PM, working from a moving car, but QTH not known.

One or two portables have been operating, notably in Merioneth and on Islay, which should have given the keen-eared types some new counties. G. C. Allen (Thornton Heath) heard them both. R. Ibball (Worksop), using his 0-V-0, logged GI, DL, HB and sundry new counties.

BACK TO 14 MC

The remainder of the mail seems mostly concerned with 14 mc, so here is a summary. G. Moses pulled in HE1JJ, PX2AA and ZA1A for new ones. I haven't heard anything about that PX, but let's hope he is genuine. G. C. Allen heard HR1GM (with W6BYB on the key) for rather a rare one on the band; and also W1RPL/AB, 11,000 feet up over the Atlantic.

R. A. Hawley (Goostrey) collected his first new country for a very long time, in the guise of UJ8BW. Otherwise his best on Twenty have been EQ3FM, VS2CU and some VE8's. J. R. Paul (Lymington) asks whether EA9AI is the only active station in Spanish Morocco. Well, there are quite a few others, notably EA9BB, who also works on 7 mc. He, too, heard SU1MR, who seems to have been very active. I don't know whether the SU's are being licensed once again, or whether this chap is Under Cover.

D. G. Martin (Cheltenham) winkled out HC1FG, VP6SD and YN4CB, all on phone, and wonders how many kilowatts TA3GVU is using. (I think the answer is 600 watts). A. H. Edgar (Newcastle) says the only consistent thing has been the noise, but admits that there have been some remarkable spells around 1500-1700 GMT. He logged three new countries on CW—CR5AD, CR8AB and an HE, and is of the opinion that there are two BM7KA's—one a European phoney, and the other possibly genuine DX.

E. H. Williams (Poole) was very disappointed with the SLP's, and found that the rule of "no Europeans" practically ruled everything out. He has only been listening spasmodically of late, but has seldom found anything of interest.

EQ3FM gave O. A. Good (Oswestry) a new phone country on the band; another interesting logging was XZ2KN on phone at 2255-2305 GMT. ZP3CM and ZP5CM were

FOUR-BAND DX

(STARTING JANUARY 1, 1950)

Listener	28 mc	14 mc	7 mc	3-5 mc	Total Countries	Total Score ★
	(1)	(2)	(3)	(4)	(5)	
R. S. Stott (Upminster)	129	176	89	42	183	436
J. C. Beal (N. Wembley)	115	161	76	29	168	381
D. W. Waddell (Hitchin)	110	149	72	22	165	353
W. J. C. Pinnell (Sidcup)	111	150	61	22	157	344
N. S. Beckett (Lowestoft)	73	141	75	29	144	318
P. H. Strudwick (London, N.W.11) ..	124	135	26	25	157 (P)	310
D. W. Bruce (Eltham)	116	130	38	22	144	306
L. Singletary (Bicester)	95	123	50	21	142	289
E. J. Logan (Hertford)	125	106	32	20	137 (P)	283
R. A. Hawley (Goostrey)	96	126	42	17	141	281
D. S. Kendall (Potters Bar)	114	113	25	27	135 (P)	279
A. Bannister (Manchester)	101	125	30	21	136 (P)	277
A. M. Norden (London, N.W.11) ..	114	103	23	23	127 (P)	263
M. G. Whitaker (Hallifax)	97	96	33	21	129	247
L. Tombs (Swindon)	92	107	24	15	129 (P)	238
L. Corder (Hadleigh)	89	110	18	15	125 (P)	232
T. Spencer (Slimbridge)	88	107	20	16	126 (P)	231
J. P. Warren (W. Croydon)	89	110	12	14	125 (P)	225
J. M. Graham (Glasgow)	85	74	32	25	112 (P)	216
E. J. Parish (Watford)	86	96	16	17	122 (P)	215
K. M. Parry (Sandwich)	93	101	4	8	127 (P)	206
H. M. Graham (Harefield)	67	98	24	16	116 (P)	205
D. E. Tomkinson (Brighton)	60	93	19	20	112	192
E. Trebilcock (Australia)	5	118	58	3	124	184
K. Smeeton (Barnton)	39	92	35	12	106	178
R. A. Fowler (Marlow)	59	73	28	16	106	176
F. Pilkington (Colwyn Bay)	35	98	24	14	104	171
D. G. Martin (Cheltenham)	59	63	21	12	93 (P)	155
E. A. Parkinson (Leeds)	62	68	14	10	91 (P)	154
F. A. Herridge (London, S.W.12) ..	33	59	38	15	76 (CW)	145
G. Murray (Newcastle)	53	60	15	16	83 (P)	144
J. Cartwright (Letchworth)	47	67	11	16	88 (P)	141
A. L. Higgins (Aberkenfig)	33	70	16	17	88 (P)	136
G. Musk (Blackpool)	18	82	15	14	86 (P)	129
D. K. Cocking (Farnborough)	38	63	16	6	85 (P)	123
A. R. Holland (Malvern)	29	74	10	6	86 (P)	119
F. M. Spence (South Shields)	2	86	17	13	88	118
T. Ward (Ilminster)	20	72	11	10	83 (P)	113
A. O. Frearson (Birmingham)	35	48	15	8	69	106
R. Lambie (Bosham)	22	41	9	13	68	85
O. R. F. Mason (Prittlewell)	7	33	14	14	40 (P)	68
D. E. Hayes (Hoddesdon)	25	13	3	4	28 (P)	45

★ Sum of figures in Cols. 1, 2, 3 and 4.



The station of EI4X, Clontarf, Dublin, a keen CW man on the 10-, 20- and 40-metre bands, with phone operation on Forty thrown in. The Tx is VFO-TU5B-807-813, run at 100/150 watts, the Rx an S.40 and the aerial a 67-ft. Zepp.

both heard (also on phone) and PJ5TR on CW.

W. J. C. Pinnell (Sidcup) decided to stick to 14 mc CW and used the 0-V-1 for it. He was rewarded with FP8AC and also found DU1NL, FY7YB, KG4AK, MP4BAE, VS6AC and ZS3X—all nice going for a 0-V-1. But what about ER3Z? Can anyone tell us more about that one?

DX QTH's

AR8PP	Box 49, Beirut, Lebanon.
CR5AD	Box 206, Bissao, Portuguese Guinea.
OQ5CH	Dr. P. Defrenne, Box 1680, Elizabethville, Belgian Congo.
TF5TP	Thorhallur Palsson, Hafnarstraeti 39, Akureyri, Iceland.
TI2KW	Melvin Mora, Box 1634, San Jose, Costa Rica.
TI2QV	Edgard Bolanos, 8 St., 16 and 18 Ave., San Jose, C.R.
VE8MJ	J. Anderson, c/o Eastern Arctic Patrol, Ottawa.
VP8AD	Reuben McLaren, Radio ZBH, South Georgia Island.
VR2BG	Cpl. D. C. Rummins, R.N.Z.A.F., Suva, Fiji Is.
VS1BJ	Royal Signals Amateur Radio Club, Tyersall Camp, Tyersall Avenue, Singapore.
VS1DE	Maj. A. Eden (G3HAE), R.E. Officers' Mess, Gillman Barracks, Singapore.
VU7AH	K. V. C. Rajan, Box 10, Tumkur, India.

On one or two days towards the end of the month, T. G. Spencer (Slimbridge) found W's and VE's coming in practically all day; he heard HI6EC saying that he would be away for a while. E. Casley (Great Yarmouth) made hay of the band and emerged with FF8BH, HP1MM, KG4AK, VP5AL and 5AP, VP3FM, VU2JP, XZ2KN and YS1MS among the choice pieces.

R. W. Finch (Ilford) mentions as "unusual specimens" FM7WF at 2140, and PJ5RE at 0844—both CW. R. W. F., having put up a "scheme" last month, now comes out with another one. He thinks the SLP's should not be confined to one band, but should be run simultaneously on two bands, with one group of listeners tackling one and the others t'other. This would give us some information on whether (for instance) 14 mc is always good for South Africa if so-and-so is coming in on 28 mc (or 7 mc). They could be called "SMP's" (Synchronised Monitoring Periods).

C. S. Pollington (Chichester) says his best DX was KG6GD, KH6BA and Y12BJ, the most consistent countries being VS1 and 2 and YN4CB. D. Pool (London, S.E.23), as well as the previous correspondent, points out that Y12BJ is strictly under cover and hopes to spend August in Persia with the call EP3L. His palm for consistency goes to VP6SD.

DOUBLE CENTURY ON PHONE

Congratulations to E. J. Logan (Hertford) on being the first to reach the 200 mark on phone! New ones that made this possible were CR5AC (Portuguese Guinea) and FP8AC. On the 14 mc band, he says, there has always been plenty of DX, although the band has been full of people bawling its absence!

D. L. McLean (Yeovil) mentions CS3AA again, CT3AK, DL4WK/Airborne, HE1JJ, H16EC, VP3HAG and VQ3BVF—all phone. A. W. G. Boulton (Norwich) has raised his score by no fewer than six—mostly on 14 mc CW, although he also threw in SV5UN on 28 mc phone. B. W. Sutton (Liverpool) logged CR5AD and CR8AG—both 14 mc phone. L. Corder (Hadleigh) found new ones with HE1JJ, Y12BJ and XZ2KN.

A. M. Norden thought things "rather feeble" but did manage to collect some TF's, M1B, OA4BM, HC1FG, HK1WE and VS9AH. He also heard an MX station saying he was in Mukden, Manchuria, but it makes him wonder!

CHALLENGE

The same A. M. Norden wants to know if anyone can claim a more distant phone station on 7 mc than CX4EG (roughly 7000 miles). Well, can they? There is a remarkable scarcity of 7 mc news this month, considering that there's plenty of DX there for the late-stoppers and early-risers.

M. G. Whitaker says "Why can't Saarbrücken (EZ) be counted as a separate country?" Well, it's like this. . . . There is an international conspiracy among short-wave amateurs and listeners. All those who haven't heard an EZ have signed a monster petition protesting against its being counted separately. . . (Excuse me!)

J. P. Warren says "Other readers may not realise that EA8JM and 8AO are in Rio de Oro." Well, here's one that didn't. Further gen, please? J. P. W. also says that CR8AJ (Goa) is on phone in the 21 mc band, and also on 28950, using 45 watts between 1800 and 2000.

M. Shortland (Sunderland) was one of the lucky ones who unearthed KC6WC on CW—about 14100 underneath several layers of Europeans. Other good ones were LZ1Z, ZS3K, ZS3Z, UL7AB and VU2LJ—all on CW, also ZA1A on phone.

B. W. Sutton tells us that W3BXE is planning to operate as FP8AB during the first or second week in September, also that a member of the Guayaquil Radio Club has now settled on the Galapagos Islands and has requested a licence. Furthermore, there is good news from Cocos Island (T19)—another expedition will be searching for the fabulous

treasure, and the operator will be T12ES, who will operate 7 mc CW and phone—and possibly play with 14 mc as well.

STILL THERE ON EIGHTY!

The Grand Old Man of Eighty—VK5KO—is still operating there. J. L. Hall heard him working two LA stations recently. He seems to be on every Friday night at 2200 GMT. Also active on Eighty, and reported by one or two chasers, is PY2AJ, who has been heard by J. L. Hall and also N. S. Beckett (Lowestoft). The latter also reports HC2IH for a new one on 7 mc, and Y12AT on CW, up among the G phones on 7160 at 1030!

W. Kyle (South Gosforth) asks what a suffix means in a call like SM5WN/1. I presume he, although an SM5, was operating from the Swedish 1st district.

F. M. Spence (South Shields) asks whether there are any Mexicans on 14 mc phone. I



SWL W. G. Johnson, Thornton Heath, Surrey, has a neat outfit, of which the central piece is the CR-100, tuning 10-5000 metres. W. G. J. has this receiver on a turntable, so mounted for the convenience of armchair operation.

"ZONES HEARD" LISTING (POST-WAR)

Listener	Zones	Countries	Listener	Zones	Countries
PHONE and CW			PHONE ONLY		
M. E. Bazley (Kidderminster) ..	40	229	M. G. Whitaker (Halifax) ..	38	149
A. H. Edgar (Newcastle) ..	40	218	D. Vincent (Beckenham) ..	38	140
E. Trebilcock (Australia) ..	40	214	D. L. McLean (Yeovil) ..	37	176
D. W. Bruce (Eltham) ..	40	213	O. A. Good (Oswestry) ..	37	173
O. A. Good (Oswestry) ..	40	212	P. H. Strudwick (London, N.W.11) ..	37	157
R. S. Stott (Upminster) ..	40	211	J. M. Graham (Glasgow) ..	37	154
R. A. Hawley (Goostrey) ..	40	197	J. C. Beal (N. Wembley) ..	37	151
W. J. C. Pinnell (Sidcup) ..	40	192	G. Moses (Crewe) ..	37	149
D. W. Waddell (Hitchin) ..	40	191	J. P. Warren (W. Croydon) ..	37	148
J. C. Beal (N. Wembley) ..	40	183	A. M. Norden (London, N.W.11) ..	37	148
A. W. G. Boulton (Norwich) ..	40	178	K. M. Parry (Sandwich) ..	37	142
M. Shortland (Sunderland) ..	40	172	R. J. Line (Birmingham) ..	37	139
B. Davies (Beckenham) ..	40	166	E. J. Parsh (Watford) ..	36	163
R. A. Fowler (Marlow) ..	40	162	D. G. Martin (Cheltenham) ..	36	149
N. S. Beckett (Lowestoft) ..	39	177	C. S. Pollington (Chichester) ..	36	147
L. Singletary (Bicester) ..	38	177	R. A. Fowler (Marlow) ..	36	141
R. G. Goulding (Wrexham) ..	38	147	T. E. Botham (Walsall) ..	36	136
F. A. Herridge (London, S.W.12) ..	37	156	B. W. Sutton (Liverpool) ..	36	127
K. Smeeton (Barnton) ..	36	156	D. J. Williams (Pontyberem) ..	36	116
G. H. Coulter (Dover) ..	36	138	H. M. Graham (Harefield) ..	35	142
C. J. Goddard (Coventry) ..	35	123	A. L. Higgins (Aberkenfig) ..	35	136
PHONE ONLY			H. F. Webster (Darlington) ..	35	129
E. J. Logan (Hertford) ..	40	200	L. B. Bailey (Stockton) ..	35	124
D. W. Bruce (Eltham) ..	39	187	P. Bysh (London, N.8) ..	34	129
K. Parvin (Thornton Heath) ..	39	165	A. R. Holland (Malvern) ..	34	122
R. G. Poppi (Beckenham) ..	39	163	C. J. Goddard (Coventry) ..	34	112
R. A. Hawley (Goostrey) ..	38	184	A. O. Frearson (Birmingham) ..	34	110
A. Bannister (Manchester) ..	38	174	D. K. Cocking (Farnborough) ..	34	107
D. S. Kendall (Potters Bar) ..	38	170	W. C. Askew (Melton Mowbray) ..	33	122
L. Tombs (Swindon) ..	38	155	D. C. Stace (New Zealand) ..	33	116
			G. Musk (Blackpool) ..	33	114
			B. L. Stedman (Hawkhurst) ..	33	103
			O. R. F. Mason (Prittlewell) ..	32	82
			G. Murray (Newcastle) ..	31	103

seem to have noticed one or two in the Calls Heard lists this very month, but no one would pretend that they were common.

NO QTH SERVICE!

R. Iball (Workshop) asks whether we run a service whereby we can inform listeners, on receipt of a stamped addressed envelope, of any QTH which they require. We do not; but a service of this kind is supplied through the British Short Wave League, if you are a BSWL member.

I now seem to have the bulk of information in stock on the subject of listeners' receivers and aerial systems. You will probably remember that I first asked for this a couple of months back. Furthermore, I asked for one paragraph on each—in return for which I have had five-page letters on the subject of patent aerial systems, modified receivers, and all manner of strange phenomena.

I am at present sifting them out, and hope

to present the summary in a short article next month. But don't expect anything phenomenal in the way of secret information, because some of the highest scorers have very ordinary receivers and aerial systems. Conversely, some of the owners of all sorts of exotic devices have extremely humble scores. It's the chap inside the headphones (or in front of the speaker) that matters, and we can't get you full specifications of *him*. Wouldn't it be funny, though, if there were some connection between DX heard and (a) Colour of eyes, (b) Height and (c) Number of teeth?

SET LISTENING PERIODS

August 26, 1800-1900 GMT—28 mc Phone and CW.

August 27, 1100-1200 GMT—1.7 mc Phone and CW.

September 30, 2230-2330 GMT, 7 mc CW.

October 1, 0800-0900 GMT—14 mc Phone.

Let us hope that the 28 mc band will be doing things by August 26 ! It was a long shot, but it *might* come off. And for goodness' sake let us get a better band of CW listeners together, if only for the long-wave DX this winter. The real DX on the Top Band, 3.5 and 7 mc will *not be on phone* : you have three or four months to polish your speeds up, and plenty of stations to practise on right now.

When we start the monthly competitions

"PSE QSL"

This has been an established feature of *Short Wave Listener and Television Review* for the last three years, and by now we have listed probably not less than 2,500 different amateur stations, throughout the world, requiring SWL reports on their transmissions. In the nature of things, these amateurs will receive, by reason of the publicity, a very large number of reports ; in fact, we have been told by many how surprised they are at the number they do receive. Though we have also had high praise for the standard of G-SWL reporting generally, a fair proportion of reports is invariably classified as "useless." The net result of all these factors working together is that the careful SWL, making full use of "Pse QSL" and sending really useful reports, should get a return of about 80 per cent.—a higher ratio is too much to expect. But this figure is very much better than the bare 30 per cent. to be expected by those who QSL indiscriminately. The moral is to use "Pse QSL" with due regard to all the factors—and always mention *Short Wave Listener and Television Review*, not necessarily to advertise us, but because every operator appearing in "Pse QSL" is notified of publication to remind him of his obligations to SWL's who report to him. We do our part in making the tie-up complete—what you have to do is to put in reports that *are* reports, and not merely requests for his QSL !

MARCONI Canadian No. 9 Mk.1 8-valve Communications Receiver, Frequency 1.6 to 5 megs. Selectivity Control. Speaker Output, Xtal Frequency, Check 10, 100 and 1,000 kc/s with Meter. Less Power Pack, £5, each. Carriage extra. Size 14" x 14" x 10".

HALLICRAFTER S27C Communications Receivers, £25, Carriage paid.

FIELD'S

435-7 Stratford Road, Birmingham, 11
MID 3619

again—probably next month—we propose to make them of particular interest to CW enthusiasts. So Get Cracking.

Last date for the October issue is **first post on September 4**. Address all your outpourings, as usual, to DX Scribe, *Short Wave Listener and Television Review*, 53 Victoria Street, London, S.W.1. Keep your Calls Heard down in numbers but up in quality ! Until then, best of listening, 73, and BCNU.

GIFT SUBSCRIPTIONS

You may have a correspondent or a friend overseas to whom you would like to make a useful present which will be a lasting reminder of your thoughtfulness. If he is an SWL, why not buy him a year's subscription to *Short Wave Listener and Television Review*, still the only regular and established SWL periodical in the world devoted exclusively to the needs and interests of the listener. The cost is 16s. post free. And if your contact is a licensed amateur, he would be sure to appreciate our *Short Wave Magazine*, now one of the world's leading Amateur Radio publications. That would cost you 20s. for a year of twelve issues. Write The Circulation Manager, Short Wave Magazine, Ltd., 53 Victoria Street, London, S.W.1.

OPPORTUNITIES IN RADIO



Get this FREE Book!

"ENGINEERING OPPORTUNITIES" reveals how you can become technically qualified at home for a highly paid key appointment in the vast Radio and Television industry. In 176 pages of intensely interesting matter it includes full details of our up-to-the-minute home-study courses in all branches of RADIO AND TELEVISION, A.M. Brit.-I.R.E., City and Guilds, Special Television, Servicing, Sound-film Projection, Short Wave, High Frequency and General Wireless courses.

We definitely guarantee
"NO PASS-NO FEE"

If you're earning less than £10 a week this enlightening book is for you. Write for your copy to-day. It will be sent FREE and without obligation.

BRITISH INSTITUTE OF ENGINEERING TECHNOLOGY

926 Shakespeare House,
17-19 Stratford Place,
London, W.1

BIET

CALLS HEARD

SET LISTENING PERIODS

14 mc

July 28, 1700-1800 GMT

H. F. Webster, Blackwell, Darlington.

VE3BBL (Portable Labrador), VU2CJ, VS2BS, ZD4AD, 4X4DE. (Rx: AR88D.)

G. Moses, 65 Railton Avenue, Crewe, Cheshire.

EA6AT, EK1JC, FA3PN, 8DQ, OA4H, VS2BF, ZD4AB. (Rx: S.750.)

W. E. Bachell, 24 Hill Road, Prittlewell, Essex.

AR8BS, LU4DD, OQ5CF, VS1AX, VS2BS, ZD4AD. (Rx: Ham-bander.)

P. H. Strudwick, 159 Hampstead Way, London, N.W.11.

MF2AA, OQ5CF, VS1AX, 2BS, 6BI, ZD4AD, 4X4AT, 4EC. (Rx: Modified S.640.)

14 mc

July 29, 1700-1800 GMT

K. Everest, 44 Salcombe Drive, Chadwell Heath.

DUIAL, VQ4AA, VS1AX, 2CJ, 4X4AG, 4AK, 4BD, 4DV.

G. Moses, 65 Railton Avenue, Crewe, Cheshire.

CM3CF, VQ3BVF, VS1AX, 2AZ, 7BR. (Rx: S.750.)

H. F. Webster, Blackwell, Darlington.

VO6A, VQ3BVF, VQ4SC, VS1AX, VS2BS, 2CJ, VS7BR, 4X4BD. (Rx: AR88D.)

N. S. Beckett, 194 Waveney Drive, Lowestoft.

AR8BS, CN8EH, EA8AS, FA1ZF, FT4BT, OQ5BZ, VQ3BVF, VS7VR, ZE3JT. (Rx: Ham-bander.)

Please note the following simple rules for sending in lists of Calls Heard

28 and 14 mc: No Europeans.

No USA except W6 & W7

No VE except VE5, 6, 7 & 8.

7 mc: No Europeans.

Arrange logs in the form given here, with (a) prefixes in alphabetical order, but not repeated; (b) numbers in numerical order and repeated as part of the call-sign; (c) call signs in alphabetical order. For example:—
VK2GW, 3CP, 4UL, VP1AA, 6CDY, VQ3HJP, 4EJT, W6ENV, 7VY. Please underline each prefix, keep each list to one band, and, in short, make your lists exactly like those below, except that the more space you leave, the better.

K. Parvin, 98 Winterbourne Road, Thornton Heath, Surrey.

CN8EH, EA8AY, 8HS, FA8JO, 9RZ, OQ5CF, VQ3BVF, VS1AD, 1AX, 2BS, 7BR, ZD2JHP, 4AD, 4X4AT. (Rx: S.640.)

S. Smith, 40 Stoneleigh Road, Kenilworth, Warks.

OX3MC, VS2SA, 4X4BD. (Rx: R.1084.)

F. W. Hardstone, 43 Shrubbery Road, Streatham, London, S.W.16.

AR8BS, CN8EH, DUIAL, EA8HS, VQ3BVF, VS1AX, 2BS, ZD2HP. (Rx: R.F.24 into S.40A.)

P. H. Strudwick, 159 Hampstead Way, London, N.W.11.

CN8EH, EA8HS, KG6OR, OQ5DZ, VQ3BS, VS1AX, 2BS, 7BR, W2KR/Mobile, ZD2JHP, ZE3JD, 4X4ES. (Rx: Modified S.640.)

R. A. Hawley, Torview, Brookfield Crescent, Goostrey, Cheshire.

4X4BC, 4DE, EA8AX, SV0WM, VQ4AQ, W7DL, 9HEI. (Rx: AR-88 and S.504.)

W. J. C. Pinnell, 40 Melville Road, Sidcup, Kent.

CN8EH, EA8HS, FA3ZF, 8JO, 9RZ, FT4BC, OQ5DZ, VS1AX, 2BS, 7BR, ZD2JHP, 4X4AG. (Rx: V55R and converter.)

E. A. Parkinson, 8 Hawthorn Drive, Rodley, Leeds.

CN8EH, OQ5BZ, VS1AX, 2BS, 7BR, ZD2JHP. (Rx: S.504.)

W. E. Bachell, 24 Hill Road, Prittlewell, Essex.

EA8HS, FA3ZF, 8JO, 9RZ, OQ5CF, VQ3BVF, VS1AD, 2BS, 2CD, 7BR, ZD2JHP, 4X4AT, 4ES. (Rx: Ham-bander.)

GENERAL

7 mc

W. Kyle, 9 Dene Terrace, South Gosforth, Newcastle-upon-Tyne, 3.

CW: CE3AU, FA9KD, KV4AU, 4SA, PY1AX, UB5AF, VE3BON, W5KFC. (Rx: Mod. W.S.18 into BC-453.)

R. F. Pilkington, Colwyn Bay, N. Wales.

CW: W1AJ, 1GWC, 1SPR, 1WL, 2SJB, 3RAQ, 4RG. (Rx: 11164.)

3.5 mc

J. W. Cave, 12 Hilda Road, Parkstone, Dorset.

DLIKF, GC5OU, GD6IA, PA0HLZ, PY2AIL, 2DBX, W1AW, 1IXO, 4CQW, 4DCQ, 4EOZ, 4QF, 8EPN, VE1RA. (Rx: Home-bull 1-V-0.)

1.7 mc

F. A. Herridge, 95 Ramsden Road, Balham, London, S.W.12.

PHONE: GW3CDH, 3CDP, 8BW.

CW: G13GQA, GW3EFZ, PA0ZQ. (Rx: Modified R.103A.)

R. Iball, 48 School Road, Langold, Worksop, Notts.

CW: G2BQC, 3AFL, 3AKU, 3ALE/A, 3BC, 3DKO, 3FEW, 3FQH, 3FSX, 3FKK, 3GIO, 3GRF, 3GSS, 3HDW, 5RX/A, 5RS, G13GQA, GM2DRD, 5YW, 8FM, GW3EFZ, 3FWY, 8CT, DL2DV, HB9CM.

PHONE: G2ACV, 3WQ, GM2BUD, 3DZB, GW2BG. (Rx: 0-V-0.)

T. G. Spencer, Cherry Tree Cottage, Slimbridge, Glos.

G2AYN, 2PX, 3ADM, 3APY, 3CTY, 3ESY, 3FOP, 3JA, 4GA, 5MM, 5XM, 6PY, 6QB, 8UT, GW2AXT, 2BG, 2BUF, 2CUT, 3CDH, 5BI, 8BW. (31st July, 1950). (Rx: Commander.)

R. Lambie, Chequers, Chequers Lane, Bosham, Sussex.

PHONE: G2ABA, 2JG, 2XG/A, 3AGP/A, 3BGU, 3BVA, 3CTH, 3EAD, 3ECW, 3EIO, 3FEW, 3FEX, 3FRV, 3GDO, 4GA, 4IH, 6UT, 8LN, GC3FXQ, 4LI. (Rx: SX17 R103, Mk. 1.)

R. A. Savill, 23 Bosville Drive, Sevenoaks, Kent.

PHONE: G6PF, GW2AXT, 2BG, 2BUF.

CW: G2HW, 3FAB, 3FEW, 3FSX, 3GGN, 3NT, 6OX, GW3AZQ. (Rx: 1-V-1.)

28 mc

G. Moses, 65 Ralton Avenue, Crewe, Cheshire.

PHONE: AR8AB, SPO, LU4DD VPH6M, VQ2HW, 4ERR, ZS2AW 6OA, 4X4RE. (Rx: S.750 and S.640.)

J. W. Cave, 12 Hilda Road, Parkstone, Dorset.

PHONE: CE2CC, CX4CS, LU1BC, MD2GC, OQ5AB, PY2ATG, VQ4ERR, W3KIF/MM, ZD4AF, ZE3JD, ZS6CH, 6CY. (Rx: 0-V-1.)

P. H. Strudwick, 159 Hampstead Way, London, N.W.11.

PHONE: AR8AB, CE2CC, 3CE, 3CZ, CR4AC, 7IV, CX4CS, 5AT, 7WA, HC1KX, KP4LH, KZ5GM, TI2SA, VP6HM, 6RG, VQ2JO, W3D1Z/MM, 3NKS/MM, 4KEJ/MM, ZD2JHP, 4AD, ZE1JO, 2KH, ZS3D. (Rx: Modified S.640.)

D. L. McLean, 9 Cedar Grove, Yeovil, Somerset.

PHONE: AR8AB, SPO, CE3BE, 3AG, 3CZ, 3LZ, CR4AC, CX1CG, 4CS, 4CV, HC1KX, 2JR, ST2KR, VPH6M, 6RJ, VQ4ASC, 4CRO, 4ERR, 4SGC, ZD2JHP, 4AH, ZE2KH, ZS6Z. (Rx: SX28 and AR88LF.)

E. J. Logan, Linten Cottage, Fanshawe Street, Bengeo, Hertford.

PHONE: AR8AB, CS3AA, CR7IV, CX4CS, EA8AM, FA3JY, LU3BAC, 3BQ, 4AL, 4DJJ, MI3KW, OQ5AO, PY4RB, 7FC, 7RD, VQ4ERR, 4SGC, ZD1SW, 2JHP, 4AH, ZE3JD, 3V8BB. (Rx: BC 342-J/RFU32.)

D. K. Cocking, Old Meadow, Farnborough Park, Kent.

PHONE: YQ4ASC, 4ERR, 4SC, OQ5EB. (Rx: S.640.)

14 mc

H. M. Graham, 28 Park Lane, Harefield, Middx.

PHONE: CE3AE, CO2IB, CX2CL, CZ5U, EA9AI, EQ3FM, FA3ZF, HC1JW, IRK, HK1IE, KP4ES, MD2AF, MI3KV, SU1MR, TF5TP, VE8NF (Cambridge Bay), VQ3BVF, W2DD/KP4, YK1AC, YV5CM, ZC6JM, 3V8BB, 4X4BL. (Rx: 1-V-1.)

H. Froggatt, 28 Lea Street, New Mills, Stockport, Cheshire.

PHONE: CX2CO, PY2CK, LU1ABB, YV5AB, ZD1AR.

CW: EA8LP, FF8JC, LU6DJ, 8EN, 9BO, PY1HW, 2WB, 2CK, 7LI, PU1UF, VQ3BNU, VU2BC. (Rx: R1155A and S358X.)

S. Smith, 40 Stoneleigh Road, Kenilworth, Warks.

CN8EB, EA8AP, FA3DS, 3GZ, 3JY, 9ML, MI3AB, PY1AT, 2CK, 3ALP, 7XC, TA3GVU, VP6SD, VQ3BUS, YO3GH, 3RJ, ZA1A, 4X4AU, 4AD, 4BD. (Rx: R1084.)

D. C. Stace, Spring Creek, New Zealand.

PHONE: EA7BA, OE13EG, PK6FM, VE8MB, 8AW, W5MPG, 7IWW, 7UPR, 9QEL, KG6CX/KX6.

G. Moses, 65 Ralton Avenue, Crewe, Cheshire.

PHONE: CE3CU, CP4DG, EA9AI, HC1KV, HE1JJ, HK4DF, MI3LV, OA1A, PJ5RX, PX2AA, PZ1PZ, TI2GR, 2KW, 2SA, 2TG, VK5MS, VP3MCB, 3TY, 5AA, 5AL, VQ3BVF, VS7NG, ZA1A, ZD1SS. (Rx: S.750 and S.640.)

F. M. Spence, 69 Morton Street, South Shields.

PHONE: CE6BU, CN8EH, CO8MP, FA9WU, HI6EC, HP1EA, KP4ES, LU8FS, MD2MD, MIB, OX3BD, PY7DE, TE5TP, VK3AUP, VP4LS, 6SD, 9NN, VQ4RF, VS1AA, 7BR, YK1AC, YV5AB. (Rx: R.1155.)

K. Parvin, 98 Winterbourne Road, Thornton Heath, Surrey.

PHONE: CR6AI, 6AV, EQ3FM, FF8JC, HR2RF, KG6USA, KL7ADN, PZ1PZ, 1QM, SU1MR, VP4LS, VQ3BVF, VS1AD, 1AX, 2BS, 7BR, 7SV, ZD1SS, 1SW, 2JHP, 4AB, 3AC, 4AD, ZP2AC. (Rx: S.640.)

J. R. Paul, Nethercourt, Sway Road, Lymington, Hants.

PHONE: CO2IC, CX2CO, EA9AI, HC2OT, HI6VP, HK3CO, HP1CM, KH6ACQ, KL7ADN,

OQ5BZ, PZ1QM, SU1MR, TI2OE, VK3LD, VP7NU, 9NN, VS1AX, 7BR, 9AH, VU2LJ, XE2KW, XZ2KN, YN4CB, YS1MS, ZS6Q. (Rx: S.640.)

A. H. Edgar, 15 Dene Terrace, South Gosforth, Newcastle-on-Tyne, 3.

CW: AP2N, CR5AD, 8AB, FM8AD, HS1AS, HZ1AB, JA2CU, KC6WR, KG6BI, 6GU, 6USA, KR6CG, MP4BAE, PK1TM, 4KS, UJ8KAB, VS1DB, 6AC, 7PS, Y13DYN, 3ECU, ZM6BF. (Rx: S.640.)

D. Pool, 8a Ebsworth Street, Forest Hill, London, S.E.23.

PHONE: AR8AB, CO2IB, CX2CO, EK1AQ, FNSBKF, HC1FD, HE1MJ, KP4HF, MI3OB, OX3MC, SU1MR, TF5TP, TI2OE, VK5RN, VP6SD, VQ3BVF, 4AA, VS2CU, YI2BJ, YU1AB, ZB1AR, ZD4AD. (Rx: Sky Champion.)

R. G. Poppi, 274 Kent House Road, Beckenham, Kent.

AP2N, CP1JK, EQ3FM, KG6GD, KH6GS, 6DX, VS1AD, 2AR, 2BS, 7BD, 7BR, 9AH, VU2LJ, 2SC, YI2BJ. (Rx: Battery 1-V-1.)

R. W. Finch, 36 Bathurst Road, Ilford.

CW: EA6AF, FM7WF, KL7ADR, KP4JK, 4KX, PJ5RE, TF3ZM, VP6CDI, W6TBL, 6ZZM, ZB1BE. PHONE: YV5BZ. (Rx: 3-V-2.)

R. J. Riding, Trewatha, Fibbersley, Wednesfield, Staffs.

AR8JT, CN8EE, 8MI, CO2SG, CS3AA, CX2CO, EA8AS, 8AW, EK1AD, FA3GZ, HC1FG, LU1AAP, MD2RF, PY8AJ, VP6MO, W6CZV, 7MBX, YV5AB, ZD1SS, 4AD, 4X4BL. (Rx: 1-V-1.)

J. P. Colwill, Hay Common, Launceston, Cornwall.

PHONE: AR8UN, CE1AM, CN8EA, CS3AA, EK1CG, FA3TN, 9RZ, LU7PY, MD2PJ, OQ5CF, 5DZ, PY2AJN, 2AKQ, 4KL, 7DE, 7EE, TF5TP, VK2ABU, 2HA, 3HV, VP6SD, VQ3BVF, W61TA, 7AJS, YVBBB. (Rx: Roberts' P4D.)

B. Davies, 73 Eden Road, Elmers End, Beckenham, Kent.

CW: AP2N, FM7WF, HP1BR, KG6GH, PK1HK, 1RI, 4KS, UL7AB, VQ8AS, VS1BJ, 1BQ, 1BX, 1DE, 1DR, 1DY, 6AC, 7KR, 7NG, 7PS, VU2BC, 2CV, 2CX, 2GU, ZD2FAR, ZS3X. (Rx: 640.)

O. A. Good, 1 Western Drive, Oswestry, Shropshire.

PHONE: EQ3FM, HI6EC, HP1LO, VP3HAG, 3MCB, VQ3BVF, XE1AC, IID, XZ2KN, YN4CB, ZP3CM, 3CM. CW: PJ5TR, UA6AA, UL7AB. (July 1-12 only.)

R. S. Fraser, 26 Dirckhill Road,
Bradford, Yorks.

PHONE: CE1AM, 3AE, HC1FG,
HI6EC, KH6OR, MD2FJ, 2PJ,
OQ5CF, UNIAB, VE8MB, VP6SD,
W6BVK, 6ITA, 6NIG, 7AJS,
YN7BM, YV1AA, 5AB, 5CC.
(Rx : Battery 1-V-1.)

P. A. Strudwick, 159 Hampstead
Way, London, N.W.11.

PHONE: CR6AV, EQ3FM,
KG6OR, KL7ADL, OQ5CF, 5DZ,
5KZ, PK4KS, VQ2WD, 2WR, 3BS,
3BV, VS1AX, 2BS, 2CJ, 2CU,
6BI, VU2CP, ZD1SS, 1SW, 2FAR,
2JHP, 4AC, 4AD, ZE3JD. (Rx :
Modified S.640.)

R. J. Brooker, 77 The Cottages,
Rosendale Road, S.E.24.

PHONE: CT3AK, FO8AB,
VP3MCB, VQ3BVF, VS2BS,
VU2SC, ZD4AD.

CW: AP2N, PK1RI, UF6AC,
6KAF, UL7AB, VQ4KRL, VS1BJ,
ZS3K. (Rx : 1-V-1.)

K. Everett, 44 Salcombe Drive,
Chadwell Heath, Essex.

PHONE: CX2CA, DU1AL,
HC1JW, 2KM, HI6EC, HP1CM,
KG4AK, KZSNM, OX3BD,
VP2MCB, VQ3BVF, US1AX, 2CJ,
YN4CB, YS1MS, XE1KW, 1WW,
XZ2KN. (Rx : R.107.)

R. Lambie, Chequers, Chequers
Lane, Bosham, Sussex.

PHONE: CN8EE, CS3AA,
EK1AD, PY7XC, VQ4RF, W6FSJ,
6KFQ, 7ADS, 7MBX, YV5AB,
ZD4AC, ZS8QJ. (Rx : R103,
MK. 1.)

R. A. Hawley, Torview, Brookfield
Crescent, Goostrey, Cheshire.

PHONE: CE1AM, CX2CO,
EK1RW, EQ3FM, HC1FG, HI6EC,
KP4HF, LU3DH, MD2MD, 2PJ,
PY6DJ, 7RD, TF5TP, UJ8BW,
VE8MB, 8NF, VK3HW, 3RE,
VO1AG, VP4IG, 6IS, VQ4SC,
4SG, VS2CU, ZA1A. (Rx :
AR-88 and S.504.)

C. S. Pollington, 8 Cleveland Road,
Chichester, Sussex.

PHONE: CE1AM, EQ3FM,
KG6GD, KH6BA, VS1AD, 1AX,
2BS, 2CU, 9AH, Y12BJ, YN4CB,
ZL2JB. (Rx : AR88LF.)

D. L. McLean, 9 Cedar Grove,
Yeovil, Somerset.

PHONE: AR8AB, HC1FG,
HI6EC, KP4ES, 4HE, MI2LV,
OX3BD, OQ5CF, VE7VO, 8MB,
8MP, 8SD, VP3HAG, 6MO, 6SD,
VQ2WR, 3BVF, 4RF, 4SC, ZD1SS,
4AC, 4AD, ZS6JF, 6OY, 6QJ.
(Rx : SX28 and AR88LF.)

J. Jones, 13 Boswall Terrace,
Edinburgh, 5, Scotland.

CW: FK8AC, FM7WE, FP8AO,
FY8AC, KG6HG, KH6IG,
KV4AA, KX6BA, PJ5TR, VP8AK,
VS6BO, ZK2AA. (Rx : S.640.)

E. A. Parkinson, 8 Hawthorn Drive,
Rodley, Leeds.

PHONE: CE1AM, CN8BZ,
EA8AP, ET3FM, FA3ZH, KG4AK,
LU8FS, OQ5CF, PK4KS, PY1FT,
TF5TP, VE8MF, VP5AY, 6SD,
VQ3BDF, 4RF, 4SC, VS1AD,
9AH, YV5AY, 5CM, ZC6DH,
ZS4NB, 3V8AV, 4X4AG, 4AQ.
(Rx : S.504.)

E. J. Logan, Linten Cottage,
Fanshawe Street, Benzeo, Hert-
ford.

PHONE: AR8JT, CE6BS,
CR5AC, 5AD, 6AL, EQ3FM,
FF8FP, FP8AC, HI6EC, HK3FA,
KH6BA, LU9MK, MI3VS,
OQ5BZ, PY7RD, SU1MR, TF5TP,
UA9CL, VE8SQ, VP3HAG, 6AL,
VS1AX, XU2CX, ZD1SS, 4AD.
(Rx : BC342-J.)

D. K. Cocking, Old Meadow,
Farnborough Park, Kent.

PHONE: CE3AE, CS3AA,
LU4BH, MD2MD, VP6SD, W9HP.
(Rx : S.640.)

Have you got The Radio Amateur Call Book?



If you are an active SWL or amateur transmitter operating on the DX bands, one of your most pressing needs is a directory of Amateur Radio stations, available for constant reference.

THE RADIO AMATEUR CALL BOOK is this directory, and the only one of its kind. But the *Call Book* does much more than list amateur stations throughout the world, alphabetically by callsign (for this alone it is worth every penny)—It gives you the Continental area in which each country is included, and the Zone listing of that country. The *Call Book* also shows the QSL Bureau address for every country, the callsign districts into which many countries of the world are divided for radio purposes, and provides time-conversion charts based on GMT; it also lists the Q-Code, the international language of radio, as used by amateurs all over the world.

The layout and arrangement of the *Call Book* are such that all this vital information can be obtained in a matter of seconds, whether it is the name and address of an amateur in Tibet or the QSL Bureau for Paraguay.

The *Radio Amateur Call Book* is a large volume of nearly 400 pages, published four times a year: Spring, Summer, Autumn and Winter. The callsign lists and addresses are under constant revision and each issue is right up-to-date, with hundreds of new callsigns and changes of address.

We can always supply the latest CALL BOOK

Prices : Single copy, 16s. (post, 10d.)—or for any two issues to choice, 29s. (post, 1s. 8d.)
—or for a year of four quarterly issues, delivered on publication, 53s. 6d. (post, 3s. 4d.).

GAGE & POLLARD, Publishers' Agents

49 VICTORIA STREET, LONDON, S.W.1

ABBEY 5342

PSE QSL

The operators listed below have informed us that they would like SWL reports on their transmissions, in accordance with the details given. All correct reports will be confirmed by QSL card. To maintain the usefulness of this section please make your reports as comprehensive as possible.

- CE2EL *Castilla 310, Valparaiso, Chile.* 14 mc phone and CW, 1800 GMT and weekends.
- DL1FQ *Elmshornerstr. 100, Itzehoe, Germany.* 3-5 and 14 mc phone, operating weekends.
- DL1WJ *Buchel 5, Loope/Kcln, Germany.* 14080 kc CW, operating in afternoons.
- DL1ZV *Schulstr. 20, Hamburg-Wellingsbuttel, Germany.* 3-5, 7, 14, 28 and 144 mc phone and CW, 0300-0600 and 1600-2000 GMT. Comparative reports. Details quality, modulation, QSB.
- DL2PO *F. Bolton, 434 G.C.L.O. (BSE), Neumunster, B.A.O.R.6, Germany.* 3-5, 14 and 28 mc phone, 1500-2100 GMT.
- DL2QE *Cpl. G. White, "A" Sqdn., Royal Horse Guards, Berlin, B.A.O.R.2, Germany.* 7 mc CW, operating mornings and evenings.
- DL3KB *Brandsbornstr. 42, Offenbach/Main, Germany.* 3-5 mc phone and CW, 0515-0645, 1700-1830 GMT.
- DL3MT *Luisenstr. 47, Krefeld/Rhein, Germany.* 3-5 mc phone and CW, at 0500 and 2100 GMT.
- DL3NX *W. Kluge, Sinshelm (Els), Gartenstadt, Germany.* 7 and 14 mc CW, 1400-1700 and 2100-2200 GMT.
- DL4AA *Schroederstr. 79, Heidelberg, Germany.* 14150, 14350 and 28300 kc phone, 1900-2200 GMT and weekends. Effect of speech clipping.
- EZ4AE *Blumenstr. 18, Saarbrücken 3, Saar.* Reports on 3-5, 7 and 14 mc phone.
- F9TE *R. Duret, Caserne Colbert, Escalier F, Rheims, Marne, France.* 14 and 28 mc CW.
- GW2BBF *Midland Bank House, Whitland, Carmar. 7029 kc CW, 1900-1930 GMT Mondays and Tuesdays.* Reports from over 150 miles.
- G3CXG *Chingsford Community Centre, Friday Hill House, Chingsford, E.A.* Details of any 3-5, 7, 14 mc phone or CW QSO's intercepted since 10.5.49.
- G3ESG *83 Rock Avenue, Gillingham, Kent.* 3-5 and 7 mc phone and CW, evenings and weekends.
- HH2PAS *P.O. Box A-134, Port-au-Prince, Haiti.* 14 and 28 mc phone, 1200 GMT onwards.
- HR1RL *Cap. Hector R. Lagos, c/o Escuela Fuerza Aerea, Toncontin, Tegucigalpa, D.C., Honduras.* 28400 and 28480 kc phone, 1800-1900 GMT.
- IIA1K *Via Merliani 123, Napoli, Italy.* Reports on 7, 14 and 28 mc phone.
- II1CB *Strada Guardiella 18, Trieste.* 7 and 14 mc CW, 1800 GMT onwards.
- LX1AC *Rue Pierret 1a, Luxembourg, Luxembourg.* 3-5, 7, 14 and 28 mc phone, 1300-1400 and 1800-2000 GMT.
- MI3LV *P.O. Box 374, Asmara, Eritrea.* Reports on 14 and 28 mc phone.
- OZ9KW *Kogevel 7, Haslev, Denmark.* 3-5, 14 and 28 mc phone and CW, 1530-2300 GMT.
- PA0JI *Denneboschweg 101, Hengelo (O), Holland.* 3-5, 7 and 14 mc phone and CW, 1800-2359 GMT.
- PA0PZW *Stadhouderslaan 34, Hilversum, Holland.* Reports on 14 mc CW.
- PY1ANU *Rua Artur Menezes 4, Maracana, Rio de Janeiro, Brazil.* 14 and 28 mc phone, weekends.
- PY2AKA *P.O. Box 22, Sao Paulo, S. Paulo, Brazil.* 14175, 14200 and 28300 kc phone and CW, 1230-1900 GMT. Comparative reports and modulation.
- SM2BQE *S.a. Jarnvagsgatan 79, Skelleftea, Sweden.* 7000-7150 kc CW, 1530-0100 GMT.
- SM5AFU *Hornsgatan 51, Stockholm, Sweden.* 3-5, 7, 14 and 28 mc CW, 1900-2359 GMT. QRG, estimated as exact as possible.
- SM6AHC *Kv. 40, Box 50, Sollebrunn, Sweden.* 3-5, 7 and 14 mc phone and CW, 1900-0100 GMT.
- SM7AWU *Avd. VII. F.12, Kalmar, Sweden.* 7 and 14 mc phone and CW, 0400-0700 and 1800-2359 GMT.
- VE2AFC *132 Aberdeen Street, Quebec City, Canada.* 14 mc CW, 1630-1730 and 2200-2300 GMT.
- VE5GU *Box 60, Mazenod, Saskatchewan, Canada.* 14172 and 14312 kc phone and CW.
- VE7AJM *307 Sixth Avenue, Chapman Camp, B.C., Canada.* Reports on 14064 kc CW.
- VE8AW *Box 76, Whitehorse, Yukon, Canada.* 14 mc phone and CW, 0700-1900 GMT. Comparative reports.
- VK5WF *379 Esplanade, Henley Beach, S. Australia.* 14 mc phone and CW, 0700-1200 GMT.
- VP3ZM *45 Hadfield Street, Lodge Village, British Guiana.* 14 mc phone. Quality and modulation.
- W1CBV *26 13th Street, Bangor, Maine, U.S.A.* 14200-14250 kc phone, 1200-1400 GMT.
- W2PYS *403 E. 153rd Street, Bronx, N.Y.C., U.S.A.* Reports on 28-5-29-7 mc phone.
- W2RA *387 Autumn Avenue, Brooklyn, 8, N.Y., U.S.A.* 14 mc CW, VFO, 1500-1800 GMT.
- W2ZRY *141rd 22nd Street, Brooklyn, N.Y., U.S.A.* Reports on 7 and 28 mc transmissions.
- W3NNU *330 S. Calhoun Street, Baltimore 23, Md., U.S.A.* 28-6-29-1 mc phone, 1200-1400 GMT.
- W3OIT *Box 529, Irwin, Pa., U.S.A.* Quality of 28-6-28-8 mc phone, 1400-2000 GMT.
- W3OSE *356 Central Avenue, North Hills, Pa., U.S.A.* 7000-7080 kc CW, VFO, 0300-0800 GMT.
- W3PXI *937 Harrison Avenue, Scranton, 10, Pa., U.S.A.* Reports on 28-5-29-7 mc phone.
- W4DSY *3315 Selwyn Avenue, Charlotte, N.C., U.S.A.* 14220 kc phone at 2300 GMT.
- W4KAE *316 Marlemont Drive, Lexington, Ky., U.S.A.* Reports on 14290 kc phone.
- W4NHC *1504 So. Summerlin Street, Orlando, Fla., U.S.A.* 28-5-29-7 mc phone and CW, mornings.
- W5DAD *812 N. Kansas Avenue, Roswell, N. Mex., U.S.A.* 28-30 mc phone, 1700-1900 GMT.
- W5HFQ *P.O. Box 405, Dell, Ark., U.S.A.* 14-2-14-3 mc phone, 0001-0800 GMT. Comparative reports.
- W7ADS *109 No. 32 Avenue, Yakima, Wash., U.S.A.* Reports on 14206-14250 kc phone.
- W7KSA *4325 S.E. 75th Street, Portland 6, Oregon, U.S.A.* 14 and 28 mc phone, 0200-0800 and 1600-2359 GMT. Comparative reports.
- W8TUO *646 Abbott Road, East Lansing, Mich., U.S.A.* 14 mc phone and CW, 0400-0700 GMT.
- W9CPF *6816 S. Rockwell St., Chicago, Ill., U.S.A.* Quality of NBFM and constant modulation, of 28-5-29-7 mc phone, weekends 0900-1400 GMT.
- W0JXJ *2905 Prospect Street, Kansas City, Mo., U.S.A.* 28616-29000 kc phone, 1400-1800 GMT.
- W0LQV *4844 Booth Street, Kansas City 3, Kansas, U.S.A.* Reports on 29 mc phone.
- W0LVG *2505 Thomas Avenue So., Minneapolis, Minn., U.S.A.* 14294 and 28700 kc phone, afternoons and evenings.
- YU1CAF *P.O. Box 48, Belgrade, Yugoslavia.* VFO-controlled 7, 14 and 28 mc phone and CW.
- ZE2KJ *Box 999, Umtali, S. Rhodesia.* 7070, 7075, 7125, 14140, 14150 and 14250 kc phone, 1700-1900 GMT.
- ZS1KF *C. K. Hall, Aeradio Station, Alexander Bay, C.P., S. Africa.* 14 mc CW, 1300-1900 GMT.
- ZS5CZ *52 Northway, Durban North, S. Africa.* VFO-controlled phone and CW, all bands.
- ZS6VH *13 Contact Street, Wentworth Park, Krugersdorp, Transvaal, S. Africa.* 14 and 28 mc CW, reports after 2100 GMT only.
- 4X4AL *115 Hayarkon Street, Tel-Aviv, Israel.* 14 and 28 mc phone and CW, 2000-0800 GMT.

THE V H I F END

by A. A. MAWSE

Conditions Poor Generally— Activity or Propagation ?— Some Aerial Notes— Individual Reports and Tables

JULY was a poor month for VHF work. Some correspondents blame it on activity and some on conditions. There is always the easy explanation that the transmitter folk are out with the XYL, gardening, looking at TV or even working DX on the lower frequencies. It is an interesting experience to spend an hour or two listening on Two Metres in some part of the country far from home. In all probability a completely new set of calls will be heard and you will be told by your host that these stations are active most evenings. He, in his turn, will ask you, in a disparaging manner, what has happened to activity in your district. This is not imagination ; it is the first-hand experience of your A.A.M. There is regular and consistent activity in many parts of the country. Much of it, however, is never heard more than 20 or 30 miles away except when conditions are good—and if July was a poor month for Two, then primarily the reason was bad conditions. Of course, poor conditions result in poor activity on the part of those stations only interested in DX ; the fact remains that most of them do put in an appearance, at least for a short while most evenings.

During the bad-weather period at the end of July and beginning of August there was an almost complete absence of northern signals on the South Coast ; yet on August 4, as a ridge of high pressure crossed the country, things improved considerably and the northerners were found to be still there. G2FMI, G3ATZ, G3CXD, G4NB, G5JU, G8QY and G8SB were amongst a number of calls heard that evening. Earlier in July, some Continental signals had been logged in South and East England, but, in general, there was little about which one could get excited.

Beams

Is a beam with sharp horizontal directivity a help or a hindrance ? This question is raised by

R. L. Bastin (Coventry), who has been testing his wide-spaced *Short Wave Listener* beam against a dipole. He has no doubts of the superiority of the beam from the point of view of gain when it is pointed at the desired station, but comments that its sharpness causes much DX to be missed. The figures he quotes show that R.L.B.'s version of the beam is sharper than the prototype, but nevertheless one of the characteristics of a high-gain Yagi is this directional property. This particular Yagi was designed for use at a location close to a main trunk road, where car ignition (particularly at week-ends in the summer) is extremely bad. If an omni-directional aerial is used, then all signals, from whatever direction they may emanate, have to be received through a high background noise. When a highly directional Yagi is used, the effect is to reduce the noise to a negligible value over 180 deg. of beam rotation, while over the remaining half rotation the noise is reduced in comparison with signals, as the QRM from only a small section of the road is accepted in any one position. Thus, signal-to-noise ratio is vastly improved by using a sharply directive beam.

It is essential with any form of highly directional aerial to have a ready means of rotating it. If you have to run down two flights of stairs, unbolt the back door and dash down the garden every time you want to move the beam, then you *will* miss some DX. However, it is good exercise !

TWO-METRE DX

G. E. Magrow (Dawlish)	PA0UW	387 miles
E. A. Lomax (Bolton)	PA0IK	340 miles
R. Hastie (Hayes)	F3DC	221 miles
R. A. John (Swansea)	G3BLP	168 miles
A. F. Hayton (Palmers Green)	G5BD	116 miles
R. L. Bastin (Coventry)	G3BLP	110 miles
P. Flinn (Iver)	G3EHY	102 miles

Note : All claims for this Table must be accompanied by QSL card to verify and must be for distances in excess of 100 miles.

Station News

E. A. Lomax (Bolton) describes July as a "funny peculiar" month, with conditions poor, but more stations logged. From July 10 to 16, things were extremely bad in Bolton, and E.A.L. comments that the barometer was reading as low as 28.5 in. G5BY was his best DX during the month, the distance being 240 miles. He points out that in the list of possible countries to be logged on Two, which we gave last month, GI was omitted. He further suggests that EI, GC and GD should also be included. It is agreed that if there was anything doing in those countries there would be every possibility of hearing something of it, but your A.A.M. rather thinks it is better not to list them as "possibles" until there is some more regular activity. However, there are known to be stations on 2 metres in HB, I, OH, OZ and SM, so these might also be listed as possibles in view of the most recent American record for the band of 1,196 miles.

E.A.L.'s "City Slicker" continues to give a good performance, and he hopes to raise it another 10 ft. in the near future. New stations active in his area include G2CYN (Birkenhead), G3BOC (Heswell), G3TM and G2FCV (Warrington), and GW3KY (Holyhead). 70 cm news is that at least seven transmitters are testing on the band, and E.A.L. himself is actively preparing for that wavelength.

B. Priestley (Northwich, Cheshire) is trying to find two metres. He has modified a Type 27 unit working into a 12-mc IF strip. The only aerial so far available is a folded dipole in the roof. L. B. Bailey (Stockton-on-Tees) is another newcomer and has heard a number of local signals, the best being G3DMK at 23 miles; he is using a Type 27 converter

**TWO METRES
BEST TEN OF THE MONTH
(July 1950)**

Operator	Location	Total Miles	Best DX (Miles)
E. A. LOMAX	Bolton	1,944	240
A. L. MYNETT	Wembley	1,629	181
R. L. BASTIN	Coventry	993	110

For this monthly table send details of the best ten DX signals heard on two metres. Signals may be logged once per day (0600 to 0600). Give date, time and details of all signals.

modified according to the *May Short Wave Listener*. His aerial is a dipole with reflector fed with 300-ohm line. L.B.B. has also been receiving pictures from Sutton Coldfield with an aerial in the loft!

L. A. Whitmill (Harrow Weald) lists G3DUP and G3EHY as his best DX for the month. He describes activity as good! In all, 77 stations were logged during July. Midlanders and Northerners who grumble about Southern activity please note! L.A.W.'s new converter consists of 6AK5 RF stage, 6J6 mixer and 6J6 oscillator; he had some trouble taming the oscillator, but now finds this new line-up very good from the point of view of signal-to-noise ratio. The station score at Harrow Weald is now the goodly one of 178.

R. L. Bastin (Coventry) is one of those who blames activity rather than conditions. His only DX heard during July consisted of

TWO-METRE CALLS HEARD

L. B. Bailey, 16 Fulthorpe Road, Norton, Stockton-on-Tees.

G2FO, 3DMK, 3EHZ, 3QU, 5XT.

R. L. Bastin, 101 Aldermans Green Road, Coventry.

0-50 miles: G2AOK/A, 2ATK, 2BFT, 2FNW, 2HCG, 2RI, 3ABA, 3BJO, 3BPW, 3BVJ, 3DJQ, 3DUP, 4NB, 4RK, 5SK, 6CI, 8MZ.

50-100 miles: G3CXD, 5BM.

Over 100 miles: G3BLP, 3EHY. (July 7 to 31, 27 Unit with 955 osc. into BC 342N. *Short Wave Listener* 4-ele. w.s. beam.)

E. A. Lomax, 28 Welbeck Road, Bolton, Lancs.

G2AOK/P, 2ATK/P, 2BUJ, 2FCV, 2FUZ, 2OI, 2MV, 2XC, 2XS, 2XV, 2XV/P, 3ABA/P, 3ABH, 3AHT, 3AGS, 3A00, 3ATZ, 3BLP, 3BOC,

3BW, 3BY, 3CGQ, 3COJ, 3CXD, 3CZV/P, 3DA, 3DCI, 3DMU, 3DUP, 3ELT, 3EHY, 3FMI, 3FUM, 3GMX, 3TM, 3WW, 4DC, 4HT, 4LU, 4MW, 4OS, 5BM, 5BY, 5CP, 5MA, 5RW, 5TH, 5TP, 5VN/A, 5VN/P, 5WP, 6NB, 6TL, 6VX, 6XM, 8KZ/P, 8SB, 8SY, 8VR, GW2ADZ. (July 1-30, 6J6 (G2IQ) into AR88 on 10 mc. *City Slicker* aerial, N/S, 40 ft. high. QTH 650 ft. a.s.l.)

L. A. Whitmill, 762 Kenton Lane, Harrow Weald, Middx.

G2AHP, 2AIG, 2ANT, 2BMJ, 2BH, 2CIW, 2DD, 2DT, 2HDZ, 2MV, 2QY, 2XC, 2XV, 3AAB, 3BLP, 3BOB, 3BPW, 3BYY, 3CFB, 3CGQ, 3CVO, 3DUP, 3EAB, 3EBW, 3EIV, 3EHY, 3FD, 3FAN, 3FXG, 3FF, 3GBO, 3GSE, 3SM, 3WW, 4CI, 4DC, 4HT, 4KD, 4MW, 5BC, 5CD, 5DS, 5DT, 5KH, 5LI, 5LK, 5LN, 5MA, 5OO, 5PY,

5QB, 5RD, 5TP, 5WP, 6CB, 5HG, 6KB, 6LO/A, 6LK, 6LR, 6LX, 6OH, 6NB, 6NF, 6PA, 6SC, 6VX, 6WU, 6XM, 6YP, 6GX, 6SK, 6KZ, 8QC, 8SM, 8TB. (6J6 preselector—RF27-640; and 6AK5-6J6-6J6 into 640; 3-ele. beam. August 4-31.)

A. L. Mynett, 29 Sunleigh Road, Alport, Wembley, Middx.

50-100 miles: G2ATK, 2FNW, 2HCG, 2XC, 2XV, 3ABH, 3AKU, 3BK, 3BNC, 3CFR, 3CJY, 3DAH, 3DIV/A, 3DUP, 3EBW, 3FAN, 3WW, 4MW, 5BM, 5MR, 5UD, 8DM/A, 8IL, 8SY.

100-150 miles: G2CPL, 2IQ, EHY 3VM, 5UF, GW3EJM.

150-200 miles: F8GH, G2BME, 3AHT, 3COJ, 3CQC, 5BY, GW2ADZ. (6J6 converter Two 3-ele. very wide-spaced Yagis. Location 100 ft. a.s.l. July 8-30.)

**TWO-METRE
COUNTIES HEARD**

Starting Figure, 10

P. J. Towgood (Bournemouth)	36
A. L. Mynett (Wembley)	35
E. A. Lomax (Bolton)	31
R. Rew (Birmingham)	30
L. A. Whitmill (Harrow Weald)	28
A. W. Blandford (Mitcham)	26
R. L. Bastin (Coventry)	16
P. Finn (Iver)	15

G3BLP and G3EHY. R.L.B. would like to award a medal to the latter for his consistency in putting a good signal into Coventry. A. W. Blandford (Mitcham) also failed to hear much of interest, two Cambridge stations forming his DX for the month. Similarly 430 mc has been a blank for him.

P. J. Towgood (Bournemouth) heard a new station in G3BJQ (Rugby) on August 1, while G2XV (Cambridge) has been his most consistent DX. On July 29, he visited G3CFR, also in Bournemouth, and was there when that station's first 70 cm contact with G5BY was made. (That same evening G2XC and G5BY had their second 435 mc contact.) Northern signals heard in Bournemouth during

the month included G3ATZ (Chester), G3COJ (Hull) and G6TF (Sheffield).

From A. L. Mynett (Wembley) comes another report of poor conditions during the month, though he remarks that G2IQ and G6VX work one another practically every evening over the Hayes-Sheffield path—which shows what can be done. A.L.M. visited G5MR (Hythe) while on holiday, and was very surprised at the poor level of activity within G5MR's range, comparing with the 30 or so stations to be heard in the London area almost any night. (This fully bears out our own earlier remarks, above.) On one of the "good" occasions, A.L.M. succeeded in bringing in G3COJ for his second Hull station on Two.

In Conclusion

Not a very exciting story this month, but if it was not for the dull periods in between, the spells of good DX reception (when the PA, ON and even DL signals are heard) would fail to delight our ears to the same extent—so one can only continue to listen night by night, perhaps keeping an eye open for those anticyclones and ridges of high pressure, and at the same time always improving beams and receivers so that when the DX does break through it will not be missed.

Next month's reports should be addressed to A. A. Mawse, *Short Wave Listener and Television Review*, 53 Victoria Street, London, S.W.1, to reach us by **September 7** at very latest. Let us hope for better breaks to be reported next time.

DO YOU KNOW

That you can obtain *Short Wave Listener and Television Review* from us by direct subscription? The cost is 16s., post free, for a year of twelve issues, and despatch is on the day of publication, the third Thursday in each month. This ensures arrival of your copy punctually every month.

PHOTOGRAPHS

We are always glad to see photographs of Amateur Radio interest, for reproduction in these pages. All those used are paid for, and can be returned undamaged. Prints sent us must, however, be clear and sharp, and identified on the back, with an accompanying note covering the subject. Address "For the attention of the Editor."

ANOTHER USEFUL LIST

The latest list, No. 7, issued by Messrs. Clydesdale's is well worth having and should be in the hands of every reader who wants a guide to the very wide range of surplus radio equipment that they have available. Running to some 230 pages, it costs but 6d. Write Clydesdale Supply Co., Ltd., 2 Bridge Street, Glasgow, C.5, mentioning *Short Wave Listener and Television Review*.

NATIONAL RADIO EXHIBITION

This year's Radio Show favours the Midlands in that it is being held at Castle Bromwich, Birmingham. Dates are September 6-16. Nearly 100 exhibitors, covering all sections of the Industry, are listed as taking stand space.

The Short Wave Magazine is our Parent Publication

1.7 mc on the R.1155

MODIFICATION FOR TOP BAND COVERAGE

THE R.1155 is a good receiver from the amateur point of view for many reasons, not the least of which is the fact that it is available at very reasonable prices. It covers the 14, 7, and 3.5 mc amateur bands, and in addition three LF bands. The gaps in the amateur

As the writer is very much against delving into closely wired coil units and possibly damaging the whole receiver, rewinding the 85-200 kc coils was considered out of the question. It was therefore decided to add the three extra coils required to the coil unit, with the minimum of disturbance to the remainder of the receiver. Position 5 of the range switch controlling the 85-200 kc coverage could be used, however, as it was accessible.

The extra coils were therefore wound on iron-cored Aladdin formers (see Fig. 2), as are used in the other ranges of the receiver. In addition to these coils the only extra com-

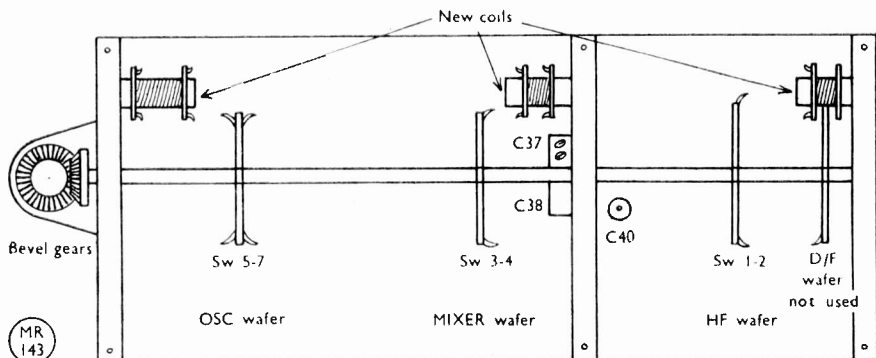

Fig. 1. Rear view of coil housing in the R.1155, with cover removed, showing positions for new 1.7 mc coils connected to Range 5 on the wave-change switch. (See Fig. 2 for details of coils.)

range are 28 mc and the Top Band ; while a converter is the logical answer for Ten, 1.7 mc coverage is rather a different matter.

Range 5 on the 1155 is for 85-200 kc and is of little use to the amateur ; the other LF ranges can be used for BC listening but it was thought that the 85-200 kc coverage would be of more use if it could be modified for, say, 1.5-3.0 mc and so bring the Top Band on to the receiver.

ponents needed are a 0.05 μ F and a 100 μ FF condenser, and an RF choke the last item being salvaged from the DF section of the set.

Modification Details

Reverse the chassis and with the rear of the set facing, remove the cover of the coil unit. In conjunction with Fig. 1 note the switch wafers for each stage and with the switch set to Range 5 gently rock the knob and locate the

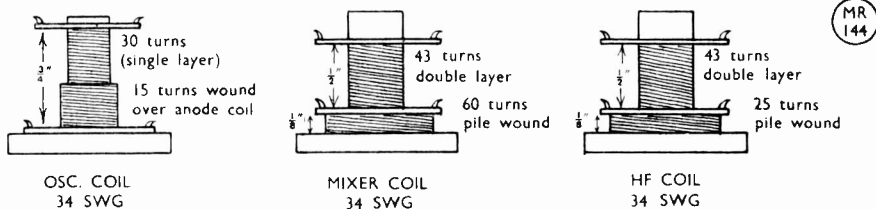

Fig. 2. Constructional details for coils to cover the 1.7 mc band on the R.1155, using the disconnected Range 5 section of the wave-change switch.

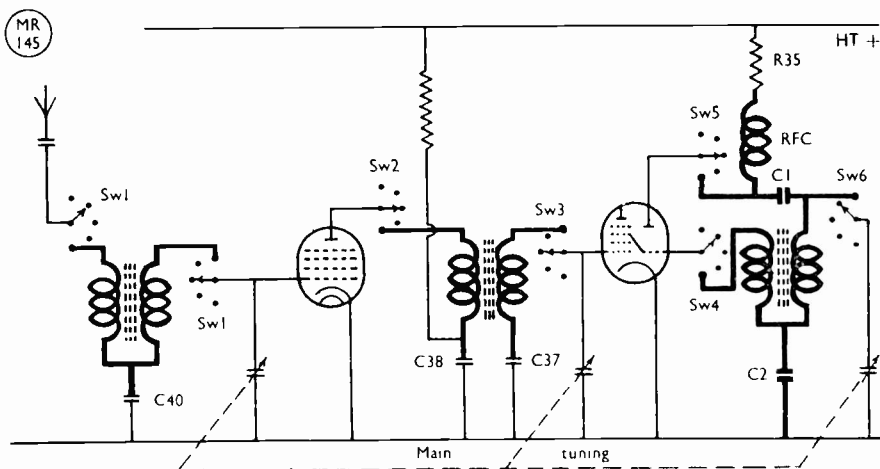

Fig. 3. Essential circuit showing new wiring in heavy lines ; no other circuit changes are necessary, except that the existing 85-200 kc coils are disconnected from the Range 5 wave-change switch setting. Values marked are : C1, 100 μ F ; C2, .05 μ F ; RFC, choke. The new coils are wound on iron-core Aladdin formers, as Fig. 2.

contacts for this range on each wafer. This should be done carefully so as to avoid interfering with the other coils and it is worth spending a few minutes extra making sure about it before cutting any wires. When the contacts have been located remove the wiring to the existing coils, leaving the trimmer leads in place. Next the coils (previously wound as shown in Fig. 2) are fitted to the top front corners of their appropriate sections using four BA bolts. There is just room for them in this position and all leads are reasonably short.

The wiring is then carried out as shown in the circuit diagram ; it is quite straightforward and no snags should be encountered. The positions of C37, C38 and C40 in the original circuit are shown in Fig. 3, for convenience, and the two extra condensers and choke were fitted in the wiring.

Testing

On switching on no lack of signals should be experienced, as there always appears to be a representative of the kipper fleet on the air. If, however, no signals are heard reverse the connections to the oscillator *grid* coil and all should then be well. If a signal generator is available the circuit may be aligned in the usual manner, but if not, it is simple, if a little tedious, to align on steady signals at each end of the range by careful adjustment of cores and trimmers.

A scale for the new range may be added to the dial simply by gluing it over the existing

scale, which fortunately is at the bottom of the dial ; a half circle of white cartridge paper is all that is required.

AIDS FOR THE DX LISTENER

We can still supply our *DX Operating Manual*, which, in seven well-written chapters, tells you all you need to know about the practice of amateur band DX—and the cost is but 2s. 8d. post free. The other important aid is our *DX Zone Map*, still in steady demand—and no wonder, for it is a beautifully produced wall-mounting map of the world in colour, drawn to a great circle projection centred on the U.K. This means that you see the shape of the world as wireless waves travel, and the map gives true bearings and straight-line distances for all parts of the world relative to the U.K., with a world time-scale based on GMT. It also shows the Zone System, with the geographical limits of each of the 40 Zone Areas and a list of prefixes in each Zone. Thus, all the information you require appears on the same sheet. The price is 6s. post free, so that for a total outlay of 8s. 8d. for *DX Manual* and *Zone Map* together you bring yourself right up to date in DX matters. Order on the Circulation Manager, Short Wave Magazine, Ltd., 53 Victoria Street, London, S.W.1.

WORLD WIDE RECEPTION OF SHORT WAVE PROGRAMMES

DX *broadcast*

MONTHLY COMMENTARY BY R. H. GREENLAND, B.Sc.

This month, instead of the usual Tabulated Schedules page, and in response to the requests of many readers, we are setting out a typical letter and report in the Spanish language.

A number of our listeners feel that the Latin-American stations are loath to reply to a letter written in English, and we ourselves have had the experience on more than one occasion of receiving no verification for a report submitted in this manner. In many cases, no doubt, the reason is that no member of the staff at the radio station concerned has a knowledge of our tongue!

It is to be hoped that the accompanying specimen letter in Spanish (with, of course, the necessary reception details added) will meet the requirements of all, and that the bulk of Spanish-speaking broadcasting stations will thus be encouraged to send you their respective verification cards. We would add that Latin-Americans in general are most likely to reply when an International Reply Coupon is submitted. For the reporter this is an expensive business, as the Coupon (obtainable at all main Post Offices) costs 8d., and the postage on a foreign letter is now 4d. A further increase in cost is, of course, inevitable when the reporter requires an early reply and sends his letter by air-mail. Much depends on the financial position of the radio station itself, and in South and Central America there are quite a number of low-powered broadcasters owned and operated for commercial purposes by individual persons.

Asia

We have received from J. South (Bournemouth) a letter enclosing a cutting from a Singapore newspaper. The information contained in it concerns the new Johore station of the British Far Eastern Broadcasting Service. A new self-contained "Radio town" is being built at Tebrau and will have all the equipment necessary for relaying broadcasts in English, Malay, Chinese, Japanese, Burmese and Siamese from the BBC in London. Ten of the masts will reach to a height of 325 ft. and

others to an altitude of 275 ft. There will be buildings for two 100-kW giant transmitters and four smaller ones, their generating plant, their own water supply, and accommodation for about fifty families. With the exception of a few specialist personnel from the United Kingdom, the whole construction work and erection plant is being carried out by Malay workmen in accordance with the requirements of local contractors.

It is expected that the installation will be completed and the station in operation by the end of the present year.

J. C. Catch (South Shields) provides the information that YDC, Djakarta, 15150 kc, is audible at 1530 with an English programme and News in that language at 1550. YDF2, 11784 kc, was logged by him at 1700 with the slogan: "Radio Nacional en Indonesia" and a broadcast in French following. S. Neeld (Walton-on-Thames) and I. W. McDermid, G3ANV (Clifton, Bristol), have lately received Radio Indonesia's schedule, and G3ANV's letter from them includes the following interesting information: The description of our antennae system needs some words. We use the Blawknex system with towers 210 ft. high, with an antenna-array of 11785 kc/s. It consists of four doublets (two collinears above two other collinears at a distance of a half wave-length) with similar parasitic reflectors. Main direction: India-Europe.

The antenna-array of 15150 kc/s has six doublets (three parallel systems of two collinear doublets) and a reflector of the same as the above, fed in phase. Main direction: India-Europe-Australia.

Finally, the antenna-array of 6045 kc/s has a special system on low poles with the first main lobe of 320 deg. (direction: Sumatra-India) and the second main lobe of 80 deg. (direction: Celebes-California).

Radio Indonesia's address for reports is: Medan Merdeka Selatan No. 17, Djakarta.

It is reported by Radio Australia that Radio Tibet has been identified on 7255 kc between 1500 and 1600. This is the station operated by AC4YN for the Tibetan Government. (over)

ALL TIMES GIVEN IN THIS ARTICLE ARE GMT EXCEPT WHERE STATED

SPECIMEN REPORT AND LETTER IN THE SPANISH LANGUAGE

Model Letter for despatch to Latin-American Stations

Address
Date in Figures

The Manager,
El Gerente,

Station :
Radiodifusora

Town.
Country.

Dear Sir,
Muy Senior Mio, or
Distinguido Senior,

I am pleased to inform you that at (Time) GMT
Me da mucho gusto avisarle que a las
horas..... GMT

on (Date), I was successful in logging your short wave broadcast
el....., conseguí captar su transmisión de onda corta

over (Name of Station) on Kilocycles per second.
de la Emisora.... sobre..... Kilociclos/sec.

Reception was (Good, Normal or Poor)
La recepción fue (bien, regular or mal)

on my Receiver : Type : (Superheterodyne) No. of Valves :
por mi receptor : Tipo : (S)heterodino No. válvulas :

Aerial : (External) ; Height above ground : metros.
Antena : (Aerea) ; Altura desde el suelo : metros.

Length : Metros.
Largo : Metros.

I heard the following :
Oí lo siguiente :

Time :
Hora :

(Give details here).

Please permit me to say that your programme was
Permítame decirle que su programa fue

excellent and that I derived great satisfaction through listening to it.
excelente y que me fue sumamente agradable el escucharlo

I shall be most grateful if you will kindly
Le ruego me haga el favor que le agradecería

send me your verification card, and I hope to devote more time
muchísimo de mandarme su tarjeta de verificación, y espero dedicar
in the future in listening to your entertaining broadcasts.
mas tiempo en adelante a la recepción de sus transmisiones tan
agradables.

Soy de vd. Atto S. S.,

Q. E. S. M.,

(Signature)

N.B. A Yard may be taken as a rough approximation for a
Metre.

From India, B. P. Middleton (Clapham, S.W.11) hears excellent signals at 0800 over 17840 kc. Again at 1500 they have been S9 plus with dance music followed at 1530 by English News over 15290 kc.

A newcomer, G. Roberts (Leeds, 12), reports the Delhi 9620 kc transmitter with News in English at S7 at 1530.

Radio Pakistan gives English News each day as follows: 0130—9645 kc, 11570 kc; 1300—9645 kc, 15335 kc; 1710—15270 kc only; 1810—11845 kc, 15270 kc; 2300—11845 kc, 11570 kc. Radio Goa in Portuguese India uses 9610 kc between 1630 and 1730. The direction is: "Emissora de Goa," and it is reported to be on the air also from 1115 onwards on both 9610 kc and 17780 kc.

P. E. Woolmer (Grant-ham) informs us that Kol-Israel has been testing on 9500 kc instead of 9000 kc. He mentions, too, "The Voice of Elatt" in the south of Israel; this one broadcasts music for the Israeli soldiers between 1300 and 1430 on Saturdays on a frequency of 6520 kc. Radio Iraq in Basra can be heard broadcasting in Arabic from 0400 to 0600 on a frequency of 11935 kc.

E. F. Jubb (Orford, Warrington) has received a QSL for the new Turkish transmitter TAT on 9515 kc; it gives the news that the power of TAT is 100 kW: F. H. Bliss (Harrow, Middx.) has a verification for TAV, 17840 kc, also using 100 kW; both TAT and TAV are in the experimental stage and have as yet no fixed programme.

Africa

Mozambique has claimed J. C. Catch's attention, for he heard CR7BU, 4930 kc, with Morning Music at the early hour of 0440; there

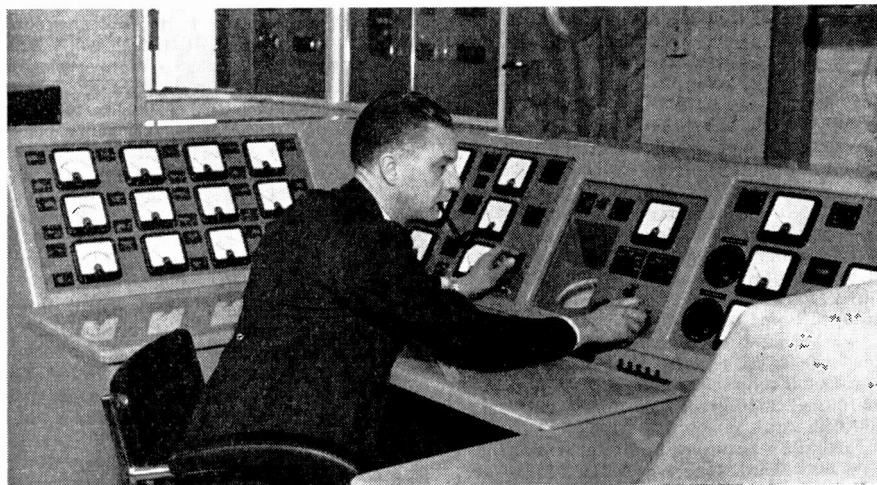

Control desk for the Sutton Coldfield Sound-Vision transmitter.

were frequent time announcements in English. CR7BE, 9671 kc, was logged at 0515 with chimes and call in Portuguese. It is reported elsewhere that CR7BJ has lately been heard on a new frequency of 9787 kc.

ZRB, Waterkloof, Pretoria, 9110 kc, with faint signals, was heard by the writer for a brief spell with its morning "Physical Jerks" programme at 0455 on Midsummer Day. Their verification contains this most enlightening statement: "The South African Air Force Broadcast station is dedicated to the services of Safety for the Airman, whether he is flying in a Civil or Service capacity."

Southern Rhodesia now seems to have found a permanent place in the realms of short-wave broadcasting. Using a power of 15 kW, its schedule is: Weekdays: 7290 kc: 0930-1115, 4896 kc: 1555-2000; Sundays: 7290 kc: 0830-1115, 4896 kc: 1755-2000. S. Neeld mentions that they regularly use 3320 kc for the evening session and that 4896 kc and 6018 kc are experimental only. Recently we heard the Radio Club do Cabo Verde station CR4AA, located in Praia on 5895 kc, with a Balalaika musical excerpt at 2110; all announcements were in the Portuguese language. R. A. Savill (Sevenoaks, Kent) gives the frequency of CR4AA as 5920 kc, and says that it is on the air from 2100 to 2200 with signals peaking to S7. R.A.S. also logged CSA93, Ponta Delgada, Azores, 4845 kc, with excellent S8-9 signals before the close-down at 2300.

From French West Africa, B. P. Middleton

has received a verification for Radio Dakar; included is their latest schedule which reads: 11897 kc (25.22 m.); 0700-0800, 1200-1330 and 1800-2300; 15340 kc (19.55 m.): 1900-2030. Their English News is at 1900 and their colourful card bearing the coat-of-arms of Senegal is signed by the Station Director. B.P.M. gives the news that the Cairo, Egypt station SUX, 7860 kc, is on the air daily at 2000 with talks in Arabic; at 2015 they give the direction: "Hoona el Kahireh," and this is followed by a broadcast of Arabic music. Verifications have been sent to P. E. Woolmer for reception reports on Radio Algeria on 9570 kc and for Radio Africa, Tangier, on 7080 kc. R. A. Savill has similarly received a letter verification in French for EA9AA, Radio Africa; the address is: Bureaux Transférés, Rue Jeanne d'Arc No. 2, Tangier.

Australasia

Station FZP8, Radio Takiti in Papeete, 12080 kc, has not been regularly heard during the summer months, but on July 8 at 0435 its News in French was audible despite heavy interference from a commercial phone station on the same frequency.

In New Zealand, ZL3, 11780 kc, is the most reliable channel. Its Children's Half-hour is a regular feature at 0500 daily, and on June 19, boys and girls in the studio in a "Twenty Questions" programme were asked to identify "The Tower of London." At 0530 the direction was: "Station 2YL. The time is 5.30 and we present Song Time." On July 1 at 0250 we

listened to a running commentary on the Third Rugby Union Test Match between the British Isles and New Zealand broadcast from Wellington. At half-time (0315) the direction was given: "This is Radio New Zealand calling Australia and the Islands," and a request for reception reports was made, these to be submitted to: Radio New Zealand, P.O. Box 3045, Wellington, New Zealand. On July 8, at 0415, we had as a diversion a horse-racing commentary on the Yale One-Mile Handicap at the Wellington Open Fence Meeting; great excitement prevailed as Robin Redbreast went into the lead at the three-furlong post and galloped home to win in convincing fashion. C. P. Turner (Crewe) sends us Radio New Zealand's latest programme schedule, a six-page leaflet containing by way of illustration a charming photograph of New Zealand's Southern Alps.

Australia's Saturday Sporting Session has been well heard, too, over VLH5, 15230 kc, around 0430. On July 8 at 0540, VLB5, 21540 kc, provided an excellent signal for the Carlton versus Melbourne Australian football match, and during the commentary a break was made to announce the result of the Rugby League encounter at Brisbane between the England Touring Team and Ipswich. Both VLC, 15200 kc, and VLG11, 15210 kc, were audible at 0250 on one occasion during the regular daily transmission to Asia. Over VLC, Fraser Park, in a farming feature, gave a most fascinating discourse on the various Australian soils.

North America

M. C. Cobb (Harrow, Middx.) has lately received a card from KGEX direct and one for this station from the Voice of America, New York, and both relative to an AFRS broadcast! M.C.C. adds: "In connection with the American call-letter alterations, the CBS Engineer at Brentwood tells me that all the East Coast transmitters (presumably he is referring only to Columbian Broadcasting System stations) are now WABC." KRCA3, San Francisco, 15250 kc, was noted by J. C. Catch on July 12 between 0630 and 0700, with a play entitled "Box 13," and English News was given at 0700. R. A. Savill's latest Voice of America card is for KCBR2, Los Angeles, California, which employs a frequency of 21740 kc. Twice during the past month we have logged WRCA opening up at 0315 with the playing of "The Star Spangled Banner" and the direction: "This is Radio Station WRCA, Bound Brook, New Jersey, operating on a frequency of 9615 kc."

B. P. Middleton, having heard the Radio Amateurs' Hour in the Voice of America Sunday broadcast, has received a special QSL card for his report on this particular pro-

gramme. It is signed by Bill Leonard, W2SKE, who mentions that they will shortly be bringing in an American SWL to speak over the VOA microphone in this feature. B.P.M. also offers the latest Canadian Broadcasting Corporation schedule which is: Daily 1415-1630, CKCX, 15190 kc and CKNC, 17820 kc; 1630-2330, CKCS, 15320 kc and CKNC, 17820 kc. E. F. Jubb suggests that "Now It's History" on Fridays at 2230 is a worth-while programme; he heard "The Battle of Quebec" as given by CBC reporters on the spot on July 7.

J. C. Catch forwards a newspaper cutting from the "Newcastle Journal" referring to the Canadian radio station using the identification: "CFYK, Yellowknife, The Voice of The Golden North," and asks for further particulars. So far as we are aware, this is not a short-wave broadcasting station. It is, perhaps a medium-waver located in the northern regions of Manitoba or the North-West Territory.

Other Canadians have been logged by us as follows. CKRA, Sackville, 11760 kc, giving a Canadian International Trade Fair report at 0235 on June 23. A Miss Hall, of Sheffield, England, was interviewed in connection with the replica of an old English inn—the original Barrel Inn in Derbyshire—of which she was in charge. CKLX, Sackville, 15090 kc, opened with station direction at 0400 on June 29, and the information that at this time from Tuesday to Saturday it was at the disposal of the United Nations; then came the words: "We now join United Nations Radio," and news of events in Korea followed.

South America

Ecuador. R. W. Finch, G3FJW (Ilford, Essex), has heard HCJB, Quito, 17890 kc, as late as 2330 on June 21 with a feature entitled "Bible Club" in which Ecuadorean children were rendering cheerful hymns. A week later over HCJB on 12460 kc, at 0535, we listened to a hymn and address in the Russian tongue; signal strength was S9 plus 12 dB on the meter. J. C. Catch is to be congratulated on discovering a new one on 4673 kc (actually quoted as operating on 4710 kc). This is HC2BK, Guayaquil, which can be identified by its frequent slogan: "Transmite Radio El Mundo en Guayaquil"; it signs off at 0430 with final announcements in Spanish and the playing of spectacular jazz music: we logged this one at 0400 on July 12 with pianoforte syncopations and clear direction at 0405. J.C.C. has since received a letter verification from Gabriel V. Jiminez, Manager of Radio El Mundo, 9 de Octubre No. 308 y General Cordova, P.O. Box 3311, Guayaquil. The translation reads: "We have in our possession

your recent letter in which you inform us of the way you receive in your country our wavelength of 4710 kc/s, for which we send you our compliments and appreciation. The Engineer of this station has taken note of your remarks and he receives great satisfaction in knowing that our equipment is in good operation, and appreciates your report. We would appreciate very much if you will continue listening and reporting to us, and will always be grateful to receive your welcome letters."

P. E. Woolmer gives HC2FO, Radio Continental, 6065 kc, which operates as follows: Week days: 1700-2000. 2230-0400; Sundays: 1600-1800, 0100-0230; the address is: Apartado 4020. Guayaquil. HC2RL, Quinta Piedad, Guayaquil, 6635 kc, though often weak can yet be classified as a regular; you will hear either operatic selections or orchestral recordings around 0245. HC4EB, Radio Manta, 6870 kc, has lately emerged with dance music including vocal fox-trots around 0315; it closes at 0330 after giving the direction: "Radio Manta—Hatchay-Say-Cuatro-Eh-Bay." Others heard were HC2ET, Radio El Telegrafo, Guayaquil, 7712 kc, with a programme of dance music at 0300, News in Spanish at 0320 and closing down at 0330; HC2AK, Radiodifusora del Ecuador, Guayaquil, 4651 kc, with an orchestral number at 0335; and HC6VT, La Voz de Tungurahua, Ambato, 4721 kc, with announcements in Spanish followed by vocal music at 0340.

Colombia. Here, HJCX, La Voz de Colombia, Bogota, 6018 kc, has been the most consistent: J. C. Catch logged it at 0345 on June 29 with a football commentary (S7-9), and P. E. Woolmer has just received their card in bold, black-and-white design depicting a map of Colombia. We logged HJBB, La Voz de Cucuta, 4815 kc, at 0245, with three sets of fanfares preceding the Spanish direction and a Spanish News at 0257. HJAB, Emisoras Unidas, Barranquilla, 4785 kc, was noted at 0335, with vibraphone notes preceding the call: "Hatchay-Yay-Ah-Bay." This station has a "Colombiana" programme from 0430 up to the close down at 0500. The Venezuelan YVMG, Maracaibo, 4810 kc, gave popular fox-trots and tangos with appropriate applause after each item between 0430 and 0444 on July 5; the call and slogan: "Radio Popular" were easily followed at 0445.

Brazil and Peru. P. E. Woolmer advises us that ZYK3, 9565 kc, now broadcasts the English feature, "Brazil Calling," daily at 0105 instead of on Sundays at 2030; ZYB8, 11765 kc, is on the air 2000-0330 and uses the slogan "Radiodifusora de Sao Paulo" as a means of identification. ZYB9, Sao Paulo,

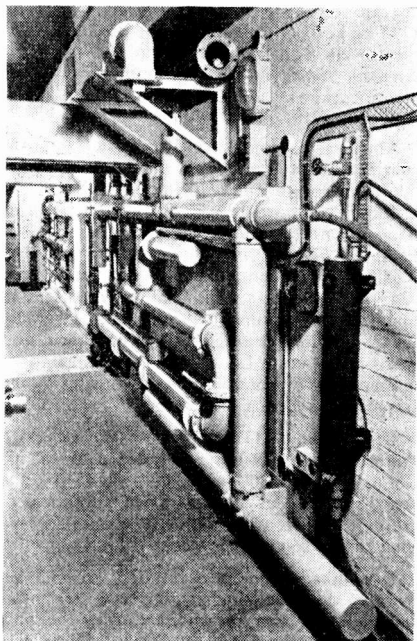

Since the Sutton Coldfield TV transmission operates on the vestigial sideband principle—that is, only the lower frequency sideband is fully radiated—an upper sideband filter is required. This is it, constructed of lengths of concentric feeder, and consisting of high-pass and low-pass sections, with a water-cooled absorber load.

15155 kc, has lately provided R. A. Savill with its card, and he has further logged PRA8, 6016 kc, audible from the early evening and peaking to S8 by 2200.

OAX4Z, Lima, 5896 kc, was a good S9 when transmitting a programme from the "BBC de Londres" at 0415 on June 24; at 0425 came the words: "Radio Nacional de Peru" and "Muchas gracias por sa atención," and the Peruvian National Anthem brought the proceedings to a close at 0426. OAX4V, Radio America, 5908 kc, is nothing like so consistent; on July 12 at 0320, however, its dance music could be followed without undue strain.

Dutch Guiana. PZH5, Paramaribo, using 5730 kc, has provided R. A. Savill with some good musical programmes after 2200 daily.

Central America and West Indies

Panama. HOHM, Radio Continental, 6040 kc, broadcasts the same features as HP5A, 11697 kc, and closes down at 0500.

El Salvador. HUB, Radiodifusora Nacional, San Salvador, which is supposed to

operate on 4845 kc, was logged by us on 4795 kc at 0345 on July 7; the broadcast was sponsored and consisted mainly of vocal tangos. Severe morse interference prevented identification by the precise station call at the close down at 0400.

Another comparatively unknown station heard at 0410 on the same day was YSC operating on 6010 kc, with a "Coca-Cola Calling" programme; at 0415 after a series of gong notes came the direction: "Yay-Essay-Say, Radio Mil Veinti-cincuo." YSUA, Radio Mil Cincuenta, 6250 kc, was heard from 0243 until 0455 on June 24; programmes in Spanish were sponsored, one being given by La Compania Westinghouse en Salvador, and items consisted of Latin-American dance tunes interspersed by such familiar favourites as the Indian Love Lyrics.

Guatemala. TGWA, on 15170 kc, with marimba band music, was heard by J. C. Catch between 2200 and 2300; on 9764 kc he heard TGWA at 0330, with a similar programme and frequent calls. G. Roberts heard the 9764 kc transmission at 0415 at 57.

Honduras. The new station HRX, on 9000 kc, has been logged by the writer on at least six different occasions during the past month. A pianoforte version of "Tea For Two" was one item heard at 0235 on June 28, and after a fox-trot at 0345 on July 8 came the direction: "Esta es Hatchay-Erray-Ekis": a single gong-note precedes certain of the Spanish announcements. On July 5, at 0422, HRX was engaged in relaying a running commentary on a pelota game in which the words Nicaragua and El Salvador figured prominently. HRN, 5875 kc, was giving the same commentary and finally closed with the Ted Lewis Good Night Melody at 0441. HRX normally closes down with a March at 0400.

HROW, Radio Monserat, in the city of Tegucigalpa, is a new one on 6025 kc; it operates with a power of 3 kW from 0330 to 0500 daily.

British West Indies. VP4RD, Radio Trinidad, Port of Spain, 9625 kc, is on the air daily at 1000-1800 and 2000-0300. We logged it at good strength on one occasion at 0215, when the announcer said: "This is Radio Trinidad. We are asked to announce the following death. . . . A service will be held in St. Margaret's Church tomorrow afternoon." Subdued music followed this and other similar announcements. VPO3, Bridgetown, Barbados has, on occasions, been operating between 0300 and 0345 on both 10605 kc and 11780 kc. ZQ1, Kingston, Jamaica, 3480 kc, is a variable signal; on July 12 at 0300, however, it was particularly good with recent dance tune "hits."

Curacao, Haiti and Cuba. PJC1, Willemstad, Curacao, 5010 kc, with a power of 4 kW, provides a good enough signal if you are up early enough to hear it; on June 28 we were just able to listen to its concluding direction and the Dutch National Anthem at 0225.

4VRW, Port-au-Prince, 10205 kc, was also an excellent signal on the same date at 0230 when two gong notes preceded the French call; then came the English announcement for the "Bringing Christ To The Nations" session, in which Dr. Peacock gave the address. The missionary station 4VEH, Cap-Haitien, 9886 kc, has been a star turn with its hymns sung by a mixed choir and sermons in Spanish. On July 1 it closed at 0210 with this English announcement: "This is Radio Station 4VEH, Cap-Haitien, Haiti. We shall be very glad if you will write and tell us how you have received our transmission; our address is: Box 1, Cap-Haitien, Haiti. We shall be on the air tomorrow at 7 a.m. and again at 7 p.m. Eastern Standard Time. Until then—Good-night."

Lastly, J. C. Catch has checked COKG's frequency as 8956 kc; at 0345 he heard the following clear direction: "Cadena Oriental de Radio, Santiago de Cuba."

R. W. Finch would like a long-term competition in which listeners would, from a given date, attempt to log all South and Central American countries, or, to make it a little more difficult, seek to identify three radio broadcasting stations, say, in each.

Though there would not be any prize, a "ladder" could be prepared each month indicating the varying stages reached by each entrant.

Perhaps other readers would care to offer suggestions for such a contest?

Europe

M. C. Cobb asks about call-signs of BBC short-wave stations; these assignments are quite definite in the official lists, but so far as we are aware, the actual call-letters are never mentioned by the BBC announcers. M.C.C. wonders why FET should be used by Alicante, Spain, seeing that F is the initial call-letter for all French stations; the double letters FE appear to be used for quite a number of Spanish commercial broadcasting stations, and probably indicate the initial letters of some important (possibly political) network. Our correspondent also asks for the frequency of the Austrian Blue Danube short-wave station, and M. A. S. Race (Alton, Hants) kindly supplies the answer. He writes that Radio Station KZCA at Salzburg is heard at good strength on 9620 kc, between 0830 and 1515 each day. M.A.S.R. has also received PCJ's

photograph depicting their rotary beam and the Swiss Broadcasting Corporation's card and programme schedule.

S. Neeld heard News from London at 1300 on July 22, when listening to the Forces Broadcasting Station, Malta, on 11895 kc, and D. K. Cocking (Farnborough Park, Kent) suggests that the direction: "This is Your Forces Broadcasting Service, Middle East" in the 60-metre band is an ever-present even when all other DX in that range is missing. G. Bennett (Bramhall, Cheshire), once stationed near the Salonika Broadcasting House, is interested in broadcasts from Greece; the main English transmissions from Athens are as follows: Daily: 15345 kc: 1545-1600 and 2230-2245: this information comes from the Managing Director of the National Broadcasting Institute, No. 4 Rigillis Street, Athens. The Greek Armed Forces Radio Station on 6745 kc, using 500 watts, operates as follows: 0430-0630; 1000-1300 and 1600-2100 daily. P. E. Woolmer tells us that a station at Chania, Crete, is working daily on 10050 kc from 1030 until 1200.

B. P. Middleton says that Radio Italiana, Rome, has a new English programme beamed to the Far East at 0815, which goes out on 17860 kc, 17750 kc, 15380 kc, 15150 kc and 11810 kc; M. C. Cobb notes that 17860 kc and 17750 kc are used for the South African service at 1830.

G. Roberts heard HVJ, Vatican City, 9660 kc, broadcasting the canonisation ceremonies for Saint Maria Garretti on June 24; for him, he says, it was indeed an impressive and unusual experience.

Budapest radiates an English broadcast daily at 2100 on 9820 kc, according to B. P. Middleton; they devote a considerable amount of time to Hungarian gypsy music. YUC, Belgrade, 9506 kc, has interested D. K. Cocking as early as 0545 with English News and subsidiary items.

R. A. Savill says that Luxembourg on 6090 kc has been excellent of late, and M. C. Cobb notes that while waiting for the Voice of America Munich transmitter on 15280 kc to open up at 1600, he heard the following direction on the same channel: "DTSP, Munich, closing down." He therefore concludes that such American-operated stations are now using German call-letters exclusively.

Finally, R. A. Savill has a verification for OZU, Denmark, 7260 kc; it depicts the Entrance Hall of the Radio House in Copenhagen: the Danish State Radio broad-

casts "Everybody's Programme" in English every second Tuesday over OZF, 9520 kc, from 0300 to 0330, and over OZH, 15165 kc, from 1020 to 1050.

Lack of space prevents further discussion of interesting letters received this month from P. Inman and E. Strangeway (Cottingham, E. Yorks), C. P. Turner (Crewe), G. Howell (Swaffham, Norfolk), J. S. Ballard (Chester), R. J. Riding (Wednesfield, Staffs) and A. E. Nichols (North Shields), but their contents will be dealt with in full in the next issue. Further correspondence is invited. Kindly send all comments and short-wave broadcasting news to reach this office not later than September 15. The address is: R. H. Greenland, *The Short Wave Listener and Television Review*, 53 Victoria Street, London, S.W.1.

ADDRESS NOTE

When writing to us on any subject, you should direct your letter not only to the department concerned within our own organisation (as DX Scribe, Circulation Manager, or Advertising Manager), but it is also essential to add our name, "Short Wave Magazine, Ltd." (or *Short Wave Listener and Television Review*) as well. The reason is that No. 53 is a large building accommodating the offices of some 60 business concerns, and some of them are publishers quite unconnected with our own activities. So if you address your letter simply "DX Scribe, 53 Victoria Street," you can imagine that it will wander round for days before finding its rightful home!

SMALL ADVERTISING

The attention of all readers having "Small Wants or Disposals" is drawn to the valuable feature in our back pages, the Small Advertisement Section. The rates are low and the coverage excellent, and we feel that this space is not being used as freely as it could be, having regard to our total average readership. If you have something of radio interest to sell, or some particular requirement, why not try a Small Advertisement?

TV Q. and A. SERVICE

The attention of readers interested in Television is drawn to the note appearing on p. 294 of our August issue. If you have a query, send it in. We want to run a regular Question and Answer feature in *Short Wave Listener and Television Review*.

The Short Wave Listener covers every SWL interest

SMALL ADVERTISEMENTS

CHARGES : *Readers'*, 2d. per word, minimum charge 3s. *Box Nos.* 1s. 6d. extra. *Trade*, 6d. per word, minimum charge 7s. All advertisements must be of radio interest only. Add 25% extra for Bold Face (heavy type) announcements. Copy date for next issue, September 11, addressed Advertisement Manager, *Short Wave Listener*, 53 Victoria Street, London, S.W.1.

QSL CARDS AND LOG BOOKS. APPROVED G.P.O. SAMPLES FREE. ATKINSON BROS., PRINTERS, ELLAND, YORKS.

FOR sale. Eddystone 640 in perfect condition, operated for only 127 hours. Barkain at £25. J. Wagstaffe, 8 Bitton Crescent, Teignmouth, Devon.

R1116, completely modified mains, seven octal valves, S-meter, good condition. Offers £6.—Rolfie, 140 Normanshire Drive, Chingford, London, E.4. (SIL. 3258.)

BC348R with 230v AC power supply, first-class condition, six new spare valves, £17. Premier VCR97 TV, complete with spare CRT, spare valves, cabinet, £20. Coils and metalwork for *Wireless World* superhet television receiver. £2. Twenty copies *Short Wave Magazine*, 1949-1950, 12s. Seventeen copies *Short Wave Listener*, 6s.—Martin, 3 Cliff Avenue, Loughborough, Leicester.

R1155A as new. PP, speaker, amplifier, in walnut case. Twelve *Short Wave News*. Nearest £14.—Froggatt, 28 Lea Street, New Mills, Stockport, Cheshire.

PUBLICATIONS OF THE SHORT WAVE MAGAZINE, LTD.

Short Wave Magazine, 80 pp., published first week each month, 20s. a year, post free.

Short Wave Listener & Television Review, 40 pp., published third week each month, 16s. a year, post free. With *BSWL Review*, 52 pp., membership 17s. 6d.

DX Operating Manual,* 36 pp., seven chapters, art production, price 2s. 8d., post free.

Principles of Short Wave Reception,* 32 pp., reprint articles from early issues of the *Magazine*, price 1s. 8d., post free.

The Zone Map,* Great Circle map of the World, size 21 in. by 35 in. for wall-mounting, in five colours on heavy linen-backed paper, giving Zone areas, Zone prefix lists, GMT time scale, exact bearing and rough distances for all parts of the world relative to the U.K., price 6s., post free.

Calls Heard Report Forms, for sending lists in to us for publication or checking, free on application with stamped addressed envelope.

* Trade Supplies Available

THE CIRCULATION MANAGER,
SHORT WAVE MAGAZINE, LTD.,
53 VICTORIA STREET, LONDON, S.W.1

PERSONAL portable 4-valve TRF receiver, medium wave, brand new, £8.—Hayes, 8 Althorpe Crescent, New Bradwell, Wolverton, Bucks. (Phone WOLVERTON 2280.)

S640 under 100 hours' use. Guarantee till September. Bargain, £21, plus carriage. WS21 receiver, new, unused, 9 valves, 31s. 6d.—Curtis, Northfield Road, Milford-on-Sea, Lynton, Hants.

FOR Sale : Hambander, 12 months old, excellent condition, 1-7 to 33 mc. £10 or nearest offer.—6/242 Royal College Street, London, N.W.1.

EDDYSTONE 750, used week only, fully guaranteed. £42 10s. Owner unexpectedly called abroad, must sell.—Box No. 796.

WANTED : HRO G.C. coil pack for 80/960/kc. Good price paid.—Ascoli, Letham, Angus.

WANTED : Service handbooks on Marconi B36 and R.A.F. Types 76 and 78 receivers, or any information which would assist in putting into working order.—Box No. 798.

640 Eddystone as new, perfect condition, and performance excellent, only just out of guarantee, with Eddystone matching speaker, £21. Buyer collects.—L. F. Gasden, Torweigan, Halliford Road, Sunbury-on-Thames, Middlesex.

BARNES RAD-ELEC & WHOLESALE CO.

12 Pipers Row, Wolverhampton Central

We can still supply all items mentioned in "Mag." and "Listener" for last 3 months, but deliveries are longer than we should like due to pressure of orders and increase in stock due to further big purchases ready for your winter needs. We hope to have catalogue ready soon, meanwhile watch for bargains; 250v workshop distribution boards, 15" x 4", backs fully insulated and 3/4" panel with 28 of 15 amp. terminals, jocking type, ready to screw on wall, 6/6, post free; S.130 stabilizer valves, 10/- pair; bases for V.C.R. 138/139a/3141, etc. Small cath. tubes, 2/6; VCR97 screens, 4/-; BC624Rx, 32/-.

JOIN THE LEAGUE !

The steady increase in the membership of our British Short Wave League is a sure sign that SWL's generally recognise not only the value of the work the BSWL is doing for them, but also the advantages of membership. One of these is the *BSWL Review*, incorporated with the *Short Wave Listener & Television Review*, the subscription thus covering the combined journal of 52 pages, free to all League members.

For Further Information and Form of Application write :

The Manager,
British Short Wave League,
53 Victoria Street,
London, S.W.1.

You must have good Books!

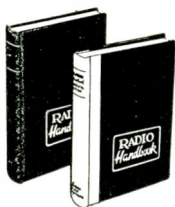

RADIO HANDBOOK

Eleventh Edition, 1949. Theory with emphasis on Amateur Radio. 25s. Post 1s. 2d.

Twelfth Edition, 1950. Practical and Constructional Material only (see previous advertisements) for the Radio Amateur and Experimenter. *Immediate delivery.* 25s. Post 10d.

RADIO AMATEUR'S HANDBOOK

An A.R.R.L. publication. Now in its 27th Edition! 600 pages on Theory, Design, Construction and Practice. A leader in its class. *Immediate delivery.* 18s. 6d. Post 10d.

ANTENNA MANUAL

Design and Construction of Aerials of every kind, for Radio Amateurs, Engineers and Technicians. (300 pages). *Immediate delivery.* 27s. Post 10d.

ANTENNA HANDBOOK

Fifth Edition of the A.R.R.L.'s own publication on Aerial Theory and Installation. *Immediate delivery.* 11s. Post 7d.



SURPLUS CONVERSION MANUALS

Giving much detailed practical information on the adaptation of a wide range of American surplus items. Well illustrated with circuit diagrams, drawings and photographs. In two Vols. *Immediate delivery.* per Volume 21s. Post 5d.

HINTS & KINKS

Useful collection of technical ideas and practical workshop data, written up in shortened form. An A.R.R.L. publication. *Immediate delivery.* 11s. Post 5d.

RADIO AMATEUR CALL BOOK

The World's only directory of amateur stations—Over 100,000 callsigns and addresses, alphabetically—Constantly revised and kept up to date. *Immediate delivery.* Latest quarterly issue, 16s. Post 10d.

Any American Radio or Technical Publication Supplied. Ask for our Quotation

QST, the leading American monthly on Amateur Radio, established over 30 years ago. For a year of 12 issues 36s.

CQ, an independent American magazine for Radio Amateurs, monthly. 12 issues 29s.

AUDIO ENGINEERING

A monthly of quite unusual value and interest to all concerned with the design, construction and operation of audio equipment of every kind. 12 issues. 29s.

Suppliers of Technical Books and Publications to Schools, Universities, British and Colonial Government Departments.

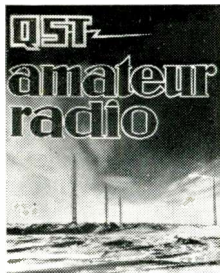

GAGE & POLLARD, Publishers' Agents,

49 VICTORIA STREET, LONDON, S.W.1.

Abbey 5342

CLYDESDALE

Bargains in Ex-Services Radio and Electronic Equipment

"SHIPPING"



"TOP BAND"

"DX BANDS"

These are all features of the Ex.-R.A.F. R1124A, plus the fact that NO MAINS SUPPLY is required for this excellent little communications receiver. The R1124A operates from an H.T. supply of 120v D.C., L.T. supply of 2 volts, and a Grid bias battery. This enables the set to be taken away from the home QTH to the 'P' location without bother.

Frequency coverage is 1 to 9 mc/s (300 to 33.3 metres) in three bands, and the slow motion dial provides extraordinary ease of tuning on 40 and 80. "Top Band"—160 metres is included in the range together with "Shipping," and the H.F. end of the Broadcast band.

Very few receivers offer so much for the Amateur, S.W.L. or lay-man operator who has no Power Supplies from the Mains.

R.F. Stage, 470 kc/s I.F., 600 ohms or Hi-imp headphone outputs, Slow motion tuning, reaction control. The valve line being—VP23 (R.F.), FC4 (Mixer), VP23 (I.F.), 21OLF (Det.), 220 PA (Output).

Enclosed in a wooden cabinet (less batteries) with calibrated chart on hinged lid. Dim.—14½ × 10 × 9½ in. Finished in grey.

Clydesdale's
Price only

£5/19/6 each

Carriage
paid

Circuit and data for R1124A available at 1/3 each, post paid.

"SHARP CHANNEL" QS'R OR CAR RADIO

46129 (equivalent BC453) Command Receiver is quite effective and justifiably popular as a sharp channel I.F. system to follow any conventional communications receiver having an I.F. of 190 to 550 kc/s. The receiver operates with an I.F. of 85 kc/s. Except for re-wiring the heater circuit (24v as is) to conform with the supply available, no further major modifications need to be done.

The BC453 makes an excellent car radio for M.W. reception, and can be readily modified by installing the M.W. COIL UNIT, price, 10/-, from us, and correcting the valve heater circuit to conform with supply available, and installing a speaker and H.T. Vibropack.

Clydesdale's **63/-** Carriage
Price only paid
Circuit diagram supplied with each unit.

V.H.F. CONVERTER

The RF27 is a tunable converter covering 65-85 mc/s (3.5-8.5 metres) and can be used in conjunction with practically any receiver which tunes 7 mc/s (40 metres). The oscillator output of the RF27 being 7 mc/s. A short co-axial lead can be taken from the output plug of the RFU to the aerial terminal of the receiver.

The line-up includes an R.F. stage VR136 (EF54), Mixer VR136 (EF54) and Oscillator VR137 (EC52). Contained in a metal case, 9½ × 7¼ × 4½ in.

Clydesdale's **35/-** Post
Price only paid

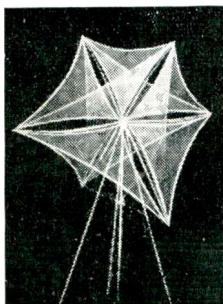

REFLECTOR AERIAL

This unit provides an excellent aerial for mounting in the loft for indoor use, but can be mounted outdoors.

Makes an extraordinary FB omnidirectional portable unit for either receiving or transmitting (can be loaded admirably on "40" by using Collins Coupling).

Packed in original moisture proof carton with assembly instructions.

Height assembled, 6 ft. approximately.
Width assembled, 4 ft. approximately.

Clydesdale's
Price only

5/6 each

Post
paid

MODULATOR

The BC456 is a speech modulator which can be modified for use from A.C. mains supply, ample room being available on the chassis for the installation of the P.P.

The unit employs a 1625 directly driven into the grid, a 12J5 side-tone monitor, and a VR150/30. Components include, Transformers, Chokes and relays.

Chassis dimensions, 10½ × 7½ × 4½ in.
Clydesdale's **19/6** each Post
Price only paid
(less dynamotor)

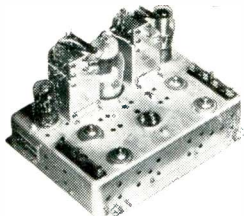

5 VALVE SUPERHET FEEDER

Type 78 Superhet "feeder" receiver unit with a frequency range of 2.4 to 5 and 5.8 to 13 mc/s in two switched bands. This receiver can be easily modified for use with a Mains power unit.

FEATURES:—Built in 100 kc/s crystal sub-standard. 53:1 ratio frequency calibrated drive. Dessigny trimmer control provides a 15 kc/s remote variable tuning control. Illuminated dial, etc.

Originally intended for a 26v heater supply, but can be very simply altered for standard input.

Clydesdale's
Price only

47/6

Carriage
paid

Circuits supplied with each unit.

Order direct from:—

*Phone: SOUTH 2706/9

CLYDESDALE SUPPLY CO. LTD. • 2 BRIDGE STREET
GLASGOW - C.5

VISIT OUR BRANCHES IN SCOTLAND, ENGLAND AND NORTHERN IRELAND