

AUG

# THE RADIO REVIEW

A MONTHLY RECORD OF SCIENTIFIC  
PROGRESS IN RADIOTELEGRAPHY  
AND TELEPHONY

VOL. II

AUGUST, 1921

No. 8

Editor :

PROFESSOR G. W. O. HOWE, D.Sc., M.I.E.E.

Assistant Editor :

PHILIP R. COURSEY, B.Sc., F.Inst.P., A.M.I.E.E.

---

## CONTENTS

### Editorial

The Heart-shaped Polar Diagram and its Behaviour under Night Variations . . . . . G. M. WRIGHT and S. B. SMITH

A High-frequency Machine of Greater Specific Power and Higher Efficiency . . . . . MARIUS LATOUR

Radio Telephone Circuits and Modulation . . . . . W. A. MACDONALD

On the Function of the Variable Anode Tap Connection in Triode Generators . . . . . E. V. APPLETON, M.A., M.Sc.

The "Feedback" or "Regenerative" Valve Circuit

Receiving Valve Patent Action

Notes : Personal, Commercial, General

Review of Radio Literature :—

Abstracts of Articles and Patents

Book Reviews

---

*Five Shillings Net*

# Radio Books for the Library.

---

## Telephony Without Wires.

By COURSEY, PHILIP R. (B.Sc. (Eng.), A.M.I.E.E.). 414 pages. Demy 8vo. 249 Diagrams and Illustrations. Price 15/- net. Postage 9d. extra.

## The Thermionic Valve and its Development in Radiotelegraphy and Telephony.

By FLEMING, J. A. (M.A., D.Sc., F.R.S., etc.). Demy 8vo. 279 pages. 144 Diagrams and Illustrations. Price 15/-. Postage 6d. extra.

## Standard Tables and Equations in Radiotelegraphy.

By HOYLE, BERTRAM (M.Sc.Tech., A.M.I.E.E.). Demy 8vo. 159 pages. Price 9/- net. Postage 6d. extra.

## The Oscillation Valve—The Elementary Principles of its Application to Wireless Telegraphy.

By BANGAY, R. D. Crown 8vo. 215 pages. Price 5/-. Postage 4d. extra.

## Vacuum Tubes in Wireless Communication.

By BUCHER, E. E. Second Edition. Demy 8vo. 178 pages. 130 Diagrams and Illustrations. Price 9/- net. Postage 6d. extra.

*Published by*

**THE WIRELESS PRESS**  
LIMITED

12-13, Henrietta Street, London, W.C.2

Telephone :  
GERRARD 2807.

Telegrams :  
"RADIONIC, RAND, LONDON."

# THE RADIO REVIEW

A MONTHLY RECORD OF SCIENTIFIC PROGRESS IN  
RADIOTELEGRAPHY AND TELEPHONY

Editor : Prof. G. W. O. HOWE, D.Sc., M.I.E.E.      Asst. Editor : PHILIP R. COURSEY, B.Sc., A.M.I.E.E.

SUBSCRIPTION RATES.—£3 per annum, post free.      Single copies, 5/-. or post free, 5/3.

<b>Vol. II. No. 8</b>	Registered at the G.P.O. for transmission by Magazine Post to Canada and Newfoundland.	<b>AUGUST, 1921</b>
-----------------------	--	---------------------

## Contents

	PAGE
EDITORIAL . . . . .	393
THE HEART-SHAPED POLAR DIAGRAM AND ITS BEHAVIOUR UNDER NIGHT VARIATIONS. By G. M. WRIGHT and S. B. SMITH . . . . .	394
A HIGH-FREQUENCY MACHINE OF GREATER SPECIFIC POWER AND HIGHER EFFICIENCY. By MARIUS LATOUR . . . . .	403
RADIO TELEPHONE CIRCUITS AND MODULATION. By W. A. MACDONALD . . . . .	409
ON THE FUNCTION OF THE VARIABLE ANODE TAP CONNECTION IN TRIODE GENERATORS. By E. V. APPLETON, M.A., M.Sc. . . . .	419
THE "FEEDBACK" OR "REGENERATIVE" VALVE CIRCUIT . . . . .	424
RECEIVING VALVE PATENT ACTION . . . . .	430
NOTES :—	
Personal . . . . .	430
Commercial . . . . .	431
General . . . . .	431
REVIEW OF RADIO LITERATURE :—	
Abstracts of Articles and Patents. . . . .	432
Book Reviews :	
"Continuous Wave Wireless Telegraphy." By W. H. Eccles, D.Sc. . . . .	446
"Relativity, The Electron Theory and Gravitation." By E. Cunningham, M.A. . . . .	447
Correction : "Current Suppression by means of Parallel Resonance." By H. G. Cordes . . . . .	448

# THE RADIO REVIEW

## INFORMATION FOR CONTRIBUTORS

All correspondence relating to contributions should be addressed to *The Editor, The "Radio Review," 12 & 13, Henrietta St., Strand, London, W.C. 2.*

Correspondence intended for publication in the "Radio Review" must be accompanied by the full name and address of the writer, not necessarily for publication if a "nom-de-plume" is added, and should reach the Editor not later than the 7th of the month, for publication in the next issue.

The copyright of all articles accepted for publication in the "Radio Review" becomes the property of *The Wireless Press, Ltd.*, unless special arrangements are made with the author at the time the article is submitted. Limited portions or abstracts of articles, or editorial notes, may however be reprinted on the express condition that specific reference is made to the "Radio Review" as the source of such material.

All manuscripts will be acknowledged as soon as received. The Editor will not be responsible for the return of manuscripts unless they are accompanied by a stamped addressed envelope, or by an international postage coupon in the case of foreign contributions. Manuscripts should be as complete as possible, with all necessary diagrams and illustrations. Line diagrams accompanying manuscript should only be in rough form, and will be redrawn before publication. Illustrations of apparatus should not be too small. They are best for reproduction when in the form of good photographic prints, wherever possible on glossy paper.

In articles involving the use of mathematical expressions and formulæ, the internationally recognised standard symbols should be employed wherever possible, and be given their most generally accepted significations.

Reprints of articles published in the "Review" can be supplied to authors at the following rates if they are ordered when returning the corrected proofs of the article.

RATES FOR REPRINTS (postage extra).

No. of Copies.	4 Pages.			6 Pages.			8 Pages.			10 Pages.			12 Pages.			14 or 16 Pages.			Extra for Cover.		
	£	s.	d.	£	s.	d.	£	s.	d.	£	s.	d.	£	s.	d.	£	s.	d.	£	s.	d.
25 . . . . .	1	4	9	1	19	9	2	15	0	3	10	0	3	19	9	4	13	6	0	16	6
50 . . . . .	1	5	9	2	1	0	2	16	3	3	12	0	4	2	3	4	16	3	0	18	0
75 . . . . .	1	6	6	2	2	6	2	18	3	3	14	3	4	4	9	4	19	0	0	19	3
100 . . . . .	1	7	3	2	3	9	3	0	0	3	16	6	4	7	3	5	1	9	1	0	9
150 . . . . .	1	9	0	2	6	6	3	3	3	4	0	9	4	12	3	5	7	3	1	3	6
200 . . . . .	1	10	9	2	9	3	3	6	0	4	5	0	4	17	0	5	12	9	1	6	3
250 . . . . .	1	12	3	2	12	0	3	10	0	4	9	9	5	2	0	5	18	3	1	9	0



# THE RADIO REVIEW

---

VOL. II

AUGUST, 1921

No. 8

---

## Editorial.

**A New Direction Finder.**—In this issue we publish a description of a new method of direction finding developed by the engineers of the Marconi Company. The advantage claimed for this new method is that it is less seriously affected by the reflection and refraction phenomena which are usually known as night effect. It is now well known that an ordinary direction finder of the single or crossed-coil type may give very erratic results at night and more especially at sunrise and sunset, the direction of the transmitting station appearing to wander about, the deviation in some cases reaching  $90^\circ$  from the true bearing. In the paper published in the February issue of the RADIO REVIEW Mr. T. L. Eckersley showed that one of the main causes of this aberration was the presence of a wave with a horizontal electric field coming down at an angle on to the receiver after reflection from the upper atmosphere. Such effects would therefore be expected when receiving from an inverted "L" aerial, broadside on to the receiving station, since the horizontal portion would radiate waves polarised in the direction to produce these disturbing effects. The system described by Messrs. Wright and Smith consists of the well-known combination of the Bellini-Tosi aerial and an open aerial, adjusted to give a heart-shaped diagram with a single zero. The plain aerial effect which was regarded as an evil by the users of the frame direction finder is here made to serve a useful purpose. The diagrams which accompany the paper show how the polar curve would be distorted by the night effect on certain assumptions. These diagrams indicate, however, that a receiver of this type may give very inaccurate results, since, although the position of the minimum remains unchanged, the shape of the curve on either side of it may be very different. If the signals are so strong that the minimum is sharply defined there should be no difficulty; this agrees with the results given in the paper, the signals from Lyons and Clifden being relatively strong. With weak signals, however, where one would find a wider silence range the correct zero could not be determined so accurately. The fact that experimental results agree with those predicted from these diagrams serves as a further confirmation of Eckersley's theory of the cause of the night effects.

**E. H. Armstrong v. Lee de Forest.**—We publish in this issue the judgment delivered by Judge Mayer in the action brought by Armstrong for infringement of his well-known feedback or retroactive receiving circuit.

c o

It will be seen that this is wholly in favour of the plaintiff. We feel justified in reproducing this judgment almost in full both because of its historical importance and because of its scientific and commercial importance. There is moreover much human interest in Judge Mayer's account of the early struggles of the "enthusiastic never-say-die young student—feed-back Armstrong—with but one thought possessing him." [3004]

## The Heart-shaped Polar Diagram and its Behaviour under Night Variations.\*

By G. M. WRIGHT and S. B. SMITH,  
*Marconi Research Department.*

The polar curve of a single frame aerial is the well-known cosine diagram and that of a vertical aerial is a circle. If their characteristics be combined in the correct manner a heart-shaped polar curve will be the resultant. To obtain this result the currents induced in a frame aerial and a vertical aerial by an incoming signal must be combined in the correct phase and amplitude. Assuming both to be in tune with the wave frequency, the current in the vertical aerial is in phase with the wave and the current in the frame lags  $90^\circ$  behind the wave. This follows at once from the fact that in the case of an open aerial the E.M.F. induced is proportional to the number of lines cutting the conductor whereas in the case of the frame the E.M.F. is proportional to the rate of change of the number of lines cutting or linking with the frame. Now in order that a perfect minimum may be obtained it is necessary that these two currents shall be in phase, consequently the open aerial current must be made to lag  $45^\circ$  on its E.M.F., and the current in the frame must lead  $45^\circ$ . This shifting of phase is accomplished by a slight mistuning of the two circuits, the vertical aerial being tuned to a little longer wavelength than the signal and the frame a little shorter. It is to be noted that a pure minimum will be obtained by interchanging the mistuning, but the direction of the minimum will be of opposite sense to that previously given.

It will be understood that this adjustment of the phase is necessarily of a very critical character, a very small change of tune producing a large shift of phase in the current in the circuit (providing that the damping is not very large). It is customary in practice to use the Bellini-Tosi system of aerials in preference to a rotating frame, and this complicates the question of phasing still further.

If the aerials are not tuned by variable condensers but are tightly coupled to the search coil of the radiogoniometer then the circuits can be considerably simplified and the critical phasing adjustments eliminated.† This is the so-called "Aperiodic Aerial" method of using the Bellini-Tosi system of

\* Received June 14th, 1921.

† See H. J. Round, *Journal of the Institution of Electrical Engineers*, 58, pp. 224—257, March, 1920.

aerials and is superseding the tuned aerial system. Referring to Fig. 1 a b c is a closed loop aerial which has connected in series with it one field coil of a radiogoniometer  $L_1$ ; a similar loop is arranged at right angles to it, and is connected to the other field coil of the radiogoniometer. The search coil of the radiogoniometer is connected to the coils  $L_4$  and  $L_5$  in series, and the circuit is tuned by a variable condenser C.  $L_6$  is the jigger secondary coupled to  $L_5$  and is tuned by a variable condenser, the amplifier being connected across its terminals. The vertical aerial A is connected through a resistance R and the coil  $L_3$  to earth. The radiogoniometer is arranged to have as tight a coupling as possible in order that it may act as a transformer and so allow the frame aerial to be effectively tuned by means of the condenser C. The inductance of the field coils should be reasonably large compared with that

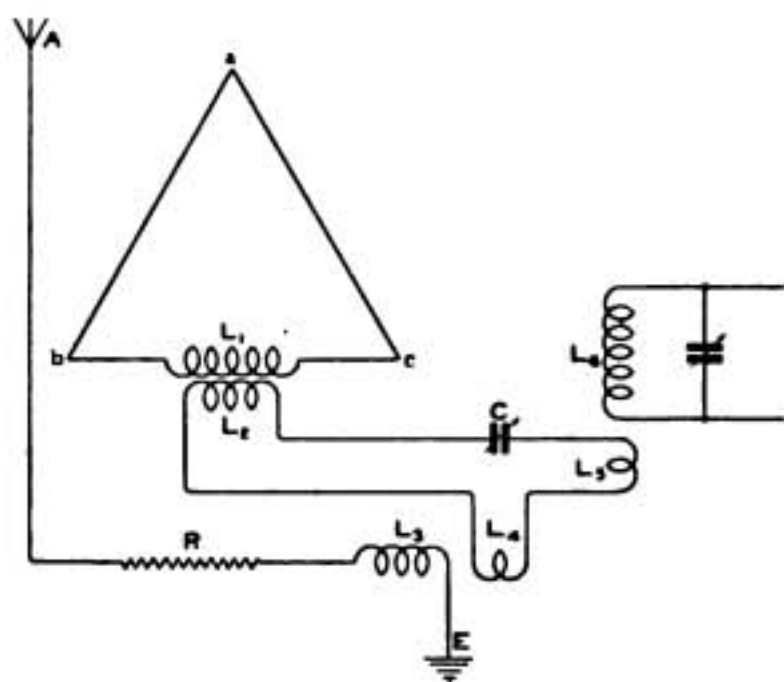

FIG. 1.

of the aerials, and the winding of the search coil must nearly fill the space enclosed by the field coils. If the leakage factor is in this way reduced to the lowest possible value, the maximum aerial tuning effect by the condenser C is obtained when the leakage inductance of  $L_1 L_2$  is equal to the inductance of the aerial.

The coil  $L_4$  is provided for the introduction of the E.M.F. due to the vertical aerial A.

Now assuming the coupling between  $L_3$  and  $L_4$  and the value of the resistance R to have been suitably adjusted, let us consider the state of affairs existing when a signal arrives from the direction of zero reception of the system. In Fig. 2 let the vector  $E_v$  represent the direction and magnitude of the E.M.F. induced by the wave in the vertical aerial. Then the E.M.F. induced in the loop will lag  $90^\circ$  behind  $E_v$  and can be represented by  $E_f$ . If R is sufficiently large compared with the reactance of the open aerial, the current in this circuit will be in phase with  $E_v$ . On the other hand, owing to the fact that the impedance of the loop is mainly inductive the current in it will lag  $90^\circ$  behind  $E_f$  as shown by the vector  $I_f$ . The vectors  $I_v$  and  $I_f$  are  $180^\circ$  apart in phase and are consequently in the correct positions to give a balance when the amplitude of  $I_v$  is right; which condition is secured by the adjustment of the coupling between  $L_3$  and  $L_4$  (Fig. 1) and, within limits, of the resistance R.

The coil  $L_4$  is provided for the introduction of the E.M.F. due to the vertical aerial A.

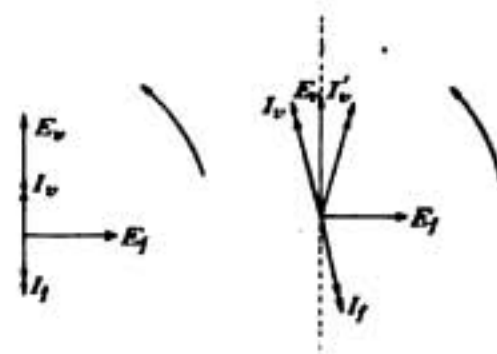

FIG. 2.

FIG. 3.



It might, at first sight, be thought that the above reasoning was incorrect owing to the fact that no account has been taken of any shift of current phases in the loop or open aerial circuits by the tuning of the circuit  $L_2 L_3 L_4 C$ . But it must be borne in mind that *at the minimum of the heart-shape diagram* (which is the point to which we have referred in the foregoing argument) there is no current in this circuit, and consequently as far as the aerial circuits are concerned  $L_2 L_3 L_4 C$  does not exist; therefore, we are perfectly justified in considering the phases, etc., of the currents in the aerials only.

These currents will induce E.M.F.'s in  $L_4$  and  $L_2$  and the condition to be obtained is that the instantaneous E.M.F. in  $L_4$  must be equal and opposite to the E.M.F. in  $L_2$  at all times. This point was brought out experimentally in the first trials of the arrangement. In this case the coil  $L_4$  was not used, but  $L_3$  was coupled on to  $L_5$  and  $L_6$  together. It was found that a slightly different adjustment of  $L_3 L_2$  and  $C$  was required to obtain a perfect balance for different couplings between  $L_5$  and  $L_6$ . This was due to the fact that the circuits would actually be adjusted so that the current in  $L_5$  produced an equal and opposite E.M.F. in  $L_6$  to that induced by the current in  $L_3$ . Under these circumstances the tuning of the circuit  $L_2 C L_5$  would influence the phase of the current in the loop aerial and so upset the balance. It is for this reason that the separate coils  $L_4$  and  $L_5$  are provided for the application of the E.M.F.'s to the circuit  $L_2 C L_5 L_4$ .

It is also necessary that the coil  $L_3$  should be of such an inductance that the natural frequency of the open aerial circuit is a little higher than the frequency of the received wave. The reason for this will be seen by a closer study of the vector diagram of E.M.F.'s and currents in the circuits. In Fig. 3  $E_o$  and  $E_f$  again represent the E.M.F.'s in the open and closed aerials respectively, being  $90^\circ$  out of phase. Then it is clear that, no matter how large the resistance  $R$  is made, the current can never be exactly in phase with  $E_f$  but will occupy some phase position such as  $I_r$  or  $I_r'$  depending upon whether the natural frequency of the circuit is higher or lower than that of the wave. Also since the loop aerial and radiogoniometer field coils possess resistance the current  $I_f$  will not lag quite  $90^\circ$  behind  $E_f$ . From the figure it can at once be seen that the purest minimum will be obtained when the current in the open aerial occupies the position  $I_o$ , that is when the periodic time of that circuit is a little shorter than that of the wave.

The general shape of the polar diagram of the system is shown in Fig. 4, the plane of the frame aerial being along  $OX$ . The equation to the curve is  $r = R(1 + \sin\theta)$  where  $2R$  is the maximum ordinate on the curve. Hence the points of maximum slope occur at  $p$  and  $q$ .

A good method of employing the combination as a direction finder having only one minimum is to connect a reversing switch in the search coil of the radiogoniometer. The pointer is then adjusted until no change of strength occurs upon throwing over the switch. Directions taken in this manner must always be treated with suspicion

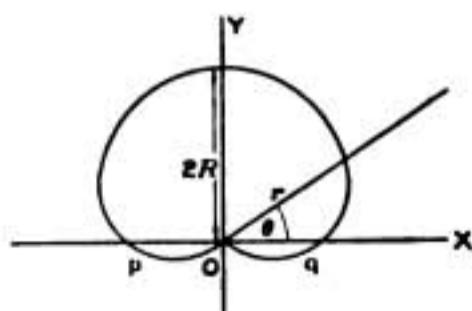

FIG. 4.



during the night, as we shall see later that the bearings obtained are subject to "night effect."

In adjusting the coupling with the vertical aerial it is to be noted that if the E.M.F. induced by the coil  $L_3$  (Fig. 1) is too large a bad minimum is obtained, if on the other hand this E.M.F. is too small two minima appear as shown in Fig. 5. At the correct coupling only one minimum results, which minimum is the direction ( $+ 0^\circ$  or  $+ 180^\circ$ ) of the sending station.

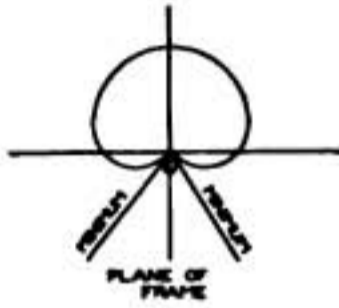

FIG. 5.



FIG. 6.

#### NIGHT VARIATIONS.

The discussion which follows is based upon the theory of night variations proposed by T. L. Eckersley, which theory receives very strong support by observations of the behaviour of the heart-shape diagram during periods of violent night effects on the ordinary direction finder.

During the day time the atmosphere becomes more or less ionised under the action of ultra-violet light emitted from the sun. This ionisation extends from the surface of the ground to the highest layers of the upper air. As soon as the sun sets and the ultra-violet rays are withdrawn the ions formed during the day commence to recombine, and since the rate of recombination is proportional to the pressure the ionisation disappears very rapidly near to the earth and very slowly at great heights. The net result of this process is that during the night a more or less sharp dividing line exists between the un-ionised and ionised portions of the atmosphere as shown in Fig. 6. Estimates as to the height of the dividing line vary from 30 miles to 100 miles or more. An ionised gas behaves much in the same way as a partial conductor towards an electric wave. It will refract or reflect the ray, the reflecting power depending upon the angle of incidence of the ray. During the night, therefore, a wave has two alternative paths from the sending to the receiving stations—(1) directly from one station to the other along a great circle on the earth's surface, and (2) by one or more reflections from the ionised layer, the path of this layer still lying approximately in the plane of the same great circle. Owing to the fact that the direct ray travels over the conducting surface of the earth it must arrive at the receiving station polarised at such an angle that the magnetic force is parallel to and the electric force is perpendicular to the ground, both of course being at right angles to the direction of propagation of the wave. A ray of this type will in future be termed "normally" polarised. On the other hand, in the case of the indirect ray which arrives at the receiving

station after reflection from the ionised layer, there is no such natural limitation to the angle of polarisation, and the ray may travel with magnetic force horizontal or vertical or any intermediate angle. Of course this presupposes that the indirect ray from the transmitter is either emitted with an abnormal polarisation or is abnormally polarised by some kind of reflection or refraction.\*

When a normally polarised ray impinges on a vertical frame, arranged so that its plane is perpendicular to the direction of propagation of the wave, no E.M.F. is induced in the loop because there is no linkage of the flux in the wave with the closed aerial, also it is to be noted that such a ray will never produce an E.M.F. no matter what its

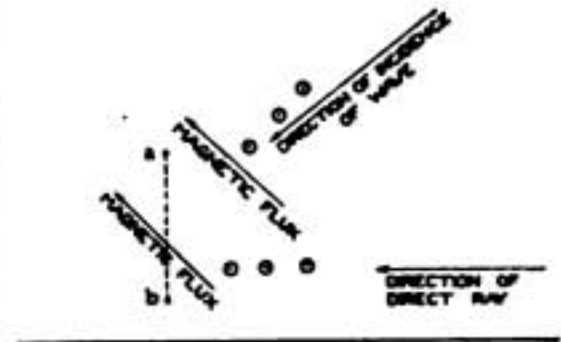

FIG. 7.

vertical angle of incidence may be. Consequently if the plane of the frame be turned at right angles to the direction of the transmitting station, no E.M.F. will be induced in it by either the direct or reflected rays of Fig. 6 so long as they are normally polarised. But there is no particular reason why the indirect ray should be so polarised, and if the magnetic flux has a component in the vertical plane of the ray, *i.e.*, at right angles to the normally polarised component, then an E.M.F. may be induced in the frame. This is shown in Fig. 7 where *ab* is the frame turned so that its plane is perpendicular to the direction of the direct ray. The arrow heads  $\odot$  show the direction of the magnetic flux in this ray. The direction of the indirect ray is shown as coming down at a vertical angle on to the frame and the arrows indicate the component of the flux in the vertical plane. It is obvious that this flux is linked with the frame, and so induces an E.M.F. in it.

It is convenient therefore to split the field of the reflected ray up into two components; namely, one horizontally polarised and the other vertically. The difference between the true direction of the transmitting station and the observed direction is dependent upon:—

- (1) The intensity and phase of the reflected ray.
- (2) Its angle of polarisation.
- (3) The vertical angle of incidence.

We are now in a position to study the effects upon a loop aerial under various conditions. In Fig. 8 curve A represents the reception due to the direct ray, curve B is that due to the normally polarised component of the reflected ray. It is to be noted that the phase relationship between these curves can vary through  $180^\circ$ , so their relative amplitudes will vary considerably. During the day time only A can exist, unless the transmitter be a nearby aeroplane. While during night time B may under certain conditions become comparable with A. The third curve C is due to the other

\* See T. L. Eckersley, RADIO REVIEW, 2, pp. 231—248, May, 1921.



component of the reflected ray and from a study of Fig. 7 it is obvious that it should be at right angles to the curves A and B. Curves B and C need not necessarily be in phase, for instance, they may be due to separate reflections.

We have shown that during the day time conditions only curve A can exist, therefore the observed direction of the transmitting station will be at right angles to the plane of the frame. Let us now consider the simple case when B and C are  $180^\circ$  out of phase with A, then as soon as the reflected ray is received B and C of Fig. 8 will appear. As B increases in amplitude the resultant of A and B will diminish with the result that component C will become more effective in the determination of directions. The result will be a rotation in the direction of the arrow, finally when the resultant of A and B is zero the frame will have rotated through  $90^\circ$  and its plane will be in the direction of the transmitting station. At this point it should be observed that the frame is unaffected by the resultant of all the components of the wave particularly the vertically polarised component. This will be referred to later when considering the heart-shaped polar curve. (Any further rotation of the frame will cause a reversal of the sign of the component C.) If B now increases in amplitude still further the frame will again receive and a rotation still in the direction of the arrow will be observed, until finally the observed direction will have rotated through  $180^\circ$ . If on the other hand B decreases in amplitude the rotation will be in the opposite direction to that indicated and the direction will consequently have rotated back through  $90^\circ$ . Both of these effects can often be observed during periods of violent night effect. From the foregoing reasoning it can be seen that the deviation from true bearing of a transmitting station can vary between the limits  $\pm 90^\circ$ .

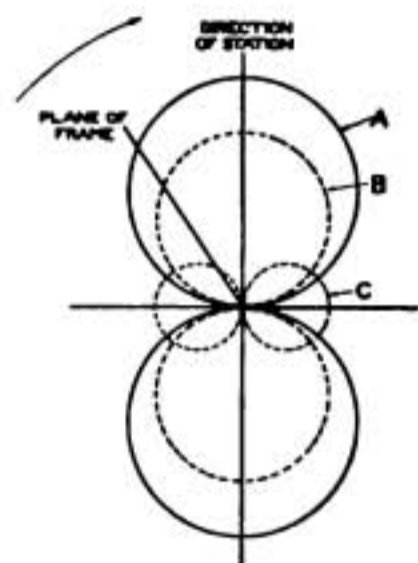

FIG. 8.

Now the heart-shaped polar curve is the result of combining the E.M.F.'s induced in a vertical aerial and a frame and in this case the minimum of signals is obtained when the effects of the frame and open aerial are equal and opposite. Thus if we so arrange matters that the E.M.F. induced in an intermediate circuit by the current in the open aerial is just equal to (and in phase with) that induced by the current in the frame when at its position of maximum reception we obtain the ordinary heart-shaped diagram having one minimum. It should be observed that the direction of zero reception of a normally polarised ray lies in the plane of the frame, and from the remarks on the previous page it will be clear that a minimum reception for an abnormally polarised ray will also exist in the same direction. (The curve C of Fig. 8 being at the minimum.) The purity of the minimum in the case of the reflected ray will depend upon the vertical angle of incidence of the ray. If the vertical angle of incidence is steep the receiving power of the vertical aerial to the normally polarised component of the reflected ray

will be reduced, whilst the linkage with the frame will remain constant and consequently the minimum will become impure, in fact there will be two minima their angular displacement being governed by the difference in amplitude between the frame and vertical reception due to this ray. There is reason to believe that the reflected ray is always arriving at a fairly small inclination and therefore the minimum should always remain nearly pure.

In Figs. 9 to 13 are shown the types of heart-shaped polar diagrams obtained under the influence of night effect.

Fig. 9 is the ordinary diagram of a frame and vertical aerial with no indirect ray. Fig. 10 illustrates the effect of an indirect ray in phase with the direct ray and of such an intensity as to give a night effect of  $30^\circ$  on the frame alone. It will be noted that there are two minima, one in the same position as the

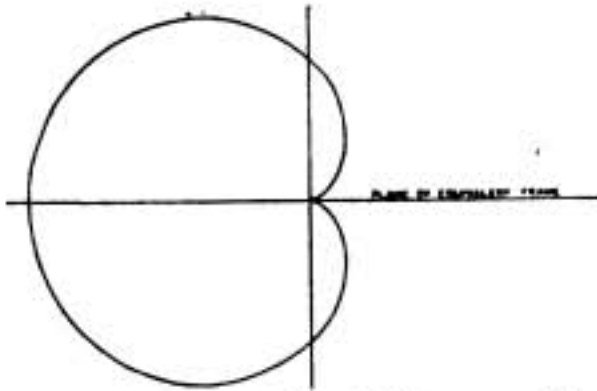

FIG. 9.—Heart-shaped diagram with no reflected ray (day time).

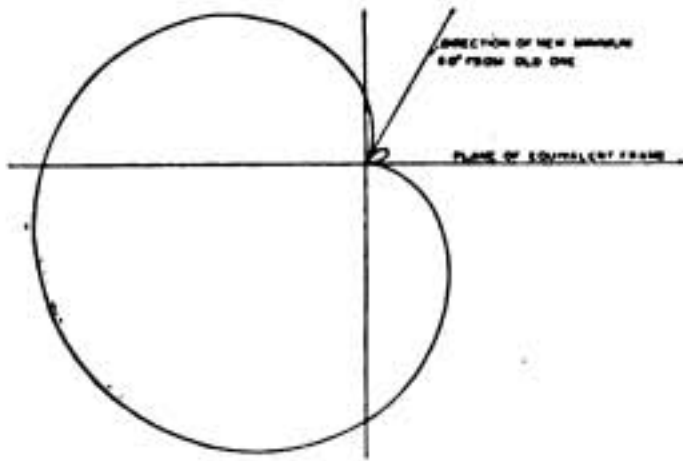

FIG. 10.—Reflected ray in phase with direct ray.

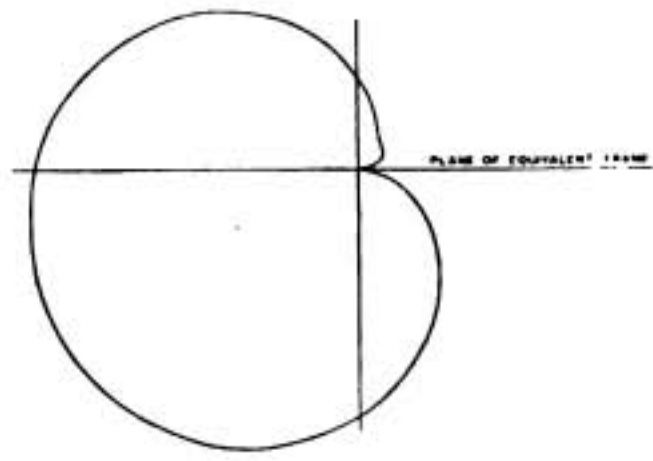

FIG. 11.— $30^\circ$  out of phase.

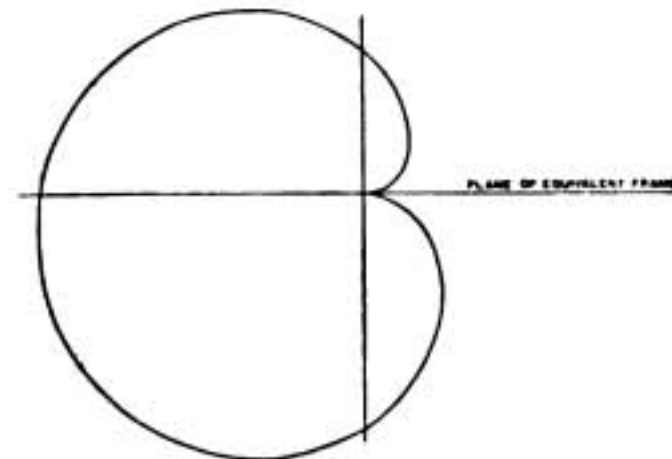

FIG. 12.— $60^\circ$  out of phase.

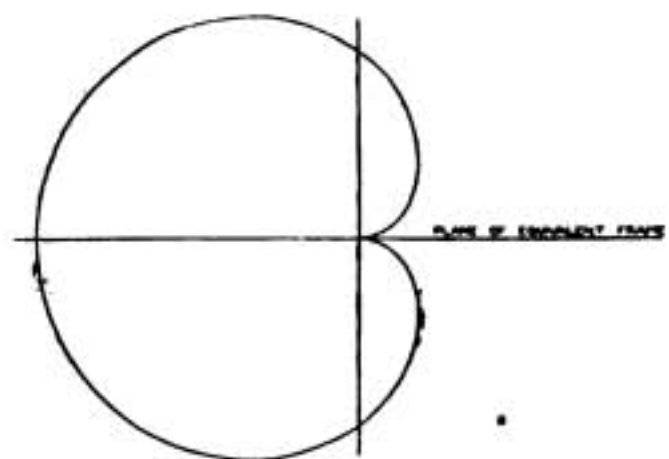

FIG. 13.— $90^\circ$  out of phase.

FIGS. 10, 11, 12, and 13.—Heart-shaped diagrams with night variations. In each case balance adjusted on direct ray in day time, and reflected ray = 0.577 of the intensity of the direct ray.



normal minimum of Fig. 9 and a second one  $60^\circ$  away from it. This development of two minima is characteristic of the behaviour of the diagram whenever the reflected ray is in phase with the direct ray.

Fig. 11 is the diagram when the indirect ray is  $30^\circ$  out of phase with the direct ray. In this case the second minimum has become impure and is filling up.

Fig. 12 shows the case of  $60^\circ$  phase difference between the rays. There is now a decided flattening remaining on the side of the diagram where the second minimum existed.

Fig. 13 shows the case when there is a phase difference of  $90^\circ$  and now the curve is symmetrical on both sides of the minimum and comparison with Fig. 9 will show, however, that the minimum is much sharper than when no reflected ray existed.

The important point to notice is that theoretically the direction of zero signals of Fig. 9 remains unchanged throughout all variations of phase and intensity of the reflected ray.

If a series of resulting polar curves of a simple frame are constructed for various night effects, it will be noticed that there are broadly two classes of polar curve obtained namely :—

- (1) Minima well defined but quite incorrect.
- (2) Minima ill defined, and almost impossible to obtain a direction.

Both types are very commonly met with in practice and upon such occasions ample proof of the stability of the heart-shaped polar curve can be obtained. The second type is very prevalent and upon such occasions the general shape of the polar curve is very similar to that shown in Fig. 13.

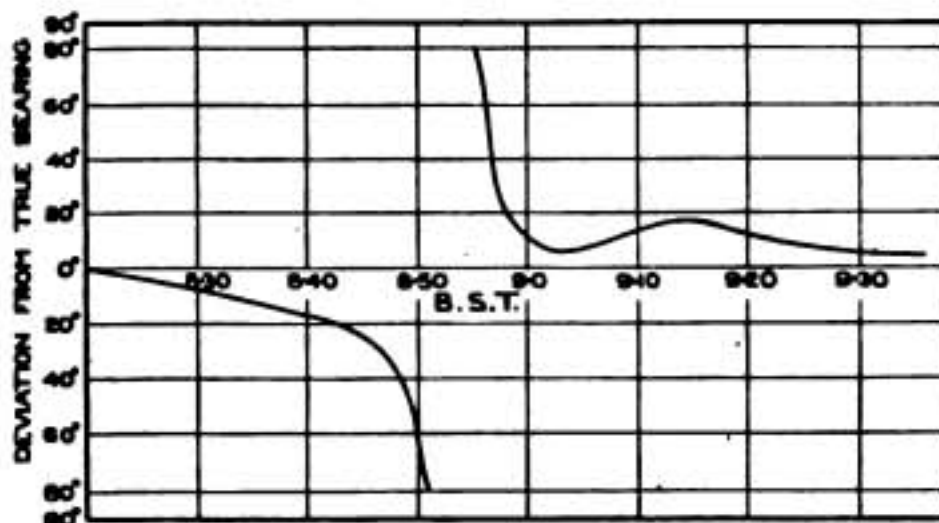

FIG. 14.—Variation of bearings on Bellini-Tosi Direction Finder. Lyons arc sending. Sunset, August 7th, 1920.

(NOTE.—B.S.T. = British Summer Time, one hour ahead of Greenwich Mean Time.)

A large number of variations upon Figs. 9 to 13 at once suggest themselves; the cases chosen are only very simple illustrations, and in these cases the A and C rays are only being received, C being vertically polarised.

Owing to the large fading in signal strength at sunset and sunrise it appeared quite reasonable to make observations at such times. Observa-

tions on the Lyons arc transmitter were made at Chelmsford during the early summer of 1920, using the Bellini-Tosi direction finder and a heart-shaped polar curve. The difference in bearing of the marking and spacing waves of Lyons often differed by  $45^\circ$  also the minima on one wave would be sharp while the other would be very ill defined. The varying polarisation and phase relations of the direct and reflected rays could often be heard taking place, and quite frequently the sharp minima would become blunt and *vice versa*. At sunset these variations are often very rapid and consequently it is very difficult to obtain a continuous record of the variations. Fig. 14 shows the deviation from true bearing of the Lyons signal during a sunset period. It is to be observed that the bearings rotated through  $180^\circ$ , at 8.53 p.m., B.S.T.,\* and for a few seconds the polar curve of the frame was

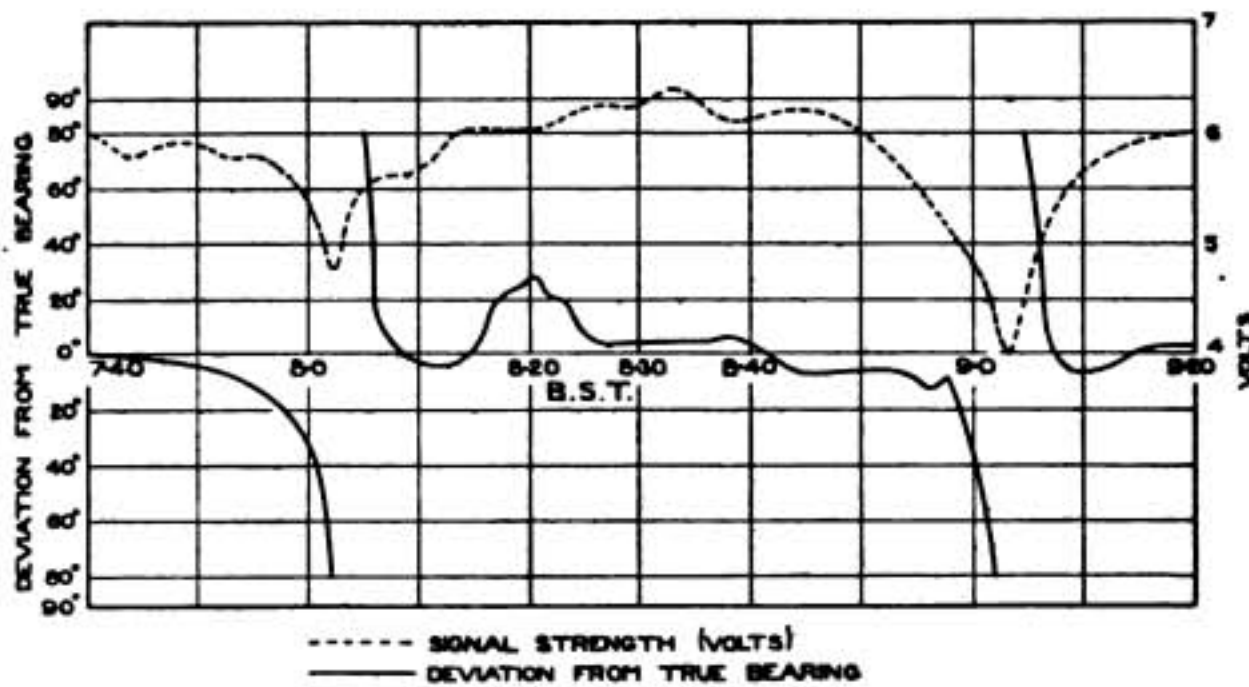

FIG. 15.—Signal strengths and variation of bearings on Bellini-Tosi Direction Finder. Clifden transmitting on 6,000 metres C.W., September 28th, 1920. Sunset at Clifden = 7.25 p.m. B.S.T.\* Sunset at Chelmsford = 6.38 p.m. B.S.T.\*

practically a circle. At the same time the heart-shape curve was very much after the form of Fig. 13. During the whole of this series of observations the minimum of the heart-shape curve remained correct but of course considerable changes in the shape of the curve each side of the minimum were recorded. At the point of maximum night effect a very large change in signal strength was recorded, probably the direct ray and the normal component of the reflected ray were of equal amplitude and opposite phase, so that the only remaining signal will be that due to the vertically polarised component.

In September a new series of observations on the Clifden valve transmitter were made, and a qualitative record of the signal strength was made on a vertical aerial and the night effect observed upon a direction finder and a heart-shaped polar curve. The variations were extremely marked

\* B.S.T. = British Summer Time, one hour ahead of Greenwich Mean Time (G.M.T.).

during the early part of this month, but as winter approached they became much less. In fact during the latter part of October only minor changes in bearings and signal strength were observed.

In Fig. 15 is shown the deviation from true bearing plotted with the variation of signal strength. Normally at sunset there is only one period of violent variation, that shown in Fig. 14 being quite typical, but of course the maximum effects are not always recorded, very often the deviation only varies  $\pm 20^\circ$ . On some occasions the bearings will remain high in a positive direction and no negative variations are recorded probably due to the extremely variable nature of the whole phenomena. It is very interesting to note that at the point of maximum night effect (Fig. 15) the signal strength undergoes a very marked reduction.

During a long series of observations on the Clifden transmitter the minimum of the heart-shape polar curve has always been constant, this fact seems to prove that the angle of incidence of the reflected ray is always small otherwise this minimum would become impure, also that the angle of the plane of the ray is vertical.

The most important points to note are as follows:—

The minimum of the heart-shaped diagram always gives the true bearing of the transmitting station and is therefore an aid in direction finding when night variations are known to be prevalent.

Owing to the above-mentioned fact the system is of great utility when the minimum is employed to obtain a balance for duplex purposes, the day time balance remaining constant during periods of night effect.

## A High-frequency Machine of Greater Specific Power and Higher Efficiency.\*

By MARIUS LATOUR.

In recent years, the chief problem connected with the production of high-frequency currents by dynamo-electrical machinery has been the possibility of obtaining frequencies of the high order required. With that end in view, different types of machines have been devised, several of which have interested the author and he has described them in a previous publication.†

The technique of high-frequency machines has already evolved considerably, and it is appropriate to discriminate between the different types of machines from the point of view of weight per kilowatt and efficiency.

After a thorough investigation and while awaiting the more precise data which should be forthcoming from the manufacturers shortly, it would appear, from the above standpoint, that the machine marketed by the Société Française Radio-Electrique (see my *American Patent* No. 1234914 and my *British Patent* No. 107193) which I have designated under the

\* Received June 22nd, 1920.

† See Latour, *Proceedings of the Institute of Radio Engineers*, 8, pp. 220—237, June, 1920; *RADIO REVIEW*, 1, p. 491, July, 1920, and Abstract No. 781, September, 1920.



name of "homopolar machine with partial utilisation of the periphery" or "homopolar machine with a reduced number of stator slots," is deserving of the highest merit.

May I be permitted to recall here that the losses in iron at high frequencies are calculable beforehand with precision in comparative designs, using the formulæ already published by the author.\*

Allotting the symbols :

$2a$  = thickness of laminations,

$\mu$  = permeability,

$\rho$  = resistivity,

$\tau$  = hysteretic angle,

$B_{app.}$  = apparent flux in the laminations,

$\frac{2\pi}{\omega}$  = frequency of the magnetic field,

and putting  $m = \sqrt{\frac{2\pi\mu\omega}{\rho}}$ ,  $\alpha = \sqrt{1 + \sin \tau}$ , and  $\beta = \sqrt{1 - \sin \tau}$ , the total losses  $W$  are expressed by the following formula :

$$W = \frac{\omega^2 a}{4m\rho} \cdot \frac{\alpha \sinh 2m\alpha a - \beta \sin 2m\beta a}{\cosh 2m\alpha a - \cos 2m\beta a} B_{app.}^2$$

The hysteretic angle  $\tau$  of very thin laminations can easily be determined by using a reactance coil, the closed core of which is made up of these laminations, and measuring the power factor  $\cos \phi$  of the coil when it is being energised by a low-frequency current (50 cycles). Under those conditions there remain only the losses by hysteresis, and we have  $\sin \tau = \cos \phi$ . In fact, the angle of hysteresis of very thin laminations is greater than that of ordinary laminations.

Fig. 1 represents the curves corresponding to the observed total losses (heavy line) and the computed total losses (dotted line) in the case of silicon laminations 0.07 mm thick, for frequencies of 17,000 and 30,000. It will be noted that these curves very nearly coincide. This holds good for frequencies and qualities of laminations within wide limits of variation.

Thus, with the formula quoted, it is possible to predetermine the electrical efficiency of an alternator.

The laminations of recent manufacture are far superior to those of previous make, and there is reason to hope for still further improvement in the near future.

If, however, we confine ourselves to the laminations at present available and which conform to the following constants:  $2a = 0.05$  mm,  $\rho = 30$  microhms/cm,  $\sin \tau = 0.4$ , it is possible to construct an alternator type S.F.R., of 200 kW, at 20,000 cycles, having an efficiency proper of 80 per

\* See, for instance, *Proceedings of the Institute of Radio Engineers*, 8, pp. 220—237, June, 1920; *RADIO REVIEW*, 1, p. 491, July, 1920, and Abstract No. 781, September, 1920.



cent., including all electrical and mechanical losses.\* It is doubtful if this efficiency can be obtained elsewhere.

The second type of machine suggested, namely, the homopolar machine with variable reluctance (see my *American Patent No. 1330638*), cannot,

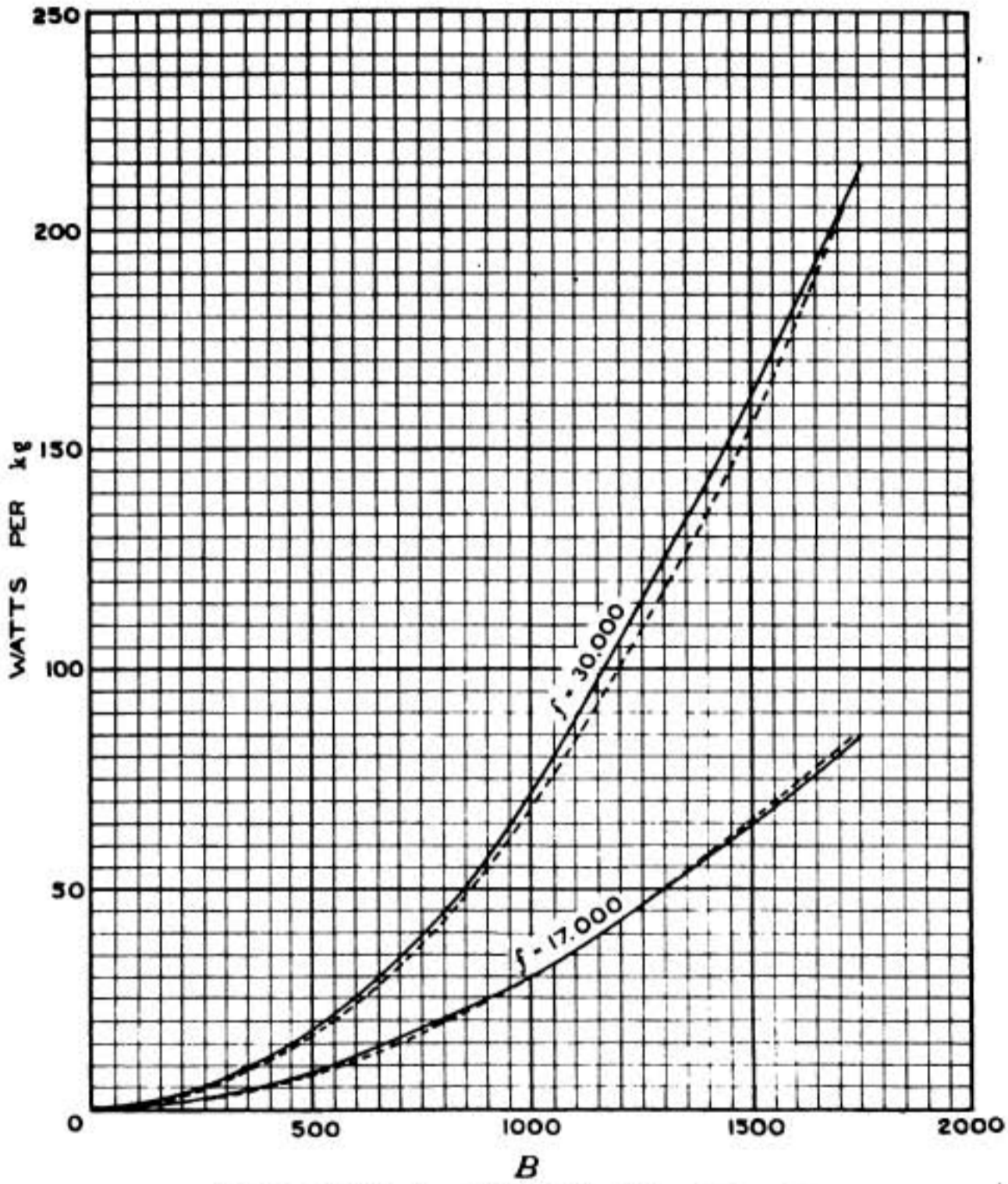

— LOSSES PER kg MEASURED BY WATTMETER  
 - - - - LOSSES PER kg CALCULATED BY LATOUR FORMULA

FIG. 1.—Losses in silicon sheet  $\frac{1}{16}$ ths mm thick.

without modification, attain an equal efficiency. This particular type of machine is represented in Fig. 2 for a two-coil model which has been tested

\* This efficiency is already practically reached in the alternator at Coltano which is made up of laminations of a lower grade than those now available.

for 30,000 cycles. Fig. 3 indicates the coupling of the two coils with the exciting circuit and the antenna. As a matter of fact, the "dampers" or metallic masses inserted between the bundles of laminations and shown

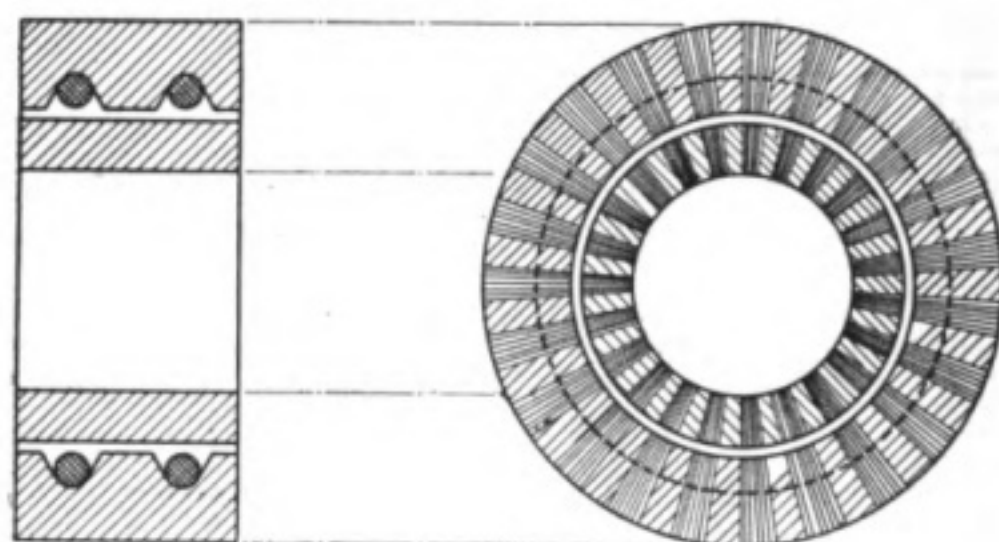

FIG. 2.

in the cross-section perpendicular to the shaft, Fig. 2, are far from providing sufficient shielding from side leakage fluxes which emanate from the walls of the bundles of laminations perpendicularly to the plane of the laminations, at least for spacings of 2 mm, at 30,000 cycles corresponding to the relatively low peripheral speed of 150 metres per second. Under those conditions, it is impossible to realise a greater efficiency without resorting to a different type of construction.

This very peculiar type of machine, which, by the particular arrangement of its circular winding, can produce directly any desired frequency, might undoubtedly have had a real success some years ago, but it cannot to-day compete with the homopolar machine with reduced number of stator slots, already on the market.

Leaving aside the fairly complicated Goldschmidt machine the efficiency of which is unquestionably lower, it remains to be decided if the homopolar machine with reduced number of stator slots is finally superior to the ordinary homopolar machine which is a real industrial possibility at 20,000 cycles. It is well known that the Alexanderson machine is but a particular form of this ordinary machine.

Figs. 4 and 5 exhibit in their natural sizes the outline of the opposite teeth of an ordinary homopolar, also for a homopolar machine in which the number of slots on the stator has been reduced to one-third. Both machines are designed to furnish 20,000 cycles at equal peripheral speeds, namely, 150 metres per second.

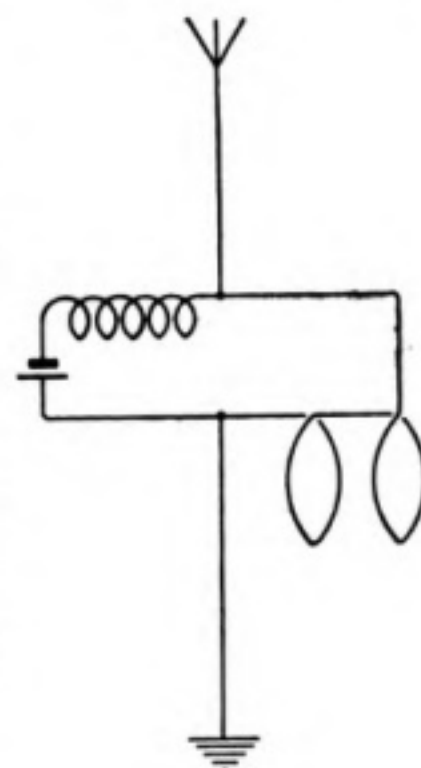

FIG. 3.

In both cases the slots are of equal depth. The proportion between the width of the teeth and the slots is also the same in both cases, the teeth having, at their narrowest point, a width equal to half that of the slots.

Under such conditions, if we admit of an equal value for the alternating induction in the iron of the teeth of both machines, *i.e.*, the same variation in the steady flux which permeates the teeth, the three coils in series in Fig. 4 would enclose the same variable flux as the single coil of Fig. 5 and would therefore give exactly the same E.M.F. as the single coil of Fig. 5. Hence, to obtain the same output in both cases, the slots would have to allow the passage of the same current. One readily notices that, even without making allowance for the greater space taken up by the insulation in the machine of Fig. 4, the copper losses would be exactly nine times greater than those in the case of Fig. 5. In fact, the cross-section of the conductor in Fig. 4 is three times smaller and the length of the circuit three times as long as that in Fig. 5. Taking into account the space taken up by the insulation, which in the case of Fig. 4 is necessarily three times that in Fig. 5, it is safe to assume that the copper losses in the machine of Fig. 4 would be fifteen to eighteen times as great as those in the case of Fig. 5 for equal outputs. If we also take into account the inadmissible local heating up which would ensue, it is easily seen that the machine of Fig. 4 could not give the output of that in Fig. 5 when keeping up the same flux variation.

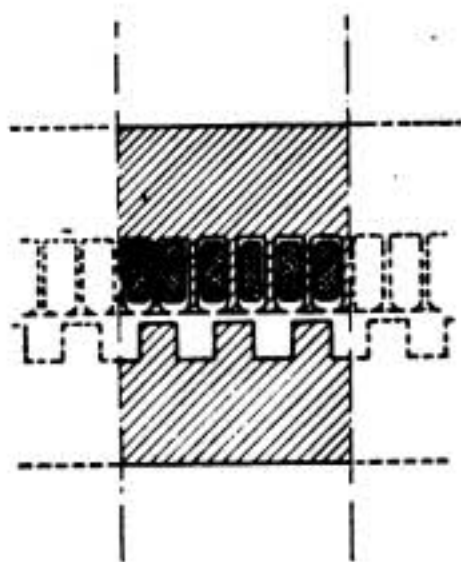

FIG. 4.

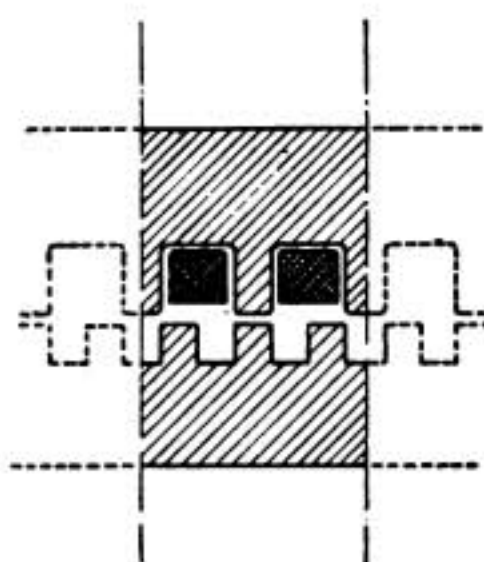

FIG. 5.

In practice, it would be necessary to boost the flux variation through the teeth to a much higher value in the case of Fig. 4 than in the case of Fig. 5, and the current through the slots would be thereby decreased, but the iron losses would simultaneously increase.

At all events, the total losses in the stator will be appreciably greater in the case of Fig. 4 than in the case of Fig. 5. It does not appear that, even with a powerful artificial cooling, it would be possible to draw the same maximum power per centimetre of armature width in the case of the machine of Fig. 4 as in the machine of Fig. 5.

However, in so far as the iron losses in the rotor are concerned, the ordinary



machine is more advantageous. In fact, in the machine of Fig. 4, the rotor teeth are subjected to negligible flux variations, while those in the machine of Fig. 5 alternately face an open stator slot and a tooth, and they therefore undergo appreciable flux variations at a frequency of  $20,000/3$  which entails important losses. But figures show that this increase in losses is considerably lower in practice than the increase in stator losses in the ordinary homopolar machine. It is immediately seen that as soon as the quality of laminations improves, these rotor losses will decrease, and that the machine of Fig. 5 will score over that of Fig. 4.

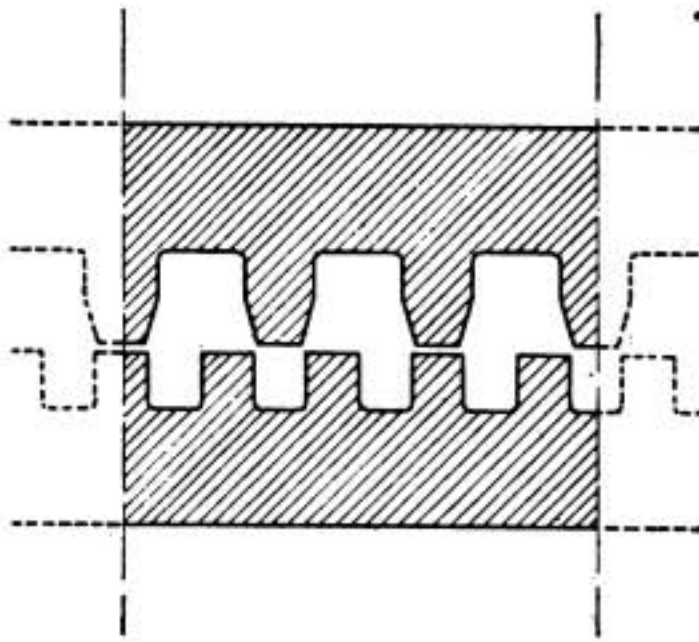

FIG. 6.

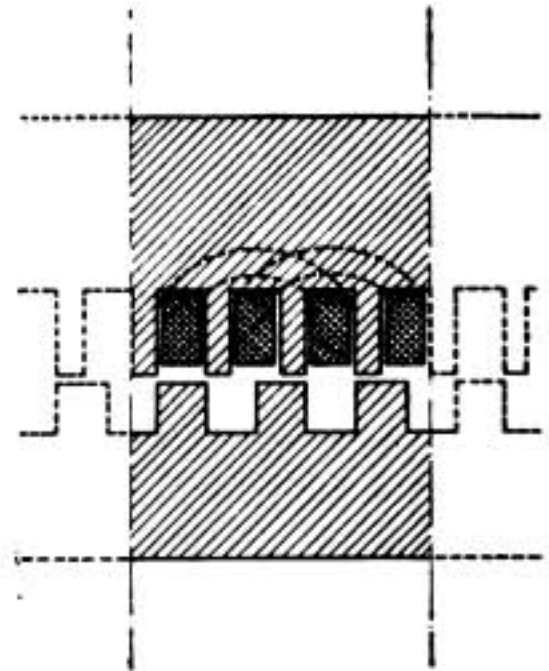

FIG. 7.

It is to be noted that in the case of the machine with reduced number of slots, it is possible to minimise the iron losses in the stator by not utilising entirely the available space for the copper, and by increasing the cross-section of the teeth at the bottom of the slots in such a manner as to decrease the magnetic induction. This leads to an outline of "meshing" teeth.\* Fig. 6 shows the outline of the teeth of a machine for 500 kW at 15,000 cycles having a peripheral speed of 150 metres per second. One may reckon on an efficiency approximating 85 per cent.

The author has thought of obtaining an intermediate solution between the type of machine of Fig. 5 and the ordinary machine, by resorting to a two-phase machine whose tooth outline is shown in Fig. 7 (see *German Patent* No. L—50841 now granted).

According to the author, the two phases are connected in parallel to the antenna with series capacities

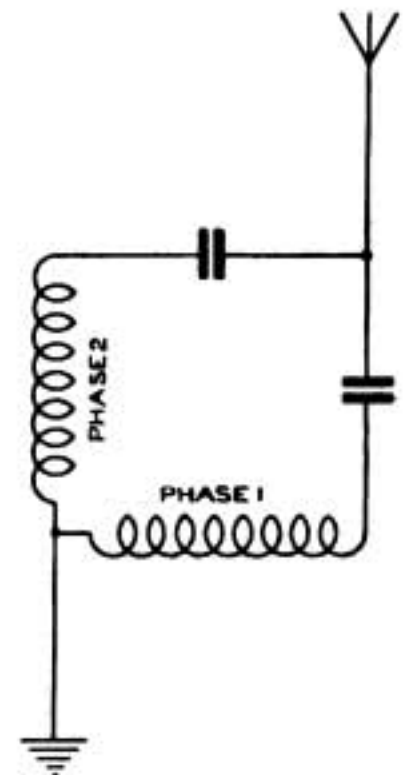

FIG. 8.

\* This outline has been suggested by Mr. Belfils of the Société Alsacienne de Constructions Mécaniques.

of different values as shown in Fig. 8, so as to re-establish a coincidence of phases and thus transform the two-phase output of the machine into single-phase output in the antenna as formerly suggested by Bethenod.

Again, it would be possible to use directly the two phases of this machine for directional radiotelegraphy, using two antennæ separated by a quarter of a wavelength such as had been anticipated by the author and suggested independently by Professor Howe.

This two-phase machine, the idea of which aimed at a reduction of the iron losses, and which is very tempting from a theoretical point of view, reveals itself, after rather minute computations, somewhat inferior in efficiency to the machine of Fig. 5. Its superiority would only become apparent at greater peripheral speeds, such as 200 metres per second.

It therefore appears that the specific power and efficiency of the machines shown in Figs. 5 and 6, are really remarkable.

Lastly, a very interesting advantage of the S.F.R. machine from the practical standpoint, is that from the fact that we are working with weaker flux variations in the stator, the number of parallel circuits in the machine for a given terminal P.D., is lower.

## Radio Telephone Circuits and Modulation.\*

By W. A. MACDONALD.

In the design of continuous wave signalling apparatus, especially of units not greater than 10 kilowatts output it is generally recognised that the three-electrode valve presents greater advantages than other known means.

During the past few years much interest has been manifested in the application of the three-electrode valve to radio telephone communication and consequently numerous circuits and methods of modulation have been devised, a few of the more desirable of which will be discussed in the following paragraphs.

Three general methods of controlling high frequency oscillations in accordance with speech frequencies have been used, with varying degrees of success, namely, (A) antenna absorption; (B) grid control; and (C) plate control.

In the absorption method probably the first means of varying the amplitude of the high frequency oscillations was by inserting a microphone directly in the antenna circuit, or shunting it around a portion of the antenna loading inductance. This method, however, proved entirely impracticable except for very small powers because of the difficulty in the design of a microphone sufficiently heavy to handle

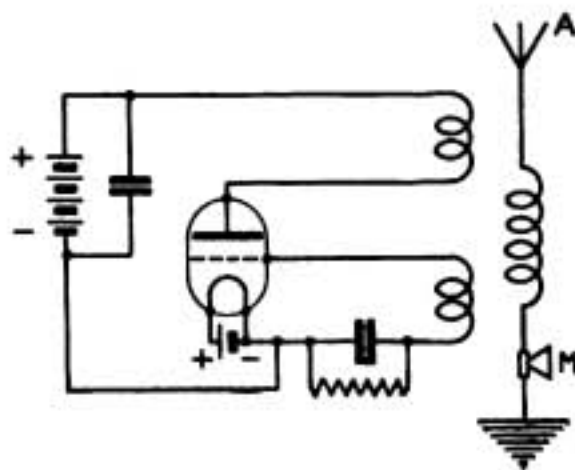

FIG. 1.

\* Received December, 1920.

large currents (Fig. 1). Another method which is more applicable to higher powers is to have the antenna current absorbed by an appropriate number of three-element valves, and dissipated in the valves in the form of heat (Fig. 2).

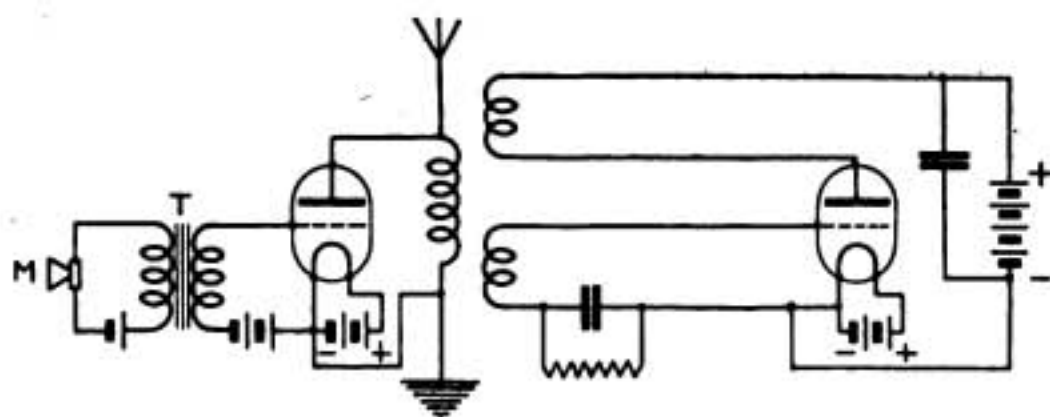

FIG. 2.

Grid modulation has been used to some small extent, but never with any very great success, due principally to the poor efficiency at which the circuits could be operated, and still obtain good modulation. Modulation in this manner can be accomplished by inserting a microphone and speech transformer in the grid circuit of a three element valve (Fig. 3).

When speech is impressed on the microphone M the grid is thrown either positive or negative with respect to its former value, by means of the speech transformer T, which varies the direct current load on the plate circuit, and consequently the alternating component or antenna current.

The circuit generally associated with plate control is that known as the constant-current system, in which one or more valves are used as oscillators and an appropriate number as modulators (Fig. 4). In this system the total plate current is supplied through a large choke coil L, both oscillators and modulators being adjusted to take equal current. When the grid voltage of the modulator tube is varied by means of the microphone M and speech transformer T the resistance varies between infinity and almost zero, making available for the oscillator, twice the voltage, when the resistance of the modulator is infinity and practically nothing when the resistance falls to almost zero. This system of modulation depends entirely on the presence and character of the choke L in the circuit. If this choke coil is properly designed and has a high impedance compared to the impedance of the tube for voice frequencies it is obvious that the total load to the plates

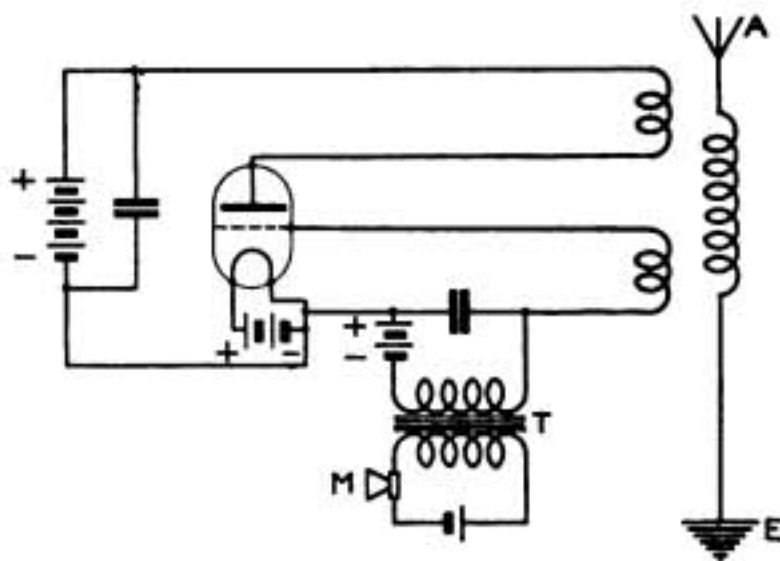

FIG. 3.



will remain constant regardless of the change in the resistance of the modulator tube. Hence a modulated wave of varying amplitude will be radiated varying between zero and twice the average. This is only true, however, when the tube has ample electron emission from the filament.

Numerous methods of modulation study have been used, the most common

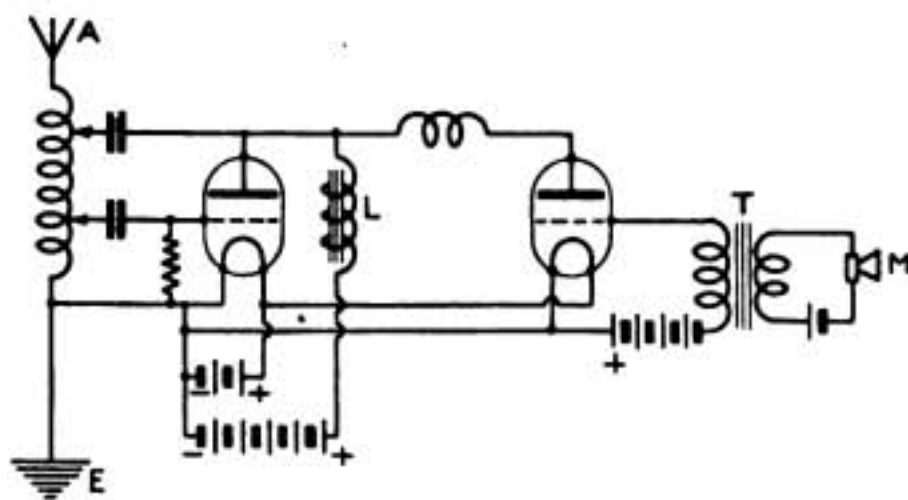

FIG. 4.

being that of observing the amplitude of the direct current plate supply to the oscillator and modulator on an oscillograph. This method may be considered as entirely satisfactory where it is known that the output is proportional to the input. In the following experimental work, however, as a large variety of circuits and tubes were used, it was considered that there would be less chance for error to occur if a low impedance rectifier suitably coupled to the antenna and connected to an oscillograph were used (Fig. 5).

As a number of complete telephone sets were available it was considered that it would be of value to determine what order of modulation to expect. The first set and circuit studied was one using plate current control and known as the constant-current plate method of modulation. The complete set is used by the U.S. Signal Corps—U.S. Army—and is known as the S.C.R. 67.

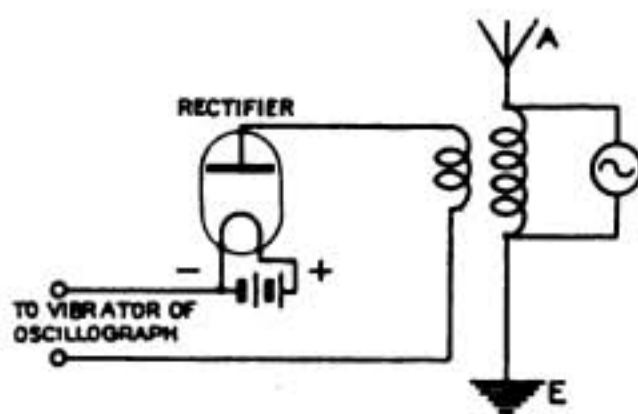

FIG. 5.

This employs two type VT-2 transmitting tubes (oxide coated platinum filaments) one being used as an oscillator and the other as a modulator. The complete unit is rated at about 5 watts high frequency output.

Fig. 6 represents an oscillogram of the rectified antenna current for the vowels  $\bar{O}$  and E. Referring to the oscillograph line A is the zero line of the oscillograph, line B the average value of unmodulated high frequency current, and line A' and B' the peak values of modulated speech. In this particular case the average value of antenna current was 0.6 amperes. As the deflection

of the oscillograph is proportional to the antenna current, it is apparent that a modulated wave is radiated varying about 80 per cent. above and below the average value.

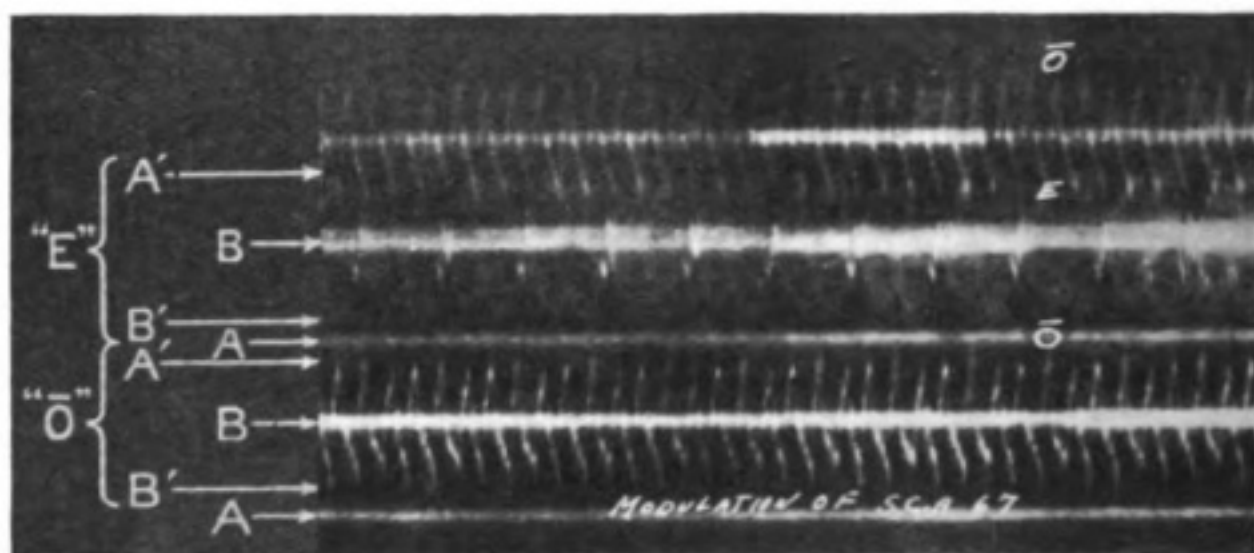

FIG. 6.—Modulation of S.C.R. 67. (From A to B = 0.6 ampere.)

This amount of modulation varies of course with different tones of the voice and in some cases is much less than that shown. Although in this case it was necessary to talk considerably above the average tone to obtain this amount of modulation, generally speaking between 80 and 90 per cent. modulation while talking in the ordinary conversational tone seems to be the most desirable. This allows sufficient margin so that even when speaking above the average tone of voice the modulated wave will never quite decrease to zero.

Fig. 7 shows an oscillogram for practically the same type of circuit as

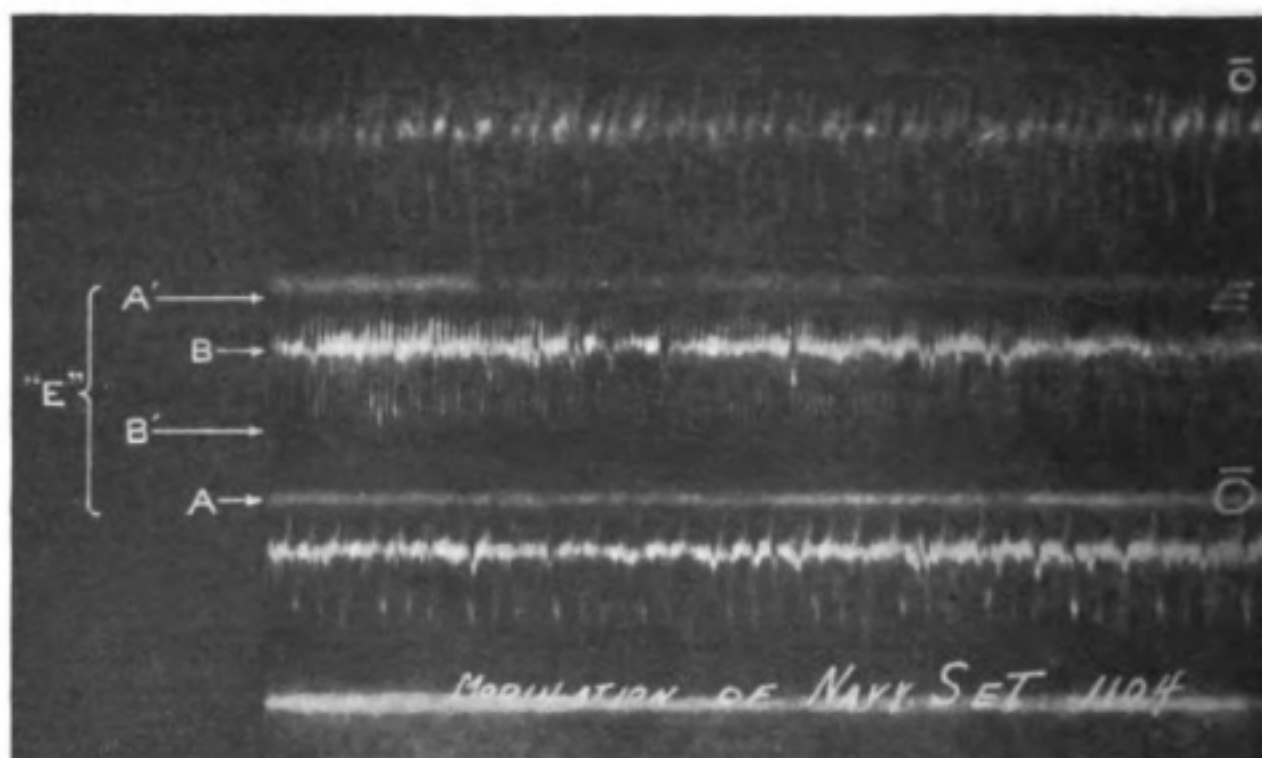

FIG. 7.—Modulation of U.S. Navy Radiotelephone Set. (From A to B = 0.9 ampere.)

previously shown except that type VI-14 (tungsten filament) tubes were used.

It will be noted in this case that the modulation is only slightly above the average output and about 50 per cent. downward. This may be caused by

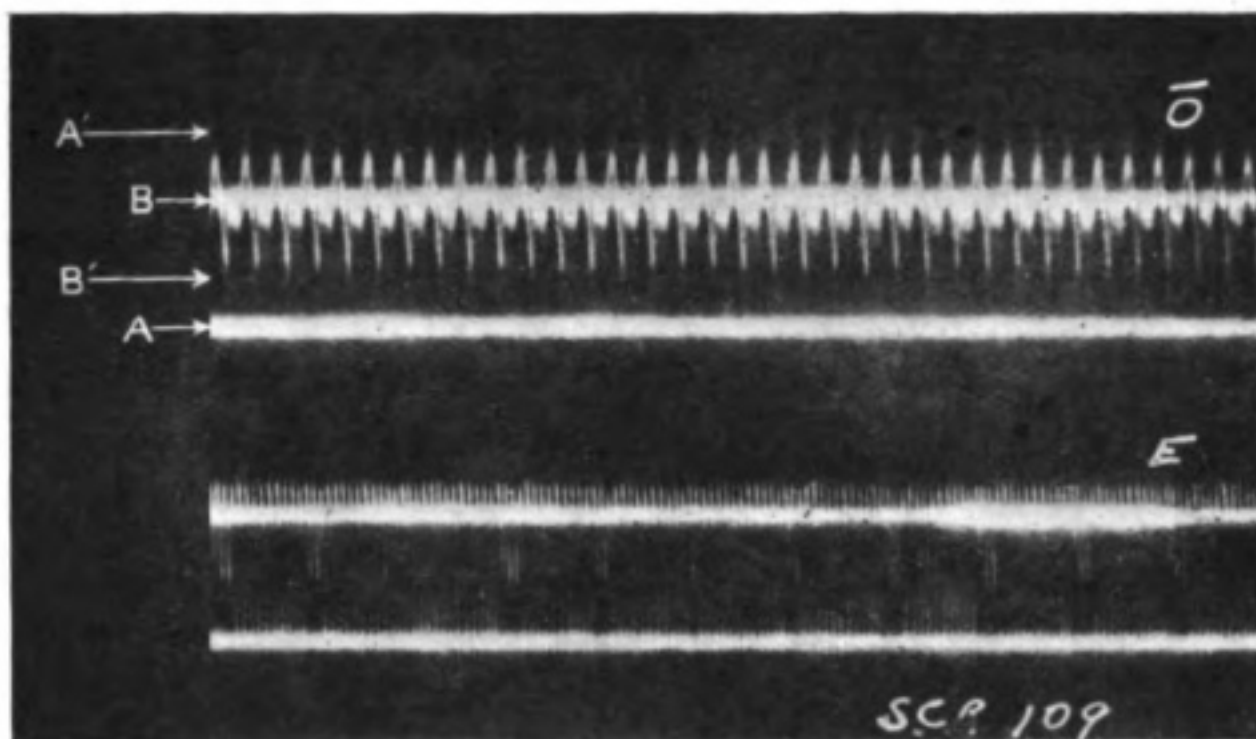

FIG. 8.—Modulation of S.C.R. 109.

a poorly designed choke coil in the plate circuit, but points more directly to the fact that with a given filament current the tube has reached saturation, and the electron emission is not sufficient to take care of the additional load of the modulator during speech.

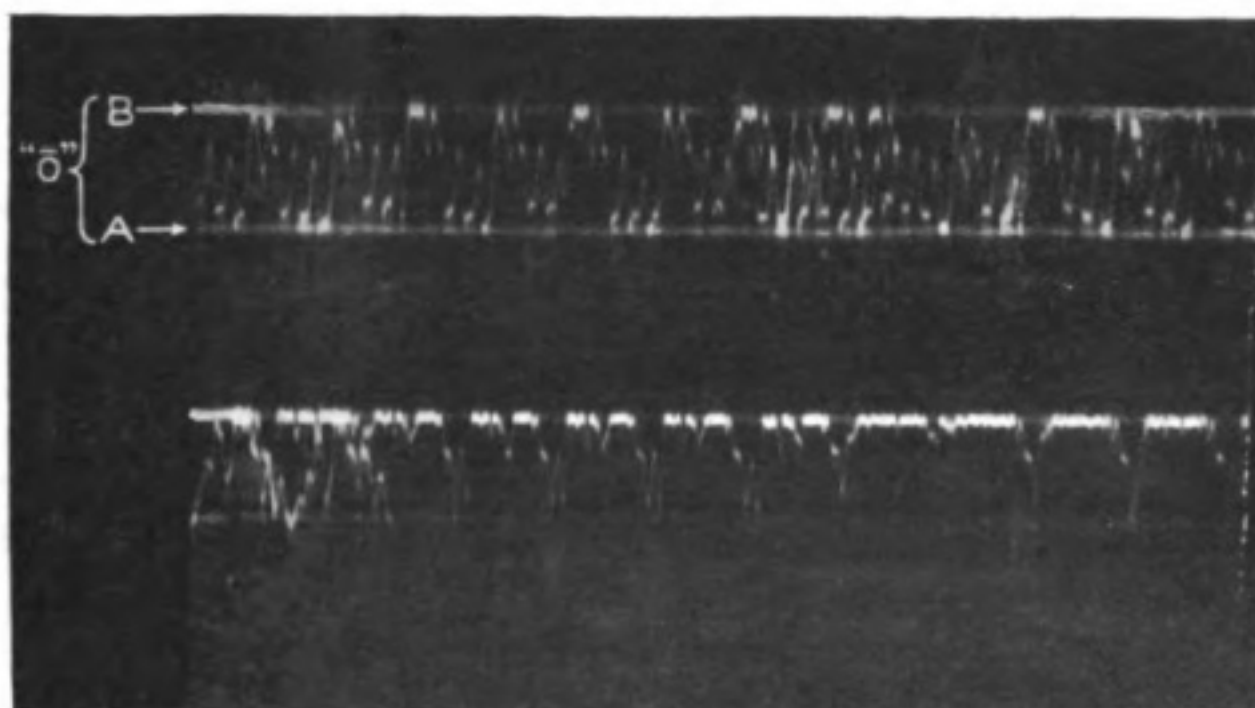

FIG. 9.—Modulation of 1 kW de Forest Radiotelephone Set. (Modulation by absorption method.)



Fig. 8 shows another oscillogram of practically the same circuit with the exception that two 50 watt (tungsten filament) tubes were used, and in addition a speech amplifier, to amplify the voltage impressed on the grid of the modulator from the microphone and speech transformer. As in Fig. 7 the modulation does not go very much above the average value although in one case it is driven to zero. This further bears out the theory that while operating the tube at its maximum output it has practically reached saturation. The fact of its being driven to zero is directly due to the speech amplifier which amplifies the voltage impressed on the grid of the modulator sufficiently, so that for the downward half of the cycle the resistance of the modulator tube is practically zero.

Fig. 9 represents an oscillogram of a telephone set manufactured by the De Forest Telephone Company, and rated as a 1 kilowatt unit.

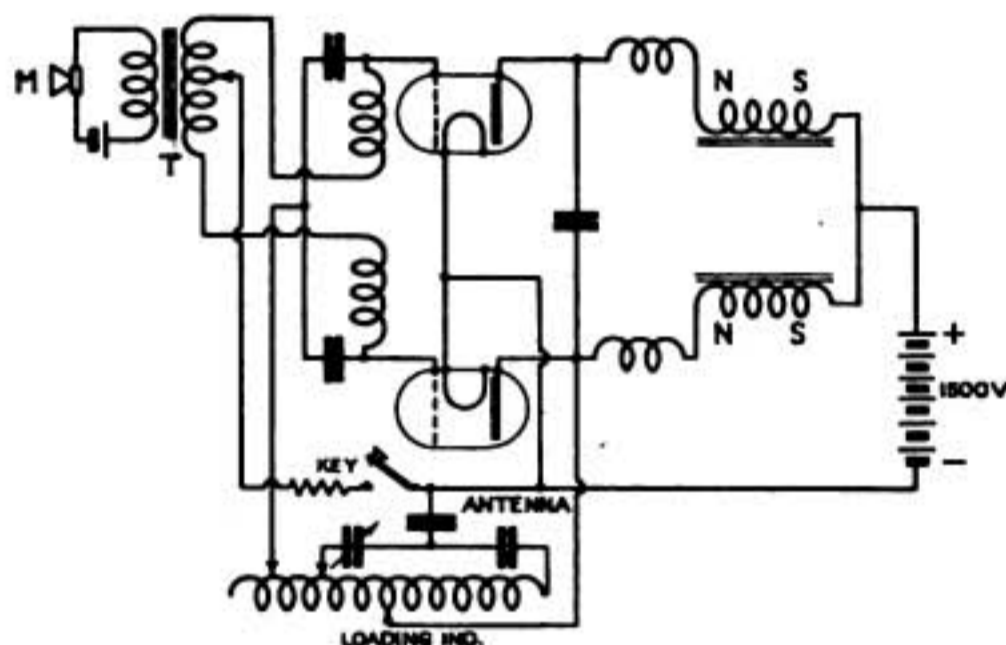

FIG. 10.—Circuit of de Forest 1 kW Radiotelephone Set.

Referring to the oscillogram (Fig. 9) and the circuit diagram (Fig. 10), it can be readily seen that this is purely an absorption method of modulation, where the efficiency is so low at the best adjustment for telephone operation that it would be practically prohibitive.

Summing up the results so far obtained it is readily seen that Fig. 6 represents the most desirable form of modulation. That is, using the constant current method of modulation in connection with a tube of ample electron emission.

Theoretically if this circuit is properly designed it should radiate a modulated wave varying between zero and twice the average value, or for peak values give twice the current or four times the power.

In the design of practically all classes of continuous wave transmitting apparatus, considerable trouble has been encountered in the past, in changes in the frequency while transmitting. It is a well-known fact that in continuous wave telegraphy where the signal is received by virtue of the difference in frequency between the incoming signal and a local heterodyne that any

slight changes in the oscillating circuit of the transmitter will cause perceptible changes in the received frequency, in many cases causing total loss of signal. This is of course less pronounced in radiotelephony or buzzer modulated telegraphy but it is still a very objectionable feature.

The need for absolutely constant frequency apparatus on the smaller installations, such as ships, airplanes, dirigibles, etc., is apparent when it is considered that the antenna is continually swaying back and forth causing changes in frequency as great as 20,000 cycles in 500,000.

A form of constant frequency circuit used with considerable success by the U.S. Signal Corps, in France is known as a power amplifier (Fig. 11). This circuit employs one three element valve as an oscillator, the output of which is impressed on the grid of one or more amplifying valves and suitably coupled to the antenna. Any changes now occurring in the antenna circuit will only tend to slightly reduce the antenna current, the frequency being previously determined by the fixed oscillating circuit.

Using then as a working basis a power amplifier and combining with it the most desirable method of modulation, as previously shown (Fig. 6), a circuit is obtained as shown in Fig. 12.

A circuit of this character was set up under laboratory conditions, using as a master oscillator and modulator two VI-2 valves, the output of which was amplified by two 50 watt valves in parallel. (Western Electric type G tubes.)

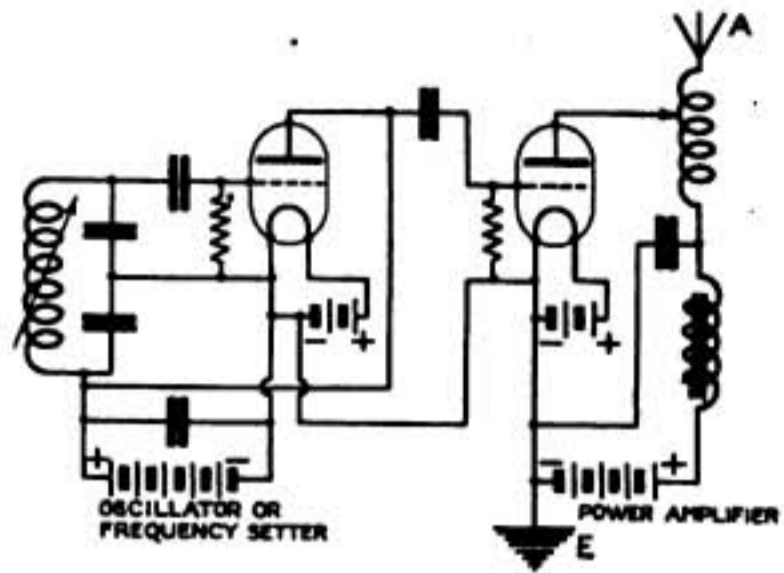

FIG. 11.

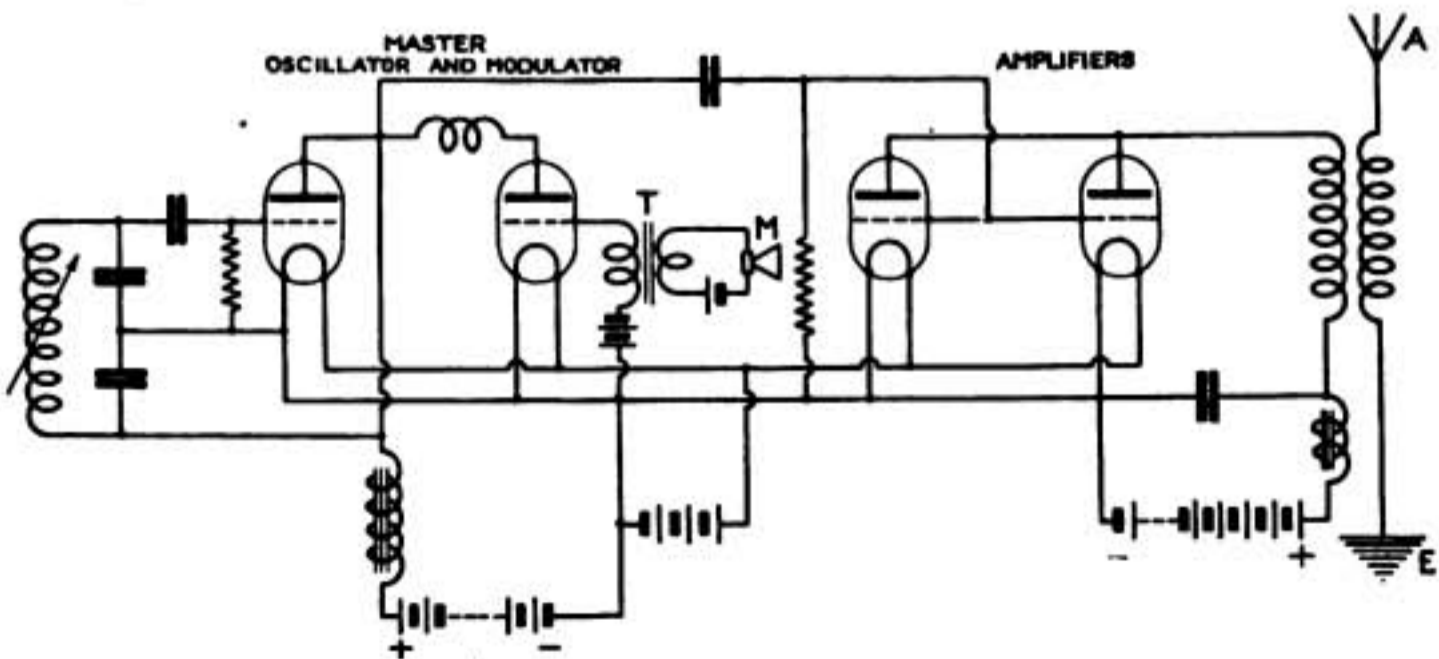

FIG. 12.

A circuit of this character was used on the U.S.S. *George Washington*. Two type P pliotrons were used as master oscillator and modulator, the output of which was amplified by twelve type P pliotrons. Thirty-two amperes was obtained in the antenna. Fig. 13 shows the modulation obtained with this form of circuit.

In this case the average antenna output was 3.5 amperes or 120 watts. For peak values of modulated current, where approximately 30 per cent. increase in current was obtained, the current was 4.55 amperes or 207 watts. This then makes available for the antenna a current of amplitude varying between zero and 4.55 amperes for peak values. As can be observed from the oscillogram the bottom of the modulated wave is more or less distorted, and is not symmetrical above and below the average antenna value. From

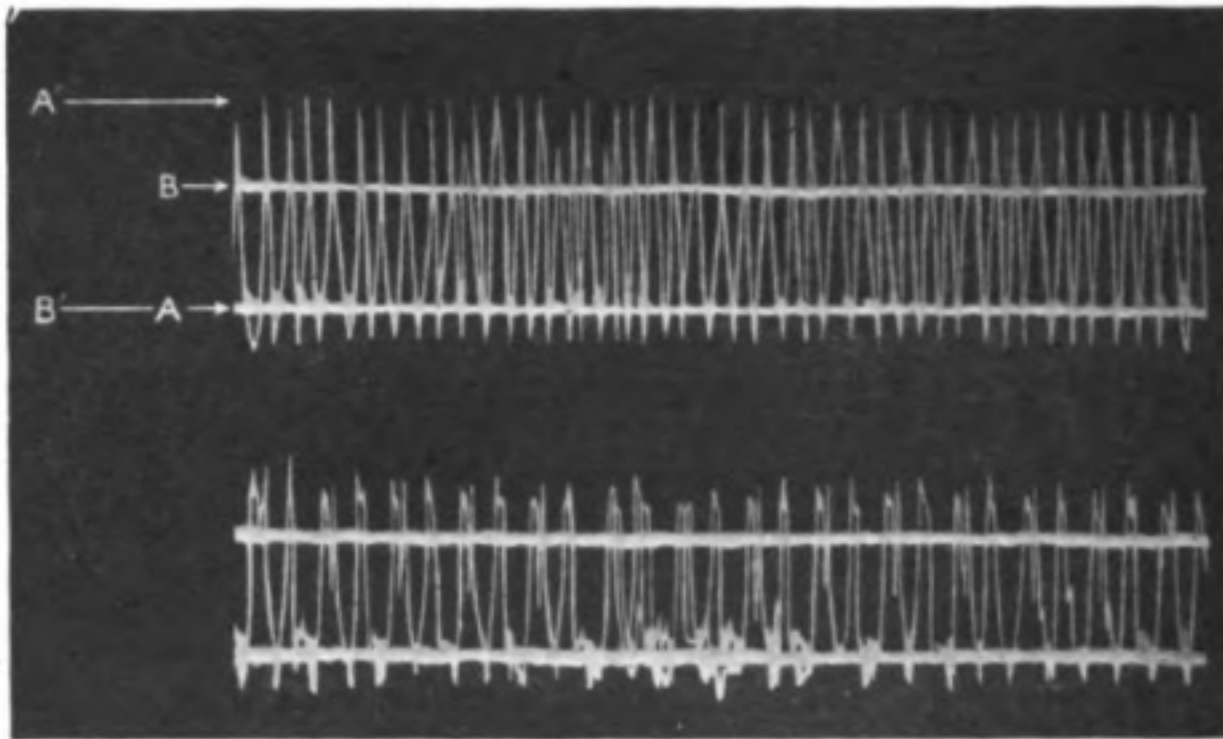

FIG. 13.—Modulation of Radiotelephone using Power Amplifier.

observation of the oscillogram it would seem then that the speech was more or less distorted. This was proved experimentally by listening to the speech at a distance of thirty-five miles. Although the speech could be readily understood, considerable distortion was apparent, especially on the letters of higher frequency.

Although this form of circuit more nearly approaches constant frequency than any of the others previously discussed, it can hardly be considered as constant frequency in the true sense of the word.

Let us consider the action in the master source of supply before being amplified. For convenience consider an oscillator and modulator as represented by two resistances in parallel which are being supplied by current through a common choke coil (Fig. 14). Assuming now that by some means the resistance of  $R_2$  is for an instant of time reduced to practically zero. If the total supply is through the choke  $L$  and this choke presents a sufficiently



high impedance at the frequency at which the resistance is being varied, the total input to the two resistances will remain practically constant. For an instant of time then the resistance  $R_2$  takes all the energy in the circuit. In the reverse manner, of course, when the resistance of  $R_2$  is made very great the energy is then made available for  $R_1$ .

Applying this now to the case of the oscillator and modulator, the oscillator being considered as  $R_1$ , a voltage varying in amplitude in accordance with speech frequencies will be impressed on the plate. It is obvious then that with this change in load on the plate circuit both the impedance and capacity of the tube will change, causing changes in frequency.

Any such changes arising in the master source of supply will naturally be amplified and transferred to the antenna in a corresponding degree.

A circuit which more nearly meets the requirements of absolutely constant frequency is that shown in Fig. 15. For this purpose a master oscillator or frequency setter is used which supplies an exciting potential to the grid of a suitable amplifier. Modulation can be accomplished by any of the known means, preferably plate modulation.

Any changes in the constants of the amplifier, modulator, or antenna systems will not affect the transmitted frequency, as the exciting frequency is of constant value and the amplifier can be considered as a one way device which cannot react on the source of supply.

Fig. 16 represents an oscillogram of the speech obtained from the circuit as shown in Fig. 15, Fig. 17 represents the modulation obtained from the same circuit but with the addition of a speech amplifier.

The laboratory arrangement used employed four tubes, two Western

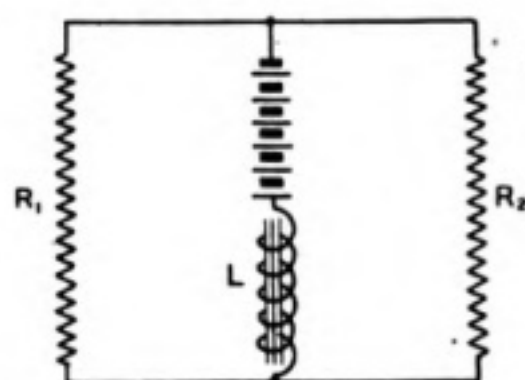

FIG. 14.

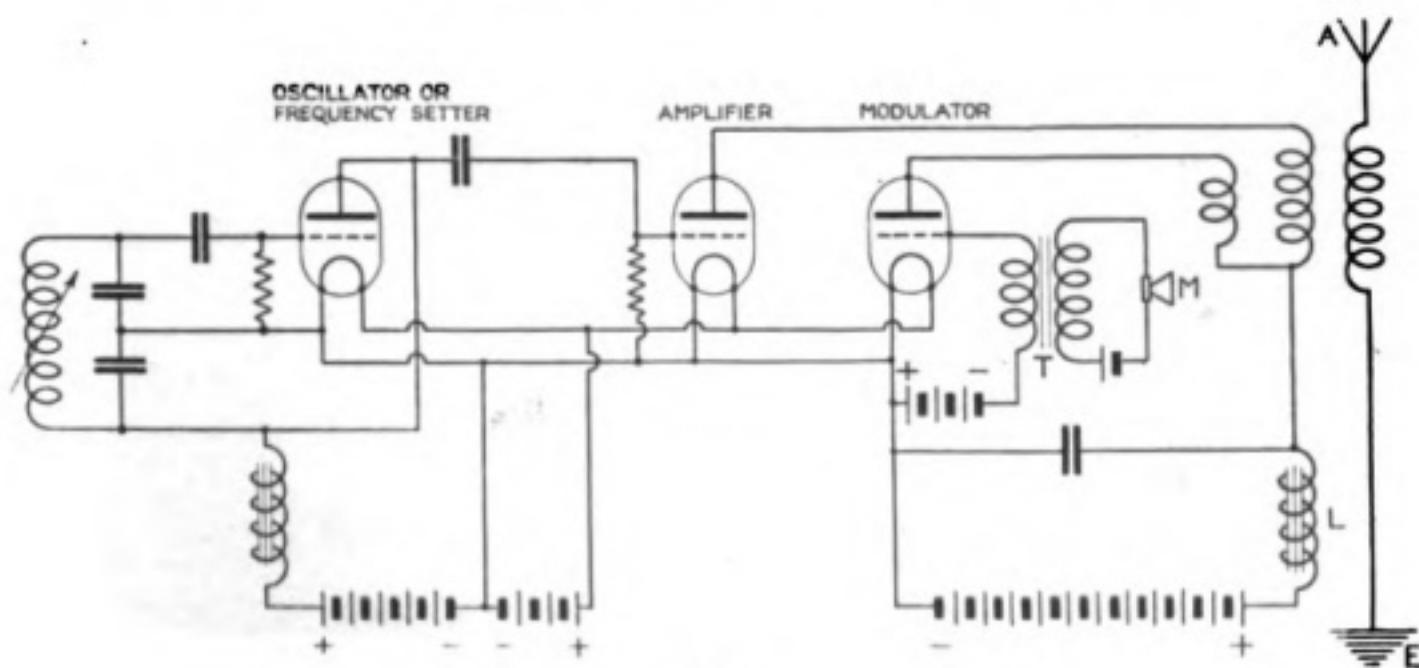

FIG. 15.

Electric 50 watt tubes for the amplifier, and modulator, and two VT-2 tubes for master oscillator and speech amplifier. By using this circuit in preference to that shown in Fig. 12 a greater total output is obtained with an equal

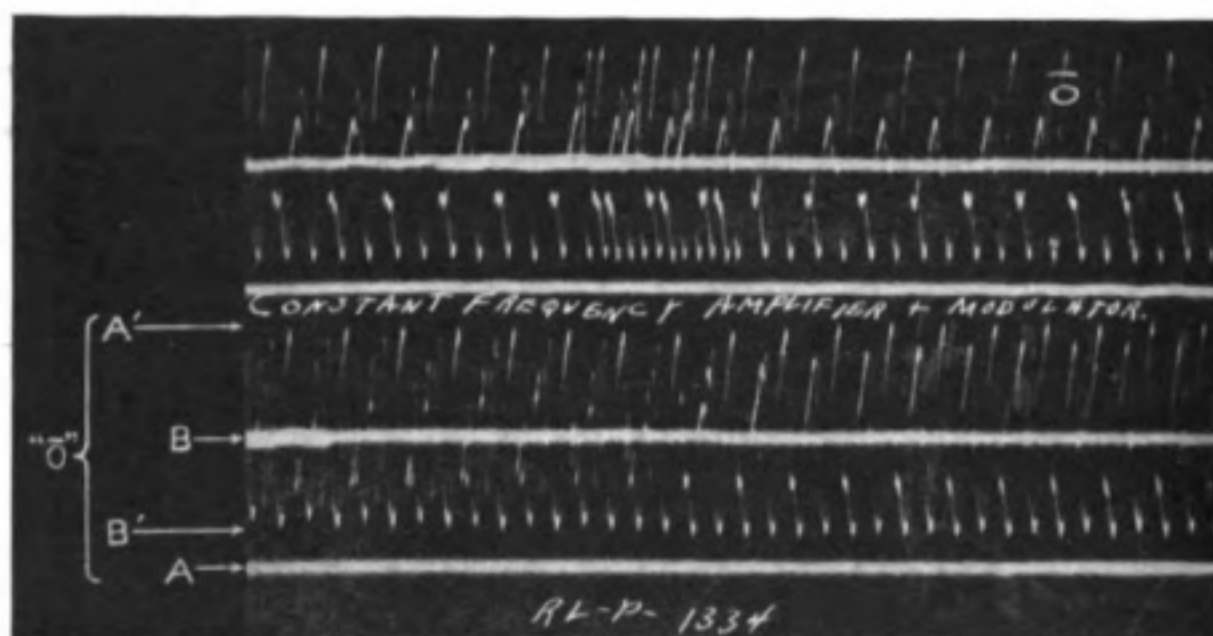

FIG. 16.—Modulation of Set using constant frequency Oscillator and Modulator.

number of tubes. For example: the average antenna current was 2.5 amperes (62.5 watts). For peak values twice the current or 5 amperes (250 watts) is obtained. This makes available for the antenna a current varying in amplitude between zero and 5 amperes. Comparing this with the values obtained in the previous circuit, 43 watts is actually gained.

Even more desirable than the small saving in efficiency is the smooth symmetrical form of the modulated wave, which is practically free from distortion.

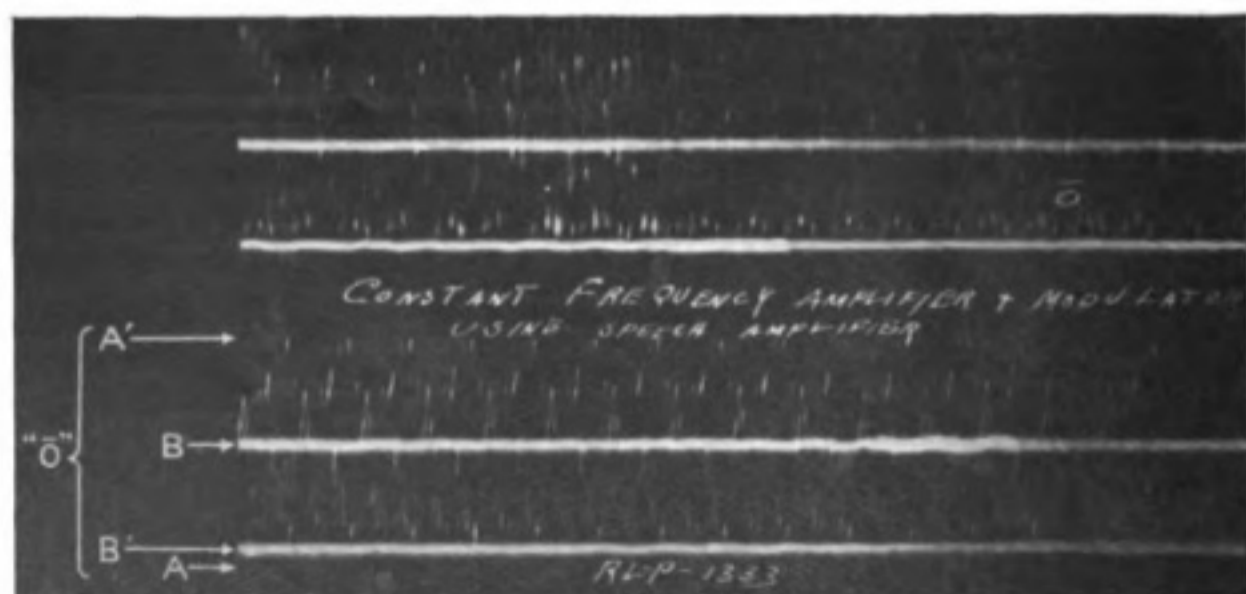

FIG. 17.—Modulation of Set using constant frequency Oscillator and Modulator with Speech Amplifier.

Based on the above experimental data, together with a great number of field tests, results indicate that suitable modulation of an *amplified* high frequency carrier wave give not only more efficient operation but a much superior quality of speech.

## On the Function of the Variable Anode Tap Connection in Triode Generators.\*

By E. V. APPLETON, M.A., M.Sc.

It was discovered during the war that the output current of a triode generator can very often be increased by a careful adjustment of the point at which the anode is connected to the aerial tuning inductance. Thus in the well-known circuit of Fig. 1 there is one position of the anode contact K along the coil  $L_1 + L_2$  which gives maximum oscillatory current. This note deals with the theoretical significance of this optimum position.

It will be seen from the figure that although the whole of the inductance  $L_1 + L_2$  is used in the oscillatory circuit only a portion of it (*i.e.*,  $L_1$ ) is included in the anode circuit. We shall call this latter portion the anode circuit inductance. Our problem thus resolves itself into determining the relation between  $L_1$  and the other electrical constants of the circuit to give optimum oscillatory current.

The problem is best approached by considering first the simpler case in which the anode contact is made at A instead of at K. The oscillatory circuit may then be regarded as equivalent to a non-reactive resistance of value  $\frac{L}{CR}$  for alternating currents of its natural frequency. (In this case  $L = L_1 + L_2$ )† We may thus regard the total anode circuit resistance as being equal to  $\rho + \frac{L}{CR}$  where  $\rho$  is the mean internal resistance of the triode.

Let us assume that during an oscillation the maximum grid voltage reached is  $v_g$ . The anode current changes produced may be regarded as being due to an electromotive force  $gv_g$  acting in a circuit of resistance  $\rho + \frac{L}{CR}$  where  $g$  is the voltage amplification factor of the tube. The anode

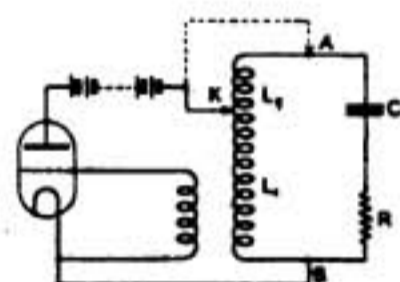

FIG. 1.

\* Received January 21st, 1921.

† [If  $L_1$  and  $L_2$  have mutual inductance, see equation (4).—ED.]



current  $i_A$  will then be given by  $\frac{g v_g}{\rho + \frac{L}{CR}}$  where the symbols of the variables

all refer to maximum values. Now the ratio of the oscillatory current  $J$  in the circuit LC to the anode current  $i_A$  in such a case is known to be  $\frac{L\omega}{R}$  where

$\omega^2 = \frac{1}{LC}$  We thus have

$$J = \frac{L\omega}{R} \cdot i_A = \frac{g v_g}{\rho + \frac{L}{CR}} \cdot \frac{L\omega}{R} = \frac{g v_g L \omega}{R \rho + L^2 \omega^2} \dots \dots (1)$$

This last quantity is a maximum when  $L\omega = \sqrt{R\rho}$ , that is, when  $L/C = R\rho$ . It thus appears that for all wavelengths a definite ratio of inductance to capacity gives maximum oscillatory current for a given antenna resistance. But in most transmitters in which a range of wavelengths is used it is impossible to keep to such a ratio as the aerial capacity is usually fixed. Thus for long wavelengths, when  $L$  is of necessity made large, the condition mentioned above is no longer maintained resulting in a small value of  $J$ . By the use of the anode tap connection K it is possible to bring about the increase of wavelength by an increase of self-inductance, at the same time keeping the ratio of the anode circuit inductance to capacity such as to produce optimum oscillatory current.

To make the alterations from the simple case outlined above to the case in which the contact is at K we require to find

- (a) The equivalent resistance of the oscillatory circuit from K to B.
- (b) The ratio of the oscillatory current  $J$  to the anode current  $i_A$ .

The oscillatory circuit and connections are represented diagrammatically in Fig. 2 where  $i_1$  and  $i_2$  are the currents through  $L_1$  and  $C$  respectively;  $i_A$  is the anode current, and  $v_A$  the potential difference between points K and B. From Kirchhoff's equations we have

$$i_A = i_1 + i_2$$

$$i_1 = \frac{v_A}{j\omega L_1}$$

$$i_2 = \frac{v_A}{R + j\omega \left( L_2 - \frac{1}{\omega^2 C} \right)}$$

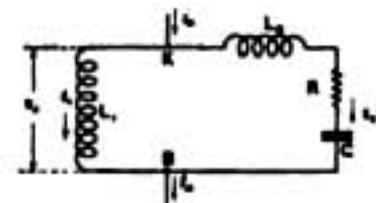

FIG. 2.

Eliminating  $i_1$  and  $i_2$  we have

$$\frac{i_A}{v_A} = \frac{R + j\omega L_1 + j\omega \left( L_2 - \frac{1}{\omega^2 C} \right)}{Rj\omega L_1 - \omega^2 L_1 \left( L_2 - \frac{1}{\omega^2 C} \right)}$$

that is, since  $L_1\omega \gg R$

$$\frac{i_A}{v_A} = \frac{R}{-\omega^2 L_1 \left( L_2 - \frac{1}{\omega^2 C} \right)} = \frac{R}{L_1^2 \omega^2}$$

Thus the equivalent resistance of the oscillatory circuit to alternating current of its natural frequency is  $\frac{L_1^2}{CR(L_1 + L_2)}$ . (Cf.  $\frac{L}{CR}$  when  $L_2 = 0$ .)

Therefore in the case where the anode connection K is used the total anode circuit resistance is given by  $\rho + \frac{L_1^2}{CR(L_1 + L_2)}$ . Thus for a grid voltage change of maximum value  $v_g$  we have

$$i_A = \frac{g v_g}{\rho + \frac{L_1^2}{CR(L_1 + L_2)}} \dots \dots \dots (2)$$

The relation between the oscillatory current  $J$  and the anode current  $i_A$  may be obtained from considerations of the energy supplied to the oscillatory circuit. Thus we have

$$i_A^2 R' = J^2 R$$

where  $R'$  is the equivalent resistance of the oscillatory circuit.

Substituting for  $i_A$  from (2) we have

$$J^2 = \frac{R'}{R} \cdot \left\{ \frac{g v_g}{\rho + \frac{L_1^2}{CR(L_1 + L_2)}} \right\}^2$$

and

$$J = g v_g \cdot \frac{L_1 \omega}{R \rho + L_1^2 \omega^2}$$

The value of  $J$  is found to be a maximum when

$$L_1 \omega = \sqrt{R \rho} \dots \dots \dots (3)$$

In a practical case where  $L_1$  and  $L_2$  are portions of a single coil the mutual inductance  $M$  between these portions may be considerable. If this is taken into account it may be shown in the same way that maximum oscillatory current is obtained when

$$(L_1 + M)^2 = \frac{R \rho}{\omega^2} \dots \dots \dots (4)$$

A further note as to the meaning attached to  $\rho$  (the mean internal resistance) is necessary. It is a well-known experimental fact that maximum oscillatory current is obtained when the anode current with the valve not oscillating is equal to half the saturation value ( $i_s$ ). In such a case the mean anode circuit resistance would be written approximately as  $\frac{2v_0}{i_s}$  where  $v_0$  is the voltage of

the anode battery. The final formula for optimum conditions may therefore be written

$$L_1 + M = \frac{1}{\omega} \sqrt{\frac{2v_0 R}{i_s}} \dots \dots \dots (5)$$

When the coil of which  $L_1$  and  $L_2$  are parts consists of a single layer the determination of the inductance  $L_1 + M$  is a simple matter if Nagaoka's factors are used. Thus in a coil of total length  $l$  and inductance  $L$ , comprising two portions of length  $l_1$  and  $l_2$ , of self-inductances  $L_1$  and  $L_2$  and mutual inductance  $M$ , we have

$$L = L_1 + L_2 + 2M$$

or 
$$\pi^2 d^2 n^2 \kappa \left(\frac{d}{l}\right) = \pi^2 d^2 n^2 l_1 \kappa \left(\frac{d}{l_1}\right) + \pi^2 d^2 n^2 l_2 \kappa \left(\frac{d}{l_2}\right) + 2M$$

where  $d$  is the diameter of the coil,  $n$  the number of turns per unit length and  $\kappa \left(\frac{d}{l}\right)$ ,  $\kappa \left(\frac{d}{l_1}\right)$  and  $\kappa \left(\frac{d}{l_2}\right)$  are Nagaoka's factors.

Thus 
$$L_1 + M = \frac{\pi^2 d^2 n^2}{2} \left\{ l \kappa \left(\frac{d}{l}\right) - l_2 \kappa \left(\frac{d}{l_2}\right) + l_1 \kappa \left(\frac{d}{l_1}\right) \right\}.$$

On testing this for typical examples it is found that  $L_1 + M$  is approximately directly proportional to  $l_1$ . Thus as an approximate formula for optimum conditions we have

$$f \doteq \sqrt{\frac{2v_0 RC}{i_s L}}$$

where  $f$  represents the fraction of the length of the aerial tuning coil included in the anode circuit.

The amplitude of the oscillation reached in a case in which the anode contact is made at K (see Fig. 1) will now be considered.

The usual method of arriving at the conditions for infinitesimal oscillations is to find the differential equation representing the relation between one variable electrical magnitude of the oscillatory circuit (*e.g.*, voltage across the condenser or inductance) and time. This equation can usually be written in the form

$$\frac{d^2 v_a}{dt^2} + 2\kappa \frac{dv_a}{dt} + \omega^2 v_a = 0 \dots \dots \dots (6)$$

where  $\kappa$  and  $\omega$  are functions of the slopes of the voltage-current characteristics of the tube. These slopes may only be considered constant for small changes of  $v_a$ . Thus for infinitesimal oscillations  $\kappa$  must be zero,  $\omega$  being for practical purposes the angular frequency of the oscillation. Proceeding in this way we may show for the above circuit that for  $\kappa$  to be zero we must have

$$M' = - \frac{\kappa_2 L_1 + \frac{L_2 + L_1}{L_1} CR}{\kappa_1} \dots \dots \dots (7)$$



where  $\kappa_1 = \frac{\partial i_a}{\partial v_g}$ ,  $\kappa_2 = \frac{\partial i_a}{\partial v_a}$  and  $M'$  is the mutual inductance between  $L_1 + L_2$  and  $L_3$ .

But this limiting condition does not represent the case of a tube producing vigorous oscillations in which case  $M'$  is numerically greater than the value demanded by (7). For such a practical case the question of stability becomes of importance. If we restrict the symbol  $v_a$  as before to the variable

part of the anode voltage we have  $v_g = -\frac{M}{L_1}v_a$ , a relation which holds for

all values of the current through  $L$ . Thus it is immediately possible to draw on the characteristic diagram an "oscillation characteristic" which represents all values of the anode current for which the above-mentioned relation is fulfilled. The conditions during an oscillation are then represented by a point which oscillates on this curve.

During an oscillation the representative point in travelling to and fro on the oscillation characteristic will reach regions where the limiting conditions obtain, e.g., at points A and B in Fig. 3.

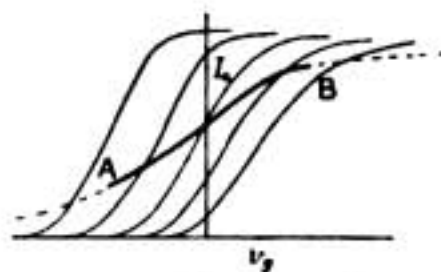

FIG. 3.

For positions of the representative point between these two limits the triode and its connections act as a negative resistance across the oscillatory circuit. For positions of the representative point beyond these limits (shown dotted in diagram) this shunt resistance becomes positive and tends to increase the damping of the oscillatory circuit.

It might at first be thought that the oscillation is maintained at the limiting points A and B but this cannot be the case as energy cannot be supplied to the oscillatory circuit indefinitely. We might put the matter in another way and write equation (6) as

$$\frac{d^2v_a}{dt^2} + \left\{ \phi(v_a) - A \right\} \frac{dv_a}{dt} + \omega^2v_a = 0$$

where  $A$  is constant in which case  $2\kappa$  is negative for small values of  $|v_a|$  but becomes zero when  $\phi(v_a)$  equals  $A$ . Assuming some function for  $\phi(v_a)$  is tantamount to assuming some equation for the static characteristics. Thus if we use the empirical relation used by van der Bijl ( $i_a = A'(v_0 + v_a + gv_g)^2$ ) it may be shown that in a symmetrical case the

maximum voltage reached is  $\frac{3\pi}{4}$  times the voltage required to bring the representative point to a portion of the characteristic surface where the limiting condition just obtains. Of course no importance must be attached to the exact value of the constant  $\frac{3\pi}{4}$ . The important thing in connection with the present method of considering the problem is that it should be shown to be greater than unity.

In the case of an unsymmetrical oscillation characteristic such as is almost always found in practice it is difficult to find a suitable mathematical expression to represent the curve. The following method may then be used. It depends on the assumption that the output current is practically sinusoidal. We have already seen that an oscillatory voltage  $v_a \sin \omega t$  between the points K and B must be accompanied by a grid voltage of magnitude

$-\frac{M'}{L_1} v_a \sin \omega t$ . From the oscillation characteristic it is possible to draw

out the anode current variations consistent with these potential changes. These in general will not be sinusoidal and may be expressed as a Fourier series

$$i_a = i_{a0} + i_{a1} \sin \omega t + i_{a2} \sin 2\omega t + \dots \\ + i'_{a1} \cos \omega t + i'_{a2} \cos 2\omega t + \dots$$

The first term of this series represents the rise or fall of the mean anode current as read by a direct reading instrument when the oscillation begins. Now to a sinusoidal change of angular frequency  $\omega$  the oscillatory circuit acts as a non-reactive resistance of value  $\frac{L_1^2 \omega^2}{R}$  and we may thus write

$$i_{a1} = \frac{v_a}{\frac{L_1^2 \omega^2}{R}}$$

The conditions of stability are thus such that the anode voltage change  $v_a \sin \omega t$  with its attendant grid voltage change  $-\frac{M'}{L_1} v_a \sin \omega t$  should produce anode current variations the fundamental component of which has the maximum value  $\frac{v_a R}{L_1^2 \omega^2}$ . Such a value of  $v_a$  can only be obtained by means of a tedious harmonic analysis of the oscillation characteristic but such appears to be the only method available for unsymmetrical cases.

---

### The "Feedback" or "Regenerative" Valve Circuit.\*

A suit for infringement of Claims 1, 2, 3, 5, 8, 9, 12, 14, 15, 16, 17, and 18 of U.S. Letters Patent No. 1113149 of October 6th, 1914 (on application filed October 29th, 1913), issued to Edwin H. Armstrong for "Wireless Receiving System," in which Edwin H. Armstrong and the Westinghouse Electric and Manufacturing Co. were plaintiffs against the de Forest Radio Telephone and Telegraph Co., has recently terminated by a judgment in favour of the plaintiffs. The suit was tried by District Judge J. M. Mayer, extracts from whose judgment are reprinted below.

MAYER, District Judge:—

This is a suit of major importance. It concerns an invention of high merit and the cause

---

\* Extracts from report of the judgment received from Messrs. Pennie, Davis, Marvin and Edmonds, Councillors at Law, New York.



has been presented ably and comprehensively. While the record is voluminous, it differs from some long records in that, by reason of the issues of fact involved, its length is fully justified. The defences are many but the principal attacks are directed against the priority of Armstrong. It is claimed for Armstrong that his date of invention is at least as early as January 31st, 1913, and thus antedates Schloemilch and Von Bronk, Meissner, and de Forest. Before discussing the questions involved in the priority contest, it is desirable to ascertain what the patent is and what is its accomplishment.

At the outset, it should be stated that the Armstrong feed-back circuit, as it has come to be known familiarly, must be recognised as a contribution of marked value to the practical art. Its employment has so greatly increased both the loudness and the definition of the sounds heard in the receiver that long distance radio communication has been remarkably improved and thus greater reliability has been attained.

"The present invention," Armstrong stated in his specification, "relates to improvements in the arrangement and connections of electrical apparatus at the receiving station of a wireless system, and particularly a system of this kind in which a so-called 'audion' is used as the Hertzian wave detector, the object being to amplify the effect of the received waves upon the current in the telephone or other receiving circuit, to increase the loudness and definition of the sounds in the telephone or other receiver, whereby more reliable communication may be established, or a great distance of transmission becomes possible. To this end I have modified and improved upon the arrangement of the receiving circuits in a manner which will appear fully from the following description taken in connection with the accompanying drawings. As a preliminary, it is to be noted that my improved arrangement corresponds with the ordinary arrangement of circuits in connection with an audion detector to the extent that it comprises two interlinked circuits; a tuned receiving circuit in which the audion grid is included, and which will be hereinafter referred to as the 'tuned grid circuit,' and a circuit including a battery or other source of direct current and the 'wing' of the audion, and which will be hereinafter referred to as the 'wing circuit.' As is usual, the two circuits are interlinked by connecting the hot filament of the audion to the point of junction of the tuned grid circuit and the wing circuit. I depart, however, from the customary arrangement of these circuits in a manner which may, for convenience of description, be classified by analysis under three heads; firstly the provision of means or the arrangement of the apparatus, to impart resonance to the wing circuit so that it is capable of sustaining oscillations corresponding to the oscillations in the tuned grid circuit; secondly, the provision of means supplementing the electrostatic coupling of the audion to facilitate the transfer of energy from the wing circuit to the grid circuit, thereby reinforcing the high frequency oscillations in the grid circuit, and thirdly the introduction into the wing circuit of an inductance through which the direct current of the wing circuit flows, and which is so related to the grid circuit that the maintaining electromotive-force across the terminals of the inductance due to reduction of the direct current, is effective in the tuned grid circuit to increase the grid charge and consequently to further reduce the current in the wing circuit and in the telephones."

The "firstly" and "thirdly" *supra* were in the original specification; the "secondly" was inserted during the prosecution of the patent application.

The first statement is illustrated in the drawings of the patent, and an illustrative claim is No. 1, which specifies, *inter alia*, "a resonant wing circuit" and reads as follows:—

"1. An audion wireless receiving system having a resonant wing circuit interlinked with a resonant grid circuit upon which the received oscillations are impressed, the resonant grid circuit having a capacity so related to the grid as to receive and retain the charge which accumulates thereon."

The second statement which defines broadly the instrumentalities of the first and third statements is represented by each of the figures of the patent drawings and illustrated by claim 9 which reads as follows:—

"9. An audion wireless receiving system having a wing circuit interlinked with a resonant grid circuit upon which the received oscillations are impressed, and an inductance through which the current in the wing circuit flows, the grid circuit including connections for making effective upon that circuit the potential variations resulting from a change of current in the wing circuit."



In one form of language or another, what is set forth in the third statement, is embodied in claims 3, 5, 8, 12, 14, and 17. Claim 17 will suffice for illustration :—

" 17. An audion wireless receiving system having a wing circuit interlinked with a resonant grid circuit upon which received oscillations are impressed and an electrostatic coupling between the circuits supplementing the coupling of the audion to facilitate transfer of energy from the wing circuit to the grid circuit, whereby the effect upon the grid of high frequency pulsations in the wing circuit is increased."

For so difficult a subject matter, the specification and claims as originally filed fared very well in the Patent Office. The first fourteen claims were allowed as filed and they constitute all of the original claims except one originally numbered 13, which was rejected on reference to the Schloemilch and Von Bronk patent. Out of the mass of testimony and argument too extensive to quote or to discuss in complete detail, it is well to settle one proposition at the start. The Armstrong specification and claims show that the invention was for an instrumentality. The feed-back circuit was well defined in the record on a number of occasions. Professor Hazeltine, plaintiff's expert, stated that the fundamental principle of Armstrong's invention was "the provision of an arrangement for transferring oscillating current energy from the plate circuit to the grid circuit whereby oscillations present in the grid circuit are assisted." "Any arrangement by which oscillating current energy is transferred from the output or plate circuit of the audion to the input or grid circuit to sustain the oscillations in the grid circuit is included in the principle of the Armstrong invention."

Defendant asserts that the question is whether the invention resides in the reamplifying audion or in the oscillating audion or in both or in "some more basic idea" and then contends that the patent is limited by its own terms to the reamplifying audion.

All of these arguments and all the analysis of the Armstrong patent language and claims come down to a single proposition. If Armstrong invented a new instrumentality he is entitled to the fruits of all its uses, whether he understood them or not and whether his theory of operation was right or wrong, comprehensive or limited. Given the new instrumentality the question is what it does, not how or why it does something. It is urged that the error of the argument for Armstrong is "primarily in the assumption that the invention is a specific recognisable thing called a 'feed-back,' a definite group of mechanical or electrical elements which like a tool may be used for various purposes." *That* is not the invention. The invention is ". . . a particular use of an otherwise old circuit by an adjustment of the constants so as to produce reamplification."

The discussion of the limitations upon the patent by its own terms includes quotations from the patent at those places where Armstrong pointed out that if the ratio of feed-back coupling exceeded a certain amount, the audion would become a high-frequency generator setting up disturbing oscillations in the grid and wing circuits and informed the art how maximum amplification of damped wave signals could be obtained below oscillation. But, the fact is that defendant's oscillating audion does regeneratively feed back energy from the plate circuit to the grid circuit to amplify cumulatively the received signals. This seems satisfactorily shown by Hazeltine, by Dr. Austin's paper and by Armstrong's paper, and his testimony in the Interference Record. The patent does not indicate any use of the audion in the oscillating condition, but when the audion is oscillating, due to feed back, it is coincidentally regenerating.

Leaving now the construction of the patent as it is written and the action and results which occur from following the teaching of the patent, it is next desirable to ascertain Armstrong's date of invention.

This case is another contribution to the romance which has so often characterised the history of forward inventions. Armstrong was graduated at about twenty-two years of age from Columbia University in June, 1913, as an electrical engineer. As a boy of fifteen he became interested in radio and erected a radio station at his home. He obtained his first vacuum tube detector, a so-called Fleming valve, in 1908 from Mr. Charles R. Underhill. Later, about 1910 or 1911 he obtained a so-called de Forest audion or three-element vacuum tube detector. In the spring of 1912, he began a close study of the fundamental action of the audion and read all the literature on the subject.

Some time during this period he connected a condenser across the telephone of a simple audion receiving system and noticed that on some bulbs an increase in signal strength would

result. It is important, at this point, to realise that Armstrong is a remarkably clear thinker. His modest demeanour belies his extraordinary ability. His achievement was not the result of an accident, but the consummation of a thoughtful and imaginative mind. Step by step he proceeded with study and experiment from the summer of 1912 until the fall of that year. The apparatus which he used—the long wave apparatus and short wave apparatus—are in evidence. He was obtaining what seemed to him remarkable results and he showed his apparatus to his father and let him listen to his signals and asked his father to advance money for a patent application. Mr. Armstrong, Sr., was evidently not impressed and refused his son financial help. On December 7th, 1912, Armstrong told his college mate Burgi that he had succeeded in improving the sensitiveness of the audion by means of a new connection and Burgi noted this in his diary on that date as follows: "Armstrong told me he had a connection for intensifying sound." About the end of 1912, he explained to Mr. Thomas Ewing that he wished to make tests with a new receiver he had invented and obtained Mr. Ewing's permission to string the antenna (Armstrong having erected a mast at his home) into Mr. Ewing's adjoining property.

About the same time Armstrong showed the receiver to his uncle, Mr. Smith, and tried to get him to advance money for the patent application. This Mr. Smith did not do, but advised Armstrong to make a drawing of the connections and have it witnessed by a notary. During the fall of 1912 and the winter of 1912—1913, Armstrong showed his receiving results to a number of radio amateurs without disclosing the circuits. The description by the amateurs of the result corresponds with what the court heard at the trial during the demonstrations at Columbia University. The amateurs testified that they knew now (*i. e.*, when they testified) that this result must have been produced by the Armstrong feed-back. The testimony of the amateurs is impressive as to its truth and as to accuracy of recollection.

On January 31st, 1913, Armstrong went with his college mate Burgi to Goodwin's Real Estate Office at 123rd Street and Lenox Avenue with a drawing on tracing cloth of his circuit connections and had the drawing witnessed by the notary. It was shown to Armstrong's uncle, Mr. Smith, at about the time it was made, although Mr. Smith did not have such knowledge of wireless apparatus or systems as would enable him to understand the circuits. Burgi testified that he might have understood the circuits at the time but would not be able to reproduce them from memory, but he identified the sketch as the one shown to him and witnessed by the notary in his presence. This drawing is reproduced in the patent as Fig. 2 and it includes both the adjustable tuning inductance in the plate circuit and the telephones located in the common path.

I have no doubt, whatever, either as to the existence of the apparatus on January 31st, 1913, which contained Armstrong's feed-back circuit arrangement and operated practically and successfully or of the accuracy of the date on the drawing of January 31st, 1913. That drawing was a record of an invention then completed and reduced to practice. Armstrong had one objective upon which he concentrated all there was in him of ability, of perseverance, and of courage against what were great odds to a young man.

That no one of the witnesses saw or understood the circuits is, in the circumstances of this case, immaterial and unimportant. I see no legal obstacle to fixing January 31st, 1913, as at least the date of the invention, and I am so completely satisfied with the evidence that I am not embarrassed by any question of fact.

On questions of invention date, much is said about corroboration, but I do not understand that corroboration in the sense of full knowledge by a witness of the inventive conception and an understanding of the apparatus in addition to the inventor is necessary. The question always is as to what will satisfy the trier of the facts; and, in the case at bar, there is not only Armstrong's testimony to which I accord absolute credibility, but in addition, the apparatus and the sketch—physical things—the testimony of the amateurs and all the surrounding circumstances leave no doubt that Armstrong's date is at least as early as January 31st, 1913.

Considering the difficulties with which the young student was confronted, he moved diligently and finally succeeded in filing his application for the patent on October 29th, 1913.

The merit of the invention was soon recognised and the very apparatus with which Armstrong made the invention was subsequently utilised commercially at Sayville, Long Island, shortly after the outbreak of the war in 1914, to overcome difficulties in the reception of signals from Nauen, Germany, and this apparatus continued in use at Sayville for some time.



As indicative of the appreciation of the commercial value of the invention, licences were taken at an early date by the Atlantic Communication Company, the Goldschmidt Company and the Marconi Company.

The Meissner United States application was filed on March 16th, 1914. The oath recites four German applications, the earliest of which was dated April 9th, 1913. This application (now German Patent No. 291604, dated June 23rd, 1919) discloses the regenerative or feed-back circuit adjusted to produce oscillations but it does not state that it is for radio reception and the antenna and ground connections are omitted.

It is unnecessary, however, to discuss this patent in detail because by according to Armstrong the date of January 31st, 1913, he preceded Meissner by about 2½ months.

Schloemilch and Von Bronk, U.S. Patent No. 1087892, issued February 17th, 1914, was filed on March 14th, 1913, subsequent to Armstrong's date, but, in any event, it would not have embarrassed Armstrong; for it did not occur to Schloemilch and Von Bronk to re-amplify the high frequency variations by feeding them back to the grid circuit. In other words, this patent failed to point out, and its authors evidently did not appreciate, the essential point of Armstrong's invention.

The Reisz patent No. 1234489, filed April 9th, 1913, and issued July 24th, 1917, does not call for discussion.

We thus come to the de Forest defence. It is no reflection on de Forest to observe that in a number of instances in this record his memory has proven faulty. This is not strange. During the years 1912, 1913, and 1914, de Forest was confronted with many difficulties and many obstacles. He had much to contend with and, besides, he was experimenting in numerous directions and, in such circumstances, independent memory is not always reliable.

The work with the audion from 1912 to 1914 had to do primarily with two uses of the audion (1) as a telephone relay and (2) as an amplifier of telephone and detected radio signals and the use of the amplifier to record radio signals on a telegraph wire. The "howling" of an audion oscillating at audio frequencies would defeat both of these purposes for the obvious reason that the noise of the "howling" audion would destroy telephone conversation and radio signals alike. On the other hand, the feed-back circuit would have been of great service in the amplification of radio signals and in recording them on a telegraph wire.

The documentary evidence of the work of de Forest and his associates begins with the entry in the de Forest experimental notebook (under date of June 21st, 1912), where he enters the observation of a beat or high-frequency note with the straight audion hook-up. His notes show this to have been transient and incapable of reproduction and he recognised that it was not the true heterodyne effect.

The entry of June 21st, 1912, so far as it is pertinent to the present inquiry, shows that de Forest did not then know how to produce a beat note with an audion receiver.

The next entry is in the Van Etten notebook under date of August 6th, 1912. Van Etten was working on the audion as a telephone relay and amplifier. He had looked up the two-way telephone relay in Kempster B. Miller's well-known work on the subject of telephone engineering and had learned that a mechanical telephone relay when used in a two-way circuit would sing and howl unless precautions were taken to prevent it.

On July 23rd, he entered in this notebook a two-way telephone circuit using two audions under the heading "Think the following arrangement (doped out yesterday) would possibly make a good telephone repeater." It happened as de Forest testifies that they did not have two audions available and on July 24th Van Etten attempted to set up this two-way circuit of his with a single audion having two grids and two plates. The arrangement did not work because as Van Etten said in an entry dated August 5th "Above n. g. because audion does not get in the game—simply two repeater coils in series—see inked ckt."

The following day, August 6th, he connected the input circuit of a double audion to the output circuit and in this accidental way found that the audion would howl or sing. He pointed out in his notes that the arrangement gave a beautiful clear tone which lowered and raised in pitch as the B-battery was varied, and could be wiped out by a magnet "and then the watch ticks came through as before." He says "This phenomenon is apparently similar to the 'howl' produced in an ordinary C B telephone when the receiver is placed against the transmitter but nevertheless as shown by variation of number of cells in battery B and by magnetic wiper is also intimately associated with the audion."

On the same day he set up a balanced two-way telephone circuit corresponding to the



two-way balanced telephone circuit shown in Miller which is used to prevent the howling of mechanical telephone relays, and made the entry "Tried following circuit, but it was n. g., could not make it boost at all, could only make it howl."

From this point on his notes show a continuing attempt to produce a telephone relay circuit in which the audion would not howl and in this effort he succeeded on or about August 29th, 1912.

The August 6th, 1912, entry of Van Etten was not copied in the laboratory notebook nor was anything done which showed that any one appreciated the phenomenon. De Forest's testimony on the point is not sufficiently clear and definite to be satisfactory.

The entry of February 7th, 1914, shows that where de Forest duplicated the arrangement he referred to it as "This new and simplified circuit" and regarded it as useful only for the "trigger effect." In de Forest's article in the *Electrical World* on February 20th, 1915, no mention is made by de Forest of the August 6th, 1912, entry of Van Etten.

On August 29th, after entering in his own notebook the two-way circuit which did not howl, Van Etten made an entry showing the use of two audion amplifiers in cascade. He explained this arrangement to de Forest, it was considered of great importance, and was copied into de Forest's notebook by Van Etten under that date.

This is the invention de Forest afterward sold to the A. T. & T. and about which he said "When I made this interesting discovery I lost interest in the oscillating feature."

In the Van Etten notebook it is described merely as an amplifier, but in the de Forest notebook it is noted that by reversing certain connections the arrangement makes all sorts of musical notes in the telephones and that the notes could be changed by putting very small capacities, such as the capacity of one's body or from thumb to finger, between ground and grid, wing or filament.

It is testified by de Forest that these effects were due to a feed-back brought about by the fact that the coils numbered 1 and 5 on the sketch were placed close together on the table, although there was no indication of that in the sketch or notes. Van Etten fails to corroborate him as to the existence of any feed-back in this circuit.

Although there was in fact an accidental capacity feed-back between the output circuit of the second audion and the input circuit of the first audion in this cascade system, that coupling was not apparent in the diagram, was not mentioned in the notes, and was not understood by de Forest.

The arrangement did not indicate to de Forest or Van Etten how to control the oscillations, or that they were due to any circuit arrangements, and not due to some peculiar and obscure characteristic of the audion.

Without indulging in further detail, it is enough to say that the proof falls far short of any conviction that in 1912 either de Forest or Van Etten had any realisation of what is now the invention of the patent in suit.

The first application by de Forest of the oscillating audion to any useful purpose was in a laboratory experiment on April 17th, 1913. The entry on that date beginning "This day I got the long looked for beat note" indicates that, theretofore, de Forest had not been able to get this heterodyne phenomenon. There was no sketch of the circuit arrangement nor was the circuit disclosed to any one, scientist or layman. It is argued that, for several reasons, the circuit described in the note was not a feed-back circuit, but, whichever way the entry may be construed, it is at least open to debate and in view of the lack of corroborating circumstances, a debatable entry not clearly illustrated and not disclosed to any one at the time, leaves the matter in doubt. The de Forest notebook entries of 1914 need not be analysed in view of Armstrong's date.

It was not until September, 1915, that de Forest filed any application showing what he claimed to be a feed-back circuit, and in the meantime he had filed thirty patent applications.

Armstrong's counsel do not contend that de Forest's lack of knowledge that the ultraudion circuit was a feed-back circuit would deprive him of whatever benefit might accrue to him from the invention of that circuit in the spring of 1914; but it is their contention that the invention of the ultraudion circuit in February, 1914, the failure to recognise it as a feed-back circuit, and the filing of the ultraudion applications without including any circuit of the 1912 notes, completely negative the idea that he had invented the feed-back circuit in 1912. With this view I agree.

It is not practicable to discuss the testimony in all its elaborate detail. All has been con-

sidered, although some has not been mentioned, such as that of Logwood; which needs no serious comment. On the one side is an enthusiastic, never-say-die young student—feed-back Armstrong—with but one thought possessing him. He not only discloses to many persons his belief that he has invented something worth while but he produces his apparatus and he produces a sketch which is extraordinary for its clear and unmistakable description to one skilled in the art and the date of that sketch is incontrovertibly fixed.

On the other side is a then experienced and able worker in the art experimenting along certain lines who is unable to rely solely on notebook entries which are not clear but require construing and who supplements these entries by recollection which is fallible and not certain.

If de Forest in 1912 or 1913 invented the feed-back circuit the obvious financial reward in store for him would have induced him, notwithstanding all his difficulties, to do one of two things (1) that which Armstrong did, that is, in some way make a clear memorandum and have somebody know about it or (2) file an application for a patent in the same way that during the period concerned he filed many other applications.

Holding, then, that Armstrong is the first inventor and that his claims in suit should be construed as he contends the sole remaining question is that of infringement. It will suffice to say that on this branch of the case I accept Hazeltine's testimony, from which it appears that all the claims are infringed.

Plaintiffs may have a decree in accordance herewith, with costs.

JULIUS M. MAYER,  
*District Judge.*

May 17th, 1921.

---

### Receiving Valve Patent Action.

In an action for infringement of patents between Marconi's Wireless Telegraph Co., Ltd., plaintiffs, and A. W. Gamage, Ltd., defendants. the following judgment was delivered by Mr. Justice Eve on July 12th, 1921:—

"Upon motion made unto this Court this day by counsel on behalf of the above-named plaintiffs and upon reading the statement of claim and particulars of breaches filed in this action and the plaintiffs and defendants by their counsel consenting to this order

"This Court doth order that the defendants their servants agents and workmen be restrained during the continuance of the plaintiffs' Letters Patent No. 13636 of the year 1913 and No. 28413 of the year 1913 and any extension thereof or of either of them from infringing the said Letters Patent and each of them.

"And it is ordered that the defendants do pay to the plaintiffs within fourteen days from the date of this order the sum of £150 as the agreed damages sustained by the plaintiffs by reason of the infringement of the said Letters Patent by the defendants.

"And it is ordered that the defendants do forthwith upon oath destroy by dismantling and breaking up into their constituent parts all articles and apparatus being receiving systems or apparatus for receiving electric oscillations (including "Polaris" receiving apparatus) made or used by the defendants in infringement of the said Letters Patent as aforesaid which are in the possession custody or power of the defendants or their servants or agents or workmen.

"And it is ordered that the defendants do pay to the plaintiffs their costs of this action such costs to be taxed by the taxing master."

The patents referred to above were issued to C. S. Franklin and H. J. Round respectively, and cover the use of magnetic retroaction coupling between the anode and grid circuits of a receiving valve, and the use of the detecting valve for also producing local oscillations to set up beats with the incoming signals (autodyne). [3689]

---

## Notes.

### Personal.

**Mr. M. A. Noss** has been appointed chief engineer of the Telepost Co. of New York, and is engaged in wire and radio communication research in conjunction with **Mr. P. B. Delany**. [8135]



**K. A. Christiansen** has left the Federal Telegraph Co., Palo Alto, California and joined the Pacific Telegraph and Telephone Co. of San Francisco, Cal. [3141]

**Mr. Churchill** has accepted the chairmanship of the Imperial Communications Committee. The Inter-departmental Imperial Communications Committee was established in 1919 under the chairmanship of the Colonial Secretary (Lord Milner). It has under control matters connected with cable, wireless, and air communication. [3364]

**Professor Edouard Branly** has been awarded this year's Nobel Physics Prize for his researches in connection with radio work. [3365]

### Commercial and General.

The Compagnie Générale de Télégraphie sans Fil has concluded a contract for a period of thirty years with the Government of Ecuador for the working of the telephones, telegraphs and wireless service in that State. The Government of Ecuador will pay the company an annual subsidy of about 1,200,000 francs. The State will have a share in the net profits. [3036]

The new wireless station at Port Elizabeth (S. Africa), which was opened on May 3rd, has a guaranteed daylight range of 300 miles, but tests have shown the possibility of communicating over 1,000 miles under favourable conditions at night. The power of the station is  $1\frac{1}{2}$  kW, and the aerial is of the umbrella type supported by two 80-ft. masts. [3030]

The number of radio stations operated and controlled in the Australian Commonwealth was recently stated by the Minister of Defence to be twenty, exclusive of naval stations at Garden Island, Jervis Bay (N.S.W.) and Williamstown. In addition to the Commonwealth stations there are eight under the jurisdiction of the Administrator of the New Guinea territory. [3034]

The Japanese Government has erected two new wireless stations at Okinawa (Liu-kiu Islands) and Kogoshima for ship traffic. Military and naval stations are to be built at Hokkaido and Otaru at a cost of 6 million yen. [3032]

A demonstration was recently given by Messrs. R. M. Radio, Ltd., at their new premises, 5, Regent Square, W.C. 1, of their ship installations — recently described in these columns—and of a new pattern of triode receiving valve which is the invention of Captain H. de A. Donisthorpe. This valve has a hemispherical anode and grid mounted over a loop filament, and is of the "soft" variety.

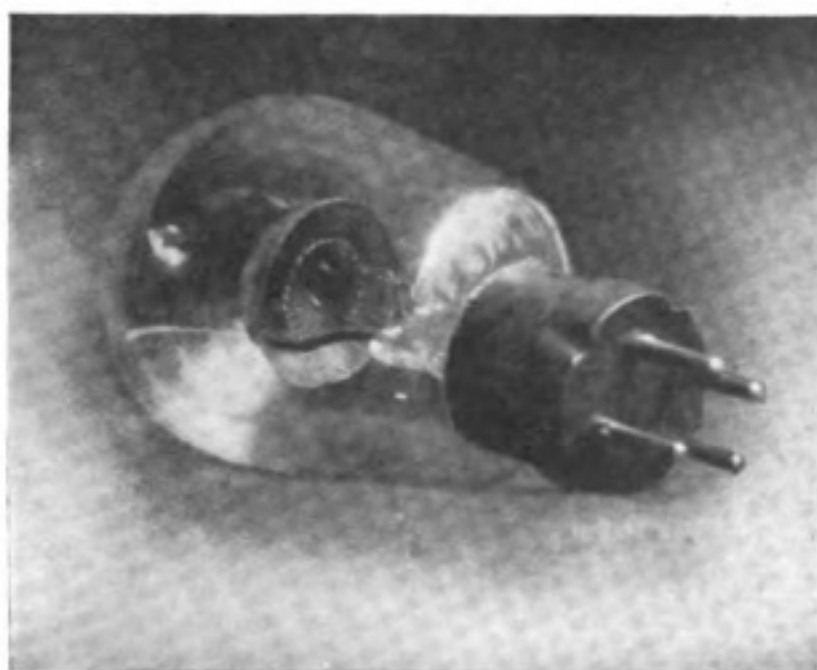

The R.M.R. Triode.

When in use a coil is placed round the bulb, and a direct current from a few cells is passed through its windings. The resulting magnetic field serves to concentrate the streams of ions and electrons into favourable directions under the anode, and improves the qualities of the tube as a detector, a most marked increase in the strength of signals being observed when the coil is in place. The valve is remarkably free from locally produced noises, due to vibration, etc., and this increases its value when receiving weak signals. [3367]

duced noises, due to vibration, etc., and this increases its value when receiving weak signals. [3367]



# Review of Radio Literature.

## 1. Abstracts of Articles and Patents.

### (P.) High-frequency Circuits and Measurements.

#### (2) THEORY OF ELECTRIC CIRCUITS ; COUPLING, ETC.

2095. **F. J. W. Whipple.** Equal Parallel Cylindrical Conductors in Electrical Problems. (*Proceedings of the Royal Society*, 96A, pp. 465—475, February 3rd, 1920. *Science Abstracts*, 23A, p. 399, Abstract No. 1004, July 31st, 1920—Abstract. *Journal de Physique et le Radium*, Abstract Supplement p. 35, August, 1920—Abstract.)

A more general treatment of a problem previously discussed by A. Russell enabling the current density and the magnetic flux to be calculated for high-frequency currents flowing in long parallel conductors.

2096. **E. Bellini.** Three-magnetically Coupled Circuits. (*Electrician*, 85, p. 78, July 16th, 1920. *Science Abstracts*, 23A, pp. 586—587, Abstract No. 1476, November 30th, 1920—Abstract. *L'Elettrotecnica*, 7, p. 615, December 5th, 1920—Abstract. *Revue Générale de l'Électricité*, 8, p. 109D, October 9th, 1920—Abstract.)

A mathematical discussion of three inductively coupled circuits tuned to the same frequency. It is concluded that a frequency of the oscillations in the two extreme circuits always remains that of the common frequency to which all the circuits are tuned, however close the couplings may be, and also that two coupling frequencies exist in all three circuits. Some experimental results are given confirming these conclusions. In the case when the intermediate circuit has no condenser it is shown that the extreme circuits possess two frequencies, while in the intermediate circuit only one of them is present.

2097. **J. R. Carson.** Theory and Calculation of Variable Electrical Systems. (*Physical Review*, 17, pp. 116—134, February, 1921.)

The paper deals with the extension of the theoretical methods of solution of invariable electrical systems to include variable systems in which one or more of the circuit elements are definite functions of time, or in which the relation between current and applied E.M.F. is non-linear. This is done by the application of integral equations.

The application of the method is given to a number of radio problems, including the circuit equations of the Goldschmidt H.F. alternator, the three-electrode valve, microphone transmitter, etc.

2098. **F. C. Blake.** On Electrostatic Transformers and Coupling Coefficients. (*Journal of the American Institute of Electrical Engineers*, 40, pp. 23—29, January, 1921. *Science Abstracts*, 24B, p. 156, Abstract No. 307, March 31st, 1921—Abstract. *Physical Review*, 15, p. 340, April, 1920—Abstract.)

Starting from the experimentally determined fact that the capacity of an air condenser is independent of the frequency of electrical oscillation, it is shown by means of Lord Rayleigh's equations for the mutual reactance between two circuits each having inductance, resistance and capacity, that for high-frequency conditions when the resistance is negligible compared to the reactance, the capacity reaction between the two circuits can be expressed best in terms of elastances. Definitions are given for self and mutual elastances as well as for self and mutual capacitances and the definitions are tested by our knowledge of spherical condensers. The coefficient of elastic coupling is shown to be the ratio between the mutual elastance and the square root of the product of the two self elastances, the analogy with the coefficient of inductive coupling being exact. The coefficient of capacitive coupling between two circuits each having capacity with a capacity in the branch common to both is shown to be a limiting case of the coefficient of elastic coupling and thereby a condenser of the ordinary or close form is shown to be an electrostatic transformer with a coupling coefficient of unity. The true relationship between Maxwell's coefficient of capacity and the elastances or capacitances is pointed out in the case of the spherical condenser. The ideas developed are applied to the thermionic tube and thereby the behaviour of the ultraudion and the experiments of

van der Pol are readily explained. Attention is called to the alternative view of the behaviour of condensers toward alternating currents, viz., instead of being paths of low impedance, they are paths of ready yielding or low stiffness or elastance, as suggested by Heaviside and by Karapetoff.

2099. **A. Press.**  $Q_m$ -Operators and Hysteresis Harmonics. (*Electrician*, 86, pp. 72—73, January 14th, 1921. *Science Abstracts*, 23B, Abstract No. 154, p. 79, February 28th, 1921—Abstract. *Revue Générale de l'Électricité*, 9, pp. 805—806, June 4th, 1921.)

An extension of earlier work on  $Q_m$ -operators,\* and in particular an investigation of the justification of the assumption made in the earlier work that adding current harmonics on the primary side of a transformer was equivalent to superposing linearly the corresponding voltage harmonics on the secondary side obtained independently by means of the  $B-H$  curve. It is concluded that where the width of the hysteresis loop is not too great, the assumption is justified.

2100. **A. F. Zahm.** Harmonic Oscillations. (*Journal of the Franklin Institute*, 191, pp. 381—404, March, 1921.)

A mathematical study of harmonic motion.

2101. **A. Hund.** Complex Angular Velocities and their Application to Electrical Problems. (*Jahrbuch Zeitschrift für drahtlose Telegraphie*, 16, pp. 431—457, December, 1920; 17, pp. 40—50, January, 1921; pp. 98—118, February, 1921.)

Translation of a paper in the *Proceedings of the Institute of Radio Engineers*.†

2102. **A. W. Porter and R. E. Gibbs.** On Systems with Propagated Coupling. (*Philosophical Magazine*, 41, pp. 432—440, March, 1921.)

In the majority of electrically coupled circuits the two circuits are so close together that the time of propagation of the mutual action between them can be neglected. For great distances of separation, or for very high frequencies, this would no longer be true, and the mathematical theory of this effect is given in the paper for various cases.

2103. **L. E. Whitmore.** Capacitive Coupling in Radio Circuits. (*Physical Review*, 15, pp. 559—562, June, 1920.)

Equations are derived for an electrostatic coupling of two oscillation circuits by means of two condensers and formulæ are derived for the frequencies of the coupling oscillations. The conclusions are supported by cathode ray oscillograms.

2104. **C. S. Perkins.** A Study of Electrical Resonance in Radio Transmitters. (*Wireless Age*, 8, pp. 23—24, February, 1921.)

2105. **W. Rogowski.** The Damping in Two Inductively Coupled Oscillatory Circuits with Tight Coupling. (*Archiv für Elektrotechnik*, 9, pp. 427—438, March, 1921.)

A theoretical investigation intended as an introduction to a later paper on the phenomena occurring in a triode oscillator with coupled oscillatory circuits. The coupled frequencies are first determined for various ratios of natural frequencies, neglecting resistance. An approximate solution is then obtained for the case when the resistances are small but not negligible. The method is based on the supposition that the resistance alters the coupled frequency from  $\Omega$  to  $\Omega' = \Omega(1 + \xi)$  where  $\xi$  is so small that on expanding powers of  $1 + \xi$ , all powers of  $\xi$  above the first may be neglected. It is then shown that the voltage  $V_1 = A e^{i\Omega t} = A e^{i\Omega t} e^{i\xi\Omega t} = A e^{i\Omega t} e^{-\alpha t}$ , that is to say that the frequency is not appreciably changed but the oscillation has a damping index

$$\alpha_1 = \frac{R_1}{2L_1} U_1 + \frac{R_2}{2L_2} U_2$$

for the high-frequency oscillation and

$$\alpha_2 = \frac{R_1}{2L_1} u_1 + \frac{R_2}{2L_2} u_2$$

for the low-frequency oscillation.

\* See RADIO REVIEW, 1, pp. 575—576, August, 1920.

† See RADIO REVIEW Abstract No. 1186, December, 1920.



Formula are developed for the weighting factors  $U$  and  $u$ , and the results discussed and illustrated by means of curves.

2106. **A. Mestrap.** On an Electrical Analogy for Undamped Oscillations. (*Revue Générale de l'Électricité*, 9, pp. 363—368, March 12th, 1921.)

The oscillations set up by a series dynamo are discussed mathematically.

2107. **P. Joye** and **M. Besoson.** Distributed Capacity in Transformers and Induction Coils; The Discrepancy between Theory and Experiment. (*Bulletin of the Schweizerische Elektrotechniker Verein*, 12, pp. 37—41, February, 1921. *Science Abstracts*, 24B, p. 196, Abstract No. 393, April 30th, 1921—Abstract.)

2108. **R. B. Abbott.** Damped Electric Oscillations. (*Physical Review*, 17, pp. 482—492, April, 1921; pp. 510—511, April, 1921—Abstract.)

A summary of previous work is given with references to important papers. This is followed by a mathematical treatment of damped oscillations with solutions of the differential equations for four types of oscillations: (1) simple harmonic; (2) logarithmically damped; (3) linearly damped; and (4) combined logarithmically and linearly damped oscillations. The mathematical treatment is simplified by an analogy between the dynamical and electrical differential equations of motion.

(3) AND (4) INDUCTANCES AND CONDENSERS (THEORY, DESIGN, ETC.).

2109. **C. O. Gibbon.** Design of Air Core Inductance Coils of Minimum Weight for a given Inductance and Resistance. (*Journal of the American Institute of Electrical Engineers*, 39, pp. 660—665, July, 1920. *Electrical World*, 76, p. 647, September 25th, 1920—Abstract. *Technical Review*, 7, p. 426, December 28th, 1920—Abstract. *Science Abstracts*, 23B, p. 416, Abstract No. 796, September 30th, 1920—Abstract. *Revue Générale de l'Électricité*, 8, p. 129D, October 23rd, 1920—Abstract.)

2110. Physical Society's Exhibition. (*Electrical Review*, 88, pp. 121—122, January 28th, 1921. *Electrician*, 86, pp. 131—133, January 28th, 1921.)

See RADIO REVIEW, 2, pp. 94—97, February; pp. 152—153, March; pp. 201—203, April, 1921.

2111. **F. W. Grover.** The Inductance of Coils wound on Polygonal Forms. (*Physical Review*, 15, p. 532, June, 1920.)

An abstract of an American Physical Society paper dealing with a comparison of the inductances of coils wound on circular and polygonal forms. Tables of equivalent radii have been calculated.

2112. **F. Duroquier.** Multilayer Inductance Windings. (*La Nature*, 49(1), Supplement pp. 107—108, April 2nd, 1921.)

Illustrated constructional details.

2113. **B. Steinmetz.** Multilayer Inductances for Long Waves. (*Wireless Age*, 8, pp. 29—30, January, 1921.)

2114. **W. Geiss.** Natural Frequency and Harmonics of Single Layer Coils. (*Annalen der Physik*, 64, pp. 377—400, February 24th, 1921. *Science Abstracts*, 24A, p. 295, Abstract No. 711, April 30th, 1921—Abstract.)

A description of experiments made to check Lenz's formulæ for the natural frequency of coils, and also the relation of the harmonic frequencies to the fundamental. Experiments were made with both short and long coils, and the results were found to agree with theory.

2115. **A. Esau.** Self-inductance of Multi-layer Coils. (*Jahrbuch Zeitschrift für drahtlose Telegraphie*, 15, pp. 2—26, January, 1920. *Science Abstracts*, 24A, p. 299, Abstract No. 720, April 30th, 1921. *Electrical World*, 75, p. 1207, May 22nd, 1920—Abstract.)

See RADIO REVIEW Abstract No. 329, May 1920.

2116. **L. Segal.** Condenser. (*French Patent* 502781, July 8th, 1919. Published May 26th, 1920. *British Patent* 146925, March 5th, 1920. Convention date July 8th, 1919.)

The specification describes a polyphase condenser comprising a number of conducting plates coiled about a common axis with a di-electric material between the layers.



2117. **Galvanophoren-Werke (System Vogt.) S. Szubert, Commandit-Gesellschaft and Vereinigte Elektrizitäts-Werke, G.m.b.H.** Condenser. (*French Patent* 506651, November 20th, 1914. Published August 27th, 1920.)

The specification describes a process of manufacturing electrical condensers so that the groups of plates form a solid block with the separating elements. The plates are formed by casting and the separating material is introduced by injection. There are no drawings to the specification.

2118. **A New Type of Variable Condenser.** (*Q.S.T.*, 4, p. 19, August, 1920.)

Describes a variable condenser in which the distance between the plates is the variable factor.

2119. **A. W. Isenthal.** Electric Condensers. (*British Patent* 153858, October 28th, 1919. Patent accepted November 18th, 1920.)

An adjustable condenser for tuning oscillatory circuits and other uses; the capacity is varied by unwrapping or wrapping one of the plates on the surface of a thin dielectric which is mounted on the surface of a metallic drum. The metal plates may be of triangular form or of any shape to give any desired scale calibration.

2120. **M. Adam.** The Construction of a Variable Condenser. (*Radioélectricité*, 1, pp. 602—603, May, 1921.)

(5) AND (6) MEASUREMENTS OF H.F. INDUCTANCE, CAPACITY, DECREMENT, ETC.

2121. **Research Laboratories of the American Telephone and Telegraph Company and of The Western Electric Company, New York** A High Frequency Bridge. (*Electrical World*, 77, p. 163, January 15th, 1921.)

A short note with regard to the development of a bridge for frequencies up to  $10^6$  cycles per second. An accuracy of less than  $\frac{1}{4}$  per cent. is obtainable.

2122. **F. C. Blake.** On the Effective Capacity and Resistance of a Condenser for High Frequency Currents. (*Physical Review*, 16, pp. 540—557, December, 1920; and 15, p. 148, February, 1920—Abstract. *Electrical World*, 77, p. 102, January 15th, 1921—Abstract. *Science Abstracts*, 24A, p. 222, Abstract No. 524, March 31st, 1921—Abstract.)

Experiments are described for measuring the capacity of condensers arranged to form the end condensers of a Lecher wire system. It is found that the capacity of such condensers is independent of the frequency of the oscillations. Rayleigh's equation for the effective stiffness of the circuit due to the mutual reactions between two circuits each containing inductance, capacity and resistance is verified. Use is made of the above equation for effective resistance to determine the mutual resistance of two reacting circuits.

2123. **F. C. Blake and C. Sheard.** On the Dielectric Constant of Kerosene and Water for High-frequency Currents. (*Physical Review*, 15, pp. 148—149, February, 1920.)

2124. **E. Glebe and E. Alberti.** Capacity Effects in High-frequency Measurements. (*Jahrbuch Zeitschrift für drahtlose Telegraphie*, 16, pp. 242—251, October, 1920. *Science Abstracts*, 24B, pp. 212—213, Abstract No. 429, April 30th, 1921—Abstract. *Radio-électricité*, 1, p. 99D, March, 1921—Abstract.)

2125. **J. J. Dowling.** Sensitive Valve Method for the Measurement of Capacity. (*Proceedings of the Dublin Royal Society*, 16, pp. 175—184, December, 1920. *Science Abstracts*, 24A, p. 299, Abstract No. 719, April 30th, 1921—Abstract.)

In its simple form the apparatus used in this method was arranged as follows:—One terminal A of an A.C. source was connected directly to the negative end of the filament of a valve, and also through a milliammeter or, preferably, a sensitive galvanometer, to the negative terminal of the anode battery. A was also connected through a resistance of 0.5 megohm to the grid and thence through the condenser C under test to the other terminal of the A.C. source. The filament battery was shunted by a potentiometer and a tapping from this was joined through a 10,000 ohm resistance to the negative terminal of the anode battery, the positive terminal of which was joined directly to the anode. If the greater part of the anode current is balanced by the current from the filament battery due to the P.D. across that part of the potentiometer in use, accurate comparison can be made between two condensers of

nearly equal capacity introduced at C, or a study can be made of slight variations in a single condenser. With the arrangement described above the relation between galvanometer deflection and capacity is almost linear. Unsteadiness of the galvanometer deflections was eliminated by suitable metallic screening and insulation of the various parts of the apparatus.

2126. **E. Merritt.** Polarisation Capacity and Polarisation Resistance as Dependent upon Frequency. (*Physical Review*, 17, pp. 524—525, April, 1921—Abstract.)

Refers to the experiments by G. O. Squier in which high-frequency signals are sent along bare wires immersed in water.\* Experiments are described on the electrolytic capacity of platinum wires immersed in acid over a wide range of frequencies. It was found that for frequencies up to one million the capacity is approximately inversely proportional to the square root of the frequency and that for the range of frequencies between half million and four million the variation is more nearly proportional to the reciprocal of the frequency.

2127. A Decimeter for the Amateur. (*Science and Invention*, 9, p. 50 and p. 84, May, 1921.)

Two small glow lamps are used for the comparison of the currents in resonance and out of resonance—one being connected in the wavemeter circuit and the other in series with a local battery.

(7) AND (8) MEASUREMENT OF H.F. CURRENTS, ETC.; H.F. OSCILLOGRAPHS.

2128. **W. H. Wilson** and **Miss T. D. Epps.** The Construction of Thermo-couples by Electrodeposition. (*Proceedings of the Physical Society of London*, 32, pp. 326—340, August 15th, 1920. *Nature*, 105, p. 842, August 26th, 1920. *Engineer*, 130, p. 143, August 6th, 1920—Abstract. *Electrical World*, 76, p. 584, September 18th, 1920—Abstract. *Technical Review*, 7, p. 257, November 23rd, 1920—Abstract. *Scientific American*, 123, p. 443, October 30th, 1920—Abstract. *Science Abstracts*, 24A, p. 137, Abstract No. 303, February 28th, 1921—Abstract.)

The method described consists in using a continuous wire of one of the elements and coating those parts of it which have to form the other element of the couple by an electrolytic deposit of another metal. The short-circuiting effect of the core is generally not serious. Constantan wire coated with either silver or copper sheaths was found suitable.

The construction of multijunction couples for the measurement of high-frequency currents is also described.

2129. **W. F. Powers** and **J. C. Hubbard.** On the Use of Continuous Waves for the Measurement of Dielectric Constants of Liquids. (*Physical Review*, 15, pp. 535—536, June, 1920.)

2130. **J. Guinebant.** The Standardisation of Antenna Ammeters. (*Radioélectricité*, 1, pp. 441—442, February, 1921.)

The method proposed consists in the coupling of a "frame" or coil to the conductor carrying the current to be measured, and reading the voltage induced in the coil by means of an electrostatic voltmeter. If the dimensions of the coil, or frame, are  $a$  cms parallel to the long straight conductor, and  $b$  cms perpendicular to it, and it is placed with its axis  $l$  cms from the axis of the conductor, it is shown that the voltage induced in the coil is given by

$$E = 2a \frac{I}{10} \omega \log_e(1 + b/l) \times 10^{-8}$$

where  $I$  is the current to be measured. A more accurate expression is given to allow for the turns of the coil not all being in one plane, but it is shown that the error in the simpler formula is small.

2131. **W. S. Flight.** Spark-over Voltages through Air. (*Beama Journal*, 7, pp. 367—374, November, 1920; pp. 467—474, December, 1920; and 8, pp. 23—29, January, 1921.)

An examination of the published data connected with spark-over voltages through air, and includes the results of additional tests carried out where necessary to amplify the previously published information. The following factors are considered as influencing the

\* RADIO REVIEW Abstract No. 854, September, 1920.



spark-over voltage. Spark length, shape of conductors, proximity of grounded objects, shape of the insulator, density of air, impurities, duration of application of voltage, etc.

2132. **J. B. Whitehead** and **F. W. Lee**. The Electric Strength of Air under Continuous Potentials as influenced by Temperature. (*Journal of the American Institute of Electrical Engineers*, 40, pp. 373—386, May, 1921.)

The critical corona forming electric intensities at several constant temperatures and at various pressures have been investigated for a number of different sizes of wires. The results are given in the form of tables and curves.

2133. **P. R. Coursey**. High-frequency Currents—Their Detection and Measurement. (*Wireless World*, 8, pp. 667—670, December 25th, 1920. *Radioélectricité*, 1, p. 113D, April, 1921—Abstract.)

2134. **W. Rogowski**. Improvements in Cathode Ray Oscillographs. (*Archiv für Elektrotechnik*, 9, pp. 115—120, July 8th, 1920. *Electrical World*, 76, p. 888, October 30th, 1920. *Science Abstracts*, 24A, p. 60, Abstract No. 140, January 31st, 1921—Abstract.)

2135. **J. B. Johnson**. A Low Voltage Cathode Ray Oscillograph. (*Physical Review*, 17, pp. 420—421, March, 1921.)

A short description is given of a tube containing a small quantity of gas and having a Wehnelt cathode. The tube operates on 500 volts, and has higher sensitivity than the usual patterns.

The spot on the fluorescent screen can be seen in daylight, and can be photographed with an ordinary camera in from one to ten seconds.

2136. **A. Dufour**. The Cathode Ray Oscillograph. (*Journal de Physique et le Radium*, 1, pp. 147—160, November, 1920. *Bulletin de la Société Belge des Electriciens*, 35, pp. 77—79, March—April, 1921—Abstract.)

#### (9) PROPERTIES OF IRON AT HIGH FREQUENCIES.

2137. **E. F. W. Alexanderson**. Magnetic Losses at High Frequency. (*Electrical World*, 77, p. 163, January 15th, 1921.)

A short note with regard to research on the magnetic properties of iron at high frequencies, from which it was concluded that Steinmetz's laws with regard to hysteresis, eddy currents and skin effects are as accurate at  $10^7$  cycles as at 25 cycles per second.

2138. **R. G. Loyarte**. Magnetic Permeability of Iron and Nickel for Hertzian Oscillations. (*Science Abstracts*, 24A, pp. 141—142, Abstracts Nos. 311 and 312, February 28th, 1921, abstracted from the *Publications of the University of La Plata*, 1, pp. 453—498, March, 1917, and 2, pp. 105—135, December, 1917.)

An account of experiments on the high-frequency magnetic properties of iron and nickel. Frequencies up to 500 million were used.

2139. **A. W. Smith**. The Effect of a Superposed Constant Field upon the Alternating Current Permeability and Energy Loss in Iron. (*Physical Review*, 17, pp. 416—418, March, 1921.)

2140. **W. Fondiller** and **W. H. Martin**. Hysteresis Effects with Varying Superposed Magnetising Forces. (*Journal of the American Institute of Electrical Engineers*, 40, pp. 149—158, February, 1921. *Science Abstracts*, 24B, p. 243, Abstract No. 489, May 31st, 1921—Abstract.)

An oscillographic study of hysteresis effects in iron subjected to magnetising currents of two frequencies.

2141. **R. Gans** and **R. G. Loyarte**. The Permeability of Nickel at High Frequencies. (*Annalen der Physik*, 64, pp. 209—249, February 9th, 1921.)

After reviewing other work on the subject, it is shown that the damping of the magneton oscillations should cause the induction to lag behind and be no more proportional to the field strength. To examine this point experimentally similar rectangular circuits were made up of nickel wire and of copper wire, and these were alternately connected to the condenser and excited by a quenched spark gap transmitter. Resonance curves were taken and the permeability calculated from the results. The results indicated a decrease of permeability for very high frequencies ( $\lambda = 20$  cm); similar results were obtained for iron.



2142. **R. Gans.** The Permeability of Nickel for Short Hertzian Waves and the Measurements of Arkadiew. (*Annalen der Physik*, 64, pp. 250—252, February 9th, 1921.)

A critical discussion of Arkadiew's results (see *Annalen der Physik*, 58, p. 105, 1919) and a comparison with those referred to in the preceding abstract.

2143. **F. Margand.** On the Question of the Existence of Two Resonant States in Circuits containing Iron. (*Revue Générale de l'Électricité*, 9, pp. 635—637, May 7th, 1921.)

Referring to the theory of the resonant phenomena in such circuits previously put forward by Boucherot.\* The author discusses the conditions determining instability of one or more of these states and the influence of capacity, resistance, etc.

2144. **P. Boucherot.** On the Existence of Two Resonant States in Circuits containing Iron. (*Revue Générale de l'Électricité*, 8, pp. 827—829, December 11th, 1920. See also *Comptes Rendus*, 170, pp. 725—728, March 22nd, 1920.)

### (Q.) Short Wave Apparatus.

2145. **G. C. Southworth.** Electron Tube Generators of Alternating Currents of Ultra-radio Frequencies. (*Technical Review*, 7, p. 323, December 7th, 1920. *Science Abstracts*, 24A, p. 53, Abstract No. 123, January 31st, 1921—Abstract.)

RADIO REVIEW, 1, pp. 577—584, September, 1920.

### (R.) Radio Direction Finding.

#### (1) AND (2) THEORY.

2146. **E. Bellini.** The Errors of Direction Finders. (*Electrician*, 86, pp. 220—222, February 18th, 1921. *Science Abstracts*, 24B, pp. 213—214, Abstract No. 431, April 30th, 1921—Abstract. *Electrical World*, 77, p. 839, April 9th, 1921—Abstract. *Annales des Postes, Télégraphes et Téléphones*, 10, pp. 336—346, June, 1921—Abstract.)

Various suggestions have been put forward to account for the observed errors at radio direction finding stations. This article discusses the errors that may arise from the reflection of waves from the Heaviside layer—this is considered as homogeneous and continuous—and by the influence of the horizontal parts of the sending antennæ on the horizontal parts of the receiving loops. If a truly vertical transmitting aerial is reflected in a horizontal Heaviside layer the image in space will also be vertical and therefore no effect will be produced on the apparent directions of the waves as observed at a D.F. station; but if the transmitting aerial has a horizontal part the imaginary radiation from the image of that part in the Heaviside layer will also affect the receiving station with the result that in general an elliptical rotating field will be set up. This causes the minimum in many cases to be broad or almost non-existent, so that the bearing is inaccurate. Errors up to 90° are accountable for in this manner and the effect is closely analogous to that observed when bearings are taken on an aeroplane trailing wire aerial.

It is also shown that if the antenna of the D.F. station has no horizontal parts no errors in the bearings would be observed and it is suggested that the double loop receiver used by Weagant † and the special receiving loops of Franklin should furnish exact bearings. As confirmation of the theory observations are cited on the Hanover station which uses a symmetrical umbrella aerial which apparently causes no errors.

2147. **M. Rothé.** The Influence of Atmospheric Conditions on Radio Direction Finding. (*Comptes Rendus*, 172, pp. 1345—1347, May 30th, 1921. *Revue Scientifique*, 59, p. 313, June 11th, 1921.)

A brief account of some experiments carried out at Strassbourg between July 20th and October 10th, 1920, on signals sent out from the Eiffel Tower, Poldhu and Nauen. The object of the tests was to determine whether any variation in apparent direction of the waves in the daytime could be observed corresponding with meteorological changes, and with the changes of signal intensity. It is concluded that during the day the meteorological conditions do not have any serious effect on D.F. work.

2148. **J. Hollingworth.** Directional Measurements with the R.A.F. System. (See pp. 282—301 in June, 1921, issue.)

\* See RADIO REVIEW Abstract No. 2144.

† RADIO REVIEW Abstract No. 18, October, 1919.

## (3), (4) AND (5) D.F. ON LAND, SHIPS AND AIRCRAFT.

2149. **H. Marchand.** Radio Direction Finding. (*Bulletin de la Société Belge des Électriciens*, 35, pp. 3—14, January—February, 1921.)

An illustrated descriptive article dealing with D.F. apparatus manufactured by the Marconi Company.

2150. **Marconi's Wireless Telegraph Company Limited.** Directive Signalling. (*French Patent* 507360, December 12th, 1919. Published September 14th, 1920. *L'Électricien*, 52, p. 115, March 1st, 1921—Abstract.)

The specification describes a transmitting system comprising a number of independent aerials, a separate valve amplifier for each aerial and a central generator to control the oscillations generated by the separate valves. A central dynamo supplies power to each valve or each valve may have a separate source of power.

For further particulars see the corresponding *British Patent* 140538 in the name of **C. S. Franklin**.\*

2151. **J. Erskine-Murray and J. Robinson.** Direction Finding Apparatus. (*French Patent* 507388, December 13th, 1919. Published September 14th, 1920.)

The specification describes apparatus for determining the direction of arriving electromagnetic waves by obtaining equality of signal strength for two positions of a rotary aerial or goniometer coil.

Further particulars may be obtained from the corresponding *British Patent* 136600. (See **RADIO REVIEW** Abstract No. 506, July, 1920.)

2152. **J. B. Will.** Radio Compasses. (*Proceedings of the U.S. Naval Engineers*, 46, pp. 851—855, June, 1920.)

Gives a general outline of the U.S. Navy arrangement of radio compasses.

2153. **G. W. Littlehales.** The Prospective Utilisation of Vessel-to-Shore Radio Compass Bearings in Aerial and Transoceanic Navigation. (*Journal of the American Society of Naval Engineers*, 32, pp. 38—44, February, 1920. *Journal of the Washington Academy of Sciences*, 11, p. 59, February 4th, 1921—Abstract.)

The method of finding latitude and longitude in aerial and marine navigation from vessel-to-station radio compass bearings is described, and its mathematical theory is expounded.

2154. **H. J. Round.** Direction Finding Apparatus. (*British Patent* 160475, August 19th, 1919. Patent accepted March 31st, 1921. *Engineer*, 131, p. 499, May 6th, 1921—Abstract.)

Deals with an arrangement for compensating the errors in direction finding on board ship using aerials of the Bellini-Tosi type. The aerial in the fore and aft line of the ship is provided with chokes or other means to reduce its receptive qualities.

2155. **A. Perry.** Aeroplanes and Radiogoniometers. (*Radio News*, 2, p. 683, and p. 752, April, 1921.)

A general summary of the uses of D.F. apparatus on aircraft.

2156. **E. C. Hanson.** Aircraft Landing Stations. (*British Patent* 156768, January 7th, 1921. Convention date, March 5th, 1921. Patent not yet accepted.)

Refers to the use of an induction arrangement for enabling the aircraft to locate the landing stations.

2157. **S. O. E. T. Frost.** Directive Wireless Signalling. (*British Patent* 151253, July 17th, 1920. Convention date, July 19th, 1919. Patent not yet accepted.)

An aerial system adapted to the determination of the direction of the waves in three dimensions in space.

2158. **H. R. C. van de Velde and J. M. Furnival.** Direction Finding Apparatus. (*British Patent* 161667, January 12th, 1920. Patent accepted April 12th, 1921. *Engineer*, 131, pp. 583—584, May 27th, 1921—Abstract.)

In D.F. apparatus for aircraft the search coil of the radiogoniometer may be controlled by the rudder of the machine so that by keeping the signals at minimum strength the correct course to the W/T station is maintained.

\* See **RADIO REVIEW** Abstract No. 811, September, 1920.



## (6) RADIOPHARES.

2159. **F. A. Kolster.** Development of the Radio Beacon. (*Wireless Age*, 8, pp. 16—17, March, 1921.)

A short illustrated description of wireless D.F. installations on lighthouses in Chesapeake Bay.

2160. **G. P. Grenfell, J. Erskine-Murray, J. Robinson and H. L. Crowther.** Radio Direction Finding Apparatus. (*British Patent* 161448, April 23rd, 1920. Patent accepted April 14th, 1921.)

A special arrangement of radiophare is described in which a rotating frame aerial is excited from a coil which is rotated at a slightly different rate. The direction of minimum rotation therefore rotates at a speed equal to the difference of the speeds of rotation of the frame and coil.

2161. **F. Murphy.** Wireless Direction Finding Systems. (*British Patent* 160975, January 13th, 1920. Patent accepted April 7th, 1921.)

See RADIO REVIEW, 2, p. 155, Note No. 2169, March, 1921, for Abstract.

2162. **J. Erskine-Murray, J. Robinson and H. L. Crowther.** Wireless Direction Finding Apparatus. (*British Patent* 160250, December 15th, 1919. Patent accepted March 15th, 1921.)

In a wireless D.F. system a directional transmitting station is adapted to emit successively along compass bearings between north and south a continuous wave of short wavelength which is constant for all directions of transmission and has its amplitude modulated at a supersonic frequency which varies as a function of the direction of transmission.

2163. **J. Erskine-Murray, J. Robinson and H. L. Crowther.** Wireless Direction Finding Apparatus. (*British Patent* 160251, December 15th, 1919. Patent accepted March 15th, 1921.)

In a direction finding system of the type in which the frequency of the transmitted wave is a function of the direction of transmission the receiving station is provided with a tuned circuit to give heterodyne effect of high or inaudible frequency, and with another tuned circuit on which the supersonic beats are impressed so that they are reheterodyned to an acoustic frequency.

2164. **J. Erskine-Murray and J. Robinson.** Determining Bearings by Wireless. (*British Patent* 158005, April 11th, 1919. Patent accepted February 3rd, 1921.)

Relating to systems where a wireless "beam" rotating at a known rate is transmitted and the receiving station determines its bearing by observing the time-interval between a special signal emitted when the "beam" points north and the moment when the received signals are of maximum or minimum intensity.

2165. **Gesellschaft für drahtlose Telegraphie.** Wireless Direction Finding Apparatus. (*British Patent* 147442, July 7th, 1920. Convention date, June 11th, 1918. Patent not yet accepted.)

For the directive propagation of waves, using widely separated aerials excited by oscillations having a definite phase relation with each other, currents of relatively low frequency and of small intensity are supplied from a central station and are amplified and raised in frequency at the transmitting stations.

2166. **J. Erskine-Murray.** Wireless Navigational Apparatus. (*British Patent* 152758, July 18th, 1919. Patent accepted October 18th, 1920.)

The transmitting station has two rotating directional aerials radiating waves of slightly different frequency; and the receiver uses a heterodyne having a frequency differing slightly from both transmitted waves. When the energy received from one of the rotating aerials is zero, the heterodyne note becomes pure.

## (8) GENERAL D.F. APPARATUS.

2167. **E. Bellini.** Wireless Direction Finding Apparatus. (*French Patent* 504014, January 7th, 1918. Published June 23rd, 1920. *Radioélectricité*, 1, p. 93D, February, 1921—Abstract.)

The invention comprises a receiving radiogoniometer in which the conditions of resonance are a function of the angle between the direction of the transmitting station and of the movable member of the instrument, in such a manner that when this angle is  $0^\circ$ , the intensity



of reception is a maximum. The instrument consists of a magnetic receiver coupled to the aerials by a radiogoniometer loosely coupled with the aerials and connected to the detector, the two movable members being arranged with a right angle between them.

2168. **M. Jeanco.** Wireless Direction Finding Apparatus. (*French Patent* 507344, March 7th, 1919. Published September 10th, 1920.)

A pair of aerial coils have their circuits connected to a reversing switch, whereby they may be connected in series or in opposition to the detector circuit. One coil is turned to its minimum position and by means of the switch the effect of the other coil is added to or subtracted from it. The coils are rotated until equal sounds are heard in both positions of the switch. For further particulars see *British Patent* 158284.\*

2169. **J. Robinson** and **H. L. Crowther.** Directive Wireless Signalling. (*British Patent* 161449, April 23rd, 1920. Patent accepted April 14th, 1921.)

Relates to a receiving system for analysing the direction of incoming signals. Two rotatable frame aerials mounted at an angle to each other are connected to the grids of two amplifying valves. The secondary winding of a transformer, the primary of which is connected to a low frequency oscillating source is connected between the grids of the two valves, so that the valves are in operation during the peaks of alternate half oscillations. The required direction of propagation is found by swinging the pair of frame aerials until the combined effect of the received signals produces a pure tone in the telephones. The two aerials are then equally inclined to the direction of the incoming signals.

2170. Absolute Direction Finding with a Loop Aerial. (*Wireless World*, 8, pp. 350—351, August 7th, 1920. *Telegraphen- und Fernsprech-Technik*, 10, p. 30, March, 1921—Abstract.)

Describes a combination of loop and elevated aerial for giving the "sense" indication in D.F. work with a loop aerial.

2171. **M. Latour.** Wireless Direction Finding Systems. (*British Patent* 148950, July 10th, 1920. Convention date December 7th, 1918. Patent not yet accepted.)

A wireless direction finder comprises two frame aerials fixed at an angle to one another and associated with a differential detector, which gives a null effect when the direction of the sending station bisects the angle between the coils. The arrangement may be adapted to the distant control of movable apparatus.

2172. **E. F. Huth.** Wireless Directional Receiving Apparatus. (*British Patent* 149212, July 12th, 1920. Convention date October 25th, 1918. Patent not yet accepted.)

A radiogoniometer apparatus for directive wireless reception and the elimination of undesired signals comprises two or more directive aerials at different angles, and connected to the input side of thermionic valves, the output circuits including the radiogoniometer coils set at the same angles as the aerials.

2173. **J. Erskine-Murray** and **J. Robinson.** Means for Comparing Sounds. (*British Patent* 159601, December 1st, 1919. Patent accepted March 1st, 1921.)

In comparing the intensities of sounds, particularly in wireless direction finding systems, in which the received signal strengths from two coils are to be compared, the sounds are listened to alternately, the alternations being made so rapidly that the sounds cannot be independently distinguished. The alternations may be effected by a rotary commutator, and a pure note is obtained when they are of equal intensity, and a throbbing sound when they are unequal.

2174. **M. Jeanco.** Wireless Direction Finding Apparatus. (*British Patent* 158284, April 12th, 1919. Patent accepted February 10th, 1921.)

Two receiving loops at right angles have their circuits connected to a reversing switch so that they may be connected in series or in opposition in the detector circuit.

2175. **Gesellschaft für Drahtlose Telegraphie.** Direction Finding Apparatus. (*British Patent* 147700, July 8th, 1920. Convention date June 3rd, 1918. Patent not yet accepted.)

In a receiver using a rotating loop aerial the capacity of the aerial to earth is augmented to increase the absorption of energy. The receiver is loose coupled to regain the selectivity.

\* RADIO REVIEW Abstract No. 2174.

2176. **E. Bellini.** Electrostatic Coupling. (*British Patent* 145049, June 15th, 1920. Convention date November 4th, 1916. Patent accepted October 7th, 1920.)

An addition to *British Patent* 22879/1914. Details are given of the means of constructing the coupling condensers, and the equations determining their form.

2177. **Gesellschaft für drahtlose Telegraphie.** Directive Wireless Reception. (*British Patent* 148530, July 10th, 1920. Convention date June 18th, 1918. Patent not yet accepted.)

A combination of loop and elevated aerial in which the latter screens the loop in one direction. Similar arrangements may be used for lessening interference from a transmitter in a given direction.

2178. **J. Robinson.** Wireless Direction Finding Apparatus. (*French Patent* 508119, January 3rd, 1920. Published October 2nd, 1920.)

The specification describes a wireless direction finder in which a directive system is combined with a non-directive system so that the intensity of minimum signals observed is not zero as in the case when the directive system alone is used. See also *British Patent* 134342. (*RADIO REVIEW* Abstract No. 810, September, 1920.)

### (S.) Distant Control by Wireless.

2179. **J. Bethenod.** Wireless Control of Distant Apparatus. (*British Patent* 143456, September 9th, 1919. Patent accepted May 27th, 1920.)

In order to maintain a distant movable object on its correct course, the moving vehicle (or vessel, aircraft, etc.) is provided with a radio transmitter, and two D.F. receiving aerials are arranged to receive equal strength signals when the vessel is on its correct course. If the received signal strengths are unequal a correcting impulse is automatically transmitted from a central radio station connected by land lines with the two receivers.

2180. **J. H. Hammond.** Wireless Control of Distant Apparatus. (*British Patent* 143581, November 14th, 1917. Convention date September 28th, 1916. Patent accepted June 3rd, 1920.)

To obtain the necessary selectivity and freedom from interference at least three frequencies are employed—the carrier wave frequency, a supersonic modulating frequency, and a lower group frequency which divides the supersonic modulating frequency into low frequency sections or groups. The circuits of the receiver should be syntonised to these three frequencies, and include a mercury vapour valve relay controlling a slow acting relay for operating the pneumatic valves of the driving or controlling mechanism of the dirigible or other moving vessel.

Details are given of the spark gap apparatus for producing the desired radiations, and of the slow acting relay mechanism for the receiver.

2181. The Exhibition of the Société Française de Physique. (*Radioélectricité*, 1, p. 548, April, 1921.)

A short account of some exhibits which included some distant control apparatus.

2182. **W. W. Conners.** Wireless Control of Distant Apparatus. (*British Patent* 144622, May 25th, 1920. Convention date June 12th, 1919. Patent not yet accepted.)

The specification relates to apparatus controlled by wireless waves for indicating and recording on a chart carried by a moving body the course over which it travels. The apparatus may be adapted to perform many minor functions such as—to record the time certain points are reached, to keep the moving body on a desired course, to indicate and regulate its speed, to record the distance it travels, etc.

2183. **J. H. Hammond.** Wireless Signalling Systems. (*British Patent* 158200, March 8th, 1918. Convention date March 17th, 1917. Patent not yet accepted.)

A selective wireless system for distant control consists of a transmitter emitting waves and wave groups, and a receiving system comprising circuits tuned to the wave and wave group frequencies respectively, circuits tuned to a beat frequency (derived from a local heterodyne) and a mercury vapour detector. The detector circuit includes a high-frequency alternator and a telephone receiver or the relay controlling the apparatus to be directed.



2184. **E. C. Hanson.** Wireless Steering of Torpedoes and Submarine Vessels. (*British Patents* 154532 and 154533, November 23rd, 1920. Convention dates June 4th, 1918, and February 20th, 1919, respectively. Patents not yet accepted.)

**(T.) High-frequency Wire Telegraphy and Telephony.**

2185. **G. A. Campbell (Western Electric Company).** Electric Filter Circuits. (*British Patent* 142115, April 21st, 1920. Convention date July 15th, 1915. Patent accepted January 13th, 1921.)

Relates to filter circuits of a general type to permit of the passage of one or two bands of frequencies and the suppression of all others. The filters described in Patent No. 135635\* constitute a special case of this general form, which consists of a series of units consisting of impedances in series with (usually a capacity in series with an inductance) and of impedances in shunt to the lines (usually a capacity in parallel with an inductance). A general mathematical investigation is given to enable the dimensions of the impedances to be calculated to pass any given bands of frequencies. By suppressing one or more of the series or shunt impedances the simplified case above referred to is obtained.

2186. **H. J. Vennes (Western Electric Company).** Generating Harmonics of Electric Oscillations. (*British Patent* 142474, April 27th, 1920. Convention date April 28th, 1919, Patent accepted December 30th, 1920.)

For the generation of currents of frequencies which are harmonics of a given supply frequency, a resistance is joined in the plate circuit of a three-electrode valve of a value large compared with the internal impedance of the valve, so as to distort its characteristic curve. A circuit is given suitable for the generation of such harmonics. It consists of a valve having a high resistance in its plate circuit, and with its grid supplied from the source of given frequency, a shunt rejector circuit being added to by-pass all frequencies other than the fundamental. The output circuit of the valve which introduces the distortion may be joined to a second amplifying valve before attachment to the final output circuit. Additional filtering out of the fundamental frequency may be obtained on the output side of the distorting valve by the use of appropriate shunting impedances.

2187. **Western Electric Company.** Generating Electric Oscillations. (*British Patent* 142571, February 12th, 1919. Patent accepted May 12th, 1921.)

In an arrangement primarily intended for multiplex high-frequency wire telegraphy or telephony, the currents of different frequencies are generated by introducing harmonics into a supply source of given frequency by means of a valve operated near the saturation point. The various harmonics may be separated by appropriate filters.†

2188. **P. R. Coursey.** Wired Wireless Transmission. (*Wireless World*, 8, pp. 699—701, January 8th, 1921. *Electrical World*, 77, p. 611, March 12th, 1921—Abstract.)

A general summary of the methods of communicating by high-frequency currents along wires, and in particular describing the methods used in the German high-frequency telephone exchanges.

2189. **C. A. Culver.** Guided-wave Telephony. (*Journal of the Franklin Institute*, 191, pp. 301—328, March, 1921. *Electrical World*, 77, p. 781, April 2nd, 1921—Abstract. *Technical Review*, p. 144, May 31st, 1921—Abstract.)

A short summary of Gen. Squier's contribution to the development of high-frequency wire telephony, is followed by sections devoted to the principles involved in this method of communication, and the applications of the three-electrode tube, including a consideration of the various methods of modulation, and of the number of separate channels that can be worked on a given line. The use of a modulation circuit equivalent to the "quiescent-aerial" radiotelephone transmitter, in which the generation of high-frequency oscillations only takes place when the microphone is spoken to, is also discussed in its bearing on the number of channels that can be worked simultaneously. Six separate channels can at present be used between 15,000 ~ and 500,000 ~, using different carrier frequencies for each direction of

\* RADIO REVIEW Abstract No. 523, July, 1920.

† Compare also RADIO REVIEW Abstracts Nos. 2185 and 2186.



each conversation. Sections are also devoted to attenuation and efficiency and the power required for various ranges.

2190. **Multiplex Telegraphy and Telephony with High-frequency Currents along Wires.** (*Schweizerische Bauzeitung*, 76, pp. 230—232, November 13th, 1920. *Revue Générale de l'Électricité* 9, p. 59D, February 19th, 1921—Abstract.)

A summary of the development of high-frequency communication along wires, and a discussion of the economies possible by its use.

2191. **R. D. Duncan.** Recent Attainments in Wired Radio. (*Journal of the Franklin Institute*, 191, pp. 23—56, January, 1921. *Telegraph and Telephone Age*, 39, pp. 74—76, February 16th; pp. 98—101, March 1st; pp. 122—124, March 16th; pp. 146—147, April 1st; pp. 173—174, April 16th; pp. 196—197, May 1st, 1921. *Electrical World*, 77, p. 498, February 26th, 1921—Abstract. *Nature*, 107, p. 87, March 17th, 1921—Abstract. *Revue Générale de l'Électricité*, 9, p. 167D, May 21st, 1921—Abstract. *Radio News*, 2, pp. 592—593, and 640, March, 1921—Abstract. *Technical Review*, 9, p. 172, June 14th, 1921—Abstract. *Science Abstracts*, 24B, p. 312, Abstract No. 635, June 30th, 1921—Abstract.)

A short summary is given of some of the most noteworthy historical developments of "wired radio," followed by a more complete account of later work carried out on the lines of the New York Central Railroad Company. Several illustrations of the apparatus are included, with circuit diagrams and oscillograms of the modulation. A section of the paper is devoted to the mathematical theory of the propagation of high-frequency currents along telephone lines, and many measurements of line constants, at high frequencies, are given in the form of curves.

2192. **G. A. Beauvals.** High-frequency Signalling. (*French Patent* 503943, December 14th, 1917. Published June 21st, 1920.)

The specification describes broadly the method of signalling along conductors by means of high-frequency currents, in which three-electrode tubes are employed.

2193. **J. B. Pomey.** Submarine Telegraphic Transmission. (*L'Électricien*, 52, pp. 31—33, January 15th; pp. 202—205, May 1st, 1921.)

Deals with Squier's and other arrangements of multiplex high-frequency telegraphy along wires and cables.

2194. **B. W. Kendall (Western Electric Company).** Repeaters for Multiplex Signalling Systems. (*British Patent* 153563, August 18th, 1920. Convention date August 31st, 1919.)

Describes an arrangement of two-way valve repeater having a substantially rectilinear characteristic so as to enable it to amplify modulated carrier currents of different frequencies in multiplex high-frequency wire telephony.

2195. **Western Electric Company (U.S.A.).** Signalling by Electric Oscillations in Line Wires. (*British Patent* 153672, August 12th, 1919. Patent accepted November 12th, 1920.)

The specification relates to multiplex systems in which the speech currents are transmitted as modulations of high-frequency carrier currents. Carrier currents of different frequencies are supplied to balanced valve modulators arranged so as to suppress unmodulated carrier currents while transmitting carrier currents which have been modulated. Filter circuits are used between the transmitters and the line wires.

2196. **Gesellschaft für drahtlose Telegraphie.** Telephone Systems. (*British Patent* 161573, April 11th, 1921. Convention date April 12th, 1920. Patent not yet accepted.)

The exchange arrangements for trunk line high-frequency wire telephony are described.

2197. **E. F. Huth.** Telephone Systems. (*British Patent* 161577, April 12th, 1921. Convention date April 12th, 1920. Patent not yet accepted.)

Relates to an arrangement for high-frequency telephony along power lines in which the energy for the plate circuits of the valves is derived from the same power supply. The same valve can be used for both transmission and reception by means of simple change-over switches.

2198. **P. Gehne.** Wireless Telephony and High-frequency Telephony along Wires. *Zeitschrift für deutsche physikalische und chemische Unterr.*, 33, p. 68, 1920.)

2199. **B. Rosenbaum and S. Loewe** (E. F. Huth Gesellschaft). Telegraphy and Telephony. (*British Patent* 149191, July 12th, 1920. Convention date September 15th, 1915. Patent not yet accepted.)

Relates to high-frequency telephonic and telegraphic systems with or without wires. Spark gap apparatus of supersonic group frequency, or thermionic valves may be used as sources of the high-frequency current.

2200. **Gesellschaft für drahtlose Telegraphie.** High-frequency Telephony. (*British Patent* 156655, January 6th, 1921. Convention date January 7th, 1920. Patent not yet accepted.)

In a high-frequency wire telephone system means are provided for preventing injurious coupling between the circuits of the oscillating valve and the detecting and receiving valve. A species of "bridge" connection is used for this purpose.

2201. **Gesellschaft für drahtlose Telegraphie.** High-frequency Line Telegraphy. (*British Patent* 158198, January 14th, 1921. Convention date January 16th, 1920. Patent not yet accepted.)

Relates to means of transmitting buzzer calling signals over a high-frequency wire telephone circuit.

2202. **Gesellschaft für drahtlose Telegraphie.** High-frequency Signalling. (*British Patent* 147464, July 7th, 1920. Convention date May 28th, 1919. Patent not yet accepted.)

Relates to means for bridging over a shunting apparatus connected to power mains or telephone systems the lines of which are used for high frequency telegraphy or telephony.

2203. **Gesellschaft für drahtlose Telegraphie.** Wave Telephony. (*British Patent* 147699, July 8th, 1920. Convention date January 17th, 1919. Patent not yet accepted.)

A coupling is provided between the transmitter and adjacent receiver to eliminate interference in two-way high-frequency telephony.

2204. **Gesellschaft für drahtlose Telegraphie.** High-frequency Telegraphy and Telephony. (*British Patent* 154884, October 22nd, 1920. Convention date December 1st, 1919. Patent not yet accepted.)

The stations are capacitatively coupled to the lines at distances from the ends equal to a quarter of the wavelength, so that the electrical portion of the E.M. field is used for the coupling.

2205. **Gesellschaft für drahtlose Telegraphie.** Multiplex High-frequency Telephony. (*British Patent* 148444, July 10th, 1920. Convention date May 27th, 1919. Patent not yet accepted.)

## (U.) Miscellaneous Methods of Communication.

### (1.) BY LIGHT RAYS.

2206. **A. M. McMahon.** The Action of Roentgen and Gamma Radiations upon the Electrical Conductivity of Selenium Crystals. (*Physical Review*, 16, pp. 558—564, December, 1920. *Science Abstracts*, 24A, p. 137, Abstract No. 304, February 28th, 1921—Abstract.)

2207. **Miss E. F. Sellar.** Colour Sensitiveness of Photoelectric Cells. (*Astrophysical Journal*, 52, pp. 129—153, October, 1920. *Science Abstracts*, 24A, pp. 136—137, Abstract No. 302, February 28th, 1921—Abstract. *Physical Review* 15, p. 550, June, 1920—Abstract.)

Deals with experiments on the sensitiveness of photoelectric cells for light of various colours. Many different types of cells were experimented with containing a variety of alkaline hydrides.

2208. **L. Ansell.** Selenium and its Applications. (*L'Elettrotecnica*, 8, pp. 201—203, March 25th, 1921.)

2209. **T. W. Case.** New Strontium and Barium Photoelectric Cells. (*Physical Review*, 17, pp. 398—399, March, 1921.)



2210. **E. Furet.** Telegraphy by Light Rays. (*French Patent* 506757, November 29th, 1919. Published August 30th, 1920.)

The specification describes a method of communicating with a train.

2211. **L. A. Charbonneau.** Signalling by Infra-red Rays. (*British Patent* 146138, June 23rd, 1920. Convention date February 11th, 1918. Patent not yet accepted.)

The infra-red rays are used to wipe out the phosphorescence of certain substances (such as zinc sulphide) at the receiver.

2212. **W. Scheffer and A. Helbemann.** Observing and Signalling through Fog. (*British Patent* 157399, January 10th, 1921. Convention date December 8th, 1916. Patent not yet accepted.)

Objects to be observed through fog are illuminated by red or long-wave light and red or long-wave searchlights are used for signalling, the dispersion of light by fog being greater the shorter the wavelength of the light.

2213. **C. C. Murdoch.** A Study of the Photo-active Electrolytic Cell, Platinum—Rhodamine B—Platinum. (*Physical Review*, 17, pp. 626—647, May, 1921.)

2214. **M. Larigaldi.** Recent Applications of Infra-red Radiations. (*Bulletin de la Société Française des Électriciens*, 1, (4th Series) pp. 185—189, April, 1921.)

Discusses their uses for signalling purposes and when associated with a valve amplifier and tikker for reception and also deals with their uses at sea for the detection of shipwrecks.

## 2. Books.

CONTINUOUS WAVE WIRELESS TELEGRAPHY. Vol. I. By W. H. Eccles, D.Sc. (London: *The Wireless Press, Ltd.* 1921. Pp. vii + 407. 8½" × 5½". Price 25s. net.)

The preliminary announcement of Professor Eccles' book was made so many months ago that one recently began to doubt whether it would ever appear. The publication now, however, happens to coincide with a pause in the development of the subject, and because of this and also because of the necessary incompleteness of any book on wireless published during war-time conditions, one guesses that the volumes of this treatise will not have suffered for the delay.

To a certain extent the volume is somewhat of a surprise in that it is wholly introductory; that is to say the subject proper of Continuous Wave Telegraphy is not yet reached. Dr. Eccles deals mainly with difficulties which must be satisfactorily surmounted before the main problem can be attacked. Thus two-thirds of the volume are devoted to the fundamental principles of electromagnetism and the rest to the physics of ionic tubes. We hope that this means that the treatment of the whole subject is going to be on the same comprehensive scale, though one must admit that an author who can count on his readers possessing such a groundwork of fundamental theory as is developed in this first volume will find brevity and pertinence possible in his later ones.

The first four chapters contain a short sketch of the history of the subject followed by a very thorough treatment of electrostatics, electrodynamics and alternating current theory. It is very difficult to produce something fresh in a treatment of the elementary facts of electricity, yet Professor Eccles has managed to do so. As a typical example we might cite the novel proof on page 34, in which it is shown that the lateral pressure of a tube of electric or magnetic force is equal to the longitudinal tension. We have in mind more than one proof of this theorem in standard text-books that weary the student unnecessarily.

In the treatment of electromagnetism the author thinks it wise "to follow Oliver Heaviside's and J. J. Thomson's methods of combining the purely physical intuition of Faraday with the mathematical reasoning of Maxwell." Thus the treatment throughout is based on J. J. Thomson's assumption that the magnetic effects of a current are due to the motion of Faraday tubes. This point of view was first developed comprehensively by J. J. Thomson in his supplementary volume to Maxwell's Treatise, and also in his "Elements of the Mathematical Theory of Electricity and Magnetism." It is the only satisfactory treatment possible if, as throughout the present volume, the physics is counted as being of greater importance than the mathematical processes.



The subject of self and mutual inductance is mainly developed from a consideration of the energy in the field of a current, though Neumann's formula for the mutual linkages of two circuits is also given. The calculation of the inductance of certain simple geometrical forms is, however, carried out with the simplest mathematics.

The treatment of the second law of electromagnetism is again based on the conception that the magnetic field is due to moving Faraday tubes, but here the effective inertia of the tubes becomes of importance and we are concerned with the electric forces necessary for accelerating and retarding the motion of the tubes. This portion of the book closes with a section on units in which the author makes the suggestion that as names have already been given to the principal practical units (*e.g.*, farad) we might consider this term as generic and shorten our usual expression "electromagnetic unit of capacity" to "emfarad" and so on.

The treatment of alternating currents and oscillations is throughout a graphical one, much use being made of crank or Argand diagrams. The section on harmonics leads naturally to a practical discussion of Fourier analysis, the whole of which is summarised in a very useful paragraph which also includes rules for the rough analysis of a periodic curve by inspection. The mathematical treatment of oscillatory circuits includes an analysis of almost every combination of inductance, capacity, and resistance than can be conceived, but, by the use of Heaviside's "resistance operators" the mathematical formulae are never allowed to become unwieldy.

The section on ionic tubes is the most exhaustive discussion of the physics of the triode that has yet appeared in English. Though much has been written on this subject the author has again something fresh and new (*e.g.*, in the section on soft tubes). But probably the most interesting portion of this chapter is that dealing with the theory of the action of the control electrode. So very much work has been done using experimentally obtained characteristics that it is refreshing to find an attempt to interpret these curves in terms of known physical laws. The case of the planar triode is of course satisfactorily dealt with in Maxwell's Treatise, but the author prefers to deduce an expression for the voltage factor from first principles, arriving at a result which is practically identical with Maxwell's. What one misses here is a definite statement as to what the voltage factor really is physically. Thus an interpretation of one of the equations here used shows that the voltage factor is taken as the ratio of the difference of potential between the anode and the mid-point of one of the grid spaces to the difference of potential between the mid-point previously mentioned and the grid wire. It is not, however, difficult to show that the value of the voltage factor here used is really equal to the ratio of the number of lines of force ending on the grid to the number ending on the anode when the two electrodes are maintained at the same potential with respect to the filament. This alternative definition emphasises the superiority of the grid over the anode for use in controlling the field strength near the cathode in an amplifying tube.

In the section on grid currents some quite new material is introduced. The question as to how the total thermionic current is divided between the two positive electrodes is a matter of great interest and one very much regrets that considerations of space prevented Professor Eccles from developing in full the formula he gives for this distribution. There still appears to be much work necessary before the relations between grid and anode currents and the electrode potentials are fully elucidated, as secondary emission appears to play quite an important part at relatively low potentials.

The volume closes with a very exhaustive account of the many methods now in use for measuring the various parameters of triodes.

The index is admirable in every way and adds greatly to the value of the book. There are a few errors in the text, but we understand that a table of errata is soon to be published.

E. V. APPLETON.

RELATIVITY, THE ELECTRON THEORY AND GRAVITATION. By E. Cunningham, M.A. (London: Longmans, Green & Co. Second Edition, 1921. Pp. vii + 148. 8 $\frac{1}{2}$ " x 6". Price 10s. 6d. net.)

The publication of this, the second edition of "Relativity and the Electron Theory," makes a valuable addition to the literature of these subjects. The original work was devoted to a consideration of both theories (Theory of Relativity and the Electron Theory) and of their mutual consequences, and in the new edition the matter has been much added to, and the treatment improved by the inclusion of later work.

The consideration given to the subject now goes beyond Einstein, and shows that his Generalised Relativity Theory is by no means the last word on the subject. The final chapter of the book gives this further generalisation, and includes Weyl's theory of Electricity, and makes it clear that the laws of Nature do not supply us with an absolute criterion of equality of intervals of space and time, except of course the criterion of coincidence. Weyl's theory provides for electricity as natural a place as that accorded to gravitation in Einstein's theory, with the result that gravitation and electricity rank together as two fundamental properties of matter, forming together the basis of all natural systems of measurement.

The book has been approximately doubled in size by the inclusion of this new matter, and in spite of its somewhat mathematical appearance, provides very interesting reading.

P. R. C.

## Correction.

### CURRENT SUPPRESSION BY MEANS OF PARALLEL RESONANCE. By H. G. CORDES.

The following corrections were received from the author too late for inclusion in the article which was published in the last issue :—

Page 362, equation (20), should read :

$$U = (\omega^2 L_x C_x - 1) \left[ \frac{1}{C_x} + \frac{\omega^2 L_z C_z - 1}{\omega^2 L_x C_x C_z + \omega^2 L_z C_z C_y - (C_y + C_z)} \right] \frac{1}{\omega} \quad (20)$$

Page 369, line 12, for "one form of rate of change" read "a negative rate of change . . ."

The lower half of p. 369, and the first four lines of p. 370, including Fig. 7, should read as follows :—

Fig. 7 shows a wave tester comprising a suppressor LC, a coil aerial  $L_a$ , a thermocouple T, a galvanometer G, a coil aerial circuit resistance  $r$ , a non-inductive resistance R and a throw-over switch.

The wave of the transmitter to be tested is impressed upon  $L_a$ . Maximum suppressive impedance is indicated by  $I_{(min.)}$  through T. The value of R is made equal to the maximum

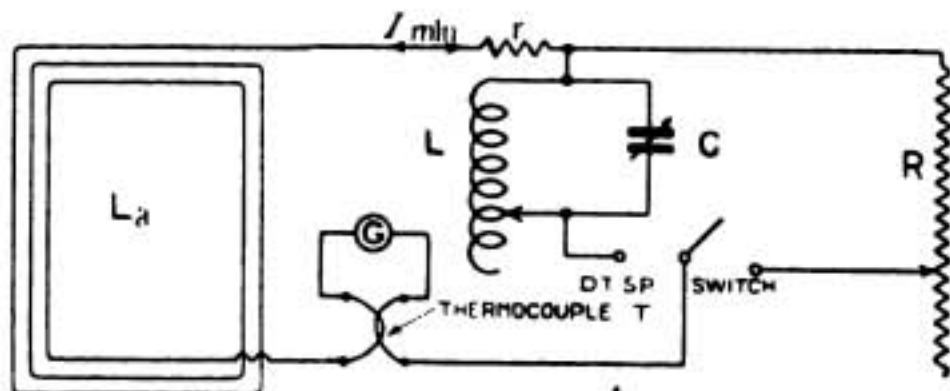

suppressive impedance of LC ; this value of R is determined by throwing the switch S to the right without changing the value of  $I_{(min.)}$ . The resistance  $r$  renders the coil aerial circuit aperiodic when the maximum suppressive impedance has an effective negative reactive component.

The quality of a wave can be expressed numerically as the ratio of R for the tested wave to R for a sine wave of constant frequency and constant amplitude. The latter value of R may be either measured with a sine wave or calculated from the constants of the suppressor by equation (16). The only part of this arrangement which would require standardisation is the suppressor circuit.

Suppressive impedance as a standard has the advantage of being a comparatively large quantity and neither potential nor current values need be determined. Suppressive impedance is decreased when the wave has a decrement, an increment or a harmonic. Sharpness of resonance is reduced by a harmonic in selective suppression but not in selective reception ; harmonics cause interference in selective reception.