

FEB
1920

THE RADIO REVIEW

A MONTHLY RECORD OF SCIENTIFIC
PROGRESS IN RADIOTELEGRAPHY
AND TELEPHONY

VOL. I

FEBRUARY, 1920

No. 5

Editor :

PROFESSOR G. W. O. HOWE, D.Sc., M.I.E.E.

Assistant Editor :

PHILIP R. COURSEY, B.Sc., A.M.I.E.E.

CONTENTS.

- A Method of Direction Finding of Wireless Waves and its Applications to Aerial and Marine Navigation**
Capt. J. ROBINSON, R.A.F., M.Sc.
- Damped Oscillations in Coupled Circuits**
G. BRAMWELL EHRENBORG
- The High Frequency Resistance of Wires and Coils**
G. W. O. HOWE, D.Sc., M.I.E.E.
- Direction and Position Finding . . .** Capt. H. J. ROUND
- The Transmission of Electromagnetic Waves about the Earth**
J. ERSKINE-MURRAY, D.Sc., F.R.S.E.
- A Comparative Method of Testing Thermionic Valves for Passing no Reverse Current**
N. W. MACLACHLAN, D.Sc. M.I.E.E.
- The Physical Society of London Exhibition.**
- Review of Radio Literature :**
Abstracts of Articles.
Review of Books.
- Correspondence.**

Two Shillings and Sixpence Net

THE RADIO REVIEW

VOL. I

FEBRUARY, 1920

No. 5

A Method of Direction Finding of Wireless Waves

And its Applications to Aerial and Marine
Navigation.*

By Capt. JAMES ROBINSON, R.A.F., M.Sc., Ph.D.

SUMMARY

1. Introduction.
2. Description of Method.
3. Sensitiveness of D.F. Coils.
4. Ambiguity.
5. General Application of the Method.
6. D.F. on Aircraft.
7. Design of Coils for any Wavelength.
8. Types of Coil.
9. Appendix.

I. INTRODUCTION

THE principal methods hitherto used for finding the direction of wireless waves make use of the well-known properties of a loop, that, when the plane of the loop is perpendicular to the direction of the waves, no energy is absorbed, and, when parallel to the direction of the waves, the maximum amount of energy is absorbed. In order to find the direction most accurately, use is made of the fact that the rate of variation of the energy

* Paper received August, 1919.

absorbed is greatest near the minimum. The loop is swung through the minimum position until signals can just be heard on either side. The positions where the signals are just audible are noted, and the position half way between taken as the indication of the minimum. The variation of intensity of signal is so slow at the maximum that it is impossible to fix the maximum within 5° or 10° .

The minimum method is used in two well-known cases :—

(a) Where the aerial consists of a single loop of one or more turns, the loop being capable of rotation about a vertical axis.

(b) In the Bellini Tosi method, where two fixed aerials at right angles are used, and where the moving part is a small coil inside an instrument known as a radiogoniometer.

The accuracy of such a method depends on various things, one of which is the strength of signal. For very weak signals the region of silence may be large, and at times it may exceed 90° . In such a case, the positions where the signal is just audible have to be estimated very accurately, in order that a reliable determination of the minimum can be obtained. Again, it is often difficult to guarantee to within a few degrees just where the signal is audible. External noises have great influence on the determination of the positions where the signal is just audible, and this becomes serious in cases where the disturbances vary in intensity in different directions, as is often the case with atmospherics, and also on aircraft where there is a lot of external noise.

Hence it seems advisable to have a method for finding direction where the coils can be placed actually on the position which indicates the bearing, thus avoiding the necessity of having to determine two positions where signals are just audible. This will again be increased in importance if the signal can be heard whilst the bearing is being taken. The method about to be described fulfils these wants.

2. DESCRIPTION OF THE METHOD

The method will first be described for the case of aerial coils which can be rotated about a vertical axis. Two coils at right angles are used, being rigidly attached so as to be rotatable together. Obviously, if one coil is at the minimum position for incoming waves, the other will be at the maximum. In order that signals may be heard whilst taking a bearing, the coils are

placed so that one coil is near its maximum. To do this, arrangements are made so that this coil can be used alone. We have seen that the maximum position of this coil, which we shall call the main coil, can only be roughly determined in this way. When, however, the other coil, called the auxiliary coil, is introduced, there will be a change in intensity of signal, unless this coil is at its zero position. If there is such a change of intensity the system is rotated slightly until the signals are of equal intensity, when the pointer will indicate the direction of the incoming waves. In practice, however, it is preferable not to change from main coil to main and auxiliary coil, but to proceed as follows. The maximum of the main coil is determined approximately. The auxiliary coil is then introduced and its connections reversed a few times, thus adding or subtracting the E.M.F. of the auxiliary coil to or from the E.M.F. of the main coil. When the auxiliary coil is at its minimum position the reversals will produce no change in intensity of signal.

One method of applying this system is shown in Fig. 1.

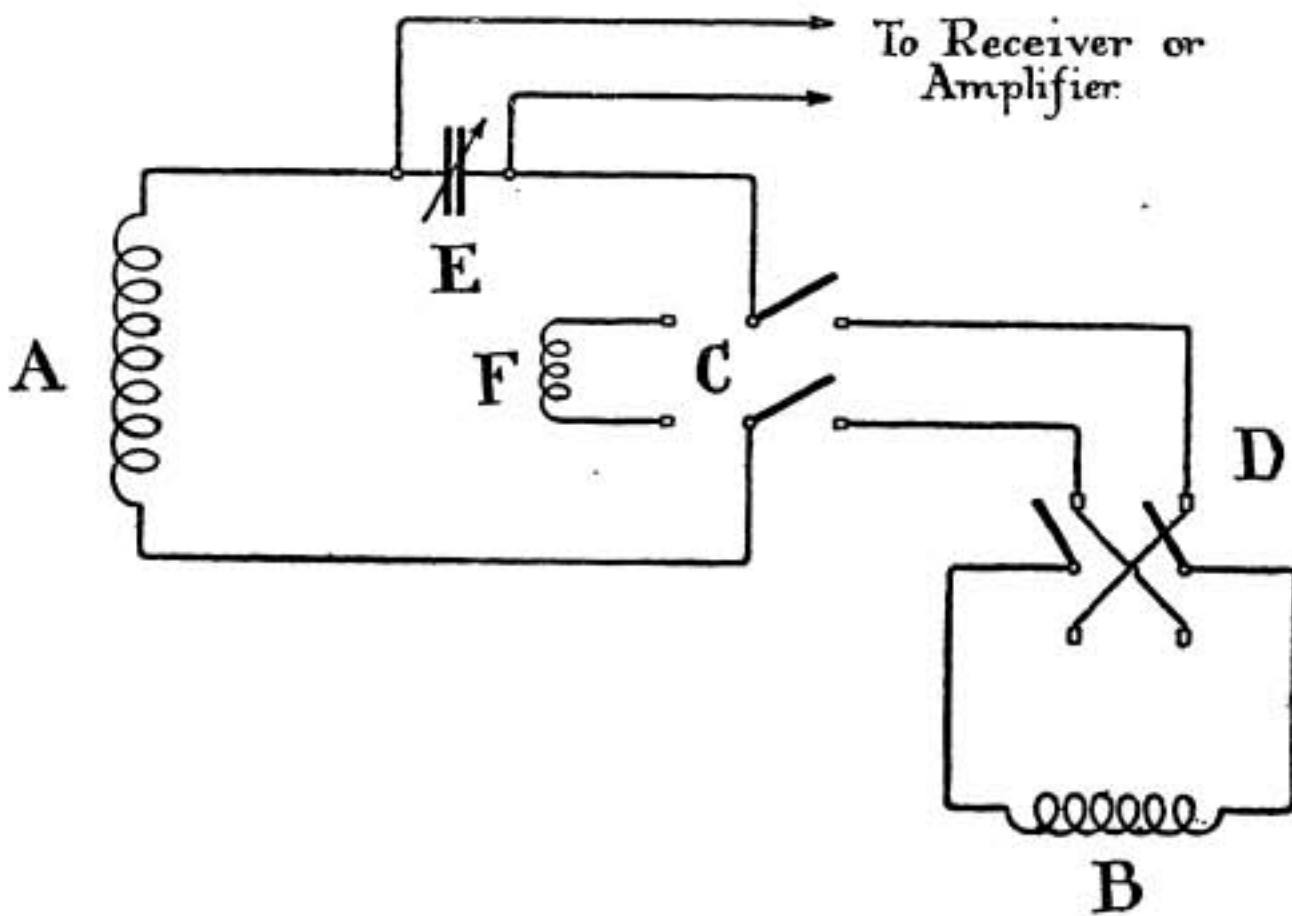

FIG. 1.

A is the main, and B the auxiliary coil. C is a change over switch, so that either the main coil alone, or the main and auxiliary in series can be used. D is a reversing switch to reverse the

connections of the auxiliary coil. E is a tuning condenser from the terminals of which leads are taken to the receiver or amplifier. It is convenient to arrange that there shall be no change of tuning when the auxiliary coil is introduced. For this purpose a balancing inductance, F, is used of the same inductance as the auxiliary coil, but of small dimensions, so that it picks up a negligible amount of energy from the waves.

The method of using this to find a bearing is as follows:— Contact is made with the change over switch, C, to the left. The signals are tuned in by the condenser, E, and the coils rotated to obtain the approximate maximum position of the aerial coil, A. The change over switch, C, is now placed to make contact on the right, and the reversing switch, D, moved from side to side a few times. If the signals are of different intensity, the aerial coils are moved slightly until a position is found where the signal strength is the same on reversal of the auxiliary coil. Then the direction of the incoming waves is given by the plane of the main coil.

An alternative way of applying this method is shown in Fig. 2.

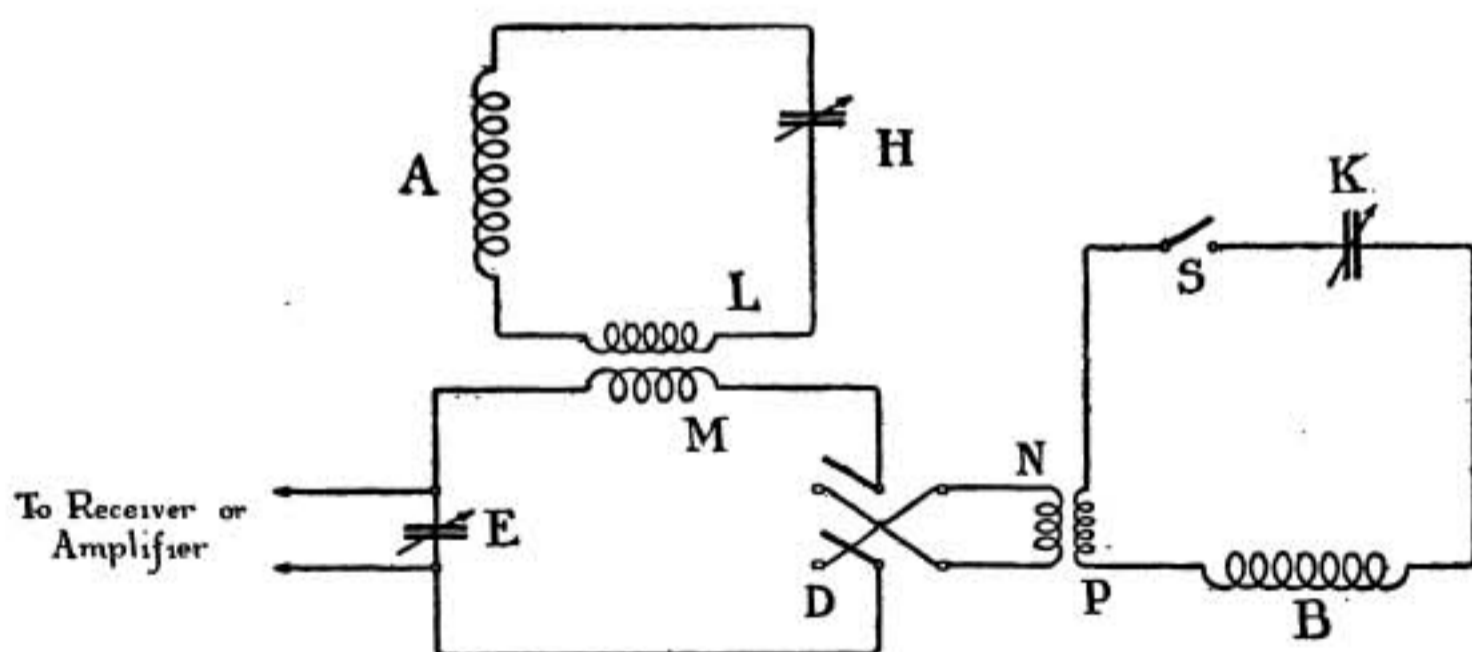

FIG. 2.

In this arrangement each aerial coil is in its own tuned circuit. The effects from the main and auxiliary coils, A and B, are combined in a circuit, MNDE, by means of the coupling coils, LM and NP.

The effects from the auxiliary coil are reversed by the reversing switch, D. In order that the main coil alone can be used to obtain its approximate maximum a make-and-break switch, S, is inserted in the circuit of the auxiliary coil, B. This method is

not so simple as that in Fig. 1, because of the necessity of having to use three tuning condensers. It should be noted, however, that there is no necessity to have extremely accurate tuning of any of the condensers, as is the case with the Bellini Tosi system.

3. SENSITIVENESS OF D.F. COILS.

By this system of direction-finding, the coils are placed in a definite position which indicates the direction of the incoming waves. As it is necessary to judge when signals are of equal strength, it may be presumed that there is a small angle in which it is difficult to decide whether the signals are of equal intensity or not. The magnitude of this angle determines the sensitiveness of the system, and we shall now proceed to consider the conditions controlling the sensitiveness.

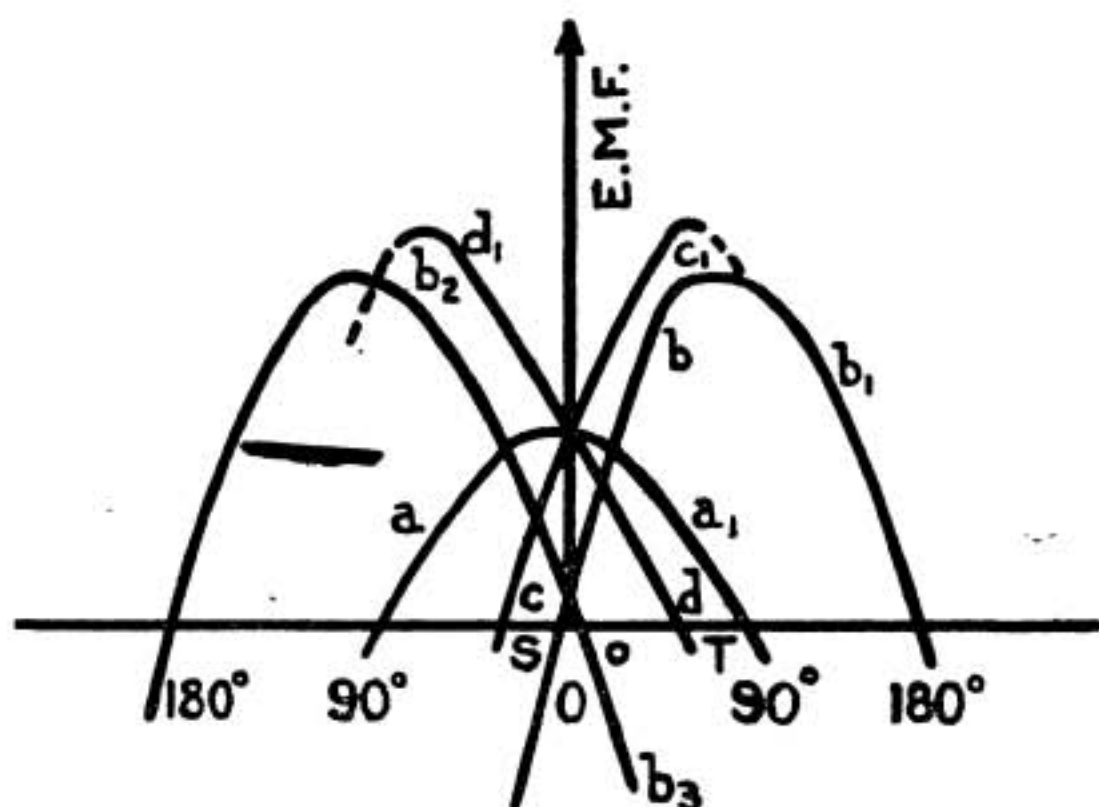

FIG. 3.

In Fig. 3 is shown the E.M.F. produced in the coils from electromagnetic waves from some constant source, for various orientations of the coils. The curve aa_1 shows the E.M.F. for the main coil, this being represented so as to be a maximum for 0° , and minimum or zero for $\pm 90^\circ$. This curve is a curve of trigonometrical form.

Curve bb_1 , also a curve of trigonometrical form, shows the E.M.F. for various orientations of the auxiliary coil, the maximum now being at $\pm 90^\circ$ and the zero value at 0° . When the connections of the auxiliary coil are reversed the E.M.F. curve becomes b_2b_3 .

When the main and auxiliary coils are used together we get curves cc_1 or dd_1 , according to whether the one or other auxiliary curves, bb_1 or b_2b_3 , is used.

Main coil curve aa_1 is represented by $y_1 = a \cos \theta$.

Auxiliary coil curve bb_1 is represented by $y_2 = b \sin \theta$.

Combined curve cc_1 is $Y_1 = a \cos \theta + b \sin \theta$.

Combined curve dd_1 is $Y_2 = a \cos \theta - b \sin \theta$.

These curves cross when

$$\begin{aligned} Y_1 &= Y_2, \\ \text{i.e., } a \cos \theta + b \sin \theta &= a \cos \theta - b \sin \theta, \\ \text{i.e., for } 2b \sin \theta &= 0, \\ \text{i.e., } \theta &= 0, \end{aligned}$$

which is for the maximum of the main coil and minimum of the auxiliary coil. The sensitiveness of the system is determined by the angle $2d\theta$ about the position $\theta = 0$, in which the ear cannot determine any difference in intensity, this angle $2d\theta$ being composed of $d\theta$ on each side of the maximum position of the main coil. At a position $d\theta$ from the position of equal signals we have

$$\begin{aligned} Y_1 &= a \cos d\theta + b \sin d\theta. \\ Y_2 &= a \cos d\theta - b \sin d\theta. \end{aligned}$$

The difference in E.M.F. is $Y_1 - Y_2 = Y_3$, and the mean E.M.F. is $\frac{Y_1 + Y_2}{2} = Y_4$.

The ratio $\frac{Y_3}{Y_4}$, i.e., the ratio of the difference in E.M.F. to the mean E.M.F. is intimately bound up with the sensitiveness

$$\frac{Y_3}{Y_4} = \frac{2b \sin d\theta}{a \cos d\theta},$$

which is approximately $2 \frac{b}{a} \sin d\theta$.

The term $\frac{b}{a}$ is the ratio of the maximum E.M.F.'s produced in the auxiliary and main coils. This ratio we shall call k . Under normal conditions k is equal to the ratio of the area-turns of the auxiliary and main coils, where by area-turns of a coil is meant the summation of the areas of each turn of the coil.*

Then we have $\frac{Y_3}{Y_4} = 2k \sin d\theta$.

* See below for evidence to support this view.

Taking $d\theta$ as some small angle, say 1° , the ratio $\frac{Y_3}{Y_1}$ can easily be calculated for various values of k . The following table contains some values :—

$k = \text{ratio}$ $\frac{\text{Auxiliary}}{\text{Main}}$ Area-turns.	Per cent. change of E.M.F. for 1° $= 2k \sin 1^\circ \times 100.$	$k = \text{ratio}$ $\frac{\text{Auxiliary}}{\text{Main}}$ Area-turns.	Per cent. change of E.M.F. for 1° $= 2k \sin 1^\circ \times 100.$
$\frac{1}{4}$	0.9 per cent.	1.5	5.2 per cent.
$\frac{1}{3}$	1.2 "	2.0	7.0 "
$\frac{1}{2}$	1.75 "	2.5	8.7 "
$\frac{3}{4}$	2.65 "	3.0	10.5 "
1	3.5 "	5.0	17.5 "
		10.0	35.0 "

Taking any particular value of k , say, $k = 2.5$, we find that, when 1° away from the true position, there is an 8.7 per cent. change in E.M.F. on reversal of the auxiliary coil. Without going into the difficult problem of what percentage change of intensity of sound the ear can determine, it is found in practice with the coils that have been used in the services that this 8.7 per cent. change of E.M.F. can be distinguished. Thus, for the ratio of auxiliary to main area-turns = 2.5, there is no doubt in the observer's mind that the signals are of different intensity when he is 1° away from the true position.

For such a system of coils the sensitiveness is such that there is certainty of being within 1° of the correct position. Naturally, training is of great importance, and trained operators can be certain of even greater accuracy.

For a ratio $k = 10$ there is 35 per cent. change of E.M.F. when 1° from the correct position, and the system has been found, in practice, to be sensitive to $\frac{1}{4}^\circ$.

This method thus shows how it is possible to determine the direction of incoming waves with any accuracy required up to what has so far been found to be the highest practicable accuracy of $\frac{1}{4}^\circ$.

(To be concluded.)

Damped Oscillations in Coupled Circuits*

By G. BRAMWELL EHRENBORG

THE starting-point of a mathematical discussion of the phenomena in two coupled circuits is a system of two linear differential equations of the second order. Each of these equations belongs to one circuit, in the sense that the majority of the terms in it refer to the voltage (or current) in that circuit; but there are also terms, which may conveniently be called cross terms, which are derived from the voltage in the other circuit, and which constitute the mathematical formulation of the effect of the latter circuit on the former. If the cross terms were absent, the integration of the differential equations would of course depend on the solution of quadratic equations. Owing to the presence of the cross terms, the two differential equations must be combined so as to form a single differential equation of the fourth order, the integration of which depends on the solution of a biquadratic. If the resistances are so small that their squares can be neglected, a manageable solution of the biquadratic can be found. This has been done by various writers; two of the more recent papers on the subject have been published in the *Jahrbuch der Drahtlosen Telegraphie*, one by Mackù (Vol. 3, p. 329) and the other by John Stone Stone (Vol. 7, p. 8). The former contents himself with solving the biquadratic, while the latter carries out the integration completely.

There is, however, another method of dealing with the problem. The fact that there is a biquadratic to solve instead of two quadratics was seen to be due to the presence of the cross terms, and it therefore seems worth while to try to effect such a change of variables that in the transformed system of differential equations the cross terms are as small as possible; if the damping is small, one would naturally try to arrange matters so that the only cross terms are damping terms. Transformations of this nature have been known and studied for well over a century, but as they are hardly ever dealt with outside the pages of advanced textbooks on dynamics and other publications entirely devoted to the interests of pure mathematicians, they have not received the attention they merit from radio engineers. The only instance known to the writer in which they have been applied to the problem now under discussion is in a paper by Louis Cohen (*Jahrbuch der Drahtlosen Telegraphie*, Vol. 2, p. 448), and in that article the author unfortunately chooses a transformation which would be suitable if the square of the condenser voltage were negligible in comparison with the square of the voltage drop in the resistance, whereas the exact opposite is what usually occurs in practice.

The object of the present paper is to apply the above-mentioned method to the study of the free oscillations in two circuits electromagnetically coupled, that transformation being chosen which is most nearly in accord with practical conditions. It will be found that the biquadratic can then in

* Paper received in final form, October 21st, 1919.

general be broken up into two quadratic factors without any serious error. There are other advantages also. It will be at once apparent that if a certain relation holds between the resistances and the capacities, the error vanishes so that the solution obtained is exact. Further, an estimate can easily be made of the magnitude of the error when this relation no longer holds. Finally, the evaluation of the integration constants is a far less laborious process than would have been the case if no change of variables had been carried out.

Consider two circuits, each of which contains a condenser in series with one of the windings of an oscillation transformer and (possibly) with some other inductance as well. In the first circuit let the total self-inductance be L_1 , the capacity of the condenser C_1 , the resistance R_1 , the potential difference on the condenser terminals v_1 and the current i_1 . Let the corresponding quantities in the second circuit be L_2 , C_2 , R_2 , v_2 and i_2 respectively, and let the mutual inductance between the two circuits be M . All inductances, capacities and resistances are assumed to be constant. If we make the convention that the current is positive when it flows from the positive condenser terminal through the metallic part of the circuit to the negative terminal, we have

$$i_1 = -C_1 \frac{dv_1}{dt}; \quad i_2 = -C_2 \frac{dv_2}{dt}.$$

The equations of the two circuits are

$$i_1 R_1 = -L_1 \frac{di_1}{dt} - M \frac{di_2}{dt} + v_1;$$

$$i_2 R_2 = -L_2 \frac{di_2}{dt} - M \frac{di_1}{dt} + v_2;$$

If we express the currents in terms of the voltages and introduce the fluxional notation (*i.e.*, $\dot{v}_1 = \frac{dv_1}{dt}$, $\ddot{v}_1 = \frac{d^2v_1}{dt^2}$, etc.), these equations transform into

$$L_1 C_1 \ddot{v}_1 + R_1 C_1 \dot{v}_1 + v_1 + M C_2 \ddot{v}_2 = 0$$

$$M C_1 \ddot{v}_1 + L_2 C_2 \ddot{v}_2 + R_2 C_2 \dot{v}_2 + v_2 = 0$$

It is convenient for future work to employ the following notation:—

$$L_1 C_1 = u_1; \quad L_2 C_2 = u_2; \quad \frac{M}{\sqrt{L_1 L_2}} = k; \quad \frac{v_1}{\sqrt{L_1}} = v_1'; \quad \frac{v_2}{\sqrt{L_2}} = v_2';$$

Then the equations become

$$\left. \begin{aligned} u_1 \ddot{v}_1' + R_1 C_1 \dot{v}_1' + v_1' + k u_2 \ddot{v}_2' &= 0 \\ k u_1 \ddot{v}_1' + u_2 \ddot{v}_2' + R_2 C_2 \dot{v}_2' + v_2' &= 0 \end{aligned} \right\} \dots \dots \dots (1)$$

The constant k is called the coefficient of coupling between the two circuits; it is always less than the coefficient of coupling of the oscillation transformer considered by itself, since the self-inductance of each of the windings is necessarily less than the total self-inductance of the circuit of which it forms a part. k is therefore always less than unity, but it may yet be far from

negligible, and it is the presence of the terms of which k is a factor which causes the difficulty of integrating the two equations. The difficulty is surmounted in the following way:—

Multiply the first equation by μ_1 and the second by μ_2 and add; we obtain

$$(\mu_1 u_1 + \mu_2 k u_1) \ddot{v}_1' + (\mu_1 k u_2 + \mu_2 u_2) \ddot{v}_2' + \mu_1 R_1 C_1 \dot{v}_1' + \mu_2 R_2 C_2 \dot{v}_2' + \mu_1 v_1' + \mu_2 v_2' = 0 \quad (2)$$

Now introduce a new variable ξ such that

$$\begin{aligned} (\mu_1 u_1 + \mu_2 k u_1) v_1' + (\mu_1 k u_2 + \mu_2 u_2) v_2' &= \xi \\ \mu_1 v_1' + \mu_2 v_2' &= \lambda \xi \end{aligned}$$

where λ is a constant to be determined.

The last two equations will be consistent for all values of v_1' and v_2' if

$$\begin{cases} (u_1 - \frac{1}{\lambda}) \mu_1 + k u_1 \mu_2 = 0 \\ k u_2 \mu_1 + (u_2 - \frac{1}{\lambda}) \mu_2 = 0 \end{cases} \quad (3)$$

If these equations are to have any other solution than $\mu_1 = \mu_2 = 0$ (which is of no value to us), we must have

$$\begin{vmatrix} u_1 - \frac{1}{\lambda} & k u_1 \\ k u_2 & u_2 - \frac{1}{\lambda} \end{vmatrix} = 0, \text{ or } \left(\frac{1}{\lambda} - u_1\right) \left(\frac{1}{\lambda} - u_2\right) = k^2 u_1 u_2 \quad (4)$$

This is a quadratic in $\frac{1}{\lambda}$ which, written in the usual form, reads

$$\frac{1}{\lambda^2} - (u_1 + u_2) \frac{1}{\lambda} + (1 - k^2) u_1 u_2 = 0.$$

If this equation is satisfied when $\lambda = p^2$ and when $\lambda = q^2$, we know from the theory of quadratic equations that

$$\begin{cases} \frac{1}{q^2} + \frac{1}{p^2} = u_1 + u_2 \\ \frac{1}{p^2 q^2} = (1 - k^2) u_1 u_2 \end{cases} \quad (5)$$

On solving the quadratic we find

$$\begin{cases} \frac{1}{p^2} = \frac{1}{2} \left(u_1 + u_2 - \sqrt{(u_1 - u_2)^2 + 4k^2 u_1 u_2} \right) \\ \frac{1}{q^2} = \frac{1}{2} \left(u_1 + u_2 + \sqrt{(u_1 - u_2)^2 + 4k^2 u_1 u_2} \right) \end{cases} \quad (6)$$

If, as is customary, we take $\sqrt{(u_1 - u_2)^2 + 4k^2 u_1 u_2}$ to mean the positive square root of $(u_1 - u_2)^2 + 4k^2 u_1 u_2$, we see that $\frac{1}{p^2}$ is always less than $\frac{1}{q^2}$. If k were = 1, $\frac{1}{p^2}$ would be zero, but as k is always less than that, $\frac{1}{p^2}$ is always

positive. A little consideration will show that both u_1 and u_2 lie between $\frac{1}{q^2}$ and $\frac{1}{p^2}$, and by writing the first of the equations (5) in the form $\frac{1}{q^2} - u_1 = u_2 - \frac{1}{p^2}$ we see that $\frac{1}{q^2}$ is greater than u_1 by the same amount as $\frac{1}{p^2}$ is less than u_2 . When $k = 0$, $\frac{1}{p^2} =$ the lesser of u_1 and u_2 , and $\frac{1}{q^2} =$ the greater.

Either of the two roots when substituted in equations (3) will give us a value of the ratio $\frac{\mu_1}{\mu_2}$ which will make the two equations giving ξ in terms of v_1' and v_2' consistent. The actual values of μ_1 and μ_2 are indeterminate, but that is a matter of no importance to us, for we see that the effect of multiplying each of these quantities by a given constant is to multiply equation (2) by the same constant, a process which makes it neither easier nor more difficult to integrate.

When $\lambda = p^2$, the first of equations (3) gives us $\frac{\mu_1}{\mu_2} = -\frac{ku_1}{u_1 - \frac{1}{p^2}}$, and the second, $\frac{\mu_1}{\mu_2} = -\frac{u_2 - \frac{1}{p^2}}{ku_2}$; we see at once that these two values of the ratio are equal, since $\frac{1}{p^2}$ is a root of (4). For future work we shall make use of the former of the two values, and we shall take the actual values of μ_1 and μ_2 to be respectively ku_1 and $-\left(u_1 - \frac{1}{p^2}\right)$ when $\lambda = p^2$.

When λ has this value let ξ have the value x , and when $\lambda = q^2$ let $\xi = y$. Then the equation $\mu_1 v_1' + \mu_2 v_2' = \lambda \xi$ becomes in these two cases respectively

$$\left. \begin{aligned} ku_1 v_1' - \left(u_1 - \frac{1}{p^2}\right) v_2' &= p^2 x \\ ku_1 v_1' - \left(u_1 - \frac{1}{q^2}\right) v_2' &= q^2 y \end{aligned} \right\} \dots \dots \dots (7)$$

if we take $\mu_1 = ku_1$ and $\mu_2 = -\left(u_1 - \frac{1}{q^2}\right)$ when $\lambda = q^2$.

We now return to equation (2) and write down the two forms it takes when $\lambda = p^2$ and $\lambda = q^2$. These are

$$\begin{aligned} \ddot{x} + ku_1 R_1 C_1 \dot{v}_1' - \left(u_1 - \frac{1}{p^2}\right) R_2 C_2 \dot{v}_2' + p^2 x &= 0 \\ \ddot{y} + ku_1 R_1 C_1 \dot{v}_1' + \left(\frac{1}{q^2} - u_1\right) R_2 C_2 \dot{v}_2' + q^2 y &= 0 \end{aligned}$$

To complete the transformation to the new variables we simply have to solve equations (7) and substitute the values of v_1' and v_2' thereby obtained in the above two equations. We find

$$\left. \begin{aligned} v_1' &= \frac{\frac{1}{q^2} - u_1}{\left(\frac{1}{q^2} - \frac{1}{p^2}\right) k u_1} p^2 x + \frac{u_1 - \frac{1}{p^2}}{\left(\frac{1}{q^2} - \frac{1}{p^2}\right) k u_1} q^2 y \\ v_2' &= -\frac{1}{\frac{1}{q^2} - \frac{1}{p^2}} p^2 x + \frac{1}{\frac{1}{q^2} - \frac{1}{p^2}} q^2 y \end{aligned} \right\} \dots \dots \dots (8)$$

Now the differential equations become

$$\left. \begin{aligned} \ddot{x} + 2\alpha \dot{x} + p^2 x + f \dot{y} &= 0 \\ g \dot{x} + \ddot{y} + 2\beta \dot{y} + q^2 y &= 0 \end{aligned} \right\} \dots \dots \dots (9)$$

where

$$\left. \begin{aligned} f &= \frac{u_1 - \frac{1}{p^2}}{\frac{1}{q^2} - \frac{1}{p^2}} (R_1 C_1 - R_2 C_2) q^2 \\ g &= \frac{\frac{1}{q^2} - u_1}{\frac{1}{q^2} - \frac{1}{p^2}} (R_1 C_1 - R_2 C_2) p^2 \end{aligned} \right\} \dots \dots \dots (10)$$

$$\left. \begin{aligned} \alpha &= \frac{\left(\frac{1}{q^2} - u_1\right) R_1 C_1 + \left(u_1 - \frac{1}{p^2}\right) R_2 C_2}{2 \left(\frac{1}{q^2} - \frac{1}{p^2}\right)} p^2 \\ \beta &= \frac{\left(u_1 - \frac{1}{p^2}\right) R_1 C_1 + \left(\frac{1}{q^2} - u_1\right) R_2 C_2}{2 \left(\frac{1}{q^2} - \frac{1}{p^2}\right)} q^2 \end{aligned} \right\} \dots \dots \dots (11)$$

It is convenient to express α as the sum of two terms, one of which depends on $R_1 C_1 + R_2 C_2$ and the other on $R_1 C_1 - R_2 C_2$, and similarly for β . If we write $R_1 C_1$ in the form $\frac{R_1 C_1 + R_2 C_2}{2} + \frac{R_1 C_1 - R_2 C_2}{2}$ and $R_2 C_2$ in the form $\frac{R_1 C_1 + R_2 C_2}{2} - \frac{R_1 C_1 - R_2 C_2}{2}$, and if we make use of the first of equations (5), we find

$$\left. \begin{aligned} \alpha &= \frac{R_1 C_1 + R_2 C_2}{4} p^2 - \frac{R_1 C_1 - R_2 C_2}{4 \left(\frac{1}{q^2} - \frac{1}{p^2}\right)} (u_1 - u_2) p^2 \\ \beta &= \frac{R_1 C_1 + R_2 C_2}{4} q^2 + \frac{R_1 C_1 - R_2 C_2}{4 \left(\frac{1}{q^2} - \frac{1}{p^2}\right)} (u_1 - u_2) q^2 \end{aligned} \right\} \dots \dots \dots (12)$$

(To be continued.)

The High-Frequency Resistance of Wires and Coils.*

By Prof. G. W. O. HOWE, D.Sc., M.I.E.E.

THE last five years have seen a remarkable development of the application of high-frequency currents to telegraphy and telephony. In all cases, it is a matter of importance to be able to calculate or, at least, to predict the losses occurring in coils when carrying high-frequency currents.

No attempt is made to deal exhaustively with the subject in this paper. An explanation is given of the principles involved and it is shown how these principles can be applied to the calculation of the resistance of wires and coils.

STRAIGHT ROUND WIRE.

In a previous paper † the author has shown how the well-known telephone transmission formulæ may be used to calculate the skin effect in many cases. It is there shown that in a solid round wire carrying a current of such a high frequency that the penetration is small, the ratio of the high-frequency resistance R_f to the steady current resistance R_0 is given by the formula

$$\frac{R_f}{R_0} = \pi r \left(\sqrt{\frac{f\mu}{10^9\rho}} \right) + 0.25$$

where r is the radius of the wire, f the frequency, μ the permeability, and ρ the specific resistance.

PARALLEL STRIPS.

When it is desired to keep the inductance of a circuit as low as possible, parallel strips placed close together are frequently employed. If the frequency is so high that the current density at the back of the strips is practically zero, this is the simplest of all skin-effect calculations; it is considered in detail on pages 473 to 475 of the previous paper.† The resistance and losses are shown to be the same as if the total current were distributed uniformly over a layer of depth t where $t = \frac{1}{2}\pi\sqrt{\frac{10^9\rho}{f\mu}}$.

For copper at a frequency of a million, $t = 0.066$ mm. If the frequency and the thickness of the strips are such that the current penetrates appreciably throughout the whole cross-section, the problem is analogous to that of the telephone line when the current is not attenuated to zero before arrival at the far end, in which case a reflected wave is superposed upon the forward wave. The formulæ for this case are well known and are used daily by telephone and alternating-current power-transmission engineers. They are employed on pages 478 and 479 of the previous paper† to calculate the current

* Abstract of paper read before the Institution of Electrical Engineers (Wireless Section), on December 19th, 1919.

† "The Application of Telephone Transmission Formulæ to Skin-Effect Problems," *Journal Inst. Electrical Engineers*, 54, p. 473, 1916.

density at different depths and the resultant resistance. It is shown that $\frac{R_f}{R_o} = \frac{\beta\tau}{\gamma}$ where $\beta = 2\pi\sqrt{\frac{f\mu}{10^9\rho}}$, τ = the thickness of the strip, and $\gamma = \frac{\cosh 2\beta\tau - \cos 2\beta\tau}{\sinh 2\beta\tau + \sin 2\beta\tau}$.

For small values of $2\beta\tau$ that is, for low frequencies or very thin strips, this reduces to

$$\frac{R_f}{R_o} = 1 + \frac{2}{3} \cdot \frac{(2\beta\tau)^4}{5!}$$

which for copper may be written $R_f/R_o = 1 + 47.5 (\tau\sqrt{f})^4 \cdot 10^{-6}$.

The value of R_f/R_o for any value of $\beta\tau$ can be read directly off the curve in Fig. 1.

SINGLE-LAYER CYLINDRICAL COILS.

Coils wound with Rectangular Wire.—In the previous paper the author has shown that the resistance of a long coil closely wound with a single layer

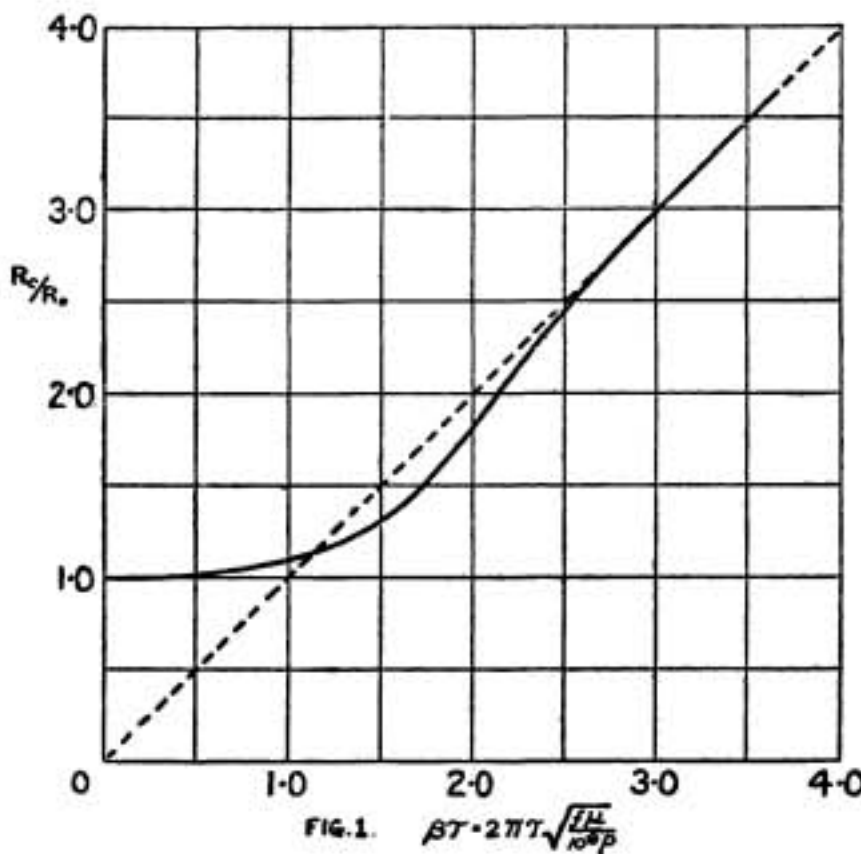

of square or rectangular wire is given accurately by the same formula as that already found for the parallel strips, viz.

$$R_c = R_o \frac{\beta\tau}{\gamma},$$

where τ is the radial thickness of the wire. The values of R_c/R_o are plotted in Fig. 1 against values of $\beta\tau$.

If there is a small space between adjacent turns, the magnetic field within the conductor and in the spaces between the turns will still be approximately linear and parallel to the axis of the coil, but for a given current density the magnetic flux density will be reduced. The same result would be caused by a decrease in the permeability and either would lead to an increased penetration. If the wire has a square section of side τ cm. and if S is the number of turns per cm., $S\tau$ is the fraction of the axial length occupied by the conductor, the remainder being occupied by insulation or air space. The penetration would be the same if the turns were close together, but the permeability of the material reduced from 1 to $S\tau$. Assuming the conductor to have unit permeability, β would be reduced from

$$2\pi\sqrt{\frac{f}{10^9\rho}} \text{ to } 2\pi\sqrt{\frac{S\tau f}{10^9\rho}}$$

For many purposes it is convenient to consider the ratio of the high-frequency resistance R_c of the coil to the high-frequency resistance R_f of the same wire when straight. In the present case this would necessitate a knowledge of the ratio R_f/R_o for a straight wire of square section. At low frequencies the resistance of a square wire approximates to that of a round one of equal cross-section, whereas at very high frequencies its resistance is inversely proportional to its periphery, and, neglecting the fact that the current density is slightly greater near the edges than near the middle of the faces, approximates to that of a round wire of the same periphery. For intermediate cases it will lie somewhere between these two limiting values. Now the area of a circle inscribed in a square has an area $\pi/4$ of that of the square and also a periphery $\pi/4$ of that of the square. Hence a round wire equal in diameter to the side of a square wire has $\pi/4$ times its resistance both at very low and at very high frequencies. It may be assumed therefore as an approximation that this ratio is constant at all frequencies. The resistance of linear conductors of square section has been investigated theoretically and experimentally by H. W. Edwards.* It will be found, however, that the inscribed circle method gives results in as good agreement with his observations as his own theoretically established formula. The biggest difference between the calculated and observed results is about 4 per cent. for values of $\tau\sqrt{f}$ ranging from 0 to 42.

The values of R_c/R_o and R_c/R_f have been calculated for a solenoid of square wire with $S\tau = 1.0, 0.8, 0.5$ and 0.25 respectively, that is, for coils in which τ is 100, 80, 50 and 25 per cent. of the pitch of the turns. The results are given in Fig. 2. The curves are calculated by the above formulæ but the points marked are experimental results obtained by Esau who measured the high-frequency resistance of single-layer coils of square section. For the sake of comparison the curves have

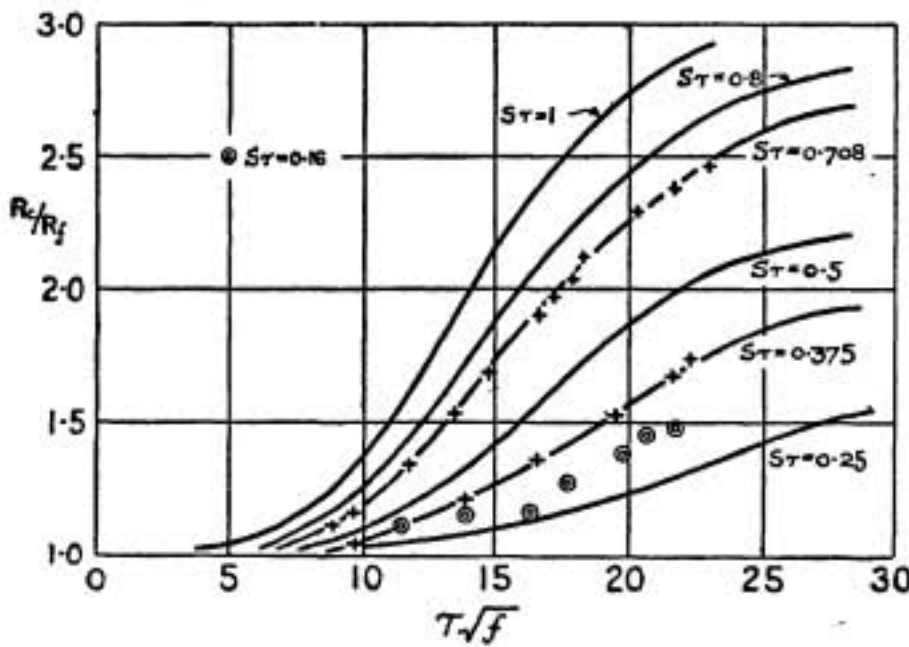

FIG. 2.

also been drawn for the values of $\tau\sqrt{f}$ and of $S\tau$ which were employed by Esau. It will be seen that the agreement is very good except for the lowest values of $S\tau$. Since the calculation is based on the assumption that $S\tau$ is not much less than unity, the accuracy with which the observed points lie on the curve when $S\tau = 0.375$ is somewhat surprising, more especially in view of the enormous discrepancies when $S\tau = 0.161$. It must

also been drawn for the values of $\tau\sqrt{f}$ and of $S\tau$ which were employed by Esau. It will be seen that the agreement is very good except for the lowest values of $S\tau$. Since the calculation is based on the assumption that $S\tau$ is not much less than unity, the accuracy with which the observed points lie on the curve when $S\tau = 0.375$ is somewhat surprising, more especially in view of the enormous discrepancies when $S\tau = 0.161$. It must

* *Electrician*, Vol. 68, p. 728, 1912; and *Physical Review*, Vol. 33, p. 184, 1911.

be remembered that it has been assumed that the coils are long and that the diameter is large compared with the pitch.

Solenoid wound with Round Wire.—If the coil is wound with round wire the problem is more difficult. The only writers who appear to have attacked the problem rigidly are Picciati and Sommerfeld. Others have considered the problem, but have assumed, either that the wire is square, or that the current distribution in the round wire is similar to that in the square wire. Cohen assumed that the results obtained by him for square wire could be applied to round wire. His formula is only applicable to very closely wound coils,

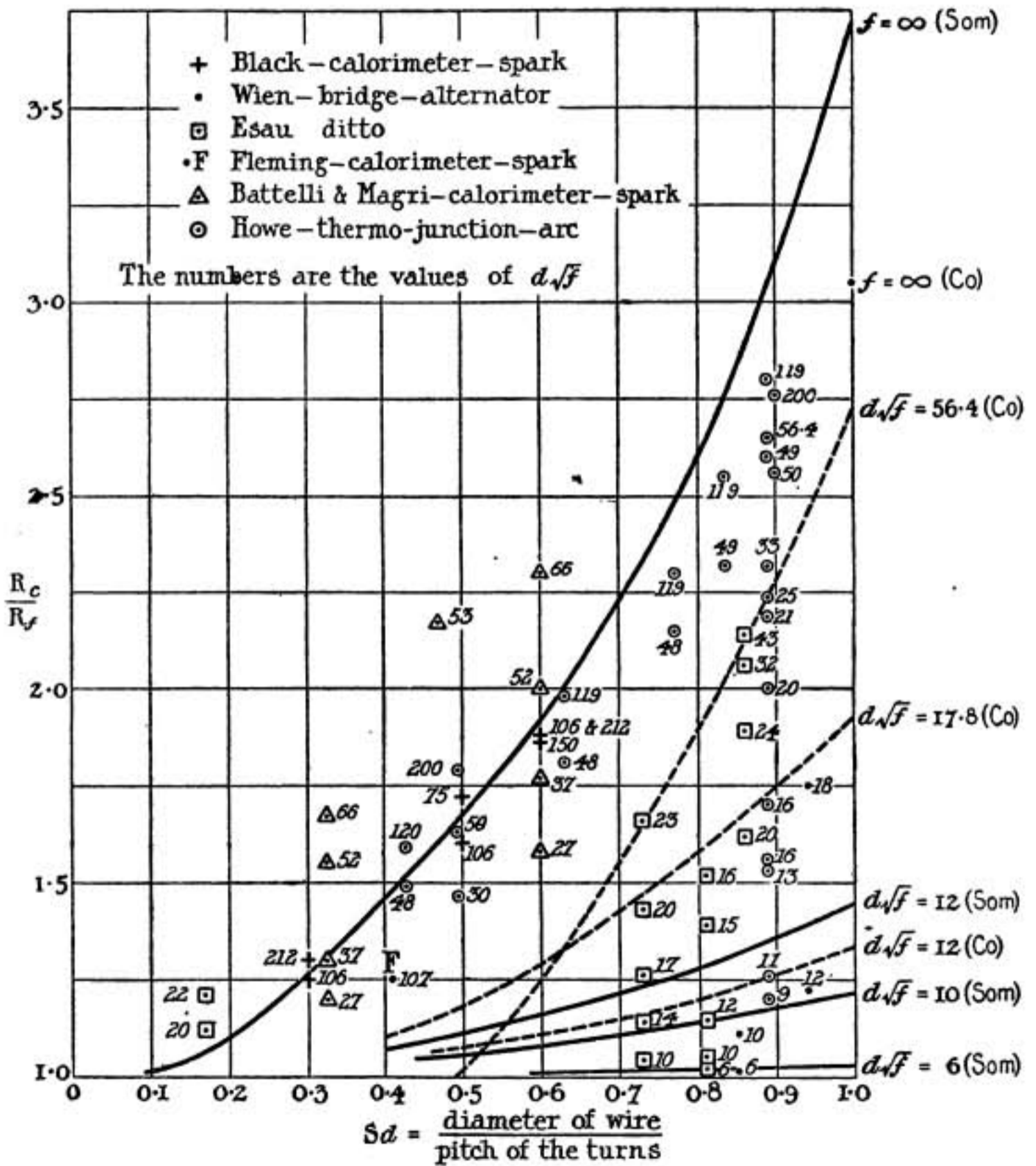

FIG. 3.

and if applied to coils in which $Sd = 0.5$, that is, in which the space between the wires is equal to the diameter of the wire, it may lead to coil resistances less than that of the wire when straight. As an example, the dotted curve in Fig. 3 is calculated by Cohen's formula for $d\sqrt{f} = 56.4$. At low frequencies, however, Cohen's formula gives good results, even for coils which are not closely wound, as can be seen from the lower dotted curves in Fig. 3, for $d\sqrt{f} = 17.8$ and 12.0 respectively.

For low frequencies M. Wien obtained the formula

$$R_c/R_o = 1 + 0.272 \pi^2 \omega^2 \sigma^2 r^4 (2\pi r S)^2$$

which, for copper, may be written

$$R_c/R_o = 1 + 23 \cdot 10^{-6} (d\sqrt{f})^4 \cdot (Sd)^2$$

This is somewhat similar to the formula for low frequencies obtained by Sommerfeld, viz.

$$\frac{R_c}{R_o} = 1 + 0.25 \pi^2 \omega^2 \sigma^2 r^4 \left\{ \frac{1}{3} + (2\pi r S)^2 + \frac{(2\pi r S)^4}{216} + \dots \right\}$$

which, for copper, may be written

$$\frac{R_c}{R_o} = 1 + 2.12 \times 10^{-6} (d\sqrt{f})^4 \left\{ \frac{1}{3} + \pi^2 (Sd)^2 + \frac{\pi^4}{216} (Sd)^4 + \dots \right\}$$

If Sd is not much less than unity, the second term is much bigger than any other, and we have approximately

$$R_c/R_o = 1 + 22.7 \times 10^{-6} (d\sqrt{f})^4 (Sd)^2$$

which is practically the same as Wien's formula. As mentioned in connection with parallel strips the accurate formula for closely-coiled square wire, viz. $R_c/R_o = \beta\tau/\gamma$, can be modified for small values of $\beta\tau$ by expanding the trigonometrical and hyperbolic functions and neglecting the higher powers of $\beta\tau$; in this way one obtains

$$\frac{R_c}{R_o} = 1 + \frac{2}{3} \cdot \frac{(2\beta\tau)^4}{5!}$$

$$= 1 + 47.5 \times 10^{-6} (\tau\sqrt{f})^4 \text{ for copper.}$$

We have also shown that, if not closely wound, the effect is similar to that of reducing the permeability from 1 to $S\tau$, which would reduce β^4 in the ratio of 1 to $(S\tau)^2$, and give the formula

$$R_c/R_o = 1 + 47.5 \times 10^{-6} (\tau\sqrt{f})^4 \cdot (S\tau)^2.$$

If this formula is assumed to hold approximately for round wires of equal cross-section, we have

$$\tau = 0.886d; (\tau\sqrt{f})^4 = 0.617 (d\sqrt{f})^4; (S\tau)^2 = 0.785 (Sd)^2$$

and

$$R_c/R_o = 1 + 23 \times 10^{-6} (d\sqrt{f})^4 (Sd)^2$$

in exact agreement with Wien and Sommerfeld. This formula is only applicable to low frequencies ($d\sqrt{f}$ less than 10).

At very high frequencies the replacement of closely-wound round wire by square wire of equal section also leads to results almost identical with those obtained by Sommerfeld. It should be mentioned that Sommerfeld only succeeded in solving the problem for the case of the turns in actual contact,

i.e. for $Sd = 1$; for values of Sd less than unity, he used the experimental results of T. P. Black. We are therefore entirely dependent on experimental observations except for certain special cases. The results obtained by various experimenters have been plotted in Fig. 3; beside each point is given the value of $d\sqrt{f}$. The results are very discordant, but it must be remembered that the measurements have been made by different methods and with different sources of alternating currents; some with damped and some with undamped oscillations. The curves shown have been calculated by the various formulæ to which reference has been made. None of these formulæ take into account the effect of the diameter of the coil, which may be an important factor for small values of Sd ; the formulæ assume the coils to be very long in comparison with their diameters, and they would obviously be very inaccurate if applied to narrow coils of large diameter (see section on "Short Coils").

EXPERIMENTAL.

A number of measurements of the high-frequency resistance of coils have been made at the Imperial College of Science and Technology during the last three or four years. The temperature rise of the coil was determined by means of a thermo-junction of very fine wires soldered to a point of the coil near its centre; these wires could be disconnected from the galvanometer circuit except when a reading was to be made. If I_0 is the direct current required to give the same temperature rise as the alternating current I_c , then $I_0^2 R_0 = I_c^2 R_c$.

The results obtained by this method are shown in Figs. 4 and 5. In Fig. 4 the coil consisted of 92 turns of 0.264 cm. wire, the total length of the coil was 26.9 cm. and its external diameter 2.86 cm. The ratio of the diameter of the wire to the pitch of the turns = $Sd = 3.42 \times 0.264 = 0.9$. A fair curve has been drawn through the observed points. A square wire of equal cross-section would have a side $\tau = 0.234$, therefore $S\tau = 0.79$, and $\sqrt{S\tau} = 0.89$.

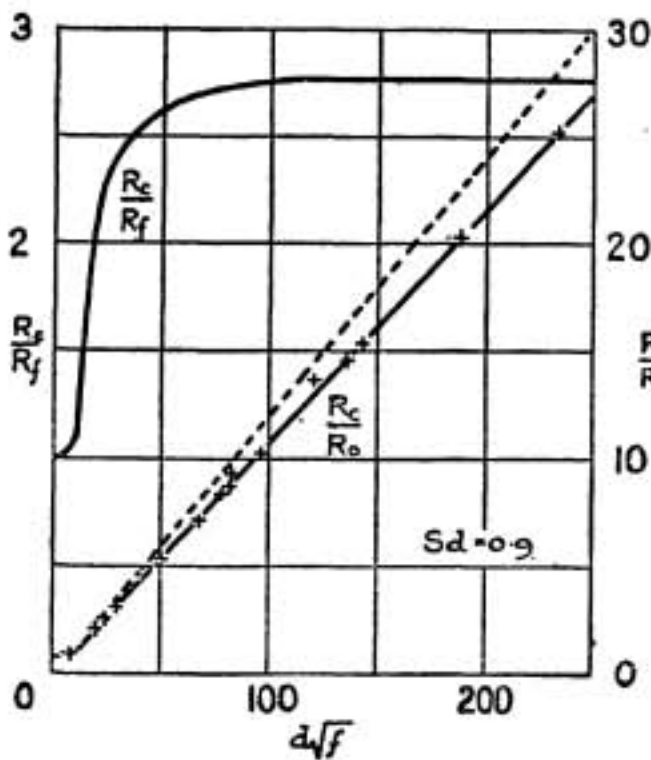

FIG. 4.

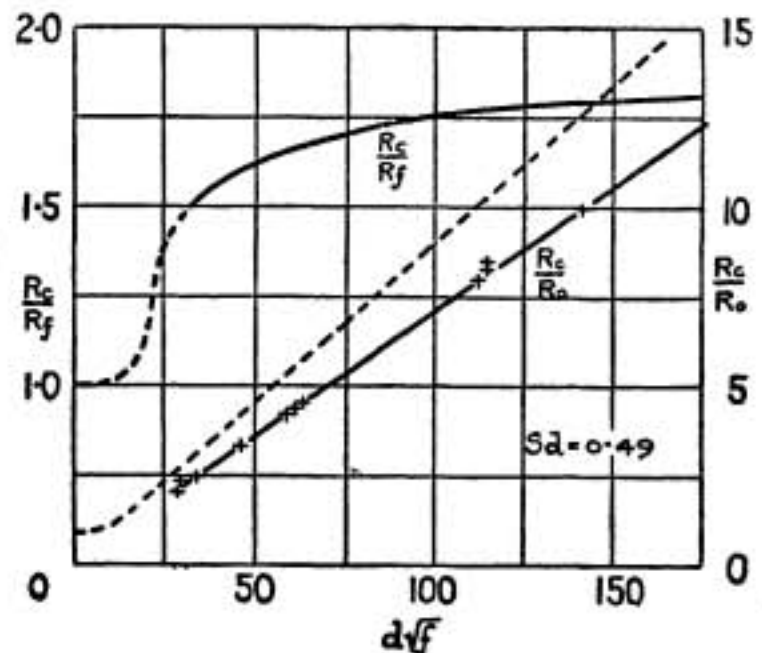

FIG. 5.

Applying the formula for a coil wound with square wire, we have $\frac{R_c}{R_o} = \frac{\beta\tau}{\gamma}$, where $\beta = 0.152\sqrt{f} \times \sqrt{S\tau}$, $\therefore \beta\tau = 0.0316\sqrt{f}$. The corresponding values of R_c/R_o can be read off the curve in Fig. 1. These calculated values for the equivalent square wire are shown by the dotted curve in Fig. 4; they are about 11 per cent. greater than the measured values of R_c/R_o .

In Fig. 5 the coil consisted of 62 turns of wire 0.163 cm. diameter with a total length of 20.4 cm. and a pitch of 0.33 cm. A square wire of equal cross-section would have a side $\tau = 0.144$ cm., $S\tau = 0.436$, and $\sqrt{S\tau} = 0.66$. Therefore $\frac{R_c}{R_o} = \frac{\beta\tau}{\gamma}$, where $\beta = 0.152\sqrt{f} \times \sqrt{S\tau}$, $\therefore \beta\tau = 0.1044\sqrt{f}$. The dotted curve shows the values of R_c/R_o calculated in this way. They are 26 per cent. higher than the measured values.

Exigencies of space sometimes compel the designer of radio apparatus to employ coils with more than a single layer of wire. The inductance increases as the square of the number of turns in a given length, whereas the resistance to steady currents is directly proportional to the turns. At high frequencies, however, the resistance may be greatly increased by the addition of a second or third layer.

Consider a long solenoid wound with three lengths of square wire. Numbering the layers from the outside, the magnetic field in the first annular space is due only to the current in the first layer, that in the second annular space is due to the currents in the two outer layers, and that inside the solenoid to the total current. These fields are therefore in the ratio of 1 : 2 : 3. If the frequency is very high the currents will be such as to prevent the penetration of these magnetic fields into the wires. The current I will be confined to the inner skin of the outer layer, the lost energy being transmitted radially into the wire from the annular gap. The flux will be prevented from penetrating very deeply into the second layer by a current I in the reverse direction in its outer skin, and a current $2I$ —the field being twice as strong—in the forward direction in its inner skin. Similarly in the inner layer the penetration of flux is prevented by currents of $-2I$ and $+3I$ in the outer and inner skins respectively. The resultant current is of course the same in every layer, viz. I . Since the power lost is proportional to the square of the current the effective resistances are as tabulated below.

Hence if the size of wire and the frequency are such that the skin effect is very pronounced, the effective resistance increases much more rapidly than the inductance as the number of layers is increased. When, however, the penetration into the wires is considerable, the calculation of the effective resistance is much more complicated.

This problem was worked out in an appendix where it was shown that the power dissipated in any layer per axial centimetre is

$$P = i_2^2 \beta \rho F(\beta\tau, k)$$

where i_2 is the imaginary line current supplied at the outer end of the fictitious transmission line, ρ the specific resistance, τ the radial depth of each layer,

and $F(\beta\tau, k)$ a complicated function, values of which were tabulated in the appendix.

If I be the actual resultant current in the coil per axial centimetre, the value of i_2 for the n^{th} layer is $(n - 1)I$ and

$$P = (n - 1)^2 I^2 \beta \rho F(\beta\tau, k)$$

whereas with an equal direct current $P = I^2 \rho / \tau$. Hence for the n^{th} layer

$$R_c/R_o = (n - 1)^2 \beta \tau F(\beta\tau, k).$$

The values of R_c/R_o have been calculated by this formula for the second, third, and fourth layers, and the results are tabulated both for the individual layers and for the complete coils.

MULTI-LAYER COILS.

Number of Layers.	Current in Outer and Inner Skin.	Relative Power dissipated in each Layer.	Relative Power dissipated in all Layers.	$\frac{R_c}{R_o}$	Relative Inductance.
1	$\left\{ \begin{array}{l} 0 \\ I \end{array} \right.$	$\left. \begin{array}{l} 0 \\ 1 \end{array} \right\} 1$	1	$\beta\tau$	1
2	$\left\{ \begin{array}{l} -I \\ 2I \end{array} \right.$	$\left. \begin{array}{l} 1 \\ 4 \end{array} \right\} 5$	6	$3\beta\tau$	4
3	$\left\{ \begin{array}{l} -2I \\ 3I \end{array} \right.$	$\left. \begin{array}{l} 4 \\ 9 \end{array} \right\} 13$	19	$6\frac{1}{3}\beta\tau$	9
4	$\left\{ \begin{array}{l} -3I \\ 4I \end{array} \right.$	$\left. \begin{array}{l} 9 \\ 16 \end{array} \right\} 25$	44	$11\beta\tau$	16
5	$\left\{ \begin{array}{l} -4I \\ 5I \end{array} \right.$	$\left. \begin{array}{l} 16 \\ 25 \end{array} \right\} 41$	85	$17\beta\tau$	25

The curves in Fig. 6 give the values of R_c/R_o for coils with various numbers of layers. For high values of $\beta\tau$ the curves approximate to the dotted lines in accordance with the values given in the Table above.

These curves refer to long coils closely wound with square or rectangular wire, and corrections must be applied for the spaces between adjacent turns, and for the coil not being very long compared with its diameter. The results are not affected, however, by the space between adjacent layers. As we have shown in the case of single-layer coils, the effect of spacing between adjacent turns, if not excessive, can be allowed for by taking the value of R_c/R_o for $\beta\tau\sqrt{S\tau}$ instead of for $\beta\tau$, where S is the number of turns per centimetre and τ is the side of the square. With round wire an approximate result can be obtained by assuming it to be replaced by square wire of equal sectional area.

THE USE OF MULTIPLY STRANDED INSULATED WIRE.

The author referred to a previous paper* on this subject in which

* *Proceedings of the Royal Society, A*, Vol. 93, p. 468, 1917.

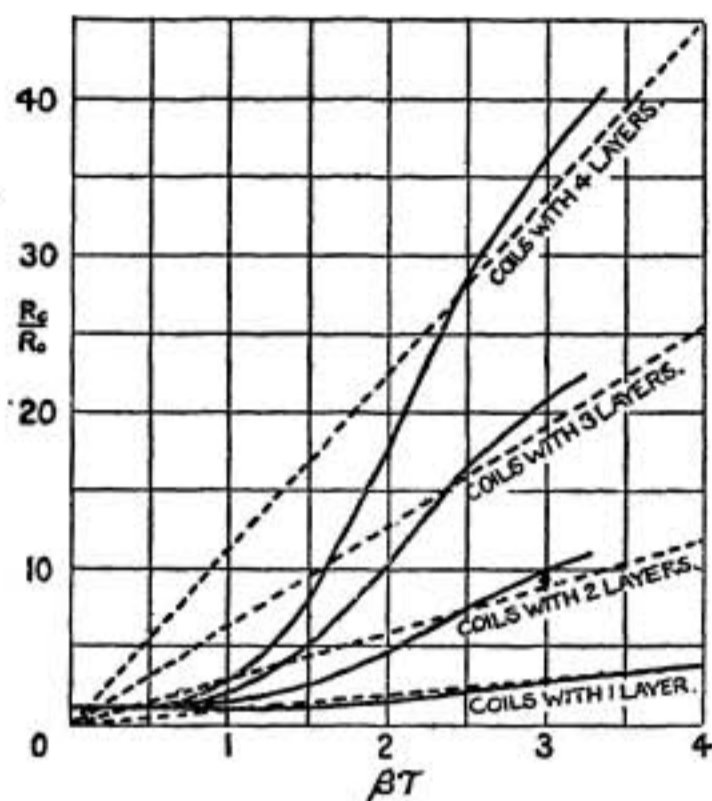

FIG. 6.

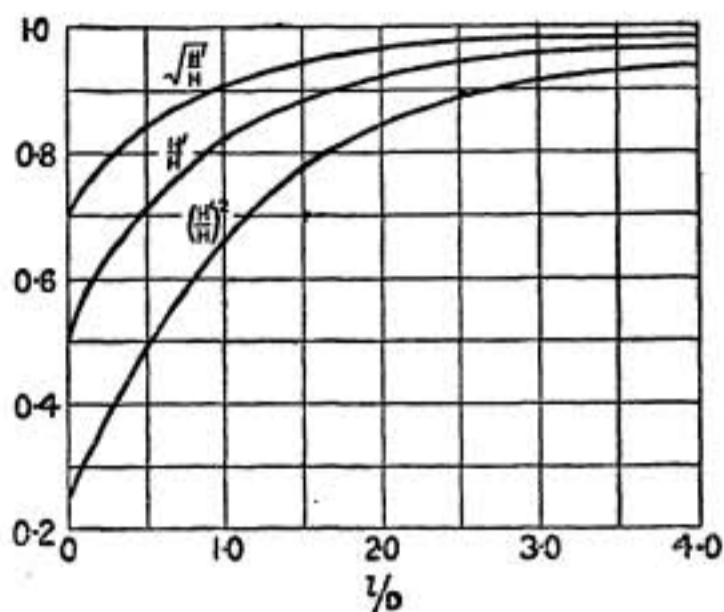

FIG. 7.

formulæ were given for the calculation of the high-frequency resistance of multiply stranded insulated wire. An application of the formula to a coil of given dimensions gave results in good agreement with the measured values.

Another interesting fact which was shown in the paper referred to was that the minimum high-frequency resistance was not obtained by putting as many individual wires as possible into the available space, but that there is an optimum space-factor beyond which the addition of more wires increases the resistance.

In many cases the fine wires are not distributed uniformly throughout the cross-section of the conductor but are confined to the outer surface, the wires being plaited around a non-conducting core. The formulæ can easily be modified and applied to such cases.

The use of stranded wires in coils of more than one layer has not yet been considered but presents no difficulties. Numbering the layers from the outside the average values of H^2 in the first three layers are in the ratio of 1 : 7 : 19, and the eddy losses are proportional to these values. Hence in a two-layer coil the total eddy loss is eight times that in a single-layer coil, whilst in a three-layer coil it is twenty-seven times that in a single-layer coil. The ratios of the eddy loss to the steady current loss are therefore as 1 : 4 : 9 and the formulæ become:—

$$\text{In a single-layer coil } R_c = R_0 \{ 1 + 35.6 \times 10^{-6} n f^2 d^4 a (S\tau)^2 \}$$

$$\text{In a two-layer coil } R_c = R_0 \{ 1 + 4 \times 35.6 \times 10^{-6} n f^2 d^4 a (S\tau)^2 \}$$

$$\text{In a three-layer coil } R_c = R_0 \{ 1 + 9 \times 35.6 \times 10^{-6} n f^2 d^4 a (S\tau)^2 \}.$$

These formulæ assume infinitely long solenoids; if the coil is short the value must be corrected as explained under "Short Coils." The formulæ will not be accurate for values of $S\tau$ less than about 0.5.

SHORT COILS.

The calculated formulæ for the high-frequency resistance of coils are all based on the assumption that the coils are very long in comparison with the diameter. In a short coil the density of the magnetic flux at the inner side of the wire is less than in a long coil with the same number of ampere-turns per centimetre. The effect of spacing between adjacent turns was shown to be equivalent to a reduction of the permeability in the expression for β for a closely-wound coil. The reduction of flux density due to the coil not having infinite length can be treated in the same way. The value of R_c/R_f for a short coil can be read off the curve for a closely-wound infinitely long coil if instead of $\beta\tau$ one takes the value

$$\beta\tau\sqrt{S\tau} \cdot \sqrt{H'/H}.$$

where H is the flux density in a long solenoid and H' that in the short coil, the values being determined at the inner side of the wire. The correcting factor $\sqrt{S\tau}$ has already been discussed.

The author has calculated the ratio H'/H for various values of l/D and the results are shown in Fig. 7.

The effect on R_c/R_f of multiplying $\beta\tau$ by $\sqrt{H'/H}$ may be small or great depending on the value of $\beta\tau$ as can be seen in Fig. 1.

In the case of multiply-stranded insulated wire the eddy-current loss in the individual wires is proportional to H^2 . In this case the term in the expression for R_c/R_o which depends on the eddy-current loss, that is, the second term, must be multiplied by $(H'/H)^2$. An example of this correction occurred when considering the experimental result obtained by Lindemann.

DISCUSSION.

Professor C. L. FORTESCUE said that although the transmission line idea might be helpful to those who were very familiar with it, it was not essential in considering high-frequency resistance. He maintained that there were many cases in which the use of insulated stranded wire was thoroughly justified; he gave a numerical example in support of this view. He also pointed out that at high frequencies the self-capacity of a coil caused the current in it to differ from that read on the ammeter in series with the coil.

Mr. P. R. COURSEY also referred to this point and drew attention to the correction factor obtained by assuming the self-capacity C_o to be connected between the terminals, in which case it is easily seen that

$$\frac{\text{apparent current}}{\text{real current}} = 1 - \omega^2 C_o L_o.$$

Mr. Coursey also gave some measured values of R_c/R_o , some of which were considerably greater than the calculated values.

Mr. H. W. TAYLOR pointed out that the losses in the inner layers of a multilayer coil could be determined by adding the losses due to their own magnetic fields to those due to the field produced by the other layers. These components can be determined by relatively simple hyperbolic formulæ. The results so obtained agree with those given in the paper. Mr. Taylor thought that the term 0.25 in the formula for the value of R_f/R_o for a straight round wire was due to an error in the approximation made.

Mr. FRANK MURPHY referred to the losses which may occur in the dielectric used to insulate the wires.

Mr. R. C. CLINKER pointed out the possibility of non-uniform heating of the coil under experiment due to the effect of the end turns.

Dr. ECCLES drew attention to the fact that the author had followed Sommerfeld and others in plotting curves which were supposed to apply when the frequency was infinitely great. Long before this was reached, however, the current in the coil would have nodes and antinodes owing to the capacity effects.

Direction and Position Finding.*

By Captain H. J. ROUND.

THE major portion of this paper is confined to a sketch of the war development of direction and position finding as far as it was known to the author. An elementary account of the general ideas involved in wireless direction finding is first given, dealing with the phase difference between the currents induced in two receiving aerials spaced a fraction of a wavelength apart, and of its resulting applications in frame or loop aerial reception. A number of polar diagrams are given for various aerial arrangements.

HISTORICAL SKETCH OF DEVELOPMENT.

Fitzgerald, before Hertz, suggested frames for radiating, and probably with his insight into things, noted possible directional properties. Hertz undoubtedly recognised directional properties in his receiving loop. About 1899, 1900, and 1901, S. G. Brown and others suggested the use of spaced aerials for the purpose of obtaining non-circular radiation. The frame aerial was probably first suggested by Lee de Forest. In 1906 Braun combined aerials to give heart-shaped polar diagrams of radiation. Marconi arranged the first direction-finding system which utilised the position given by signals when at their maximum strength.

In 1905 a number of experiments were carried out by the author using multi-turn receiving frames. Signals were received up to three miles. Artom suggested and used a directional method, but the indefiniteness of the original description prevented any clear conception of his ideas. Bellini and Tosi revived the subject, and in 1912 Major Prince modified the Bellini aerial to complete frames. The development of simplified receiving circuits using triode valves for both high and low frequency magnification suggested the revival of the radiogoniometer almost immediately after war broke out.

Early War Trials.—In the preliminary experiments (September, 1914) a number of errors were encountered, due apparently to two causes :

(1) Coupling between the two aerial systems not due to the search coil. This gave maximum errors in the plane of either aerial.

(2) Incorrect tuning and consequent mis-phasing of the two aerial systems. This gave maximum errors in the plane of 45° between the two aerials.

Another series of errors appeared afterwards due to badly constructed aerial tuning condensers and to dielectric losses in these condensers. Even with air condensers losses due to imperfect contact with the vanes also gave trouble.

Aerial Systems.—The first aerial systems were small diamond-shaped frames supported by 70-foot wooden masts. A little later on four masts were used to support square frame aerials. This seems to be the best form for all-round accuracy. Still later, on account of the cost of masts, the

* Abstract of paper read before the Institution of Electrical Engineers (Wireless Section) on January 14th, 1920.

diamond-shaped frames were reverted to, supported by one high central mast and four small corner masts.

Radiogoniometers.—During the war practically no changes were made in the dimensions of the radiogoniometer coils designed by Bellini, except in the number of turns on the windings.

Two dimensions of coils were used for different circumstances:—

- (a) "Tight coupled," fixed coil $5\frac{7}{8}$ inches high \times $5\frac{1}{4}$ inches wide, moving search coil $4\frac{1}{2}$ inches high \times 4 inches wide.
- (b) "Loose coupled," fixed coil same as (a), moving search coil $3\frac{1}{8}$ inches diameter.

Actually both types were tightly coupled at the maximum.

It was found that if the aerials were tuned to, say, 800 metres, and carefully balanced or phased, then by returning the intermediate and final circuits, but without altering the aerial tuning, signals could be received with only slight falling off in strength between 600 and 1,000 metres. This was due to the above-mentioned tight coupling of the radiogoniometer.

Apart from the above-mentioned errors, others were not at first serious.

First Valves and Circuits.—In the first year of work soft valves were used. No hard valve has been constructed which can compare with these "C" type tubes as high-frequency magnifiers. A comparison of characteristics indicates that the "C" valve is equal in magnifying power either to sixteen hard "French" tubes in parallel, or to three in cascade. With the "C" valve the average high-frequency magnification, using reaction, was about 150.

Everything seems to suggest that long ageing is necessary to produce a steady valve unless success is obtainable with a gas such as helium or neon. Curiously enough a spectrum analysis of an old tube never showed anything but hydrogen, but with hydrogen the author was never able to make a tube that was any good.

Another Source of Error.—Quite early in 1915 another error appeared which was nicknamed "Vertical." It was noticed that the two positions of zero reception were seldom opposite to one another. This was traced to a small "vertical aerial" receptive power of the loop, chiefly due to the difference in the capacity of the grid of the valve to earth, and of its battery to earth. It was corrected at first by adding a small condenser from the grid of the valve to earth. The capacity of this condenser should equal the capacity of the batteries to earth. With the use of hard valves, these "vertical" troubles increased, and they increased still more when aperiodic aerials were used.

Night Errors.—Probably it has occurred to some that the extraordinary variation of signals at night, so different from the constancy during the day, might be accompanied by variations in apparent direction. Captain Tremellen working at a D.F. station at Abbeville (France) noticed this effect first with KAV. A copy of his original curve taken of KAV's apparent movements during the sunset period is shown in Fig. 1. This curve is typical of a sunset movement. This night variation remained throughout the war a serious defect in the direction finding work. Captain Tremellen and

Lieutenant Adcock in France and particularly Lieutenant Eckersley in Egypt succeeded in obtaining valuable information about these variations. An interesting point regarding these effects was discovered later. The

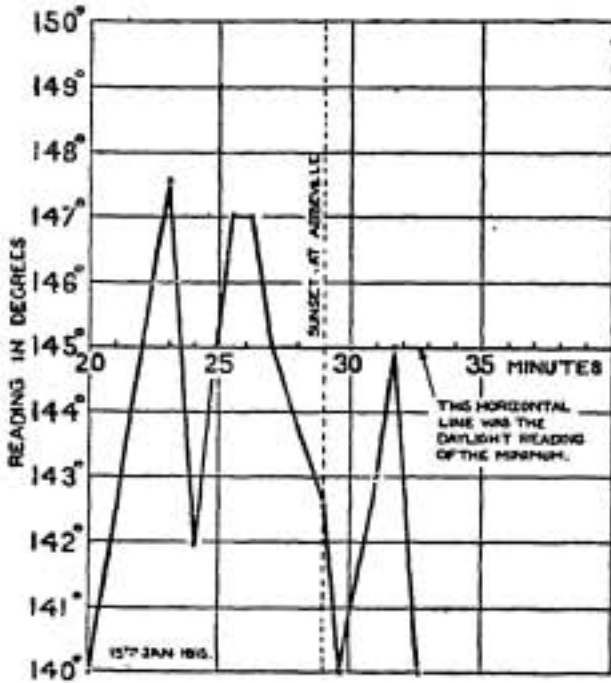

FIG. 1.

Captain Tremellen was able to note a large variation in the apparent direction of these stations at night as the frame rotated. Unfortunately these stations have now stopped work or a complete investigation of this effect would have been undertaken.

(To be concluded.)

The Transmission of Electromagnetic Waves about the Earth.*

By J. ERSKINE-MURRAY, D.Sc., F.R.S.E.

This paper gave a brief *résumé* of the known facts about the transmission of electrical waves round the earth.

An account was first given of the classical experiments made by Duddell and Taylor at Howth, after which the lecturer showed diagrams illustrating the form in which the waves are bent back by reason of the energy wastage by the currents induced in the earth. From this it follows that the effective waves arriving at a receiving station must have reached that station from some part in the upper atmosphere, as the direction of maximum energy slopes down towards the receiving aerial. This energy must therefore have left the transmitter in an upward sloping direction, and the idea is thus introduced of the reflection or refraction of the waves somewhere in the upper atmosphere, in order to account for the waves being bent down again towards the receiver. The first suggestion of such a conducting and reflecting

* Abstract of paper read before the Wireless Society of London, December 19th, 1919.

surface in the upper atmosphere was due to G. T. Fitzgerald in 1893. Heaviside also brought forward the same idea at a later date.

The variation in the received signal strength by day and by night was first noticed by Marconi in 1902 in some tests made in a voyage across the Atlantic. The classical experiments of Dr. Austin were also referred to, and it was pointed out that Dr. G. N. Watson has recently shown that a layer of ionised air having a specific resistance of 6.95×10^5 ohms and at a height of about 100 km. would just give the same results as Austin's formula.

The major portion of Dr. Erskine-Murray's paper was devoted to an account of some extensive experimental work carried out by Dr. de Groot in the Dutch East Indies.

The 5-kw. station at Sabang, which has a normal range of only 150 miles, can at night be heard at a distance of about 3,000 kms. and again at about 6,000 kms. at Osaka, in Japan. At the intermediate points this station is not heard. A very regular reflection of the waves by the ionised layer is thus indicated. In the case of stations nearer to the transmitter the waves would require to be reflected by the ionised layer at a much greater angle than for the stations further away. When the angle of incidence of the rays at the reflecting layer is large a considerable proportion of wave energy passes through, but as the angle is reduced a point is reached at which practically all the energy is reflected. This angle is such that the reflected waves reach the earth's surface again at about 3,000 kms. from the transmitter.

The most interesting part of de Groot's work deals with daylight transmission, and in particular transmission between two stations about 1,000 kms. apart (Sitoebonda and Koepang). Curves of signal strength measurements were taken over prolonged periods by de Groot and some sample curves were shown in the paper.

In these curves the sunrise and sunset effects which figure so prominently in transmission in the Northern latitudes have practically disappeared and in their place there was found a large absorption somewhere near mid-day. De Groot found that there were certain definite relations between the sun's position and these maxima of absorption, and that whenever the sun was vertical over either one or other of four great circles of the earth, the absorption was greatest.

The chief conclusions drawn from these tests seemed to indicate that the ionised layers are bent down to be as nearly as possible always perpendicular to the sun's rays, hence near mid-day there is a fairly regular reflection and refraction of the waves between the two stations.

In the morning or evening the ionised layers are apparently bent down to an angle somewhere near 45° to the earth's surface and hence the waves which normally leave the transmitter at somewhere about that angle in order to reach the receiver only graze along the surface of these layers and are reflected off into space and their energy is lost. For a wave to reach the receiver it must leave the transmitter in an almost vertical direction, in order to strike the ionised layers at suitable angles for reflection and refraction down to the receiving station. But the energy which normally leaves the transmitting aerial in a nearly vertical direction is very small as compared

with that leaving horizontally, so that at this time in the day very little energy will reach the receiving station. Later on as the layers become more level the conditions become more regular, but still later when they are inclined again on the evening side of mid-day conditions are similar to those in the morning and a minimum of received energy is again found.

Some rather complex diagrams were given by Dr. Erskine-Murray illustrating the various planes and reflecting layers concerned in this transmission, but the general result of all the experiments cited seemed to support the views expressed above.

In the discussion, the question was raised as to whether freak communications in and around Europe took place more frequently in the North-South or East-West direction, but it was pointed out that although such communications apparently occurred most frequently in a North-South direction this is in all probability due to the larger number of stations lying in that general direction which are heard on such occasions.

It was also stated that the receiver used by de Groot was a carefully calibrated crystal detector and that the signal strength measurements were made by the shunted telephone method. It was suggested that some of the variations in the apparent direction of a station as determined by direction-finding apparatus may be due to these variations which take place in the planes of the ionised layers.

A Comparative Method of Testing Thermionic Valves for Passing no Reverse Current at High Voltages.*

By N. W. MACLACHLAN, D.Sc., M.I.E.E.

In using two three-electrode thermionic valves for determination of the maximum or peak voltage of an alternating current supply, and in the determination of the decrement of a circuit in which the damping is very high, it is essential that the valve should pass no reverse current. The author in this paper describes some experimental tests carried out with a view to ascertaining the magnitude of the reverse current passed by such valve rectifiers.

The simplest method of carrying out such tests is to use a high tension direct current source. This may be obtained by rectification and storage in condensers as recently described by Professor Fortescue.†

As an alternative method two rectifying valves may be connected in series in opposition to one another and fed from a high tension A.C. supply. As a convenient method of indicating the reverse current passed by the valves a condenser may be joined in the circuit with them and a low reading voltmeter connected across its terminals. Both the valves and their filament batteries must be very well insulated. If neither valve passes any reverse current there will obviously be no reading on the voltmeter connected across the condenser, but if either of the valves passes some current a reading will

* Abstract of paper read before the Physical Society of London, December 12th, 1919.

† *Proceedings of the Physical Society of London*, 31, pp. 319-337, August, 1919 (RADIO REVIEW, Abstract No. 12).

be obtained. Tests are mentioned in the paper of two valves connected in this way supplied from 18,000 volts, when no reverse current was indicated by an E.S. voltmeter which could indicate down to five volts.

The second section of the paper deals with the measurement of the decrement of highly damped oscillations with the aid of a rectifying valve. The method described is indicated in Fig. 1.

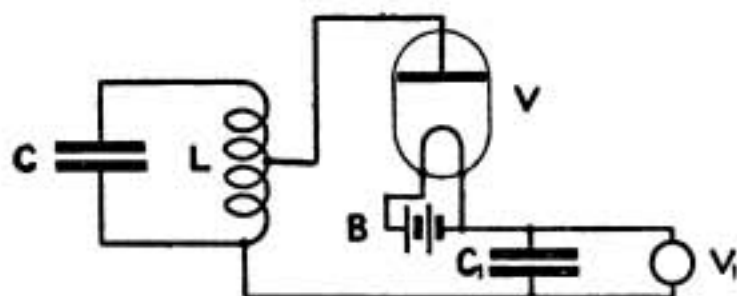

FIG. 1.

circuit CL, and by reversing the valve the peak voltage of the next semi-oscillation is obtained.

The third section of the paper deals with the measurement of decrement in a magneto using a similar method to the above.

The Physical Society of London Exhibition.

The tenth annual exhibition of the Physical and Optical Societies was held at the Imperial College of Science, South Kensington, on January 7th and 8th.

Amongst the usual exhibits of physical apparatus there were several of wireless interest, amongst which may be mentioned:—*The Edison Swan Electric Co., Ltd.*, who exhibited: A series of service valves for wireless reception and transmission; a series of Marconi valves made by the Edison Swan Co.; a series of original types of receiving valves for amateur and commercial use; and various special types of rectifying and transmitting valves designed by Mr. Scott-Taggart.

Marconi's Wireless Telegraph Co., Ltd., showed some instruments suitable for measuring high-frequency currents; their new Marine pattern of Radio direction-finding apparatus; and their seven-valve amplifier, connected to a frame aerial receiver.

The Marconi-Osram Valve Co. exhibited a large number of different types of receiving, transmitting and rectifying valves manufactured by them, including some recent designs for commercial use.

The Dubilier Condenser Co., Ltd., showed various patterns of high-tension and receiving condensers manufactured for wireless use.

Messrs. H. W. Sullivan demonstrated a special oscillating valve set for generating alternating currents of any desired frequency for use in electrical measurements, also the production of beats between two such oscillators; and a number of different patterns of variable condensers for wireless receiving and other uses.

Amongst the exhibits of captured German apparatus were types of Telefunken transmitters and receivers, and also a valve amplifier.

Review of Radio Literature.

1. Abstracts of Articles.

180. THE WAVELENGTHS RADIATED FROM OSCILLATING VALVE CIRCUITS. S. R. Humby and B. F. J. Schonland. (*Electrician*, 83, pp. 443—444, October, 1919.)

When two oscillation circuits are coupled together and oscillations are set up in them there are usually two oscillation frequencies established. This paper investigates this case when the oscillations are maintained by a valve, the two coupled circuits being included in the grid and plate circuits respectively of the valve.

It is shown that when the coupling is in the normal direction for the maintenance of oscillations, there is only one wavelength radiated (with its harmonics) of length equal to the longer of the two "coupling" waves. With the reaction coupling reversed the wavelength radiated (when the valve oscillates) is the shorter one only of the two coupling waves. It is stated that the authors have been led to the conclusion that the phase difference between the oscillatory currents in the grid and plate circuits can be either 0° or 180° , but cannot have values differing sensibly from these.

A mechanical analogy of the valve operation is given, and also some further measurements on the wavelengths radiated when the aerial circuit is directly coupled to the plate circuit, by tappings from the plate-circuit inductance—referred to as the "anode tap" connection.

181. APPLICATIONS OF THE CATHODE RAY TUBE IN RADIO WORK. L. E. Whitmore and L. M. Hull. (*Physical Review*, 14, pp. 266—267, September, 1919. Abstract of paper read before American Physical Society.)

Two general types of cathode ray tube have been used for investigating the oscillations in radio frequency circuits at the Bureau of Standards, Washington, those having the usual plain cathode and those having a hot filament cathode. The former require exciting voltages of from 8,000 to 20,000 volts and are suitable for the investigation of oscillating current of the order of magnitude of one ampere. The high-tension voltage is obtained by double-valve rectifiers from an A.C. supply, using condensers and choke coils to smooth out the rectified wave. With the second type using a Wehnelt cathode, from 500 to 1,000 volts is required and the tube is suitable for the investigation of oscillating currents of the order of 0.05 amp. On account of the relatively low exciting voltage this type of tube is much more sensitive to electrostatic and electromagnetic deflections. These oscillographs are being used in an investigation of the harmonics in aerial circuits excited by vacuum tube generators.

182. A SIMPLE DERIVATION OF THE FORMULÆ FOR THE RESONANCE CURVES OF A DAMPED VIBRATION AND SOME PROPERTIES THEREOF. Balth. van der Pol. (*Electrician*, 83, pp. 225—228, 251—252, September, 1919.)

The Bjercknes resonance curve formula is only strictly applicable under certain conditions of coupling and damping, and only over a limited range of frequency difference. The mathematical development of the formula is greatly simplified by introducing these limitations at an early stage, since approximations can then be made, which would not be permissible in a general treatment of the problem. By adopting this procedure the author gives a relatively simple derivation of the Bjercknes formula. He also derives the formula for the dynamometer method due to Mandelstam and Papalexii, in which the reading passes through zero at the resonant point. Attention is drawn to a number of interesting relationships between the two types of resonance curves and their similarity to resonance curves met with in other branches of science, *e.g.* in the motional resistance and reactance of a telephone diaphragm and in the variation of absorption with the frequency when light passes through an absorbing medium.

183. THE MEASUREMENT OF ALTERNATING WAVES WITH THE BRAUN TUBE. E. Lubke. (*Archiv. für Elektrotechnik*, 5, pp. 314—334; 6, pp. 161—164. *Jahrbuch der Drahtlosen Telegraphie*, 13, p. 102. *Electrician*, 83, pp. 270—273, September, 1919.)

The author deals with the application of the Braun Cathode ray oscillograph to the delineation of A.C. wave forms, not by the usual method in which the curves are traced out on the fluorescent screen, but by the use of the Joubert contact method. For this purpose the stream of cathode rays is employed to form the contact maker. The arrangement is thus available for much higher frequencies than when the customary mechanical contact is employed.

The beam of cathode rays is caused to rotate and trace out a cone-shaped figure under the influence of the magnetic field due to the oscillations whose wave form is to be investigated. At one point in its rotation the beam passes through a narrow slit and then between two small condenser plates—thus ionising the space between them. These condenser plates take the place of the usual contact maker, and the ionisation of the space between them completes the circuit of an electrostatic voltmeter at any desired point in the cycle of the oscillations. By moving the deflecting magnet round the axis of the Braun tube this point in the cycle may be varied at will.

Examples of curves taken with this method are given in the paper.

For very high frequencies the condenser plates "contact" are replaced by a second smaller tube containing a fluorescent screen, and constricted near the slit to enable the beam entering this second tube from the slit in the first

tube to be deflected electrostatically by the potential to be measured at that instant in the cycle. The measurements are thus made from point to point through the cycle as before but by the deflection of the spot on the screen in the second tube instead of on the E.S. voltmeter.

With this apparatus the wave form of oscillations of frequencies up to $3 \times 10^6 \sim (\lambda = 100 \text{ metres})$ can be delineated using cathode rays excited by a 220-volt source. With higher voltages, and higher speed rays, still higher frequencies are possible.

184. AN IMPROVED METHOD FOR DETERMINING THE ELECTRICAL CHARACTERISTICS OF HIGH-FREQUENCY OSCILLATION CIRCUITS. N. P. Hinton. (*British Patent 132022*, September, 1918. Patent accepted, September 2nd, 1919.)

The arrangement described is indicated in Fig. 1. The buzzer B is used to excite oscillations in the circuit $C_1 L_1$ and is coupled to the tuned circuit $C_2 L_2$ and thence to the two circuits $L_3 A E$ and $L_4 C_3 L_5 R$ in parallel. The coils $L_3 L_4$ are coupled to $L_6 L_7$ which are joined in series with the detector D and the telephones T. To carry out a test the condenser C_1 is set to the required wavelength, the measuring circuit $C_3 L_5 R$ is disconnected and the aerial circuit A E is tuned by adjusting the condenser C_2 and the inductance L_2 . The standard circuit $C_3 L_5 R$ is then reconnected, and the condenser C_3 , the inductance L_5 , and the resistance R are adjusted until no sound is heard in the

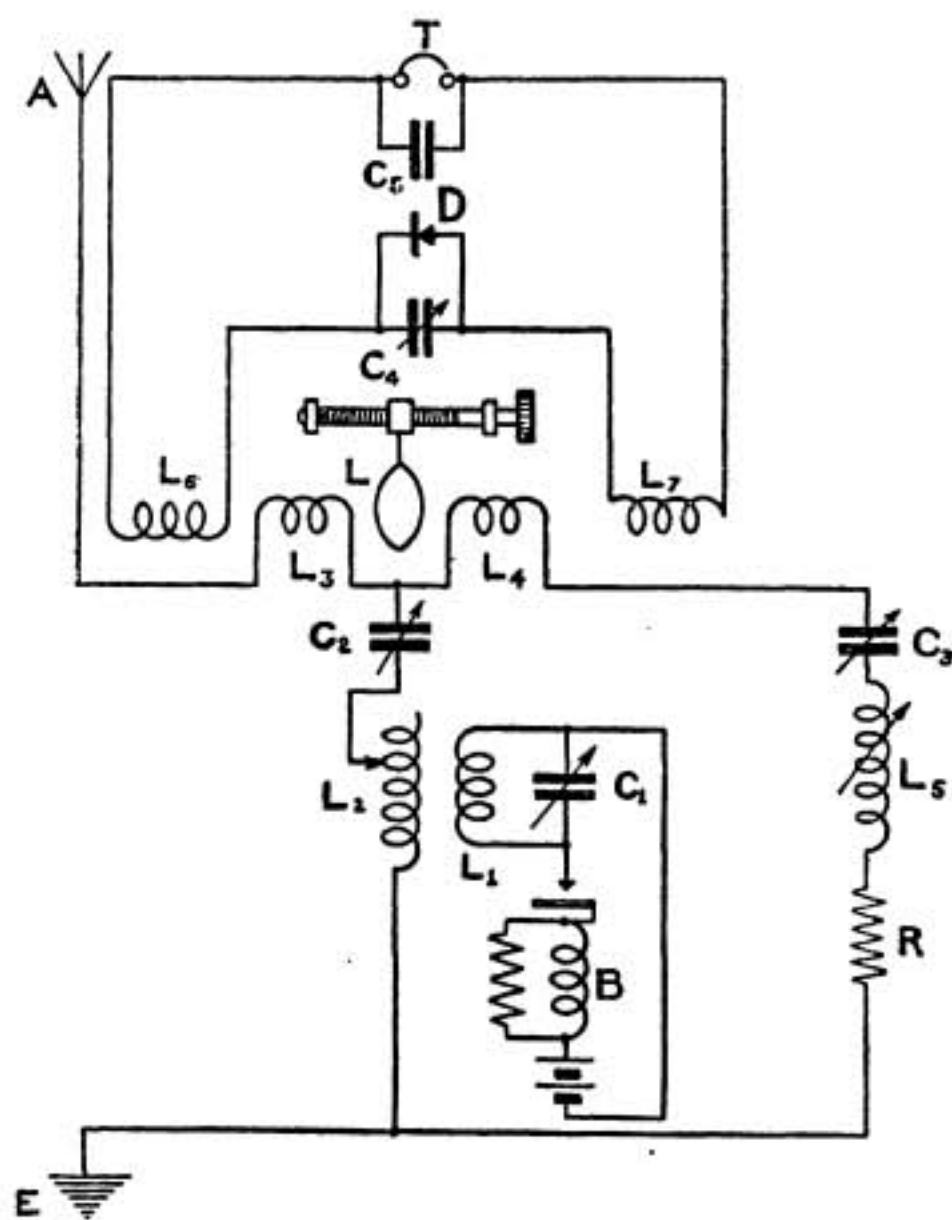

FIG. 1.

telephones T. A switch is provided for interchanging the primary coils $L_3 L_4$ to eliminate any errors arising from inequalities in their windings. The mean of the two values obtained for the capacity C_3 , the inductance L_5 , and the resistance R gives the values of the corresponding characteristics of the aerial circuits which were to be measured.

185. QUANTITATIVE EXPERIMENTS WITH COIL ANTENNAS IN RADIOTELEGRAPHY. L. W. Austin. (*Revue Générale de l'Électricité*, 6, pp. 551—552, October, 1919.)

See RADIO REVIEW, Abstract No. 3 for the original paper.

186. THE USE OF AMPLIFIERS FOR MEASURING SMALL DIFFERENCES OF POTENTIAL. A. Blondel. (*Revue Générale de l'Électricité*, 6, pp. 163—177, August, 1919.)

This paper deals with the use of amplifying valves for the measurement of small differences of static potential. Various arrangements are described and formulæ given for the calculation of their sensitiveness. The various methods dealt with are classified into:—

- (1) Thermionic Balance Method.
- (2) Static Bridge Method.
- (3) Deflectional Bridge Method.
- (4) Potentiometric Methods.

(1) The leading idea of the first group is the use of a differential galvanometer, one winding of which forms part of the plate circuit of the valve, while the circuit through the other includes only a resistance to balance the internal resistance of the valve, and so reduce the galvanometer deflection to zero. A small E.M.F. applied to the grid of the valve causes a deflection of the galvanometer. In a modification a valve may be included in each winding of the galvo to give increased sensitiveness.

(2) In the second type of arrangement the valve forms one arm of a Wheatstone bridge. Readings are obtained by rebalancing the bridge when the E.M.F. to be measured is applied to the grid of the valve. Alternatively two valves may be used in adjacent bridge arms, with their grids so connected that on the application of the E.M.F. to be measured the effective resistance of one valve is increased, while the other is reduced.

(3) The third method is essentially the same as the second except that the bridge is not rebalanced for each reading, but measurements are made by

noting the deflection of the bridge galvanometer when the bridge is put out of balance by the application of the E.M.F. to be measured.

An initial amplification stage may be added to any of these methods, and results in increased sensitiveness.

(4) The fourth class of arrangement considered in the paper is an application of the

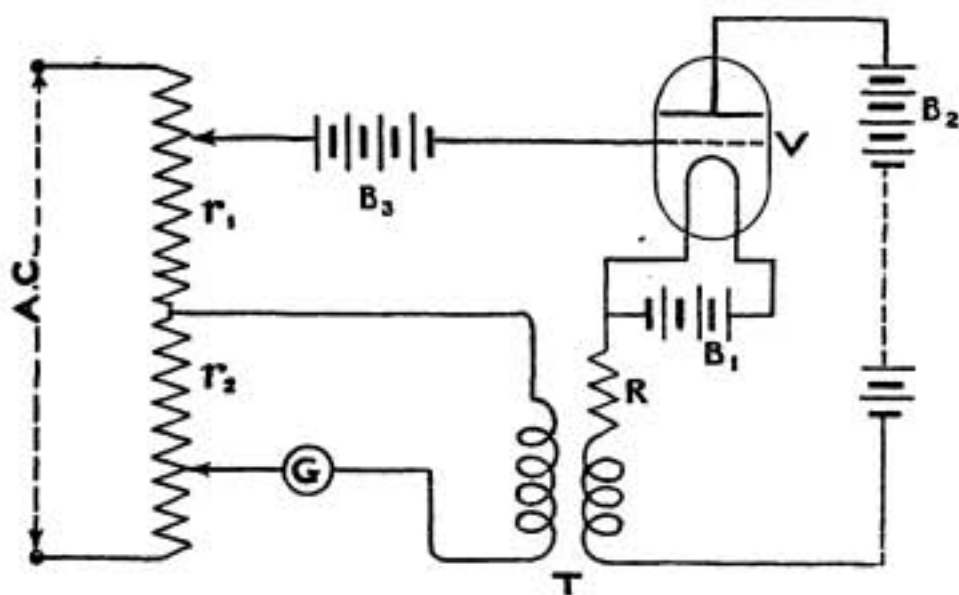

FIG. 2.

known methods of measurement of the amplification ratio of a valve, by using a potentiometer to apply a voltage to the grid circuit and to balance out the resultant amplified voltage in the plate circuit. Two modifications of this are described to enable the amplification ratio to be measured with the valve under working conditions, viz., with the plate circuit closed and the normal current flowing. One of these with a transformer winding in the plate circuit is indicated in Fig. 2.

An appendix to the paper describes the measurement of the internal resistance of a valve by including the valve in one arm of a bridge, with the bridge battery to supply the plate circuit, and with a superposed A.C. source in the battery arm of the bridge.

187. ROTARY SPARK GAPS. Compagnie Générale de Radio-Télégraphie. (*French Patent* 494557, filed January 8th, 1919. Published September 12th, 1919.)

This patent relates to a rotary spark gap in which the spark is displaced on the electrodes and in the gap quicker than the peripheral speed of the moving parts, by causing it to follow the continuous movement of the teeth on the rotating member very obliquely in relation to the teeth on the fixed member. The object of the quick displacement of the spark is to reduce wear of the electrodes and to obtain an energetic and automatic quenching of the spark. It is stated to be applicable in the case of shock excitation.

188. SPARK GAPS. Alphonse Kowalski. (*French Patent* 495034, filed July 16th, 1917. Published September 26th, 1919.)

In a spark gap with two electrodes arranged one above the other, for high frequency sparks, the lower electrode is formed by a metal tube connected to a supply of gas under pressure, and is surrounded, with a space between, by an insulating tube which projects upwards to the lower extremity of the upper electrode. This tube is also connected with a supply of gas under pressure, but lower than the pressure of the gas connected to the electrode, so that the spark produced between the electrodes is guided towards the walls of the tube, without, however, touching them, and then towards the space between the insulating tube and lower part of the upper electrode.

189. IMPROVEMENTS RELATING TO RADIOTELEGRAPHIC TRANSMITTING SYSTEMS. A. Taylor. (*British Patent* 131561, April, 1919. Patent accepted, August 28th, 1919.)

In radiotelegraphic transmission systems in which signalling is effected by altering the inductance of the aerial circuits, arrangements are made so that this inductance is split up into a number of separate sections which are short-circuited independently. These short-circuiting contacts are all operated by a single solenoid switch actuated by the signalling key.*

190. ELIMINATING PARASITIC SIGNALS. L. Lévy. (*British Patent* 133306, October, 1918. Abridgment published, December 3rd, 1919.)

The receiver described is suitable for C.W. heterodyne reception and is

* See also RADIO REVIEW, Abstract No. 114.

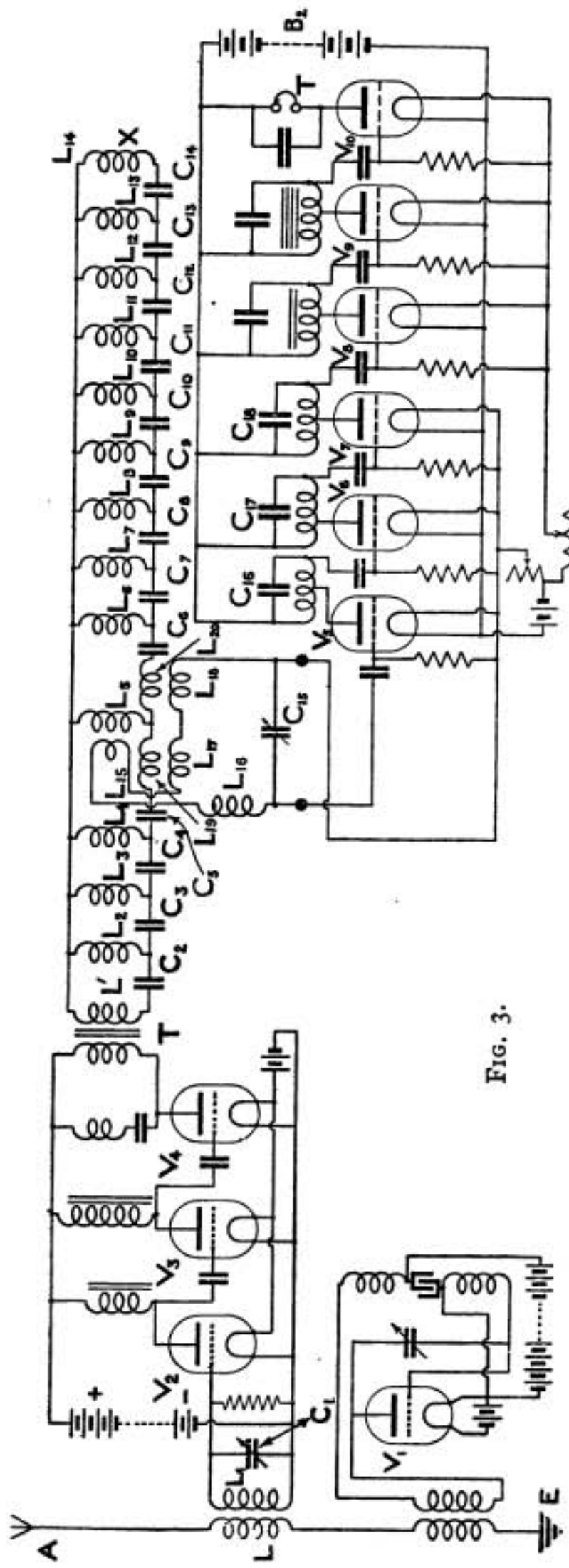

FIG. 3.

specially arranged for eliminating parasitic disturbances. The incoming oscillations from the aerial circuit ALE (Fig. 3), are heterodyned by the local oscillations set up by the oscillating valve V_1 , which is arranged so that the beat frequency is supersonic—say about 10,000 \sim . The resulting currents are amplified by valves V_2, V_3, V_4 (which form a cascade amplifier as indicated), and are then impressed through T upon the filter circuit TX, made up of condensers and inductances $C_2L_2, C_3L_3, C_4L_4 \dots C_{14}L_{14}$. The natural wavelength of this circuit is adjusted to resonate with the chosen supersonic beat frequency. Stationary waves are set up in this circuit by reflections at the terminal inductances L', L_{14} which have twice the inductance of the others. The circuit $L_{15}L_{16}L_{17}L_{18}C_{15}$ is tuned to the beat frequency, and is coupled to one of the filter coils—say L_5 —and to two additional coupling coils (L_{19}, L_{20}) joined in series between adjacent filter circuit condensers. By connecting the “potential” coupling $L_{15}L_5$ in opposition to the “current” coupling coils L_{17}, L_{18} it is claimed that the effect of an atmospheric on circuit $L_{15}L_{16}C_{15}$ can be eliminated, since an atmospheric will set up only one or two oscillations which will travel through the filter as a progressive wave, instead of setting up a stationary wave. The purified supersonic current is further amplified by the valves V_5-V_{10} . The circuits of V_5, V_6 and V_7 are tuned to a

frequency near to the supersonic beat frequency,—the capacities of C_{16} , C_{17} , C_{18} being greater than the resonance value and increasing in this order. An audible beat frequency is thus obtained, which is amplified by V_8 , V_9 , V_{10} for detection by the telephones T . In a modification the filter may be distributed along the aerial circuit.

191. SYSTEM OF ELECTRICAL TRANSMISSION SPECIALLY APPLICABLE TO WIRELESS TELEGRAPHY AND TELEPHONY. L. Lévy. (*French Patent 493660*, August, 1917. Published August 19th, 1919.)

The object of this invention is to provide a multiple secondary tuning with the object of completely eliminating disturbances arising from undesired

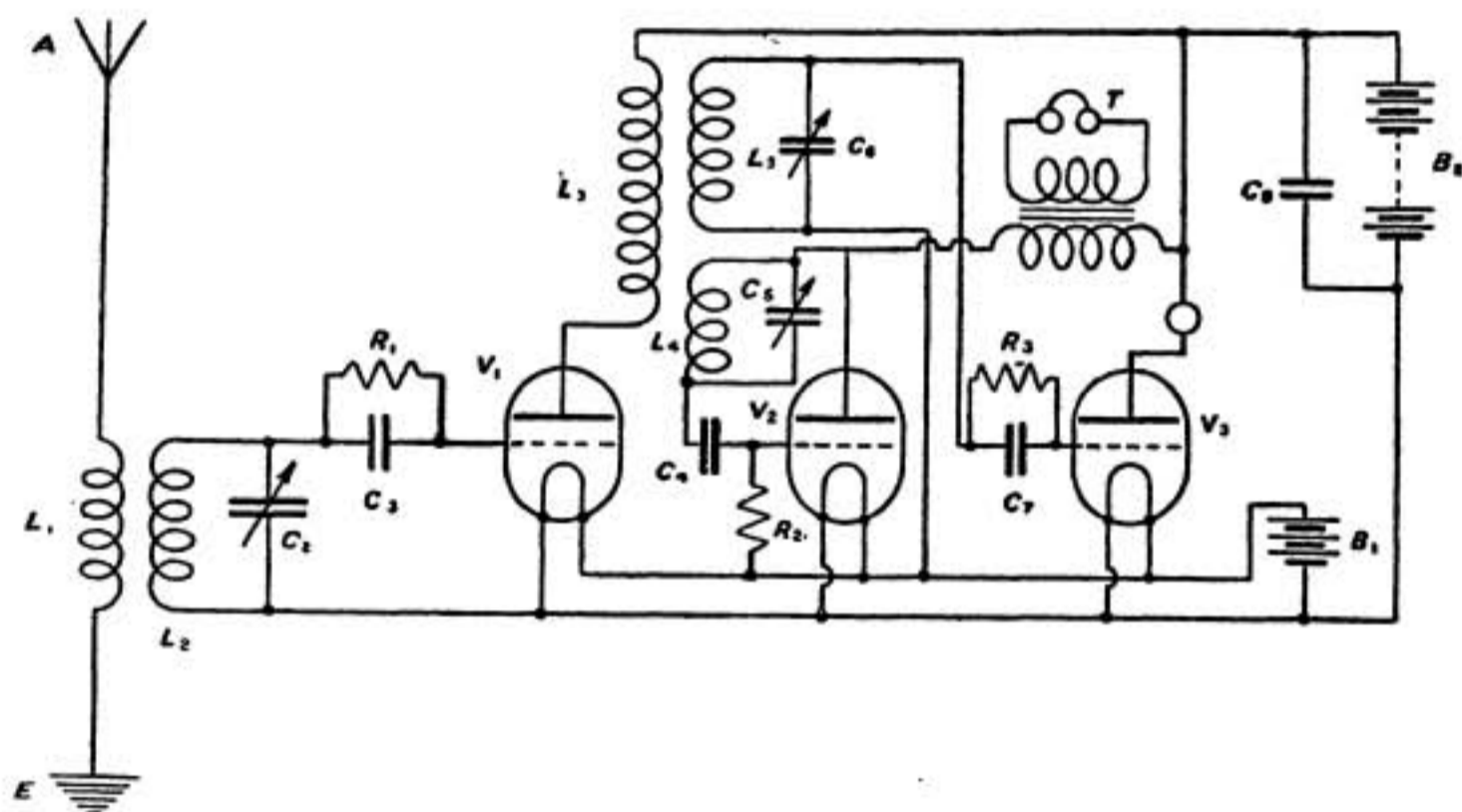

FIG. 4.

signals and from atmospherics. A number of successive secondary selections can be effected in this manner but generally two are sufficient. One typical circuit diagram is given in Fig. 4.

192. CRYSTAL DETECTOR. Perret-Maisonneuve. (*French Patent 494882*, filed January 4th, 1918. Published September 20th, 1919.)

This patent relates to a crystal detector in which the exploring point is moved in conjugate circles; the point carrier is mounted in an elastic sheath and compensation for wear is provided. The arrangement is such that the apparatus may be dismantled by unscrewing a single screw.

193. SELF INDUCTANCE. Lucien Rouzet. (*French Patent 495037*, filed June 15th, 1919. Published September 26th, 1919.)

This patent relates to a regulatable self-inductance for high-frequency circuits.

194. WIRELESS IN THE A.E.F. L. R. Krumm and W. H. Taylor. (*Wireless Age*, 6, pp. 11—18, September, 1919; pp. 9—21, October, 1919.)

A general account of the radio activities of the American Expeditionary Force.

In the second article the general layout of the radio communications in France is given with considerable detail of the circuit diagrams of the amplifiers and other apparatus used. The transmitting connections for the radiotelephone are indicated in Fig. 5. The receiving amplifiers described are all of the iron-core transformer coupled type for low frequency magnification.

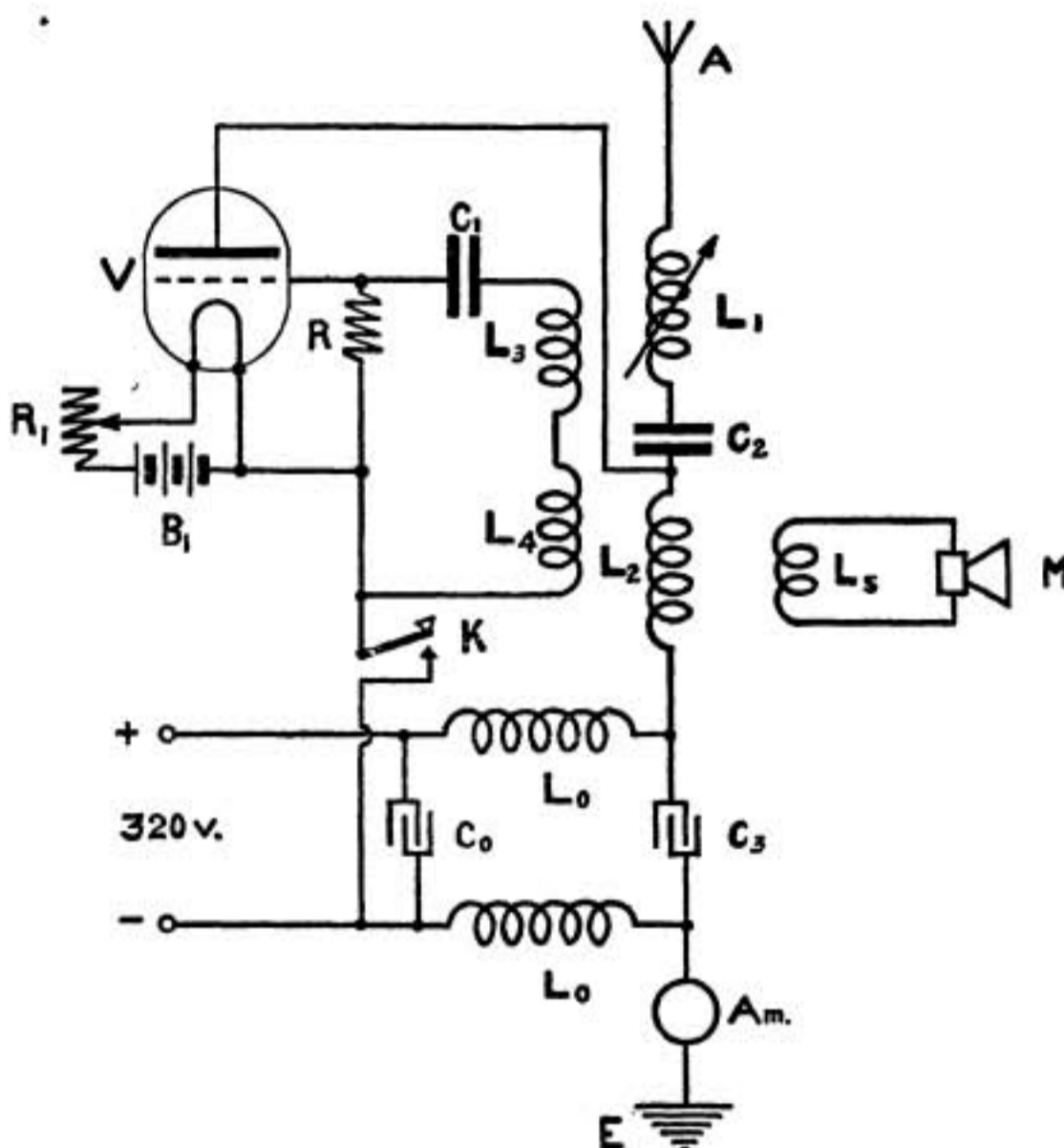

FIG. 5.

195. IMPROVEMENTS RELATING TO TELEGRAPHIC AND OTHER INSTRUMENTS AND INSTALLATIONS. J. Hettinger and C. A. Vandervell. (*British Patent* 130368, January, 1918. Patent accepted, August 7th, 1919.)

Relates to an optical indicator for multiplex telegraphy or radiotelegraphy. Other electrical applications are also mentioned.

196. IMPROVEMENTS RELATING TO ELECTRIC RELAYS. L. B. Turner. (*British Patent* 130408, February, 1918. Patent accepted, August 7th, 1919.)

The application of a three-electrode valve to serve as a relay. Use is made

of the change in anode current when the tube starts oscillating. The grid potential is adjusted to a point just below the value necessary to cause the oscillations to start. A small external P.D. applied to the grid causes the oscillations to commence and an ordinary relay in the plate circuit to be operated. The signalling impulse may be amplified by three-electrode valves in the usual manner, before it is applied to the grid of the relay valve.

197. IMPROVEMENTS RELATING TO RECORDING APPARATUS FOR ELECTRIC CURRENT IMPULSES. The General Electric Co., U.S.A. (*British Patent* 130762, August, 1918. Patent accepted, August 7th, 1919.)

A photographic recorder for wireless signalling systems comprises a tuned reed mounted between two permanent magnets and operated upon by signalling currents which pass through windings surrounding the reed. The reed operates a mirror mounted upon a shaft, and the light from two lamps is reflected by the mirror to pass through two slits. One of these serves for adjustment only, while the sensitive paper is moved past the second. The complete apparatus comprises developing and fixing tanks in addition to the electrical mechanism.

193. IMPROVEMENTS RELATING TO WIRELESS SIGNALLING SYSTEMS. The General Electric Company (U.S.A.). (*British Patent* 130064, January, 1918. Patent accepted July 31st, 1919.)

A transmitting aerial system comprises a primary aerial supplied by a high frequency source and a number of secondary aerials supplied with high frequency current by a transmission line from the primary aerial. In an alternative construction a long horizontal aerial system is used connected to earth through tuning inductances at a number of points along its length. The object of the arrangement is to set up in the aerial stationary waves of adjustable length. By altering the ratio of the wave length of the stationary wave to the wave length of the wave that is radiated, the whole arrangement may be made non-directive, or directive in any particular direction as desired. Inductance may be inserted in the leads between the tops of the aerials so as to displace the phase of the oscillations in the successive aerials and so aid the desired directive effect.

199. AERIAL ARRANGEMENTS FOR LONG WAVELENGTHS. Société Française Radioélectrique. (*French Patent* 493609, October, 1916. Published August 14th, 1919.)

In order to increase the inductance of the aerial it is proposed to insert inductance coils at intervals along the lengths of the wires.

200. IMPROVEMENTS IN WIRELESS TELEGRAPH TRANSMITTERS. C. S. Franklin and Marconi's Wireless Telegraph Company. (*British Patent* 128983, September, 1917. Patent accepted July 10th, 1919.)

Wireless telegraph transmitters of the coupled circuit type, particularly

those designed to emit very short waves, have the condenser, spark gap, and inductance of the primary circuit arranged symmetrically about a common axis. The antenna consists of one or more metallic rods arranged parallel to the axis of the transmitter, the closeness of the coupling depending upon the position of the rods. Alternatively a metallic cylinder enclosing the whole apparatus may serve as the antenna.

201. PHOTOPHONES. F. Tavani. (*British Patent* 128831, November, 1918. Patent accepted July 3rd, 1919.)

In photophones and similar apparatus in which selenium cells are employed, the effects of lag in the selenium are diminished by a mechanical arrangement for periodically substituting a fresh cell for the cell normally in use. The cells out of use can recover their sensitiveness in the dark, and it is claimed that as a result much more rapid response to the fluctuations of the incident beam may be obtained by this arrangement.

202. IMPROVEMENTS RELATING TO WIRELESS SIGNALLING SYSTEMS. The General Electric Company (U.S.A.). (*British Patent* 130090, January, 1918. Patent accepted July 31st, 1919.)

An arrangement for duplex wireless signalling using a separate transmitting and receiving aerial at each station. The effect of the emitted waves on the adjacent receiving aerial is neutralised by connecting the transmitting aerial to the receiving circuits by an arrangement of condensers or by electromagnetic coupling, or both. One arrangement is shown in Fig. 2, of RADIO REVIEW Abstract No. 75.

203. NAVAL RADIO REMOTE CONTROL. P. H. Boucheron. (*Scientific American*, 121, p. 234, September, 1919.)

On account of the large increase in traffic being received at the New York wireless stations, arrangements have been made for a central control station to supervise the whole of the radio communications of the port. The following stations are affected: Montauk, Long Island (NAH1); Fire Island, Long Island (NAH2); Rockaway, Long Island (NAH3); Brooklyn Navy Yard (NAH4); Bush Terminal, New York City (NAH5); Sea Gate (NAH6); and Mantoloking, N.J. (NAH7). Each station is told by the control which calling vessel it is to communicate with, or any station may be directly operated by remote control apparatus from the control station.

204. INTER-IMPERIAL COMMUNICATION THROUGH CABLE, WIRELESS AND AIR. C. Bright. (*Electrician*, 83, pp. 441—442; 464—466, October, 1919.)

205. TELEPHONE RECEIVERS. André Bloch. (*French Patent* 494654, filed April 20th, 1917. Published September 16th, 1919.)

This patent relates to telephone receiver head-dress.

206. INTERRUPTER. E. Abegg. (*French Patent* 494908, filed January 20th, 1919. Published September 24th, 1919.)

This patent relates to an interrupter in which the elements are formed of flexible material having about the same elasticity as rubber, and are adjustable by means of a button so that they transmit movement to the movable contacts. The elastic material may be reinforced by metal springs. The moving contacts are carried on revolving arms mounted on the spindle of the interrupter, and connected to one extremity of a cylinder of elastic material which surrounds the spindle, and which is connected at its other extremity to means to cause it to turn in steps after a tension has been produced in the said cylinder by the rotation.

207. THE CONTROL OF A TORPEDO BY HERTZIAN WAVES FROM AN AEROPLANE. R. Martin. (*French Patent* 493731, December, 1916. Published August 20th, 1919.)

The wireless receiving arrangement attached to the torpedo controls through the medium of relays the movements of the steering and other motors and the ignition of the firing fuses.

208. MOVEABLE APPARATUS CONTROLLED BY ELECTRIC WAVES AND SUITABLE FOR USE IN WARFARE. G. de Trarrazaval. (*French Patent* 493137, November, 1917. Published July 31st, 1919.)

Engines for use in warfare provided with explosives, etc., and under the control of electric waves from a distant point.

209. A METHOD OF MEASURING WITHOUT ELECTRODES THE CONDUCTIVITY AT VARIOUS POINTS ALONG A GLOW DISCHARGE AND IN FLAMES. Balth. van der Pol. (*Philosophical Magazine*, 38, p. 352, September, 1919.)

The method of measurement used in the course of these researches depends on the production of stationary waves along a Lecher system of parallel wires.

210. ELECTRIC SIGNALLING APPARATUS. Oliver Arc Lamp Company, Ltd. (*French Patent* 494608, filed April 20th, 1917. Published September 13th, 1919.)

This patent corresponds to the British Patent No. 104077, and relates to apparatus employed in electric signalling.

211. THE METEOROLOGICAL TELEGRAMS OF THE EIFFEL TOWER. (*La Nature*, 47, Supplement p. 165, November, 1919.)

Full particulars of the messages and of the codes used, as revised March, 1919.

2. Review of Books.

TEXT BOOK ON WIRELESS TELEGRAPHY. Vol. I. GENERAL THEORY AND PRACTICE. By Rupert Stanley, B.A., M.I.E.E. (London: Longmans, Green & Co. Pp. xiii. + 471. Price 15s. net.)

The first edition of this book was published in September, 1914; it was in a single volume. The subsequent development of the thermionic valve has led the author to issue this second edition in two volumes, the first covering much the same ground as the earlier edition and the second devoted entirely to the thermionic valve and its manifold applications.

The book is of the non-mathematical type and the author assumes that the reader has a very limited knowledge of mathematics and no knowledge of electrical science. The earlier chapters are devoted to an elementary explanation of the nature of matter, electric and magnetic fields, potential difference, etc. We are sorry to see that both here and throughout the book the author ignores the recommendations of the International Electrotechnical Commission with regard to symbols; this is a serious defect in a book intended for students and is sufficient to deter many teachers from recommending it. The specific resistance of copper is given as 0.0000066; is the reader not expected to know the meaning of 10^{-6} or is it given in this form to exercise him in counting noughts? On pages 77 and 78 Spielrein is misspelt Spielman. The usual formula is given for the inductance of a straight wire l cms. long and d cms. diameter, with the usual absence of any explanation or warning. Successive chapters are devoted to capacity effects and condensers, induction effects, induction coils, alternators and transformers, oscillatory discharges. In Chapter X. the author gives an account of the historical development of radio-telegraphy. The quenched spark is attributed to Wien without any reference to Lepel, although full justice is done to the Lepel system in a subsequent chapter. There is little doubt that, although Wien first clearly understood and explained the quenching action, the type of gap was due to Lepel. One is surprised to read that "in 1913 the Lieben and Reisz valve relay with three electrodes was produced and *about the same time* Dr. de Forest patented a similar thing in the Audion valve." Dr. de Forest's three-electrode valve patent was applied for in 1907 and published in 1908. A chapter is devoted to the effect of tight coupling in spark transmitters, the meaning of decrement, etc. Chapter XII. deals with the propagation of electromagnetic waves. Fig. 81 would be improved by indicating the directions of the magnetic lines by crosses and dots. When describing the radiation from the aerial the author states that "as the strain effects move outwards through the ether, they will also *probably* penetrate upwards in it." There is an unnecessary air of uncertainty about this.

The effects of the resistance of the earth and the conductivity of the upper atmosphere are considered in a simple but clear manner. Various spark transmitting sets are described and the subject of resonance in the charging circuit is considered. A number of practical hints are given dealing with

faults in transmitting sets. Fig. 94 showing a quenched spark-gap is unfortunately upside down.

Various types of aerials, insulators, etc., are described and Howe's method is given for calculating the capacity of aerials.

Very full descriptions are given of various types of detectors and receiving circuit arrangements. A chapter is devoted to the various methods of producing continuous waves. In describing the discovery of the musical-arc, the actual date would be far preferable to the erroneous statement obviously carried over from the first edition that it took place fourteen years ago. Arc generators are now made for much greater power than 100 kilowatts.

After dealing with miscellaneous apparatus such as direction finders, buzzers, etc., a chapter is devoted to high-frequency measurements. The final chapter is a new one on accumulators.

At the close of each chapter is a useful collection of exercises by which the student can test his knowledge of the subject.

This volume can be recommended to any one wishing to obtain a good working knowledge of the subject without going into any mathematical theory.

G. W. O. H.

TEXT BOOK ON WIRELESS TELEGRAPHY. Vol. II. VALVES AND VALVE APPARATUS. By Rupert Stanley, B.A., M.I.E.E. (London: Longmans, Green & Co. Pp. viii. + 357. Price 15s. net.)

Mr. Rupert Stanley is to be congratulated on being so early in the field with Volume II. of his "Text Book on Wireless Telegraphy." Dealing as it does in great part with the three-electrode valve and its applications, the subject-matter contains much of the greatest interest, and cannot fail to hold the attention of the uninitiated reader, anxious to bridge the gap of five years' rapid development. Mr. Stanley, in his position of military instructor of wireless telegraphy with the British Expeditionary Force in France, has had most excellent opportunities of handling, testing, and comparing the various types of signalling apparatus that have come into service during the war and also of entering into what must have been a most pleasant and helpful *liaison* with the French signal service, a *liaison* which has clearly had a very powerful influence on his thought and pen.

It is indeed refreshing to see such unstinted praise lavished on the French "Service de la Télégraphie Militaire" and its chief General Ferrié, whose portrait, admirably reproduced, forms the frontispiece of the volume. No praise can be too great and no recognition too full for this devoted little band of physicists and engineers, many of high academic rank in French universities, working under one of the most able and charming men it has been the reviewer's good fortune to meet.

Mr. Stanley has done well to draw so largely on the numerous military publications emanating from the Boulevard de Latour Maubourg.

It is impossible, however, when dealing with the general content of the

book to refrain from drawing attention to the extraordinary reticence shown in regard to British efforts in the domain of wireless. No one relying entirely on the "Text Book" for information would for a moment suspect that any research or design had been carried out by the British Government along lines parallel to the French, since the only British apparatus mentioned—and deservedly so—is that of the Marconi Company. Yet there were, in point of fact, three large and active Government establishments working for the Navy, Army and Air Force respectively, *from which the great majority of the new wireless apparatus used in the services originated.*

The unfortunate omission on Mr. Stanley's part of any explicit reference to British official apparatus and design detracts considerably from the value of his book.

As for the detailed contents of the volume: in seventeen chapters of 350 pages the author leads us in pleasant if somewhat discursive style from a consideration of the fundamental ever present electron to the part it plays in the modern hard valve and thereafter by easy stages to the circuits, arrangements and use of the complete valve wireless set.

The first chapter deals in an extremely elementary way with electrons and atomic structures. After reading it, one wonders why the author did not seize the opportunity of discussing in detail the emission of electrons from hot bodies, a subject which is of such primary importance in the modern valve.

A few errors have crept into this opening chapter, as for example on page 3, where the very under-estimated speed of 50,000 km. per second is given for cathode rays in a hard tube, and on page 10, where a few thousand volts is given as the gas sparking potential, whereas in reality it may be even less than a hundred. It appears to the writer that it would have been better to instance the better known Rutherford-Böhr atom model rather than that of Vegard.

Chapter II. contains a good general account of the hard valve and its characteristic curves, the excellent mathematical treatment of Professor Gutton being first introduced here. It may prove a little puzzling perhaps to some readers to see on page 28 two apparently contradictory formulæ for the plate current of a valve, the one proposed by Langmuir, the other by Gutton; the difference between them is hardly made sufficiently clear. An historical inaccuracy occurs on page 34, where the relation $\frac{1}{2}mv^2 = eV$ is attributed to Dr. Eccles—as every advanced student of physics knows this very formula was used more than a quarter of a century ago by the pioneer workers on the ratio e/m for an electron long before the advent of the valve.

Passing on to Chapter III., the detecting properties of a valve and its associated circuits are here described along orthodox lines.

There is some ambiguity in the wording at the top of page 40, where the author in explaining that no rectification can occur when working on the straight part of a valve characteristic appears to leave the erroneous impression that the slope must be 45° .

Mr. Stanley throughout the book recognises the power of the graphical method in explaining qualitatively valve properties and in this chapter uses the method. But in proving, on page 46, the very important proportionality

relation between extent of current rectification and the square of the potential oscillation a general function is expanded by Taylor's theorem and high terms in the expansion neglected. A much simpler proof involving in the long run the same assumptions, and one often more convincing, can however be arrived at geometrically; for if we approximate and suppose that the characteristic bend is an arc of a circle, of radius R , then it follows at once from the well-known rectangle property of a chord bisected by a diameter at right angles, that $2R \times$ (small current change) = (potential change)² which is, of course, the desired relation.

Chapter IV. deals with the various methods of amplifying high frequency oscillations. It is not clear why the author separates this chapter from the seventh, which (in a more natural position following the section on oscillations) deals with the same subject.

The two chapters together are rich in excellently drawn standard circuit diagrams, well explained. Insufficient stress however seems to have been laid on the real object of high frequency magnification which is to increase the oscillation amplitude until rectification can be efficiently applied. The British official types of instrument are here, as elsewhere, omitted.

Chapter V. gives a further instalment of Professor Gutton's mathematical treatment of the valve, now regarded as an oscillator.

Chapter VI. deals with the use of the valve in low-frequency amplifying apparatus and the standard iron core transformer circuits are clearly described. The author apparently considers that the terms "relay" and "amplifier" are synonymous and interchangeable, a point of view which can, in the present writer's opinion, only lead to confusion of thought. It would be convenient to reserve the term "amplifier" for instruments which reproduce a more or less faithful copy on a larger electrical scale of an initial varying current or potential—in this class would fall all the valve amplifiers described in Mr. Stanley's book.

The relay class would include such instruments as the Post Office relay and the electromagnetic key.

The value of the chapter would have been enhanced had the author explained the standard method of measuring the amplification produced by a polystage amplifier; mention might also have been made of the possibility of constructing low-frequency amplifiers using condenser connections between the valves instead of transformers.

Chapters IX. to XI. give a good though incomplete account of some standard types of valve.

Chapters XII., XIII. and XIV. discuss the general arrangements and working of continuous wave and telephone sets, with particular reference to those sets which the author has himself used. These chapters are less complete than many of the preceding ones, particularly in the section dealing with telephony. Some interesting photographs are added to the numerous diagrams.

Chapter XV. is a short semi-historical survey of the development of high frequency transmitters and is interesting in spite of being outside the true scope of the book.

The chapter includes in passing references to H.F. alternators and methods of microphonic control of oscillating currents, but it is disappointing not to see here even a short account of the very interesting two-wave system.

Chapter XVI. gives a very practical account of the earlier earth signalling apparatus using buzzer and amplifier. The Government Fullerphone, which has revolutionised earth signalling, is not mentioned.

The last chapter contains a few short and disconnected accounts of various apparatus not included in previous chapters, such, for example, as the heterodyne wavemeter, the telephone "repeater," the generation of short wavelengths and some others.

In conclusion it is the feeling of the reviewer that in spite of the many small mistakes that have crept in, and the very regrettable omissions, the book will prove useful to those seeking a general acquaintance with the subject.

It is clearly printed on good paper, with a large number of excellently reproduced diagrams in the text, and like other books by the same publishers is singularly free from printer's errors.

R. WHIDDINGTON.

Correspondence.

ON THE GONIOMETRIC FUNCTIONS APPLICABLE TO DIRECTIVE AERIALS.

TO THE EDITOR, THE "RADIO REVIEW."

SIR,—I have examined the October, 1919, issue of the RADIO REVIEW and desire information concerning the first and second pages of the issue on which reference is made to *British Patent 15527* of July 11th, 1902, to A. Blondel, with the statement that this patent refers to radio-goniometric closed coil frames.

On examination of this patent it is not seen that the specification relates to coil antennæ.

On page 2, reference is made to *German Patent 237,486* of January 15th, 1910, as describing the use of coil antennæ. This number does not refer to a radio patent and information is requested concerning the correct citation.

J. B. BRADY.

Navy Department, Bureau of Steam Engineering,
Washington, U.S.A., November 19th, 1919.

TO THE EDITOR, THE "RADIO REVIEW."

SIR,—In your October issue, on page 1, M. Blondel states in a foot-note that his *British Patent No. 15527* of July 11th, 1902, discloses "the use of a closed frame for radio-goniometric purposes." I have carefully examined this patent, but am unable to find any drawing or description therein which warrants such a statement. The patent cited is in fact for a system of radio-telephony, and so far as any aerials are shown or described, they are of the ordinary elevated-conductor-and-ground type.

In a continuation of the above foot-note, on page 2, M. Blondel attributes to himself, as of the year 1908, the use of "these frames closed by a condenser," and gives certain other dates, all apparently as a brief history of the loop aerial radio compass. Although I dislike to trespass on your valuable space in a mere matter of priority, M. Blondel's bibliography is so inaccurate (as pointed out above) and incomplete as to demand correction.

My own early publications dealing with the radio compass are given below, and so far as I am aware they are the first to describe adequately a coil or loop aerial, tuned by a series variable condenser and operating independently of a ground connection.

"An Ungrounded, Closed Circuit for Receiving Wireless Signals," *Electrical Review*, New York, June 15th, 1907. See also editorial note in the same issue. An abstract of this article appears in the London *Electrician* of July 19th, 1907.

United States Patent No. 876996, filed June 10th, 1907, and issued January 21st, 1908. In addition to showing an ungrounded loop aerial, tuned by series capacity, this patent also discloses for the first time the combination of open and closed aerial reception, often though erroneously attributed to MM. Bellini and Tosi.

"Determination of Wireless Wave Fronts." *Electrical Review*, New York, October 3rd, 1908. This is an illustrated article, showing a multiturn ungrounded loop, one meter in diameter, employed as a portable radio compass.

United States Patent No. 956165, filed September 3rd, 1907, and issued April 26th, 1910. This patent shows loop aeriels, separated on centres by thousands of yards, and coupled by way of phase adjusting means to a common or central secondary circuit. It is of passing interest to note that this is the arrangement employed by Weagant, and shown in Fig. 4, page 50, of the October RADIO REVIEW.

GREENLEAF WHITTIER PICKARD.

Newton Centre, Mass., U.S.A.

November 26th, 1919.

The above letters have been submitted to M. Blondel, who has replied as follows:—

TO THE EDITOR, THE "RADIO REVIEW."

SIR,—Replying to your letter I beg to submit the following corrections to the citations given in my paper in the RADIO REVIEW* :—

Instead of *British Patent* 15527, July 11th, 1902, read *British Patent* 11427/1903, Fig. 7.

Instead of *German Patent* 237486, read *German Patent* 237456, January 15th, 1910, page 5, lines 88 to 105.

A more complete list of references to my patents and work on directive aeriels follows :

"The constitution of simple frames with two conjugate aeriels" was first

* RADIO REVIEW 1, foot-note to pages 1 and 2, October, 1919.

described by me in 1902, *Belgian Patent* of May 28th, 1902. *British Patent* 11427 of 1903 covers practically the same subject-matter. The same arrangements were made the object of a publication in the form of a Memoir presented to the Congress of the French Association for the Advancement of the Sciences, at Angers in 1903, Memoir No. 138562, page 11 of the reprint; the closed frames are there described on page 16. Tests made on the Blondel type of closed frames were described in the notice of the French Minister of Public Works on the apparatus exhibited by the Service des Phares Français at the Franco-British Exhibition in London and at the Exhibition in Marseilles—Fig. 5, on page 94 of that Notice, to which the second half of page 93 refers, indicates the dimensions given to the directive closed circuit frames.

The experimental researches on these Blondel frames were carried out by le Capitaine du Génie Ferrié, and the installations by Lieutenant Brenot. It is shown in the test records held by the latter that the frame comprised several closed turns, short-circuited by a capacity, and that in this closed circuit sometimes half-wavelengths and sometimes complete wavelengths were obtained.

A fresh reference to this arrangement was made in a *German Patent* (A. Blondel) No. 237456 of January 15th, 1910, page 5, lines 88 to 105. In March, 1910, in collaboration with Captain Brenot, with the assistance of Mons. Polak and under the direction of General Ferrié, I took up the study of closed frames comprising several turns oscillating in complete waves, the circuit being closed by a capacity. To obtain the required sensitiveness the necessary dimensions of these frames were unfortunately very large, but in October, 1915, General Ferrié conceived the idea of combining an amplifier with them, thus enabling a considerable increase in sensitiveness to be obtained, and the dimensions of the frame to be reduced so that it could be freely turned about a fixed axis.

There is also *Belgian Patent* No. 169746, "Improvements in Receiving Apparatus for Wireless Telegraphy and Telephony" covering the Thermo-electric Receiver and the Monotelephone which I invented; and *American Patents*, Nos. 824682, and 783992, both of February 7th, 1905, relative to the use of musical waves for the selection of signals.

Finally, there is my *United States Patent* No. 1218237 of November 4th, 1913, for "A Method of determining the Direction of a Wireless Station ('phare')." "

A. BLONDEL.

Paris.

December 10th, 1919.

THE ELIMINATION OF MAGNETO DISTURBANCE.

TO THE EDITOR, THE "RADIO REVIEW."

SIR,—In this month's RADIO REVIEW, Captain Robinson refers to the fact that, by choosing suitable valves, magneto disturbance can be eliminated by adjusting the filament current to a certain value—depending of course on the valve in use. Might I offer a possible explanation?

The capacity between grid and filament together with their inductance and

that of the connections, if adjusted carefully, provide a small oscillatory circuit of the frequency necessary to absorb the short waves received from the magneto in the same manner as the extra circuit mentioned earlier in the article. A very small change in the oscillation constant of such a short wave circuit is enough to prevent this absorption. The filament on being gradually raised in temperature, expands; this alters the capacity by placing more surface in contact with the dielectric and by setting the filament nearer to the grid. At a certain point the capacity reaches the required value and "tunes out" the disturbances. Further increase in the filament current throws the circuit again out of tune, and the disturbance reappears. The rather sudden action would be accounted for by the sharpness of tuning at such high frequencies.

The slightest differences between valves would be sufficient to throw the range of tune outside that required; *e.g.*, the grid support is often of two wires twisted together. If the flux used in soldering to the seal worked between these wires it would give a different value to \sqrt{LC} , enough to destroy the required action. It would be interesting to know whether this action of a valve persists or whether the "tuning current" requires to be of larger value as the filament gets "worn thin." The rheostat used, too, might make it impossible to get the required values of current exactly; the best form of filament rheostat would appear to be a continuously variable one, such as the form in which carbon blocks are compressed by a screw.

L. J. Voss.

Plympton, Devon.

December 18th, 1919.

"THE THERMIONIC VALVE AND ITS DEVELOPMENTS IN
RADIOTELEGRAPHY AND TELEPHONY."

TO THE EDITOR OF THE "RADIO REVIEW."

SIR,—I have just read the last volume of Professor Fleming on the thermionic valve. I am extremely surprised that Professor Fleming does not mention any French name among those of engineers who have studied the three-electrode valves.

(1) After Dr. Langmuir had published the curves of plate current and grid current in the *General Electric Review* of May, 1915, I published myself, before anybody else, in the *Electrician* of December 1st, 1916 (see also my *British Patent* No. 127318 of April 15th, 1916), the very simple mathematical theory of the operation of the three-electrode valve based on the knowledge of the slopes of these curves. This my theory is now classical and has been reproduced, and possibly developed, by different authors (Hazeltine, van der Bijl, Carson, Ballantine, etc.). But having myself an obvious priority founded on a *British* publication, I feel naturally very much surprised that Professor Fleming does not mention my name at all when writing on the mathematical theory of the three-electrode valve.

(2) Referring to resistance amplifiers, I beg to call attention to the fact that these amplifiers have been first used and patented by French engineers

(*French Patent* of Péri, February 1st, 1916; *French Patent* of Beauvais and Brillouin, March 20th, 1916).

(3) Referring to high-frequency amplifiers with iron-core transformers, I have been the first to consider them (see my *British Patent* No. 127318), and have furnished a large number to the British forces during the war. I cannot admit that the use of iron powder (as known for loading coils) instead of sheet iron changes anything in the principle. Furthermore, the tuning at every stage with iron-core transformers, as in the amplifier No. 55 of the Marconi Company (see Fig. 131 of the volume), is described in my *British Patent* No. 130056.

I have published in the *Electrician*, of May 16th, 1919, the very interesting results obtained with tuned high-frequency amplifiers with iron-core transformers of my construction.

(4) It may be that Professor Fleming, the inventor of the valve, has also designed three-electrode valves according to Fig. 67 of his volume (page 128), but as a matter of fact this type of valve is known as the "French valve" and covered by the *British Patent* No. 126658 of Biguet and Péri.

MARIUS LATOUR.

Paris,

December 29th, 1919.

The above letter has been submitted to Professor Fleming, who has replied as follows:—

TO THE EDITOR OF THE "RADIO REVIEW."

SIR,—M. Marius Latour expresses his extreme surprise to you that I have not made reference in my book on "The Thermionic Valve" to certain French patents or to a paper by him in the *Electrician* of December 1st, 1916. Considering that the said patent specifications or their British equivalents were not open to public inspection at the date when most of my book was in print it would have been still more surprising if I *had* mentioned them. As regards his paper on which he lays so much stress, owing to pre-occupations, I did not happen to notice it at the time it was published, or if I did, I failed to make a note of it, as I had then no thought of writing a book on the subject.

Having now, however, looked at this paper, I must confess I do not think his treatment of the subject in it is so epoch-making or novel that all other writers on the theory of the three-electrode valve should consider themselves as anticipated by, or under debt to it. The discussion of the problem in my book taken from the papers of Vallauri, Hazeltine, van der Bijl, and Ballantine, with simplifications of my own is, in my view, more elucidatory than that of M. Latour. If, however, the opportunity occurs of mentioning his contribution to the subject in a second edition of my book, I shall be pleased to do it, although I cannot share his opinion as to its fundamental importance. As regards the coupling of valves in cascade by resistance coupling or iron-cored transformers, or his assumed anticipations of any of the types of valve receiver designed and made by the Marconi Company, I must decline to be drawn into the discussion of any questions of priority. The proper place for the settlement of these questions is a court of law, and

not the columns of a scientific journal. I have had quite enough of these controversies in the past with respect to my own share in the evolution of the thermionic valve in which the final conclusion has only been reached after judgments given by such courts.

With respect to his remark on the "French valve," I knew perfectly well in 1917 that a certain type of valve much used in the war was so called, but I intentionally abstained from making reference to it by that name, or to the origin and use of the valve figured on my page 128 for the following reasons: My book was written and almost entirely in print before the armistice was declared, and no one knew at that time when the war would be ended. It was necessary, therefore, for me to exercise a certain discretion in reference to apparatus in actual use in the field of war. Moreover, I did not consider this type of valve involved any great novelty. In 1915, I had a "hard" or high-vacuum valve made to my design, having a cylindrical anode and a spiral wire grid concentric with the cylinder.

In my laboratory notebooks I find records of experiments made with this valve on January 14th, 1916. Now the British patent application of Péri and Biguet was not made until October 23rd, 1916 (No. 15072/16), and the complete specification was not accepted until May 22nd, 1919. The specification was not open for inspection until still later. Hence information as to it was not until then public property. As I had in my possession a valve of similar construction, viz., cylinder and spiral grid, made for me ten or eleven months previously to the British patent of Péri and Biguet, I could not see any good reason for particularly nationalising this type as "the French valve," although it had many good points, such as the small bulb and convenient four-pin attachment.

In any case, the claims of the patent, even from the Convention date, would be limited to the precise form of valve figured. After all, the main question at issue is whether the author of a book shall retain the right of private judgment in the selection of his material, or whether he shall be moved by the possibility of "extreme surprise" on the part of some one if he omits to include all that other writers consider important, or to have claims to priority.

In this case my book was chiefly written during the greatest struggle in history, under a strict censorship, with patent publication mostly restricted, information closely guarded, and much knowledge carefully withheld. My object was not to give publicity to everything written by every one on the subject, but to give as lucid a description as possible of the developments and operation of the thermionic valve.

J. A. FLEMING.

London,

January 5th, 1919.

HARDENING AND SOFTENING OF IONIC TUBES.

TO THE EDITOR, THE "RADIO REVIEW."

SIR,—The alternative explanation of the changes of gas pressure in thermionic tubes elaborated by Dr. Eccles in his suggestive letter in your

x

November number calls for a re-consideration of the grounds on which the older view is based, even though no observations contradictory to the former explanation be forthcoming.

The effects in question were systematically investigated by Dr. Bryan under conditions differing little from those of modern practice as long ago as December, 1914, and the conclusions then reached, namely, that increase of anode voltage is followed by disappearance of gas, and *vice versa*, have been amply confirmed by later work both before and after the stabilisation of the vacuum by a suitable "ageing" treatment was introduced as the final stage of the manufacturing process.

Both theories therefore aim at explaining the same observed facts, and these facts may be considered well established.

Dr. Eccles puts forward the view that the gas when it disappears goes into the filament. If it does so it is no mere surface condensation that is involved, but a dense impregnation of the body of the filament with gas. An example will show this. The limiting amount of gas that can be made to disappear from the body of an ordinary small bulb of some 80 c.c. capacity is enough to produce an increase of pressure of about $\frac{1}{30}$ mm. of mercury in such a bulb. This quantity of gas compressed to atmospheric pressure would have volume about ninety times that occupied by a filament of ordinary dimensions, *e.g.* 2.2 cms. long and 0.006 cm. diameter. Again, if this gas were supposed fully condensed, with its molecules brought into contact with each other, it would occupy a volume of as much as one-fifteenth of that of the filament which, on Dr. Eccles' view, is to absorb it. Now such observations as have been made on the amount of gas given out even by a fresh piece of metal, such as nickel or tungsten, when first heated in a vacuum, hardly approach this quantity, and further, from the fact that subsequent melting of the metal need not be followed by any marked additional evolution, it seems the metal can be made to give up the whole of its gas. In face of this it is difficult to imagine a filament which is already heated to incandescence taking up so large an amount of gas as the hardening of a valve may require.

The older theory may be tested by means of the same numerical example, but before that there is a misconception, from which Dr. Eccles seems not entirely free, to be touched upon.

The effect of the rise of anode voltage in increasing the number of positive ions derived from the gas will not be large in an ordinary high-vacuum valve even though the rise be from 100 to 2,000 volts, for in the transit across the tube of such few electrons as do collide with gas molecules one collision only will occur, and in either case that collision will be sufficient to result in ionisation, both voltages being far above the critical ionising value.

It is not, therefore, the anode voltage, but the chance of collision that chiefly determines the number of positives, and this chance depends at a given pressure on the length of path traversed by the electron. Those electrons that travel from cathode to anode by a circuitous route will stand the most chance of colliding. On the older theory this is clearly a point of importance. Many of the positives will be formed in the outer regions of the bulb, and in the cases of puncture cited by Professor Fortescue and Dr. Bryan these ions

used to give visible evidence of their undesirable presence by local patches of glow. The fate of such ions is much more likely to be impact on some part of the walls of the tube than on the cathode. Such impacts are of a violence far beyond that of the ordinary impacts to which the pressure of the gas is due, but otherwise little is known of their nature. It seems, however, far more likely that such ions will become permanently embedded in the cold walls than that those which strike the incandescent cathode, the surface of which has a very small area, and is also in a state of relatively violent temperature agitation, will remain there.

Nor is the quantity of gas previously considered in any way excessive for retention by the walls. On the contrary, if spread uniformly over them it would be only a trifle more than enough to form a layer a single molecule in thickness. The probable existence of such layers, and their stability when formed is generally recognised. It is thus scarcely necessary in the case considered to assume that the gas must be able to penetrate into the body of the glass.

It seems reasonable to interpret the following observation, recently made in this laboratory, as a visible demonstration of the existence of such a surface layer. If a valve which has been freed from gas to the normal extent by thorough bombardment of the anode is allowed to cool, and then a trace of gas is admitted, *e.g.*, by heating to the softening point a part of the exhaust stem, the anode may present a very curious appearance when bombardment is resumed. The surface of the anode is seen to be covered with a very thin uniform film of blue glow, like the bloom on a fruit, and this without the appearance of any trace of glow in the body of the tube. As the anode heats the glow disappears, and does not appear again on repetition of the bombardment, unless more gas has been admitted in the meantime. The effect occurs in spite of the valve being connected to a diffusion pump throughout the experiment. This peculiar glow would appear to come from a film of gas "*adsorbed*" on the cold nickel surface, and there ionised by the impinging electrons. Similar effects have been observed at the surface of fresh glass, but were ascribed to a fugitive fluorescence.

Consideration of relevant facts additional to those taken into account by Dr. Eccles in his letter thus inclines to the support of the older view of the physical phenomena involved.

There is a point that appears obscure in the bird's-eye view of the normal working of the valve given in the earlier part of the letter—"The electron flow will be sufficient to prevent the positive ions reaching the cathode in any considerable numbers." Now can the electron flow produce such an effect? It might certainly do something of the kind either by deflecting the positive ions from their path towards the cathode, or by combining with them, destroying their ionic property, and re-constituting ordinary uncharged gas molecules, of which a great excess is present already.

But to what extent can either of these effects be supposed to be going on? In the first case, the momentum of the positive as it comes up to the neighbourhood of the filament is greater, many thousands of times greater, than that of the electrons in that region, both by reason of its greater mass and

by reason of the much greater velocity acquired since its formation. Hence if the motion of the positive is to be reversed not one, but hundreds of collisions must take place, and we must imagine an electron atmosphere near the cathode of a very high density, relatively to the residual gas, for instance. The requirements for re-combination are similar, though less in degree. Here also the velocity of the positive must be reduced in some way to a value comparable at most with the ionisation voltage of an ordinary gas, ten to twenty volts or so.

The question is therefore one of the density of the negative space-charge at various distances from the filament outwards, and is one that is easier to state than to follow up analytically even did your space permit. An investigation of the matter would make clearer and more precise our mental picture of the physical conditions in one of the most important regions in the valve.

B. S. GOSSLING.

The Research Laboratories of the General
Electric Company, Hammersmith,
January 10th, 1920.

(Owing to pressure of space some correspondence has been unavoidably held over.—ED.)

ERRATA.

Page 182, Fig. 1. Transformer $T_1 T_2$ should be a step-up one similar to $T_3 T_4$.

Page 194. Fig. 5 has been incorrectly drawn. The proper arrangement is indicated below:

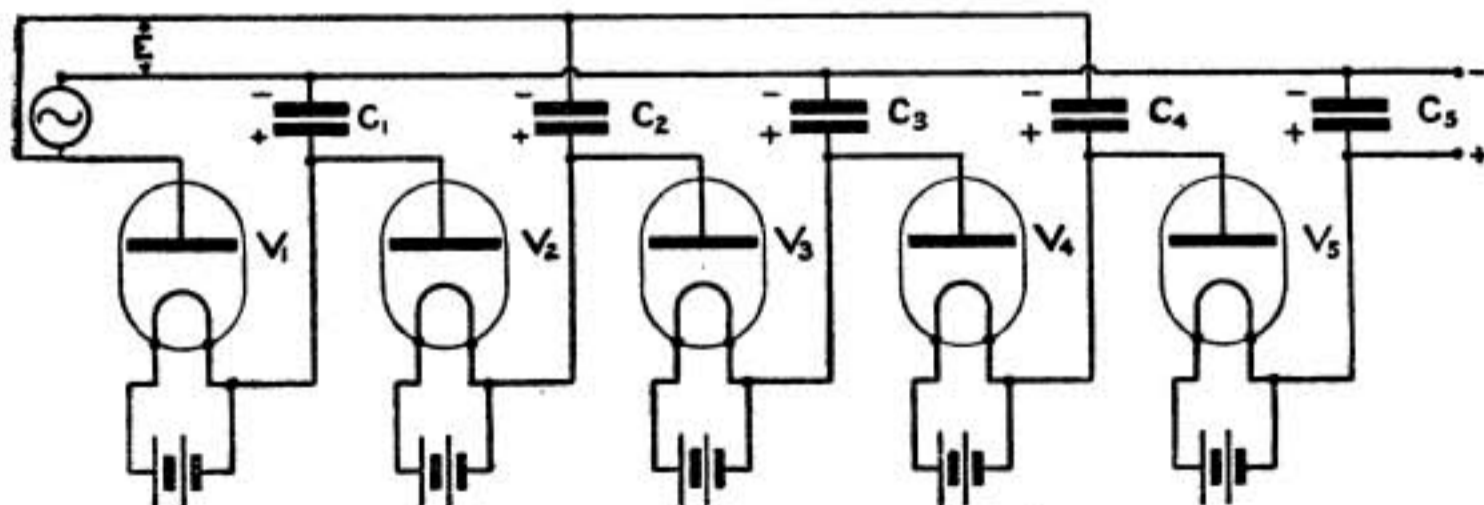

Page 208, Fig. 12. A connection should be taken from the negative side of B_1 to the wire immediately below it—i.e. connecting together the negative terminals of B_1 and B_2 .