

Radio

Quarterly

No. 1

JUNE 1953

VOL. I

**IN
THIS
ISSUE**

<i>Three Band HF/VHF Converter</i>	4
<i>A Handy Absorption Wavemeter</i>	15
<i>Short Waves and The Amateur</i>	20
<i>Country List by Prefixes</i>	22
<i>A Frequency Meter and CW Oscillator</i>	40
<i>"Pse QSL"</i>	49
<i>Tracing Television Troubles</i>	52
<i>Radio Clubs and Societies</i>	62
<i>Short Wave Broadcast Listening</i>	65
<i>Short Wave Broadcast Station List</i>	83
<i>QSL Bureaux of The World</i>	91
<i>The Amateur Transmitting Licence</i>	95

PUBLISHED QUARTERLY PRICE FOUR SHILLINGS

World Radio History

Model
**20,000 ohms
 per volt plus**
**AUTOMATIC Overload
 Protection**

**UNIVERSAL
 AVOMETER**

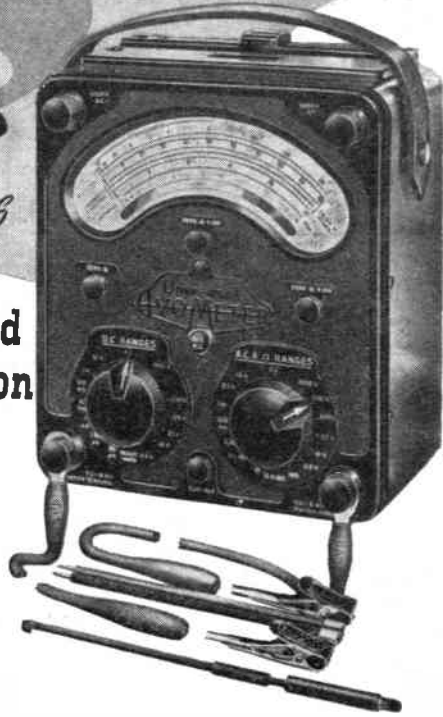

Produced in response to a demand for a high sensitivity version of the world-famous Universal Avometer, this model incorporates the traditional design features of its predecessors, so highly valued for simplicity of operation and compact portability.

It has a sensitivity of 20,000 ohms per volt on all D.C. voltage ranges and 1,000 ohms per volt on A.C. ranges from 100 V. upwards. A decibel scale is provided for audio frequency tests. In addition, a press button has been incorporated which reverses the direction of current through the moving coil, and thus obviates the inconvenience of changing over test leads when the current direction reverses. It also simplifies the testing of potentials both positive and negative about a common reference point.

A wide range of resistance measurements can be made using internal batteries, separate zero adjustment being provided for each range.

It is of importance to note that this model incorporates the "AVO." automatic cutout for protection against inadvertent overloads.

Size: 8½ in. x 7½ in. x 4½ in.

Weight: 6½ lbs. (including leads)

£23 : 10 : 0

The following accessories are available to widen still further the ranges of the instrument:- A Resistance Range Extension Unit to extend the limits of measurement from 0.025 ohm to 200MΩ, a 10KV. D.C. multiplier and a number of A.C. current transformers.

D.C. Voltage	D.C. Current	A.C. Voltage	A.C. Current	RESISTANCE
2.5V.	50μA.	2.5V.	100mA.	First indication 0.5Ω
10V.	250μA.	10V.	1A.	Maximum indication 20MΩ.
25V.	1mA.	25V.	2.5A.	0—2,000Ω } using
100V.	10mA.	100V.	10A.	0—200,000Ω } internal
250V.	100mA.	250V.	—	0—20MΩ } batteries.
1,000V.	1A.	1,000V.	—	0—200MΩ } using
2,500V.	10A.	2,500V.	—	0—200MΩ } external
				batteries.



THE AUTOMATIC COIL WINDER & ELECTRICAL EQUIPMENT CO. LTD.
 WINDER HOUSE · DOUGLAS STREET · LONDON S.W.1 Telephone VICTORIA 3404-9

Radio Quarterly

Vol. 1

JUNE 1953

No. 1

PRINCIPAL CONTRIBUTORS

L. H. THOMAS, M.B.E., G6QB

R. H. GREENLAND, B.Sc.

W. N. STEVENS, G3AKA

J. N. WALKER, G5JU

G. P. WATTS

A. J. DEVON

EDITOR

AUSTIN FORSYTH, O.B.E., G6FO

STRICTLY COPYRIGHT

Price 4s.

Annual Subscription 16s.

AUTHORS' MSS.

Contributions for RADIO QUARTERLY are invited and should be addressed to The Editor. Articles must be typed double-spaced on quarto or foolscap sheets, on one side of the paper only, with wide margins. Diagrams and photographs should be separate and clearly identified with the article. Payment at good rates is offered for all material used and it is a condition of acceptance that copyright passes to Short Wave Magazine, Ltd., on publication.

Radio Quarterly

Published by SHORT WAVE MAGAZINE, LTD.

55 Victoria Street, London, S.W.1.

(ABBey 5341)

FOREWORD

We have pleasure in presenting the first issue of RADIO QUARTERLY, a new appearance in the semi-technical field, designed to catch the eye and please the mind of the keen amateur listener-constructor.

In this first issue will be found several articles of more than usual interest, particularly to the owners of what are known as "all-wave" BC receivers. We show how such receivers can be operated at much higher frequencies than their scaled wave-range, without any alterations having to be made to the set itself. We also suggest an external unit for the accurate measuring of frequencies over the actual short-wave tuning range of almost any "all-wave" receiver; and give full details as to how this unit can be used to make CW reception possible on a set not normally intended for listening to Morse stations.

It will be our object to provide, in each issue of RADIO QUARTERLY, new articles suggesting fresh lines of thought for the constructor. In addition to all this there will be a quantity of general-interest material, together with discussions on a wide range of subjects by well-informed and authoritative contributors.

With RADIO QUARTERLY, it is our intention to strike a new note, and as time goes on readers will find that our range of subjects covers a field wide enough to interest the listener, the constructor, the experimenter and the licensed amateur operator.

We look forward to your support and, in return, feel sure that we shall be able to hold your interest.

Austin Forsyth, G6FO

THREE BAND HF/VHF CONVERTER

Extending Broadcast Receiver Range from Ten to Two Metres

The principle of using radio frequency converter units to extend the tuning range of existing receivers is well known. Apart from enabling any given receiver to be operated over a wider range of frequencies, a properly designed converter ensures more efficient reception over the desired bands because its circuits can be chosen for those particular frequencies. The main receiver becomes in effect an IF/AF strip, since the RF tuning and first frequency change are carried out in the converter. What this means in practice is that any ordinary broadcast receiver having the usual short wave tuning can be used with a suitable converter to bring in the higher frequency bands. The converter described here gives coverage in three bands from 28 mc (ten metres) up, and can be operated with any receiver which tunes to 10 mc (30 metres) in its short wave range. On these bands can be found a large number of interesting transmissions, including the two-metre amateur band, and this is the first design ever published for making such reception possible on an ordinary broadcast receiver.

IT is evident from the number of enquiries received on the subject that quite a lot of interest in the very high frequencies exists among listeners. Usually, information is asked for on the construction of equipment for use on such frequencies. Most listeners know that a specially designed converter is necessary, used in conjunction with a receiver having a short wave coverage, but it does not seem always to be realised that a full communication receiver is by no means essential. Many domestic receivers possess a short wave range and can be pressed into service without any modification. Some listeners will have a home-constructed short wave receiver, probably of the TRF type, and again such a receiver will function well with a converter in front of it. As a matter of interest, when operating portable on two metres the writer invariably uses a small three-valve TRF receiver in conjunction with a converter, in order to save weight, bulk and current

consumption, and excellent results have been secured with this combination.

The converter described in the following paragraphs has been designed chiefly to give the newcomer to the higher frequencies an opportunity to carry out some interesting exploratory work. Taken as a whole, the instrument may appear somewhat complicated but it breaks down into sections, each of which is as straight-forward as can reasonably be expected when dealing with the very high frequencies. Provided due care is exercised in following the instructions, and no attempt made to rush through the constructional work, a satisfactory performance should be obtained without difficulty.

Coverage

Whilst three different ranges are provided in the prototype model, it may be that the constructor is not interested in all of them and some simplification is

THREE BAND HF/VHF CONVERTER

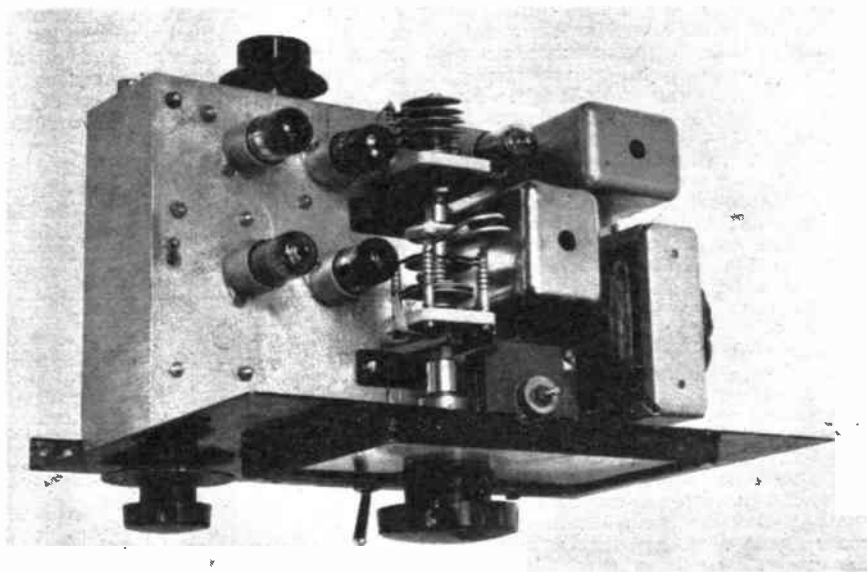

Interior layout view of the HF/VHF converter, which is self-powered. Only external connections required are a suitable aerial (see Fig. 3), a coaxial lead for the BC receiver with which it is to work, and an AC mains connection.

possible if one band is omitted. Reception of the Wrotham experimental transmissions will depend not only on the distance from the station but also on the location of the receiving station and on whether or not a good aerial can be erected. In a poor location or at distances greater than say 40 miles, it is doubtful if Wrotham will be receivable at worth-while strength, although there are other transmissions of interest in the range covered. Again, conditions and therefore reception on the two-metre band can be erratic and the constructor may consider leaving that band out, temporarily perhaps. Finally where cost is a factor, one or other section can be built and the other added at a later date.

The Design in General

The converter is arranged to cover three bands. The first of these is the amateur ten-metre band, on which at times many foreign stations come in at good strength while at others only comparatively local stations will be heard. Telephony is generally used and some-

thing of interest will be found by the listener who has not graduated to the stage where CW (Morse) can be read. In frequency the coverage is from 28 to 29.5 mc.

By the turn of a switch, the second band is brought in and this one covers from 80 to 95 mc approximately and, if in range, Wrotham will be received on 93.8 mc, near the higher frequency end of the scale. It is most unlikely the associated receiver will accept frequency modulation and although something may be heard of the FM signal on 91.4 mc, reception will not be clear.

The third range includes the amateur two-metre band and, for technical reasons, it is necessary to employ separate valves and tuning condensers, so that this part of the receiver forms a section on its own. The total coverage is from 138 to 148 mc and the change-over is effected by simply throwing a switch on the front panel. One aerial input socket is provided for the first two bands, and a second socket for the third.

The converter changes the incoming

THREE BAND HF/VHF CONVERTER

signal to a frequency near 10 mc (30 metres) and further amplification at this frequency occurs in the associated main receiver with which the converter is to work. As the latter is unlikely to be fitted with an RF stage, an IF stage is included in the converter to make up for a possible lack of sensitivity in the main receiver.

The instrument is provided with its own small AC power unit and there are two good reasons for its inclusion. One is that there is then no need to interfere with the domestic receiver in any way, and the second reason is that the power consumption of the converter, although not high, may be a little more than the power unit in the receiver can be expected to supply.

A total of five valves is used, but only three are energised at any one time. On each band there is a frequency changer and a separate oscillator—at these frequencies, the latter has definite advantages over the triode-hexode type of mixer found at lower frequencies. On the first two ranges, a pair of coils is provided for each stage, the change-over being effected with a Yaxley switch. There would be great difficulty both in making the circuit function properly and in obtaining a reasonable performance, if a third switched position were to be adopted for the highest frequency range and the only satisfactory solution is to use another pair of valves in an entirely separate section. Another factor which influences this is that the tuning condensers for the lower bands have too great a value for 145 mc. To avoid duplication of the tuning controls, the condensers are ganged. The circuit constants are such that most of the ten-metre band (all the generally used part, anyway) is covered and a fair range is provided on the other two bands.

The oscillator circuit adopted with V4 on the first two ranges enables a single coil to be employed and also give a useful degree of bandspread. The only drawback is that C16 and C17 must be of close tolerance, but such condensers can be obtained fairly readily. The same circuit does not function satisfactorily on the highest frequency and the familiar Hartley is used here. In both cases, the control grid, cathode and screen-grid form a triode oscillator and the output is taken from a resistive load in the anode circuit. Coupling is therefore

electronic and better stability is thereby secured. The oscillator voltage is injected into the control grid of the frequency-changer, which system is generally the most satisfactory of the several possible methods which could be employed.

Changing over from one pair of valves to the other is effected simply by energising the appropriate heaters. The HT voltage is also switched although this is not really necessary. The unwanted

Table of Values

Fig. 1. Circuit of the HF/VHF Converter

C1, C6	= 2 or 3 μ F ceramic
C3, C16	= 20 μ F ceramic or silvered mica
C4, C5, C12, C13	= 500 μ F Mica-disc (T.C.C.)
C8, C11	= 40 μ F ceramic or silvered mica
C9, C14	= 3 or 5 μ F ceramic
C17	= 25 μ F ceramic or silvered mica
C18	= 50 μ F ceramic or silvered mica
C19, C20, C22, C23, C24, C25	= .001 or .002 μ F moulded mica (physically small)
C21	= 100 μ F silvered mica
C26, C27	= 32 or 50 μ F electrolytic (250 v. or more wkg)
R1, R7	= 1 megohm $\frac{1}{2}$ watt
R2, R8	= 470 ohms, $\frac{1}{2}$ watt
R3, R9, R16	= 10,000 ohms, $\frac{1}{2}$ watt
R4, R10	= 47,000 ohms, $\frac{1}{2}$ watt
R5, R12	= 20,000 ohms, $\frac{1}{2}$ watt
R6, R11	= 4,700 ohms, $\frac{1}{2}$ watt
R13, R17	= 1,000 ohms, $\frac{1}{2}$ watt
R14	= 470,000 ohms, $\frac{1}{2}$ watt
R15	= 200 ohms, $\frac{1}{2}$ watt
R18	= 1000 to 1500 ohms, wirewound, 5 watt.

List of Parts

- 1 Chassis, diecast aluminium Cat. No. 643 Eddystone
- 1 Panel (or cabinet) to dimensions given
- 1 Mains Transformer & Metal rectifier
- (200 v. 50mA 6.3 v. 1.4 a.) Marks*
- 5 Valveholders B7G with screening cans McMurdo
- 4 Valves E91 (Mullard), or Z77 (Osram) or 6AM6 (Brimar).
- 1 Valve (V5) 6BA6 (Brimar)
- 2 10 mc I.F. Transformers Cat. No. 728 Eddystone
- 4 Metal Brackets Cat. No. 708 "
- 2 Variable Condensers (C10, C15) 12.5 μ F "
- 2 " (C2, C7) 15 x 15 μ F "
- 2 Flexible Couplers Cat. No. 529 "
- 2 Solid Couplers Bulgin
- 4 Polystyrene Coil Formers Cat. No. 847 Eddystone
- 1 R.F. Choke Cat. No. 1010 "
- 1 Full Vision Dial Cat. No. 598 "
- 1 Direct Drive Dial Cat. No. 595 "
- 1 Knob (for S2) Cat. No. 2416P "
- 2 Tag Strips 5 way Cat. No. 649 "
- 1 Yaxley Switch 2 or 3 pole, 2 way (S2) Webbs Radio
- 1 Toggle Switch D.P.C.O. (S1) Bulgin
- 2 Coaxial Sockets
- Coaxial Cable, Sleeving, etc.

* C. Marks & Co., 88 Commercial St., Newport Mon.

THREE BAND HF/VHF CONVERTER

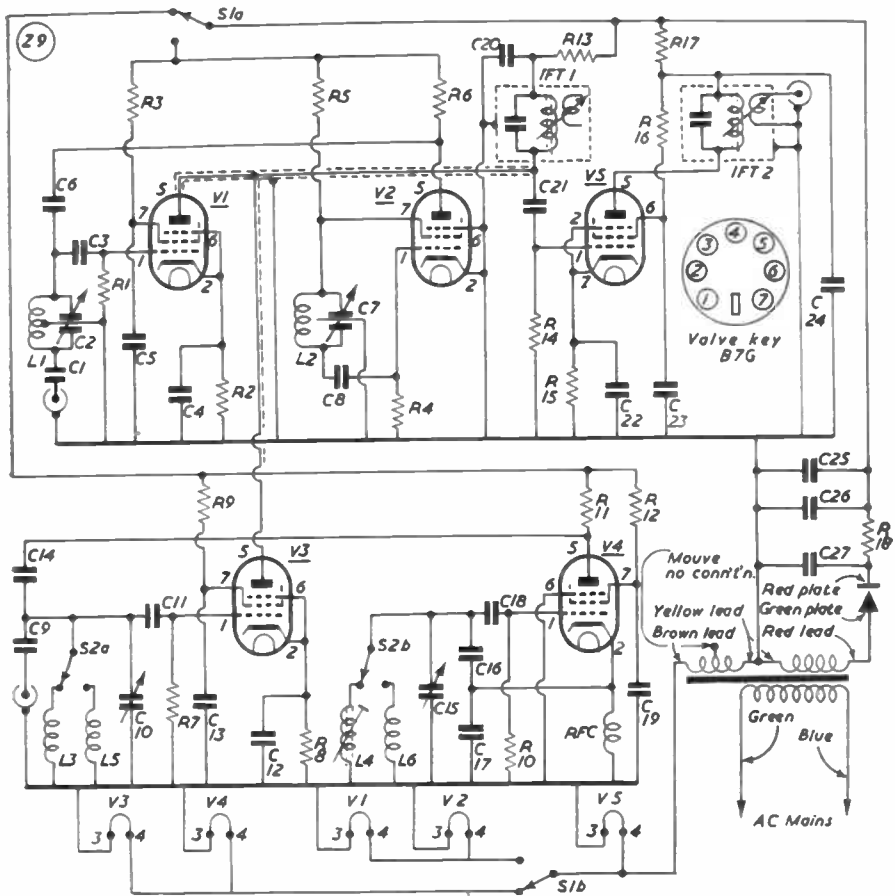

Fig. 1. Circuit diagram of the three-band HF/VHF Converter Unit, which is complete with its own power supply. The RF-mixer sections operate separately for the ranges covered.

oscillator is thus out of action—"birdies" would otherwise probably be heard—whilst the drain on the mains transformer is reduced.

The anodes of the frequency-changer valves are connected in parallel and taken to the first IF transformer primary. Capacity coupling is used to the grid of the 6BA6 high-gain IF amplifier valve, which of course, remains energised all the time. Placing the anodes of the two valves in parallel has no deleterious effect, particularly as only one valve is

energised. The output is taken from the low impedance winding in the second IF transformer and a piece of coaxial cable, of any reasonable length, connects to the aerial and earth terminals of the main receiver.

The power unit must necessarily be compact and, although of a relatively simple type, it is fully adequate for the purpose. In actual fact, it utilises only five components—a mains transformer, a metal rectifier, two high capacity electrolytic condensers and a wirewound

THREE BAND HF/VHF CONVERTER

resistor. The aerial input has been arranged so that either a length of wire can be used, or a dipole fed with coaxial line. The latter is to be preferred and some hints on aerials are given later.

As illustrated, the instrument is built in chassis and panel form. Construction is thereby rendered somewhat easier but it is of course quite in order to instal the unit in a cabinet if desired. A good slow-motion dial must be fitted to the oscillator tuning condensers but direct drive is satisfactory on the input stage condensers.

If the construction is attempted in a haphazard manner, it is probable a number of snags will be encountered, particularly in the wiring of the valveholders, and for this reason a definite schedule of operations should be followed. When it comes to the wiring, a soldering iron with a pencil bit is practically essential and one of the quick heating type, with a wire bit, and capable of doing fine work in a restricted space, is a most useful tool.

The drawings give details of the positions of the main components and of the holes required when mounting them. The first thing to do is to drill out the holes in the panel—incidentally the latter may be of hardboard although a 16 gauge aluminium panel will be found quite easy to work.

The panel is then bolted to the chassis and the wall of the latter marked to coincide with the holes for the switch and for the condenser control spindle. Next the assembly of the oscillator condensers and brackets should be proceeded with and the greatest possible care is necessary to ensure the components are all exactly in line. The slots in the brackets enable proper alignment to be obtained easily in the vertical plane but the fitting of the brackets to the chassis must be accurate if the drive is to operate smoothly. To bring the condensers into their correct positions, each spindle has to be shortened by $\frac{1}{4}$ ". A solid coupler is used between the driving head and the front spindle of C15 and a small flexible coupler between the rear spindle of C15 and the front spindle of C7.

It is now necessary to remove all the parts so far fitted and work then commences on the larger holes in the chassis. The openings previously marked on the front of the chassis wall

are drilled out, the holes on top made for the valveholders and those in the rear wall formed ready to accept the wavechange switch and the coaxial sockets. Two $\frac{1}{4}$ " holes are required on the side near the mains transformer for the mains power lead and the coaxial output cable. Directly beneath the position to be occupied by the mains transformer a row of six holes should be made to enable the leads from the transformer to pass through into the interior of the chassis. Those leads carrying mains voltage and HT should be well protected with sleeving.

Before any parts are actually mounted, the positions for the brackets holding the input stage tuning condensers should be located. The brackets are mounted as close as possible against the side of the chassis wall and the plan layout indicates the appropriate points for the fixing bolts. As before, care is required to ensure the spindles are in line with the hole made in the front wall of the chassis. Again, a solid coupler, with a piece of brass rod about $1\frac{1}{2}$ " long, is used on the front spindle of C2 and a flexible coupler between the two condensers. The spindle of the rear condensers (C10) is shortened by $\frac{1}{4}$ " to bring the two condensers closer together. The photograph of the chassis underside shows just how the condensers are fitted to the brackets—the stator of C10 is on top, looking at the instrument as in the photograph, whilst C2 presents two opposing stators to the left hand side, for connection (later) of the tuning line.

It may appear a nuisance but, to enable the wiring to be carried out, again the condensers must at this stage be removed from the chassis.

The valveholders can now be permanently mounted. It is important to follow the orientation indicated in the drawing since the length of the leads in the RF sections must be reduced to a minimum. The positions of the valveholders and the IF transformers are as seen *looking down* on top of the chassis and not from underneath. Soldering tags should be placed beneath those bolts nearest pin 3 of each valveholder, for making connections between these heater pins and chassis.

Next, the mains transformer and the metal rectifier can be bolted in position. Whilst not essential, it is preferable to insulate the centre rod of the metal

THREE BAND HF/VHF CONVERTER

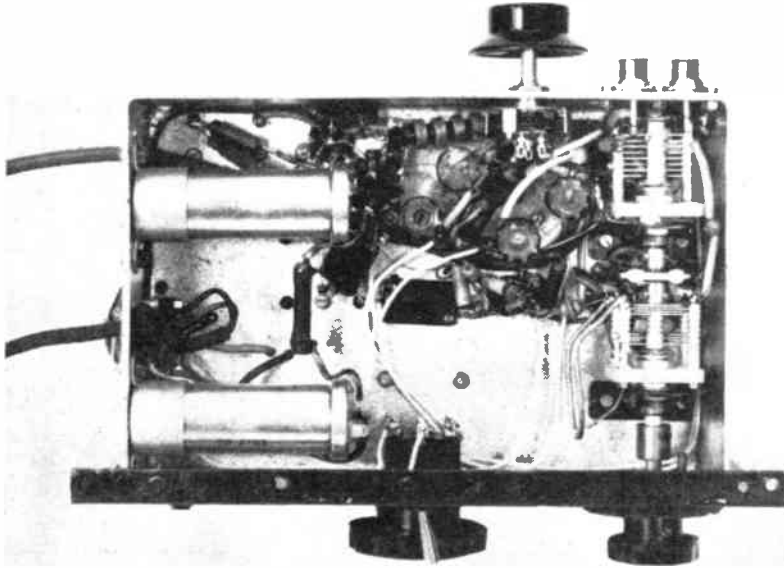

Layout and construction under-chassis of the Converter for extending BC receiver frequency coverage. The RF tuned circuits are to the right—see Fig. 1.

rectifier and this can be done with paxolin washers and a small piece of sleeving to fit over the rod where it passes through the chassis. Where the wires from the mains transformer come through the wall, a five way tag strip is fitted and used to anchor the leads. One LT and one HT lead are soldered direct to an earthed soldering tag. Two holes in the chassis are required to pass leads through to the metal rectifier. At this point, it is as well to make the holes for fixing the electrolytic condensers but these are not actually mounted until most of the wiring has been completed.

The oscillator condensers are re-mounted (holes beneath the stators and one also below the rotor tag of C10 should be made for leads to pass through), the two switches are fixed in position, and holes made in preparation for mounting the coil formers at a later stage.

First of all, the wiring associated with the power unit should be completed as far as possible. Although the circuit is

relatively simple, it is possible to make a mistake and the colour coding as found on the specified transformer and rectifier and shown in the circuit should be followed.

Next the heater wiring is proceeded with. It should be noted that, from the anchoring tag near the mains transformer, one lead is taken to pin 4 of the 6BA6 valveholder and one to the switch. The connections to the other valves are taken from the switch contacts. Each pin 3 is connected to an earth tag, as also is the centre metal boss of the valveholder and, in the case of V2 and V4 the suppressor grid (pin 6) is likewise directly earthed.

The wiring associated with the 1F stage is then given attention. A tag strip-mounted near the V5 valveholder assists in supporting the various resistors. In the Table of Values it is mentioned that the moulded mica condensers must be of physically small size and the reason will be demonstrated when it comes to mounting them near the V5 holder. In

THREE BAND HF/VHF CONVERTER

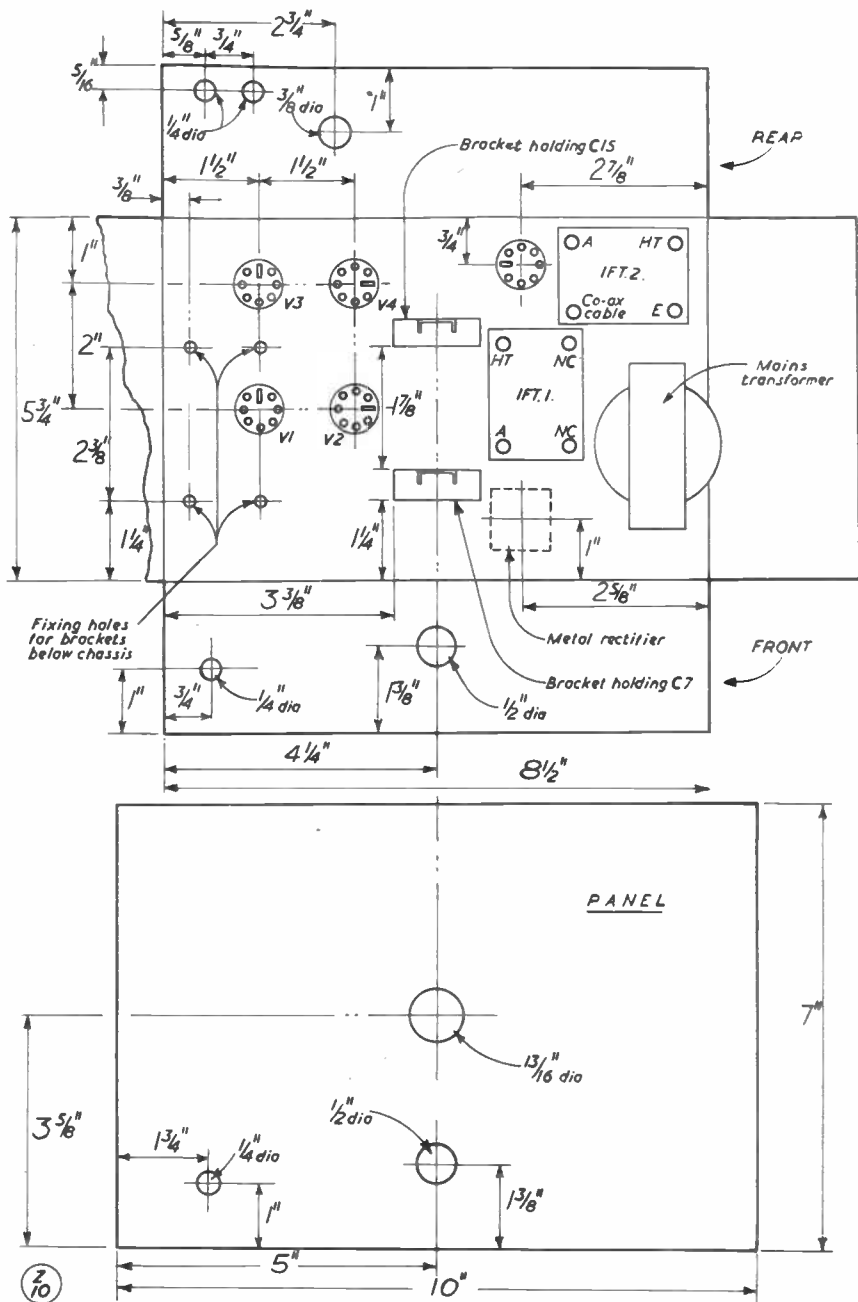

THREE BAND HF/VHF CONVERTER

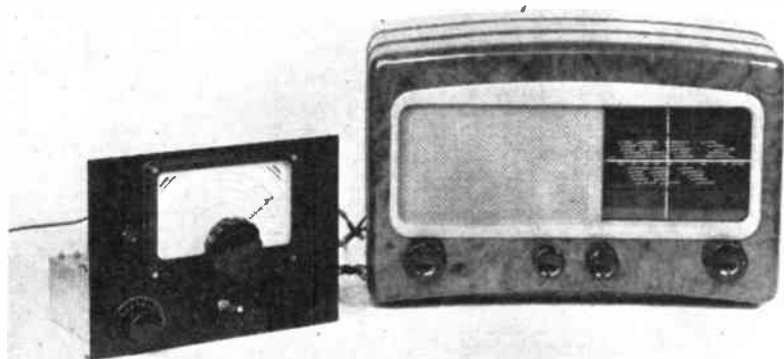

By using the HF/VHF converter described in the text, the frequency coverage of a Cossor Model 500 ("Melody Maker") broadcast receiver can be extended right up into the amateur two-metre band.

the circuit diagram, the length of screened lead between the frequency-changer anodes and the first IF transformer appears to be rather long but in actual fact a five-inch length of $\frac{1}{4}$ " coaxial cable is ample.

The RF and oscillator sections for the highest frequency range are readily accessible and do not present any particular problems. The connections to C2 will of course have to wait until this condenser is finally mounted. The constructor may be a little puzzled about the best way of fitting the Micadisc condensers which, by the way, are of great assistance in keeping these radio frequency stages stable. At least, as far as amateurs are concerned, these condensers would be improved if the "case" had a 6BA screw for direct mounting to the chassis but, failing this, it is necessary to polish one small part of the metal exterior so that it takes solder easily and quickly and so attach

a short length of 16 gauge wire, also treated to take the solder quickly. The condenser can then be fitted close up to the appropriate points.

The other sections come close to the rear wall of the chassis and it is unavoidable that a certain amount of cramping occurs around the V3 and V4 valveholders—it is here that a small soldering iron will be an advantage. The wiring and fitting of the small components should be carried out before any attempt is made to fix the coils. As can be seen in the photograph, the RF choke in the cathode circuit of V4 is made to lie near the wall of the chassis, the earthed end being held by a tag on the strip associated with V5. The choke is thus kept out of the way of other components.

The coil formers are of a new type recently introduced by Eddystone and are ideal for the present purpose. They can be used with or without an adjustable powdered-iron core—in this instance, three are air-cored and the fourth, the oscillator for 28 mc (the working frequency is near 18 mc) is fitted with the core. To make the formers fit comfortably into the restricted space, it is necessary to cut off the normal mounting flange (and also a little of the base) and then make a single 6BA hole in the

Fig. 2. Dimension drawing of the mechanical layout of the Converter, showing the hole positions in the top and walls of the chassis and in the panel. Note that the orientation of the valve holders and IF transformers is as seen when looking down on the top of the chassis.

THREE BAND HF/VHF CONVERTER

portion of the base remaining. Each pair of coils), *i.e.* the two oscillator coils and the two RF coils) is mounted with a single 6BA screw. To reduce lead lengths and to lift the coils clear of the wiring and components around the valveholders, a spacing pillar $\frac{1}{8}$ " deep, preferably of plastic material, is inserted between the coil bases and the chassis. The way the coils are positioned should be studied before winding so that the ends of the windings can be brought out on the sides nearest the wavechange switch. Details of the actual windings and of the loops for Range 3 are given in the panel.

The "earthy" ends of the coils are soldered to the nearest available chassis points and the other end taken to the switch contacts. The switch in the model photographed has three poles but only two are used, the top one being left blank. It will be found easier to solder C16 and C17 in position *after* mounting the coils but it will be well to arrange in advance a short stiff lead coming away from the cathode pin of V4 as this will be somewhat inaccessible otherwise.

The RF tuning condenser assembly is now finally fitted in position and connections made to the stator vanes. The large rotor tag on C10 is used as the earth point for the RF stage coils. It should have been mentioned earlier that a lead is taken through the chassis to the

Coil Data

CIRCUIT REF.	STAGE	DETAILS
L1	145 mc input	Five inches 14 gauge wire bent into a loop and the ends soldered to the opposing stators on C2. Centre tap from bend of loop connected to rotor tag of C2.
L2	145 mc oscillator	Four inches wire (14 gauge) formed into a $1\frac{1}{2}$ turn coil, approximately $\frac{1}{4}$ " diameter. Ends soldered directly to opposing stators of C7.
L3	28 mc input	Eight turns 22 gauge enamelled wire close wound near top of former (Eddystone Cat. No. 847)
L4	28 mc oscillator	Ten turns 22 gauge enamelled wire close wound near top of former Core fitted.
L5	90 mc input	Two turns 20 gauge enamelled wire widely spaced (occupying about $\frac{1}{2}$ " near top of former.
L6	90 mc oscillator	Two turns 20 gauge wire very widely spaced at top of former (ends $\frac{1}{2}$ " apart).

In each case, the ends of the coils are brought out on the side nearest the wavechange switch. The wire may be fixed either by drilling a small hole in a rib or making a saw cut into which the wire fits tightly.

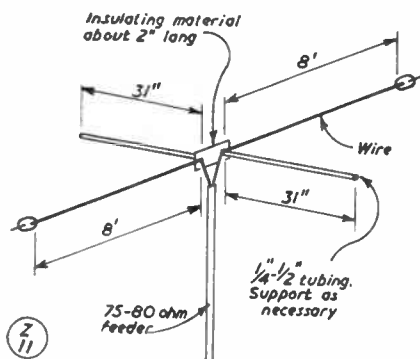
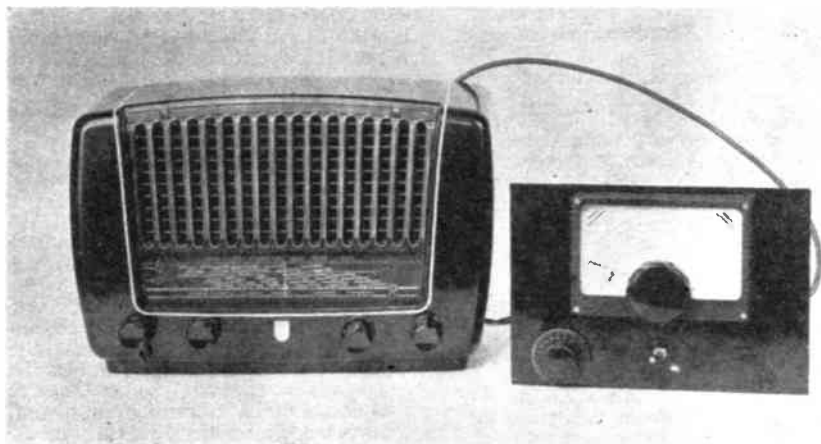

Fig. 3. Design for a dual dipole type of aerial system suggested for the wide HF coverage of the HF/VHF Converter. It calls for only one feeder line and covers the two lower frequency ranges of the Converter. For reception on Two Metres, a separate aerial system would be needed (see text).

V4 earthing point for the large tag on C15—this was found to stop a slight oscillator "jitter" which occurred at times.

A few final operations remain. The electrolytic condensers are mounted and the wiring associated with them completed. The coaxial sockets are bolted on and the small coupling condensers attached. Power leads and a length of coaxial output cable for attachment to the receiver are fitted. Finally, the panel should be secured to the chassis (the nut holding S2 is removed and replaced after fitting the panel). the slow motion dial coupled up the oscillator condensers, and the other dial to the RF condensers. The dials are set to 0° with the condensers at maximum capacity, so that the dial readings *increase* with frequency. The instrument is then ready for testing.

THREE BAND HF/VHF CONVERTER



The HF/VHF Converter Unit in use with a Philips 310A broadcast receiver, which has a scaled short wave tuning range of 16-50 metres.

Initial Test

The first test is to connect the instrument to the mains supply and check that a voltage of 150 or more builds up across C26 and that three of the valve heaters light up. The other two heaters should become energised when the switch S1 is moved.

Next, it is necessary to ascertain that the oscillator valves are functioning properly. The voltmeter should be connected between chassis and the anode pin of either V2 or V4 (whichever is in use). The reading will be something less than the full HT voltage and, on touching a "live" point (alive at RF)—the stator vanes of the tuning condenser for example—the voltage should drop abruptly.

On all three ranges, the oscillator operates some 10 mc less than the signal frequency. If the instructions have been followed closely, the actual ranges will come fairly near to those obtained in the prototype. The only adjustment which may be necessary is to the core in the Range 1 oscillator coil. If an independent check is possible, the core should be set so that a frequency of 18 mc results with C15 at full mesh. If no check can be made, the core is screwed in until it is just below the level of the former.

The coaxial cable coming from the converter is now connected to the receiver—the inner wire to the aerial terminal and the outer screen to the earth terminal. With the receiver tuned to 30 metres (10 mc), the cores in the two IF transformers (accessible through the holes in the top), should be rotated and left at the settings where the increased noise level which results is at a maximum.

On connecting an aerial, the converter is ready for use. Tuning should be carried out slowly and carefully as it is possible to pass right over a signal, especially on the two higher frequency ranges, if the dial is moved rapidly. The dial controlling C3/C10 should be rotated to the point where a slight but definite increase in noise level occurs. Thereafter, on each range, only small movements will be necessary to keep the input stage in tune.

The input circuit is of course tuned to a frequency 10 mc higher than the oscillator and normally the converter will be found quite stable—that is, free from self oscillation. However, if the input stage is tuned near the oscillator frequency—and this is possible if the oscillator condenser is near minimum capacity and the RF condenser near maximum—self oscillation will almost certainly occur on the two higher

THREE BAND HF/VHF CONVERTER

frequency ranges. This is not a fault but purely a matter of correct adjustment.

On first switching on and tuning in a signal, a certain amount of frequency drift will be experienced, due to the valves warming up, and slight re-tuning may be necessary until the converter settles down and the oscillator becomes steady. This effect will be the more noticeable the higher the frequency.

Aerial Systems

The performance obtained—and in particular the range over which stations are heard—will depend to a large extent on the efficiency of the aerial used with the converter. For a first try-out, a length of wire, say, between 20 and 30 feet, preferably out in the clear, can be used. The end should be taken to the inner contact of the coaxial socket and the stronger signals should then become audible. For reception of weak signals, and possibly if considerable distances are involved, then a dipole aerial is called for and this is definitely advised when attempting to receive Wrotham. As a dipole forms a tuned circuit in itself, the dimensions vary according to frequency and normally three dipoles and three feeders—one for each band—are required. This may be feasible if the aerials can be erected near the receiving position. Incidentally, the roof space

often offers good possibilities and putting the aerials out of sight may avoid arguments concerning the garden being draped with numerous wires!

The lengths for each arm of the dipoles are as follows:—

28 mc	eight feet
90 mc	thirty-one inches
145 mc	nineteen inches

Wire (14 or 16 gauge) is quite adequate for 28 mc but, because it gives a wider bandwidth—that is, tunes over a wider range of frequencies without appreciable loss of signal strength—tubing is recommended for the higher frequencies. The wall thickness does not matter but the outside diameter should be as large as is obtainable or is convenient to mount. In all cases, the aerials should be erected in the horizontal plane although some signals on the 90 mc range will be better on a vertical aerial. Ordinary feeder cable—coaxial or twin—of 75/80 ohms impedance is suitable in all cases for making the connection between aerial and converter.

A compromise is possible which allows some simplification of the aerials. Two can be connected in parallel to a single feeder as shown in Fig. 3 and in extreme cases, it might even work if all three aerials were connected to a single common feeder.



A HANDY ABSORPTION WAVEMETER

Constructing a Simple Measuring Device

The humble absorption wavemeter—calibrated, and with a set of coils to cover all working bands—is still an important tool in every radio workshop. Though not capable of high accuracy in terms of frequency measurement, the essential point is that it will locate an approximate frequency with certainty; accurate measurement or checking of that frequency is then a matter for the heterodyne frequency meter. In receiver and transmitter construction, an absorption wavemeter is the only sure way of “finding the band.”

ONE of the most useful little pieces of equipment in the radioman's workshop or “shack” is the ordinary absorption wavemeter. To the listener-constructor it provides a simple means of making approximate frequency checks on the receiver, an invaluable asset where home-wound coils are the general practice.

For the transmitter, of course, the absorption wavemeter is essential. It differs from the heterodyne type of frequency meter in several important respects. It is not so accurate, because the resonance indication is relatively flat compared to the “zero beat” precision of the more elaborate instrument. Secondly, and most important, the absorption wavemeter will only indicate resonance on the fundamental frequency determined by the tuned circuit.

In these days of variable frequency oscillators, frequency multiplying stages, triode oscillators and so forth, it is a simple matter to pick out the wrong harmonic. Using a heterodyne-type frequency meter, which relies on its harmonic output for providing wide coverage, much confusion can, and does, occur. In cases where the output of a frequency multiplier is to be measured, the absorption wavemeter is the safest and simplest instrument to use.

The actual circuit comprises two components: A coil tuned by a variable condenser. The coil has a loosely-coupled link winding in series with an ordinary flashlight bulb. In practice,

the main pick-up winding absorbs a small amount of RF energy from the oscillating circuit under test, which is induced into the link winding, thus lighting the bulb. Resonance indication can also be observed by the behaviour of the anode current meter of the circuit under test—the anode current will rise as the wavemeter is tuned to resonance, or will give a sharp upwards jump if the coupling is very loose. The flashlight bulb, however, is often more convenient as it enables checks to be made without having to bend yourself double to be in two places at once. Also, the oscillator may not be metered. Where the instrument is to be used only by the listener, the link winding and bulb need not be included, although we strongly recommend that they be fitted—it will save a certain amount of time and work when that transmitting licence arrives one day!

Mechanical Design

The only variations in this simple type of absorption wavemeter that the designer can make concern the mechanical details. Many wavemeters in general use are clumsy, awkward to use and sometimes even dangerous. When very small RF fields are to be checked, as where the apparatus is of compact construction or where the vital coils are “tucked away” in obscure corners, it often becomes difficult to insert the pick-up coil near enough for measuring purposes. Another common drawback is

A HANDY ABSORPTION WAVEMETER

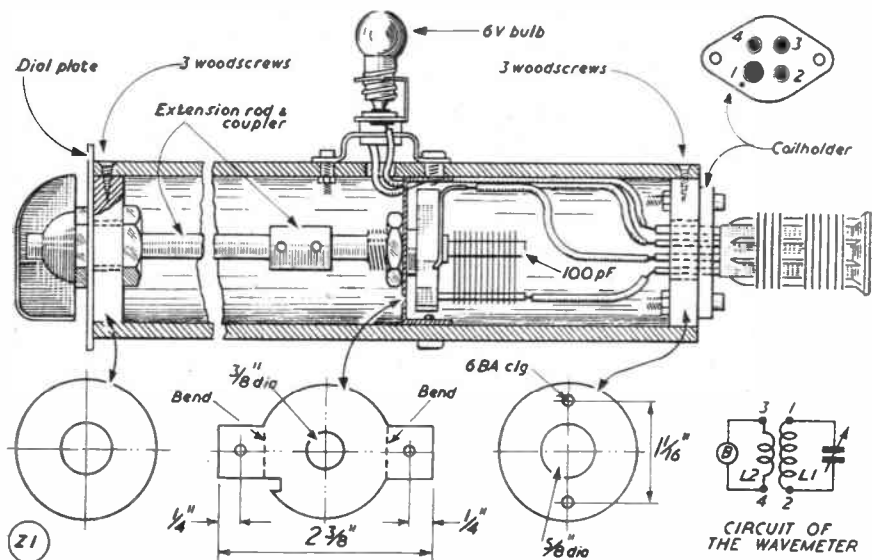

Fig. 1. Drawings show the mechanical construction and, lower right, the circuit of the Absorption Wavemeter. The tubular body permits the instrument to be brought near the test circuit in boxed apparatus.

when the wavemeter is built on a metal structure or in a metal box. Taking the worst combination of faults, imagine inserting the wavemeter into a transmitter to check the output of, say, a PA tank circuit. One hand is grasping a metal box and the other is adjusting a tuning knob within a fraction of an inch from that metal surface. Both hands are inside the transmitter cabinet within easy reach of HT and RF leads. How easy to make just one little slip!

The wavemeter about to be described mainly overcomes these difficulties. In the first place, the body of the instrument is of insulating material, and secondly the circuit can be brought to resonance by "remote control." The sketches of Fig. 1 illustrate the general details of construction.

The body was made up from some paxolin tubing, which the writer had stored in the "spares box." It has an inside diameter of $1\frac{1}{2}$ inches and should be simple enough to find at most radio stores; in any case, the diameter is not important, although the size mentioned

is just about right for the job. After probing about with a piece of this tubing on the receiver and transmitter, a length 9 inches long was sawn off. This again is a matter of personal preference, but it should not be made much shorter, otherwise the object of the design will be defeated.

Coils were the next consideration. Standard $1\frac{1}{2}$ inch diameter plug-in coils were ruled out for two reasons—(1) their size, and (2) the fact that no satisfactory means could be devised of fitting the coil holder neatly to the end of the tubing. The Denco plug-in coil formers were considered but rejected, although they would, of course, have been satisfactory in principle. The larger ones use an octal holder which gets back to the first difficulty again. The smaller type are fitted with cores, and that would have defeated one of the objects of this article—to give calibration curves.

The only suitable formers were the Eddystone miniature type (Cat. No. 763 and 765). In addition to being small

A HANDY ABSORPTION WAVEMETER

physically ($\frac{1}{8}$ " diameter), the holder fits conveniently into the end of the paxolin tubing. To fix the coil holder, a piece of wood about a quarter-inch thick is cut as shown in the diagram. A clearance hole $\frac{1}{8}$ " diameter is drilled and two 6BA holes are needed to bolt the holder to the wooden collar. The coil-holder assembly can then be left until later.

The main job is fitting the variable condenser. This is a 100 $\mu\mu\text{F}$ miniature ceramic air-spaced trimmer, mounted inside the tubing. It is mounted on a metal cut-out, the dimensions of which are given to the diagram. When bolted to the metal cut-out, two leads are

soldered to the tags. They should be of reasonably heavy gauge that will "stay put" when bent to shape, and sleeved. Length: about 3 inches.

A length of quarter-inch diameter paxolin (or similar) rod is then fitted to the rotor spindle by means of a solid coupler, leaving sufficient rod to extend from the rear end of the tubing when the condenser is in position. Some constructors may find difficulty in fitting the nuts to the two fixing bolts which hold the condenser assembly to the tubing. If none of the usual dodges are any use, try using self-threading screws, which were used in the original model. For

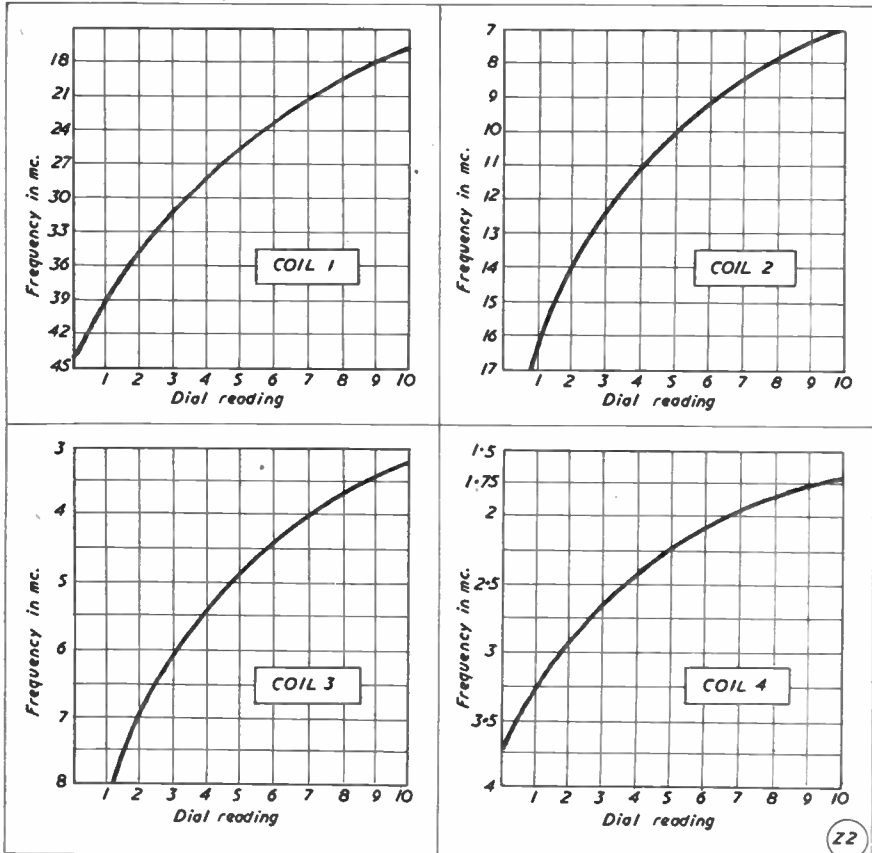

Fig. 2. The calibration curves obtained with the Absorption Wavemeter over the whole of its range.

convenience, one of these holes was also used as one of the fixing holes for the lamp-holder. Note that a larger hole is needed to feed the lamp leads through the tube.

The condenser assembly and the lamp-holder can now be fitted, feeding the lamp leads through two notches cut in the condenser support-bracket. The operating-end is then tackled. Here again a circular piece of wood is needed with one clearance hole in the centre. As the extension rod is some 5-6 inches long, it was considered necessary to fit some kind of bush to prevent "wobble." Anything with a quarter-inch clearance hole can be used, and a search in the junk box will no doubt be rewarding. In the original model, the end nut of an old-type phone jack was used; it has a hexagonal end section, turned down and finally threaded, and has a nice easy slide fit for a quarter-inch rod. When some form of bushing has been fitted and a dial plate bolted on with it, the assembly is slid into the tubing. If the dial plate is made larger in diameter than the tubing, the assembly cannot be pushed piecemeal into the interior of the tube! The assembly is fixed firmly into position by three wood-screws equally spaced around the diameter of the tubing. At this stage, the knob should be fitted. It is adjusted to read maximum on the dial when the condenser (which can be inspected through the other—open—end of the tube) is also at maximum.

All that remains is to fit the coil-holder assembly. The two leads from the lamp are soldered to two of the under-pins, and the two leads from the condenser to the remaining pins. It matters little which pins are chosen, but make sure you have a written note as to which are which! For forgetful types, the pin connections in the drawing of Fig. 1 have been enumerated; if you follow these there will be no mistake.

When soldering the leads to the coil-holder, note that they will have to be bent conveniently because, in the confined space, they may foul the rotor plates of the condenser. After the leads have been snipped off and soldered, make sure the condenser can be fully rotated without touching any stray leads. The coil-holder assembly is then fitted to the tubing as the rear-end assembly—by three wood-screws.

Coil Table

COIL 4	
L1	74 turns of 30 SWG silk covered single enamelled copper wire closewound. Coil is wound in two "layers" of 37 turns each layer.
L2	18 turns of 30 SWG silk covered single enamelled copper wire.
COIL 3	
L1	40 turns of 30 SWG silk covered single enamelled copper wire closewound.
L2	8 turns of 30 SWG as above.
COIL 2	
L1	18 turns of 22 SWG enamelled copper wire, closewound.
L2	5 turns of 22 SWG enamelled copper wire.
COIL 1	
L1	5 turns of 18 SWG enamelled copper wire spaced to 5/8 inch long.
L2	3 turns of 18 SWG enamelled copper wire.

NOTES

Coils 2, 3 and 4 are wound on plain formers (Eddystone Cat. No. 763).

Coil 1 is wound on a threaded former (Cat. No. 765). Both windings are spaced by two grooves; that is, to approximately 10 turns per inch.

All pick-up windings (L1) are started right at the top end of the formers to enable easier coupling to be made with the circuit under test. The link windings (L2) are all started quarter of an inch below the pick-up windings. Note that the degree of coupling between these two windings will affect calibration.

Coils 2, 3 and 4 are given a coat of polystyrene dope to prevent shifting and to protect the covering on coils 3 and 4 which tends to be easily frayed.

Coverage and Calibration

For the original wavemeter, four ranges were provided, giving complete coverage of all the short-wave bands continuous down to and below the 28 mc band. Full details of coil winding are given in a separate table, and the intending builder should strictly adhere to the instructions given.

It will be noted that at the high-frequency end of most ranges the calibration begins to be critical. In actual fact, due to the low minimum capacity of the ceramic variable, calibration between 0-1 divisions on the dial is so cramped as to be almost useless. However, the coils have been designed so that there is suitable "overlap" between successive ranges, so that the cramped portion of one range is available as the

A HANDY ABSORPTION WAVEMETER

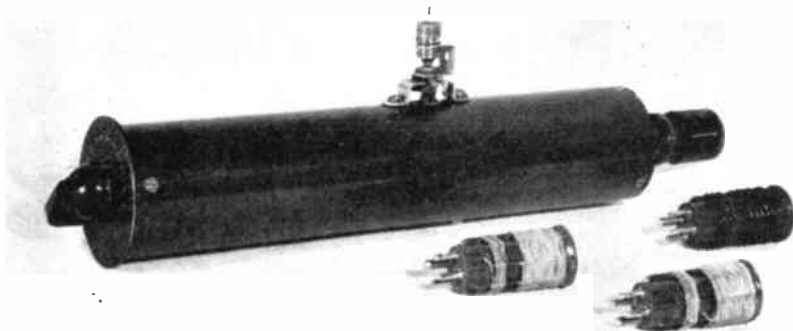

The constructional design of the Absorption Wavemeter described in the article, and see Fig. 1. By the use of a loose-coupled lamp circuit sharp indications of resonance can be obtained. The actual curves given by the model as illustrated and described are shown in Fig. 2.

“flat” portion of the next highest range.

As mentioned in the opening paragraphs of this article, the absorption wavemeter is not a precision instrument. Therefore a few words on the calibration curves given are appropriate. The curves prepared from the original model are accurate for that particular instrument. Slight variations in coil winding may affect the calibration, although there should be no major discrepancy. What is much more important is to realise that the calibration of *any* given absorption wavemeter may vary *according to the circuits being tested and the degree of coupling used.*

Co-operation

When using the wavemeter avoid over-coupling. Unfortunately, many tests require close coupling to obtain adequate pick-up, and if this coupling is too heavy, either the wavemeter or the oscillating circuit (or even both) will be

pulled somewhat out of tune. The effect of this detuning will depend, of course, on the degree of coupling and the type of circuits involved. Working in conjunction with a medium-power transmitter and a superheterodyne receiver, the writer was able (by judicious over-coupling) to obtain overall variations of nearly one division on the scale. As an example—by overcoupling on receiver and transmitter tests it was possible to obtain a “7 mc” indication between 1.2 and 1.8 on the dial.

By using loose coupling, these discrepancies can largely be avoided, but when carrying out tests on the receiver, not that the effect of tuning the wavemeter to resonance may introduce pulling between the RF amplifier and mixer or mixer and oscillator. Close coupling will almost certainly ensure this effect! Despite these slight (and they are slight for practical purposes) inaccuracies, the curves shown will largely hold true providing the coils are wound identically.



SHORT WAVES AND THE AMATEUR

Discussing Interests, Activities and Scope

This informative article tells you in broad outline what is meant by Amateur Radio, and covers in some detail the whole system under which radio amateurs pursue their hobby. Answers to all the problems of the newcomer—and those of many more experienced amateurs, too—will be found under the twenty or so headings into which the subject divides itself by the natural sequence of the discussion.

THE term "radio amateur," as most people are well aware, has gradually come to be associated exclusively with short-wave work. Presumably the keen high-quality enthusiast, the model controller, even the television constructor, have equal rights to be known as radio amateurs—but they are not. An "amateur"—synonymous with a "ham"—is one who is keen on short-wave reception and transmission. His main interest is *communication*, preferably over longish distances.

To analyse the whole vast extent of his interests is a tall order, but it should be possible in one comprehensive article to give a fairly complete account of his major activities. And this, for the benefit of the uninitiated, is our attempt to describe the somewhat specialised world of radio in which our amateur pursues his hobby.

Amateur and Professional

To some people it is strange that so many of these short-wave enthusiasts should call themselves "amateurs" although they are engaged on a whole-time basis in some branch of the radio profession. It is a fact that quite a large proportion of shortwave transmitting enthusiasts are radio engineers, servicemen, retailers or research workers with well-known commercial concerns—even including the BBC and the GPO.

The explanation lies in the fact that Amateur Radio as a hobby is very far

removed from any commercial form of radio. One engages in it purely for the enjoyment of building one's own gear, trying out one's own aerial and control systems, making one's own contacts and, in short, doing what one likes (within the terms of the licence!)

To individuals engaged in almost any aspect of commercial radio, it is nothing but a complete change to be able to sit down at home and talk, by means of either key or voice, to someone in the United States, South Africa or New Zealand. Even if some little time has to be spent on maintaining and servicing the gear, there is quite a different feeling about it! Improving the condition of one's own private possessions is far removed from carrying out routine servicing on a commercial chassis belonging to someone whom one will never meet.

At the other extreme among the amateur fraternity, there are, of course, many thousands to whom it is their *only* interest in radio. Insurance clerks, grocers, postmen, stockbrokers and doctors—practically every occupation or profession is to be found represented among the ranks of the amateurs. To such, the hobby represents a complete and absolute escape from the daily toil and responsibility. Usually, such amateurs are no less capable than their professional brothers, as, indeed, is the case with most other hobbies.

So imagine an extremely mixed array,

spread over some 250 different countries of the world, comprising men and women of every race, every creed and every social stratum. All are able to converse with each other in terms of the common interest—Amateur Radio. Now for what they talk about and how they do it!

Call-Signs and Prefixes

Just as every commercial or service wireless station in the world must be capable of being instantly identified, so with the amateurs. Every amateur (and there are more than 100,000 of them) has his own personal call-sign, usually consisting of a figure followed by either two or three letters. Ahead of this is a "prefix," consisting of either one or two letters, which merely shows what country the call-sign hails from. This combination of prefix and call-sign constitutes a "signature" which is never repeated; meaning that it is a complete and sufficient identification of a particular amateur station. The writer's own call-sign is 6QB, with the prefix G (for Great Britain); there are other 6QB's, such as LA6QB (Norway), SM6QB (Sweden) and ZS6QB (South Africa), but there is no other G6QB. Thus the system is kept in order, and every amateur has his own individual call-sign.

One slight deviation from this simple procedure is perhaps worth a mention. In the case of some British and American possessions (and in other instances also) the figure also forms part of the prefix rather than the call-sign. Thus ZD1 represents Sierre Leone, ZD2 Nigeria, ZD3 Gambia, ZD4 the Gold Coast, and so on. "ZD" alone does not tell you where the station is located. On the American side, KP4 is Porto Rico, but KP6 Palmyra Island; KS4 is Swan Island and KS6 American Samoa. But still the complete call-sign, including the prefix, remains unique to one particular station, and is complete identification of who and where he is.

In the past few years the various national licensing authorities have found themselves running out of letters for amateur prefixes, and a new hybrid has come to be heard on our bands—a prefix consisting of a figure and a letter, instead of the traditional one or two letters. Thus we have a prefix like "4X" for Israel, and the stations have

call-signs beginning with the figure 4 also. The combination produces stations signing 4X4BX, 4X4CL, and so on. From Tunis we have a prefix "3V," giving 3V8AB, 3V8AN, and the like. The latest of these is 4S7 for Ceylon.

In spite of all this, an amateur type of call-sign remains easily recognisable, and should there be the slightest doubt about its status, there is always the matter of the frequency on which the station is heard, for the amateurs are confined to a number of narrow bands.

The Amateur Bands

There was a time when the world's amateurs used a wave-length of 1,000 metres! But those were the days when anything much shorter than that was not considered practicable for "wireless" communication. Their next hunting-ground was on 440 metres, in among the embryo broadcasting stations of the pre-1922 era. Then, when broadcasting started in earnest and mutual interference resulted, the amateurs were moved down to the little-occupied (and less understood) territory between 150 and 200 metres.

Contrary to the expectations of the theorists, it was found that communication on these wavelengths was far more efficient than on the former bands, and the pioneering work of the amateurs led to the establishment of commercial stations on these "very short waves." Gradually the amateurs were allotted shorter and shorter wavelengths to conquer, always with the idea that such wavelengths would be of no use to anyone else; but, thanks to the experimental work of the early amateurs, the whole short-wave spectrum was opened up and the peculiar phenomena of long-distance communication rationalised and understood. The story of the discovery of short-wave radio is, in fact, the story of the amateurs. Time and time again they achieved the "impossible," simply because they *were* amateurs and didn't know it to be impossible.

In the twenties the amateur bands were centred around 175, 90, 45 and 23 metres, until an International Conference straightened things out on a world-wide basis and allotted the present bands of 160, 80, 40, 20 and 10 metres (in 1928). Ever since then these bands have remained, in greater or lesser

LIST OF COUNTRIES BY PREFIXES

Correct to June, 1953

AC3	Sikkim	FP	St. Pierre and	KT1	<i>see</i> EK
AC4	Tibet		Miquelon	KV4	Virgin Is.
AG2	Trieste	FQ	French Equatorial	KW6	Wake Is.
AP	Pakistan		Africa	KX6	Marshall Is.
AR1	<i>see</i> YK	FR	Reunion	KZ5	Panama Canal
AR8	<i>see</i> OD	FT	<i>see</i> 3V		Zone
C	China	FU	New Hebrides	LA	Norway
C3	Formosa	FW	Wallis Is.	LA	Jan Mayen Is.
C9	Manchuria	FY	French Guiana	LA	Spitzbergen
CE	Chile	G	England	LI	<i>see</i> 5A
CM/CO	Cuba	GC	Channel Is.	LU	Argentina
CN2	Tangier	GD	Isle of Man	LX	Luxembourg
CN8	French Morocco	GI	Northern Ireland	LZ	Bulgaria
CP	Bolivia	GM	Scotland	M1	San Marino
CR4	Cape Verde Is.	GW	Wales	MB9	<i>see</i> OE
CR5	PortugueseGuinea	HA	Hungary	MD1, 2	<i>see</i> 5A
CR5	St. Thomas and	HB	Switzerland	MD4, MS4	Italian Somaliland
	Prince Is.	HC	Ecuador	MD5	<i>see</i> SU
CR6	Angola	HC8	Galapagos Is.	MD7	<i>see</i> ZC4
CR7	Mozambique	HE	Liechtenstein	MF2	<i>see</i> AG2
CR8	Goa	HH	Haiti	M13	Eritrea
CR9	Macao	HI	Dominican	MP4	Bahrein
CR10	Timor		Republic	MP4	Kuwait
CT1	Portugal	HK	Colombia	MP4	Trucial Oman
CT2	Azores	HL	Korea	MP4	Qatar
CT3	Madeira	HP	Panama	OA	Peru
CX	Uruguay	HR	Honduras	OD	Lebanon
CZ	<i>see</i> 3A	HS	Siam	OE	Austria
DL	Germany	HV	Vatican City	OH	Finland
DU	Philippine Is.	HZ	Saudi Arabia	OK	Czechoslovakia
EA	Spain	I	Italy	ON	Belgium
EA6	Balearic Is.	I5	<i>see</i> MD4	OQ5	Belgian Congo
EA8	Canary Is.	IS	Sardinia	OQ0	Ruanda-Urundi
EA9	Spanish Morocco	IT	Sicily	OX	Greenland
EA9	Ifni	I/Trieste	<i>see</i> AG2	OY	Faeroe Is.
EA0	Spanish Guinea	JA	Japan	OZ	Denmark
EI	Eire	JA0	Iwojima	PA	Netherlands
EL	Liberia	JY	Transjordan	PJ	Dutch West Indies
EP/EQ	Persia	K	<i>see</i> W	PK1, 2, 3	Java
ET	Ethiopia	KA	<i>see</i> DU	PK4	Sumatra
F	France	KB6	Baker, Canton,	PK5	Dutch Borneo
FA	Algeria		Howland and	PK6	Moluccas and
FB	Madagascar		American		Celebes
FB	Kerguelen Is.		Phoenix Is.	PK6,7	Dutch New Guinea
FB	New Amsterdam	KC6	Caroline Is.	PX	Andorra
FC	Corsica	KC6	Palau Is.	PY	Brazil
FD	French Togoland	KG4	Guantanamo Bay	PZ	Surinam
FE	French	KG6	Mariana Is.	SM	Sweden
	Cameroons	KG6I	<i>see</i> JAO	SP	Poland
FF	FrenchWestAfrica	KH6	Hawaii	ST	Sudan
FG	Guadeloupe	KJ6	Johnston Is.	SU	Egypt
FI	French	KL7	Alaska	SV	Greece
	Indo-China	KM6	Midway Is.	SV	Crete
FK	New Caledonia	KP4	Puerto Rico	SV5	Dodecanese
FL	FrenchSomaliland	KP6	Palmyra Is.	TA	Turkey
FM	Martinique	KR6	Okinawa	TF	Iceland
FN	French India	KS4	Swan Is.	TG	Guatemala
FO	French Oceania	KS6	American Samoa	TI	Costa Rica

SHORT WAVES AND THE AMATEUR

LIST OF COUNTRIES BY PREFIXES

TI9	Cocos Island	VP8	Graham Land	ZC1	<i>see</i> JY	
TT	Tannu Tuva		(Antarctica)	ZC2	Cocos Is.	
UA1	Franz Josef Land	VP9	Bermuda	ZC3	Christmas Is.	
UA1, 3, 4, 6 }	USSR (Europe)	VQ1	Zanzibar	ZC4	Cyprus	
UA9, 0 }		USSR (Asia)	VQ2	Northern Rhodesia	ZC5	British North Borneo
UB5	Ukraine		VQ3	Tanganyika	ZC6	Palestine
UC2	White Russia	VQ4	Kenya	ZD1	Sierra Leone	
UD6	Azerbaijan	VQ5	Uganda	ZD2	Nigeria	
UF6	Georgia	VQ6	British Somaliland	ZD3	Gambia	
UG6	Armenia	VQ8	Mauritius	ZD4	Gold Coast	
UH8	Turkomen	VQ8	Chagos Is.	ZD6	Nyasalaand	
UI8	Uzbek	VQ9	Seychelles	ZD7	St. Helena	
UJ8	Tadzhik	VR1	Gilbert and Ellice Is.	ZD8	Ascension Is.	
UL7	Kazakh			ZD9	Tristan da Cunha	
UM8	Kirghiz	VR1	British Phoenix Is.	ZE	Southern Rhodesia	
UN1	Karelo-Finnish Republic	VR2	Fiji Is.	ZK1	Cook Is.	
		VR3	Fanning Is.	ZK2	Niue	
UO5	Moldavia	VR4	Solomon Is.	ZL	New Zealand	
UP	Lithuania	VR5	Tonga	ZM	Western Samoa	
UQ	Latvia	VR6	Pitcairn Is.	ZP	Paraguay	
UR	Estonia	VS1	Singapore	ZS1, 2, 4, 5, 6 }	Union of South Africa	
VE	Canada (including Labrador and Newfoundland)	VS2	Malaya			
		VS5	Brunei	ZS2	Marion Is.	
VK	Australia	VS5	Sarawak	ZS3	South West Africa	
VK1	Heard Is.	VS6	Hong Kong	ZS7	Swaziland	
VK1	Macquarie Is.	VS7	Ceylon	ZS8	Basutoland	
VK9	New Guinea	VS9	Aden	ZS9	Bechuanaland	
VK9	Papua	VS9	<i>see</i> MP4 (Trucial Oman)	3A	Monaco	
VK9	Norfolk Is.	VU	India	3V	Tunis	
VO	<i>see</i> VE	VU	Andaman and Nicobar Is.	4S7	Ceylon	
VP1	British Honduras	VU		4X	Israel	
VP2	Leeward Islands	VU7	<i>see</i> MP4 (Bahrein)	5A	Tripolitania and Cyrenaica	
VP2	Windward Is.	W	U.S.A.	7B	<i>see</i> PX	
VP3	British Guiana	XE	Mexico	9S	Saar	
VP4	Trinidad and Tobago	XZ	Burma		} <i>Pre-fixes as notified</i>	
		YA	Afghanistan			
VP5	Jamaica	YI	Iraq			
VP5	Cayman Is.	YJ	<i>see</i> FU			
VP5	Turks and Caicos Is.	YK	Syria			
VP6	Barbados	YN	Nicaragua			
VP7	Bahamas	YO	Roumania			
VP8	Falkland Is.	YS	Salvador			
VP8	South Georgia	YU	Yugoslavia			
VP8	South Orkney Is.	YV	Venezuela			
VP8	South Sandwich Is.	ZA	Albania			
VP8	South Shetland Is.	ZB1	Malta			
		ZB2	Gibraltar			

degree, in the hands of amateur transmitters.

But they are not by any means *exclusively* amateur, especially the longer wavelengths. The 160-metre band is

shared with ship-to-shore telephony, lightships, trawlers and all manner of other services; the 80-metre band is shared with Service and commercial stations of various kinds. The 40-metre

band is not even "shared" — the amateurs have been almost forced out of it by broadcasting stations, but they manage to retain their somewhat precarious hold and work "in the cracks" between the high-powered stations which make things so difficult for them.

The other bands are 20, 15 and 10 metres, and these three are, to all intents and purposes, exclusive amateur territory. This is fortunate, for most of all the long-distance work which is the life-blood of Amateur Radio is carried out on these three bands. The 15-metre, or 21-mc. band, was only opened to the amateurs in 1952, although scheduled for their use ever since the end of the war. Work on that band is therefore still in the embryo stage, and no one yet knows quite what its possibilities may be, but they are certainly interesting.

How the Bands are Used

Each one of these bands of wavelengths has its own particular function. All through the radio spectrum there is a constant change in the characteristics of the various wavelengths, and this change is nowhere more apparent than on the shorter waves. For the benefit of the uninitiated, let us simply state a startling fact: That at, say, 1 p.m. in England an amateur with a 10-watt transmitter might put out a call on the 160-metre band. He would certainly not make his signals heard over a distance greater than about 100 miles, and *that* distance would be quite satisfactory communication for *that* band. But the same amateur, with the same transmitter, might put out a similar call on 20 metres or 15 metres, and would probably be heard in the U.S. or Canada—or at an even greater distance.

So, to understand the use of the various wave-bands, we must discuss their particular properties. All long-distance communication on the short waves is dependent upon "skip"—the phenomenon caused by the emitted waves travelling upwards until they are reflected by one of the various layers situated above the earth's surface. They are bent back from this layer until they strike the earth again at a distant point, from which the waves may again be reflected upwards from the earth, striking the layer a second time and being reflected downwards yet again.

All long-distance transmissions are single-hop or multiple-hop signals, because it is not in the nature of radio waves to bend themselves round and follow the earth's curvature. True, there is a "ground-wave" which does just that, but the distance which it will travel varies with the wave-length. On longer wavelengths the ground wave, if the transmitter is powerful enough, will cover hundreds of miles; medium-wave broadcasting reaches you by ground-wave, at least in daylight. (When you suffer from "fading," after dark, you are the victim of "skip"—you are receiving *two* waves. One of them is a steady ground-wave, and the other is a reflected wave, coming down from the sky, and varying somewhat in intensity and other characteristics. The mixture of the two causes the fading that is so troublesome at long distances after dark.) But on shorter wavelengths the ground-wave weakens very quickly and does not travel so far.

Another complication now has to be faced: that the manner in which the all-important reflections from up above take place is dependent upon the time of day, the season of the year, the state of the sun, *and* the wavelength concerned. So the process becomes quite tricky to understand and to forecast.

To simplify it for you, we will consider only two kinds of reception—daylight and after-dark. In *daylight* the longer bands (160, 80 and 40 metres) are mostly confined to short and medium-distance work, coming into their own after dark. This applies most definitely to the 160 and 80-metre bands; the 40-metre band is a kind of half-way case.

The 20, 15 and 10-metre bands are practically daylight bands, fading out after dark. Again, this applies most definitely to 10 and 15 metres, with the 20-metre band in a kind of half-way condition.

So, putting the two previous paragraphs together in another way, we can see that if we want to cover a longish distance (say anything upwards of 1500 miles) we could use 10 or 15 metres during daylight, 80 or 160 metres after dark, and 20 or 40 metres nearly all the time.

Seasonal Changes

As the hours of darkness vary with

the seasons of the year (and also, of course, with the latitude in which we are situated), the use of the various bands to the best advantage has a definite, though not very simple pattern.

The 40- and 80-metre bands come into their own in the winter, when the hours of darkness are long for us; likewise the 20-, 15- and 10-metre bands, during the same season, are more restricted in their hours, since daylight fades quite early in the afternoon and is late coming in the morning.

One of the accompanying Tables shows a very much simplified pattern of the behaviour of the five "DX" bands in the United Kingdom at different times of day. This Table is in two parts, labelled "Summer" and "Winter," but it must be appreciated that the time-table is varying steadily all through the year, and that a separate one should really be given for each month. This simplified version is merely to introduce you to the general behaviour pattern, and is far from correct in details.

Sunspots

We now come to another all-too-familiar snag. The layers in the upper atmosphere or stratosphere are always in existence; but they move about! Their height above the earth varies, and their condition for reflecting radio waves also varies. One of the chief causes of these variations is the radiation from the sun. It is this which causes "ionisation" of particles in these layers, and it is the phenomenon of ionisation which affects the way in which the layers react to our radio waves.

The reflecting layers (they are at two main heights, but there may be three or even four layers) are in a constant state of turbulence, rather like roughish water in a pond, and they are also constantly changing their heights, not only with the movement of the earth, but with the rotation of the sun on its own axis, and with a long-term (eleven-year) cycle of sunspots. So our short-wave communication is always dependent upon what we all call "conditions," and these conditions do not vary in any simple manner. The forecasting of the propagation conditions has only recently become organised, and it is an extremely complex business.

To all the above variables we must add another. It is not possible to say

that at a certain time, on a certain wavelength, it will be possible to communicate over, say, 5,000 miles. This would imply that the possibility covered every direction, and it certainly does not. Contacts over a North-South path are possible under much worse conditions than East-West contacts. This is partly because both ends of a North-South path are in the same Time Zone; in an East-West direction we have to face the additional hazard of one end being at 8 a.m. and the other at midnight (or, of course, one end being 8 a.m. and the other being 4 p.m.). So that communication on a "daylight" band, while feasible for one station, is impossible for the other.

To avoid confusing the issue beyond all explanation, we can relieve your anxiety about all these variables by saying that they do all condense down into a kind of pattern of behaviour for the various bands. Table I shows the kind of communication that is possible on a normal day, on five of the bands concerned—80, 40, 20, 15 and 10 metres. There is a certain amount of overlapping, as you will see, but to maintain contact with any part of the Globe for long periods it is necessary to use all bands at their most effective times.

So much for the natural hazards that beset us on the short waves. They are most important, and a fair understanding of them is necessary before one can make any sort of sense out of short-wave work, whether it be just listening to broadcast stations, following the amateurs, or actually transmitting.

The Amateur Set-Up

For those who have evolved some slight interest in the amateur fraternity and are now at the stage of wondering what they do and why they do it, it is necessary to delve back into the history of the movement. "Amateur" transmitters were, originally, a band of experimenters who were granted licences to carry out their own scientific work in the newly-discovered art of wireless telegraphy. The early amateurs played with spark coils, coherers, magnetic detectors and all the familiar apparatus of the old-time electrical laboratory.

Being amateurs in the strict sense of the word—meaning that they were not harassed by any commercial requirements and were free to go ahead and

TABLE 1 (A)—SUMMER, 1953

Band	EUROPE	N. AFRICA Middle East	ASIA	N. AMERICA	S. AMERICA	FAR EAST PACIFIC	AUSTRALIA	NEW ZEALAND	SOUTH AFRICA
80 METRES	All Times	2000—0800	0001-0400	2200—0800	0001—0400	Improbable	1800—2000	0600—0800	Improbable
40 METRES	0800—2200	All Times	2300-0500	2100—0800	2300—0600	1400—1600 0001—0500	2200—0200	2200—0100 0600—0900	1900—2100
20 METRES	0800—2000	0800—2300	1300-1800	0600—0800 1200—1800	0600—0800 1900—2300	1100—1400	1200—1400	0700—0900	1700—2000
15 METRES	Erratic	0900—1800	1000-1600	1200—1700	1200—1900	0900—1200	1000—1200	1000—1200	1400—1700
10 METRES	Erratic	1000—1500	1000-1400	Improbable	1200—1700	Improbable	Improbable	Improbable	1200—1900

TABLE 1 (B)—WINTER, 1953

Band	EUROPE	N. AFRICA Middle East	ASIA	N. AMERICA	S. AMERICA	FAR EAST PACIFIC	AUSTRALIA	NEW ZEALAND	SOUTH AFRICA
80 METRES	All Times	1800—0800	2200-0400	2100—0900	2200—0500	2300—0200	2000—2300	0500—0900	2000—2300
40 METRES	0900—2100	All Times	1900-2400	2100—0900	1200—0500	1400—1700 0001—0300	1900—2400	0600—0800	1800—2200
20 METRES	0900—1700	0900—1900	1100-1600	1200—1700	1600—2100	1200—1500	0800—1000	0700—1000	1600—1900
15 METRES	Erratic	1000—1600	1000-1400	1200—1600	1200—1800	1000—1300	1000—1100	1000—1200	1300—1800
10 METRES	Erratic	1000—1600	Improbable	Improbable	1000—1500	Improbable	Improbable	Improbable	1200—1700

These Tables give the approximate times in GMT when signals on the different bands can be expected from the areas indicated. The Summer Season can be taken to be until mid-October this year, and the Winter Season from October 1953 until March 1954. As implied in the text, these are forecasts based on reasonable probabilities, but they should not be read as firm predictions. All DX paths are subject to numerous irregularities, so that the true picture can only be built up from the results actually obtained.



Throughout the country, there are many Club groups and local organisations devoted to the hobby of Amateur Radio. Some of these periodically put on public demonstrations, or take part in local exhibitions. This fine display of equipment was shown at the Morecambe and Heysham Hobbies Exhibition, promoted by the Rotary Club of that area during April last, and the Stand pictured here represents the co-operative effort of the Amateur Radio enthusiasts of the district. A live demonstration was given with a fully operational station working in the 80-metre amateur band, and many over-the-air contacts were made from the stand during the run of the Exhibition. A special card for G3BAP/A was minted for the occasion.

Photograph: "Morecambe Visitor"

find things out just for their own edification—they naturally did some unconventional things. These led to discoveries of the type made by true amateurs in any sphere—discoveries of strange and (then) unexplained phenomena which have since become perfectly understood.

But the main thing to remember is that the early amateurs were granted their licences for *experimental* purposes—not just for the purpose of talking to each other if and when they could. Indeed, in Great Britain the amateur licence was an Experimental Licence right up to September 1939, when they were all suspended. Since the war we have been licensed as *amateurs* with permission and authority to *communicate*, and there is no definite obligation to carry out any experimental work.

The good old tradition, however, has persisted, and thus you will find that amateurs, all over the world, talk more

about their home-built gear, their tests and experiments, and, most of all, their results, than about non-radio matters. Thus they have acquired the name, among the general public, of being a group of people whose chatter is quite unintelligible; in fact, of being a somewhat eccentric or even freakish crowd of fanatics.

This, admittedly, is just what they sound like to the uninitiated. Nothing could be less intelligible to the casual listener than two amateurs discussing the latest "mod" to some Government-surplus gear (especially as many of them use queer abbreviations and slang terms unknown even in the radio industry!) But it all adds up to a certain amount of sense when you know the jargon.

A Typical Contact

Everyone visiting an amateur station for the first time asks the same ques-

tions: "How do you call somebody, and how do you know he is there?" The answer is that we only call somebody if we *do* know he is there! The good and considerate operator, whom we will talk about for a while, will go about things like this:—

Switch on and warm up. Listen round, on the band on which work is to be carried out. Note a station calling "CQ" (universal radio abbreviation for "all stations"). Silently tune the transmitter so that it is ready to operate on the same frequency as the calling station. When the "CQ" has finished with the words "G3XYZ" standing by, or "G3XYZ listening," call him. If on telephony, the form is "G3XYZ, G3XYZ, G3XYZ, this is G3ZYX, G3ZYX calling" repeated, perhaps, three times), concluding with "and G3ZYX is standing by (or "listening," or "over")."

Then, if the other station has heard our specimen amateur, he will immediately come on in reply to him, and a two-way contact will result. This is not a "duplex" contact, like a chat on the telephone, as neither station can talk and listen at the same time. So the "over-to-you" technique is used, with each station transmitting for not more than about five minutes at a time before listening for the other's reply. During the course of the contact, another station or stations may want to break in and make a threesome or foursome of it (this, by the way, is a post-war habit and perhaps not altogether a good one). To do this without causing annoyance is a tricky business and involves setting the third's man's transmitter dead on the frequency of one of the others, then giving a quick call at the exact moment when one of them goes over.

So, just as G3XYZ has said "G3XYZ over for G3ZYX," before 'ZYX has had time to switch his carrier on, 'XYZ will hear the third man (call him G3YYY) say "And G3YYY is standing by on the frequency." So the other two will know that he is there and will probably forge a place for him in the scheme so that the three always work round in the same order. Other stations may join in from time to time.

Amateurs who favour these multi-way contacts (and not all of them do) will usually leave a pause for the express purpose of seeing whether anyone else

wants to break in. So you will hear "G3XYZ standing by for G3ZYX, with a pause"—and a few seconds of silence between transmissions, to give the possible breaker-in an opportunity to do so.

All this, of course, has dealt with a typical contact on telephony. But rather more amateur work is carried out on CW than on telephony, and to cover the entire amateur world you will doubtless want to familiarise yourself with the Morse code and its method of use.

A CW Contact

The procedure is almost the same. Our specimen station will be found calling CQ again, but, in Morse, he will be sending "CQ CQ CQ de (from) G3XYZ G3XYZ G3XYZ." This will be repeated three or four times, ending with "AR (end of message) K (transmit)." And the replying station will come up on, or near, the same frequency, sending "G3XYZ G3XYZ G3XYZ de G3ZYX, G3ZYX G3ZYX . . . AR . . . K." So 'XYZ now knows that the 'ZYX has heard him, is listening on the frequency, and ready for a two-way contact. And so it proceeds, with the traditional "AR . . . K" instead of the "Over to You." There will not, in general, be breakers-in on a CW contact, unless one of the stations is in a particularly rare corner of the world and countless other amateurs are anxious to get him. In such a case patience often runs out, and the contacts must be cut very short in order to give everyone a chance.

Operating sometimes becomes so short-tempered that many stations can be heard calling the rare bird even while he himself is sending, and the general pile-up of jamming on his frequency is one of the problems that we have to contend with to-day. But the average CW contact is a simple two-way affair and does not often turn into a multi-way "net," like a phone contact.

Translation Needed

Now we arrive at the stage which baffles the newcomers. Whether the contact is on phone or CW, many strange sayings and abbreviations will give the impression that Amateur Radio is an esoteric hobby which makes sense to none but the initiated. To a small degree this is correct, but the codes and ciphers employed are very simple, avail-



Amateurs are ever resourceful. To get good radiation characteristics when transmitting on the 160-metre band, it is desirable to have an aerial as high and as long as possible. W1BB of Winthrop, Mass., U.S.A. lets his up on a kite-balloon (termed a "Kytoon") and in this photograph we see him with the winch gear and the radio-frequency matching and coupling unit in its weatherproof housing.

able to all and, really, quite sensible.

It may come as a shock to tune in your very first amateur and to hear an apparently sane and sensible human being saying "Very glad to QSO, old man, but you're only RS 4 and 6 with heavy QSB and a certain amount of QRM. The name here is Honolulu America Radio Radio Yesterday"

A translation of the above would read "Very glad to make contact with you, old man, but your signals are only readable with slight difficulty and fair strength, with heavy fading and a certain amount of interference. The name here is Harry. . . ."

Most of us deplore the phonetic spelling of simple words like the name, but

that is the sort of thing you will hear, and you may as well be prepared for it. And, in particular, the use of place names for phonetic alphabets is remarkably silly, but it seems to be a tradition that has grown up in certain quarters, and many of its devotees simply can't be made to alter their technique.

This is seen at its worst when used for prefixes and call-signs. You may switch on and hear "This is Libya" . . . but actually you are hearing "This is Libya America Number Five X-Ray X-Ray," or, in other words, LA5XX, a station in Norway and nothing to do with either Libya or America. But there it is!

The "Q" Code

The "Q" Code was devised for general communication purposes and contains a whole series of abbreviations applicable to commercial radio. The amateurs have, however, adopted it for themselves (somewhat modified), and you are almost certain to hear them using the abbreviations shown in the table of Q Code Signals.

There are many more official "Q" signals, but the above are those mostly used (and "intelligently misused" by the amateurs. On CW they also use several other recognised abbreviations, most of which are obvious, such as "Ur" for "Your"; Cuagn" for "See you again," "Tks" for "Thanks"—and so on. Strictly speaking, the "Q" signals should only be used on CW, but they are very frequently and rather unnecessarily, used on telephony as well.

The DX Craze

It has already been made clear that the different bands give quite different results, since the distances they cover vary considerably. This also gives rise to the fact that they are put to very different uses and, one might almost say, are used by different types of people.

The letters "DX" originally stood for "distance," in the sense of "My DX from you is 3000 miles"; but nowadays they mean something much more mystic and hard to define. The art of working DX is the art of contacting more stations, and particularly more "rare" ones, than the man next-door. DX work is long-distance work, but, to illustrate our point, one solitary station

in the Solomon Islands is better "DX" than twenty stations in New Zealand, although the actual distance is not so great.

These solitary stations are much sought-after just because they are so elusive and difficult to work. It is almost as though the amateur, having broken down the barriers of sheer distance, had to set himself another and more difficult goal, by setting out to fill up all the gaps in his coverage. It is quite natural that any amateur, keen on long-distance working, should want to see how many areas of the globe his signals really *do cover*; and the amateur population of the world is so widespread that a grand opportunity presents itself. Some of the world's leading operators have worked nearly 250 different countries out of a possible total of roughly 269.

The difficult problem of "When is a country not a country?" has to be solved every now and then by consultation between the various national societies and the writers of the various DX columns throughout the world, but there are now only a very few doubtful cases.

Thus the incessant quest for DX means that an amateur station in Saudi Arabia is quite a nice "catch" but by no means a rarity; when, however, the same station moves itself across the border into the territory of Yemen (recognised as a separate country and with a prefix of its own) he becomes a fabulous collectors' piece and everyone in the world is on his tail at once!

This gives a hint of the implications of the term "DX"—and, as you might imagine, some sort of proof of contact is essential.

The QSL System

Many years back a British operator, G2UV, startled the stations he contacted by following up his chats over the air with a post-card, bearing details of his station and also the signal "QSL" (meaning "Please acknowledge"). This certainly started something; brighter and better cards were produced, usually with the call-sign in brilliant colours and large letters, and someone had the brain-wave of papering the walls of the station with these trophies.

The craze became the fashion and an essential part of Amateur Radio, and no

SHORT WAVES AND THE AMATEUR

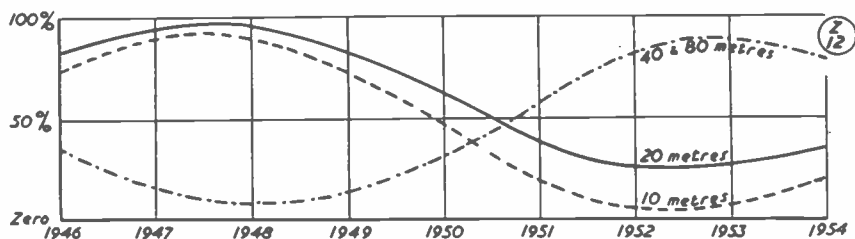

Showing what may be termed the relative usefulness of four of the amateur communication bands for long-distance working, as affected by the eleven-year cycle of solar activity.

good DX contact was complete until the other fellow's "QSL card" had been received. QSL's were regarded as the final proof of a contact and a deterrent to one or two optimistic spirits who were given to drawing the long bow. As the number of amateur stations increased, it became expensive to QSL every contact by direct post, and so the system of "QSL Bureaux" grew up. In each country of any importance there is now a Bureau (and in many cases more than one) which takes care of all the outgoing cards, sorts them and despatches them to the various addresses; and, conversely, receives the incoming cards from the other Bureaux throughout the world, sorts them and sends them to their destinations in the home country. Users of the Bureau merely keep it supplied with a few self-addressed, stamped envelopes, and as soon as a few cards accumulate for each owner of envelopes, they are put into one and duly despatched.

This cuts QSL costs down to a minimum, as the international traffic in these cards now takes place largely by means of fat parcels instead in individual cards.

All kinds of designs have been developed since the early days, in which the convention was to have a rather full description of the station, with spaces, of course, for the signal report, and a huge overprint of the call-sign. These gave way to more individualistic and more artistic designs, and some of the cards from remote parts are now very interesting souvenirs. Many people even regard them as too good to impale on the wall with drawing-pins, and they either file them in a cabinet or keep them in an album.

Certificates and Awards

Once it was realised that a QSL card could be regarded as a satisfactory proof of contact, it was obvious that the demand for various trophies and certificates should arise. One of the earliest, for instance, was a "Worked All Continents" certificate, issued by the ARRL and universally known as a WAC. This was no mean feat back in 1925 and thereabouts, when contacts between Europe and Australasia had only just been made for the first time, and the original WAC-holders had something they could really be proud of—but they could not claim this award, or any other, without the production of the QSL cards. And so it has been ever since, with the list of available awards growing and growing until, nowadays, the hard worker should be able to paper, not only his radio room but the entire house, with certificates of this and that!

After the WAC came the WBE (Worked British Empire). Then, for really top-notch operators in pre-war days, came the DXCC (DX Century Club), to become a member of which meant working 100 different countries. This was no mean feat in the 1930's, but nowadays many members of the DXCC have over 200 to their credit.

The WAZ (Worked All Zones) was based on a division of the world into 40 different zones, some of which presented a really difficult problem. Particularly tough was Zone 23, which included only Tibet and the remoter parts of China and Mongolia! For many years the only station in this huge zone was AC4YN in Lhasa, Tibet, who became quite fabulous and was undoubtedly "the rarest DX in the world."

From these beginnings, it now seems that almost every national society has originated its own particular awards. So we have a WAVE for Canada, a WASM for Sweden, a DUF for France and the French Colonies, a WAB for Brazil, and so on almost *ad infinitum*.

SHORT WAVE MAGAZINE has originated five Certificates for DX workers: The Magazine DX Award, a very difficult goal to aim at (only two have been issued)—for worldwide work on five different bands; the WFE (Worked Far East); the WNACA (Worked North American Call Areas); the FBA. (Four-Band Award); and the WABC (Worked All British Countries)—the latter being for the 160-metre band only.

So QSL cards in bundles of various sizes continue to circulate briskly around the world in order that keen DX men can collect more and more trophies as some sort of return for their concentration and burning of midnight oil.

For the Listener

Keen short-wave listeners, while not trafficking in QSL cards to the extent of the transmitters, do, of course, send out postal reports to rare stations that they hear, in the hope of receiving a QSL in return. Discriminating reporters do well in this respect, by writing only to stations that do not appear to be receiving many replies to their calls; by confining themselves to the wave-bands on which DX reception is less easy; and by keeping a watch on one particular station and sending a useful "period report" covering, perhaps, many days or even weeks.

QSL cards are not invariably forthcoming in return for listeners' reports. A station with an outstanding signal, especially if he be rare DX from the Cook Islands or Tristan da Cunha, will have no difficulty in working scores of amateurs whenever he comes on the air. All these transmitters will naturally want a QSL from him; and if he is deluged with dozens of listeners' reports as well (which will tell him very little that is news to him) he may well give up the whole business as too expensive or too time-wasting.

But the fact remains that *some* short-wave listeners, who are intelligent in their choice of stations to report on, and who often succeed in winking out some

very weak signals that are not being replied to, do acquire extremely good collections of cards for their trouble. By specialising, for instance, in DX on 40 or 80 metres, it is possible to hear stations to whom it really is news that their signals are getting as far as this and they are duly grateful, and QSL.

Among the leading short-wave listeners in this country you will find "scores" of over 100 countries heard on 80 metres; nearly 200 on 40 metres; well over 200 on 20 metres; and perhaps 150 or so on 10 metres. The over-all score of countries heard may be over 240.

But not all listeners are as keen as this on DX work, and some, with little or no knowledge of the Morse code, confine their energies to 'phone transmissions, their scores therefore being considerably lower.

Much amusement may also be derived from listening merely to the local and semi-local stations; in fact, it is probable that the vast majority of short-wave listeners are by no means keen on DX for the sake of DX. On the 160-metre band there is a very friendly collection of British stations working 'phone, as well as CW. Many of *them* are glad of listeners' reports on quality of transmission; and even if you are an SWL and never bother to send out postal reports, you soon feel that you are part of the scheme of things. You find that certain transmitters become quite old friends, and when the supreme moment comes for you to take out your own licence, you know the ropes. And you find that you can join in the fraternity of transmitters without making yourself look foolish, because the "procedure" and the jargon are so well-known to you by then.

Every new transmitting operator on the air has "served an apprenticeship" of at least some time as a short-wave listener; and there is no training to compare with it. It is rather like learning road sense by riding a bicycle before aspiring to the ownership of a small car.

Many ex-Service receivers are now available which, with slight modifications, put up really excellent performances on the amateur bands. They are, in fact, largely used by the transmitters, relatively few of whom can aspire to receivers specially built for amateur-band reception. Home-built receivers

SHORT WAVES AND THE AMATEUR



What will be a not uncommon sight in many parts of the country this summer—an amateur station operating in the open, under what is known as "field day" or "portable conditions."

are even more fascinating and give as much scope for skill and knowledge as home-built transmitters—probably even more so.

But the complete newcomer should be warned that we are now right in the trough of the eleven-year cycle of sun-

spots and that conditions this year are very discouraging. Throughout this summer real DX may be quite difficult to come by. Next winter, too, may be a very dull season for DX. But we are just about at the bottom of the trough, and we have five or six years of steadily-

improving conditions to look forward to—an encouragement to start short-wave work *now*.

Contests and Competitions

Most of the Certificates and Awards already mentioned may be gained in the course of one's ordinary radio operating. Casual contacts are just as likely to count for a future award as any other kind of contacts. But, naturally, the intensely competitive spirit of the hobby demands some organised contests, and these now exist in plenty.

Usually held at week-ends, there are several worldwide Contests which stir up a tremendous amount of activity on all bands. The annual *ARRL DX Contest* is probably the oldest-established event of this kind, and occupies no fewer than four complete week-end periods of 48 hours each. Two of these are devoted to CW and two to telephony. In this contest the amateurs of the USA endeavour to work as many foreign countries as they can, on all bands; while the stations outside the USA score their points according to the number of U.S. and Canadian "districts" they contact. (USA, Canada, and many other large countries are divided up into numerical districts, the number in the prefix indicating which part of the country the station is located in).

In such contests as this one, it is usual for the number of basic points to be decided by the number of actual contacts; but there is then a "multiplier," representing the number of different countries (or Districts) worked on each band. So huge scores are piled up by the leading stations, with thousands of contacts and a multiplier of something over 100!

The *CQ DX Contest*, traditionally held in the autumn (the *ARRL* event is in the spring) leaves everyone free to work as many other countries as possible, and the multiplier tends to be even larger, for it represents the number of Zones, as well as countries, worked.

The *RSGB's* big event is the *BERU* (British Empire Radio Union) Contest, embodying the features of most of the others, but confined to stations in the British Dominions and Colonies. They are grouped into Zones (not the same as the *CQ* system of Zones) to decide the "multiplier," but the scoring system, instead of involving actual multiplica-

tion, is based on the award of high points for the first contacts with each Zone, tapering off until each contact only scores one point (the first contact scores 15).

Other large-scale affairs are run by other national societies (not forgetting the Russians, who confine their activities to the countries within the Soviet Union and the satellites, and seem to sponsor some sort of contest almost every week-end!).

Other events in the competitive world are "Top-Band" (160-metre) Contests, Field Days, Club Contests (the "MCC," or *Magazine Club Contest*, organised by *SHORT WAVE MAGAZINE*, is a popular and interesting example) and all manner of semi-private feuds run by small local societies and clubs.

In most of these affairs there is scope for the receiving enthusiast as well as the transmitter; and even if he does not formally enter for a contest, the much-increased activity which results from the bigger events rewards him handsomely for a week-end's listening.

Results to be Expected

For the benefit of the absolute novice at the art of short-wave reception, it is probably necessary to give some idea of the sort of results that should be expected this summer. Bearing in mind that conditions are unusually poor, especially on the shorter bands, we will not attempt to predict conditions on the 10-metre or 14-metre bands. On 20 metres, however, it is still possible with the simplest of gear to hear several continents, if not all of them, by careful choice of listening time.

On "Twenty," whether you are listening to phone or CW, it should be possible to hear the United States coming across on three days out of five, the best times being 1200-1400 GMT and again from 1600-1900 GMT. These times are roughly right for May, and the evening period will extend during June and July to a much later hour.

South Africa should be expected between 1700 and 2000; South America from 2000 onwards; Asia is somewhat elusive and thinly populated with amateurs, but is often there between 1400 and 1700. Europe is always present (unfortunately) with signals strong enough to blot out much of the DX. Thus we are left only with



An interesting amateur station photograph—YU2DB of Zagreb, Yugo-Slavia, with his display of QSL cards.

Oceania. Normally, in a good year, the Australians and New Zealanders are very prolific and very strong in the mornings between 0600 and 0900 or later; but in these lean years they are rather erratic and may not be heard at all for long periods.

In this particular summer the pattern seems to be that New Zealand comes in before 0800 and Australia around mid-day—but this is not the normal behaviour.

All the foregoing covers the 20-metre band only, and it is, nearly always, the best all-round band for DX work.

Listening on Forty Metres is much more trying, as the band is full of broadcast and commercial stations, with the amateurs only audible "in the cracks." You will not extract much DX phone from the band until you are really expert at listening to weak signals through strong interference.

For CW reception things are a little easier, and at the low-frequency edge of the band (roughly 7000-7050 kc) you should hear plenty of North and South Americans late at night and, in fact, through most of the hours of darkness. South Africa can be heard in the even-

ings (1800-2100 or thereabouts) and Oceania very often at 2300 or midnight. Asia is very seldom heard on the band under our present bad conditions, but the best time is probably in the late evenings. New Zealand, in particular, is quite likely to come in well in the early mornings (0600 onwards).

On the 80-metre band there is no DX to be found except during the hours of darkness—or thereabouts. When conditions are good a few New Zealanders will “hang on” quite late, and they have been heard here, in the winter, right up to 0900. But the peak is earlier. The usual pattern is for South Africans to be heard fairly early in the evening, South Americans later, North Americans at almost any time of the night, and Oceania in the early morning.

Sometimes, however, Australia makes itself heard in the early evening, although Asia (scarcely ever heard at all) tends to arrive after midnight. DX signals on this band are weak, and local signals stronger on other bands—so 80-metre DX is difficult.

Listening and Concentration

New converts to short-wave listening are apt to think that they have only got to turn the dial of their receiver until they hear a signal, loud and clear, to become experts in the art of DX-chasing. Alas! a disillusioning awaits them. The “loud and clear” signal is nearly always a European. The most interesting signals are usually the weakest ones, and the really rare DX is not only weak but usually half-buried under local jamming.

As the sunspot cycle progresses and conditions improve, this will not always hold good. Back in 1947 one could hear almost any country in the world, on 10 metres, at S9 on phone—merely by picking the right time and having a certain amount of luck with the right day. Nowadays, however, it would be a miracle if this happened, and we must all resign ourselves to one or two more very lean years before the DX begins to pour in again at full strength.

So never neglect anything because it is weak and apparently unreadable. By concentration it may be possible to winkle it out from the jamming (and the jamming may even cease for a while!)—and then it will be just the signal you have been looking for. You may even be the only one to hear it, but in that

case it is safe to assume that it must have been very weak and very badly jammed.

Needless to say, a selective receiver, rather than a noisy one, is a prized possession. Such aids as converters and pre-selectors are extensively used, and the receiving aerial itself is of great importance. Never be deluded into thinking that “a piece of wire” is good enough for reception; the better the aerial, the better the results. Most transmitting amateurs use their transmitting aerials for reception, and this is usually why some of our less expert SWL's often hear a transmitter (even in their own neighbourhood) working someone that they cannot even detect. The aerial is everything.

If you are interested in several bands a long wire is probably the most useful. If you specialise in one band, a dipole (folded or otherwise) is excellent. Vertical ground-planes are another type that has become popular, and they have the peculiar advantage of reducing the strength of semi-local signals (up to 1000 miles or so), thus making the real DX easier to find. But a detailed description of aerial types is outside the scope of a general article of this nature.

Telephony or Telegraphy

These two separate types of communication are both used extensively, for a variety of reasons. A CW signal will be audible, and readable by a good operator, when it would be quite impossible to make telephony intelligible. Thus CW is the ideal medium for low-power work, for high-power work when conditions are bad, and for long-distance work on bands where it is not usually feasible. Only when the transmitter and the receiver are both capable of producing a good strong CW signal is it practicable to communicate on 'phone.

Telephony means extra complications at the transmitting end, and extra concentration or skill at the receiving end—unless one is just interested in listening to the 'phones that roll in without any trouble.

Some telephony enthusiasts look upon CW as a primitive and outmoded means of communication, just as some CW experts are unduly prejudiced against telephony and regard themselves as the true progressives. In fact, of course, there is scope for both systems; the

faithful band of CW users have developed an extremely friendly means of communication out of mere dots and dashes, and the telephony stalwarts have practically invented their own language!

One fact should not be overlooked—that by virtue of natural laws it is inescapable that CW occupies less room on the bands than telephony does; likewise that phone causes more interference to CW than *vice versa*.

The bands are not officially divided (except in the USA and a few other countries) for phone and CW, but there is an unofficial understanding, or "band plan," among the national societies. The result of this is that, in theory, the CW is confined roughly to the lowest 100-kc stretch of each band, telephony occupying the rest.

In the case of the 10-metre band (28000-29700 kc) we have a division of this kind:—28000-28200 kc, CW (world-wide); 28200-28500 kc, Phone (except USA); 28500-29700 kc, Phone (USA). But this does not mean, of course, that that wide stretch of the band cannot be used by anyone who pleases. The fact is that when the USA phones are active within it, it is not an easy place to squeeze into.

All the other bands are much narrower, the USA phone allocation being proportionately smaller (for instance, 14200-14300 kc in the 20-metre band).

Listeners who are not familiar with the Morse code will, of course, be somewhat restricted in the DX they can hear, especially when conditions are bad. CW stations continue to come in from many countries whence it would really be an achievement to hear phone; and some rare countries, represented, perhaps, by only one amateur station, may not even have a phone transmission on the air at all.

Modern Procedure

Amateur procedure, in general, has changed a lot since the pre-war days. It has had to—by virtue of the enormous increase in amateur activity, and therefore in QRM (see list!) In the old days, when none of the bands was really populated to bursting point, G3XYZ would transmit, probably using crystal control, on any convenient frequency within the band; if he called CQ, he would listen round the whole of the

band for a reply. If he called another station, he would still transmit on whichever crystal frequency he happened to be favouring on that particular day.

Nowadays, however, it is the custom (or, rather more emphatically, one might say the rule) to call stations *on*, or *near*, their own frequency. Crystals are no longer the last word; it is everyone's ambition to make and use a VFO (variable frequency oscillator) that *sounds* just as good as a crystal but leaves one free to settle on any spot in the band.

So if G3XYZ calls CQ today, he will expect to hear replies within a hairs-breadth of the spot on the dial where his own transmission comes in, on his own receiver; and he will probably not bother to tune more than 5 or 10 kc on either side of that spot. Likewise, if he hears a desirable DX station calling CQ, he will hurriedly adjust his own VFO

DISCUSSED IN THIS ARTICLE

Amateur and Professional
Call-Signs and Prefixes
The Amateur Bands
How the Bands are Used
Seasonal Changes
The Amateur Set-Up
A Typical Contact
A CW Contact
" Translation Needed "The Q Code
The DX Craze
The QSL System
Certificates and Awards
For the Listener
Contests and Competitions
Results to be Expected
Listening and Concentration
Telephony or Telegraphy?
Modern Procedure
Nets and Parties
Summary

Do You Know All The Answers ?

to that frequency and reply on the other station's own spot.

This has its advantages—it confines the QRM caused by one rare station and all his callers to a few degrees on the dial. But that can also be a disadvantage, and often the unfortunate G3XYZ, switching over hopefully to his receiver to see if the DX is replying to him, can hear nothing but dozens of other stations still calling the DX man—with longer calls than he himself put out. And when the DX man returns to one of the crowd who called him, he, in turn, may not be able to hear the station of his choice because of the antics of all the others on the same frequency.

From the listener's point of view, this VFO procedure can be quite helpful, since, if he hears a strong station calling or working one that intrigues him, he has only to stay around the same frequency and he will probably hear the other end of the contact as well. The most successful short-wave listeners are those possessed of plenty of patience—to such an extent that if they merely hear a rare station being *called*, they will probably be content to stay near the spot for an hour or two on the off-chance of hearing the DX man finally emerge in a clear spot.

Nets and Parties

Quite separate from the DX-chasing fraternity are the many stations who are content to work regularly, or, at least, very frequently, with the same locals or semi-locals. These people form themselves, for convenience, into "nets"—several stations working on one spot-frequency and taking it in turn to transmit. This is an excellent procedure if someone is in control and brings the various stations on in the correct order. Often, however, the net is very much out of control, and sometimes seven or eight stations will all be in a considerable muddle as to whose turn it really is. In this case all the arguments cause a considerable waste of time and space, especially as someone has just dropped out and someone also has come in! But it makes entertaining listening of a very lazy variety, for all that the listener has to do is to sit back and let his receiver and loud-speaker do the rest.

In the USA there are large numbers of nets, some of them concerned with Civil

Q CODE ABBREVIATIONS AND MEANINGS

QRG :	Frequency (in kc)
QRI :	Tone
QRJ :	Signals are weak
QRK :	Signals received
QRL :	I am busy
QRM :	Interference
QRN :	Static
QRO :	High power
QRP :	Low Power
QRQ :	Send faster
QRS :	Send slower
QRT :	Stop transmitting
QRU :	I have nothing for you
QRV :	I am ready
QRX :	Stand by
QRZ :	You are being called by
QSA :	Readability
QSB :	Fading
QSC :	Faded out
QSL :	Acknowledgment (see text)
QSO :	Contact
QSP :	Pass message
QSV :	Send series of V's
QSY :	Change frequency

Defence and some with the Military Amateur Radio Service (MARS), but in this country the amateurs are all strictly amateur and no emergency services or training programmes are, at present, allowed. One could wish, however, that some of the nets and parties were organised as if they had some serious object in view, for they certainly sound pretty wild at times.

Summary

It would indeed be difficult to describe the peculiar world of Amateur Radio in the course of a few paragraphs. If, however, the reader has had the patience to follow this article through its tortuous paths, a short summary will probably be perfectly understood and, possibly will prove enlightening.

The average amateur, in these post-war days, is primarily a *communicator*. It is his joy to play with (or in more serious instances, shall we say to *work on*) his own complicated electrical and electronic apparatus in order that he can use it for communicating with all parts of the world.

To do this, he has to understand the behaviour of certain natural forces (sun-

spots, ionized layers, and so on); he also has to know which frequency band to use, at which season of the year, and at what time of day.

He must know how to design and erect an aerial system which puts his signals out in the most efficient manner on each of these bands. His receiving department must be as efficient as his transmitting gear; his operating must be constantly kept up to date with modern practices.

He may be heard talking in a leisurely manner, on telephony with local stations; or he may be heard fighting his way through interference to get his Morse signals to some remote part of the Globe. He may be operating fiercely for hours on end in a contest of some sort, or just "lazing around" on a band in the hoping of hearing, and contacting, some interesting new place.

But all the time he is very much the

amateur, pursuing his hobby for the best of all reasons—that he likes doing it. He can be observed in his habits by anyone keen enough to set up the simplest of gear, whether it be a home-built two-valve receiver or a ready-bought superhet. Many home broadcast receivers have been used with great success to listen to amateur telephony on the 40- and 20-metre bands, although they are useless for CW unless modified for that purpose. But it is safe to say that *anyone* with the inclination to investigate this fascinating branch of radio can do so—with varying degrees of intensity! Start with the home set, build a two-valver, modify an ex-Government communications job, buy a real amateur-band superhet and finish up as a hopeful applicant for a transmitting licence . . . that is the usual sequence. And we can promise you that there is never a dull moment.

BURN ENGINEERING

for

ALL FORMS OF RADIO METALWORK

CHASSIS : PANELS : CABINETS

RACK ASSEMBLIES : INSTRUMENT CASES, etc.

METAL WORK TO ORDER : TRADE SUPPLIED

Latest catalogue on application

PRODUCE EXCHANGE BUILDINGS

8 · VICTORIA STREET · LIVERPOOL · 2

A FREQUENCY METER AND CW OSCILLATOR

Combination Instrument for the Broadcast Receiver

This is a combined heterodyne frequency meter and beat oscillator, designed as a unit for external use with any receiver having a short wave coverage. It is used for the accurate measuring of frequencies and for setting the receiver to any required frequency within the tuning range. It can also be employed as a CW oscillator, producing a beat on the IF of the receiver, thus making possible the reception of Morse signals. The unit takes its power, consumption being quite small, from the receiver with which it is to work. It is easily built, full details are given for calibration and operation, and the unit will be found to extend very considerably the usefulness of any ordinary broadcast receiver. Indeed, it may be said to be an indispensable instrument for the keen short wave listener.

AMONGST the readers of this journal, there are probably many keen listeners who use what is often referred to as an "all-wave" receiver of the domestic type, for exploring the short waves. The better models of such receivers can certainly give worth-while results, particularly when some trouble is taken over the erection of a really efficient aerial. Later on, when sufficient knowledge has been acquired, the enthusiast may embark on the construction of a receiver designed for short-wave reception or, if the depth of pocket permits, he may graduate to a full-blooded communications receiver.

However, the aim at the moment is to assist the owner of an "all-wave" set. As the inverted commas indicate, the term is somewhat of a misnomer, since generally the short-wave coverage is restricted to something of the order of 15 metres to 50 or 60 metres. Be that as it may, it is a fact that much of interest lies in this range of wavelengths containing, as it does, two amateur bands and quite a number of officially allocated broadcast bands. Except in the overseas models fitted with special

bandsread systems, it is usually none too easy to know just where to look for a given station on a known frequency (frequency will be used in preference to wavelength hereafter). For one thing, the scale is probably marked in wavelengths and, for another, the dial calibrations may leave much to be desired—this particularly where the set is a few years old and has, perhaps, received attention, not always skilful.

So a frequency measuring device which is neither unduly difficult to construct nor expensive and which does not take up much room can be a most useful accessory. And, as the photographs show, the construction is reasonably easy, and building the unit will be good practice for the not-too-experienced constructor.

What it is

The title of "heterodyne frequency meter" is perhaps a high-falutin' one for so simple an instrument, but really there is no other term which adequately describes it! First of all, for the benefit of the uninitiated, a heterodyne frequency meter generates an artificial

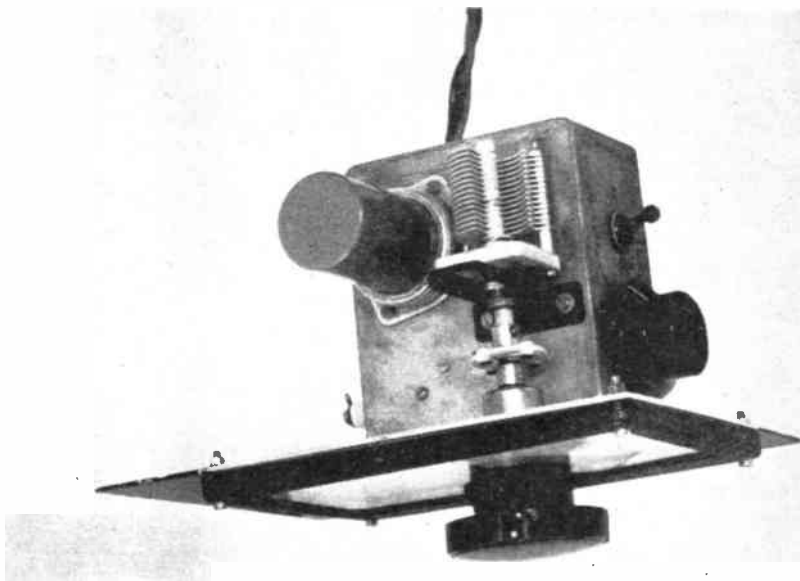

The construction of the HFM/BFO is shown in this view. The wave-change switch is at the right on the chassis, and the unit can be powered from the BC receiver with which it is to operate, as the load it imposes is quite small and well within the capacity of the average set.

signal, the frequency of which is known within close limits and which can be picked up on a receiver and therefore enables a measurement to be made on an incoming signal. Or *vice versa*—that is to say, the correct spot on the receiver dial at which to look for a wanted signal can be determined.

If a station is already being received, the artificial signal will be heard as a whistle or heterodyne note, the pitch varying as the tuning condenser of the HFM is moved. Where no genuine signal is coming in, the HFM will be heard as a plain unmodulated carrier, tuned in by listening to the "swish" each side of centre.

The higher the degree of accuracy to which the dial of the HFM can be calibrated, the better. That is why a rather large full vision dial has been fitted. It possesses the added advantage that frequency points can be marked directly on the scale, but generally it will be advisable to draw a graph of frequency *versus* scale reading. A smaller dial, of

the circular type, can, of course, be fitted as an alternative. There may be some difficulty in obtaining an adequate number of reliable frequency markers from which to draw a curve, but this subject is dealt with later.

The BFO Section

After listening to amateur telephony stations and then reading of the choice DX stations to be heard on CW only, many readers will have made an effort to master the Morse code. But, again having in mind the all-wave receiver, there is now the handicap that, lacking a beat frequency oscillator, CW signals cannot be properly received. True, there are ways and means of treating the receiver—one, for instance, is to make the 1F stage oscillate—but they involve delving into the "innards" and, if an external unit can be made to do the job, it is better to leave the set well alone. In actual fact, an external and separate BFO unit is much the better way of rendering audible CW signals and is a

A FREQUENCY METER AND CW OSCILLATOR

Table of Values

C2 =	50 μ F	Ceramic or Silvered Mica
C3 =	500 μ F	" " " "
C4, C5 =	100 μ F	" " " "
C7 =	Silvered Mica type	—see text for value
C6 =	.002 μ F	Moulded Mica (Metalmite)
C8 =	.01 μ F	Tubular Paper (Metalmite)
R1 =	22 to 33 ohms	$\frac{1}{2}$ watt
R2, R4 =	47,000 ohms	$\frac{1}{2}$ watt
R3 =	10,000 ohms	$\frac{1}{2}$ watt

List of Parts

1	Diecast Box	Cat. No. 650	Eddystone
1	Metal or Hardboard Panel	8" by 6"	
1	Full Vision Dial	Cat. No. 598	Eddystone
1	Variable Condenser	Cat. No. 586 (C1)	
1	Metal Bracket	" " 708	
1	All-wave Choke	" " 1066	
1	Flexible Coupler	" " 529	
2	Coil Formers	" " 648	
1	Lead-through Insulator		
		Cat. No. 1019 or 695	
1	Knob	Cat. No. 2416	
1	I.F. Transformer Coil	(see text)	
1	Valveholder (B9G) with clamping ring	Belling-Lee	
1	Valve type EF50 (VR91)	Mullard	
1	On/Off Toggle Switch	Bulgin	
1	Yaxley Switch single pole, three-way	Webbs Radio	

lot easier to control.

So, as it was quite feasible to do so, the heterodyne frequency meter has been made to function also as a beat frequency oscillator. It oscillates on or near the intermediate frequency of the receiver and is made to interact with the latter so that CW signals passing through the receiver become audible just as with a true communications receiver. Also, as with the latter, the pitch of the note can be adjusted to suit individual taste.

Brass Tacks

So much for what the instrument will do—and no apologies to those who

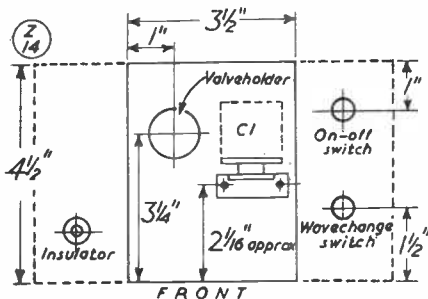

Fig. 2. Dimensions of the box chassis on which the HFM/BFO can be constructed, showing drilling details.

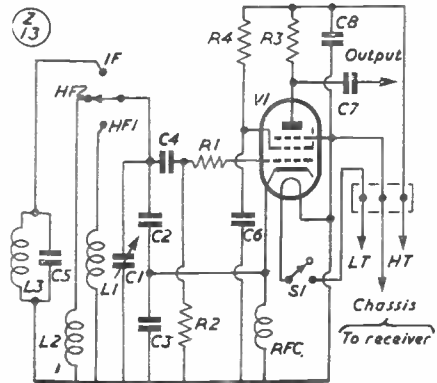
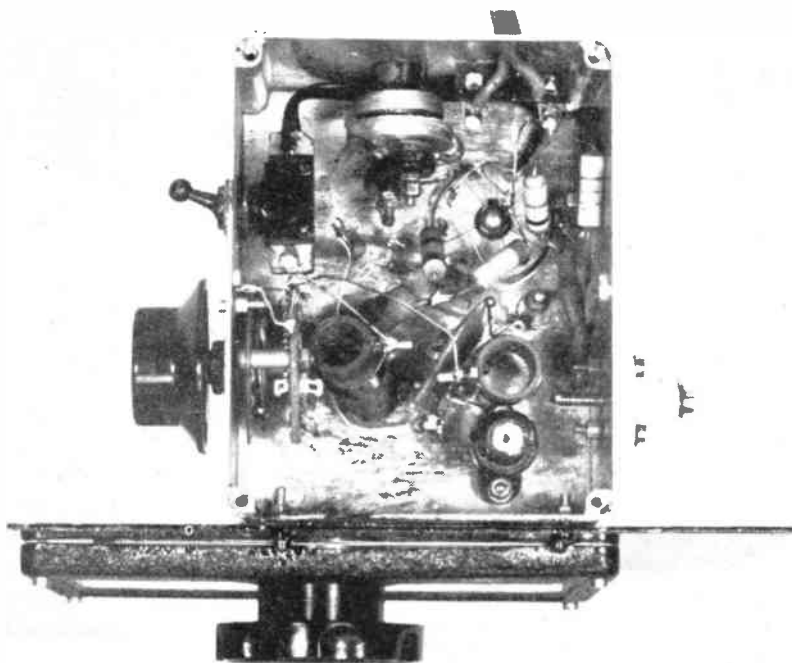

Fig. 1. Circuit diagram of the HFM/BFO, which is essentially no more than a calibrated single-valve oscillator, powered from the main receiver.

already know all that! The unit is simply a single valve oscillator built into a small metal box. It is important that the calibration, once carried out, can be relied upon to maintain accuracy over an indefinite period—in other words, the oscillator must be very stable—and the circuit chosen (one well known to amateur transmitters, and shown in Fig. 1) is extremely good in this respect. It also has other attributes, notably that a single coil (for any given range) suffices—no tap or reaction winding is necessary—whilst it oscillates readily with any reasonable HT voltage.

A three-way single pole switch selects the desired frequency range. To the first two contacts are connected simple solenoid coils, having inductances such that the usual short-wave band of a domestic receiver is covered in two steps. The third contact brings into circuit a standard IF transformer coil covering approximately 480 kc to 430 kc, in which range falls the intermediate frequency of most domestic receivers.

Probably the most important parts are the variable condenser and the indicating dial. The former must be of high quality to ensure good frequency stability, whilst the accuracy of setting the instrument to a given frequency will depend largely on the closeness to which the dial scale can be read. Naturally, a slow-motion drive is essential. A small 2in. dial lends itself to a compact assembly, and there



Layout inside the HFM/BFO. The connection for a short aerial (pick-up lead), if needed, is the stand-off insulator to the right of the chassis.

is a larger 3½ in. dial fitted with a vernier indicator. However, the large, full vision dial enables the scale divisions to be read closely and is recommended. Incidentally, the front panel can be of metal or of hardboard, the latter being quite presentable and having the advantage that the hole to take the slow-motion head can be more easily made.

Practical Construction

With the aid of the detailed drawing of the layout, which shows the exact positions occupied by those components fitted to the top and sides of the box, and also of the under-chassis photograph, the constructor will find no difficulty in building an instrument which is a faithful copy of the original. Although the box is small, so is the number of components housed in it, and there is no undue cramping to cause confusion.

The toggle switch is in series with the LT supply to the valve heater, and is a convenient means of switching the unit on and off. HT remains applied, but this is no drawback. Incidentally, in Fig. 2 the switch has been drawn in a position further back than it actually occupies in the photograph, as it is better thus.

The two high frequency coils are wound on Eddystone Cat. No. 648 formers, which are ½ in. diameter and threaded to hold the wire firmly. The first coil (L1) has nine turns 22-gauge enamelled wire, and the second coil (L2) nineteen turns of the same wire. The coils are held securely by soldering the lower ends to tags bolted to the inside face of the box in appropriate positions. The particular IF coil (L3) used (taken from an Eddystone transformer) has holes in the base for secur-

A FREQUENCY METER AND CW OSCILLATOR

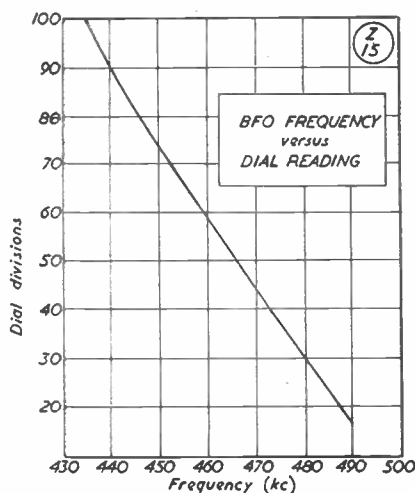

Fig. 3. Curve of the intermediate frequency coverage, showing that the instrument can be used as a CW oscillator (BFO) with any receiver having an IF of between 440 and 480 kc.

ing it by means of 6BA bolts—where no holes exist, a small angle bracket should be made.

The slow-motion head must line up accurately with the variable condenser, and the best way to set about this operation is as follows: The panel is first bolted in position and the spindle of the variable condenser (the latter being on its bracket so as to give a small clearance from the "chassis") held against it. The point of contact is marked, the panel removed, and the hole for the head, 13/16" diameter, made. The dial is then fitted to the panel and the latter bolted in position on the box. The flexible coupler is attached to the spindle projecting from the slow-motion head, and the spindle of the condenser fitted into the other end of the coupler. The holes for the condenser bracket can now be marked accurately and drilled.

Now for a few words about the value of C5, which is not given in the table, for the good reason that it depends on the value of the condenser originally used with the IF transformer coil selected. This original condenser will not do because a fair amount of parallel

capacitance already exists in the BFO unit. The new condenser—C5—should have a value between 100 $\mu\mu\text{F}$ and 150 $\mu\mu\text{F}$ less than the original. For instance, in the actual unit shown, the transformer had a parallel condenser of 500 $\mu\mu\text{F}$ and C5 is 400 $\mu\mu\text{F}$, the resulting curve being shown in Fig. 3.

The output is taken from the anode of the valve, a connection being taken via a 100 $\mu\mu\text{F}$ condenser to the small insulator mounted on the side of the box.

The dial is fitted in such a way that the pointer is at zero degrees when the variable condenser is at maximum mesh. The dial reading then increases with frequency, and it is on this basis that the accompanying curves have been drawn.

Power Supply

The power requirements of the unit are small—6.3 volts 0.3 amperes LT and anything between 150 and 250 volts at about 4 or 5 milliamperes HT. These can be drawn from the receiver with no risk of overloading the mains transformer. A three-way cable is made up of flexible insulated wire and connections made at any convenient points inside the receiver, to chassis (common

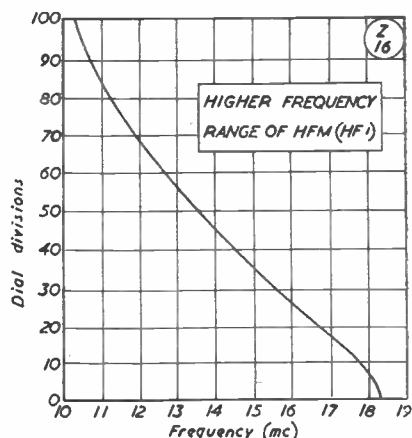

Fig. 4. Curve of the Heterodyne Frequency Meter over a main receiver tuning range of 11-18 mc, enabling stations within this range to be accurately located.

A FREQUENCY METER AND CW OSCILLATOR



In this photograph, an Ecko A.144 broadcast receiver is shown with the HFM/BFO on the left (the instrument on the receiver is the HF/VHF Converter described in another article in this issue). Full details for the operation of the HFM/BFO with any such BC receiver are given in the text.

LT and HT negative), to LT 6.3 volts, and to HT positive.

By the way, it has been assumed that the receiver is a modern type using 6.3 volt valves and operating from AC mains. If it is an older type, with 4-volt valves, the valve in the HFM should be changed to a Mazda SP41 or SP42, which will work equally well. In the case of a receiver of the universal AC/DC type, it is *definitely not advisable* to interfere with the series connected heater chain, and then a small separate power unit is the only answer.

Testing

A check that the unit is functioning properly is very simply made with the aid of a voltmeter (of 1000 ohms per volt or more). The positive lead is clipped to the anode tag on the valve-holder (No. 3) and the negative to the box, the voltmeter being set to read 250 volts or more. With the unit and the receiver switched on, the volts will rise, then fall back as the valve heaters warm

up—the final reading should be in the region of 130 to 150 volts, depending on the applied HT voltage. A flick may be noticed as the voltage rises, indicating the commencement of oscillation, and, touching the stator vanes of the variable condenser, should cause the voltage to drop. This test should be repeated with the switch set to each of the three positions. If the HT reading is low—100 or less—and does not move, the valve is not oscillating and the reason should be investigated. It may be an incorrect connection, a dry joint, a weak valve or a poor fixed condenser, especially in the C2 and C3 positions.

Calibration

Now to the difficult part—finding out the exact range covered by the instrument and obtaining some spot frequency checks wherewith to make a graph. The curves taken from the original HFM are reproduced here and will form a useful guide—near agreement should be found in an instrument built closely on

the lines of the one illustrated, although exact coincidence with the curve is not to be expected.

If it is possible to enlist the aid of a friend who is the fortunate possessor of a communications receiver with an accurately calibrated scale, the task is greatly simplified. The signal from the HFM will easily be picked up on such a receiver and a fairly accurate chart can be prepared for each of the HF ranges.

Supposing reliance must be placed entirely on the domestic receiver, it is first of all necessary to make sure the signal from the HFM is being picked up at a satisfactory strength—this must, of course, be done in any case. The receiver should be tuned as near as possible to 6 mc (50 metres) and the dial of the HFM moved around the 80 to 100 degree section on Range 2 (the lower frequency one), the switch being in the middle position. Assuming the instrument is on or near the domestic receiver, a "swish" should be heard as the HFM passes through the frequency to which the receiver is tuned—if a real signal happens to be coming in at the same time, a whistle will also be heard. In the absence of this effect, a foot or two or wire should be attached to the output insulator terminal, when there should be no further difficulty in identifying the HFM signal.

The HFM switch is then moved to the higher frequency range and the same test made with the receiver tuned to about 11 mc (roughly 27 metres). From here on, checks must be made against short-wave broadcast stations, and a list of such stations is a valuable asset. Elsewhere in this issue of RADIO QUARTERLY will be found a comprehensive list of short-wave broadcasting stations of known frequency, and a selection of those easily receivable can be used for calibration purposes.

It is well to select the strong, easily identified stations and particularly the American ones, which are to be found in each of the officially allocated bands and which usually announce their call-signs and frequencies at regular intervals. Once a few definite frequencies have been ascertained and the dial readings of the HFM noted at the points where the artificial signal beats against the real signal, a curve can be drawn. It can safely be taken for granted that

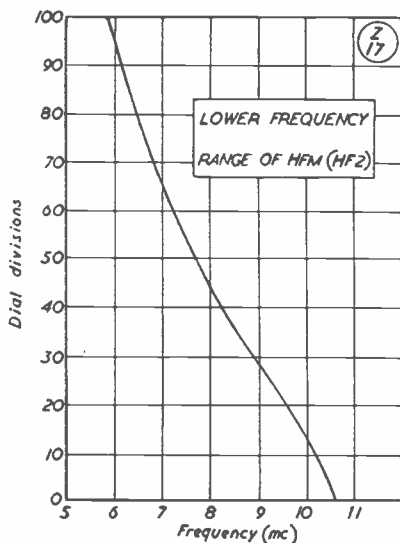

Fig. 5. Calibration curve of the HFM over the main receiver tuning range 6-10 mc, corresponding to wavelengths of 30-50 metres in the short wave band.

the same general shape (slightly curved) of the original will apply, and any gaps can be filled in with a fair degree of accuracy. As time goes on and further stations are identified, a corrected graph can be drawn if necessary. From there on, the curves will be found of great assistance in searching for new stations, since the appropriate section of the receiver scale can quickly be selected by first locating the artificial signal.

Calibration Check

A first-class spot frequency check is obtainable if the receiver is sensitive enough to pick up the standard frequency transmissions radiated continuously by the American Bureau of Standards station at Washington, which has the call WWV. If the aerial is a good one, it should at least be possible to hear WWV on 15 mc during a spell of good conditions. Transmissions are made on a number of frequencies, and those covered by the HFM are 5, 10 and 15 mc. The accuracy of the transmitted frequency is *extremely high*, and

A FREQUENCY METER AND CW OSCILLATOR

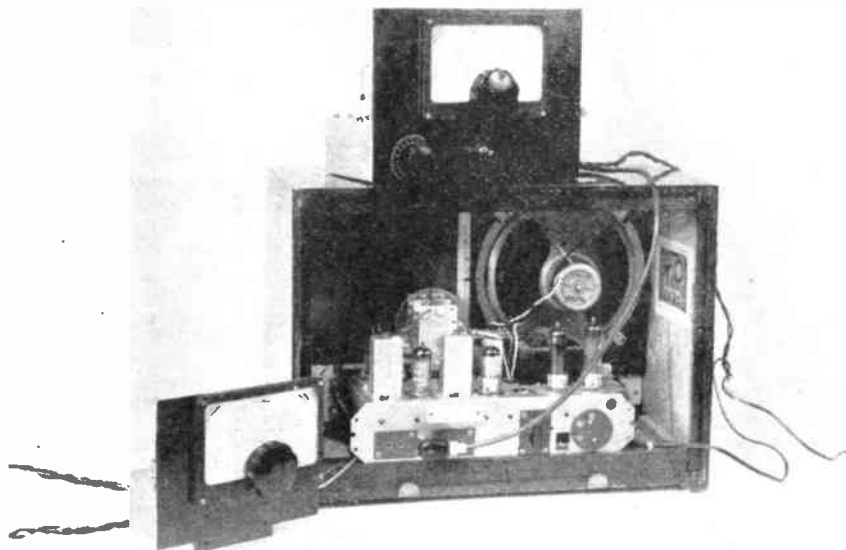

Rear view of a Ferguson 321A Broadcast Receiver with the HFM/BFO (lower left) and the HF/VHF Converter connected. The small unit described in this article draws its power from the receiver, but in the case of the HF/VHF Converter (on top of the cabinet) which is self-powered, a mains connection is necessary.

the signal is characterised by its steady 400-cycle modulation, superimposed on which is a tick every second. The best time to look for the 15 mc signal is late afternoon or evening; the 10 mc transmission is more likely to be heard late at night or in the early morning. Only rarely will it be possible to receive the 5 mc signal on a domestic receiver.

The Amateur Bands

The curves already obtained will give a fair indication of the positions of the 14 and 7 mc amateur bands, but it is useful to know just where the edges—or at least the low frequency edges—lie. On 14 mc this can be done by carefully listening to the type of signals being received. Over one part of the band will be found telephony stations, which usually occupy from about 14100 to 14350 kc (but some European stations work wherever they feel disposed!) On the lower frequency side of these telephony transmission will be heard

Morse at varying speeds, and a little lower again the Morse becomes both very loud and at high speed. These latter are commercial transmissions, and the point of deviation should be carefully noted as marking the low-frequency edge of the amateur band. Similar at the high frequency edge, the amateur telephony will suddenly again give place to what are obviously commercial transmissions of one kind or another. The points can be transferred to readings obtained on the dial of the HFM, then marked on the graphs, and thereafter it will be easy to locate the amateur band at any time desired.

The same principle holds good on 7 mc (40 metres), but it is not so easy in practice, as this band is a shared one (very much so!) and the band is often cluttered up with all sorts of signals—amateur and commercial telegraphy and telephony, broadcast stations, and some signals which completely defy description! Careful listening, particularly

during daylight hours when skip is short and local amateurs may be active, will assist considerably, and a Sunday morning will prove a good time.

Using the BFO

So much for the HF part of the instrument. When using it as a BFO—or beat frequency oscillator for CW Morse reception—the length of wire attached to the output terminal may have to be longer. The correct degree of pick-up can only be found by trial and error, as the amount of screening in the broadcast set will vary considerably between one model and another, and it may even be necessary to allow part of the wire (well insulated, of course) to lie near the IF stage inside the receiver. A signal should be tuned in on the latter and the tuning condenser of the BFO swung until a beat note becomes audible, varying in pitch with the setting of the BFO but not altering with the tuning of the receiver. With the pitch set to give a pleasing note, the BFO dial reading should be noted for future reference and, from then on, CW signals can be received equally well with telephony.

Referring back to the degree of coupling, if it is found that switching on the BFO causes a noticeable drop in the strength of the incoming signal, the coupling is too great. The BFO, in fact, is adding to the AVC action of the receiver and, whilst this effect cannot be altogether avoided, it can be reduced to small proportions. Conversely, if the beat note is weak with an incoming signal of reasonable strength, steps should be taken to increase the coupling.

As stated earlier, the intermediate frequency of a modern receiver is almost certain to lie between 450 and 470 kilocycles, but if a beat note cannot be obtained, it will be well to ascertain from the makers or from a service instruction sheet just what the intermediate frequency is.

Added Refinements

The instrument has been described in a basic form, suitable for the majority, and an individual reader may wish to add embellishments and refinements, a few of which come to mind.

Although the unit is not unpleasing in appearance to the eye of an enthusiast,

it may be that others will be better pleased if the instrument is boxed in, using either metal or hardboard for the purpose. Again, it may be desired to attach the unit to the receiver only when searching the short wave bands and, both on this score and for general convenience, it will be better to bring out the power leads from the set to a socket (an octal valve base serves well) mounted at the rear of the receiver and to fit an appropriate plug to the cable coming from the HFM.

The suggested method of obtaining BFO injection is a little on the crude side, and it would be aesthetically and technically superior to fit a lead-through insulator on the rear chassis wall of the receiver. A length of wire terminated with crocodile clips would be used to feed the output of the BFO to this insulator, to which, on the inside, would be connected a piece of stiff insulated wire, the length and position being adjusted to give a suitable amount of injection.

There is room in the box for a potentiometer, of 10,000 ohms and preferably wire-wound, to be fitted and connected in place of R3, the moving contact being taken to C7. This would form an attenuation control and, whilst not fully effective on the higher frequency ranges (because of direct radiation) it would be an asset when using the unit as a BFO.

Lastly, the range of frequencies covered can readily be extended by fitting an additional coil or two, the number of contacts on the switch being increased accordingly.

NEW PRODUCTION GENERAL PURPOSE

CABINETS & CHASSIS

12" x 8" x 8" 10" x 7" x 2"

FINEST VALUE IN THE TRADE

Precision made in mild steel with removable aluminium front panel and chassis. Adequate ventilation bottom and rear panel. Superb stove enamel finish in new light grey, durable and dust-free—superior to crackle. Immediate delivery, by return.

32/6 PAIR
Carriage Paid

JOHNSONS (RADIO)

46 FRIAR STREET, WORCESTER Tel: 5740

Pse QSL

AMATEURS THROUGHOUT THE WORLD ASK FOR SWL REPORTS

In these two pages we give details of amateur transmitters, in all parts of the world, who have informed us that they would welcome reception reports from listeners. Useful and correct reports, made in accordance with the details requested under each callsign, will be confirmed by QSL card, either direct or through our Bureau. If you are interested in amateur band reception and in acquiring an interesting collection of QSL cards, use your receiver to find these stations. Make out a clear, concise and accurate report and send it to the address given, mentioning "Pse QSL" in this issue. As it is intended to retain this feature in future editions of RADIO QUARTERLY, please make your report as comprehensive as possible. Another list, of about 100 or more stations different from those listed here, will appear in our next issue.

-
- CN8EY J. M. O'Hara, VR-24, Box 301, Navy 214, c/o F.P.O., N.Y.C., U.S.A. 14 mc phone and CW. Details of modulation.
- CO2KC Box 1723, Habana, Cuba. 28 mc phone, weekends 1600-2200 GMT.
- CR4AC M. Tomaz Dias, Praia, Ilha de Santiago, Cape Verde Islands. Reports required on 7, 14, 21 and 28 mc phone and CW.
- CR6AJ Adelino dos Santos, C.F.B. Estudos, Nova Lisboa, Angola. 14 and 28 mc phone and CW, operating 1900-2359 GMT.
- CR6CM P.O. Box 1, Caala, Angola. VFO-controlled phone, operating 1700-2300 GMT.
- CR7LU Lucia dos Santos Tome, C.T.T., Beira, Mozambique. CW, and occasional phone: 7 mc, 0300-0500 GMT; 14 mc, 1600-2000 GMT.
- CT1FP Rua Passos Manuel 39-1, Porto, Portugal. Reports on 3.5, 7, 14 and 28 mc phone.
- CX5AF Casilla de Correo 546, Montevideo, Uruguay. Reports on 7060, 14125 and 28450 kc phone.
- CX7AC Canelones 1417 Apto 7, Montevideo, Uruguay. 14048, 14150, 28096 and 28300 kc phone and CW, operating 2100-0400 GMT.
- DL3QA Schlosserstr. 18, Alsdorf-Aachan, Germany. 144.79 and 145.3 mc phone and CW, 2000-2200 GMT. Keying, modulation, condx.
- DL4USA Radio Coy., 97th. Sigs. Ops. Bn., APO. 46, c/o P.M., N.Y.C., U.S.A. 14200 and 14320 kc phone, 0700-0800 and 1600-2100 GMT. Details of modulation.
- DL4XK H.M. Flora, A.F.N., APO. 69, c/o P.M., N.Y.C., U.S.A. 3.5, 7 and 14 mc phone, 1200-1300 and 2000-2300 GMT.
- DL9DQ Finkenstr. 4, Furth (Bay), Germany. 7, 14 and 21 mc CW, 1700-2230 GMT and weekends.
- DL9SG Zeppelinstr. 6, Muenster/Westf, Germany. 3.5, 7, 14, 21 mc QRP phone and CW, 2100 GMT.
- F8LP 14 Rue Mottet de Gerando, Lyon, Rhone, France. 7 and 14 mc phone and CW.
- F9JC 32 bis Rue des Bois, Les Richardets, Noisy le-Grand, S-et-O, France 7 and 14 mc phone, 0800-1100 and 1300-1800 GMT. Modulation.
- G31KM 90 Beverley Road, Hessele, E. Yorkshire. 3.5, 7 and 14 mc CW: 1200-1245 and 1330-1415 GMT; Saturdays 1200-1700, Sundays 1000-1230 GMT. Details of keying, any chirp.
- G3IKO 15 Waverley Avenue, Chingford, London, E.A. 1.8 mc and 3503, 3510, 3569 kc CW, weekends. Critical keying reports, any chirp.
- G3IKT 79 Smith House Lane, Brighouse, Yorks. 1.8 and 3.5 mc CW, operating 2030-0100 GMT. Details of Wx.
- G3ITY 38 Durham Road, Blacon, Chester, Ches. 1870, 3550 and 7050 kc CW, 1900-2359 GMT and weekends. Critical reports with details of Wx, any QSB, any chirp or key-clicks.
- G3IUD Dorny, Kings Road, Wilmslow, Ches. 432.415, 434.16, 435.0 and 436.9 mc phone. MCW and CW, 1830-2000 GMT. Reports on quality.
- G3IUL 4 Edward Road, East Bedfont, Middlesex. 1750-1850 and 3510-3550 kc CW, Mondays to Fridays 2230-2330 GMT.
- HH2FL P.O. Box 153, Port-au-Prince, Haiti. VFO-controlled 7 and 14 mc CW, 1200 GMT.
- HK5ER P.O. Box 99, Buenaventura, Colombian Republic. 7, 14, 21 and 28 mc phone and CW, operating 2140-2359 GMT.
- HS1SS U.S. Air Attache Office, American Embassy, Bangkok, Thailand. 14 mc phone and CW.
- I1BBH 24 Via 5 Giornate, Como, Italy. 3.5, 7 and 14 mc phone; 1215-1330, 1730-1830 and 1900-2100 GMT.
- I1CSP Frazione Parola 9, Fontanellato, Parma, Italy. 7, 14, 21 and 28 mc phone and CW, 0600-0800 and 1800-2300 GMT.
- I1ER Via Volterra 3, Milano, Italy. 7014, 7030, 7042, 14060 and 14084 kc CW, 0630-0700 and 1800 GMT onwards.
- I1MA Via S. Pietro 5, Bolzano, Italy. 7 and 14 mc phone and CW, 1100-1300 and 1700-2359 GMT. Speech quality and modulation.
- I1TGE Via S. Stefano 35-37, Bologna, Italy. 14 mc phone, operating 1300-1500 GMT.
- I1VS Dr. C. Feruglio, c/o S.A.I.C.I., Torviscosa, (Udine), Italy. 14, 21 and 28 mc phone, 1130-1300 and 1700-2100 GMT.
- JA1AH Yukio Komiya, c/o Egota P.O., Nerima Tokyo, Japan. 7, 14, 21 and 28 mc phone and CW.
- JA3AA Isaji Shima, 17 Kajiya-cho, Otsu, Shiga, Japan. Reports on 7, 14, 21 and 28 mc CW.
- LU9DEA Mitre 877, San Martin, Buenos Aires, Argentina. Reports required on 14050 kc CW.

- MP4BBI *H. T. Falstein, I.A.L., Muharraq, Bahrein, Persian Gulf.* 14 mc phone, 1400-1800 GMT.
- OD5AJ *P.O. Box 352, Tripoli, Lebanon.* 14 and 21 mc phone, operating 1500 GMT onwards.
- OD5BA *Box 493, Beirut, Lebanon.* 14, 21 and 28 mc phone, 1200-1800 GMT and weekends.
- OE8TR *Ing. Herbert Sommer, Hauptpostlagernd, Klagenfurt, Austria.* 14 mc phone, 1600-1800 GMT, Sundays 1200-1800 GMT. Modulation, speech quality, any QSB.
- OH2MA *Tenholankatu 83, Hanko, Finland.* 1715-1925 kc CW, 2100-2359 GMT, Sundays 0100-0400 GMT.
- OH3QU *Varuskunta rak 44, Riihimäki, Finland.* Requires reports on 7 and 14 mc CW.
- ON4FU *Neerstraat 29, Tessenderlo, Limb., Belgium.* 3.5 and 7 mc CW, Sundays 0830-1800 GMT.
- PA0GIN *Bankastraat 40-B, Groningen, Netherlands.* Reports required on 7 mc CW operation.
- PA0TAU *Star Numanstraat 113-B, Groningen, Netherlands.* 3.5, 7, 14, 21, 28 and 144 mc phone and CW.
- PA0UL *Jagerskampen 4-A, Haren, Gn., Netherlands.* 1.7, 3.5, 7, 14, 21 and 28 mc CW. Critical tone and comparative reports.
- PJ2AD *P.O. Box 9, Oranjestad, Aruba, Neth. West Indies.* 7 and 14 mc phone and CW, 0100-0500 GMT. Speech quality and modulation.
- PJ2CA *S. Reitsma, c/o C.P.I.M., Curacao, Neth. West Indies.* 14 and 28 mc phone, 2130-2359 GMT, Sundays 1130-0200 GMT.
- PY3QX *Box 69, Cruz Alta, Rio Grande do Sul, Brazil.* VFO-controlled phone and CW, operating early mornings and evenings.
- PY6QM *Rua Santa Lucia 602, Aracaju, Sergipe, Brazil.* 14.1-14.3 mc VFO-controlled phone, 0500-0700 and 1200-1300 GMT.
- SP2KGA *Ul, Kopernika 18, Gdansk, Poland.* Reports on 3.5, 7 and 14 mc phone and CW.
- SMSAFU *Hornsgatan 51.III, Stockholm, Sweden.* 3.5, 7 and 14 mc CW, 1700 GMT onwards.
- SMSARP *Cirkelyaegen 13, Enskede, Sweden.* Phone and CW; 7 mc, 1900-2100 GMT; 14 mc, 1700-1900 GMT. Details of modulation.
- SM6BR *P.O. Box 675, Dals LaANGED, Sweden.* 14 mc CW, operating Sundays 0500-0700 GMT.
- SV5UN, SV0WG *Courier Radio Club, Rhodes, Greece.* Operating phone and CW, all bands.
- VE1AAF *252 Robinson Street, Moncton, N.B., Canada.* 3.5 and 7 mc phone and CW, 0400-0700 and 2200-2359 GMT.
- VE1KB *P.O. Box 567, Yarmouth, N.S., Canada.* 3.5 and 14 mc phone and CW, 1400-2200 GMT.
- VE1PP *Box 71, Windsor, Nova Scotia, Canada.* 1.8, 3.5, 7, 14 and 28 mc phone and CW, evening and weekends.
- VE1US *P.O. Box 403, Liverpool, N.S., Canada.* 3.75-3.845 mc, 14160 and 14200 kc phone, 1700-1800 and 2000-2100 GMT. Modulation.
- VE1YT *P.O. Box 1126, Yarmouth, N.S., Canada.* 14 mc phone and CW, operating 1400-2200 GMT.
- VE1YW *R. J. Kavanagh, Lady Beaverbrook Residence, University of New Brunswick, Fredericton, N.B., Canada.* 1805 kc CW, 0300-0700 GMT; 3549 and 3608 kc CW, 2300-0400 GMT. Comparative reports with other VE1-stations.
- VE3ABP *W. Wells, Albion Falls, c/o Station "D", Hamilton, Ontario, Canada.* 7, 14 and 28 mc phone and CW, weekends.
- VE3AHR *P.O. Box 194, Cardinal, Ontario, Canada.* 14 mc phone, operating 1500-0100 GMT.
- VE3BCS *89 Belmont Avenue, Hamilton, Ontario, Canada.* 3.5-3.7, 7.0-7.1 and 14.0-14.2 mc CW, 1500-1900 and 2330-0300 GMT.
- VE3NN *116 Catharine Street, Belleville, Ontario, Canada.* 14 mc phone, 1815-1900 GMT.
- VK2ADN *P.O. Box 11, Coffs Harbour, N.S.W., Australia.* Reports required on 14 mc CW.
- VK4LN *71 Channon Street, Gympie, Queensland, Australia.* 7, 14 and 28 mc phone, 0600-0730 GMT. Depth of modulation.
- VK5CE *Box 107, Whyalla, S. Australia, Australia.* 14050-14350 kc phone, 2000-0230 GMT. Modulation. Comparative reports with other VK5-stations.
- VK5GT *3 Clifford Street, Lockleys, S. Australia, Australia.* 14.1-14.3 mc phone, 1200-1500 GMT. Speech quality and modulation.
- VP2LE *Box 170, Castries, St. Lucia, Windward Islands, B.W.I.* 14.2-14.3 mc phone, 2000-0600 GMT. Details of modulation.
- VQ2AH *P.O. Box 95, Ndola, N. Rhodesia.* 7 and 14 mc phone and CW, 1600-2300 GMT.
- VQ2AT *Resident Engineer, Broken Hill Hospital, P.O. Box 17, Broken Hill, N. Rhodesia.* 14150-14200 kc phone, 1600-2000 GMT. Reports from London and near suburbs.
- VS2DF *J. Bewley, P.O. Box 600, Penang, Malaya.* 14 mc phone and CW, 1200-1830 GMT.
- VS6CL *J. E. Jeckway, P.O. Box 541, Hong Kong.* 14012, 14024 and 14030 kc CW, 1000-1600 GMT.
- V57GV *144/1 Kandy Road, Kurunegala, Ceylon.* 7, 14 and 21 mc phone and CW. Speech quality.
- W1BB *36 Pleasant Street, Winthrop, Mass., U.S.A.* 1813 kc phone and CW, 0500-0800 GMT.
- W1LYV *Box 123, Waquoit, Mass., U.S.A.* 1800-1825 and 1897.6 mc phone and CW, 0500-0800 GMT.
- W1ODW *R. G. Rowe, Black Rock Turnpike, Redding Ridge, Conn., U.S.A.* Phone and CW, all bands; 0001-0400, 1000-1200 and 2100-2300 GMT.
- W1TSL *26 Hatch Street, Mystic, Conn., U.S.A.* CW and phone, all bands 3.5 to 28 mc. Modulation.
- W1TVB *C. A. Dykeman, RFD. 1, Gray Road, Gray, Maine, U.S.A.* 7 and 14 mc phone and CW, 1500-2000 GMT.
- W2ADQ *48-23 42nd Street, Long Island City 4, N.Y., U.S.A.* 14 mc phone and CW, 1500-2100 GMT. Keying, stability and quality.
- W2BBV *49 Frum Avenue, Yonkers, N.Y., U.S.A.* 14 mc phone, weekends 1400-1800 GMT. Comparative reports with other E. Coast stations.
- W2CVW *E. Erickson, Gross Lane, South River, N.J., U.S.A.* 3.5, 7 and 14 mc CW, 0330-0600, 1100-1300 and 2000-2359 GMT.
- W2EAF *21 N. 11th Avenue, Mt. Vernon, N.Y., U.S.A.* 7, 14, 21 and 28 mc phone and CW. Quality.
- W2KGN *555 East 5th Street, Brooklyn 18, N.Y., U.S.A.* 7, 14, 21 and 28 mc phone and CW, 0100-0500 GMT, Sundays 1500-2100 GMT.
- W2MB *L. Spangenberg, RFD. 6, c/o Brown's Trailer Court, Lodi, N.J., U.S.A.* Reports required all bands, phone and CW.
- W3TES *508 S. Potomac St., Waynesboro, Pa., U.S.A.* 14 mc CW, at 1200, 1800 and 2100 GMT. Keying.
- W4DGW *E. W. Tonjes, c/o M. V. Del Campo, 408 Baronne Building, New Orleans, 12, La., U.S.A.* 28560 and 28700 kc phone, 1600-2000 GMT.
- W4DVR *Windy Hill, Lemon Avenue, Ocala, Fla., U.S.A.* 7004, 7050, 7115, 14008 and 28230 kc CW, 1000-1300 GMT. Details of QSB.
- W4POF *W. Brown, Rt. 1, Box 278, West Palm Beach, Fla., U.S.A.* 3.5, 3.8, 7, 14, 27 and 28 mc phone and CW.
- W4TWW *C. Rowland, Rt. 7, Box 861, Charleston, S.C., U.S.A.* 3920 kc phone and CW, 0830 GMT.
- W5LGG *1620 Pasadena Street, San Antonio, 1, Tex., U.S.A.* Reports on 3.5, 7 and 14 mc CW.
- W6MYC *69 Mar Vista Avenue, Pasadena, Calif., U.S.A.* Requires reports on 14 mc phone.
- W6QVN *7346 Oak Park Ave., Van Nuys, Calif., U.S.A.* 7 mc phone and CW; 0500-0800, 1400-1530 GMT.
- K8FCA *R. C. Blake, Brookfield, Ohio, U.S.A.* Reports on 3.5, 3.8, 7 and 14 mc phone and CW.

W8JGU *Box 121, Stow, Ohio, U.S.A.* Reports on 7.0-7.1 mc CW, 2200 GMT onwards.
 W9JLH *205 S. 9th Street, La Crosse, Wis., U.S.A.* 14.2, 21 and 28 mc phone, 2230-0600 GMT.
 W9WHF *263 Bloom Street, Highland Park, Ill., U.S.A.* 3.5 and 7 mc CW, 0300-0900 GMT : 14 mc CW, 1300-2100 GMT. Reports especially from Ayrshire, Scotland.
 WOZFO *E. E. Snader, Box 41, Panora, Iowa, U.S.A.* 3.5, 3.8, 7, 14, 21 and 28 mc phone and CW.
 XE2OD *P.O. Box 717, Monterrey, N.L., Mexico.* 14304-14310 kc phone and CW, 0300-0600 GMT.
 YI2AM *RAF Club Station, RAF Habbaniya, Iraq, MEAF 19.* 7042 kc CW, 2000-2200 GMT ; 14084 kc CW, 0700-0900 GMT. Reports required when not working G-stations. Details of stations heard calling YI2AM.
 YU1AM *P.O. Box 48, Beograd, Yugoslavia.* Reports on 3.5, 7 and 14 mc CW.
 YU2ARS *P.O. Box 9, Rijeka, Yugoslavia.* Requires reports on 3.5 and 7 mc CW.
 YU2CE *P.O. Box 95, Pula, Yugoslavia.* 7 mc CW and 7110 kc NB.FM phone.
 YU2DB *Kraseva 7, Zagreb, Yugoslavia.* 3.5, 7, 14, 21, 28 and 144 mc phone, 2000-2359 GMT, weekends 0800-2000 GMT.
 YU2DE *45 Daniciceva, Zagreb, Yugoslavia.* 3.5, 7 and 14 mc CW, operating at 0700 GMT.

YV5FL *Apartado Postal 6, Laguaira, D.F., Venezuela.* 7, 14, 21 and 28 mc phone and CW, 1600-2359 GMT.
 ZB1BU *R. N. Wireless Station, Zebbug, Malta.* 14 and 28 mc phone and CW, early mornings and evenings. Details of modulation.
 ZD2RRW *R. Williams, Orthopaedic Hospital, Igbobi, Lagos, Nigeria.* 14150 kc phone, 1600-1700 GMT. Reports especially from GW.
 ZL2GS *H. Green, Clifford Road, Johnsonville, New Zealand.* Reports required on 21 mc CW, operating 0800-1000 and 1830-1930 GMT.
 ZS1MG *S. Coosner, c/o Postmaster, George, Cape, S. Africa.* 7 and 14 mc CW, 1500-2000 GMT.
 ZSSJQ *202 Bulwer Road, Durban, Natal, S. Africa.* Reports required on 21 and 28 mc CW.
 ZS6AFN *P.O. Box 4494, Johannesburg, S. Africa.* 14 mc phone, operating 1600-1800 GMT.
 ZS6VF *P.O. Box 276, Standerton, S. Africa.* 14340 kc phone, 1600-2000 GMT.
 ZS6WO *189, Elston Avenue, Benoni, S. Africa.* 14 mc phone and CW, 1600-2300 GMT.
 5A1TC *S/Sgt. Martindale, 580th Comm. Sqn., APO.231, c/o P.M., N.Y.C., U.S.A.* 14 mc CW and phone, 1700 GMT onwards.
 5A1TF *P.O. Box 372, Tripoli, Libya.* 14180 kc phone, operating 0700-2300 GMT.
 9S4BS *An der Trift 34, Saarbrucken 3, Saarland.* 3.5 and 14 mc phone and CW, 1600-2200 GMT.

G2AK ————— *Everything for* ————— **G2AK**
Constructors and Experimenters

DIALS		BOOKS
VALVES		METERS
SPEAKERS	AMPLIFIERS	CHOKES
CRYSTALS	RECORDERS	PICK-UPS
T.V. TUBES	SWITCHES	C. R. TUBES
RECEIVERS	PHONES	INSULATORS
RESISTORS	KNOBS	MICROPHONES
CONDENSERS	WIRE	SCAN COILS
TAPE HEADS		GRAM-MOTORS
OSCILLATORS		TRANSMITTERS

SERVICE and ADVICE backed by over a Quarter of a Century of experience in AMATEUR RADIO

CHAS. H. YOUNG, G2AK

CENtral 110 DALE END · BIRMINGHAM 1 **MID**land
 1635 Mail Order : 102 Holloway Head · Birmingham 1 3254

TRACING TELEVISION TROUBLES

Symptoms and Cures in Home-Built or Commercial Receivers

For those who have built themselves a TV receiver, or whose knowledge is wide enough to diagnose faults in commercial designs, this article will be of special value and interest. It is in any case certain that there are many receivers which are working at a far lower level of efficiency than they need be. It is not enough merely to "suspect that the CRT is ageing"; in fact, as is shown here, certain presentation faults are not due to the tube at all, but to maladjustment or failure of components in the circuits feeding it.

THE advent of nation-wide television has reawakened interest in home construction. Not only have radio enthusiasts in general taken up the new branch of the hobby but many erstwhile constructors have been roused from their lost enthusiasm to start afresh.

The popularity of home TV construction did not stop with war-surplus concoctions using VCR97's; it progressed to 9-inch magnetic types, thence to 12-inch tubes and, at present, the new 16-inch metal CRT's are enjoying a measure of popularity curbed only by the rather high cost of building such televisors.

The picture presented by the hosts of TV constructors is therefore rather mixed; we have old and new constructors, some of considerable technical ability and others very much in the "raw beginner" class. Some still prefer (or through circumstances are forced to restrict their activities to) converted war-surplus equipment; others have no thoughts for anything but the latest and best.

When it comes to preparing an article on TV fault-finding any writer has all this to bear in mind. Assuming that there is such a person as the Average Constructor, the following notes are directed to that individual. It has been assumed that the reader is well versed in standard radio technique and has a working knowledge of television circuitry. That much is really desirable in

any case if TV construction is contemplated.

The newcomer to TV is often rather apprehensive—it looks so *very* complicated compared to ordinary radio. Can you remember building that first superhet? How terrifying it all seemed after hearing about the troubles likely to be encountered and how simple it became in actual fact! TV is something like that—not that we must underestimate its trouble-making potential, but rather realise that its "bark is perhaps worse than its bite."

The newcomer must bear in mind two important facts. First, the habit of thinking in "block diagrams," will help materially in reducing time spent chasing faults. Secondly, the behaviour (or absence) of the picture or raster on the CRT is a first class indication in many cases of where the fault(s) is located.

Owing to the added complexity of the circuits, fault finding can be more troublesome in tracing than in radio or audio work, but on the other hand the very functions of these circuits can make localising of faults much easier. It is simply a matter of observation and diagnosis. One need not be a technical genius.

The newcomer must learn to interpret the symptoms exhibited on the CRT and this is easier than it sounds. And this is where the block diagram system comes in. Fig. 1 shows typical sectionalised receivers which covers the

TRACING TELEVISION TROUBLES

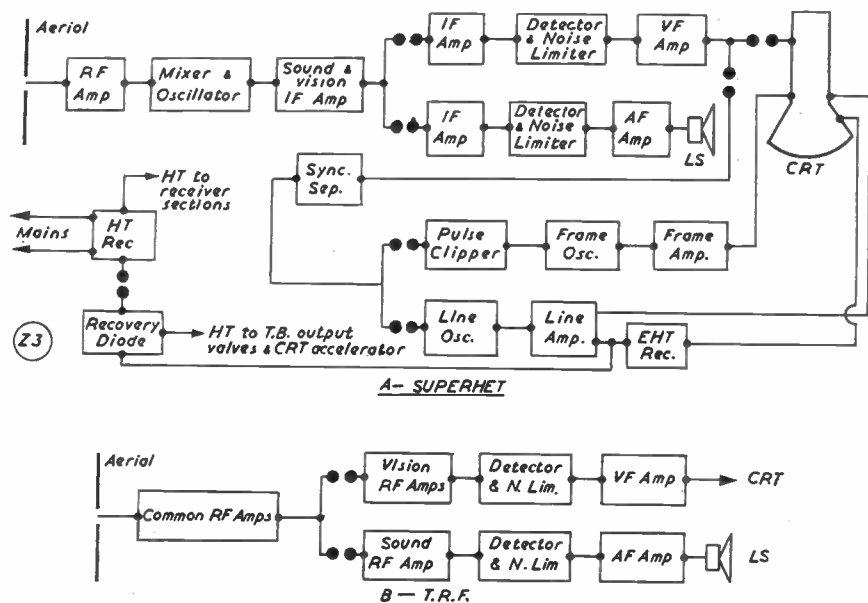

Fig. 1. (A) Block outline of a typical superheterodyne television receiver, illustrating how the units can be sectionalised to assist in fault-finding. The video and sound sections of a typical TRF receiver are shown at (B). The scanning and power circuits for the TRF type are the same as those shown for the superheterodyne design.

majority of modern designs. If you have a set to service which does not fit these block outlines, sketch out the correct version on a scrap pad—it will only differ in small detail.

Examples for Study

A study of the block diagram and the symptoms exhibited by the CRT and speaker will in many cases suggest immediately the source of trouble. To take some elementary examples. If the sound is normal but no picture modulation appears on the raster, the trouble is somewhere between the RF section and the CRT; if both sound and vision are absent the fault is almost certainly in the RF section common to both circuits (the development of simultaneous faults in both vision and sound channels is not often encountered, unless the HT supply breaks down). In the scanning circuits the same principles apply. The

failure of one time base produces unmistakable symptoms—lack of scan in one direction. This observation may not always apply due to the incorporation of special circuit features, as for instance, in receivers using fly-back derived EHT systems. Obviously, cessation of the line time-base will not only result in lack of line scan but also in no EHT, hence no tube illumination at all. In the case of normal sound and a raster of normal brilliance but with neither time-bases “locking” the fault is likely to be in the sync separator section.

Thus, by correctly analysing the symptoms a great time of time can be saved. Whole sections can be passed over and the trouble centre pin-pointed. The golden rule, especially for newcomers, is to take great care in the original study of the symptoms. Time so spent will save much unnecessary work. Calm and logical reasoning is called for

in all TV servicing jobs.

Having ascertained the approximate section, it remains for further elimination, component by component, until the exact source of trouble is found. The procedure will, of course, differ according to the circuits under test but normal voltage, current, resistance and continuity checks will be sufficient in most cases.

The notes which follow are not intended to be a complete treatise on TV servicing. They are intended to serve as a guide to some of the more common troubles likely to be encountered in the video circuits, bearing in mind that many readers have limited experience in the practical side of television.

INSTABILITY

High on the list of trouble makers to the builders of television receivers, especially newcomers, is instability in one or more of its guises. Unless a logical and methodical approach is made, the tracing and curing of such trouble can assume gigantic proportions. It is, in any case, often one of the most difficult of all troubles to clear.

The home constructor who is cursed with gremlins of the Instability genus should observe two golden rules: (1) Pay keen attention to the symptoms exhibited on the CRT and/or by the speaker, (2) Bear in mind that, fundamentally, all instability is the product of some undesirable coupling between stages or between sections of one stage.

Post-detector Instability

Instability originating in a VF stage is usually easy to diagnose and cure, as is instability in the AF stages of the sound receiver. Since the sound and vision sections (VF and AF) are widely isolated by their respective detectors instability in one seldom affects the other. Normal AF instability will be recognised by most constructors so there is no need to delve too deeply into that problem.

Instability in the VF amplifier stage usually manifests itself by an irregular ripple on the picture, sometimes with ragged and wavy edges. Ripple due to poor HT smoothing is similar but has a regular form; any doubt can be quickly checked by examining an unmodulated raster. If this indicates no sign of ripple, then the HT supply circuits can be cleared.

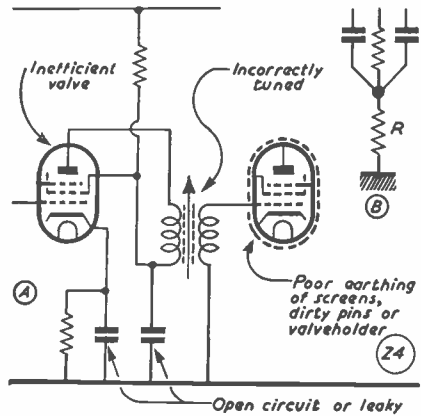

Fig. 2. Possible causes of instability in the video circuits are shown here. In (B) the resistance R represents a bad joint at a common earthing point, showing how such a contact can bring about a common impedance coupling, sometimes the direct cause of instability.

Instability in the VF stage(s) is usually due to low capacity electrolytics, open circuit or leaky decoupling condensers and defective earthing of valve screens. First, however, check the valve by direct replacement by one of known efficiency.

Decoupling condensers, especially of the waxed-paper type, are frequent offenders. A common fault in these components is the development of an internal high-resistance contact—overheating when soldering is a not uncommon cause of this trouble and constructors should take special care in wiring-in such components. Better still, use mica types where possible. In either case, make certain that the wire-ends are scrupulously clean before soldering into position. What may pass for a good joint in ordinary radio work can be quite useless in television work.

Another frequent cause of instability is high-resistance earthing connections, not only of valve screening cans but the valve pins themselves. Miniature types such as the B7G range are particularly prone to corrosion and in any suspected case should be scraped carefully clean and the valveholders given a carbon tetrachloride treatment. As an illustration, the writer recently replaced two valves in a vision receiver but with the

new B7G's in position loss of gain and definition with some instability was experienced. After scraping the pins (which looked quite clean—the valves were brand new) the troubles vanished.

Pre-Detector Instability

Instability originating at the detector or pre-detector level can and usually does, find its way into other sections. It is also more severe in effect due to the fact that the parasitics are subject to further amplification along the chain. Thus the very severity of the observable symptoms indicates to some degree how far back the fault lies.

As the instability increases in severity so does the quality of the picture deteriorate until, in bad cases, it breaks up completely. Jagged white lines float up and down the screen and "herring bone" patterns appear. Synchronisation may be affected. If the trouble originates in the early stages the picture usually vanishes completely, rising to peak white level and staying there. Sometimes the sound also disappears, preceded by a loud "plop" as the picture is obliterated.

The causes and cures, however, are the same as previously mentioned. A quick way to localise the fault is to remove the valves, one by one, starting at the aerial end, until the symptoms disappear thus indicating that the offending stage has been traced. This procedure cannot, of course, be used in AC/DC receivers with series-heater circuits but there are other methods.

Ideally one should use a valve voltmeter, probing from the RF end of the the vision chain forwards, checking the anode and grid circuits until an abnormal reading is obtained—the offending valve, of course, giving a low anode voltage reading, the usual indication of an oscillating valve. An ordinary meter is not suitable due to its damping effect.

Without instruments, the constructor can follow normal sound radio methods shorting each grid to chassis, starting at first RF amplifier, preferably with a normal current meter inserted in the anode circuit (on the cold, or remote, side of the anode load).

Once the faulty stage has been located it is simply a matter of trial-and-error checking of decoupling condensers (by shunting a good condenser across each suspected one), poor screening, high-resistance contacts and so forth.

Other Causes

Before spending hours chasing faulty components and bad mechanical connections, make sure that the IF and/or RF circuits are correctly aligned. Many commercial receivers can be pulled well out of alignment and remain stable. Others are more touchy. A good few home-constructed receivers are in the last-named category.

The effect is always the same; in some cases it needs only a slight alteration of the IF or RF tuned circuits for the stages concerned to burst into uncontrollable oscillation. Hundreds of home constructors must have been driven frantic by instability of an especially stubborn nature which was not, in fact, due to wiring or component faults but because of inaccurately aligned tuned circuits. Some widely used home-constructor designs are notably prone to this trouble. The answer, of course, is to lay your hands on a signal generator and line up the receiver properly. No amount of twiddling the cores on Test Card C can do the job so well as half an hour with a test oscillator.

Unfortunately there remains those extremely difficult cases. It sometimes happens that alignment is correct, the valves are efficient, the seating, screens and decouplers are in order—and yet instability persists. In such instances

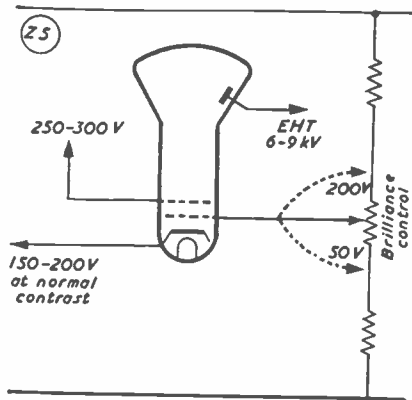

Fig. 3. Typical operating voltages (measured to chassis) which can be expected under practical conditions. These will of course vary according to the particular CRT and circuit arrangements of the receiver.

one must consider carefully point (2) mentioned earlier. In other words, stray coupling exists somewhere.

There are numerous possibilities, which will vary according to the particular circumstances. Some known causes have included stray coupling due to pick-up on leads to aerial terminals, deflection coil assemblies and loudspeakers. Other cases were due to leads lying within "coupling distance" of tuned circuits or valves; such instances in an early RF stage can give rise to severe instability. Look also for under-chassis leads which may be introducing just that amount of coupling capable of causing instability. And more than once, an aerial feeder running too near the mains lead has created the coupling.

From the preceding comments it will be obvious that when building a receiver from a published design, it is important to adhere closely to the instructions given. If the wiring is substantially similar to the recommended layout, instability should be easy to cure. If not, the wiring may have to be rearranged (this applies mainly to beginners—experienced constructors will realise what liberties can be taken in wiring).

Common RF stages, including mixer and oscillator in superhets, are more liable to oscillate parasitically than later stages, and superhets in general are more liable to instability than TRF circuits. The chief causes of instability (not in order of incidence) are:—

- (1) Faulty decoupling condensers (low, open-circuit or high-resistance), especially where the condenser decouples both screen and anode. Note that a component which functions well in a late stage may be quite inadequate in an early RF stage due to the more exacting conditions prevailing.
- (2) Faulty valves—loss of emission, electrode faults. Also high-resistance pin contacts due to corrosion, etc., and dirty valveholder sockets.
- (3) Poor earthing contacts, notably valve screening cans, base screens, etc.

CRT FAULTS

A constant source of anxiety to many TV constructors, and naturally so, is the picture tube. Everyone takes great care in handling the tube, not only because of the hard cash involved but also due to the risk of implosion and the consequent possibility of damage to life and limb. It is natural that many troubles, in reality originating in the

vision receiver or scanning circuits, cause concern as being possible CRT defects.

Fortunately CRT faults fall into clearly defined categories and are not difficult to diagnose.

Loss of Emission.

Generally speaking, most tube faults are due to (a) Loss of emission or (b) Inter-electrode short circuits.

Symptoms of failing emission are lack of brightness, poor contrast ("washy" picture), deterioration of definition and general defocussing of image. Brilliance control action becomes erratic in many cases. Sometimes the image turns "negative" when the manual control is advanced and the effect is similar to that obtained by excessive contrast. In other cases an increase in brilliance causes blacks to turn grey and give "thin" pictures—there being no true blacks or peak whites.

An overall deterioration of focus is often a sign of an ageing tube, although this can be caused by various other faults. If halation accompanies the lack of focus, it is almost certainly the tube, however.

The above symptoms can develop not only in old tubes but in relatively new ones. A good guide is that if the symptoms appear suddenly it is unlikely the tube is at fault. Loss of emission is a slow process and the symptoms get progressively worse; constant viewing of the receiver would make it difficult to observe the worsening conditions.

Inter-electrode Short Circuits.

Most likely trouble in this direction is a heater-cathode short, which manifests itself by uncontrollable brilliance. In circuits using grid-modulation the picture can sometimes be seen faintly "underneath" the vivid white raster. In the more usual cathode-modulation circuits, the screen may sometimes be half blotted out due to hum bars—this depending on the exact nature of the fault and the CRT heater arrangements.

Grid-cathode short circuits produce similar results but there will be no sign of picture modulation as it will be shorted out. Under these conditions the video amplifier anode voltage or the brilliance control voltage will be very low, according to whether grid or cathode modulation is used.

A partial grid-cathode short may result in the brilliance increasing as the control is turned to *minimum*. A hum bar is also likely. Not so uncommon as it might seem is an internal open circuited grid—it produces, of course, a raster at full and uncontrolled brilliance. Rather rarer is an open circuit cathode—result, no raster.

More difficult to trace are intermittent short circuits. When it concerns the grid-cathode path sudden and erratic changes in brilliance can be expected. A grid-cathode short quite often appears during the initial “warming-up” period and disappears once the set has settled down. Other intermittent shorts cause a vivid glare over the screen completely obliterating the picture, only to return to normal for no apparent reason. A gentle (note: *gentle*) tap on the neck of the tube will often partially confirm an intermittent short by the disappearance of the trouble—temporarily!

Gassy, or soft, tubes exhibit similar symptoms to a tube with failing emission—poor focus, lack of definition and a general weak and washed out picture. Incidentally, it should be noted that, unlike ordinary valves, what we call inter-electrode short circuits seldom give any measureable leakage on test so that if the test meter shows “no reading” this does not necessarily exonerate the tube.

Testing the CRT

So much for symptoms. And now to prove or disapprove whether or not the tube is at fault.

A number of faults indicative of a defective CRT, already mentioned, may often originate elsewhere. The experienced TV experimenter can tell by a study of the symptoms if the tube is faulty but the newcomer may be excusably bewildered. The table gives common CRT faults and similar faults originating elsewhere.

CRT			
Symptoms Displayed	Alternative	Faulty	Circuits.
1 Lack of brilliance, with poor focus.	Defect in EHT system, causing low EHT.		system,
2 Poor contrast (washed pictures)	Low video valve emission, leaky decoupling condensers in video stage(s), faulty coupling components, or misalignment of video tuned circuits.		

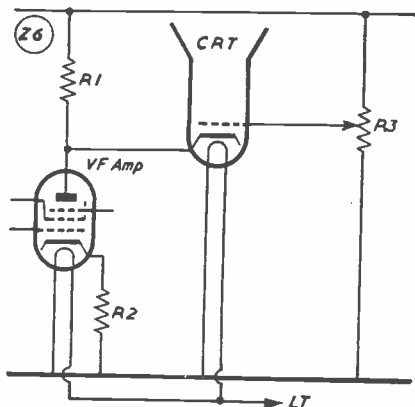

Fig. 4. A CRT coupling arrangement and brilliance control system which have several undesirable features, as discussed and explained in the text.

- | | |
|---|--|
| 3 Poor definition | Insufficient video band-width (alignment incorrect, damping resistors open circuit, etc.). Low emission in video valve(s). |
| 4 Erratic brilliance control | Faulty potentiometer, or fluctuating EHT voltage. |
| 5 Raster at full brilliance (no control action) | Open-circuit resistor in brilliance network, CRT modulation coupling condenser leaky. |
| 6 No raster | Cessation of supplies to CRT, EHT system, video or scanning circuits. |
| 7 No focus | If electro-magnetic focussing : Open or short circuited turns in focus coil, or short circuit in focus coil, or short circuited focus smoothing condenser.
If PM focussing : Loss of magnetism, damage to focus ring. |

Further analysis and observation will locate the exact fault. In example (1) above, for instance, if the EHT is low the raster will be of increased size. In example (2) the condition is invariably accompanied by a “smudgy” background and general loss of definition if it is due to an inefficient tube. In (6) much can be deduced if line fly-back EHT is used; a fault which renders the line time-base inoperative will automatically stop the supply of EHT to the tube. The high-pitched whistle which

emanates from the line output transformer is a useful pointer—no whistle, faulty time-base. Condition (3) normally has accompanying symptoms. For instance, if the trouble is due to a vision section fault, erratic synchronisation is experienced due to the loss of the pulses in the amplifier. If the raster can be focussed sharply, the tube is almost certainly not at fault.

A gassy ("soft") tube usually exhibits a blue glow round the electrode assembly and a tube which has an air-leak (*i.e.* has partially lost its vacuum) accumulates a white deposit round the gettering within the glass envelope.

In many cases, it becomes necessary to check the CRT operating voltages. Fig. 3 shows the essential points and the readings to be expected—these vary, of course, according to the tube type, and manufacturer's data should be consulted. The behaviour of the CRT readings is a good indication of its efficiency.

On making tests, if the grid shows a high positive potential with respect to cathode the tube is practically certain to have been destroyed. This assumes cathode modulation injection. A good check for a soft tube can be made by observing the EHT when the lead to the final anode is disconnected; if it rises substantially, the tube is gassy. Similar tests can be made in the following manner:

The behaviour of the anode current will give positive proof of the tube's efficiency and a 0.1 millimeter in conjunction with a kilovoltmeter can be set up. Note, however, that the millimeter should be mounted on an insulated frame and shunted with a 0.1 μ F high voltage condenser. Unless the constructor has adequate facilities and confidence such tests should not be made as the EHT voltage can be dangerous. Assuming that the equipment can be set up, rotate brilliance and contrast controls to minimum and switch on receiver. Readings should be: Anode current—zero; Anode voltage—normal.

If the anode current is high and the brilliance control has no effect on reading, check the grid bias voltage. If cathode and grid voltage are in order, the tube is gassy.

Most tubes are rated at about 150 microamps anode current but some efficient tubes may pass as much as 200 μ A. Providing that check (1) is satis-

factory increase brilliance, carefully noting the behaviour of the milliammeter; at full brilliance the reading should be between 150-200 μ A but if anode current becomes excessive during this process the tube is certainly soft.

Where ion traps are fitted, this should be taken into account when tracing tube troubles in newly constructed receivers. Incorrect setting of the trap can cause shadows or even blot out the raster completely. The tube makers instructions should be consulted. Also note that in circuits which incorporate a diode "spotter" circuit between the VF amplifier and the CRT, faults in the diode can affect picture quality.

Though not actually anything connected with fault finding, perhaps a few words on the care and protection of the CRT would be appropriate. Constructors designing their own receivers should pay marked attention to the CRT circuits. The cathode ray tube is subjected to wear and tear and in obedience of the laws of nature will one day outlive its usefulness. But although the CRT has a limited life (usually reckoned as 1,000 hours as are normal radio valves) the day of reckoning can be postponed (or hastened) by the operating conditions and general handling.

General rules worth observing include running the tube at as low an EHT voltage as possible consistent with good image reproduction. It is also desirable

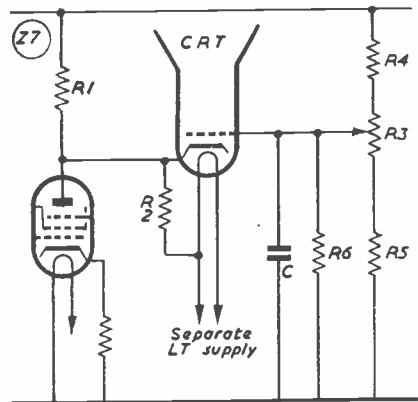

Fig. 5. A better circuit than Fig. 4, embodying protective arrangements.

TRACING TELEVISION TROUBLES

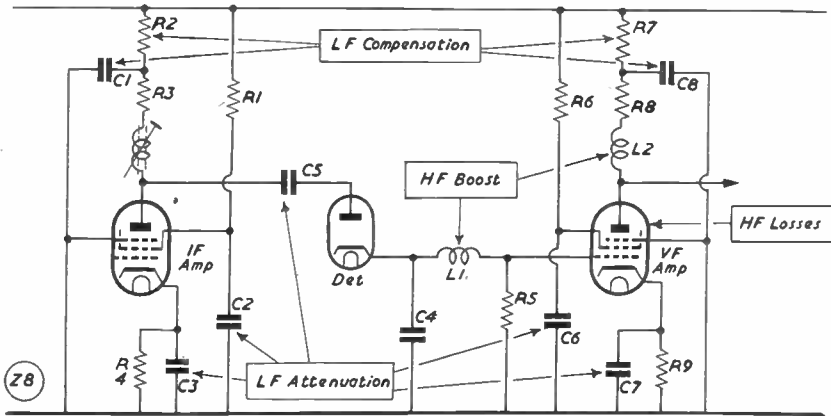

Fig. 6. Typical video receiver circuit showing the effect of certain components on HF and LF response. C2/C3 and C6/C7 introduce LF attenuation which is compensated for by R1/C1 and R7/C8.

to keep the screen away from direct sunlight. Although modern tubes are much better in this respect, older tubes are more liable to suffer decreased sensitivity of the phosphor coating (which affects the afterglow) due to receiving ultra violet rays from the sunlight. Simple swing doors or a drape are no trouble to fit and may save many precious hours of life for the tube.

Coupling between the video amplifier should be watched. Fig. 4 shows a circuit which contains many inherently bad features. The heater of the CRT is taken from an LT winding common to the other valves. This, in itself, is no disadvantage if everything is functioning normally. But the heater-cathode insulation must be watched.

Under normal conditions, the voltage drop across R1 prevents excessive cathode potential—it will be around 100 volts or so; this also is the potential difference across the heater-cathode circuit since one side of the heater is returned to chassis. Now if the VF amplifier fails (or R2 goes open circuit) there will be no voltage drop across R1 and the tube cathode will receive the full HT voltage and the increased heater-cathode potential will injure the tube.

Now look at the brilliance control R3. For normal operation (with a cathode voltage around 150) grid voltage will be something like 0-130 from beam

current cut-off to full brilliance. In the circuit shown it is possible to apply the full HT line voltage to the grid at the extreme end of the potentiometer track. Thus one golden rule will be broken—the grid will be positive with respect to cathode, with subsequent damage to the tube.

Fig. 5 shows another arrangement embodying more satisfactory arrangements. First, the tube heaters are fed from a separate heater winding and a high resistance R2 (usually 1 megohm) wired between heater and cathode to prevent a high potential difference developing. The brilliance control R3 is now part of a potential divider network across the HT supply. R4 prevents excessive HT and consequently it is impossible to swing the grid positive. R5 is not essential but with a suitable value relative to R3 and R4 it provides better manual control—the grid potential being adjustable from just about cut-off point to *very slightly* positive.

Another safety device is R4 (1 megohm). If the potentiometer R3 becomes open circuited (not unusual) a resistance is still in circuit and so the tube is biased to cut-off. The condenser C (0.01 μ F) is a normal by-pass component to ensure freedom from hum and similar spurious modulation.

When tracing faults in circuits the application of plain reasoning will point to the source. For instance, a short-

circuit in C will result in no beam current and hence no raster; if R4 becomes open circuit the grid will be at earth potential and thus minimum brilliance will be experienced. Any fault which results in the cathode becoming *less* positive will cause an increase in beam current and in extreme cases the action of R3 may be practically ineffective. One common cause of this type is the VF load resistor R1 going "high"—probably through overheating due to self-oscillation. Any change in the working conditions of the VF amplifier can upset the brilliance control system since the amplifier forms part of the cathode circuit of the tube.

VISION RECEIVER FAULTS

The newcomer may be somewhat mystified by certain troubles which arise in the video section. It is important to realise, however, that basically the faults which develop are similar to those experienced in normal sound radio; it is the effects produced which may be baffling. Faults which are ignored in sound radio become important in video work. For instance, inadequate HF or LF response is quite often passed over in an ordinary radio receiver, but the eye is a more critical organ than the ear and such defects in a vision receiver are quite unacceptable.

In complete breakdowns valves are high on the list of culprits, particularly mixers in superhet circuits. They should be tested by substitution starting at the VF amplifier and working back towards the "front end." If sound is also absent, the search narrows to the common RF stages; if only vision is absent, the RF section can be cleared. This practice is not advisable in AC/DC type receivers because some heater chains use series-parallel arrangements and damage will invariably result.

Assuming that no signal generator is available, quick checks can be made simply by scraping the grid pins of each valve in turn—a stage in working order will give flashes (in the form of "spots") on the screen. Video troubles are often caused by quite commonplace faults; next to valves, open-circuit feed resistors and defective decoupling condensers are frequent troublemakers. Other oft-met faults are feed resistors which have "gone high" or changed value considerably, and open-circuit decoupling con-

densers (which cause a considerable loss of output).

We are more concerned here, however, with comments on "faults" which may be due to inherently bad design or poor construction in addition to actual component breakdowns.

The main headings under which these faults lie are:

- (1) *Plastic*: The main outline of an image is sharply defined, but the picture as a whole takes on a uniform greyish tone. Large objects tend to "smear."
- (2) *Black after White*: An echo, of reversed order, appears slightly to the right of clearly defined vertical elements. May appear as a single shadow or a series of shadows of diminishing intensity. Sometimes applied judiciously to help "sharpen" the picture. Often called "ringing."
- (3) *Flare*: Horizontal streaks to the right of vertical images, sometimes with a general darkening of picture background.
- (4) *Poor Definition*: Spot is well focussed but images not clearly defined. Sometimes accompanied with flaring and some loss of fine vertical detail.

One important point emerges: Any one of these faults can be caused by incorrect alignment of the tuned circuits! Thus it becomes important to make sure the IF and/or RF stages are adjusted correctly before hours are spent trying to trace imaginary component faults.

The basic causes of the above troubles are inadequate LF response ("plastic"), excessive LF response ("flare"), phase distortion ("black after white") and inadequate bandwidth ("poor definition"). These faults may be caused by incorrect operating conditions in the VF amplifier, the RF or IF circuits or both. If the trouble is due to tuned circuits misalignment other symptoms occur; improper alignment of the RF stage(s) will usually distort the audio output so that if the sound is perfectly normal the fault is usually in the main vision section. Again, if the video IF (or RF) stages are off tune we can expect stray modulation bars undulating on the picture due to audio voltages breaking through ("sound-on-vision").

Assuming alignment is correct (and, if

a superhet, the oscillator has been checked for drift) the usual causes for most of the troubles are incorrect operating voltages and faulty condensers.

Common causes of Plastic are faulty (usually low capacity) decoupling condensers in the VF amplifier or, if used, poor coupling condensers and/or DC restorer diode. Flare is usually caused by a fault in the LF compensating network in video amplifier, with condensers again high on the list of suspects. If the video amplifier is receiving too low a bias voltage the tube will be easily overloaded due to grid current, while low anode and/or screen grid voltages will also cause the effect. In this case the diagnosis may be confirmed by adjusting the contrast control—if the flaring varies with contrast settings the trouble is almost certainly due to low voltage, caused usually by a feed resistor “gone high.” All by-pass, dropping and decoupling components should be checked; open circuit or low capacity condensers are frequent offenders.

Black-after-White is often used discriminally to sharpen the picture, but home constructors should note that the deliberate misalignment should be obtained by slight detuning of the oscillator and *not* in the IF stages. Serious “ringing” is often caused by the HF correction network. Peaking chokes are frequently included to correct the attenuation at HF caused by stray capacities in the circuit. They also, however, add to the phase lag and in practice the designer compromises between attenuation and phase lag. It is obvious that these components must be carefully chosen and one of the chief disadvantages is that correction chokes are liable to be “peaky”; that is, in conjunction with their self capacities they form resonant circuits.

If ringing persists after correct alignment, check the usual items which affect stability—decoupling condensers, etc. Check also that damping resistors across the tuned circuits are not open-circuited or faulty. In severe cases it may be necessary to reduce the value of the damping resistors or even to shunt the peaking choke with a damping resistor (which should be as high as possible to avoid deterioration of the HF content).

Some of the causes of poor definition have already been discussed. Often the effect exhibited is similar to flaring and

the cause is due to inadequate HF response. Check for correct alignment, bandwidth and VF amplifier efficiency (by direct replacement). The effect is often inherent in cheap receivers but where the trouble has developed in a hitherto satisfactory receiver the above comments will apply. Also, the H.F. compensating chokes may be the cause.

Much can be done by home constructors to ensure adequate performance of the video amplifier. Care in wiring is extremely important. Fig. 6 shows a typical video detector and amplifier arrangement. The diode load resistor R5 should be low (3,300-4,700 ohms is usual) and the condenser C4 about 20 μF . Stray capacities, due to poor wiring, can add substantially to this nominal capacity with a subsequent deterioration of quality. Again, the peaking choke L1 can impose a considerable load on the circuit if its capacity to chassis is too large.

In the VF amplifier, stray capacities can completely ruin an otherwise satisfactory electrical arrangement. Owing to the fact that the valve has to handle a very wide range of frequencies, a resistance is used as the anode load (R8 in the diagram) thus preserving the higher frequency element necessary for good definition. However, there are numerous stray capacities—those of the valveholder, circuit wiring, the output capacitance of the valve, the capacity to chassis of the coupling condenser (to the CRT), and so forth. All these strays are, in effect, shunted across the load resistor since the HT positive line and chassis are at the same potential from an AC point of view, and so the accumulated stray capacities simply by-pass the HF component. The larger the total stray capacitance the more HF will be lost.

To retain as much HF as possible, the load resistor must be lower in value than the reactance of the total stray capacities at the highest frequency handled. And this is where the trouble starts; in most cases the value would be so low that the gain of the amplifier would suffer. By increasing the value of the resistor (and hence the gain) definition falls.

That is why peaking chokes are often used. Even so, many home-built receivers are still far from satisfactory,

And the answer is to reduce the strays to the lowest possible value. If a DC restorer is used it is advisable to select a type such as the EA50 (VR92) which have a very low input capacitance. Complete re-wiring of the video amplifier circuit may be necessary to reduce the effect of strays.

As a check on efficiency, try experimenting with the value of the anode load resistor. Start off with about 6,000 ohms and reduce this progressively down to about 1,800 ohms. Naturally, there will be progressive loss in gain but the important thing to note is the picture quality. If this improves considerably as the load is reduced then it is certain that there are excessive stray capacities and a new wiring layout is indicated.

To sum up these notes on video faults here are some general observations: Breakdowns are caused mainly by faulty valves and condensers, followed closely by resistors of changed value (usually

high). Always be wary of "surplus" condensers as a large proportion of the paper type are not suitable for service in the video stages. Use mica types where possible. Never take a resistor for granted—some have a disturbing habit of being perfectly normal when "cold" but suddenly changing value when warm, either going open circuit or increasing in value.

Whatever trouble besets the home TV constructor, there is one invariable approach: Study the symptoms carefully and diagnose which parts of the receiver can be considered as working satisfactorily. Further narrow down the search to a particular section; then to a particular stage. Finally: visual, continuity, voltage and replacement checks to locate the faulty component(s).

It is not, of course, always as easy as that but with a methodical approach the tracing and curing of video faults can be considerably simplified.

RADIO CLUBS AND SOCIETIES

Full List of Active Local Groups

If there is a radio club in your district, its title and the name and address of the honorary secretary appear in this List. If you are not already a member, why not get in touch with him and ask for details? All Clubs and Societies listed here are active, holding regular meetings and they are all glad to welcome new members. Secretaries of Clubs not shown in this List are asked to send us necessary details for publication in the next issue of RADIO QUARTERLY.

ACTON, BRENTFORD & CHISWICK RADIO CLUB

R. G. Hindes, 51 Rusthall Avenue, Bedford Park, London, W.4.

ARMY APPRENTICES' SCHOOL RADIO CLUB

F. A. Hall, G3GBU, Tels. Dept., A.A.S., Arborfield, Reading.

BALDOCK & DISTRICT RADIO CLUB

A. Fussell, G3HBH, 6 Clare Crescent, Baldock.

BARNSELY & DISTRICT AMATEUR RADIO CLUB

P. Carbutt, G2AFV, 33 Woodstock Road, Barnsley.

BATTERSEA POLYTECHNIC RADIO SOCIETY

J. C. Watson, G3HHY, 41, Wroughton Road, London, S.W.11.

BIRMINGHAM & DISTRICT SHORT WAVE SOCIETY

A. O. Frearson, 66 Wheelwright Road, Birmingham 24.

BOURNEMOUTH RADIO & TELEVISION SOCIETY

J. Ashford, 3 Stevenson Court, 57 Alum Chine Road, Bournemouth.

BRADFORD AMATEUR RADIO SOCIETY

A. R. Bailey, G3IBN, Scarr Croft, Parkside, Bingley, Yorks.

BRENTWOOD & DISTRICT AMATEUR RADIO SOCIETY

J. S. Thornton, G3FQQ, 18 Western Road, Billericay, Essex.

BRIGHTON & DISTRICT RADIO CLUB

R. T. Parsons, 14 Carlyle Avenue, Brighton 7.

RADIO CLUBS AND SOCIETIES

BTH (RUGBY) RECREATION CLUB
RADIO & TELEVISION SECTION
 P. N. Prior, Electronics Engineering
 Dept., BTH, Rugby.

BURY ST. EDMUNDS AMATEUR RADIO SOCIETY
 C. A. King, 358 Medium Regt., R.A.
 (T.A.), T.A. Centre, Bury St.
 Edmunds.

CAMBRIDGE & DISTRICT AMATEUR RADIO CLUB
 T. A. T. Davies, G2ALL, Meadow Side,
 Comberton, Cambridge.

CHELTEHAM AMATEUR RADIO SOCIETY
 E. A. J. Miles, G3GCR, Hamble, 8
 Elmfield Road, Cheltenham.

CHESTER & DISTRICT AMATEUR RADIO SOCIETY
 N. Richardson, 1 Victory Villas, Upton
 Lane, Chester.

CLACTON RADIO CLUB
 R. F. E. Bliss, 67 Salisbury Road,
 Holland-on-Sea, Essex.

CLIFTON (LONDON) AMATEUR RADIO SOCIETY
 W. Wooller, G3GYZ, 7 Neptune House,
 Neptune Street, London, S.E.16.

COVENTRY AMATEUR RADIO SOCIETY
 K. Lines, G3FOH, 142 Shorncliffe Road,
 Coventry.

DARTMOUTH & DISTRICT AMATEUR RADIO SOCIETY
 B. Farleigh, G4RJ, Montpelier, Lower
 Contour Road, Kingswear.

DERBY & DISTRICT AMATEUR RADIO SOCIETY
 F. C. Ward, G2CVV, 5 Uplands Avenue,
 Littleover, Derby.

DORKING & DISTRICT RADIO SOCIETY
 J. Greenwell, G3AEZ, 7 Sondes Place
 Drive, Dorking.

EAST GRINSTEAD & DISTRICT AMATEUR RADIO CLUB
 L. E. Miller, 30 Forest View Road,
 East Grinstead.

EAST SURREY RADIO CLUB
 L. Knight, G5LK, Radiohme, Madeira
 Walk, Reigate.

ECCLES & DISTRICT RADIO SOCIETY
 A. Gray, 2 Egerton Road, Monton Green,
 Eccles.

EDGWARE & DISTRICT RADIO SOCIETY
 R. H. Newland, G3VW, 10 Holmstall
 Avenue, Edgware.

EDINBURGH AMATEUR RADIO CLUB
 D. B. R. Black, 16 Edina Place, Edin-
 burgh.

EDINBURGH (LOTHIANS) RADIO SOCIETY
 I. Mackenzie, GM3FGJ, 41 Easter
 Drylaw Drive, Edinburgh 4.

GRAFTON RADIO SOCIETY
 A. W. H. Wennell, G2CJN, 145 Uxendon
 Hill, Wembley Park, Middx.

GRAVESEND AMATEUR RADIO SOCIETY
 R. Appleton, 23 Laurel Avenue, Graves-
 end.

HARROW, RADIO SOCIETY OF
 S. C. J. Phillips, 131 Belmont Road,
 Harrow Weald.

HASTINGS & DISTRICT AMATEUR RADIO CLUB
 W. E. Thompson, 8 Coventry Road, St.
 Leonards on Sea.

HOUNSLOW & DISTRICT RADIO SOCIETY
 J. Clarke, 124 Springwell Road, Heston,
 Middx.

ISLE OF MAN RADIO SOCIETY
 R. S. Trickey, Aigburth, Sunningdale
 Drive, Onchan, I.O.M.

IXWORTH RADIO CLUB
 P. G. Wright, Thurston Road, Great
 Barton, Bury St. Edmunds.

KINGSTON & DISTRICT AMATEUR RADIO SOCIETY
 R. Babbs, G3GVU, 28 Grove Lane,
 Kingston, Surrey.

LEICESTER RADIO SOCIETY
 W. N. Wibberley, 21 Pauline Avenue,
 Belgrave, Leicester.

LINCOLN SHORT WAVE CLUB
 G. C. Newby, G3EBH, 18, Birchill,
 Fiskerton, Lincoln.

LIVERPOOL & DISTRICT SHORT WAVE CLUB
 A. D. H. Looney, 81 Alstonfield Road,
 Knotty Ash, Liverpool 14.

MANCHESTER & DISTRICT RADIO SOCIETY
 K. Brockbank, 17 Burleigh Road,
 Stretford.

**MEDWAY AMATEUR RECEIVING & TRANS-
 MITTING SOCIETY**
 D. H. Brett, 14 Connaught Road, Luton,
 Chatham.

MIDLAND AMATEUR RADIO SOCIETY
 P. L. Hunt, G3FWB, 39 Antrobus Road,
 Birmingham 21.

NEATH, PORT TALBOT & DISTRICT AMATEUR RADIO CLUB
 G. Thomas, B.Sc., 7 Evelyn Road,
 Skewen, Neath, Glam.

NORWICH & DISTRICT RADIO CLUB
 D. Youngs, 53 Salisbury Road, Norwich.

NOTTINGHAM & DISTRICT SHORT WAVE CLUB
 K. Hourd, 132 Bannerman Road,
 Bulwell, Nottingham.

PORTSMOUTH & DISTRICT RADIO SOCIETY
 L. Rooms, G8BU, 51 Locksway Road,
 Milton, Portsmouth.

PURLEY & DISTRICT RADIO CLUB
 A. Frost, G3FTQ, 18 Beechwood
 Avenue, Thornton Heath.

- QAU CLUB, JERSEY, C.I.**
Miss Valerie Hunt, c/o 5 Valley Gardens,
Bel Royal, St. Lawrence, Jersey, C.I.
- QRP RESEARCH SOCIETY**
J. Whitehead, 92 Ryden's Avenue,
Walton-on-Thames, Surrey.
- RAVENSBORNE AMATEUR RADIO CLUB**
J. H. F. Wilshaw, 4 Station Road,
Bromley, Kent.
- READING RADIO SOCIETY**
L. Hensford, G2BHS, 30 Boston Avenue,
Reading.
- ROCHDALE RADIO & TELEVISION SOCIETY**
J. Riley, 1 Darley Bank, Britannia,
Bacup.
- ROMFORD & DISTRICT AMATEUR RADIO SOCIETY**
D. L. K. Coppendale, G3BNI, 9 Morden
Road, Chadwell Heath, Essex.
- SALISBURY & DISTRICT SHORT WAVE CLUB**
V. G. Page, G3IVP, 32 Feversham Road,
Salisbury.
- SCARBOROUGH AMATEUR RADIO SOCIETY**
P. Briscoombe, G8KU, 31 St. Johns
Avenue, Scarborough.
- SHEFFIELD AMATEUR RADIO CLUB**
L. Sarjeant, G3HGC, 86 Western Road,
Sheffield 10.
- SLADE RADIO SOCIETY**
C. N. Smart, 110 Woolmore Road,
Birmingham 23.
- SOLIHULL AMATEUR RADIO SOCIETY**
W. T. Bastin, G2BFT, 386 Lugtrout
Lane, Catherine de Barnes, Solihull.
- SOUTHEND & DISTRICT RADIO SOCIETY**
G. Chapman, B.E.M., 20 Leigh Hill,
Leigh on Sea, Essex.
- SOUTH MANCHESTER RADIO CLUB**
M. Barnsley, G3HZM, 17 Cross Street,
Bradford, Manchester 11.
- SOUTH-WEST ESSEX RADIO CLUB**
B. W. le Grys, G3GOT, 75 Shaftesbury
Road, Romford.
- SPEN VALLEY & DISTRICT RADIO & TELEVISION SOCIETY**
N. Pride, 100 Raikes Lane, Birstall,
near Leeds.
- STOCKPORT RADIO SOCIETY**
G. Phillips, G3FYE, 7 Germans
Buildings, Buxton Road, Stockport.
- STOKE-ON-TRENT AMATEUR RADIO SOCIETY**
J. R. Brindley, B.Sc., G3DML, 45
Rosendale Avenue, Chesterton,
Newcastle, Staffs.
- SUNDERLAND RADIO SOCIETY**
C. A. Chester, 38 Westfield Grove,
High Barnes, Sunderland.
- SURREY RADIO CONTACT CLUB**
(CROYDON)
S. A. Morley, G3FWR, 22 Old Farleigh
Road, Selsdon, South Croydon.
- SUTTON & CHEAM RADIO SOCIETY**
F. J. Harris, 143 Collingwood Road,
Sutton, Surrey.
- SWANTON MORLEY AMATEUR RADIO CLUB**
F/L A. E. White, G3FNX, RAF Swanton
Morley, East Dereham, Norfolk.
- TEES-SIDE AMATEUR RADIO CLUB**
H. Walker, G3CBW, 64 Ayresome
Street, Middlesbrough.
- THAMES VALLEY AMATEUR RADIO TRANS-MITTERS' SOCIETY**
K. A. H. Rogers, G3AIU, 21 Links
Road, Epsom, Surrey.
- ISLE OF THANET RADIO SOCIETY**
J. Barnes, G3BKT, 18 Grange Road,
Ramsgate.
- TORBAY AMATEUR RADIO SOCIETY**
L. D. Webber, G3DW, 43 Lime Tree
Walk, Newton Abbot, Devon.
- WANSTEAD & WOODFORD RADIO SOCIETY**
C. Stevenson, 45 Dacre Road, London,
E.13.
- WARRINGTON & DISTRICT RADIO SOCIETY**
G. S. Leigh, G2FCV, 49 School Road,
Orford, Warrington.
- WATFORD AMATEUR RADIO SOCIETY**
J. A. Káne, 23 Oaklands Avenue,
Oxhey, Herts.
- WEST KENT RADIO SOCIETY**
F. R. Freeman, 1B Queens Road,
Tunbridge Wells.
- WEST LANCs. RADIO SOCIETY**
B. J. Whitty, G3HWX, 46 Argo Road,
Waterloo, Liverpool 22.
- WEST MIDDLESEX RADIO CLUB**
P. W. Smith, 121 Richmond Avenue,
Hillingdon, Middx.
- WEST RAYNHAM RADIO SOCIETY**
Cpl. M. Allenden, C. R. W., RAF
West Raynham, Fakenham, Norfolk.
- W.F.S.R.A. ("Bedfast Club")**
D. W. Auton, G3IHI, 36 Elborough
Road, Moreton, Swindon.
- WIRRAL AMATEUR RADIO SOCIETY**
L. Roberts, 18 Croxteth Avenue,
Wallasey.
- WORCESTER & DISTRICT AMATEUR RADIO CLUB**
J. Morris-Casey, G8JC, 4 Kennels Road,
Station Road, Fernhill Heath,
Worcs.
- WORTHING & DISTRICT AMATEUR RADIO CLUB**
R. Chidzey, 33 Bruce Avenue, West
Worthing.
- YEovil AMATEUR RADIO CLUB**
D. L. McLean, 9 Cedar Grove, Yeovil.
- YORK AMATEUR RADIO SOCIETY**
G. Nottingham, G3DTA, 51 Carr Lane,
Acomb, York.

SHORT WAVE BROADCAST LISTENING

How to Make the Most of Your Receiver

Practically every broadcast receiver in use today has a short wave tuning range which will bring in large numbers of distant foreign stations. This can add enormously to the variety and interest of general reception. All over the world, there are now scores of thousands of short wave enthusiasts who spend much of their listening time tuning round the world's broadcasters. This article explains how to find and recognise these stations, giving much invaluable detailed information based on practical experience. Even to read through this intensely interesting article is to realise how much your broadcast receiver can offer you — and how much you are missing if you do not make full use of its short wave tuning ranges.

SOME twenty years ago, listeners to radio broadcasts on the short waves were very few indeed. The era of the all-wave band receiver had not arrived, and reception on the straight sets and converters was often noisy and unreliable; programmes, too, were in the experimental stage.

Yet there was romance in short-wave listening, and this has not decreased throughout the years; on recalls the voice of Señor Amando Cespedes Marin, owner-operator of TI4NRH in Heredia, Costa Rica, who said: "This is the smallest broadcasting station in the world, but the one with the biggest heart." Later, there were such excitements as the relay of the finish of the Melbourne Centenary Air Race, and, during the World War II period, a direct broadcast from Admiral Byrd's Expedition base at the South Pole. In those early days it was often the unexpected signal which gave the listener his or her big thrill, and, in some measure, this is true today.

Reliability is the watchword of all the principal short-wave broadcasting networks at the present time, however, and, given favourable conditions, the listener can generally expect to hear the programme of his choice, provided that

the transmission is directed towards his particular location. How some broadcasts are deliberately obliterated will be discussed later; for the moment, we are concerned with what broadcasting has to offer, both for the experienced listener and for the newcomer to short-wave listening.

The great advantage of tuning-in to programmes on the short-wave bands rather than to those from foreign stations on medium waves is that quite 50% of the announcements and talks on the former are presented in the English tongue.

We now come to this business of short-wave bands. In the first place, it is an accepted fact that short-wave transmissions are made on the higher frequencies. In the early days of broadcasting, those stations operating adopted wave-lengths measured in metres and receivers were calibrated accordingly; nowadays, many commercial all-wave sets are calibrated in this manner, but short-wave communications receivers are normally furnished with frequency-marked scales. The relationship between *wave-length* and *frequency* is better understood by reference to the well-known formula: $v = n\lambda$, where v = velocity, n = frequency and λ = wave-

ALL TIMES GIVEN IN THIS ARTICLE ARE GMT EXCEPT WHERE STATED

SHORT WAVE BROADCAST LISTENING

length. The approximate velocity of wireless waves is 300,000,000 metres per second. The frequency used by a radio station is the exact number of waves, measured from crest to crest, which it radiates each second; a thousand waves are a thousand "cycles" or one kilocycle.

$$\therefore 300,000,000 \text{ (v)} = 1000 \text{ n} \times 1 \text{ (metres)}$$

$$\text{metres per second} \quad \text{cycles per sec.}$$

$$\text{Hence : n (kilocycles/sec.)} = \frac{300,000}{1 \text{ (metres)}}$$

$$\text{or : 1} = \frac{300,000}{\text{n}}$$

We shall refer to kilocycles as "kc" and metres by the single letter "m." Frequencies are sometimes quoted in megacycles per second and 1 mc = 1000 kc.

If you wish to convert a wave-length of 40 metres to a frequency measurement, all that is necessary is to divide 300,000 by 40 = 7500 kc = 7.5 mc; or the reverse: $12000 \text{ kc} = \frac{300,000}{12,000} = 25$ metres.

In the short-wave bands, more stations can be accommodated in a given space than is possible on medium waves, and the lower the wave length, the greater the number. However, there must be a separation of at least 9 kc, otherwise broadcasts from two adjacent transmitters will interfere with each other and a heterodyne whistle will be heard.

It is perhaps unfortunate that short-wave broadcasting is generally restricted to a few comparatively narrow bands, so that a number of transmitters are required to use the same channel. However, it is arranged, as far as possible, that these shall be operating at different times during the twenty-four hours of each day.

In the matter of tuning, the standard method adopted by the manufacturers of all-wave receivers is that of the fast and slow motion drive, where a small knob superimposed on the main tuning control provides the slow motion, while the main knob engages a much higher gear. On some receivers, vernier scales are provided with separate pointers to give more accurate calibration.

Whatever method is employed, however, short-wave broadcast stations can only be logged, *i.e.* traced on the receiver, if the listener turns the tuning

knob or knobs very carefully; skill and not a little patience are demanded.

There are some ten bands—two of them minor ones—which are associated with broadcasting within the bounds of the short-wave spectrum. They are, respectively, 21 mc (13 metres), 17 mc (16.9 metres), 15 mc (19 metres), 11-12 mc (25 metres), 9 mc (30-31 metres), 7.9-8.2 mc (36 metres), 7-7.3 kc (40 metres), 5.9-6.3 mc (48-50 metres), 4.7-5 mc (60-62 metres) and 3.2-3.5 mc (84-91 metres). There are a number of transmitters scattered throughout the world which occupy channels outside these ranges, but it can be said that, generally speaking, the great majority adhere to positions in the recognised bands.

Finding the Stations

Our next procedure is to discover how best to fix the channels of the ever-present stations firmly in our minds, assuming that we are not the fortunate possessor of one of the very efficient but expensive wavemeters on the market.

One of the simplest methods of discovering the spot occupied by a particular transmitter is by reference to a graph or mathematical picture drawn on squared paper for each definite band. All that is necessary is to record the vernier scale readings of two or three of the principal stations, together with their respective frequencies, and to plot these figures on the two axes of the graph. We suggest the use of 1-inch large squares, each sub-divided into ten equal parts. As far as possible, readings for the two stations at the extreme ends of the band should be recorded, so that all intermediate channels are included, and it is worth your while to keep the frequency axis the same for each graph—shall we suggest the horizontal for this purpose?

Here are two actual examples, one for the 9 mc band, the other for the 15 mc band.

9 mc	Station	Frequency (kc)	Vernier Reading
	Madrid	9363	54
	Shepparton (Vict.)	9580	83
	Sackville (Canada)	9585	84
	New York	9650	93
	Kabul	9975	134

The horizontal axis commences at reading 50 and terminates at reading 140; the vertical axis gives frequencies

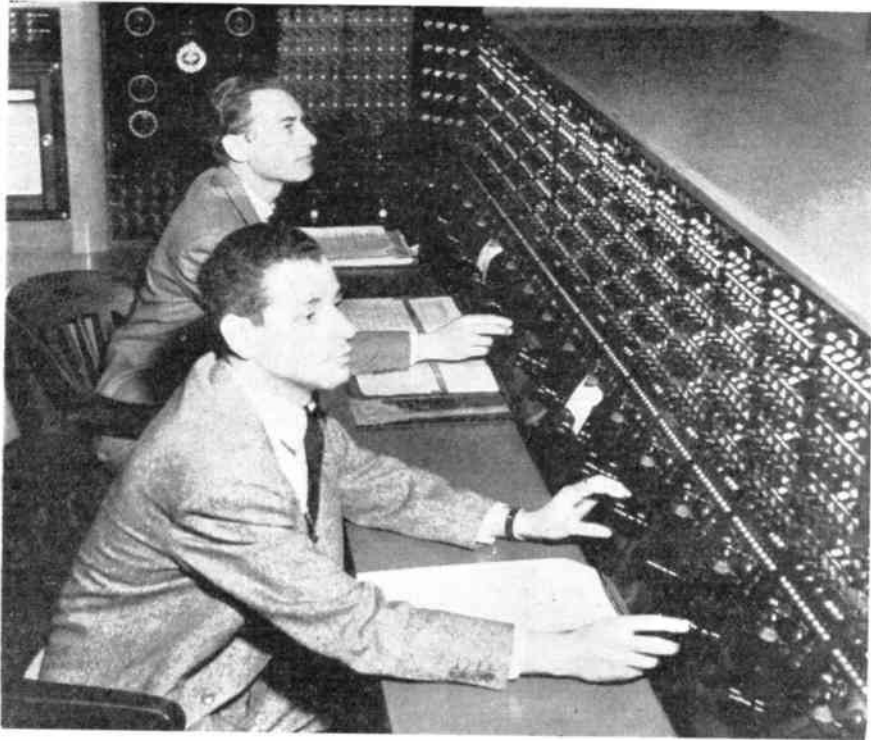

The VOA master-control and distribution board, which is equipped to handle 20 programmes from 40 outgoing channels simultaneously. All this involves an immensely complicated wiring system, and an elaborate time-schedule for the personnel involved.

from 9300 kc to 10000 kc. and the graph is, to all intents and purposes, a straight line. If now, one wishes to identify a station audible on reading 102.5, draw a vertical line from the horizontal reading 102.5; where it meets the line of the graph, draw a horizontal line to intersect the vertical axis. The corresponding frequency reading is 9725 kc, which corresponds to the station bearing the call-letters HI2T at Ciudad Trujillo in the Dominican Republic.

15 mc	Station	Frequency (mc)	Vernier Reading
	London	15.14	16
	Tangier	15.28	29
	Buenos Aires	15.29	30.5
	Shepparton (Aust.)	15.32	33.5

Suppose we wish to log Radio Addis Ababa, Ethiopia, which uses 15060 kc or 15.06 mc during the summer months;

we can trace this reading horizontally until it meets the graph line, then draw a vertical line to intersect the reading axis. This gives 7.5, which is the scale reading at which we shall expect to find signals from Addis Ababa on the receiver. Or we may hear a religious Revival Service on reading 31.5, which corresponds to a frequency of 15.3 mc. By reference to our list of short-wave stations we shall, without difficulty, identify our station as DZH8 of the Far East Broadcasting Company in Manila, Philippine Islands, which is listed on 15300 kc.

“Conditions”

It is generally accepted that short-wave reception is closely related to the condition of that part of the upper atmosphere known as the *ionosphere*,

which itself is controlled by the degree of solar activity prevalent at the time. Maximum conditions for reception on the highest frequencies occur every ten years, approximately, and at the present time we are experiencing a period of minimum activity. Consequently, we shall expect to find reception of distant stations best on the short-wave bands of lower frequencies. However, there are seasonal trends in short-wave reception, and during the summer months in the Northern Hemisphere we can expect to find improved conditions on the higher frequencies, due to the increase in solar activity.

Bearing in mind the fact that these tendencies are now prevailing, we shall later attempt to make a forecast of those transmissions which ought to be audible in the United Kingdom during the next three to four months. Despite the fact that Summer Time is now operating, it will be convenient to refer to all transmissions in terms of Greenwich Mean Time; readers should *add* one hour in order to convert to British Summer Time.

Before embarking on a detailed study of the main short-wave broadcasting networks, it is perhaps pertinent to mention the abnormal amount of interference now being caused by organised jamming of signals. Up to the year 1935, a short-wave listener could, given normal conditions, expect to hear the broadcast of his choice on a particular frequency; some slight interference was at times caused through two stations using the same frequency.

During his Abyssinian campaign, Mussolini caused certain broadcasts to be jammed and, later, the Nazi machine introduced organised jamming by installing transmitting apparatus capable of producing such noises as would overwhelm any foreign broadcast which it did not wish the world to hear. In recent years, this same procedure has been a feature of the cold war—at least, on one side; we read in the daily press that behind the Iron Curtain there are powerful transmitters capable of producing all kinds of undesirable jamming signals.

Listeners will probably know from their own experience that there have been occasions when an entire short-wave broadcasting band has been

obliterated by these seemingly childish practices.

Broadcasts in the Slav languages and in Chinese from Nationalist sources are the principal targets for this intensive jamming. The Voice of America and BBC Eastern European transmissions particularly have been subjected to this man-made interference, and what has been the result?

Overcoming Jamming

In the first place, a number of additional transmitters have been brought into service to carry the same programme, and it is claimed that beamed signals are actually penetrating the jamming barrier. Secondly, the United States authorities have endeavoured to combat this man-made obstruction by three projects which they refer to as "Baker," "Ring" and "Vagabond."

The first-named is given to the scheme for the construction of super-transmitting stations sufficiently strong to blast their way through all obstacles; "Baker East" and "Baker West" are two plants under construction in America as part of this plan. Under the heading "Ring," the United States plans to extend its present system of relay stations built at strategic points around the globe. The Tangier relay base is a typical example.

It began operations in January, 1950, and includes four 100, two 50 and two 25 kilowatt short-wave transmitters and numerous directional aerial systems, all for the purpose of speeding the Voice of America programmes on their way.

The "Vagabond" project aims at launching a fleet of mobile, sea-borne transmitters, which shall cruise in seas adjacent to the target areas and which will beam their programmes from close range. The U.S. cutter, *Courier*, which is the first of this flotilla, has for some months been operating in the Eastern Mediterranean off the island of Rhodes.

Vast sums of money are being spent on all these developments, and to what end? To quote from the Voice of America declaration: "In all these undertakings, America is seeking to tighten the spiritual bonds that unite all freedom-loving peoples, to strengthen the morale of those numbed by frustration and fear, and to reassure them that in this desperately divided world, the United States stands shoulder-to-



A studio, converted from a hotel bar room, often used by the "Voice of Canada" for musical productions.

shoulder with them in the struggle for a safer and a happier life."

And what of the opposition? That the jamming of broadcasts does prevent certain peoples from hearing the truth, we can presume to be partially true, else it would not be continued and augmented. At the same time, the perpetrators of these objectionable devices cannot but defeat their own object in the long run, for no rational being can be expected to wish to listen to broadcasts in the reverse direction, even if they do occasionally escape the attentions of their own jamming engineers.

The listener will, by experience, learn to avoid those parts of the short-wave bands which are, at a given period of the day, subject to such jamming. Many of the single-channel stations are themselves selecting new frequencies (sometimes outside the recognised bands), and the patient listener will find that there is still much to be heard that is interesting within the compass of the short-wave register.

Identification

It was mentioned earlier that some 50% of the operating short-wave broadcast stations use English, in which cases identification is a comparatively simple matter. Many of the large networks,

besides their English transmissions, give broadcasts in many other tongues, and in some instances, when the language is not well known, they may be mistaken for some distant and not normally receivable stations. On looking through the Voice of America World Programme Schedules, for instance, we find that broadcasts are made in the following languages: English, Finnish, Albanian, Arabic, Armenian, Azerbaijani, Bulgarian, Czech and Slovak, Estonian, German, Italian, French, Georgian, Greek, Hebrew, Hungarian, Latvian, Persian, Lithuanian, Polish, Portuguese, Rumanian, Russian, Spanish, Tartar, Turkish, Ukrainian, Yugoslav, Turkistani, Chinese, Japanese, Korean, Burmese, Indonesian, Hindi, Malay, Thai, Urdu and Vietnamese — some forty tongues all told!

Vatican City prefaces all its transmissions with the Latin words: "Laudetur Iesus Christus" (*May Jesus Christ Be Praised*), so that identification is easy.

French is commonly used, not only by Paris and Brussels, but by French and Belgian colonial stations and many others. Brazzaville, French Equatorial Africa, which can be heard with excellent signals in this country, may be identified by the words: "Ici Brazza-

ville, Poste Nationale Française"; this network can further be identified between programmes by an interval signal consisting of five musical notes played on the Kisanzi—a native instrument consisting of a number of vibrating metal bars attached to a wooden box. The Senegal, French West African station, merely announces as: "Ici Dakar" (*Here is Dakar*).

On rare occasions, signals from the glamorous Pacific island of Tahiti penetrate to the British Isles at the early hour of 0400, when you will hear the identification: "Ici Radio Tahiti, La Voix de la France dans l'Océanie." (*Here is Radio Tahiti, the Voice of France in Oceania*). Saigon, capital of French Indo-China (Viet Nam) is regularly heard here and can be identified by the statement: "Ici Radio France-Asie, la Voix de la France en Extrême Orient." (*This is Radio France-Asia, the Voice of France in the Far East*).

The West Indian Republic of Haiti uses French as its language medium; you may be able to locate station 4V2S, 5952 kc at 0015, with the direction: "Ici Radio Port-au-Prince, poste 4V2S operant sur la fréquence de 5952 kc à Port-au-Prince, Haiti, Grandes Antilles." Another on 10072 kc and on 5842 kc simultaneously, gives this direction at 2400: "Vous écoutez Radio Haiti, postes 4VW, 4VRW et 4VHW, travaillant simultanément dans les bandes de 29, 49, 230 mètres. à Port-au-Prince, capitale de la République d'Haiti, affiliée à la Columbia Broadcasting System et à la chaîne de la Paix de Nations Unies."

German and Austrian networks, generally, use the German language for their compatriots abroad. In the British Zone of Germany we can log Hamburg with the words: "Hier ist der Nordwestdeutsche Rundfunk Hamburg," and in Austria, Vienna may be found with the words: "Hier ist die Sendergruppe Rot-Weiss-Rot, Wien, Salzburg und Linz." (*This is the Red-White-Red Network, Vienna, Salzburg and Linz*).

Portugal boasts a considerable number of colonial broadcasting stations, chiefly in Africa. We may take as a typical example, Radio Diamang of the Angola Diamond Company at Dundo, which operates on several frequencies,

the most commonly used being 8300 kc; the announcement is: "Aqui Dundo, Angola, Africa Ocidental Portuguesa. Estacao Emissora CR6RG. Radio Diamang." (*This is Dundo, Angola, Portuguese West Africa, Radio Station CR6RG, Radio Diamond*). Many of these African stations are run by local radio clubs, with the result that this fact is included in the identification, as, for instance, that for the Cape Verde Islands, which reads: "Aqui Praia, Radio Clube de Cabo Verde."

Scandinavian stations are not always easy to identify, but the following may help. Norway: "Dette er Norskrik-skringkastning"; Sweden: "Sveriges Radio, Stockholm"; Finland: "Suomen Yleisradio"; and Denmark: "Danmarks Kortbølgesender."

If you are lucky enough to log Greenland at 2130 on 5964 kc, you will hear the words: "Grønlands Radiofoni. Godthaab. God-aften." (*Radio Greenland, Godthaab. Good Evening*).

Dutch directions are given from Surinam, Dutch Guiana and from the West Indian island of Curaçao; the former uses PZH5, 5752 kc, and PZC, 15405 kc; the latter is sometimes audible on 5017 kc at 2200-0230 with the identification: "Juliana Zender Curaçao."

Arabic-speaking stations often give terse identification announcements; the Egyptian State Radio, which can be heard nightly over Station SUX on 7860 kc, opens up with the three words: "Huna El Kahere" (*This is Cairo Calling*): when about to broadcast an Arabic programme, the Lebanon Broadcasting Station, on 8036 kc, announces as: "Houna Beyrou, Mahattat al'Iza'a al Loubnaniat" (*Here is Beirut, broadcasting station of the Lebanese Republic*).

If you aim at being a specialist in Latin-American stations, which are normally audible between 2200 and 0500—and there are hundreds of them—you must acquire a knowledge of Portuguese for Brazilian broadcasters, and for all other South American Republics it is advisable to be equipped with a number of basic Spanish phrases, particularly as very little English is employed, and even more so because the announcers have a habit of saying as much as possible in a limited period of time!

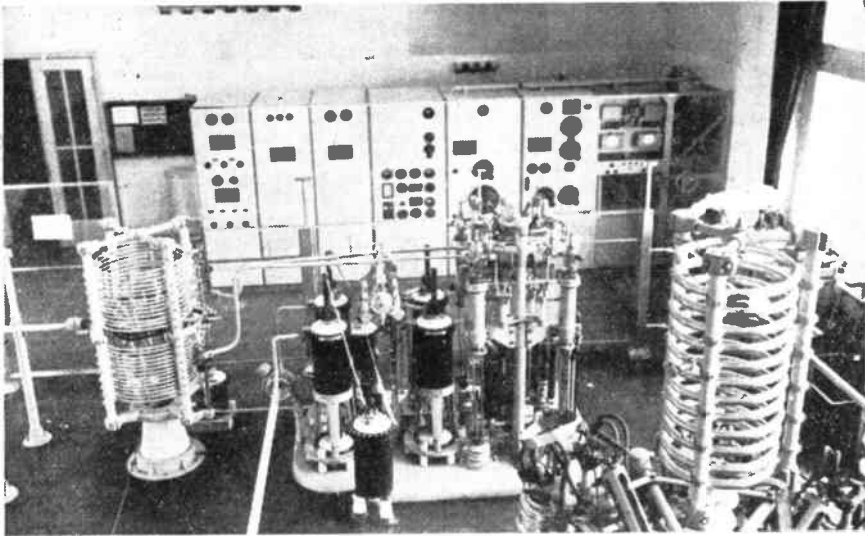

An impression of the high-power short wave transmitter of the German radio network.

Quite a number of these stations preface their directions with distinctive vibraphone notes, however, which is certainly an aid to those listeners who are not well acquainted with the Spanish tongue.

In Venezuela, Station YVQE, 4900 kc, at 2235, gives high-pitch chimes and the identification: "Radio Bolivar, YVQF y YVQE en Ciudad Bolivar, Republica Venezuela, America del Sur." (*Radio Bolivar, YVQF and YVQE in Bolivar City, Republic of Venezuela, South America*). If you log a station on 3490 kc, you may hear the words: "Yay-Vay-Erray-Bay onda larga y Yay-Vay-Erray-Ah onda corta—Radio Monagas." (*YVVB long wave and YVVB short wave—Radio Monagas*).

The Santiago de Chile broadcaster on 6220 kc will be heard at 2355 with three vibraphone notes and call: "Transmite CB106, CE622 y CE1173. Radio Sociedad Nacional de Minería" (*Broadcasting Stations CB106, CE622 and CE1173, National Mining Company Radio*). CE1174, 11743 kc, is another which announces on the hour as: "Esta es las emisoras de Nuevo Mundo transmite desde Santiago, CB93 y CE1174 en la banda de 25 metros" (*This is the*

New World Broadcasting Station transmitting from Santiago, CB93 and CE1174 in the 25-metre band). The principal short-wave broadcasting station in Lima, Peru, is OAX4Z, which operates on 6082 kc and gives the direction: "Oh - Ah - Ekis - cuatro - Zata, Radio Nacional" at the close-down at 0500 (it refers to OAX4Z, Radio Nacional). Radio Encarnacion in Paraguay gives its call-sign as: "Zata-Pay-Ah-cincuo" (ZPA5), and the frequency is 11950 kc.

In Central America, the majority of the short-wave stations use Spanish directions; here are two typical examples: XEWW, Mexico City, 9500 kc, gives the following announcement at 0500: "La Voz de la America Latina desde Mexico — Ekis-Eh-Dooblevey y Ekis-Eh-Dooblevey-Dooblevey, Ciudad de Mexico." (*The Voice of Latin America from Mexico — XEW and XEWW, Mexico City*); the call is preceded by four descending chimes. TGLA, Guatemala City, 6290 kc, may be logged at 2330 with the following statement: "Esta es La Voz de Centro America" (*This is the Voice of Central America*).

Many more examples can be quoted.

but at this stage the reader should be sufficiently equipped to be able to spot and to identify some of the more powerful transmissions.

Selecting Programmes

We are now in a position to enumerate some of the broadcasts and the radio stations which make short-wave listening really worth while. Short-wave broadcast listeners can be divided into two main groups, namely, those who desire to tune in to outstanding "outside broadcasts" from all parts of the world, and those who require regular entertainment from abroad.

The survey which follows is intended for those in the latter category, but as we shall be discussing some of the major world networks in greater detail later, here we will make only a brief reference to any particular system.

Antipodes. In the Antipodes we have the New Zealand Broadcasting Service, which has, as its short-wave division. Radio New Zealand.

The transmissions are beamed to Australia and to the Pacific Islands, with programmes designed particularly for the peoples occupying those territories. Though some of the transmissions have at times been logged at good strength in the United Kingdom, the enthusiast must not be too optimistic when trying to tune in a particular programme in this Service; it is suggested that station ZL8, Wellington, on 9620 kc, is a possibility at 0700, however.

The Australian Broadcasting Commission, besides operating a large number of short-wave stations for use in the Commonwealth itself, uses the subsidiary Radio Australia for its external services. Signals are beamed, and those directed towards the British Isles are, in general, heard at excellent strength. In addition, you will probably be able to log broadcasts directed to South-East Asia, and sometimes you can listen to signals which have reached this country *via* America and the Atlantic Ocean.

At the time of writing, the current schedule for the British Isles and Europe is as follows: 0645-0815, daily except Saturdays, VLB11, 11760 kc; 0645-0815, Saturdays, VLA11, 11760 kc; 0659-0815, Weekdays only, VLA9, 9580 kc; 0650-0815, Sundays only, VLA9, 9580 kc; 1800-2000, Sunday to Thurs-

day, VLA7, 7220 kc; 1800-2300, Daily, VLC11, 11760 kc. The well-known "Australian DX'ers" weekly short-wave session is given on Sundays, to the following schedule: The name of the country given in brackets is that to which the transmission is directed. 0745: 11760 kc (British Isles, Europe, New Zealand); 15320 kc (South Europe); 17840 kc (South and South-East Asia); 1330: 11840 kc (East Coast of North America); 0400: 15200 kc (West Coast of North America); 0530: 15200 kc (Africa).

If you are up at 0630 on a Saturday morning during our summer months, you make like to hear a variety of running commentaries on football and horse racing from the Australian continent. These are included in a "Sporting Session" which is available over VLB21 on 21540 kc. There will be Rugby Union from the Melbourne Cricket Ground and Rugby League games from Sydney, New South Wales, not to mention the intriguing game of Australian football (with its mammoth scores comprising six points for an actual goal between the posts and a single point for a kick over the line elsewhere between two end corner flags). The Australian Grand National Steeplechase is an annual whose commentary should not be missed—usually at 0500 on the first Saturday in July.

In the 60-metre band, VLM4, Brisbane, 4918 kc, puts in an appearance in the evenings around 2010, but remember that it is early morning in Queensland and that news and market price quotations can be expected around 6 a.m. there. Sometimes the Brisbane short-wave station VLQ9, 9660 kc, is audible at 1315 with a regional news, and when it closes down at 1330 (1400 on Saturdays) it gives the call-letters of all the Queensland State metropolitan and regional transmitters then operating.

Africa On the African continent, the South African stations are always of interest to British listeners. The "Calling Africa". Service operates at 0830-1215, 1400-1545, 1600-2005.

15230 kc is used in the mornings; other frequencies operated later in the day are 11937 kc and 9600 kc. Johannesburg, on 11937 kc, is best heard after 1700; on Saturdays you can listen to English news, sports results and occasional cricket commentaries and, later,

SHORT WAVE BROADCAST LISTENING

a radio play. This Service uses English on Tuesdays, Thursdays and Saturdays, and Afrikaans on other days.

In Southern Rhodesia, Salisbury on 3320 kc is a possibility with an English broadcast which closes down at 2000.

The Central African Broadcasting Station at Lusaka in Northern Rhodesia caters for the native fraternity. The daily programme consists of continuous music from 1200 to 1400 (7220 kc, 4826 kc); National broadcast (native) from 1400 to 1800 (7220 kc until 1730, 3275 kc commencing at 1700, 4826 kc throughout); an Advanced English broadcast from 1800 to 1900 over 3275 kc and 4826 kc. The last-named channel is often audible here for this English broadcast, and the station can be identified at the close by the playing of the Bantu National Anthem, "Nkosi Sikelel i'Afrika" and "God Save The Queen."

The Nigerian Broadcasting Service has this year come into prominence with a regular transmission over a 7½ kW station at Lagos, using 4800 kc; it is planned to increase this power to 20 kilowatts later in the year. The Nigerian Broadcasting Service provides National and Regional broadcasting for the Africans of Nigeria and the British Cameroons. The national transmitter is at Lagos, the capital, this station acting as the western regional transmitter during part of each evening. The northern region transmitter (7170 kc and 3300 kc) is situated at Kaduna, and should be audible here when the power is increased to 7½ kilowatts.

The eastern region station at Enugu uses 7097 kc (2½ kW). At Ibadan, there is a studio centre which collects a considerable amount of programme material both for use over its local radio relay system and also for transmission over the Lagos station.

The Nigerian interval signal is a most interesting one; Yoruba talking drums beat out the message: "This is the Nigerian Broadcasting Service." Soon there will be four large mobile recording units for the purpose of collecting programme material from the more remote parts of the country and also for use for outside broadcasts. All the frequencies mentioned here are subject to alteration at any time; a Nigerian news bulletin in English is given daily at 1815 over the 60-metre Lagos station

and is frequently heard here.

The following is the latest schedule for Nigeria, according to information received direct from Lagos.

Lagos :	0500-2200	6100 kc.
	1000-1300	4800 kc.
	1600-2000	4933 kc.
Kaduna :	1000-1600	7170 kc.
	0440-0545	} 3300 kc.
	1615-1700	
Enugu :	Weekdays : 1000-2200	} 7097kc
	Sundays : 0500-2310	

The Cable and Wireless Broadcasting Station at Nairobi, Kenya, has for many years been heard regularly on 4855 kc between 1930 and 2000, at which time you will hear some excellent recorded music of the semi-classical variety.

A Portuguese colonial station which you ought to be able to log is CR7BU, Lourenco Marques, Mozambique, 4918 kc with an all-star variety show at 1830; it is easy to identify this station from its slogan: "Lourenco Marques for happy listening in the 60 and 85-metre bands from six o'clock in the morning until eleven o'clock at night." This is sponsored network which advertises a variety of commercial products over the air.

Another ever present on Sundays and Thursdays only is CR5SB, Sao Tomé, 17677 kc, which transmits between 1200 and 1300 on those days. It opens up with gong notes and the words: "Aqui Sao Tomé; Radio Clube de Sao Tomé e Principe," and closes with the playing of the Portuguese national anthem. Situated on the equator, this island (Sao Tomé) offers short-wave broadcasts which come over surprisingly well.

Radio Brazzaville, French Equatorial Africa, operates on 11970 kc and 9440 kc, and can be heard between 2330 and 2300, with the English feature: "Africa Today" taking the air for the final quarter-hour. Cairo, Egypt, on 11815 kc, is on the air at 1830 with a ten-minute News in English; the Egyptian State Radio plans to increase the number and size of their operative transmitters so as to ensure a greater world coverage. Lately, Cairo has been heard testing on 9750 kc and 6085 kc between 1600 and 1800.

With the Sudan in the headlines in recent months, Radio Omdurman's signals have been of particular interest. At the time of writing, it is using 7664 kc

and 6438 kc for its short-wave outlets. The English broadcast at 1730 on Fridays is heralded by the playing of the "Colonel Bogey" March and the direction: "Good Evening, Everybody; this is the Sudan Broadcasting Service transmitting from Omdurman on the short-wave lengths of 39 and 48 metres and on a medium-wave length of 524 metres." English is also used on Sundays and Wednesdays at 1615. The type of transmitter in use is the Marconi SWBII Major with an output of 6.5 kW. The aerial system is a top folded dipole, aligned East/West and, as this is a broadside fire array, maximum coverage is obtained in the North/South Zones, where the majority of the local listeners in the Nile Valley live. Reception in the British Isles is consequently quite good.

Radio Africa, Tangier. 7126 kc. is normally a worth-while signal around 2200; the identification signal is a gong note, and directions are usually given in French and Spanish. Radio Tangier International, Tangier, which operates a 50 kW transmitter in the medium-wave band and a short-wave station on 6110 kc, has aerials erected at Beni-Makada on the outskirts of the International Zone.

The "Dr. Walter A. Maier Memorial Broadcasting Station" in Tangier adopts this frequency on Fridays; using various languages, it beams the programmes to the countries where these languages are spoken. The schedule is: Fridays: 1700. Ukrainian; 1715, Lithuanian; 1730, Armenian; 1745, Hungarian. Its postal address is: French Post Office, Box 375, Tangier, Morocco.

Radio Addis Ababa, Ethiopia, operates on 15060 kc and 9658 kc. but you will be very lucky if it is audible on the latter channel. The daily English schedule is: 0430-0530, 1000-1100, 1600-1630, 1815-1930. and you should have little difficulty in logging these transmissions on 15060 kc. Frequencies in the 16 and 46-metre bands will be employed in addition, shortly.

If you write to: The Voice of Ethiopia, P.O. Box 364, Addis Ababa, it is probable that a reply to your letter will be made over the air; answers to letters and musical requests are given on Thursdays at 1845.

Far East · We must now consider short-wave broadcast signals which emanate in the Far East. British listeners should be able to log some of the English broadcasts from the Central People's Broadcasting Station, Peking. The schedule is:—2230-2300: 6100 kc, 7500 kc, 9040 kc, 10260 kc, 11690 kc, 15060 kc and 15170 kc; 0900-0930: 6100 kc, 10260 kc, 11690 kc and 15060 kc; 1330-1400: 11690 kc and 15060 kc. The 15060 kc channel is usually fairly reliable at 0900.

The Voice of Free China operating at Taipei, Taiwan (Formosa) has an English broadcast beamed to Europe at 1820-1845 daily over 11920 kc, but this station is often blotted out by the more powerful Europeans. The Voice of Righteousness at Shih Lin, Taipei, uses a frequency of 7400 kc on the following schedule:—Chinese: 2300-2400; English: 2400-0200; Chinese: 1400-1800.

Saigon, French Indo-China (Vietnam) is audible during the summer months between 2230 and 2250 for its transmission to the European continent over its 9735 kc channel. An English broadcast from this station is given also from 1600 to 1630 daily on the same frequency.

In the Philippine Islands, the Voice of America relay base at Manila operates on 15245 kc, on which frequency it should be audible here around 1300 daily. The Far East Broadcasting Company is a religious venture for the purpose of spreading the Gospel in the various islands. At the time of writing, the following English transmissions are on the air: 2330-0130, 0500-0600, 0800-1015, 1200-1400 and 1500-1530 over DZI6, 17805 kc; DZH8, 15300 kc; DZH7, 9730 kc; DZH6, 6030 kc; and DZB2, 3320 kc.

DZH8 is a good summer signal between 1430 and 1600, and DZB8 has been heard here in the late evenings. The station can often be identified by the frequent use of its slogan: "The Voice Of The Orient." Station DZB2 is primarily used for the purpose of providing the missionaries in the field with reliable signals for their small battery-operated receivers way back in the jungle beyond the normal power lines. More will be said about these missionary broadcasting stations later on.



The final amplifier (PA) stage of one of the "Voice of America" transmitters in the broadcasting ship *Courier*. The engineer-in-charge is recording an explanation of the equipment. The *Courier* has a world-wide cruising range and carries one 150 kW transmitter and two 25 kW sets.

In the Republic of Indonesia, English broadcasts are made from Djakarta, the capital, at 1100-1200 and 1415-1530 on 9710 kc; the former 15150 kc channel was inactive in March this year; working in parallel with 11770 kc, it formerly provided good signals at 1900-2000. This evening English Hour from 1900 to 2000 is now transmitted over 11770 kc and 9710 kc; after clock chimes, the opening announcement is: "This is the Voice of Indonesia." Interesting features broadcast regularly are: "Juke-Box Sunday Night" and "Strictly Jazz." This same service has also been heard over 4910 kc on occasions.

All-India Radio will best be found in signals directed from Delhi, though you can expect to hear native and possibly English broadcasts from Madras (VUM2), 4920 kc; Bombay (VUB2), 4840 kc; and Calcutta (VUC2), 4880 kc, in the late afternoons: VUM2 usually

carries the English News from the Delhi studios at 1530. English News from Delhi direct can be heard at 0730 (17705 kc), 1330 (15190 kc, 11790 kc) and 1530 (11790 kc).

The principal directed English broadcast to the British Isles can now be heard with good strength daily at 0730-0830 over 15380 kc and 17705 kc. You are invited to send your comments and suggestions to the Director of External Services, All-India Radio, New Delhi.

Radio Pakistan can be heard with an English bulletin of news in its Home Service broadcast at 1515; in Eastern Pakistan, Dacca broadcasts this news on 3325 kc, whilst in Western Pakistan, Karachi does likewise on 9645 kc and 5990 kc. Other English bulletins are given as follows: 0230 (Karachi, 5980 kc, 15335 kc); 0700 (Karachi, 15270 kc, 17710 kc; Dacca, 7150 kc); 0830 (Karachi, 9645 kc, 17710 kc; Lahore,

6138 kc; 1230 (Karachi, 7096 kc, 11690 kc; Lahore, 3469 kc; Dacca, 4807 kc).

Broadcasts in English to Turkey (1930-2015) and the United Kingdom (2015-2100) are received here at excellent strength over 7010 kc and 6235 kc.

The Commercial Service of Radio Ceylon is a great favourite with listeners here, despite its many advertisements of proprietary articles. Signals during the afternoons on 11975 kc are excellent, and in the early mornings, too, around 0630 on 15120 kc. Radio Ceylon's current schedule is:—0145-0345, 1130-1415: 7190 kc, 15120 kc; 0430-0730, 1430-1645: 7190 kc, 11975 kc.

Coming westwards on our world tour, unknown Afghanistan can be heard daily with English at 1555 over 9975 kc. You will hear the following direction: "This is Kabul giving you the news." On Sundays and Wednesdays there is a session of request recorded music from 1600 to 1625, when the station closes down with the words: "You have been listening to a programme from the Kabul studios of the Afghan Broadcasting System. Here's wishing you all, wherever you may be, good night, good luck and good listening."

Middle East · In the Middle East, Beirut, Lebanon, 8036 kc, gives English at 1500; Damascus, Syria, 11915 kc, at 2130-2230; and Baghdad, Iraq, 11724 kc and 6135 kc, at 1915. Radio Ankara, Turkey, is a firm favourite with British listeners. During the summer months the channels used are normally TAU, 15160 kc, and TAP, 9465 kc, from 2100 to 2145 nightly. The interval signal is an old Turkish folk tune, and on Sundays at 2130 you will hear a most interesting Mail-Bag feature.

Another Turkish station which can be logged here is that of the Technical University of Istanbul. Professor Adnam Ataman writes to say that the transmitter is located in the radio laboratory of the University. It has an aerial power of 500 watts, but it will shortly be replaced by a 1 kW transmitter now under construction. The frequency is 7030 kc and is shifted slightly if interference is observed. Broadcasts are given every evening except Saturdays from 1815 to 2000, and consists of classical, light orchestral and Turkish music. Mozart's Turkish March is played as a signature

tune, both at the beginning and end of each transmission. The address is: Gümüssuyu Cad. 87, Teknik Üniversite, Beyoglu, Istanbul.

The Israel Broadcasting Service operates 4XB31, 6830 kc, and 4XB21, 9010 kc, both situated in Tel Aviv. News in English can be heard daily at 2015; signals are normally excellent. Radio Tashkent, Usbek, USSR, gives broadcasts of English news each day at 1500-1530 and 1600-1630 over 6825 kc.

North America · In North America. Radio Canada, International Service of the Canadian Broadcasting Corporation, broadcasts regularly to Europe and other areas of the world. English broadcasts to Britain are as follows: 1700-1730 (CKCS, CHOL), 1845-1900 (CKCS, CHOL), 2230-2300 (CKCS, CHOL). CKCS operates on 15320 kc. CHOL on 11720 kc. This is effective from the May 31, 1953, schedule, and there may be changes to higher frequencies during the summer months. Newscasts are presented daily at 1700, 1845 and 2230. "Canadiana" at 2240 comprises stories and descriptions of various parts of the Canadian provinces. On Sundays, Canadians and visitors speak about their particular fields of interest at 1705 and 1850; "How We Live" on Tuesdays at 2245 tells all about everyday events in Canadian towns, cities and villages. At the same time on Thursdays, "Canada At Work" is a commentary on finance and trade; and on Saturdays, at 1705 and 1850, there are critical reviews of new publications, music, painting and drama. "Canadian Chronicle" is another popular programme given daily except Sunday at 1715, and on Monday, Wednesday and Friday at 2245.

The Voice of America · The Voice of America is the mouthpiece of the Broadcasting Service of the United States Department of State's International Information Administration. Programmes originate in New York City and Washington, D.C., and besides being broadcast from the United States itself, are relayed from installations located at Honolulu, Manila, Colombo, Munich, Tangier, Salonika and the U.S. coast-guard cutter, *Courier*. The World-Wide Foundation's station, WRUL (The Voice Of Freedom, Boston, Massachusetts) is a great favourite with British listeners.

The transmitters, which are located at Scituate, carry the programmes from the Boston studios. For this country, their English broadcast is given from 2015 until 2115 over 15280 kc and 11740 kc; the American Businessman's Programme at 2100 includes the latest stock market prices.

The Sunday evening Radio Amateur Programme conducted by W2SKE, Bill Leonard, at 1915, is a popular feature here. During this quarter-hour session you will be taken on a tour of some important radio centre, as, for example, the American Radio Relay League's Headquarters at Hartford, Connecticut, where, in the lobby museum, there are such famous exhibits as an original Fleming valve, a 1922 Reinhartz tuner, and the historic receiver on which the first trans-Atlantic signals were picked up.

Those who send reception reports to short-wave broadcasting networks overseas will become the possessors of some interesting foreign stamps when the verification cards arrive; the Voice Of America has a special programme at 2000 on Sundays, which deals with the fascinating subject of philately.

Latin America · Mention has already been made of the numerous Latin-American short-wave broadcasting stations, of which the greater part do not use English. An outstanding one is The Voice Of The Andes, Station HCJB ("Heralding Christ Jesu's Blessings") in Quito, capital of Ecuador, which station, as its slogan implies, is primarily a missionary outlet. On Christmas Day, 1931, a small group of missionaries, gathered together with a 200-watt transmitter, inaugurated the first missionary radio station in the world. Experiments on a second station designed to serve Quito listeners were made in 1934; a 1 kW station to serve other Latin-American countries came in 1937; and on Easter Sunday, 1940, the President of Ecuador declared open the 10 kW HCJB transmitter. Nowadays, HVJB uses various channels, including 6050 kc, 9745 kc, 11915 kc, 15115 kc and 17890 kc. The last two named may be audible in the United Kingdom around 2100-2200 daily, except Mondays. HCJB is empowered by the Ecuadorean Government to broadcast the official time signal for the Republic; this is

done on the hour and half-hour during hours of normal broadcasting.

Another Quito station which has been heard here around 0145 is HCAC1, La Voz de la Democracia, 6210 kc, with programmes entirely in Spanish. HCRL2, Radio Quinta Piedad, Guayaquil, 6400 kc, only uses 200 watts power, but has been heard there in the early mornings up to 0430 on Wednesdays only.

In Uruguay, Radio El Espectador, CXA19, is often prominent around 2215-2230 on 11835 kc. At 2210 or thereabouts, there may be directions in various languages, including English.

In the same band, CE1174, Radio Nuevo Mundo, Santiago, Chile, is frequently a good one on 11740 kc. The Argentine International Broadcasting Service operates a service to the British Isles which varies in time according to the period of the year. At the time of writing, this daily transmission takes place at 2000-2100 over LRS on 11880 kc. You can hear English news, talks on holidays in Argentina, folk music and tango rhythm.

In Brazil, one of the most interesting networks is Radio Jornal de Commercio, Recife, Pernambuco, which operates short-wave stations ZYK3 on 9565 kc and 11825 kc. The transmitters are Marconi SWB10, input 15 to 20 kW, with high-level plate modulation. The well-known English feature, "Brazil Calling," which is introduced by Dr. Janet Slater Swaton, is heard at good strength nightly at 0005-0025. On Sundays, "Brazil Calling" is given at 2130-2155 over 9565 kc. ZYK2, 15145 kc, is often heard as early as 1800, to close at 1830 with station identification given by Dr. Swaton.

Station ZFY, Radio Demerara, Georgetown, British Guiana, is a commercial concern which can be heard at good strength after midnight. It operates on 5980 kc with pleasing dance and vocal recordings at 0010. Radio Rumbos, Caracas, on 4970 kc, is one of the few Venezuela broadcasting stations to use English, usually for the period 2300-2400, though these times vary each night. The programme is a sponsored one, often by Royal Dutch Air Lines, and there is an English newscast at 2345: the call-letters of Radio Rumbos are YVLK.

West Indies . In the West Indies, Radio Jamaica, of the Jamaica Broadcasting Company, Ltd., operates daily on 4950 kc, and later on 3305 kc, when it can best be heard here around 0330-0400, when it closes down to the playing of "God Save The Queen." Another colonial station which operates on special occasions only is the Cable and Wireless, Ltd., 5 kW. ZNX32, Bridgetown, Barbados, using a frequency of 7547 kc and a directional aerial designed to give a good signal in Trinidad and British Guiana; reception of ZNX32 is quite good in the United Kingdom, but the only regular features broadcast are inter-colonial cricket, tennis and Turf Club race meetings.

Another of the scattered missionary stations is Radio Cap Haitien, Haiti. Here the transmitter is housed in the new Gospel Tabernacle, about five miles south of Cap Haitien, and is operated by the East and West Indies Bible Mission. It uses 9685 kc and 9710 kc, the latter on Sundays only, and is chiefly audible here with English around 0200-0300. This station first started broadcasting on May 20, 1950, according to G. T. Bustin, Director of Radio and Mission at Cap Haitien.

Two Central American stations are often well heard in the early hours. They are HRA, La Voz de Lempira, Tegucigalpa, Honduras, 5920 kc, audible around 0400; and HROW, Radio Monserrat, La Emissora de los Hondurenos, Tegucigalpa, 6675 kc, audible around 0230.

Europe . On the European Continent, certain networks can be distinguished by their definite English broadcasts. The Swiss Short Wave Service, operating from Neuengasse 23, Berne, Switzerland, transmits daily to the United Kingdom and Ireland at 1845 over HER2, 6055 kc, and HEU3, 9665 kc; included in the programme schedule are the items: "Requestfully Yours," "Music from the Mountains," "Hill-Top Yodels," and "Light and Likeable." There is a weekly "Women's Diary"; "Information Desk" is a feature which includes answers to listeners' questions about Switzerland. There is a "World Youth Magazine" for younger listeners, and you will be certain to enjoy listening to some of the important personalities who come to the

microphone when they are: "Guests Of Switzerland."

The Swiss Radio has a special DX programme for listeners in the British Isles; it is presented on the first Tuesday of each month at 1905 over 6055 kc and 9665 kc.

The well-known "Sweden Calling DX'ers" programme in English, compiled by Arne Skoog in Stockholm, is broadcast at 1545 and 2230 on Fridays and at 0715 on Saturdays over 6065 kc.

Norsk Rikskringkasting (Radio Norway) offers a "Norwegians Abroad" at 0100-0200, 1100-1200, 1900-2000, and 2300-2400; the last fifteen minutes of each session consists of musical items by Norwegian composers or performers and is introduced both in Norwegian and English. On Sundays there is added a quarter-hour programme in English, entitled: "Norway This Week."

Salzburg is the headquarters of the Austria Zone Command, United States Army Radio Station KZCA, which operates on 9617 kc with a power of 0.35 kW. It announces as: "This is the Blue Danube Network." KZCA was evolved from a mobile unit following the cessation of hostilities in Europe in World War II. Originally situated between Salzburg and Hellbrunn, it commenced operations in September, 1945; later, it was moved to the present studios at the top of the Hotel Pitter in Salzburg. Programme facilities which are available to KZCA are news releases from the Information Service Branch, Army News Service and the Armed Forces Radio Service in Los Angeles, California and in Germany; it operates for a period of eighteen hours each day from 0500 to 2300 (0600-2300 on Sundays). KZCA, Salzburg, broadcasts the world-famous annual Salzburg festival; during this period—and at any other time, for that matter—visitors are invited to make an inspection of the studios of KZCA, which are located, as previously mentioned, in the Hotel Pitter.

Radio Monte Carlo, which is in part a commercial enterprise, has its main transmitter housed on the slopes of Mont Agel, some 2500 feet above the waters of the blue Mediterranean Sea. The aerial mast, which is 520 feet high, crowns the summit of Mont Agel.

In the studios in Monte Carlo itself,

there are facilities for three simultaneous broadcasts, two on short wave; actually, there are seven large and eleven small studios in buildings interspersed by palm and olive trees in the very heart of the Principality of Monaco. Hours of broadcast are: 0600-0830, 1100-2300, and the frequencies 7350 kc (3AM4) and 6035 kc (3AM3) are in general use. English programmes are: Baltimore Gospel Tabernacle, Wednesdays 2205-2300; Back To The Bible, Fridays 2230-2300; Hour of Decision, Thursdays 2230-2300.

Spain has an English broadcast from Radio Nacional de Espana, Madrid, every night at 2015-2045 over 9363 kc, where you can hear excellent talks about parts of Spain which you may one day like to visit.

B.B.C. Activities

At this stage it will be reasonable to review in greater detail some of the more important short-wave broadcasting organisations in the world. It is therefore proposed to open this section with a general account of the short-wave activities of the British Broadcasting Corporation.

The B.B.C. has been broadcasting to overseas listeners since 1932, when, on its own initiative, it inaugurated a short-wave service to the Dominions and the Colonies. This was, initially, an English-speaking concern which, in due course, provided a valuable link between the Mother Country and the other nations of the British Commonwealth. It was in 1938 that foreign language broadcasts were first made by the BBC; today it broadcasts in forty-three languages other than English, Gaelic and Welsh, and the purpose of its foreign language transmissions is amply and clearly expressed in the words of Sir Ian Jacob, Director-General of the Corporation: "Many nations broadcast to their neighbours. Some use the opportunity to indulge in undisguised political warfare; others seek to amuse; others combine information with interest in a synthesis of friendship. It is among the latter that the BBC places itself in the confident hope that by straightforward, friendly and impartial speaking, it is contributing to the future peace of the world." News is the keynote of the BBC's External Services. For its resources, the BBC depends upon the

leading news agencies, monitored material based on broadcasts from abroad, and on reports of its own correspondents in twelve foreign capitals.

The BBC uses short-wave broadcasting for its Foreign Service. There is a European Service with broadcasts in many languages, a General Overseas Service in English, and a number of special programme services with broadcasts directed to specific areas of the world. In addition, the British Far Eastern Broadcasting Service in Singapore, which is controlled by the BBC, operates high-powered transmitters which relay programmes from the United Kingdom, often in the form of recorded extracts. Listeners in the Far East are thus enabled to hear news from London under well-nigh perfect conditions.

A brief reference to the current list of transmitters employed by the BBC for short-wave operation alone indicates that there are four transmitters in the 11-metre band, seven in the 13-metre band, eight in the 16-metre band, eleven in the 19-metre band, eighteen in the 25-metre band, eighteen in the 30/31-metre band, thirteen in the 41-metre band, fourteen in the 48-49-metre band, and GRC which is to be found on 2880 kc. Of these ninety-four call-signs, the majority are prefixed by the letter G, but within recent months the following have been put into operation: MCQ, 11945 kc; MCO, 11910 kc; MCN, 9770 kc; MCR, 9760 kc; MCP, 9735 kc; MCM, 7135 kc; and MCS, 7110 kc. It is anticipated that 17890 kc will be used shortly by the BFEB, Singapore.

The work of the BBC's External Services is carried out at the Maida Vale studios in London. Her Majesty The Queen saw something of this during her recent tour of the BBC premises.

In Canada

The Canadian Broadcasting Corporation is a vast organisation which extends the length and breadth of the land. It must be remembered that short-wave coverage is necessary for so extensive an area as Canada itself, so that there are a number of transmitters which may not be heard in places as distant as our own country. The CBC National Service short-wave stations are mostly situated at Montreal, there being nine with the

prefix CB, such as CBLX, 15090 kc, all of which use a power of 7.5 kW. In addition, CBNX, St. John's, Newfoundland, operates on 5970 kc with a power of 300 watts, and CBRX, Vancouver, British Columbia, on 6160 kc with a power of only 150 watts.

There are also a number of private short-wave broadcasting stations in Canada: CFCX, owned by the Canadian Marconi Company, Montreal, operates on 6005 kc; their verification card states that power output "is in excess of 75 watts," and that CFCX broadcasts simultaneously the daily seventeen-hour schedule of medium-wave CFCF.

Station CJCX, on 6010 kc, relays medium-wave CJCJ of Sydney, Nova Scotia; and CFVP, Calgary, Alberta, on 6030 kc, uses the slogan: "The Voice Of The Prairie." CFRX, Rogers Radio Broadcasting Company, Toronto, operates on 6070 kc and relays medium-wave CFRB; CKFX, 6080 kc, is a low-powered Vancouver transmitter, but you may be able to log the East Coast station CHNX, Halifax, Nova Scotia, relaying medium-wave CHNS programmes over a frequency of 6130 kc—the power is 500 watts and the station is owned and operated by the Maritime Broadcasting Company, Ltd., of Tobin Street, Halifax, N.S.

Not the least interesting of these private short-wave broadcasting stations is VED of the North-West Territories and Yukon Radio System, operating from Edmonton, Alberta, over 7320 kc with a power of 5 kilowatts. Programmes are designed for listeners in the sub-Arctic regions and are transmitted by means of a rhombic aerial in a direction beamed on the North-West Territories. Actually, broadcasts from the local Edmonton station CBX are relayed by VED for the benefit of these isolated northern settlements, where, under normal conditions, broadcast stations are seldom heard. The Royal Canadian Corps of Signals operates Station VED at Edmonton, and, in addition, a few low-powered medium-wave transmitters at places such as Whitehorse, Dawson City, Yellowknife and other detached settlements in the bleak and frozen North.

The Canadian Broadcasting Corporation's International Service—"The Voice Of Canada"—is its pride and joy. It shares with the National Service of the

CBC the facilities of the new Radio Canada Building in Montreal. It speaks in fifteen languages, and for eight and a half hours each day, the Voice of Canada sends programmes to the continent of Europe, with another five and a half hours devoted to broadcasts to Latin-America and Australasia.

When the Canadian short-wave service was originally planned in 1942, the choice of the most suitable location was of paramount importance. In Canada, this was particularly true, because of the proximity to the North Magnetic Pole, which is the centre of a zone having relatively high absorption to radio waves.

This zone covers in its quiescent state the greater part of Canada, and radio waves passing through it are subject to undesirable transmission phenomena which result in greater fading, weaker signals, and generally more erratic behaviour than in those transmissions which do not have to pass through this disturbed area.

The CBC chose as their transmitter site the Tantramar marshes near Sackville, New Brunswick, a location well removed from the zone of high absorption and one characterised by unusually high conductivity. The choice of this location, coupled with the fact that design of the aerial arrays has been most carefully planned, is the cause of Canada's Voice being most clearly heard all over the globe.

The aerials are the multiple-element curtain type, capable of withstanding winds up to 120 miles an hour and an ice-coating half an inch thick. There are three arrays, the European, the largest, being 1220 feet long. It is slung from four steel towers, two 379 feet, one 217 feet and one 175 feet high. The other arrays cover South America and Australasia. Each consists of two "curtains" of aerial wires, one behind the other. One curtain reflects and focusses in the desired direction the radio waves radiated by the other. The aerials are fed from two 50-kilowatt transmitters housed in a reinforced concrete building which is linked by 600 miles of land-line to the studios in the Radio Canada Building in Montreal.

The Latin-America Service is on the air from 2350 to 0400 daily over CKCX, 15190 kc; CHOL, 11720 kc; and CKLO, 9630 kc. The Australasian Ser-

vice is broadcast from 0845 to 0950 on Sundays and Wednesdays over CKLO and CKNA, 5970 kc. Listeners in this country cannot fail to hear the special broadcast at 1220-1405 on Sundays for Canadian Forces in Europe, over CHOL, 11720 kc, and CKLX, 15090 kc.

For the normal European broadcasts described earlier, you may find CKCS, 15320 kc, and CKCX, 15190 kc, in addition, each with a signal of tremendous volume, according to time of day.

The International Service News Room in Montreal gives accurate and comprehensive reports of Canadian and World News; paying special attention to United Nations' activities, it is linked by direct wire to United Nations Headquarters at Lake Success.

Finally, we must refer to that very fine pamphlet, entitled "This Is Canada," containing details of forthcoming programmes and brief informative articles about Canada, distributed free each month to all listeners, on request. If you would like your name put on the mailing list, the address is: Canadian Broadcasting Corporation, P.O. Box 7000, Montreal, Quebec—and there is no charge!

Story of Radio Saigon

The history of Radio Saigon in French Indo-China makes interesting reading. One day, in the summer of 1928, the Director of the French Radio-Electric Society in his office in the Boulevard Haussman, Paris, sent for his commercial agent, for a customer, who had just arrived from Saigon, wished to purchase a twelve kilowatt short-wave broadcasting station. At this time, only the most important countries possessed such luxuries! When further enquiries were made, it was found that the man, M. Joseph de la Pommeraye, was not a joker but a truly serious customer.

With a group of friends, he wished to endow Indo-China with a powerful radio station. Twelve months later, the France Indo-Chinese Radio Company bought a piece of land at Chi-Hoa, on the outskirts of Saigon, and had buildings constructed there. Two engineers came from France, also a fine orchestra, certainly the best that Indo-China had ever known; out of the seven musicians engaged, five were first-prize winners from the Paris Conservatoire. On July 18, 1930, the first Radio

Saigon broadcast took place in the presence of the Governor-General. From the start, results were excellent, except within a radius of about 150 miles and in Cambodia.

Considerable improvement was achieved by the addition of new aerials, and the broadcasts were heard in the four corners of the globe. In Indo-China, however, the population was not fully equipped to hear the new station's broadcasts, for, in 1930, there were only 108 radio sets in the entire country. To make matters worse, because of the heavy expenses incurred, Radio Saigon was obliged to cease transmitting in April, 1932. It was not until 1938 that a new Indo-Chinese Broadcasting Company was floated. With a new transmitting site at Phu-Tho and studios in Saigon itself, a new series of transmissions began on April 1, 1939.

At first, the authorities had frequent break-downs in the technical side, and they were especially short of gramophone records. Later, broadcasts became more varied and daily transmissions were given in French, Cochinchinese, Tonkinese, English, Dutch, Cambodian, Chinese and Siamese.

Then came World War II, and Radio Saigon found itself unable to continue as a private enterprise. Government aid was sought and granted, and the Voice Of France in the Far East continued to be heard abroad. This short-wave station, with the call-letters FZR, operated on 11780 kc and was regularly heard by the writer at 1630 daily with a lady announcer giving the direction: "Hullo, Everybody! This is Radio Saigon, the Voice of France in the Far East." News in English was relayed from Paris Mondial and was followed by the playing of popular tunes on records.

Then France capitulated, and all telephonic and telegraphic communication with Indo-China ceased. Radio Saigon continued to be heard, however, but with the advent of the Japanese, the station was turned by them into a pro-Japanese mouthpiece, despite the stubborn underground opposition of some, at least, of the staff. After the complete collapse of the French administration, the Japs' dream of transforming Radio Saigon into a branch of the Nippon propaganda machine soon became a

SHORT WAVE BROADCAST LISTENING

fact, and it was not until the British troops came in September, 1945, that the Japanese turned the station over to the Viet-Minh, who, in turn, abandoned it immediately.

That same month saw the re-introduction of normal broadcasting services by Radio Saigon, despite the fact that much of the original equipment had been sabotaged. Yet fate still continued to be unkind to Radio Saigon, for in April, 1946, an arsenal, which was just on the opposite side of the street, was accidentally blown up. Radio Saigon was practically burned down, all the technical equipment being completely destroyed.

The first explosion occurred at 10.20 a.m., yet, because of the grit and fortitude of the operators, broadcasting recommenced the same day at 6 p.m. They had borrowed material from the Post Office and from the Army, installed it in a private house, and just went on the air!

Nowadays, Radio France-Asie is, in very truth, the Voice of France in the Far East—a well-developed and permanent affair with a 1.5 kW medium-

wave station and short-wave transmitters employing 25 kilowatts. Their verification card mentions the use of four different short-wave outlets, and English sessions of broadcasting are advertised for: 2230-2300, 0030-0100, 0930-1015 and 1300-1515. Monsieur Jean Papon, who is a virile head of the English Department, is always pleased to hear from listeners at any time. Letters and reports should be sent to: Radio France-Asie, 86 Rue Maréchal de Lattre de Tassigny, Saigon, and please remember that a 4d. stamp is required for all foreign letters. In addition, if an International Reply Coupon, which can be purchased at any main Post Office at a cost of 8d (an Imperial Reply Coupon for the British Commonwealth countries costs 6d.) is enclosed with your letter, you can almost certainly anticipate a reply.

In future issues of RADIO QUARTERLY it is hoped to deal with the development of other radio systems which have specialised in short-wave broadcasting, and to give further forecasts of what readers can expect to hear during that particular period of the year.



SHORT WAVE BROADCAST STATIONS

Giving Frequency, Wavelength, Callsign, Location and Schedule

This list covers the 13-120 metre section of the waveband within which all short-wave broadcasting services of the world operate. Only those stations normally receivable in this country are included, and the schedules given are for English broadcasts or transmissions beamed on Europe. The list comprises a total of more than 600 stations and is the most comprehensive and authoritative of its kind yet published. It should be noted that many of these stations are liable to un-announced frequency (wavelength) changes, or alterations in schedule. Amendments will appear in future issues of RADIO QUARTERLY.

Fre- quency Kilo- cycles	Wave- Length metres	Callsign	Location	Schedule GMT	Fre- quency Kilo- cycles	Wave- Length metres	Callsign	Location	Schedule GMT
21740	13.80	KCBR1	Delano, Calif.	2200-2330				Helsinki,	
21730	13.81	LLQ	Oslo, Norway					Finland	1200-1220
21710	13.82	GVS	London		17790	16.86	GSG	London	
21700	13.82	VUD10	Delhi, India		17784	16.87	HER7	Berne,	
21690	13.83		Tangier (VOA)	1230-1445				Switzerland	
21675	13.84	GVR	London		17780	16.87	WRCA5	Bound Brook, N.J.	1300-1930
21660	13.85	VUD10	Delhi, India					Delhi, India	
21640	13.86	GRZ	London		17775	16.88	VUD10/11 PHI	Hilversum, Holland	
21610	13.89	WRCA2	Bound Brook, New Jersey	1530-1745	17770	16.88		Tangier (VOA)	1230-1600
21590	13.90	WGEO2	Schenectady, New York	1445-1745				Rome, Italy	
21570	13.91	WDS11	Brentwood, N.Y.	1230-1730				Karachi, Pakistan	
21560	13.89		Rome, Italy		17760	16.89	WGEO3	Schenectady, N.Y.	1600-1800
21550	13.92	GST	London		17755	16.90		Singapore (BFEB)	
21540	13.93	VLB21	Shepparton, Aust.	0255-0545 and later	17750	16.90	WRUL5	Scituate, Mass.	1530-1930
21530	13.93	GSJ	London		17740	16.91		Lisbon, Portugal	
21510	13.95	VUD5/11	Delhi, India		17730	16.92	GVQ	London	
21500	13.95	WRCA3	Wayne, N.J.	1515-1715	17720	16.93	LRA	Buenos Aires, Argentina	
21470	13.97	GSH	London		17715	16.93	GRA	London	
21460	13.98	KRCA2	Dixon, Calif.	0315-0345	17705	16.94		Delhi, India	0730-0830
17890	16.77	HCJB	Quito, Ecuador	2100-2200 (Exc. M.)	17700	16.95	GVP	London	
17870	16.79		Munich (VOA)	1230-1330 1345-1415	17677	16.97	CR5SB	Sao Tome	1200-1300 (Sun., Thu.)
17865	16.80		Damascus, Syria	1445-1545				Brazzaville, French Equatorial Africa	
17860	16.80	ORU	Wavre, Belgium	1000-1100	15550	19.29		Moscow	
17850	16.81		Paris, France		15450	19.42	GRD	London	
17845	16.82		Moscow		15440	19.43	WRCA1	Bound Brook, N.J.	1600-2245
17840	16.82	VLG17	Hamburg, Germany		15435	19.44	GWE	London	
		VUD5/10	Shepparton, Aust.	0255-0945				Singapore (BFEB)	
17835	16.82		Delhi, India		15400	19.48		Rome, Italy	
17830	16.83	WDS13	Karachi, Pakistan		15390	19.49		Moscow	
17825	16.83	LLN	Brentwood, N.Y.	1230-1930	15380	19.51		Delhi, India	0730-0830
17820	16.84	CKNC	Oslo, Norway					Lisbon, Portugal	
17810	16.84	GSV	Sackville, N.B.		15370	19.52	ZYC9	Rio de Janeiro, Brazil	
17805	16.85	DZ16	London		15360	19.53		Moscow	
18700	16.85		Manila, P.I.	1200-1400 1500-1530	15350	19.54		Paris, France	
			Rome, Italy						

SHORT WAVE BROADCAST STATIONS

Frequency Kilo- cycles	Wave- Length metres	Callsign	Location	Schedule GMT	Frequency Kilo- cycles	Wave- Length metres	Callsign	Location	Schedule GMT
15340	19.56		Tangier (VOA)	1230-1845	15155	19.80	ZYB9	Sao Paulo, Brazil	
15335	19.56		Karachi, Pakistan	0230-0245	15150	19.80	YDC	Djakarta, Indonesia	
15330	19.57	WGEO1	Schenectady, N.Y.	1330-2200	15140	19.82	GSF	London	
15320	19.58	CKCS	Sackville, N.B.	1700-1730 1845-1900 2230-2305	15135	19.82	PRB23	Sao Paulo, Brazil	
		VLA15	Shepparton, Aust.	0650-0815 (Sun.)	15130	19.83	WRCA6	Bound Brook, N.J.	
		VLG15	Lyndhurst, Vict.	0845-1355	15125	19.83		Lisbon, Portugal	
		OLR5B	Prague, Czechoslovakia		15120	19.84		Colombo, Ceylon	0430-0730
		OZF9	Copenhagen, Denmark		15115	19.85	HCJB	Rome, Italy Quito, Ecuador	2100-2200 (Exc. M.)
		WRUL1	Scituate, Mass.	2245-0000	15110	19.85	GWG	London	
15310	19.60	GSP	London		15100	19.87	EPB	Teheran, Iran	1220-1405 (Sun.)
15305	19.60	HER6	Berne, Switzerland		15090	19.88	CKLX	Sackville, N.B.	1345-1405 (Weekdays)
15300	19.60	DZH8	Manila, Phil. Is.	1200-1400 1500-1530	15085	19.89		Delhi, India	
		GWR	London Singapore (BFEB)		15075	19.90	ZJA6	Georgetown, B.G.	1800-2000 2230-2300 0900-0930 1330-1400
15295	19.61		Tangier (VOA)	1200-1900	15060	19.92		Peking, China	
15290	19.62	LRU	Moscow Buenos Aires, Argentina		15060	19.92		Addis Ababa, Ethiopia	1000-1100 1815-1930
15280	19.63	WRUL1 ZL4	Scituate, Mass. Wellington, N.Z. Munich (VOA)	2015-2115 0600-1600	15000	20.00	WWV	Washington, D.C.	TimeCheck every 5 minutes
15270	19.65	WDS12	Moscow Brentwood, N.Y.	1230-2245 2300-0000	12175	24.64	TFJ	Reykjavik, Iceland	1615-1630 (Sun.)
			Karachi, Pakistan	0700-0715	12095	24.80	GRF	London	
15260	19.66	GSI	London		12040	24.92	GRV	London	
15245	19.68		Manila, Phil. Is.	0900-1600	12032	24.94		Bucharest, Roumania	
15240	19.68		Tangier (VOA)	1515-1630	11975	25.05		Colombo, Ceylon	1430-1645
15230	19.70	WRUL2	Paris, France Scituate, Mass. Johannesburg, Transvaal	1600-2045 0830-1215	11970	25.06		Brazzaville, French Equatorial Africa	
15220	19.71	ZL10 PCJ	London Wellington, N.Z. Hilversum, Holland		11964	25.08		Lisbon, Portugal	
15210	19.72		Munich (VOA)	0600-1200	11960	25.09		Moscow	
		GWU	London		11955	25.09		Singapore (BFEB)	
15205	19.73	WLWO5	Bethany, Ohio	1530-2000	11950	25.10	ZPA5	Encarnacion, Paraguay	
15200	19.74	CKCX	Sackville, N.B.		11945	25.12	CE1173 MCQ	Santiago, Chile London	
15190	19.75	VUD11 OIX4 PRK9	Delhi, India Pori, Finland Bele Horizonte, Brazil	1330-1345 1200-1220	11940	25.13		Tangier (VOA) Lisbon, Portugal	1615-2215
		GSO	Moscow		11937	25.14		Johannesburg, Transvaal	1600-2005
15180	19.76	LKV	Oslo, Norway		11930	25.15	GVX	London	
15170	19.78	TGWA	Guatemala City, Guatemala		11925	25.16	CE1190	Santiago, Chile	
		VUD10	Delhi, India		11920	25.17	BED4	Taipei, Taiwan	1915-1940
15165	19.78	WLWO3 OZF7	Bethany, Ohio Copenhagen, Denmark		11915	25.17	HCJB	Quito, Ecuador Damascus, Syria	2130-2230
15160	19.79	TAU	Ankara, Turkey	2100-2145	11910	25.18	MCO	London Budapest, Hungary	
					11905	25.19		Moscow	
					11900	25.21	WGEO2	Schenectady, N.Y. (AFRS)	1800-2200

SHORT WAVE BROADCAST STATIONS

Fre- quency Kilo- cycles	Wave- Length metres	Callsign	Location	Schedule GMT	Fre- quency Kilo- cycles	Wave- Length metres	Callsign	Location	Schedule GMT
11895	25-22		Manila, Ph. Is. (VOA)	0715-0845 (Tu.-Sun.)			WRUL4	Scituate, Mass. Warsaw, Poland	2015-2115
11890	25-23	WRCA2	Dakar, Senegal Bound Brook, N.J.	1800-2200	11735	25-56	LKQ	Oslo, Norway	1415-1445
11880	25-25	GWV LRS	London Buenos Aires, Argentina	2000-2100	11730	25-58	GVV CE1173	London Santiago, Chile Hilversum, Holland	
11875	25-26	OLR4C	London Moscow Prague, Czechoslovakia		11724	25-58		Baghdad, Iraq.	1915-2000
11870	25-27	WDS15	Brentwood, N.Y.	1800-2245	11720	25-60	CHOL	Sackville, N.B.	0230-0300 1700-1730 1845-1900 2230-2300
11865	25-28	HER5	Berne, Switzerland				OQ2AA	Leopoldville, Belgian Congo	
11860	25-30	GSE	Moscow		11718	25-60		Athens, Greece	1745-1800
11850	25-32	ORU	Wavre, Belgium		11710	25-62		Tangier (VOA)	1415-1900
		VUD4/7 TGNC	Delhi, India Guatemala City, Guatemala	0300-0400	11705	25-63		Stockholm, Sweden	
11845	25-32	LLK	Oslo, Norway Karachi, Pakistan	0230-0245	11700	25-64	GVV HP5A	London Panama City Paris, France Peking, China	2230-2300 0900-0930 1330-1400
11840	25-34	OLR4A	Paris, France Prague, Czechoslovakia		11690	25-66			
11835	25-35	GWQ CXA19	London Montevideo, Uruguay	2200-2230	11685	25-67	HVJ11	Vatican City Karachi, Pakistan	1230-1245
11830	25-36	WDS11	Brentwood, New York Tangier (VOA)	1800-2000 0600-1200 1215-1730	11680	25-68	GRG	London	
			Saigon, Indo-China		11630	25-79		Moscow	
11825	25-37	ZYK3	Recife, Brazil	0005-0025	11090	27-05	CSA92	Ponta Delgada, Azores	
11820	25-38	GSN	London		10260	29-24		Peking, China	2230-2300 0900-0930
11815	25-39		Cairo, Egypt Warsaw, Poland	1830-1900	10000	30-00	WWV	Washington, D.C.	TimeCheck every 5 minutes (Sun.)
11810	25-40		Rome, Italy		9975	30-07		Kabul, Afghan.	
11805	25-41		S.S. "Courier"		9970	30-08		Brazzaville, French Equatorial Africa	
11800	25-42	GWV	London		9915	30-26	GRU	London	
11790	25-45	WRUL3	Scituate, Mass.	1600-2045 2100-2245	9825	30-53	GRH	London	
		GWV VUD3/7	London Delhi, India	1330-1345 1530-1545	9800	30-61		Moscow	
11785	25-45	YDF2	Moscow Djakarta, Indonesia		9780	30-67		Moscow	
11780	25-47	ZL3	Wellington, N.Z.	2200-0545	9770	30-70	MCN	London	
11775	25-48	WRCA3	Bound Brook, New Jersey	1730-2245	9760	30-74	TGWA	Guatemala City, Guatemala	
11770	25-49	YDF7	Djakarta, Indonesia	1900-2000	9755	30-76	MCR	London	
11765	25-50	GVU ZYB8	London Sao Paulo, Brazil		9746	30-78		Paris, France Lisbon, Portugal	
11760	25-51	VLB11	Moscow Shepparton, Australia	0645-0815	9745	30-78	HCJB	Quito, Ecuador	
		OLR4B	Prague, Czechoslovakia		9740	30-80		Moscow	
		CKRA	Sackville, N.B. Tangier (VOA)	1200-1745	9735	30-82	HI2T	Trujillo, Dominican Republic	
11750	25-53	GSD	London				MCP	London	
11740	25-55	CE1174 HVJ12	Santiago, Chile Vatican City		9730	30-83		Saigon, Indo-China	1600-1630 2230-2255
					9720	30-86	PRL7	Berlin, Germany	
					9710	30-90		Rio de Janeiro, Brazil	
					9700	30-93	WRCA5	Moscow Djakarta, Indonesia	1900-2000
							CE970 GWY	Rome, Italy Bound Brook, N.J. Santiago, Chile London	2000-2245

SHORT WAVE BROADCAST STATIONS

Frequency Kilo- cycles	Wave- Length metres	Callsign	Location	Schedule GMT	Frequency Kilo- cycles	Wave- Length metres	Callsign	Location	Schedule GMT
9690	30-96	GRX LRA1	London				GWB	London	1545-1615 1900-2000 2115-2145
9685	30-98	4VEH	Buenos Aires, Argentina	0315-0415	9545 31-43 9543 31-44		LKJ	Oslo, Norway	2315-0300
9680	30-99	HI2A	Cap Haitien, Haiti	0200-0300	9540 31-45			Rangoon, Burma	1445-1515
9675	31-01	GWT	Tangier (VOA)	1900-2000				Munich, Germany (VOA)	0600-1515 1615-2215
9670	31-02	WGEO3	Trujillo, Dominican Republic	2115-2200	9535 31-46			Paris, France	
			Tangier (VOA)		9530 31-48		WDS13	Stockholm, Sweden	
			Paris					Brentwood, N.Y.	0300-0345
			London				WRUL5	Scituate, Mass.	2000-2200
			Schenectady, New York	1815-2245	9525 31-50 9520 31-51		GWJ OZF5	London	
			Lisbon, Portugal		9510 31-55 9505 31-56		GSB HOLA	Copenhagen, Denmark	
9665	31-04	HEU3	Berne, Switzerland	1845-1930				London Colon, Panama	
9660	31-06	VLQ9	Vienna, Austria				PRB22	Sao Paulo, Brazil	
9650	31-09	ZJM8	Brisbane, Queensland		9500 31-58			Belgrade, Yugoslavia	0630-0645
			Limassol, Cyprus		9480 31-65 9465 31-70		TAP	Mexico City, Mexico	1630-2200
			Brentwood, New York	2000-2200	9440 31-78			Tangier (VOA)	
9645	31-10		Karachi, Pakistan	1515-1530			XEWW	Moscow	
9640	31-12	GVZ	London	1200-0630	9465 31-70			Ankara, Turkey	2100-2145
9635	31-14		Tangier (VOA)	0230-0300				Brazzaville, French Equatorial Africa	
9630	31-15	CKLO	Sackville, N.B.		9410 31-88 9363 32-04 9210 32-57		GRI	London	2015-2045
9625	31-17	VUD3/11 GWO XEBT	Delhi, India	1615-1645			OTH	Madrid, Spain	
9620	31-19	VUD5/7 ZL8	London	1800-2145 0600-1045				Leopoldville, Belgian Congo	
			Delhi, India		9010 33-30		4XB21	Tel Aviv, Israel	2015-2030
			Wellington, N.Z.		8955 33-50		COKG	Santiago, Cuba	
9617	31-20	KZCA	Paris, France		8825 33-92 8230 36-45		COCQ ZNB	Havana, Cuba	
9615	31-20	WRCA3	Salzburg, Austria	0215-0245 2330-2345				Mafeking, Bechuana- land	1800-1930
			Bound Brook, New Jersey	2100-2145	8036 37-34		FXE	Beirut, Lebanon	1500-1600
			Brentwood, New York		7940 37-78 7935 37-81		HLKB	Alicante, Spain	
9610	31-22	LLG	Oslo, Norway		7860 38-17 7850 38-20		SUX ZAA	Pusan, Korea	
9600	31-25	GRY	London		7670 39-11 7664 39-14			Cairo, Egypt	
			Johannesburg, Transvaal					Tirana, Albania	2100-2130
9595	31-27	CE960	Santiago, Chile	1800-2230				Sofia, Bulgaria	
9590	31-28	VUD3/7	Tangier (VOA)					Omdurman, Sudan	1730-1800 (Fri.) 1615-1645 (Sun.)
			Delhi, India		7547 39-75		ZNX32	Bridgetown, Barbados	
			Hilversum, Holland	0659-0815	7500 40-00 7420 40-50 7350 40-81		3AM4	Peking, China	2230-2300
9585	31-30	CKLP	Sackville, N.B.	2230-2300				Athens, Greece	1800-2205
9580	31-32	VLA9	Shepparton, Australia					Monte Carlo, Monaco	0600-0830 1100-2300
			London	1800-2000				London	
			London	2015-2115				Athens, Greece	1730-2100 2230-0000
			Scituate, Mass.	2115-2245					
9570	31-34	GSC GWK WRUL1/2	London	2130-2155 (Sun.)					
9565	31-36	ZYK3	Recife, Brazil						
9555	31-40		Warsaw, Poland						
			Helsinki, Finland	1200-1220					
9550	31-41	HVJ8 OLR3A	Vatican City		7320 40-98 7300 41-10		GRJ	London	
			Prague, Czechoslovakia						

SHORT WAVE BROADCAST STATIONS

Fre- quency Kilo- cycles	Wave- Length metres	Callsign	Location	Schedule GMT	Fre- quency Kilo- cycles	Wave- Length metres	Callsign	Location	Schedule GMT
7295	41-12		Munich, Germany (VOA)	1645-2200	6752	44-43		Larissa, Greece	
7290	41-15		Hamburg, Germany		6725	44-61	4XB44	Tel Aviv, Israel	1630-2000
7288	41-17	TAS	Ankara, Turkey		6675	44-94	HBQ	Geneva, Switzerland	1830-1845
7280	41-21	GWN	London		6620	45-32	TG2	Tegucigalpa, Honduras	
7270	41-27		Tangier (VOA)	1745-0630	6460	46-44	TGWB	Guatemala City, Guatemala	
7260	41-32		Lisbon, Portugal		6450	46-51	COCY	Guatemala City, Guatemala	
7250	41-38		Moscow Munich, Germany (VOA)	0600-1215 1630-2130	6438	46-58		Havana, Cuba Omdurman, Sudan	0530-0700 1730-1800 (Fri.) 1615-1630 (Sun., Wed.)
7240	41-44		London Paris, France Tangier (VOA)	0300-0545 1900-0245	6400	46-86	HCRL2	Guayaquil, Ecuador	0400-0530
7235	41-47		Tangier (VOA)	1900-0245	6360	47-16		Lisbon, Portugal	
7230	41-49	GSW	London		6350	47-24	HRP1	San Pedro, Honduras	
7225	41-52	VLA7	Moscow		6320	47-47		Baden-Baden, Germany	
7220	41-55	YDF5	Shepparton, Australia Jakarta, Indonesia	1800-2300	6295	47-66	TGLA	Guatemala City, Guatemala	
7210	41-61	GWL HE13	Tangier (VOA) Paris, France London Berne, Switzerland	1200-1400 1615-1700	6275	47-81	ZPA1	Asuncion, Paraguay	
7203	41-65		Warsaw, Poland		6260	47-90		Rome, Italy	
7200	41-67	GWZ	London S.S. "Courier" (VOA)	1530-0345	6240	48-08		Rome, Italy	
7190	41-72		Colombo, Ceylon	1430-1645	6235	48-12		Karachi, Pakistan	
7185	41-75	GRK	London		6220	48-23	CE622	Santiago, Chile	
7170	41-84		Tangier (VOA)	1930-2145	6210	48-31	HCAC1	Quito, Ecuador	
7160	41-89		Moscow Paris, France		6203	48-38	HJCQ	Bucharest, Roumania	
7155	41-93	VUD7	Delhi, India Warsaw, Poland		6200	48-39		Bogota, Colombia	
7150	41-96	GRT	London		6195	48-43	GRN	Paris, France	
7140	42-02	EDV10	Madrid, Spain		6190	48-47	WRCA3	London Bound Brook, N.J.	0315-0345
7135	42-05	MCM	London		6185	48-50	VUD2/7 KRCA3	Delhi, India Dixon, Calif.	0900-1600 0715-0845 (Tue.-Sun)
7126	42-10		Tangier, Africa	2000-2200				Munich, Germany (VOA)	1615-2200
7120	42-13	GRM	London		6180	48-54	GRO	London	1615-1700
7115	42-16		Paris, France Moscow Karachi, Pakistan	1230-1245	6175	48-58	WDS11	Brentwood, New York	2330-2345
7110	42-19	MCS	London		6170	48-62	JKI WDS11	Nazaki, Japan Brentwood, New York	0215-0245 0300-0345 1830-1845 1900-2015 2100-2145
7096	42-27		Munich, Germany (VOA)	1615-2215			GSZ	London	
7075	42-40		London				OLR2D	Prague, Czechoslovakia	
7030	42-67		Istanbul, Turkey	1815-2000 (Exc. Sat.)	6165	48-66	HER3	Berne, Switzerland	
7010	42-80		Karachi, Pakistan Valladolid, Spain	1930-2100	6160	48-70	GWK KRHO	London Honolulu, Hawaii	0900-1600
6995	42-89		Valencia, Spain		6155	48-74	CXA13	Montevideo, Uruguay	
6940	43-23		Malaga, Spain				WLWO7	Bethany, Ohio	0215-0245 0315-0345
6830	43-82	4XB31	Tel Aviv, Israel	2015-2030				Lisbon, Portugal	
6825	43-96		Tashkent, USSR	1500-1530 1600-1630					
6790	44-18	ZJM6	Limassol, Cyprus						

SHORT WAVE BROADCAST STATIONS

Fre- quency Kilo- cycles	Wave- length metres	Callsign	Location	Schedule GMT	Fre- quency Kilo- cycles	Wave- Length metres	Callsign	Location	Schedule GMT
6150	48.78	CE615	Valparaiso, Chile		6060	49.50	GSK WRUL1	London Scituate, Mass.	1745-2145 0215-0245 0300-0345
		GRW	London Belgrade, Yugoslavia				KWID1	San Francisco, Calif.	0900-1600
6147	48.82	PRL9	Rio de Janeiro, Brazil		6055	49.55	HER2	Berne, Switzerland	1845-1930
6145	48.82		Paris, France				PRB21	Sao Paulo, Brazil	
6140	48.85		Munich, Germany (VOA)	0600-2200	6050	49.59	GSA	London	1615-1645
			Tangier (VOA)	2230-0600	6045	49.63	YDF	Djakarta, Indonesia	
6135	48.90		Baghdad, Iraq	1915-2000	6040	49.67	WLWO7	Bethany, Ohio	0315-0345 0415-0600 (Tue.-Sun.)
6130	48.94	CHNX	Halifax, Nova Scotia				GSY	London	
		LKJ2	Tromso, Norway		6035	49.71	CXA30	Montevideo, Uruguay	
6125	48.98	CXA4	Montevideo, Uruguay				GWS 3AM3	London Monte Carlo, Monaco	2230-2300
		GWA	London Manila, Philippine Is. (VOA)	0900-1600 2200-0000	6030	49.75	HVJ3	Vatican City Stuttgart, Germany	
6120	49.02	WDS12	Brentwood New York		6025	49.79	PGD	Moscow Hilversum, Holland	
		ZJM4	Limassol Cyprus	0315-0345	6020	49.83	WRCA1	Bound Brook, New Jersey	0215-0245 0315-0345
6115	49.06		Warsaw, Poland				ELB1	Monrovia, Liberia	
6110	49.10	GSL	London Tangier (Radio International Singapore (BFEB))		6018	49.84	HJCX	Bogota, Colombia	
		WRCA2	Bound Brook, New Jersey	0215-0245 0315-0345 0630-0645 1700-1715 1815-1830 2145-2200	6015	49.88	PRA8	Recife, Brazil S.S. "Courier"	1630-2215 2230-0345
			Belgrade, Yugoslavia		6010	49.92	OLR2A	Prague, Czechoslovakia	
6095	49.22	ZYB7	Sao Paulo, Brazil				GRB CJCX	London Sydney, Nova Scotia	
		OLR	Prague, Czechoslovakia		6005	49.96	HVJ2	Rome, Italy Vatican City Berlin, Germany	
6090	49.26	GWM LRY1	London Buenos Aires, Argentina		6000	50.00	ORU	Wavre, Belgium	1845-1900 (Tues.)
6085	49.30		Cairo, Egypt	1600-1930			CXA2	Montevideo, Uruguay	
6082	49.32	OAX4Z	Lima, Peru	0300-0500			PRK5	Belo Horizonte, Brazil	
6080	49.34		Munich, Germany (VOA)	1530-2215	5995	50.04		Warsaw, Poland	
			Tangier (VOA)	2245-0630	5990	50.08		Delhi, India	
6075	49.38	KGE12	Belmont, Calif. Karachi, Pakistan	0900-1600	5980	50.16	ZFY	Georgetown, B.G.	
6070	49.42		Sofia, Bulgaria	2100-2115				Andorra la Vieja, Andorra	
6067	49.45	EA9AH	Moscow Tetuan, Spanish Morocco	1400-1500 2030-2230	5975	50.21		Karachi, Pakistan Moscow Djeddah, Saudi-Arabia	1605-1835
6065	49.46	SBO	Stockholm, Sweden	1545-1600 2230-2245 (Fri.) 0715-0730 (Sat.)	5970	50.25	HI4T	Warsaw, Poland Trujillo, Dominican Republic	
6062	49.48	LRA1	Buenos Aires, Argentina				CBNX CKNA	Saint John's, Newfoundland Sackville, N.B.	

SHORT WAVE BROADCAST STATIONS

Fre- quency Kilo- cycles	Wave- Length metres	Callsign	Location	Schedule GMT	Fre- quency Kilo- cycles	Wave- Length metres	Callsign	Location	Schedule GMT
5959	50.36	HJCF	Bogota, Colombia		4900	61.23	HJAG	Barranquilla, Colombia	
5952	50.45	TGNA	Moscow Guatemala City, Guatemala				ZYZ20	Rio de Janeiro, Brazil	
5920	50.70	HRA	Tegucigalpa, Honduras	0330-0400	4897	61.26	V LX4	Perth, Western Australia	
5912	50.74		Moscow		4895	61.28	PRF6 HJCH	Manaos, Brazil Bogota, Colombia	
5890	50.93		Cape Town, South Africa		4890	61.35	YV KC	Caracas, Venezuela	
5885	50.94	CR4AA	Praia, Cape Verde Is.	2000-2200	4880	61.48	VUC2 YV KF	Calcutta, India Caracas, Venezuela	
5875	51.06	HRN	Tegucigalpa, Honduras		4870	61.60	VUD HJBG	Delhi, India Cucuta, Colombia	
5838	51.38	CQM4	Bissau, Portuguese Guinea		4865	61.66	CSA93 HJFA	Ponta Delgada, Azores Pereira, Colombia	2100-0000
5752	52.11	PZH5	Paramaribo, Surinam				PRC5 VQ7LO	Belem, Brazil Nairobi, Kenya	
5060	59.30	HJKH	Bogota, Colombia		4855	61.79		Barquisimeto, Venezuela	
5056	59.36	HJDW	Medellin, Colombia		4850	61.86	YVMS	Barquisimeto, Venezuela	
5050	59.41	YVKD	Caracas, Venezuela		4847	61.92	HJGF	Bucaramanga, Colombia	
5045	59.46	ZYP23	Petropolis, Brazil		4845	61.92	ZYU8	Teresina, Brazil	
5030	59.67	YVKM	Caracas, Venezuela		4840	61.98	VUB2 YVOI	Bombay, India Valera, Venezuela	1530-1600
5017	59.80	PJC2	Willemstad, Curacao		4830	62.11	YVOA CR7BN	San Cristobal, Venezuela Lourenco Marques, Mozambique	
5000	60.00	WVV	Washington, D.C.	TimeCheck every 5 minutes			ZQP	Lusaka, Northern Rhodesia	1800-1900
4995	60.05	ZYY20	Porto Velho, Brazil		4825	62.18	ZYE7	Parnaiba, Brazil	
4990	60.12	YVMO	Barquisimeto, Venezuela		4820	62.24	HJDE	Cali, Colombia	
4980	60.25	ZOY	Accra, Gold Coast	1730-1830	4815	62.31	HJBB	Cucuta, Colombia	
4975	60.30	ZYY9	Sao Luiz, Brazil		4810	62.37	YVMG	Maracaibo, Venezuela	
4970	60.36	YVLK	Caracas, Venezuela	2300-0000	4807	62.40		Dacca, Pakistan	
4965	60.42	HJAE	Cartagena, Colombia		4805	62.43	ZYS8	Manaos, Brazil	
4960	60.48	VUD2 YVQA	Delhi, India Cumana, Venezuela	1530-1545	4800	62.50	YVMF	Maracaibo, Venezuela Lagos, Nigeria	1730-2000
4955	60.55	HJCQ	Bogota, Colombia		4790	62.63	YVQC	Bolivar, Venezuela	
4950	60.60	ZQI	Kingston, Jamaica		4783	62.70	HJAB	Barranquilla, Colombia	
4945	60.67	HJCW	Bogota, Colombia		4780	62.75	YVLA	Valencia, Venezuela	2300-0200
4940	60.73	VUD2 YVMQ	Delhi, India Barquisimeta, Venezuela		4774	62.83		Rangoon, Burma	1500-1515
4935	60.80	ZY121	Natal, Brazil Karachi, Pakistan		4770	62.89	YVMW	Punto Fijo, Venezuela	
4930	60.90	HJAP	Cartagena, Colombia		4768	62.96	HJEF	Cali, Colombia	
4920	60.99	CR7BO	Lourenco Marques, Mozambique	1800-2100	4750	63.19	YVMA	Maracaibo, Venezuela	
		VUM2	Madras, India	1530-1545	4655	64.80	HCAJ2	Guayaquil, Ecuador	
4918	61.01	VLM4	Brisbane, Queensland	2000-2100	3970	75.57		Delhi, India	
4910	61.10	YVMM	Coro, Venezuela		3955	75.85		Karachi, Pakistan	
		JK1	Nazaki, Japan		3950	75.95		Djeddah, Saudi-Arabia	1605-1835
		YDB2	Djakarta, Indonesia	1400-1500					

SHORT WAVE BROADCAST STATIONS

3930 76-34		Rome, Italy	
3550 84-51	YVOC	San Cristobal, Venezuela	
3490 85-96	YVRA	Maturin, Venezuela	
3450 86-60	YVQI	Barcelona, Venezuela	
3420 87-72	YVOK	Merida, Venezuela	
3410 87-98	YVML	Cabimas, Venezuela	
3390 88-50	YVKX	Caracas, Venezuela	
3380 88-76	YVQO	Porto la Cruz, Venezuela	
3370 89-02	YVMJ	Maracaibo, Venezuela	
3365 89-15	VUD2	Delhi, India	1530-1545
3350 89-55	YVKU	Caracas, Venezuela	
3340 89-82	YVMU	Carora, Venezuela	
3335 89-96		Lahore, Pakistan	
3330 90-09	YQL	El Tigre, Venezuela	
3325 90-24	ZYJ21	Campina Grande, Brazil	
3320 90-36	DZB2	Manila, Philippine Islands	
	ZEAF	Salisbury, Southern Rhodesia	
	YVQV	Barcelona, Venezuela	
3310 90-63	YVOG	Trujillo, Venezuela	
3305 90-76	ZQI	Kingston, Jamaica	0330-0400

WE PAY TOP PRICES

FOR

American Surplus Electronic Equipment

Any quantity or condition

Look at these Examples

For equipment in good condition

SCR291, complete	£350
Receiver R54/APR4 with all tuning units	£135
Receiver BC348, R model only	£25
Frequency Meter TS 175	£80
TX/RX RT18/ARC1	£50
Test Set TS/13	£100
Valve 223A/B	£3

We Pay Similar Remarkable Prices for

Receivers, APRI, APR4, APR5, R5/ARN7, BC348, 8C342, 8C312, APN9.

Frequency Meters TS174/U, BC221.

Test Sets, TS3, TS13, TS14, TS34, TS45, TS59, TS102, TS118, IE19, TS148.

Transmitters ART13, ARC3, TRC1, TCS6-12-13, ET4336.

Synchronisers BC1148 Modulators 8C1142 Indicator BC1151

And almost every American made unit even it not mentioned above.

Phone us immediately, transfer charge

★ Note our new address

ALTHAM RADIO CO.

JERSEY HOUSE, JERSEY STREET,
MANCHESTER 4 TEL : CENtral 7834/5/6

QSL BUREAUX OF THE WORLD

Latest Address List Alphabetically by Prefix

This List, corrected to the middle of May 1953, gives the local address to which QSL cards may be sent in bulk for distribution within any of the 150 prefix-areas shown. From time to time, amendments or additions to this List will be published in RADIO QUARTERLY

- AC3 Sikkim—P. T. Namgyal (AC3PT), Maharaj Kumar of Sikkim, Gangtok, Sikkim State, via Calcutta, India.
- AG2 Trieste—A.P.O. 209, c/o Postmaster, New York City, U.S.A.
- C China—C.A.R.L., P.O. Box 409, Shanghai, China.
- CE Chile—Radio Club, of Chile, Casilla 761, Santiago, Chile.
- CM Cuba—Radio Club of Cuba, Lealtad 660 Bajos, Havana, Cuba.
- CN2 Tangier Zone—Tangier Amateur Radio Club, French P.O. Box 150, Tangier, Tangier Zone.
- CN8 French Morocco—A.A.E.M., P.O. Box 2060, Casablanca, French Morocco.
- CO Cuba—Radio Club of Cuba, Lealtad 660 Bajos, Havana, Cuba.
- CP Bolivia—Radio Club Boliviano, Casilla 2111, La Paz, Bolivia.
- CR6 Angola—Joao Carlos Chaves (CR6AI), P.O. Box 20, Caala, Angola.
- CR7 Mozambique—L.R.E.M., Caixa Postal 812, Lourenco Marques, Mozambique.
- CT1 Portugal—R.E.P., Travessa Nova de S. Domingos 34-1, Lisbon, Portugal.
- CT2 Azores Islands—(via CT1-QSL Bureau)
- CT3 Madeira Islands—Alberto C. de Oliveira (CT3AA), Beco Chao da Loba 14, Funchal, Madeira Islands.
- CX Uruguay—Radio Club of Uruguay, Casilla 37, Montevideo, Uruguay.
- DJ Germany—D.A.R.C., P.O. Box 99, Munich 27, Germany.
- DL1, 3, 6, 7, 9, 0 Germany—(via DJ QSL Bureau).
- DL2 Germany (British Zone)—George Verrill (G3IEC), 64 Forton Road, Gosport, Hants, England.
- DL4 Germany (American Zone)—A.P.O. 757, c/o Postmaster, New York City, U.S.A.
- DL5 Germany (French Zone)—(via F-QSL Bureau).
- DU Philippine Islands—Philippine Amateur Radio Assn., c/o Radio Training Institute, 2046 Taft Avenue, Pasay City, Philippine Islands.
- EA Spain—U.R.E., Box 220, Madrid, Spain.
- EI Eire—I.R.T.S. 23 Orwell Gardens, Rathgar, Dublin, Eire.
- F France—R.E.F., 3 Avenue Hoche, Paris, 8, France.
- FA Algeria—Gaston & Jacqueline DeVill (FA9RW), Boite Postale 21, Maison-Carree, Alger, Algeria.
- FKS8 Austrian French Zone—(via F-QSL Bureau).
- G, GC, GD, GM, GW Great Britain—R.S.G.B., A. Milne, 29 Kechill Gardens, Hayes, Bromley, Kent, England ;
- or*
- BCM/QSL, London, W.C.1.
- GI Northern Ireland—W. H. Martin, Swallow Lodge, Greenisland, Co. Antrim, Northern Ireland ;
- or*
- BCM/QSL, London, W.C.1.
- HA Hungary—Hungarian Short-Wave Radioamateur League, Box 185, Budapest, 4, Hungary.
- HB Switzerland—U.S.K.A., P.O. Box 1203, St. Gallen, Switzerland.
- HB4—via Rene Benz (HB9U), Usterstr. 93, Dubendorf, Zurich, Switzerland.
- HC Ecuador—HC1—via Victoriano Salvador (HC1JW), P.O. Box 2536, Quito, Ecuador.
- HC2—via Guayaquil Radio Club, Casilla 784, Guayaquil, Ecuador.

QSL BUREAUX OF THE WORLD

- HE Liechtenstein—(via HB-QSL Bureau).
 HH Haiti—Radio Club d'Haiti, P.O. Box A-116, Port-au-Prince, Haiti.
 HK Colombian Republic—Liga Colombiana de Radio-Aficionados, Apartado Postal 584, Bogota, Colombian Republic.
 HP Panama Republic—Liga Panamena de Radio Aficionados, Apartado 1616, Panama, Panama Republic.
 HR Honduras—Oscar Alvarado Trochez (HR1AT), P.O. Box 244, Tegucigalpa, D. C., Honduras.
 I Italy—A.R.I., S. Paulo 10, Milan, Italy.
 JA Japan—J.A.R.L., Box 377, Tokyo, Japan.
 KA Japan—F.E.A.R.L., A.P.O. 500, c/o Postmaster, San Francisco, California, U.S.A.
 KB6 Canton Islands—Fred V. Carpenter (KB6AY), United States Post Office 06-50000, Phoenix Group, South Pacific.
 KG4 Guantanamo Bay, Cuba—Box 13, Navy 115, c/o F.P.O., New York City, U.S.A.
 KG6 Marianas Islands—P.O. Box 145, c/o C.A.A., Agana, Guam, Marianas Islands.
 KH6 Hawaiian Islands—Andy H. Fuchikami (KH6BA), 2543 Namauu Drive, Honolulu, Hawaiian Islands.
 KL7 Alaska—J. W. McKinley (KL7CK), Box 73, Douglas, Alaska.
 KP4 Puerto Rico—E. W. Mayer (KP4KD), P.O. Box 1061, San Juan, Puerto Rico.
 KR6 Okinawa Islands—Okinawa Radio Amateur Club, c/o Staff Signal Office, A.P.O. 331, c/o Postmaster, San Francisco, California, U.S.A.
 KT1 Tangier Zone—(via CN2-QSL Bureau)
 KV4 Virgin Islands—Richard C. Spenceley (KV4AA), Box 403, Charlotte Amalie, St. Thomas, Virgin Islands.
 KX6 Marshall Islands—Box 3, Navy 824, c/o F.P.O., San Francisco, California, U.S.A.
 KZ5 Panama Canal Zone—Canal Zone Amateur Radio Assn., Box 407, Balboa, Panama Canal Zone.
 LA, LB Norway—Norwegian Radio Relay League, P.O. Box 898, Oslo, Norway.
 LU Argentina—Radio Club Argentino, Av. Libertador General San Martin 1850, Buenos Aires, Buenos Aires, Argentina.
 LX Luxembourg—Guillaume Berger (LXIAB), 40 Rue des Trevires, Luxembourg, Luxembourg.
 LZ Bulgaria—P.O. Box 830, Sofia, Bulgaria.
 MB9 Austrian British Zone—C.S.O. Branch, H.Q. B.T.A., Klagenfurt, B.T.A.2.
 MF2 Trieste—M. H. R. Carragher (MF2AA), Villa Arra, Via Fabio Severo 62, Trieste.
 MI3 Eritrea—Eritrea Radio Society, P.O. Box 247, Asmara, Eritrea.
 MP4K Kuwait—W. N. Burgess (MP4KAC), c/o Kuwait Oil Co., Ahmadi, Kuwait, Persian Gulf.
 OA Peru—Radio Club of Peru, Box 538, Lima, Peru.
 OE Austria—O.V.S.V., Strohhberggasse 6, Vienna XII, Austria.
 OE13 Austrian American Zone—Signal Section, U.S.F.A., A.P.O. 168, c/o Postmaster, New York City, U.S.A.
 OH Finland—S.R.A.L., Post Box 306, Helsinki, Finland.
 OK Czechoslovakia—C.A.V., Post Box 69, Praha. I, Czechoslovakia.
 ON Belgium—U.B.A., Post Box 634, Brussels, Belgium.
 OQ Belgian Congo—P.O. Box 271, Leopoldville, Leopoldville, Belgian Congo.
 OX Greenland—(via OZ-QSL Bureau).
 OY Faeroes Islands—(via OZ-QSL Bureau).
 OZ Denmark—E.D.R., P.O. Box 79, Copenhagen, Denmark.
 PA, PE, PI Netherlands—V.E.R.O.N., Post Box 400, Rotterdam, Netherlands;
 or
 V.R.Z.A., P.O. Box 190, Groningen, Netherlands.
 PJ Neth. West Indies—Sjoerd Heeringa (PJ2AA), Dakota Airport, Aruba, Neth. West Indies.
 PY Brazil—L.A.B.R.E., P.O. Box 2353, Capital Federal, Rio de Janeiro, Brazil.
 SM Sweden—Sveriges Sandare Amatorer, Stockholm. 4, Sweden.
 SP Poland—P.Z.K., P.O. Box 320, Warsaw, Poland.
 SV Greece—C. Tavanotis, 17a Bucharest Street, Athens, Greece.
 TF Iceland—I.R.A., Box 1080, Reykjavik, Iceland.
 TG Guatemala—P.O. Box 12, Guatemala City, Guatemala.
 TI Costa Rica—Federico Gonzales (TI2FG) P.O. Box 365, San Jose, Costa Rica.

QSL BUREAUX OF THE WORLD

- U Soviet Union—Central Radio Club, Postbox N-88, Moscow, U.S.S.R.
- VE1 Canada—L. J. Fader (VE1FQ), 125 Henry Street, Halifax, Nova Scotia, Canada.
- VE2 Canada—Austin A. W. Smith (VE2UW), 6164 Jeanne Mance, Montreal, 8, Quebec, Canada.
- VE3 Canada—W. Bert Knowles (VE3QB), Lanark, Ontario, Canada.
- VE4 Canada—Len Cuff (VE4LC), 286 Rutland Street, St. James, Manitoba, Canada.
- VE5 Canada—Fred Ward (VE5OP), 899 Connaught Avenue, Moose Jaw, Saskatchewan, Canada.
- VE6 Canada—W. R. Savage (VE6EO), 329 15th Street North, Lethbridge, Alberta, Canada.
- VE7 Canada—H. R. Hough (VE7HR), 1330 Mitchell Street, Victoria, British Columbia, Canada.
- VE8 Canada—W. L. Geary (VE8AW), Box 76, Whitehorse, Yukon Territory, Canada.
- VK1 Australian Expedition Stations—Box 2611, W. G.P.O., Melbourne, Victoria, Australia.
- VK2 Australia—J. Corbin (VK2YC), 78 Maloney Street, Eastlakes, Mascot, New South Wales, Australia.
- VK3 Australia—Ray E. Jones (VK3RJ), 23 Landale Street, Box Hill, Victoria, Australia.
- VK4 Australia—J. C. Files (VK4JF), Vanda Street, Buranda, South Brisbane, Queensland, Australia.
- VK5 Australia—G. W. Luxon (VK5RX), 8 Brook Street, West Mitcham, South Australia, Australia.
- VK6 Australia—James E. Rumble (VK6RU), 15 The Grove, Wembley, West Australia, Australia.
- VK7 Australia—T. A. Allen (VK7AL), 6 Thirza Street, New Town, Tasmania, Australia.
- VK9 New Guinea (only)—G. A. Warner (VK9GW), c/o O.T.C., 3½-mile, Port Moresby, Papua Territory.
- VO Newfoundland—Newfoundland Amateur Radio Assn., P.O. Box 660, St. Johns, Newfoundland.
- VO6 Labrador—Doug Ritcey (VO6U), Department of Transport, Goose Bay, Labrador.
- VP1 British Honduras—Dwight Hunter (VP1AA), Box 178, Belize, British Honduras.
- VP3 British Guiana—Desmond E. Yong (VP3YG), P.O. Box 325, Georgetown, British Guiana.
- VP4 Trinidad—John A. Hafford (VP4TT), 88 Abercromby Street, Port of Spain, Trinidad.
- VP5 Jamaica—Thomas Myers (VP5AD), 97 Harbour Street, Kingston, Jamaica.
- VP6 Barbados—Wood Goddard (VP6PX), Kenilworth, Welches, Christ Church, Barbados.
- VP7 Bahama Islands—C. N. Albury (VP7NM), P.O. Box 362, Nassau, Bahama Islands.
- VP8 Falkland Islands—(via G-QSL Bureaux).
- VP9 Bermuda Islands—James A. Mann (VP9D), c/o Cable & Wireless, St. George, Bermuda Islands.
- VQ2 Northern Rhodesia—H. G. L. Windsor (VQ2HW), Box 332, Kitwe, Northern Rhodesia.
- VQ4 Kenya—East Africa QSL Bureau, P.O. Box 1313, Nairobi, Kenya.
- VQ5 Uganda—Amateur Radio Society of Uganda, P.O. Box 139, Kampala, Uganda.
- VQ8 Mauritius—Volcy de Robillard (VQ8AF), Box 155, Port Louis, Mauritius.
- VR2 Fiji Islands—S. H. Mayne (VR2AS), P.O. Box 184, Suva, Fiji Islands.
- VS1 Singapore—Singapore Amateur Radio Transmitters Society, P.O. Box 176, Singapore 1, Malaya.
- VS2 Malaya—Charles E. Salton (VS2DV), Postal Services Dept., G.P.O., Penang, Malaya.
- VS6 Hong Kong—Hong Kong Amateur Radio Transmitting Society, P.O. Box 541, Hong Kong, Hong Kong.
- VU India—Amateur Radio Society of India, Box 534, New Delhi, India.
- W1 K1, U.S.A.—J. Ralph Baker (W1JOJ), Box 232, Ipswich, Massachusetts, U.S.A.
- W2, K2 U.S.A.—Henry W. Yahnel (W2SN), Lake Avenue, Helmetta, New Jersey, U.S.A.
- W3, K3 U.S.A.—Jesse Bieberman (W3KT), Box 34, Philadelphia, 5, Pennsylvania, U.S.A.
- W4, K4 U.S.A.—Thomas M. Moss (W4HYW), Box 644, Municipal Airport Branch, Atlanta, Georgia, U.S.A.

QSL BUREAUX OF THE WORLD

- W5, K5 U.S.A.—Oren B. Gambill (W5WI), 2514 North Garrison Avenue, Tulsa, 6, Oklahoma, U.S.A.
- W6, K6 U.S.A.—Horace R. Greer (W6TI), 414 Fairmount Avenue, Oakland, California, U.S.A.
- W7, K7 U.S.A.—Mary Ann Tatro (W7FWR), 513 North Central, Olympia, Washington, U.S.A.
- W8, K8 U.S.A.—Norman Aiken (W8LJS), 701 East 240th Street, Euclid, 23, Ohio, U.S.A.
- W9, K9 U.S.A.—John F. Schneider (W9CFT), 311 West Ross Avenue, Wausau, Wisconsin, U.S.A.
- W0, K0 U.S.A.—Alva A. Smith (W0DMA), 238 East Main Street, Caledonia, Minnesota, U.S.A.
- XE Mexico—L.M.R.E., Apartado Postal 907, Mexico, D. F., Mexico.
- XZ Burma—Burma Amateur Radio Society, P.O. Box 611, Rangoon, Burma.
- YN Nicaragua—Luis Bonillas S. (YN1LB), Bolivar Ave. 106, Managua, Nicaragua.
- YO Roumania—A.A.U.S.R., Box 95, Bucharest, Roumania.
- YS El Salvador—Oscar R. Orellana (YS1O), Apartado 329, San Salvador, El Salvador.
- YU Yugoslavia—S.R.J., P.O. Box 48, Beograd, Yugoslavia.
- YV Venezuela—Radio Club Venezolano, P.O. Box 2285, Caracas, Venezuela.
- ZB1 Malta—Robert F. Galea (ZB1E), Casa Galea, Railway Road, Birkirkara, Malta.
- ZB2 Gibraltar—Edwin D. Wills (ZB2I), 9 Naval Hospital Road, Gibraltar.
- ZC4 Cyprus—Sid Parks (ZC4XP), P.O. Box 451, Nicosia, Cyprus.
- ZD2 Nigeria—Donald C. Piccirillo (ZD2DCP), Radio Officer, Posts and Telegraphs, Ikeja, Lagos, Nigeria.
- ZD6 Nyasaland—Chief Officer, P.O. Box 72, Zomba, Nyasaland.
- ZE Southern Rhodesia—R.S.S.R., Box 2377, Salisbury, Southern Rhodesia.
- ZK1 Cook Islands—C. Doug. Cunnold (ZK1AB), P.O. Box 41, Rarotonga, Cook Islands.
- ZL1 New Zealand—F. L. Hawthorn, (ZL1GX), 77 Wainui Avenue, Auckland W.3., New Zealand.
- ZL2 New Zealand—W. Fouhy (ZL2LB), 99 Washington Avenue, Wellington S.W.1., New Zealand.
- ZL3 New Zealand—I. A. McCulloch (ZL3IC), 38 Retreat Road Christchurch S.E.1., New Zealand.
- ZL4 New Zealand—H. W. Natta (ZL4AR), 137 Bayview Road, Dunedin S.2, New Zealand.
- ZP Paraguay—Radio Club Paraguayo, Casilla de Correo 512, Asuncion, Paraguay.
- ZS Union of South Africa—S.A.R.L., P.O. Box 3037, Capetown, Union of South Africa.
- 3V8 Tunisia—Maurice Bord (3V8AI), 22 Rue Parmentier, Tunis, Tunisia.
- 4S7 Ceylon—N. Gunasekara (4S7NG), 158 Queen Mary's Road, Gampaha, Ceylon.
- 4X4 Israel—I.A.R.C., P.O. Box 4099, Tel Aviv, Israel.
- 5A Libya—P.O. Box 372, Tripoli, Libya.
- 9S4 Saarland—K.W.A.C.S., P.O. Box 310, Saarbrucken, Saarland.

We purchase surplus gear at your price

Send us details by return of post, we will make you a liberal offer.

WANTED AT ONCE !

BC221s Frequency Meters, TS174/U or TS175, TS47 AP, TS13 or TS45, TS 148, TSX45E, TS127, Receivers : RCA AR88s, Hallicrafters SX28, S27 or S27CA. U.S.A., APR1 or APR4 with tuning units TN16, 17, 18, 19, Klystrons Type 723/AB, CV129, 2K33, 2K39, 2K40, 2K41, 2K42-3-44, etc., BC348 or 342 Receivers, and any high grade Laboratory gear by Marconi, General Radio, Ferris, etc.

WE PAY TOP PRICES AND SPOT CASH FOR ALL EQUIPMENT

★ Our Only Address is—

UNIVERSAL ELECTRONICS

27, Lisle Street, Leicester Sq., W.G.2.

Shop hours, 9.30 a.m. to 6 p.m. Thursday 9.30 a.m. to 1 p.m.
Write call or Telephone: GERrard 8410 (Day) MEAdway 3145 (Night)

THE AMATEUR TRANSMITTING LICENCE

Some Notes on Conditions and Exemptions

Most readers of *RADIO QUARTERLY* are either interested listeners to amateur transmissions on the short wave bands, or are keen to obtain transmitting licences of their own. These two pages outline the procedure involved—like many other things, it all seems very complicated until you know how. Actually, there is no difficulty about getting a Licence provided you are really interested in the technique of short wave transmission and prepared to learn the fundamentals of Amateur Radio operating.

THE majority of short-wave enthusiasts aim eventually to obtain a transmitting licence, so that they may themselves take a more active part in Amateur Radio and join the ranks of the operators they frequently hear on the amateur bands. Naturally, it would not be prudent (nor fair to existing transmitters) to issue licences indiscriminately to whomsoever requested permission to transmit! The would-be transmitting amateur must provide the authorities with the necessary evidence that he has the technical knowledge and Morse code proficiency necessary to operate an amateur short-wave station efficiently.

The standard required is not really high and should in no way deter the enthusiastic listener even should he be the merest novice. The qualifications needed are (1) Technical, and (2) Morse code. The technical requirements demand some understanding of the theory and practice of radio communication, including a working knowledge of simple receiving and low-powered transmitting apparatus, wave propagation, auxiliary equipment (such as wavemeters) and a good understanding of the transmitting licence conditions. A grounding in elementary radio calculations is essential.

The Postmaster General—as licensing authority—is prepared to consider exemptions from the normal technical

and/or Morse tests where the applicant considers he is already qualified, e.g. professional certificates, diplomas or degrees, which are equivalent to, or more advanced than, the standards required. Additionally, certain Service trade personnel may claim exemption.

Applications for a transmitting licence under either of these conditions must be made to:—

*Engineer-in-Chief,
Radio Branch,
W5/5 Brent Buildings,
North Circular Road,
London, N.W.2.*

Where no existing technical qualifications can be put forward, the prospective operator can avail himself of the special Radio Amateurs' Examination, conducted by the City and Guilds of London Institute. The examination is held annually (in May) and takes place at a number of centres throughout the country—usually at the local Technical College. Prospective candidates should apply to their Local Education Authority for information. If no examination centre can be found, the candidate should apply for advice to:—

*The Superintendent,
City & Guilds of London Institute,
Department of Technology,
31 Brechin Place,
South Kensington,
London, S.W.7.*

THE AMATEUR TRANSMITTING LICENCE

A fee of 10/- is charged and the examination centre may, additionally, ask for a small accommodation fee. Three hours are allowed to complete the paper—but the majority of candidates find that two hours is generally adequate.

The Licence

There are a number of qualifications for licensees and operators. Technical knowledge, with a pass certificate in the R.A.E., higher grade examinations of a similar nature, or by Service exemption, have already been discussed. Additionally, the prospective operator must furnish proof of ability to send and receive the Morse code at a speed of not less than 12 words per minute.

The procedure generally adopted is to obtain the necessary proof of technical knowledge—by examination or claim for exemption—and fill in an application form for a transmitting licence. *Form E-in-C 447*, obtainable from the Brent Buildings address previously given. If the applicant has, also, proof of Morse code ability, this should be enclosed with the form. If not, he should state at which Head Post Office he would be prepared to take the Morse test; arrangements will then be made to accommodate the applicant, and the Test will be at the rate of 12 words per minute, sending and receiving.

The applicant for an amateur transmitting licence must produce evidence of British nationality, and two recent references as to character. A birth certificate should be enclosed with the application form (if possible, but this may not be insisted upon if the referees testify of their own knowledge that the applicant is of British nationality). The referees must be persons of British nationality and of standing, not related to the applicant. Where the applicant is under 21 years of age, evidence of British nationality and references must be provided in respect of both the applicant *and* of his parent or guardian.

A charge is made for a licence to cover the Post Office expenses in connection with its issue and subsequent inspection of the station. This charge covers the use of receiving apparatus for amateur communication purposes only, but if a broadcast receiver is also in use,

the usual wireless receiving licence must be obtained. Most amateurs naturally make sure that they have this licence!

The scale of fees is dependent on the power input of the transmitter to be used. The initial charge of 10s. is made on the issuing of the licence, in addition to the annual royalty. Thus, a 10-watt licence will cost £1 10s. 0d. on issue and £1 0s. 0d. a year subsequently. The transfer fee to higher power is also made independently of the annual royalty fee; no charge is made for transfer from 25 watts to higher power. When a licensee is authorised to transfer to higher power, a rebate on the annual royalty for the current licence, proportionate to the period still to run, is allowed.

Power in excess of 25 watts is not normally granted initially. However, after the first year of operation, the licensee may apply for permission to use the maximum power of 150 watts. Additionally, the first year is confined to the transmission of CW (or MCW) only. Permission to operate telephony is automatically granted when the licence is renewed for the second year of operation.

Since the "conditions of the licence" figure prominently in the Examination, and in view of the fact that these must, in any case, be thoroughly understood by the prospective transmitting amateur, they should be carefully studied by reference to *Form E-in-C 428*.

Exemptions

The Radio Amateurs' Examination consists of eight questions covering (a) Theoretical knowledge, including high frequency wave propagation, (b) The technique of operating transmitters, of lining-up and frequency control, and (c) Operating procedure.

When applying for exemption from the technical examination, these points must be borne in mind, because although the more usual academic qualifications would embrace (a), it is extremely unlikely that (b) and (c) would also be covered. Thus, should the intending amateur hold suitable qualifications for (a), it is regarded as necessary that he should also have had practical experience to enable him to qualify in respect of (b) and (c).

ESSENTIAL BOOKS FOR THE RADIO ENTHUSIAST

IMMEDIATE DELIVERY



RADIO AMATEUR CALL BOOK.

The World's only directory of amateur stations; giving call signs, names and addresses of amateur stations throughout the world and much useful information for the DX man. The G section alone lists some 7,500 amateurs. Complete

Edition 25/-, Foreign Section (Complete Edition less the American amateur listings) 10/-.

HOW TO LISTEN TO THE WORLD

Containing information suitable for beginners, for it deals with the mechanism of short wave propagation, gives advice on how to use the short wave bands, and explains how to prepare a log-book and how to write up a report, using the appropriate international abbreviations.

1/11

WORLD RADIO HANDBOOK

Revised and enlarged 1953 edition of this indispensable handbook, containing authoritative information on the World's Broadcasting and Television Stations. Recommended by such authorities and organisation as UNO, UNESCO and BBC.

9/-



RADIO AMATEUR'S HANDBOOK.

An A.R.R.L. publication now in its 30th Edition. 800 pages on Theory, Design, Construction and Practice. An essential buy for every amateur.

31/-

Other publications available from our comprehensive range of Radio books.

RADIO HANDBOOK	
12th	26/-
13th Edition	49/6
ANTENNA MANUAL	27/11
ANTENNA HANDBOOK	11/7
HINTS AND KINKS	11/5
HAM'S INTERPRETER	5/-
POST-WAR COMMUNICATION	
RECEIVER MANUAL Vol. 1	28/6
Vol. 2	28/6
A COURSE IN RADIO	
FUNDAMENTALS	4/10
THE RADIO AMATEUR'S LICENCE	
MANUAL	4/10
HOW TO BECOME A RADIO	
AMATEUR	4/10

LEARNING THE RADIO TELE-	
GRAPH CODE	2/8
SURPLUS CONVERSION MANUAL	
In two vols. Vol. I	21/5
Vol. II	21/5
WORLD RADIO VALVE	
HANDBOOK	11/10
PRACTICAL DISC RECORDING	6/4
THE CATHODE RAY	
OSCILLOSCOPE	6/5
PUBLIC ADDRESS GUIDE	6/4
HIGH FIDELITY TECHNIQUES	8/5
MODEL CONTROL BY RADIO	8/5
BASIC RADIO COURSE	18/7
RADIO TUBE FUNDAMENTALS	8/4
RADIO AND TV HINTS	8/5

Magazines by Subscription.

	One Year	One Year	
Radio Electronics	33/-	RCA Review	20/-
Popular Mechanics	32/-	Tele-Tech	40/-
Radio Electronic Engineering	56/-	Television	48/-
Service	24/-	Television Engineering	32/-
F.M. and Television	32/-	CQ	29/-
Electronics	160/-	Audio Engineering	29/-
Popular Science	32/-	Radio and Television News	36/-
Proc. I.R.E.	152/-	QST	36/-

SHORT WAVE MAGAZINE

(Publications Department).

55 VICTORIA STREET, LONDON, S.W.1

Abbey 5341

Smith's of EDGWARE ROAD

ELECTRONIC COMPONENT SPECIALISTS

Since Broadcasting Started

● EVERYTHING FOR THE CONSTRUCTOR ●

TRANSFORMERS

Wide range in stock. Specials to order. Power, Auto, Filament, Modulation, Output, Charger, EHT, Audio, Televator, Pickup, Microphone.

CAPACITORS

Electrolytic, Paper, Mica, Ceramic, Oilfilled, High-Voltage, Close-tolerance, Tuning, Transmitter, Trimming, Neutralising.

RESISTORS

Fixed—Carbon (1/10 to 5 watt), Wire-wound (5 to 100 watt), Brimistors, High-stabs, Potentiometers—Carbon and Wirewound, Slider Rheostats.

TEST EQUIPMENT

Panel and Multi-Meters, Analysers, Signal and Pattern Generators, Bridges, Insulation Testers, Oscillators, EHT Testers.

GRAMOPHONE PARTS

Motors, Auto-Changeers, Pick-ups, Pick-up Adaptors, Needles, Stylis, Frequency Records, Pressure Gauges, etc.

TELEVISION PARTS

Scanning Coils, Focus Coils and Magnets, Tuning Coils, Ion Traps, CR, Tubes, Masks, Filters, etc.

ALSO

Batteries
Blue Prints
Books
Cabinet Polish
Cement
Chokes A. F.
Chokes R. F.
Coils
Coil Cans
Coil Formers
Coil Units
Component Bins
Crystals
Crystal Diodes
Dial Lamps

Fuses and Holders
Grommets
Group Boards
Headphones
Knobs
Lamp Holders
Loud Speakers
Magazines
Microphones
Mic. Stands
Motors F.H.P.
Neons
Neon Testers
Nuts and Screws
Panels

RECORDER EQUIPMENT

Complete Recorders, Decks, Heads, Motors, Tape, Spools, Parts and accessories.

WIRE

Tinned Copper, Enamelled, Double Cotton Covered, Plastic Covered, Resistance, Litz, Flexible etc.

CABLE

Electric Wiring, Co-Axial, Feeder, Microphone, Multi-Core, Screened, E.H.T., Line Cord.

TOOLS

Drills, Soldering Irons, Screwdrivers, Pliers, Cutters, Strippers, Spanners, Trimmers, Valve Jigs and Extractors, Chassis Cutters.

Aerials. Television, Radio, Car. Also Wire, Rods, Leads, Insulators. Cabinets. Gram, Radio-Gram, Television, Recorder, Speaker. Switches. Toggle, Wafer, Rotary, Micro, Lever, Push-button, etc. **Plugs and Sockets.** Single, Twin, Multi, Co-Axial, Jack, Mains, etc. **Chassis.** Wide range of sizes. **Specials to order.** Punching and Drilling. **Insulating Material.** Sheet, Tubing, Rod, Tape, Sleeving, Beads. **Cases—Instrument, Amplifier, Transmitter, etc.** **Clips—Condenser, Grid, Cable, Crocodile, etc.** **Valve Holders—Paxolin, Moulded, Ceramic, etc.** **Insulators—Standoff, Feed-thro', Aerial etc.** **Metal—Sheet, Tubing, Rod.**

Panel Lamps

P. K. Screws
Racks
Rectifiers
Relays
R. F. EHT. Units
R. F. EHT Coils
Rotary Trans.
Rubberset M'nts
Scales
Scr. Sleeving
Solder
Solder Tags
Speaker Cones
Speaker Grill

Speaker Separators

Spindle Couplers
Suppressors
Switch Cleaner
Tag Strips
Terminal Blocks
Terminals
Tuning Dials
Tuning Drives
Valves (see below)
Valve Cans
Valve Caps
Vibrators
Voltage Stabilisers
Voltage Selectors

EX-SERVICE UNITS ETC.

VALVES—Over 800 types in stock

A. B. METAL
ACOS
ADCOLA
ADVANCE
ALLEN
AVO
B.E.C.
BELLING-LEE +
B.I.
BRANDENBERG
BRIMAR
B.S.R.
BULGIN
CELESTION
CLINCH
CLIX
COLLARO
COLVERN
CONNOISSEUR
COSSOR

CYLDON
DECCA
DENCO
DUBILIER
EDISWAN
ELAC
ELECTROVOICE
ELSTONE
E.M.I.
ENGLISH ELECTRIC
ERIE
EVERY-READY
F.C.I.
FERRANTI
GARRARD
G.E.C.
GOODMAN
HAMRAD
HANDY-UTILITY
HAYNES
HELLERMAN

HUNTS
J. B.
K. A.
LEMCO
LONG & HAMBLY
MAZDA
MARCONI-OSRAM
MCMURDO
MORGANITE
MULLARD
MULTICORE
OSMOR
PANREK
PARKER-KALON
PHILPOTTS
PLESSEY
Q-MAX +
RADIO-SPARES
RELIANCE
RESLO
ROLA

RONNETTE
ROTHERMEL
SCANCO
SOLON
S.T.C.
STENTORIAN
TAYLOR
T.C.C.
TRIX
TRUVOX
TUNGSRAM
WALEY
VITAVOX
WAVEMASTER
WEARITE
WELWYN
WEYMOUTH
WESTINGHOUSE
WINDSOR
WHARFEDALE
WODEN

No General Catalogue — Send for Quotation

H. L. SMITH & CO. LTD.

287/9 Edgware Road, London, W.2

Telephone Paddington 5891 - Hours 9 till 6 (Thursday 1 o'clock)

Near Edgware Road Stations, Metropolitan and Bakerloo