

# RADIO & ELECTRONICS CONSTRUCTOR

NUMBER 1973

2

72296

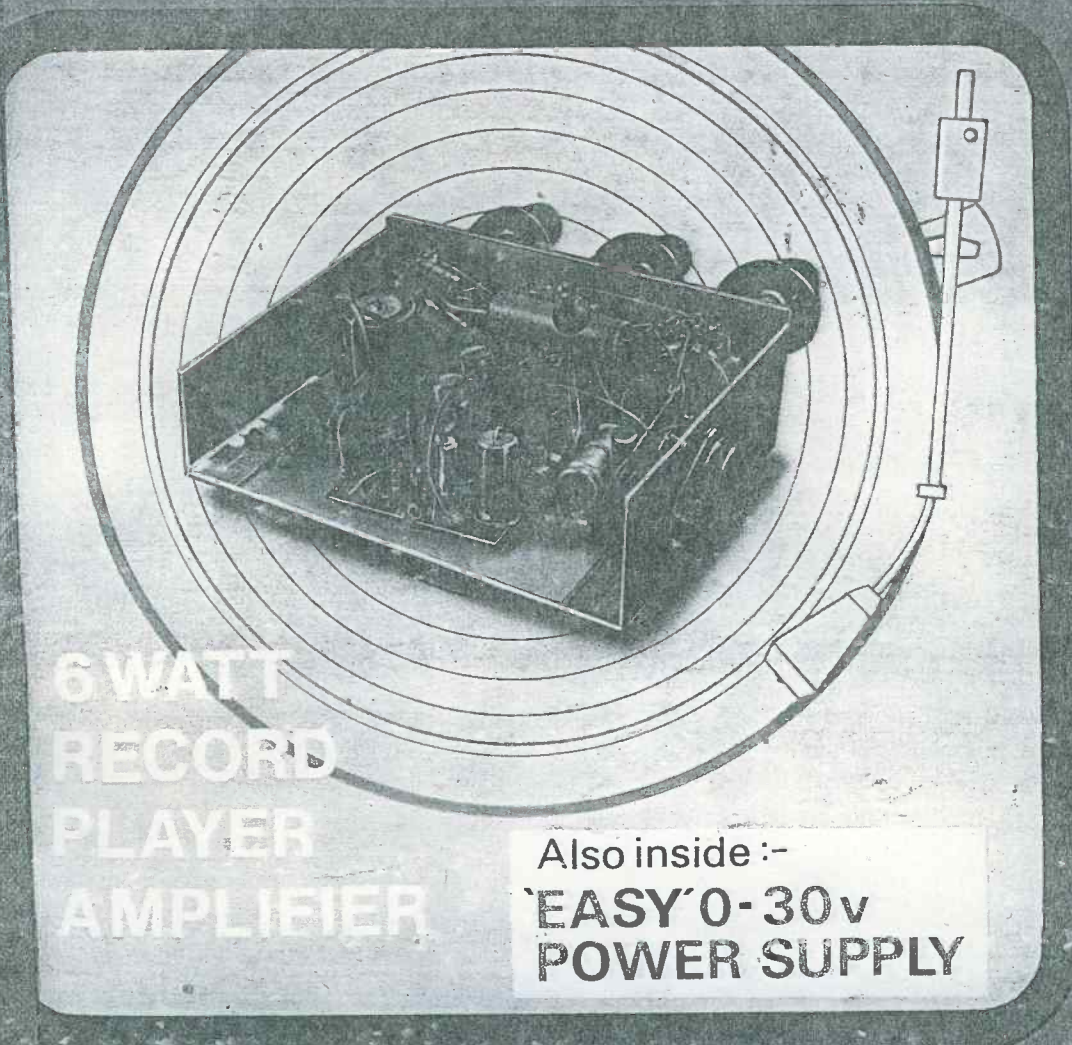

6 WATT  
RECORD  
PLAYER  
AMPLIFIER

Also inside :-  
EASY 0-30v  
POWER SUPPLY

URED

FOUR AUDIO BUILDING BLOCKS

# RADIO & ELECTRONICS CONSTRUCTOR

SEPTEMBER 1973

CONTENTS

Vol. 27 No. 2

Published Monthly (1st of Month)  
First Published 1947

*Incorporating The Radio Amateur*

*Editorial and Advertising Offices*  
57 MAIDA VALE LONDON W9 1SN

Telephone  
01-286 6141

Telegrams  
Databux, London

© *Data Publications Ltd.*, 1972. Contents may only be reproduced after obtaining prior permission from the Editor. Short abstracts or references are allowable provided acknowledgement of source is given.

*Annual Subscription:* £2.70 (U.S.A. and Canada \$7.00) including postage. Remittances should be made payable to "Data Publications Ltd". Overseas readers please pay by cheque or International Money Order.

*Technical Queries.* We regret that we are unable to answer queries other than those arising from articles appearing in this magazine nor can we advise on modifications to equipment described. We regret that such queries cannot be answered over the telephone; they must be submitted in writing and accompanied by a stamped addressed envelope for reply.

*Correspondence* should be addressed to the Editor, Advertising Manager, Subscription Manager or the Publishers as appropriate.

*Opinions* expressed by contributors are not necessarily those of the Editor or proprietors.

*Production.*—Web Offset.

EASY 0-30V POWER SUPPLY by F. G. Rayer, Assoc. I.E.R.E., G30GR	78
RECENT PUBLICATIONS	84
OSX by Frank A. Baldwin	85
NEWS AND COMMENT	86
TRIAC TIMER (Suggested Circuit 274) by G. A. French	88
EXPERIMENTAL A.F. OSCILLATOR by S. Jeffrey	90
AERIAL BEAM SYSTEM by A. C. Gee, G2UK	92
6 WATT RECORD PLAYER AMPLIFIER by R. A. Penfold	96
SHORT WAVE NEWS — For Dx Listeners by Frank A. Baldwin	102
4 BAND TRANSISTOR SUPERHET — Part 2 by R. A. Penfold	104
NEW PRODUCTS	109
FOUR AUDIO 'BUILDING BLOCKS' by A. Foord	110
RADIO TOPICS by Recorder	113
IN YOUR WORKSHOP Readers' Hints	114
CONSTRUCTOR'S DATA SHEET No. 78 (Resonant Frequencies VI)	iii

Published in Great Britain by the Proprietors and Publishers, Data Publications Ltd, 57 Maida Vale, London, W9 1SN

The *Radio & Electronics Constructor* is printed by Carlisle Web Offset.

OCTOBER ISSUE WILL BE  
PUBLISHED ON OCTOBER 1st

# EASY 0-30V POWER SUPPLY

by

F. G. Rayer, Assoc. IERE, G30GR

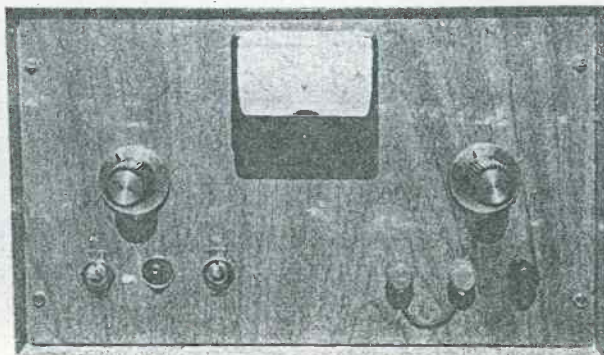

The front of the prototype power supply. The knobs provide 'Coarse' and 'Fine' voltage control. The left-hand toggle switch is for the a.c. mains input and the right-hand switch controls the d.c. output. The terminals allow for positive or negative earth

This power supply offers a continuously variable output voltage from zero to 30 volts at currents up to 1 amp. An ingenious switching circuit enables dissipation in the output series transistor to be kept at a low level, and the output may have either the positive or the negative side earthed.

THIS REGULATED POWER SUPPLY HAS A VERY STRAIGHTFORWARD circuit. It is a thoroughly practical and very useful piece of equipment, and of professional appearance. Its output is completely variable from 0 to 30 volts.

Though circuit complications are omitted, the unit is easily of adequate performance for all ordinary purposes, and the output voltage is substantially constant with widely varying loads.

It is thus suitable for operating a wide range of equipment, from the smallest units drawing very small current at low voltage up to equipment requiring a maximum of 1 amp at 30 volts.

Output is continuously adjustable from zero to 30 volts and the output voltage is shown at all times by a large single-range voltmeter with an f.s.d. of 30 volts. Some supply units have a meter with two or more ranges, selected by a switch. But a clearly calibrated single range meter has the advantage that there can never be a mistake in reading the output voltage. Such mistakes can have serious consequences to apparatus connected to the supply, and it is for this reason that the single range voltmeter is used here.

Terminals are fitted to give either a positive or a negative earthed line in order to suit the equipment fed by the supply. It will provide current for a considerable range of equipment, such as radio receivers, amplifiers, tape recorders, and other apparatus including experimental gear.

## CIRCUIT

Fig. 1 shows the circuit. Transformer T1 provides the required low voltage outputs and S1 is the main on-off switch. The panel neon bulb assembly, NE1, indicates when the supply is on.

There are two secondary circuits. One provides the controlling reference voltage, and the other the output current which actually reaches the powered equipment.

Dealing first with the reference voltage section, the full secondary of T1 provides 50 volts for the rectifier D1. The rectified voltage is smoothed by C1, R2 and C2, so that there is a steady flow of current through R3 and the zener diode D2. It will be noted that D1 conducts on half-cycles when the upper end of T1 secondary is negative. So also does D6 in the main bridge rectifier to provide the positive internal line. On the alternate half-cycles, D5 in the main bridge rectifier conducts, but D1 is then non-conductive.

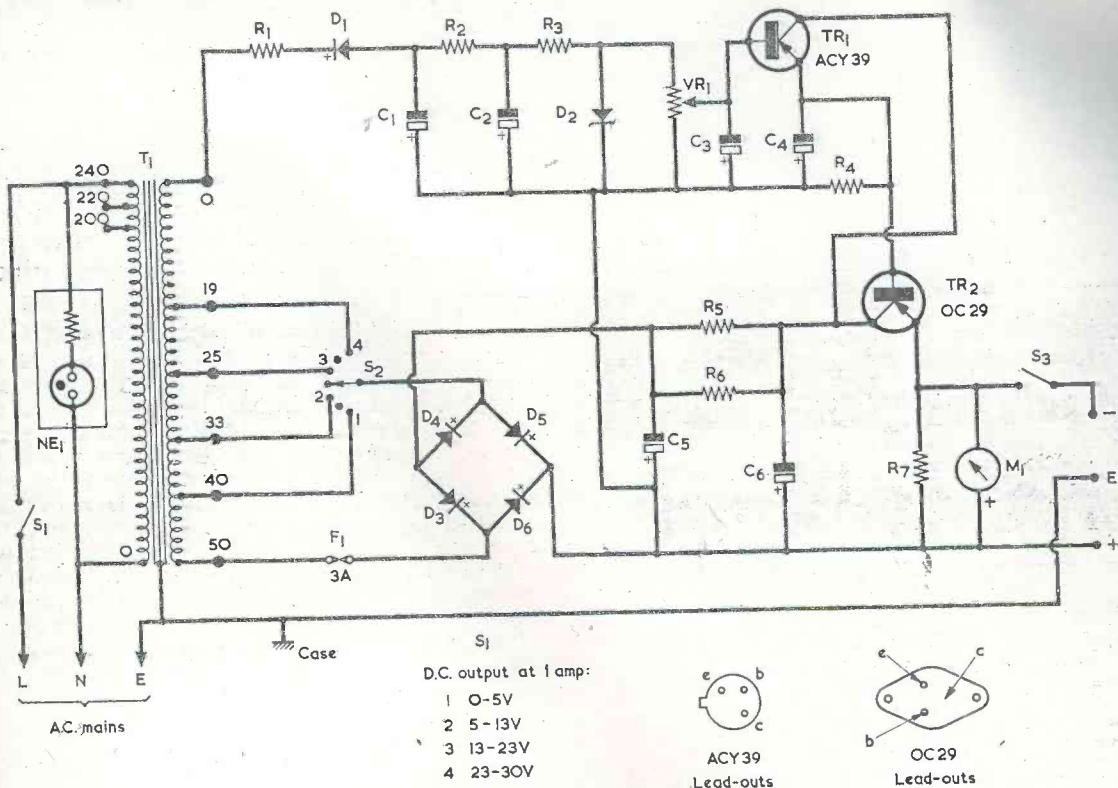

Fig. 1. The circuit of the power supply

## COMPONENTS

### Resistors

(All fixed values 10% unless otherwise stated)

- R1 100Ω 5% 1 watt  
 R2 470Ω 5% 1 watt  
 R3 470Ω 5% 1 watt  
 R4 3.3kΩ 1 watt  
 R5 8.2Ω or 10Ω 3 watts (see text)  
 R6 8.2Ω or 10Ω 3 watts (see text)  
 R7 270Ω 4 watts  
 VR1 2kΩ potentiometer, 3 watts, wire-wound

### Capacitors

- C1 100μF electrolytic, 250 V.Wkg.  
 C2 1,000μF electrolytic, 100 V.Wkg.  
 C3 250μF electrolytic, 50 V.Wkg.  
 C4 250μF electrolytic, 50 V.Wkg.  
 C5 1,000μF electrolytic, 100 V.Wkg., high ripple (see text)  
 C6 1,000μF electrolytic, 100 V.Wkg.

### Transformer

- T1 Mains Transformer, secondary 0-19-25-33-40-50 volts at 2 amps, Douglas type MT104AT

### Semiconductors

- TR1 ACY39  
 TR2 OC29  
 D1 BY100  
 D2 Zener diode 33V 5%, 1 watt  
 D3-D6 BYX38-300

### Meter

- M1 0-30V panel-mounting voltmeter. Harris Electronics type V-T2 (Home Radio Cat. No. TG81)

### Neon

- NE1 Neon assembly, red

### Switches

- S1 S.P.S.T., toggle  
 S2 Standard wafer 1-pole 9-way 5 amp (see text)  
 S3 S.P.S.T., toggle

### Fuse

- F1 3 amp cartridge fuse

### Miscellaneous

- Black terminal  
 Red terminal  
 Green terminal  
 Heat sink type LK-1131 (Lektrokit)  
 Instrument case (Home Radio Cat. No. BX5)  
 'Universal Chassis' flanged member, 6 × 4 in. (Home Radio Cat. No. CU41B)  
 'Universal Chassis' flanged member, 4 × 2 in. (Home Radio Cat. No. CU133)  
 2 pointer knobs  
 1 7-way tagstrip, end tags earthed  
 2 3-way tagstrips, centre tag earthed  
 1 2-way tagstrip  
 1 chassis-mounting fuse-holder  
 Heat sink compound (see text)  
 Mains lead, wire, etc.

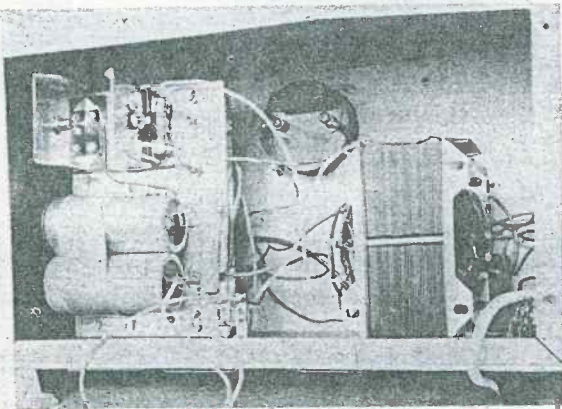

*A view inside the case with the back removed. The multi-ratio transformer is on the right and the internal chassis on the left. This chassis is insulated from the metal case*

D2 is rated at 33 volts and so maintains 33 volts across the potentiometer VR1, which is the 'Fine' panel voltage control. Rotating the slider of VR1 allows any wanted voltage up to 33 volts to be taken to the base of TR1. TR1 is an emitter follower, and its emitter potential remains close to the base voltage. C3 and C4 ensure steady d.c. operating conditions for TR1, which in turn controls TR2 and the power supply output. This is a form of 'electronic smoothing' since it prevents hum and fluctuations in voltage at the collector of TR2 from appearing at its emitter and, hence, at the power supply output. The stabilized reference voltage from TR1 remains the same, despite changes in the current drawn from the supply unit. In the same way, fluctuations in mains input voltage have no effect on the output voltage of the supply unit.

Turning next to the section which provides the output current, this employs full-wave rectification by means of the four diodes D3 to D6. The 'Coarse' voltage control switch S2 is connected so that any one of four tappings on T1 secondary can be selected. Operating this switch causes different rectified voltages to be applied to the collector of TR2. The emitter voltage of TR2 remains unaltered, however, because it is held fixed by the reference voltage from TR1. The purpose of S2 is to reduce the power dissipated in the output transistor, particularly when low output voltages at high currents are required. The ranges overlap but it is intended that S2 be set to position 1 for output voltages from 0 to 5 volts, to position 2 for output voltages from 5 to 13 volts, to position 3 for output voltages from 13 to 23 volts, and to position 4 for output voltages from 23 to 30 volts.

The operation of S2 does not introduce any hazard to equipment connected to the supply unit. If S2 is at a lower range than that for the required voltage it will simply be found that rotating the 'Fine' control, VR1, does not make sufficient output voltage available. So, if a greater output voltage is required S2 is moved to the appropriate higher range. At the same time, should S2 be inadvertently set to a higher range than is needed, the output voltage is not altered because of the control exercised by TR1 and TR2.

When, however, the current drawn from the supply is of the order of 200mA or more it is important to see

that S2 is set properly to the correct position for the output voltage required, since this will then ensure that an excessive voltage is not dropped between the collector and emitter of TR2. At output currents of this level it is possible for high dissipation to be given in TR2 if S2 is set incorrectly, and this could, in some circumstances, be sufficient to damage the transistor. The necessity for adjusting S2 correctly should always be borne in mind when output currents are high.

C5 and C6, with R5 and R6, provide smoothing. C5 is a 'high-ripple' canned type with a maximum ripple current rating of 1.4 amps, and was obtained from Electrovalue Ltd. A suitable alternative is the R.S. Components 1,000 $\mu$ F, 100 V.Wkg. single-ended canned type, which has a ripple current rating of 1.6 amps. C6 can be the same type as C5, although it does not pass as high a ripple current. The smoothing resistance is given by R5 and R6 in parallel. If desired, a single 4.7 $\Omega$  or 5 $\Omega$  6 watt resistor may be fitted here instead of the two parallel resistors. It will probably be found easier, however, to obtain the two lower wattage resistors.

M1 is a large and clearly calibrated voltmeter, in circuit at all times. In use, the 'Coarse' control is set to the wanted range, and the 'Fine' control adjusted to give the required meter reading. No other adjustments are necessary. When M1 indicates the desired voltage, S3 is closed to apply this voltage to the external equipment.

## TRANSFORMER

The secondary of the transformer is tapped at 19, 25, 33, 40 and 50 volts, but taps at these voltages are somewhat higher in voltage than is required in the present application. In consequence, the 50 volt end of the secondary is used as the zero volts point, and the taps then provide 10, 17, 25 and 31 volts for the rectifiers, the full secondary giving 50 volts as before. These taps provide maximum d.c. output voltages on full load of approximately 5, 13, 23 and 30 volts.

Fuse F1, rated at 3 amps, is wired between the transformer secondary and the rectifiers. This is a standard cartridge fuse fitted in a chassis-mounting holder. Despite the fact that a heavy surge current flows through it when switching on the a.c. mains at S1, this fuse has not blown in the prototype despite considerable usage of the supply unit.

## SWITCHING

S1 is the main on-off switch. Neon assembly NE1 glows when the a.c. power is on.

S2 is a rotary switch which selects the tappings on T1 secondary. A break-before-make action is essential here as, otherwise, there will be momentary short-circuits across portions of the secondary as the switch is rotated. Unfortunately, a break-before-make switch is not easily obtained in a suitable type, and so a make-before-break switch is employed instead, one spare way being left unused between each position. Thus, there are no short-circuits across the transformer taps when the switch is operated.

The miniature type of rotary switch does not have contacts of sufficient current rating for present requirements and so cannot be used for S2. A single-pole 9-way component with 5 amp contacts, described as a 'standard wafer switch', is obtainable from J. Bull (Electrical) Ltd., 7 Park Street, Croydon, CRO 1YD, and this switch is employed for S2. Actually, only 7 ways are necessary, and the unwanted contacts are left unused

As mentioned, S3 makes the voltage selected available for the external equipment, and it is not closed until meter M1 indicates the wanted output voltage. S3 is particularly useful in the control of experimental equipment, or for removing the supply voltage when connecting plugs or leads.

## OUTPUT CONNECTIONS

A red terminal is fitted for the positive output connection and a black terminal for the negative output connection. These circuits are isolated from the metal case and earth. A green terminal is provided for the earth connection. An external wire link is fitted between the green and red terminals for equipment having a positive earth line, or between the green and black terminals for equipment having a negative earth line.

The usual care must be taken to connect external equipment with the correct polarity. Sockets, snap fasteners or any other types of connector required can be wired to the terminals to suit the equipment being powered.

The terminals are available from Home Radio under Cat. No. PK12C. Since one Cat. No. covers more than one colour, the terminal colours must also be specified when ordering.

## COMPONENTS

Some of the components and their availability have already been discussed. As mentioned previously, C6 is a canned type. So also are C5, C1 and C2, and all four capacitors have their tags at one end. C3 and C4 have wire lead-outs. All capacitors are generously rated in terms of working voltage.

The four rectifier diodes, D3 to D6, are BYX38-300's. If diodes type BYX38-300R, as opposed to BYX38-300 happen to be on hand or easily available they must not be used here, since the letter 'R' in the type number denotes reverse polarity.

The neon assembly specified for NE1 is suitable for 200 to 250 volts.

The heat sink is a Lektrokit part type LK-1131 and this is supplied with fixing arrangements for insulating.

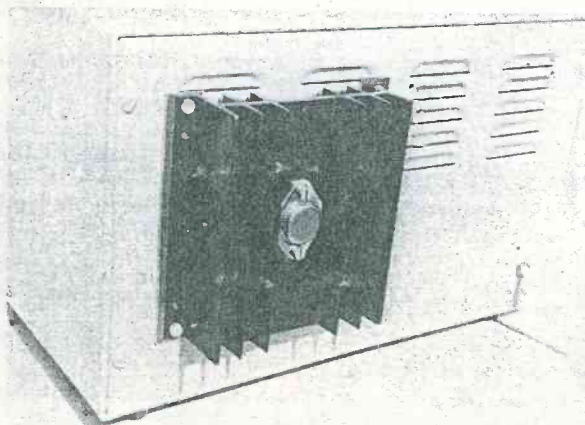

The output transistor is mounted on a large heat sink secured to the back of the case. The heat sink is insulated from the case and should not be allowed to make electrical contact with any external metal objects or chassis

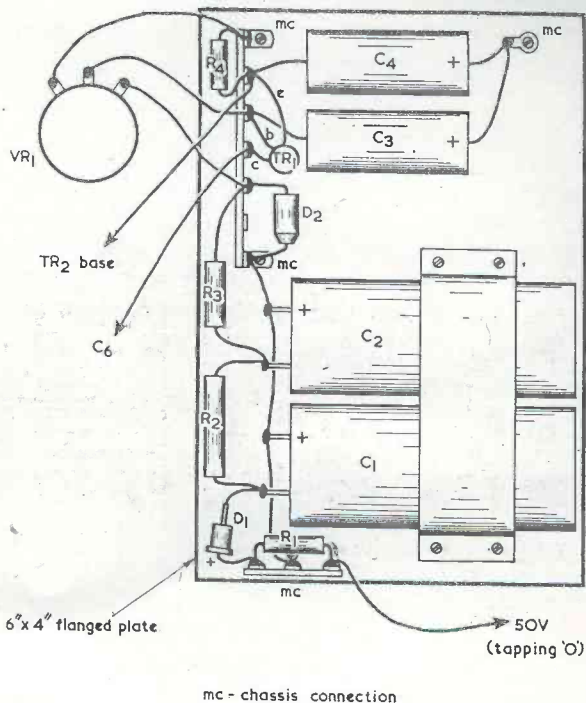

Fig. 2. Layout of the components in the reference voltage section

In the present design the output transistor is bolted direct to the heat sink and the latter is insulated from the metal case of the supply unit. As a very tight thermal coupling to the heat sink is necessary, it is desirable to use a heat sink compound as well. This may be a silicone grease specifically intended for this purpose.

A 7-way tagstrip with end tags earthed is required, as shown in Fig. 2.

## CONSTRUCTION

Most of the components are fitted on the two sides of a 6 by 4 in. flanged 'Universal Chassis' member as shown in Figs. 2 and 3. Fig 2 shows the components associated with the reference voltage supply, the remainder, which mount on the other side of the plate, appearing in Fig. 3. Holes required for the components in Fig. 2 may affect the positioning of holes needed for the parts in Fig. 3, and *vice versa*, whereupon it is desirable to study both diagrams before holes are drilled. All holes, in both diagrams, have to be cut out before components are mounted and wiring commences. The fuse-holder for F1 appears in a different position in Fig. 3 than it does in the photograph of the power supply interior, in which it is shown mounted on one of the rectified brackets. The positioning shown in Fig. 3 is to be preferred. Potentiometer VR1 is fitted to the front panel of the unit and TR2 to the heat sink at the rear. The four holes for the aluminium clamp which secures C1 and C2 in Fig. 2 are also used for the clamp which secures C5 and C6 in Fig. 3. The clamps should be proportioned accordingly, but this should not be a difficult process as the two pairs of capacitors will normally take up about the same amount of space.

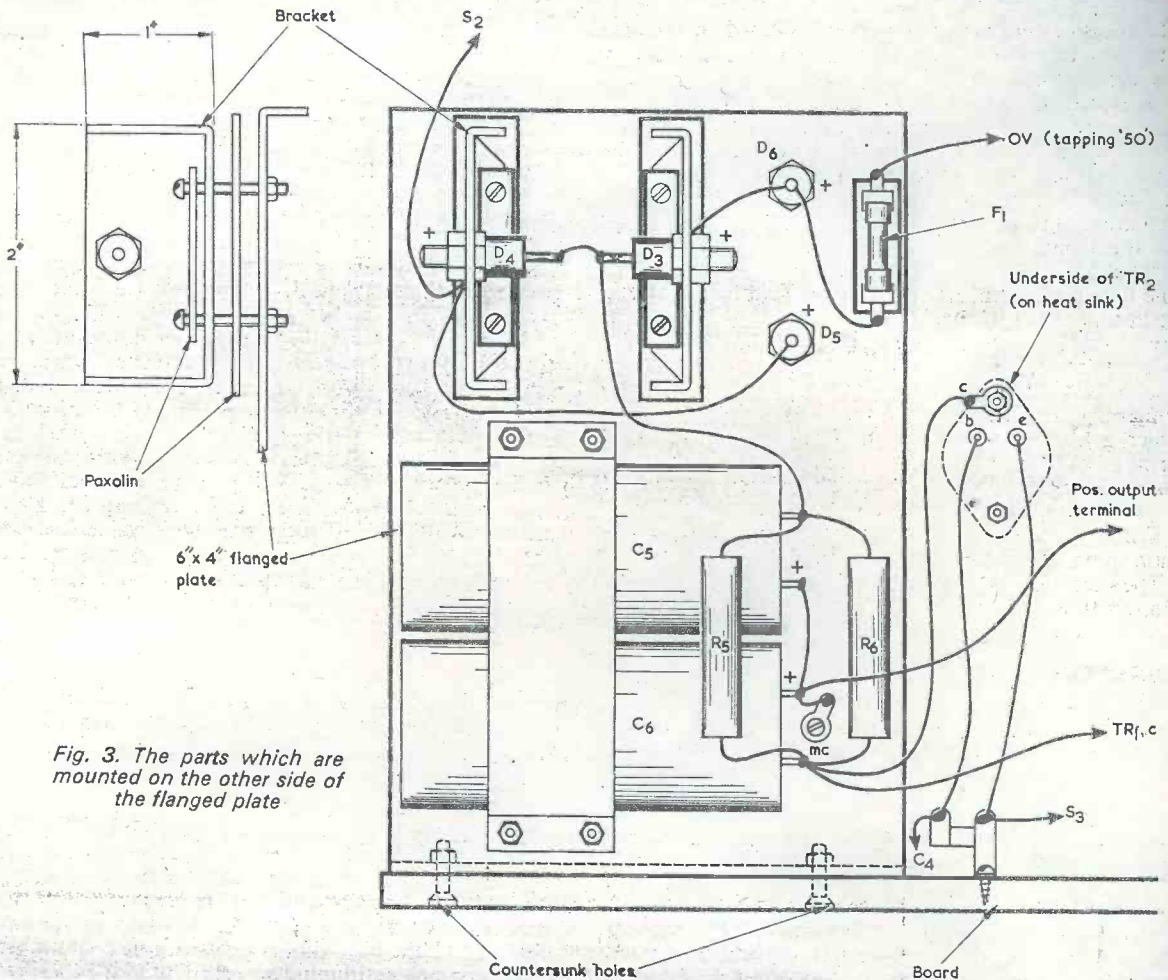

Fig. 3. The parts which are mounted on the other side of the flanged plate

In Fig. 2, C1 and C2 are mounted as just described, whilst C3 and C4 are supported by their end wires. The metal cans of these four capacitors must not touch the metal of the chassis member, or each other. Usually, these capacitors are sleeved in insulating material. If not, position C3 and C4 accordingly, and place card or other insulating material around C1 and C2.

The 7-way tagstrip and a 3-way tagstrip in Fig. 2 support resistors and other items. Points marked 'MC' indicate connections to the metal plate. These are referred to in the diagram as 'chassis connections', the 'chassis' in this case being the flanged member. This piece of metal is, however, insulated from the metal case of the power supply. The leads from TR1, D1 and D2 can all be about  $\frac{3}{4}$  in. or so long. Connect D2 with the polarity indicated in the circuit diagram of Fig. 1.

Flexible leads about 9 in. long run from VR1 to the top 'MC' tagstrip tag, to TR1 base and to the negative side of D2. VR1 is later fitted to the front panel.

A flexible lead is also provided from R1 to run to the 'O' secondary tag of T1, which now provides 50 volts.

A lead from the negative wire of C4 will run to a tag, shown in Fig. 3, which is used as a junction point for the base circuit of TR2.

The wire from TR1 collector passes round the plate to C6 negative.

In Fig. 2 the flanges point towards the reader. They are omitted from the diagram for reasons of clarity.

## OUTPUT SUPPLY

Most of the output supply circuitry is assembled on the other side of the flanged member, as in Fig. 3. C5 and C6 are secured under their clamp. Like C1 and C2, their metal cans must not be in contact with each other or the metal plate. The two resistors, R5 and R6, are connected in parallel as shown.

D5 and D6 are fixed by their positive studs to the 6 by 4 in. plate. D3 and D4 are mounted on metal brackets cut from a 4 by 2 in. flanged 'Universal Chassis' member, and are thereby insulated from the 6 by 4 in. plate. This is done by strips of  $\frac{1}{8}$  in. thick Paxolin under the bolt heads, and between the brackets and plate, as shown. The bracket holes are drilled to about  $\frac{1}{4}$  in. diameter and rough edges are cleared. Insulated washers or very short pieces of sleeving are put on the bolts here. The bolts are 6BA. Care must be taken to ensure that the insulation between the rectifier brackets and the 6 by 4 in. plate is reliable.

## MAINS TRANSFORMER

The mains transformer and the flanged member are secured to a wooden baseboard measuring 10 by 4 $\frac{3}{4}$  by  $\frac{3}{8}$  in. thick. As seen from the back, the transformer is secured to this board on the right and the chassis member of Figs. 2 and 3 on the left, with the Fig. 3 side, D3 to D6 at the top, towards the back. A 3-way tagstrip with centre tag earthed is fixed by a bolt near

the transformer. When the board is fitted in the case this bolt passes through the board and case bottom, thereby earthing the case.

A 3-core mains lead, which passes through a grommet in the case back, is connected in the following manner. Yellow-green (earth) connects to the earthed tag of the 3-way tag just referred to. A lead runs from this same tag to a tag bolted under one of the transformer mounting lugs, and then on to the green earth terminal on the front panel. Thus, the transformer frame is earthed and an earth is available at the green terminal. The blue wire (neutral) of the mains lead is soldered to an insulated tag of the 3-way tagstrip, and a lead runs from this tag to the 'O' primary tag of the transformer. One side of the neon assembly also connects to this tag. The brown mains cord wire (live) is soldered to the remaining insulated tag of the 3-way tagstrip, from which a lead runs to S1 at the front panel. The other terminal of S1 connects to the remaining tag of the neon assembly and to the 200, 220 or 240 volt primary tag of T1, according to the local mains voltage.

Correctly terminate the mains cord with a 3 pin mains plug, fitting this with a 2 amp or 3 amp fuse.

The secondary tapping tags of the transformer connect to S2 in the manner shown in Fig. 4.

### ASSEMBLY

The 6 by 4 in. flanged member of Figs. 2 and 3 is secured vertically to the board in the position already mentioned. The bolts or screws pass through holes in

the flange at the bottom. If wood screws are used they should be of such a length that they do not penetrate right through the board. If bolts are used, they should be countersunk, as in Fig. 3, since there must be no metal contact between the case and this internal assembly.

The screw which secures the 2-way tagstrip to the board in Fig. 3 must similarly not penetrate through the wood. Alternatively, a 3-way tagstrip with centre tag earthed may be used instead, whereupon this precaution need not be observed. With the 3-way tagstrip the emitter and base connections to TR2 are made at the two outside insulated tags.

The board is fixed inside the case by four bolts which pass up through holes drilled in the case bottom and through the board. One of these bolts is that securing the 3-way tagstrip for the mains lead, as described.

The panel is prepared to take the items shown in Fig. 4. The meter hole is made with an adjustable tank or washer cutter or by drilling a ring of small holes, removing the central piece, and finishing off with a half-round file. When using the metal panel provided with the case the red and black terminals must be fitted with the insulated bushes which are supplied with them. (The unit in the photograph actually has a panel cut from other material.)

With the panel resting flat in front of the case, complete the wiring shown in Fig. 4. It is helpful to use leads of various colours for the connections. If wished, the unit can be tested with the panel in this position.

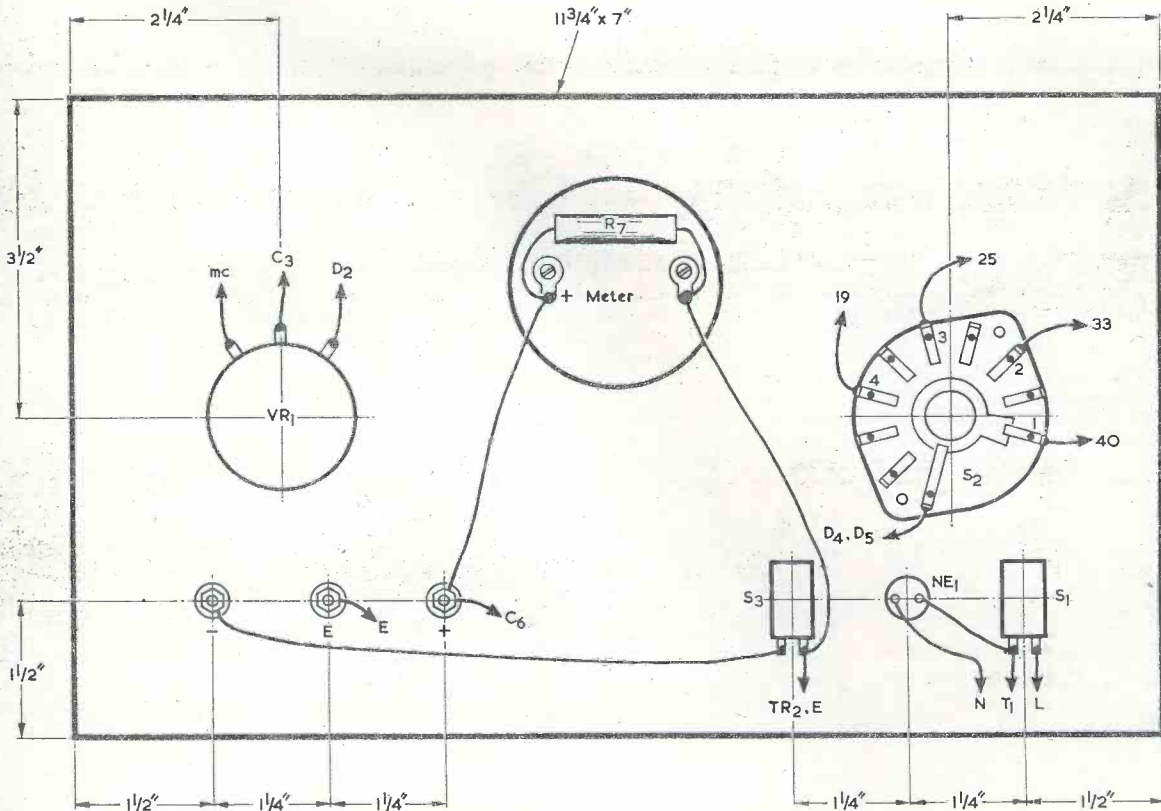

Fig. 4. Control positioning and wiring on the front panel



## HEAT SINK

The heat sink for TR2 is in free air at the rear of the case. The case back is fitted with its projecting ventilation slots facing inwards so as to clear the sink.

Bolt TR2 to the prepared area of the sink, with its pins as in Fig. 3. A little silicone grease is smeared on the bright area of the sink in advance. Secure a tag under the upper mounting bolt to provide the collector connection. Solder three differently coloured wires to the base, emitter and collector and make a note of the colours.

Place the sink on the case back, mark through the fixing holes, and drill the back to suit. Thread the leads through the ventilation slots, and bolt the sink in position, using the insulated bushes and washer provided, so that the sink is insulated from the back. If a sink is obtained with no bushes and washers, insulation can be devised from Paxolin strips and very short lengths of insulated sleeving. Make completely sure that no metal-to-metal contact can arise between sink and back. When the power supply is in use, the heat sink should not be allowed to touch adjacent metal objects as this could cause short-circuits to earth.

The leads from TR2 are cut to length and those from the base and emitter are soldered to the tags of the 2-way tagstrip of Fig. 3. (As was just mentioned, a 3-way tagstrip could be used here instead.) The collector lead from TR2 connects to the negative tag of C6, also as in

Fig. 3. If desired, the supply can be tested with the back off and lying flat.

## TESTING

Closing switch S1 should cause the neon assembly to glow. Adjusting the 'Coarse' control should enable the ranges of voltage listed in Fig. 1 to be selected by VR1. The two controls should enable a range of output voltage from zero to 30 volts to be obtained.

When connecting equipment, join the green earth terminal to the red or black terminal to suit the need for positive or negative earthing. Always adjust S2 then rotate VR1 to secure the wanted voltage in the meter before closing S3.

In the prototype, test voltages with respect to the positive line were as follows: negative tag of C1, 55 volts; negative tag of C2, 44 volts; junction of R3 and D2, 33 volts. The last voltage depends upon the individual zener diode and anything from around 31.5 to 34.5 volts is satisfactory. The voltages at the negative tags of C1 and C2 are given for guidance and the actual readings obtained may vary slightly due to such things as variations, within tolerance, in the resistor values.

The unloaded voltages (S3 open) at the negative tag of C6 and for different settings of S2 were: 1, 13 volts; 2, 23 volts; 3, 34 volts; and 4, 44 volts. With the output circuit taking 1 amp in all cases, maximum d.c. voltages shown by the meter were: 1, 5 volts; 2, 13 volts; 3, 23 volts; and 4, over 30 volts. ■

## RECENT PUBLICATIONS



### 50 PHOTOELECTRIC CIRCUITS AND SYSTEMS. By P. S. Smith

91 pages, 136 x 215 mm. (5¼ x 8½ in.) Published by Iliffe Books. Price: hard cover £2.30, limp £1.30.

This book offers a wide range of circuits incorporating photosensitive devices, the latter including photodiodes, phototransistors and photoconductive cells. Each circuit is accompanied by a short text explaining its operation together with a list of the components required. Resistor and capacitor values are specified, though some of these may require to be modified to suit particular conditions of use.

The circuits include an AND gate, an OR gate, a light-operated Schmitt trigger, a low level exposure meter, a film sound track pick-up, a constant light source, a scaler, a colour code detector, a smoke detector, a car parking light, a binary-to-decimal decoder, an infra-red image converter and many more. There are, as the title states, 50 circuits in all, and those just listed give an idea of their diversity.

This is a useful book and will appeal to the serious engineer as well as to the amateur who likes to make up novel and unusual equipment. Probably its greatest asset is the fact that it presents new ideas which, in turn, generate further ideas.



### TELEVISION ENGINEERS' Pocket Book, Sixth Edition. Edited by P. J. McGoldrick, C.Eng., M.I.E.E., M.S.M.P.T.E.

380 pages, 120 x 185 mm. (4¾ x 7¼ in.) Published by Newnes-Butterworths. Price £2.50.

The last edition of this well established book appeared in 1968, after which year there was a considerable upsurge in colour television in the U.K. The present edition reflects this fact and contains a considerable amount of new material on colour circuits and colour receiver operation. There is also new material covering integrated circuits, and all sections of the book have been updated and revised.

The section on colour television is written by J. P. Hawker and includes details of the Trinitron tube in addition to the shadowmask tube. The remainder of the book gives comprehensive information on virtually all aspects of the modern television receiver, with emphasis placed mainly on the needs of the service engineer. Specialist contributors are J. P. Hawker, Gordon J. King, J. A. Reddihough, J. I. Sim, G. R. Wilding and 'Telegenic'.



# Q S X

By

**FRANK A. BALDWIN**

(All Times GMT)

To the broadcast bands Dixer, the two bands probably of greatest interest are the 60 metre (4750 to 5060kHz) and the 90 metre (3200 to 3400). In the short wave listener press, more space is taken up with reports on, and articles about, the 60 metre band than any other broadcast range. In this article however is presented some of the results obtained during a recent survey of the 90 metre band. Success of any note over the range 3200 to 3400, as the writer has found from practical experience, depends to a great degree on the location of the listening post and the aerial system. In general terms, town dwellers with limited space for aerial systems designed for LF band reception and, even more important, beset by mains borne and radiated QRM, stand little chance of any long term results on this band. Based in London for most of the year, it has been noted that operation over the 90 metre band, almost impossible at times, produces poor listings. Operations in a quiet Suffolk rural area with a 132ft. long wire aerial, free from man-made QRM, results in the discovery that stations abound from end to end of the band when conditions are favourable.

## ● 90 MÈTRE BAND SURVEY

The results listed represent a period of five days during which listening sessions were carried out mostly in the evenings but with two late night and one early morning forays.

- 3200 1902 Fukien Front, China, with OM in Chinese, choral marching songs.
- 3210 2100 Radio Clube Mozambique, four chimes, identification by YL then typical Portuguese musical programme.
- 3227 2205 R.St. Elwa, Liberia, OM in African vernacular till 2210 then QRM blotting out signal.
- 3232 2220 R.TV Congolaise, typical African music with chants, terrific signal (44333).

- 3250 0240 SABC Johannesburg, musical selections from British musical comedy productions.
- 3260 1855 Niamey, Niger, OM in vernacular, just audible, signal wiped out by commercial QRM at 1900.
- 3264 1850 R.TV Congolaise, talk in French by OM under hetro.
- 3285 1918 SABC Johannesburg, light music then OM with a talk in English.
- 3295 1910 Lusaka, Zambia, OM with local news (Zambia mentioned several times), signal S9 + 40dB.
- 3307 1905 Rhodesia (transmitter location unknown) European 'pops' with announcements in vernacular.
- 3320 1937 SABC Johannesburg, piano solos then songs by OM in Afrikaans, 'open' carrier QRM.
- 3325 0020 YVRA Radio Monogas, Venezuela, LA songs and music, identification at the half hour.
- 3331 1840 ORTF Comoro Islands, OM and YL in Comorian, local music with drums, songs by YL, Teletype QRM slightly LF of channel. Heard several times during the course of the survey, this station tends to 'peak' around 1900.
- 3339 1916 R. Tanzania, Zanzibar, talk by OM in Swahili through to 1930 then local music and songs.
- 3340 1925 Kampala; Uganda, OM in vernacular through to 1927 then local music and songs.
- 3346 2024 Lusaka, Zambia, local music and songs, announcements in vernacular.
- 3350 1955 Ejura, Ghana, local music and songs mixed with transmission in

- 3355 0335 French from Franceville. OBX4Z Radio Luz, Peru, typical Andean flute music with announcements by YL. Station identification by OM at 0402.
- 3375 1944 CR6RZ Em. Official, Angola, OM in Portuguese, guitar music and songs, continuous hetro LF of channel.
- 3375 0140 ZYK28 R.Olinda Pernambuco, LA songs and music, YL announcer, station identification twice by YL at 0157, short choral song, National Anthem and off at 0200.
- 3375 0203 YVMI La Voz de la Fe, Venezuela, OM in Spanish, adverts, local music, songs by OM. Audible after ZYK28 off.
- 3380 1843 Blantyre, Malawi, programme of 'pop' records with announcements in English.
- 3386:5 0405 YVQI Radio Barcelona, Venezuela, LA music, identification and off abruptly, no NA, at 0408.

## ● TWO PRESUMPTIONS

Arising out of the survey, we report two loggings for which no positive identifications were possible and which are open to question as listed here. Perhaps some Dixer, reading these lines, will be in a position to unravel the mysteries.

- 3340 0050 CP103 Radio 27 de Deciembre, Bolivia, (presumed) OM in Spanish just audible through summer static. Military music 0056 to 0058 then OM with songs. Announcements (identification?) at 0100 impossible. Reported to have vacated this channel some two years ago.
  - 3570 0105 HCOS4 Voz del Rio Carrizel, Ecuador, (presumed) OM with talk in Spanish through till 0120, short musical interlude then more talk. No break at 0115, still talking at 0125. Also heard on a later occasion at 0135 with more talk in Spanish.
- The above are listed exactly as we heard them and no comment is offered except to add that, in the latter logging, we gained the impression that readings were being made from a local newspaper - but that is only an impression!

## IMPROVING AMPLIFIER SOUND CONTROL

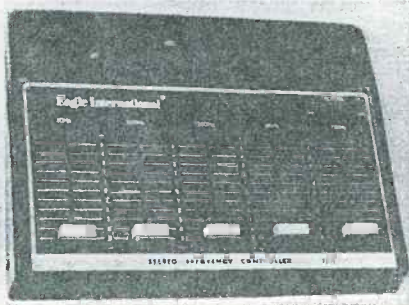

New from Eagle International is the FF11 stereo frequency controller and pre-amplifier. This is a unit designed to put enhanced amplifier performance, through professional-type sound control, into the hands of the intelligent hi-fi enthusiast. The unit can be used with practically every matching audio or discotheque system.

The FF11 uses the same principle as Eagle's successful AA.6 stereo amplifier. There are five graphic equalisers to provide a controlled 10dB boost or cut in five carefully selected frequency bands: 40, 200, 1200, 6000 and 15,000 Hz. The overall effect is to augment or diminish parts of the audio spectrum, to compensate for unsuitable room acoustics, or other quirks in the listening area or audio system, over which the user has no other means of control.

The recommended retail price is £31.30 plus VAT.

## NOSTALGIC NOTE: REMEMBER YOUR FIRST CRYSTAL SET?

Veteran readers will remember with nostalgia the fun they had building crystal sets in the 1920s.

BBC engineer, Henry Hatch who regularly broadcasts in the BBC DX programme 'World Radio Club', is shown here explaining to a member of the younger generation how to share the same thrill by building a small transistor radio using simple components ranging from a length of wire to a cotton reel!

Each week World Radio Club broadcasts information for short-wave enthusiasts in non-technical language. Membership is open to all write to World Radio Club, BBC, Box 76, Bush House, Strand, London, WC2B 4PH.



RADIO & ELECTRONICS CONSTRUCTOR

## FREE VEROBOARD

As a consequence of the great success of our Special Issue offer last October, when we gave away a piece of Veroboard on which various projects could be constructed, we are pleased to announce that in our next issue, there will be included **FREE** with each copy, a piece of Veroboard of 0.15in. matrix having 7 strips by 16 holes.

Two very attractive projects have been especially designed by our Technical Editor - J. R. Davies. The projects are a **GRAM AMPLIFIER** and an **A.F. OSCILLATOR**.

There will be many other attractive articles including **THE 'BAFFLETTE'**, a novel superhet receiver by F. G. Rayer, and articles on Varicap Tuning Diodes, High Impedance A.C. Millivoltmeter etc., and all the usual features.

As the issue, on sale 1st October, will sell very quickly, readers who have not placed a regular order with their newsagent are advised to order **NOW**.

## A WORD TO THE MERMAIDS

It is a good thing to sometimes look outside our immediate hobby interest in radio, to earlier and still much used methods of world-wide communications.

An opportunity to do this is being given at the Science Museum, London, where a special presentation celebrates one of the great human endeavours of the Victorian Age, the development of a network of underwater cables. Grand in concept, as a means of placing London in instantaneous contact with remote corners of the earth (especially with those that were part of the British Empire), it was also grand in terms of technical execution.

The original technology was largely British. But the major emphasis in the 1850s and 1860s was towards laying a transatlantic cable. This was achieved through extensive British-American co-operation, a tradition that is continued in the modern era. The exhibition highlights this fact by bringing together objects from both countries.

In the exhibition an attempt is made to recapture some of the feeling the Victorians had for this enterprise. The social consequences are presented along with the evidence of the technological achievement.

The exhibition will be open from Monday to Saturday 10 a.m. to 6 p.m. and on Sundays 2.30 p.m. to 6 p.m., and is expected to continue for the next four months or so.

There is a booklet obtainable from the Science Museum price 40p by post.

# COMMENT

## TALKING THROUGH YOUR EARS

You might not think it possible – but your voice, as well as coming out from your mouth, comes out of your ears! Strange as it may seem, this is turned to good effect by Standard Telephones & Cables, who have taken out a British Patent on a microphone placed over one ear, and mounted in a headphone assembly. It was featured on BBC World Service.

It has the valuable advantage of leaving the user's hands and mouth free, and avoiding the aesthetically unpleasant effect of a throat microphone.

How the sound gets to the microphone is not so surprising to students of anatomy – a tube, called the *eustachian* tube connects the back of the throat with the back of the ear drum, to equalize air pressure on both sides of the drum.

Speech sounds get up the eustachian canal and make the eardrum vibrate, so making, in turn, speech sounds come out of the ear. You couldn't do this with a microphone in front of the mouth, because of the need to breath while speaking.

## RADIO AMATEURS' EXAMINATION COURSES

Acton Technical College, High Street, London, W3 6RD. Wednesdays, 6.30–9.00 p.m. commencing 19th September. Enrolments: 6th and 12th September, 6.15–8.15 p.m. Room 26. Fee: for 3 terms, £4.00.

Gosforth Grammar School, Gosforth, Northumberland. Tuesdays/Wednesdays, 7.00–9.00 p.m. commencing September. Enquiries to the Principal.

Glasgow College of Nautical Studies, 21 Thistle Street, Glasgow, C5. Tuesdays and Thursdays, 7.00–9.30 p.m. Fee: £3.00. Students, under 18 on 1st August 1973, free.

Intending examinees for the RAE in December, are reminded that application forms together with the appropriate fee should be submitted to the candidate's local examination centre not later than Wednesday, 31st October, 1973.

## IN BRIEF

■ Professor Sir Martin Ryle, F.R.S., the Astronomer Royal, has accepted an invitation to become an honorary member of The Radio Society of Great Britain.

Sir Martin, who has been a member of the Society since 1936, has the call sign G3CY.

■ New regulations controlling interference from the ignition systems of internal combustion engines were recently laid before Parliament.

The new regulations extend the frequency range to 250 MHz for all vehicles manufactured on and after 1st October 1973.

■ EMI have developed a low-cost sound amplification system for all sound reproduction requirements in mini cinemas seating up to 800 people.

Known as the EMI 'OP1', this high specification equipment reproduces sound from any 35mm or 16mm film projector, and from other sources such as disc or tape players and microphones. Cost is under £450 including VAT.

■ Five young men will commence university courses this autumn under a scheme designed by The General Electric Co. Ltd., to help employees develop their careers with the company.

The GEC Fellowship is now in its fourth year and is open to employees who have been with the company for at least two years. Studies can be in any branch of science, technology, manufacture, management or commerce.

Those chosen for a Fellowship remain on full salary.

## IMPROVED SOLID STATE AMPLIFIER



In the improved Viscount III solid state amplifier from R. & TV Components Ltd., 21J High Street, London, W3 6NG, power output has been increased from 14 watts to 20 watts per channel.

Prior to the introduction of VAT the 14w Viscount was priced at £22, but when purchased as part of a complete stereo system – including a pair of speakers and a Garrard record deck, the VAT increase has been absorbed by R. & TV C and there will be no increase in the cost of either of the total systems offered by the company.



'Here you are folks, modern science's latest gift to the eskimo—the prefabricated, bijou, fully insulated, all-electric home!'

# TRIAC TIMER

by G. A. FRENCH

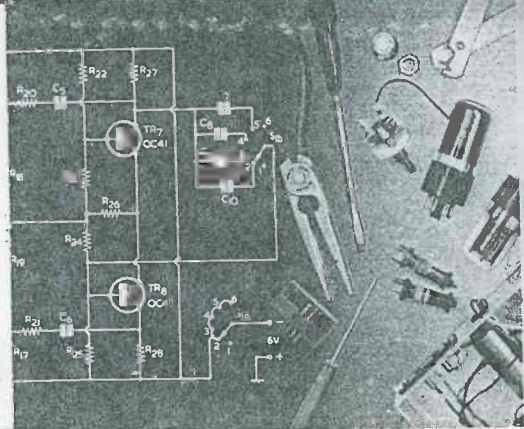

In "Suggested Circuit" No. 271, published in the last June issue, the author described an automatic lamp switch which enabled a mains 100 watt bulb to be turned on at dusk. Switching was achieved by means of a photoconductive cell which controlled a Schmitt trigger circuit. The Schmitt trigger, in turn, actuated a triac in series with the bulb. This combination of Schmitt trigger and triac lends itself to several other applications including, in particular, the photographic timer which is described in the present article.

## THE CIRCUIT

THIS TIMER FUNCTIONS FROM THE A.C. mains and is capable of controlling a domestic mains bulb having a wattage of 100 watts or less. Timing periods available with the prototype were continuously variable from 3 to 45 seconds. Shorter or longer periods can be obtained, if desired, by employing a timing capacitor of different value.

The circuit of the timer appears in the accompanying diagram. When on-off switch S3 is closed, the a.c. mains is applied to the primary of transformer T1. The secondary of this transformer couples to the bridge rectifier given by D1 to D4, with the result that a rectified voltage of around 10 volts appears across reservoir capacitor C2. Closing S3 also causes the mains supply to be applied to the lamp and triac circuit. For focusing purposes the lamp can be lit, independently of the timer, by closing S2. Switch S2 is kept open when the timer is in use.

The Schmitt trigger is given in the circuit comprising TR2 and TR3. If TR2 is non-conductive, as occurs when its base potential is at or close to that on the lower negative supply rail, it draws no collector current through R4. Under these conditions TR3 is hard on, its base being taken positive by the current which flows through R4 and R6. Its emitter current flows through R5, causing the emitter of TR2 to be positive of the negative supply rail.

If, now, the potential on the base of TR2 is made to go continually positive, a situation will be reached in

which the base of this transistor is positive of its emitter. After a further slight excursion, to overcome voltage drop in its base-emitter junction, TR2 will start to conduct, drawing current through R4 and thus decreasing the base current available for TR3. This transistor will, in turn, draw less current through R5, thereby decreasing the positive voltage on the emitter of TR2 and causing the latter to draw more collector current again. The total effect is cumulative and abrupt, and results in TR2 being turned hard on and TR3 becoming non-conductive. The two transistors remain in this condition if the base of TR2 is made to go further positive.

The two transistors can be made to revert to their original state by taking the base of TR2 negative. The changeover is again abrupt, and it occurs at a lower voltage on TR2 base than that which initiated the previous changeover.

TR1 is an emitter follower, and its emitter couples direct to the base of TR2. It is employed as a simple current amplifier and it enables a small current at its base to provide the larger current required at TR2 base when this transistor turns on. In consequence, the timing circuit given by VR1, R1 and C1 can have relatively high values in the resistive section. R2 is a current limiting resistor and it prevents the flow of unnecessary high current in TR1 when this transistor conducts.

Turning next to the triac, the Main Terminal 1 and Main Terminal 2 of this device are in series with S1(b) and the 100 watt bulb PL1. The triac fires and becomes conductive when, with S1(b) closed, a current of sufficiently high amplitude is caused to flow between its gate and Main Terminal 1. This current is provided when TR3 is conductive, and is limited by resistors R5 and R8.

We may now consider the overall functioning of the circuit. When a timing run is not in progress switch S1(a)(b) is in the "Reset" position, as shown in the diagram. Section S1(a) of this switch short-circuits C1 via the current limiting resistor R3, with the result that the positive plate of C1 and the base of TR1 are at the same

potential as the negative supply rail. As a result, TR1 and TR2 are turned off, whilst TR3 is hard on. A current capable of triggering the triac passes through its gate and Main Terminal 1. However, this device cannot become conductive because the circuit to its Main Terminal 2 is broken by S1(b).

To start a timing period, S1(a)(b) is set to "Operate". Section S1(a) removes the short-circuit from C1 and this capacitor commences to charge via VR1 and R1. At the same time, section S1(b) completes the circuit to the Main Terminal 2 of the triac and this device, due to the gate current provided by the conducting TR3, turns on and causes the 100 watt bulb to be illuminated. As C1 charges, its positive plate and, hence, the base of TR1, goes positive. After a period, the base of TR1 becomes sufficiently positive for this transistor and TR2 to start conducting. The abrupt changeover in the Schmitt trigger then takes place, with TR2 becoming hard on and TR3 turning off. There is now no gate current from TR3 collector for the triac, and the triac turns off also, causing the lamp to extinguish.

The circuit remains in this state until S1(a)(b) is returned to "Reset". Section S1(a) once more short-circuits C1 and reduces the voltage across its plates to zero. The Schmitt trigger returns to its initial condition with TR2 off and TR3 hard on. However, the triac cannot operate because, at the same time, section S1(b) of the switch breaks the circuit to its Main Terminal 2. Another timing period can be initiated by putting S1(a)(b) to "Operate".

The rate at which C1 charges is controlled by the resistance inserted into circuit by VR1. In consequence, this component controls the length of the timing period and can be fitted with a scale calibrated in terms of seconds.

## COMPONENTS

The three transistors type BC107 and the four diodes type IN4002 are all standard components, and are readily available. The triac type 40430 is available from several suppliers including Henry's Radio Ltd. The mains

RADIO & ELECTRONICS CONSTRUCTOR

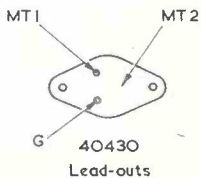
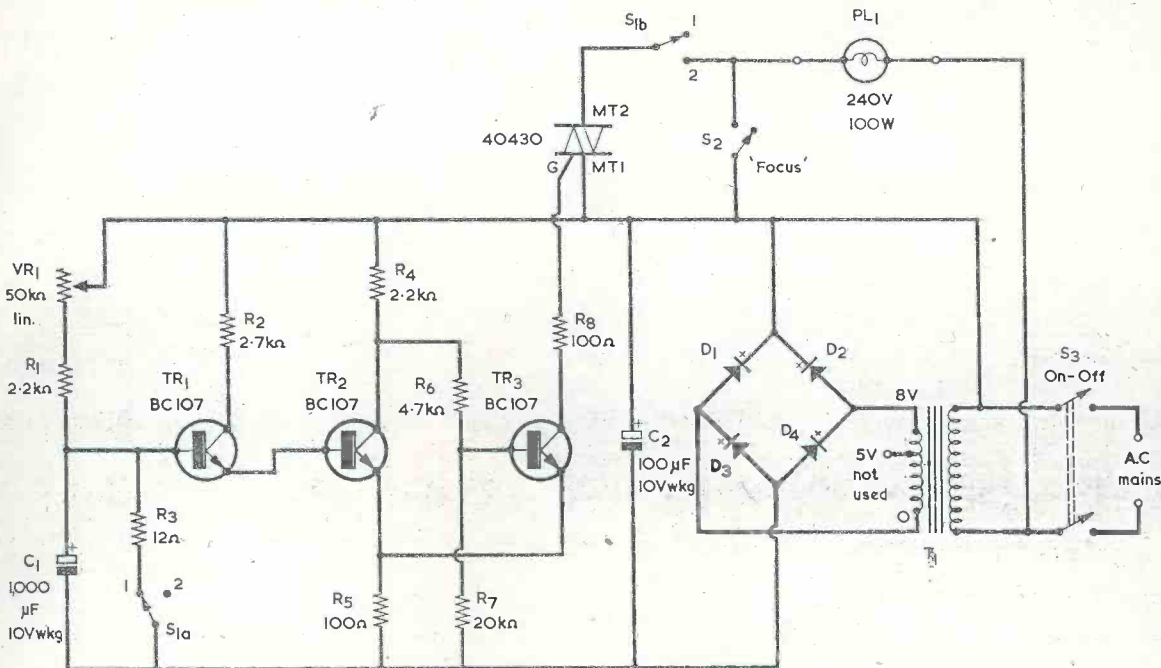

S<sub>1</sub> positions : 1 - 'Reset'  
2 - 'Operate'

D<sub>1</sub> - D<sub>4</sub> : IN4002  
R<sub>1</sub> - R<sub>3</sub> 1/2 watt 10%  
R<sub>4</sub> - R<sub>8</sub> 1/2 watt 5%  
VR<sub>1</sub> - see text

Circuit of the triac photographic timer. This employs a Schmitt trigger to control a triac which, in turn, controls the 100 watt lamp

transformer is a small bell transformer and can be purchased at the electrical counters of Woolworths' stores.

The three switches are all toggle types. Miniature switches should not be used here because of the high switch-on surge current of the lamp, which is much higher than its burning current. Capacitor C<sub>1</sub> should be a good quality modern component. The author used a Mullard Miniature Electrolytic here.

The fixed resistors are as specified in the diagram. The variable resistor, VR<sub>1</sub>, passes track currents of the order of 4mA when it is set to give short timing periods, and this current necessitates a wattage rating of at least 1 watt in this potentiometer. Wattage ratings for carbon potentiometers are not always stated in component suppliers' sales literature but it can be assumed that a standard sized "moulded track" potentiometer will have a satisfactory rating. Miniature potentiometers should *not* be employed. An excellent alternative choice for VR<sub>1</sub> would be given by a 3 watt wire-wound component. Although its wattage rating would be significantly higher than the figure required it would have the advantage of long life

and reliable mechanical operation.

Construction should be quite straightforward and there are no unusual requirements so far as layout is concerned. It must be remembered that all components and wiring are at or near mains potential and that all precautions against shock must be observed during construction, testing and subsequent use of the timer. A good procedure consists of fitting all the components, apart from PL<sub>1</sub>, in an insulated housing, with a 2-pin mains socket on the side to provide connection to the lamp. If VR<sub>1</sub> has a metal spindle it should be provided with a plastic knob.

In the prototype, the triac was mounted on a flat metal heat sink about 1½ in. square. However, this component runs very cool, as do all the other parts excepting, of course, the 100 watt lamp which is outside the housing. Only a small amount of ventilation is required, in consequence, in the component housing. The heat sink for the triac is in contact with its Main Terminal 2, and its size causes it to present a particular shock hazard when the unit is out of its housing and being tested. The controlled lamp may have a wattage rating lower than 100

watts, if desired, but lamps with ratings in excess of this figure should not be used. If the lamp is of the projector type the maximum wattage figure is 80 watts.

After the unit has been completed and checked out, about half a dozen timing periods with VR<sub>1</sub> set to insert maximum resistance should be carried out. This will ensure that C<sub>1</sub> is fully "formed" and has settled down to its final capacitance value. VR<sub>1</sub> may then be calibrated in terms of seconds with the aid of a stop watch, or a watch having a sweep second hand. The prototype circuit gave a period of about 3 seconds when VR<sub>1</sub> was set to insert minimum resistance and about 45 seconds when VR<sub>1</sub> was adjusted to insert maximum resistance. There will be some small variance from these figures in other units built up to the circuit due to differences, within tolerance, in the value of capacitors fitted in the C<sub>1</sub> position and to slight differences in triggering voltage of the Schmitt trigger. If shorter periods, from about 1.5 to 22 seconds are required, these would be given by changing the value of C<sub>1</sub> to 500µF. Increasing the value of C<sub>1</sub> to 2,000µF would result in a range from approximately 6 to 90 seconds.

# EXPERIMENTAL

## A. F. OSCILLATOR

by  
S. Jeffrey

A low-cost oscillator which represents a useful project for the experimenter.

THIS LITTLE A.F. OSCILLATOR REQUIRES TWO inexpensive transistors, one capacitor, two fixed resistors, a potentiometer and a small 25Ω loudspeaker, and it is capable of offering a surprisingly high output level for currents of 10mA or less from a 6 volt battery. Frequency is variable from around 200Hz to 2kHz. The only disadvantage is a very slight risk that the oscillator may not run with some transistors of the type specified, whereupon the circuit has to be placed in the experimental category.

### CIRCUIT OPERATION

The circuit of the oscillator appears in the accompanying diagram and its operation may be described by starting at a point in the cycle when C1 holds a charge such that its left-hand plate is negative. This causes TR1 to be cut off. In consequence, no collector current from this transistor flows in the base circuit of TR2, and TR2 is similarly cut off. The collector of TR2 is, therefore, at the same potential as the negative supply rail.

C1 discharges by way of R1 and VR1 until an instant is reached when the base of TR1 becomes sufficiently positive for this transistor to pass collector current. The collector current flows in the base of TR2 which starts to become conductive, drawing current through the 25Ω speaker. The right-hand plate of C1 now goes positive, whereupon further current flows into the base of TR1. The overall effect is cumulative, resulting in both TR1 and TR2 coming hard on, and the collector of TR2 being slightly negative of the positive supply rail. The left-hand plate of C1 is held at about 0.6 volt positive of the negative supply rail because the base-emitter junction of TR1 functions as a diode. In consequence, C1 is charged nearly to the full supply potential with its left-hand plate negative.

After TR2 and TR1 have become fully conductive, the discharge current from C1 into the base of TR1 decreases. It is feasible also that the impedance of the

speaker is high during the rapid increase of collector current in TR2 and then falls as the collector current becomes static, thereby producing a fractional increase in negative voltage at TR2 collector. The first factor (together with, possibly, the second) produces a small negative-going voltage at TR1 base. The combined

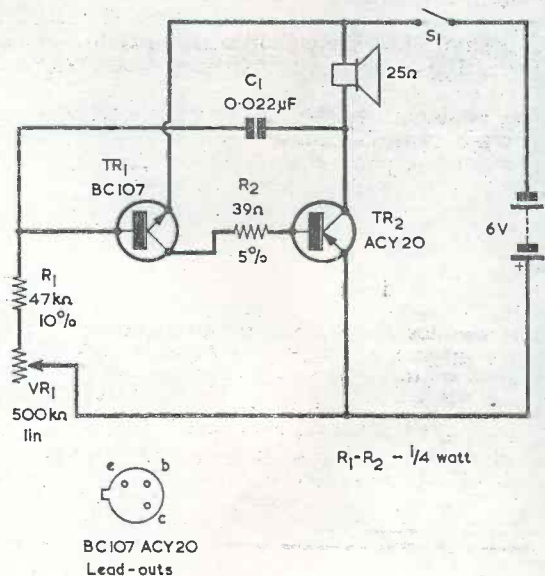

The circuit of the oscillator. This provides a relatively high output and draws only a low current from the battery

amplification of the two transistors results in a higher negative voltage appearing at TR2 collector, thereby biasing TR1 base further negative. Again, there is an overall cumulative effect and it finishes with both TR1 and TR2 cut off and the base of TR1 held negative by the charge in C1. C1 now begins to discharge again via R1 and VR1 and a further cycle proceeds.

It will be apparent that a series of pulses is fed to the 25Ω speaker, the repetition frequency being governed by the rate of discharge in C1. This rate depends upon the resistance offered by R1 and VR1 in series, whereupon VR1 can be employed as a frequency control.

There is a weak point in the design, this being evident at the transition, during the cycle, from the fully hard on state in the transistors to the fully cut off condition. There is only a little more than sufficient energy in the circuit to trigger this part of the cycle and there is a slight risk that, after switching on, the presence of R1 and VR1 may cause TR1 to become partly conductive and TR2 fully conductive with no oscillation taking place at all. It was found that the value of R2 played an important part here and that the circuit would not oscillate if this resistor had a value higher than some 68Ω. The author's circuit oscillated reliably when R2 had the value shown in the diagram, and this resistor then limits collector current in TR1 to about 150mA, which is within the maximum collector current rating of 200mA specified for the BC107. It is important that R2 should not have a value lower than 39Ω and that the battery voltage should not be greater than 6 volts. A second reason for not employing a battery voltage higher than 6 volts is that this represents the maximum reverse base-emitter voltage quoted for the BC107.

Because of the weak point in circuit functioning, there is a slight possibility that the oscillator will not run with some transistors type BC107 and ACY20, and the constructor has to accept this factor if he sets out to assemble the oscillator. The author checked the circuit with several different transistors in both the TR1 and TR2 positions and the circuit worked reliably with all of these. The risk of non-functioning would therefore seem to be low but the fact that it exists must still, of course, be stated. Another possibility is that the circuit may cease to operate when VR1 inserts minimum resistance into circuit since, once again, this could turn TR1 partly on and TR2 fully on. Should such an eventuality occur, the value of R1 should be increased slightly so that oscillation occurs over all the range offered by VR1.

As just mentioned, the author's circuit worked reliably. Average current consumption from the 6 volt battery was less than 2mA at the lowest frequency, and approximately 10mA at the highest frequency. The 25Ω speaker used was a small 3½ in. model.

There are many applications for the oscillator and it can prove, in particular, extremely useful for Morse code practice. In this case the Morse key is connected in place of the on-off switch, S1. ■

#### SILICON NETWORK POCKET PORTABLE

On page 698 of the June 1973 issue reference is made in the text of the above article to C6 and C8 having values between 0.4 and 0.5μF. These values should be 0.04 and 0.05μF.

## Use the NEW Strip-fix Plastic PANEL SIGNS



- ★ SET 3 - Wording - WHITE
- ★ SET 4 - Wording - BLACK

Over 1,000 words and symbols,  
covering more than 300 terms, in  
each set

Illustration of actual size = RADIO

SET 5 Dials. 6 sheets containing one  
Large and two Medium scales, Large  
Horizontal Tuning scale, Frequencies  
12 Control Panels

- Easy to fix - Just cut out words  
required remove backing and press down
- Staped in booklet form
- Designed to hang above workbench
- Pocket for loose cuttings
- Professional finish

## 38p per set

including V.A.T.  
(postage 3p)

The Perfect Transfer for  
the Home Constructor

Available from

Data Publications Ltd.  
57 Maida Vale, London W9 1SN



# AERIAL BEAM SYSTEM

by  
Arthur C. Gee, G2UK

## Details on the erection of a rotatable 2 metre aerial array.

UNDER THE TITLE "GETTING STARTED ON TWO METRES" the writer, in the issue of this magazine for September 1971, gave some advice to those wishing to get going on the 2-metre amateur band. His advice in that article was to the short wave receiving enthusiast, and was such as to enable the s.w.l. to get results with quite rudimentary equipment. The aerial systems suggested were of the simplest, ranging from dipoles to a ground plane antenna. However, he did say: "If you get really keen on v.h.f. working and particularly if you are interested in hearing the Dx type of signals referred to earlier, you will want ultimately to go in for one of the rotatable beam antennas . . ."

### ROTATABLE ANTENNA

Having recently installed an antenna of this type to improve the performance of his own 2 metre gear, the writer thought that readers who had read the first article might like to progress to a more efficient aerial system, and would find a few notes on installing such a beam helpful.

One can say, straight away, that a rotatable beam aerial will improve results with the more distant stations quite remarkably. Nearby strong signals do not, naturally enough, undergo much improvement, but the increase in signal strength from the weaker and more distant stations is quite outstanding when the beam is directed at their source. So, too, is the difference in strength of a weak signal when the beam aerial is directed right at its source and when it is at right angles to the signal path. There is also a marked difference between the signal strengths which occur when the beam is directed towards the source and when it is directed the opposite way. What the beam aerial does, therefore, is to effectively focus the radio waves from the direction in which it faces. If it were used for transmission instead of reception it would function rather like a search-light beam.

Unfortunately the simpler beam aeriels are not nearly so effective as a search-light, however, and quite a lot of radiation takes place from the sides and the back. The actual distribution of the radiation from a beam aerial is shown by its polar diagram, this being a drawing which shows the distribution and power of the aerial

in respect to its configuration. The distribution of maximum radiation (when transmitting) or maximum sensitivity (when receiving) is called the major lobe. Various small minor, or "spurious", lobes occur around the aerial, as indicated in the typical polar diagram shown in Fig. 1.

If you get a catalogue of beam aeriels suitable for v.h.f. work from one of the firms who specialise in making this sort of equipment you will see various terms referred to in the specifications which need a little explanation. For instance you may read that "the horizontal beam width between half power points is 55°". This means that the angle between the points on the radiation pattern at which the power radiated (assuming that the aerial is used for transmission) is half the power on the forward centre line of the beam is 55°. In Fig. 1 the half power beam width is angle ABC. The half power beam width gives an indication of the "sharpness" of the radiation pattern and is as applicable

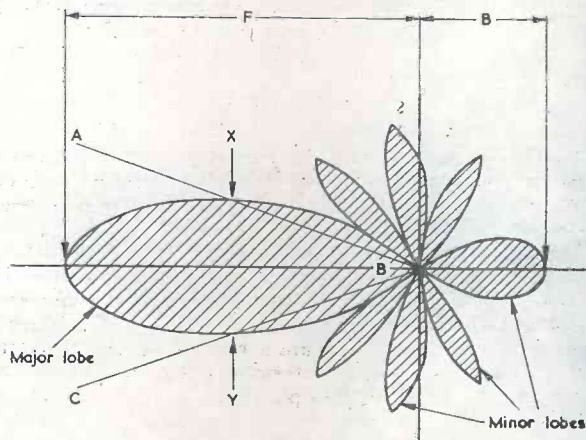

Fig. 1. Polar diagram for a simple v.h.f. beam aerial. The front to back ratio is given by the ratio of F to B. If X and Y represent half power points of the major lobe, the half power beam width is the angle ABC

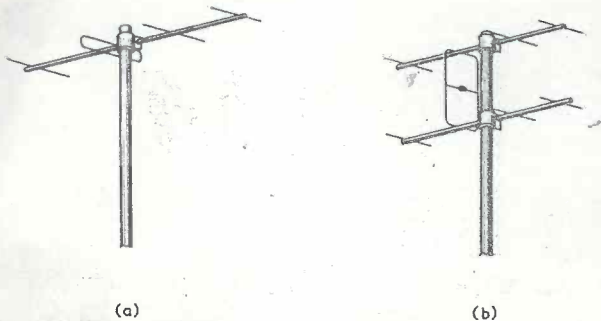

Fig. 2 (a). The 4 element Yagi  
 (b). The "Four over Four" slot fed Yagi.  
 Both these aerials are available from  
 J Beam Engineering Ltd.

to reception as it is to transmission. Another term you are likely to come across is "front to back ratio". This is the ratio between radiation to the front and radiation to the rear of the beam aerial. Front to back ratio becomes better, and beam width narrower, as the aerial array becomes more elaborate. This usually means more aerial elements, a longer array, greater weight, increased susceptibility to damage by gales and, in a rotatable system, the necessity for more power to turn it.

So, as with most things in life, a compromise has to be reached. Of the types of antenna usually employed for 2 metre beam arrays, two are most favoured by the writer. These are the normal Yagi aerial and what is described as the "slot fed double Yagi" aerial. Both are manufactured by J. Beam Engineering Ltd., Rothers-thorpe Crescent, Northampton, and 4-element examples of each type are illustrated in Figs. 2(a) and (b). The aerial shown in Fig. 2(b) may also be referred to as a "Four over Four" array. Which type you decide to install will depend very much on the position and facilities you have available for supporting it. The normal Yagi goes more conveniently on the end of a roof ridge, or a chimney stack, whilst the four over four type can be easily supported by a free standing pole or mast.

In the writer's case, it was required to mount the aerial on the end of the roof ridge, in the position previously occupied by the ground plane aerial shown in the previous article. Obviously the most convenient type of beam aerial to put up in this position would be a simple Yagi.

In order to keep its size down to reasonable proportions, the smallest model available was chosen, this being a simple 4 element type. You can get 6 element Yagi aeriels and 8 element Yagi aeriels "off-the-peg" so to speak, and if you are a real enthusiast, you can build yourself still bigger ones, but they escalate in length alarmingly as you put on more elements! The J Beam 4 element 2 metre Yagi has a length of 44 in. (112 cm.) and the J Beam 8 element Yagi has a length of 102 in. (260 cm.). The half power beam width of the 4 element Yagi is 55°, whereas that of the 8 element Yagi is only 40°, which is of course much sharper. But the writer had to meet a compromise, as already stated, and he settled for the 4 element simple Yagi.

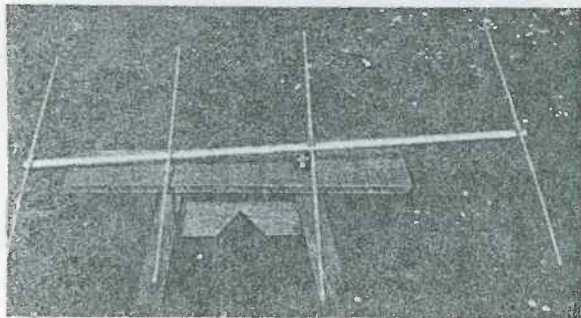

Assembly of the Yagi is quick and simple.  
 No "tuning" is required

## AERIAL ROTATION

Another point to be considered regarding the size and weight of the beam aerial is the question of how to rotate it. By far the most convenient way is to fit an electrically driven beam antenna rotator, a piece of equipment consisting of a weather proofed electric motor and gearing to which the beam array is attached. The whole assembly is mounted at the top of the mast or on the roof or chimney stack, and is connected to a control unit which can be located by the side of the radio gear in the shack. There are several small beam aerial rotators available on the market in this country, these being designed to rotate television and small f.m. receiving aeriels as well as amateur radio aeriels, and they are very suitable for rotating a small 2 metre Yagi beam array. The type purchased was one of the Stolle units manufactured by the German firm of Karl Stolle, and this is supplied complete with control unit and control cable. The units may be purchased from radio and TV dealers and are also available from J. Beam Engineering direct.

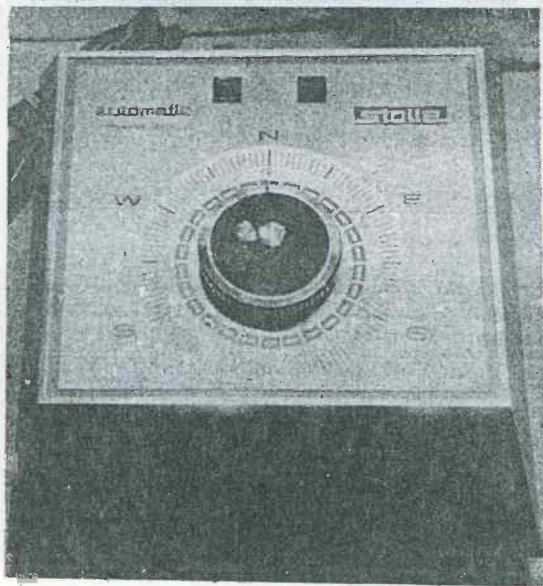

The Stolle "Automatic" rotator control unit.  
 This is located inside the house alongside the  
 receiver

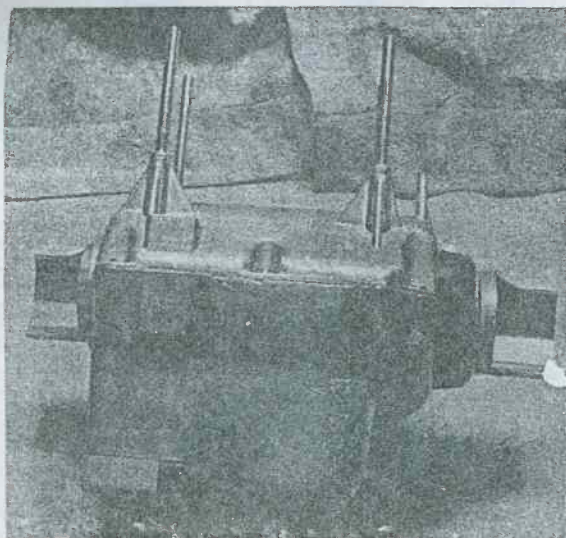

*The Stolle rotator, showing mounting bolts and the rotating shaft. A short length of light alloy tubing, to which the beam array is attached, is inserted in this shaft*

The 4 metre Yagi is supplied disassembled and beautifully packed, and is simplicity itself to assemble. No "tuning" is necessary, element lengths being correct for resonance in the middle of the 2 metre band. You just bolt it together with thumb screws and it is only a matter of minutes before it is completely assembled. It is a good idea to order a sufficient length of coaxial cable at the same time as you order the beam array.

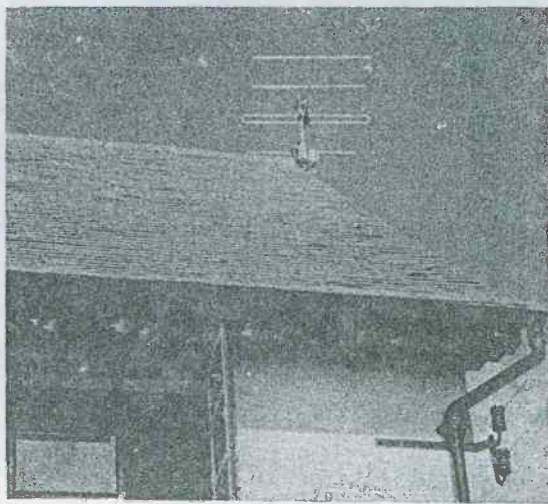

*The 4 element 2-metre Yagi installed, with remotely controlled rotator, on the end of the roof ridge*

There are two types in the Stolle range. One is the "Automatic", and in this a central knob on the control panel is turned to the aerial direction required, as indicated on a scale behind it. The aerial then rotates in this direction. Indicator lamps light up during rotation and extinguish when the beam reaches the desired position. The other type is known as the "Memomatic". With this, one of two push-buttons is pressed to give rotation in a clockwise or anti-clockwise direction. A dial pointer "follows the beam round" on the control panel, giving a clear indication of its position. Either type is quite suitable for amateur 2 metre band use. The writer purchased the "Automatic" variety, but if he bought again would probably buy the "Memomatic" version, as the two push-buttons make "searching" easier. The units work directly off the mains a.c. supply, but the control cable to the rotator motor carries low voltage only. After the aerial has been turned to a new position the unit shuts off automatically and draws no current until it is activated by again turning the control knob or depressing the push-buttons. Full installation instructions and wiring diagrams are supplied with the units, and so there is no need to cover these points in this article.

A weather-proof connector is provided on the beam for attachment of this cable. When installing the cable at the aerial end requires sufficient slack to allow for rotation. The aerial is attached to a short length of light alloy tube of diameter  $1\frac{1}{2}$  in. (38 mm.) and this in turn fits into the rotator. The latter is fitted with clamps for attachment to its mounting.

The photographs accompanying this article and their captions give a good idea of the stages in erection, and little difficulty should be encountered. Much of interest will be in store for the 2 metre enthusiast who is using a rotatable beam for the first time and, in the writer's view, the installation is well worth the expense incurred.

## BACK NUMBERS

For the benefit of new readers we would draw attention to our back number service.

We retain past issues for a period of two years and we can, occasionally, supply copies more than two years old. The cost is the cover price stated on the issue, plus 6p postage.

Before undertaking any constructional project described in a back issue, it must be borne in mind that components readily available at the time of publication may no longer be so.

We regret that we are unable to supply photo copies of articles where an issue is not available. Libraries and members of local radio clubs can often be very helpful where an issue is not available for sale.

# FREE VEROBOARD IN NEXT MONTHS ISSUE

## Veroboard Project One

This simple oscillator offers a wide range of applications and may be readily assembled on the free Veroboard panel.

## A.F. OSCILLATOR

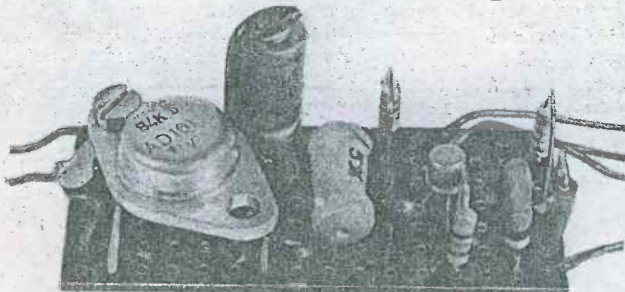

## Veroboard Project Two

Capable of providing an output of 200mW, this amplifier has been specifically designed for assembly on the free Veroboard panel.

## GRAM AMPLIFIER

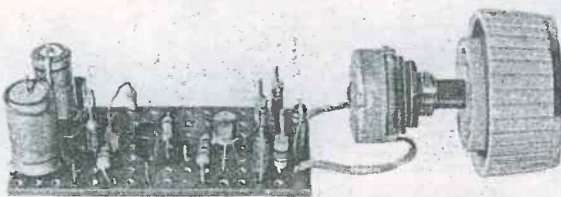

## Novel Superhet Receiver

Copies may also be obtained direct from the Publishers, 26p, including postage.

Published by  
Data Publications Ltd.,  
57 Maida Vale,  
London W.9.

This novel superhet receiver requires the minimum of carpentry, and yet offers a pleasant and stylish appearance. Construction is eased by the use of a ready-made a.f. amplifier module.



## The 'BAFFLETTE'

**MANY OTHER  
ARTICLES -  
EXTRA PAGES**

**ON SALE 1st OCTOBER**

**20p**

*Make very certain of your copy* **ORDER NOW!**



## Cover Feature

# 6 WATT PLAYER

THIS AMPLIFIER IS INTENDED FOR USE IN A MONO record player using either a crystal or ceramic cartridge. A maximum output in excess of 6 watts is available when the circuit is correctly loaded by a loudspeaker of  $15\Omega$  impedance. A tone control network is included, and this has separate bass and treble controls.

Silicon planar transistors are used throughout, and this results in a good frequency response and a low noise level. The frequency response is also aided by the use of a transformerless circuit, using a generous amount of negative feedback. This also gives a low distortion figure at all power levels.

The amplifier is quite compact, the main assembly measuring approximately  $4\frac{1}{2}$  by  $3\frac{1}{2}$  by  $1\frac{1}{2}$  in., excluding control spindles. The power supply is a separate unit.

### POWER AMPLIFIER

The circuit of the power amplifier section is given in Fig. 1. VR1 is the volume control and C2 couples the input signal to the base of TR1. TR1 is wired with TR2 as a Darlington pair, which gives an extremely high gain.

TR3 and TR4 are the complementary driver transistors, and are directly coupled to the collectors of TR1 and TR2. TR3 is connected as an emitter follower, this giving a gain of almost exactly unity together with a high input impedance and a low output impedance. The input and output signals are in phase.

TR4 is the only p.n.p. transistor in the circuit, and it is connected as a common emitter amplifier. This would normally give a considerable voltage gain but, as it is effectively connected between the amplifier output and the negative supply rail, the stage has 100% voltage negative feedback, and thus has unity voltage gain. Like TR3, TR4 has a high input impedance and a low output impedance, but the signal undergoes a  $180^\circ$  phase change since this is a common emitter amplifier.

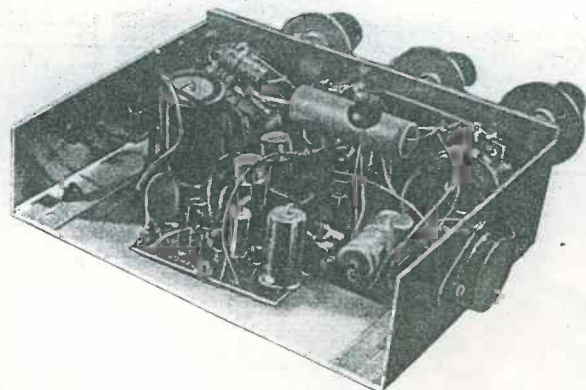

Featuring a transformerless high quality amplifier with bass and treble tone controls feeding an output power

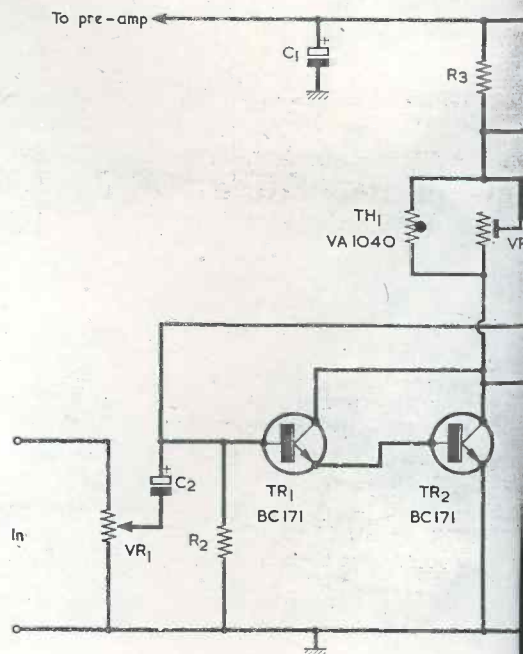

Fig. 1. The circuit of the power amplifier section.

# 6 WATT RECORD LAYER AMPLIFIER

by R. A. Penfold

Featuring a transformerless circuit design, the high quality amplifier described here incorporates bass and treble tone controls and is capable of feeding an output power of 6 watts to a 15Ω loudspeaker.

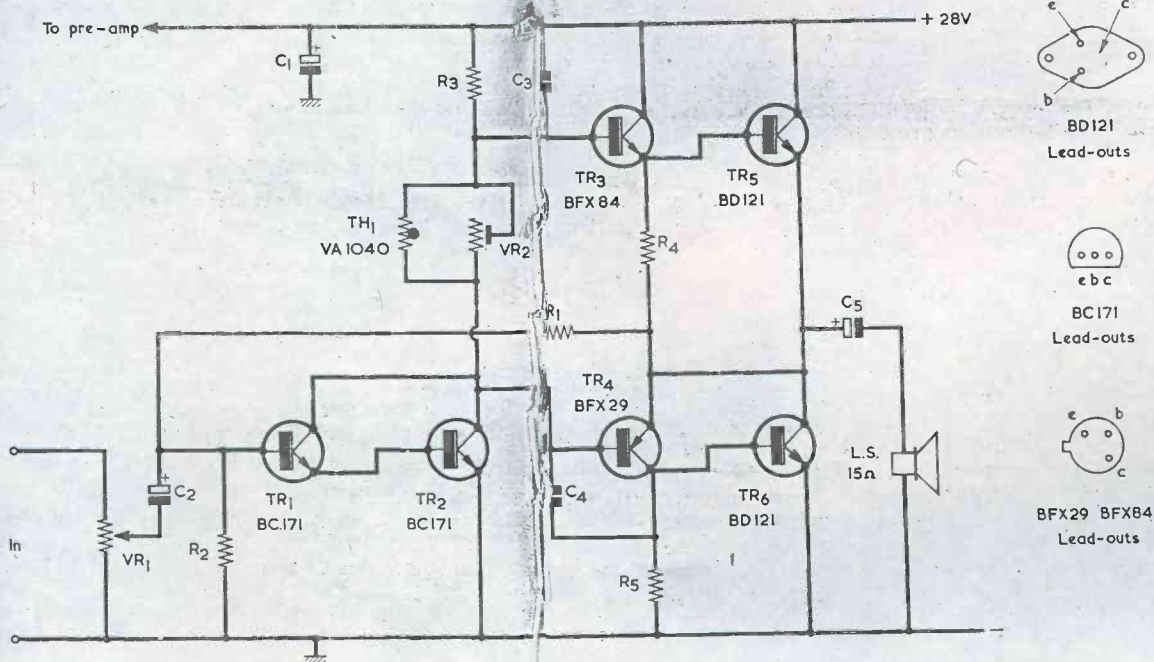
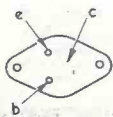
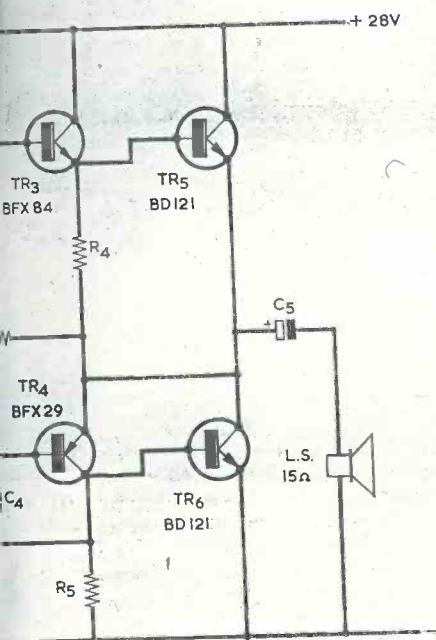

Fig. 1. The circuit of the main section of the 6 watt amplifier

# RECORD AMPLIFIER

enfold

less circuit design, the  
described here incorporates  
controls and is capable of  
r of 6 watts to a 15Ω  
peaker.



BD121  
Lead-outs



BC171  
Lead-outs



BFX29 BFX84  
Lead-outs

## COMPONENTS

### Resistors

(All fixed values  $\frac{1}{4}$  watt 10% unless otherwise stated)

R1	220kΩ
R2	27kΩ
R3	820Ω
R4	220Ω
R5	220Ω
R6	1.5kΩ
R7	150Ω
R8	10kΩ
R9	150kΩ
R10	560kΩ
R11	100kΩ
R12	150kΩ
R13	2.7kΩ
R14	0.5Ω 2.5 watt, wire-wound
VR1	5kΩ potentiometer, log
VR2	1kΩ potentiometer, subminiature skeleton, horizontal mounting.
VR3	5kΩ potentiometer, linear
VR4	5kΩ potentiometer, linear

### Capacitors

C1	100μF electrolytic, 30 V.Wkg.
C2	10μF electrolytic, 10 V.Wkg.
C3	1,000pF disc ceramic
C4	1,000pF disc ceramic
C5	400μF electrolytic, 25 V.Wkg.
C6	0.1μF plastic foil
C7	1μF plastic foil
C8	0.1μF plastic foil
C9	1μF plastic foil
C10	200μF electrolytic, 10 V.Wkg.
C11	0.1μF disc ceramic
C12	16μF electrolytic, 10 V.Wkg.
C13	10μF electrolytic, 10 V.Wkg.
C14	2,500μF electrolytic, 30 V.Wkg.
C15	2,500μF electrolytic, 30 V.Wkg.

### Transformer

T1 — Mains transformer, secondary 20V at 2A (see text)

### Semiconductors

TR1	BC171
TR2	BC171
TR3	BFX84
TR4	BFX29
TR5	BD121
TR6	BD121
TR7	BC171 (see text)
D1-D4	1N4002

### Thermistor

TH1 VA1040

### Switch

S1 d.p.s.t. toggle

### Miscellaneous

Veroboard, 0.1 in. matrix (see text)  
3 control knobs  
18 s.w.g. aluminium sheet  
Paxolin panel, 4½ by 3¼ by ¼ in.  
Nuts, bolts, etc.

Capacitors C3 and C4 attenuate the high frequency response of the amplifier. The only frequencies seriously affected are well outside the audio range. These capacitors are necessary to give good stability.

The output transistors are TR5 and TR6. TR5 is direct coupled to the output of TR3, and TR6 to the output of TR4. If a positive-going signal is present at the collector of TR2, the emitter follows TR3 and TR5 cause the output voltage to rise by a virtually identical level. An extremely low output impedance is given at the emitter of TR5. Under quiescent conditions, the voltage at the junction of TR5 emitter and TR6 collector is approximately half the supply voltage. A positive-going signal has no effect on TR4 and TR6, other than to turn them off. With TR6 turned off, the loudspeaker, via C5, forms the load for TR5.

When a negative-going signal is present at TR2 collector, TR3 and TR5 will be turned off whilst TR4 and TR6 will be biased into conduction. Like TR4, TR6 operates as a common emitter amplifier with 100% voltage negative feedback and it also inverts the phase of the signal applied to it. In consequence, the twice inverted signal at TR6 collector will be almost identical with that at TR2 collector. It will also be at an extremely low impedance allowing the loudspeaker to be driven via C5.

C1 is the supply decoupling capacitor. VR2 and thermistor TH1 provide a small voltage between the bases of TR3 and TR4. This ensures that a small biasing current is available for the driver and the output transistors, thereby reducing cross-over distortion. TH1 helps to stabilize this current for variations in temperature. The thermistor is shown in the accompanying photographs on long leads as the author had been experimenting to find the best position for it. It was found, however, that its position was not critical, although it should not be placed too near either of the output transistors. In amplifiers built up to the circuit, the thermistor may have short leads of normal length.

## PRE-AMPLIFIER AND TONE CONTROLS

A circuit diagram of the pre-amplifier and the tone control network is given in Fig. 2. The tone control

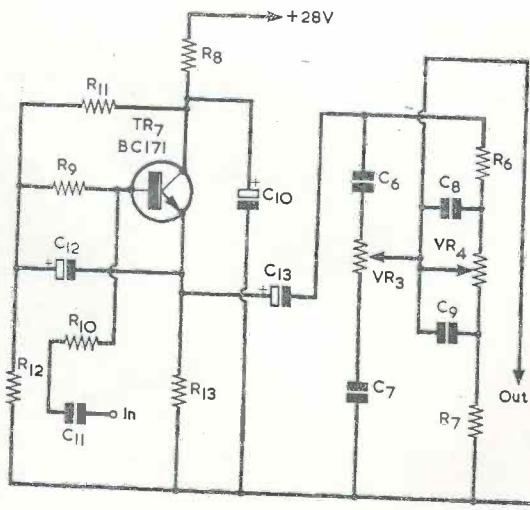
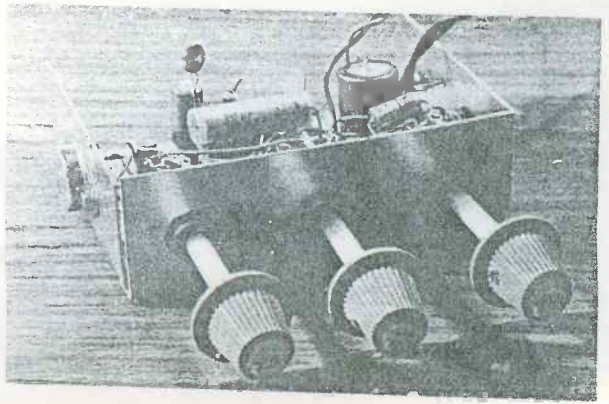

Fig. 2. The pre-amplifier and tone control circuits



Front view of the completed amplifier. This features compactness and small size

system is a simple passive one, having separate bass (VR3) and treble (VR4) tone controls.

Since a crystal or ceramic pick-up has quite a high voltage output, the only requirement of the pre-amplifier is to match the high output impedance of the cartridge to the comparatively low input impedance of the main amplifier.

The pre-amplifier circuit uses a high gain silicon transistor in the emitter follower mode. This obtains its supply potential from the main positive supply rail via R8, C10 being the decoupling capacitor. R11 and R12 form a potential divider which provides bias for the transistor. The shunting effect these resistors would otherwise have on the input impedance is greatly reduced by the use of the bootstrapping technique. In Fig. 2, bootstrapping is provided by coupling the emitter back to the junction of R11 and R12 by way of C12.

An input impedance of  $1M\Omega$  is required, but the input impedance to the base of TR7 will be only about half this figure. It is necessary, therefore, to add resistor R10 in series with the input in order to raise it to the required impedance level.

R13 is the emitter load resistance for TR7. The output is coupled to the tone control network via C13.

## CHASSIS

Constructional details for the chassis are given in Fig. 3. The front panel and the two heat sinks, on which TR5 and TR6 are mounted, are made from 18 s.w.g. aluminium. The baseboard consists of  $\frac{1}{8}$  in. Paxolin, or a similar insulating material. Apart from the control bush holes, all holes are drilled 6BA clear, except those in the heat sinks for the mounting bolts and lead-outs of the output transistors. These holes are drilled 4BA clear. Approximate dimensions for the transistor holes are given in Fig. 3 but, if a TO3 mica insulating washer is to hand, marking out the holes can be made a great deal easier by using this as a template. The holes in the front panel and the heat sinks are drilled before the flanges are bent over at  $90^\circ$ , as indicated in the diagram.



observed, as heavy currents can flow, with consequent risk of damage to components, if there is a short-circuit between either heat sink and the panel. A solder tag is secured under one of the mounting nuts of each output transistor. Connections to the transistor collectors are made by way of these tags.

Exactly how the parts of the chassis fit together can be seen from the photographs of the finished article. The heat sinks and the panel are each secured to the baseboard using two  $\frac{1}{4}$  in. 6BA bolts. Two  $\frac{1}{4}$  in. 4BA bolts are required to mount each output transistor.

The approximate positioning, on the baseboard, of the main amplifier and the pre-amplifier is shown in Fig. 3. Capacitors C5 and C11 are included to indicate which way round the two boards are fitted.

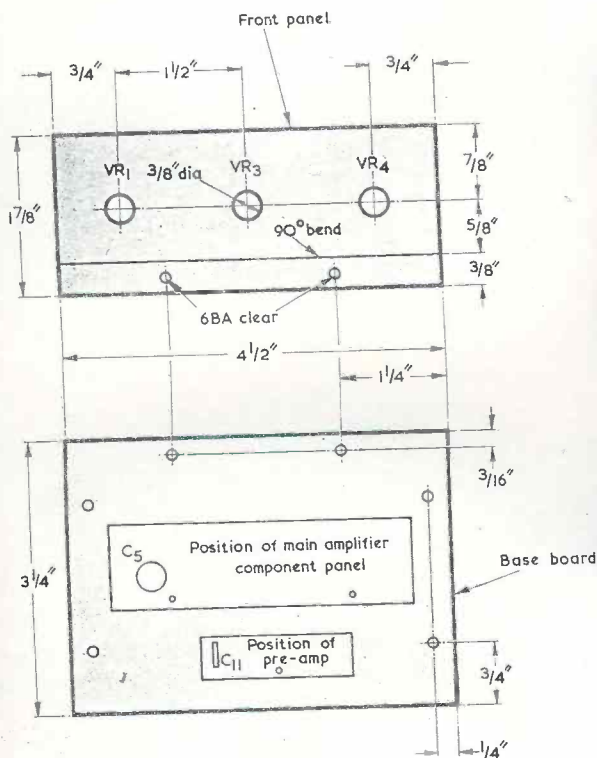
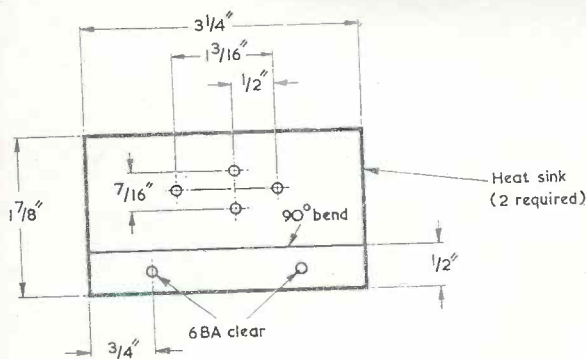
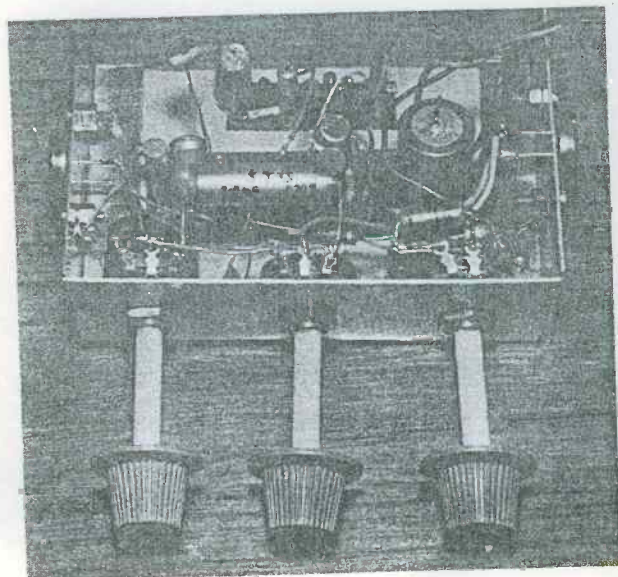

Fig. 3. Details of the heat sinks, front panel and baseboard. Capacitors C5 and C11 appear in the baseboard diagram to show the way in which the two Veroboard panels are fitted



The amplifier as seen from the top

Aluminium is fairly soft, and is easily bent provided a small vice is available. The flange on the front panel is bent back, away from the reader. It is immaterial which way the heat sink flanges are bent.

No insulating washers are used on the output transistors and so the heat sinks must be insulated from the front panel. This is achieved by mounting the heat sinks with their flanges above the baseboard, and the front panel with its flange below the baseboard. If it is felt that there is any risk of the front edges of the heat sinks touching the front panel, the edges should be covered with insulating tape to ensure that no electrical connection can take place. This point must be carefully

## MAIN AMPLIFIER

All the components for the main amplifier, with the exception of VR1 and the output transistors, are mounted on a Veroboard panel of 0.1 in. matrix, having 10 copper strips, each with 32 holes. The component side of this board is illustrated in Fig. 4.

The copper strips should be cut at the places indicated in the diagram and the two 6BA clear holes drilled before any components are soldered into circuit. The link wire connecting TR1 and TR2 collectors should be connected first, since this is difficult to fit once the other components are in position and can easily be forgotten altogether. The transistors should be soldered in last of all. The amplifier board is mounted on the baseboard, with C5 at the end indicated in Fig. 3, by means of two  $\frac{1}{4}$  in. 6BA bolts. Insulated spacing washers may be fitted between the Veroboard and the baseboard if the solder joints on the underside of the Veroboard prevent it from being level.

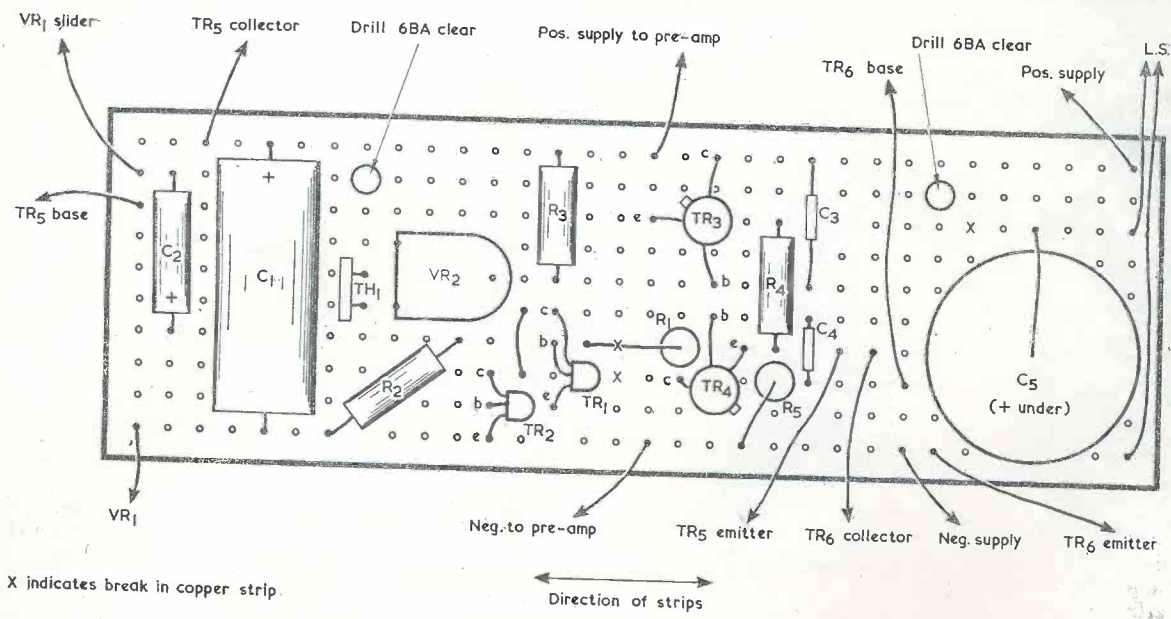

Fig. 4. The component side of the main amplifier board

### TONE CONTROLS AND PRE-AMPLIFIER

A wiring diagram for the tone and volume controls is given in Fig. 5. Construction is easiest if the components are wired into circuit in the following order: R7, C8, R6, C6, C7, C9 and, finally, the two insulated leads connecting together VR3 and VR4 sliders and the high-volume end of VR1 track. Input and output connections may then be made. The front panel should be common with the negative supply rail, and Fig. 5 shows this connection being made by means of a lead from the earthy tag of VR1 which is soldered to the back of VR1 body. The connection to the panel is then made via the potentiometer metal-work. If the potentiometer employed for VR1 does not have a construction which would provide this connection, the negative supply rail may be connected to a small tag bolted to the panel or

by any other convenient means. (When the accompanying photographs were taken, the volume control fitted was a type having an integral on-off switch. This was later changed for a potentiometer without a switch.)

The pre-amplifier is wired on another piece of Veroboard of 0.1 in. matrix, this having 5 copper strips, each with 17 holes. The component side of this board is shown in Fig. 6. There are three breaks in the copper strips, these being between the positive supply lead and C11, between R12 and C11, and between the two connections to C12. These cuts should be made and the 6BA clear mounting hole drilled before any parts are fitted. TR7 is the last component to be soldered into circuit. C11 is a 0.1μF disc ceramic capacitor. Disc ceramic capacitors in this value are available from many suppliers, including Henry's Radio.

Although the pre-amplifier board is rather small and the components a little cramped, construction is quite straightforward. If preferred, 0.15 in. matrix Veroboard can be used instead, and there is just sufficient space on the baseboard for this. The board is mounted as in Fig. 3, with C11 at the end indicated, by means of a single 6BA ½ in. bolt. As with the main amplifier board, an insulated spacing washer can be fitted between the Veroboard and the baseboard if desired.

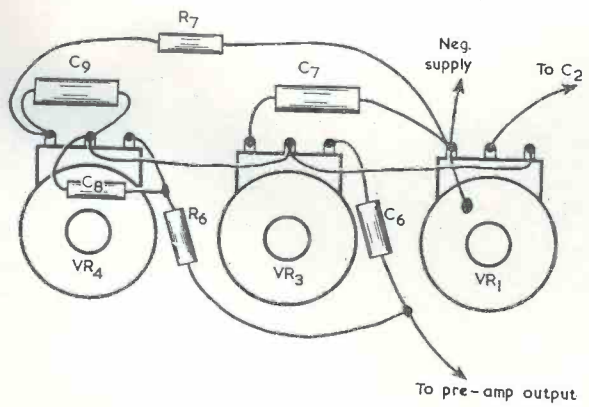

Fig. 5. The tone and volume control wiring

### POWER SUPPLY UNIT

Ideally, a regulated power supply should be used to power the amplifier. However, this is not essential and the simple supply circuit shown in Fig. 7 will give adequate results. Any reasonable layout and method of assembly may be employed.

Transformer T1 has a 2 amp secondary which gives 20 volts r.m.s. off-load, the component used by the author being a 2 amp battery charger type described as a '17 volt transformer'. Battery charger transformers tend to give secondary voltages which vary quite

Fig. 6. The pre-amplifier board, as seen from the component side

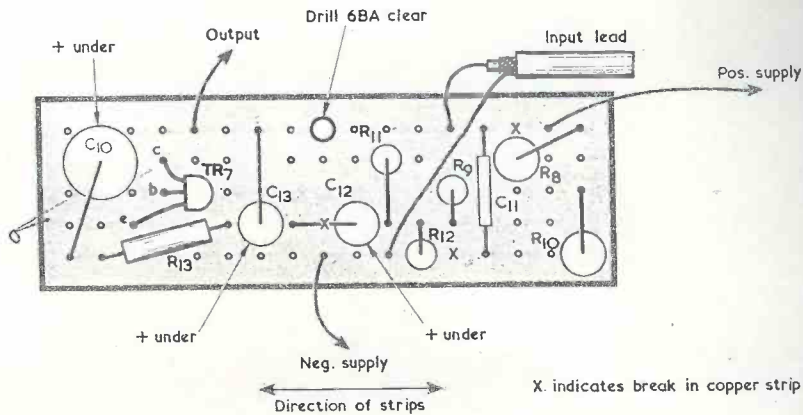

considerably from the stated figure and the reader is advised not to purchase a transformer of this type for the present application, although it would of course be perfectly in order to use a 2 amp charger transformer (or any other transformer with a 2 amp secondary) which happens to give a secondary voltage of some 19 to 21 volts r.m.s. and which is already to hand. Alternatively, the Douglas transformer type MT3 may be used. This has a 2 amp secondary tapped at various voltages up to 30 volts including a 0-20 volt section. The Douglas MT3 transformer is available from Home Radio under Cat. No. TMM1.

Also, VR1 should be set for minimum volume. No supply should be applied until these points have been attended to.

Next, insert a multimeter switched to a high current range in series with the positive supply lead, connect the negative supply lead and switch on the mains supply. Under these conditions the current drawn by the amplifier should be a few milliamps only. Then switch off the mains, set the multimeter to a current range which allows 25mA to be indicated conveniently, switch on again and slowly adjust VR2 until the meter indicates this current. VR2 should not be adjusted beyond the point at which the quiescent current is 25mA. Switch off once more, remove the multimeter and connect the positive output of the power supply unit direct to the positive supply rail of the amplifier. The unit is then ready for use.

As the input impedance is high it is essential that the input wiring is screened. The braiding of the input screened wiring is common with the negative supply rail.

The amplifier should not be used with a speaker having an impedance of less than 15Ω, as this could result in damage to the output transistors due to the power rating of the circuit being exceeded. Speakers having an impedance greater than 15Ω may be employed but the output power will be less than that quoted. The speaker leads must not be accidentally short-circuited when the amplifier is in use.

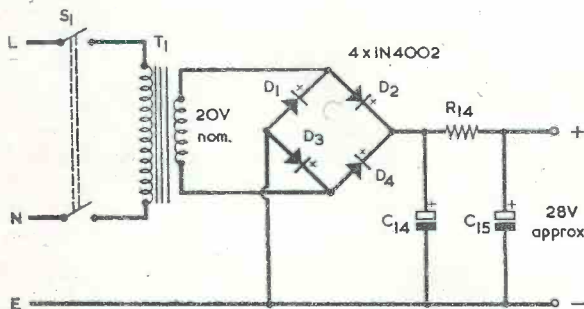

Fig. 7. A suitable power supply

C14, in Fig. 7, is the reservoir capacitor and C15 the smoothing capacitor. R14 needs to have a very low value, so that the supply has a low internal resistance. There will, in consequence, be only a very small drop in output voltage on peaks of current consumption. The output voltage under quiescent conditions will be of the order of 28 volts.

## NOTES ON USE

After the wiring has been completed, a check should be made to ensure that all connections are accurate and that there are, in particular, no short-circuits between the positive and negative supply rails. VR2 must be adjusted to insert minimum resistance into circuit, this being given when its slider is turned fully clockwise.

Fig. 8. A transistor type BC169C can, if desired, be employed for TR7. Its lead layout is given here

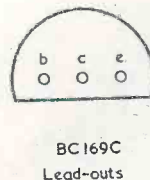

The circuit may be found to have inadequate sensitivity with some low-output cartridges. The sensitivity can be approximately doubled by replacing TR7 with a higher gain type, such as the BC169C. The lead-out layout of this transistor is given in Fig. 8. R10 can then be removed and C11 connected direct to the base of the BC169C which is now in the TR7 position.

# SHORT WAVE NEWS

FOR DX LISTENERS

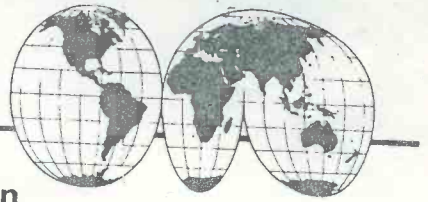

By Frank A. Baldwin

Times=GMT

Frequencies=kHz

One of the 'plums' of broadcast band listening is the logging of a station, sometimes quite unexpectedly, which is not all that easy to hear in the U.K. Recently we logged BED60 Taipei, Taiwan, on the regular 15125 (19.83m) channel at 1850, when the programme consisted of excerpts from a Chinese drama with a following explanation in English. Identification in English at 1857, in Chinese at 1858, local music and sign-off at 1900. The scheduled English programme is from 1800 to 1900 daily but attendant or nearby jammer transmitters make life rather intolerable for the s.w.l. Other channels tried during the above transmission were 15345 (19.55m), 15370 (19.52m) and 17720 (16.93m); they were all heavily jammed.

Turning to another matter, if you enjoy trying to identify an unlisted station, you may care to tune to 4742 (63.28m) from around 2030, when a USSR transmitter can often be heard. Sign-off is at 2100 with the Kremlin chimes for midnight and the 'Internationale'. The channel is surrounded by a veritable sea of QRM and, in general, the station can only be heard when conditions are right for the reception of signals from the Far East.

## CURRENT SCHEDULES

### ● CHINA

Radio Peking broadcasts a programme in English, directed to Europe, from 2030 to 2130 on 6610 (45.38m), 6825 (43.96m), 7590 (39.53m), 8490 (35.34m) and on 9030 (33.22m). From 2130 to 2230 on all the foregoing channels and with the addition of 11675 (25.70m).

### ● ALBANIA

Radio Tirana has an English schedule for Europe as follows - from 0630 to 0700 on 7065 (42.46m) and on 9500 (31.58m). From 1630 to 1700, from 1830 to 1900, from 2030 to 2100 and from 2200 to 2230 on 7065 and on 9480 (31.65m).

### ● BULGARIA

Radio Sofia has the following schedule in English for the U.K. and Eire. From 1930 to 2000 and from 2130 to 2200 on 6070 (49.42m) and on 9700 (30.93m).

### ● NORTH VIETNAM

"The Voice of Vietnam", Hanoi, directs a programme in English to Europe from 1800 to 1830 on 10040 (29.88m) and on 15012 (19.99m). The frequencies given here are, at times, subject to some variation (usually plus or minus 5kHz.)

The clandestine "Liberation Radio" has a programme in English for Europe from 2030 to 2045 on 12115 (24.76m) and on 14990 (20.13m). Although claiming to be located in a communist controlled area of S. Vietnam, Liberation Radio in fact uses the transmitting facilities of R. Hanoi.

### ● USSR

Radio Kiev broadcasts in English to Europe on Mondays, Thursdays and Saturdays from 1930 to 2000 on 7205 (41.64m), 9480 (31.65m) and on 11705 (25.63m).

Radio Vilnius radiates a programme in English to Europe on Saturdays and Sundays from 2230 to 2300 on 9665 (31.04m), 9750 (30.77m), 11735 (25.56m), 11770 (25.49m), 11820 (25.38m), 11920 (25.17m) and on 15440 (19.43m).

### ● AUSTRALIA

Radio Australia directs a programme to the U.K. and Europe in English from 0645 to 0745 on 11765 (25.50m). Also on 9570 (31.35m) from 0700.

## AROUND THE DIAL

### ● KUWAIT

Radio Kuwait can be heard at 1730 on 15415 (19.46m) with a newscast of Arabian and African affairs in English, this being followed by a list of pharmacies open for late shoppers, local weather forecast, low and high tide times and a local press report.

### ● MALAYSIA - 1

The BBC Far East Relay at Tebrau may be logged at 1750 or so with a newscast of U.K. affairs in English on 15310 (19.60m).

### ● TAIWAN

The opening paragraph of this article dealt with the reception of Taiwan on the higher frequency bands; we have since tried the listed channels further down the dial but were successful only on 9685 (30.98m) at 1810 when a news review of events on the island was heard. Identification by YL at 1813 and also at 1815 by OM. The 9765 (30.72m) and 11825 (25.37m) channels were hopeless, jamming making reception impossible.

### ● NIGERIA - 1

Calabar can sometimes be heard on the regular 6145 (48.82m) channel from around 2130 onwards. We were fortunate in hearing the station identification by YL at 2129 "You are tuned to NBC Calabar" under an unmodulated Moscow carrier. Needless to say, the Moscow carrier was well and truly modulated at 2130!

### ● ECUADOR

Our old friend HCJB Quito continues to provide me with some column inches! Heard recently at 0800 on 9745 (30.78m) with identification and programme in English; at 0730 on 9710 (30.90m) with identification and English programme for Europe and at 2130 on 17870 (16.79m) with identification in English then into Spanish.

● **INDIA**

AIR Bombay may be logged on **15080** (19.98m) at 1750 with Indian songs and music, the announcements being in English.

● **YUGOSLAVIA**

Radio Belgrade can be heard at 2000 on **6100** (49.18m) with identification, world news and programme in English.

● **ASCENSION ISLAND**

BBC Relay on this island can be tuned in on **15400** (19.48m), we heard them at 2100 with identification and programme in English about African affairs.

● **UGANDA**

Kampala on the regular **4976** (60.29m) channel is often worth tuning in around 2030. Logged here at 2036 with a programme of local 'pops' in a record request programme.

● **NIGERIA - 2**

In addition to Calabar, this country can also be logged by listening to Lagos on **4990** (60.12m); we heard them when an African song and music programme was being radiated and also on **15120** (19.84m) at 1915 with a similar type of programme.

● **SAUDI ARABIA**

Riyadh with the General Service in Arabic can be heard at 1340 on **11950** (25.10m), sign-off is at 1400.

● **CAMEROON**

Radio Buea can often be heard on **3970** (75.57m) around 2030. Although scheduled to close at 2100, we recently logged them at 2145 when a newscast by YL in English, followed by identification at 2201 and sign-off with National Anthem at 2202 was heard, probably on extended schedule for some special reason.

● **GHANA**

Listen on **4915** (61.03m) at 2000 for Accra giving station identification, the news in English and, at 2014 "Ghana Radio Corporation presents Ghana Newsreel".

● **SWITZERLAND**

On **3985** (75.28m) at 2100 Berne is to be heard with "Dateline", a world news and comment programme.

● **AUSTRALIA**

If conditions are right, and you tune your receiver to **4920** (60.98m) just before 2000, you may hear VLM4 Brisbane with 6 'pips' for 6 a.m. local time, good morning greetings and the news.

Australia can also be heard on **11765** (25.50m) at 0730, we heard a musical programme with announcements in English.

● **HONDURAS REPUBLIC**

Tegucigalpa in the form of HRVC Voz Evangelica operates on **4820** (62.24m) where we heard them at 0259 with station identification and announcements in English, including the address for reports and "three IRC's for airmial reply".

● **MALAYSIA - 2**

Kajang may sometimes be logged on **4845** (61.92m) when opening at 2200. Indian-type music is a feature of this station and the language used is Tamil.

Penang can also be sometimes logged on **4985** (60.18m), we heard a programme of light music, songs in English and Chinese-style music, all with announcements in English from 2310 onwards.

● **MOZAMBIQUE**

Radio Clube de Mozambique is to be heard on **4855** (61.79m) fairly regularly, often being one of the best signals on the 60m band. We noted them recently at 1850 with a musical programme, being followed at 1900 with 6 'pips' and station identification.

RCM Beira on **4890** (61.35m) is also often a good signal, heard here quite often around 1900.

Mozambique on **4925** (60.90m) is also around at the same time, we heard them recently when signing-off with the National Anthem "A Portuguesa" at 2201.

● **EQUATORIAL GUINEA**

EAJ206 Bata, Rio Muni, on occasions can be heard from around 2030 on **4926** (60.90m). Sign-off is at 2200 daily according to the schedule but this station is apt to be off the air for whole periods of time, on occasions for several weeks, only to reappear just as suddenly as it vanished. Logged at 2031 with station identification followed by local music programme.

● **N. VIETNAM**

For some weeks up to the time of writing, Hanoi has been using **7085** (42.34m) for a programme in Vietnamese presumably for S. Vietnam. The transmission can be heard closing around 1750 (varies) with identification "Day la Vietnam", song in Vietnamese by YL and off.

● **VENEZUELA**

YVMG R.Popular, Maracaibo, can often be heard during the late evenings on the regular **4810** (62.37m) channel. Logged several times from 2330 to 0230.

● **CLANDESTINE**

On several occasions of late we have drawn readers' attention to many of these stations, here are another two for your lists.

"Voice of Iranian Freedom Lovers", an anti-Shah station, can be heard from 1030 to 1130 and from 1600 to 1700 in Farsi, Kurdish and Azerbaijani on **7210** (41.61m).

"Voice of Iranian Kurdistan", another anti-Shah transmitter, can be heard from 1400 to 1420 on **9630** (31.15m).



# FOUR-BAND

# TRANSISTOR SUPERHET

Part 2

by R. A. Penfold

In this concluding article details are given of the a.f. amplifier section, the power supply and the S-meter circuit of the receiver. Also described are its setting-up and operation.

## A.F. AMPLIFIER

THE A.F. AMPLIFIER SECTION OF THE RECEIVER incorporates a transformerless circuit with silicon transistors. This is shown in Fig. 9. The amplifier has a high input sensitivity and gives approximately 1.5 watts maximum continuous output at low distortion into an 8Ω speaker. The latter is plugged into the jack socket on the front panel of the receiver.

The input stage is given by TR5, and this couples to the Darlington pair driver stage incorporating TR6 and

TR7. The stage drives the two output pairs, TR8, TR10 and TR9, TR11, which are connected in a complementary configuration.

The transistors used in the amplifier section are, in most instances, generally available. The BC172 used for TR6 is available from Bi-Pak, and the 2N5172 specified for TR7 from both Bi-Pak and Electrovalue. (A BC172 with a letter suffix may have a different lead-out layout than that shown.)

The assembly of the a.f. amplifier board follows

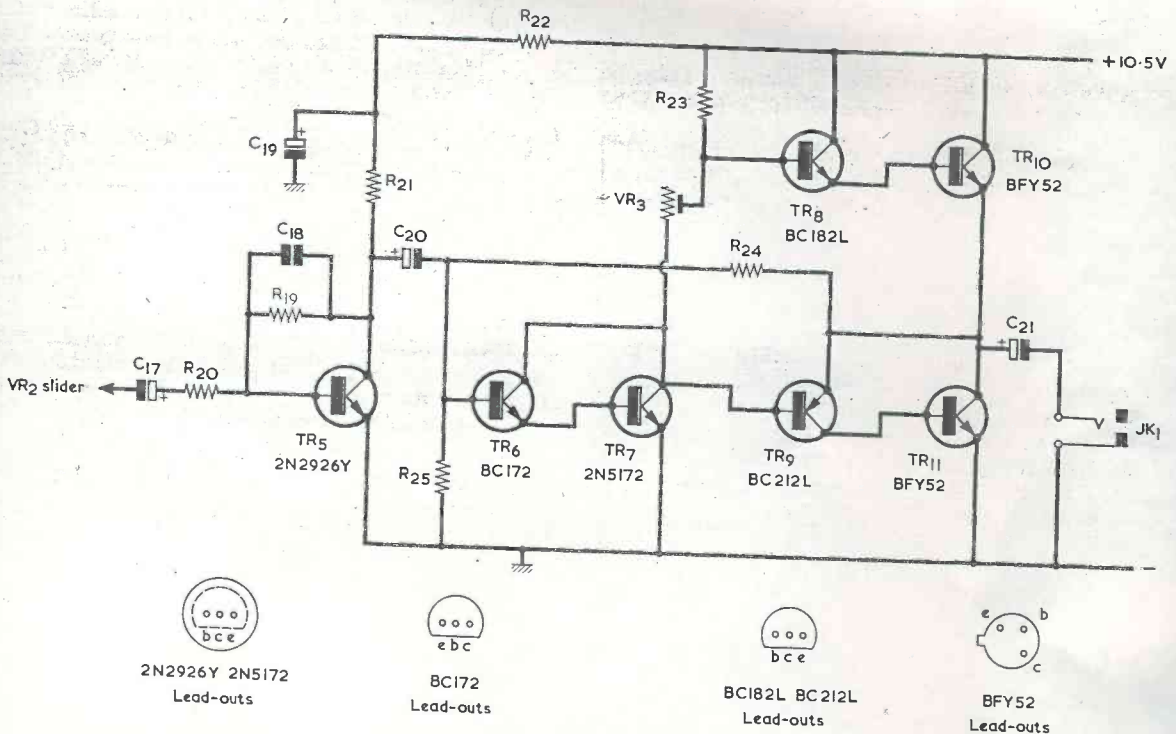

Fig. 9. The a.f. amplifier section of the receiver. This offers an output power of 1.5 watts into an 8Ω speaker

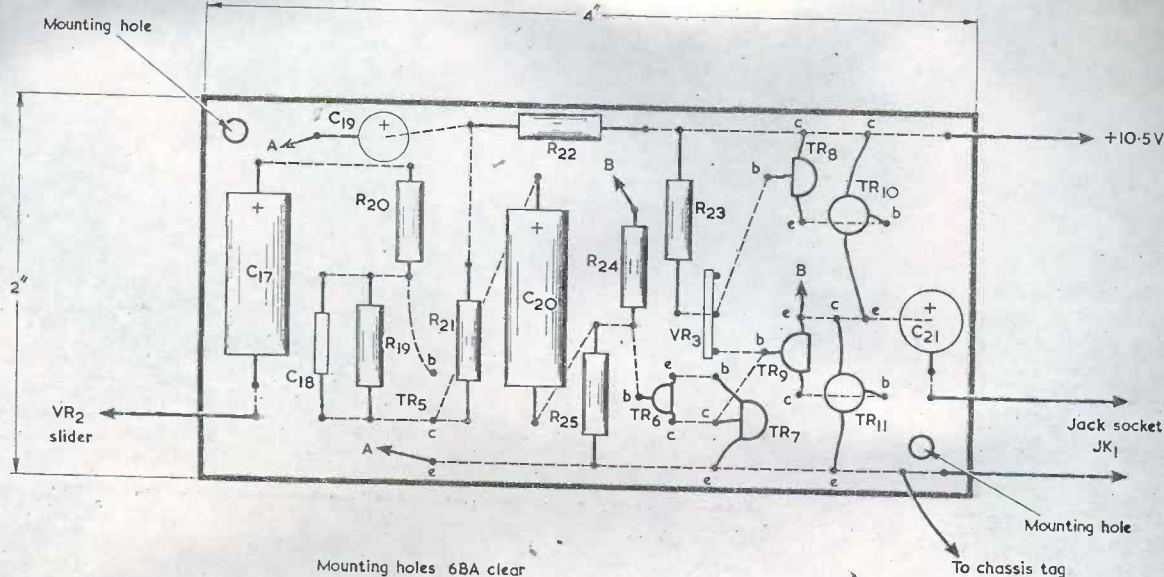

Fig. 10. The component side of the a.f. amplifier board, which is reproduced full size

similar lines to that for the i.f. amplifier. The components are fitted to a  $\frac{1}{8}$  in. Paxolin panel measuring 4 by 2 in. and this is shown full size, as seen from the component side, in Fig. 10. In this diagram the body of TR5 is omitted for reasons of clarity. The two points 'A' are joined together by a short insulated lead, as also are the two points 'B'.

The two output transistors, TR10 and TR11, need to be fitted with small clip-on heat sinks.

The board is mounted on the inside of the receiver chassis in the position shown in Fig. 3 (published last month) and with the output transistors towards the chassis rear. The method of mounting is the same as with the i.f. board. The chassis connection for the board may be obtained from a solder tag secured under the mounting nut at the output transistor end.

The wiring to volume control VR2 follows the circuit diagram given in Fig. 7 (also published last month). The non-earthly a.f. output lead from the i.f. board connects to the end of the track corresponding to the maximum volume setting. The slider of the potentiometer connects to C17 at the a.f. board and the remaining end-track tag to the chassis tag at the amplifier board. There is no necessity to use screened wire for the volume control connections, but the lead from the slider

The a.f. amplifier board. The two output transistors have clip-on heat sinks

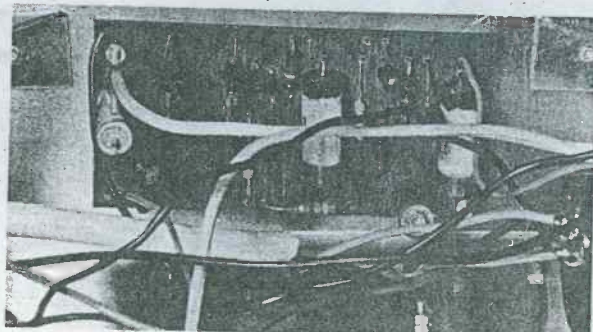

should be spaced away from the amplifier output lead to the jack socket.

### POWER SUPPLY UNIT

The receiver could be supplied by batteries but, due to its rather high power consumption, this would be very expensive. A mains power supply is therefore used.

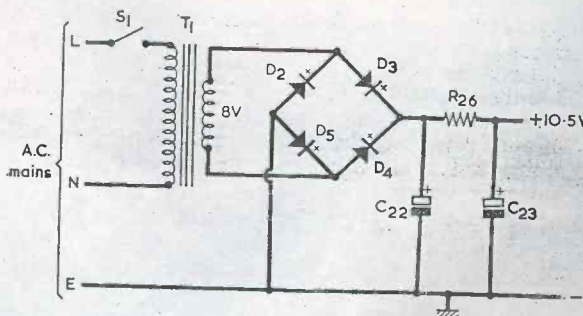

Fig. 11. The power supply for the receiver

The circuit of the supply unit appears in Fig. 11. In the prototype T1 is a non-standard bell transformer offering an output of approximately 8 volts at 0.25 amp. Any small transformer offering about the same voltage at a similar current or more can be employed here. A suitable component would be the bell transformer listed by Home Radio under Cat. No. TM50, which has a secondary rating of 8 volts at 0.5 amp.

The four silicon rectifiers in Fig. 11 form a full-wave bridge rectifier circuit with C22 functioning as a reservoir capacitor and R26 and C23 providing smoothing. Approximately 10.5 volts at a maximum current of about 0.25 amp is available at the output, this being more than adequate.

Apart from S1 and T1, all the components for the power supply unit are mounted on a Paxolin panel measuring 2½ by 2 in. and this is shown full size, as

Fig. 12. Component side of the power supply board, also reproduced full size

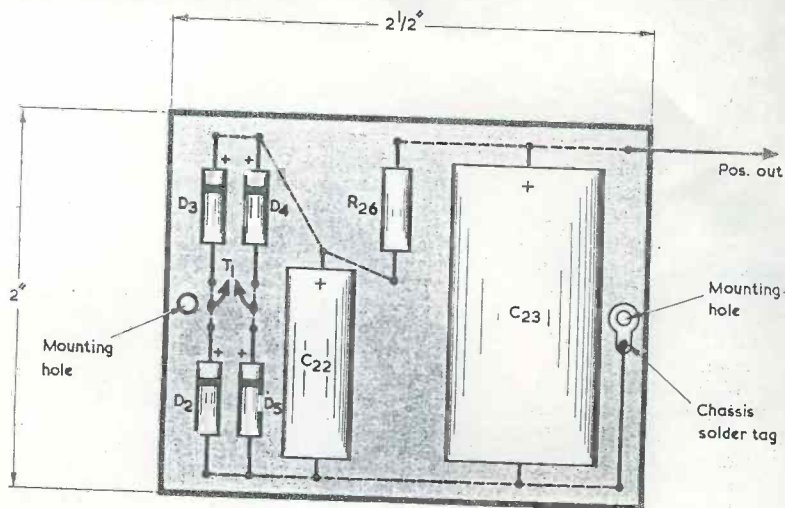

Mounting holes 6BA clear

seen from the components side, in Fig. 12. It is assembled and mounted in the same way as the two previous boards. The board and the transformer take up the positions shown in Fig. 3.

The negative output of the supply section is taken to a solder tag under one of the mounting bolts for the board. The positive output is taken to an under-chassis 2-way tagstrip which is mounted under one of the securing nuts for T1. The 10.5 volt positive supplies for the receiver sections already discussed are taken from this tag.

Switch S1 is ganged with the volume control VR1, and the live mains input lead is routed via this switch to the primary of transformer T1. The chassis holes through which all leads pass, including in particular mains leads, must be fitted with grommets. The mains input connection must be made via a 3-core lead whose

earth wire (green-yellow) is reliably connected to the receiver chassis at the 2-way tagstrip secured under the mounting nut for T1. (If the mains transformer has a Bakelite instead of a metal frame, it would be preferable to connect the mains earth wire to a separate tag positioned nearby which is bolted directly to the chassis.) The mains lead must be properly terminated in a 3-pin mains plug.

### SETTING-UP

The receiver in its basic form is now completed, but some initial adjustments have to be made before it is ready for use.

On the a.f. amplifier board, pre-set resistor VR3 is set to insert *minimum* resistance into circuit. The trimmer capacitors TC1, TC2 and TC3 are adjusted so that their moving vanes are one-half to three-quarters enmeshed with the fixed vanes. VC4, VC5 and VC6 are set at approximately half their maximum capacitance. VR1 is adjusted to insert maximum resistance.

Having given the receiver a final check for mistakes in the wiring and ensured that there are no short-circuits across the supply lines, an 8Ω speaker is plugged into the output jack. It is recommended that a speaker of at least 5 in. diameter be employed and it should be housed in a suitable case so as to provide a reasonable response. The receiver is then plugged into the mains and switched on. With VR2 fully advanced there should be virtually no noise from the speaker, except perhaps for a very slight mains hum.

VR3 is now carefully adjusted so that the resistance it inserts into circuit increases, and it is set up for an increase in transistor hiss from the speaker. Its final setting is that which offers the minimum resistance which will give this hiss. If later, when the receiver is in use, distortion can be detected on low level outputs, VR3 may be adjusted very slightly higher in resistance until this distortion disappears. VR3 must not be set up to insert excessive resistance as the a.f. output transistors can then pass too much current and may suffer damage.

A set of coils should now be inserted into the  
RADIO & ELECTRONICS CONSTRUCTOR

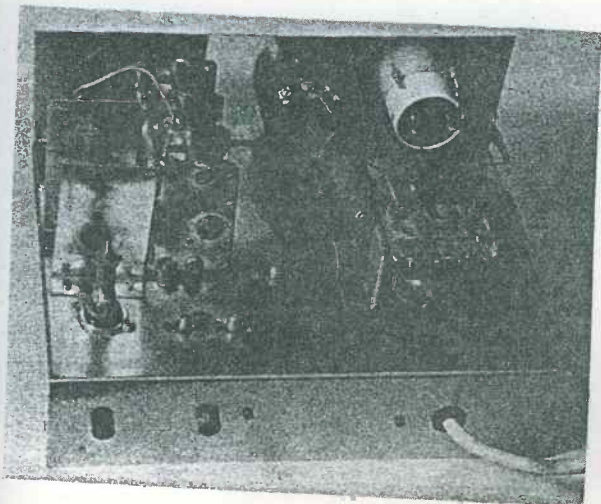

A rear view of the prototype receiver



appropriate holders, the Blue coil in the holder at the front, Yellow at the centre and Red at the rear. For initial testing, a Range 2 or Range 3 set of coils is recommended. An aerial and an earth should be connected to the appropriate sockets at the rear of the receiver. If an earth is not available, the earth connection provided by the mains supply will be adequate for testing purposes.

The cores of the coils should be adjusted such that about  $\frac{3}{8}$  in. of the brass thread is visible at the top of each coil, and it should then be possible to tune in a number of stations on the receiver. Tune accurately to a transmission at the centre of the band and then adjust the cores of L1 (Blue) and L2 (Yellow) to peak the signal.

If this process is carried out after an S-meter has been fitted, the latter may be used to indicate the peak adjustment. Alternatively a multimeter, preferably with a sensitivity of 10,000 ohms per volt or more, may be connected across VR2 with positive to chassis. The meter should be switched to a low volts range of the order of 5 volts f.s.d. In either case the coil cores are adjusted for maximum reading in the meter. It is advisable to tune to a fairly strong station, if possible, as this will be less prone to fading and will give a more steady reading. To prevent the cores from shifting as the coils are handled when changing bands, they may be locked in position by placing a 6BA nut on the protruding brass threaded section, this being carefully tightened so as not to alter the setting of the core. This procedure must be repeated on each of the three other ranges.

With the receiver tuned near the band edges it will probably be found that L1 and L2 are no longer properly aligned. The two front panel controls, VC4 and VC5, are then used to peak the tuned circuits and maintain alignment.

After the constructor has aligned the i.f. stages and obtained some experience with the receiver, trimmers TC1 and TC2 may be adjusted to provide a compromise alignment for the four ranges. It may be found that, at the high frequency ends of Ranges 4 and 5, a signal can be received at two settings of the 3-gang tuning capacitor. Should this occur, the correct setting of the capacitor is that which offers the lower capacitance, which means that the oscillator frequency is then higher than the signal frequency.

Adjustments to TC3 will vary the range covered by the receiver.

## I.F. ALIGNMENT

The two i.f. transformers are supplied pre-aligned and the only further adjustment they require is a final peaking-up of their cores. (IFT2 is pre-aligned to 470kHz but the greater selectivity offered by IFT1 will ensure an optimum initial response around 465kHz, and IFT2 can be readily tuned down to this frequency.) A correct plastic trimming tool should be used for the alignment, and not a metal screwdriver blade which could crack the core.

It will be necessary to temporarily remove the i.f. amplifier board from its mounting in order to gain access to the i.f. transformer cores. There are two cores in IFT1 (one adjusted from above and the other from below) and one in IFT2. Adjust the upper core of IFT1, first, then the lower one, and finally adjust the core of IFT2. The cores can be set up on a received signal using the same method as was employed to peak the r.f. coils.

For normal reception of a.m. signals the selectivity

control, VR1, should be turned fully anti-clockwise. If the required signal is suffering from adjacent channel interference, or is being lost in the general noise level, advancing VR1 may help to resolve the signal. Due to the narrow bandwidth this produces, accurate tuning is essential if the signal is to be understandable.

If VR1 is advanced too far the circuit will break into oscillation, this being heard as a whistle as the receiver is tuned across an a.m. station. Selectivity is at its greatest with VR1 set just below the point at which oscillation occurs.

For the reception of c.w. signals, VR1 can be set just above the point at which oscillation occurs, the oscillating i.f. amplifier then acting as a b.f.o. With careful tuning, s.s.b. signals may also be resolved when the receiver is in this condition.

No r.f. gain control is provided, but r.f. gain can be reduced on strong signals by detuning either VC4 or VC5.

If instability or squegging (evident as a loud hiss) should occur at the high frequency end of any band, the value of R8 can be increased slightly in order to obtain correct operation. The effect is most likely to occur on Range 4 or Range 5.

## AERIAL AND EARTH

The best type of aerial for use with the receiver is a long wire type. As the name implies, this is merely a length of insulated wire, which is as long and set as high as possible. A length of 50 feet or more is preferable. The receiver is very sensitive, and if a good outdoor aerial is not available a short indoor wire will provide a large number of stations, but for the reception of distant stations a good aerial is essential. For reception on the medium wave band, a few feet of wire is all that is required, and using a longer aerial gives no advantage.

An ordinary mains earth (which is the minimum requirement for reasons of safety) is quite adequate, but if a more comprehensive earthing system is available this will usually improve performance slightly.

## S-METER

An S-meter is a signal strength meter, calibrated in 'S' units from 1 to 9 and in decibels over 9. It provides readings of the relative strengths of signals and is a useful feature in any short wave receiver. It can also be

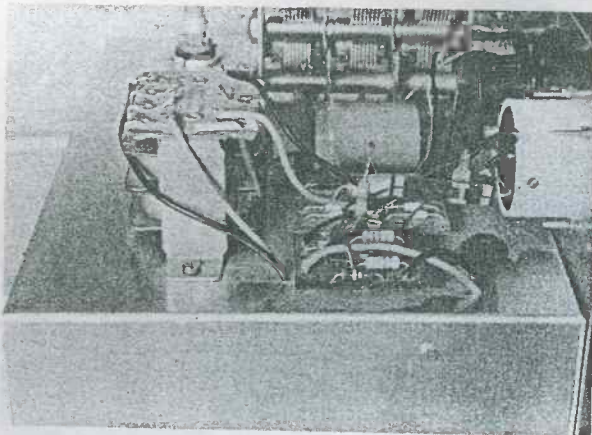

Side view of the S-meter board. R30 and VR4 may be seen between this board and the meter terminal

Components and wiring on the S-meter board

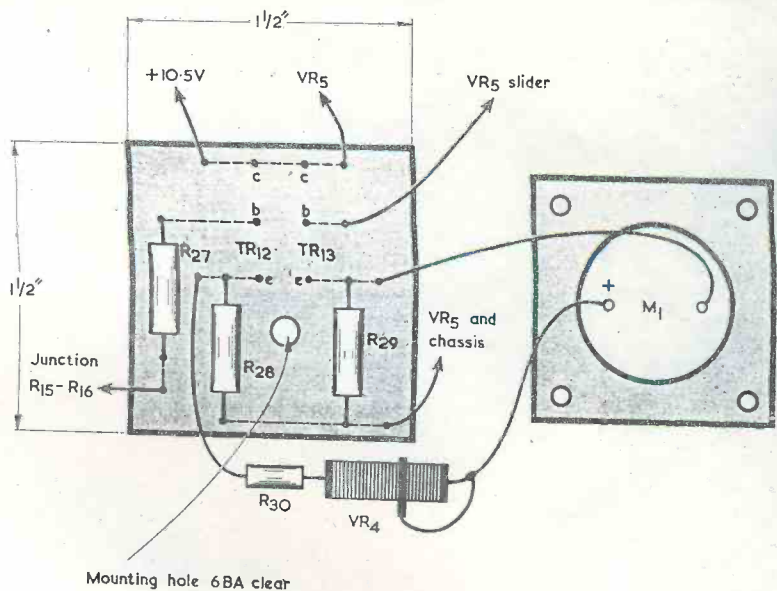

Mounting hole 6BA clear

used as a tuning meter and is very helpful when peaking VC4 and VC5. Due to the very simple method used for the resolution of c.w. signals the S-meter is inoperative in this mode.

The S-meter circuit used in the present receiver is shown in Fig. 13. A simple bridge arrangement is employed, the meter measuring the unbalance of the bridge. TR12 and TR13 are emitter followers, and the panel control VR5 is used to adjust the circuit so that the voltages at the two emitters under no-signal conditions are identical. The bridge is then balanced and the meter is zeroed. The input to the circuit is taken to TR12 base. Any change in voltage at the base of TR12 will cause an almost identical voltage change at the emitter, and this will cause a deflection of the meter needle. The extent of this deflection is proportional to the voltage change at TR12 base. Pre-set potentiometer VR4 allows a small variation in the sensitivity of the circuit.

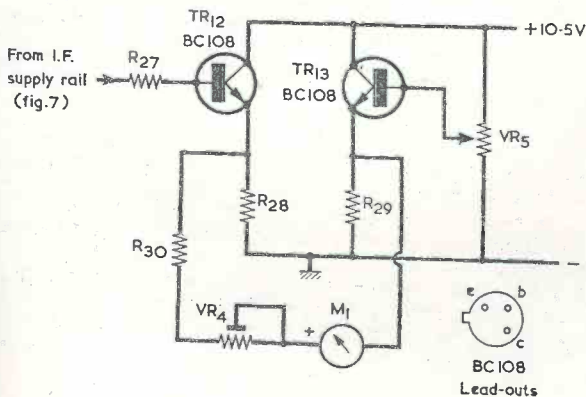

Fig. 13. The S-meter circuit

The input to the S-meter circuit is taken from the junction of R15 and R16 in the i.f. amplifier whose circuit appears in Fig. 7 (published last month). It is necessary to examine Fig. 7 to understand how S-meter indications are obtained.

On receipt of a signal, diode D1 on the i.f. amplifier board causes a rectified voltage to appear across VR2, the non-earthly end of the track being negative. This negative potential is passed via R18 to the base circuit of TR3, thus reducing the gain of TR3 and its collector current. This next reduces the current drawn through R15 and the voltage dropped across it. The voltage at the lower potential end of R15 therefore increases, causing the base of TR12, in Fig. 13, to go positive and deflect the S-meter needle. The meter deflection is proportional to the rectified voltage which originally appeared across VR2 and this, in turn, is proportional to the strength of the received carrier.

Most of the S-meter components are mounted on a Paxolin panel measuring 1 1/2 by 1 1/2 in. This is mounted above the chassis in the position indicated in Fig. 3, with R27 nearest the adjacent edge of the chassis. R30 and VR4 connect directly between the board and the positive terminal of the meter.

When the wiring has been completed, VR4 is adjusted to insert full resistance, VR5 is set to a central position, and the receiver is then turned on. No aerial should be connected. The needle will be deflected as soon as the receiver is switched on, and VR5 must be immediately adjusted to zero the meter. An aerial is then connected and a few stations tuned in to check that the meter circuit is functioning correctly. VR4 is finally adjusted so that meter deflection is a little short of f.s.d. on the strongest signals.

(Concluded)

Electrolytic capacitor C24 was omitted from the Components List in Part 1. This capacitor is 10μF, 10V. Wkg.

# New Products

## TOUGH RIVETS FROM RAWLPLUG

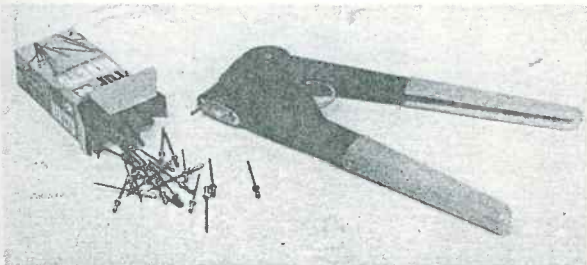

Tuf Rivets for repair and other DIY jobs around the house have just been launched by The Rawlplug Company Ltd. They are designed with the home handyman in mind, for small repair jobs on sheet metal, plastic and other materials. They make secure fixings in seconds, and will have many uses for car maintenance, repairs to tubular furniture, bicycles, caravans, boats, garden equipment, kitchen utensils and equipment, toys, suitcases, and many others.

Fixing is by means of Tuf Riveting pliers, obtainable in a kit with a supply of rivets and a twist drill for making the correct size hole. Any drill can be used, however, and accurate hole sizing is not essential. The rivets can be used with other suitable riveting pliers.

There are three sizes of Tuf Rivets,  $\frac{1}{8}$  in.,  $\frac{3}{16}$  in. and  $\frac{1}{4}$  in., and each size comes in one length only. Supplies of rivets are available in small prepacks and boxes of approximately 100. Full instructions are given on the back of each pack as well as on the Tuf Rivet kit.

Recommended retail prices (excluding VAT) are £2.50 for the Tuf Rivet kit; for the boxes,  $\frac{1}{8}$  in. 60p,  $\frac{3}{16}$  in. 75p, and  $\frac{1}{4}$  in. 45p for a box of approximately 50. The small packs sell at 16p each.

Further information from The Rawlplug Company Ltd., Rawlplug House, London Road, Kingston-upon-Thames, Surrey.

## SOLDERING IRON WITH A GENTLE TOUCH

The Litesold Conqueror at only 1½ oz. (less flex) is one of the lightest general purpose soldering irons on the market. The combination of small size, low weight and high efficiency has been achieved by careful design using modern materials.

The specially designed soldering bit completely encloses the element ensuring that all the heat produced is transmitted to the joint being soldered.

This featherweight iron is the ideal tool for radio construction, model making, car electrical repairs and any other jobs requiring a delicate touch.

The Litesold Conqueror Soldering Iron costs £2.04 (incl. p&p & VAT) for the iron on its own, or complete with special spring stand and four alternative size bits, £5.08 (incl. p&p & VAT). Available from Light Soldering Developments Limited, 28, Sydenham Road, Croydon, CR9 2LL, Surrey.

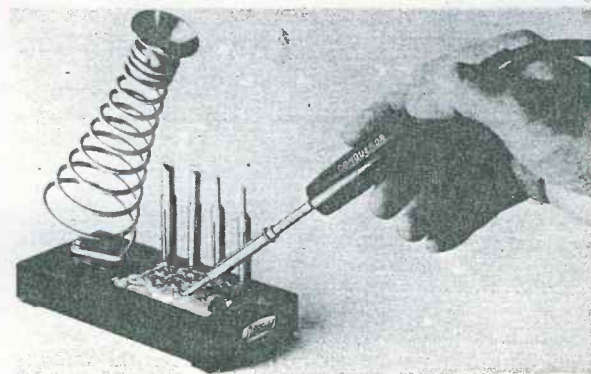

Photograph shows the featherweight Litesold Conqueror Soldering Iron with specially designed spring stand which holds the four alternative size bits.

## HIGH POWER LOW VOLTAGE TIMERS

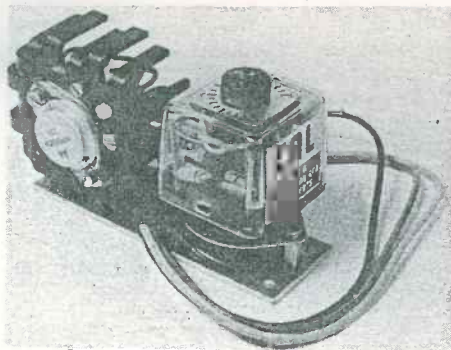

Recent additions to the extensive range of electronic timers designed and manufactured by Controls & Automation Ltd., the new low voltage timers with solid state switching have thyristor controlled power output up to 25A.

Operating from a supply of 12V or 24V, a.c. or d.c., with a voltage supply tolerance of  $\pm 20\%$ , there are options for delay or interval time functions, with accuracies within  $\pm 1\%$ .

Standard timer ranges (0-1 sec. to 0-120 sec.) are available, and other ranges can be supplied to meet customer specifications.

These low voltage timers with thyristor controlled output have evolved with the development of the CAL Series 1600 circuitry, and are provisionally designated CAL 1600.S49. Price, £7 each basic (up to £15 each depending on specification) reducing for quantity orders. Controls & Automation Ltd., Regal House, Hitchin, Herts.

# FOUR AUDIO

# 'BUILDING BLOCKS'

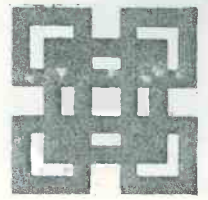

This short article describes four audio 'building block' circuits which have proved to be reliable with a variety of transistor types.

IN AUDIO EXPERIMENTAL WORK THERE ARE OFTEN interfacing difficulties; these appearing where, for instance, a crystal microphone will not match into a transistorised pre-amplifier, or where the output from a tape recorder needs bass boost, etc. The four circuits discussed here were developed for this sort of contingency. They are not 'state of the art' high performance circuits, but represent good reliable designs which may be easily constructed. In each case the performance is well defined by negative feedback, whereupon almost any modern high gain small signal silicon transistors can be used.

## IMPEDANCE MATCHING UNIT

In ordinary domestic tape recording a crystal microphone is often used for reasons of economy and sensitivity. Similarly in a record player of modest performance a ceramic cartridge may be used. The normal requirement for these transducers is that they have a high impedance load, so that the low frequency output of what is essentially a capacitive source is preserved.

The self-capacitance of a ceramic cartridge would typically be 1,000pF, and for the lower 3dB down point to be at 20Hz this demands a load impedance of 8M $\Omega$ . In practice several cartridge manufacturers recommend lower impedance (about 470k $\Omega$  or 1M $\Omega$ ) but our figures give us the order of input impedance required.

Since most transistorised circuits have lower input impedances (in tens of kilohms) a high-to-low impedance matching unit is required. Several different circuit arrangements are possible, but the one shown here has several advantages.

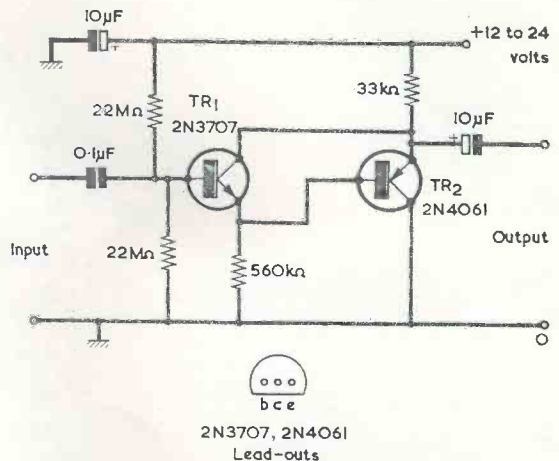

Fig. 1. A unit with high input impedance and low output impedance

The circuit of Fig. 1 uses a complementary emitter follower configuration, in which the emitter of TR2 can be connected directly to the collector of TR1. This bootstraps the collector of TR1 and holds its base to collector potential constant at 0V even at high signal levels. The low collector to base potential reduces the internal feedback capacitance and helps maintain a good frequency response.

It is interesting to note that for this particular application there is no real need to maintain a very low input capacitance, since the source impedance is also reducing as frequency increases. However the circuit is useful for instrumentation applications where this condition may not apply. The 22M $\Omega$  bias resistors will shunt the input, but a high input impedance can still be achieved without difficulty. For this circuit it is typically 6 to 8M $\Omega$ .

22M $\Omega$  10% resistors in 1 watt rating may be obtained from Home Radio under Cat. No. R6. Alternatively, each resistor may be made up from a 10M $\Omega$  resistor and a 12M $\Omega$  resistor connected in series.

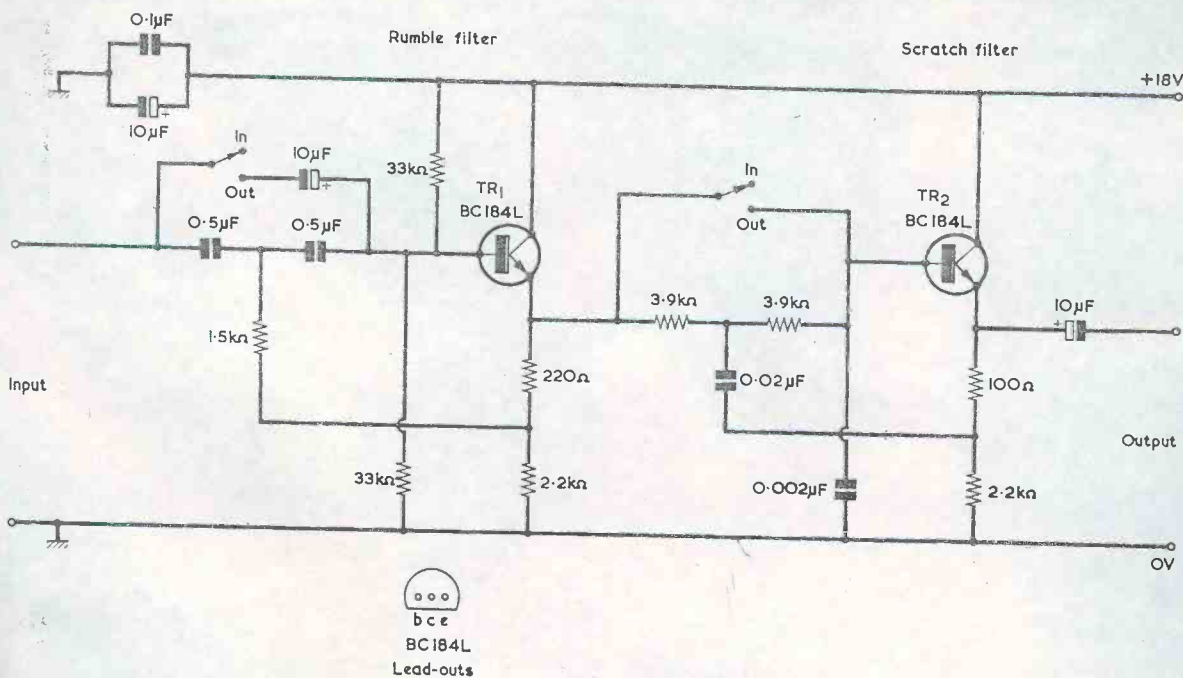

Fig. 2. Scratch and rumble filters

## SCRATCH AND RUMBLE FILTERS

The scratch and rumble filters of Fig. 2 are based on the Sallen and Key forms often found in audio equipment. Their frequency responses are shown in Figs. 3(a) and (b).

Dealing with the scratch filter first, this offers the performance illustrated by Fig. 3(a). There is unity gain at 1kHz, and the response is 3dB down at 8kHz and 20dB down at 20kHz, the ultimate slope being 12dB per octave. A +2dB peak appears at about 4.5kHz.

The response of the rumble filter is given in Fig. 3(b). This shows unity gain at 1kHz, and is 3dB down at 45Hz and 19dB down at 20Hz. The ultimate slope is 12dB per octave. There is a +1.5dB peak at about 80Hz.

The frequency response without the filters extends well outside the audio band, while the low frequency response is determined by the input and output coupling capacitors.

## TONE CONTROL UNIT

A circuit for a simple tone control unit is shown in Fig. 4, with its frequency response in Fig. 5. This circuit gives an overall gain of unity with tone controls flat. Also, frequency response is  $\pm 1$ dB from 10Hz to 100kHz with the tone controls flat. Response variation at 20Hz ranges between +19dB and -25dB. At 20kHz the range is from +13dB to -13dB. Current consumption from the 18V supply is 3.5mA.

The range of the treble tone control can be increased if required by removing or reducing the 4.7kΩ end resistors. The input source impedance for the tone control network should be 220Ω or less. If it is higher the tone control characteristics will be slightly affected.

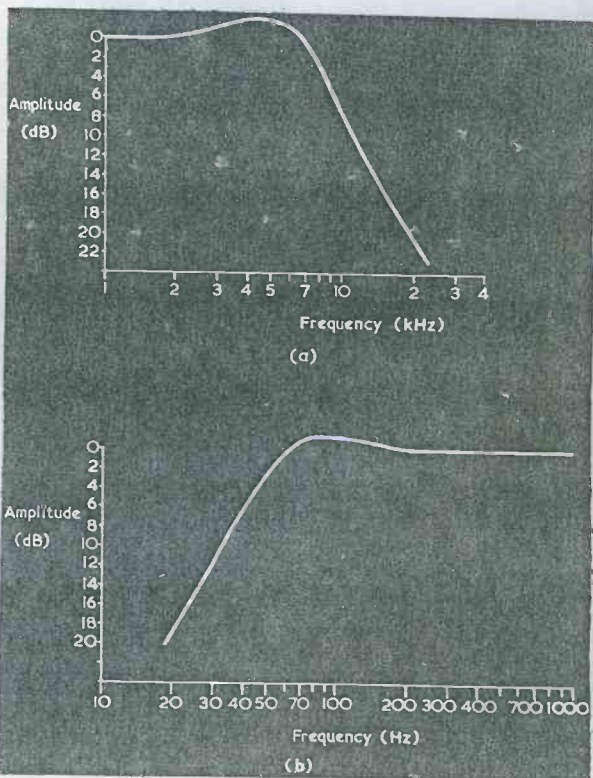

Fig. 3 (a). The frequency response of the scratch filter of Fig. 2  
(b). The response of the rumble filter

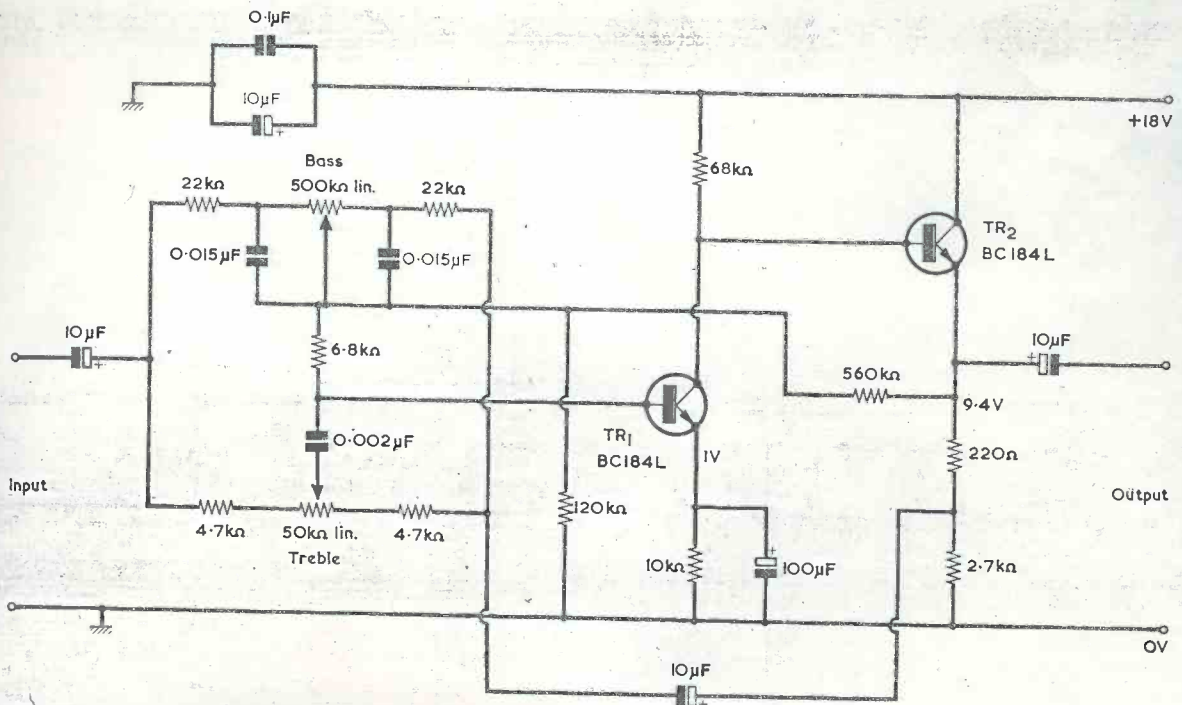

Fig. 4. A unit which incorporates both treble and bass tone controls

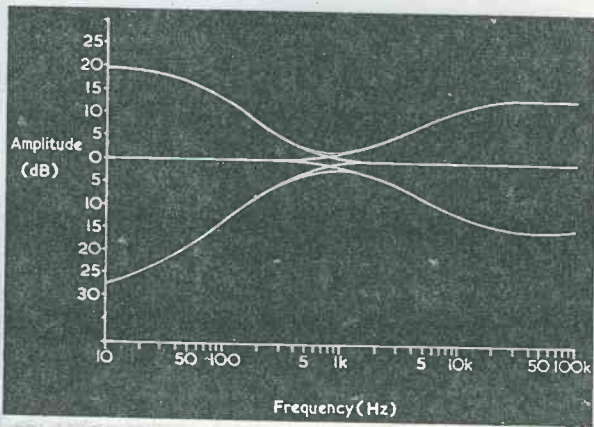

Fig. 5. The frequency response of the tone control unit

### SIMPLE AMPLIFIER

The simple circuit of Fig. 6 is based on the amplifier used for the tone control unit, the frequency selective components having been removed. It offers a gain of about 10 times (20dB) and has an input impedance of approximately 56kΩ. The output impedance is low. As occurs with the tone control amplifier, the current drawn from the 18 volt supply is 3.5mA.

### SUITABLE TRANSISTORS

As was previously mentioned, almost any high gain small signal silicon transistors can be used in the circuits. Taking in those already shown in the diagrams these include, for the p.n.p. positions, BCY71, BC159, 112

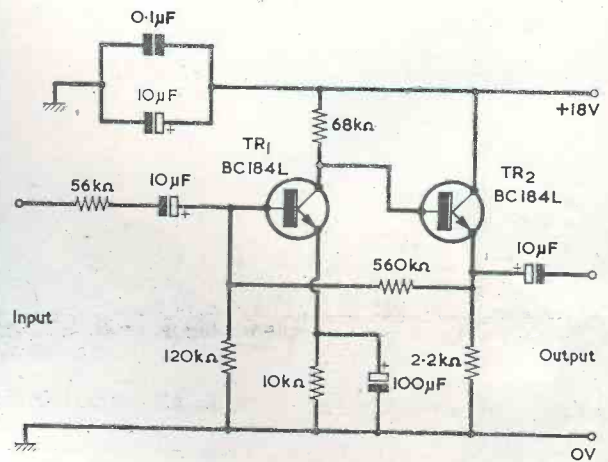

Fig. 6. A simple amplifier offering a gain of about ten times

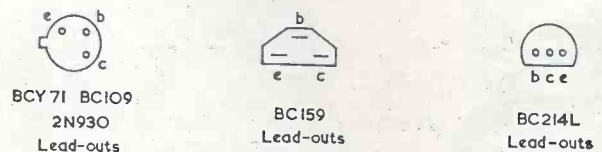

Fig. 7. Lead-out layout diagrams for alternative transistors

BC214L and 2N4061. For the n.p.n. positions, suitable types include BC109, BC184L, 2N930 and 2N3707. Lead-out diagrams which have not already appeared in the circuit diagrams are given in Fig. 7.

# Radio Topics

## By Recorder

### HOLOGRAPHY CAMERA

I see that a holography camera which can make extremely precise recordings in three dimensions of shapes and structures will now be available commercially for the first time in Britain. It is being produced as a self-contained unit ready for direct application to development, testing and research work in engineering and education. Holography has until now only been possible in controlled conditions and with large and costly installations.

The Neutron Division of Marconi-Elliott Avionic Systems Limited, at Airport Works, Rochester, Kent, is extending its range of laser-based devices and is now able to offer the self-contained, portable holography camera (designed by the Fuji Photo Optical Company in Japan) together with a wide range of accessories for an average system cost of not much over £1,400.

This system will enable organisations to make practical use of holography in research and development work or in the dimensional testing and inspection of high precision components without elaborate preparations or specialist experience.

The Fujinon camera consists of a cabinet weighing 55lb. and containing its own HeNe gas laser, beam reflection devices, a holder for 90 by 60mm. plates and a mounting base for objects measuring up to 150 by 150 by 150mm. Normal domestic power is used.

A hologram is taken of an object mounted on the stage inside the camera and is then developed. When reinserted into the plate holder and viewed under the illumination of the camera's internal laser, the hologram reproduces a three-dimensional image

of the object as if it were in its original place inside the camera.

Then if another, identical, object is positioned on the stage inside the camera, the hologram and the object can be seen apparently superimposed and the slightest difference, whether caused by stress or imperfection, can be observed from the resulting pattern of light interference fringes.

### QUADRAPHONIC TURNTABLE UNIT

My photograph shows the Garrard QZ 100S quadraphonic playing system, this being a single play automatic transcription turntable which incorporates built-in decoders for both Discrete and Matrix 4-channel recordings.

A few words on quadraphonic systems may be helpful here. The Discrete (or CD-4) system is that backed by RCA, and it works basically with the same techniques that are used for stereo broadcasting. There are two 45-45 degree tracks in the disc, as in a normal stereo record, and these carry a left front plus left rear signal and a right front plus right rear signal respectively. The two grooves are also recorded with a 30kHz carrier modulated by left front minus left rear for one groove and modulated by right front minus right rear for the other groove. There are in consequence four signals in the two grooves, the two sum signals being recorded in the audio spectrum and the two difference signals in the supersonic range. A decoder following the pick-up extracts the four basic signals in a manner reminiscent of an f.m. broadcast receiver stereo decoder. If the record is played by an ordinary stereo pick-up the two channels reproduce the sum signals and the supersonic difference signals are ignored.

In the Matrix approach (as used by Columbia and Sony) the left front and right front signals are recorded on the two grooves in the normal way. The left back and right back signals also

modulate the grooves, the left back in the form of a clockwise helix and the right back in the form of an anti-clockwise helix. The subsequent decoder sorts out the four signals by means of a matrix. You will remember that, in colour TV, a "matrix" is used to pick out the R-Y, B-Y and G-Y signals. The quadraphonic matrix is not, of course, the same as a colour TV matrix, but it resembles it insofar that it is a device which adds and subtracts signals so as to obtain decoding. A Matrix record can go straight on the air in an f.m. stereo transmission, the Matrix decoding taking place at the receiver.

The Garrard QZ 100S has a special high quality magnetic pick-up with an extended frequency response of 20 to 50,000Hz to reproduce the wide-band Discrete recording and carrier. A "CD-4" lamp lights during playback of Discrete 4-channel recordings.

Matrix 4-channel facilities in the QZ 100S consist of a decoder which produces 4-channel outputs from Matrix disc recordings. 2-channel stereo recordings may be reproduced in the normal way into the front left and right channels. Inputs are provided for connection to an f.m. stereo radio tuner to enable 4-channel Matrix encoded broadcasts to be reproduced.

An enhanced 4-channel stereo output can be obtained by reproducing stereo broadcasts through the Matrix decoder, although some slight loss in left-right separation occurs. This enhancement is particularly evident with recordings made in reverberant surroundings. Alternatively, stereo broadcasts or recordings may be played in the normal way but with some degree of reinforcement from the rear channels. In both cases additional special effects may be added to stereo recordings.

The controls of the QZ 100S player comprise four push-buttons for selection of Discrete, Matrix or stereo operation from disc or radio. Two individual slider controls adjust the front and rear pairs of channels. After initial balancing of left and right channels on the amplifiers, the listening level and balance for the listening position can be adjusted with the player controls.

The pick-up arm embodies the Garrard "Zero 100" principle whereby the pick-up head pivots laterally as it tracks across the record, to maintain negligible tracking error. The arm is fitted with a magnetic anti-skating system, calibrated for both spherical and elliptical cartridge styli. The arm is lowered gently onto the record by a viscous damping system.

The QZ 100S is available for power supplies of 110 to 120 volts and 220 to 240 volts 50Hz, the power consumption being approximately 18 watts. Output is 300mV nominal per channel, equalised. Typical wow figure is 0.07% r.m.s. The dimensions, with cover fitted, are 7½ in. high, 15½ in. deep and 17¾ in. wide.



The Garrard QZ 100S quadraphonic record player system. This incorporates built-in decoders for both Discrete and Matrix 4-channel recordings

# In your workshop

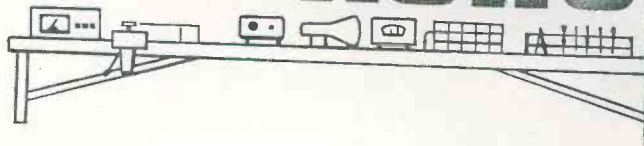

This month we join Dick and Smithy as they enjoy an unexpected sunny spell outside the Workshop. The atmosphere is just right for them to relax from bench work and to undertake a review of the latest hints received from readers.

SMITHY ROCKED HIS STOOL BACK AND rested his shoulders against the outside wall of the Workshop as he basked in the unusually warm early September sun. A handkerchief with a knot at each corner was pulled over his head to protect his pate from possibly injurious ultra-violet radiation and the odd cosmic ray.

Dick, clad in a short jersey and faded jeans, had taken up a similar position alongside the Serviceman. His defences against the sunlight consisted, not of a handkerchief, but of a pair of very large and impenetrably dark sun-glasses which gave him the air of a bit player seeking recognition.

The pair, having eaten their lunch, had left the stuffy confines of the Workshop and were now allowing their digestive systems to function undisturbed in the open air.

## READERS' HINTS

The silence of this idyllic scene was suddenly broken by an irregular and haphazard buzzing. A lone wasp flew around aimlessly, then decided to alight on the handkerchief over Smithy's head. The Serviceman became at once galvanised into action and, sitting forward abruptly, he tore the handkerchief from his head and waved it around feverishly. The wasp, dislodged, fluttered around in a random manner, then decided to seek a less violent venue. Smithy examined his handkerchief very carefully, then replaced it on his head.

"Blooming wasps," he grumbled wrathfully. "At this time of the year they're like Kamazi suicide pilots."

"True enough," agreed Dick lazily.

"That darned wasp has upset me now," continued the Serviceman in an aggrieved tone. "After all that activity I don't feel like settling down again."

Shaken out of his somnolence, Smithy looked around him irritably then glanced at his watch.

"There's another quarter of an hour to go before the end of lunch-break," he announced. "I feel like doing something in that time."

"Why don't you simply take it easy?"

"I'm not in the mood any more,"

replied Smithy. "Ah, I know what I'm going to do!"

Rising abruptly, he walked into the workshop, to reappear after a short period carrying a sheaf of letters. The small area of countenance visible outside Dick's sun-glasses betokened an expression of interest.

"Are we," he asked eagerly, "going to have a sesh on readers' hints?"

"We are," confirmed Smithy. "It's a fairly long time since we had our last session, and quite a few good hints have come in since then. Bring your stool over and I'll tell you about them."

"Good show," said Dick keenly, as he carried over his stool and placed it alongside Smithy's. "I always like hearing these hints."

"Righty-ho then," said Smithy, examining the top letter in the sheaf. "Well, here's a nice simple one to start off with, and it has to do with the sorting out of wires."

Smithy concentrated on the letter.

"Actually," he said, "there are several hints here all on the same subject which, as I said just now, has to do with the identification of wires. The instance can sometimes arise where a set of wires passes from one room in a house to another or from one building to another. These wires may be used for an intercom, an extension loudspeaker or a similar facility, and it is often necessary to make connections to them at both ends with the correct polarity. If the wires aren't colour

coded, this can raise a few difficulties." "How does the reader suggest the job is tackled?"

"He recommends several ways of sorting out the wires," replied Smithy. "To start off with, if there are two wires these can be sorted out by connecting a battery or silicon diode to them at one end. Like this."

Smithy showed Dick a sketch in the letter he was holding. (Figs. 1(a) and (b).)

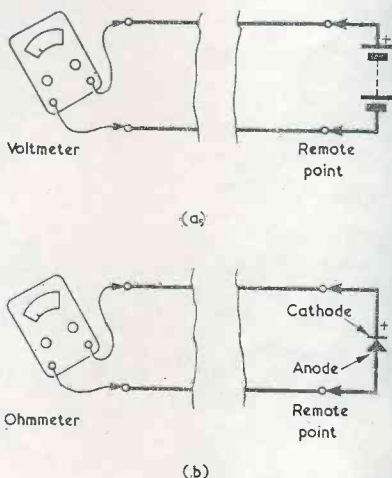

Fig. 1. Two methods of finding the polarity of a pair of wires. In (a) a battery is connected at the remote end whilst in (b) the component at the remote end is a silicon diode



"At the other end of the wires," he resumed, "you can check for polarity with a multi-testmeter. If you've put a battery at the remote end, then you switch the testmeter to a suitable volts range and connect it across the wires. This will tell you the polarity of the voltage on the wires. If, on the other hand, you've put a diode at the remote end you switch the testmeter to an ohms range. A standard testmeter will then give a forward resistance reading when its positive prod connects to the wire which goes to the diode cathode."

"That seems a good idea," stated Dick. "Any further variations on these themes?"

"There are several more," said Smyth, indicating two further sketches in the letter. (Figs. 2(a) and (b).) "If there's a mains earth connection available at either end, one of the wires at the remote end can be connected to this, and it can then be identified at the local end by a continuity tester or ohmmeter. Or a battery can be connected between the wire and mains earth at the remote end, whereupon the wire is then identified at the local end by a meter switched to read volts. These last two ideas are most helpful when there are more than two wires to identify."

#### SERVICING AID

"Well, those certainly seem to be good ideas to get the ball rolling," commented Dick. "What's the next hint, Smyth?"

Smyth examined the letters in his hand.

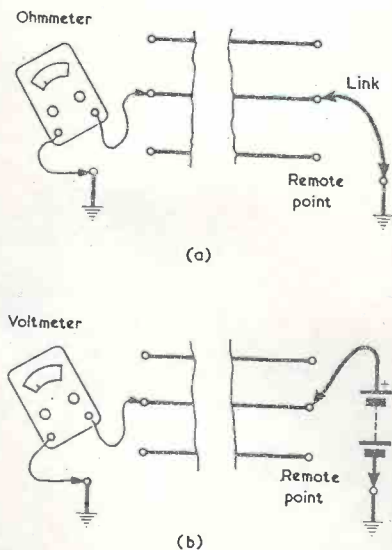

Fig. 2. If a mains earth is available at both ends of the lines, these can be identified by connecting each in turn to the earth as in (a), or via a battery as in (b)

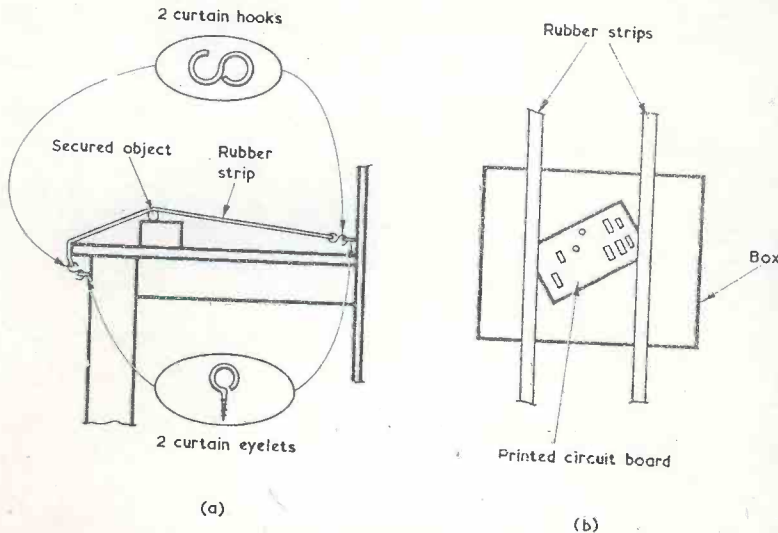

Fig. 3 (a). Fitting a rubber strip to a bench to provide a means of securing light objects  
(b). If two strips are used, a printed circuit board can be secured by the edges

"I see," he remarked after a moment, "that we've got two hints in separate letters from a single reader next. Let's commence with the first one. This letter points out the problems involved when soldering or working on small and fragile items like coils, TV tuner biscuits and small printed circuits. These have an annoying habit of skating around all over the bench and are difficult to hold down. The solution is to provide the bench with a rubber strip which is capable of holding small items in position. A curtain eyelet is screwed in at the back of the bench and another at the front under the overlap. A strip of rubber is then cut from an old car tyre tube and this is fitted with a curtain hook at each end. The rubber strip is used rather like the straps employed by motor cyclists for luggage, but the rubber gives a more gentle and clinging grip. The length of the strip should be a little shorter than bench depth. The item to be worked on is then placed on a box and secured in position with the rubber strip. Like this."

Smyth showed Dick a drawing of the strip. (Fig. 3(a).)

"A further adaptation," he continued, "is to fit two strips side by side. These can then hold printed circuit boards by the corners."

Dick glanced at a sketch in the letter which illustrated this variation. (Fig. 3(b).)

"That seems to be a jolly good idea," he remarked. "I could use a pair of rubber strips like that on my own bench."

"The scheme should be really helpful," agreed Smyth. "One of the advantages of the idea is that the strip

or strips can be set up very quickly. When they're not wanted they're hung up on a peg at the side of the bench out of the way. Now let's have a look at the second hint from this reader."

Smyth scanned the next letter, then grinned.

"This hint gives a scheme for making up low value resistors from old electric fire element wire. There's a sample clipped to the letter."

Smyth passed the sample resistor to his assistant. (Figs. 4(a), (b) and (c).)

"This looks knobby," remarked Dick, as he examined the resistor. "Tell me how it's made up."

"The idea," said Smyth, "is to use short lengths of old electric fire elements for low value resistors of the order of 1Ω or less. The main difficulties involved here are in making reliable connections to the wire. This sort of wire doesn't solder readily and so a pressure type of connection has to be used, this being done by fitting a brass eyelet at each end. The eyelets to use have an inside diameter of slightly more than an eighth of an inch and are available from most tool shops in packets of several hundred, together with a pair of eyelet pliers. Some of the eyelet types available have coloured heads but this doesn't matter and they can still be used. After measuring up the length of element wire needed and allowing for the short pieces required at the terminations, the wire is cut out, and the ends straightened. The ends are next scraped clean with a pen-knife and then bent into single loops. The eyelets are next fitted on the loops and folded over with the eyelet pliers. To make doubly sure, each eyelet is finally nipped, but not too tightly, in a vice.

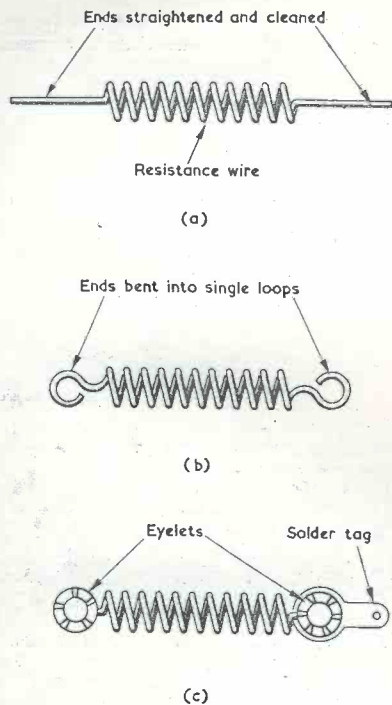

Fig. 4 (a). First step in making low value resistors from short lengths of electric fire element wire  
 (b). The cleaned ends are bent into single loops  
 (c). Eyelets are then fitted tightly over the loops. A solder tag can be included under an eyelet, if desired

A solder tag can be fitted on the eyelet before it is bent over if a soldered connection to the home-made resistor is required. Alternatively, the termination can consist of the eyelet on its own, and this is just right for fitting over a 4BA bolt."

"Well," chuckled Dick, "you certainly get a true wire-wound resistor with this scheme. Will the resistance change with temperature?"

"It shouldn't much," said Smithy. "The wire used for electric fire elements normally has a pretty stable resistance. So far as the current carrying capability of the home-made resistor is concerned, you can work this out from the wattage of the fire which provided the element. If it was a 1 kilowatt fire then the wire glows red at a current of around 4 amps. It should be quite safe for a resistor using the element wire to pass currents up to an amp or so."

## RUBBER FEET

Smithy put the letter he had been reading to the bottom and looked at the next one.

"Here's a really basic one," he remarked. "The idea simply consists of fitting rubber or p.v.c. grommets to the bases of metal instrument cases instead of rubber feet. All you have to do is to cut out four holes in the base of the case, these having the size required by the grommets, and then fit the grommets in normal manner so that half of the grommet is inside the case and half is outside. The advantages are that the grommets are much cheaper than rubber feet and they take up less space. At the same time they still allow the case to be placed on a polished surface without any fear of scratching."

"That's a crafty scheme," stated Dick. "I must remember that for any bits of gear I make up in the future."

"Fair enough," commented Smithy absently, as he turned his attention to the next letter. "Now here's something that's quite different."

"What is it?"

"It's a reader's approach towards obtaining high selectivity on medium waves with a single tuned circuit."

Smithy passed a circuit diagram over to his assistant. (Fig. 5.)

"As you can see," he went on, pointing to the diagram, "the circuit is a bit experimental. Also, the reader says he used odd transistors which he happened to have on hand. The medium wave ferrite rod coil is a commercially wound job, the tap

which would normally couple into the base of the first transistor being ignored. The coil and tuning capacitor couple to TR1 via a 10pF capacitor, and this transistor couples in turn to the second and third transistors in the manner shown. The first two transistors are silicon r.f. types and the third transistor is an OC71. A detected a.f. output is available at the collector of the OC71, and the two pots are set up for optimum signal strength. I wouldn't like to commit myself off-hand as to whether detection is taking place in the second or the third transistor, but I would hazard a guess that it's occurring in the third."

"Why should this circuit give a high level of selectivity?"

"Because there is hardly any loading on the tuned circuit," replied Smithy. "Indeed, the only loading that occurs is given by the 10pF capacitor in series with the input impedance of the first transistor. The resultant loading is relatively very low, this being particularly true when the tuning capacitor is set to around 100pF and above, and the consequence is that the ferrite aerial coil can exhibit virtually its full Q value. The reader states that the selectivity is so good that it's almost necessary to fit a slow-motion drive to the tuning capacitor. The loose coupling between the coil and the base of the first transistor means that the signal level at that base is low, and it is desirable to have an a.f. amplifier after the collector of the OC71. Nevertheless, the scheme is of quite a lot of interest from the home-constructor point of view."

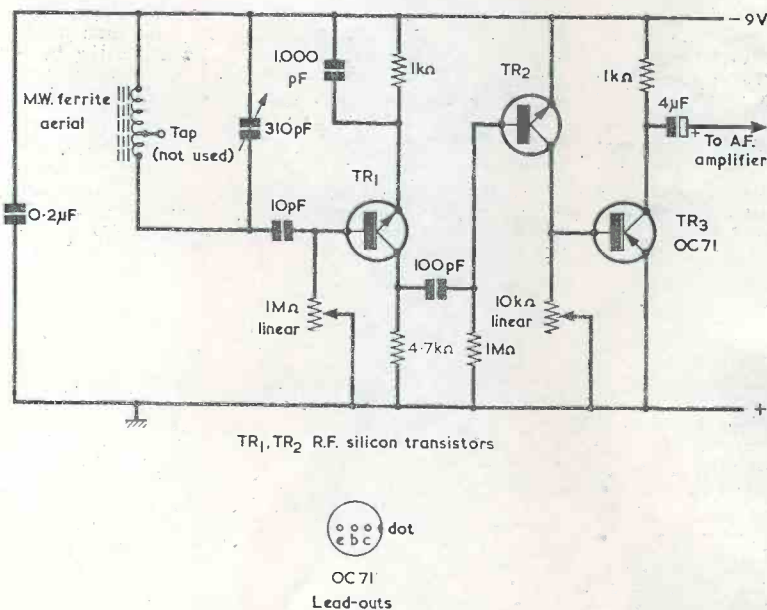

Fig. 5. An experimental medium wave receiver circuit. Despite the fact that there is only a single tuned circuit it offers a high level of selectivity

"I think I'll try it out when I get a chance," said Dick. "I always like playing around with experimental circuits."

Dick started to pass the circuit back to Smithy, but it slipped from his hand and fell to the ground. As he bent forward to pick it up, the bottom of his jersey rose above the top of his jeans, to reveal a two inch strip of bare skin at his back.

"Dash it all, Dick," said Smithy irritably. "Haven't you got anything else on except that jersey and those jeans?"

"Of course I have," replied Dick as he straightened up. "I've got my pants and socks on as well."

"Well, I think you should wear a vest too. I don't think it's seemly for a service engineer to exhibit bare skin all over the place."

Smithy turned a further disapproving glance at his assistant.

"Ye gods," he snorted irately.

"That jersey's got all rumpled up in the front as well. I can see your navel!"

"So what?" retorted Dick hotly. "You've got a navel, too."

"Possibly I have," conceded Smithy.

"But I take great care to keep it firmly covered up. Ugly things, navels."

"No, they're not," argued Dick.

"Cleopatra used to keep a ruby in hers. Besides, a navel's useful."

"In what way?"

"Well, for instance, you can use it to keep salt in whilst eating chips in the bath."

Smithy glared suspiciously at his assistant, but was unable to penetrate the blackness of that worthy's sunglasses.

"Humph," he grunted, defeated.

"Well, that's as may be. At any event I don't want to spend any more time looking at your navel, so kindly take steps to conceal it."

"All right," replied Dick equably.

He pulled his jersey down and the offending organ disappeared from view. He then handed Smithy the piece of paper he had picked up from the ground.

"What's this?" asked Smithy.

"It's the circuit diagram for the last hint you read out."

"Oh yes, so it is," remarked Smithy, taking the paper from his assistant.

"I'd almost forgotten for the moment that we were dealing with readers' hints!"

He put the circuit diagram and its accompanying letter to the bottom of the pile and turned his attention to the next letter.

## FERRITE COIL SECURING

"Well now," he remarked, his mind obviously concerned once more with matters electronic rather than matters imbibic. "Let's see what we have here."

He read for a few moments. "This is another case where we have no hints from one reader," he

announced. "The first of these concerns ferrite aerial coils. Our correspondent has difficulty with these moving along the ferrite rod during alignment, and the cure is to simply slip a short rubber band twice round the coil former and the rod. One turn of the band goes round the former and the other round the rod, and this holds the coil quite steady."

Dick glanced at a sketch of the arrangement. (Fig. 6.)

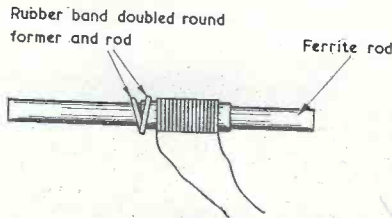

Fig. 6. A simple scheme for maintaining a ferrite rod coil in position on the rod

"That's a helpful idea," he commented. "What's the second hint?"

"It's a means of allowing equipment battery voltage to be checked without removing the back," replied Smithy.

"Two insulating bushes are fitted to the bottom of the equipment case and two Veroboard pins, or similar, are driven into them so that the lower ends of the pins are just short of the lower ends of the bushes. Battery voltage can then be checked at any time, either on load or off load, by connecting a meter to the pins. The bottom of the case has, of course, to be fitted with rubber feet, or with grommets as in the earlier hint we had today, to give clearance for the insulated bushes. Since the pins are inside the bushes, the battery can't be short-circuited if the bushes come in contact with a sheet of metal."

"That's neat," commented Dick, thoughtfully, looking at the reader's diagram. (Fig. 7.) "Those insulated test points could alternatively be put on the front panel or on the back, couldn't they?"

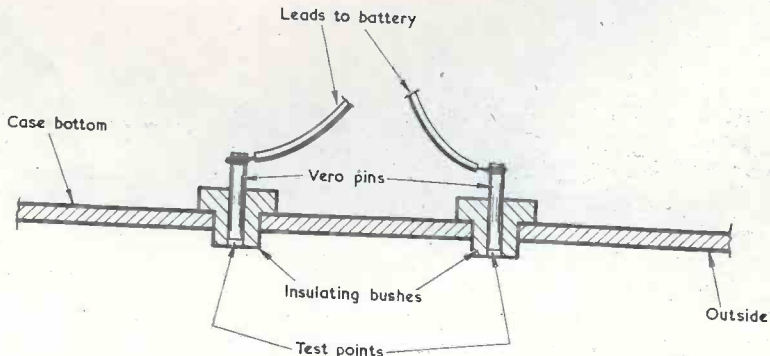

Fig. 7. How to provide test points for checking battery voltage in an item of equipment

"They could," confirmed Smithy. "You might have to hunt around in the junk box for suitable insulated bushes, and an alternative idea would be to use a small 2-way socket with recessed pins or something like that."

"It's an interesting scheme," agreed Dick warmly. "Do you know, Smithy, we're getting some jolly good hints today."

"We always do," replied Smithy.

"Anyway, let's take a butcher's at the next one. I'll read the letter out to you."

"An increasing number of portable receivers," it says, 'have provision for f.m. signals on v.h.f., many of them relying on a single short telescopic aerial. In fringe areas it will quite often be found that a further extension to the telescopic aerial can work wonders. Rather the same applies to short wave receivers using telescopic aerials.'

Smithy turned a page of the letter.

"Most of these aerials have a knob screwed to the threaded end of the top, thinnest section," he went on.

"This knob can in a number of cases be removed and replaced with an ordinary bicycle spoke nipple. Some aerials, such as the popular Eagle swivel aerials type TA627 and TA632, have a thread which will take the nipple directly. With other aerials a drop of solder may be required. A bicycle spoke can then be screwed into the other end of the nipple giving, with a 28 inch wheel spoke, an extension of about 12 inches. This spoke cannot be retracted of course, but it can easily be removed when not required."

"That's quite a useful idea," remarked Dick. "It's surprising how much difference a short addition to a telescopic aerial can make in some instances."

"That's very true," agreed Smithy.

"Theoretically, a v.h.f. telescopic aerial should in most cases be a quarter wavelength long, but the fact that the counterpoise for the aerial is only a small transistor radio chassis causes quite unpredictable results to be obtained in practice. The writer of this letter states that he used the spoke idea with a home-built v.h.f. receiver and that it resulted in a weak distorted

## Your Local Supplier

LONDON

### THE MODERN BOOK CO.

Largest selection of English & American radio and technical books in the country.

19-21 PRAED STREET,  
LONDON, W2 1NP  
Tel: 01-723 4185/2926

## ST. HELEN'S RADIO

Hi-Fi Equipment  
Tape Recorders  
Radio Receivers  
Television

SPECIALISTS IN RADIO  
& ELECTRONIC TEXTBOOKS

ST. HELENS GARDENS  
LONDON, W.10  
Tel: 01-969 3657

HAMPSHIRE

## BOURNEMOUTH

LARGEST HI-FI AND  
RADIO COMPONENT  
STORE IN THE SOUTH

FORRESTERS NATIONAL  
RADIO SUPPLIES LTD.

70-72 Holdenhurst Road  
Bournemouth  
Telephone 25232

SURREY

## WITWORTH TRANSFORMERS

TV Line out-put transformers

Manufacturers of the largest range in the country. All makes supplied.

Free catalogue.

Models...

BAIRD, BUSH, GEC, PHILIPS

Replacement types ex-stock.

For "By-return" service, contact London  
01-948 3702

Tidman Mail Order Ltd., Dept. R.C.,  
236 Sandycombe Road,

Richmond, Surrey TW9 2EQ

Valves, Tubes, Condensers, Resistors,  
Rectifiers and Frame out-put Transformers,  
Mains Transformers also stocked.  
Callers welcome.

output changing to one which had good quality and was at the full output of the receiver. There's a sketch of the arrangement here."

Smithy indicated the diagram to Dick (Fig. 8.) then passed on to the next hint.

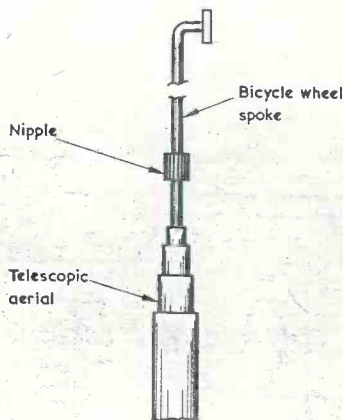

Fig. 8. An extension piece can be added to a telescopic aerial in the manner shown here

"Ah," he remarked, reading the letter carefully. "This is yet another instance of two hints from a single reader. The writer starts off by referring to the problems incurred when using dual-in-line integrated circuits in experimental circuits."

"He's got a point there," broke in Dick. "The terminal pins on these i.c.'s are so thin and weak that they often short together or break off in experimental hook-ups unless you take considerable care in handling. You're not always out of trouble if you use an i.c. holder either, because the terminal pins on some i.c. holders are as fragile as those on the i.c. itself."

"I wouldn't argue with you there," said Smithy. "Well, the scheme proposed here is that dual-in-line i.c.'s intended for experimental work be soldered onto small pieces of 0.1 inch Veroboard, each board having eight holes, and as many strips as the i.c. has terminal pairs. Here's the idea."

Interestedly, Dick examined a diagram in the letter. (Fig. 9.)

"You'll note," resumed Smithy, "that the strips are all cut between the two sets of terminal pins. The integrated circuit is fitted into the holes as indicated, and its terminal pins are soldered to the strips. External circuit connections can then be made to the end holes of the strips, and the whole assembly is extremely robust, with no mechanical strain being put on the integrated circuit at all. Our corres-

pondent says that the small time he spent initially cutting up and preparing the pieces of Veroboard has been repaid many times over by the saving in time resulting from the use of the completed assemblies. They can be hung up in the wiring of experimental circuits, and solder connections can be added and removed with no risk of damage to the i.c. whatsoever."

"That's neat," commented Dick quickly. "Incidentally, it's just occurred to me that if you used i.c. holders whose terminal pins have the same spacing as the i.c. itself, you could solder a holder to the piece of Veroboard."

"So you could," replied Smithy. "And this would give you more versatility since you could then plug any dual-in-line integrated circuit having the requisite number of pins into the holder. The i.c. would still be protected mechanically and would still be part of a rugged assembly."

"You approve of my suggestion?"

"I do indeed. Very good. Now the second hint is also about mounting

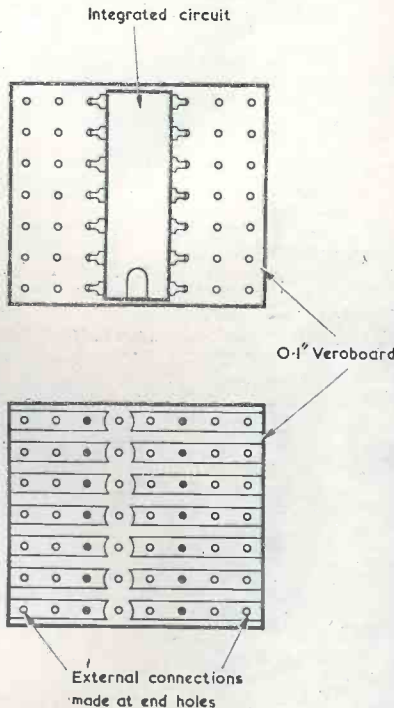

Fig. 9. Dual-in-line integrated circuits may be fitted to small pieces of Veroboard when it is desired to employ them in experimental circuits. This provides a robust assembly with no risk of damage to the fragile i.c. terminal pins. The diagram shows the top and copper sides of the board

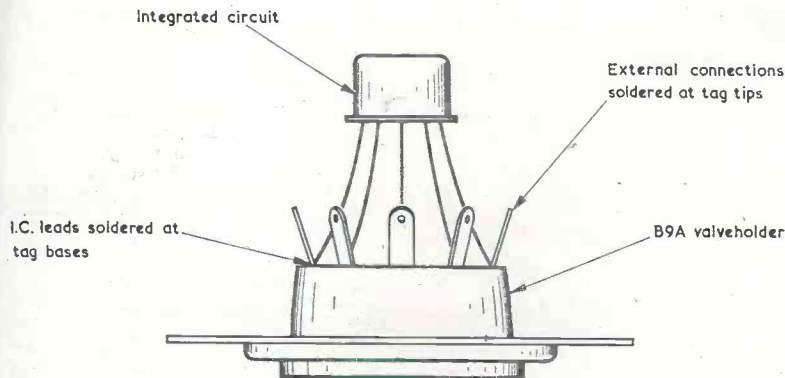

Fig. 10. Many multi-lead integrated circuits can be conveniently mounted on an inverted valveholder

i.c.'s for experimental circuits, but in this case the i.c.'s concerned are the multi-lead types whose lead-outs appear in a circle."

Dick groaned. "I know all about them," he said morosely. "They're all right if they fit into a printed circuit pattern that's designed for them, but they can be the devil to connect up otherwise."

"The answer to that," grinned Smyth, "is to solder them to a B9A valveholder!"

"Hey?" "I'm perfectly serious," Smyth chuckled. "If you turn a B9A valveholder upside-down it becomes possible to solder a multi-lead i.c. to it with hardly any trouble at all. You gently splay out the leads from the i.c. and then solder these to the valveholder tags near the points where the tags enter the plastic. The outer ends of the tags can then take external connections. Not all multi-lead integrated circuits can be connected up in this manner because they may have too many leads or the leads may be too short, but most of them can. If the i.c. has seven leads or less, a B7G valveholder can be used instead of a B9A type. In most cases you'll have to cut down the centre spigot of the valveholder. If the cut-down centre spigot is connected

to earth it may in some cases provide screening between the input and output of the integrated circuit. Assuming, of course, that the i.c. is a linear type. Here's the general approach."

Smyth indicated a second sketch in the letter he was holding, (Fig. 10) then consulted his watch.

#### TEMPUS FUGIT

"Blimey," he remarked, "we should have been back at work ten minutes ago!"

"Not to worry," replied Dick soothingly. "We may not have spent those ten minutes in fixing sets but we have at least used them to further our electronic education. Besides, I enjoy these readers' hint sashes."

"So do I," remarked Smyth, as he picked up his stool and proceeded to carry it back into the Workshop. "There's nothing like a pooling of ideas for making you think up new approaches."

As Dick stooped and picked up his stool, his jersey rolled up again. Hastily he pulled it down before Smyth could once more comment on the exposed patch of skin at the front. Besides, as he reasoned considerably to himself, the Serviceman had far more weighty matters to contemplate than his assistant's navel. ■

#### EDITOR'S NOTE

The hints appearing in this month's episode of 'In Your Workshop' were received, in the order they appear, from T. Matthews, D. Smith, A. Rawlings, D. R. Whittle, G. M. Watson, Sir Douglas Hall and J. P. Evans.

Further hints for this feature are welcomed and payment is made for all that are published.

## Your Local Supplier

SUSSEX

### E. JEFFRIES

For your new television set  
tape recorder, transistor radio  
and hi-fi equipment

PHILIPS, ULTRA, INVICTA  
DANSETTE, MASTERADIO, PERDIO,  
MARCONI, PHILCO FIDELITY

6A Albert Parade  
Victoria Drive,  
EASTBOURNE SUSSEX

EIRE

### PEATS for PARTS

ELECTRONIC COMPONENTS  
RADIO & TELEVISION

For the convenience of Irish  
enthusiasts we supply

The Radio Constructor  
Data Books and  
Panel-Signs Transfers

Also a postal service

Wm. B. PEAT & Co. Ltd.  
28 PARNELL STREET  
DUBLIN 1

## RADIO & ELECTRONICS CONSTRUCTOR

ANNUAL  
SUBSCRIPTIONS  
to this magazine  
may be obtained  
through your  
newsagent  
or direct from the  
publishers  
ONLY £2.70  
per year, post free

Please send remittance with name  
and address and commencing issue  
required to:

DATA PUBLICATIONS LTD  
57 Maids Vale London W9 1SN