

THE Radio Constructor

RADIO
TELEVISION
AUDIO
ELECTRONICS

VOLUME 16 NUMBER 1
A DATA PUBLICATION
PRICE TWO SHILLINGS

August 1962

Transistorised Electronic Organ

- Low Cost Record Player Amplifier
- A Decibel Meter
- A Valve Tester Design
- Radio Veronica
- Photoflash Slave Unit
- High-Low Impedance Microphone Pre-Amplifier
- Cathode Followers and their Uses
- Small Power Supply Unit
- The Good Companion Transfilter Portable



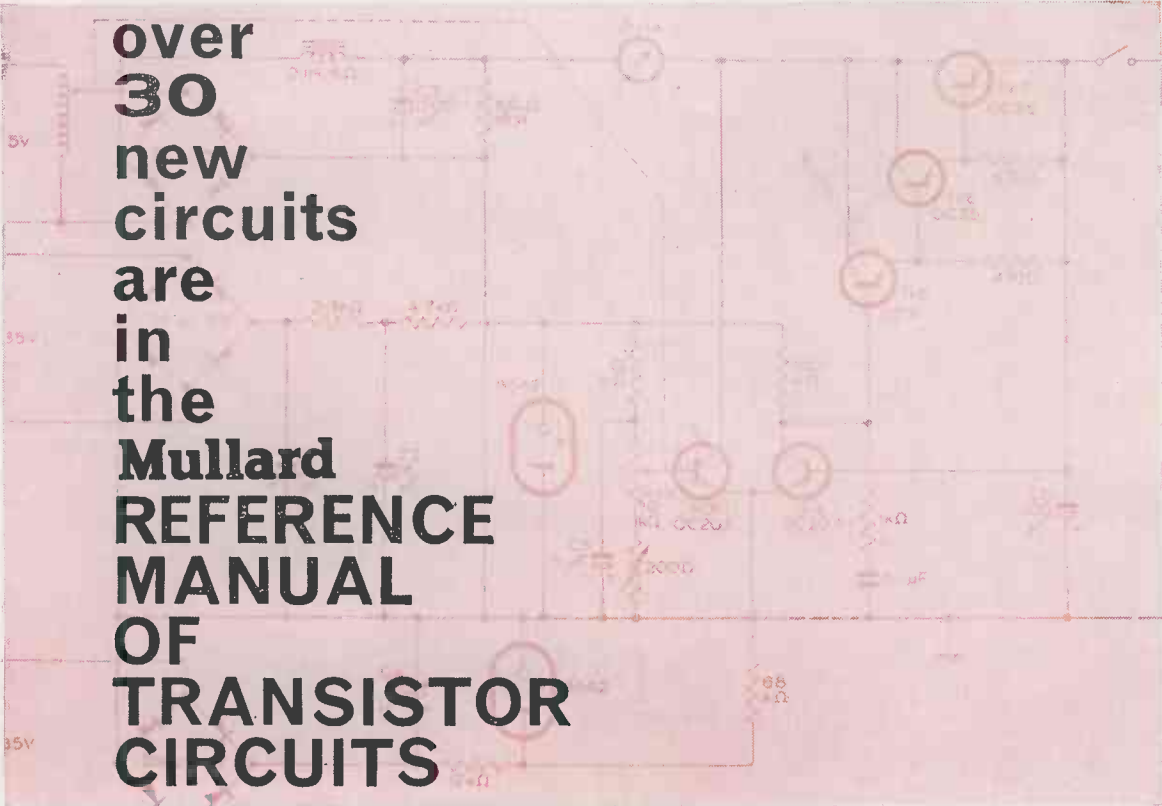

over
30
new
circuits
are
in
the
Mullard
**REFERENCE
MANUAL
OF
TRANSISTOR
CIRCUITS**

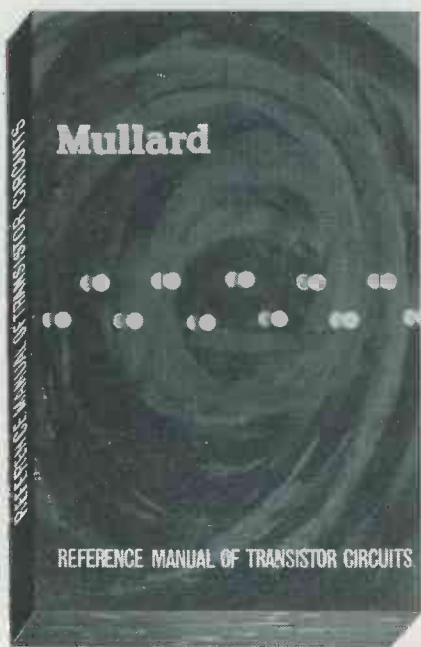

This manual of transistor circuitry has been prepared by Mullard engineers, as an up-to-date and readable volume which will be of use and interest to technicians, service engineers, junior designers and electronics students.

It has a page size of $8\frac{1}{2}$ " x $5\frac{1}{2}$ " and describes more than 60 circuits — over 30 are made generally available for the first time—including both domestic and industrial applications.

308 PAGES · 241 DIAGRAMS · U.K. PRICE 12s. 6d.
PUBLISHED BY MULLARD LTD.

Get your copy of the Mullard "Reference Manual of Transistor Circuits" today from your radio dealer, or order direct from Mullard Ltd. (postage and packing 1s. 0d. extra in U.K.).

MULLARD LIMITED · MULLARD HOUSE · TORRINGTON PLACE · LONDON W.C.1
Overseas readers should enquire of their local Mullard Agents.

SUPERB COMMUNICATION RECEIVERS

AMERICAN AR88D RECEIVERS. Fresh release of these renowned sets. 14 valves, 6 wavebands, covering 500 kc/s-32 Mc/s. Incorporate every possible refinement and have internal A.C. mains pack for nominal 115/230V. Thoroughly reconditioned, immaculate in appearance, and in perfect working order. **ONLY £35** (add carriage 30/- and 50/- deposit on returnable transit case). S.A.E. brings illustrated leaflet.

MARCONI CR. 100/8 COMMUNICATIONS RECEIVER. Covers 60 kc/s to 30 Mc/s. Complete with all valves, maker's instruction manual, and internal A.C. power unit for 200/250 volts. **BRAND NEW IN ORIGINAL TRANSIT CASES.** Aerial tested before despatch. **ONLY £35** (carr. etc., 40/-). S.A.E. for full details.

TEST METERS FOR EVERY PURPOSE & POCKET

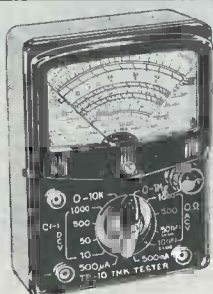

2,000 O.P.V. MODEL TP-10. Reads A.C. and D.C. volts up to 1,000; D.C. Current to 500mA; resistance to 1 Meg; Capacitance to 1µF; Decibels from -20 to +36; Output jack for Audio Measurements. Size 3½" x 5" x 1½". **£3.19.6**

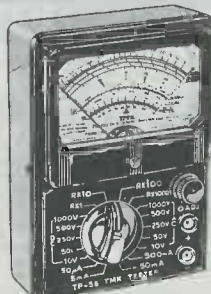

20,000 O.P.V. MODEL TP-5S. Reads Voltage up to 1,000; D.C. at 20,000 ohms per volt and A.C. at 10,000 o.p.v.; D.C. Current to 500mA; Resistance to 10 Meg.; Capacitance to 0.1µF; Decibels from -20 to +36. Size 3½" x 5¼" x 1½". **£5.19.6**

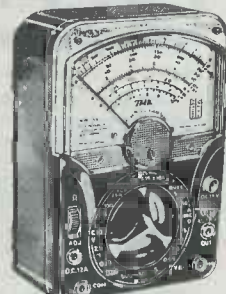

30,000 O.P.V. MODEL 500. Volts to 1,000; D.C. at 30,000 o.p.v., A.C. at 20,000; 12 Amps D.C. Current; 60 Meg. Resistance; -20 to +56 Decibels; Internal buzzer short circuit warning. Size 3½" x 6½" x 2½". **£8.19.6**

All new stock, with leads, prods & internal batteries. 6 mths. guar. backed by full service facilities. Details S.A.E.

AMPLIFIER TYPE A1413. Ex-R.A.F. For normal A.C. mains use. 5Z4 rectification with 6V6 output. Input and output jack sockets, gain control, fully fused. 600 ohms output transformer, easily changed for 3 ohms type. Standard rack mounting size 19" x 7" x 6". Used, good condition. **ONLY 59/6** (carriage, etc., 10/6).

POWER UNITS TYPE 234. Primary 200/250V 50 cycles. Outputs of 250V 100mA and 6.3V 4A. Fitted double smoothing. For normal rack mounting (or bench use) having grey front panel size 19" x 7". Fitted input and output voltmeter, 79/6, or model less meter, 59/6 (carriage either type 10/6).

12 VOLT AMERICAN DYNAMOTORS. Deliver 220 volts at 100mA. Size 5½" x 3½" diameter. Ideal for running Electric Shaver, etc., from car battery. **ONLY 32/6** (post 2/6).

AVOMETER MODEL 7 LEATHER CASES, fitted with carrying handle and long strap. **BRAND NEW. ONLY 32/6** (post 2/6).

PCR COMMUNICATION RECEIVERS

Manufactured by Pye and Philips. One of the Army's most versatile and sensitive sets. RF stage and 2 of IF, using 6 British I.O. type valves. Large 180 degrees. Illuminated and Calibrated Dial. Flywheel tuning with locking device. Aerial trimmer. Tone and volume controls. Band switch from panel jacks for speaker or phones. In black metal case, size 17" L x 8" H x 10" D. Model PCR covers 6-18 Mc/s, 200-550 metres and 850-2,000 metres and has internal 5" speaker. **£6.19.6.** Model PCR2 has similar L & M waveband coverage. Short wave 6-22 Mc/s, but no speaker. Used but excellent condition, **£5.19.6.** Every receiver aerial tested before despatch. Add 10/6 carr. all models. Designed to operate from bulky EXTERNAL power supply, but any set can be fitted with **BRAND NEW COMPONENTS INTERNAL PACK** for 200/250V a.c. at extra cost of **£2.**

S.A.E. FOR ILLUSTRATED LEAFLET

"P.W." 6 TRANSISTOR PERSONAL RECEIVER

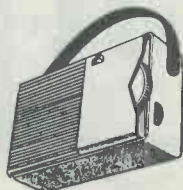

BATTERY AND CABINET NOW **£8.10.0.** S.A.E. for 7 transistor version.

Designed by the technical staff of Practical Wireless: easy to build, using printed circuit and 1st grade Matched Transistors and Diode. Full Medium and Long Wave coverage to internal speakers. All parts sold separately (new components only) enabling you to buy as required, and full detailed price list will be sent on request. Constructional details 1/6. Newly designed OSMOR Cabinet and reduced price. **TOTAL COST INCLUDING £8.10.0.** S.A.E. for 7 transistor version.

THE "GOOD COMPANION" Mk. II

Using transfilters, the latest manufacturing technique to save alignment difficulty.

THE FINEST COMBINED PORTABLE AND CAR RADIO YET DESIGNED FOR THE HOME CONSTRUCTOR

★ 750mV output.

★ 6 transistors and 2 diodes.

★ Full Medium and Long Wave coverage.

★ Quality speaker.

★ Brilliantly styled 2-tone cabinet, size 11" x 8" x 3".

★ Very fine tuning with calibrated dial.

★ Latest printed circuit. ★ Internal high gain aerial with car aerial socket. Easy to follow construction data (available separately 3/6). All parts sold separately and full illustrated details will be sent on request.

Total Cost **£9.19.6**

With alternative luxury cabinet using 7" x 4" speaker, **£10.19.6.** Either type, plus 5/- post and ins. (Battery 3/6 extra.)

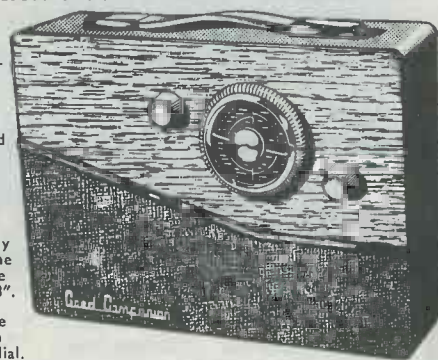

"POCKET 4" TRANSISTOR RECEIVER

Uses miniature speaker, proper tuning condenser, and volume control. Built-in aerial makes unit efficient and portable. Ideal for the beginner. Full medium wave coverage. All components and case for only **42/6** (p. & p. 2/6). Ten-page constructional book free with parts or separately 1/6. S.A.E. for parts price list.

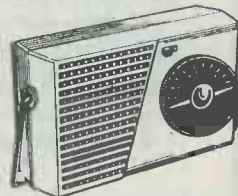

HARRIS ELECTRONICS (LONDON) LTD

(DEPT. M)

138 GRAY'S INN ROAD LONDON WC1

Telephone TERminus 7937

Please include carriage costs on ALL items.
(Open until 1 p.m. Saturdays.) We are 2 mins. from High Holborn (Chancery Lane Station) and 5 mins. by bus from King's Cross.

FREE TO AMBITIOUS ENGINEERS

— THE LATEST EDITION OF ENGINEERING OPPORTUNITIES

Have you sent for your copy?
ENGINEERING OPPORTUNITIES is a highly informative 156-page guide to the best paid engineering posts. It tells you how you can quickly prepare at home for a recognised engineering qualification and outlines a wonderful range of modern Home Study Courses in all branches of Engineering. This unique book also gives full details of the Practical Radio & Electronics Courses, administered by our Specialist Electronics Training Division—the *B.I.E.T. School of Electronics*, explains the benefits of our Employment Dept. and shows you how to qualify for five years promotion in one year.

We definitely Guarantee
“NO PASS — NO FEE”

Whatever your age and experience you cannot afford to miss reading this famous book. If you are earning less than £25 a week send for your copy of “ENGINEERING OPPORTUNITIES” today—FREE.

BRITISH INSTITUTE OF ENGINEERING TECHNOLOGY (Incorporating *E.M.I. Institutes*)
 (Dept. SE/23), 29 Wright’s Lane, London, W.8

WHICH IS YOUR PET SUBJECT?

Mechanical Eng.,
 Electrical Eng.,
 Civil Engineering,
 Radio Engineering,
 Automobile Eng.,
 Aeronautical Eng.,
 Production Eng.,
 Building, Plastics,
 Draughtsmanship,
 Television, etc.

GET SOME LETTERS AFTER YOUR NAME!

A.M.I. Mech. E.
 A.M.I.C.E.
 A.M.I. Prod. E.
 A.M.I.M.I.
 L.I.O.B.
 A.F.R. Ac. S.
 B.Sc.
 A.M. Brit. I.R.E.
 City & Guilds
 Gen. Cert. of Education
 Etc., etc.

PRACTICAL EQUIPMENT

Basic Practical and Theoretic Courses for beginners in Radio, T.V., Electronics, Etc., A.M. Brit. I.R.E. City & Guilds Radio Amateurs’ Exam. R.T.E.B. Certificate P.M.G. Certificate Practical Radio Radio & Television Servicing Practical Electronics Electronics Engineering Automation

INCLUDING TOOLS!

The specialist Electronics Division of *B.I.E.T. (Incorporating E.M.I. Institutes)* NOW offers you a real laboratory training at home with practical equipment. Ask for details.

B.I.E.T. SCHOOL OF ELECTRONICS



POST COUPON NOW!

Please send me your FREE 156-page “ENGINEERING OPPORTUNITIES”
 (Write if you prefer not to cut page)

NAME

ADDRESS

SUBJECT OR EXAM THAT INTERESTS ME

THE B.I.E.T. IS THE LEADING ORGANISATION OF ITS KIND IN THE WORLD

THE MODERN BOOK CO

- The Radio Amateur’s Handbook. By A.R.R.L. 1962. 36s. Postage 2s.
- Newnes Radio Engineer’s Pocket Book. 10s. 6d. Postage 6d.
- Basic Radar. Part 1. Pub. Technical Press. 16s. Postage 1s.
- The A.R.R.L. Antenna Book. 18s. Postage 1s. 3d.
- World Radio TV Handbook 1962. 18s. 9d. Postage 1s.
- Cabinet Handbook. By G. A. Briggs. 7s. 6d. Postage 6d.
- Radio Valve Data. 7th Ed. Compiled by “W.W.” 6s. Postage 10d.
- Elementary Telecommunications Examination Guide. By W. T. Perkins. 17s. 6d. Postage 9d.

- Electronic Music and Musique Concrete. By F. C. Judd. 16s. Postage 1s.
- The Organ. By W. L. Sumner. 45s. Postage 1s. 6d.
- Hi Fi for Beginners. By J. Borwick. 7s. 6d. Postage 6d.
- Radio-Controlled Models. By R. H. Warring. 16s. Postage 1s.
- R.S.G.B. Amateur Radio Call Book. 1962 Ed. 4s. 6d. Postage 6d.
- Short Wave Receivers for the Beginner. A Data Pub. 6s. Postage 6d.
- The Home Electrician. By F. J. Camm. 12s. 6d. Postage 6d.
- Romping through Mathematics. By R. W. Anderson. 5s. Postage 6d.

We have the Finest Selection of British and American Radio Books in the Country
 Complete catalogue 1s.

19-21 PRAED STREET (Dept RC) LONDON W2

Telephone PADdington 4185

TECHNICAL
TRAINING
in radio
television
and
electronic
engineering
with

The decision is **YOURS**. To be a success in your chosen career; to qualify for the highest paid job . . . to control a profitable business of your own. ICS home-study courses put your plans on a practical basis; teach you theory and practice; give you the knowledge and experience to take you, at your own pace, to the top.

Choose the **RIGHT** course.

RADIO & TELEVISION
 ENGINEERING . INDUSTRIAL
 TELEVISION . RADIO AND TV
 SERVICING . RADIO SERVICE
 AND SALES . ELECTRONICS .
 COMPUTERS AND PROGRAMMING

ICS provides thorough coaching for professional examinations: A M BRIT. I R E, City and Guilds Telecommunications. C. & G. Radio and TV Servicing, C. & G. Radio Amateurs.

LEARN AS YOU BUILD

Practical Radio Course

Gain a sound up-to-professional-standards knowledge of Radio and Television as you build your own 4 valve T R F and 5 valve superhet radio receivers, signal generator and high-quality multimeter. At the end of the course you have three pieces of permanent and practical equipment and a fund of personal knowledge and skill . . . ICS Practical Radio courses open a new world to the keen radio amateur.

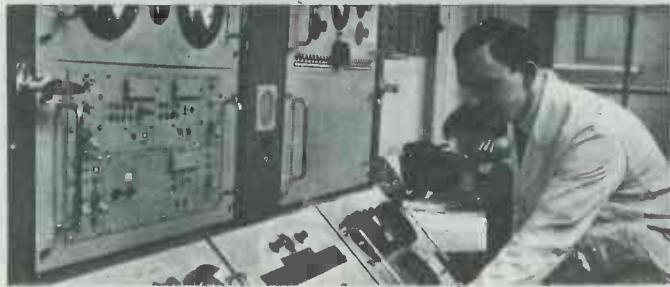

THERE ARE ICS COURSES TO MEET YOUR NEEDS AT EVERY STAGE OF YOUR CAREER.

Post this coupon today: In return you will receive the **FREE** 60-page ICS Prospectus listing technical examinations and their appropriate ICS courses **PLUS** details of over 150 specialised subjects.

Other ICS courses include:

MECHANICAL, MOTOR, FIRE, CHEMICAL, ELECTRICAL AND CIVIL ENGINEERING, ETC. SELLING AND MANAGEMENT, ARCHITECTURE, WOODWORKING, FARMING, GARDENING, ART, PHOTOGRAPHY.

Please state subject in which you are interested on coupon.

ICS

INTERNATIONAL CORRESPONDENCE SCHOOLS

(Dept. 248) Intertext House Parkgate Road London SW11

NAME.....

ADDRESS

OCCUPATION..... AGE.....

SUBJECT..... 8.62

Heathkit

DAYSTROM



SB-10U

SINGLE SIDEBAND ADAPTOR, Model SB-10U. May be used with most A.M. transmitters. Less than 3w R.F. input power required for 10w output. Operation on 80, 40, 20, 15 and 10m bands on U.S.B., L.S.B. or D.S.B. **£37.6.0**



DX-40U

AMATEUR TRANSMITTER, Model DX-40U. Covers all amateur bands from 80 to 10 metres; crystal controlled. Power input 75W C.W., 60W peak controlled carrier phone. Output 40W to aerial. Provision for V.F.O. Filters minimise TV interference. **£32.10.0**



GD-1U

GRID-DIP METER, Model GD-1U. Functions as oscillator or absorption wave meter. With plug-in coils for continuous frequency coverage from 1.8 Mc/s to 250 Mc/s. **£10.9.6**

Three Additional Plug-in Coils Model 34-1U extend coverage down to 350 kc/s. With dial correlation curves. **15/-**



O-12U

TRANSISTORISED VERSION, Model XGD-1. Similar to GD-1U. Fully transistorised with a frequency range of 1.8 to 45 Mc/s. **£10.8.6**

5" OSCILLOSCOPE, Model O-12U. Has wide-band amplifiers, essential for TV servicing, FM alignment, etc. Vertical frequency response 3 c/s to over 5 Mc/s, without extra switching T/B covers 10 c/s to 500 kc/s in 5 ranges. **£36.10.0**



S-3U

2 1/2 in. SERVICE SCOPE, Model OS-1. Light, compact portable for service engineers. Dim. 5" x 8" x 1 1/4" long. Wt. 10 1/2 lb. **£19.10.0**

ELECTRONIC SWITCH, Model S-3U (Oscilloscope Trace Doubler.) Enables a single beam oscilloscope to give simultaneous traces of two separate and independent signals. Switching rates approx. 150, 500, 1,500, 5,000 and 15,000 c/s. Sig. freq. response 0-100 kc/s. +1dB. Separate gain controls and sync. output. Sig. input range 0.1-1.8V r.m.s. **£10.15.6**



C-3U

RESISTANCE CAPACITANCE BRIDGE Model C-3U. Measures capacity 10pF to 1,000µF, resistance 100Ω to 5MΩ and power factor. 5-450V test voltages. With safety switch. **£8.6.6**



AG-9U

AUDIO SIGNAL GENERATOR, Model AG-9U. 10 c/s to 100 kc/s, switch selected. Distortion less than 0.1%, 10V sine wave output metered in volts and dB's. **£19.19.6**

TRANSISTOR INTERCOM, Models XI-1U & XIR-1U. The master unit uses a 4-transistor amplifier, constructed on a printed circuit board, and an internal 9V battery. Remote stations use a similar battery for call only. Up to five remote units can be ordered for each master. **£4.3.0**

XIR-1U (remote) **£10.15.6**

XI-1U (master) **£10.15.6**

SUGDEN MOTOR UNIT "CONNOISSEUR CRAFTSMAN." Heavy duty motor operating at 33 1/3 and 45 r.p.m. Very heavy 12" turntable. Virtually no rumble. **£18.3.6**

Prices include free delivery in the U.K.

MONEY-SAVING "PACKAGED DEALS"

For the benefit of customers wishing to purchase several units of their Hi-Fi equipment at the same time, useful price reductions are offered. Such "Packaged Deals" may include RECORD PLAYERS and TAPE DECKS of your preference, not necessarily featured in our catalogue. Two money-saving examples are given here and quotations for your own special requirements will gladly be sent on request.

AMATEUR TRANSMITTER, Model DX-100U. The world's most popular, compact and completely self-contained Amateur Transmitter. Covers all amateur bands: 160-10 m. 150W d.c. input. Careful design has achieved the stability and high performance for which the DX-100U is noted and no less than 35 disc ceramic capacitors reduce TVI to a minimum. **£71.10.0**



DX-100U

VARIABLE FREQUENCY OSCILLATOR, Model VF-1U. Calibrated 160-10 m. Fundamentals on 160 and 40 m. Ideal for our DX-40U and similar transmitters. **£11.2.0**



VF-1U

BALUN COIL UNIT, Model B-1U. Will match unbalanced co-axial lines to balanced lines of either 75 or 300Ω impedance. **£4.9.6**

THE "MOHICAN" GENERAL COVERAGE RECEIVER, Model GC-1U. With 4 piezo-electric transmitters, variable tuned B.F.O. and Zener diode stabiliser, this is an excellent fully transistorised general purpose receiver for Amateur and Short wave listeners. Printed circuit boards, telescopic whip antenna, tuning meter and large slide-rule dial, 10 transistors. **£38.15.0**



GC-1U

THE BEST QUALITY

4-WAVEBAND TRANSISTORISED PORTABLE RECEIVER, Model RSW-1. This model possesses Medium, Trawler and two Short-wave bands and is midway between the domestic broadcasting and professional general communications receiver. Ideal and inexpensive for those who wish to listen to world broadcasts, shipping and aviation communications. It is not the set to buy if you wish only to enjoy domestic broadcasting. In a handsome leather case, it has retractable whip aerial and socket for car radio use. **£21.6.0**



RSW-1

TRANSISTOR PORTABLE RADIO, Model UXR-1. Pre-aligned I.F. transformers, printed circuit and a 7" x 4" high-flux speaker. Real hide case. **£14.3.0**



UXR-1

HI-FI AM/FM TUNER, Model AFM-1. Available in two units which, for your convenience, are sold separately: Tuning heart (AFM-T1—£5.5.6 incl. P.T.) and I.F. amplifier (AFM-A1—£19.8.0). Printed circuit board, 8 valves. Built-in power supply. Total **£24.13.6**

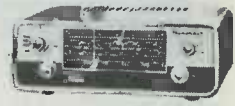

AM/FM TUNER

HI-FI FM TUNER, Model FM-4U. Also available in two units as above: R.F. tuning unit (£3.2.0 incl. P.T.) with I.F. output of 10.7 Mc/s, and amplifier unit, with power supply and valves (£11.11.0). Total **£14.13.0**

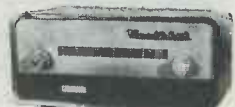

FM TUNER

POWER SUPPLY UNIT, Model MGP-1. Input 100/120V 200/250V, 40-60 c/s. Output 6.3V, 2.5A, A.C.; 200, 250, 270V, 120mA max. D.C. **£4.16.6**

Prices will be approximately 5% greater after 20th August

Packaged £50.12.0

Packaged £59.10.0

GL-58 Transcription Unit	£19.12.6	TA-1M	£18. 2.6
S-33 Stereo Amp.	£12. 8.6	Collaro "STUDIO"	£17.10.0
Twin SSU-1 Speakers		USC-1	£18.18.6
(Bookcase Type)	£21. 8.0	MA-12	£10.19.6

£53. 9.0

£65.10.6

All models directly available from the makers:

DAYSTROM Ltd GLOUCESTER



"GLOUCESTER"



GL-58

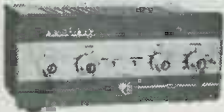

S-33

HI-FI EQUIPMENT CABINETS. Our four equipment cabinets meet a wide variety of tastes and requirements: the "CHEPSTOW" was designed for those who have little floor space, the contemporary "MALVERN" for the Tape and Gram. enthusiast, and the "GLOUCESTER" Mk. I and II for those with traditional tastes. All parts are pre-cut and drilled for easy assembly, and left "in the white".

Prices from **£11.12.6** to **£18.10.0**

TRANSCRIPTION RECORD PLAYER (STEREO). Manufactured by Goldring-Lenco. This 4-speed unit is fitted with a G60 pick-up arm. Infinitely variable speed adjustment from 33 $\frac{1}{2}$ to 80 r.p.m. Fixed speed of 16 r.p.m. Its balanced turntable (3 $\frac{1}{2}$ lb) reduces rumble, wow and flutter to very low level. The unique lowering device fitted provides absolutely safe means of placing pick-up on record **£19.12.6**

6W STEREO AMPLIFIER, Model S-33. 3 watts per channel, 0.3% distortion at 2.5 w/chnl., 20dB N.F.B. Inputs for Radio (or Tape) and Gram., Stereo or Monaural, ganged controls. Sensitivity 100mV. **£12.8.6**

AT LOWEST PRICES



Truvox D83



"STUDIO"

TRUVOX D83 & D84 TAPE DECKS. High quality mono/stereo tape decks. D83, 2 track, for highest fidelity. **£31.10.0**

D84 (identical presentation), 4-track, for most economical use of tape. **£29.8.0**

COLLARO "STUDIO" TAPE DECK. The finest buy in its price range. Operating speeds: 1 $\frac{1}{2}$, 3 $\frac{1}{2}$ and 7 $\frac{1}{2}$ i.p.s. Two tracks. "Wow" and "flutter" not greater than 0.15% at 7 $\frac{1}{2}$ i.p.s. Long Term Speed Stability better than 0.5%. **£17.10.0**

HI-FI STEREO/MONO PRE-AMPLIFIER, Model USP-1. Extremely versatile unit. Gain may be preset over a wide range. Input 2mV-20mV. Output 20mV-2V **£6.17.6**

HI-FI SINGLE CHANNEL AMPLIFIER, Model MA-12. 12W output, wide freq. range, low distortion. **£10.19.6**

TAPE RECORDING AND REPLAY HI-FI AMPLIFIER

Mono model TA-1M, Stereo model TA-1S. For use with most tape decks. Thermometer type recording indicators, press-button speed compensation and input selection, 3-position bias level and printed circuit construction.



TA-1S



USC-1

TA-1M **£18. 2.6**
 TA-1M & Collaro STUDIO **£30.10.0**
 TA-1M & TRUVOX D83 ... **£47. 2.6**
 TA-1M & TRUVOX D84 ... **£45. 5.0**
 TA-1S **£23. 6.0**
 TA-1S & STUDIO **£35.14.0**
 TA-1S & TRUVOX D83 ... **£52. 6.0**
 TA-1S & TRUVOX D84 ... **£50. 9.6**
STEREO CONTROL UNIT, Model USC-1. Push-button selection, accurately matched ganged controls to ± 1 dB. Negative feedback, rumble and variable low-pass filters. Printed circuit boards. **£18.18.6**

FINEST ELECTRONIC KITS IN THE WORLD

VALVE VOLTMETER, Model V-7A: 7 voltage ranges d.c. volts to 1,500 a.c. to 1,500 r.m.s. and 4,000 peak to peak. Resistance 0.1 Ω to 1,000M Ω with internal battery. D.C. input impedance 11m Ω . dB measurement has centre-zero scale. Complete with test prods, lead and standardising battery. **£13.0.0**



V-7A

MULTIMETER, Model MM-1U. Ranges 0-1.5V to 1,500V A.C. and D.C.; 150 μ A to 15A D.C.; 0.2 Ω to 20M Ω . 4 $\frac{1}{2}$ " 50 μ A meter. **£11.18.6**



MM-1U

R.F. SIGNAL GENERATOR, Model RF-1U. Up to 100 Mc/s fundamental and 200 Mc/s on harmonics and up to 100mV output on all bands. **£11.18.0**



RF-1U

AUDIO WATTMETER, Model AW-1U. Up to 25V continuous, 50W intermittent. **£14.14.0**

AUDIO VALVEMILLIVOLTMETER, Model AV-3U. 1mV-300v A.C. 10 c/s to 400 kc/s. **£13.18.6**

AUDIO SINE-SQUARE WAVE GENERATOR, Model AO-1U. Covers 20 c/s to 150 kc/s and square waves to 50 kc/s in four ranges. Maximum output 10V, distortion less than 1%. **£12.18.6**



AO-1U

CAPACITANCE METER, Model CM-1U. Direct-reading 4 $\frac{1}{2}$ " scale. Full-scale ranges 0-100 μ F, 0-1,000 μ F, 0-0.01 μ F and 0-0.1 μ F. **£14.15.0**

HI-FI SPEAKER SYSTEM, Model SSU-1. Ducted-port bass reflex cabinet "in the white". Twin speakers. With legs **£11.15.0** **£10.14.0**

HEATHKIT ELECTRONIC WORKSHOP, Model EW-1. This educational kit will teach and amuse your children. It can make 21 exciting experiments including transistor radios, burglar alarm, radio or TV silencer, intercom., etc. **£7.18.0**



EW-1

JUNIOR TRANSISTOR RADIO, Model UJR-1. Single transistor set. Excellent introduction to radio. An instructive present. **£2.13.6**

HI-FI STEREO AMPLIFIER, Model S-99. 18W output. Ganged controls. Stereo/mono gram., radio and tape recorder inputs. Push-button selection. Printed circuit construction. **£26.19.0**

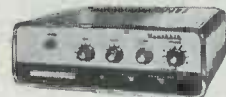

S-99

THE "COTSWOLD". This is an acoustically designed enclosure 26" x 23" x 15 $\frac{1}{2}$ " housing a 12" bass speaker with 2" speech coil, elliptical middle speaker together with a pressure unit to cover the full frequency range of 32-20,000 c/s. Capable of doing justice to the finest programme source, its polar distribution makes it ideal for really Hi-Fi Stereo. Delivered complete with speakers, crossover unit, level control, Tygan grille cloth, etc. All parts pre-cut and drilled for ease of assembly and left "in the white" for finish to personal taste. **£21.19.0**



THE "COTSWOLD"

Deferred terms available on orders over £10

See the whole range at **STAND 15, The Radio Show, Aug. 22-Sept. 1**

★ SEND THIS COUPON NOW FOR FURTHER INFORMATION

(Please write in BLOCK CAPITALS)

NAME

ADDRESS

Without obligation please send me

BRITISH HEATHKIT CATALOGUE.....

(Tick here)

FULL DETAILS OF MODEL(S)

DAYSTROM LTD DEPT RC8 GLOUCESTER ENGLAND

A member of the Daystrom Group, manufacturers of the **WORLD'S LARGEST-SELLING ELECTRONIC KITS**

ARMSTRONG AF 208 AM/FM RADIOGRAM CHASSIS



★ Full VHF Band (87-108 Mc/s.) and Medium Band, 187-570M. ★ 7 Valves ★ 5 Watts Output ★ 15dB Negative Feedback ★ Separate wide range Bass and Treble Controls ★ 2 Compensated Pick-up Inputs ★ Frequency Response 30-22,000 c.p.s. ★ 2dB ★ Tape Record and Playback Facilities ★ Continental Reception of Good Programme Value ★ For 3, 7½ and 15 ohm speakers. Send S.A.E. for leaflet.

Price £22.18.0 Carr. Free

LATEST "E.M.I." 4 SPEED SINGLE RECORD PLAYER

Acos Hi-Fi Pick-up for LP, and/or 78, 7", 10" and 12" records. Silent motor, heavy turntable, auto stop. Completely assembled on base plate. £6.5.0 post/free

SINGLE PLAYER BARGAIN

Ready built complete with B.S.R. TU9 4-speed Gram Pick-up unit. Handsome portable case. 3-watt amplifier with 2 valves and speaker.

Our Price £8. 19. 6.

SUMMER SALE PRICES

New boxed VALVES 90-day Guarantee

024	5/-	6K7G	5/-	EABC80	8/-	PCL82	10/-
1R5	6/-	6K8G	5/-	EB91	4/-	PCL84	10/-
155	6/-	6L6G	8/-	EB41	8/-	PL81	10/-
174	3/-	6N7M	5/-	EB81	8/-	PL83	8/-
2X2	2/-	6O7G	6/-	EB80	7/-	PY80	7/-
354	7/-	65N7	5/-	EB42	9/-	PY81	8/-
3V4	7/-	6V6G	5/-	EB81	9/-	PY82	7/-
3Q5	7/-	6X4	5/-	EB85	6/-	PY83	8/-
5U4	6/-	6X5	6/-	EB89	8/-	PO25	7/-
5Y3	6/-	12A7T	6/-	EL32	5/-	SP41	3/-
5Z4	9/-	12AU7	6/-	EL84	7/-	SP61	3/-
6AC7	4/-	12AX7	7/-	EY51	9/-	UJ22	7/-
6AM6	4/-	12BH7	7/-	EY86	9/-	UBC41	8/-
6AT6	6/-	12K7	5/-	EZ40	7/-	UBC81	9/-
6BA6	7/-	12K8	14/-	EZ80	7/-	UBF89	9/-
6BE6	5/-	12Q7	5/-	EZ81	7/-	UCH81	9/-
6BW6	7/-	25Y5G	9/-	EL148	10/-	UCL82	10/-
6C4	5/-	35L6	9/-	HABC80	10/-	UCL83	12/-
6D6	5/-	35Z4	5/-	HVR2A	5/-	UF89	9/-
6G6	4/-	807	5/-	KT32C	8/-	UL41	9/-
6H6	3/-	954	2/-	KT76	8/-	UY41	7/-
6J5	5/-	DAF96	8/-	MU14	7/-	UY85	7/-
6J6	5/-	DF96	8/-	PCC84	8/-	UU9	7/-
6I7G	6/-	DK96	8/-	PCF80	8/-	VR150	7/-
6K6	5/-	DL96	8/-	PCF82	8/-	WB1	6/-

SETS OF VALVES

DK96, DF96, DAF96, DL96 8/- each or 2/9/6 set. 1R5, 174, 155, 354 or 3V4 Set of four 1/9/6

NEW ELECTROLYTICS

TUBULAR	TUBULAR	FAMOUS MAKES CAN TYPES
1/350v.	2/-	50/350v.
2/350v.	2/3	100/25v.
4/450v.	2/3	250/25v.
8/450v.	2/3	500/12v.
16/450v.	3/-	500/12v.
32/450v.	3/9	8+8/450v.
50/25v.	1/9	8+16/450v.
50/25v.	2/-	16+16/450v.
50/50v.	2/-	32+32/350v.
		50+50/350v.
		100+200/275v.

QUALITY 2-STAGE HI-FI AMPLIFIER
A.C. only, 200-250V Valves ECL82 and E280. 3 watt quality output. Mullard tone circuits, bass boost, treble and volume controls. Separate engraved front-panel with de-luxe finish. Heavy duty output transformer 3 ohm. Shrouded mains transformer. Stove enamelled chassis size 6in. x 5in. x 3in. Bargain price £4.10.0. Circuit supplied.

COMPLETE RADIO CHASSIS £4.19.6 p. free

4 Mullard valves, 5" speaker, frame aerial. 4 pre-set stations. 1 long, 3 med. wave. Superhet Circuit. Size 9" x 6" x 5½" high. Tested ready for use. 200/250V A.C.-D.C. Mains. Brand New Guaranteed 12 months

DE LUXE MODEL

As above but with illuminated dial. Fully tunable over medium wave 200-550 M and long wave 1,000-2,000 M. Guaranteed 12 mths. Bargain Price £5.19.6

MAINS TRANSFORMERS

200/250 AC Post 2/- each

STANDARD 250-0-250, 80 mA., 6.3 v. 2.5 a. tapped 4 v. 4 a., Rectifier 6.3 v. 1 a. tapped 5 v. or 4 v. 2 a. ... 22/6
Ditto 350-0-350 ... 29/6
MINIATURE, 200 v. 20 mA., 6.3 v. 1 a. 10/6
MIDGET, 220 v. 45 mA., 6.3 v. 2 a. ... 15/6
SMALL, 220-0-220 v. 50 mA., 6.3 v. 2 a. 17/6
STANDARD, 250-0-250 65 mA., 6.3 v. 3.5 a. ... 17/6
HEATER TRANS., 6.3 v. 1½ a. ... 7/6
Ditto 6.3 v. 4 a. ... 10/6
GENERAL PURPOSE LOW VOLT. AGE. Outputs 3, 4, 5, 6, 8, 9, 10, 12, 15, 18, 24 and 30 v. at 2 a. ... 22/6
AUTO. TRANS. 150 w., 0, 10, 120, 200, 230, 250 v. ... 22/6
AUTO. TRANS. 500 w., 0, 115, 200, 230, 250 v. ... 82/6
PARMEKO MAINS TRANSFORMER. Made for special contract, the ratings can safely be doubled. Guaranteed 2 years. Primary 0-110-210-230-250 v. H.T. 300-0-300 v. 50 mA. L.T. 6.3 v. 1.8 a. Weight 6 lb. ... Price 17/6, post 2/6
MAINS POWER PACK. Size 3½ x 4½ x 4in. with mains transformer, metal rectifier and condensers to provide smoothed H.T. output 220 v. 45 mA. D.C., L.T. 6.3 v. 2 a. Centre tapped A.C. All ready built on a strong metal chassis. Brand new. ... Bargain 29/6, post 2/6

O.P. TRANSFORMERS. Heavy duty 50 mA., 4/6. Miniature 3V4, etc., 5/9. Small, pentode, 4/6. Multi-ratio push-pull, 7/6. Multi-ratio push-pull 10 w., 15/6. Goodmans heavy duty 10/20 w. 6K push-pull, 30/-; Estone ultra-linear OT/ML 10 w. 45/-.
L.F. CHOKES 15/10 H. 60/65 mA, 5/-; 10 H. 85 mA, 10/6; 10 H. 120 mA, 12/6; 10 H. 150 mA, 14/-

TELEVISION REPLACEMENTS

Line Output Transformers from 45/- each, NEW Stock and other timebase components. Most makes available. S.A.E. with all enquiries

FULL WAVE BRIDGE CHARGER RECTIFIERS. 2, 6 or 12 v. 1½, 8/9; 2 a., 11/3; 4 a., 17/6. Free charger circuit.

CHARGER TRANSFORMERS. Tapped input 200/250 v. for charging at 2, 6 or 12 v. 1½ a., 15/6; 2 a., 17/6; 4 a., 22/6.

4 AMP. CAR BATTERY CHARGER with amp. meter Leads, Fuse Case, etc., for 6 v. or 12 v., 69/6

BOOKS (List S.A.E.)

40 Circuits for Germanium Diodes 3/-
 "W.W" Radio Valve Data 6/-
 High Fidelity Speaker Enclosures 5/-
 Valve and TV Tube Equivalents 9/6
 TV Fault Finding 9/6
 Quality Amplifiers 4/6
 Radio Valve Guide. Books 1, 2, 3 or 4, 5/- each
 Transistor Superhet Receivers 7/6
 Practical radio Inside Out 3/6
 Master Colour Code 1/6

TINNED COPPER WIRE 16 to 22 s.w.g. 1 lb. 3/-
COPPER ENAMEL WIRE 1 lb. 16 to 22 s.w.g. 2/9, 24 to 30 s.w.g. 3/6, 32 to 40 s.w.g. 4/6

CRYSTAL MIKE INSERT 6/6
 Precision engineered. Size only 1½" dia. x 1"

ACOS STICK MIKE 39-1 ... 35/-
T.S.L. DE LUXE STICK MIKE ... 25/-

SPEAKER FRET. Gold cloth, 17in. x 25in., 5/-; 25in. x 35in., 10/-. **TYGAN**, various colours, 52in. wide, from 10/- ft.; 26in. wide from 5/- ft. Samples S.A.E. Expanding Metal, Gold, 12in. x 12in., 6/-

BAKER SELHURST LOUDSPEAKERS

12" Baker 15W Stalwart 3 or 15C2, 45-13,000 c.p.s. 90/-

12" Stereo 12W, 35-16,000 c.p.s. Foam suspension £6.17.6

12" Baker Ultra Twelve, 20 c.p.s. to 25 kc/s £17.10.0

15" Auditorium, Bass Mk II 35W 20 c.p.s. to 12 kc/s £18

Send S.A.E. for leaflet and enclosure details



LOUDSPEAKERS P.M. 3 OHM. 2½in. 3in. 4in. 19/6; 5in. 25/-; 8in. 17/6; 7in. x 4in., 18/6; 4in. Hi-Fi Tweeter, 25/-; 8in. Plessey, 19/6; 6in. Goodmans, 18/6; 10in. R.A., 30/-; 12in. Plessey, 30/-; 10in. x 6in. E.M.I. 27/6; E.M.I. 13½" x 8" 45/-; Stentorian HF102 10in., 95/-; HFI016, £8. 12 in. R.A. 152/45.-

CRYSTAL DIODES. G.E.C., 2/-; GEX34, 4/-; OAB1, OA70, 3/-; Crystal Coils HAX, 1/-; DRR2, 4/-; CRYSTAL SET BOOKLET 1/-

H.R. HEADPHONES, 4,000 ohms, brand new, 15/- pair. Low resistance phones, 7/6 pair, SWITCH CLEANER FLUID, squirt spout, 4/6 tin.

C.R.T. BOOSTER TRANSFORMERS

For Cathode Ray Tubes having heater cathode short circuit and for C.R. Tubes with falling emission, full instructions supplied.

TYPE A. LOW LEAKAGE WINDINGS. CONDITIONS: 25% and 50% BOOST ON SECONDARY: 0.4 V. OR 6.3 V. OR 10.3 V. OR 13.3 V. WITH MAINS PRIMARIES. 10/6.

TWIN GANG CONDENSERS. Transistor 208 pF and 176 pF, with trimmers and screen, 12/6 each; 365 pF, miniature, 1½in. x 1½in. x 1½in., 10/-; 500 pF standard, with trimmer, 9/-; midget, 7/6; midget with trimmer, 9/-; 500 pF slow motion drive, 9/-; **SHORT WAVE.** Single 10pF, 25pF, 50pF, 75pF, 100 pF, 160 pF, 5/6 each.

TUNING AND REACTION CONDENSERS. 100 pF, 300 pF, 500 pF, 3/6 each, solid dielectric. **CONDENSERS.** 0.001 mfd. 7kV T.C.C., 5/6; ditto 20 kV, 9/6; 0.1 mfd. 7 kV, 9/6; 100 pF to 500 pF Micas, 6d.; Tubular 500 v. 0.001 to 0.05, 9d.; 0.1, 1/-; 0.25, 1/6; 0.1/350 v., 9d.; 0.5/500 v., 1/9; 0.01/2,000 v., 1/9; 0.1/2,000 v., 3/6.

CERAMIC CONDENSERS. 500 v. 0.3 pF to 0.01 mfd., 9d. 0.1/30v., 1/3.

SILVER MICA. 10% 5 pF to 500 pF, 9d.; 600 pF to 3,000 pF, 1/-; close tolerance (plus or minus 1 pF), 2/2 pF to 10 pF, 1/-; ditto 1% 50 pF to 815 pF, 1/-; 1,000 pF to 5,000 pF, 1/9.

465 Kcs. SIGNAL GENERATOR. Price 15/- Uses B.F.O. Unit ZA 30038 ready made with valve 155. **POCKET SIZE** 2½in. x 4½in. x 1in. Slight modifications required, full instructions supplied. Battery 8/6 extra 69 v. + 1½ v. Details S.A.E.

WAVECHANGE SWITCHES

2 p. 2-way, or 2 p. 6-way, long spindle ... 3/6
 3 p. 4-way or 1 p. 12-way, long spindle ... 3/6
 4 p. 2 way or 4 p. 3-way, long spindle ... 3/6
 8 p. 4-way 2 wafer, long spindle ... 6/6

Wavechange "MAKITS". Wafers available: 1 p. 12 wafer, 2 p. 6 wafer, 3 p. 4 wafer, 4 p. 3 wafer, 6 p. 2 wafer, 1 wafer, 8/6; 2 wafer, 12/6; 3 wafer, 16/-; Additional wafers up to 12, 3/6 each extra.

TOGGLE SWITCHES, s.p., 2/-; d.p., 3/6; d.p.d.t., 4/-; Rotary Toggles, s.p., 3/6, d.p., 4/6.

JACKS. English open-circuit 2/6, closed-circuit 4/6, Grundig-type 3-pin 1/3

JACK-PLUGS. English 3/-, Screened 4/-, Grundig 3-pin 3/6.

JASON F.M. TUNER COIL SET, 29/-
 H.F. coil, aerial coil, oscillator coil, two i.f. transformers 10.7 Mc/s., detector transformer and heater choke. Circuit and component book using four 6AM6, 2/6. Complete Jason FMTI kit, Jason chassis with calibrated dial, components and 4 valves, £6.5.0.

VALVEHOLDERS. Pax. int. oct., 4d. EA50, 6d. B12A, CRT, 1/3. Eng. and Amer. 4, 5, 6, and 7 pin, 1/-; MC LED, MAZDA and int. Oct., 6d.; B7G, B8A, B8C, B9A, 9d.; B7G with can, 1/6; B9A with can, 1/9. Ceramic, EFG, B7G, B9A, Int. Oct., 1/-; B7G, B9A cans, 1/- each.

RADIO COMPONENTS

Our written guarantee with every purchase. Buses 133 or 68 pass door. S.R. Stn. Selhurst

VOLUME CONTROLS

Long spindles. Midget 5K ohms to 2 Meg.
L/S 3/- DP. 4/6
Stereo L/S 10/6 DP. 14/6
Linear or Log Tracks.

80 ohm Coax CABLE

Semi-air spaced .3in.
Stranded core, 6d. yd. 40 yds. 17/6; 60 yds. 25/-
Fringe Quality, Air Spaced 1/- yd.

EXTENSION SPKR. CONTROL 10 Ohm 3/- TELESCOPIC CHROME AERIALS 13in. extending to 43in. 8/6 each.

RESISTORS. Preferred values. 10 ohms to 10 meg. 1 w., 4d.; 1 w., 4d.; 1 w., 6d.; 1 w., 8d.; 2 w., 1/-
HIGH STABILITY. 1 w., 1/6; 2/-, Preferred values. 10 ohms to 10 meg. Dito 5%, 10 ohms to 22 meg. 9d.
5 watt WIRE-WOUND RESISTORS 1/3
10 watt 10 ohms-10,000 ohms 1/6
15 watt 1/2
2.5K to 50K 10 w 3/-

I.F. TRANSFORMERS 7/6 pair
465 kc/s Slug Tuning Miniature Can. 2in. x 1in. x 1in. High Q and good band width. Data sheet supplied.

WIRE-WOUND Pots. 3 WATT. Pre-set Min. TV Type. All values 10 ohms to 25K, 3/- ea.; 30K, 50K, 4/-; Carbon 30K to 2 meg., 3/-
TRIPLEXERS, Bands I, II, III, 12/6
COAXIAL PLUGS, 1/-; PANEL SOCKETS, 1/-
LEAD SOCKET, 2/-; OUTLET BOXES, 4/6
BALANCED TWIN FEEDER, 6d. yd., 80 or 300 ohms
TWIN SCREENED FEEDER, 1/6 yd., 80 ohms
TRIMMERS. Ceramic 30, 50, 70 pF. 9d.; 100 pF. 150 pF. 1/3; 250 pF. 1/6; 600 pF. 750 pF. 1/9; Philips, 10 pF. 30 pF. 1/- each.

WIRE-WOUND

4 WATT POTS. Long Spindle, Values, 50 ohms to 50K, 6/6; 100K, 7/6

1962 RADIOGRAM CHASSIS

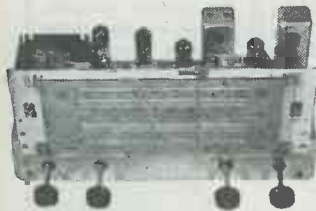

Three Wavebands S.W. 16 m.-50 m. Latest Mullard M.W. 200 m.-500 m. ECH81, EF89, EBC81, L.W. 800 m.-2,000 m. ELB4, EZ80
12-month Guarantee. A.C. 200-250V, 4-way switch. Short-Medium-Long-Gram. A.C.C. and Negative Feedback, 4.2 watts. Chassis 13 1/2" x 5 1/2" x 2 1/2". Glass dial size 10" x 4 1/2", horizontal or vertical. Two Pilot Lamps. Four Knobs, Walnut or Ivory. Aligned and calibrated. Chassis isolated from mains.

BRAND NEW £9.10.0 Carr. 4/6
Matched Speakers 8" 17/6; 10" 25/-; 12" 30/-

BLACK CRACKLE PAINT. Air drying, 3/- tin.
NEON MAINS TESTER SCREWDRIVER, 5/-
SOLDER RADIOGRADE, 4d. yd., 1 lb. 5/-

HIGH GAIN TV PRE-AMPLIFIERS BAND I B.B.C.
Tuneable channels 1 to 5. Gain 18 dB. ECC84 valve. Kit price 29/6 or 49/6 with power pack. Details 6d. (PCC84 valves if preferred.)
BAND III I.T.A.—Same prices
Tuneable channels 8 to 13. Gain 17 dB.

PAXOLIN PANELS, 1/2in. x 10in. x 8in., 2/-
MINIATURE CONTACT COOLED RECTIFIERS. 250 v., 50 mA., 7/6; 250 v., 60 mA., 8/6; 250 v., 85 mA., 9/6; 200 mA., 2 1/2/-; 300 mA., 27/6. Full Wave Bridge 250v. 75mA. 10/-; 120mA. 15/-
SELENIUM RECT. 300 v. 85 mA. 5/-
COILS. Wearite "P" type, 3/- each. Osamor Midget "Q" type, adj. dust core from 4/- each. All ranges.
TELETRON D.W.R. L. & Med. T.R.F. with reaction, 4/-; Med. only DR. 3/6.
FERRITE ROD AERIALS. M.W., 8/9; M. & L., 12/6.
FERRITE ROD AERIALS. L. & M. for transistor circuits, 10/- each. FERRITE RODS 8in. x 3in., 3/-; 8in. x 1/2in. 3/-; 6in. x 3in., 3/-

ALUMINIUM CHASSIS. 18 s.w.g. Plain, undrilled. 4 sides, riveted corners, lattice fixing holes. 2 1/2in. sides. 7in. x 4in., 4/6; 9in. x 7in., 5/9; 11in. x 7in., 6/9; 13in. x 9in., 8/6; 14in. x 11in., 10/6; 15in. x 14in., 12/6; 18in. x 16in. x 3in., 16/6.

ALUMINIUM PANELS. 18 s.w.g., 12in. 12in. 4/6; 14in. x 9in., 4/-; 12in. x 8in., 3/-; 10in. x 7in., 2/3. 8in. x 6in. 2/-

H.F. CHOKES, 2/6. Osamor QCI 6/9.
T.R.F. COILS A/HF, 7/- pair; HAX, 3/-; DRR2, 4/-
ALADDIN FORMERS and cores. 3in. 8d., 1in. 10d.
0.3in. FORMERS 5937 or 8 and cans TV1 or 2, 3in. sq. x 2 1/2in. or 3in. sq. x 1 1/2in., 2/- with cores.
SLOW MOTION DRIVES. Epicyclic ratio 6-1, 2/3.
SOLO IRON, 25 w., 200 v. or 230 v. 24/-
PRECISION Sub-miniature Iron. 200 or 240 v. 29/6:

4 TRANSISTOR PUSH-PULL AUDIO AMPLIFIER

Size 3 x 1 1/2 x 7/8

A ready built miniature push-pull amplifier with input and output transformers, 4 transistors. Ideal for use with record players, intercoms, etc. Complete with full instructions and circuit.

PRICE 52/6 9v Batt. 2/3. 2 1/2" SPEAKER 15/-

MAINS DROPPERS. Midget. With adj. sliders. 0.3A, 1,000 ohms 5/-; 0.2A 1,200 ohms, 5/-; 0.15A 1,500 ohms, 5/-; 0.1A, 2,000 ohms, 5/-

LINE CORD. 0.3 A. 60 ohms per foot, 0.2 A. 100 ohms per foot, 2-way, 1/- per foot; 3-way 1/- per foot.

MIKE TRANS. 50:1, 3/9.
P.V.C. CONN. WIRE, 8 colours, 2d. yd.
SLEEVEING, 1 or 2 mm, 2d.; 4 mm, 3d.; 6 mm, 5d. yd.

AMERICAN "BRAND FIVE" PLASTIC RECORDING TAPE

Reel	Length	Price	Spare Plastic Reels
Double Play 7"	2,400 ft.	60/-	
5"	1,200 ft.	37/6	
Long Play 7"	1,800 ft.	35/-	3" 1/6
5 1/2"	1,200 ft.	23/6	4" 2/-
5"	900 ft.	18/6	5" 2/-
Standard 7"	1,200 ft.	25/-	5 1/2" 2/-
5"	600 ft.	16/-	7" 2/6

"Instant" Bulk Tape Eraser and Head Defluxer, 200/250V A.C. 27/6. Leaflet S.A.E.

QMAX CHASSIS CUTTER

The cutter consists of four parts: a die, a punch, an Allen screw and key.

1 1/2" 14/6, 3/4" 14/9, 3/8" 15/6, 3/16" 15/9, 1/4" 17/6, 1/8" 17/6, 1/16" 20/-, 1/32" 20/6, 1/64" 22/6, 2" 34/3, 2 1/2" 37/9, 2 3/4" 44/3, 1" square 31/6, 1 1/2" square 28/-

"REGENT" 4 VALVE

"96" RANGE

VALUES

Kit Price

£6.60

carr. 4/-



PRINTED CIRCUIT BATTERY PORTABLE KIT

Medium and long wave. 7 x 4 in. Speaker. Printed Circuit. Components clearly identified with assembly instructions. Ferrite Aerial. Resine covered cabinet. Size 12 in. x 8 in. x 4 in. Batteries used B126 (L5512) and AD35 (LS040), 10/9 extra. Instructions 9d. (free with kit).

MONARCH RECORD PLAYER



BUILD IT YOURSELF using 4-SPEED BSR MONARCH AUTOCHANGER READY BUILT 3W AMPLIFIER, HAND-SOME PORTABLE CASE. HIGH FLUX LOUDSPEAKER. FULL INSTRUCTIONS
Total Price Carr. and ins. 5/- **£12.10.0**

RECORD PLAYER BARGAINS

4 Speed Autochangers: POST 2/- each
BSR, U.A.14 £7.10.0
BSR, U.A.12 Stereo/Monaural £8.5.0
Garrard Autostim Changer £7.19.6
Garrard 209 Changer £9.9.0
4 Speed Single Players:
Garrard TA Mk. II £8.0.0
Garrard 4 HF Transcription £17.19.6
All Sapphire Stylii available from 6/-

All Crystal Cartridges available from 21/-
AUTOCHANGER ACCESSORIES
Amplifier player cabinets with cut boards, 63/-
2-valve amplifier and 6" speaker for above, ready mounted on baffle, 12in. x 7in., 3in. deep, Wired and tested ready for use. £4.15.0.

ARDENTE TRANSISTOR TRANSFORMERS
D3035, 7.3 CT: 1 Push Pull to 3 ohms for OC72, 9/6.
D3034, 1.75:1 CT. Push Pull Driver for OC72, 9/6.
D3058, 11.5:1 Output to 3 ohms for OC72, etc., 9/6.
D167, 18.2:1 Output to 3 ohms for OC72 etc., 12/-
D239, 4.5:1 Driver, 3in. x 3in. x 3in., 10/-
D240, 8.5:1 Driver, 3in. x 3in. x 3in., 10/-
ARDENTE TRANSISTOR VOLUME CONTROLS. Type VC1545, 5K with switch, dia. 9in., 8/-
Type VC1760, 5K with switch, dia. 7in., 10/6.
DEAF AID EARPIECE Xtal or magnetic 7/6.

WEYRAD

COILS AND TRANSFORMERS FOR A 2-WAVE TRANSISTOR SUPERHET WITH PRINTED CIRCUIT AND FERRITE ROD AERIAL

Long and Medium Wave Aerial—RA2W. On 6in. rod, 7in. diameter, 208 pF. tuning, 12/6.
Oscillator Coil P50/IAC. Medium wave. For 176 pF. tuning, 5/4. Car aerial coil 1/-
1st and 2nd I.F. Transformer—P50/2CC. 470 kc/s, 1 1/2in. diameter by 3in. high, 5/7.
3rd I.F. Transformer—P50/3CC, to feed diode detector, 6/-; 24-Fixed resistors 10/6.
Driver Transformer—LFD4, 1 1/2in. x 3in. x 1 1/2in., 9/6. 16-Fixed condensers 21/-
Printed Circuit—PCAL. Size 2 1/2in. x 8in. Ready drilled and printed with component positions, 9/6. Jackson 00 gang 10/6.
35 ohm Speakers, 7in. x 4in., 25/-; 3 1/2in., 19/6.
Wavechange Switch 3/6. Volume Control 4/6.
Set of 6 Mullard Transistors and diode, 42/6.
These components are approved by transistor makers and performance is guaranteed.
Constructor's Booklet with full details, 2/-

NEW-MULLARD TRANSISTORS
Audio OC71 ... 6/- R.F. OC44 ... 8/9
OC72 ... 7/6 OC45 ... 8/6
Sub-miniature Electrolytics (15 V.) 1 mfd. 2 mfd., 4 mfd., 5 mfd., 8 mfd., 16 mfd., 25 mfd., 30 mfd., 50 mfd., 100 mfd., 2/6.
Diodes OAF1, OAB1, 3/-; GEX 34 4/-

B.B.C. 2 Transistor. M.W. and L.W. Radio Kit, 22/6. Earpiece, 7/6. Battery 2/3.

6 TRANSISTOR RADIO MED. & LONG WAVE KIT

First-class components to make a 6-transistor 2-waveband superhet chassis. Ideal for portable or table radio. All parts including BVA transistors ferrite aerial, printed circuit, 8in. x 2 1/2in., but EXCLUDING speaker and cabinet. Simple instructions, 1/6 (Free with kit). 35 ohm 7in. x 4in. Speaker 25/- extra. 35 ohm, 3 1/2 in. 19/6. £4.5.0

SPECIALISTS

337 WHITEHORSE ROAD
WEST CROYDON Telephone
THO 1665

& P. charge 1/-, New List, 1/-, C.O.D. 2/-, (Export welcome. Send remittance and extra postage)

HOME RADIO OF MITCHAM

Dept. AC, 187 London Road,
Mitcham, Surrey. MIT 3282
Shop Hours: 9.0 to 6.0 p.m.
(Weds. 1.0 p.m.)



NEW GOODMAN'S 12" SPEAKERS

AXIOM 201

High fidelity twin diaphragm 12" speaker with FERObA 11 magnet to handle up to 15 watts. PRICE £9.15.0

AXIOM 301

Luxury super quality twin diaphragm 12" full range speaker with massive FERObA 11 magnet up to 20 watts. PRICE £14.0.0
Send 3d. stamp for full details.

BUILD A MARTIN RECORDAKIT

It is easy and economical to build a quality tape recorder with one of the completely trouble-free Martin Recordakits. High quality amplifier already assembled and wired on to printed circuits and tested. A few simple tools are all that is required to build, and thus save pounds.



Send 3d. stamp for details of all models.

RECORDAKIT "C"

Comprises twin-track three-speed Collaro Studio tape deck complete with ready wired high quality amplifier, Hi-Fi 9" x 5" speaker, attractive modern two-tone leatherette covered carrying case, full instructions. PRICE £29.18.0

WE ARE ACTUAL STOCKISTS FOR HEATHKITS

SOME MODELS NOW ON DEMONSTRATION

MULLARD ECL 86 10 WATT AMPLIFIER

We are now able to offer the ready drilled printed circuit panels for this remarkable amplifier, which provides compact high quality reproduction. Ideal for stereo. Printed circuits 12/6 each, post 1/-. Trade enquiries invited.

STOCKISTS FOR "LETROKIT" SYSTEMS

RONETTE STEREO PICK-UPS

Limited number only of this Ronette lightweight slender high quality Stereo pick-up. Fitted with BF40 cartridge and stylus for LP and Stereo reproduction. USUAL PRICE £7.15.0. While
last £2.15.0, post 2/-



HOLIDAYS AHEAD

The UNIC Dry Electric Shaver operates from a single U2 cell and will give you a quick clean shave anywhere. Ideal for holidays, camping, car rallies, etc. Swiss precision engineered.

PRICE £2.19.6 complete

ACKNOWLEDGED TO BE THE BEST COMPONENT CATALOGUE

A
MUST
for every
radio
enthusiast



2/6
plus 9d. post



NOW
166 pages
Over **600**
illustrations
Over **5000**
components listed

This is today's most up-to-date and most comprehensive component catalogue for the radio constructor, experimenter, electronic engineer and hi-fi enthusiast.

POST
COUPON
TODAY
Write
CATALOGUE
on top left of
envelope.
Enclose P.O. 3/3

Name _____

Address _____

Home Radio Ltd., (AC), 187 London Road, Mitcham, Surrey

THE Radio Constructor

Incorporating THE RADIO AMATEUR

AUGUST 1962

Vol. 16, No. 1
Published Monthly

Annual Subscription 29/-
(including postage)

*Editorial and
Advertising Offices*

57 MAIDA VALE LONDON W9

Telephone
CUNningham 6141
(2 lines)

Telegrams
Databux, London

Suggested Circuits No. 141: Low Cost Record Player Amplifier, <i>by G. A. French</i>	12
A Decibel Meter, <i>by T. W. Carreyett, Grad.Brit.I.R.E.</i>	15
Book Reviews	19
A Valve Tester Design, <i>by P. A. Robinson</i>	20
Radio Veronica	25
Can Anyone Help?	26
Understanding Radio, Part 12, <i>by W. G. Morley</i>	27
News and Comment	33
New High Gain Double Triode, the ECC807	34
In Your Workshop	35
A Transistorised Electronic Organ, Part 1, <i>by S. Asley</i>	41
Photoflash Slave Unit, <i>by B. S. Muncaster</i>	48
High-Low Impedance Microphone Pre-Amplifier, <i>by K. Berry</i>	52
The Good Companion, Mark II Transfilter Portable, <i>described by W. Holmes</i>	54
Cathode Followers and their Uses, Part 1, <i>by J. B. Dance, M.Sc.</i>	59
Small Power Supply Unit, <i>by A. S. Carpenter</i>	61
Radio Topics, <i>by Recorder</i>	65

© Data Publications Ltd, 1962

CONTENTS may only be reproduced after obtaining prior permission from the Editor. Short abstracts or references are allowable provided acknowledgment of source is given.

CONTRIBUTIONS on constructional matters are invited, especially when they describe the construction of particular items of equipment. Articles should be written on one side of the sheet only and should preferably be typewritten, diagrams being on separate sheets. Whether hand-written or typewritten, lines should be double spaced. Diagrams need not be large or perfectly drawn, as our draughtsmen will redraw in most cases, but all relevant information should be included. Photographs should be clear and accompanied by negatives. Details of topical ideas and techniques are also welcomed and, if the contributor so wishes, will be re-written by our staff into article form. All contributions must be accompanied by a stamped addressed envelope for reply or return, and should bear the sender's name and address. Payment is made for all material published.

OPINIONS expressed by contributors are not necessarily those of the Editor or the proprietors.

TRADE NEWS. Manufacturers, publishers, etc., are invited to submit samples or information of new products for review in this section.

TECHNICAL QUERIES must be submitted in writing. We regret that we are unable to answer queries, other than those arising from articles appearing in this magazine; nor can we advise on modifications to the equipment described in these articles.

CORRESPONDENCE should be addressed to the Editor, Advertising Manager, Subscription Manager or the Publishers, as appropriate.

REMITTANCES should be made payable to "DATA PUBLICATIONS LTD."

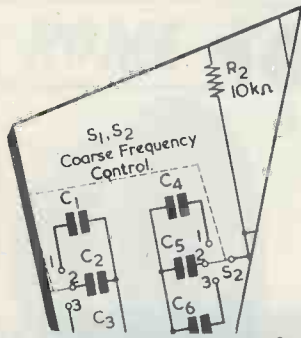

suggested circuits



The circuits presented in this series have been designed by G. A. FRENCH, specially for the enthusiast who needs only the circuit and essential data

No. 141 Low-Cost Record Player Amplifier

IN THE MARCH ISSUE of *The Radio Constructor* our contributor Recorder pointed out, in the "Radio Topics" feature, that it would be of interest to include a low-cost gram amplifier in "Suggested Circuits", and that such an amplifier could employ the UL84-UY85 combination now commonly used in the more inexpensive commercially made record players.

The writer agrees that an amplifier of this type may well be of interest to readers, not only because it could be built at a relatively small expenditure, but also because it could demonstrate several circuit practices which are relatively "standard" in commercial design and which may not be generally known amongst amateurs.

In order to keep costs at a low level the design described in the present article employs a transformerless power supply, with the result that the amplifier chassis is connected to one side of the mains. It is essential, in consequence, that the details given later concerning safety precautions be carefully followed.

The Circuit

The circuit of the amplifier appears in Fig. 1 and, as may be seen, it employs a single UL84 amplifier which obtains an h.t. supply by means of a UY85 rectifier.

The UL84 is commonly used in commercially manufactured record players and, on its own, is capable

of driving a loudspeaker at adequate volume when supplied by a high output crystal pick-up of the type fitted to most popular 4-speed gram decks and auto-changers. It has a fairly high mutual conductance of around 9mA/V, and it offers an output power of 5.2W at 10% distortion. The last point ensures that it will not be readily overloaded under the operating conditions envisaged here. The UL84 draws a high anode current (60mA at 200V under normal working conditions) but this factor represents no great disadvantage when half-wave rectification direct from the mains supply is employed. On the other hand, the high anode current precludes the use of inexpensive mains transformers having half-wave h.t. windings for home-constructor applications, as the maximum h.t. current rating available in components of this class is 45mA only. It is for this reason that a transformerless power supply, similar to those employed in commercial record players, is suggested here.

The amplifier is by no means in the high fidelity class, emphasis being placed more on economy than on audio quality. Nevertheless, it should be capable of offering an output which is comparable with that given by a mains table model receiver.

In Fig. 1 the output of the crystal pick-up is applied, via the isolating capacitors C₁ and C₂, to the volume

control R₁. R₁ has a fairly low value for crystal pick-up operation, and this fact, together with the presence of C₁ and C₂, causes some bass cut in the input applied to V₁. This bass cut is not necessarily a disadvantage in the present application.

V₁ amplifies in conventional fashion, it being biased by the cathode components R₄ and C₄. The amplified signal is applied to the primary of the speaker transformer. The UL84 requires a fairly low anode load impedance, and this is provided by an output transformer having a ratio of 30:1.

A top-cut control is provided by C₃, R₂ and R₃. The use of a tone control across the primary of the output transformer is far from being a high fidelity design technique, but it offers an advantage here. Theoretically, it might seem preferable at first sight to put the tone control in the grid circuit of the amplifier, and have a "tone correction" circuit consisting of a fixed resistor and capacitor in series across the transformer primary. However, a fixed "tone correction" circuit would cause a permanent reduction in the output of the higher audio frequencies, and the separate tone control could only introduce further losses. In the present circuit it is desirable to obtain the maximum amount of gain possible from the single amplifier valve employed, with the result that it is beneficial to make the "tone correc-

six inches in diameter, or an equivalent elliptical unit.

The amplifier dissipates some 40 watts of heat (R_7 alone dissipates nearly 16 watts) and it will be necessary to provide a means of ventilation. Fortunately, the volume of air in the average record player cabinet is large in proportion to that of an amplifier employing the circuit of Fig. 1, and it is fairly simple to provide the requisite ventilation apertures at convenient points.

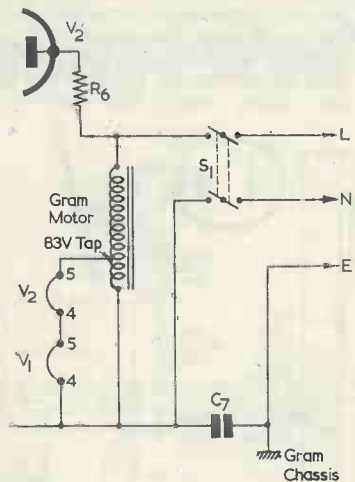

Fig. 2.

M448

Performance

As was stated earlier, the amplifier should give a comfortable volume when driven by a high-output crystal

pick-up of the type fitted to most popular 4-speed gram decks and auto-changers. If it is desired to check the output level of a particular pick-up before commencing on the construction of the amplifier, this may be done by using a temporary mock-up of the circuit with such components as C_3 , R_2 and R_3 omitted. Alternatively, the pick-up may be temporarily applied to the output pentode grid circuit of a conventional mains radio receiver. The output pentode stage of such a receiver should offer a degree of gain fairly close to that given with the present amplifier.

When completed, it will be found that the amplifier causes a perceptible hum level to be heard in the speaker, although this should be unnoticeable when a record is played at normal level. Sound quality should be adequate, considering the limitations of the circuit, and will of course be equivalent to that given by commercially manufactured record players employing the same type of amplifier.

Alternative Heater Supply

The motors in a large number of gram decks and auto-changers supplied to record player manufacturers nowadays have an 83 volt tap (or "80 volt tap") in the windings. The function of this tap is to provide a supply for the heaters of a UL84 and UY85 in series. If the home-constructor obtains a gram deck having such a tap the heaters of V_1 and V_2 may be connected up as shown in Fig. 2. The circuit of Fig. 2 has the advantages of deleting the heater dropper, R_7 , and of conse-

quently reducing the overall heat dissipated by the amplifier.

British Standard 415

The isolating capacitors employed in the present circuit have values considerably lower than those used in many commercially manufactured record players currently on sale or in production. British Standard 415:1957 (Safety Requirements for Radio or other Electronic Apparatus) lays down that the leakage current to earth from the whole group of terminals intended for the connection of modulating apparatus (in this case, the pick-up) shall not exceed 2mA. For a 250 volt mains supply, this corresponds to a total isolating capacitance of 0.0025 μ F. The present circuit meets the 2mA requirement provided that the connections to the pick-up cannot be touched by the user, whereupon the only component providing isolation is C_7 .

Many commercial manufacturers employ isolating capacitors having an a.c. working voltage of 300, as are specified here, but such capacitors do not meet all the voltage requirements in B.S.415. Specially produced ceramic isolating capacitors which meet the specification, and which are usually marked "B.S.415", are available to manufacturers but not, so far as the writer is aware, to the home-constructor.

The present circuit meets the requirements of B.S.415 if the connections to the pick-up cannot be touched by the user and if the connection to the mains is via a three-way socket which causes the gram chassis to be reliably earthed.

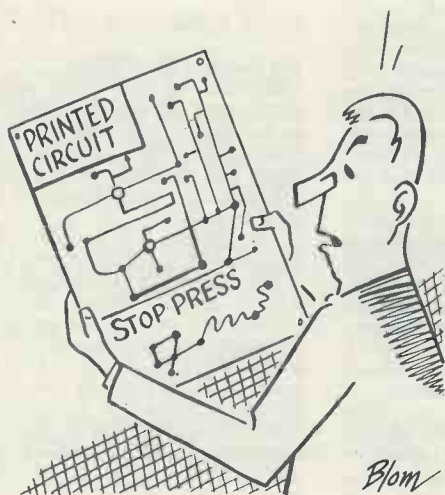

EMI TV Cameras used in Jet Aircraft Tyre Tests

E.M.I. Electronics high definition, closed-circuit television equipment is being used to observe aircraft tyres undergoing high-speed testing in the U.S.A.

Stresses placed on tyres of modern jet aircraft during take-off and landing call for the highest safety margins, and a comprehensive tyre test simulator at the Baltimore, Maryland, factory of the Schenit Rubber Company is designed to show response under the most severe operating conditions.

Failure of a tyre or test assembly at high speed can result in an explosion, and to protect operating personnel from exposure to flying fragments two E.M.I. television cameras replace the human eye in supplementing complex instrumentation for obtaining maximum test data.

The E.M.I. cameras, supplied to Schenit by Fairbanks Morse, are mounted behind bullet-proof glass in the test areas and are fitted with remote-control zoom lenses. Large screen monitors at the simulator's main control console enable operators to observe closely as the tyres are subjected to stress greatly in excess of those likely to be met with under actual operating conditions.

Automatic light control provides for optimum viewing conditions at any time, and the cameras produce steady, clear pictures despite interference by complex adjacent electrical and electronic equipment.

A Decibel Meter

By T. W. CARREYETT, GRAD. BRIT. I.R.E.

THIS ARTICLE DESCRIBES THE DESIGN, TOGETHER with some development notes, of a rather special type of peak valve voltmeter. The output meter is calibrated in decibels on a linear scale over a 10dB range. The full reading of the meter could cover about a 25dB range, but the output circuit alignment has been concerned with obtaining the maximum linear decibel scale only. As the decibel is proportional to a given change in a ratio of two powers, and since one of these powers is the reference power, calibration to such a reference power has been left to the user who can mark or note a position on the output meter for such an input. The standard reference power is 1mW developed across 600Ω. Therefore, if the output meter is marked for an input of 0.775V across a 600Ω load, this point can always be referred to as a decibel zero level. In the prototype, with 60dB of attenuation built-in, the sensitivity could be adjusted to obtain a centre reading on the output meter when zero level was applied.

The sensitivity catered for in the instrument is from 1mV to 25V. This range has been well covered as, with maximum sensitivity, readings below 1 mV can be taken and, with full attenuation, input volts well above 25V can be read off. Within this range lie the general responses of most equipment whose outputs are generally calculated in decibels. On the maximum sensitivity range responses of pick-ups, tape heads, microphones, and the like, can be read directly off the meter. With the use of the attenuators responses of pre-amplifiers (for a variety of inputs) or power amplifiers can easily be calibrated.

The input of the meter consists of two attenuators, between which a series of taps in 2dB steps enables a selection from 0-98dB to be built into the input circuit and read off from the attenuators. This wide range of attenuation is useful in checking the response of filters, transformers and attenuators, etc. As the amplifier has a gain of over 60dB the meter can also be used for checking on signal-to-noise ratios, and with the use of a couple of parallel 'T' filters simple intermodulation and harmonic distortion tests can be carried out as well.

Readers will probably think of many other useful tests for which the meter can be used to gather interesting information, and these could include loudspeaker responses (the prototype had no loss in its response at 10 c/s), or cross-talk measurements

between circuits or tape tracks. It was with the view of tackling these type of tests that the author developed the present instrument. Some references of circuit information are given at the end of the article.

The block layout of the meter is shown in Fig. 1. As can be seen from this the input signal is applied through an attenuator. The attenuator comprises two circuits, one working in steps of 20dB from 0dB to 80dB, and the other in steps of 2dB from 0dB to 18dB. The total amount of attenuation which can therefore be built into the circuit is 98dB. Following the attenuator is an amplifier, the gain of which is about 60dB, and which incorporates a sensitivity control. The output of the amplifier is taken from a see-saw phase inverter and the balanced

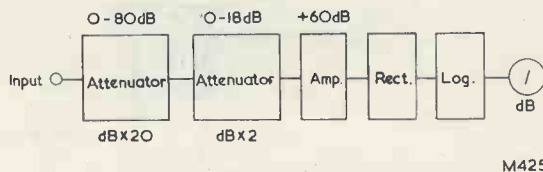

Fig. 1. Block layout of the meter

two-phase output applied to a full-wave diode rectifier circuit. The smoothed d.c. voltage is the peak output for the input signal, and this is now used as bias to operate a variable- μ pentode. The pentode characteristic is aligned to enable it to operate as a logarithmic stage. The output meter is connected in the anode circuit of the pentode and registers, over a reasonable part of its scale, the logarithm of the applied d.c. input. Because of this characteristic the scale may be calibrated in decibels, a fair proportion of the scale being linear.

The Attenuator Circuit

The input to the meter is provided by the attenuators, these being built into two cathode-follower stages as shown in Fig. 2. The input impedance is quite high (10MΩ), thus avoiding any insertion losses which could give false results. The attenuation required is selected from a tapping in the cathode load. The series of tappings of the first cathode load has been arranged to give 20dB steps.

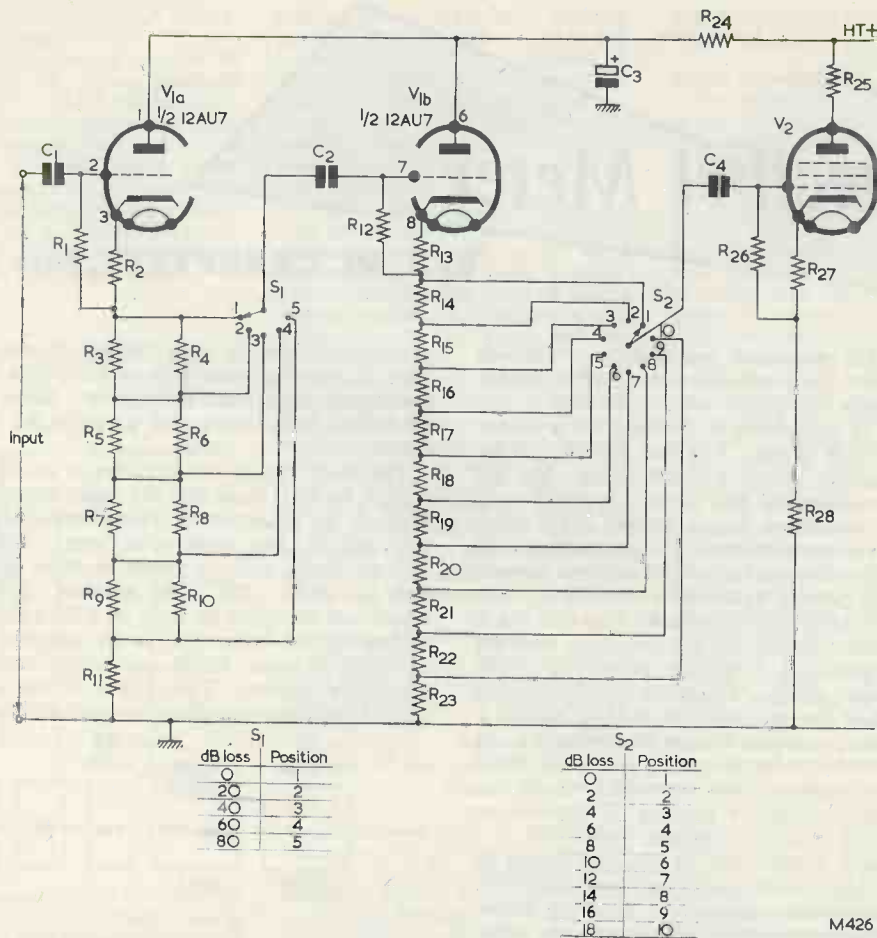

Fig. 2. The attenuator circuits. V₂, C₄ and R₂₅ to R₂₈ are part of the amplifier circuit and appear also in Fig. 3

The second cathode follower is designed from the same principles, with its load arranged to provide tapings in 2dB steps.

The loss for the attenuators was derived as follows. Since the loss in decibels is $20 \log_{10}$ voltage ratio and since the current through the cathode load and tapping points will be the same, then in place of voltage ratio resistance ratio can be used. Therefore, with reference to the standard dB voltage ratio tables, the required resistance values can be found. For example, to find the required tapping point from a $100k\Omega$ load to produce an attenuation of 18dB a voltage ratio of 7.94 is required. In consequence, $\frac{100k\Omega}{R_x} = 7.94$ and $R_x = \frac{100}{7.94}$ so that R_x is $12.6k\Omega$. All other values are found from the same principle.¹ Since a voltage ratio of 10 corresponds

¹ A possibly simpler approach would consist of using tables which give ratios less than unity. Thus, the voltage ratio for 18dB is 0.126, and the corresponding resistor in a $100k\Omega$ chain would then be $12.6k\Omega$.—Editor.

to 20dB the required resistance ratio for the 20dB tapping points is therefore 10, and since the load value is $100k\Omega$, for a loss tapping point of 20dB the required resistance tap will be a $\frac{100k\Omega}{10}$ or $10k\Omega$.

The 40dB tap will be at $\frac{100k\Omega}{100}$ or $1k\Omega$ and so on.

The attenuator resistors can be built around the switches and the entire assembly should then be well screened.

The insertion loss introduced by each attenuator stage was found to be about 1.5dB. So the total loss to be accounted for in the subsequent amplifier due to these stages was 3dB only which, of course, presented no problems. The frequency response of the attenuator stages was found to be satisfactory from 10 c/s to 60 kc/s. Also, no signal distortion was introduced with amplitudes ranging from 1mV to 25V. The output from the attenuator stage is fed into the amplifier, the time constant of the

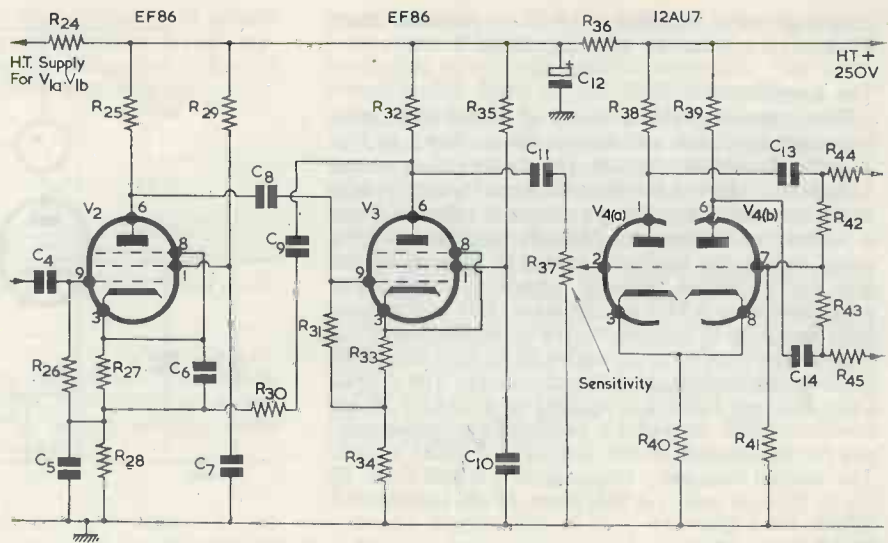

Fig. 3: The amplifier.

M427

Components List

Resistors (all $\frac{1}{4}$ W 10% unless otherwise stated)

R ₁	10M Ω 20%	} Close tolerance, according to meter accuracy required
R ₂	3.9k Ω	
R ₃ , R ₄	180k Ω	
R ₅ , R ₆	18k Ω	
R ₇ , R ₈	1.8k Ω	
R ₉ , R ₁₀	180 Ω	
R ₁₁	10 Ω	
R ₁₂	1M Ω 20%	
R ₁₃	3.9k Ω	
R ₁₄ to R ₂₃	See table. Close tolerance, according to meter accuracy required	
R ₂₄	5.6k Ω 20%	
R ₂₅	220k Ω	
R ₂₆	1M Ω 20%	
R ₂₇	2.2k Ω	
R ₂₈	100 Ω	
R ₂₉	1M Ω	
R ₃₀	100k Ω	
R ₃₁	1M Ω 20%	
R ₃₂	220k Ω	
R ₃₃	2.2k Ω	
R ₃₄	100 Ω	
R ₃₅	1M Ω	
R ₃₆	8.2k Ω 1W 20%	
R ₃₇	1M Ω potentiometer, log track	
R ₃₈ , R ₃₉	100k Ω matched 5%	
R ₄₀	2.2k Ω	
R ₄₁ , R ₄₂ , R ₄₃	270k Ω matched 5%	
R ₄₄ , R ₄₅	100k Ω matched 5%	
R ₄₆	2.7M Ω	
R ₄₇	2.5k Ω potentiometer, wirewound	
R ₄₈	82k Ω	
R ₄₉	47k Ω	
R ₅₀	50k Ω potentiometer, linear track	
R ₅₁	47k Ω	

Capacitors

C ₁ , C ₂	0.1 μ F
C ₃	16 μ F electrolytic, 275 w.v.

C ₄ , C ₅	0.1 μ F
C ₆	0.01 μ F
C ₇	0.5 μ F
C ₈	0.1 μ F
C ₉	2 μ F paper
C ₁₀	0.5 μ F
C ₁₁	0.1 μ F
C ₁₂	16 μ F electrolytic, 275 w.v.
C ₁₃ , C ₁₄	0.5 μ F
C ₁₅	0.1 μ F

Valves

V ₁	12AU7
V ₂ , V ₃	EF86
V ₄	12AU7
V ₅	EB91
V ₆	EF92

Meter

0-1mA meter

Switches

S ₁	1-pole
S ₂	1-pole 10-way

TABLE
Suggested preferred values (k Ω)
in parallel to produce desired
resistance

Resistor	
R ₁₄	20.6k Ω 56 and 33k Ω
R ₁₅	16.4k Ω 180 and 18k Ω
R ₁₆	13k Ω 100 and 15k Ω
R ₁₇	10.2k Ω 68 and 12k Ω
R ₁₈	8.2k Ω —
R ₁₉	6.6k Ω 15 and 12k Ω
R ₂₀	5.2k Ω 22 and 6.8k Ω
R ₂₁	4k Ω 10 and 6.8k Ω
R ₂₂	3.2k Ω 18 and 3.9k Ω
R ₂₃	12.6k Ω 82 and 15k Ω

coupling being arranged so that frequencies down to about 5 c/s can be accommodated.

The Amplifier

The main amplifier consists of two EF86's with interstage feedback and the circuit is shown in Fig. 3. The feedback extends the range from about 15 kc/s to 40 kc/s, a further extension to over 50 kc/s being arranged by peaking capacitors. One of these is connected across the cathode resistor and the other across the feedback injection resistor of the first EF86. These peaking capacitors cause some overshoot on a 4 kc/s square wave, but at the same time they help to provide a reasonable flat frequency response for sine waves to above 60 kc/s for the entire amplifier (including the phase inverter). The output from the two EF86's is applied to a 12AU7 phase inverter, which provides a balanced two-phase output for application to the full-wave rectifier circuit. The overall frequency response is $\pm 0.2\text{dB}$ from 10 c/s to 20 kc/s and $\pm 0.5\text{dB}$ from 25-60 kc/s.

The Rectifier Stage

The rectifier-stage is shown in Fig. 4. The circuit is conventional and has no other purpose than to rectify the input signal. A full-wave diode rectifier was used in order to maintain a reasonably linear response from about 5 c/s, as at such low frequencies the linearity of a half-wave circuit tends to fall off. The reliability of a thermionic diode was also favoured as the meter may be damaged if a diode failed. The d.c. output from the rectifier is taken from the anode load, where it is smoothed by a $0.1\mu\text{F}$ capacitor. The negative voltage output is then applied to the logarithmic stage. A negative voltage output was chosen so as to form a meter guard.

The Logarithmic Stage

The logarithmic stage, which is shown in Fig. 5,

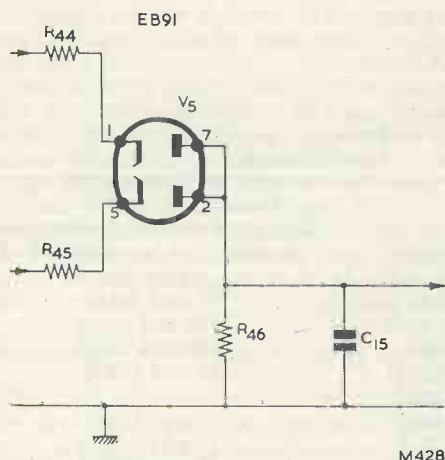

Fig. 4. The output of the amplifier is applied, via R_{44} and R_{45} , to the rectifier stage, shown here

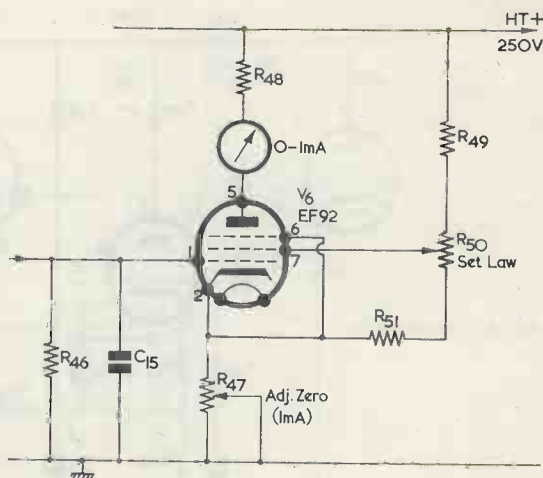

Fig. 5. The logarithmic stage. The rectified peak voltage appears across R_{46} and C_{15} (Fig. 4) and is applied to G_1 of V_6

is virtually a d.c. amplifier arranged with a logarithmic characteristic. The search for a suitable valve was very soon narrowed down on looking at the characteristic curves for variable- μ pentodes, the final choice being an EF92. By adjustment of the screen voltage, this EF92 characteristic can be arranged to provide a good approximation to a logarithmic curve over a reasonable range. Therefore the output current will be approximately the logarithm of the applied input voltage, and can be read off in decibels by a milliammeter connected in the anode circuit. A total range of about 25dB can be accommodated on the scale of which 10dB is linear. Since only a small accurate range was required a span of 10dB was quite adequate, larger measurements being made with the aid of the attenuators. The meter used has a f.s.d. of 1mA and the Adjust Zero control is adjusted for f.s.d. with zero signal input. The negative voltage applied to the grid of the EF92 biases back the valve, reducing the anode current. From the valve curves it can be seen that, with an anode voltage of 250V and a screen voltage of 150V, the first part of the curve appears to be more linear than logarithmic. However, from about 0.7mA a slope approximating to a logarithmic curve is found. The point of using a negative bias voltage is that this automatically provides a meter guard, since any high input peaks will only drive the meter towards its mechanical zero.

As a guide to the alignment of this stage the following readings were taken after aligning the logarithmic stage in the prototype:

H.T. rail	260V
Anode	160V
Screen	150V

These readings were given with G_1 taken to chassis via a $2.7M\Omega$ resistor in parallel with a $0.1\mu F$ capacitor. The meter readings for changes of 2dB were as follows, 0.5mA corresponding to zero dB:

dB	mA	dB	mA
0	0.5	0	0.5
-2	0.6	+2	0.4
-4	0.68	+4	0.3
-6	0.74	+6	0.2
-8	0.82	+8	0.12
-10	0.87	+10	0.05

With the meter aligned to 0.4 a fairly linear scale of $\pm 5dB$ is given.

Power

The power requirements call for an h.t. voltage of 250 and a current of 8mA. A humdinger across the heater supply may be found helpful when operating at maximum sensitivity.

General Points

If the attenuator having the 2dB steps is to be used with low inputs of 1mV it will be advisable to use the best resistors one can afford, for here is a

stage that can really make a lot of noise on a low level input if noisy resistors are used. It may be preferable to use high stability resistors. The same remarks also apply to the 20dB attenuator.

Another point is that the attenuator circuits including the switch, should be well screened with the shortest run of input cable possible. The input cable should come directly into the attenuator without going through input terminals if the high input impedance is to be preserved.

The accompanying table shows suggested values of resistor for making up the resistors in the 2dB chain. Thus, the $20.6k\Omega$ resistor may be provided by a $56k\Omega$ and a $33k\Omega$ resistor in parallel. No parallel combination is needed for the $8.2k\Omega$ resistor, as this is already a preferred value. The figures in the table give a very close approximation to the required value.

References

Studio Engineering, B.B.C. Training Staff (Iliffe)
Vacuum Tube Voltmeters, J. F. Rider (J. F. Rider Publications)

Book Reviews . . .

THE ELECTRONIC MUSICAL INSTRUMENT MANUAL. By Alan Douglas, M.I.R.E., M.A.I.E.E. 302 pages, $5\frac{1}{2} \times 8\frac{3}{4}$ in. Published by Sir Isaac Pitman & Sons Ltd. Price 37s. 6d.

Some years ago, the reviewer had the experience of being shown around an electronic organ factory. At the end of the assembly line was a test room in which each organ was brought up to peak performance by a competent musician who was also an electronic engineer. The concept of someone laying down a testmeter to play a snatch of Bach conveys only some of the fascination which exists in this combined world of electronics and music.

The book under review, now in a revised and enlarged fourth edition, covers all important facets of electronic musical instruments including, in particular, the electronic organ and allied instruments. Its chapters cover conventional multi-note instruments; the production and mixing of electrical oscillations; amplifiers, tone controls and loudspeaker equipment; commercial electronic instruments; and experimental methods of tone generation. The section on commercial instruments has no less than 108 pages devoted to it, and these include full circuit diagrams, of which nine are printed on insets folded into the leaves of the book.

The Electronic Musical Instrument Manual is a book which can be read with pleasure by any engineer who is interested in unusual applications for valves or transistors, and it is an essential work for those who are active in the field of electronic instruments. It is admirably set up, provides extensive references, and is generously illustrated.

RADIO ENGINEERING FORMULAE AND CALCULATIONS. By W. E. Pannett, A.M.I.E.E. 216 pages, $4\frac{3}{4} \times 7\frac{1}{4}$ in. Published by George Newnes Ltd. Price 21s.

Radio Engineering Formulae and Calculations now appears in its second edition, a new section on Sound Reproduction having been added to the 1959 first edition, together with the amendment of several examples. The book is aimed primarily at the practising engineer who, because of preoccupation with administrative, constructional or maintenance work, has allowed his earlier skill in handling formulae and calculations to become dulled. It can, however, be of equal value to the junior engineer and the student.

This book is attractive because it compresses, in a non-bulky volume, a very large mass of formulae and allied information. Whenever a formula is introduced, worked examples follow with each step clearly shown. The range covered is very diverse, and includes such subjects as the sag of the wire rope holding a curtain aerial under wind load to the formulae needed for calculating crossover network components in a high fidelity loudspeaker system.

TELEVISION RECEIVER SERVICING, Volume Two, Second Edition. By E. A. W. Spreadbury, M.Brit.I.R.E. 475 pages, $5\frac{1}{2} \times 8\frac{3}{4}$ in. Published by Iliffe Books Ltd. Price 35s.

Television Receiver Servicing is a comprehensive work in two volumes, of which Volume Two has now been published in its second edition. The second edition of Volume One was reviewed in our August 1961 issue.

The present edition of Volume Two has been brought up to date and covers the video stage, tuning circuits, sound channel, and power supplies of the television receiver. There is also a large section devoted to aerials, aerial installations, and signal distribution systems. A short chapter at the end of the book compares 625 and 405 line operation and refers to the effect on service work of the increased number of lines.

The text is aimed primarily at service engineers who already have a reasonably good grasp of radio servicing principles, and illustrates the fact that the author is fully conversant with the day-to-day problems and activities of a practical service workshop.

A VALVE TESTER DESIGN

By P. A. Robinson

COMMERCIAL MANUFACTURED VALVE TESTERS offering a comprehensive number of checks are expensive, but they are nevertheless of considerable use to the amateur. The writer, who had been requiring a valve tester for a considerable time, decided to build one himself, and the resulting instrument is the subject of this article. The complete tester offers a considerable number of checks, these including mutual conductance, inter-electrode leakage and emission. The valve under test may also be made to function as an a.f. amplifier, signal input being provided either by a small medium-wave receiver or by a neon oscillator. Many other checks are possible by reason of the extreme flexibility of the design.

An important feature of the tester is the use of terminals and flying leads for interconnection between the valveholders and the power supply and test components. These enable any test circuit within reason to be rapidly built up and applied to the valve for a speedy examination of its capabilities.

Apart from the mains transformer, which was specially wound, nearly all the components employed in the writer's unit were obtained from salvaged or ex-Service equipment, and the cost of construction was extremely low.

Basic Layout

As may be seen from the illustrations, the unit is built into a small wooden case. This was an ex-W.D. spare valve box, with internal dimensions of $6\frac{1}{2} \times 6 \times 8\frac{1}{2}$ in, plus a further $1\frac{3}{8}$ in depth in the lid. The valveholders are mounted on one side and a control panel fitted at the top. The pins on the valveholders are wired to a set of terminals numbered 1 to 9, each terminal corresponding to the similarly numbered pins of the valveholders. Terminal 10 connects to centre spigots, where applicable. Also appearing on the panel are terminals carrying different services, and these are coupled to the numbered valveholder terminals by flying leads as required. Thus, a very large number of different circuit combinations may be set up at will. Also available at the panel is a continuously variable heater voltage with potentials up to 51 volts, and two potentiometers which may be conveniently wired in for specific checks. A further set of terminals offers a typical a.f. amplifier anode circuit, whilst a socket provides an audio output from a neon oscillator. Two wander plugs and sockets

enable h.t. rectifiers to be checked in a working circuit. One further terminal is blank, and provides an anchor point for components or wiring. An external meter (or meters) is employed with the tester, this being connected into circuit as required. Another facility consists of the provision of a small medium-wave crystal receiver in the lid of the case. This enables speech and music to be fed into a valve under test and offers a particularly useful check on the functioning of the valve as an audio amplifier.

The whole basis of the tester rests on the fact that any circuit required by the user may be quickly wired up and put into practice. In the prototype, the writer went to considerable trouble to obtain old-fashioned pillar-type terminals for the panel as, in his opinion, these are far and away the best for this particular job.

The Power Supply

The power supply circuit is given in Fig. 1. In this diagram, a mains transformer has an h.t. secondary offering 240 volts at 100mA, and an l.t. secondary offering 6.3, 21 and 51 volts at 1A. The h.t. secondary is applied via rectifier W_1 to the reservoir capacitor C_1 , the rectifier being connected into circuit via wander plugs and sockets. The

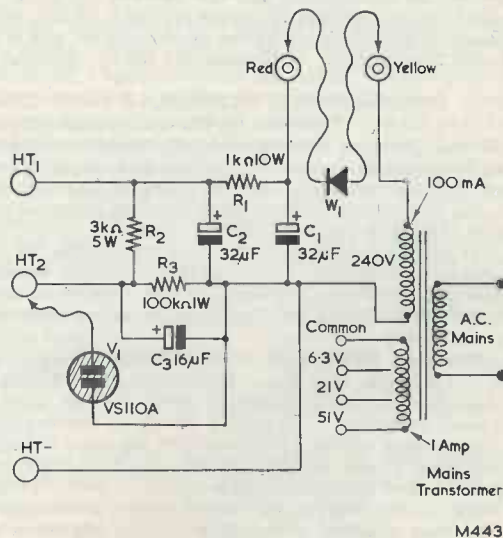

Fig. 1. The circuit of the power supply

rectified h.t. voltage across C_1 is smoothed via R_1 and C_2 and is applied to the h.t. +1 terminal. This offers an output of some 250 volts.

An h.t. +2 terminal is also provided, this being connected to C_2 by way of R_2 and C_3 . The voltage available here is of the order of 220 volts, but this drops to a stabilised 110 volts when the wander lead from the VS110A stabiliser is connected to the terminal. The stabilised h.t. facility is not essential but was included for two reasons. Firstly, it was felt that mutual conductance tests for an anode voltage of 100 would be desirable, and the VS110A gives a voltage of 110, which is sufficiently near this figure for most rough practical work. Secondly, as will be seen later, the 110 volt potential is extremely useful for checking inter-electrode insulation.

The l.t. secondary of the transformer is applied to four terminals on the panel, these being labelled with the appropriate voltages. Adjacent to these terminals is an 80Ω heater shunt resistor wound on a flat strip of mica and fitted with two flying leads.

In use, the valve to be tested is plugged into the appropriate socket and two flying leads terminated in crocodile clips connected to the terminals corresponding to the heater pins. Also connected across these terminals is an a.c. voltmeter, the type employed by the writer being a Universal Avominox. The ends of the shunt resistor are connected to the appropriate l.t. secondary terminals, and the two heater crocodile clips are then applied experimentally to the shunt resistor until the required heater voltage is obtained. This process is quite quick but it is advisable, of course, to commence with the crocodile clips close together and to keep a watchful eye on the meter. For 6.3 volt valves the shunt resistor is not needed, the valveholder heater terminals being connected direct to the 6.3 volt secondary terminals.

This method of heater voltage selection satisfies all valves with heater requirements up to 50 volts, and offers an extremely cheap and simple solution to the heater voltage problem which appears in all valve testers. It is preferable not to use the shunt resistor with 1.4 volt battery valves, and for these a separate dry cell should be employed.

The shunt resistor employed by the writer was home-constructed and employed wire taken from a 750 watt bowl fire replacement element purchased at Woolworth's stores. The wire was wound on to a stout mica strip measuring $2 \times 6\frac{1}{2}$ in. No attempt should be made to straighten out the spiral wire before winding on to the mica strip because it is too tough and springy. Instead, the wire should be wound directly on to the mica straight from the spiral. The wire is pulled through the finger and thumb held together as tightly as possible, whereupon the spiral uncoils itself against the other side of the finger and thumb.

In the writer's tester the power supply circuit was mounted on its own baseboard (see illustration), this being then fitted to the bottom of the case; also shown is the terminal panel, the valveholder panel, and the heater shunt resistor.

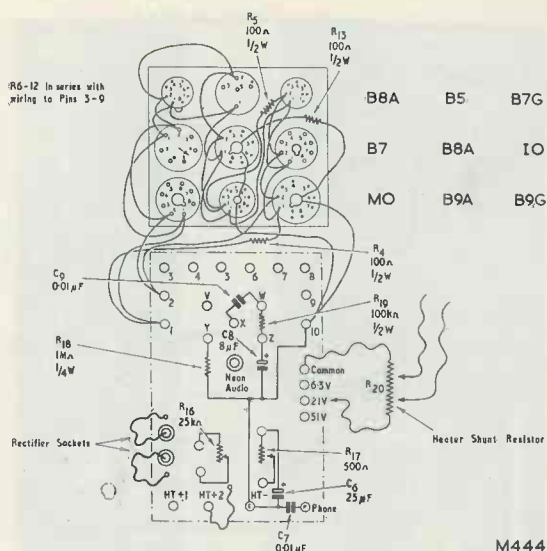

Fig. 2. Top panel and valveholder wiring

Testing H.T. Rectifiers

It is possible to test h.t. rectifiers by connecting these into circuit in place of the power supply rectifier, the wander plugs for the latter being removed from their sockets. The rectifier to be tested is then connected to these sockets. A metal rectifier may be connected directly, whilst valve rectifiers will require a heater voltage which may be obtained from the shunt resistor. The heater should not, of course, be connected to the h.t. — terminal



Testing the triode section of an ECL80

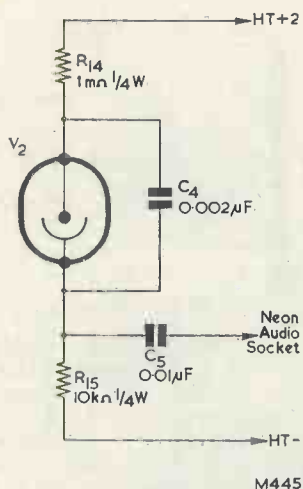

Fig. 3. The neon audio oscillator

with directly heated rectifiers although it may be so connected if the cathode-heater insulation of indirectly heated rectifiers allows the rectified h.t. voltage to appear between these two electrodes. Great care should be taken to ensure that the rectifier is connected with correct polarity as, otherwise, the electrolytic capacitors in the tester will break down, with resultant damage to the mains transformer and the rectifier itself.

A suitable load resistor may be connected between the h.t. +1 and h.t. - terminals, a testmeter switched to the requisite current range being inserted in series. The load resistor should have a value applicable to the rectifier being tested. It may also be necessary to insert a limiting resistor in series with either the anode or cathode of the rectifier under test, and the value required here may be determined from the literature for the valve. Mains transformer losses will provide a limiting resistance on their own and this may be roughly assessed by measuring the resistance of the secondary winding. The physical limiting resistor inserted in series with the rectifier under test may then have a value equal to the limiting resistance specified for the valve minus that of the secondary winding.

If a good quality rectifier is employed in the tester, it can provide a useful basis of comparison with the rectifier under test.

Testing for Cathode-Heater Leakage

A simple and effective method of checking for cathode-heater leakage consists of connecting the VS110A stabiliser to the h.t.+2 terminal and applying this voltage, via a series 22kΩ resistor and a testmeter switched to read 5mA f.s.d. or more, to the cathode. The heater is connected to the h.t.- terminal. With this arrangement short-circuits which appear only when the valve under test has really warmed up can almost be "seen"

coming on. This test may also be carried out with the heater positive and the cathode negative.

Short-circuits between other electrodes may similarly be detected by use of the 110 volt h.t. supply together with the series resistor and meter.

Connections to the Valveholders

It was intended with this valve tester to not only take static readings of valve characteristics but also to have provision for running valves under dynamic conditions, such as would be given by operating them as a.f. amplifiers and the like. Initially, this proposed method of working was unsuccessful as, due to the considerable amount of wiring around the valveholders, it was almost impossible to eradicate instability. The writer contacted the Automatic Coil Winder & Electrical Equipment Co. Ltd., who very kindly sent a detailed description of a method used by them many years ago when they developed their first valve testers and encountered the same trouble.

The scheme is very simple and very effective. It consists of making any wiring associated with the valveholder pins and their junction block terminals into a "ring main", and of inserting at some convenient point in each "ring" a 100Ω resistor. This resistor damps down surges in its "ring" and so prevents feedback via the wiring.

In the writer's tester this wiring method was adopted, and Fig. 2 illustrates the "ring main" wiring for pins 1 and 2 and the centre spigots. Other pins are wired up to their terminals in the same manner.

The Neon Oscillator

A neon oscillator circuit is employed in the tester and is incorporated in the power unit. It employs the circuit given in Fig. 3.

The a.f. output from the neon oscillator is applied via C₅ to the a.f. output socket on the panel situated midway between terminals Y and Z.

Panel Components

A number of components are fitted to the panel terminals to facilitate testing and to enable circuits to be quickly set up. These are shown in Fig. 2.

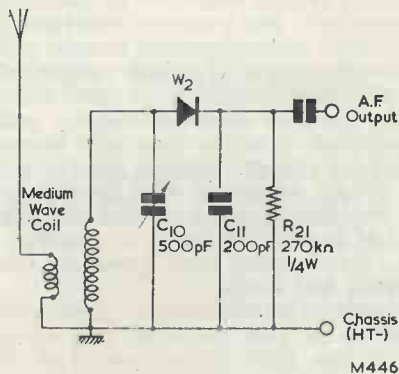

Fig. 4. The crystal receiver circuit

The first of these to consider is R_{16} . This is a $25k\Omega$ variable resistor and may be employed to vary the h.t. voltage applied to the anode of a valve under test. R_{17} is a 500Ω variable resistor and will normally be interposed between the h.t. — terminal and the cathode of the valve under test. It may then be adjusted to provide different values of bias for the valve, either for static or dynamic testing. The cathode of the valve is automatically decoupled by C_6 when this method of connection is adopted.

Resistors R_{18} and R_{19} , together with capacitors C_8 and C_9 , are also permanently wired on to the panel, these connecting to the h.t. — terminal and to terminals W, X, Y and Z, as shown in Fig. 2. The values of R_{18} , R_{19} and C_8 are typical of those employed in normal a.f. amplifying circuits, in which R_{18} would function as a grid leak, R_{19} as an anode load resistor and C_8 as an h.t. decoupling capacitor.

Terminal V is blank, and may be employed for anchoring purposes.

The Crystal Receiver

The crystal receiver is included merely to provide an inexpensive source of speech or music for testing purposes. Its circuit is given in Fig. 4 and, as may be seen, it is quite straightforward in design.

The components are mounted on the lid of the unit.

Testing a Valve

When a valve is to be tested, its pin connections and electrode potentials are checked in the appropriate literature and it is plugged into the tester. Connections are then made to the terminals as applicable, after which the correct heater voltage is set up in the manner described earlier.

The tests which follow depend upon the constructor's requirements, it being remembered that

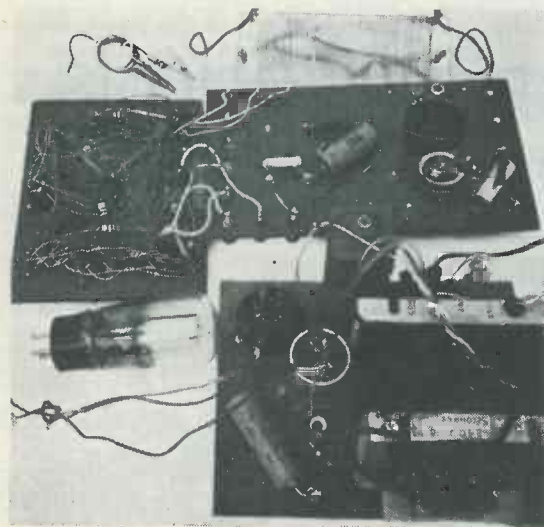

The basic components of the tester

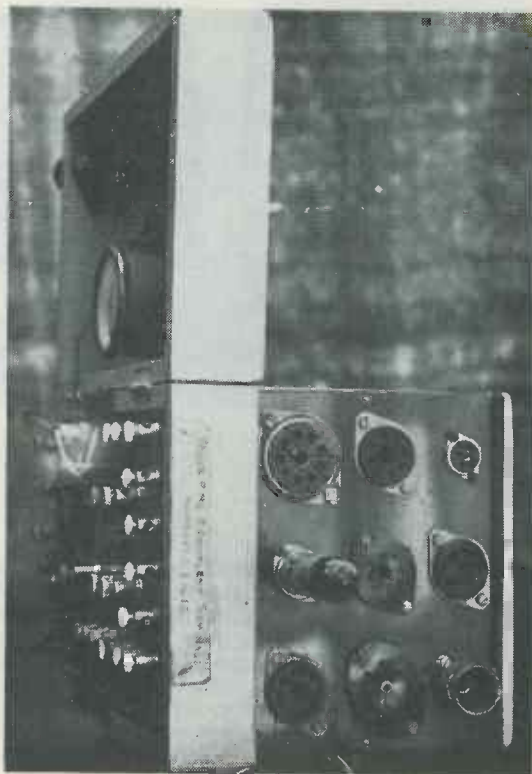

The valveholders mounted on the side of the tester

the flexibility offered by the terminal connections enables many different circuit combinations to be quickly set up. With the aid of an external meter, or meters, static checks can be carried out. These include tests for emission and mutual conductance. The latter may be checked by measuring the change in anode current against change in grid voltage, the latter being varied by adjusting R_{17} .

Dynamic tests at a.f. can also be carried out, a particularly useful check consisting of testing as an a.f. amplifier. For this, the grid of the valve is coupled to terminal Y and the anode to terminal W. Terminal Z is then connected to the h.t.+1 or h.t.+2 terminal, the latter being stabilised or not according to requirements. R_{18} now functions as a grid leak and R_{19} as an anode load. The output from the neon oscillator or crystal receiver is then applied to the grid. One of the leads from a pair of high impedance headphones is next connected to the Phone terminal shown in Fig. 2. To evaluate the degree of amplification given, the remaining headphone lead is applied to the valve grid, at terminal Y, and to its anode, at terminal X. In both instances, the headphones are isolated from the flow of direct current by C_7 . They are also isolated from the h.t. positive potential on the anode by C_9 . When the headphones are connected to

terminal X, the effects of varying bias may be judged by adjusting R₁₇.

Final Points

Several points need to be dealt with before finally concluding.

The first of these is that there is, of course, no necessity to fit the valve tester into the particular case chosen by the writer. Any suitable housing can be employed, and it may be found that wiring is simpler to carry out if terminals, sockets and

valveholders are all mounted on a single panel.

Secondly, the use of terminals allows flexibility together with a considerable saving in cost as compared with a tester employing switching. A little practice soon makes the user familiar with the terminals, and initial checks can be made with valves already in stock. It is helpful to provide a circuit diagram in the lid which shows the terminal functions, and this can consist of a reproduction of Fig. 2 without the valveholders or the wiring thereto from terminals 1, 2 and 10.

Components List

Resistors

R ₁	1kΩ 10W
R ₂	3kΩ 5W
R ₃	100kΩ 1W
R ₄₋₁₃	100Ω ½W
R ₁₄	1MΩ ¼W
R ₁₅	10kΩ ¼W
R ₁₆	25kΩ w.w. potentiometer
R ₁₇	500Ω w.w. potentiometer
R ₁₈	1MΩ ¼W
R ₁₉	100kΩ ½W
R ₂₀	Heater shunt resistor (see text)
R ₂₁	270kΩ ¼W

Capacitors

C ₁	32μF 350 w.v. electrolytic
C ₂	32μF 350 w.v. electrolytic
C ₃	16μF 350 w.v. electrolytic
C ₄	0.002μF mica or paper
C ₅	0.01μF paper
C ₆	25μF 25 w.v. electrolytic

C ₇	0.01μF paper
C ₈	8μF 350 w.v. electrolytic
C ₉	0.01μF paper
C ₁₀	500pF variable, solid dielectric
C ₁₁	200pF mica

Miscellaneous

V ₁	Stabiliser type VS110A
V ₂	Neon bulb
W ₁	Metal rectifier, 250V 100mA
W ₂	Crystal diode, OA71 or equivalent
	Mains transformer: Non-standard, specially wound for tester. Secondaries: 240V at 100mA; 0-6.3-21-51V at 1A
	Medium-wave coil with coupling winding
	Valveholders—as required
	27 pillar-type terminals
	3 sockets
	3 wander plugs
	Crocodile clips, flexible connecting leads, etc.

SEMICONDUCTOR DIMENSIONS

AN AID FOR EQUIPMENT DESIGNERS

As the dimensions of semiconductor devices are an interchangeability feature of importance to all equipment manufacturers, the Electronic Valve and Semiconductor Manufacturers' Association (V.A.S.C.A.) has published a booklet, "Record of Semiconductor Outlines". This contains 43 drawings of semiconductor outlines and bases which have reached an advanced stage of standardisation in the Services, British Standards Institution and the International Electrotechnical Commission.

The primary object of the drawings is to indicate the space which should be allowed in an equipment for the devices and also any other features of importance to interchangeability. This dimensional information should enable equipment designers to achieve a design which allows for the maximum mechanical interchangeability between devices supplied by different manufacturers. The drawings, it is hoped, will also assist makers of accessories.

The booklet, which covers a variety of diodes, transistors, rectifiers and controlled rectifiers, also gives advice on the interpretation of the drawings and includes an explanation of the symbolic names in current use.

There is also an index of cross references to related drawings in K1007, J.E.D.E.C. and I.E.C. documents. The booklet which follows closely on the release of another V.A.S.C.A. publication on semiconductor devices, is produced by V.A.S.C.A. as a service to industry and is being distributed by its members. It can also be obtained from V.A.S.C.A. headquarters, Mappin House, 156-162 Oxford Street, London, W.1, price (prepaid) in the U.K., 7s. 6d. (post free)—overseas 1s. extra towards packing and postage.

Radio Veronica



DURING A RECENT VISIT TO HOLLAND, THE writer had the unique experience of visiting the broadcasting station Radio Veronica which, as some readers are probably already aware, is located on board a ship laying some miles off the Dutch coast. The reason for this unusual location is also possibly known—it is a pirate station, using the term pirate in the same sense as applied to illicit amateur radio transmissions. The story behind this venture, if all the details could be revealed, makes as exciting reading as many a more classical story of piracy on the high seas. Be it sufficient for the moment to say that the whole idea occurred to three Dutch industrialists, whose request to the licensing authority for permission to operate a commercial broadcasting station for advertising purposes, had not unexpectedly been turned down, there being a Government broadcasting monopoly.

In order to surmount this difficulty, the industrialists purchased a ship in a foreign port, fitted her out with a broadcast radio station and then towed her to the present position some six miles off Scheveningen, from where she has radiated programmes of music interspersed with advertisements for the past year or so. To date, none of the authorities concerned have discovered a method of stopping the radiations, although they have made some ingenious attempts to do so!

Our trip to Radio Veronica was a memorable one. Having had our passports checked at the small port from which we left, we boarded a small fishing vessel now converted to act as a tender to Veronica. Along with the relief crew, abundant provisions, barrels of oil and some crates of radio equipment, we headed out into the North Sea on a cold and blustery morning. However, the trip out was of no account with the hazards of getting aboard in the rather turbulent sea that was running at the time. The tender came alongside and, as the two ships rose and fell, one had to jump for it at just the right moment—or else! Fortunately we landlubbers just made it!

The vessel is shown in the QSL card illustration. She was originally a lightvessel used by the German Navigational Authority, most of her original engines and equipment having now, of course, been removed. Two diesel generators now provide the quite considerable amount of electric power required to operate the transmitter and other equipment.

A most attractive little studio has been built in what was formerly the main cabin area, this being illuminated from the deck skylights above. As may be seen from the illustration, a console having four



tape decks, switches, control panels, etc., provides for programme and control. All programme material is recorded on magnetic tape ashore and taken out to the ship for subsequent use.

The transmitter has been built into a nearby bay and much of the work on it has been carried out by the radio engineering staff of the vessel. Due to the comparative high power used, together with the added difficulties of damp and confined space, forced air cooling is most extensively used and one of the ducts used for this purpose can be seen in the illustration showing the main amplifying valve.



Radio Veronica transmits on a frequency of 1,563 kc/s with a power of 2.5kW in the aerial. A normal multiwire broadcast aerial is used and some trouble has been experienced with induced current in the wire rigging of the ship, this gradually being overcome by the expedient of putting insulators in all the affected guy wires and stays.

The programmes emanating from Radio Veronica are, of course, in Dutch but despite this they are becoming popular with a wide audience both on the Continent and in this country. Good reception is apparent along most of the south and east coasts of England and reception reports are very welcome. The attractive QSL card will be sent to those who report and the address is: Radio Veronica, Zeedijk 27A, Hilversum, Holland.

CAN ANYONE HELP?

Requests for information are inserted in this feature free of charge, subject to space being available. Users of this service undertake to acknowledge all letters, etc., received and to reimburse all reasonable expenses incurred by correspondents. Circuits, manuals, service sheets, etc., lent by readers must be returned in good condition within a reasonable period of time

CR100 Receiver.—J. F. Adams, 54 Richmond Road, Gillingham, Kent, would like to obtain the manual for this receiver, either on loan or purchase.

* * *

A.C. Stabilising Transformer Unit.—L. Abell, 98 Ash Road, Denton, near Manchester, seeks information on this unit, marked SR/T.568T 500V.A. LTP2067, and would appreciate circuit details and original usage.

* * *

Transistor Signal Strength Meter.—E. R. Geyer, Annville, Torryburn, Fife, would like to obtain a circuit for use in setting TV aerials.

* * *

T1941 (T28/APT1) Radar Transmitter.—A. Mirfin, 55 Glen View Road, Greenhill, Sheffield 8, wishes to borrow for a few days the circuit or any other information on this American equipment.

* * *

Gram-Deck.—D. Byrne, G3KPO, Jersey House, Eye, Peterborough, wishes to obtain information on this unit and also the Cossor 343 oscillator and the Admiralty Test Set SE2.

* * *

Spencer West TV Model 181.—C. H. Wood, Eastone House, York Road, South Milford, Yorks, requires the loan (or would purchase) the manual or circuit diagram of this receiver. Photostat copy, or any other information would be greatly appreciated—all expenses defrayed.

* * *

Receiver Unit Type 159, Switch Unit Type 35A.—D. G. Chapman, 20 Sackville Road, Hove, Sussex, requires any information available on these units, particularly with regard to connections and power requirements.

* * *

Transistorised Grid Dip Oscillator.—E. L. Simpson, G3GRX, 31 Dukes Road, Hexham, Northumberland,

requires any information on the Heathkit G.D.O. or any other transistorised unit having a 500 μ A meter, also circuit, etc., of a small all-band transmitter built into a TU5 cabinet.

* * *

Test Set 74A.—G. Ferguson, 7 Beech Avenue, Cudworth, near Barnsley, requests information and circuit diagram of this unit.

* * *

Measuring Pressure.—S. F. Goodyear, White Chimneys, New Road, Hythe, Southampton, would like to know if any reader can suggest a means of measuring the pressure applied by an instrumentalist's fingers. Whatever the measuring instrument is, it should be able to be applied to any of the string instruments and to as many of the woodwind instruments as possible—wherever there is not a hole under the key—and should register the pressure immediately, and preferably on to a dial or roll of paper. This implies very small dimensions where it is attached to the musical instrument—not exceeding $\frac{1}{4}$ in thickness and pressure should be registered whilst the instrument is being played. Best solution offered to date is that of stress gauges, but these would be affected by nearness of the hand and of the string or key.

* * *

Rolex Amplifiers.—A. Sproston, 2 Laings Corner, Mitcham, Surrey, has obtained a four and a six valve amplifier which were made in India. The units are designed to work either from a 6V vibrator or the 240V a.c. supply but are less the valves and vibrator. Could any reader please supply information on the valve line-up or lend the circuits of these amplifiers?

* * *

PCR2 Communications Receiver.—R. J. Ellis, Pines, Woolton Hill, near Newbury, Berks, is anxious to obtain the circuit diagram of this 6–22 Mc/s receiver and any details of bandspread modifications.

The twelfth in a series of articles which, starting from first principles, describes the basic theory and practice of radio

part 12

understanding radio

By W. G. MORLEY

IN LAST MONTH'S ISSUE WE COMPLETED OUR DISCUSSION on the subject of capacitance and capacitors. We shall now turn our attention to another basic property of radio. This is inductance, which must be introduced by a preliminary consideration of magnetism.

Magnetism

Magnetism is a familiar phenomenon. We have all encountered typical examples of magnetism, these being probably most frequently shown by the behaviour of *permanent magnets*. Permanent magnets can be made from alloys of iron and other metals (the proportion of iron predominating) and they have the ability to retain their magnetic qualities over very long periods of time, if not indefinitely.¹ Commonly met permanent magnets are the bar magnet and horseshoe magnet, as shown in Fig. 58. If a bar magnet or horseshoe magnet is dipped into a container of iron filings it is found that most of the filings adhere to the ends, and it follows that the magnets exert greatest external magnetic influence at these points. The ends of a magnet are described as its *poles*.

When a bar magnet is suspended by a cord, or pivoted at its centre, it takes up a constant position relative to the Earth. This is because the Earth itself has the properties of a magnet, one magnetic pole being situated near the geographical north pole, and the other magnetic pole being situated near the geographical south pole. One pole of the pivoted bar magnet is attracted towards the north and this is known as the north-seeking pole of the magnet.

¹ A typical permanent magnet alloy may contain small proportions of aluminium, nickel, cobalt and copper. Since the war, permanent magnets have been made also from "ferrites", these being ceramic-like materials consisting of oxides of iron and other metals.

The other pole is attracted towards the south, and is described as the south-seeking pole. In practice, the word "seeking" is deleted from the description of the magnet poles, and these are known in abbreviated form as the *north pole* and *south pole* respectively. The pivoted bar magnet is a *compass*, insofar that it indicates the direction of the magnetic north and south poles of the Earth.

If the north pole of one bar magnet approaches the south pole of another, as in Fig. 59 (a), the two poles are attracted together. If, however, two north poles are brought together, as in Fig. 59 (b), they repel each other. Repulsion occurs also when two south poles are brought together. This behaviour may be summarised by stating that *unlike magnetic poles attract each other and like magnetic poles repel each other*.

It is possible to convert a rod of steel or similar material into a bar magnet by stroking it in one direction for a dozen or so times with a pole of a permanent magnet. See Fig. 60 (a). After this

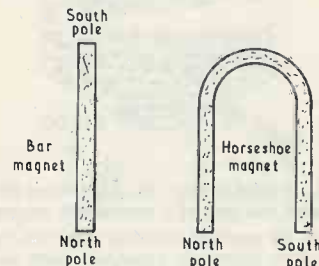

E 237

Fig. 58. Two typical permanent magnets: the bar magnet and the horseshoe magnet

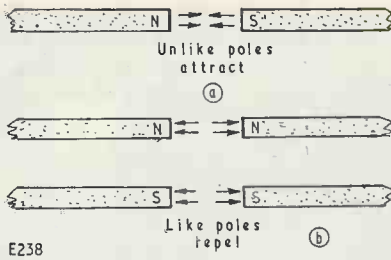

Fig. 59 (a). If the north and south poles of two magnets are brought together they attract each other
 (b). When like poles are brought together, they repel each other

treatment the rod of steel becomes capable of picking up iron particles by itself, and shows all the characteristics of a bar magnet. A simple explanation of this effect may be made by assuming that the steel rod is made up of a very large number of particles, each exhibiting the properties of a bar magnet. Before the external magnet was applied these particles were arranged in random fashion, as in Fig. 60 (b), with the result that the net magnetic effect was negligible. Stroking the rod caused the particles to become arranged in more orderly fashion, as in Fig. 60 (c). If the bar had been stroked by the south pole of the external magnet the particles would have become orientated such that their north poles were all pointing in the direction of the stroking movement. Because, after the stroking process, the particles have like poles all facing in the same direction, their combined effect is to cause the rod to behave as a bar magnet.

Magnetism may be made to appear in a magnetic

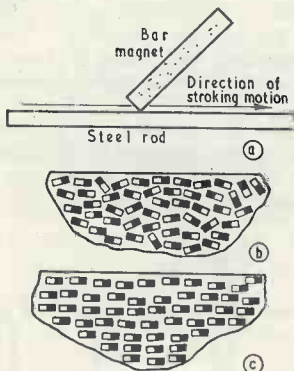

Fig. 60 (a). A steel rod may be magnetised by stroking it with one pole of a permanent magnet
 (b). It may be assumed that the steel rod consists of many particles randomly arranged, each having the properties of a bar magnet
 (c). The stroking process orientates the particles so that they form an orderly pattern with similar poles in one direction

material by processes other than stroking with a permanent magnet. A typical instance is given in Fig. 61 (a). In this diagram a rod of soft iron has one end held near the north pole of a permanent magnet. The rod then behaves like a bar magnet, the south pole of which is towards the north pole of the permanent magnet. This effect may be explained by stating that the north pole of the permanent magnet attracts the south poles of the particles in the rod, with the result that their combined effect causes the rod to behave as a bar magnet. It is usual to say, in this instance, that the permanent magnet *induces* magnetism into the rod. If the rod is brought closer to the permanent magnet its magnetic strength increases. When it is in contact with the permanent magnet, as in Fig. 61 (b), it functions largely as an extension of the permanent magnet, whose effective pole shifts almost entirely to the end of the rod. This effect is of value in many radio applications, because it enables the poles of a permanent magnet to be applied effectively to specific points or areas by way of rods, or other shapes, functioning like the soft iron rod of Fig. 61 (b). Piece-parts which effectively extend the poles

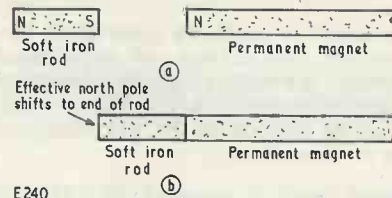

Fig. 61 (a). Magnetism may be induced in a soft iron rod by holding it close to the pole of a permanent magnet

(b). If the soft iron rod is in contact with the magnet, the pole of the latter shifts largely to the end of the rod

of permanent magnets in this manner are known as *pole-pieces*.

We have already seen that certain alloys of iron retain magnetism almost indefinitely and that they can, therefore, be used for permanent magnets. On the other hand, there are magnetic materials which do not retain magnetism and cannot therefore be so employed. Such materials readily allow magnetism to be induced in them, however, and are especially useful for such applications as the pole-pieces just discussed. The rod shown in Fig. 61 (b) was made of soft iron but, for practical pole-pieces, it would be preferable to employ iron alloys which exhibit similar or improved magnetic properties in this respect, and which are physically more durable. Typical "soft" magnetic materials² are alloys of iron and silicon.

The individual poles of a horseshoe magnet have a magnetic effect immediately around them which is similar to that of the poles of a bar magnet. When a rod of soft iron (or similar material) is positioned

² "Soft" because their magnetic behaviour is like that of soft iron.

as shown in Fig. 62 (a), the rod effectively extends the pole with which it is in contact, and brings it close to the other pole of the magnet. A high level of attraction exists between the two unlike poles with the result that, unless prevented from doing so, the rod of soft iron will rapidly move into contact with the remaining pole, as in Fig. 62 (b). A magnetic circuit is, in consequence, set up. If the soft iron rod were returned to the position of Fig. 62 (a) the magnetic circuit would then be broken. This is analogous with behaviour in an electric circuit. Whereas in the latter a cell or battery may provide an electromotive force, in this instance the permanent magnet provides a magnetomotive force.

Magnetic Fields

We have already seen³ that when an e.m.f. appears across two conductors (in the case discussed, the plates of a capacitor) lines of electric force appear between them. These lines of electric force constitute an electric field. A similar effect appears between magnetic poles, and Fig. 63 (a) shows the magnetic field around a bar magnet. It is always assumed that magnetic force operates from north pole to south pole and the lines of magnetic force shown in the diagram are given arrows which indicate this direction. The lines of force are more concentrated at the poles, these being the points where the magnet has greatest external influence. Although not shown in Fig. 63 (a), each line of force is unbroken. It leaves the bar magnet at the north pole, continues externally to the south pole, then returns to the north pole through the magnet itself.

It is possible to determine the shape of a magnetic field by holding a card over the magnet and sprinkling iron filings over it. If suitably dispersed, the iron filings then follow the lines of force existing in the plane of the card's surface. The magnetic field may also be plotted with the aid of a compass, as in Fig. 63 (b). The indications given by the compass at various points around the magnet show the direction of the field at those points.

In Fig. 64 (a) we see an electric conductor in the form of a wire passing through a card at right angles, a source of e.m.f. being applied such that a current flows through the wire. If we held a compass near the wire we would find that it would be deflected from its normal position, and if we were to move the compass about the wire we would find that we could plot a magnetic field in the same manner as occurred in Fig. 63 (b). The field would consist of a number of concentric circles whose direction, as indicated by the arrows in Fig. 64 (a), is clockwise when the upper end of the conductor is connected to the positive terminal of the source of e.m.f. If we were to reverse the connections to the source of e.m.f. so that the upper end of the conductor connected to its negative terminal, we would obtain the same field as before, but its direction would be anti-clockwise.⁴

³ In "Understanding Radio" part 8, April 1962 issue.

⁴ It is assumed here that the field around the conductor is sufficiently strong to override the Earth's magnetic field, which would otherwise affect the compass indications.

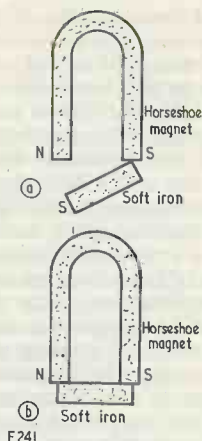

Fig. 62 (a). When a soft iron rod is positioned as shown here, a high level of attraction exists between the north pole and the extended south pole in the rod (b). A magnetic circuit is set up when the rod is in contact with both poles

Fig. 64 (a) demonstrates the important fact that, when an electric current passes through a conductor, a magnetic field is set up about that conductor. It is possible to cause the field around the conductor to become considerably stronger by winding the conductor into the form of a coil, as in Fig. 64 (b). A source of e.m.f. having the polarity indicated can then be applied. Fig. 64 (c) shows a cross-section through the coil and illustrates the behaviour of the magnetic fields around the individual conductors. If this diagram is considered with reference to Fig. 64 (b) it will be seen that the current flowing through the upper set of conductors is that which would be given if the positive terminal of the source of e.m.f. were on our side of the paper. The direction of the lines of force immediately around the upper conductors is, in consequence, clockwise. The current flowing through the lower set of conductors is that which would be given by a positive terminal below

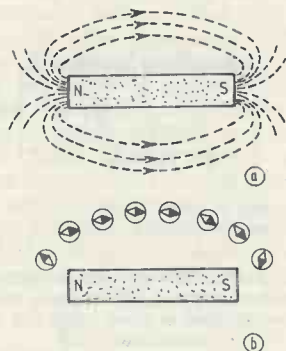

Fig. 63 (a). The magnetic field around a bar magnet (b). The field may be plotted with the aid of a compass moved about the magnet

the paper, and the direction of the lines of force immediately around the lower conductors is anti-clockwise. However, it is only the lines of force that are close to the conductors which retain the circular form. Those further away combine with others from neighbouring conductors to form a composite field which extends through and outside the complete coil. The fact that the upper conductors have a clockwise field and the lower conductors an anti-clockwise field further assists in the production of a strong composite field, because the combined lines of force from both sets of conductors are in the same direction inside the coil, and are in the same direction outside the coil.

The overall effect of winding the conductor into a coil is that a composite magnetic field is obtained which is very nearly the summation of the individual fields around the length of the conductor. This combined field is much stronger than that around a single straight conductor carrying the same current.

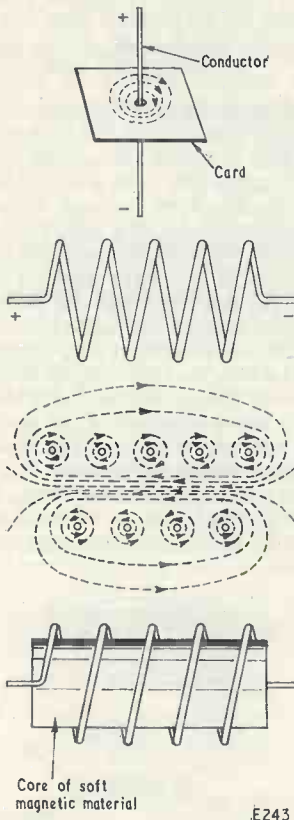

Fig. 64 (a). When a current flows through a conductor, a circular magnetic field appears around it
 (b). A stronger field is given when the conductor is wound into a coil
 (c). Cross-section through the coil, showing how the lines of force around each conductor combine to form a single composite field
 (d). The strength of the magnetic field may be increased by inserting a core of soft magnetic material

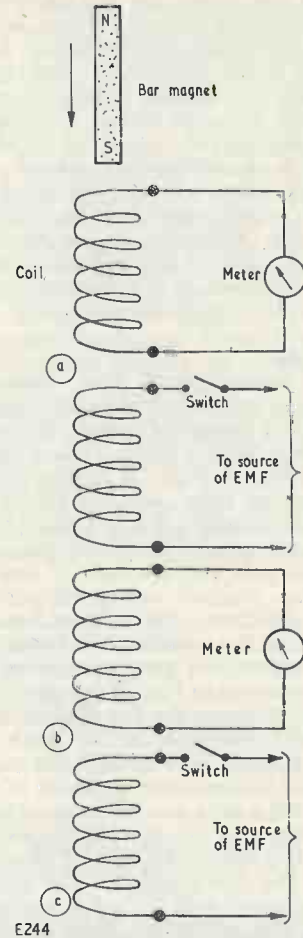

Fig. 65 (a). A voltage is induced in the coil shown here if the magnet is lowered into or raised out of it
 (b). A voltage is similarly induced in the lower coil when the switch connected to the upper coil is opened or closed
 (c). Illustrating the effect of self-inductance

An even stronger field may be obtained by placing a rod, or *core*, of soft magnetic material inside the coil, as in Fig. 64 (d). The lines of magnetic force now become concentrated in the core, which then exhibits the same properties as a permanent bar magnet. The reason why the core allows a stronger magnetic field to appear is that it has the ability to allow more lines of magnetic force to pass through it than does a similar quantity of air of the same dimensions. This ability is defined in terms of the *permeability* of the core material. In general terms, the higher the permeability of the core in Fig. 64 (d), the stronger will be the magnetic field produced by the combination of coil and core.

There is, however, a complicating factor here, this being due to the fact that if the magnetomotive

force applied to the core is increased (by means which we shall discuss in the next paragraph) a point is reached at which this core becomes *saturated* and can offer no further increase in the strength of the magnetic field. The permeability of the core is, in consequence, considerably lower at saturation point than when it supports magnetic fields of lower strength. The permeability of a practical core material varies continually as the magnetic field it supports alters in strength, and so permeability cannot be looked upon as a constant factor. The relationship between permeability and magnetomotive force is complex, and we shall deal with this in greater detail in a later article in this series.

As is to be expected, the strength of the magnetic field given by the coil and core of Fig. 64 (d) will change according to the current flowing through the coil and the number of turns it possesses. In fact, the magnetomotive force operating in the core varies directly as current and turns, with the result that this force is doubled either if current is doubled or if the number of turns in the coil is doubled.

Since the core of Fig. 64 (d) becomes magnetised due to the passage of an electric current, the combination of coil and core is normally described as an *electro-magnet*.

Induction

Fig. 65 (a) illustrates a coil of wire connecting to a sensitive moving-coil meter. A bar magnet is held above the centre of the coil. If we quickly lower the magnet into the coil the meter will show a sudden deflection, falling to zero again after the magnet has come to rest. The reason for the momentary deflection is that a voltage has been *induced* in the coil by the lines of magnetic force around the magnet, this voltage being generated when the lines of force are in motion relative to the coil. When the lines of force are stationary, as occurs when the magnet is brought to rest inside the coil, no further voltage is induced and the meter returns to zero. If we quickly raise the bar magnet from the coil the meter will once more give a momentary deflection, but this will now be in the opposite direction. By raising the magnet we are once again moving the lines of force relative to the turns of the coil and are thus once more inducing a voltage. However, the direction of movement of the field is opposite to that in the previous case, and so the polarity of the voltage becomes reversed.

Summing up the effect we may say that if a moving magnetic field cuts the turns of a coil a voltage is induced in that coil. If the moving field is reversed in direction, the polarity of the voltage reverses also. Obviously, voltage will be induced in the same manner if the magnetic field is stationary and the coil is moving.

Fig. 65 (b) shows two coils mounted side by side. The upper coil is connected to a source of e.m.f. by way of a switch, and the lower coil is connected to a sensitive moving-coil meter in the same way as the coil of Fig. 65 (a). Let us now examine what happens when we close the switch. Immediately before the switch is closed, there is no magnetic

field about the upper coil and the meter gives a zero indication. When the switch is closed a magnetic field at once begins to form around the upper coil. This field does not become established immediately—it has instead to build up until it reaches full intensity. In the process of building up, lines of magnetic force pass outwards and away from the upper coil and some of these cut through the turns of the lower coil. In consequence a voltage is induced in the lower coil and the meter suffers a temporary deflection, returning to zero when the magnetic field from the upper coil is fully established and is at rest. If, now, the switch is opened, the magnetic field around the upper coil commences to collapse and, once more, moving lines of force cut the turns of the lower coil. This time, however, they are moving in the reverse direction. Again, a voltage is induced in the lower coil and the meter suffers a temporary deflection, this deflection now being in the opposite direction to that given previously.

In Fig. 65 (c) we have a single coil connected via a switch to a source of e.m.f. When the switch is closed, a magnetic field at once commences to build up around the coil. What we must now consider is the fact that this *increasing field causes lines of force to cut the turns of the coil which produces the field*. Thus, whilst the coil is itself producing an increasing field, the field is in turn inducing a voltage in the *same coil*. The induced voltage *opposes* the applied voltage, with the result that the initial current flow is relatively low. As the field expands, the induced voltage drops and current increases. When the field is fully established the induced voltage is at zero, and the only factor which limits current is the resistance of the wire forming the coil. Briefly, it may be stated that, if a voltage is suddenly applied to a coil, the electro-magnetic properties of the coil offer an opposition to the flow of current through its turns.

This same opposition will be evident if there are *any* changes of current in the coil. When a steady current flows through the coil a stationary magnetic field appears about it and the coil offers resistance only. If an attempt is made to change the current (either to raise or lower it) the coil will at once produce an induced voltage which will oppose the change in current. The new current will only flow after a period of time has elapsed.

The ability of a coil to oppose changes in the current flowing through it is defined in terms of its *self-inductance* or, more usually, *inductance*. A coil with high inductance offers a greater opposition to current change than does a coil with low inductance.

The basic unit of inductance is the *henry*,⁵ this being subdivided into the *millihenry* (one thousandth part of a henry) and the *microhenry* (one millionth part of a henry). All three units are frequently encountered in radio work. The abbreviation for henry is H, for millihenry mH, and for microhenry μ H.

We have already noted that the magnetic field

⁵ A coil has an inductance of one henry if, when the current flowing through it changes at the rate of one ampere per second, the e.m.f. across its terminals is one volt.

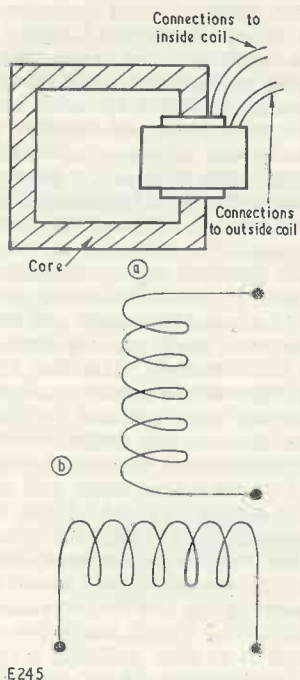

Fig. 66 (a). Two coils having high mutual inductance (b). When the axes of two coils are at right angles there is a very low mutual inductance between them

produced by a coil increases in strength when the number of turns in the coil is increased. Since the magnetic field strength increases with increased turns we may reasonably expect the inductance of the coil to increase also, as there is then a stronger field to induce the voltage which opposes changes in current. This is, in fact, true, and an increase in turns causes an increase in inductance. Similarly, inserting a core of soft magnetic material into a coil causes an increase in inductance, because we are once more causing an increase in magnetic field strength.⁶

Mutual Inductance

We examined the set of circumstances given in Fig. 65 (b) before carrying on to the single coil of Fig. 65 (c) because it is desirable to establish initially the fact that a coil may produce an expanding magnetic field which is capable of inducing a voltage in a second coil. This point being appreciated, it then became easier to understand how an expanding field may induce a voltage in the coil which produces the field. The reason why the upper coil of Fig. 65 (b) did not produce a magnetic field instantaneously was, as we may now see, due to its own self-inductance!

Fig. 65 (b) showed us also that a changing current

⁶ Under certain conditions a magnetic core may not cause an increase in coil inductance, and may even result in a decrease. This point will be dealt with at a later date.

in one coil can induce a voltage in a second coil. Because of this the coils are stated to have *mutual inductance*. Mutual inductance may be expressed in terms of henrys, millihenrys and microhenrys in the same manner as self-inductance.⁷

Coils having mutual inductance are frequently described as being *coupled* together. If the coils are brought closer together their mutual inductance increases. Mutual inductance increases further if they share a common core of soft magnetic material. A high level of coupling exists if one coil is wound on top of the other, as in Fig. 66 (a), the two coils sharing a common core of soft magnetic material which not only passes through them but forms a complete magnetic circuit outside.

A very low mutual inductance is given when the axis of one coil is at right angles to the axis of the other; as shown in Fig. 66 (b). Expanding or contracting fields from the upper coil in this diagram cut the turns of the lower coil symmetrically about its centre, and whatever voltages are induced tend to cancel out. Sometimes, coils are purposely mounted with their axes at right angles to each other in order to achieve a low mutual inductance.

The coupling between two coils is frequently qualified by the terms "loose" or "tight". These terms are relative and have no quantitative meaning. As a comparison, it could be stated that the two coils of Fig. 65 (b) are *loosely coupled* whilst those of Fig. 66 (a) are *tightly coupled*.

Terminology

Before proceeding further, one or two points of terminology need to be cleared up.

We referred earlier to the induced voltage in the single coil of Fig. 65 (c) which opposes the change of current through the coil. This voltage is known as the *back e.m.f.* of the coil.

Coils employed in radio equipment are frequently given alternative names. The generic term for a component possessing inductance is *inductor*. Occasionally, the term *inductance* is applied to the component as well as to the property, but this is an undesirable practice. In some circuits, inductors are employed to prohibit regularly occurring changes in current being passed from one point to another, and they may then be classified as *chokes*.

Next Month

In next month's article we shall carry on to practical inductors, as are employed in radio equipment.

⁷ A mutual inductance of one henry is given if, when the current in the first coil changes at the rate of one ampere per second, the e.m.f. across the second coil is one volt.

INDEX—VOLUME 15

The Index for Volume 15 (August 1961–July 1962) of *The Radio Constructor* is now available. Direct subscribers will receive a copy of the Index with this issue of the magazine.

Copies of the Index are available, direct from us, at 6d. each plus 3d. postage, etc.

NEWS and COMMENT

AS READERS WILL BE AWARE, THE Report of the Pilkington Committee covers a very wide range of subjects within its terms of reference, the more controversial of these—relating to programme material and the constitution of the Independent Television companies—having been given considerable prominence in the lay Press. There are, also, a number of important technical recommendations, which we are summarising here; these will be dealt with in greater detail in "Radio Topics" in our next issue.

Technical Aspects of the Pilkington Report

Like all European countries, the United Kingdom has undertaken to employ 8 Mc/s channel spacing on u.h.f. (Bands IV and V). Because of this, u.h.f. offers the same number of channels with either the 405 line system (5 Mc/s bandwidth) or a 625 line system (8 Mc/s bandwidth for the standard recommended by the Television Advisory Committee 1960). The Pilkington Committee recommends that a change from 405 to 625 lines be authorised forthwith.

Two methods of achieving the change of standards were put to the Committee. The first is the "duplication" method, which was generally accepted until the I.T.A. submitted a "switchover" scheme in July 1961. Under the "duplication" method the existing two programmes would continue to be transmitted on v.h.f. (Bands I and III). At the same time, duplicate 625 line transmissions of these programmes would be introduced in Bands IV and V. (These signals would, in fact, be generated on the 625 line standard, the 405 line version being obtained by standards conversion.) A third (and possibly a fourth) 625 line programme on Bands IV and V would also be started. After five years there should be about 70% population coverage of all programmes on Bands IV and V, and the remaining coverage would be built up over the following five years or so. The 405 line v.h.f. service in an area would be closed down when a satisfactory u.h.f. service had been provided and an appropriate time allowed for receiver obsolescence. When all 405 line transmissions had been closed down, Bands I and III would be available for re-exploitation using the 625 line standard. The whole

process might take ten to fifteen years. With the "switchover" scheme, "shadow" plant would be installed at existing B.B.C. and I.T.A. transmitters during a seven to ten year transition period. This plant would consist of new transmitters and aerials arranged for 625 line operation on re-spaced channels in Bands I and III. At an appointed date the 405 line transmissions would cease, and the two programmes would be switched over to 625 lines from the "shadow" network. Two or more new 625 line programmes could, in the meantime, have been introduced on u.h.f.

Under the "switchover" scheme the situation cannot arise where, for a period of time, national coverage would be on u.h.f. only, with Bands I and III not employed. However, the change-over would have to be synchronised with a change by the French broadcasting authorities to 8 Mc/s channelling, a situation which is not wholly within the control of the U.K. There would also be heavy loading on retail and servicing organisations at the date of "switch-over", and there would be no margin for unforeseen difficulties. Also, with the "switchover" method all viewers would be required to previously purchase 405/625-v.h.f./u.h.f. receivers, whilst the "duplication" method allows at least some viewers to buy v.h.f./u.h.f. receivers for 625 lines only. The Committee concludes that the "duplication" method is to be preferred, although it must remain for the opening of a public u.h.f. service to confirm the usefulness of such a service.

U.H.F. transmitting stations for both the B.B.C. and I.T.A. should be co-sited and should have a common aerial mast.

The Committee recommends the introduction of a compatible colour television service (colour system not specified) on 625 lines when the latter is established.

It is recommended that no subscription television service (wherein payment is made by coin-box, or billing, for reception time) be authorised. This applies whether distribution be by wire or by radio transmission.

It is recommended that one service only of local sound broadcasting be planned, and that this should be run by the B.B.C. and financed from licence revenue. At present only the range 88 to 95 Mc/s is employed for

f.m. broadcasting in Band II (87.5 to 100 Mc/s), the remainder of the Band being taken up by services such as fire brigade and police. With the present 88 to 95 Mc/s range, a local service in some 250 localities could be provided. More localities, with a better service, would be given if 95 to 97.6 Mc/s were used for local broadcasting, and these frequencies would be preferred if they could be made available. The introduction of local service transmitters should not delay the completion of f.m. coverage of the three national B.B.C. services.

At present, "music by wire" is distributed over G.P.O. lines to business and other premises to provide background music by Reditude Ltd. and Planned Music Ltd. (Muzak). Planned Music Ltd. proposed that their service should be allotted radio frequencies for distribution, but this proposal was rejected by the Committee.

Electronic Expansion

The recent death of Sir Allen Clark, chairman and managing director of the Plessey Company Ltd., is a reminder of the wonderful growth, under Sir Allen's energetic leadership, of the Plessey Company from small beginnings in 1920 with a half a dozen or so employees to the world-famous firm of today. Plessey were, of course, pioneers in the production of portable radios and, later, commercially produced television sets.

Are there opportunities for small businesses to expand in a similar way today?

Judging by the details published by Perdio Electronics Ltd., as required by the regulations of the London Stock Exchange prior to a "placing" of shares, the answer is probably yes.

Perdio was formed early in 1956 and rapidly established an excellent reputation with their portable transistor radios; the name "Perdio" is a contraction of the words personal radio.

From the figures issued by the Central Statistical Office, it appears that for the first two months of this year Perdio sold more than one in eight of all radio sets sold by United Kingdom manufacturers during that period. The Company intends to market shortly a transistorised battery operated television set!

R.A.F. Award Winner

Thanks to the initiative of Flight Sergeant Downie, an air wireless fitter now stationed at Headquarters,

Fighter Command, Royal Air Force, aircrew will in future have better reception in their aircraft.

Flight Sergeant Downie evolved a method of checking and adjusting very high frequency radio sets which the Air Ministry has adopted, and rewarded him with £300.

Since he passed out of No. 1 Electrical Wireless School at Cranwell, in the middle 1930s, he has been associated with radio, spending much of his spare time in research. During the last war Flight Sergeant Downie was for a considerable time flying as a wireless operator in Vickers Vincent aircraft of No. 8 Squadron based at Aden.

B.B.C Instals Band IV TV Aerial

The B.B.C. have awarded a contract to Marconi's Wireless Telegraph Company Limited for the supply and erection of a Band IV

television aerial to be mounted above the existing Band I aerial at Crystal Palace.

The aerial will be omni-directional, horizontally polarised and of high gain.

It will be of novel design, consisting of eighty elements of end-fire stacked dipoles mounted in angled fashion from the corners of the tower. This new aerial will have a bandwidth which will cover several television channels and will be extremely simple to erect. It is believed that this will be the first of this type of u.h.f. aerial to be installed for television anywhere in the world.

It is planned to have the aerial available for use early in 1963.

New Factory for Morganite Resistors Ltd.

Morganite Resistors Limited, a member of the Morgan Crucible

Group, announce that arrangements have been made with the Board of Trade and the Industrial Estates Management Corporation of England for the building of a 50,000 sq. ft. factory on the Bede Trading Estate, Jarrow.

Morganite Resistors manufacture components for the radio, television, electronic and light electrical industries. This new factory—their third—will take over the manufacture of the special types of resistors now made at the Morgan Crucible Group's factory at Norton, Worcester, and will thus concentrate at Jarrow their complete range of electrical resistance products used by all sectors of the electrical industry. The move will involve the transfer of some employees from Norton, but the majority of the 500 required for the new factory will be recruited locally.

NEW HIGH GAIN DOUBLE TRIODE the ECC807

MANY NEW VALVES WITH A VERY HIGH VALUE of mutual conductance have been put on the market during the last few years in order that higher stage gains may be obtained from r.f. and i.f. stages. The gain of a triode *audio* amplifier, however, depends more on amplification factor than on mutual conductance. The new double triode introduced by Brimar, the ECC807, is capable of giving very high stage gains, as its amplification factor is 140. This may be compared with the amplification factor of a commonly used double triode, the ECC83 (equivalent to the 12AX7 and the CY492), which has a value of 100.

Uses

The ECC807 has been specifically designed for use in high gain pre-amplifier stages operating from low level inputs and is especially suitable for use in tape recorders and in instrumentation. When the two sections are connected in cascade, a total gain of over 5,500 can be obtained.

Hum

The triode unit connected to pins 1, 8 and 9 should be employed as the input stage when the two triode sections are used in cascade, since this method of connection enables a lower hum level to be attained. When the heater centre-tap is earthed, the average hum level referred to the grid is $3\mu\text{V}$ average (maximum value = $5\mu\text{V}$), but if either side of the heater is earthed, the maximum value of the hum voltage at the grid would be of the order of $10\mu\text{V}$.

The heater rating is 6.3 volts at 0.32 amp.

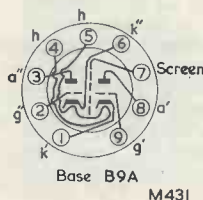

Limited Ratings

Anode supply voltage: 550 volts max.
Anode voltage: 300 volts max.
Anode dissipation: 1.0 watt max.
Negative grid voltage: 50 volts max.
Cathode current: 8.0mA max.

Maximum Values of Grid-Cathode Resistance:

- (1) Fixed Bias: 1.0M Ω max.
- (2) Cathode Bias: 2.2M Ω max.
- (3) Grid Current Bias: 22M Ω max.

Typical Operation (one section)

Anode supply voltage: 250 volts
Anode resistor: 220k Ω
Cathode resistor: 2.7k Ω
Cathode bypass: 50 μ F
Grid resistor: 470k Ω
Grid resistor of following stage: 470k Ω
Input voltage (source impedance=600 Ω): 285mV
Output voltage (5% distortion): 21.2 volts
Gain per stage: 74.5

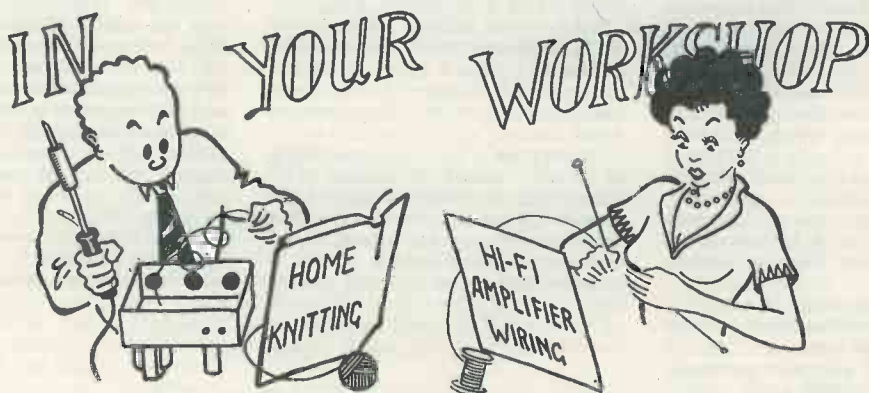

This month we find Smithy the Serviceman, together with his able assistant Dick, embarking on a typical summer holiday adventure—a coach Mystery Tour. Somehow or other, they find time also to discuss the question of radiation from television receivers

“YOU’RE NOT SUPPOSED TO KNOW where you’re going,” explained Dick. “This is a Mystery Tour.”

Glumly, Smithy the Serviceman gazed out of the coach window at the passing countryside.

“Well, I don’t know,” he grumbled. “It seems a funny business to me, not knowing where you’re headed for.”

“But that’s the whole idea,” said Dick. “The destination is kept a secret until you get there.”

The Serviceman’s expression took on an even more gloomy appearance. “Well, let’s hope,” he remarked morosely, “that the driver knows, anyway.”

“Dash it all Smithy,” protested Dick. “You are ungrateful. Here I am actually treating you to a coach tour, and all you do is moan about it.”

A look of unbelieving wonder crept over Smithy’s face.

“This,” he remarked incredulously, “is *your* treat?”

“Nothing less,” replied Dick. “You’ve just started your holiday and I’m on the last day of mine. It’s so happened that we’ve both chosen the same holiday resort and I thought, therefore, that I’d plan a nice little surprise for you when you got here.”

“That’s very decent of you,” said Smithy. “Although I must admit that I was a little shaken at first when you popped round to the hotel and told me about the trip. And I must say, also, that it’s very pleasant to be driven around the countryside like this instead of being stuck in the Workshop, as I was yesterday.”

“Don’t talk about the Workshop,” said Dick. “I’ll be back in it tomorrow!”

Interference

The pair gazed contentedly through the window as the coach drove along its way. The seats were all occupied,

and Smithy found himself becoming more and more appreciative of Dick’s action as he realised that his assistant must have booked their places quite some time in advance.

A pastoral scene swung into view, complete with the regulation farmhouse, hay stacks, cows and sheep.

“Isn’t that a lovely old cottage?” remarked Dick, pointing to the farmhouse. “And isn’t it beautifully situated?”

Smithy focused his eyes on the building.

“I wouldn’t say that,” he remarked critically. “So far as I can see from their aerial they must be right on Channel 10 fringe.”

“Corluvaduk,” exclaimed Dick. “You’re supposed to be looking at the countryside, not at TV aerials! For instance, take a dekho at that line of hills over there. Don’t they look smashing?”

“I suppose so,” said Smithy guardedly.

"And don't you think," continued Dick, carried away by his newly acquired love of nature, "that they're spoilt by all those pylons going over them?"

A gleam of intense interest shone in Smithy's eyes.

"Ah," he exclaimed enthusiastically. "Now I've been watching those pylons closely. The big fellows going right over the top of the hills must be nearly a hundred and fifty feet high and I should guess that they're part of the 275kV Super-grid. Just think of it, Dick my lad—275kV!"

Despite his previous championship of the rural scene, Dick was impressed.

"Gosh," he said, "that's over a quarter of a million volts."

"Those smaller jokers," continued Smithy, "will probably be part of an earlier line running at 132kV."

The pair studied the pylons, and the sagging wires strung between them.

"It makes you think, doesn't it?" said Dick eventually. "Especially when, tomorrow morning, I'll probably be trying to stop corona in some old telly or other at a mere 15kV."

"What you've said is not only probable," commented Smithy cheerfully, "but dead certain. I've left you a telly with just that particular snag as your very first job."

Dick tore his eyes and thoughts away from the verdant scene outside the windows of the coach.

"It's nice to have friends," he remarked bitterly. "Is the corona obvious?"

"You can't see it," replied Smithy happily.

"Come off it, Smithy," protested Dick. "Doesn't it even cause flashes on the screen of the set?"

"Nope."

"Then what does it do?"

"It causes flashes," explained Smithy, "on the screen of the set next door!"

"Blimey," said Dick in disgust. "I've just about heard everything now. How on earth can you locate a fault when it only shows up on the set next door?"

"It's easy enough," chuckled Smithy. "But before I go into an explanation, I'd better tell you the history of the fault first. The initial complaint was from a customer who said that every now and again a vertical line composed of bright dots appeared on the screen. Sometimes the vertical line remained in position fairly steadily, but most of the time it kept moving to left or right. After doing a quick check I found that the receiver was using an indoor aerial

and that it was O.K. in itself. I then told the customer that the interference was coming from a neighbour's set, and that it would be doubtful if it were more than two or three doors away."

"What happened next?" asked Dick, absorbed in Smithy's story. "Did you call in the Post Office to find the source of interference?"

"Nothing as official as that," grinned Smithy. "Fortunately, they're a matey bunch in the street concerned, and it needed only a little experiment to locate the set that was causing all the trouble. It so happened that it was next door, the interference clearing when it was switched off. And that's the set I've left for you to fix."

Dick looked baffled.

"All this is very well," he remarked helplessly. "But I just haven't got a clue where to start. I don't even understand how the interference is being caused."

"I suppose it is a little confusing at first," remarked Smithy, "although the process is actually quite simple. What is happening is that the faulty receiver has a snag in the line output stage which causes a pulse of r.f. to be radiated during

each flyback period (Fig. 1(a)). Most probably there is a spark somewhere, and this takes place every time the line output transformer swings over to give the e.h.t. pulse at the end of the scan period. The radiated pulse given by the spark can be picked up on any other television receiver with the result that, under certain conditions, it shows up on the screen."

"But why," asked Dick, "isn't it picked up by the same receiver which generates the spark? After all, this is the nearest receiver to the spark!"

"It probably is picked up," replied Smithy, "but it still won't show up on its screen. You see, the spark appears during flyback when the spot is travelling rapidly back across the screen. The effect of the spark may be a slight brightening of the flyback line, but that will be about all. Also, the receiver may have line flyback suppression, and this will make the tube less sensitive to signals applied to it during flyback. Another point is that if the faulty receiver has a well-matched coaxial cable going up to an outdoor aerial its input circuits will be fairly well screened from the spark. Again, if the set is receiving a strong signal via that outside aerial, its a.g.c.

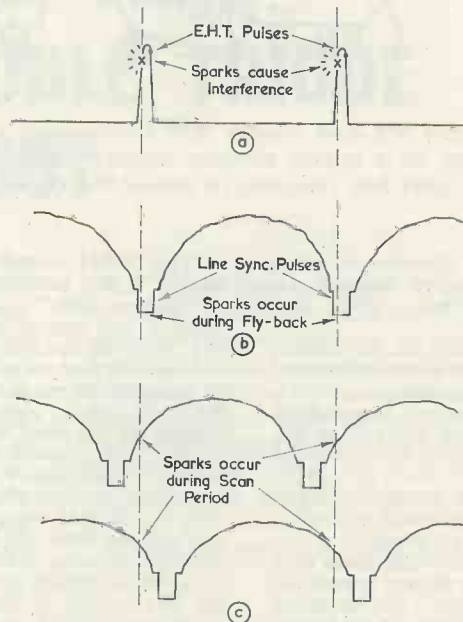

M449

Fig. 1 (a). A pulse can be generated in the line output stage during flyback by a spark (or other source of interference)
 (b). The spark occurs during flyback in a receiver locked to the signal that synchronises the faulty timebase
 (c). The interference caused by the spark is visible on receivers locked to another programme

circuits will cause it to be in a relatively insensitive state."

"I see," remarked Dick. "It sounds to me as though the other receiver picked up the interference partly because it was using an indoor aerial."

"That's probably right," confirmed Smyth. "The second set was in a sensitive condition because it received a lowish signal from the indoor aerial. Also, this aerial was well in the field of the interference."

"I'm clear so far," said Dick. "What I don't yet understand is why the interference showed up as a vertical line moving from side to side."

"That," chuckled Smyth, "is the interesting bit! Since the spark appears during flyback, it also appears during the line sync pulse in the transmitted signal (Fig. 1(b)). If the second receiver were tuned to the same programme as the first, the sparks would then occur during its line flyback period as well, and they would similarly be unnoticeable on the screen."

"Hey?"

"That's right," grinned Smyth. "If, however, the second receiver is tuned to a different programme, the transmitted line sync pulses which control it will be out of step with those which control the interfering receiver, and the sparks will then cause interference on the screen" (Fig. 1(c)).

"Wait a minute," said Dick, excitedly. "Let's get this straight! First of all, am I correct in assuming that the line sync pulses transmitted by the B.B.C. and by I.T.V. are not synchronised with each other?"

Smyth nodded.

"You're perfectly correct," he said. "Each transmitter sets up its own line sync pulses. The two 405 line frequencies are *nominally* 10,125 c/s, of course, but there is always some discrepancy between them in frequency and phase. Incidentally, there is no tolerance on line frequency for the 405 line system quoted in the latest C.C.I.R. Report, although a figure of $\pm 0.1\%$ is given for line frequency in the 625 line system. If this figure were to apply to the 405 line system the B.B.C. and I.T.V. line frequencies could be 20 c/s away from each other and still be within tolerance."

"Right," said Dick. "That answers my first question. The next one is that, if the interference is to become noticeable, one receiver *must* be tuned to the B.B.C. and the other to I.T.V."

"That's right."

"Does it matter which is tuned to which?"

"That *could* have an effect," said Smyth. "The interference from the faulty set will be at constant level, whatever programme it is tuned to. The level of interference in the other receiver will then depend on its sensitivity for the two Bands, and on the frequency spectrum of the interference itself."

"I see," said Dick. "Now let's take it a stage further. If the line sync pulse arrives a little later at the interfering receiver than at the other receiver, can I assume that the spark will then appear on the left of the other receiver's screen?"

"That's right," said Smyth. "And, of course, it will appear on every line going down the picture, so that you get a vertical line made up of bright spots."

"And if," continued Dick, "the interfering pulse occurs just before the line sync pulse in the other receiver, will the vertical line then be on the right of the picture?"

"You've got it," said Smyth. "The vertical line moves from left to right according to the line frequency phase difference between B.B.C. and I.T.V. programmes."

"Well, I'm dashed," remarked Dick. "You learn something new every day! Incidentally, how were you able to diagnose the trouble so readily when you first encountered it?"

"Just experience," said Smyth. "We had a whole rash of this trouble when I.T.V. first started. Previously, television sets didn't cause interference with each other in this manner because they were all locked to the one B.B.C. programme. When I.T.V. came on the scene, receivers were tuned to different programmes and the faulty ones soon made their presence known."

"It seems to me," remarked Dick, "that the best thing to do is to live next door to people who always watch the same programme as you do!"

Sparking

Smyth laughed and looked at his watch. A sudden thought made him change the subject.

"These Mystery Tours are all right, I suppose," he remarked, "but I'm getting a little peckish. When do we get back to base?"

"We haven't even got to the *place* yet," replied Dick. "When we do we'll have something to eat there. The normal form is to stop at some tea-rooms for an hour or so."

"Are refreshments included with the ticket?" asked Smyth.

"Oh no," said Dick airily. "You buy your tea separately."

Smyth looked suspiciously at his assistant.

"Are you," he queried, "including tea in your treat?"

Dick looked a little uncomfortable.

"Well, no," he said reluctantly, "not exactly. I was rather hoping that we might be able to arrive at an amicable agreement concerning tea."

"What sort of amicable arrangement?"

"One in which you paid for both of us!"

Smyth sighed.

"I thought there would be a catch in it," he remarked resignedly.

Dick assumed a hurt expression.

"After all, Smyth," he pointed out reproachfully, "I did get the tickets, you know."

"Oh all right then," grumbled Smyth. "But I'm beginning to wonder whether I should have come in the first place. By rights, I should be down on the beach now, acquiring a glowing healthy tan to last me through the winter."

Having won his point Dick changed the subject abruptly.

"How will I cure this receiver which causes the interference?"

"What receiver?"

"The one," explained Dick, "which you've left in the Workshop for me."

"I'd forgotten," said Smyth, his complaints slipping from his mind, "about that! Well, the process of repair should be fairly easy. You'll need another set to pick up the interference, and you can run this from an indoor aerial."

"Any obvious things to look for?"

"The most obvious causes of the trouble," said Smyth, "are a missing line output cage screen, or bad valves. The trouble is very liable to happen if a previous service engineer has omitted to put the line output stage screen back on again after he has done a job on the set. Such a screen should be fitted correctly with all screws secured up tight. The next possibilities are the line output valve, the booster diode and the e.h.t. rectifier. Either of these could give rise to a spark during flyback. There is a slight possibility that the interference is caused by Barkhausen oscillations or a similar effect instead of sparks, and changing the line output valve should clear up that one also."

"Could corona be the cause?"

"I'm not certain about that," replied Smyth. "I know that corona can result in quite a few bright patches on the screen, and it could, I suppose, cause the trouble here. In any case it's worth looking for, and there's no harm done if you round off any spiky e.h.t. joints you

run into. It's also worthwhile checking flexible e.h.t. leads. Frequently, one or more strands of these leads break off at connection points and cause quite a lot of corona. It's a good plan also to blow out any dust from the line output transformer cage. Dust reduces the ionisation path between e.h.t. points and chassis."

"Any other things to try?"

"Definitely," replied Smithy. "If there aren't any obvious points where corona or sparking occurs, check for poor solder joints. A dry joint can often cause the interference to occur, if it is directly in the line output transformer circuit. Some of the top cap connectors used for line output valves and booster diodes have a mechanical connection which can also cause trouble in this respect. (Fig. 2 (a).) The wires to these are

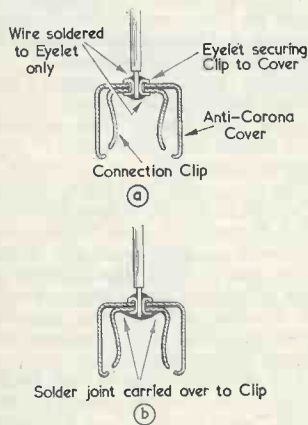

M450

Fig. 2 (a). Cross-section through a top cap connector encountered in some television receivers. The wire is soldered only to the eyelet

(b). A better connection is made by continuing the solder joint to the connection clip. If desired, the joint may also be carried over to the anti-corona cover

soldered to an eyelet which exerts mechanical pressure only on the springy metal connector clip. If this mechanical joint is soldered over (Fig. 2 (b)) you may find that the interference ceases. It is worth suspecting the line deflection coils also, as these have fairly heavy voltages impressed on them during flyback."

"Take it easy," protested Dick. "You'll have me re-building the set next!"

"It does sound rather a tall order," agreed Smithy. "But you'll probably find the trouble will be of quite a simple nature. If you're unlucky, it could be something like the line output transformer, of course, so I'll keep my fingers crossed for you!"

"Thank you very much," said Dick, sardonically. "I know I'll be sweating it out whilst you're wallowing in the fleshpots here, but please don't rub it in as well."

"You'll be back amongst friends, at any rate," remarked Smithy, soothingly. "You'll be able to get back with your mates at 'Le Chat Noir' again."

"'Le Chat Noir'?"

"Joe's Caff."

"Oh, we've gone off that place now," said Dick. "It was all right whilst Joe was going Espresso, but he's way out Beat now."

"Joe's a Beat?"

"All the way. The last I heard was that he's changed the name to 'Joe's Pad', and he never cleans it out at all."

"Very unhygienic."

"It is. It was the sauce bottles that finally made us leave."

"The sauce bottles?"

"That's right. In the old days the metal screw-on caps used to corrode on to the bottle tops, but Joe would at least change the bottle when the sauce came out through the cap."

"What happens now?"

"He just screws another metal cap down over the corroded one."

"It's only right and proper then," said Smithy, primly, "that you should leave."

Tuner Unit Interference

"One comfort," said Dick, his thoughts still occupied with his coming labours, "is that I've only got a single case of interference between one telly and another to clear up when I get back."

Smithy chuckled.

"Don't you be too certain of that," he grinned. "There's another one waiting for you as well. In this case the I.T.V. signal breaks through on B.B.C."

"Come again?"

"The I.T.V. signal breaks through on B.B.C." repeated Smithy. "I haven't had a chance of looking at it myself, but I can pass on the report that every now and again quite a clear I.T.V. signal appears behind the B.B.C. signal. The I.T.V. signal isn't properly synchronised and it goes from left to right in just the same way as the vertical line of bright spots we've just discussed. Also, the I.T.V. picture moves up and down vertically from time to time."

"What causes a snag of that nature?"

"Very probably another television installation," replied Smithy, blandly. "I would guess that the interfering installation almost certainly has one of those old Band III converters which changed the I.T.V. signal to the local channel and then applied it to the aerial input of the receiver. There are quite a few of those knocking around still. The fact that the interference only comes on now and again is a clue to the fault, because the times of interference will occur when the people using the converter switch over to Band III."

"Where does the radiation come from?"

"From the output of the converter," replied Smithy. "Converters of the type we're discussing had pretty simple Band I-Band III switching circuits. (Fig. 3.) On Band I, the Band I aerial switches straight over to the coaxial lead running to the receiver, and the signal goes straight in. On Band III the h.t. supply is applied to the converter valves, and the coaxial lead to the receiver is then switched to the secondary of the converter output coil. In consequence, the Band III signal goes into the converter from its separate aerial and comes out again as Band I. The only other job the switching circuits have to do is to ensure that the converted Band I signal isn't radiated from the Band I aerial so that it interferes with other receivers."

"Could the radiation come from anywhere else?"

"Oh yes," replied Smithy. "A likely spot consists of the coaxial cable to the receiver. Radiation from this cable is kept to a low level by ensuring that there is as good a match as possible at both ends. Radiation from the Band I aerial is killed by shorting it out when Band III is selected."

"Wouldn't it be better to terminate the Band I aerial feeder with a 75Ω resistor?" asked Dick. "That would prevent standing waves and things like that."

"It might seem so," said Smithy, "but in actual practice you get less radiation by shorting out the Band I aerial dead."

Dick considered for a minute.

"It seems that my first job", he remarked, "will be to locate the interfering installation. What do I do after that?"

"Check whether the radiation is coming from the Band I aerial," replied Smithy, "by disconnecting it and seeing if the interference disappears. If it does, it's possible that the short-circuiting contacts on the

Band I-Band III switch in the converter aren't doing their job properly. They will then need cleaning up and the wiring checked. When there is radiation from the Band I aerial it may help also if you reduce converter gain and increase receiver gain to make up for it. The Band I aerial can then be attenuated before it goes into the converter.

"If", continued Smithy, "your radiation is coming from the lead between the converter and the receiver you want to check that the coaxial outer conductor is reliably earthed at both ends. Surprising as it may seem, you may also be able to reduce radiation from this cable by popping in a 6dB attenuator at one end or the other. The attenuator irons out any bad mis-matches which may exist, even though it does give you a loss in gain. Another dodge is to change the length of the coaxial cable by lengthening it, or shortening it, by half a wavelength at the Band I frequency. Even moving it to a new position reduces the radiation in some cases."

"Well, I'm dashed," said Dick. "You're certainly introducing me to some new snags today, Smithy."

"Actually", admitted Smithy, "interference from converters is rather an oldie. However, it's rearing its ugly head again these days because some of the converters which are still in use require attention and because more and more people are using indoor aerials and portable receivers. The latter are more likely to pick up local radiation from a Band III-Band I converter than is the case when an outdoor aerial is employed."

Smithy paused, as a thought struck him.

"Turning away from technical matters," he remarked, "I've just realised something. Haven't you had any feminine company on this holiday?"

"Oh yes," replied Dick enthusiastically. "I met a real smasher the first night. At the Roller Skating and Bingo Festival."

"At the what?"

"Roller Skating and Bingo," repeated Dick. "Actually, we'd intended to go on today's Mystery Tour ourselves."

Smithy frowned.

"Am I to understand," he remarked somewhat heavily, "that the only reason you've invited me on this trip is because your girl has stood you up?"

"She has *not* stood me up," snorted Dick indignantly. "She's had to put off the trip because she's got an aunt coming down. We'll be meeting later on tonight for the

Trad and Twist Dance. Care to come?"

Smithy swallowed.

"No, thanks," he replied. "I don't think that would be quite in my line."

"As you like," said Dick, in a relieved tone of voice. "Anyway, as I said, she's a smasher. Her father's got stacks of lolly, too."

"Not", remarked Smithy, "a disadvantage."

"He's rolling in it," continued Dick enthusiastically. "For instance, he owns the coach we're riding in now."

A suspicion no larger than a man's hand suddenly appeared in Smithy's mind. Broodingly he looked out at the rustic scene rolling past the windows of the coach.

It is a well-known fact, for instance, that the line output stages of badly screened receivers cause a lot of interference with the Light Programme on 200 kc/s. The nominal line frequency for 400 lines is 10,125 c/s, as I said just now, which means that the 20th harmonic comes up at 202.5 kc/s. This is only 2.5 kc/s away from 200 kc/s, and it gives you a nice whistle at this frequency, modulated by line frequency! You'd be surprised how much trouble is caused, even nowadays, by interference from line output stages in areas where the long-wave Light Programme is at low strength. Fortunately, the effect seems to be worst when aerial pick-up is largely capacitive and it doesn't cause too much trouble if the

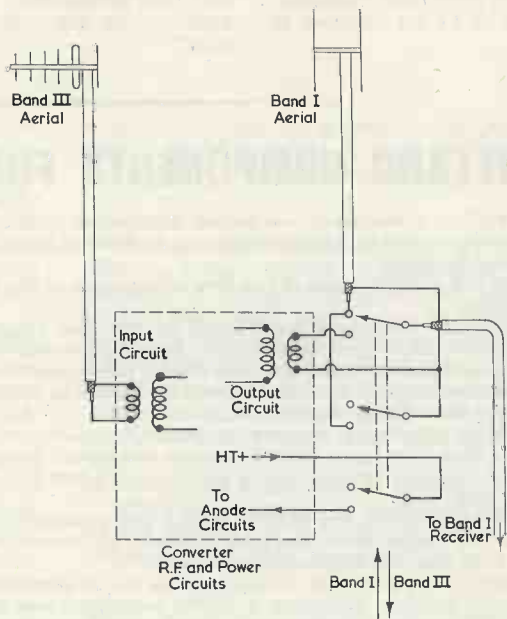

M451

Fig. 3. Switching arrangements for a typical Band III-Band I converter. The 3-pole switch would, in practice, be housed in the converter case

Other Interference

But Dick had returned to their main topic of conversation.

"I hadn't realised", he remarked, "that television sets could cause so much interference."

Smithy came out of his reverie and concentrated on the matter in hand.

"What you have to remember," he stated, "is that there are some circuits in television receivers which handle quite a lot of power. This is particularly true of the line output

receiver is fitted with a ferrite frame."

"Any other sorts of radiation?"

"Not of similar importance," said Smithy. "You occasionally hear of f.m. or short-wave radios picking up the television sound signal via a TV receiver. Such a signal is probably being radiated by the sound detector circuits in the TV set, as these work at fairly high level and aren't usually screened as efficiently as the video detector circuits. However, the

effect is not of great importance, and normally occurs only when the two sets of equipment are close together. Then, of course, you get X-ray radiation."

"From a television set?"

"That's right," said Smithy.

"There are relatively very high voltages across the e.h.t. rectifier and these may cause the radiation of X-rays for tube voltages above 16kV or so. And, finally, there's light radiation."

"Light radiation?"

"From the screen, you twirp," chuckled Smithy. "Which is the sole function of the television set!"

Mystery Solved

"Well, you caught me that time," laughed Dick. "And it looks as though we've pretty well exhausted the mysteries of TV set radiation as well."

But Smithy's thoughts had returned to his earlier suspicion. This was, by now, almost completely filling his mind.

"Tell me, Dick," he asked tentatively. "If your girl friend's father owns this coach, how did you get the tickets for this trip?"

Dick looked somewhat embarrassed.

"Well, to tell you the truth," he said unwillingly, "he sort of rather gave them to me."

"With the result," exploded Smithy, "that not only have you talked me into going on this tour, because your girl couldn't come, but you've also shanghai'd me into standing you a free tea as well! You, Dick, are the tightest man I know."

"Now, don't be like that, Smithy," said Dick persuasively. "You must admit you've had a pleasant coach ride."

"I suppose so," grunted Smithy. "Although I've hardly looked out of the windows once. Hallo, we seem to be stopping."

"So we are," said Dick. "Well, at any rate, we'll now find out where the Mystery Tour was going to. Come on, Smithy, let's pop out and find out where we are."

The pair rose from their seats and made their way, in company with the rest of the passengers, to the door of the coach. In front of them they found a wooden establishment carrying a very large sign which proclaimed to the world:

THE IMPERIAL TEA ROOMS

Smithy blinked short-sightedly around him in the strong sunlight.

"That place", he remarked suspiciously, "seems to look very familiar."

Dick gave a groan of utter misery. "Don't you know what it is," he wailed. "It's Joe's Caff!"

MULLARD COMPONENTS FOR SERVICE ENGINEERS

Ranges of Mullard components—consisting of polyester, miniature foil, and miniature electrolytic capacitors—already introduced to the setmaker industry, are now available through Mullard wholesalers to dealers' service organisations for maintenance purposes.

This follows the increasing use of the new components in the latest radio and TV sets and audio equipment coming on to the market.

Several important advantages are claimed for the new ranges: greater reliability, improved performance, closer tolerances, smaller size, robust construction, exacting electrical specification and highly competitive prices.

Polyester Capacitors. These are made from a non-inductive winding of thin polyester and aluminium, coated with a special protective lacquer. Both lead wires are soldered to the metal foils in a way which eliminates contact resistance and ensures the lowest possible self-inductance.

Compared with paper types they are claimed to be smaller, more resistant to moisture and able to withstand higher temperature. They have lower dielectric losses and higher insulation resistance.

A feature of particular interest to the service man is that the outer casing is proof against accidental contact with a hot soldering iron.

Close tolerance is $\pm 10\%$ and stability is such that capacitance change will not exceed $\pm 5\%$ over working life.

Miniature Foil Capacitors. Designed primarily for transistorised circuits where their rectangular shape, insulated coating and small size are of greatest advantage.

The loss factor, say the makers, is less than half that of ceramic disc capacitors and the variation with temperature is also considerably smaller. Tolerance is $\pm 20\%$ and capacitance change over working life will not exceed $\pm 10\%$.

Miniature Electrolytic Capacitors. These have a greatly increased voltage-capacitance product for a given can size. Small dimensions and an insulating sleeve allow them to be mounted together or against a metal plate.

It is these properties which make them eminently suitable for use in modern personal portable radio receivers.

Brochure. Mullard have prepared a special brochure, giving full technical and marketing information, and price lists of the available types. Both will automatically be sent to those dealers, special buyers, etc., who return the reply-paid postcard sent with the company's mailing shot on 2nd July.

S.T.C. Selenium Stacks to Protect Silicon Rectifiers

A range of selenium semi-conductor units has been introduced by Standard Telephones and Cables Limited for the protection of silicon rectifiers against transient voltages. These selenium stack assemblies are called Safe-T-staCs, being manufactured and marketed by the S.T.C. Rectifier Division, Edinburgh Way, Harlow, Essex (Harlow 26811).

Unlike selenium plates, silicon rectifiers and controlled rectifiers have a low thermal capacity which leads to rapid overheating in the presence of voltage transients. This overheating can destroy the rectifying junction if left unprotected, resulting in equipment breakdown.

Safe-T-staCs have the ability to absorb substantial current overloads of short duration and may be applied to any silicon rectifier circuit to protect it from damage and to enable the equipment in which it is used to give reliable, uninterrupted service.

The application of the new units generally allows the use of silicon rectifiers of lower ratings than would otherwise be necessary. Full details of the application of Safe-T-staC units, including suggested circuits, are available from S.T.C.'s Rectifier Division.

Cover Feature

A TRANSISTORISED ELECTRONIC ORGAN

Part 1

By S. ASTLEY

This is the first in a series of four articles describing a transistorised electronic organ. Apart from the fact that transistors are employed, thereby reducing heat dissipation and assembly time, the organ has the further advantages that it is fully polyphonic on both manuals and pedals, that it employs no elaborate solenoid switches, and that all pitches and voicing are selected by electronic means

THE ORGAN DESCRIBED IN THIS AND THE SUCCEEDING articles uses some 72 transistors or more. It has two 61-note keyboards and a standard pedal board. There are approximately 30 stops and a crescendo pedal (volume). Also, it is fully polyphonic on both keyboards and pedals, and no elaborate electro-magnetic switches are used to provide 16, 4, 2 and $2\frac{3}{4}$ ft pitches, all selection being achieved electronically.

Perhaps the most important feature of the organ is the use of transistors, since this fact at once brings about the consequent advantages that negligible heat is dissipated, that space is saved, and that power supply problems are reduced by a considerable extent. There are no heaters to feed and the only h.t. requirement is 9 volts at a maximum current of 35mA. A final, and not unimportant, point is that the use of transistors also reduces the time spent in construction: not only is there no heater wiring to install but there is also no need to mount valveholders. The transistors employed may be connected directly into circuit by way of their lead-out wires.

It cannot be over-emphasised that the highest quality components and workmanship should be incorporated into the construction of this organ, otherwise much disappointment will be caused due to frequency drift and similar faults.

The writer does not intend to give working practical layouts for the organ although, as far as is possible, full information will be given to allow the amateur with a good knowledge of radio to tackle the project. The constructor new to this field of electronics is strongly advised to examine an organ console, perhaps getting an organist to explain the various operations of the stops, etc. The writer realises that there are many readers who can play the piano or accordion a little, and who would attempt the construction of an organ if they more

fully understood the general layout of the instrument. For this reason a short description will be given before construction is described.

The Pipe Organ

The pipe organ was, originally, no more than an effort to bring a number of flutes under mechanical control. A penny whistle is very similar to the present-day "flue" pipe (wood or metal) organ in which air is forced against the sharp lip of the pipe. The air in the column is set into vibration, the length of the pipe determining the pitch of the note. There are, also, "reed" pipes which have a reed similar to that of the mouthorgan placed in the pipe in such a position that, as its tongue beats, the air in the column is again set in motion.

When an organ key is depressed air is admitted to the pipe via a valve which is operated by an electromagnet or by pneumatic means. This same



A view of the completed instrument

key can actuate many more pipes, these being reed or flue and having different diameters and shapes, whereupon different tones can be given to the initial note or frequency. The additional pipes are controlled by stops. Stops select the particular rank of pipes required, or cut off the wind supply to the pipes not wanted. (See Fig. 1.)

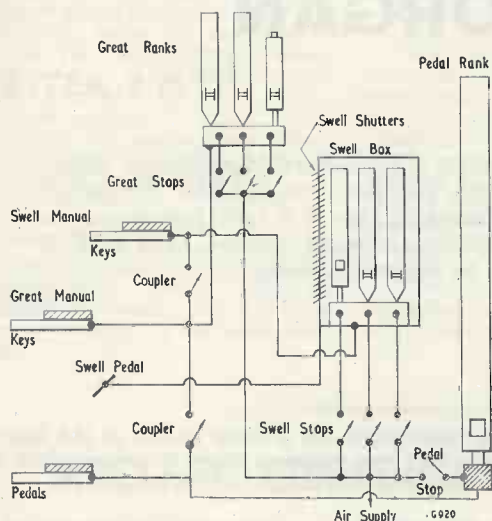

Fig. 1. Block diagram of a simple pipe organ

In a two-manual¹ church organ the lower keyboard is known as the Great manual. The upper keyboard is the Swell, and controls pipes enclosed in a large box (the Swell box) fitted with hinged shutters. The latter are adjustable and may be set so that they completely enclose the Swell box or leave one side almost fully open. The position of the shutters is controlled by a foot pedal, with the result that the volume of sound from the Swell pipes is adjustable. A third keyboard could be fitted below the Great manual. This would be known as the Choir manual, and would produce tones principally of a soft nature, suitable for choir accompaniment. A fourth keyboard, above the Swell and known as the Solo manual, would, as the name implies, have on it stops of a solo character, such as Trumpet, Oboe and Flute, etc. A fifth manual may provide an Echo, whereby the associated pipes are positioned a distance away from the main instrument.

The pedals of the organ have "black" and "white" keys, as with the manuals, and are played with the feet. They control very large pipes which can be 32ft in length, and which give a ground bass of great depth, reinforcing and giving support to the harmonics produced by the manuals.

By means of couplers it is possible to couple say, a lower manual to an upper, allowing pipes belonging to the upper to be controlled by, or added to, the lower. Also, the pedals may be coupled to the

¹ A manual is a keyboard.

manuals. Typical stop functions could, therefore, be Swell to Great, or Great to Pedal.

Another stop, Tremulant, or Vibrato, provides a means of modulating the air supply, so causing a pathetic trembling of the note.

Stops

Assuming that only one of a rank of pipes is actuated, if the lowest note on the manual, C², is played, the note heard will be

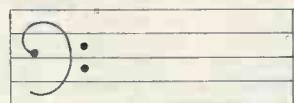

and the pipe would be physically 8ft long. The corresponding stop could be of any name or tone colour, but underneath its name will be seen the legend "8 ft." A pipe 4ft in length and stopped at one end will give the same note. One pipe might for instance be an Open Diapason 8ft or a Stopped Diapason 8ft (tone).² Now if, instead of the 8ft stop, another stop of 4ft was drawn, then when the same key was depressed one would hear C³, an octave above:

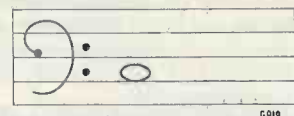

A 2ft stop would give an octave above this, i.e. C⁴, whilst a 16ft stop would give an octave below C², i.e. C¹. Thus, all these pipes can be made to sound in octaves when the stop for the appropriate footage is drawn, but we are still only pressing down one key—C². Other stops will add intermediate notes such as a Twelfth (2½ft) which, for the same note, C², would give not C but G³. This addition of harmonics gives improved tone colouring, and some electronic organs rely on this system to give the tones required, this being done by the addition of 2nd, 3rd, 4th, 5th, etc., harmonics to the fundamental.

Other stops have many pipes to each note and are known as compound stops. Often, and in cinema organs in particular, a separate rank of pipes is installed. These are not used for each stop; instead, borrowing takes place so that several stops may use the same rank to obtain say, a 16ft, 8ft or 4ft note.

Fig. 2 illustrates the standard keyboard showing approximate frequencies at each C. Also shown are the ranges for 16ft, 8ft, 4ft, and 2½ft tones which are employed in the transistorised electronic organ.³

² Diapason is the foundation-tone of an organ, and has the characteristic sound of the church (pipe) organ.

³ The notation C¹, C², etc., used in Fig. 2 and in the preceding text is a common one, the suffix number applying to all notes in the octave up to the next C. Thus, the B below C² is B¹.

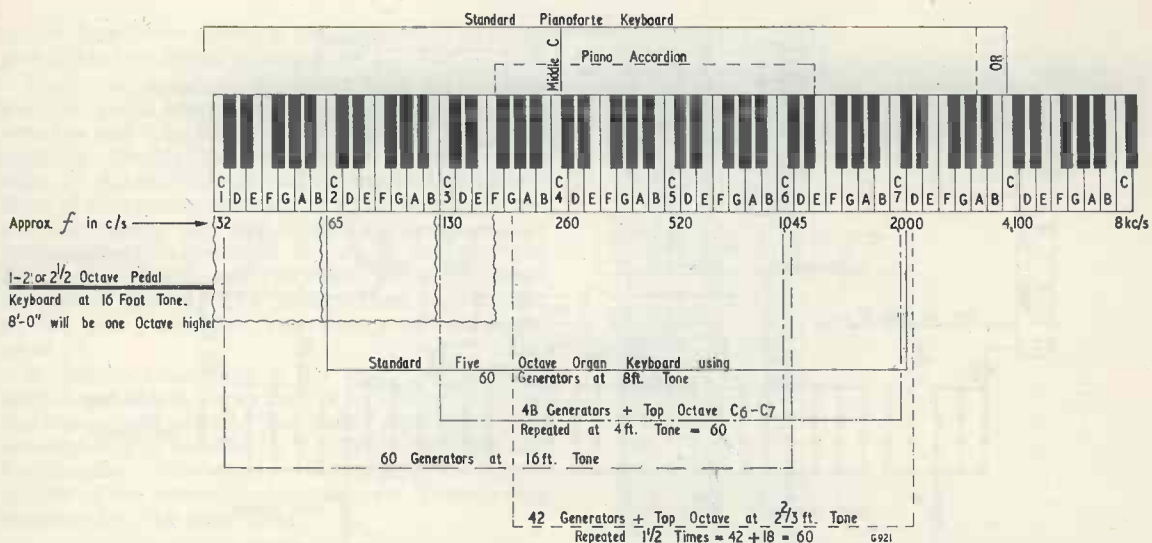

Fig. 2. Keyboard layout, showing approximate frequencies together with ranges for 16ft, 8ft, 4ft and 2 2/3ft tones

It is hoped that these brief notes will assist the constructor to realise the electrical problems as we approach them later. Further reference should be made to the excellent books which have been published on the subject, including those listed at the end of this article.

Pipe versus Electronic

The differences of opinion which have arisen over the years concerning the respective merits of electronic and pipe organs would fill volumes. The writer is of the opinion that the pipe organ is supreme, but that some electronic types are a very close imitation. Electronic organs are certainly very useful where portability is required or where confined space considerations have to be met, these points applying especially in the home.

In electronic organs, much work has gone into obtaining the correct starting tone when a key is depressed, and the elimination of clicks due to contact make or break. Also, the chorus effect of many ranks of pipes sounding together is hard to imitate with one set of generators and a single amplifier and speaker system. Here, reverberation helps.

With regard to tone there are two basic types of electronic organ on the market. One of these endeavours to imitate the traditional instrument; whilst the other, the Entertainment type, has its own characteristic tone (as the Hammond) but can still produce a reasonable church, or diapason, tone. The writer's organ is of the latter type, and will be found to give a good all-round tone. Also, the voicing, or tone colour, can be altered to the constructor's own wishes.

The waveform generated in the writer's organ is sawtooth which, as is known, is very rich in har-

monics. By arranging suitable filters the waveform is modified to the tone colour required.

If there were a separate oscillator for each note, the organ would produce a much better chorus effect, as discussed earlier. Unfortunately, it is difficult for the amateur to tune an organ of this nature and, in our model, it is necessary to set up, by means of pre-set potentiometers, the 12 notes of one octave only, the other octaves (sub-multiples of frequency) being automatically locked in to the master octave by means of frequency dividers.⁴ Some purists do not like the locked-in system because the octaves are absolutely related in frequency and phase, but the writer—whilst agreeing to some extent—prefers the system to be described because of its ease of tuning by the amateur and

⁴ A thirteenth oscillator—for C¹—has also to be tuned, this being a simple operation which can be carried out after the main oscillators and dividers have been set up.



Side view of the manual and stops

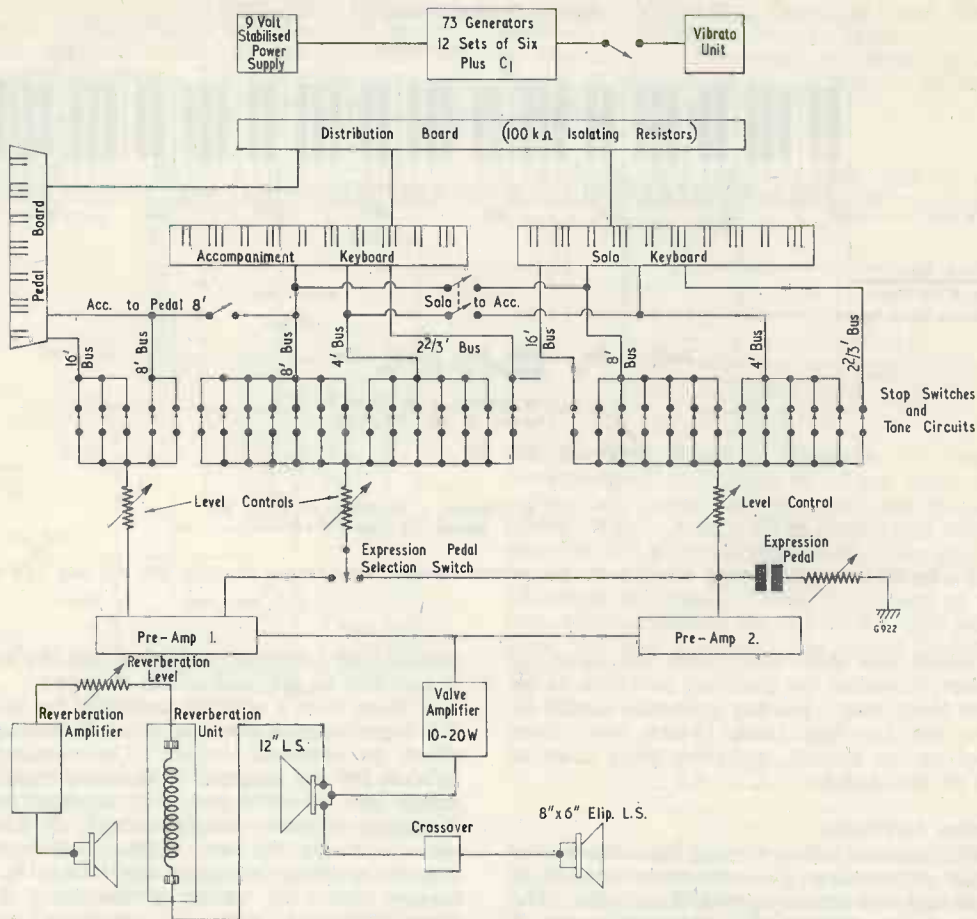

Fig. 3. The basic layout of the transistorised electronic organ

because of other factors which will become evident later.

In the writer's organ, the use of transistors raises the question of stability due to temperature changes, and by careful design no troubles in this direction have been experienced. Even in the hottest weather the instrument has not required attention, and there is, of course, negligible dissipation of heat from the transistors themselves. When silicon types are cheaper, no worries in this direction will be necessary.

The writer has tried to put the pros and cons forward without bias and believes that, with care, the circuitry to be described should produce an instrument giving lasting pleasure and a grand hobby.

The Basic Instrument

Fig. 3 gives a block diagram for the instrument. Apart from the C¹ generator, the generators consist of 12 units, each comprising a master oscillator and five frequency dividers. These feed into a distribution board in which a 100kΩ isolating resistor is

inserted in series with the feed to each key switch, or pedal board contact.

As this is an Entertainment organ, the upper of the two keyboards is known as the Solo manual, and the lower as the Accompaniment manual (unlike the names given to the pipe organ manuals of Fig. 1). The right hand then usually plays the Solo manual. In Fig. 3 the Solo keyboard is shown on the right and the Accompaniment keyboard on the left. As we shall see in more detail later, each key when depressed couples a note from a particular footage range to a corresponding busbar (or bus). Thus, when C⁴ key on the Solo manual is pressed, C³ generator is coupled to the 16ft bus, C⁴ generator is coupled to the 8ft bus, C⁵ generator is coupled to the 4ft bus, and G⁵ generator is coupled to the 2 2/3ft bus. Fig. 2 illustrates the ranges for 16ft, 8ft, 4ft and 2 2/3ft tones as applied to the keys.

Each key on the Solo manual of Fig. 3 has four contact sets, these coupling to the four buses leaving the manual. Similarly, each key on the Accompaniment manual has three contact sets, these coupling

to the three buses shown in the diagram. The pedal board has two buses leaving it.

The keyed signals on the buses from the manuals and the pedal board are next passed to the stop switches and tone filters. Also shown in Fig. 3 are couplers offering Accompaniment to Pedal, and Solo to Accompaniment. The required combinations of tone colour are selected by the stop switches, and the signals are then routed to the respective pre-amplifiers. Provision is made to cut the Expression pedal out on the Accompaniment manual, if desired. The pre-amplifiers then couple to the main amplifier and thence to the loudspeakers.

A reverb unit is fed from the amplifier output and this is very effective in adding "life" to the reproduced sound. The signal from the reverb unit is handled by a separate amplifier and loudspeaker. Also capable of changing the overall quality of the reproduced sound is the Vibrato unit connected to the generators.

Key Connections

Tables 1 and 2 augment the information given in Fig. 2 and show clearly which generator couples to each key and, thence, to the appropriate bus. The master oscillator numbers are 61-72, numbering then proceeding downwards through the frequency dividers. A separate oscillator is used for C¹, and this is indicated by the letter X in the tables.

Table 1 is applicable to both the Solo and Accompaniment manuals. The Solo manual has four buses and the corresponding generator numbers for these appear at the appropriate parts of the Table. Thus, when key No. 27 (D⁴) is pressed, generator No. 58 is applied to the 2 $\frac{3}{4}$ ft bus, generator No. 50 to the 4ft bus, generator No. 38 to the 8ft bus, and generator No. 26 to the 16ft bus. The Accompaniment manual has three buses and, in the writer's organ, these are 8ft, 4ft and 2 $\frac{3}{4}$ ft as shown in Fig. 3. Some constructors may prefer to delete the 2 $\frac{3}{4}$ ft bus from the Accompaniment manual, and make this 16ft instead.

Table 2 gives the corresponding generator numbers for the pedal board, this having two buses at 8ft and 16ft.

Fig. 4 illustrates the contact arrangements at one key (C⁴) on the Solo manual. The lines inclined at 45° represent the contact sets and the straight lines indicate the contacts which are pressed down when the key is depressed. These then connect to the lower angled contacts (shown dotted) and pass the output of each generator to the corresponding bus. When the key is at rest the straight line contacts connect to the earthed rhodium bar, thereby short-circuiting the generator output (after its 100kΩ isolating resistor) to chassis. The key contacts are described in detail later.

Harmonics and Tone

Now that we have seen the basic form of the transistorised organ, it might be advisable at this stage to briefly reconsider the question of harmonics

STOP BUS	NAME OF NOTE MANUAL KEY No.	GENERATOR No.																																									
		LOW	MIDDLE				HIGH																																				
2 $\frac{3}{4}$ 4 8 16	C ²	31	32	33	34	35	36	37	38	39	40	41	42	43	44	45	46	47	48	49	50	51	52	53	54	55	56	57	58	59	60	61	62	63	64	65	66	67	68	69	70	71	72
	C ³	1	2	3	4	5	6	7	8	9	10	11	12	13	14	15	16	17	18	19	20	21	22	23	24	25	26	27	28	29	30	31	32	33	34	35	36	37	38	39	40	41	42
	C ⁴	1	2	3	4	5	6	7	8	9	10	11	12	13	14	15	16	17	18	19	20	21	22	23	24	25	26	27	28	29	30	31	32	33	34	35	36	37	38	39	40	41	42
	C ⁵	1	2	3	4	5	6	7	8	9	10	11	12	13	14	15	16	17	18	19	20	21	22	23	24	25	26	27	28	29	30	31	32	33	34	35	36	37	38	39	40	41	42
	C ⁶	1	2	3	4	5	6	7	8	9	10	11	12	13	14	15	16	17	18	19	20	21	22	23	24	25	26	27	28	29	30	31	32	33	34	35	36	37	38	39	40	41	42
	C ⁷	1	2	3	4	5	6	7	8	9	10	11	12	13	14	15	16	17	18	19	20	21	22	23	24	25	26	27	28	29	30	31	32	33	34	35	36	37	38	39	40	41	42
	C ⁸	1	2	3	4	5	6	7	8	9	10	11	12	13	14	15	16	17	18	19	20	21	22	23	24	25	26	27	28	29	30	31	32	33	34	35	36	37	38	39	40	41	42
	C ⁹	1	2	3	4	5	6	7	8	9	10	11	12	13	14	15	16	17	18	19	20	21	22	23	24	25	26	27	28	29	30	31	32	33	34	35	36	37	38	39	40	41	42
	C ¹⁰	1	2	3	4	5	6	7	8	9	10	11	12	13	14	15	16	17	18	19	20	21	22	23	24	25	26	27	28	29	30	31	32	33	34	35	36	37	38	39	40	41	42
	C ¹¹	1	2	3	4	5	6	7	8	9	10	11	12	13	14	15	16	17	18	19	20	21	22	23	24	25	26	27	28	29	30	31	32	33	34	35	36	37	38	39	40	41	42
	C ¹²	1	2	3	4	5	6	7	8	9	10	11	12	13	14	15	16	17	18	19	20	21	22	23	24	25	26	27	28	29	30	31	32	33	34	35	36	37	38	39	40	41	42

X DENOTES SEPARATE GENERATOR

MIDDLE

C

GENERATORS FOR SOLO AND ACCOMPANIMENT MANUALS

MASTER OSCILLATOR NOS. ARE 61-72
 ASSUMING THAT MO AND ITS 5 DIVIDERS
 ARE BUILT ON ONE UNIT. A C UNIT THIS
 WOULD BE 72-60-48-36-24-12 RESPECTIVELY.
 THIS CHART IS IDENTICAL FOR EACH MANUAL
 DEPENDENT ON NUMBER OF BUSES REQUIRED

TABLE 1

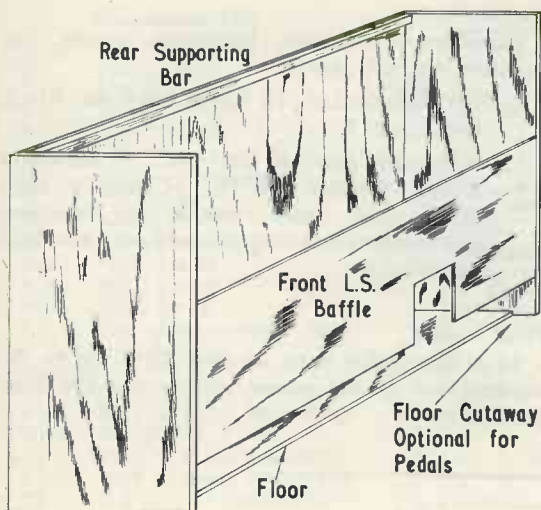

(a)

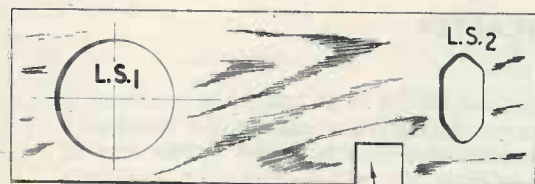

(b)

G924

Fig. 5 (a). A suitable method of constructing the case

(b). Front view of the baffle, showing the position of the apertures for the pedal board and the Expression pedal

The Case

A case for the organ may be made, or it can be purchased.⁵ The design will be greatly influenced by the builder's domestic circumstances, and by the pedal board size. The pedal board should be made detachable. Manufacturers' literature should be studied and this can give rise, also, to quite some good ideas. If the constructor wants to go the whole hog there are plenty of old Wurlitzers in the cinemas these days, whose consoles could be easily adapted! Fig. 5 shows a suitable framework that can be quite simply constructed. It would be advantageous to fit Sheppard's Castors to such a framework.

Whatever the decision on case design, the use of transistors makes it possible to get the case down practically to Mini-Piano size, provided, of course, that adequate room is available for the knees under the keyboards and for ease of pedalling. The right

⁵ Suppliers of cases, keyboards, pedal boards and organ components are listed at the end of this article.

foot should also be able to move above the pedals to reach the Expression pedal without cramping. The aperture for the Expression pedal should be approximately two-thirds of console width from the left. The pedal board recess in the front baffle is only necessary if the contacts are placed on the console floor.

If the instrument is not required to be self-contained, the constructor is advised to use a separate loudspeaker enclosure. The pedal notes, which run down to 30 c/s and are of large amplitude will soon find any resonances, and they will, of course, be better reproduced by a speaker in a properly designed cabinet.

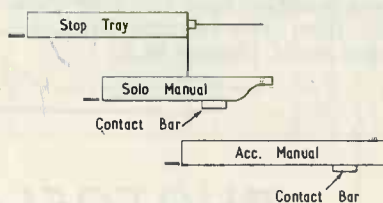

(a)

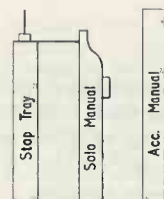

(b)

G925

Fig. 6 (a). The stop tray, Solo manual and Accompaniment manual in their normal positions

(b). The tray and the two manuals may be hinged back, as shown here, for adjustments and maintenance

Keyboards and Pedals

Keyboards and pedals are available from the suppliers listed at the end of this article. Alternatively, it is possible to obtain redundant units from organ builders. Pipe organ builders often advertise surplus units in the magazine *Musical Opinion*, and offer pedals and keyboards for sale at very low prices. Although the contacts for these are often silver wire (for electro-magnetic current keying) and are not suitable for a.f. keying, as is used in the present model, the units may still be capable of modification. The writer recently saw three manuals complete in frames offered for £10, with pedals at £5.

Components and Keyboard Mounting

The rest of the components required for the organ are familiar radio types. The stops use telephone jack switches. The Expression pedal potentiometer is operated by a rack and pinion. In the writer's organ the stop switches and tone filters are com-

pletely contained in a 16 s.w.g. mild steel tray 3ft long by 1ft wide, and 2½in deep. This tray and the two keyboards are hinged so that they may be lifted up through 90°. This is a desirable feature as it readily enables contacts, etc., to be examined or adjusted. Fig. 6 shows the two manuals and the stop tray in the normal, and in the folded back positions.

Recommended Books

Recommended books for the constructor are:

- (1) *The Electronic Musical Instrument Manual*, Fourth Edition, by Alan Douglas, M.I.R.E., M.A.I.E.E. (Pitman).
- (2) *Electronic Musical Instruments*, by Richard Dorf, Schober Organ Co., New York. (Available from The Modern Book Co., 19-21 Praed Street, London W.2.)

Suppliers

Suppliers of consoles, keyboards, pedals, key contacts, etc., etc., are:

- (1) Clyne Radio Ltd., 18 Tottenham Court Road, London, N.7.
- (2) Copeman Hart & Co. Ltd., 3 Barandon Street, London, W.11. (Copeman Hart & Co. Ltd. make consoles to individual requirements and designs, and have a standard keyboard.)

Next Month

In next month's issue we shall carry on to the construction of the power supply and the tone generators.

PHOTOFLASH SLAVE UNIT

By B. S. MUNCASTER

This article describes a unit which enables two electronic flashes to be tripped in synchronism with a master flash. Alternatively, the slave flashes may be tripped on receipt of a sound such as the breaking of glass or the bursting of a balloon. More than two slave flashes may be employed, if desired, and it is only required that their firing circuits should present an isolated negative voltage together with a positive trip voltage. This requirement is satisfied in standard electronic photoflash equipment

THE CIRCUIT OF THE PHOTOFLASH slave unit to be described was developed to enable the writer to utilise several electronic flash units together in pursuance of his hobby of colour photography. As most photographers know, electronic flash is balanced for use with daylight type colour film and its use indoors enables the photographer to mix indoor and outdoor shots on the same roll of film without recourse to filters. An additional advantage of flash is its high intensity when compared with photoflood or other tungsten lighting, and the absence of heat which invariably accompanies such lighting. This makes for greater comfort for both photographer and subject.

Good colour photography usually demands the use of more than one light source; in portraiture, for example, at least three lights are needed. When the writer tried to synchronise two or three electronic flash units together it became obvious that this was not just a matter of connecting the flash leads in parallel

to the camera shutter. Over the years the writer has acquired four electronic flash units, all of different types, and when attempts were made to couple them together the snags became apparent. Sometimes, when the flash leads were paralleled it was not possible to get any unit to flash, at other times one would flash but not the others. With two of the units coupled together an interaction took place between the triggering circuits which resulted in one flash continuing to trigger off as soon as there was a sufficient charge in the capacitors.

Photography under these circumstances was hardly possible and the only way out was to couple all the flash leads to a four-way push button and use "open flash" technique. This meant that the ambient room lighting had to be kept at a fairly low level, the subject made ready, then the camera shutter set at "B" (bulb or brief time), and the shutter opened. The flashes were then fired and the shutter closed again. With some practice this became quite a

speedy operation but it was difficult to capture just that right moment which makes the difference between the mediocre and the good photograph. It became necessary to find some way of tripping all the flash units from the camera shutter, and the circuit to be described was evolved.

Thyratron Valve Control

Since the use of multiple flash was confined to indoor work, the fact that the slave unit developed by the writer is mains operated presents no great disadvantage. All the flash guns used will operate either from the mains or from their own batteries, although they are invariably used from a mains source if this is possible. An evening's photographic session keeps the capacitors well formed, re-charging of the flash unit capacitors is quite automatic, and all flashes are available again about half a minute after an exposure has been made. If the flash units were used on their own batteries it would be necessary to switch them all off after

Components List

Resistors

R ₁	10kΩ	½ watt
R ₂	100kΩ	½ watt
R ₃	2.2MΩ	½ watt
R ₄	22kΩ	½ watt
R ₅	470Ω	½ watt
R ₆	500kΩ potentiometer	
R ₇	27kΩ	½ watt
R ₈	100kΩ	½ watt
R ₉	470Ω	½ watt
R ₁₀	1MΩ	½ watt
R ₁₁	10kΩ	½ watt
R ₁₂	50kΩ	2 watt
R ₁₃	3kΩ potentiometer, wire-wound	

Capacitors

C ₁	0.002μF
C ₂	32μF 275 w.v. electrolytic
C ₃	0.002μF
C ₄	16μF 275 w.v. electrolytic
C ₅	16μF 275 w.v. electrolytic
C ₆	8μF 275 w.v. electrolytic

Valves

V ₁ , V ₂	EF91
V ₃ , V ₄	2D21

Phototransistor

OC71 (see text)

Rectifiers

MR₁, MR₂ Contact cooled (see text)

Transformers

T₁ "Converter" mains transformer secondaries: 220V 11mA minimum, 6.3V 1.8A minimum

T₂ See text

Sockets

Jack with contact leaf (see circuit diagram)

Non-reversible flash lead sockets

an exposure then switch them on again after the next shot was set up, a time-wasting procedure, indeed, for the amateur working on his own.

The unit described here triggers the slave flash units by the use of an electronic switch, a thyatron valve. In early experiments to find a way of triggering several flashes the writer used a high speed relay to make the flash contacts, and whilst this arrangement was reliable when employing expendable flash bulbs, it was not so with electronic flash. This was due in the main to the very high speed of the flash; the whole energy of the flash unit is expended in about 1.2 milliseconds and the relay took about 2 milliseconds to pull in. Whilst this delay is of no consequence photographically, the fraction of a millisecond difference between the speed of the flash and the speed of operation of the relay was enough to cause failure of synchronisation.

The thyatron valve was the answer. This is a triode valve which

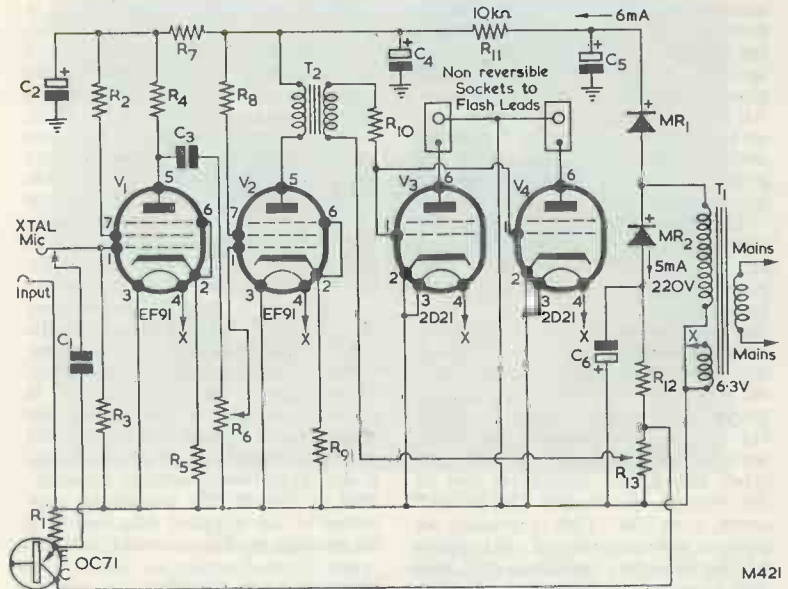

Fig. 1. Circuit of the slave unit

has a gas filling and behaves in a slightly different manner to the normal hard vacuum valve. If a negative voltage is applied to the grid before any potential is applied to the anode, the valve will not conduct. If the grid bias is reduced in value or made to swing positive, even momentarily, anode current will flow and the gas filling of the valve becomes ionised. Once this happens the grid has no further control over the current through the valve, and in order to stop the thyatron conducting either the anode circuit must be broken or the voltage on the anode reduced to the point where de-ionisation takes place, this being somewhere in the region of 8 to 10 volts. In the circuit shown de-ionisation is quite automatic since the voltage applied to the thyatron is taken from the controlled flash gun itself. When the flash takes place the flash trigger capacitors are discharged and the anode voltage is at once removed. The negatively biased grid can then resume control and the thyatron ceases to conduct even though the anode voltage is gradually built up again as the flash gun re-charges. The circuit shown is extremely sensitive, it will work at great distances from the primary flash (operated by the camera shutter) and it will trigger the slave units when used in bright room lighting or even in daylight.

Phototransistor

As will be seen from the accompanying circuit diagram (Fig. 1) the

light-sensitive device is a phototransistor, in fact an OC71 with the protective paint scraped off! The impulse from this transistor is coupled into the grid of the first valve through the low value capacitor C₁. The value of C₁ is deliberately made low in order that large signal voltages are not passed when the slave unit is used in the presence of a.c. mains lighting. If a component of larger capacity were used the hum voltages from the lighting may be sufficiently high to trigger the thyatron and lead to spurious flashing of the slave unit. The input circuit is broken by the introduction of a

¹ The OC71 is, theoretically, operated outside maximum ratings here, by reason of the 15 volts applied to it from R₁₃. An OCP71 phototransistor would, alternatively be within ratings and should function as well as the OC71.—Editor.



microphone jack plug, of which more later. The amplifier section of the slave unit is very simple, we are not after hi-fi reproduction and the circuit is bereft of any trimmings. All the amplifier has to do is to step up the voltage pulse from the phototransistor (or microphone) to the point where it will trigger the thyratrons.

The main item which calls for comment is transformer T_2 . Almost any transformer will work in this position but some, of course, work better than others. It will be realised that the final sensitivity of the slave unit is dependant upon the relationship between the negative grid bias on the thyatron, and the positive-going pulse which arrives from V_2 via T_2 . In the prototype the writer tried several transformers of different types and finally settled on one of the Wright & Weaire "Hyperloy" series, type 208. This is actually an output transformer of 8:1 ratio having a primary resistance of 2.2k Ω and a secondary resistance of 64 Ω . It is connected into the circuit "about face", the low resistance winding being in the anode circuit of V_2 . This is an obvious mis-match of course, but the arrangement does give a large voltage swing. Other transformers tried include a blocking oscillator transformer, and the junk box should be explored before purchasing a new component. If, however, one must be bought, the Radiospares "Midget" L.F. transformer of 5:1 ratio serves very well in this position. If a normal output transformer is used, the difference between the negative bias voltage and the signal voltage may be very small and the adjustment of the bias potentiometer R_{13} will be quite critical.²

With a suitable transformer the voltage swing to the thyatron grid is so great that the potentiometer R_{13} may be exchanged for a fixed resistor of the same value. The grid bias tap is then made at the same point as the supply for the OC71. This results in a negative grid voltage of about 15 being applied, and is sufficiently high to ensure that any hum present in the amplifier does not trigger the slave flashes in the absence of a primary flash. The 1M Ω resistor, R_{10} , in the grid circuit of the thyatron prevents excessive grid current flow when the grids are made positive.

The power supply is quite conventional and the mains transformer is

² The pulse at the anode of V_2 is negative-going, and the transformer should be so connected that a positive pulse is applied to the thyratrons. If in doubt, connections to the primary or secondary may be reversed experimentally.—Editor.

a small "converter" type having a single h.t. winding and a heater winding. If the heater winding will take the load, there is no reason why other thyratrons should not be added to the circuit to control as many flashes as are required. The two metal rectifiers are of the contact cooled type and may be of very low current rating. The actual current consumption is 6mA to the amplifier and 5mA through the negative bias bleeder circuit. The only essential is that a double-wound mains transformer is used to ensure that no mains voltages are present in the external flash circuits. If a transformer is used which has the usual centre-tapped h.t. winding it is merely a matter of connecting the centre-tap to chassis and putting the rectifiers in each leg of the windings. It should be remembered in construction to connect the smoothing capacitor of the negative bias line with its positive lead to chassis.

External Flash Circuits

As far as the external flash circuits are concerned it will be realised that the anode of the thyatron must be connected to the positive side of the flash lead. For this reason non-reversible connectors should be used and a check made on the flash gun to ascertain which of the trigger leads is positive. Usually the centre pin of the coaxial flash lead is positive, but this is not an invariable rule. It is quite easy to determine the polarity of the flash lead if it is connected to a voltmeter. It will not of course be possible to actually measure the voltage on the flash lead by this means as the triggering circuits of electronic flash units are usually fed through resistors of several M Ω . However, on connection of the flash lead to the voltmeter the needle will give a slight kick and from the direction of its movement it is quite apparent which of the leads is positive. The trigger voltage presented at the flash leads of most electronic flash units is between 100 and 200 and this is well within the limits of the thyatron used. Incidentally, the 2D21 thyatron also has a screen-grid in its construction. For this particular application the screen-grid was not used and the appropriate valve pins were simply left unconnected.

It will also be seen that no mains switch is fitted. Since the unit is connected to the mains only when it is required for use there seemed little point in including this extra component. The unit was built with economy in view as well as absolute reliability. The writer has seen 2D21 valves advertised in the columns of

The Radio Constructor for as little as 5s. 6d. and most of the other components can be obtained quite cheaply from the surplus stores.

Construction and Setting Up

The construction of the unit is quite straightforward and in no way critical as regards layout. Everything fits quite easily into a 6 x 4in chassis. As will be seen from the accompanying photograph, the phototransistor is mounted in a glass tube so that when the unit is put into its case the phototransistor projects from the top where it can receive the light from the primary flash. There is no particular merit in this form of mounting, of course, and the constructor may have his own ideas on the matter. When scraping the paint from the OC71 be sure to leave the spot on the side for identification of the leads. The photo-sensitive side of the transistor junction was found to be towards the observer when the spot was on the left of the transistor (see Fig. 2).

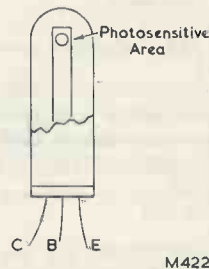

Fig. 2. Photo-sensitive area of the OC71

There is very little to the setting up of the unit, and the procedure is as follows. Ensure that the flash gun to be used as a slave presents its positive trigger lead to the anode of the thyatron, plug in the unit to the mains and allow the heaters to run for at least half a minute before connecting the slave flash gun. This is to ensure that the cathode of the thyatron is at the correct working temperature before any h.t. voltage is applied. Set the gain control R_6 to minimum and switch on the flash gun. Set the bias control R_{13} to maximum and when the neon of the flash gun shows that it is fully charged back off R_{13} until the unit flashes. This indicates the critical point of balance between the anode and grid voltages. If the flash gun is re-charged the bias control should be advanced slightly and the gain control of the amplifier also advanced. If at any point below the maximum

setting the flash triggers, the bias control should be advanced further. R_{13} should finally be set at a point where the flash just fails to trigger when the amplifier gain control is set at maximum. This will then ensure that sufficient bias is applied to the thyatron grid to prevent spurious triggering from hum voltages, etc., and the unit is now ready for use. R_{13} should not require any further adjustment. If another flash is now used anywhere in the same room as the slave unit, the slaved flash will trigger.

The Microphone Jack

The microphone jack is an optional feature of the unit, but it will enable the photographer to photograph any action which makes a noise, and it also enables a sequence of photographs to be taken with very accurate timing. The drill for using the microphone to take a photograph is quite simple. Open flash technique is used in a darkened room. The distance between the source of noise and the microphone will give a varying time delay and can be easily calculated. Since the speed of sound in air is 1,100 feet per second, the delay works out roughly at 1/1000th of a second per foot of distance between the microphone and the source of sound. Typical subjects include bursting balloons, breaking light bulbs, crockery, etc. It will be realised that for this sort of photography one subject, one sound, and one flash is the rule. For a sequence of photographs one must have available several balloons



Above—chassis view of the completed unit

or bulbs, etc. A point to remember when using the microphone is that it is non-selective and any sound may trigger the flash. Judicious use of the gain control is necessary to ensure that the flash is not triggered by accident from another source of noise. With the gain control at maximum the flash will trigger from a snap of the fingers or a mere whisper into the microphone.

Conclusion

In conclusion the writer would like to say that this unit has been invaluable to him in following his hobby. It has proved absolutely

reliable and provides positive synchronisation every time. With so many types of electronic flash on the market a slave unit as described would be an asset to any serious colour user and its use at a photographic club would enable members to pool their equipment for use on practical nights, etc. There is no fear of damage to any flash gun used with it as no external voltages are applied to the slave units to trigger them. All the external flash circuits, although with a common negative line, are quite independently switched, each thyatron acting as a separate switch for each slaved flash unit.

British Monitors for Italy's First Nuclear Power Station

When the reactor at Italy's first nuclear power station, at Latina, near Rome, goes critical in about a year's time, employees whose duties bring them into contact with radioactive materials will be checked for contamination on the latest type hand and clothing monitors. Four of these instruments have been ordered from E.M.I. Electronics Ltd., through Bay & Co. of Milan, by Societa Italiana Meridionale Energia Atomica, the Italian operating company for the new power station.

It is an important consideration at the vast Latina power station that a large number of personnel be checked for contamination as quickly as possible. The E.M.I. hand and clothing monitor checks both hands of personnel simultaneously for alpha and beta contamination, and at the same time it checks two other people's clothing and footwear.

The count time for checking hands is five seconds. Visible and audible alarms operate immediately the maximum permissible level of contamination has been reached or if personnel remove their hands before the end of the count period.

A special dual-phosphor technique is used when checking the hands and two independent probes check clothing—a scintillation counter for alpha contamination and a Geiger-Muller counter for beta-gamma contamination.

The power station authorities need not take special care to avoid background radiation when siting the four hand and clothing monitors, as a detector continuously monitors any background radiation—up to 0.5 mR/Hr—and makes any necessary subtraction from the total measured count.

This order, valued at over £8,000, is the most recent of many contracts placed with E.M.I. by nuclear establishments in the United Kingdom and throughout the world.

High-Low Impedance Microphone Pre-amplifier

By K. BERRY

In this article our contributor describes a three transistor pre-amplifier, originally designed for use with a crystal microphone, which is capable of accepting a high impedance input signal and of offering a low impedance output with a gain of some 20dB. It should be pointed out that, for speech and music applications, the input impedance is really too low to allow direct connection of a crystal microphone, as bass attenuation will result. Nevertheless, a crystal microphone can be employed for the recording of bird song, and this has been successfully achieved by the author. The input impedance may be increased to allow for normal applications with a crystal microphone by the addition of a series input resistor, this reducing the gain to zero dB. In this instance the pre-amplifier still retains the advantage of enabling the microphone to be positioned a considerable distance away from the main amplifier, since the inter-connecting cable can then carry the low impedance output from the pre-amplifier. Losses due to cable capacitance are thereby very considerably reduced.

The pre-amplifier can, of course, accept most other low-level high impedance inputs directly.
—Editor.

THIS PRE-AMPLIFIER WAS DESIGNED TO ENABLE a crystal microphone to be used some distance from a tape recorder. Long distances are not normally possible as a crystal microphone requires to work into a high impedance, and the use of a long screened microphone lead will result in such a large shunt capacitance being connected across the microphone that heavy attenuation may occur. Also, due to the fact that both the microphone and its load are at high impedance, the use of a long lead would result in difficulties with hum.

The unit which was evolved is small, light, and self-powered. It is fully transistorised and employs a 9 volt layer type battery which has a long shelf life.

Circuit Description

The circuit diagram is shown in Fig. 1. The first stage is an emitter follower giving a high input impedance, the transistor recommended being an OC45. This transistor was selected because of its low leakage current, and the fact that the OC45 tends to be less noisy than the lower frequency OC71.

The second stage employs an OC71 as a common emitter amplifier giving about 20dB of gain. This feeds the third and last stage, which is another OC71 connected as a further emitter follower. The third stage ensures that a low output impedance is obtained and allows a long coaxial cable to be used between the pre-amplifier and the load without losses or the introduction of hum.

Technical Considerations

When the requirement for the pre-amplifier arose the circuit described was designed and the unit made and found to be satisfactory. However,

at a later date, some thought was given to seeing whether the performance could be improved. Instead of using an emitter follower input stage to give a high impedance, a pre-amplifier was made with a common emitter input stage. The input impedance of such a stage is typically about 2 or 3k Ω , and this was increased to 200k Ω by means of a 200k Ω series resistor. This version was, however, found to be considerably noisier than the circuit described.

It will be seen that the values of resistance used in Fig. 1 are much higher than those normally encountered in transistor circuits operating at the supply voltage shown. The reason for this is that the stages run at low collector current, this being 0.4mA approximately for all three stages. These low values of collector current have been chosen to obtain the lowest possible noise figure. Whilst the original unit was made with 10% grade 2 resistors, some reduction in noise may be obtained if grade 1 high stability resistors are employed, since these should be inherently less noisy than ordinary composition resistors.* A further reduction in noise might be obtained by using silicon transistors such as the OC202, but since these are rather expensive the question of employing such transistors will not be pursued further.

In case it should be wondered who so much attention has been paid to the question of noise, it must be pointed out that the input to the pre-amplifier may be less than 1mV. Thus, any noise generated by the pre-amplifier is of importance.

Low Frequency Response

The input impedance of this pre-amplifier is

* Grade 1 resistors are high stability (cracked-carbon) types; Grade 2 resistors are normal composition types, as are employed generally in radio work.—Editor

Components List

Resistors

$\frac{1}{4}$ watt, Grade 1 or Grade 2 10% (see text).

R ₁	470k Ω
R ₂	10k Ω
R ₃	18k Ω
R ₄	22k Ω
R ₅	4.7k Ω
R ₆	10k Ω
R ₇	18k Ω
R ₈	22k Ω
R ₉	10k Ω

Capacitors

C ₁	0.25 μ F 150 w.v.
C _{2,3,4}	8 μ F 6 w.v. Electrolytic
C ₅	0.25 μ F 150 w.v.

Transistors

TR ₁	OC45, Mullard
TR _{2,3}	OC71, Mullard

Miscellaneous

- 2 Jacks, (see text)
- 1 Die-cast box, 4 $\frac{1}{8}$ in by 2 $\frac{1}{2}$ in by 3 $\frac{3}{8}$ in, Eddystone
- 1 Battery, type PP3, Every Ready

only 150k Ω , and its use with a crystal microphone will lead to a fall-off of output below about 500 c/s.

For the original application for which the unit was intended (i.e. the recording of bird song) this was no disadvantage, although it would be so if other purposes were intended. Fortunately, the difficulty can be largely overcome by artificially increasing the input impedance to 1.5M Ω approximately, this being effected by connecting a 1.5M Ω resistor in series with the 0.25 μ F input capacitor. It should be noted that if this modification is made, the unit will then have an overall gain of one—i.e. no gain at all. It will still, nevertheless, enable the microphone to be connected to the recorder or main amplifier by long leads at low impedance, thereby considerably reducing cable losses and hum pick-up.

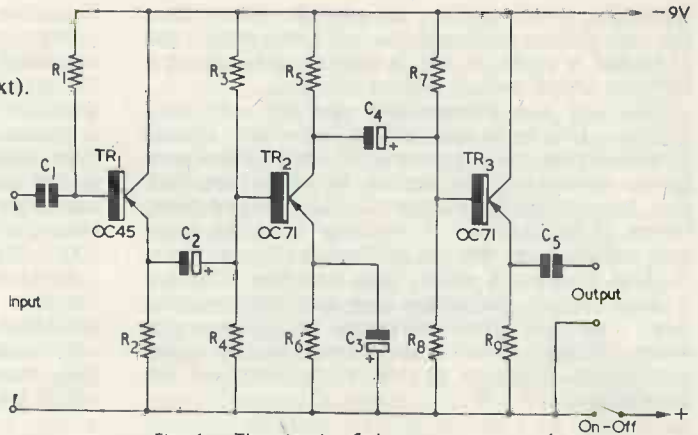

Fig. 1. The circuit of the pre-amplifier

M360

Electrical Performance

The frequency response of the pre-amplifier is shown in Fig. 2. It was measured with a source impedance of 600 Ω , and a load impedance of 100k Ω . The gain of the pre-amplifier (when used with the crystal microphone) into a load impedance of 100k Ω is approximately 20dB or ten times.

The noise output voltage measured across a 100k Ω load is 1/3 millivolt.

Input Impedance	= 150k Ω
Output Impedance	= 300 Ω
Current Consumption	= 2mA

Construction and Components

The pre-amplifier was made in an Eddystone die-cast box, of size 4 $\frac{1}{8}$ in by 2 $\frac{1}{2}$ in by 3 $\frac{3}{8}$ in approximately. The input and output connections are made by means of 1granic jack sockets. The input socket has a "make" contact which connects to the outer of the jack plug when it is inserted in the socket, this contact is connected in series with the positive lead from the battery and auto-

Fig. 2. The frequency response of the pre-amplifier for a source impedance of 600 Ω and a load of 100k Ω

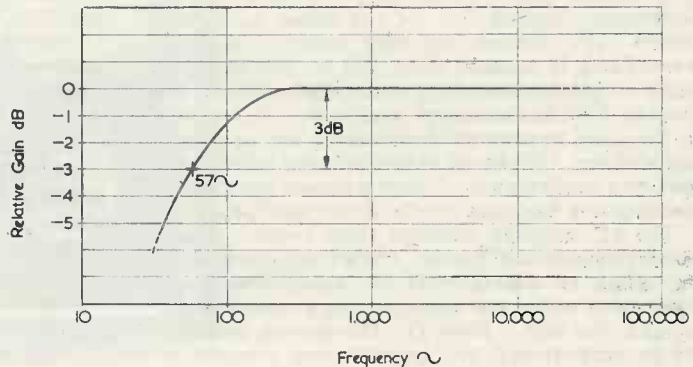

M361

matically switches the pre-amplifier on when the microphone is plugged in. If some other type of socket is preferred, e.g. a coaxial socket, then a separate on-off switch will be required.

None of the components specified are very critical. The input and output capacitors should be paper types and not electrolytic, whilst transistors having characteristics similar to those specified may be used as alternatives to the Mullard transistors if so desired. A warning must be given with reference to the use of "surplus" transistors. If these transistors suffer from excessive collector leakage current, the circuit may not function well. Also, "surplus" transistors may introduce extra noise. Whilst neither of these troubles may occur in practice, it is just as well to be aware of the possibility.

Operation

Once the pre-amplifier has been wired and assembled, no trouble should be experienced. If coaxial cable is used for the lead from the pre-amplifier to the tape recorder or main amplifier, a maximum lead length of 1,000 feet is suggested from calculations. Small diameter screened lead is not recommended as it has a much higher capacitance per foot than coaxial cable; nevertheless, even this type of lead should suffice for leads of 100 to 200 feet long.

It should be noted that this pre-amplifier is only intended to handle small input voltages, such as are obtained from a crystal microphone. It will not handle large signal voltages and, because of this, may prove unsuitable for other purposes where amplification is desired.

The Good Companion Mk. II Transfilter Portable

Described by W. HOLMES

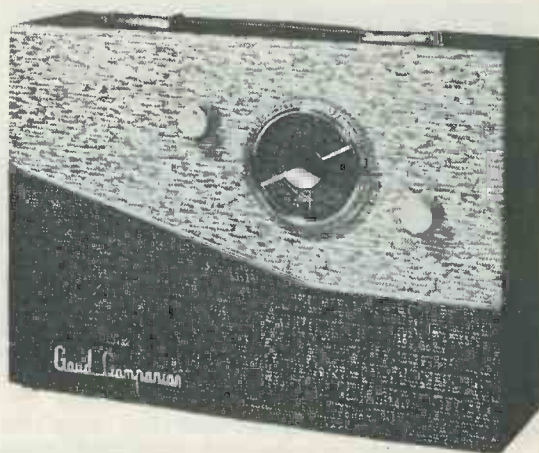

A 6-transistor medium and long wave portable receiver featuring singled-ended a.f. output together with resonant ceramic i.f. transformers

THE "GOOD COMPANION" MK. II RECEIVER COMBINES a number of design features which not only cause it to be an attractive proposition for the home constructor but which also make it of interest to readers concerned with new developments. The receiver employs a ferrite frame fitted with an additional coupling coil for car aerial input, and covers both medium and long waves. The long-wave band is tunable from 160 to 280 kc/s. A single-ended a.f. output circuit is used, enabling the push-pull OC81 transistors to deliver a high power to the speaker without the necessity for an output transformer. A pre-set potentiometer adjusts a.f. gain by a combination of varying bypass capacitance and negative feedback for the driver transistor.

The i.f. amplifier employs three ceramic transfilters resonant at 470 kc/s. These components take the place of conventional i.f. transformers and function in rather the same manner as piezoelectric crystals, but with a lower Q. The ceramic elements are so dimensioned, and have silvered connections

fired on them in such a manner, that they offer a passband at 470 kc/s which is equivalent to that offered by high grade i.f. transformers. In consequence, not only do they replace comparatively expensive wound components, but they also reduce alignment problems in the receiver in which they are installed. In the Good Companion Mk. II the only i.f. transformer employed is that which provides a low impedance feed for the detector. This transformer is the only component in the i.f. amplifier which has to be aligned.

The Good Companion Mk. II has a sensitivity, for 50mW output, of approximately $25\mu\text{V}/\text{metre}$ on medium waves and approximately $35\mu\text{V}/\text{metre}$ on long waves. A 9 volt battery provides power, consumption under quiescent conditions being 8 to 10mA and, at average volume level, 10 to 20mA. The panel controls are combined volume and on-off switch, wave-change and tuning. The tuning control has an integral slow-motion drive.

The Circuit

The circuit of the receiver appears in Fig. 1. In this diagram L_1 to L_5 are the windings on the ferrite rod aerial. L_1 is the medium wave tuned coil and L_3 the long wave tuned coil, coupling to TR_1 being effected by L_2 and L_4 respectively. Trimmer C_4 is permanently in circuit across tuning capacitor C_3 , additional fixed and trimming capacitance being provided on long waves by C_5 and C_6 . L_5 is the coupling coil for the car aerial socket, and it allows the car aerial to be inductively coupled into the rod, thereby obviating any excessive capacitive loading on the tuned circuits.

The signal frequency from the ferrite rod assembly is fed into the base of TR_1 in normal manner. TR_1 functions as a self-oscillating mixer, feedback being effected via the central tuned coil of the oscillator transformer OT_1 . On medium waves this coil is tuned by the parallel combination of tuning capacitor C_9 and trimmer C_{10} , additional trimming and fixed capacitance (C_{11} and C_{12}) being connected into circuit on long waves.

The intermediate frequency appears at the collector of TR_1 , and this is applied directly to transfilter TF_1 . The remaining non-earthly electrode of TF_1 then couples directly to the base of TR_2 . The transfilter requires a polarising voltage and this is offered automatically by R_{24} and R_5 , these being the resistors which provide h.t. feed to the collector of TR_1 and bias to the base of TR_2 respectively. It will be noted that the components associated with TF_1 are no greater in number than would be required in a simple cascade a.f. coupling circuit.

The emitter of TR_2 is coupled to the positive supply line via R_7 in parallel with the two-electrode transfilter TF_2 . This transfilter functions rather as a series resonant circuit, offering a low impedance at resonant frequency. Emitter degeneration is therefore at a minimum at the desired frequency, with the result that the overall i.f. response is further improved. The collector of TR_2 couples into the

base of TR_3 by way of transfilter TF_3 , employing the same basic circuitry as appears between TR_1 and TR_2 . The relatively low value resistors R_{24} and R_{26} provide a small, and acceptable, level of loading on transfilters TF_1 and TF_3 . Nevertheless, this loading is of a sufficient order to ensure that neutralising components are not, in practice, required for either TR_2 or TR_3 . Use of transfilters, therefore, brings about the deletion of these components from the i.f. amplifier.

The single i.f. transformer IFT_1 has a low impedance winding feeding diode D_1 . The detected output from D_1 passes through the filter C_{20} , R_{12} , C_{27} and appears across the diode load VR_1 . The diode is connected such that the rectified voltage on the upper terminal of VR_1 is positive, and this positive voltage is applied, via R_8 , C_{17} and R_{25} , to the base of TR_2 . As a result, an a.g.c. loop is set up: increasing signal voltage at the diode causes an increased positive bias at the base of TR_2 , with consequent reduction in i.f. amplification.

The diode load VR_1 is also the volume control, the desired volume level being tapped off by its slider and applied to the base of the driver transistor TR_4 . This couples into transformer T_1 , the latter having two separate secondary windings feeding, in anti-phase, the bases of TR_5 and TR_6 . TR_5 and TR_6 form a single-ended Class B push-pull output stage, the a.f. voltage at their junction being coupled to the speaker via C_{24} . The speaker has an impedance of 25–35 Ω to permit adequate matching to be achieved.

A proportion of the voltage across the speaker is fed, by way of R_{23} and VR_2 , to the emitter of TR_4 . VR_2 is a pre-set component. When the slider of VR_2 is at the top end of its track C_{23} is short-circuited, and maximum negative feedback from the speaker is applied to TR_4 . When the slider of VR_2 is at the lower end of its track the negative feedback voltage from the loudspeaker is short-circuited, and C_{23} functions as a bypass component. Intermediate

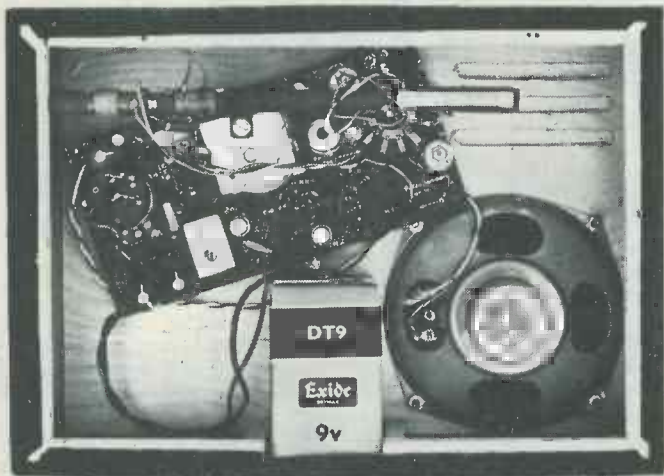

Inside the cabinet. The three transfilters appear immediately above the battery and are grouped around TR_2

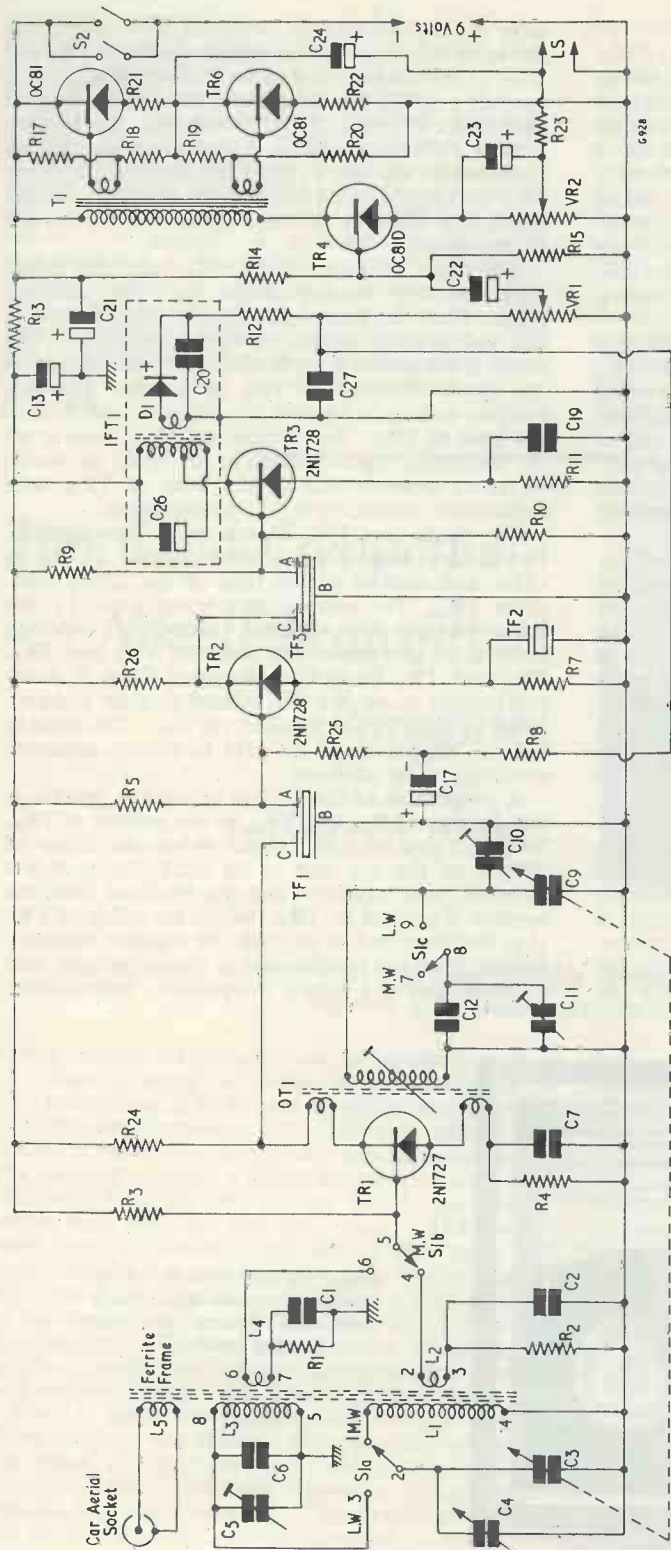

Fig. 1. The circuit of the Good Companion Mk. II Transfilter Portable

Components List

- Resistors** (all 1/4W, 20% unless otherwise stated)
- R1 12kΩ
 - R2 8.2kΩ
 - R3 39kΩ
 - R4 1.8kΩ 5%
 - R5 39kΩ
 - R7 680Ω
 - R8 3.9kΩ
 - R9 22kΩ
 - R10 4.7kΩ
 - R11 1kΩ 10%
 - R12 560Ω
 - R13 560Ω
 - R14 33kΩ

- C9 174pF, variable, part of 2-gang
- C10 Trimmer on C9
- C11 3-30pF, trimmer
- C12 330pF
- C13 100μF electrolytic
- C17 8-10μF electrolytic
- C19 0.05μF
- C20 Fitted in IFT₁
- C21 100μF electrolytic
- C22 10-30μF electrolytic
- C23 50μF electrolytic
- C24 100μF electrolytic
- C26 Fitted in IFT₁
- C27 0.01μF

- Semiconductors**
- TR1 2N1727 Philco
 - TR2 2N1728 Philco
 - TR3 2N1728 Philco
 - TR4 OC81D Mullard
 - TR5 OC81 Mullard
 - TR6 OC81 Mullard
 - D₁ Fitted in IFT₁
- Transformers**
- TF₁ *Clevite T002D
 - TF₂ *Clevite TFO1D
 - TF₃ *Clevite T002D

Note: TR₅ and TR₆ should be matched.
 TR₄, TR₅ and TR₆ may be in audio package LFH3

- Inductors**
 L₁ to L₅
 OT₁
 IFT₁
 T₁
Switches
 S₁
 S₂
Speaker
 5in round, 25-35Ω impedance
Battery
 9 volts, EverReady PP9, Exide DT9 or Vidor equivalent
Miscellaneous
 *Printed circuit board
 *Knobs, dial, drive
 *Cabinet
 *Car aerial socket
 Wire, nuts, bolts, etc.
 *Electronic Precision Equipment Ltd.
- Resistors**
 R₁₅ 10kΩ
 R₁₇ 2.7kΩ
 R₁₈ 100Ω
 R₁₉ 2.7kΩ
 R₂₀ 100Ω
 R₂₁ 3.3Ω
 R₂₂ 3.3Ω
 R₂₃ 3.3kΩ
 R₂₄ 3.9kΩ
 R₂₅ 2.9kΩ
 R₂₆ 2.7kΩ
 VR₁ 10kΩ potentiometer log
 VR₂ 500Ω potentiometer lin. pre-set
- Capacitors**
 C₁ 0.05μF
 C₂ 0.05μF
 C₃ 343pF, variable, part of 2-gang
 C₄ Trimmer on C₃
 C₅ 3-30pF, trimmer
 C₆ 100pF
 C₇ 0.01μF
- Transformers**
 *Ferrite rod aerial JB128/1
 *Oscillator transformer JB285
 *IF transformer and diode assembly JB139
 *Driver transformer
- Switches**
 *3-pole, 2-way
 *2-pole, 1-way. Ganged with VR₁
- Speaker**
 5in round, 25-35Ω impedance
- Battery**
 9 volts, EverReady PP9, Exide DT9 or Vidor equivalent
- Miscellaneous**
 *Printed circuit board
 *Knobs, dial, drive
 *Cabinet
 *Car aerial socket
 Wire, nuts, bolts, etc.
 *Electronic Precision Equipment Ltd.

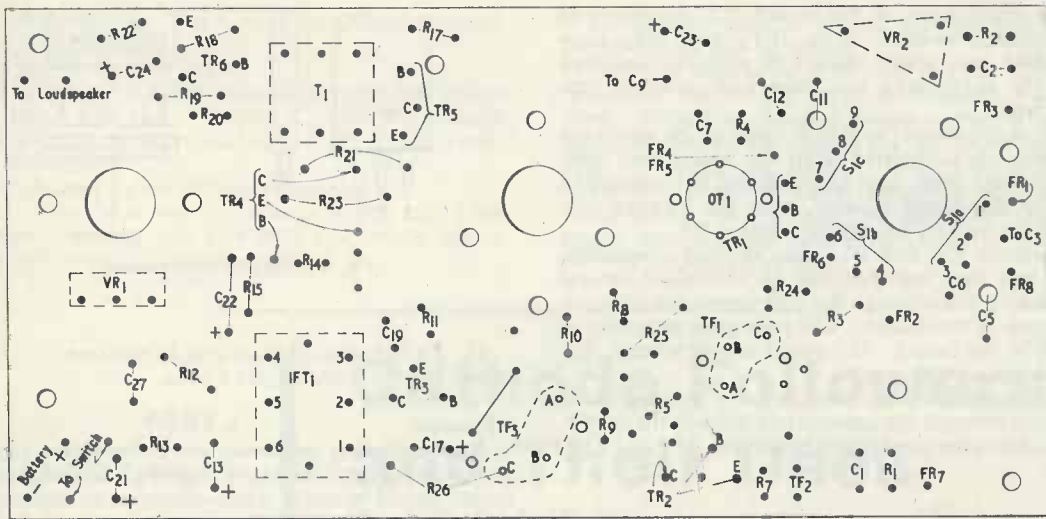

Fig. 2. Component connections to the printed circuit board

settings of VR₂ give results lying between these two conditions, and VR₂ may be set up to give whatever degree of negative feedback is desired by the user.

The power supply circuit follows conventional practice. A 9 volt battery is employed, this being bypassed by C₂₁ to ensure that there is no falling-off in performance due to increase of battery internal resistance with age. The supply for TR₁, TR₂ and TR₃ is decoupled by R₁₃ and C₁₃.

Construction

The construction of the receiver is considerably simplified due to the use of a printed circuit board, and components are inserted as indicated in Fig. 2. It is important to note that the board supplied is pre-fluxed and that no attempt should be made to clean this in any way. All connections must be made with high-grade resin cored solder.

A heat shunt is essential when soldering transistors, and TR₁, TR₂ and TR₃ should be wired into position with approximately 1/4in of lead-out between the body of the transistor and the printed circuit board. Transistors TR₄, TR₅ and TR₆ require lead-out wires of at least 1in. It is recommended that all transistor lead-out wires be sleeved, employing white sleeving for the collector, green for the base and red for the emitter in order to prevent mistakes. Fig. 3 shows the layout of lead-outs for the transistors employed in the receiver.

When fitting electrolytic capacitors to the board it is necessary to ensure that correct polarity is observed. Driver transformer T₁ is mounted with its blue spot facing the adjacent edge of the chassis. Transformer IFT₁ has an orange spot and this also faces the adjacent edge of the board. Pins 3 and 6 of this transformer are not soldered into circuit. The oscillator transformer OT₁ is colour coded violet-red, and this coding must be towards the

nearer short edge of the board, i.e. towards the wave-change switch. Both IFT₁ and OT₁ have mounting lugs which should be carefully soldered after the component has been fully inserted into the board.

The wavechange switch S₁ has to be mounted carefully. It is inserted from the non-copper side, and all tags must pass through the corresponding holes in the board as, also, must the locating lug. The same applies to volume control VR₁.

Trimmers C₅ and C₁₁ are Mullard concentric types and they are mounted so that their central conductors pass through the hole nearer the adjacent long edge of the board. The twin-gang capacitor is bolted to the board. The aerial tuning section, C₃, is that nearer the spindle.

The transfilters are mounted by passing their lead-outs through the appropriate holes in the board. Fig. 4 shows the connection layout for TF₁ and TF₃.

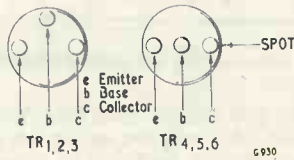

Fig. 3. Transistor lead-outs

It should be noted that the centre lead-outs of these two transfilters must be bent over and soldered to an earthy section of the copper foil.

The order of assembly is as follows:

1. Fit all fixed resistors, fixed capacitors, VR₂, C₅, and C₁₁, to the board.
2. Fit IFT₁, OT₁ and T₁ to the board.
3. Fit S₁ and VR₁/S₂ to the board.
4. Fit transistors and transfilters to the board.
5. Fit and wire the two-gang capacitor to the board.
6. Fit and wire the ferrite rod. The rod is secured by a plastic clamp bolted to the rear of the two-gang capacitor. The connections to the ferrite frame coils are shown in Fig. 5, the numbered tags corresponding to the similarly numbered points (preceded by the letters "FR") in Fig. 2. The car aerial coupling coil is not wired at this stage.
7. Complete the wiring to S₂ and fit leads for the battery and the speaker.

All connections should be thoroughly checked at this stage. If desired, the receiver may be switched on and tested, the knobs being temporarily fitted and the speaker connected for this purpose. The following steps cover installation in the cabinet.

8. Mount the speaker.
9. Attach leads to the car aerial socket and mount this socket to the cabinet.
10. Mount the board with 6BA ¼in bolts using the pillars provided.
11. Connect the car aerial socket to the car aerial coupling coil.
12. Connect up the speaker.

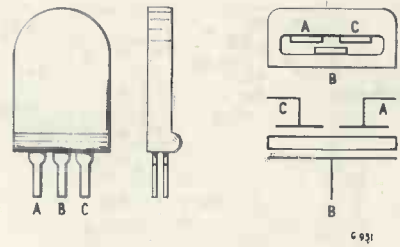

Fig. 4. Transfilter connections

13. Fit the self-adhesive dial in position.
14. Fit the pointer and knobs.

Alignment

Alignment may be carried out either with a signal generator or on broadcast signals. Final adjustments should be made with volume set to maximum and with minimum input signal, the latter being achieved when using broadcast signals by suitably rotating the set. The signal generator may be coupled to the ferrite frame by a 4 turn loop of 6in diameter positioned several feet away.

1. Align pointer so that it is vertical when C₃C₉ is fully closed or open.
2. Tune in a local station (or select medium waves, fully close C₃C₉, and inject 470 kc/s from the signal generator) and align IFT₁.
3. Tune in a station on medium waves between 475 and 550 metres, and as close to 550 metres as possible (or inject 540 kc/s). Adjust OT₁ so that pointer indicates correct wavelength (or C₃C₉ is fully closed for 540 kc/s).
4. Adjust L₁ along the ferrite rod for maximum output.
5. Tune in a station on medium waves between 200 and 225 metres, and as near as possible to 200 metres (or inject 1640 kc/s). Adjust C₁₀ so that pointer indicates correct wavelength (or C₃C₉ is fully open for 1640 kc/s).
6. Adjust C₄ for maximum output.

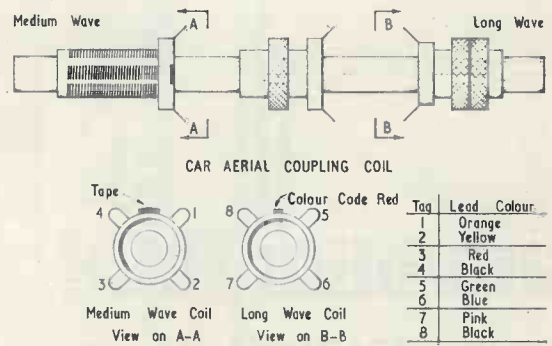

Fig. 5. Connections to the ferrite frame assembly

7. Repeat steps 3 to 6 until no further improvement can be made.

8. Switch to long waves.

9. Tune in the Light Programme on 1,500 metres (or inject 160 kc/s). Adjust C_{11} so that pointer indicates correct wavelength (or C_3C_9 is fully closed for 160 kc/s).

10. Adjust L_3 for maximum output.

11. Tune in a station between 1,300 and 1,100 metres (or inject 280 kc/s with C_3C_9 fully open). Adjust C_5 for maximum output.

12. Repeat steps 9, 10 and 11 until no further improvement can be made.

13. If the receiver is to be used in a car, couple it, inside the car, to the aerial with which it will be used. Switch to medium waves, select a station near 200 metres, and adjust the car aerial coupling coil for maximum output. Alternatively, inject 1,500 kc/s from the signal generator into the car aerial socket, tune around 200 metres for optimum signal strength, and adjust the car aerial coupling coil for maximum output.

PART I BASIC THEORY

Cathode Followers and Their Uses

By J. B. DANCE, M.Sc.

A CATHODE FOLLOWER IS A VALVE circuit with connections which are somewhat different from those of a conventional valve amplifier. The performance of the valve circuit is very much modified by the negative feedback which occurs in the cathode follower circuit. One of the three electrodes of a triode valve is normally operated at chassis potential with respect to a.c. signal voltages. In most conventional amplifiers this electrode is the cathode, but in grounded grid amplifiers, it is the grid and in cathode followers it is the anode.

The basic cathode follower circuit is shown in Fig. 1. The anode is bypassed to earth by the capacitor and the input voltage is applied between the grid and the lower end of the cathode resistor. This is not the same as between grid and cathode, as the cathode is not bypassed to earth. The output is taken from across the cathode resistor; this resistor is the load resistor and in most simple cathode follower circuits it is also the bias resistor.

Why "Cathode Follower"?

If an input signal is applied to the circuit shown in Fig. 1 so that the grid becomes more positive, the anode current will increase. This will cause the voltage across the cathode resistor to increase and the cathode will therefore become more positive. The cathode potential is said to "follow" the grid potential because, if the grid voltage changes, the cathode voltage will also change in the same direction. The change in cathode voltage is almost as great as the change in grid voltage; the

voltage between the grid and cathode is therefore comparatively constant.

Gain

The circuit of Fig. 1 may, for a.c. calculation purposes, be replaced by the constant current equivalent generator circuit shown in Fig. 2, providing that the shunting effect of the load is negligible. If the load is not negligible, the effective value of R_k and the load in parallel must be calculated and used in place of R_k in the equations below; this value may not be a pure resistance. In the circuit of Fig. 2, the valve itself is represented by the components within the dotted lines where r_a is an imaginary resistor of value equal to the anode resistance of the valve and the other component is an imaginary device which generates a constant a.c. current of $g_m V_{gc}$ amps where g_m is the mutual conductance of the valve in amps per volt and V_{gc} is the a.c. voltage between the grid and cathode of the valve.

The a.c. current from the imaginary generator divides itself between r_a and R_k , but, as r_a is very much greater than R_k , it is reasonable to assume that all of the current passes through R_k . This current is $g_m V_{gc}$ amps and the voltage across R_k is therefore $g_m V_{gc} R_k$ volts a.c.

From Fig. 1, taking polarity into account, it can be seen that:

$$V_{in} = V_{gc} + V_{out}$$

$$\text{Therefore } V_{in} - V_{out} = g_m V_{gc} R_k$$

$$= V_{gc} (1 + g_m R_k)$$

$$\text{Gain} = \frac{V_{out}}{V_{in}} = \frac{g_m V_{gc} R_k}{V_{gc} (1 + g_m R_k)}$$

$$= \frac{g_m R_k}{1 + g_m R_k}$$

From this equation it can be seen that the gain is always less than unity; that is, the cathode follower cannot give any amplification whatsoever. The gain of a practical cathode follower is usually between about 0.7 and 0.95. The input and output a.c. voltages are therefore practically identical. If it had not been assumed that R_k is much less than r_a , the following equation would have been obtained:

$$\text{Gain} = \frac{g_m R_k}{1 + g_m R_k + \frac{R_k}{r_a}}$$

The fact that cathode followers cannot be used to amplify is the only reason why they are not more widely used. An extra valve which

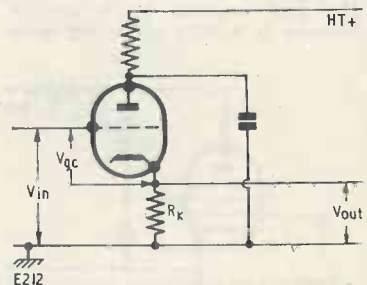
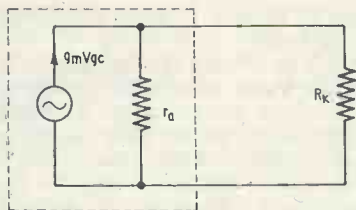

Fig. 1. Basic circuit of a cathode follower. The d.c. grid return is via the signal source. If the signal source has an extremely large d.c. resistance, a large value resistor should be connected between grid and chassis



E213

Fig. 2. The constant current equivalent generator of a cathode follower. The valve is represented by the components within the dotted lines

gives no amplification is not economical if a suitable alternative can be found. In order to ascertain some of the uses to which a cathode follower can be put, it is first necessary to consider the input and output impedances of the circuit.

Input Impedance

One of the great advantages of the cathode follower is that its input impedance is very high. This means that it imposes practically no load on the previous tuned circuit; a cathode follower can be used to take a signal from almost any circuit with very little effect on that circuit. There are two main reasons for the high input impedance of the cathode follower circuit. The grid-cathode impedance is high due to the feedback, and the circuit shows no Miller effect between the grid and anode because the anode is at a constant potential. The apparent grid-cathode impedance is very much higher when the valve is working than when it is cold because the cathode follower action leads to an effect between grid and cathode which is exactly opposite to the usual Miller effect between grid and anode. The load imposed by a cathode follower is usually quite negligible

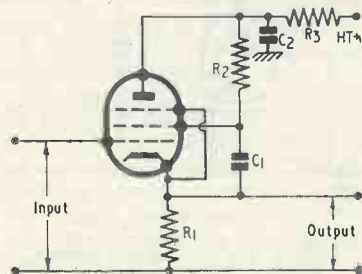

E214

Fig. 3. Circuit of a cathode follower which gives true pentode operation

up to frequencies of 1Mc or over.

It should be noted, however, that if a large input voltage is applied to a cathode follower, the anode current may be cut off or the valve may start to take grid current. In the latter case the input impedance will be much less than under normal conditions of operation.

Output Impedance

The output impedance of a cathode follower circuit is much lower than that of almost any other valve circuit. This means that a comparatively large current (i.e. a few milliamps) can be taken from the output of the circuit without the output voltage dropping appreciably. The cathode follower behaves as a source of a.c. voltage of low internal resistance.

The actual output impedance of a cathode follower is

$$\frac{\mu}{g_m(\mu+1)} \text{ or, approximately, } \frac{1}{g_m}$$

μ is the amplification factor of the valve. If the valve used has a g_m of 8mA per volt, the output impedance will be 125 Ω . Load impedances as low as about 2k Ω can therefore be connected across the output with little change in the output voltage. The output can even be matched very approximately into coaxial cable.

Other Features

The cathode follower operates with 100% negative feedback and the distortion from the circuit is therefore very low. If the input voltage is very high, however, plate current cut-off or grid current may lead to distortion. The maximum input voltage which can be fed to a cathode follower without distortion can best be calculated graphically.

The fact that the input and output are in the same phase is sometimes useful, especially in pulse amplifiers. Cathode followers can be used over an extremely wide frequency range, partly because of the negative feedback.

Any suitable small triode or triode-connected pentode can be used as a cathode follower. The results obtained with all valves are almost identical because of the negative feedback. If the valve characteristics change during life, it is unlikely that it will be possible to measure any appreciable change in performance of the circuit as a whole.

Pentode Cathode Followers

If a pentode is connected with the screen-grid bypassed to chassis (as is usual in pentode amplifiers), the

pentode will automatically become triode-connected if it is used as a cathode follower. If, however, the circuit shown in Fig. 3 is used, true pentode operation is obtained. The screen-grid is bypassed to the cathode in this circuit and therefore operates at constant voltage with respect to the cathode. The screen-grid dropping resistor, R_2 , cannot be omitted or the output which is developed across the cathode resistor would be short circuited by C_1 and C_2 in series. R_2 is effectively in parallel with R_1 with respect to a.c. voltages and allowance should be made for this in any calculations involving the cathode resistor. If R_2 is large, however, it may be neglected.

If a cathode follower is pentode-connected as in Fig. 3, the input capacity between grid and anode is small enough to be neglected. The total input capacity is very much smaller than if the same valve were to be operated as a triode cathode follower. The input impedance at high frequencies is therefore greater in the case of the pentode cathode follower.

Noise

A cathode follower has the same equivalent noise resistance as when the valve is used with the conventional anode loading but, when a cathode follower is used as an r.f. valve, the high input impedance tends to improve the signal to noise ratio. A pentode cathode follower generates more noise than the same valve connected as a triode.

Output

The maximum undistorted output voltage from a cathode follower with a certain value of cathode resistor is usually slightly greater than that which could be obtained from the amplifier with an anode load resistor of the same value. The cathode follower will, of course, require a much greater input voltage.

The value of load resistor chosen for a cathode follower is by no means critical, but there is a rough optimum value. The primary of a transformer can also be placed in the cathode circuit as a load.

Cathode followers find a wide range of uses as impedance transforming devices with a high input and a low output impedance. Next month the uses of the cathode follower will be discussed with practical circuits. Particular reference will be made to the wide variety of uses which cathode followers have in radio receivers.

(To be continued)

SMALL POWER

SUPPLY UNIT

By A. S. CARPENTER

In this article, our contributor describes a simple power unit which will be of particular value to the beginner

WHILST A CONSTANT VOLTAGE POWER PACK is, under certain circumstances, very desirable, it is often possible to make do with less ambitious power supplies. Sometimes, simple one or two valve receivers and other items of equipment requiring driving power are made up experimentally. When the time comes to test them it is a good plan to have handy a simple power unit fitted with a socket into which external apparatus may be plugged; such a unit does not cost a great deal either in time or money and will rapidly earn its keep. A simple unit of this type is described in this article.

The Circuit

The circuit of the power unit is shown in Fig. 1. A mains isolating transformer, T_1 , connects to the a.c. supply via a 2-pole switch and two fuses. Only two secondary windings are fitted to the specified transformer, one being rated at 250-0-250V

at 60mA and the other 6.3V at 2A. The latter supply is intended to supply valve heaters in the usual way, and the high voltage winding is connected to the anodes of a valve rectifier V_1 , via R_2 and R_3 . R_2 and R_3 are limiting resistors and reduce current flow when the reservoir capacitor C_1 charges during the a.c. cycle. The minimum limiting resistance for V_1 , under the conditions in which it is used here is 125Ω per anode and this is, in practice, largely contributed by the main transformer itself. The additional resistance inserted by R_2 and R_3 further limits charging currents and ensures cool running of the transformer and rectifier.

V_1 functions as a full-wave rectifier and the rectified d.c. voltage appears at its cathode several seconds after the on/off switch, S_1 , is closed. This delay is a desirable improvement over the almost instantaneous potential that appears when a metal rectifier is used, since the valves of externally

Components List

Capacitors

$C_{1a, b}$ 32+32 μ F dual electrolytic
 C_2 0.01 μ F tubular, 250V a.c. wkg.

Resistors

R_1 100k Ω 1W
 R_2 100 Ω 1W
 R_3 100 Ω 1W

Mains Transformer

T_1 Mains a.c. input. Secondaries: 250-0-250V 60mA., 6.3V 2A. Messrs R.S.C. (Manchester) Ltd.

Fuse Holder

Radiospares type FH2 (with home-made cover) or Belling-Lee type L.1033/C3. (See text)

Meter Sockets

Insulated, chassis mounting—Radiospares

Valveholders

I.O. (1). Noval (1).

Warning lamp

6.3V, 0.15A

Warning Lens

Bulgin D196, Red

Switch

d.p.s.t. toggle

Chassis

8 x 4 x 2in

Tagstrip

See text.

Miscellaneous

Spire clips, 6BA nuts and bolts, solder, wire, etc.

LFC

Choke, 10H, 60mA
 V_1 EZ80

Fuses

1A cartridge

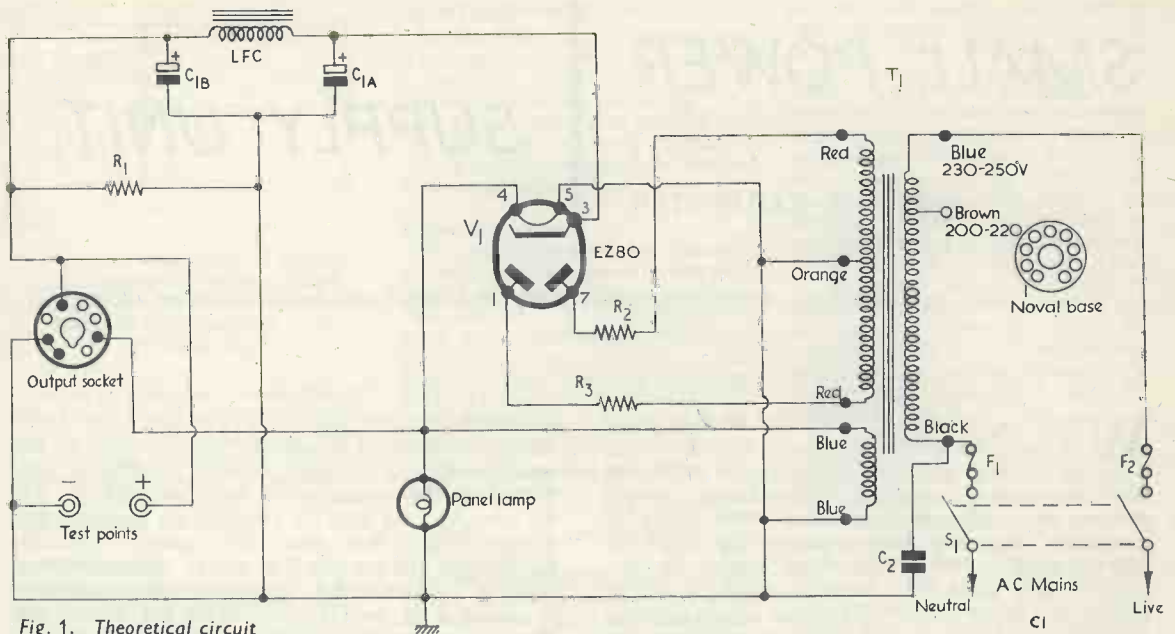

Fig. 1. Theoretical circuit

connected apparatus can receive a period of warming up before the full h.t. is applied.

Connections to T_1 are by means of flying leads and are colour coded as shown in Fig. 1.

The reservoir and smoothing capacitors are C_{1A} and C_{1B} respectively, the choke, LFC, smoothing out ripple in conjunction with these components.

The output is fed to a standard international octal valveholder which is used as the supply point to which external apparatus can be connected.

Resistor R_1 is fitted to provide a discharge path for the electrolytic capacitors should a charge be unwittingly left due to disconnecting the external apparatus too soon. The fixed capacitor C_2 effectively earths not only the unit chassis but also, via the h.t. negative line, any equipment connected to it; an adequate rating is essential for this component and only a high grade item should be used. It is also convenient to mount a pair of sockets on the panel into which the leads from a testmeter may be plugged for voltage monitoring purposes. Visual warning of operation is provided by a panel lamp.

Output Services

The unit provides h.t. voltage at currents up to 60mA plus a 6.3V 1.25A heater supply, and this is sufficient for a great many workshop purposes. The available h.t. voltage is dependent upon the load connected externally, the output potential falling as current demand increases and vice versa. The curve of Fig. 2 is representative of what is to be expected.

Layout and Constructional Notes

The design employed completely eliminates uninsulated high potential points above chassis with the exception of the fuses and these are provided a removable home-made cover.¹

The layouts both above and below chassis are shown clearly in Figs. 3 and 4 together with the wiring. In Fig. 4 the front chassis flange is shown

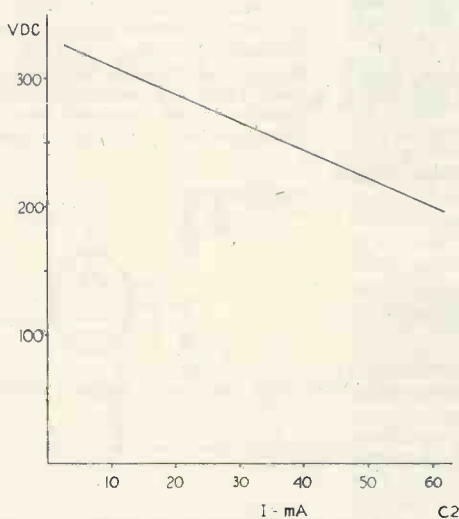
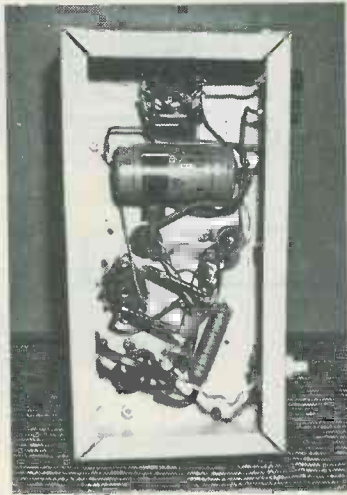

Fig. 2. Graph relating voltage and current

¹ A suitable fuseholder, alternative to that specified by the author, is the Belling-Lee type L.1033/C3 twin safety type. This is completely enclosed when the fuses are fitted, and has connections at the back.—Editor.



Under-chassis view of the power supply unit

pressed out flat to reveal the connections more clearly. A sectional chassis consisting of a separate top and four sides was used in the prototype but a conventional type will also be quite satisfactory.



Fig. 5. Details of the tagstrip

Note the large grommetted hole in the chassis top plate used to convey all leads below.

The mains lead is brought in through the rear chassis flange via a grommetted hole (not shown in Fig. 4) and the simple tagstrip illustrated in Fig. 5 provides all necessary anchors for the flying leads, and component wires.

Fig. 6. Dimensions for the front flange

No fuse is fitted to the secondary circuit of T_1 but one may easily be incorporated by connecting the Orange lead (centre tap) to chassis via a 0.15A torch bulb instead of directly as shown; this would ensure safety should a fault develop on the h.t. line of the pack or connected apparatus.

Since the layout is clear from the photographs and diagrams no general chassis drilling diagram is given except for the front flange, and for this refer to Fig. 6.

The mains lead should be connected in the correct sense as shown in Fig. 1, and a 3-pin plug fitted at its far end.

The transformer primary is shown connected

for 230–250 volt a.c. inputs in both Figs. 1 and 4. In this instance the unused brown lead from the transformer should be taped and neatly positioned out of the way. If the mains supply voltage is 200–220, the blue lead from the primary should be taped, the brown lead connecting to the appropriate fuse tag in its place.

Testing

On completion, an ohmmeter should be connected between pin 4 of the output socket and chassis,

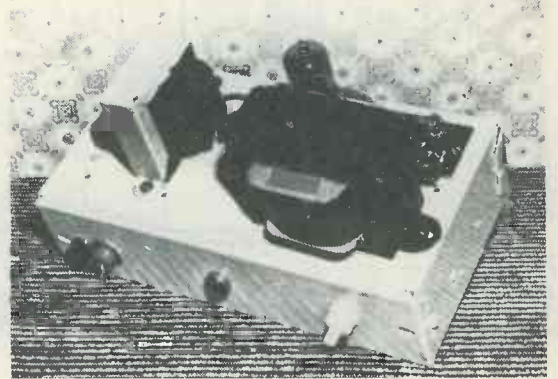

Above-chassis view of the completed power pack

whereupon its pointer should swing rapidly to indicate low resistance then gradually fall to a higher reading. The initial low reading is due to changing current in C_{1a} and C_{1b} . Should the ohmmeter read zero a fault exists, and should be cleared straight away. Ohmmeter readings should also be taken between pins 1 and 7 of V_1 and chassis in turn, and low readings obtained. A zero reading should be obtained when the meter is connected between pin 7 on the output socket and chassis,

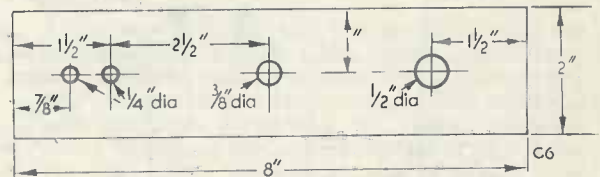

and infinity, except for a slight kick as C_2 charges when the resistance to chassis of either side of the mains plug (with S_2 closed) is checked. Finally the meter prods should be connected across the mains plug pins and S_1 checked for correct operation. With S_1 closed a low reading will be given.

If all is in order the meter should be set to read d.c. volts—not less than 500V—and connected with correct polarity to the test terminals. The unit can then be given an operational trial to ensure correct operation.



RADIO

topics

By RECORDER

laid down in the 1929 Royal Charter and it is worthwhile detailing these in full, as they define very clearly the principles under which British Standards are drafted and issued. The purposes are:

"(a) To co-ordinate the efforts of producers and users for the improvement, standardisation and simplification of engineering and industrial materials so as to simplify production and distribution, and to eliminate the national waste of time and material involved in the production of an unnecessary variety of patterns and sizes of articles for one and the same purpose.

"(b) To set up standards of quality and dimensions, and prepare and promote the general adoption of British Standard specifications and schedules in connection therewith and from time to time to revise, alter and amend such specifications and schedules as experience and circumstances may require.

"(c) To register, in the name of the Association, marks of all descriptions, and to prove and affix or licence the affixing of such marks or other proof, letter, name, description or device.

"(d) To take such action as may appear desirable or necessary to protect the objects or interests of the Association."

It will be noted that the primary function of the Institution is to *standardise*, and to thereby reduce the time and money wasted in producing many different varieties of the same object. Standardisation is achieved by the preparation of British Standard specifications (or British Standards), and such specifications are only issued after full and thorough consultation has taken place between producers, distributors, consumers and any other bodies who have an interest in the particular product or field of products.

The word "specification" infers also that a standard of "goodness" has to be met, and this is a very important point. What are, effectively, requirements for "goodness"

appear in most British Standards, in addition to such things as purely dimensional requirements. Thus, in the Standards for enamel covered copper winding wires we find not only specifications for the diameter of the wire and the thickness of its insulation, but we also find requirements which define the mechanical and electrical strength of the enamel, and the number of pinholes which are permissible in a given length. Specifications covering wire dimensions are an obvious approach to standardisation. If a transformer manufacturer has been winding his components with 26 s.w.g. wire bought from Messrs. X Ltd., he manifestly wants his windings to come out the same size if he changes over to 26 s.w.g. wire from Messrs. Y. It is in the other specifications, those covering enamel qualities and pinholes, that the question of "goodness" arises. The wire manufacturer is obviously going to keep his wire within standard dimensions, or his product won't get past the first coil-winding girl on his customer's shop floor. But he has also got to keep his wire up to the standard of "goodness" dictated by the subsequent specifications. These specifications won't mean a thing to the girl winding the coil, but if the coil subsequently breaks down they may mean quite a lot to the owner of the equipment in which it is fitted.

Although British Standards generally incorporate this effective requirement of "goodness" in the product covered, we will see shortly that this does not mean that they necessarily lay down exceptionally high standards which are difficult to meet. Also, there is no obligation on the part of any manufacturer to satisfy any British Standard at all (provided, of course, that he does not falsely claim to meet such a Standard). Indeed, it seems in some fields (not electronic products) that a proportion of manufacturers do not claim that their products meet a British Standard even though those products may be *better* than its specifications require. Further, newly introduced products may be unable to meet a British Standard because such a Standard has not yet been published.

Preparing a Standard

A British Standard has, initially, to be proposed. Proposals may come from manufacturers, users, or any other persons interested in the field to be covered. No work is started on the Standard unless there is support for it from the responsible bodies concerned.

EVERY NOW AND AGAIN IT IS MY pleasant duty to take a stroll down London's Park Lane as I go shopping for Standards. Park Lane nowadays has one-way traffic, with the result that it resembles a Speedway for London Transport; but it is possible to get right away from the roar of the buses by turning off, half-way down the Lane, into Park Street.

British Standards House is at No. 2 Park Street. After entering, I pass the board showing the Committee meetings for the day and go into the room designated "Sales". The young lady behind the counter then passes me the particular British Standard I wish to buy, and in return I hand over my hard-earned cash (later to be reimbursed, I must hasten to add, by Data Publications Ltd.).

British Standards Institution

Altogether nearly all of the manufactured goods we buy are governed, either in whole or in part, by British Standards, many people have only a hazy idea of what the British Standards Institution sets out to do and how it achieves its ends. The Institution is very active in the electronic field, and a number of British Standards cover the performance of electronic components as well as dealing with such things as safety precautions and interference.

It was in 1901 that standardisation work in this country commenced. In that year the Institution of Civil Engineers set up an Engineering Standards Committee which became, later, the British Engineering Standards Association. This Association received a Royal Charter in 1929, and the name was changed to the British Standards Institution in 1931. The purposes of the Institution were

After a successful proposal, a Technical Committee is formed, this including representatives from all interested bodies, and the process of working out a draft specification commences. This can take quite a number of Committee meetings to finalise, in which the most time-consuming topics may include the means of test of specific qualities and the reconciling of any conflicting views which may arise between, say, manufacturers and users. Eventually, a specimen draft is worked out and this is sent to all bodies concerned so that people other than committee representatives may make any further comments. If all goes well, the draft then becomes approved and published. It should be noted that specifications are only published if they have the general support of manufacturers as well as users.

From time to time British Standards are brought up to date, either by the addition of amendment slips or by the issue of a revised Standard. The date of issue of a Standard is indicated by the second group of figures in its title. Thus, B.S.1568:1960 (Magnetic Tape Sound Recording and Reproduction) was issued in 1960.

The number of bodies participating in the preparation of a particular Standard may be very large, especially if, as occurs occasionally, the Standard covers a wide field and is not applicable to a single set of products. One typical example is B.S.905:1959 (Interference Characteristics and Performance of Radio Receiving Equipment for Aural and Visual Reproduction) in the preparation of which no less than 44 bodies took part, 23 sending Committee representatives. These bodies included the War Office, the British Radio Equipment Manufacturers Association, British Railways and the Radio Society of Great Britain.

At a Committee Meeting

Technical Committees are served by Sub-Committees for some of the detailed work, and I sat in at several of these sub-committee meetings myself some years ago. The meetings commenced at 10.30 a.m., a Technical Officer on the Institution staff acting as secretary. Our time was devoted to getting an early draft specification into shape, much of this being spent on discussing means of measurement. As I recall it, we devoted a considerable period to the best method of determining corrosion factor in electrical self-adhesive tape, this being a process which cannot be determined without extremely specialised laboratory equipment. Refreshment was brought

round half-way through the morning session (coffee and bikkies) and half-way through the afternoon session (tea and bikkies). An interesting and enlightening experience; and I regret that, due to the hurly-burly of life these days, I have not been able to follow the subsequent history of the embryo Standard we discussed at those meetings.

I should add that, on my initial nomination, I received a very helpful leaflet entitled *Notes for B.S.I. Committee Members*. The information concerning the history of the Institution and its Charter reproduced here is taken from this leaflet.

The Kitemark

As many readers will be aware, manufacturers of some products append the B.S.I. Kitemark to their goods. These Kitemarks imply that the product meets the appropriate British Standard, and they are used under licence from the B.S.I., which carries out periodic inspection and testing of the product.

The Council of Industrial Design

Another body which examines manufactured goods operates along completely different lines to the British Standards Institution. This is the Council of Industrial Design, whose function is to examine the appearance of a particular product and judge it thereby, efficiency and performance being of secondary importance. If a product is considered satisfactory for appearance it is entered in the Design Index, which may be consulted at the Design Centre in the Haymarket, London. Also shown at the Design Centre is a display of approved products.

The fact that the efficiency of a product is of secondary importance makes the Design Index of rather doubtful value. Thus, the March and June issues of the Consumer Association publication *Which?* refer to a mains-driven photographic slide projector in which a live point could be touched. (The manufacturer has now added a protective covering). However, this potentially dangerous device was listed in the Design Index of the Council of Industrial Design.

You Can't Win—1

Changing to an entirely different topic, the wife of a friend of mine recently talked me into volunteering to repair their a.m. steam radio, which had become very insensitive indeed.

When I got the set home I found that I had been preceded by Smithy's Phantom Fiddler, who had cured a case of instability by the delightfully

simple process of detuning the i.f. cores. A little digging around revealed that a 0.02 μ F decoupling capacitor was not working as it should, and a replacement cleared out the whistles altogether. I was then able to bring up the i.f. transformers to correct alignment, whereupon the set assumed that gratifying liveliness which demonstrates that all tuned circuits are peaked to perfection and that the repair job has been well and truly done. A swing of the dial down to 208 metres brought in Luxembourg at good strength, and the receiver could then be described as offering an adequate performance for the average British listener.

I took the set back next day and demonstrated its capabilities. I was just about to prove the sterling worth of my friendship by saying that I was not going to make a charge for the repair when the wife turned round and spoke to me.

"You're not", she said, "going to make a charge for the repair, are you?"

Sometimes you just can't win.

You Can't Win—2

Which reminds me of the only printable story I have heard over the last year or so.

Jones and Robinson were co-directors of a large company, but Robinson was always one up on Jones. Robinson bought his Bentley just before Jones did, he got his country home just before Jones, and he similarly beat him to the installation of his swimming pool.

One morning Jones got out of his car at business just as Robinson arrived in his. What was more, Robinson was very busily talking over a brand-new radio-telephone installed in his car. Furious, Jones stalked up to his office and immediately contacted the G.P.O., who said they were very sorry but they could allow no further car telephone installations in the district as the very last available frequency had been bagged by "a Mr. Robinson."

Jones was not to be beaten, however, and after several months of wire-pulling he eventually acquired a fully licenced car telephone of his own.

The next morning, as he was driving to business, he decided to ring Robinson who would be similarly travelling up in his car. A delighted grin came over Jones's face when, after a few moments, he heard Robinson's voice in his receiver.

"Just a minute, Jones," said Robinson. "I'm busy on the other line."

SPECIAL BARGAIN OFFER!

"6 + 1"

TRANSISTOR RADIO KIT

PRICE BARRIER SLASHED—A further bulk purchase of this popular Kit enables us to pass on latest price reduction direct to Constructor. Kit is a modern, sensitive, quality receiver with all latest circuit features and is complete with 7" x 3 1/2" speaker (3 ohms), and all circuit and assembly instructions. 6 BVA transistors and germ. diode. Printed Circuit. Med. and L/W. Ferrite aerial and car radio coupling. 500mW output. Attractive gilt dial and slow motion drive with "Clear Vu" tuning knob, etc.

... using 3 latest type surface Barrier Transistors

Now Only £6.19.6

Complete Kit carriage 2/6



Contemporary two-tone cabinets 9" x 5" x 3 1/2" available 25/- extra

New Boxed	VALVES	All Guaranteed	Electrolytics	All Types New Stk.
1T4	6/-	ECC83 8/-	PCC84 9/6	25/25V 1/9
1R5	7/6	ECL82 10/6	PCF80 9/6	50/12V 1/9
1S5	7/6	ECL80 10/6	PCF83 12/6	50/50V 2/-
3S4	7/6	EF80 8/-	PCL84 12/6	100/25V 2/-
3V4	7/6	EF86 12/6	PL81 12/6	8/450V 2/3
DAF96 9/6	EL84 8/6	PL82 9/6	4/350V 2/3	275V 12/6
DF96 9/6	EY51 9/6	PL83 10/6	16+16/450V 5/6	100+200/ 275V 12/6
DK96 9/6	EY86 10/6	PY32 12/6	32+32/450V 6/6	
DL96 9/6	EZ81 7/6	PY81 9/6		
ECC81 8/6	GZ32 12/6	PY82 7/6		
ECC82 8/6	EM84 9/6	U25 12/6		

RECORDING TAPE—REDUCED BARGAIN PRICES
Famous American Columbia (CBS) Premier Quality Tape at **NEW REDUCED PRICES**. A genuine recommended Quality Tape—TRY IT! Brand new, boxed and fully guaranteed. Fitted with leader and stop foils.

Standard	Long Play	Double Play
5" 600ft, 13/-	900ft, 17/6	1,200ft, 31/6
5 1/2" 900ft, 16/-	1,200ft, 19/6	1,800ft, 37/6
7" 1,200ft, 21/-	1,800ft, 28/6	2,400ft, 47/6

post and Packing, per reel, 1/-, plus 6d. each for additional reels.
SPECIAL OFFER—3" mfrs. surplus tape, 225ft, 4/9. P. & P. per reel 6d. Plastic Tape Reels 3" 1/3, 5" 2/-, 5 1/2" 2/-, 7" 2/3. Plastic Spool Containers, 5" 1/6, 5 1/2" 2/-, 7" 2/3. 3" message tape 150/39/6.

Alumin. Chassis. 18g. Plain Undrilled, folded 4 sides, 2" deep. 6" x 4", 4/6, 8" x 6", 5/9, 10" x 7", 6/9, 12" x 6", 7/6, 12" x 8", 8/- etc.

Alumin. Sheet. 18g. 6" x 6", 1/-, 6" x 9", 1/6, 6" x 12", 2/-, 12" x 12", 4/6 etc.

Jack Plugs. Standard 2 1/2" Igranit Type, 2/6. Screened Ditto, 3/3. Miniature 1 1/2", 2/3. Screened Ditto, 2/6.

Jack Sockets. Open Igranit Moulded Type, 3/3. Closed Ditto, 3/9. Miniature Closed Type, 1/9. Sub-min (deaf aid) ditto, 1/3.

Phono Plugs 1/-. Phono Sockets (open), 1/-, Ditto Closed, 1/6. Twin Phono Sockets (open), 1/6. Soldering Irons. Mains 200/220V or 230/250V. Solon 25 watt Inst., 22/6. Spare Elements, 4/6. Bits, 1/- 65 watt, 27/6 etc.

Mains Neon Tester—Vest Pocket Screwdriver with Neon Indicator. For 200/250V Mains, Bargain, 2/9.

Condensers—Silver Mica. All values, 2pF to 1,000pF, 6d. each. Ditto, Ceramics 9d. Tub. 450V T.C.C., etc., .001 mfd. to .01 and 1/350V, 9d. .002-1/500V 1/-, .25 Hunts 1/6. .5 T.C.C. 1/9, etc., etc.

MULLARD "3—3" HI-FI AMPLIFIER

3 VALVES 3 WATT

3 ohm and 15 ohm Output 3 ohm and 15 ohm Output
A really first-class Amplifier giving Hi-Fi quality at a reasonable cost. Mullard's latest circuit. Valve line-up: EF86, EL84, EZ81. Extra H.T. and L.T. available for Tuner Unit addition. This is the ideal companion Amplifier for FM tuner units.

TECHNICAL SPECIFICATION—Freq. Response: ± 1dB. 10 Kc/s. Max. Bass Boost 14 dB. at 80 c/s. sensitivity: 100 MV. for 3W, output. Output Power (at 400 c/s): 3W. at 1% total harmonic distortion. Hum and Noise Level: At least 70 dB. below 3W.

COMPLETE KIT (incl. valves, all components, wiring diagram and special quality sectional Output Trans.)

ONLY £6/19/6 carr. 4/6d. Complete wired and tested 8 gns. Wired power O/P socket and additional smoothing for Tuner Unit, 10/6 extra.

Bronze Escutcheon Panel, Printed Vol., Treble, Bass, On-Off, supplied with each Kit.

Recommended Speakers—WBHF 10 £2.65, Goodmans Axiom 10 £5/15/8. Axiote £6/10, or Axiom 112 £8/10.

Volume Controls—5K-2 Meg-ohms, 3" Spindles Morganite Midget Type. 1 1/2" diam. Guar. 1 year. LOG or LIN ratios less 1 Sw. 3/-. DP. Sw. 4/6. Twin Stereo less Sw. 6/6. D.P. Sw. 8/-.
COAX 80 OHM CABLE
High grade low loss Cellular air spaced Polythene—1/4" diameter. Stranded cond. Famous mfrs. Now only 6d. per yard. Bargain Prices—Special lengths 20 yds. 9/-. P. & P. 1/6. 40 yds. 17/6. P. & P. 2/-. 60 yds. 25/-. P. & P. 3/-. Coax Plugs 1/-. Sockets 1/6. Couplers 1/3. Outlet Boxes 4/6.

Close Tol. S/Micas—10% 5pF-500pF 8d. 600-5,000pF 1/-, 1% 2pF-100pF 9d. 100pF-500pF 11d. 575pF-5,000pF 1/6. Resistors—Full Range 10 ohms-10 megohms 20% 1/4 and 1/2W 3d., 1/2W 5d. (Midget type modern rating) 1W 6d, 2W 9d. Hi-Stab 10% 1/2W 5d., 1/2W 7d. 5% 1/2W 9d., 1% 1/2W 1/6. W/W Resistors 25 ohms to 10K 5W 1/3, 10W 1/6, 15W 2/-. Pre-set T/V Pots. W/W 25 ohms—50 K 3/-. 50 K-2 Meg. (Carbon) 3/-.
JASON FM TUNER UNITS
Designer-approved kits of parts: FMT1, 5 gns. 4 valves, 20/-. FMT2, £7. 5 valves, 37/6. JTV MERCURY 10 gns. JTV2 £13.19.6. 4 valves, 32/6.

NEW JASON FM HANDBOOK, 2/6. 48 hr. Alignment Service 7/6. P. & P. 2/6.
Speakers P.M.—3 ohms 2 1/2" E.M.I. 17/6. Goodmans 3 1/2" 18/6. 5" Rola 17/6. 6" Elac 18/6. 7" x 4" Goodmans 18/6. 8" Rola 20/-. 10" R. x A. 25/-. 9" x 6" Goodmans 25/-. E.M.I. Tweeter 29/6.
Speaker Fret—Expanded bronze anodised metal 1/4" & 1/2" diamond mesh, 4/6 sq. ft., multiples of 6" cut. Max. width 4 ft.

TYGAN FRET (contemp. pat.) 12" x 12" 2/-. 12" x 18" 3/-. 12" x 24" 4/-. 18" x 18" 4/6
4-SPEED BARGAINS PLAYER UNITS
Single Players carr. 3/6
Garrard TA Mk. 2 £7.19.6
Gollaro "Junior" 75/-
B.S.R. Latest Model TU12 79/6
E.M.I. Junior "985" 89/6
Auto-Changers carr. 5/-
Garrard RC209 9 1/2 gns.
Garrard "Auto-Slim" £8.12.6
Collaro C60 £7.15.0
B.S.R. (UA14) De-Luxe Model £7.10.0

Speakers P.M.—3 ohms 2 1/2" E.M.I. 17/6. Goodmans 3 1/2" 18/6. 5" Rola 17/6. 6" Elac 18/6. 7" x 4" Goodmans 18/6. 8" Rola 20/-. 10" R. x A. 25/-. 9" x 6" Goodmans 25/-. E.M.I. Tweeter 29/6.
Speaker Fret—Expanded bronze anodised metal 1/4" & 1/2" diamond mesh, 4/6 sq. ft., multiples of 6" cut. Max. width 4 ft.

RECORD PLAYER CABINETS
Contemporary style, rexine covered cabinet in mottled red and white polka dot. Size 18 1/2" x 13 1/2" x ht. 8 1/2", fitted with all accessories including baffle board and anodised metal fret. Space available for all modern amplifiers and auto-changers, etc. Uncut record player mounting board 14" x 13" supplied.
Cabinet Price £3.3.0 Carr. and Ins. 5/-
2-VALVE 2 WATT AMPLIFIER
Twin stage ECL82 with vol. and neg. feedback tone control. A.C. 200/250V with knobs, etc., ready wired to fit above cabinet. £2.17.6. P. & P. 1/6. 6" Speaker and trans, 22/-, P.P. 2/-
Complete R/Player Kit as ill. inc. BSR UA14 Unit, £12.19.6. Carr. 7/6.

TRIMMERS, Ceramic (Compression Type)—30pF, 70pF, 9d.; 100pF, 150pF, 1/3; 250pF, 1/6; 600pF, 1/9.
PHILIPS, Bee Hive Type (conc. air spaced)—2.8pF, 1/-; 3.30pF, 1/-.
KNOBS—Modern Continental types: Brown or Ivory with Gold Ring, 1" dia., 9d. each; 1 1/8", 1/- each; Brown or Ivory with Gold Centre, 1" dia., 10d. each; 1 1/8", 1/3 each. LARGE SELECTION AVAILABLE.
METAL RECTIFIERS, STC TYPES—RM1, 4/9; RM2, 5/6; RM3, 7/6; RM4, 16/-; RM5, 21/-; RM4B, 17/6.
SIEMENS TYPES—Contact cooled, 250V, 50mA, 7/6; 250V, 85mA, 10/-; 250V, 125mA, 15/-; 250V, 300mA; 26/6.

Send for detailed bargain lists, 3d. stamp. We manufacture all types Radio Mains Transf. Chokes, Quality O/P Trans., etc. Enquiries invited for Specials, Prototypes for small production runs. Quotation by return.
RADIO COMPONENT SPECIALISTS
70 Brigstock Rd., Thornton Heath, Surrey
THO 2188 Hours: 9 a.m.—6 p.m., 1 p.m. Wed. Terms C.W.O. or C.O.D. Post and Packing up to 1/2 lb 9d., 1 lb., 1/3 3 lb., 2/3 5 lb., 2/9 8 lb. 3/6

T S
Est. 1946

ENAMELLED COPPER WIRE—1/16 lb reels, 14g-20g, 2/6; 22g-28g, 3/-; 30g-40g, 3/9. Other gauges quoted for.

PVC CONNECTING WIRE—10 colours (for chassis wiring, etc.)—Single or stranded conductor, per yd., 2d. Sleeving 2d. yd.

TRANSISTOR COMPONENTS

Midget I.F.'s—465 Kc/s. 1/16" diam. 5/6
Osc. Coil—1/16" diam. M/W. 5/3
Osc. coil M. & L.W. 5/9
Midget Driver Trans. 3.5:1 6/9
Ditto O/Put Push-pull 3 ohms 6/9
Elect. Condensers—Midget Type 12V 1mfd-50mfd, ea. 1/9. 100mfd, 2/-, .25 mfd., 1/3. 5 mfd., 1/6, etc.
Tuning Condensers. J.B. "00" 208+176pF, 8/6. Ditto with trimmers, 9/6. 365pF single, 7/6. Sub-min. 3" DILEMIN 100pF, 300pF, 500pF, 7/-, .25 mfd., 1/3. 5 mfd., 1/6, etc.
Midget Vol. Control with edge control knob, 5kΩ with switch, 4/9, ditto less switch, 3/9.
Speakers P.M.—2" Plessey 75 ohms, 15/6. 2 1/2" Continental 8 ohms, 13/6. 7" x 4" Plessey 35 ohm, 23/6.
Ear Plug Phones—Min. Continental type, 3ft. lead, jack plug and socket, High Imp. 8/-. Low Imp., 7/6.

TRANSISTOR BARGAINS

Brand New—BVA 1st Grade		
OC44	10/6	OC70 5/6
OC45	9/6	OC71 6/-
OC81	7/6	GEX34 2/9
2/OC81	15/6	OA70 2/9
GET114	6/6	OA81 2/9
		OC72 7/6

SPECIAL OFFER
OC44 } 21/6
2/OC45 }
OC81D } 19/6
2/OC81 }

RECORD PLAYER CABINETS
Contemporary style, rexine covered cabinet in mottled red and white polka dot. Size 18 1/2" x 13 1/2" x ht. 8 1/2", fitted with all accessories including baffle board and anodised metal fret. Space available for all modern amplifiers and auto-changers, etc. Uncut record player mounting board 14" x 13" supplied.
Cabinet Price £3.3.0 Carr. and Ins. 5/-
2-VALVE 2 WATT AMPLIFIER
Twin stage ECL82 with vol. and neg. feedback tone control. A.C. 200/250V with knobs, etc., ready wired to fit above cabinet. £2.17.6. P. & P. 1/6. 6" Speaker and trans, 22/-, P.P. 2/-
Complete R/Player Kit as ill. inc. BSR UA14 Unit, £12.19.6. Carr. 7/6.



AMAZING RESULTS

FROM THE "OLIVER" 5 STAGE TRANSISTOR RECEIVER



A highly sensitive receiver using top grade transistors and components. Fully tunable over medium and long waves.

- Can be built in 1 hour
- High flux moving coil speaker
- Built-in ferrite rod aerial
- Specially designed coils for maximum signal strength
- Volume on/off control
- Eyeletted circuit board
- Easy to-follow building plans

Send S.A.E. for
FREE Layout plans and parts lists

Total Building Costs
ONLY

65/- Plus P. & P. 2/6

EXPLORE THE WORLD ON THIS 1-VALVE SHORT WAVE RADIO



Total Building Costs only
35/-
P. & P. 2/-

- ★ Receives speech and music from all over the world.
 - ★ Construction price includes valve and one coil covering 40-100 metres.
 - ★ Can be extended to cover 10-100 metres.
 - ★ Can be converted to 2 or 3 valve.
- Send 2/- for wiring diagram and components price list.

R.C.S. PRODUCTS (Radio) LTD
11 Oliver Road · London · E17 (Mail Order Only)

New dial assembly FOR "Mercury Six" PLASTIC CASE and other Transistor Receivers

with instructions **14/6** (Postage 1/6)

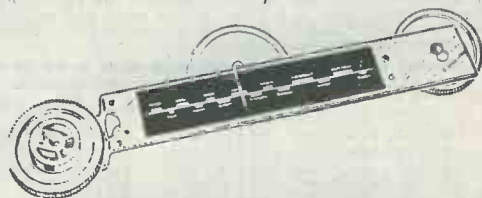

OSMOR RADIO

418 BRIGHTON ROAD S. CROYDON

PLEASE SEND A-Z FREE INFORMATION
ON "MERCURY SIX" & OTHER SETS

NAME

ADDRESS



SCOTTISH INSURANCE CORPORATION LIMITED

38 EASTCHEAP · LONDON · EC3

TELEVISION SETS, RECEIVERS AND TRANSMITTERS

Television Sets, Receivers and Short Wave Transmitters are expensive to acquire and you no doubt highly prize your installation. Apart from the value of your Set, you might be held responsible should injury be caused by a fault in the Set, or injury or damage by your Aerial collapsing.

A "Scottish" special policy for Television Sets, Receivers and Short Wave Transmitters provides the following cover:

- (a) Loss or damage to installation (including in the case of Television Sets the Cathode Ray Tube) by Fire, Explosion, Lightning, Theft or Accidental External Means at any private dwelling-house.
- (b) (i) Legal Liability for bodily injury to Third Parties or damage to their property arising out of the breakage or collapse of the Aerial Fittings or Mast, or through any defect in the Set. Indemnity £10,000 any one accident.
- (ii) Damage to your property or that of your landlord arising out of the breakage or collapse of the Aerial Fittings or Mast, but not exceeding £500.

The cost of Cover (a) is 5/- a year for Sets worth £50 or less, and for Sets valued at more than £50 the cost is in proportion. Cover (b) and (ii) costs only 2/6 a year if taken with Cover (a) or 5/- if taken alone.

Why not BE PRUDENT AND INSURE your installation—it is well worth while AT THE VERY LOW COST INVOLVED. If you will complete and return this form to the Corporation's Office at the above address, a proposal will be submitted for completion.

NAME (Block Letters)

If Lady, state Mrs. or Miss

ADDRESS (Block Letters)

J/B

SMALL ADVERTISEMENTS

Private: 3d. per word, including address.
Minimum charge 2/6.

Use of Box Number, 2/- extra.

Trade: 9d. per word. Minimum charge 12/-.
Terms: Cash with order.

All copy must be received by the 6th of the month for insertion in the following month's issue. The Publishers cannot be held liable in any way for printing errors or omissions, nor can they accept responsibility for the *bona fides* of advertisers.

PRIVATE

WANTED. C.R.T. ICPI, ICP31, D113-9F, etc. State condition.—Robertson, 9 Meadway, Knebworth, Herts.

FOR SALE. Heathkit Daystrom scope. 0-12U. Perfect condition. £25. Buyer collects.—K. E. Griffiths, 127 Utting Avenue East, Liverpool 11.

WANTED. Newnes *Radio and Television Servicing 1960-1961* edition.—45 Chanel Road, Coolock, Dublin.

FOR SALE. Complete Ham station. R1155, F/meter, Type D transmitter, power packs, keys, all accessories. Going cheap. Offers?—Tenford, Beeches Close, Kingswinford, Staffs.

TRADE

LEARN RADIO AND ELECTRONICS the NEW Practical way. Very latest system of experimenting with and building radio apparatus—"as you learn".—FREE Brochure from: Dept. RC10 Radiostructor, Reading, Berks.

PANL, recognised for many years as the unique one-coat black crackle finish. Brush applied, no baking. Available by post in eighth-pint cans at 3s. 9d. from G. A. Miller, 255 Nether Street, London, N.3.

THE INCORPORATED PRACTITIONERS IN RADIO AND ELECTRONICS (I.P.R.E.) LTD. Membership conditions booklet 1s. Sample copy of I.P.R.E. Official Journal 2s. post free.—Secretary, 20 Fairfield Road, London, N.8.

SERVICE SHEETS (1930-1962) from 1s. Catalogue 6,000 models, 1s. 6d. S.A.E. enquiries.—Hamilton Radio, 13 Western Road, St. Leonards, Sussex.

"MEDIUM WAVE NEWS." Monthly during DX season.—Details from B. J. C. Brown, 196 Abbey Street, Derby.

METALWORK. All types cabinets, chassis, racks, etc., to your specifications.—Philpott's Metalworks Ltd., Chapman Street, Loughborough.

RADIO AMATEUR COURSE. A postal course for those wishing to take the Amateur Examination. A sound basic training in radio communication. Very reasonable terms. Send for brochure.—Premier School of Radio, 3 Kerry Crescent, Calne, Wiltshire.

"AMPLIFIERS AND FEEDERS." Covers the construction of direct-coupled amplifiers and an assortment of radio feeders. Price 3s. 6d.—High Fidelity Co., 18 Melville Road, Birmingham 6.

PRIVATE TUITION given in G.C.E. ordinary level mathematics (London area). Terms reasonable.—Box No. F154.

THE IDEAL transmitting and receiving aerial. VQ9A and four JAS were worked recently by G3NFV on 15 with an INDOOR "JOYSTICK" antenna 7ft 6in long (G3NFV operates from a bungalow), GB3WRC exchanged 5 and 8/9 reports with GM2CPC on 40M phone using a "JOYSTICK" aerial at GROUND LEVEL (Broadstairs). On 80M G3CED gets as good as he gives with an INDOOR "JOYSTICK" and a DX40 transmitter. Detailed performance figures on request. The "JOYSTICK" is robust, weather-proofed and beautifully finished. De Luxe version £4 10s. 0d. Standard version £3 10s. 0d. Carriage paid U.K.—Partridge Electronics, 17 Ethel Road, Broadstairs, Kent. Telephone Thanet 62839.

FIND TV SET TROUBLES IN MINUTES from that great book *The Principles of TV Receiver Servicing*, 10s. 6d., all book houses and radio wholesalers. If not in stock, from Secretary, I.P.R.E., 20 Fairfield Road, London, N.8.

continued on page 71

SITUATIONS VACANT

MINISTRY OF AVIATION

E. I. D.

ELECTRONIC INSPECTORS

required for

Radio, Radar, Components and Electrical Ancillaries in laboratories at Bromley and Woolwich, and for inspection at firm's works in various parts of London and Southern England on a resident or a visiting basis. Varied and interesting work with opportunities for gaining valuable experience and further training. Excellent prospects of promotion to grades with pay ranging up to £1,400 a year.

PAY for FULLY SKILLED men:

£13.6s.0d.—£14.1s.0d. per week or:

£14.6s.0d.—£15.6s.0d. per week.

Rate varies according to ability and class of work available.

For men not fully skilled, but with several years' experience in electronic work, there are vacancies at BROMLEY and WOOLWICH, with the following scales of pay:

£12.11s.2d.—£12.19s.2d. per week

£13. 0s.2d.—£13. 6s.2d. per week

(with prospects of further progression)

All rates quoted are for the London area and for a 5-day week; in the provinces rates are slightly less.

Post coupon (or telephone IMPERIAL 2600 Extension 19) for further information.

To: **The Personnel Officer, Inspection Division, Aquila, Golf Road, Bromley, Kent.** (RC)

Please send me further details of skilled posts in

..... (Type of work desired)

at (area)

Name

Address

SMITH'S of Edgware Road BLANK CHASSIS

Precision made in our own works from commercial quality half-hard Aluminium. Two, three or four sided.

SAME DAY SERVICE

of over 20 different forms made up to YOUR SIZE. Order EXACT size you require to nearest $\frac{1}{16}$ " (maximum length 35", depth 4").

SPECIALS DEALT WITH PROMPTLY

SEND FOR ILLUSTRATED LEAFLET

Or order straight away, working out total area of material required and referring to table below, which is for four-sided chassis in 18 s.w.g. (for 16 s.w.g. add 2 th)

48 sq. in.	4/-	176 sq. in.	8/-	304 sq. in.	12/-
80 sq. in.	5/-	208 sq. in.	9/-	336 sq. in.	13/-
112 sq. in.	6/-	240 sq. in.	10/-	368 sq. in.	14/-
144 sq. in.	7/-	272 sq. in.	11/-	and pro rata	
P. & P. 2/6		P. & P. 2/9		P. & P. 3/-	

Discount for quantities. Trade enquiries invited. Spray finish arranged for quantities of 25 or over.

FLANGES ($\frac{1}{4}$ ", $\frac{3}{8}$ " or $\frac{1}{2}$ ") 6d. per bend.

STRENGTHENED CORNERS, 6d. each corner. PANELS. The same material can be supplied for panels, screens, etc. Any size up to 3ft at 4/6 sq. ft. (16 s.w.g. 5/3). P. & P., up to 72 sq. in. 1/3, 108 sq. in. 2/-, 144 sq. in. 2/6 432 sq. in. 2/9, 576 sq. in. 3/3.

H. L. SMITH & CO. LTD

287/289 EDGWARE ROAD LONDON W2
Telephone PAD 5891/7595

★ VALVES New Tested & Guaranteed

1R5 6/6	6X4 7/6	DK96 8/-	EZ40 6/6
1S5 6/6	12A77 6/-	DL92 6/9	EZ80 6/6
1T4 4/6	12A77 6/-	DL94 7/6	EZ81 7/-
3S4 6/9	12AX7 7/6	DL96 8/-	GZ32 10/6
3V4 7/6	12BH7 10/6	EB91 4/6	KT66 15/-
5U4G 6/-	12K7GT 8/6	EBC41 9/6	PL81 12/6
5Y3GT 7/6	12K8GT 13/6	ECC81 6/-	PL82 10/6
5Z4G 9/-	12Q7GT 6/6	ECC82 6/-	PY81 8/-
6AK6 6/6	25A6G 10/6	ECC83 7/6	PY82 7/-
6AL5 4/6	25L6GT 9/-	ECC84 7/6	PCC84 9/6
6AM6 4/-	35Z4GT 8/6	ECC85 8/6	PCF80 9/-
6AT6 7/6	35L6GT 9/6	ECC87 7/6	PCF82 11/-
6BA6 8/6	57G3 10/6	ECH81 10/6	PCL82 7/6
6BE6 7/6	DAF91 6/6	ECH42 8/6	PCL83 12/6
6BR7 10/6	DAF96 8/-	ECL80 9/6	PCL84 8/6
6BW6 8/6	DCC90 11/6	EF41 8/6	U76 8/6
6J7GT 8/6	DF91 4/6	EF80 8/-	UBC41 10/-
6K7G 7/6	DF96 8/-	EF86 9/6	UCH42 10/6
6K8GT 8/6	DH76 8/6	EF91 4/-	UF41 10/-
6Q7G 7/6	DH77 7/6	EL41 9/-	UL41 8/-
6SL7GT 8/-	DK91 6/6	EL84 7/6	UY41 8/-
6V6G 7/6	DK92 7/6	EY51 7/6	W76 8/6

MATCHED PAIRS. EL84, 17/-; EL85, 25/-; 6V6G, 17/-; 6BW6, 18/-; KT33C, 19/6; 80Z 14/6 pair; KT66, 32/6.

SETS OF VALVES

DK96, DF96, DAF96, DL96 "REGENT"	29/6 per set
DK91, DF91, DAF91, DL92, or DL94	21/- per set
1R5, 1T4, 1S5, 3S4, or 3V4	21/- per set
6K8, 6K7, 6Q7, 6V6, 5Z4, "G" Types	27/6 per set
12K8, 12K7, 12Q7, 35L6, 35Z4, "GT" Types	35/- per set
ECH42, EF41, EBC41, EL41, EZ40	37/6 per set
UCH42, UF41, UBC41, UL41, UY41	35/- per set

P.P. OP. TRANSFORMERS. MR 3-15 ohms for EL84, 6V6, 6BW6, etc., 18/6; Op. Pen. 50mA, 5/6; 30mA, 4/6.

P. & P. 6d., over £1 post paid. C.O.D. 3/-

R. COOPER G8BX 32 SOUTH END
CROYDON SURREY CROYDON 9186

FREE!

EARN



There's plenty of room at the top for technically trained men—room for YOU if you want quick promotion or a better-paid, more interesting career. N.I.E. can quickly give you a guaranteed spare-time Postal Training, in the comfort of your own home, and open up a whole new world of opportunity for you.

MORE

Mech. Eng. Draughtsmanship
Struct. Eng. Aero & Auto Eng.
A.M.I.Mech.E. A.M.Brit.I.R.E.
A.M.I.M.E. L.I.O.B.
A.M.I.Mun.E.

Elect. Eng. Civil Eng.
Handicrafts Radio & TV
A.M.I.C.E. A.M.I.P.E.
A.F.R.Ae.S. A.M.I.Struct. E.
M.R.S.H., etc.

Find out, as thousands of others have done, how easy it is to learn at home with N.I.E. Send for *Success in Engineering*—136 pages of information you can use—and details of pay-winning Courses in all branches of Engineering, Building, Local Government, etc. Get your copy today—FREE!

SOON

N.I.E. Guarantees—
"Success—or no Fee"

POST COUPON NOW!

Please send me a FREE copy of "Success in Engineering".



NAME

ADDRESS

Subject or exam of interest

NATIONAL INSTITUTE OF ENGINEERING
(Dept. 445) 148-150 Holborn London EC1

THE GATEWAY TO BETTER LIVING

TV FAULT FINDING DATA BOOK SERIES NO. 5

Contains information and fault finding details of both the B.B.C. and I.T.A. transmissions. Lavishly illustrated by photographs taken from the screen of a television set exhibiting the faults under discussion. A comprehensive fault finding guide is included, and this is cross referenced to the book itself.

Over 100 Illustrations and Diagrams

104 pages, high quality paper with laminated plastic board cover

Price 5/- Postage 5d.

"... A book that should be in every television dealer's service workshop and in every home-constructor's, for that matter."—*Journal of the Television Society.*

"... The book will undoubtedly be of value to TV service engineers, particularly those who are not fully experienced in translating the appearance of faulty pictures into the necessary adjustments or receiver fault location."—*Wireless and Electrical Trader.*

Available from your usual supplier, or direct from

DATA PUBLICATIONS LTD
57 Maida VALE London W9

SMALL ADVERTISEMENTS

continued from page 69

TRADE—continued

VALVES. 9d.: 6AL5, 6AM6, 6D2, 6F12, 6F13, 6F14, 6F15, 8D23, 9D2, 15D2, 78, C2C, D1, D77, D152, DD6, EB91, EF50, EF91, P61, SP61, UB41, UF42, VR35, VR51, VR107, VR137, VR201, Z77. More at 1/9, 2/9 and 5/9. Post: 1—9d., 6—1/6. Stamp for FREE list.—P.P. Components Ltd., 623 Romford Road, Manor Park, London, E.12.

JOIN THE INTERNATIONAL S.W. LEAGUE. Free Services to members including Q.S.L. Bureau, Amateur and Broadcast Translation, Technical and Identification Dept.—both Broadcast and Fixed Stations, DX Certificates, contests and activities for the SWL and transmitting members. Monthly magazine, "MONITOR", containing articles of general interest to Broadcast and Amateur SWLs, Transmitter Section and League affairs, etc. League supplies such as badges, headed notepaper and envelopes. QSL cards, etc., are available at reasonable cost. Send for League particulars. Membership including monthly magazine, etc., 21s. per annum.—Secretary ISWL, 12 Gladwell Road, London, N.8.

THE INTERNATIONAL HAM HOP CLUB is a non-profit making organisation open to RADIO AMATEURS AND SHORT WAVE LISTENERS. OBJECT: To improve international relationships through an organised system of hospitality. MEMBERS offer overnight hospitality to visiting members, subscription 10s. per annum. ASSOCIATE MEMBERS invite radio amateurs to visit their stations. Associate membership 5s. per annum. FAMILY EXCHANGE holidays arranged, also FRIENDSHIP LINKS between radio clubs. The Club's official journal is free to both Full and Associate members.—Hon. Gen. Secretary: G. A. Partridge, G3CED, 17 Ethel Road, Broadstairs, Kent.

COMPREHENSIVE SERVICE SHEETS with free advice 3s. 6d. each. Mail order only.—Adams, 79 Birmingham Street, Halesowen, Wores.

ELECTRONIC ORGAN. A 6d. air-letter to us gets you full information about obtaining very detailed constructional data.—The Electronic Organ Company (Australia), 11 Cadow Street, Pymble, N.S.W., Australia. We will reply by air.

SITUATION VACANT

ELECTRONICS ENGINEER REQUIRED: Small, rapidly expanding company specialising in the manufacture of miniature coils and transformers requires an Electronics Engineer to work and co-operate with Production Manager. Well paid and progressive position which would appeal to a resourceful man of varied experience. Please reply in strict confidence.—Box No. F156.

G2ACC offers you . . .

CATALOGUE NO. 12

9d. post free, refunded on first order.

56 pages, over 2,000 guaranteed items by the leading manufacturers with data.

SOUTHERN RADIO AND ELECTRICAL SUPPLIES

SORAD WORKS REDLYNCH SALISBURY WILTS Telephone Downton 207

What about that 12 w.m.p.

Morse Code Test ?

You can only reach the goal by keen listening and constant practice with a Morse Key. The amount of "hard labour" involved depends on the method of training.

The CANDLER System

will help you as it has helped thousands of others over many years, and give you a sound basis. It turns a difficult task into a pleasurable pursuit.

Send 3d. stamp for details of our Special Course for Amateur Transmitting Licence

The CANDLER System Co.

Dept. RC, 52b ABINGDON ROAD, LONDON, W8

Candler System Co., Denver, Colorado, U.S.A.

SITUATIONS VACANT

Meteorological Office

Vacancies exist for men of good educational standard in posts as Radio (Meteorological) Technicians.

Qualifications. Apprenticeship or equivalent experience in one of the following: Radar, Telemetry, general electronic circuitry or facsimile equipment. Training will be given in specific equipment but candidates will be expected to be conversant with the basic technique.

Salary. £810 at age 25 rising by annual increments to £930. Deductions are made for each year under 25.

Conditions. Candidates must be British Subjects, and must accept the liability of transfer to any station in the U.K. and, if physically fit, overseas. Removal expenses for subsequent moves after the initial post will be refunded.

Shift duties, including night duties, are worked at some stations and additional allowances are paid for this.

Successful candidates will be eligible for established posts after a period of service.

Application forms may be obtained from

The Secretary Meteorological Office
M.O.10b London Road
Bracknell Berks



TRAINEE ELECTRO-MECHANICAL ENGINEERS

The opportunity occurs for bright young men (age 18-22), looking to the future, to build their careers in the computer field.

DO YOU have a real interest in repairing light electro-mechanical equipment and have you, through your hobbies, work or studies, acquired a basic working knowledge of electrical engineering? Are you keen to learn more and willing to work in order to advance?

If so IBM offers you practical training (on overhaul of punched card machines initially) and theoretical instruction in the engineering school, together with assistance with your college studies. After 18-24 months, according to ability, you can progress via the overhaul of more complex machines to a responsible appointment in the Workshop or to the highly responsible position of field Data Processing Customer Engineer. The starting salary is not less than £520 p.a. with free Life Insurance and Pension plans.

Write now to the
Manager of Personnel Selection
IBM United Kingdom Limited
101 Wigmore Street London W.1
or telephone or call on
Mr. W. E. Cross (BY:Ron 7286)
Stanley Road, South Harrow, Middlesex
Quoting reference CE/RC/19.

NEW  **MARKED** 
MONEY BACK GUARANTEE. **AND TESTED SUCH AS**
XA101, XA102, XB103, XC101, ETC.
20/- PER PACKET OF 10.

TRANSISTORS

UNMARKED BUT TESTED MOST RADIO 
TYPES 20/- PER PACKET OF 16.

UNMARKED UNTESTED 20/- PKT OF 40. **POST**
DUDS MAY BE SUITABLE AS DIODES 20/- PKT OF 80. **FREE**

ANY 2 PACKETS 37/6 **CASH WITH ORDER** **QUANTITY**
K.R. WHISTON (DEPT RC T). NEW MILLS, STOCKPORT. **DISCOUNT**

The thrills of VHF can now be yours for only 39/6d, complete kit! Tunable 150-100 Mc/s. simplified construction, write today for leaflet. Also, if a newcomer to Amateur Radio, ask for free copy of the world famous "Globe-King" kits and receivers, stamp please to cover postage:
Johnsons (Radio) St. Martin's Gate Worcester

H.A.C. THE ORIGINAL SUPPLIERS OF SHORT-WAVE KITS
 One valve Super Sensitive All-dry Short-wave Receiver, Model "K". Complete kit including valve and chassis, 77/-. (Other S.W. kits from 25/-) Before ordering call and inspect a demonstration receiver, or send stamped envelope for full specification, catalogue and order form.
H.A.C. SHORT-WAVE PRODUCTS (DEPT. R)
44 OLD BOND STREET LONDON W1

LEARN
RADIO & TV SERVICING
 For your own business / hobby
 by a new exciting no maths system, using practical equipment recently introduced to this country
FREE BROCHURE FROM
RADIOSTRUCTOR
DEPT. G103 · READING · BERKS.
 8.62

SURPLUS RADIO SUPPLIES
2 LAING'S CORNER MITCHAM SURREY
SEND 2/6 FOR OUR CATALOGUE OF 400 BARGAINS
 (2/- REFUNDED ON FIRST ORDER OVER 10/-)
 Send S.A.E. FOR OUR LIST OF METERS

BRASS · COPPER · DURAL · ALUMINIUM · BRONZE
 ROD, BAR, SHEET, TUBE, STRIP, WIRE.
 3,000 STANDARD STOCK SIZES.
 No Quantity too small List on application
H. ROLLET & CO LTD
6 CHESHAM PLACE SW1 BELGRAVIA 4300
 Also at Liverpool, Birmingham, Manchester, Leeds

Quality Components FOR CONSTRUCTORS
 capacitors, resistors, coils, valves, diodes, controls, chassis, transformers, speakers, pick-ups, cartridges, stylis, and all types of components in stock.
PRICE LISTS AVAILABLE ON REQUEST
J. T. FILMER **82 DARTFORD ROAD DARTFORD KENT Telephone Dartford 24057**

"LITON" Photoelectric Construction Manual
 2nd edition coming out shortly
 10 interesting **PHOTOELECTRIC PROJECTS** fully described with building plans and circuit diagrams which can be easily made by amateurs from standard components. Hints on the use of photo-cells and phototransistors. A mine of practical information for the experimenter. All units available built and tested, or in kit form.
 1. Battery burglar alarm 7. Long range infra-red mains alarm kit, 65/-
 2. Mains burglar alarm 8. "MIRA" miniature infra-red battery alarm. Total consumption 0.2 watt.
 3. Light saver
 4. Customer announcer
 5. Simple garage door opener 9. Motorised garage door opener
 6. Photoelectric counter. Price (2 to 6) Kit £4.12.6. 10. Door opener with electronic lock. Built £5.10.0.
 If you are interested in electronics or electro-mechanical gadgets send 1/- stamp for this 24-page profusely illustrated publication to:
"ST. JOHN'S RADIO" 3 Jews Row London SW18

The SAVOY SUPER-3
3-TRANSISTOR **POCKET RADIO**
 with miniature loudspeaker
NO SOLDERING NO DRILLING
 47/- 3 transistors and 2 diodes. Full medium wave coverage.
 Battery 1/- Size 4½" x 2½" x 1½". Full P.P. 2/- ex. instructions provided.
All parts sold separately
 with 4 transistors and 2 diodes, in a 5 stage reflex circuit. Size 5½" x 3" x 1½" **75/-** Battery 2/3 P.P. 2/9 ex.
or - SAVOY-4
SAVOY ELECTRONICS LTD **15 Maiden Lane Strand London WC2 (Back of Adelphi Theatre)**



ALL-TRANSISTOR TIME SAVER OFFICE OR HOME TELEPHONE PICK-UP AMPLIFIER

★ No more "holding on" wasting time waiting for your call to come through. When it does the amplifier can be switched off if required. No connections, just press the pick-up coil to back of phone as below. Fully Guaranteed. Housed in attractive Gold Finish Cabinet.

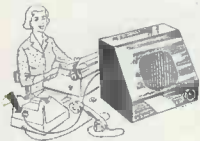

BUILT, TESTED, READY TO USE

£5. 10. 0
P.P. 2/6.

TRANSISTOR BABY-ALARM
Very sensitive, **£5.10.0** P.P. 2/6.



MODEL TH-L33

2,000 ohms per volt AC/DC.
Size
5" x 3½" x 1½".

79/6 Fully Guaranteed

with test leads, battery and instructions.

0/10/50/250/500/100 volts D.C.,
0/10/50/250/500/1000 volts A.C.,
0/500µA/10/250mA., D.C.

3 ranges resistance 0/10K/100K/1 Meg.
Capacity and dB ranges. Large scale.

MODEL 500

500

30,000 ohms per volt multimeter

£8. 19. 6



8 Ranges D.C. volts to 1 kV.
7 Ranges A.C. volts to 1 kV.
5 Ranges D.C. current to 12 amps.
3 Range resistance to 60 meg.
Short circuit, Buzz test. Output meter, dB, etc., etc. Size 6¼" x 4¼" x 2¼". With Leads, Batteries and Instructions.

MODEL TP55

A.C./D.C. voltage up to 1,000 in 5 ranges. D.C. current 4 ranges up to 500mA. 4 range resistance to 10 megs. Capacity dB scales, etc.

20,000 ohms/volt. Fully Guaranteed **£5. 19. 6**

With Test Leads, Battery and Instructions. Size 5½" x 3½" x 1½".



ALL METERS FULLY GUARANTEED FOR 6 MONTHS

WE CAN SUPPLY MOST OF THE COMPONENTS USED ON CIRCUITS PUBLISHED IN THIS AND OTHER MAGAZINES QUOTATIONS BY RETURN NEW ILLUSTRATED CATALOGUE 1/-

- 4-Transistor Two-way Intercomm. 2-way buzzing, 2 speakers, ready to use, 8 gns. P.P. 2/6.
- Miniature 15 watt Solder Iron, ⅜" bit. Ideal for all printed circuit work, 29/6. P.P. 1/6.
- New Model Control Book with 60 pages of transistor circuits, 7/6. P.P. 6d.
- Complete Set of Meter Leads with Prods, Clips, etc., with pouch, 8/6. P.P. 1/-.
- Telephone Recording Coil to record conversations. For all amplifiers and recorders, 14/- P.P. 9d.
- Printed Circuit Kit, to etch your own circuits. Complete with boards and details, 19/6. P.P. 1/-.
- Miniature 850 ohm Record/Playback Tape Head, with mounting block, 12/6. P.P. 9d.
- 4,000 ohm lightweight Headphones with leads. Very sensitive, 12/6. P.P. 1/-.
- Transistor Pocket RF, IF Generator for Radio, TV, etc. Fault finding, 52/6. P.P. 1/-.
- 8-Range All Transistor Signal Generator, 200 kc/s to 220 Mc/s: RF, AF, IF, HF, etc., £7.10.0. P.P. 3/6.
- GS12C (Dekatron) Bi-directional 12-way indicator tube. Brand new, 25/-.
- Caby M1 Pocket Multimeter, 2,000 ohms per volt. With leads and instructions, 54/- P.P. 1/6.
- 4½-9 volt Tape Recorder Motor, 12/6. P.P. 1/-.
- 30 watt Pocket Solder Iron, with pocket pouch and mains plug, 18/6. P.P. 1/-.
- 931A Photo Multiplier. Brand new, 60/-.
- 1 kc/s Transistor Audio Test osc., variable output, 39/6. P.P. 1/6.
- Crystal Contact Microphone. Very sensitive. Ideal for Guitar, 12/6. P.P. 9d.
- 4-Transistor Telephone Amplifier. Amplifies without connection to phone. Ideal for office, works or home, £5.10.0. P.P. 2/6.
- Practical Transistor Circuits. 40 circuits to build, 3/6.
- Personal Earphones with leads, Jack plug and socket, 600 ohm, 10/6; 1,000 ohm, 12/6; Crystal 9/6. (1/6 cheaper less socket.)
- W/W Erase Head, FE7, 7/6. P.P. 6d.
- Dynamic Microphone, 49/6. P.P. 1/6.
- Transistor Signal Injector. A new design pocket size tester for fault finding on valve or transistor radios, TV, amplifiers, etc. Built-in indicator and batteries with detachable probe, 52/6. P.P. 1/6.
- Extension Speaker Unit. Plugs into phone socket of most portables. Gives big set volume. Ideal for car use, 57/6. P.P. 1/6.
- New 2-way Intercomm. for office, home or works. 2-way calling, etc. Moulded Cabinets, 89/6. P.P. 1/6.

Miniature Panel Meters

0/50µA (D.C.) 39/6 0/5mA (D.C.) 27/6
0/500µA (D.C.) 32/6 0/300V (D.C.) 27/6
0/1mA (D.C.) 27/6
Brand New Boxed

26. 7-Section Telescopic Aerial, 12/6. P.P. 1/-.
27. LA1 Ferrite Pot Core, 12/6. P.P. 6d.
28. New 4-station Transistor Intercomm. Calling, Talking, etc. Complete, 13gns. P.P. 3/6.
29. No. 19 Set Crystal Calibrator with Handbook, 79/6. P.P. 2/-.
30. ACOS 43-2 High Output 2½" Xtalmic Insert, 10/6. P.P. 6d.
31. Stereo stethoscope type min. phones. Ideal for all equipment. 27/6 P.P. 1/6.

4 TRANSISTOR PUSH-PULL AUDIO MODEL PK-543 AMPLIFIER

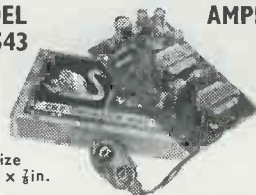

Size
3 x 1½ x ¾ in.

A ready-built, miniature 250mW push-pull amplifier incorporating input and output transformers, 4 transistors, 9 volt battery snap cord, speaker and volume connection leads. Ideal for use with record players, intercoms, hearing aids, tape recorders, etc. Complete with full instructions and circuit diagram.

PRICE **52/6** P.P. 1/6.
SUITABLE 2½" SPEAKER, 16/6.

TRANSISTORS 1st GRADE

AF117 9/6	OC83 6/-	OC139 13/6
AFZ12 35/-	OC84 8/6	OC140 29/-
AC107 14/6	OC75 7/-	OC200 10/6
OC71 5/6	OC35 18/-	OC201 31/-
OC72 7/-	OC44 9/3	OC22 23/-
OC76 7/-	OC45 8/6	OC71 29/-
OC81 7/-	OC170 9/6	OC41 9/-
OC78 7/-	OC171 10/6	OC42 9/6
AF102 27/6	AF115 10/6	ORP12 15/6

Send for New List of Fully Guaranteed Transistors, Diodes, Zener Diodes, Silicon Rectifiers, etc. All 100% 1st Grade. We stock a semi-conductor device for every need.

SPECIAL REDUCTIONS FOR SETS

2 WATT POWER STAGE

A new ready built amplifier for boosting the output of your portable or pocket radio when used in a car. Runs from 12 volt car battery. 69/6, P.P. 2/-.

CRYSTAL MICROPHONES

- ACOS 39-1. Stick Microphone with screened cable and stand (list 5 gns.), 32/6. P.P. 1/6.
- ACOS 40. Desk Microphone with screened cable and built-in stand (list 50/-), 15/- P.P. 1/6.
- ACOS 45. Hand Microphone with screened lead, very sensitive, 25/- P.P. 1/6.
- 100 C. Stick Microphone with muting switch and screened cable, detachable desk stand, cord and neck, 39/6. P.P. 1/6.
- MC 24. Stick Microphone with muting switch and cable, 25/- P.P. 1/6.
- LAPEL. Miniature Mic. With clip. Ideal for recording, 15/- P.P. 1/-.

BATTERY ELIMINATOR AND CHARGER

Replaces PP3 or T6003 9 volt batteries to run transistor radios from mains. Also charges to give 5 times normal battery life. Fitted neon indicator and supplied with full details, 29/6. P.P. 1/6. 'Petit' type 18/6, P.P. 1/6.

BATTERY RECORD PLAYER



★ 6-7½ volt Garrard turntable with crystal pick-up. Plays 45 r.p.m. Ideal for above amplifier.

65/- P.P. 1/6.

★ **PORTABLE RECORD PLAYER CABINET** for above player and amp., 22/6 for 7" x 4" speaker. P.P. 1/6.

Henry's Radio Ltd

PAOdington 1008/9
5 HARROW ROAD LONDON W2
Open Mon. to Sat. 9-6, Thurs. 1 o'clock
Send 1/- stamp for Illustrated Price List
★ Turn Page ★

Partridge

Redesigned 'Contessa' Mk. III

★ combined portable and car radio ★

- NOW WITH 600mW MELLOWTONE OUTPUT ON MEDIUM AND LONG WAVES
- NOW FITTED HORIZONTAL TUNING SCALE WITH ALL STATIONS CLEARLY MARKED
- NOW SUPPLIED WITH SIX MULLARD TRANSISTORS AND TWO DIODES
- NOW FITTED RECORDING SOCKET AND CAR AERIAL SOCKET
- NOW SUPPLIED WITH TWO-TONE BEIGE OR TWO-TONE BLUE CABINET WITH GOLD FITTINGS

GUARANTEED THE VERY BEST OBTAINABLE

- All parts sold separately ●

The New "CONTESSA" 6-Transistor Portable Superhet Radio. Features simple printed circuit construction and fully illustrated building instructions, with all parts clearly marked and identified. Fitted with 8" Ferrite aerial. Double IFTs and the latest in components and design. Full tuning of both Medium and Long Wave bands with unbeatable selectivity and sensitivity. Clearly marked station dial and room-filling "MELLOWTONE" push-pull output are standard features.

★ ALL THESE EXTRA FEATURES AT NO EXTRA COST ★

TOTAL COST
£10.19.6 P.P. 3/6

OVERALL SIZE
10 $\frac{1}{2}$ " x 7 $\frac{3}{8}$ " x 3 $\frac{3}{8}$ "

- Detailed Leaflet on Request ●

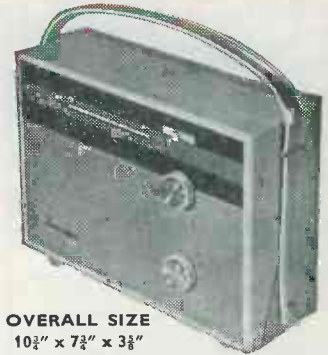

— THE IDEAL PORTABLE WHEREVER YOU MAY BE —

"TRANSFIVE" PORTABLE RADIO



Medium and Long Wave Portable

8 $\frac{1}{2}$ " x 6 $\frac{1}{2}$ " x 3 $\frac{1}{2}$ in.

£6.19.6
P.P. 2/6

A simple to build 5-Transistor and Diode, Printed Circuit, Medium and Long Wave Portable. Features 5" speaker, Car aerial socket, Mullard transistors and carded components. Building plans free on request. THE IDEAL PORTABLE.

Full after-sales service and guarantee.

"QUINTET" MEDIUM AND LONG WAVE POCKET RADIO

PUSH-PULL SPEAKER OUTPUT

Size

5 $\frac{1}{2}$ " x 3" x 1 $\frac{3}{8}$ "

Red or Blue with Gold trim

Total Cost
£5.10.0 P.P. 2/-

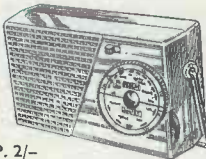

A 5-Transistor and Diode medium and Long Wave Printed Circuit loudspeaker Radio. Features Mullard transistors and plainly marked printed circuit with carded components. Excellent results with full station separation guaranteed. Including Radio Luxembourg. Push-pull output up to 200mW. Fitted phone/record socket and car aerial socket.

Full after-sales service and guarantee.

PLEASE TURN PAGE

Henry's Radio Ltd

PADddington 100819

5 HARROW ROAD LONDON W2

Open Monday to Sat. 9-6. Thurs. 1 o'clock

Send 1/- Stamps for Illustrated Price Lists

"CAPRI" POCKET SIX. 6-TRANSISTOR MEDIUM AND LONG WAVE POCKET SUPERHET RADIO

- SIZE 4 $\frac{1}{2}$ " x 2 $\frac{3}{8}$ " x 1 $\frac{1}{2}$ " REALLY POCKET SIZE ●

The most compact 6-transistor and diode radio with speaker available to the home constructor. Features the latest in miniature components and circuitry. Supplied with Mullard transistors and two-tone moulded cabinets in red/white or blue/white with gold fittings. All components are supplied in packets and clearly identified. A printed circuit is used with fully illustrated building instructions. Push-pull output coupled with a sensitive and selective circuit make the "CAPRI" hard to beat. Fitted Earphone/Record socket.

- FULL AFTER-SALES SERVICE AND GUARANTEE

- ALL PARTS SOLD SEPARATELY—DETAILED LEAFLET ON REQUEST

★ DESIGNED BY EXPERTS FOR THE HOME CONSTRUCTOR ★

TOTAL COST **£6.19.6** P.P. 2/- (Battery 2/6)



"CARVERTER"

Mobile Transistor Short Wave Converter

As featured in the May edition of *The Radio Constructor*. Just plugs into the aerial socket of your car radio. Crystal controlled—covers amateur and Short Wave broadcast bands from 5 to 16 Mc/s.

Supplied complete with long life battery and 39/40 metre band crystal. Send 1/- stamp for full Booklet.

No modifications to car radio at all.

Total cost with sprayed cabinet, etc.

69/6 P.P. 2/-

750mW 4-TRANSISTOR PUSH-PULL AMPLIFIER

(over 1 watt peak output)

Uses OC71/

OC81D,

2-OC81

±3dB 70 c/s

to 12 kc/s

★ Overall size 4" x 2 $\frac{3}{8}$ " x $\frac{3}{4}$ "

★ Built on printed circuit

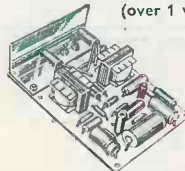

BUILT & TESTED 69/6 P.P. 1/6 OR P.P. 6/6 COMPLETE KIT 59/6

Ideal for Record Player, Intercom., Baby Alarm for Tuners, etc.

3 ohm output, fully guaranteed, 9 volt operated. Descriptive leaflet with uses

FREE on request

"PW-6" SUPERHET RADIO

Medium and Long Wave Radio

Size

5 $\frac{1}{2}$ " x 3 $\frac{3}{8}$ " x 2in.

£7.19.6 P.P. 2/-

Modified version of previously advertised "PWV" Superhet. Now with new style Two Tone Cabinet. First grade components and transistors. Printed circuit. Features matched set of 6 Transistors. New 2 $\frac{1}{2}$ " quality speaker and new illustrated building instructions.

NOW AVAILABLE A 7-TRANSISTOR VERSION OF ABOVE £8. 10. 0. P.P. 2/-.



"RANGER 3"

Size 4 $\frac{3}{8}$ " x 3" x 1 $\frac{1}{4}$ "



69/6 P.P. 1/6

A Three-Transistor Two Diode Personal Radio for Medium Waves and Amateur top band and shipping. Quality output on personal phone. Fitted air spaced tuner, vol. control. No aerial or earth. Luxembourg guaranteed.