

The RADIO Constructor

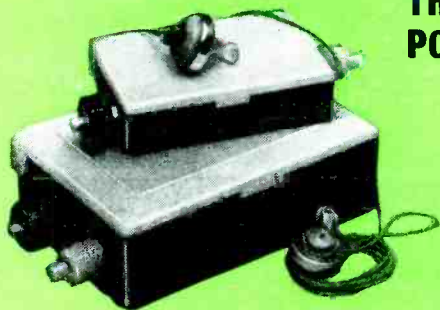

RADIO • TELEVISION • AUDIO • ELECTRONICS

THE MINOR ONE & MAJOR TWO POCKET TRANSISTOR RECEIVERS



THE COOPER-SMITH PRODIGY 6-Watt High Fidelity AMPLIFIER



Included in this issue

- 3-VALVE BROADCAST BAND SUPERHET
- WIDE RANGE BATTERY GRID DIP METER
- FITTING A TUNING INDICATOR
- "TRANSIDYNE" TRANSISTOR POCKET PORTABLE, Part 2
- "WAVEMASTER" R/C CABIN CRUISER, Part 3
- EASY TRAWLER BAND CONVERSION

DATA
Publications 1⁹

THE MODERN BOOK CO

A Beginner's Guide to Television.
By F. J. Camm. 7s. 6d. Postage 6d.

TV Fault Finding. A Data Publication.
5s. Postage 6d.

Oscilloscope Equipment. By D. W.
Easterling. 5s. Postage 4d.

Elements of Tape Recorder Circuits.
By H. Burstein and H. C. Pollak. 23s.
Postage 9d.

The Radio Amateur's Handbook.
By A.R.R.L. 32s. 6d. Postage 1s. 9d.

**World Radio Handbook for Listen-
ers.** 1958 ed. 13s. 6d. Postage 1s.

Radio Valve Data. 6th Ed. Compiled
by "WW". 5s. Postage 9d.

Quality Amplifiers for A.C. Mains.
Data Publications. 4s. 6d. Postage 4d.

Electronic Puzzles and Games. By
M. Mandl. 15s. Postage 8d.

**An Electronic Organ for the Home
Constructor.** By A. Douglas. 15s.
Postage 9d

Electronic Hobbyists' Handbook.
By R. P. Turner 20s. Postage 9d

High Fidelity Sound Reproduction.
By E. Molloy. 20s. Postage 1s.

**Basic Mathematics for Radio and
Electronics.** By F. M. Colebrook and
J. W. Head. 17s. 6d. Postage 1s.

Transistor Circuits. By R. P. Turner.
22s. Postage 9d.

We have the Finest Selection of British and American Radio Books in the Country

Complete catalogue 6d.

19-23 PRAED STREET (Dept RC) LONDON W2

Telephone PADington 4185

RADIO SOCIETY OF GREAT BRITAIN



RADIO HOBBIES

EXHIBITION

Royal Horticultural Hall • Vincent Square • London SW1

WEDNESDAY to SATURDAY — NOVEMBER 26th to 29th — 11 a.m. to 9 p.m.

ADMISSION 2/-

HOME CONSTRUCTION
DO-IT-YOURSELF
FEATURES

Kits of Parts to BUILD
Receivers, Transmitters, Televisors,
Hi-Fi Amplifiers, Test Gear, Tape
Recorders, and Transistor Equipment

First Public Colour Television Show

Live Radio Station Army, Navy and Royal Air Force Displays

WIN A WORLD FAMOUS £400 RACAL COMMUNICATIONS RECEIVER See next month's entry card

FURTHER DETAILS FROM P. A. THOROGOOD G4KD 35 GIBBS GREEN EDGWARE MIDDX

data for **AUDIOPHILES** *

EF86



ECC83



EL34



GZ34



EL84



EZ81



Audiophiles all over the world are demanding Mullard audio valves for their high quality sound equipment. And who can blame them when they know that the Mullard World Series of Audio Valves is the finest in the world.

Fill in the coupon below for free data on Mullard World Series Audio Valves.

* *Audiophile—Enthusiast for high quality sound reproduction who is satisfied with nothing but the best.*



This popular book is available now from most dealers, price 3/6d. It contains designs and full constructional details of the new Mullard EL34 High Quality 20 Watt Amplifier, a Mullard Band II F.M. Tuner, pre-amplifiers for the Mullard EL34 Amplifier and for the popular Mullard 5 Valve 10 Watt Amplifier, together with other useful technical information.

COUPON

TO: MULLARD LTD., PUBLICITY DIVN.

Please send me, free of charge, leaflets on the Mullard World Series of Audio Valves, and details of "High Quality Sound Reproduction".

NAME

ADDRESS

Mullard

**WORLD SERIES
AUDIO VALVES**



Mullard Ltd · Publicity Division
Mullard House Torrington Place
London WC1

MVM 349A

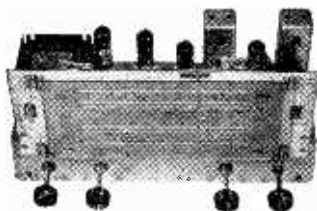

1958 RADIOGRAM CHASSIS

THREE WAVEBANDS FIVE VALVES
 S.W. 16 m.-50 m. LATEST MULLARD
 M.W. 200 m.-550 m. ECH42, EF41, EBC41,
 L.W. 800 m.-2,000 m. EL41, EZ40
 12 month Guarantee. A.C. 200/250V, 4-way switch.
 Short-Medium-Long-Gram. A.V.C. and negative feedback.
 4.2 watts. Chassis 13 1/2" x 5 1/2" x 2 1/2". Glass dial
 10" x 4 1/2" horizontal or vertical available. 2 pilot lamps.
 Four knobs, walnut or ivory, aligned and calibrated.
 Chassis isolated from mains. Immediate delivery.

BRAND NEW £9.10 Carr. 4/6

TERMS: Deposit £5.50 and 5 monthly payments of £1
 MATCHED SPEAKERS: 8" 17/6, 10" 25/-, 12" 30/-

★ GARRARD 4-SPEED SINGLE RECORD PLAYER 4SP ★

£8 AUDIO PERFECTION **POST FREE**

Designed to play 16, 33, 45, 78 r.p.m. Records, 7", 10", 12". Lightweight Xtal pick-up, GC2 turnover head, two separate sapphire styli. Standard and L.P.

BUILD THIS REPRODUCER BARGAIN SPECIAL SINGLE PLAYER KIT

COLLARO 4-speed Gram-Pick-up Unit **£4.12.6**
 Handsome portable case 17 1/2" x 13 1/2" x 7" **£2.5.0**
 Ready-built 3 watt amplifier with two valves and 7" elip. speaker, printed circuit **£3.12.6**

All available separately

£9.15.0 complete kit post free

I.F. TRANSFORMERS 7/6 pair

465 kc/s slug tuning miniature can 2 1/2" x 1" x 1". High Q and good band width. By Pye Radio. Data sheet supplied.
 Wearite M800 Midget I.F.S. 465 kc/s **12/6 pair**
 Wearite 550 Standard I.F.S. 465 kc/s **12/6 pair**

New boxed VALVES 90-day Guarantee

1R5	8/6	6K8	8/6	EAS0	1/6	EZ81	11/6
1S5	8/6	6L6	10/6	EABC80	1/6	E1148	1/6
1T4	8/6	6Q7	10/6	E891	8/6	HABC80	12/6
2X2	2/6	6SA7	10/6	EBC33	8/6	HVR2A	7/6
3S4	8/6	6SJ7M	10/6	EBC41	10/6	MU14	10/6
3V4	8/6	6SN7	8/6	EBF80	10/6	P61	6/6
5U4	8/6	6V6G	7/6	ECC84	12/6	PC84	12/6
5Y3	8/6	6V6GT	8/6	ECF80	11/6	PCF80	11/6
5Z4	10/6	6X4	7/6	ECF82	11/6	PCF82	11/6
6AM6	8/6	6X5	7/6	ECH42	10/6	PCL82	11/6
6B8	5/6	757	10/6	ECL82	12/6	PEN25	6/6
6BE6	7/6	12AH8	10/6	EF39	7/6	PL82	10/6
6BH6	10/6	12AT7	10/6	EF41	10/6	PY80	10/6
6BW6	10/6	12AU7	9/6	EF50	5/6	PY81	10/6
6CH6	10/6	12AX7	9/6	Equip.		PY82	10/6
6D6	7/6	12BE6	9/6	EF50	8/6	SP61	5/6
6F6	7/6	12K7	8/6	Sylv.		UBC41	10/6
6H6	3/6	12Q7	8/6	EF80	10/6	UCH42	10/6
6J5	6/6	35L6	9/6	EF92	5/6	UF41	10/6
6J6	7/6	35Z4	9/6	EL32	5/6	UL41	10/6
6J7	8/6	80	10/6	EL84	10/6	UY41	10/6
6K6	6/6	807	6/6	EY51	12/6	U22	10/6
6K7	5/6	954	1/6	EZ40	10/6	X79	10/6

C.R.T. ISOLATION TRANSFORMERS

For Cathode Ray Tubes having heater-cathode short circuit and for C.R. Tubes with falling emission.
Type A. Low leakage windings. **Optional 25%** and **50%** boost on secondary: 2V, or 4V, or 6.3V, or 10.3V, or 13.3V, with mains primaries, 12/6
Type B. Mains input. Low capacity. Multi-output 2, 4, 6.3, 7.3, 10 and 13V. Boost 25% and 50%. This transformer is suitable for all TV tubes. 2/- each
Type C. Low capacity transformer for 2V tubes with falling emission. Mains input. Output 2, 2 1/2, 2 1/2, 3V at 2A, 17/6 each

RESISTORS. Preferred values. 20% 10 ohms to 10 meg, 1/2W 4d., 1/2W 4d., 1W 6d., 1 1/2W 8d.
HIGH STABILITY. 1/2W 1%, 2/- . All preferred values 100Ω-10MΩ. Ditto 5% 100Ω-5MΩ 9d. each

5 watt } **WIRE-WOUND RESISTORS** { 1/3
 10 watt } 25 ohms-10,000 ohms { 1/6
 15 watt } { 2/-

15,000 ohms-50,000 ohms, 5W, 1/9; 10W, 2/3
WIRE-WOUND POTS 3W Lab. Colvern, etc. Pre-set min. TV type. Standard size Pots, 2 1/2". Knurled slotted knob. All values 25 ohms to 30k, 3/- each. 50k, 4/-
 Ditto Carbon Track 50k W/W EXT. SPEAKER to 2 Meg, 3/- CONTROL 10Ω, 3/-

MAINS TRANSFORMERS

STANDARD. 250-0-250, 80mA, 6.3V tapped 4V 4A. Rectifier 6.3V 1A tapped 5V 2A and 4V 2A **22/6**
 Ditto 350-0-350 **22/6**
MINIATURE. 200V 20mA, 6.3V 1A **10/6**
MIDGET. 220V 45mA, 6.3V 2A **15/6**
SMALL. 220-0-220, 50mA, 6.3V 3A **17/6**
STANDARD. 250-0-250, 65mA, 6.3V 3.5A **17/6**
HEATER TRANS. 200/250V, 6.3V 1 1/2A **7/6**
 Ditto, tapped sec. 2, 4, 6.3V 1 1/2A **8/6**
 Ditto, sec. 6.3V 3A **10/6**
 Mullard "510" Mains Transformers **38/6**

O/P TRANSFORMERS. Heavy duty 50mA, 4/6. Multi-ratio push-pull, 7/6. Miniature 3V4, etc., 4/6. Small pentode, 4/6. Hygrade push-pull 7 watts, 15/6. Mullard "510" 6k or 8kΩ, 30/-

L.F. CHOKES 15/10H 60/65mA, 5/-; 10H, 85mA, 10/6; 20/15H, 120/150mA, 12/6; 5H-, 250mA, 15/-

CRYSTAL MIKE INSERT by Acos. 6/6
 Precision engineered. Size only 1 1/2" x 1 1/2"
ACOS CRYSTAL HAND MIKE, complete, 25/-

ALADDIN FORMERS and cores. 1 1/2" 8d., 3/4" 10d. 0.3" FORMERS 5937/8 and cans TV1.2. 3/4" sq. x 2 1/2" and 3/4" sq. x 1 1/2", 2/- complete with cores

SLOW MOTION DRIVES. Epicyclic ratio 6-1, 2/3
TYANA. Midget Soldering Iron. 200/250V or 240/250V, 16/9. **SOLO N MIDGET IRON**, 25W, 23/-

MAINS DROPPERS. 3" x 1 1/2". Three adj. sliders, 0.3A 750 ohms, 4/3; 0.2A 1,000 ohms, 4/3

LINE CORD. 0.3A 60 ohms per foot, 0.2A 100 ohms per foot, 2-way, 6d. per foot; 3-way, 7d. per foot
MIKE TRANSF. 50:1, 3/9; 100:1, potted, 10/6

LOUDSPEAKERS. P.M. 3 ohm. 2 1/2" and 5", 17/6; 7" x 4" Goodmans, 21/-; 4" Hi-Fi Tweeter, 25/-; 8" Plessey, 19/6; 6 1/2" Goodmans, 18/6; 10" R.A., 30/-; 12" Plessey, 30/-; 8" 2.5k field tapped, o.p. trans., 24/6; 15 ohm Plessey 10W 12", with tweeter, 97/6; Stentorian HF1012 10" 3 to 15 ohms 10W, 99/6

CRYSTAL DIODES. G.E.C., 2/- GEX34, 4/-
40 CIRCUITS FOR GERMANIUM DIODES, 3/- TUNING AND REACTION CONDENSERS 100pF, 300pF, 500pF, 3/6 each, solid dielectric

H.R. HEADPHONES 4,000 ohms, brand new, 16/6 pair
SWITCH CLEANER FLUID, squirt spout, 4/3 tin
TWIN GANG CONDENSERS. 365pF, miniature, 1 1/2" x 1 1/2" x 1 1/2", 10/- . 0.0005 standard with trimmers, 9/-; less trimmers, 8/- . Midget 7/6; 50pF single, 2/6

48-HOUR POSTAL SERVICE

Our written guarantee with every purchase

RADIO COMPON

Buses 133 or 68 pass door S.R. Stn, Selhurst

Aluminium Chassis. 18 s.w.g. Plain, undrilled, with 4 sides, riveted corners and lattice fixing holes, with 2½" sides. 7" x 4", 4/6; 9" x 7", 5/9; 11" x 7", 6/9; 13" x 9", 8/6; 14" x 11", 10/6; 15" x 14", 12/6; 18" x 16" x 3", 16/6

Volume Controls

Midget size
Long spindles. Guaranteed 1 year. All values 5,000 ohms to 2 Meg.
No Switch D.P. Switch
3/- 4/9
Linear or Log Tracks

80Ω Coaxial Cable

Semi-air spaced Polythene insulated ¼" dia. stranded core. Ideal Band III 9d. yd
Losses cut 50%

FRINGE QUALITY

Air-spaced Coaxial 1/6 yd

Coaxial Plugs 1/- **Double Socket** 1/3
Sockets 1/- **Outlet Boxes** 4/6
Balanced Twin Feeder, per yd 6d., 80Ω or 300Ω
Twin Screened Balanced Feeder, 1/6 yd, 80 ohms
Trimmers, Ceramic, 30, 50, 70pF, 9d.; 100pF, 150pF, 1/3; 250pF, 1/6; 600pF, 750pF, 1/9; Philips, 1/- each
BLACK CRACKLE PAINT, Air drying, 3/- tin
P.V.C. CONN. WIRE, 8 colours, single or stranded, 2d. yd. Sleeving 1, 2mm, 2d., 2, 3mm, 3d., 6mm, 5d. yd
5" RADIO SCREWDRIVERS, 6d. each
NEON MAINS TESTER SCREWDRIVERS, 5/3
SOLDER RADIOGRADE, 3 yds 9d., 1lb 2/6
Sentercel Rectifiers, E.H.T. Type Flyback, Voltages: K3/25 2kV, 5/-; K3/40 3.2kV, 7/-; K3/45 3.6kV, 7/6; K3/50 4kV, 8/-; K3/100 8kV, 14/6

50 cps voltage 30% of above ratings

Mains Type RM1, 125V 60mA, 5/-; **RM2** 100mA, 6/-; **RM3** 120mA, 8/-; **RM4** 250V 275mA, 16/-; **RM5**, 20/-
Miniature Contact Cooled Rectifiers, 250V 50mA, 8/6; 250V 85mA, 9/6; **Selenium Rect.** 300V 85mA, 7/6
Coils, Wearite "P" type, 3/- each. Osrom Midget "Q" type, add dust core, from 4/- each. All ranges
Teletron, L. & Med. T.F.R. with reaction, 3/6
Ferrite Rod Aerials, M.V.V., 8/9; M. & L., 12/6
T.R.F. Coils A/H.F., 7/- pair, H.F. Chokes, 2/6
Speaker Fret, Gold cloth, 17" x 25", 5/-; 25" x 35", 10/-; Expanded metal, silver, 15½" x 9½", 2/- each; **Tygan**, 4" 6" wide, 10/- ft; 2" 3" wide, 5/- ft. Samples

SUPERHET COIL PACK 27/6

Miniature size high Q coils. Short, Med., Long, Gram. switching, with connection diagram. 465 kc/s i.f.

Condensers. New stock, 0.001μF 7kV T.C.C., 5/6 ditto 20kV, 9/6; 100pF to 500pF Micaf, 6d.; Tubular 500V 0.001 to 0.01μF, 9d.; 0.05, 0.1, 1/-, 1.25, 1/6; 0.5, 1/9; 0.1/350V, 9d.; 0.01/2,000V, 1/9; 0.1/2,000V, 3/6
Ceramic Condensers, 500V 0.3pF to 0.01μF, 3/6
Silver Mica, 10%, 5pF to 500pF, 1/-; 600pF to 3,000pF, 1/3; close tolerance (plus or minus 1pF), 1.5pF to 47pF, 1/6; ditto 1%, 50pF to 815pF, 1/9; 1,000pF to 5,000pF, 2/5
NEW ELECTROLYTICS FAMOUS MAKES

TUBULAR	TUBULAR	CAN TYPES			
1/350V	2/-	100/25V	2/-	8+16/450V	5/-
2/450V	2/3	8+8/500V	6/-	16+16/450V	5/6
4/450V	2/3	16+16/500V	6/-	6,000V/F 6V	6/6
8/450V	2/3	CAN TYPES	3d.	32+32/350V	4/6
8/500V	2/9	Clips	3d.	32+32/450V	6/6
16/450V	3/6	16/500V	4/-	64+120/275V	7/6
16/500V	4/-	32/350V	4/-	60+100/350V	11/6
32/450V	5/6	100/275V	5/6	100+200/275V	11/6
25/25V	1/9	50+50/350V	7/-		10/6
50/25V	2/-	500/12V	3/-	1,000+1,000/6V	
50/50V	2/-	2,500/3V	4/-		6/6

Full Wave Bridge Selenium Rectifiers, 2, 6 or 12V 1½A, 8/9; 2A, 11/3; 4A, 17/6. Free charger circuit
Charger Transformers, Tapped input 200/250V for charging at 2, 6 or 12V 1½A, 15/6; 2A, 17/6; 4A, 22/6

12/6 PURETONE RECORDING TAPE, 1,200ft on standard fitting, 7" metal reels. Spare reels 7" metal, 2/3; 5½" plastic, 3/-; 7" plastic, 4/-
SUPERIOR 1,200ft plastic tape, 21/-; 7" plastic reel
EMITAPE 7" Long Play 1,800 ft, 45/-
INSTANT bulk tape eraser, 27/6

TELETRON MINIATURE

"TRANSIDYNE" Superhet Portable

6 Transistors, T.C.C. Printed Circuit

Ferrite aerial, cabinet and all parts. For medium and long wave reception

Our price

£12.19.6

post free



Size 6" x 4" x 1½"

Plans and parts list

9d.

6 GENUINE PYE GOLTOP TRANSISTORS ARE INCLUDED WITH THIS KIT, FOR MAXIMUM RESULTS

TRANSISTORS. Pye Goltop Audio V10/15A, 15/-; R.F. 3 Mc/s, V6/R2, 24/-; Sub-miniature Electrolytics 5μF 12V, 8μF 6V, 16μF 12V, 25μF 6V, 3/- each

THE HIGH GAIN BAND III TV PRE-AMP Tunable Channels 8, 9 and 10, Gain 17dB, Cascode Circuit. Complete kit with ECC84 valve, plans and instructions, 29/6 less power, or 49/6 with power pack. Plans only, 6d. Band I version available for channels 1 to 5, same prices

Wavechange Switches, 2 p 2-way, 3 p 2-way, short spindle, 2/6; 5 p 4-way 2 wafer, long spindle, 6/6; 2 p 6-way, 4 p 2-way, 4 p 3-way, long spindle, 3/6; 3 p 4-way, 1 p 12-way, long spindle, 3/6; wave change "MAKITS", 1 wafer, 8/6; 2 wafer, 12/6; 3 wafer, 16/-; 4 wafer, 19/6; 5 wafer, 23/-; 6 wafer, 26/6
Toggle Switches, s.p. 2/-, d.p. 3/6, d.p.d.t. 4/-

JASON FM TUNER COIL SET, 26/-; H.F. coil, aerial coil, oscillator coil, two i.f. transformers 10.7 Mc/s, detector transformer and heater choke. Circuit and component book using four 6AM6, 2/-
Complete Jason FM Kit, with valves and Jason superior calibrated dial, £6.15, post free
Mullard 3-3. Amplifier ready built, with power socket for tuner, £7.17.6

Valveholders. Pax. int. oct., 4d. EF50, EA50, 6d. B12A, CRT, 1/3. Eng. and Amer. 4, 5, 6, 7 and 9 pin, 1/-
MOULDED Mazda and int. oct., 6d., B7G, B8A, B8G, B9A, 9d. B7G with can, 1/6. VCR97, 2/6. B9A with can, 2/6. Ceramic, EF50, B7G, B9A int. oct., 1/-; B7G with can, 1/9; B9A with can, 2/9

HANDY VOLTMETERS, 2" Twin Range 0-25V, 0-250V d.c. with leads and leather case, 9/6 each

TV Fault Finding. Data Publications 5/- each
Radio Valve Guide. Books 1, 2 or 3 5/- each

TELETRON 'COMPANION' PRINTED CIRCUIT TRANSISTOR THREE

£5.15.0

WITH 3 PYE GOLTOP TRANSISTORS



Pocket receiver kit, 4½" x 3" x 1½" with plans, cabinet, all parts and batteries. Fitted speaker reproduces strong local stations on Ferrite Aerial. Distant reception with simple aerial or earth

IT SPECIALISTS

337 WHITEHORSE ROAD WEST CROYDON

Catalogue 6d.

Telephone THO 1665

& P. 1/-, over £2 post free. C.O.D. 1/6 (Export C.W.O. post extra, no H.P.)

OPEN ALL DAY (Wed. 1 p.m.)

CLYNE RADIO LTD.



"The Component Specialists"

ALL POST ORDERS AND CORRESPONDENCE TO
162 HOLLOWAY ROAD · LONDON N7
NOR 6295/6/7

18 TOTTENHAM COURT RD. LONDON W1
MUS 5929/0095

Callers welcome at both branches

PRINTED CIRCUIT

THE "TRANSIDYNE"

TRANSISTOR POCKET SUPERHET

A printed circuit pocket size Transistor Receiver, professional in appearance and of outstanding performance. Incorporates T.C.C. printed circuit, six transistors (push-pull) to cover medium and long waves, utilises 2 Ever-Ready, or equivalent, No. 8 batteries. Attractive cream and red plastic cabinet with engraved dial. Overall dimensions $6\frac{1}{2}'' \times 3\frac{1}{2}'' \times 1\frac{1}{2}''$. Total weight when assembled, including batteries, only 20 oz. Our price for all required components, including batteries,

£11.19.6 plus 2/6 p.p.



A NEW TELETRON PRODUCT

(as described in Sept. issue)

A receiver can be seen and heard working at both our branches, and is of outstanding value at the price

All resistors and condensers are identifiable and individually mounted on cards. Full instructions and individual priced parts list 1/- post free. All components can be supplied separately, for example: Complete cabinet and dial assembly, printed circuit, battery holder, nuts and bolts and full assembly instructions. 25/- plus 1/6 p.p.

3 required Audio Transistors—22/6 per set

3 required R.F. Transistors—45/- per set

"R.E.P. MINI-7"

POCKET TRANSISTOR PORTABLE

STAR FEATURES

- ★ Utilises 7 specially selected transistors
- ★ Push-pull output
- ★ Hi-Grade $2\frac{1}{2}''$ p.m. loudspeaker
- ★ Ferrite slab aerial
- ★ Most attractive appearance
- ★ Exceptionally good quality output
- ★ Unequaled performance

Overall dimensions only $5\frac{1}{8}'' \times 3\frac{1}{8}'' \times 1\frac{1}{8}''$. Powered by two miniature 3V transistor batteries. Plastic case finished in dove grey with scarlet knobs.

ALL NECESSARY COMPONENTS AT SPECIAL INCLUSIVE PRICE OF

£9.19.6

P. and P. 2/6

PRINTED CIRCUIT

TELETRON

COMPANION

(As described in July issue.) All required components available at special INCLUSIVE price of 99/6 plus 1/6 p. and p.

Constructional details and itemised price list 6d. post free

CONSTRUCTORS BARGAINS!

Mains Transformer (Special). Superior quality drop through type, half shrouded. Primary 200/250V Secondary 350-0-350V at 80mA, 6.3V 3A, 5V 2A. Ex-equipment, but guaranteed O.K. Only 9/6 plus 1/- p. & p.

6V Vibrator Pack. Ex-W.D. Output 140V 30mA. Fully smoothed. Size only $6\frac{1}{2}'' \times 5'' \times 2\frac{1}{8}''$. New condition. 12/6 plus 1/6 p. and p.

12V Vibrator Pack. Mallory, brand new. Output 150V 40mA. Complete with synchronous vibrator. 12/6 plus 1/6 p. and p.

12" Plessey P.M. Loudspeaker. 3 ohm speech coil, Brand new. Only 32/6 plus 2/6 p. and p.

12" Bakers Selhurst Loudspeakers. 15 ohm, 15 watt, 30/14,000 r/s. Few only. Brand new. £4 10s. plus 3/6 p. and p.

10" Recond. good quality Loudspeaker. Complete with o.p. transformer, as good as new. 17/6 plus 1/6 p. and p.

Wiring Wire. 5 coils 10yd each coil, in different colours, contained in cellophane bag. 5/- plus 9d. p. and p.

3-Section Whip Aerials. Ideal for fishing rods, etc. Each section 4ft. Only 7/6 set, plus 2/6 p. and p.

H.G.P.59 Crystal Insert. Complete with i.p. and std. sapphire styli. Brand new, 18/- plus 9d. p. and p. Suitable for B.S.R., Monarch, etc.

Manufacturers' Surplus Component Strips. Comprising approx. 12 capacitors from 0.25µF to 100pF and approx. 12 resistors. All useful values. Mounted on sturdy tag board. 4 Strips (approx. 100 components) for 5/- plus 1/- p. and p.

Nylon Drive Cord. 12yd reels. Best quality 3/6 plus 6d. p. and p.

CLR Low Impedance Headphones 7/6 pair plus 1/- p. and p.

Brand new imported High Impedance Lightweight Headphones. Finished in cream. 15/- pr. plus 1/- p. and p.

Carbon Hand Microphones complete with press to talk switch. Lead and jack plug. 5/- each, plus 1/- p. and p.

Morse Keys. Superior Quality. Brand new 2/6 plus 1/- p. and p.

Octal Plugs. Ex-equip. 9d. each, plus p. and p. 6d.

Packard Bell Pre-Amplifier. Snip! With 6SL7GT, 28D7GT, plugs, hand switch, many components contained in useful metal case. Brand new, boxed complete with circuit diagram and instruction book. Only 12/6 plus 1/6 p. and p.

Polystyrene Coil Cement. 1/10 per bottle plus 6d. p. and p.

We Specialise in VALVES · COMPONENTS · AM & FM CHASSIS
TUNERS · AMPLIFIERS · LOUDSPEAKERS · CABINETS · RECORD
PLAYERS · TAPE RECORDERS and all HI-FI EQUIPMENT Enquiries invited



Radio Component Specialists since 1946. Staffed by Engineers and Radio Amateur Constructors who enthusiastically try to give you a square deal and

FULL VALUE FOR MONEY—

Try Us!

SPEDY MAIL ORDER SERVICE

BAND III TV CONVERTER

180 Mc/s-205 Mc/s

Suitable London, Birmingham, Northern, Scottish, Welsh and I.O.W. ITA transmissions

Mk. 2 Model. Latest cascade circuit using ECC84 and EF80 valves giving improved sensitivity (12 dB) over standard circuits, built-in power supply a.c. 200-250V. Dimensions only 6½" x 3" ht 4". Simple and easy to fit—only external plug-in connections. Wired aligned and tested ready for use. State channel required. Guaranteed. Bargain offer—good results or full refund. **ONLY £3.19.6** Carr. and pkg. 2/6

Band I/Band III changeover switch and B.B.C. aerial socket can now be fitted and wired to the above converter for 8/- extra

R.E.P. MINI-7. Kit of parts for this popular pocket transistor portable, 9½ gns., p. and p. 2/6

CONDENSERS. Mica or s. mica. All pref. values. 2pF to 680pF, 6d. each. Ceramic types, 2.2pF to 5,000pF, 9d. each. Tubulars, 450V, Hunts and T.C.C., 0.001, 0.005, 0.01 and 0.1, 350V, 9d.; 0.02, 0.05, 0.1, 500V Hunts, T.C.C., 1/-; 0.25 Hunts, 1/6; 0.5 Hunts, 1/9; 0.001 6kV T.C.C., 5/6; 0.001 20kV T.C.C., 9/6, etc.

RESISTORS. Pref. values 10 ohms to 1megohms, 20% tol., 1W, 3d.; ¼W, 5d.; 1W, 6d.; 2W, 9d.; 10% h-stab., ¼W, 5d.; ½W, 7d.; 5% tol., ¼W, 9d.; 1% h-stab., ¼W, 1/6

PRE-SET W/W POT. TV knurled slotted knob type. 25 ohms to 30,000 ohms, 3/-; 50,000 ohms, 4/-; 50,000 ohms to 2 Megohms (carbon), 3/-

VOLUME CONTROLS. Log or Lin. ratios, 10,000 ohms-2 Megohms. Long spindles. 1 year guarantee. Midget Ediswan type, 1½" dia. No sw. 3/-. D.P. sw. 4/9

S.T.C. RECTIFIERS. E.H.T. types, K3/25 2kV, 5/-; K3/40 3.2kV, 6/9; K3/45 3.6kV, 7/3; K3/50 4kV, 7/9; K3/100 8kV, 13/6, etc. Mains types: RM1 125V 60mA, 4/9; RM2 125V 100mA, 5/6; RM3 125V 120mA, 7/6; RM4 250V 250mA, 16/-; RM4b type 250V 275mA, 17/6, etc.

LOUDSPEAKERS. P.M. 3 ohm, 3" Rola, 17/6; 3½" Goodmans, 18/6; 5" R. & A., 17/6; 6" Celest., 18/6; 7" x 4" Goodmans, 18/6; 8" Rola, 20/-; 10" R. & A., 25/-, etc.

SPEAKER FRET. Expanded bronze anodised metal; 8" x 8", 2/3; 12" x 8", 3/-; 12" x 12", 4/6; 12" x 16", 6/-; 24" x 12", 9/-, etc. **TYGAN FRET** (Murphy pattern): 12" x 12", 2/-; 12" x 18", 3/-; 12" x 24", 4/-, etc.

L.F. CHOKES—10H 65mA, 5/-; 15H 100mA, 10/6; 10H, 120mA, 10/6; 20H 150mA, 15/6

RECORD PLAYER CABINETS

Contemporary style rexine covered cabinet in two-tone fawn and brown. Size 18½" x 13½" x ht. 8½", fitted with all accessories, including speaker baffle-board and plastic fret. Space available for all modern amplifiers and auto-changers, etc. Uncut record player mounting board 14" x 13". Cut mounting boards available 2/6 extra **Cabinet Price £3.3.0** Carr. and ins. 3/6

2-VALVE AMPLIFIER Mk 1. 200/250V a.c. modern circuit with high gain EL84 output and double wound mains transformer, variable tone and volume controls, wired and tested with 6" speaker and o/p trans., complete with knobs and drilled ready to fit baffle-board in above cabinet. Only £3.12.6. Carr. and pack. 2/6

We can only show a small selection from our vast stocks in this advert. Write now for full Bargain Lists, 3d.

RECORD PLAYER BARGAINS

New Reduced Prices!

SINGLE PLAYERS. 4-speed BSR (TU9), 92/6; 4-speed **COLLARO JUNIOR**, 90/-; 4-speed **GARRARD** (4 S.P.), £7.5.0, carr. and ins. 3/6

AUTO-CHANGERS. 4-sp. BSR (UA8), £6.19.6; 4-sp. **COLLARO**, £7.19.6; ** 4-sp. BSR (UA12), 8½ gns.; 4-sp. **GARRARD** (RC120/4H/2), £9.10.0; * 4-sp. **GARRARD** (RC121/4/D Mk. 2), 10 gns., carr. and ins. 5/-. All above units are latest 4-speed models, fitted lightweight crystal p.u. and twin sapphire styli. Complete and ready to use.

FINEST SELECTION AVAILABLE—ALL BRAND NEW AND GUARANTEED

* Adapted for stereo operation
** Fitted with stereo cartridge

80 OHM CABLE COAX

NOW ONLY 8d. YARD!

Highest Quality Cable, lossless Polythene Aerialax, semi-air spaced, feeder losses cut 50%. Standard ¼" dia. Stranded core. 20 yds 12/6, carr. 1/6 40 yds 20/-, carr. 2/- **Coax Plugs 1/-, Coax Sockets 1/-, Couplers 1/3, Outlet Boxes 4/6, B1-B3 Xover Unit 7/6**

C.R.T. HEATER ISOLATION TRANS.

New improved types—mains prim. 200/250V tapped. All isolation transformers now supplied with alternative no boost, plus 25%, and plus 50% boost taps at no extra cost, all in one transformer. 2V 2A type, 12/6; 6.3V 0.6A type, 12/6; 10.5V 0.3A type, 12/6; 13V 0.3A type, 12/6. P. and p. 1/6. Other voltages in course of production. Small size and tag terminated for easy fitting. p. and p. 1/6.

OUTPUT TRANS. Standard pentode, 4/6; push-pull 12W, 13/6. Small pentode, 3/9. Midget battery pentode (15A, etc.), 4/6

ELECTROLYTICS—ALL TYPES—NEW STOCK

Tubular—Wire Ends	Can Types, Clips 3d. each
25/25V, 50/12V	1/9 8+8/450V T.C.C. 4/6
25/50V T.C.C.	2/- 8+16/450V T.C.C. 5/-
50/50V, 4/500V	2/- 16+16/450V T.C.C. 5/6
100/25V, 2/450V	2/- 32/350V B.E.C. 4/-
8/450V T.C.C.	2/3 32+32/275V Hunts 4/6
8+8/450 B.E.C.	4/6 32+32/450V T.C.C. 6/6
8+16/450V T.C.C.	5/- 250/350V B.E.C. 8/6
16+16/500V Dub.	6/- 100+200/275V 12/6
16/450V B.E.C.	3/6 60+250/275V 12/6

MIDGET TRANSISTOR TYPES. T.C.C. 2½F, 4½F, 8½F 6V, 3/6; 6½F, 10½F, 16½F 3V, 3/6; 32½F 1½V, 3/6, etc.

VALVES—NEW BOXED—ALL GUARANTEED

1R5, 1T4, 7/6; 155, 154, 7/6; 354, 3V4, 8/-; 5Z4, 9/6; 6AT6, 8/6; 6X7, 6/6; 6K8, 8/6; 6Q7, 8/6; 6SN7, 8/6; 6V6, 7/6; 6X4, 7/6; 6X5, 7/6; 7C5, 9/-; 7Y4, 8/6; DAF96, 9/-; DF96, 9/-; DK96, 9/-; DL96, 9/-; 35L6, 10/6; EABC80, 9/6; EB91, 6/6; EBC41, 10/6; EBC33, 8/6; ECC84, 12/6; ECH42, 10/6; ECH81, 10/6; ECL80, 12/6; EF41, 10/6; EF80, 10/6; EF86, 13/6; EF91, 8/6; EY51, 12/6; E240, 8/6; EZ80, 8/6; MU14, 9/6; PCC84, 10/6; PCF80, 10/6; PCF82, 10/6; PCL83, 12/6; PL81, 14/6; PL82, 10/-; PL83, 11/6; PY80, 9/6; PY81, 9/6; PY82, 8/6; U25, 13/6; UY41, 8/6

SPECIAL—1R5, 1T4, 155, 154 or 354 or 3V4 per set 27/6

Hours 9 a.m.—6 p.m., 1 p.m. Wed.



Est. 1946

RADIO COMPONENT SPECIALISTS

70 Brigstock Road Thornton Heath Surrey

Telephone THO 2188

Terms: C.W.O. or C.O.D. Post and packing up to ½lb 7d., 1lb 1/1, 3lb 1/6, 5lb 2/-, 10lb 2/9

AN ELECTRONIC ORGAN
FOR THE
HOME CONSTRUCTOR

By Alan Douglas, M.I.R.E., M.A.I.E.E.
Here is a do-it-yourself book which gives straightforward instructions for building an inexpensive electronic organ. Compact and easily transportable, the instrument has been specially designed for amateur use in church, hall or home. Detailed step-by-step instructions are given, as well as a complete list of materials and their suppliers. Illustrated with photographs and diagrams. From booksellers, 15/- net.

PITMAN

Parker St. Kingsway London WC2

No Resistance with ERSIN MULTICORE SOLDER

One imperfectly soldered joint can ruin reception and frustrate hours spent in assembly work. Be sure you use Ersin Multicore Solder on all connections in your equipment. Five cores of extra-active, non-corrosive Ersin flux, prevent oxidation, clean surface oxides and eliminate 'dry' and H.R. joints. The Size One Carton gives you waste-free, trouble-free soldering without the need for extra flux. Get a carton today — and ensure good reception.



SIZE 1 CARTONS 5/- RETAIL

Catalogue Ref. No.	Alloy Tin/Lead	S.W.G	App. T'grn per carton
C 16014	67/30	14	19 feet
C 16018	67/37	18	51 feet
C 14013	40/60	15	17 feet
C 14016	40/60	16	33 feet

MULTICORE SOLDERS LTD., MULTICORE WORKS.
HEMEL HEMPSTEAD, HERTS (BOXMOOR 3636).

POST 21 SELF-CONTAINED RANGES COUPON NOW

You, too, can be SELF-CONTAINED, or completely equipped to tackle any testing job, by owning one of the well-known M.I.P. Series 100 Multi-Range Test Sets. You can have one sent to you almost immediately, simply by sending a deposit of 47/6. Balance is payable in 6 monthly instalments of £1.6. Cash price is £12.7.6. Post coupon for full details.

- ★
- 10-1,000 d.c. volts
- 10-1,000 a.c. volts
- 100 Microamps to 500 Milliamps d.c.
- 100 Microamps a.c.
- 0-1 Megohm
- 0-10,000 ohms

★
There is also the **SERIES 90 MULTI-RANGE TEST SET** having 19 SELF-CONTAINED ranges:
ac/dc volts up to 1,000V
dc current up to 500mA
ac current up to 200mA
Resistance 0-200,000Ω
Deposit 35/- and six monthly payments of 28/10 (Cash price £9.15.0)



GD21

MULTI-RANGE TEST SET - SERIES 100

To MEASURING INSTRUMENTS (Pullin) Ltd

Electrin Works, Winchester Street, Acton, W.3

Please send illustrated leaflet of the Series

100 with details of easy payment scheme

Ditto Series 90

*Please indicate instrument required

NAME

ADDRESS

F1058

EMI

"HIS MASTER'S VOICE"
MARCONIPHONE · COLUMBIA

Announce

NEW PRACTICAL WAY OF LEARNING AT HOME

NEW— completely up-to-date methods of giving instruction in a wide range of technical subjects specially designed and arranged for self-study at home under the skilled guidance of our teaching staff.

NEW— experimental outfits and lesson manuals are despatched on enrolment and remain the student's property. A tutor is allotted to each student for personal and individual tuition throughout the course.

Radio and television courses, with which specially prepared components are supplied, teach the basic electronic circuits (amplifiers, oscillators, detectors, etc.) and lead, by easy stages, to the complete design and servicing of modern Radio and T/V equipments.

If you are studying for an examination, wanting a new hobby or interest, commencing a career in industry or running your own full-time or part-time business, these practical courses are ideal and may be yours for moderate cost. Send off the coupon to-day for a free Brochure giving full details. There is no obligation whatsoever.

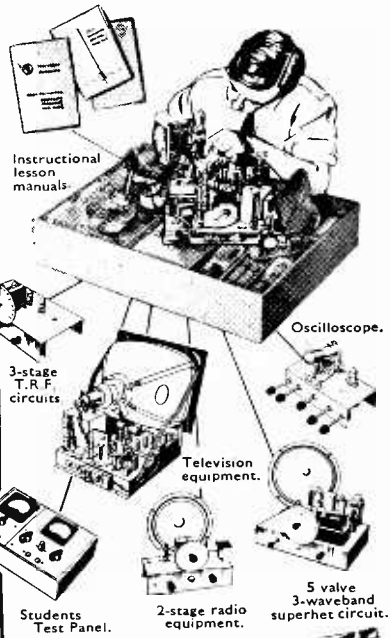

Courses with Equipment

- RADIO · SHORT WAVE RADIO**
- TELEVISION · MECHANICS**
- CHEMISTRY · PHOTOGRAPHY**
- ELECTRICITY · CARPENTRY**
- ELECTRICAL WIRING · 'HI-FI'**
- DRAUGHTSMANSHIP · ART, etc.**

E.M.I. Factories at Hayes, England.



EMI INSTITUTES

Fill in for **FREE BROCHURE**
E.M.I. INSTITUTES, Dept. 179X, London, W.4.

Name Age
(If under 21)

Address

I am interested in the following subject(s) with/
without equipment.
(We shall not worry you with personal visits)



BLOCK CAPS PLEASE

IC.107 Oct '53

The only Home Study College run by a World-wide industrial organisation.

There's nothing so good

AND IT'S BEST IF IT'S A

Jasonkit

When good circuitry and design are presented with straightforward, easily followed instructions, it becomes relatively simple to build technically advanced items of radio, audio and electronic equipment. There are already years of specialised experience in kit design and production behind the new Jasonkit programme. From it, the constructor can choose stereo amplifier and pre-amp designs, first-class f.m. tuners, and soon, a number of items of valuable electronic test equipment. Such is the quality of Jason designs that even to-day, the popularity of the original f.m. tuner, which was the first Jasonkit to be produced, is as great as ever and large numbers continue to be built with complete success.

No special tools or experience are required to build Jasonkits. To the satisfaction of building your own apparatus is added the knowledge that its performance will be the finest possible in its class. Kits are complete, too, down to the last detail, and include chassis and panels punched and drilled to size. Only valves are extra except where otherwise stated.

BRITISH THROUGHOUT

Details of kits in which you are interested gladly sent on request

THE JASON MOTOR & ELECTRONIC SALES CO

as building it yourself

FM tuners
 am/fm tuners
 fm/tv tuners
 stereo amplifiers
 stereo pre-amplifiers
 electronic instruments



AUDIO

	STANDARD FM TUNER in chassis form (less valves)	£5.5.0
	Power Pack Kit	£2.1.9
ARGONAUT AM/FM TUNER.	As tuning unit only (less valves)	£10.10.0
	As complete receiver (less valves)	£11.10.0
MERCURY SWITCHED FM TUNER including front end with 2 valves		£9.0.0
STEREO AMPLIFIER (10+10 watts) Power Amplifier with 7 valves	£17.8.0
STEREO PRE-AMP J.4-4 with case, but less valves	£16.10.0
STEREO PRE-AMP J.3-3 with valves and case	£16.15.0
STEREO PRE-AMP J.3-3 with valves, less case	£16.0.0
SIMPLIFIED STEREO AMP with tone, balance and channel controls (3+3 watts) with valves and case	£13.19.0
FRINGE FM TUNER , self-powered, less valves	£8.5.0
SWITCHED FM/TV SOUND TUNER , self powered, less valves	£12.19.0

INSTRUMENTS

VALVE VOLTMETER: WOBBULATOR: STABILISED POWER PACK: OSCILLOSCOPE:—For all who wish to build and experiment to a high degree of accuracy. These kits have attractive uniformly styled front panels and may be built with or without the standardised cases. **FOR RELEASE SHORTLY.**

3-4(E) GT. CHAPEL STREET OXFORD STREET LONDON W1

(between Tottenham Court Road and Oxford Circus Station Underground)

Telephone GERrard 0273/4

◆ ◆ ◆ ◆ REPANCO ◆ ◆ ◆ ◆

HIGH GAIN COILS and QUALITY COMPONENTS for the constructor

TRANSISTOR COMPONENTS

FERRITE SLAB AERIAL TYPE FS2. A new super-sensitive aerial, Long and Medium Wave, specially designed for transistor portable receivers. Complete with fixing brackets. Length 5½"	12/6
COMBINED OSCILLATOR AND 1st I.F. TRANSFORMER TYPE OT1 (315 kc/s, fully screened, 1½" x 1½" x 1½"	11/6
2nd I.F. TRANSFORMER TYPE TT2 (315 kc/s), 1" x ¾" dia.	5/-
3rd I.F. TRANSFORMER TYPE TT3 (315 kc/s), 1" x ¾" dia.	5/-
PUSH-PULL INTER-STAGE TRANSFORMER TYPE TT4. Ratio 1:1 ct. Stack 1½" x 1¼" x 7/8"	8/6
PUSH-PULL OUTPUT TRANSFORMER TYPE TT5. Ratio 15:1 ct. Stack 1½" x 1¼" x 7/8"	8/-

MINIATURE RANGE—For pocket receivers

FERRITE SLAB AERIAL TYPE FS3. Medium Wave only. With fixing grommets. Size 3" x ½" x ½"	7/6
OSCILLATOR COIL TYPE XO8. Medium Wave only. Overall size ½" dia. x 1". Enclosed in Ferrite pots	5/-
I.F. TRANSFORMER TYPE XT6. Suitable for 1st and 2nd I.F. 455 kc/s. Size ½" sq. x 1½" ...	10/-
I.F. TRANSFORMER TYPE XT7. Designed for 3rd I.F.T. or detector I.F.T. 455 kc/s. Size as XT6	10/-
PUSH-PULL INTERSTAGE TRANSFORMER TYPE TT9. Ratio 1:1 ct. Radiometal Core. Size ¾" x ¾" x 1½"	12/6
PUSH-PULL OUTPUT TRANSFORMER TYPE TT10. Ratio 8-1 ct. Matched to 3 ohm speaker. Size as TT9	12/6

Practical and Theoretical circuits enclosed with each Repanco Transistor Component

COILS AND TRANSFORMERS FOR TRANSISTORISED CAR RADIO

Medium Wave Aerial Coil Type XMA16	10/-	} Interstage Transformer Type TT11... .. .	10/-
Medium Wave H.F. Coil Type XMF17	10/-		Output Transformer (12 volt Radio) Type TT12... .. .
Long Wave Aerial Coil Type XLA18	6/9	} Output Transformer (6 volt Radio) Type TT13... .. .	12/6
Long Wave H.F. Coil Type XLF19	6/9		
Oscillator Coil Type XO15	5/-		

All this range boxed with circuit and practical diagram of all-Transistor Car Radio

REPANCO EASY-TO-BUILD RECEIVERS

Constructors' Envelopes of easy wiring plans, instructions and detailed price lists of components

THE HIWAYMAN	Envelope 1/6 (post 3d.)
Four-valve superhet Dual-range Portable using Ferrite Rod Aerial	
REPANCO ONE-VALVE	Envelope 9d. (post 3d.)
Beginner's Dual-range Radio Set for use with headphones	
REPANCO FM TUNER UNIT	Envelope 1/6 (post 3d.)
Using 4 EF91, 1 EB91, 1 EM80 Valves, Ratio Detector	
REPANCO "THREE DEE"	Envelope 9d. (post 3d.)
Dual-range Transistor Radio using 3 Transistors and Crystal Diode. Amazing loudspeaker reception from 7½ volt battery supply	
REPANCO "TRANSEVEN"	Envelope 1/6 (post 3d.)
A new 7 Transistor superhet Portable with preset station tuning using Repanco transistor components	
REPANCO "MINI-7"	Envelope 1/6 (post 3d.)
The amazing new transistor pocket portable radio with all the technical features of a standard receiver. Seven transistors, superhet circuit, fully tunable over medium wave. Size 5½" x 3½" x 1½"	

MAIL ORDER and TRADE—

RADIO EXPERIMENTAL PRODUCTS
LIMITED
33 MUCH PARK STREET COVENTRY
Telephone 62572

WHOLESALE and EXPORT—

REPANCO LTD
O'BRIEN'S BUILDINGS
203-269 FOLESHILL ROAD COVENTRY
Telephone 40594

Wanted!

QUALIFIED MEN AND WOMEN

Industry and Commerce offer their best posts to those with the qualifications — appointments that will bring personal satisfaction, good money, status and security. As part of a modern industrial organisation, we have skilled knowledge of what is required and the best means of training personnel for its present day and future requirements. We specialise also in teaching for hobbies, new interests or part-time occupations in any of the subjects listed below. Write to us to-day for further information. There is no obligation of any kind.

PERSONAL & INDIVIDUAL TRAINING IN—

- | | | |
|---------------------------------------|----------------------------------|----------------------------------|
| Accountancy | Electronics | Production |
| Advertising | Electronic | Planning |
| Aeronautical Eng. | Draughtsmanship | Radar |
| A.R.B. Licences | Eng. Drawing | Radio |
| Art (Fashion, Illustrating, Humorous) | Export | Radio Amateur's (C&G) Licence |
| Automobile Eng. | General Certificate of Education | Radio & Television Servicing |
| Banking | Heating & Ventilating Eng. | Refrigeration |
| Book-keeping | High Speed | Sales Management |
| Building | Oil Engines | Sanitary Eng. |
| Business Management | Industrial Admin. | Salesmanship |
| Carpentry | Jig & Tool Design | Secretaryship |
| Chemistry | Journalism | Shorthand & Typing |
| City & Guilds | Languages | Short Story Writing |
| Exams | Management | Short Wave Radio |
| Civil Service | Maintenance Eng. | Sound Recording & Reproduction |
| Commercial Subjects | Mathematics | Telecommunications |
| Commercial | M.C.A. Licences | Television |
| Art & Drawing | Mechanical Eng. | Time & Motion Study |
| Customs Officer | Metallurgy | Tracing |
| Draughtsmanship | Motor Eng. | Welding |
| Economics | Painting & Decorating | Workshop Practice |
| Electrical Eng. | Photography | Works Management and many others |
| Electrical Installations | P.M.G. Cert. | |
| | Police | |
| | Production Eng. | |

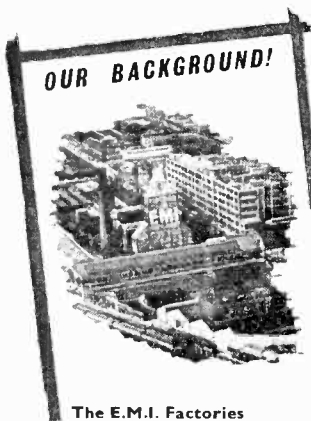

The E.M.I. Factories at Hayes, England.

Also courses for GENERAL CERTIFICATE OF EDUCATION, A.M.I.H.&V.E., A.M.S.E., A.M.Brit.I.R.E., A.M.I.Mech.E., A.M.I.E.D., A.M.I.M.I., A.F.R.Ae.S., A.M.I.P.E., A.M.I.I.A., A.C.C.A., A.C.I.S., A.C.C.S., A.C.W.A., City & Guilds Examinations, R.T.E.B.Serv. Cert. R.S.A. Certificates, etc.

The only Home Study College
operated by a world-wide
manufacturing organisation

NEW! Courses with **PRACTICAL EQUIPMENT**
IN RADIO · TELEVISION · MECHANICS · CHEMISTRY
ELECTRICITY · DRAUGHTSMANSHIP
PHOTOGRAPHY, ETC., ETC.

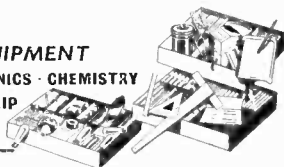

EMI

INSTITUTES

POST THIS TODAY

E.M.I. INSTITUTES, Dept. 179K, London, W.4

NAME

AGE
(if under 21)

ADDRESS

I am interested in the following subject(s) with/without equipment

Oct/58

(We shall not worry you with personal visits).

FREE

BLOCK
CAPS
PLEASE

IC 92

The only Home Study College run by a World-wide industrial organization

The

Radio Constructor

incorporating THE RADIO AMATEUR



VOL. 12 No. 3

OCTOBER 1958

ANNUAL SUBSCRIPTION 25/- (including postage)

CONTENTS

- 174 Suggested Circuits: An Inexpensive 3-Valve Broadcast Band Superhet, *by G. A. French*
- 178 In Your Workshop
- 185 Understanding Television, Part 10
by W. G. Morley
- 191 Book Reviews
- 192 The Cooper-Smith "Prodigy" 6-Watt High Fidelity Amplifier, Part 1
- 198 Technical Forum
- 200 A Wide Range Battery Operated Grid Dip Meter
by D. W. Easterling
- 204 The "Minor-One" and "Major-Two" Personal Transistor Receivers
designed by D. J. French, Grad.I.E.E.
- 208 Models for Radio Control—The "Wavemaster" Kit, Part 3, *by Raymond F. Stock*
- 210 Radio Miscellany, *by Centre Tap*
- 212 The Teletron "Transidyne" 6 Transistor Pocket Portable Superhet Receiver, Part 2,
described by Edwin Marshall
- 214 A Constructor Visits the 1958 National Radio and Television Show
- 216 Fitting a Tuning Indicator
by R. H. Wright, G3IBX
- 218 Repairing a Damaged Meter
by Chas. T. J. Dainty
- 220 Easy Trawler Bard Conversion, *by G3XT*
- 221 Can Anyone Help?

Editor

C. W. C. OVERLAND, G2ATV

Associate Editor

A. C. GEE, G2UK

Business Manager

J. H. BURROWS, A C A

Advertising Manager

F. A. BALDWIN, A M I P R E

Offices

57 MAIDA VALE LONDON W9

Telephone

CUNNINGHAM 6141
(2 lines)

Telegrams

DATABUX, LONDON

NOTICES

THE CONTENTS of this magazine are strictly copyright and may not be reproduced without obtaining prior permission from the Editor.

ARTICLES appearing in this magazine which describe kits are inserted only on condition that such kits, or special components thereof, are freely available at a trade discount to all retail advertisers.

OPINIONS expressed by contributors are not necessarily those of the Editor or proprietors.

THE EDITOR invites original contributions on construction of radio subjects. All material used will be paid for. Articles should preferably be typewritten, and photographs should be clear and sharp. Diagrams need not be large or perfectly drawn, as our draughtsmen will redraw in most cases, but all relevant information should be included.

ALL MSS must be accompanied by a stamped addressed envelope for reply or return. Each item must bear the sender's name and address.

TRADE NEWS. Manufacturers, publishers, etc., are invited to submit samples or information of new products for review in this section.

QUERIES. We regret that we are unable to answer queries, other than those arising from articles appearing in this magazine; nor can we advise on modifications to the equipment described in these articles.

ALL CORRESPONDENCE should be addressed to THE RADIO CONSTRUCTOR 57 Maida Vale London W9
REMITTANCES should be made payable to "DATA PUBLICATIONS LTD."

Suggested Circuits

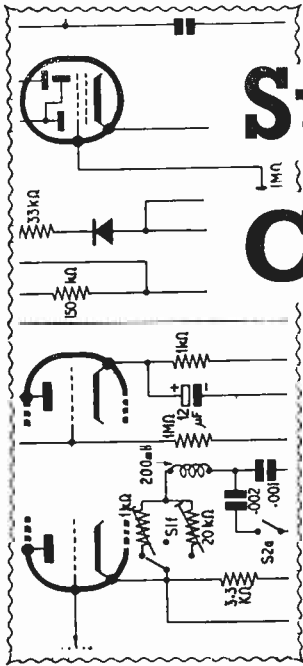

The circuits presented in this series have been designed by G. A. FRENCH, specially for the enthusiast who needs only the circuit and essential relevant data

No. 95 An Inexpensive 3-Valve Broadcast Band Superhet

ONE OF THE MORE INTRIGUING FEATURES of the hobby of amateur electronics is that a number of circuits which by now should have become well established show no evidence of becoming finally stabilised whatsoever. A typical example of a circuit arrangement which should have settled into its own fixed groove many years ago is the "four-plus-one" superhet a.m. sound receiver. The term "four-plus-one" qualifies a valve line-up which has been found, with time and experience, to provide very good results at a proportionately low cost. The "four" refers to the four valves in the receiver—viz. frequency changer, i.f. amplifier, a.f. amplifier and detector, and output valve—whilst the "one" refers to the mains h.t. rectifier.

At the present time the "four-plus-one" type of receiver is still in heavy demand in the commercial field, its specifications satisfying especially the requirements of cheapness and good performance. However, it now appears very frequently as a "three-plus-one," the a.f. amplifier and output valves having been combined in a single envelope. Also, the rectifier may nowadays be a very small

contact-cooled component instead of a valve or a large metal unit.

This month's article describes a three-valve superhet receiver which has been primarily designed with economy in mind. Despite this, the circuit still employs the basic features which are given by its larger and more expensive brethren; and there is no sacrifice of such things as sensitivity and selectivity. The circuit is particularly suited for "miniature" construction, and should be of marked interest to those constructors who like to squeeze a quart into a pint pot. Two features tending to keep cost and space requirements as low as possible are that the number of components is reduced to a minimum consistent with stability, and that layout is made less critical by the use of an "oscillator bias" circuit. This latter enables the cathodes of all valves except the output pentode to be kept at chassis potential, thereby minimising the clustering of components which is otherwise liable to occur around the valveholders. There is also the minor advantage that the risk of possible instability in the a.f. amplifier section is reduced, as there is now no necessity to use

the conventional bias circuit wherein one resistor is common to both triode and pentode cathodes. In addition, the "oscillator bias" arrangement requires slightly fewer components than would otherwise be needed if conventional cathode bias circuits were employed.

The Circuit

The circuit of the receiver accompanies this article. Three valves are employed, these being an ECH81 triode-heptode frequency changer, an EBF89 double-diode-pentode, and an ECL83 triode-pentode a.f. amplifier. A contact-cooled rectifier supplies h.t., whilst a heater transformer provides heater power.

Commencing at the input section of the circuit, it will be noted that a ferrite frame aerial is specified. Such an aerial has been selected because the sensitivity it offers should be more than adequate for most parts of the U.K., and also because such an aerial takes up little space and requires no complex wiring and switching circuits. It was decided to utilise a two-waveband circuit because receivers capable of functioning on medium waves only do not cater for those people who reside outside the range of the Light Programme on 247 metres. If, however, the constructor decides to build a medium-wave-only version of the set, the wavechange switch $S_{1(a)}$ could be dispensed with, a single-coil medium wave frame being connected directly between C_3 and the grid of $V_{1(a)}$.

The frequency changer, V_1 , functions in fairly conventional manner, with the exception that its screen grid is connected directly to the screen grid of the i.f. amplifier V_2 . This method of connection enables a single resistor and condenser, R_1 and C_{12} , to carry out a function normally handled by two separate resistors and two separate condensers. An economy in components is thereby achieved. Another somewhat unfamiliar feature of the frequency changer circuit is that its cathode is returned to chassis, and that the oscillator grid leak is split into two separate resistors, R_3 and R_4 , in series. At the junction of these resistors appears a negative potential which is used for biasing all the valves except $V_{3(b)}$. (The negative potential is a fraction, determined by the values of R_3 and R_4 , of the total given, at the grid of $V_{1(b)}$, by the leaky-grid action of the oscillator). This is the "oscillator bias" circuit referred to above¹. The negative

voltage appearing at the junction of R_3 and R_4 will have a value of approximately 1.5 volts, this being adequate, under conditions of zero a.g.c. voltage, for the frequency changer and i.f. amplifier, and being the correct bias voltage required by the triode section, $V_{3(a)}$ of the ECL83. The negative voltage at the junction of R_3 and R_4 is decoupled by C_4 and is applied to the a.g.c. diode load resistor, R_6 , and to the grid resistor of $V_{3(a)}$, R_9 . We shall deal further with the bias arrangements when we come to consider the detector circuit.

The oscillator section of the frequency changer employs two coils, L_3 , L_4 and L_5 , L_6 , these being switched by $S_{1(b)}$, $S_{1(c)}$. If a medium-wave-only version of the set were envisaged the wavechange switch could be dispensed with, C_5 and C_6 being connected directly to the appropriate windings of L_5 , L_6 .

The intermediate frequency appears at the anode of the heptode $V_{1(a)}$, and is applied to the primary of the first i.f. transformer. The secondary of this transformer connects to the grid of V_2 , which amplifies in normal manner, feeding into the primary of the second i.f. transformer, IFT₂.

The secondary of IFT₂ connects into the detector circuit, this consisting of two sections. The first of these to be considered is the a.f. detector section. The a.f. detector section is provided by diode D_1 of V_2 , the i.f. transformer secondary, and resistor R_7 . Both R_7 and the cathode of V_2 connect to chassis, giving thereby a conventional series diode circuit, detected a.f. being built up across R_7 . The components C_{14} , R_8 and C_{16} next ensure that adequate filtering of i.f. voltages takes place before the detected a.f. is fed to the grid of $V_{3(a)}$. In practical versions of the set it might quite possibly be found that R_8 and C_{16} can be dispensed with, whereupon C_{15} should be connected directly to the top end of the volume control, R_9 .² However, the filtering required in the detector circuit is somewhat dependent on general layout and on any feedback paths which may appear in the practical, built-up model; and the constructor is advised to include R_8 and C_{16} , even if only during the time when the set is being initially brought into working order. Condenser C_{15} carries out the normal function of d.c. blocker, it preventing the rectified negative voltage appearing at the upper end of R_7 from being applied to the grid of $V_{3(a)}$. The volume control, R_9 , has a value which ensures that the a.f. detector a.c./d.c. diode load ratio is sufficiently close to unity to obviate the risk

¹ Oscillator bias has been previously employed in "A Miniature Six-Valve Superhet," by E. P. Meredith. *The Radio Constructor*, August 1955. See, also, Suggested Circuits No. 32. *The Radio Constructor*, August 1953.

² This modification may necessitate increasing C_{14} to 400pF.

of distortion on heavily modulated transmissions. The lower end of R_9 is connected direct to the junction of R_3 and R_4 , thereby ensuring that $V_{3(a)}$ is biased by the 1.5 volt negative potential appearing at this point.

The a.g.c. diode circuit operates in a somewhat different manner. The reason for this is that it is necessary for the a.g.c. line to continually carry the negative voltage provided by the "oscillator bias" circuit, a.g.c. voltages given by signal detection then causing this line to go further negative. This method of operation enables both $V_{1(a)}$ and V_2 to have a standing bias voltage even when absence of signal, or reception of weak signals, causes negligible a.g.c. voltage to appear. To provide the requisite standing negative voltage the a.g.c. diode load resistor, R_6 , is returned to the junction of R_3 and R_4 , and a shunt detector circuit is formed by connecting C_{13} across the two diode anodes of V_2 . The a.g.c. detector circuit is then made up by the secondary of the i.f. transformer connecting to the a.g.c. diode, D_2 , via C_{13} , and to chassis via C_{14} . The fact that R_6 is returned to a point more negative than chassis is unimportant here, due to the shunt detector arrangement. I.F. voltages rectified by the a.g.c. diode cause the upper end of R_6 to go further negative, with the result that a control voltage for a.g.c. purposes becomes available. This voltage is filtered by R_5 and C_3 , after which it is applied to $V_{1(a)}$ via the ferrite frame windings, and to V_2 via the secondary of IFT₁.

The a.f. voltage tapped off by the volume control R_9 is applied to triode $V_{3(a)}$ in normal fashion. This triode couples into the output pentode $V_{3(b)}$, which then feeds, in its turn, into the output transformer and speaker. The 0.01 μ F condenser, C_{18} , across the output transformer primary provides "tone correction" in normal fashion.

High tension is provided by a conventional half-wave rectifier having a minimum rating of 60mA. A contact-cooled component is specified in the circuit diagram, but any other suitable type of rectifier, metal or valve, may be employed instead. (A valve would, of course, necessitate altered specifications for the heater transformer.) The limiter resistor, R_{14} , serves a conventional purpose as, also, do the smoothing components C_{20} , C_{21} and R_{13} .

A heater transformer is employed instead of a dropper resistor as it does not demand such extensive heat dissipating arrangements. Heater transformers seem to compare quite favourably with droppers these days, both cost-wise and space-wise. If, however, it is definitely intended to use a dropper instead of the heater transformer the circuit will still function satisfactorily provided, of

course, that the heater circuit is changed to series operation. Both the ECH81 and EBF89, which have 0.3 amp heaters, are suitable for series running, but it would be necessary to employ a PCL83 (heater 0.3 amp. at 12.6 volts) in place of the ECL83. The PCL83 heater should then be that which is connected at the chassis end of the chain, it being followed by the heaters of the ECH81 and EBF89 respectively.

An anti-mains-modulation condenser, C_{27} , is also shown in the diagram. In some instances it may be possible for this component to be deleted, without loss of performance, but this point can only be determined after the receiver has been built. It should be borne in mind, incidentally, that mains modulation may not be evident when the receiver is employed in one location, but that it may be very troublesome when the receiver is used elsewhere.

Practical Points

The three-valve superhet receiver should not prove too difficult to build and get into working order, provided that the conventional common-sense rules of layout and wiring are observed. In order to reduce any risks of instability IFT₁ and IFT₂ should be mounted on opposite sides of V_2 , IFT₁ and V_2 valveholder being orientated such that a short lead can connect the secondary of this transformer to the grid of V_2 . The wiring and components in the anode and diode circuits of V_2 should be kept well away from this grid lead, and it would be preferable to employ a valveholder having a metal central spigot in this position. The metal spigot should be connected to chassis. It will be found that the pin layout of the EBF89 lends itself very readily to these requirements. A further point is that condenser C_{12} should be mounted close to V_2 rather than close to V_1 . Condensers C_3 and C_4 should be mounted fairly close to V_1 . The leads to the ferrite frame should be dressed away from the i.f. and a.f. stages. The ferrite frame itself must, of course, be kept clear of metal parts and of the chassis.

The alignment of the receiver will be quite conventional. The writer has specified good quality branded components (Teletron) both for the ferrite frame and for the oscillator coils, as this enables him to give firm values and circuitry for the frequency changer stage.

Warning

Before concluding this article it must be emphasised that the circuit described above employs a "live" chassis, and that all the relevant precautions must be taken to prevent shock and accident.

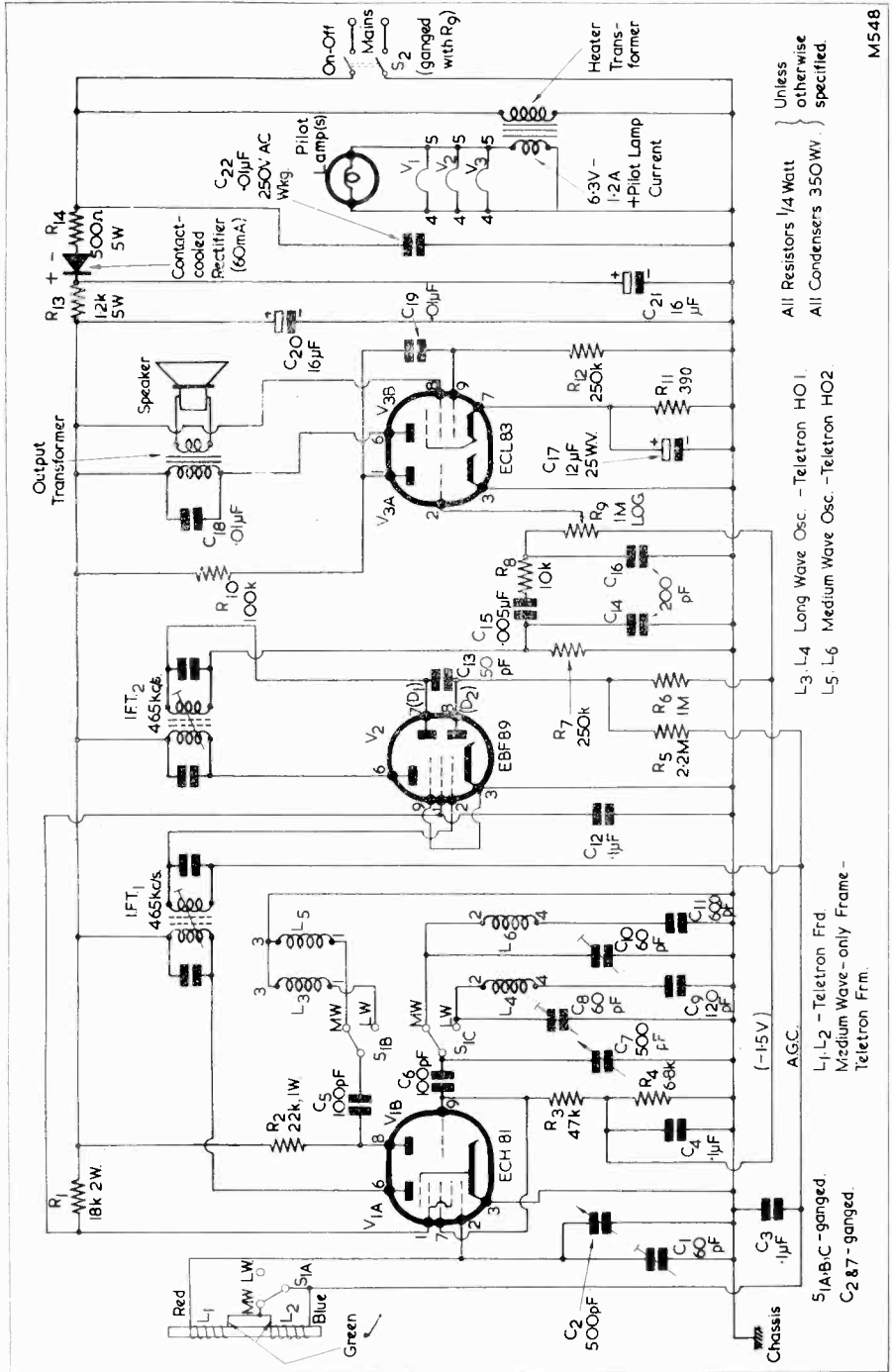

All Resistors 1/4 Watt
 All Condensers 350WV } Unless otherwise specified

L3, L4 Long Wave Osc. - Teletron HO 1.
 L5, L6 Medium Wave Osc. - Teletron HO 2.

(-15V) AGC.
 L1, L2 - Teletron Frd
 Medium Wave - only Frame -
 Teletron Frm.

S1A, B, C - ganged
 C2 & 7 - ganged



Aided by his able assistant, Dick, Smithy the Serviceman continues to run the Workshop

"SHE'S A BIG FAT GIRL," SANG DICK, AS he energetically applied himself to his work.

*"Twice the size of me,
Hair, before she washes it,
Like branches on a tree,
She can run, jump, push, dig,
Wheel a barrow, dance a jig,
That's my girl, Salome!"*

Dick emphasised the last words of his song by crashing his soldering iron down on its rest, whereupon he then proceeded to carry the set he had just finished over to the "Repaired" rack.

"There you are, Smithy," he called out to the long-suffering Serviceman, "that's five this morning. This is going to be one of those good days!"

"It's certainly going to be one of those nostalgic days," replied Smithy over his shoulder, "if you keep singing all those old war-time songs. What's happened to your predilection for rock-'n'-roll?"

"You mean, have I lost the message?" asked Dick, as he carried a small medium and long wave receiver back to his bench. "Oh, that's old stuff. My uncle stayed with us over the week-end and he taught me quite a few of those war-time songs. You know, there's plenty of life in them."

"With their original words, yes," chuckled Smithy. "Anyway, if singing them keeps you on your toes, I suppose that you'd better keep at it."

Unstable I.F.

However, Dick's vocal enthusiasm began to show signs of waning as he concentrated on the receiver he had just selected for repair. It was an inexpensive superhet in a plastic cabinet, and it employed a ferrite frame aerial. Dick had first of all connected the receiver to the mains, switched on and waited for it to warm up. After a short while the receiver had come to life, whereupon Dick swung the tuning knob across the band. The set appeared to have normal sensitivity and selectivity, and there was no evidence of any fault condition on either of the two bands. Suspecting an intermittent snag Dick frowned a little. He looked inside the cabinet for any obvious faults which could possibly cause trouble, but his examination was fruitless. The receiver had an aerial input socket and Dick idly connected the bench aerial to this. The receiver became rather more sensitive, but the increase was not marked. Also, there was still no evidence of any fault.

Dick removed the aerial, to find that the receiver reproduction suddenly appeared to suffer from noticeably increased top-cut. He detuned the receiver slightly off the station to which it had been set, whereupon very heavy distortion became evident. Dick re-connected the aerial and the distortion cleared, reverting to that normally given by an off-tune a.m. receiver. Dick removed the aerial from the receiver socket once more.

This time, not only did the distortion return but it was also accompanied by a whistle which was of the same order of loudness as the programme modulation. As Dick tuned through the station the whistle changed in note, being at zero-beat when the set was correctly tuned in. Indeed, apart from the marked top-cut (which Dick, rightly, attributed to the greater selectivity offered by the i.f. tuned circuits when feedback was present), the reproduction was still of entertainment value at this setting of the tuning dial.

Dick's brows settled into a deeper frown. After disconnecting the receiver from the mains, he removed its chassis from the cabinet, reconnected the mains, and switched on. When a few moments had passed the set commenced working, correctly. However, a minute or so later the whistle re-appeared, clearing only when the bench aerial was applied.

"Smithy," called out Dick. "I've got quite a queer snag here. Could you have a look at it for me, please?"

The Serviceman wandered over to Dick's bench and listened to his assistant's description of the receiver's fault symptoms. He then adjusted the tuning control of the receiver with and without the aerial. The same symptoms were evident on all stations received.

"What makes you think that?" asked Dick.

"There are several reasons," replied Smithy. "The first of these is that the whistle you get when detuning is relatively weak. When a sound receiver goes unstable in the i.f. stage the resulting heterodynes are usually so fierce that it is well nigh impossible to receive a station without considerable distortion. Also, in this case, the whistle clears when you apply an aerial, which means that a small extra amount of a.g.c. voltage is sufficient to stop oscillation."

"Why do you say a *small* amount of a.g.c. voltage?" asked Dick. "Shouldn't applying an aerial cause a *considerable* increase of sensitivity and, hence, a.g.c. voltage?"

"Not in this type of receiver," replied Smithy. "You see, this particular set employs a ferrite frame which, under normal conditions, is more than adequate for reception of the stations the ordinary listener requires. When an aerial socket is provided the circuit coupling this to the input tuned circuit is usually, therefore, of a very simple order indeed. This receiver is a case in point. If you look at it you'll see that the aerial socket is connected to the input tuned circuit by a low-value condenser only." (Fig. 1.)

"That's true enough," confirmed Dick, as

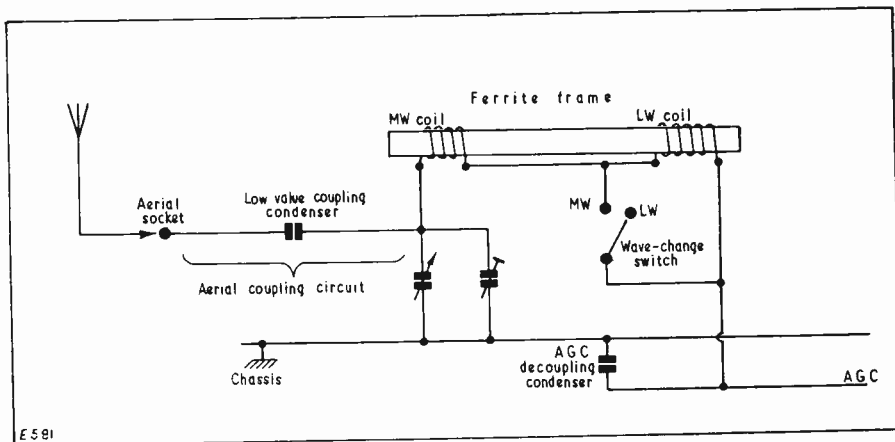

Fig. 1. In receivers which are intended to function, in most instances, with their own ferrite frame aerials, external aerial coupling circuits usually take up very simple forms. The tuning condenser and wavechange switch shown here are ganged with similar components in the oscillator section

"Well," he remarked, at length, "it seems to me that all you've got here is a case of i.f. instability. With the qualification that the receiver is only just breaking into oscillation."

he examined the chassis, "and the series condenser fitted here has a puffage of five only. Why do the manufacturers use a coupling arrangement like this, Smithy?"

"There is one reason only," laughed the

Serviceman, "to save lolly! A much better arrangement would consist of fitting an aerial coupling winding to the ferrite frame. However, the receiver is meant to be as inexpensive as possible and it is intended to be run with its own internal aerial in almost all instances; with the result that the additional cost of fitting coupling windings is just not justified."

"Nevertheless," said Dick, "a 5pF coupling condenser is hardly liable to cause much transfer of energy at medium and long wave frequencies."

because the heterodyne whistles were weak and because they ceased after the small increase in a.g.c. voltage given by plugging in an aerial. Incidentally, there is also the fact that the oscillation doesn't commence until the set has been switched on for some five minutes or so. Assuming no other fault, it wouldn't be too unreasonable to assume that the oscillation can only commence when the valves have warmed up sufficiently to give their last final ounces of slope."

"O.K.," said Dick briskly. "Now where do we go from there and what do we do?"

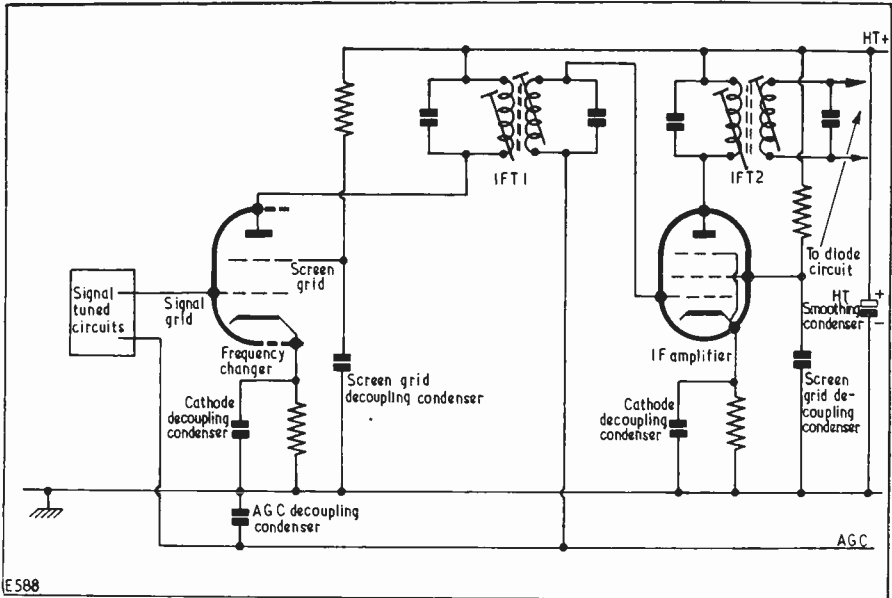

Fig. 2. Illustrating the various decoupling condensers referred to by Smithy whilst discussing i.f. instability. Only two grids (the screen grid and signal grid) of the frequency changer are illustrated

"It isn't," agreed Smithy. "To get the best results from such an input circuit you would need quite a large aerial, and certainly one that is better than the bits of wire which are strung across the Workshop. Increasing the value of the coupling condenser would increase energy transfer from the aerial, but it would also result in greater detuning and damping of the input tuned circuit when an aerial was connected. So the 5pF condenser represents a compromise. A compromise in a piece of circuitry which, I must repeat, is normally not required."

"Anyway, we're straying away from the original point. I said a few moments ago that the receiver was only just oscillating

Clearing the Fault

"Oh, the usual sort of thing," replied Smithy carelessly. "First of all shunt the appropriate decoupling condensers with one known to be good. As with all sets of this nature, one electrolytic condenser bypasses all the h.t. returns." (Fig. 2.) "Slap another electrolytic, with short leads, across the one in the chassis."

Detuning the receiver slightly, so that the whistle became evident, Dick did as he was bid. There was a spark as the external condenser bridged that in the receiver, but the whistle remained unchanged.

"Hmm," said Smithy, frowning. "Try another condenser, say of 0.01μF, across the

electrolytic. Sometimes a conventional electrolytic has a high impedance to r.f., and a paper or ceramic condenser across the h.t. line clears instability."

Dick found a $0.01\mu\text{F}$ condenser and followed Smithy's instructions. The whistle remained unaltered.

"Fair enough," remarked Smithy. "Now try your $0.01\mu\text{F}$ condenser across the condensers decoupling the i.f. amplifier and frequency changer screen grids. As is to be expected, the a.g.c. line has only one decoupling condenser, so I should next shunt your test condenser across that. Although it is doubtful if they are causing any trouble, I should finish off by putting your test condenser across the cathode bias decoupling condensers. You never know."

the whistle remained. When you applied it to the output anode the top-cut was less, because of the reduced impedance at this point, but there was still a whistle."

"These last tests don't make a lot of sense to me," commented Dick. "What were we looking for?"

"We were looking for the presence of i.f. in the a.f. stages," replied Smithy, "with consequent amplification and feedback. Applying the $0.01\mu\text{F}$ condenser across the points I mentioned was a brute-force method of bypassing any i.f. which might be present down to chassis. If we'd found that the whistle cleared when the $0.01\mu\text{F}$ condenser was connected to the grid or anode of the first a.f. amplifier I would have assumed that i.f. was present at these points and would

Fig. 3. It is possible, in occasional cases, for i.f. instability to occur if a tone-correction condenser connected directly across the output transformer primary goes open circuit. The value for a condenser in this position is normally of the order of $0.01\mu\text{F}$

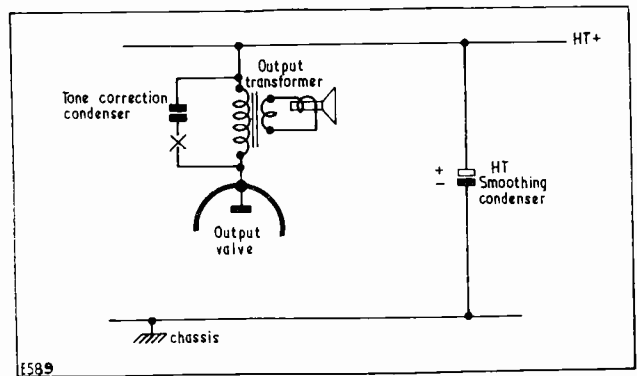

Dick connected his test condenser across all the points suggested by Smithy, but the whistle still remained.

"This needs a little further examination," commented the Serviceman. "If this were an older receiver I would say that we should also have checked the metallising on the frequency changer and i.f. valves for adequate connection to chassis. But on modern valves there ain't no metallising!"

"Our next step, therefore, is to have a quick wander into the a.f. department. Would you please apply your $0.01\mu\text{F}$ condenser between chassis and the following points: the grid and anode of the first a.f. amplifier, and the anode of the output valve?"

Whilst his assistant carried out these checks Smithy listened attentively.

"No go," he remarked, a little disconsolately, when Dick had finished. "When you applied your condenser to the grid, and then to the anode, of the first a.f. valve there was plenty of top-cut, as one would expect, but

have undertaken a few very quick experiments to clear it. Quite often I have cleared up instability of the type we have here by the simple process of connecting a 100 or 200pF condenser between the grid or anode of the first a.f. amplifier and chassis. The initial test with the $0.01\mu\text{F}$ condenser would have given me a lead as to where I should apply the lower value condenser. Putting the $0.01\mu\text{F}$ condenser between chassis and the output valve is, similarly, a check for the same sort of thing. I remember one or two occasional cases in which an open-circuit tone-correction condenser" (Fig. 3) "has caused i.f. instability. The test you've just done would have shown that up."

"Well, we don't seem to have cleared up the trouble," remarked Dick.

"We haven't," agreed Smithy. "And yet we've checked all the points which, in some ninety-nine cases out of a hundred, would have led us to the cure. Incidentally, although it has taken me quite a while to describe the test procedure you've just

followed, its actual carrying out, in practice, takes only a few minutes.

"Anyhow, we haven't cured the receiver, and so we must carry on to Stage Two. You can do this quite easily yourself. First of all, make a quick check of anode, screen grid and cathode potentials in the frequency changer and i.f. stages. If these show nothing madly wrong, pop in new bottles in these stages, giving the new valves plenty of time to warm up so that the instability has a chance to show. After that, report smartly to me."

"Aye, aye, sir," said Dick.

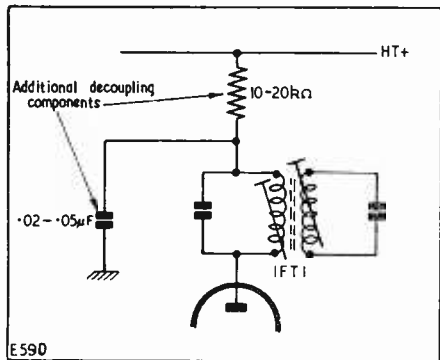

Fig. 4. Very obstinate instability may sometimes be cleared by providing additional decoupling as shown here. The frequency changer anode circuit shown here should be compared with that of Fig. 2

Further Decoupling

Smithy returned to his own work whilst Dick carried out his instructions. After some ten minutes had passed, Dick called out to the Serviceman.

"I'm afraid it's still the same," he remarked.

Smithy returned to the faulty receiver.

"Well, we've certainly got something on our plate this time," he commented. "It almost looks as though the set, in its manufactured form, is inherently unstable. Funnily enough, I've bumped into several sound receivers like this recently. I don't know why it should be, but those with ferrite frame aerials seem to have a greater tendency to instability than do sets with normal aerial coils. Perhaps it's the widely spread magnetic field in the frame which causes unwanted couplings."

"Could we cure the instability by damping one of the i.f. windings with a resistor?" asked Dick.

"Certainly not," replied the Serviceman. "If it's necessary to apply some form of attenuation to the i.f. amplifier there's no point in reducing its selectivity as well. No, I think the first thing we should do is to add extra decoupling to the frequency changer anode circuit. Like this." Smithy scribbled out a circuit (Fig. 4). "The value I've specified here for the decoupling condenser 0.02 to 0.05μF, is rather high for a job of this nature, but no harm should result from our erring on the generous side."

Whilst Smithy was talking, Dick had started connecting the additional decoupling components into circuit. When he had finished he switched on the receiver again—to find that the instability had, at last, cleared.

Smithy raised a somewhat cynical eyebrow.

"We were dead lucky there," he confessed.

"The chances of that additional decoupling removing the instability were quite low."

"What would you have done if the instability had remained?" asked Dick.

"I would have had recourse," replied Smithy, "to what I can only describe as 'cheating.' There are one or two last-ditch dodges which I've used now and again, but I've never really liked employing them. One of these consists of reversing the connections to the primary of the first i.f. transformer. If you're lucky, this will change the feedback from positive to negative. However, even if it does effect a cure, I still don't look upon it as a nice thing to do because it means that you're using the first i.f. transformer in a manner different to that intended by the designer of the set. Another dodge, if you really have your back to the wall, is to insert a small resistor in series with the grid of the i.f. valve (Fig. 5 (a)). This is better than your suggested idea of damping out one of the i.f. windings because it does not reduce the selectivity they offer. To my mind, the series resistor is nothing more or less than a common or garden attenuator, it causing, in combination with the grid-cathode capacity, a reduction in signal input level to the valve (Fig. 5 (b)). Fitting a series grid resistor is, therefore, really an admission of defeat; although I must admit I've had to do it myself on one or two very rare occasions. I've usually said to myself that so long as the series resistor doesn't have a value higher than 1kΩ, its fitting isn't too bad a modification from the technical point of view."

Dick looked a little glum.

"We certainly seem to have got into the wars this time," he remarked. "And all because of a footling little broadcast band set."

"Sometimes," said Smithy, "the jobs which look the simplest are the worst. Incidentally, talking about getting into wars,

in what war was that uncle of yours who taught you those songs?"

"He wasn't in any war," replied Dick, innocently. "He's the one who's the steward at your club."

perfectly. I was just about to put the set back on the rack as being repaired, when I had a look inside the dud rectifier. As far as I could see, the wire in the internal structure connecting to the cathode seemed

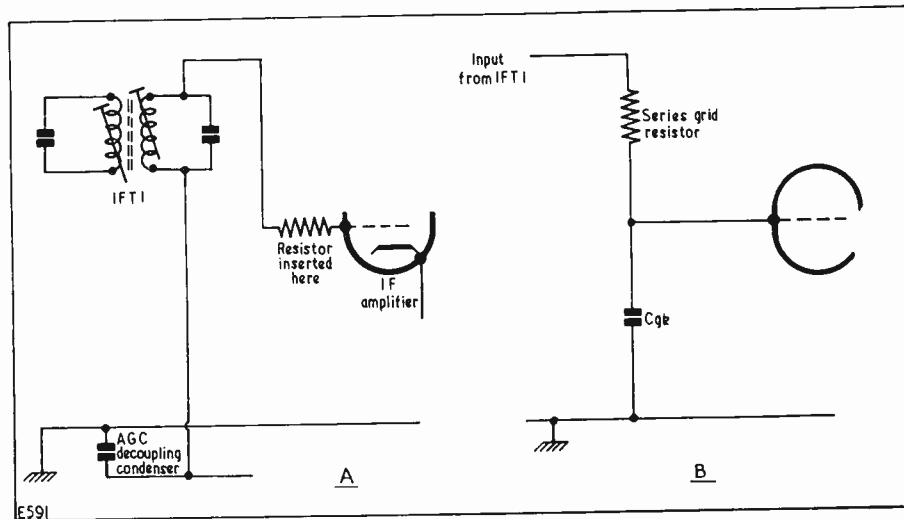

Fig. 5 (a) Inserting a low-value resistor in series with the grid of an i.f. amplifier, as described in the text. (b) In company with the capacity between grid and cathode the series resistor forms the top section of a potentiometer, thereby causing some attenuation of the signal from the first i.f. transformer

Quick Answers

Smithy forebore to answer, and returned to his work. Dick, now that the medium and long wave set had been cleared, re-applied himself zealously to his own job. As a result the Workshop once more became filled at intervals with what Smithy recognised with relief were bowdlerised versions of songs which had never achieved the protection of copyright.

The morning passed so quickly that both Smithy and his assistant were surprised when lunchtime loomed close. Dick, who had been mentally accumulating a stock of queries in the interval, decided to tackle Smithy on these.

"You know, Smithy," he remarked, interrupting the Serviceman as he prepared for his lunch, "I had *another* little broadcast set this morning which I couldn't finally cure."

"Oh, yes?" replied Smithy, with something of a lack of interest in his voice.

"Yes, indeed," pursued Dick. "When I switched it on there was no h.t., and the rectifier seemed to have failed. I tried a new rectifier—the set used a valve rectifier—after checking for h.t. shorts, and the set went

to have just melted away. So I decided to leave the set on one side until I spoke to you about it."

"You did right there," remarked Smithy. "I've had one or two cases like that myself. What I've found is that, when the rectifier shows visible signs of excessive loading, the associated receiver has insufficient limiting in the rectifier circuit. If, indeed, it has any at all. (See Fig. 6.) The risk when there is insufficient limiting occurs when the set is switched off and switched on again whilst the rectifier cathode is still at emitting temperature. Since the reservoir condenser would then be discharged a very heavy initial current can flow, and it's quite possible for the rectifier, or the reservoir electrolytic, to go pop under such circumstances."

"I see," remarked Dick thoughtfully. "I suppose that the real answer to a set of that type is to fit a limiter resistor as well as a new rectifier."

"That's right," remarked Smithy cheerfully, seeing an end to the conversation. "A couple of hundred ohms at a few watts is all you need for the limiter resistor in simple sound receivers, and you can insert it either side of the rectifier. (Fig. 6.) Do that, and

you won't see the set back any more for rectifier trouble."

"Won't the limiter resistor cause the h.t. voltage to drop?"

circuit conditions the relay energises and its changeover contact breaks the h.t. supply to the equipment and connects to resistor R₂. Resistor R₂ causes the relay to remain in the

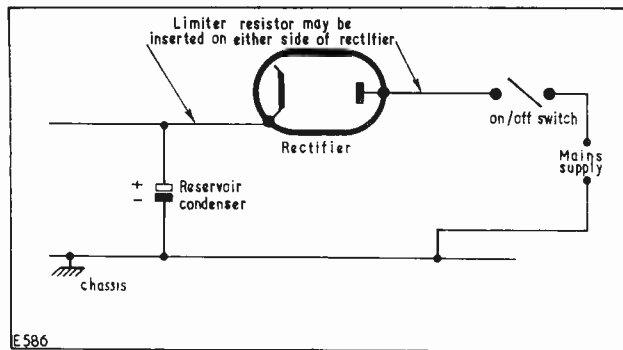

Fig. 6. A resistor, to limit surge currents, may be inserted on either side of the h.t. rectifier

"Only by a few volts in most cases," said Smithy, shortly. "Nothing to worry about." He glanced pointedly at the clock.

"Another thing," continued Dick, relentlessly. "I've got a piece of experimental gear at home which is always blowing h.t. fuses when I work on it. Is it possible to make a simple h.t. cut-out which will save all this business of replacing fuses?"

Smithy, with a look of desperation on his face, grabbed a piece of paper and scribbled a circuit on it. (Fig. 7.)

energised position and you press the push-button to de-energise the relay when you've cleared your short. If you like, you can connect a warning neon across R₂ to tell you when the cut-out has tripped. Resistor R₁ has a value which just prevents the relay from energising under normal h.t. current conditions and resistor R₂ has a value which just maintains the relay in the energised position after it has tripped. The only critical part of the arrangement is in the contact setting.

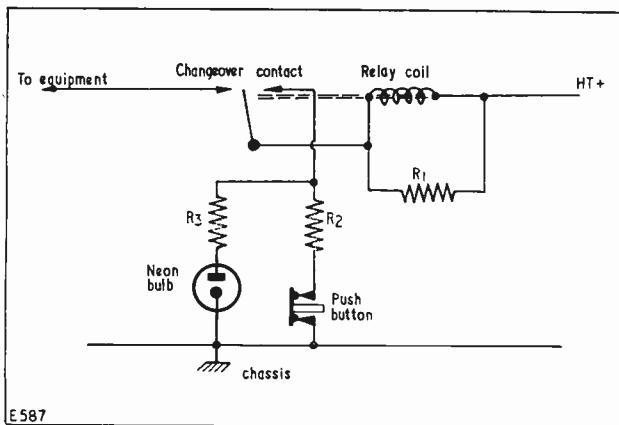

Fig. 7. A simple h.t. cut-out. The neon bulb, together with its series resistor R₃, provides warning that the cut-out has tripped

"Here you are," he said. "The circuit of a simple h.t. cut-out. Normally, the h.t. current flowing through the coil of the relay is insufficient to energise it. Under short-

You have to make certain that, during energising, the changeover contact makes its connection to R₂ before breaking the h.t. supply to the equipment"

"I can see a snag here," remarked Dick, slowly. "Once the relay has tripped you need a current greater than the normal h.t. current to keep it energised."

"Not entirely," said Smithy. "The current needed to *keep* a relay energised is quite a lot lower than that needed to actuate it. And now, my boy, it's time for my lunch."

Dick grinned.

"O.K. Smithy," he remarked, "I'll leave you in peace. I shan't even tell you about my brother Sylvest's possessions."

"What's he got?" asked Smithy, unguardedly.

"He's got a row of forty medals on his chest," sang Dick triumphantly, neatly dodging Smithy's egg and tomato sandwich.

THEORY



UNDERSTANDING TELEVISION

PART 10

By **W. G. MORLEY**

The tenth in a series of articles which, starting from first principles, describes the theory and practice of television

IN LAST MONTH'S ARTICLE WE INTRODUCED the subject of the tuner unit which constitutes the "front end" of the modern television receiver. We shall now carry on to a detailed examination of the circuits these units employ.

The Cascode

Conventional television tuner units employ two valves, one of these being an r.f. amplifier whilst the other is a combined oscillator and mixer valve. In order to assist in a description of the functioning of the tuner unit, it is helpful to consider the circuits in which each valve works as a separate item, these being joined together by a bandpass tuned circuit adjusted to respond at signal frequency.¹

This arrangement is illustrated by the block diagram of Fig. 51. We shall begin with the r.f. amplifier section.

The valve circuit arrangement which is at the present moment universally employed in Great Britain for television tuner r.f. amplifier stages is the *cascode*. A cascode amplifier incorporates a double triode valve which is especially designed to operate at frequencies up to the highest encountered in Band 3. The cascode offers a high signal/noise ratio at Band 3 frequencies, especially when compared with more conventional amplifiers such as pentodes. Cascode valves currently employed in British tuners are the PCC84, 30L1, 7AN7 and B319 (all of different manufacture and directly interchangeable). Cascode valves having frame grids² and

¹ Signal frequency, as opposed to such terms as oscillator frequency and intermediate frequency, refers to the frequency of the desired signal as picked up by the aerial.

² A frame grid differs from the normal type of grid element insofar that it has thinner wires which are mounted closer together (if this is desired) and which are secured to a rigid "frame."

consequently improved performances have been introduced on the Continent and in the United States, and should be used shortly in this country as well. These new valves should then oust the types just mentioned, which have tended to become "standard" during the past few years.

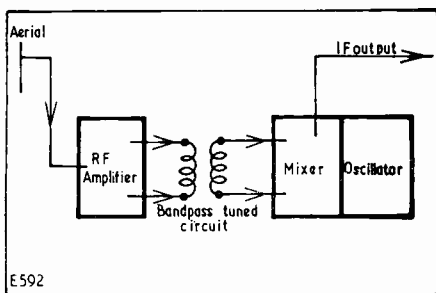

Fig. 51. Block diagram illustrating the basic sections of the television tuner unit

Fig 52 illustrates the basic circuit in which a cascode valve appears. As will be seen, the anode of one of the triodes connects, via a *peaking choke*, to the cathode of the second triode. Of the two triodes, the lower one functions as an earthed cathode amplifier (Fig. 53 (a)), whilst the second acts as an earthed grid, or grounded grid amplifier,³ (Fig. 53 (b)). An earthed cathode amplifier has the advantage of possessing a high input impedance, that between grid and cathode, and the disadvantage, when it is working at radio frequencies, of allowing feedback to occur between anode and grid circuits due to the unavoidable capacity which exists between these two elements. Such feedback can result in instability unless a suitable neutralising circuit is provided, the purpose of the neutralising circuit being that of feeding a second signal from the anode to the grid in such a manner that it is 180 degrees out of phase with that passed via the anode-grid capacity. When the neutralising circuit is adjusted such that the out-of-phase signal is equal in amplitude to that passed via the anode-grid capacity the effect of the latter becomes cancelled out, and the valve is capable of amplification without instability.

The difficulties caused by feedback do not arise in the grounded grid amplifier. This is partly due to the fact that in this case the input signal is applied to the cathode and

that this element is screened from the anode by the grounded grid. In consequence the capacity between anode and cathode can be made very low, and feedback between output and input circuits kept down to a negligible level. Because of the low level of feedback in the grounded grid amplifier it is extremely useful for r.f. amplification at Band 3 frequencies. It suffers, however, from the disadvantage that it has a low input impedance.

The cascode amplifier circuit makes use of the advantages of both the earthed cathode and grounded grid amplifiers, whilst causing their disadvantages to be largely overcome. The earthed cathode triode is that to which the input signal is applied, with the consequence that a high impedance input circuit becomes available. The anode of the first triode then feeds into the low impedance of the grounded grid triode. Because of this low impedance the first triode provides little voltage amplification, and the risk of instability due to feedback via the anode-grid capacity is correspondingly reduced. When considering the cascode it might prove of assistance to look upon the function of the first triode as that of "driving" the second triode, it offering little voltage amplification in the process. The second triode, functioning as a conventional grounded grid amplifier, makes the major contribution to overall voltage amplification. (In order to enable h.t. supply connections to be made, the "ground" connection to the second triode is made via a high value condenser having a very low impedance at the signal frequencies being handled.)

As we have already seen, a peaking choke is shown in Fig. 52, this being inserted between the anode of the first triode and the cathode of the second triode. This choke is part of a pi tuned circuit which, in most tuner designs, resonates at a frequency slightly higher than the highest signal frequency which the associated tuner unit is to handle, and its main function is to provide increased gain at these higher frequencies.⁴ Due to the fact that increased gain is given at frequencies close to that at which the peaking choke tunes there is a tendency in some tuner units for the r.f. amplifier to approach instability at these frequencies. The regenerative effect given thereby may increase gain and this is a desirable characteristic, provided that actual instability does not occur. The capacities tuning the peaking choke are shown in Fig. 54, and consist of the capacity between anode and cathode of the first triode, the capacity between cathode and grid of the second triode, together with "stray" capaci-

³ The word "ground" is used in American terminology instead of "earth," with the result that the alliterative expression "grounded grid" has become generally accepted.

⁴ A pi tuned circuit has the arrangement shown in Fig. 54, and is so called because the circuit elements take up the form of the Greek letter π .

ties (as exist between wiring and chassis, and so on.)

The circuit arrangement of Fig. 52 represents the basic cascode circuit encountered in practically all commercially available television tuners. Despite the fact that the cascode arrangement largely overcomes the

do not employ variable components, such as trimmers, to enable adjustments for optimum neutralising to be made. Fixed value components, with fairly close tolerance, are used instead.

A final point of interest in the cascode valve itself is that this has two cathode pins

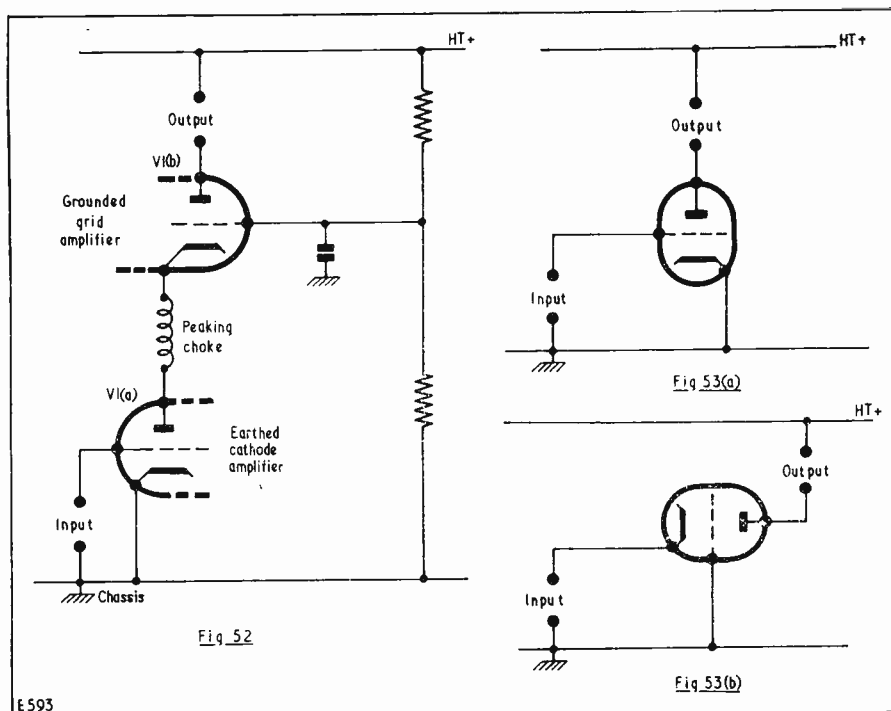

Fig. 52. The basic cascode r.f. amplifier circuit, as employed in television tuners. No bias circuit is shown for the earthed cathode amplifier, and this would normally be provided by cathode bias, by applying a negative voltage to the grid, or by a combination of the two. The output circuit would normally consist of the primary coil of the bandpass tuned circuit of Fig. 51. The condenser coupling the grid of the second triode to chassis has a low impedance to r.f., and the voltage provided at the junction of the two resistors is roughly half the h.t. potential

Fig. 53 (a) An earthed cathode amplifier

Fig. 53 (b) A grounded grid amplifier

risk of instability in the earthed cathode triode, it is still common practice to employ a simple neutralising circuit around this valve. Such a circuit, when correctly adjusted, helps to reduce noise generated in the input circuit, and also reduces the amount of voltage at oscillator frequency which may find its way back to the aerial and be subsequently radiated.⁵ Such radiation can cause interference with other receivers. In many practical tuners cascode neutralising circuits

for the first triode instead of one. These pins connect inside the glass envelope to the cathode element itself and have the effect of reducing the inductance in the cathode wiring. Fig. 55 (a) shows a valve having a single cathode lead, whilst Fig. 55 (b) illustrates the inductance offered by that lead.

⁵ The neutralising circuit component values required for minimum noise generation and for minimum oscillator radiation may both slightly differ from each other and from that which provides optimum neutralising at signal frequency.

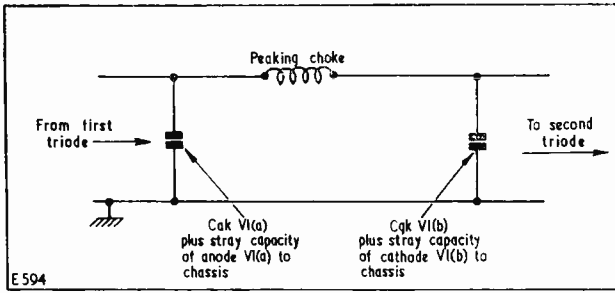

Fig. 54. The capacities tuning the peaking choke of Fig. 52. "C_{ak}" and "C_{gk}" refer to capacities between anode and grid and cathode and cathode respectively

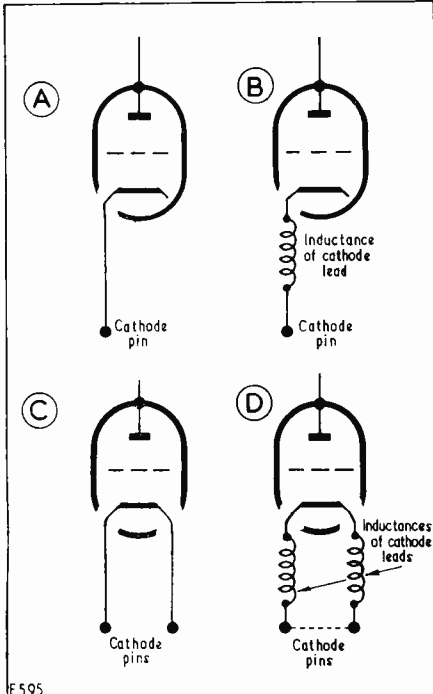

Fig. 55 (a) A conventional internal cathode connection. (b) Illustrating the inductance of the single cathode lead inside the valve envelope. (c) Two internal cathode leads are shown here, these connecting at one end to separate pins and at the other end to the cathode. (d) The inductances of the two cathode leads. When the pins are joined together (as shown by the dotted line) the overall inductance is significantly lower than that of the single cathode lead

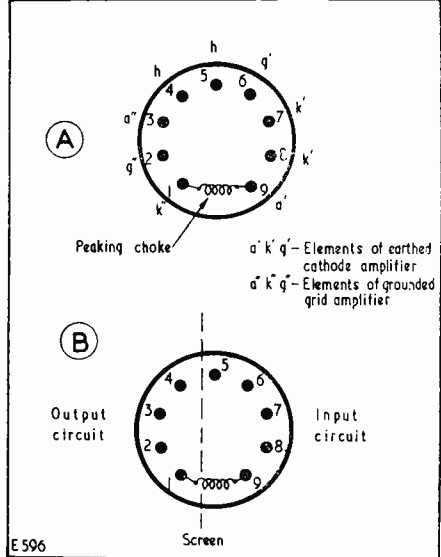

Fig. 56 (a) The pin layout of the B9A-based cascode amplifier enables the peaking choke to be conveniently mounted between pins 1 and 9. (b) In most tuners a screen passes across the cascode valvebase, as shown here, giving good isolation between input and output circuits. (In the valve itself, an internal screen between the two triodes is connected to the grounded grid pin)

In Fig. 55 (c) we have a valve having two cathode leads. The inductances of these two leads can then be connected in parallel, as is shown in Fig. 55 (d). The result is that the overall inductance in the cathode circuit of Fig. 55 (c) is significantly lower than that in the cathode circuit of Fig. 55 (a). This point

is of interest here not only because it represents an important feature of cascode valve design, but also because it brings home forcibly the fact that even the inductances of straight pieces of wire have to be considered in the design of amplifiers working at Band 3 frequencies.

Another feature in the pin layout of the cascode valve is that, with B9A valves, the anode of the first triode is brought out to pin 9 and the cathode of the second triode to pin 1. This layout enables the peaking choke to be very conveniently mounted between these pins. See Fig. 56 (a). The remaining pins of the cascode valve are laid out so that the centre screen of the associated tuner may straddle the valvebase across its centre, as shown in Fig. 56 (b). Such a layout enables the input and output wiring to the cascode valve to be efficiently screened from each other.

outer conductor of the coaxial cable is connected effectively to earth at the television chassis. (It is this earth connection which causes the input circuit to be termed "unbalanced." A "balanced" input circuit has both conductors of the feeder disconnected from earth.)

The aerial coil, L_1 , L_2 , of Fig. 57 consists of an r.f. transformer, the secondary of which, L_2 , is tuned to resonate at signal frequency. L_2 has more turns than the primary winding, L_1 . The ratio of secondary to primary turns is such that the 75 ohm impedance of the aerial feeder is correctly matched into the input impedance of the cascode. The secondary winding of the aerial coil is tuned by adjustment of an internal core which is normally brass for coils working at Band 3 frequencies, and which is brass or iron-dust for coils designed to work at Band 1 frequencies. The capacity

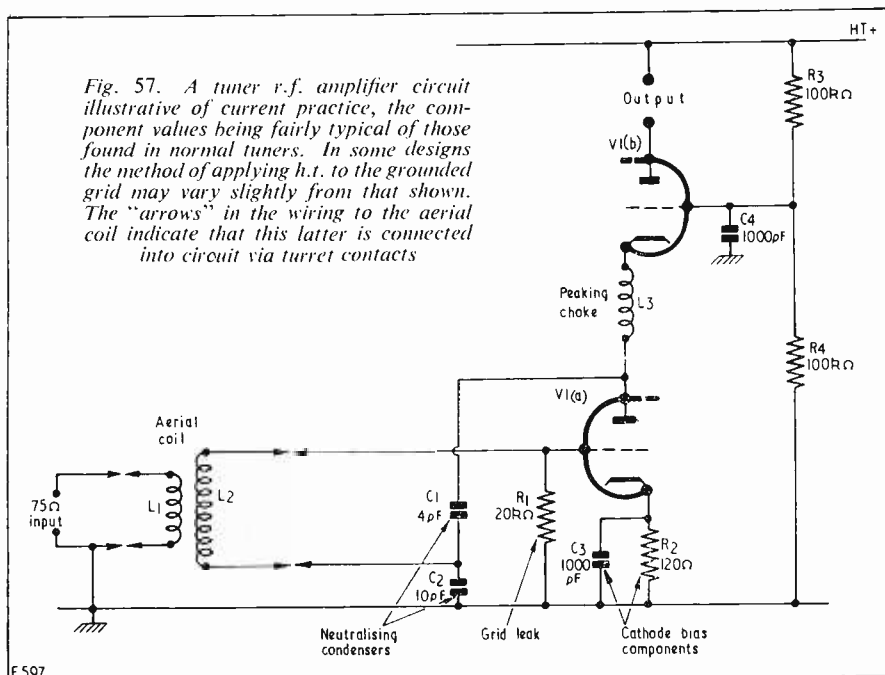

The Aerial Input Circuit

Fig. 57 illustrates a cascode stage typical of those encountered in British television tuners. Starting at the left-hand side of the circuit, we have the aerial input. In Britain the standard aerial input impedance for television receivers is 75 ohms unbalanced, the feeder between the aerial and the receiver consisting of 75 ohm coaxial cable. The

completing the tuned circuit in which the secondary winding appears is provided by the cascode valve and by stray capacities. However, the presence of the neutralising capacitors C_1 and C_2 makes the situation slightly more complex and it is necessary to study the effect that these components have before determining the capacities which tune L_2 .

In Fig. 58 (a) we see the secondary of the aerial coil connected to the first triode in the same manner as it is in Fig. 57. We also see the "hidden" capacities which are contributed by the valve. As we have already mentioned, feedback occurs via the capacity between anode and grid of the first triode, and this capacity is represented in Fig. 58 (a) by C_{ag} .

C_2 . Since the voltage at one end of the inductance of a tuned circuit at resonance is 180 degrees out of phase with the voltage at the other end, the neutralising voltage given at the junction of C_1 and C_2 appears at the grid 180 degrees out of phase with the voltage passed via C_{ag} . Provided that C_1 and C_2 have the requisite values the neutralis-

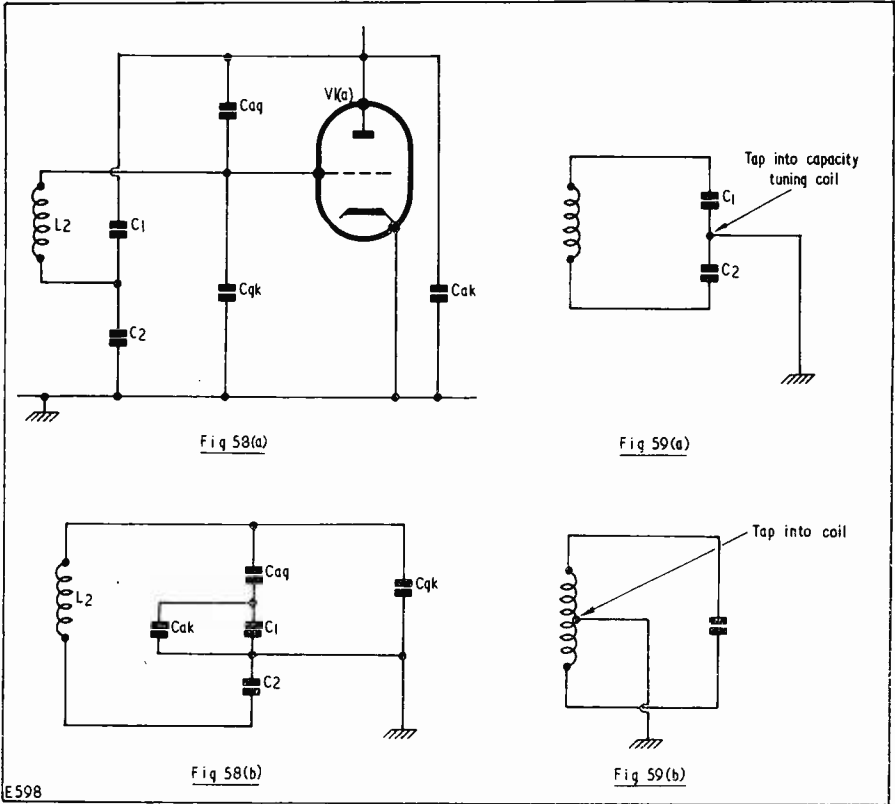

Fig. 58 (a) The "hidden" capacities appearing in the circuit around $V_{1(a)}$ and L_2 of Fig. 57. (The suffix letters a, g and k refer to anode, grid and cathode respectively.) (b) The circuit of (a) re-arranged to show more clearly the capacities tuning L_2 . Fig. 59 (a) A tuned circuit having a tap into its capacitive section. (This circuit is similar to that of Fig. 58 (b), the capacities C_{ak} , C_{ag} , C_{gk} and C_1 of that diagram being combined into a single condenser, shown here as C_1 .) (b) A tuned circuit having a tap into its coil

In order to neutralise the first triode it is necessary to apply a second r.f. voltage, which is equal and opposite in phase to the feedback voltage, to the grid. This second voltage is fed to the end of L_2 which is remote from the grid by means of the condenser potentiometer provided by C_1 and

ing voltage appearing at the grid will be equal to the feedback voltage via C_{ag} , and correct neutralising will occur. Fig. 58 (b) shows the circuit of Fig. 58 (a), rearranged, to illustrate the capacities tuning L_2 .

The neutralising effect may be more clearly studied if the circuit of Fig. 59(a) is examined.

This diagram shows the manner in which an earth tap is made into the *capacity* tuning the coil (as occurs in Fig. 58 (b)). The resultant effect, at resonant frequency, is exactly the same as if an earth tap had been made into the *coil*, as in Fig. 59 (b). In either instance both ends of the coil carry r.f. potentials, and in either instance these r.f. potentials are 180 degrees out of phase with each other. We should now look a little further into the fact that there is a point somewhere between the ends of the coil of Fig. 59 (a) which is at earth potential so far as r.f. at the resonant frequency is concerned. The position of this "earthy" point will shift along the coil as the values of the condensers C_1 and C_2 change. If C_1 and C_2 both have the same value, the "earthy" point will be at the centre of the coil. If C_2 has a lower value than C_1 (and, consequently, a higher impedance) the "earthy" point will be above the centre; and vice versa. The position of the "earthy" point in the aerial coil is of importance in initial tuner design as it is normally desirable to wind the primary coil on top of the secondary coil (or to interwind it, as shown in Fig. 50 (a) of last month's article) in order to give a high degree of

coupling, whereupon the primary should be positioned as close to the "earthy" point of the secondary coil as possible. This results in the coupling between primary and secondary being mainly inductive, rather than a mixture of inductive and capacitive which could cause detuning or mismatching with different aeriels and feeders.

Figs. 58 (a) and (b) do not illustrate stray capacities and inductances. In tuner unit design these stray capacities have to be kept to a minimum, in which case they should not materially affect the working of the circuit just mentioned. However, they cannot be ignored and their effects have to be allowed for in the initial practical design of the tuner.

Next Month

In next month's article we shall continue with our examination of the r.f. amplifier circuits of the modern television tuner, dealing first of all with the single winding aerial tuned circuits which have been recently introduced in this country. We shall also discuss the Neutrode amplifier, as currently employed in the United States, and carry on to other important features of present-day design.

BOOK REVIEWS

AN INTRODUCTION TO THE CATHODE RAY OSCILLOSCOPE. By Harley Carter, A.M.I.F.E. 95 pages, 90 diagrams. Published by Philips Technical Library, obtainable in England from The Cleaver-Hume Press Ltd., 31 Wright's Lane, Kensington, London, W.8. Price 12s. 6d.

A cursory examination of this little book might easily give the impression that it is just another book on oscilloscopes, but a more detailed study quickly reveals that it contains a great deal more information and practical knowledge than one expects to find. Basic principles of each circuit are discussed, and developed stage by stage into the several forms of circuits comprising the different functional parts of oscilloscopes. For this purpose the chapters deal with the cathode ray tube's electrical functions, timebase circuits, vertical deflection amplifiers, power supplies, and the practical applications of the oscilloscope.

The chapters on timebases and vertical deflection amplifiers are comprehensive in the sense that they cover a wide variety of circuits used for these purposes. Though brief in some respects, they are logically developed into modern circuits which are simple and reliable.

A very useful and interesting feature of the book is the chapter on four complete oscilloscope circuits which can be constructed fairly easily. The complete circuit diagrams are given on fly-leaves at the end of the book. Two of these circuits are quite simple, using only five valves, two of which are rectifiers for h.t. and e.h.t. The third circuit uses six valves, while the fourth circuit seems particularly attractive in that it has two double-triodes in both the timebase and vertical amplifier circuits, and metal rectifiers for h.t. and e.h.t. supplies. An unusual feature of this design is the timebase circuit, which normally runs as a blocking oscillator and, by simple switching, can be converted into a horizontal amplifier similar in circuitry and characteristics to the vertical deflection amplifier.

A few errors were noticed in the text, but it is understood that steps have been taken to insert an errata slip in available copies of the book. These errors are not serious, and are in any case no reflection on the usual standard of literature in the Philips Technical Library.

ELECTRONIC HOBBYISTS' HANDBOOK. By Rufus P. Turner. 160 pages, 116 diagrams. Published by Gernsback Library Inc., New York. Obtainable in England from The Modern Book Co., 19-23 Praed Street, (Dept. RC), London, W.2. Price 20s., postage 1s.

Enterprising young men of today leave back-street milk bars and pin-table saloons of questionable repute to those who have neither brains nor ability to do anything better with their spare time; they seek occupational pastimes which have educational value, frequently with a view to increasing their knowledge in electronics. For those who want to start from scratch and emerge fairly well versed in some knowledge of electronic circuits, apparatus, and the making of it, this book would be a wise investment.

Typically American in its style, as is to be expected, it does nevertheless provide plenty of scope for the fledgling to develop into a fairly wise old bird. First and foremost, particular (and commendable) emphasis is given to safety precautions to be observed by the newcomer. Secondly, the use and care of tools, and workshop practice is well covered.

Circuits and constructional details for many useful pieces of equipment are given in seven chapters, ranging from simple radio receivers to test equipment, transmitters, photoelectric devices, and model control apparatus. Transistorised circuits appear in a few places, so the text is not exactly old-fashioned. Although American components are specified for the designs, in nearly every case English equivalents could be obtained, though identification of them would perhaps require the assistance of someone familiar with the characteristics of such components.

The circuit diagrams are neatly drawn and in every case are simple. Each one is well described; theory of operation, construction, and testing methods are dealt with in good detail.

Many of the circuits are "hook-ups" intended to be made for educational purposes—a good feature which teaches the know-how of more complicated equipment. Much of this work can be done at low cost in terms of money, even if the price of the book tends to burn a hole in a young man's pocket. None the less, it is fair value.

W. E. THOMPSON

AUDIO

The Cooper-Smith PRODIGY

6-watt
high
fidelity

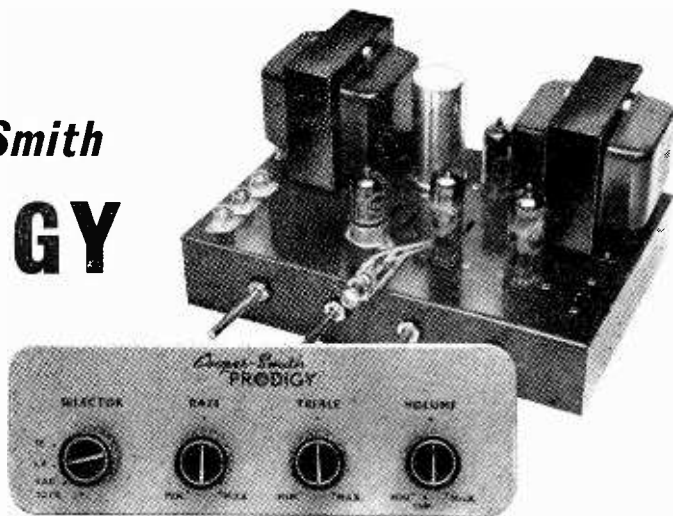

AMPLIFIER

PART I

SPECIFICATION

Inputs—Gram. 8–10mV; Tape 100–150mV; Radio 100–150mV.

Controls—4-position Selector Switch (78, LP, Radio, Tape); Treble and Bass Cut and Lift; Volume/On-Off.

Power available for Tuner, etc. (output socket provided)—250V at 40mA d.c. (decoupled); 6.3V at 2A a.c.; Output socket (200–250V a.c.) for gram. motor.

Output—6 watts undistorted, 9 watts peak; Push-pull ECL82s, ultra-linear.

Frequency response—30–25,000 c/s \pm 1dB.

Harmonic Distortion—0.2% at 6 watts.
Negative feedback—15dB.

Output impedances—3.75 Ω , 7.5 Ω , 15 Ω .
Mains—200–210, 220–230, 240–250V a.c.

Size—10½ in x 7 in x 5½ in.

Weight—11½ lb approx.

Finish—Bronze.

Control panel—9 in x 3 in, Hammered gold finish, with warning light.

THE DEMAND AND ENTHUSIASM SHOWN FOR the Cooper-Smith B.P.I. Amplifier following its description in this magazine last year has been, and, it seems, will be for some considerable time, very great. Nevertheless, it has become obvious from enquiries received that there is still a large section of the public who consider an amplifier of quite modest output capabilities more than adequate for their requirements, the Cooper-Smith B.P.I. being either beyond their means or unnecessarily powerful for the size of their listening rooms or the disposition of their neighbours.

The amplifier to be described was designed to meet the demands of these good people; and it has been christened the "Prodigy" because, for its size and cost, its efficiency, flexibility and output could well be described as prodigious!

Circuit Details

Stage 1.—This stage is one-half of a double triode (12AX7) with negative feedback from anode to grid. Three input sockets are provided, for radio, equalised tape and gram. The basic sensitivity of each is arranged by the feedback. The required input is selected by S_1 . At the radio and tape positions the feedback is purely resistive and merely serves to reduce the gain of the stage to accommodate the output from a radio tuner or tape pre-amp. The basic sensitivity here is in the order of 100mV and the response is flat. On switching to the gram, the position the feedback becomes frequency selective by means of the network $R_4, 5, C_3, 5$ (L.P.), $R_1, 2, 3, C_2, 4$ (78). Two gram. positions are provided—78 and L.P. The L.P. equalisation follows the R.I.A.A. curve and the 78 the E.M.I. Although the recording characteristic may vary somewhat

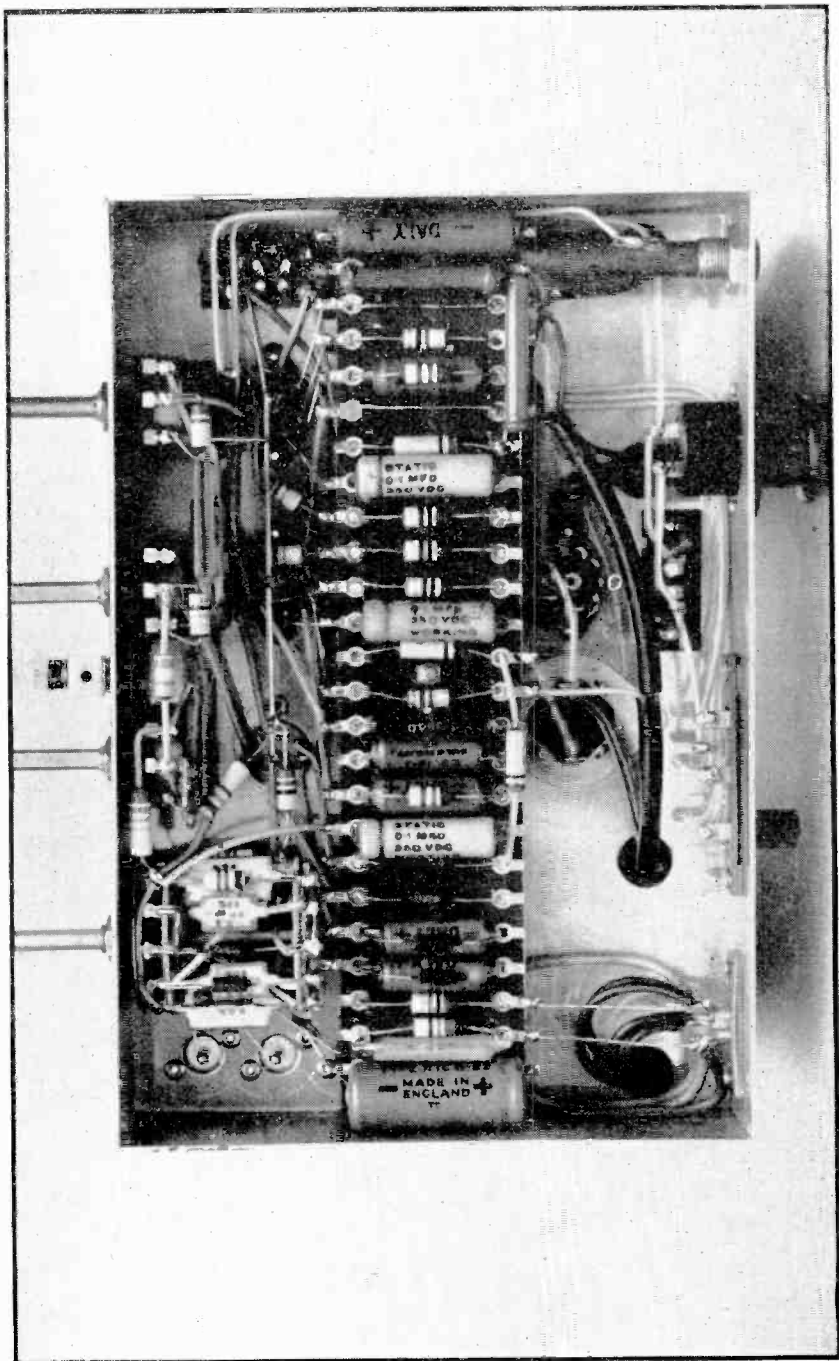

Underneath view of the Prodigy 6-watt amplifier

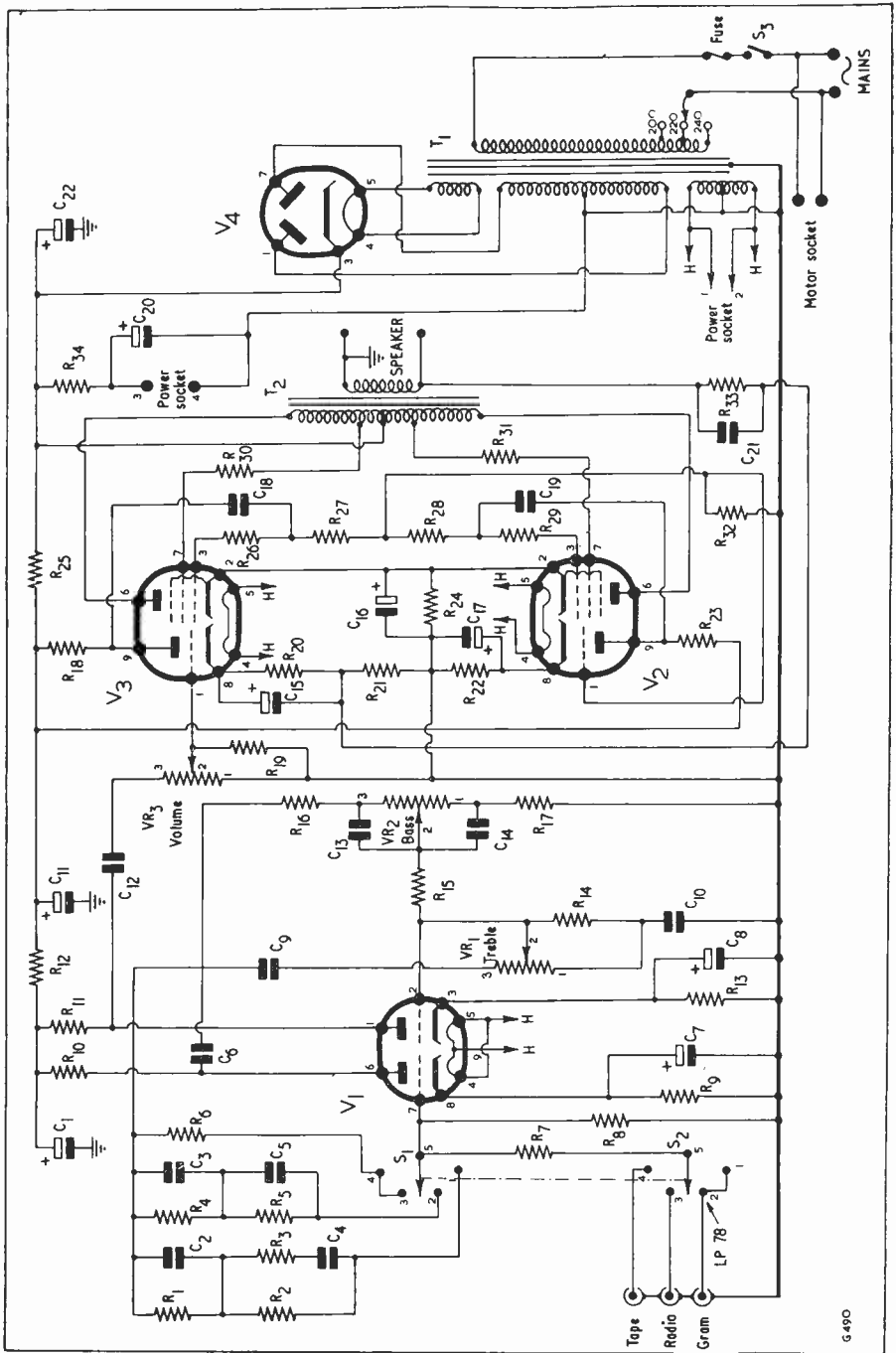

G 490

**DIMENSIONS AND DRILLING
DETAILS OF CHASSIS**

Note: Ventilation should be provided by drilling holes near centre of chassis

- A - $\frac{3}{8}$ " dia. 6 BA Fixing holes. $\frac{3}{4}$ " centres
- B - $\frac{5}{8}$ " " " " " $\frac{1}{4}$ " "
- C - $\frac{3}{4}$ " " " " " $\frac{1}{8}$ " "
- D - $1\frac{1}{4}$ " " 4 " " " $1\frac{1}{4}$ " "

- E - $1\frac{1}{4}$ " dia. 4 BA fixing holes. $1\frac{1}{8}$ " centres
- F - 4 BA clearance
- G - $\frac{3}{8}$ " dia.
- H - $\frac{1}{2}$ " " (grommet holes)

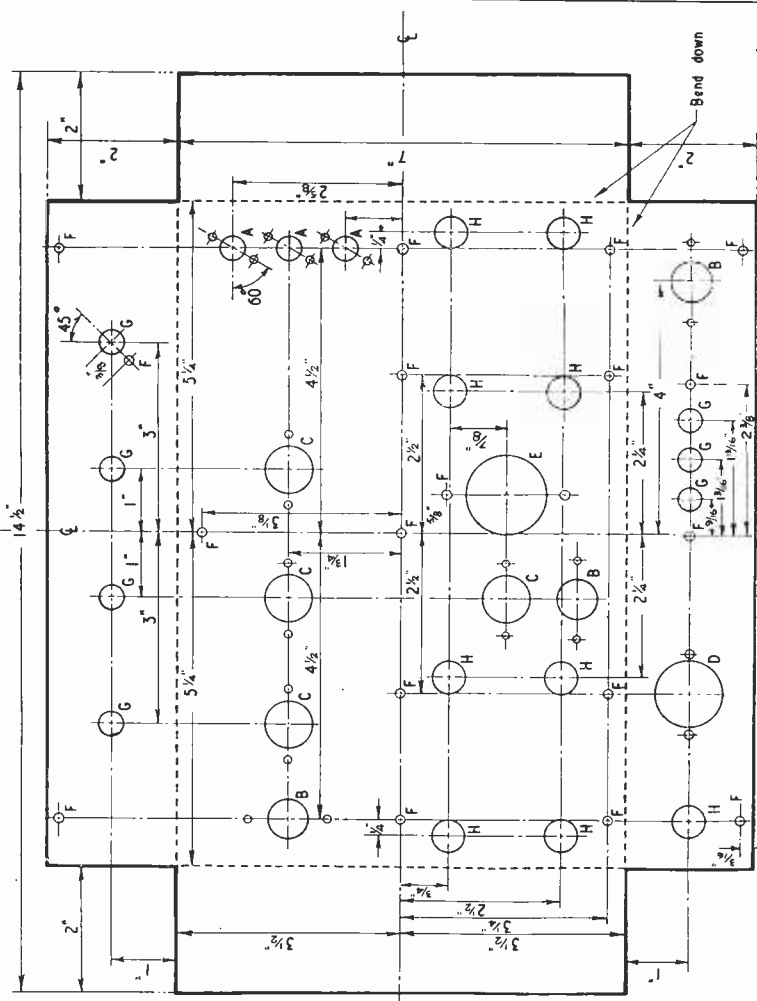

from make to make, these two curves have been found adequate, and any discrepancies in the corrections may be made up for by judicious use of the wide range tone controls, which are of the "passive" type* fed from the anode of stage 1 to the grid of stage 2. The basic sensitivity at the gram. input is 6-8mV. An attenuator will be required before the input when using a crystal pick-up.

pick-up input, the value of the resistor depending upon the make of pick-up. A crystal pick-up, as mentioned above, will require an attenuator; this may be in the form of a volume control, the value being 100k Ω . This latter should be adjusted so that the main volume control gives a smooth increase of volume and on loud passages begins to overload the amplifier at about

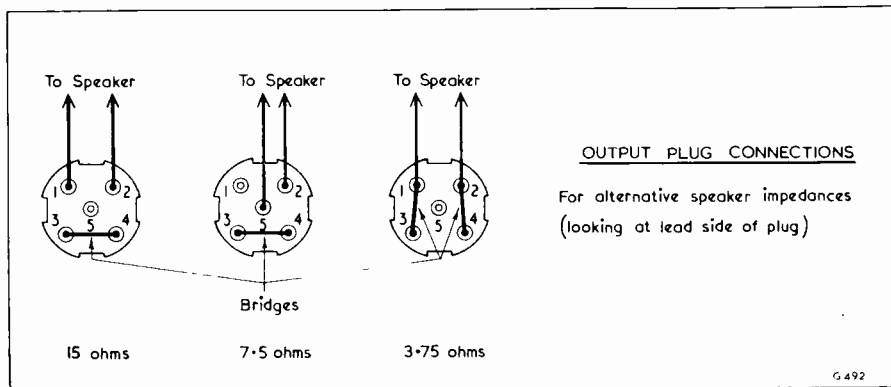

Stage 2.—The second half of the 12AX7 is purely a voltage amplifier and serves merely to replace the gain lost in the tone control circuit.

Stage 3.—We now come to a very important part of the circuit—the phase-splitter. The type used here is one which has been in use for a great number of years and which has proved highly satisfactory for this particular application. With the careful choice of components a high degree of balance and a low degree of distortion may be achieved. The circuit utilizes the triode portion of triode/pentodes ECL82, the pentode sections being used in the output stage. The output valves are connected as pentodes in the now almost universal "ultra-linear" fashion. An unusually large output transformer has been used in this amplifier, and this to a very large degree accounts for the extremely high standard of reproduction and stability attained. Approximately 15dB of negative feedback is provided by R₃₃ and C₂₁ from the secondary of the output transformer back to the cathode of the phase-splitter input valve.

Note re Pick-ups

A load resistor will be required across the

* D. H. W. Busby, "Design for a Pre-amplifier," *Wireless World*, July 1955.

three-quarters of maximum rotation.

Regarding magnetic pick-ups, the load resistor will vary from 100k Ω downwards. The correct value is usually specified by the makers. No attenuator will be necessary.

Construction

The layout of the "Prodigy" has been designed for ease of construction consistent with neatness, compactness and professional appearance. The stage-by-stage wiring diagrams, in conjunction with the following instructions and the point-to-point checks, should enable even the tyro to make a successful job of it, no knowledge of electronics being necessary.

The chassis is of straightforward design, with no screens or other bits and pieces, and may be made of any metal. For those who wish to make their own, a working drawing with all dimensions (taken from centre lines for ease of measurement) is given opposite but it can also be obtained ready-punched in 16 gauge aluminium finished in bronze.

Next Month

Fully detailed stage by stage instructions with point-to-point wiring diagrams and stage checks.

Technical Forum

Cooling Transistors

THE TERM "HEAT SINK" HAS BEEN IN USE in certain spheres for some time now, but it may well be new to some readers. It is an expressive term based on the assumption that a sink is a device which is instrumental in disposing of waste liquids. It follows that the heat sink is a device used to dispose of, or remove, unwanted heat from a component. The term seems to have come into more general use during the past few years as the circulation of transistors has increased. Transistors offer the equipment designer many advantages in the form of robustness, long life, low operating voltage and better power efficiency than the valve because there is no loss in a heater. However, it is with the problem of heat that the

be employed has, as a result of this, to bear two particular requirements in mind.

- (1) That under no conditions of operation will the transistor be over-dissipated and consequently subject to too high a temperature. The maximum temperature at the collector to base junction is usually specified by the manufacturers, and although it may vary slightly from type to type it is usually in the region of 80 C.
- (2) The characteristics of the transistor change as the temperature rises.

In the main this change occurs because the resistance of the transistor decreases as the temperature rises and this in turn results in an increase in current. If unchecked this can be a dangerous state of affairs, which may finish as a runaway condition because the extra current will cause a further rise in temperature which reduces the resistance and again raises the current. This process can continue until the transistor is destroyed.

Thus, to a very large extent, the life and performance of a transistor are dependent upon its operating temperature, and this in turn is governed by the power dissipated in the transistor and the efficiency of the heat sink. Particularly with power output transistors, when it is an advantage to dissipate the highest possible power in order to obtain the maximum output, the importance of providing an efficient heat sink cannot be overstressed.

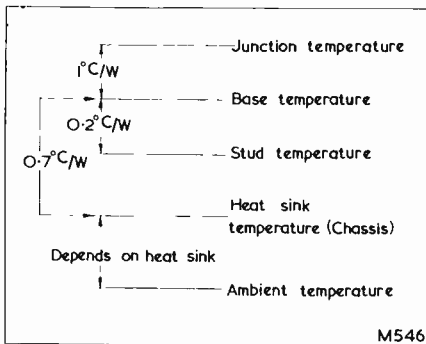

Fig. 1. Diagram showing the relative levels of temperature from the transistor junction to air

present-day transistor shows its major shortcoming. Practically all transistors manufactured today are made from germanium crystals which are inherently temperature conscious. Any designer considering a circuit in which a germanium transistor is to

Thermal Resistance

The hottest point of the transistor is the junction of the collector electrode to the base as it is here that the maximum dissipation occurs. From this point the heat drains away through the structure of the transistor to its mounting face, and then via the fixing arrangement to the heat sink. Some small amount of heat is directly radiated to the surrounding air, but this is relatively small. The temperature gradient may be considered as the rate at which the temperature

decreases as one moves away from the crystal junction, and may be expressed as a value of thermal resistance. For example, aluminium readily conducts heat and has a low value of thermal resistance whereas wood is a poor conductor of heat and is said to have a high thermal resistance. To take this a stage further, we might consider a strip of copper which is known to have a thermal resistance of 1.5 C/watt along its length. Then if heat to the value of 10 watts is fed on to one end of the strip the temperature rise at the other end will be $10 \times 1.5 = 15$ C. In practice the heat from the junction will travel via a path which consists of a number of sections each having a different thermal resistance. The cumulative effect is obtained by considering each as being in series with the remainder, and its actual value is simply the arithmetical sum of the individual sections. The manner in which these sections are constituted may be better appreciated by reference to Fig. 1. This diagram is applicable to all transistors but for the sake of clarity a few typical values have been included, and these refer to the Mullard OC16 power transistor. The method of mounting this transistor will be clear from the sketch (Fig. 2) and the relative temperature levels of Fig. 1 refer to this diagram. It will be noted that in this example a mica washer has been used to electrically isolate the transistor from the chassis; this is necessary because

measured either by means of a suitable thermometer or a calibrated thermo-couple. In other instances the maximum junction temperature is stated together with a value for the thermal resistance between the junction and the mounting base; this latter value is inherent in any design of transistor and is sometimes referred to as the "kappa" value.

Design Considerations

The design of a heat sink is not purely a question of obtaining the maximum radiating surface area to place in physical contact with the transistor; there are other factors to be considered. Firstly, the choice of material is important because of differences in the thermal resistance. Copper is one of the first choices of materials because of its high thermal conductivity, but it is rarely used for chassis on account of its relatively high cost. Steel and aluminium are perhaps the most popular choice, and of the two aluminium has the higher thermal conductivity. The better the conductivity the more uniform will be the temperature over the radiating surface and the more efficient will be the heat sink. Aluminium also has other advantages which are well known to the home constructor, and these are associated with the greater ease with which it can be worked. In general, a heat radiating fin is conveniently made from $\frac{1}{16}$ in aluminium, but the efficiency

Fig. 2. The mounting arrangement for the Mullard OC16 transistor

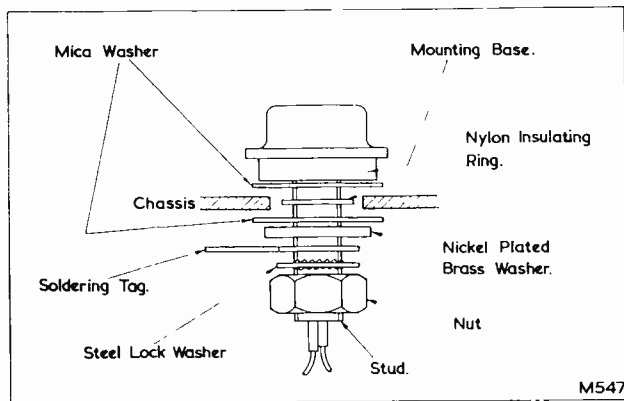

the base of the crystal element is in both thermal and electrical contact with the metal case. The electrical insulation has been obtained therefore at the expense of some loss in heat radiating efficiency.

In published data some transistor manufacturers quote the maximum permissible mounting base temperature, which may be

may be further improved by increasing the thickness to $\frac{1}{8}$ in. Such an increase will be most marked under conditions where the transistor is mounted to one side of the fin or where the fin is elongated. In such circumstances the improvement in thermal resistance resulting from the increase in thickness is of

(continued on page 219)

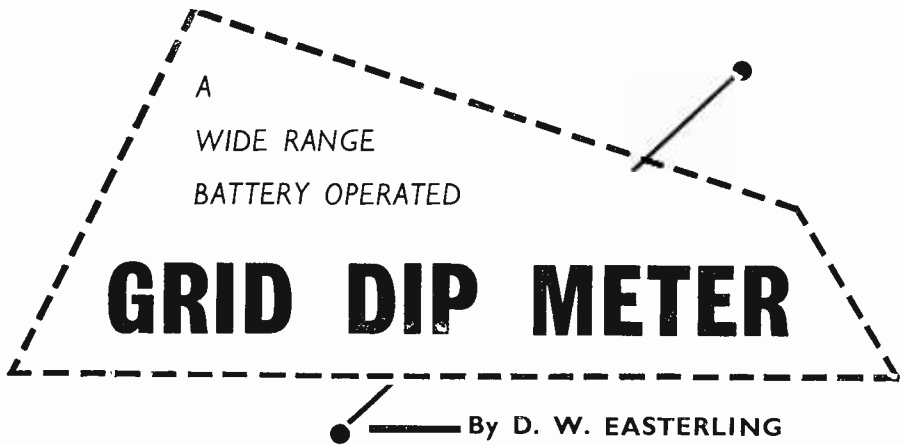

A
WIDE RANGE
BATTERY OPERATED

GRID DIP METER

By D. W. EASTERLING

A SUITABLY COUPLED TUNED CIRCUIT will absorb power from an r.f. oscillator, proportionally reducing the oscillator valve's negative grid current. This effect is made use of in the grid dip meter, which enables the resonant frequency of any external tuned circuit to be determined. Apart from being of great value to the home constructor, especially on the v.h.f. bands, the grid dip meter enables service engineers to locate faults not always so obvious by other test methods. The G.D.M. is easily adapted for use as an absorption wavemeter, simple signal generator, and oscillating detector. Not only frequency measurements but inductance and capacitance measurements are also possible. Its portability, simplicity and economy of components are other virtues attractive to the home constructor.

In designing a grid dip meter, its mode of operation should be considered. Efficient coupling is most easily achieved by direct inductive method. A small self-contained unit, with the tuning coil projecting, is usually the best arrangement. The coil should be of the plug-in type if more than one range is required. While it is possible to achieve a fair degree of compactness with a mains driven unit, the mains lead tends to be a nuisance, and the instrument's scope is severely limited, especially on outside work. Hearing aid batteries were used in the unit to be described, and have proved reasonably economical, since power is only drawn for short periods at a time.

The Circuit

The circuit is straightforward, consisting of a DL94 B8G type battery valve working as

a Shunt Colpitts Oscillator. R_1 is a grid stopper, the negative potential developing across it and VR_1 . The slider of VR_1 is taken to the grid of V_2 , a DM70 magic eye. The display of the DM70 consists of a line of light similar in shape to an exclamation mark, its length depending on the grid voltage, 5 volts negative being needed for complete cut-off. It will be seen that any variation across VR_1 will vary the magic eye display, readily indicating any changes in oscillator power. Adjustment of VR_1 enables the magic eye to work at optimum sensitivity, this occurring when the display is approximately 5 mm. long. The DM70 is cheaper than the usual series meter, requires much less space, and has no mechanical inertia.

S_2 , the on-off switch, is conveniently mounted on the back of VR_1 ; while S_1 disconnects the h.t. from the oscillator valve, causing it to behave as a diode detector and enabling the unit to function as an absorption wavemeter. A telephone jack wired across VR_1 enables headphones to be used for the detection of very weak signals. The same point may also be used for the injection of modulating signals derived from an audio oscillator, 50 c/s mains (low voltage via a transformer!) or some other source.

Construction

The prototype was built in an Eddystone die-cast box measuring $3\frac{1}{2}$ in x $4\frac{1}{2}$ in x $2\frac{1}{4}$ in. Apart from the valves and batteries, no special miniaturised components were used. Fig. 2 illustrates the internal and Fig. 3 the external layout, although individual layouts will depend on the components to hand.

The DM70 is connected to a tag strip with its glass envelope supported by two rubber

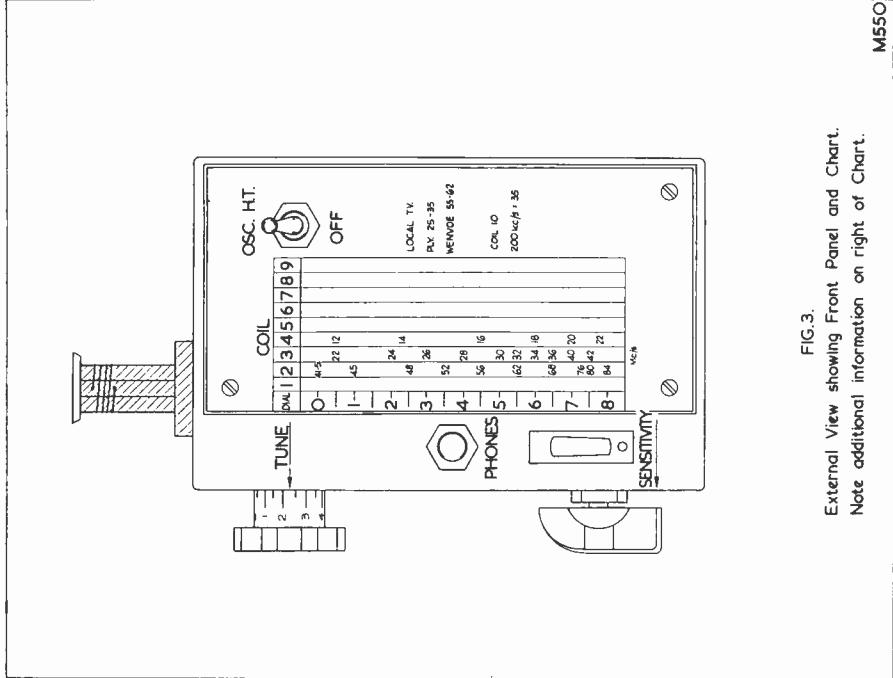

FIG. 3. External View showing Front Panel and Chart. Note additional information on right of Chart.

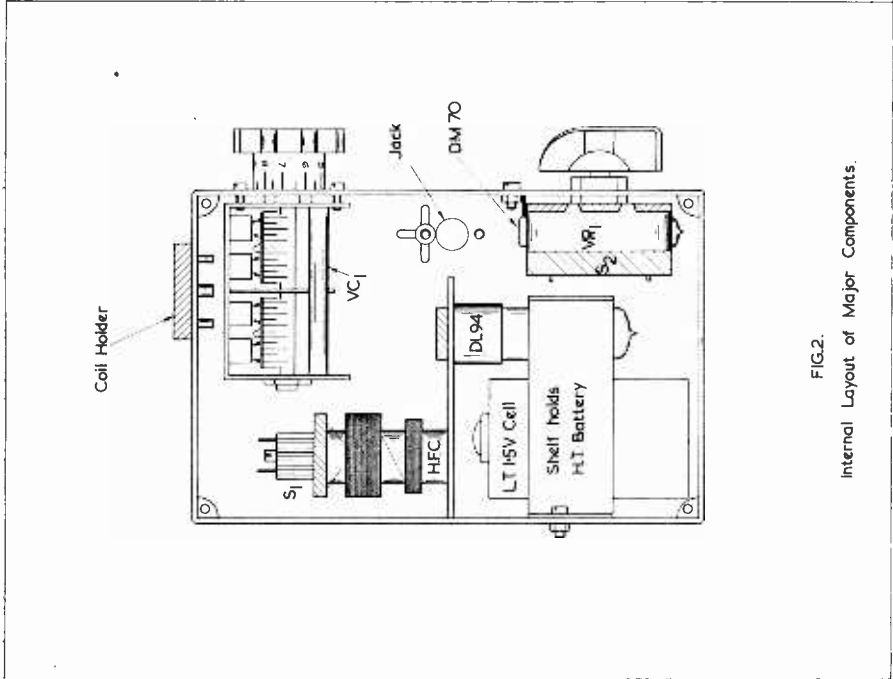

FIG. 2. Internal Layout of Major Components.

brilliance, which is high compared to the usual mains type magic eye. Now switch on the oscillator h.t. with sensitivity control at maximum. This should decrease the display or black it out completely. With sensitivity control adjusted to optimum, absorb power from the oscillator by touching the coil; this will increase the display, indicating that the unit is functioning correctly.

Calibration

A receiver, wavemeter or calibrated oscillator may be used. With the first, place the G.D.M. away from the receiver so that the signal, a hissing noise, is only just heard with the volume control at normal. Make sure the signal is not breaking through on the i.f. or on second channel. With the other two methods, couple the G.D.M. very loosely so that indication is only just noticeable. Take care not to be confused by harmonics, especially at higher frequencies.

Using the Grid Dip Meter

To measure the resonant frequency of a tuned circuit, bring the meter coils close to it, tuning for maximum display. Where it is not possible to couple by direct mutual inductance, capacitive coupling from a tap near the centre of the meter coil to the "hot" side of the circuit under test may be tried. Avoid over-coupling, which will cause inaccuracies. To measure the frequency of an oscillator by the absorption method couple as before, and tune for minimum display with the G.D.M. oscillator h.t. off.

To measure the frequency of a weak oscillator by detection method, plug in headphones, and tune for a beat note with the G.D.M. oscillator h.t. on.

To measure a capacitance, form a tuned circuit with a known inductance, find its resonant frequency, and then determine the capacitance using an abac or the formula: $C = 10^9 / (2\pi f)^2 L$. C = capacitance in pF, L = inductance in μH , f = frequency in Mc/s.

To measure an inductance, form a tuned circuit with a known capacitor and then determine the inductance as above using the formula: $L = 10^9 / (2\pi f)^2 C$.

The latter case does not take into account the inductor's self-capacitance, therefore make the known capacitance fairly high.

It is often possible to roughly compare the Q of two or more tuned circuits of the same resonant frequency, by noting the position of the sensitivity control with a given display. The circuit of highest Q will give the best dip providing coupling arrangements are identical.

The unit described, although very sensitive, does not employ a powerful oscillator, and is therefore unlikely to cause interference providing reasonable care is taken. Make a habit of working away from neighbour's aerials, and switch off immediately any test has been made.

No comprehensive coil data is given, the writer using old receiver coils for the low frequencies. High frequency coils were wound on Eddystone coil formers type 765

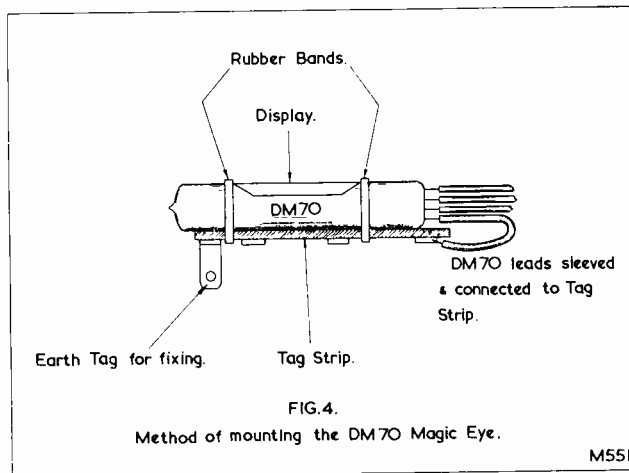

which have winding grooves 20 per inch. Coils 1, 2 and 3 have windings pitched 10 turns per inch, while coil 4 is the same pitch as its former. Holes for the wire are easily bored using an ordinary twist drill.

Coil 1. Range 60 Mc/s to 180 Mc/s. Single turn.

Coil 2. Range 40 Mc/s to 80 Mc/s. Three turns.

Coil 3. Range 20 Mc/s to 40 Mc/s. Nine turns.

Coil 4. Range 12 Mc/s to 20 Mc/s. Eighteen turns.

Efficiency on Range One drops very rapidly, and if it is intended to use this range frequently, the h.t. should be increased to 90V. Below the 450 kc/s i.f. range, a centre-tapped coil should be used, converting the oscillator to a Hartley circuit.

..minor-one

The

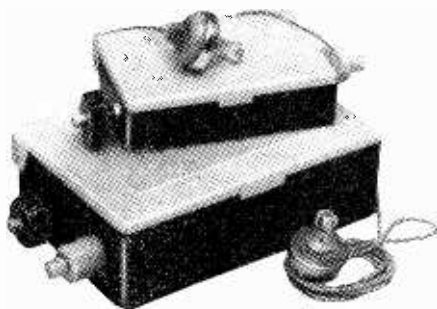

*Personal
Transistor
Receivers*

..major-two

Designed by D. J. FRENCH, Grad.I.E.E., of Henry's Radio Ltd.

THE TWO POCKET PORTABLE TRANSISTOR receivers about to be described have been designed specifically for the home constructor who, whilst wishing to build a transistorised personal set, does not possess the proverbial "long pocket" mostly associated with the more ambitious receivers. In the present instance, two differing designs, each of a correspondingly different price range, are offered to those who aspire to build a small compact receiver.

Both receivers, when completed, are contained in an attractive black and white moulded plastic case complete with the protruding controls on/off push-button switch and tuning knob. A deaf-aid insert is utilised in both designs as the audio output device.

The "Minor-One"

The circuit of this is shown in Fig. 1, from which it will be seen that it is a three-stage reflex circuit. The transistor functions in the first instance as an r.f. amplifier, the resultant r.f. being fed, via C_3 , to the crystal diode. The rectified signal is then fed back, via C_5 and the ferrite secondary winding, to the base of the transistor. The audio signal is then amplified by the transistor and fed, from the collector and via the r.f. choke, to the output transformer. This stage operates in the earthed emitter mode, R_1 and C_2 providing the required emitter bias voltage. This ingenious arrangement provides virtually the absolute maximum performance that can be expected from a single transistor at the

present stage of development. So efficient is this arrangement that with this local-station receiver, the Home Service has been regularly received some 50 miles from the transmitter without an external aerial or earth.

The pre-punched and riveted chassis, together with the pre-punched case, ensures that the beginner—with the minimum of tools—is perfectly able to undertake the construction of this efficient little receiver. The case measures only some 3in x 2½in x 1½in, and the total weight of the whole assembly is less than 2 ounces. The average battery consumption is less than 1mA, thus a very long life may be expected with the battery specified (see component list).

The small and compact nature of this receiver may be seen from the illustration. The construction involved for this receiver is virtually the same as for the first stage of the "Major-Two". Due regard must, however, be paid to the fact that some of the components, occupying a similar position in the circuit, have different values.

The "Major-Two"

This receiver is a more ambitious design than that of the "Minor-One" for, in addition to the basic circuit of the latter, there is the added audio stage. The circuit of this receiver is shown in Fig. 2. In this, a four-stage reflex circuit, TR_1 is used first as an r.f. amplifier, the signal passing via C_3 to the diode detector. From there, the rectified audio is taken, via C_5 , to the base of TR_1 where the audio is amplified and passed, in

turn, via the r.f. choke and C_7 to the base of the audio stage (TR_2). The amplified signal is then fed from the collector of this transistor to the output transformer and thence to the hearing aid insert. Both transistors operate in the earthed emitter mode. For

however, it is worth noting that overloading of the output transistor has been noted in strong signal areas.

Notes Applicable to both Receivers

When wiring the receivers, it is essential

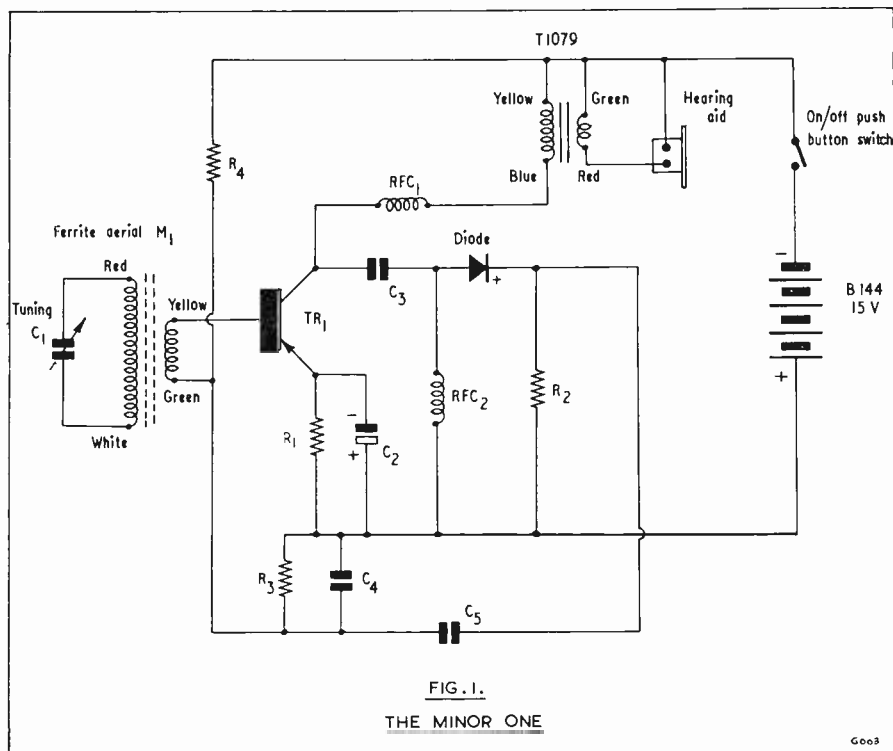

FIG. 1.
THE MINOR ONE

Component List "MINOR-ONE"

Resistors

- R_1 1k Ω $\frac{1}{2}$ watt
- R_2 10k Ω $\frac{1}{2}$ watt
- R_3 10k Ω $\frac{1}{2}$ watt
- R_4 100k Ω $\frac{1}{2}$ watt

Condensers

- C_1 250pF, variable
- C_2 30 μ F, electrolytic, 6V wkg.
- C_3 47pF, tubular ceramic
- C_4 0.005 μ F
- C_5 0.1 μ F, 150V wkg.

Sundries

Ferrite Rod Aerial, type M1 (Henry's Radio Ltd.)

Output transformer—Type T1079 (4.5:1 ratio)

RFC1, RFC2—1.55mH (Henry's Radio Ltd.)

Battery—Ever-Ready type B144

Transistor holder

Transistor—White Spot type

Push-Button switch

Cabinet and chassis (pre-punched/riveted) (Henry's Radio Ltd.)

Hearing Aid Insert (Henry's Radio Ltd.)

Crystal Diode—OA70, GD3, GEX34 or similar

those requiring more audio than is delivered by the transistors specified, the use of an XC101 in the position of TR_2 will result in more than sufficient audio for most needs. With the use of the transistors specified,

that the colour coding of the aerial windings and of the output transformer leads are observed. The correct polarity of the electrolytic condensers and the battery should also be noted.

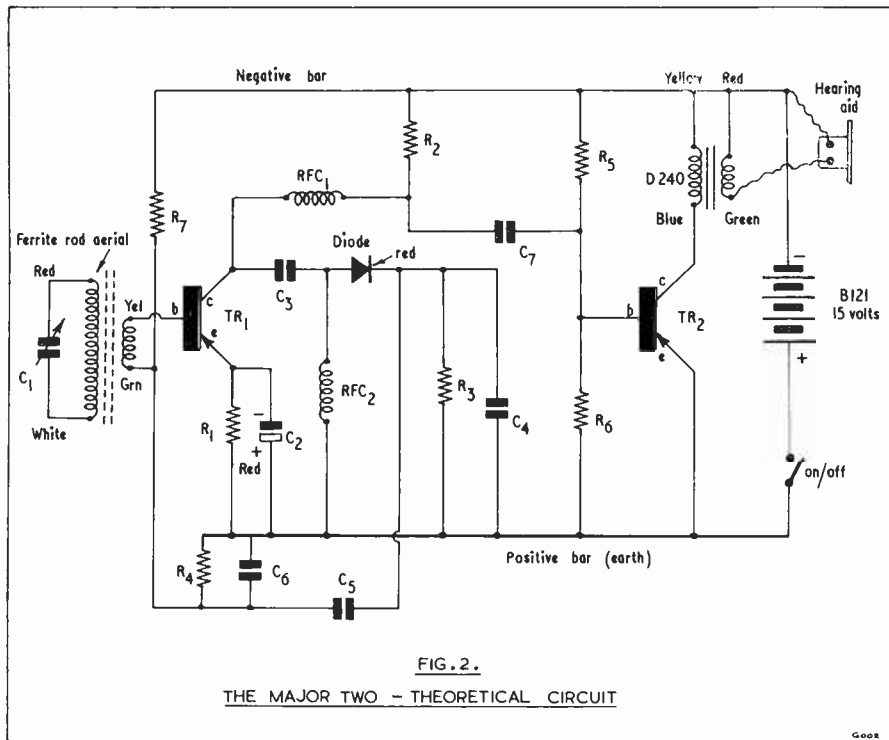

Component List "MAJOR-TWO"

Resistors

- R₁ 1kΩ ¼ watt
- R₂ 4.7kΩ ¼ watt
- R₃ 10kΩ ¼ watt
- R₄ 10kΩ ¼ watt
- R₅ 680kΩ ¼ watt
- R₆ 10kΩ ¼ watt
- R₇ 100kΩ ¼ watt

Condensers

- C₁ 250pF, variable
- C₂ 25μF, electrolytic, 25V wkg.
- C₃ 47pF, tubular ceramic
- C₄ 0.1μF, 150V wkg.
- C₅ 0.1μF, 150V wkg.
- C₆ 0.005μF
- C₇ 0.1μF, 150V wkg.

Sundries

Ferrite Rod Aerial, type M2 (Henry's Radio Ltd.)

Output Transformer, type D240 (8.5:1 ratio)

Battery—Ever-Ready type B121

Crystal Diode—OA70, GD3, GEX34 or similar

RFC₁, RFC₂, 1.55mH (Henry's Radio Ltd.)

2 Transistor holders

TR₁ RF White Spot type

TR₂ Audio transistor (Red Spot type), see text

Pre-punched cabinet, riveted chassis, etc. (Henry's Radio Ltd.)

Push-button switch

Deaf Aid Insert (Henry's Radio Ltd.)

Aerial Mounting Bracket (Henry's Radio Ltd.)

The transistors specified and supplied are coded with a white dot denoting the collector. Any transistor with an alpha cut-off of greater than 2 Mc/s may be used in the position of TR₁, and any low consumption audio transistor may be utilised in the

position of TR₂. Transistor holders are used in both receivers, thus eliminating the need to solder the actual connecting wires to the various circuit points, with the consequent damage that this operation may cause.

An excellent idea of the layout of the

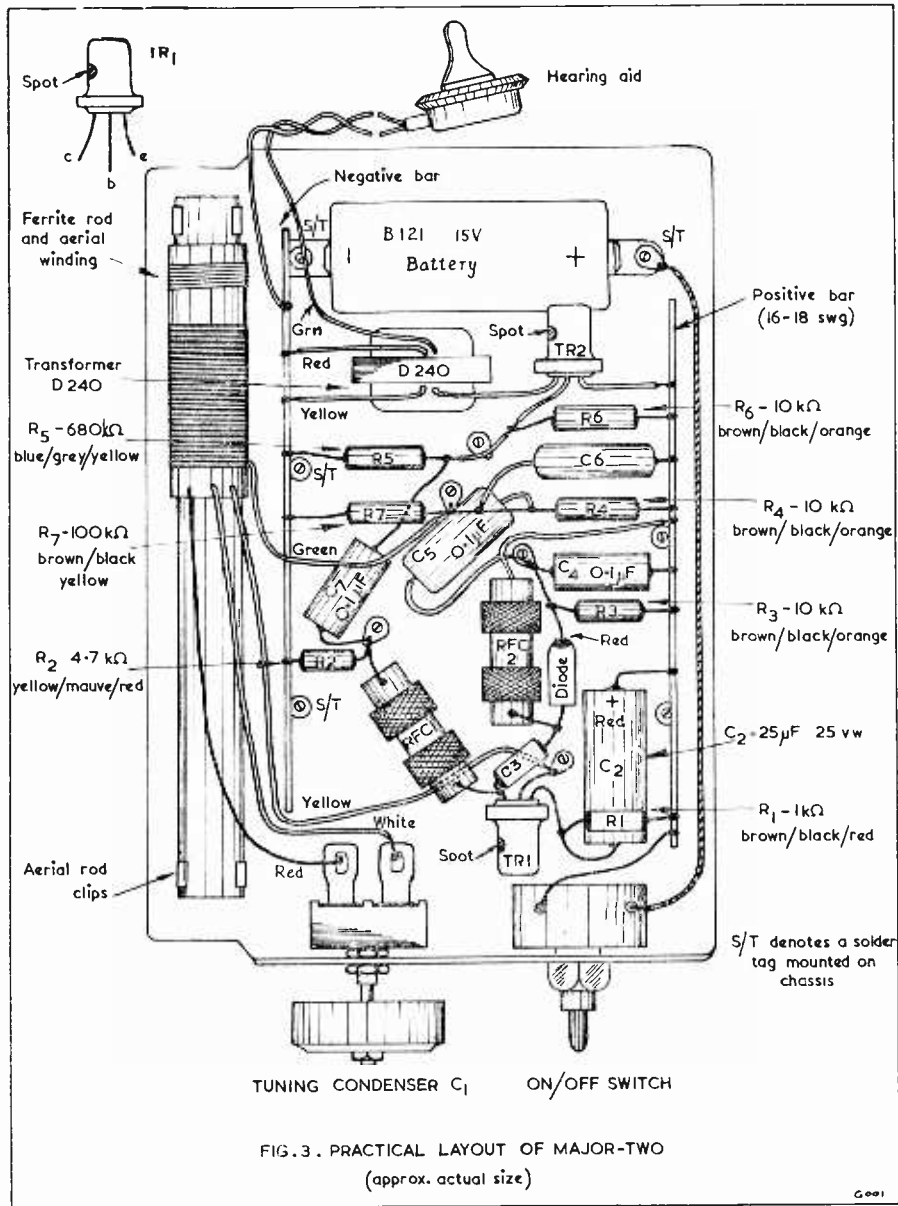

"Major-Two" will be obtained from the accompanying illustration, from which it will be noted that the arrangement is both neat and direct. No difficulty will be experienced by the average home constructor in building this receiver. The total weight of the

"Major-Two" is less than 4 ounces, and cabinet size is 4½ in x 3 in x 1½ in. The average battery consumption is less than 2mA, thus a very long life may be expected from the B121 battery, which has twice the capacity of that specified for the "Minor-One."

MODELS FOR RADIO CONTROL

THE "WAVEMASTER" KIT

Part 3

by Raymond F. Stock

Engine Installation

MANY CONSTRUCTORS WISH TO TAKE advantage of the power/weight ratio of an I.C. installation, but are worried by the considerable noise usually associated with these motors. The writer has invariably tried to counter this disadvantage which not only has a nuisance value but is quite out of scale with the model and detracts from the general impression given.

soft soldered. A capacity of at least 15 times the engine rating is needed. Wire wool may be introduced (with discretion) as a muffling agent, but it is most important to avoid back pressure in the system, and a simple expansion chamber is often as good as a packed silencer.

The considerable volume of liquid oil in the exhaust gases of a "diesel" must be properly eliminated. If possible, the outlet

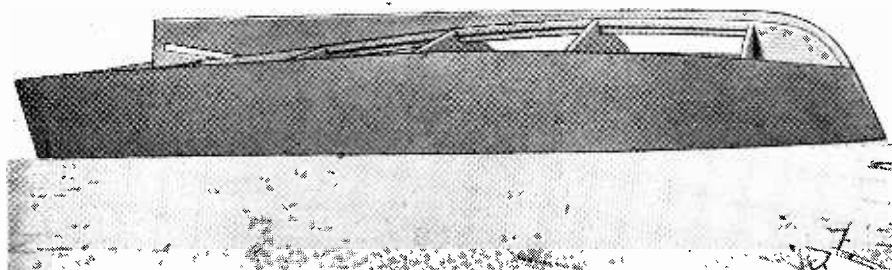

Side skins fitted

It appears from tests that the sound is due largely to mechanical noise radiated and conducted from the engine, and only partly due to the exhaust. The latter noise can be greatly reduced by providing an expansion chamber close to the engine in the exhaust system. A suitable can may be adapted for the purpose, but in general this component is best fabricated from very thin brass sheet,

pipe from the expansion chamber must come from the lowest point, or a drain must be fitted.

A considerable reduction in the mechanical noise level of an engine can be achieved by lining the whole engine room with acoustic lagging. This may be an inorganic type of proprietary material or solid blocks of very soft balsa wood.

If possible the lagging should be on all sides of the engine and above and below it; a thickness of one inch is suitable. Boxing-in the engine in this way must not, of course, be considered unless a water-cooled engine is used. Lagging materials tend to be porous and trap oil, etc.; when they are used it is advisable to line the engine room with very thin aluminium sheet or tinplate.

Even when an adequately water-cooled engine is installed, acoustic lagging will cause the air temperature to rise in the engine room and a fresh air supply must be taken (from, say, a large ventilator) to a point near—but not connected to—the engine air intake. It is advisable, also, to site the fuel tank outside the lagging to prevent evaporation of the lighter fuel elements.

When planning an engine installation it is rather important to remember that starting can be difficult if the engine is too confined. Normal starting technique with miniature engines is by means of a leather thong or cord pulled smartly upwards around the bottom of the grooved flywheel. Room must

worth noting. The space between any two bulkheads, if not otherwise required, may be sealed off completely to form a buoyancy chamber. The chances of a serious accident to a boat of this nature are remote, but a valuable safety measure is the provision of sufficient sealed flotation capacity to keep the model afloat should the free space in the hull become *completely waterlogged*. Often the space between bulkheads cannot be spared, in which case buoyancy tanks can be built into the structure along each side of the hull for, perhaps, the width of the frames and extending over most of the hull length. Balsa wood, $\frac{1}{8}$ in thick, is quite suitable for the purpose provided it is well doped or varnished, since strength is not important.

As designed, the *Wavemaster* has a cabin structure integral with the hull, the cabin roofs being removable for access to equipment. This is a good design feature since any water washing over the deck stands little chance of entering the hull. In some cases the amount of equipment installed

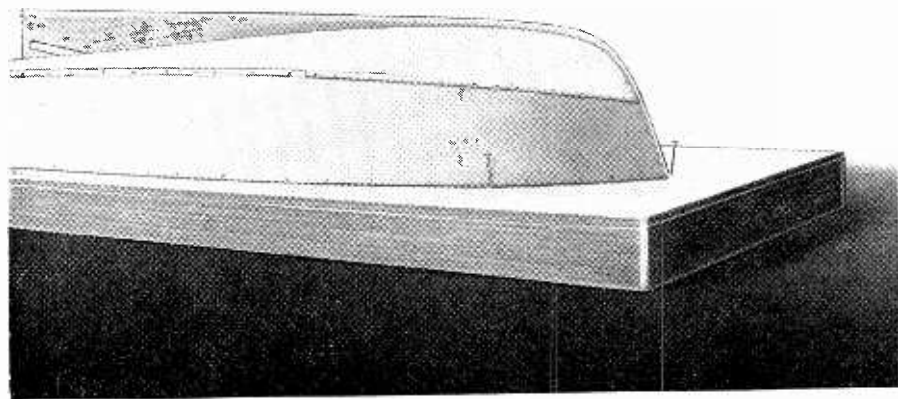

Completely skinned hull; rubbing strakes being fitted

be provided for threading the cord under the flywheel, and no vulnerable gear should be adjacent to it, otherwise it may be damaged by the cord as it leaves the flywheel.

Buoyancy Tanks

One further point regarding bulkheads is

needs unobstructed access and the constructor will want to make the whole of the superstructure removable, from deck level. In this case it is necessary to frame the opening in the deck, very rigidly, and to make a reasonably watertight joint where the cabin joins it. *(To be continued)*

radio

miscellany

ONCE AGAIN I FIND MYSELF HAVING TO write this column from a hospital bed. This opening, by the way, is not intended to angle for a repeat of the kind sympathy I received last time, but is by way of an explanation for unanswered correspondence. I cannot bring myself to scribble replies; indeed, if it was not for the patience of the Editor who has promised to decipher and put together the scraps intended to be this month's "Miscellany" its long unbroken sequence would be shattered. This time I am right among all the electrical gadgetry—but they won't let me touch it! Perhaps when I am a little better, and the "Professor" in charge of it all gets more used to my face, I may be allowed to have a peep at the inside of some of the more interesting pieces. I seem to have touched on most aspects of radio and electronics in the past—now, perhaps, I shall learn something of an angle hitherto neglected as far as I am concerned, the medical side!

Repeat Performance?

The last time I was in hospital and away from home for months, my Den t.v. stood completely idle. The first time I switched it on following my return it promptly blew the 0.3 amp fuse. A careful check was made and everything appeared to be in order. Thinking it must have been simply a surge reaching the peak just at the moment the contacts made, I replaced the fuse; only to have it blow again immediately after switching on. An even more thorough check-over followed, and absolutely nothing wrong could be discovered. Eventually I cautiously switched on again after inserting a third fuse (they are not cheap anyway!) when everything behaved normally and continued to do so right up to the time I left home.

I can only suppose the electrolytics had become partially unformed and returned to normal working after receiving a couple of charges. It will be interesting to see if the trouble recurs on my next homecoming.

Incidentally, I always make a practice of applying a low voltage and gradually building up with new electrolytics. One never knows how long they have stood idle. Theoretically it's a good idea to build them up gradually and if the explanation is, as I suspect, due to their partial unforming, theory is once again well supported by practice.

Pure Science to Application—100 years

I recently referred to scientific knowledge, ideas and inventions—and several correspondents have shown interest. During a recent discussion on transistors, it forcibly struck me how closely linked they are. As long ago as the early 1830's Michael Faraday noted negative temperature co-efficient of resistance and by 1855 rectification, photo-conductivity and photoelectromotive force had also been observed. It was on these our knowledge of semi-conductor materials has been built up, leading (nearly a hundred years later) to the development of the transistor. The transistor made its debut in 1948, by the way, and the junction transistor in 1951.

Several letters from would-be inventors have come to hand, so more on this subject later.

Long-felt Want—Still Felt

The t.v. in the ward here suffers from a "wozzy" switch in the coil turret and the one in the Day Room is similarly afflicted. Sister says it's no good sending them for repair. It's months before they come back and they are soon as bad as ever. It is easier to waggle the switch a few times until a good contact is found. Both of my home t.v.'s behave in the same way, although on the home-built model it only occurs when the turret is in the I.T.A. position. Yet the contacts look clean and mechanically perfect, and the springing snaps into position with a satisfying click. All the usual dodges and cleaning agents have so far failed to effect a permanent cure. Switch troubles seem to be common in a high percentage of sets and in

each case I have recently checked it is significant that the coil turret has been situated in the top of the cabinet. This must be the warmest part of the set (due to the heat rising). Does oxidation of the contact points occur more readily in the dry warmth?

Right from the earliest days of radio the design of switches and volume controls has lagged behind general radio technique. Even the money-no-object types in carefully designed Services equipment were far from trouble-free, and the self-wiping patterns never seem to "wipe" clean. Unfortunately, there is not much scope here for the lone amateur inventor unless he has the co-operation of experts on metals that don't lose their springiness, and surfaces that don't oxidise, etc.

Cutting It Fine

Talking of volume controls reminds me of one of my last jobs before coming here—the fitting of a new volume control to our breakfast-table portable. I like to know exactly how many minutes I have left to gulp that last cup of coffee! With a newly built receiver one never knows exactly how much of the control shaft to cut off until the chassis is fitted in the cabinet. With the volume control it is best to remove it from the chassis, and clamp it in the vice by the shaft end in order to cut away the surplus length. If, as sometimes happens in the case of midget sets, the removal of the control means a lot of work such as moving other components, the shaft should be held in a vice and the cut made with a fine metal-cutting fretsaw. I did exactly this in the presence of a beginner. He said "Surely it would be quicker and easier to use a hacksaw." I simply pointed out that I expected it to last a week or two before it started developing bad habits in the matter of "frying" and crackling. I have since wondered if some of the complaints we hear about controls that were noisy "right from the start" were due to clumsy cutting in the matter of shaft shortening.

response of their equipment, etc., but, quite rightly, they felt a comparison of the low-priced long-plays against standard recordings played under identical conditions, even if it has known shortcomings, would be equally helpful. After all, the vast bulk of records are used with reasonably good, but far from perfect, equipment.

To summarise, everyone spoke highly on the quality of Ace of Clubs records. Almost equally well praised were the even less costly Classics Club recordings. These are distributed strictly on "club" lines and have quite an enthusiastic following. A number of their "members" sent along their monthly news sheet together with a list of the discs now available.

The records of another "club" were unanimously condemned by five readers, and no one wrote to praise them. They were described as "below expectations," "third-class," "most disappointing" and as possessing "distressingly bad surface noise." It is notable that four of these readers, obviously trying to be fair, mention that their experience of them is anything between 18 months and 2½ years old. I express the hope that the quality has since been improved. Apparently the early samples, which seem to have been much inferior to contemporary commercial pressings, put them off later purchases.

A Photo-Electric Finish!

In the good old days a radio receiver could be built from scratch in a couple of hours or so. Hence enthusiasts were constantly pulling down and re-building. This was not only good fun in the days of simple receivers but a matter of necessity—there were no electronic sidelines to create a diversion! Today only the over-enthusiastic newcomer tackles more than about three sets a year, and once he has equipped his workshop with test apparatus he begins to apply his radio knowledge to his other hobbies. Amateur

Centre Tap talks about items of general interest

Gramo-Philes

I was pleasantly surprised by the number of readers who wrote on the question of the quality of the various low-priced long-play records. Unfortunately space does not permit me to deal with them in detail, but nevertheless my thanks to all those good enough to write.

Most of the correspondents were quite modest on points of claimed frequency

photographers, especially, seem to find plenty of scope ranging from remote control of the shutter and electronic flashes in taking the picture, to timers for determining the exposure needed for the final enlargement to finish it. A recent innovation has been the automatic coupling of a photo electric cell to the aperture, and now comes an even more ingenious idea.

continued on page 213

The Teletron

“TRANSIDYNE”

6 Transistor Pocket Portable Superhet Receiver

described by EDWIN MARSHALL

PART 2, conclusion

Alignment

FOR THIS PROCEDURE A SIGNAL GENERATOR is ideally required and, where this is available, the following order of adjustment should be carried out.

Set the signal generator to a frequency of 470 kc/s and connect the output to the base of TR₃ via a 0.1 μ F condenser. Adjust the iron dust core of IFT₃ for maximum output.

Following this, connect the output of the signal generator to the base of TR₂ and adjust IFT₂ for the maximum output. Finally, connect the generator output to the base of TR₁ and adjust IFT₁ for best results. The signal generator output should be decreased as each additional tuned circuit is dealt with. It is advisable now to repeat the above process until no further improvement can be obtained.

It should be noted that all iron dust cores must be rotated slowly, and a suitable trimming tool for this purpose may easily be made from a plastic knitting needle of suitable gauge.

The signal generator should next be coupled to the Medium wave ferrite winding (L₂) by means of a single turn loop of insulated wire around the ferrite rod, first removing the 0.1 μ F condenser from the generator output. Set the generator output to a frequency of 600 kc/s. Position the tuning condenser C_{2a}/C_{2b} to near maximum capacity (vanes nearly fully meshed) and adjust the ferrite winding position on the

ferrite rod material, in conjunction with rotation of the oscillator coil L₃ iron dust core for maximum output. Secure the MW winding into final position by means of a small piece of Sellotape material.

Next, switch to the LW position and adjust the appropriate winding position only, in conjunction with rotation of the tuning condenser. Secure this winding into a final position in the same manner as above.

As explained in the last issue, the value of R₆ is nominally 1k Ω , and a variable resistor of 10k Ω in value should be connected into circuit and adjusted to maintain stability during the alignment procedure. The final value of R₆ may lie somewhere between the limit values of 500 Ω to 2.2k Ω . With the alignment procedure completed, this empirically found value should be permanently wired into circuit.

Where the constructor is not in possession of a signal generator, the above procedure, with regard to the adjustment of the various cores and the positioning of the tuning condenser, should be carried out using a transmitted signal near the 600 kc/s frequency (vanes nearly fully meshed). The i.f. transformers are supplied pre-aligned to the 470 kc/s intermediate frequency and, consequently, only a small amount of variation of these dust cores are required to bring the receiver into line. This may be carried out using the reception of a Medium wave signal.

With the lining-up process completed, the

receiver should now be fitted into the plastic case, carefully positioning the volume control, wavechange switch and condenser spindle through the actual casing. The tuning dial may now be fixed to the condenser spindle in such a manner that the dial is correctly located with respect to the wave-length markings. The backing may next be fixed into position.

Summary of Possible Faults

In order that the constructor may deal quickly and efficiently with various possible faults, the following guide is offered. Reference to Table 1, showing various voltage and current readings at specified circuit points,

Low Gain

If this fault is apparent, reduce the value of R_5 . Another cause of low gain is that TR_2 or TR_3 may be faulty.

Receiver Unstable

The cure here is to increase the value of R_5 . Causes of this trouble may be ageing batteries or C_{14}/C_{17} being open circuit. Should the receiver be unstable at the high frequency end of the Medium waveband, then increase the value of R_3 .

I.F. Amplifier

Should the i.f. amplifier stages be working

TABLE 1

	Emitter volts	Base volts	Collector volts	Current (mA)
TR_1	0.4	0.2	4.4	0.11
TR_2	0.5	0.4	4.4	0.3
TR_3	2.0	1.5	3.0	2.2
TR_4	0.7	0.5	4.3	3.1
$TR_{5/6}$	0.04	0.2	5.2	2.0 each

Measured on 10V range of a Model 7 AVO.

Variable condenser at maximum capacity.

Total battery current, for no signal conditions = 12mA nominal.

Voltage at a.g.c. line = 0.04 for no signal conditions.

should be made during the fault-finding process.

Receiver "Dead"

Faulty battery connection or a badly soldered joint or joints. A faulty or damaged transistor or transistors.

Distorted Reproduction

Reduce the value of R_{16} and, if this does not effect a cure, then the transistors TR_5 and TR_6 are incorrectly matched.

ERRATA.—On page 125 of the September issue, it was stated that the Medium wave winding of the ferrite rod aerial should be positioned nearest to the ganged condenser; this should, of course, have read *Long* wave winding, as shown in the component layout diagram on page 124.

radio miscellany *continued from page 211*

Most negatives contain a great deal more detail than can be put into the print or enlargement by normal means. The high-lights appear as an expanse of white and the darker areas are lost in a mist of murkiness. In the past this had to be countered by masking off parts of the print to hold off the light to prevent overprinting of some areas. Conversely, shadow details had to be held back to enable full printing elsewhere making enlarging a sort of trial and error game to be performed by dexterous finger manipulation and specially shaped card kept in motion to avoid hard edges. My own negatives invariably seem to require lots of hand-

but no signals be apparent, check the switch S_1/S_2 for contact continuity.

Instability on Long Waveband

This fault may be cured by fitting a 0.01 μ F condenser from the slider of the volume control R_{15} to chassis. In order to enable this to be done, an 8BA solder tag should first be fitted behind the volume control fixing screw, this being the slider connection. The chassis connection may be one of the i.f. can solder lugs.

shading and several test papers before a satisfying result can be obtained!

The basic difficulty, of course, is that the light used is of fixed intensity all over the picture area. If a finger of light can be made to scan the picture area, electronically controlled so that its intensity is reduced or increased to suit the image on the negative, a much more delicate gradation would be obtainable. Such an idea has now been developed. It is soon to be put into use for medical, scientific, newspapers and commercial photography, but it is likely to be mighty expensive. How soon will it be before we see an amateur version?

**A
Constructor
visits the**

.....

1958 NATIONAL RADIO and TELEVISION SHOW

THAT GRAND OLD CLICHE, "A SIGNIFICANT TREND," fits very aptly the situation which existed at this year's Silver Jubilee Radio Show at Earls Court. For the first time since the war television took an unprecedentedly withdrawn back seat, giving unreserved way to a comparative newcomer to domestic electronics: stereophonic high fidelity sound reproduction. Not only were stereo reproducers exhibited at a number of stands and demonstration rooms on the ground floor at Earls Court, they also occupied an entire wing on the first floor. This area of the exhibition, the Audio Hall, enclosed forty-nine stands, each of which had its own demonstration room.

The almost startling shift of Radio Show focus from television to stereo is the result of several important factors. As should be well known, stereo on tape has been available to the general public for a number of years; but it has never caused any marked attention or comment. Rather, it has tended to fall only within the province of the hi-fi-minded. In very recent months, however, the stereo *disc* has arrived and this, capable of being played with a special pick-up on a conventional turntable, seems to have been the main cause of this sudden attempt on the part of the radio industry to capture a wider spread lay interest. A second factor is that television has now become very stabilised in design, showing no signs whatsoever of any prospective dramatic changes. The most recent novelty, Band 3, is now a matter of well-established history; and such things as colour are much too far away to be given any serious attention in a show of this type. Finally, there is the fact that British manufacturers of sound reproducing equipment have won an excellent reputation overseas for the quality of their products. Nearly one-quarter of the total forty million pounds value of radio exports last year consisted of hi-fi gear. As such, it is only proper that manufacturers of sound gear should be given adequate space and publicity at the British Radio Show. This point carries the corollary that the high fidelity industry deserves a lively home market in order to buttress its export sales. If the Audio Hall at Earls Court brings people's minds closer to the American outlook (wherein the next thing to get, after you have bought the fridge, the t.v., and the washing machine, is the hi-fi) this last object will be at least partly achieved.

Because of the emphasis on audio which was prevalent at the show, most of this report is devoted to sound reproduction exhibits.

Demonstration Difficulties

One of the most difficult things to cater for at an exhibition in which sound reproduction equipment is displayed is that of providing adequate demonstration facilities for each manufacturer. The two main problems consist of providing individual demonstration

rooms which are sufficiently well insulated from each other to prevent mutual interference, and of organising the manner in which the public may visit such rooms. The first problem was met fairly satisfactorily at the show. As one approached the Audio Hall one could hear the faint taps and thumps which indicate, when filtered through walls of a temporary nature, that wide-range audio amplifiers are at work. Inside the demonstration rooms themselves the interference from neighbouring exhibits was in some cases loud enough to be annoying, but it was never sufficiently troublesome to prevent adequate judgment being made on the merits of the particular equipment under examination. The second problem, that of ensuring that the public could listen to demonstrations at will and in comfort, was not handled by any means as well. In the Audio Hall most manufacturers adopted one of two opposing methods to meet this problem. One method consisted of leaving the demonstration room continually open, so that people could drop in and out as they chose. This idea works satisfactorily provided that the number of people using the room is low and that someone is at hand to usher them in and out. Without chivvying, a certain percentage of the general public confronted with audio demonstration rooms seems to become completely *lost*. These hapless ones mass at narrow doorways, completely unable to decide whether they should listen inside in comfort or leave altogether. At the Audio Hall one quite frequently saw a dozen people sitting contentedly in the chairs of a demonstration room whilst, several yards away, another dozen wedged themselves tightly into the doorway, getting in everyone's way, and staring with dim, uncomprehending eyes at the demonstration speakers and equipment. A peculiar phenomenon. The second method of organising sound demonstration rooms at the Radio Show consisted of opening these at fixed times only and for ticket holders at that, no gate-crashers being allowed. (In at least one of the rooms run on these lines each batch of visitors was immured behind Yale-locked doors!) So far as audio demonstrations are concerned this scheme is good, and it is especially valuable when stereo is being demonstrated. The correct number of people can be admitted, they may be comfortably seated in the best area for stereo listening (and, let's face it, stereo *does* require the listener to occupy a position centrally disposed before the speakers) and they may be given full information on the equipment by the demonstrator, with questions afterwards. The snag with this second method of giving demonstrations is that, if a number of equipments of different make are to be judged, a somewhat time-consuming and carefully planned programme is required of the visitor to the show. The average casual visitor may not be prepared to go to the trouble of picking up tickets (sometimes at a stand removed from the demonstration

room) for demonstrations held at arbitrarily chosen times. The business of planning a number of successive visits to different ticket-only demonstrations is hardly a relaxing way in which to enjoy a visit to an exhibition.

As may be gathered from the above, the writer's opinions on the running of demonstration rooms at the Audio Hall are that this is capable of much improvement. Perhaps some imaginative exhibition may, in the future, find a way of overcoming the present difficulties.

Stereo

However, problems of presentation apart, the Audio Hall provided excellent examples of good high fidelity stereo reproduction. As was mentioned earlier, the present considerable interest in stereo appears to have been brought about by the appearance of the two-channel disc. Despite its very recent introduction, it is pleasing to note that the international recording companies have already reached agreement on a standard system of recording. With disc stereo the two sound channels are recorded in one groove, the planes in which they are cut being at right-angles to each other and at 45 degrees to the surface of the record. The reproducing pick-up has a single stylus, this being coupled to two coils or crystals (according to the type of pick-up) each of which responds to one of the two tracks on the record. Thus, two separate signals become available at the pick-up head itself. These signals may be fed to separate amplifiers and, hence, to separate speakers mounted some distance away from each other. Given correct phasing, and roughly correct listener positioning, the stereophonic effect recorded into the disc may then be recaptured. A point which can help in reducing the costs of stereo systems is that, since lower notes do not exhibit directional properties, these may be reproduced from one loud-speaker only, the stereo effect being still attainable if the remaining speaker handles middle and high frequencies. This cost-cutting idea was not, incidentally, employed on all the stereo equipments at the Show. Another important feature of stereo is that, since two amplifiers and two speakers are now employed, output power ratings may be reduced in proportion. Thus, two 6-watt amplifiers in a stereo system give an output roughly similar to that of a single 12-watt amplifier. This can result in a marked reduction in expense, the double stereo amplifier costing only slightly more than a single channel amplifier of twice the power.

At the Show manufacturers showed several different ways of attacking the stereo problem. One was given by the use of conventional record players or grams which were "wired for stereo." "Wired for stereo" simply means that the pick-up arm carries a monaural, single-channel cartridge or a stereo cartridge as desired. When the stereo cartridge is used an additional amplifier and speaker for a second channel may be run from terminals on the existing unit. An alternative system consisted of two units, one containing the turntable and pick-up, both stereo amplifiers, and one of the loudspeakers. The remaining loudspeaker was then housed in a separate enclosure. A third system consisted of a single unit containing turntable, pick-up and double amplifier, and two separate speaker units. There were also stereo versions of the unit systems offered by hi-fi manufacturers employing separately housed pre-amps, main amplifiers, and so on. In some instances stereo outfits were capable of a considerable amount of versatility. A good example was that shown by Ferguson. The basic unit here consisted of a large cabinet housing turntable and stereo amplifiers (together, incidentally, with a pull-out radio). The main cabinet contained speakers at either end which, on their own, could handle either channel of the stereo system. Alternatively, the stereo channels could be fed to two column speakers, these being separate from the main unit. Yet a third alternative consisted of employing the speakers in the main cabinet to handle the lower frequencies whilst the separate speakers handled the middles and tops. With the main cabinet positioned between the two separate speakers this latter arrangement gave the impression of a very well balanced source area of large size.

It would be pointless to attempt to criticise the performances of individual items in an exhibition of this nature. All were good, and some were very, very

nice indeed. For those who have not heard stereo it is, perhaps, just a little difficult to explain the effect provided. The value of stereo from the writer's own viewpoint lies in the enhanced presentation of orchestral music, wherein the sound appears to emanate from an area roughly bounded in the horizontal sense by the two speakers themselves. After hearing a good stereo reproduction one feels dissatisfied with monaural equipment. Stereo reproduction can also, of course, be used, as it very frequently is, to give a realistic impression of such things as trains passing through stations, and so on. Which is all right if you like that sort of thing.

The writer was happy to note that Jason were well to the forefront in stereo equipment, their J.210 amplifier and JSM.2 pre-amp being put through their paces very creditably in demonstration room 441. This company has always given much thought and careful attention to the home-constructor, a policy which is not readily evident amongst many other hi-fi manufacturers.

Two comments overheard by the writer in the Audio Hall are worth passing on. One was in the form of a question to a demonstrator: "I understand that the two stereo sound signals cross over at a point in front of the loudspeakers. If a listener sits behind that cross-over point, won't his left ear hear the right-hand channel and his right ear the left-hand channel, so that he gets the stereo effect wrong way round?" The second was a remark to his friend from an earnest and worried-looking young man who had spent some five minutes listening intently to a system: "You know, George, those violins should be over on the left. I've just discovered that what's wrong is that we're *behind* the orchestra instead of in front of it."

Before concluding on the subject of stereo, brief reference should be made to a press notice from E.M.I. released at the show. This states that an E.M.I. stereo system, the Percival system, is undergoing tests by the B.B.C. The Percival system functions by adding *directional* information to a transmitted sound carrier. A receiver tuned to a signal modulated in this manner feeds two stereo channels, the additional information on the carrier controlling the direction from which the reproduced sound appears to come. The system requires only one carrier and is compatible; that is to say, a normal monaural receiver may pick up the stereo programme and reproduce it in normal fashion.

Other Exhibits

The remainder of the show at Earls Court was, to a very large extent, the mixture as before.

As we have already noted, television showed few dramatic changes. Cabinets are shallower this year now that the 90 degree tube has become standard, and chassis layouts in consequence tend to become more and more miniaturised. To be perfectly frank, your technically-minded reporter found more changes in cabinet designs and presentations than he did in purely technical details. "Boxes" varied from the very functional housings of the less expensive transportable televisions—and transportable televisions are usually less expensive *because* the portable design idiom allows the use of functional cabinets—to the more glossy Continental stylings employing shiny polyester wood finishes and gold trims. Incidentally, the newly-introduced polyester finishes are almost incredibly hard wearing, the advertised statement that a cigarette may be stubbed out against a polyester finished cabinet is perfectly true.

On the radio side the most noticeable change occurred in transistorised receivers. These are still somewhat expensive but prices are dropping slowly. Corsor, Channel, Pam, Vidor and Perdio all exhibited transistor miniatures which definitely fell into the pocket portable class. The latest Perdio model is only 5½in x 3½in x 1½in overall. A new development came from Vidor, who showed a table model transistor receiver whose low running costs are particularly aimed at country dwellers isolated from supply mains.

Transistors also played an important role in a newly introduced range of car radios (Ekco, Masteradio and Philips) which are designed to run direct from 12-volt car batteries. These receivers employ valves designed to work from a 12-volt h.t. line, with output stage consisting of two transistors in push-pull.

Fitting a Tuning Indicator

By
R. H. WRIGHT
G3IBX

IT IS STRANGE, BUT NEVERTHELESS TRUE, that the female members of one's household frequently find it somewhat difficult to tune in a broadcast station correctly. If the domestic receiver has some form of tuning indicator, the tuning-in process is easy; but if no indicator is fitted, how often there is some sideband cutting or interference from the sideband of a neighbouring (in terms of frequency) broadcast station leading to an irritating background of "monkey chatter".

Tuning indicators of the "magic-eye" type are frequently advertised in this magazine at reasonable prices, and these may easily be fitted to many types of receiver by the average reader.

The indicator consists, basically, of a

shadow should decrease, minimum shadow indicating the correct tuning point.

Fig. 2 shows the theoretical diagram of the indicator and its associated circuit, and it will be seen that between the cathode and target electrode is another electrode which is connected to the anode of the triode amplifier section. This electrode is variously known as the Ray Control Electrode or Deflector Wire, and it protrudes into the path of the electrons flowing towards the target anode. The dish-shaped target anode is coated with a material which glows green when bombarded by electrons, but the field around the deflector is such that it deflects the electron flow in its vicinity and so causes a shadow to appear on the target.

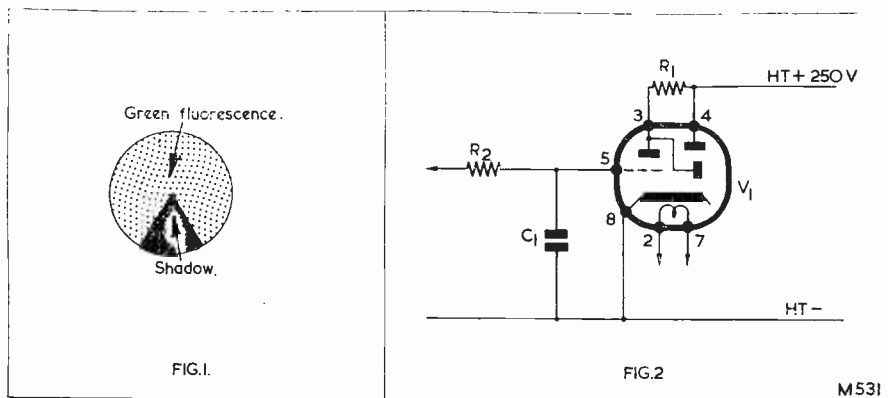

triode amplifier valve together with a miniature cathode ray device in the same envelope. The valve has the usual heater-cathode assembly, but an extension of the cathode allows electrons to strike the dish-like target which is visible through the end of the glass envelope. When the indicator is in use, the target electrode will exhibit a greenish glow with a V-shaped black shadow, as in Fig. 1. As the signal is "tuned-in" the extent of the

The grid of the tuning indicator is connected to the a.g.c. line of the receiver and, in consequence, anode current of the triode section will be fairly high in the absence of a signal (with no a.g.c. voltage being produced). This value of anode current will produce a large voltage drop in the anode resistor, R_1 so that the triode anode and also the deflector wire will be at a potential very much below that of the target anode. This will result in

the deflector having a considerable effect on the electron flow and a wide shadow will result. When a station is being tuned in, the receiver a.g.c. voltage will rise to a maximum value and anode current through the triode will decrease. This will cause the anode—and deflector—potential to rise and the effect on the electron stream to the target will be reduced, so that the shadow will decrease in area. Minimum shadow thus indicates correct tuning.

Escutcheon plate designed by A. F. Bulgin and Co. Ltd., specifically for use with this type of tuning indicator. This escutcheon is available with either a Chrome or Florentine-Bronze finish. Two fixing holes ($\frac{1}{8}$ in diameter) are provided in the escutcheon and the indicator octal base may be held in position by means of suitable lengths of screwed rod, as shown in Fig. 3 (a). An alternative method of mounting may be by means of a metal bracket, drilled to take the octal base, and

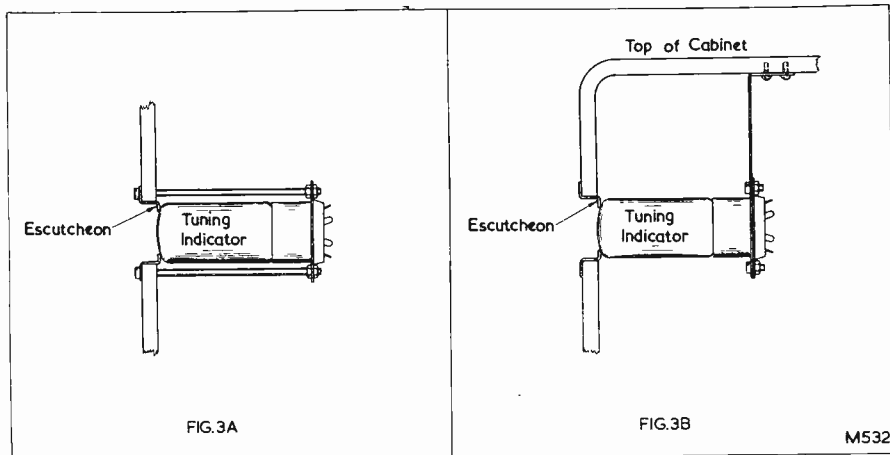

Installation

Five connections between the indicator holder and the receiver will be required. These are two heater wires, h.t. positive, cathode to h.t. negative, and the connection to the receiver a.g.c. line. The resistors R_1 and R_2 , together with the capacitor C_1 , may be mounted on the valveholder, blank pins being used for anchoring purposes. The mounting position for the indicator will depend upon the available room in the cabinet but will involve the cutting of a hole in the cabinet (of $1\frac{3}{8}$ in diameter for the I.O. type). This size of hole will accommodate an

screwed into the top of the cabinet, as in Fig. 3 (b).

Components List

- R_1, R_2 $1M\Omega$ resistors, $\frac{1}{2}$ watt.
 - C_1 $0.1\mu F$ capacitor
 - V_1 Tuning indicator, Osram Y63, or American 6U5G Octal base holder
 - Bulgin Magic-eye Escutcheon, Type E.7, Chrome; Type E.8, Florentine-bronze
- The indicator will require an h.t. supply of 250 volts and an l.t. supply of 6.3 volts at 0.3 amps.

CALL-SIGN PLATES

Kar Kee Tags, of 116 Commercial Road, Totton, Southampton. Hants. have sent us a sample of their key tag, designed to attach to a key-ring and normally carrying the car registration number. The firm has received a number of requests for these tags to be embossed with amateur call-signs, and is prepared to supply these at 4s. each, plus postage. The size of the plate is roughly $1\frac{1}{2}$ in long by $\frac{1}{2}$ in wide, and just over $\frac{1}{16}$ in thick. Made of aluminium, the outer border and the lettering is raised and left natural colour, whilst the sunken background is enamelled black. Apart from being used as a key tag, these plates can easily be fixed to receivers, transmitters and other apparatus to enhance their appearance.

HIGHER RATED TRANSISTORS

There is, today, an increasing demand for transistors with higher ratings for specialised applications. To meet this demand Newmarket Transistors have now considerably raised the dissipation rating of their audio and r.f. transistors.

This is the result of improved manufacturing processes and application technique. The transistors are now supplied with an increased dissipation rating which can be raised to the maximum rating by mounting the transistors with a special clip supplied by the manufacturers. There is no change in price—the clips are supplied free.

Repairing a DAMAGED METER

By Chas. T. J. DAINTY

SOME YEARS AGO, AN OVERDOSE OF electrons severely damaged the internal organs of a 500 μ A meter in use at the time to such an extent that it was relegated to the junk box, and replaced by a new and somewhat costly item—much to my regret.

Recently, during one of my infrequent periods of junk disposal made necessary by a domestic crisis in which lack of space was the major issue, I came upon the damaged meter and was on the point of throwing it into the dustbin when it occurred to me that it might be interesting to try and effect a repair. If it did not succeed, there was always the dustbin! At least, the effort would be better than spring cleaning.

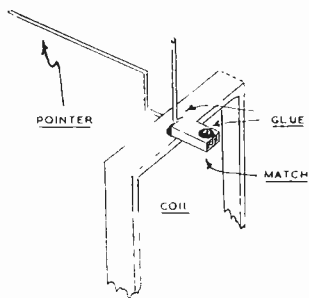

Fig. 1. Showing replacement balance weight

The coil, I knew, was not burnt out and the movement was quite free on its bearings. However, the pointer looked rather silly and readings varied according to the position in which the meter was held. Upon inspection, I found that the latter was due to the pointer balance weight having broken off. Clearly, this would have to be replaced and, if successful, a little careful work on the pointer would complete the job. As the first was going to be difficult, if not impossible,

and any meter is quite useless without a pointer, I decided to tackle the needle first. Unfortunately, during the straightening process I broke the tiny round disc near the point. It simply fell off and promptly lost itself.

The needle, however, was straight and otherwise undamaged. I turned my attention to the balance weight. Now, this required some furious thought and the final solution and complete repair of the instrument may be of interest to readers with a similar piece of wreckage on their hands.

The materials and tools required are two spent matches, one tube of Croid glue, a pair of tweezers and a magnifying glass. A good pair of eyes should be a satisfactory substitute for the last item.

First of all, split one of the matches lengthwise and cut off a piece about a quarter of an inch long. Squeeze out a blob of glue on to the bench and, holding the piece of match firmly with the tweezers, dip one end of it into the blob of glue so that only a little adheres to the extremity. At this point, it must be stressed that too much glue is quite fatal as the tiniest bit of it in the wrong place will literally gum up the works!

Still with the scrap of wood gripped firmly by the tweezers, apply the glued end carefully but firmly to the coil at a point diametrically opposite the needle, and leave it to set. Do not be tempted to remove it and re-stick, otherwise "hairs" of glue will certainly jamb the movement. Even if it is a little drunken in appearance, it won't matter much. Leave it overnight and it will then be found quite secure.

Next, to find a suitable substitute for the tiny disc near the tip of the needle. Sharpen the second match to a point and squeeze out another blob of glue on to the bench. Pick up a little, very little, of the glue on the sharpened point and rotate between the fingers to make sure there are no fatal "hairs." Then transfer the glue to form a round nodule resting on the needle about $\frac{3}{16}$ in from the point. If it is not big enough,

let it dry and then add more. Too much on the first application will simply slide down and fix the needle to the scale.

Final balancing is carried out by adding a further spot of glue either to the end of the wooden balance "weight" or to the needle tip. Correct balance is indicated by the reading on the scale remaining constant in both the vertical and horizontal positions of the meter. A point to remember during this process is that the weight of the glue will decrease as it dries out.

In the unlucky event of the movement sticking due to an excess of glue or dust, it may be cleared by the careful insertion of a strip of paper between the coil former and the iron slug or pole pieces.

One final word of warning. Lay down a clean sheet of paper on the bench before opening up the meter. Iron filings have a nasty habit of leaping into the breach (air gap) and they are quite impossible to extract.

If this should happen, it must be the dustbin after all!

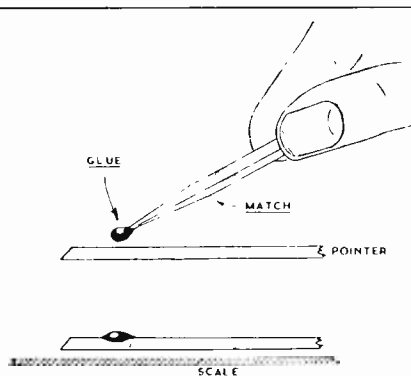

Fig. 2. How new pointer disc is formed

Technical Forum *continued from page 199*

some importance. Some care is required in preparing the mounting surfaces for the transistor as all surfaces making contact must be flat and free from all burrs and similar protrusions. Similar precautions are also required where the actual heat sink is made in two or more parts.

The general shape of the heat sink also has a marked effect upon its efficiency. A vertical surface will radiate heat more readily than a horizontal one, and usually some further improvement can be achieved by bending the sink into a chimney form with sufficient space at the bottom to allow air to flow freely up through the centre. The use of a chimney radiator increases the cooling by convection air currents, but reduces it slightly by lowering the level of direct radiation. The surface finish and colour of the fin are also of some importance, and measurements have shown that a matt black surface is some 30% better than the untouched aluminium finish.

Having obtained a heat sink of convenient shape and supposedly adequate size, it is necessary to check that it is capable of

retaining the temperature of the transistor within the limit specified by the makers. This is done by running the transistor under its maximum working conditions; that is, with the full supply voltage, and in the case of a Class B stage at the maximum signal level. During the test the temperature should be measured at a point on the transistor specified by the makers, and if it shows signs of exceeding the maximum safe value the operation should be discontinued until either the transistor dissipation is lowered by a modification to its working conditions or the heat sink size is increased to remove more heat. The test must be made in a heated compartment where the ambient temperature is equal to the greatest under which the equipment is expected to work. Generally the maximum ambient temperature is taken to be 45–50°C.

Readers will appreciate that much of the foregoing applies to the general problems of cooling components and is not peculiar to transistors, although the introduction of such devices has laid particular emphasis on the subject.

A Corner Reflector Aerial

Owing to a cursor error, the table given on page 131 of the September issue was slightly at fault. Slightly, because the aerial is flatly tuned. The correct figures are: $d=5640/f$; $r=6925/f$; $a=5840/f$; $b=1130/f$; and $c=792/f$. A lighter gauge wire than the

6 s.w.g. mentioned for the reflectors—say, 14 s.w.g.—will be quite satisfactory provided that provision is made to support the upper ends. An additional wood "V," suitably fixed to the existing one, may be used for this purpose.

Easy TRAWLER BAND Conversion

by G3XT

SINGLE-WAVEBAND ("MEDIUM WAVE ONLY") sets are ideal for quick and easy conversion to trawler-band, with amateur "top-band," possibly amateur 80-metre band, and Radio Luxembourg (208 metres English transmission) thrown in for good measure!

Owing to their obvious limitations for ordinary broadcast reception, single-waveband sets can often be picked up very cheaply second-hand in good working order. British manufacturers put a few of these "medium wave only" models on the market just after the war, and one may also have a chance of getting a much more recent American or Canadian M.W. set. A lot of small but efficient single-waveband sets are brought over from the States by U.S.A.F. personnel stationed in this country, so you might get one of these second-hand.

When you get such a set, there is more than one way of altering the wavelength range to cover the required band of, say, 80 to 210 metres or thereabouts.

Alternative Methods

I have done two or three very successful conversions recently using different methods, and all are reported to be working well. One set was of Canadian manufacture, brought back from that country by someone who had lived over there. It was quite an old set, using octal valves, and after conversion it is actually working a lot better on trawler-band than it did on the ordinary medium-wave broadcast band for which it was designed.

This set had a small built-in frame aerial. I removed this completely and substituted a home-wound aerial/grid coil with provision for a short indoor aerial of single flex. I also removed the original oscillator coil and fitted a simple home-wound one. The whole conversion was very easy, and the coils took only a few minutes to wind, on Government-surplus formers, with adjustable iron-dust cores. The optimum number of turns was found by trial and error; cores and trimmers were adjusted to cover the range required. A *Radio Constructor* Panel Transfer was used to form a new tuning dial, enabling the set to be re-calibrated for the trawler waveband.

Listening to Lifeboats

I rigged up this particular set for a member of the local lifeboat crew. The main idea was that his wife could follow the progress of the local boat when her husband was out on life-saving service. The set has picked up a large number of stations over a range of hundreds of miles; but the local boat project has, so far, misfired! By some queer twist of fate, our local lifeboats have only been called out once since I converted the set some months ago, and even then the crew never got further than the beach, as the distress call turned out to be a false alarm and the service was cancelled before launching!

Another set I converted was a British-made one, released in 1946 by a well-known manufacturer. This also used octal valves, the line-up being X76M, W76, DH76, KT71 and U76. In this case I used a different method, giving a coverage of the bulk of trawler-band plus the "bottom edge" of the medium-wave broadcast band so that Radio Luxembourg could be heard too.

This set also used a built-in frame aerial, with sockets for external aerial and earth. In this instance I left the frame aerial *in situ*, but removed a few turns to lower the wavelength range. I also left in the original oscillator coil in the frequency-changer triode circuit, but lowered its wavelength range by taking out the iron-dust core and adjusting the trimming condensers. (I believe I also found it necessary to put in a different padding condenser, but cannot remember for sure!)

Results were not quite as good as those with the Canadian set, but were nevertheless quite reasonably satisfactory.

Other Methods

There are still other methods of achieving conversion, and it is best to carry out some practical experiments to find which expedients are best suited to any individual receiver.

If the original coil-windings are easily un-windable (i.e. are not impregnated with wax or other compound), taking off a few turns at a time on the "cut and try" principle will perhaps be the easiest and cheapest method. Start with the oscillator coil, which is most critical, then bring the aerial/grid tuned circuits into correct alignment.

If, however, the windings cannot be easily altered, it will be preferable to fit new coils, either home-wound or ready made, suitable for the range of wavelengths one wishes to cover.

The great advantage of a single waveband set from the conversion viewpoint is that it has no wavechange switching arrangements to make things complicated. You have only single coils to deal with, and you can't upset performance on other wavebands because there aren't any!

If you happen to live on the coast (as I do), a short indoor aerial, or even the frame aerial, will probably suffice, but at greater distances inland (or for weak amateur signals) a good outdoor aerial may be needed to ensure best results.

One final word of warning: if you get an American or Canadian set, don't forget that it may be designed for 110-120 volt operation only. Before attempting to use it, you must adapt it for the British mains voltage, say, by adding a suitable linecord, or mains dropping resistor, or mains (step-down) transformer (220-240 to 110-120 volts) or suitable auto-transformer, which will lower the mains input from British to American standard voltage.

Can Anyone Help?

Requests for information are inserted in this section free of charge, subject to space being available

D. TAYLOR, 59 Loughboro Avenue, Sneinton Dale, Nottingham, is anxious to purchase the circuit diagram for the Pye mains/battery radio PE94MBQ/LW, 16-2,000m.

A. REDMAN, 46 Tukes Avenue, Bridgemary, Gosport, Hants, asks if anyone can sell or lend the manual for the AR77E receiver, and details of using the BC.624A on 2 metres. Any expense will be refunded.

G. POWELL, c/o Raymond Way, 10 Kilburn High Road, London N.W.6, requires information on adding another valve in place of the quartz crystal in the Navy receiver 1392 (P.104). Can anyone oblige and supply a circuit?

S. WEBBER, 27 Alkham Road, London N.16, wishes to borrow or purchase the circuit diagram of the R.107 receiver, also details of inter-connection of various units and any useful modifications. Expenses gladly repaid.

M. BUTTON, 7 Upper Flowerfield, Nunney, Frome, Somerset, requires details of converting the RF.26 or RF.27 Units for use on 144-146 Mc/s, and for converting the R.1132A to the 50-54 Mc/s band. He is prepared to pay for any details received.

R. A. WILLIAMS, Brickfield House, Stone Street, Newtown, Montgomeryshire, would like to buy, borrow or beg the instruction booklet on the G.E.C. Battery All-Wave 5 Receiver, cat. no. BC4956.

R. WHEELER, G3MGW, 9 Bateman Road, Brightlingsea, Essex, wishes to buy, hire or borrow the circuit of the Army Sender No. 12.

Y. Y. JOSLIN, 64 Gladstone Road, London S.W.14, is anxious to obtain a service manual or circuit diagram of the Eddystone 358X receiver. Can anyone help?

B. H. ADAMS, 56 Wontford Road, Purley, Surrey, asks if any reader can supply the circuit or any other information applicable to the V.H.F. Unit R-4/ARR-2, R.A.F.R.1585.

S. BEVERIDGE, 4 Blantyre Terrace, Edinburgh 10, wishes to buy or borrow the circuit diagram of the MCR-1 receiver, and also asks where valves may now be bought for this set.

A. MERIGAN, 334 Alexandra Park Road, Wood Green, London N.22, wishes to obtain the circuit and the other data for the National HRO receiver. Can anyone help?

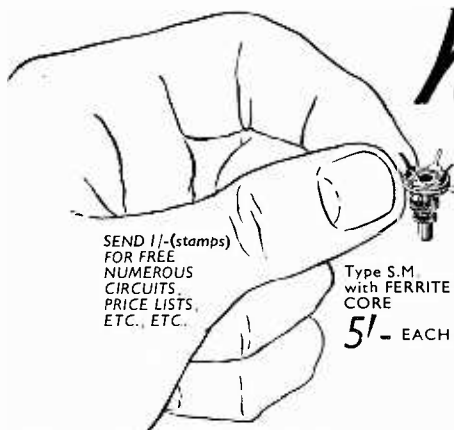

SEND 1/- (stamps)
FOR FREE
NUMEROUS
CIRCUITS
PRICE LISTS
ETC., ETC.

Type S.M.
with FERRITE
CORE
5/- EACH

OSMOR

New

**SUB-MINIATURE
HIGH Q COIL
RANGE**

"That's what I call
stupendous performance"

for SUPERHET — T.R.F. —
TRANSISTOR CIRCUITS

(Dept. 27) 418 BRIGHTON RD. SOUTH CROYDON
SURREY Telephone CROydon 5148/9



The
Cooper-Smith
"Prodigy"
High Fidelity Amplifier

COMPONENT PRICE LIST

Buy direct from the Designers to ensure 100% results
 All enquiries promptly dealt with

R1	10M Ω high stability $\frac{1}{2}$ W	...	6d.
R2	390k Ω high stability $\frac{1}{2}$ W	...	6d.
R3	680k Ω high stability $\frac{1}{2}$ W	...	6d.
R4	12M Ω $\frac{1}{2}$ W	...	3d.
R5	390k Ω high stability $\frac{1}{2}$ W	...	6d.
R6	180k Ω high stability $\frac{1}{2}$ W	...	6d.
R7	47k Ω $\frac{1}{2}$ W	...	3d.
R8	2.2M Ω $\frac{1}{2}$ W	...	3d.
R9	1.8k Ω high stability $\frac{1}{2}$ W	...	6d.
R10	100k Ω high stability $\frac{1}{2}$ W	...	6d.
R11	47k Ω high stability $\frac{1}{2}$ W	...	6d.
R12	100k Ω $\frac{1}{2}$ W	...	4d.
R13	1.2k Ω high stability $\frac{1}{2}$ W	...	6d.
R14	47k Ω $\frac{1}{2}$ W	...	3d.
R15	39k Ω $\frac{1}{2}$ W	...	3d.
R16	68k Ω $\frac{1}{2}$ W	...	4d.
R17	6.8k Ω $\frac{1}{2}$ W	...	4d.
R18 & 23	*100k Ω $\frac{1}{2}$ W	pair	1/4
R19	270k Ω $\frac{1}{2}$ W	...	3d.
R20	1.2k Ω $\frac{1}{2}$ W	...	3d.
R21	100 Ω $\frac{1}{2}$ W	...	3d.
R22	1.2k Ω $\frac{1}{2}$ W	...	3d.
R24	390 Ω wire wound 5W	...	2/-
R25	2.2k Ω 1W	...	6d.
R26	10k Ω $\frac{1}{2}$ W	...	3d.
R27, 28 & 32	*1M Ω $\frac{1}{2}$ W	set	1/9
R29	10k Ω $\frac{1}{2}$ W	...	3d.
R30 & 31	47 Ω $\frac{1}{2}$ W	pair	6d.
R33	680 Ω $\frac{1}{2}$ W	...	3d.
R34	(See note on power output)	...	1/6

*Matched to within 5%

VR1 & VR2	250k Ω ...	each	3/6
VR3	250k Ω with switch	4/6
C1	16 μ F 275V electrolytic	2/6
C2	470pF silver mica 5%	7d.
C3	270pF silver mica 5%	6d.
C4 & 5	68pF silver mica 5% ...	pair	1/-

C6, 12, 18 & 19	0.1 μ F 350V paper	each	9d.
C7, 8, 15 & 17	50 μ F 12V electrolytic	each	1/7
C9	560pF silver mica 20%	...	7d
C10	8,000pF (2 x 4,000pF) silver mica 20%	...	2/2
C11 & 22	50-50 μ F 350V electrolytic	...	8/6
C13	2,000pF silver mica 20%	...	9d.
C14	0.02 μ F moldseal	...	1/-
C16	50 μ F 25V electrolytic...	...	1/10
C20	8 μ F 350V electrolytic...	...	2/6
C21	3,000pF silver mica 20%	...	1/-
V1	12AX7 (inc. P.T.)	...	18/11
V2 & 3	EZB2 (inc. P.T.)	each	22/4
V4	EZB1 (inc. P.T.)	...	11/6

(No Purchase Tax is payable on the valves when included in a kit)

Mains Transformer (T1), A.E.E.	...	51/8
Output Transformer (T2), A.E.E.	...	49/6
Switch, 2-pole 4-way (S1, S2)	...	10/6
Voltage selector	...	1/6
Mains plug and socket	...	3/9
Output plug and socket 5-pin	...	9d.
Power plug and socket 4-pin	...	9d.
Motor plug and socket 2-pin	...	7 $\frac{1}{2}$ d.
Coaxial sockets (3)	each	1/3
Coaxial plug	...	1/3
Fuse, 2A and holder	...	4/-
Valveholder, with skirt	...	3/10
Valveholder, paxolin (3)	each	6d.
Group board, 26-way, 1 blank	...	4/6
Panel light holder and bulb	...	1/3
Knobs, pointer (4)	set	5/-
Nuts, screws, solder tags	...	4/-
Wire, flex, sleeving	pkt.	2/-
Chassis, punched, bronze finish	...	17/6
Base plate, with screws	...	2/6
Grommets (8)	...	6d.

TOTAL **£15.56**

INCLUSIVE PRICE FOR COMPLETE KIT ... £13.7.6
LABORATORY-BUILT AND TESTED ... £16.16.0

Carriage free in U.K.

H. L. SMITH & CO LTD

287/9 EDGWARE ROAD . LONDON W2 . Telephone Paddington 5891



BRIMAR 6T8

TRIPLE DIODE TRIODE

The Brimar 6T8 is a triple-diode-triode in which one diode has a separate cathode. The triode section has a high amplification factor making the valve suitable for use in AM/FM receivers in the demodulation and first stage audio circuits. The diodes may be used in series shunt limiter circuits, for example in the audio sections of television and communications receivers, followed again by the triode section for AF amplification.

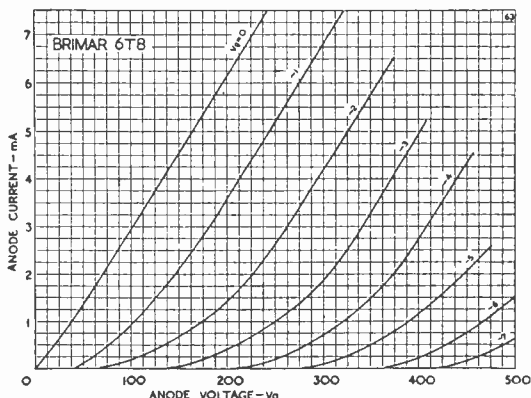

Near Equivalents

EABC80
DH719
6AK8

Typical Triode Operating Characteristics as an R.C. coupled amplifier

Heater Voltage	6.3 volts	Heater Current	0.45 amp
Anode Supply Voltage	250	250 volts	
Anode Load Resistor	0.25	0.25 megohms	
Grid Resistor	1.0	10 megohms	
Cathode Bias Resistor	3	0 kilohms	
Peak Output Voltage	43	40 volts	
Stage Gain (for 24V peak to peak output)	42	42	
Distortion (for 24V peak to peak output)	1	5%	

Cut this out for further reference or write to the Publicity Department at Footscray for a data sheet



Standard Telephones and Cables Limited
(Reg. Office 63 Aldwych London WC2)

FOOTSCRAY SIDCUP KENT

Telephone 3333

BAND III CONVERTER

Suitable
Wales,
London,
Midlands,
North,
Scotland,
etc. All



the parts including 2 EF80 valves, coils, fine tuner, contrast control, condensers and resistors. (Metal case available as an extra.) Price only 19/6, plus 2/6 post and ins. Data free with parts or available separately 1/6

A.C./D.C. MULTIMETER KIT

Ranges: d.c. volts
0-5, 0-50, 0-100,
0-500, 0-1,000,
A.C. volts 0-5,
0-50, 0-100, 0-500,
0-1,000. D.C. milli-
amps 0-5, 0-100,
0-500. Ohms 0-
50,000 with internal
batteries. 0-
500,000 with external
batteries.



Measures a.c./d.c. volts, d.c. current and ohms. All the essential parts including metal case, 2" moving coil meter, selected resistors, wire for shunts range selector, switches, calibrated scale and full instructions. Price 19/6 plus 2/6 post and ins.

MORGANITE POTENTIOMETERS

Single and 2-gang
types available,
standard size with
good length spindle
all new and
boxed. Single
types 1/- each.

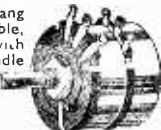

Values available: 5k, 10k, 25k, 50k, 100k, 250k, 1Meg, 2Meg. Gang type, 3/- each. Values available: 5k+5k, 100k+100k, 1/2Meg+1/2Meg, 2Meg+2Meg.

YAXLEY SWITCHES

3-pole, 2-way	1/3
12-pole, 2-way	1/6
3-pole, 3-way	1/6
9-pole, 3-way	2/-
2-pole, 4-way	2/-
6-pole, 4-way	2/6
4-pole, 5-way	2/6
2-pole, 6-way	2/6
1-pole, 7-way	2/6
1-pole, 12-way	2/6
6-position shorting switch ...	2/-
Double-pole mains switch for attaching to Yaxley switches	1/6

Discount of 10% allowed where a dozen of one type ordered. Special quotes 144 or over.

PULLIN SERIES 100 TEST SET

Undoubtedly a most useful instrument by a firm long famous for fine instruments. Entirely redesigned, it has a square movement with diacon plastic cover; this makes for a brighter, more readable scale, extra scale length and wider angle of vision. With the test set is included a pair of combined test prods and crocodile clips also a stand for inclining the meter at the best reading position.

Ranges: a.c. volts: 0-10, 0-25, 0-100, 0-250, 0-500, 0-1,000; ditto d.c. A.C. current: 0-100mA; d.c. current: 0-2.5, 0-10, 0-100, 0-500mA. Resistance: 0-1M and 0-10kΩ. Price £12.7.6 plus 5/- carr. and ins. or £1 deposit and 24 weekly payments of 10/- FREE GIFT. All purchasers this month will receive a Series 100 range extender scale and data, which adds capacity 0-0.1 μF. in two ranges, inductance, E.H.T. and many others.



THE TRANSIDYNE SUPERHET

As described in this journal

Including six transistors, T.C.C. printed circuit, ferrite rod aerial, cabinet, speaker and all parts for medium and long wave operation—only £11.19.6, or with Pye Goldtop transistors, £12.19.6



FOUR ITEMS FOR PRICE OF ONE

This set of modern TV parts is equally suitable for modernising an old television or for building into a new one. Suitable for wide angle 14" or 17" tubes using E.H.T. or 12-14kV. The four items comprise (1) line output E.H.T. transformer, (2) 70° scanning coils on ferrite yokes, (3) width control with ferrite core, (4) frame output transformer. With these parts we also give free, complete circuit diagram of a modern television which uses them. We offer the whole lot at the price of the line output transformer only, namely 57/6, plus 2/6 post and insurance

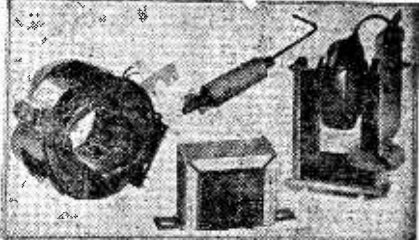

SHORT WAVE COMMUNICATIONS RECEIVER R.208 10/- DOWN

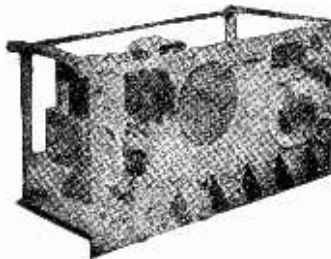

A super short-wave receiver covering 5-30 metres (10-60 Mc/s). Has R.F. stage, 2 I.F. stages, B.F.O., etc. Muirhead instrument drive, internal mains power packs, p.m. speaker. Provision for phones and speaker muting. Complete in metal transit case, size approx. 24" x 18" x 12", weight 70lb. In perfect condition, practically unused. Tested before despatch and guaranteed. Handbook free with each. Price £6.19.6, carriage and insurance 15/-, or 10/- deposit plus 15/- carriage and ins., then 15 weekly payments of 10/- each

Super Sensitive (2,000 O.P.V.) Multimeter Kit
17 ranges including d.c. volts to 1,000V, a.c. volts to 1,000V, d.c. milliamps to 500, ohms to 2 meg. capacity and inductance. All the essential parts, including metal case, selected resistors, wire for shunts, selected switches, calibrated scale and instructions, 32/6 plus 2/6 post and ins.

ELECTRONIC PRECISION EQUIPMENT LTD

For prompt attention post orders should be sent to our Eastbourne address marked Dept. 7

42/46 Windmill Hill
Ruislip Middlesex
Telephone RUISlip 5780
Half-day Wednesday

66 Grove Road
Eastbourne
Sussex
Half-day Saturday

29 Stroud Green Road
Finsbury Park N4
Telephone ARChway 1049
Half-day Thursday

266 London Road
Croydon
Telephone CROydon 6558
Half-day Wednesday

*Technical
training
in radio
television
and
electronics
engineering
with*

The decision is YOURS. To be a success in your chosen career: to qualify for the highest paid job . . . to control a profitable business of your own ICS home-study courses put your plans on a practical basis; teach you theory and practice; give you the knowledge and experience to take you, at your own pace, to the top.

Choose the **RIGHT** course.
RADIO AND TELEVISION
ENGINEERING · RADIO AND
TV SERVICING · RADIO SERVICE
AND SALES · ELECTRONICS ·
VHF/FM ENGINEERING

ICS provides thorough coaching for professional examinations: AM BRIT. IRE., City and Guilds Telecommunications, Radio Servicing; Radio Amateurs PMG CERT. (MARINE).

THERE ARE ICS COURSES TO MEET YOUR NEEDS AT EVERY STAGE OF YOUR CAREER.

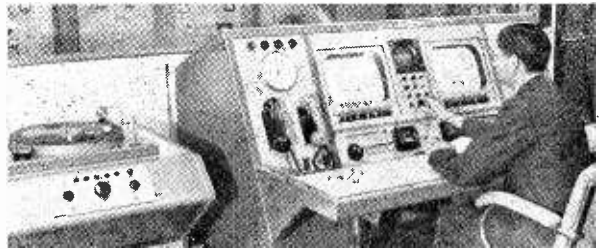

The first step towards success is to fill in and post this coupon today:

In return you will receive the FREE 60-page ICS Prospectus listing technical examinations and their appropriate ICS courses PLUS details of over 150 specialised subjects.

AN EYE-OPENING SURVEY OF THE ICS WAY TO COMPLETE TECHNICAL TRAINING

LEARN AS YOU BUILD
Practical Radio Course

Gain a sound up-to-professional-standards knowledge of Radio and Television as you build YOUR OWN 4 valve TRF and 5 valve superhet radio receivers, signal generator and high-quality multi-tester. At the end of the course you have three pieces of permanent and practical equipment and a fund of personal knowledge and skill . . . ICS Practical Radio courses open a new world to the keen radio amateur.

OTHER ICS COURSES INCLUDE: AGRICULTURE · HORTICULTURE ARCHITECTURE · WOODWORKING · SALESMANSHIP AND SALES MANAGEMENT · ART · PHOTOGRAPHY · MECHANICAL, MOTOR, FIRE AND CHEMICAL ENGINEERING, ETC. A WHOLE WORLD OF SKILL AND KNOWLEDGE FOR THE KEEN STUDENT.



INTERNATIONAL CORRESPONDENCE SCHOOLS
Dept. 248B International Buildings Kingsway London WC2

NAME AGE

ADDRESS

.....

OCCUPATION 10.58

Build your own HI-FI

— with an
entirely
NEW
range of
Hi-Fi
units and
cabinets!



Amplifier



Pre-Amplifier

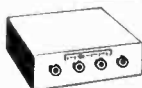

AM/FM Tuner



Tape Recorder



Record Player



Speaker System



Cabinet

Imagine the pleasure of having this magnificent Hi-Fi equipment in its beautiful contemporary style furniture for your home . . . and experiencing an entirely new realism in sound reproduction. Yet the Emistructor Hi-Fi will save you money and give you all the *extra* fun and satisfaction of building it yourself—and being able to service and maintain it afterwards. Special instruction manuals guide you at each stage and teach you all about the equipment in simple terms as you build. No skill or experience is needed—only a few simple tools.

Emistructor equipment is made to the highest quality standards and is a product of E.M.I. Institutes Ltd.—part of a Company world famous for sound recording and reproducing equipment.

There is a wide variety of equipment and cabinets at different price levels to suit individual tastes and requirements. The range varies from a complete HI-FI installation with separate speaker enclosures to a simple all-in-one compact system for those with more modest requirements. All equipment is suitable for stereo or non-stereo reproduction of records. Full details and complete specifications will be sent with our free Brochure

FREE BROCHURE—POST TODAY

To: "Emistructor," (Dept. H.F. 179)
43, Grove Park Road, London, W. 4.

Please send, without obligation, details of your Hi-Fi equipment.

NAME

ADDRESS

IC. 136

Oct/58

EMISTRUCTOR

Associated with one of the World's largest recording organisations comprising—

"HIS MASTER'S VOICE"

CAPITOL • COLUMBIA

PARLOPHONE • MGM • ETC.



PRECISION - BUILT COMPONENTS

JACKSON

'O' GANG CONDENSER

Miniature model in 1 or 2 gang, capacities up to 365pF swing, front area $1\frac{3}{8}'' \times 1\frac{1}{4}''$ including sweep of vanes, length 1 gang $1''$, 2 gang $1\frac{1}{4}''$, spindle $\frac{1}{4}''$ dia. x $\frac{3}{8}''$ long. Aluminium vanes, cadmium plated steel chassis

- 1 gang 7/6
- 2 gang 11/6

**It's Reliable
If It's Made
By JACKSONS**

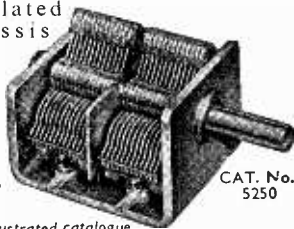

CAT. No. 5250

Please write for illustrated catalogue

JACKSON BROS. (London) Ltd

Kingsway · Waddon · Surrey Phone CR0ydon 2754/5

RADIOSETTE

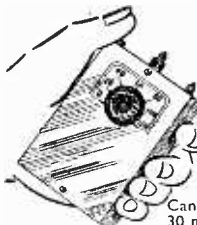

The ideal low cost transistor pocket radio for the beginner. The circuit utilises the new R.C.S. VARILoop-STICK transistor coil. A specially designed miniature .0004 tuning condenser permits the set to be in a case which fits the palm of your hand.

Can be built in 30 minutes **30/-**

All components are sold separately, full construction data including plan of parts, 2/-

ALL-WAVE RADIO **35/-**

Ideal for the beginner or for those requiring a simple stand-by receiver



This 1 valve S.W. receiver can be built for 35/- from our list of components, which can be purchased separately. It includes valve and 1 coil covering 20-40 metres. Provision is made to increase to 2 or 3 valves if required, and all components are colour-coded so that the beginner can build this set quite easily. Send 2/- for specification, wiring diagram, layout and price list.

Postage: Under 10/-, 9d. Under 40/-, 1/6. Over 40/-, best free

R.C.S. PRODUCTS (RADIO) LTD.

11 Oliver Road London E17 Mail Order only

TRANSFORMERS

- Mains Power Trans. 15/9.** 350-0-350V 250mA. 4V 5A. 6.3V 5A, 4V 5A centre tapped. Drop through type. Post 3/9
- Mains Power Trans. 9/9.** 350-0-350V 250mA. 22V 3A, 6.3V 5A, 6.3V 4A, 4V centre tapped. Post 3/9
- Mains Trans. 5/9.** 280-0-280V 80 mA, 6V-4V heaters. 200-250 prim. Post 2/3
- Mains Trans. 3/9.** 350-0-350V 80mA, 12V-4V heaters. 200-250V prim. Post 2/3
- Mains Trans. 1/3.** Salvage, guaranteed. Standard size. 2-5 ohms. Post 1/-, 20 for £1, carr. 5/6

VOLUME CONTROLS

- 1/9. $\frac{1}{2}$ M Ω . New, boxed. Long spindle. Post 1/-
- 1/3. 20k Ω . Unused. Short spindle. Carbon. Post 1/-
- 2/6 doz. Assorted parcel of volume and tone controls from working chassis. Post 1/9
- Ganged Condensers 1/9.** 2 and 3-gang 0.0005 μ F (500pF) standard size. Salvage. Post 1/3
- Resistors 6d. doz.** 270k Ω $\frac{1}{2}$ W ceramic. Post 6d. Post on 4 doz. 1/-, on 10 doz. 2/6
- Insulating Tape 1/6.** 75 ft x $\frac{1}{2}''$ wide, in sealed tins. Always handy. Post 9d. Post on 6 tins 2/-
- Solder Reels 1/6.** 60/40 Ersin 3-core. 20 ft on plastic spool. Post 6d.
- Valve Screening Cans 1/- doz.** Latest midget type. Aluminium. No bases. 2" x $\frac{3}{8}''$ dia. Post 6d.
- Chassis 1/- each.** 6 or 8 valve. Latest midget valve type, for a.m. or f.m. New. Cadmium plated on s.w.g. steel, 12 $\frac{1}{2}''$ x 7 $\frac{1}{2}''$ x 2". Post 1/9. Post on 4, 3/-; 12 for 10/-, carr. 5/-

I.F. STRIPS—POWER PACKS

- Sound & Vision Strip 10/6.** S/het. Takes 6 EF91, 1 6D2, 1 6F14. Valves extra. Not tested. Free drawing. Post 2/6
- Sound & Vision Strip Plessey 25/6.** S/het. Takes 6 6F1, 2 6D2 valves (extra). Tested. Free drawing Post 2/6
- Power Pack & Amplifier 19/6.** Output stage PEN45. Smoothed h.t. 325V 250mA. O.p. trans., choke, etc.; 4V 5A, 4V 5A centre tapped. Less valves. Not tested. Carr. 5/6
- Timebase 4/9.** Including scanning coil, focus unit, line trans., etc., less valves. Bargain. P. & p. 3/6
- Co-ax. Cable 6d. yd.** Good quality. Cut to any length. Post on 20 yds 1/6. 45/- per 100 yds. P. & p. 3/6
- 17" TV Mask 14/9.** Brand new. P. & p. 2/3
- 12" TV Mask 1/9.** Soiled, easily cleaned with detergent. Post 2/3

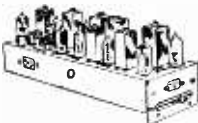

FOCUS MAGNETS

- Elac Focus Magnet 5/9.** 35-38 mm. Permanent magnet. Salvage. P. & p. 1/9
- Elac Focus Magnet 12/9.** Brand new. 35-38 mm. Post 1/9
- Plessey Focus Magnet 3/9.** 35 mm. Permanent magnet type. Salvage. P. & p. 1/9
- Frame Output Transformer 3/9.** To match low impedance coils. Post 1/3
- Visiconal Condensers 5/9.** 0.1 μ F at 7kV working and 0.001 μ F at 12.5kV working. Post 1/-
- Rectifiers 2/9.** 250V 100mA. Full or half-wave. Salvage. Post 1/3
- I.F. Transformers 1/- pair.** 465 kc/s. Tested. Post 9d.
- Coil Packs 3/9.** 3 waveband. Incl. pair 465 i.f.s, 2-gang cond., paper dial. P. & p. 2/3

SPEAKERS **8/9**

Ideal for extension in kitchen or bedroom. With o.p. transformer. 10/-, P. & p. 2/9

EXTENSION SPEAKER 29/9.

Complete in attractive cabinet, with switch and lead. Ideal present. P. & p. 3/6

Car Aerials 6/9. Plated, whip antenna, 50" long, collapses to 11". 1-hole fixing. Post 1/-



P.P. Components Ltd

(Dept. C.10) Send stamp for FREE Catalogue
219 ILFORD LANE ILFORD ESSEX ILF 0295
Closed Thursday 1 p.m.

Ask "ARTHURS" First

NOTE NEW ADDRESS AT
125 Tottenham Court Road
London WC1
Close to Warren Street Station

You will have the same service and obtain all your requirements in Radio Components, Electrical Goods, Accessories and Television as previously.

Test Instruments in stock include Avo, Taylor, Cossor and Advance. List on request

VALVE MANUALS AVAILABLE
Mullard 10/6 Brimar No. 7 6/-
Osram Part 1, 2nd Edition 7/6
Post and packing 9d. each extra

Arthurs first Est. 1919

Proprietors ARTHUR GRAY LTD

Gray House
125 Tottenham Court Road
London WC1
Telephone EUSton 5802/3/4

The Teletron TRANSIDYNE

Portable 6-Transistor Superhet
Receiver with printed circuit

Circuit diagram with
instructions available
from most advertisers
in this magazine, 1/-
post free

SAM MOZER LTD

288 Hedge Lane London N13
Telephone PALmers Green 1748
Sole Distributors to the Trade

TV FAULT FINDING

Data Book Series No. 5

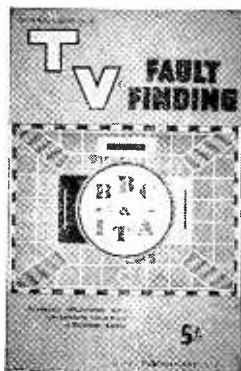

This latest edition now includes, for the first time, information and fault-finding details of both the B.B.C. and I.T.A. transmissions. Completely revised and enlarged, and especially useful in that it is lavishly illustrated by photographs taken from the screen of a television exhibiting the faults under discussion. A comprehensive fault-finding guide is included, and this is cross referenced to the book itself.

OVER 100 Illustrations and Diagrams

NOW 104 pages, high quality paper
with laminated heavy art
board cover

PRICE 5s. Available from your usual supplier, or direct Postage 5d.

"... A book that should be in every television dealer's service workshop, and in every home-constructor's, for that matter."
Journal of the Television Society

"... The book will undoubtedly be of value to TV service engineers particularly those who are not fully experienced in translating the appearance of faulty pictures into the necessary adjustments or receiver fault location."—*Wireless and Electrical Trader*.

Published by

DATA PUBLICATIONS LTD

57 MAIDA VALE · LONDON W9

Telephone CUNningham 6141 (2 lines)

Telegrams Databux London

The Teletron TRANSIDYNE 6-Transistor Pocket Portable

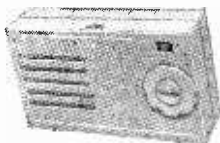

COMPLETE KIT
as specified

£11.19.6

1/6 postage

Teletron **COMPANION** complete kit including printed circuit **£5.5.0**, postage 1/3

ELEC-RADIO

172a BLACKSTOCK ROAD HIGHBURY
LONDON N5 Telephone CANonbury 1672

Res/Cap Bridge

FOR

35/- ONLY

P. & P. 2/-

For checking all types of resistors and condensers

BUILT IN 1 HOUR!

READY CALIBRATED!!

Stamp for details of this and other instruments

RADIO MAIL Dept. CB Raleigh Mews
Raleigh Street Nottingham



CONSTRUCTOR CHASSIS SERVICE

With our products the amateur
can obtain that Professional look

MULLARD "510" ready punched (except transformer holes) including base plate and alternative rectifier plate ... 18/9
Postage and packing ... 1/6

MULLARD "TYPE C" TAPE AMPLIFIER ready punched to designer's specification with all screws and brackets ... 29/6
Postage and packing ... 1/6

Power Pack Chassis ... 11/-
Postage and packing ... 1/3

Control panel, drilled, sprayed gold hammer and clearly lettered—stove-enamelled mild steel ... 7/-
Postage and packing ... 1/-

MULLARD 2-VALVE PRE-AMP, ready punched, with all screws and brackets, in aluminium ... 14/-
Postage and packing ... 1/3

Control panel, drilled, sprayed gold hammer and clearly lettered—stove-enamelled mild steel... 7/-
Postage and packing ... 1/-

Other well-known designs available, details on request. All above may be obtained from your usual supplier or, if any difficulty, please write to address below

Trade enquiries invited

BERON LTD 34 NAPIER ROAD BROMLEY KENT

RADIO AMATEURS . . .

get your Licence in

Half The Usual Time!

You must be a good Morse operator!

A "slap-dash" 12 w.p.m. neither satisfies the authorities, yourself, nor your operator friends. Morse operating is an exacting art unless your training is made simple and is based on sound fundamentals. For this reason, the Candler System was invented to take the "grind" out of Code tuition, turning a tricky subject into a pleasurable pursuit.

★ Send 3d. stamp for the "Book of Facts"

CANDLER SYSTEM CO

(Dept. 55 RC) 52b Abingdon Rd London W8
Candler System Company Denver Colorado U.S.A.

COME TO . . .

Open all day Sat.

Burleigh's

for your "WAVEMASTER" BASIC KIT
72/6 plus 3/6 p. & p.

We also keep in stock suitable Diesel and Electric Motors, Receivers & Kits, Actuators & Servos, Steering mechanisms and all requirements for a first class job

BURLEIGH of Edgware Road Ltd.

303 Edgware Rd W2 Telephone PAD 8827-8-9

Let us supply

your new

PULLIN

SERIES 100

MULTI-RANGE TEST SET

on easiest of terms



Completely restyled with new Diakon meter cover giving wide angle of vision and very clear scales. Carrying handle and ingenious three-position stand incorporated. Printed circuit gives a rugged accurate instrument. 21 ranges and sensitivity 10,000 ohms per volt. Full data on request.

CASH PRICE £12.7.6

Deposit £2.10.0 (delivery by return) and balance by nine monthly payments of £1.4.6.

WE STOCK FULL RANGE OF "BERON"
CHASSIS ADVERTISED IN THIS ISSUE

Meet us at the

RADIO HOBBIES EXHIBITION

in London 26th-29th November

HOME RADIO

Dept. C

(MITCHAM) LTD.

Telephone
Mitcham 3282

187 LONDON ROAD • MITCHAM • SURREY

Shop Hours 9-6.30 p.m. Wednesdays 9-1 p.m.



TELETRON MINIATURE TRANSISTOR 42/-

Superhet coil kit (as illustrated)

470 kc/s I.F. Transformers and Oscillator coil in screening cans $\frac{3}{4}$ " x $\frac{1}{2}$ " dia. Dual wave Ferrite rod aerial $5\frac{1}{2}$ " x $\frac{5}{16}$ " dia. Designed for the TRANSIDYNE miniature superhet receiver.
Descriptive folder with circuit and assembly instructions Price 9d.

TELETRON Type FX.25

Self-tuned, dual wave
Ferrite rod aerial. 15/- each



Specified for the "Companion" 3 Transistor regenerative pocket receiver.
Type 24 Inductor 3/6 each



TRANSISTOR I.F. TRANSFORMERS

High Q "potted" construction, with Ferrite screw cores. Mounted in screening cans 1 " x $\frac{3}{4}$ " dia., 6/6 each. Oscillator coil, 6/6. Transistor type Ferrite rod aerial for MW band, 10/-. Selective crystal diode coil type HAX, 3/- each. Type HAX.L (for LW band), 3/6. Dual wave TRF coils, type A/HF, matched pair, 7/-, with adjustable iron dust cores.

FERRITE ROD AERIALS

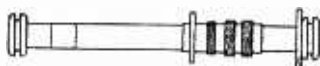

Wound on high permeability Ferroxcube rod. No external aerial required. Full sensitivity. Ideal for battery portable receivers. Medium wave, type FRM 4 " x $\frac{5}{16}$ ", 8/9. Dual wave type FRD, 8 " x $\frac{5}{16}$ ", 12/9. Miniature R.F. Chokes, wound on iron dust cores, with wire end terminations. 2.5 and 5mH, 3/- each; 10mH, 3/6

BAND III PRE-AMP COIL SET

(as featured in March issue)

Types 20T, 21T and 22T 9/- per set

Send 5d. in stamps for complete data and circuits. All types available from advertisers in this Magazine and local component stockists

THE TELETRON COMPANY LIMITED

112b Station Road . Chingford . London E4

Telephone SIL 0836

Trade enquiries to sole distributor

S. Mozer Ltd 288 Hedge Lane N13

Telephone PAL 1748 or EDM 7707

PREMIER RADIO COMPANY

B. H. MORRIS & CO (RADIO) LTD

Telephone
AMB 4033
PAD 3271

Open till
6 p.m. Saturday

(Dept. R.C.7) 207 EDGWARE ROAD LONDON W2
Also 23 Tottenham Court Road London W1



THE "PETITE" PORTABLE MAY BE BUILT FOR **7** GNS.

plus 3/- post. & pkg.

Batteries extra
H.T. 10/- (Type B126) or
equivalent.
L.T. 1/6 (Type AD 35) or
equivalent.

- ★ Size only 8" x 8" x 4½"
- ★ Weight including batteries 5½lb
- ★ 4 valves of the economy type
- ★ Medium and long wave superhet circuit
- ★ High Q frame aerial
- ★ High sensitivity on both wavebands
- ★ Pre-aligned i.f. transformers
- ★ 5" speaker of the latest type
- ★ Automatic on/off switch operated by lid
- ★ Designed in our own laboratory
- ★ Backed by an up-to-date Technical Information Dept.
- ★ Components available separately if desired
- ★ Simple to construct, using normal soldering methods
- ★ Instruction book 1/6

THE "PETITE" PORTABLE & REPRODUCER MAY BE BUILT FOR **13** GNS.

plus 5/- post. & pkg.

Batteries extra: H.T. 10/-
(Type B126 or equiv.) L.T.
996, 3/6

45 r.p.m. Single Record Player
£5.5.0 including P.T.

"Petite" Components
£5.13.0

Portable Case £2.10.0

- ★ Size 10½" x 9½" x 6"
- ★ Weight including batteries 7lb
- ★ 45 r.p.m. single record player complete with pick-up
- ★ 6V battery operated



- ★ Incorporates pick-up head protection dome and automatic stylus cleaning brush, overall size 7¼" x 6" only
- ★ Automatic stop-start
- ★ Completely battery operated
- ★ Attractive two-tone rexine covered case
- ★ Construction simplicity itself
- ★ Components available separately if required
- ★ Instruction Book 1/6

THE RADIO CONSTRUCTOR

BOUND VOLUMES

(COMPLETE WITH INDEX)

Attractively bound in blue cloth, with gold-blocked spine

Vol. 10, August 56 to July 57 £1.5.0, postage 1/9

Vol. 11, August 57 to July 58 £1.5.0, postage 1/9

Where readers return all issues of a volume for exchange,
the price is 12/6, plus postage 1/9

Please note:—we regret that we can no longer undertake to bind readers' own copies.
(Many newsagents can arrange for books to be bound, and/or sell self-binding kits.)

DATA PUBLICATIONS LTD 57 MAIDA VALE LONDON W9

* This handsome
all British Tape
Deck with three speed Control
Knob incorporates the very
latest in design and construction

Details on request Patents pending

M O T E K K9

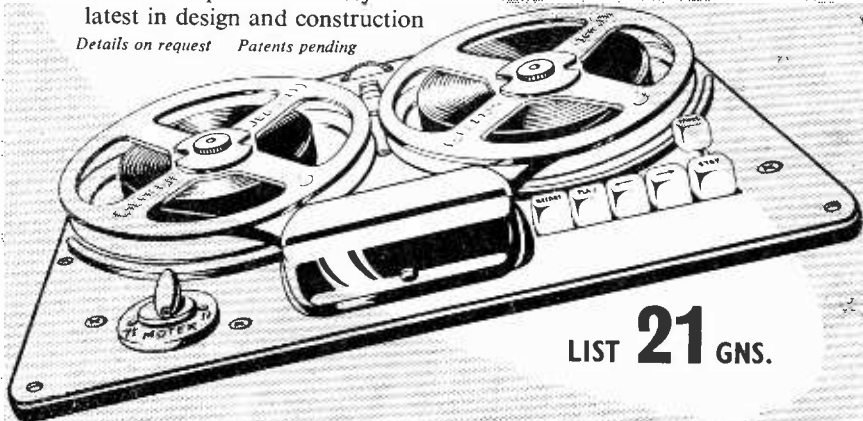

LIST 21 GNS.

MODERN TECHNIQUES

Wedmore Street, London, N.19. Tel: ARChway 3114

★ VALVES NEW TESTED AND GUARANTEED ★

1R5	7/6	6X4	7/6	DK91	7/6	EP92	5/6
1S5	7/6	6X5G	6/-	DK92	9/-	EL41	10/-
1T4	6/-	12AH8	9/6	DK96	9/-	EL84	9/-
3S4	7/6	12AT7	7/6	DL92	7/6	EL91	7/6
3V4	8/-	12AU7	7/6	DL94	8/-	EY51	10/6
5U4G	6/-	12AX7	9/-	DL96	9/-	EZ35	8/-
5Z4G	9/-	12K8GT	13/6	EB91	5/6	EZ40	8/-
6AM6	6/9	12K7GT	8/6	EBC41	8/-	EZ80	8/-
6AL5	5/6	12Q7GT	7/-	EBF80	9/6	EZ81	8/6
6AT6	7/6	25A6G	10/6	ECC81	7/6	KT33C	9/6
6BA6	8/6	25L6GT	7/6	ECC82	7/6	PCF82	11/-
6BE6	7/6	35Z4GT	8/6	ECC83	7/6	PL82	10/6
6BR7	10/6	35L6GT	9/6	ECC84	8/6	PY81	8/-
6BW6	8/6	53KU	11/6	ECH82	11/-	PCC84	9/-
6J5G	5/6	807	6/9	ECH81	10/6	PCF80	9/6
6J7GT	8/6	5763	10/6	ECH42	10/-	U76	8/6
6K7G	2/6	DAF91	7/6	ECL80	12/6	UBC41	10/-
6K8G	7/6	DAF96	9/-	EF36	7/6	UCH42	9/-
6Q7GT	8/6	DF91	7/6	EF39	5/6	UF41	10/-
6SL7GT	8/-	DF96	9/-	EF41	9/-	UL41	9/6
6SN7GT	8/6	DH76	8/6	EF80	8/-	UY41	8/-
6V6G	7/6	DH77	7/6	EP91	6/9	W76	8/6

Matched Pairs. EL84, 23/-; 6V6G, 17/-; 6BW6, 18/-; KT33C, 19/6; KT66, 27/6; 807 14/6 pair

1R5, 1T4, 1S5, 3S4, 3V4, DK91, DK92, DF91, DAF91, DL92, DL94, any four, 27/6 per set

P.P. Op. Transformers. MR 3-15 ohms for EL84, 6V6, 6BW6, etc., 18/6; Op. Pen. 50mA, 5/6; 30mA, 4/6

Volume Controls. All values, long spindle. L/S 3/-, s.p. 4/-, d.p. 4/9, ext. spkr. control 3/-

W. W. Pots. Pre-set 3/-; 3W long spindle 5/6, s.p. 6/6

P.M. Speakers. 3 ohm. 5" 16/6, 6½" 17/6, 8" 21/-, 10" 25/-, 12" 30/-, Bakers 12" 15 ohm 15W, 90/-

Coaxial Cable. 75 ohm ¼" stranded, 8d. yd; semi-air spaced, 9d. yd; screen cable single and twin, 9d. yd

Coaxial Plugs 1/- each; Sockets 1/- each

P. and p. 9d. to £1; 1/6 to £2; over £2 post free. C.O.D. 2/6

C.R.T. Isolation Transformers with nil, 25% and 50% boost, low capacity a.c. mains 200/250V for 2V, 4V, 6.3V and 13V tubes. All 10/6 each

Valveholders. 4, 5, 7 pin English and U.S.A. B7G, B9A, 1.0 Mc. B8G, 9d. each; B7G, B9A with screening can, 1/6; B12A, 1/3. Aladdin formers ½" with core, 8d. each

Scotch Boy Recording Tape, 1,200ft reels, 27/-

Jack Plugs, miniature standard, 3/-; Sockets 3/-

2-Gang Condensers, 0.0005 small size, 7/6

I.F. Transformers, 465 kc/s, small size, 7/6 pair

Capacitors, small mica, 5% 1pF to 100pF, 8d.; 120pF to 1,000pF, 9d.; 1,000V wkg. .01, .0015, .0025, .004, .005, 1/- each

Crystal Diodes, G.E.C., 1/6 each

Headphones, lightweight, 4,000 ohm, 16/6 pair

Ceramic Capacitors, close tol. 500V for V.H.F., 9d.

Paper Capacitors, tubular, .01, 1,000V, 1/-; 0.1 to 0.5 500V, 10d.

Paper Blocks, 4µF, 1,000V wkg., 3/6

Rectifiers, contact cooled, 250V 50mA, 7/6; 85mA, 9/6

Reaction Condensers, .0001, .0003, .0005, 4/6 each

Heater Trans. 200/240V, 6.3V, 1.5A, 7/6

Resistors, ½ and ¼W, insulated, 4d. and 6d.; 1W, 8d. 6W W.W., 1/-; 10W, 2/-

Electrolytics. Wire ends. 25/25V, 1/6; 50/50V, 2/-; 12/50V, 9d.; 8/450V, 2/-; 16/450V, 2/9; 16/500V, 3/6;

32/450V, 4/-; 8+8/450V, 4/6; 8+16/450V, 4/6; can types: 16/450V, 3/6; 16+16/500V, 6/-; 32/500V, 6/6;

32/450V, 6/6; 20+20/450V, 4/6; 64+120/275V, 7/6

Wavechange Switches, midget: 1p 12W, 2p 6V, 3p 4W, 4p 3W, 4p 2W, long spindles, 4/6

Toggle Switches. QMB, s.p.s.t., 2/-; s.p.d.t., 3/3; d.p.s.t., 3/6; d.p.d.t., 4/-

Chokes, 80mA, 15H, 8/6; 100mA 10H, 10/6; 150mA 10H, 14/6

★ Solder, Multicore, 4d. yd; sleeving 2mm, 3d. yd

R. COOPER G8BX 32 SOUTH END CROYDON SURREY CROYDON 9186

REGETTERED IMPROVED VACUUM TV TUBES

17" £7.10.0 12 MONTHS GUARANTEE 14" £5.10.0

Our 12 months guarantee (6 months full replacement, 6 months progressive) illustrates our supreme confidence in the tubes we are offering. We sell hundreds a week all over this country, as indeed we have done for the past 7 years. Many of them go to the trade, i.e. to Insurance Companies, Renters and Retailers, who are thoroughly satisfied with our supplies. Our tubes also hold a 10-day money back guarantee. 9", 10", 14", 15" AND 16" ROUND TUBES. Our special offer of these sizes, £5. 12" TV Tubes, £6. Three months guarantee on round tubes. Ins. carr. 15/6



17" TV Chassis Tube and Speaker £19.19.6

17" Rectangular Tube on modified chassis. Supplied as single channel chassis covering B.B.C. channels 1-5 or incorporating Turret Tuner which can be added as an extra, at our special price to chassis purchasers of 50/- giving choice of any 2 channels (B.B.C. and I.T.A.). Extra channels can be supplied at 7/6 each. Chassis size 12" x 14 1/2" x 11" less valves. Similar chassis were used by well-known companies because of their stability and reliability. With tube and speaker £19.19.6. With all valves £25.19.6. Complete and working with Turret Tuner £28.9.6. 12 months guarantee on the tubes, 3 months guarantee on the valves and chassis. Ins. carr. (including tube) 25/-

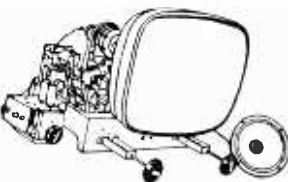

ELECTRIC CONVECTOR HEATERS 99/6



Start to prepare for winter now! Draughty corners no longer necessary. Electric convector heaters will give you a steady comfortable heat. They can be used in any part of the house where there is a plug. Don't forget—luxurious warmth at an economical price. A.C./D.C. switched for 1 or 2kW. Illuminated grille. Size 26" x 18" x 7 1/2" deep. Ins. carr. 10/6

TRANSFORMERS

MAINS TRANSFORMERS 15/9. 350-0-350V 250mA, 6V at 5A, 4V at 4A, 22V at 6A, extra winding for 2V or 4V tubes. Primary 200-250V 50 c/s. Postage and packing 3/9

MAINS POWER TRANSFORMER 12/9. 350-0-350V 250mA, 6V heater at 5A, 4V at 5A, 4V centre tapped. Drop through type. Primary 200-250V (4 1/4" x 5" x 5"). Post 3/9

MAINS TRANS. 3/9. 350-0-350V 80mA, 4V, 4V heaters. 200-250V prim. Post 2/3

MAINS TRANS. 5/9. 280-0-280V 80mA, 6V, 4V heaters. 200-250V prim. Post 2/3

O.P. TRANS. 1/3. Standard size. 2-5 ohms. Post 1/-, 20 for £1, post 5/6

MAINS TRANS. 12/9. 425V 300mA. Single secondary. 6.3V at 12A, 6.3V at 0.6A. 200-250V screened primary. Post and packing 3/6

TV MASKS 14/9. 17" brand new. Grey or white plastic. Good quality. Postage 2/-

COAX CABLE 6d. yd. Good quality, cut to any length. 1/6 post on 20 yards. 45/- per 100 yds, p. 3/6

INSULATING TAPE 1/6. Finest quality, 75 ft x 1/4" wide. Post 9d.



SOLO SOLDERING TOOL 19/6. 110V or 6V (special adaptor for 200/240V 10/- extra). Automatic solder feed, including a 20ft reel of ERSIN 60/40 solder and spare parts. It is a tool for electronic soldering or car wiring.

Revolutionary in design. Instantly ready for use and cannot burn. In light metal case with full instructions for use. Post 2/9

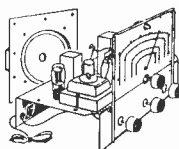

SUPER CHASSIS 99/6

5-valve superhet chassis, including 8" p.m. speaker and valves. Four control knobs (tone, volume, tuning, w/ change switch). Four w/ bands with position for gram. p.u. and extension speaker. A.C. Ins. carr. 5/6

EXTENSION SPEAKERS 29/9

Fitted with 8" p.m. speaker. W.D. or Goodmans, of the highest quality. Standard matching to any receiver (2-5 ohms). Switch and flex included. Unrepeatable at this price. Money back if not completely satisfied. Ins. carr. 3/6



Why let work interfere with your programme enjoyment when you can so cheaply relay that programme to all parts of the house with our 8" P.M. SPEAKER, 8/9. With o/p transformer fitted. 10/- Postage 2/9

PLESSEY SOUND AND VISION STRIP—25/6

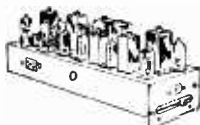

Superhet. Untested. I.F.s 10.5 Mc/s sound, 15 Mc/s vision. 8 valve basis (6 6F1's and 2 6D2's, not included). Size 8 1/2" x 5" x 4 1/2" high. Post and packing

2/6. The Turret Tuner plugs directly into this chassis. State channel required.

SOUND AND VISION STRIP 10/6. Superhet. Complete vision strip. Less valves. Not tested. Drawings free. Postage 2/6

POWER PACK AND AMPLIFIER 19/6. Output stage 6V6 with o/p trans. Smoothed h.t. 350V 250mA. 6.3V at 5A, 22V at 3A, 6.3V at 4A centre tapped. Less valves. Free drawings. Ins. carr. 5/6

POWER PACK AND AMPLIFIER 19/6. Output stage PEN45 o/p trans., choke. Smoothed h.t. 325V at 250mA, 4V at 5A, 6.3V at 5A, 4V at 5A centre tapped. Less valves. Ins. carr. 5/6

TIMEBASE 4/9. Complete, including scanning coil, focus unit, etc. Less valves. Post and packing 2/6

GANG CONDENSERS 1/9. 2 and 3 gang. 500pF. Standard salvaged. Tested. P. and p. 1/3

Send for FREE 1958 Catalogue

Liverpool St. to Manor Park Stn. 10 mins.

OPEN ALL DAY SATURDAY THURSDAY CLOSED 1 p.m.

DUKE & CO (Dept. K.10) 621/3 ROMFORD ROAD MANOR PARK EI2 Telephone ILF 6001/3

TERMS AVAILABLE

"THE MINOR"

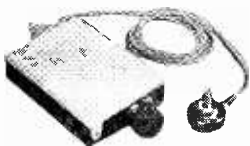

- ★ Economical (less than 1mA)
- ★ Drilled and mounted chassis
- ★ May be built within half an hour
- ★ Complete layout diagrams

- ★ Size 3" x 2" x 1/2"
- ★ Less than 2 oz weight
- ★ Variable tuning over medium waves
- ★ Three stage reflex circuit
- ★ No aerial (in areas of reasonable reception)
- ★ Easy to build

Complete set of components including case, battery, personal earphone, can be supplied for **52/6** post free

All parts sold separately

Circuit diagram and shopping list **FREE**

CALL AND HEAR DEMONSTRATION MODEL

SEE THIS EDITION FOR FULL WRITE-UP

"THE MAJOR"



STAR FEATURES

- ★ Variable tuning over medium waveband
- ★ Home, Light and Third programmes
- ★ Internal ferrite aerial
- ★ Drilled and mounted chassis
- ★ Four-stage reflex circuit
- ★ Highly efficient
- ★ No aerial or earth
- ★ 1 1/2 mA consumption
- ★ May be assembled within an hour
- ★ Complete layout diagrams

We can supply all items including battery, case and personal earphone for **72/6** post free

All components sold separately

Circuit diagrams and shopping list **FREE**

CALL AND HEAR DEMONSTRATION MODEL

SPUTNIK - SPECIAL — THE WORLD IN YOUR HOME

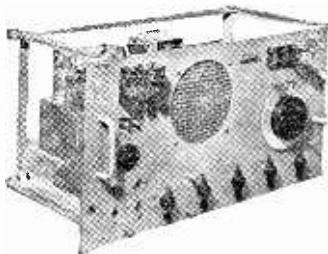

SHORT-WAVE RECEIVER 10-60 MC/S (5-30 Metres) RECEPTION SET TYPE 208

Complete with 6 valves, 2 6K8G, 2 EF39, 6Q7G and 6V6G. Internal mains power pack and 6V vibrator pack. Built-in 6 1/2" speaker. Muirhead slow-motion drive. B.F.O. and R.F. stage. I.F. freq. 2 Mc/s. Provision for phones and muting and 600 ohms. Input 110/250V a.c. 6V vibrator pack included for battery operation. All sets in new condition and air tested **£6.19.6**. carr. 15/6

Includes mains plug, booklet etc.

NO WORK REQUIRED:

JUST PLUG IN AND SWITCH ON!

"EAVESDROPPER"



- ★ Tunable over medium waves
- ★ Internal ferrite aerial
- ★ Three transistors
- ★ "Straight" circuit
- ★ Economical
- ★ Size 4 1/2" x 3" x 1 1/4"
- ★ Drilled chassis
- ★ Colour code chart included
- ★ Layout diagram

All items can be purchased for 70/- post free. With miniature hearing aid, 86/-. All parts sold separately. Circuit and shopping list **FREE**

373 MINIATURE I.F. STRIPS 9.72 MC/S

The ideal f.m. conversion unit as described in P.W., April/May, 1957. Complete with 6 valves, three EF91's, two EF92's and one EB91. I.F.T.'s etc., in absolutely new condition. With circuit and conversion data

12/6 (less valves) **42/6** (with valves)

Postage and packing 2/6 (either type)

FM AT ITS CHEAPEST!

CRYSTAL MIC. INSERTS

1/2" square, 3/6; 1/2" round Acos, 5/-; 1 1/2" round Acos, 7/6; 2 1/2" round Acos, 12/6. Moulded plastic hand mic. case suitable for any of above, only 2/6

A.C./D.C. 200/250V PORTABLE-GRAM AMPLIFIER

Completely assembled on baffle board size 12 1/2" x 4 1/2", depth 3". Containing two Mullard valves type UL84 and UY85, Elac 7" x 4" elliptical speaker, volume control, tone control. Nothing else to buy, just plug in to mains and connect your crystal pick-up to amplifier. **Absolute bargain 67/6** Carr. 2/6

U.S.A. TESTMETER TYPE 834-S

AC/DC 15-RANGES F.S.D. 1,000 O.P.V.
AC/DC Volts 12/60/300/600/1,200/6,000
Milliamps 1.2/12/60/600
Ohms 5,000/5 Meg. **£6.19.6**
Complete in wooden carrying case with leads and internal batteries

TRANSISTOR SIGNAL TRACER. Complete kit with 2 Transistors, Components, Phones and Circuit and plastic case **37/6**

Send 3d. stamp for new transistor components list; new quartz crystal list; valve list; transistor receiver circuits, etc. Complete Catalogues 6d.

TRANSISTOR SQUARE GENERATOR. Complete kit with 2 Transistors, Components, Circuit and plastic case **20/-**

HENRY'S RADIO LTD · 5 HARROW ROAD · LONDON W2

(DEPT. RC 0)

Telephone **PAD**ddington 1008/9

Teletron "TRANSIDYNE" Superhet

Six-Transistor Pocket Radio

CAN BE BUILT FOR £11.19.6

SPECIAL FEATURES

- T.C.C. Printed Circuit
- Medium and Long Waves
- Internal Ferrite Aerial
- Six Transistors
- All Modern Components carded with values shown
- Rola 2½" Speaker
- Attractive Plastic Case size 6½" x 3½" x 1½"
- Powered by two No. 8 Batteries
- Complete Layout Diagrams
- Total weight 20 oz

This set is truly recommended as an ideal pocket portable containing all the latest features, giving not only simplicity in construction, but when built is really sensitive and selective, bringing in a host of foreign stations.



ALL COMPONENTS FOR CONSTRUCTION, INCLUDING CABINET, CAN BE SUPPLIED FOR

£11.19.6 P.P. 2/6

All parts sold separately. Send 9d. for Circuit, Plans and Prices

CALL & HEAR DEMONSTRATION MODEL

The "TRANSISTOR - 8"

Push-Pull Portable Superhet

TWO SETS FOR PRICE OF ONE

COMBINED CAR RADIO & PORTABLE

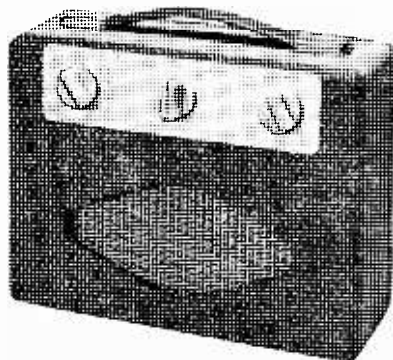

- ★ Eight transistors
- ★ 250 Milliwatts output push-pull
- ★ Medium and long waves
- ★ Internal ferrite rod aerial
- ★ Highly sensitive
- ★ Drilled chassis 8½" x 2½"
- ★ Point-to-point wiring and practical layout
- ★ Economical. Powered by 7½V battery
- ★ Ideal as a car radio
- ★ Attractive lightweight contemporary case

Send stamps for Instruction Booklet

325mW version 40/- extra

All components as specified can be supplied at an inclusive price of **£11.10.0** p.p 2/6
Car radio conversion components 8/- extra
All components sold separately

CALL AND HEAR DEMONSTRATION MODEL

This Portable 8-Transistor Superhet is tunable for both Medium and Long Waves and is comparable in performance to any equivalent Commercial Transistor Set. Simplified construction enables this set to be built easily and quickly into an attractive lightweight cabinet supplied.

CONSTRUCTOR'S PARCEL FOR TRANSISTOR POCKET RADIO

Perdio attractive moulded cabinet 15/-
J.B. twin gang screened 208 + 176pF condenser 10/-
Perdio 2½" miniature 3 ohm speaker 27/6
Single-ended output transformer to match 10/-

Size 5½" x 3½" x 1½"

All for only **52/6** post free

THE IDEAL BASIS FOR A MINIATURE POCKET TRANSISTOR RECEIVER

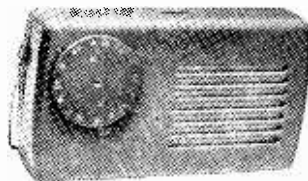

HENRY'S RADIO LTD · 5 HARROW ROAD · LONDON W2

(DEPT RC 0)

Telephone PADDington 1008/9

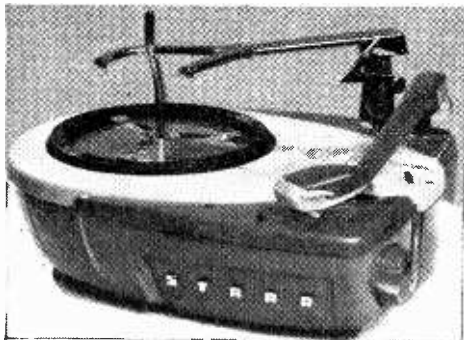

4 SPEED STAAR GALAXY

LAST FEW RECORD PLAYERS as illustrated, Sapphire turnover pick-ups. Plays 10 records of any size or speed through your radio. 200/250 volts a.c. **£5.15.0** (Post 4/-)

AUTOCHANGERS, GARRARD. RC75A 3-spd. de luxe £8.19.6. RC80M 3-spd. a.c./d.c. £10.19.0. 120D Mk. II 4-spd. £11.10.0. 121D Mk. II 4-spd. £11.19.0. B.S.R. A.U.8 4-spd. £7.19.0. **COLLARO RC511** 3-spd. £4.19.6. Conquest 4-spd. £8.19.0. (All 4/- carr.)

4-spd. SINGLE PLAYERS. Consisting Collaro latest 4-speed turntable together with Staar Galaxy turnover crystal/sapphire pick-up. This month's special snip **£3.10.0** (Carr. 3/-) Garrard 4-spd. type 4SP £7.7.6

SIGNAL GENERATORS. B.S.R. LO50A, 30 c/s-18 kc/s, £12.10. Marconi TF517F, 150-300 Mc/s, £9.200/250V

AMPLIFIERS. Quality 5 watt 6J5, 6J7, 6V6, 5Z4, Parmeko mains and output trans., £2.19.0

2-VALVE GRAM. AMPL. fit most portable cases, mounted on gold spkr. baffle with speaker, £3.19.0.

POWER PACKS. 230V a.c., 2 separate smoothed outputs of 375, 550 or 620V 200/250mA. 6.3V 5A. Sealed cases, 4 5U4G, £7.10.0. Less valves, £6.10.0

MAINS TRANSFORMERS. 230V in., 525-0-525V 150mA, 6.3V 5A, 5V 3A, 25/-, Chokes, 150mA 6/- L.F. CHOKES. 10H 80mA, 5/-; 5H 250mA, 4/6

RECTIFIERS. Iron Selenium. 12V 1A, 5/-; 12V 2A, 7/6; 12V 3½A, 9/6; 250V 80mA, 5/-; 250V 250mA, 12/6; contact cooled, 250V 50mA, 7/6; 250V 250mA, 19/-; 250V 300mA, 23/-

ION TRAPS, standard type, 4/-

VALVE VOLTMETERS. Marconi, standard type. Measures from 0.1 to 150 volts, transit cases, £9

TV CABINETS. 14" table with mask glass, front 7" x 4" speaker fret, attractive, 25/-, carr. 4/-

FOCUS MAGNETS, wide angle, with centring and mounting, 9/6. Ditto double magnet 12/6

CONDENSERS. U.S.A. 0.1µF 350V metal tub., 6/- doz. 16+16, 350V, small, 3/-; 100µF 6V, 1/3; 100+200µF, 275V wkg, can, 5/6; 0.001µF, 18kV Visconal, 4/6

FLUTED KNOBS. 2½" instrument ½" sp., 1/3 each

GERMANIUM CRYSTAL DIODES 9d., 8/- doz.

TRANSISTORS. Red Spot (up to 800 kc/s), guaranteed, 7/-; White Spot (up to 2.5 Mc/s) guaranteed, 14/-

GORLA FM KITS, Complete FM tuning heart with ECC85 valve, 2 a.m./f.m. i.f./discrim. transformers, complete instructions, unrepeatable snip 69/-

ALADDIN COILS. ½" screened, slugged, 6/- doz.

PLAYER KITS

Consisting of Galaxy 4-speed autochanger, 2 valve mains amplifier, 6" speaker, quality 2-tone portable case. Nothing more to buy.

£10.19.0

(Carr. 6/-)

Galaxy Spares. We keep a large range of spares for this changer. Please send S.A.E. for list.



TV TUBES (ex-Equipment). Guaranteed 6 months, carr. and ins. 12/6

12" MW31/74, CRM123, etc.	£5.5.0
14" MW36/24, CRM141 4/14, etc.	£4.10.0
15"-16" 152B, 41/1, etc.	£5.0.0
17" MW43/64, CRM171, etc.	£5.15.0
21" MW53/80, CRM211	£8.10.0

AM/FM CHASSIS. Famous make, 12" x 3", gold/black dial. Complete 6 latest f.m. valves. Limited number, unrepeatable. **£11.19.0** (carr. 5/-)

TV AERIALS By "View-Well." Top quality finish.

Unapproachable value. Please state channels. E.M.—existing mast. W.—wall mounting. Number—No. of elements. Carr. 3/-
 Band III Aerials: 3 E.M. 26/-, 4 E.M. 31/-, 5 E.M. 38/6, 6 E.M. 43/6, 8 E.M. 53/6; 3 W. 30/-, 4 W. 35/-, 5 W. 42/6, 6 W. 47/6, 8 W. 57/6
 Combined Band I/III (consisting B.B.C. folded dipole mounted with I.T.V. multi-element): C3 W. 34/-, C4 W. 39/-, C5 W. 46/6, C6 W. 51/6, C8 W. 61/6

GUARANTEED VALVES (24-hour service)

1R5	7/6	6SJ7M	7/-	ECC81	8/-	HVR2A	5/-
1S5	7/6	6SK7GT	5/-	ECC82	6/6	KTW63	6/-
1T4	7/6	6SN7GT	5/9	ECC83	8/6	MU14	9/-
5U4G	6/6	6U4GT	12/6	ECC84	10/6	N78	8/-
5Z4G	9/-	6V6G	6/-	ECC85	9/-	P61	2/6
6AC7	5/-	6V6M	7/-	ECF80	11/-	PCC84	9/-
6A8	9/-	6X4	6/-	ECF82	11/-	PCC85	11/6
6AL5	5/6	7B7	7/6	ECH42	9/6	PCF80	10/6
6AM6	6/9	7C6	7/6	ECL80	12/6	PCF82	11/-
6BA6	6/6	12A7	8/-	EF36	4/-	PEN25	5/-
6BE6	6/6	12A7U	6/6	EF37	7/-	PL81	13/6
6C4	4/9	12AX7	8/6	EF39	5/-	PL82	9/-
6C6	4/6	12K7GT	6/6	EF50(B)	3/6	PL83	10/-
6D6	4/6	12Q7GT	7/6	EF50(A)	4/9	PY80	8/6
6H6	2/-	25L6GT	8/6	EF54	3/6	PY81	8/6
6J5M	5/-	35Z4GT	7/6	EF80	8/9	PY82	8/6
6J5GT	4/6	80	7/6	EF85	7/6	PY83	9/6
6J5G	3/-	83	7/6	EF89	9/6	SP4B	9/6
6J7G	5/-	807	3/9	EF91	6/9	SP61	2/6
*6K7G	4/6	EA50	1/3	EL32	4/-	U22	7/6
6K7GT	5/6	EB34	1/6	EL84	9/9	U52	6/6
*6K8G	7/6	EB91	5/6	EY51(Sm)		UY41	8/-
6L6G	8/6	EBC33	7/6			VR150/30	
6SA7M	7/-	ECC31	9/6	EZ80	7/6		6/-
6SG7M	5/6	ECC32	9/-				

SEND S.A.E. FOR SPECIAL LIST 500 ITEMS

All items less 5% and post free for a dozen or more. Postage 1/- in £1 (1/9 in £1 speakers/trans.). Min. 6d. No C.O.D. Trade Enquiries Invited

Please pay us a visit when in this area

TECHNICAL TRADING CO (M.O.) 350/352 FRATTON ROAD Telephone 22034
 PORTSMOUTH

SMALL ADVERTISEMENTS

Readers' small advertisements will be accepted at 3d. per word, including address, minimum charge 2/- . Trade advertisements will be accepted at 9d. per word, minimum charge 6/- . If a Box Number is required, an additional charge of 2/- will be made. Terms: Cash with order. All copy must be in hand by the 12th of the month for insertion in the following month's issue. The Publishers cannot be held liable in any way for printing errors or omissions, nor can they accept responsibility for the bona fides of advertisers.

PRIVATE

PRIVATE TUITION given in radio theory for the R.T.E.B. examination in radio servicing. Terms reasonable.—Box No. E.182.

FOR SALE. "Mini-7" pocket portable receiver in attractive red and yellow plastic case. Medium and Long wave, needs aligning. £10 10s. 0d. Also complete power pack for R1155 Receiver, £2. Box No. E.183.

NEW SWITCH-TUNED FM UNITS WITH AFC. Gold Hammered panel engraved Home, Light, Thrd, £10 15s. 0d. With internal power supply, £13 10s. 0d. Write for details.—Box No. E.184.

FOR SALE. *The Radio Constructor*, volumes 8, 9, 10, 11, mint condition, 15s. each.—9 Hazelwood Road, Bolton, Lancs.

CHEAP for quick sale. Gortler AM/FM tuner kit, Gortler FM tuner kit, condensers, resistors, transistors, receivers, etc. Send S.A.F. for list.—J. Hopkinson, 12a High Street, Pershore, Worcestershire.

2 VALVE S/Wave receiver kit, complete with 5 lesson course of theory and construction. £3.—Box No. E.185.

FOR SALE. Marconi B28 (CR100). £13.—Phone Gulliver 1487 (London) after 6.30 p.m.

WAVEMASTER Boat 3-5 Diesel Radio Control complete. Snip £17 10s. 0d.—Janes, 359 Hanworth Road, Hounslow, Middlesex.

HI-FI enthusiast has for disposal Collaro transcription motor and transistor tape deck Mk. II also BT tangential arm and Studio P insert new sapphire also G.E.C. speaker cabinet complete 3 speakers. Offers and/or enquiries.—Humphrey, The Old Palace, Brenchley, Kent.

TRANSISTOR-8, less transistors and speaker, tested, but unused, first reasonable offer.—Egan, 43 Hamilton House, Hogarth Lane, Chiswick, W.4.

ASPDEN 750 Tape Deck with rewind motor, amplifier and power pack, perfect working order, £10 o.n.o.—Brownlow, 1 Widdicombe Way, Bevedean, Brighton.

EIGH FIDELITY AMPLIFIER. Linear Diatonic in excellent condition. £7.—Swindell, 14 Rossington Road, Sheffield, Yorks.

EDDYSTONE S.W. RECEIVER, with "S" meter, speaker and phone jack, as new, £25.—B. Everley, 27 Clayton Way, Cowley, Middlesex. Uxbridge 6989.

NEW SURPLUS...

1A3	2/6	6L6G	9/-	803	17/6	EL41	10/-
1L4	5/-	6L6M	10/6	808	17/6	EL84	9/6
1R5	7/6	6Q7G	7/6	830B	15/-	EM40	10/-
1S5	7/6	6Q7GT	9/6	866A	15/-	EZ40	8/6
2A3	8/6	6SA7M	7/6	959	5/-	EZ80	8/6
2X2	3/6	6SG7M	7/6	1616	5/-	EZ81	9/6
3A4	4/6	6SH7M	5/-	1629	4/-	GT1C	10/-
3Q4	7/6	6SJ7M	7/6	EA50	1/6	HK24G	25/-
354	8/6	6SK7M	6/6	EABC8010	6/6	KT33C	9/6
5763	12/6	6SL7GT	7/6	EAC91	4/6	PCC84	10/6
5B/254M		6SN7GT	6/6	EAF42	10/6	PCF80	13/6
	21/-	6SQ7M	7/6	EB34	2/6	PCF82	10/-
5Y4G	6/6	6X4	6/6	EB91	5/6	PL82	9/6
6AC7M	5/-	6X5GT	7/6	EBC33	7/6	PL83	10/6
6AG5	3/6	7B7	8/6	EBC41	10/6	PY80	9/6
6AK5	5/-	7C5	8/6	EBF80	10/-	PY81	9/6
6AL5	5/6	7C6	8/6	EBF89	10/-	PY83	11/6
6AM6	6/6	7S7	10/-	ECC82	9/6	R19	12/6
6AQ5	8/6	7Y4	8/6	ECC84	11/-	TT11	4/-
6AT6	8/-	12A6M	7/6	ECC85	10/6	UAF42	10/6
6AU6	8/6	12A7	8/-	ECC86	12/6	UBC41	10/6
6BB8	4/6	12A7T	9/6	ECF82	11/6	UBF89	10/6
6BA6	8/6	12AU6	9/-	ECH42	10/6	UCH85	10/6
6BE6	7/6	12AU7	8/6	ECH81	10/6	UCH42	10/6
6BH6	7/6	12BE6	8/6	ECL80	13/6	UF41	10/6
6BJ6	7/6	12CBM	7/6	ECL82	12/6	UF89	10/6
6BR7	11/6	12Q7GT	7/6	EF36	4/-	UL41	10/6
6C4	5/-	12K7GT	7/6	EF39	5/-	UY41	8/6
6C5M	5/6	12SC7M	2/6	EF41	10/6	UY85	8/6
6F6M	5/6	12SK7M	5/6	EF50	3/-	UABC80	
6F8G	4/6	12SQ7M	8/6	EF50(S)	4/6		10/6
6G6G	4/6	35L6GT	9/6	EF55	7/6	VU39	9/6
6J5GT	5/-	35Z4GT	7/6	EF80	9/-	VR150/30	
6J5M	6/-	35Z5GT	8/6	EF85	10/-		7/6
6J6	4/-	42	7/6	EF86	15/6	VR116	4/-
6K7G	5/6	50L6GT	9/6	EF89	10/-	V570	3/-
6K8G	7/6	80	8/6	EF91	6/6	XP1.5	3/-
6K8M	10/4	4A6A	10/6	EF32	4/-	Z77	6/6
6H6M	3/6	801A	7/6				

SPECIAL OFFER

Units of the Famous R107

- 1. Complete Front End**, r.f. mix, osc., 3 bands 1.2-18 Mc/s with large half-moon calibrated dial and slow-motion drive
- 2. Power Pack** for either 12V d.c. or 100-250V a.c. input. You only need an i.f. strip and output stage to make a first-class Short Wave Receiver. We offer both units brand new and boxed (less valves and vibrator) for only 52/6 the pair, plus 7/6 carriage
- 3. I.F./O.P. Unit** less valves, 35/-, or 30/- if ordered with units 1 and 2. **R.F. Unit** only, 40/-, carr. paid

Miniature Rotary Transformers, Input 12V d.c., o/p 310/365V 30mA. Size 4½" x 2½". 15/- each, p.p.

Latest Model Acos Crystal Stick Microphones MIC39-1, Frequency response flat to 6 kc/s, and within 5dB to 12 kc/s. List price £5.5.0. Our price 67/6 or 55/- less stand. New, boxed. Post paid

Transistors, Yellow/green, aud. 250mW, 7/6; OC70, 12/6; OC71, 15/-; yellow/red, r.f. to 8 Mc/s, 15/-

Midget Mains Transformers (same size as std. sprk. o/p). Input 230/250V, o/p 220V 20mA, 6.3V 0.6A. Ditto but 175V 25mA, both types 11/9 each, post paid

Transmitter/Receivers, Army Type 17 Mk. 2. Complete with h.r. phones, hand mike and valves. 44-61 Mc/s. In good used condition, 29/6 each. Carr. paid. Few only. New ones 45/- each

SPECIAL OFFER

Performance Meters No. 2, Comprising 230V 50 c/s mains trans. 250.0-250V 30mA, 6.3V 1½A 5V 2A (60mA h.t. may safely be drawn), 20H choke, 524, Y65 magic eye, 2 EF50, 1 EC52, 1 EA50, dozens of components, all in smart grey louvered case 10" x 9" x 9". Made by Parmeko. Brand new and boxed. Unrepeatable component value at only 32/6 each carr. paid (U.K. only)

Post 9d. Free over £2

S.A.E. Enquiries

JOHN ANGLIN

385 CLEETHORPE ROAD GRIMSBY Lincs
Telephone 56315

continued on page 239

EDDY'S (NOTTINGHAM) LTD

(DEPT. RC) • 172 ALFRETON ROAD • NOTTINGHAM
Telephone NOTTINGHAM 74015

ACOS CRYSTAL MIKES. Excellent for tape recorders, baby alarms, amplifiers, etc. List price 50/- . Our price 29/11 plus 3/- post. Brand new and boxed.

ACOS MIKE INSERTS 4/11 each. High quality. Can be used for tape recorders, baby alarms, musical instruments, etc. Post and packing 8d. Brand new and boxed.

ACOS CRYSTAL TURNOVER PICK-UPS (2 sapphire styli) 29/11 post post 2/6 extra. Brand new and boxed.

GERMANIUM DIODES 1/- each, 10/- doz. Post, etc., 4d. extra.

25 x 25µF CONDENSERS, midget, 1/3 each. Post, etc., 4d. extra.

MIDGET BATTERY ELIMINATORS to convert all types battery portables to mains operation. 57/6 each plus 2/6 post. Smaller than h.t. battery alone. Size 3.7" x 2.5" x 1.8". Please state make and model number. Brand new and boxed.

MORSE TAPPERS. Plated contacts, adjustable gap. Heavy duty. Good quality. 3/6 each, 9d. extra post.

B.S.R. MONARCH 4-SPEED AUTOMATIC CHANGER. Complete with high fidelity turnover head type HGP 37-1. Capacity of 10 records plays 12", 10", 7" intermixed in any order 78, 45, 33, 16 r.p.m. for a.c. mains 100-250 volts. £6.19.6, post, etc., 5/- extra. Brand new with full instructions

AZ1 12/11	ECH35 10/11	EZ81 9/11	UC-H42 9/6	3Q5GT 8/6	615G 2/11	6X5GT 6/6	25A6G 12/11
AZ31 12/11	ECC81 8/-	EY86 14/6	UF41 8/-	5U4G 6/6	6K7G 2/11	7B7 8/-	25L6GT 9/11
CY31 12/11	ECC82 8/-	GZ32 12/6	UL84 9/6	5Y3G 7/6	6K8G 7/6	7C5 8/-	35A5 10/6
DAF96 9/6	ECC83 8/11	KT33C 8/6	UY41 7/6	5Z4G 9/-	6L6G 6/11	7C6 8/-	35L6GT 9/11
DL96 9/6	EF41 9/6	L63 6/-	UY85 8/11	6AG5 5/11	6L18 12/6	7H7 8/-	35Z3 13/6
DK96 9/6	EF42 12/6	PEN36C 12/6	1D5 10/-	6B16 7/6	6Q7G 8/6	7S7 9/11	807(B) 3/9
DM70 7/11	EF89 9/11	PCL83 15/6	1R5 7/6	6B8G 2/11	6SN7GT 5/9	7Y4 7/11	807(USA) 3/9
DH77 7/11	EF50 3/11	PL38 19/6	1S5 7/3	6B9V6 9/6	6SK7GT 6/-	10F9 10/6	954 1/6
EB91 6/6	EF50(R) 6/-	PY81 8/6	1T4 6/6	6F1 13/11	6V6G 5/11	12AH7GT 7/6	955 3/11
EBF80 9/11	EZ80 8/3	TDD4 12/6	3D6 5/-	6F13 12/6	6V6GT 6/11		956 2/11

ANY PARCEL insured against damage in transit for only 6d. extra per order. All uninsured parcels at customer's risk

GUARANTEED NEW AND SURPLUS VALVES
All tested before despatch
C.O.D. or C.W.O. only

Postage and packing 6d. per valve extra. Over £3 Free
S.A.E. with all enquiries

Build your own 5 Transistor **POCKET RADIO** (Size 5 $\frac{3}{4}$ " x 3 $\frac{1}{4}$ " x 1 $\frac{1}{4}$ ")

using a **PRINTED CIRCUIT**

Send for **FREE** price list (all parts sold separately) and/or **3/-** for instruction booklet with suggested circuits and assembly details.

OUR CIRCUITS OFFER

HIGH SENSITIVITY
HIGH SELECTIVITY

using:—

- 3 RF Transistors **1 gn.** each
- 2 LF Transistors **10/-** each

all specially selected to give
HIGH OVERALL GAIN with AVC

for as little as **£9.18.0** Medium wave
or **£10.6.6** Medium and Long wave

- Miniature Loudspeakers only $\frac{1}{8}$ " deep x 2 $\frac{3}{8}$ " diam. **27 6**
- Miniature oscillator and I.F. coils $\frac{1}{8}$ " high $\frac{3}{8}$ " diam. **8.-**
- Jackson 00 twin gang tuning condenser with intersection screen **10 6**
- Attractive High Impact Polystyrene Cabinet with fittings for tuner, trimmers, speaker and circuit board **12 6**

— MANY OTHER SUB-MINIATURE COMPONENTS AVAILABLE —

SPECIALISED ELECTRONIC COMPONENTS 8 ECCLESTON SQUARE • LONDON . SW1

Mail Orders only

SMALL ADVERTISEMENTS

continued from page 237

PRIVATE—continued

WANTED Cheap. Line O.P. Transformer for Old Age Pensioner's TV, Bush TV22; good one from old set will do.—15 Lowton Road, Golborne, Warrington.

PHILIPS 600A projection. G.E.C. 12in Console, Pye B16T, Murphy V114, Bush TV12AM. 9in converters, all needing attention, complete with service manuals, exchange for anything photographic, lenses, etc.—W. Stedman, 36 Curtis Street, London, S.E.1.

CR100 60 kc/s—30 Mc/s Receiver with maker's manual. £12. Rotary converter input 6V output 200V—80mA. £1. Home Lab signal generator 100 kc/s—100 Mc/s. £3. Veritas heater, 60 hrs per gallon, paraffin. £4.—19 Bramar Gdns, Colindale, London, N.W.9.

"MAYFAIR" Television for Sale. Wired, working all channels, with cabinet, full length doors. All new. Requires tube. As illustrated cover Sept. 1957 issue *The Radio Constructor*, £30.—Hughes, 137 Widdenhams Road, Holloway, London, N.7. After 6 p.m.

SERVICE SHEETS. Fine opportunity to get those you need much more reasonably than usual. Also manuals, radio mags, and large quantity radio gear. Send requirements and S.A.E. All answered.—GB. 185 Priory Road, Hastings, Sussex.

FOR SALE. R107 and manual, RF24, RF26 and strobe unit.—Gregory, 34 Furnival Avenue, Slough, Bucks.

1155B with power pack, output stage fitted current and volt meters. £8. R107 world beater, perfect. £7 10s. 0d. HMV 9in TV, perfect picture. £4.—McGowan, 208 Beam Avenue, Dagenham, Essex.

WANTED to purchase or loan. Circuit and/or servicing data for Goodsell FMT401 FM Receiver unit.—Box No. E.186.

TRADE

VALVES. X78 new, boxed, 7s. 6d.—F.S.G. Ltd., 127 Bow Road, E.3. P. & P. Is. 6d., over £2 post free.

SERVICE SHEETS for sale and hire, Radio/Television, S.A.E. enquiries.—J. Palmer, 32 Neasden Lane, London, N.W.10.

"MEDIUM WAVE NEWS," monthly during DX season.—Details from B. J. C. Brown, 196 Abbey Street, Derby.

TELETRON "Transidyne" kits, standard parts. £11 10s. 0d. post paid. "Mini-7" kits, £9 15s. 0d., post paid. Parts available separately. Immediate delivery.—Webbs Radio (Mail Order), 610 London Road, Westcliff-on-Sea.

MINT SURPLUS EQUIPMENT, valves, components. Bargains for constructors. State requirements.—S.A.E. Jasper, 42 West Bar, Sheffield 3.

MORSE CODE TRAINING. Special course for Beginners. Full details from (Dept. RC), Candler System Company, 52 Abingdon Road, London, W.8.

ILLUSTRATED CATALOGUE No. 13 containing over 450 items of Government Surplus and Model Radio Control Equipment. 2s. 2d. Refunded on purchase of goods, 2s. 6d. overseas seairmail.—Arthur Sallis Radio Control Ltd., Department R.C., 93 North Road, Brighton. Telephone 25806.

continued on page 240

BRIDGE COMPONENTS

If you require a stockist of High Grade Components, we are the people for the job.

If you are fitting converters, Why not fit the best?

The Brayhead Turret Converter available for all channels from stock. Price £7.7.0, with adaptor 7/6 each extra. Order, stating channels required (two as specified by you supplied with converter—extra channels £1.1.0 extra). Normal trade discount—full fitting information available from:

The High Fidelity Co

18 MELVILLE ROAD EDGBASTON BIRMINGHAM 16

(Proprietors Kendall & Mousley Ltd)

REVACUUMED TV TUBES

SIX MONTHS STRAIGHT GUARANTEE

Mullard		Mazda	
14" MW 36-22	£5.10.0	14" CRM 141	£5.10.0
14" MW 36-24	£5.10.0	14" CRM 142	£5.10.0
14" MW 36-44	£5.10.0	14" CRM 143	£5.10.0
14" AW 36-21	£5.10.0	15" CRM 153	£6.10.0
17" MW 43-43	£7.10.0	17" CRM 171	£7.10.0
17" MW 43-64	£7.10.0	17" CRM 172	£7.10.0
17" MW 43-69	£7.10.0	21" CRM 211	£10.10.0
21" MW 53-20	£10.10.0	21" CRM 212	£10.10.0
21" MW 53-80	£10.10.0		
Cossor		Brimar	
14" 141K	£5.10.0	14" C14BM	£5.10.0
17" 171K	£7.10.0	14" C14FM	£5.10.0
17" 172K	£7.10.0	17" C17BM	£7.10.0
		17" C17FM	£7.10.0
		17" C17JM	£7.10.0

14" Marconi, Emitron, Ferranti, G.E.C. £5.10.0
17" Marconi, Emitron, Ferranti, G.E.C. £7.10.0

Carriage and Insurance 12/6 (U.K.) Cash with order
Personal Callers Welcome

VIDIO REPLACEMENT CO

HALES STREET DEPTFORD HIGH STREET LONDON SE8

Telephone TIDeway 4506

No connection with any firms of a similar name

Forrest

Transistor Transformers
for Quality Equipment

H. W. FORREST (TRANSFORMERS) LTD
349 Haslucks Green Road Shirley Solihull
Warwickshire Telephone SHlrley 2483

NYLON • P.T.F.E

ROD BAR SHEET TUBE STRIP WIRE
No quantity too small List on application

BRASS COPPER BRONZE
ALUMINIUM LIGHT ALLOYS
H. ROLLET & CO. LTD.

6 Chesham Place SW1 SLOane 3463
Also at Liverpool, Birmingham,
Manchester, Leeds

INDEXES—"The Radio Constructor"

Indexes are now available for Volume 11, Aug. '57 to July '58 inc., price 6d. postage 2d. A limited number of indexes are also available for volumes 4, 6, 8, 9 and 10, at the same price.

Data Publications Ltd

57 Maida Vale London W9

H.A.C. THE ORIGINAL SUPPLIERS OF SHORT-WAVE KITS

One-valve Kit, price 25/-. Two-valve Kit, price 50/-. Improved designs with Denco coils. All kits complete with all components, accessories and full instructions but less valves. Before ordering, call and inspect a demonstration receiver, or send stamped envelope for catalogue.

H.A.C. SHORT-WAVE PRODUCTS (DEPT. R)
11 OLD BOND STREET LONDON W1

HIGH FIDELITY

Quality components of all types always in stock for the

MULLARD 2-VALVE PRE-AMPLIFIER and
MULLARD 3-VALVE 3-WATT AMPLIFIER

Circuits free on request

510 AMPLIFIER FM TUNER	circuits 3/6
912 PLUS AMPLIFIER	" 4/-
JUPITER STEREO UNIT	" 2/6
RADIO CONSTRUCTOR FM	" 2/-
MERCURY SWITCHED FM	" 2/-
DENCO FM TUNER	" 1/-

Price list available on request

J. T. FILMER 82 DARTFORD ROAD
DARTFORD KENT
Telephone Dartford 4057

NEW EDITION

"Basic Mathematics for Radio and Electronics"

by F. M. Colebrook, B.Sc., D.I.C., A.C.G.I., revised and enlarged by J. W. Head, M.A. (Cantab), 18/4 by post available from **MODERN BOOK CO.**, 19 Praed Street, London, W.2. Immediate delivery.

SMALL ADVERTISEMENTS

continued from page 239

TRADE—continued

PANL, recognised for many years as the unique one-coat black crackle finish. Brush applied, no baking. Available by post in 4th pint cans at 3s. 9d. from G. A. Miller, 255 Nether Street, London, N.3.

LEARN as you do it—we provide practical equipment combined with instructions in Radio, Television, Electricity, Mechanics, Chemistry, Photography, etc. —Write for full details to E.M.I. Institutes, Dept. RC47, London, W.4.

INCORPORATED Practical Radio Engineers home study courses of radio and TV engineering are recognised by the trade as outstanding and authoritative. Moderate fees to a limited number of students only. Syllabus of Instructional Text is free. *The Practical Radio Engineer*, journal, sample copy 2s. 6,000 Alignment Peaks for Superhets, 5s. 9d. Membership and Entry Condition booklet, 1s., all post free from the Secretary, I.P.R.E., 20 Fairfield Road, London, N.8.

FREE. Brochure giving details in Home Study Training in Radio, Television and all branches of Electronics. Courses for the hobby enthusiast or for those aiming at the A.M.Brit.I.R.E., City and Guilds, R.T.E.B., with other Professional examinations. Train with the college operated by Britain's largest Electronics organisation. Moderate fees.—Write to E.M.I. Institutes, Dept. RC28, London, W.4.

SITUATIONS VACANT

EXAMINERS (Unestablished) required for Aeronautical Inspection Service, Radar and Wireless Divisions, at R.A.F. units at Carlisle, Stafford, Henlow, Bedfordshire, and in the Gloucester and Wiltshire area.

Also vacancies for **TECHNICAL GRADE III** (Radio) unestablished, at No. 90 Group, R.A.F. Medenham, Bucks, for assistance in installation, design and technical investigation of R.A.F. Radio/Radar communication, navigation and approach aids.

Quals. C. & G. Intermediate Group certificate in telecommunications engineering or equiv. theoretical knowledge with experience in industry or Services. Commencing salary age 28 and over £705 p.a. on scale £625-£820 (Men). Prospects of promotion and establishment. Age up to 55 years. Applications to Air Ministry, C.E.4h, Cornwall House, Stamford Street, London, S.E.1, or any Ministry of Labour & National Service office, quoting Westminster 1540/1545.

SMALL ADVERTISEMENTS

Readers' small advertisements will be accepted at 3d. per word, including address, minimum charge 2/- . Trade advertisements will be accepted at 9d. per word, minimum charge 6/- . If a Box Number is required, an additional charge of 2/- will be made. Terms: Cash with order. All copy must be in hand by the 12th of the month for insertion in the following month's issue. The Publishers cannot be held liable in any way for printing errors or omissions, nor can they accept responsibility for the bona fides of advertisers.

SCOTTISH INSURANCE CORPORATION LTD



62-63 Cheapside
London EC2

TELEVISION SETS, RECEIVERS AND TRANSMITTERS

Television Sets, Receivers and Short Wave Transmitters are expensive to acquire and you no doubt highly prize your installation. Apart from the value of your Set, you might be held responsible should injury be caused by a fault in the Set, or injury or damage by your Aerial collapsing.

A "Scottish" special policy for Television Sets, Receivers and Short Wave Transmitters provides the following cover:

- (a) Loss or damage to installation (including in the case of Television Sets the Cathode Ray Tube) by Fire, Explosion, Lightning, Theft or Accidental External Means at any private dwelling-house.
- (b) (i) Legal Liability for bodily injury to Third Parties or damage to their property arising out of the breakage or collapse of the Aerial Fittings or Mast, or through any defect in the Set. Indemnity £10,000 any one accident.
- (ii) Damage to your property or that of your landlord arising out of the breakage or collapse of the Aerial Fittings or Mast, but not exceeding £500.

The cost of Cover (a) is 5/ a year for Sets worth £50 or less, and for Sets valued at more than £50 the cost is in proportion. Cover (b) and (ii) costs only 2/6 a year if taken with Cover (a), or 5/ if taken alone.

Why not BE PRUDENT AND INSURE your installation—it is well worth while AT THE VERY LOW COST INVOLVED. If you will complete and return this form to the Corporation's Office at the above address, a proposal will be submitted for completion.

NAME (Block Letters)

If Lady, state Mrs. or Miss

ADDRESS (Block Letters)

/JB

YOU CAN RELY ON US



The New AVO MULTIMINOR

A first quality pocket instrument

Sensitivity 10,000 Ω /V 0 to 1A in five ranges, 0 to 1,000V in 7 ranges. A.C. volts 0-1,000 in 5 ranges. Resistance 0-2 Meg in two ranges.

PRICE £9.10.0 Leather Case 32/6
or 63/4 Deposit and 6 Payments of 22/2 or 9 monthly payments of 23/3

ALL AVO INSTRUMENTS IN STOCK

COSSOR HI-FI AMPLIFIER KIT

3 valve 3W, Printed Circuit, twin speaker. Beautifully kitted by Cossor Radio and Television Ltd to the last nut and bolt.

COMPLETE KIT or 65/- Deposit and 6 monthly Payments of 23/4
£9.15.0 or 23/10 Deposit and 8 monthly Payments of 23/10

82 SOUTH EALING ROAD
LONDON W5 Tel EAL 5737

RADIO SERVICING CO

RADIO



BOOKS

DATA BOOK SERIES

- DB5 TV Fault Finding.** Profusely illustrated with photographs taken from a television screen depicting the faults under discussion, and containing a wealth of technical information, with circuits, enabling those faults to be eradicated. B.B.C. and I.T.A. 5/-. Postage 5d.
- DB6 Radio Amateur Operator's Handbook.** Contains Prefix Lists, Zone Boundaries, Call Areas, Code and Mileage Tables and much other useful operating data. * 1958/9 Edition available next month. 3/6, Postage 4d.
- DB8 Tape and Wire Recording.** A selection of articles covering both the theory and practical applications. 4th Edition. 3/-. Postage 4d.
- DB9 Radio Control for Model Ships, Boats and Aircraft.** By F. C. Judd, G2BCX. Now considered a standard work on this subject. Standard edition 8/6, Postage 7d. Clothbound edition 11/6, Postage 8d.
- DB10 Radio Control Mechanisms.** By Raymond F. Stock. The only book devoted to this subject, and complementary to DB9. 4/6, Postage 4d.
- DB11 Quality Amplifiers.** Contains a selection of popular quality amplifiers, including latest versions of the Mullard "3-3" and "5-10" 4/6, Postage 4d.

RADIO REPRINT SERIES

- RR1 Inexpensive Car Radio** 1/6, Postage 2d.
- RR2 FM Tuner Units for Fringe and Local Area Reception.** A Jason design. 2/-. Postage 4d.
- RR3 The Argonaut AM/FM/MW/VHF Tuner Receiver.** A Jason design. 2/-. Postage 4d.
- RR4 The "Eavesdropper." 3-Transistor local station pocket receiver.** 1/6, Postage 2d.
- RR5 Mercury Switched-Tuned FM Tuner.** A Jason design. 2/-. Postage 2d.
- RR6 The Cooper-Smith B.P.I. High Fidelity 10-12 watt Amplifier and Control Unit.** 2/6, Postage 4d.
- RR7 A Versatile 2-valve Audio Pre-Amplifier.** A Mullard design. 1/-. Postage 2d.
- RR8 High-Gain Band 3 Pre-Amplifier.** 1/-. Postage 2d.
- RR9 The Jupiter Stereophonic Amplifier and Pre-amplifier.** 2/6, Postage 4d.

All available from your local bookseller, or from

DATA PUBLICATIONS LTD

57 MAIDA VALE LONDON W9

Telegrams Databux London

Telephone CUNningham 6141 (2 lines)

Published in Great Britain by the Proprietors and Publishers

Data Publications Ltd 57 Maida Vale London W9

Printed by A. Quick & Co. (Printers) Ltd 125 High Holborn London WC1 England also at Clacton-on-Sea
Obtainable abroad through the following Collects Subscription Service Continental Publishers & Distributors Ltd
William Dawson & Sons Ltd Australia and New Zealand Gordon & Gotch Ltd South Africa Central News Agency
Holland "Radio Electronica"

Registered for transmission by Magazine Post: Canada (including Newfoundland)

www.americanradiohistory.com