

RADIO



BOOKS

Tape and Wire Recording. A selection of articles reprinted from the pages of *The Radio Constructor*, covering both the theory and practical applications. A really useful book on this latest development of the hobby. **2/6 post 3d.**

Receivers, Preselectors and Converters. Practical articles, again reprinted from past issues of *The Radio Constructor*, which will prove of interest to many radio enthusiasts. **2/6 post 3d.**

TV Fault Finding. Profusely illustrated with photographs taken from a television screen depicting the faults under discussion, and containing a wealth of technical information, with circuits, enabling those faults to be eradicated. **5/- post 4d.**

Inexpensive Television. Build yourself a television from surplus. Latest edition includes all the data necessary for any area. **2/6 post 3d.**

F. M. Tuner Units for Fringe and Local Area Reception. Including optional Tuning Indicator and circuit of Osram 912 Amplifier. **2/- post 2d.**

Report Pads. If you need that QSL card, send a comprehensive report. A convenient and accurate form for reporting. **3/6 post 4d.**

Radio Amateur Operator's Handbook. An indispensable aid to the amateur transmitter and listener, containing all details of information which are constantly required. Prefix Lists, Zone Boundaries, Call Areas, Codes, and Mileage Tables, together with Maps and much other useful operating data. 1956 edition now available. **3/- post 3d.**

Inexpensive Car Radio. In which two versions, one constructed from surplus and one from new components, are described. **1/6 post 2d.**

Radio Control for Model Ships, Boats and Aircraft, by F. C. JUDD, G2BCX. A comprehensive work on this fascinating subject. Standard edition, **8/6 post 5d.** Cloth bound edition, **11/6 post 7d.**

All available from your local bookseller, or from

DATA PUBLICATIONS LTD

57 MAIDA VALE LONDON W9

Telegrams **Databux London**

Telephone **CUNningham 6141 (2 lines)**

Printed in Great Britain for the Proprietors and Publishers Data Publications Ltd., 57 Maida Vale, London, W.9, by A. Quick & Co. Ltd., Oxford House, Clacton-on-Sea, England. Is obtainable abroad through the following: Collets Subscription Service, Continental Publishers & Distributors Ltd., William Dawson & Sons Ltd. Australia and New Zealand: Gordon & Gotch Ltd. South Africa: Central News Agency. U.S.A.: Gilfer Associates. Holland: "Radio Electronica." Registered for transmission by Magazine Post to Canada (including Newfoundland).



NEW BEGINNER'S SERIES (Pt. 2)

The **RADIO Constructor**



FOR THE RADIO AND TELEVISION ENTHUSIAST

VOLUME 9

NUMBER 7

FEBRUARY 1956

THE TRANSISTORETTE

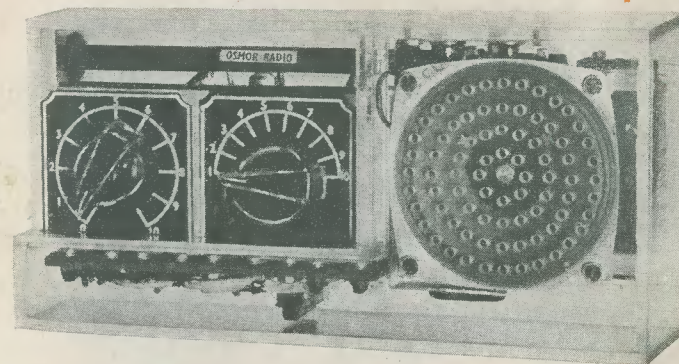

A MINIATURE TRANSISTOR RECEIVER

by **G. A. FRENCH**

Also in this issue

MICROAMP—POINT-TO-POINT WIRING
DESIGN CHARTS FOR CONSTRUCTORS, No. 3
MODERN PRE-SELECTOR · RADIO CONTROL, Pt. 4
PRACTICAL BAND III TELEVISION, Part 8
TABLE TOP L.F. TRANSMITTER
and all the usual features.

DATA Publications 1/6

LANES (RADIO) LTD The Amateur's ... Paradise...

11 GARDNER ST. BRIGHTON

BRIGHTON 20773

The LANE 4 WATT QUALITY AMPLIFIERS

Modern miniature valves. Independent treble, middle and bass controls allow for correct handling of input from 78-45-331/3 records. Valves 6BR7, 6BW6, 6X4. Output 4 watts matched to 2-3 ohms. Mains input tapped 200-250V a.c. Quality mains transformer supplies adequate additional current for feeder unit if required.

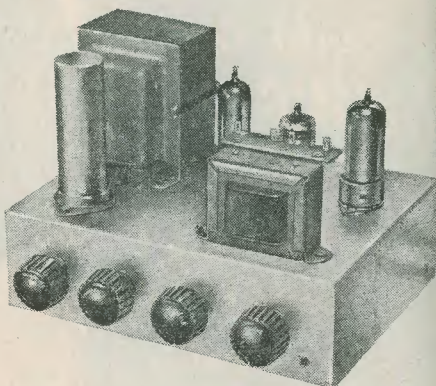

£6 . 12 . 6

CRYSTAL DIODES 1/6 each	32 x 32μF 450V 6/-	EXTENSION CABINET
SMOOTHING CHOKES 60m/a 200 ohm, 15 hy. 5/6 each	Radio Screwdrivers 4" & 6" 1/- each	CABINET LOUDSPEAKERS
.001μF MICA COND. 4d. each	Screwdriver Mains Tester 5/6 each	Polished Soundboard
BIB WIRE STRIPPERS 3/6 each	Universal Tool Sets with three screwdrivers, Philips tools, etc. 8/9	5" £1 . 19 . 6
	RADIO PLIERS 7/6	6½" £2 . 5 . 6

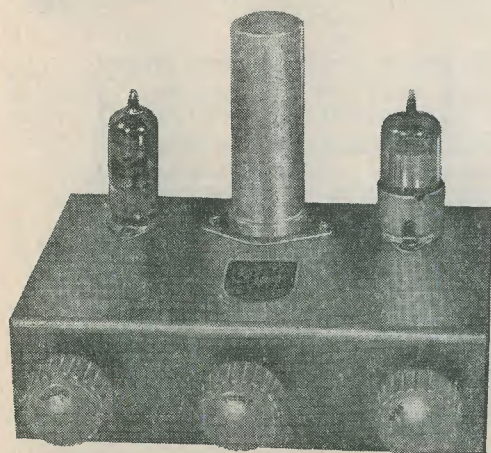

The BAXENDALL NEGATIVE FEEDBACK TONE CONTROL AND PRE-AMP

Size 6" x 4". Two valves, 6BR7, EF91. Power requirements 250V h.t., 6.3V l.t. ±20db bass and treble controls. Input sensitivity 100 mV, output 4V R.M.S. Completely wired and tested.

£4 . 7 . 6

LANES (RADIO) LTD 11 GARDNER ST. BRIGHTON

BRIMAR

transistors
are good!

These long life transistors in your circuits will save space and power and incidentally save weight.

Brimar transistors are the result of extensive development. Exhaustive tests have proved their reliability over a long period.

Brimar are now able to offer several types in small quantities for development work.

BRIMAR

The BRIMAR TP1 and TP2 are point contact, in type, germanium transistors. Type TP1 may be used in control and switching circuits at frequencies up to 100 Kc/s and will work consistently and reliably within this range. Type TP2 may be used as an amplifier or oscillator at frequencies up to 2 Mc/s. Collector dissipation 150 mW max. at 20°C. The BRIMAR TS1, TS2 and TS3 are p.n.p. alloyed junction transistors intended for use in low frequency applications up to 500 Kc/s. These transistors replace the earlier types TJ1, TJ2 and TJ3, and are fully hermetically sealed. They are thus immune from the effects of humidity and noxious atmospheric conditions. The small size and low power consumption of these transistors permits the design of light, compact equipment. Since the cases are of metal there is little danger of accidental fracture, and the transistors are also thereby rendered lightproof.

Collector dissipation 50 mW at 20°C.

Type TS1, TS2 & TS3
are specified for the
TRANSISTORETTE
described in this issue

Send for data sheet of these transistors to

Standard Telephones and Cables Limited

Publicity Department FOOTSCRAY SIDCUP KENT Telephone FOOTSCRAY 3333

Smith's of EDGWARE ROAD

Component Specialists Since Broadcasting Started

Can now supply a full range of 4-sided Blank Chassis of 16 Gauge half-hard aluminium.

Size (in)	Price	Size (in)	Price
6 x 4 x 2	4/6	10 x 8 x 3	8/6
7 x 5 x 2	5/-	13 x 8 x 2½	8/9
8½ x 5½ x 2	5/6	12 x 9 x 2½	8/11
10 x 4 x 2½	6/-	14 x 7 x 3	9/-
9 x 7 x 2	6/6	13 x 10 x 2½	9/9
12 x 4 x 2½	6/6	14 x 10 x 2½	10/-
9 x 8 x 2½	7/3	12 x 10 x 3	10/3
10 x 8 x 2½	7/6	15 x 10 x 2½	10/6
12 x 5 x 3	7/9	17 x 10 x 2½	11/3
12 x 7 x 2½	7/11	17 x 9 x 3	11/9
11 x 8 x 2½	8/-	17 x 10 x 3	12/6

Other sizes pro rata plus 2/6
Keep this List for reference

H. L. SMITH & CO. LTD

287/9 Edgware Road London W2
Telephone Paddington 5891

Hours 9 till 6 (Thursday 1 o'clock)

Nr. Edgware Road Stations, Metropolitan & Bakerloo

OSMOR'S unique service



**FREE TO THE RADIO
CONSTRUCTOR**

Whichever published circuit you decide to construct, ask Osmor for a practical wiring diagram with full lists of components required. We cannot provide diagrams for all circuits but in due course we will. We build the latest circuits published in *Practical Wireless*, *Wireless World* and *Radio Constructor* and stock the components specified. Send 7½d. in stamps for circuits, fully descriptive literature together with coil and coilpack leaflets, component lists, chassis drawings and templates.



OSMOR Miniature 'Q' COILS

A complete range is available for all wave-band and purposes and ideally suitable for all circuit positions. All high 'Q' values. Iron-dust cored. Easy connection tags. Simple 'press home' fixing. 'Q' of "potted" types up to 300.

Ultra-small Ceramic Neg. Tem Co-eff. Capacitors for V.H.F., etc., from 1pF ±0.5pF to 10,000pF ±100%—20%, 10d. each. Small ½ watt Resistors 10Ω ±10% to 10m ±20% 6d. each.

Full list of types, co-eff. and values on application

OSMOR RADIO PRODUCTS LTD
418 BRIGHTON ROAD, SOUTH CROYDON
SURREY Telephone CROYdon 5148-9

ARTHURS HAVE IT!

Large Stocks of Valves and C.R.T.s
Full Range of Meters available
Avo, Taylor, Cossor, Advance, etc.
Particulars on Request

FM Kit of Parts £5, less valves
(Ref. *Radio Constructor* July, 1954)

Amplifier Tape Recorders and
Loudspeakers

Jason FM Tuner Unit £15 17 0
Jason Power Pack £3 10 0
Radios and Television always in stock

VALVE MANUALS

Mullard, Brimar No. 6, Osram, Part 1, 5/-;
Osram Part II, 10/-; Mazda, 2/-
Postage 6d. each extra

Publications: "Lodestar" Tape Recorder, 3/6

Goods offered subject to price alteration and
being unsold

Arthurs first

Est.
1919

Proprietors: ARTHUR GRAY LTD.

OUR ONLY ADDRESS Gray House
150-52 Charing Cross Road
London WC2

TEmple Bar 5833/34 and 4765

HOME RADIO of MITCHAM FOR

EDDYSTONE

SHORT WAVE COMPONENTS & RECEIVERS

Fully illustrated Eddystone catalogue of all
their quality components sent by return,
price 1/-

3 SPEED GRAM MOTORS

Heavy duty A.C. induction motor for 200/
250V. Complete with cream enamelled turn-
table and rubber mat. With three speed and
neutral selector lever. Ideal for modernising
that old gram to take the latest L.P. records.

★ PRICE £3.0.0 plus 2/6 postage ★

Mullard 5-10 amplifier and F.M. tuner components
in stock. S.A.E. for list.

HOME RADIO of MITCHAM
187 LONDON ROAD MITCHAM SURREY
Telephone MIT 3282



**POST TODAY FOR OUR BROCHURE ON
THE LATEST METHODS OF HOME
TRAINING FOR OVER 150 CAREERS
& HOBBIES**

PRIVATE & INDIVIDUAL TUITION IN YOUR OWN HOME

City and Guilds Grouped Certificates in Telecommunications: A.M.Brit. I.R.E. Examinations, Radio Amateur's Licence, Radio and Television Servicing Certificates, General Radio and Television Courses, Radar, Sound Recording, etc. Also Courses in all other branches of Engineering and Commerce.

The advantages of E.M.I. training

★ The teaching methods are planned to meet modern industrial requirements. ★ A tutor is personally allotted by name to ensure private and individual tuition.
★ Free advice covering all aspects of training is given to students before and after enrolling with us.

NEW LEARN THE PRACTICAL WAY COURSES WITH EQUIPMENT

With many of our courses we supply actual equipment which is sent upon enrolment and remains your property. Courses include: Radio, Television, Electronics, Draughtsmanship, Carpentry, Photography, and Commercial Art, etc.

Courses
from 15/-
per month

POST THIS COUPON TODAY

Please send without obligation your FREE book.
E.M.I. INSTITUTES, Dept. 179K, Feb.
Grove Park Road, London, W.4.

NAME _____

ADDRESS _____

SUBJECT(S) _____ IC.38

EMI INSTITUTES
The only Postal College which is
part of a world-wide Industrial Organisation.

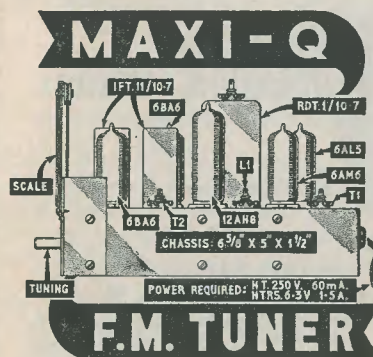

The guaranteed components described below have been acclaimed by thousands as the finest obtainable.

Full constructional details, point-to-point wiring diagram and alignment instructions are given in our Technical Bulletin DTB-8, price 1/6.

F.M. SCALE. A bronze finished scale with yellow markings (0-20 Log) for use with all types of f.m. tuners or receivers. Consisting of metal scale, pointer, cord drive spindle, pulleys, 2½" drum, cord and instructions for the assembly of the cord drive. The scale measures 5½" x 3" and is for a cabinet aperture of 4" x 1½", price 9/-.

RD.T.1/10.7 Mc/s. A transformer for use in ratio discriminator type circuits. Can size 1½" square x 2½" high. Secondary winding of bifilar construction, iron dust core tuning, polystyrene formers and silver mica condensers, price 12/6.

PDT.1/10.7 Mc/s. A miniature phase discriminator transformer for use in frequency modulation detector circuits where the limiter/Foster-Seeley type of circuit is employed. Designed for carrier deviation of ±75 Kc/s. Ok = 1.5. Screening can 1½" x 1½" square, price 9/-.

IFT.11/10.7 Mc/s. A miniature i.f. transformer of nominal frequency 10.7 Mc/s. The transformer is primarily intended for the i.f. stages of frequency modulation receivers and converters. The Q of each winding is 90 and the coupling critical. Dimensions as PDT.1., price 6/-.

IFT.11/10.7/L. As IFT.11/10.7 but with secondary tap for limiter input circuits, price 6/-.

COILS Type L1, T1 and T2. These coils are specially designed for use in the "MAXI-Q" F.M. TUNER, price 3/11 each. Chassis and screens for the above unit, completely punched in aluminium, 7/6.

Obtainable from all reputable stockists or, in case of difficulty, direct from works: GENERAL CATALOGUE covering technical information on full range of components 1/- post free.

STOP PRESS: Available to retail customers only. "Maxi-Q" F.M. Tuner Unit assembled and valved at £7 2s. 6d. plus £2 17s. P.T., also Power Pack at £3. OSRAM F.M. Tuners completely assembled and valved at £22 plus £8 16s. P.T.

Coil Turret CT.7/B. This turret has been specially designed for use in the "Britannia" communications receiver described in the October and November

DENCO (CLACTON) LTD OLD ROAD · CLACTON-ON-SEA

issues of the "R.S.G.B. Bulletin," price £3 15s. Mullard 5-10 T.C.C. Printed Circuit Chassis, 7/9 (plus 1/- postage). The metal work and coils for the "View-master" Band III converter will be available shortly.

WORLD-WIDE DX IS CERTAIN
with the
Labgear 150 Watt TRANSMITTER
MODEL LG300 MK II

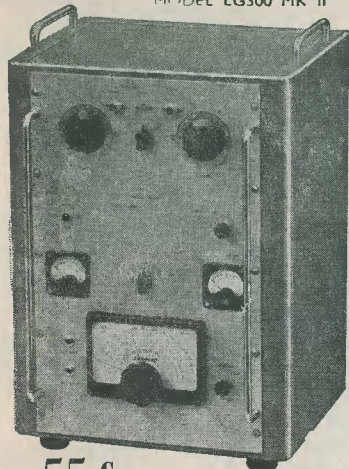

PRICE 55 Gns. (With all valves except 813)

Companion Power Unit/Modulator now available
Send S.A.E. leaflet RC5035

Labgear (Cambridge) Ltd
WILLOW PLACE · CAMBRIDGE · Telephone 2494

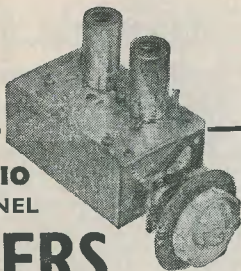

VALRADIO
13 CHANNEL
TUNERS

NOW AVAILABLE TO THE
HOME TV CONSTRUCTOR

Adapt your set to receive the Commercial TV programmes. Valradio tuners are suitable for home constructed receivers including "The Wireless World," "Magnaview," etc. I.F. outputs, 9-14 mcs; 16-20 mcs; 19-24 mcs; and 34-40 mcs. Complete with fitting instructions ... **£6**
Bracket for fixing tuner to cabinet ... 2/6

Valradio

Valradio Limited, F Ith m, Middlesex
Telephone Feltham 4242 & 4337

No Resistance with
ERSIN MULTICORE

SOLDER



One imperfectly soldered joint can ruin reception and frustrate hours spent in assembly work. Be sure you use Ersin Multicore Solder on all connections in your equipment. Five cores of extra-active, non-corrosive Ersin flux, prevent oxidation, clean surface oxides and eliminate 'dry' and H.R. joints. The Size One Carton gives you waste-free, trouble-free soldering without the need for extra flux. Get a carton today — and ensure good reception.

SIZE 1 CARTONS 5/- RETAIL

Catalogue Ref. No.	Alloy Tin/Lead	S.W.G.	App. l'gth per carton
C 16014	6/40	14	19 feet
C 16018	6/40	18	51 feet
C 14013	40/60	13	17 feet
C 14016	40/60	16	36 feet

MULTICORE SOLDERS LTD., MULTICORE WORKS,
HEMEL HEMPSTEAD, HERTS (BOXMOOR 5636).

Frequency Modulation Tuner

described in the July and Sept. 1954 issues.

JACKSON BROS. dial and condenser **£1 5 3**

Completely drilled chassis **8/-**

All coils with S.M. Condensers and cans **£1 2 6**

Reprint of articles including Fringe model details, power pack, tuning indicator, 912 amplifier, point-to-point diagram **2/-**

Complete Tuner, assembled and aligned, with dial calibrated in M/cs **£15 17 0**
(including P.T.)

JASON MOTOR COMPANY

328 CRICKLEWOOD LANE
LONDON, NW2

NEW!

EXPERIMENTAL KITS
in Radio, T.V. etc.

LEARN THE PRACTICAL WAY

Specially prepared sets of radio parts from which we teach you, in your own home, the working of fundamental electronic circuits and bring you easily to the point when you can construct and service radio sets. Whether you are a student for an examination; starting a new hobby; intent upon a career in industry; or running your own business — these Practical Courses are intended for YOU — and may be yours at very moderate cost.

EASY TERMS FROM 15/- A MONTH

With these outfits, which you receive upon enrolment, you are instructed how to build basic Electronic Circuits (Amplifiers, Oscillators, Power Units, etc.) leading to complete Radio and Television Receiver Testing and Servicing.



BEGINNER'S RADIO OUTFIT

— For carrying out basic practical work in Radio and Electronics, from first principles and leading to the design and building of simple Receivers.

ALL EQUIPMENT SUPPLIED IMMEDIATELY AND REMAINS YOUR PROPERTY

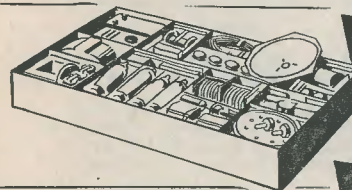

ADVANCED RADIO OUTFIT

— With this equipment, you are instructed in the design, construction, testing and servicing of a complete modern T.R.F. Superhet Radio Receiver.

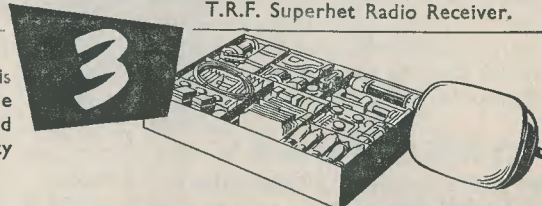

TELEVISION — With this equipment you are instructed in the design, construction, servicing and testing of a modern high quality Television Receiver.

OTHER COURSES WITH EQUIPMENT INCLUDE:

MECHANICS · ELECTRICITY
CHEMISTRY · PHOTOGRAPHY
CARPENTRY

ALSO

DRAUGHTSMANSHIP · COMMERCIAL ART
AMATEUR S.W. RADIO · LANGUAGES · ETC.

POST THIS COUPON TODAY

Please send me your FREE book on Practical Courses.

Subject(s) of interest.....

To: E.M.I. INSTITUTES, Dept. 179x, Grove Park Road, London, W.4.

NAME

ADDRESS

E.M.I. INSTITUTES

The only Postal College which is part of a world-wide Industrial Organisation

★ ★ ★ ★ ★ ★ ★ ★ ★ ★
 ★ MODERN PRACTICAL ★
 ★ RADIO ★
 ★ AND ★
 ★ TELEVISION ★



★ Not too advanced ★
 ★ for the amateur ★
 ★ —a boon for the ★
 ★ expert. ★

★ Written by ★
 ★ C. A. Quarrington, A.M.Brit.I.R.E., ★
 ★ it is an amazingly good buy. ★

★ Crammed from cover to cover with a ★
 ★ wealth of general and specialised ★
 ★ knowledge—knowledge that everyone ★
 ★ interested in Radio and Television ★
 ★ should have ready at their fingertips ★

★ CIRCUITS AND DATA ★
 ★ Supplied with "Modern Practical Radio ★
 ★ and Television" there is a separate ★
 ★ booklet, bound to match, which gives ★
 ★ details of 48 circuits and models, and ★
 ★ a mass of useful formulae and data. ★

★ THE ILLUSTRATIONS: 16 full-page ★
 ★ plates, over 400 diagrams in the text ★
 ★ and 7 large folding insets. Each illus- ★
 ★ tration has been specially selected for ★
 ★ its practical utility. ★

★ — send today — ★

★ To THE CAXTON PUBLISHING ★
 ★ COMPANY LTD., ★
 ★ 73 Morley Hall, St. George Street, ★
 ★ Hanover Square, London, W.1 ★

★ Please send me without obligation ★
 ★ FREE PARTICULARS of *Modern ★
 ★ Practical Radio and Television*, to- ★
 ★ gether with your terms of easy ★
 ★ payment. ★

★ Name

★ Address

★ RT2073

★ Send this form in unsealed envelope, ★
 ★ 1½d. stamp

G2ACC offers you . . .
SALE BARGAINS
 AT
Greatly Reduced Prices

Many unrepeatable new lines surplus to our requirements are listed in our new stock-taking bargain list No. 12. Many of these items will be discontinued in our forthcoming new edition of our illustrated catalogue now in the course of preparation.

BARGAIN LIST No. 12 FREE ON REQUEST

**Southern Radio
 and Electrical Supplies**
 SORAD WORKS
 REDLYNCH . SALISBURY . WILTS
 Telephone Downton 207

VIDEO ELECTRONICS
 (LONDON) LTD
 Head Office: 27 Bacon Street London E1
 Works: 16/22 Bacon Street E1
 Telephones Bishopsgate 0419/0410

TV Tubes
 Cheap, reliable high-grade seconds and reconditioned C.R.T.s, as supplied to the trade and leading Television Insurance Companies, prices from £3

Valves
 Send at once for our useful list of cheap valves which will save money. We are the cheapest in the trade

Condensers
 Electrolytics, bias, coupling, etc., etc., at give-away prices. All types stocked

Resistors
 A fine stock of these at very low prices

TV and Radio Cabinets
 A few 17" table cabinets, new, ex-famous manufacturer, and about 500 very handsome radio cabinets made for export.

Send for stock list of speakers, valves, components and TV and Radio Spares. All our goods are guaranteed

The
Radio Constructor
 incorporating THE RADIO AMATEUR



CONTENTS FOR FEBRUARY

VOL. 9. NO. 7
 FEBRUARY 1956
 ANNUAL SUBSCRIPTION 20/-

Editorial and
 Advertising Offices
 57 MAIDA VALE LONDON W9

Telephone
 CUNNINGHAM 6141
 (2 lines)

Telegrams
 DATABUX, LONDON

Editor
 C. W. C. OVERLAND, G2ATV

Advertising Manager
 F. A. BALDWIN, A MIPRE

- 402 Suggested Circuits: A Shorted Turns Tester for Line Output Transformers, *by G. A. French*
- 404 Can Anyone Help?
- 405 Band III Television for the Home Constructor, Part 8, *by S. Welburn*
- 409 In Your Workshop, *by J.R.D.*
- 415 Radio—And Control, Part 4, *by Raymond F. Stock*
- 418 Radio Miscellany, *by Centre Tap*
- 420 A Modern Pre-Selector, *by James S. Kent*
- 424 The "Transistorette," Part 1, *by G. A. French*
- 430 Right—From the Start, Part 2: Wiring, *by A. P. Blackburn*
- 435 Further Notes on the Microamp, *by O. J. Russell, G3BHI*
- 437 Club News
- 438 Technical Forum
- 441 A Small Table-Top Transmitter for the Lower Frequencies, *by A. C. Gee, G2UK*
- 444 An Improved Tuning Wand, *by G3XT*
- 445 Book Reviews
- 446 Design Charts for Constructors. No. 3: Voltage Divider Combinations, *by Hugh Guy*

THE CONTENTS of this magazine are strictly copyright and may not be reproduced without obtaining prior permission from the Editor.
 Opinions expressed by contributors are not necessarily those of the Editor or proprietors

NOTICES

THE EDITOR invites original contributions on construction of radio subjects. All material used will be paid for. Articles should preferably be typewritten, and photographs should be clear and sharp. Diagrams need not be large or perfectly drawn, as our draughtsmen will redraw in most cases, but all relevant information should be included.

All MSS must be accompanied by a stamped addressed envelope for reply or return. Each item must bear the sender's name and address.

TRADE NEWS. Manufacturers, publishers, etc., are invited to submit samples or information of new products for review in this section.

ALL CORRESPONDENCE should be addressed to THE RADIO CONSTRUCTOR 57 Maida Vale London W9

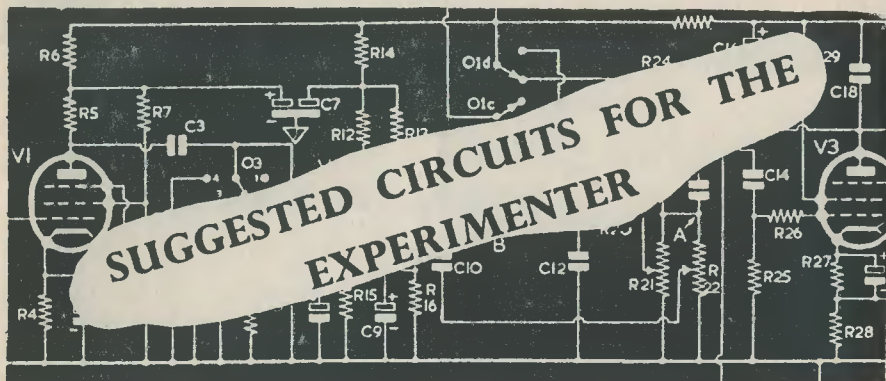

The circuits presented in this series have been designed by G. A. FRENCH, specially for the enthusiast who needs only the circuit and essential relevant data

No. 63. A Shorted-Turns Tester for Line Output Transformers

ONE OF THE MORE DIFFICULT FAULTS TO detect, during the servicing of television receivers, is that of short-circuited turns in the line output transformer. Troubles of this nature are unfortunately somewhat frequent, and they are difficult to diagnose because their existence does not necessarily result in complete loss of picture or horizontal scan. Particularly is this true if the short-circuit occurs between adjacent turns in the line output transformer, or between turns in successive layers. In such instances it is practically impossible to detect any fault in the transformer by normal ohmmeter readings, since the resistance of the transformer coil will only be very slightly lower than that of a serviceable winding. Furthermore, the resistance of the faulty coil may remain within the limits imposed by wire and winding tolerances.

Despite these points, it is still possible to detect a line output transformer with short-circuited turns by reason of the fact that the short-circuit causes both the inductance and Q of its winding to drop considerably. This alteration in value enables certain checks to be made on a line output transformer without removing it from its television, and an experimental item of test equipment suitable for making such checks is described this month.

This Month's Circuit

The circuit of the test equipment accompanies this article. It will be seen that it comprises a simple a.f. triode oscillator employing grid-leak bias and a conventional series-fed tuned circuit arrangement. The triode may be any low- μ valve of the 6J5 class. Two test prods are connected effectively across the oscillator tuned circuit; the latter consisting of the coil L_1 and the condenser C_2 .

Connected in series with the grid leak of the oscillator is a microammeter with an f.s.d. of $500\mu\text{A}$. The purpose of this microammeter is to show the negative voltage at the grid of the triode and thus provide an indication of the oscillatory voltage-built up across L_1 .

The test equipment is employed by connecting its test prods across the anode winding of a line output transformer which is suspected of having short-circuited turns. If the transformer is serviceable it will impose little loading on the tuned circuit and the microammeter reading will remain unaltered or will drop only slightly. If the line output transformer has short-circuited turns it will impose considerably heavier loading on the tuned circuit, with the result that the microammeter reading will drop by a large amount. This drop will still occur,

incidentally, if the short-circuited turn is in the e.h.t. winding; since the load, imposed by the faulty e.h.t. coil will be reflected back to the anode winding.

A particularly useful point about the test gear is that it may be used to check the line output transformer in some receivers without disconnecting the transformer at all. Such occasions exist when the transformer windings are not heavily damped by parallel resistors, width-controls, or by similar components. The fact that the deflector coils remain connected to the transformer being tested should not normally cause any difficulty. If a short-circuited turn is indicated, the deflector yoke may then be disconnected. Should the short-circuited condition disappear then there is the strong probability that the fault lies in the deflector coils themselves.

Technical Details

It was mentioned above that a series-fed oscillator is employed. The reason for this choice, instead of a parallel-fed circuit, is merely that of obviating the high-inductance choke which would otherwise be needed in the anode circuit of the oscillator valve. The series-fed circuit has the slight disadvantage of necessitating the employment of h.t. isolating condensers in the test leads. One of these condensers, C_4 , is that which is employed, in conventional manner, for decoupling the h.t. rail. The other, C_1 , provides d.c. isolation between the "hot" end of L_1 and its test prod. The resistor R_1 is included to prevent static voltages with respect to chassis appearing on the "hot" test prod.

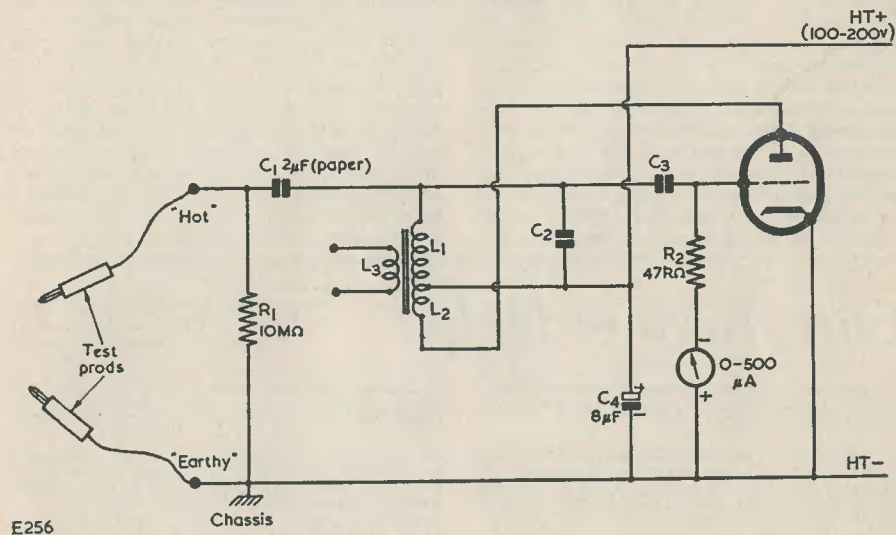

E256

An important precaution to observe when using the test equipment is that it should be connected across all, or nearly all, of the line output transformer anode winding. If it were connected across, say, two adjacent windings, the low value of inductance existing between such windings would load the tuned circuit too heavily to enable precise readings to be obtained.

As will be imagined, the gear should be capable of checking quite a large number of inductors having relatively high values of inductance, in addition to line output transformers. It might be inadvisable to employ the equipment to check inductors wound with very fine wire, such as are used in hearing-aids.

The tuned circuit inductor, L_1 , is the most important part of the equipment. It is necessary for this inductor to have a relatively low value of inductance in order to prevent large alterations in oscillator frequency when the transformer winding under test is connected across it. A good practical choice for the inductor would be a small or "miniature" speaker transformer intended for use with mains output valves. The primaries of such transformers do not have a large amount of inductance, and what inductance exists can always be reduced by removal of some of the laminations, or by increasing the space in the butt joint between the two sets of laminations. Many miniature speaker transformers have a tapping in the primary

at about a quarter to a third of the number of turns from one end. A transformer of this type is illustrated in the diagram, it being assumed that the tuned inductor, L_1 , is provided by the winding between the tap and one end of the primary. L_1 should constitute the greater number of turns, the remainder of the primary being employed for the feedback coil, L_2 . The secondary of the speaker transformer, L_3 , is used only during the initial setting up of the instrument.

Setting Up

Setting up the test gear should prove to be quite simple to carry out in practice. A condenser of approximately 500pF should be connected temporarily in the C_3 position, and a pair of high-resistance (2,000 ohm) headphones, or an a.f. amplifier with a high-impedance input, connected to the secondary, L_3 , of the speaker transformer. This enables a check to be kept on the frequency of oscillation. Different values of condenser should then be inserted in the C_2 position until a pure a.f. oscillation with a frequency around 1,000c/s is obtained. The temporary 500pF condenser should now be removed, and the value of C_3 increased in stages, starting from 100pF. The idea behind this operation is to find a value for C_3 which enables maximum current sensitivity to be obtained. The best value will

be that which causes the microammeter to indicate about 75 per cent of the maximum possible reading obtainable before squegging sets in. (A normal reading would be around 300 to 400 μ A.) The headphones, or amplifier, may then be disconnected from L_3 .

The instrument can next be checked by connecting its test prods across the anode winding of a line output transformer known to be good. This should cause a slight drop in microammeter current. Two adjacent taps on the winding should then be temporarily short-circuited together, whereupon a considerable drop in current reading should occur. The temporary short-circuit should next be removed and a final test for sensitivity made by looping a piece of wire around the line output transformer core alongside the anode coil and touching its ends together to constitute a single shorted turn. If the test gear is sufficiently sensitive a marked drop in microammeter current will result.

If it is found that, on initially connecting the test prods to the serviceable line output transformer winding, a large drop in microammeter current occurs, too high an inductance in L_1 is indicated. Its inductance should then be reduced in the manner described above, i.e. by removing laminations or by increasing the butt joint gap. Reducing the inductance of L_1 will, of course, necessitate finding a new value for C_2 .

Can Anyone Help?

D. JOSEPH, 16 Hurley House, Kingswood Estate, Dulwich, London, S.E.21, is anxious to obtain data on the TR1154M transmitter.

A. HARRISON, 12 Frankland Street, Elland Road, Leeds 11, wishes to buy or borrow the circuit or switching arrangements for valve testing for the "Dynamic Mutual Conductance Tube Tester 1-177," made in U.S.A.

J. G. EUSTON, 12 Blackthorne Avenue, Manchester 19, is anxious to hire or buy service sheets, circuits only, or any helpful data on the Lissen 8317 receiver and/or the Reax L53V receiver.

A. C. BINSTEAD, 1 Wickham Close, Crookham, near Aldershot, Hants, wishes to buy or borrow the circuit of the Brunswick model BTA/3.

E. PRICE, "Arfryn," Penybally Road, Holywell, Flintshire, requires the circuit and/or data on the 6-valve short wave battery receiver R.1139, ref. 10D/11742, covering 31/80 metres. He is particularly puzzled by the two terminals marked 1/C and H.T.+1/C, and is willing to pay for any help.

J. K. OWEN, 3 Carlton Avenue, Westcliff-on-Sea, Essex, wishes to buy or borrow the circuit or service data of the Murphy V114 and V116 television receivers.

C. GALLOWAY, 177 Broom Lane, Levershulme, Manchester 19, wishes to obtain the circuit or any data on the Indicator Unit type 62A, ref. 10Q/37, serial A.C.C.C. 34170.

Requests for information are inserted in this section free of charge; subject to space being available

D. BYRNE, 3 St. Saviour's Road, St. Helier, Jersey, C.I. would greatly appreciate any information on the Hallicrafters S38 receiver, the B21, or the Hambander.

W. S. MCGREGOR, 50 Belleville Street, Greenock, Renfrewshire, wishes to buy or borrow the circuit and conversion data of the Bendix R.A.10.F.B. Aircraft Receiver, to operate from a.c. mains.

D. F. HARVEY, 11 Lynmouth Place, High Heaton, Newcastle-upon-Tyne 7, requires on loan, or to buy, information on the Tx/Rx type 38 Mk. 2, particularly the plug connections.

W. CHILD, 4 Woodland Dell, Charlestown, Hebden Bridge, Yorks, would like to obtain, on loan or otherwise, the handbook for the Tuner Amplifier B21B, Admiralty Pattern W.1516.B.

J. ROSS, 57b Valon Road, Arborfield, Berks, wishes to obtain information on the McMurdo-Silver "15-17" or other model using a comparable chassis (I.F. is 465 kc/s—Ed.), and on the Philips model 799A Projection T.V. All letters answered and reasonable payment made where necessary.

G. NORMANTON, 299 Priory Road, Hull, Yorks, wishes to buy or borrow the manual of the DST-100 Mk. 2 communications receiver.

J. BELL, G3DII, "Ennerdale," Greenfield Road, Stafford, wishes to borrow the handbook on the B.C.348.C and to buy a calibration book for the ex-A.M. Wavemeter W.1117.

BAND III TELEVISION for the HOME CONSTRUCTOR

PART 8. by S. WELBURN

This month our popular contributor discusses interference on Band III, including especially that given by asynchronous line timebases between two televisions tuned to alternative programmes. He also introduces the new Osmor Band III Converter, which will be fully described in next month's issue

A CONSIDERABLE AMOUNT OF INTEREST has been caused recently in the trade by an article which appeared in the November issue of *Wireless World**. In this article it is stated that Band III converters having an output at a channel in Band I for connection to the aerial socket of an existing television are liable to cause re-radiation and interference with neighbouring Band I televisions. The article then goes on to describe methods of curing the trouble.

Aerial Radiation

Whilst the *Wireless World* article introduced a new and most interesting sidelight on the question of possible mutual interference between televisions, the present writer feels that one or two of the points raised in it might merit further discussion.

Let us begin with the type of interference described. It was pointed out in the article that the trouble of mutual interference is most probably liable to arise when the Band III-Band I converter is used with a t.r.f. receiver. In such a case the Band III signal is converted to Band I and amplified by the r.f. strip of the television until it has an amplitude of several volts at the video detector. At this amplitude it is quite possible for re-radiation to occur, thereby causing interference with neighbouring receivers. The frequency at the output of the converter will not be exactly that of the Band I signal, but will float around that frequency as the oscillator in the converter drifts. In consequence, interfering patterns are liable to be given on the screens of neighbouring receivers tuned to the Band I signal. (It has to be pointed out here that the

re-radiation could be just as severe when the t.r.f. receiver is tuned to the Band I signal as when it is used with its Band III converter. However, as the neighbouring receiver would also be tuned to the same Band I frequency no beat patterns would be visible. It requires the slightly off-set frequency of the converted Band III signal to provide the visible interference pattern.)

It is stated in the *Wireless World* article that the high-amplitude signal at the video detector may be picked up by the Band I or Band III aerial leads and re-radiated. No emphasis is laid, however, on the possibility of radiation by the circuits in the receiver itself or by the mains lead and wiring. Whilst it is obvious that re-radiation may occur via the Band I aerial, it must be pointed out that if the Band I aerial downlead were capable of picking up radiation from the video detector circuits, such pick-up would form a feedback loop with possible resultant instability when the t.r.f. receiver was employed in its normal manner.

There is also the fact that, in most converters, the Band I output is connected to switch contacts which are very close to those switching the Band I aerial itself. There is, therefore, a greater possible source of trouble at this point, where stray coupling capacities can be high, than is given by the pick-up of energy from the video detector circuits. In the November issue of *The Radio Constructor* the writer dealt in some detail with Band I-Band III switching circuits, and it would appear that the circuit given in Fig. 2 in that issue should provide a very good protection against re-radiation via the Band I aerial. As was stated in that article, the Band I aerial could be terminated, via a pair of switch

* "Interference from Band III Converters" by F. Howard Steele, *Wireless World*, Nov., 1955.

contacts, with a short-circuit or a 75 ohm resistor; and the switch contacts used for this job were screened from those handling the converter output.

Timebase Interference

Another source of mutual interference which, to the best of the writer's knowledge at the time of writing, has not yet been mentioned in the technical press, is asynchronous line timebase interference. This interference occurs when radiation from the line timebase of one receiver interferes with the picture of another receiver tuned to a different programme.

As is well known many line timebase circuits create radio interference, this being due mainly to the fact that pulse voltages at high power are handled by the line output stage and deflection yoke. Radiation at frequencies which are multiples of the line frequency are often detected by sound receivers positioned close to the television concerned.

The greatest voltage surge in the line output stage occurs during the flyback period. It is possible to pick up and observe pulses of energy during this period with the aid of an oscilloscope having an unscreened input lead held near the timebase of the television concerned, or with the aid of another television working in an unsynchronised state. (The reason for the necessity of the second television being unsynchronised will become apparent shortly.)

So far as r.f. is concerned, it is also possible that the bursts of radiation occurring during the flyback period may be made stronger by the presence of corona, or even sparking, in the line output transformer or deflector coils, or at any other high voltage point in the line output stage before the e.h.t. reservoir condenser. This surmise is certainly borne out by practical television experience; although how far such a state of affairs (i.e. corona and sparking) can be allowed to become apparent before breakdown occurs in the associated receiver is problematic. It may be recalled that G. A. French recently contributed a suggested circuit for a "corona probe" in which advantage was taken of the fact that corona frequently occurred in pulses at line frequency.

If a television emits bursts of r.f. energy during the flyback period, these bursts of energy can be picked up on a neighbouring receiver. If, however, both receivers are tuned to the same signal, a negligible amount of visible interference will occur. This is due to the fact that the interference pulse will be received by the second receiver during its own flyback period, with the result that it will be blanked out. If the interfering pulse exists for a short time after the end of the blanking

period of the second receiver, the interference will only show at the extreme left of the picture, where its visual effect would be very small and where it could even be completely hidden by the picture tube escutcheon. This second state of affairs should be quite infrequent, as it requires either a slow retrace time with consequent foldover in the interfering receiver, or very heavy ringing in the e.h.t. coil of its line output transformer.

The situation becomes quite different when the two receivers are tuned to alternative programmes. In this case the two retrace periods do *not* occur at the same time because the synchronising frequencies employed by either transmitter will not have exactly the same value. What will then happen is that the interfering pulses from one receiver will reach the other at any point during its line timebase cycle. If they reach the second receiver with sufficient strength during part of its scanning period they will become visible on its screen.

The writer has seen several instances of this interference in a block of flats in London, and it seems possible that the trouble may become fairly widespread as more I.T.A. transmitters come on the air. The interference appears as a vertical line which travels fairly rapidly across the picture, and which is liable to drift either to left or to right in random fashion. The vertical line itself may appear to have a broken appearance, in so far as it may be built up from a series of white dots occupying a slightly different position on each successive horizontal line. The brightness of the line will, of course, depend on the nearness of the interfering receiver to the aerial of the second receiver, the effective gain of the latter, and the intensity of the pulses radiated by the interfering receiver.

Fortunately, the trouble should not normally be too difficult to clear. In the instances checked by the writer, the sets receiving the interference employed indoor aerials which were fairly close (walls intervening) to the interfering receiver. A solution was found either by moving the indoor aerial further away from the interfering receiver or by re-positioning the latter a greater distance from the neighbouring aerial. A better solution from the technical point of view would have been given by providing more effective screening in the interfering receiver or by attempting to reduce its line timebase radiation by other means; but this did not prove necessary in the particular cases examined. It was interesting to note that the trouble only occurred when the interfering receiver was tuned to Band III and the neighbouring receiver to Band I. Even when, during a later check in the workshop, an experimental Band III dipole was brought close to an interfering receiver tuned to

Band I, no noticeable interference resulted.

Although he has not encountered this himself personally, the writer has also heard of one or two instances in which asynchronous line timebase interference has been picked up via an external Band I aerial, and not via an indoor aerial close to the interfering television. If this is so, the radiation from the interfering receiver would be fairly strong, and it seems safe to say that the set had a line output stage which was suffering from quite severe corona or incipient sparking. Clearing up this trouble would then involve the normal checks carried out on line output components and wiring for these two faults. It should be remembered that the line output valve, the booster diode, and the e.h.t. rectifier are occasionally capable of causing radiation troubles, and that the fault could conceivably be cured by replacing one of these. A cheaper solution would sometimes be provided by connecting a small choke in series with the anode of the line output valve. Such a choke could be made very easily by close-winding 20 to 30 turns of 32 to 36 s.w.g. wire on a small half-watt high-value resistor. (The purpose of the resistor is merely that of providing a convenient former, and it could have any value in excess of, say, 200 k Ω .) Such a choke occasionally provides strikingly successful results when used in this fashion.

It is interesting to see that asynchronous line timebase interference does not appear to have been reported in America, where the large number of alternative programmes might have made it quite a common complaint. This is possibly due to the fact that the negative video modulation employed in the

States makes interference of this nature far less noticeable than occurs with a positive modulation system. Alternatively, there is the possibility that outside aerials are used more extensively than they are in this country.

Interference from F.M.

This month's contribution appears to have become almost entirely devoted to interference. So much so, indeed, that the writer feels almost reluctant to draw attention to yet another possible source of trouble! Nevertheless, the question of interference from f.m. receivers also deserves mention in these columns.

It might appear, at first sight, that the most obvious cause of interference from f.m. receivers would be radiation of the oscillator frequency. At the present moment, however, this is not the case. To take an example, let us assume that an f.m. receiver is tuned to the lowest f.m. frequency at present in use, that of 89.1 Mc/s. If the oscillator tuned above the signal frequency and the i.f. of the f.m. receiver was the conventional 10.7 Mc/s, the oscillator frequency would be 99.8 Mc/s. The second harmonic of this is 199.6 Mc/s. Fortunately, this frequency lies outside our existing Channel 9 (194.75 Mc/s video and 191.25 Mc/s sound) but it falls almost exactly on the Channel 10 video frequency of 199.75 Mc/s. At the time of writing there is a strong possibility that the third I.T.A. station may come on the air on Channel 10 (its alternative channel is Channel 7) with the result that, whilst the question of interference from f.m. receiver oscillators does not trouble us at the present moment, it is quite on the cards that it may do so in the future.

The equipment shown on the right is all the work of reader Russell Haigh, of Wakefield, Yorks. The tape recorder is self-contained, and can be removed for outside use; several recording channels are provided via internal links. The television is a 5-channel single-sideband superhet with 12-in tube. On the extreme right is a 5-waveband superhet tuner, above a 3-speed auto-changer; these feed into a push-pull 6L6 amplifier. A single 12-in heavy duty speaker is switched to the unit in use by the same push-button that selects the unit's mains supply.

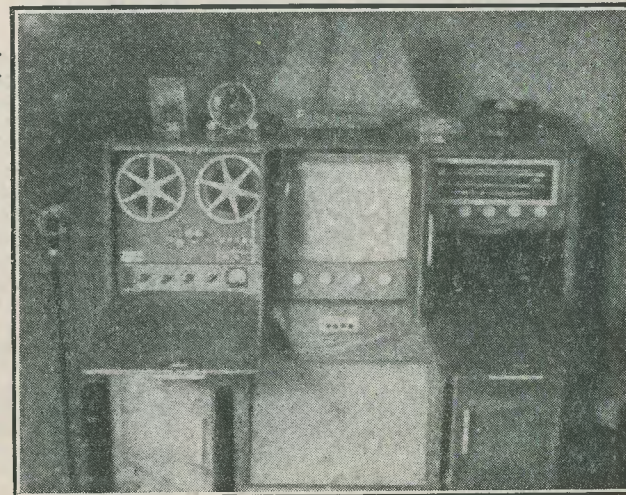

The writer would hasten to add that a good f.m. receiver is designed such that it will not radiate interference from its oscillator. Also, in some f.m. receivers the oscillator frequency is below that of the incoming signal.

What appears to the writer to be a more probable cause of interference is radiation from the i.f. stages of f.m. receivers. At the limiter and discriminator stages of many f.m. receivers an i.f. signal can appear with high voltage amplitude and an almost square waveform. In consequence a considerable number of harmonics may be present, and such harmonics can easily interfere with television receivers. The writer has encountered one instance of this. The televisior, using indoor aerials both on Band I and Band III, suffered interference when an adjacent f.m. receiver was tuned in to a signal. The fact that interference appeared only when the f.m. set was actually tuned to a signal provided sufficient evidence that the trouble was given by i.f. radiation. The i.f. of the f.m. receiver was a nominal 10.7 Mc/s (later tests showed it to centre at 10.8 Mc/s), which allowed a fourth harmonic of 43.2 Mc/s to interfere with Channel 1 and an 18th harmonic of 194.4 Mc/s to interfere with Channel 9. As was to be expected, interference on Band I was far more noticeable than on Band III.

This, again, provides an instance in which interference would have been negligible on either Band if an outside aerial had been used.

Cleveland Television Converter

A new unit which has been passed to the writer for review is the Television Converter type AC.29. This is made by Cleveland Electronic Products, Ltd., and was submitted by Wireless Marketing Supplies Co. of 29 Praed Street, London, W.2.

The Cleveland converter is a small manufactured unit which is housed in a neat hammered-grey metal case whose dimensions are approximately 9in by 4in by 2 in. Two controls are provided, a "Gain" control and a "Band I-Band III" switch, and these are mounted on one of the 2in sides. Shaped holes are provided in the back plate enabling the unit to be fixed to the rear of the televisior without the need for disassembly of the converter. The two control knobs should then project at the rear side of the televisior for adjustment by the user.

Although the Band I aerial is not terminated in a short-circuit or 75 ohm resistor on Band III, care has been taken to completely screen the switch wafer which switches out the Band I aerial. Such screening is a good design point. So also is the fact that full isolation from the mains is achieved by a small mains transformer. Rectification for h.t. is provided by a Westinghouse contact-cooled rectifier operated well within its limits. Yet another good feature is that, if slight re-alignment is ever required, it is possible to reach the slugs of all coils through small holes in the case, even after the unit has been mechanically fixed to the televisior with which it is to be used. Alignment instructions are provided with each unit.

No on-off switch is provided on the converter, and it would probably be best to connect it to the same mains socket as that feeding the televisior. Both televisior and converter could then be switched on and off at the same time by the switch at the socket. Alternatively, the converter could be wired into the televisior itself so that the televisior switch also controlled the mains to the converter as well. No circuit details were available to the writer but it was noted that two EF80 valves were employed.

Summing up, it can be said that the Cleveland Television Converter, which retails at £7 10s. 0d., is a very neat instrument which has been designed with imagination and considerable care.

The Osmor Converter

A unit now available to the home constructor is the Osmor Television Converter. This unit embodies the coils manufactured by this company, and employs the latest techniques acquired from practical field experience of Band III transmissions.

A three-valve circuit is used, this consisting of a cascode input stage, a triode oscillator, and pentode mixer (the separate oscillator is chosen in the interests of frequency stability). The unit is fully isolated from the mains and metal rectifiers are employed for h.t. Full Band I-Band III switching is provided.

Full constructional and wiring details for this converter will commence in next month's *Radio Constructor*.

transmitting stations are requested to keep clear of this region of the band during the period 1055 to 1120 a.m. Reports on reception are welcomed, and a special Q.S.L. card will be sent in verification.

IN YOUR WORKSHOP



In which J. R. D. discusses Problems and Points of Interest based on Letters from Readers and his own experience

AS IS BORNE OUT BY THE LETTERS continually arriving at the offices of *The Radio Constructor*, an important proportion of the readers of this magazine consist of those enthusiasts who have not yet been "in the game" for very long. Many of these readers are attempting to get together test gear for use in their own workshops, and some are finding that this process is a little expensive. Such a state of affairs is especially true of some particular items of manufactured test equipment: and our contributor, W. Pickering, is to be commended for the series of articles describing the construction of an inexpensive a.m.-f.m. signal generator which has been appearing in the last few issues of this magazine.

Testmeters

Manufactured signal generators are always a little costly, and the possibility of their construction at home definitely represents a useful saving in cash. Their construction also provides useful practice in the functioning, design and operation of test equipment.

This month I would like to talk about another similarly useful and indispensable piece of workshop gear. This is the multi-testmeter, an instrument capable of taking a large amount of different voltage, current and resistance readings, and employing as its central unit a reasonably sensitive moving-coil milliammeter or microammeter. Now, I know that descriptions of multi-testmeters have been appearing with steady regularity in the constructional press for at least the last twenty years, so I must hasten to point out that I am *not* going to give full constructional details, nor am I about to describe at great length the box in which the meter is to be

fitted, or the exact components which must be employed. Instead I hope to give a general outline of the best methods of tackling the design and construction of a reliable and accurate multi-testmeter using whatever materials may be to hand, or whatever components are available at reasonable prices.

Voltmeter or Voltammeter?

Before going any further, the first thing to be decided is the question of how ambitious the completed instrument is going to be. This raises the supplementary question of the number of ranges which are to be fitted to the testmeter, and the functions these are intended to carry out.

Basically, a multi-testmeter consists of a moving-coil milliammeter which has suitable values of resistance connected in series with it to make it read volts, which has suitable shunts connected in parallel with it to make it read current, and which has a suitable battery and resistance circuit connected to it to enable it to measure resistance.

Probably the easiest circuit to fit in a home-made testmeter is the last of the three mentioned above, that which requires fitting a battery and resistance arrangement in order to make the basic meter function as an ohmmeter. The reason for this is that there is no necessity to choose accurate values of resistor for this purpose. Apart from certain precautions (which will be dealt with next month) it is safe enough to say that discrepancies in individual resistor values can be taken up in the variable series resistor which is used for setting the meter to the "zero-ohms" position.

The next circuit in descending order of "easiness" is that of fitting the various series

R.S.G.B. NEWS BULLETIN SERVICE

Our readers' attention is drawn to the weekly amateur news service being currently transmitted by the R.S.G.B. station GB2RS on a frequency around 3,600 kc/s every Sunday morning at 1100 G.M.T. Amateur

resistors needed to enable the moving-coil meter to cover a series of voltage ranges. Such a process is reasonably easy because the switching circuits are simple and because the series resistors required can be made up from components which are readily available. Also, the equipment needed for finding the values of series resistance in the testmeter is well within the scope of the amateur.

Probably the hardest job in constructing a multi-testmeter consists of making the shunts needed for the current ranges. This is due to the fact that the business of preparing shunts is somewhat fiddling, and because the apparatus required for providing steady test currents needs more preparation than that needed for steady test voltages. In addition, switching circuits have to be designed with care if accidental damage to the meter is to be avoided.

I feel, personally, that for general radio work a home-made multi-testmeter which covers voltage and resistance only is very nearly as useful as one which has additional current ranges as well. Many radio networks in which current flows have a convenient relatively low-value resistor somewhere in the circuit across which it is possible to measure a voltage. In such cases it is quite a simple matter to determine by calculation the current flowing through the resistor. Indeed, it is frequently also *quicker* to measure the voltage across a resistor and work out the current flowing through it than it is to go to the trouble of unsoldering one end of the resistor so that a meter can be inserted to read the actual current directly. To take an example, if a valve has a cathode resistor of $2k\ \Omega$ and this resistor has a potential of 5 volts across it, then it does not take many seconds to calculate that the current flowing through the resistor is 2.5mA.

In consequence of the above, I do not think I would be giving bad advice if I suggested to the novice who does not feel like tackling a really ambitious instrument in one operation that he starts off by making a multi-testmeter which covers volts and ohms only. The current ranges could then be added later, with the realisation that these were gilding a lily which on its own represented a most useful and serviceable item of workshop equipment. Whatever choice the reader makes (and I hope it is no worse than my choice of metaphor in the last sentence!) he will always be in possession of a testmeter suitable, as it stands, for constructional and service work.

Calibration

One of the things which is usually glossed over in the description of home-constructed testmeters concerns the question of calibration. This point is, in fact, one which could raise quite considerable difficulties for some

readers. The reason for this is that it is advisable to check the calibration of the home-constructed testmeter with another which is known to be good; and the latter may, in some cases, be difficult to obtain. Even if the constructor employs very low tolerance series resistors and shunts (a somewhat expensive process) another testmeter is still desirable to check the finished product for accuracy. Many of those readers who are not already in possession of a reliable testmeter of their own will have access to suitable instruments—at their work perhaps—and the loan of such meters for several evenings can often be arranged. Others less fortunately placed might be able to get help from their local radio club. Some small radio shops, especially in the provinces, can be surprisingly obliging in the matter of the loan of a testmeter. This particular question is really one of trying to make best advantage of what is available in one's own particular circumstances.

The Basic Meter

The most important part of the testmeter is the basic meter itself, i.e. the milliammeter or microammeter around which the instrument is to be built. A little care in selection is definitely very wise here.

It is first of all desirable to obtain a meter which is reasonably sensitive and which has an easily read scale. There are several types of meter movement available on the surplus market which do not have the normal appearance of a meter, and which are employed in such things as aircraft indicators and similar devices. The usefulness of such instruments is rather problematic. If the constructor is prepared to undertake the job of mounting such meter movements in more or less conventional arrangements with home-made scales, he is welcome to do so. However, there is a lot of work involved in such an operation and the risk of damage is high. Also, the saving in cash given by the purchase of such meters is not always very large.

Another possible source of sensitive moving-coil movements is offered by thermo-couple ammeters, the idea behind their purchase being to remove the thermo-couple and connect up to the meter movement proper. Unfortunately, whilst such movements are frequently quite sensitive they do not always exhibit dead-beat characteristics once the low resistance external circuit provided by the thermo-couple has been removed. In consequence, their needles may jitter for an appreciable time around the final reading before settling to rest. For those who like to experiment it might be possible to clear this trouble by connecting a low-voltage electrolytic condenser of some $100\mu\text{F}$ or more across the coil of the meter

(employing correct polarity); but I would not like to guarantee the success of such an arrangement, or its long-term stability.

Probably the best choice for the basic movement is a conventional meter intended for use as a milliammeter or microammeter. In the surplus market there are still some excellent meters of this type available, and the prices are still reasonably low. A particularly good choice is provided by ex-Air Ministry 0-1 milliammeters intended for panel mounting and requiring a $2\frac{1}{2}$ -inch cut-out. Some of these have 75 ohm, and others 100 ohm coils, but the difference in coil resistance is immaterial for our purposes here. (The coil resistance of these meters, incidentally, is usually shown on the scale.) Such meters are sometimes mounted in small desk-panels bearing the words: "For use with R.1084." The prices at which these ex-A.M. meters are offered is liable to vary between retailers, and it is advisable to do a little scouting around before making the final purchase.

Other, cheaper, meters of the same size, but having an f.s.d. of 5 or 10mA, are also fairly easy to obtain. However, the voltmeter section of a multi-testmeter employing a 0-10mA meter as a basic unit is liable to be rather insensitive by radio standards.

The Voltmeter Circuit

When used as a voltmeter, the testmeter circuit which is switched in consists essentially of the basic meter movement in series with a resistor. This arrangement is shown in Fig. 1. What we have to do is to vary the value of the series resistance by suitable switching circuits in order to read different ranges of voltage.

A useful technique for working out the values of series resistance required for the testmeter is given by finding its sensitivity in "ohms per volt" for the particular basic meter employed. The number of ohms per volt then tells us very quickly the series resistance required for each range.

To give an illustration, let us assume that the meter shown in Fig. 1 has negligible coil resistance, and that it has a full-scale deflection of 1mA. If we wish to use it as a voltmeter having a full scale deflection of 1 volt, the series resistance must have a value such that 1mA flows through it and the coil of the meter when 1 volt is applied to the two test terminals. The value of resistance required is, of course, 1,000 ohms. In consequence of this we can now say that, when a 0-1mA meter is employed as the basic unit in a testmeter, the meter has a sensitivity of 1,000 ohms per volt. The usefulness of this concept should at once be apparent. If, for example, we wish to have an f.s.d. of 20 volts then the series resistance will need to be 20,000 ohms. In a similar manner, whilst a 0-1mA meter provides a voltmeter sensitivity

of 1,000 ohms per volt, a $100\mu\text{A}$ meter has a sensitivity of 10,000 ohms per volt, a 5mA meter one of 200 ohms per volt, and so on.

Four practical multi-range voltmeter arrangements are shown in Fig. 2. In each case a different value of resistance is connected in series with the meter for each voltage range. In Fig. 2 (a) and (b) separate sockets are employed, in Figs. 2 (c) and (d) a switch is used. So far as the home-constructor is concerned there is little to choose between any of the arrangements shown.

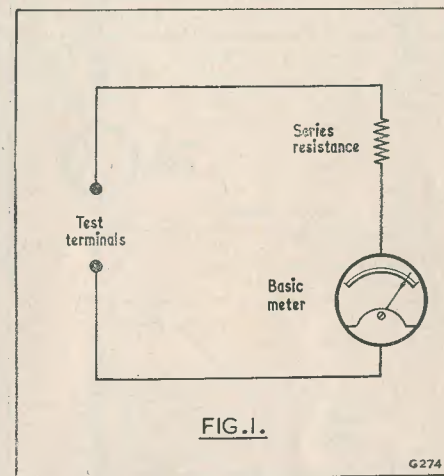

Fig. 1. The basic arrangement needed to enable a moving-coil meter to function as a voltmeter

Practical Values

When, just now, we discussed the number of ohms per volt of our multi-testmeter we assumed negligible resistance in the coil of the basic meter. In practice, of course, this cannot be assumed, and we have, in consequence, to subtract the value of the coil resistance from the total calculated resistance for each voltage range to find the actual series resistor required. Thus, if a 0-1mA meter has a coil resistance of 75 ohms and is required to read 1 volt, the actual value of series resistance required will be 1,000-75 (i.e. 925) ohms. At high voltage ranges, however, the coil resistance will normally be too low compared with the series resistance to be of any great account.

In the construction of a practical meter we have two methods of approach to the question of fitting the various series resistors needed. One consists of working out the exact values

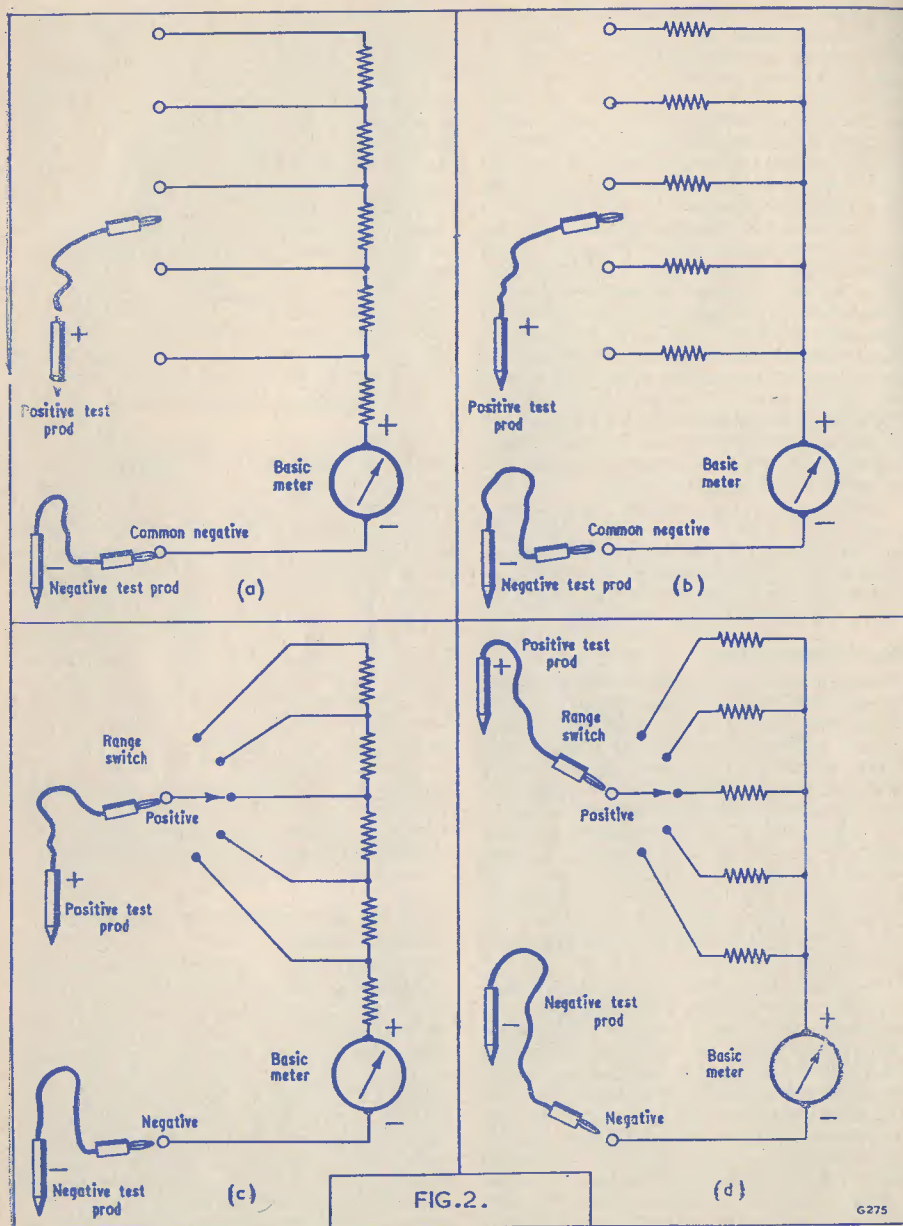

Fig. 2. Four methods of connecting resistors in series with a basic meter to provide a number of voltage ranges. In (a) and (b) range selection is achieved by plugging the positive test lead into the appropriate socket, in (c) and (d) a range selector switch is employed

of resistance needed for each range, and of obtaining these in low-tolerance ($\pm 1\%$) types. The other consists of "manufacturing" the resistors required by empirical means. Of the two techniques the second is cheaper and entails only a little additional effort on the part of the constructor.

A very simple method of "manufacturing" the series resistors consists primarily of setting up the basic meter in the circuit shown in Fig. 3. The source of voltage shown in this diagram may be a battery, an h.t. point in a receiver chassis, or any similar steady source of potential. What is required is to find a physical resistor which, when connected in series with the meter of Fig. 3, enables it to show a reading which corresponds to that given by the calibrating meter. The latter is, of course, an ordinary testmeter which is used as a standard.

value can be made up by the combination of several resistances in parallel or series-parallel. If the required resistance value is below, say, 20,000 ohms it is a good plan to initially fit a resistor having a slightly higher value (shown by a slightly low reading on the basic meter) and "trim" it by connecting high value resistors across it. By starting at 2M Ω and "working down," the requisite value should not normally take long to find. If the series resistance required is fairly high, say, above 20,000 ohms, a reverse method may prove useful. This consists of starting off with a resistor whose value is slightly below that required, and of then inserting small value resistors in series with it until the correct value is found. After the correct combination of resistors for each voltage range has been found it may then be soldered permanently into the instrument. If the

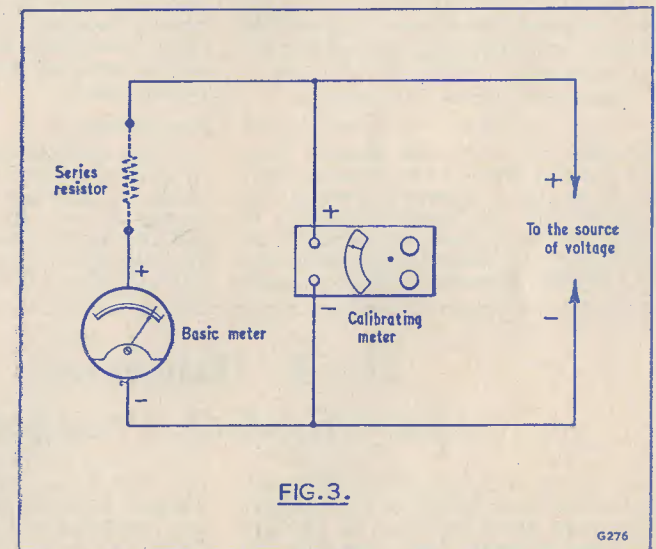

Fig. 3. The simple apparatus needed to obtain the series resistors required for a multi-range volt-meter

The constructor will know, from the number of ohms per volt required by the basic meter, the calculated value of series resistance needed for each range. In consequence, it is a good plan to commence operations at each range by trying out, in the test circuit, one's stock of individual low-tolerance (10 or 20%) resistors having approximately the calculated value, in order to see if one of these fortuitously happens to have the required resistance. If none of the resistors checked happens to have the correct value then, still working empirically, that

circuits of Figs. 2 (a) and (c) are employed, it is necessary to commence with the lowest voltage range first and add each successive range afterwards. If the circuits of Figs. 2 (b) and (d) are used, the series resistor combinations may be made up in any order because one does not affect the others. Assuming a reasonable stock of resistors, it should be possible to use two resistors only (either in parallel or in series) for each range combination. At worst, only three should be required when any particular combination is finally "trimmed up."

There are several advantages to the technique just described. The first of these is that conventional 10 or 20% resistors are

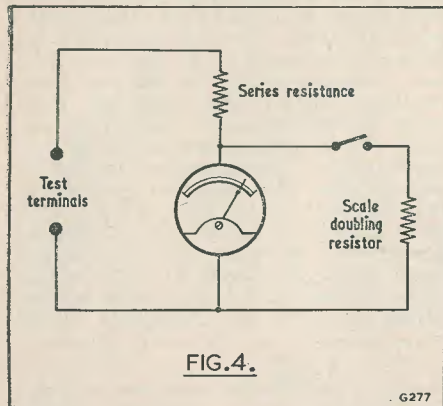

FIG. 4.

Fig. 4. A "scale-doubling" circuit which can extend the usefulness of a testmeter considerably, and at little extra cost

employed, and costly low-tolerance components are avoided. A second advantage is that, if resistors of reasonably good quality are employed, they should be capable of holding their values over quite a considerable period of time. (Such stability with time could not be guaranteed if the occasionally

Mr. R. Hammans is new R.S.G.B. President

Mr. R. H. Hammans, G2IG, President-Elect of the Radio Society of Great Britain, is currently Chief Engineer to Granada Television Network Ltd., who are the Independent Television programme contractors for weekdays in the North Region.

Mr. Hammans, who has held an Amateur Transmitting Licence since 1929, is Vice-Chairman of the Society's Technical Committee and a past winner of the Norman Keith Adams Prize.

During the early 1930's Mr. Hammans installed ship-to-shore radio equipment for International Marine Radio Company. He joined the B.B.C. in 1935, in which service he remained until taking up his present appointment a few months ago. Whilst with the B.B.C. Mr. Hammans undertook the first radio link television outside broadcast ever to be transmitted in a public service—Wimble-

recommended practice of filing V-cuts in the resistor until it has the correct value is employed.)

Scale Doubling

A very useful addition to the voltage ranges of a home-constructed multi-testmeter is given by means of a scale-doubling switch. All this switch needs to do is to connect a resistor whose value is equal to the coil resistance across the basic meter. A typical arrangement is shown in Fig. 4. As will be seen from this diagram, when the switch is closed it is necessary for twice the voltage to be applied to the test terminals to provide the same scale deflection. In consequence, a very acceptable increase in the number of effective voltage ranges is obtained at little extra cost.

The value of the scale-doubling resistor required in Fig. 4 can be found empirically by employing the same method as was used for finding the series resistor combinations described above. It is best found when the meter is switched to a fairly high voltage range, because the scale-doubling circuit is liable to introduce slight inaccuracies at low voltage ranges.

Next Month

In next month's issue we will be carrying on to discuss ohm and current ranges, the former including both "series" and "shunt" circuits. It is also hoped, if space permits, to give a circuit for a complete multi-testmeter. This will show values suitable for use with any reasonably sensitive basic movement.

don 1937. From 1939 to 1943 he was at Tatsfield Receiving Station, from which he was transferred in 1943 to the Transmitter Drive Section of the B.B.C. After three years he went back into television, in the Planning and Installation Department. During the succeeding nine years in that Department he became Head of the Television Unit.

In amateur radio circles Mr. Hammans has made many technical contributions to the R.S.G.B. *Bulletin*. He has specialised in the design and construction of measuring equipment and communications receivers for amateur frequencies.

Mr. Hammans has represented the R.S.G.B. at International Amateur Radio Union conferences in Paris, Lausanne and Amsterdam, and is a member of the I.A.R.U. Region I International Committee.

RADIO-AND CONTROL

PART 4.

by RAYMOND F. STOCK

Practical Pulse Systems

THE UNITS UP AND US, PREVIOUSLY referred to, must produce a small angular movement (of constant value) for each pulse received, and the easiest method of ensuring this is to use an electromagnetically driven ratchet wheel.

Fig. 16 shows the idea, which is self-explanatory except, perhaps, for the inset (right), which illustrates the design and operation of the pawl and teeth. D prevents any backward movement of the wheel, P is the pawl which rides back over a tooth when the electromagnet is energised; at the

locking of the wheel between movements. The wheel cannot rotate in reverse due to the action of D. Should it tend to rotate forward it could only do so by lifting the pawl away from the centre due to the wedging action of the tooth angle. This is prevented by the fixed stop S.

These points are noted in case it may be desired to make such a unit, but a fair degree of precision (and access to machine tools) would be necessary, so most amateurs will use the mechanism of a rotary selector switch which is very suitable for the purpose. Two such units are needed, one receiving

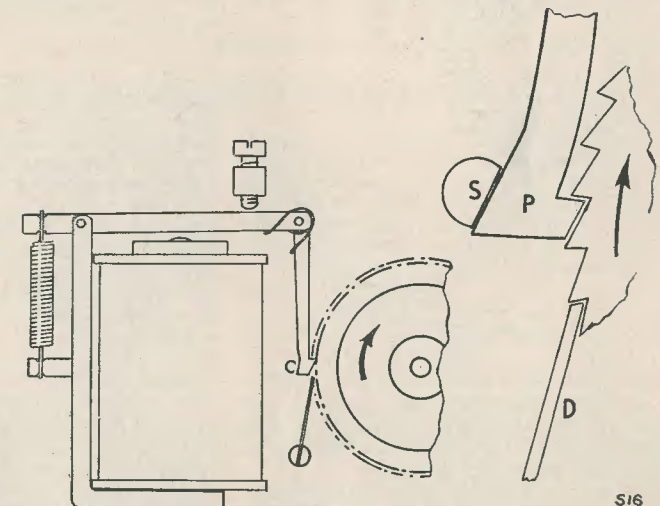

Fig. 16. General principle of ratchet mechanism. The geometry is exaggerated slightly for clarity

end of a pulse the armature returns, spring loaded, and carries the wheel round one tooth. This principle of making the return stroke the working movement is very important as, firstly, it ensures that each wheel movement occurs with a fixed, reproducible torque independent of variations in battery voltage; secondly, it facilitates the

port-going pulses and the other starboard-going pulses.

Fig. 17 shows how the two units are combined "back to back" with a differential gear between them to combine their separate outputs.

The differential could be made from Meccano parts, but surplus computing gear

frequently contains just the right unit. In any case, the principle must be that the two opposite-handed outputs are fed to the two bevels BP and BS. The bevel pinions

A steering unit of this type is usually known as a ratchet motor, and can be made up quite well from surplus components using only hand tools.

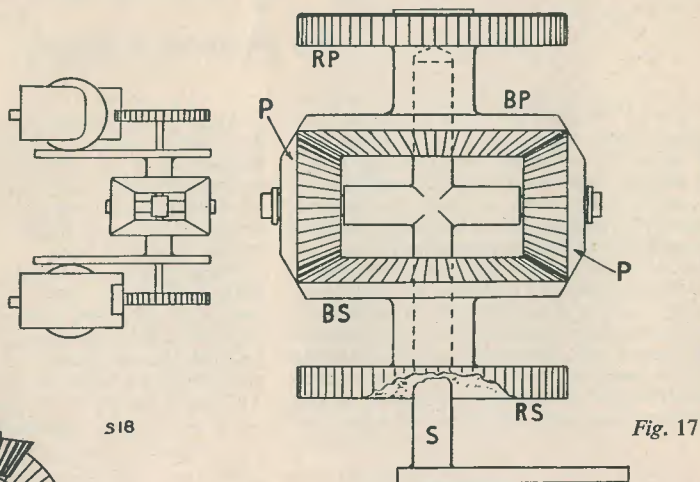

Fig. 17

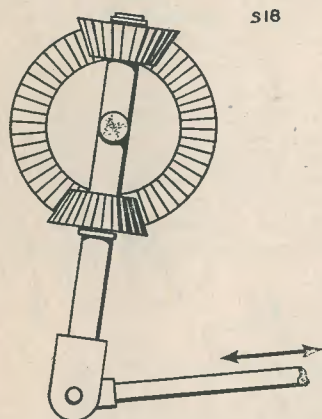

Fig. 18

P can rotate freely on their cross-shaft but the cross-shaft is rigidly connected to the centre spindle S, free to move within the two ratchet wheels RP and RS.

The spindle S rotates either way, depending on whether port-going or starboard-going pulses are fed in, and (irrespective of the size of the bevel pinions and gears, of course) always turns at half the speed of the selected ratchet wheel.

In many cases it may be found difficult to bring S out through an existing ratchet wheel assembly, particularly when the latter is a commercial product, and in this case, because the angular movement of the pinions is usually limited, the cross-shaft may be extended one side and coupled to the rudder by a push-pull rod. Fig. 18 shows this.

An interesting feature of the idea is that should pulses be fed simultaneously to the two ratchets—this, of course, needs two independent radio channels—then the two angular movements are cancelled out by the differential and no rudder movement occurs; but if a pair of auxiliary contacts is arranged, one on each electromagnet, so that the armatures close them when attracted, then by connecting these contacts in series we have another virtual channel for control at no extra expense. Fig. 19 indicates this arrangement.

Control Gear

It is neither possible nor desirable to transmit the pulses for this system manually.

If the gear is to be considered truly proportional it must have a reasonably high resolution—say, within 2° (though this is an arbitrary figure and must depend upon one's own taste and the type of model).

Now, any control channel will have a limiting speed of operation, usually set by the electro-mechanical components. Let us suppose that the gear can handle up to 20 pulses per second on either channel; if we fix the minimum movement (resulting from one pulse) at 2° we can operate at a maximum rate of movement of 40° per second, and to go from amidships to port 30° —the usual maximum rudder angle—would take $\frac{1}{4}$ -sec. If a finer degree of control was

required we could alter the ratchet wheels (or the gear ratio to the rudder) and produce steps of only 1° ; but now it would take $1\frac{1}{2}$ -secs to put the helm hard over.

the system will respond to only a proportion of the pulses sent. The remaining pulses will be lost, and the rudder will then be out of phase with the steering wheel. This is a

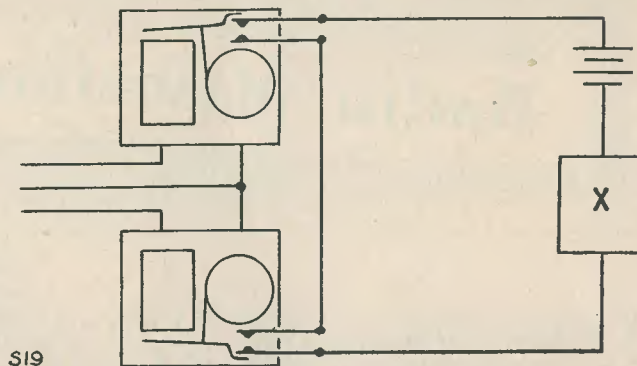

Fig. 19. X could be any Secondary Control unit

Whichever combination seems desirable, it is obviously a good thing to keep the pulse-handling rate as high as possible; but there is always the chance that the control wheel will be turned too fast, in which case

danger which can only be avoided by operating well within the speed of the gear; but it will be remembered that no such snag occurred in continuous systems.

(To be continued)

PHILIPS "RECORDERGRAM MAJOR"

A new, portable, twin-track, magnetic tape recorder, the "Recordergram Major" (Model AG8106), has been introduced by Philips Electrical Ltd.

It incorporates all the well-known features of its forerunner, the "Recordergram," plus the following up-to-the-minute refinements:

(a) A three-figure counter, rather like a taximeter, which counts the revolutions of the tape spool and permits immediate selection of any desired passage for playback.

(b) A foot-pedal (available at extra charge) for starting and stopping the tape; this leaves both hands completely free.

(c) Two recording speeds, $3\frac{3}{4}$ " and $1\frac{1}{4}$ " per second. A normal 600ft reel of tape provides one hour's recording at $3\frac{3}{4}$ " per second, and two hours at the slower rate. With an 850ft reel of long-playing tape, three hours recording is possible at the $1\frac{1}{4}$ " per second rate.

The "Recordergram Major" was developed in Holland and is suitable for operation on 110-150/200-250V a.c. 50 c/s. It is contained in a washable plastic carrying case, which is fully ventilated. A "magic eye" modulation indicator facilitates well balanced recording and special switching arrangements guard against accidental erasures. The instrument is provided with a highly sensitive moving coil microphone fitted with a long lead. Recorded

music and speech can be mixed in any required ratio and intensity. In addition to the instrument's self-contained amplifier and loudspeaker, there is provision for playback through a radio or external amplifier, and the instrument can also be used as an amplifier for microphone or gramophone reproduction.

Other details:

Model	AG8106—"Recordergram Major"
Price	62 gns. (free of tax). The optional foot-pedal is £2 2s. 6d. (free of tax).
Accessories ..	Moving coil microphone, reel of tape and spare take-up reel.
Consumption ..	60W maximum.
Speaker	5in.
Controls	Knobs and push-buttons.
Valves	EF86 (2) EL84, ECL80, EZ80, EM34 ("magic eye").
Weight	32lb
Dimensions ..	$16\frac{3}{4}$ " \times $12\frac{1}{4}$ " \times $8\frac{1}{4}$ ".
Frequency range	$3\frac{3}{4}$ " 50/10,000 c/s, $1\frac{1}{4}$ " 75/4,500 c/s.
Fast Wind or rewind (600ft tape)	2 minutes.

Radio Miscellany

ON A NUMBER OF OCCASIONS I HAVE FELT it would be rather interesting to know just how long some copies of *The Radio Constructor* remain in circulation. Some may even pass from hand to hand until they literally fall to pieces. That they keep going for many months is certain, and occasionally I receive letters from readers referring to topics I wrote about months earlier. Once a reader concluded his letter by saying he was glad I had an enjoyable holiday. This puzzled me sorely until I recalled that nearly twelve months earlier I had described a ham shack visit which I had made while on holiday. As a change from the age-old custom of throwing a note sealed in a bottle into the sea, it would be an idea to start a marked copy of R.C. on its way. With radio being the most international of hobbies, one can never tell where it might finish up.

The latest example of this delayed action is brought to mind by a letter, from a South African reader, which refers to some notes I made a long while back. It concerned the shaping of Perspex to make meter scale windows, transparent bow-fronted tuning scales, etc. Since then I have exhausted my small stock of "surplus" Perspex. When I last went to buy a little the price nearly paralysed me, so now I make do with glass instead! However, I gladly pass on the hints offered—instead of bending (in a wooden mould) when submerged in hot water (as I recommended), it is better done in thin clear oil. This, I am told, will leave a brilliant, glass-like surface finish without any tendency to "whit n" or cloud over.

It certainly seems well worth while trying. If you should happen to roughen the surface of Perspex it is a long job getting a high gloss finish back again. Normal polishing by an electric buff usually develops frictional heat which softens the surface and makes it look smeary.

A Quarter of a Century Back

Thinking of readers' letters brings me to one from Mr. R. Allen, of Newton Ferrers, Plymouth. He sends along an interesting Radio Diary for the period 1931-32. One unusual feature about it—it covers a period of sixteen months, from September 1931 to December 1932. It is just a year younger than himself, and he pays tribute to its compilers in saying that he still finds many sections of it useful for reference purposes. It was published by A. C. Cossor Ltd., and was obviously designed to cover both the needs of "the trade" (as distinct from "the industry") and the amateur.

True to its period, only one of the many circuits included is for a "supersonic heterodyne receiver." This is a 6-valve battery portable using a separate triode oscillator. A "straight" portable is also depicted—a five-valve affair using all triodes!

This well-produced diary contains much information which is still of contemporary reference value, as well as features which, if brought up to date, might well be included in 1956 versions. Sixteen pages are given over to definitions, and there is a "Valve Stock" table (based on actual experience) of the types a dealer is recommended to keep on hand. Typical of the period, the dealer who carries a stock of 100 replacement valves is recommended to keep 80 battery types and only 18 mains valves. But what about the odd two, you ask? Well, they are a couple of small rectifiers for use in the then popular H.T. Eliminators—a great many of the latter, of course, used metal rectifiers.

The section on fault-finding reveals that trouble shooting in those days must have been a simple business, although it may not have seemed so at the time. Motor-boating (an effect which some of our younger readers may not even have heard) is given a special section to itself.

Altogether a very interesting pocket reference book containing a surprising amount of information which is more or less permanently up to date. Can anyone beat it with a still earlier one?

TV Battle-front

Provincial readers must wonder whether converters for I.T.A. programmes are going to be a worth-while proposition for them—depending on which newspaper they favour. A couple of our national daily newspapers apparently lose no opportunity to headline any report, however slightly unfavourable, to "commercialised" T.V. Oddly enough, another daily reports all I.T.A. news very

jingles. The family still give a little more time to I.T.A. than to B.B.C., but personally I find the former's programmes less satisfying than they were. Several of the better items have been cut in length or taken out of the popular hours. However, the public seem to like it, and it is no unusual experience for me to find myself in a minority.

All the independent polls taken so far show that the majority of viewers with access to both programmes prefer I.T.V. Yet the B.B.C. Listener Research Department managed to make the comparison look so favourable that I am almost convinced they are in the wrong line of business. They ought to be in advertising!

CENTRE TAP

talks about

THIS and THAT

favourably. The latter, taking the long view, secured some interest in I.T.V., and I can only imagine the former are jealously anxious of the threat by an over-successful I.T.A. to part of their advertising revenue.

If you should have any doubts as to the influence of newspaper publicity, ask the opinion of anyone who has never even seen I.T.V. on what they think about it. Often they have very definite opinions on the subject, based on prejudices formed by their daily reading. According to one survey, only 4% of the listeners were irritated by the advertising. I am one of the 4%—not because it is advertising. It is those maddeningly stupid

Popularity

Unlike some Editors and columnists who unblushingly write of the dozens of Christmas cards they receive from their admiring readers, I had only one. Even this, I suspect, is from the same joker who a year or two back sent me a card of Ye Olde Snow-Covered Cottage on which he had drawn several long wire aerials with lead-ins entering via the chimney and letter-box, a 10-metre beam and a wobbly T.V. "H" aerial. This year he added an I.T.A. aerial and touched up both T.V. antennas with shiny silver paint. Serves me right, I suppose, for swanking about how long my ex-W.D. dural has lasted.

FINDING INDUCTANCE OF L.F. CHOKES

Very often the experimenter has a smoothing choke on his hands and would like to know its inductance. A simple method of determining the inductance is described below.

The choke is connected across the 5-volt winding of a mains transformer, in series with an a.c. current meter, and the current flowing in mA is put into the following formula:—

$$\text{Inductance} = \frac{16}{I \text{ (mA)}} \text{ henrys}$$

Thus, if the current were 2mA, the inductance would be 8 henrys.

Proof

This may be proved by applying Ohm's law. The impedance Z (reactance plus resistance) of the choke may be found from $Z^2 = R^2 + (2\pi fL)^2$ (Z in Ω , f in c/s, L in H).

R^2 will be of the order of $40k\Omega$ and $(2\pi fL)^2$ will be over $1M\Omega$, thus R^2 can be ignored, i.e. $Z = 2\pi fL$.

$$\text{By Ohm's law, } I = \frac{E \times 1,000}{Z}$$

where I is in mA, E in volts and Z in ohms.

$$\text{or, } I = \frac{E \times 1,000}{2\pi fL} = \frac{5 \times 1,000}{2 \times 3.14 \times 50 \times L}$$

$$= \frac{5,000}{314 L}$$

Thus, $I = \frac{16}{L}$ or, to put it another way,

$$L = \frac{16}{I} \text{ henrys}$$

J. E. GUNN

A MODERN PRE-SELECTOR

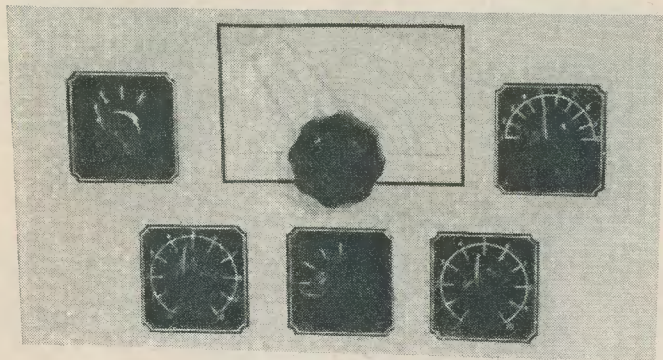

by JAMES S. KENT

AT SOME TIME OR ANOTHER MOST SHORT wave listeners, whether owners of commercially built or home constructed receivers, eventually encounter the problem of improving both the selectivity and the sensitivity of the equipment in use. The solution to these problems lies in the construction of a carefully designed pre-selector, the main purpose of which is the amplification of signals received from the aerial in order that they may be passed to the receiver input terminals at greatly increased strengths. In addition to acting as a voltage amplifier, the pre-selector also considerably assists in obtaining greater selectivity—particularly if the receiver in use has no existing r.f. stages.

Most pre-selector designs usually only feature one r.f. pentode in the circuit and, while one r.f. stage is better than none at all, little or no attempt is made to match the output into the receiver input. Again, such designs are, more often than not, coupled direct to the aerial, i.e., no buffer stage is included—the result being that the loading effects of the aerial cause indifferent performance at various frequencies.

In the design presented herewith, it will be found that a buffer stage (untuned) completely isolates the aerial from the following stage (tuned), and the resultant r.f. amplified voltage is passed on via a cathode follower output valve. The first stage imparts a small

gain to the r.f. signal; this being tuned by V_2 , greatly amplified, and passed to V_3 . The function of this latter valve is mainly to match the output of V_2 at the correct impedance into the receiver. Although theoretically there is little inherent gain in a cathode follower stage, there is in practice an apparent gain due to the correction of any mismatch between the output of V_2 and the receiver.

Most receivers of the communications type are designed to have an impedance at the aerial terminals of some 400Ω and, to obtain a good transfer of r.f. voltage, the pre-selector output should be at the same value of impedance at whatever frequency, or band of frequencies, over which the unit may be tuned; the cathode follower stage ensures that this is so. In order to further illustrate the value of including V_3 , consider a pre-selector with an output impedance of $1.5M\Omega$ as would be the case using a valve such as the 6BA6—a high slope vari-mu r.f. pentode—and feeding direct from the anode, via a condenser, into the receiver input terminals. Assuming the receiver input to have an impedance of 400Ω then the mismatch would be 3750 to 1, not a very good match by any standard—and yet such designs are fairly common! The correction of this mismatch has to be heard to be believed, the overall gain (apparent) of the cathode follower making its inclusion virtually a necessity if

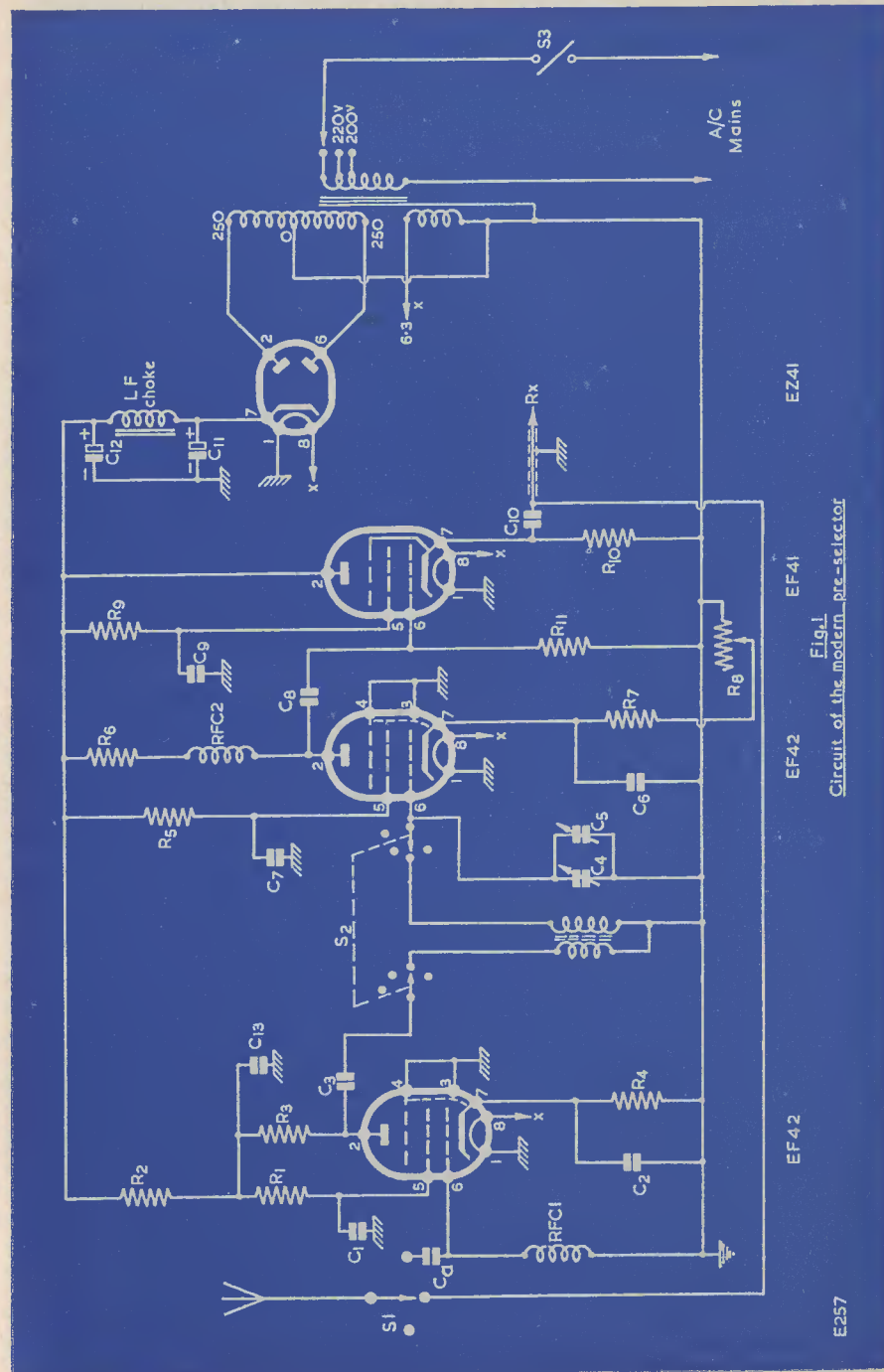

EZ41

EF41

EF42

EF42

Fig. 1
Circuit of the modern pre-selector

E257

maximum performance and efficiency is to be achieved.

General Features

The unit was designed for rack mounting, but inclusion within a cabinet is perfectly possible if so desired. The front panel photograph shows the various controls before the appropriate wording and calibration of the dial had been completed. The top left-hand control is the 3-way yaxley switch S_1 of Fig. 1. In the left-hand position the aerial is switched off, centre position the aerial is fed direct to the receiver input bypassing the pre-selector, while the remaining position is used for bringing the aerial into circuit with the unit. By its inclusion the operator is able to bring the pre-selector into use or, alternatively, either connect or disconnect the aerial at will. The top right-hand control is C_5 of Fig. 1, a small trimmer condenser across the main tuning control used for bandspread and fine tuning. The left-hand bottom control is R_8 , a 5k Ω potentiometer used as r.f. gain. Centre is the wavechange switch, S_2 of Fig. 1, and from this it may be seen that four ranges are available. These are 10-30, 15-50, 50-220 and 200-750 metres. The right-hand control is the on/off switch S_3 of Fig. 1, an old pot. with switch being used for this purpose; only the switch portion, of course, being utilised.

Circuit

The first r.f. stage is untuned and merely acts as a buffer between the aerial and the following tuned stage. A gain of about ten may be expected from this stage. The aerial is fed into the grid via C_a and coupled to earth via R.F.C.1 (see component list). The anode and screen h.t. supply are both taken from R_2 , this being a one-watt component. Cathode bias is obtained from R_4 and C_2 . Note particularly that the suppressor grid and the internal screen should be joined externally and taken direct to chassis. This stage is capacity coupled, via C_3 —a mica type condenser—into the following tuned circuit. Both of the first two stages are constructed around the Mullard EF42, which is somewhat similar in characteristics to the wartime EF50 but is more efficient and compact.

The EF42 has a slope of 9mA/V at an anode current of 10mA, and with this high mutual conductance the inter-electrode capacities are very small, being only 9.4pF input and 4.3pF output. The whole of the electrode system is enclosed within an internal screen, thus obviating the use of external screening.

The output of V_1 is fed into the primary winding of the coils, only one of which is shown in the circuit diagram for purposes of clarity, via one side of a two-pole four-way yaxley switch (S_2), the individual coils being

selected by rotation of this switch. The secondary winding is connected to the tuning assembly and the grid of V_2 via the second half of the two-pole four-way yaxley. The r.f. gain control, R_8 , is inserted in the cathode line, C_6 being a mica type condenser. As in the first stage, the suppressor grid and internal screen are joined externally and taken direct to chassis. The output from this tuned r.f. stage is taken via C_8 , a ceramic type condenser, to the grid of the following stage.

The purpose of V_3 has already been explained; it is a cathode follower stage and the impedance of the output is maintained at 400 Ω by feeding into the receiver from the cathode of V_3 via the condenser C_{10} , which is another mica component. It is extremely important that the cathode resistor should be one of 400 Ω (see component list), and no other value should be substituted. The cathode follower stage is built around the Mullard EF41.

The power supply is conventional and needs little explanation. In order to conform with the other valves used in the circuit, another of the same range has been selected, the Mullard EZ41 full-wave rectifier. All the valves used in this design are of the B8A range.

Construction

The mains transformer, C_4 and C_5 , together with S_1 , are mounted above the chassis while the remainder of the components are contained underneath. It will be noted that C_4 , although shown in the circuit diagram as a single gang condenser is in fact a two-gang component. Only one-half of this, however, is used, the inclusion of a two-ganged condenser being by virtue of the fact that a single gang is rather difficult to obtain in the normal way.

The coils as received are single items, i.e., not as a coil pack, and these are therefore mounted on a small piece of aluminium, one end of which is bolted to the chassis. These must then be wired to the yaxley switch (S_2 of Fig. 1). The coils required are those supplied by the Teletron Company and are: HFA4, 10-30; HFA3, 15-50; HFA7, 50-220 and HFA5, 200-750 metres. Each of these coils has a variable iron dust core and is wound on an Aladdin former with a fitted tag ring.

The aerial input used is of the co-ax. connector type, but this may have to be varied to suit individual requirements. The output connection will, of course, also be of the co-ax. type. The short length of co-ax. used for connecting the pre-selector to the receiver must have the metal braiding earthed at both ends in order to eradicate unwanted direct signal pick-up on the connecting wire.

The h.t. components supplying the anodes of V_1 and V_2 are wired direct to the anodes, the h.t. being brought to a 3-way tag strip mounted on the chassis wall. The l.f. choke is bolted to the chassis wall and the associated condensers are soldered direct to the choke tags.

Once construction has been completed, it is an easy matter to calibrate the dial simply by keeping the unit in step with the receiver and matching the dial calibrations of the latter by tuning the pre-selector to exact resonance, marking off the dial at each megacycle or 100kc/s point as desired.

In operation the unit will be found to give all the gain that can possibly be required. The receiver selectivity and sensitivity will be greatly improved, and freedom from second channel interference will be most marked. The overall performance of any receiver will be improved out of all proportion to the cost and time involved in the construction of this modern pre-selector.

Component List

Resistors

R_1	100k Ω $\frac{1}{2}$ watt $\pm 10\%$
R_2	5k Ω 1 watt $\pm 10\%$
R_3	10k Ω $\frac{1}{2}$ watt $\pm 10\%$
R_4	100 Ω $\frac{1}{2}$ watt $\pm 10\%$
R_5	100k Ω $\frac{1}{2}$ watt $\pm 10\%$
R_6	5k Ω 1 watt $\pm 10\%$
R_7	100 Ω $\frac{1}{2}$ watt $\pm 10\%$
R_8	5k Ω potentiometer
R_9	47k Ω $\frac{1}{2}$ watt $\pm 10\%$
R_{10}	400 Ω $\frac{1}{2}$ watt $\pm 10\%$
R_{11}	250k Ω $\frac{1}{2}$ watt $\pm 10\%$

Mains Transformer

Ellison, type MT162; 250-0-250V, 60mA; 6.3V at 3A

Coils and R.F. Chokes

Teletron Co. (see text)

Switches

2-pole, 4-way yaxley

1-pole, 3-way yaxley

S_3 see text

Other Components

Co-ax. connectors, chassis and panel, knobs, wire, etc.

Panel-Signs

Condensers

C_a	100pF, ceramic
C_1	0.1 μ F, 350V wkg, TCC type CP45N
C_2	0.1 μ F, 350V wkg, TCC type CP45N
C_3	100pF, $\pm 10\%$, ceramic
C_4	500pF variable (see text)
C_5	25pF variable
C_6	0.001 μ F, mica
C_7	0.1 μ F, 350V wkg, TCC type CP45N
C_8	100pF, $\pm 10\%$, ceramic
C_9	0.1 μ F, 350V wkg, TCC type CP45N
C_{10}	0.01 μ F, Mica
C_{11}	8+16 μ F, electrolytic, 450V wkg,
C_{12}	TCC type BEC
C_{13}	0.1 μ F 350V wkg, TCC type CP45N

L.F. Choke

10H, 60mA

Valvebases

McMurdo, B8A

Valves

V_1	EF42 Mullard
V_2	EF42 Mullard
V_3	EF41 Mullard
V_4	EZ41 Mullard

LABGEAR TV INTERFERENCE FILTERS

These filters have been designed to eliminate interference by strong radio signals at frequencies outside the normal TV channels. Such signals if allowed to reach the receiver input cause cross-modulation, and severe interference results.

Model E 5028 is a high-pass filter and eliminates interference at frequencies lower than Band I. It is suitable for use with TV sets on both Band I and III and also for f.m. on Band II.

Model E 5031 is a low-pass filter which eliminates interference arriving at frequencies of over 70 Mc/s. Many viewers experience interference from V.H.F. transmitters such as f.m. broadcast, taxis, radar, police, ambulances, fire services, etc., etc. The Labgear low-pass filter enables interference from these and like sources to be removed from normal Band I reception.

Both models are fitted with standard co-axial terminations and plug in between the aerial lead and the input socket of the receiver. Retail price (either type) 30s. each.

Further details of the complete range of aerials, cross-over units and filters are available upon application to Labgear (Cambridge) Ltd., Willow Place, Cambridge.

USEFUL HINTS

Small jars with screw tops can be fixed to the underside of a shelf by the aid of two small screws through the lid. This is a safe and inexpensive method of storage of small components, nuts, bolts, etc. The method ensures that they are stored at eye-level in a position where they can be seen, so saving much time in finding.

A piece of old linoleum tacked to the top of the workbench gives a working surface that is easy to keep clean and free from grit. If the linoleum is brushed off prior to a receiver being serviced, then the chance of scratching the cabinet is greatly reduced. The material is insulating.

The storage of tools in their correct places can be made easier if the clips and hooks for the various tools have a white or black outline of the tool drawn around them, so that it is easy to see if a tool is missing from its place and where any tool should go.

A board at the rear of the bench and to one end fitted and wired with all types of mains socket, will save a very considerable amount of time when servicing—it takes time to change a plug.

The "TRANSISTORETTE"

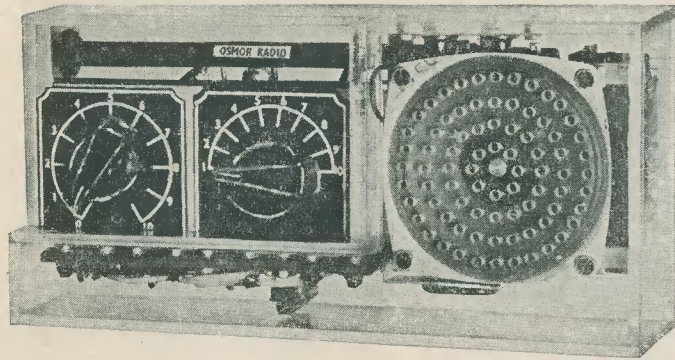

PART 1.

by G. A. FRENCH

Introducing the miniature transistor receiver which created so much interest when it was exhibited at the last National Radio Show at Earl's Court

AS SOON AS TRANSISTORS BECAME AVAILABLE on the British market, *The Radio Constructor* commenced experiments in order to produce a practicable transistor receiver which could be built at home by the amateur. A considerable amount of development work was undertaken, and, as a result, we now introduce the little receiver which is to be described in this and the following articles.

This receiver, the Transistorette, is intended to provide good loudspeaker strength reception on the medium-wave band with the aid of a short aerial and an earth connection. Headphones are not required. It is hoped, at a future date, to dispense with the aerial and earth connection and make the receiver fully portable; and further experimental work to this end has already been set in progress. In the meantime, it is pointed out that the present version, requiring the aerial and earth system, is capable of giving excellent results in its existing form, and that it represents the nearest approach to a really "personal" transistor receiver yet to be described in the British constructional press. It is also emphasised that, apart from one or two resistors and similar small components, the receiver now

under discussion will be capable of lending itself to the future modification for portable working without the necessity of any changes to the main chassis assembly at all. What extra circuitry is required will be accommodated by a small "add-on" chassis assembly. In consequence, constructors who built the present receiver will not have to make major changes when modification details are later published.

The Circuit

The circuit of the Transistorette is given in Fig. 1. As may be seen, the receiver consists of a three-transistor a.f. amplifier following a simple detector and input tuned circuit. It would be advisable to commence the theoretical consideration of this circuit by starting at the output stage and working backwards.

The output stage consists of a Brimar transistor type TJ3 (TR₃ in Fig. 1) operated as an earthed emitter a.f. amplifier. This choice of operation is due to the fact that the earthed emitter circuit enables maximum gain to be obtained from the transistor. It is probable that slightly increased power output would be obtainable if the output

transistor stage were employed in an earthed base circuit, but critical listening tests did not detect any significant difference between the two different modes of operation. So far as practical circuitry is concerned, the earthed emitter arrangement has the additional advantage of enabling a very simple biasing arrangement to be employed without the need for separate biasing supplies. Since it was intended that the completed receiver be made to function from a single battery, this point, whilst not of itself being sufficient to justify the choice, had nevertheless to be taken into full account.

The h.t. current flowing through the emitter-collector circuit of the output transistor is approximately 2.25mA. Assuming negligible resistance in the speaker transformer primary, such a current indicates a dissipation in this transistor of some 51mW (the h.t. voltage is 22.5). The maximum total dissipation figures quoted by Standard Telephones and Cables for the transistor used here is 200mW at 20°C., and 100mW at 50°C. Thus, the output transistor is operated well within its maximum dissipation figure.

Due to the component values employed in the output stage, a very good match into the loudspeaker transformer primary is achieved. With negligible distortion it is probable that at least 30mW of audio are fed to the speaker. If distortion is allowed to occur (due to overload) a higher power output is available. The distortion given by overload is not of an unpleasant nature, fortunately, and can be tolerated without discomfort. Overloading would normally occur only during heavy peaks in, say, a musical programme or in a programme in which speech and music are interspersed. The loudspeaker specified for the Transistorette is very sensitive for its size, and the output of this little set compares most favourably in practice with that of a conventional "personal" portable employing valves.

The bias for the output transistor is obtained via the 1MΩ resistor R₇. This resistor plays an extremely important part in the output stage since it limits the bias current passed by TR₃ to a safe value. If R₇ should happen to be accidentally reduced in value, the output transistor bias current would increase, thereby possibly increasing the collector current beyond its safe maximum. Before proceeding further, it must be pointed out that the value of R₇ can be accidentally decreased by mounting it on a "leaky" tag panel, by accidentally bridging it with the hands or fingers, or by carelessly applying the prods of a test meter to it. For these reasons, some care has to be taken when handling the chassis of this receiver

when the h.t. battery is connected. The golden rule with this, as indeed with almost all other transistor receivers, is to disconnect the h.t. supply before making internal adjustments to the receiver.

A further precaution to limit the bias current to TR₃ is provided by the input circuit to its base. Fig. 2 (a) shows the usual method of coupling one transistor stage to the next when earthed emitter circuits are employed. The circuit of Fig. 2 (a), however, suffers from one important disadvantage. This is the fact that, when the h.t. voltage is switched off, the coupling condenser between the two transistors is discharged. As soon as h.t. is switched on, therefore, this condenser commences to charge, causing a momentary charging current to pass through the collector load resistor of the first transistor, and the internal base-emitter path of the second transistor. This momentary charging current results in the sudden application of a high value of bias current to the second transistor, causing a similarly high collector current. At low operating voltages such surges are normally within the rated maximums of the transistors concerned, but at higher operating voltages, such as are found in the output stage of the Transistorette, they might result in damage. To ignore such surges would be definitely unwise.

In the Transistorette a simple surge limiting circuit is provided by means of the arrangement illustrated in Fig. 2 (b). When the h.t. supply is switched on in this circuit the initial charging current to C₆ passes through R₅ and R₆. A very small momentary voltage appears at the upper end of R₆ at the instant of switching on, but the resultant charging current through C₇ and the base-emitter path of TR₃ is considerably smaller than that occurring in Fig. 2 (a). Because of this, relatively high h.t. voltages may be employed for TR₃ without risk of damage due to surges.

It will be noted that the two electrolytic coupling condensers in Fig. 2 (b), C₆ and C₇, are fitted into the circuit such that their positive plates connect to R₆. This method of connection is correct because the upper end of R₆ is at chassis potential, so far as d.c. is concerned, whilst both the collector of TR₂ and the base of TR₃ are at negative potential.

From the point of view of a.f. amplification, the circuit of Fig. 2 (b) gives similar results to that of Fig. 2 (a). The 5kΩ resistor R₆ causes little diminution in a.f. voltage (the collector load resistor for TR₂, R₅, has a value of 2.2kΩ only) and the two condensers in series replace the single condenser of Fig. 2 (a).

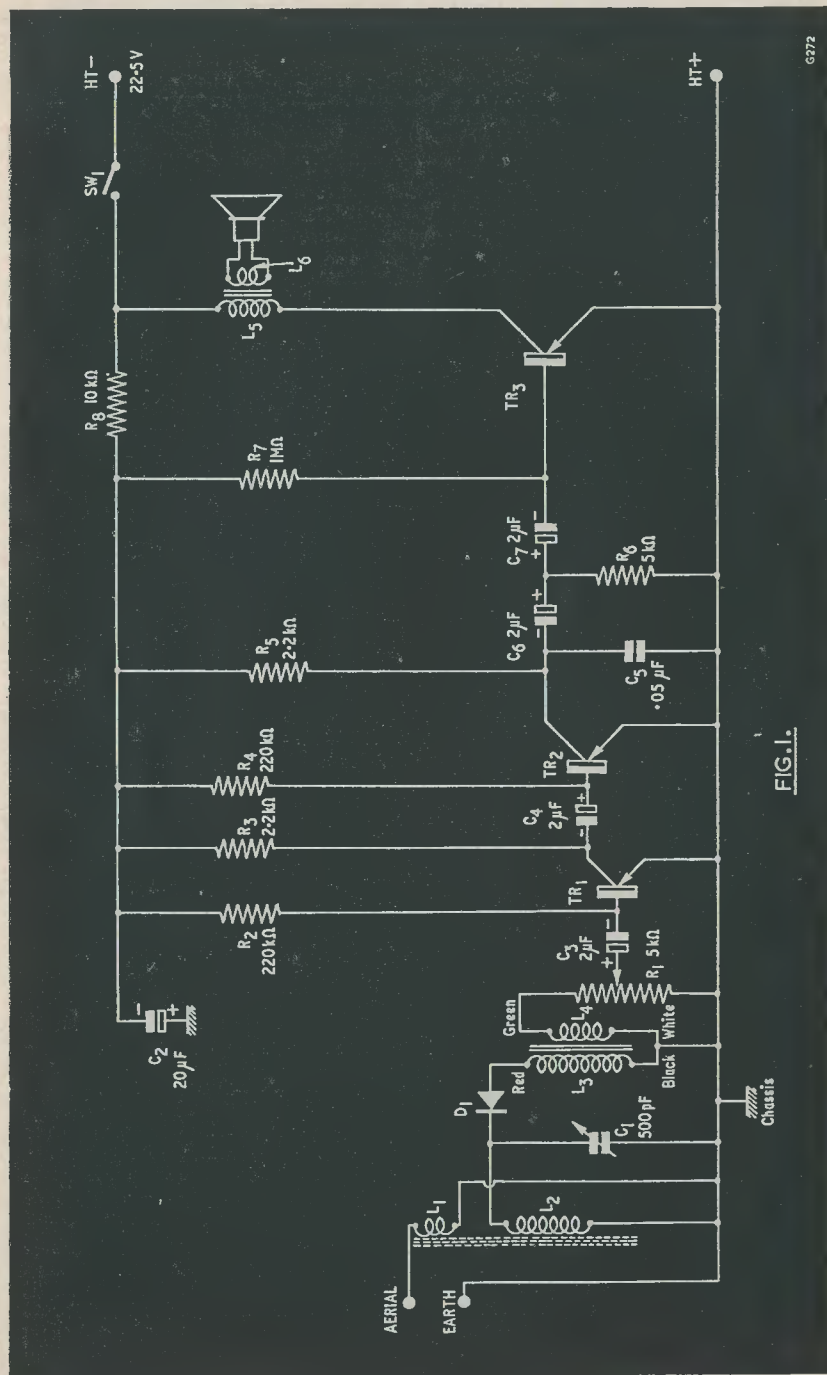

Fig. 1. The complete circuit of the Transistorette

TR₁ and TR₂

The circuit of Fig. 2 (b) is, of course, that employed in Fig. 1 to provide coupling between TR₂ and TR₃. Not shown in Fig. 2 (b), however, is the 0.05 μ F condenser C₅. The purpose of this condenser is mainly that of tone correction; although it may help, in one or two instances, to reduce any possible r.f. instability which may be caused by the relatively high gain of the a.f. strip at supersonic frequencies.

TR₁ and TR₂ are Brimar transistors type TJ2, and they form a conventional two-stage transistor a.f. amplifier. Both function in earthed emitter circuits. The two transistors are operated at a lower h.t. potential than that supplied to the output transistor, this lower potential being provided through the resistor R₈ decoupled by the condenser C₂. As a result of the lower h.t. voltage, surge precautions as used in the output stage are not required, and the more conventional transistor circuitry can be employed. This state of affairs does not infer, incidentally, that component values can be altered by any large amount from those shown in the parts list. If optimum results are required, component values in the TR₁ and TR₂ stages are still somewhat critical. The h.t. potential applied to TR₁ and TR₂ (i.e. that appearing across the decoupling condenser, C₂) lies between 7 and 9 volts.

The input circuit for TR₁ is very simple, consisting of the deaf-aid type step-down transformer L₃, L₄. The secondary of this transformer, L₄, connects to the 5k Ω volume control R₁, the a.f. tapped off by the slider of this potentiometer being passed to the base of TR₁ via C₃. (The isolating condenser, C₃, is needed because the base of TR₁ requires a small negative bias potential with respect to chassis, and this would otherwise be short-circuited by R₁.)

Signal selection is provided by the tuned circuit L₂, C₁. The r.f. appearing across this circuit is applied to the primary, L₃, of the step-down a.f. transformer via the germanium diode D₁. The self-capacity of L₄ is sufficient to by-pass the r.f. appearing in the rectified output from D₁ and no further r.f. filtering is required. L₂ is wound on a long ferrite core as this enables a tuned coil to be obtained with a high value of Q. The coil assembly is very similar in practice to a "ferrite frame" and it is, in fact, possible to obtain weak signals with this alone. However, performance in this respect can by no means be guaranteed, and it is pointed out again that the main reason for using the ferrite core is given by the high value of Q that it provides.

The coupling winding L₁, which is also wound on the ferrite core, enables an aerial and earth to be connected to the receiver.

Components List for the Transistorette

Resistors

- All $\frac{1}{4}$ or $\frac{1}{2}$ watt. (See note below).
 R₁ 5k Ω volume control with s.p.s.t. switch. Radiohm miniature. (H. L. Smith, Edgware Road).
 R₂, R₄ 220k Ω , 10%
 R₃, R₅ 2.2k Ω , 10%
 R₆ 5k Ω , 20%
 R₇ 1M Ω , 10%
 R₈ 10k Ω , 20%

N.B.—Maximum individual resistor dimensions are $\frac{1}{16}$ in. long by $\frac{1}{8}$ in. diameter. These may be specified as $\frac{1}{4}$ W or $\frac{1}{2}$ W by different suppliers.

Condensers

- C₁ 500pF bakelite dielectric (linear capacity). (Wavemaster)
 C₂ 20 μ F 12V Pk. wkg. T.C.C. type CE30B
 C₃, C₄, C₆, C₇ 2 μ F 150V Pk. wkg. T.C.C. type CE30B
 C₅ 0.05 μ F 200 W.V. T.C.C. Miniature Metalmite (case insulated) or equivalent wax finish

Inductors

- L₁, L₂ Ferrite Frame, medium-wave, type QFR1 (Osmor)
 L₃, L₄ Hearing-aid a.f. transformer. Type T100 (Multitone)
 L₅, L₆ Output transformer, "Transistorette Miniature"—7,000 Ω . (H. L. Smith, Edgware Road)

Transistors and Diode

- TR₁, TR₂ Junction transistor type TJ2 (3X/301N) or T.S.2—Brimar
 TR₃ Junction Transistor type TJ3 (3X/302N) or T.S.3—Brimar
 D₁ Germanium Diode type GD3—Brimar

Loudspeaker

- 2 $\frac{1}{2}$ in. cone diameter, type 2P/O1 (Elac)

Battery

- 22.5 volt hearing-aid battery. Type B110 or B122 (Ever-Ready).

The Aerial System

Due to the low input impedance offered by L_1 , an earth connection is desirable in addition to an aerial. Although the necessity for an earth connection may appear at first sight to be a disadvantage, quite the reverse holds true in practice. The reason for this is that it is in many cases possible to obtain a certain effective pick-up through the earth connection itself, whereupon only a short aerial wire is needed. If, for instance, the earth terminal of the receiver is connected to, say, the mains conduit in a house, adequate sensitivity can often be obtained with the aid of an aerial only five to ten

In another locality similar results were given merely by twisting the earth lead several times around the mains flex to a reading lamp. The coupling in this case was provided by the capacity existing between the two leads. By the use of techniques such as this, there is no reason why the receiver should not be able to give good results when used as a travelling companion in hotel rooms, on picnics or in similar locations. The use of a short aerial, incidentally, assists in reducing any damping of L_2 which may occur.

In localities where interference is very high, the simple tuning arrangements em-

the fact that, should any mistakes be made in the application of voltage to any transistor, it can be immediately and irrevocably ruined. This point has already been discussed above in some detail with regard to the bias circuit for TR_3 . The following reminders may help to show some of the other precautions which should also be taken.

1. Never connect an h.t. battery to transistor equipment with incorrect polarity, or the transistors will almost certainly be damaged. In the Transistorette the chassis is *positive* and h.t. rail *negative*. Connecting the h.t. battery wrong way round will burn out TR_3 and will possibly damage TR_1 and TR_2 as well.

2. Never make any circuit adjustments or even handle the components in the Transistorette circuit whilst the h.t. battery is connected. Accidental surges may easily damage a transistor, and it is very easily possible for one's hands or fingers to bridge critical components with resultant damage.

3. If testmeter readings must be taken when the h.t. supply is connected, care should be taken in the choice of test points. In the construction of the Transistorette no test readings (apart from those given by a milliammeter in series with the h.t. supply) are required at all. Voltage readings at transistor terminals should not be taken unless it is certain that the current flowing through the meter will not cause excess bias current to flow in the transistor. Ohmmeter readings, when the h.t. supply is switched on, may also cause trouble if the internal battery in the meter happens to be connected such that it applies additional bias current to a transistor.

4. If a transistor amplifier breaks into violent a.f. oscillation it is advisable to switch off at once. This is due to the fact that excessive a.c. voltages could cause damage. The fault causing the oscillation should be rectified by normal test procedure with the h.t. switched off or reduced in voltage.

The above precautions may appear at first sight to err on the side of excessive caution, but the writer would be failing in his duty to his readers if he did not draw their attention to them. It will be remembered that transistor replacements are liable to be somewhat expensive.

The Transistorette Supply

In the Transistorette a fairly high h.t. potential (22.5 volts) is employed. It is advisable, when the receiver is being tested immediately after construction, to employ a much lower voltage than this to guard against possible component failures and mistakes in wiring, etc. One of the best methods of checking the receiver consists of employing two 9-volt grid bias batteries in series to provide h.t. for testing purposes, these being connected to the set via a moving-coil milliammeter whose f.s.d is 10mA or thereabouts. During tests, the h.t. voltage may then be tapped up in 1.5 volt stages, whilst an eye is kept on the milliammeter for excess current. The Transistorette will function reasonably well during test, incidentally, with an h.t. potential between 6 and 9 volts only.

Next Month

In next month's article, the first constructional details of this modern receiver will be given.

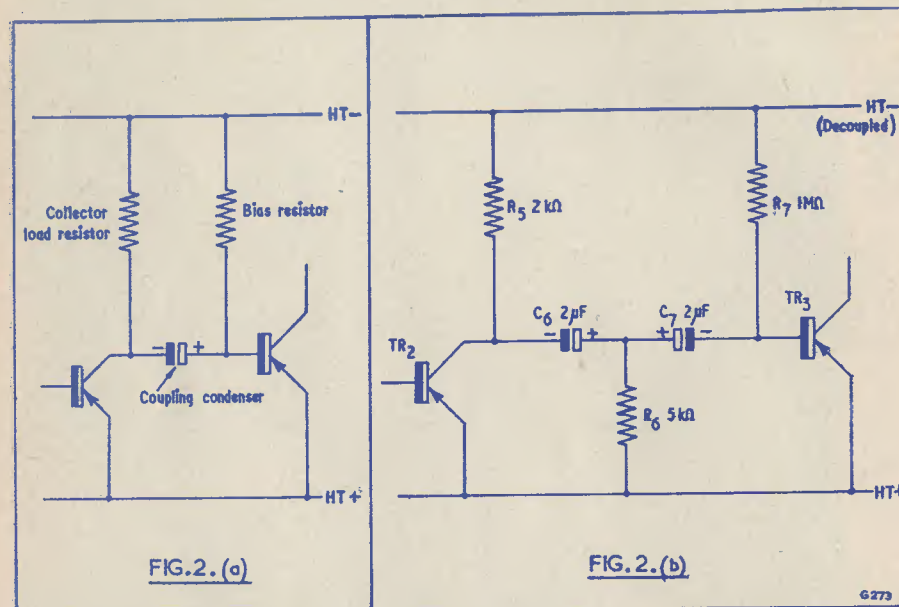

Fig. 2(a). A typical resistance-capacity coupling circuit as fitted between two earthed-emitter transistors. (b). The coupling circuit used to feed the output stage of the Transistorette. This circuit has the advantage of obviating bias current surges at the instant of switching on the h.t. supply

feet long. The same applies to any other effective earths which may be available where the set is to be used. Such earth connections may be given by water pipes, wire fences and so on. To quote examples experienced with the prototype, it was possible to obtain excellent reception of the Light Programme and Home Service in the London area with a "flex" aerial only ten feet long. The various earth connections employed were water pipes, mains conduit and the metalwork of a telephone dial.

employed in this version of the receiver may not be adequate for clear reception of the local medium wave transmitters. In such instances it may be necessary to fit an external wavetrap in order to improve selectivity. This point is dealt with later in this present series of articles.

Precautions

As readers will be aware, great care has to be taken when working with circuits which employ transistors. This is due to

THE LONDON AUDIO FAIR 1956

The first London Audio Fair is to be held at the Washington Hotel, Curzon Street, London, W.1, on 13th, 14th and 15th April, 1956, immediately following the R.E.C.M.F. Exhibition, which closes on the 12th. The Fair will be open from 11.00 a.m. to 9.00 p.m. each day. The object of the Fair is to present high grade equipment for high quality sound reproduction to the general public as well as to the trade in a more effective manner than the National Radio Show can achieve with its accent on domestic radio and television.

To this end the greater part of the ground floor will be taken up by stands for static displays; the principle accent, however, will be on demonstration of equipment under conditions similar to those encountered in the home, and for this purpose the whole of the first and second floors, with one wing of the

third floor, has been taken over, and the double bedrooms on these floors are being allocated one to each exhibitor for use as demonstration rooms.

Firm applications to exhibit have been received from Acoustical Manufacturing Co. Ltd.; Collaro Ltd.; Cosmocord Ltd.; Decca; Garrard Engineering & Manf. Co. Ltd.; Goldring Manf. Co. (G.B.) Ltd.; Goodmans Industries Ltd.; Gramplan Reproducers Ltd.; H. J. Leak & Co. Ltd.; Lowther Manfg. Co.; M.S.S. Recording Co. Ltd.; Pamphonic Reproducers Ltd.; Philips Electrical Ltd.; Plessey Co. Ltd.; Pye Ltd.; R.C.A.; Reslosound Ltd.; Simon Sound Service; A. R. Sugden & Co. Ltd.; Tannoy Products Ltd.; Trix Electrical Co. Ltd.; Vitavox Ltd.; Wharfedale Wireless Works; Wright & Weaire Ltd.; and Iliffe & Sons Ltd. at the time of writing.

RIGHT—From the Start

PART 2: WIRING

by A. P. BLACKBURN

LAST MONTH I TALKED ABOUT SOME common circuit symbols and what they meant. They are not so mysterious as they first appear, after all. We can, therefore, move safely on now to a more interesting stage: translating a circuit into a working model.

For this purpose we can take the simplest type of receiver—partly because it is a receiver and therefore a more absorbing subject; partly because it will cover most of the types of components we discussed last month.

One thing is important to remember, however. A lot of careful thought *before* you reach for the soldering iron saves a lot of heartbreaking dismantling afterwards. No one leaps straight into the design of anything; they sit and stare into space for hours, worrying the problem before even picking up their pen. This is as true of radio as anything else, but it is especially true if no component layout has been suggested to the constructor.

Deciding on a layout is not child's play: it requires a lot of skill, and very often experience, if "extensions" on the chassis are to be avoided. However, for guidance there are certain rules which can be used as a basis on which to work.

V_2 , a pentode. We need not worry too much at this stage how the circuit actually works. We can go into the theory more fully later on. For the moment, let's accept the fact that the first valve V_1 , and its associated components, forms the detector stage. This stage converts the incoming signal into voltages suitable for amplification and connection to a loudspeaker.

The second stage, comprising V_2 and its associates, is responsible for the amplification of the signal received by the first stage; it also drives the loudspeaker.

Although there is no hard and fast rule, and no one but a purist will get upset if you decide against it, it is a generally accepted practice to draw circuits with the aerial on the left and the loudspeaker on the right, this being the direction, of course, which the signal takes between aerial and speaker.

Working from the left, the first thing we meet that is unfamiliar is C_1 , to which the aerial is connected. This symbol was not included in last month's batch: it is another, and miniature, form of variable capacitor, called a "trimmer." From C_1 the signal passes to L_1 . Now all three coils— L_1 , L_2 and L_3 —would be wound on the same former, and these become what is virtually an air-

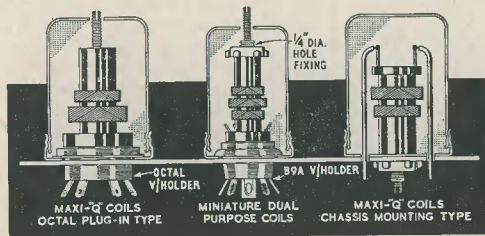

Three types of tuning coil, with screening can.

The Circuit

The circuit of a simple receiver is shown in Fig. 1, and contains 2 valves: V_1 , a triode, and

cored transformer, indicating that the signal appears in L_2 .

The components C_2 and L_2 form the

"tuning circuit" in which C_2 is the control used to tune in the wanted signal from the front of the set. The signal has now arrived at the grid of the triode valve V_1 , via the fixed capacitor C_3 . The position of C_3 and R_1 earn them the names of grid capacitor and grid leak (R_1) respectively.

The valve V_1 "detects" the signal, as we already know. (It also has an amplifying effect on the signal, but this is not its real job, and is really poaching on V_2 's ground.) The extra winding on the coil L_3 is a reaction winding, used to increase the sensitivity of the receiver. Capacitor C_4 is the reaction control. We can conveniently defer further explanation on this subject until a later article.

circuit of V_2 an electrolytic capacitor is used to by-pass the resistor R_3 . As we discussed last month, the component values are marked on the circuit to conform with convention.

The description of this circuit is necessarily brief and some terms I have used have been left unexplained. However, I did not intend to explain the working of the circuit in detail, but only to get the reader familiar with the use of symbols in circuit diagrams.

Layout and Wiring

No doubt you will find, when you start to make your instrument, that although the circuit is given, no suggestions are made for layout or wiring, these details being left to the constructor's discretion.

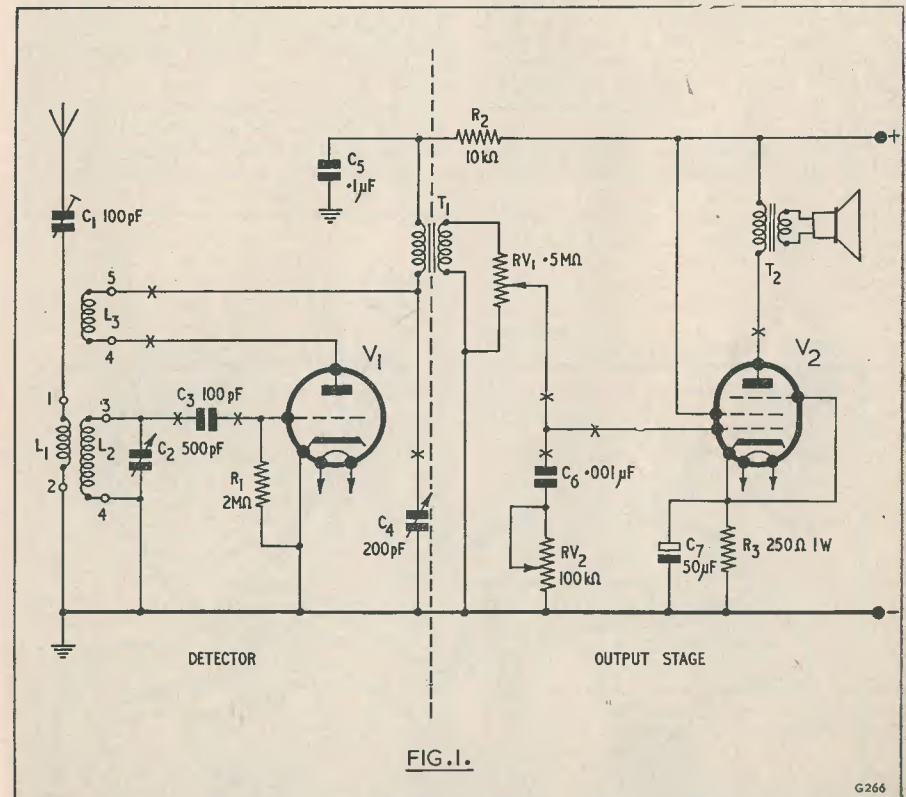

The transformer T_1 couples the output of V_1 to the grid of V_2 by way of the volume control potentiometer RV_1 . The tone control circuit is formed by C_6 and RV_2 . We know that the pentode V_2 amplifies the signal and also drives the loudspeaker. In the cathode

Of course, no single layout will do duty for every variation of an instrument; the requirements will differ from type to type. There are, however, some important basic principles, which must be closely observed. The first of these is the matter of long leads.

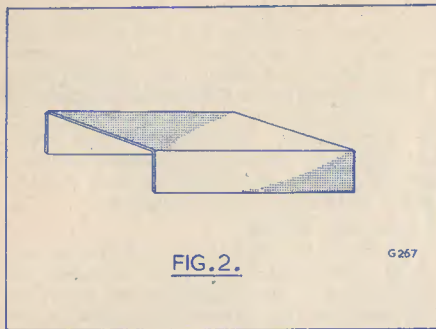

A common mistake, which can be fatal to the finished product, is to spread the circuit out. This involves using long lengths of lead to connect up the various components, which done indiscriminately has a disastrous effect on performance. To ensure the best results, the circuit should be laid out logically, the general direction of the signal being followed through.

Obviously, that rule can't be rigidly applied, and the art lies in knowing which leads must

be kept short and which can be left long. The really important connections—which must be *short*—are marked with a cross in Fig. 1. With medium wave receivers and most amplifiers, earth leads and cathode, heater and h.t. leads can be left quite long without affecting the operation of the circuit. Grid and anode leads *must* be short.

While we're on the subject of grids and anodes, there is one most important point which should never be overlooked, and that is: never run these two leads parallel for any distance. It may be easier to remember this rule if you can learn to identify the grid as the input and the anode as the output; input and output leads of any circuit must not travel together for any distance. This is illustrated in Fig. 1, where the anode wiring of V_2 is kept well away from its own grid, but at the same time it should not, under any circumstances, mix in with the wiring of V_1 grid.

Another advisable precaution, with valves whose heaters are fed with alternating current supplies, is to keep the heaters away from grid and anode wiring as much as possible.

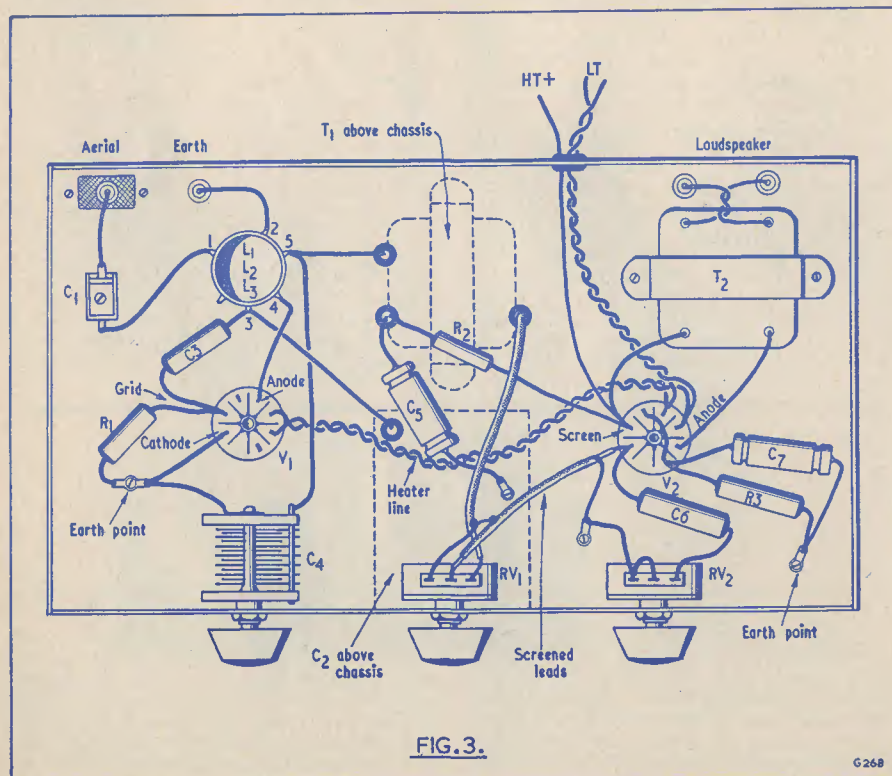

FIG. 3.

Very often, of course, the aggravating situation arises when, having carefully and methodically planned the ideal wiring arrangement, you find that it will have to be modified to allow the controls to be placed symmetrically on the front panel. Under these circumstances, the compromise between wiring efficiency and aesthetic considerations can become a problem of disproportionate magnitude. Clearly a decorative set that defies all attempts to get it working is not so fruitful a labour as one which, although not particularly attractive, goes like a bomb. The moral is, therefore, not to worry too much about sacrificing performance to looks (your attitude to the fair sex could be an excellent guide here).

The Chassis

Nowadays, it is normal practice to build everything on a chassis. Fig. 2 shows a simple type. As you can see, the ends may be closed or left open; without the end pieces, the construction is even more simple: the metal is merely bent in two places.

Suggestions for a possible layout of the circuit shown in Fig. 1 are sketched in Fig. 3. It has been laid out specifically to illustrate the compromise between efficient operation and symmetrical front panel design.

One method is to stretch the lead connecting T_1 and C_4 well across the chassis. This can, of course, be avoided if the whole layout is re-designed, with T_1 placed close to C_4 . Such an arrangement would mean that T_1 would be some distance from V_1 and the coil. The layout shown is, however, perfectly satisfactory.

In Fig. 3, the components C_3 , C_5 , C_6 , R_1 and R_3 are all sufficiently small and light to be supported on their own wire ends, and this is true of many parts used in such instruments. However, C_7 may be large enough to require a clamp to secure it to the chassis. This would depend on the manufacturer.

The aluminium chassis acts as the earth line, which has been drawn heavily in Fig. 1 to emphasise the fact. You will see in Fig. 3 that R_1 and C_4 are earthed at one point and C_7 is earthed elsewhere. There is nothing wrong with that idea, providing the circuit diagram specifies nothing different. An example of a circuit where "single point earthing" is required is shown in Fig. 4. This particular method of drawing means that L_1 , C_1 , R_1 , C_2 and C_3 must all be connected to chassis at the same earth tag. It is a practice very often encountered in very short wave receivers and television receivers.

Tolerances and Types

Now there is one stumbling block which nearly every constructor building his first receiver will fetch up against. He will set out

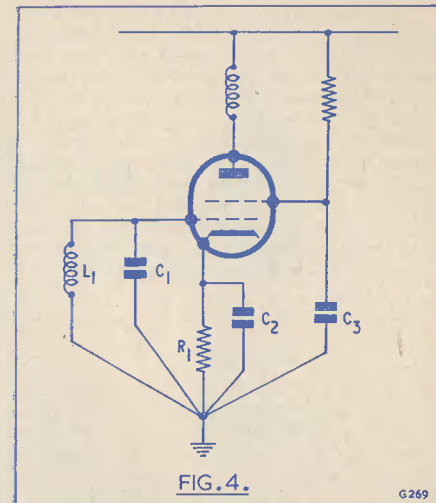

FIG. 4.

with a list of components, having special values, and to his annoyance he may very likely find that in his particular area his specified types aren't available. His local dealers will glibly offer alternatives. Not unnaturally, the customer experiences suspicion and uncertainty. He is determined that the components and their values are obtainable somewhere, and he continues his search.

If he takes this attitude, it is clear that what he does not appreciate is that, in a well-designed circuit, there should be few critical components. Resistors, for example, are made with tolerances ranging from $\pm 1\%$ to $\pm 20\%$. Most receivers and amplifiers only require $\pm 20\%$ tolerance resistors. Look at R_1 in Fig. 1, specified as $2M\Omega$. A $\pm 20\%$ component could have any value between $1.8 M\Omega$ and $2.2 M\Omega$.

The circuit is unaffected by such small discrepancies in value, and if a $2.2 M$ resistor only is available, well then it can be used quite happily with no ill effects. Don't forget, though, that a $2.2 M\Omega$ resistor would itself have a tolerance of $\pm 20\%$, which means its value may be anywhere in the range of 1.98 to $2.42 M\Omega$. The same applies to capacitors—in fact, nothing is exact, every component has tolerances!

Not so easily dealt with are the other ratings. Take C_5 in Fig. 1, for example. It should be a 250V working component. A 200V working capacitor will not therefore be suitable, but a 350V one will. Then again, R_3 should be a 1 watt resistor, so nothing below 1 watt should be used. This will, of course, be somewhat confusing to start with, but practice will soon sort it out until you are picking the right value almost automatically.

With electrolytic capacitors you are completely at sea. They often have tolerances of +100%–0%; in other words, they can have any value between that marked on the case to twice the amount. Really, your first reaction might be, why bother to mark them at all?

However, unless it is specifically stated on the circuit that close tolerances *must* be used, it is quite safe to assume that $\pm 20\%$ is good enough. But on no account be lulled into believing that unlimited licence can be taken with a circuit, otherwise your performance and operation will suffer acutely for it.

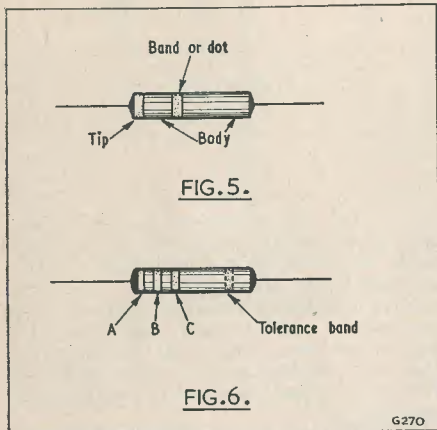

The Colour Code

This is a very crafty but at first confusing system for marking the values on resistors. The value is seldom printed on these components nowadays, and instead it is striped and spotted according to a carefully devised code. Once the code has been memorised it becomes second nature to identify the values—and saves tedious peering and uncertainty at minute figures half obliterated by wear. A typical resistor and its marking is shown in Fig. 5.

There is a definite order of reading the colours which must be strictly observed. This is: body, tip and band. Sometimes the band is not used, but a dot. Then the reading

is: body, tip and dot. The table of colours is as follows:

Colour	Figure
Black	0
Brown	1
Red	2
Orange	3
Yellow	4
Green	5
Blue	6
Violet	7
Grey	8
White	9

The first (body) colour gives the first digit, the tip colour the second digit and the band (or dot) colour the *number of noughts*.

So, a resistor having a brown body, a black tip and a yellow band has the value of 100,000 ohms, or 100 k Ω . Yellow body, violet tip, red band means 4,700 ohms, or 4.7 k Ω .

If the band is omitted, it is to be assumed that it is the same colour as the body. For example, brown body and black tip means 100 Ω .

An alternative method of marking is shown in Fig. 6. These are read in the order: A, B, C. If A were blue, B grey, and C yellow, the value would be 680,000 ohms, or 680 k Ω . On this type a further band is sometimes included. This band marks the tolerance (silver, $\pm 10\%$; gold, $\pm 5\%$); they are quite distinctive colours, and are never confused with the value markers.

* * *

This article is the second in this series. Do not be discouraged by the spade work. If you are impatient, and anxious to skip the first few lessons because it seems perhaps a little too elementary, you will find that the basic principles are later taken for granted, and much of what you are trying to learn will be meaningless. It is more difficult to unlearn wrong conceptions than to start from scratch and learn the right ones.

Once learned, the elements of radio stay in the memory, and there is no need for you to consciously remember them. They are there to stay, with no more effort on your part. This leaves you with plenty of room to learn new things, and puzzle out complexities.

NEW MULLARD LINE OUTPUT PENTODE FOR 90° SCANNING

The Mullard PL36 is an output pentode primarily designed for the line timebases of television receivers using picture tubes with a deflection angle of 90°, and 16kV e.h.t. The new valve is octal based, and has a 25V, 0.3A heater, suitable for series operation.

NEW MULLARD RECTIFIER VALVE

The Mullard PY32 is a new half-wave power rectifier valve for use in television receivers with series-connected heaters. The valve has a maximum rated output current of 275mA, a typical d.c. output voltage being 190V when the valve is supplied direct from a.c. mains, 200V.

Further Notes on THE MICROAMP

by O. J. RUSSELL, B.Sc.(Hons.) G3BHJ

SEVERAL REQUESTS HAVE BEEN RECEIVED from readers for details of the layout of the "Microamp" miniature hi-fi amplifier (Sept. issue). While many readers will have no difficulty in wiring up the amplifier in some form or other, details for those seeking guidance have been prepared. There are, of course, three main ways of wiring up a circuit. One way is the "components-slung-in-the-wiring-glued-on-to-valveholder-tags-and-stuck-in-anywhere." Another way is to use a tagboard for a few heavy items, and to suspend minor components in the wiring. The third method is to put all possible components on to a tagboard.

Actually—for beginners—the "all on a tagboard" method is quite simple if a tagboard layout is published for them to follow. For the "Microamp," a single "Radiospares" tagboard with two rows of 18 tags has just enough tags to accommodate the components. The first diagram shows the tagboard with the interconnecting wires in position. These are run in 20 or 22 s.w.g. wire insulated by sleeving, so that the "Earth" and "H.T." busbars can be run neatly along at the top. While shown outside the tagboard, these busbars are only so drawn for clarity, and in real life are carried closely along the tagboard. Also certain tags lead to valveholders and potentiometers, so that long "tails" are initially left where shown, so that they can be cut to size when the board has been mounted on the chassis and the connection to valveholders, etc., are being made. The second tagboard drawing shows the components attached to the board in the correct positions. Thus after wiring in the busbars and crossover wires on the board, the components are wired on to the board, and the board mounted to the chassis for the final connections to potentiometers and valveholders, etc., to be effected. Once a tagboard layout is effected, the job of wiring up tagboards and mounting in position is easier than jumbling components suspended in the wiring.

Incidentally, one or two other points raised in correspondence might be mentioned. A low cost high fidelity speaker appears to be sought by some readers. Well, the "Stentorian" models of the Whiteley Electrical Radio Co., will provide this. The celebrated "W.B." hi-fi speakers are very reasonable—a ten-inch speaker costs just under £4 while an eight-inch model costs just over £3. These speakers, while "inexpensive," are built to really hi-fi standards. Please note that the ten-inch model has a bass resonance of 35 cycles, so that the best performance will be obtained in a substantial large size enclosure. The eight-inch model has a bass resonance of 65 cycles, so that a smaller enclosure may be used, although the bass will "cut off" an octave higher than the ten-inch model. The

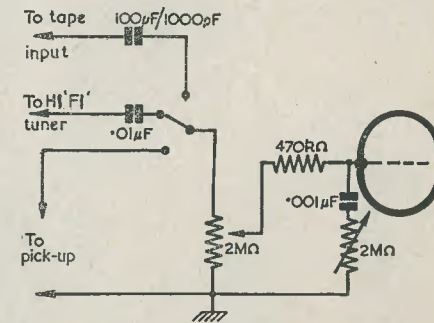

Switching arrangements for records, radio & tape inputs

E235

Whiteley people have, in fact, a pamphlet giving full details of suitable enclosures for these speakers. For the small enclosure to be described later, the very reasonable six-inch W.B. speaker at 52s. 6d. will be found very suitable. However, if you do decide to go in for a larger speaker, the details of the W.B.

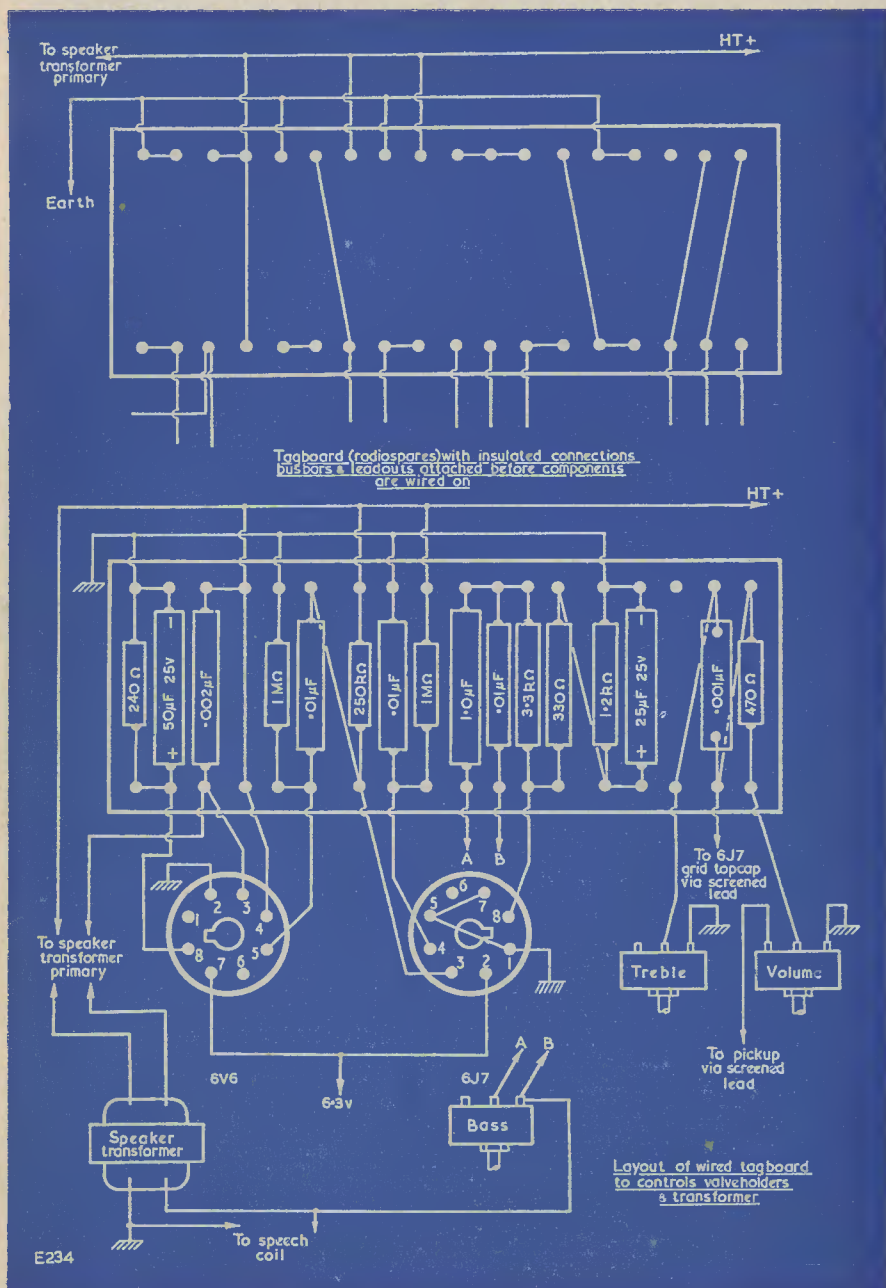

range of speakers may be obtained by dropping a line to Whiteley Electrical Radio Co. Ltd., Mansfield, Notts., and requesting details

of these speakers and also of the drawings of suitable enclosures to house them.

A further point raised by constructors of the

"Microamp" is its use in conjunction with f.m. tuners and with tape reproducers. Most f.m. tuners incorporate an "F.M. Corrector" to "de-emphasise" the top boosted in the f.m. transmissions, so that all these tuners deliver a "straight-line" output and this can be fed directly into the "Microamp" via a suitable coupling capacitor. As $0.01\mu\text{F}$ is ample, this should be used as the minimum, although if a larger condenser is available it will do no harm.

Some tape enthusiasts have found that feeding output from a tape unit into the "Microamp" gives too much bass. Generally, the simplest way of overcoming this is to record the tapes with the recording bass control at minimum. In this way the bass level comes within the "Microamp" bass control range, which was designed for record or radio reproduction and not for tape use. Moreover, the recommendation to record with minimum bass amplitude is one often urged by tape unit manufacturers. However, in cases where excessive bass is obtained—as perhaps from commercial tape recordings—then the solution is to use a "bass corrector" input network. A simple and effective way of doing this is to choose an input capacitor

giving enough "bass roll-off" to bring the tape input within the range of Microamp bass control. With the 2 megohm volume control specified in the original circuit, this requires only a 100pF coupling capacitor. To tidy up the requirements of records, radio input and tape inputs, therefore, a suitable input selecting circuit is given, so that the Microamp may be used for records, radio or tape reproduction. However, where tape input has not got excessive bass amplitude, the coupling capacitor should be increased to 1000pF , or even to $0.01\mu\text{F}$, and readers can make this adjustment to suit their own tape machine and reproducing head characteristics.

Finally, the author would like to thank the many letter-writers who have reported excellent results from the "Microamp," and regrets that he is unable to thank them all individually. Many points on which guidance was requested have also been dealt with, and some of these points have been dealt with above, as they are of general interest. Correspondence has, in fact, shown that there is a very high level of interest in "hi-fi," and that a simple low cost amplifier design has been welcomed as a respite from the more complex designs!

CLUB NEWS

Details for insertion in this section should reach us not later than 7th of the month of publication. Insertions are subject to space being available.

CLIFTON AMATEUR RADIO SOCIETY

Meetings are held every Friday at 7.30 p.m. at the clubrooms 225 New Cross Road, London, S.E.14, where visitors and new members will receive a warm welcome. Details of membership can be obtained from the Hon. Secretary, C. H. Bullivant G3DIC, 25 St. Fillans Road, Catford, London, S.E.6.

Q.R.P. SOCIETY

The Society is preparing a certificate to be awarded to any S.W.L.'s producing confirmations from ten or more transistor stations. It will be available to both members and non-members. Commencing with the current issue, a new layout is being adopted for the Society's journal, "Q.R.P." This will enable members to build up a comprehensive Q.R.P. Handbook in loose-leaf form. The Society is also interested in starting a new section catering for those schools which include elementary radio in their science curriculum. Interested science masters are invited to send comments and inquiries. Hon. Secretary, J. Whitehead, 92 Rydens Avenue, Walton-on-Thames, Surrey.

THE WANSTEAD AND WOODFORD RADIO SOCIETY

The Society meets every Tuesday at 8 p.m. at Wanstead House, two minutes from Wanstead station. Club transmitter is operated by G6SG on 144 Mc/s, having worked to date 15 countries, including PE1PL and F9CQ. Meetings are informal and provision for practical work is available. A welcome is given to all visitors. Hon. Secretary, C. Stevenson, 25 Boundary Road, Barking, Essex.

ABERDEEN AMATEUR RADIO SOCIETY

Meetings are held in the clubrooms at 6 Blenheim Lane every Friday evening at 7.30 p.m., where lectures and demonstrations are given. Visitors and prospective members will be made most welcome. The Club has its own licence (GM3BSQ), workshop and canteen facilities. Hon. Secretary, A. G. Knight, 6 Blenheim Lane, Aberdeen.

ROMFORD AND DISTRICT AMATEUR RADIO SOCIETY

The Society's programme includes film shows, lectures by members, construction evenings and the monthly "junk" sales. The Club net meets every Saturday evening on 28 Mc/s, the participating stations being G3EBF, G3FKJ, G2FWJ, G2BVN and G3AUG. The Society meets every Tuesday evening at 8.15 p.m. at R.A.F.A. House, 13 Carlton Road, Romford, and all visitors and new members will be warmly welcomed. Further information can be obtained from the Hon. Secretary, N. Miller, 55 Kingston Road, Romford.

THE MEDWAY AMATEUR RECEIVING AND TRANSMITTING SOCIETY

All meetings are held at the Club headquarters, "Golden Lion," Old Brompton, on alternate Monday evenings at 7.30 p.m. Club transmitter G2FJA is regularly on the air operated by transmitting members. Some Club calls include G6NU, G3GSP, G6CH, G3KNO, G2CBA, G3BRJ and G2ZP, etc. Kent/Essex "Round Robin" first Sunday in each month on Top Band. Hon. Secretary, H. G. Cheeseman, G3KNO, 265 Cliffe Road, Strood, Kent.

THE SLADE RADIO SOCIETY

The Club station at the Church House is open every day of the week for the use of members. Instructional classes are held every Monday, Tuesday and Wednesday evening and on every second Friday evening, Feb. 24th, Special D.F. Meeting. All members interested in D.F. are asked to attend this meeting. Full particulars of the Society and its activities may be obtained from the Hon. Secretary, C. N. Smart, 110 Woolmore Road, Erdington, Birmingham 23.

NOTTINGHAM AND DISTRICT AMATEUR RADIO SOCIETY

Meetings are regularly held on the third Friday of each month at Sherwood Community Centre, Mansfield Road, Sherwood, at 7.30 p.m. Hon. Secretary, F. M. Hyde, 77 Sherwood Vale, Nottingham.

Technical Forum

Electrostatic Loud Speakers

ALTHOUGH THE PRINCIPLE OF THE ELECTROSTATIC speaker has been known for over 30 years, its use has not been seriously considered either by amateurs or receiver manufacturers until quite recently. This is attributed partially to improvements which have lately been made in the design of such speakers and partially to the ever-growing interest which is being shown in better quality sound reproduction. A loud speaker, being essentially a device for creating sound waves, must be capable of agitating the air in such a manner that the required waves are formed. This agitation is usually brought about by mechanical means such as the piston-like movement of the cone of a normal speaker. However, for a cone speaker to be able to reproduce both high and low frequencies at the correct intensities it must possess negligible mass and be completely rigid. This is obviously impossible, although some speaker manufacturers have made very good compromises between mass and rigidity in their cones. In general, a cone which is large enough to reproduce low frequency notes will be unable to move sufficiently fast in its entirety to satisfactorily reproduce the higher frequencies. Parts of the cone may move, whilst other parts remain relatively still; this effect produces waves travelling outward from the centre of the cone and seriously reduces the high frequency response. With the electrostatic speaker this trouble is overcome, because the mechanical drive to the diaphragm is applied uniformly over its surface, thus ensuring uniform movement and the elimination of cone "break-up." This is the term used to describe the non-uniform movement of the cone or diaphragm under high frequency oscillation. It is the idea of utilising to the full this possibility of uniform drive over the whole surface of the diaphragm which has attracted the attention of speaker designers for so long.

There are, however, certain inherent limitations to the electrostatic speaker, the first being that to achieve a reasonable sensitivity a very small spacing must be employed between the plates, thus limiting the movement of the diaphragm and hence the audio output. The second disadvantage

is purely a physical one in that to reproduce bass frequencies in the region of 50 c/s the diaphragm would have to have an area in the region of 75 sq. ft. Except in a few very special applications, this requirement is likely to limit the use of electrostatic speakers to the higher audio frequencies. It is, in fact, for use as "tweeters" that the electrostatic speakers now being offered for sale are made. These units are small in size, being in the region of 5 x 4 inches, and they possess a frequency response of around 6 kc/s to 20 kc/s. They are entirely unsuitable for use by themselves, as they have virtually no output below about 2 kc/s and are not, therefore, capable of providing intelligible sounds. They are, nevertheless, admirably suited for use in conjunction with a normal speaker, which most probably has a maximum top response of 6 kc/s, to extend the range up to 20 kc/s. In this capacity they have been used in the more expensive a.m./f.m. receivers in Germany for some years, and at least one English set-maker has now followed suit.

In keeping with most other high frequency reproducing devices, the electrostatic speaker is rather directional in that the sound is radiated over a limited angle. To offset this disadvantage two such speakers are often mounted on opposing sides of the cabinet, with the main speaker occupying the conventional position in the centre. In receivers in which one electrostatic speaker is employed it is best mounted as close to the main speaker as possible. Where space is limited the additional speaker may be suspended in front of the main unit by strands of elastic.

Construction of Speaker

It is well known that two oppositely charged bodies will attract one another whilst like charged bodies repel. Thus when a voltage is applied across the plates of a capacitor there is attraction between the plates. This does not normally result in any displacement of the plates, because of their rigid fixing. However, if one of the plates were free to move it would do so in sympathy with any fluctuation in the applied voltage. This, then, is the principle of the electrostatic speaker. In its most popular form the rigid plate is perforated and forms

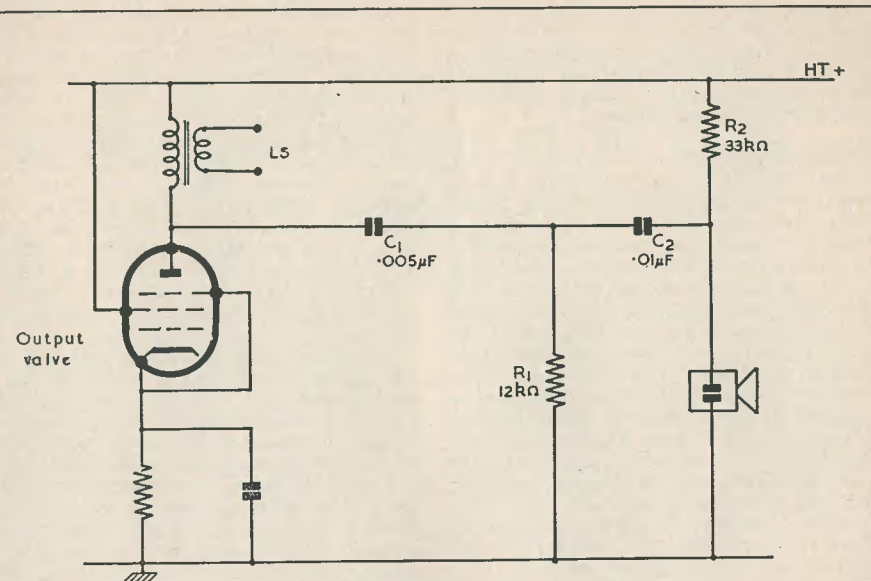

Fig. 1

Connection for single-ended circuit.

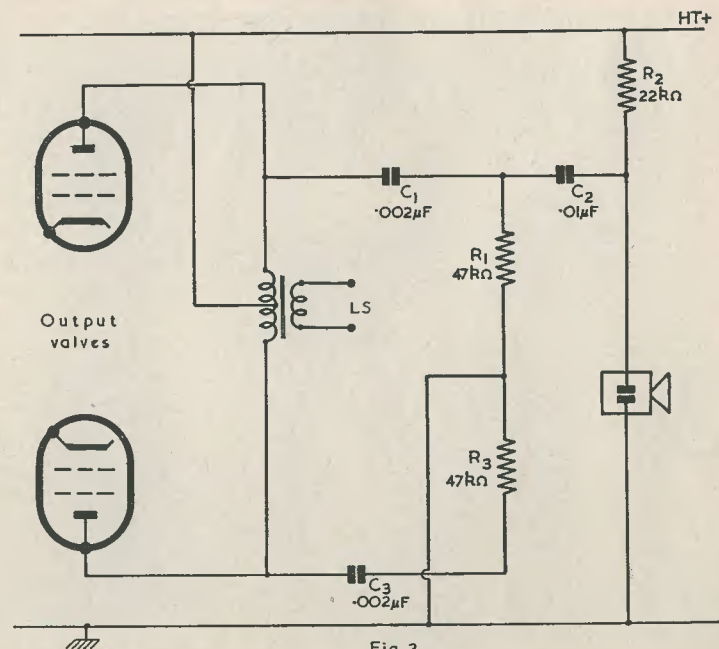

Fig. 2

Connection for push-pull circuit.

E258

the outer case for the unit. The moveable plate is a thin metallic foil which is coated with a very thin layer of insulating plastic. The foil is held in close proximity to the rigid plate by a pressure pad of foam rubber or similar highly resilient material.

Feeding the Speaker

The electrostatic speaker, being a high impedance device, may be fed from a relatively high impedance source at a voltage which is very high compared with that applied to normal moving coil speakers. E.S. units of the type under consideration require from 60 to 100 volts of signal to drive them. Such a voltage is most easily obtained from the primary of the speaker output transformer. With all electrostatic speakers it is necessary to employ a polarising voltage, which must be in excess of the peak of the signal voltage. Without polarisation the speaker diaphragm would move twice on each cycle (once on the negative half and once on the positive half), providing a frequency doubling effect. The polarising voltage is most conveniently obtained from the h.t. supply in the receiver via a suitable limiting resistor.

The circuit diagram (Fig. 1) shows a

typical method of connecting an electrostatic speaker to a single-ended output stage. The filter combination $C_1 R_1$ serves to attenuate the lower frequencies but passes the upper frequencies without loss. This in effect assists in reducing intermodulation distortion in the speaker itself. The capacitor C_2 is for the purpose of blocking the d.c. path to earth. Between 250 and 300 volts are normally employed for polarisation, and where the h.t. does not exceed the upper limit it may be applied as shown in Fig. 1. If the h.t. is higher than this a simple resistive divider must be employed, R_2 being taken to a tap at about 250 volts on the divider.

When the output stage is in push-pull, an unbalanced arrangement as shown in Fig. 2 may be employed. If more than one E.S. speaker is used the second unit is connected directly across the terminals of the first one, all component values remaining unchanged.

In conclusion, it is worth repeating that a small electrostatic speaker by itself will not provide intelligible sounds, but when used in conjunction with a normal speaker it will enhance the top note response, giving a more realistic reproduction.

TESTING AN OUTPUT STAGE FOR LEAKY COUPLING CONDENSER AND ALSO FOR VALVE GRID CURRENT

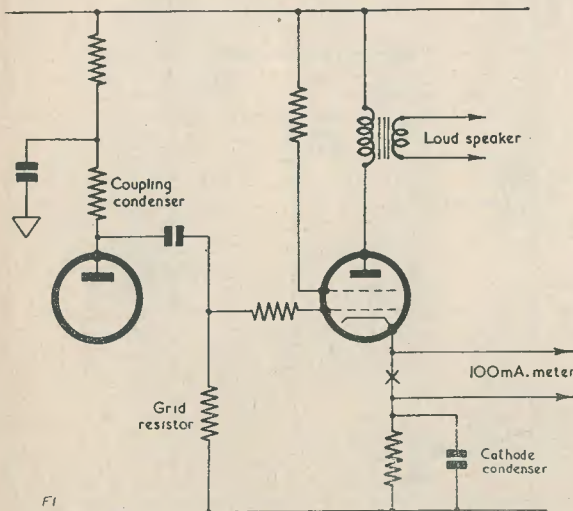

If you have a set with an output stage which sounds slightly distorted or as if there is "just something wrong," the following test may show up the trouble.

Insert a 100mA meter in the cathode lead. Short the grid to chassis and see whether the anode current changes. If so, disconnect the coupling condenser and again short the grid to chassis. If now no change, the condenser is leaking. If there is a change, the valve is faulty and needs to be replaced. A temporary cure may be found by reducing the value of the grid leak.

—G.B.

A SMALL TABLE-TOP TRANSMITTER FOR THE LOWER FREQUENCIES

by A. C. GEE, G2UK

THIS SMALL TRANSMITTER HAS BEEN USED quite successfully during the past year or so by the writer as a portable and fixed station unit on 3.5 Mc/s c.w. It is presented as a very suitable unit for R.A.E.N. use, as its power requirements are small. Together with an Eddystone 640 receiver, it has been run off a rotary converter giving 100 watts of 230 volt a.c. current. The one used by the writer was a war surplus 24 volt input type, which in its turn was driven by a 24 volt d.c. petrol generator. The whole station—transmitter and 640 receiver—can therefore be run either from the house a.c. mains or from the rotary and petrol engine. A very versatile set-up is thus available, ideal for R.A.E.N. service.

The Circuit

The circuit is pretty straightforward. An EF50 strapped as a triode is used as a cathode coupled oscillator. A second EF50 also

As described, a 230-0-230V receiver type transformer is used for the power supply and this gives the transmitter an input of ten watts. This is quite suitable for top band, R.A.E.N. service and general portable work, but for regular use on the 3.5 Mc/s band it was found that the QRM from high power transmitters made communication difficult. However, by enlarging the chassis and cabinet and substituting a 500 volt power supply, a useful increase in input can be obtained without any modification to the circuit.

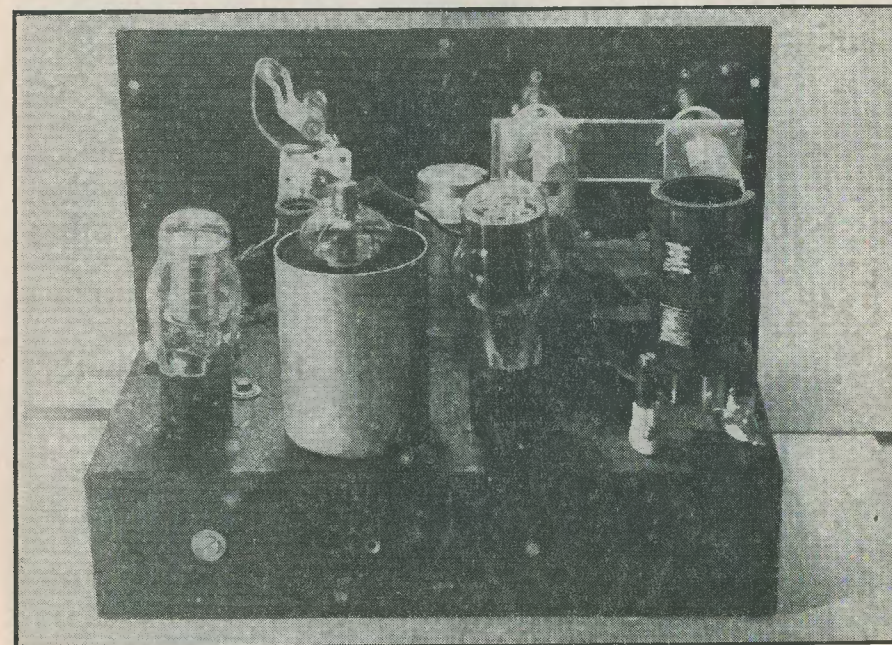

Rear top view of the L. F. Transmitter

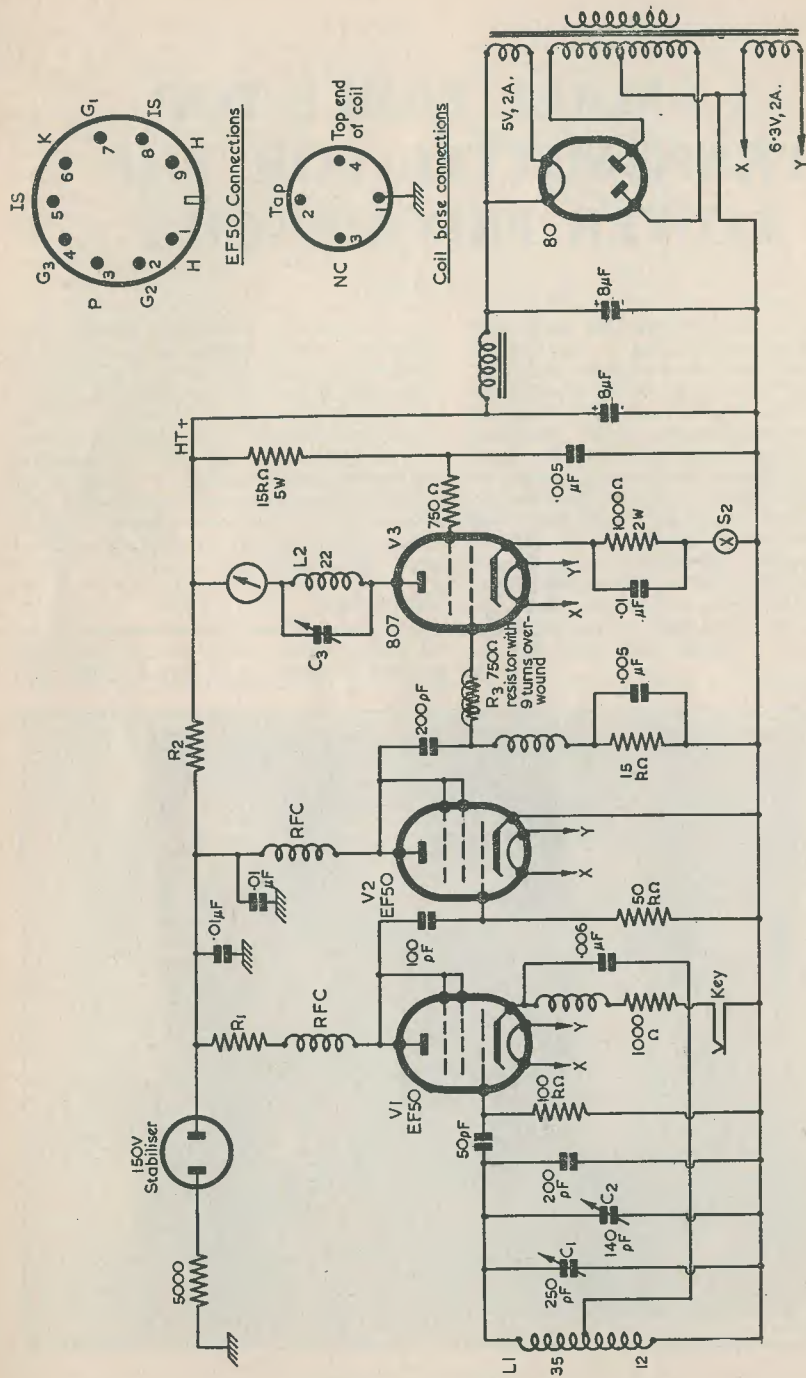

Circuit of table top transmitter for lower frequencies

E225

connected as a triode acts as an untuned buffer stage, and the versatile 807 is used as the p.a. Keying is arranged in the cathode of the oscillator and a switch, S2, is connected in the cathode of the 807 so that the oscillator can be put "on frequency" without the 807 radiating, when QSY'ing.

A chassis 12" x 8" x 2" deep, and cabinet to fit, can be obtained from one or other of our advertisers who specialise in this type of work. C₁ is used as the main capacitor in the oscillator circuit, with C₂ the bandspread; C₃ must be insulated from the metal chassis, and as can be seen from the photo, is mounted on a piece of polystyrene supported on two metal brackets held in place by the transformer fixing bolts. A fourth variable capacitor (not shown in the circuit diagram) can be seen in the photo. This is an aerial tuning variable capacitor, used if a Marconi type aerial is used, but more of this later under the heading of aeriels.

The oscillator coil L₁ is wound on an Eddystone miniature type former. The required number of turns for 3.5 Mc/s and the cathode tap are shown in the circuit diagram. By using really thin enamelled wire (28 s.w.g.) this number of turns can be got on to one of these miniature coil formers. For 1.8 Mc/s, twice the number of turns are required, which means extending the former somewhat to take them. The best way to do this is to slip a piece of paxolin tube over the existing former, or alternatively to turn down one end of a short length of wooden rod to a diameter similar to that of the former, until a collet is formed which will slip into the end of the former, where it can be retained by a little glue.

L₂ is wound on a standard 4-pin former, using 20 s.w.g. enamelled wire or similar.

Aeriels

A few words about aeriels. For 3.5 Mc/s it may be possible to use a half-wave dipole with low impedance twin feeder. In this case all that is necessary in the way of coupling arrangements is a two or three turn loop coil wound on the end of L₂. A little experiment-

ing may be necessary to find the best distance of this loop coil from L₂. A spacing of 1/4 in will probably prove about right. However, it is more likely that one of the "Marconi" types of aerial system will be favoured, i.e. a length of wire—preferably a half-wave length—tuned by a coil and variable capacitor in series with it and ground. You will have to find the number of turns necessary to tune your particular aerial by experiment. The variable capacitor can be identical with C₃ and mounted alongside it as shown in the photo.

As has already been mentioned, a receiver type transformer is used in the power pack. This was necessary in order to conserve space, the usual higher voltage types being too large to incorporate in a small table top unit of this sort.

As mentioned, however, those who wish to build this unit for fixed station use can, if they wish, put in a higher voltage transformer, using a bigger cabinet to accommodate it, without modifying the circuit materially. In the ten watt model, R₁ is 7.5 kΩ and R₂ is omitted. With a higher voltage transformer, R₁ should be increased a bit to bring the voltages on the first EF50 to a sufficiently low value. With a 500 volt supply, R₁ should be about 10 kΩ of 5 watt rating. A second resistor, R₂, may well be inserted as shown to reduce the voltage on the second EF50. This should be approximately 7.5 kΩ of 10 watt rating. These figures are approximate only. Choose suitable resistors to give sufficient voltage on V₁ to give a stable signal of sufficient power to just drive V₂, and to ensure that the voltages on V₂ do not exceed their correct values.

R₃ is a small 750Ω 1/2-watt resistor, with 9 turns of 22 s.w.g. enamelled wire overwound on it. It acts as a parasitic stopper.

No TVI measures have been described here for this transmitter, as each case requires individual treatment. The fact that an entirely enclosed unit is used, of low power, is a good start to the TVI problem, and those who wish to entirely TVI-proof this rig should have little difficulty in applying the usual procedures.

BOOK and CATALOGUE RECEIVED

R.S.G.B. Amateur Radio Call Book. The 1956 Edition gives a comprehensive list, in order of call sign, of the licensed amateur radio transmitters in the United Kingdom and Eire, with addresses and, where applicable, addresses of alternative (A) locations. Obtainable from the Radio Society of Great Britain, New Ruskin House, Little Russell Street, London, W.C.1, price 2s. 6d. (2s. 9d. by post).

Radio and Television Component Catalogue. The 1956 40-page catalogue just issued by Messrs. J. T. Filmer, 21 Old Bexley Lane, Maypole Estate, Bexley, Kent, lists pretty well everything likely to be wanted by the average radio and television constructor, including aerial accessories, and there are also price lists of components for popular designs. It is sent free on application to the above address.

BOOK REVIEWS

AN IMPROVED TUNING WAND

by G3XT

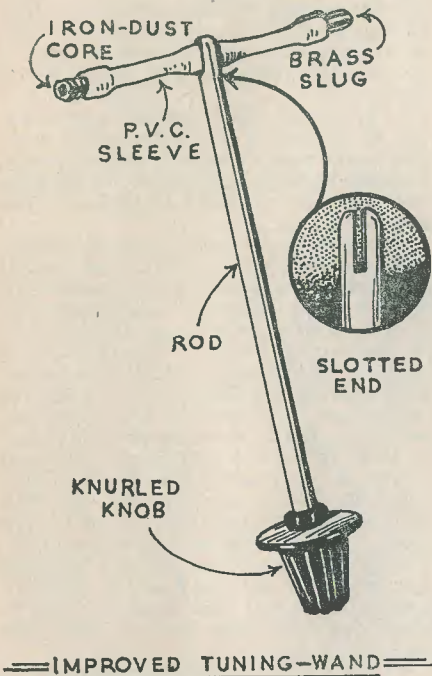

Materials required are a 3-in length of PVC sleeving of suitable diameter, an iron-dust core (which should not be too small), a brass slug, an insulating rod about 4 or 5 inches long and $\frac{1}{8}$ -in diameter, and a small bakelite knob to fit. (I got the rod and knob complete from a variable-inductance unit in a Government surplus Tx.)

Construction takes only a minute or two. Screw the iron core half-way into one end of the sleeve, and force the brass slug half-way into the other end. Make a saw-cut in one end of the rod, squeeze the sleeve flat in its middle and force it into the slot formed by the saw-cut. Fit the knob (if not already on) and the tuning-wand is ready for use. (I gave the whole thing a protective coat of transparent varnish.)

Inserting the dust-core in the end of a coil will *increase* strength if the inductance is too *low*, or tuned to too high a frequency, and inserting the brass slug will *increase* strength if the inductance is too *high*, or tuned to too low a frequency. When the coil is correctly tuned and adjusted, inserting either the iron-core or the brass slug will *decrease* strength.

In the case of coils with adjustable iron cores which already fill up the inside of the coil-former, you may have to hold the wand ends against the outside of the coil winding instead of inserting it in the centre of the winding.

THE NOVEL T-SHAPED TUNING-WAND SHOWN in the sketch is an improvement on the ordinary straight type. It speeds up the work a little when several coils have to be checked, and the fact that it is flexible enables it to reach coils in awkward corners of a chassis. In a few cases it may even save quite a bit of time by enabling adjustments to be made without removing the chassis from the cabinet.

The device works on the usual principle of an iron-dust core at one end of the wand and a brass "slug" at the other. The knurled knob at the handling end of the rod enables it to be twirled round quickly so that the iron-dust and brass inserts can be tried alternately as adjustments are carried out.

HI-FI FOR PLEASURE. By Burnett James. 134 pages. Published by Phoenix House Ltd., 38 William IV Street, Charing Cross, London, W.C.2. Price 9s. 6d.

If you want to sit down to read about high-fidelity equipment and learn about it in a chatty and non-technical fashion, this is the book that should be in your hands. It is a guide for those who want to get the best listening without having to bother themselves about the intricacies of circuits.

The author concerns himself only with telling you how to enjoy quality reproduction and what equipment is required to obtain it. Several typical amplifiers, speaker systems, pick-ups, etc., are discussed, and many hints are given on securing proper reproduction to suit the listener's home circumstances.

Chapters dealing with the care of records, the playing of old records, and the use of the tape recorder in the sphere of musical reproduction will add to the pleasure to be obtained by the audiophile.

An informative and pleasant-to-read book.

RADIO SERVICING POCKET BOOK. Edited by E. Molloy and J. P. Hawker. 200 pages, with 188 tables and illustrations. Published by George Newnes Ltd., Tower House, Southampton Street, Strand, London, W.C.2. Price 10s. 6d.

This can be regarded as a companion volume to the Television Engineers' Pocket Book that was reviewed in these pages in July, 1954. Prepared by the same editors, it is factual and comprehensive.

Some useful tips are given on workshop organisation and practice, and the brief details of test equipment that is either necessary or desirable will provide a good guide on what to acquire for efficient servicing.

The chapter on modern circuitry tends to be brief in text, though the circuits themselves form a handy reference to some of the latest techniques.

Two chapters dealing with fault finding and receiver alignment provide practical information without wasting words. The constructional details of a dummy aerial for aligning receivers with frame aerials is to be commended. Other chapters deal with f.m. receivers, aerials and earths, location and suppression of electrical interference, and gramophone reproduction.

Nearly half the book is devoted to tables and reference data. Valve data gives pin connections, functions, and heater voltage and current of most current types, as well as a table of equivalents. A comprehensive list of current receiver models gives essential details such as valve line-up, valve functions, i.f. frequency, h.t. line voltage, etc., and is a most useful reference. A rather unique table details equivalents for several makers' dry batteries.

A very useful book for the service engineer.

INTRODUCTION TO TV SERVICING. By H. J. Swaluw and J. Van der Woerd. 276 pages, 326 diagrams and illustrations. Published by Philips Technical Library. Obtainable in England from The Cleaver-Hume Press Ltd., 31 Wright's Lane, London, W.8. Price 40s. 0d.

Although this book is devoted to receivers for use with 525 and 625 line systems, a great deal of the information it contains can be used for considering the British system of 405 lines.

It is a book that imparts practical knowledge without recourse to the mathematics frequently encountered in this library. Of particular interest is the series of photographs depicting fault conditions as seen on the tube face. Many of these excellent pictures show faulty reproduction of a test card alongside the same condition as revealed by a pattern generator. Causes and remedies for these faults are described, and references to pages for further information on them are given.

ELECTRONICS. By A. W. Keen, M.I.R.E., A.M.I.E.E. 256 pages, 191 diagrams, 30 plates. Published by Ward Lock & Co. Ltd., 143 Piccadilly, London, W.1. Price 25s. 0d.

In the 17 chapters of this book the author takes the reader through practically every aspect of present-day electronics and contrives to give some understanding of the many and varied applications of this modern art. Starting with the nature of electrons, he leads his reader into an easy comprehension of the principles of control devices, circuit elements, radio communication, television, navigational aids, computers, industrial electronics, and so on.

The many diagrams reflect the care and thought that has gone into their preparation, and reveal the author's flair for clear expression to a nicety.

A minor error is noticed on page 205 where it is stated that the frame frequency of 50 cps in a television transmission is derived from double the line frequency (20,250 cps) by three dividers in cascade, using steps of 5, 5 and 9.

This book is informative rather than instructive, and does at least reveal the enormous field covered by that convenient word, "electronics."

W. E. THOMPSON

WORLD RADIO AND TELEVISION HANDBOOK. 10th Edition, edited and published by O. Lund-Johansen. 168 pages. Price 10s. 6d., postage 6d. Obtainable from Data Publications Ltd., 57 Maida Vale, London, W.9.

World Radio Handbook now appears in its 10th edition. Its editor and publisher, Mr. O. Lund-Johansen, thus celebrates a jubilee and must feel satisfaction that the idea of this international book has proved a success, admitted and acclaimed by the United Nations, UNESCO, the international radio federations and broadcasting organizations and thousands of listeners all over the world.

When the editor first toyed with the idea in the last year of the war, there were not many who believed in it. That it has caught on is shown by the fact that the circulation and the contents of the edition have been increased five-fold.

The head of the Dutch "Happy Station" states that the World Radio Handbook is just as important to a broadcasting establishment as is a telephone book for the use of the telephone.

This is true. With W.R.H. at hand one possesses a guide enabling one to listen to all the stations in the world. By its help one can bring into one's room the most distant areas of the globe. The Handbook suggests various listening ideas and makes it possible to determine the identity of the many stations which can be picked up.

In the world of radio and television, changes are constantly taking place. All these are brought up to date in World Radio Handbook. Excellent tables show the position of the various transmitting stations, and under the sections dealing with the broadcasting of the individual countries will be found not only all stations, their wavelengths and powers, but also times of transmission, regular programmes, names of the leading personalities, and much else. If you hear an interval signal you can identify the station by help of the Handbook, as the notes of the different signals are given.

In addition to broadcasting stations, television stations are also brought up to date. It is a fact that World Radio Handbook is used everywhere in the world where people are interested in broadcasting and television. World Radio Handbook is a Danish production, but as it must be used all over the world the text is in English, and it thus helps to carry interest and understanding across national frontiers.

World Radio Handbook's 10th Edition is nicely produced and contains a mass of interesting illustrations from all over the world.

DESIGN CHARTS FOR CONSTRUCTORS

No. 3 VOLTAGE-DIVIDER COMBINATIONS

by HUGH GUY

DURING THE COURSE OF ALMOST ANY circuit construction, the enthusiast finds it necessary to produce a specific voltage at the junction of two resistors forming a bleed or dividing chain across either an h.t. supply or part of a circuit. Very often the voltage divider thus formed is used to provide a fixed biasing potential for a particular stage; at other times the divider may be an attenuator. Whatever its function, however, the calculation of actual values for resistors forming the network is often complicated by the fact that one is limited to certain values of resistance.

This chart has been designed to obviate some of the difficulties, being constructed around 10% component values. (It will be seen later that any value of resistor can be used by interpolation.)

The mechanism of the voltage-divider is appreciated by reference to Fig. 1, which shows an example often encountered in practice; namely that of providing bias to a cathode follower stage. Invariably the cathode of such a stage is of the order of 100 volts or more with respect to earth. To preserve the relatively small bias that the stage requires (say -1 or -2 volts) it is necessary to fix the junction of the two bias resistors within this value of cathode voltage. Having fixed this bias value, it merely remains to select those value of resistor, R_1 and R_2 , conforming, say, to the 10% standard tolerance range, which give the desired value of bias at the grid.

Let us consider a practical example: a cathode follower stage operates from an h.t. supply of 300 volts. Cathode voltage is 100 volts, and the grid bias for correct circuit operation is -3 volts. What are the values of R_1 and R_2 to provide correct operation?

Obviously the bias potential must be 97 volts. Therefore the voltage across R_2 is 97 volts while that across R_1 is 300-97 or 203 volts.

Before we can use the chart we must determine what the ratio of the voltage drops is. In our example this ratio will be $\frac{203}{97}$ which is 1.985.

It is easy to see that this voltage drop ratio is also equal to the resistance ratio $\frac{R_1}{R_2}$.

Reference to the chart will show that the horizontal axis is calibrated in this ratio but

is limited to values between 0.1 and 1.0. We therefore regard our ratio as being 0.1985, remembering that we must correct for this error when we finally determine values for R_1 and R_2 .

Locating this value as nearly as possible on the horizontal axis, we then seek a value of R_1 which intersects a value of R_2 at the required ratio.

The standard 10% range of resistance values are plotted on the sloping lines for R_2 , whilst those for R_1 are plotted horizontally.

Our example is typical in that no two standard values in the 10% range give the exact ratio we require and it is therefore necessary to seek an intersection of R_1 and R_2 values as close as possible to the fractional ratio. The best that can be achieved is obtained when R_1 reads 68 and R_2 reads 330, giving a fractional ratio of 0.206.

Use of a 43 value for R_1 (which is a 5% component) will give a ratio of 0.196 if used in conjunction with a 220 value for R_2 . This can be seen by interpolation as mentioned earlier.

We must now make the correction for the ratio and this is achieved, obviously, by multiplying the R_1 value by 10.

Finally it remains to allocate practical values to R_1 and R_2 as determined from the chart. For the case in question, since the resistors are providing only a bias voltage, the current that the components draw is best kept to a minimum and a 680k Ω and 330k Ω resistor will be used for R_1 and R_2 respectively.

Of course the design chart is not restricted in its use to bias chains alone, but as mentioned earlier, may be used for attenuating resistance calculations and bleed chain designs for e.h.t. supplies and, in fact, in any similar circuit configuration in which no additional current is drawn from the junction of the two resistors forming the chain. It is important that this limitation is borne in mind when the circuit is designed.

Preceding next month's article, a method will be given enabling dividing chains to be designed in which a known amount of current may be drawn from the junction. This method will involve the use of this chart and that of last month's article and makes the potentialities of the chart much wider.

Next month's article: Reactance/Resistance Chart.

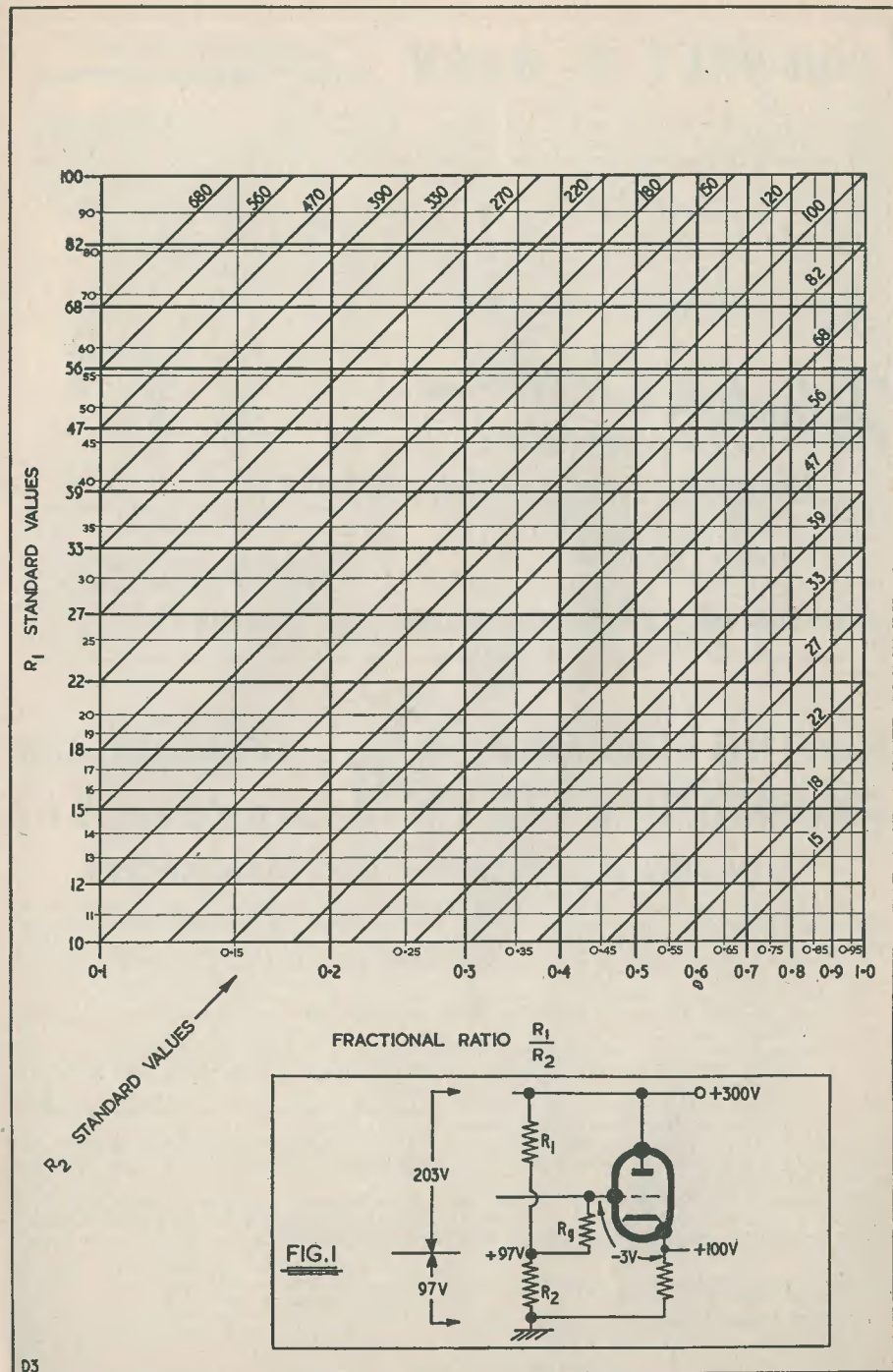

FOR ONLY 30/- DOWN

Choose now one of the wonderfully useful B. & D. Home Workshop Outfits—to drill, sand, polish, de-rust, buff, grind, saw or turn wood. Any one of 8 different outfits based on either the $\frac{1}{2}$ " Utility Drill or more powerful high-speed Sander-Polisher-Drill (both fully suppressed against TV interference) can be yours on the new reduced easy H.P. terms!

A typical outfit—Sander-Polisher-Drill, Polish Pack, Horizontal Stand, Portable Saw Attachment and Buffing and Polishing Kit—costs 30/- down, 12 monthly payments of 27/- (cash value £15 10 6).

Black & Decker

HANDY UTILITY TOOLS

WE CAN SUPPLY ALL your TV and Radio component requirements. Specialists in TELEKING, SOUNDMASTER, VIEWMASTER, W. W. FM TUNER, TELETRON Convertors, etc., ENQUIRIES WELCOMED.

(Terms C.W.O. or C.O.D. plus post and packing)

MARYLANDS ELECTRICS 6 MARYLANDS ROAD LONDON W9 Telephone CUN 7877

WE BOUGHT OUR OWN HOME WORKSHOP OUTFIT

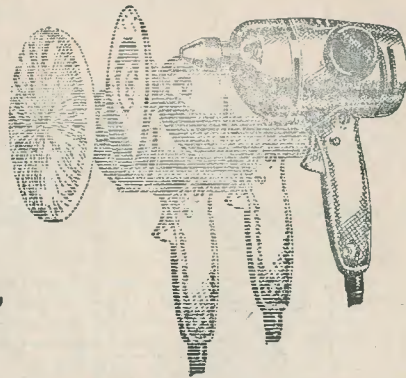

FREE GIFT OFFER

12 one-yard lengths of various coloured sleeving given FREE with all orders of 10/- or over.

100 ASSORTED RESISTORS 10/-
100 ASSORTED CONDENSERS 12/6

SCOTTISH INSURANCE CORPORATION LTD



62-63 Cheapside London EC2

TELEVISION SETS, RECEIVERS AND TRANSMITTERS

Television Sets, Receivers and Short Wave Transmitters are expensive to acquire and you no doubt highly prize your installation. Apart from the value of your Set, you might be held responsible should injury be caused by a fault in the Set, or injury or damage by your Aerial collapsing.

A "Scottish" special policy for Television Sets, Receivers and Short Wave Transmitters provides the following cover:

- Loss or damage to installation (including in the case of Television Sets the Cathode Ray Tube) by Fire, Explosion, Lightning, Theft or Accidental External Means at any private dwelling-house.
- (i) Legal Liability for bodily injury to Third Parties or damage to their property arising out of the breakage or collapse of the Aerial Fittings or Mast, or through any defect in the Set. Indemnity £10,000 any one accident.
- (ii) Damage to your property or that of your landlord arising out of the breakage or collapse of the Aerial Fittings or Mast, but not exceeding £500.

The cost of Cover (a) is 5/- a year for Sets worth £50 or less, and for Sets valued at more than £50 the cost is in proportion. Cover (b) (i) and (ii) costs only 2/6 a year if taken with Cover (a), or 5/- if taken alone.

Why not BE PRUDENT AND INSURE your installation—it is well worth while AT THE VERY LOW COST INVOLVED. If you will complete and return this form to the Corporation's Office at the above address, a proposal will be submitted for completion.

NAME (Block Letters).....
If Lady, state Mrs. or Miss
ADDRESS (Block Letters).....

/JB

COMPLETELY BUILT SIGNAL GENERATOR

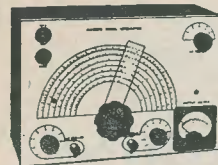

Coverage 120 Kc/s-320 Kc/s, 300 Kc/s-900 Kc/s, 900 Kc/s-2.75 Mc/s, 2.75 Mc/s-8.5 Mc/s, 8 Mc/s-28 Mc/s, 16 Mc/s-56 Mc/s, 24 Mc/s-84 Mc/s. Metal case 10" x 6 $\frac{1}{2}$ " x 4 $\frac{1}{2}$ ". Size of scale 6 $\frac{1}{2}$ " x 3 $\frac{1}{2}$ ". 2 valves and rectifier. AC mains 230-250V. Internal modulation of 400 c.p.s. to a depth of 30 per cent, modulated or unmodulated RF output continuously variable 100 milli-volts. CW and mod. switch, variable AF output and moving coil output meter. Black crackle-finished case and white panel. Accuracy $\pm 2\%$. £4 19 6 or 34/- deposit and 3 monthly payments 25/-. P. and p. 4/6 extra

VERY LIMITED QUANTITY RADIOGRAM CHASSIS

SPECIAL OFFER 7-VALVE PUSH-PULL AC MAINS 200/250V 3 wave band, coverage short wave 16-50m, medium wave 187-550m, long wave 900-2,000m. 4 controls, volume control, on-off, tone control, tuning and wave change with gram position. Valve line-up: X79, W727, two DH77's, two EL41's and EZ30. Output 7 watts. Size of chassis 16" x 7" x 2 $\frac{3}{4}$ ". Size of scale 12" x 4". Overall height including back plate 7 $\frac{3}{4}$ ". BRAND NEW. Fully guaranteed. P. & p. 7/6. £9 19 6

Three-speed automatic changer B.S.R. Monarch, current model. Will take 7", 10" or 12" records mixed. Turnover crystal head. Brand new. AC mains, 200/250. £7 15 0, p. and p. 3/6

3-speed TRANSCRIPTION MOTOR BY FAMOUS MANUFACTURER

Complete kit of parts comprising accurately balanced precision made heavy turntable with rubber mat, large constant speed condenser starting motor, base plate. Can be assembled in half an hour. AC mains 200/250V. Fully guaranteed. Parts sold separately. £6 19 6, post paid

GARRARD RC/110 3-speed automatic changer

Ten records, turnover crystal head, brand new, current model. AC mains 100/250V (list price £14 10 0). £8 19 6, p. and p. 5/-

USED 9" TUBE 22/14C with ion burn, 17/6, post paid
Used Mullard 9" Tube 22/17 and 18 ion burn, 25/-, p.p.

Line and EHT Transformer, 9kV. Ferrocarr core. EY51 heater winding, complete with scan coils and frame output transformer and line and width control. P. and p. 3/-, 35/-

As above but complete with line and frame blocking transformers, 4 henry 250mA choke, 100 mfd and 150 mfd 350 wkg 380mA AC ripple. P. and p. 3/-, £2 9 6
Standard Wave-change Switches. 4-pole 3-way, 5-pole 3-way, 3-pole 3-way, 1/9 each. 9-pole 3-way, 3/6. Miniature type, long spindle 4-pole 3-way and 4-pole 2-way, 2/6 each. 2-pole 11-way twin wafer, 5/-; 1-pole 12-way, 5/-, P. and p. 3d.

USED Metal Rectifier, 250V 150mA, 6/6
Combined 12" Mask and Escutcheon perspex. New aspect, edged in brown. Fits on front of cabinet, 12/6. As above for 15" tubes, 17/6

Polishing Attachment for electric drills. $\frac{1}{2}$ " spindle, chromium-plated 5" brush, 3 polishing cloths and one sheepskin mop mounted on a 3" rubber cup. Post and pkg. 1/6. 12/6. Spare sheepskin mops, 2/6 each

Line or Frame Oscillator Blocking Transformers, 4/6 each. Smoothing Choke, 250mA, 5 henry, 8/6; 250 mA, 10 henry, 10/6; Wide Angle PM Focus Unit vernier adj., state tube, 15/-, PM Focus Unit for Mullard tubes with vernier adjustment, 15/-
Ion Traps for Mullard or English Electric tubes, 5/-, post paid.

PATTERN GENERATOR

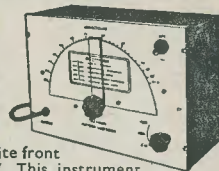

40-70 Mc/s direct calibration, checks frame and line timebase, frequency and linearity, vision channel alignment, sound channel and sound rejection circuits and vision channel band width. Silver-plated coils, black crackle-finished case 10" x 6 $\frac{1}{2}$ " x 4 $\frac{1}{2}$ " and white front panel. AC mains 200/250V. This instrument will align any TV receiver, accuracy $\pm 1\%$. Cash price £3 19 6 or 29/- deposit and 3 monthly payments of £1. P. and p. 4/6 extra

← Both generators guaranteed for 12 months ↑

COMPLETELY BUILT TV CONVERTER

for the new commercial stations, complete with 2 valves. Frequency can be set to any channel within the 186-196 Mc/s band. IF will work into any existing TV receiver between 42-68 Mc/s. Input arranged for 80 ohm feeder. EF80 as RF amplifier, ECC81 as local oscillator and mixer. The gain of the first stage RF amplifier 10dB. Required power supply of 200 DC at 25mA, 6.3V AC at 0.6 amp. Input filter ensuring freedom from unwanted signals. Simple adjustments only, no instruments required for trimming. Will work into any TRF or superhet. Incorporating band switch and wire-wound gain control. Fully screened in black crackle-finished case, size 5 $\frac{1}{2}$ " long, 3 $\frac{3}{4}$ " wide, max. overall height 4 $\frac{1}{2}$ ". £2 19 6, p. & p. 2/6. As above with built-in power supply, £3 19 6, p. & p. 2/6. AC mains 200/250V.



40 WATT 17/6

40 watt Fluorescent kit, AC mains, 230/240. Comprising choke, power-factor condenser, 2 tube holders, starter and starter-holder, p. & p. 3/-, 17/6. No metal work or tube supplied.

20-watt AC or DC 200/250V. Fluorescent kit, comprising trough in white stove enamel, 2 tube holders, starter, starter-holder and barretter, p. & p. 1/6, 12/6
TV Coils, moulded former, iron cored, wound for rewinding purposes only. Ali-can 1 $\frac{3}{8}$ " x $\frac{1}{8}$ ", 1/- each; 2 iron cores Ali-can, 2 $\frac{3}{8}$ " x $\frac{1}{8}$ ", 1/6 each. Suitable for Band III Converters.

Dubilier, 0.001 10kV working, 3/6
1,200ft High Impedance Recording Tape on aluminium spool, 12/6, post paid

Valveholders,	16mfd, 500 wkg	3/3
octal Mazda and local, 7d.	8mfd, 500V wkg,	
each. Paxolin, octal Mazda and local, 4d.	wire ends	2/6
Moulded B7G, B8A and B9A, 7d. each. B7G and B9A moulded with screening can, 1/6 each.	8 mfd, 350V wkg tag ends	1/6
32mfd, 350 wkg	100+150 mfd, 350V wkg	4/6
16 x 24, 350 wkg	280mA, AC ripple	4/6
4mfd, 200 wkg	100+200mfd, 275 wkg	7/6
40mfd, 450 wkg	50mfd, 180 wkg	3/3
16 x 8mfd, 500 wkg	65mfd, 220 wkg	1/6
16 x 16mfd, 500 wkg	8mfd, 150 wkg	1/6
16 x 16mfd, 450 wkg	60+100mfd, 280 wkg	7/6
32 x 32mfd, 350 wkg	50mfd, 12 wkg	11d.
25 mfd, 25 wkg	50mfd, 50 wkg	1/9
250mfd, 12V wkg	Miniature wire ends moulded, 100pF, 500pF and 0.001, each	7d.

R. & TV COMPONENTS (ACTON) LTD

23 HIGH STREET ACTON LONDON W3

Where cost and packing charge is not stated, please add 1/6 up to 10/-, 2/- up to £1 and 2/6 up to £2. All enquiries SAE. Lists 5d. each

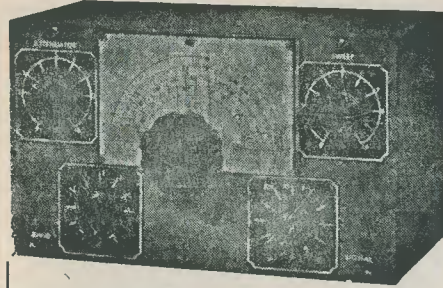

For a really professional finish use . . .

PANEL-SIGNS TRANSFERS

Set No. 1: Receivers and Amplifiers
Five sheets $8\frac{1}{2}'' \times 5\frac{1}{4}''$ containing one Large scale, twelve control panels and wording. 3s. 6d. Postage 2d.

Set No. 2: Test Instruments
Five sheets $8\frac{1}{2}'' \times 5\frac{1}{4}''$ containing two Medium scales, twelve control panels and wording. 3s. 6d. Postage 2d.

Set No. 3: Wording
Wording for Receivers, Amplifiers, Transmitters, Test Equipment and other Radio Apparatus. 4 Sheets, Approx. 400 words, 2s. 6d. Postage 2d.

Panel-Signs Transfers Fixing Varnish 1s. per bottle. Postage 4d.

Published by

DATA PUBLICATIONS LTD

57 MAIDA VALE • LONDON W9

Telephone CUNningham 6141 (2 lines)

Telegrams Databux London

Trade Enquiries Invited

VALVES

NEW TESTED AND GUARANTEED

1R5	7/6	6F8G	8/6	12AX7	8/6	EF36	7/6
1S5	7/6	6G6G	4/9	5B	7/6	EF37A	14/6
1T4	7/6	6J5G	5/6	5763	7/6	EF39	7/6
3S4	7/6	6J5GT	6/6	AZ31	10/6	EF80	10/-
3V4	7/6	6K7G	6/-	DF91	7/6	EF85	10/6
5U4G	8/6	6K8	8/6	DK91	7/6	EF91	7/6
5Z4G	8/6	6K8G	8/-	DAF91	7/6	EF92	4/9
6AG5	6/9	6K8GT	8/6	DL92	7/6	EL32	7/6
6AM6	7/6	6L6G	9/6	DL94	7/6	EM34	12/6
6AL5	6/6	6Q7GT	8/6	DK92	7/6	EY51	11/6
6AT6	8/-	6SN7GT	8/6	DK96	9/-	EZ35	8/-
6BE6	8/-	6SL7GT	8/-	EB91	6/6	KT33C	12/-
6BW6	8/-	6SS7	6/6	EBC33	8/6	KT66	11/6
6B8	7/6	6V6G	7/6	ECC81	10/6	PL81	10/6
6B8G	7/6	6V6GT	7/6	ECH35	10/6	PL82	10/6
6BA6	8/6	6X4	8/-	ECH42	11/6	UCH42	11/6
6SA7	8/6	6X5GT	8/-	ECL80	10/6	PCC84	11/6
6F6G	8/-	12AT7	9/-	EF22	7/6	X65	10/6

Matched Pairs KT66, 25/-; 6V6G and GT, 17/- per pair; 6K8G, 6K7G, 6Q7G, 6V6G, 5Z4G, 34/6 per set; 1R5, 1T4, 1S5, 3S4 or 3V4, 27/6 per set.

Volume Controls. All valves, long spindle. L/S 3/-, SP 4/-, DP 4/6

W.W. Pots. Preset 3/-; 3W, long spindle 5/6, SP 6/6

Coaxial Cable. 75 ohm $\frac{1}{2}''$ stranded, 8d. yd; semi-air spaced, 9d. yd; screened cable single and twin, 9d. yd.

Band III Converter Kits for Midland Litchfield Transmitter. Complete kit of parts, including ready wound coils, two EF80 valves, drilled chassis and wiring diagram. For a.c. mains 200-250V. £3 10s. 0d., p. and p. 1/6
As above less power pack components. Power required, 200V 20mA, 6.3V 0.6A. £2 5s. 0d., p. and p. 1/-
Teletron Band III Coil Set. Mk I 15/-, Mk II 17/6; Osrom Coil Set 17/6
Aerials. Band I from 13/6; Band II 17/6; Band III 6/6

Spare parts for Philips Radio and TV Receivers and most other makes supplied

P. and P. 6d. Over 1/-
post paid except where stated

R. COOPER G8BX

32 SOUTH END CROYDON SURREY CROYDON 9186

Coaxial Plugs and Sockets 1/- each

Valveholders, 4, 5, 7 pin English and U.S.A. B7G, B9A 1.0 Mc, B8G, 9d. each; B7G, B9A with screening can, 1/6

2-Gang Condensers, .0005 small size 6/6

I.F. Transformers, 465 kc, small size 9/6 pr.

Capacitors, small mica, 5% 1pF to 100pF, 8d.; 120pF to 1,000pF, 9d.

Ceramic Capacitors, close tol. 500V for V.H.F., 9d.

Paper Capacitors, tubular, .01 1,000V, 1/-; 0.1 to 0.5 500V, 10d.

Paper Blocks, 4 mfd, 1,000V wkg., 2/3; 2 mfd 350V, 2/-; 4 mfd/350V, 2/6

Recording Tape. 1,200ft on standard plastic spools, 17/6

Resistors, $\frac{1}{2}$ and $\frac{1}{4}$ W, insulated, 4d. and 6d.; 1W, 8d.; 6W W.W., 1/-; 10W, 2/-

Electrolytics. Wire ends. 25/25V, 1/6; 50/50V, 2/-; 12/50V, 9d.; 8/450V, 2/-; 16/450V, 2/9; 32/450V, 4/-; 8+16/450V, 4/6; can types: 16/450V, 3/6; 32/500V, 6/6; 32+32/450V, 6/6

Wavechange Switches, midget: 1P 12W, 2P 6W, 3P 4W, 4P 3W, 4P 2W, long spindles, 4/6

Toggle Switches. QMB, s.p.s.t., 2/-; s.p.d.t., 3/3; d.p.s.t., 3/6; d.p.d.t., 4/-

TRANSFORMER SNIP

11/6

Post 2/-

Fully shrouded—standard 200-250V primary. 280-0-280 at 80mA, 6.3V at 3A, 5V at 2A.

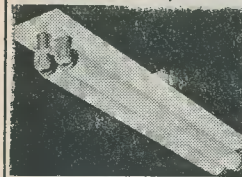
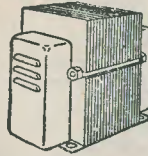

THE TWIN 20

This is a complete fluorescent lighting fitting. It has built-in ballast and starters—stove enamelled white and ready to work. It uses two 20-watt lamps. Price, with two tubes, 39/6. Post and insurance 5/-, Extra 20-watt tubes, 7/6 each

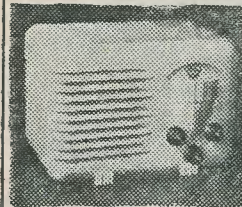

1956 T.R.F.

32/6

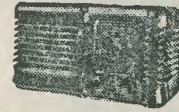

For the benefit of those who already have a loud-speaker and odds and ends the "1956 T.R.F." is available in basic form. This contains all the essential items, i.e. prepared metal chassis, 3 valves, mains transformer, gang condenser, coil, volume control, valveholders, smoothing condenser, bias condenser, 6 paper and metal condensers, 7 resistors, and data. The total list value of all the items is 52/6, but as a special offer to publicise the set, we offer all for 32/6, plus 2/6 post and insurance. Remember, if pleased with results, you can add the extra parts to make the "de luxe" set as illustrated

THIS MONTH'S SNIP
The "Estronic" Band III Converter

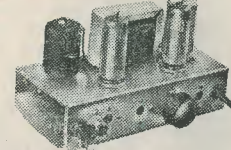

To-day's best value in Band III converters suitable for your TV or money refunded. Complete ready to operate, 59/6 non-mains, or 85/- mains, post & insurance 3/6

RADIO SCALES 4/- PER DOZEN

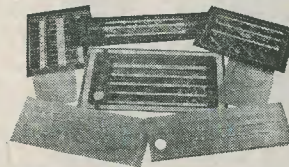

MAINS—MINI T.R.F.

Uses high-efficiency coils—covers long and medium wavebands and fits into the neat white or brown bakelite cabinet—limited quantity only. All the parts, including cabinet, valves, in fact, everything, £4 10 0, plus 3/6 post

MULTI-METER KIT

Parts suitable for making a multi-meter to measure volts, milliamperes and ohms. Kit containing all the essential items including moving coil meter, resistors, range selector, calibrated scale, etc., is 15/-, plus 1/- post and packing

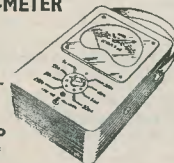

ELECTRIC BLANKET WIRE

Waterproof P.V.C. covered—so blanket washable. $16\frac{1}{2}$ ohms per foot—1/6 per yard. 14 yards ideal for average blanket £1 post free

12" TV CABINET 15/-

We are offering these at not much more than the cost of the plywood they contain. If not wanted for TV, many useful items can be made—record storage cabinet, h.f. loud-speaker case, bookcase, etc. Price 15/-, carr. 7/6

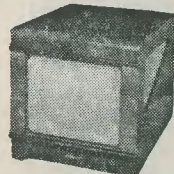

RADIO CONTROL RECEIVER

All parts including valve, paxolin panel, coil formers, etc., to build regenerative receiver, given in Sept. Practical Mechanics, 14/6, plus 2/- post.

NEW AMERICAN EQUIPMENT

Insert Microphone, ref. No. Mic. 253-A. A really beautifully made magnetic mike of little over 1" in diameter. Price 8/6 post free
Low-High Adaptor
Changes low resistance headphones to high resistance. Ref. No. MC-385-C, standard jack plug fitting. Price 4/6 each
Push Pull Output Transformer. Potted midget type, standard matching. Ref. No. 866. Size 1" x 1" x 2 3/4". Price 8/6 post free
Push Pull Input Transformer. Potted midget type. Ref. No. 4358. Size 1" x 1" x 1 1/2". Price 6/6 post free

RI155 YOURS FOR £3



As you know the RI155 is one of the finest communications receivers available to-day. Covering 75 kc/s to 18 Mc/s it will give you world-wide reception. Made originally for the R.A.F. it is obviously a robust receiver which will give years of service. Practically unused but, nevertheless, checked and tested and guaranteed for 12 months. Price, complete with 10 valves ready to operate is £8 19 6 or H.P. deposit of £3, balance by 12 monthly payments of 11/6. If not collecting please include 15/- carriage and transit case. Mains Power Pack with speaker £5 10 0, or in wooden case £6 15 0.

THE CLEVELAND ORGANTONE

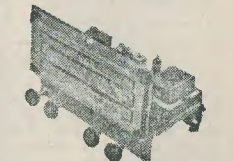

5 valve superhet covering Long, Medium and Short waves. Miniature valves, low loss coils, permeability tuned i.f.s., full a.v.c., variable negative feedback, gram. position, 4 watts output, particularly fine tone. Price £11 10 0, carriage and insurance 7/6

ELECTRONIC PRECISION EQUIPMENT LTD

Post Orders should be addressed to Dept. 34, 123 Terminus Road, Eastbourne

Personal shoppers, however, can call at

42-46 Windmill Hill
Ruislip, Middx.
Telephone RULslip 5780
Half-day Wednesday

152-3 Fleet Street
E.C.4
Telephone FLEet 2833
Half-day Saturday

29 Stroud Green Road
Finsbury Park, N.4
Telephone ARChway
1049. Half-day Thurs.

249 High Rd. Kilburn
Telephone
MALda Vale 4921
Half-day Thursday

BAND III CONVERTER UNIT

Complete kit of parts for "Teletron" Converter. Including 2-EF80 and chassis and wiring diagram. Voltage required 200V 30mA, 6.3V 0.6A ... 48/6 plus 2/- p.p.
Or assembled and tested... .. 67/6 plus 2/- p.p.
Power supply components 22/-
The Unit complete with power supply. Tested and ready to plug in 97/6

HIGH GAIN MODEL TELETRON Mk 2

Teletron Mk 2 coil set 17/6
Additional resistors each 3d.
Additional condensers each 9d.
Valves, type PCF80 (tax paid) 12/6
Valves, type PCC84 (tax paid) 12/6

Or the complete Mk 2 Kit at 59/6



QUARTZ CRYSTALS

TYPE FT243 fundamental frequencies. 2 pin $\frac{1}{8}$ " spacing. 200 types in the following frequencies: 5675 Kc/s to 8650 Kc/s (in steps of 25 Kc/s); 5706 Kc/s to 8340 Kc/s (in steps of 33.333 Kc/s). All brand new 10/- each. Special price for complete sets of 80 or 120. Above are suitable for regrounding.

TYPE FT241A 54th harmonic Crystals. 2 pin $\frac{1}{8}$ " spacing. 21.1 Mc/s, 21.2 Mc/s, 21.4 Mc/s, 21.5 Mc/s, 22.0 Mc/s, 22.8 Mc/s, 22.9 Mc/s, 23.2 Mc/s, 23.4 Mc/s, 26.0 Mc/s, 26.1 Mc/s, 26.4 Mc/s, 27 Mc/s. All brand new 7/6 each. FT241A 200 Kc/s 10/- each. FT241A 465 Kc/s 10/- each. Crystal Holders for both types 1/3 each



INDICATOR UNIT TYPE 182A

Unit contains VCR517 Cathode Ray 6" tube, complete with Mu-metal screen, 3 EF50, 4 SP61 and 1 5U4G valves, 9 wire-wound volume controls and quantity of resistors and condensers. Offered BRAND NEW (less relay) at 67/6 plus 7/6 carr. Radio Constructor 'scope circuit included.

CATHODE RAY TUBES

VCR139A. 2 $\frac{1}{2}$ " C/R Tube. Brand new in original cartons (carr. free) £1 15 0
VCR97. Guaranteed full T/V picture (carr. 2/-) £2 0 0
VCR517C. Guaranteed full T/V picture (P.P. 1/6) 10 0
6" ENLARGER for VCR97 or 517 (P.P. 1/6) 17 6
VCR97. Slight cut-off (carr. 2/-) 15 0
3BP1 brand new £1 10 0

TRANSMITTER/RECEIVER "38" WALKIE TALKIE SETS

Complete with 5 valves, four VP23 and ATP4. These sets are not guaranteed but are serviceable. Circuit supplied. Freq. range 7.4 to 9 Mc/s. Range approx. 5 miles. 25/- Junction Box 2/6 extra.

AN/APA.I CATHODE RAY INDICATOR AMPLIFIER UNIT

Complete, comprising 3BP1 C.R.T., 7-6SM7gts, 1-6H6, 1-6G6, 1-2X2, 1-6X5 valves. Brand new. £4 19 6 plus carriage 7/6

RECORD CHANGERS

B.S.R. "Monarch," plays mixed records. 3-speed. Listed £16 10 0. Brand new £7 19 6

Post Free unless otherwise stated
SEND STAMPS FOR 28-PAGE CATALOGUE

62A INDICATOR UNIT

Containing VCR97 with Mu-metal screen, 21 valves: 12-EF50, 4-SP61, 3-EA50, 2-EB34. Plus pots., switches, H.V. cond., resistors, Muirhead S/M dial, double deck chassis and crystal. BRAND NEW ORIGINAL CASES, 67/6, carriage 7/6

U.S.A. INDICATOR UNIT Type BC929A

In black crackle cabinet 14 $\frac{1}{2}$ " x 9" x 9". Complete with 3BP1 C/R Tube, shield and holder, 2 6SN7GT, 2 6H6GT, 1 6X5GT, 1 2X2, 1 6G6, V/controls, condensers, etc. Ideal for 'scope. Brand new, 65/-, carriage paid

PYE 45 Mc/s STRIP TYPE 3583 UNITS

Size 15" x 8" x 2". Complete with 45 Mc/s Pye Strip, 12 valves: 10 EF50, EB34 and EA50, volume controls, and hosts of resistors and condensers. New condition. Modification data supplied. Price 69/6, carriage paid

CRYSTAL MICROPHONE INSERTS

7/6 POST FREE
Ideal for tape recording and amplifiers. No matching transformer required

HENRY'S

(RADIO LTD)

SHOP HOURS

Mon.-Sat. 9 a.m.-6 p.m. Thursday 1 p.m.
Telephone Paddington 1008/9 & 0401

5 HARROW ROAD LONDON W2

SMALL ADVERTISEMENTS

Readers' small advertisements will be accepted at 3d. per word, including address, minimum charge 2/-. Trade advertisements will be accepted at 9d. per word, minimum charge 6/-. If a Box Number is required, an additional charge of 1/- will be made. Terms: Cash with order. All copy must be in hand by the 8th of the month for insertion in the following months' issue.

PRIVATE

FOR SALE. 17" CRT Brimar C17BM, in excellent order. No ion burns or cathode heater short, £11. Box No. E101.

FOR SALE. Eddystone 640 Receiver with matching speaker and "S" meter, £16. Ward, 30 Gravel Hill, Addington, Croydon.

FOR SALE. AR88LF Receiver in perfect condition. Best offer over £30. Box No. E102.

FOR HIRE. Taylor All-Wave Signal Generator. 7s. 6d. day, or part. £5 deposit. GUL 6641.

HELP. Can any amateur repair continental Philips wireless. Prepared to pay well. CUN 2744.

FOR SALE. Philips PCR Receiver, built-in speaker. Separate power pack. Little used, £12. Brimar C12FM unused with manufacturer's guarantee, £12. Brown, 32 Craikhill Avenue, Immingham, Lincs.

FOR SALE. R1155 AC/DC operation completely self-contained, current meter, 3 ohm 4 watt output, top grade, £9. Rotary converter 230V DC in, 230V AC 50 cycles out, 180 watt, fully fitted, £6. Transformer 230V 50 cycle input, secs 6.3V at 8A, 5V at 6A, 500-0-500 250mA, 25/- Barber, 24 Beatrice Road, London, S.E.1.

FOR SALE. CR100 Marconi naval communications receiver complete, 10-5,000 metres continuous, 6 bands, £1 service manual, 11 valves, own mains power pack, good condition, £17. Cordingley, 86 Tennant Street, Bradford, Yorks.

FOR SALE. Eddystone 740 with "S" meter, 500 hours use. Offers? Tring, 65 Stapleton Hall Road, London, N.4.

SENSATIONAL CLEARANCE. If you want a small portable, easy to use S.W. receiver that pulls in DX, at a give away price, plus 10/- worth of free gear, send a large SAE to Box No. D179.

JERSEY HOLIDAY. Near sea, town centre. Ham shack. Photo darkroom. SAE please for brochure. GC3KPO, "The Lincoln," 3 Saviours Road, Jersey.

HAM S.W. CLEARANCE. Limited quantity S.W. m/bat receivers. TRF, all bands, hardly used, bargain prices (e.g. from 35/- only). About 10/- worth new free gear given away with orders. Unrepeatable. Send large SAE without delay to Box No. D177.

WANTED. G5RV Tx or similar, less power pack, valves. J. Walker, G2DCF, 40 Devon Street, Beswick, Manchester 12.

WANTED. 1132A preferably without valves. A. Jones, 80 Louis Street, Liverpool 5.

TRADE

FM DIPOLE, comprising two rod elements complete with junction box, suitable indoor or outdoor erection, 8/3 plus 6d. carriage. BAND III TV aerial, suitable loft or outdoor erection, complete with junction box, 7/6, carriage 6d. Cheapest aerials on the market. Complete range Teletron coils at list prices. All radio components stocked. Goods sent per return. Wireless Marketing Co. (Supplies), 29 Praed Street, London, W.2. Telephone PAD 1903.

(continued on page 455)

THERES ALWAYS GOOD VALUE AT

The Walk-around Shop

BENDIX RECEIVER Type MN.26C RADIO COMPASS. A superb 12 valve 3-band receiver covering 150-1,500 kc/s, i.f. frequency 112 kc/s. Valve line-up: 6K7 1st and 2nd R.F., 6L7 mixer, 6J5, Osc, 6K7 I.F. amp., 6B8 1st and 2nd det. and a.v.c., 6J5 b.f.o., 6F6 audio output, compass mod. 6N7, audio oscillator 6N7, loop amp. 6K7, compass output 6K7. 28 volt supply to motor generator which can be easily changed to 12 volts (details available). Circuits, etc., free with each unit. **The Perfect Car Radio.** Size 15 $\frac{3}{4}$ " x 11 $\frac{3}{4}$ " x 6". Power supply 6.3V and 250V. Price £3 10 0 plus 7/6 pk'g and Cr'g.

POWER PACK Type 173. 12 to 24 volt l.t. input. 120V 60mA output. Fully smoothed, size 10 $\frac{1}{2}$ " x 6" x 3". Containing two 120 volt 60mA selenium rectifiers. One V.S.110 voltage stabiliser; 12 volt vibrator and transformer, chokes and condensers, 12/6 post paid.

MAKE A MINIATURE POCKET RADIO. Incorporating high "Q" technique using the new Ferrite rod. Made possible by simple conversion of an ex-Govt. hearing aid. £2 6 0 post paid, with circuit diagram and full instructions. Batteries extra: 1.5V l.t. (type D18), 8d., 30V h.c. (type B19), 4/3.

F.L.8a FILTERS. Splendid value, 10/-, packing and postage 1/6.

R.F. UNITS. R.F.24 20/30 Mc/s, switched tuning, fully valved, 9/6 each. R.F.25 40/50 Mc/s, switched tuning, fully valved, 9/6 each.

NOTE.—Orders and Enquiries to Dept. "R".

PROOPS BROS. LTD Open all day Saturday
52 Tottenham Court Road W1
Hours 9-6 p.m. Thursday to 1 p.m. LANgham O141

TV 12" CHASSIS, 97/6. Easily adapted to channel 9 (I.T.A.). Drawing 2/6, or free with order. Complete chassis by famous manfr.; r.f. e.h.t. unit included. Owing to this chassis being in 3 separate units (power, s/vison, t/base interconnected) it is easily fitted to table or console model. This chassis is less valved and tube, but see our list for cheap valves, by request. Carriage: 5/- London, 10/- Provinces.

RADIOGRAM CHASSIS, 29/9. Including 8" speaker, dial and knobs. 5-valve s/het 3 wave band, a.c. mains. Complete, tested, guaranteed. Less valves. P. & p. 4/6
"SUPER" R/G CHASSIS, £6 17s. 6d., with speaker. 8" p.m. 4 w/band 5 valve s/het, famous manfr. Complete with octal valves, 4 controls. Dial 5 $\frac{1}{2}$ " x 9" Carr. 4/6

V.H.F. 1125 RECEIVER, 7/9. Complete with valves. Drawings free. Post 2/3. New. Ex-W.D.

V.H.F. 1124 RECEIVER, 17/6. Complete with valves. New condition. Receives TV sound, police, fire, amateurs. 30.5 to 40 Mc/s, i.f.s. 7 Mc/s. Drawing and conversion data free with order. Carriage 2/6.

V.H.F. 24 RECEIVER, 10/6. Complete with valves. New, ex-W.D. Post 2/3.

V.H.F. 1466 RECEIVER, 27/6. Complete with valves, similar to the 1124 receiver but with a tuning dial. Carriage 2/6.

AMPLIFIER No. 165, ex-W.D., 5/9. Contains a host of resistors, conds., coils, trans., etc., with drawings. Less valves. Post 1/9.

RECEIVER No. 71, 6/9. Ex-W.D. Full of gear, resist., etc. Works v.h.f. with drawings. Post 1/9 (less valves).

TRANSMITTER No. 50, 6/9. Ex-W.D. V.H.F. with coils, tuning conds., fixed conds., resist., switching, etc. Less valves. Post 1/9.

DUKE & CO

621 ROMFORD ROAD · LONDON · E12

Telephone GRA 6677

CABINETS HI-FI EQUIPMENT . . .

We can supply any cabinet to your own specification

- The cabinet illustrated can be supplied in any shade of walnut, oak or mahogany for . . . 19 gns.

We can supply and fit into any cabinet all the latest hi-fi amplifiers, tuners, transcription units, record changers and speakers.

Send for free illustrated catalogue of cabinets, chassis autochangers and speakers, etc. H.P. can be arranged

LEWIS RADIO COMPANY

120 GREEN LANES • PALMERS GREEN • LONDON N13

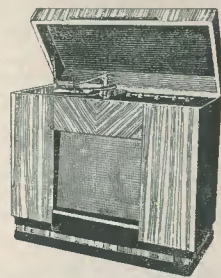

Telephone BOWes Park 6064

Band III Converters for LONDON and BIRMINGHAM

SPECIAL OFFER

Band III Cleveland Converter, complete with 3-element Band III aerial with wall fixing bracket. Both suitable London or Birmingham. Converter completely built, including internal power supply, switching, gain control, external adjustment, etc., in grey hammered metal case, internal or external fixing. Only £7 10s. 0d., carriage 2/-

Teletron Mark 1 Converter Kit. Complete kit of parts, including coils and valves, etc., £2 9s. 6d., post 6d.

Teletron Mark 2 Converter Kit. As featured in this issue. Complete kit of parts, as illustrated above, including valves (PCC84 & PCF80) and coils, etc., £3 2s. 0d., post 6d. Mk. 2 Kit, less valves, £2 3s. 0d., post 6d.

Mark 1 Coil Set, complete with wiring diagram, circuit and alignment instructions, 15/-, post 3d.

Mark 2 Coil Kit, complete with wiring diagram, circuit and alignment instructions, 17/6, post 3d.

Heater Transformers. Mains input, 6.3V, 1A output, 4/6 each, post 6d.

Monarch 10 record changer, 3 speed, complete, £7 19s. 6d., carriage 2/-

Condensers. Ceramic, temperature compensated, in sealed plastic case, T.C.C., 330pF and 470pF, 9d. each, post 3d.; 0.5μF, 350V wkg, chassis fixing screw type, metal can, 1/- each, post 3d.

Teletron "Skymaster" I.F. Transformers, type N/R, N/S, 7/6 each

We have a Large Selection of perfect C.R. Tubes. Every Tube carries a 6-week guarantee. Callers can see picture on premises

9"	£4 0 0
12"	£6 10 0
14"/17"	£8 10 0

Post, Packing and Insurance 10/-

Wireless Marketing Co

29 PRAED STREET LONDON W2
Established 1926 Telephone PAD 1903

WORLD RADIO HANDBOOK

1956 Edition

NOW AVAILABLE

Price 10/6

Post 6d.

DATA PUBLICATIONS LTD
57 Maida Vale London W9

V.H.F. F.M.

JASON TUNER KIT

Including dial and valves, and all necessary items such as screws, tags, etc.

Complete Kit £6 15 0, postage 2/6

Jason 32-page booklet 2/-, postage 2d.

POWER PACK KIT

Chassis 6" x 4"	4/10	16 x 16 Condenser	6/6
Transformer	28/6	(1) Valveholder	10d.
Choke	8/6	(1) Valve 6X4	6/6
(2) 4-pin Plugs and Sockets	2/-	(1) Switch	3/6

Complete Kit £3 1 2

Circuit Diagram 1/- (Free with kit)

AUDIO STAGE KIT

Chassis 6" x 4"	4/10	Resistor Kit	3/6
(2) Valveholders	1/8	Condenser Kit	5/3
1/2M Volume Control	3/6	(1) Valve 6BW6	6/6
Output Transformer	7/6	(1) Valve 6AM6	6/-

Complete Kit £1 18 9

Circuit Diagram 1/- (Free with Kit)

Both above items are suitable for use with the Jason FM Tuner
Postage extra

Also **BAND III CONVERTER KIT £2 8 0**

All above items can be seen and heard at:—

TELEKIT SUPPLY
104 HIGH STREET BECKENHAM KENT
Telephone BEC 3720

SMALL ADVERTISEMENTS

(continued from page 553)

TRADE

BLUEPRINTS. High Gain 10 metre converter, with a de luxe circuit comprising EF91 r.f. stage, ECC91 double triode mixer and oscillator, EF92 i.f. amplifier, with stabilised voltage supply via a 7475, 1/8 post free with full instructions. Data Publications, 57 Maida Vale, London, W.9.

COILS, COILS, COILS. We can supply coils for all frequencies, r.f. chokes, etc. Send SAE for circuits and data. The Teletron Co., 266 Nightingale Road, London, N.9.

I.P.R.E. PUBLICATIONS. 5,500 alignment peaks for superhets 5/9. Sample copy *The Practical Radio Engineer*, 2/-, Membership examination particulars, 1/-, Syllabus of TV and Radio Courses free and post free. Secretary, I.P.R.E., 20 Fairfield Road, London, N.8.

GOVERNMENT SURPLUS ILLUSTRATED CATALOGUE No. 12, containing over 400 items of electrical, mechanical and radio equipment for experiments, etc., price 1/6, post free. Arthur Sallis, 93 North Road, Brighton, Sussex.

JOIN THE INTERNATIONAL S.W. LEAGUE. Free Services to members including Q.S.L. Bureau, Translation, Technical and Identification Depts.—both Broadcast and Fixed stations, DX Certificates, contests and activities for the SWL and Transmitting members. Monthly magazine, "MONITOR" containing articles of general interest to Broadcast and Amateur SWL's, Transmitter page and League affairs, etc. League supplies such as badges, headed notepaper and envelopes, QSL cards, etc., are available at reasonable cost. Send for League particulars. Membership, including monthly magazine, etc., 12/6 per annum. Secretary, ISWL, 86 Barenger Road, London, N.10.

GUARANTEED VALVES BOXED. PCC84, PCL83, PCF80, 10P14, U251, 10/-, 6F15, 10C1, EF80, ECL80, EBF80, 1D5, U281, 9/-, ECC81, 12J7GT, 12K7GT, 12K8GT, 6K8G, 6K8GT, 10F1, 10C2, DH150, DH77, 35ZAGT, 20L1, 1N5GT, 1H5GT, X150, 8/6, 6V6G-GT, 25Z6GT, 6Q7GT, 6SN7, 7/6, EL84, 11/-, W. Fewell, 19 Mapledene Road, Dalston, London, E.8. (CLI 7882.)

BOUND VOLUMES. *The Radio Constructor*, a limited number of Volume 8 only are available, price 21/-, post free.

BUILD YOUR OWN TV and learn about its operation, maintenance and servicing. Qualified engineer-tutor available whilst you are learning and building. Free brochure from E.M.I. Institutes, Department R.C. 58, London, W.4 (associated with H.M.V.).

LEARN AS YOU DO IT—we provide practical equipment combined with instruction in radio, television, electricity, mechanics, chemistry, photography, etc. Write for full details to E.M.I. Institutes, Department R.C. 47, London, W.4.

OSMOR—for efficient coils, coilpacks, etc. Send 5d. stamp for FREE circuits and lists. Dept. R.C.C., Osmor Radio Products Ltd., 418 Brighton Road, South Croydon, Surrey. Telephone Croydon 5148/9.

TAPE RECORDINGS transferred to disc. 78's and L.P.'s. Queensway Recording Studios, 123 Queensway, London, W.2. Telephone BAY 4922.

TRANSFORMERS. 6V 5V heaters, 200-250V primary, 350-0-350 sec., 5/9. 4V, 4V heaters, 3/9. 4V 12V heaters, 3/9. Post on each 2/3.

COIL PACKS, 3/9. 3 band. Complete with pair 465 i.f.s 2-gang conds. and dial. Similar drawing free Post 1/9. Duke & Co., 621 Romford Road, London, E.12. (Tel. GRA 6677.)

NEW SURPLUS . . .

0Z4A	6/-	6K7GT	6/6	832	30/-	EF91	6/-
1R5	8/6	6K7M	6/6	866A	12/6	EF92	5/-
1S5	7/6	6K8M	9/6	9003	4/6	EL32	4/-
1T4	7/6	6L6M	9/6	9006	5/-	EL41	10/6
1A3	4/6	6L7M	7/6	CB11	10/-	EL84	10/6
1L4	4/6	6Q7GT	8/6	CV286	7/6	EL91	5/-
1LN5	5/-	6SA7M	7/6	CV287	7/6	EM80	9/-
2A3	7/6	6SC7M	8/6	DL33	9/6	EY51	11/6
3A4	6/6	6SG7M	7/6	DAF96	9/6	EZ40	8/6
3D6	5/-	6SK7M	7/6	DF96	9/6	EZ80	7/6
3Q5GT	9/6	6SL7GT	7/6	DK96	9/6	PCC84	11/6
3S4	7/6	6SN7GT	6/6	DL96	9/6	PCF80	11/6
3V4	8/6	6SJ7M	8/6	EASO	2/-	PCF82	11/6
5U4G	8/6	6SO7M	8/6	EABC80		PL81	11/6
5Y4G	7/6	6V6GT	7/6		10/-	PL82	9/6
5Z4G	8/6	6V6M	9/6	EAF42	9/6	PL83	11/6
6AC7M	6/-	6X4	7/6	EBC3	10/-	PY80	10/-
6AG7M	9/-	6X5GT	7/6	EBC33	7/6	PY81	10/-
6AK5	6/6	7B7	9/-	EBF80	11/6	PY82	9/6
6AL5	6/6	7C5	9/-	EB91	6/-	RI9	12/6
6AM6	6/-	7C6	9/-	EBC41	10/-	TT11	4/-
6AQ5	8/6	7Y4	8/6	ECC81	10/6	TZ40	25/-
6AT6	8/-	12A6M	7/6	ECC82	10/-	SP61	3/-
6AU6	8/6	12AU7	8/6	ECC84	13/6	UBC41	10/6
6B8M	6/6	12BE6	8/6	ECH82	13/6	UCH42	10/6
6BA6	8/6	12J7GT	9/-	ECH35	10/-	UF41	10/6
6BE6	7/6	12K7GT	9/-	ECH42	10/6	UL41	10/6
6B16	7/6	12Q7GT	9/-	ECH81	10/6	UY41	8/6
6B57	7/6	15D2	4/6	ECL80	10/6	VR105/30	
6BW6	7/6	25L6GT	10/-	EF5	7/6		7/6
6C4	5/-	35L6GT	9/6	EF6	7/6	VR150/30	
6CH6	6/6	35Z4GT	9/6	EF50	4/-		7/6
6F7	8/6	50L6GT	8/6	EF50 (S)	6/-	VS110A	4/6
6F8G	5/-	80	9/6	EF36	4/-	VT62	10/6
6G6G	4/-	220P	3/-	EF39	6/-	W77	5/-
6J5M	6/-	807	7/6	EF41	10/6	X66	7/6
6L6	5/-	808	25/-	EF80	10/-	XPI.5	3/-
6K7G	5/-	813	60/-	EF86	12/6	Z77	6/-

Power Unit Type 247. Input 230V 50 c/s, output 580V 200mA d.c. (service rating). Fitted 5U4G, two 4mfd 1kV wkg block condensers and heavy duty shrouded choke. In smart grey stoved louvered case 8" x 9" x 11", weight 30lb. Brand new and a gift at only 49/6 each, carriage paid.

B7G and B9A Moulded Valveholders, 1/- each 9/6 doz.; with screens, 2/- each 22/6 doz.

"PANL" Crackle Paint. Black, brown, green, 3/- tin

Midget Mains Trans. (same size as std. spkr. o/p trans.). Input 230/250V, output 6.3V 0.6A 250V 20mA, 10/6 each, post 1/3

Midgeat 465 kc/s I.F.s, 1 1/2" x 3/4" sq., 9/6 pair

Canadian Power Packs Type 19-2. For 115V input. Comprises two identical packs on one chassis wired to supply two stabilised outputs of 150V 30mA (transformers each give 300-0-300V 70mA 6.3V 3A, 5V 2A). Fitted two 5Y4G, two VR150/30 plus one of each spare; four 10mfd 600V wkg oil-filled blocks; four shrouded 10H 70mA chokes. Could be used off standard mains by feeding inputs in series and outputs in parallel. Terrific component value. Brand new, only 59/6 each, carriage paid

SPECIAL

Triplett Multi-range Foundation Meters.

Scaled for volts, ohms and mA. 2 1/2" rectangular dial. FSD 400 micro-amps. Int. res. 50m ohms. Complete with engraved top plate. Brand new. Only 27/6 each, carriage paid

MC Meters, flush round plug-in type. 2" round. 0-500 micro-amps (scaled 0-10V), 17/6. Ditto 2 1/2" round, 0-250 micro-amps, 22/6. 2" sq. fl. mtg. 0-50mA, 0-150mA, 0-500mA RF T/C, 7/6 each. 3 1/2" round (2 1/2" dial), 0-200mA, 0-500mA, 0-2A, 0-15V (M1 cal. at 50 cps), 12/6 each.

Special Valve Offer. EL32 and TT11, 3 for 9/6, 28/6 doz.

We regret we cannot accept Eire and Overseas Orders
Post/Packing—Under 10/- (9d.), 20/- (1/3), 40/- (2/-)

JOHN ANGLIN

160 CLEETHORPE ROAD GRIMSBY Lincs
Telephone 56315

H.A.C. SHORT-WAVE EQUIPMENT

Suppliers for over 18 years of Radio S.W. Receivers of Quality One-valve Kit, price 25/-. Two-valve Kit, price 50/-. Improved designs with Denco coils. All kits complete with all components, accessories and full instructions. Before ordering, call and inspect a demonstration receiver, or send stamped addressed envelope for descriptive catalogue.

H.A.C. SHORT-WAVE PRODUCTS (DEPT. R)
11 OLD BOND STREET LONDON W1

PANL

Most of the nationally known mail order houses now stock this popular air-drying crackle finish as a regular line at 3/- per 3/4 pt. can, in black only. If you have any difficulty in obtaining your supply, send 3/6 to

(Dealers' and wholesalers' enquiries welcomed)

G. A. MILLER

8 Kenton Park Crescent Kenton Middx

ADCOLA

(Regd. Trade Mark)

SOLDERING INSTRUMENTS



Reg. Design No. 860302 (British, U.S. and Foreign Patents)

Designed for wireless assembly and maintenance

Supplied for all volt ranges from 6/7V to 230/250V 3/16" dia. Bit Standard Model, 25/6

Sole Manufacturers — ADCOLA PRODUCTS LTD.

Sales Office and Works

Gauden Road London SW4 (MAC 4272)

BRASS, COPPER, DURAL ALUMINIUM, BRONZE

ROD, BAR, SHEET, TUBE, STRIP, WIRE
3,000 STANDARD STOCK SIZES

No Quantity too Small List on application

H. ROLLET & CO. LTD.

6 Chesham Place SW1 Telephone SLOane 3463
also at Liverpool Birmingham Manchester Leeds

HIGH FIDELITY

COMPONENTS IN STOCK FOR THE

MULLARD AMPLIFIERS	circuits 3/6
OSRAM 912 PLUS AMPLIFIER	" 4/-
DENCO FM TUNER	" 1/6
RADIO CONSTRUCTOR FM TUNER	" 2/-

Price lists available on request

J. T. FILMER MAYPOLE ESTATE
BEXLEY KENT

Telephone BEXLEYHEATH 7267

GUARANTEED VALVES — Over 3,000 in Stock

6AM6, 6C4, EF92, 6AL5, EAC91, 6J6	... 5/-
12AT7, 12AX7, 6AK5, 6F33, EC91, EL91, 6SN7, 6SL7, 6SK7, 6SJ7, R10, 6BA6, 6F17, 6CH6, 6BW6	... 7/6
12AU7, 2D21	... 9/-

A. A. W. SKILLMAN

74 FRANCHISE STREET : WEYMOUTH

REPANCO HIGH GAIN SUPERHET COIL PACK Type LMS

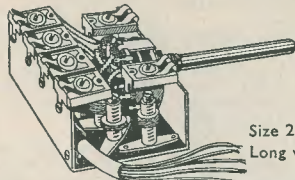

Size 2 3/8" x 2 3/8" x 1 1/2"

Long wave 800-2,000 m.

Medium wave 190-550 m.

Short wave 16-60 m.

Aligned at works before despatch

36/- INCLUDING TAX

COMPLETE with 5 Valve Superhet Wiring Diagrams

Send S.A.E. for Catalogue of complete range of Coils

REPANCO

Self-contained power supply. Easy to build.

HIGH GAIN LOW NOISE BAND III CONVERTER

Envelope of comprehensive wiring plans and instructions 1/9 post free

RADIO EXPERIMENTAL PRODUCTS LTD

33 MUCH PARK STREET COVENTRY

Telephone 62572

RADIO CONTROL

FOR MODEL SHIPS, BOATS AND AIRCRAFT

by F. C. JUDD, G2BCX

To operate a model ship or aircraft is a most interesting hobby. But how much more fascinating it would be if one could emulate the skipper or pilot and remain in control after the model has been set off on its course. This, thanks to radio control, can now be done, and enthusiasm for it is steadily mounting. Radio Control for Model Ships, Boats and Aircraft has become a recognised handbook in this field.

144 pages 135 diagrams and illustrations

Standard Edition, art board cover, 8s. 6d. post. 5d.

Cloth bound, with gold lettering, 11s. 6d. post. 7d.

DATA PUBLICATIONS LTD

57 MAIDA VALE LONDON W9

CONSTRUCTORS build these at low cost !

PERSONAL PORTABLE RADIO

30/-

Post Free

This little set was designed to give you a real personal portable radio that you can enjoy anywhere without disturbing others. Ideal for the holiday, hiking, fishing, camping, cycling, etc. Use it at home, at the office, in bed, or just anywhere.

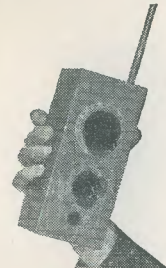

POWER PACK TYPE PU2

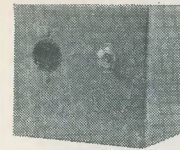

Suitable for Teletron Band III Converter, small receivers, test gear, etc., and specified for the AM/FM Signal Generator.

Complete kit of parts (as illustrated) ... 40/-

Cabinet, panel and chassis, complete ... 10/6 (For AM/FM Signal Generator, etc.)

ALL-WAVE RADIO

30/-

Ideal for the beginner or for those requiring a simple standby receiver.

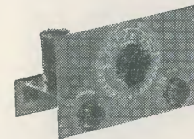

This 1 valve S.W. receiver can be built for 30/- from our list of components, which can be purchased separately. It includes valve and 1 coil covering 20-40 metres. Provision is made to increase to 2 or 3 valves if required, and all components are colour-coded so that the beginner can build this set quite easily. Send 2/- for specification, wiring diagram, layout and price list.

Send 2/- for layout, wiring diagram and components price list.

R.C.S. PRODUCTS (RADIO) LTD
11 OLIVER ROAD (Mail order only) LONDON E17

YOU CAN RELY ON US

We specialise ONLY in radio and electronic components, a comprehensive stock of which are held by us, to supply Government, educational and commercial laboratories. Can we be of some help to you, the experimenter and constructor ? ?

Here are a few of our many stock lines—

Tapped Volume Controls, 1/4mg, 1/2mg, 1mg, 7/6 each; Linear, 1/4mg, 1/2mg, 1mg 6/6; Surplus Stock Potentiometers, less switch 2/3; with 4/3; D/P 5/-; midget wirewound, preset etc. in stock.

All J.B. Scales and Gangs. Full vision 13/9; SL8 27/6; SL5 26/-; 3-gangs in .0003 and .0005 18/3; Single gang .0005 9/-; Twin midget gang covered 11/-.

Bulgin Plugs, Sockets, Panel Lights, etc. Belling-Lee Co-ax. Plugs, 1/3, Sockets, 1/2. Plugs Sockets etc. Resistors, 10 ohms to 15 mgs in 1/4W 1/2W 4d.; 1W 8d.; 2W, 1/4; midget 1/4W 'T' type, 6d.; High stability 2% 100-2 megs, 1/6 each; wirewound (green vitreous), 33 ohms to 10K, 10 watts max., 2/- each.

Over 200 T.C.C. types of Condenser. 189 types of Hunts. Electrolytics new and surplus. 10,000 surplus Valves plus large stock BVA Valves.

1% Silver Micas, 1.5pF to 100pF, 1/-; 100pF to 280pF, 1/2; 300pF to 500pF, 1/4; 515pF to 815pF, 1/6; 1,000pF to 5,000pF, 2/6.

COILS.—COMPLETE RANGE OF DENCO, WEYMOUTH, WEARITE, OSMOR, R.E.P., TELETRON, DENCO F.M. UNIT PARTS, '912' PARTS, MULLARD '510' PARTS—ALL TAYLOR, AVO INSTRUMENTS IN STOCK, CELESTION, ROLA, ELAC, W.B., WHARFEDALE, GOODMAN'S SPEAKERS.

Send now for our Supplementary Winter List with H.P. Terms—Quotes S.A.E. Please. Postage extra

Next to South Ealing Tube Station 65 Bus

82 SOUTH EALING ROAD
LONDON W5 Telephone EAL 5737

RADIO SERVICING CO