



Radio Constructor

Vol. 1, No. 9

Annual Subscription 16/-

April, 1948

Editors:

ARTHUR C. GEE, G2UK

W. NORMAN STEVENS, G3AKA

Technical Editor:

LIONEL E. HOWES, G3AY4

Advertisement & Business Manager:

C. W. C. OVERLAND, G2ATV

Editorial

SOME interesting points are raised in a lengthy letter from reader A. S. Torrance of West London. From his own store of bitter experience he draws some reflections that must have their counterparts in very many amateurs' experiences. The fact that though most sets work all right, they are soon stripped down to make way for the next experiments, is mentioned. The failures are considered in the philosophy that they are enjoyable inasmuch as the knowledge gained will be useful in the future. Though we feel that this is the right approach, we wonder just how many readers share this view. We have our own ideas on gear that refuses to work!

Going a step further, Mr. Torrance considers that every constructor about to embark on a new set should first ask himself, "is the set I am planning to be permanent or to be pulled to pieces for that super job I have in the back of my mind?" Too many amateurs dabble and many try to run before they can walk, is the verdict. Though we consider that planning can become too inflexible, there is no doubt that with a little previous planning much of the gear that did NOT work would have been successful.

Ohms Law is not fully understood by many, particularly when applied to meters, is another considered opinion of our reader. Also, many make do without a meter—a bad fault, as a good meter can save endless trouble (and expense). Mr. Torrance goes on to say that the beginner is not catered for enough and because of this is adept in building unstable receivers, mainly due to bad planning, or the total lack of it. How many times have the

words "if the wiring is kept short and the usual precautions followed, good results should be obtained" at the foot of an article entirely missed their point because the would-be constructor does not know what the "usual precautions" are? The fault, declares A.S.T., is 'due to a good many publications' lack of understanding of the beginner.

Though many other interesting points were raised (the letter was nine pages in all!) we will concentrate on those already mentioned. The main theme seems to be that the beginner gets a raw deal. Now, we have stated before, and will reiterate, that the policy of *Radio Constructor* is a middle-of-the-road policy—in other words, to cater for the average constructor. This policy has a slight bias towards the beginner and many of the articles published are aimed directly at these newcomers. The whole point is—what information does the average beginner need?

Does he need articles on theory, or does he prefer to read standard text-books on that subject? Or does he find text-books dry and a bit tricky to follow? Then again, it may be practical rather than theoretical information he seeks. Our personal view is that he needs both, but with a great emphasis on the practical aspects of the hobby. From the wonderful response to our recent series, "Making a Start," it seems that this is definitely the type of thing in general demand. There are others, of course, and that is where you can help us. Let us know what information you need, the snags you meet, and so on, then we will try to satisfy your demands. Yes, what does the beginner need most in the way of advice?

W.N.S.

NOTICES

THE EDITORS invite original contributions on construction of radio subjects. All materia used will be paid for. Articles should be clearly written, preferably typewritten, and photographs should be clear and sharp. Diagrams need not be large or perfectly drawn, as our draughtsman will redraw in most cases, but relevant information should be included. All MSS must be accompanied by a stamped addressed envelope for reply or

return. Each item must bear the sender's name and address.

COMPONENT REVIEW. Manufacturers, publishers, etc., are invited to submit samples or information of new products for review in this section.

ALL CORRESPONDENCE should be addressed to *Radio Constructor*, 57, Maida Vale, Paddington, London, W.9. Telephone: CUN. 6579.

AUTHENTIC AND UP-TO-THE-MINUTE INFORMATION ON VHF, BROADCAST BAND AND AMATEUR ACTIVITIES IS GIVEN IN OUR MONTHLY PUBLICATION "SHORT WAVE NEWS."

A Versatile Test Instrument

By D. Lisney, I.S.W.L./G52

THIS handy instrument can be used to service or check any receiver and can be handled by anyone with but a slight knowledge of radio.

For ease in description and construction it is split into its three fundamental parts. (A) The 465 kcs signal generator, (B) The Audio Oscillator, and (C) The Signal Tracer, and will be described in that order.

(A) The Signal Generator, using a 1S4 Tungram Valve.

This consists of a Wearite Midget 465 kcs I.F. Transformer tuned by the iron core in a Tuned Anode, Tuned Grid circuit, the output being taken from the anode by a $30\mu\text{F}$ fixed capacitor (C5). The grid leak being a $1\text{ meg}\Omega$ resistor (R5), and the control grid capacitor being $350\mu\text{F}$ (C6). The screen is fed by a $10\text{K}\Omega$ resistor from the main HT line.

(B) The Audio Oscillator, using a 1S5 Tungram Valve.

The note is generated by the midget audio transformer used in the conventional manner, the primary side being connected between the control grid and earth, and the secondary between the HT line and the triode connected screen and anode. The audio output being taken from the anode via a $0.01\mu\text{F}$ fixed capacitor and a $500\text{K}\Omega$ volume control. If the oscillator does not oscillate, reversal of either the primary or secondary, but not both, will effect a cure.

(C) The Signal Tracer, using a 1S5 Tungram Valve.

The heart of this novel and interesting circuit is the 1S5, a diode pentode used as a detector and amplifier. The input is taken to the diode via a $500\text{K}\Omega$ volume control (R1), and a grid capacitor $0.002\mu\text{F}$ (C1) the grid leak is a $10\text{ meg}\Omega$ resistor (R2). The screen and

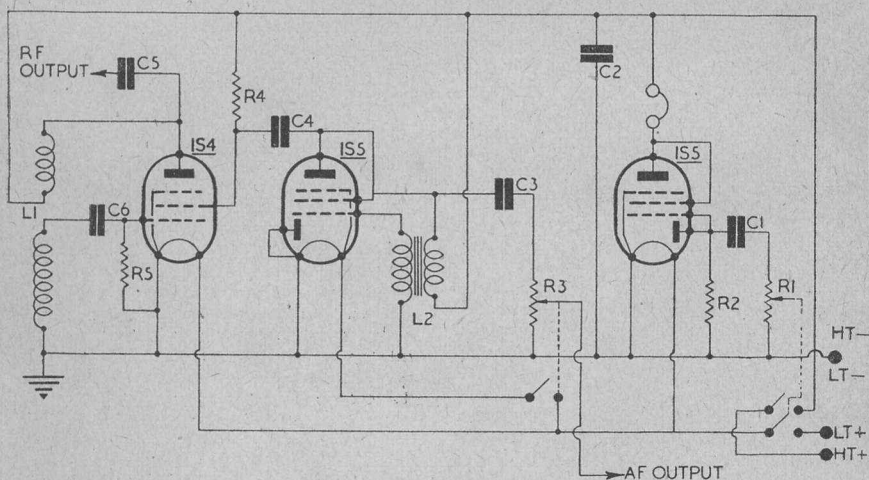

Fig. 1. Theoretical Circuit.

- C1. $0.002\mu\text{F}$ tubular.
- C2. $4.0\mu\text{F}$ 150 VDC electrolytic.
- C3. $0.01\mu\text{F}$ midget tubular.
- C4. $0.01\mu\text{F}$ midget tubular.
- C5. $30\mu\text{F}$.
- C6. $350\mu\text{F}$.
- R1. $500\text{K}\Omega$ volume control with D.P. switch.
- R2. $10\text{ Meg}\Omega$ $\frac{1}{4}$ watt.

- R3. $500\text{K}\Omega$ volume control with S.P. switch.
- R4. $10\text{K}\Omega$ $\frac{1}{4}$ watt.
- R5. $1\text{ Meg}\Omega$ $\frac{1}{4}$ watt.
- 3 Clix valveholders.
- L1. Wearite 465 kcs. I.F. transformer.
- L2. Midget intervalve transformer ratio 3-1.
- 2 1S5 Tungram valves.
- 1 1S4 Tungram valve.

anode are strapped together and the output is taken to a pair of phones. The probe used is a piece of paxolin or polystyrene tube with a 300 μ F fixed capacitor in the centre.

Construction.

If the lay-out illustrated is used, no great difficulty will be met. The chassis is wired and tested stage by stage before the main panel is fixed. HT and LT connected, and then you are ready to test the circuits.

The IF generator can be aligned by any receiver capable of receiving 465 kcs. and fitted with a BFO or receiver having an IF of 465 Kcs. In the former case, the generator is coupled to the aerial of the receiver, and with the BFO ON and receiver tuned to 465 kcs., the slug on the Wearite transformer is tuned for "zero beat" and then sealed with a drop of paint. In the latter case the generator signal is fed into the IF stages and with the receiver tuned to receive a broadcast signal, the slug on the transformer is "tuned" for "zero beat."

The audio oscillator is simple to check by connecting a pair of phones from C3 to earth. If no signal is heard, reverse one of the windings as mentioned earlier.

The signal tracer can now be checked by feeding the output of the IF generator into C1 with phones connected as in the circuit.

With everything working satisfactorily, the main panel can now be fixed and the wiring completed.

The test leads were made of co-axial but the IF and AF output need only be ordinary screened wire, if desired. The probe is used with the signal tracer.

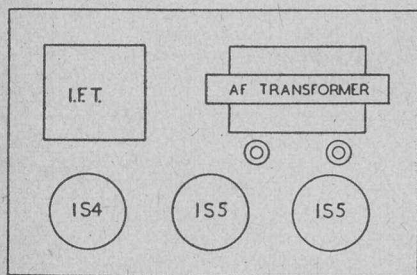

Fig. 2. Underview showing lay-out.

Operation.

To line up the IF of a superhet it has only been found necessary to switch on, but if the IF's are far out of alignment, then a signal can be injected on to the frequency changer grid. The audio oscillator is used for circuit checking in LF amplifiers and checking loud

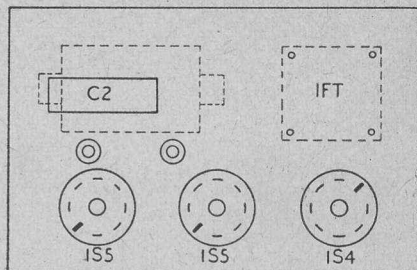

Fig. 3. Top lay-out.

speakers or any circuit where a constant pitch note is desired.

R3 controls the AF output and switches off the LT to the audio oscillator when not required, or when an unmodulated signal of 465 Kcs. is required.

The signal tracer is one of the most useful gadgets to be found in any shack. Its name gives its use, it traces any signal RF or AF through any set. Put the probe on to the antenna terminal and one or more stations may be heard if the antenna system is O.K. At the grid of the first stage it should be possible to select one or two stations on the receiver dial, if not, look for open or shorted elements in the circuit. Go through the receiver stage by stage from control grid to anode of each valve, and it does not take many minutes to locate which is the faulty stage. As you move towards the output stage reduce the volume control and such reduction will give you an idea of the stage gain per valve.

I should like to take this opportunity of thanking the ISWL Valve Data Service and Messrs. Tungram for their invaluable help in matters appertaining in choice of valves and their characteristics.

Advice on this circuit will be given to any member who writes enclosing S.A.E. either direct to me or via the Editors.

Voltage and Current Analysis.

With HT battery giving 55V using Taylor meter 83c.

Anode of signal tracer with 2,000 Ω phones in series—50 Volts Current 1.7 mA.

Anode of Audio Oscillator, 52 Volts Current 3.0 mA.

Anode of IF Generator, 50 Volts.

Screen " " 40 "

Anode Current, 1.7 mA.

Total current with all three sections working, 6.4 mA.

Filament Voltage of all valves, 1.4V.

(continued on page 227)

"Pre-Fab" Receivers

By Centre Tap

IN recent months much has been said both for and against the possibilities of "printed" circuits in radio receiver production and whether we shall see them in use in the near or the very remote future. In past years I have ventured in a number of mild prophecies, but this is a subject which finds me sitting on the fence discreetly pushing forward the suggestion that your guess is as good as mine, although I am willing to stake that we shall soon see sections of receivers appearing in the printed form.

Labour costs in modern industry have risen enormously as the result of higher wages and shorter hours (or crudely put, less work for more money) and today this is the chief item in "costing" a domestic receiver. As various Ministers have recently reminded us, the Sellers' Market is disappearing and we shall have to market our products in face of stern and increasing world competition. In seeking to reduce production costs the work charge is one which offers the most promising prospects. A manufacturer has little or no control over the price of raw materials and he cannot himself reduce costs of Rent, Rates, Taxes, Distribution, Advertising, Marketing, Depreciation, etc. Thus to reduce the amount of work put in on a receiver becomes a prime objective. This new technique is therefore likely to be most carefully studied and developed by Radio Engineers and Designers, although there are many factors governing its more general use.

It would be as well to trace in the broadest terms the forms which domestic receivers have taken since the earliest days of broadcasting when the ebonite panel was the vogue and connections were made via a mass of terminals. It is interesting to note that this was a legacy, or influence of the electrical practice of those days, reluctant to give way to the more rational breadboard assembly. Even then, soldered connections were few and far between—components were generally self-contained and had their own terminals built in. With the metal chassis the terminal gradually vanished, superseded by soldered and tag connections.

As the demand for radios became enormous so the endless belt and production line methods, borrowed from other industries, were adopted by the Radio Engineer and Designer. Production was broken down to one or two simple operations per worker, each of whom might

be unskilled in the sense that he, or more usually she, need have neither previous experience or the faintest knowledge of radio theory, and could become proficient with but little instruction. Indeed, during the war, I had opportunity to study at first-hand the production of transmitters and receivers of elaborate design, and in some instances nearly 95 per cent. of the labour was unskilled or simply machine-minding, and of the remainder more than half only semi-skilled. An important item, of course, was testing and inspection at various stages of manufacture and the more use of mechanical processes the less the need for operators, testers and inspectors.

Those who have never had the opportunity of seeing modern factory practice can perhaps get a clearer idea by touring "surplus" stores, where completed sub-assemblies are offered; complete resistor and capacitor boards, tuning units, valveholders with their own associated group of components, wired and ready to fix and connect to the chassis proper.

It is to partial assembly that the "printing" method is likely to be of the greatest immediate significance. "Printing" in its simplest form began in the early days when a pencilled line or one drawn with Indian ink served well as a grid leak and even metallised spraying for valve screening has been practised for many years. The idea itself is far from new; the newness is in its application. Electroplated "printing" and other methods have been successfully used, including printing with high conductivity inks and with metallic silver deposits upon sheets of bakelite, paxolin or similar material. The "wiring" proved as good as solid wire with "connections" being a mere continuation of the print eliminating possibility of movement or wiring mistakes. Low wattage resistors printed with special compounds, by no means new, are automatically incorporated.

The problem of crossing non-connecting lines is overcome by printing on both sides of the sheet. Capacitor printing can be performed as in the case of silvered-mica capacitors by spraying on both sides of a dielectric, while inductors might be printed in spiral form and tuned by changing their relative positions by means of sliding sheets (as in the variometer), or by the movement of a metal surface (as in some of the early crystal sets), or by adjustable powdered iron cores.

Valve sockets, etc., and connections from one bakelite sheet to another when built up

in "lamination" form, can be carried out by using eyelets of springy metal machined in position, flanged to make good contact with the printed wiring lines and components. A plain sheet at the top and bottom of the laminations would serve for insulation, completed with a sealing around the edges for the exclusion of dirt and moisture. Some components in their present form may disappear before this new technique, just as the spaghetti resistor went out of use when terminal wiring vanished before the soldered connection.

Already simple receivers made along these lines are being exported in quantity to India and the Arab States where there is an enormous demand for cheap sets. Just how soon or how extensively is this practice going to influence the home and European market design? Well, as I said at the start, your guess may be as good as mine!

(TEST SET—continued from page 225).

Filament Current, 1S4 valve 0.1A.
 " " 1S5 " 0.05A.
 " " 1S5 " 0.05A.

Base connections 1S4.
 1. Filament Negative. 5. Filament Negative.
 2. Anode. 6. Anode.
 3. Control Grid. 7. Filament Positive.
 4. Screen Grid.

Base connections 1S5.
 1. Filament Negative. 5. Anode.
 2. Not used—blank. 6. Control Grid.
 3. Diode. 7. Filament Positive.
 4. Screen Grid.

VIEWES, PLEASE.

What are you favourite articles in *Radio Constructor*? What would you like to see and what don't you care for much? We want to know the answers to these questions, so why not drop us a line sometime? Thanks, OM's.

OUR NEXT ISSUE

will include articles on an All-Dry Superhet, Making Short Wave Coils, a 1-v-2 for the Short Waves, practical circuits for the 6B8 valve. Also the first instalment of a new series, "Radio Simplified" and, of course, our old pal Centre Tap will be there as usual. To wind up, further modifications to the R1155, Query Corner and Part 2 of Thermionic Valves, will be published.

Now Available :

DATA BOOKLET No 1.

(The Basic Superhet)

Describing the construction of a simple superhet receiver for use on AC mains, together with details of further stages which can be added to convert it into an efficient communications receiver.

- The Basic Receiver
- Adding a BFO Stage
- Adding an RF Stage
- A Preselector Unit
- Valve Connections
- Coil Data

A valuable booklet for the newcomer to superhet construction

Obtainable through your local bookseller at 1/- or direct from the publishers at **1/2** post paid

AMALGAMATED SHORT WAVE PRESS, 57, MAIDA VALE, LONDON, W.9

The Theory of Thermionic Valves

By Kenneth R. Goodley

Part 1

Thermionic Emission • Space Charge • The Diode Evacuation • Diode Characteristics • Uses of the Diode

This series will consist of six parts, to be divided up as follows:—

Part 1: see heading.

Part 2: The triode; Effect of the grid; Triode characteristics; Mutual characteristics and anode characteristics; Triode constants; AC resistance and impedance; Amplification factor; Types of triodes; Effect of an alternating potential on the grid; Inter-electrode capacity.

Part 3: The tetrode; Effect of screen-grid; Tetrode characteristics; Secondary emission; Comparison of triode and tetrode characteristics.

Part 4: The Pentode; Effect of suppressor; Pentode characteristics; Variable- μ valves.

Part 5: Dynamic characteristics; Indirectly heated cathodes; The CR tube and time bases.

Part 6: Alternating potential applied to diode; Resistance as anode load; Capacitor in diode circuit; Capacitor and resistor in diode circuit.

Thermionic Emission.

WHEN certain substances are heated and reach a certain temperature, the "free electrons" contained in their molecules are so agitated that some leave the surface of the material. This phenomenon is known as Thermionic Emission. If there are no external forces acting on these "free electrons" they will return to the surface of the material.

Thus, we can see that around a conductor which is sufficiently heated, there exists a cloud of electrons which are continually being expelled from, and attracted back to, the conductor. This cloud is known as the Space Charge.

If this conductor is now placed in a glass envelope and the air withdrawn so that a near or perfect vacuum exists, the mean free path of the "free electrons" is increased, due to the absence of air molecules with which they would normally collide, and therefore tend to impede their paths.

The Diode Valve.

This consists of an evacuated glass envelope containing a filament surrounded by a metal cylinder, termed the PLATE or ANODE.

There is no internal connection between these two electrodes. The filament may be heated by a low-voltage battery or by the mains. It should be noted that this is merely to raise the temperature of the filament and cause it to emit its "free electrons."

A fact that must be remembered is that a positively charged electrode will attract a negatively charged body, so that if the anode is made heavily positive, the "free electrons" emitted by the filament will travel to it across the vacuum. This is illustrated in Fig. 1, and it can be seen that current is flowing round the circuit as indicated by the arrows.

If the anode is negatively charged no current will flow, since the emitted electrons will fall back to the filament.

Thermionic Emission may be increased by using special metals in the construction of the filament. The three principal materials used are:—

1. Pure Tungsten.
2. Thoriated Tungsten.
3. Oxide Coated.

The last two require less heating current and the filament glows less brightly. Almost all ordinary receiving valves are of the third type.

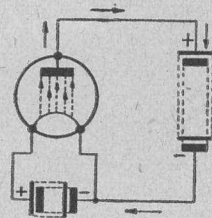

Fig. 1. Flow of current in a diode.

Evacuation Process.

Air is evacuated from the valve, and while this ensues, the valve is baked in an oven to eliminate all occluded gases. An additional process is that of *gettering*. During assembly, a small piece of magnesium, or alloy containing

barium, is attached to a small copper or nickel disc and placed in such a position that it can be heated during the use of the valve. The "getter" is volatilised and settles on the inside of the glass envelope in fine particles forming a highly absorbent mirror which combines chemically with any minute traces of gas still remaining free in the valve, or which may subsequently be evolved.

Diode Characteristics.

The "characteristic" of a valve is the graphical representation of the voltages and currents resulting from certain stable combinations of "constants" in relation to each other. A glance at Fig. 2 will show that it is possible to measure three things—the filament current, the voltage at the anode and the anode current, known as I_f , V_a , and I_a , respectively. The graph in Fig. 3 shows variation in Anode

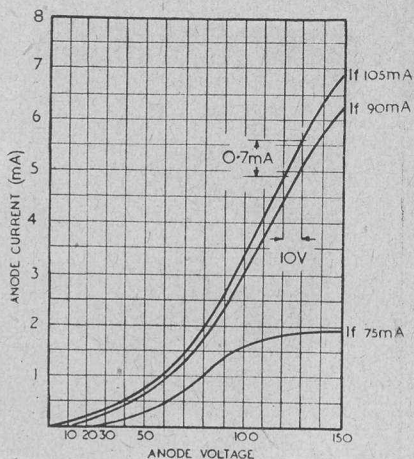

Fig. 3. Characteristics of a diode valve.

Saturation, or, as in the case of the lower curve in Fig. 3, by greatly reducing the filament current, which has a similar effect.

The AC resistance or impedance ("Ra") is the ratio between a small change in V_a and in I_a over the straight part of the characteristics:—

$$R_a = \frac{\Delta V_a}{\Delta I_a} = \frac{10}{0.7} = \frac{100,000}{7} = 14,300 \Omega \text{ (approx.)}$$

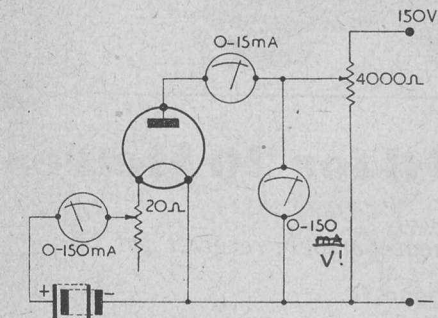

Fig. 2. Circuit used to determine the characteristics.

Current resulting from variations in anode voltage for three selected values of filament current. The results are tabulated at the end of this article. Four conclusions may be noted from the results obtained.

1. An increase in anode voltage will cause an increase in anode current—up to a certain point.
2. That over the straight part of the characteristic known as the "working portion" equal changes in V_a result in equal changes in I_a . This fact is very important.
3. An increase in I_f raises the temperature of the filament and therefore increases the I_a for a given anode voltage.
4. A point is eventually reached there an increase in V_a does NOT increase I_a . This is called the Saturation Point, and is the flattened portion at the top of the curves on the graph.

In practice, the Saturation Point is never reached, as the filament is designed to give ample emission for the highest anode voltage that is likely to be employed. It is only by exceeding this that it is possible to attain

The ratio of a given change in V_a to a given change in I_a , over the straight portion of the characteristic is a constant known as the AC RESISTANCE or "Ra" of the valve.

The Diode is the simplest Thermionic valve and has three main uses: Power Rectification of AC supplies; Detection of Modulated Waves and the provision of various forms of Automatic Volume Control (AVC).

Anode Voltage	Anode Current (mA)		
	$I_f = 105 \text{ mA}$	$I_f = 90 \text{ mA}$	$I_f = 75 \text{ mA}$
10	0.1	0	0
30	0.3	0.2	0.05
50	0.9	0.7	0.35
70	1.6	1.4	0.85
90	2.6	2.4	1.4
110	4.2	3.7	1.7
120	4.9	4.4	1.8
130	5.6	5.1	1.84
140	6.3	5.7	1.87
150	6.9	6.3	1.88



A Button Base TRF 3 for 20 Metres

*Describing the construction of a neat portable receiver for the
14 Mcs. band*

By E. I. Vaughan

Introduction.

ABOUT a year ago the prospect of many months of travelling from place to place, prompted the writer to produce the receiver which is the subject of this article. A really portable outfit suitable for use anywhere was the object, and how this has been achieved may be judged from the photographs and following description.

At the time of construction the 20 metre band had just been reopened for British amateurs and it was therefore decided to build the receiver to cover this band only. This decision made it possible to produce a very compact unit, which would not have been the case had it been necessary to make provision for plug-in coils or band switching.

A small wooden case measuring overall $8\frac{1}{2}'' \times 7'' \times 5\frac{1}{2}''$ was on hand and it was decided to use this if possible. A search for suitable batteries produced two Ever-Ready 45 volt Deaf-Aid Packs (W1321) for High Tension, and an Ever-Ready U14 Gas Lighter Cell for Low Tension. After fitting these batteries

into the case with a partition to keep them in place, it was found that $5\frac{1}{4}'' \times 4'' \times 3''$ was available for the actual receiver. The fact that it was possible to make a set to suit this small space was due entirely to the tiny components and valves which were available. The depth of $1\frac{1}{2}''$ in the lid allows a pair of Brown's Featherweight Headphones to be fitted round the knobs projecting from the panel, also about 20 feet of flex for a throw-out aerial.

The writer would like to make it perfectly clear from the start that this receiver was not made for a novelty but to do a proper job of work. The performance has more than justified the trouble taken to construct it and although much more powerful receivers are now on the same bench as the "Pup"—as it is affectionately known, it has the uncanny knack of being able to hold its own with any of them. During the past summer it has made trips all over the country and no matter what aerial was used and where the location, it has given good results.

Components.

The fact that tiny components and valves were used has already been mentioned, and it might be as well to give a few details of these essential items. The valves used are the Button Base RF pentodes 1T4 (2) and one 1S5, and are well-known now and easily obtainable. The components may be more difficult to collect, but so far the writer has been able to buy further supplies in the form of small group-boards from quite a few of the well-known surplus stores. These group-boards vary in size and shape, but usually include about six capacitors of 0.1 to 0.01 μF , which measure only $\frac{5}{8}$ " long by $\frac{5}{16}$ " diameter, and about the same number of resistors of numerous values which are $\frac{1}{8}$ or $\frac{1}{4}$ watt size.

Some advertisers in this journal have been offering small IF and AF units which it is understood include these minute components in addition to the Button Base valves.

Wearite "P" coils and a midget 25 μF two gang variable capacitor were obtained to complete the tuning arrangements. The remainder of the parts required are of more normal size and do not need any comment.

Standard GT 1.4V valves could be used together with normal components if the constructor is willing to sacrifice the portability. A receiver has been built on these lines using the same circuit and the performance is very similar to the miniature version. Details of this receiver will be given if it arouses sufficient interest.

Batteries.

When designing the receiver the small size and weight of the batteries was of paramount importance but at the same time due consideration was given to the length of service which might be reasonably expected. At the time of purchase (June, 1946), the High Tension batteries were the smallest of suitable voltage available. Since, however, many alternatives have been found and at present two smaller layerbuilt packs are being used. The original Low Tension has just been replaced although it still works the set and shows a voltage reading of 1.3 under load.

There are possibilities for experiment with the power supply. Wiring the valve filaments in series would allow the use of a standard 4.5 volt flat flashlamp battery for Low Tension and is worth trying on the score of reduction, in the size of the case.

A small eliminator has been rebuilt to supply the needs of the receiver when electric power is available. Since the photographs were taken a socket strip has been fitted to the lid of the battery compartment. This, together with the toggle switch shown, enables a change-over from batteries to mains by means of the switch, and at the same time prevents a constant drain on the batteries through the detector screen potentiometer. It is expected that at a later date a very small eliminator will be designed to fit the vacant space in the battery compartment.

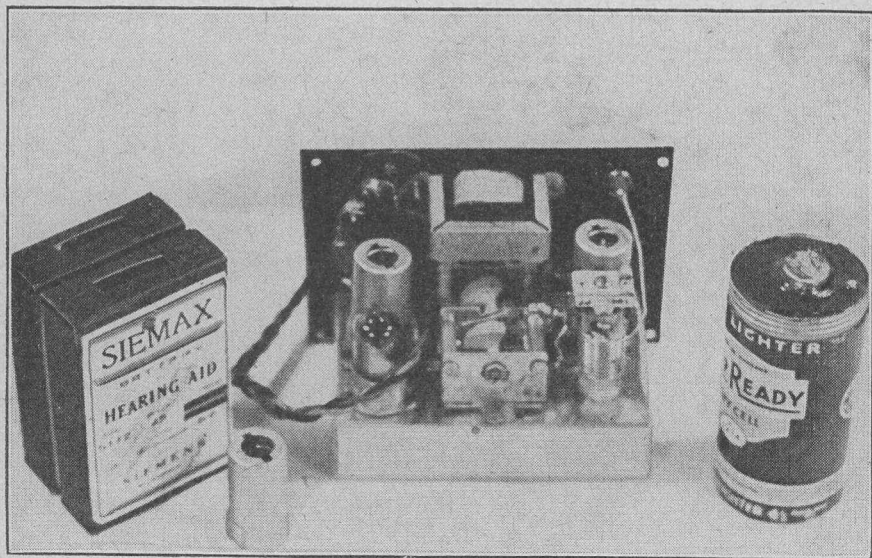

The receiver with cabinet removed. The actual size can be gathered by the batteries alongside.

Circuit.

The circuit shown in Fig. 1 consists of a tuned RF stage (1T4); tuned anode coupled to a leaky grid detector (1T4), and resistance coupled AF stage (1S5), with choke feed output to the headphones.

The tuning arrangements consist of Wearite "P" coils with the secondary winding of each tuned by a 100 $\mu\mu\text{F}$ postage stamp trimmer for bandset (C1 and C2). Bandsread is provided for both by the 25 $\mu\mu\text{F}$ two gang capacitor (C3 and C4), which spreads the band over approximately 50 degrees on the 180 degree dial. This is controlled by a large Raymart knob through an epicyclic drive, giving about 4:1 reduction. This drive is the variety which is fitted with a flange which projects through the panel. It revolves at capacitor speed and has been fitted with a cursor made from a piece of perspex.

The primary of the tuned anode coil (L3 and L4) is used for reaction and it was found necessary to increase this winding from three to six turns, interwound as before. Reaction is controlled by the potentiometer (R5) in the detector screen circuit.

No trouble has been experienced with hand capacity effects even though the receiver is rarely used with an earth. This is no doubt due to the use of a metal panel and chassis, and the choke capacity output.

Referring to the photograph of the panel it will be seen that there are three controls. In the centre is the large tuning knob. The left-hand pointer knob controls reaction and that on the right is the low tension on/off switch. The socket on the top left is for the aerial plug and the headphones are connected to the socket strip on the right of the dial.

Construction.

The chassis measures $4\frac{3}{4}$ " long, 3" wide and $1\frac{3}{8}$ " deep. It was bent up from a piece of 20 gauge aluminium and the corners riveted. Fig. 3 gives full details of the chassis with the positions of all holes except those concerned with the fixing of the two gang capacitor. The reason being that there are a variety of these about at present and the chassis should be drilled to suit the one available.

The panel is a piece of $\frac{1}{16}$ " thick steel measuring $5\frac{1}{2}$ " x 4" and is finished black crackle. It is fastened to the chassis by one bolt on the centre line and the fixing bushes of the switch and potentiometer. Details of the panel are given in Fig. 3 also.

The scale used was off an old Utility dial and was bolted to the panel with countersunk 6 B.A. bolts after all other components had been mounted. The cursor, as mentioned before, was cut from a piece of perspex and a hair line scored on the underside with a scriber. The actual shape is a matter for personal taste.

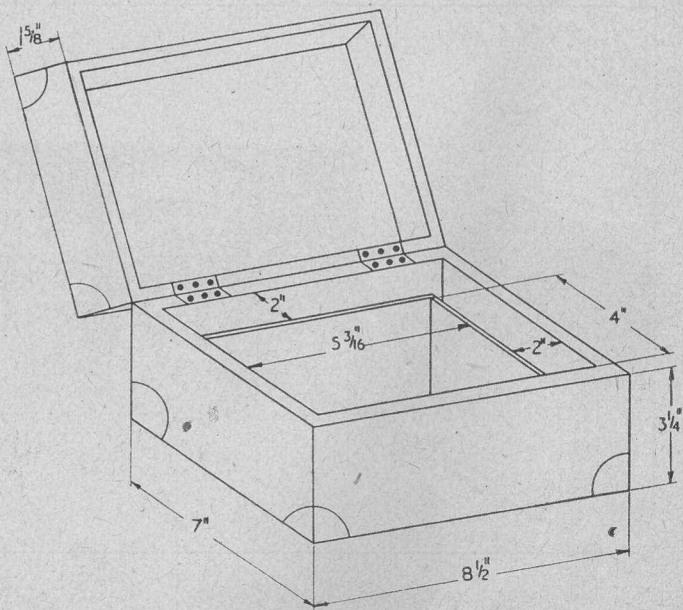

Fig. 2. Sketch of the wooden cabinet which houses the receiver. By covering with resine a smart appearance may be obtained.

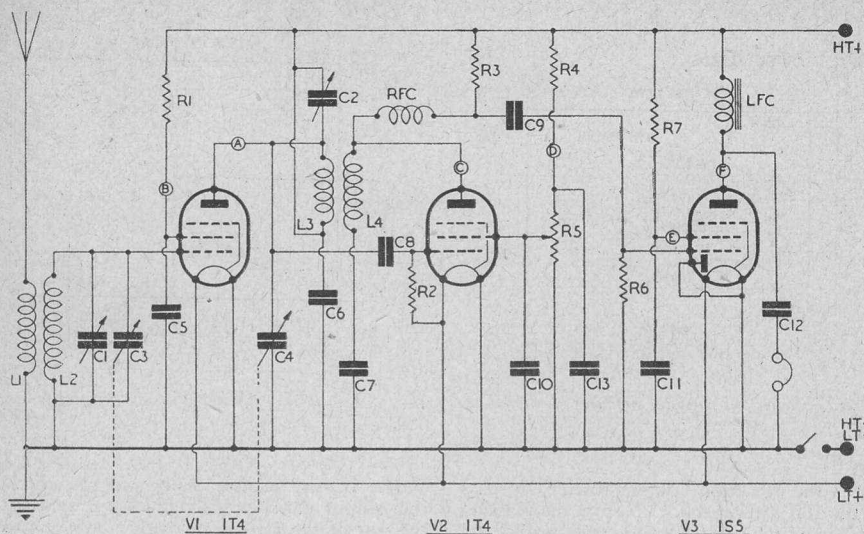

Fig. 1. The circuit.

BUTTON BASE TRF3 FOR 20 METRES.

Components Required.

- | | | | |
|----|--|----------|---|
| R1 | 18 K Ω RF Screen Dropper. | C1 | 100 $\mu\mu\text{F}$ Trimmer. Aerial Bandset. |
| R2 | 2 M Ω DET Grid Leak. | C2 | 100 $\mu\mu\text{F}$ Trimmer. RF Bandset. |
| R3 | 100 K Ω DET Anode Load. | C3 & C4. | 25 $\mu\mu\text{F}$ 2 Gang. Bandspread. |
| R4 | 100 K Ω DET Screen Dropper. | C5 | 0.1 μF RF Screen Decoupling. |
| R5 | 250 K Ω DET Screen Potentiometer. | C6 | 0.1 μF RF Anode Decoupling. |
| R6 | 5 M Ω AF Grid Leak. | C7 | 100 $\mu\mu\text{F}$ Reaction. |
| R7 | 18 K Ω AF Screen Dropper. | C8 | 100 $\mu\mu\text{F}$ DET Grid. |
| V1 | 1T4. | C9 | 0.05 μF DET/AF Coupling. |
| V2 | 1T4. | C10 | 0.1 μF Reaction Decoupling. |
| V3 | 1S5. | C11 | 0.1 μF AF Screen Decoupling. |
| | | C12 | 0.1 μF Output. |
| | | C13 | 0.1 μF DET Screen Decoupling. |
- All Resistors, $\frac{1}{4}$ or $\frac{1}{8}$ W.
 Wearite P coils, PA3 and PHF3.
 R.F.C. - Denco Standard S.W. Choke.
 L.F.C. - Franklin 40 milliamp choke.

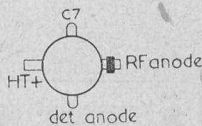
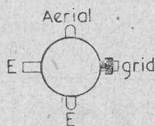
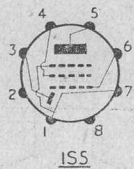
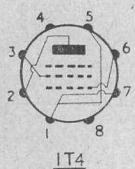
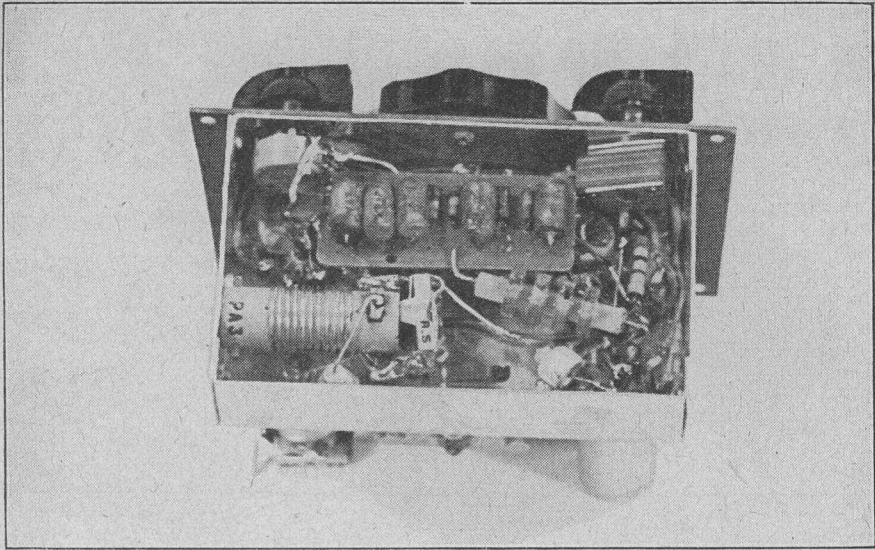

Fig. 5. Valve and coil connections.

The position of the output choke at the back of the panel should be noted, and care taken when mounting to see that it does not interfere with the capacitor drive. A Franklin 40 mA choke is used but there are many other makes

available about the same size, and some even smaller.

Fig. 4 gives full size details of the group board. This is a strip of paxolin $2\frac{1}{2}$ " x $1\frac{1}{8}$ " and has all the resistors and condensers mounted on it,



Underchassis view of the receiver. Note group board and positions of main components.

“D”	Junct. of R4 & R5	...	15	„
“E”	AF Screen	...	52	„
“F”	AF anode	...	77	„

The readings as shown were given by the 100 volt range of a Universal Avo Minor. Allowances should be made for this when using other meters.

The initial adjustment of the 100 μ F trimmers on the coils is tricky and if a Signal Generator is available it will simplify matters considerably. The set can be trimmed by using a strong signal, as was done with the original, but it requires a steady hand and quick ear. The adjustment of both C1 and C2 is very sharp, no doubt caused by the RF valve having both grid and anode circuits tuned, and results in the selectivity being quite good for this type of circuit. This has probably something to do with the receiver's ability to bring in the DX and the writer can assure anyone taking the trouble to build this little job that they will be agreeably surprised with the results.

The Case.

This was made before the set was thought of, but turned out to be just what was required. Fig. 2 is an outline drawing giving all dimensions. It is constructed of $\frac{1}{4}$ " thick wood except for the larger partition and the top and bottom, which are of plywood. The various pieces were glued and pinned together and then covered with leather. The inside of the lid and the top of the battery compartment being covered with some rexine to match. To

protect the outside still further metal corner plates were attached and a chromium carrying handle fitted to match them. The photograph will give a good idea of the finished appearance. It will be necessary to make a hole in the larger partition to allow the battery leads to pass through. This should be arranged to suit the batteries used.

THE EDITORS INVITE . .

- Constructional articles suitable for publication in this journal. Prospective writers, particularly new writers, are invited to apply for our "Guide to the writing of Constructional Articles" which will be sent on request. This guide will prove of material assistance to those who aspire to journalism and will make article writing a real pleasure!
- Constructive criticisms and suggestions on the magazine. Let us know what you like and what you don't like.

CLYDESDALE

GM3BL
GM3ASM

FOR BARGAINS IN EX-SERVICE

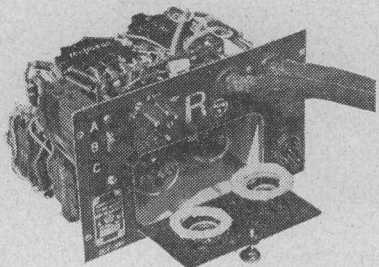

REPEAT OFFER ——— FURTHER SUPPLY

A.1134 BATTERY AMPLIFIER WITH JUNCTION PANEL

2 valve, 2 stage pre-amp-intercom. unit, with OP21 and 210LF trans, condensers switches, 10 and 4 pin plugs, etc., in metal cabinet 7in. x 5in. x 4½in., with circuit Plus Junction Panel, containing 10 and 4 way sockets, 6-2 way and 2-3 way terminal blocks, switches, etc., on board. 6in. x 4½in.

CLYDESDALE'S PRICE ONLY **19/6** each

Post Paid



EX U.S.A.A.F. BC348 RECEIVER

A communication Receiver, covering 1.5-18.0 Mcs. and 200-500 kcs. with 8 valves plus stabilizer, built-in power pack. (AC Model has high imp. phone and 2-3 ohm LS outputs). (DC Model has 2 high imp. outputs). Vernier tuning control, crystal filter, noise limiter, AVC, MVC and BFO controls, in black crackle case, 18in. x 10in. x 8in. complete with circuit; tested in operation before despatch.

For AC Mains 200/250v operation with Internal Power Pack.

CLYDESDALE'S PRICE ONLY **£27 10s.**

Carriage & Packing Paid

For DC 28 volts operation with Internal Power Pack.

CLYDESDALE'S PRICE ONLY **£19 10s.**

Carriage & Packing Paid

BRAND NEW—VARIABLE AIR SPACED CONDENSER (STRATTON 339)

Lab. built, on DL9 insulation, brass vanes. Caps. 3/50pF or 2/100pF or 4/200pF as connected. Size 2½in. x 2½in. x 1½in.

CLYDESDALE'S PRICE ONLY **4/11** each Post Paid



BRAND NEW—R1132 RECEIVER

A VHF Receiver Unit for 100-124 Mcs. with 10 valves plus stabilizer, screened RF unit, SM tuning dial calibrated 0-180 'S' meter, BFO. Attenuator, etc., rack mtg., enclosed chassis, finish light grey. 19in. x 10½in. x 11in., with circuit. Tested in operation before despatch. Power supply required 210v. mA, smoothed DC. 6.3v., 3.5a., AC.

CLYDESDALE'S PRICE ONLY **£8 19s.6d.** Carriage & Packing Paid

BRAND NEW—R1481 RECEIVER

As R1132 but for 65-86 Mcs. Dark grey finish.

CLYDESDALE'S PRICE ONLY **£7 19s.6d.** Carriage & Packing Paid

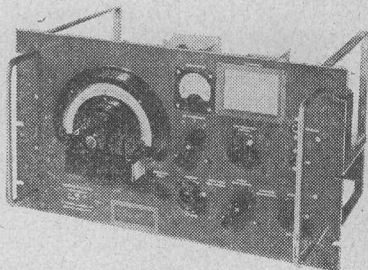

SEND NOW FOR NEW ILLUSTRATED LIST.

(Write Name and Address in BLOCK LETTERS please).

CLYDESDALE SUPPLY CO LTD

● The Radioman's Shop ●

ES ELECTRONIC EQUIPMENT

**BRAND NEW—
EX U.S.N. AIRCRAFT RADAR EQUIPMENT**

AN/APA-1, comprising Cathode Ray Indicator 3 BPI, CRT in adjustable case. Repeater Amplifier with 11 valves, 7/6Sn, 7G's, 6H6, 6G6G, 2X2/879, 6X5GT plus other VHF gear. Control Unit and Instruction Book for 110/115v, 400/2,400 c/s.

CLYDESDALE'S PRICE ONLY **£4 17s.6d.** Packed in wood box Carriage Paid

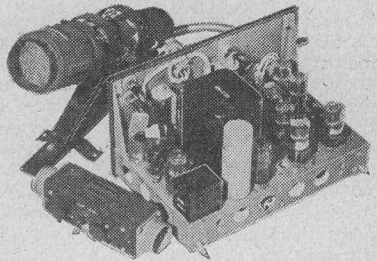

BRAND NEW—Set of Plugs for AN/APA-1

CLYDESDALE'S PRICE ONLY **7/6** per set Post Paid

BRAND NEW—EX R.A.F. SLOW MOTION DRIVE

Muirhead 48-1 ratio. 3in. dia. for standard spindle, milled edge on main drive, four drilled holes allow for fitting an escutcheon. A metal tongue is provided to lock the drive to the panel.

CLYDESDALE'S PRICE ONLY **7/6** each Post Paid
2 for 13/6.

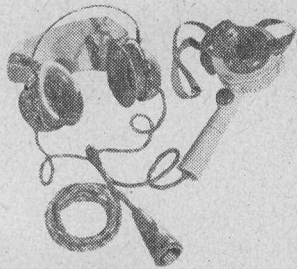

**BRAND NEW—
MICROPHONE AND HEADPHONE ASSEMBLY**

Consisting of a Carbon Hand Power Microphone (Tannoy) in diecast case with press switch. Moving Coil Headphones, 40 ohms coil, sealed and moisture proof, fitted with rubber earpieces. Connecting cable terminating in a 5 point plug.

CLYDESDALE'S PRICE ONLY **15/6** each Post Paid

**BRAND NEW—REMOTE CONTRACTOR NO. 4
(Venner Time Switches Ltd.)**

A Relay Unit used for remote Switching of Transmitters. Comprising 24v. relay and drive mechanism. On/off switch and resistor, etc., in round metal case, with black plastic top, Perspex window. Dia. 4in.

CLYDESDALE'S PRICE ONLY **3/11** each Post Paid

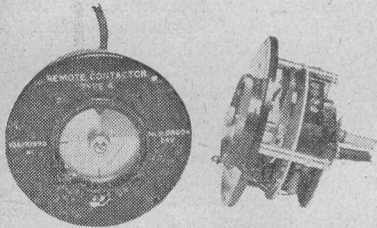

BRAND NEW—DIPOLE AERIAL

Half-wave Dipole aerial 9ft. 3in., with reflector, 9ft. 7in., and crossarm, 4ft. 11 1/2in., plus 39ft. co-axial cable and co-axial plug for approx. 6 meters, either vertical or horizontal mtg. to existing mast or wall bracket. Robust construction.

CLYDESDALE'S PRICE ONLY **21/-** each Carriage Paid

or packed in a stout wood case (non-returnable), 28/6 each, carriage paid.



CO-AXIAL CABLE. Coil (12 yds.) first-class co-axial cable, approx. 80 ohms. AT SPECIAL PRICE 7/6 per coil. Post Free.

2 BRIDGE STREET, GLASGOW, C.5

Phone : SOUTH 2706/9

VISIT OUR BRANCHES IN SCOTLAND, ENGLAND AND NORTHERN IRELAND

The Fork

Something new in indoor aerials

By D. H. G. Tyrell-Lewis, ISWL/GI411

THE writer is at present working "fixed-portable" at a location where an outdoor aerial for receiving is quite out of the question. It was decided, therefore, to try to construct an indoor aerial which, while efficient, would at the same time not be unsightly or hamper ordinary bed-sitting-room activities. It is to be hoped that the notes to follow will be of assistance to those readers who are similarly in an unfortunate position with regard to erecting an outdoor aerial and want an indoor one that is neat to observe and yet is efficient in operation.

Three stages had to be passed through in order to arrive at the desired result. Firstly, a folded-T was tried as shown in Fig. 1. Secondly, it was thought that an improvement might result if C and D were linked and E and F



Fig. 1. $A=10\text{ft.}$ $B=8\text{ft. }4\text{in.}$ with all "legs" parallel.

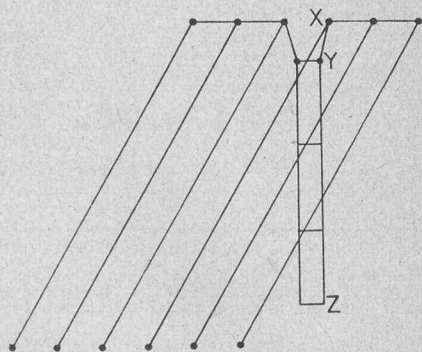

Fig. 2. $X\text{ to }Y=8\text{in.}$ $Y\text{ to }Z=4\text{ft. }6\text{in.}$ Feeders spaced 2in.

removed. This was found to be a correct conclusion. It thus became a six-pronged fork. There was, however, a finishing touch to be made: namely, the introduction into the system of twin feeders, the finished product appearing as shown in Fig. 2.

The Fork is suspended between two picture rails out of the way and to the casual observer, the writer finds, out of sight. The feeders (spaced with cycle brake-blocks!), run down to a desk approximately six inches from the wall vertically, but this measurement will naturally vary according to circumstances.

Performance at the higher frequencies is definitely good. At this QRA, the room is in the second storey of a three-storey building. The aerial runs roughly NE/SW and seems to give adequate coverage; good signals being had from Greenland, Australia, Africa, and the Americas. For 3.5 Mcs., 1.8 Mcs. and normal broadcast reception the ends of the feeders should be joined and the aerial connected as an ordinary single-wire array. The writer believes that the Fork offers plenty of scope for further experiment in the matter of its dimensions which, in this case, were largely governed by the size of the room. It may quite possibly have good possibilities as an outdoor aerial system, too.

FROM THE MAILBAG

Dear Sirs,

Mr. Mackintosh's letter in the No. 5 issue is rather provoking. There are several reasons why it is better to increase the number of IF stages rather than the RF stages. Today, ganged capacitors are taken for granted as having identical sections. This, however, is not the case always. There are also mechanical reasons why these sections are the practical limit consistent with reasonable accuracy in tracking. With one tuned section per stage, this limits the tuned stages to RF Mixer and Oscillator in a superhet receiver. Also, in a straight receiver to two RF stages and detector.

While it is possible to use a separate tuning capacitor for each stage, this would mean in effect lining up the set for every station received. Old hands, like myself, remember sets with as many as five tuning dials, but it is not a very practical idea!

Since IF stages are all tuned to one previously fixed frequency, an additional stage presents very few difficulties in design and practice.

Regarding the 6B8 valve, this is dealt with fully in many valve manuals. It should, however, be remembered that a diode detector has a "threshold" signal strength below which it will not function efficiently so that the 6B8 would require a previous RF stage, making 2 RF and diode detector. A better scheme would be 2 RF (6J7), diode detector, with the pentode portion of the 6B8 as first AF followed by a 6L6 (or a push-pull output).

As regards the 6F6 used as a triode, details are as follows:—

	V_a	I_a	V_g	AC res.
Class A	250	31 mA	—20 V	2,600 Ω
Push Pull	350	50 mA	(Bias resistor— 730 Ω)	
Class AB2	350	48 mA	(Separate bias— 38 V)	
		<i>Load</i>	<i>Power</i>	<i>Output</i>
Class A	4,000 Ω	0.85 watts
Push Pull	10,000	9.0 watts
Class AB2	6,000	13.0 watts

It will be noticed that there is a big drop in output due to the valve still handling the same input swing in grid volts, but reduced amplification factor, as triode reduces output even under theoretically perfect conditions.

Since beam tetrodes such as the 6V6 and 6L6 give similar characteristics regarding frequency distortion (i.e., emphasise even

harmonics) when used alone or in push-pull they give as good reproduction as triodes and no useful purpose is served by using them so.

Yours faithfully,

J. N. GILL (Sidcup, Kent).

(Next issue, we will feature a short article on the use of the 6B8, together with circuit values, etc.—Ed.)

EUROPEAN BAND PLANNING.

The following Band Plan drawn up by the Codes of Practice Committee of the Radio Society of Great Britain, and approved by the Council of that body, has been submitted for consideration to all I.A.R.U. Societies in Europe. Copies of the plan have been forwarded to I.A.R.U. Headquarters and to the W.I.A. (Australia), N.Z.A.R.T. (New Zealand), and S.A.R.L. (South Africa) for information.

The Council of the Society recognises that any form of Band Planning will fail unless it is introduced into the licence and enforced by the respective licensing authorities. For this reason the European Societies have been asked, when commenting on the plan, to indicate whether they consider that their licensing authority will agree to make the plan mandatory if it is finally adopted.

Details of the Plan are set out below:—

Band	Frequencies	Proposed Occupancy
1.7 Mcs.	—	Telephony and C.W. (no sub-division considered necessary).
3.5 Mcs.	3500—3550	C.W. only.
	3550—3750	Telephony and C.W.
	3750—3800	Telephony only.
7 Mcs.	7000—7050	C.W. only
	7050—7100	C.W. and Telephony
	7100—7150	Telephony only
14 Mcs.	14000—14050	C.W. only
	14050—14200	C.W. and Telephony
	14200—14250	Telephony only
	14250—14350	C.W. and Telephony
21 Mcs.	21000—21100	C.W. only
	21100—21150	C.W. and Telephony
	21150—21250	Telephony only
	21250—21450	C.W. and Telephony
28 Mcs.	28000—28100	C.W. only
	28100—28400	C.W. and Telephony
	28400—28500	Telephony only
	28500—29700	C.W. and Telephony
Above 28 Mcs.		No sub-division between Telephony and C.W.

Query Corner

A "Radio Constructor" service for readers

Motor Boating.

"I recently built a tuning unit and amplifier, the results being satisfactory, but for one fault. When the base boost control is turned to a point approaching its maximum a form of motor boating commences. The actual position of the control at which oscillation commences depends upon the setting of the volume control. The H.T. for both the tuning unit and amplifier is drawn from a common power pack and the anode circuits of the valves in the amplifier are effectively decoupled. Can you offer any solution to the problem?"

—W. Bishop, Lewisham.

During the past few months we have received a surprisingly large number of queries regarding instability, its causes and its cures. When the instability occurs in the RF side of a receiver, and in spite of all precautions having been taken as regards screening and decoupling, the trouble may safely be attributed to a bad lay-out. This applies equally well to both straight and superhet receivers, although with the latter class it is frequently found that the only satisfactory cure lies in the complete re-design of the RF Section of the receiver. When considering the lay-out it is always a good plan to mount the valves in a straight line in the order in which they appear on the circuit diagram. The components associated with each valve should then be mounted so as to keep the length of the connecting leads down to a minimum.

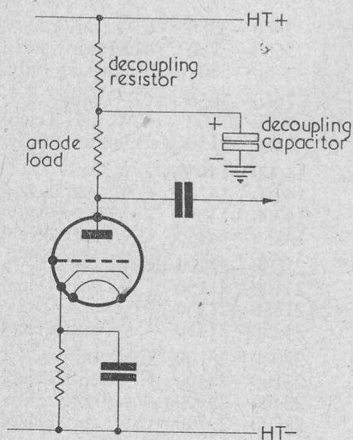

Fig. 1.

In the case of the audio amplifier, instability is normally less difficult to cure, providing a conventional layout is employed; the judicious use of screened cable usually provides complete freedom from this most annoying defect. There is, however, one form of instability upon which the cures so far mentioned will have little or no effect, namely, motor boating. This is the result of coupling between the output stage and one or more of the preceding stages via the HT line, such coupling is caused by the fluctuations in HT current drawn by the output stage resulting in corresponding fluctuations in HT voltage. These voltage fluctuations being fed to the anode and consequently the grids of other valves in the amplifier. If the overall gain is sufficiently high low frequency oscillation will be maintained. The most obvious cure is to prevent the HT voltage changing with changes in HT current; this is another way of saying that the regulation of the HT supply should be extremely good. In practice such regulation is expensive to obtain as it requires the use of transformers and chokes having the lowest possible resistance. Mercury vapour rectifiers are an added advantage in the larger type of power supply owing to their low voltage drop. However, by far the cheapest and most practicable method of preventing motor boating is to use a power supply which has an average regulation characteristic and then to provide each voltage amplifying valve with its own separate smoothing circuit. The average anode current of a resistance-capacitance coupled stage is normally of the order of one to two milliamps and hence resistance-capacitance smoothing may conveniently be employed without any undue loss of HT voltage. The decoupling resistor should have a value of approximately one-tenth that of the anode load, whilst the decoupling capacitor should have a value of between one and eight micro-farads depending upon the amplification following the stage which is being decoupled. The highest value of capacitor should be used in the anode circuit of the first audio valve. In severe cases of motor boating it may be necessary to employ two stages of decoupling.

Upon checking the circuit diagram of the tuning unit and amplifier it was found that the decoupling in the anode circuit of the infinite impedance detector was inadequate. The motor boating or low frequency oscillation occurred only when the base boost control was set towards its maximum as the gain of the amplifier at low frequencies is greatest under this condition.

AC/DC Receiver.

"I wish to construct an AC/DC receiver having the smallest possible dimensions but at the same time a reasonable power output. I am only interested in medium wave reception and would be grateful if you would recommend a circuit."

—W. Evans, Colne.

We are including this particular query as it is felt that other readers may also be interested in constructing a small universal receiver. Upon looking down the list of valves which are readily available at the present time, it was decided that the triode hexode and the output pentode from the new loctal range would

conveniently form the basis of a small 1-V-1 type of receiver. The hexode section of the triode hexode is completely isolated from the triode section and hence it may conveniently be used in a conventional tuned RF circuit, the screen and anode voltages are obtained from a common decoupling resistor in order to economise in components. The triode section is connected up as a leaky grid detector; it should be noted that the grid leak is returned directly to the cathode in order to obtain optimum operating conditions. The two coils, which may conveniently be of the Wearite

(continued on page 247

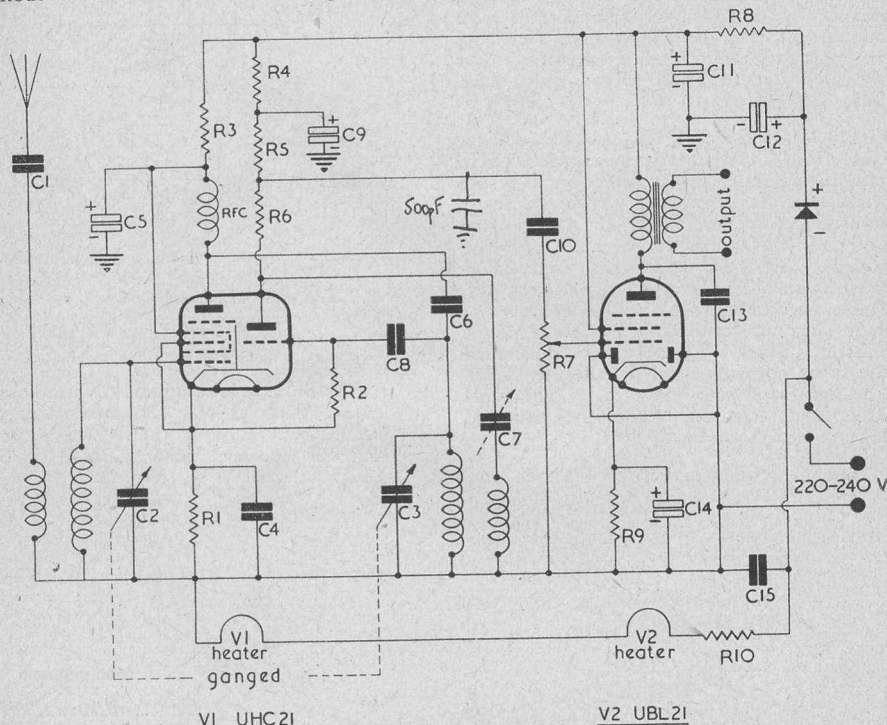

Fig. 2. AC/DC Receiver.

- | | | | |
|-------|---------------------------|-----|------------------------|
| C1, 8 | 200 μ F | R1 | 200 Ω |
| C2, 3 | 500 μ F twin-gang | R2 | 1 M Ω |
| C4 | 0.1 μ F | R3 | 2,000 Ω |
| C5 | 2.0 μ F | R4 | 10,000 Ω |
| C6 | 100 μ F | R5 | 50,000 Ω |
| C7 | 100 μ F trimmer | R6 | 100,000 Ω |
| C9 | 4.0 μ F | R7 | 0.5 M Ω |
| C10 | 0.02 μ F | R8 | 2,500 Ω 10 watt |
| C11 | 16.0 μ F | R9 | 150 Ω |
| C12 | 8.0 μ F | R10 | 1,600 Ω |
| C13 | 500 μ F 0.005 μ F | | |
| C14 | 50 μ F, 12 V. wkg. | | |
| C15 | 0.01 μ F | | |

All electrolytics should be 350 V. wkg. unless stated otherwise.

Optimum load of output valve is 3,000 Ω .
Selenium rectifier: 250 V. 50 mA.

Pin connections for valves are:—

UCH21	UBL21
1 Heater	Heater
2 hexode anode	anode
3 triode anode	grid 1
4 triode grid	grid 2
5 grids 2 and 4	diode
6 grid 1	diode
7 grid 3	cathode
8 heater	heater
Spigot—cathode	

The junior op. tries his hand at pulling in some DX on the modified receiver.

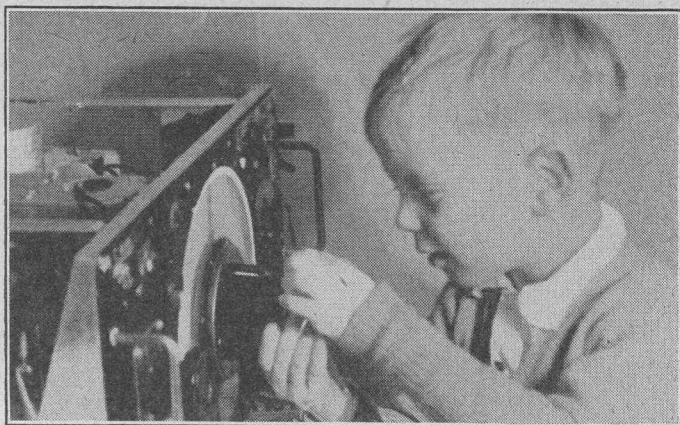

The modifications are based on the circuit, published in the July, 1946 issue of *Wireless World*, of the communications section of the R1155. When referring to the sketches in this article it should be noted that where a component value is given this indicates that the particular value is an additional one to be fitted. Existing components are not given values, though in some cases a reference number appears (this indicates the reference number as used in the *Wireless World* circuit). Now follows a stage-by-stage description of the modifications.

Aerial Circuit.

AVC circuit modified to shunt feed in order to prevent pick-up of audio on aerial from modulating AVC line. All coils earthy. Aerial

switches are shorted as shown and a 0.001 μ F capacitor inserted for safety purposes. R1, C1, C2 and C3 are removed from the receiver. See Fig. 1.

Mixer Stage.

No modifications have been carried out on this stage.

First IF.

The screen-divider network has been modified to sliding screen, the object being to reduce HT consumption. This also slightly reduced the effect of AVC and gives greater "S" meter deflection. The "S" meter itself is inserted in the anode circuit across the existing anode decoupling resistor. Full AVC is applied to this stage and gives largest deflection. R12 and R13 are removed. See Fig. 2.

Second IF.

The only modification to this stage is the alteration of the screen divider network as in the First IF stage: R16 and R17 are removed. See Fig. 3.

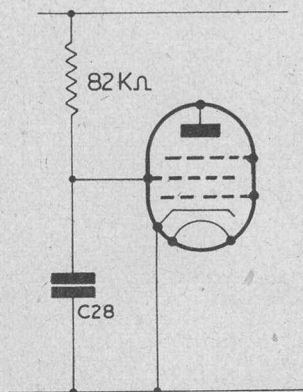

Fig. 3. Second IF stage screen divider network is modified.

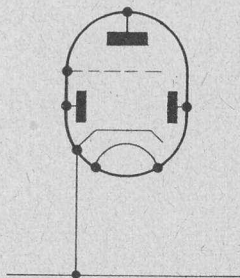

Fig. 5. BFO cathode is earthed and three resistors are removed.

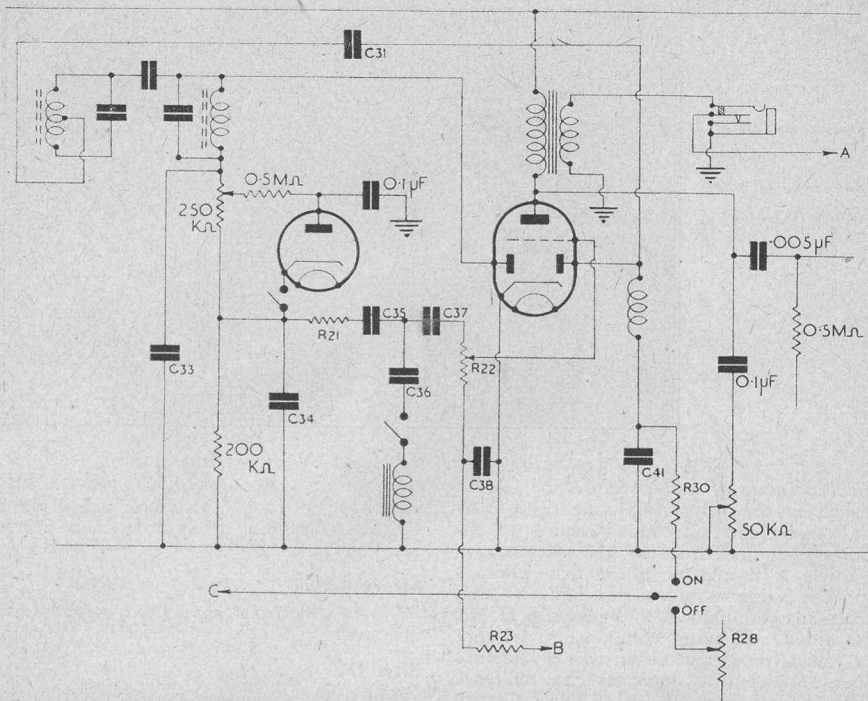

Fig. 4. Detector stage noise limiter is added. Point 'A' goes to earthy heater connection of output valve. Point 'B' goes to junction of R28/R33. Point 'C' is the lead normally taken to wiper of S10.

Detector Stage.

Noise limiter diode, an EA50, is inserted with level control and in/out switch. (R19, R20 and R24 are removed). The AVC is brought on to the spare diode of V5, the delay is now reduced to make the "S" meter effective on lower signal inputs. Biasing circuits are modified to suit. A toggle switch is installed to replace S10 for AVC on/off. A phone jack is inserted in the anode circuit of V5 and cuts off heater voltage of output valve with plug inserted. See Fig. 4.

BFO.

Cathode is earthed and R32, R38 and R39 are removed. In economy operation, for telephony, this valve can now be entirely removed. See Fig. 5.

Magic Eye.

This valve and its complementary circuit is completely removed.

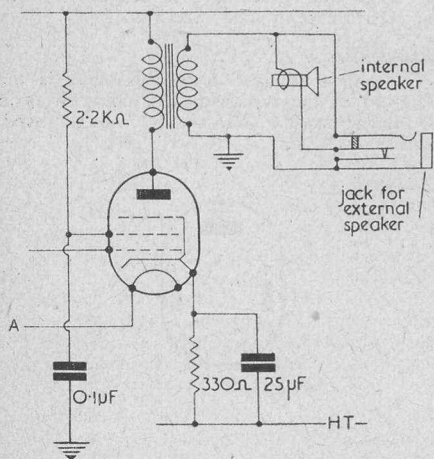

Fig. 6. Output stage. Point 'A' goes to jack terminal 'A' on detector stage (see Fig. 4).

Output Stage.

A 6G6G economy output stage installed with internal speaker and output transformer. A jack is inserted for operation of external speaker—mutes internal speaker. See Fig. 6.

Structural.

1. All DF components are removed, with DF wiring, etc.
2. Power sockets are removed.
3. Plate installed over space left by power socket and then fitted with octal holder, for power input, and two phone jack sockets.
4. Magic eye removed.
5. Plate covering magic eye hole holds "S" meter zero control (wire-wound potentiometer with isolated spindle).
6. EA50 diode is fitted under cover in rear section of BFO box. Noise limiter components

fitted on small panel attached to this cover. Noise limiter controls are fitted on front panel, adjacent, so making all noise limiter connections as short as possible and away from any source of pick-up.

7. Other panel controls to be fitted to suit individual taste.
8. 6G6 installed in vacant socket at rear of chassis in place of one of the redundant DF valves.
9. Small half-inch ceramic stand-off insulator fitted in coil unit near aerial switch for aerial connection, with hole in coil box and receiver dust-cover for stand-off to project through. A 0.001 μ F mica capacitor also fitted inside coil box next to the stand-off.
10. Miniature $2\frac{1}{2}$ Ω speaker fitted internally with output transformer.

At work on the "innards" of the R1155.

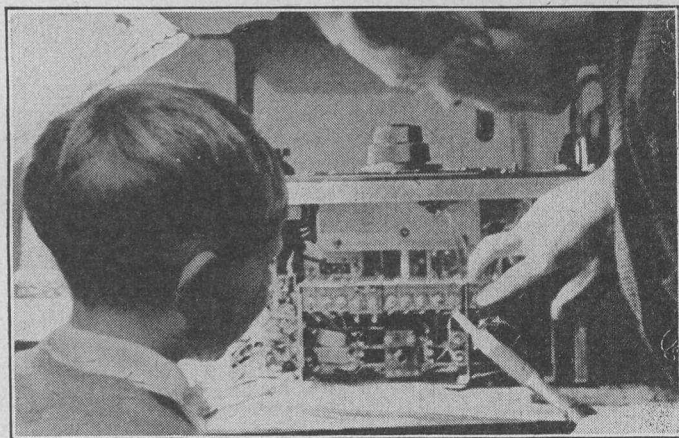

COMPONENT DENOMINATIONS

referred to in the text, as used in the *Wireless World* circuit diagram of the R1155 receiver.

R14	2,200 Ω	C26	0.1 μ F
R21	22,000 Ω	C28	0.1 μ F
R22	500,000 Ω	C31	4 μ μ F
R23	100,000 Ω	C33	100 μ μ F
R25	150,000 Ω	C34	0.1 μ F
R26	150,000 Ω	C35	0.001 μ F
R28	50,000 Ω pot.	C36	0.004 μ F
R30	56,000 Ω	C37	0.001 μ F
R33	120 Ω	C38	0.1 μ F
C22	0.1 μ F	C41	200 μ μ F

Your Accumulator

By G3AKA

THOUGH these notes are written primarily for the beginner, the older hands may find some of the hints of useful interest in the upkeep and care of their accumulators.

Accumulator Capacity.

The beginner is often at a loss to know exactly how large an accumulator to purchase. The "size" of an accumulator is called the capacity and this is measured in ampere-hours—that is to say, its ability to supply a pressure and thereby cause a current to flow for a given length of time. Thus, an accumulator of 20 ampere-hour rating will deliver a current of 1 ampere for 20 hours, 2 amperes for 10 hours, and so on. When purchasing an accumulator for your battery receiver this capacity is an important point to watch as it must be adequate for the requirements of the receiver. For a single-valve or two-valve receiver, a 20 ampere-hour accumulator should suffice, but it is preferable (and more economical) to use one of a higher rating such as 40 AH. An accumulator, if of insufficient capacity, will tend to be overloaded and will need frequent re-charging if the receiver is used at all extensively.

Re-Charging.

Your accumulator should be re-charged regularly and not left idle for long periods. If it is not being used for some time it is important to keep it in a charged condition. These are necessary precautions since in periods of non-use an accumulator will deteriorate rapidly and the plates may suffer damage. In normal circumstances, the positive plate will appear as a rich brown colour and the negative plate will have a greyish tint. If the accumulator is neglected, the colour of the plates may change and in this case a visit to your local charging depot is of paramount importance!

An extreme case is when sulphating takes place (*i.e.*, the plates become coated with lead sulphate) which shows itself in the form of white flecks on the positive plate. This can be remedied to a certain extent, but it is difficult to remove the deposit and the capacity of the cell so affected will be considerably reduced permanently.

The Electrolyte.

This is the solution inside the accumulator and it consists of dilute sulphuric acid and distilled water. It is of importance that the electrolyte should be at the level indicated on

the outside of the accumulator. If it falls below this level, it should be "topped off" with distilled water but never, in any circumstances, should acid be added. The proportion of the ingredients is also of importance and the enthusiast may test this himself by means of an instrument called a hydrometer. This instrument measures the specific gravity of liquids, having a glass body on which is inscribed a graduated scale, terminating in a rubber ball. When the tip is inserted in the electrolyte and the rubber ball squeezed, a reading will be obtained which indicates the condition of the electrolyte. Normally, a reading of around 1.260 will indicate that the accumulator is fully charged, a reading of less than 1.230 that it is only partly-charged, whilst if the reading were as low as 1.180 an immediate re-charge would be indicated. Some accumulators have an automatic charging indicator on the side and this is a great advantage indeed as it allows one at a glance to observe if a re-charge is necessary.

Terminals.

These are apt to be neglected but are, nevertheless, another important item to bear in mind. Corrosion is the thing to look for and this will occur even with the "non-corrosive" type if the accumulator is not given its due attention and care. It is seen as a crystalline deposit and is caused by allowing the terminals to become excessively dirty or acid to accumulate around them. Corrosion will, if left unattended, ultimately eat away the terminals and reception will frequently be accompanied by displeasing crackles should any corrosion be present.

The best method of cleaning corroded terminals is by giving them a good scrub, preferably with an old toothbrush and using hot soda water. Excessive corrosion can first be filed away before the brushing and soda water treatment. After cleaning the terminals, they should be smeared generously with vaseline as a precaution against a renewal of the corrosion.

If a terminal becomes difficult to unscrew, owing to corrosion or any other cause, do not try to force it. In no circumstances use pliers, as there is always the possibility that some damage may be inflicted—such as breakage. The better method of unscrewing a terminal that is definitely more than finger-tight is to immerse a rag in boiling water, squeeze out quickly and then wrap around the stubborn terminal. Repeat this several times. In most cases this will do the trick.

After Re-Charging.

Quite often, when an accumulator is returned from the charging depot, it is not in that state of cleanliness that is so very much desired. Maybe some acid has overflowed and run down the glass sides. It should be cleansed immediately with a strong soda water solution for two reasons: (a) to prevent corrosion on the terminals, and (b) because acid burns and you may stand the accumulator accidentally on some item of value!

General Notes.

Owing to the disintegration of the active material on the plates, a sediment is formed on the bottom of the accumulator. Sometimes this brown deposit can become too excessive, in which case it should be observed that it does not reach the bottom of the plates. If this does occur, there is an obvious danger of a short circuit between the plates which, owing to the low resistance of the cell, would cause a very heavy current to flow, causing, possibly, permanent damage to the plates. It is advisable to entirely re-fill the accumulator with fresh electrolyte about once a year. Most people will have this done by a radio shop, but if it is done oneself make certain that the accumulator is not left empty for more than a few minutes.

Summary of Important Points.

- Re-charge your accumulator at regular intervals.
- Never leave it idle for long periods without frequent re-charging.
- Keep your eye on the sediment on the bottom of the cell.
- Keep the terminals well greased.
- Make sure that the electrolyte never falls below the top surface of the plates.
- Look for sulphating on the plates.
Adhere to the makers' instructions.
- Keep your accumulator scrupulously clean and treat it with as much care as you do valves and other components—it will pay you in the long run!

25 WATT TRANSMITTER.

Apologies to the author of this article in our last issue, for printing his call-sign as G3CLD. This should have read **G3CLB**. One other error in this article was that a 20,000 resistor should have been shown from the screen-grid of V4 to the HT line.

(QUERY CORNER—continued from page 241)

“P” type, may be tuned by means of a midget two-gang capacitor. A screen should be interposed between the two coils. 50 μ F trimmers should be connected across each section of the tuning capacitor if these are not already provided as part of this component. Fixed reaction is employed, the initial setting being by means of a 100pF trimmer. This should be adjusted in order to obtain adequate selectivity over the whole wave range. The output stage is a conventional circuit employing a double diode pentode, the diode section being neglected. HT is provided by means of a selenium rectifier which coupled with a resistance-capacity smoothing circuit affords the maximum economy in space, and, incidentally, in expense. The heater current for the valves is obtained via a line cord which should be capable of carrying 100 milliamps. If this receiver is carefully constructed and adequate screening provided in the Rf section, the performance should be at least equal to that obtained with a commercial universal straight receiver.

“Query Corner” Rules

- (1) A nominal fee of 1/- will be made for each query.
- (2) Queries on any subject relating to technical radio or electrical matters will be accepted, though it will not be possible to provide complete circuit diagrams for the more complex receivers, transmitters and the like.
- (3) Complete circuits of equipment may be submitted to us before construction is commenced. This will ensure that component values are correct and that the circuit is theoretically sound.
- (4) All queries will receive critical scrutiny and replies will be as comprehensive as possible.
- (5) Correspondence to be addressed to “Query Corner,” Radio Constructor, 57, Maida Vale, Paddington, London, W.9.
- (6) A selection of those queries with the more general interest will be reproduced in these pages each month.



Coming Shortly
1948 Edition of the
Short Wave
Listeners Annual

Proofs are now being read for this enlarged and revised edition of our famous, year book. Watch “Short Wave News” and “Radio Constructor” for notices of availability. Do not send cash until the book is announced as ready.

3/6 plus 3d. postage.

An Amalgamated Short Wave Press Publication

Standard Colour Codes

Resistors.

THE colour of the body gives the first figure of the value, and the colour of the tip or end band gives the second figure. The colour of the spot or centre band indicates the number of cyphers that follow these two figures. Where the spot is not evident, it is the same colour as the body.

Colour : Black, 0 ; Brown, 1 ; Red, 2 ; Orange, 3 ; Yellow, 4 ; Green, 5 ; Blue, 6 ; Violet, 7 ; Grey, 8 ; White, 9.

Examples : Brown body, Green tip, Yellow spot=150,000 Ω.

Red body, Black tip, Black spot=20 Ω.

Small Capacitors.

The figures represented by the colours are the same as given above for resistors. The capacity is given in micro-micro-farads ($\mu\mu\text{F}$) by the three coloured dots on the trademark side of the case. These are read from left to right, the first dot giving the first figure, the second dot the second figure, and the third dot the number of cyphers. Where three significant figures are needed, the first two dots are coloured, the third left blank, and the remainder of the code given on the reverse side of the case.

Examples : Green, Black, Brown=500 $\mu\mu\text{F}$ =.0005 μF .

Red, Green, Black, Green, Brown=2,550 $\mu\mu\text{F}$ =.00255 μF .

Multiple Capacitor Blocks.

The lead out wires or tags are coloured as follows :—

Highest capacitance positive voltage	...	Red
2nd highest	ditto	... Yellow
3rd highest	ditto	... Green
4th highest	ditto	... Blue
5th highest	ditto	... Violet
Main negative connection Black
2nd negative	ditto	... Brown
3rd negative	ditto	... Grey
Centre connection for voltage doubler	...	White

Where two capacitances are equal, the section having the higher voltage rating is given the higher colour in the table.

Common positive junctions are marked	... +
Common negative junctions are marked	... -
Series connections are marked	... ±
Unconnected sections are marked	... &

Mains Transformer Leads.

(1) British.

Primary :—

Mains Common	...	Black
10 volt tap	...	Black/Green
210 volt tap	...	Black/Yellow
230 volt tap	...	Black/Red
250 volt tap	...	Black/Brown

Secondaries :—

Rectifier Heater	...	Green
Rectifier Heater C.T.	...	Green/Yellow
HT Winding	...	Red
HT Winding CT	...	Red/Yellow
Valve Heaters	...	Brown
Valve Heaters CT	...	Brown/Yellow
Additional Heaters	...	Blue
Additional Heaters CT	...	Blue/Yellow
Static Screen	...	Bare Wire

(2) American.

Primary :—

Mains Common	...	Black
Mains tap	...	Black/Yellow
Highest tap	...	Black/Red

Secondaries :—

Rectifier Heater	...	Yellow
Rectifier Heater CT	...	Yellow/Blue
HT Winding	...	Red
HT Winding CT	...	Red/Yellow
Valve Heaters	...	Green
CT	...	Green/Yellow
Valve Heaters 2	...	Brown
CT	...	Brown/Yellow
Valve Heaters 3	...	Grey
CT	...	Grey/Yellow

If Transformers, American.

Anode (Plate) Lead	...	Blue
HT + Lead	...	Red
Control grid or diode anode	...	Green
HT—, AVC or diode load	...	Black

Where the secondary is centre-tapped, the tap is Black, and the second outside connection is Green/Black.

Af Transformers, American.

HT+ (HT— or GB in para-feed)	...	Red
Anode (C in parafeed)	...	Blue
Anode 2, on centre-tapped primaries	...	Blue or Brown
HT— or GB	...	Black
Control Grid	...	Green
Control Grid 2 where tapped	...	Green or Yellow

(continued on next page)

(COLOUR CODES—continued from page 248)

TRADE NOTES

Field Windings, American.

Unsmoothed Black/Red
Smoothed Yellow/Red
Tappings Grey/Red

Speaker Leads, British.

Transformer Primary Winding Green & Brown
Transformer Primary Winding CT Red
Transformer Secondary Winding White & Maroon
Field Winding Yellow & Black

Wander Plugs and Battery Leads.

Highest Positive Voltage (HT)	Red
2nd highest Positive Voltage (HT)... ..	Yellow
3rd highest Positive Voltage (HT)... ..	Green
4th highest Positive Voltage (HT)... ..	Blue
Low Tension Positive (LT+)	Pink
Common Negative (LT—)	Black
(HT—)	”
(GB+)	”
Maximum GB Negative	Brown
2nd maximum GB Negative	Grey
3rd maximum GB Negative	White

Any additional potential, such as 5th greatest HT positive, or 4th greatest GB negative, is *Violet*, and any centre tap *White*.

Cartridge Fuses.

60 mA, *Black*; 100 mA, *Grey*; 150 mA, *Red*; 250 mA, *Brown*; 500 mA, *Yellow*; 750 mA, *Green*; 1 Amp, *Dark Blue*; 1.5 Amp, *Light Blue*; 2 Amp, *Purple*; 3 Amp, *White*; 5 Amp, *Black/White*.

The Mail Order Supply Co. announces that, owing to expansion of business, a new Mail Order Office has been opened at 3, Robert Street, Hampstead Road, London, N.W.1. Will readers please note that in future all *Post Orders* should be addressed to the above, and all other enquiries to 24, New Road, London, E.1, as hitherto.

An illustrated brochure has been received from **Stratton & Co., Ltd.**, of Birmingham, giving details of the latest *Eddystone* lines. These include a streamlined semi-automatic morse key, fully adjustable, which retails at £3/17/6, an 'S' meter designed for their 640 receiver at £5/5/0, a modulation level indicator at £8/15/0, a crystal calibrator (signal generator) at £12/0/0, and several other interesting lines.

The Automatic Coil Winder & Electrical Equipment Co., Ltd., of Winder House, Douglas Street, London, S.W.1, have sent an illustrated booklet containing details of their famous *AVO* test instruments, together with details of the delivery period for each model.

A folder from **Goodmans Industries, Ltd.**, of Lancelot Road, Wembley, Middx., gives some useful data on their Heavy Duty 15in. and 18in. Loudspeakers, and a suitable line transformer. The latter has a handling capacity of 50 watts AC maximum, and is wound to an impedance match as specified when ordering.

Technical Information on the Dry Accumulator is the title of a booklet received from **Varley Dry Accumulators, Ltd.**, of By-Pass Road, Barking, Essex. In its 16 pages it explains the construction and electrical details of the dry accumulator and is well illustrated. Many curves are shown with respect of discharge rates, influence of temperature on discharge, etc.

"You'll probably get it at

Smith's of Edgware Road"

The Book on how to make it.
The Material to make it with.
The Components to put in it.
The Equipment to test it with.
The Cabinet to put it in.
(AND a fair deal!)

H. L. SMITH & CO. LTD.

287-9 EDGWARE ROAD, LONDON, W.2

Near Edgware Road Met. and Bakerloo

Phone PAD. 5891 :: Hours 9-6 (Thurs. 1 o/c.)



We have the finest stock of
British and American radio
books in this country.

Write or call for complete list—

THE MODERN BOOK COMPANY
(Dept. RC)

19-23 Praed Street, London, W.2

SMALL ADVERTISEMENTS

Readers' small advertisements will be accepted at 3d. per word, minimum charge 3/-. Trade advertisements will be accepted at 6d. per word, minimum charge 6/-. If a Box Number is required, an additional charge of 1/6 will be made. Terms: Cash with order. All copy must be in hand by the 10th of the month for insertion in the following month's issue.

PRIVATE

WANTED URGENTLY. Permanent magnet loud-speaker 12in. or 18in. model. Must be in good condition. Also 1A7 and X66 valves. Gram motor with turntable, preferably with auto-stop and changer MCRI. Reasonable offers in cash for above or will exchange any of the following items: R1155 receiver, internal power-pack 230 v. AC mains. Excellent condition, and in working order. American AC/DC battery portable radio, medium wave, excellent condition (makers Zenith Radio). 14 valve home-built communications receiver. Every component brand new and set only needs realignment and wiring of the tuning coils, 5 wave-bands, 2RF, Mixer, Osc., 2 If's, noise limiter, S meter, MAGIC eye, etc. 12in. mains energised loudspeaker. Also the following valves: 829, 832, 715A, 211, PT15, 807, 1625, 1R5, 6AK5, 6AG5, 6J6, 717A, 956, 955, 954, 959, 957. Majority of all other popular valves and a few of the more remote types. Offers to ISWL/G15, 64, Cavendish Road, Kilburn, London, N.W.6. (Write or call evenings.)

ENTHUSIAST'S REMOVAL necessitates immediate sale. £12 worth unused components, £10. Box 104.

SALE: MCRI, power-pack, spare IT4 and IT5. Special 10-16m. coil. Also LS amplifier to match. Price £10 A. T. Butler, 25, Crediton Road, N.W.10.

SALE, 1155, Power Pack, Speaker. Ready to switch on. Reason for sale: moving to house without electricity. £18/0/0.—Mjdwinter, 11, The Leaze, Burford, Oxon.

TRADE

VALVES—10,000 in stock. Most types available. Send for valve list, enclosing S.A.E.: Ransom, Bond Street, Brighton.

G6MN for the "best" QSL's and approved log books, send for samples: G6MN, Bridge Street, Worksp, Notts.

QSL's and G.P.O. approved log books, samples free, from Atkinson Bros., Printers, Elland.

COPPER WIRE. Enamelled, Tinned, Cotton, Silk-covered. All gauges. Screws, nuts, washers, soldering tags, eyelets, Ebonite and laminated Bakelite panels. Coil formers. Covered wires, ear-phones, etc. List S.A.E. Post Radio Supplies, 33, Bourne Gardens, London, E.4.

KYNRAD SUPPLIES LIMITED—The Premier House for the Radio Amateur. Meters 0.5 mA 5/6 each; Speakers—Elac 5½in. with Transformer 17/6; Truvox 6in. less Transformer 15/-; Multi-Ratio Output Transformers 7/6; 60 mA Chokes 7/6; Valve Holders, Octals or Button Base 6d.; Condensers Split Stators 5 pF and 10 pF 1/- each, 100 pF 1/-, 0.1 mfd. 150 volt 1/- dozen, 0.1 mfd. 350 volt and 500 volt 4d. each, 0.5 mfd. 500 volt 4d. each, 0.25 mfd. 350 volt 4d. each; Soldering Irons 60 watt 10/6. This is only a small selection of our varied Stock. Write for list, S.A.E. to: Kynrad Supplies Limited, 10 and 12, Spring Hill, Birmingham, 18.

RADIO CAREERS

AN IMPORTANT GUIDE

"Engineering Opportunities" indicates clearly how all engaged in the rapidly expanding Wireless industry can safeguard their future by becoming technically equipped to accept highly paid key appointments that will not be affected by any return to competitive labour conditions.

This modern guide contains 112 pages of highly useful information. It gives full details of our very comprehensive series of modern WIRELESS COURSES, including General Wireless, Short Wave, Wireless and High Frequency, Sound-film Projection Engineering, Television and Radio Servicing, etc.

TELEVISION AND RADIO SERVICING. There is no doubt about it that there will shortly be an enormous boom in Television and unlimited opportunities for trained men. Our special TELEVISION and SERVICING Courses are fully described in the handbook.

WE DEFINITELY GUARANTEE

"NO PASS—NO FEE"

The Wireless industry is alive with possibilities. In your own interests you should write for your copy of "ENGINEERING OPPORTUNITIES" today. It will be sent FREE, and the book is bound to indicate more opportunities which otherwise you might miss.

BRITISH INST. OF ENGINEERING TECHNOLOGY

854, Shakespeare House,
17/19, Stratford Place, London, W.1.

METAL WORK

with a Difference!

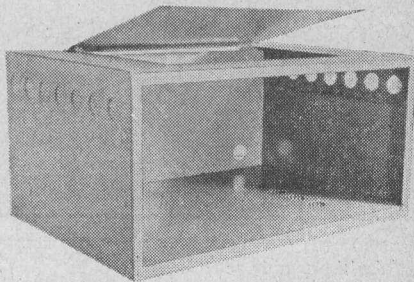

This is an example of gear which can be made to YOUR OWN dimensions and layout.

For full details and address of nearest agent, contact—

L. J. PHILPOTT (G4BI)

(E. J. PHILPOTT)

Chapman St., Loughborough Tel. 2864
Leics.