

RADIO & ELECTRONICS WORLD

70p

Win

a **PM2521 MPU controlled DMM**

- **Bus/directly controllable CMOS synthesisers**
- **Zilog's one chip BASIC MCU**
- **70cms converter**

REVIEWS

Acorn Atom

**TEK's new
60MHz scope**

FT290R



**A comprehensive
8-digit 500MHz frequency
counter/capacitance meter**

TESTING MOBILE RADIOS?

... catch this bus with Farnell

and arrive economically at an efficient ATE workstation.

Comprehensive testing under low cost desk computer control.

Manual systems too.



Farnell

INTERFACE WITH US NOW!

Ask for details from:



RADIO & ELECTRONICS WORLD

Issue two - volume one
November 1981

Published by Broadercasting Ltd.,
117a High Street, Brentwood, Essex.
R&EW is published monthly, on the
first Thursday of each month.

Editor

William Poel

Technical editor

Stephen C. Taylor

Practical features editor

Roger Ray

Production editor

Jack Burrows

Art/Production Manager

Patrick Haylock

Art Editor

Sally Bennett

Editorial Secretary

Kim Mitchell

Computing Consultant

Jonathan C. Burchell

RF Consultant

Timothy Edwards

Editorial Offices

117a High Street Brentwood

Essex CM14 4SG

telephone (0277) 213819

Advertising Manager

Barry Hewson

Hillcroft House 16 The Avenue

Highams Park London E4 9LD

telephone 01-531-7621

Subscription Manager

Owen Rundle

Published by

Broadercasting Limited

Distributed by

SM Distribution Ltd

16/18 Trinity Gardens

London SW9 8DX

telephone 01-274-8611

Printed by

LSG Printers Lincoln

Photosetting by

Delafield Reprographic Service

481 Ongar Road

Brentwood Essex

Cartoons

Mike Turner

Framed original 'Turners'

are available from R&EW

for £25.00 each.

First come, first served.

Subscriptions

Rates for 12 months

UK £9.50

Europe £10.50

US/Canada £15.00

Editorial

The World is your oyster 3

New Products

From tube rejuvenators to hard discs 6

News

Cordless phones on the rampage 8

A UHF Receiver Converter

Timothy Edwards leads onward and upward 10

News Background

Would the last person to leave Britain please turn out the lights 16

USA News

HP writes its own micros 17

The Philips PM2521 DMM+

The latest thing in DVMs reviewed. Ever seen a DVM spectrum analysed? 18

The UK CB Licence Application

Sneak a look at the terms and conditions - but still no firm start date 20

Readers' Letters

Zilog's new Z-8 21

R&EW reviews the micro of the moment 22

Complink

Printers and interfaces - Accumulators - RF matching BASIC program 24

DFCM500 - A combined DFM and Capacity Meter

Part one of a comprehensive test instrument from AF to 650MHz 30

The FT290R : Pros and Cons

An extensive assessment of the 2m transportable 36

The Last Word

The late, late news page 44

Tektronix' new 'Baby' Dual Beam Scope

A brief look at the 'value for money' scope before they took it away again 45

Watervole (II)

Make 270,000,001 of these, and Sony might get nervous 47

Short Wave News for DX Listeners

Frank Baldwin wanders the wireless waves 50

Pushing the Boat out

The R&EW launch party: a day at the dockside 53

Motorola's 60MHz CMOS synthesiser devices

The first part of an evaluation of the state of the PLL art 55

An Automatic Modulation Meter - 1

An auto-tuning NBFM modulation meter for 20 - 175 MHz, and beyond.... 58

The Acorn Atom

The computing dept. split open the Atom and its secrets 64

A Simple DVM

A "no-frills" approach to producing a utility DVM 67

Competition Time

Win a PM2521 by using your imagination 70

Next month

The HA12002 Explained

The 'Ins and Outs' of this versatile protection system IC 71

In Your Workshop

Tracker gets a 'bang' out of Guy Fawkes night, and Dick sees the logic (?) 74

Higher Fidelity (II)

When is an earth not an earth? Mike Creek extrapolates on amplifier design 79

Response Page

Origami for beginners, and the 'Bingo' numbers for you to tick 95



SOUTH MIDLANDS COMMUNICATIONS LIMITED



COMPLETE SYSTEMS FOR COMMERCIAL AND AMATEUR APPLICATIONS



FIRST THE STATION NEXT THE WORLD

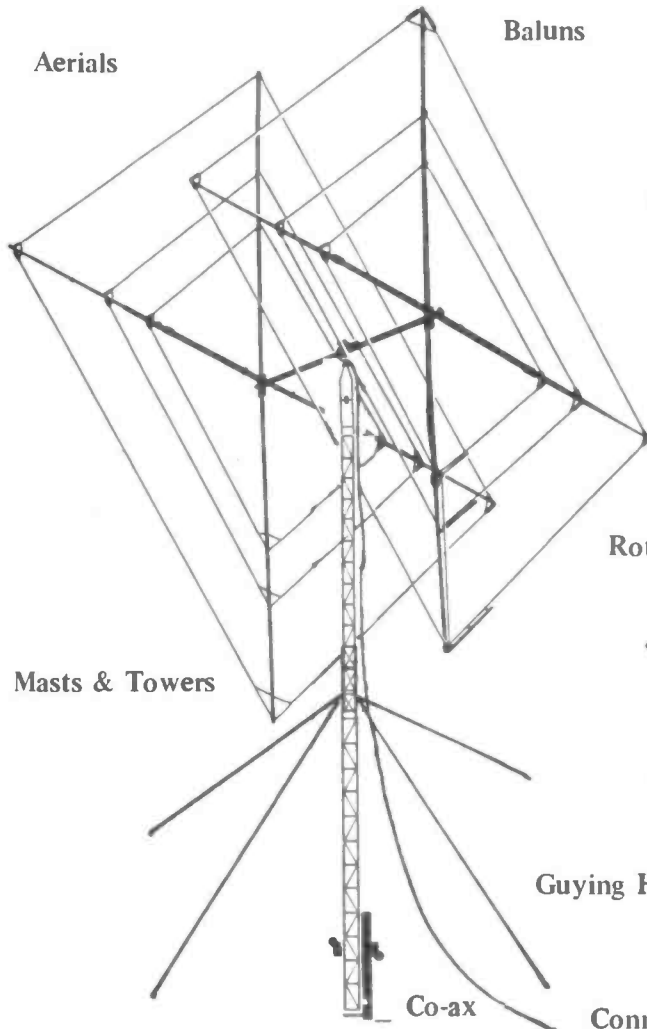

Baluns

Rotators

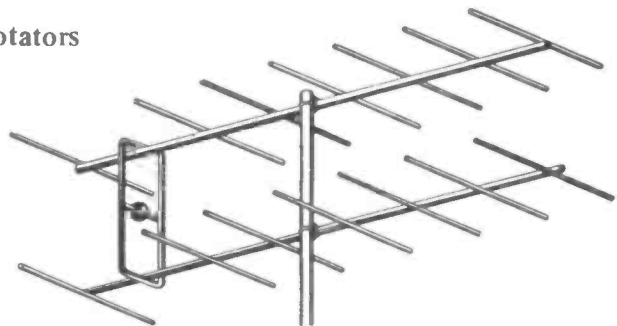

Guying Hardware

Connectors

Transmitters

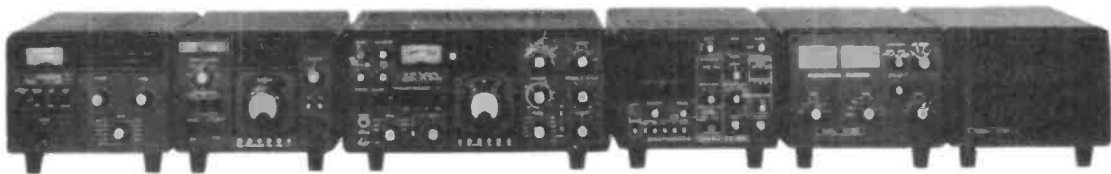

For everything from the mains plug to the aerial system call or write to SMC and we will be happy to offer advice and help as required.



SOUTH MIDLANDS COMMUNICATIONS LTD

S. M. HOUSE, OSBORNE ROAD, TOTTON, SOUTHAMPTON SO4 4DN, ENGLAND

Tel: Totton (0703) 867333, Telex: 477351 SMCOMM G, Telegram: "Aerial" Southampton

2 for further details

EDITORIAL

The 'World' is your oyster

It's early days to judge the reaction of the 'market' to the appearance of **Radio and Electronics World** - but we are interested to see that other electronics publications have been making plans to respond to the gauntlet thrown down by **R&EW's** uncompromising approach to provide professionally researched features in a market that has hitherto largely been fed on junk box fallout.

If you too want to take up the challenge of launching a publication to rival **R&EW**, then here's the secret - invest £75,000 in technical support facilities, collaborate closely with authors on the design and production of features, pay a realistic rate and approach the subject with *electronics* and not publishing as your prime motive. The rest follows naturally....

The market for electronics has grown steadily on a commercial level since the transistor was invented, so it is distressing to find that the enthusiastic end of the business seems to have failed to maintain growth during the past year. Maybe this is the result of the ubiquitous recession (no, it isn't over yet), or maybe it is a more disturbing manifestation of the failure of the educational system to embrace electronics more eagerly and seriously - and a shortage of the right sort of stimulation and encouragement to get out there and do something with the burgeoning technology.

Ideas and opportunities in electronics will abound for many years yet, and we want **R&EW** to help in the exploitation of this technology. Our reader response system is an innovation in the area of 'bookstall' electronics publications, and we hope that you will use the system to provide us feedback on what you want - and what you don't.

One down

Now that the first issue is in the bag, and we have had time to consider the style, appearance and mistakes (yes, there were a few), we hope that we have learnt a few lessons on the way the issue is presented. So that we can gather your reactions to number two, we present a brief survey within the format of the reader response page - shoot from the hip, we can take it!

Perhaps the classic *faux pas* in Number One was the appearance of the UK Microprocessor Centre on the cover - but nowhere else. The feature was held over at the last minute, since we were in the throes of negotiating to become the NMEC's major 'mouthpiece', to boost awareness of this very well conceived and carefully presented permanent exhibition of electronics in the Nation's capital.

Well, it's been settled - and we present some details of the NMEC herein, since this was the venue chosen for the 'formal' portion of the launch festivities. We will be carrying regular details of the 'goings on' at the centre, and

using the extensive facilities of the centre to provide occasional presentations for our readers. In particular, we hope to be hosting a series of illustrated lectures with **R&EW** contributors describing and discussing features and general topics of interest within the field of electronics, communications and computing.

Since we are entering uncharted waters (yet again) we don't really know how many of you would be interested to attend, so please circle number 278 if the idea of attending 'forums' on subjects that range from VHF receiver design to the Zilog one-board BASIC microcomputer appeals to you. The fee will be around £8 a head. There is no commitment implied in circling the number, we would just like to get a feeling for the numbers likely to attend.

William Bar



Sinclair ZX81 Personal Computer the heart of a system that grows with you.

1980 saw a genuine breakthrough – the Sinclair ZX80, world's first complete personal computer for under £100. Not surprisingly, over 50,000 were sold.

In March 1981, the Sinclair lead increased dramatically. For just £69.95 the Sinclair ZX81 offers even more advanced facilities at an even lower price. Initially, even we were surprised by the demand – over 50,000 in the first 3 months!

Today, the Sinclair ZX81 is the heart of a computer system. You can add 16-times more memory with the ZX RAM pack. The ZX Printer offers an unbeatable combination of performance and price. And the ZX Software library is growing every day.

Lower price: higher capability

With the ZX81, it's still very simple to teach yourself computing, but the ZX81 packs even greater working capability than the ZX80.

It uses the same micro-processor, but incorporates a new, more powerful 8K BASIC ROM – the 'trained intelligence' of the computer. This chip works in decimals, handles logs and trig, allows you to plot graphs, and builds up animated displays.

And the ZX81 incorporates other operation refinements – the facility to load and save named programs on cassette, for example, and to drive the new ZX Printer.



New BASIC manual

Every ZX81 comes with a comprehensive, specially-written manual – a complete course in BASIC programming, from first principles to complex programs.

Kit: £49.⁹⁵

Higher specification, lower price – how's it done?

Quite simply, by design. The ZX80 reduced the chips in a working computer from 40 or so, to 21. The ZX81 reduces the 21 to 4!

The secret lies in a totally new master chip. Designed by Sinclair and custom-built in Britain, this unique chip replaces 18 chips from the ZX80!

New, improved specification

- Z80A micro-processor – new faster version of the famous Z80 chip, widely recognised as the best ever made.
- Unique 'one-touch' key word entry: the ZX81 eliminates a great deal of tiresome typing. Key words (RUN, LIST, PRINT, etc.) have their own single-key entry.
- Unique syntax-check and report codes identify programming errors immediately.
- Full range of mathematical and scientific functions accurate to eight decimal places.
- Graph-drawing and animated-display facilities.
- Multi-dimensional string and numerical arrays.
- Up to 26 FOR/NEXT loops.
- Randomise function – useful for games as well as serious applications.
- Cassette LOAD and SAVE with named programs.
- 1K-byte RAM expandable to 16K bytes with Sinclair RAM pack.
- Able to drive the new Sinclair printer.
- Advanced 4-chip design: micro-processor, ROM, RAM, plus master chip – unique, custom-built chip replacing 18 ZX80 chips.



Built: £69.⁹⁵

Kit or built – it's up to you!

You'll be surprised how easy the ZX81 kit is to build: just four chips to assemble (plus, of course the other discrete components) – a few hours' work with a fine-tipped soldering iron. And you may already have a suitable mains adaptor – 600 mA at 9 V DC nominal unregulated (supplied with built version).

Kit and built versions come complete with all leads to connect to your TV (colour or black and white) and cassette recorder.



uter-



Available now- the ZX Printer for only £49.⁹⁵

Designed exclusively for use with the ZX81 (and ZX80 with 8K BASIC ROM), the printer offers full alpha- numerics and highly sophisticated graphics.

A special feature is COPY, which prints out exactly what is on the whole TV screen without the need for further instructions.

At last you can have a hard copy of your program listings – particularly

useful when writing or editing programs.

And of course you can print out your results for permanent records or sending to a friend.

Printing speed is 50 characters per second, with 32 characters per line and 9 lines per vertical inch.

The ZXPrinter connects to the rear of your computer – using a stackable connector so you can plug in a RAM pack as well. A roll of paper (65 ft long x 4 in wide) is supplied, along with full instructions.

16K-byte RAM pack for massive add-on memory.

Designed as a complete module to fit your Sinclair ZX80 or ZX81, the RAM pack simply plugs into the existing expansion port at the rear of the computer to multiply your data/program storage by 16!

Use it for long and complex programs or as a personal database. Yet it costs as little as half the price of competitive additional memory.

With the RAM pack, you can also run some of the more sophisticated ZX Software – the Business & Household management systems for example.

sinclair ZX81

6 Kings Parade, Cambridge, Cambs., CB2 1SN.
Tel: (0276) 66104 & 21282.

How to order your ZX81

BY PHONE – Access, Barclaycard or Trustcard holders can call 01-200 0200 for personal attention 24 hours a day, every day.

BY FREEPOST – use the no-stamp-needed coupon below. You can pay

by cheque, postal order, Access, Barclaycard or Trustcard.

EITHER WAY – please allow up to 28 days for delivery. And there's a 14-day money-back option. We want you to be satisfied beyond doubt – and we have no doubt that you will be.

To: Sinclair Research Ltd, FREEPOST 7, Cambridge, CB2 1YY.				Order
Qty	Item	Code	Item price £	Total £
	Sinclair ZX81 Personal Computer kit(s). Price includes ZX81 BASIC manual. excludes mains adaptor.	12	49.95	
	Ready-assembled Sinclair ZX81 Personal Computer(s). Price includes ZX81 BASIC manual and mains adaptor.	11	69.95	
	Mains Adaptor(s) (600 mA at 9 V DC nominal unregulated).	10	8.95	
	16K-BYTE RAM pack.	18	49.95	
	Sinclair ZX Printer.	27	49.95	
	8K BASIC ROM to fit ZX80.	17	19.95	
	Post and Packing.			2.95
<input type="checkbox"/> Please tick if you require a VAT receipt				TOTAL £
*I enclose a cheque/postal order payable to Sinclair Research Ltd, for £				
*Please charge to my Access/Barclaycard/Trustcard account no.				
*Please delete/complete as applicable.				Please print
Name: Mr/Mrs/Miss				
Address:				
FREEPOST – no stamp needed. Offer applies to UK only.				REW 11

NEW PRODUCTS

Tube tester/rejuvenator, from Leader

The LCT-910A is a universal tube tester/rejuvenator for black and white and colour cathode ray tubes, designed for easy measurement of a tube condition plus for clearing shorts.

It has facilities for measuring or reactivating colour CRT guns independently as well as checking gun tracking.

The tester is housed in a briefcase-type of case to provide good protection in field and bench applications.

The unit comes complete with a range of sockets covering most current CRT's.

The LCT-910A is available from Sinclair Electronics Ltd, St Ives, Cambs.

150 for further details

Superbrain Hard Disc, from Clenlo

Clenlo's new interface unit allows Ten Megabyte, Twenty Megabyte or Twenty-Four Megabyte, Morrow Designs Hard Discs to be attached to a Superbrain microcomputer.

As the S-100 controller used by the hard discs can drive up to four hard discs, it is possible to connect up to 100 megabytes of fast access disc storage directly to the Superbrain.

Using the Ten Megabyte Memorex Hard Disc, the disc is set up as logical drivers C: and D: under CP/M with a storage capacity of 5 megabytes each. An attached Twenty Megabyte Hard Disc is set up as logic drives C:, D: and E: with the first two drives having a data capacity of 8 megabytes each, and the last 4 megabytes.

The operating software (CP/M) to drive the whole system resides on the hard disc. A special set of programs is supplied on a Superbrain floppy disc which automatically load CP/M from the hard disc when the Superbrain reset keys are pressed.

A cartridge tape backup unit can be added which confess the ability to manipulate larger data files than can be saved onto the floppy discs. The unit backs up 10 megabytes in less than twenty minutes.

The interface unit/S-100 controller, hard discs and the modified CP/M are available from Clenlo Computing Systems Limited, London.

151 for further details

Remote control receiver, from Plessey

The new ML923 remote control receiver, based on the ML920 receiver, has a single analogue output, 16 available

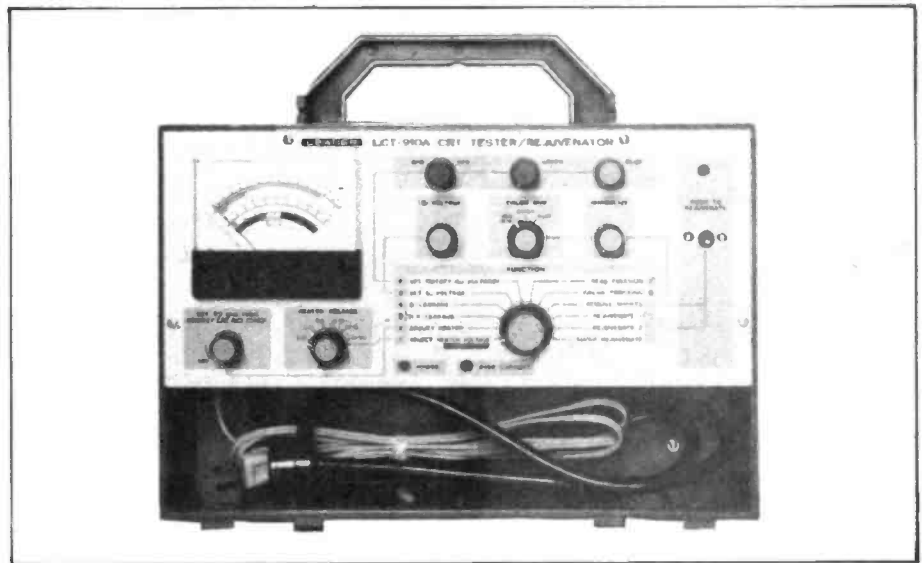

channels in a 4 bit binary form and channel step, set on AFC defeat, recall, mute and analogue normalise functions. Used with the SL480 pre-amplifier and SL490 transmitter, the ML923 system is suitable for almost all domestic televisions.

The device is available in 18 pin plastic DIL and is specified over the temperature range -10 degrees Centigrade to $+65$ degrees Centigrade.

It joins a range of other receivers which can be used for toy or lighting control, industrial applications and monitoring, all available from Plessey Semiconductors, Swindon.

152 for further details

Hand-held multimeter, from Sabtronics International Inc.

The 2035A is a hand-held LCD multimeter, featuring 0.1% DC accuracy.

It measures DC and AC volts (100V-1000V) DC and AC current (0.1uA-2A) and resistance (0.1 ohms-20M ohms).

Special features include a band gap reference element for long term stability, a laser trimmed divider network for range accuracy, high and low ohms measurement and the THP-20 'touch and hold' probe as an optional accessory. The latter permits a reading to be held in the display and is thus useful for taking measurements under circumstances where the probe requires the user's undivided attention.

The 2035A is available in kit or built form and is powered by mains adaptor or PP3 battery.

In addition to the 32 measurement ranges and six functions offered by the 2035A, the 2037A model has a further temperature measurement function with two resolution ranges (0.1 degree and 1 degree).

UK distributors: Black Star Limited, St Ives.

153 for further details

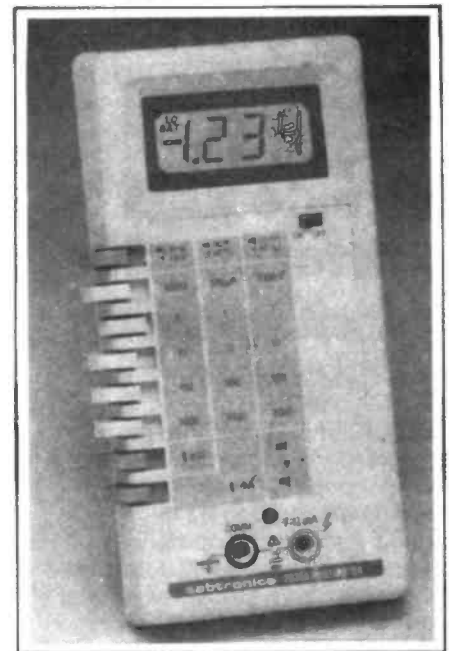

Miniature rotary switches, from Highland Electronics

Series 75 single deck, ten position switches for printed circuit board mounting, are now available with a choice of terminal dimensions suiting various types of pcb construction.

The switches have round bodies of 7.56mm diameter with terminals arranged in circles at the opposite end of the body to the actuator. They are available with straight 2.77mm length pc pins in a 4.75mm circle or with splayed terminals in a 7.6mm circle.

NEW PRODUCTS

Switches of both terminal layouts are available with a choice of actuators - with an integral knurled edge knob, mounting bush and shaft actuator, or flat blade screwdriver slot.

The switches can carry between 50 and 250mA at 115V AC/30V DC maximum. They have non-shorting wiping contacts, a single deck and can be used as single pole switches or two pole switches with up to five positions.

They are available from Highland Electronics Ltd, Brighton.

31 for further details

Sodium/Potassium blood analyser, from Corning Medical

Corning Medical have applied the principles of ion exchange coupled with microprocessor-based electronics to produce a new direct, digital readout analyser which determines sodium and potassium ion activities in biological samples (serum, plasma and whole blood) without the need for pre-dilution and separation.

The principle of operation is based on ion separation in an electrolyte and the accurate measurement of potentials developed between two ion-selective electrodes and a reference electrode. These potentials are processed by differential amplifiers; a microprocessor then converts the analogue signals into a digital form to drive the two digital displays. Output signals from the two channels are sampled every 500 millisecond (approx).

To pump fluid into the electrodes from two containers, a Portescap Escap 23L motor and B24 gearbox combination driving a cage pump which operates two pump tubes was used.

Such a device illustrates the successful marriage of the products of three individual developmental fields (that is, ion exchange, microelectronics and motors) in medical analytical applications.

32 for further details

Bubble cards, from Hitachi

Hitachi's bubble memory cards are available with memory capacities ranging from 8k to 128k bytes

They are designed for such industrial and commercial applications as process control equipment, printers, word processors and portable terminals, and have access times ranging from 7.2mS to 13mS. With a maximum data transfer rate of 100k bits per second.

Other features include a large capacity, solid state memory without mechanical moving parts, non-volatile, rewritable, memory and a special control

LSI used for easy connection to 8-bit microcomputers such as M6800, Intel 8085 and Zilog Z-80. All circuits are mounted on single small circuit cards.

The memory cards are available from Dialogue Marketing (Electronics) Ltd, Bourne End.

33 for further details

Resistant gaskets for RFI integrity, from RFI Shielding

TWINSEAL, a weather resistant material which suppresses RF interference is available as custom specified gaskets or in bulk to enable the user to make his own gaskets as required.

The material is of a two part design - a knitted wire mesh strip bonded to a sponge elastomer. Three wire mesh materials are available (Monel, Copperweld and Aluminium), the choice being dependent on the interference frequency to be screened and type of metal flanges being mated. Two elastomers are available, neoprene being recommended for RF interference shielding, plus protection from dust and silicone for applications requiring an extended life (up to 20 years) in a wider temperature range environment. The silicone elastomer has better fungus resistant properties than the neoprene type.

Each TWINSEAL combination is available with pressure sensitive adhesive backing, neoprene elastomer being also available with 'dryback' adhesive which is activated with a solvent at installation.

The wire mesh materials exhibit typical shielding properties of 110dB at 10MHz and 95dB at 1GHz. Increased shielding can be obtained using the double mesh TWINSEAL, composed of the same sponge elastomers but with wire mesh strips on both sides.

TWINSEAL is available from RFI Shielding Ltd, Braintree.

34 for further details



Micro-controlled intercom, from Blick International

MICOM is a compact, micro-computer controlled loudspeaker intercom system serving up to sixteen extensions and featuring high loudspeaker sound quality and an easy-to-set volume control to meet local noise levels or individual preference.

One or two digit numbers are used to call another station which activates automatically. A red pilot light on the caller's station indicates 'engaged', a flashing red light indicates conversation with another station.

General calls to all stations are made by dialling '00', individual stations being excepted if necessary. Persons being paged dial '9' on any station for automatic connection to the caller.

Callers or receivers can use their stations in private or open mode by operation of a slide control on the fascia.

The system is available on rental or for purchase. Wall mounted sets can have 10W power amplifiers for driving separate loudspeakers for large area use.

Blick International Systems Ltd, Swindon.

35 for further details

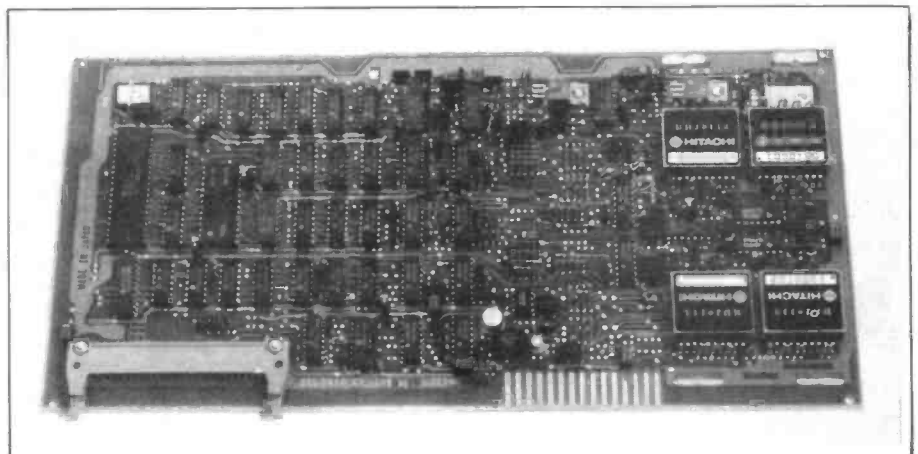

NEWS

VLSI '81 - a more imposing event than the title suggested?

Edinburgh University hosted the first international conference on **Very Large Scale Integration** to be held in the UK during August 18th-21st.

The assertion by Professor Carver Mead (Mr VLSI, himself - or to be precise, '*Professor VSLI*') that basic circuit and logic design had just about run out of fresh ideas, whereas the semantics of VLSI were largely unexplored, probably provided a pointer to the purpose of the gathering. In other words, now that the 'nuts and bolts' of computer design have been largely established and become freely available to any design team - VLSI affords an opportunity for the 'thinkers' of design to revert from being prompted by technological innovation, back to the more cerebral considerations of how to handle the organization and programming of the massive complex concurrent systems available through VLSI.

Delegates were treated to the proud statement from Iann Barron of our very own 'Inmos', that all his products came supplied with 'built-in redundancy'. Aptly demonstrating a redundant 'n' and 'r' in his own name, Iann Barron's allusions were to the trend towards providing a

degree of spare capacity on-chip to account for unforeseen errors. After all, a 63.75k RAM won't quite do when a 64k device is called for. A classic example is perhaps those examples of the 8k EPROM, type 2716, that are in truth 2732s that only half made it. A question of verbal semantics if you like.

IBM's contribution was to stir the pot on bubble memory with predictions of 4M bit products in 1982 - and the redoubtable Bell labs (homeland of the transistor) told about a 32 bit CPU they had on the stocks.

Dr Melvin Larkin (Plessey Semiconductors) extrapolated the £1.50 IBM370 chip, and quickly poured cold water on the idea by wondering if anyone would know what to do with such a 'doomsday' device. Just think what sort of 'Space Invaders' game you could produce - or a fruit machine with four dimensional lemons....

Judging from the absence of Ferranti and GEC - who both failed to support the conference platform - there are those amongst us in this country who feel they have enough business on their hands already, without worrying too much about developments that the future holds in store. We shall see.

Give them an inch - and they take 11 metres...

Now that CB is in the bag, the next commercial target for those naughty folk who make a handsome living out of the 'illegal to use in this country' market, is the cordless telephone extension. The Home Office's current bout of realism appears to be extending to a stark realization that the numbers of cordless telephone users has created a secondary CB situation, requiring a semblance of orderly regulation before it all gets out of hand.

British Telecom has even pitched in with a promise to offer a suitable system around the end of the year - although the first reports of this rather surprising about-face have not included any mention of the technical specifications. It seems hard to believe that the bootleggers' 49 MHz *phone to base*/1.8 MHz *base to phone* would be sanctioned - but these are indeed interesting times for the Radio Regulatory Division of the Home Office.

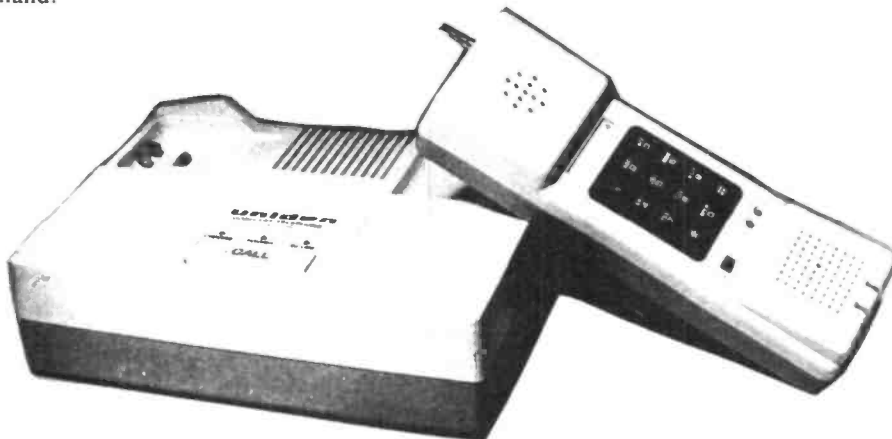

One of the cordless wonders on offer

The view from down under, up over here.....

The subject of innovation and the UK is very close to the hearts of **R&EW** people - so any book entitled *Industrial Innovation in the United Kingdom, Canada and the United States* deserves a closer look.

Written by Dr Kerry Schott, a non-male (we know how touchy some of these Australian academics get over the question of gender) Australian economist currently lecturing at the University College, London, the book manages to draw the usual wincing from those of us who had heard it all before.

This is not to say that it doesn't need to be repeated often, only that no-one ever seems to take the matter seriously enough. Sit tight, here we go. Unnerving statistics department:

Table One : Increase in industry funded R&D : 1965-1975

Japan	100%
West Germany	35%
US	10%
UK	-10%

Table Two : Increase in R&D at universities and polytechnics

Japan	90%
West Germany	60%
US	nil
UK	nil

Table Three : Productivity

Japan	100%
West Germany	50%
UK	25%
US	13%

A number of background hypotheses emerge on the significance of these figures - the low level of UK and US industry funded R&D is attributed to the poor technical quality of management and government, with the consequent failure to appreciate the significance of advances in basic research. The 'I'm a silly Billy, I can't mend fuses - but I can recite from Hamlet' syndrome.

The productivity figures are quite surprising. That the US should rate behind us is probably a reflection of the extremely high productivity achieved by the US up to the period of this survey, with the inevitable relaxation of standards whilst the workers are enjoying some of the fruits of their labours. Remember, this is *all* industry, not just electronics.

Table Four : ratio of investment on 'general advancement' and defence

Japan	55% : 2.2%
West Germany	51% : 11%
France	25% : 29%
UK	21.4% : 48.9%
USA	3.9% : 49.8%

A UHF Receiver Converter

Timothy Edwards

Before committing yourself to the expense of a piece of commercial UHF transceiver equipment, you might like to have a look and see what it's all about 'up there'. After all, dark tales of souls lost forever in the barren wastes of the 70cm amateur communication band could have coloured your outlook on what is really a rather bigger and more useful version of the 144-146MHz band.

The relative scarcity and higher cost of UHF equipment is certainly a problem, but if you can overcome this, then there are MegaHertz out there just waiting to be explored. In fact, more MegaHertz than the rest of the lower frequency allocations put together, although for practical reasons, only the 432-434MHz band is widely used for voice communications.

The converter described herein could easily be adapted for anywhere in the 380-500MHz region with appropriate changes in the mixing frequencies and filters. But primarily, it is intended to offer a low cost, repeatable and high performance 'way in' to 70cm communications, by providing you with the means of checking your local operating conditions for about £15.

Do not be deceived by the low cost, the performance figures speak for themselves:

Terminations	50 ohm
Gain	28dB nominal, 25dB band edge
Noise figure	1.8-2.5dB
Power source	12v DC
Selectivity	Image better than -60dB

Design Philosophy

Although this feature is presented as a 70cms (432-434MHz) down converter to 28-30MHz for reception on a standard communications receiver (or tunable IF system) - the basic principles hold good for any combination of RF and IF frequencies in this range.

One of the criteria of this feature - as with all R&EW projects is that it is 'state of the art', and cheaper to build than to buy. This raises some serious considerations over the question of the time taken to 'get something going' - since although corners can be cut from costs, these usually reappear in the convenience and ease of construction and testing.

At UHF, the prime problem for the constructor is knowing exactly where he is - since a 100pF capacitor may appear nothing like 100pF to the circuit. Due to lead inductance and the like, the familiar

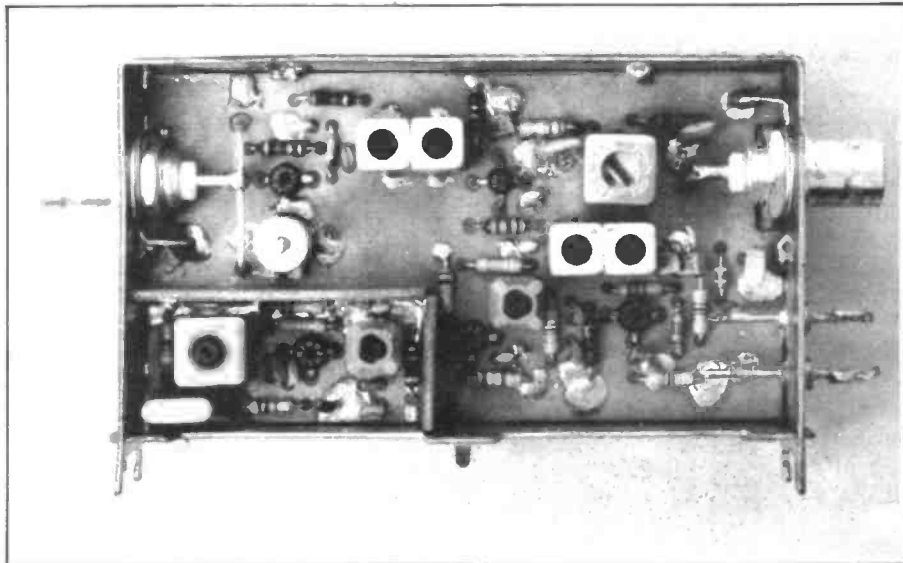

terms of reference of lower frequencies are completely lost. Tuned circuits at 432MHz are basically bits of straight wire with trimmer capacitors at the ends, and these tuned lines can easily be out by a factor of 80MHz - due to stray circuit problems mentioned above.

The answer at lower frequencies is to use a standard coil assembly which will not be more than a few MHz off alignment, and thus within the trimmable range. Block filters for IF filtering applications are ubiquitous at frequencies up to 45MHz these days, and now it is gratifying to note that prealigned block filters are at last available for VHF and UHF.

This converter is designed using the new TOKO 7HW series filters (*photograph one*), which are based on helical filter practise. This form of resonator offers a very high Q - and should not be confused with a conventional LC circuit at these frequencies. Practical RF Communications Data pages 68-71 provides a good introduction for the unfamiliar. (*Reference one*).

By using these filters, the converter has immediately been transformed from a tricky constructional exercise into something that can be tackled by an 'average' enthusiast (whatever that might be). If you have access to professional test equipment, then so much the better, but this is not a prerequisite as it would have been if the circuit employed home-made resonators throughout.

Circuit Design

The block diagram of the converter is given in *Figure 1*. The breakdown of selectivity and amplification is designed to optimise the noise figure of the converter,

without compromising other factors affecting its performance.

The helical block filter used in the RF path is placed after some amplification, since if used immediately after the antenna input, the insertion loss of the filter would simply add to the noise figure of the input stage. At VHF and beyond, the extraneous 'external' noise that characterises HF reception is of little consequence to the receiver designer, and so great effort must be made in such design to keep the noise figure of the circuit to a minimum.

The output of the local oscillator chain is fed via the second helical filter block, thus effectively removing all the unwanted harmonics of the basic crystal oscillator frequency, and preventing confusion during alignment as a result of the image frequencies that would otherwise proliferate.

The detailed circuit diagram of *Figure 2* shows that a bipolar device is used in the RF stage, when many people would perhaps consider that a MOSFET device is more fashionable. Certainly, a MOSFET might have a better strong signal performance in an extreme application, but for the majority of applications envisaged for this converter, the prime consideration is that of the noise figure of the unit. Accordingly, the BFR91 has been selected since it has a noise figure of approximately 1.5dB at 432MHz when operated in the configuration shown. It provides a simple, cheap and easily repeatable amplifier when used in conjunction with the TOKO filter. The mixer stage is a dual gate MOSFET, the prototype used the NEC 3SK88 MOSFET, which along with the BF960 is widely appreciated as being the current state of

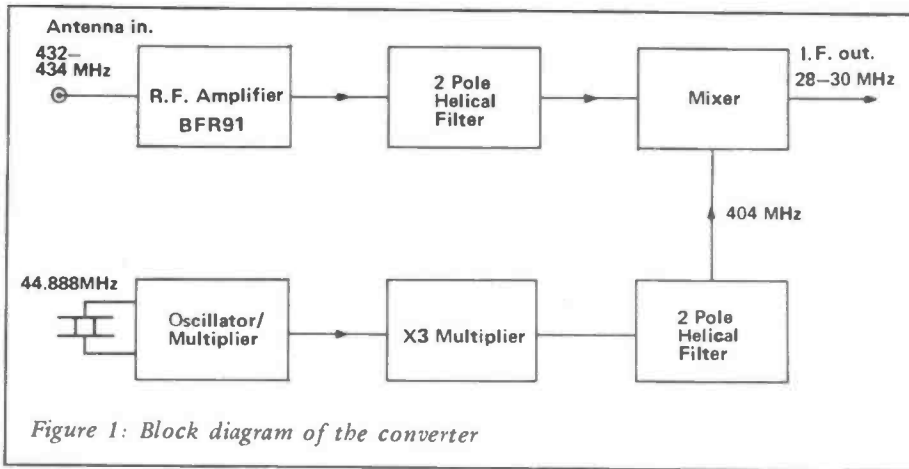

Figure 1: Block diagram of the converter

the art in low noise VHF/UHF MOSFET technology.

It is quite possible that there are devices of superior performance, (and the author would like to hear about any that the readers may know of), but the 3SK88 provides an unequalled price-performance ratio, when compared to some of the more esoteric gallium arsenide devices available. The converter circuit will also accept a BF960 transistor, although it is possible that there would need to be some minor revision of circuit values.

The MOSFET mixer stage is fed from the local oscillator and multiplier chain, where the 44.8889MHz crystal is operated in a 'Clapp' circuit - where the crystal is operated in what amounts to a Colpitts configuration, but the collector mode of the oscillator transistor is tuned to the third harmonic. The second stage of the multiplier is simply a buffer which provides sufficient drive to the final tripler for an adequate output after filtering to provide mixing via the source of the 3SK88.

The intermediate frequency output is

taken from the drain of the mixer stage via a standard RF coil using a very high inductance to capacity ratio, to maintain a broad bandwidth over the two MHz of the band in question.

The final point to note is the use of a 1N4148 diode in the supply line to prevent accidental damage though reverse polarity.

Practical Considerations

The major consideration of any UHF project is the selection of suitable components and techniques. The helical filters have been mentioned already, but it is as well to bear in mind that any component lying in the signal path at UHF (that includes the oscillator chain) must be selected for reasonable performance at this frequency, and mounted on the board with leads kept as short as physically possible. The stray inductance of even a short lead on a capacitor at UHF will cause unaccountable problems during alignment, and simply cannot be tolerated. For the same reasons, decoupling components at UHF may look rather inadequate to those of you familiar with lower frequencies. A particularly good example is C20, which although only 47pF, provides entirely adequate decoupling at this frequency. A much

Figure 2: detailed circuit diagram

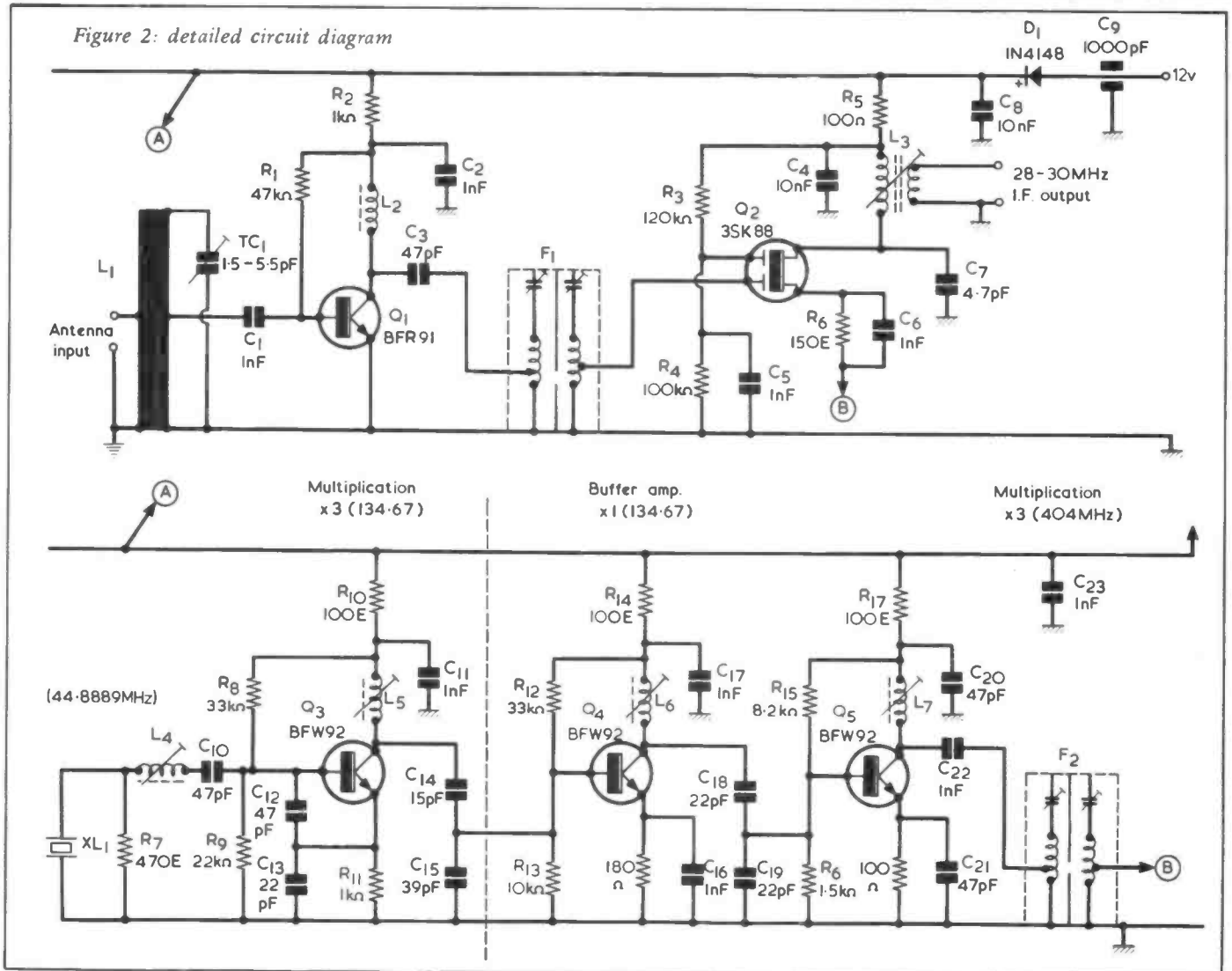

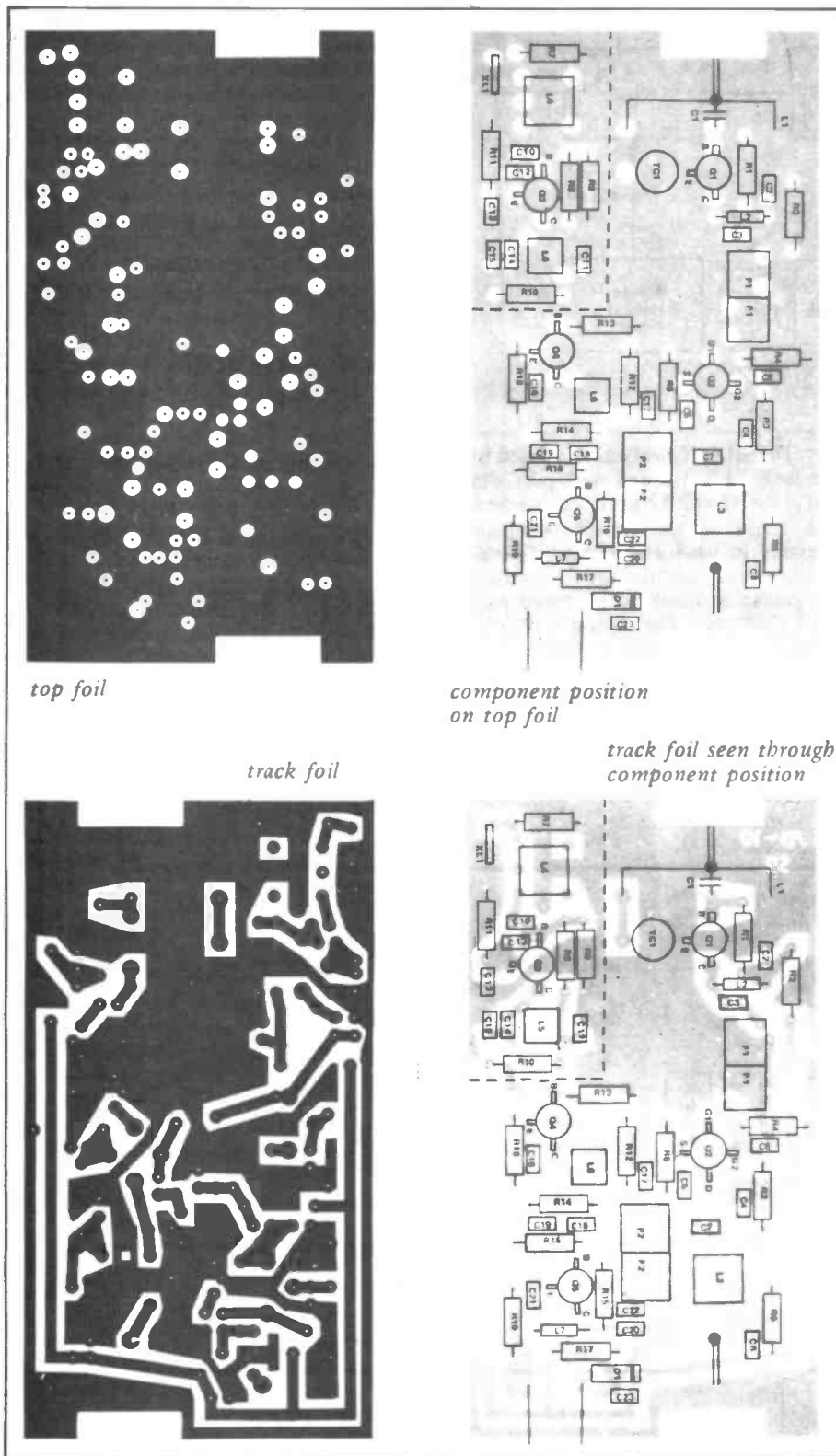

top foil

track foil

component position on top foil

track foil seen through component position

larger value than this could conceivably be detrimental to the circuit performance for reasons of self resonance and reactance.

The transistors chosen for the oscillator chain may be considered to be slightly more generously specified than usual, but the cost penalty is minor when compared to the ease with which the system may be subsequently aligned.

Construction

Figure 3 details the vital part of this project, namely the printed circuit layout of the top and underside of the board.

There is no reliable alternative to following this circuit layout, and certainly no alternative technique such as veroboard. The use of helical filters has simplified the circuit layout design somewhat, though not to the point where good UHF layout practice can be totally disregarded. The only point of potential concern to the constructor is the tuned line inductor at the antenna input stage which must be fitted in accordance with Figure 4.

The rest of the construction is really quite straightforward, the only remaining

points of note being the positioning of screening around the local oscillator and the positioning of the through connections on the earth plane of the circuit board.

The RF chokes wound on 470 ohm resistors need to be checked for correct termination before insertion into circuit, since it is very easy to wrap a piece of 36SWG around the resistor lead and apparently solder it, without actually making contact with the copper beneath the insulation layer.

Switch On and Test

Assuming that the converter has been constructed in accordance with all the details preceding, switch on and test ought to present few traumas. Those of you with previous experience in UHF converter construction may be wary of this stage in the process, but your fears ought to be unfounded.

Some form of UHF signal source is useful although in this particular instance, the presence of a beacon or repeater station within the band in question is frequently adequate for the purpose of 'setting up'. The tunable IF or communications receiver at the far end of the process should have an accurately calibrated scale (preferably digital frequency readout), in order that known beacon frequencies may be accurately tuned-in to assist in the process of alignment and seeking out signals.

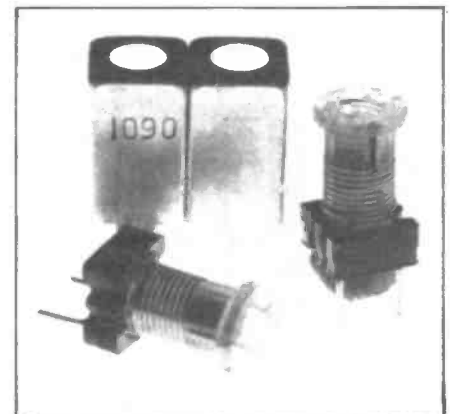

TOKO 7Hw Helical Filter

The tricky bit will be setting up the multiplying stages accurately. The first thing to determine is that the crystal is in fact oscillating, and there are a variety of techniques for achieving this. Perhaps the easiest way is to disconnect the crystal from the circuit whilst monitoring the quiescent current, and notice if there is any change when the crystal is reconnected. A slight increase in current as the crystal is reconnected indicates that at least something is going on, and the chances are it is the required third overtone oscillation!

You can check more precisely by measuring the voltage on the emitter of Q3, and checking that this rises from about 3.2v to 3.5v with the crystal connected. The multiplier stages may be

similarly peaked by measuring the voltage at the emitter, and adjusting the collector tuned circuit for maximum emitter voltage.

If you can hear a signal, then simply peak all coils in the multiplier for maximum signal level - including the coils in F2, which will need to be screwed down so that the top of the adjuster 'core' is 3mm below the top of the filter can to reduce the frequency to that of the LO injection. This distance is fairly predictable, and this filter may be preset by measuring the height of the core below the can, and subsequently peaking for maximum signal.

If you are still without signal, and the total quiescent current drain is under 50mA, switch the converter on and off, whilst listening to the output of the tunable IF strip, and note if there is an increase or decrease in the noise level as the converter is switched on and off. There should be a noticeable increase in noise level with the converter switched on, which may be peaked by adjusting the IF output coil for maximum.

Photograph 2 indicates the RF bandwidth of the converter as viewed at the input to the mixer stage, with a 1MHz horizontal scale and 10dB vertical scale. The centre frequency of this particular spectrum analyser photograph is 433MHz. PC1 at the antenna input stage should be trimmed for maximum signal, when a signal is present at the input, and this should have no effect on the noise output

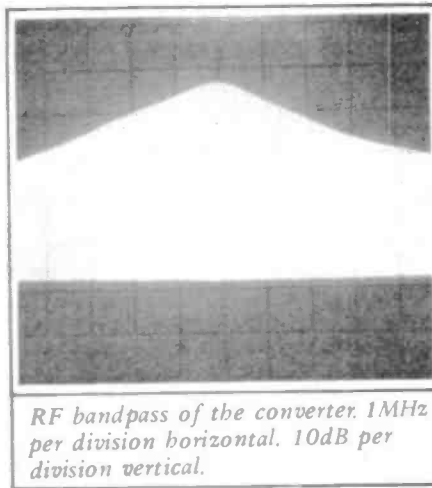

as monitored on the tunable IF strip. If it makes a substantial difference to the overall noise 'sound', then suspect that perhaps the RF stage is going marginally unstable, and make certain the 'through' links from one side of the earth plane to the other are making good contact, and that all decoupling capacitors use short leads.

The image response of the converter (required RF frequency - 2 times the IF frequency) at 375MHz is 60dB below the main response, and the converter exhibits 28dB of gain mid-band, with a realistic noise figure of 2-2.5dB overall.

And finally...

If you end up hard against the

buffers in your attempts to align the R&EW 70cm converter, then remember R&EW's technical facilities are available (at a reasonable cost) to help untangle problems of alignment. For about £5, R&EW's laboratory will align your converter on a spectrum analyser and thereby prevent your efforts from taking their place alongside some of those other magazine projects which 'never quite made it'. It is important to remember, that the alignment facility is primarily

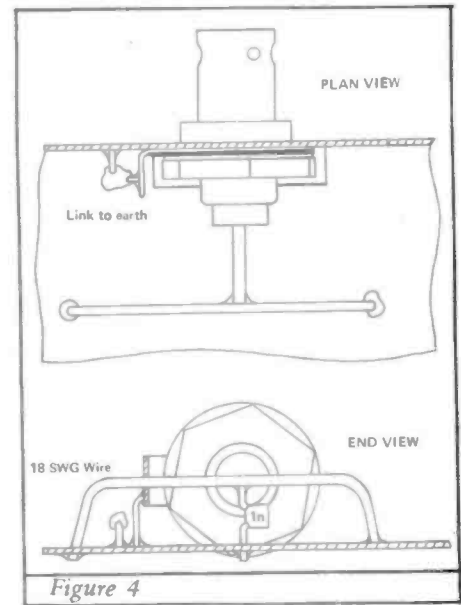

continued on page 15

Sowter Transformers

With 40 years' experience in the design and manufacture of several hundred thousand transformers we can supply

AUDIO FREQUENCY TRANSFORMERS OF EVERY TYPE

YOU NAME IT! WE MAKE IT!

OUR RANGE INCLUDES:

Telex: 987703 SOWTER

Microphone transformers (all types), Microphone Splitter/Combiner transformers, Input and Output transformers, Direct Injection transformers for Guitars, Multi-Secondary output transformers, Bridging transformers, Line transformers, Line transformers to G.P.O. Isolating Test Specification, Tapped impedance matching transformers, Gramophone Pickup transformers, Audio Mixing Desk transformers (all types), Miniature transformers, Microminiature transformers for PCB mounting, Experimental transformers, Ultra low frequency transformers, Ultra linear and other transformers for Transistor and Valve Amplifiers up to 500 watts, Inductive Loop transformers, Smoothing Chokes, Filter, Inductors, Amplifier to 100 volt line transformers (from a few watts up to 1,000 watts), 100 volt line transformers to speakers, Speaker matching

transformers (all powers), Column Loudspeaker transformers up to 300 watts or more.

We can design for RECORDING QUALITY, STUDIO QUALITY, HI-FI QUALITY OR P.A. QUALITY. OUR PRICES ARE HIGHLY COMPETITIVE AND WE SUPPLY LARGE OR SMALL QUANTITIES AND EVEN SINGLE TRANSFORMERS. Many standard types are in stock and normal despatch times are short and sensible. OUR CLIENTS COVER A LARGE NUMBER OF BROADCASTING AUTHORITIES, MIXING DESK MANUFACTURERS, RECORDING STUDIOS, HI-FI ENTHUSIASTS, BAND GROUPS AND PUBLIC ADDRESS FIRMS. Export is a speciality and we have overseas clients in the COMMONWEALTH, EEC, USA, MIDDLE EAST, etc. Send for our questionnaire which, when completed, enables us to post quotations by return.

E. A. Sowter Ltd.

Manufacturers and Designers

E. A. SOWTER LTD. (Established 1941), Reg. No. England 303990
The Boat Yard, Cullingham Road, Ipswich IP1 2EG, Suffolk, P.O. Box 36, Ipswich IP1 2EL, England
Phone: 0473 52794 & 0473 219390

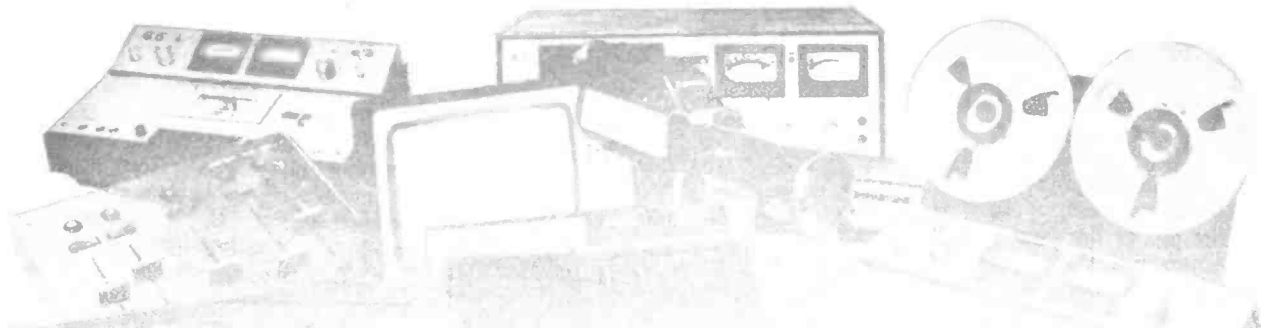

The 9908 Universal Counter is the finest counter in the world in its class.

In operation it will help you to provide a better service for all your customers.

That's because it's designed and manufactured to give unrivalled versatility, greater accuracy and a long dependable life.

For all service organizations actively involved with the repair of mobile radios, CB and Open Channel radios, VCRs, teletext colour televisions, and other video systems, the 9908 measures the widest range of frequency and time.

Features include frequency coverage to 1200 MHz, 10mV sensitivity, 0.1 parts per million crystal standard, and a large, 8-digit LED display. You'll also find the 9908 demonstrates the high quality and design integrity on which Racal has built its reputation.

And that's more than a claim because we'll guarantee the whole unit for two years and the LSI chip for a lifetime.

Send off for the facts, and you'll find that when it comes to quality we'll give you all the reasons for specifying the 9908.

The Ninety-nine hundred and eight gives you every good reason for counting on Racal-Dana.



£495
Price applicable to UK only.

Please give me every good reason for counting on the 9908.

Name _____

Company _____

Position _____

Address _____

Tel: _____

RACAL-DANA

Racal-Dana Instruments Limited, Duke Street, Windsor, Berkshire SL4 1SB. Telephone: (07535) 69811 Telex: 847013

Racal-Dana Instruments Limited, Duke Street, Windsor, Berkshire SL4 1SB

RACAL

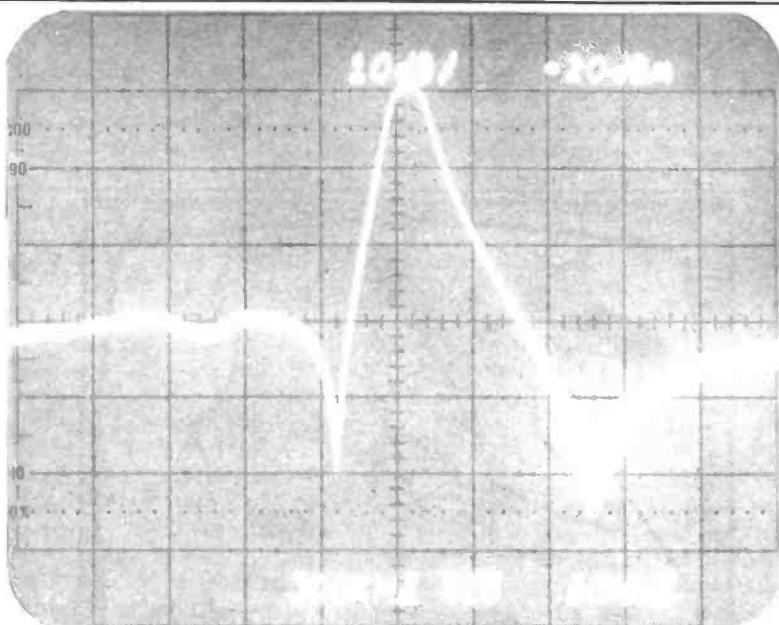

7Hw Filter Bandpass 10dB vertical, 430MHz centre, 50MHz per division

only that, which means that converters which are incorrectly constructed, and have basic soldering and assembly problems are **not** covered in this service, since it is impossible to account, in a flat rate charge, for the the number of different problems that can arise at the hands of the enthusiastic, but not too experienced constructor.

Converters for Other UHF Frequencies

The basic techniques and sums employed in designing this converter may be applied to provide converters operating anywhere from 400-500MHz with the appropriate choice of block filter and crystal oscillator. However, the only frequency of interest to the radio enthusiast will be the 70cm band,

although the performance of this unit is more than adequate for certain types of commercial/professional radio receiving applications. If enough interest is shown, we may publish a further article describing the adaptation of this converter to spot frequencies in the commercial bands.

It is quite possible that your tunable IF strip or communications receiver covering 27-30MHz does not possess a suitable NBFM demodulator. Don't panic, an early issue of **R&EW** will be describing in some detail a suitable NBFM adaptor for most known communication systems, complete with squelch and other facilities to make listening easy. ■

Reference:

Practical RF Communications Data :
Doug DeMaw. (Publisher Howard Sams.)
Available from **R&EW** Book Service.

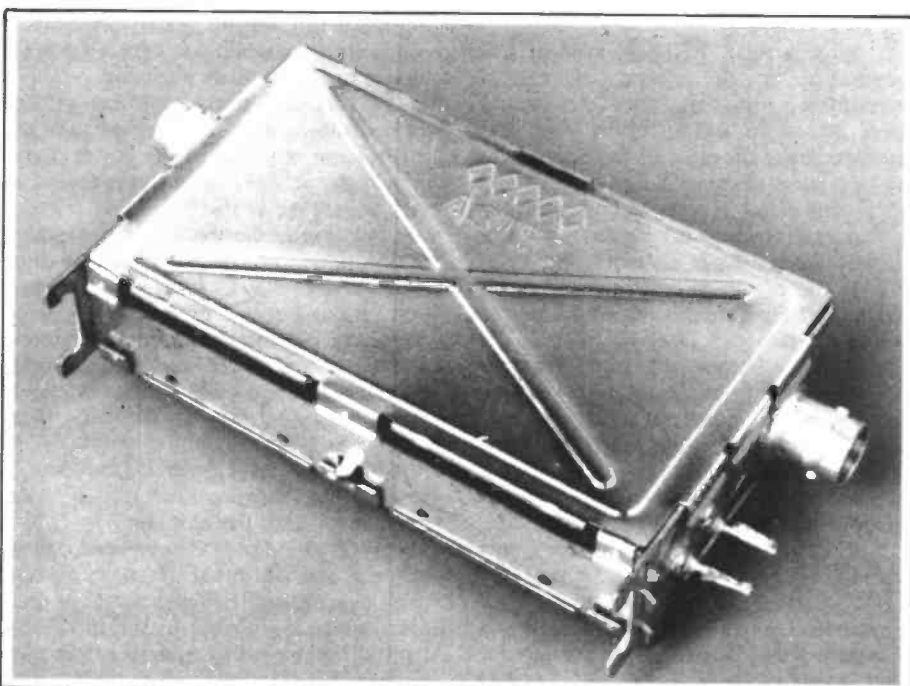

Components List

Resistors 5%, 1/4 watt

- R1 47k
- R2 1k
- R3 120k
- R4 100k
- R5 100R
- R6 150R
- R7 470R
- R8 33k
- R9 22k
- R10 100R
- R11 1k
- R12 33k
- R13 10k
- R14 100R
- R15 8k2
- R16 1k5
- R17 100R
- X1 44.8889MHz series
- D1 1N4148

Ceramic disc/plate

- C1 1n0
- C2 1n0
- C3 47p
- C4 10n
- C5 1n0
- C6 1n0
- C7 4p7
- C8 10n
- C9 1n0 feed through
- C10 47pF
- C11 1n0
- C12 47pF
- C13 22pF
- C14 15pF
- C15 39pF
- C16 1n0
- C17 1n0
- C18 18pF
- C19 22pF
- C20 47pF
- C21 47pF
- C22 1n0
- C23 1n0
- TC1 1-6pF

Semiconductors

- Q1 BFR91
- Q2 3SK88
- Q3 BFW92
- Q4 BFW92
- Q5 BFW92

Inductors

- L1 25mm tap 5mm up 18SWG
- L2 7t 36SWG on 470R
- L3 154FNA 6431 (TOKO)
- L4 KXNK3766EK (TOKO)
- L5 TOKO MCI19/4.5t
- L6 TOKO MCI19/4.5t
- L7 7t 36SWG on 470R

Filters

- F1 252MT 1001A TOKO
- F2 252MT 1001A TOKO

Your Reactions.....	Circle No.
Immediately Applicable	133
Useful & Informative	134
Not Applicable	135
Comments	136

NEWS BACKGROUND

MAP: The Department of Industry is waiting to hear from you...

Remember those halcyon days when Tony Benn was Minister of Technology? The government had just discovered the 'micro chip', and was thinking up ways of supporting the British high technology industry with all sorts of schemes and aid programmes. Amongst the gems dreamt up was the Microprocessor Application Project (MAP), whose aim in life was/is to spread awareness of the application of microelectronic technology to industrial applications.

Briefly, the MAP set out - in fairly dramatic terms - to try and frighten the remnants of British manufacturing industry to adopt new technology and adapt to new ways of performing traditional tasks. A number of 'before and after' examples are offered to point out that unless cam timers are ditched in favour of MCUs (Micro Controller Units - implying an 'applied' MPU solution), then the customers will ditch the cam timers in favour of companies prepared to accept the microprocessor and its associated technologies.

The DoI offer to pay the first £2000 of the fees of consultants approved under the MAP scheme. Thereafter, a couple of alternative schemes exist to see a product into the marketplace with either grants or joint venture funding.

It's a bit of a shame therefore, that with all this technological emphasis, it seems quite impossible to communicate with the MAP after 5.00pm on a Monday. Perhaps a telex would be a good idea - after all, most other DoI offices are listed - although attempts to contact DoI HQ's telex to pass the message on were frustrated by the line being 'occupied' from 5.30pm to 7.00pm when we gave up trying.

We phoned the next day, and the man 'who can deal with your question' was too busy to talk on the telephone - and we were asked to apply in writing instead. Such treatment at the hands of the MAP will not really assist in the furtherance of their laudable aims and objects - especially when we are seeking information in order that we could assist in the dissemination of those very aims through the medium of **R&EW**. The message eventually got through, and we are pleased that a member of the MAP scheme was able to attend our launch gathering.

The nine-to-five Nation

Go anywhere in the USA, and you will find that life exists after 5.00pm. Most of the Hypermarkets stay open until after 8.00 or 9.00pm, and many services



and products are available 14 hours a day in any moderate size town. Walk down the main street of an English town at 6.00pm and for all the life and activity going on, it might as well be the day after Armageddon.

About the only thing going on is the consumption of intoxicating liquor. Need a spare battery for your torch? Forget it. Even petrol stations that used to remain open until 9.00pm now seem to be closing at 7.00pm. Perhaps when there's 55 million unemployed people in the land, there might be someone willing to man the till until 7.30pm??

Why is this? The high cost of UK overheads in the shape of capital investment, property, rates etc. would seem to make it imperative that any business made the most of these resources by operating as many hours as possible. Flexi-time exists in some organizations to try and spread the working day - but not usually much outside 8.00am to 6.00pm.

Is the compulsive attraction of TV too much? Does the Nation rush home to watch Crossroads? Does 24 hour TV in the USA alleviate the need for its population to try and cram in the viewing in the available hours, in much the same way as the UK's licencing laws are blamed for the way in which the customers are inclined to cram in as much drink as possible before someone calls 'Time'?

Then we have the 'well, there's only 25 minutes before it's time to go, so I won't bother to start anything now' syndrome. It all adds up to a rather frustrating and difficult time for anyone that actually wants to do anything not

connected with drinking/eating and leisure outside the hours of 9-5.

We would like your ideas and opinions on the basic reasons underlying this curious affinity that the British working person has for the hours between 9.00am and 5.00pm. Is it really so unreasonable to expect to find businesses operating say between 8.00am and 7.30pm? (Giving a fair slice of time outside the 'penalty' telephone rates enforced during the 'working' day.) It's true that many businesses are manned outside strict office hours, but only very much on an ad-hoc basis, whereas it would seem reasonable to expect a regular service might be made available.

Credit card purchasing has offered an easy means of taking the money of the customer at any time of the day or night, so why are so few businesses prepared to take advantage of this?

As most electronics development engineers will probably know, it is quite difficult to tear away from an experiment that is nearing completion. If it is physically possible to do so, most engineers with an interest in the work will probably try and hang on to see the thing completed. How frustrating then to find that there isn't a single distributor available to provide a comment from a data sheet or stock/price information on a vital component until the next day.

Well, there probably are one or two around, and we would like to encourage them by offering to publish details of their after hours availability in the form of a register that we will be updating from time to time. We ask that firms connected with



USA

the electronics business who operate regularly outside the hours of 8.00am and 6.00pm should send in details of the products and services available - and we will give them a free listing.

Never on a Sunday

At the risk of incurring the wrath of the Lord's Day Observance Society, we would like to question the rationale behind the way in which industry abandons the weekend at around 4.00pm on Friday.

Surely most of us are now old and responsible enough not to need to be herded about the week like schoolchildren? If we choose to work on Saturday or Sunday and take another day 'in lieu', then why should anyone object? (Other than on religious grounds - and that must surely be up to the individual's conscience.)

Sporting events have crept into Sundays, many shops are open on Sundays (with or without the approval of local authorities), and the the premise supporting the medieval concept of resting on the 7th day has taken on a different perspective in the twentieth century.

We have trade unions and the like to ensure that the workers are not likely to become exploited by the grasping Barons of industry as a result of a general deregulation of the working week. But in order to get anyone to work on a Sunday, it seems necessary to offer substantial bribes in the shape of double and treble time. The only concrete results of the policy of 'abandon all work ye who enter the weekend' seems to be the lemming like rush for the resorts, and the inconvenience of discovering that the very day the consumer is largely 'at large', the consumer supply industry largely is not.

The Silly Season ...

From the very unpatriotic celebrations of Mayday onto the end of August, we are blessed with various enforced 'Bank Holidays' - whether it suits us or not. These occasions rarely seem to tie up with those of our overseas trading partners, and serve largely to frustrate those who are only too well aware that the rent, rates and wage bill don't seem to be similarly relieved for those days of enforced non-productivity.

Surely a better solution is put these days onto the annual holiday allowance and thereby keep GB Limited ticking over with fewer hiccups.

Devil's advocate

Of course, there are arguments in favour of the concept of fixed hours and holiday times. However, the basic premise does not seem to get very seriously questioned - and the inconveniences are usually soon forgotten after the holiday season is over. So we invite ideas and comments from readers on the need for such rigidly enforced working times.

The nature of the electronics industry probably permits more flexibility in working hours and times than most - and there are a growing number of examples (in the USA) where the argument is taken a stage further with employees working from a computer terminal at home on a very laissez-faire basis. As society moves closer towards the 'electronic office', so the need for the personal appearances of the workers will tend to diminish.

Perhaps, with a little luck, you may one day find that you can get your TV repaired when someone is actually around at home to let the service man in. Or your carpet is delivered and fitted when it suits you - or you can get a pint of milk at 9.00pm when you need it - it doesn't take that much imagination, does it ?

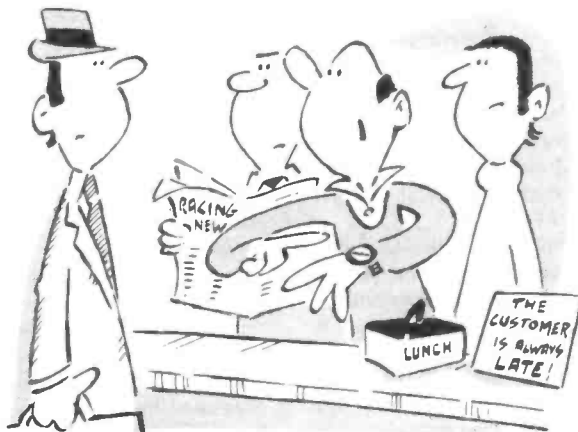

"... A TAP WASHER AT FIVE TO FIVE!
WHERE D'YOU THINK YOU ARE, LAS VEGAS!"

HP 'writes' its own Micros

Hewlett-Packard's newly announced electron beam lithography process is capable of producing MPU with around 450,000 transistors, at the rate of five wafers per hour.

The 600nA 0.5 micron wide electron beam can be placed anywhere in the 11.7 x 11.7cm 'field' with an accuracy of +/-0.125um. The data processing required to perform this degree of accuracy, consumes no less than 10,000 16k dynamic RAMs in the pattern memory.

It is anticipated that ICs using 1 micron geometry, with registration accuracies of 0.1 to 0.2 micron are going to be viable production items.

Pirates to be keelhauled

Whilst most of us here find it difficult to work up much enthusiasm for the Great Copyright debate, the widespread use of Satellite broadcasting with the prime program material offered therein has made the question all the more urgent in the USA. So concerned in fact, that there is a bill in the Senate to upgrade the crime to a felony, (more than just a parking ticket), with a fine of up to \$250,000 and five years in jail for the big operators.

Perhaps those who are trying to tidy up the archaic copyright laws that relate to the 'video' boom in this country might like to take note of these draconian measures to see just how seriously this form of theft is taken in the USA.

IBM's personal computer

After a considerable gestation period, IBM have launched their much discussed personal computer on the US market. It appears to be everything that the industry had come to expect from IBM - being basically a fairly restrained presentation of some of the most advanced 'small' computer thinking yet.

The basic 16k machine sells for US\$1,565 - and let's hope that UK price isn't simply a \$/£ swap - although a realistic 'system' comprising 64k main memory, single diskette, and display will cost around \$3,000. The business package with twin disk drives and 80 cps bidirectional printer is about \$4,500.

On the face of it, these prices are relatively high compared to a PET installation, but the ability to address 262,144 bytes of RAM, 40k of ROM (including a 16k BASIC interpreter), the speed and versatility of 16 bit processing, the scope offered for the implementation of high level languages, plus the experience of IBM all seem to add up to a 'personal' computing package, that will have most of the rival suppliers becoming distinctly nervous.

The PM2521

The Philips PM2521 digital voltmeter-cum-general purpose test meter vies with a low-ish cost oscilloscope at around £295. Whilst you can't really directly compare the functions of two instruments, which one should take precedence when considering the 'budget' available. Here's a few pointers...

Please don't call the PM2521 a DVM

In the attempt to underline the fact that the PM2521 is a lot more than a 4.5 digit DVM, Pye Unicam have perhaps gone slightly over the top with the accolade of 'Digital Measurement Centre'. However, notwithstanding this, the PM2521 is exceptional value for money, and should certainly encourage many users who have been hovering on the brink of a 4.5 digit DVM to plunge in and get one.

Apart from a highly accurate (0.03%) voltmeter and current measuring device, you get a reciprocating frequency counter up to 10MHz, automatic ranging line level indications from 1mV to 600V (dB relative to 1mW into 600 ohms), automatic ranging time measurements up to 100,000 seconds - not displayed in hours/minutes format, (if you want to know the 'real' time, ask a policeman etc.), and automatic ranging measurements of relative levels.



five minutes rushing around looking for a series of voltages to measure that put the autoranging through its paces.

The second most important aspect to the harassed engineer is the fact that the device seems capable of absorbing AC mains at any input. (Except the current ranges between 200mA and 20A, when the maximum overload is 20 amps for 20 seconds.) The best of us have probably zapped a multimeter or two in our time, so this is far from an idle gimmick on any such test instrument.

The broad technical specification is set out in *Table One*, and the third thing you will notice about the PM2521 is that unless you are very fortunate, you will probably not have any means of checking this degree of accuracy anyway. It sets its own standards, and so it is perhaps reassuring that whenever it is turned on, the display shows 'CAL' (see photo) whilst the MPU takes the instrument through its own internal calibration checking process.

The ability to manually hold a range is useful - since where the last μV of resolution is unnecessary, you can halve the response time if autoranging isn't required. If you are delving into a circuit where the maximum voltage will not be exceeding 19.999V, then set the meter to the 20V range or you may be driven scatty whilst the PM2521 deliberates between the 200mV and 2V ranges. You will still get resolution to 0.001V.

The relative reference is useful if you are performing gain checks on audio amplifiers, or checking circuit/systems in relation to an established standard. It doesn't quite replace the function of a moving needle meter when it comes to circuit 'tweaking' for maxima and minima, but it certainly saves the mental contortions of having to subtract the datum level to establish if things are getting better or worse. This facility is also available on the resistance ranges - so you

can zero out the probe resistance when getting down to really low measurements (relay contacts etc.)

Spectral purity

One aspect of this type of equipment that frequently gets overlooked is the RF radiation from both the instrument 'case' (or through the case, since most are plastic), and more insidiously, down the input leads.

It is very difficult to relate the sort of RFI experienced to any meaningful 'absolute' or quantitative measurement, so we will be trying to establish a basic 'norm' in the course of R&EW equipment reviews. Any comments from readers are most welcome - but we don't yet have a fully screened room and the necessary funds to install a completely calibrated interference measuring system. Readers wishing to support the 'help R&EW lab equipment fund' are invited to send donations so that we can bring you even more thoroughly documented features and reviews...

The easiest way out at the present time is for us to present you with a 'before and after' view of the RF spectrum visible at the ends of the probe leads. Without having yet established the ideal 'datum' test fixture referred to above, the best we can say is that there is certainly more RF present on the probe leads after switch on (see *spectrum analyser photos*) - and enough RF to cause confusion when used around sensitive RF environments.

We are particularly keen to establish this aspect of equipment that passes through our hands - since many, many hours have been wasted on receiver tests and designs as a result of spurious 'noise' generated in DVMs. DVMs based on the Intersil CMOS 7106 device seem to possess hardly any RFI - so little we couldn't spot it on the equipment available (Tek 7L12 analyser and FET probe).

The PM2521 uses an 8035 NMOS

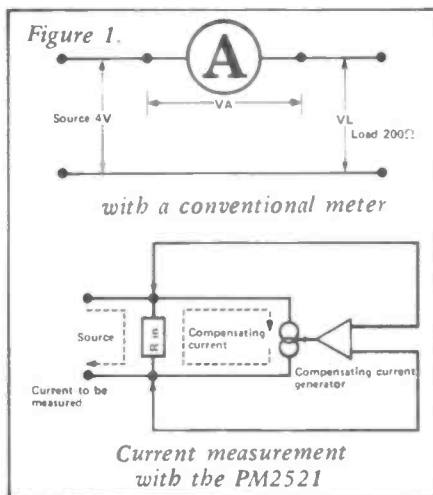

The current ranges up to 20mA are measured in conjunction with a very thoughtful process that involves balancing out the current flow through the meter (*Figure 1*), so that the voltage drop across the meter is less than 25mV - as opposed to the more usual 200mV on straightforward 'shunt' systems.

Using the PM2521

If you have never had the luxury of an autoranging DVM, the first thing you notice is the joy of not having to continually switch the ranges when delving into circuits of 'unknown' potential. In fact, you will probably spend

Measuring quantity	VDC	VAC AC coupled RMS Crest factor 2	VAC dB 0 dB reference = 1 mW in 600Ω	Freq.	Time	Level
Max. display	± 21000	21000	± 99.9	99.999	99.999	± 2000
Ranges (all auto-ranging)	200 mV 2 V 20 V 200 V 1000 V	200 mV 2 V 20 V 200 V 800 V	± 57.7 dB to ± 57.7 dB	10 kHz (manual ranging only) 100 kHz 1 MHz 10 MHz	10 s 100 s 1000 s 10000 s	2 V 20 V 200 V 800 V
Max. resolution Limit lowest reading	10 µV	10 µV 0.5% range	0.1 dB	0.1 Hz	100 µs 10 ms	1 mV 10 mV
Accuracy (% reading + digits)	0.03% + 2 d	Table I	Table II	0.005% + 1 d (up to 1 kHz) 0.01% + 1 d	0.005% + 1 d	10 digits
Temp. coeff. /°C	0.01%	0.03% + 1 d	0.02 dB	0.0005%	0.0005%	
Input characteristics				Input impedance up to 2 V 20 V range over 20 V		
CMRR DC AC 50 Hz ± 1% Max. CM voltage SMRR 50 Hz ± 1%	100 dB 100 dB 400 V _{rms} 80 dB	100 dB 80 dB 400 V _{rms}		Settable trigger level + and - (See Vlevel) Trigger modes see table III		
Response time Response time (ind. ranging) Overload protection	< 0.7 s < 1.5 s 1000 V	< 1.5 s < 3 s 800 V	800 V	800 V	800 V	
Relative reference Range of reference & subsequent signals Max. reading	yes in one range ± 40 000		yes 1 mV... 800 V ± 99.9			

DC	AC AC coupled RMS Crest factor 2	R	Voltage over forward resist. at 1 mA	Temp. with Pt 100 probe
± 2100	2100	21000	21000	2100
2, 20, 200 µA 2, 20, 200 mA 2, 10 A		200 Ω 2 kΩ 20 kΩ 200 kΩ 2 MΩ 20 MΩ	2 V	- 80°C to + 200°C
1 mA		0.1 Ω	1 mV	0.1°C
0.8% range				
0.2% + 1 d	0.4% + 2 d (up to 1 kHz)	0.2% + 20 d over 200 kHz 1% + 20 d	0.2% + 20 d	1% + 0.2°C over 100°C and under 0°C m ± 3% + 0.2°C
0.02%	0.03% + 0.2 d	0.02% + 2 d		
Voltage drop < 2.5 mV up to 2 mA < 25 mV 20 + 200 mA range < 250 mV 2 + 10 A range		Voltage at open input 4 V		
		Measuring current		
		2 V/rng end value		
		1 mA		
< 0.7 s < 1.5 s < 265 V	< 1 s < 3 s < 255 V	< 0.7 s (< 200 kHz) < 2.5 s 265 V	265 V	
Over 20 mA unprotected Max. cur: 20 A for 20 s, 16 A continuously				
		yes in one range ± 21000	yes in range ± 2100	yes in range ± 2600

microprocessor - amongst other things - and so we were naturally placed on guard as a result of many interfering experiences at the hands of NMOS MPUs. The RFI present on the PM2521 is by no means severe, but it must be borne in mind when used with a radio receiver. Always establish your 'datum' noise level with the DVM switched off.

In any case, the majority of uses for this DVM are likely to be well removed from such considerations, and the brave may like to break in and fit a filter on the input, as we have done to several pieces of R&EW lab equipment.

RF immunity

The 1.5W of 145MHz from an IC2E transceiver with helical antenna seemed to upset only the DC voltage ranges. Which is rather curious - since the AC ranges that might have been expected to be more sensitive were almost totally unmoved - even when the input leads were wrapped around the antenna.

An 8.2V battery read 9.4V with the IC2E transmitting about 5 feet away, so bear this in mind if you use the instrument near transmitting installations. We feel that this is another area where we need to get a 'standard' test fixture together, so maybe the answer will be to plug the received RFI test lead into the transmitter output. Watch for developments of this idea - but there are so many variables in such a high impedance measurement system that the results will have to be a guide rather than a scientific quantitative analysis.

Extras

The back of the trilingual handbook contains details of the many accessories available for the PM2521. The most useful is probably the 'data hold' probe, which latches the displayed reading so you can extract the probe from a delicate area before looking up to see what the reading is/was. The switch contacts for this function are available on the DIN socket on the front panel anyway - and perhaps a foot switch plugged in here would be more helpful? The £36 thus saved on the data hold probe could be better spent.

The HF probe, type PM9210 will measure from 150mV to 15V over the range 100kHz to 1GHz - or 15V to 200V with the attenuator supplied with the probe. At £110, the PM9210 is about par for the market, but at over 30% of the instrument's basic cost, it's only likely to be used by those with a serious purpose.

AC currents with frequencies from

45Hz to 1kHz can be measured using a 1000:1 'clamp' probe transformer type PM9245.

Scope or DVM? Conclusions

Obviously, we'd all like both. A 'scope (PM3207 - around £325) is also a reasonably useful voltmeter - and since it must be assumed that a cheap multimeter is already around, then this class of DVM is probably best left until after the 'scope is installed and understood. A 'real time' indicator like an oscilloscope is a very useful thing - most engineers fly by such analogue instruments in the first case, only referring to the precision of digital versions when basic parameters (like whether or not the circuit 'works') have been established. Wait until the cheap DMM meets its inevitable fate on the wrong end of 240v AC.

The main thing this DVM does is save time, and for any professional organization, that is certainly the most precious and easily wasted commodity on the premises. You won't waste time digging around for the different items of equipment that are encompassed within the one box. And you don't waste time wondering if the results are accurate enough - most users will probably ignore the last digit(s), although it is comforting to know it's there if you are really keen.

Please excuse the generalisations if they don't happen to apply to your circumstances. The R&EW lab is about as general a situation as it is possible to find, so we hope these observations will find widespread application amongst our readers. ■

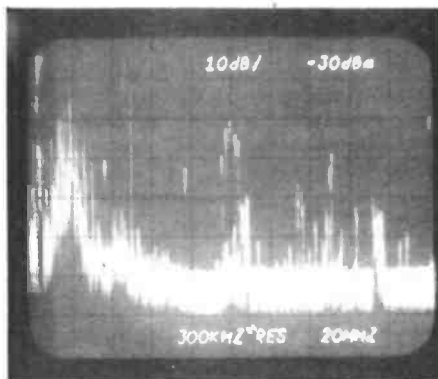

RFI - 'before' switch on

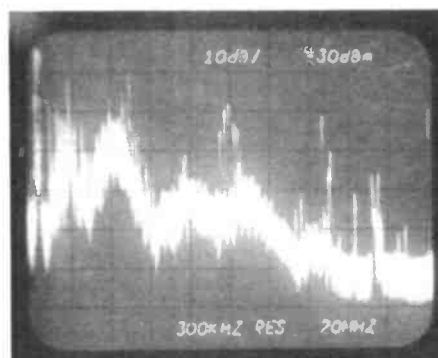

RFI after switch on

Your Reactions.....	Circle No.
Immediately Applicable	158
Useful & Informative	159
Not Applicable	160
Comments	161

STOP THE WORLD

CITIZENS' BAND RADIO LICENCE APPLICATION

V.B.F. Ltd. 58 1555 7781 910750 35066

To obtain your licence turn to the licence form underneath
USE A BALL POINT PEN AND.

1. Indicate how many sets you intend this licence to cover.
2. If this is a renewal place a tick in the box provided.
3. Leave the expiry date and fee to be entered by the clerk.



4. Enter IN CLEAR BLOCK CAPITALS keeping within the boxes provided:—
a. Your title (by deleting Mr. or Ms. as appropriate) followed by the initials of your forenames.
b. Your surname.

c. Full postal address including postcodes. Enter each line of your address on a separate line where possible.
YOUR POSTCODE IS IMPORTANT PLEASE ENTER IT

5. Unless the licence is to cover more than 15 sets, hand the complete form together with the fee as prescribed at the time of application to the clerk. Cheques should be made payable to the 'Post Office' and crossed A/c payee. If you wish to pay by National Girobank transfer use one of your personal transfer forms. The clerk will tell you the Head Postmaster's account number to be entered in the credit section.

6. If you need this licence to cover more than 15 sets postal application is necessary. Send the completed form and your remittance to:— CB Licensing Unit, Chetwynd House, Chesterfield, Derbyshire S49 1PF.

WARNING

Before leaving the counter you should ensure that your licence has been initialed by the issuing officer and that it bears the appropriate licence fee stamp/s and date stamp impression.

CB01 MISC 406 370324

† Note

Suitable equipment may be recognised by the presence of the following symbol engraved or stamped on the front panel of the equipment



Equipment should be certified by manufacturers as complying with the appropriate interference regulations

LICENCE CONDITIONS

2 Use of the apparatus is subject to the condition that the apparatus may be operated only by the licensee or the following persons with the licensee's permission:—

- a any person who resides with the licensee at the licensee's usual place of abode
- b any employee of the licensee acting in the course of the licensee's employment.
- c any person who hires the apparatus from the licensee for a period not exceeding 28 days

and use of the apparatus otherwise than in accordance with this condition shall not be authorised by this licence

3 This licence is not transferable

4 The apparatus shall be so designed, constructed, maintained and used that its use does not cause any undue interference to wireless telegraphy

5 The apparatus and this licence shall be available for inspection on demand by a constable or a person acting under the authority of the Secretary of State

6 All transmissions, other than selective calling signals or digital transmissions designed solely to identify the transmitter, shall be in plain speech only

7 The equipment may not be installed or used in any aircraft or other airborne vehicle

8 No transmission which is grossly offensive or of an indecent or obscene character shall be sent

9 The apparatus shall not be used for the purpose of advertising or soliciting goods or services of any kind.

10 The Secretary of State may at any time after the date of issue (i) revoke this licence or vary the terms, provisions or limitations thereof by a notice in writing served on the licensee or by a general notice published in the London, Edinburgh and Belfast Gazettes, or in a newspaper published in London, a newspaper published in Edinburgh and a newspaper published in Belfast addressed to all holders of Citizens' Band radio licences or (ii) revoke this Licence by a general notice published by being broadcast by the British Broadcasting Corporation addressed to all holders of Citizens' Band radio licences. Any notice given under this clause may take effect forthwith or on such subsequent date as may be specified in the notice. A licence which has been revoked by a notice in writing served on the licensee shall be returned to the Secretary of State

11 In this licence 'Secretary of State' means the Secretary of State for the Home Department and except where the context otherwise requires, expressions in this licence have the same meaning as they have in the Wireless Telegraphy Act 1949 and regulations made thereunder

Just as this issue was being 'put to bed', the enclosed appeared through the letter box, and we thought you would find the details thereon illuminating.

This is an abstract from the complete version of the form which will be available from your local post office.

As has been widely predicted, the terms are very liberal, being basically only those conditions which stand any chance of enforcement, and the adherence to common decency. The licence will largely be 'policed' by the attitudes of users, and there should be little cause for complaint in this innocuous set of rules.

The 'launch' date is still under debate, and the fact that the EEC have made polite enquiries as to why the HO failed to adopt the Euro 'Standard' set in CEPT regulations is not likely to make any difference. Readers of last month's R&EW will recall that there really isn't such a thing as a Euro 'Norm' (apart from a few coincidental channel frequencies) anyway, although there appears to be a migration towards FM and the adoption of 2-4W of RF output.

The impact of CB on all aspects of the electronics and communications business in this country cannot be overstressed. R&EW's coverage is intended to be rather more circumspect than the outright 'CB' press, and to emphasise the fact that all users of electronic equipment, must rapidly take account of the effects of 'mass' RF on systems ranging from burglar alarms to microcomputers and measurement systems.

Next month sees the start of a series on how to keep CB in its place, since even those of you who must be heartily sick of the machinations of CB will have to face up to the need to observe precautions when designing any type of micro-electronic equipment.

THE SCHEDULE

1 **Combined Apparatus**
Apparatus conforming to Home Office specification MPT 1321 may be combined with apparatus conforming to Home Office specification MPT 1320, but such apparatus may not be combined with any other wireless telegraphy apparatus

2 **Power Limits**
The radio frequency power specified in the relevant MPT specification for apparatus with provision for connection of an external antenna and the effective radiated power specified in the relevant MPT specification for apparatus with an integral antenna may not be increased

3 **Antennae**
a 27 MHz apparatus with provision for connection of an external antenna shall be connected to a single element rod or wire antenna with a base mounted loading coil, overall length of the antenna excluding the loading coil shall not exceed 1.5 metres
b The antenna for 934 MHz equipment with provision for connection of an external antenna shall consist of a maximum of four elements none of which may exceed 17cm in length
c Where an antenna for use with Citizens' Band radio equipment is installed or used in or on any structure at a height above ground level exceeding 7 metres for 27 MHz equipment or 10 metres for 934 MHz equipment either a 10 dB attenuator shall be fitted between the transmitter output and the feeder or the integral attenuator provided by the manufacturers shall be used to reduce the power

4 Other

Power amplifiers and antennae other than those specified in paragraph 3 of this Schedule are not permitted

Penalties — It is an offence under Section 1 of the Wireless Telegraphy Act 1949, to install or use Citizens' Band radio apparatus except under and in accordance with this licence

Enquiries — Enquiries about the issue of this licence should be addressed to CB Licensing Unit, Chetwynd House, Chesterfield, Derbyshire, S49 1PF

READERS LETTERS

Dear Sir

Firstly, may I offer my congratulations on the release of your superb magazine. My first impressions were, 'Oh no, not another one!', but after reading it - my view is that it is a highly comprehensive magazine that deals with electronics in a refreshing manner, which doesn't make electronics boring, as some other publications manage to do.

How nice it is to see a magazine that is not a stereotype of others, and which is written in an amusing and informative manner.

M Kennedy
Lincoln

R&EW:

Thankyou, let's hope there's another 70,000 of you out there? □

Just to prove we don't write all our own letters, here's from the postbag on the morning of "press day"..... (thanks Mum!)

H550W
CAMBS.

Dear Editor,

Congratulations on your new magazine R & E W.

I have read every page - and I mean every page - I have no complaints whatsoever. You seem to have the "mix" right regarding subject matter.

(Not me anyway).

I own a 'Nascom II' micro computer - just waiting for something to do, apart from Chess (Soregen). Look forward to your series of interfacing. I am also interested in Amateur Radio (for 40 years) and - as you may notice by my requests for more information - intending to buy a 'transceiver'.

May I request a few articles on Electronic Music/Computers and projects.

So often in magazines, one gets details of projects and have extreme difficulty in procuring the parts. Your "Associates" is a good idea - I assume the pricing is competitive!

I hope you can keep up the standard of issue one in future issues. I can now cancel those magazines - which are redundant - and buy R & E W, a saving of \$1.50 a month - Thankyou.

A satisfied customer.

D McFarlane.

Dear Sir

I was pleased to see the first issue of R&EW and have placed an order with my newsagent for future copies. May I congratulate you and your staff on a really interesting and slightly different style of magazine. I look forward to the next issue.

I was delighted to see the "In Your Workshop" feature - streets ahead of any of the similar series. Much better, for example than (we had better not embarrass our 'competitors' yet - ed). I do hope that this style will be retained.

I have been somewhat disillusioned by recent issues of several electronics magazines, and feel sure that a market exists for interesting designs which do not use components which are not available from usual sources. I hope that arrangements will be made so that readers are not frustrated by difficulties in obtaining parts. Some firms are notorious for 'single sourcing', and will only sell complete kits which are featured as magazine constructional projects.

P.D.Coker
Kent.

R&EW:

Thanks for the comments. We are pleased to see that R&EW has been recognised as being 'slightly different', since we are at some pains to stress that we do not wish to simply emulate the existing publications in this field.

Your comments regarding parts sourcing are not uncommon, and so we have instigated a very comprehensive means of ensuring that any 'unusual' parts featured in R&EW will certainly be made available without the need to buy complete 'kits'.

A complete 'blow by blow' analysis of all published circuits does not necessarily fit this format, since we must make certain assumptions that cannot account for all levels of experience. However, we would stress again that our book service is the only one we are aware of, that is actually subjected to careful editorial analysis to ensure that it provides exactly the sort of background you ask for, without consuming a vast amount of space in the issue. We hope that R&EW readers are enthusiastic enough to invest a little in the foundations of their interests. □

Zilog's new 8-bit family of microprocessors greet the World

Charles Wales



Zilog - manufacturers and designers of the highly successful Z-80 microprocessor, (the de-facto standard of the S-100 bus, and other machines by virtue of its ability to support the CP/M operating system) has announced the availability of a new family of single chip MPUs.

A 'single chip' micro includes all the parts of a complete computer system in one package: e.g. contained within the device is the Central Processing Unit, RAM, ROM, and Input/Output interfacing circuitry. Obviously, the ROM (Program Memory) is not user programmable, and must actually be programmed during manufacture. Great if you want to make 10,000 of something but not a lot of use to the development engineer or amateur constructor.

However, Zilog have solved this particular problem rather neatly. They have produced a version of the Z-8 which has been programmed to execute tiny BASIC programs directly. And in case you are still suffering from the night-before I'll explain that again; the new device needs only to be connected to some RAM for program storage and an RS232 terminal and you can begin to enter and run programs in a high level language.

It's not a new idea, *National Semiconductor* had a similar device over a year ago, but as we shall see, the Z-8 architecture is extremely powerful. More so than the original National implementation.

The Z-8 Architecture

The Z-8 architecture is shown in Figure 1. Most of the pins of the 40 pin device are dedicated to I/O functions. If your mass production use for the Z-8 does not require any external memory, then 32 pins of the Z-8 are available to control the outside world. If you require to add external memory, then the Z-8 can be expanded with up to 60k bytes of external program storage, and 60k bytes of data memory.

The architecture includes two timer counters with programmable prescalers - one of which may be driven from an external source. A complete Universal Asynchronous Receiver Transmitter with parity and programmable baud rates (via one of the counter timers), a 144 byte random access register file containing 124 general purpose registers, four I/O port registers and 16 control and status registers.

The Z-8 also has six interrupt modes, all of which are prioritised. It is especially suited to control applications and may be made to act as a node of a parallel

Figure 1: The internal architecture of the Z-8

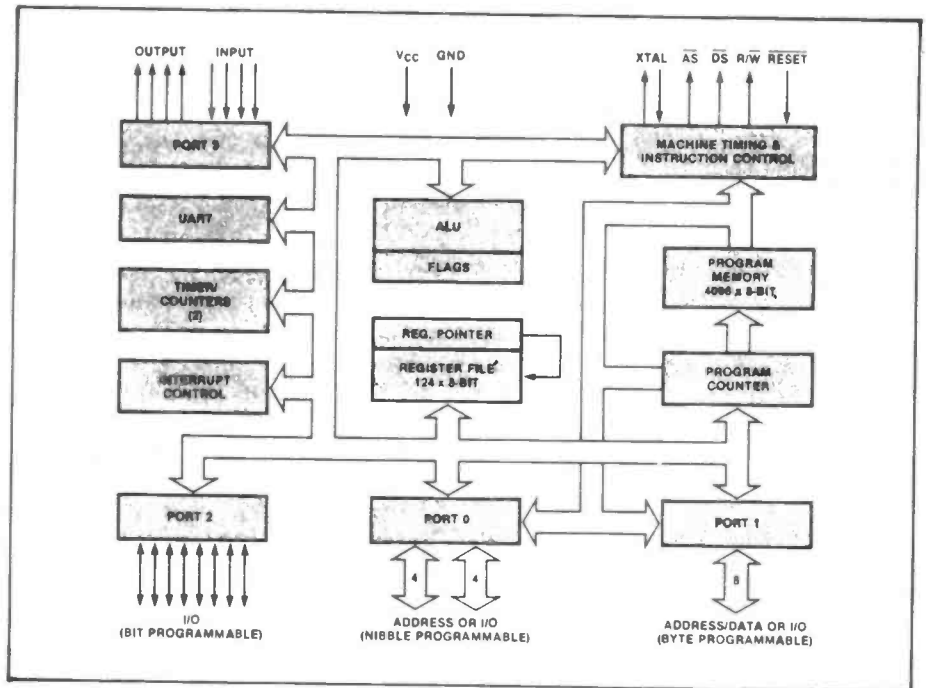

LOCATION	IDENTIFIERS
258	STACK POINTER (BITS 7-0) SPL
264	STACK POINTER (BITS 16-8) SPH
263	REGISTER POINTER RP
262	PROGRAM CONTROL FLAGS FLAGS
261	INTERRUPT MASK REGISTER IMR
260	INTERRUPT REQUEST REGISTER IRR
259	INTERRUPT PRIORITY REGISTER IPR
248	PORTS 0-1 MODE P01M
247	PORT 3 MODE P3M
246	PORT 2 MODE P2M
245	T0 PRESCALER PRE0
244	TIMER/COUNTER 0 T0
243	T1 PRESCALER PRE1
242	TIMER/COUNTER 1 T1
241	TIMER MODE TMR
240	SERIAL I/O SIO
	NOT IMPLEMENTED
127	GENERAL-PURPOSE REGISTERS
4	PORT 3 P3
3	PORT 2 P2
2	PORT 1 P1
1	PORT 0 P0

(left) Z-8 Register Organization

executing the current instruction. Like a greedy schoolboy eating doughnuts, who instead of finishing one doughnut before taking another, eats with his right hand whilst selecting the next doughnut with his left.

Z-8 Basic / Debug

This is the rather unexciting name given by Zilog to their version of the Z-8 which is programmed to execute Tiny-BASIC. Tiny-BASIC is a subset of standard Dartmouth BASIC which has been enhanced and optimised for the writing of control programs, allowing for direct manipulation of memory and various Z-8 registers.

It is also possible to specify statements to be executed in the case of external interrupts. Tiny BASIC is integer only, (no floating point calculations) and deals with numbers from 32767 to -32768. However, numbers may be either decimal or hexadecimal, making the manipulation of memory and registers very easy.

Machine language subroutines are also supported. Z-8 Tiny-BASIC programs are ROMable, and a minimum control system might consist of simply the Z-8 and an EPROM, see Figure 2.

processing system by linking it with the other nodes via Zilog's 'Z-bus'.

The Z-8 is fast: most instructions are executed in 1.5-2.5 microseconds with an 8MHz clock. This high speed is partly due to the use of a technique called pipelining, which means the processor fetches the next instruction for execution whilst it is

Figure 2: A minimum parts - tiny basic control system

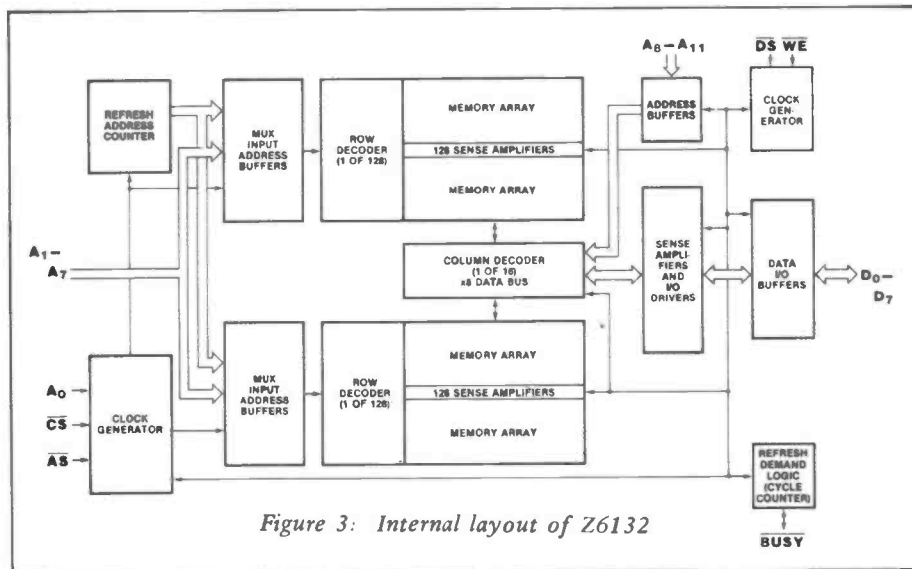
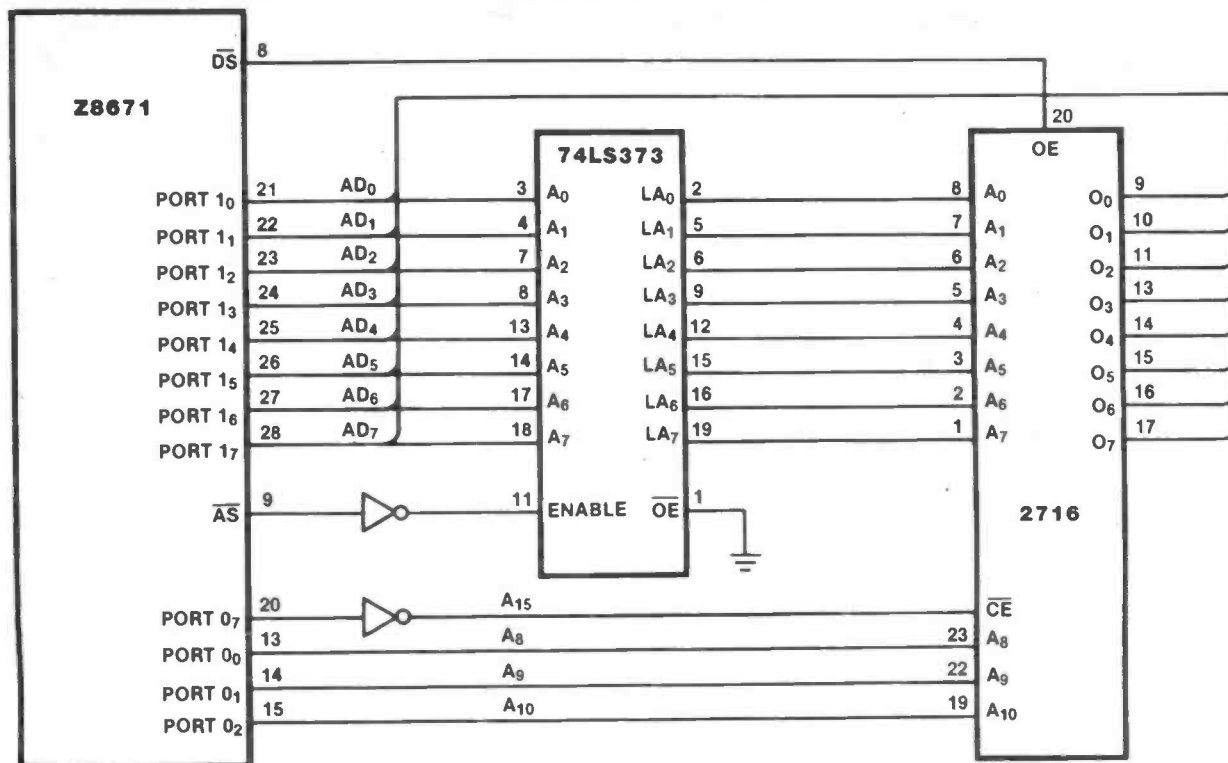

Figure 3: Internal layout of Z6132

The Z6132 Intelligent memory, 32k Quasi-Static RAM.

The Z6132 is a quasi-static RAM organised as 4096 word by 8-bits. Although the internal cell structure of the RAM is dynamic, it can handle all of its own refresh requirements and thus looks to the outside world as though it is static in nature. The Z6132 is packaged in a 28 pin DIL package and can be interchanged with the 2716/2732 EPROM packages. (Figure 3)

The Z6132 will interface directly with the Z-8 and 4k of program memory will hold a basic program of around 256 statements or more. The Z6132 can also be easily interfaced to other machines.

R&EW and the Z-8

Zilog were kind enough to lend us a Z-8 demonstrator, which we put through its paces. We were very impressed, so impressed that we set the R&EW design team to work, their mission (which they gladly accepted) is to produce a Z-8 based control board with a Z6132 on board plus EPROM Programmer and cassette interface.

We asked for it to be ready yesterday, but realistically we should have the details and constructional information in the January issue of R&EW, so save some of the Christmas present money to treat yourself to an R&EW Tiny-BASIC board.

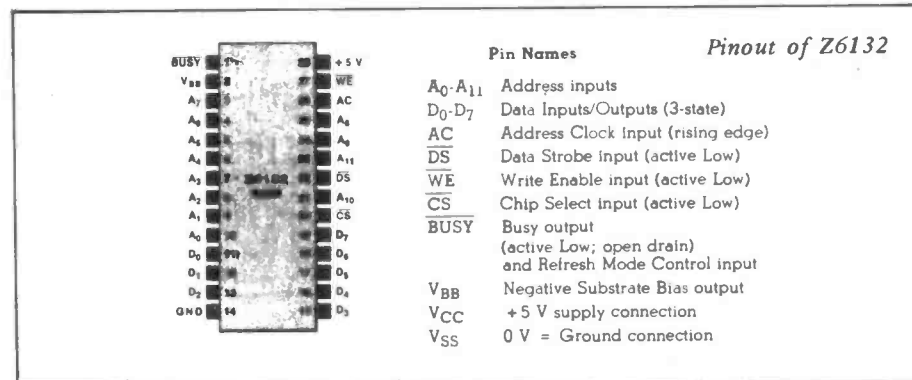

Z-80 and Z-8 are registered trade-marks of Zilog Inc.

Your Reactions.....	Circle No.
Immediately Applicable	109
Useful & Informative	110
Not Applicable	111
Comments	112

The parallel interface is cheap to implement and is general purpose. The need for handshaking to be carried out makes it slightly less universal than the second type of interface we shall look at, which is the *serial* or *RS232* interface.

The Serial interface

As explained earlier, the value to be transmitted is presented sequentially in a *serial* interface. The interface is *asynchronous*, e.g. the data is not presented in synchronism with any timing signal or clock, and the receiver must recover the information by itself, by reference to its own local clock - which hopefully is set to the same frequency as its counterpart in the transmitter.

In its simplest form, the serial interface can consist of just two wires: a signal wire and a ground reference. The logic levels on the signal wire are referred to as *mark* and *space*. A *mark* condition is represented by the presence of a voltage of less than -3 volts, but greater than -12 volts, whilst the *space* condition is represented by a voltage of more than 3 volts but less than 12 volts.

The timing of a transmission is shown in *Figure 4*, the basic unit of time is referred to as the *bit time*. To start a transmission, the transmitter must bring the signal wire from a *marking* state for one *bit time*. This first bit is referred to as the *start bit*, next the data follows, with the least significant bit being transmitted first. A logical '1' in the data is represented by a *mark*, whilst a zero is represented by a *space*, following the data bits, a parity bit may or may not be transmitted.

Parity is a checking mechanism used by the transmitter to enable the receiver

Figure 5: RS-232-C Signal Lines by Pin Number

Pin Number	Circuit	Description
1	AA	Protective Ground
2	BA	Transmitted Data
3	BB	Received Data
4	CA	Request to Send
5	CB	Clear to Send
6	CC	Data Set Ready
7	AB	Signal Ground (Common Return)
8	CF	Received Line Signal Detector
9	-	Reserved for Data Set Testing
10	-	Reserved for Data Set Testing
11		Unassigned
12	SCF	Sec Rec'd Line Sig Detector
13	SCB	Sec Clear to Send
14	SBA	Secondary Transmitted Data
15	DB	Transmission Signal Element Timing (DCE Source)
16	SBB	Secondary Received Data
17	DD	Receiver Signal Element Timing (DCE Source)
18		Unassigned
19	SCA	Secondary Request to Send
20	CD	Data Terminal Ready
21	CG	Signal Quality Detector
22	CE	Ring Indicator
23	CH/CI	Data Signal Rate Selector (DTE/DCE Source)
24	DA	Transmit Signal Element Timing (DTE Source)
25		Unassigned

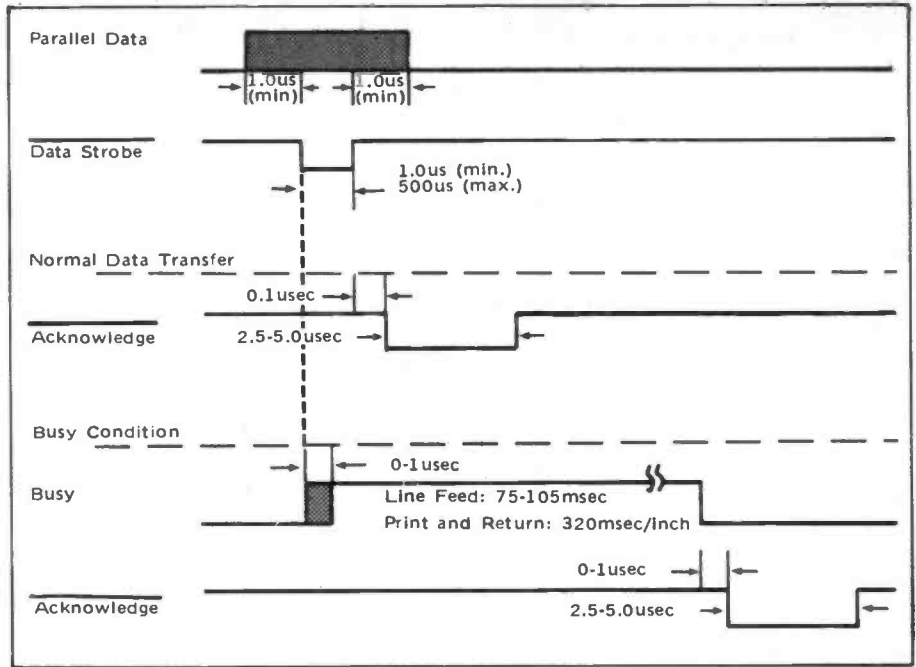

Figure 3: Parallel Interface Timing

logic to ascertain whether or not it has received the data correctly. The number of 'ones' in the word to be transmitted are counted by the transmitter logic, and the *parity bit* given a value (e.g. one or zero) such that the total number of 'ones' transmitted is always an even number.

The receiver simply has to check that each transmission contains an even number of 'ones' to ensure that it received the word correctly. (*Parity* will not detect a double failure in the transmitted word, and there is also an equally valid system known as *odd parity* where the number of 'ones' transmitted is always arranged to be an odd number.)

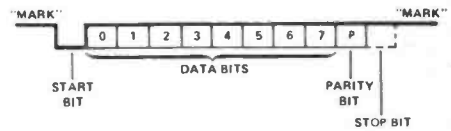

Figure 4: Serial Data Stream Example

Finally, the signal line is brought back to a 'marked' condition for one *bit time*, this period is known as the *stop bit*, and marks the end of the transmission.

Before transmission starts, a number of parameters must be defined at both the transmitter and receiver: such as the number of data bits to be transmitted, the type and presence of parity - and the rate at which data is transmitted.

The data rate is often referred to as the *Baud rate* being a set of precise crystal controlled frequencies which result in *bit times* from 13 crystal derived frequencies. These result in *bit times* from 13 milliseconds to 52 microseconds, or 75 to 19200 Baud. In the case of a transmission which consists of:

one start bit, eight data bits, one stop bit and no parity, (e.g. 10 *bit times*) this corresponds to data rates of 7.5 to 1920 characters per second.

Thus simple serial interfaces are slower than the parallel equivalent, although the limiting factor with a printer interface is often the printer itself. The increased signal range of RS232 does raise the transmission distance to around 15 metres. The link is also somewhat less sensitive to electrical noise and interference.

At its simplest level, no *handshaking* takes place in a serial/RS232 link, although various lines exist which allow the transmitter and receiver to handshake with each other. Some links use these lines in a manner similar to the *busy* or printer *ready* lines of the Centronics interface.

As stated earlier, the terms 'RS232'

```

cccccc
cc      0000000  mmmmmmm  ppppppp  uu  uu  ll      iiiiill  nn  n  kk  kk
cc      00  00  nn  k  mm  pp  pp  uu  uu  ll      ii  n  n  n  kk  kk
cc      00  00  mm  k  mm  ppppppp  uu  uu  ll      ii  n  n  n  kkkk
cc      00  00  mm  mm  pp      uu  uu  ll      ii  n  n  n  kk  kk
cccccc  0000000  mm  mm  pp      uuuuuuu  lllllll  iiiiill  n  nn  kk  kk

```

and 'serial link' have come to mean almost the same. The 'RS232' is in fact the designation of the specifications of the transmitted and received signals, together with the electrical interface. 'RS232' also defines the function of 25 wires which are listed in Figure 5, the most common connector used in implementing the interface is a 25 pin Cannon plug and sockets from the DB-25 range.

The conversion of parallel data to its serial form for transmission, and the reconstruction of this data from the link is a task often assigned to special hardware. The hardware is available as a single 'chip' and belongs to a class of devices called *UART's* (Universal Asynchronous Receivers Transmitters). Some *UART's*, which are designed to work in a 'stand alone' environment, allow the parameters of the transmission such as parity and number of data bits, to be defined by logic levels connected to various pins of the device. Other *UART's* are designed specifically to be driven by a microprocessor. The various parameters of the transmission and the data to be transmitted, is placed into registers within the *UART*. These registers appear within the address space of the microprocessor and thus the device forms a true interface from the microprocessor to the outside world. A latter article will look at these devices together with the 'hardware' and 'software' aspects of their use.

**OP PRESS.....STOP PRESS.
.....STOP PRESS.....STOP PR**

Sinclair to Sell ZX-81 Retail

Clive Sinclair's ZX-81, a Z-80 based personal computer, has until now been available only via mail-order.

However, Sinclair Research and W. H. Smith recently signed a trial agreement, which means that the ZX-81 will go on sale in over 100 W. H. Smith High Street stores.

Smith's are said to be setting up special departments to sell only the Sinclair range, staff have been specially trained to demonstrate the ZX-81 and to provide an after-sales information service.

Sinclair will continue to sell the 81 direct, but hopes that the Smith's deal will help those customers who like to see before buying.

The press release claims that 20,000 ZX-81's a month are being sold.

Your Reactions.....	Circle No.
Immediately Applicable	154
Useful & Informative	155
Not Applicable	156
Comments	157

The Accumulator and program counter

Last month we had a look at the concept of programming and the idea of a programmable machine. This month we will start to take a look at machine code programming.

Cracking the code

Whilst every microprocessor user will not necessarily wish to program his microprocessor in *machine code* - machine code is the most basic form of programming and represents the 200 or so built-in instructions of a microprocessor - a thorough understanding of the subject and the basic principles behind *program structure* can help in all areas of programming.

We will start with a very simplistic representation of the inside of a microprocessor and expand it until we have created a representation known as the *programmer's model*. The programmer's model details to the machine code programmer, the internal registers (a register is simply a box, see later), and *architecture* of the machine. (*Architecture* : the internal functions that are available in terms of the number of registers etc).

As it will not aid our understanding to talk about 'binary number system' or 'flip-flop' logic we won't. At least not until much later in this series.

The first box, the accumulator

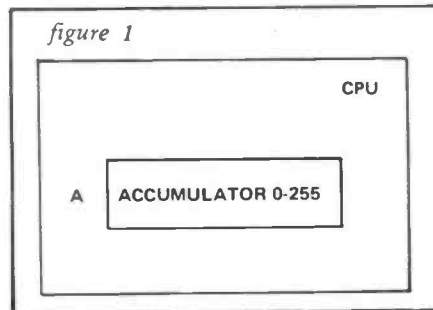

Figure 1 shows the first box we shall have in our programmer's model, it is called the *accumulator* and is the box or *register* in which nearly all of the manipulation of data within the microprocessor takes place. If we want to alter the value of data stored within the memory, we must first load it into the accumulator, manipulate it, then load it back into memory. Let's look at the accumulator in our machine a bit more closely.

First, we will specify that it is capable of holding numbers, and only numbers from 0-255 (255 is the maximum *decimal* value an 8-bit binary number can have, and memory locations are normally 8-bits wide), furthermore it is capable of being operated on by a number of instructions from the microprocessor's instruction set. These instructions might well be of the form:

Clear the accumulator (e.g. set the contents of the accumulator to zero)
 Increment the accumulator (e.g. increase the current contents by one)
 Decrement the accumulator (e.g. subtract one from the accumulator)
 Load the accumulator with (x) (e.g. put into the accumulator the numeric value of (x), this operation destroys or overwrites any previous number which was contained within the accumulator).
 Add (x) to the accumulator (e.g. if (x) equals 9 then add 9 to the contents of the accumulator)

Even with these five instructions, we can write a simple program to add two numbers together, so here it is:
 100 Load the accumulator with 4 (Result: the accumulator now contains the number 4)

200 Add 5 to the accumulator (Result: 5 is added to the accumulator which now must contain 9)

This simple program adds together the numbers 4 and 5 leaving the result 9 in the accumulator. Often it is possible to write a sequence of instructions which have the same effect as another instruction, notice how:

10 Load the accumulator with (x)
 is in fact the same as;
 14 Clear the accumulator
 22 Add (x) to the accumulator

This ability to achieve the same result in many different ways is most important. Not all microprocessors have exactly the same instruction set, but you can nearly always achieve the result you desire simply by making it up from a collection of other instructions.

Looking at the examples above, (which are in fact small programs), you will see that before every instruction or

program statement we place a number. These numbers are very important, as they tell the microprocessor in which order to execute the instructions. When working with the machine code, these numbers actually have a physical entity: they are the memory *locations* which hold the machine code instructions.

A machine code program is held in successive memory locations, and the microprocessor fetches first one instruction from memory. Then having completed it, it fetches the next, usually from the next higher memory location.

As explained in the first article in this series, we need a *pointer* or 'finger' to keep our place in the sequence of instructions, and we call it the *program counter*. Let's add it to our programmer's model, *Figure 2*. Like the accumulator, the program counter is only capable of holding numeric values.

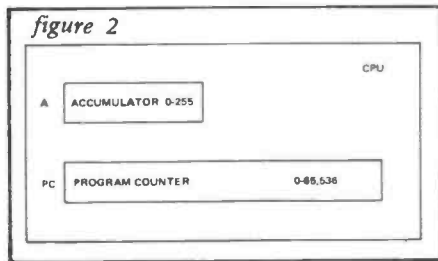

We've made it larger than the accumulator because it is capable of holding values from 0 to 65,536 (the maximum value a 16-bit number can represent, 16 bit numbers are built up by using two memory locations to hold them). Unlike the accumulator, the program counter is not directly under the programmer's control, but nevertheless it is still very important, as we shall see. Some instructions have important effects on the program counter. *Figure 3* illustrates the sequence of operations that take place in the addition program of *example one*, the important point about the program counter is that it directs the *flow* of the program.

The mechanism by which it points to the next instruction to be executed is referred to as *addressing*, the instructions of a microprocessor are not always the same length (e.g. do not always take up the same number of memory locations). However, when the microprocessor fetches an instruction (from the location pointed to by the program counter), it decodes the length from the instruction, (e.g. is there any more left to fetch), fetches the rest if need be, and increments the program counter to point to the next instruction.

Instructions such as: 'Clear the accumulator, increment the accumulator, and decrement the accumulator', will most probably fit into a single memory location. There is no further information that needs to be supplied to the microprocessor, and the instruction is internally self-contained. We will call this type of instruction *Inherent Mode* - simply

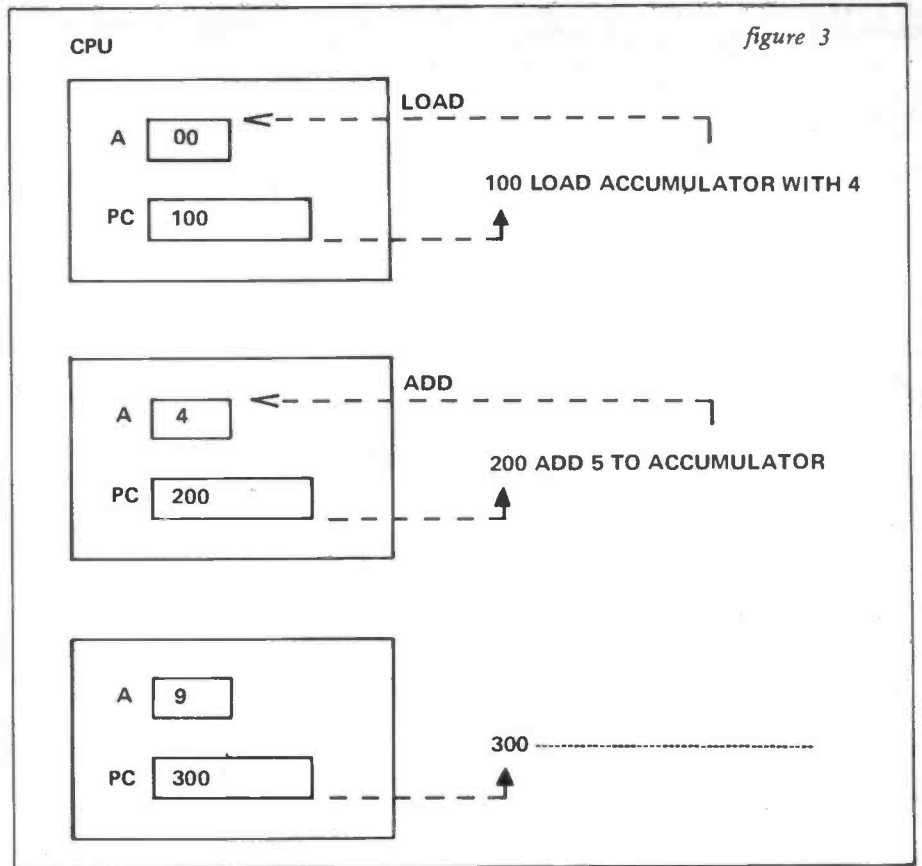

because everything we need to know is inherent in the instruction.

The second set of instructions we looked at were of the form:
Load the accumulator with (x)
Add to the accumulator the value (x)

Here, the *Load the accumulator*, and the *Add to the accumulator* part will each take a single memory location, but we also need to specify with what (x). To do this, we place the (x) bit into the next successive

memory location after the instruction it belongs to, thus these types of instructions will take two memory locations. We can further divide the instructions by referring to parts of them as the *operator field*, and the *data field*, thus in the instruction: 'Load the accumulator with (x)' *load the accumulator* is the operator and (x) is the data field.

We will call this second form of instruction *immediate mode*, because the

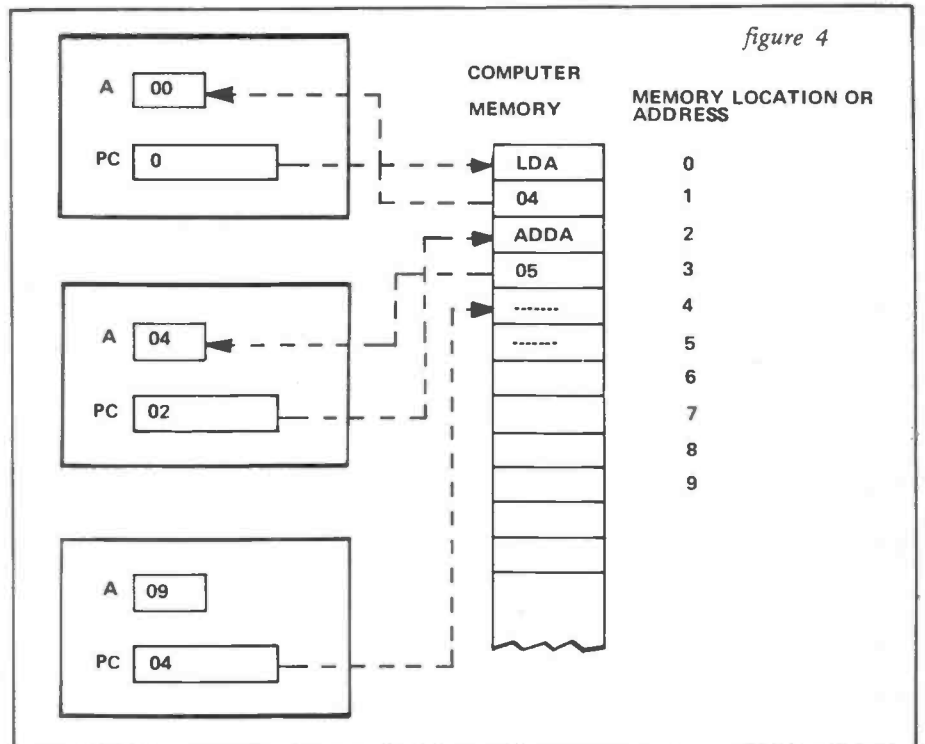

data field follows *immediately after* the operator field. The data field of these instructions will be capable of assuming values from 0-255, e.g. the same as the accumulator which they affect, and capable of fitting into a single memory location.

The sequence of diagrams in *Figure 4* illustrates our example addition program in more detail, we have removed the line numbers and placed the instructions into real memory locations. Notice how in this example both instructions occupy more than one memory location, thus each time the microprocessor fetches the instruction, and the data, then increments the program counter by two, so as to point to the next instruction.

As it is rather tedious to keep writing out the whole of an instruction each time, we will introduce a short form for each instruction known as its *mnemonic*, thus for 'Load the accumulator with (x)' we will substitute *LDA (x)*. The short form of the other instructions is shown below.

Clear the accumulator (CLRA)
 Increment the accumulator (INCA)
 Decrement the accumulator (DECA)
 Add (x) to the accumulator (ADDA(x))

You will see that in this form it is also easier to distinguish the operator and data fields of the instruction.

In order to be really useful, we need to add some instructions to our 'set' which allow the manipulation of data stored in memory:

Store the accumulator at memory location (xx)
 Load the accumulator from memory location (xx)
 Add the contents of memory location (xx) to the accumulator.

If we define the short form (mnemonic) of these as:
 Store the accumulator (STAm(xx))
 Load the accumulator (LDAm (xx))
 Add the contents of memory location (xx) to the accumulator (ADDAm(xx))

The data field of these instructions will need to be able to take on values from 0 to 65,535, to enable the instruction to address the same range of memory locations as the program counter. The data fields are so large that they will not fit into a single memory location, and will in fact need to occupy two, completing the whole instruction. Operator and data fields occupy three memory locations, so when the microprocessor encounters one of these instructions, it must fetch the contents of two more successive memory locations to complete it, and increment the program counter by three in order to point at the next instruction to be executed.

We will refer to this last class of instruction as *extended address*, because their power of specifying memory locations is extended over the *complete address space* (all the possible memory locations) of the microprocessor.

We can now write a program to add together two numbers held in memory, and store the result in a third location.

COMPUTER MEMORY	MEMORY LOCATION OR ADDRESS
LDAm	X
10	X+1
23	X+2
ADDAm	X+3
05	X+4
69	X+5
STAm	X+6
02	X+7
00	X+8

figure 5

Storing the accumulator into memory will completely destroy the previous contents of that location, whilst loading from memory does not affect the contents of the memory location that has been interrogated.

Conclusions

Here is the program, we've also added some headings to the 'Listing' (a word for a print-out of a program).

Operator field (data field) comment
 LDAm (1023) Load the accumulator from memory location 1023
 ADDAm (569) Add the contents of memory location 569 to the accumulator.
 STAm (200) Store the result in memory location 200.

Figure 5 shows how this program would look when actually stored in memory, and *Figure 6* the before and after picture of the memory after the program has been *run* or *executed* by the MPU.

This completes our first foray into the mysterious inside of a microprocessor. *Next month* we will look at some more instructions and registers to add to our programmer's model, and begin to see how decision making can be used to alter the flow of the program.

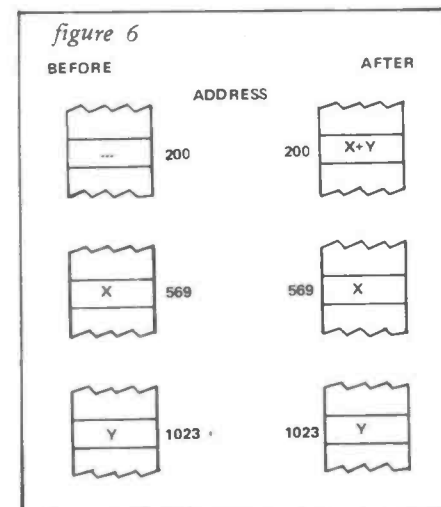

Your Reactions.....	Circle No.
Immediately Applicable	142
Useful & Informative	143
Not Applicable	144
Comments	145

N. GARDNER

Programs which do something No. 1

The program presented opposite is entirely in keeping with our policy the microprocessors should be used to do something useful. It is written in no specific dialect of BASIC and should already be sufficiently 'standard' enough to run on any system featuring BASIC.

We invite readers to submit programs of their own design, on any subject they wish, but preferably not games.

Code your program in any standard BASIC (Microsoft, MBASIC, SWTP BASIC) and try not to use any machine specific coding e.g. machine code, or mysterious PEEKs and POKEs to the monitor etc.

If your program plays with the screen graphics of your VDU then place this code in a section such that it can easily be modified or removed, also document the effects of various statements carefully. Finally, print your program out on the best possible printer you can lay your hands on. That way we can use it directly for publishing and thus avoid any transcription errors.

The following program is a simple RF package. It allows the user to quickly design various common RF circuits and, where applicable, will print the circuit on the VDU with the various component values printed on the circuit diagram. (See the examples).

As can be seen from the listing, the program is fairly self-explanatory. It consists of four major routines at lines 2, 1000, 2000, 3000 all of which are called by the main selection routine at line 4000. All of the four major routines are self-contained and use no subroutines.

The manner in which the program has been written is such that the user may easily add his/her own routines for any other functions not already provided, by simply extending the selection routine at 4000 to make it jump to any new routines written by the user.

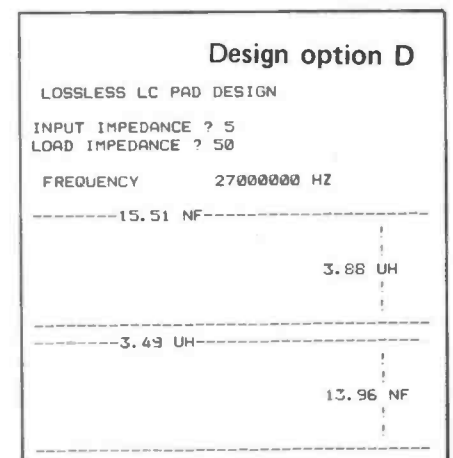

R. F. DESIGN PACKAGE

RF OUTPUT STAGE

Design option A

SUPPLY VOLTAGE VSS =12 V
 SATURATION VOLTAGE VD =2 V
 OUTPUT POWER P =4 W
 FREQUENCY F =27000000 HZ
 LOAD RESISTANCE RL =50 OHMS
 OUTPUT CAPACITANCE COUT=20 PF
 MINIMUM Q =1.734128
 DESIGN Q =5

L1 =364.532583 NH
 C1 =48.2687554 PF
 C2 =48.2687554 PF

AIRCORE INDUCTOR DESIGN

Design option B

DIAMETER (MM), LENGTH (MM), INDUCTANCE (MH)
 7.10.3
 NUMBER OF TURNS REQUIRED = 15.21
 USE 22 SWS

TUNED IMPEDANCE MATCH

Design option C

Q, FREQ., CAPCITANCE, NO. OF TURNS, ZTAP
 100.27E6, 100E-12, 10.50

TOTAL IMPEDANCE = 5892.93 OHMS
 COIL IS TO BE TAPPED AT 0.92 TURNS FROM GND

```

0001 GOTO 4000
0002 PRINT CHR$(26):REM CLEAR SCREEN
0004 PRINT " T NETWORK OUTPUT STAGE "
0006 PRINT
0050 PRINT :PRINT
0055 INPUT "VSS, SATURATION VOLTAGE, POWER (W) ",A,B,C
0060 INPUT "FREQ (HZ), RL, OUTPUT CAPACITANCE (F) ",F,E,D1
0132 LET D=1/(6.285*F*D1)
0150 K=R1*D/((R1)^2+(D)^2)
0160 R2=D*K
0170 X1=R2*K
0171 IF R2>E THEN 191
0175 IF E<R2 THEN PRINT "IMPOSSIBLE.":GOTO 670
0180 Q1=SQR((E/R2)-1)
0190 PRINT "Q MIN=";Q1
0191 INPUT "WHAT VALUE FOR Q ",Q2
0200 X2=Q2*R2-X1
0210 N=R2*(1+Q2^2)
0215 IF (N/E-1)<0 THEN PRINT "IMPOSSIBLE.":GOTO 670
0220 M=SQR((N/E)-1)
0230 C2=M*E
0240 C1=N/(Q2*M)
0250 J1=1/(6.285*F*C1)/1E-12
0260 J2=1/(6.285*F*C2)/1E-12
0271 LET H=X2/(6.285*F)*1E9
0400 PRINT CHR$(26):REM CLR SCRNM
0410 PRINT :PRINT
0425 PRINT " RF OUTPUT STAGE "
0430 PRINT
0435 PRINT
0440 PRINT "-----> VSS "
0450 PRINT " |"
0460 PRINT " | RFC"
0470 PRINT " |"
0480 PRINT "-----L1-----C2----->"
0490 PRINT " | | |"
0500 PRINT " | | |"
0510 PRINT " | C OUT C1 RL"
0520 PRINT " | | |"
0530 PRINT " | | |"
0540 PRINT "----->"

```

```

0550 PRINT
0560 PRINT "SUPPLY VOLTAGE VSS =" ;A;"V"
0570 PRINT "SATURATION VOLTAGE VD =" ;B;"V"
0580 PRINT "OUTPUT POWER P =" ;C;"W"
0590 PRINT "FREQUENCY F =" ;F;"HZ"
0600 PRINT "LOAD RESISTANCE RL =" ;E;"OHMS"
0610 PRINT "OUTPUT CAPACITANCE COUT=" ;D1*1E12;"PF"
0620 PRINT "MINIMUM Q =" ;Q1
0630 PRINT "DESIGN Q =" ;Q2
0640 PRINT
0645 PRINT " L1 =" ;H;"NH"
0650 PRINT " C1 =" ;J1;"PF"
0660 PRINT " C2 =" ;J2;"PF"
0670 PRINT :INPUT "REPEAT (Y/N) ",A$
0680 IF A$="Y" GOTO 2
0700 GOTO 4000
1000 PRINT CHR$(26)
1005 PRINT :PRINT
1010 PRINT "LOSSLESS LC PAD DESIGN"
1020 PRINT :PRINT
1057 PRINT "LOAD IMP TO BE > THAN INPUT IMP"
1058 PRINT
1060 INPUT "INPUT IMPEDANCE ",Z1
1070 INPUT "LOAD IMPEDANCE ",Z2
1077 IF Z2<Z1 THEN PRINT:GOTO 1057
1080 INPUT "FREQUENCY IN HZ ",F
1085 W=F/6.28318
1090 X1=Z2*SQR(Z1/(Z2-Z1));X2=SQR(Z1*(Z2-Z1))
1100 S1=1E9/(W*X2);H1=X1*1E6/W
1110 S1=INT(S1*100+0.5)/100;H1=INT(H1*100+0.5)/100
1120 S2=X2*1E6/W;H2=1E9/(W*X1)
1130 S2=INT(S2*100+0.5)/100;H2=INT(H2*100+0.5)/100
1135 PRINT :PRINT
1136 PRINT "FREQUENCY =" ;F
1137 PRINT
1140 PRINT "-----" ;S1;"NF-----"
1150 PRINT " |"
1160 PRINT " |"
1170 PRINT " | ;H1;"UH"
1175 PRINT " |"
1180 PRINT " |"
1185 PRINT "-----"
1190 PRINT "-----" ;S2;"UH-----"
1200 PRINT " |"
1205 PRINT " |"
1210 PRINT " | ;H2;"NF"
1215 PRINT " |"
1220 PRINT " |"
1225 PRINT "-----"
1240 INPUT "REPEAT (Y/N) ",A$
1245 IF A$="Y" THEN GOTO 1000
1255 PRINT :PRINT:GOTO 4000
2000 PRINT CHR$(26)
2010 PRINT :PRINT " TUNED IMPEDANCE MATCH "
2035 PRINT :PRINT
2040 INPUT "Q, FREQ., CAPACITANCE, NO. OF TURNS, ZTAP ",Q,F,C,N,Z
2045 Z1=Q/(6.28318*F*C)
2050 N1=SQR(((N)^2*Z)/Z1)
2053 N1=INT(N1*100)/100
2055 PRINT "TOTAL IMPEDANCE =" ;Z1;"OHMS"
2060 PRINT "COIL IS TO BE TAPPED AT ";N1;" TURNS FROM GND"
2065 PRINT :INPUT "REPEAT (Y/N) ",A$
2070 IF A$="Y" THEN GOTO 2035
2080 PRINT :PRINT:GOTO 4000
3000 PRINT CHR$(26):REM CLEAR SCREEN
3040 PRINT " AIRCORE INDUCTOR DESIGN "
3045 PRINT :PRINT:PRINT
3050 INPUT "DIAMETER (MM), LENGTH (MM), INDUCTANCE (MH) ",D,L,I
3055 D=D/25.4;L=L/25.4
3060 N1=SQR((4.5*D*L)/(D/2)^2)
3070 N=INT(N*100)/100
3080 PRINT "NUMBER OF TURNS REQUIRED =" ;N
3090 F=L/N
3100 IF F>0.138 THEN PRINT "CHANGE COIL SIZE, WIRE TOO BIG ":GOTO 3240
3110 IF F>0.112 PRINT "USE 10 SWS ":GOTO 3240
3120 IF F>0.092 PRINT "USE 12 SWS ":GOTO 3240
3130 IF F>0.077 PRINT "USE 14 SWS ":GOTO 3240
3140 IF F>0.056 PRINT "USE 16 SWS ":GOTO 3240
3150 IF F>0.042 PRINT "USE 18 SWS ":GOTO 3240
3160 IF F>0.032 PRINT "USE 20 SWS ":GOTO 3240
3170 IF F>0.025 PRINT "USE 22 SWS ":GOTO 3240
3180 IF F>0.020 PRINT "USE 24 SWS ":GOTO 3240
3190 IF F>0.0166 PRINT "USE 26 SWS ":GOTO 3240
3200 IF F>0.0136 PRINT "USE 28 SWS ":GOTO 3240
3210 IF F>0.0116 PRINT "USE 30 SWS ":GOTO 3240
3220 IF F>0.01 PRINT "USE 34 SWS ":GOTO 3240
3230 PRINT "CHANGE COIL SIZE, WIRE TOO SMALL"
3240 PRINT :INPUT "REPEAT (Y/N) ",A$
3250 IF A$="Y" GOTO 3000
3260 GOTO 4000
4000 PRINT CHR$(26):REM CLEAR SCREEN
4010 PRINT "RF PACKAGE BY N.C.GARDNER"
4020 PRINT :PRINT " THE FOLLOWING PROGRAMS ARE AVAILABLE :-"
4030 PRINT :PRINT " A: T NETWORK OUTPUT STAGE"
4040 PRINT " B: INDUCTOR DESIGN"
4050 PRINT " C: L C MATCHING NETWORK"
4060 PRINT " D: IMPEDANCE MATCHING"
4100 PRINT :PRINT
4105 INPUT "SELECT FUNCTION ",A$
4110 IF A$="A" THEN GOTO 2
4120 IF A$="B" THEN GOTO 3000
4130 IF A$="C" THEN GOTO 2000
4140 IF A$="D" THEN GOTO 1000
4150 GOTO 4105
4200 END

```

The DFCM500 - A Combined 8 Digit Frequency and Capacitance Meter for Mains or Ni-Cad Battery Operation

Pt.1

A. L. Bailey



The digital frequency meter is a well established and very useful piece of test equipment for anyone working with audio or radio frequencies. The instrument described here covers all frequencies likely to be of interest to home constructors, radio amateurs and most commercial applications from audio (1Hz) to UHF (in excess of 500MHz). In addition, it has the unique ability to measure and display, within the same instrument, capacity in 2 ranges from 1pF to 1000uF.

The project is well within the average constructor's ability, with the comprehensive constructional details supplied. To ease the constructor's workload, a complete kit of parts, (including the case and all required hardware), down to the last nut and bolt and connecting wire, is obtainable from R&EW's project services department - or any stocking retailer.

The only alignment required is that of the master crystal frequency, and calibration of the capacitance section against a known close tolerance capacitor. All circuits are built on printed circuit boards, including a mains power supply, and constant current ni-cad battery charger, allowing portable operation if required. These pcb's are supplied with the kits, and are fully drilled and screened with the component positions.

Circuit Description

The circuitry of the DFCM may be roughly split into 4 areas - frequency measuring preamplifiers and pulse shapers, capacitance measuring circuit, multiplexed 8 digit display and driver, and the power supply/battery charger.

Frequency Amplifiers (Figure 1)

The instrument has 3 separate input amplifiers, each optimised for a specific frequency coverage, rather than attempting to do the whole coverage with one or two amplifiers. The low frequency amplifier, primarily designed for the audio spectrum, accepts inputs from 1Hz to 500kHz minimum, displaying the frequency to a resolution of 1Hz or 0.1Hz, depending on the gate time of the main counter circuit. The input voltage is limited by D3/D4, connected in anti-phase. TR7 provides the signal amplification, driving TR8 with positive halfwaves via D5, which acts as a switch. TR9/10 convert the resultant pulses to TTL level, and shapes them to square waves, ready to drive the main 7216C counter, via the control logic.

The high frequency amplifier will process signals from about 300kHz to 50MHz minimum (see later) at levels from 50mV to 1V at the input. TR2/3 provide the amplification, and TR4-6 pulse shaping and level shifting to TTL. As the 7216C will not accept frequencies above 10-15MHz, division by 10 is required of the amplifier output to get the higher frequency signals down to this range. IC3 does this, with the divided output taken from Qc (Pin 2) rather than Qd (Pin 12) as the pulse width is greater at this pin and ideally suited to the 7216C's input signal specification. The IC specified for this divider is a 74196N, which is guaranteed to toggle at 50MHz minimum, and it is this IC which sets the upper frequency limit obtainable from this amplifier. If this IC is replaced with a 74S196N (at greater cost!) frequencies up to 100MHz may be processed in this amplifier, as the 'S' version has a guaranteed minimum toggle frequency of 120MHz. However, frequencies above 30MHz may also be

used with the VHF/UHF amplifier, and it is only if the increased resolution of the HF amplifier is required that this will need to be done. Resolution at HF is 10Hz or 1Hz while at VHF, 100Hz or 10Hz which is probably going to be limited by the reference accuracy.

The VHF/UHF input signals are limited by D1/D2 and amplified by TR1, a stripline construction device with an Ft of 1600MHz. Amplified signals are processed and divided by 10 by IC1, an 11C90 high speed prescaler with a minimum toggle frequency of 650MHz, although in general the chip will function well in excess of this frequency - one of the prototypes was still counting at 780MHz. To be able to display the highest frequency possible, the following stage, IC2, (which further divides by 10 down to the 7216C input range), must be a 74S196N. If sufficient, a 74196 will give a minimum upper frequency limit of 500MHz+. Other options are available if the UHF capabilities are not required, in that the 11C90 may be replaced by a 95H90, with minimum count frequency of 350MHz, at reduced cost, or by the SP8647, (a low power version of the 95H90), counting to 250MHz minimum. Resolution for this amplifier is 100Hz at a 1 second gate time or 10Hz at 10 second gate time.

A BNC socket connects the VHF/UHF input directly to the above amplifier, while the HF and AF inputs share a common socket, switched to the appropriate amplifier via the switch bank.

The control logic, consisting of IC4/5, (see Figure 2) routes the output of the selected amplifier after signal processing, via control resistors R32-35. To select an input, the appropriate resistor is taken to +5v via the switch bank, and the other resistors are all

connected to ground, only allowing signals from the selected source to pass through to the 7216C.

Multiplexed Display / Driver

(Figure 3)

This is the heart of the instrument and is a complete frequency meter in its own right. A single LSI chip was chosen for this application to make construction easier, and replaces the 5-34 CMOS/TTL chips sometimes seen in other designs. The IC is the Intersil ICM7216C and provides all of the functions required to construct a frequency meter covering 1Hz-10MHz (minimum) and includes circuits for constant current display drivers, needing no current limiting resistors for the display LED's, automatic decimal point, leading zero blanking and a master crystal oscillator. The only external circuits required, is amplification of the input signal and level shifting, and this is provided by the previously described amplifiers. All power is derived from a single +5v source.

Pin 2 provides a 'measurement in progress' (MIP) signal which is used in this application to trigger the capacitance measuring circuitry from its trailing edge, which coincides with the start of the counters measurement cycle. 4 gate periods are available, 10, 1, 0.1 and .01 seconds, but only two of these are used in this application. Normal operation uses the 1 second gate, providing resolutions of 1Hz, 10Hz, and 100Hz at AF, HF and VHF respectively. By selection of the 10 seconds period, this is increased by a factor of 10 on all ranges except capacitance, which remains fixed at 1

second always, giving an available resolution of 0.1Hz at audio frequencies if required. The time between each gate period is fixed at 0.2 seconds, during which time the counter is cleared ready for a new measurement, and the display updated with the previous measurement. A useful feature of the IC is that if the gate period is changed during a measurement, the counter is cleared without updating the display so as not to present an erroneous measurement.

A 10MHz crystal is used as the master reference, with trimmer capacitor TC1 being used to set this to frequency accurately. A 1MHz crystal could also be used as the chip contains circuits to allow this, and also an external oscillator input if required, such as from an oscillator locked to an accurate frequency standard such as MSF. The crystal is the reference for the whole counter and the accuracy of the measured frequency depends on how accurately this is set up. As with all digital instruments, there is a built in inaccuracy of ± 1 count in the last digit.

As the HF and VHF amplifier outputs are 'prescaled' down by factors of 10 and 100 respectively, the automatic decimal point option would give an incorrect display and is not used. Instead, decimal point position is selected by the switch band, and is appropriate to the input in use. At audio frequencies the display is in kHz, the other two ranges being in MHz. Capacity is displayed in nF (1nF + 1000pF) for the 1uF FSD range, and in uF direct for the 1000uF range. R54 and D8 select the manual decimal point option on IC11.

The multiplexed display uses 8

common anode LED displays, mounted on a separate pcb which provides the necessary connections to multiplex the displays, and plugs into the main driver pcb. These displays must be the right hand decimal point variety, as the internal construction of IC11 only allows for use of these. This display board also accommodates the other single LED's which are used as status indicators for power source (DC or AC) and counter gate operation. A signal LED is also provided which shows that a signal is present at the 7216C input pin and is derived from IC12, a 74121 monostable IC, which samples the signal arriving at the 7216C input and lengthens the pulses to drive the display LED. Attempting to drive this LED direct without this pulse lengthening, results in a very dim display at high frequencies due to the short duty cycle. The indicator shows that sufficient signal is arriving at the appropriate amplifier's input to correctly drive IC11. In capacity measuring mode, this will indicate for a short period during each gate cycle, depending on the capacitor being measured. The counter gate LED is driven via the MIP output from TR11.

Capacitance Measuring Circuit

(Figure 4)

In order to use the DFM as a digital capacitance meter, it is necessary to provide the DFM section with a frequency input which is linearly related to capacity. To achieve this, an NE555 timer is used in the astable mode, with its output period

Figure one: block diagram

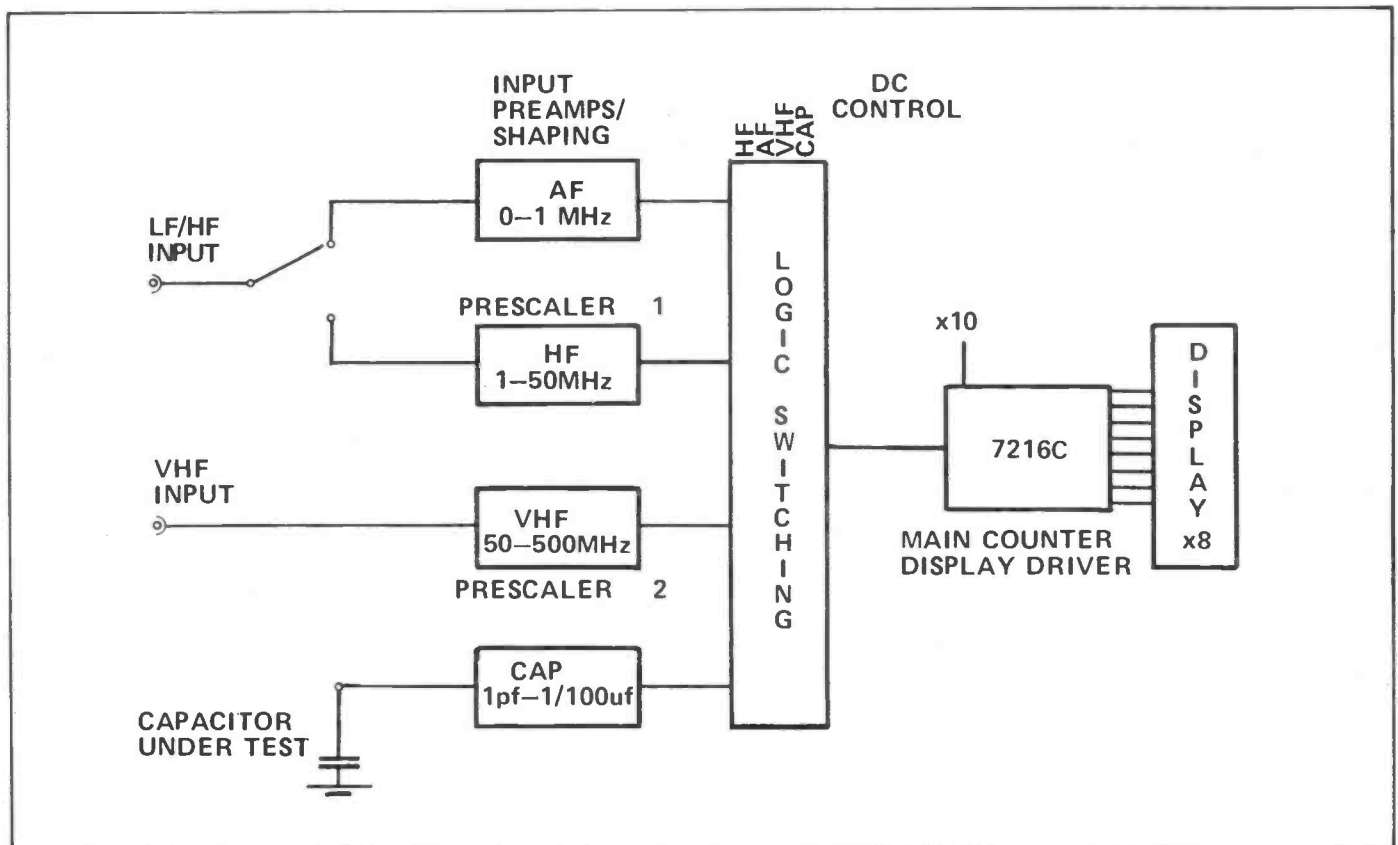

So you've fancied some WHARFEDALE E90 speakers –

But the bank manager won't co-operate! Don't despair – now there are Wilmslow Audio flat-pack kits for the Wharfedale E50, E70 and E90. A few hours of easy and interesting work will complete your speakers at a very considerable saving on buying 'assembled' E systems.



The kits contain all cabinet components – accurately machined for easy assembly – all drive units, crossover networks, acoustic wadding, reflex port trim, nuts, bolts, terminals, grille fabric, etc. The cabinets can be painted or stained or finished with iron-on veneer. Easy, foolproof assembly instructions are supplied – no electronic or woodworking knowledge necessary.

Prices: E50 kit **£182** per pair including VAT, carriage and insurance £ 8
E70 kit **£220** per pair including VAT, carriage and insurance £ 8
E90 kit **£330** per pair including VAT, carriage and insurance £10

Credit terms available: Deposit 20%, balance over 12 months (charges currently 26.9 APR) Through a leading finance house. Written details on request.



0625 529599

35/39 Church Street, Wilmslow, Cheshire SK9 1AS



Lightning service on telephoned credit card orders!
19 for further details



Happy Memories

Part type	1 off	50-99	100 up
4116 200ns	1.20	1.05	.95
4116 250ns	1.10	.95	.85
2114 200ns	1.55	1.40	1.30
2114 450ns	1.50	1.35	1.25
2708 450ns	2.90	2.50	2.25
2716 450ns 5 volt	2.95	2.65	2.40
2716 450ns three rail	7.40	7.00	6.75
2732 450ns Intel type	6.40	5.60	5.00
2532 450ns Texas type	6.40	5.60	5.00

Low profile IC sockets: Pins 8 14 16 18 20 22 24 28 40
Pence 9 10 11 14 15 18 19 25 33

Soft sectored mini discs in plastic library case of ten discs:

1 case: £19 10 cases: £17 25 cases: £15.50

TRS-80 Memory upgrade kits (4K to 16K) £10.50

Other kits available, please phone for details

Please add 30p post and packing to orders under £15 and VAT at 15%

Access and Barclaycard accepted

24-hr. service on (054 422) 618

Government and Educational orders welcome, £15 minimum
Trade accounts operated, phone or write for details

**HAPPY MEMORIES, DEPT. R & EW
GLADESTRY, KINGTON
HEREFORDSHIRE HR5 3NY
Tel. (054422) 618 or 628**

20 for further details



EP4000 EPROM EMULATOR PROGRAMMER

- * COPY/PROGRAMME/EMULATE 2704/2708/2716(3)/2508/2758/2516/2716/2532/2732 EPROMS
- * 4k x 8 STATIC RAM
- * VIDEO O/P AND 8 DIGIT LED DISPLAY
- * EMULATES SIMPLY AT THE PUSH OF A KEY
- * POWERFUL EDITING FACILITIES
- * COMPREHENSIVE IN/OUT (RS232, TTL, 20MA LOOP, PARALLEL, DMA), AS STANDARD
- * 2764 ADAPTOR NOW AVAILABLE
- * EP4000 EX-STOCK AT £545 + VAT + £12 DELIVERY.

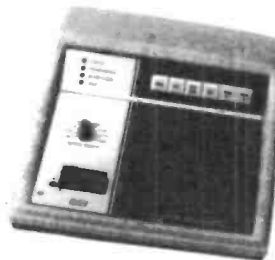

P4000 EPROM PRODUCTION PROGRAMMER

- * PROGRAMME UP TO 8 EPROMS SIMULTANEOUSLY
- * COVERS SAME EPROMS AS EP4000
- * POWERED DOWN SOCKETS
- * INDEPENDENT BLANK CHECK/VERIFY/PROGRAM MODES
- * SIMPLE TO USE WITH MODE PASS/FAIL LEDS
- * EX-STOCK AT £545 + VAT + £12 DELIVERY



UV141 BENCH TOP

UV140 EPROM ERASERS

- * TWO UNITS WITH 14 EPROM CAPACITY
- * SAFETY INTERLOCKED
- * ELECTRONIC TIMER (UV141)
- * UV141 EX-STOCK AT £78 + VAT
- * UV140 EX-STOCK AT £61.50 + VAT



GP INDUSTRIAL ELECTRONICS LTD
UNIT 6, TOTNES INDUSTRIAL ESTATE
TOTNES, DEVON TQ9 5XL Tel: (0803) 863360 Telex: 42596

GP

21 for further details

RADIO & ELECTRONICS WORLD

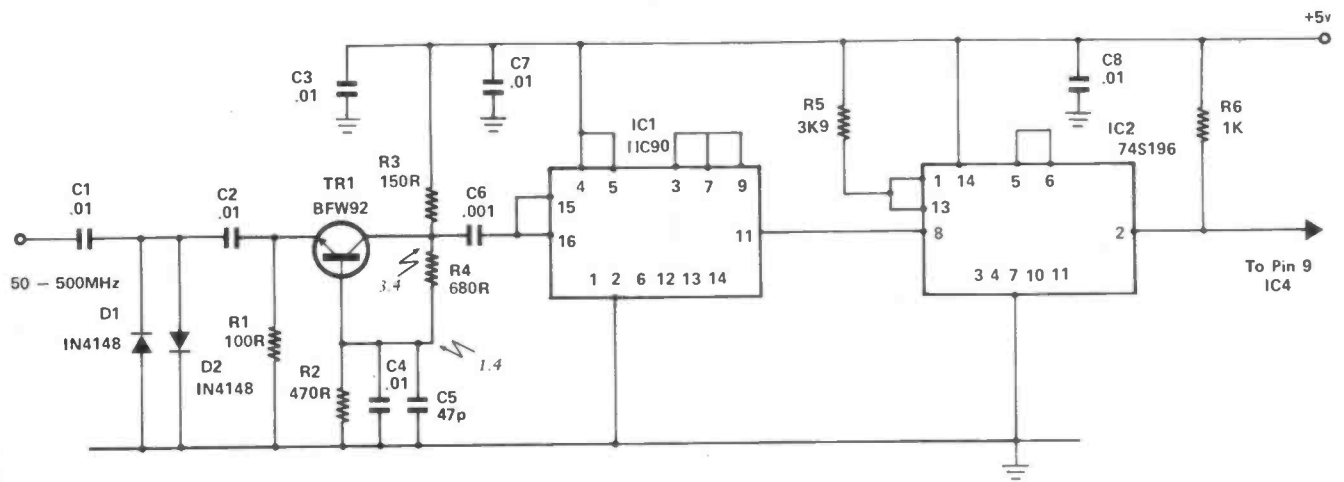

Figure 2a: VHF Amplifier and Prescaler ($\div 100$)

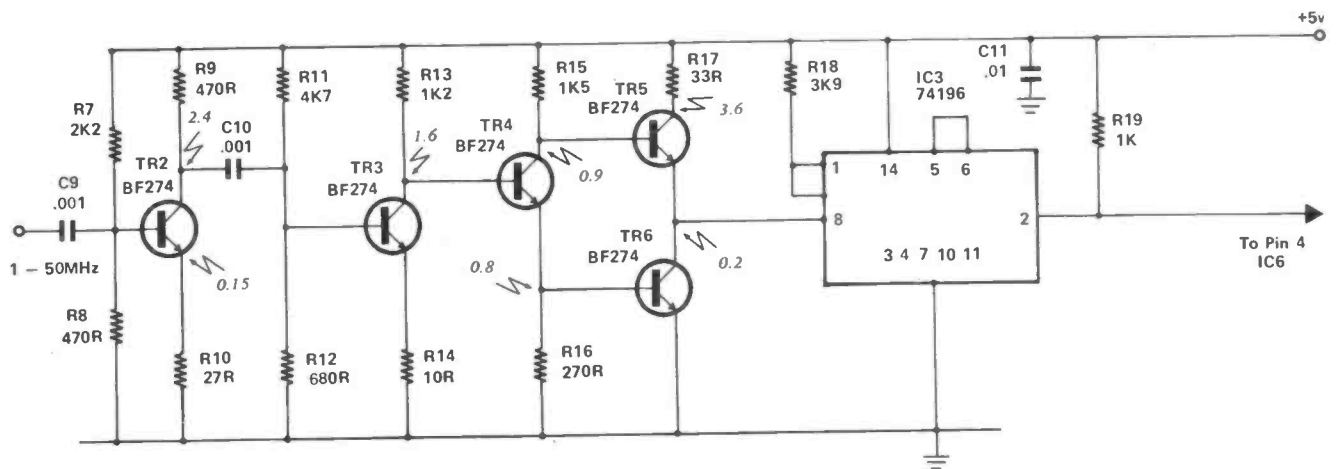

Figure 2b: HF Amplifier and Prescaler ($\div 10$)

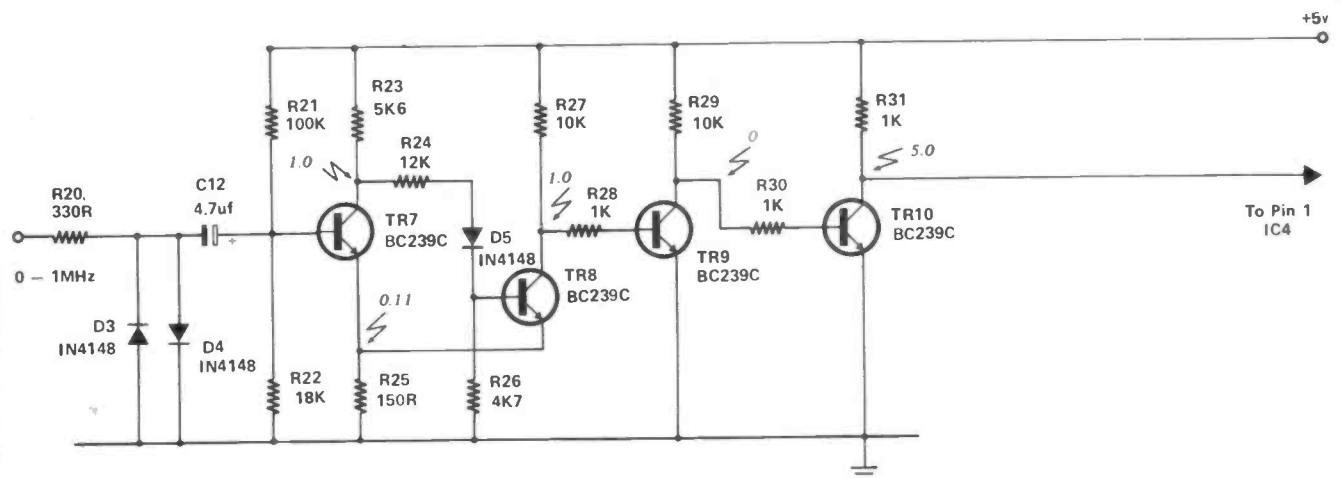
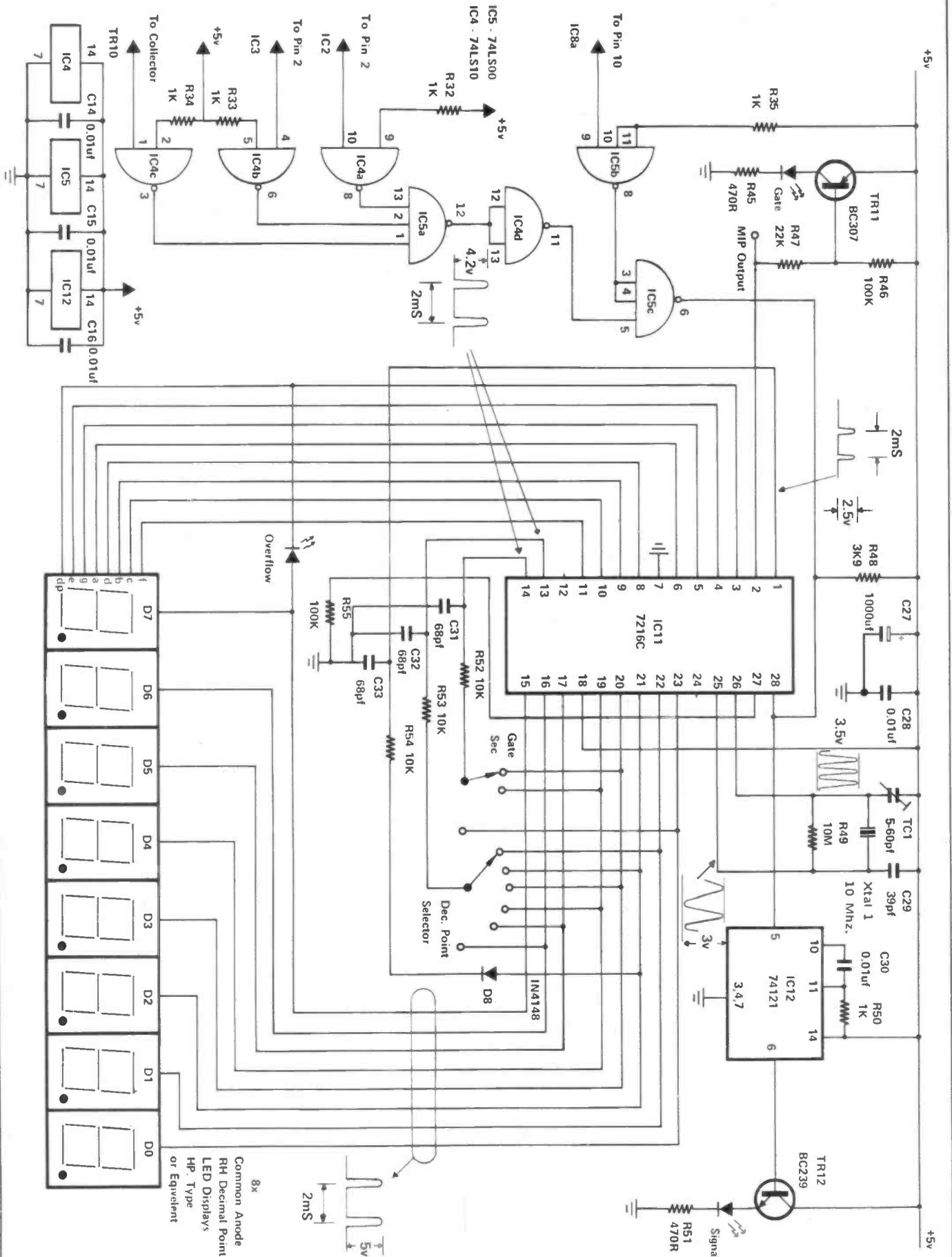

Figure 2c: LF Amplifier

All test voltages shown with no signal input.
 Inputs from BNC sockets. VHF input fed directly, HF and LF inputs share common sockets switched via switch bank. Outputs to logic switching, see Figure 3.

Figure 3: Logic switching, counter and multiplex display.



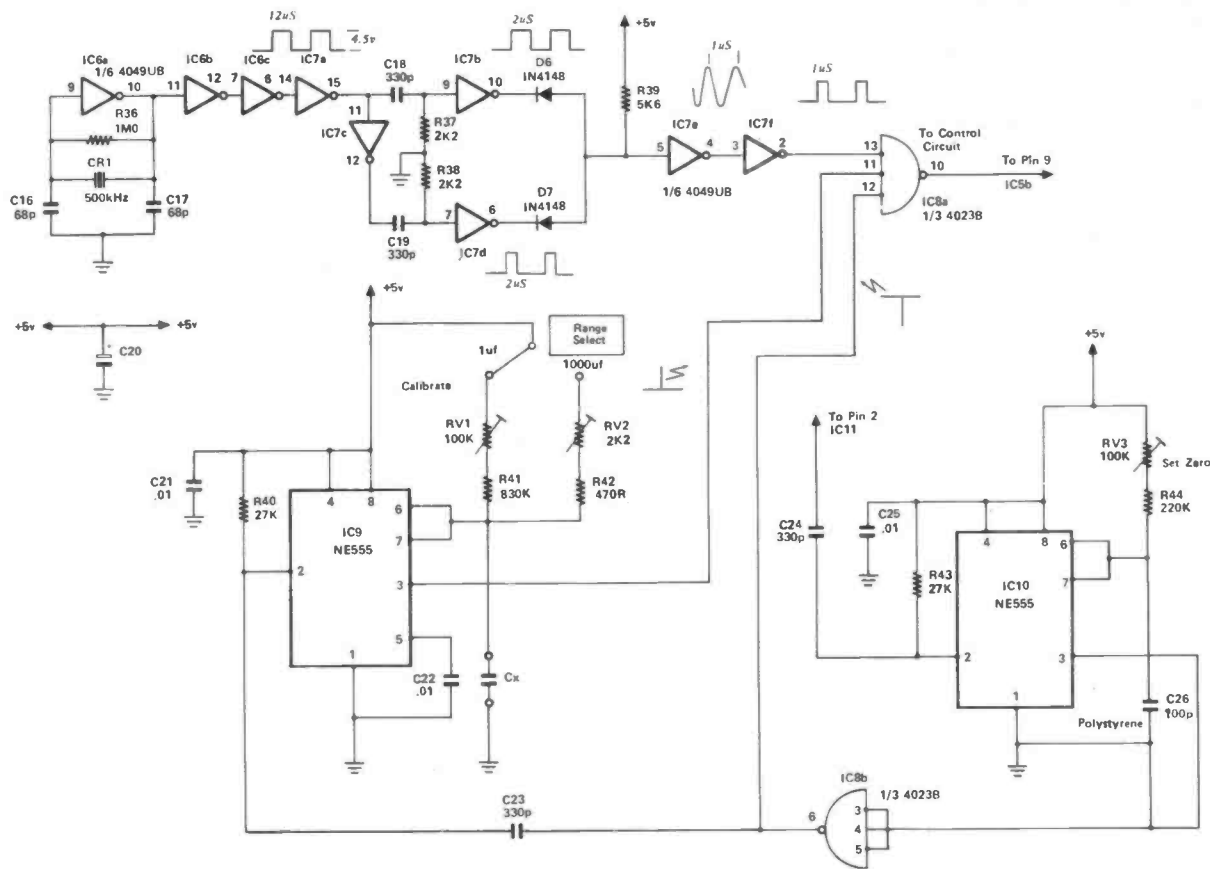

Figure 4: capacitance measuring circuit

being determined by the value of the capacitor under test plus a series resistor. If, for example, this period is arranged by a suitable choice of the resistor to be 1 second, for a capacitor value of 1 microfarad, then gating this period with an oscillator running at 1MHz, allows 1,000,000 pulses through the gate to the counter input during the time the astable output is active. Varying the capacitor value will change the period in a linear relationship, and thus the counter will display the capacity directly - in this example in picofarads. By suitable choice of the decimal point position, the display can be in any units chosen, uF, pF or nF.

IC9 is the main astable referred to above, with VR1 and R41 providing the required resistance, and Cx being the capacitor under test. Rather than use an expensive 1MHz crystal as the source for the gated signal, a cheaper oscillator using a 500kHz ceramic resonator CR1, and a pulse doubling circuit comprising IC6 and 7 was adopted. C16 and C17 are lower in value than is actually required for the main oscillator to run at 500kHz, to ensure that the doubled output is greater than 1MHz, making sure that 1uF capacitor can be measured with a small 'overhead' in a time of 1 second.

The astable operation must be synchronised with the start of each gate period of the main counter, and the MIP output of the 7216C is used to achieve this. This MIP pulse consists of a positive going leading edge which remains high for

200mS, and a trailing edge which coincides with the start of the measurement cycle. The NE555 requires a negative going pulse at Pin 2 which returns high before the astable period is finished, and the MIP pulse will not always achieve this, so a further NE555 is required to give the correct pulse to initiate IC9 at the commencement of each gate period. The trailing edge of the MIP pulse thus initiates IC10 and the leading edge of this IC's output after inversion by IC8b, in turn initiates IC9.

A further feature of the circuit is that if the inverted output of IC10 is also gated with the output of IC9 and IC7f (the 1MHz output), then a 'set zero' function can be implemented by varying the pulse width of IC10 via VR3. This then removes the reading of approximately 30pF, that results from circuit strays, and enables readings to be made down to 1pF. IC3, a 3-input NAND gate, provides the gating function referred to, with all 3 inputs needing to be at logic 1 before the output will change state. Figure 4 illustrates the waveforms at each point in the circuit as an aid to understanding operation.

By lowering the calibration resistance of IC9 by a factor of 1000, the maximum capacity measureable is increased by the same factor, and VR2/R42 is selected instead. Note however, that the measurement of electrolytic or other high leakage types will give readings that are higher than 'true' due to this leakage lengthening the astable time. The effect of this is lower

than it might be, due to the low value of the effective calibration resistance. The absolute value of such capacitors is not however normally of vital importance, comparative measurements more often being required. An indication of the leakage current of a capacitor is given by the stability of the reading obtained - e.g. polystyrene and mica capacitors give stable readings with their low leakage.

When measuring capacitors, it is always advisable to discharge them first, especially large electrolytics, to avoid damaging the measurement circuitry. In turn, never discharge a large electrolytic by shorting the terminals with a screwdriver or similar implement, unless you wish to weld the two together, and probably damage the capacitor with the extremely high discharge current which results. Use a low value resistor of suitable wattage. A guard against this could be made by an additional switch, with its contacts normally shorting the measurement terminals with a low value resistor, but has the disadvantage that the display will continuously indicate the reference oscillator frequency while shorted, rather than zero.

Continued next month....

Your Reactions.....	Circle No.
Immediately Applicable	101
Useful & Informative	102
Not Applicable	103
Comments	104

FT290R Review

Yaesu/Sommerkamp wheel on the first (just) multimode 2 metre (144-146 MHz) portable transceiver. Following a brief preview in R&EW October, your intrepid reviewer gets to grips with the 290's operation and circuitry.

First impressions on picking up this combined FM-SSB-CW transceiver are very favourable. It simply *looks* how a 2 metre portable ought to look. Although the front panel is necessarily small - the control knobs and buttons are easily manipulated. Frequency readout is provided on a clear LCD display, although the relegation of some of the more useful features to the rear panel is a little annoying at times.

What the buttons do

The advantages of having two VFOs on the FT290R become quickly apparent (processor generated, not physically separate). One VFO can be left in the SSB segment of the band, while the other is up the 'other end' on an FM channel. Although once the ten memories are programmed with your favourite simplex/-repeater channels, the VFO's provide a further two 'memories', more usefully on two SSB frequencies.

Storing memory frequencies is simply a matter of winding up the desired frequency, selecting the desired memory (1-10) and pushing the 'M' button. With the ten memories and two VFO's, any of twelve frequencies can be recalled without touching the tuning knob. To prevent the memories being reset when the set is turned off, an internal back-up lithium battery is provided.

Rotation of the main 50 click tuning knob changes the frequency in 100Hz/-1kHz steps on SSB/CW and 12.5/25kHz steps on FM. The 'STEP' button changes the channel increment rate in each mode, switching from the 12.5kHz step on FM to SSB results in the 1kHz rate on SSB, and not the 100Hz as one might expect.

Memory (MR)/main VFO (DIAL) changeover is activated by two separate buttons. These become the priority channel (PRI) and split frequency (S) controls when the 'F' button is first depressed (acting as a keyboard 'shift'). The latter two functions provide monitoring of Memory 1 channel every 5 seconds while on the main VFO, and split frequency operation transmitting on the VFO frequency and receiving on the selected memory.



The remaining two buttons are the 'CALL' and 'CLAR' (clarifier) functions. Repeater access tone is generated by the 'CALL' button only - and cannot be keyed from the PTT line. The 'CLAR' button allows receiver tuning +/-9.9kHz from the transmit frequency.

Selection of any desired function is quite easy once one is familiar with the set. One definite minus point on the front panel is the meter, which can only be described as barely adequate. The manufacturers must have spent many weeks scanning the back streets of Hong Kong, to find one as indifferent as the one used. Surely with all the refinements of the FT290R, a few more yen could have been spared for the meter to complete the good looks and ergonomics of the set?

The 'SCAN' function is selected by depressing either the 'UP' or 'DWN' buttons on the microphone for more than half a second. Scanning is either in the selected frequency steps of the main tuning, or of the memory channels - when the memory selector switch is switched to MS. Internal selection of scanning for clear or busy channels is available.

On the air

The weekend picked for air testing the FT290R coincided with an Auroral opening on 2 metres. This gave a few DX contacts (using the R&EW add-on linear amplifier), and brought to light a slight weakness in the memory. A succession of frequencies of wanted SSB stations were programmed into the memories. Recalling these memories brought back the original frequencies, but with the raspy auroral 'note' these then required slight adjustment. The RIT (CLAR) function could be used - but this left the transmit frequency independent of the received frequency. It would have been useful to have been able to tune (Tx and Rx

simultaneously) from the recalled memory frequency.

On the air, the FT290R performed extremely well. All reports received on transmission quality were complimentary. Signal strength reports were consistent with the power differences of stations being worked.

Portable and mobile ...

...the transceiver's operation was faultless. The microphone failed to impress, since I found that it was very easy to accidentally press the PTT switch when picking it up, and the metal clip on the back made the microphone uncomfortable to hold. Being able to scan memory channels was ideal for mobile FM operation, while scanning the SSB segment in 100Hz steps gave a new dimension to mobile SSB operation.

And then the sun came out

Having left the FT290R in the car all afternoon (I don't make a habit of it, so don't hang around waiting to pinch it!) I turned the set on and nothing.... it was totally dead - panic.

After a lot of fanning and heart pounding, the FT290R started working again. Admittedly it must have been extremely hot, but the set's non-operation was very disconcerting. Under less extreme conditions the operating point of the mute varies with temperature, and this is a common problem when relying on the internal mute circuitry of the MC3357. Icom's IC2 (see last month's R&EW) series provides a good example of solving this particular problem.

Another problem encountered while mobile was with the power connector. The external surface of the plug is the positive supply connection. Hence the inevitable happened, the plug touched the chassis and **bang** - one fuse down. When using the proper mobile mounting tray this should

not happen, but at a cost of over £20 for the tray - a packet of fuses are cheaper.

Specification/Measurements (in brackets)

Frequency coverage:
144-146 MHz (other ranges possible - see text)

Modes of operation:
SSB, CW, FM

Synthesiser steps:
SSB/CW 100 Hz, 1 kHz
FM 12.5 kHz, 25 kHz (others possible -see text)

Power requirement:
8 C-size dry batteries or ni-cads
External 8.5-15.2V DC, 70 mA receiver,
800 mA max transmit.

Size/weight:
58x150x195 mm. 1.3 Kg

Transmitter

Power output:
2.5 watts (3.25 watts)
Carrier suppression (SSB)
Better than 40dB (USB - 46dB, LSB -49dB)
Also see the spectrum analyser pics, on page 78 of October issue.
Spurious radiation:
Better than 60dB (just! 2nd, 6th and 7th harmonics marginal VFO-58dB)

Receiver

Type:
SSB/CW single conversion 10.81 MHz IF
FM double conversion
10.81 MHz/455 kHz
Sensitivity:
SSB/CW 0.5 uV for 20 dB S/N (0.32 uV for 20 dB S/N)
FM 0.25 uV for 12 dB SINAD (0.17 uV for 12 dB SINAD - after replacing the RF stage MOSFET with a 3SK88)

Selectivity:
SSB: 2.4 kHz-6 dB
4.1 kHz-60 dB
FM: 14 kHz-6 dB
25 kHz-60 dB
(adjacent channel LF-73 dB, HF-78 dB)
Image rejection:
Better than 60 dB (SSB-74 dB, FM-78 dB)
Audio output:
1 watt at 10% THD

The figures speak for themselves, showing very reasonable performance. Third order IMD is good at 28 dB below the two tone level. Higher order products should preferably roll off a little faster -especially on the LF side.

The Circuit

Circuitry of a synthesised multimode is necessarily complex. The block diagram should give some insight into the operation of the transceiver. The majority of the circuit works from a stabilized 6.8V rail, and only the transmit PA stages and audio amplifier use the 'raw' supply. This gives good frequency and performance stability and allows the use of a 10V nicad supply.

Receiver front end consists of the usual dual-gate MOSFET RF amplifier and mixer. Due to the large frequency range (144-148MHz in the US version), varactor tuned filter stages are used in both the receive and transmit chains. The IF frequency is unusual being 10.81MHz. There is probably a good reason that relates to the choice of synthesis technique for the choice, but it is not immediately apparent to the reviewer. Two 30kHz wide monolithic crystal filters provide 'roofing' FM selectivity.

The take-off for the effective noise blanking circuitry is between the two filters. FM demodulation and squelch function are taken care of in the MC3357

already mentioned, 455kHz being used as the second conversion IF frequency. For SSB reception, further selectivity is provided by a 2.4kHz bandwidth crystal filter. The rather long-in-the-tooth MC1496 is used as product detector, and also doubles as balanced modulator in the transmit chain. The same 2.4kHz crystal filter is used to select the desired side band. Two single gate FET's comprise the transmit balanced mixer, followed by a controlled MOSFET stage. Amplification of the transmit signal to the 2.5 watt level is performed by a further three transistor stages.

The numbers game

The required local oscillator frequency range is 133.19-135.19 MHz. A VCO output in this range is mixed with a VXO whose basic frequency of circa 18.7 MHz is multiplied up to 131.9-131.999 MHz. The VXO is controlled from a D/A converter derived directly from the MPU's outputs - a fascinating solution to the tricky problem of 100Hz resolution at VHF.

This gives an IF in range 2-3.99 MHz in 10kHz steps. A programmable divider (200-399) brings the IF down to 10kHz, where it is phase compared to the reference. All the clever control work is done in a Hitachi CMOS 4-bit micro-processor, which derives the display from program control rather than frequency count.

Note that this process avoids the use of a current hungry prescaler, but places emphasis on the RF and filter skills of the designer.

Modifications

Comparisons were made of signal/noise measurements on the FT290R with other commercial transceivers. This showed the FT290R to be on

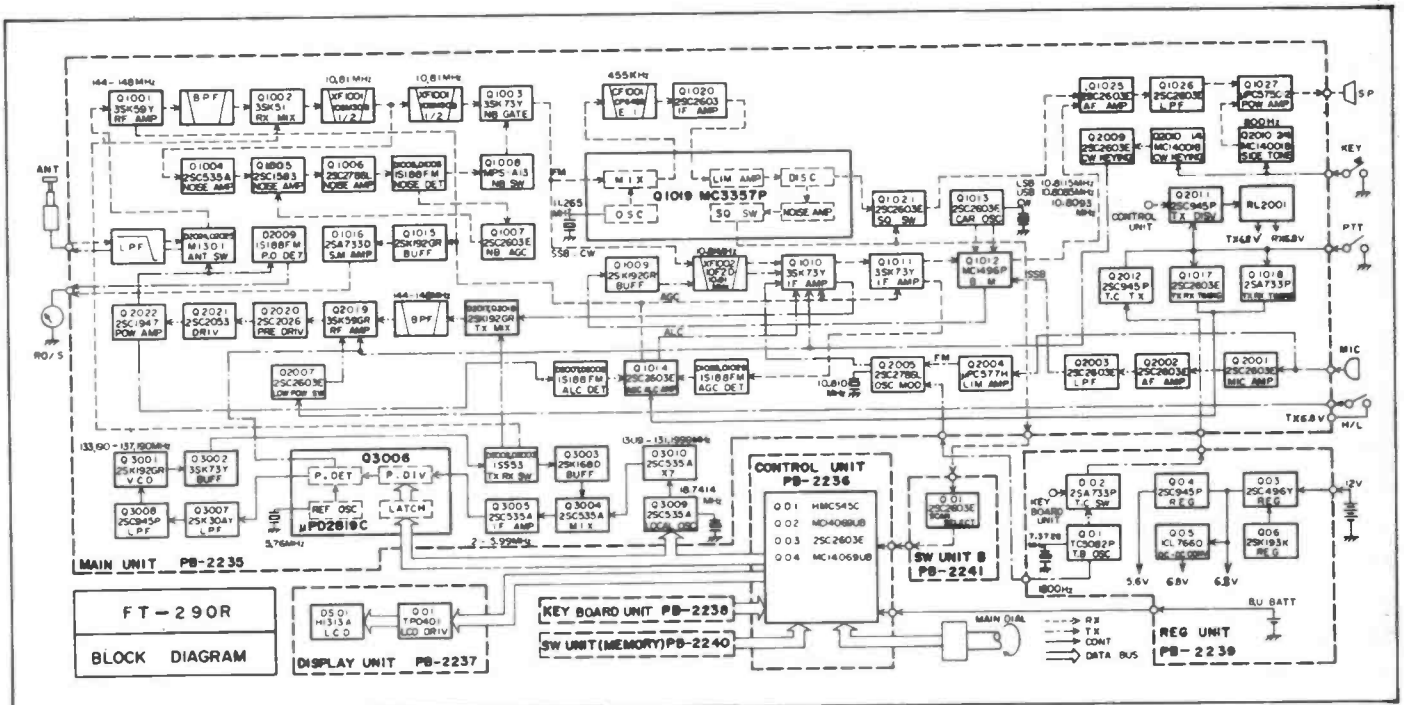

a par with the IC202S on SSB, but about 6dB worse than the IC2E on FM. Throwing caution to the wind I replaced the RF amplifier Q1001 (3SK59Y) with a 3SK88. Although the circuit voltages are not optimum for the 3SK88, the replacement brought the signal/ratio to within a dB of the IC2E. The modification is best performed by removing the original transistor and then soldering the 3SK88 on the trackside of the board. Transformers T1001 and T1002 require slight retuning, but are easily peaked for largest 'S' meter reading on a weak signal.

The European version of the FT290R covers 144-146MHz with FM steps of 12.5 and 25kHz. Other versions are available for other markets, with 144-148MHz coverage and 5/10/20kHz steps available. Hard wired links on pins 38-41 determine which version is which. Hence it is quite easy to change from one version to

Table 1

Version	Freq. Range	Steps	Coding
B (Normal UK)	144-146MHz	25/12.5	1001
C	144-148MHz	25/12.5	1000
D	144-148MHz	10/5	1110

another, by wiring the pins on to miniature DIL switches (See Table). The wider coverage can make the FT290R useful as a microwave IF, while the 10kHz spacing would be required for a 144/27MHz transverter (of which more anon).

The reader should note that any modification may invalidate the manufacturer's warranty.

Conclusions

The overall impression given by the FT290R is one of a well designed and manufactured portable transceiver. At a cost of around £225 it is exceptionally good value for money. The cost of the 'official' accessories is high, so here is a good opportunity for home construction.

YAESU FT290R Multimode

O Rosindell - G3XDG

When reviewing a piece of gear, it is sometimes useful to get two entirely independent views of the same thing. This second foray into the FT290 provides another user's viewpoint - this time from the predominantly 'FM' user's point of view.

Several comments have appeared in various magazines on this new 2 metre portable multimode, and having recently got my hands on two separate rigs, I have been asked by R&EW to comment on my findings.

Main tuning knob. Step (7) and clarify (9) buttons

Smooth in operation and positive in detent. Note that when the mode switch is on FM, synthesiser steps are normally 25kHz, and 100Hz on SSB. These steps are modified to 12.5kHz and 100kHz respectively when the step size button - one of eight push-buttons on the keypad - is depressed. Although it is true that the rig can go to any 100Hz tuning step simplex or duplex, FM mode transmit can only be achieved at 12.5 or 25kHz steps on the main tuning knob. If you want to go to 5kHz for example of 100Hz steps on FM. You are forced to change the mode switch to SSB or CW, tune in the exact frequency desired, and then either deposit this in to a memory for use - or do not touch the main tuning knob after switching back to FM, as the synthesiser will automatically jump up to the next 12.5kHz or 25kHz step.

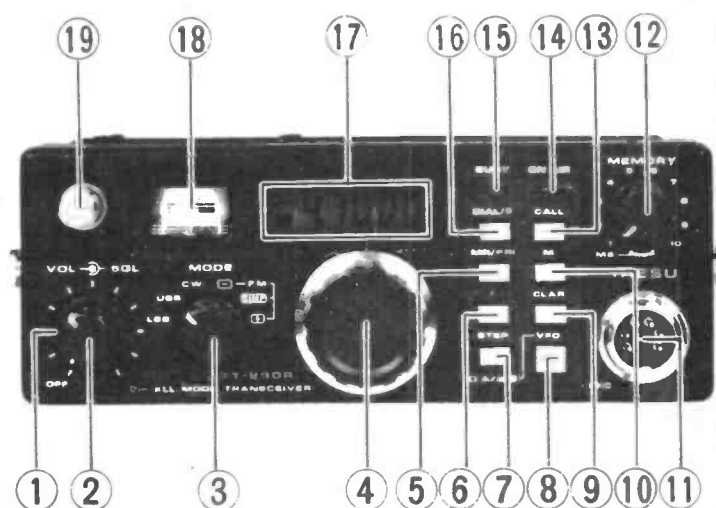

VFO and call button (8 & 13)

The FT290R has two VFO's which are selected by the two position button (8) - this is an extremely useful feature for quick pre-selected frequency changes. Pushing the call button activates the transmitter, (regardless of whether or not the PTT button on the microphone has been pressed), and transmits a 1750Hz tone for repeater access. A useful refinement would have been inclusion of a feature to transmit this tone automatically when PTT is pressed twice in succession, or a simple tone burst on/off switch as found on the Trio TR2300.

A further problem is that when scanning, all ten memories are irrevocably 'locked in' i.e. you cannot scan just two memories for a pre-arranged contact. Remember also that when the set is

initialised, all memories are set to 145.000MHz which is a repeater input. If one wants to scan just two channels - say S20 (145.500MHz) and S16 (145.400MHz) it is thus imperative to store the two frequencies *alternately* throughout all ten memory positions.

When using a memory stored channel, e.g. using the above case, and you have just established contact on S16 and want to 'QSY' (change frequency) to S15, one finds it is not possible to modify the frequency. So you have to switch back to VFO and tune up. This takes some considerable time....

The twelve position switch then has ten memory positions, the last two being used for memory scanning. Since both positions provide the same function, a thoughtful design feature would have

been omission of the slide switch in Figure 2 with the two modes of scan selectable from the front panel. Incidentally, the internal slide switch has a third (manual) position. This scans the channels regardless of whether they are occupied or busy, leaving the operator to halt by pressing the PTT.

Split channel operation

Set the memory switch to a position in which has been loaded a frequency on which you wish to receive. Depression of button F (12) followed by DIAL/S (9) places the rig in split channel operation, when the transmit frequency is selected by the VFO and you will receive on the selected memory channel. When transmitting, a large dash appears on the LCD and this will have the M underneath when receiving.

This feature is useful for any unusual repeater splits or semi-duplex working.

Priority channel working

Depression of the F (12) button followed by MR/PRI causes a large P to appear followed by a frequency as set by VFO. Any memory channel now selected will be scanned every few seconds for activity strong enough to break the squelch. If this happens, the 'blip' is heard, cancelling the scan and placing the rig on this memory position - the priority channel. A badly set squelch will produce the same effect as a station transmitting on your priority channel. Whilst scanning the decimal point after MHz on the LCD will flash.

Depression of DIAL/S (9) button removes the transceiver from either of the above two modes immediately, or indeed from the memory reference mode but note that memory scanning must first be halted by pressing PTT.

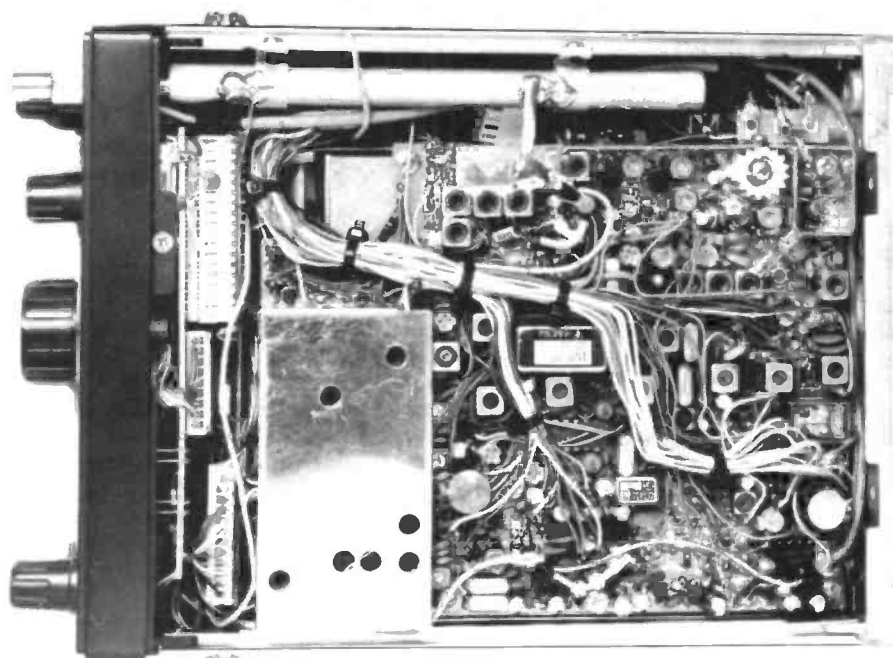

Signal strength/power output meter/battery check (17)

This meter - although small and not easy to interpret - is a very useful addition, and is indeed a prerequisite for a transceiver of this kind. I found its use and indications given whilst receiving to be quite accurate, and in line with the usual 'trained ear' readability/strength reports one makes.

Aerial - Telescopic (18)

This is severely mismatched on the set I have and requires a small capacity 'Hat' on top of the whip when fully extended to give anything like satisfactory operation. These comments apply to both TX and RX operation.

The easy way to fit a 3SK88

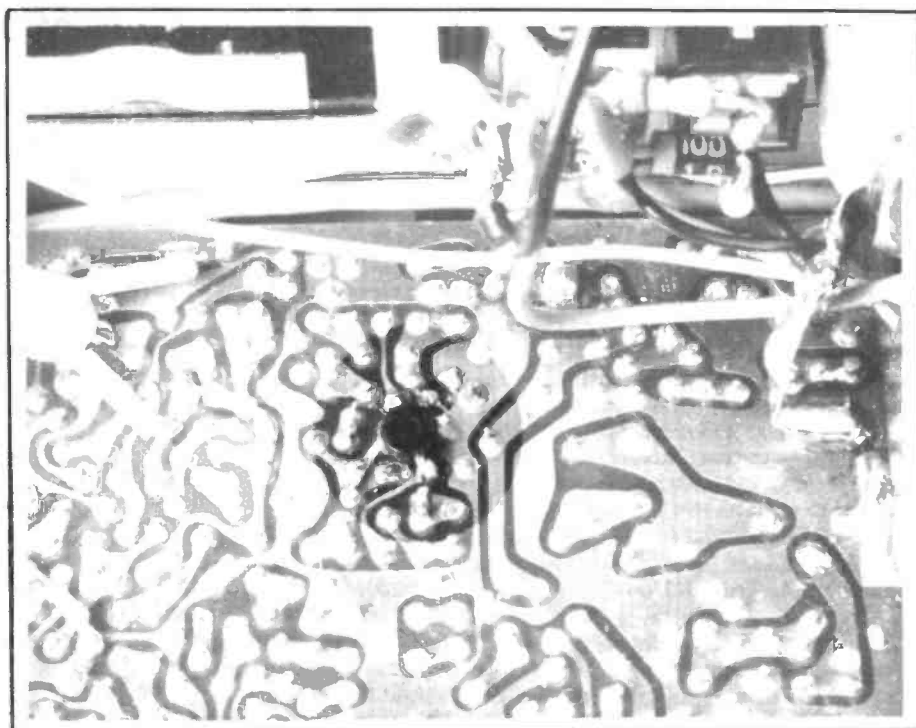

The receiver

This was found to be somewhat 'deaf' on the first set I tried, and I had reports through third stations that I was being called by amateurs over 100 miles away in Derby whilst working a local station. This problem seems to have been cured on the rig I am now reviewing, but I understand that a modification to the RX front end has been done by the R&EW lab - a 3SK88 RF transistor substitution.

The transmitter

Satisfactory in operation both in FM and SSB (CW not tested.)

Summary

The Yaesu FT290R is certainly good value for the price and has a host of features included, many of which are not present on quite expensive base stations today. I do feel however, that this is the first batch of a new generation of transportable multimodes, and a little more care at the design stage would have produced a better piece of equipment. (Unfortunately also perhaps more expensive in the process.)

As a footnote, I would recommend a linear amplifier for use with this rig as a mobile or base station, and understand that a suitable design will appear elsewhere in R&EW. Secondly, note that Ni-cads and charger is not supplied with the transceiver. A carrying strap is provided, but not case - another extra, costing about £7.00-£10.00.

Your Reactions.....	Circle No.
Immediately Applicable	281
Useful & Informative	282
Not Applicable	283
Comments	284

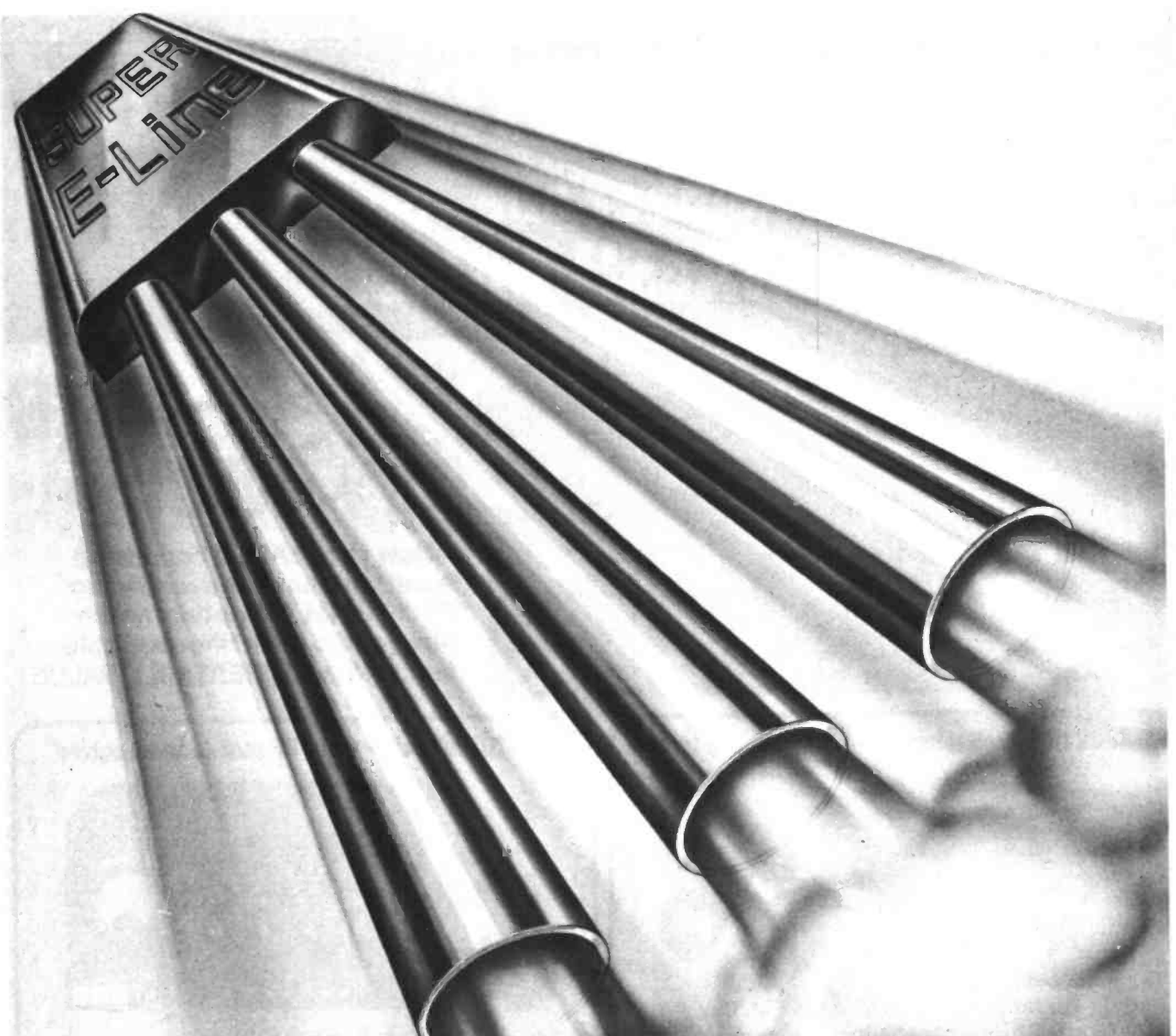

Extra power!

You can now get high performance power transistors in Ferranti E-line.

We call it Super E-line.

It means a smaller device than you've been using before. And a lower price.

But super performance.

Super E-line has 1.5W capability at 25°C and takes voltages up to 100V. Minimum gain of 25 at a continuous 2A, 55 at 1A. And under surge conditions Super E-line can handle up to 6A. We don't believe it's ever been done before in a TO92 type package device.

Super E-line's performance means you can use it in audio amplifiers and complementary drivers for hi-fi amplifiers as well as solenoids, actuators, relays and lamp switching. It's a brand new range of npn and pnp transistors for the power market.

It's leadership - from Britain's leadhouse for discretes. Send for the data sheet today.

Contact: Discrete Component Marketing
at Ferranti Electronics Limited,
Fields New Road, Chadderton,
Oldham OL9 8NP
Telephone: 061-624 0515 Telex: 668038

FERRANTI

Semiconductors

6 for further details

AMATEUR ELECTRONICS UK



Your number one source
for **YAESU MUSEN**



NEW **FT-101ZD
Mk. III**

Now from YAESU comes the latest version of the renowned FT-101 - AM/FM option, notch filter, audio peak filter, variable bandwidth - **UNBEATABLE VALUE**

FT-480R High technology all-mode 2 metre mobile



The most advanced 2 metre mobile available today - USB, LSB, FM, CW full scanning with priority channel, 4 memory channels, dual synthesized VFO system.

FT-707 All solid-state HF mobile transceiver



The definitive HF mobile rig, digital, variable IF bandwidth, 100watts PEP SSB, AM, CW (pictured here with 12 channel memory VFO).

As factory appointed distributors we offer you - widest choice, largest stocks, quickest deal and fast sure service right through -



or attractive H.P. terms readily available for on-the-spot transactions.

Full demonstration facilities.

Free Securicor delivery.

FT-707 In base station format



Here we show the 707 together with the matching FP-707 PSU, FC-707 ATU and FV-707DM VFO memory.



For full details of these new and exciting models, send today for the latest YAESU CATALOGUE and LEAFLETS. All you need to do to obtain the latest information about these exciting developments from the world's No. 1 manufacturer of amateur radio equipment is to send 36p in stamps and as an added bonus you will get our credit voucher value £3.60 p - a 10 to 1 winning offer.

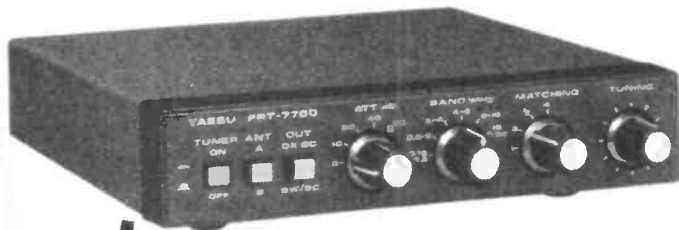

FRT-7700

ATTENTION FRG-7700 owners!

Exploit the full potential of your receiver with YAESU's new FRT-7700 antenna tuner and FRV-7700 converter.



FRV-7700

New on two!

FT-290R All-mode 2m portable



10 memories, 2 VFO's, LCD display, C size battery, easy car mounting tray, 2.5 watts out.

New on seventy!

FT-780R All-mode 70 cm mobile



4 memories, memory and bandscan from microphone, conservative 10 watts out - All the features of the FT-480 on 70cm.

AGENTS

NORTH WEST - THANET ELECTRONICS LTD, GORDON, G3LEQ, KNUTSFORD (0565) 4040.
 WALES & WEST - ROSS CLARE, GW3NWS, GWENT (0633) 880 146.
 EAST ANGLIA - AMATEUR ELECTRONICS UK - EAST ANGLIA, DR T. THIRST (TIM) GACTT, NORWICH 06925 865
 NORTH EAST - NORTH EAST AMATEUR RADIO, DARLINGTON 0325 56969
 SOUTH EAST - AMATEUR ELECTRONICS, UK - KENT, KEN McINNES, G3FTE, THANET (0843) 291297

WHERE TO FIND US

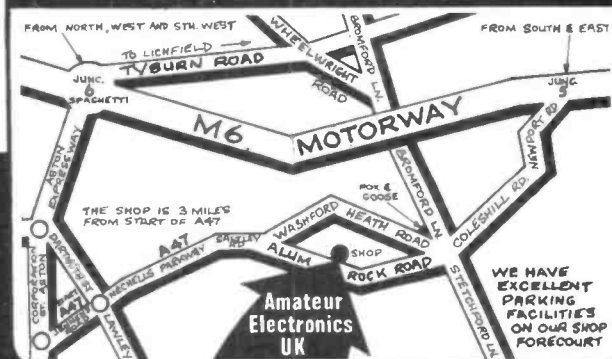

Amateur Electronics UK
508-516 Alum Rock Road - Birmingham 8
Telephone: 021-327 1497 or 021-327 6313
Telex: 337045
Opening hours: 9.30 to 5.30 Tues. to Sat.
continuous - CLOSED all day Monday.

The last word

This page is written literally hours before the issue is presented to the printers - so please excuse the typewritten text. We hope it reflects the urgency of the conditions under which it is produced....

Zilog stirs - again

Although an industry leader in the field of 8 bit MPU supply, Zilog manages to maintain a fairly low profile, and leave most of its 'second sources' to go around blowing the horn for the long established Z80 family. However, recent developments at Zilog are turning out at a rate that will surprise Zilog followers, and hot on the heels of the Z8000, Z8, the enhanced speed Z80B and the Z6132 comes the Z800.

The Z800 is claimed to be three times as powerful as the Z80, yet maintaining compatibility with the Z80 instruction set, enabling existing software to be run without trouble. The Z800 contains circuits to enhance multiplication, division, and memory mapping to access up to 4 MByte of memory.

Both non-multiplexed and Z-bus compatible versions are planned to enable the device to operate as a peripheral in a Z8000 configuration. Watch this space for further news of what promises to be the micro of the moment.

CBM unveil the 6502 update

The successor to the widely used 6502 is at last on view in the shape of the 6508. 256 bytes of programmable memory and an 8 bit parallel port seem to be the main new features on offer, although it remains compatible with the 6502 instruction set. More members of the family are on the way.

Reader responses

As many of you will appreciate, a national 'bookstall' monthly like R&EW has to be produced around 3 weeks before the official publication date. In practice, a few copies leak out two or three days earlier - so at the time of writing, we have had less than a week to assess the immediate reaction to the first issue. One or two letters are printed herein, and we invite more. Many of you appear to be taking the opportunity of the reader response card to make comments, and we will be offering this as a regular feedback medium.

The numbers of readers converting straight to an annual subscription is very heartening, and we shall be doing our best to assure you that your faith is not misplaced.

Use the information request and response page (we hope to have organized cards for the next issue) - the origami lesson is entirely free of charge - and the savings you make on 'phone calls and letters will buy your next copy.

VHD: one size suits all

The Japan Victor Corporation have now managed to produce the VHD video disc system that can play discs encoded in any of the various broadcast systems, by looking up a format code on the disc itself. European screens suffer a small shrinkage at the top and bottom, but all else remains intact.

In view of the burgeoning numbers of disc/tape standards, and the general inconvenience of it all, this must be regarded as something of a breakthrough for both JVC and the public.

REVIEW TEKTRONIX 60 MHz OSCILLOSCOPE

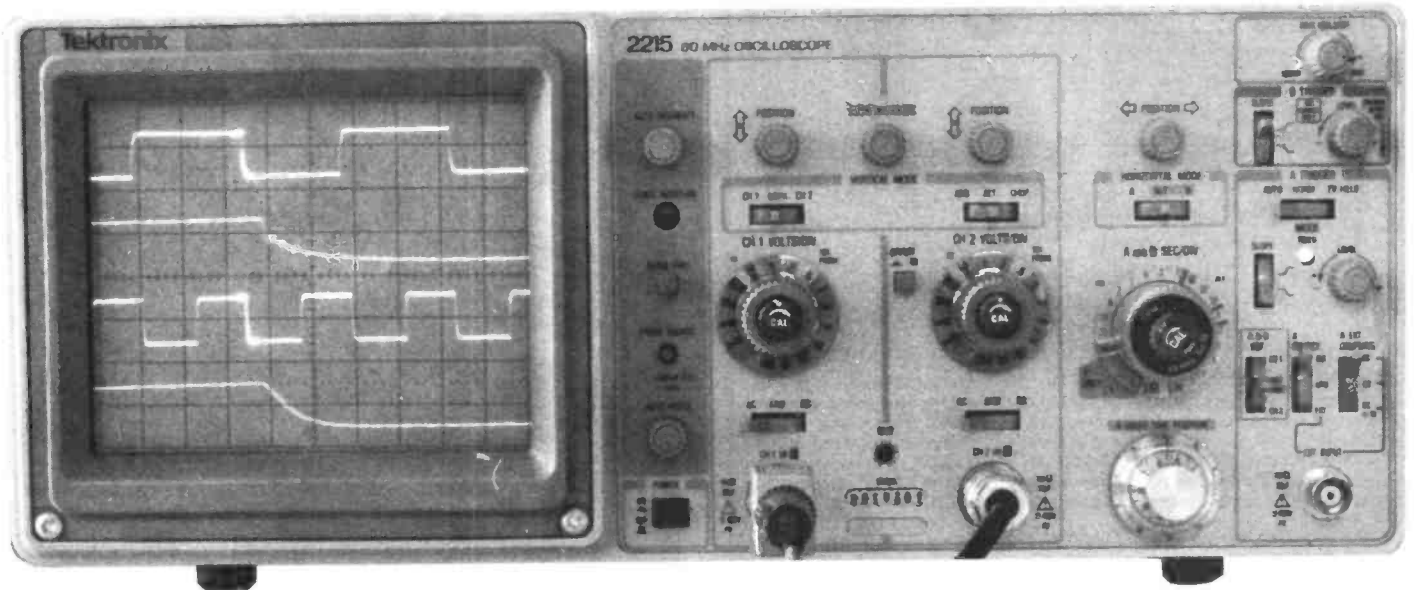

The new Tektronix 60MHz Oscilloscope

The Tektronix 2215 is a reasonably priced 60MHz oscilloscope, featuring dual trace and a delayed time base. This general purpose portable oscilloscope meets a wide range of requirements for the service workshop and development laboratory.

The 2215 made a rather brief appearance in the R&EW laboratory. Just long enough to put it to good use and provide us with enough experience for this 'user's' review.

Vertical deflection accuracy is $\pm 4\%$ over the 0-50 degrees Centigrade temperature range - which is adequate for most applications. A calibrated output

signal is not available on the 2215 to check this however. Triggering on the 2215 is very good, and must be one of its best features. It readily triggers on TV line and field syncs, allowing the delaying trace to be used for close examination of video waveforms. The variable hold-off gives stable triggering on complex digital signals. Automatic triggering operates over a greater range than some of its rivals, with triggering being unaffected by vertical position. Tektronix have used some clever circuitry to allow triggering on asynchronous waveforms when in the dual channel alternate position.

Sweep rate is 0.5 seconds to 50nS, with the X10 magnifier extending the maximum sweep speed to 5nS per

division. Delayed sweep is available from 50mSto 5nS (X10) per division. Accuracy of the delayed sweep dial is $\pm 1.5\%$ of full scale. Alternate sweep switching, A/B sweep separation control and B triggering after delay functions are available for jitter-free delayed-time measurements.

The intensity and focus are maintained to a fair degree over all sweep speeds.

There isn't really any sort of 'power on' indication. Perhaps Tektronix regard the rather loud 'hum' that the oscilloscope makes as suitable warning. A sprinkling of LED's could be put to good use on the front panel to indicate 'power on', and when controls are not in the 'CAL' positions. Users of the 7000 series with the superb 'on screen' indicators of the function settings may find this paucity of indication takes a little getting used to, but then again, the oscilloscope comes complete with probes for £785 plus VAT at the time of writing.

Two types of probe tip are provided. One conventional, and the other of novel design resembling the rear end of an earwig. The later with sideways gripping action was not very effective in practice.

The overall impression of the 2215 is of a well-designed instrument meeting all the requirements of a general purpose oscilloscope, and with the Tek pedigree. ■

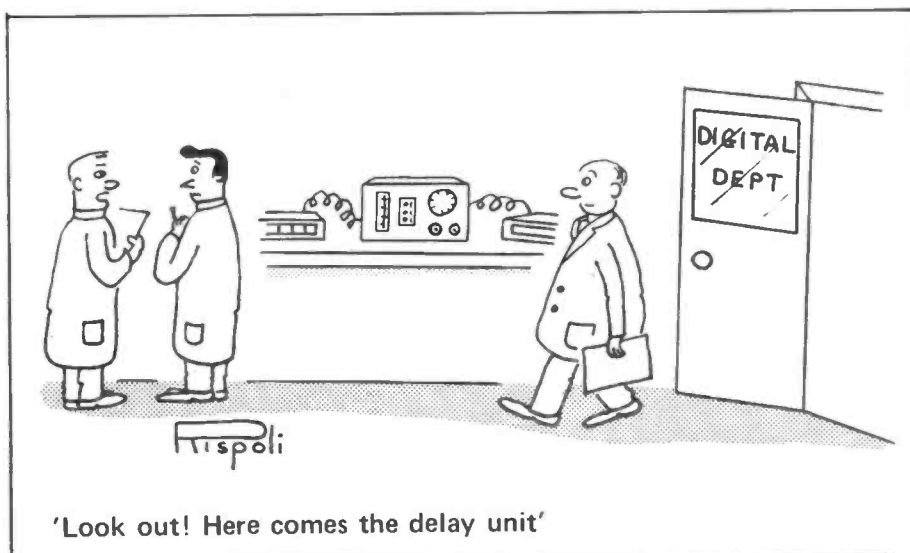

Your Reactions.....	Circle No.
Immediately Applicable	175
Useful & Informative	176
Not Applicable	177
Comments	178

BUILD A PAIR OF MICRO MONITORS!

Just a few hours easy and interesting work and you'll have a superb pair of compact loudspeakers for about half the price of equivalent 'assembled' models.

The Wilmslow Audio Micro Monitor will stand comparison with any speaker of similar size (at any price!). Don't take our word for it - call for a demonstration!



The Micro Monitor kit contains all the components needed - a pair of cabinets in flat-pack form - accurately machined for easy assembly, all drive units, crossover networks, acoustic wadding, grille foam, velcro, nuts and bolts, etc. No electronic or woodworking knowledge required - simple, foolproof instructions supplied. The cabinets can be stained, painted or finished with iron-on veneer. Dimensions of assembled cabinet: 32x24x20cms. Suitable for amplifiers of 20 - 50 watts.

Price: £103.95 per pair including VAT. Carriage and insurance £5.95



☎
0625 529599

35/39 Church Street, Wilmslow, Cheshire SK9 1AS



Lightning service on telephoned credit card orders!
25 for further details



Lamps for ANY purpose ANY shape ANY size...

INDICATORS
NEONS & FILAMENTS

THE COMPLETE ALBA RANGE!

From the Sole UK distributors:-

JAYLAMPS

J+H ASSOCIATES LTD

The Maltings, Sawbridgeworth, Herts
0279-723156

26 for further details

£14.95 inc
VAT & P/P

**R&EW
SPECIAL OFFER**

**QUARTZ
STOPWATCH
CHRONOGRAPH
TIMEPIECE.....**

Call it what you will, this device tells the time, has an utterly comprehensive stopwatch facility, with alarms, day, date etc.

Count the 1/100ths of a second until the next R&EW is published.

Send Cheque, P/O or credit card no. to:- Stopwatch Offer,
R&EW, 200 North Service Road, Brentwood, Essex, CM14 4SG.

Shown approx.

1.3 x full size.



AM / FM Radio R&EW Watervole Part 2

Richard Collins



....completing R&EW's attempt to undermine the entire Far Eastern transistor radio industry by presenting the enterprising British public with a 'state-of-the-art' LW, MW and FM battery portable radio design

Volume Control Mounting

The volume control and on-off switch is mounted on the dial back plate, which is itself attached to the PCB by means of a tin plate bracket shown in *Figure 5*. The bracket should be bent up using a heavy vice and a small hammer. Once made, the bracket can be fitted to the PCB and the mounting tabs twisted in their respective slots to hold the assembly firmly. Each tab may also be soldered to the copper earth plane.

Volume Control

This may now be wired up to the PCB as shown in *Figure 6*. Once connections are complete, the control should be fitted onto the scale backplate. Note that a screened lead is used for both the connections from the battery to the switch and from the switch to the PCB. 'fixer' which must be sprayed on. **DO NOT** attempt to use a brush as this will cause the transfers to move out of place and possibly break-up. A scale pointer must also be made up from piano wire (or

stiff copper wire) and sleeved with coloured plastic tubing.

Once completed, the dial assembly should be fitted to the PCB. Attachment is made with bolts to the wavechange switch frame and the mounting bracket below the volume control.

Dial Backplate Assembly

This is fabricated from aluminium, and provides a mounting for the drive spindle, drive cord guide wheels, scale backplate and the volume control. The assembly is shown in *Figure 7*. In addition to the metal backplate the scale is also shown. This is made from clear or white plastic sheeting. The numerals are put down using 'Letraset' dry transfers - as are the waveband markings.

The transfers should be protected with a coating of varnish.

Dial Drive Cord

The dial drum should be fitted onto the tuner spindle and the plastic tuner support bracket should be fitted between the dial plate and the tuner top as shown in the drive cord routing diagram, *Figure 8*. The drive cord should be fitted as shown, paying particular attention to the number of turns around the drive spindle

Figure 6

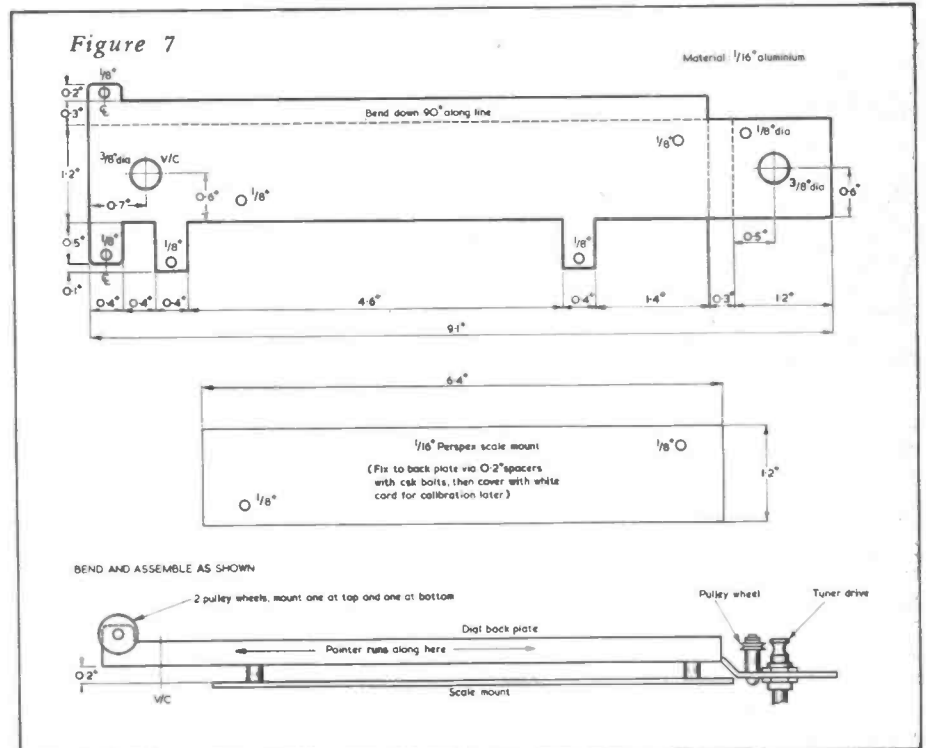
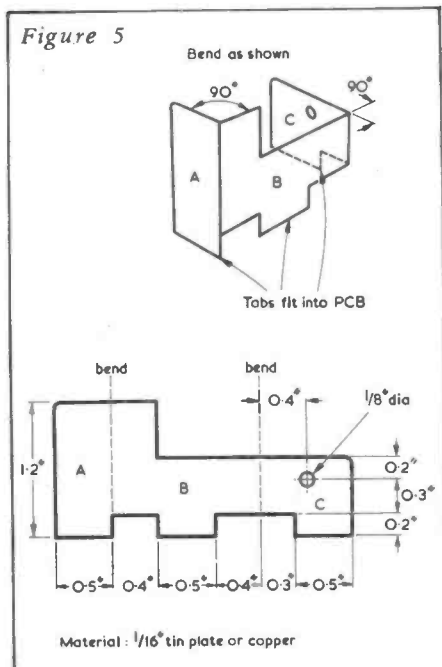
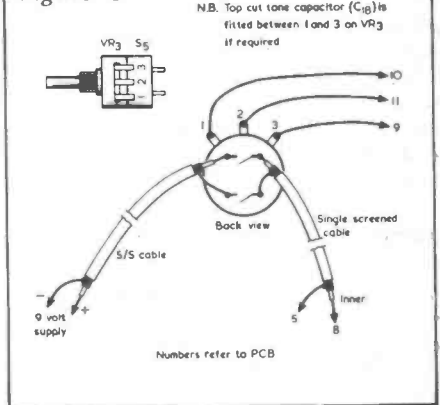

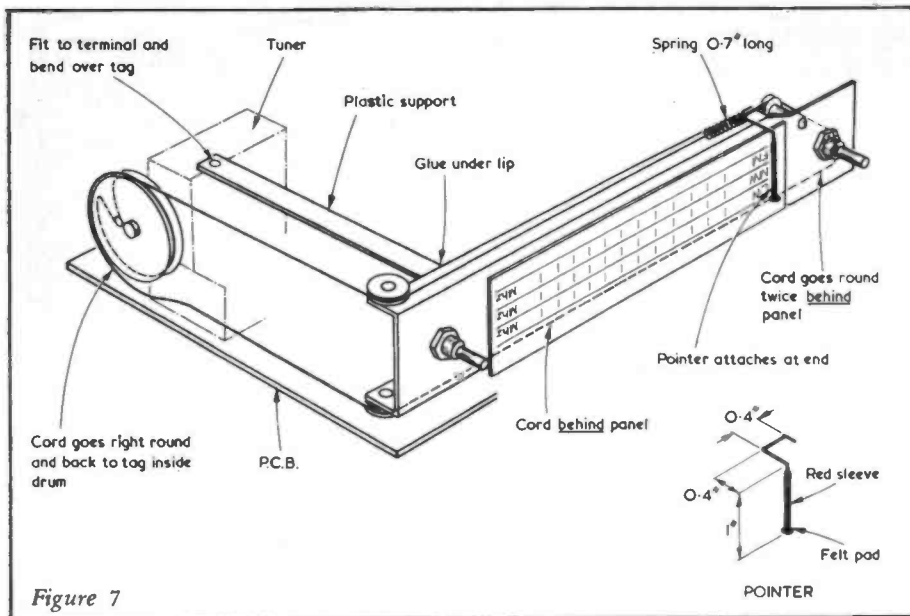

Figure 7

and the drum on the tuner. Tension in the cord is maintained by a small spring positioned adjacent to the scale pointer. Note that the cord is fitted as shown with the tuning capacitors **fully meshed** and the pointer at the drive spindle (low frequency) end of the scale. Note also that the nuts holding the drive cord guide wheels are locked in place with cellulose paint and that the knots at the ends of the drive cord should be similarly treated. The pointer is also locked in place with paint.

Ferrite Rod Aerial

The medium and long wave aerial coils should be fitted to the ferrite rod, and wired up to each other and the PCB as shown in *Figure 9*. Once wired, the aerial should be clipped to the PCB in the plastic forks fitted earlier.

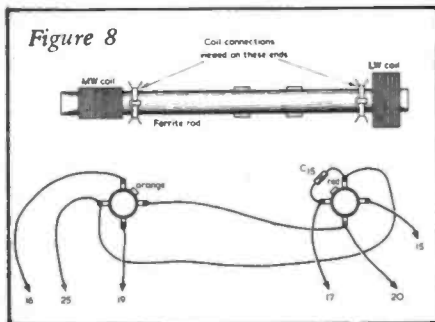

Figure 8

Final Assembly

The loudspeaker lead is made from single screened cable and connects to the PCB with screen to point 14 and inner to point 13. Wire links are connected also as per the following table:-

- 1) Point 27 to 3
- 2) Point 26 to 18
- 3) Point 22 to 7
- 4) Point 12 to 6
- 5) Point 21 to 4
- 6) Point 23 to 1
- 7) Point 24 to 2
- 8) From top of T1 to top of L1
- 9) From C20 to CF1

Loudspeaker

Basically any 8-16 ohm loudspeaker that will fit into the case may be used. The original design utilised a small elliptical unit designed for use in a portable TV made by Thorn. However, most types of small loudspeakers capable of handling up to one watt will be suitable for this application. A major consideration will be the impedance of the loudspeaker chosen, since the use of loudspeakers with an impedance of less than 8 ohms will result in excessive battery drain, and problems that arise from motorboating and instability as a result of the inability of the supply decoupling to cope with the peak currents involved. It is quite possible that an efficient 16-30 ohm loudspeaker will provide perfectly adequate volume whilst at the same time keeping battery consumption under control thereby saving considerable expense.

Connect the speaker to the screened cable and fit a strap from an 'earthy' connection to the speaker frame.

Testing and Alignment

Before connecting up to a 9 volt supply, make a thorough visual inspection of the PCB to check that all components are in the correct places, that electrolytics are correctly polarised and that there are no short circuits between copper tracks. Once satisfied that all is correct, check that the power switch is 'off' and insert the integrated circuit into the socket, ensuring that the ident. mark is towards R6, C5. Connect the 9 volt supply with a meter in series with the positive lead.

The meter should be set on a 50mA scale, or similar. Switch 'on' the radio and note the meter reading. The current should be approximately 15mA on AM or 30mA on FM. If the current is appreciably higher switch 'off' immediately and investigate thoroughly since a fault obviously exists. If the current is correct, remove the meter and reconnect the supply. Select 'MW' and advance the

volume control. There should be a fair amount of noise in the loudspeaker. If there is not, turn VR2 fully anti-clockwise to set the IF gain at maximum, when signals should be heard. Tune along the waveband until a weak, but stable signal is located. The cores of T1 and T2 may now be adjusted for maximum sound. Do not use a metal screwdriver for core adjustments, as ferrite cores are easily broken - use either a proprietary trimming tool or a shaped plastic knitting needle.

Once the cores are adjusted, the IF stages are correctly tuned, the proper frequency having been assured due to the inclusion of the ceramic filter in the IF input circuits. Alignment of the RF stages may now commence, and the scale plate may simultaneously be calibrated. With 'MW' and 'AFC' buttons (S1 and S2). This position corresponds to 330 metres and the BBC station 'Radio 2'. With the volume control and VR2 set for maximum, tune the oscillator coil (L1) until the required station is received check a copy of the *Radio Times* for frequencies. (The trimmer capacitors on the main tuning gang should be open approximately 2 full turns during this operation). Having set the frequency, the MW coil may be moved axially along the ferrite rod for maximum signal. Ensure also that the radio itself is orientated correctly for maximum signal strength by turning it through a 90 degree arc. Back off VR2 approximately 25%, reduce the volume setting and check again that T1 and T2 are set for maximum volume.

Finally check the MW aerial coil position once again. Fine adjustment of frequency of the oscillator and tuning of the aerial may be made using the trimmers on the tuning gang.

Retune the dial such that the pointer lines up with the edge of the dial plate cut out, adjacent to the 'AFC' switch (S1). This corresponds to 275 metres and BBC 'Radio 1'. The station should be received very close to this position, assuming the tracking of the oscillator is correct. Once received, the RF trimmer may be adjusted to peak the signal. Go back to 'Radio 2' and recheck the adjustments. The RF trimmer must be set to give the best possible gain at both 'Radio 1' and 'Radio 2' - some compromise between equal reception and maximum signal will be necessary. The scale may now be calibrated directly from the tuned stations that may be located along the scale.

Constructors with access to a signal generator will no doubt prefer to align the receiver by more conventional means, although the final results will be no better than the method suggested here.

Next the 'LW' band should be selected, and the scale pointer set in line with the 'MW' switch (S2). Now adjust trimmer TC on the PCB until 'Radio 4' is received. Once set, the LW aerial coil should be positioned on the ferrite rod for maximum volume and/or minimum background noise. (Do not forget to orientate the receiver for maximum signal.) Switch

back to 'MW' and recheck all adjustments, and then finally recheck the 'LW' settings. Calibrate and mark the LW scale as required. Finally, seal the aerial coils and the AM trimmers with a little 'Evostick' or paint. Do not apply excessive amounts or the adjustments will no longer be correct due to changes in the capacitance caused by the glue or paint.

'FM' should now be selected.

A considerable amount of noise is to be expected when no signal is being received. Extend the telescopic aerial fully and connect this to the VHF aerial terminal on the PCB. Set the dial pointer in line with the centre of the 'FM' switch (S4). Adjust the oscillator trimmer of the VHF tuner such that 'Radio 4' is received. Mark the scale 'Radio 4' and then adjust the cores of T3 and T4 for maximum, undistorted sound. Maximum volume will not give maximum clarity - this is normal, the correct setting giving excellent fidelity and adequate volume. The IF core on the tuner may also be 'peaked' as may the VHF RF trimmer. It may also be necessary to orientate the aerial to obtain a good signal. Radio 2, 3 and local stations should be located, and the scale marked accordingly. The RF trimmer should be set to give the best overall performance on all stations.

Cabinet Assembly

Some constructors may consider it slightly quaint that this receiver has been built in a custom wooden box, but it should be borne in mind that the best portable radios have always tended to use wood for their cabinets due to the more

agreeable and mellow tone achieved therefrom. For the same reasons, any half reasonable HiFi loudspeaker is made from some form of chipboard laminate. It is impossible for a home constructor to conjure up the sort of plastic case available to the Far Eastern radio manufacturers by simply using some proprietary plastic or metal cabinet. So the effort involved in a decent wooden box may well be considered justifiable.

The prototype cabinet was assembled from 4mm plywood sheeting mounted onto a 5mm square hardwood frame which is glued to end 'cheeks' made from 90mm hardwood approximately 10mm thick. A shaped hardwood was obtained for the prototype as shown in the diagram (Figure 10). This enhanced the overall appearance and is preferable to square sides.

The ends are cut to size, sanded smooth and then the 5mm hardwood framing is glued into position using *Araldite* or similar resin glue.

The back is made up in a similar way, although it is not permanently fitted to the rest of the cabinet. The completed radio is fitted to the back by means of 4 wood screws. The whole assembly is then held into the case by two wood screws.

Finishing touches

The case is equipped with a perspex escutcheon which forms the top of the radio and covers the calibrated scale plate and the pointer. This is shown in Figure 11. The case is completed by covering the main body in rexine or vinyl cloth, fitting a chrome bezel over the speaker aperture

and adding a handle (Figure 11). The end 'cheeks' are stained and varnished or french polished. A set of knobs carefully chosen to match the scale decor adds the final professional touch. In the prototype the escutcheon was finished in light grey, with white styling lines and black lettering. The colouring is applied to the underside of the perspex, having firstly masked the aperture over the scale plate.

To make the styling lines, a tile cutter or similar tool is used to cut 'V' notches through the basic colouring into the underside of the perspex. White paint enamel, not cellulose, is then used to fill in the notch. From the correct side a good straight and fine line is seen. Using 'Letraset', label the switches FM, LW, MW and AFC and the two controls VOLUME and TUNING. Another professional touch is to add a personalised LOGO to the scale (your initials, for instance) using italic script transfers. All lettering should be carefully varnished for protection. Your AM/FM portable is now completed and should serve you well for many years, only another 270,000,000 to go before you get the Japanese worried!!

There is sufficient room within the cabinet to house a 9 volt PP9 battery or a rechargeable NI-CAD pack, the latter being by far the cheapest power source in the long run.

Your Reactions.....	Circle No.
Immediately Applicable	125
Useful & Informative	126
Not Applicable	127
Comments	128

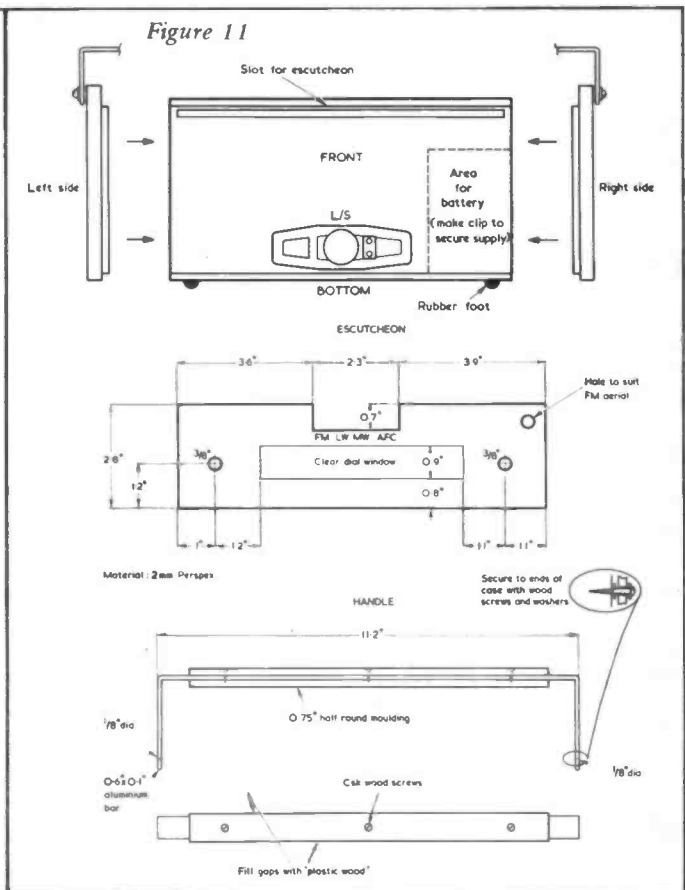
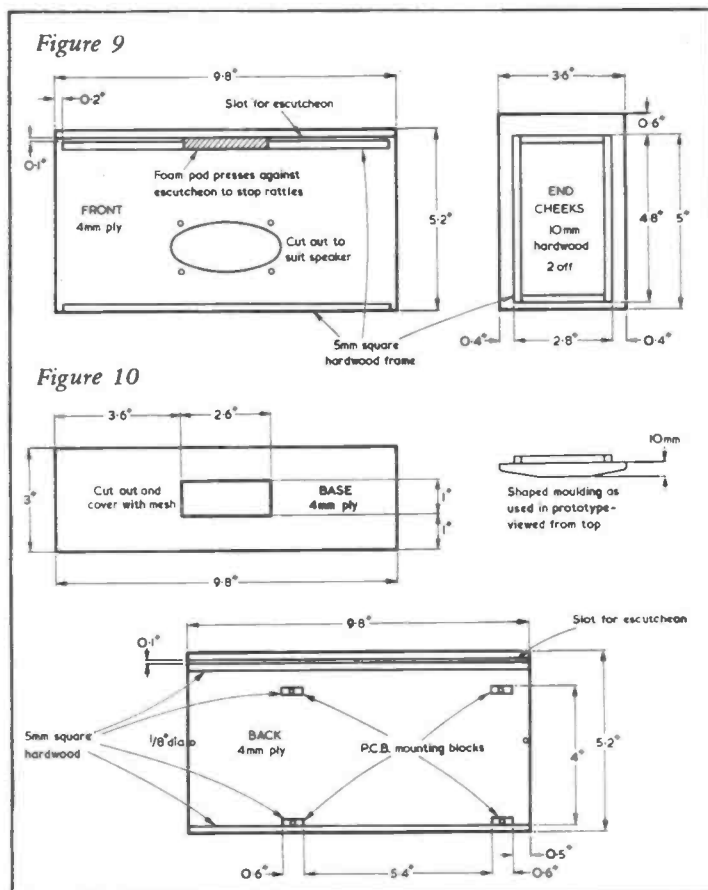

SHORT WAVE NEWS FOR DX LISTENERS

Frank A. Baldwin

All times in GMT, bold figures indicate the frequency in kHz.

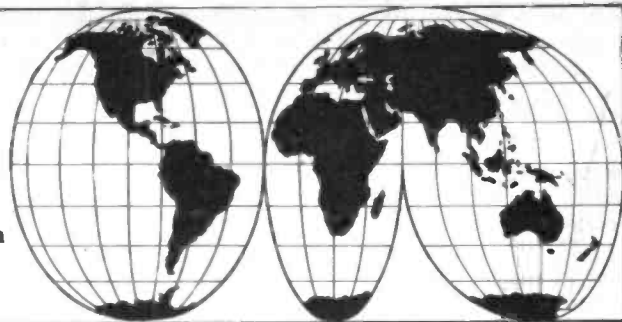

The 49 metre band (5950 to 6200) is one that is not often visited by the writer, partly by reason of not being around when some of the best Dx may be heard given good conditions and partly because for most of the day much of the band is occupied by the more powerful transmitters. The band however can, and often does, produce some worthwhile signals from the Dxers point of view. A couple of recent forays produced the following.

Uruguay

Radio Carve, Durazno, on **6155.5** at 2348, OM announcements in Spanish, YL folk song.

Brazil

Radui Guaiba, Port Alegre, on **5965** at 0240, OM in Portuguese, YL with pop song, heard under BBC tuning signal.

Radio Bandeirantes, Sao Paulo, on **6185** at 0105, OM with a sports commentary in Portuguese.

Radio Inconfidencia, Belo Horizonte, on **6000** at 0111, YL's with pop song.

Colombia

Em. Nueva Granada, Bogata, on **6160** at 0019, a political harangue in Spanish all about democracy and the President. Identification as "Radio Nacional, Colombia" at 0020.

Nicaragua

Radio Zinica, Bluefields, on **6120** at 2356, OM in Spanish, OM with identification at 2357 then OM and YL alternately in Spanish. Lots of talk, no music.

Bolivia

Radio Illimani on **6025** at 0005, local pops, OM identification and location at 0015.

Around the Dial

In which are featured some of the stations recently logged, some of the programme content and some of the schedules - all of which it is hoped will interest the reader of this feature - both SWL and Dxr alike.

We commence with

Spain

Madrid on **15395** at 1820, male (OM) and female (YL) announcers with the

Spanish programme for Europe and the Middle East, scheduled from 1800 to 2010 and continuing to Europe until 2040. Also to Africa from 1830 to 1930 (Monday to Saturday).

Austria

Vienna on **15560** at 1831, OM with station identification followed by YL with the programme in English intended for Europe, the Middle East, South and East Africa, scheduled from 1830 to 1900. The programme commences with a newscast of both Austrian and world events.

Finland

Helsinki on **15265** at 1839, OM with "Northern Report" in the English transmission directed to Europe and Africa and scheduled from 1830 to 1900.

Romania

Bucharest on **15270** at 0535, YL with a newscast in the English programme for Africa, scheduled from 0530 to 0600.

Bulgaria

Sofia on **15285** at 0539, YL with the news and a review of world affairs in the French programme to Africa, scheduled from 0500 to 0600.

Sweden

Stockholm on **21550** at 0550, OM with a relay of the Domestic Programme intended for reception by Swedish seamen on the high seas, Swedes abroad etc., directed to Australia and South Asia and scheduled from 0530 to 0700 to these target areas. The transmission is in SSB.

Switzerland

Berne on **11715** at 0602, YL with local news in the French programme for the North American West Coast, scheduled from 0600 to 0630.

Berne on **9535** at 0731, OM with a review of the world news and events in the Italian programme beamed to Australia, the Far East, South Asia and Europe, being scheduled from 0730 to 0800 on this channel and in parallel on **9560**. The former frequency provides the better reception here in the UK.

West Germany

Cologne on **9700** at 0740, YL with the programme in French for West Africa, scheduled from 0700 to 0800.

Cologne on **11905** at 0609, OM with a newscast in the English programme for West Africa, scheduled from 0600 to 0630. Also logged in parallel on **11765**. The former channel is best for UK listeners.

Pakistan

Karachi on **11670** at 1720, YL (female announcer) and OM alternate with comments on world events in the English programme to the UK scheduled from 1645 to 1740. The Urdu programme follows until 1855 when the transmission in Sylheti begins, this latter programme closing at 1915.

New Zealand

Wellington on **15485** at 0350, a programme of light orchestral music followed by six 'pips' at 0400, OM with station identification and a newscast in English.

Wellington on **17860** at 0550, OM with a programme for the Pacific area then into English for a newscast after six 'pips' time-check. This channel is subject to some interference at 0600 from Radio Canada.

Ecuador

HCJB Quito on **11900** at 0717, OM and YL with the English programme intended for the Pacific Area and scheduled from 0700 to 1030 on this frequency.

La Voz de los Caras, Bahia de Caraquez, on **4795** at 0358, YL with a ballad in Spanish then local pops non-stop - which is characteristic of this station. The schedule is from 11 to 0430 (Sundays 0200, Fridays 0500) and the power is 3kW.

Radio Dif. del Ecuador, Guayaquil, on a measured **4656.6** at 0207, OM announcements in Spanish, local pops. The schedule is from 2300 to 0400 and the power is 5kW.

Radio Quito, Quito on **4920** at 0224, OM with a talk in Spanish, logged under a continuous heterodyne which spread right across the frequency - it happens at times! The schedule is from 1030 to 0500 but this can vary and has been reported opening at 1000 and closing at 0400 on occasions. The power is 10kW.

Radio Ria Amazonas, Macuma, on **4870** at 0213, YL's in chorus, OM with a folk song in an Indian vernacular - it most certainly wasn't in Spanish! The schedule is from 1100 (Sundays 1030) to 0430

The DX'ers delights

Next month's R&EW includes a comprehensive look at HF receiver design concepts, using the R1000 and the FRG7700 as the basis of the present state of the art.



Both are 150kHz to 30MHz synthesised receivers using 1MHz 'bands' and tunable interpolation. Coverage may be extended down to 40kHz if you apply our simple mod.

The similarity between the two receiver designs often raises the question: "Which is best?"

...but as you will see, there is no hard and fast answer to this question. The FRG7700 includes a very useful NBFM demodulator to offset one or two niggles about shortcomings in the signal processing department - but we also provide details of an NBFM adaption for the R1000.



(Fridays and Saturdays 0300, Sundays 0200). The power is 10kW.

Radio Popular, Cuenca, on 4801 at 0440, OM with songs in Spanish. The schedule is from 1000 to 0530 and the power is 2kW. This one can vary in frequency from 4800 to 4802 at times.

Radio Luz y Vida, Loja, on a measured 4851 at 0443, local pops, OM in Spanish at 0445 with identification. The schedule is from 0900 to 0330 (Sundays to 0400) and the power is 2kW.

Radio Federacion, Sucua, on 4960 at 2323, folk music in typical local style, OM announcer in Spanish. The schedule is from 1030 (Sundays 1100) to 0300 (Saturdays 0400, Sundays 0100) but has been reported opening at 1150 and closing as early as 0200 on occasions. The power is 5kW.

Brazil.

Radio Sao Carlow, Sao Carlos, on 2420 at 0040, OM in Portuguese, OM with pop song, all just audible at times above the general noise level. Tentative logging this one, but if not Sao Carlos then what else! The schedule is from 0830 to 0300 and the power is 0.25kW.

Radio Ribamar, Maranhao, on 4785 at 0246, OM in Portuguese, local pops. Logged on USB to clear co-channel hetro. The schedule is from 0800 to 0400 and the power is 5kW.

Radio Borborema, Campina Grande, on 5025 at 0232, OM with announcements in Portuguese, many place names mentioned. Signed off at 0313 after station identification and the National Anthem. The schedule is from 0800 to 0300 and the power is 1kW.

Radio Rural, Santarem, on 4765 at 0535, YL with pop song, OM announcer. The schedule is from 0800 to 0400 and the power is 10kW.

Peru

Radio Andina, Huancayo, on 4996 at 0258, OM with a folk song in Spanish then into a programme of that lovely sounding Andean pipe music. The schedule is from 0900 to 0500 (Saturdays/Sundays 0830 to 0400) but can vary when closing to 0730. The power is 1kW.

Radio Loreto, Iquitos, on a measured 5048.5 at 0431, OM with a ballad in Spanish OM with station identification at 0439. The schedule is from 1100 to 0700 and the power is 2kW.

Rado Chinchaycocha, Junin, on 4860 at 0423, OM ballad in Spanish, OM station identification at 0423. The schedule is around-the-clock and the power is 0.5kW.

Radio Atlantida, Iquitos, on 4790 at 0407, OM announcements in Spanish, local-style dance music. The schedule is from 0900 to 0500 (Sundays until 0400) but does sometimes operate throughout 24 hours. The power is 1kW.

Radio Tropical, Tarapoto, on a measured 4936 at 0338, OM song in Spanish, Andean-type flute music. The schedule is from 0900 to 0500 (Saturdays/Sundays from 1045 to 0600). The power is 1kW.

Bolivia

Radio Padilla, Padilla, on a measured 3479.5 at 2340, YL's with pop song chorus, OM announcements in Spanish. The schedule is from 2300 to 0230 but the closing time can vary to 0253. The power is 0.3kW.

Radio Nueva America, La Paz, on a measured 4796.5 at 0032, OM with a

ballad in Spanish, OM with announcements. The schedule is from 1000 to 1830 and from 2100 to 0400 (Sundays until 0200). The power is 1kW.

Nigeria

Kaduna on 4770 at 0403, OM in Hausa, YL's in chorus with local songs. The schedule is from 0430 to 2305, the power is 50kW. An early opening probably for some special event coverage.

Lagos on 4990 at 0453, OM with a religious talk in English then into Arabic for a quotation from the Holy Quran then back into English. The schedule is from 0430 to 1000 and from 1700 to 2310, this being the National Programme in English and vernaculars. The power is 20kW.

Gabon

La Voix de la Renovation, Libreville, on 4777 at 1958, OM with a talk in French. The schedule is from 0430 to 0630 (Sunday opening at 0530) and from 1630 to 2400. The power is 100kW.

Niger

Niamey on 3260 at 1946, OM with a talk in French, just audible on peaks under a co-channel utility transmitter. The schedule of Niamey is from 0530 to 0630 on weekdays and from 1700 (Saturdays/Sundays from 1630) to 2130 (Saturdays until 2300). The power is 4kW.

Mozambique

Maputo on 3210 at 1943, YL with announcements in Portuguese, YL with songs. The schedule is from 0255 to 0515 and from 1655 to 2210. The power is 100kW.

Mali

Bomako on 4838 at 1942, OM in French, YL with a folk song - sounded more like wailing than singing! The schedule is from 0600 to 0800 and from 1700 (Fridays/Sundays from 1830) to 2400. The power is 18kW.

Upper Volta

Ougadougou on 4815 at 1952, drums and percussion orchestra with local-style music. The schedule is from 0530 (Saturdays/Sundays from 0700) to 0900 and from 1600 to 2400. The power is 20kW. This one was once reported by an exasperated Dixer as 'you know where' -and I wasn't surprised!

Haiti

4VEH Cap Hatien on 11835 at 2345, YL with a religious song in English and a talk in the same language. The late evening programme in English is from 2300 to 2400. ■

Your Reactions.....	Circle No.
Immediately Applicable	121
Useful & Informative	122
Not Applicable	123
Comments	124



RTTY ART CONTEST

The Southern Counties Amateur Teleprinter Society of California, organizes each year a Worldwide RTTY Art Contest.

What is "RTTY Art"? Well, it is possible to send on your teleprinter, if you participate in this mode of amateur radio, a series of single characters, which when seen on the print-out as a whole, make up a pattern which produces a visual picture. It is quite a skilful business, and a contest is a good way of bringing out the ingenuity of those who have mastered the technique.

We show some examples here, taken from the journal "RTTY" - a privately circulated publication now edited and published by Dee Crumpton of Cardiff-by-the-Sea, CA 92007, USA, which illustrate well the sort of pictures which can be produced by this method.

Once the design has been worked out, it is transferred onto punched tape, which when run through a tape reader into a page printing teleprinter, will reproduce the picture as a full page reproduction. The technique lends itself to much skill and imagination!

This year's SCATS RTTY Arts Contest began on September 1st, and concludes November 30th, 1981. A very successful contest is anticipated as interest in this special-mode amateur radio activity has been escalating in recent years. The organizers report that they have received several entries from foreign countries recently and they hope to receive even more this year. Due to the interest of European countries, one important change has been made in the rules this year. Each line of "art" must be limited to a maximum of 68 characters and spaces, so as to accommodate those radio amateurs who cannot utilize 72 spaces as found on many American teleprinter keyboards. Entries must have been originated by means of manual inputs to a teleprinter using standard communications keyboards. Tapes must be limited to a maximum running time of 40 minutes at 60 words per minute. Each entry must have been transmitted for the first time via amateur radio after 1st September 1981 and must be accompanied by a confirmation of at least one receipt of its transmission identifying the title of the "Art" and the call signs of the receiving and transmitting stations. Entries should be sent to: RTTY Art Contest, c/o Norm Koch, K6ZDL, PO Box 1351, Torrance, CA 90505, USA, and must include the tape, printout and the transmission/reception confirmation.

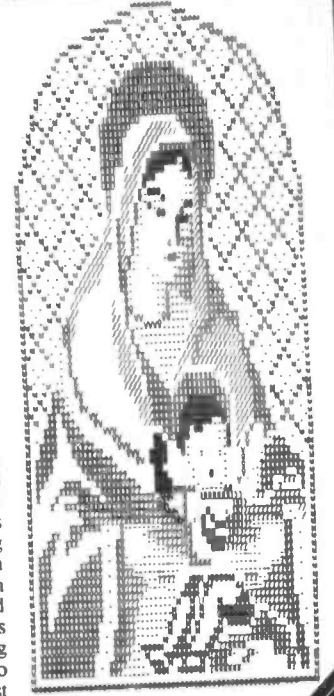
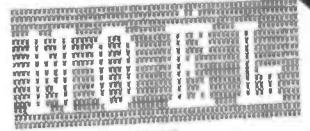

BNOS

BNOS is pleased to announce that we will be supplying built versions of the superb amateur radio projects that appear in R&EW.

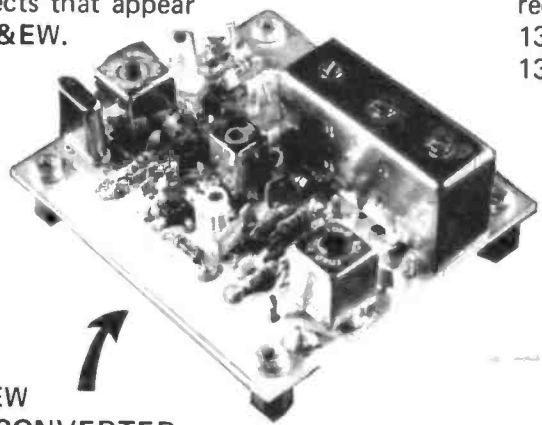

(1)
R&EW
2m CONVERTER
Price: £22.95 (inc case)

.....BNOS Specials.....

- 100W 2m Linear Amplifier. 10W input with receiver preamp £105.00
- 13.8V/20A PSU - stabilised OA
- 13.8V/5A PSU - stabilised £ 20.00

from this issue:
(2) 70cm CONVERTER Price: £23.95

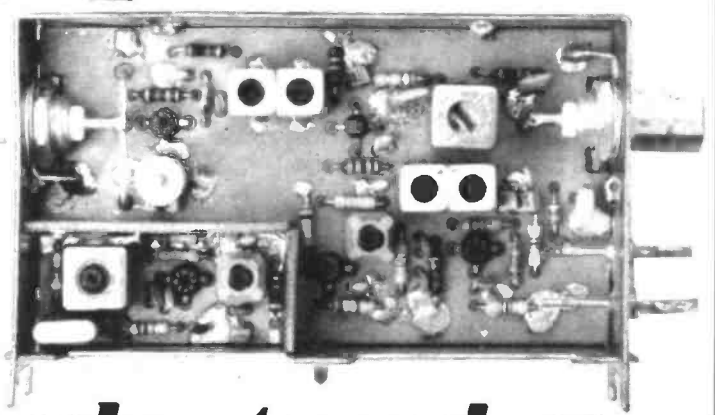

mail order only, please:
Greenarbour, Dutton Hill
Great Dunmow, Essex CM6 3PT

electronics

The beginning of the World Pushing the boat out

Part One

The launch festivities of **Radio and Electronics World** were scheduled in two parts - a gathering at the National Microprocessor and Electronics Centre (inside the World Trade Centre building, next to the Tower of London), to be followed later on in the afternoon by a 'beano' for those who prefer their magazine launch parties uncluttered with the paraphernalia of 'presentations' and carefully contrived selling attempts.

If there's one thing people in this business dread more than a visit from the life insurance salesman, it's a chat with the magazine ad space salesman - so it wasn't surprising to find that the evening gathering on board the S.S. St. Katherine attracted the largest following.

We won't regale you with photographs of the NMEC in this issue (most of you know what an electronics exhibition looks like anyway), but since the sun shone impeccably all day, the pictures of St. Katherine's Dock (the view from the NMEC) are possibly more invigorating. Indeed, when the development of the Dock site is complete, then the whole area will be quite delightful.

Part Two

The national press had been invited to come and quiz us on some of the more original and 'daring' aspects of **R&EW**. We would have thought that the concept of supplying free components to people with initiative might rate a mention in between the usual 'Man Bites Dog', and 'Crazed Nun on Motorcycle Disrupts Test Match', sort of reporting.

Or the fact that the government could conceivably coin in another £300m if all the illegal users of CB were rounded up with the advent of the Rigalizer.

Or a sneak preview of a forthcoming **R&EW** attraction for providing multilingual tracks at the cinema and theatre.

But obviously the ton-up nuns were out in force on the 27th.

The happy band (bottles were opened at 3.30pm) moved from the NMEC to the boat at 5.30pm, and the uncomplicated festivities were well populated with advertisers (potential and actual), members of the magazine distributive trade, contributors and fellow members of the electronics and publishing fraternity.

One or two less cautious revellers took full advantage of the hospitality, and your Editor was nearly obliged to take customer relations above and beyond the call of duty. The project's assistant spent a happy twenty minutes gazing at the ripples in the Dock as he leaned across the rail, and the band played on.



The view from the NMEC

R&EW at the NMEC

The National Microprocessor and Electronics Centre is a permanent exhibition along the lines of an *unmanned* version of the *All Electronics Show*. The basic concept of translating the many nomadic exhibitions into a permanently located 'centre' seems excellent - and the fact that the NMEC is not better known is rather a shame. As well as the exhibition aspects, the centre provides a prestigious London *pied a terre* for its supporters, with an array of presentation facilities and areas equipped with the latest audio visual aids.

In recognition of the fact the NMEC is at last embarking on a campaign of *awareness* and promotion, **R&EW** is very pleased to announce that we shall be participating both as exhibitors and as reporters of the various *goings on* of the centre and fellow exhibitors. **R&EW** will be providing a monthly display at the centre, based around the contents of the current issue - and using the centre for presentations and lectures.

The present exhibitors at the NMEC span a very wide range of electronics - from the esoterica of Prosser Scientific Instruments' electronics anemometers, to the more down to earth offerings of GSC and Thurlby. Whilst English manufacturers prevail, there is no hard and fast rule on the subject, and we would like to

encourage anyone in the *business* to seriously consider using the NMEC as a London shop window and presentation centre.

It seems likely that the exhibition will be evolving into specialist groups, with office electronics and computing being one of the more obvious areas of delineation. The original concept was part-sponsored by the DoI's MAP scheme, and whilst the aim of the MAP scheme is primarily 'to boldly go (with microprocessors) where no new technology has gone before' - but the NMEC would be missing the opportunity of providing a fixed alternative to the occasional *roving* caravans of exhibitors if it concentrated too heavily on trying to bemuse the uninitiated with the wonders of the silicon age.

In other words, the NMEC is gently feeling its way along, and we hope to provide some additional driving force for the expansion and diversification of the exhibition.

Advertisers note: NMEC members will be able to get preferential advertising rates in **R&EW**.

The London World Trade Centre is for the businessman who wants everything

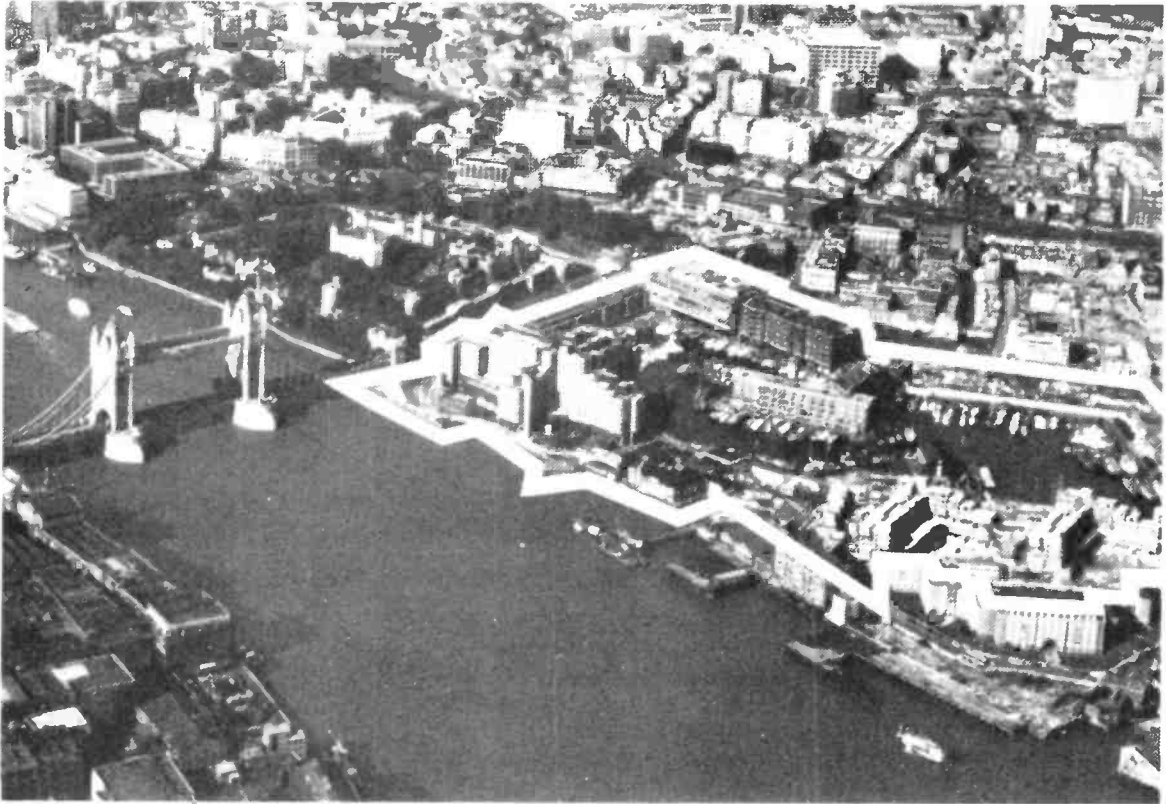

In fact one of the most complete business centres in the world.

Permanent and temporary office suites ... multi-lingual secretariat ... telephone answering and telex services ... conference and exhibition facilities ... research unit ... 826 bedroomed hotel ... riverside service apartments.

Every facility and amenity right in the commercial heart of London and within the World Trade Centre complex itself.

For further information contact:
Marketing
World Trade Centre, London E1 9AA
Telephone 01-488 2400 Telex 884671



London World Trade Centre

Motorola produce a complete family of 60MHz CMOS synthesiser parts

Signetics original series of 560/1/2/3/5, complete phase locked loop systems on a single IC have been 'around' now for about a decade. Variations on the theme have evolved in the course of the development of frequency synthesis systems - and the new Motorola MC145XXX series of silicon gate devices are a considerable step forward in terms of power consumption, speed and versatility.

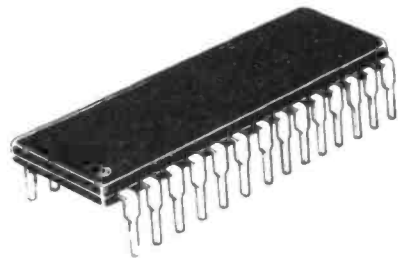

Although announced towards the end of 1980, these devices have only managed to get into production during the past few months. Early samples showed great promise - and the R&EW lab has been developing circuits using these since around last November.

Stated simply, this family (table 1) of devices represents the biggest single advance in 'mass market' frequency synthesis since the original Signetics NE56X series. The VCO is kept outside the IC in the Motorola devices, but any RF designer would usually prefer to keep this crucial aspect of the design under his control anyway.

The complete family comprises devices to suit all tastes, with both parallel and serial devices that offer essentially the same electrical and PLL characteristics - enabling designs of MPU controlled systems to 'emulate' the synthesis section using a directly programmed parallel version. Thus establishing some of the basic parameters before moving onto the serial developments. The parallel devices are also quite pertinent to many end user applications anyway, since the very simple programming keeps the total system cost to a minimum. (Figure 1)

The MC145151

Although the MC145144/5/6 appear to precede the MC145151 in terms of numeration - the MC145151 has been put into production in the first 'phase'. Since this is easily the most 'usable' part in the range, (and it's available), we'll start here...

The block diagram of the MC145151 is shown in figure 2. In common with the other members of the family, the device comprises a crystal derived reference divider, programmable 'n' counter (14 bit in this case - the two modulus versions use 7 bit 'A' and 10 bit 'n' counters), and a choice of either a two output ('high' or 'low') phase detector, or a low noise tri-state ('high', 'low', or 'hold') phase detector. Due to an apparent shortage of

Table 1

RELATED PHASE LOCKED LOOPS

Part Number	Format	Prescale	Phase Detector
MC145144	4-Bit Data	Single Modulus	3 State
MC145145	Bus Input	Single Modulus	3 State/2 Output
MC145146	Format	Dual Modulus	3 State/2 Output
MC145151	Parallel Input	Single Modulus	3 State/2 Output
MC145152	Format	Dual Modulus	2 Output
MC145155	Serial Input	Single Modulus	3 State/2 Output
MC145156	Format	Dual Modulus	3 State/2 Output

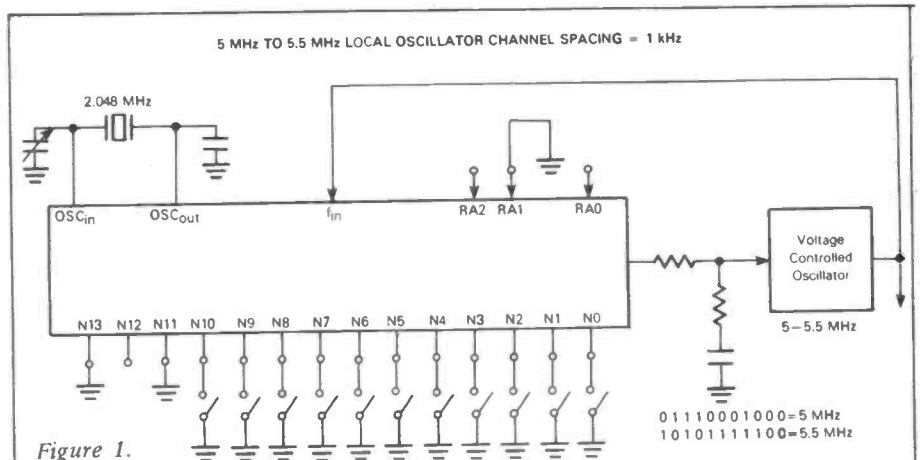

Figure 1.

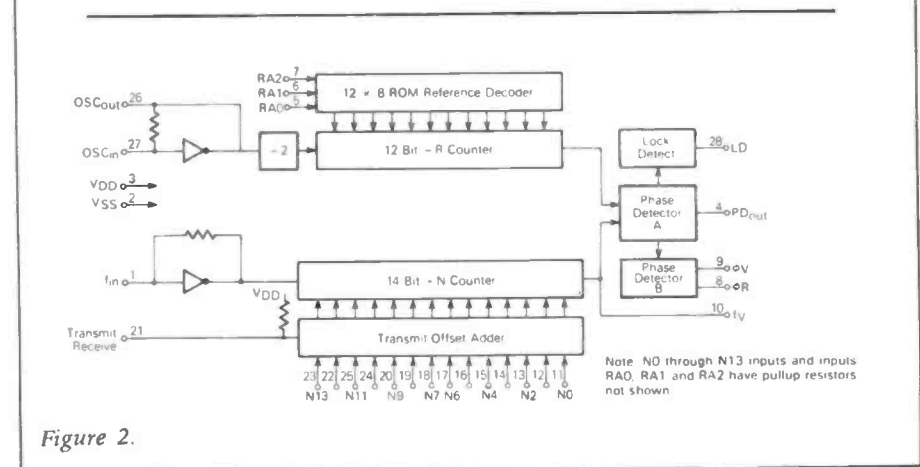

Figure 2.

pins, the 2 modulus version of the directly programmed device (MC145152) uses a single dual output phase detector.

According to the data sheet, the devices operate from 3 to 9 v DC, consuming between 800 & 1600 microamps, whilst functioning up to 52 MHz at the input to the programmable divider with a 9 v supply. (the device is optimised for 25 degrees Centigrade). Tests on our early samples usually showed speeds past 60 MHz were possible. The actual range of guaranteed frequencies lurches around fairly dramatically with respect to temperature, so the figures of *table 2* will provide a guide to the suitability of the device in any given application.

Table 2

Characteristic	Symbol	VDD		25°C			T _{high}		Units
		Min	Max	Min	Typ	Max	Min	Max	
Operating Frequency OSC _{in}	Input = SQ Wave V _{DD} - V _{SS}	f _{max}	3	17	27	14	12	21	MHz
			5	33	56	27	27	33	
			9	36	66	36	36	33	
	Input = Sin Wave 500 mVp-p	f _{max}	3	11	21	10	9	15	MHz
			5	20	34	17	17	15	
			9	17	34	17	17	15	
Operating Frequency f _{in}	Input = SQ Wave V _{DD} - V _{SS}	f _{max}	3	9	15	8	7	15	MHz
			5	19	30	15	15	15	
			9	31	52	26	22	22	
	Input = Sin Wave 500 mVp-p	f _{max}	3	10	15	7	6	15	MHz
			5	18	31	15	15	15	
			9	21	31	15	15	15	

T_{low} = -40°C
T_{high} = 85°C

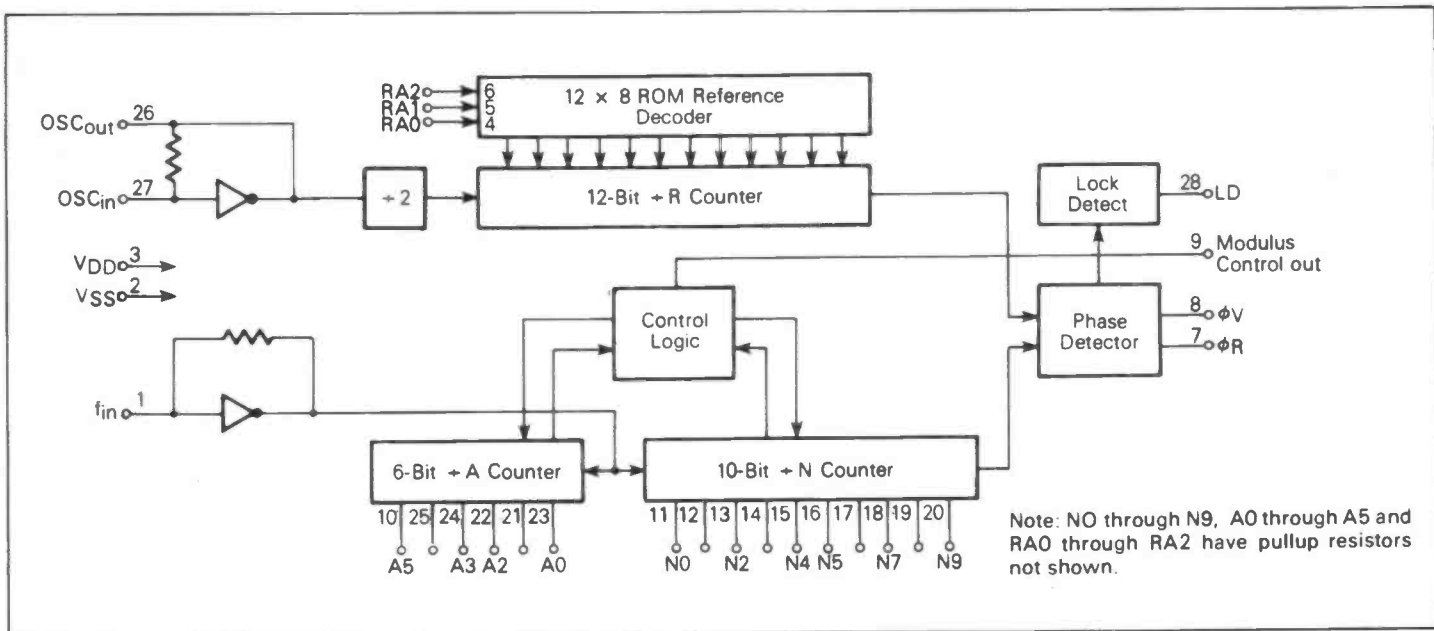

The internal layout of the MC14512 dual modulus system

The 'serial' version of the MC145152 - the MC145156

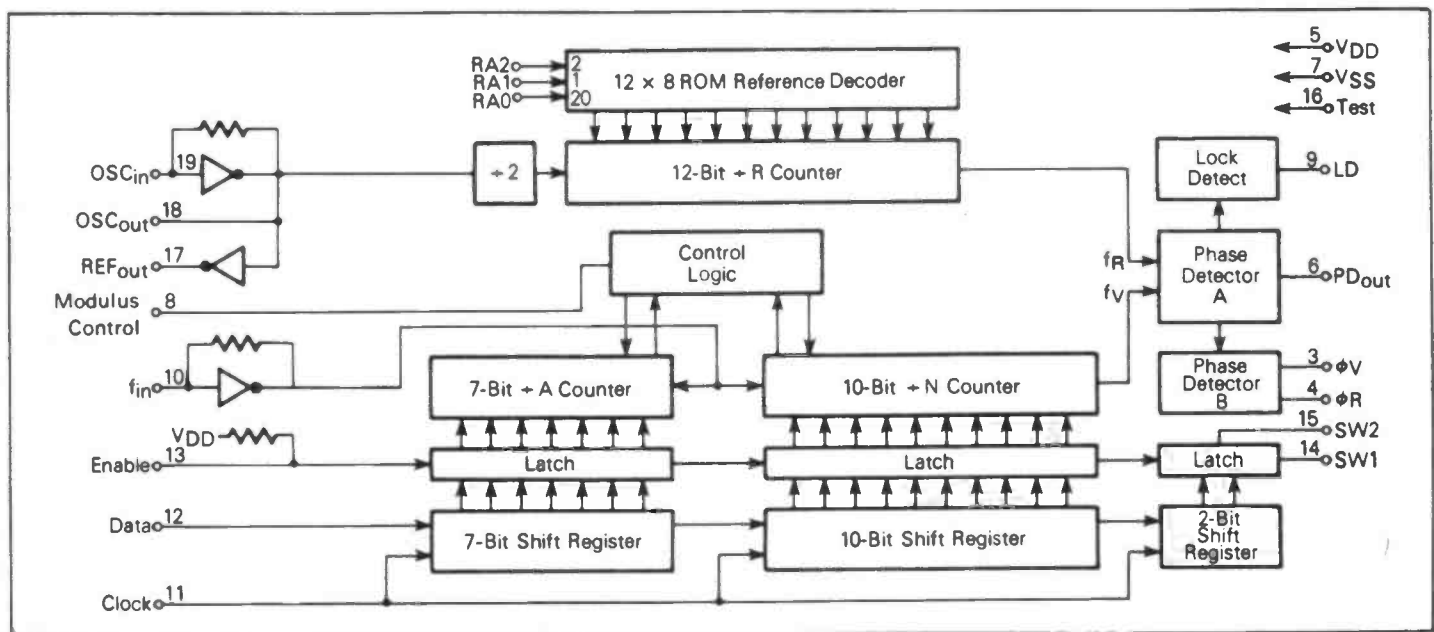

Next month continues the series with practical examples, and a discussion of the choice of suitable VCO systems



WHAT?

The NEW Leicester Amateur Radio Exhibition. That's what.

WHERE?

The Granby Halls, "as usual," but with improved facilities including new catering arrangements, easier car parking and quicker admission. That's where.

WHEN?

Friday, Saturday, Sunday, 23, 24, 25 October 1981, 10am-6pm Fri/Sat, 10am-5pm Sun. That's when.

WHO?

At this independent show you will find some of the best-known retailers in the country. You will also find many specialist traders not previously invited to participate at Leicester. This way you'll have a real chance of finding the rig you want – at a keen price too – and also some of those awkward bits and pieces you're always looking for and can never track down. That's who you'll see there.

ADMISSION: £1

Refundable by certain exhibitors against purchases over £30.

BRING-AND-BUY/TALK-IN on 2m and 70cm.
Both organised by the Leicester Radio Society.

Part I An FM Deviation Meter covering CB, Amateur and PMR allocations from 20-175MHz.

Automatic Modulation Meter

by Roger Ray

Part I covers the circuitry and theory of operation while Part II (next month) gives constructional information and ideas for adding percentage AM readout.



This article takes the basis of the CB Band Deviation Meter (R&E October 1981) and expands it into a fully automatic meter covering 20-175MHz (500MHz with reduced accuracy).

The operation of the instrument is such that it will lock on to any signal applied to the input. Provided of course it is in the working frequency range and of sufficient level (>20mV).

If that signal is FM the frequency deviation will be displayed on the meter, if AM is present the brilliance of the AM LED will vary with modulation.

Two switched ranges of 2.5kHz and 10kHz deviation are provided. An audio output is available allowing the AF waveform to be displayed on an oscilloscope.

Theory of operation

The block diagram (Figure 1) gives insight into the operation of the circuit as a whole.

Signals in the range 20-175MHz applied to the input pass through the high pass filter and attenuator, to the RF port of the mixer. If an oscillator is connected to the mixer LO port and its frequency is ± 10.7 MHz from the input signal, the product will pass through the IF amplifier.

The oscillator being used is swept in frequency from 30-55MHz. Therefore if the input signal is in the range 19.3 to 65.7MHz at some point during the sweep a product will be present in the IF amplifier. By generating the second and third harmonic of the oscillator and adding them to the fundamental, the input range is increased to 19.3 to 175.7MHz (Figure 2).

The IF amplifier is 300kHz wide (10.7MHz ± 150 kHz) and the FM demodulator 'S' curve is linear over that bandwidth. Therefore a CW signal within the IF passband will give a DC output from the FM demodulator. This DC voltage will be dependent on the signals position on the 'S' curve (See Figure 3).

The FM demodulator output is connected to a pair of voltage comparators. These act as a window

detector sensing when the DC voltage applied to them, is between 3 and 8 volts (Linear region of the 'S' curve).

A sweep generator producing a linear ramp is sweeping the VCO (Voltage Controlled Oscillator) over the range 30-55MHz. The sweep generator develops a voltage across a capacitor which is connected to the frequency controlling element of the VCO. When an output is given from the window detector, the control voltage is held at that instant by being stored in the capacitor.

This means that if while the VCO is being swept, a signal appears in the IF amplifier, causing a DC output within the detected window. The frequency of the VCO will be held at that point, keeping the signal within the IF pass band. Thus the instrument will 'lock' onto the applied input signal. If the IF signal moves outside the linear region of the 'S' curve, the sweep circuitry will again be activated until 'lock' is again established.

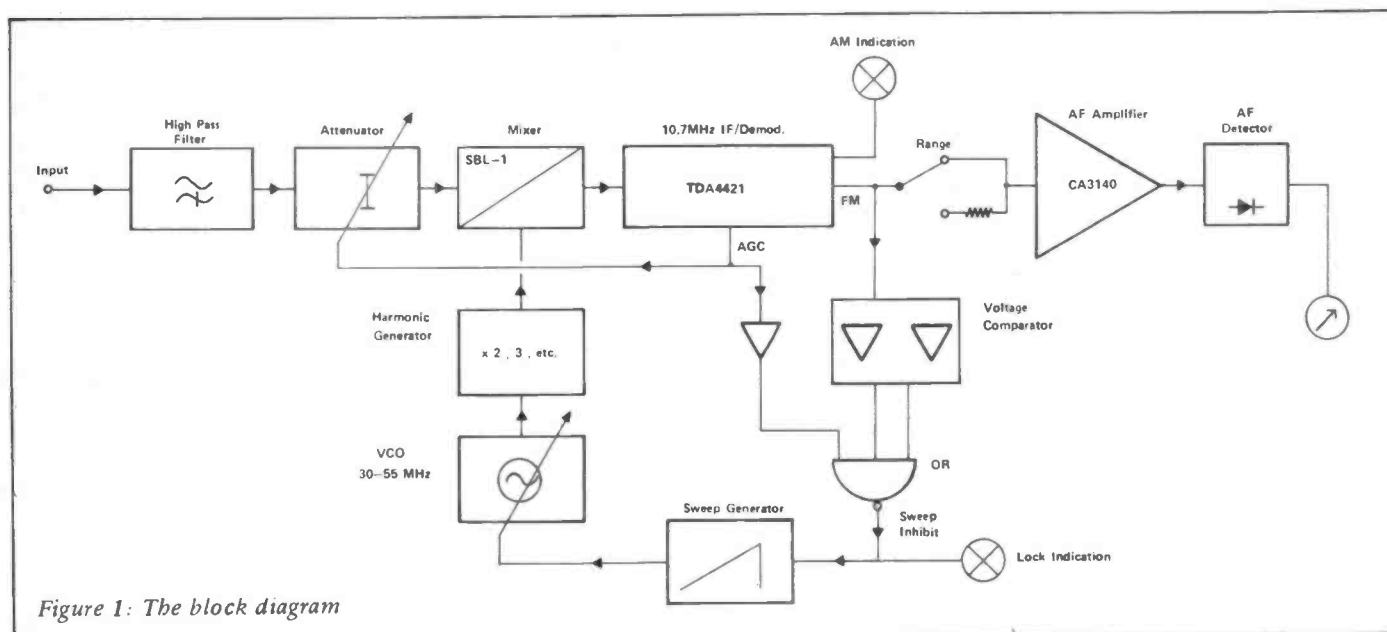
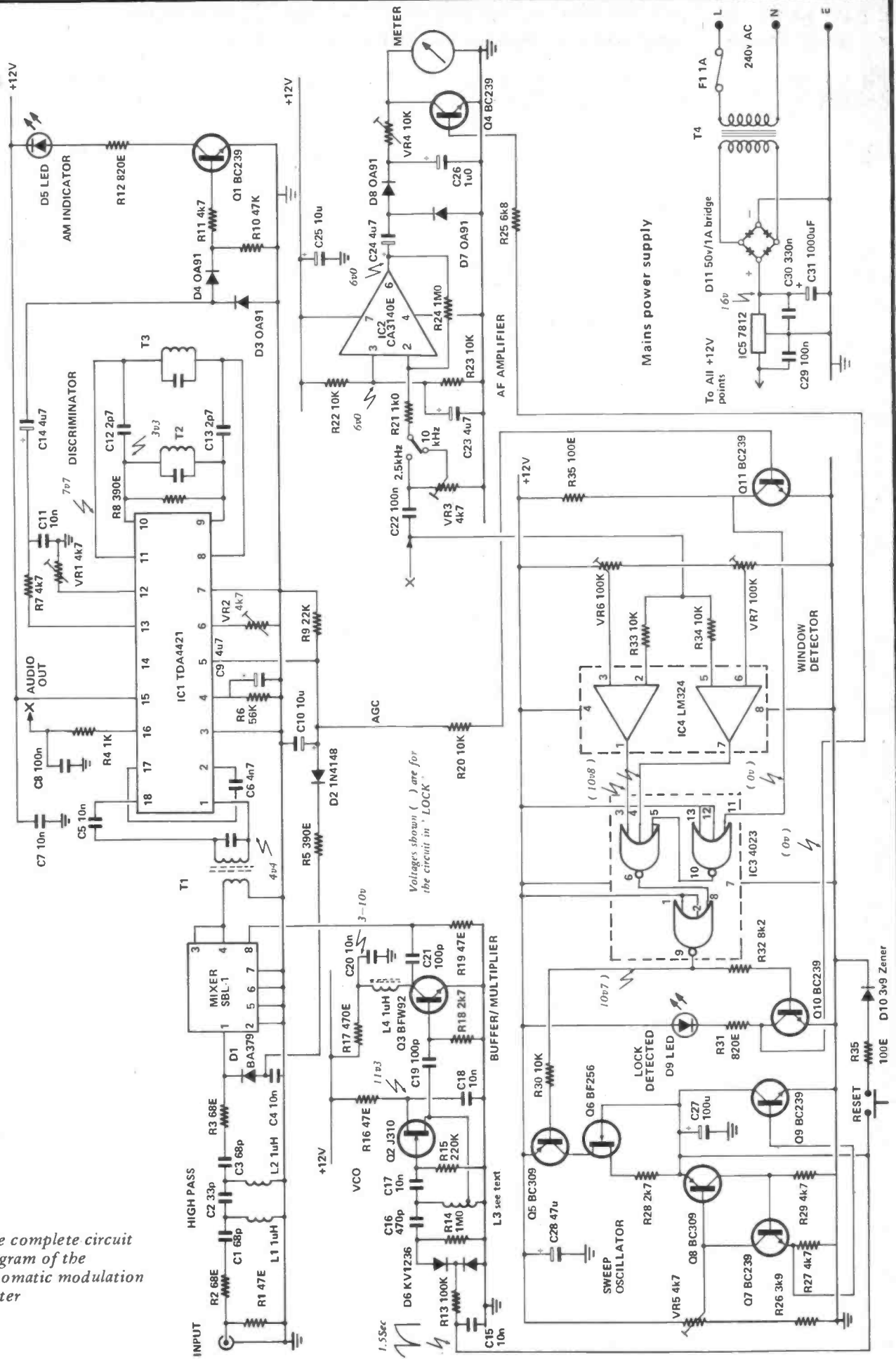

Figure 1: The block diagram

The complete circuit diagram of the automatic modulation meter



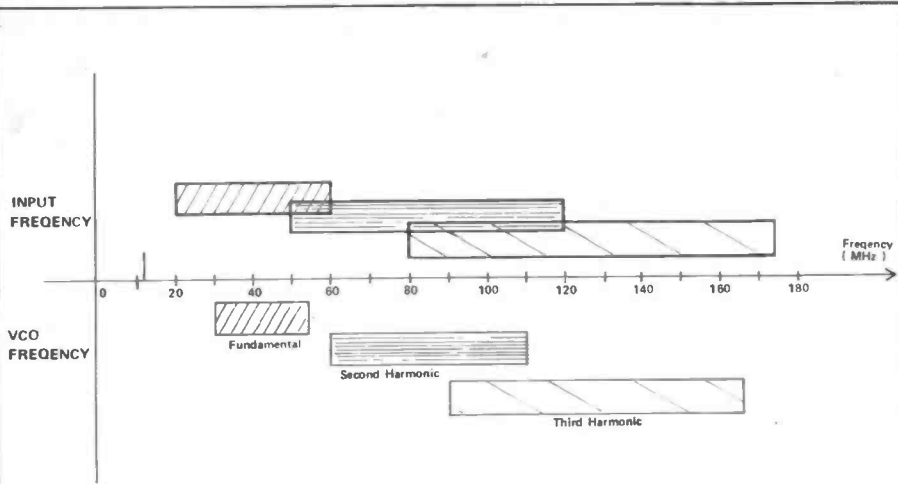

Figure 2: Bar diagram showing the VCO frequency range and its harmonics - together with the input frequency range. Operation at higher frequencies (although possible with increased 'jitter') is not shown here. The circuit will work up to 500MHz with increased settling time.

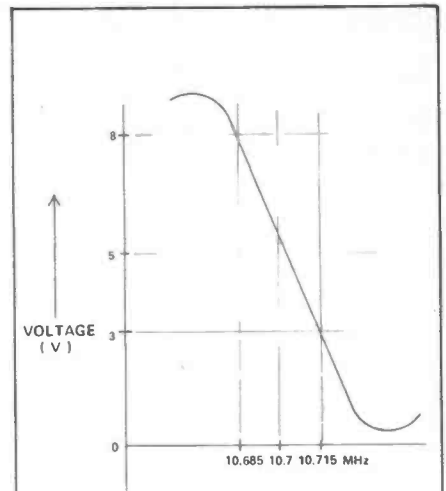

Figure 3: FM demodulator 'S' curve.

The operation is slightly more complicated than this, because the FM demodulator DC output can be within the window when no signal is present. To overcome this the AFC output is required to be above a certain level before the sweep can be inhibited. This is simply accomplished by combining AGC and voltage comparator outputs in a logic OR gate. The OR gate output inhibits the sweep generator and illuminates a 'lock' LED.

If the input signal is frequency modulated when the circuit is in the 'locked' condition. The signal will be demodulated, the audio being passed through the AF amplifier. The amplified audio is then detected and the resultant DC used to drive a meter calibrated in kHz frequency deviation.

Circuit description

The input 20MHz high pass filter, consists of C1, C2, C3, L1 and L2. A pin diode D1 shunts the signal path at high signal levels avoiding over-driving of the SBL-1 mixer. The double balanced mixer greatly eases the design of the circuit, providing wide frequency range, good isolation, and superior cross modulation performance.

A J310 J-FET (Q2) is used for the VCO in a Hartley configuration. A high capacitance swing varactor (D6) tunes with L3 to comprise the resonant circuit. The tap on L3 provides a low impedance point to drive the multiplier Q3. The BFW92 makes a high efficiency multiplier. Limiting the collector current through the device with the high value of R17 (470R) results in a relatively flat amplitude/frequency response. The level into the mixer LO port is about 5mW.

IC1 is a combined AM and FM, IF amplifier and demodulator working at 10.7MHz. Transformer T2 centres the FM demodulation point, while T3 provides

Components List

Resistors 0.25W 5%

R 1	47R
R 2	68R
R 3	68R
R 4	1k0
R 5	390R
R 6	56k
R 7	4k7
R 8	390R
R 9	22k
R10	47k
R11	4k7
R12	820
R13	100k
R14	1M0
R15	220k
R16	47R
R17	470R
R18	2k7
R19	47R
R20	10k
R21	1k0
R22	10k
R23	10k
R24	1M0
R25	6k8
R26	3k9
R27	4k7
R28	2k7
R29	4k7
R30	10k
R31	820R
R32	8k2
R33	10k
R34	10k
R35	4k7
VR1	4k7 preset
VR2	4k7 preset
VR3	4k7 preset
VR4	10k preset
VR5	4k7 preset
VR6	100k preset
VR7	100k preset

Capacitors

C 1	68p
C 2	33p
C 3	68p
C 4	10n
C 5	10n
C 6	4n7
C 7	10n
C 8	100n
C 9	4u7 16v electrolytic
C10	10u 16v electrolytic
C11	10n
C12	2p7
C13	2p7
C14	4u7 16v electrolytic
C15	10n
C16	470p
C17	10n
C18	10n
C19	100p
C20	10n
C21	100p
C22	100n
C23	4u7 16v electrolytic
C24	4u7 16v electrolytic
C25	10u 16v electrolytic
C26	1u0 16v electrolytic
C27	100u 16v electrolytic
C28	47u 16v electrolytic
C29	100n
C30	330n
C31	1000u 25v electrolytic

Integrated Circuits

IC1	TDA4421
IC2	CA3140
IC3	4023B
IC4	LM324
IC5	7812

Transistors

Q 1	BC239
Q 2	J310
Q 3	BFW92

Q 4	BC239
Q 5	BC309
Q 6	BF256
Q 7	BC239
Q 8	BC309
Q 9	BC239
Q10	BC239
Q11	BC239

Diodes

D 1	BA379
D 2	1N4148
D 3	0A91
D 4	0A91
D 5	Red LED
D 6	KV1236
D 7	0A91
D 8	0A91
D 9	Green LED
D10	3v9 zener 400mW
D11	1A bridge

Inductors

L 1	1uH
L 2	1uH
L 3	S18-8.5 turn
L 4	1uH
T 1	KALS4520A
T 2	KALS4520A
T 3	KALS4520A
T 4	Mains 6VA 6-0-6V

Miscellaneous

Mixer	SBL-1
S 1	Single pole c/o
S 2	push to make
F 1	1A fuse plus holder
PCB	
SCB1	screening box
SCB2	screening box
Case	

the AM and AGC tuning. Audio output from the FM section is amplified in IC2 and then rectified by D7 and D8. As the meter would read maximum with no signal present (due to noise from the FM demodulator), the meter is clamped by transistor Q4. This transistor being turned on, when the instrument is in the 'unlocked' state. Range switching is provided by S1. VR4 is used to calibrate the meter on the 2.5kHz range, and VR3 on the 10kHz range.

AM derived audio from IC1 is rectified by D3, D4 and the resultant DC used to drive Q1. AM modulation will cause the LED in Q1's collector circuit to light, and vary in brilliance with modulation.

DC output from the FM demodulator is connected to a pair of voltage comparators (IC4). The switching point of the low voltage comparator is adjusted by VR7, while the high voltage switching point is adjusted by VR6. The 'window' between these points is adjusted to be within the linear region of the FM demodulator 'S' curve (Figure 3). The voltage comparator outputs are connected to the CMOS OR gate (IC3 triple 3 input NOR function). The other OR gate input is driven from the AGC switch Q11 via another section of the 4023 wired as an inverter. The point at which Q11 switches is dependent on the setting of VR2 (delayed AGC from IC1). Output from Pin 9 of the 4023 is only 'high' when an AGC output is present and the FM DC output is within the window set by IC4.

The sweep generator consists of a constant current generator (Q6) charging a capacitor (C27). At the high voltage end of the sweep Q8 is turned on causing current to be drawn through R29. This turns on Q7 causing Q8 to be turned on harder giving a Schmitt trigger action. Transistor Q9 is turned on by Q7 rapidly discharging C27. Q8 is now turned off so the capacitor starts charging again and the process is repeated. The point on the ramp where switching occurs is adjusted by VR5. A manual reset is also provided by S2. The voltage across the capacitor C27 controls the frequency of the VCO by varying the capacitance of D6. Transistor switch Q5 is ON when the OR gate output is a 0 (Pin 9 IC3). When IC3 output is a 1,

Q5 is turned OFF and C27 stops being charged. The voltage of the ramp, at the instant Q5 was turned OFF is held on C27. This completes the control loop, Q10 also being turned on from IC3's output illuminating the 'LOCK' indication D9.

Mains power supply for the instrument comprises T4, D11 and C31. 12 volt regulation being provided by IC5.

Your Reactions.....	Circle No.
Immediately Applicable	105
Useful & Informative	106
Not Applicable	107
Comments	108

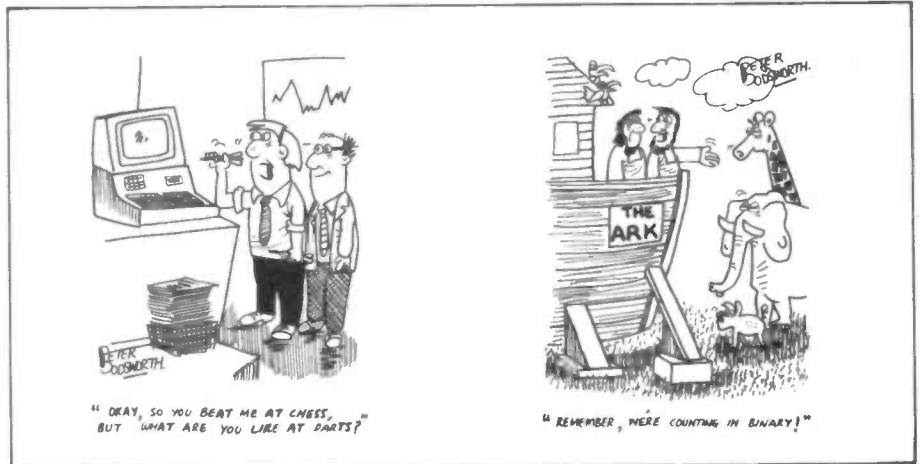

ENTER THE NEW WORLD of KW + TEN - TEC

Introducing a New Concept in HF communications

A NEW SERIES WITH NEW FEATURES, NEW PERFORMANCE, AND ALL 9 HF BANDS.



KW + TEN - TEC OMNI-C*

- with comprehensive facilities • superb SSB with 8 pole filter • all 6 present HF bands (+ all 3 new bands 10.18 + 24.5 MHz) covering 10-160 meters
- 2 speed CW break — in facility • new "hang" AGC for smoother operation
- 200 watts max input power.

Come to KW for all your other amateur radio requirements KW service and guarantee — KW maintains the tradition of service the company is renowned for Output-transistors unconditionally guaranteed for 12 months. The KW — TEN — TEC units offered above are introduced as a prelude to fully UK assembled equipment.

KW + TEN - TEC DELTA*

- HF transceiver 10 — 160 meters. 9 bands including new bands
- 200 watts max input power
- compact yet easily serviceable
- superb mobile transceiver, nominal 13v D.C. input.

KW + TEN - TEC ARGONAUT*

- the best in QRP is now better than ever
- total solid state full band coverage 10-80 meters
- 5 watts input • imported receiver sensitivity
- full CW break-in
- WWV receive at 10 and 15 MHz.

(* A full range of accessories is available for KW + TEN - TEC equipment)

- other KW units available.
- KW 107 Supermatch KW trap dipole
- KW E-Z match KW traps
- KW Balun KW antenna switch

KW COMMUNICATIONS LTD

Vanguard Works, Jenkins Dale, Chatham ME4 5RT
Tel: 0634-815173 Telex: 965834 KW COMM G

FREPAR

plug-in cases
12 & 16 TERMINALS

Mounting base Connection screws M 3,5 with self-lifting clamping plates, maximum cable cross section $2 \times 1,5 \text{ mm}^2$ (also suitable for use with cable shoes).

Gold plated contact springs guarantee good contact even at low currents or voltages (contact resistance approximately $10 \text{ m}\Omega$). Separators between the terminals guarantee leakage path and voltage spacings in accordance with VDE 0110/11,72, § 5, insulation group C at 250V AC/300V DC. Cable entries: 5 (in ZA 12) or 6 (in ZA 16) PVC cable entry sleeves

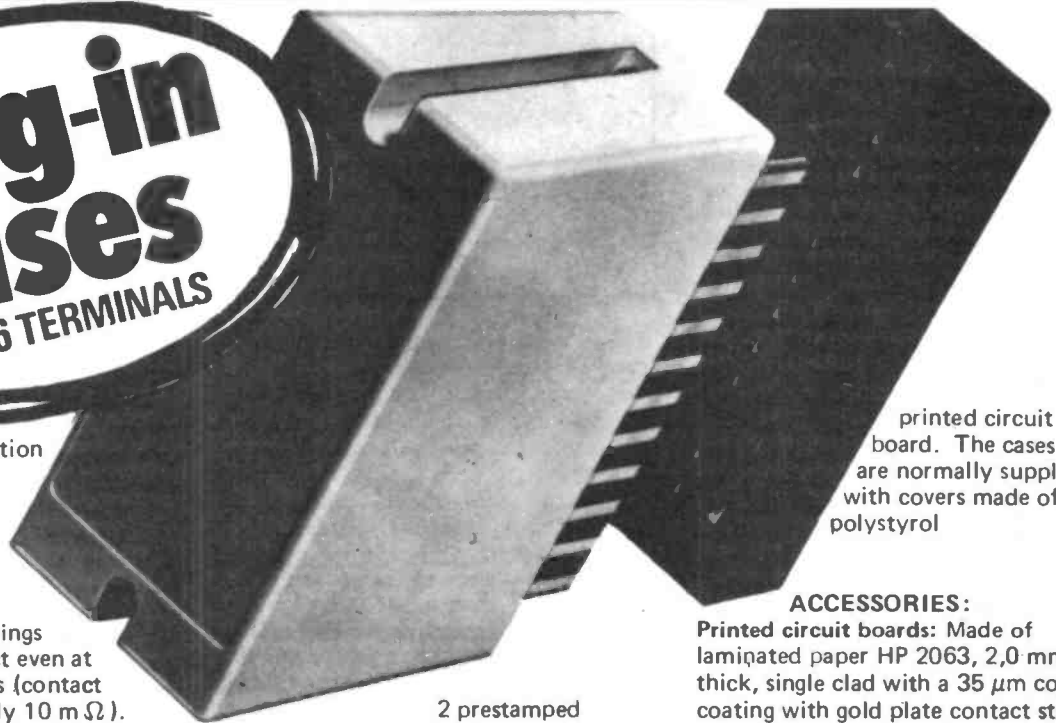

printed circuit board. The cases are normally supplied with covers made of polystyrol

ACCESSORIES:

Printed circuit boards: Made of laminated paper HP 2063, 2,0 mm thick, single clad with a $35 \mu\text{m}$ copper coating with gold plate contact strips.
Front labels: Made of light grey PVC without printing
Size for ZA 12 = $83,5 \times 44,5 \text{ mm}$
Size for ZA 16 = $119,5 \times 67,5 \text{ mm}$
Earthing terminal block: 4-pole
Coding Bars: For polarising of printed circuit boards.

2 prestamped cable entries in the base.

Cover: Closed, without holes, with a recess 0,6 mm deep for an adhesive label, two mounting screws for attaching the plug-in upper part to the base. Intermediate plate for covering the equipment space and for retaining the

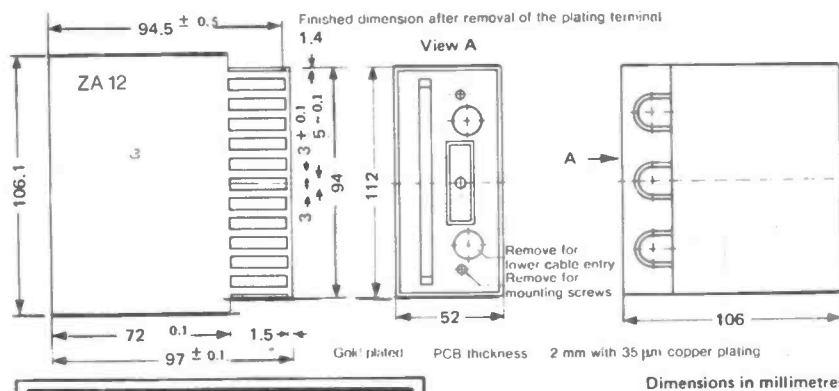

FREPAR

ELECTRONICS LTD

119 Newland Street Witham Essex CM8 1BE England Tel Witham (0376) 516617

43 for further details

REVIEW-THE ACORN ATOM

Jon Burchell has a go at splitting the Atom and discovers that it possesses a certain "charm"....

The stable element

The Atom is a British designed and built personal computer which has been on sale in the UK for around 18 months. Like many small personal computers it comes complete with the ability to run a high level language, in the case of the Atom, as with PET and others, this language is BASIC.

Although the Atom is very professionally presented, it is also ideally suited to the enthusiast. The Atom is available in a number of different versions, the cheapest being simply the most expensive with a few of the chips missing. You may then upgrade the Atom from this starting point - as funds allow.

As with the TRS-80 and other small personal machines, a cost saving is achieved by not supplying the Atom complete with VDU or monitor. However, the built in modulator allows it to be used with any UHF television.

As can be seen from the photographs, the Atom is a very neat 'free standing' machine, a little larger than an average computer keyboard. All the electronics are contained within this box, and it is only necessary to connect the Atom to a television and an external 8 volts power supply to have your computer 'up and running'. The built-in cassette interface allows the storage and recall of programs from an ordinary audio cassette player.

The cheapest version of the Atom comes with an 8k ROM containing the BASIC and cassette operating systems, with 2k of RAM for program storage. Most of this is used by the system and only 512 bytes are available for storing your own BASIC programs - which is not a lot.

The upgrades consist of adding more RAM for program storage and graphics expansion, and of adding another 4k ROM which extends the BASIC by adding floating point numbers, scientific and trigonometric functions, printer driver software and colour graphics routines.

Acorn supplies the machine either as a kit or ready-assembled and built. The version we reviewed was already assembled - however, a glance inside the case revealed that the single PCB construction and the use of IC sockets throughout should not pose any serious construction problems for all but the most inexperienced constructor.

The documentation supplied with the Atom consists of a construction guide designed primarily for kit builders. This little book is useful to all Atom owners as



it also describes some of the hardware details and possible expansion options for the Atom. I was a little disappointed in the quantity and quality of constructional information supplied, although cross-referencing the parts list, PCB and PCB component ident should enable most potential ambiguities to be resolved.

I was very disappointed to see that no information is given to enable the builder to debug a constructed, *not-working* Atom. A few voltage measurements and scope pictures would be a great help, and would doubtless help free the Acorn 'phone line from much of its 'traffic'. However, Acorn offer a *get it going* service to constructors, so you shouldn't be left with a totally dead machine if you avail yourself of this. A complete circuit diagram of the electronics is included, and this would be of use to the experienced constructor.

Also included is a free manual entitled *Atomic Theory and Practice* and subtitled a beginners course in BASIC and machine code programming. In general this book is well written and conforms to the aims of its title quite well. More regarding software later.

The feature that sets the Atom apart from any other contemporary personal computer in a similar price bracket is the ability of the Atom to produce high resolution graphics - and also via an external PAL encoder, colour graphics. The Atom has nine graphics modes which vary according to the RAM available, the limits are 256/192 points (pixels) in black and white, and 128/192 points in any of four selectable colours. The graphics are well supported by commands available in BASIC which allow plotting of points, drawing of lines, and selecting of point colour.

Inside the shell, the bare nucleus

The Atom is another 6502 based machine. This is the same microprocessor as used in the PET and KIM micro-computers and well suited to this sort of application. The rest of the hardware design is neat and tidy, the keyboard is interfaced to the micro via some I/O logic, and the scanning and debouncing of the keyboard is under software control. It should therefore be quite easy to re-assign key functions for special projects. Likewise the cassette interface is under software control and could be used at other speeds and with other standards.

The display section of the Atom is very flexible, being based around the Motorola 6845 LSI VDU controller chip. This device provides the interface and controlling logic of a VDU - but unlike a lot of dedicated hardware designs, the parameters of the display such as graphics resolution or alphanumeric are under software control. Acorn are to be congratulated in this approach to producing a graphics display. The flexibility obtained in this approach - as opposed to dedicated hardware - more than outweighs the extra programming effort needed to get it all going, the device generates the composite video signal and also the colour information for the encoder board.

The hardware contains a 6522 Versatile Interface Adaptor to provide an interface from the micro to the outside world. The VIA provides 24 lines of I/O, two counter times, and a shift register which may be used for *parallel-to-serial* and *serial-to-parallel* conversion. Also provided is a high current printer buffer/driver (Centronics) driven from the 6522, and special routines in the BASIC. The Acorn 'bus' is also available, and can be used for expansion purposes.

REVIEW~THE ACORN ATOM

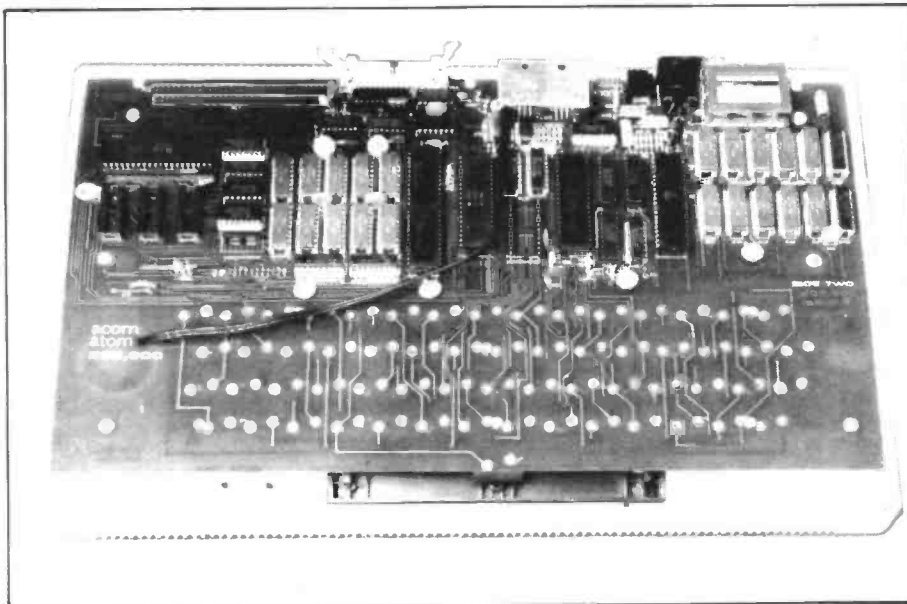

The strong force

The binding force of the Atom is its software, the main glue is the BASIC interpreter and assembler provided by the 12k of ROM. The BASIC is 'powerful', and a listing of the commands available is given in *Table 1*.

The BASIC contains many useful statements to help with the creation and plotting of graphics, it also allows the use of *in-line* assembler statements. There should be no problems converting programs from another BASIC into Atom BASIC, although the same cannot be said of converting Atom programs to run on other machines, as Atomic BASIC is non-standard. Atom BASIC has one feature which I find irksome, namely its use of labels within a BASIC program.

A line such as 'Gosub g' or 'Goto a' is valid. I can see no particular reason for this feature, and its main use is in

Table 1

ABS	GET	PLOT
AND	GOSUB	PRINT
BGET	GOTO	PTR
BPUT	IF	PUT
CH	INPUT	REM
CLEAR	LEN	RETURN
COUNT	LET	RND
DIM	LINK	RUN
DRAW	LIST	SAVE
DO	LOAD	SGET
END	MOVE	SHUT
EXT	NEW	SPUT
FIN	NEXT	STEP
FOR	OLD	THEN
FOUT	OR	TO
TOP	UNTIL	WAIT

conjunction with the Atom's 'renumber' feature which does not alter line numbers within the statements. Thus its main strength is through weakness!

The atom assembler is powerful enough for most purposes, the ability to have assembler code within a BASIC program is excellent, and opens up the whole machine to the persistent programmer. An extensive cassette operating system is also provided to manage and maintain files on audio cassette.

The valent Atom

There are two main reaction routes which allow the Atom to react with the outside world: Firstly via its built-in 6522 and printer buffer; and secondly expansion via the *Acorn bus* which allows the addition of floppy disk controllers, Prestel adaptors and lots of other goodies. It is also possible to equip the Atom with a communications interface allowing it to communicate with other Atoms - and a 'hard disk' for mass storage.

The Atomic order...

On the whole I am very impressed with the Atom. The major gripes I have about it are the lack of documentation for the kit builder with enough expertise to undertake the debugging and fixing of an Atom himself, and the fact that the use of a non-standard BASIC could lead to problems in the field of computer literacy.

As a value for money machine with the capability to be expanded in all sorts of ways as confidence/knowledge/funds grow, then it is an ideal choice, the insides and hardware are much more accessible than with the PET or TRS-80 type of machine, and documented via the circuit diagrams. Certainly when comparing an

expanded ZX-81 with 16k of RAM, and the BASIC Atom, I believe there is no contest if your interest in computing is already established, and you want to go places then the extra cost of the Atom is worthwhile.

The big question mark over the Atom must be:

" what support will continue to be given to it when the BBC microcomputer becomes fully available ? "

especially when the advertising copy for the BBC machine claims 'we believe that this computer will far out-perform any other computer for home, school or business use'?

According to Acorn, a retro-fit option will be made available to Atom users to allow the Atom to run the BBC BASIC (a version of Microsoft BASIC) -thus some of the BBC software will be available to the Atom owners. Although it will still not be possible to add the BBC peripherals and goodies, such as the second language processor.

However, as well as continued support from Acorn (the Atom has an undefined half-life at this point in time), there are sufficient machines in use, (and user's clubs) to prevent a melt down of the atomic reaction for a number of years.

Listed below is the atomic periodic table, giving some facts and figures about the Atom.

Acorn Atom

CPU 6502

Built-in BASIC interpreter and assembler. Cassette interface. Cuts standard 6522 VIA interface.

Prices (inc VAT & p&p)::

ATOM KIT—8K ROM+2K RAM (MIN), £140.00

ATOM ASSEMBLED—8K ROM+2K RAM (MIN), £174.50

ATOM KIT—12K ROM+12K RAM (MIN), £255.00

ATOM ASSEMBLED—12KROM+12K RAM (MAX), £289.50

Available from Acorn Computer Ltd, 4a Market Hill, Cambridge CB2 3NJ

Your Reactions.....	Circle No.
Immediately Applicable	117
Useful & Informative	118
Not Applicable	119
Comments	120

RADIO & ELECTRONICS WORLD

Please send me 2732 EPROMS at £5.17 each (inc VAT)

I enclose payment of £
Access/Barclaycard No.
Name:
Address:
Postcode:

Send to R&EW EPROM OFFER, 117a High Street, Brentwood, Essex.

The quantity available on this special offer is limited, please send a Stamped Addressed Envelope for us to return your order in case offer is oversubscribed.

R&EW SPECIAL OFFER

2732 450ns 4Kx8-BIT U.V. ERASABLE EPROMS

£4.50 + VAT EACH

In keeping with our policy of supplying the highest technology goods at the best possible prices, we offer you the 2732 EPROM at an unbeatable price. These devices can be used in applications as diverse as programmed sequencers, frequency synthesisers and, of course, computers. R&EW will be describing a 2732 EPROM programmer, and these devices will also be used in the R&EW control computer.

- PRIME, UNUSED, FULL SPEC DEVICES
- FULL DATA SUPPLIED WITH EACH DEVICE

The 2732 is a 32,768-bit ultraviolet erasable and electrically programmable read-only memory (EPROM). The 2732 operates from a single 5-volt power supply, has a standby mode, and features an output enable control. The total programming time for all bits is three and a half minutes. All these features make designing with the 2732 in microcomputer systems faster, easier, and more economical.

An important 2732 feature is the separate output control, Output Enable (OE) from the Chip Enable control (CE). The OE control eliminates bus contention in multiple bus microprocessor systems.

The 2732 has a standby mode which reduces the power dissipation without increasing access time. The maximum active current is 150mA, while the maximum standby current is only 30mA, an 80% saving. The standby mode is achieved by applying a TTL-high signal to the CE input.

Please allow 21 days delivery

PIN CONFIGURATION

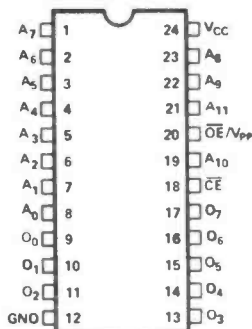

PIN NAMES

A ₀ -A ₁₁	ADDRESSES
CE	CHIP ENABLE
OE	OUTPUT ENABLE
O ₀ -O ₇	OUTPUTS

BLOCK DIAGRAM

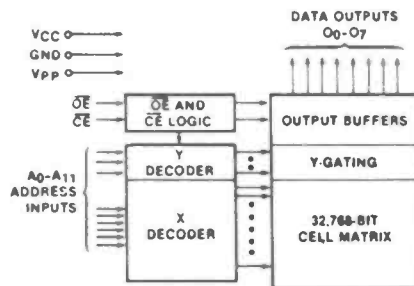

- * Fast Access Time: - 450ns Max. 2732
- * Single +5V +/- 5% Power Supply.
- * Low Power Dissipation: 150mA Max. Active Current 30mA Max. Standby Current
- * Simple Programming Requirements - Single Location Programming - Programs with One 50ms Pulse.
- * Three-State Output for Direct Bus Interface.
- * Pin Compatible to 2716 EPROM
- * Completely Static

RADIO & ELECTRONICS WORLD
SPECIAL OFFER

ALL ORDERS MUST BE ACCOMPANIED BY THE TEAR-OFF COUPON AND BE PRE-PAID.

A Simple Digital Voltmeter

Leslie Hill

A low cost 'easy to build' unit providing an ideal introduction to digital measuring techniques.

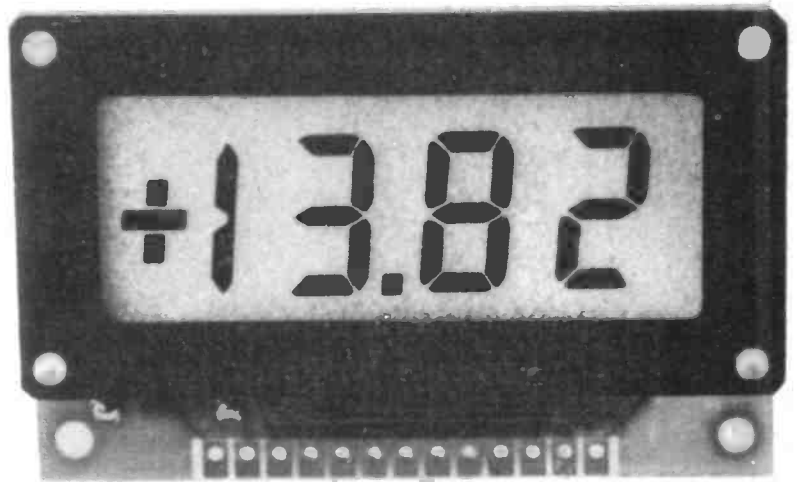

Whilst a number of ready-made, kit and magazine designs for DVM's appear with regularity - there are many applications where a simple one or two range DVM would be perfectly suitable.

This article sets out to achieve just this end. If a DVM is made with a simple 20v DC and 200mA range, it can be used in many applications encountered in everyday electronics. For different 'prime' requirements, alternative values are given to provide other ranges of voltage/current.

The total accuracy of the DVM depends on the tolerance of the shunt and multiplier resistances used. 1% types can be easily obtained, and are practical for most everyday uses.

Resolution of the 20v/200mA model is 10mV/100uA and 100mV/1mA when using the 200v/2A version.

To further simplify construction and calibration, a ready-made module is used for the basic DVM. This module is based on the ICL7106 IC from Intersil. It comes completely built, tested and housed in a plastic case only 60 x 38 x 50mm in size. A 1/2in. LCD is used - and a built-in detector circuit will indicate 'BAT' on the display when it is necessary to replace the 9v battery. This circuit operates when the supply falls to typically 7.2v and reliable use after the 'BAT' sign appears is not available for very long.

The DVM176 utilises the dual slope analogue to digital conversion technique. It is not easily described within the scope of this article and readers who are not familiar with this device are recommended to read the data sheet published by Intersil which describes the A/D conversion in some detail.

The circuit for the 20v/200mA DVM is shown in *Figure 1*. At first glance the resistor values shown look rather strange but are in fact made up using resistors in series in some cases, e.g. for the 20V range; R1 equals 9M9 - made up of one 9M0 resistor plus one 900k resistor in series. R2 equals 90k, and R3 equals 10k.

These three resistors form the voltage divider to provide a 20v range when S1 is in the 'I' position. As this DVM is primarily designed for ease of construction and low cost, no specific

overload protection is fitted. The constructor must therefore ensure that excessive voltages/currents are not applied to the unit. If a voltage above 20v and a current in excess of 200mA is applied the DVM will indicate an 'over range' condition. This is indicated by the display showing a single '1'. As noted however, substantial excess voltage or current will destroy the DVM176 - so be warned!!

Connections to the DVM176 are achieved via an edge connector at the bottom of the module. All connector positions have holes drilled as well - so normal wire connections can be soldered direct to the DVM176. It should be noted that two terminals are marked 'LMP'. These are provided for connecting an internal backlight. The lamps are not fitted to standard DVM176's.

No case details are shown, as doubtless readers will have various ideas on shapes and sizes for use with this design. One of the more likely applications would be to fit the DVM in an existing adjustable power supply to provide accurate setting of the voltage.

If fitting the module into a power

supply for this reason **do not** attempt to power the DVM from the supply it is measuring. Due to the design of the 7106 IC used in the DVM176, it is not possible to join the '1N LO' and 'VBS' terminals together in any circumstances. A bezel (MB-10) is also available to provide easy front panel mounting.

Other combinations of voltage and current ranges can be used as shown in *Table 1*. Likewise the module may be constructed with only one function - i.e. 20v DC only.

The DVM should function immediately upon switching on, and if 1% or better resistors are used, should be sufficiently accurate for 'normal' use without calibration. Should the user have access to an accurate voltage source, the display can be calibrated by adjustment of the preset resistor fitted to the rear of the DVM176. A small amount of glue is normally to be found on this resistor and after adjustment of this trimmer, it is advisable to reseal with a dab of nail varnish etc. Do not tamper with this control unless you do have an accurate calibration source. (*Enter our competition to win a Philips PM2521 -ed*).

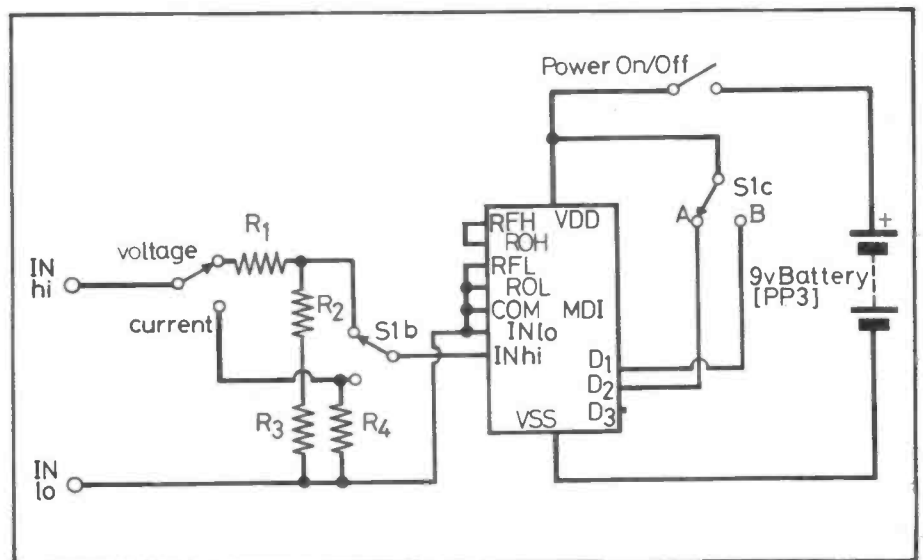
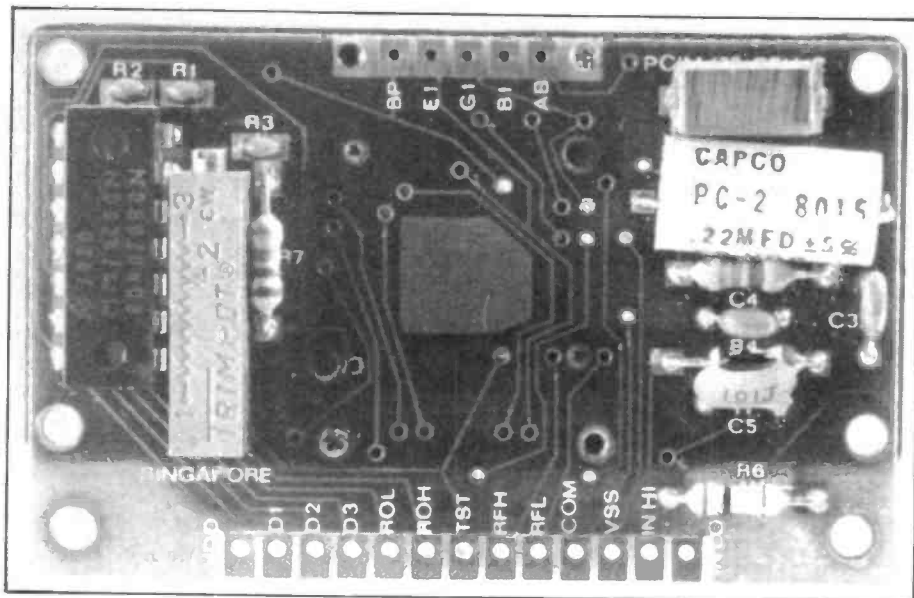

Figure 1 : Circuit Diagram of the Simple DVM



Required Max. Voltage Input	R1	R2	R3	SI (c) Terminal A Connect to:
200mV DC	link	none	none	D1
2V DC	9MΩ	900K + 90K	10K	D3
20V DC	9MΩ + 900K	90K	10K	D2
200V DC	9M+900K+90K	link	10K	D1

Required Max. Current Input	R4	SI (c) Terminal B Connect to:
200μA DC	1KΩ	D1
2mA DC	100Ω	D3
20mA DC	10Ω	D2
200mA DC	1Ω	D1
2A DC	0.1Ω	No Connection

Photograph above shows the rear view of the DVM module.

Table 1: Selection chart for voltage/current ranges.

Battery life will depend on the amount of use, but a couple of months in normal use should be obtainable from a PP3 size.

The two input terminals are marked 'IN HI' and 'IN LO'. The DVM will measure a circuit either way round, but for normal use, 'IN HI' should be regarded as the equivalent to the +ve terminal on a normal test meter. A negative voltage will cause a '-' sign to be displayed on the LCD, thus indicating a negative voltage with respect to 'ground' or 'IN LO'. A positive voltage will blank the '-' symbol. SI(c) selects the correct decimal point via internal circuitry within the DVM176. If using different ranges alternative decimal points may be needed - See Table 1.

Components List

- R1, R2, R3, R4 - depend on range required see Table 1. To 1% or better .25W (Min).
- S1 3P CO
- S2 SP on/off
- B1 9v battery (PP3 or similar)
- MD1 DVM176 (Ambit, Watford)
- Misc. Mounting bezel BEZ-10
- Connection for PP3 battery Case

Your Reactions.....	Circle No.
Immediately Applicable	146
Useful & Informative	147
Not Applicable	148
Comments	149

Infra Computer Components Ltd

Pendrorric House, 7 Westfield Road, Great Shelford, Cambridge CB2 5JW, England

Telephone (0223) 841728/843953
Telex 81574 Attn. lcc.

Eproms	1.99	100+
2708 450 nS	1.97	1.70
2716k 450 nS	2.45	2.19
2716 350 nS	3.98	3.42
2532 450 nS	5.82	4.83
2732 450 nS	5.80	3.42
Cmos Rams		
5101 (256 x 4)	2.90	
TC5514p 4k (1kx4) 450 nS	3.25	
HM6116 P3	11.50	9.85
HM6116 LP3	12.00	10.25
CPUs		
6809	12.30	
6802	5.50	
6502	5.50	
Z80 CPU2.4MHz	5.25	
Z80 CPU.4MHz	6.25	
8255 support device	4.10	
Rams		
2114	1.26	1.09
4116 150 nS	1.05	.91
4116 200 nS	.79	.68
4118	4.50	3.99
Crt Controllers		
SFF 96364E	7.00	
6845	10.00	
6847	10.50	

Cmos B	
4001b	.12
4006b	.50
4011b	.15
4017b	.60
4020b	.70
4023b	.20
4025b	.20
4027b	.40
4028b	.70
4031b	1.45
4042b	.60
4049ub	.25
4066b	.38
4068b	.22
4071b	.20
4073b	.20
4093b	.40
4510b	.65
4511	.75
4520b	.75
4555b	.75

LS Series	
74 LS85	.79
74 LS138	.34
74 LS139	.37
74 LS145	.74
74 LS153	.38
74 LS157	.34
74 LS161	.40
74 LS174	.71
74 LS240	.95
74 LS241	.95
74 LS242	.84
74 LS244	.80
74 LS245	1.17
74 LS266	.24
74 LS273	.89
74 LS283	.44
74 LS373	.74
74 LS374	.74
74 LS393	.59
74 LS670	1.74

Minimum Orders £10.00
Please ring for 1000+ prices.
Please add 50p for postage and packing and 15% VAT.

DATONG PRODUCTS

DESIGNED BY ENTHUSIASTS FOR ENTHUSIASTS!

SEE US IN HALL 3A
AT THE
ARRA EXHIBITION,
DORNINGTON PARK,
29th - 31st OCTOBER

KEYBOARD MORSE SENDER - THE ULTIMATE KEYBOARD - CHECK THESE FEATURES

- CONVENIENCE - no need for a power cable, four internal pen cells last for 300 hours and give continuous memory back up.
- EXCLUSIVE COLOUR CODED KEYBOARD DESIGN - Separate key switches beneath a tough polycarbonate membrane combine excellent "feet with a splash proof wipe clean surface
- LAVISH MEMORY - four 64-character memories with auto-repeat and programmable "pause" function for all the routine sending
- BUFFER MEMORY - ensures perfect sending despite less than perfect typing
- COMPREHENSIVE CHARACTER SET - includes punctuation, procedure signals, accented letters. Plus a "merge" key for making any non-standard character
- BEAUTY AND STYLE - only one inch thin and with four-colour panel Model MK looks every bit the thoroughbred it is. Model MK is supplied with output leads and spare connectors but without batteries (four HP7 pen cells)



Model MK

MODEL ASP - THE "INTELLIGENT" RF CLIPPER

Model ASP modifies your speech signal direct from the microphone and makes it more effective at modulating your transmitter. The effect is as if the transmitter peak power were to increase by between two and three times. "Intelligent" means that unlike other speech processors, Model ASP automatically senses your voice level and reacts accordingly to always maintain the degree of true r.f. clipping selected (in decibels) by the panel push-buttons. Special circuitry does this without the undesirable side effects of simple a.g.c. devices. Adding a Datong r.f. clipper to a normal SSB transmitter has a similar effect to adding a linear amplifier but without the high cost and risk of TVI

Model FL2

Model PC1

Model ASP



Reviewed
73 Mag. July

GB's - ARE YOU MISSING OUT?

Unless you can monitor the other bands you are missing a lot. If you have a 2 metre all-mode receiving set up, just add Model PC1 in series with its antenna and you have a superb general coverage receiver. What better way to listen in to all the non-VHF amateur bands, not to mention everything else from 60 kHz to 30 MHz? For sheer value for money there is no better way to get high performance general coverage reception. After all what a waste it is if your expensive 2 metre all-mode rig covers one band only?



Model PC1

ATTENTION VHF SCANNER OWNERS!

Did you know that Model PC1 will extend the coverage of your SX 200 type scanner to include all the long, medium and short wave bands as well? This is an excellent way to listen to your favourite short wave broadcast stations without the extra expense of a complete new receiver.

MINIATURE RECEIVING ANTENNAS

If you don't have enough space to put up traditional receiving antennas, our active antennas are the answer. They need no tuning yet have constant sensitivity from 200 kHz to well over 30 MHz. Results are quite comparable to full size conventional antennas but the space saving is enormous. The indoor version (AD270) is 3 metres long and the outdoor version (AD370) is 2 metres long.



Model AD270

A TV-type feeder cable of any reasonable length can be used yet because the antennas are balanced dipoles any interference picked up by the feeder is rejected. Because of their wide frequency coverage Datong Active Antennas are ideal accessories for modern general coverage communications receivers.



Model AD370

Reviewed
Shortwave
Mag. Aug



Model DC144/28

YET ANOTHER 2 METRE CONVERTER?

Yes but not just another. Model DC144/28 is designed to overcome the overload and spurious signal problems experienced by conventional converters. It uses a Schottky diode balanced mixer with about 7dbm of local oscillator drive. This, coupled with a 3SK88 r.f. amplifier, gives an excellent combination of low noise figure and strong signal handling capability. Its input and output gain controls also help you get the best out of your main receiver without flattening it with excessive gain. Model DC144/28 is available either as a complete cased unit (die cast box, S0239 connectors) or as a ready built and tested PCB module.

MODEL D70: THE GO-ANYWHERE MORSE CODE TRAINER

For building up your morse code reception speed there is no better method than the Datong "Morse Tutor". You learn the code with the characters at normal speed but with an extra delay between each one. As you improve you reduce the "DELAY" control until, with it fully reduced, you find you are reading code at the chosen speed and with correct spacing.

An important feature is that the unit is completely portable. This allows you to practise wherever and whenever you find it most convenient. The all-CMOS design gives about 60 hours of practice from a lowcost PP3.

Model D70



NEW PRODUCTS PREVIEW

Model DF1

Direction finder attachment for FM, VHF receivers/transceivers, gives directional readout on circle of LED's. Connects to loudspeaker and antenna jacks.

Model RFA

R.F. switched broadband preamplifier. Boosts gain and noise figure of receivers from 30 to 200 MHz.

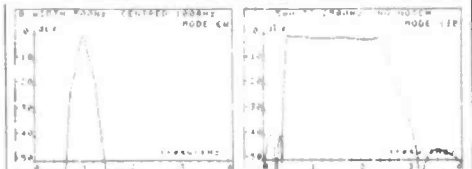

VARIABLE SELECTIVITY FOR ANY RECEIVER

Have a look at these curves (and the others in our data sheet) and you will see why a U.S. reviewer commented that the FL2 is "incredible - it's like having a tunable crystal filter." With Model FL2 connected in series with your speaker you can wipe out off-tune "monkey chatter", unwanted tones and sundry "bubbles" from SSB, while for CW the ultra-steep skirts allow you to use wider bandwidths for a given rejection of off-tune signals. This makes tuning easier and reduces listening fatigue.

Model FL2 costs little more than a single special accessory filter yet it offers better performance, extreme versatility, and can be used with any receiver.

*R. S. Dicks, 73 Magazine, July 1981 p 119.

Reviewed
CQ-DL Feb. 1981



Model FL2

Products not shown in this advertisement

- Model Datest 1 Transistor Tester
- Model Datest 2 Transistor Tester
- RF Speech Processor Model D75
- Model RFC/MRF - Speech Processor PCB Module
- Model MPU Mains Power Unit
- Accessory Leads
- Model VLF
- Model FL1



INGENIEURBÜRO ULRICH HANSEN

VHF & UHF PREAMPLIFIERS: A new range from Ulrich Hansen of West Germany. A range of high quality in-line preamplifiers for 2 metres or 70 cms, featuring ultra-low noise figures and state-of-the-art design. The range includes R.F. switching capability from 60 watts P.E.P. to 500 watts P.E.P. and choice of silicon low noise devices or the latest gallium arsenide MESFETs for the best possible noise figure. Indoor or mast mounted options are also included. Full details free on request. These units represent a cost-effective way of improving your DX receiving capability.

PRICES: All prices include delivery in U.K. basic prices in £ are shown with VAT - inclusive prices in brackets.

FL1	59.00 (67.85)	VLF	22.00 (25.30)	AD270	33.00 (37.95)	MPU	6.00 (6.90)
FL2	78.00 (89.70)	D70	43.00 (49.45)	AD370	45.00 (51.75)	DC144/28	31.00 (35.65)
PC1	105.00 (120.75)	D75	49.00 (56.35)	AD270 + MPU	37.00 (42.55)	DC144/28 Module	25.00 (28.75)
ASP	69.00 (79.35)	RFC/M	23.00 (26.45)	AD370 + MPU	49.00 (56.35)	Keyboard Morse Sender	140.00 (161.00)

DATONG ELECTRONICS LIMITED
Spence Mills, Mill Lane, Bramley, Leeds LS13 3HE, England. Tel: (0532) 552461

Whilst one competition featuring this DMM offers TV/Radio sets as its prizes, we would prefer to remain in sight of our objectives—and offer you the means of designing and making a better TV instead. So the prize is the PM 2521 itself.



Give us the tools....

It is quite difficult to get involved in the design end of electronics these days unless you are provided with a reasonably comprehensive array of test equipment. The days when the designer could scrape through with an AVO and ex-WD 'scope are long since gone.

Start the right way with a DMM

A good example is the Philips PM 2521 which uses an MPU to perform a multiplicity of tasks in the guise of a DMM. If you would like to enter the contest to WIN the PM 2521 — four runners-up will receive £25 Vouchers for use in our companion 'World of Radio & Electronics' Catalogue, then read the review on page 18 and design the best accessory to complement any aspect of the device. Some of the more obvious ideas may be quite valid, originality and elegance will play a considerable part in deciding the winning entry. You must summarise the purpose of the accessory in less than 30 words and the full description should not occupy more than a single A4 sheet.

The total cost of the accessory should be less than £30 at one off prices.



Rules

1. All entries must be accompanied by the coupon on this page.
2. The closing date is 20th November 1981.
3. Entries will be judged by a panel appointed by R&EW.
4. The judges decision is final and no correspondence will be entered into.
5. Employees of the publishers or Pye Unicam Ltd. are not eligible to enter.

dmm comp.

NAME

ADDRESS

.....

Postcode

Send your entry to: RADIO & ELECTRONICS WORLD
 DMM Competition,
 117a, High Street, Brentwood,
 Essex CM14 4SG
 to reach us by 20th November 1981.

NEXT MONTH



➔ 25W 2m amplifier/preamp

Timothy Edwards provides a boost for owners of 1-3W 2m transceivers.

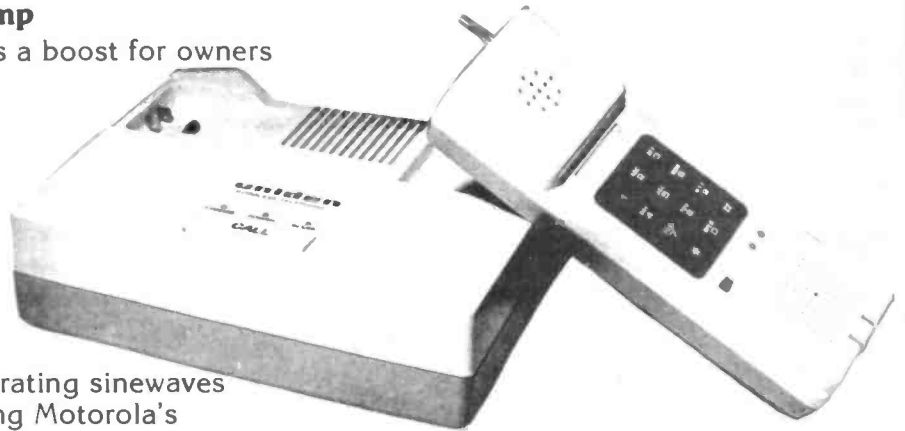

➔ Frequency synthesis

Getting to grips with generating sinewaves under digital control - using Motorola's silicon gate LSI systems.

➔ An RS232 A/D/A Converter

A universal microprocessor I/O interface via the standard RS232 port

➔ Cordless phones

Techniques, circuits and thoughts on providing a viable UK standard.

➔ Back to Back: R1000/FRG7700

R&EW reviews these two popular HF receivers with step by step spectrum analysis to answer the question, Which one is best?

The review also highlights many aspects of modern RF design to lead onto the R&EW MCI controlled HF receiver.

➔ Plus:

Build a logic probe
Compulink - UARTs
Hall Effect - principles and designs
Standards for CB
News etc.



RADIO &
ELECTRONICS
WORLD

On Sale November 5th

The INS AND OUTS of HA12002

A close look at the internal functions of the HA12002 loudspeaker protector.

For anyone unfamiliar with transistor logic, a close look at the HA12002 can be an interesting and simple introduction to the fascinating subjects of combinational and sequential logic.

Stephen C Taylor B.Sc. AMIEE

Unlike most logic chips which contain either individual standard logic elements for the assembly of strictly digital systems or analogue circuit elements for signal amplification and control functions, the HA12002 contains a combination of sensing circuits and logic elements which are designed to fulfil the particular purpose of loudspeaker protection.

In conjunction with a few external components, which can be selected to adapt, it to a range of amplifier/loudspeaker systems, plus one or more relays to perform the low impedance heavy current switching, this IC will protect HiFi and PA loudspeakers from many of the damaging overdrive conditions which can be applied inadvertently to their input terminals. However, elements of the internal circuit can be used in a variety of simple applications.

The internal operation

The internal arrangement of the IC is shown as an equivalent circuit in Figure 1.

It can be considered as a set of individual logic functions interconnected so as to control the output at lead 1.

For loudspeaker protection the external positive supply - backed relay connected to lead 1 is normally held *operated* so as to connect the loudspeakers to the amplifier outputs. This is a fail-safe arrangement such that the relay will release if the power is removed or if the pull-down condition on lead 1 is removed. The relay drive current amplifier (TR13 and TR14) which is in section J of Figure 1 is an inverting amplifier. Thus to *release* the relay the internal 'control line' must be pulled down to ground potential.

Leads 7 and 2 are the positive and ground supplies to the chip. The remaining leads are the various controlling inputs.

In Figure 1 the circuit is shown sectioned off into the various functional blocks which separately, or in combination, apply conditions to the relay control line. Sections A and B are identical. Via leads 3 and 4 they can

independently monitor for external voltages which are above or below thresholds of +0.6V and -1.2V respectively. Their outputs are commoned into section C which is a current amplifier which can pull the relay control line low via transistors TR3 and TR4.

Section D includes circuitry which is biased so that it will pull the control line low unless an input signal more negative than -6V is applied to lead 5 to overcome the internal bias. This function can be used to monitor the system's AC power supply and give a fast switch-off facility. Diode D1 protects TR8 and TR9 from reverse bias breakdown which could occur with excessive negative inputs on lead 5.

Section E involves a sequential operation and is most easily understood by reference to Figure 2. TR6 and TR7 form an Eccles-Jordan bistable with an output amplifier TR5 which can pull the control line low.

At switch-on diode D2 ensures that the power supply to TR7 rises later and lower than the supply to TR6. Hence after switch-on TR7 is normally OFF and TR6

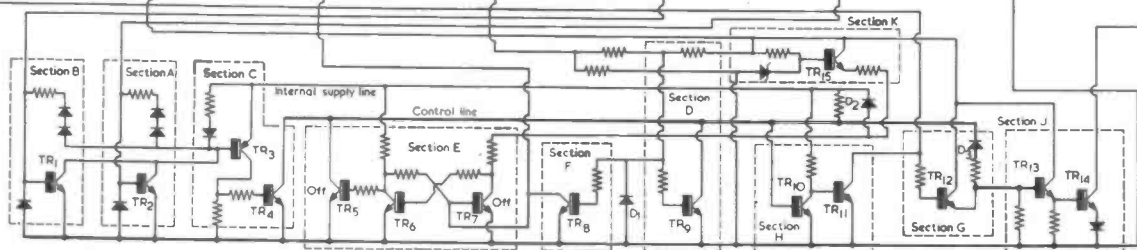

Figure 1: An equivalent circuit of the HA12002.

is normally ON, thus holding TR5 OFF and thereby *not* pulling the control line low. A positive voltage of more than about 0.6V (current limited to not more than 3mA) at lead 6 will cause the bistable to toggle and TR5 to latch the control line low. So long as power is supplied to the IC (at lead 7) the control line will remain latched low and can only be *reset* by the negative signal at lead 5 being removed. Section F contains an inverter (TR8) which will then reset the bistable. However, TR9 in section D will still hold the control line low until the potential at lead 5 again goes below -6V.

Section G provides a delayable switch-on facility. Unless and until lead 8 is taken more than 6V positive, TR12 will not provide the bias to the relay drive circuit. Diode D3 and TR12 form an AND gate, thus if either the control line or the input to lead 8 is low then the input to section J will be low. When power is first supplied to the whole system, lead 8 can be kept low for a short period by means of external timing circuits. Thus during the initial 'system settling down' period the relay will remain released.

Section H is a current amplifier which whenever the control line goes LOW, provides a rapid discharge of the external timing capacitor used to provide the switch-on delay. This ensures that there will be the full delay even if the switch-on immediately follows a switch-off.

A typical application

A practical loudspeaker protection circuit is shown in Figure 3. With the few components and connections shown, the following facilities are obtained.

1. Delayed switch-on. The charge-up times of electrolytic capacitors in the power supplies and signal paths can cause unacceptably large transients and offsets at the amplifier output. A loudspeaker switch-on delay of 1 or 2 seconds will mask these effects.
2. Fast switch-off. At switch-off or during mains drop-outs the electrical noise from the mains switch and the different discharge rates for power supply lines can cause excessively large signals and transients at the output. The very fast switch-off facility protects the loudspeaker from these undesirable signals.
3. DC offset monitoring and protection. A major cause for

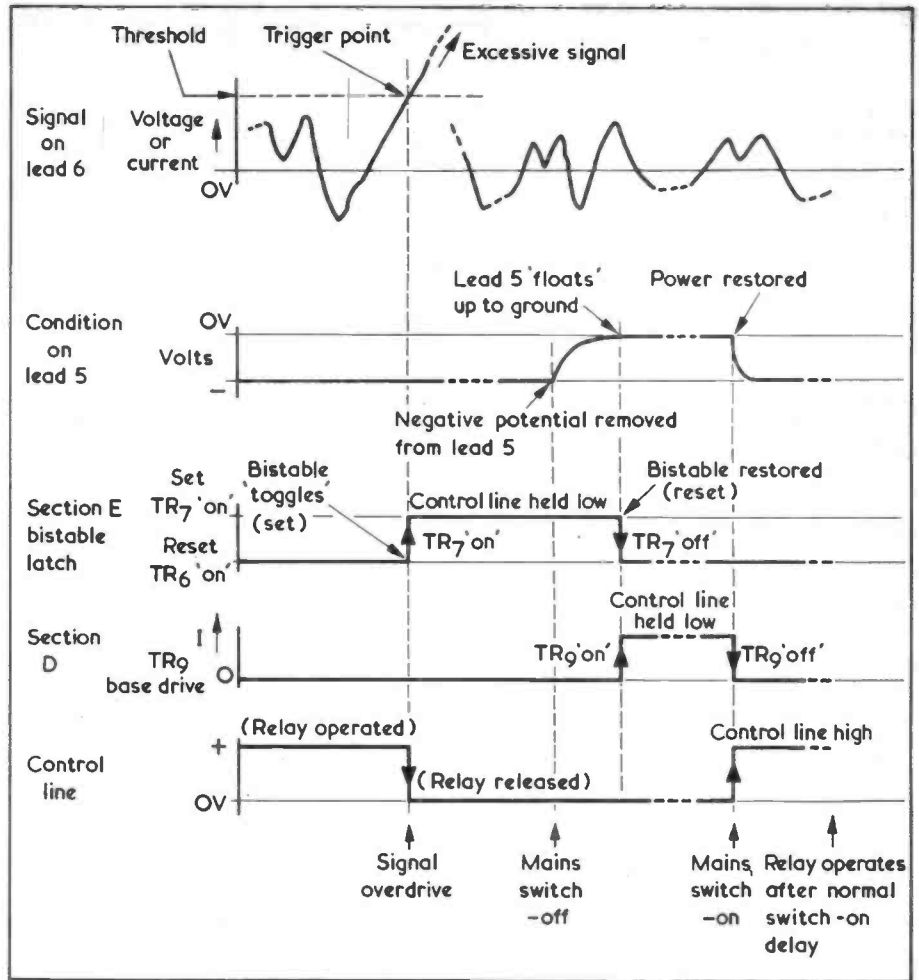

Figure 2: Timing sequence for sections D, E and F. Once the voltage or current applied to lead 6 has exceeded the threshold, the

relay is released and will not re-operate until the negative potential on lead 5 is first removed and then replaced.

concern with modern DC coupled HiFi and PA amplifiers is the unnoticed dc offset which can easily be present. A few volts of offset can burn out the loudspeaker drive coil. The HA12002 will detect less than 1.5V DC offset, isolate the loudspeakers and remain latched in this safe condition until the unwanted offset is corrected.

4. Thermal overload protection. Thermal overload is potentially disastrous for bi-polar amplifiers, since in power output stages the overheating can lead to thermal runaway. By using one or more temperature sensors located within the main amplifier the HA12002 will

remove the loudspeaker load from the amplifier thus reducing the tendency to overheat and protecting the loudspeakers in case of a complete amplifier breakdown. This particular facility can be either latching or self-resetting.

5. Audio power overdrive. The overdrive detector can be set to trip at any desired signal voltage peak at the loudspeaker terminal. Since the cause of damaging transient spikes may still be present (excessive volume, loose connections, intermittent howl-round etc.) this is a latching detector. It is reset by a manual reset switch or by switching off the mains supply.

Other loudspeaker protection circuits can be easily devised to suit particular cases provided the conditions applied to the IC do not exceed the ratings shown in Table 1.

If the internal functions of the IC are clearly understood the operation of the example circuit in Figure 3 is reasonably self-explanatory. The options shown in that figure are:

- A. Thermal cutouts can be latching or non-latching depending on preference. For the non-latching

Lead	1	2	3	4	5	6	7	8
Volts	60	Output signal ground			-10		8 (note 1)	V _{pin 7}
Milliamps	80	Not-VCC	+/-3	+/-3		3	25 (note 2)	50 (peak)

Table 1: Maximum permissible lead conditions. The external circuitry must correctly apply all input conditions simultaneously for the protection relay to operate.

Note 1: The HA12002 operates with an 8V supply

at pin 7. For use with high voltage supplies see Note 2.

Note 2: When operated from a positive supply greater than 8V the input current should be limited by series resistance to 25mA.



Smithy quietly opened the workshop door, stepped in out of the afternoon rain and carefully hung his jacket on a coat-hook. With a barely audible sigh he picked up Dick's old anorak from the floor and hung it on the other hook, over Dick's raincoat.

"Oh there you are," said young Dick sharply. "I was wondering where you'd got to."

It was not unusual for Dick to be working alone in the workshop, yet Smithy's late return from lunch seemed to have peeved the young assistant.

"Problems?" asked Smithy mildly.

"Only this old colour set," said Dick nodding towards the dusty beast on his bench. The idiot's changed all the valves round and I can't find the service book for it," he added pointedly.

Smithy glanced at the sets back cover.

"Ah yes," he said. "I think that's in my car. Wasn't that first reported in as a 'dim picture' fault?" he mused thoughtfully.

"No picture at all now," replied Dick brusquely.

A few moments later and Smithy returned with the necessary information. "There's the valve layout," he said helpfully pointing to the opened page.

A few more moments and the set came dimly to life. "Try the PL509 line output valve. A new one could be all that's needed," said Smithy brightly.

"OK, OK," said Dick as he busied himself rummaging in the spares cupboard.

Smithy took a set from the 'awaiting repair' rack and attended to the 'red picture' fault.

After a few minutes Smithy tried a new conversational tack.

"Seen the cat this afternoon?" he asked.

"Oh that pointy-eared alien," remarked Dick dismissively. "It's gone off its food."

"Unusual," commented Smithy mildly. "It usually eats well."



With Dick AND/OR Smithy

"Well not today," rejoined Dick slowly. "It bit me when I pushed it towards its dish of food." And he carefully rubbed an apparently damaged hand. "So I pushed it right out the door!"

Smithy looked surprised. Tracker was like a feline dustbin and devoured anything put down for it. "Probably a bit off..."

"Can't be. I opened it fresh this morning," interrupted Dick defensively.

"No, the cat - silly," replied Smithy, and added, "did you try that new brand? 'Spock Nosh' or something. The telly ad says it's 'the most logical cat food'. Should be just the thing for a 'pointy-eared alien'."

"Nothing is logical around here," grumbled Dick, refusing to be jollied out of his black mood.

"I agree," chuckled Smithy ignoring Dick's mood. "I've just been to look at that 26 inch colour set which they said 'couldn't be moved'. Do you remember that job?"

Dick nodded glumly.

"Well its OK now - the mains dropper had gone open circuit - but guess why they couldn't bring it in to us."

Dick shrugged.

"They've had a room divider built, and now the set won't go through the new doorway." Smithy laughed and added, "goodness knows what they'll do when it finally dies."

Dick smiled weakly, turned to the tea things and started to fill the kettle-cum-teapot.

Smithy, having previously cleared the fault in the Blue-Yellow preamplifier of his set and allowed the set some warming-up time now quietly attended to resetting the colour balance.

Dick noisily busied himself making the afternoon tea.

Finally, with the colour nearly balanced to give the correct white tone and the set left running to warm up a little more before finally tweaking the colour controls, Smithy picked up his tea cup and turned and spoke to his companion. Dick was sullenly looking out of the window at the rain drizzling from a grey sky. "Come on Dick - what's the problem?"

"Problems," mumbled Dick emphasising the plural. He nodded toward the small heap of goodies on his bench. "That 'personal stereo' has bad battery contacts," he said. "It's been back twice but the contacts keep corroding."

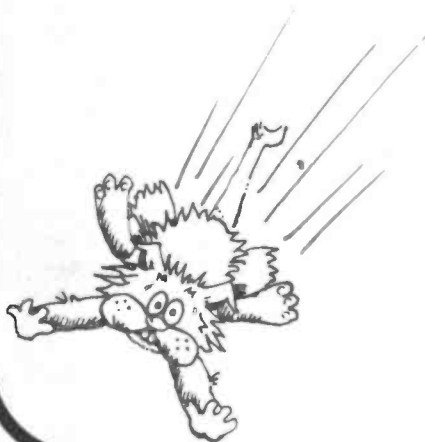

"And the cat bit you," interjected Smithy jokingly.

"Yes and to avoid the 'penny for the guy' crowd at the railway station this morning I used the footbridge. But they've got that posted at both ends..."

"So you were caught twice! Beneath that gruff exterior there beats a generous heart." Smithy laughed.

"Hub!" snorted Dick. "And last night's evening class wasn't too good either," finished Dick.

Smithy considered his companion's sorry tale for a moment.

"It never rains," he muttered "but..."

"It blooming well chucks it down!" growled Dick. "Yes that's what started this corrosion," he said pointing to the portable stereo player, "and it's stopping me from going and getting my fireworks," he finished.

It wouldn't help thought Smithy to mention that he, Smithy, had bought his fireworks a week before in plenty of time for tonight's bonfire celebrations, so he took an interest in the stereo player. "Corrosion?" he queried.

"Yes, they bought it for the summer but the batteries have leaked at sometime and now when its used out in the rain..."

"Say no more," interjected Smithy. "I expect you've cleaned it thoroughly," he said brightly and without waiting for Dick's reply continued, "but the plating will have gone from the contacts."

"Yes," confirmed Dick. "I was going to put some solder on them to make a fresh surface."

"No don't do that," said Smithy gently but firmly. "The heat would de-temper the spring contacts and that would probably make matters worse. What we need to do is arrest the corrosion. The problem is the combination of current, dissimilar metals and atmospheric moisture."

Dick frowned slightly. "What can we do about that?" he asked. "We're stuck now with the metal surface we've got and we can't stop the current!"

"Try vaseline," said Smithy concentrating closely on the ravaged spring contacts.

"Do what?" chuckled Dick looking suspiciously at his companion.

"Vaseline petroleum jelly. In the first aid box," repeated Smithy trying unsuccessfully not to grin. "For the contacts - not your hand," he added innocently.

Dick looked back at the dull contact surfaces "You mean 'grease them'?" he queried.

"Certainly not - not with ordinary car grease," said Smithy firmly. "That dries out in time - but petroleum jelly doesn't - and it 'creeps' over the surface."

"Won't it get in the way - I mean if it gets all over the actual contact?" asked Dick. "Then you'd be worse off."

"No," explained Smithy, "you see it flows away from mechanical pressure points and fills the interstices." Smithy paused.

"The intercity what?" gasped Dick.

"The interstices - they're the tiny cracks and pores in the metal surface where damp and corrosion can get a hold. No moisture - no corrosion," he finished.

"So I'll put the batteries in and smear some jollop around," said Dick cheerfully.

"It's best to put the petroleum jelly on first," explained Smithy. "Give all the contacts a generous coating - you can quickly touch each contact with your iron and the stuff will flow all over the warm metal - then put in the batteries."

"Slip them in you mean," chuckled Dick.

"Well yes, thats another advantage - it does lubricate," and Smithy quickly picked up the old batteries. "Er - and fit new alkalines not these," he said. "I don't know why people don't use Ni-Cads," he added thoughtfully. "They're much better than these ordinary Zinc Carbon batteries and that personal stereo would be much better with them."

"I know," agreed Dick. "We worked it out at College that its five hundred times cheaper to use Ni-cads."

"Not just that," added Smithy. "They don't fade away - they give their full voltage all the time - so the motors and amplifiers get the proper power. Its exactly what a good quality stereo set needs."

Dick cheerfully replenished their mugs and Smithy set about the final adjustments to the set on his bench.

Suddenly just outside the window there was a whoosh! Followed by a deafening Bang! Smithy leapt back from his set as though the EHT had got him and the tube had imploded simultaneously.

Dick dropped his empty mug and rushed to the window.

"It's a rocket," he cried. "A bloomin' rocket - right outside our window." Outraged he flung open the window and yelled, "clear off - bloomin' kids. Can't they wait 'till tonight - more money than sense."

Smithy laughed at Dick's uncharacteristic venom. "Well if you will give them all your money" he joked and then stopped as Tracker, his fur standing on end, shot in through the window like a furry ball of fear and disappeared under Smithy's bench.

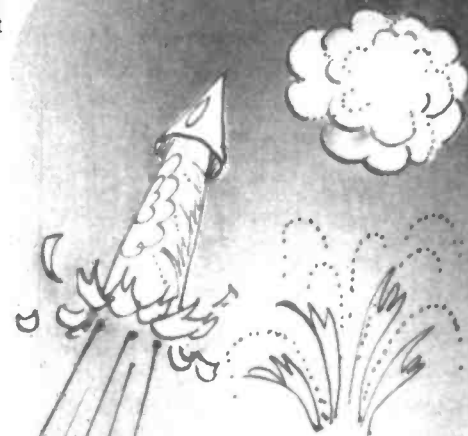

"Ah yes!" mused Smithy. "I should have realised earlier. That's what's upsetting him. All the whizz-bangs. Logical really."

Dick groaned in mock pain. "Oh that word again - logical."

"Could this be last night's evening class problem?" surmised Smithy.

"Yes," admitted Dick. "But look - its stopped raining. Can I pop round the corner and get some fireworks?"

"OK," said Smithy affably. "But before you go, tell me about your problems with last night's evening class and I'll try to think up some answers."

A couple of minutes later Dick snatched up his anorak and banged out of the workshop, leaving Smithy busily sketching, the silence punctuated by the occasional early firework.

When Dick staggered back into the workshop with a huge cardboard box loaded with gaudy potential pyrotechnics, Smithy acknowledged that his companions family bonfire might well rival last July's Hyde Park celebrations.

"Don't forget to lubricate the Catherine wheel pin," reminded Smithy.

"Yeah - but not with grease - eh!" replied Dick slightly breathless. "Now. Can you make this logic more logical for me."

"OK," chuckled Smithy, "look at this sketch here."

Smithy pointed to his first sketch.



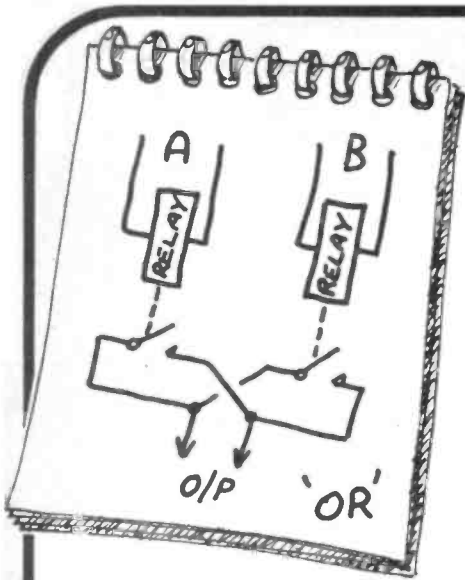

"First I've drawn a single relay logic circuit to start us off."

"I can see that its an 'OR' gate straightaway," said Dick.

"Why?" asked Smithy.

"Well its obvious," explained Dick.

"If either control signal A or control signal B is present, then we get an output."

"Yes," agreed Smithy hesitantly.

"But its important that we agree what is an output and what isn't."

"Well, when we get volts, that's an output isn't it," insisted Dick.

"OK then," replied Smithy to the perplexed Dick. "That will be our standard. So now look at our second sketch."

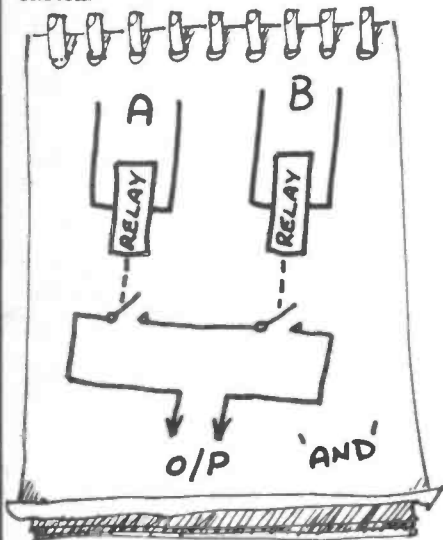

"This is an 'AND' thingy," said Dick flatly.

"Is that a dogmatic assertion or an educated guess?" chuckled Smithy.

"Well you have to have both A and B contacts closed to get an output," Dick explained.

"OK. What's this then?" And Smithy turned over his third sketch which had only three pieces of wire joined together.

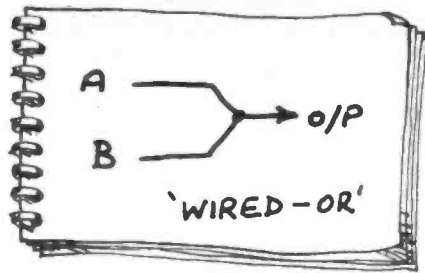

"You serious?" said Dick querulously

"Perfectly serious," stated Smithy.

"You see up to now, with relay logic, we've been able to isolate the input circuits from the output. In fact we could use levers pushing switches if we wished. This ultra simple circuit is a 'WIRED-OR' logic function and it illustrates two important points."

"Go on," said Dick wryly. "I should have guessed that the simplest circuit would be most important."

"First it shows how the inputs and outputs are usually part of the same system and so their voltages and currents are not isolated. And secondly it shows that really we need to prevent one input from interfering too much with any other input."

"Too right!" suddenly exclaimed Dick. "Suppose you connected input A to positive and input B to ground. What then?"

"Quite," said Smithy noncommittally. "So let's look at some simple logic functions which are really semiconductor based. See here." He pointed to his fourth sketch. "If we put diodes in the input leads then one input

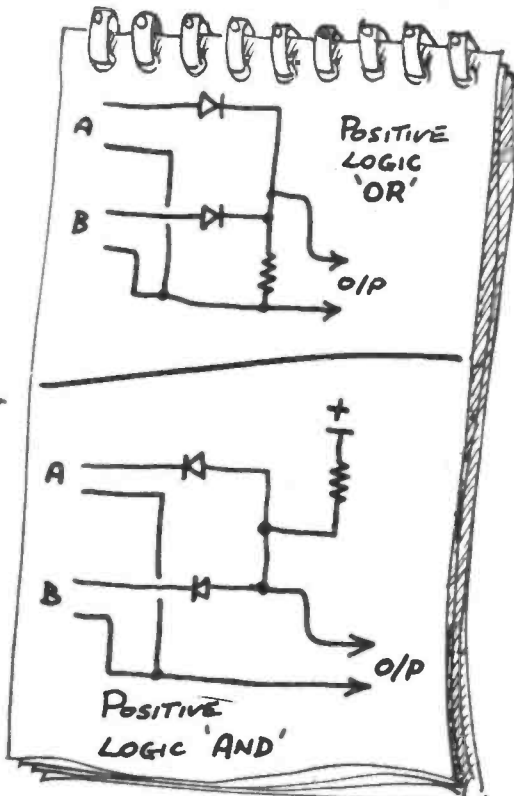

won't affect the other because if 'A' is positive the 'B' diode is reverse biased."

"Cut off," agreed Dick.

"We-ell," said Smithy slowly, "I think the term 'cut off' is better applied to transistor circuits. But you get the point."

"Yes," said Dick. "If A or B goes positive then the output goes positive."

"Whereas here," and Smithy pointed to the other part of the sketch, "both A and B must go positive if the output is to go positive."

"Why?" said Dick after a moment.

"Because the resistor is trying to pull the output positive but the inputs are holding it down via their diodes."

"Oh - so the inputs don't just float about if they're not doing anything then."

"No, no," said Smithy hurriedly.

"No, the inputs are like all signals - well most signals in a binary system. They have only two states, HIGH or LOW."

"So the inputs can 'pull down' the output as well as pull it up!" exclaimed Dick.

Smithy guessed this was the root of Dick's misunderstandings at College, so to emphasise the point he quickly drew another sketch.

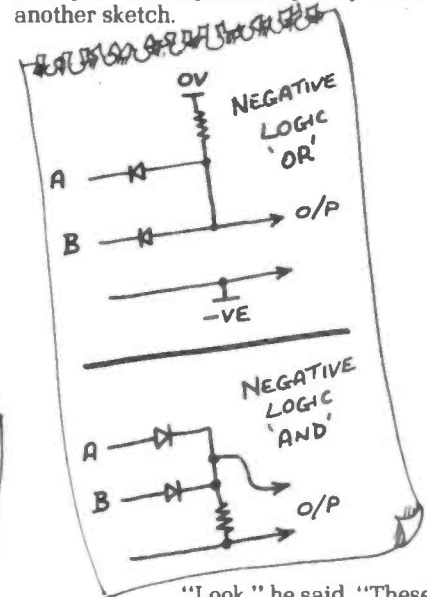

"Look," he said. "These circuits may look familiar but suppose we were using negative logic. What's this first one?"

Dick puzzled for a moment. "It's the same as the AND function for the positive logic in your fourth sketch. So how is it different?"

"Well its negative logic so if either A OR B goes negative the output will be pulled down negative."

"Oh I see!" cried Dick. "And this one is an AND because both A AND B must go down to let the output go down."

"Twice correct," beamed Smithy.

"And that's why you made the point about the logic voltage with the relay logic circuits," said Dick. "But whats the point of it all. I mean what use is it?"

Suddenly a thought struck Smithy. "Well take our burglar alarm for



PIEZO ACOUSTIC SOUNDERS

The most efficient sounders yet devised, with over 90dB SPL with only 2mA/5v drive at the resonant peak of 5kHz. Over 80dB at 1.5kHz too.



PB2720:100-499 25p ea

TOKO UK Ltd: tel (07535) 54057; tlx 848095

Stocked and distributed in the UK by:

Ambit int: tel (0277)230909 tlx 995194 ambit g

57 for further details



CHOKES: TOKO 8RB series.....

5mm pin spacing fixed inductors, with a full choice of values from 100uH to 33mH - most E12 values ex-stock.

Prices:

1-25: 19p/ 25-99: 13p/ 100+: 11p



TOKO UK Ltd: tel (07535) 54057; tlx 848095

Stocked and distributed in the UK by:

Ambit int: tel (0277)230909 tlx 995194 ambit g

58 for further details



CHOKES : now 1uH to 1.5H !!

Not a mistake, TOKO's new 10RBH series extends the range to one and a half HENRIES. Only 10.5mm dia by 14mm tall. And only 26p in 100off.



TOKO UK Ltd: tel (07535) 54057; tlx 848095

Stocked and distributed in the UK by:

Ambit int: tel (0277)230909 tlx 995194 ambit g

59 for further details



TUNABLE LF INDUCTORS

AMBIT's stock ranges of TOKO coils includes a range of LF adjustable coils that span the range 4mH to 55mH. (Each coil tunes approx. 30% of its nominal value.) Custom types available if required.



TOKO UK Ltd: tel (07535) 54057; tlx 848095

Stocked and distributed in the UK by:

Ambit int: tel (0277)230909 tlx 995194 ambit g

60 for further details



COILS : RF, IF, OSC etc.

TOKO quality and reliability simply cannot be beaten - and with the only stocking distribution service in the world for signal coils/chokes - nor can the price, availability and stock range .

Coils for 1kHz to 300MHz.



TOKO UK Ltd: tel (07535) 54057; tlx 848095

Stocked and distributed in the UK by:

Ambit int: tel (0277)230909 tlx 995194 ambit g

61 for further detail.



CERAMECHANICAL FILTERS :

TOKO's CFM2 series of filters combine the tight passband shaping of ceramic IF filters - coupled by a carefully selected mechanical element that keeps spuri to a very low level. Stock types 455/468kHz. Various bandwidths.

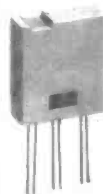

TOKO UK Ltd: tel (07535) 54057; tlx 848095

Stocked and distributed in the UK by:

Ambit int: tel (0277)230909 tlx 995194 ambit g

62 for further details



CHOKES: TOKO 7BA series.....

5mm pin spacing fixed inductors, with a full choice of values from 1uH to 1mH. E12 series available ex-stock in the UK, with the lowest prices:

1-25: 16p/ 25-99: 10p/ 100+: 8p



TOKO UK Ltd: tel (07535) 54057; tlx 848095

Stocked and distributed in the UK by:

Ambit int: tel (0277)230909 tlx 995194 ambit g

63 for further details



CERAMIC RESONATORS : MPU,

REMOTE CONTROL, DVMs etc

TOKO's new CRM (parallel) and CFE (Series) ceramic resonators offer 10ppm stability at a fraction of the cost of crystal. Available at 200-500kHz (stock type 455kHz)

1-24: 32p/ 25-99: 24p/ 100+:19p



TOKO UK Ltd: tel (07535) 54057; tlx 848095

Stocked and distributed in the UK by:

Ambit int: tel (0277)230909 tlx 995194 ambit g

64 for further details



Advertising in R&EW is easily the best value on the market.

Not only is R&EW read by the real 'doers' of the electronics scene (professionals, enthusiasts, enthusiastic professionals), it offers an unmatched cost per thousand of only £6.03 per thousand - based on our initial print orders of 63,000 issues.

The space on the left would cost you only £105 for a single shot - or £94.50 for a 12 month run. The £6.03 'cost per thousand' mentioned above is based on a full page insertion, and the only other 'bookstall' electronics magazine with a reader response service costs over £12 per thousand to reach UK readers.

The reactions from R&EW readers clearly indicate that we have identified a 'need' in the market, and that we are attracting exactly the type of readership we have promised in our prelaunch campaigns. Readers who are active, and who appreciate the difference between and electronics 'magazine' and an electronics "periodical".

Advertisers booking space now will be entitled to preferential options in some of the forthcoming R&EW 'events' - circle the number below for further details, or call Barry Hewson on (01-531-7621) for details of availability.

R&EW will be maintaining the highest editorial/advertising ratio (one of our stated intentions from the outset) in the market. Our readers don't waste money paying to read adverts, and our advertisers don't get lost in the wilderness of their competitors advertising.

53

example," he said. "There's a break contact at the window and another at the door so that if either the window or door is opened then the circuit is broken. Like this - look," and Smithy sketched two contacts in series. "Now for our alarm system," continued Smithy, "this is used as an OR circuit. You see

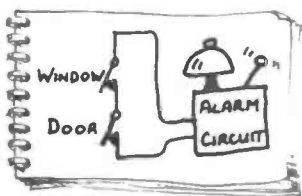

normally both contacts are closed - at least they are when you close the door and window," he added wryly, leaning forward and closing the window. "But if either the window OR the door is opened, this circuit is broken and the alarm is set off."

"But it looks like your first sketch," protested Dick. "And you said that was an AND circuit."

"So it is," chuckled Smithy. "But I've inverted the logic level by looking for a broken circuit. You see now its an OR circuit because either contact will break the loop. If you were looking to see if and when the loop is completed then its an AND circuit because you need both the door and the window to be closed."

Dick rolled his eyes in mock

despair. "Well when would you use this series circuit as an AND thingy?" he asked.

Smithy paused and then suddenly grinned. "If you were launching a really big rocket, like NASA," he explained, "you'd need to know if all the vital systems were functioning correctly. So you could take a signal from each system and put them into an AND circuit which would include the firing button. So you could only launch the thing when everything was OK, the fuel level and the communications links and the life support system and of course the firing button had been pressed. Mind you it would be a bit more complicated than our simple series circuit."

Dick digested all this information and was silent for a moment. "I wonder," he said, "if you could use your wired-OR as a wired-AND in any way."

"Not really," laughed Smithy. "Without the isolation between inputs, it's still a recipe for a loud bang."

"Rockets and bangs," thought Dick, and suddenly he looked at the window. "Hey look it's dark," he cried. "Time for whizz-bangs!" He rummaged under his bench for his box of fireworks. "Thanks for explaining all about logic," he said over his shoulder.

"Well there's a fair bit more to it than that..." started Smithy.

"Right," said Dick shrugging on his raincoat. "TTL and CMOS and all that.

If I get any problems I expect you can sort them out for me. Bye...." and Dick rushed out into the cool dark night leaving the door wide open behind him.

As silence settled on the workshop Smithy glanced at the digitally tuned radio on the 'awaiting repairs' rack. "Oh there'll be plenty of problems," he thought.

Alone, Smithy moved to the workshop door, hung up his white coat, slipped into his jacket, glanced at Dick's crumpled anorak which was back on the floor and sighed quietly. As distant fireworks crackled and flared in the night sky he bent to pick it up but saw Tracker curled up on it.

"Yes, you're safer and better-off there tonight," he murmured and after gently stroking the sleeping bundle he straightened up, glanced at the mains switches over the benches, switched off the lights and stepped out into the night.

Smithy quietly closed the door behind him.

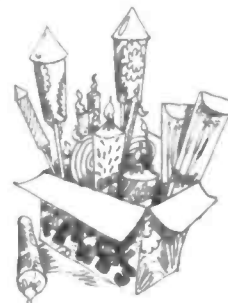

Higher Fidelity

Mike Creek

PART II

..... following on from last month's loudspeaker protection circuit.

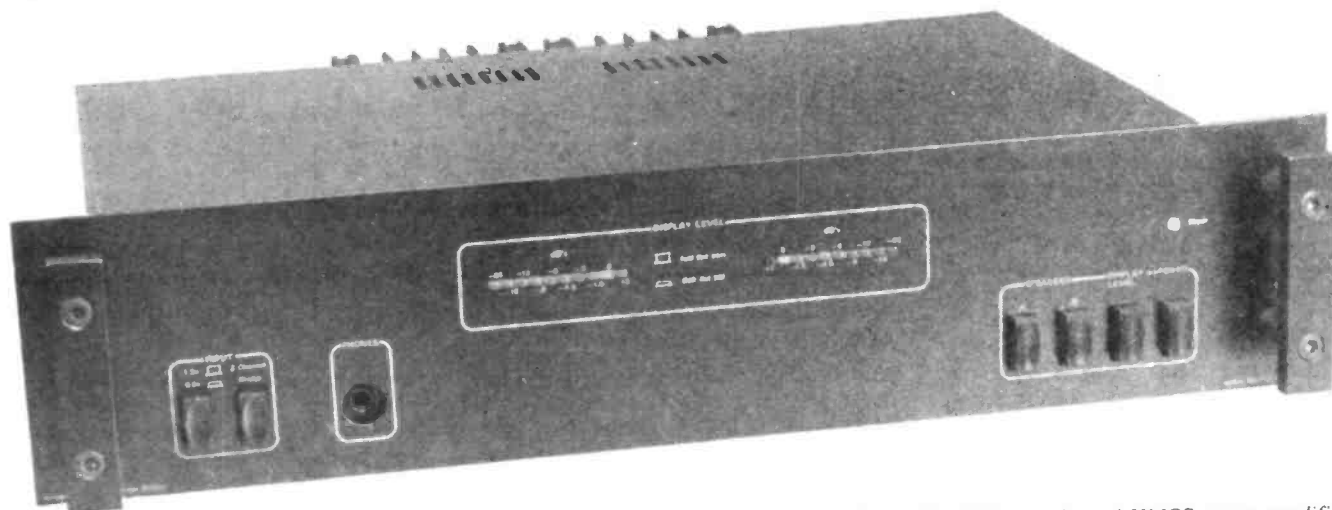

The much-refined 150w RMS per channel HMOS power amplifier

The power supply and amplifier.

In view of the varying ideas and opinions on what constitutes the 'correct' power output for a 'Hi Fi' amplifier, it is necessary to examine the reasoning for such a large power output - when only around 10-20W average will be required.

If you need to reproduce the dynamic range (difference between the loudest and quietest sounds) and frequency information found on the latest analogue and digital recordings, then you must have an amplifier which is capable of reproducing at least 90dB, and allowing for some extra headroom so that the amplifier does not clip at that level, then an extra 10dB or more is desirable. The amp must also be able to follow fast transient information accurately, so it must also have a fast slewing (dV/dt) capability. As the power for the amplifier is derived by the power supply (minus the resistance of the output devices 'Ron') whose function is to modulate the DC power supply with an audio signal, it is essential to have a very low impedance power supply. In fact, the power supply is just as important as the actual amplifier if the full potential of the system is to be realised.

With this design, it is possible to run each channel of the amplifier with a completely separate power supply. This will give the ultimate in low and middle frequency crosstalk figures, providing that correct earth wiring is maintained. The effectiveness of the power line decoupling is rather better at the higher audio frequencies, so the the PSU does

not play quite such an important role above 1kHz.

So that the design can be built 'on easy terms', a single power supply version can be expanded with a second PSU at a later stage.

As mentioned earlier the voltage drop across the output devices (*Ron*) is a significant factor in the efficiency of the power amp. MOSFET's have a higher *on* resistance than bipolar transistors, therefore more power is dissipated in a MOSFET output stage than a bipolar equivalent. However, one of the many features of HMOS devices allows you to simply parallel several pairs of devices, without the awkward side effects encountered when trying to place bipolar devices in parallel. Each additional pair

reduces *Ron* and increases the current capability - making it possible to dissipate more power into the load and not into the heatsink.

The basis of this design is a compact module which has all its inputs, outputs and power rails plugged-in to one PC socket and the output devices mounted on a bracket and soldered directly onto the PCB, allowing for repeatability of manufacture and performance.

How it works

The circuit with its long-tailed pair on the input can be likened to a large operational amplifier with the positive input being the main signal input (TR1) and the negative input (TR2) being used for the negative feedback connection. Since the input will respond down to DC as well as AC, there is a requirement for a DC sensing circuit (LS1000 - see part one in last month's issue) to protect your speakers. The signal is then fed to the

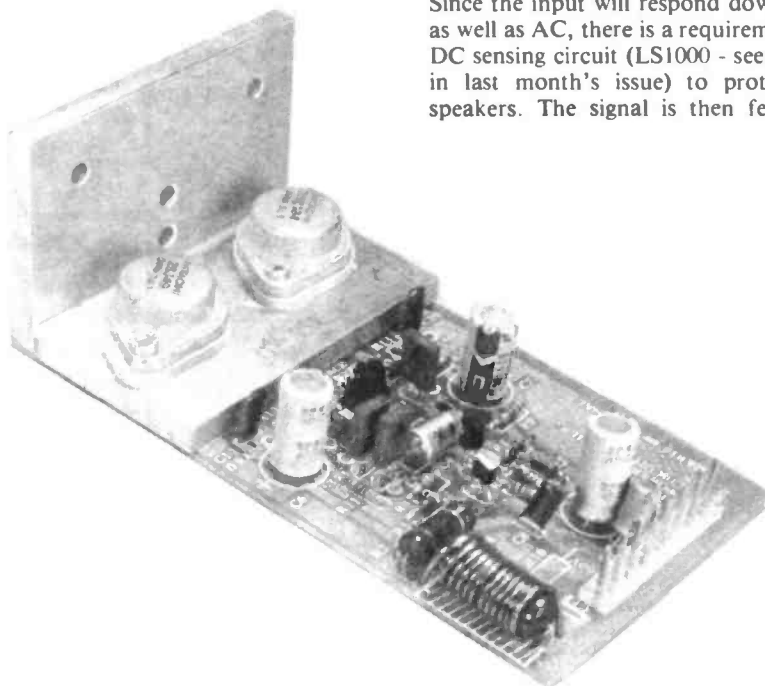

differential pair (TR4 & 5) where the positive and negative half sine waves are amplified by TR3 and 5. These transistors need only be modified TO92 package devices, as very little driver power is needed to overcome the capacitance effects of the FET's gate.

The HMOS FET's are complementary P and N Channel devices and are connected in a source follower mode. This is similar to the conventional push-pull emitter follower method as used in bipolar designs, which provides a wide transfer bandwidth and good stability.

Whilst the forward transconductance, Y_{fs} of power MOSFET's is as large as 1 S (Siemens or 'Mho') - this is only a fraction of that of a bipolar transistor, which leads to higher open loop distortion. Since the power MOSFET produces an open loop distortion of about 20dB greater than a bipolar device, it is necessary to use larger open loop gain and more negative feedback. Purists who have listened to the arguments about the efficacy of negative feedback with respect to TIM may consider this a bad thing - but the speed of the MOSFET makes up for increased NFB.

Applying negative feedback in relatively slow bipolar amplifier designs will cause a large phase shift to occur, forcing a compromise in frequency/gain characteristics in a phase compensation circuit. With a single MOSFET device in source follower mode, much feedback can be applied over a wide bandwidth, to reduce distortion to lower levels than those achievable in a bipolar design, and with a good deal less complication.

The MOSFET does not require a conventional class B driver stage. Therefore, the frequency compensation 'poles' of the amplifier can be reduced,

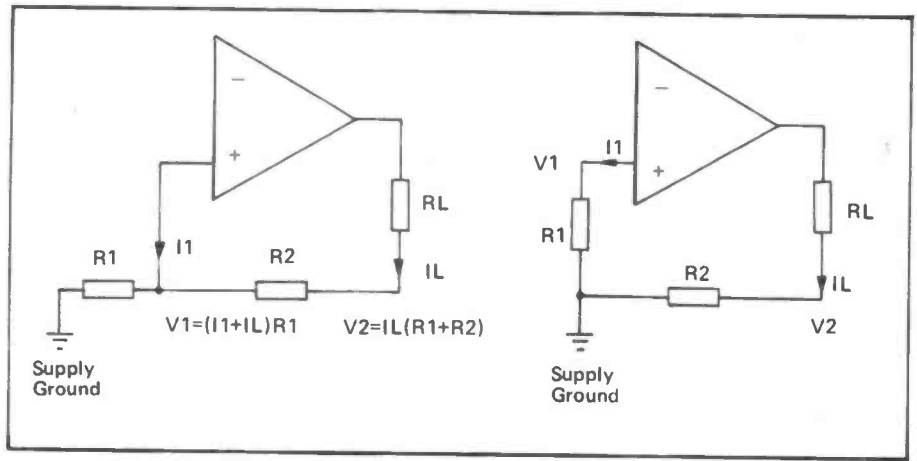

Figure 2 : Ground Loop Example

Figure 2.2 : Single Point Ground System

and a large and stable DC negative feedback can be formed which does not compromise the amplifier's dynamic performance (transient). R7-22k and R6-1k form the feedback attenuator, and allow for 23 times voltage gain i.e. 1.25v RMS input will give 120 watts output into an 8 ohm load, using separate 250VA transformers and a single pair of output FET's. If two pairs of FET's are used - then approximately 160W into 8 ohms is possible using the same power supply.

C3 is the feedback ground reference and effects the low frequency 3dB 'roll off' point. In theory the larger the value the lower the frequency and vice versa. With C3 at 100uF, the 3dB point is approximately 5Hz.

Since the amplifier is designed for Class AB operation, it is necessary to bias the output stage into its most linear region. A high quality cermet preset is used between the gates of the two FET's and should be adjusted to make the amp draw a standing (quiescent) current of

approx 80mA - although this is not particularly critical. If sustained high power is required, then a lower current may be desirable to keep the temperature of the heatsink lower.

A Zobell network at the output is necessary to prevent HF instability when looking into reactive loads - which encompasses just about everything that isn't a pure resistance. The 3dB point of this low pass filter is at 1.5MHz, so it will have no effect on the audio performance. This also applies to the output coil which is designed primarily for stopping RF from such things as adjacent radio transmitters getting into the feedback path, as this also has its 3dB point at 1.5MHz.

A complete kit of parts for making a mono amplifier module is available - with optional heatsink mounting bracket or 'U' channel that can be used for mounting either two or four FET's, and soldering two directly to the PCB and hardwiring to the other pair. HMOSFETs are inherently

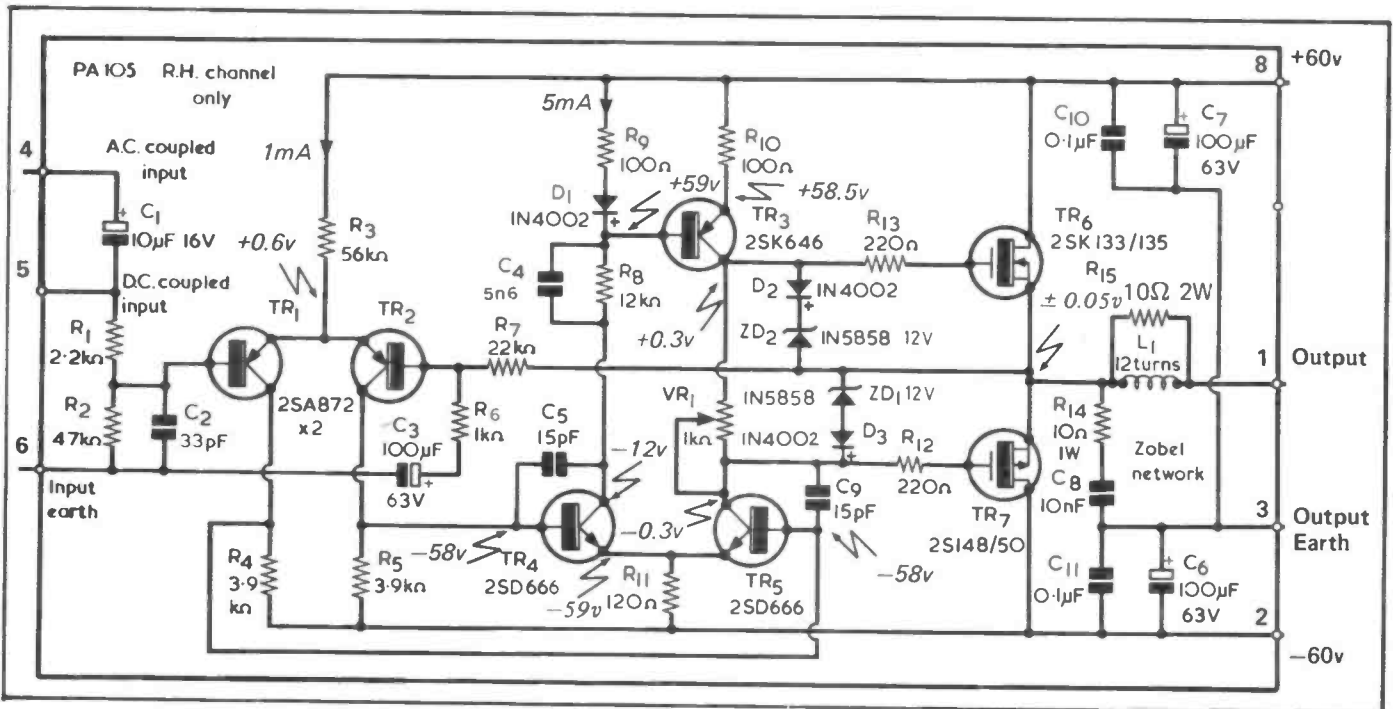

Figure 1: Circuit Diagram of PA105 Power Amplifier Module.

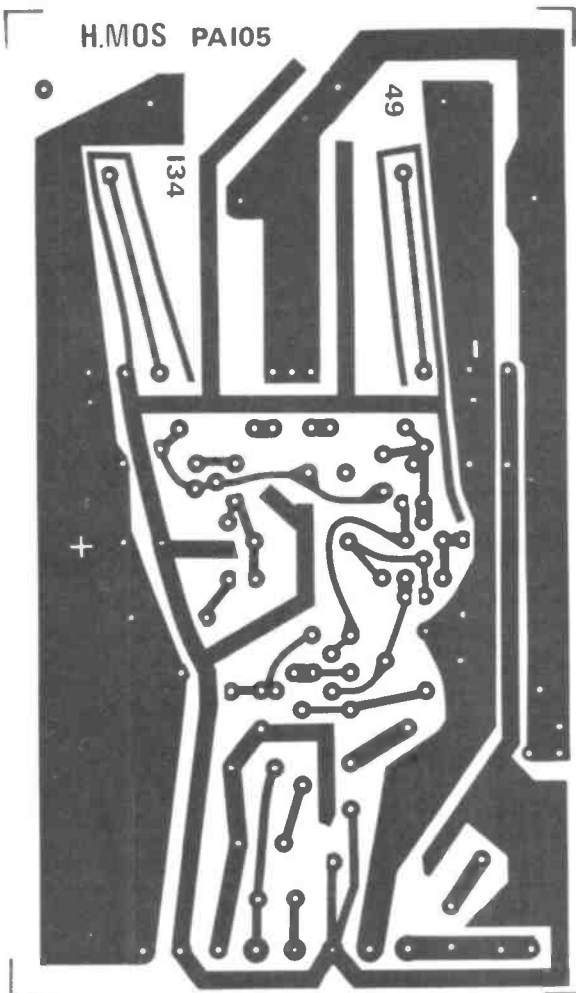
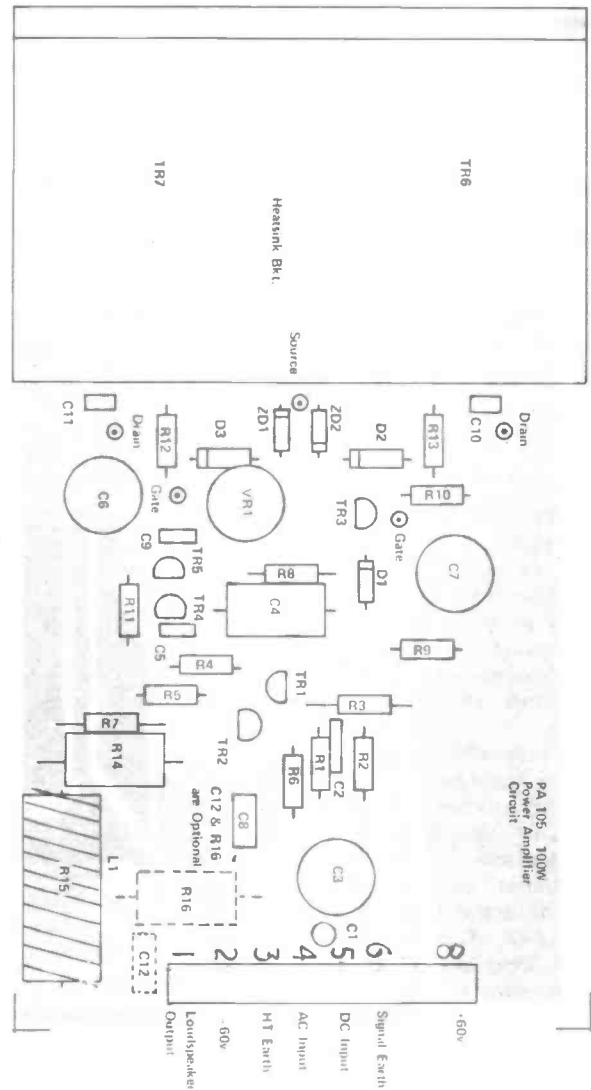

Figure 3
PC foil and overlay
detail for the PA105
amplifier module



thermally protected by their negative temperature coefficient, which will actually reduce the drain current if the junction temperature rises above 75 degrees centigrade.

The MOSFET gates are provided with zener diode clamp protection to clip the drive voltage to below the 14v maximum permissible. In normal use, the gate voltage will never reach anywhere near this. However, it is in the nature of the zener diode to offer capacitance if whilst reverse biased - so it can be detrimental to the high frequency dynamic performance if the diodes are left in circuit.

No drain (emitter) resistors are required, simplifying the wiring with only a resistor of 100/200 ohms required in the gate lead to damp the input to the device and prevent parasitic oscillation from occurring. This resistor forms a low pass filter in conjunction with the device input capacitance.

It is very important to wire the various sections of the amp together in the manner described, or instability may occur due to earth loops etc.

Earth Consideration

Perhaps the most important aspect of high current amplifier design is the correct layout of earth paths. An earth is not truly an earth unless it is 0 ohms impedance, anything more than this is dicing with potential differences between one section of 'earth' and another. Figure 2 illustrates this theory very well. Real earth leads contain finite resistance, so in the example shown the load current (1L) will be far greater than the input bias current - so V1 will follow the output voltage directly. Since the input current is basically feeding the positive side of the amplifier the result is positive audio feedback, which can very easily lead to complete instability, or at the very least, increased distortion. Thus the policy of single point earthing should be maintained at all times. The temptation to lump earth's together for the sake of convenience must be avoided.

Assembly

Solder in all the components making sure that part numbers given on the parts list match up with the legend information printed on the PCB. Make sure that all electrolytics, transistors and diodes are correctly polarised. The FET's connections are arranged with the source

being the case, and the gate lead being underneath the word 'Hitachi', which is printed on top. The Drain lead is then left.

When assembling the FET's, care should be taken not to short the case of the devices down to ground with the screws touching the heatsink bracket. Also make sure that the sources are joined together with the speaker output track on the PCB with solder tags. See figure 4. Wind 12 turns of enamel copper wire around the 10 ohm 2W resistor to be certain to scrape off all the enamel at each of the coil.

Test

To test this module, you need a low distortion signal generator, oscilloscope, multimeter and a dummy load. (8 ohm resistive 150W). This may be beyond the scope of most constructors, so you may need to compromise with cursory check using a multimeter. This should be done to check that the power supply rails are at the correct voltage: approx +/-60v off load for a 100W amplifier. The meter should then be connected in series with one of the HT rails (watch out for the smoothing capacitors, they bite) in a high current range. The amp module should then be plugged in, switched on and VR1

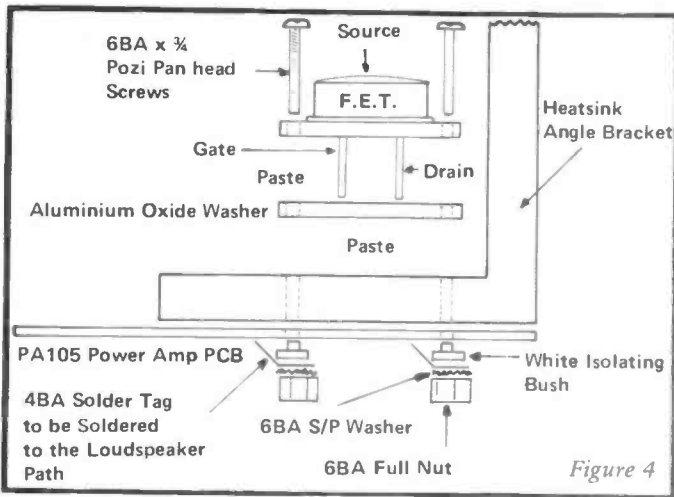
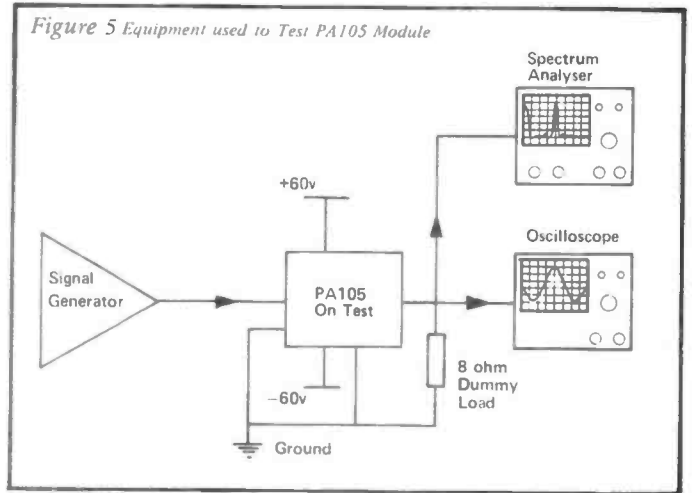

Figure 4



should be adjusted so that the unit draws approx 80mA. If you are still on the 30A current range of your meter and the needle has just fallen off, then after a clean set of underwear you should check for shorts on the FET's to ground (via some whiskers on the heatsink brackets), or perhaps the output devices are reversed.

If no problems occurred on this test, then after reconnecting the HT, measure the offset voltage on the loudspeaker path. This should be below 250mV, normally as low as 5mV. You are now in a 'Go' situation, and a proper signal can be passed through to a pair of loudspeakers without fear of blowing them up. This however does not guarantee that the signal is pure and free from crossover distortion or HF instability.

This is where it is an advantage to have the rest of the test equipment, see Figure 5 for details.

The results you should be looking for are firstly a symmetrical sinusoidal wave form, which should remain so up to approx 90 volts peak to peak on your scope or 31v RMS. This voltage into an 8 ohm load will produce in excess of 120W. No instability should be present at any level, and if you have a squarewave output on your generator, you can see if the frequency response is flat. Remember to check the test set up calibration, or like us, you may find yourself occasionally chasing your tail due to HF rolloff in the probe leads.

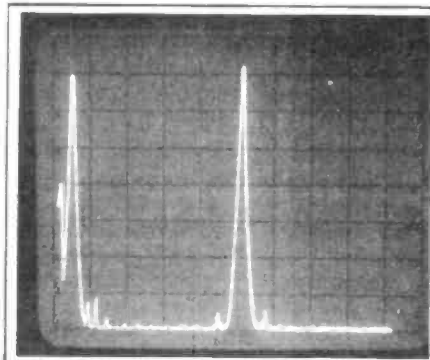

100W 8Ω
63Hz and 1kHz intermod

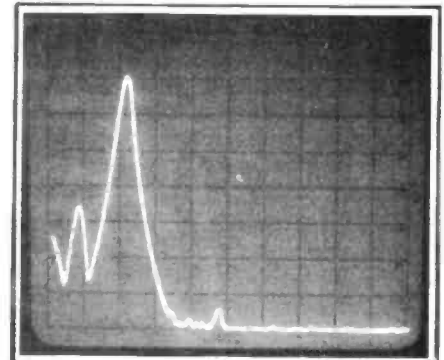

100W 8Ω 63Hz

All spectrum analyser pictures: 10dB vert. 0Hz left screen

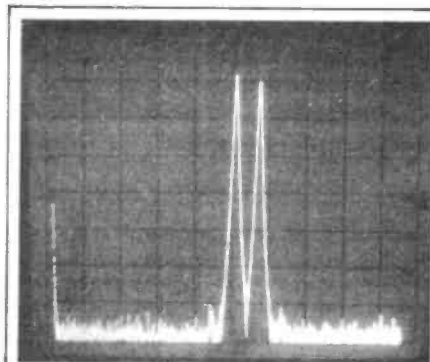

100W 8Ω
10k and 11kHz intermod

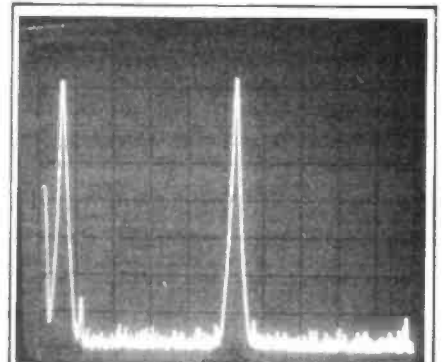

100W 8Ω
1k and 10k intermod

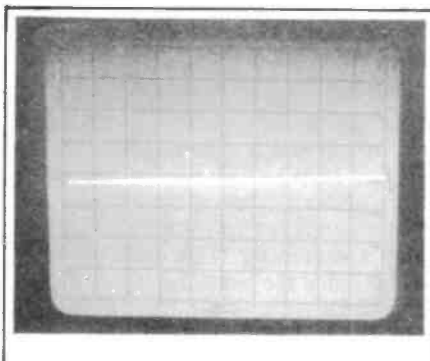

Bandwidth 100W 8Ω
0-200kHz

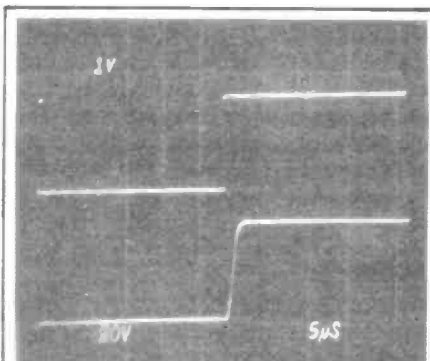

1kHz Square Wave
(input : top trace)

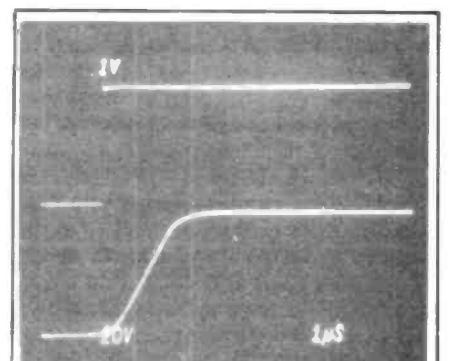

16kHz Square Wave
(input : top trace)

Components List

Resistors (All .25W 5% carbon film except R14, R15)

R 1	2k2
R 2	47k
R 3	56k
R 4	3k9
R 5	3k9
R 6	1k
R 7	22k
R 8	12k
R 9	100R
R10	100R
R11	120R
R12	220R
R13	220R
R14	10R 1W 5% carbon film

R15	10R 2W 5% carbon film
VR1	1k0 Min. Horizontal Cermet Preset

Capacitors

C 1	10uF 25v tantalum
C 2	33pF 100v min plate ceramic
C 3	100uF 63v electrolytic
C 4	5n6 polystyrene 100v
C 5	15pF 100v min plate ceramic
C 6	100uF 63v electrolytic
C 7	100uF 63v electrolytic
C 8	10nF 100v mylar
C 9	15pF 100v min plate ceramic
C10	47n 100v disc ceramic
C11	47n 100v disc ceramic

Miscellaneous

PCB	PA 105
1 x	8 way 0.2" connectors
2 x	Aluminium Oxide isolating washers
4 x	White isolating bushes
4 x	6BA x .75" pozi pan head screws
4 x	6BA x full nuts
4 x	6BA shakeproof washers
3 x	4BA solder tags
1 x	aluminium angle bracket
1 x	Extruded 3" long ally heatsink
45cms	16SWG enamel copper wire
3 x	No6 x .5" pozi pan-head.

Semiconductors

ZD1-2	BZY88C12V
D1-3	1N4001
TR1-2	2SA872
TR3	2SB646
TR4-5	2SD666
TR6	2SK134
TR7	2SJ49

Specification

Power Output	2 F.E.T. per channel	120W into 8 ohms	160W into 8 ohms
	4 F.E.T. per channel	160W into 4 ohms	230W into 4 ohms
Frequency/power bandwidth	5Hz to 200kHz —3dBs at rated output		
Slew rate	40v per uS		
Damping Factor	Better than 100 at 100Hz		
Distortion	Better than 0.03% 20Hz to 20kHz at rated output		
Intermodulation distortion	Better than 0.03% 100Hz and 10kHz		
Signal to noise	Better than 110dB		
Overload recovery	Instantaneous		
Sensitivity	1.25v RMS input for rated output		

Next month...

Assembly of complete amplifier, with careful attention to the detail of the wiring layout.

Build a pair of DALESFORD D speakers

The Dalesford D has enjoyed consistently good reviews and is acknowledged to be one of the best compact loudspeakers available. It is now offered in kit form at a considerable saving over the assembled speaker.

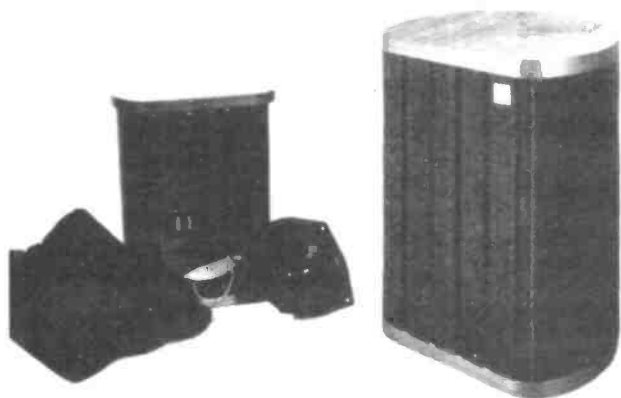

The kit includes complete and finished cabinets, grille foam, wadding, drive units, crossovers, etc. — everything, in fact, to make a pair of excellent compact loudspeakers.

Suitable for amplifiers of 20 – 70 watts

Size: 340x220x265mm. Finish: Walnut/black foam.

Price: £69.95 VAT per pair plus carriage £3.95 inc.



0625 529599

35/39 Church Street, Wilmslow, Cheshire SK9 1AS



Lightning service on telephoned credit card orders!



49 for further details

Radio and Electronics World

ANNUAL SUBSCRIPTIONS

to this magazine may be obtained through your newsagent or direct from the publishers

INLAND... £9.50 — OVERSEAS... £10.50 — per year, post free.

Please send remittance with name and address and commencing issue to:

45 Yeading Lane, Harrow, Middlesex.

MAIL ORDER PROTECTION SCHEME

The publishers of this magazine have given to the Director General of Fair Trading an undertaking to refund money sent by readers in response to mail order advertisements placed in this magazine by mail order traders who have become the subject of liquidation or bankruptcy proceedings and who fail to supply goods or refund money. These refunds are made voluntarily and are subject to proof that payment was made to the advertiser for goods ordered through an advertisement in this magazine. The arrangement does not apply to any failure to supply goods advertised in a catalogue or direct mail solicitation.

If a mail order trader fails, readers are advised to lodge a claim with the Advertisement Manager of this magazine within three months of the appearance of the advertisement.

For the purpose of this scheme mail order advertising is defined as:

"Direct response advertisements, display or postal bargains where cash has to be sent in advance of goods being delivered".

Classified and catalogue mail order advertising are excluded.



World's most powerful

**BASIC pocket computer
CASIO FX-702P**

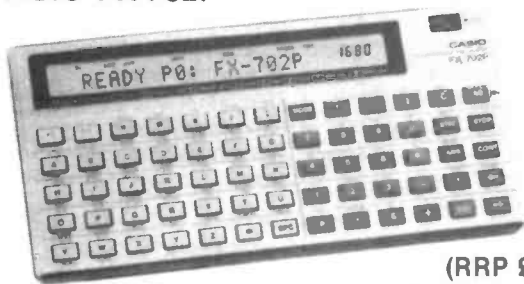

(RRP £134.95)

ONLY £119.95

High speed computer using BASIC language, with program/data storage on cassette tape via optional FA-2 adaptor.

AVAILABLE SOON: Plug in ROM program modules and FP-10 Mini Printer for program/data printout.

LCD dot matrix scrolling display. Input can be varied from 1680 program steps, with 26 independent memories, to 80 program steps with 226 memories, plus text display memory (string and string manipulations), all with power back-up. Up to 10 program storage.

Subroutines: 10 levels. FOR NEXT looping, 8 levels.

Debugging by tracing. Editing by moving cursor.

55 built-in functions including **Regression Analysis and Correlation Coefficient** all usable in programs. Program/data storage on cassette tape. Two lithium batteries give approximately 200 hours continuous use, with Auto Power Off after 6 mins disuse.

Dimensions: 17 x 165 x 82mm. (3/8 x 6 1/2 x 3 1/4). Weight 180g (6.3oz).

FX-602P Advanced programmable. Up to 512 steps **£74.95**
Plus **FREE Professional Programmable Pack** (RRP £12.95)

NEW! **FX-3600P** 38 program steps **£22.95**



World's most versatile

**alarm chronograph watch
CASIO AX-210**



(RRP £34.95)

ONLY £29.95

Hourly time signal "Big Ben" chimes at noon. Easily switched on or off.

Countdown alarm timer mode

* Amazing ANALOGUE display, plus digital countdown. Normal and net times from 1 to 60 minutes with automatic retrieval of pre-entered time.

Stopwatch mode

* ANALOGUE countup, with digital timing of net, lap and first and second place times from 1/100 sec to 1 hour. Confirmation signal.

Easy setting of times and alarm with forward and backward stepping and rapid run facility. Dimensions: 9.25 x 35 x 36mm approx. Mineral glass. Long life lithium battery. Accuracy ±15 seconds/month.

10 alternative displays
Over 60 useful functions

ANALOGUE display of time plus:-

* Digital time display, 12 or 24 hour system.

* Digital date, month and year, plus day flag.

* Full month calendar display, current month.

* Full month calendar display, next month.

Auto calendar pre-programmed to the year 2029.

Dual time modes

* ANALOGUE display of local time, plus digital second time zone, 12 or 24 hour system.

Alarm mode

* ANALOGUE time with "Alarm Set" digital time, 24 hour system. AM/PM and "alarm on" indicators. Buzzer for 20 seconds, or select "Dixieland" "Green Sleeves" or "My Darling Clementine".



CASIO PROGRAMMABLES

With power back-up for memories and programs

NEW FX-602P

LCD dot matrix scrolling display. 32 to 512 program steps. 22 to 88 memories. 33 parentheses, 11 levels. Editing by cursor.

Jumps.
9.6 x 71 x 141.2mm.
100g.

(RRP £84.95) **£74.95**

Plus **FREE Professional Programming Pack** (RRP £12.95)

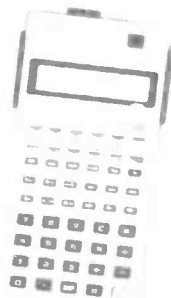

THESE SPACE INVADERS WILL ALARM YOU

Casio's most amazing watches ever!

CA90 (left)

£19.95*

CA901 (right)

£29.95



Time and auto calendar, calculator, alarm, hourly chimes, stopwatch, dual time.
DIGITAL SPACE INVADER GAME.

* CLAIRVOYANT CALCULATOR

Fortune Teller, Matchmaker, Calendar and Alarm Clock

CASIO FT-7



(RRP £18.95)

ONLY £16.95

Predictions of individual fortunes (Health, Gamblene/Investment, Business and Love) or the compatibility between two persons on any given day.

6 digit clock. Auto calendar pre-programmed from 1901 to 2099. Daily alarm and hourly chimes can be easily switched on or off. Calculator with full memory, %. One year battery life (2 x LR44).

7.9 x 114 x 56.5mm (3/8 x 4 1/2 x 2 1/4"). 58g (2oz). With wallet.

NEW FX-3600P

Up to 38 steps and 2 programs, plus 7 memories. 18 parentheses, 6 levels. 61 functions, including Integrals & Regression Analysis. Long life Lithium battery.
8.7 x 71.5 x 134mm. 64g.
(RRP £25.95) **£22.95**

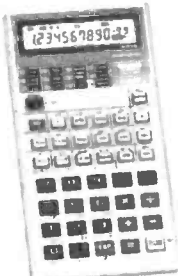

NEW MG-885

"Game II" and calculator. Full memory and % plus 3 level digital space invader game.

(RRP £12.95) **£10.95**

The highly successful MG-880 calculator/game plus **FREE** cubik puzzle
ONLY £10.95

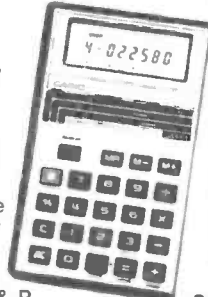

SHORT FORM CATALOGUE

Available October
14p stamp appreciated

Delivery normally by return of post. Prices include VAT and P & P.
Send your cheque, P.O., or phone your ACCESS of B'CARD number to:

THE LEADING U.K. REPRESENTATIVE,
Dept. REW/11,
164/167 East Road, Cambridge, CB1 1DB
Tel: 0223 312866

TEMPUS

VIVID REALISM

Sound is the criterion when judging a musical instrument. Our CASIOTONE keyboards are outselling all others because of their superb reproduction, quality and legendary reliability

Order today, play tomorrow

SECURICOR 24 hour delivery included in price, or RETURN OF POST (small keyboards) or CASH & CARRY

The Professionals
THE EXCITING NEW CASIOTONE CT-202

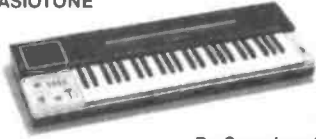

(RRP £325)
By Securicor ONLY £275

"Son of success...The two harpsichords demonstrate the Casiotone's talent for sparkling, crystal clear tones...Even more impressive is the clav." (Melody Maker).

8-note polyphonic playing of 49 instruments over 4 octaves. 4 voice memory function with push-button selection. 3 Vibrato settings and Sustain switch. Integral amplifier and speaker (10 watts o/p). Line Out and headphone jacks, Foot volume and sustain pedal jacks. Pitch control.

CASIOTONE MT-30



(RRP £115.00)
ONLY £95.00

22 instruments over 3 octaves. 4-position sound memory. Battery or mains. O/P jack. Dims: 2 1/2 x 22 3/4 x 6 1/2". 6lb.

Vivid realism for beginner and expert
CT-401



(RRP £345)
By Securicor ONLY £295

8-note polyphonic playing of 14 instruments over 4 octaves. 16 rhythm functions with full-in auto rhythm. A fill-in button adds variety. Casio Auto Chord system for one-finger accompaniment (major, minor and seventh chords) or automatic chord and bass accompaniment. With Vibrato. Delayed Vibrato, Sustain and Hold switches. Integral amplifier and speaker. Line and headphone jacks. Foot volume and sustain pedal jacks. Pitch control. AC only. 4 1/4 x 31 1/8 x 12 1/2 inches. Weight 28.2lbs.

CT-301. Similar to the 401 without Casio Auto Chord £199
MT-30. 22 instruments. 3 octaves. Vibrato, Sustain.

Mains/Battery. £95

BECOME AN INSTANT MUSICIAN

"Tomorrow's World" featured this resounding success. Hundreds sold already. Create your own music with a VL-TONE. You combine the sound, rhythm and tempo and the VL-TONE plays it back...beautifully!

CASIO VL-TONE (VL-1)

Electronic Musical Instrument

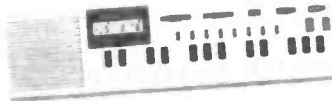

(RRP £39.95)
ONLY £35.95

This complete 29 note (expandable) synthesizer records and plays back up to 100 notes. Enter the notes of a melody into the memory and recall them in sequence with the One Key Play button, varying tempo and duration of each keystroke to create a melody. Mistakes can be corrected and individual notes added or deleted. Your best performance can be re-recorded back into the memory, then re-played at a touch of the Auto Play key. Choose an instrument (Piano, Violin, Flute, Guitar or Fantasy) or switch to A.D.S.R. and program your own unique sound from one of 80 million combinations. Select one of the ten Auto Rhythm accompaniments, adjust the Tempo Control and play back your composition, then try a variation. Facilities: Digital display of notes and tempo. Mains or battery operation with battery saving Auto Power Off, with protection of the stored melody and preset A.D.S.R. data. Built-in amplifier/speaker. Output Jack. Pitch Control. 11 1/2 x 11 1/2 x 3 inches. Weight 15.4oz.

illustrated catalogue of Casio and Casiotone 20p

Conquer the chip!

The silicon 'Chip', the microprocessor, and the whole field of modern electronics will revolutionise every human activity over the next decade... If you are looking for a new job or career, promotion, your own business or simply want to keep abreast of modern developments - you will need to master the subject. It can be done simply and efficiently, in a practical way. No previous knowledge is needed. Write to us now - without the slightest obligation... We have been successfully training people in electronics at home, for over 40 years!



MASTER ELECTRONICS

LEARN THE PRACTICAL WAY BY SEEING AND DOING

- Building an oscilloscope • Recognition of components
- Understanding circuit diagrams • Handling all types Solid State 'Chips'
- Carry out over 40 experiments on basic circuits and on digital electronics.
- Testing and servicing of Radio, T.V., Hi-Fi and all types of modern computerised equipment.

MASTER MICROPROCESSORS

LEARN HOW TO REALLY UNDERSTAND MICROPROCESSORS, HOW THEY WORK AND THEIR APPLICATION TO COMPUTER TECHNOLOGY.

- Complete Home Study Library • Programming
- Special Educational Microprocessor Equipment supplied
- Services of skilled tutor available throughout course

MASTER THE REST

- Radio Amateurs Licence • Logic/Digital techniques
- Examination courses (City & Guilds etc.) in electronics
- Semi-conductor technology
- Training Kits (Signal Generators, Digital Meters etc.)

FREE	Please send your FREE brochure without obligation to	I am interested in -
	Name	PRACTICAL ELECTRONICS
	Address	MICROPROCESSORS
		OTHER SUBJECTS
		<small>(Please state your interest)</small>
BLOCK CAPS PLEASE		

BRITISH NATIONAL RADIO & ELECTRONICS SCHOOL
READING, BERKS. RG1 1BR REW 11/81 7R



Just **50p** will bring you the latest Wilmslow Audio 80 page catalogue packed with pictures and specifications of HiFi and PA Speaker Drive Units, Speaker Kits, Cabinet Kits....

1000 items for the constructor.

- CROSSOVER NETWORKS AND COMPONENTS.
- GRILLES, GRILL FABRICS AND FOAM. PA, GROUP
- DISCO CABINETS - PLUS MICROPHONES - AMPLIFIERS - MIXERS - COMBOS - EFFECTS - SPEAKER STANDS AND BRACKETS - IN-CAR SPEAKERS AND BOOSTERS ETC. ETC.

- ★ Lowest prices - Largest stocks ★
- ★ Expert staff - Sound advice ★
- ★ Choose your DIY HiFi Speakers in the comfort of our listening lounge. (Customer operated demonstration facilities)
- ★ Ample parking ★
- ★ Access - Visa - American Express accepted ★



0625 529599

35/39 Church Street, Wilmslow, Cheshire SK9 1AS



Lightning service on telephoned credit card orders!



MULLARD UNILEX

A mains operated 4 + 4 stereo system. Rated one of the finest performers in the stereo field this would make a wonderful gift for almost anyone. In easy to assemble modular form this should sell at about £30 — but due to a special bulk buy and as an incentive for you to buy this month we offer the system complete at only £16.75 including VAT and post. **FREE GIFT** — buy this month and you will receive a pair of Goodman's elliptical 8"x5" speakers to match this amplifier



DELAY SWITCH

Mains operated — delay can be accurately set with pointers knob for periods of up to 2 1/2 hrs. 2 contacts suitable to switch 10 amps — second contact opens a few minutes after 1st contact. £1.95.

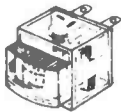

LEVEL METER

Size approximately 3/4" square, scaled signal and power but cover easily removable for rescaling. Sensitivity 200 uA. 75p.

1/2 PRICE CABLES! Flat P.V.C. covered mains cables — for lighting and power installations.

SIZE	TYPE	100 Metres	CARRIAGE
1.5mm	Single	£ 3.95	£2.00
1.5mm	Flat twin	£ 6.50	£2.50
1.5mm	Flat three core & E	£ 9.85	£3.00
6mm	Single	£ 7.50	£2.50
4mm	Flat twim	£11.50	£3.50
6mm	Flat three core	£34.50	£4.50
16mm	Twin & E	£65 + £9.75	£10.00

INSTRUMENT BOX WITH KEY

Very strongly made (ply-wood sides with hard board top and bottom). This is black grained effect, vinyl covered, very pleasing appearance. Internal dimensions 12 1/2" long, 4 1/4" wide, 6" deep. Ideal for carrying your multi-range meter and small tools and for keeping them in a safe place. £2.30. Post paid if ordered with other goods, otherwise £1.00.

COMPUTER KEY SWITCHES (make your own keyboard)

These are for making up on a p.c.b. and consist of a vertical mounting computer type reed switch, which makes circuit when a magnet passes over it. The magnet is located in the plastic plunger which in turn is depressed by a push rod, to which the legended top is fixed. These are made up in banks of 6, price £2.30 per bank of 6 (including tops)



OUR CAR STARTER AND CHARGER KIT has no doubt saved many motorists from embarrassment in an emergency you can start car off mains or bring your battery up to full charge in a couple of hours. The kit comprises: 250w mains transformer, two 10 amp bridge rectifiers, start/charge switch and full instructions. You can assemble this in the evening, box it up or leave it on the shelf in the garage, whichever suits you best. Price £11.50 + £2.50 post.

GPO HIGH GAIN AMP/SIGNAL TRACER. In case measuring only 5 1/2" x 3 1/2" x 1 1/2" is an extremely high gain (70dB) solid state amplifier designed for use as a signal tracer on GPO cables, etc. With a radio it functions very well as a signal tracer. By connecting a simple coil to the input socket a useful mains cable tracer can be made. Runs on standard 4 1/2v battery and has input, output sockets and on-off volume control, mounted flush on the top. Many other uses include general purpose amp, cueing amp, etc. An absolute bargain at only £1.85. Suitable 80ohm earpiece 69p.

MINI MONO AMP on p.c.b., size 4 1/2" x 2 1/2"

approx. Fitted volume control and a hole for a tone control should you require it. The amplifier has three transistors and we estimate the output to be 3W rms. More technical data will be included with the amplifier. Brand new, perfect condition, offered at the very low price of £1.15 each, or 10 for £10.00.

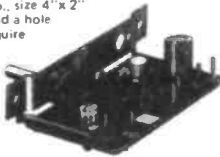

12V FLUORESCENT LIGHTING

For camping — car repairing — emergency lighting from a 12v battery you can't beat fluorescent lighting. It will offer plenty of well distributed light and is economical. We offer an inverter from a 12v 13 watt miniature fluorescent tube. £3.45. (tube not supplied).



SONY HI-FI SPEAKER CABINETS

Made for an expensive Hi-Fi outfit — will suit any decor. Resonance free cut-outs for 6 1/2" woofer and 2 1/2" tweeter. The front is thick and stuck in after the speakers are fitted and the completed unit is most pleasing. Colour teak. Supplied in pairs, price £6.90 per pair (this is probably less than the original cost of one cabinet) carriage £3.50 the pair.



TANGENTIAL BLOW HEATER

2.5 Kw quiet, efficient instant heating from 230/240 volt mains. Kit consists of blower as illustrated, 2.5 Kw element, control switch and data all for £4.95, post £1.50.



MOTORISED DISCO SWITCH

With 10 amp changeover switches. Multi-adjustable switches all rated at 10 amps, this would provide a magnificent display. For mains operated 8 switch model £6.25, 10 switch model £6.75, 12 switch model £7.25.



3 CHANNEL SOUND TO LIGHT KIT

Complete kit of parts for a three-channel sound to light unit controlling over 2000 watts of lighting. Use this at home if you wish but it is plenty rugged enough for disco work. The unit is housed in an attractive two-tone metal case and has controls for each channel, and a master on/off. The audio input and output are by 3/8" sockets and three panel mounting fuse holders provide thyristor protection. A four-pin plug and socket facilitate ease of connecting lamps. Special snip price is £14.95 in kit form or £19.95 assembled and tested.



THIS MONTH'S SNIP

COMPUTER PRINTER FOR ONLY £4.95

Japanese made Epson 310 — has a self starting, brushless, transistorised d.c. motor to drive the print hammers, print drum — tape forward/reverse and paper feed. Complete in module form with electronics including Printer Synchro Signal Amplifier & Printer Reset Signal Amplifier. Brand new and with technical and practical data. £4.95 post £1.25. Data separately for £1.00.

EXTRACTOR FANS — Mains Voltage

Ex-computer, made by Woods of Colchester, ideal as blower; central heating systems, fume extraction etc. Easy fixing through panel, very powerful 2,500 rpm but quiet running. Choice of 2 sizes, 5" £5.50, 6" £6.50, post £1 per fan.



100uA PANEL METER

Japanese made (Shinohara Electrical) so very good quality, these have a full vision front, are approx. 2" square and come complete with mounting studs and nuts. A thoroughly reliable instrument usually retailed at over £4, offered at a snip price this month of £2.85 or 10 for £25.00.

12v MOTOR BY SMITHS

Made for use in cars, these are series wound and they become more powerful as load increases. Size 3 1/2" long by 3 1/2" dia. These have a good length of 1/4" spindle — price £3.45. Ditto, but double ended £4.25.



EXTRA POWERFUL 12v MOTOR

Made to work battery lawnmower, this probably develops up to 1/4 h.p., so it could be used to power a go-kart or to drive a compressor, etc. etc. £6.90 + £1.50 post.

MINI-MULTI TESTER Deluxe pocket size precision moving coil instrument, Jewelled bearings: 2000 o.p.v. mirrored scale.

11 instant range measures: DC volts 10, 50, 250, 1000. AC volts 10, 50, 250, 1000. DC amps 0 — 100 mA. Continuity and resistance 0 — 1 meg ohms in two ranges. Complete with test prods and instruction book showing how to measure capacity and inductance as well. Unbelievable value at only £6.75 + 50p post and insurance.



FREE Amps range kit to enable you to read DC current from 0 — 10 amps, directly on the 0 — 10 scale. It's free if you purchase quickly, but if you already own a Mini-Tester and would like one, send £2.50.

FREE OUR CURRENT BARGAIN LIST WILL BE ENCLOSED WITH ALL ORDERS.

TRANSMITTER SURVEILLANCE

Tiny, easily hidden but which will enable conversation to be picked up with FM radio. Can be made in a matchbox — all electronic parts and circuit. £2.30. (Not licenced in the U.K.).

RADIO MIKE

Ideal for discos and garden parties, allows complete freedom of movement. Play through FM radio or tuner amp. £6.90 comp. kit. (Not licenced in the U.K.).

FM RECEIVER

Made up and working, complete with scale and pointer needs only a speaker, ideal for use with our surveillance transmitter or radio mike. £5.85.

CB RADIO —

Listen in with our 40-channel monitor. Unique design ensures that you do not miss sender or caller. Complete kit with case, speaker and instructions only £5.99.

NEW ADDRESS FOR CALLERS: —
2, Bentham Road, Off Elm Grove, Brighton.
Telephone: Brighton 671457. Please phone before calling for anything special.

VENNER TIME SWITCH

Mains operated with 20 amp switch, one on and one off per 24 hrs, repeats daily automatically correcting for the lengthening or shortening day. An expensive time switch but you can have it for only £2.95. These are new but without case, but we can supply plastic cases (base and cover) £1.75 or metal case with window £2.95. Also available is adaptor kit to convert this into a normal 24hr. time switch but with the added advantage of up to 12 on/off per 24hrs. This makes an ideal controller for the immersion heater. Price of adaptor kit is £2.30.



STEREO HEADPHONES

Japanese made to very good quality. 8 ohm impedance, padded, terminating with standard 1/4" jack-plug. £2.99 Post 60p.



TIME SWITCH BARGAIN

Large clear mains frequency controlled clock, which will always show you the correct time + start and stop switches with the dials. Comes complete with knobs. £2.50.



SAFE BLOCK

Mains quick connector will save you valuable time. Features include quick spring connectors, heavy plastic case and auto on and off switch. Complete kit. £1.95.

6 WAVEBAND SHORTWAVE RADIO KIT

Bandspread covering 13.5 to 32 metres. Based on circuit which appeared in a recent issue of Radio Constructor. Complete kit includes case materials, six transistors, and diode — condensers, resistors, inductors, switches, etc. Nothing else to buy if you have an amplifier to connect it to or a pair of high resistance headphones. Price £11.95.

SHORT WAVE CRYSTAL RADIO

All the parts to make up the beginner's model. Price £2.30. Crystal earpiece 65p. High resistance headphones (gives best results) £3.75. Kit includes chassis and front but not case.

RADIO STETHOSCOPE

Easy to fault find — start at the aerial and work towards the speaker — when signal stops you have found the fault. Complete kit £4.95.

INTERRUPTED BEAM

This kit enables you to make a switch that will trigger when a steady beam of infra-red or ordinary light is broken. Main components — relay, photo transistor, resistors and caps etc. Circuit diagram but no case. Price £2.30

MUGGER DETERRENT

A high-note bleeper, push latching switch, plastic case and battery connector. Will scare away any villain and bring help. £2.50 complete kit.

8 POWERFUL BATTERY MOTORS

For models, Meccanos, drills, remote control planes, boats etc. £2.50.

WATERPROOF HEATING WIRE

60 ohms per yard, this is a heating element wound on a fibre glass coil and then covered with p.v.c. Dozens of uses — around water pipes, under grow boxes in gloves and socks. 23p per metre.

COMPONENT BOARD Ref. W0998

This is a modern fibreglass board which contains a multitude of very useful parts, most important of which are: 35 assorted diodes and rectifiers including 4 3amp 400v types (made up in a bridge) 8 transistors type BC107 and 2 type BFY-51 electrolytic condensers, SCR ref 2N 5062, 2500uf 100v DC and 100uf 25v DC and over 100 other parts including variable, fixed and wire wound resistors, electrolytic and other condensers. A real snip at £1.15.

FRUIT MACHINE HEART. 3 wheels with all fruits, motorised and with solenoids for stopping the wheels with a little ingenuity you can defy your friends getting the "jackpot". £9.95, + £4 carriage.

4-CORE FLEX CABLE

White pvc for telephone extensions, disco lights, etc. 10 metres £2, 100 metres £15. Other multicore cable in stock.

J. BULL (Electrical) Ltd.

(Dept. W), 34 - 36 AMERICA LANE,
HAYWARDS HEATH, SUSSEX RH16 3QU.

Established
30 YEARS

MAIL ORDER TERMS: Cash, P.O. or cheque with order. Orders under £10.00, add 60p service charge. Monthly account orders accepted from schools and public companies. **ACCESS & BARCLAYCARD** orders phone Haywards Heath (0444) 54563. **CALLERS:** to Haywards Heath or 2, Bentham Road, Off Elm Grove, Brighton. **BULK ORDERS:** Please write for special quotation.

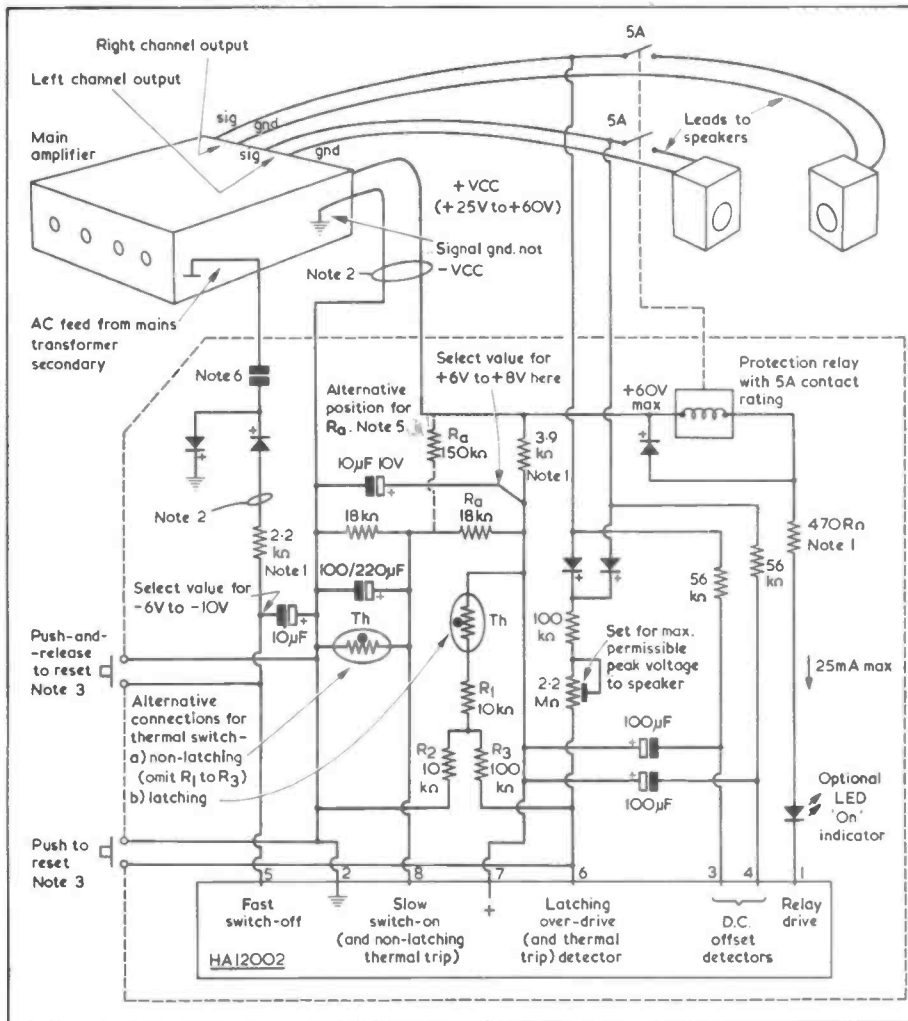

Figure 3:
One example of a loudspeaker protection circuit realised using the HA12002. This circuit includes various options for:

- A) latching/non-latching thermal cutout
- B) manual reset by 'push to reset' and 'push-and-release to reset'
- C) switch-on delay may include main amplifier power-up period.

Notes:

- 1. Values shown are typical for a +60V supply rail.
- 2. The +ve, ground and AC feeds can be derived either from the main

amplifier or external PSU. The fast switch-off facility will be retained if the mains to the PSU is switched via the main amplifier.

- 3. The manual reset is an optional facility. The latch will normally be reset by switching the mains power off and then on again.
- 4. All diodes are 1N4002
- 5. If the main amplifier PSU charge up time is to be included in the overall switch-on delay, then Ra is connected to the +Vcc rail of the main amplifier. A suitable value for Ra is 150k.

option R1,R2 and R3 can be omitted

B. If the protection circuit is an add-on to an existing amplifier/loudspeaker setup then the positive, common (ground) and AC supplies to the IC can be derived from a separate power supply. In this case the power supply must be switched via the main amplifier power switch if the fast switch-off facility is to be retained.

C. The internal latch can be manually reset by a simple push-to-make switch which grounds either lead 5 or 6. By grounding lead 6 the relay will re-operate as soon as the button is pressed. By grounding lead 5 the relay will re-operate only when the push button is released after being pressed

D. If the amplifier's main power supply charge-up time is to be included in the overall switch-on delay then Ra is connected to the +Vcc rail. A suitable value then is 150k ohms.

Other applications

Although primarily designed for loudspeaker protection applications the novel set of functions including the high voltage relay switching circuit contained within the HA12002 make it a potentially useful low cost device for 'relay controlled' and other applications, for example:

Industrial Control:

Single or multiple point safety cutout controls in machine rooms.
Overheating cutout.

Generator overload protection.
Contactless (optical) limit switch control.
Load control during generator run up.
Safety guard touch detector.

Security System:

Sensitive loop 'break' and/or 'make' intruder detectors.
Infra-red beam monitor.
Automatic sprinkler/alarm controls
Mains failure detectors
Microwave/radiation leakage detectors.

Communications:

Carrier failure monitors.
Over/under voltage monitors.
SWR monitor with cutout.
Microwave field strength monitor with safety cutout.
System power supply monitoring with switch-on delays.
Telephone exchange low-voltage logic/50 volt relay-switching interface.
Telemetry and remote control buffered switch.
Over-modulation detector.
Line signal level monitors.

General:

Thermostatic control of refrigerators, ovens and industrial processes.
Mains failure standby generator start-up.
Power-up sequencer.
Smoke and gas detectors with relay output.
Audio amp mute or squelch.

By feeding back the output condition on lead 1 to leads 3 and/or 4 further

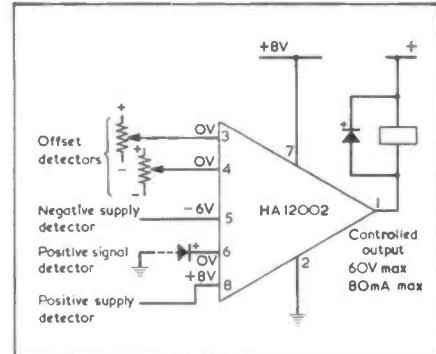

Figure 4:
With all the pin conditions shown, the relay will operate.

combinations of latching and non-latching functions can be achieved. For example, in a production line test station or a technical training situation some minor faults causing relay trip could be made locally resettable, whereas serious or hazardous faults could be made resettable only by qualified personnel or from a safe location.

The pin voltages for normal relay operation are shown in Figure 4. ■

Your Reactions.....	Circle No.
Immediately Applicable	113
Useful & Informative	114
Not Applicable	115
Comments	116

BOOK REVIEWS

MICROWAVE DEVICES & CIRCUITS

Samuel Y. Liao

530 pages; 227 x 160 mm; Hardback; 1980; ISBN 0-13-581207-0;

Published by Prentice-Hall, Inc.

Price: £24.70 at the time of writing.

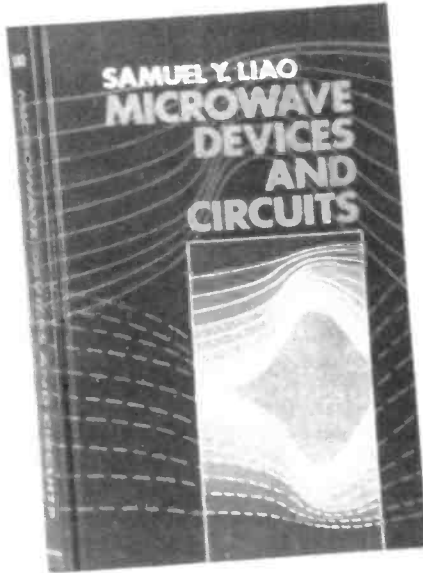

Any professional engineer engaged in communications will be well aware of the rapid growth of microwave systems. The recent advances in low cost microwave technology have accelerated this already rapid growth, so a really thorough book like this is a valuable reference work for anyone seeking to either learn from scratch, or refresh existing knowledge.

This sound analysis of the subject of microwaves will ensure that this work will endure the ravages of technological advance. At least the laws of physics and their mathematical interpretation seem to remain relatively consistent.

The American influence of the author is apparent throughout the book, but since the United States seems to be at the fore of the subject anyway, this is by no means an impediment to the way in which the subject is broached. Unlike many books I have seen on the subject, *Microwave Devices and Circuits* manages to remain entirely readable despite an abundance of 'large sums'. However, the author manages to resist plunging into the abstruse and obtuse, with the result that even the non-mathematical reader will still learn a great deal from the sections on Smith Chart analysis, and the descriptions and explanations of the hardware of the subject.

In fact, much of the book is reminiscent of 'A-level' physics - and this serves to remind the reader that

microwave technology is rather more of a precise science than many aspects of electronic technology. Many tables and standard formulae are provided - and chapter six includes no less than 181 fully documented references, and 17 suggested titles for further reading. Is this a record ??

To summarize, *Microwave devices and circuits* is written by someone anxious to communicate the subject, and not simply scoring a stream of boring academic points. The diagram presentation is superb (as you might expect in a book costing this much), and the net result is probably the nearest thing to a definitive work on the subject as you are likely to find. Book it at your library now, but be warned, you will probably be obliged to buy a copy once you have seen it!

DESIGN OF OP-AMP CIRCUITS — with experiments

by H M Berlin

1977; 224 pages; 135 x 215mm; Paperback

£6.25

Complete introduction to almost every op-amp application. It teaches the reader all there is to know about op-amp circuits with a series of 37 methodical experiments covering linear circuits, differential amplifiers, integrators, comparators, oscillators, non linear circuits and active filters.

HOW TO BUILD A FLYING SAUCER

by T B Pawlicki

1981; 151 pages; 135 x 215mm; Paperback

£4.45

This book will delight everyone from archaic physicists to the insatiably curious. Each

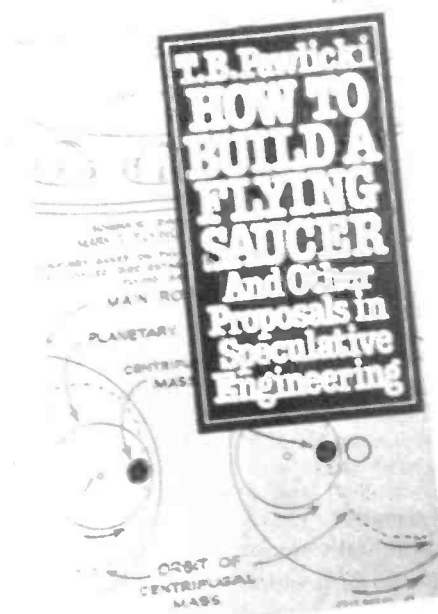

chapter deals with such questions as "how the pyramids and Stonehenge were really built", or "whether the alchemists really transmuted iron to gold" and "...if the Russians can trigger earthquakes in the US". The book reveals the known technology and forgotten inventions that show how many 'impossible' inventions of the past might actually be accomplished today.

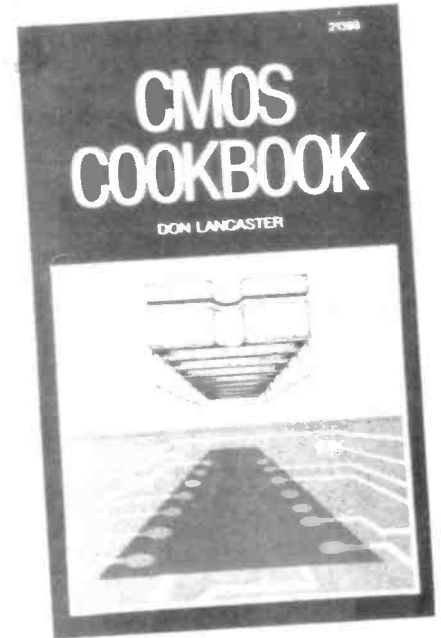

CMOS COOKBOOK

by Don Lancaster

1977; 416 pages; 135 x 215mm; Paperback

£7.40

Tells all you need to know to understand and profitably use this inexpensive and genuinely fun to work with digital logic family. First an explanation of what CMOS is, how it works, and how to power it, plus usage rules, state testing, breadboarding, interface, and other basics is given. Then a minicatalogue of over 100 devices, including pinouts and use descriptions is given. Subjects covered include gate fundamentals, tri-state logic, redundant logic design techniques, multivibrators, nonvolatile memory techniques, clocked JK and D flip-flop, counter and register techniques, op-amps, analogue switches, phase-locked loops and much more. A must for the student, hobbyist teacher, technician, or engineer who wants to learn about CMOS. Filled with many practical applications and circuit suggestions.

DESIGN OF VMOS CIRCUITS — with experiments

by R T Stone & H M Berlin

1980; 176 pages; 135 x 215mm; Paperback

£7.65

The vertical metal oxide semiconductor, or VMOS, is a new and exciting device that may be a giant step towards the ideal active circuit element. This book written to whet your appetite, features 11 chapters on the VMOS and its characteristics. Chapter 11 presents a series of experiments that demonstrate a number of the concepts discussed in earlier chapters.

COMPUTER BOOKS

THE ADA PROGRAMMING LANGUAGE by J C Pyle	£8.95
THE ARCHITECTURE OF CONCURRENT PROGRAMS by P B Hansen	£19.45
BASIC BUSINESS SOFTWARE by E G Brooner	£6.95
CIRCUIT DESIGN PROGRAMS FOR THE TRS-80 by Howard M Berlin	£9.05
COMPUTER GRAPHICS PRIMER by M Waite	£9.05
COMPUTER LANGUAGE REFERENCE GUIDE by Harry L Helms	£4.85
CP/M PRIMER by S Murtha & M Waite	8.35
CRASH COURSE IN MICROCOMPUTERS by Louis E Frenzel	£12.30
EXPERIMENTS IN ARTIFICIAL INTELLIGENCE by J Krutch	£4.85
GUIDEBOOK TO SMALL COMPUTERS by W Barden Jnr.	£3.45
HOW TO PROGRAM AND INTERFACE THE 6800 by A C Staugaard Jnr	£11.15
HOW TO TROUBLESHOOT AND REPAIR MICROCOMPUTERS by John D Lenk	£5.95
INTRODUCTION TO MICRO-COMPUTERS FOR THE HAM SHACK by Harry L Helms	£3.45
MICROCOMPUTER INTERFACING WITH THE 8255 PPI CHIP by P F Goldsbrough	£6.25
MICROPROCESSOR SOFTWARE, PROGRAM CONCEPTS AND TECHNIQUES by G A Streitmatter	£14.25
MOSTLY BASIC: APPLE II by H Berenbon	£7.65
MOSTLY BASIC: PET by H Berenbon	£7.65
MOSTLY BASIC: TRS-80 by H Berenbon	£7.65
OSCILLOSCOPES BY Stan Prentiss	£8.20
PRACTICAL HARDWARE DETAILS OF Z-80, 8080, 8085 & 6800 MICROCOMPUTER SYSTEMS by J W Coffron	£16.45
PROGRAMMING AND INTERFACING THE 6502 - WITH EXPERIMENTS by Marvin L De Jong	£11.15
SOFTWARE MAINTENANCE GUIDEBOOK by R L Glass & R A Noiseux	£16.45
STRUCTURED COBOL, A PRAGMATIC APPROACH by R T Grauer & M A Crawford	£13.45
THE 8080 A BUGBOOK by Peter R Rony	£8.35
TRS-80 ASSEMBLY LANGUAGE by H S Howe	£7.45
TRS-80 INTERFACING BOOK 1 by Jonathan A Titus, Christopher Titus & David G Larsen	£6.25

TRS-80 INTERFACING BOOK 2 As for Book 1	£7.65
Z-80 MICROCOMPUTER DESIGN PROJECTS by W Barden Jnr	£9.05
6502 SOFTWARE DESIGN by Leo Scanlon	8.10
6809 MICROCOMPUTER PROGRAMMING AND INTERFACING - WITH EXPERIMENTS by A C Staugaard	£9.75
THE S100 AND OTHER MICRO BUSES by E C Poe & J C Goodwin	£6.95

RADIO BOOKS

AMATEUR ANTENNA TESTS AND MEASUREMENT by H D Hooton	£6.25
CB RADIO CONSTRUCTION PROJECTS by Len Buckwalter	£2.75
MICROWAVE THEORY AND APPLICATIONS by S F Adam	£17.95
PRACTICAL RF COMMUNICATIONS DATA FOR ENGINEERS AND TECHNICIANS by M F Doug DeMaw	£6.25
QUESTIONS AND ANSWERS ABOUT CB OPERATIONS by L G Sands	£2.65
TV ANTENNAS AND SIGNAL DISTRIBUTION SYSTEMS by M J Salvati	£6.95

GENERAL BOOKS

ABCs OF FETS by R P Turner	£2.75
ABCs OF INTEGRATED CIRCUITS by R P Turner	£2.75
ACTIVE FILTER COOKBOOK by Don Lancaster	£10.45
DESIGN OF PHASE-LOCK LOOP CIRCUITS - WITH EXPERIMENTS by H M Berlin	6.95
HOW TO BUILD YOUR OWN STEREO SPEAKER by Christopher Robin	£5.20
INTEGRATED CIRCUIT PROJECTS by R P Turner	£3.90
LOGIC AND MEMORY EXPERIMENTS USING TTL BOOK 1 by D G Larsen & P R Rony	£7.65
LOGIC AND MEMORY EXPERIMENTS USING TTL BOOK 2 by D G Larsen & P R Rony	£7.65
99 PRACTICAL ELECTRONIC PROJECTS (2nd Edition) by Herbert Friedman	£3.45
ONE EVENING ELECTRONIC PROJECTS by Calvin R Graf	£4.15
OP AMP HANDBOOK by F W Hughes	£16.45
OPERATIONAL AMPLIFIER CHARACTERISTICS AND APPLICATIONS by R G Irvine	£18.70
PRACTICAL LOW-COST IC PROJECTS (2nd Edition) by Herbert Friedman	£3.20
SECURITY ELECTRONICS (2nd Edition) by J E Cunningham	£4.15
SON OF CHEAP VIDEO by Don Lancaster	£6.25

UNIQUE ELECTRONIC WEATHER PROJECTS by Tom Fox	£5.55
---	-------

New Titles

ANALOG I/O DESIGN ACQUISITION: CONVERSION: RECOVERY by P H Garrett	£16.45
BEGINNER'S HANDBOOK OF IC PROJECTS by D L Heiserman	£9.70
CALCULATOR CLOUT - PROGRAMMING METHODS FOR YOUR PROGRAMMABLE by M D Weir	£6.70
AN END-USER'S GUIDE TO DATA BASE by James Martin	£16.45
PET BASIC: TRAINING YOUR PET COMPUTER by R Zamora et al	£9.70
PRACTICAL TROUBLESHOOTING TECHNIQUES FOR MICROPROCESSOR SYSTEMS by J W Coffron	£14.95
A PRIMER ON PASCAL by R Conway et al	£9.70
SYSTEMS PROGRAMMER'S SOLVER by W S Mosteller	£14.20
VIDEO/COMPUTERS, HOW TO SELECT, MIX AND OPERATE PERSONAL COMPUTERS AND HOME VIDEO SYSTEMS C J Sippl & F Dahl	£5.95



“making performance affordable”

WR&E
DECEMBER
87

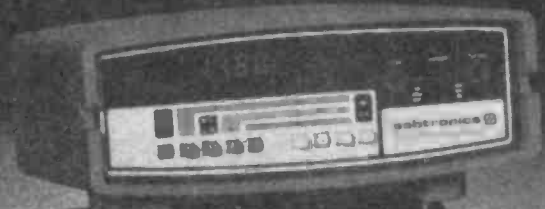

2010A 3 1/2 LED DMM



2015A 3 1/2 LCD DMM



8610A 600MHz
8-digit frequency counter



5020A 1Hz to 200kHz function generator



8000B 1GHz 9-digit frequency counter



2035A
3 1/2 LCD Handheld DMM



2037A
3 1/2 LCD Handheld DMM temp

Sabtronics high quality, low cost digital test instruments are now available in the UK from Black Star. Accuracy, good looks and facilities needn't cost you the earth.....any longer.



PRICES	BUILT	KIT
2010A	£83.00	£64.00
2015A	£95.00	£82.00
8610A	£99.00	£82.00
5020A	£86.00	
8000B	£160.00	
2035A	£83.00	£64.00
2037A	£95.00	£82.00

PRICES EXCLUDE VAT

sabtronics

Available direct, and from approved stockists

BLACK STAR LTD. 9A CROWN STREET, ST. IVES,
HUNTINGDON, CAMBS, PE17 4EB, ENGLAND.

TEL : ST. IVES (0480) 62440
TELEX : 32339

R&EW PROJECT PACKS R&EW PROJECT PACKS R&EW PROJECT PACKS

R&EW PROJECT PACKS R&EW PROJECT PACKS R&EW PROJECT PACKS

R&EW Watervole

Portable AM-FM radio with pre-aligned FM tunerhead, ceramic AM and FM filters, single IC Electronic parts kit includes, PCB with component overlay, all components, loudspeaker switches and telescopic aerial. (Sorry no case).

WR&E Stock No. 40-01060
Price (ex VAT) £17.50



R&EW Project Packs

Kits of parts for current R&EW features. Please note that the prices are VAT exclusive. Postage is 50p per order - but if you buy a copy of the WR&E catalogue, you may be able to use one or more of the £1 discount vouchers against these purchases.

PA105

High quality HMOS 120 watt power amp. Kit contains fibre-glass PCB, pair HMOS FETs, and all components. Bracket and heatsink also available.

Kit:	WR&E Stock No.	Price (ex VAT)
PA105	40-90105	£14.00
Bracket	21-08040	£ 1.48
Heatsink	21-08030	£ 4.50

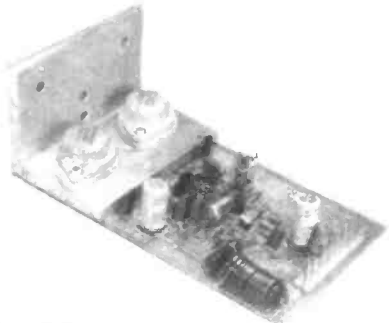

SIMPLE DIGITAL VOLTMETER

Dual range DVM with components for; 200mV, 20V or 200V FSD voltage range and 200mA FSD ampere range. Kit includes DVM176 module, precision resistors, bezel, switches and battery connector.

WR&E Stock No: 40-01176
Price (ex VAT) £20.34

UHF Converter

432-434MHz to 28-30MHz converter.

Incorporating; latest low noise transistors, dual gate MOSFET and pre-aligned Helical Filters. Kit includes double sided fibre-glass PCB, all components, Xtal, case and sockets.

WR&E Stock No: 40-01433
Price (ex VAT) £14.91

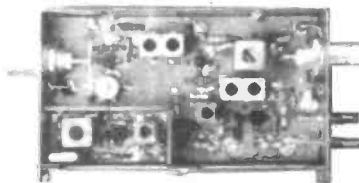

RADIO & ELECTRONICS WORLD

R&EW PROJECT PACKS R&EW PROJECT PACKS R&EW PROJECT PACKS

R&EW PROJECT PACKS R&EW PROJECT PACKS R&EW PROJECT PACKS

DFCM500

Complete kit of parts to build this superb wide range digital frequency and capacitance meter. Frequency ranges: 0-1MHz, 1-50MHz and 80-500MHz.

Capacitance ranges: 1pF to 1uF and 1uF to 1,000uF. Mains or Ni-Cad battery operation with built in charger. Kits available for full 500MHz version or 50MHz version (omitting VHF prescalers). Parts include all PCBs (fibre glass), components thereon, LED display, switches, plugs and sockets, and case with punched and drilling front panel. Kits available from next month.



Kit:	WR&E Stock Number	Price (ex VAT)
DFCM500	40-01500	£95.95
DFCM50	40-01050	£79.95

RADIO & ELECTRONICS WORLD

CLASSIFIED ADS

SELF ADHESIVE labels for home brewers, 18 labels per pack, in 3 subtle shades, 65p per pack inc post and VAT. Minotaur Print Series: 15 West Grove, Woodford Green, Essex IG8 7NS.

CONSTRUCTORS: Bargain packs, 100 mixed resistors for £1, 1000 for £7.50. Post Free. JKS Electronics, 2 Poundfield Road, Debden, Loughton, Essex.

T & J ELECTRONIC COMPONENTS. Quality components, competitive prices. Send 45p cheque or postal order for illustrated catalogue, 98 Burrow Road, Chigwell, Essex IG7 4HB.

AUTOMATIC MORSE DECODER - Low cost easy build 9V circuit. Accepts audio input or practice key. Gives continuous readout on 12 character alphanumeric display. Send £3.95 plus large S.A.E. for fully detailed 17-page construction manual. Parts and pcb available. N. MacRitchie (Micros), 100 Drakies Avenue, Inverness IV2 3SD.

PRE-PACKED screws, nuts, washers, solder tags, studding. Send for price list. All Sales (RE) PO Box 402, London SW6 6LU.

WANTED. High voltage gas discharge tubes, i.e. Tesla tubes, 'Maltese Cross' tube, small gas discharge tubes, neons etc. to work from induction coil for demonstration purposes. Details to Box No. G404.

WIRELESS, VALVES, PRE-WAR INWARD S.A.E. Modern bargains list 15p. Sole Electronics, (REC), 37 Stanley Street, Ormskirk, Lancs L39 2DH.

INTERESTED IN RTTY? You should find the **RTTY Journal** of interest. Published in California, USA, it gives a wide outlook on the current RTTY scene; RTTY-DX; DXCC Honour Roll: VHF RTTY news; and up to date technical articles are included. Specimen copies 35p from: The Subscription Manager, RTTY Journal, 21 Romany Road, Oulton Broad, Lowestoft, Suffolk NR32 3PJ.

1 PR 60W COLUMN SPEAKERS 4x10" Goodmans - suit PA/Disco use. £50 ONO Tel (0277) 214071.

CB RADIO CONVERSIONS. Add extra channels to most modern CB radios using a resistor, a switch and our comprehensive data on PLL chips. E.g. sharp 40CH + 1k/res. equals 64CH. Also crystal substitution information and much more. Send £1 for details. Mark your reply for the attention of J. McMahon, Selectronics Inc. PO Box 5, Ennis, Co. Clare, Ireland. Selectronics technical services to the home, hobby and industry.

WANTED: Two Books - *Circuit Consultants Handbook* by T K Hemingway, 1970 and *Practical Design with Transistors* by M Horowitz, 1969. Box No. G405

FOR SALE: Unmarked zener diodes BZY88 type and 2W type. 50 for £1. J Fulton, Derrynaseer, Dromore, Co. Tyrone, N Ireland.

JOIN THE INTERNATIONAL SW LEAGUE. Free services to members including QSL Bureau, Amateur and Broadcast Translation, Technical and Identification Dept. - both Broadcast and Fixed Station, DX Certificates, contests and activities for the SWL and transmitting members. Monthly magazine, **Monitor** containing articles of general interest to Broadcast and Amateur SWLs, Transmitter Section and League affairs, etc. League supplies such as badges, headed notepaper and envelopes, QSL cards, etc. are available at reasonable cost. Send for league particulars. Membership including monthly magazine etc., £9.00 per annum UK overseas rates on request, Secretary, Grove Road, Lydney, Glos GL15 5JE.

TR2300 2m FM transportable, with case and 10W booster amp., 'rubber duck'... £170 ONO. Phone (0277) 822720. G3XDG.

WANTED: Radio & Electronics Constructor, Volumes 1 to 8 1947-1955 bound or unbound. To give away: various separate copies 1955, 1956, 1958, 1959, 1960, 1961, 1967, 1968, 1973 & 1976. All letters answered. Marcel Volery, Poste Restante, CH-8953 Dietikon/2, Switzerland.

WANTED: Handbook for Eagle communications receiver Model RX-80. Phillips, 18 Chestnut Avenue, Hedon, Yorkshire. Tel 0482-899167.

WANTED: FAX equipment manuals, service sheet, etc. G2UK, 21 Romany Road, Oulton Broad, Lowestoft, Suffolk NR32 3PJ.

BREAKTHROUGH FOR BATTERY USERS. If you use a PP9 or PP3, you need a "Battery Miser". Gets up to twice normal life. Just clips to your battery. £2.00 includes VAT and postage UK. Mail order only. Stephenson Evans, The Radio Station, Parbold Hill, Lancs WN8 7TG.

4 DIGIT LCDs with pin terminations, std Hamlin/LXD types. Gd no junk, £3 each, 10/£22. Box REW7.

INTERESTED IN OSCAR? Then join AMSAT-UK. Newsletters, OSCAR NEWS Journal, prediction charts etc. Details of membership from: Ron Broadbent, G3AAJ, 94 Herongate Road, Wanstead Park, London E12 5EQ.

FOR SALE: Hand held 4-game television game £19.50. J Fulton, Derrynaseer, Dromore, Co. Tyrone, N Ireland.

PRACT. HI-FI TRANSMISSION LINE SPEAKERS Superb value £100 ONO. Box REW8.

THE RADIO AMATEUR INVALID & BLIND CLUB is a well established Society providing facilities for the physically handicapped to enjoy the hobby of Amateur Radio. Please become a supporter of this worthy cause. Details from the Hon. Secretary, Mrs F E Woolley, 9 Rannoch Court, Adelaide Road, Surbiton, Surrey KT6 4TE.

HIGH VOLTAGE FROM 9 VOLTS. This circuit will convert a low battery voltage into 450 volts or more. Applications include high voltage for neon display, geiger counters, strobes, etc. Supplied working and assembled. Price £3.95 plus 35p P&P. POs to P D Crisp, 32 Churchill Crescent, Wickham Market, Suffolk IP13 0RW.

SPECIAL OFFER. Portable 40CH CB monitors. Also receives 54-176MHz. Telescope aerial. Squelch control. Only £15.95. Convert standard card radio to 40CH CB receiver. CB/Normal switch. Easily installed. £10.45. All post paid. Killinghall Electronics, 16 Killinghall Rd., Bradford 3, Yorkshire.

QSLs, letterheads, general offset up to A3 size. A/W, camera facilities - S.A.E. details to Box REW9.

MICRO TRANSMITTERS. Highly sensitive. Range up to 1 mile. Tuneable 60-150MHz. Receive on VHF/FM radio. Supplied, assembled and working with sensitive microphone and data. £4.75 + 25p P&P. To: P D Electronics, 11 Bluebell Close, Orpington, Kent BR6 8HS.

INTERESTED IN CB? Be the first in your street with the very latest receiver. It's legal and cover 2 CB bands, PB/WB and medium wave/AM/FM/VHF aircraft and 2M ham. In fact everything you ever wanted in a radio. Its just arrived in England so it's not in the shops yet! Send cheque or PO for £24.50 inclusive to S&M Sales, 99 St Leonards Road, Windsor, Berks.

VALVE USER? Large selection of used valves for sale, many rarities. 50p P/O. for lists. Box REW10.

BREAKER, BREAK. Build your own CB rig. (27MHz AM transceiver). Circuit diagram, parts list, etc. All components available in UK. Send £3.95 and large S.A.E. to: P Sherwood, 8 (T) Aylestone Walk, Manchester, M10 9NU. I'm down and on the side.

Personal

TWO'S COMPANY for friendship/marriage. Introductions with the personal touch for people of discernment. Brochure on request. Two's Company Dept 1E/R, 111 High Holborn, London WC1V 6JS. Tel: 01-242 2345.

CLASSIFIED ADS

IF YOU HAVE ENJOYED A HOLIDAY on the Norfolk Broads, why not help to preserve these beautiful waterways. Join the Broads Society and play your part in determining Broadlands future. Further details from The Hon. Membership Secretary. The Broads Society, "Icknield", Hilly Plantation, Thorpe St Andrew, Norwich NOR 85S.

CLOSE ENCOUNTERS GROUP. Personal introductions/dances, parties, talks, social events. Meet interesting, attractive people. All areas. Telephone Liverpool 051-931 2844 (24 hours)

SPONSORS required for exciting scientific project Norwich Astronomical Society are building a 30" telescope to be housed in a 20" dome of novel design. All labour being given by volunteers. Already supported by Industry and Commerce in Norfolk. Recreational. Educational. You can be involved. Write to NAS, Secretary, 195 White Woman Lane, Old Catton, Norwich, Norfolk.

BROADLANDS RESIDENTIAL CLUB for elderly people. Are you recently retired and looking for a home? We have a delightful top floor room overlooking Oulton Broad, facing south. Write to:

The Warden, Broadlands Residential Club, Borrow Road, Oulton Broad, Lowestoft, Suffolk.

LEARN TO RELAX. Reduce stress and tension. Learn how to improve your memory for electronics, CB jargon, etc. Learn how to stop smoking, to stop nail biting, to reduce weight, to reduce headaches, etc., with our self help tapes. We also manufacture and supply bio-feedback units. Self help tapes are £4.50 inc Post & Packing. Bio-feedback units from £25. For more details send stamped addressed envelope to: Ramsden Electronics (Bio-Aid Centre), 10 St Thomas Street, Penryn, Cornwall.

ANY SINGLE SERVICE SHEET £1 plus S.A.E. Thousands of different service/repair manuals/sheets in stock. Repair data your named TV £6 (with circuits £8). S.A.E. newsletter, price lists, quotations. (0698-883334). Ausrec, 76 Churches, Larkhall, Lanarkshire.

T & J ELECTRONIC COMPONENTS. Quality components, competitive prices. Send 45p cheque or postal order for illustrated catalogue. 98 Burrow Road, Chigwell, Essex IG7 4HB.

PUSH BUTTON G.P.O. TELEPHONES. Saves you time and improves your image and efficiency. £35 + £2 P&P. Returnable if not satisfied. P D Electronics, 11 Bluebell Close, Orpington, Kent BR6 8HS.

Rate: 12p per word. Minimum charge £2.00
Box No. 30p extra

SMALL ADVERTISEMENTS

Advertisements must be prepaid and all copy must be received by the 4th of the month for insertion in the following month's issue.

The Publishers cannot be held liable in any way for printing errors or omissions, nor can they accept responsibility for the bona fides of Advertisers.

Where advertisements offer any equipment of a transmitting nature, readers are reminded that a licence is normally required. Replies to Box Numbers should be addressed to: Box No..., Radio and Electronics World, 117A High Street, Brentwood, Essex.

ADVERTISERS INDEX

Acorn Computer Limited	Inside B/C
Amateur Electronics UK	42, 43
Amateur Radio Exhibition	57
Ambit International	94
BNOS	52
British National Radio & Electronics School	85
J Bull (Electrical) Limited	86
Datong	69
Farnell	Inside F/C
Ferranti Semiconductors	41
Frepar Electronics	63
GP Industrial Electronics Limited	32
Happy Memories	32
Infra Computer Components Limited	68
John Woolfe Racing Ltd	9
KW Communications Limited	62
Racal-Dana Instruments Limited	14
Service Trading Company	38
Sinclair Research Limited	4, 5
Skywave	9
South Midlands Communications Ltd	2
E A Sowter Limited	13
Tempus	84, 85
Watford Electronics	46, 60
Wilmslow Audio	32, 46, 83, 85
World Trade Centre	54

RADIO & ELECTRONICS WORLD

WATFORD ELECTRONICS

SPEAKING CLOCK

As featured in R&EW



Full Kit £37.50 plus 50p post & packing plus VAT
Kit without case, mains power supply, displays £23.50 plus 50p post & packing plus VAT.

WATFORD ELECTRONICS
33/35 CARDIFF ROAD, WATFORD, HERTS, ENGLAND

Mail order, Callers Welcome

Telephone Watford (0923) 40588/9

R&EW's reader response system

Please circle appropriate numbers for further information from advertisers and/or to register your reaction to articles.

Overseas Enquiries - This facility will have to be charged at the rate of 25p per enquiry number ticked, minimum charge £2.00.

Post your completed order form to:-
Radio and Electronics World, (Book department), 117a High Street, Brentwood, Essex.

Please supply the following books:	Quantity:	Price: £	p
POSTAGE & PACKING 75p for the first book of any order, thereafter 25p per book. Orders over £50 - FREE DELIVERY	Total:		

Name
 Address
postcode

I herewith enclose *Cheque/PO No.....
 value £..... made payable to **RADIO & ELECTRONICS WORLD**. Please debit my *Access/
 Barclaycard No.
 *delete as applicable. Please allow up to 21 days for delivery.

CLASSIFIED ADVERTISEMENT ORDER FORM – PLEASE COMPLETE BELOW

- **Write Your Ad. Below** In the boxes - one word per box please. Underline words required in Bold type. Your name, address, and/or telephone number, if to appear, must be included in the boxes and must be paid for. Telephone numbers
- count as two words. Please use **BLOCK CAPITALS**.
- -Advertisements are accepted on the understanding that the details stated comply with the conditions of the Trade Description Act, 1968.
- -Whilst every care is taken to ensure accuracy, we do not accept liability for inaccuracies should they occur.
- -Cancellations must be notified by telephone or in writing by the 6th of the month preceding publication.

				£2.00
£2.04	£2.16	£2.28	£2.40	£2.40
£2.52	£2.64	£2.76	£2.88	£2.88
£3.00	£3.12	£3.24	£3.36	£3.36
£3.48	£3.60	£3.72	£3.84	£3.84
£3.96	£4.08	£4.20	£4.32	£4.32

RATES
 All cheques should be made payable to Radio & Electronics World.

12p per word -
 minimum charge £2.00

Tick this box if you require a box number charged at 30p

I enclose remittance of £ : p

NAME ADDRESS
 POSTCODE

USE THIS PREPAID READER RESPONSE CARD TO MAIL YOUR ADVERTISEMENT

PTO for the numbers - this form is valid until December 15th 1981

Your name: _____ Title/Job Function _____

Company name _____

Company address/ Home address (delete as applicable) _____

County/City _____ Country _____

Postcode _____ Office telephone number _____

If you would like to receive a personal copy of R&EW - then please enter your Access / Barclaycard number

_____ Signature _____ (Rates on page 1)

Amount _____ for _____

The complementary component catalogue *the World of Radio and Electronics* should be available from your local newsagent - but in case of difficulty, current copies can be obtained from here at 60p each - which may be added to the above.

1 11 21 31 41 51 61 71 81 91
 2 12 22 32 42 52 62 72 82 92
 3 13 23 33 43 53 63 73 83 93
 4 14 24 34 44 54 64 74 84 94
 5 15 25 35 45 55 65 75 85 95
 6 16 26 36 46 56 66 76 86 96
 7 17 27 37 47 57 67 77 87 97
 8 18 28 38 48 58 68 78 88 98
 9 19 29 39 49 59 69 79 89 99
 10 20 30 40 50 60 70 80 90 100

101 111 121 131 141 151 161 171 181 191
 102 112 122 132 142 152 162 172 182 192
 103 113 123 133 143 153 163 173 183 193
 104 114 124 134 144 154 164 174 184 194
 105 115 125 135 145 155 165 175 185 195
 106 116 126 136 146 156 166 176 186 196
 107 117 127 137 147 157 167 177 187 197
 108 118 128 138 148 158 168 178 188 198
 109 119 129 139 149 159 169 179 189 199
 110 120 130 140 150 160 170 180 190 200

201 211 221 231 241 251 261 271 281 291
 202 212 222 232 242 252 262 272 282 292
 203 213 223 233 243 253 263 273 283 293
 204 214 224 234 244 254 264 274 284 294
 205 215 225 235 245 255 265 275 285 295
 206 216 226 236 246 256 266 276 286 296
 207 217 227 237 247 257 267 277 287 297
 208 218 228 238 248 258 268 278 288 298
 209 219 229 239 249 259 269 279 289 299
 210 220 230 240 250 260 270 280 290 300

FIRST FOLD HERE

THIRD FOLD HERE

Postage will be paid by licensee

Do not affix Postage Stamps if posted in Gt. Britain, Channel Islands, N Ireland or the Isle of Man

BUSINESS REPLY SERVICE
 Licence No. CL754

RADIO & ELECTRONICS WORLD,
 117a, HIGH STREET,
 BRENTWOOD,
 ESSEX CM14 5YE

2

SECOND FOLD HERE

FOURTH FOLD HERE TUCK INSIDE THIRD FOLD

COMMENTS (circle relevant article number if you complete this space)



CHOOSE ATOM POWER

At work or play - everything you need in a personal computer

The Atom is a machine to be used. Every day, day after day. It's a full function machine - check the specification against others. It's rugged, easy to operate built to last and features a full-size typewriter keyboard.

Just look at some of the features!

- More hardware support than any other microcomputer
- Superfast BASIC - can be updated to BBC BASIC if required
- High resolution and comprehensive graphics ideal for games programmers and players*
- Integral printer connection*
- Software available for games, education, maths, graphs, business, word processing, etc.
- Other languages: Pascal, FORTH, LISP
- I/O port for control of external devices
- Built-in loudspeaker
- Cassette interface
- Full service/repair facility
- Users club

* Expanded version only

Optional Extras

- Network facility with Econet
- Disk
- PAL UHF colour encoder
- Add-on cards include 32K memory, analogue to digital, viewdata VDU, disk controller, daisywheel printer, plus many, many more!
- Power supply

FREE MANUAL

The Atom's highly acclaimed manual comes free with every Atom and leaves nothing out. In just a while you'll be completely at ease with your new machine! Within hours you'll be writing your own programs.



YOU AND YOUR CHILDREN

More and more schools are buying Atoms. More and more children will learn on an Atom. You can give them that extra familiarity with an Atom in the home.



4a Market Hill,
CAMBRIDGE CB2 3NJ

When you order your Atom we will include full details of all software packs and the optional hardware.

To: Acorn Computer Limited, 4A Market Hill, Cambridge CB2 3NJ.

I enclose a cheque/postal order for £.....

Please debit my Access/

Barclaycard No.....

Signature.....

Name (please print).....

Address.....

Telephone Number.....

Registered No. 1403810 VAT No. 215 400 220

Quantity	Item	Item price inc. VAT + P&P	Totals
	Atom Kit 8K ROM+ 2K RAM	@ £140.00	
	Atom Assembled 8K ROM+2K RAM	@ £174.50	
	Atom Assembled 12K ROM+12K RAM	@ £289.50	
	Power Supply	@ £ 10.20	
	TOTAL		

Computer stores are stocking Atoms - there's a list below, but if you have any problems getting hold of one just fill in the coupon and we'll rush one to you within 28 days. If the machine isn't all you expected, or all we've told you, just return it within 14 days for a full refund.

MOM, Aberdeen 22863. Broadway Elect, Bedford 213639. Owl Computers, Bishops Stortford, 52682. Eltec Services, Bradford 491371. Gamer, Brighton 698424. Electronic Information Systems, Bristol 774564. Cambridge Comp Store, Cambridge 65334. Cardiff Micros, Cardiff 373072. Bellard Elect. Chester 380123. Emprise, Colchester 865926. Silicon Centre, Edinburgh 332 5277. Esco Computing, Glasgow 204 1811. Control Universal, Harlow 31604. Unitron Elect, Haslington, Castle Elect, Hastings 437875. Currys Micro Systems, High Wycombe. Customised Electronics, Leeds 792332. D.A. Computers Leicester 708402. Micro-digital, Liverpool 236 0707. Barrie Elect, London 488 3316. Eurocalc London 729 4555. Microage London 959 7119. Sinclair Equip. Int (Export) London 235 9649. Off Records, SW12, 674 1205. Technomatic, NW10 452 1500. NSC Comp Shops, Manchester 832 2269. Customised Electronics, Middlesborough 247727. Compshop, New Barnet 441 2922. H.C.C.S., Newcastle. 821924. Newcastle Comp Services, Newcastle 615325. Anglia Comp Centre, Norwich 29652. Leaslink Viewdata, Nottingham 396976. R.D.S. Electrical Portsmouth 812478. Computers for All, Romford 751906. Intelligent Artefacts, Royston, Arrington 689. Computer Facilities Scunthorpe. Datron Micro Centre Sheffield 585490. Superior Systems, Sheffield 77824. Q-TEC Systems, Stevenage 65385. 3D Computers, Surbiton (01) 337 4317. Abacus Micro Comp, Tonbridge, Paddock Wood 3861. Northern Comp, Warrington 601683. Compass Design Wigan Standish 426252.

Your passport to the WORLD OF RADIO & ELECTRONICS

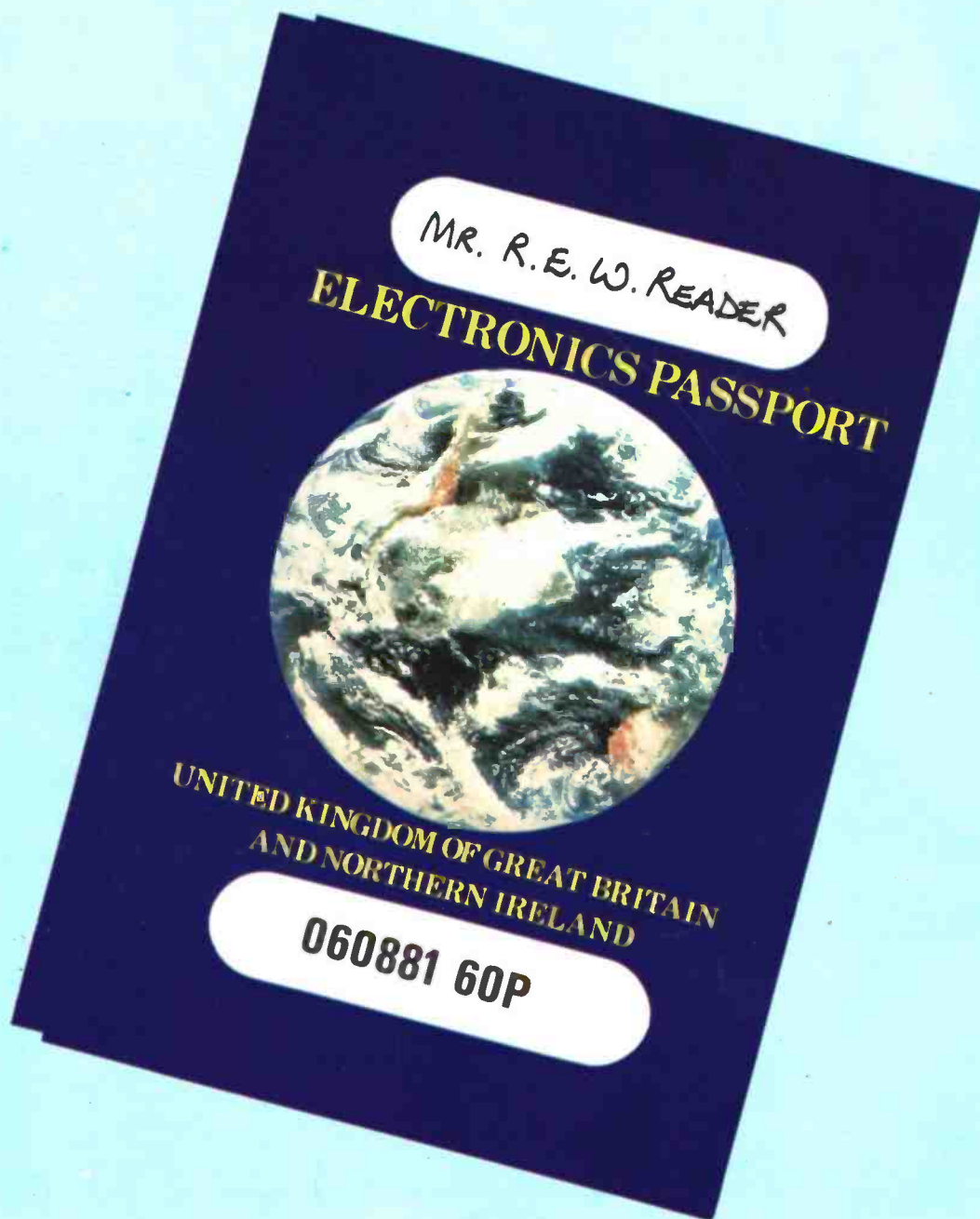

The World of Radio & Electronics is a quarterly concise electronic component catalogue, with prices printed alongside the items to provide readers of **R&EW** with a full range of components for **R&EW** articles and general electronic, computing and communication requirements. It contains everything from a humble resistor — to Z8001 16 bit CPUs, and microwave balanced mixers.

R&EW's experience enables you to choose from a wide range of top quality components at the lowest prices.

Each issue of '**The World of Radio & Electronics**' contains 3 x £1 vouchers, each redeemable against purchases of over £10.