

PRACTICAL
WIRELESS

PW

RADIO NAVIGATION

*Featuring the Racal-Decca Navigator
assisting the Dorset Police with
marine enquiries*



FEBRUARY 1990
£1.60

ISSN 0141-0857



9 770141 085006

BUILD - A TRANSISTOR FET & DIODE TESTER
REVIEW - TEN-TEC OMNI V TRANSCEIVER
WORLD SERVICE - HIDDEN VOICE OF THE BBC

PACKET RADIO - COMPETITION - TEN SPOT
PLUS LOTS, LOTS MORE INSIDE YOUR BIGGER,
BRIGHTER PRACTICAL WIRELESS

THE NEW

FT-1000

FOR DYNAMIC DX

YAESU

The FT-1000 is a new top of the range all mode h.f. transceiver that is the result of more than 25,000 hours of intensive research by Yaesu's top design engineers. They have adopted a completely new approach to the application of digital and RF technology. The extensive use of surface mounted components has allowed six microprocessors and five Direct Digital Synthesisers to be integrated with a simple to use operator interface to give a highly reliable full featured transceiver that has been optimised for serious h.f. applications. Please write or call SMC or your local authorised Yaesu dealer for the full specifications of this dynamic new transceiver and discover how you can open up the bands.



YAESU

UK Sole Distributor

South Midlands Communications Ltd
S.M. House, School Close,
Chandlers Ford Industrial Estate,
Eastleigh, Hants SO5 3BY
Tel: (0703) 255111

Prices and specifications are subject to change without notice

YAESU

Contents February 1990

PRACTICAL
WIRELESS
PW

FEBRUARY 1990
(ON SALE JAN 11)
VOL. 66
NO. 2
ISSUE 995

Editorial and Advertisement

Offices:

Practical Wireless
Enefco House
The Quay
Poole
Dorset BH15 1PP
☎ Poole (0202) 678558
(Out-of-hours service by
answering machine)
FAX Poole (0202) 666244
Prestel 202671191

Advertisement Manager

Roger Hall G4TNT
PO Box 948
London SW6 2DS
☎ 01-731 6222
Cellphone 0860 511382
FAX 01-384 1031

Advert Copy and Make-up

(Poole Office)
Marcia Brogan
☎ Poole (0202) 678558 or 676033
FAX Poole (0202) 666244

Editor

Rob Mannion G3XFD

Assistant Editor

Dick Ganderton C.Eng MIEE G8VFN

Art Editor

Steve Hunt

Technical Features Editor

Elaine Richards G4LFM

Technical Projects Sub-Editor

NG ("Tex") Swann G1TEX

Technical Artist

Rob Mackie

Editorial Assistant

Sharon George

Administration Manager

Kathy Moore

Accounts

Alan Burgess

Clerical Assistant

Rachel Parkes

Regular Features

111	Advert Index
106	Book Service
89	Backscatter
23	Helpline
17	Keylines
20	News Desk '90
72	PCB Service
105	Radio Diary
18	Receiving You
23	Subscriptions
41	Wanna Swap



50



55



74

19	Competition Corner <i>Spot The Difference</i>
27	Simple FET and Transistor Tester <i>J.A. Brett G6EBR</i>
34	Understanding Circuit Diagrams -22 <i>Ray Fautley G3ASG</i>
42	PW Irwell QRP Transmitter Part 2 <i>Rev. George Dobbs G3RJV</i>
47	Errors & Updates <i>PW Irwell Part 1</i>
48	Antenna Clinic Session 11 <i>Fred Judd G2BCX</i>
50	On Track with the Racal-Decca Navigator <i>Rob Mannion G3XFD</i>
55	Review - Ten-Tec Omni V <i>Mike Richards G4WNC</i>
62	RF Interference from Vehicle Engines <i>B.A. Berry</i>
65	PW Glyme - Short wave converter for amateur band receivers <i>Brian Robertson G4POL</i>
70	Practically Yours <i>Glen Ross G8MWR</i>
71	What is Propagation? <i>Ron Ham</i>
74	World Service - Hidden Voice of the BBC <i>Rob Mannion G3XFD</i>
81	Ten Spot <i>John Petters G3YPZ</i>
82	Packet Update 8 <i>Roger J Cooke G3LDI</i>
84	Portable Ring Base 144MHz Antenna <i>C.R. Eve GJ7AOG</i>
86	G'day - News from Down Under <i>Greg Baker</i>

COPYRIGHT © PW PUBLISHING LTD. 1989. Copyright in all drawings, photographs and articles published in *Practical Wireless* is fully protected and reproduction or imitation in whole or part is expressly forbidden. All reasonable precautions are taken by *Practical Wireless* to ensure that the advice and data given to our readers are reliable. We cannot however guarantee it and we cannot accept legal responsibility for it. Prices are those current as we go to press. PUBLISHED on the second Thursday of each month by PW Publishing Ltd., Enefco House, The Quay, Poole, Dorset BH15 1PP. Printed in England by Blackmore Press, Shaftesbury, Dorset. Tel: 0747 53034. Distributed by Seymour, Winsor House, 1270 London Road, Norbury, London SW16 4DH. Tel: 01-679 1899, Fax: 01-679 8907, Telex: 8812945. Sole Agents for Australia and New Zealand - Gordon and Gotch (Asia) Ltd.; South Africa - Central News Agency Ltd. Subscriptions INLAND £15.50, EUROPE £18, OVERSEAS (by ASP) £19, payable to PRACTICAL WIRELESS, Subscription Department, PW Publishing Ltd., Enefco House, The Quay, Poole, Dorset BH15 1PP. PRACTICAL WIRELESS is sold subject to the following conditions, namely that it shall not, without the written consent of the publishers first having been given, be lent, re-sold, hired out or otherwise disposed of by way of trade at more than the recommended selling price shown on the cover, and that it shall not be lent, re-sold, hired out or otherwise disposed of in a mutilated condition or in any unauthorised cover by way of Trade, or affixed to or as part of any publication or advertising, literary or pictorial matter whatsoever.

ICOM

Count on us!

IC-725 Budget HF



- General Coverage Receiver
- 105dB Dynamic Range
- 100W Output
- DDS System
- 26 Memories
- Scanning
- CI-V Computer Control
- Semi Break-in

The new ICOM IC-725 budget H.F. has been produced due to the demand for a simple, high specification transceiver. Despite the limited features, compared to more expensive equipment this set retains a superior level of technical performance necessary to operate on the H.F. bands today.

Additional features include Noise Blanking, Pre-amp, Attenuator, AGC and RIT. The DDS System (Direct Digital Synthesizer) ensures fast Tx/Rx switching times, ideal for Data Communications. An A.T.U. controller is built

into the IC-725 for use with the AH-3 H.F. Automatic Antenna Tuner for mobile or base station operation.

Accessory options available are the PS-55 20A P.S.U., AH-3 Auto Antenna Tuner, UI-7 AM Tx. FM Tx/Rx Unit, FL-100 500Hz-CW Filter, FL-101 250Hz CW Narrow Filter and SP-7 External Loudspeaker.

For more information on the IC-725 budget H.F. and other ICOM amateur equipment contact your nearest authorised ICOM dealer or phone us direct.

Icom (UK) Ltd.

Dept PW, Sea Street, Herne Bay, Kent CT6 8LD. Tel: 0227 363859. 24 Hour.

Helpline: Telephone us free-of-charge on 0800 521145. Mon-Fri 09.00-13.00 and 14.00-17.30. This service is strictly for obtaining information about or ordering Icom equipment. We regret this cannot be used by dealers or for repair enquiries and parts orders, thank you.

Datapost: Despatch on same day whenever possible.

Access & Barclaycard: Telephone orders taken by our mail order dept. instant credit & interest-free H.P.





ICOM

Count on us!

IC-735 Compact HF.



As predicted the Icom IC-735 has rapidly gained the reputation it deserves. This compact transceiver is ideal for mobile, portable or base station operation. It has a general coverage receiver from 0.1Mhz to 30Mhz with superb sensitivity in all modes, SSB, CW, AM and FM. Spectacular specifications are also achieved on RF Intercept, Dynamic Range, Reciprocal Mixing and I.F. Blocking. As HF conditions improve over the next few years it is equipment like the IC-735 that will provide clear reception even under the worst pile-ups.

The IC-735 has a built-in receiver attenuator, preamp, noise blanker and RIT passband tuning and a sharp IF notch filter ensures clear reception. The twin VFO's and 12 memories can store mode and frequency.

Scanning functions include program scan, memory scan and frequency scan. The HM12 scanning microphone is supplied.

RF output is approximately 100 watts and can be continuously adjusted down to 10 watts. The IC-735 is one of the first HF transceivers to use a liquid crystal display, which is easily visible under difficult conditions. Controls that require rare adjustment are situated behind the front cover but are immediately accessible.

Options include the PS-55 AC Power Supply, AT150 Automatic Antenna Tuner, AH2a Automatic Antenna Tuner, SM6 and SM8 Desk Mics, SP7 External Loudspeaker. Why not find out more about the IC-735 contact your local ICOM dealer or contact ICOM (UK) LIMITED.

Icom (UK) Ltd.

Dept PW, Sea Street, Herne Bay, Kent CT6 8LD. Tel: 0227 363859. 24 Hour.

Helpline: Telephone us free-of-charge on 0800 521 145, Mon-Fri 09.00-13.00 and 14.00-17.30. This service is strictly for obtaining information about or ordering Icom equipment. We regret this cannot be used by dealers or for repair enquiries and parts orders. thank you.

Datapost: Despatch on same day whenever possible.

Access & Barclaycard: Telephone orders taken by our mail order dept. instant credit & interest-free H.P.



MULTIMETERS from Cirkit

THEY'RE D-MM GOOD VALUE!!



TM115



TM135



TM175

Cirkit's new range of Digital Multimeters offer a quite unbeatable combination of features and value:

- Ranges include; frequency, capacitance and temperature
- Housed in strong ABS cases
- Overload protection on all ranges
- Full one year warranty
- 3½ digit, auto zero, auto polarity LCD, plus low batt indication
- 200 hour battery life
- All meters supplied with test leads, battery and manual



TM5315B



TM5365



TM5375

SMC

South Midlands Co

SCHOOL CLOSE, CHANDLERS FORD IND. EST., EASTLEIGH, HA

FREE FINANCE — BUY NOW SAVE MONEY

THE NEW FT1000

Designed with no spared effort or expense for optimum performance and operability, the FT-1000 is the fruit of over 25,000 man-hours of intensive research and development by Yaesu's top design engineers. Instead of merely offering incremental improvements on existing designs or adding bells and whistles to an old model, the FT-1000 project involves a wholly new approach to the application of the latest digital and RF technologies to today's most demanding needs on the hf bands. Extensive surface-mount component technology allowed six microprocessors and five Direct Digital Synthesizers to be harmoniously integrated with a simple operator interface into a highly reliable full-featured transceiver optimized for serious hf applications.



ADDITIONAL FEATURES

Other features include adjustable IF width, IF shift, IF notch and APF controls. AGC presentable for fast, medium and slow + defeat, on/off selectable, preamp + adjustable attenuator -6dB, -12dB, -18dB. Adjustable — mic gain, RF power o/p, processor and drive controls. Built in electronic keyer with adjustable speed control. Twin independent frequency displays with mode indication + much more.

OPTIONS

SP5 external L/S with audio filter
DVS-2 Digital voice message storage system
BPF-1 Sub VFO filter unit

YH-77ST Headphone for stereo or mono dual receive
TCXO-1 High Stability oscillator unit

BRIEF SPECIFICATIONS

- ★ General Coverage Receiver 100kHz-30MHz
- ★ Ham bands TX 160-10m
- ★ Modes CW, USB, LSB, AM, FM, RTTY and PACKET
- ★ D.D.S. Direct Digital Synthesiser
- ★ Power output up to 200 watts P.E.P. 50W AM 250Hz
- ★ Selectable receiver band widths 2.4Khz, 2Khz, 500Hz, 250Hz
- ★ Dual band receiver tuning and monitoring with balance control

LIGHT IN THE HAND AND ON THE WALLET

The newest range of handhelds from Yaesu have all the very best in current electronic circuit technology combined with outstanding ergonomic design to produce a powerful yet extremely compact family of radios. The cases have rubber gasket seals around all the external controls and connectors to keep out dust, rain or spray and are fully compatible with all the existing FT23R accessories.

Top of the range must be the amazing FT470 Dualbander with a full 5W RF output on both 2m and 70cm (with FNB12). Dual independent IF circuits allow simultaneous reception on both bands with an audio balance control. Forty-two memories, 4 VFO's, 20 button keypad, defeatable Automatic Power Off and Power Saver are just a few of the functions available at the touch of a button.

Next in line are the FT411 and FT811, single band 2m or 70cm transceivers. Up to a full 5W RF output is available (with FNB 12). A 16 button keypad gives access to all the comprehensive user functions including forty-nine memories, dual VFO's, defeatable Automatic Power Off and Power Saver to name but a few.



LEEDS
SMC (Northern)
Howell Lane
Industrial Estate
Leeds LS9 6JE
Leeds (0532) 350606
9-5.30 Mon-Sat
Closed Sat afternoon

CHESTERFIELD
SMC (Midlands)
102 High Street
New Whittington
Chesterfield
Chest. (0246) 453340
9.30-5.30 Tues-Sat

JERSEY
SMC (Jersey)
1 Belmont Gardens
St. Helier, Jersey
Jersey (0534) 77067
9-5 pm Mon-Sat
Closed Wed

BIRMINGHAM
SMC (Birmingham)
504 Alum Rock Road
Alum Rock
Birmingham B8 3HX
(021-327) 14976313
9.00-5.00 Tues-Fri
9.00-4.00 Sat

AXMINSTER
Reg Ward & Co Ltd
1 Western Parade
West Street
Axminster
Devon EX13 5NY
Axminster (0297) 34918
9-5.20 Tues-Sat



SOUTHAMPTON SHOWROOM open 9.00-5.00 Monday to Friday, 9.00-1.00 Saturday. Service Dept open Mon-Fri 9.00-5.00.

SOUTH WALES AGENT: John Doyle, Transworld Comms, Neath (0639) 632374 Day (0639) 642942 Eve. Closed Thursday.

NTS. S05 3BY TEL: 0703 255111 FAX: 0703 263507 TLX: 477351

— 0% INTEREST SUBJECT TO STATUS

TOKYO HY-POWER PRODUCTS AND ACCESSORIES

Now available from stock are the complete range of HF transceivers, the HT100 series. These HF SSB/CW monoband transceivers are both compact and lightweight whilst providing all the necessary operating features for the discerning HF operator. Simplicity is the key with the HT100 series being ideal for mobile/portable operation. There are 3 versions, all are 13.8vdc, 10W P.E.P. RF output, the HT120 20m, the HT180 80m and the HT106 6m. A comprehensive series of accessories are also available to further enhance and personalise the system as required.

HT106 6m SSB/CW TRANSCEIVER

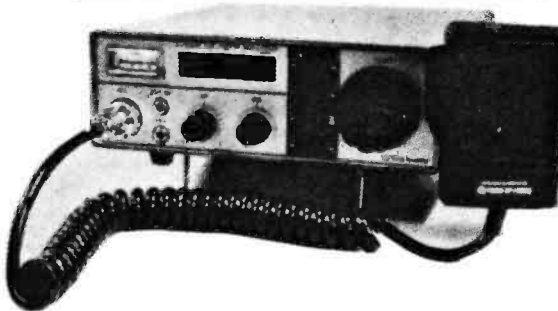

- HT106 6M CW/SSB 10W PEP £299.00
- HT120 20M CW/SSB 10W PEP £299.00
- HT180 80M CW/SSB 10W PEP £299.00

Transceiver Accessories

- HP100S MAINS PSU FOR HT Series £99.00
- HC100 ANTENNA TUNER 80-10M 200W £109.00
- HCF100 CW FILTER HT Series £39.00
- HNB100 NOISE BLANKER UNIT HT Series £19.95
- HBK100 Mobile Bracket HT Series £9.99

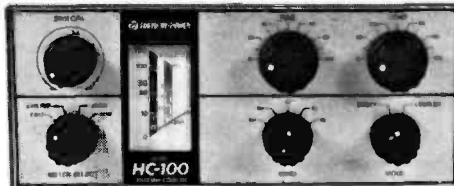

HC100



HC400L

Antenna Tuners

- HC200A 80-10M 200W PEP £115.00
- HC400L 160-10M 350W PEP £199.00
- HC2000 160-10M 2kW PEP £359.00

HX240 2m to HF TRANSVERTER

Only

£249.00
Inc VAT



HX240: 2m to HF Transverter
 Frequency Coverage: 80m, 40m, 20m, 15m, 10m
 Output power: 30-40W PEP (SSB/CW)
 RF Drive: 2.5W/10W Selectable
 Rx Preamp Gain: 8-10dB
 Power Requirement: DC 13.8V, 7A

Additional features: Carrier operated switching or by remote socket, power output meter, switchable preamp, Hi/Lo output selectable, visual indication of antenna mismatch.

ALSO AVAILABLE HX640 for 6m TRANSCEIVERS

SMC NORTHERN (LEEDS) CLOSED SATURDAY AFTERNOONS

*FREE FINANCE ON SELECTED ITEMS

On many regular priced items SMC offers Free Finance (on invoice balances over £120) 20% down and the balance over 6 months or 50% down and the balance over a year. You pay no more than the cash price! Details of eligible items available on request. *Subject to status.

Free interlink delivery on major equipment

Small items, Plugs, Sockets, etc by post £1.75. Antennas, cables, Wires & larger items. Lymx up to £5. Interlink delivery available, upon request for items other than radios from £7.30 depending on weight. Same day despatch whenever possible.

YAESU DISTRIBUTOR WARRANTY

Importer warranty on Yaesu Musen products. Able staffed and equipped Service Department. Daily contact with the Yaesu, Musen-factory. Tens of thousands of spares and test equipment.

PRICES & AVAILABILITY SUBJECT TO CHANGE WITHOUT PRIOR NOTICE

SMC

South Midlands Communications Ltd.

AMPLIFIERS

LINEARS QRO

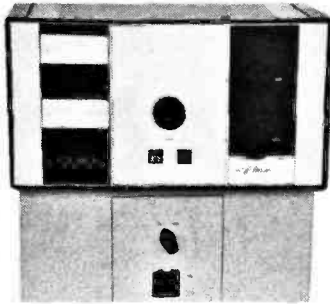

TEMPO 3K PREMIER

160-10m HF Linear. 3kW P.E.P. RF Input.
100W Drive. 1 x 3CX1200A Triode.

£2995.00

Also available 3002A 2kW O/P. 2m version.
100W Drive. 8877 Triode.

£2395.00

TEMPO 5K CLASSIC

80-10m 3kW RF O/P. 100-200W Drive.

£3895.00



TOKYO HY-POWER HL2K

160-10m HF Linear. 2kW P.E.P. RF Input.
60-120W Drive.

2 x 3-500Z.

£1425.00



TOKYO HY-POWER HL1K

160-10m HF Linear. 1kW P.E.P. RF Input.
70-120W Drive.

2 x 4CX250B Valves.

£945.00

Also available HL1K/6. 6M Linear. 10W Drive.

2 x 4CX250B Valves

£945.00



SAGRA 600

2m Linear. 600W Output. 25W Drive.
2 x 4CX250B.

£769.00

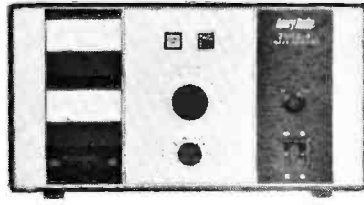

TEMPO 2002A

2m Linear. Max. Input 2kW.
25-40W Drive. Typical.
1 x 3CX800A7 C/W Coax Relay.

£1395.00



YAESU FL7000

160-10m HF Linear.
500W P.E.P. RF O.
100W D. Four FT757GX, FT747GX, FT767GX

£1600.00

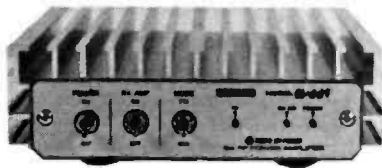

70cms 2004A. Max. Input 2kW.
25-40W Drive.

1 x 3CX800A7 W/O Coax Relay.

£1395.00

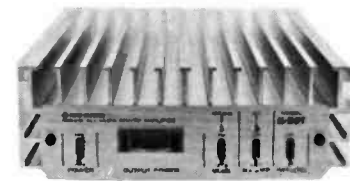

HL36U	70cm 3/10W in 40-50W out	
	RX Preamp	£135.00
HL60U	70cm 12W in 50W out	
	RX Preamp	£179.00
HL130U	70cm 3-25W in 120W out	
	RX Preamp	£369.00

HL100B/10	10m 10W in 100W out PEP	£179.00
HL100B/20	20m 10W in 100W out PEP	£179.00
HL100B/80	80m 10W in 100W out PEP	£179.00
HL66V	6m 10W in 50-60W out	
	RX Preamp	£129.00
HL168V	6m 3/10W in 80-160W out	
	RX Preamp	£249.00

HL37V	2m 3W in 32W out RX Preamp	£ 89.00
HL62V	2m 10W in 60W out RX Preamp	£135.00
HL110V	2m 2/10W in 100W out	
	RX Preamp	£215.00
HL180V	2m 3-25W in 120W out	
	RX Preamp	£295.11

LINEAR CLEARANCE SALE — ONLY AVAILABLE WHILST STOCKS LAST

LPM144-1-100	2m 1W in 100W out	£165.00
LPM144-10-100	2m 10W in 100W out	£169.00
LPM144-3-100	2m 3W in 100W out	£195.00
MML144/100LS	2m 1/2W in 100W out	£140.00
MML144/30LS	2m 1/2W in 30W out	£100.00

MML144/50S	2m 10W in 50W out	£100.00
MML432/100	70cms 10W in 100W out	£275.00
MML432/50	70cms 10W in 50W out	£ 95.00
MML432/30L	70cms 1/2W in 30W out	£175.00
MMT144/28R	Transverter 10m-2m	£239.00

MMT432/144R	Transverter 2m-70cms	£175.00
MMT432/28S	Transverter 10m-70cms	£155.00
MMT50/144	Transverter 2m-6m	£240.00
MMT50/28S	Transverter 10m-6m	£240.00
MMT1432/144S	Transverter 2m-70cms	£175.00

CARRIAGE ON ALL THESE LINEARS £5.00

SOUTHAMPTON (0703) 255111
CHESTERFIELD (0246) 453340
AXMINSTER (0297) 34918

LEEDS (0532) 350606
BIRMINGHAM 021 327 1497
For full addresses see previous page.



SITUATED AT SOUTHERN END OF M23 — EASY ACCESS TO M25 AND SOUTH LONDON

RECEIVERS	
HF225	£395
ICR71	£855
R2000	£595
VC10 V.H.F. Converter	£161
FRG8800	£649
FRV8800 V.H.F. Converter	£100
R5000	£875

HF TRANSCEIVERS	
TS940s	£1995
TS440s	£1138
TS140s	£862
TS680s	£985
FT767GX	£1599
FT757GX2	£969
FT747GX	£659
IC765	£2499
IC751A	£1500
IC735	£979
IC725	£759
IC726	£989

2M TRANSCEIVERS	
TH25E	£238
TH205E	£189
TH218E	£238
TS711E	£898
TR751E	£599
TM231	£289
FT23R + FNB10	£243
FT411 + FNB10	£259
FT290R II	£429
FT211RH	£309
FT212RH	£349
IC2GE	£265
IC228H	£385
IC275E Inc PSU	£1069
IC25E	£275
IC2SET	£295

70CM TRANSCEIVERS	
TS811E	£908
TR851E	£699
TH405E	£245
TH415E	£268
FT73R + FNB10	£263
FT790Rii	£499
FT711RH	£349
FT712RH	£375
IC4GE	£299
IC4SE	£310
IC448E	£429

DUAL BAND TRANSCEIVERS	
TM721E	£699
TS790E	£1495
FT470R + FNB10	£423
FT736R	£1369
FT4700RH	£675
IC32E	£399
IC3210E	£499
IC2400E	£635
IC2500E	£675

SCANNING RECEIVERS	
ICR7000	£989
FRG9600M	£509
RZ1	£485
AR2002	£487
R535 Airband	£249
STANDARD AX700E	£575

ANTENNA TUNER UNITS	
FRT7700	£59
FC757AT	£349
AT230	£208
AT250	£366
ICAT100	£379
MFJ941D	£105
MFJ949C	£158

DATONG		P&P
AD370 Active Antenna	£77.62	3.00
FL3 Multimode Filter	£145.54	2.00
D70 Morse Tutor	£83.40	2.00
ASP Speech Processor	£93.15	2.00

COAXIAL SWITCHES		
SA450 2way SO239	£19.49	1.50
SA450N 2way N	£26.99	1.50
Dræe 3way SO239	£18.69	1.50
Dræe 3way N	£24.15	1.50
C54 4way BNC	£30.39	1.50
MFJ-1701 6way SO239	£30.72	1.50

POWER SUPPLIES		
BNOS 12/5E	£74.75	5.00
BNOS12/20E	£178.25	5.00
DRAE 6amp	£78.72	3.00
DRAE 12amp	£104.71	5.00
DRAE 24amp	£151.34	5.00

HAND HELD RECEIVERS		
R537S Airband	£69.00	2.00
Sony Air7	£249.00	2.00
Win108 Airband	£175.00	2.00
AORAR900	£235.00	2.00

PALOMAR ANTENNA PRODUCTS		
Antenna Noise Bridge — Up to 100MHz	£59.95	without
Tuner-Tuner — Tune your ATU	£249.00	transmitting
LED S.W.R. Meter — Auto SWR up to 2kW	£124.95	P.E.P.
9:1 Balun. For the T2FD Antenna.	£23.95	
Preamplifier Tunes 160 to 6 meters	£119.95	

ANTENNA RANGE	
J Beam 'Minimax' Tribander	£361.00
J Beam TB3 MK3 Tribander	£348.00
Butternut HF6VX	£159.00
Butternut HF2v	£142.00
Cushcraft A3 Tribander	£299.00
Cushcraft 2M 215WB	£99.00
Tonna 20505 Sele 50MHz	£50.72
Tonna 20809 9ele 144MHz	£33.12
G Whip tribander 10-15-20	£41.00

MORSE KEYS		P&P
Kent Morse key kits	£31.00	2.50
Kent Twin-paddle Kits	£39.50	2.50
Hi Mound MK 704	£20.00	2.00
Hi Mound MK 706	£22.00	2.00
Vibroplex original std	£70.54	2.50
Vibroplex Iambic std	£66.33	2.50
Bencher BY2 Chrome Base	£76.97	2.50

FILTERS	
AKD HPF1	£6.75 1.00
AKD Braid Breaker	£6.75 1.00
AKD Notch Filter	£7.75 1.00
BNOS Low pass filter 6m	£29.95 1.50
LF30A Low pass filter	£32.25 2.00

ANTENNA BITS	
Hi-Q Balun 1:1 5kW PEP.	£13.95 1.00
Bicommm Balun 4:1 1kW	£13.80 1.00
Bicommm 7.1MHz Epoxy Traps (pair)	£12.65 1.50
Self Amalgamating Tape 10m x 25mm	£4.25 0.75
T-piece polyprop Dipole centre	£1.60 0.25
Small ceramic egg insulators	£0.65 0.20
Large ceramic egg insulators	£0.85 0.20

CABLES ETC.	
URM67 low loss coax 50 ohm per metre	£0.95 0.25
UR76 50 ohm coax dia. 5mm per metre	£0.35 0.10
UR70 70 ohm coax per metre	£0.35 0.10
UR95 50 ohm coax dia. 2.3mm per metre	£0.40 0.10

PALOMAR TUNER-TUNER™



£99.95

Do you use an antenna tuner? Then you need the new Palomar Tuner-Tuner to tune it to your operating frequency without transmitting. Just listen to the Tuner-Tuner's noise with your receiver. Adjust your tuner for a null and presto! you have 1:1 SWR. It's as simple as that.

PALOMAR R-X NOISE BRIDGE

£59.95

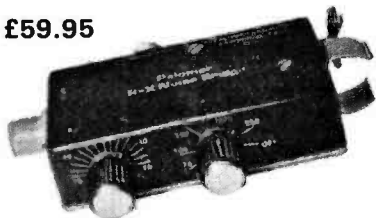

PALOMAR SWR & POWER METER

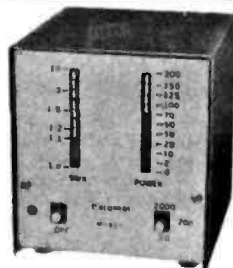

£124.95

●The only meter that shows PEP output directly, accurately, instantly.

Shows power and SWR on bright red light bars. See PEP and SWR while you talk! Automatic "hands-off" SWR reading. Power ranges 20-200-2000 watts. Works from 1-30 MHz. Power required 12-V DC.

●Learn the truth about your antenna.

The Palomar R-X Noise Bridge tells you if your antenna is resonant or not and, if it is not, whether it is too long or too short. It gives resistance and reactance readings on dipoles, inverted Vees, quads, beams, multiband trap dipoles and verticals from 1 to 100 MHz.

GOODS NORMALLY DESPATCHED WITHIN 24 HRS. — PRICES CORRECT AT TIME OF GOING TO PRESS — E&OE

MAIL ORDER & RETAIL

BREDHURST ELECTRONICS LTD HIGH ST, HANDCROSS, W. SUSSEX. RH17 6BW (0444) 400786

Open Mon-Fri 9am-5pm except Wed 9am-12.30pm. Sat 10am-4pm

PALOMAR PREAMPLIFIER

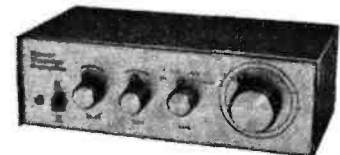

£119.95

Can't hear the weak ones when conditions are bad? Receiver lacks sensitivity on 20, 15 or 10? Get the world famous Palomar preamplifier. Tunes from 160 to 6 meters. Gives 20 dB extra gain and a low noise figure to bring out those weak signals. Reduces image and spurious responses too.

An RF sensing circuit bypasses the preamplifier during transmit. The bypass handles 350 watts.

BALUNS SPECIAL ORDER ONLY



1:1 & 4:1 HIGH POWER VERSIONS ALSO AVAILABLE

1.7-30 MHz. 350-W PEP. Ratios to match 50/75/100/150/200/250/300/375/450/600/800 ohms. Specify ratio. Model PB **£23.95**

I'm certain that, like me, at least half the readership of any magazine is infuriated by adverts for equipment which do not include the prices. So — just to turn the tables I thought I would give you a list of prices without pretty pictures of the equipment. Detailed brochures are always available on request, either by mail from Matlock, or by calling it at any of our branches up and down the country. See bottom of page for their telephone numbers. Read the list of prices carefully; there is sure to be something from the Kenwood range for you.

KENWOOD EQUIPMENT		Price	Carr.	MICROPHONES		Price	Carr.
TS950SD	NEW Deluxe HF Transceiver From Kenwood with DSP	3199.00	8.00	MC50	Deluxe dual impedance desk microphone, 4 pin plug fitted	46.08	2.50
TS950S	NEW Standard version of TS959SD (both models have built in ATU.).....	2499.00	8.00	MC60A	Deluxe desk microphone with built in pre amp	88.22	2.50
DSP10	NEW Digital signal processor unit for TS950S	399.00	8.00	PG4	Mic lead for MC60A/MC85 4, 6, or 8 pin Please state which	9.87	1.00
SM230	NEW Station monitor with Pan Display ..	773.00	8.00	MC80	Electret desk microphone with UP/DOWN facilities	53.98	2.50
SO2	NEW High stability TCXO for TS950S..	99.00	1.00	MC85	Deluxe desk microphone with built in Audio Level Compensation	99.00	2.50
VS2	NEW Voice synthesizer module	32.26	1.00	MC35S	Fist microphone 50K impedance	21.72	1.50
SP950	NEW External loudspeaker unit with switched filters	87.55	2.50	MC43S	Up/down hand microphone for TS930S etc.	22.22	1.50
For crystal filter options please refer to CRYSTAL FILTER section				MC44DME	Up/down hand mike with built in DTMF key pad	42.60	1.50
TS940S	HF Base Station Transceiver. General coverage receive	1995.00	8.00	MC55	Mobile microphone with control box (up/down etc.) 6 or 8 pin	52.67	2.00
AT940	Automatic ATU 160M-10M ham bands. Fits inside TS940S	244.88	8.00	MJ86	8/6 pin mic adapter, Also MJ84, MJ68, MJ64, MJ48, MJ46	6.59	1.00
SP940	External speaker unit with switched filters	87.55	2.50	HSMX2	Mobile microphone with control box (Made by HOKUSHIN)	39.80	2.00
940MOD	Special TS940S receiver upgrade modification	98.00	8.00	VHF-UHF BASE STATION TRANSCEIVERS			
SO1	Temperature compensated oscillator unit	193.53	1.00	TS711E	2M Base station multimode transceiver with DCS	898.00	8.00
VS1	Voice synthesizer module	32.26	1.00	SP430	Attractive matching speaker for TS711/811E	40.81	2.50
TS440S	HF band transceiver with gen. coverage receiver	1138.81	8.00	VS1	Voice module	32.26	1.00
AT440	Internal automatic ATU for TS440S 80-10M ham bands	144.82	8.00	TS790E	NEW Dual band all mode transceiver 2m/70cm with 1296MHz option	1495.00	8.00
PS50	Heavy duty PSU for TS440 (PS430) can also be used	222.49	8.00	PS31	Matching power supply for TS790	186.00	8.00
VS1	Voice synthesizer module	32.26	1.00	SP31	External speaker for TS790	63.46	3.00
*NB	Speaker and mobile mount see TS140S			UT10	23cm. transceiver option module	379.51	8.00
TS140S	HF transceiver 160-10M. Ask for details	862.00	8.00	VS2	Voice module	32.26	1.00
TS680S	Similar to TS140S with 10W 6M. PA ...	985.00	8.00	VHF/UHF MOBILE TRANSCEIVERS			
PS430	Mains PSU for TS140S with built in cooling fan	173.78	8.00	TR751E	2m multi mode mobile/fixed station transceiver	599.00	8.00
VOX4	VOX unit for TS680S	58.42	2.00	TR851E	70cm multi mode mobile/fixed station transceiver	599.00	8.00
SP430	Attractive matching speaker for TS140S/430S	40.81	2.50	MU1	DCL option for TR751E/851E	30.95	1.00
AT250	Automatic ATU for TS140S/430S. Can also be used with other rigs	366.00	8.00	VS1	Voice module	32.26	1.00
AT130	Compact mobile or base ATU 80-10M ..	140.58	3.00	TM231E	NEW Compact 2m mobile transceiver, 50/10/5W	289.00	8.00
MB430	Mobile mounting bracket for TS140/430S	15.80	2.00	TM431E	NEW Compact 70cm mobile transceiver, 35/10/5W	318.00	8.00
AT230	All band ATU and power meter. General purpose ATU	208.67	8.00	TM531E	NEW Compact 23cm mobile transceiver, 10/1W	385.00	8.00
HF STATION ACCESSORIES		Price	Carr.	RC10	Remote controller/handset	169.00	3.00
TL922	160-10M 2KW linear. 3-500Z valves included	1495.00	8.00	RC20	Full function remote controller	165.20	3.00
SM220	Station monitor scope	343.62	8.00	IF20	Interface unit	152.43	3.00
BS8	SM220 panoramic display option. TS830/940	77.00	1.50	PG4H	Interface connecting cable	9.38	1.00
LF30A	HF Low pass filter 1KW rating	32.26	2.00	PG4J	Extension cable kit	30.47	1.00
CRYSTAL FILTERS		Price	Carr.	DRU1	Digital recording system for TM231E/431E	85.72	1.00
YK88A	AM 6kHz for TS430 TS670	49.37	1.00	TM701E	NEW Compact 2m/70cm mobile transceiver. 25w (VHF and UHF)	469.00	8.00
YK88A1	AM 6kHz for TS940 TS930 R5000	48.05	1.00	RC10	Remote controller/handset	169.00	3.00
YK88C	CW 500Hz for TS430/440 TS530/830 TS670 R5000	46.08	1.00	RC20	Full function remote controller	165.20	3.00
YK88C1	CW 500Hz for TS940 TS950S	48.05	1.00	PG4G	RC10 extension cable	9.87	1.00
YK88CN	CW 270Hz for TS430/440 TS530/830 TS670 R5000	54.64	1.00	SP4I	Mobile speaker unit for most models	18.61	1.00
YK88S	SSB 2.4kHz TS440	47.40	1.00	SP50	Mobile speaker unit for most models	20.41	1.50
YK88SN	SSB 1.8kHz for TS430/440S TS530 R5000	46.74	1.00	TM731E	NEW Deluxe Dual band 144/432MHz. Mobile transceiver. 50w/35w	665.00	8.00
YG455C	CW 500Hz for TS830 R2000	110.58	1.00	TM721E	Dual band 144/432 mobile transceiver. SPECIAL OFFER PRICE	525.00	8.00
YG455CN	CW 270Hz for TS830 R2000 SPECIAL OFFER PRICE	39.50	1.00	TSU6	CTCSS unit for TM721E	30.68	1.00
YG455C1	CW 500Hz for TS950S TS940S TS140S ..	112.57	1.00	MB11	Mobile mounting bracket. For TW4100E, TR721E, and TR731E	15.54	2.00
YG455CN1	CW 270Hz for TS950S TS940S	131.66	1.00	MA 700	NEW VHF/UHF mobile antenna with diplexer	54.50	8.00
YK455C1	CW 500Hz for TS140S	54.04	1.00				
YG455S1	NEW Extra SSB filter for TS950S	112.57	1.00				

LOWE ELECTRONICS LIMITED

Chesterfield Road, Matlock, Derbyshire DE4 5LE Telephone 0629 580800 (4 lines) Fax 580020 Telex 377482

Practical Wireless, February 1990

25 YEARS IN AMATEUR RADIO

VHF/UHF HAND HELD TRANSCEIVERS

		Price	Carr.
TH25E	2m FM compact handheld transceiver ...	238.00	8.00
TH45E	70cm FM compact handheld transceiver	269.00	8.00
TH75E	NEW Dual band FM 2m/70cm handheld transceiver	398.00	8.00
TSU6	CTCSS unit for TH75E	30.68	1.00
RA5	Dual band telescopic aerial	18.45	1.00
HMC2	Headset/mic. with VOX/PTT	34.25	2.00
DC1	DC Adaptor. Use with PG2V to power TH25/45E	13.62	0.75
SMC31	External speaker/microphone	29.79	1.50
SMC32	Miniature speaker/microphone with earphone socket	23.95	1.50
PB5	Ni-cad battery pack. 7.2V, 200mAh	26.96	1.50
PB6	Ni-cad battery pack. 7.2V, 600mAh. (supplied).....	26.96	1.50
PB7	Ni-cad battery pack. 7.2V, 1100mAh	41.53	2.00
PB8	Ni-cad battery pack. 12V, 600mAh	38.64	2.00
BT6	AA battery case (batteries not supplied) .	7.27	1.50
BC9	Spare charger for TH25/45/75E transceivers	14.95	1.00
BC10	Compact drop in charger	20.42	2.50
BC11	Rapid drop in charger	100.43	3.00
SC14	Soft case (using PB5). For TH25/45E ...	7.27	1.00
SC15	Soft case (using PB6, BT6). For TH25/45E	8.02	1.00
SC16	Soft case (using PB7, PB8). For TH25/45E	8.79	1.00
SC22	Soft case for TH75E (using PB5, PB6, BT6)	11.83	1.00
SC23	Soft case for TH75E (using PB7/8/9) ...	11.83	1.00
WR1	Water resistant bag	7.27	0.50

ACCESSORIES FOR OLDER TRANSCEIVERS

		Price	Carr.
PB21	Ni-cad battery pack for TH21E/41E	24.36	1.50
PB21H	High cap, battery pack TH21/41E. Charges with BC2 or BC6	32.26	1.50
PB26	Ni-cad battery pack for TR26/3600E Can also fit 2500/3500	37.54	1.50
BC2	Charger for TR2600/3600E and PB21H	11.86	1.50
DC21	Mobile DC converter for the TH21E/41E	25.00	1.50
C6	Desk charger/PSU for TH21/41E Can charge 2 nicad packs together	99.00	2.50
BT2	Dry battery case for TH21E/41E	11.86	0.75
BT4	Dry battery case for TH21/41E	13.82	1.00
SC11	Soft case for TH21E/41E when using PB21H	10.47	0.75
AD1	Screwed phono to BNC adapter for TH21/41E ant	3.85	0.50
RA8A	Stubby helical antenna for TH21E	8.56	1.00
TH205E	2m handheld transceiver with LCD readout	199.00	8.00
TH215E	2m handheld transceiver with keypad entry	228.00	8.00
TH405E	70cm handheld transceiver with LCD display	245.00	8.00
TH415E	70cm handheld transceiver with keypad entry	268.00	8.00
PB1	Nicad pack 12V 800 mAh	57.27	2.00
PB2	Nicad pack 8.4V 500 mAh	34.22	2.00
PB3	Nicad pack 7.2V 800 mAh	38.82	2.00
PB4	Nicad pack 7.2V 1600 mAh	63.19	2.00
BT5	Dry battery case	11.86	1.50
BC7	Rapid nicad charger	97.42	3.00
BC8	Compact nicad charger	38.82	2.00
SC12	Soft case (for PB2/3)	13.82	1.00
SC13	Soft case (for PB1/4)	14.49	1.00
BH4	Belt hook for TH205/215E	4.60	1.00
BH5	Swivel mount for TH205/215E	31.59	1.50
MB4	Mobile mounting bracket for TH205/405 series. (Needs BH4)	9.22	2.00
PG2V	DC power cable	3.96	1.00

SMC31	Speaker microphone for TH205E/TH215E	29.79	1.00
SMC32	Miniature speaker/microphone with earphone socket	23.95	1.50
RA3	Telescopic whip antenna for TH205E/TH215E	13.17	0.75
RA8B	Stubby helical antenna for 2m. BNC plug	13.82	1.00
HS2RB	Rubber flexible antenna for 2m. hand helds. BNC plug	8.00	0.75

RECEIVERS AND CONVERTERS

		Price	Carr.
R5000	HF General coverage receiver. See CRYSTAL FILTERS	875.00	8.00
DCK2	Option kit for 12Volt DC operation	9.29	1.00
VC20	VHF converter option for R5000 108-174MHz	167.21	3.00
VS1	Voice module for R5000	32.26	1.00
R2000	General coverage receiver with host of features See CRYSTAL FILTER	595.00	8.00
DCK1	Option kit for 12 Volt DC operation	4.00	1.00
VC10	VHF converter for R2000 118-174MHz .	161.94	2.50
RZ1	Wide range scanning receiver. Send for details	465.00	8.00
HS6	Ultra light deluxe headphones	24.36	2.00
HS5	Deluxe headphones for all KENWOOD equipment	37.54	2.00

ACCESSORIES

		Price	Carr.
AL1	Lightning and static protector 100w S0239 connector	32.91	1.00
AL1N	Lightning and static protector 100w N connector	39.50	1.00
AL2	Lightning and static protector 1Kw S0239 connector	39.50	1.00
PL1	Power lead for TR2200/2300 series and AR2001/2.....	1.44	0.50
PG3A	Mobile transceiver DC line filter	9.87	1.50
PG2R	12V DC lead for TR7800/7850/7950/7930/9130/130V	8.56	1.00
PG2L	12V DC lead for TM201A/401A/211E/411E/4000A/TR7730	3.29	1.00
PG2U	12V DC lead for TS711E/811E	5.92	1.00
PG2P	12V DC lead for TR7500/8400/R600/R2000 etc	3.29	1.00
PG2N	12V DC lead for TM2550E/TR751E/TR851E	6.59	1.00
PG2S	12V DC lead for TS440S/TS140S/TS680S/TS790	9.22	1.50
PG2V	12V DC lead for TH205/215E TH405/415E	3.96	1.00
MB201	Mobile bracket for TM201/401/211E/411E	11.86	2.50
MB4000	Mobile bracket for TW4000A	12.50	2.50
MB430	Mobile bracket for TS430S/711E/811E/440S/670 etc	15.80	3.00
MB10	Mobile bracket for TR751E/851E and TM2550E	18.45	2.50
MB11	Mobile bracket for TW4100E, TR721E and TR731E	15.54	2.00
MB4	Mobile mounting bracket for TH205/405 series. (Needs BH4)	9.22	2.00

COMPUTER INTERFACE UNITS

		Price	Carr.
IF232C	RS232 Interface adaptor. TS711/811E/TS940/440S/R5000/TS140/TS680	69.13	2.00
IF10A	Interface unit for TS711/811E	53.98	2.00
IF10B	Interface unit for TS940S	53.98	2.00
IF10C	Interface unit for TS140S/TS680S	31.87	2.00
IC10	Interface unit for TS440S and R5000	27.65	2.00

Shops in GLASGOW Telephone 041-945 2626, DARLINGTON Telephone 0325 486121, CAMBRIDGE Telephone 0223 311230, BARRY Telephone 0446 721304, LONDON Telephone 01-429 3256, BOURNEMOUTH Telephone 0202 577760
All branches are closed all day Monday.

Save £££'s now!

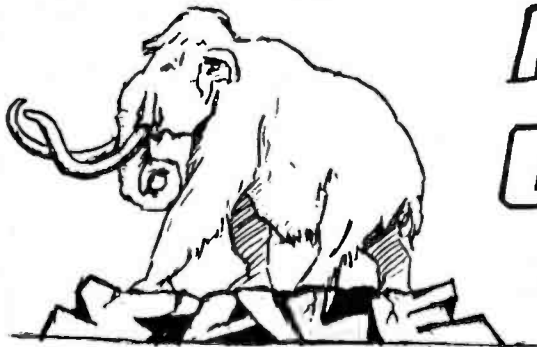

MAMMOTH

Discounts!

On

ICOM

YES! OUR BULK BUYING MEANS THE BEST DEAL
FOR YOU... TOP DISCOUNTS,
TOP TRADE-IN PRICES

FINANCE AVAILABLE ON OUR DISCOUNT PRICES
(subject to status)

PHONE ANY OF OUR FIVE NUMBERS

ARROW ELECTRONICS LTD

5 The Street, Hatfield Peverel,
Chelmsford, Essex CM3 2EJ.
Tel: 0245 381626/381673
Fax: 0245 381436

Hours: 9-5 (Closed Thursdays)

GLASGOW SHOWROOMS

Unit 17, Six Harmony Row, Govan, Glasgow, Scotland G51 3BA.
Tel: 041 445 3060.
Hours 8.30-5.30 Mon-Fri. (Closed Saturday).

AGENTS

LEICESTER — DAVE FOSTER Tel: 0533 608189
WIGAN — JIM COOK Tel: 0942 713405

Latest calls 8.30pm please!



RSGB CREDIT CARD.
ACCEPTED

YOUR ORDER CAN BE TELEPHONED WITH CREDIT
CARD DETAILS & DESPATCHED IMMEDIATELY!

FREE FINANCE ON MANY MAJOR ITEMS AT RRP.
(Ask for details of qualifying items).

INVITATION

OUR 1990 "OPEN-DAY" WILL BE ON 24th FEBRUARY

BETWEEN 10 A.M. & 5 P.M. OUR WHOLE GANG WILL BE AT HATFIELD PEVEREL TO SHOW YOU THE LATEST, THE BEST, THE NEW, MAYBE EVEN THE UNUSUAL!!!

FREEBIES!!! REFRESHMENTS!!!

Hatfield Peverel Showrooms are just off the A12 main road. Railway Station 3 minutes. Call G3LST on 145.550 if you get lost!

ARROW — FOR THE BEST DEAL IN AMATEUR RADIO!!

TH75E KENWOOD DUAL BANDER

with receive
140/169 & 430/460 Mhz
Nicad & Charger
£398.00

**NEW! C528 STANDARD
DUAL BANDER**
with receive 130/172
350/470 & 890/960 Mhz!
£379.00



NEW! IC-24E



ICOM mini dual bander
2M & 70cms FM
DISCOUNT PRICE £349
incl. nicad, charger

TS440S KENWOOD

HF Base Station
with Internal ATU
Please Phone for Price

FT470R DUAL-BANDER

Yaesu's famous mini for
2m & 70cms Handy.
ONLY £389
INCL. nicad & charger.



TS140S or TS680S with 6M



Phone for
Best Price

SCANNER BARGAINS FROM AOR

AR800 Now AR900UK Now AR950 NEW!
only £169 Only £199 £249

An SAE brings our Scanner Catalogue!

NEW!! AR1000 15 — 1300 Mhz 1000 memories £275!!



TR751E — FREE CREDIT

EXCELLENT 2 Metre
performance from this
great allmode rig.
Dep: £199 + 9
payments £44.44.



**FRG8800
YAESU EXCELLENT
GENERAL COVERAGE
RECEIVER
ONLY £549**

FT736 V/UHF Base



SPECIAL
PRICE £1275

NEW! IC2400 FREE CREDIT



NEW ICOM 2M & 70CM
FM 45 W Full Duplex.
simultaneous receive.
£211 DEP. + 9
payments £47.11.

IC-2SE

A 2M micro Handy & a
SCANNER! Comes complete
with nicad, charger & receive.
Extended 80-190Mhz!
DISCOUNT PRICE £249



IC-4SE

Amazing micro 70cms handy
with nicad + charger. Receives
380-500 & 800-950 Mhz!!
DISCOUNT PRICE £279.

ONLY £499!!

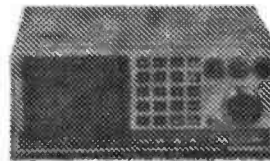

The most remarkable Scanner
yet. AX700 with Panoramic
Display.

JUPITER SCANNERS!

25-1300 Mhz with
exceptional performance
(really sensitive
at 900 Mhz!)

MTV5000 Handheld £275
MTV6000 Base/Mobile
£349

(Super slimline design)



R-7000

ICOM's superb VHF/UHF/ SHF receiver



£895 DISCOUNT
PRICE

IC-726 ICOM HF MINI



A really great rig HF &
SIX.AM/FM, Microphone,
general coverage receiver,
DISCOUNT PRICE £899.00

IC735 STAR BARGAIN £865



with FREE
SM6 Desk
Mic!!

Finance arranged subject to status. APR typical 34.4%. Written quotations on request.

COMET ANTENNAS

An excellent performance combined with super quality at a BARGAIN price from our directly imported range including:

CHL21J Micro mobile 144/432 0/2.15dB .29m 150W	£ 14.95
CHL23J Mini mobile 144/432 2.15/3.8dB .5m 150W	£ 16.75
CHL25J Mobile 144/432 3/5.5dB .93m 120W	£ 29.95
CA-702 Mobile 144/432 3/5.5dB 200W	£ 24.22
CA-2x4FX Base 144/432 4.5/7dB 2.02m F/Glass	£ 52.50
CA-2x4WX Base 144/432 6.5/9dB 3.18m F/Glass	£ 74.00
CA-2x4SUP Base 144/432 6/8.4dB 2.54m	£ 69.00
CA-2x4 MAX Super gain 144/432 8.5/11.9dB 5.4m F/Glass	£125.00
CA-ABC22A Base Colin. 2m 6.5dB 2.87m	£ 36.00
CA-ABC23 Base Colin. 2m 7.8dB 4.5m	£ 59.50
50CA-285E 5/8 Wave Mobile 144	£ 15.00
CA-ROD2 BNC loaded tele. whip for Handy's	£ 12.95

Comet Meters NEW!

CD120 SWR + Power 15/60/200W with PEP & averaging 1.8-200MHz	£ 86.95
CD270D SWR + Power as above for 140-525MHz	£ 88.95
CFX140 Triplexer for 50/144/432 MHz	£ 33.40

Send SAE for COMET CATALOGUE

NEW NW SHOWROOM OPEN AT GREENSWAY ARCADE,

Gerrards Street,
Ashton-in-Makerfield,
Wigan, Lancashire

Tel: 0942 713405

Jim Cook, G6TYB, is at your service Mon-Sat.

ARE

COMMUNICATIONS
The very latest "2 in 1"
ICR7000HF Receiver
500kHz — 2GHz



**EXCLUSIVE TO
A.R.E. COMMUNICATIONS**

YES, 500kHz to 2GHz CONTINUOUS receive in one unit. Using the ICR7000 multimode facilities, this probably makes the "2 in 1" ICR7000HF Receiver the most versatile scanner available today. Because of the enormous frequency coverage, the ICR7000HF has 200 mode sensitive channels for increased flexibility.

With excellent strong handling characteristics, using a direct fed Double Balanced Mixer, the need for a pre-amp is unnecessary.

Now available on A.R.E. super credit terms.
48 monthly payments of £33.22 A.P.R. 29%
Cash or credit card price £989.

*Also available as an after-fit to your existing ICR7000
only £139 incl. VAT.

Opening hours Monday - Friday 9.30-5.30 Saturday 10.00-1.00.

WE ARE PLEASED TO ANNOUNCE OUR NEW E
NO DEPOSIT AND 4 YEARS TO PAY ON ALL A
IF THE RIG YOU ARE LOOKING FOR IS NOT HE

AND NOW THE NEW JUPITER RANGE

BASE AND HANDHELD

General Features

- Switchable AM/FM.
- 25-550MHz & 800-1300MHz.
- Proper manual up/down electronic tuning.
- 100 memories in 5 banks of 20.
- Selective bank scanning.
- 10 programmable band segments.
- Priority channel.
- Any memory channel can be temporarily passed.
- Steps of 5, 10, 12.5, or 30kHz.
- Auto frequency correction for step changes.
- Band Search or Memory Scan.
- Carrier or audio locking.
- Permanent/temporary hold.
- Delay.
- Slow/Fast speed (20 steps per second).
- Battery saver circuit.
- Large speaker for good audio.
- BNC Socket.
- Proper English manual for UK market.
- Not an American import.
- Key lock.
- Telescopic antenna.



48 monthly
payments of
£10.04
or cash/cheque/credit card
£ 299.



JUPITER BASE STATION

NO DEPOSIT. 48 monthly payments
£12.59
or £375 cash/cheque/
credit card

PHONE 01-997 4476

**A.R.E.
COMMUNICATIONS
6 ROYAL PARADE
HANGER LANE
EALING
LONDON W5A 1ET**

PHONE
01-997 4476
FAX:
01-991 2565

LICENSED CREDIT BROKERS A.P.R. 29% S

EASIEST OF EASY TERMS —
 AMATEUR EQUIPMENT OVER £200
 PHONE — PHONE FOR QUOTE — 01-997 4476



Brenda
G4VXL

Both Brenda
and Bernie
will be
pleased to
welcome you
at their
Ealing Shop



Bernie
G4AOG

FOR THOSE WHO DEMAND THE BEST
 LISTEN TO THE WORLD IN DETAIL

IC-R9000 COMMUNICATIONS RECEIVER

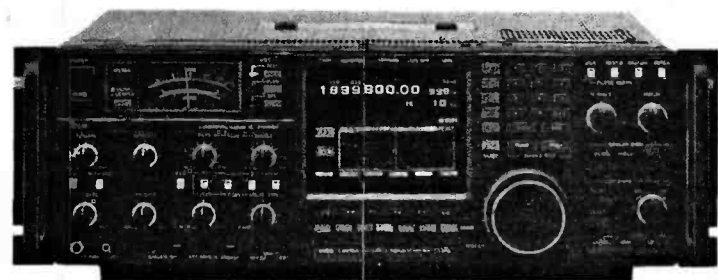

The world is now at your fingertips with ICOM's elite new IC-R9000, a communications receiver truly in a professional class all of its own. With the IC-R9000's continuous all mode, super wideband range of 100kHz to 1999.8MHz, ICOM's unique CRT display and numerous scan functions, local and distant spots on the globe are now within earshot in one single receiver.

The IC-R9000's versatile receive capability allows you to receive many different mode signals. Listen to AM used by broadcast stations and VHF airband. Use SSB (U.S.B./L.S.B.) and CW to receive Commercial and Amateur stations on shortwave.

Tune into CB (Citizen Band), Marine and Amateur stations using FM or use wide FM to

receive FM broadcast stations and TV signals. FSK (Frequency Shift Keying) is also built in for receiving RTTY from news agencies. With an advanced range like this you'll have no trouble in hearing stations near to home or on the other side of the planet.

NOW NO DEPOSIT
 48 payments of £126.00

CASH/CHEQUE/
 CREDIT CARD
£3750

UNIDEN BEARCAT 200XL

FREQ. 66-88MHz
 118-174MHz
 406-512MHz
 806-956MHz

200 Memories
 10 Priority channels
 Superb Sensitivity

OR 48 MONTHLY PAYMENTS OF £7.35

SUBJECT TO STATUS

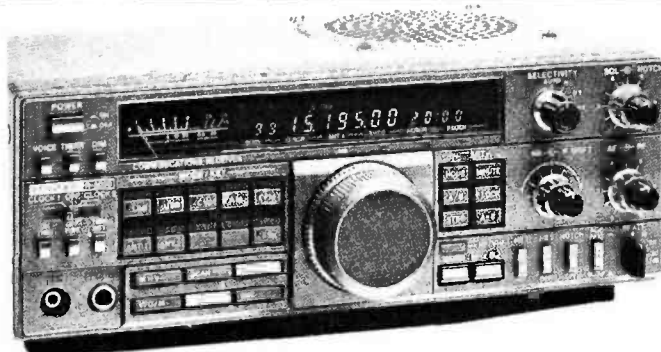

The R-5000 from Kenwood
 100kHz-30MHz. SSB/AM/CW/FM/FSK
 CV-10 converter 118-174 MHz

Now available on 48 monthly
 payments of £26.70

OR
 cash/cheque/
 credit card **£795**

PHONE 01-997 4476

NO DEPOSIT
 48 monthly payments
 of £33.42.



The NRD-525 from JRC

J.R.C. ARE RENOWNED FOR THEIR
 COMMERCIAL RADIO EQUIPMENT AND THEIR
 AMATEUR BAND EQUIPMENT ENJOYS THE
 SAME REPUTATION

OR CASH/CHEQUE/
 CREDIT CARD **£995**

NEVADA.....TALK TO THE WORLD

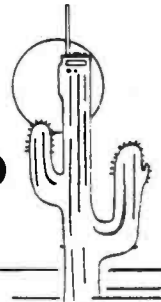

TALK KENWOOD

We are now officially appointed Kenwood dealers for the South Coast - and carry the complete range in stock. Heres a selection:-

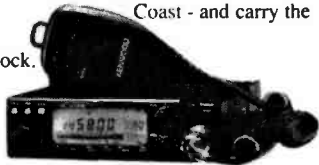

- TS 950SD New Digit HF Transceiver.....£3199
- TM 231E 2 Mtr mob£289
- TM 431E 70cm mob£318
- TM 701E 2/70cm mob£469
- TR 751E 2m multi-mode mobile£599
- TS 711E 2 Mtr multi-mode(s/soiled).....£799
- TS 440S HF.....£1138
- TS 940S HF.....£1995

We always carry a large selection of used eqpt. ring for details

TALK ATU'S

TM 1000 1 KW ALL BAND ATU

Using our unique high power wideband roller coaster this ATU gives effortless matching of all long wire, G5RV, vertical and coax fed antennas. (Add £5.75 carriage for all models)

- Standard Model TM1000.....£168
- Balun Model TM1000B.....£199
- Standard TM1000 Kit Form.....£138



BUILD YOUR OWN AMPLIFIER OR ATU WITH OUR RANGE OF HIGH POWER COMPONENTS

- Roller Coaster 30 µH.....£28.00
- Var. cap 150 pF (4Kv) (For mag. loops)£16.95
- Var. cap 250 pF (10Kv)£19.95
- Var. cap 250 + 250 pF (10Kv)£28.00
- Var. cap 750 pF (4Kv)£28.00
- Turns Counter (For Roller).....£14.95
- Empty ATU Case.....£26.00
- 2Kw Balun Assembly£28.00

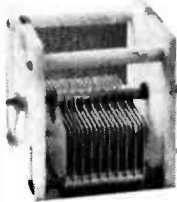

TALK ICOM

As ICOM main South Coast dealers we are always pleased to discuss prices, part exchanges and finance.....Give Paul Martin, our ICOM specialist, a call now!

- IC - 2SE.....Call
- IC - 32E 2/70 H/held.....Call
- IC - 3210E 2/70 Mobile.....Call
- IC - R7000 Receiver.....Call
- IC - R71E Receiver.....Call
- IC - 725 HF TCVR.....Call
- IC - 735 HF TCVR.....Call
- IC - 751A HF TCVR.....Call
- IC - 761 HF TCVR.....Call
- IC - 765 HF TCVR.....Call
- IC - 228H 2m/45w.....Call
- IC - 448E 70/25w.....Call

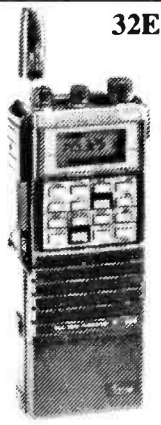

32E

TALK SCANNERS

We probably carry the largest stocks of scanners in the UK. Our NEW BUMPER CATALOGUE features all the latest models.

Here is a small selection:-

NEW FAIRMATE HP100E THE ULTIMATE HANDHELD

- * Freq: 25 - 550 MHz
830 - 1300 MHz
- * 1,000 Channels of mem.
- * Keypad or rotary control
- * AM/Narrow FM/Wide FM
- * Search steps from 5KHz to 995KHz.

EVERY SET SUPPLIED WITH:-
Full set high PWR nicads
2 antennas, carrying case,
earphone, DC cable, belt clip
shoulder strap.(charger extra...£7.76)

£299

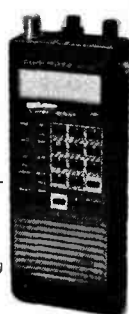

NEW MULTI PURPOSE PRE-AMP

SUITABLE FOR SCANNERS & TRANSCIEVERS

- * 25 - 2100 MHz
 - * Full RF switching for transceiver use
 - * Low noise GaAs Fet
 - * Variable Gain
 - * Band pass filters
- Boost reception on your scanner, handheld transceiver, communications receiver with this superb new unit high quality japanese workmanship

£79.95

SCANNER ANTENNAS

- Nevada Discone (50 - 700 MHz).....£24
- WB1300 Discone (25 - 1300 MHz).....£59.95
- PA15 Colinear (200 - 960 MHz).....£49.95



TALK ACCESSORIES

REMOTE MAST HEAD SWITCH

NEVADA CAS - A2 £49.95

Freq:- DC - 1.3 Ghz

Connectors:- 'N' Type

Power:- 150/300 Watts

SADELTA XL30 Mic

A new electret base mic. that will give your Kenwood, Yaesu, Icom, or other leading brand of Transceiver extra 'punch' and 'clarity'. The mic may be powered from the Transceiver direct or with an internal PP3 battery.

Introductory Offer £39.95

SADELTA CM 40 Mic

As the XL 30 above, but with Vol/Tone controls

Introductory Offer £49.95

NEW DOCKING BOOSTER

Boost the output of your 2mtr handheld to 25 watts suitable for use at Home or in the car.

Model BS25

For ICOM, CTE, Kenpro

Model BS23

For some Yaesu models

Both Models £59.95

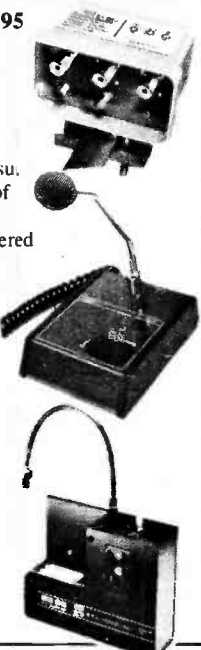

TALK AMPLIFIERS



B300P

MOBILE AMPS

- B150 180w (26 - 30 Mhz)£54.95
- B300P 300w (6 - 30 Mhz+pre amp).....£147.52
- B550P 500w (6 - 30 Mhz).....£237.00
- B303 200w (6 - 30 Mhz).....£114.67
- TC50 15w (50 - 52 Mhz).....£29.95
- HL 66V 60w (50 - 52 Mhz) S/hand.....£95
- BRL31 28w (26 - 30 Mhz)£19.95
- B250 250w (6 - 30 Mhz) 24 volt.....£115



TC50DX 50 MHz amplifier

- 737 80w (26 - 30 Mhz).....£35.41
 - 735 35w (26 - 30 Mhz)£18.54
 - B110 110w (142 - 170 Mhz).....£145
- ### BASE AMPLIFIERS
- B132 240w (6 - 30 Mhz)£129
 - BV131 250w (26 - 30 Mhz)£115
 - B507 300w (6 - 30 Mhz)£278
 - HL1K/6 500w (50 -52 Mhz).....£695

SEND IN NOW JUST £2 FOR OUR NEW BUMPER CATALOGUE (INCLUDES £2 VOUCHER)



NEVADA COMMUNICATIONS.....WE TALK YOUR LANGUAGE

189 LONDON ROAD, NORTH END, PORTSMOUTH, PO2 9AE, ORDER HOTLINE 0705 662145

Keylines



Rob Munton G3XFD

Ever since I first started reading *PW* nearly 40 years ago, I've always enjoyed building my own radio projects. The circuits have been varied and some of them have been unusual to say the least! Receivers, transmitters, test equipment and one-off items such as the *PW* 'Treasure Tracer' have provided much fun, experience and education.

But why build your own equipment now? Financially the argument could be proved I'm sure, that by building his own the amateur will lose money and time. However, the satisfaction of building your very own simple transmitter or receiver, with parts often coming from the junk box, radio jumble sale or mobile rally, has to be felt to be appreciated.

Some of the most pleasing amateur radio QSOs I've had have been achieved by using less than 10W d.c. input to a c.w. transmitter running into simple antennas. So, I've got to nail my own colours to the mast and admit that I'm a QRP (low power operation) enthusiast who enjoys the challenge that this particular operating technique of amateur radio offers.

Fortunately, home construction and low power operating seem to go together like the proverbial peaches and cream. Looking back over the years since I be-

came licensed, it comes as no surprise to see that most of the transmitting designs built from *PW* circuits have been for equipment with d.c. inputs of less than 50W. In fact, my most successful project was the *PW* Severn, a design originating from George Dobbs G3RJV, and this little transmitter has provided excellent results despite its low level output.

I was attracted to the *PW* Severn because of the fun that I had from building and operating a Heathkit HW7 direct-conversion transceiver in the early 1970s. Unfortunately, I made the mistake of selling the HW7 a few years back...and now regret parting with the rig!

Many home-constructed radio projects can soak up a great deal of time and money before they are completed. Despite the fact that such equipment can then give many years of trouble free service, even well built home-made gear fetches very poor prices when sold on the open market. This sad fact of life can deter many would-be constructors, who shy away from complex and costly projects which could

show them a very poor financial return.

Heathkit equipment, which I'm pleased to say is still popular in America, never seemed to suffer very much in this way and second-hand items would often appear (and be sold) at realistic prices whether it was factory assembled or home-built. What a pity that some of the excellent home-made, one-off projects that I've seen in the past have not repaid the dedicated designer/builder in a more handsome way. Perhaps it's down to us to be prepared to look more closely at the home-brewed equipment on offer at the next 'junk' sale. Who knows what well-built bargain could come our way?

The commercial kit such as those made by the Heath Company have a particular advantage over the 'one off' design in that they'll have a well known and published specification. The equipment and its capabilities will also be known to many enthusiasts via 'hands-on' experience and through comments by other operators and listeners.

Completed construc-

tional projects built by enthusiasts from *PW* articles may not be factory produced, but you can be sure that the equipment design will have been tried, tested and modified where needed, before it is presented to the reader. Many projects are also accompanied by an option to purchase a ready-made, professionally designed printed-circuit board.

The option of the prepared p.c.b. will encourage many constructors to "have a go" and naturally, much feedback is generated by the builders as they discuss modifications, problems and the various ways to trim costs, etc!

With this in mind, I would very much like to hear from *PW* readers who have built any of our published projects in recent years. I would especially like to see any of your own ideas for future projects and remind potential contributors that they will be paid for any design published in the magazine. Don't be put off by the fact that you may not have the time or facilities to submit a constructional project, if you have an

idea and think it may be original, different, or be particularly attractive to other radio enthusiasts, drop me a line and tell me all about it!

While on the subject of home construction, I should also admit to you all that I still use valves! And judging by the interest shown in Pat Hawker's 'Technical Topics' in *Radcom* whenever a valve project is mentioned - many other radio enthusiasts use them too!

At the Leicester show I was approached by several readers asking for the occasional valved-equipment project. It was interesting to see that of the four people that requested valve projects, only two of them had actually been born when valves were in general use!

Equally I should state that one or two readers approached me (on hearing the pro-thermionic discussion) and voiced their disinterest in the revival of such projects in *PW*. What do you think? Would you be interested in one or two *PW* valved circuits using valves that are available? Don't forget that many circuits will work with a very wide range of valves, especially in transmitter circuits where you can quite safely have a mis-match and not damage your final amplifier! So, let's be hearing from you on this point, at least in the winter our shacks could be warmer!!

Receiving You...

Send your letters to the Editorial Offices in Poole, the address is on our contents page. Writer of the Star Letter each month will receive a voucher worth £10 to spend on items from our PCB or Book Services, or on PW back numbers, binders, reprints or computer program cassettes. And there's a £5 voucher for every other letter published.

Letters must be original, and not duplicated to any other magazines. We reserve the right to edit or shorten any letter. Brief letters may be filed via our Prestel Mailbox number 202671191. The views expressed in letters are not necessarily those of *Practical Wireless*.

Dear Sir

Whilst between QSOs the other Sunday, I heard a Dutch station say that reciprocal licences will in future not be required by licensed amateurs visiting member states of the European Community.

I am sure you have not heard of this yourself as otherwise you would have made some remark in *PW* September.

Your comments on this, especially if the Dutch colleague was right, would be greatly appreciated as this news would be of great interest to many fellow radio amateurs.

Thank you for a wonderful magazine.

Louis Payas
Gibraltar

The RSGB Replies

David Evans G3OUF, Secretary and Chief Executive of the RSGB, replies to the letter from Mr Louis Payas, Gibraltar.

"The RSGB have advised that discussions are taking place within Europe on a Euro-Licence similar in concept to an international driving licence, however, no such licence is yet in place or indeed likely to be for many years to come.

There are two forms of international licensing currently in operation. First of all, reciprocal licences. To obtain a reciprocal licence in a European country the British amateur concerned has to apply in advance of the date of his/her visit. Normally a fee is payable. The second type of licence is known as a CEPT licence. This permits British amateurs to operate under certain conditions within other countries who are members of the CEPT organisation (The conference of European Posts and Telecommunications Administrations). While the CEPT organisation includes some of the countries within Europe, it also includes some countries who are not in Europe. So far as British amateurs are concerned, a list of countries that British amateurs can operate in without prior formalities under the CEPT agreement is listed on the licence validation document. UK radio amateurs who have received their validation document since January 1989 will have this list. The RSGB hopes that the above will put the remarks of the Dutch amateur radio station into context.

Full information of the CEPT licence, etc., is available to RSGB members from the Membership Services Department at RSGB HQ".

Kindest regards.

David Evans G3OUF
Secretary & Chief Executive
RSGB

Dear Sir

I am disgusted with A. J. Hind's letter in your December 1989 *Practical Wireless*, concerning QSL cards. May I remind him that amateur radio is a hobby and a very good one.

If an amateur station does not send QSL cards fair enough, but I think they should at least have the manners to return the IRC, etc. Also, all s.w.l.s. do not send bad reports, in fact, I have had some very nice letters thanking me for such good detailed reports.

I think A. J. Hind should get off his high horse and leave other people, such as myself, to enjoy the hobby.

Oh Ed, keep up the good work with your magazine.

P. J. Lloyd
Essex

Dear Sir

With increasing numbers crossing the Atlantic, both for business and pleasure, it must have occurred to many radio amateurs undertaking the journey, that it might be advantageous to buy gear in the States. What are the snags?

Unfortunately, with the present exchange rate of the dollar and the pound, there would appear to be little advantage in buying anything new - as both import duty and VAT have to be paid at the Customs on bringing it into the country.

However, second-hand (or "used" as it is called in the States) apparatus is quite a different matter, for the Americans are continually changing "old for new", and the prices drop substantially after only a few years. They also keep their sets in truly immaculate condition, with a view to an exchange later - and go to the length of storing the original cardboard box! Then, they do have capacious cellars.....

However, I ran into two serious problems, on a recent trip to Iowa. The first was that all the stores selling amateur gear were hundreds, if not thousands, of miles away - either on the East or West coasts, with none in the corn-belt of the mid-West.

That meant having to use the phone, but at least the calls were free with their 0800 system, and the salesmen I spoke to were all well-informed and courteous. Finally, settling on a transceiver, only a few years old and about half the price asked in this country, I thought all my troubles were over - when problem number two appeared from nowhere!

The store refused to accept payment by Access or Visa card unless presented in person, and there certainly wasn't the time to send a cheque through the post. It was explained that for security reasons all cards from outside the USA had to be "fed into the machine", which made me wonder if they had a robot computer which lived on a diet of plastic bank cards!

Fortunately, my host came to the rescue by offering the use of his banker's card, which was accepted as he had a permanent address in the States plus a local bank account.

Three days later the set arrived via UPS for a transit cost of less than five dollars, packed securely in a large cardboard box, and in what can only be described as immaculate condition - a real bargain, even after paying import duty and VAT.

Douglas Byrne G3KPO
Isle of Wight

Dear Sir

Please use every inducement you can muster to persuade Peter Rouse GU1DKD, to write at least one more article to follow 'Batteries Not Included', December *PW*. It was your best feature this year.

Peter's wit is hilariously funny because it is so wickedly close to the truth. 'Sprocket Radio' is a gem and should go into the *Radio Amateurs' Handbook*.

Jack Pemberton
East Sussex

★★★★★STAR LETTER★★★★★

Dear Sir

For a number of years I have been against capital punishment. However, since spending many hours straining my eyes over 'Wordsearch' (not that I ever win anything) I have since changed my mind.

How could you be so wicked as to torment us so!!!

Hang the Editor? Well, not until after the December issue of *PW*!! Joking aside - Great Fun. Great Prizes.

What other dastardly competitions have you in mind?

Frank Thornton, Clwyd

Wait and see! Ed.

Competition Corner *Spot The Difference*

Spot the twelve differences and circle them in ink.

PRIZES...

First prize will be awarded to the first correct entry drawn from a 'hat' on monday 19 February 1990 and the winner can choose either a one year PW subscription or £20 in vouchers for the book service.

The two runners-up drawn from the same 'hat' can choose from either a six month PW subscription or £10 in book vouchers.

Circle the twelve differences, fill in the form below and send your entry to PW Publishing Ltd., February 1990 Spot The Difference Competition, Enefco House, The Quay, Poole, Dorset BH15 1PP.

Closing Date last post received Friday 16 February 1990.

The Editor's decision on the winner is final, no correspondence will be entered into.



Name Address

Please tick choice of prize if you win.

Subscription

Vouchers Postcode

Newsdesk '90

On-screen Cursors

The latest GoldStar instrument available from Alpha Electronics is an oscilloscope with a c.r.t. readout that enables waveform settings and measured values to be displayed on the screen. The OS 8020R has mobile on-screen cursors which make the unit extremely simple to operate. The cursors provide a direct readout of voltage, time and frequency without the need for time consuming calculations.

Front panel controls for this feature include push-button keys for selection, directions and frequency measurement plus adjustable intensity.

With the cursor func-

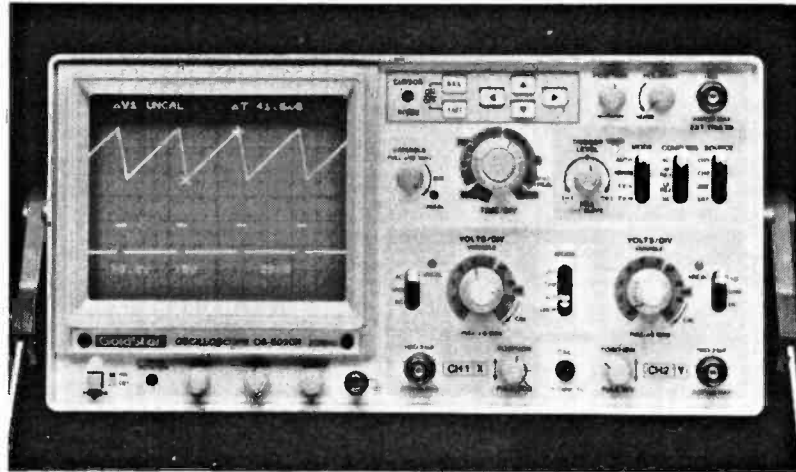

tion off, the 'scope remains a dual-trace 20MHz unit which features scale illumination and beam rotation on a 6in rectangular c.r.t. with an internal graticule.

Sensitivity is to 1mV/div and sweep speed to

100ns/div. The unit measures 290 x 145 x 375mm and weighs 7.4kg with a carrying handle that doubles as a safe tilt stand. The unit costs £490 including two switched probes but excluding VAT, and is fully guaranteed for 3 years

by Alpha.
Alpha Electronics Ltd., Unit 5, Linstock Trading Estate, Wigan Road, Atherton, Manchester M29 0QA. Tel: (0942) 873434.

All Change

Allweld Engineering are moving to new and larger premises later this year. As from January they will be based in South Wales at the Cross Hands Business Park, Cross Hands, Llanelli, Dyfed. Here they are erecting a purpose-built factory which will be ready in March. Until then, they will be nearby at **Unit 1 Plot 27.**

The new site has easy direct access from the M4 motorway, ample free car parking, they will have an increased product range with more on display and they will be within 200 yards of a large shopping complex. The new telephone number is **0269 845251.**

Star Electronics

Star Electronics in Tyne & Wear have been appointed authorised dealers for Yaesu/SMC products and Northern distributor for Revco. They also stock Met antennas, Howes kits and Navico products.

Star Electronics, Unit 5c Robert Frazers, Industrial Estate, Station Road, Hebburn, Tyne & Wear NE31 1DB. Tel: (0836) 293738.

BARTG

The British Amateur Radio Teledata Group (BARTG) have set the rates for the 1990 subs at: UK - £10, Europe & Eire - £13, Overseas surface mail - £13 and Overseas air mail - £24. For membership please contact:

Miss Anne Reynolds G6ZTF, 169 Bell Green Lane, Coventry, Warks CV6 7GW.

Special Event Stations

GM90CC: On January 20/21 this station will be on air for Glasgow Cultural City of Europe 1990 under the auspices of West of Scotland ARS.

GB2SSD: On May 12/13 this station will be on the air as part of the Heritage of Whiskey Event. Four distilleries will be on the air and certificates are available.

GB2RBC: On June 9/10 a station will be on air from Balmoral Castle, they have been invited to return to this venue.

GB2NTS: From Jul 15 to 22 there will be four NTS castles on the air, again certificates will be available.

GB2NTS: On September 22/23 there will be the five nations NTS event for the second year.

For further details of these stations and the various awards available, send an s.a.e. to:
GM3MTH, PO Box 59, Hamilton ML3 6QB.

Triple Output PSU

The UK-manufactured Model 1300 has a fixed output of 5V d.c. ($\pm 0.25V$) at 1A maximum, with a line regulation of 0.2%, load regulation of 1.0% and a maximum ripple of 10mV peak-to-peak.

The outputs can be used independently, or can be interconnected to accommodate voltage and current requirements. Current limiting prevents damage from short circuit.

The front panel voltage and current meter has an accuracy of $\pm 5\%$ of full scale. Also included is an i.e.d. overload indicator.

The Model 1300 measures on 76 x 254 x 178mm and weighs 2.7kg. The cost of the p.s.u. is £89.50 plus VAT.

Global Specialties, Rackery Lane, Llay, Wrexham, Clwyd LL12 0PB. Tel: 0978 833920.

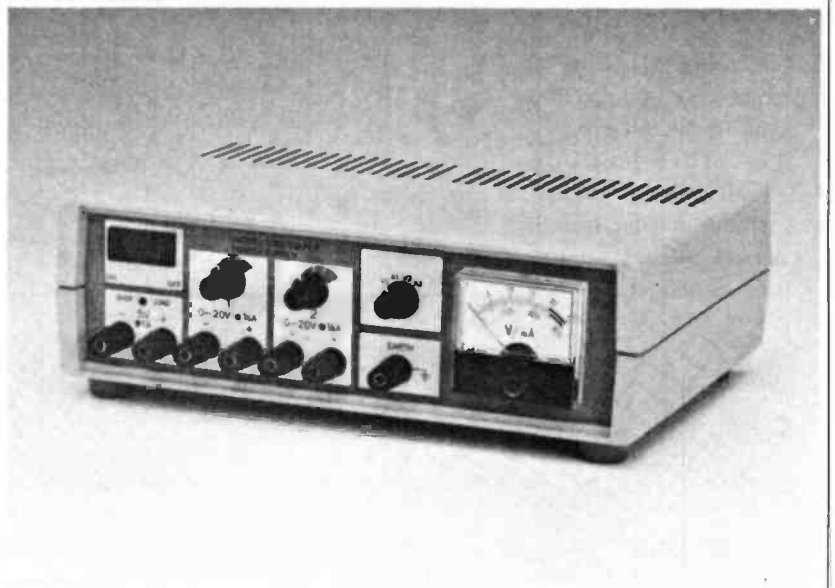

Newsdesk '90

CQ GN-950

A famous proverb, amongst the citizens of the city of Groningen in the Netherlands is: "People that don't know about Groningen, don't know the Netherlands".

That is one of the main reasons for the radio amateurs in this city giving special attention to the 950th anniversary of their town.

Starting on January 13, the radio amateurs of Groningen will man an exhibition that will last a fortnight. During this exhibition, a special event station will operate from the exhibition site in the building of Groningen's Regional Broadcasting Organisation Radio Noord.

One of the highlights will be on January 20 when Radio Noord will put the spotlight on amateur radio. That day, the station will try and contact many former Dutch amateurs and many former townsmen around the world.

The operators of PA6GN will operate on at around the following frequencies:

3.530MHz c.w. - 3.660MHz s.s.b.

7.030MHz c.w. - 7.060MHz s.s.b.

14.030MHz c.w. - 14.260MHz s.s.b.

21.030MHz c.w. - 21.260MHz s.s.b.

28.030MHz c.w. - 28.560MHz s.s.b.

and for local and regional stations they will also be using 145.25MHz f.m.



Amateur Glasnost

On Saturday 7 October 1989, HMS *Warrior* was visited by Igor Khurstalev UA3QJC at the special invitation of Captain Colin Allen and Rodney Smith G0ERS, manager of GB3HMS. During the visit, the group were unexpectedly joined by Calvin Bacon KC2KD from Long Valley, New Jersey.

Both stations were invited to use the radio equipment at GB4HMS by the station manager and Captain Allen. The photograph shows Igor using the 14MHz band equipment and Calvin using the 144MHz band equipment.

Catalogues

Electrovalue have sent us a copy of their latest catalogue. It's got 134-pages and can be sent free to any address in the world. All you have to do is write, 'phone or FAX them with the details. **Electrovalue Ltd., FREEPOST, 28 St Judes Road, Englefield Green, Egham, Surrey TW20 0BR. Tel: (0784)**

433603, FAX (0784) 435216.

STC Electronic Services have produced a new 10-page technical brochure on the Aerovox M range of computer grade and snap-mount aluminium electrolytic capacitors. The publication features details of performance characteristics such as voltage, capacitance tolerance, QA stability, ripple current recommendations and d.c. leakage current. Copies are available, free-of-charge from: **The Capacitor Group. STC Electronic Services. Tel: (0279) 503173.**

SRS has introduced a new brochure on the Dimension 90 range of desk-top enclosures.

Highlighting the many advantages of the new series which is designed for the electronic housing requirements of the 1990s,

the publication details standard as well as the customised products offered. **SRS. Tel: (0279) 418401.**

Video Repeater Group

The inaugural meeting of the Dorset Video Repeater Group was held on 29 November 1989 in Weymouth. The group have set an initial subscription level of £5, any financial donations would be greatly appreciated. The group are aiming towards a 24cm TV repeater (GB3DV?).

For further information contact:

**Les G0FAJ,
29 Overlands Road,
Wyke Regis,
Weymouth,
Dorset.**

Batteries

A wide variety of batteries, from NiCads to sealed lead-acid batteries in boxes are available from Strikalite. Readers may have seen the company at some of the radio rallies around the country last year.

Other products available are emergency luminaires, button cell telephone packs as well as packs of batteries made up to your specification. For more details, contact: **Strikalite. Laurel Drive, Rugeley Road, Burntwood, Staffs WS7 9BL.**

Tel: (05436) 3122.



Strikalite

Newsdesk '90

Worked All Britain Award

The WAB Group was founded in 1969 by the late John Morris G3ABG. The group aims to promote a greater amateur radio interest in Great Britain and Northern Ireland through an award scheme. This scheme is based on the geography and administration of the UK.

These awards are available on a world-wide basis to all radio amateurs and short wave listeners. QSL cards are not required for any of the awards and they can be claimed on any band (including 10, 18 and 24MHz) or by any mode open to radio amateurs.

WAB is an independent, self-financing, group and life membership is via the purchase of a WAB record book. The group also makes, when possible, financial donations to groups helping disabled radio amateurs and short wave listeners.

The main award from the group is The WAB Award and is based on working WAB areas. WAB areas are based upon map references used on official (OS) maps of Great Britain and Northern Ireland. The map reference system divides the country into 100 x 100km grid squares. These are referred to as **large squares**. In Great Britain these are given a two letter reference (e.g. SP, SS, NN, SC) while in Northern Ireland they are given a single letter reference (C, D, G, H, J).

These large squares are then broken down into 10 x 10km squares. Two digits are added to the large square reference, the first digit gives the position on a horizontal scale and the second digit the position on the vertical scale (e.g. SP38, SS99, NN72, etc.).

The final stage is to add the administrative county to the 10 x 10km square to give the WAB area. There are over 4000 WAB areas. This award is given for working various numbers of these areas. There are six classes of award:

Basic, Bronze, Silver, Gold, Platinum and Sapphire.

A certificate is given for the Basic Award and endorsement stickers for the higher classes of award. There are more higher classes of award and an Honour Roll for working areas beyond the requirement for the Sapphire Award. Specially engraved trophies are given out for these classes.

Stations outside Europe must work:

100, 200, 400, 600, 800 and 1000 areas on the h.f. bands.

Stations in Europe must work:

300, 500, 750, 1000, 1500 and 2000 areas on the h.f. bands, v.h.f. requirements are lower.

Stations in the UK must work 250, 500, 750, 1000, 1200 and 1350 areas.

The WAB Large Squares Award is given for working the 100 x 100km squares. A certificate is awarded for working 30 large squares and endorsements for 40, 55 and all 61 large squares.

The WAB Counties Award is offered for working counties in Great Britain and Northern Ireland. It has two classes, Class II for 55 counties and Class I for 76 counties.

The WAB Islands Award is given for working off-shore islands. There are well over 2000 such islands around the county although many of them are uninhabited. A certificate is awarded for working 25 islands and endorsements for 40, 50, 60, etc islands.

The WAB Bookholders Award is awarded for working 100 bookholders, endorsements are given for each additional 100 bookholders worked. To keep track of WAB contacts members are issued with a sequentially numbered WAB record book.

The WAB Overseas Introductory Award is intended for stations who live outside Europe as an introduction to WAB. A certificate is awarded for working 25 WAB areas and 10 counties.

The various costs for awards and the life membership record book costing £7 (or 12\$ US) and can be obtained from:

**The Membership Secretary,
Brian Morris G4KSO,
22 Burdell Avenue,
Sandhills Estate,
Headington,
Oxford OX3 8ED.**

Glasgow 1990

Glasgow 1990 - Cultural Capital of Europe. A prize draw will decide the winner of a seven day trip to Glasgow, Scotland. This will include return air fares for two people from the winner's country of origin to Glasgow, hotel accommodation for the winner and a guest in Glasgow and complimentary tickets to events taking place in Glasgow during the winner's stay. A secondary prize of two 7-day Freedom of Scotland Rover Tickets will be offered.

Amateur Radio Clubs in the Greater Glasgow Area have joined forces in celebrating from club premises and cultural events during the year. The main callsign for Glasgow 1990 is **GM9OCC**. The participating club callsigns are: **GB0CCE, GB2CCE, GB4CCE, GB5CC and GB6CC**.

Callsigns at other special events include: **GB8CA - GB8CZ, GB1CCE, GB6CCE and GB8CCE**.

To enter the draw you need one contact with **GM9OCC** on any band and any mode plus any four of the other stations. Send your QSL for **GM9OCC** only, via the GM Bureau or direct to PO Box 599, Glasgow G1 1EW. Quote the other four stations you have contacted on that QSL card. Please do not QSL individual GB callsigns involved in this event unless requested to do so by the station.

The draw will take place on 1 May 1990.

If you wish your card to be entered for the secondary prize draw, please mark 'Flying Scotsman' on your QSL card. This draw will take place on 1 June 1990.

Pocket-sized Tester

A new range of electrical circuit testers is now available in the UK from Longs Ltd of Surrey. The digital volt meters made by Soar are unusual because of their compact size.

The virtually drop-proof circuit testers measure about the same size as a

pocket calculator weighing in at just 100g. They can be operated by one hand to show accurate readings of a.c. or d.c. volts and ohms test on large digital displays.

Top of the range is the high speed ME3060 which has a bar graph display for fast and accurate readings. This unit costs £35.08 including carriage and VAT. Its battery life should give

over 250 hours of operation as it has an automatic shut-off safety function.

The ME3020 costs £23.58 including carriage and VAT and this unit is fully protected up to 450V r.m.s.

**Longs Ltd.,
Hanworth Lane,
Chertsey,
Surrey KT16 9LZ.
Tel: (0932) 561241.**

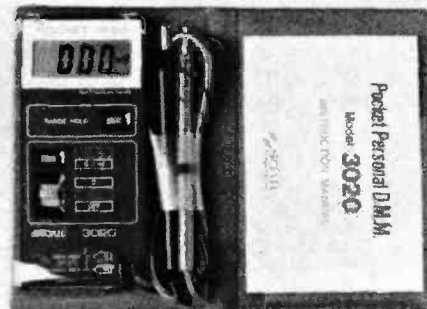

Newsdesk '90

Aircastle Products

We recently carried a series of advertisements for Aircastle Products. We would now like to hear from anyone experiencing difficulty in obtaining goods or refunds from this company. Please contact:

Roger Hall,
PO Box 948,
London SW6 2DS.

Waived Subscriptions

The RSGB have the mechanism whereby certain members may have their annual subscription waived.

The applicant must be a **current member** of the Society and have been a member for at least one year.

The member must be **blind or disabled** such that he/she is unable to obtain or follow full-time employment.

The member must either be a **UK resident or an expatriate.**

The applicant must complete the appropriate form, sign the declaration and return it together with a Doctor's certificate/letter to:

The RSGB, Lambda House, Cranborne Road, Potters Bar, Herts EN6 3JE.
Tel: (0707) 59015.

Wireless Line

Starting on January 8 readers can call PW's new dial-and-listen service on (0898) 654632 for up-to-date news and information catering for the radio enthusiast and licensed amateur.

Updated every Friday evening, calls are charged at 38p per minute peak, 25p per minute off peak.

Helpline

Mr F. J. Dooley is looking for any information at all on an **American Sky rider SX-2B** he has picked up. Can you help? He may be contacted on **Woodford Green 01-505-8080.**

Mr Jennings is looking for details on the **Thorn TX10 Export tuner**, especially the pin connections. He wants to know where the supplies should be connected to the tuner and the attached +256 prescaler. **Mr Jennings, 407 Heath Road South, Northfield, Birmingham B31 2BB.**

Has anyone got a copy of the instructions for a Trio h.f. receiver, **9R59DS. Gareth Morris, 7 Renfrew Road, Norton, Cleveland TS20 1JH.**

Bill Vann is looking for a circuit or any other information on the **GEC Communications receiver serial No 516.** This is a four-waveband 2-20MHz, 12-valve, 12 volt input c.w. and m.c.w. unit. **Bill Vann GM3TBV, 'Birchwood', Emma Terrace, Blairgowrie, Perthshire PH10 6JA.**

It is rumoured that there are some **R1155** receivers being issued from an Ex-WD warehouse in the Liverpool area. Any details to **R. Smith. Tel: (0223) 464005.**

Has anyone got an **Eddystone Circular Speaker** they wish to dispose of? If so contact: **Mr R. Williams, 62 Kingscliffe Road, Grantham, Lincs NG31 8ET.**

Can anyone help in identifying the **frequencies** used by Formula One racing teams, either the voice comms or the car data. **Peter Collins, 6 King Street, Earls Barton, Northants NN6 0LQ.**

John Hackett is renovating a **Codar AT5** a.m./c.w. transmitter along with its 250/S power supply. Has anyone got circuit diagrams, operating manual, etc., for this equipment. All reasonable costs met. **John Hackett, 42 Central Avenue, New Basford, Nottingham NG7 7AF.**

USE THIS COLUMN WHEN YOU THINK THERE'S NO HOPE FOR THAT ODD PROBLEM...SOMEONE, SOMEWHERE MIGHT BE ABLE TO HELP!

SUBSCRIPTIONS TO NEW STYLE PW

Please indicate the type of subscription required:

PRACTICAL WIRELESS 1 YEAR

- £19.00(UK)
- £21.00 (Europe)
- £22.00(Rest of World)

SHORT WAVE MAGAZINE 1 YEAR

- £19.00 (UK)
- £21.00 (Europe)
- £22.00 (Rest of World)

SPECIAL JOINT SUBSCRIPTION 1 YEAR ONLY

- £32.00 (UK)
- £35.00 (Europe)
- £37.00 (Rest of World)

Prices current at January 1990
Subscription to commence with issue dated.....

Practical Wireless, February 1990

To: PW Publishing Ltd., FREEPOST, Subscriptions Dept., Enefco House, The Quay, Poole, Dorset BH15 1PP

Name.....

Address.....

.....

.....

I enclose cheque/PO (Payable to PW Publishing Ltd) £.....

Charge to my Access/Visa Card the amount of £.....

Card No.

Valid from to

Signature.....

Credit Card Orders can be taken on (0202) 665524.

ICOM

LOOK TO THE FUTURE WITH



Features:

- AC power supply
- Automatic antenna tuner
- Multi function CRT display
- Twin passband tuning
- Dual-watch
- 99 memories

Advanced engineering from ICOM has produced the most sophisticated Amateur HF transceiver on the market today, whether DX'ing, contesting or simply enjoying top performance the IC-781 is a top of the line performer. A unique multi-functional CRT displays frequencies, modes, memory contents, operating notes, RIT, two menu and seventeen optional screens. The soft orange display also serves as a display for DATA modes such as RTTY, AMTOR and PACKET.

The PAN display continuously indicates all signal activities and pile-ups with your operating frequency in the centre. Selectable frequency spans of 50kHz, 100kHz and 200kHz. Vertical range indicates relative signal strength. Twin passband tuning with separate controls for second and third IF stages increases selectivity and narrows bandwidth, independently varies low and high frequency response or functions as a IF shift.

Icom (UK) Ltd.

Dept PW, Sea Street, Herne Bay, Kent CT6 8LD. Tel: 0227 363859. 24 Hour.

Count on us!

HF TRANSCEIVER IC-781



The IC-781 has a dual-watch function which allows simultaneous receive of two frequencies in the same band. Balance controls adjust VFO A/B receive strength levels. This feature is especially useful on Dx-expeditions or contests to check band activity or to tune in your next contact. The newly developed ICOM DDS (Direct Signal Synthesizer) system is incorporated to provide a fast transceiver lock-up time. This is essential for data communication systems.

The IC-781 communication system includes a built-in 100% AC supply, high speed automatic antenna tuner, iambic keyer, semi-automatic, or full QSK CW break in to 60 wpm, audio peaking filter, RF speech processor, multi-scanning plus much more. Look into the future of Amateur communications, ICOM products will be setting the pace others try to follow. For more information on the IC-781 contact your local authorised ICOM dealer or phone ICOM (UK) Ltd direct.

- SSB, CW, FM, AM, RTTY
- 160-10m/general coverage receiver
- Direct keyboard entry
- 150 watt output
- QSK up to 60 wpm
- CI-V communications interface

Helpline: Telephone us free-of-charge on 0800 521145, Mon-Fri 09.00-13.00 and 14.00-17.30. This service is strictly for obtaining information about or ordering Icom equipment. We regret this cannot be used by dealers or for repair enquiries and parts orders, thank you.

Datapost: Despatch on same day whenever possible.

Access & Barclaycard: Telephone orders taken by our mail order dept, instant credit & interest-free H.P.



Reg Ward & Co. Ltd.

1 Western Parade, West Street, Axminster, Devon, EX13 5NY.
Telephone: Axminster (0297) 34918

Yaesu

FT767	HF Transceiver	1699.00	(-)
FEX767(2)	2m Module (767)	169.00	(3.00)
FEX767(70)	70cm Module (767)	215.00	(3.00)
FEX767(6)	6m Module (767)	169.00	(3.00)
SP767	Speaker	89.96	(2.50)
FT747GX	Budget HF Transceiver	659.00	(-)
FT757GX	Mkil HF Transceiver	969.00	(-)
FP700	20A P.S.U.	219.00	(4.00)
FC700	Manual ATU	149.00	(3.00)
FP757HD	Heavy Duty 2m P.S.U.	258.75	(4.00)
FAS14R	Remote Aerial Switch	80.00	(3.00)
FT4700	New 2m/70cm Dual Band FM Mobile	675.00	(7.00)
FT290	Mkil Super 290 2m Multimode 2.5W	429.00	(-)
FT690	Mkil 6m M/Mode 2.5W	399.00	(2.00)
YHA15	2m Helical	7.50	(2.00)
YHA44D	70cm $\frac{1}{2}$ wave	12.60	(2.00)
YM43	Speaker Mike	23.00	(2.00)
MMB15	Mobile Bracket	14.55	(2.00)
FT411	New 2m H/H Keyboard	225.00	(3.00)
FTB11	New 70cm H/H Keyboard	239.00	(3.00)
FT470	New 2m/70cm Dual Band H/H	389.00	(3.00)
FT23R	2m Mini H/H	209.00	(3.00)
FT73R	70cm Mini H/H	229.00	(3.00)
FNB9	Nicad Battery Pack (23/73)	34.50	(2.00)
FNB10	Nicad Battery Pack (23/73)	34.50	(2.00)
FNB11	Nicad Battery Pack (23/73)	87.85	(2.00)
NC18C	Charger (23/73)	17.71	(2.00)
SMC28	Charger (23/73) 13A Plug	17.71	(2.00)
NC28	Charger (23/73)	17.71	(2.00)
NC29	Base Charger (23/73)	89.00	(3.00)
PA6	Car Adapt Charger (23/73)	24.15	(2.00)
MH12A2B	Speaker Mic	31.05	(2.00)
MH18A2B	Speaker Mic Miniature (23/73/727)	31.05	(2.00)
FNB3	Spare Battery Pack (FT209)	41.00	(2.00)
FNB4	Spare Battery Pack (FT709)	46.00	(2.00)
FNB5	Empty Cell Case (FT727)	10.00	(2.00)
FRG9600M	60-950MHz Scanning RX	509.00	(-)
PA4C	Power Supply for 9600	29.00	(2.00)
MMB10	Mobile Bracket	10.00	(2.00)
NC9C	Charger	11.50	(2.00)
PA3	Car Adaptor/Charger	21.85	(2.00)
YM24A	Speaker Mike	31.05	(2.00)
FRG8800	HF Receiver	649.00	(-)
FRV8800	Converter 118-176 for above	100.00	(2.50)
FRT7700	RX ATU	59.00	(2.50)
MH1B8	Hand 600 Bpin mic	21.00	(2.00)
MD1B8	Desk 600 Bpin mic	79.00	(2.00)
MF1A3B	Boom mobile mic	25.00	(2.00)
YH77	Lightweight phones	19.99	(2.00)
YH55	Padded phones	19.99	(2.00)
YH1	H/weight Mobile H/eat-Boom mic	28.75	(2.00)
SB1	PTT Switch Box 208/708	22.00	(2.00)
SB2	PTT Switch Box 290/790	22.00	(2.00)
SB10	PTT Switch Box 270/2700	22.00	(2.00)
FT736 NEW	2/70cm 25W Base Stn.	1,359.00	(-)
FT2311R	23cm FM Transceiver	476.00	(-)
FT211RH	2m 45W FM Mobile	309.00	(-)
FT212RH	New 2m 45W FM Mobile	349.00	(-)
FL2025	25W Linear	115.00	(3.00)
FL8020	6m 10W Linear	109.00	(3.00)
QTR24D	World Clock	39.00	(3.00)

Antennas

VLF	50-500MHz RX Discone	22.50	(3.00)
D130	26-1300MHz Discone	75.00	(3.00)
Jaybeam	TB3 MkIII 3e HF Tribander	348.45	(8.00)
Hygain	TH3JNR 3e HF Tribander	299.00	(8.00)
Creative	CD318 JR 4e HF Tribander	299.00	(8.00)
Creative	CD318 JR 4e HF Tribander	349.00	(8.00)
CA2X4KC	2/70cm Mobile	39.95	(3.00)
WX1	2m/70cm Base Fibre Glass	54.99	(4.00)
CA2X4Max	2m/70cm Base Fibre Glass	99.95	(4.00)
IC765 NEW	HF Transceiver	2499.00	(-)
IC751A	HF Transceiver	1485.00	(-)
IC735	New HF Transceiver	949.00	(-)
IC725	HF Base Transceiver	979.00	(-)
AT100	100W ATU (751/745)	366.00	(3.50)
AT150	150W ATA (735)	315.00	(3.50)
PS65	Ext PSU (735)	185.00	(3.00)

ICOM

IC605	50MHz multi-mode portable	499.00	(-)
IC290D	2m 25W M/Mode	542.00	(-)
IC228E	2m 25W FM Mobile	365.00	(-)
IC25E	2m Handheld	275.00	(-)
IC2GE	FM H/Held NEW	285.00	(3.00)
IC275E	New 2m 25W Base Stn IC75E	1069.00	(-)
IC4GE	70cm H/Held NEW	299.00	(3.00)
IC4SE	70cm H/Held NEW	310.00	(-)
IC32E NEW	2m/70cm Dual Band H/Held	399.00	(3.00)
IC490	70cm 10W M/Mode	617.00	(-)
IC3210	2m/70cm FM Dual Band Mobile	499.00	(4.00)
IC2400E NEW	2m/70cm Mobile	635.00	(-)
IC12E	23cm H/H	428.00	(3.00)
ICR71	Gen Cov RX	825.00	(-)
IC7000	VHF/UHF Scanner	957.00	(-)
AH7000	25-1300MHz Discone	82.00	(3.00)
SP3	Ext Speaker	61.00	(2.50)
CK70	DC Cable (R70/R71)	7.00	(2.00)
EX257	FM Board (R70/R71)	41.00	(2.00)
GC5	World Clock	43.00	(2.50)
AC2	Waterproof Bag all Icom H/H	14.38	(2.00)
BC35	Desk Charger	70.15	(2.50)
BP3	Battery Pack 8.4V (2/4E/02/04E)	29.90	(2.00)
BP4	Empty Battery Case (2/4E/02/04E)	9.20	(2.00)
BP5	Battery Pack 10.8V	60.95	(2.50)
CP1	12V Charge Lead BP3/7B	6.90	(2.00)
DC1	DC/DC converter operate from 12V	17.25	(2.00)

HM46	NEW Mini speaker mic	24.15	(2.00)
HM9	Speaker/Mic	21.85	(2.50)
HS51	Headset inc PTT/Vox unit	41.25	(2.00)
LC24	Micro + BP22/23	7.50	(2.00)
LC41	IC32 + 8P3	9.20	(2.00)
LC42	IC32 + BP5	9.20	(2.00)
SMB	1.3k μ /600 μ BP Base Mic	82.00	(2.50)
SM10	Comp/Graphic Mike	116.20	(3.00)

C W Keyers

HI-MOUND			
HK702	Straight key (adjustable tension)	42.49	(2.00)
HK703	Straight key (adjustable tension)	38.45	(2.00)
HK704	Straight key (adjustable tension)	26.35	(2.00)
HK705	Straight key (adjustable tension)	22.49	(2.00)
HK706	Straight key (adjustable tension)	21.80	(2.00)
HK707	Straight key (adjustable tension)	20.15	(2.00)
HK802	Straight key (Deluxe-Brass)	109.00	(3.50)
HK803	Straight key (Brass)	104.50	(3.50)
MK703	Squeeze key	34.50	(2.00)
MK704	Squeeze key	30.00	(2.00)
MK705	Squeeze key	32.78	(2.00)
MK706	Squeeze key	30.48	(2.00)
STARMASTER			
Dewabury	Electronic Keyer Unit (No Paddle)	54.70	(3.00)
Dewabury	Electronic Memory Keyer (No Paddle)	95.00	(3.00)

Rotators

G250	Light Duty	78.00	(4.00)
AR200XL	Light Duty	38.50	(4.00)
G400	Medium Duty	139.00	(4.00)
G400HC	Medium Duty (Round Face)	169.00	(5.00)
G600RC	Medium/Heavy Duty	219.00	(5.00)
G200RC	Heavy Duty	445.00	(5.00)
G500	Elevating Rotator	149.00	(5.00)
GR5400	Azimuth/Elevating	279.00	(5.00)

KENWOOD

TS950S	NEW Transceiver	P.O.A.	(-)
TS940S	9 Band TX General Cov RX	1995.00	(-)
AT940	Auto/ATU	244.88	(3.00)
SP940	Ext Speaker	87.65	(3.00)
TS140	HF 9 Band Gen. Cov. TX/RX	862.00	(-)
TS880S	HF/6m TX Gen. Cov. RX	985.00	(-)
TS440	9 Band TX General Cov RX	1138.81	(-)
AT440	Auto/ATU	144.82	(3.00)
PS60	H/Duty PSU	222.49	(3.00)
AT230	All Band ATU/Power Meter	208.67	(3.00)
SP230	External Speaker Unit	86.49	(3.00)
PS430	Matching Power Supply	173.78	(3.50)
SP430	Matching Speaker	40.81	(3.00)
SM220	Station Monitor	343.62	(3.50)
BS8	Band Scope Unit (830/940)	77.00	(2.50)
TL922	10/160 2kW Linear	1495.00	(7.00)
TH25	NEW 2m H/Held	238.00	(3.00)
TH45	NEW 70cm H/Held	289.00	(3.00)
TH75	NEW 2m/70cm H/Held	P.O.A.	(-)
TH205	2m H/H	215.26	(3.00)
TH215	2m 25W M/H Mobile	252.13	(3.00)
TR751	2m 25W M/H Mobile	599.00	(-)
TS790	VHF/UHF Transceiver	1495.00	(-)
R2000	Gen Coverage HF/RX	599.00	(-)
VC10	118-174MHz Converter (R2000)	161.84	(2.50)
R5000	General Coverage HF/RX	875.00	(-)
VC20	118-174MHz Converter (R5000)	167.21	(2.50)
TM701	NEW 2m/70cm FM Mobile	489.00	(5.00)
TM721	2m/70cm FM Mobile	675.00	(6.00)
TM231E	NEW 2m FM Mobile 50/10/5W	289.00	(6.00)
TM431E	NEW 70cm FM Mobile 35/10/5W	318.00	(5.00)
SMC30	Speaker/Mic TH21/4/2600	28.31	(2.00)
MC50	4P Desk Mic	46.08	(3.00)
MC80A	8P Desk Mic	88.22	(3.00)
MC80	Electric Desk Mic	63.96	(3.00)
MC85	Desk Mic Audio Level Comp	99.00	(3.00)
MC43	8P Fist Mic	22.22	(2.00)
MC35	4P Fist Mic	21.72	(2.00)
MC55	Mobile Mc (6p.o. 8p)	52.67	(3.00)
LF30	HF Low Pass Filter	32.28	(2.50)
HS6	Lightweight H/phones	24.36	(2.50)
HS5	Deluxe H/phones	37.54	(3.00)
RZ1	500Hz-950MHz AM/FM Scanner	465.00	(6.00)

SWR/PWR Meters

HANSEN			
W720S	130/440MHz 20/200W	52.75	(2.50)
JD110	1.5-150MHz	12.50	(2.00)
YMX1	3.5-150MHz	31.50	(3.00)
Yaesu Y560	1.6-60MHz	93.15	(3.00)
Yaesu Y500	140-525MHz	81.65	(3.00)
Hanson FS500H	1.5-30MHz	53.40	(3.00)

Miscellaneous

SMCS 2U	2 Way SO239 Switch	18.95	(2.50)
SMCS 2N	2 way 'n' Scks Switch	23.50	(2.50)
Kenpro KP21N	2 way Switch 'n' Socket Deluxe	27.00	(2.50)
T30	30W Dummy Load	10.29	(2.50)
T100	100W Dummy load	45.00	(3.00)
T200	200W Dummy load	65.00	(3.00)
WAI	Wavemeter 120-450MHz	24.95	(2.00)
PK232	Packet/RTTY Terminal	299.95	(3.00)
Datong D70	Morse Tutor	63.40	(3.00)
Datong FL2	Audio Filter	100.91	(3.00)
Datong FL3	Audio Filter/Autonotch	145.61	(3.00)
Datong ASP	Processor 4pin	93.15	(3.00)
Datong ASP	Processor 8pin	93.15	(3.00)
Datong AD370	Active Antenna	77.62	(3.00)
Datong PCI	General Coverage Converter	164.80	(3.00)

Instant credit available

Mail/Telephone order by cheque or credit card Cheques cleared before goods despatched. (E&DE)



OPEN TUES.-SAT. 9.00-5.30
(CLOSED MONDAYS)

STOCK ITEMS USUALLY
DESPATCHED WITHIN 48 HRS

DELIVERY/INSURANCE PRICES
IN BRACKETS



A Simple Transistor & FET Tester

Construction

The circuit described in this article will check *pn*p and *npn* transistors, small signal *p*- and *n*-type f.e.t.s, along with diodes.

If checking a transistor, then the unit will automatically show the type of transistor connected to the terminals be it *npn* or *pn*p. There is also a provision to measure the H_{FE} at a collector current of 5mA. This value of H_{FE} , or static (d.c) current gain, is useful when calculating the resistors required for biasing purposes. The parameter, H_{fe} or small signal (dynamic) gain of the transistor is very close to value of H_{FE} , and for most purposes may be assumed to actually be the same.

When measuring either *n*- or *p*-channel f.e.t.s a simple approximation of transconductance (G_m) may be made using the calibrated gate voltage level and the meter indicating drain current. An additional test position enables normal diodes and low voltage Zeners to be tested with their polarities indicated.

Method of Testing

Referring to the circuit diagram shown in Fig. 1, the transistor under test is subject to an alternating low voltage square wave. As the reverse voltage is kept to a low value the transistor under test (t.u.t) is in no danger of being damaged. This statement however, does not apply to ALL f.e.t.s. These are unipolar devices, and so are capable of passing current when connected 'the wrong way round'. So to minimise the chances of this changing, or even destroying the device, the circuit has been set up to ensure that the f.u.t. (f.e.t. under test) has only the correct voltages applied to it. There are two test positions specifically for f.e.t.s., these are of course suitably marked as, '*p*-channel' and '*n*-channel'.

When power is applied to the circuit by pressing S2, the integrated circuit IC1 begins to toggle the output line pin 3 between 0 and 9 volts, with a frequency of around 500Hz. The mark-to-space ratio is almost 1:1, meaning the time at 0V is the same as the time at 9V. Diodes D2-5 and D6-9 serve to limit the swing between 2.6 and 2.8V in any one direction. This arrangement is used rather than a Zener diode as it has a better stabilising action, in that the dynamic impedance is around 25Ω as opposed to the 100Ω of a 400mW Zener.

Consider now the switch S1 in the position for a testing a transistor. Resistors R1 & 2 form a potential divider to set the emitter of the t.u.t at half the battery voltage. The base current flows through limiting resistor R8 and the variable resistor R12 into the t.u.t during the period in which it is forward biased. As the device will only conduct when the correct polarity is applied across it, pulses of current are driven through the meter only in conduction.

In both f.e.t. testing modes the method of working is the same, merely the polarity changes. Diode D10 in conjunction with C3 (or D11 and C4) act as peak sample and hold networks, the value of which is dependent on the setting of R11, resistors R6 or R7 forming a discharge path for the capacitor.

The arrangement described above and steering diodes D12 and 13 make sure that the f.u.t always has the correct polarity across the drain-collector path and is always reverse biased, the value of biasing being set by varying R11.

Meter Shunting

Meter M1 is a 50-0-50μA meter with a shunt resistor R9 across it. This shunt resistor gives an

How many of us have 'just wanted to test the odd transistor', well J.A. Brett G6EBR obviously had such a need. This superbly simple project is his answer to that need, and also to 'I wish I knew the gain of this f.e.t!' as well as 'I wonder if this diode is OK, and which is the cathode end?'

Fig. 1: Circuit diagram of the unit, simple yet belying its capabilities

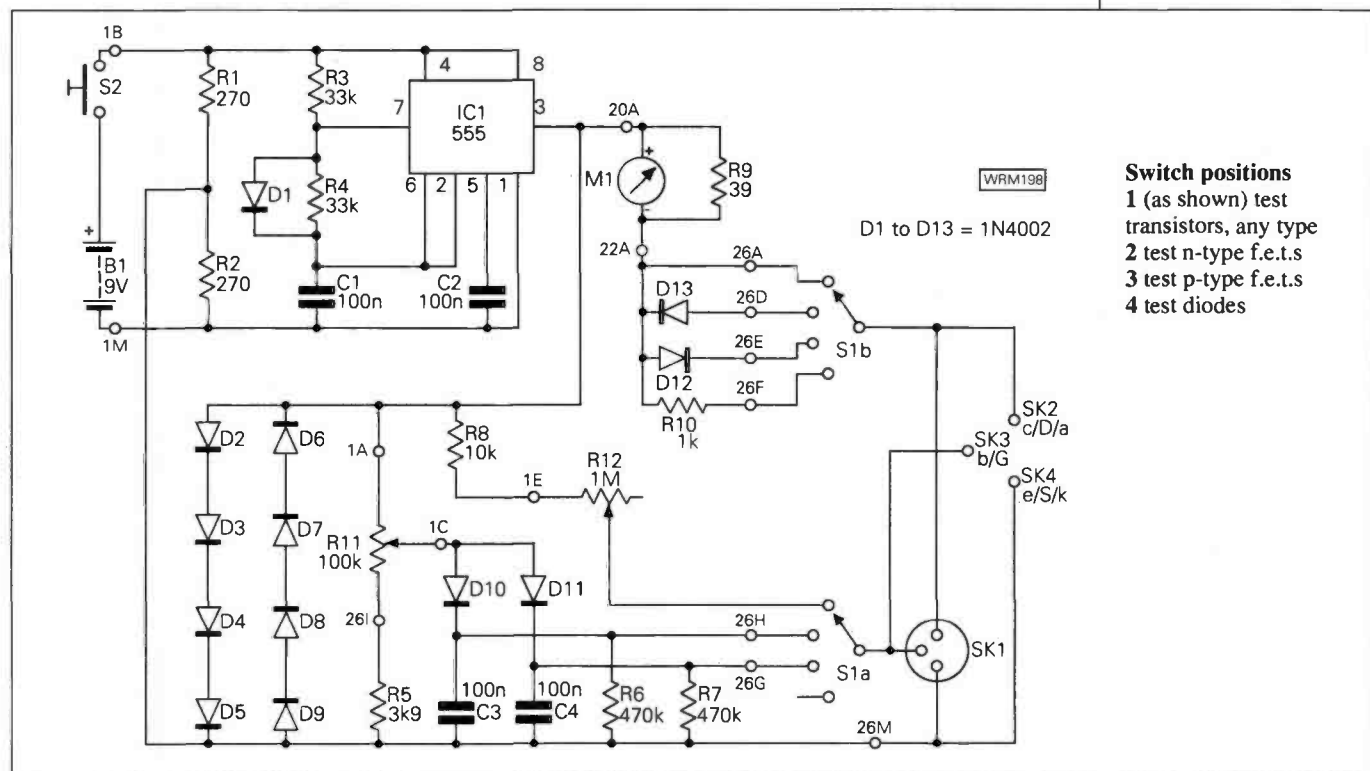

Switch positions
 1 (as shown) test transistors, any type
 2 test *n*-type f.e.t.s
 3 test *p*-type f.e.t.s
 4 test diodes

TABLE 1
Table of calculated
HFE figures against
total resistance of
R8+R12 for the t.u.t.

Gain figure	Resistance
10	10.5kΩ
20	21kΩ
40	42kΩ
80	84kΩ
160	168kΩ
320	336kΩ
640	672kΩ
960	1010kΩ

f.s.d. of 2.5-0-2.5mA, but due to current only flowing half of the time it should be marked as 5-0-5mA. By this means the deflection is used to gauge both polarity and H_{FE} of the t.u.t. The mathematics to enable you to change this value of f.s.d are relatively simple. Divide the new f.s.d. (in our case 2.5mA) by $50\mu A$ (50 in our case) then add 1 to it i.e. 51, then using this figure, divide the meter resistance to find the shunt resistor value. Again in our case $2000\Omega + 51 = 39.216\Omega$. Take the nearest preferred value of 39Ω as the value of the shunt resistor. If this were to be altered to 1mA f.s.d. then this shunt would be 181.8Ω . Do not forget though, that the meter would have to be marked 2-0-2mA.f.s.d.

If the recommended meter is used then little needs to be done to remark the scale. Using either a modelling knife or a razor blade gently scrape away the unwanted zeros from the scale. When using another meter this becomes more of an artistic exercise, as the complete face may need rewriting using a fine nibbed pen and ink.

Construction

The majority of the circuit has been built on a strip of 0.1in pitch Veroboard of 13 tracks of 26 holes, and Fig. 2 shows the layout. Using a sharp 2.5mm drill make the track cuts as shown in Fig. 2, before starting to assemble the circuit. Then using a 3.0mm drill carefully drill completely through the board at locations 2K and 26K, these are the mounting points, through which the screws to hold

the board in place will pass. After drilling these holes, carefully countersink the track side back a little more, so as to ensure that the track cannot touch these screws on assembly.

Referring again to Fig. 2, solder the rest of the components into their correct places, taking care with the orientation and location of each item. Then place and solder the connecting leads into their respective holes on the board. That completes the circuit board construction. We now turn to marking and drilling the box, Fig. 3a shows the drilling template if using the recommended Bimbox of 152 x 82 x 50mm dimension. Care taken at this stage, to achieve accuracy, will enhance the whole look of the completed project. Socket SK1 should be a tight fit in its hole at this point and when satisfied with the fit, roughen the sides of the socket with emery paper to enable the epoxy glue a good surface to adhere to.

Dry transfer lettering may also be used to good purpose to annotate the various control and socket functions and positions. The marking of the scale for potentiometer R11 should be simple to do, being a linear one varying between 0 at minimum and 2 volts at the maximum. The calibration markings for variable resistor R12 are somewhat more difficult to arrange. Refer to Table 1, in which the values of H_{FE} are shown against the total resistance value of R8 & R12 in series. Final calibration marking should be done after complete assembly of the unit. Using Table 1 as a guide, with the unit switched off, attach an ohmmeter between the test terminal marked 'b/g', and the positive side of the meter, and

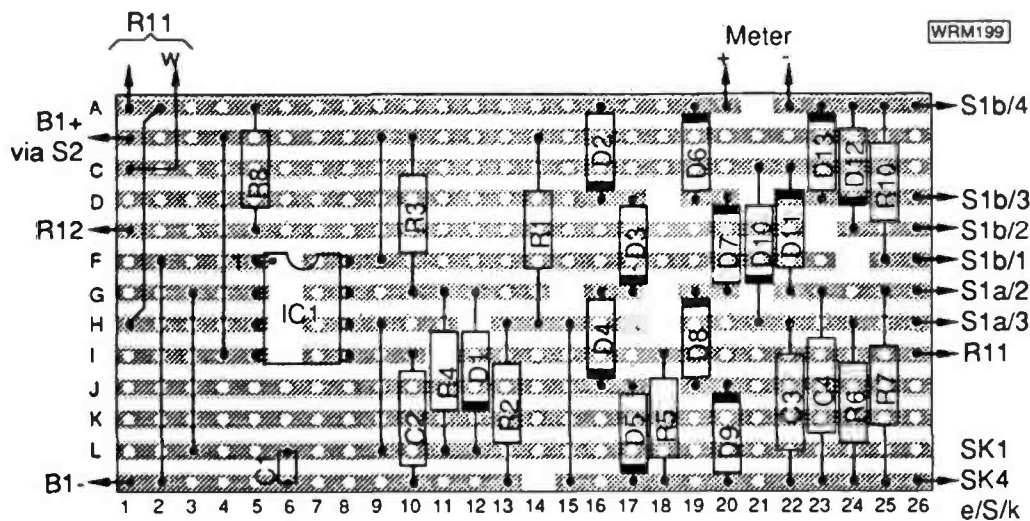

- Track breaks at:-
- 21A
 - 18D,21D
 - 23E
 - 6F,24F
 - 6G,15G,18G,21G
 - 6H,12H,18H
 - 6I,11I
 - 18J
 - 14M

Fig. 2: Layout and track cutting pattern

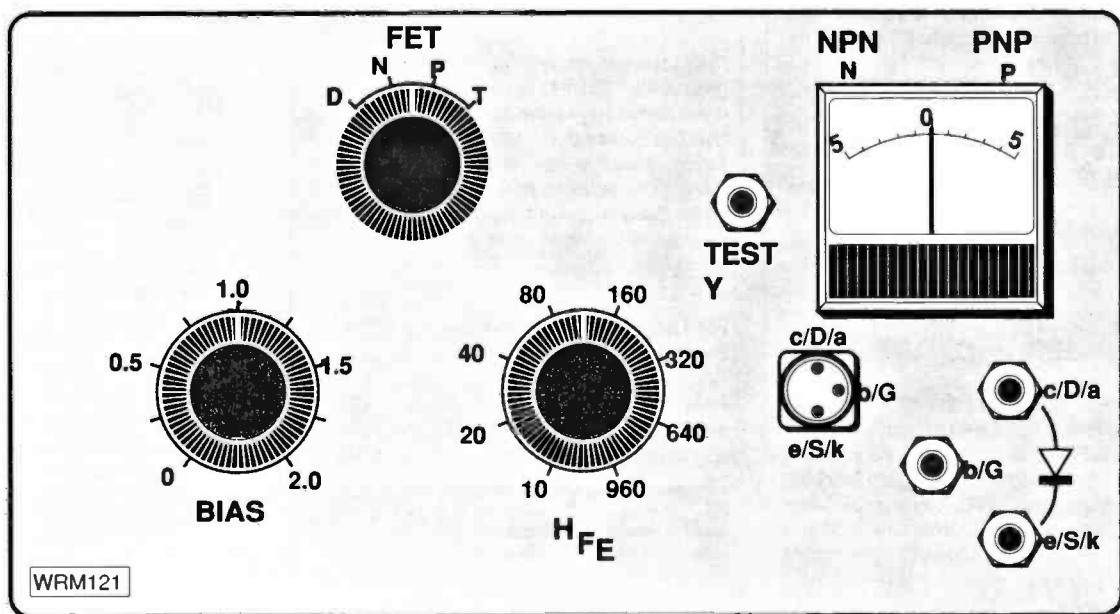
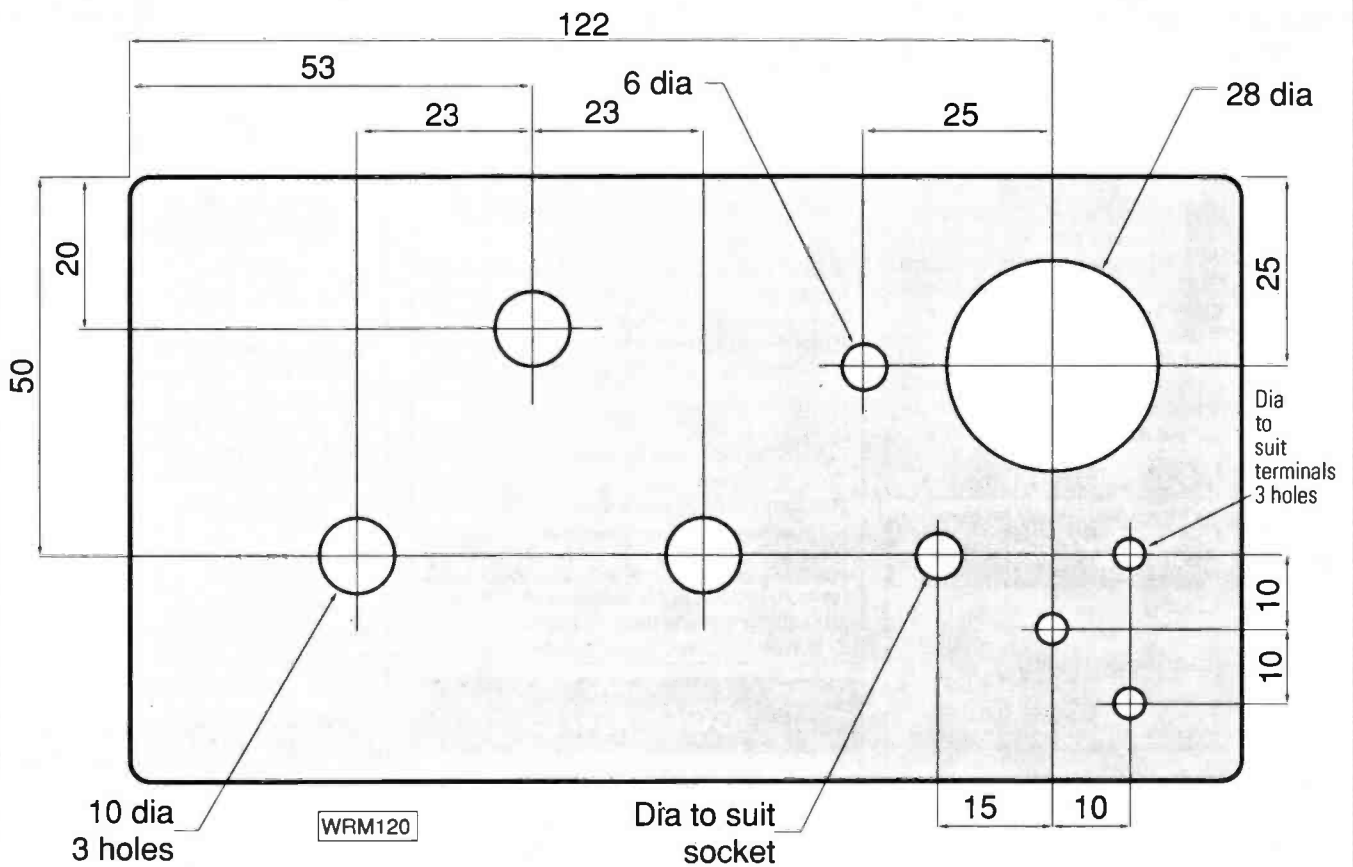

Fig. 3a: Marking and drilling template

Fig. 3b: Drawing of the finished front panel

WITH THE GRAND OPENING OF OUR NEW AMATEUR SHOP
RAYCOM ANNOUNCES NEW DIRECT PHONE NUMBERS
 SALES HOTLINE 021 552 0073 and HELP LINE 021 552 0051 (73's and 51's)

JUPITER II



Save money when you buy this top-of-the range scanner. 100 memories, coverage from 25-550/800-1300 MHz, priority channel monitor, channel lock-out delay and auto AM/FM switching go to make a great package and we add further value still.

Choose either a **free** broadband mag-mount or a **free** mast-mount SkyScan scanner antenna worth £14.95 and a **free** cigar adapter kit when you order your Jupiter II (and £20 off RRP!)

£299.00 .. save £39.90

760 XLT

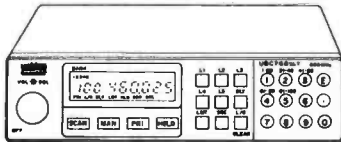

With coverage from 66 to 956 Mhz (with gaps), 100 memories, fast search, high sensitivity (0.3 mV) and 2 watt of audio this compact mobile scanner is ideal for beginner and enthusiast alike! Raycom adds £20 worth of free antenna, and base power supply and drops the price to bring a blistering scanner package to our customers. Call now for an information leaflet!

£239.99 .. save £30.00.

ICOM IC-R7000



An unbeatable offer from Raycom - £30 off the retail price and a **free** Bearcat handy scanner covering 29-512MHz (with some gaps) worth £99.95 - a total saving of an incredible £129.95! Can't believe it? Send SAE for an information leaflet and offer details. Raycom Credit Card is available - just £96 deposit and £36 per month!

£959.00 .. save £130.00

ICOM IC-3210



ICOM's popular dual bander, 25 watts on both bands, great looking and readable display, full duplex capability, 40 memories and input monitor for instant repeater check. All you need add is an antenna and we have taken care of that.

Regular retail prices:
 IC-3210 £499.00
 Broadband mag-mount antenna £14.95
 Total regular price £513.95
 Raycom package price £479.00

SAVE £35!

Raycom Credit Card is available on this pack, just £48 deposit and monthly payments of just £18! *Why wait, send for written details now!*

ICOM IC-725



ICOM's latest addition to the family, the 725 gives a full 100 watts of multi-mode power and is the second rig to use the DDS (Direct Digital Synthesizer) system. 10 Hz steps for smooth tuning, all mode squelch, 26 memories, and many other features make the 725 the starter rig for those who want more than a starter rig - it's unbeatable value - just look!

Regular retail prices:
 IC-725 £759.00
 FM TX/RX (AM RX) board £40.00
 20 Amp PSU £129.99
 G5RV 1/2-sized antenna £14.95
 Fist mic £21.00
 Total regular price £964.94
 Raycom package price £849.00

SAVE £116!

Raycom Credit Card is available on this pack, just £85 deposit and monthly payments of just £32! *Why wait, send for written details now!*

YAESU FT-747GX



HF all mode 100W transceiver, 0.1-30MHz, with the exclusive **Raycom** mod improving receiver dynamic range by 15-20 dB. Turns a good receiver into a **great** receiver. Ideal as a base and particularly suited for mobile/marine use with its light weight and click-stop dial. Save money with the **RAYCOM STARTER PACK** - it's unbeatable value - just look!

Regular retail prices:
 FT-747GX £659.00
 Raycom RX mod £59.00
 20 Amp PSU £129.99
 G5RV 1/2-sized antenna £14.95
 Fist mic £21.00
 Total regular price £883.94
 Raycom package price £749.00

SAVE £135!

Raycom Credit Card is available on this pack, just £77 deposit and monthly payments of just £28! *Why wait, send for written details now!*

YAESU FT-470



Yaesu's new dual bander is ex-stock at last and packed with features - dual display, dual band monitor, 4 VFO's and 42 memories, power saver, auto power off, CTCSS, DTMF autodial and a wide range of options - SAE for information sheet.

Regular retail prices:
 FT-470 £389.00
 FNB-10 nicad 7.2v, 600mAH £34.50
 Wall charger £17.71
 Soft carry case £10.58
 Broadband mag-mount antenna £14.95
 Total regular price £466.74
 Raycom package price £425.00

SAVE £42!

Raycom Credit Card is available on this pack, just £45 deposit and monthly payments of just £16! *Why wait, send for written details now!*

RAYCOM COMMUNICATIONS SYSTEMS LIMITED, INTERNATIONAL HOUSE, 963 WOLVERHAMPTON RD, OLDBURY, WEST MIDLANDS B69 4RJ. TEL 021-544-6767, Fax 021-544-7124, Telex 336483 IDENTI G.

RAYCOM
 COMMUNICATIONS SYSTEMS LIMITED

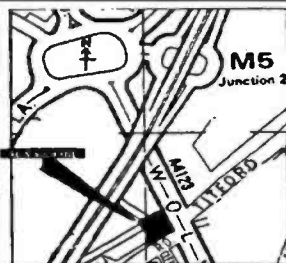

RAYCOM gives you more BUYING POWER
 ALL MAJOR CREDIT CARDS ACCEPTED. BC, ACCESS, DINERS. INSTANT CREDIT UP TO £1000 (SUBJECT TO STATUS) WITH RAYCOM CREDIT CARD (APR 34.5%). FREE CREDIT ON CERTAIN ITEMS AT MRP. CALL NOW FOR MORE DETAILS.

ORDERING INFORMATION
 WE STOCK ICOM, YAESU, BEARCAT, MFJ, BUTTERNUT, CUSHCRAFT, AEA, TONNA, NAVICO, TEN-TEC AND WELZ AMONG MANY OTHERS. SEND SAE FOR FULL LIST.

TEL: 021-552-0073
 PHONE BEFORE 4PM FOR NEXT DAY DELIVERY BY COURIER (£15.00) - OR 2PM FOR DELIVERY BY POST (£10.00 P&P). PLEASE ALLOW TIME FOR CHEQUES TO CLEAR. MANY OTHER ITEMS IN STOCK. PLEASE CALL FOR MORE INFO AND FOR EXTRA SPECIAL DEALS!

INFOLINE 0836-771500 5-9pm (weekdays)
 OPENING HOURS 9.5.30 MON TO SAT, LATE NIGHT FRIDAY TIL 7 PM. 73 DE RAY G4KZH, AND JULIAN.

RAYCOM EXCLUSIVE ACCESSORIES AND UPGRADES

THE WORLD FAMOUS RAYCOM FRG-9600 MARK II & MARK V

The Yaesu FRG-9600 has always been a desirable scanner since its first introduction, offering the user continuous coverage between 60-905 MHz with all modes (SSB up to 460MHz) at a good price and with all the options you would expect to get with a well designed scanner (TV and computer interfaces, mobile bracket, etc.) Raycom offers exclusive upgrades to new or existing units.

FRG-9600 MARK II

We extend the frequency coverage to at least 950 MHz (this depends on individual units) and fit a low loss 'N' connector. By modifications to the front-end RF switching we retain the single connector and improve the sensitivity throughout the range, typically by 3 to 4 'S' points! Beware of imitations - nobody does it as well as we do!

FRG-9600 MARK V

Incorporating all of the Mark II mods above, the Mark V adds a short wave converter board to give continuous coverage from 150 KHz to 950 MHz, retaining all the modes of the standard unit. An elliptical filter in the input circuit, combined with a high dynamic range active mixer results in a unit which will copy Radio 4 or Stateside 10 metre SSB as easily as 900 MHz FM cellphones. Please send S.A.E for an information leaflet.



FRG-9600 standard 60-905MHz	£479.00
FRG-9600 Mark II 60-950MHz	£499.00
FRG-9600 Mark V 0.15-950MHz	£625.00
FRG-9600 Mark II pack	£545.00
FRG-9600 Mark V pack	£699.00
Standard to Mark II upgrade	£40.00
Standard to Mark V upgrade	£149.00
Raycom Mark II to Mark V upgrade	£129.00

All packs include a mains power unit and ROYAL 1300 discone (as below), worth £85! Great value!

Grand opening offer, to Celebrate the Launch of our new Showroom.

Yupiteru MVT- 6000
25 to 550 Mhz and
800 to 1300 Mhz,
**ONLY £349.00 inc
accessory pack.**



RAYCOM EXCLUSIVE POWER UNITS

R1320 - 13.8 VOLTS AT 20 AMPS 100 WATT TRANSCEIVER RATED

This sturdy unit is imported directly by ourselves and represents great value for money! Further modifications are made in the Raycom workshops to improve safety, add extra features and to give additional RF immunity. A hefty mains transformer drives up to 25 amps (surge) through no less than seven 2N3055 pass transistors driven themselves by a 2N3055.

- ◆ 13.8 volt fully regulated
- ◆ 20 AMP output (30 minutes)
- ◆ 25 AMP surge
- ◆ Over voltage protection
- ◆ High current connectors fitted
- ◆ Designed for RF service

Fitted in an attractive case with chrome grab handles, the R1320 makes a worthy addition to any shack!

R1320 13.8 v 20 amp PSU £129.99 inc. VAT

RAYCOM EXCLUSIVE ANTENNAS

ROYAL 1300 DISCONE

STAINLESS STEEL CONSTRUCTION

A quality unit manufactured in Britain, the Royal 1300 is ideal for wideband scanners & scanning receivers.

Specifications:

Receive 25-1300 MHz
Transmit 50, 144,
430, 900, 1200 MHz
Power 200 watts
Connector type 'N'
Cable supplied
RA519
Type Discone 8+8
Length 1.7 metres
Weight 1 Kg

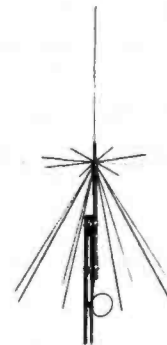

HR1300 discone £59.50

BB-145S

BROADBAND MAGMOUNT

Another exclusive Raycom import, the BB-145S is a broadband ¼ wave mag mount antenna for mobile scanners and 2 metre transceivers. Supplied complete with 4 metres of quality co-ax and PL259 plug, this easily installed antenna is compact in size due to the integral loading coil and is specified for 138-172MHz, but often loads at 70 cms!

BB-145S magmount £14.95

ANNOUNCING THE
RSGB  **1990**

... the place to be! **NEC**

NATIONAL CONVENTION AND AMATEUR RADIO EXHIBITION

Saturday 21 April — Sunday 22 April

NATIONAL EXHIBITION CENTRE, BIRMINGHAM

The premier Amateur Radio Exhibition of the year — supported by an extensive programme of lectures, presentations and events.

TRADE ENQUIRIES WELCOME

TEL 0277 225563
 office hours

R. N. Electronics

Professionally Designed Equipment for Amateurs

★ ★ NEW ★ ★

144/28MHz 10m TRANSVERTER

25W p.e.p. £189 + £4 p&p

PLUS OUR FULL RANGE OF TRANSVERTERS

Our 2m I.F. transverters require a drive level of 0.5-3.0 watts, or up to 12 watts with our 7dB switched attenuator. The 10m I.F. models can be supplied for drives between 0.25mW and 20W with a separate receive output if required.

- 144/50MHz 25W p.e.p. £189 + £4 p&p
- 28/50MHz 25W p.e.p. £199 + £4 p&p
- 145/70MHz 25W p.e.p. £239 + £4 p&p
- 145/70MHz 10W p.e.p. £199 + £4 p&p
- 28/70MHz 10W p.e.p. £199 + £4 p&p
- 7dB switched Attenuator £22 + £2 p&p

All our Transverters meet the same high specification:
 Second Harmonic: <-70dB
 Spurious: <-60dB
 Intermod: -32dB
 Noise Figure: <2.5dB

★ ★ NEW ★ ★

Low Noise GaAs Fet Masthead Pre-Amps

For 70MHz, 144MHz, 432MHz and 934MHz
 200W Power handling £99 + £4.99 p&p

PRE AMPLIFIERS

Low noise (<1dB) GaAs FET Pre-amplifiers for 6m, 4m and 2 metres. RF or DC through switching (Max 100W pep).

- Indoor boxed unit £36 + £2 p&p
- Masthead (line powered) with indoor DC feed unit £69 + £4 p&p

MET. ANTENNAS

50MHz 3 el. £42.95, 5 el. £64.40, 70MHz 3 el. £37.30 p&p £4.50

37 Long Ridings Ave, Hutton, Brentwood,
 Essex CM13 1EE. Tel: 0277 214406

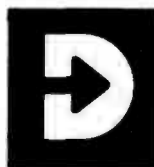

DATONG
 ELECTRONICS LIMITED

Clayton Wood Close
 West Park
 Leeds LS16 6QE
 Tel: 0532 744822
 Fax: 0532 742872

For products you can rely upon to give amazing results

For information on Active Antennas, RF Amplifiers, Converters, Audio Filters, the Morse Tutor and Speech Processors send or telephone for a free catalogue and selective data sheets as required.

All our products are designed and made in Britain. Orders can be despatched within 48 hours subject to availability.

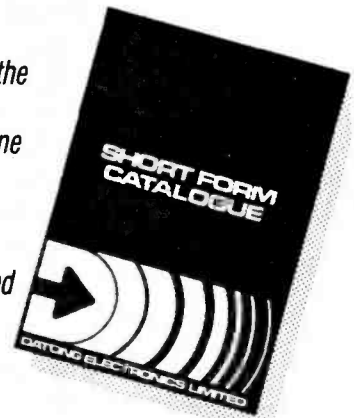

— VISA AND ACCESS WELCOME —



rotate to shaft of R12 until the resistor value is obtained and then mark the pointer position on the front panel. When all points have been marked, take the knob off and tidy up the markings. Then using the interwiring diagram shown in Fig. 4, trim to length the flying leads from the board and solder them to the appropriate place.

The board is mounted, trapped between two nuts on each of, two screws passing through the lid of the box. A plain insulating washer should be placed under the nut at the track side of the board. The battery may be held in place by two double-sided adhesive pads.

Testing

After assuring yourself that all connections are correct and in place, connect the battery with a multimeter on the current range in series. No current should flow at this time. Press switch S2, and a current in the order of 20 to 25mA should flow, but there should be no deflection at all on the centre zero meter. If all is in order, continue to the next stage otherwise stop and check all components and wiring. Place a diode with the cathode (marked end) at the terminal post marked 'e/s/k' and the other end at the terminal marked 'c/d/a'. Rotate switch S1 to the diode position then press switch S2 again. An indicated current of about 2mA should flow, and the meter should deflect to the right. Reversing the diode should now allow the meter to deflect the same amount to the left.

Testing a Transistor

Having determined that the system works take a known good transistor and connect it to the correct socket on the front panel, base to 'b/g', collector to 'c/d/a', and emitter to 'e/s/k'. Press S2 and adjust R12 to show full scale deflection of the meter. It is now possible to see the type, and gain of the transistor. Should you not be able to vary the current by use of R12, or there is no deflection at all, then check for correct orientation of the t.u.t. If after checking it is still impossible to set any deflection, then there is a fair chance that the device is dead. Conversely if it is not possible to set f.s.d., then set 1mA on the meter, and divide the gain figure read off by 5.

Testing FETs

Now moving on to testing f.e.t.s., the method used is a little different. Firstly try to establish if the device is an n-, or a p-channel one, and set the switch to the appropriate setting before connecting the f.e.t., source to 'e/s/k', gate to 'b/g', and drain to 'c/d/a'. Turn control R11 to the maximum setting and press S2, when the meter should deflect to either left or right depending if it is n-channel or p-channel. Should there be no reading then rotate R11 slowly anticlockwise until a reading is obtained. The value of the setting of R11 gives the reverse bias required for a standing current as shown on the meter.

To calculate the transconductance, a variation of this technique is used. Set a small current and note the setting of bias volts as set on R11, reset the bias volts whilst noting the new drain current. The change in current (∂I) in mA is the difference between the two current readings, similarly, calculate the change in bias volts (∂V). The transconductance in milliSiemens (mA-per-volt), is $\partial I / \partial V$.

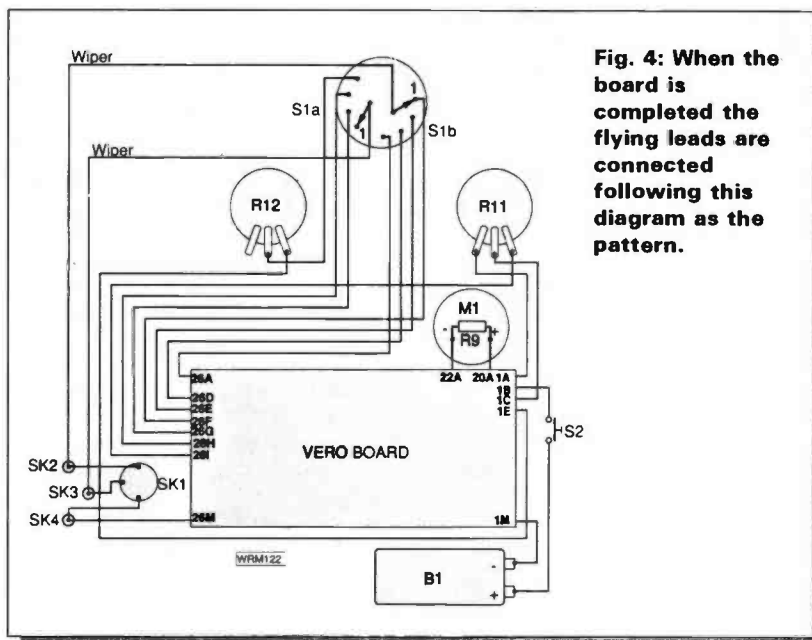

Fig. 4: When the board is completed the flying leads are connected following this diagram as the pattern.

Diodes

Lastly we come to testing diodes, and you should connect the diode between 'e/s/k' and 'c/d/a'. If the meter deflects about 2mA to the 'NPN/N' side then the cathode, (banded or marked end), is on the terminal marked 'e/s/k', and if deflected to the 'PNP/P' side then the cathode is on the post marked 'c/d/a'. If no deflection is obtained then the diode is either short or open circuit. **PW**

Shopping List

Resistors

0.25W 5% Carbon film		
39Ω	1	R9
270Ω	2	R1,2
1kΩ	1	R10
3.9kΩ	1	R5
10kΩ	1	R8
33kΩ	2	R3,4
470kΩ	2	R6,7
Potentiometer		
100k	1	R11
1MΩ	1	R12

Capacitors

Disc ceramic		
100nF	4	C1-4

Semiconductors

LM555	1	IC1 almost any '555' should be suitable.
1N4002	13	D1-13

Miscellaneous

Box 152 x 82 x 50mm, a piece of Veroboard 0.1in pitch 2.7 x 1.4in., 2 pole 4-way rotary switch (S1), push-to-make switch, 50-0-50μA meter, 2 knobs to suit, 1 off TO5 transistor socket, 3 small insulated terminals of various colours to suit, a 9V battery and connector, nuts and bolts, insulating washers to suit, double-sided sticky pads.

HOW MUCH ?

£ 19.50

HOW DIFFICULT

Intermediate

Theory

Reading & Understanding Circuit Diagrams

(with a bit of theory thrown in)

In Part 22, Ray Fautley G3ASG looks at the last three types of impedance matching circuits as well as practical examples of matching.

The first type of circuit to look at this time is Type 7. This is with one complex impedance comprising resistance and reactance in parallel. The value of the resistance in the series impedance being higher than the value of the resistance in the parallel impedance. The circuit of the matching network is shown in Fig. 22.1

(i) Let the higher value of the resistance in the series impedance be designated R_A and the lower value of the resistance in the parallel impedance R_B , regardless of which is source or load

(ii) Change the series impedance R_A and X_A to the parallel form R_A' and X_A'

(iii) Change the parallel impedance R_B and X_B to the series form R_B' and X_B'

(iv) Let $p = \frac{R_A'}{R_B}$

(v) Let $q = \sqrt{(p - 1)}$

(vi) Determine $X_1 = +(R_B' \times q)$

(vii) Determine $X_2 = -\left(\frac{R_A'}{q}\right)$

(viii) Determine $X_3 = X_1 - X_B'$

(ix) Determine $X_4 = \frac{X_2(-X_A')}{X_2 - X_A'}$

Example of Type 7. Match a series impedance of 85Ω resistance and -15Ω reactance to 12Ω resistance and $+70\Omega$ reactance connected in parallel.

(i) $R_A = 85$ and $R_B = 12$

(ii) $R_A' = \frac{85^2 + (-15)^2}{85} = 87.647$

$X_A' = \frac{85^2 + (-15)^2}{-15} = -496.67$

(iii) $R_B' = \frac{12(70^2)}{12^2 + 70^2} = 11.657$

$X_B' = \frac{12^2(70)}{12^2 + 70^2} = +1.998$

(iv) $p = \frac{87.647}{11.657} = 7.5188$

(v) $q = \sqrt{(7.5188 - 1)} = 2.552$

(vi) $X_1 = +11.657 \times 2.5532 = +29.763$

(vii) $X_2 = \frac{-87.647}{2.5532} = -34.328$

(viii) $X_3 = +29.763 - (+1.998) = +27.765$

(ix) $X_4 = \frac{(-34.328)(496.67)}{(-34.328) - (-496.67)} = -36.877$

The values are shown in Fig. 22.2.

Arithmetical check, determine Z_{in} (Fig. 22.2)

(i) Use the series form of R_B' and X_B' for R_B and X_B

$R_B' = 11.657$ and $X_B' = +1.998$

(ii) Add X_3 to $X_B' = +27.765 + (+1.998) = +29.763$

(iii) Final form of the series impedance 11.657Ω resistance and $+29.763\Omega$ reactance

$R' = \frac{11.657^2 + 29.763^2}{11.657} = 89.179$

$X' = \frac{11.657^2 + 29.763^2}{29.763} = +34.329$

(iv) Determine the effective reactance of X' (in (iii) above) and X_4 in parallel

$X = \frac{(34.329)(-38.877)}{34.329 + (-38.877)} = +496.84$

(v) Convert R' in (iii) above and X in (iv) above to series form, R_S and X_S

$R_S = \frac{89.174(496.84^2)}{89.174^2 + 496.84^2} = 86.39\Omega$

$X_S = \frac{89.174^2(+496.84)}{89.174^2 + 496.84^2} = +15.5\Omega$

Close enough to resonate X (-15Ω) leaving the resistance 86.39Ω , near enough to R_A (85Ω).

Type 8. One complex impedance and resistance in parallel, the other a complex impedance comprising resistance and reactance in series. The value of the resistance in the parallel impedance being higher in value than the resistance in the series impedance. The circuit of the matching network is shown in Fig. 22.2.

(i) Let the higher value of the resistive part of the complex parallel impedance be designated R_A and the lower value of the resistive part of the series impedance R_B , regardless of which is source or load.

(ii) Let $p = \frac{R_A}{R_B}$

Take care when doing the worked examples, make sure you have the right component values

- (iii) Let $q = \sqrt{p - 1}$
- (iv) Determine $X_1 = +(R_B \times q)$
- (v) Determine $X_2 = -\left(\frac{R_A}{q}\right)$
- (vi) Determine $X_3 = X_1 - X_B$
- (vii) Determine $X_4 = \frac{X_2(-X_A)}{X_2 - X_A}$

Example of Type 8. Match an impedance comprising 220Ω in parallel with -300Ω to an impedance of 44Ω in series with -50Ω .

- (i) $R_A = 220$ and $R_B = 44$
- (ii) $p = \frac{220}{44} = 5$
- (iii) $q = \sqrt{5 - 1} = 2$
- (iv) $X_1 = +44 \times 2 = +88$
- (v) $X_2 = -\frac{220}{2} = -110$
- (vi) $X_3 = +88 - (-50) = +138$
- (vii) $X_4 = \frac{(-110)(-300)}{(-110) - (-300)}$
 $= \frac{-110 \times 300}{+190} = -173.68$

The values of the matching reactances are shown in Fig. 22.4

Checking the arithmetic, Z_{in} in Fig. 22.4 should be 220Ω in parallel with $+300\Omega$ reactance (to tune out the -300Ω of X_A).

- (i) Add X_B to $X_3 = -50 + (+138) = +88$
- (ii) Find parallel form of 44Ω resistance in series with $+88\Omega$ reactance :

$$R' = \frac{44^2 + 88^2}{44} = 220$$

$$X' = \frac{44^2 + 88^2}{88} = +110$$

- (iii) Find value of X' in parallel with X_4 :
 $= \frac{-110(-173.68)}{110 + (-173.68)} = \frac{-110(-173.68)}{-63.68}$
 $= +300$

So finally we have 220Ω resistance in parallel with $+300\Omega$ reactance. Just right!

Continued over

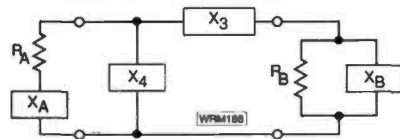

Fig. 22.1

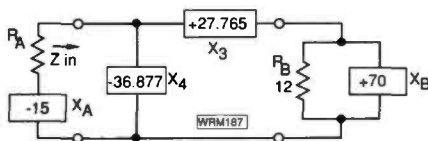

Fig. 22.2

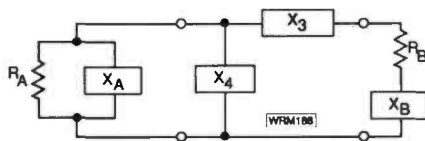

Fig. 22.3

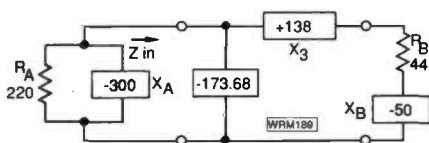

Fig. 22.4

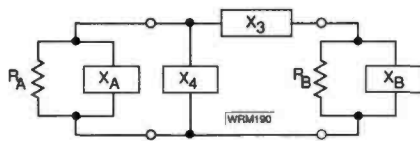

Fig. 22.5

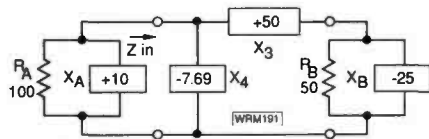

Fig. 22.6

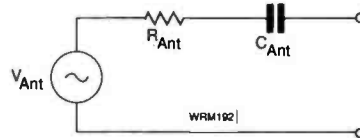

Fig. 22.7

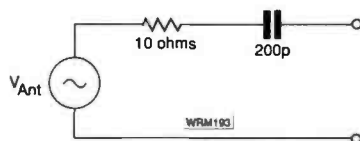

Fig. 22.8

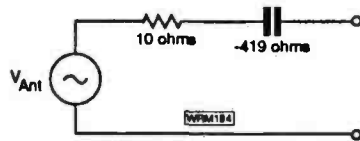

Fig. 22.9

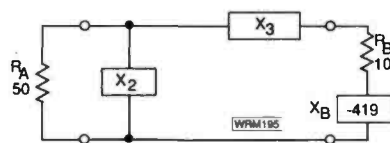

Fig. 22.10

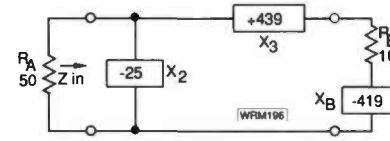

Fig. 22.11

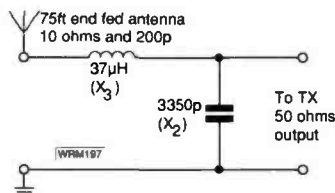

Fig. 22.12

Try the step-by-step approach on your own calculator on the worked examples.

A Practical Example

Let's take a look at an example of the practical use of impedance matching.

How to use a short end-fed antenna on Top Band.

Supposing it is required to connect to an end-fed antenna to the 50Ω output of an h.f. transmitter to enable operation on the 160m band (1.81-2MHz). This can be a difficult one to solve unless the terminal impedance of the antenna at the required operating frequency is known.

'Terminal impedance' of the antenna? This is the impedance measured between the end of its lead-in in the shack and the station earth connection. In this case, it would be required to be known at about 1.9MHz for operation on the 160m band.

If the total length of antenna wire right down to the shack is less than 38m the antenna is likely to have an effective electrical length of less than a quarter wavelength at 1.9MHz. This can be represented by the network in Fig. 22.7 where the antenna is shown as a source V_{ant} in series with a resistance R_{ant} and a capacitance C_{ant} .

The source V_{ant} is shown because when used for reception the antenna is a source, but when used for transmission it becomes a load! In the latter case, as a.c. and d.c. sources are considered to have zero impedance, they may be replaced by a dead short.

Refer back to Fig. 22.7. Why should the antenna look capacitive and not inductive? At a specified frequency, an antenna which is electrically less than a quarter wavelength long is capacitive; at exactly a quarter-wavelength long it is purely resistive; and if between a quarter and a half wavelength it's inductive. At exactly a half wave long the antenna will again be purely resistive; between a half and three quarters long capacitive; when exactly three quarters long it will be purely resistive; between three quarters and a full wave it will be capacitive and finally at exactly a full wave long it will again be purely resistive. Got it?

So, back to our imaginary end-fed antenna, which for our example we'll assume has a total length down to the shack of 23m.

Giving R_{ant} and C_{ant} values we can determine what matching elements we will need to make the antenna look like a 50Ω resistance to load the transmitter correctly.

For an antenna around 23m total length, R_{ant} would be about 10Ω and C_{ant} about 200pF at 1.9MHz our Fig. 22.7 may then be replaced by Fig. 22.8.

First, let's find the value of the reactance of the 200pF capacitance at 1.9MHz.

From the formula for capacitive reactance it will be:

$$X_C = \frac{1}{2\pi fC} = \frac{1}{2\pi \times 1.9 \times 10^6 \times 200 \times 10^{-12}}$$

$$= \frac{10^{12}}{2\pi \times 1.9 \times 200 \times 10^6}$$

$$= \frac{10^4}{2\pi \times 1.9 \times 2} = 419\Omega$$

Capacitive reactance is conventionally negative so $X_C = -419\Omega$

Now we can replace Fig. 22.8 by Fig. 22.9.

So we require a pure resistance of 50Ω (to connect to the transmitter) to be matched to the antenna which is a series connected complex impedance of 10Ω resistance and -419Ω reactance. As the pure resistance (50Ω) is a higher value than the 10Ω

Type 9. Both impedances complex comprising resistance and reactance in parallel. The circuit of the matching network is shown in Fig. 22.5.

(i) Let the higher value of resistance be designated R_A and the lower value of resistance R_B , regardless of which is source or load.

(ii) Change R_B and X_B to their series form R_B' and X_B'

(iii) Let $p = \frac{R_A}{R_B'}$

(iv) Let $q = \sqrt{(p - 1)}$

(v) Determine $X_1 = +(R_B' \times q)$

(vi) Determine $X_2 = -\left(\frac{R_A}{q}\right)$

(vii) Determine $X_3 = X_1 - X_B'$

(viii) Determine $X_4 = \frac{X_2(-X_A)}{X_2 - X_A}$

As an example of the last type, type 9, we'll match a parallel impedance of 100Ω resistance and +10Ω reactance to another parallel impedance comprising 50Ω resistance and -25Ω reactance.

(i) $R_A = 100$ and $R_B = 50$

(ii) $R_B' = \frac{50(-25^2)}{50^2 + (-25^2)} = 10$

$$X' = \frac{50^2(-25)}{50^2 + (-25^2)} = -20$$

(iii) $p = \frac{100}{10} = 10$

(iv) $q = \sqrt{(10 - 1)} = 3$

(v) $X_1 = +(10 \times 3) = +30$

(vi) $X_2 = -\frac{100}{3} = -33.33$

(vii) $X_3 = 30 + 20 = 50$

(viii) $X_4 = \frac{(-33.33)(-10)}{(-33.33) - (+10)} = -7.69$

The values are shown in Fig. 22.6

Last arithmetic check!

(i) Add X_B' to $X_3 = (-20) + (+50) = +30$

(ii) Find parallel equivalent of R_B' and +30Ω reactance :

$$R' = \frac{10^2 + 30^2}{10} = 100$$

$$X' = \frac{10^2 + 30^2}{+30} = +33.33$$

(iii) Find value of X' in parallel with X_4 :

$$= \frac{(+33.33)(-7.69)}{(+33.33) + (-7.69)} = -10$$

This gives a Z_{in} of 100Ω resistance in parallel with -10Ω reactance, just right to cancel X_A and leave 100Ω.

Ray Fautley provides a practical example - A Top Band Antenna - as an exercise

KENWOOD



Two bands are better than one

The latest handheld transceiver from Kenwood is a real eye-opener, combining as it does the facility to operate dual band FM on 2 meters and 70 centimetres in one small package.

The all new TH-75E is designed to use existing accessories from the popular TH-25E/45E range, and thus completes what must be the favourite hand held transceiver line we have seen.

When you take a serious look at what is being offered to the radio amateur today, it should make you blink in amazement. With the TH-75E, Kenwood have combined into one hand held package the sort of performance and features which would have occupied a decent size suitcase not too many years ago. Not only that, the operating convenience of the TH-75E has to be experienced to be appreciated. You can

keep an eye on both bands at the same time, with automatic band changing according to where the activity is. You can operate simplex or repeater channels with correct offsets and tones. You have duplex operation cross band for "telephone style" conversation. And more.

The TH-75E is a really interesting new transceiver, and we are looking forward to the first volume shipments soon. Keep in touch with your Kenwood approved dealer for the latest news.

LOWE ELECTRONICS LTD.

Chesterfield Road, Matlock, Derbyshire DE4 5LE Telephone 0629 580800 (4 lines)

Sole Appointed UK Distributor for KENWOOD Amateur Radio

KENWOOD



Every once in a while, something comes along which marks a true turning point in amateur radio equipment. Such was the case when Trio-Kenwood introduced the TS-120 series; the first of the small solid state HF transceivers to appear.

Following the trends of the last few years towards more "sophisticated" equipment (really meaning more and more complicated), we have seen Kenwood engineering directed more towards better performance, particularly in HF transceivers; performance which has become a standard of excellence for others to try and match.

The culmination of Kenwood design thinking is a new transceiver which I think is another turning point in HF equipment. This is the TS-140S, and I can tell you that reading the enthusiastic comments coming from happy owners, I can confidently say that the TS-140S is the "HF transceiver of the year."

The TS-140S continues the successful "1" series, which began with the TS-120S, developed into the TS-130S and has now reached what I consider to be that new direction in amateur radio equipment. In the TS-140S, Kenwood designers have given the

user a receiver section with real performance which matches today's expectations, and remember that Kenwood have consistently set the standards for many years.

It is almost impossible for any manufacturer to give every potential customer everything that the customer wants, but there is little doubt that many people have been asking for "simplicity". However, it is also possible to carry the "simplicity" concept too far, resulting in a transceiver which is certainly low priced but lacks facilities which many users see as essential. I happen to believe that Kenwood have achieved the right balance in the TS-140S.

In my opinion, the TS-140S in combining performance with simplicity at an attractive cost is giving real satisfaction to the radio amateur who wants to enjoy his hobby of communicating, rather than counting the buttons on the front panel.

73.
John Wilson
G3PCY/5N2AAC

LOWE ELECTRONICS LTD.

Chesterfield Road, Matlock, Derbyshire DE4 5LE Telephone 0629 580800 (4 lines)

Sole Appointed UK Distributor for KENWOOD Amateur Radio

The affordable way to be heard on HF, VHF and UHF.



Listen for Yaesu's FT-767GX everywhere you might hear it: HF, 6 meters, 2 meters and 70 cms.

You'll hear operators calling it the ideal HF/VHF/UHF base station.

And they'll rave about its full-featured performance and highly attractive price.

You see, the FT-767GX continues the price/performance tradition of our popular FT-757GX. But with even more features.

When you're ready to expand beyond HF coverage, just plug in optional modules for 6-metre, 2-metre, and 70-cms operation.

As standard equipment, you get a built-in HF automatic antenna tuner, AC power supply, digital SWR meter, digital power output meter, electronic keyer, and CW filter.

And operation is smooth and intuitive with keyboard frequency entry. Dual VFOs that tune in 10-Hz steps. A digital display in 10-Hz steps. And ten memories that store mode, frequency, and CTCSS tone information.

The FT-767GX is ready to operate full duty cycle at full rated power output for up to 30 minutes. And it

listens from 100 kHz to 30 MHz.

Plus your station is really complete with full CW break-in, our patented Audio Peak Filter for CW operation, a CW TX offset variable 500/600/700 Hz, IF shift, an IF notch filter, a Woodpecker noise blanker, a VFO tracking system for slaved A/B VFO tuning. And that's just a partial list!

But the best way to discover its full-featured performance is to visit your authorised Yaesu dealer today.

Yaesu's FT-767GX. The HF/VHF/UHF base station you'll hear about on the air.

YAESU

*South Midlands Communications
S.M. House, School Close,
Chandlers Ford Industrial Estate,
Eastleigh, Hants SO5 3BY
Tel: (0703) 255111*

Prices and specifications subject to change without notice.

resistive part of the antenna series impedance, the matching problem is a Type 2 case with:

$$R_A = 50, R_B = 10 \text{ and } X_B = -419$$

The required network looks like Fig. 22.10

Following the Type 2 procedure we get :

$$(i) R_A = 50 \text{ and } R_B = 10$$

$$(ii) p = \frac{50}{10} = 5$$

$$(iii) q = \sqrt{(5 - 1)} = \sqrt{4} = 2$$

$$(iv) X_1 = +(10 \times 2) = +20$$

$$(v) X_2 = -\frac{50}{2} = -25$$

$$(vi) X_3 = +20 + (+419) = +439$$

These values give us the required matching resistances, see Fig. 22.10. Check the arithmetic for yourself as we did for the original Type 2 problem. Z_i should work out to be 50Ω resistance!

All that remains to do is to determine the inductance and capacitance values having reactances of $+439\Omega$ and -25Ω respectively at 1.9MHz to complete the antenna matching problem.

$$L = \frac{X_L}{2\pi \times f} = \frac{439 \times 10^6}{2\pi \times 1.9 \times 10^6} \mu\text{H}$$

$$= \frac{439}{2\pi \times 1.9} = 37\mu\text{H}$$

$$C = \frac{1}{2\pi \times f \times X_C}$$

$$= \frac{10^{12}}{2\pi \times 1.9 \times 10^6 \times 25} \text{pF}$$

$$= \frac{10^6}{2\pi \times 1.9 \times 25} = 3350\text{pF}$$

The final antenna matching circuit is shown in Fig. 22.11 and as components in Fig. 22.12. If the inductor were to be a variable component (such as a rotary coil having a pulley wheel running along the winding to provide a continuously variable value of inductance - sometimes called a 'whirley whirley' coil) the network can be kept resonant as the frequency is changed within the band.

Fig. 22.12 illustrates the short end-fed antenna used as a practical exercise to demonstrate the technique of matching a transmitter to an antenna which is electrically short on the 160m, (1.81-2MHz) band.

How do we know when the antenna and network are resonant and presenting the correct value of resistance to the transmitter? That's something we'll talk about next.

FREE READERS' ADS

Wanna Swap!

Send your swaps to our Editorial Office in Poole, no traders...we do check.

Have Commodore CBM 4032 computer/v.d.u. and Commodore 4040 dual floppy disk drive. Would exchange for a good general purpose receiver, valve or transistor. Collins/Racal/Yaesu or similar in g.w.o. Mr. J. Ellis North Manchester (0706) 622400

Exchange Trio/Kenwood 530SP, c.w. 500Hz filter fitted. Boxed and in mint condition. Would exchange for a TS-430S with power supply, or Icom 735 with power supply. Mr B. Coam GM0BWR Tel: Alva 61299.

Have US army BC1000A manpack v.h.f. transceiver, would exchange for an s.l.r. camera in good condition. Tel: Mann Cambridge 860150

Have Grundig Satellit-300 general coverage receiver with digital readout in mint condition. Would exchange for w.h.y? N Cameron, 16 St. Mary's Crescent, Westport, Co. Mayo, Eire.

Have Vega 242, 8-band radio with external b.f.o. (too large to post) + 40 channel f.m. CB Steeplestone 5AB9, l.w., m.w., f.m., airband radio. Would exchange for a Signal R537 airband monitor or w.h.y? T Galt. Tel: 041 620 2178

Have Advance signal generator type D1. A quality instrument in good condition covering 10-300MHz. Would exchange for Racal s.s.b. adapter type RA121. J. M. Tydeman Tel: 0730 62049.

Have Icom R-7000 in perfect condition. Would exchange for Amiga Me-teosat and Facsimile equipment of equal value. I do not have transport. G.S. Dutton 40 Grafton Road, Harwich, Essex CO12 3BD.

Have Bird Thru-Line 200-50MHz 500W element. I require 110-160MHz 100W unit. Can we negotiate a swap? If so Telephone H. G. Futcher G8BTL on Woking 762671.

Have four issues of *Modern Amateur Electronics Manual* in binder. Would exchange for any portable scanner, or test equipment. Alan Morton, 21 Telford Drive, Edinburgh EH4 2NJ

Have Philips PCR3 communications receiver with p.s.u. + Murphy 674 valved radio + Sinclair ZX81 computer. Would consider exchanging for any t.l.r. or s.l.r. camera equipment. Huw Edwards, Ecclesvale, Canterbury Road, Wirksworth, Derbyshire DE4 4DY.

Have Harrier CBX 10m f.m. Spectrum converted rig, would like 70MHz transmitter. Also 12-element ZL special for 144MHz. Assembled and varnished but never used. Would like 3-element for 50MHz, or offers on either. Mr M. Colley Tel: 091 4100305 after 6pm.

Have B29 receiver, valved and covers 15-38kHz, 36-90kHz, 90-230kHz, 230-560kHz, with b.f.o. Modified for external speaker. w.h.y? Derek Rickard Tel: 01 764 5940.

Have s.w.l. a.t.u. covering 0.1-30MHz, new and unwanted gift. Cost £35-00. Would exchange for valved type radio or w.h.y. Ted More Tel: 0706 218290 after 6pm.

Have large quantity of *Practical Wireless* and old television magazines. Would exchange for a Heathkit general coverage receiver. Mr Stevenson, 124 Green Lane, Eastwood, Essex SS9 5QT.

Have Amstrad CPC664 upgraded computer with twin disk drives and monitor, also CP/M, NewWord and Word Plus. Would exchange for best 144MHz band transceiver offered, preferably in the London area. D.R. Robinson Tel: 01 360 8467 evenings.

Have two new 6146B valves, would exchange for two 6AU6s & 6BN8. I am also interested in Dragon 32 computer books and magazines. I also require a Dragon 32 manual. John G4BZQ (QTHR) Tel: Telford 727024.

PW Irwell Part 2

In this second part of the PW Irwell, The Reverend George Dobbs G3RJV describes building the transmitter power amplifier and the transmit/receive change-over board



The circuit of the transmitter board is shown in Fig. 2.1. This is a version of a circuit which I have used for several projects over the years and has a well proven record. The original idea came from W7ZOI several years ago and has been used in circuits for most of the h.f. bands. This version should be capable of at least 3W of r.f. output which is an acceptable power level for QRP work and reasonable results on the air.

The Transmitter Board

The board is a three stage amplifier using a BD131 transistor as the power amplifier. This may seem an odd choice as the BD131 is an audio output transistor. Genuine r.f. power transistors can be quite expensive and I have used the BD131 as an r.f. amplifier and it seems to work well, even up to 7MHz. The pre-driver stage, TR6, and the driver stage, TR7, are both tuned stages. The bandwidth of the amplifier stages is limited by the pre-set tuning but a maximum of 50kHz is required for c.w. operation on the 7MHz band. Peaking the tuned circuits on about 7020kHz seems to nicely cover the whole band sector usable for c.w. operation.

Inductors L2/3 and L4/5 are wound on T50-2 cores, both have link windings and L2 is centre tapped. I wound the link windings, L3 and L5, using thin pvc covered solid wire sometimes known as 'hook-up wire'. Semi-airspaced p.c.b. mounting trimmers, sometimes called 'Mullard PCB Type', are used to tune the inductors L2 and L4. Several

types of transistor would have served for TR6 and TR7 but I have quoted the easily available BC238 and 2N3866 types. The transmit board is keyed via the power supply to the two driver stages.

Output Stage

The BD131, which is mounted flush to the board, requires a small heatsink. To save space, I made a simple heatsink out of aluminium sheet cut to about twice the width of the device but a little longer. The end away from the leads is bent up into an L shaped form to give a fin rising away from the board. The heatsink will require a mica spacing sheet and insulated washer in the normal manner of mounting these devices. This heatsink, small and humble though it is, provides adequate protection for the BD131. The r.f. choke RFC2 that provides the load for TR8 is homewound. It is 10 turns of 32s.w.g. enamelled wire wound through a ferrite bead. This winding is a little tight and care must be taken not to scrape the enamelling from the wire on the sharp edges of the ferrite bead.

The power amplifier transistor TR8 is operated in 'Class C' and so is rich in harmonics requiring a comprehensive low pass filter to be added in the output circuit. The filter shown is a seven element low pass filter built to the standard capacitor specifications values provided by Ed Wetherhold W3NQN. The inductors are wound on the smaller T37-2 cores, which have proved more than adequate to handle the output power.

Fig. 2.1: Circuit diagram of the PW Irwell power amplifier

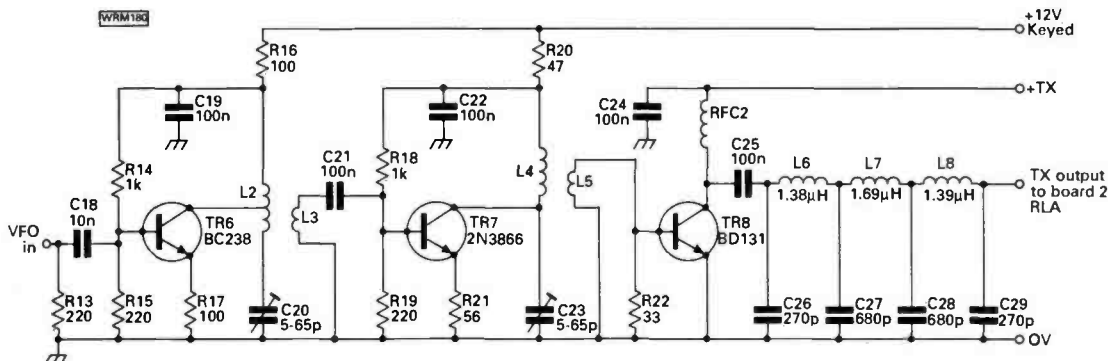

Pre-driver Stage

The layout for the Transmit Board is shown in Fig. 2.2a and b. This board can be built a section at a time and tested. Begin by building the board as far as R19. Take care to accurately count the turns on the inductor as it is wound, each pass through the core is one turn. Connect the v.f.o. to the input of the board on R13 and apply power to both the sections of the v.f.o. and to the amplifier board.

Applying the r.f. probe to the top of R19 should indicate around 1.5V when C20 is peaked to the frequency of the v.f.o. The second stage comprising TR7 and as far as R22 may be constructed and tested in the same way. On the prototype the r.f. probe when placed at the top of R22, gave a reading of about 5V when C23 was peaked for maximum output.

The power amplifier stage including the low pass filter may now be completed. This stage must not be tested without a load. A non-inductive resistance of around 50Ω and a power dissipation of at least 2W is required before the completed board may be tested. With this load connected to the output of the board, the r.f. probe can be applied to the output point. This should give a meter reading of 40V or more. The amount of output, which will vary from board to board, depends upon individual examples of the BD131.

Change-over and Keying Board

The diagram of the circuits required to control the change-over of the transmitter are shown in Fig. 2.3. The method used to key and change the transmitter from receive to transmit is the one sometimes called 'semi-break-in'. When the key is closed the transmitter is keyed via a d.c. switching transistor TR4 which provides the 12V keyed line. This action is softened a little by C15, C14 and R11. Another switch, TR5, drives a relay which changes the antenna from receiver to transmitter output and provides the +TX and +RX voltages. These two transistor are *pnp* types and are shown 'upside-down' with the emitters at the top.

This transistor includes a hang circuit. The hang is a small delay controlled by R12 and C17 which

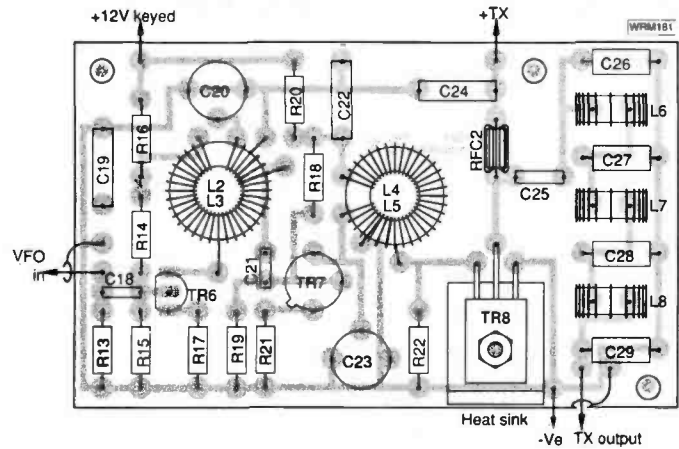

Fig. 2.2a: Component overlay of the power amplifier

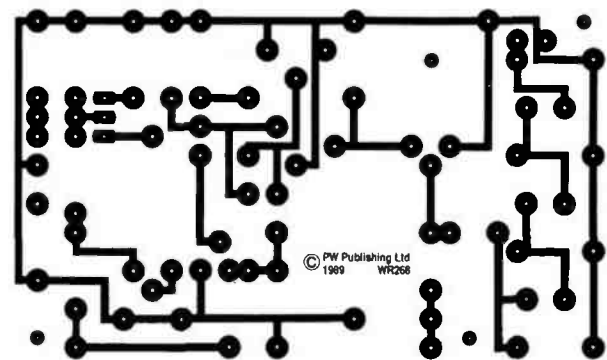

Fig. 2.2b: Track pattern of the power amplifier board



Fig. 2.3: Circuit diagram of the change-over board

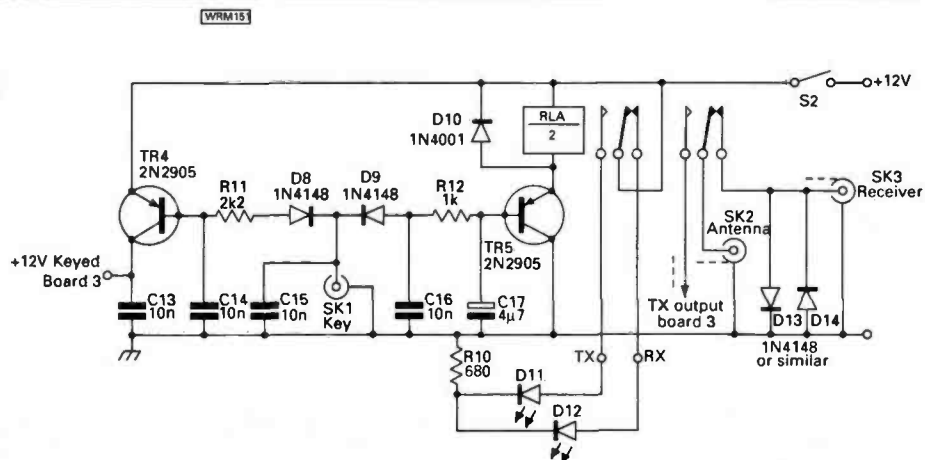

PHOTO ACOUSTICS LTD

58 High Street, Newport Pagnell, Bucks, MK16 8AQ. 0908 610625

Telephone

Kenwood

		P&P
TS950SD	NEW Top of the range HF Transceiver complete with Digital Processing Unit, Auto ATU and filters.	319.00 (-)
TS950S	NEW Top of the range HF Transceiver complete with Auto ATU but without other options	249.00 (-)
TS940S	HF Transceiver with general coverage receiver	199.00 (-)
AT940	Automatic ATU 180M-10M Ham bands. Fits inside TS940S	244.88 (5.00)
SP940	External speaker unit with switched filters	87.55 (5.00)
TS440S	HF Band Transceiver with general coverage receiver	1136.01 (-)
AT440	Internal automatic ATU for TS440S 80-10M Ham bands	144.82 (4.00)
PS50	Heavy Duty PSU for TS440S	222.49 (12.00)
TS140S	HF Transceiver 180-10M Ham bands with general coverage receiver	882.00 (-)
TS680S	HF Transceiver 180-10M plus 6M Ham bands with general coverage receiver	985.00 (-)
PS430	Mains PSU for TS140S or TS680S	173.70 (12.00)
SP430	Matching speaker for TS140S/680S	40.81 (5.00)
MB430	Mobile mounting bracket for TS140S/680S	15.80 (3.00)
AT230	All band ATU and power meter. General purpose ATU	209.87 (12.00)
TL922	180-10M 2KW HF linear. 3-500Z valves included	1495.00 (-)
LF30A	HF Low pass filter 1KW rating	32.29 (3.00)
YK89C	500 Hz CW filter for TS440S/TS530/TS830R/5000	48.08 (2.00)
YK89CN	270Hz CW filter for TS440S/TS530/TS830R/5000	54.84 (2.00)
YK89S	2.4kHz SSB filter for TS440S	47.40 (2.00)
YK89SN	1.8kHz SSB filter for TS440S/TS530S/R5000	46.74 (2.00)
MC50	Deluxe Dual impedance Desk microphone. 4 pin plug	46.08 (4.00)
MC50A	Deluxe Desk microphone with built-in pre amp	88.22 (4.00)
MC43S	Up/Down hand microphone for 8 pin rigs	22.22 (2.00)
HSMX2	Mobile microphone with control box	39.80 (4.00)
TS790E	NEW Dual Band all mode transceiver 2M/70cm with 120MHz option	1495.00 (-)
TR751E	2M multimode mobile/fixated transceiver	599.00 (-)
TM231E	NEW Compact 2M mobile transceiver. 50/10/5W	289.00 (5.00)
TMA31E	NEW Compact 70cm mobile transceiver. 35/10/5W	319.00 (5.00)
TM701E	NEW Compact 2M/70cm mobile transceiver. 25W	469.00 (5.00)
TH25E	2M FM compact handheld transceiver	238.00 (5.00)
TH45E	70cm FM compact handheld transceiver	269.00 (5.00)
TH75E	NEW 2M/70cm handheld transceiver with dual watch display	396.00 (5.00)
HMC2	Headset/mic with VOX/PTT	34.25 (3.00)
SMC31	External speaker microphone	29.79 (2.00)
SMC32	Miniature speaker microphone with earphone socket	23.95 (2.00)
TH205E	2M handheld transceiver with LCD display	199.00 (5.00)
TH215E	2M handheld transceiver with keypad entry	228.00 (5.00)
TH405E	70cm handheld transceiver with LCD display	245.00 (5.00)
TH415E	70cm handheld transceiver with keypad entry	268.00 (5.00)
H55	Deluxe headphones for all KENWOOD equipment	37.54 (4.00)
H56	Ultra light deluxe headphones	24.38 (3.00)

Icom

		P&P
IC-781	All mode general coverage transceiver. 99 memories 150W. Includes internal ATU, PSU and CRT display.	4500.00 (-)
IC-785	All mode general coverage transceiver. 99 memories. 100W. Includes internal ATU and PSU	2499.00 (-)
IC-735	SSB, CW, FM, AM, RTTY general coverage transceiver. 32 memories. 100W	879.00 (-)
IC-726	Compact HF transceiver 180-10M with 6M Ham bands plus general coverage receiver	389.00 (-)
IC-725	Compact HF transceiver 180-10M Ham bands with general coverage receiver. 26 memories. 100W	758.00 (-)
IC-575	Multimode 6M/10M Base station 10W.	1842.00 (-)
IC-575H	Multimode 6M/10M Base station 100W	1199.00 (-)
IC-2SE	FM Multifunction 2M handheld transceiver	275.00 (5.00)
IC-2SEET	FM Multifunction 2M handheld transceiver. Keypad entry - OTMF	295.00 (5.00)
IC-2SEF	FM 2M handportable 3/7W	265.00 (5.00)
IC-290D	2M Multimode mobile. 25W	568.00 (-)
IC-275E	2M Multimode Base station including PSU. 25W	1069.00 (-)
IC-275H	2M Multimode Base station including PSU. 100W	1039.00 (-)
IC-4SE	70cm FM Multifunction handheld transceiver	310.00 (5.00)
IC-4SET	70cm FM Multifunction handheld transceiver. Keypad entry - OTMF	P.O.A. (-)
IC-490E	70cm Multimode mobile transceiver. 10W. (One Only Left)	568.00 (12.00)
IC-475E	70cm Multimode Base station including PSU. 25W	1185.00 (-)
IC-32E	2M/70cm FM handportable. 3/5W	399.00 (5.00)
IC-3210E	2M/70cm FM mobile transceiver. 25W	499.00 (12.00)
IC-24ET	2M/70cm FM handportable transceiver with Dual Watch Display - DTMF - Full Duplex	365.00 (5.00)

CW/RTTY Equipment

		P&P
BY1	Bencher Morse Key (Black)	87.46 (3.00)
BY2	Bencher Morse Key (Silver)	77.00 (3.00)
HK70B	Straight Morse Key	21.85 (3.00)
HK70C	Deluxe version of above on Marble Base	43.40 (3.00)
HK70D	Straight Morse Key	23.25 (3.00)
HK70E	Straight Morse Key	24.00 (3.00)
HK70F	Straight Morse Key	22.25 (3.00)
NK70A	Squeeze paddle	20.25 (3.00)
NK70B	Squeeze paddle on Marble Base	32.20 (3.00)
Star Master Keyer.	Electronic Keyer.	54.70 (4.00)
Star Memory Keyer.	Electronic Keyer with Memories.	95.00 (4.00)
Dating PK232	070 Morse Tutor	63.40 (3.00)
	All mode Terminal Unit. Packet, Ammor, RTTY, CW, ASCII, FAX, and NAVTEX. Works with any computer equipped with an RS232 interface	289.95 (5.00)
AMT-2	All mode terminal unit. Ammor, RTTY, CW, ASCII. Works with Commodore 64, 80C8 etc	198.00 (4.00)

*****Software to suit different computers available for the PK232 and AMT-2*****

Yaesu

		P&P
FT-100D	NEW Top of the range HF transceiver 180-10M Ham Bands with general coverage receiver. Modes CW, USB, LSB, AM, FM, RTTY and Packet. Fixed Auto ATU. 200W output	P.O.A. (-)
FT-747GX	HF Transceiver 180-10M Ham bands with general coverage receiver. 100W	659.00 (-)
FP700	Power supply for FT747/FT757. 20 amp	218.00 (12.00)
FP757HD	Heavy Duty Power supply (100pc duty cycle)	258.75 (12.00)
FT767GX	HF Transceiver 180-10M Ham bands with general coverage receiver	1599.00 (-)
50767	6M module for FT767	179.00 (5.00)
144767	2M module for FT767	179.00 (5.00)
430767	70cm module for FT767	225.00 (5.00)
	*****ONE ONLY LEFT FT7266M module*****	
FT411	2M FM handheld transceiver. Keypad entry. (Radio only)	249.00 (5.00)
FT811	70cm FM handheld transceiver. Keypad entry. (Radio only)	225.00 (5.00)
FT470	2M/70cm FM handheld transceiver with Dual watch display (Radio only)	389.00 (5.00)
FT290RMKII	2M Multimode transceiver, portable/mobile/fixated. 2.5W output	429.00 (12.00)
FT690RMKII	6M Multimode transceiver, portable/mobile/fixated. 2.5W output	429.00 (12.00)
FT736R	2M/70cm Multimode Base station	139.00 (-)
FE736S1/2	6M module for FT736R	239.00 (5.00)
	1.2MHz module for FT736R	425.00 (5.00)

Standard

		P&P
C150	2M handheld transceiver. Keypad entry. Extendable frequency range on Rx.	230.00 (5.00)
C500	2M/70cm handheld transceiver	369.00 (5.00)
C528	NEW 2M/70cm handheld transceiver with Dual Watch Display, up to 5W output, Tone squelch option. P.O.A.	500.00 (5.00)
C5200	2M/70cm mobile transceiver. 45W. Dual Watch display	589.00 (12.00)

Receivers

		P&P
Lowie HF225	NEW 30kHz-30MHz. AM/SSB/CW General coverage receiver	395.00 (12.00)
D225	Narrow Band FM and Synchronous AM detector for HF225	38.50 (2.00)
K225	Genie Pad. Keypad for direct frequency entry on the HF225	39.50 (2.00)
NRD525	Top of the range General coverage receiver 0.09-34MHz	1095.00 (-)
CNK165	Optional VHF/UHF converter for NRD525. 34-80, 114-174, 423-456MHz	391.35 (5.00)
R5000	HF General coverage receiver	875.00 (-)
VC20	Optional VHF converter for R5000 108-174MHz	167.21 (5.00)
R2000	HF general coverage receiver	595.00 (-)
VC10	Optional VHF converter for R2000 118-174MHz	181.94 (5.00)
R21	Wide Band scanning receiver 500kHz-950MHz	485.00 (5.00)
AR2002	VHF/UHF scanning receiver 25-550MHz, 800-1300MHz	487.30 (5.00)
AR800E	VHF/UHF Handheld scanning receiver. 75-105, 118-174, 406-485, 830-950MHz. AM/FM selectable.	199.00 (5.00)
AR500UK	VHF/UHF Handheld scanning receiver. AM/FM selectable. 100 memories. 108-135, 137-174, 220-280, 300-300, 406-470, 830-950MHz	235.00 (5.00)
LC800	Leatherette Case for AR800	2.95 (0.75)
LC800	Leatherette Case for AR500	3.55 (0.75)
WN108	VHF Airband receiver. 108-136MHz	175.00 (5.00)
R535	Airband receiver. Covers VHF and UHF airband	249.00 (5.00)
RS37S	VHF Airband handheld receiver, tunable 118-136MHz	89.55 (3.00)
FR6800D	HF general coverage receiver 0.15-30MHz. All modes	640.00 (-)
FR6900D	VHF/UHF scanning receiver 80-950MHz. All modes	509.00 (-)
FRV800D	VHF converter for FR6800D 118-175MHz	100.00 (5.00)
AX700E	VHF/UHF scanner 52-904MHz with built in Panoramic display	575.00 (-)
Juete II	VHF/UHF handheld scanner 25-550 & 800-1300MHz. AM/FM selectable	299.00 (5.00)
Icom IC-R1	NEW All band handheld scanning receiver. 150kHz-1300MHz. 100 memories. AM/FM selectable	399.00 (5.00)
IC-R100	NEW All band receiver. 500kHz-1800MHz. 121 memory channels. AM/FM selectable	499.00 (12.00)
IC-R72	NEW HF general coverage receiver. 100kHz-30MHz. 99 memory channels	599.00 (12.00)
IC-R71E	HF General coverage receiver. 0.1-30MHz. All mode, FM optional. 32 memories	855.00 (-)
IC-R9000	HF/VHF/UHF scanning receiver. 100kHz-2000MHz. Has built in Spectrum Scope and 1000 memories	3995.00 (-)
IC-R7000	VHF/UHF Scanning receiver. 25-1000MHz & 1025-2000MHz. 99 memories	999.00 (-)
PRO-2006	VHF/UHF Scanning receiver. 400 memories. 25-520 & 790-1300MHz. AM/FM selectable	339.95 (5.00)
PRO-2022	VHF/UHF Scanning receiver. 200 memories. 68-88, 108-136AM, 136.005-174, 380-512 & 80-950MHz	239.95 (5.00)
PRO-2024	VHF/UHF Scanning receiver. 60 memories. 68-88, 118-136AM, 138-174 & 380-512	179.95 (5.00)
PRO-57	VHF/UHF Scanning receiver. 10 memories. 68-88, 138-174 & 380-512MHz	119.95 (5.00)
PRO-34	VHF/UHF Handheld scanning receiver. 200 memories. 68-88, 108-136AM, 136.005-174, 380-512 & 80-950MHz	249.95 (5.00)
20-006	Telescopic whip aerial with BNC connector. Extends portable scanner range. Nine sections centre loaded 25-1300MHz	8.99 (1.00)
270-158D	Diag. 8.99	
270-158D	Diag. 8.99	
270-158D	Diag. 8.99	
AMVHF	Aircraft Pocket Radio	14.95 (-)

Aerials & Accessories

		P&P
Revcone	Disccone antenna. 50-550MHz coverage. Ideal for use with scanner	33.75 (5.00)
Royal 1300	Wide Band Disccone antenna. 25-1300MHz	67.50 (5.00)
AR700D	Wide Band Disccone antenna. 25-1300MHz, complete with 15M of Low loss coax	82.50 (5.00)
Fan Dipole	Wide Band receiving antenna. 100-1300MHz	24.95 (5.00)
20-006	Telescopic whip aerial with BNC connector. Extends portable scanner range. Nine sections centre loaded 25-1300MHz	6.99 (1.00)
HB9CV	2M 2 element beam. Ideal for loft!	3.95 (4.00)
HB9CV	70cm 2 element beam	3.95 (3.00)
HB9CV	6M 2 element beam	12.95 (5.00)
Sim Jim	2M antenna	8.95 (4.00)
Halo	2M SSB antenna	5.95 (4.00)
GSRV	Full size 102' long. Covers 80-10M	16.95 (4.00)
GSRV	Half size 51' long. Covers 40-10M	14.95 (4.00)
Trap Dipole	80-10M Trap dipole kit. Length 110'	19.95 (4.00)
Trap Dipole	160-80M Trap dipole kit. Length 230'	27.95 (5.00)
	1:1 Ratio. 500W	12.95 (2.50)
	4:1 Ratio. 500W	12.95 (2.50)
	40M traps - 7.1MHz. 500W	9.50 (3.00)
	80M traps - 3.7MHz. 500W	8.50 (3.00)
Copper wire	500' rolls of copper wire	7.95 (3.00)
	*****Full range of Jaybeams and Torva Aerials*****	
78F	2M 1/2 wave mobile antenna	24.50 (3.00)
ZE	2M 1/2 wave mobile antenna	14.95 (3.00)
727VM	2M/70cm mobile antenna	25.95 (3.00)
727VM	2M/70cm High gain mobile antenna	40.95 (3.00)
320E	2M 1/2 wave antenna. PL259 fitting	3.50 (2.00)
SAGMS	Mag mount. Large Impet mag mount with rubber skirt	20.50 (3.00)
HSTMB	Boost mount for any of the above aerials	15.45 (3.00)
SSB2	Heavy duty Hatch Back mount for above aerials	22.35 (3.00)
2106	Heavy duty Hatch Back mount for above aerials	27.27 (3.00)
GSS	Gutter mount	6.85 (1.50)
RG44M	4M lead with SO239 socket and PL259 to go with gutter mount	6.95 (1.50)
D24N	2M/70cm Diplexer	28.95 (3.00)
GF151	2M ON-GLASS 1/2 wave mobile antenna	27.99 (4.00)
GF411	70cm ON-GLASS 3/8 wave antenna	26.89 (4.00)
	*****Full range of G-Whip Aerials*****	
Active	Antenna. Covers 0-40MHz. Comes complete with power supply and bracket	45.00 (5.00)
Global	SWL Antenna Tuner. Covers all bands from 100kHz-30MHz	69.00 (5.00)
CT1010	200W Fan cooled dummy load	89.00 (3.00)
PL259	2M Flashed 1/2 wave antenna BNC connector	11.00 (1.50)
OL60	20W continuous dummy load	11.00 (1.50)
FR7700	SWL antenna tuner	59.00 (3.00)

Books & Maps

		P&P
Confidential Frequency List 1989 edition		7.95 (1.00)
The complete guide to VHF/UHF frequencies 25-200MHz. 1989 ed		5.95 (1.00)
HF Decodes: Airband Communications		3.95 (0.75)
NEW VHF/UHF Airband frequency guide		5.95 (1.00)
World Radio and TV Handbook		17.95 (1.50)
Better Short Wave reception		5.30 (1.00)
Scanners 2		9.95 (1.00)
RSGB 1989 Callbook		7.50 (1.50)
HF Antennas for all Locations		7.25 (1.50)
Radio Amateurs Examination Manual		5.85 (1.50)
Morse Code for the Radio Amateur		3.25 (0.75)
Radio Communication Handbook. Vols. 1 & 2		13.95 (2.50)
Practical Wire Antennas (NEW for 1989)		0.25 (1.50)
How to Pass the RAE		3.80 (1.50)
Logbook		3.50 (1.00)
IARU Locator Map of Europe		2.25 (1.00)
World Prefix Map (Colour)		3.50 (1.50)
Great Circle DX Map		3.25 (1.00)
IARU Locator Map of Western Europe		3.50 (1.50)
VHF/UHF Manual		10.99 (2.00)
Amateur Radio Operating Manual		0.85 (1.50)

Power Supplies & Linear

		P&P
DRAE 24 amp power supply		151.35 (12.00)
DRAE 12 amp power supply		104.71 (5.00)
DRAE 6 amp power supply		78.72 (5.00)
BNOS 1220E 20 amp power supply		170.25 (12.00)
BNOS 1210E 10 amp power supply		132.25 (5.00)
BNOS 125E 5 amp power supply		74.75 (5.00)
Dawa P500XM Heavy Duty power supply. 24 amps. Variable volt		129.50 (12.00)
BNOS LP144-3-50 2M 50 watt linear with preamp. 3W input		138.00 (5.00)
BNOS LP144-10-50 2M 50W linear with preamp. 10W input		138.00 (5.00)
BNOS LPM144-3-100 2M 100W linear with preamp. 3W input		235.00 (5.00)
BNOS LPM144-10-100 2M 100W linear with preamp. 10W input		205.00 (5.00)
BNOS LPM144-3-180 2M 180W linear with preamp. 3W input		355.00 (5.00)

PHOTO ACOUSTICS LTD

58 High Street, Newport Pagnell, Bucks. MK16 8AQ. 0908 610625

Telephone

P
H
O
T
O

A
C
C
O
U
S
T
I
C
S

NEW — NEW — NEW
KENWOOD TS950S/SD



Available NOW this superb all band, all mode HF transceiver has too many features to mention, so send for details or come in and try one!
TS950SD = £3199.00
TS950S = £2499.00

NEW — NEW — NEW
Yaesu FT-1000

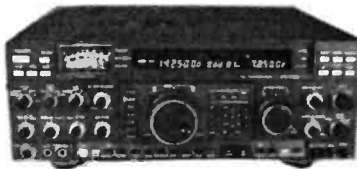

Available NOW this NEW Top of the range all band, all mode HF Transceiver from Yaesu. Again too many functions to list, so please send for leaflet!
FT-1000 = £2995.00

Icom IC-725



Compact HF transceiver with General coverage receiver. 26 memories, 100 watts output. All band, all mode, (FM optional).
£759.00 FM unit = £40.00

NEW — NEW — NEW
Standard C528

Available NOW the superb NEW C528 Dual Band handheld from Standard. This unit has dual watch facility and extended receive coverage 800 - 975MHz.



£379.00 P & P = £5.00

NEW — NEW — NEW
Icom IC-24ET

Available NOW this super compact and lightweight Dual Band handheld has a host of features including Dual watch facility, Full duplex capability, 5W output to name but a few!



£385.00 P&P = £5.00

Kenwood TH-75E

This high quality Dual band handheld is excellent value for money. Not only does it have Dual watch facility and Full duplex capability, but it comes complete with nicad, charger and aerial.

Only £398.00 P&P = FREE

ON-GLASS ANTENNAS

We have in stock the GF151 1/2 wave VHF mobile aerial and the GF411 3dB gain UHF colinear. Both of these aerials perform well and have a frequency coverage as follows:
GF151 138-175MHz and the GF411 430-470MHz.
GF151 = £27.99
GF411 = £28.99
P&P £4.00

Kenwood TM231E



Compact 2M FM mobile transceiver. 50/10/5W.
Only £289.00 P&P = £5.00

Kenwood TM431E



Compact 70cm FM mobile transceiver. 35/10/5W output.
Only £318.00 P&P = £5.00

Kenwood TM701E



Compact 2M/70cm FM mobile transceiver. 25W on both bands. Full Duplex capability.
Only £469.00 P&P = £5.00

Ten-Tec Corsair II

Excellent HF all band transceiver. Much used by the CW enthusiast!

Special Offer £1080.00
P&P = £12.00

Handheld Scanners

AR800E VHF/UHF scanner £169.00

AR900E VHF/UHF scanner £199.00

Jupiter II VHF/UHF scanner £299.00

NEW Icom IC-R1 HF/VHF/UHF scanner £399.00

P&P on any of the above £4.00

Base/Mobile Scanners

NEW Icom IC-R100 HF/VHF/UHF scanner £499.00

PRO-2005 VHF/UHF scanner £339.95

Icom IC-R7000 All mode VHF/UHF scanner £989.00

Icom IC-R9000 All mode HF/VHF/UHF scanner £3995.00

HF Receivers

Kenwood R5000 General Cov. Rx. £875.00

NEW Icom IC-R72 General Cov. Rx. £599.00

Yaesu FRG8800 General Cov. Rx. £659.00

HF225 General Cov. Rx. £395.00

Carriage on the above £12.00

Icom IC-490E



70cm Multimode. 10W output. We are offering this superb 70cm multimode at the never to be repeated price of £499.00. There is only one left so first come first served!
Carriage £12.00

AUTHORISED AGENTS FOR KENWOOD, ICOM, YAESU & STANDARD. FULL SERVICE FACILITIES AVAILABLE

SPEND UP TO £1,200 INSTANTLY WITH A PHOTO ACOUSTICS LTD, CREDIT CHARGECARD — APPLY FOR DETAILS
PART EXCHANGE WELCOME, ASK FOR KERRY G6IZF OR ANDY G4YOW
RETAIL SHOWROOM OPEN MONDAY-FRIDAY 9.30-5.30, Saturday 9.30-4.30

Goods normally despatched with 24 hours. Please allow 7 banking days for cheque clearance. Prices correct at time of going to press — E&OE



STANDARD®

Standard have done it again! You all know how popular the C500 is, well now here is their latest dual bander — the C528 (not to be confused with the Japanese only version, the C520), The European version has all the facilities that you want in a base station, let alone a hand held!

- ★ Direct 13.8V in for 5 Watts out.
- ★ VHF 2.5W, UHF 2W with GNB151 NiCad pack.
- ★ Dual displays
- ★ Power save function.
- ★ Multiple memories.
- ★ Priority channel.
- ★ Tone squelch (option).
- ★ Programmable offsets.
- ★ Coded paging function.
- ★ Various scanning modes.
- ★ Programmable step sizes.
- ★ 144-146 VHF, 430-440 UHF, 800-975 Rx only.
- ★ Separate Vol. & Squ. controls for each band.

★★★★ HAND HELD ★★★★★

★★★ REPEATER FUNCTION ★★★★★

All this in a package just 55mm wide x 157mm high x 31mm deep (2.5in x 7in. x 1.5in for us technical people).

£379.00

Norman.

PLEASE REMEMBER, WE ARE THE SOLE IMPORTER OF STANDARD EQUIPMENT IN THE UK AND WE ARE ABLE TO OFFER A FULL BACKUP SERVICE AND SPARES FROM STOCK.

TRADE ENQUIRIES WELCOMED
PLEASE PHONE 01-450 9755
★ STRICTLY TRADE PLEASE ★

LEE Electronics



AX700E SCANNER



52-904MHz
Price £575.00 incl. PSU

C150

The Standard C150 super-compact 2m transceiver having all the usual features that you would expect from a modern microprocessor controlled radio — plus several new ones. Extendable frequency range on RX.



Price £230.00

C500

THE PROVEN C500 DUAL BAND HAND HELD TRANSCEIVER STILL HELD AT ITS ORIGINAL PRICE!



Price £359.00

C5200 DUAL BANDER



45 WATTS EITHER BAND

Price £599.00

IMPORTANT NOTICE

Listed below are the names of the authorised dealers for standard communication products. Neither they, nor ourselves, will supply spare parts, technical information, service or accessories for equipment supplied by any company not authorised to sell Standard products. Parts and Accessories will only be supplied against quoted serial numbers.

We are sorry to have to take this stance but, to protect our customers, we only import equipment that has been manufactured to British specification and this is the only equipment that we will service. Please bear this in mind when you are deciding where to buy your Standard radio.

AMATEUR RADIO COMMUNICATIONS ★ DRESSLER ★ BREDHURST COMMUNICATIONS ★ ARROW ELECTRONICS ★ PHOTO ACOUSTICS ★ WATERS & STANTON ★ RAYCOM ★ ELLIOT ELECTRONICS ★ NEVADA ★ BORDER COMMUNICATIONS ★ ADITI COMMUNICATIONS ★

400 EDGWARE ROAD, LONDON W2
01-723 5521 Tx 298765

OPENING TIMES: 9.30am-5.30pm Mon-Fri. 10am-4.30pm Sat.



Normally 24hr despatch but please allow 7 days for delivery.

enables the relay to hold closed at normal keying speeds. This prevents the relay clattering on and off during the keying action, and the hang time could be changed to individual taste by altering the value of C17. Diode D10 protects the transistor emitter from back e.m.f. surges as the relay is switched off.

Also shown in Fig. 2.3 is the relay switching action. The relay is a double pole change-over type with one half used for antenna change-over and the other half to provide the +TX and +RX voltages. Two front panel l.e.d.s are used to show the receive and transmit states with voltages taken from the +TX and +RX lines. Moving on to Fig. 2.4a and b, which show the layout of the changeover and keying board. This board is the simplest of the three to build and test, but do remember that the transistors are p.n.p. type and take care to ensure their correct placement. The changeover section which provides the +TX and +RX lines is routed to tags on the board. Miniature coaxial cable should be used to interconnect the antenna socket to either the output of the p.a. board or the receiver.

To test the board apply the power and short out the the key contacts. The relay should close. On opening the key contacts, the relay contacts should open after a short delay. Opening and closing the the key contacts at a typical rate, expected in morse keying should hold the relay closed. Stopping the keying action will allow the relay to release. The output from TR4 may be checked with a meter. The 12V appearing from the collector of TR4 should follow the keying. PW

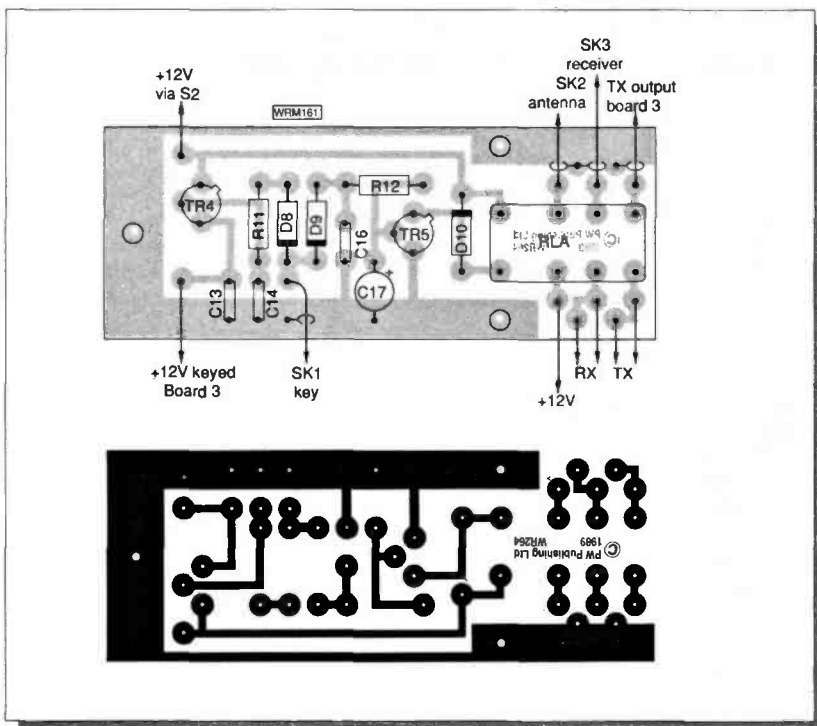

Fig. 2.4b: Track pattern of the change-over board.

TO BE CONTINUED...

PW Irwell Part 1 January 1990

An error crept into the shopping list on page 29 of the January issue of *PW*. The description of L3, the number of turns is correct at 4t thin insulated wire, but they should be wound over the coil L2 on the power amplifier board featured in this issue and not the v.f.o. coil as stated. Also R13 missed the Shopping List for some reason, it should be 220Ω along with R2,15 and 19.

The p.c.b. track pattern needs to be reprinted for those wishing to make their own boards

Errors And Updates

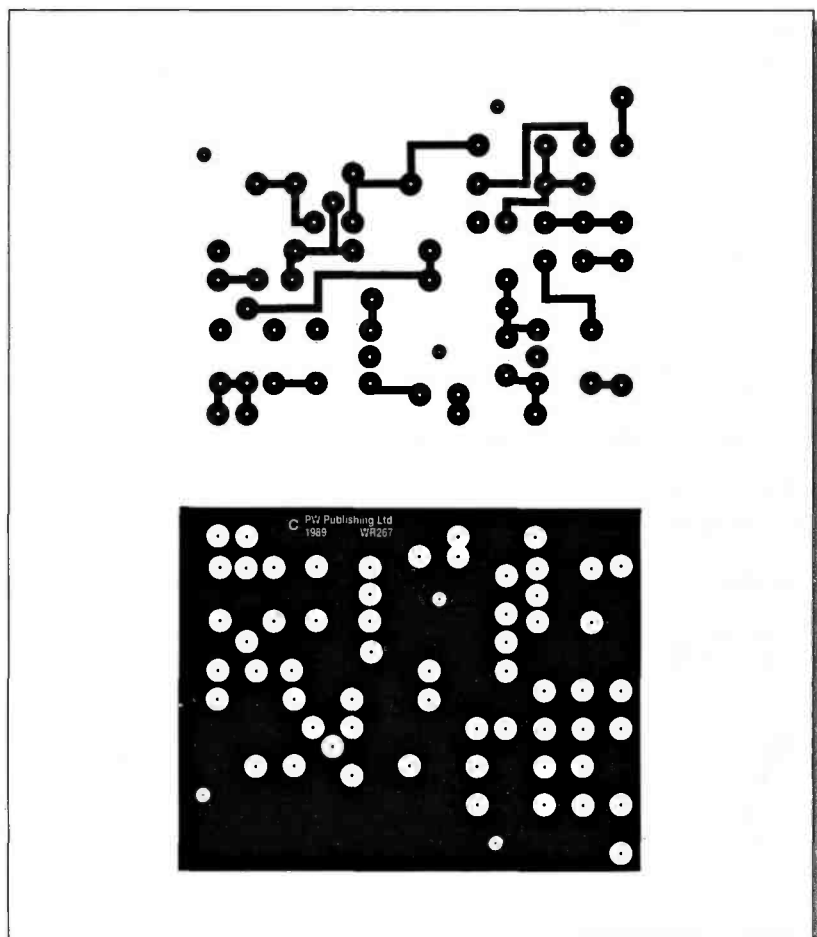

Whilst it's satisfying to receive letters from readers praising the performance of antennas they have constructed from details given in *Practical Wireless*, these often contain a query as to whether the performance of this or that antenna could be further improved. If the original design work and measurements, etc., were carried out competently and proved satisfactory, then the designer must have concluded that performance was optimum and could not be further improved. An antenna re-design to obtain a higher degree of performance may well become a different antenna entirely. This observation applies in the case of a query sent in by a reader from Malta and which is typical of others received.

Q I have constructed Slim Jim antennas, not only for the 144MHz band but for other frequency bands as well. Results in each case have been satisfactory. *Is it possible to get a better performance with this antenna?* Would a collinear antenna be worthwhile? I require an omni-directional antenna as I cannot use a multi-element beam.

A The Slim Jim has unity directivity gain (0dBd) and is an efficient antenna. Its efficiency cannot be improved. A close spaced 2-element collinear has a directivity gain of slightly less than 2dBd which would not make a great difference in performance. *Raising the height of the Slim Jim by a few feet would do more good in this respect.*

However, this reader was sent full details for the construction of a collinear Slim Jim (2-elements) published in *Practical Wireless* January 1989. He was referred to others with more elements and also warned about the performance of certain 'manufactured' v.h.f. and u.h.f. collinear antennas advertised as having a high directivity gain and generally superior performance, but which may be considerably poorer than claimed. *Caveat emptor.*

Q Way back in 1984 you very kindly advised me on the type of antenna to use in the loft for general listening on the h.f. bands. You may remember, this was a 'doublet' type made as long as possible and centre fed. It has brought in many stations from all over the world. I am very pleased with it indeed.

I would now like to construct an antenna, again for use in the loft, to cover the 'aircraft band' 118 to 136MHz. Can you please advise. Thank you.

A Dimensions, etc., were given in *Practical Wireless* April 1989 for the construction of a Slim Jim for the aircraft band. However, this band is pretty wide (18MHz) and really necessitates a wideband omnidirectional antenna. Discone? Ideal perhaps, but might be difficult to get into an average sized loft. First, how long is a half wavelength at the band centre frequency of 127MHz? Wavelength = $300/127 = 2.36\text{m}$. Halfwave = 1.18m (a little under four feet). This could be accommodated upright in most loft spaces. A possibility is a 'Butterfly dipole' as in Fig. 1. Whilst this would not provide a full linear bandwidth of 18MHz, the performance would be far better than a thin tube or wire dipole.

For omnidirectional reception it should be installed vertically and insulated from any supports or suspension. The feed cable run should be at right angles from the antenna for at least a half wavelength before being taken downwards to the receiver.

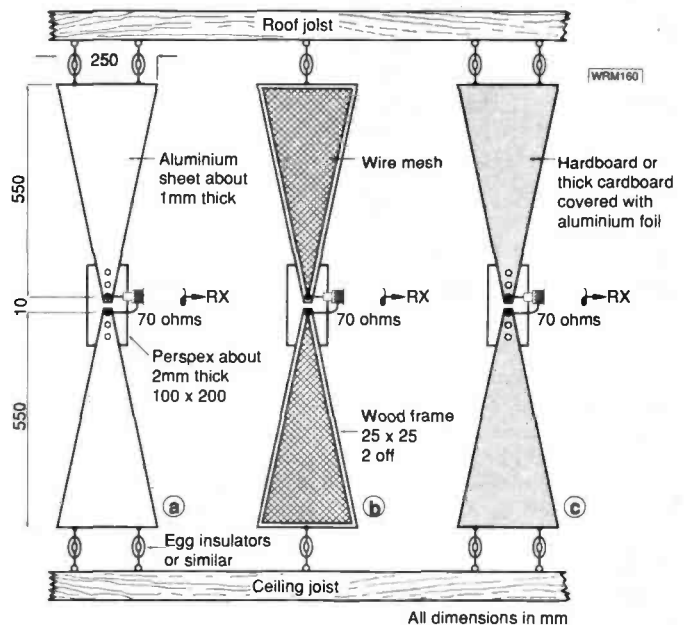

Fig. 1: Butterfly dipole for aircraft band reception. (a) made from thin aluminium sheet, (b) thin mesh wire on wood frame (small mesh chicken wire would do) and (c) hardboard (or thick cardboard) with aluminium foil pasted on as conductor, Soldered connections can be made on this material with special aluminium solder available from d.i.y. shops. Dimensions of conductor sections and Perspex centre support plate are the same for each arrangement.

Q Is it possible to construct a 12-element ZL Special for the 50MHz band? I have tried to work out the dimensions from those given for the 144MHz version but am having difficulty.

A Apart from cost and the work involved in constructing a 50MHz version of the 12-element ZL Special, even with the requisite dimensions, this reader would have encountered some difficulties he may not have foreseen. These were explained more or less as follows.

With a scaling multiplier of 2.9 (from 145MHz) the overall length of the 50MHz version would be about 30.5 feet with a width on the longest element of 9.18 feet. The elements would need to be constructed from at least 3/4in diameter aluminium tube all assembled in a boom of about 2in square, thick-walled aluminium tube. The supporting mast, or tower, would also need to be pretty substantial and well guyed to take the weight and withstand high winds. I asked the reader, "was he now having second thoughts about this?" and explained that a 3 or 4-element beam would be a much easier proposition. See *Practical Wireless* July 1989 for details of an easy to construct small beam for 50MHz. He wrote again to express agreement on this.

SANDPIPER COMMUNICATIONS

AERIAL TECHNOLOGY & DESIGN
UNIT No. 5, ENTERPRISE HOUSE
CWMBACH IND. ESTATE
ABERDARE, MID GLAM.

Telephone
(0685) 870425

Fax:
(0685) 876104

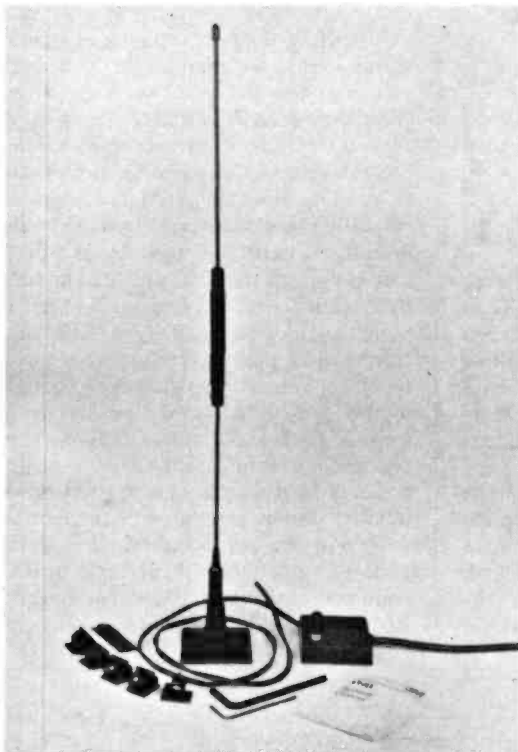

New Sandpiper
all black miniature
On Glass Aerials
only 16" high (2 mtr.).
Perform as well as some
 $\frac{5}{8}\lambda$ mobiles.

Available 2 mtrs.
2 mtrs + 7cm Dual Band
Civil Air & Military Air Band

Also available P.M.R.
Highband or Band III (3)

Other versions available Phone
requirements.

SPECIAL INTRODUCTORY OFFER

- On Glass (all versions)..... **£26.00 POST FREE**
- Mini Mag Mount **£23.50 POST FREE**
- Hatch Back **£22.00 POST FREE**
- Drill Hole Bodymount..... **£21.00 POST FREE**

All comes with moulded 5 metres of top quality coax.

Aerial available without mount in either PL259/ $\frac{3}{8}$ " UNF
or Tilt Type (fits Revco, Pye, Bantex, etc.) **£13.00.**

AVAILABLE DIRECT or from most good
Amateur Radio P.M.R./Scanning/Airband shops.

HARROGATE ELECTRONICS, Harrogate (0423) 64353 • AIR SUPPLY, Leeds (0532) 509581 • LONG COMMS, Donegal (073) 37017 • A.R.E., Ealing, London 01-997-4476 • A.R.C., Merseyside (09252) 29881

• JAVIATION, Bradford (0274) 732146 • NEVADA, Portsmouth (0705) 662145 • RAYCOM, W. Midlands 021-544-6767 • JAYCEE, Glenrothes, (0592) 756962 • STAR ELECTRONICS, Tyne & Wear (0914) 179692

On Track with the Racal-Decca Navigator



along a series of predetermined lanes. Subsequently the invasion barges, also fitted with the new invention, successfully followed the same lanes.

In 1946 the British Government gave permission to the Decca Company to further develop and market the system for international civil use. The Decca Navigator Company became part of the Racal Electronics group in 1980.

How the Racal-Decca Navigator System Works

The Racal-Decca Navigator is a radio position-fixing system for marine, air, and land-based use utilising continuous wave signals in the low frequency band 70-130kHz. The system is of the type in which fixed transmitting stations at known locations provide hyperbolic lines of position. The range of the system depends on various factors but is typically in the order of 240 nautical miles by night and about twice that distance by day. Each user craft carries a special receiver which, in its simplest form, delivers the position lines as numerical readings which are plotted manually on a lattice chart. The intersection point of two such lines gives the position fix. Automatic and computer based methods of reducing and displaying the Decca position fix are also widely used. A chain of Decca Navigator stations consists of a central master, which is often associated with a supervisory control/monitor station, together with three (in a few cases two) outlying slave stations. Each slave station generates a pattern of hyperbolic position lines in conjunction with the master. The slaves are termed Red, Green and Purple from the colours in which the

Radio communication plays many roles in the modern-day world, especially so in navigation. Rob Mannion G3XFD homes in on a radio-navigation system that entered service many years ago and yet is still a very popular aid to both professional and pleasure-craft seafarers.

The system now known as the Racal-Decca Navigator was conceived in 1937 by W.J. O'Brien an American radio engineer and was developed during the Second World War by the British Admiralty in conjunction with the Decca Record Company. Decca's Chief Engineer was then H. F. Schwartz, also an American and a friend and former colleague of O'Brien.

After a series of brief but highly successful trials the system's first operational use was during the Allied invasion of Normandy in 1944. With transmitters sited along the south coast of England, minesweepers cleared channels through the off-shore minefields navigating by the Decca system

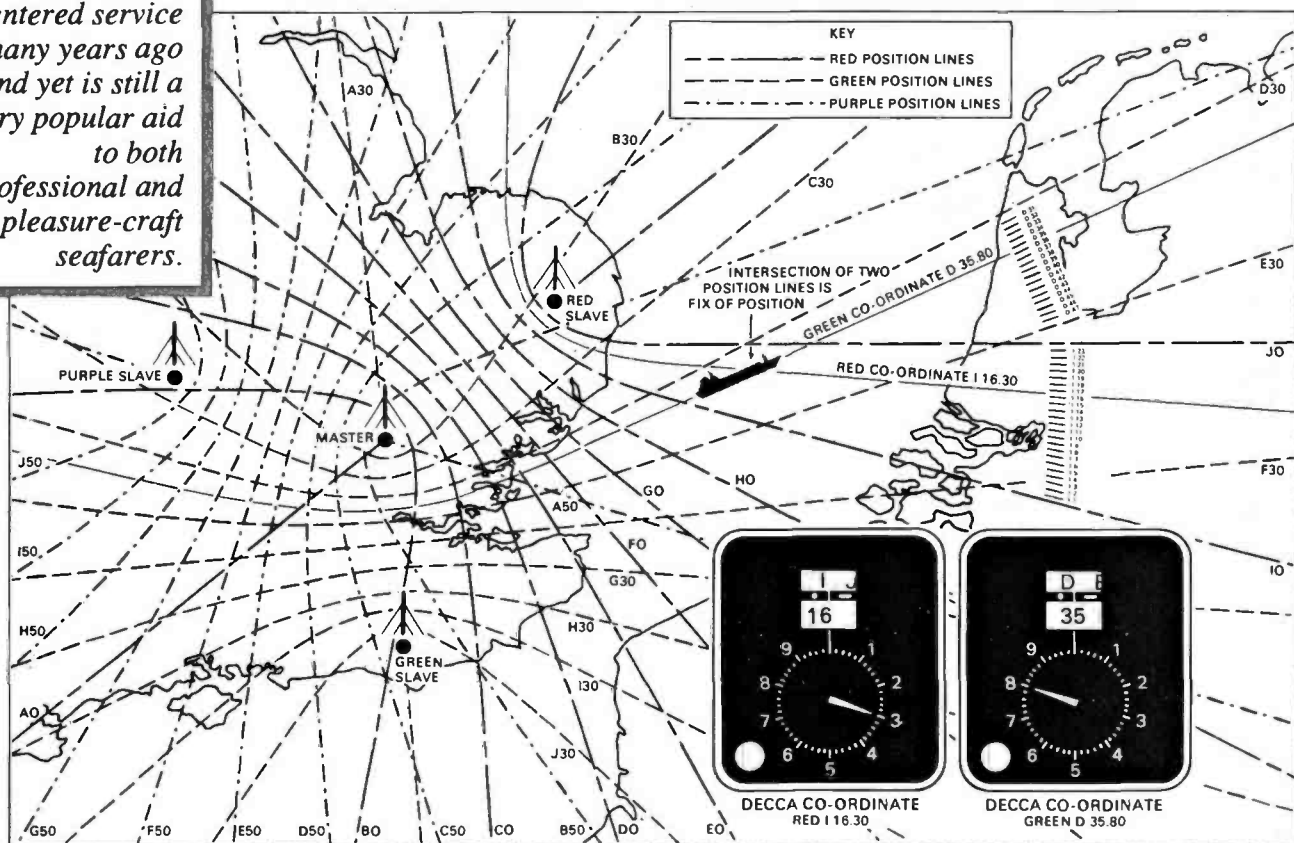

The layout of the English chain showing how a fix is obtained from the readings of the two decometer indicators

patterns are printed on the chart. The length of the inter-station baselines is generally within the limits 40-120 nautical miles (73-220km).

Position Lines

A Racal-Decca position line is generated by a pair of synchronised transmitting stations. Consider a pair of stations A and B, separated by distance S, which are assumed to be sending pure c.w. signals of identical frequency and locked in phase. At a point in the coverage at a distance r_A from the master station and r_B from the slave the phase difference will be:

$$\phi = \frac{(S + r_A - r_B)}{\lambda} + k$$

where λ is the wavelength of the common frequency

The locus of the points at which $r_A - r_B$ are constant is a hyperbola focused on the two transmitting stations, which thus constitutes a navigational position line if the station locations are known. The principle is illustrated diagrammatically in Figs. 1 and 2 in which the concentric rings represent the the wavelengths of the common frequency and the pattern assumes the form of a set of stationary waves generated by the inter-action of the two signals. Repeating this arrangement for a second pair of stations provides a second pattern of hyperbolic position lines intersecting the first and hence provides a position fix. The monitoring constant k is generally zero. The effect of transmitting signals of equal frequency from the master and slave is achieved by assigning harmonically related values to the two frequencies, so that the multiplying circuits in the receiver can derive from each a common harmonic. Thus, the red hyperbolic pattern is the result of comparing the master and slave signals after multiplication to a common frequency of 24f, where f is a non-transmitted fundamental value of about 14kHz. The master transmits a signal of frequency 6f and the red slave 8f, the respective channels in the receiver being followed by x4 and x3 multiplier stages. Geometrically the system behaves as if the common frequency 24f (about 340kHz) were radiated from the two sites. The other two patterns are generated similarly with the comparison frequencies of 18f for the green pattern and 30f for the purple pattern.

Lane Identification

To provide an independent means of reducing the lane ambiguity, so that a user can set in or check the lane numbers when uncertain of his position to within a lane, each chain radiates lane identification signals three times a minute. For this purpose the chain transmissions are periodically interrupted and regrouped so that the receiver can extract a signal of frequency f from the master and from each slave. Comparing the phase of these signals generates a coarse hyperbolic pattern confocal with the fine one, such that one cycle of phase differences embraces 18 green, 24 red and 30 purple lanes. An additional phase difference display responds to the coarse pattern and gives periodic readings which indicate, in turn, the correct lane of each pattern within a known zone. For lane identification each station in turn, starting with the master, radiates all four Racal-Decca frequencies (5f, 6f, 8f, 9f) simultaneously in a phase-coherent relationship. In

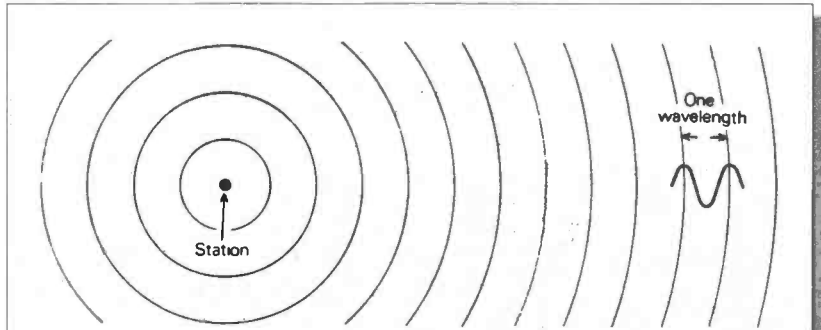

Fig.1 Continuous-wave transmission from a single station.

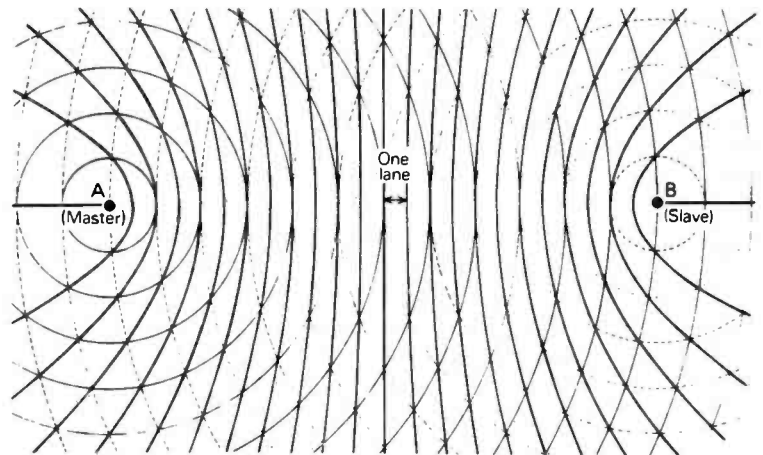

Fig.2 Position-line pattern generated by synchronised c.w. transmissions

the receiver, the four harmonics in each transmission are processed so as to derive a pulse train having the fundamental value of f, given means of memorising the master signal so that it can be compared with the successive slave, this reconstituted pulse signal forms the basis of the desired f-frequency coarse pattern. This lane identification process is known as the Multipulse.

Transmitting Stations

Each Racal-Decca Navigator transmitting station occupies a site of approximately 240m² and typically, comprises a centrally situated transmitting mast 100m high with an earth mat of 100 copper radials of equal length to the mast height. The transmitter building, diesel hut, fuel store and living accommodation where required are outside the earth mat perimeter with a trenched feeder cable run to the coil house located at the base of the mast. Modern master stations sometimes incorporate the chain control facilities and chain monitor, but this can be quite separate to suit local circumstances. Where countries have more than one Racal-Decca chain the current trend is to have just one central monitor and control station for all chains. This reduces the manpower requirements and annually recurring operational costs. All stations have standby systems for the phase control, transmitting and power equipments. Battery systems and diesel generators provide a no-break protection against mains failures. In terms of operational reliability measured over a 12 month period, Racal-Decca stations achieve an operating level of 99.95 per cent. At present there are 42 chains of Racal-Decca

Above. Continuous-wave transmission from a single station

Below. Position-line pattern generated by synchronised c.w. transmissions



The MK53 Decca Navigator which has been developed as a very reliable high performance receiver for the Fisherman and Professional Navigator

Navigator stations in 14 countries with over 140000 users, and this figure includes a large number of pleasure craft whose owners have come to appreciate the benefits of the system in the past few years.

Advancement With Technology

In line with all electronic systems the Racal-Decca Navigator has over the years, taken advantage of the rapid growth and development of the electronics industry. In the early days the ground station transmitting equipment was very large and needed extensive civil works to house the installation. All transmitter stations were attended by operators, a typical four station chain requiring up to 16 people. Due to the valve technology power requirements were heavy and expensive. In the mid-1950s a new development started, making use of solid state technology. Apart from reducing the size of the equipment and the buildings to house it, an important consideration was to find ways of reducing the number of operating staff. In the mid-1970s with the use of integrated circuits and the microprocessor, further developments were taking place to reduce the size of the two major elements, the phase control equipment and the transmitters. In so doing, the power requirements for the transmitter stations were further reduced. The size of buildings to house the latest type of equipment - referred to as the 5450 series - has been reduced by 60 percent. In areas where there are multiple chains it is possible to control the operation from one central point. A number of operating authorities are able to further reduce the cost of operating the chains by combining the resources of other marine departments.

First Users

Initially, it was the coasters of the Royal Navy Home Fleet which enjoyed the benefits of the Racal-Decca system. Then, as the system spread into Europe and other areas of the world, ferries, other merchant shipping and the fishing fleets joined the steadily increasing number of Racal-Decca fitted ships. At the end of the 1970s the first receivers incorporating microprocessor technology were developed. Modern sets process the received signals and display - virtually instantaneously - all the information that a mariner demands for safe and efficient navigation. Today the Racal-Decca

Navigator receiver market is very competitive, with many different models designed and marketed by several different European companies. Varying degrees of design sophistication are employed, aimed at different categories of vessels. Prices range from around £200 to £3000, and all now provide a computer calculated read-out of Latitude and Longitude with facilities for waypoint navigation.

Pilotage Aid.

Apart from its role in coastal navigation and fishing, Racal-Decca Navigator chains have been geographically located for the prime purpose of port-approach by very large oil tankers. An example of this application is at Europoort (Rotterdam) where the Holland chain forms an aid to pilotage for deep-draught tankers as well as contributing to the general coverage of the southern part of the North Sea. The carriage of a serviceable Racal-Decca receiver is mandatory at Europoort for all ships over a specific draught in the dredged channels. The across-track accuracy of the system for ships in the final approach channel is 11m by day and 22m at night at the 1 sigma level of probability. Other chains having a similar role are located at Dampier in Western Australia and the Gulf of Kutch in India (Salaya chain). As the Racal-Decca system is used by both ships and aircraft, it forms a common frame of positioning reference for air-sea rescue and other combined operations. The system is also used by many fixed-wing aircraft and by virtually all the helicopters operating in support of the off-shore oil activities in the North Sea. In Swedish waters it is employed for policing the off-shore fishing limits.

The Future

In spite of the availability of satellite-based Global Positioning Systems, it is not envisaged that the user demand for the Racal-Decca system will lessen as GPS receivers will be an order higher in price than Racal-Decca equipment. Another factor to be considered is that in large areas by day, the accuracy is as good if not better than standard (non-military) fix by GPS. Essentially GPS is a system designed and developed for military purposes and is fully controlled by one nation. Accordingly, other nations have already declared their intention to retain their own land-based systems for the very large number of fishing and small boat users. Marine radio-navigation in the United Kingdom waters is currently the subject of a Government Green Paper. Basically the choice lies between the Racal-Decca system or the American Loran-C system using the European stations for which the United States Navy will have no use once GPS is fully operational. Loran-C is a pulse system as compared with the Racal-Decca Navigator's use of continuous wave transmissions. Loran C requires the whole of the 90-110kHz band and begins transmission at 60kHz and finishes at 140kHz, although not authorised for this band. This is likely to cause problems of interference both to and from the Loran-C system in the already overcrowded European radio spectrum. If the decision is for Loran-C, it has been proposed that the UK Racal-Decca chains will be switched off in 1996-7. If the decision is to continue with the Racal-Decca system, then the UK chains will be updated in accordance with a proposal already in the hands of the Government. This will bring the UK into line with Denmark, Holland, Ireland and Sweden and will permit the Racal-Decca Navigator to provide a service well into the 21st Century. **PW**

GX-2 FAX SSTV TRANSCEIVE FOR THE BBC COMPUTER

Fantastic system supporting all modes of FAX and mono and colour SSTV. All facilities. Send for brochure. Complete system of EPROM, interface, leads, instructions only £99 or £119 with direct FAX printing option.

TX-3

RTTY / CW / ASCII TRANSCEIVE

Split-screen, type-ahead operation. Clock, review store, 24 large memories, call sign capture and much more. Needs TIF1 interface or T.U.

BBC-B/Master and CBM64 tape £20, disc £22
SPECTRUM tape £35, +3 disc £37 inc. adapter board (needs interface or T.U. also).
Also VIC20 RTTY/CW transceiver program £20.

RX-4

RTTY / CW / SSTV / AMTOR RECEIVE

This is still a best-selling program and it's easy to see why. Superb performance on 4 modes, switch modes at a keypress to catch all the action. Text and picture store with dump to screen, printer or tape/disc. Needs TIF1 interface. BBC-B/Master, CBM64 tape £25, disc £27. VIC20 tape £25. SPECTRUM tape £40, +3 disc £42 inc. adapter board (needs interface also). Spectrum software-only version (input to EAR socket) tape £25, +3 disc £27.

TIF1 INTERFACE Designed for TX-3 and RX-4 software only available with them. Kit 20 (assembled PCB + cables, connectors) or ready-made £40, boxed with all connections.

RX-8 FOR THE BBC COMPUTER FAX, HF and VHF PACKET, COLOUR SSTV, RTTY, CW, AMTOR, UoSAT, ASCII RECEIVE

Every possible feature and superb performance. Full printer and disc support. Send for our brochure or see review in Oct 89 Ham Radio Today.

Complete system of EPROM, interface, instructions, all leads and demo cassette £259.

BBC LOCATOR with UK, Europe, World maps £10,
MORSE TUTOR £6, LOGBOOK £8, LOCATOR £7,
RAE MATHS £9 for BBC, Spectrum, CBM64, VIC20,
Electron. BBC, CBM64 programs available on DISC at £2 extra.

Prices include VAT and p&p by return.



technical software (P.W.)

Fron, Upper Llandwrog, Caernarfon LL54 7RF

Tel: 0286 881886



Our very simple offer to hobbyists

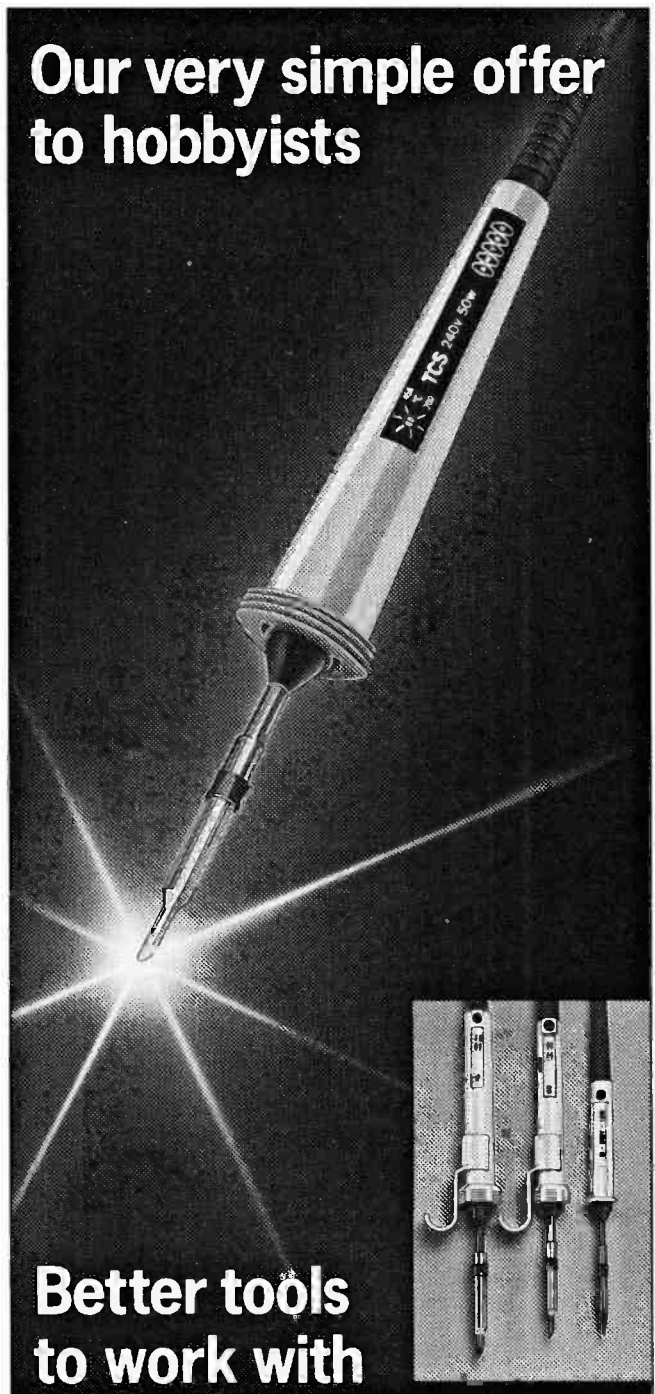

Better tools to work with

- **Antex TCS 240V 50W and TCS 24V 50W.**

- Temperature Controlled Soldering Irons for electronic and electrical applications – an essential item in the hobbyist's tool kit.

- Temperature range 200° to 450° C. Analogue proportional control ± 1%. Max. temperature achieved within 60 seconds.

PLUS

- **Antex M-12W; CS-17W; and XS-25W.** Available in 240 or 24 volt.

- Tools specially designed for fine precision soldering. **Ideal for all electronics craftsmen and hobbyists.**

For full information on the comprehensive Antex range of soldering irons, power supply units and accessories, please clip the coupon.



Antex (Electronics) Limited, 2 Westbridge Industrial Estate, Tavistock, Devon PL19 8DE. Tel: 0822 613565. Fax: 0822 617598. Telex: 9312110595 AE G. Please send me full details of the full range of Antex soldering products.

Name _____

Address _____

Postcode _____ (PW 2)

GAREX ELECTRONICS

WEATHER SATELLITE SYSTEMS

SPECTACULAR NEW ATARI ANIMATED SYSTEM

Garex are proud to announce that they are the first appointed dealer for this incredible new Timestep product. Following on from Timestep's phenomenal success in the education market a special low cost Atari ST version of their animation system is now available. Simply plug in your existing receiver to view amazing pictures. For the ultimate, add a Meteosat receiver for unbelievably smooth 14 frame animation that is completely automatic once set up. Just watch the clouds roll by! New pictures are added twice an hour if required, the oldest being discarded automatically. This sophisticated package will run on any Atari ST1040 and compatible colour monitor, comes complete with all software and colour-keyed Atari interface unit.

£299.00

Optional 16 grey scale adaptor for colour monitor

£24.95

For those who would like a one-stop-shop, we offer the complete package of a ready-to-run system:

Meteosat Dish and receiver, Atari interface unit, Grey scale adaptor, 14in Colour Monitor, Atari ST1040 computer, software (including demo-disc) AND, OF COURSE, ALL PLUGS AND CABLES.

On your doorstep £1,695.00

NEW COMMODORE "AMIGA" INTERFACE AND SOFTWARE

Superb high resolution pictures 600 pixels x 400 lines. Compatible with "PIXmate" THE fully featured image processing program.

£299.00

COMPACT FRAME STORE SYSTEM

The basic MICROWAVE METEOSAT system, no complications, a complete plug in and go package requires no computer, no software, and can be up and running, including dish alignment within 10 minutes. Nothing more to buy: Dish, Microwave Receiver, Frame Store, 12in b/w Monitor AND ALL PLUGS AND CABLES. Designed by Timestep, supplied by Garex

£995.95

SATELLITE ACCESSORIES

Meteosat Receiver, Dish input and 2 watt audio output £270.25
 Meteosat Preamp, 15dB gain 0.6dB noise figure GaAs FET £92.00
 NOAA 10 channel VHF Receiver £155.25
 NOAA BASIC Turnstile antenna £34.95
 NOAA BASIC Preamp, 3 pole filter, boxed, 14dB gain £24.95

SAE for full details and prices of other 'separates'

★ ★ ★ ★

GAREX VHF RECEIVERS

★ A simple but versatile design capable of covering spot frequencies in the range 25-200MHz.

★ Excellent sensitivity (typically 0.4uV for 12dB SINAD)
 ★ Double superhet (10.7MHz and 455kHz IFs)
 ★ Choice of IF bandwidths from "W-SAT" to "12.5kHz" PMR standards.
 ★ The basic receiver is single channel crystal controlled.
 ★ Multichannel option.

★ 2 watt audio output stage having a low quiescent current.

★ Size: 153 x 33 x 13mm ★ Requires 10-14V DC supply

PRICES Stock Versions: (fully assembled, aligned and tested boards) 6m, 4m, 2m and weather sat £49.95

Crystals extra, prices on request.

★ Mains power supply module £15.50

Other frequencies, special options, cased versions POA

GAREX VHF PREAMPLIFIERS

★ MINIATURE — GENERAL PURPOSE ★

★ Compact size: 34 x 9 x 15mm ★ Up to 26dB gain

★ Can be made for any frequency in the range 40-200MHz

★ 3dB bandwidth ±3MHz (at 145MHz) ★ Low noise

★ Input and output impedance 50 ohms

★ 1dB compression ±10dBm ★ Saturated output +15dBm

★ Supply voltage 8-17V DC at 5-10mA

Stock Versions (fully assembled, aligned and tested boards) 6m, 4m, 2m and Weather Sat £11.45

Airband 118-136MHz (reduced gain) £11.45

Other frequencies in the range 40-200MHz £13.75

★ HIGH PERFORMANCE ★ 2 metre PRE-AMPLIFIER

★ 3 band-pass stages for improved selectivity

★ 16dB gain with 1dB NF ★ Switches 35 watts

★ RF switched (fail-safe action): gas-filled relays

Assembled, tested pcb £42.50

Boxed version £49.95

Gas-filled Relays as used in pre-amp £4.95

MAIN DISTRIBUTORS FOR REVCO ELECTRONICS LTD

Prices include UK P&P and 15% VAT
 Ask for details of our interest Free Credit

GAREX ELECTRONICS

HARROW HOUSE, AKEMAN STREET, TRING HP23 6AA

TEL: TRING (044282) 8580

and CHEDDINGTON (0296) 668684

Callers by appointment only



0202 665524

VIDEO FILM MAKING

0202 665524

by Keith Brooks

First published in 1985, this 176-page book describes how video film making is done and what you can do yourself. Practical step-by-step instructions are given for making your own films.

Originally £9.95 our bargain price is just £2.95 including P&P.

SATELLITE TV — A LAYMANS GUIDE

by Peter Pearson

This book, first published in 1987, explains all about setting up your own satellite TV terminal at home. Originally sold at £4.95 it can be yours for just £1.50 including P&P.

Send your orders to:

PW Publishing Ltd. FREEPOST, Enefco House, The Quay, Poole, Dorset B15 1PP

MERLIN

MERLIN WAY, BOWERHILL, MELKSHAM, WILTSHIRE SN12 6TJ. Tel: 0225 706886. Fax: 0225 708594

SYSTEMS

WIZARDS PACKS

THIS MONTH'S WIZARDRY THE WIZARD PRECISION FILTER

240 volts AC, 13 amps input, 4 off IEC 6 amp sockets output, On/Off switch, Precision Potter block RFI filter, VDR, Mains lead and Plug, Merlin made case and built and tested.

This filter helps to remove your RF from the house wiring.

Price £27.48 VAT Paid P&P £3.00

The WIZARD'S best 13.8 volt PSU kit so project

In the kit: Pre built PCB, Super Mains Transformer, 3 inch Cube Heatsink, 60000uf Electrolytic, 25amp Bridge Rectifier, 12V DC Fan, Mains Filter, Overvolt Relay, LED Indicators, Amp Meter, Fuse Holders, Terminals and On/Off Switch.

This PSU has an output of 8amps and 8 to 18amps intermittent. With a full set of data sheets.

Price £33.80 + £4.50 P&P

LINEAR AMPLIFIER BUILDERS

8 off 220uF 400V Electrolytics with mounting clips

Price £15.00 post paid

Printed Circuit Permanent Magnet Motor/Generator with toothed belt reduction drive. Input/Output 2VDC to 30VDC at upto 10Amps. Price £14.00 + £3.50 P&P.

New in Controller Card for the above and others Input power + and - opto 50VDC. This will give a single 5k ohm pot variable speed forward and reverse. Price £7.50 + £2.50 P&P.

COMPRESSORS—Gas rotary air/vacuum pump 20psi/29invac. 1/12th HP 240Vac motor. Good for Oesoldring/Airbrush work. Just £17.00 + £3.00 P&P.

IN THE WIZARDS DEN!—We have from time to time the following new and S/H stock. Printers, Monitors mono/colour. Valve amps and PSUs. Lots of odds and ends.

MORE DATA—Ring the wizard on 0225 706886 (Day time) 0225 763027 (Home). For more information or for a visit to the works.

PAYMENT—Access, Cheque, PO and Cash Post and Packing on components £1.50, over £20.00 £1.00. Please add VAT to total.

Thank you John and Adrian the Sorcerers Apprentice!

We would like to thank all our new customers of 1989 for their support. By the way if you have a project you would like to be manufactured, we are always on the lookout for new Wizardry.

Sorry for the delay over the list, but we have put all our stock on computers and this has taken time. This is the Wizards worst enemy!

WELL A HAPPY CHRISTMAS AND ALL THE BEST IN 1990 FROM JOHN THE WIZARD

By the way if you would like to see our Kits and Packs in 1990. We cover just about all the UK at Rallies and Exhibitions, if you would like a list of these, just give me a ring!

Stormo Mobile Radio Telephone

Type 634

68-88 MHz

±2.5 kHz Channel Spacing

±2.5 kHz Deviation

Max Bandwidth 1000 kHz

RF Output Power 10 watts

Mod FM

Sensitivity 0.7uV

12 Volt or 24V Input DC with Control Gear and Data

OK for 4 mt.

Price £25.00 + £5.00 P&P

THE WIZARD POWER CUBE

Specification

- 1 20 Amp Hour Dryfit Battery
- 2 Inbuilt Mains Charger
- 3 RF Filtered
- 4 Solar Cell Input (Cells optional)
- 5 Compact Size/Portable
- 6 Merlin Made

Price £76.00 + P&P £8.00

REVIEWS

The Omni-V amateur bands transceiver from Ten-Tec is the latest release from this famous stable and represents the flag-ship of the range. The Omni-V maintains Ten-Tec's very individual styling and includes a whole host of features to enable effective operation on the amateur bands, Mike Richards G4WNC checks it out.



Ten-Tec Omni-V VHF Transceiver

In addition to the Omni-V which is actually called a Model 562, HRS Electronics, the UK agents also supplied the matching combined power supply and extension speaker.

The manual was my first stop, in order to familiarise myself with the connections and basic operation. The manual was presented in a stiff backed A4 ring file making it comparatively easy to add your own notes or associated information. The only slight problem was that the file used a three hole system which is non-standard - at least in the UK.

The content of the manual was actually very good, striking a fine balance between too much and too little detail. Some of the more complex operations were well explained using simple diagrams and the whole manual was very concise.

In addition to the operational aspect of the Omni-V the manual contained a full set of circuit diagrams and circuit board layouts which were spread over some pages. This is obviously of particular value as a transceiver ages and repairs may be required. Diagrams are also useful for those technically competent amateurs who want to undertake their own modifications to add extra features, etc.

The basic connections were simplified somewhat by the use of the Ten-Tec power unit which came complete with a four-way plug fitted, allowing direct connection to the power socket at the rear of the Omni-V. The plug used was a four-pin-in-line type and a spare plug was provided with the rig, so other power units could be easily used if required.

The antenna connection came next and this was the now standard SO-239 with a nominal impedance of 50Ω.

The supplied microphone used an electret element and connected to the Omni-V via a standard four pin microphone socket on the front panel.

For phone operation that was the full extent of the required connections. As you would expect from a top of the range model there were a number of additional connections to allow the operator access to the full range of facilities.

A separate receive antenna could be connected to a phono socket on the rear panel which could also

be used to accept the output of a v.h.f. or u.h.f. transverter when combined with transverter-out and transverter-enable sockets. The application of the transverter enable signal provides a 0dBm transmit carrier output and disables the main r.f. power amplifier.

The p.t.t. output was slightly unusual in that it was only operational on the phone modes - c.w. being entirely controlled by the key with a separate key jack for RTTY. Also connected with RTTY operation was a MARK/SPACE input which was used to key the Omni-V when operating true f.s.k. The signal levels required for this operation were 0 to -15V for a mark and +2.5V to +15V for a space. With most RTTY and packet operators using a.f.s.k. these days the audio in and out sockets on the rear panel will prove very useful. The audio out provides a line-level audio signal which is independent of the volume control setting, whilst the audio in will accept signals from the tone generator of the terminal unit/TNC.

CW operation was catered for by a standard 6.3mm key jack on the rear panel which was compatible with positive open collector keyer outputs as well as conventional keys.

The remaining two connections were for an external speaker and an unfused 13.8V output for powering auxiliary equipment such as a RTTY terminal unit or perhaps a Packet TNC.

Operation

Despite the wide range of features provided in the Omni-V, operation was very simple and the clear panel markings made the control functions obvious. This is one of those rare items of amateur radio equipment that you can operate quite happily without having to wade through the manual first!

The front panel was dominated by the large tuning knob and the main display unit. The tuning options provided were very straightforward, but also extremely effective. As the Omni-V was amateur bands only, the first job was to select the required band was achieved by a single press of the appropriate band selection button. Each band was

REVIEW

allocated its own button, with the exception of 28MHz where the band was divided into four 500kHz segments each with a separate buttons. However, once a segment had been selected you could tune across the whole 2MHz band without having to manually select the next segment.

The tuning control was of the digital shaft encoder type, so the frequency changed in steps rather than being continuously variable. However, the feel of the tuning knob was very smooth and very nicely weighted. The size of the tuning steps was dependent on the mode and the speed that the knob was turned. For all modes except f.m. the steps were 10Hz for normal tuning and 50Hz if the knob was turned quickly. On f.m. this changed to 100Hz and 500Hz respectively. For an even coarser tuning rate the FAST key could be pressed to give 500Hz steps on f.m. and 50Hz or 100Hz on the other modes.

The Omni-V was equipped with dual v.f.o.s to enable split frequency operation between any two bands or parts of bands. This aspect was well thought out and you could very quickly swap transmit and receive frequencies if necessary.

In addition to the tuning knob, there were a pair of buttons marked with up and down arrows which could be used to step the frequency either up or down in 10kHz or 30kHz steps, depending on whether or not the FAST button had been pressed. This was a useful facility for moving about the band quickly.

As with most modern transceivers the Omni-V featured a number of memories for storing both mode and operating frequencies for later recall. There are a total of twenty-five standard memories and one scratch-pad memory.

The standard memories were slightly unusual, mainly because the Omni-V lacked the usual direct entry keypad. This meant that frequencies to be stored in memory first had to be tuned in using one of the two v.f.o.s. Actually storing the frequency and mode was extremely simple, with the microprocessor automatically selecting the next free memory, as opposed to some systems where you have to decide the memory number to use. If all the memories are full you get a warning so you can decide either to abandon the operation or to clear one of the existing memories. The method of recalling memories was also slightly unusual as the main tuning knob was used to select the memories after first pressing the MT button on the front panel. The only disadvantage with the Omni-V's memory system was that there was no indication of a memory channel number. Consequently you couldn't turn to specific memory number you had to search for the frequency you wanted.

The scratch-pad memory was a very useful addition and was used, as the name implies as a temporary store - ideal for storing a working frequency when you want to look around for a quieter one, etc.

As you would expect, all the memories were protected by a battery back-up system using a 3V lithium battery. According to the manufacturers this battery should last about two years.

Incidentally, the manual described a technique for changing the back-up battery without losing the contents of the memory, which was useful.

Moving on to the audio sections, the Omni-V was very well equipped with features to tailor the audio response. The first was a conventional tone control, which was mounted concentrically with the volume control. There was also a tunable notch filter which could be used to reject interfering whistles.

One rather novel and extremely useful feature was the variable band-pass filter. This was controlled by two concentrically mounted knobs. The band-pass filter itself has a centre frequency variable between 220Hz and 1700Hz with a -6dB point of 35% of the centre frequency. By using the FADE control the audio response could be varied between flat and full band-pass - an unusual, but very useful feature.

Impulsive noise is often a problem and the Omni-V tackles this with an excellent noise blanker. Rather than operating with the fixed parameters, as is common with many receivers these days, the Omni-V features a variable width control which alters the width of the blanking pulse. This gives a very wide control range for the noise blanker.

Other receive facilities included Pass Band Tuning (p.b.t.), r.f. gain, attenuator, squelch and a.g.c. operation.

The transmit side of the Omni-V featured a fairly standard range of facilities for a modern transceiver. A fully adjustable r.f. speech processor was provided - very useful when operating under difficult conditions.

An unusual facility was the ability to select either a fast or slow recovery of the receiver when changing over from transmit to receive. The fast position provided full break-in on c.w.

The indication systems used in the Omni-V comprised the main frequency and mode display which was of the fluorescent type with usefully large 15mm digits. A conventional back-lit analogue meter was provided as a multipurpose indicator for signal strength on receive and forward power, reflected power, Ic or processing level on transmit.

Mounted on the rear panel were several pre-set controls for varying a number of of the Omni-V's parameters.

The c.w. side tone could be varied both in level and pitch which was rather novel. An interesting extra was the facility to monitor the transmit audio after the processor. This audio signal was fed into the audio stages of the receiver, the level being controlled by a pre-set on the rear panel. Of course, you really need to monitor this signal using headphones in order to avoid problems with acoustic feedback. Its main use is when sending SSTV, RTTY, etc., using tones via the mic input where the monitor facility can be used very effectively as a basic check of the modulation quality.

These days it seems as though it is essential to accompany any key press with some sort of sound, usually a beep! The Omni-V included this feature but the subtle difference being that the level could be adjust to suit the operators preference - right down to my preferred option, silent!

Voice Operated Switching (VOX) was also provided with the delay, gain and anti-vox pre-sets on the rear panel.

The i.f. filtering options were very versatile with a 2.4kHz filter being provided as standard. In addition you could have 1.8kHz, 500Hz and 250Hz installed along with an extra 6.3MHz filter on the 2nd i.f. for tightening the response even further.

Technical Performance

Due to the tight time scales for this review I was only able to make a brief visit to the Lab, but nevertheless the results were worthwhile.

I started with transmit side of the Omni-V and a check of the r.f. power output. This exceeded the specified 100 watts at all frequencies, with a maximum of 110 watts and a minimum of 106

REVIEW

watts. The spurious outputs were also well controlled at -56dBc. The three main pairs of spurious signals occurred at +-400kHz, +-1MHz and +-4MHz from the centre frequency. All other characteristics of the transmitted signal were well within the specification.

The specification stated that the Omni-V p.a. could stand 100% duty cycle operation for up to 20 minutes. This was tried successfully though, on completion, the heatsink was hot enough to cause a burn, so if you are likely to use high duty cycles it would be advisable to use some additional cooling, i.e. a fan!

The receiver sensitivity was quoted as .15µV for 10dB signal to noise on all bands. I found that the review model strayed from this on five of the ten bands though I ought to qualify this as the signal to noise measurement quoted is a difficult one to reproduce and I generally prefer to use SINAD wherever possible. The worst band was 10MHz where the sensitivity was .29µV for 10dB S/N, whilst the best performance was achieved on 3.5MHz, where the sensitivity reached an excellent 0.13µV again for 10dB S/N. That represents a range of some 7dB, which is rather more than I would have liked to see, but may be indicative of the hard treatment the review model had suffered.

The i.f. and image rejection was excellent as was the quoted third order intercept point at +12dBm. I ought to stress that I didn't have time to measure these particular parameters.

The main filter bandwidth was very well controlled and easily fell within the published specification.

The audio output at 1.5 watts was a little on the low side but shouldn't present any problems, especially as the distortion at 2% was low for a communications receiver.

Under the Bonnet

At this point I hit a problem in that section six of the manual was missing this comprised about 100 pages of circuit diagrams p.c.b. layouts and circuit descriptions, i.e. all the information I needed. However, thanks to the UK agents, HRS Electronics, I did manage to get my hands on a block diagram in time for the review.

Starting from the antenna and looking at the receive direction first. The signal passes through a set of seven switched low pass filters, which were common to both transmit and receive, before encountering the trans/receive switching. The signal is then fed to the first mixer via nine diode switched tuned circuits. The first i.f. was the standard 9MHz and the first receive filter had a bandwidth of 15kHz. This first i.f. board was also used to generate the s.s.b. signal for transmission and included an a.l.c. function. The main selectivity was also provided at 9MHz, with a 2.4kHz 8-pole crystal filter. An unusual facility was the provision of an option slot for an additional filter which is cascaded with the main filter. The object being to narrow the overall bandwidth even further.

The second and final i.f. for all modes except f.m. was 6.3MHz and it was here that the pass-band tuning facility was applied. There was also an additional 2.4kHz filter and the provision for three optional filters with bandwidths of 1.8kHz, 500Hz and 250Hz. The signal was then demodulated and filtered on the main audio board.

If the optional n.b.f.m. adaptor is fitted a third i.f. of 455kHz is introduced.

The transmit signal generation is quite straight forward with the basic signal generated at 9MHz and modulated up to the required frequency using the same local oscillator as the receiver. Final

Specifications	
Frequency Range	All amateur bands from 1.8MHz to 30MHz in 500kHz segments, plus 30kHz overshoot.
Stability	1 p.p.m. per degree C at 29.999MHz.
Accuracy	100Hz @ 25 C
Power Requirement	13.8V d.c. at 20A max
Modes	u.s.b., l.s.b., c.w., RTTY (f.s.k. & a.f.s.k.) Optional f.m.
Transmitter	
RF Output	25 watts to 100 watts
Carrier Suppression	60dB typical
Unwanted Sideband Suppression	60dB typical with 1.5kHz tone.
Spurious Output	>45dB below peak power output.
FSK Shift	170Hz
Receiver	
Sensitivity	0.15µV for 10dB S:N (s.s.b., c.w. & RTTY) 0.3µV for 12dB SINAD f.m.
Selectivity	2.4kHz -6dB or optionally 1.8kHz, 0.5kHz or 0.25kHz
I.F.s	1st 9MHz, 2nd 6.3MHz 3rd 455kHz f.m. only
Image Rejection	> 60dB
I.F. Rejection	> 60dB
Dynamic Range	97dB typical
Third order Intercept	+12dBm
Pass-band Tuning	1.2kHz
Audio Output	1.5 watts in 8Ω
Notch Filter	250Hz to 2.2kHz 50dB notch
Tone Control	15dB roll-off at 5kHz
Dimensions	
	146mm high 374mm wide 432mm deep
Weight	7.25kg

DEWSBURY



ELECTRONICS



wavecom W 4010

professional-grade, high-performance data communications decoder/analyser, yet easy to use and at an affordable price:

- decodes Morse code, standard baudot, bit-inversion, arq, fec, ASCII, packet radio and variable speed baudot and ASCII
- for professional users, 14 additional commercial data communications modes are available plus fax
- measures baud rates with high accuracy and makes synchronous and asynchronous bit analysis
- led-bar indication for tuning
- hard-and software additions and upgrade capabilities
- built in f7-b (f6) decoder
- universal microprocessor video card (24 lines × 80 characters or 18 lines × 40 characters)
- extensive rfi-filtering on all lines
- 5 int. language sets, including Cyrillic, Greek
- RS-232c/v. 24 serial port, Centronics parallel port
- optimal customer's support due to in-home r+d and 1 year warranty

PRICES FROM **£942.00** inc. V.A.T.

FOR DETAILS OF THIS AND OTHER DECODERS PLEASE SEND S.A.E.

WE ARE STOCKISTS OF POCOM — JRC — TAR — DAIWA — MICROWAVE MODULES — BNOS — LOWE
— STAR MASTERKEY — WAVECOM — VIBROPLEX — KENWOOD

Dewsbury Electronics, 176 Lower High Street, Stourbridge, West Midlands DY8 1TG

Telephone: Stourbridge (0384) 390063/371228

Fax: (0384) 371228

Instant finance available subject to status. Written details on request.



DEWSBURY



ELECTRONICS

From the makers of the world renowned STAR MASTERKEY a new MORSE KEYBOARD.

Send perfect morse as easily as typing a letter. It has never been as easy to send morse.

Variable transmission. Speed 1-99 wpm or 100-200-300-400 wpm for Meteor Scat operation.



£199.95
INC VAT
P&P £5

4 Message Memories each of 255 characters.
26 scratch pad memories each of 127 characters.
All memories stored on non volatile Ram. Messages stored for up to 5 years.

Indication of speed on 7 segment display.

Indication of operating mode on leds. Sidetone and relay output for all types of transmitter.

Full QWERTY keyboard with real keys.

Metal cased for RF immunity.



STAR MASTERKEY CMOS MEMORY KEYSER
8 MEMORIES, BEACON MODE, DIRECT & GRID BLOCK KEYING. FULL DETAILS IN PREVIOUS ADS. STILL ONLY **£95.00**

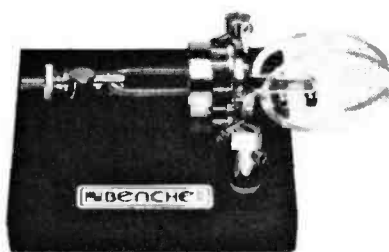

STAR MASTERKEY MKII
DOT-DASH MEMORIES IAMBIC OR SIDE SWIPE, SEMI AUTOMATIC MODE, 12 VOLT OR INTERNAL BATTERY. **PRICE £54.70**

FULL RANGE OF BENCHER KEYS

POST, PACKING AND INSURANCE ON EITHER KEYSER £3.00

FULL RANGE OF KENWOOD PRODUCTS STOCKED

We are also stockists of DAIWA — POCOM — JRC — TAR — WAVECOM — VIBROPLEX — MICROWAVE MODULES — B.N.O.S.

Dewsbury Electronics, 176 Lower High Street, Stourbridge, West Midlands DY8 1TG

Telephone: Stourbridge (0384) 390063/371228

Fax: (0384) 371228



Instant finance available subject to status. Written details on request.



REVIEW

amplification was achieved by an all solid state transmit amplifier chain.

The local oscillator used phase locked loop and mixing principles with the output well filtered by a bank of diode-switched filters.

On The Air

This is the area that really matters and one where the Omni-V fared very well. The antenna used throughout the review was my own nest of dipoles which have been cut for optimum performance in the RTTY segments of each band, i.e. between c.w. and phone. For all the tests I used the supplied fist microphone and Ten-Tec power unit.

Phone operation was tried first and on the weekend in question there was a contest running on h.f. (isn't there always!). Tuning-up was very simple thanks to the provision of the TUNE button which when depressed put the Omni-V into transmit with a carrier up. The a.t.u. could then be used if necessary to improve the match between antenna and transceiver. The panel meter when set to indicate reflected power was very responsive giving a clear indication of the ideal matching point. The Omni-V p.a. stage and a.l.c. were also very tolerant of mismatched loads with a current demand exceeding 20A being the criteria for reducing the drive level. Another feature I found extremely helpful was a small l.e.d. that was mounted adjacent to the MIC control. This indicated when the a.l.c. circuit was operating and could be used very effectively to set the optimum mic drive level. You simply adjusted the mic level so that the l.e.d. just lit on voice peaks. The transmitted audio quality was very good, being a fine balance between that required for communications under difficult conditions and the fuller quality preferred for local 'rag chewing'. I received a number of complimentary comments on the quality to back this up. Whilst working the contest I managed to achieve a high number of first time successes despite the fact that I was competing with high power stations using beam antennas. The message was also copied first time virtually every time, again confirming that the communications quality was good.

The speech processor was also very easy to use and very effective, though as with all processors it was important to avoid the temptation to over-process. Adjustment of the processing level was achieved by switching the the panel meter to the process option where the level of processing was clearly displayed. The technique then being to adjust the processor level so that the meter indication stayed within a black band on the meter scale. The fast response of the meter was particularly useful here to catch speech peaks. The on-air reports confirmed that when properly adjusted the processor added a very useful extra punch to the signal.

On the receive side the audio quality was excellent and the audio filtering facilities gave the operator a very wide range of control. The notch filter was extremely narrow with an impressively deep notch. This did however, create a problem as it required very careful tuning, particularly if you were trying to notch out a c.w. signal, as you could easily tune through the notch and not notice it. The variable band-pass filter was something I had not tried before on a communications receiver, but after some practice, I found it to be very useful for minimising the effects of an assortment of interfering signals.

One area that I was slightly uncomfortable with was the a.g.c. characteristics. This could be switched between fast and slow, whilst I thought the fast position as excellent, the slow was still too fast for my liking as it allowed recovery in natural voice breaks, thus allowing the QRM to rise. This may only be a personal preference so may be perfectly acceptable to many users. The other point that could be a little irritating was the a.g.c. pumping which became apparent when operating on a quiet band, though once again this is down to personal taste.

The VOX was slightly unusual in that the p.t.t. had to be pressed before it was activated. At first I thought this was a bit of a chore but of course it did have the advantage of preventing accidental transmissions which are so easy with some systems.

The lack of an r.i.t. control took a little getting used to, but was quite easily overcome using split frequency operation with one v.f.o. for transmit and the other for receive which could be used as the r.i.t.

Memory operation was also slightly different from many modern rigs, but it didn't cause any problems once I had familiarised myself with the operation.

Moving on to c.w., the Omni-V was exceptional, with true break-in available - you could even hear through the inter-dot pause quite comfortably. The filtering options were also very effective, especially when using the 250Hz filter with the narrow option activated. I spent quite some time operating c.w. and the Omni-V certainly rates as one of the best c.w. rigs I have encountered.

RTTY operators have the option to use true f.s.k., though the slightly odd voltage levels required for the keyer mean that operators may have to slightly modify their equipment. The other snag, for operation on this side of the Atlantic, is the receive tones used, which were the American standard of 2125Hz and 2295Hz. This is not serious however as most RTTY operators seem to use audio f.s.k. by applying tones to the mic socket and this is fine with the Omni-V. Packet and other data modes can also be operated with the Omni-V using this technique.

The only mode I couldn't evaluate was the optional f.m. as this was not fitted to the review model.

PW

Summary

The overall performance of the Omni-V was very impressive and it is likely to appeal to the serious amateur. The styling was very individual and perhaps a little old fashioned, but the facilities provided were well thought out and very effective. None of the odd shortcomings I found were serious and the build quality was very good.

Overall then, the Omni-V is a very competent transceiver which I can thoroughly recommend for the serious amateur.

The Model 562 Omni-V is available from **KW Communications Ltd., Communications Centre, Chatham Road, Sandling, Near Maidstone, Kent ME14 3AY. Tel: (0622) 692773.**

Price £1900.18(inc. VAT).

My thanks to HRS Electronics, the UK agents, for the loan of the review model.



**MICRO
N
T
A**

High Technology Test Equipment

30-Range Digital Multimeter

£69⁹⁵

Features front-panel socket for transistor and capacitor tests. Low battery indicator, diode check function and continuity sounder. Measures to 1000 VDC, 750 VAC, 10 amps AC/DC current, 20 megohms resistance. 20 μ F capacitance and transistor gain. Requires 9v battery . 22-194

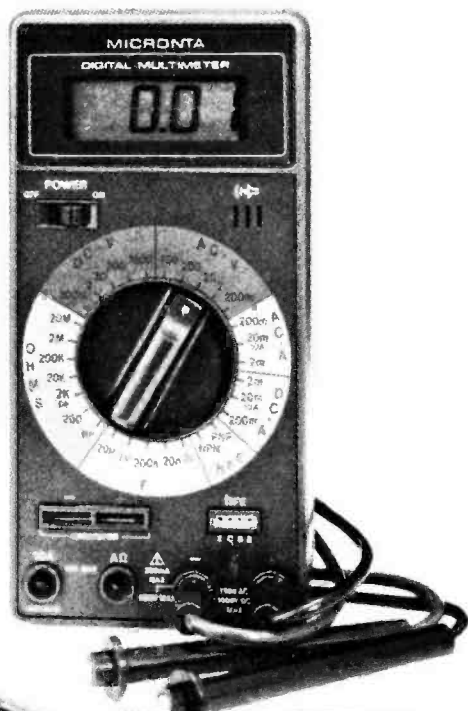

Probe Style Autoranging Multimeter



£29⁹⁵

Data hold function enables you to freeze the display and to remove it from the circuit for more convenient reading. Measures to 400 volts AC/DC and resistance in K-ohms up to 2 megohms. Includes 2 button batteries. Overload protected. With carrying case 22-165

Regulated Power Supply

£59⁹⁵



13.8 VDC Regulated Supply. Ideal for use with HAM transceivers. 5A continuous. 12A intermittent. 15A surge. 240 VAC, 50 Hz. Fused 22-7001

Tandy®

For The Best In High Quality Electronics

Over 400 Tandy Stores And Dealerships Nationwide. See Yellow Pages For Address Of Store Nearest You.

InterTAN U.K. Ltd., Tandy Centre, Leamore Lane, Walsall, West Midlands, WS2 7PS. Tel: 0922 710000

RF Interference from Vehicle Engines

With reports coming in from friends who had bought new cars, B.A. Berry is convinced there is a new style 'gremlin' in the world of mobile radio. It is due entirely to the current craze for a greater use of electronics in the car.



Major Problems!

Electronic devices, fitted in cars to reduce petrol consumption and add reliability, also bring problems with them. Not least of these is the difficulty facing the home mechanic when it comes to fault finding under the bonnet.

I came across this problem when a friend brought his car round to me in desperation. He is a radio amateur and, naturally, wished to install his 144MHz rig in the car, together with an h.f. rig for use on holiday. He has installed rigs in most cars that he has had over the years and has experienced no troubles in the past. He was well aware of the need for suppressing the ignition, charging circuits and wipers but, in this instance, although all normal precautions had been taken, he really had a problem. Two problems in fact.

The Problems

Problem number one concerned the 144MHz band rig. Receiving was fine, it was on transmit that things got out of hand. First, if he was using the indicators whilst speaking, the flashing rate speeded up so much that the indicators appeared to be on almost continuously. Secondly, the engine revs dropped! Of course, he wasn't at all happy with this, for although it was all very well and good to avoid use of the transmitter during a turn, it was definitely not on to have the engine revs dropping when driving on a straight road whilst conducting a QSO.

Problem number two occurred when transmitting with the h.f. rig. In this case the engine actually cut out completely when transmitting - which was, of course, extremely dangerous.

The Modern Car

Not owning owning a new car, I wasn't aware until I took a look under his car bonnet just how far

the craze for electronic control had spread. As an instrumentation technician by trade, I was well versed in electronic instrumentation in industrial plant - but to find, for example, a stepper motor on the carburettor was quite a shock. Knowing as I did that where there were stepper motors, a computer would not be far away I set off to find it. I eventually traced it, hidden under the dash. It was obviously receiving and processing information from six or seven sensors located in various parts of the engine compartment.

During my initial inspection, prior to an attempt at diagnosing the cause of the problems, I took a quick look at the indicator unit. Fortunately it was one whose outer case was removable. On looking inside, where I'd expected to find the old bi-metal strip, there were three or four transistors and a relay! Fine I thought. A flip-flop is definitely an improvement on the electro-mechanical version, but the outer case of the unit was plastics. Now, the cause of my friend's problem began to dawn on me.

Diagnosis & Cure

First the 144MHz band rig. Deciding to tackle the simple problem first, I started on the indicators. It was pretty certain that r.f. was getting back into the indicator unit - but from where? It couldn't have been direct radiation from the antenna, since the car formed a virtual screen around the unit. Not only that, the output of the 144MHz band rig was only 2W. The connections to the antenna were well made and it was well matched. So I turned my attention to the power cabling to the rig, which was located on the drivers side, under the dash. The power cables from the rig to the battery ran through the firewall directly behind the rig, and thence to the battery. As far as I could see, any radiation affecting the indicator unit must have been coming via these

Always a difficult thing to get rid of!



cables, since they travelled within 150mm of it. Accordingly I did a quick test by pulling and temporarily re-routing the cables away from the unit.

A transmission test showed that this was indeed the case, although the frequency of the indicators still changed, the rate of change had now diminished considerably. I was, I must admit, surprised to have my diagnosis confirmed, since I had assumed that any reasonable rig would have had r.f. filtering already on the supply lines. At the same time I was aware that it could have been a case of r.f. feedback, which is always a difficult thing to get rid of. But since there were no other indications of this I decided to go ahead with a major re-routing of the cables. The end result was that only a very small amount of interference with the indicators was now noticeable. I had previously noted that there was plenty of space inside the indicator unit itself and so I next decoupled each of the 'live' sides of the indicator unit down to earth with a couple of 10nF capacitors mounted inside the unit. This completely cleared up the problem. The re-routing of the cables also cleared up the engine revolution change and left only the question of the h.f. rig to resolve.

The HF Rig

This time conditions were rather different. The h.f. rig no longer affected the indicators, but the engine still stopped. Clearly, with the greater power of the h.f. rig something more was needed. As far as I could see the problem was occurring as a result of induction into the pick-up coil which has replaced the points and other distribution components. In view of the fact that we were now dealing with 100W of r.f., it was within the bounds of possibility that it could have been direct radiation into the engine compartment. The first action to take was to ensure that the engine compartment was as effectively screened as possible. A common problem in this respect is the hinge where the bonnet joins the chassis. Often oxidation takes place here, effectively insulating the bonnet from the rest of the chassis. The cure is simply to wire some flexible heavy duty earthing strap from the

bonnet top to the nearest point on the chassis. The next question to be settled was whether re-routing of the power cables would help. It did. Re-routing didn't completely solve the problem; the engine no longer stopped, but it still mis-fired on transmit. Obviously some other precautions were going to have to be taken. In the end, rather than attempt to modify the rig, an external filter was constructed and placed close up to the rig in each of the supply lines. Each filter consisted of winding about 20 turns of the supply lead around a 130mm length of 16mm ferrite rod, close to the point where the lead left the rig. This completely cured the problem. It is a moot point as to whether such a filter would have been needed in the negative or earth line, had it been connected to chassis near the rig, but in this instance the negative line went right back to the battery, so it was considered essential.

Conclusions

The computer itself, although also in a plastic case, seemed to be completely unaffected by r.f. However, careful thought will reveal that actual engine failure in the form of a mis-fire does not necessarily have to occur. A burst of r.f. could affect the computer in such a way, that far from ensuring maximum efficiency and economy, a drop in performance in these areas could occur for some considerable time without the driver becoming aware of it. Some items seem particularly susceptible to r.f. pick-up. In the case of the indicators there was only 2W of r.f. in the vicinity and that was being fed by coaxial cable to the rear of the vehicle where the antenna was situated. The pick-up coil for the ignition timing, senses the small magnetic field of the rotating distributor or flywheel magnet. So it obviously takes little stray r.f. to effect it, to the extent of stopping the engine.

Until manufacturers realise that high powered transmitters carried in some vehicles can affect engine performance and take the necessary steps to shield sensors that depend on a magnetic field for their operation, the trouble is going to persist.

PW

ARE

COMMUNICATIONS
THE SHOP WITH THE SMILE — OUR PRICES ARE CHEAPER!



**TOKYO HI POWER HX240
HF TRANSVERTER
2 METRE INPUT 3-10 WATTS
OUTPUT 40 WATTS ON 10-15-20-40-80 METRE BANDS**

"A DREAM COME TRUE"

TO ALL FT 290 OWNERS, OR FOR THOSE WHO WANT TO OPERATE HF FROM THEIR 2 METRE RIG.

TOKYO HI POWER HAVE PRODUCED THIS SUPERB TRANSVERTER DRIVEN FROM 144-146MHz AT 3-10W AND PRODUCING 40 WATTS OF EITHER FM OR SSB ON EITHER 10-15-20-40-80 METRES.

THE UNIT IS ABOUT THE SAME SIZE AS THE FT 290.

SO WHY NOT ENJOY THE IMPROVING CONDITIONS ON THE HF BANDS USING YOUR 2 METRE EQUIPMENT.

Opening Hours Monday-Friday 9.30 to 5.30
NOW OPEN SATURDAY MORNINGS 10.00-1pm

ARE Communications Limited, 6 Royal Parade,
Hanger Lane, Ealing, London W5A 1ET, England
Tel: 01-997 4476 Fax: 01-991 2565



REVCO

WHEN QUALITY COUNTS

REVCONE

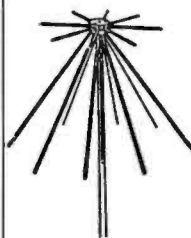

The UK's favourite discone composed of traditional British quality engineering.
The REVCONE works well without exaggerated advertising claims. It is designed to cover 50 to 500MHz, and thousands of satisfied users will testify to its efficiency. Unlike some manufacturers we do not claim a wider frequency coverage, and we do not quote inflated figures for gain. A gain figure is meaningless unless the reference point is stated.
Optional vertical whip feature: It is possible to fit a vertical whip section to a discone. We do not want to give you the "hard sell" where this vertical element is concerned, but there is some evidence that it may improve the performance of the antenna around the resonant frequency of the whip. That's why we make it an optional feature.
Another option is the N-type connector instead of the popular SO239. N-types give a better UHF performance, but they cost a bit more. The choice is yours.
Because the REVCONE is British-made by a Company which has been in business for 30 years, you buy with confidence, knowing that there is back-up should anything go wrong.

RADAC



This Wide-band antenna offers an interesting alternative to the discone. It is simply an array of dipoles, but the clever bit involves arranging the dipoles to maximise bandwidth and minimise interaction. The RADAC can be set up for a range of frequencies from 27MHz to 500MHz, and because very good impedance matches can be obtained the user can specify any six frequency bands in this range for optimised performance, either for receiving, or more usefully, for transmitting. For example, all the Amateur Bands from 10m to 70cm can be covered in one antenna. If you are in the PMR business, the RADAC can be customised for your needs. Aircraft listening enthusiasts can specify VHF & UHF Airband coverage.
What a versatile antenna! Design and engineering excellence from REVCO!

WIDE-BAND PRE-AMPLIFIERS

The problem with omni-directional wide-band antennas is their lack of gain. The REVCO PA3 range of wide-band pre-amplifiers complement the antennas and compensate for their shortcomings.

The basic specification of the products is similar: coverage 20MHz-1GHz, at 1GHz: minimum gain 13dB, noise factor 5.5dB. Choose from a mast-head version (PA3) or a standard die-cast box style (PA3I). Best results are normally obtained from the masthead model which gives a boost to weak signals which would otherwise have been lost in the feeder cable. Also feeder cable noise is not amplified which is the case if the amplifier is mounted at the base of the feeder. On the other hand, the die-cast box version requires no special installation and is readily taken out of circuit. The masthead model is supplied with a special power unit which feeds the DC supply into the antenna feeder. No psu is provided for the PA3I as any 9-15V DC source is suitable (current requirement about 25mA).

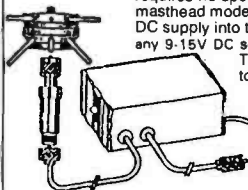

The PA3I finds application in instrument work, e.g. input to spectrum analysers, boosting the output from signal generators to give a low-power TX.
The standard version of the PA3I has BNC sockets and is designated "PA3I/B", available to special order N-type sockets ("PA3I/N") or SO239 ("PA3I/S").
A special feature of the PA3 series is a high-pass filter to attenuate frequencies below 20MHz; high-power HF & MF broadcast stations can be very troublesome!

ON-GLASS ANTENNAS

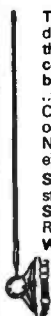

This type of antenna mount has been around for a long time, but they are very difficult to produce successfully at VHF. The Cellular Radio Industry has popularised the glass mount, but there are fewer design problems at 900MHz, because the coupling assemblies are small. REVCO's extensive experience in making the UK's best Cellular On-glass has led to the production of superior quality VHF and UHF models. Here are a few facts which you should know:
Coupling efficiency: apart from the question of effective power transfer to the outside world, you don't want too much RF floating around inside the car, do you? Not healthy for vehicle electronic systems, and possibly not good for humans either. REVCO glass mounts feature very efficient power transfer.
Sticking power: no good if they fall off half way home. A properly installed REVCO stays on. Should you change your car, a refit kit is available.
Simplicity: Some of the competition has a multitude of loose components: the REVCO has 2 pre-assembled parts: inside and outside. What could be simpler?
Weather-resistance: REVCO antennas are made from corrosion resistant materials so you can leave them out in the rain with confidence. It is not necessary to plaster the product with silicone rubber to keep the water out.
The REVCO glass mounts do cost a bit more, which reflects these superior features.

REVCO also make a full range of mobile antennas for frequencies from 27MHz to 950MHz, and new products are constantly under development. Contact your local Dealer or in case of difficulty write, phone or fax. Trade enquiries welcome.

Revco Electronics Ltd, Old Station Yard, South Brent, S Devon TQ10 9AL Tel: 0364 73394 Fax: 0364 72007

The PW 'Glyme' Construction

This converter is a simple but efficient unit which, when placed ahead of a receiver tuning from 28 to 30MHz, allows signals in the 4 to 14MHz portion of the short wave spectrum be received in five 2MHz wide portions. This portion of the spectrum is probably the busiest, as it contains numerous marine, aircraft and other utility stations as well as the 49, 41, 31, 25 and 21m broadcast bands. If your receiver has the facility to resolve both s.s.b. and a.m. then there is considerable listening scope. Perhaps though your receiver is s.s.b. only, this should present few problems, as in most receivers the stability of the v.f.o. is more than adequate to enable the resolution of an a.m. signal. This method of carrier reinsertion was used by the BBC monitoring services at Caversham Park, by using either the upper or lower side-band it allows an interfering signal to be moved further away from the desired frequency and, in most cases, an excellent audio reproduction in view of the i.f. bandwidth available.

The design of this project has been kept as simple as possible in order to make it easily reproducible, relatively cheap and easy to align with the minimum of test equipment, but without sacrificing quality. When used with a good receiver this unit will provide many hours of listening pleasure from all over the world.

Circuit Description

The block diagram of the converter in its ultimate simplicity is shown in Fig. 1, a mixer preceded by a band-pass filter. What could be simpler and yet work so well? Moving to Fig. 2, this

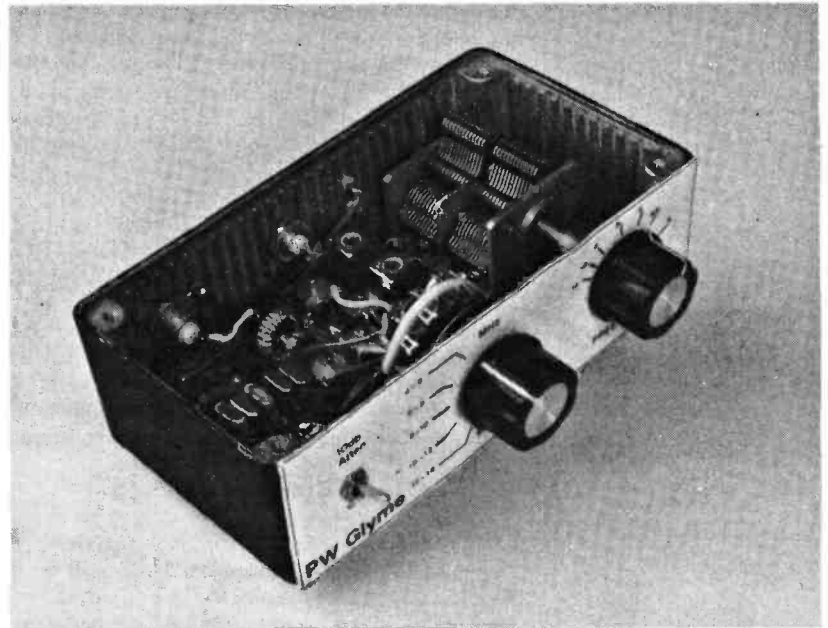

shows that the circuit diagram is in reality only a little more complex. Not shown on the block diagram, but present in the circuit diagram is a 10dB attenuator. This was found to give better results on certain bands which have high signal levels present.

Also, purists may note that the double tuned coupled filters, comprising of C9a and b with T1 and T2, are coupled directly together and not via a small value capacitor as is to be found in most text books. Measurements showed that this configuration gave more consistent bandwidth figures over the complete tunable range than the more theoretical circuit. The text book approach was found to have a bandwidth of a few kHz at the low frequency point, but at the high frequency setting this had deteriorated to several megahertz. By replacing this coupling capacitor with a direct connection the bandwidth, whilst not ideal, remained more than adequate throughout the complete tuning range. This results in a higher rejection of unwanted frequencies and a reduction in the image response of the circuit.

With a local oscillator frequency of 18MHz the resultant i.f. is 28-30MHz, for the 10-8 MHz band,

A few years ago there emerged the amateur band transceiver which also doubled as a general coverage receiver. There are a large number of the earlier type of amateur band only transceivers which are perhaps not being fully utilised. They sit idle when the bands are less active, or when the mood to operate does not prevail. This latter reason prompted Brian Robertson G4POL to design a converter which would make good use of the s.s.b. filtering which exists on most amateur receivers. Thus evolved the PW Glyme.

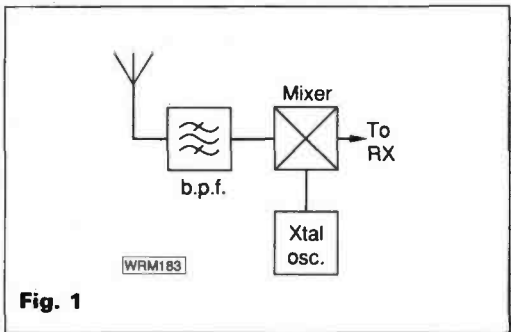

Fig. 1

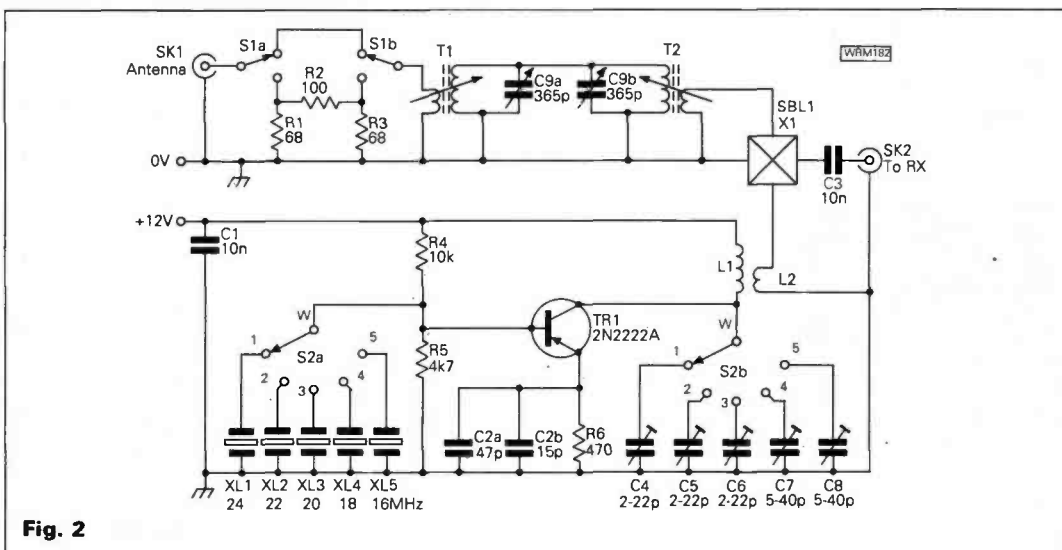

Fig. 2

but the (2 x l.o.-i.f) is 6 to 8MHz. These two responses are close to each other and, as you will find out, both may be tuned to a particular place on the dial of the preselector. So as you can appreciate the rejection has to be good. However by careful tuning the unwanted response can be substantially reduced and, with the addition of an a.t.u. in circuit, may be eliminated all together. This example has been quoted as it is the worst possible case of the five crystal l.o. frequencies.

The preselected signal output is fed directly to the 50Ω input port of the Schottky double balanced mixer X1. The local oscillator transistor TR1 generates sufficient drive (+7dBm or 5mW) for X1 on all crystal frequencies. Band switch S2 selects and tunes the correct crystal frequency.

Although the conversion loss of this unit is 7dB, it was found in practice that with a good antenna, no discernible signal losses were noticed and there were, and should be, a wealth of signals to be heard.

Construction

The component layout and track patterns are shown in Fig. 3. The circuit has been built on a double copper clad board, the upper surface of which is used as a ground plane. All copper areas

around the holes, other than those used specifically to earth the pins of the mixer and crystals pins should be cleared away from the holes by using a small sharp drill bit.

Once the board has been prepared, bend the tags on the screens of T1 and T2 then fit and solder them into place on the board. The pins connecting to the centre tap windings of T1 & 2 are not used, but should not be cut off, as damage can occur when doing so and confusion may occur when placing them on the board.

The trimmer capacitors C4-8 have their 'earthy' connections made on the upper side of the board, so these legs of the components should be bent very carefully at right angles to their original positions before placing and soldering them on the board.

Oscillator coils L1 and 2 should be wound on a T50-6 toriod, L1 being 19 turns of 24 s.w.g., and L2 being 2 turns of the same wire. When fitting this component take care that it does not touch the earth plane. A quick curing epoxy glue should be used to fix the toriod to the board then, smeared on the rest of L1 and 2 to lock the windings in place on the toriod after you are sure that the unit is functioning.

Fit the other resistors R4-6 on the board and then the transistor TR1. Solder Veropins to those places which will have external connections on them and connect short flying leads to the open ends of the crystals and the trimmer capacitors. Solder short lengths of miniature coaxial cable to the input and output points of the board. When this is done, check very carefully for orientation and correct soldering of each component, followed by a check to see there are no solder splashes on the board.

Using the layout shown in the drawing of the front panel as a guide, mark and drill the box for the switches. The input and output coaxial sockets and power supply points or leads are mounted on the back panel of the box, and may be placed in convenient positions. Mount the board inside the box as close to the band change switch as possible, so that the flying leads are ideally less than 50mm in length.

Trim the flying leads to the minimum length and solder them to the correct contacts of the band change switch. Solder the resistors R1-3 to the attenuator switch S1 in the manner shown in Fig. 3b on page 51 of the Jan 1990 *PW*, and mount it so that it comes into operation in the toggle down position. Connect the coaxial cable from the board to one side, and using more coaxial cable connect the other side to the input socket SK1. Trim and fit the output coaxial cable from the board to socket SK2.

Testing

When you are sure that all is in order, and with a multimeter measuring mA in line, connect 12V to the unit. The total current drain should be of the order of 10mA at this stage, if not switch off and find out why. If you have an r.f. probe, measuring at TP1 should give a reading at all positions of the bandchange switch. Set all the trimmer capacitors to about half mesh and the cores of T1 and 2 about 2mm below the top of the cans. Please use the correct plastic tuning tool to do this, otherwise you may damage the cores.

Assuming all is in order connect an antenna to SK1 and switch on the receiver and note the noise level. Connect the output of the unit to the antenna connections of the receiver and an increase in receiver noise level should be heard. Using an suitable r.f. measuring probe measure at test point TP1. Switching to each band in turn, peak the

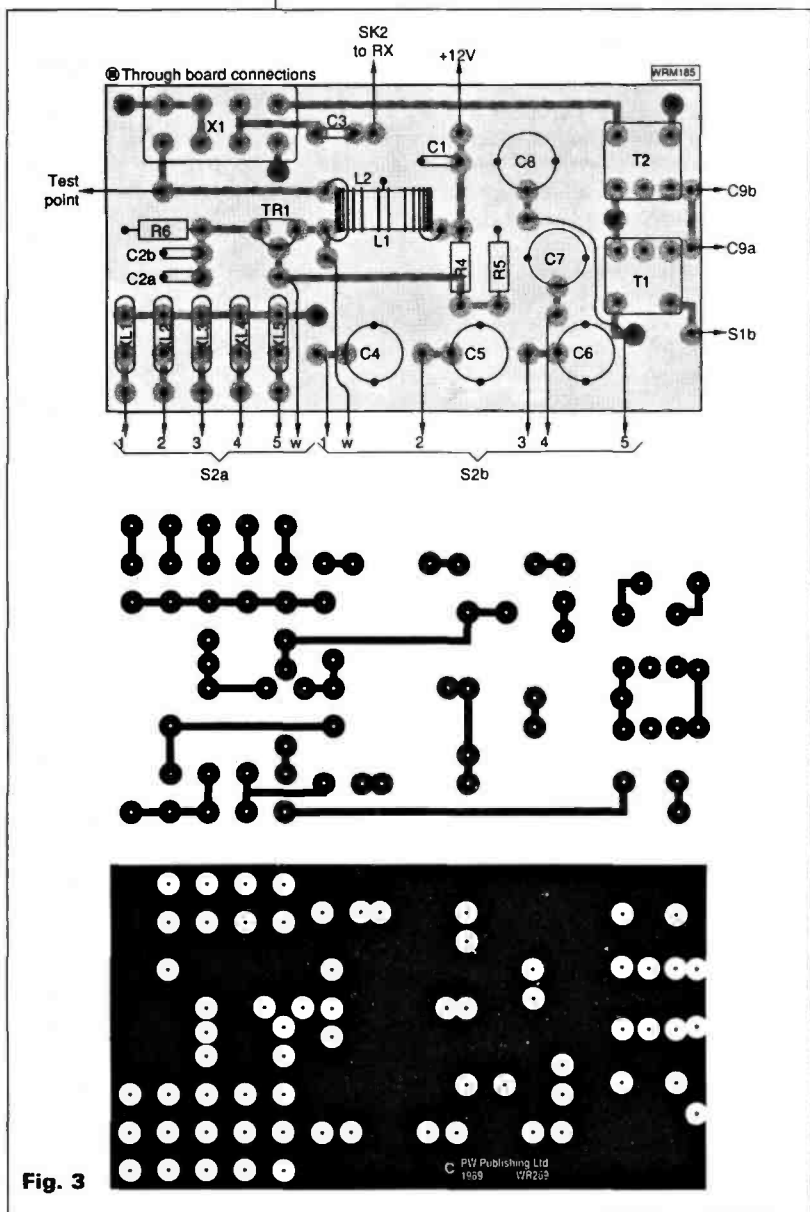

Fig. 3

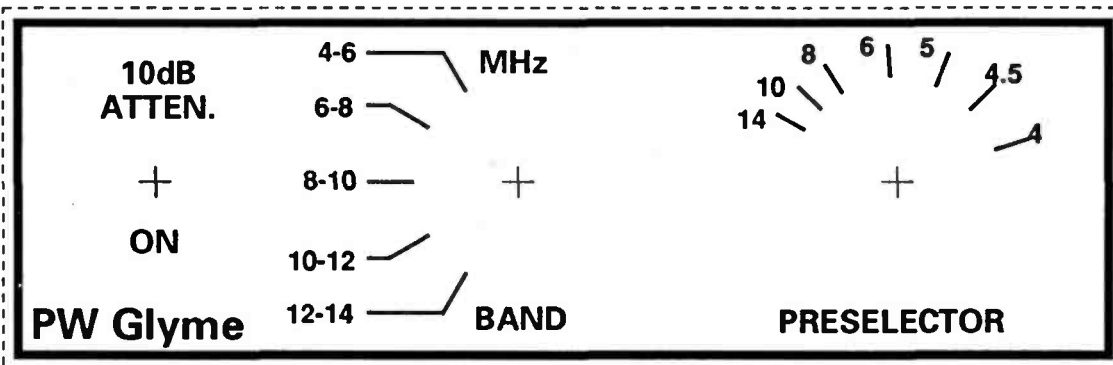

Fig. 4
Actual size

amount of mixer drive for each crystal switched into circuit.

Inductor L1 is resonated with one of the trimmer capacitors C4-8, to give a slight pulling of the crystal frequency as measured at TP1. Also at TP1, it should be possible to measure the 50Ω output drive to the mixer X1. A suitable r.f. probe for this job is shown in Fig. 1.3 on page 23 of the January 1990 PW, and a reading of around 0.6V should indicate sufficient drive.

Counterless Alignment

If a frequency counter is not available, alignment is still quite easy. First set the band switch to 4-6MHz, tune the receiver to 28.772MHz u.s.b. Peak the preselector to 4.7MHz approximately. You should now be able to hear the RAF's VOLMET broadcast on 4.772MHz. If nothing is heard then carefully adjust the trimmer capacitor C8 until something is heard. Once this has been achieved switch to 6-8MHz and tune the receiver to 28.090MHz and the preselector to 6.1MHz. This combination should enable you to hear Radio Luxembourg in the 49m band. On the 8-10MHz band with the receiver tuned to 29.535MHz and the preselector to 9.5MHz, you should hear Swiss Radio International. The band 10-12MHz and 29.2MHz (11.200MHz u.s.b.) is again RAF VOLMET which should be audible during daylight hours, if not then try for a strong signal in the 25m broadcast band. Lastly on the 12-14MHz band tune to around 13.6-13.8MHz on the preselector, receiver around 29.6-29.8MHz.

If you have access to an r.f. signal generator, it must be accurate and stable to be of use, otherwise use it as a start off and proceed as outlined above. The above frequencies have been chosen from the author's knowledge as a UK resident. If the unit is to be constructed outside the UK then some of the transmissions mentioned may not be audible. In which case one of the excellent references such as *Klingenfuss Guide to Utility Stations* or the *World Radio Television Handbook* should be consulted, and in fact are recommended reading for anyone interested in radio listening.

Once alignment is complete, fasten down the lid of the box and the world is now yours!

General

The original prototype consisted merely of the mixer and local oscillators, but it was noticed that the receiver showed signs of distress at times. With these results it was thought necessary to build an attenuator into the circuit and 10dB was found to be sufficient. The mixer contained within the unit is unlikely to overload with a long antenna and gave excellent results on a Racal RA17, a Trio 830S and

a Sony 2001D, so it should work well with any receiver tuning 28-30MHz. Although the conversion loss is 7dB, about 1 S-point, it was not noted as being insensitive, and so even modest antennas should produce good results. Good hunting! **PW**

Shopping list

Resistors

0.25W 5% Carbon film		
68Ω	2	R1,3
100Ω	1	R2
470Ω	1	R6
4.7kΩ	1	R5
10kΩ	1	R4

Capacitors

Metalised ceramic 5%		
15pF	1	C2b
47pF	1	C2a

Disc ceramic

10nF	2	C1,3
------	---	------

Variable

Miniature foil trimmers		
2-22pF	3	C4-6
5-40pF	2	C7,8

Jackson type 0

365+365pF	1	C9a,b
-----------	---	-------

Semiconductors

Schottky balanced mixer		
SLB1	1	X1

Transistor

2N2222A	1	TR1
---------	---	-----

Coils and inductors

TOKO KANK3334R	2	T1,2
----------------	---	------

L1 is formed by winding 19 turns of 24 s.w.g. enamel covered wire on a T50-6 toroid.

L2 is an overwinding of 2 turns of the same wire on the same toroidal core.

Crystals

1 off of each 16, 18, 20, 22, 24MHz HC18U5

Miscellaneous

Bimbox type 95005, p.c.b.†, double pole double throw miniature switch, 2pole 6 way switch for bandchange. Toroid T50-6, 2 coaxial sockets to suit, 2 knobs, 2 feedthroughs for the power supply lines, Miniature coaxial cable, thin insulated wire for interconnections, 18 off Veropins, nuts and bolts.

† PW PCB service

§ Gollodge Electronics, Merriott, Somerset TA16 5NS. Tel:0460 73718, Have a kit of all five crystals for £17-50 inclusive, ask for PW Glyme kit.

HOW MUCH ?

£ 47.00

HOW DIFFICULT

Intermediate

JUPITER RANGE

MVT5000	25-1300MHz handy	299.00
JUP1	Case & belt hook	9.95
JUP2	DC cigar lead	4.95
JUP3	Set of 4 nicads	6.00
JUP4	Mains adapter	14.50
DA900	Flexible antenna	9.00
MVT6000	Base/Mobile Rx	379.00

ALINCO

ALD24E	2m/70cm mobile	399.00
DR110E	2m fm 45W mobile	299.00
DR410E	70cms fm 35W mobile	375.00
DR510E	2m/70cm mobile	549.00
ALP2E	2m micro handy	169.00
EBP3N	NiCad 450 mAh/7.2V	28.95
EBP2N	NiCad 160 mAh/7.2V	23.00
EDH10	DC to DC ALX2E	16.95
ESCS	Case/belt clip	14.00
DJ100E	2m handy tvtr	219.00
DJ100EX	Extended rx	229.00
DJ500E	Dualband hand	375.00
EBP9NAZ	NiCad 7.2V 500mAh	35.95
EBP6NAZ	NiCad 9.6V 450mAh	29.95
ELH230D	2m amp. 1-5W/10-30W	75.00
ELH260D	2m amp. 1-3W/50W	119.00

AZDEN

PCS6000	2m mobile	329.00
---------	-----------	--------

DIAMOND/REVEK

L20	15-50w load PL259	15.95
L20N	15-50w load "N"	22.95
SK100	Vswr 1.6-60 MHz	95.00
SK200	Vswr 1.8-200 MHz	65.00
SK400	Vswr 140-525 MHz	79.00
SK600	Vswr 1.8-525 MHz	119.00
SK1000	Vswr 1.8-1300 MHz	159.00
P300	30 Amp psu	149.00
W510	Vswr 1.6-30 MHz	79.00
W520	Vswr 1.8-200 MHz	59.95
W540	Vswr 140-525 MHz	63.00
W544	Vswr 140-460 MHz	119.00
W570	Vswr 1.8-1300	119.00
S20	Switch 1kW SO239	26.95
S20N	Switch 1kW "N"	45.00
rodD24N	With "N" & PL259	26.95

DIAMOND ANTENNAS

CP4	10-40m vert	149.00
CP5	10-80m vert	189.00
D130N	Disc. 25-1300 MHz	82.00
X50	2m/70cm base	59.95
X500	2m/70cm base	129.00
CP22J	2m 6.5dB	49.95
EL1770H	2m/70cm whip	30.00
NR72M	70cm 5.5dB PL259	24.00
M285	2m 5/8th PL259	14.95
EL2E	2m 7/8th PL259	32.95
RH702B	70cms gain BNC	26.00
DP-GJL	Gutter mount	10.00
EC-H	PL259 cable kit	8.00
SP4	Mag. mount	23.95
TRA	Boot mount	26.95
DS05	Mobile 1.5-1300 MHz	69.00
D707	Base 1.5-1300 MHz	69.00
MB100A	Low pro. mt. TNC	39.00
MA1100	2m/70cm whip TNC	26.00
MA1000	2m/70cm whip TNC	29.00
MA200	2m whip TNC	26.00

SAGANT ANTENNAS

BL40X	1:1 balun	21.00
EL40X	80-40m 78ft	59.95
MT240X	80-10m 78ft	78.00
EL40XC	Traps for 80/40	16.95
SLIM-2	Stubby 2m BNC	9.95
SLIM-7	Stubby 70cm	9.95
S-Rod2	2m 5/8 BNC	12.95
S-Rod7	70cms version BNC	12.95
MG-Y5	Magnetic mount	14.95
ZA1.9	Zepp 160m (46m)	87.00
ZA3.5F	Zepp 80m (40m)	55.00
ZA3.5	Zepp 80m (25m)	59.95
ZA7	Zepp 40m (20m)	49.00
ZA14	Zepp 20m (10m)	55.00

TOYO

SAGMS	Mag mount rubber	19.00
-------	------------------	-------

ADONIS MICROPHONES

AM303G	Base station mic	49.95
AM303	AM303 + comp.	65.95
AM805G	Meter & 2 outputs	79.00
AP-1	Icom mic adaptor	13.95
FX-1	Mobile goose neck	55.00
FX8	Noise cancelling	55.00
P80	Spare mic. leads	6.80

MIZUHO QRP

MX3.5S	80m 2W SSB/CW	189.00
MX7S	40m version	189.00
MX14S	20m version	189.00
PM1	DC/DC 13.8V to 9.6V	19.95
MS1	Speaker microphone	29.00
XTALS	VXO xtals	10.00
BM6	Carry case	9.00
PL3.5S	80m 10W linear	129.00
PL7S	40m 10W linear	129.00
PL14S	20m 10W linear	129.00
PL1000	80-10m linear	189.00
CWS2	Sidetone CW	49.00
PR3S	Mobile mount	27.00
AN-F	40m 4ft whip	29.00
AN-14	20m whip (BNC)	29.00

CREATE ANTENNAS

5130-1	50-1300 MHz 12dB	179.00
5130-2	105-1300 MHz 13dB	99.00
730V-1	40-10M Rigid dipole	149.00

MISCELLANEOUS

ATI000	SWLHF atu	69.00
--------	-----------	-------

HP4A	TV Filter	7.95
FERRITE	1.5" Rings (TV1/AF)	0.60
HK708	Standard Morse Key	21.95
HK709	De-luxe Morse Key	23.00
HK702	Key marble base	42.00
MK704	Morse paddle	20.50
COK-2	Practice Osc.	12.50
LF40/80	80/40 dipole kit	29.00
WAZ-1	3rd VHF 25-1300 MHz	69.00
OP125	Preamp HF Ant.	49.00
M125	Mag. airband ant.	29.00

SPECIALIST PUBLICATIONS

SW Freq List	7.95	
VHF/UHF Freq. (UK)	5.95	
VHF/UHF Airband	5.95	
OCEANIC	HF Oceanic Air	3.50
MFG	Marine Freq. Guide	4.95
Learning Morse	4.95	
RTTY & Fax Stns.	2.95	
Scanners 1	7.95	
Scanners 2	9.95	
Better SW Reception	5.95	
VHF Handbook	5.95	
Low Cost Wire Ant.	6.95	
World Radio & TV	17.95	
Air Traffic (Adair)	6.99	
Airband Radio (Smith)	5.99	
Air Traffic (Duke)	3.95	
Amateur Ant H'book	6.95	
SW Radio Handbook	6.99	
Airline Fleets 1989	4.99	

KENWOOD HF

TS950S	HF trevr. + ATU	2499.00
TS950SD	HF trevr. + +	3199.00
TS940S	HF all band trevr.	1995.00
AT940	Automatic atu	244.00
SP940	Ext. spkr. + filter	87.50
VS1	Voice synthesizer	32.25
TS440S	HF transceiver	1138.00
AT440	Internal auto atu	144.75
PS50	Heavy duty PSU	222.00
TS140S	HF transceiver	862.00
TS140S + 6m module	985.00	
PS430	Mains power supply	173.75
SP430	Matching speaker	40.75
AT250	Automatic atu	366.00
AT130	Mobile atu 80-10m	140.50
MB430	Mobile mount	15.80
AT230	9 band ATU etc.	208.50
SM220	Station scope	343.50
TL922	9 band 2kW linear	1495.00
LF30A	HF Low pass filter	32.25

R5000	Deluxe HF receiver	875.00
VC20	Conv. 108-174MHz	167.00
R2000	HF receiver	595.00
VC10	Conv. 118-174MHz	161.95
RZ1	Rx 500 kHz-905 MHz	465.00

YAESU HF

F1747GX	HF Transceiver	659.00
	FM board	40.00
F1757GX2	HF Transceiver	969.00
FP700	20 Amp power supply	219.00
FC757AT	Automatic atu	349.00
FP757HD	Heavy duty psu	259.00
MMB20	Mobile mount	25.00
FC700	Manual antenna tuner	149.00
FT767GX	HF transceiver	1599.00
SP767	External speaker	69.95

YAESU VHF

FT4700RH	2m/70cm mobile 50W	675.00
FT470R	2m/70cm body	389.00
FT23R	2m body	209.00
FT73R	70cm body	229.00
FBA10	Cell case AA	11.50
FNB9	200mAh pack	34.50
FNB10	600mAh pack	34.50
NC27C	Mains charger FNB9	17.70
NC28C	Mains charger FNB10	17.70
NC29	Desktop charger	69.00
MMB32A	Mobile bracket	16.00
FNB3A	425mAh nicad FT727R	41.00
FNB4A	600mAh nicad FT727R	46.00
CSC17	Soft case	10.00
CSC18	Soft case	11.50
MMB21	Mobile mount FT727R	10.00
PA3	12V charger	21.85
NC9C	Mains charger	11.50
NC18C	Mains charger	17.50
YHA27	Dual Band helical	8.75
FT290R2	2m all mode portable	429.00
FT690R2	6m all mode portable	399.00
FT790R2	70cm mode portable	499.00
FBA5	Additional cell case	27.00
MH10F8	Speaker/mic	25.00
NC26C	Mains charger FBA-8	11.50
MMB31	Mobile mount	17.50
CSC19	Soft case	9.00
FT411	FT23 body	225.00
FT811	FT73 body	239.00
MMB34	Mobile mount	9.00
FT736R	Multimode 2m/70cm	1359.00
FT212RH	2m Trevr. FM 45W	349.00
FT712RH	70cms Trevr. FM 35W	375.00
MMB1J	Mount FT290 MK1	29.95

**MAIL ORDER OR RETAIL
FAST, FRIENDLY EFFICIENT**



KENWOOD FILTERS & MICS

Most from stock - phone.

KENWOOD VHF/UHF

TS711E	2m Base SSB/CW/FM	898.00
TS811E	70cm Base station	998.00
SP430	Matching speaker	40.75
TS790	2m & 70cms	1495.00
PS31	Matching psu	186.00
SP31	External speaker	63.00
TR751E	2m multimode mobile	599.00
TR851E	70cm multi-mode	599.00
VS1	Voice module	32.25
TM231E	2m FM 50w	289.00
TM431E	70cms FM mobile 35w	318.00
TM531E	23cms FM mobile	385.00
SP40	Mobile Speaker	21.00
SP50	Mobile Speaker	20.40
TM731E	2m/70cms mobile 50W	665.00
TM701E	2m/70cms FM 25W	469.00
TH75E	2m/70cms FM handy	398.00
TH25E	2m FM handheld	238.00
TH45E	70cms FM handheld	269.50
BC2	Charger	11.85
BT2	Dry case	11.86
SC8	Soft case	11.86
SC11	PB21H case	10.45
AD1	Screwed phono/BNC	3.95
TH205E	2m handheld	199.00
TH215E	2m handheld	228.00
TH405E	70cm handheld	245.00
TH415E	70cm handheld	268.00
SMC31	Speaker/mic	29.70
SMC32	Miniature speaker	23.95
BT3	Dry battery case	11.85
BC7	Rapid nicad charger	97.40
BC8	Compact nicad charger	38.80
SMC25	Spkr/mic	23.00

YAESU RECEIVERS

FRG8800	HF receiver	649.00
FRV8800	Conv. 118-175MHz	100.00
FRV/WFM	Module WBFM	20.00
FRA7700	Active antenna	49.00
FR7700	Antenna tuner	59.00
FRG9600M	60-950 MHz scanner	499.00
PA4C	PSU for FRG9600	25.00
FC965DX	Conv. 0.15-30 MHz	89.00

YAESU ACCESSORIES

Most mics and filters from stock. Please phone or write.

ICOM HF

IC781	HF Trevr. + ATU, CRT	4500.00
IC765	HF transceiver	2499.00
IC751A	HF transceiver	1500.00
IC726	Compact HF trevr.	989.00
IC735	HF transceiver	979.00
IC725	HF transceiver	759.00

ICOM RECEIVERS

ICR71E	100 kHz-30 MHz Rx	855.00
R7000	Rx. 25 MHz-2 GHz	989.00

ICOM VHF

IC575H	50 MHz base 100W	1199.00
IC2GE	2m FM handheld	265.00
IC2SE	2m handportable	275.00
IC2SET	2m handy	
IC2E	2m FM handy 1.5w/BP3	235.00
IC2OE	+ keypad 3w/BP3	249.00
IC228E	2m FM mobile 25w	365.00
IC228H	2m FM mobile 45w	385.00
IC290D	2m multimode mobile	559.00
IC275E	2m multimode base AC	1069.00
IC4SE	70cms FM handy	310.00
IC4SET	70cms FM handy DTMP	310.00

IC4GE	70cms FM handy	299.00
IC448E	70cms FM mobile 25W	429.00
IC490E	70cms all mode mobile	625.00
IC32E	FM 2m/70cms 3/5W	399.00
IC24ET	FM 2m/70cms	385.00
IC3210	FM 2m/70cms 25W	499.00
IC2500E	FM 2m/70cms	635.00

ICOM SUNDRIES

ICPS15	Ext. 20 amp psu	165.00
ICPS45	Ext. psu 8 Amp.	129.00
ICPS55	Ext. psu 20 Amp	192.00
EX310	Voice synthesizer	47.00
EX242	FM unit 740/745	44.00
SP3	External speaker	64.00
EX257	FM unit R70/R71	43.00
RC11	Remote for RT1E	65.00
RC12	Remote for R7000	65.00
HM9	Speaker/mic	23.00
	Most mics in stock! Phone.	
LC3	Leatherette case	9.20
	Most cases in stock! Phone.	
GC5	World clock	43.00

SONY

2001D	HF receiver + AIR	299.00
7600DS	SSB/AM HF receiver	159.0

ALINCO DR 110 2M 45 Watts!

£299

Receive Option:
140-169MHz.



The new 2 metre mobile transceiver from ALINCO is superb value. Steps of 5, 10, 12.5, 20, 25kHz plus high power make it suitable for a wide number of applications. 14 memory channels and rotary dial control make operation a joy. Improved LCD display makes night operation much easier. The diminutive size (5.5" x 2.5" x 6.75") makes for easy installation in the modern car. Other features include up/down mic., 3 way scanning, 1750Hz tone-burst, reverse input, memory skip, and of course a full mobile mounting kit. Send for colour brochure today!

KENWOOD
YAESU
ICOM

MAIL ORDER
FAST & FRIENDLY!

ALINCO
DIAMOND
JAYBEAM
TONNA

Send for our catalogue and price list

For years we have been operating a mail order service. Now it even better! Here are the facts!

We have the widest range of ham products in the South. Nearly all products advertised in this magazine are stocked by us. All the famous names and a few lesser ones as well. Our price list contains nearly 800 items. We accept most major credit cards and can arrange budget finance deals if needed.

Each order is entered on a computer and can be traced in seconds. Despatch labels and invoices are automatically generated and most orders received in the morning leave the same day. Each one is carefully packed and fully insured at our own expense. 24 hour Securicor and Datapost is available on request. And if you have any quibbles with your order we are here to put it right quickly and professionally! We take the risk out of mail order buying and our customers keep coming back. That's why we are bigger than most!

ALINCO DJ500E

£379

2m/70cms

Optional Receive
range
140-470/870-900MHz

5, 10, 12.5,
25kHz steps
2.5 Watts output
144-146/430-
440MHz Tx
Programme Shifts
Full duplex
Battery Save
20 Memories
Reverse Repeat



NO EXTRAS!

Includes:

Rubber Aerial, Ni-cads
Charger, Hand Strap,
Belt Clip.

A "WORLD FIRST" in SCANNERS!

25-1300 MHz*

Handheld
JUPITER II

£299

25-1300 MHz*

Mini-mobile/base
JUPITER 6000 inc. P.S.U.

- * AM/FM
- * Direct up/down tuning
- * 5, 10, 12.5, 25, 30 kHz steps
- * 100 memories
- * 10 programmable bands
- * Step change frequency correction
- * High speed scan 20 per sec.
- * Carrier or audio scan
- * Battery Saver
- * Telescopic antenna (BNC)
- * Fast memo load feature
- * Individual memory unload
- * Uses 4 x AA cells (Jupiter II)
- * Size 7" x 2.5" x 1.5"
- * 700 MHz first IF
- * Proper English Manual
- * Superb sensitivity.
- * Does not cover 550-800MHz.

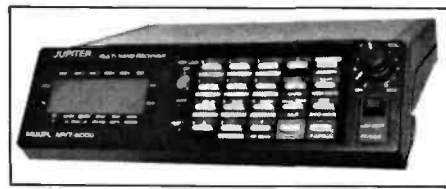

No other similar receivers offer the same features at anywhere near the price! And inside the construction is a Joy! Lots of space, nicely laid out boards all linked with quick connect plugs. Not a "Taiwanese Rat's Nest!"

- **Direct up/down control.**
No need to punch anything into memories. Just enter frequency and use up/down buttons for manual or electronic tuning.
- **AF Scan.**
No more annoying blank carriers for the receiver to lock on to. Simply tell it to ignore carriers not containing audio and it will!
- **One Button Memo Read.**
A single button takes you directly into the memory bank. Up/down or scan will quickly move you around or use direct access for a particular channel number.
- **Battery Saver.**
For long term single channel monitoring this feature will reduce battery consumption by 70%.

- **Skip Function.**
Whether you want to bypass a single memory channel or an entire bank, this control provides the answer.
 - **High Speed Scan.**
Select high speed scan or search and you will whiz through the range at a healthy 20 steps per second! That means you can scan 100 memories in 5 seconds or 1 MHz of space (25kHz steps) in 2 seconds. It really works!
 - **Fast Memo Write.**
Enables you to quickly write into the memories, no need to select a number, the receiver will use the next empty memory.
 - **User Friendly Search Programme.**
You can search in either direction and change direction at the press of a button. Total agility with a speed to match.
 - **Unique Multiband Programme.**
No less than 10 separate band segments can be stored in the receiver's memory.
 - **Total Flexibility.**
The basis upon which the receiver has been designed. It means you tailor the receiver to do exactly what you want it to do, almost like having a receiver that was designed for your own personal needs. No other receiver can match it, feature for feature and the good news is the cost!
- World demand is tremendous. We are getting only small quantities so pick up the phone now and you could be lucky!

FREE CATALOGUE & PRICE LIST! We now have an illustrated catalogue of some interesting products for the radio amateur that we have never had the space to advertise. Also details of new items coming along. Just drop us a first class stamp and we will send you this plus our price list of over 700 items!

MIZUHO "MX" QRP SSB/CW RIGS £189

Now in stock these 2 watt single banders for 80, 40 or 20 metres are real beauties. VXO control (one xtal supplied) gives 25kHz segments on 80 and 40, and 50kHz on 20 metres: Features IRT, noise blanker, S-meter, speaker, morse key. BNC socket.



Powered from AA cells or external supply. Pocket size 66W x 39H x 142mm deep. As used by GRSRN on Ben Nevis. Over 100 in use already. Send for gen.

A QRP STATION Free Offer!

Buy a Mizuho 80, 40 or 20m rig and we will give you a set of ni-cads, 12V DC charging lead and a G5RV aerial system completely free of charge! Limited offer so act now!

SECONDHAND BARGAINS!

R532	VHF Airband	169.00	Jaguar	Handheld VHF/UHF Good	149.00
R535	VHF/UHF Airband Exc.	215.00	Air-7	VHF + BC Exc	169.00
R535	VHF/UHF Airband Good.	199.00	BC100XL	Handheld VHF/UHF Exc	159.00
R5375	VHF Air Exc	45.00	AOR900	Handheld VHF/UHF Exc	159.00
PRO-2004	Base VHF/UHF Exc	239.00	ALR22E	2m FM transceiver Fair	229.00
PRO-2021	Base VHF/UHF Good	149.00	TR7730	2m FM transceiver Fair	159.00
AOR-2002	Base VHF/UHF Exc	375.00	FT-790R	70cms SSB/FM Exc	289.00
AOR-2002	Base VHF/UHF Exc	369.00	FDK700E	2m FM Mobile Fair	139.00
PRO-2009	Base VHF/UHF Exc	109.00	FR7700	Rx ATU Exc	49.00
PRO-32	Handheld VHF/UHF Exc	139.00	Datong	PCI Rx converter Mint	89.00
PRO-32	Handheld VHF/UHF Good	129.00	DJ100E	2m Handheld Mint	179.00
PRO-34	Handheld VHF/UHF Exc	199.00	DJ500E	2m/70cm Handheld Mint	319.00
BC200XL	Handheld VHF/UHF Exc	159.00	DR510E	2m/70cm Mobile Mint	469.00
PRO-30	Handheld VHF/UHF Exc	129.00	DR110	2m FM Mobile Mint	249.00

ALL FULLY CHECKED
3 MONTHS' WARRANTY

RETAIL & MAIL ORDER:- 18-20 Main Road, Hockley,
Essex SS5 4QS Tel: (0702) 206835, 204965
Visa and Access by telephone. 24hr Answerphone.

WATERS
& STANTON

Practically Yours

This month's project from Glen Ross G8MWR, is a little out of the ordinary in that we venture into the world of v.l.f. (very low frequencies). This is a part of the spectrum that few receivers cover but it contains a lot of interesting transmissions including the 15kHz output from Rugby which is able to communicate with submerged submarines anywhere in the world.

Most receivers for these very low frequencies require very large tuning coils and capacitors to resonate at the very low frequencies used but the receiver to be described uses neither.

The Circuit

The circuit configuration is that of a direct conversion receiver with a non-resonant input circuit. The oscillator is a free running multivibrator with adjustable emitter bias for frequency control, based around TR1 and 2, both of which are BC108. Using the values given for R4, R6, C3, C5 and the tuning control R13, the tuning range of the oscillator is around 15 to 30kHz. But, due to the high harmonic content of the oscillator, use can also be made of the second and third harmonics so increasing the tuning range of the receiver section from 15 to 100kHz. The tuning range can be modified easily. Increasing the value of C3 and C5 will lower the oscillator frequency. Components D1, R15 and C8 are included to ensure that the oscillator starts readily. Without them TR2 could be cut-off by the large amount of emitter resistance when the tuning control is at the top end of its travel. When power is first applied C8 has no charge and D1 conducts, effectively connecting the emitter of TR2 to ground. As oscillation builds up C8 charges positively to the point where the diode D1 is cut off, effectively removing C8 from the circuit.

Receiver Section

The detector TR3 is untuned and the antenna is connected to the base of the transistor via RFC. This serves two purposes, first it acts as a loading coil to bring, in terms of wavelength, the short antennas nearer to resonance. Its second but more important function is, that in conjunction with C2, it forms a low pass filter and effectively blocks strong broadcast band signals which would otherwise be a nuisance. The oscillator is coupled to the base of TR3 via the sensitivity control R3. The setting of the sensitivity control determines the bias level for TR3. The signal from the oscillator swings the base current of TR3 through the optimum point twice

every cycle resulting in an audible heterodyne which is then amplified in TR4.

The capacitor C7 removes any residual r.f. which appears in the amplifier circuit. The output from TR2 is sufficient to drive a pair of medium impedance headphones or it may be coupled to a small audio amplifier such as an LM380. As shown the circuit draws about 15mA from a 12V supply.

Construction

There is nothing at all critical about the layout and the prototype was built on a piece of Veroboard mounted in a small die-cast box. The tuning and sensitivity controls should both be panel mounted. The receiver should be provided with a good antenna and earth system.

In operation the sensitivity control should be adjusted to the point of maximum background noise, this corresponds to greatest sensitivity. As the main tuning is adjusted it may be found that the sensitivity control needs minor adjustment although a setting of about half rotation seems about right. **PW**

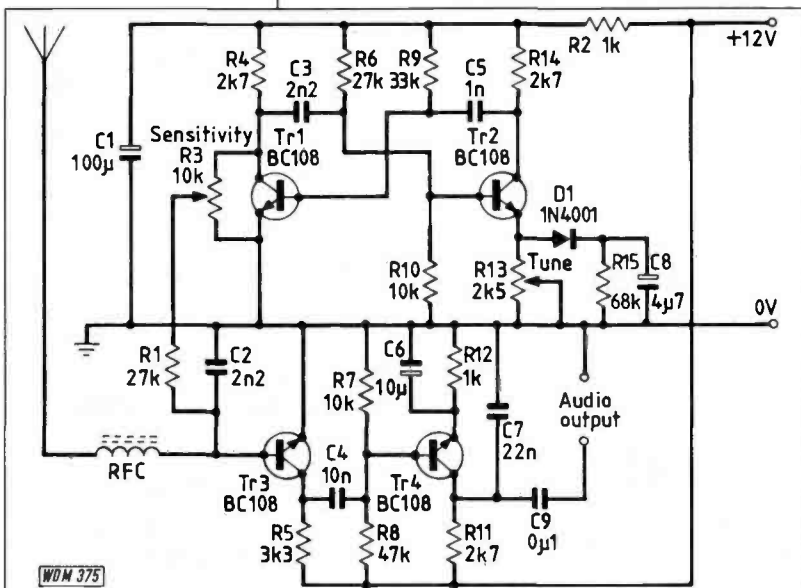

Components List

Resistors

0.25W 1% carbon film

1kΩ	1	R2, 12
2.7kΩ	3	R4, 11, 14
3.3kΩ	1	R5
10kΩ	2	R7, 10
27kΩ	2	R1, 6
33kΩ	1	R9
47kΩ	1	R8
68kΩ	1	R15

Variable Resistors Linear

2.5kΩ	1	R13
10kΩ	1	R3

Capacitors

Mylar

1nF	1	C5
2.2nF	2	C2, 3
10nF	1	C4

Polyester Layer

22nF	1	C7
100nF	1	C9

Radial Electrolytic

4.7µF	1	C8
10µF	1	C6
100µF	1	C1

Inductors

2.5mH	1	RFC
-------	---	-----

Semiconductors

1N4001	1	D1
BC108	4	TR1-4

Miscellaneous

Veroboard, Veropins, connecting wire, die-cast box, etc.

What is Propagation?

Feature

Following a period of successful tests with an electronic counter attached to my receiver, a daily observational programme began, on 27 September 1971 to count the number of times that the signal from the v.h.f. broadcast station at Gdansk was being deflected by the random ionisation left by meteor trails decaying in the earth's atmosphere. The equipment was switched on at 0800 each day and off at 2300 and a reading taken from the counter, on the hour, as often as possible throughout the period.

Interference

Transmissions from Gdansk on 70.31MHz cannot be received at my home in Sussex under normal atmospheric conditions, therefore only the receiver background noise plus the random 'pings' from their meteor reflected signals can be heard and the counter was set to respond to a positive 'ping'.

However, for most of the time this all worked well but the system had three main enemies, thunder static which added each 'crack' to the count, aurora which made the incoming signal 'burble' at the trigger level and sent the counter mad and Sporadic-E which produced such a powerful signal from Gdansk that the counter locked while the event lasted. Although these disturbances are tolerably infrequent during a year the only action to take when they manifested themselves was to close down and write off that day's count. For instance from 1 January to 31 December 1972, my first full year's observation, I lost 106 hours to interference out of a possible 5243 which was unlikely to distort the findings of the remaining 5137 hours work.

It is worth noting that visual observers also have problems because they can only watch for meteor trails during the hours of darkness and this can be further limited by overcast or moonlit skies and/or extreme cold in the winter.

Positive Results

The first seven days, or 105 hours (7 x 15), of full time observations produced 58 086 'pings' giving an average rate of 553 to the hour. I then eagerly awaited the Leonid and Geminid meteor showers to see if the results were consistent and as illustrated on the charts in Figs. 1 and 2, all was well. Both events clearly showed a rise and fall in the number of meteor 'pings' as the earth passed through these great swarms of particles on its annual orbit around the sun.

1972, The First Full Year

Throughout 1972 the equipment observed for 5137 hours and counted 1,299,587 meteor 'pings', which represents an hourly average of 253. The lowest number counted in one day was 530 on January 18 and the highest was 14500 on August 12 at the peak of the Perseid shower. The latter would have been more but the last hour 2200-2300 was lost to static and as you will see in Fig. 3, there was no observation on the 13th because the band was being used for a radio contest. The proof of the pudding came when the system observed the Geminids for the second time in December 1972, Fig. 4 and repeated that distinct peak.

PW

Ron Ham continues with his explanation of meteors and how they affect communications, especially with regard to the amateur. This month we read more about some of the experiments he has conducted.

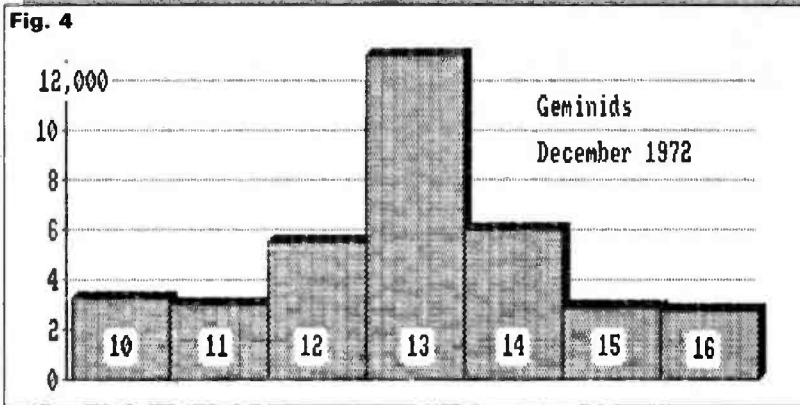
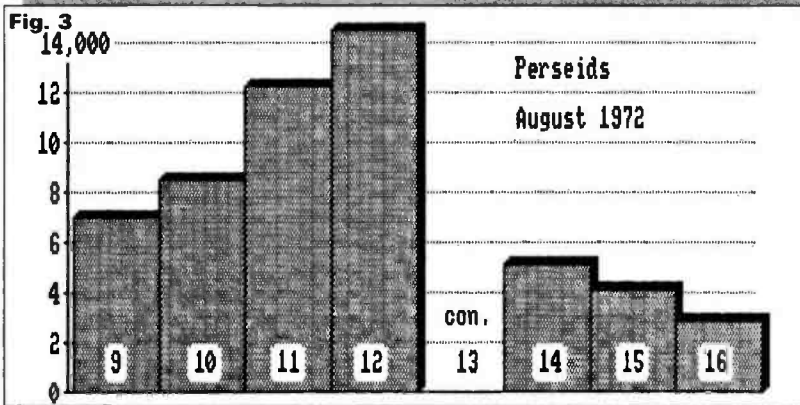
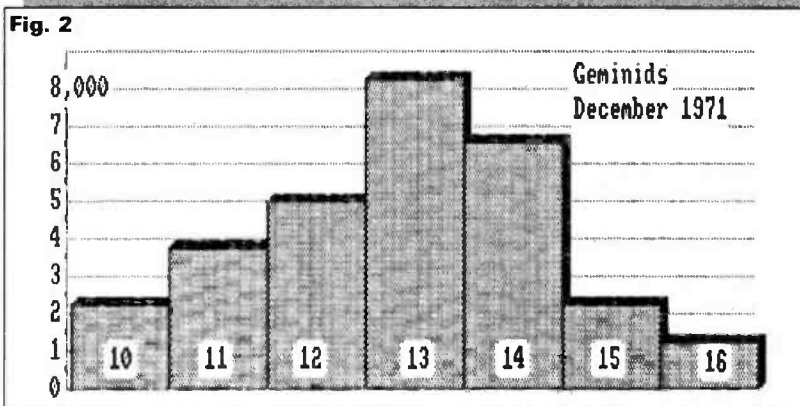
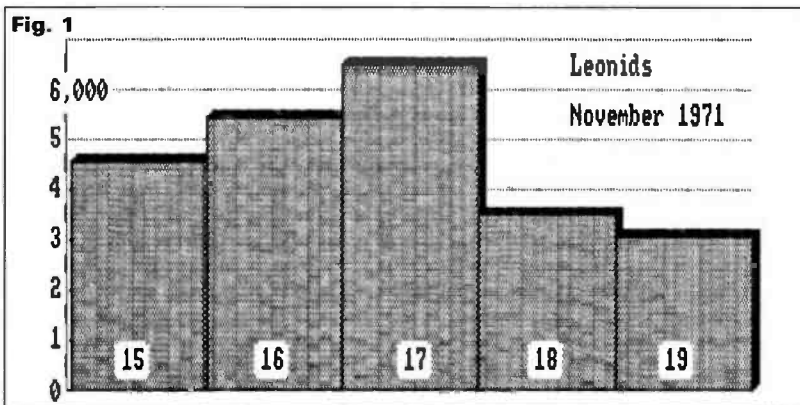



Printed circuit boards for *Practical Wireless* constructional projects are available from the PW PCB SERVICE. The boards are made in 1.6mm glass-fibre, and are fully tinned and drilled. All prices include postage, packing and VAT for UK orders.

Orders and remittances should be sent to: **PW Publishing Limited, FREEPOST, Enefco House, The Quay, Poole, Dorset BH15 1PP**, marking your envelope **PCB SERVICE**. Cheques should be crossed and made payable to PW Publishing Ltd.

When ordering, please state the Article Title and Issue Date as well as the Board Number. Please print your name and address clearly in block letters, and do not send any other correspondence with your order. You may telephone your order using Access or Visa. A telephone answering machine will accept your order outside office hours.

Please allow 28 days for delivery. Always check the latest issue of *PW* for the current details of price and availability. Please enquire for p.c.b.s not listed here.

Board	Title of Article	Issue	Price £
WR269	GLYME	FEB 90	TBA
WR268	IRWELL (r.f. p.a.)	FEB 90	TBA
WR264	IRWELL (relay)	FEB 90	5.00
WR263	IRWELL (vfo)	JAN 90	TBA
WR267	FORTYNINER	JAN 90	TBA
WR266	TUNED ACTIVE ANTENNA	JAN 90	TBA
WR265	TUNED ACTIVE ANTENNA (psu)	JAN 90	TBA
WR261	AM TX FOR 1.8MHz	NOV 89	6.50
WR260	10MHz RECEIVER	OCT 89	5.00
WR259	10MHz RECEIVER	OCT 89	5.00
WR258	10MHz RECEIVER	OCT 89	5.00
WR257	LOW BATTERY WARNING	SEPT 89	5.88
WR256	ACTIVE FILTER	AUG 89	6.96
WR254	TX CONTROL FOR MOBILE USE	JULY 89	5.08
WR253	TS940S MODIFICATION	JUNE 89	5.54
WR252	TWO TONE OSCILLATOR	MAY 89	6.52
WR251	RF OPERATED RELAY	FEB 89	3.80
WR250	DC/AC POWER CONVERTER	JAN 89	3.22
WR249	"MARLBOROUGH" MF CONVERTER	DEC 88	4.60
WR248	"BADGER" 144MHz RECEIVER	OCT 88	9.10
WR247	ZENER DIODE TESTER	AUG 88	3.56
WR246	"PORTLAND" RF VOLTMETER	JULY 88	3.59
WR244	PRACTICE MORSE KEY	JULY 88	2.96
WR245	STOPBAND FILTER FOR PW BLENHIEM	JUNE 88	2.90
WR243	VHF MONITOR RECEIVER (AUDIO)	APRIL 88	2.30
WR242	"ORWELL" VARICAP TUNE OPTION	MAR 88	2.90
WR241	"ORWELL" MED. WAVE RECEIVER SET	MAR 88	
WR240	9.10
WR239	
WR238	"OTTER" 50MHz RECEIVER	JAN 88	7.10
WR237	RTTY TUNING INDICATOR	NOV 87	5.20
KANGA	HIGH STABILITY VFO (see issue)	OCT 87	-
WR236	"BLENHIEM" VHF CONVERTER	SEPT 87	4.50
WR235	MAINS ON/OFF FOR BATT RADIOS	SEPT 87	3.00
WR234	SIDE-TONE OSCILLATOR	JUNE 87	2.70
WR233	"DOWNTON" F-V CONVERTER	JUNE 87	3.90
WR232	"AXE" SIGNAL TRACER	MAY 87	
WR231	9.20
WR230	
WR228	"BLANDFORD" RECEIVE CONVERTER	APRIL 87	
WR227	9.70
WR226	
WR298	"ITCHEN" LCR BRIDGE	APRIL 87	3.40
WR225	"WOODSTOCK" SW CONVERTER	MAR 87	4.10
WR219	MASTHEAD PRE-AMP PSU	FEB 87	2.50

Board	Title of Article	Issue	Price £
WR218	MASTHEAD PRE-AMP FOR 144MHz	FEB 87	4.20
WR224	"WESTBURY" BASIC WOBBULATOR	JAN 87	3.50
WR214	MOD SRX-30D (AUDIO)	DEC 86	3.00
WR223	HIGH-IMP MOSFET VOLTMETER	DEC 86	2.90
WR222	"TAW" VLF CONVERTER	NOV 86	2.80
WR216	LF BANDS ACTIVE ANTENNA	NOV 86	2.40
WR220	GET STARTED LOW-COST CONVERTER	OCT 86	2.40
WR217	AUTOMATIC NICAD CHARGER	OCT 86	2.40
WR215	SIMPLE 50MHz CONVERTER	SEP 86	3.60
WR213	MOD FRG-7 (CARRIER Osc)	JUN 86	2.70
WR210	"ARUN" PARAMETRIC FILTER	MAY 86	8.10
WR211	"MEON" FILTER (SMALL)	APR 86	3.10
WR209	SIMPLE AUDIO OSCILLATOR	MAR 86	4.30
WR208	RF SPEECH PROCESSOR	MAR 86	4.10
WR207	CRYSTAL CALIBRATOR	JAN 86	2.10
WR206	RTTY/MORSE MODEM (Plug-in)	JAN 86	2.80
WR205	RTTY/MORSE MODEM	JAN 86	5.40
WR204	WQ MEDIUM WAVE LOOP	NOV 85	3.00
WR203	SIMPLE CAPACITANCE METER	OCT 85	2.80
WR199	"MEON" 50MHz TRANSVERTER	OCT 85	6.70
WR202	ECONOMY UHF PRE-SCALER	SEP 85	3.70
WR201	ADD-ON BFO	AUG 85	2.50
WR200	LOW-COST CRYSTAL TESTER	JUL 85	2.50
WAD302	BATTERY CHARGER CONTROLLER	JUN 85	3.00
WR197	"COLNE" (Osc/Converter)	JUN 85	3.90
WR198	"COLNE" (Product Det/Audio)	MAY 85	3.90
A005	"COLNE" (VFO)	APR 85	3.10
A004	"COLNE" 3.5/114MHz RX (RF Amp)	APR 85	3.10
WAD249	MOD FRG-7 (BFO)	FEB 85	3.00
WAD280**	TRIANGULAR KEYS	FEB 85	7.10
WA002	"TEME" (RECEIVER)	JAN 85	4.30
WA001	"TEME" (VFO/DOUBLER)	DEC 84	2.80
WAD246	"DART" FOLLOW-UP	DEC 84	4.00
WR196	"TEME" 7/14MHz WRP (TX)	NOV 84	3.70
WR195	STABLE TONEBURST	NOV 84	2.60
WR194	MOD FRG-7 (FM/SQUELCH)	NOV 84	4.50
WR189/92 Pair	BUG KEY WITH 528-BIT MEMORY	OCT 84	8.50
WR190	MOD FRG-7 (SWITCHING)	OCT 84	4.50
WR187	MORSE SENDING TRAINER	JUL 84	4.50
WR185	AUTO-NOTCH FILTER	JUN 84	6.50
WR184	SIMPLE TOP-BAND RECEIVER	JUNE 84	6.50
WR183	TOP-BAND DF RECEIVER	APR 84	6.50
WR179	TRANSCEIVER VOX UNIT	MAR 84	6.50
WR161	"MARCHWOOD" 12V 30A PSU	JUL 83	2.40
WR165 ect set	"SEVERN" 7MHz QRP TX/RX	-	14.90
WR169	"SEVERN" (TRANSMITTER)	JUL 83	6.50
WR168	"SEVERN" (CH.OVER/SIDETONE)	JUL 83	6.50
WR166	"SEVERN" (RECEIVER/AUDIO)	JUN 83	6.50
WR165	"SEVERN" (VFO)	JUN 83	5.20
WR167	RTTY TERMINAL UNIT FOR ZX81	JUN 83	7.80
WR160	LMS REGENERATIVE RECEIVER	FEB 83	5.20
WR156	REPEATER TIME-OUT ALARM	NOV 82	5.20
WR143	ATV CONVERTER	APR 82	7.10
WR144	IAMBIC KEYS	MAR 82	6.50
WR126	"EXE" 10GHz TRANSCEIVER	AUG 81	7.70
WR095	TRANSCEIVER POWER SUPPLY	SEP 80	3.85
WR068	AF SPEECH PROCESSOR	JAN 80	5.20

HAVING DIFFICULTY GETTING YOUR COPY OF PRACTICAL WIRELESS ?

Be sure of getting your copy of PW each month. Place this regular order form with your newsagent... today

Dear Newsagent, Distributed by Seymour
please reserve / deliver my monthly copy of PRACTICAL WIRELESS

NAME

ADDRESS

.....

.....

Signed

HOW TO TURN YOUR AMATEUR OPERATION AROUND.

Simply choose an antenna rotator/controller combination from Yaesu. Each is built tough with rugged, melamine-coated, die-cast casings and heavy-duty components. Permanently lubricated for long life and low maintenance.

Plus, Yaesu antenna rotator/controllers offer something the rest seem to neglect: a high-tech approach to design and tower mounting compatibility.

Az-El ROTATORS FOR SPACE APPLICATIONS

Our G-5400B and heavy-duty G-5600B are the industry standard for satellite and moonbounce work. For maximum turning torque, each mounts separately with the azimuth rotator inside the tower.



As space applications become more popular, so does our versatile G-5400B Az-El rotator/controller



Plus for adding elevation control to an existing system, our G-500A elevation rotator is the perfect choice. It's a great way to add satellite capability to your HF system.

ANTENNA ROTATORS FOR YOUR APPLICATION

Our G-1000SDX, G-800SDX/S, and G-400RC models are popular for heavy to light-duty applications. Each features a 360° "radio compass" control head with illuminated display. Our 1000SDX and 800SDX also offer 450° range, presets, and variable speed control. Disc brakes, smooth and quiet, eliminate the neighbor-disturbing "thunk!" of traditional wedge brakes. And accessories include thrust bearings and lower mast brackets, each in two sizes.



Many world-class operators choose the performance of our heavy-duty G-1000SDX rotator/controller

Want more information? Call SMC on (0703) 255111.

Or ask your authorised dealer about Yaesu Az-El rotators and antenna rotators today. They'll turn your operation around.

UK Sole Distributor: South Midlands Communications S.M. House, School Close, Chandlers Ford Industrial Estate, Eastleigh, Hants SO5 3BY. Tel: (0703) 255111

YAESU

Prices and specifications subject to change without notice.

The World Service - The BBC's Hidden Voice

Although the BBC World Service provides 24-hour news, information and entertainment programmes that can be heard in both hemispheres, very few people realise the extent of the engineering required to maintain the service. Rob Mannion G3XFD looks at the engineering aspect and a little history of the World Service...the hidden voice of the BBC which can be traced back to the pioneering experimental service operated by Gerald Marcuse G2MN during 1927-8.

The 1930s were certainly the major growth years for international short wave broadcasting. From the early experimental broadcast test transmissions by radio amateurs - which proved beyond all doubts that the four corners of the globe could be reached with relatively low power - international short wave broadcasting grew. Unfortunately for the United Kingdom it was a decade of economic depression, and as the Second World War approached, the BBC had only eight short wave transmitters. All were located at the Daventry Northamptonshire site and because of possible enemy action it was considered undesirable to have all the BBC's short wave facilities concentrated at one station. Consequently plans were made to build additional transmitters in other areas including a modern facility in the west country county of Dorset.

The original 189 acre site at Rampisham Down, near Maiden Newton between Bournemouth and Yeovil, was purchased in November 1939. With a great deal of determination despite the inevitable wartime shortages, difficulties and labour problems, the new station came into service on 16 February 1941.

Many innovations were provided at the station, and special precautions were built to protect the four Marconi type SWB18 100kW short wave transmitters from bomb damage by separating the units from each other by heavy blast walls.

A comprehensive antenna system was installed consisting of 29 arrays supported between 15 masts of various heights between 30 and 98m. Full world coverage was given by this antenna system, although the transmissions were primarily intended for areas outside Europe.

Rampisham was the first of the BBC short wave stations to be equipped with four-wire transmission lines, following tests made at Daventry. A unique

remotely controlled switching tower for connecting any transmitter output to any antenna array was also provided.

Standby electrical power for use when the mains supply was interrupted was provided by two 750bhp diesel-driven alternator sets, originally made for railway locomotives intended for export. The usual compressed-air driven starting equipment for the diesel sets was replaced by electrical starting facilities for their use at Rampisham.

Rampisham Modernisation

Along with many other of the BBC World Service transmitter sites, Rampisham provides an essential 24-hour service and has done so since it entered service in 1941. The station radiates short wave broadcasts in English and the appropriate foreign languages to west, south-west, central and south-east Europe, northern Europe, USSR, North and West Africa, Middle East and the Americas.

Recently the Rampisham facilities have undergone a radical refit with many new ideas being incorporated. Computerised control equipment - designed and built by the BBC Research Department - enables the transmitter and antenna switching to be programmed automatically from the Bush House control centre in London, while the essential maintenance and day-to-day running of this complex installation is looked after by 40 local staff of engineers and ancillary workers. Some of the staff based at the site are responsible for the maintenance of the BBC's various u.h.f. television transmitter sites in the region, along with domestic v.h.f. and m.w. radio transmitting installations.

The refurbishment programme at Rampisham Down has included the replacement and

Ground maintenance sub-contractors at lunch, in the 180 acres of grounds that surround the BBC's short wave transmitting site at Rampisham in Dorset.

The sheep perform a vital function within the station's many acres of grassland by keeping it trimmed down to a reasonable level without causing damage to themselves or equipment. At the start of the Second World War, the BBC had only eight short wave transmitters and all were located at the Daventry, Northamptonshire, site. For obvious reasons it was considered undesirable to have all the BBC's short wave facilities concentrated at one station and plans were made to build additional transmitters at diverse locations.

The original 189 acre site at Rampisham Down, near Maiden Newton in Dorset, was purchased in November 1939. Despite wartime difficulties and labour shortages Rampisham came into service on 16 February 1941.



modernising of two 100kW, eight 500kW transmitters and by the end of 1991 will also include two new 500kW units replacing two older 100kW transmitters.

Few people, especially radio enthusiasts can fail to be impressed at the electronic engineering visible at the average broadcasting transmitting station. Many medium wave transmitters have masts over 30 metres and would be a valued possession for those of us with limited space for antennas! Modern day u.h.f. TV transmitting stations can also be impressive although they usually have but one slender, stayed structure. However, all other broadcasting stations pale into insignificance when compared with the towering and very complex antenna systems used for short wave broadcasting. Apart from the sheer size of the antenna systems...the variety of types and the huge areas of ground needed to site them has to be seen to be fully appreciated.

Many motorists will have seen the historic BBC Daventry transmitter as they drove by on the M1 motorway. Unfortunately, Daventry is somewhat dwarfed by the nearby British Telecom v.l.f. transmitting station near Rugby, but despite this, Daventry's antenna 'farm' is awesome when viewed from the town of Daventry.

It may seem odd to the s.w.l. or radio amateur that very many people in the UK don't know anything of the World Service or of their programmes. This is surprising, especially when the high opinion held by many foreign listeners for the BBC's unbiased news reporting and opinion is taken into account. Many UK residents only discover the BBC World Service when they venture abroad. This is despite the fact that many British newspapers carry World Service day-to-day schedules on the entertainment pages!

Nerve Centre

The headquarters of the World Service are located at Bush House, off the Strand in central London. The entire operation of the programming is overseen from this building. Transmitters worldwide are fed by relays, and in some cases by satellite links, to provide the reliable service which has become a watch word for many, and in the case of the recent tragedies in China, often the only way of hearing reliable news of current events.

For the listener and enthusiast in the UK, the World Service can be heard on the 648kHz frequency on medium waves. The new, high power transmitter at Orfordness in Suffolk, with an output of 1000kW (1MW) is considered to be one of the most powerful m.f. transmitters in the world. However, for many listeners in the UK the most reliable reception of the World Service programming is from the various transmitters radiating on the 6MHz (49 metre) band. On these frequencies Rampisham, Daventry, Woofferton (West Midlands, near Ludlow in Shropshire) and Skelton (near Penrith in Cumbria) can be heard.

Additionally, following the close-down of BBC Radio 4 on the 198kHz long wave frequency from Droitwich, the World Service uses that channel until 0545.

Both Skelton and Woofferton transmitters entered service in 1943 after a long search by the BBC to find suitable sites. Skelton, which was the largest transmitting station of its kind at the time, actually consisted of two transmitting stations located within the same site but separated from each other by about one mile. The equipment at the remote Cumbrian station consisted of six 100kW Marconi type SWB18 transmitters and six CS8 type transmitters supplied by STC. The latter were



Routine maintenance in the transmitting hall at Rampisham. Along with the other BBC World Service transmitter sites, Rampisham provides an essential 24-hour service. This important station radiates short wave broadcasts in English and the appropriate foreign languages to west, south-west, central and south-east Europe, northern Europe, USSR, North and West Africa, Middle East and the Americas.

Rampisham has recently undergone a radical refurbishment programme including the replacement and modernising of two 100kW, eight 500kW transmitters and by the end of 1991 will also include two new 500kW units replacing two older 100kW transmitters.

Le Electronique



STANDARD

PLEASE REMEMBER, WE ARE THE SOLE AUTHORISED IMPORTER OF STANDARD EQUIPMENT IN THE UK AND WE ARE ABLE TO OFFER A FULL BACKUP SERVICE AND SPARES FROM STOCK



C150

The Standard C150 supercompact 2m transceiver having all the usual features that you would expect from a modern microprocessor controlled radio - plus several new ones.

- ★ Frequency range 144-146MHz (with extended Rx capability. ★ Up to 5W RF output (switchable Hi-Mid-Lo). ★ 20 memories (20 banks of 10). ★ Power requirements 5.5-16V dc. ★ Super sensitivity - less than 0.16V (1208 SINAD). ★ 6 different monitoring methods (dual Watch modes!). ★ 14 different scanning modes! ★ Individual and group call paging functions available. ★ Semi-duplex operation with separate Tx and Rx frequencies. ★ Squelch Off button. ★ Battery Save and Automatic Power Off facilities. ★ Built-in S-meter. ★ Splash proof case. ★ Soft touch buttons & knobs.
- ★ Rotary knob or pushbutton frequency selection. ★ PIT and keyboard locks (rotary knob is left active). ★ Sockets for external microphone, speaker and power supply. ★ A comprehensive range of accessories is available, including DTMF and CTCSS. ★ Size 124mm H x 55mm W x 31mm D.

£230.00

AX 700E

AT LAST - a scanner from Standard! For longer than I care to remember people have been asking why Standard do not make a scanner - well now they do. I now have English speaking 'flyers' available which all s.e.c. will bring you post haste. You can see from the photograph that the AX 700E has maintained Standard's reputation for reliability. The display not only shows the frequency but also shows the signal strength. The vertical scale on the left of the display is the frequency range. This range can be set to 100, 250 or 1000kHz. The frequency displayed at the top is the frequency at the centre of the line. In other words, if the displayed frequency is 145.50MHz and the width of the display is set to 1000kHz, then the left hand side would be 145.00MHz and the right hand side would be 146.00MHz. Now comes the magic. Every time a signal comes up within that frequency range the height will show the signal strength and the position will indicate the frequency. By simply turning the tuning knob a cursor can be slid along to line up with the new signal and its exact frequency will be displayed at the top of the screen! To receive the new signal, just press a button and that signal becomes the one that is heard and the display will shift to place it in the middle of the screen. The width of the spikes is governed by the setting of the step size (10, 12.5, 20 or 25kHz) so you can see that it is possible to monitor the activity on up to 100 lines! The display is not only for you but also for your guests. The display is in English but you only know the band that it is in and not the spot frequency just set up the appropriate band edges and then sit back and watch the display. Any signals that then appear can be instantly spotted and tuned to in seconds. That's what a paramodulator can do for you!

As for the rest of the scanner, it covers 50 to 904.995MHz with AM and FM (wide & narrow). It is powered by 13.5V dc and it measures just 160mm W x 180mm D x 75mm H. There is a lot more to it but I can't describe it properly. It is a real gem. I hope you may see some radios, so come into the shop and see for yourself. You can even play with our new active antenna which should be ideal for use with this set.

£575.00 (PSU EXTRA)

Norman G4THJ

TRADE ENQUIRIES WELCOMED
PLEASE PHONE 01-450 9755
★ STRICTLY TRADE PLEASE ★

400 EDGWARE ROAD, LONDON W2
01-723 5521 Tlx 298765

OPENING TIMES: 9.30am-5.30pm Mon-Fri. 10am-4.30pm Sat.



Normally 24hr despatch but please allow 7 days for delivery.



★ Full Duplex. ★ Frequency coverage 144-146 & 430-470MHz (extended Rx capability 130-169.995 & 410-470MHz). ★ 2.55W output (depending on battery. ★ Hi/Low switchable RF output. ★ User programmable step sizes (5/10/12.5/25/50kHz), repeater offset (0-39.9MHz) and CALL button (instant OSY to a favourite channel - either band). ★ Reverse repeater. ★ Priority Channels (both bands). ★ 10 memories per band (frequency & repeater offset). ★ Numerous scanning modes (Pause or Busy-memories-band etc.). ★ Auto Power Off with Alarm (4mA on standby). ★ Battery Save on Rx (9 user programmable Rx/Off ratios). ★ Keypad & PIT locks. ★ Squelch directly from a car's cigar lighter (5W output). ★ Rotary Knob or Keypad frequency selection. ★ Dimensions 173mm H x 60mm W x 34mm D.

£359.00

C5200

This new generation dual band mobile transceiver is virtually two radios in one box. 70cms and 2m each have their own displays showing frequency, S-meter and 50 on. Both bands can be heard simultaneously through the built-in speaker or through one or two external speakers. Each band has its own Volume and Squelch controls and there is also an Automatic Mute control that can mute the audio from one band while the other is being received.

Full duplex is available (Tx/Rx either frequency) and the Rx frequency can be tuned while transmitting (45 Watts available on each band).

Each band has 4 different scan modes and 10 memories. Five step sizes are available and different ones can be set for each band, for instance 12.5kHz for 2m and 25kHz for 70cms.

The supplied microphone gives remote control of some of these functions and Tone Squelch and AGS units are available as optional extras.

This radio really is different - come into the shop and try it for yourself.

£599.00



capable of operating as six double-channel 70kW transmitters, with each pair of channels having a common modulator.

The two separate antenna systems at Skelton consisted of a total of 51 arrays supported by 31 masts ranging from 60m to 90m in height. The station was also equipped with emergency standby power supplies which could run six transmitters at 50kW and five channels with an output power of 60kW.

Amateur Radio

Short wave broadcasting from Britain can trace its origins back to the early, very successful experiments, carried out by pioneering radio amateurs in the late 1920s. Amongst these innovative experimenters was the late Gerald Marcuse G2NM who gained permission from a rather reluctant Post Office to carry out broadcasting test transmissions to the then very extensive British colonies.

Throughout the years from 1923 to 1927, Gerald Marcuse who then lived at Caterham in Surrey, had been prominent in developing the short waves for international communication. His consistent work with the Rice-Hamilton expedition in 1925, for example, had brought his name and achievements to the notice of the general public. Pictures of his station had been featured in the national and technical press of many countries and he was well known as a spokesman for the Radio Society of Great Britain on amateur radio licensing matters.

Gerald Marcuse had pressed the Post Office hard to allow transoceanic permits and for improved operating facilities. He had been one of the first British radio amateurs to use radio telephony and his voice had been heard in many parts of the world by other amateurs and keen short wave listeners using commercially made receivers.

In his life story, recorded just before he died in 1961, G2NM recalled that he was first drawn to the idea of providing a broadcasting service to the British Empire as the result of contacts with an amateur in Bermuda, who re-broadcast the G2MN transmissions to other radio amateurs in neighbouring islands.

The RSGB book *World at Their Fingertips* and the *BBC Engineering History 1922-72* (BBC Publications 1972) pay handsome tribute to his pioneering efforts and record the difficulties that lay before him in his efforts to prove the idea viable.

After a great deal of correspondence with the Post Office, Gerald Marcuse was finally informed in a letter from the Assistant Secretary, dated 9 August 1927, that the Postmaster General had decided to authorise him to "transmit speech and music for a period not exceeding six months from 1 September 1927, by means of wireless telephony with power for transmissions not exceeding 1kW and waves of 23 and 33 metres". The letter of authority also restricted his operating times to two hours on each occasion, prohibited him from broadcasting news of current affairs, limited the number of gramophone records he could use during the whole period of the experiments to 50 and prohibited him from advertising on behalf of the recording companies!



The BBC's Atlantic Relay Station on Ascension Island showing satellite receiving dish for programme feed

He was also informed that "the Postmaster General held out no hope that a licence to transmit regular programmes to the Dominions or Colonies would be granted to any body other than the British Broadcasting Corporation".

Special Concert

Marcuse officially inaugurated his programme of "experiments to the British Empire" by transmitting a special concert to Australia on 11 September 1927. Several well-known artistes were enlisted and he also arranged for Captain Ian Fraser MP G5SU (President elect of the RSGB) and the then High Commissioner of Australia to speak during the course of the broadcast.

The BBC East Asia Relay Station in Hong Kong which serves audiences in Northern and Central China, Japan and Korea. It also played an important part in the events of 1989 in that area of the world

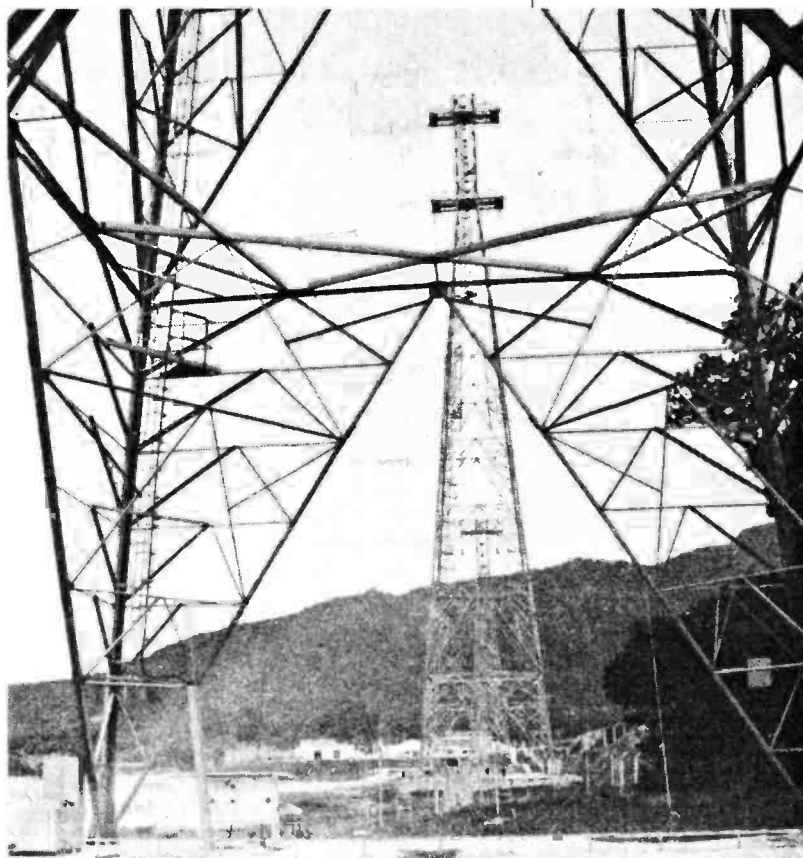

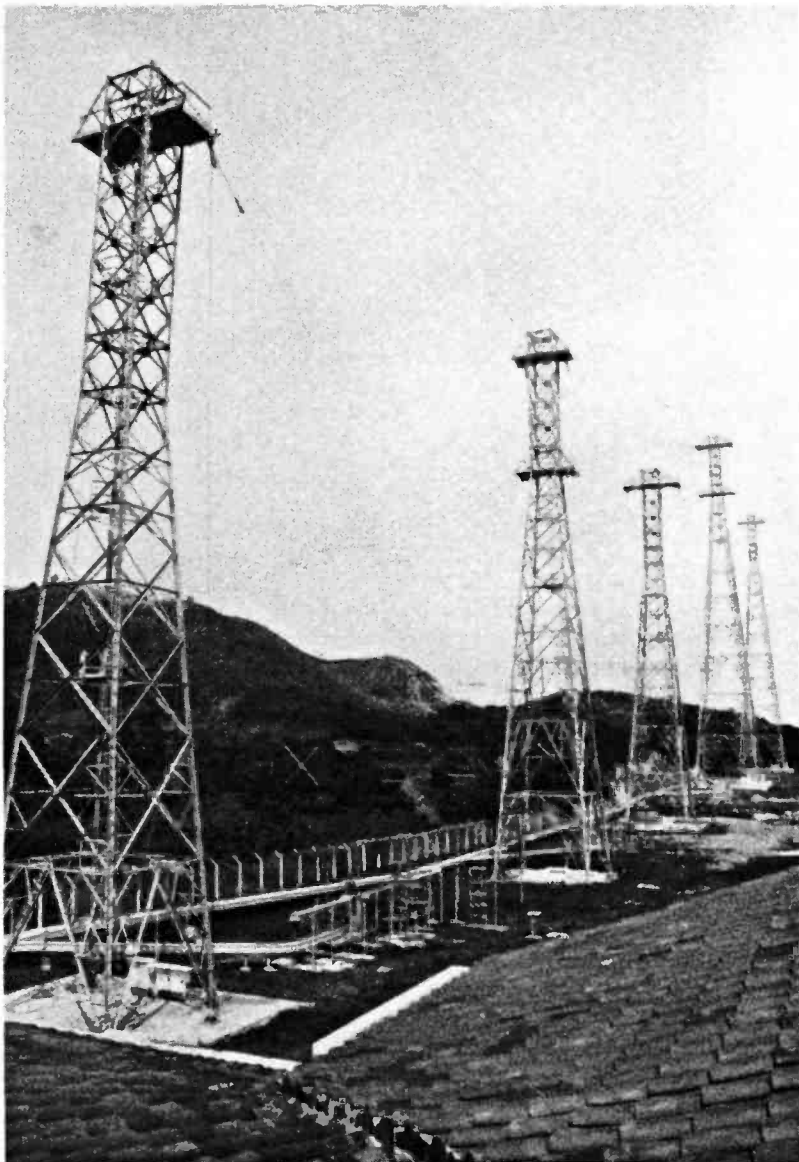

Another view of the BBC East Asia Relay Station.

All photographs supplied by BBC World Service

Unfortunately, the "experiment" was only partially successful due to a breakdown in the transmitter power supply, but enough of the programme was received in various parts of the Empire for it to be hailed a great achievement. Marcuse was showered with messages of congratulation...but an application he made to the Post Office a week later to complete the programme was rejected by the Postmaster General on the grounds that the object of the "experiment" had been achieved. Could it have been that the W/T Board, the Post Office and the BBC were all a little envious of the accomplishment of just one radio amateur?

Short wave broadcast transmissions continued almost daily from G2NM until the end of August 1928. Many years later Marcuse admitted that he had used 1.5kW into his Zeppelin antenna. His own words "the gear really did its stuff" sum up those remarkable experiments of so long ago and the test transmissions are commemorated today by a plaque mounted on G2MN's old home 'Coombe Dingle' in Caterham, which was erected by the Radio Amateur Old Timers' Association in 1962.

Empire Broadcasting

Following the successful amateur tests the BBC began experimental short wave transmissions to the Empire on 11 November 1927, from a transmitter - callsign G5SW - located at Chelmsford in Essex. Their transmissions were on a wavelength of 20m and as a result were not heard as well and as consistently in Australasia as the original experimental service from Gerald Marcuse's transmitter working on a wavelength of 33m.

The BBC's decision to proceed with a short wave service was a correct one, within three years every major nation had begun to realise the vast potential of the short waves as a means of communicating news - and ultimately propaganda - to the remote corners of the globe.

By the end of 1928 the Marconi G5SW transmitter in Chelmsford was becoming unreliable and there were many long breakdowns. The unit had been hurriedly assembled for the short-term tests and after long deliberation and examination of the costs involved - remember that this was at a time of severe economic depression - the decision was taken by the BBC to proceed alone with an Empire short wave service.

A first step was to replace the Chelmsford transmitter with a completely new station located at Daventry, and on 13 January 1932 the BBC Board approved the sum of £50 000 for the erection of this station.

Daventry, located in a county set in the heart of the English countryside, was originally equipped with two transmitters which were modulated at low level and could deliver a power output of 10 to 15kW to the antenna feeders. The higher output power was available for the longer wavelengths used, in the 49m band. Operationally it was arranged so that either transmitter could work on any of the wavelengths assigned to Daventry at that time and could be connected to any of the antennas via a two-wire open feeder system.

The station started short wave test transmissions on 14 November 1932 and the programme service began on December 1932. The Christmas Day broadcast by King George V was radiated by the Empire station and this was the first time that this special broadcast had been transmitted to listeners outside of the UK.

Thus began the long association of Daventry with broadcasts to listeners abroad and from those (compared with the service nowadays!) small beginnings, the station has grown and been modified to such an extent that it now boasts four 100kW and six 300kW transmitters for services to west, south-west, central and south-eastern Europe, northern Europe, USSR, Middle East, Africa and the Americas while also relaying programmes for Radio Canada.

As the BBC World Service approaches the 1990s, new equipment and relay stations around the world take the programmes to the listener whether they be in Iran or India, Chile or China and with the past events of 1989 to reflect on, who can doubt the important part played by the BBC's new Hong Kong transmitters in relaying information to China following the events in the summer of 1989? **PW**

GAREX THE ORIGINAL SCANNER SPECIALISTS

Pioneers in the UK scanner market. The Company that offers its customers the security of complete service backup. Experienced technical staff to help you make the right choice — we stock all major brands, so we don't pressurise you into buying the model we want you to have. Reliable equipment, fully tested before despatch with guaranteed factory-backed in-house maintenance if required. If we cannot service it, we don't sell it. You can trust Garex!

SECONDHAND STALL!

Our large turnover of scanners means we always have a range of fully reconditioned and guaranteed secondhand items. Ask for list.

LATEST MODELS

Contact us for details.

AOR 2002

THE WIDE RANGE SCANNER

- * Covers: 25-550MHz, 800MHz-1.3GHz
- * AM & NFM & WFM on all bands
- * Computer interface socket
- * 20 memories
- * Compact size
- * 12V dc operation
- * Up/down step control knob

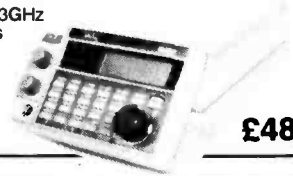

£487

REVCO RS-3000

THE COMPACT SCANNER

- * Size only 6"x2"x8"
- * Covers: 26-32MHz, 60-90MHz, 118-180MHz, 380-512MHz
- * AM & FM all bands
- * Liquid crystal display
- * 50 memories
- * Scan, search, priority



£225

AOR 800E

THE SMALLER HANDY-SCANNER

- * Covers: 75-106MHz, 118-175MHz, 406-496MHz, 830-950MHz
- * AM & NFM programmable on all bands
- * Full scan & search functions are available
- * 20 memories
- * Measures only 2.5"x5.5"x2"
- * Nicads, charger & BNC whip antenna included in the price



£169.50

JIL SX-200N

THE SUPERIOR SCANNER

- * The choice of the professionals
- * Proven reliability
- * Covers: 26-88MHz, 108-180MHz, 380-514MHz
- * AM & NFM on all bands
- * Positive action keyboard
- * 16 memories
- * 12V dc & 240V ac



£325

JIL SX-400

THE PROFESSIONAL SCANNER

- * Basic coverage 26-520MHz
- * AM, NFM & WFM
- * Expandable from 100kHz to 1.4GHz with SSB and CW
- * Computer control options
- * IF output terminals
- * Specifications set by professionals

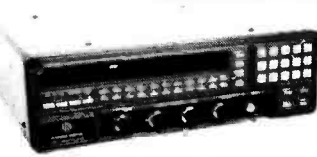

£649

BLACK JAGUAR BJ200 Mk III

THE VALUE FOR MONEY HAND SCANNER

- * UK version.
- * Wide coverage 26-30MHz, 60-90MHz, 108-180MHz, 210-260MHz, 380-520MHz.
- * AM and FM all bands, manual and programmable.
- * Nicads, charger, soft case, flexwhip antenna.
- * Car adaptors and other accessories available.

£199

AOR900 UK

THE FAVOURITE HAND SCANNER

- * UK version — full service backup.
- * Covers 108-180MHz, 220-280MHz, 300-380MHz, 420-470MHz, 830-950MHz.
- * AM and FM all bands, manual and programmable.
- * 100 memories (5 banks of 20).
- * Nicads, charger, flexiwhip antennas.

£199

WIDE-BAND PRE-AMPLIFIERS

The problem with omni-directional wide-band antennas is their lack of gain. The REVCO PA3 range of wide-band pre-amplifiers complement the antennas and compensate for their shortcomings.

The basic specification of the products is similar: coverage 20MHz-1GHz, at 1GHz: minimum gain 13dB, noise factor 5.5dB. Choose from a mast-head version (PA3) or a standard die-cast box style (PA3). Best results are normally obtained from the masthead model which gives a boost to weak signals which would otherwise have been lost in the feeder cable. Also feeder cable noise is not amplified which is the case if the amplifier is mounted at the base of the feeder. On the other hand, the die-cast box version requires no special installation and is readily taken out of circuit. The masthead model is supplied with a special power unit which feeds the DC supply into the antenna feeder. No psu is provided for the PA3 as any 9-15V DC source is suitable (current requirement about 25mA).

The PA3 finds application in instrument work, e.g. input to spectrum analysers, boosting the output from signal generators to give a low-power TX.

The standard version of the PA3 has BNC sockets and is designated "PA3/B"; available to special order N-type sockets ("PA3/N") or SO239 ("PA3/S").

A special feature of the PA3 series is a high-pass filter to attenuate frequencies below 20MHz; high-power HF & MF broadcast stations can be very troublesome!

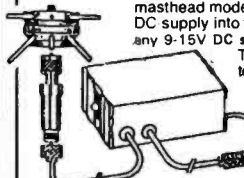

PA3 Masthead, with PSU	PA31/B BNC	£35.50
PL259	PA31/N N-type	£38.95
N-type	PA31/S SO239	£35.50

REVCONE

The UK's favourite discone composed of traditional British quality engineering. The REVCONE works well without exaggerated advertising claims. It is designed to cover 50 to 500MHz, and thousands of satisfied users will testify to its efficiency. Unlike some manufacturers we do not quote inflated figures for gain. A gain figure is meaningless unless the reference point is stated.

Optional vertical whip feature: It is possible to fit a vertical whip section to a discone. We do not want to give you the "Hard sell" where this vertical element is concerned, but there is some evidence that it may improve the performance of the antenna around the resonant frequency of the whip. That's why we make it an optional feature.

Another option is the N-type connector instead of the popular SO239. N-types give a better UHF performance, but they cost a bit more. The choice is yours. Because the REVCONE is British-made by a company which has been in business for 30 years, you buy with confidence, knowing that there is back-up should anything go wrong.

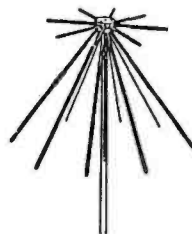

Standard model (SO239 socket) £35.95
N-socket model £37.95
Cable and plugs available



GAREX ELECTRONICS

MAIN DISTRIBUTOR OF REVCO PRODUCTS. PRICES INCLUDE UK P&P and 15% VAT. Ask for details or our interest free credit.

HARROW HOUSE, AKEMAN STREET, TRING, HERTS HP23 6AA.
Phone 0296 686644 or 044 262 8580. Callers by appointment only.



AKD

Unit 5
Parsons Green Estate
Boulton Road
Stevenage
Herts SG1 4QG



THE FILTER SPECIALISTS



MAIL ORDER DEPT.
Stock Items Normally
Despatched within 48 hours,
21 days latest.
TEL. 0438 351710

TV INTERFERENCE PROBLEMS??!!

Are you having trouble receiving a watchable picture on your TV? If so, the cause may be aerialborne interference. For many years AKD has manufactured a low cost range of in-line interference suppression filters that are easily inserted into the aerial system to help reduce the effects of interference from local taxi radio, CB, amateur radio, airport radar, etc. Each filter is terminated in standard aerial co-ax plug and socket and requires no external power. Fitting could not be more simple. No technical knowledge is needed. There are 13 standard stocked filters in our range, but individual filters can be tuned to reject interference at specific frequencies if required. If you are not sure which filter type to order or have any questions regarding interference phone our helpline on 0438 351710 and ask for John who will be pleased to assist you in making the best choice of filter.

THE FILTER RANGE IS AS FOLLOWS:

FILTER TYPE RBF1

A range of filters designed to eliminate Radar Blip, especially noticeable on video recorders. Stocked on channel 36 and 846MHz (RAF Boulmer interference) can be tuned at our factory from 420MHz to 890MHz. **£6.95 each**

FILTER TYPE TNF2 (Suitable for UHF TV only)

A range of Tuned Notch filters stocked on generally useful frequencies used by Amateur Radio operators, CB users, Private Taxi companies. Can also be factory tuned to reject any spot frequency up to 300MHz. Now stocked at 50 & 70 MHz. **£7.95 each**

FILTER TYPE HPF1

Used in weaker reception areas for general interference problems. Use with UHF TV, Video & Pre-Amps **£6.95 each**

FILTER TYPE HPFS

Used in strong signal area for severe interference on UHF only **£7.50 each**

FILTER TYPE BB1

A general purpose filter that can be used on its own or together with other filters in our range for severe interference problems. Ideal at the input of VCR and Pre-Amps. **£6.95 each**

FILTER TYPE HPF6

The HPF6 is a 6 section UHF high pass filter particularly useful for the rejection of any aerialborne interference below 450 MHz yet having minimal insertion loss on Bands 4 & 5 (UHF TV). It can be used with UHF TV, video recorders and should be sited before any aerial pre-amp. In common with all the other filters in the AKD range the HPF6 requires no external power and is simply fitted in line with the aerial co-ax with its standard terminations.

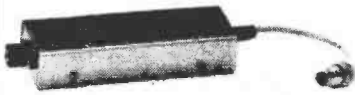

£17.00 each

Technical Details:—

Pass Band:— Frequency range 470-895MHz
Stop Band:— (inner only) DC-450MHz typical >75db @ 300MHz >30db @ 435MHz
Input & Output Impedance:— 75 ohms nominal
Case Material:— Aluminium
Case Size:— 122x40x25mm (excl socket, flylead & plug)
Terminations:— Standard Belling Lee type aerial co-ax plug and socket

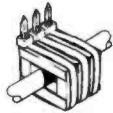

Unifilter 'CLAMP-ON' RADIO-FREQUENCY CHOKE

PHONE OR SAE FOR PRODUCT SPECIFICATION & APPLICATION NOTES

Allows leads to be toroidally protected without the need to cut or remove plugs or connectors. Ideally suited for moulded plugs, leads, ribbon, and large diameter cables. Can easily be fitted and stacked in multiples to increase rejection. 'UNIFILTER' works by suppressing the interference currents that flow along the outside of cables without affecting the signals or power flowing inside. This means that you don't need to worry about upsetting normal operation or invalidating guarantees. Suitable for both reducing the emission of, or rejecting the effect of, 'common mode' interference as experienced on computer, hi-fi & speaker leads, as well as the normal mains & aerial cables.

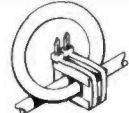

UF 4 KIT (SUITABLE FOR SMALLER INSTALLATIONS) **£9.89**

UF 8 KIT (FOR MULTI INSTALLATIONS) **£19.55**

ALL PRODUCTS ARE AVAILABLE FROM US DIRECT
MAIL ORDER OR WHY NOT MAKE USE OF OUR ACCESS
& VISA FACILITIES TO ENSURE MINIMUM DELAY

ALL AKD PRODUCTS CARRY THE USUAL AKD 2 YEAR
GUARANTEE. PRICES QUOTED ARE CORRECT AT TIME
OF GOING TO PRESS AND INCLUDE VAT,
POSTAGE & PACKING

TRADE ENQUIRIES WELCOME
TRADE ORDERS CAN NOW BE PLACED BY
FAX ON 0438 357591

Props: RT & VEL Wagstaffe. Technical Adviser: John Armstrong

COMMUNICATION CENTRE OF THE NORTH

The largest range of communications equipment available in the North.
Full range of receivers, transceivers, antennas, power supplies, meters.
Ali tubing - wall brackets - rotators - insulators.

FULL KENWOOD RANGE IN STOCK.

BUTTERNUT		SCANNING RECEIVER RANGE	
HF2V 40-80m vertical.....	£142.00	AR300 Base Station.....	£765.00
20 MRK 20m add on kit.....	£33.48	AR2002 Base Station.....	£487.00
HF6VX 6 band vertical.....	£159.00	AR950 Base Station.....	£249.00
TBR160S 160m Add on kit.....	£53.99	AR900 Hand Held.....	£199.00
HF48 Triband Mini Beam.....	£235.00	AR800 Hand Held.....	£165.00
NEW RS 5 Band Vertical.....	£259.00	JUPITER II Hand Held.....	£299.00
CUSHCRAFT		JUPITER MV600 Base Station.....	£379.00
A3 3 element Tribander.....	£329.00	ICOM R700 Base Station.....	£380.00
A4 4 element Tribander.....	£353.00	RS35 Airband Base Station.....	£235.00
10-3CD 3 element 10m.....	£115.00	WIN 108 Hand Held Airband.....	£175.00
15-3CD 3 element 15m.....	£139.75	SWR/POWER METERS	
20-3CD 3 element 20m.....	£238.00	MFJ 815 HF 2kw SWR/PWR.....	£57.32
AP8 8 band 25ft vertical.....	£164.00	Ym1E Twin Meter 3.5-150MHz.....	£32.00
AV5 5 band 25ft vertical.....	£123.00	DIAWA CN410M 35-150MHz.....	£81.72
18 element 2m Boomer.....	£106.00	DIAWA CN460M 140-450MHz.....	£65.40
15 element 2m Boomer.....	£85.00	NS660P 1.8-150MHz + PEP.....	£115.00
ANTENNA TUNERS		KOYO-100 1.8-60MHz.....	£75.00
Kenwood AT230.....	£208.00	KOYO-200 1.8-200MHz.....	£60.00
MFJ 962B 1.5k Tuner.....	£241.00	KOYO-400 140-525MHz.....	£62.00
MFJ 949C 300W Versatuner.....	£157.00	DUMMY LOADS	
MFJ 941D watt Basic.....	£105.00	DL60 60 watt.....	£10.96
MFJ 1601 Random Wire Tuner.....	£42.02	DL600 600 watt.....	£62.75
Kenwood AT250 Automatic.....	£366.00	MFJ2600 300 watt.....	£30.00
A FULL RANGE OF RECEIVERS FOR AIR-BAND - MARINE - SHORT WAVE - AVAILABLE		NEW MODEL	
G5RV full size £16.50, half size £14.50 Full range of Antenna - Accessories plus full range of VHF - UHF - HF mobile Antennas. Alpha HF Linears now available.		HF225 GENERAL COVERAGE RECEIVER £395.00	

Full range of RSGB and ARRL publications in stock.
Part Exchanges welcome. Second hand lists daily.
Send S.A.E. for details of any equipment.
HP terms. Access/Barclaycard facilities.
Open 6 days a week. 24 Hour Mail Order Service.
Goods normally despatched by return of post.

FULL TEN TECH RANGE NOW AVAILABLE

"Paragon", "Corsair",
"Argosy", "Century", "Omni V"
plus all accessories

Phone 0942-676790.

STEPHENS JAMES LTD.
47 WARRINGTON ROAD,
LEIGH, LANCS. WN7 3EA.

RST

RST MAIL ORDER CO.
LANGREX SUPPLIES LTD,
1 MAYO ROAD,
CROYDON,
SURREY CR0 2QP.
SPECIAL EXPRESS
MAIL ORDER SERVICE

£p		EM81		PL519		6AK5		6KD6	
AZ31	4.00	EM87	2.50	PL802	6.00	6AL5	1.50	6BG	7.50
CL33	6.50	EN91	6.50	PY323	2.50	GAM6	6.02	6L6C	5.00
DY867	1.50	EY51	2.75	PY81	1.50	GAN5	4.75	6L6GC	4.50
DY802	1.50	EY86	1.75	PY82	1.50	GAN8A	4.50	6L6GC GE	9.00
E88CC	10.33	EY88	1.75	PY83	1.25	6AQ5	3.25	6L7	2.50
E180F	12.05	EY500A	1.00	PY88	2.00	6AR5	25.00	6LQ6	8.50
E810F	32.48	EZ80	1.50	PY500A	4.00	6AS6	8.86	6O2	3.75
EABCS0	1.25	EZ81	1.50	PY800	1.50	6ASTG	8.75	12AX7A	4.50
EB91	1.50	GY501	3.00	PY801	1.50	BAT8	1.25	6A7	10.00
EBF80	1.50	GZ22	4.00	QQV02-6	19.50	6AUSGT	5.00	6SA7	3.00
EBF89	1.50	GZ23	4.75	QQV03-10	5.00	6AU6	2.50	6SC7	2.75
EC91	8.00	GZ34	4.75	QQV03-10 Multi	6AUBA	3.75	65G7M	2.50	
ECC33	4.50	GZ37	7.50	QQV03-10 Multi	6AUBA	3.75	6SJ7	3.25	
ECC35	4.50	KT61	7.50	QQV06-40A	27.50	6BA7	1.50	6SK7	3.50
ECC81	1.75	KT66	15.00	QQV06-40A Multi	6B8	5.00	6SL7GT	3.00	
ECC82	1.75	KT77	12.00	QQV06-40A Multi	6B6E	1.50	6SN7GT	3.00	
ECC83	3.50	KT88	15.00	QV03-12	6.80	6B8B	2.25	6SS7	2.75
ECC85	3.50	N78	15.00	R18	3.00	6B9A	2.00	6UBA	2.25
ECC88	3.50	OA2	3.25	R19	9.24	6B9B	2.25	6V6GT	4.25
ECC91	8.93	OB2	4.35	SP41	6.00	6B9C	3.50	6X4	3.00
ECF80	1.50	OC3	2.50	SP61	4.00	6BR7	8.00	6X5GT	1.75
ECH35	3.00	OD3	2.50	U19	13.75	6BR8A	3.50	12AX7A	4.50
ECH42	3.50	PC86	2.50	U25	2.50	6BS7	8.00	12AX7	1.75
U3B1	3.00	PC88	2.50	U26	2.50	6BWA	6.00	12BA6	2.50
ECL80	1.50	PC92	1.75	U37	9.00	6BWB	1.50	12BE6	2.50
ECL82	1.50	PC97	1.75	UABCS0	1.25	6C4	1.25	12BY7A	3.00
ECL83	3.00	PCF80	2.50	UBF89	1.50	6C6	3.50	12H7	4.50
ECL86	1.75	PCF82	2.00	UCH42	4.00	6C8BA	2.50	30FL172	1.38
EF37A	5.00	PCF86	2.50	UCH81	2.50	6C8C	5.00	30FL17	2.50
EF39	2.75	PCF88	2.50	UCH82	1.75	6CL6	3.75	30P19	2.50
EF41	3.50	PCF89	2.50	UCLB3	2.50	6CH6	13.00	30PL13	1.80
EF42	4.50	PCF801	2.50	UCLB8	1.75	6CMB	13.00	30PL14	1.80
EF50	2.50	PCF802	2.50	UF89	2.00	6CWA	8.00	57B2	65.00
EF54	5.00	PCF805	1.70	UL41	10.00	6D06	3.50	57B7	45.00
EF55	2.50	PCF806	1.70	UL54	1.75	6D0C5	8.50	800	7.50
EF80	1.75	PCF808	1.70	U41	4.00	6D0BB	4.75	807	3.75
EF86	5.00	PCH200	3.00	UY85	2.25	6E8	3.00	811A	10.33
EF91	2.96	PCL82	2.00	VR109/30	2.50	6E8A	1.85	812A	52.50
EF92	6.37	PCL83	3.00	VR150/30	2.50	6E8B	3.75	813	65.00
EF183	2.00	PCL84	2.00	Z758	25.00	6F6	3.00	866A	35.00
EF184	2.00	PCL85	2.50	Z803U	25.00	6GK6	3.50	872A	20.00
EH90	1.75	PCL86	2.50	ZD21	3.25	6H6	3.00	931A	19.50
EL32	2.50	PL36	2.50	ZD22	50.00	6H6B	3.75	931B	25.00
EL33	7.50	PL81	1.75	4CX250B	61.00	6J5	4.50	9573	6.00
EL34 Mullard	4.50	PL82	1.50	5R4GY	5.50	6J6	2.00	5814A	4.00
EL34 Siemens	10.00	PL83	2.50	5Y4G	4.50	6J7	4.75	5842	10.00
EL36	2.50	PL84	2.00	5Y4GT	3.50	6J8A	10.00	6146B GE	15.00
EL80	25.00	PL85	2.50	5Z4GT	4.00	6J8C	8.50	6550A	12.50
EL81	5.25	PL86	2.00	5Z4GT	2.50	6J8C	9.00	6883B	9.50
EL84	2.25	PL87	1.75	6X0L2	1.75	6K6GT	2.75	6973	8.75
EL86	2.75	PL88	5.50	6AB7	3.00	6K7	3.00	7025	4.50
EL91	7.39	PL509	6.00	6AH6	5.00	6K8	3.00	7027A	11.00
EL95	2.00							7586	15.00
EL360	18.50							7597	23.00
								7868	8.50

Tel. 01-684 1186 Open daily to callers: Mon-Fri 9 a.m.-4p.m. Fax: 01-684 3056
Valves, Tubes and Transistors - Closed Saturday
Terms C.W.O. only, allow 7 days for delivery.
Quotations for any types not listed S.A.E.
Prices excluding Post and packing £1.00 per order + VAT
VAT add 15% VISA CARDS ACCEPTABLE OVER TELEPHONE

Prices correct when going to press

Ten SpOt

Many amateurs are willing to invest vast sums of money on their rigs, but relatively few pay the same attention to the antenna system. It is a fact that a rig costing thousands-plus, running into a lump of wet string will not give as good results as a pile of junk into a good properly resonated and dedicated antenna.

The first step to being that exceptional signal on 28MHz is to decide what you want to do on the band. If you want a good all-round antenna that takes up little space and has some degree of directivity and some gain over a dipole, then the single element full wave loop either in a triangular shape (Fig. 3) or as a quad loop (Fig. 1) will give excellent results. The correct length for resonance on 28.500MHz is found by using the formula:

$$468/f(\text{MHz}) = 468/28.5 = 16.42 \text{ feet}$$

The same calculation can also be used to work out dimensions for dipoles, groundplanes and end-fed wires, etc.

The loop will work well at very low heights above ground, and in the case of the quad can be made to radiate vertical polarisation by feeding the coaxial cable halfway up the vertical section, Fig. 1, whereas horizontal polarisation can be achieved by feeding halfway along the horizontal section as shown in Fig. 2.

The radiation is broadside or through the loop and is bi-directional.

The addition of a reflector element 5% longer and spaced about 0.2λ from the driven element will provide a very potent and gainy beam antenna. Both the delta loop and the quad loop will function very well for DX as well as giving good results to like-polarised inter-G stations.

This month, John Petters G3YPZ talks about the antennas to use on the 28MHz band as this is the most dangerous area as far as success or failure on the band is concerned

It should be noted here that the polarisation of the antenna is not at all critical when working DX on skip, because the ionosphere constantly changes the polarisation of the signal. I have observed many DX signals fading into the noise on my 3-element Yagi, while building up to a considerable strength on the $5\lambda/8$ groundplane. Within a few seconds the reverse is true.

When working groundwave (spacewave) line-of-sight signals, or indeed those stations arriving on a tropospheric enhanced path it is essential to have the same polarisation. Working cross-polarised will result in losses often in excess of 20dB. Stations using beams often notice very little difference in beam direction when working local stations using vertical antennas.

If space, money, local planners and the XYL permits, the quad or the Yagi beam will give excellent results on both local and DX signals.

The most common size Yagi antenna is a 3-element. This is manageable in most gardens, with an element length of roughly 5m. Unlike the quad, which can be run at heights as low as 2m above the deck, the Yagi needs to be at least a half-wave above the ground (or the roof) and better still at a full-wave high. Running the Yagi close to the ground will result in

an undesirably high angle of radiation.

Typical range on a 2-element quad or 3-element Yagi on non-skip propagation should be in excess of 100 miles under flat conditions. Distances of 300km plus have been worked under enhanced conditions. Of course, when the band is open then the world is your oyster.

The Vertical Antenna

One of the most cost-effective antenna systems is the groundplane. The optimum length is the $5\lambda/8$ wave which gives the lowest angle of radiation and gain over a reference dipole.

There are a number of CB antennas on the market which can readily be modified for the 28MHz band. The most common being the $1\lambda/2$ wave end-fed. These antennas need to be mounted at least a $1\lambda/2$ wave above the ground, and preferably higher. Grounding to a metal pole is necessary to enable a good match. Again using the formula quoted above for the loop it is possible to calculate the resonant length for any part of the band.

These antennas use a tapped coil to match the impedance from the high Z of the half wave to the 50Ω required for the coaxial cable. In most cases it

should just be adequate to shorten the length of the vertical itself for a good 1:1 v.s.w.r. but it may in some cases require the matching network to be adjusted.

This will entail drilling the housing off, and ensuring that the assembly is satisfactorily waterproofed afterwards

NEVER, NEVER, NEVER use an a.t.u. or Transmatch when using or tuning one of these antennas. They are designed to match into 50Ω cable and if you have a high s.w.r. you will not cure the problem by inserting an a.t.u. at the shack end between two pieces of coaxial cable. The matching has to be achieved between the antenna and the cable, all they achieve is to make the feeder become part of the antenna system.

The $1\lambda/2$ end-fed does not need any radials and must be viewed as a free space antenna.

The $5\lambda/8$ is a groundplane antenna and needs a good radial system. The antenna will work at ground level but, of course, performs better at greater heights. The same calculation can be made to adjust the length of the vertical element and also of the $1\lambda/4$ radials. The matching network should not need adjusting on these antennas.

Both $1\lambda/4$ and $3\lambda/8$ antennas will work well but not as efficiently as the $1\lambda/2$ or $5\lambda/8$, but $3\lambda/4$ verticals should never be used as the angle of radiation is far too high for good results.

Trapped multi-band verticals are always a good compromise and should be avoided at all costs. They, along with mini beams, trapped dipoles, 5RVs, etc., will not give you that big signal and will no doubt leave you highly disappointed in the band.

Next month, we will take a look at mobile operation, what's happening on the band and your reports. **PW**

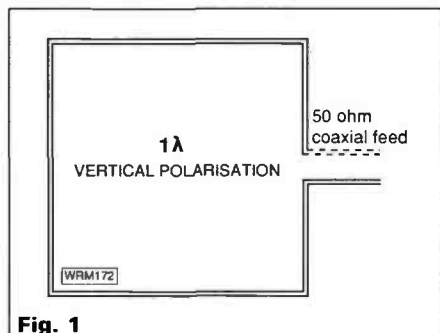

Fig. 1

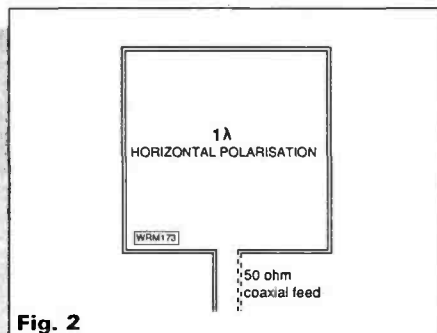

Fig. 2

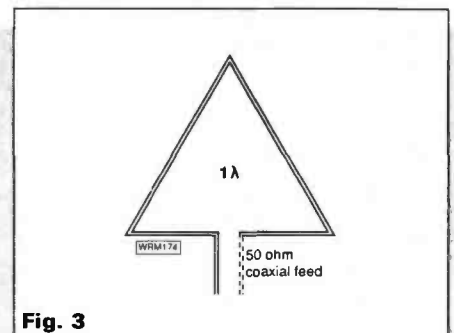

Fig. 3

Packet Update 8

*Roger J. Cooke
G3LDI continues
his popular series
with news and
views from around
the world of
packet radio*

I have received a few telephone calls during the past month or so regarding the software I described in previous articles. The concern of the callers was that despite enclosing disks, return mailers and sufficient return postage, the software has not been forthcoming. In one case, the applicant enclosed ten dollars, publicity material and double the amount of disks necessary! We all know that a certain delay is inevitable (goodness knows I am to blame for certain in that respect!) but since it was suggested in several bulletins and magazines that one should apply to these particular amateurs for this software and considering that the conditions of application were more than met, I feel it is incumbent on that amateur to supply the required software, even though the particular programs are now widely available in this country. I am sending some reminders to those suppliers on behalf of those still waiting. I should perhaps mention that the delay in question is several months, which would seem to be unacceptable.

A cry from the heart! An EI station telephoned me one evening with a request for packet software for the Sinclair QL. If anybody can help, I would be pleased to hear from you so that I may pass any information along.

AMTOR LINK

Some of you may not know that in May 1989, the GB7PLX AMTOR Gateway was fully licensed and is now operational. This makes the requirement for hierarchical addressing and forwarding more desirable than ever. Messages can be forwarded from UK packet mailboxes to the gateway and from there to a number of AMTOR mailboxes world-wide, and via several of these to the national packet networks of some foreign countries. To use the gateway, first check with the Sysop of your home BBS that he has a forwarding route to GB7PLX that is entirely via mailboxes using WORLI software with hierarchical addressing capability. (This is where the UK network comes unstuck!) If so, then you can send messages through the gateway as follows:

1: For messages to foreign packet mailboxes, enter:

SP<Callsign>@<BBS>.<ccc>. AMTOR. For example, SP VK4AHD @ VK4BBS.AUS.AMTOR. The <ccc> is the three-letter country-code. (I described this hierarchical addressing in one of my previous articles) Check with regular bulletins for the country-codes that are valid. The initial list

consists of :

NORway
SWEden
AUStralia
USA

2: For messages to world-wide AMTOR mailboxes, enter:

SP <Callsign> @ <AMTORBBS>.AMTOR

For example, SP VK2SG @ VK2AGA.AMTOR

Again, check from the bulletins which Amtor BBS callsigns can be reached. The initial list consists of:

PA0RYS
LA9OK
HB9AK
SM6GXQ
SK7CS
K5SV Texas
KB1PJ Ohio
WA8DRZ California
VK2AGE Sydney

3: To send messages just to the GB7PLX mailbox, for collection on h.f. just enter:

SP <Callsign> @ GB7PLX

If your home BBS does not have an hierarchical route to GB7PLX, then this last facility is the only one open to you. Note that return messages may not, initially, come via the same route.

Sysops en route to GB7PLX, please arrange for traffic for AMTOR and GB7PLX to be forwarded to GB7PLX via GB7KCM. This has probably already been implemented. Any queries, please address them to Peter G3PLX @ GB7PLX. Peter will be happy to help.

The AMTOR linking with the Amlink facility is very popular and useful on h.f. It provides an alternative as well as a supplement to the h.f. packet forwarding system. I receive the RTTY DX bulletins regularly from OD5NG using AMTOR as its origin.

If you are interested in trying the Amlink connection, the the stations shown in Fig. 1 are reported to be operating 24 hours a day.

A comprehensive list of commands for operating AMTOR was produced by G3XTL and is reproduced in Fig 1. This would be very useful to have by your side if you intend operating this mode.

TEXNET

The Texas Packet Radio Society (TPRS) was founded in 1985 as an educational, public service and scientific research non-profit corporation. The

Table 1

Call	SELCAL	Name	QTH	Frequency
AH6D	AAHD	Paul	Aiea, Honolulu	14.071.5, 14.0735, 14.075 & 14.0775MHz
DU9BC	DUBC	Fred	Davao City, Philippines	14.072 (24hrs) & 7.023MHz (mornings)
G4SCA	GSCA	John	Plymouth, England	14.070MHz (1800-2200UTC, temporary)
HL9TG	HLTG	Gary	Pyongtaek, Korea	14.0735MHz
KB1PL/8	KBPJ	David	Shaker Heights, Ohio	14.0705MHz
K7BUC	KBUC	Del	Phoenix Arizona	7.0475, 7.071, 10.140, 14.0725, 14.0735 & 14.074-6MHz
K5SV	KKSV	Ed	Cacyon Lake, Texas	14.0725MHz
NI9Y	NNIY	Dan	Mishawaka, Indiana	14.0725MHz
PJ2MI	PJMI	Jose	Curacao, Neth Antilles	14.0778MHz (1000-1200 & 2200-0100UTC)
VK2AGE	VAGE	Gordon	Goonellabah, Australia	7.045, 14.075, 14.077 & 21.076MHz
VK2EHQ	VEHQ	Peter	Australia	14.081MHz (1400-2300UTC beaming Europe) (2300-1000UTC Beaming South Pacific)
VK6YM	VKYM	Herve	Perth, Australia	14.081MHz (1400-2300UTC beaming Europe) (2300-1000UTC Beaming South Pacific)
WA8DRZ/6	WDRZ	Craig	Palomar Park, California	14.0725, 14.0735, 14.0745 & 14.0755MHz
WB7QWG/9	WQWG	Bob	Indianapolis, Indiana	14.0715MHz
ZFIGC	ZFGC	Frank	Georgetown, G. Caymen Is	14.0715MHz (1100-0300 Sun-Thurs, 1100-2300 Fri & 0000-0300 Sat)
ZL1ACO	ZACO	Neill	Pukekohe, New Zealand	14.0725MHz

primary goal of the TPRS is to design and research amateur radio packet networks. In 1987, the Texas VHF-FM Society commissioned the TPRS to coordinate digital communication networks within the state of Texas. Both organisations have recognised the need for reliable network systems to handle large volumes of packet radio traffic efficiently.

TPRS has organised state-wide working groups to cover various networking topics. New groups are planned to form as needed to provide channels for discussion and to help provide direction for that area of digital communications. The current working groups are the Texas Network Group, the Mailbox/BBS group, and the Texnet Support Groups (Software and Hardware).

TPRS has established a digital packet network protocol, a standard hardware package for the network nodes, and is conducting on-the-air tests of the software modules that implement the Texnet network. The basic design philosophy of Texnet is of an open, inexpensive, multi-resource, high-speed 'backbone' with access through multi-connect capable local nodes. On the high-speed side, Texnet is a 9600 baud network system. For local access, compatibility with the typical 144MHz Band, AX25, 1200 baud, AFSK/FM station is the normal system of operation. Other baud rates and modulation techniques can be supported on the primary user port or a secondary port. The system is totally compatible with both versions of the AX25 protocol specifications for user connections. With these general specifications, Texnet has been designed and tested to enable all users to take advantage of this high-speed, full protocol protected network system.

Each node offers, in addition to Texnet access, local area digipeater service, 2 conference bridges for full protocol protected roundtable or net operation, a full multi-connect, multi-user mailbox system, a local console for installation and maintenance set-ups, a debugger module for long-distance and local software monitoring, and a weather information service for the regional weather teletype wire loop.

The Texnet network system has been operational since October 1986. Use of the Texnet system is open to all amateur operators. TPRS has been coordinating the installation of the Texnet system and currently the network runs from Dallas to Rockport on the Gulf. Texnet boards have been distributed to California, Michigan, Oklahoma, Ohio, Indiana, Alaska, Belgium and Japan. Network nodes have been built primarily by local groups.

TPRS is interested in spreading the information and efforts as widely as possible. They will provide information to any group interested in using Texnet and can be contacted at the following address.

Texas Packet Radio Society,
PO. Box 831566,
Richardson, Texas, USA, 75083.

A summary of the users manual is given in Fig. 2.

PW

More next month - any news to G3LDI @ GB7LDI, QTHR or telephone 0508 70278. 73 de Roger G3LDI. Happy Packeting.

From:G3XTL @GB7MUM.GBR.EU
Msg RID:117E13B7
AMTOR LANGUAGE

A LIST OF TERMS, ABBREVIATIONS AND COMMANDS NOW IN USE FOR AMTOR AND APLINK STATIONS.

A MESSAGE STATUS (APLINK)
A ABORT COMMAND (APLINK)
AAB AUTO ANSWER-BACK (APLINK)
AMTOR AMATEUR TELEPRINTING OVER RADIO
APLINK AMTOR/PACKET LINK (MAILBOX/BBS.)
ARD AUTO REQUEST (MAIN AMTOR MODE.)
AT COMMAND TO TRANSFER FILE TO ANOTHER STATION
BK BREAK
B MODE FEC MODE
CONTROL D TERMINATOR
(CR/LF) TO COMPLETE THE COMMAND (APLINK)
FEC FORWARD ERROR CORRECTION
GA GO AHEAD (APLINK)
GPLX SELCAL OF GB7PLX
HELP COMMAND TO READ HELP MESSAGE
HBAK SELCAL OF HBAK
INPUT COMMAND TO ENTER A MESSAGE
L LIST (APLINK)
LAOK SELCAL OF LAOK
LB LIST BULLETINS (APLINK)
LIST OUTPUTS THE LIST
LOGIN COMMAND TO SIGN IN (APLINK)
LOGOFF OR
LOGOUT COMMAND TO SIGN OUT (APLINK)
LR LIST RECENT USERS (APLINK)
MB MAILBOX
MODE A ARD MODE
MODE B FEC MODE
MODE L LISTEN (TO OTHER ARD LINKS)
MSG MESSAGE
N NO (OR NOT)
NEW COMMAND TO REGISTER (APLINK)
NNNN MESSAGE ENDS (APLINK)
OUTPUT COMMAND TO READ A FILE
ORR AUTO MODE
ORT CLOSE-DOWN
ORU NOTHING FOR YOU (APLINK)
ORV READY
QUIT COMMAND USED BY SOME AUTOS INSTEAD OF ORT
OTC MESSAGE
R READ (APLINK)
RM READ MINE (APLINK)
RN READ NEW (APLINK)
S SEND (APLINK)
SB SEND BULLETIN (APLINK)
SELCAL SELECTIVE CALL (4 LETTERS IN AMTOR)
SHIPOR MARITIME (SHIP/SHORE) EQUIVALENT TO AMTOR
SP SEND PRIVATE (APLINK)
STATUS INDICATOR IN MESSAGE LIST (APLINK)
TFC TRAFFIC (MESSAGES)
VAGE SELCAL OF VK2AGE (APLINK)
VKVM SELCAL OF VK6VM (APLINK)
WUQ WHO ARE YOU ? (APLINK)
Y YES
+? CHANGES OVER
///// DELETE (APLINK)
\$ (DOLLAR) (SHIFTED D) INITIATES WRU (APLINK)

Fig. 1

Fig. 2

Texas Packet Radio Society
TexNet User's Manual 3.3 Summary
August 1, 1988
Greg Jones, WDSIVD

Introduction :

TexNet is a dedicated, remote sited, multi-access, multi-resource network system. Each node offers, in addition to TexNet access, several network services which are described below. Use of any of the node services is selected by Secondary Station Identification numbers (SSID). TexNet is open to all amateur radio operators to use.

TexNet Node Services :

Each service is connected to by using an ssid. Example : c WR5C-4 will connect the user to the DALLAS TexNet node on 145.05 in Plano, Texas.

0 - Digipeater Operation

All TexNet nodes can be used as digipeaters. The nodes call or alias can be used to digipeat through. Use of a node as a wide area digipeater is not encouraged.

2 & 3 - Conference Bridge

Each node maintains 2 conference bridges (ssid 2 & 3). Once connected all transmitted packets are sent to all other users connected to the conference bridge, providing roundtable communications. Control-U will list all other users connected to your bridge.

4 - TexNet Network

The TexNet network is made up of a network of nodes connected by 450MHz 9600 baud links (backbone). The following is a description of the current network commands. Commands are entered at the command prompt : NETWORK CMD?.

Help or ?

Returns a listing of the user commands.

Bye or b

At the NETWORK CMD ? prompt will disconnect you from the network.

Location or L

Returns a listing of all nodes on the network by name.

Message @ NODE or M @ NODE

Make a connection to a message server (PMS) @ NODE. PMS commands are a subset of the W0RL1 BBS command set. PMS Commands : Bye, List, Kill, Read, Send (B,L,K,R,S) [Example: M @ DALLAS!]

Weather or W

Make a connection to the network weather server. LW lists the general weather statements. LS lists the server weather statements.

Circuit or C

Circuit allows a user at one node to make a connection to a user at another node over the network. Example : C K5ABC @ HOUSTON would allow a user to try to connect to K5ABC at the Houston node over the network.

C CQ @ NODE

Transmits a CQ using your call at the node indicated. To respond to a CQ call, just connect to the network and then type 'C CALL @ NODE'. The network should handle the rest. To finish a CQ, one user must do a manual disconnect from the TNC cmd: prompt.

General :

The TexNet User's Manual contains a full description of the TexNet node services and network commands.

Portable Ring Base Antenna

Although C.R. Eve GJ7AOG claims no credit for the original design, he would like to share his ideas and constructional variation of Fred Judd G2BCX's 144MHz Ring Base antenna. This version should prove to be particularly useful to the radio amateur on holiday, restricted to a very small lightweight antenna or an even smaller budget!

The attractions of the GJ7AOG Ring Base antenna are the price - £4 approximately - and the compact size (240mm) of the antenna in its collapsed, ready-to-travel form. This makes the antenna small enough to carry in the average-sized briefcase when travelling. The antenna has another important benefit in that if it is damaged or lost in transit, a replacement can be built very quickly! A further advantage of this approach is that the would-be constructor will not require special materials or metal-machining facilities, as the antenna is extremely simple to produce.

Constructing The Ringbase Antenna

The list of materials needed to build the antenna are listed below, and all items are easily available. In fact, if you find yourself needing another antenna while on holiday - you could buy the materials and even make it on a rainy day!

Shopping list: One PL259 plug to fit RG58 (UR43) cable without an adaptor. The plug should have a cable-entry boss diameter of 0.5in.

One plastics core, the printing paper-feed roll, from an electronic calculator. The empty rolls are usually approximately 57mm long and have a 0.5in bore.

497mm of coat-hanger or similar heavy-gauge wire.

102mm of 0.5in diameter tube of copper or aluminium, (an off-cut of small-bore copper central heating pipe should prove ideal for this project).

One 1.31m telescopic antenna, e.g. Maplin catalogue No. LB10L.

Approximately 518mm of 16 s.w.g. copper wire.

A suitable adhesive, rapid cure epoxy resin adhesive is recommended as it will 'cure' within ten minutes or so at normal room temperature.

Construction

Form the coat-hanger wire into a circle as shown in Fig. 1, then drill a hole through the boss of the PL259 plug to take the ring as shown in Fig. 2. Then solder the ring into the PL259 plug. Drill a hole in the plastics tube, 19mm from one end, suitable in size to take the 16 s.w.g. copper wire.

Pass the 16 s.w.g. wire through the hole in the tube and wind a coil of five turns within a length of 1.125in as shown in Fig. 3. Solder a 6BA eye-tag to the top of the coil and sleeve the tail of the coil to

prevent short circuits in the plug body.

The coil assembly may now be mounted on the plug body, and the tail of the coil soldered to the centre connection of the plug, then seal it in place with the epoxy resin. The short length of copper or aluminium tube is then mounted approximately 3/16in into the coil former body and is also glued in place.

Now take a tea or coffee-break as the adhesive cures!

Final Assembly

When the adhesive has hardened, you can connect the coil to the tubing with a suitable self-tapping screw. Mount the telescopic antenna approximately 3/16in into the top of the tube and fix with self-tapping screw. Take care not to over-tighten the self-tapper as the screw will strip the thread cut into the soft material. If you should make this mistake (it's an easy one to do!) don't despair and don't drill another hole! All you have to do is to find another self-tapper which is slightly larger!

Setting Up and Testing

All that remains to do is to fully extend the telescopic antenna section and check the v.s.w.r. The antenna may require to be adjusted by up to an inch or so, moving it in the tubing until an s.w.r. of 1:1.2 or better is achieved.

Once the optimum position for the telescopic section is found, the brass bush in the base of the telescopic section can be drilled to take a self-tapping screw. The whole assembly may then be made permanent. If the antenna is found to be a 'sloppy' fit in the tube, a small amount of 'shimming' may be necessary. Cooking foil or an aluminium soft-drink can are a suitable source of shim material. By careful selection of the material it may be arranged so that the antenna is a tight fit in the tubing.

It is also possible to make the antenna an almost 'pocket-sized' device if the ring-base is cut on the straight section and a piece of 'choc-block' terminal connector used at this point.

This lightweight antenna, which does not require a ground-plane, can be suspended from a piece of string in a hotel room or wherever you're staying. It should also provide far better performance than a helical wound antenna for very little more stowage space in your luggage.

PW

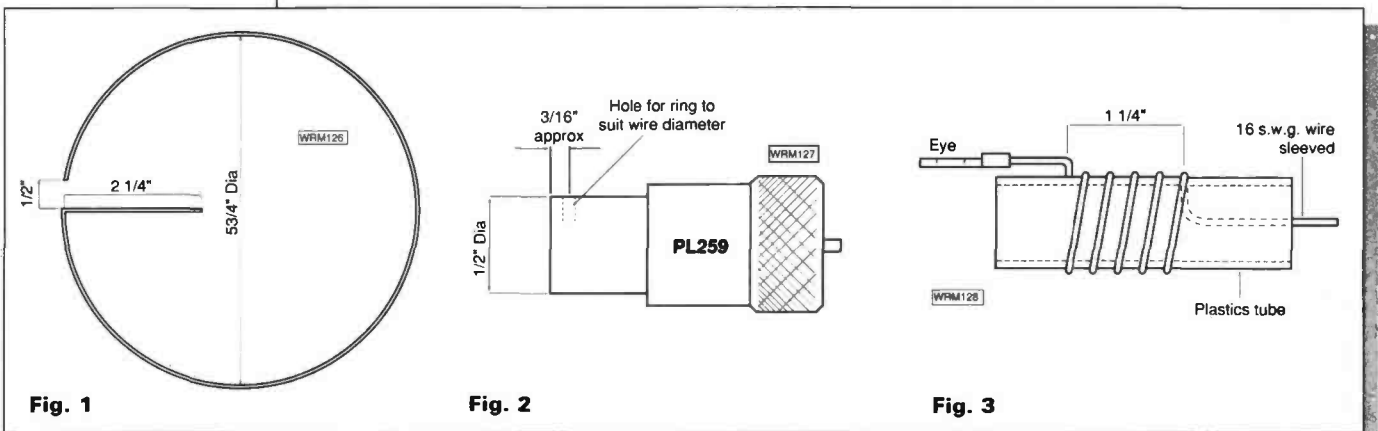

SPECIALISTS IN DRESSLER ACTIVE RECEIVE ANTENNAS

ARA 900
£139
(N-TYPE £159)

ARA 30
£129

ARA 900
ACTIVE ANTENNA

50MHz to 1300MHz
Gain 17dB Typical

TECHNICAL SPECIFICATIONS

Noise Figure
1dB at 50-180MHz
1.5dB below 300MHz
2.0dB below 350MHz
2.7dB below 400MHz
3.0dB below 500MHz
3.6dB below 650MHz
4.6dB below 1300MHz

£139.00 (PL259 Connectors)
£159.00 (N-Type Connectors)

Intercept Point 3rd Order: +18dBm at Input
Post: £3.00 or Securitor: £10.00 extra.



ARA 30 ACTIVE ANTENNA
50kHz - 40MHz WITH LIMITED PERFORMANCE UP TO 100MHz

Professional electronic circuitry with very wide dynamic range. Meets professional demands both in electronics and mechanical ruggedness. 1.2m long glass fibre rod. Circuit is built into waterproof 2.5mm thick aluminium tube. Ideal for commercial and swi-receiving systems. £129. See Review in August 1985 issue p.35

£129

Both antennas come complete with 7 metres of cable, interface, power supply and brackets. Dressler preamps available.

Also a wide range of masthead pre-amps available for most V.H.F. and U.H.F. frequencies, including scanner pre-amps from £89.



Dressler

COMMUNICATIONS LTD.

191 FRANCIS ROAD
LEYTON · E10 6NQ · LONDON G
TELEX 8953609 LEXTON G
PHONE 01-558 0854 01-556 1415
FAX 01-558 1298

OPEN MON - SAT 9AM - 5.30PM
INTEREST FREE HP FACILITIES AVAILABLE
PROMPT MAIL ORDER



Prices correct at time of going to press. Please phone for latest quote.

Or contact your local agent anytime on the following numbers:
Slawart: (Bromley, Kent) 01-468 5195; 0680 634526; Terry (Biggleswade, Beds.) 0767 316431.

SPECIAL OFFERS

IC-R9000



INCLUDING
ARA 30 +
ARA 900(N)
£3,899

IC-R7000



INCLUDING
ARA 900(N)
£999

IC-R71



INCLUDING
ARA 30
£855

KENWOOD R5000



INCLUDING
ARA 30
£899

KENWOOD

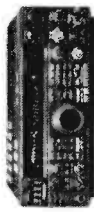

NEW TS950
H.F. TRANSCEIVER
EP.O.A.

Kenwood R5000 + ARA 30 £899
Kenwood R5000 £799
VC20 Converter £160
TS960 HF + 6 Mir. inc. Microphone £895
TS940 inc. Auto ATU inc. Microphone £1,150
TS940 inc. Auto ATU £2,000
TS960 2/70 + SAT P.O.A.
TM701 Dual Band £279
TM231 2m TX/RX P.O.A.
TH 75 New 2/70 Dual band P.O.A.

ICOM



IC781
H.F. TRANSCEIVER
EP.O.A.

PHONE FOR BEST PRICE
ICOM IC32G
ICOM IC23E
ICOM IC228
IC 4S
IC 2S
IC 32 DUAL BAND
IN STOCK

SCANNERS

AOR 2002 £475
AR 900 £235
BC 2000XLT £239
RZI KENWOOD £440
Jupiter II INC. case, NICADS, belt clip, 12v car lead £299



STANDARD
AX700

PANADAPTOR DeLuxe
£575.00



FRG 9600
50 - 950 MHz
£500.00

YAESU



FRG 8800

HF RECEIVER
£585.00

VHF CONVERTER £100.00



NEW FT1000
H.F. TRANSCEIVER
EP.O.A.

FRG9600 £475 FT47GX £599
FRG9600M £500 FT37 MHL £875
FRG8800 £585 FT23 411, 4700, 767
FRV8800 £100 + All Yaesu available

STANDARD

WE ARE **STANDARD** AUTHORISED DEALER

C500 DUAL BAND £375
C150 2 MTR £230
C528 DUAL BAND £379

SONY

SONY ICF 2001D
76-108MHz
116-136 AIRBAND
153MHz-29.995MHz
FM - AM - SSB 32 MEMORIES
INC PSU, CARRY STRAP
& EARPHONE

£299



Sony ICF 7600DS FM/AM/SSB £159
Sony SW1 150-30M C/S + FM Stereo £249
Sony Pro 80-150kHz-108MHz, 115MHz-224MHz, AM-FM-SSB £299
Sony Air 7 £229
Sony ANT Active Antenna £25
Sony Accessories Available

SONY ICF 7600DS

76-108MHz
76-108MHz
153kHz-29.995MHz
Complete with case, mains power supply, earphone and frequency list.

£159



G'day - News from Down Under

Since the last column on Australian amateur radio in August 1988, the VK amateur community has seen some changes. Greg Baker reports.



Wireless Institute

The Wireless Institute of Australia (WIA), Australia's amateur representative body, has been making a concerted effort to keep old members, attract new ones and to rein in expenditures while maintaining services. To throw off the sometimes used secret society tag, the WIA is trying, in its own words, to become a 'customer driven organisation'.

The biggest drain on WIA resources is the magazine *Amateur Radio*. While keeping control of expenditures, *Amateur Radio* has been trying to become more acceptable to amateur and provide more timely information. It has gone from microscopic print to a readable size, the lead time to publication has been reduced from about six to two weeks to improve topicality but the paper quality has been reduced. The more than 400 WIA members who failed to renew in 1989 have received letters from the Federal Office requesting information on reasons for the non-renewal in an attempt to pinpoint member dissatisfaction.

Despite these moves, however, last year's 53rd Federal WIA Convention in late April voted in favour of an increase in WIA membership fees to an

annual \$A70 (£32) Australia-wide, plus regular inflation adjustments. This \$A70 was to be split \$A47 to the Federal Office, \$A23 to state offices.

Not surprisingly, given the huge jump in fees proposed (VK6 was about \$A40, VK3 \$A49), there has been an outcry from WIA members and from the seven WIA state divisions who would need to ratify the new fee structure. According to Chris Edmondson VK3YID, editor of the commercial *Amateur Radio Action* magazine, there is WIA talk of a membership loss of up to 25% and of a split in WIA ranks. The exact percentage remains to be seen, of course, but according to WIA Federal General Manager/Secretary Bill Roper, 'human nature' will dictate a drop-off in membership.

Because of the protests, an extraordinary meeting was held in mid June. At that meeting of Federal and State representatives, it was decided to reduce the total fee to the vicinity of \$A65. The Federal Office has not budged from its \$A47 and gained an additional \$A2 for international representation. The state divisions have accepted a reduction to \$A16. However, because state division services vary, the state fee may vary from the \$A16. The VK2 division has indicated that its fee will be less.

Private QSL Bureau

Many members of WIA are mainly interested in the QSL Bureau operated by the state divisions. News that John VK5QD has opened a private QSL Bureau at \$A10 (£4.50) per annum plus five cents a card must be a well timed stroke of good fortune. VK5QD will distribute outwards cards for his clients and act as QSL Manager for inwards cards. The WIA's \$A65 annual fee may still be cheaper than QSLing direct, but *Amateur Radio Action* is pushing the line that a subscription to that magazine at \$A32.50 (£15) for 13 four weekly issues plus \$A10 to VK5QD's Bureau is better value than WIA membership!

Australian

VK4CY/MM

Amateur Maritime Mobile Station

Interference

The DoTC - the Department of Transport and Communication, the new enlarged government department covering communications - Task Force on interference has recommended the introduction of charges for the use of DoTC interference detection services. The new scheme introduced late in 1989 is to initially provide a free comprehensive self-help booklet to complainants. The booklet will be well illustrated and take readers through a step by step process to analyse the cause of their problem.

Where high voltage power lines are isolated as the source of the problem - about 40% of complaints in the past - the complainant will need to approach electricity supply authorities to rectify the problem.

For the 25 to 30% of apparent interference caused by set faults and propagation peculiarities, the customer will need to rectify the problem via their local electronics serviceman.

If the fault is found to be from other sources, there will be two approaches. The first will be for the complainant to lodge an interference report claim. DoTC will monitor these claims and take action should they receive a number of such reports pointing to a local area problem. The second will be for when a complainant wants a DoTC team to visit and investigate. In this case there will be a charge of \$A60 (£27).

As in the past, the solution will still come from making modifications at the source of the problem. If that source is an amateur operator putting out spurious emissions, clearly modifications will need to be made to that amateur's gear. If an amateur transmitting within amateur guidelines affects a neighbouring television because of television set inadequacies, the television owner will be the one to arrange appropriate modifications.

Examinations

The devolution of the role of examiner from DoTC to community clubs and organisations and to educational institutions is progressing slowly. The first non-DoTC exam is scheduled for some time after February 1990. The delays have been in finding a suitable person to fill the full-time DoTC position of Examinations Officer and in organising the new system while operating the old. The new position has now been filled and the exam system finalised though some relevant documents have yet to be finished and the data bank of questions are still in final draft form.

The banks of questions for theory and regulations exams will be made public, potential examiners receiving theirs initially in hard copy form and eventually on computer floppy disks. The question banks will then use a dBase III Plus based program to randomly select questions and form exam papers. Once formulated, exams will need DoTC approval before use. Examiners will still be able to devise their own questions if they choose though easy approval will be less certain. DoTC will reject unsatisfactory exam papers with comments

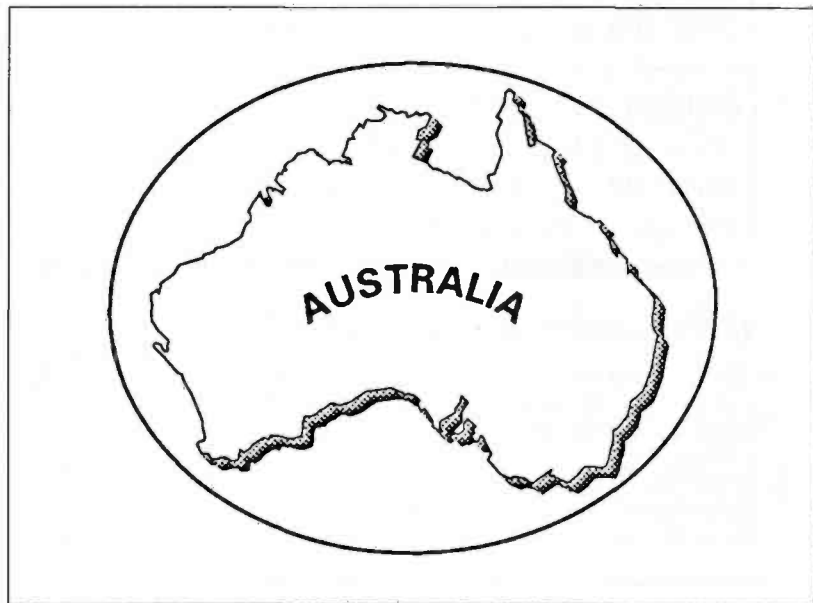

where relevant, but their role does not extend to reformulating exams for examiners. It is interesting to note that the prime approval is for the exam, not the examiner, though examiners will need to follow DoTC guidelines.

Candidates may sit exams at a v.d.u. screen, though DoTC will still require a hard copy of the paper, the answers and the resulting mark.

Morse exams are also computer generated with an IBM PC program. Program disks have now been distributed to examiners to gain experience in its use and for training purposes.

DoTC will collate information on time and place of examination both for their own use in a programme of visiting exam centres and for distribution to potential candidates. Examiners are not permitted to make conditions on who can sit their examinations. For example, a club cannot exclude non-members and a school or college cannot exclude those who have not taken their course of study.

Fees for exams are the prerogative of the examiners.

PW

Australian

VK4 CFD/MM

Amateur Maritime Mobile Station

C.M.HOWES COMMUNICATIONS



Mail order to: EYDON, DAVENTRY
NORTHANTS NN11 6PT
Tel: 0327 60178

Professional RF design, manufacture and consultancy.
HOWES KITS for the Novice and Radio Amateur

Building your own equipment is one of the most enjoyable aspects of amateur radio. Our range of kits is designed to enable you to enjoy this pleasure with the minimum of trouble. We have receiver kits to suit the beginner, and transmitters for the licenced amateur, plus a full range of accessories.

INTERLINKING MODULES

The important feature of our range is the way the kits can be linked together. If you are a newcomer to the hobby, you can start with a simple single band receiver, and later add any accessories you choose (digital readout, "S meter", extra filters, etc.) and then by adding a VFO kit and a transmitter, turn it into a full transceiver when you get your licence.

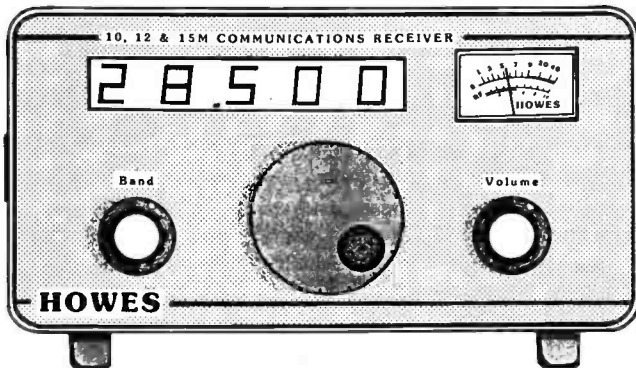

An illustration of one of our demonstration receivers.

The drawing shows the result of combining a few of our kits together and building them into one piece of equipment.

Kits used in the construction of this radio were DXR10 (three band receiver), DFD5 (Digital Readout), DCS2 ("S Meter"), and CBA2 (Buffer/Amplifier). Total cost of kits: £78.50. The performance is excellent, and with a little time, trouble and money spent on making a neat job of the construction, a receiver to be proud of. A little too ambitious a project for the beginner perhaps, but a DXR10 kit without the digital readout, meter, etc., will still hear as many stations, and is suitable for the less experienced constructor.

COMPLETE RECEIVER PACKAGES FROM £32.10

To make life easy for the newcomer we also stock "hardware" packages to go with our receiver kits. These include a case, dial, tuning capacitor(s), knobs, sockets, nuts and bolts, etc. — the mechanical bits and pieces to go with the basic kit (which contains the electronics). The total cost of a complete three band receiver package (DXR10 + hardware + P&P) comes to £39.90. Which is not bad for a radio that will receive almost as many stations on these bands as the most expensive set! A DcRx single band package works out at only £32.10.

Kit Price Assembled PCB Module

RECEIVERS

DcRx20	20M Amateur Band SSB/CW Receiver	£15.60	£21.50
DcRx40	40M Amateur Band SSB/CW Receiver	£15.60	£21.50
DcRx54	5.4MHz HF Air Band Receiver	£15.60	£21.50
DcRx80	80M Amateur Band SSB/CW Receiver	£15.60	£21.50
DcRx160	160M Amateur Band SSB/CW Receiver	£15.60	£21.50
DXR10	10, 12 & 15M Ham Bands SSB/CW RX	£24.90	£36.90
MBRX	HF SSB/CW Marine Band RX	£29.90	£44.90
TRF3	SW Broadcast TRF Receiver	£14.80	£20.20

RECEIVER ACCESSORIES

AA2	Active Antenna Amplifier	£7.50	£11.50
ASL5	External Dual B/W SSB & CW Filter	£14.90	£22.50
CBA2	Buffer/Pre-amp to feed DFD5	£5.80	£8.90
CSL4	Internal Dual B/W SSB & CW Filter	£9.90	£15.90
CTU30	HF bands + 6M ATU for RX or 30W TX	£27.90	£33.90
DCS2	"S Meter" for our receiver kits	£7.90	£11.90
DFD5	Digital Frequency Counter/Display	£39.90	£59.90
XM1	Crystal Calibrator, VLF to UHF	£16.80	£21.90

TRANSMITTERS

AT160	80 & 160M AM/DSB/CW 10W PEP TX	£34.90	£53.90
CTX40	40M 3W QRP CW Transmitter	£13.80	£19.90
CTX80	80M 5W QRP CW Transmitter	£13.80	£19.90
MTX20	20M 10W CW Transmitter	£22.90	£29.90

VARIABLE FREQUENCY OSCILLATORS (VFOs)

CVF20	20M VFO for TX or Transceive	£10.40	£16.90
CVF40	40M VFO for TX or Transceive	£10.40	£16.90
CVF80	80M VFO for TX or Transceive	£10.40	£16.90
VF160	80 + 160M VFO for TX/TCVR	£19.90	£34.20

CONVERTERS/TRANSVERTERS

CV220	2M Converter for 20M Receiver	£17.50	£23.90
CV620	6M Converter for 20M Receiver	£17.50	£23.90
HC220	20M Transverter for 2M Rig	£52.50	£83.50
HC280	80M Transverter for 2M Rig	£52.50	£83.50

MICROPHONE AND STATION ACCESSORIES

AP3	Automatic Speech Processor	£15.90	£22.80
CM2	Quality Mic with VOGAD	£11.90	£15.90
EM1	Electret Mic capsule to suit AP3	£1.90	—
MA4	Mic Filter/Pre-amp.	£5.60	£9.90
SWB30	SWR/Power Indicator/Load 30W	£12.50	£17.30
ST2	Side-tone/Practice Osc.	£8.80	£13.50

All HOWES KITS come with a good quality Printed Circuit Board which has its holes drilled, its tracks tinned, and the parts locations printed on it for easy, accurate assembly. All board mounted components are supplied, as are full, clear instructions. Technical advice, and sales are available by phone during office hours, but please send an SAE for our free catalogue and any specific product information sheets you would like to receive.

Please add £1.00 P&P to your total order value.

73 from Dave G4KQH,
Technical Manager.

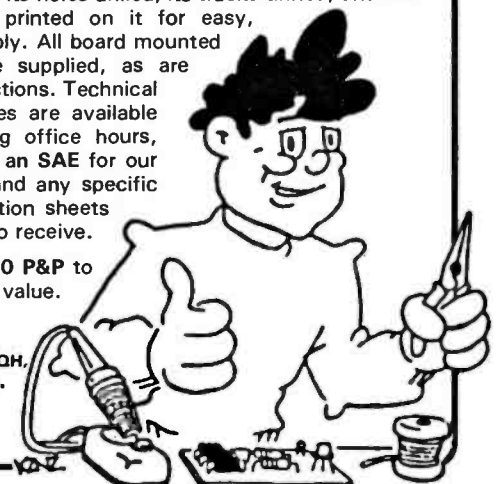

Back-Scatter

HF Bands

Reports to
Paul Essery GW3KFE

287 Heol-y-Coleg, Vaynor, Newtown, Powys SY16 1RA

As this comes to be written we are beginning to feel the icy grip of winter, and winter band conditions too. As I write, visibility is down to about a hundred yards, and the beam is well loaded with a great squad of birds - I have counted over forty on occasion and they don't seem to care if one swings the beam, although a couple of reversals of direction do shift them!

As for the bands, at times when I could get on for a session, they seem to have been up-and-down, but the good days have been as good as one could expect at this stage in the sunspot cycle.

Expedition News

The Revilla Gigedo, XF4T expedition popped up without warning over the contest period from a group of XEs. I also hear that a Mexican protest that XF4L be not accepted as there weren't enough Mexicans in the team was over-ruled by ARRL.

The activity of XW8KPL seems, at the time of writing, to be mainly based on lists, around 14.165 and 21.295 - on the latter he has been noted doing his own thing until the list-takers arrive, when he submits to their ministrations without protest. XW8KPL QSLs should be addressed to Inh Siphachanh, Deputy General Director, Khao San Pathet Lao, PO Box 310, Vientiane, PDR Laos. As for the proposed HA activity from this country, the word goes that they are in the country and operational, but up to the time of writing the answer seems to have been a lemon as far as hearing them goes. There also seems to be some question about the QSL route, as the French DX Association have dissociated themselves from the proposed operation totally.

The *Saturday Evening Post* Bouvet DX-expedition team are trying, I hear, to add VP8 South Sandwich to their show in February.

Some new prefixes: The Argentine DX Group will be celebrating their first anniversary by airing L73ADX, and LO*DX, where * is a number between 1 and 26. That gives 27 new prefixes to bite on! QSLs for all these to GADX, PO Box 36, 1834, Temperley, Buenos Aires, Argentina.

Looking for Asian low band c.w. countries? Lend an ear to K9EL's activities, back on again after a hold; on 3.5 and 7MHz about 5kHz up from the bottom, and on h.f. 20kHz up.

The rumours of a San Felix operation are, so far as I know, just that. There is no hard news at the time of writing, though it is understood a licence is in existence.

A nice one for the prefix freaks: UA6U/VE6JO on a business trip to Astrakhan from about mid-January.

New Ones

The DXAC have voted on various proposals and offerings. Arising from this we can add Conway Reef and Banaba; but the applications for Frederick Reef, Austral Is, and Marquesas Is were turned down, plus Guemes and Tatoosh Is. New country applications from the Amazon State of Brazil, and the Basilica del Santo were

deleted from the DXAC agenda for lack of paperwork submissions from the applicants in question. By the time you can read this, it is expected that rulings will have been given on Walvis Bay ZS9, and the question of DXCC endorsements for 10, 18 and 24MHz operations. (Incidentally, Walvis Bay is now ZS9.)

Contests

For the Top Band addicts the CQ WW 160 Metre CW contest is January 26-28, with the SSB leg on February 23-25. Rules are the same as in previous years; however the 1.825-1.830MHz DX Window is being phased out in favour of 1.907-1.912MHz for the Pacific DX stations. Mailing deadline for logs is February 28 (c.w.), and March 31 (s.s.b.) and they should be addressed to Donald McClenon N4IN, 3075 Florida Avenue, Melbourne, Florida 32904.

Still with the big contests, the ARRL DX CW contest is on February 17-18, the s.s.b. leg on March 3-4. March 24-25 is the CQ WW SSB Contest. No more details to hand at the moment.

Talking of the contest scene, for 23 years I have relied for the contest details on the devoted work of Frank Anzalone W1WY who even then had been doing this for years. Frank has now handed over the reins to John Dorr K1AR. To help him keep the Contest Calendar column going in *CQ* - and hence to almost every other DX column world-wide - please pass on to John the details of the one you are organising at least three or four months before the due date.

Band Round-up

Let's start with 28MHz. On this band, **GOJBA** (Sittingbourne) says, "I know there have been some really good days - but I've missed most of them!" Despite his shift work, Phil managed to get on for the CQ WW SSB Contest when, as one expects, the band stayed open later than usual - surprising what a bit of activity can do to 'conditions'! On 28MHz s.s.b. Phil mentions CU3ARA, CW8B, EA9TP, HL5FMF, HL0Y both short path, JA0FBZ, OA4AV, OH6MFD, TA3F, TI2DU, V31B, VE3NOV, VE5XO, VE6ATT, VE6BOS, VP5T, VP9AD, and all W call areas save W6. Turning to 29MHz f.m., Phil added N2EJQ, W3WSX and W5KZR.

Next we turn to **GM4ELV** (Glasgow), who netted, on s.s.b., JT0DX (QSL via HA6KNB), RZ0Y/UA9YX (via UA9YX), HS4WV, BY8AC, all W call areas, CN0A (via FDXF), PJ5JR (via KA3BYV), V47K, F5/KC1F, 6W70G, ZP5XHM, PJ1B, KP2A, 3DA0BK (via Box 122, Eveni), PZ5JR (as for PJ5JR), YV5ANF, and VP9AD. On a different tack, Dale is looking for the QSL Manager for 3B8DM and an address for KA3BYV.

Now we go over the water to hear from **ON7PQ** (Kortrijk) and his c.w. winnings. Pat offers as his crop for the month FY5YE, F5/KC1F, K4PI/PJ7, C6A/AA5AV, 5C2CW, 3C1AG, FP5HL, BZ10K, KX60I, 9M8XX, 9M8AZ, P40V, FH5EJ, C56/G30XC, ZP5AA, CW0L, ON5NT/5N0, 5U7QL, S9AGD, A35ML, KH8/SM7CKK, JW1MFA, JY9SR, KL7KJ, 3C0GD and DF3EC/ZS9.

On 28MHz, **GOHGA** (Stevenage) uses a half-wave vertical and ten watts; this combination yielded her c.w. contacts with W2LZX, W1PL, K4II and W8EGB.

Finally for this band enter **G3BDQ** (Hastings) stage left muttering my call as GW3FFE! My apologies to the true owner of that call. Anyway, John snapped up UL8AWL, UL8CWW, 9M8XX (Sarawak), YB9LC (Timor), P40V, PZ1DR, HR2/KB5CGA, CO2PX, YJ8NMB and 5T5CR - in between the times spent knocking 'em off on 50MHz.

Top Band

G2HKU (Minster) says the noise he normally notices in autumn on Top Band has spread to all the h.f. bands; locally the level is around the S7 mark, and Ted has heard other stations rumbling about it somewhat too, so it's not just local. Anyway Top Band included an s.s.b. contact with ON7BWV, while c.w. made it to SM7BIC and P14DEC.

As for G3BDQ, John mentions contacts with UA6WDT, UL7AAE, U18LA, UF7VVA, Y03APJ, HG9R, IS0XIE, CT1NK, LY2BTA, 4X4NJ, OH0MM, CT3MCT, ZB2X, LZ9A, 5N3A(??), OY9JD, VE1ZZ and EA8BTU.

GOJBA has also looked at the band when the noise was bearable, but says he "only worked the locals".

The 3.5MHz Band

Not a very popular band among those who chase the distant parts of the world, though of course there is DX about for those who want it, for 5BDXCC for example. There is also a mighty amount of assorted traffic on the band, though in general one does feel the need for a front-end attenuator almost all the time. GOHGA has some 25 watts of c.w. to a 30m wire; this produced G3TLY, G30CV, G3GIH, G4ITP, SM7GWF, OZ80, DL1GBZ, PA63DNT, PA0SOL, DK30P, DJ2GH, DF7KG, DK4TA, DL6ZBA, Y22NK, ON4DS, UZ3DYC and LY2BOQ

As for me, about all my 3.5MHz activity has been on the Sunday net, during which I discovered, the hard way, that if you trap one end of a mic lead and then step on t'other, something has to give. All I can say is "Thank Heaven for Heatherlite's service".

Turning to the activities of ON7PQ, Pat's 3.5MHz band list includes UJ8JI,

UM8MBA, ZL4IE, a doubted ZS8MI, UA10IQ, S9AGD, VU2IN, CO3LX, D44BC, 3C0GD and V31BB.

The 7MHz Band

G3BDQ says he didn't spend too much time on the band, preferring to go play on 50MHz: thus he only found UL7LEB and FY5EV.

The signals from G2HKU went out to V31BB and EA8AB - c.w. of course. Now Angie GOHGA, who has an enormous list of stations worked. Welding, alas, the pruning knife, I notice - all c.w. of course - W1HMD, K1FW, NJ1P, N3CEU, WB2Q, VE1QQ, W2VJN, ZCAJL, UZ9JXD, LY2BW was in UB and LY2BOC in UP; and the YLs noted included HA1XH, OK3YL whose OM is OK3YX and I2RLX. CT1BQH, EA2NF, EC1CWI, EC3CQV, ED2SEL, EC3CRW and EA2JJ were also noted, though most of the rest of the contacts were very much east-west in direction.

At ON7PQ the state of play included PJ2/OH4RH, C6A/AA5AF, K4SXT/DU3, VP2EZD, RJ3K/UA90CQ, 9M8AX, 3C1AG, V47KH, CM0S (=S0), HZ1AB, another doubted ZS8MI, WL7E, KH8/SM7PKK, S9AGD, ZK2VB, JY9SR, JY20D, HV0A, 5U7QL, D44BC, 9V0/JA8RUZ and 3C0GD. As to why Pat doubts his ZS8MI I don't know; ZS8MI was reported on both bands but perhaps Pat hooked the Slim who always seems to appear when a DX station is making good business.

WARC Bands

Support for these seems to have fallen away again; just two mentions this time, from G2HKU who raised KU0J and K2QIL with a burst of c.w. on 18MHz and GOJBA whose 18MHz s.s.b. reached out to IK3HXC and I6NO, while on 24MHz he made it to EA90B and W2EYI.

The 14MHz Band

This month I certainly have missed the analysis of the band by G3NOF - one hopes he hasn't blown anything up.

GOJBA is still revelling in his 'Loudenboomer' of a signal from the new tower and tri-bander, but oddly enough Phil spent half his time on v.h.f. The time spent on 14MHz though was enough to rake up s.s.b. contacts with KV4P, NB1H, VE7ARS and 5J6CQ, the latter a 'special' from Columbia.

Now G2HKU, whose c.w. connected him up to KG9U, KN7K, UA0ALE, JF6POM, VK5AGX, WA4SNI and W1AXA.

Turning to ON7PQ, Pat is 100% a c.w. man. His gleanings during the period included 5C2CW, 5W1ML, 9M8XX, A35VB, V47KH, J3/K8CV, AH6JF, 5W1VB, KH8/SM7PKK, 5U7QL, V31BB, JA4GXS/JD1, DF3EC/ZZ, ZK2RY, VP2EXX, A35ML, ZK2VB, ZS3E, 4K1F(S. Shetlands), KX60I and T28RW.

Angie, GOHGA had just twenty watts to a vertical for this band and this managed SM6BUV, AA1AHW, UA1AJV, Y3LW, UB5INN, HA3NX and GW3KGV.

G3BDQ isn't over-keen on this band,

Back-Scatter

and he only picked up a couple of contacts here, with XL3BLU (Canada), and AC0S/J6L on St. Lucia.

The 21MHz Band

The QRP at GOHGA netted Angela UA1AQZ, 15MJL, and a load of EUs stuff in the HSC test.

As for G3BDQ, John offers FY4FM

(Cayenne), HK0BKX (San Andreas), PJ4/K3IP, XF4T (Revilla Gigedo for a new one), J6DX on St Lucia, JY9MO, NL7G, AL7CQ, 9Y4VU, YV4ABR and CN0A.

As for ON7PQ, Pat made it across to EL2CX, J3/K8IV, 5W1AML, CN0S, BY4RSA, 9M8AX, ZD7KM, S9AGD, A35ML, A35ML, ZK2VB, C56/G3OXC, KH8/SM7PKK and OF3EC/ZS9 (Walvis Bay).

GOJBA discovered CU2ARA, JH1GIC,

J17GAG, K3TUP, NO11, N4WW, V47QO, W1WEF, ZL1AMH and ZL1BGB, the last two being a 55-minute natter over the long path.

Finale

That's the lot for this time. Somewhat of a dearth of reports, and an unbalance too. I could do, generally with some more

s.s.b. stations reporting, some more people mentioning the WARC bands, and above all some of the keen types on Top Band sending in their news. After all, the more reports and comments I get, the more interesting the column will be. Thanks!

For anyone new to the game, letters should be addressed to me at the address quoted, allowing good time for them to arrive. Again, Thanks.

Back-Scatter

VHF Up

Reports to
David Butler G4ASR
Yew Tree Cottage

Lower Maescoed, Herefordshire HR2 0HP

Solar Data For November 1989

From the beginning of November there was a considerable improvement in solar flux levels and, as expected, a reversal of the October radio quality indices, producing many openings on the 50MHz band. In a 10 day period, between November 9/19, there were a number of ionospheric disturbances. On the 15th, there was a large proton flare which lasted for 90 minutes. A large magnetic storm commenced on the 17th, followed by an auroral opening on the same day. Solar conditions hardly changed during the last two weeks of November. The unsettled magnetic conditions also died down leaving the levels very quiet. There were major flares on November 20/21 but nothing appeared to come of them apart from a Scottish-type aurora on November 26.

Readers may like to note that an excellent source of solar factual data is available by telephoning Boulder, Colorado, on 0101 303 497 3235. The following is the text of a typical recording made on 30 November 1989.

"Solar terrestrial indices for November 29 follows. Solar flux 224 and the Boulder A index 13. The Boulder K index at 0900UTC on November 30 was 3. Solar terrestrial conditions for the last 24 hours follow. Solar activity was low, the geomagnetic field was quiet to unsettled. The forecast for the next 24 hours follows. Solar activity will be low, the geomagnetic field will be mostly unsettled".

The message is updated every 3 hours, 0920, 1220, 1520, etc., and also give details of any flares or other events in progress. The recordings last about 30 seconds and are invaluable for real time aurora predictions and for planning when 50MHz might be open.

Those that do not wish to telephone across the pond should note that a daily report and short-term ionospheric forecast is issued by the GEC-Marconi Research Centre, on 0245 73331 extension 3152. These forecasts are updated each day at 1600UTC.

Aurora

In addition to a number of minor auroral openings during the month, there was a widespread event on November 17. The intensity was such that a number of contacts were made on the 432MHz band.

Running an FT-290R, 100 watts p.e.p. and a 16-element Yagi, **John Hilton GM1ZVJ** (LTH) reports on the usefulness of recent auroras. On October 21, ON1CAK (JO20) and F6CTT (IN97) were both worked for a new country and square, whilst a contact with GM4SIV (IO65) picked up a new square. The aurora on November 13, gave John new counties and squares when contacts were made with G7ENF (DYS), G0EMH (GLR), G1GYI (JO02), GJ6TMM (IN89) and GM0DRU (IO68).

Erwin Brown G1JUS (ATM) runs an FT-221R with muTek front end, 300 watts p.e.p. into a 9-element Yagi and is never far away when an aurora occurs. In the event on October 21, sixty-two QSOs were made with DL, F, G, GI, GM, GW, HB9, OE, ON, PA and Y.

Some of the more interesting s.s.b. contacts included HB9DFG (JN37), OE5OLL (JN68) and Y22ME (JO72). Scottish type auroras on October 28, November 2, 11 & 13 produced only a handful of contacts between them. However the opening on November 17 was much better. Between 1754-2006UTC, contacts were made into DL, F, G, GM, GW, HB9, LX and OE. Among those worked were HB9CRQ (JN47), LX1DB (JN36) and OE5VRL/5 (JN78). Unfortunately, Erwin had to close down early due to an unsympathetic television set.

Ian Wright GW1MVL (CWD) made one contact, GMOERB (IO76), in the aurora on November 13, but had far more success in the event on November 17. Using 10 watts and a 5-element Yagi fixed due

east, a number of good s.s.b. contacts were made. Apart from QSOs into F, ON and PA, contacts were also made with DC6SN, DG9KAN, DK7LZ, DL4KCU in JO30, DG1DQ, DL1EJA, DG7JK, DC8VJ in JO31, DB6BX in JO32, DC2AGD in JO40, DG2YEQ, DC6YEW in JO41, DF9QX, DG4YED in JO42, DC4BK, DK9HN in JO43 and DG40AI in JO52. SP2MSL (JO92) was heard but not worked.

Last month I welcomed **Vince Shirley G7ENF** (DYS) to the v.h.f. bands. Since his last report, major changes have been made to the antenna system, upgrading to a 16-element Yagi on 144MHz, a 3-element MET on 50MHz and a 16-element Yagi on 432MHz. On October 13, Vince encountered his first opening, when checking the DL0PR beacon and finding it fully auroral. In a three hour session, commencing at 1520UTC, contacts were made with 8 GMs, 3 GIs & 2 DLs among many G and PA stations. Best DX contacts were with SM1PDA (JO97), OZ1LZQ (JO45) and OZ1BEF (JO46). The opening on November 17 was also very productive. From 1700UTC, many stations were worked in JO30, 41, 45 & 49, on a beamheading of 035 degrees. Most pleasing were contacts with F1HFN (JN26) and F1AFJ (JN06), both being new squares and the most southerly stations worked so far by aurora. Best DX however was SP4LVG (KO13) worked at 1806UTC with reports of 57A. OE5OLL (JN68) was also worked for another new country.

The aurora on November 17 proved to be very good for **Clive O'Hennessey GW4VVX** (GWT). The event was discovered at 1530UTC with a number of strong auroral signals being heard. Clive kept his beam pointing around 025 degrees to work stations between Scotland to Austria. A total of 56 QSOs were made on s.s.b. and c.w. in 23 locator squares and 11

countries. At 2105UTC, a strong OH station called, giving Clive a 59A report but disappeared before the contact could be completed.

Ela Martyr G6HKM (ESX) found the aurora, on November 17, in progress at 1640UTC. In a two hour operating session, 36 QSOs were made, collecting two new all time squares by working SP2MSL (JO92) and SP4LVG (KO13). Other s.s.b. contacts included HB9RSO (JN36), OE5VRL/5 and Y25WA (JO64).

In previous columns I have stated that s.s.b. is an inferior mode to use during auroras. Undeniably, DX can be worked via this mode but even better DX can be worked with the use of c.w. The next two reports give details of what was worked at the c.w. end of the band. I'll leave you to make your minds up.

Ian McCabe G0FYD (LNH) caught the tail end of the aurora on November 13. Using a TS-780 and 100 watts to a 15-element Yagi, contacts were made with SK7JD (JO87), SK6EI (JO68) and LA1YCA (JO38). Gotaways included LY2BJB (KO15), SM1MUT (JO97) and LA8OW (JP50). Among the more interesting contacts, in the aurora on November 17, were OK2BWR/P (JN89), OK2HRA (JN99), OK3AL (JN97), OK3TNZ (JN97), OZ6TY (JO55), SM7BHH (JO65), SP2HHX (JO94), SP4MPB (KO03), SP9EWU (JO90), SP9KDA (JO90), Y21TC (JO63), Y22SA (JO63) and Y32NL (JO61). At 1828UTC, Ian was called by SM2EKM (KP05). Signal reports of 579 were exchanged both ways, as his signal was a pure T9 note. This contact, over a distance of 1901km, was the furthest that Ian has worked during an auroral event on 144MHz and was most likely via Auroral-Es. At the same time as this opening on 144MHz, there was Auroral-Es propagation to Finland on 50MHz. Did anyone else notice this 144MHz event during the aurora on November 17?

I had a reasonable amount of success, managing to catch openings on the 13th, 17th and 26th. The openings on November 13 and 26 were of the "Scottish" type and only produced a small number of contacts. By contrast, the event on November 17

Back-Scatter

was very widespread allowing 60 c.w. contacts to be made on 144MHz, between 1620 to 2200UTC, with DL, EI, F, GM, HB9, HG, OE, OK, PA, SM, SP, UA2 and Y. Although the majority of contacts were with West German stations, a fair proportion of QSOs were made into eastern Europe. Contacts included HG0HO, OK1AYR, OK1DDO, OK1DJW, OK1FFD, OK1MJL, OK1SC, OK2BGY/P, OK2DW/P, OK2TU, OK3KMY, OK2STK, OL4MH, SP2BSF, SP2JXN, SP4BGN, SP6FXF, SP6GVU, SP6LB, SP7BCA and SP7DCS. At 1947UTC, I was called by UA2FL (K004FO), located in Kaliningradsk, for a new DXCC country. As the aurora started to fade on 144MHz, it was observed that an Auroral-Es opening was occurring on 50MHz. Contacts on s.s.b. were made with OH1ZAA at 1855UTC and with TF6MM (IP24) at 2156UTC. Incidentally, I feed a variable audio output from both the 50MHz and 144MHz receivers into the headphones, thus enabling me to hear what is happening on either band. This is particularly useful during Sporadic-E openings, allowing me to monitor the decreasing skip distance on 50MHz whilst simultaneously waiting for an opening on 144MHz.

A number of stations concentrated on 50MHz during the recent auroral openings. **Paul Feldhahn G7CFK** (MCH) worked 23 stations between 1420-2032UTC on November 17. Among the s.s.b. contacts were QSOs with PE1LHR (JO21), PA3EUI (JO21), PE1CMO (JO22), PE1LXD (JO31) and PE1CXZ (JO32). A number of GI and GM stations were also contacted. At 1859UTC, SK3SN was heard via Auroral-Es but he faded before contact could be completed.

In the aurora on November 13, **Paul Baker GW6VZW** (GWT) worked GM0GEI (HLD) and GM0EFT (GRN) for new counties and locator squares. Other s.s.b. contacts included GM0HSC and GM6CBG.

The opening on November 17 was very much better. In total, 66 QSOs were made in 10 countries and 34 counties, encompassing 28 locator squares. Contacts made outside of the UK included EI2GB (IO62), PA0PWW (JO21), PB0AJA, PE1CMO, PE1MIS, (JO22), FC1CDS (IN77), FC1NDG (IN88), FC1CNB (JN09) and FC1DBN (JO00). Contacts via Auroral-Es were also made with OH1ZAA (KP01) at 1837UTC and with OH1AYQ (KP12) at 1840UTC. Also heard at this time were OH5IY (KP30) and SK3SN (JP80). In the second Auroral-Es opening of the evening, TF6MM (IP24) was worked at 2158UTC.

The 50MHz Band

The month of November saw the start of the 50MHz DX season. Lengthy openings were commonplace, especially to central and North America. For some ideally located stations, openings continued into the Far East and Australia. There were also numerous openings into Africa and South America. On November 5, **Geoff Brown GJ4ICD** worked all continents in less than four hours.

The North American events were characterised by an opening to call areas

W1, 2, 3 & 4, from approximately 1230 through to 1500UTC, the band then becoming less active for about an hour, until it opened up again, this time to W5, 7, 8, 9 & 0 from 1630 to 1730UTC. This trend will continue through the winter, peaking during the months of February and March. Incidentally, these two months should be the optimum period for consistently working into the west coast of America. The best times will be between 1600 to 1700UTC, with dusk at the UK end of the path and dawn at the W6 end of the path. Just like Top Band really!

Reports this month start from the north of England and work their way down to the south coast. As you can see, stations situated the length and breadth of the country enjoyed the good F2 conditions.

Clyde Hinton G1TCH (CVE) is making the best of temporary rented accommodation by using an FT-726 into an HB9CV antenna at 4 metres a.g.l. On November 12, EL2FO (IJ46) was heard but not worked. However, on November 19, conditions were very much better and contacts, between 1300-1400UTC, were made with KP2A (FK78), KP4BZ (FK78) and HH7PV (FK28). Gotaways included H18PM, H18W and TI2HL. From 1550UTC, contacts were made with K1RX, K1TOL and VE1BYP. Clyde mentions that all these stations were worked with the HB9CV beaming into the house, only 2 metres away.

In the adjacent county, **Stephen Burns G1WUS** (DHM) heard a similar amount of DX stations. Using an FT-690 and 4-element Yagi at 5 metres above ground, stations in Ecuador and Peru were copied at good strength on November 9. A few days later, on the 11th, the band was open, with Stephen, from the Caribbean area, right up to the east coast of the United States and Canada. A similar situation existed on November 12. At 1050UTC, EL2FO was heard, followed a little while later with an opening into the Cayman Islands, Haiti and Cuba.

At the beginning of the month, **John Hoban G0EVT** (YSW) made a couple of good contacts into Africa. On November 4, G3GJQ/5N0 (JJ16) was worked for a new one. Incidentally, as most of you know by now, this station cannot count for award purposes. The following day, TR8CA (JJ40) was worked, giving Dave his twenty-fourth country on the band.

Paul G7CFK (MCH) sent in a very comprehensive report of stations heard and worked during the first few weeks of November. The first day of the month provided a little taster for what was to come later. Stations heard included HC5K, OH2KQ, GJ3RAX/VE1, VE1HD and W1EJ. The CT0WW and ZD8VHF beacons were heard around 0950UTC on November 4. From 1135UTC, PA2VST, PA0HIP and VE1YX were heard on the non-great circle path of 220 degrees. A new country, Cyprus (UK bases), was worked on November 5, when ZC4MK obligingly came on the band. On the following day, Paul heard five continents, G, 5B4CY, EL2FO, HC5K and K1JRW. Another new country, in the form of HC2FG, was worked at 1231UTC on November 9. Stations in W1 & W2 were

144MHz QRB Table
Distance in kilometres

Station	Tropo	Aurora	Meteors	Sporadic E
G0CUZ	2943	1758	1996	2943
G0DAZ	1251	876	2026	2249
G0EVT	3080	1640	1808	3080
G0FYD	1315	1624	—	2019
G0ISW	1059	566	—	2057
G1DWQ	1454	1812	—	1836
G1EZF	1730	1757	1920	2375
G1KDF	3023	1421	—	2386
G1LSB	1319	733	1732	2723
G1SWH	3035	1429	—	2372
G3FPK	1835	1686	—	2337
G3LTF	1824	1846	2021	2174
G3SEK	1560	1681	1872	2154
G4ASP	2848	2029	2107	2853
G4DHF	1498	1530	2000	2448
G4JCC	1334	1158	1018	2173
G4MUT	1163	684	1533	2068
G4RGK	1466	1757	1920	2375
G4VXE	2862	1446	1501	2880
G4YTL	1404	1774	2025	2172
G4ZTR	935	1535	—	1978
G6DER	1834	997	1957	2068
G6ZOH	1357	711	—	2233
G6HCV	2880	1450	1912	2880
G6HKM	1304	1555	—	2265
G6LEU	2620	910	—	2430
G8HHI	1742	—	—	2058
G8JDX	2667	1368	—	2663
G8LHT	3070	1780	1868	2510
G8MFF	1209	1210	1329	2168
G8PYP	1083	1451	—	2318
G04XTT	3053	—	—	1700
G11JUS	3067	1614	1507	2216
G18YDZ	1216	1809	1901	2562
GJ4ICD	1620	1100	2050	2090
GM4CXM	1428	1750	2100	2023
GM4YXI	3160	1881	2048	2513
GW6VZW	2830	1473	—	2236
ON1CAK	1420	1166	1948	2725
ON1CDD	1420	1166	1948	2124

also heard during this opening which lasted to 1600UTC. The French Guiana beacon, FY7THF was heard at 599 on November 15. At the same time, 1150UTC, FY5DG (GJ35) was worked for country number thirty-one. A good north American opening, between 1200-1400UTC, on November 16, gave Paul a number of QSOs with stations in W1, W2 and W3 call areas.

At my location, the band was open to the American continent, virtually every day during the first two weeks of November. Contacts were made with stations in every call area apart from W6. More interesting contacts included HC2FG & HC5K, both in F107, on November 1 and ZC4MK (KM64) on November 5. The weekend, November 11/12, saw a terrific opening to the Caribbean area and also into Africa. Contacts were made with EL2FO (IJ46), EL2B (IJ46), F6CBC/BW1, DL3ZM/YV5 (FK60), KG4SM (FK29), KP2A (FK78), KP4BZ (FK78), P43AS (FK52) and 9Y4VU (FK90). On the following weekend, the band was again in good shape to the Caribbean area, with HK3AVR being worked on the 18th and HH7PV being worked on the 19th. Stations heard but unable to work because of the pile-ups included FY5DG, H18PM, PJ9EE, V47SIX, YV4DDK and 8P6JW. An unexpected expedition to Fernando De Noronha, (H136), by a Brazilian group, using the callsign ZW0F, was worked on c.w. at 1116UTC on November 22. Apparently the group only worked about 12 UK stations.

Dave Gray G8YYB (LDN) seems to have heard everything that was active during recent months. On October 31, VK6JJ (OF88) was heard and VK6KXW

(OF88) was worked. Both stations were heard between 0910 to 0930UTC. Another Australian, VK4ALM (QG56) was heard at 0847UTC, on the following day. Adrian ZC4MK was worked on November 5, with the 5B4CY beacon and TR8CA (JJ40) being heard. Dave copied stations in W4 and W8 on November 10, but didn't make any QSOs in the short opening. It was a completely different state of affairs on November 11. In total, 14 countries were heard but the best contact was VO1QF worked at 59 both ways. This station gave Dave his first contact with North America and in so doing obtained his 50MHz WAC. The openings during the weekend of November 18/19, gave Dave a number of new countries in the form of DL3ZM/YV5 (FK60), HH7PV (FK28), KG4SM (FK29), PJ9EE, PZ1AP (GJ25), VP5D (FL41) and 8P6JW (GK03). During this period the following were heard but not worked - HC5K (F107), H18W (FK58), HK3AVR (FJ24), V290A (FK97), V46SIX (FK87) and YV4DDK (FK50). Another good opening on November 21 gave QSOs with HC2FG and HC5K, both in locator F107. During this event, KP2A (FK78), VP5D and 8P6JW were heard between 1146-1240UTC.

What was probably the first UK-US slow scan television contact took place on November 22. **Paul Turner G4IJE** (ESX) worked WA1UQC (FN31) over a period of 50 minutes, during which several colour pictures were exchanged.

Mike Gotch G0IMG (ESX) has been mainly active on the 50MHz band. In October, both VK8GF and VK8ZLX were worked and with ZC4MK being worked in November, WAC has now been completed. Other contacts in November included HH7PV, ZF1RC and ZS6XJ.

Peter Hiron G1CEI (HPH) was very pleased to catch his first stateside opening on November 19. Using an FT726R and 5-element Yagi at 10 metres a.g.l. contacts were made with K1RX (FN42), WABCWA (FN20), K8MMM (EN91) and VE3RM (FN25).

Stations on the south coast always seem to do better than most, for a variety of reasons. **John Heys G3BDQ** (SXE) is not only ideally located but also has a great wealth of experience in v.h.f. DXing. On October 31, contacts were made with VK6HK at 1000UTC, ZS6XJ at 1156UTC, ZS6XL at 1204UTC and later in the day with 9H5AB. On November 1 at 0836UTC, VK4ALM (QG56) was worked on s.s.b. John mentions that the VK station had waited 25 years for his first G station. Between November 18/21, contacts were made with EL2B, HC2FG, KG4SM and KP2A. Running 10 watts from a TS-680S into a 5-element Yagi at 9 metres, over 120 QSOs have been made with North America, in 21 states and all call areas except W6, W7 and KL7.

Another station getting good results from the south is **Steve Damon G8PYP** (DOR). During openings to North America on November 10, 11 & 19, numerous s.s.b. contacts were made with stations in all U.S. call areas except W6, 7 & 0. Other DX stations worked included ZC4MK on November 5 and HC5K on the November

MAKE YOUR INTERESTS PAY!

More than 8 million students throughout the world have found it worth their while! An ICS home-study course can help you get a better job, make more money and have more fun out of life! ICS has over 90 years experience in home-study courses and it is the largest correspondence school in the world. You learn at your own pace. When and where you want, under the guidance of expert 'personal' tutors. Find out how we can help YOU. Post or phone today for your **FREE INFORMATION PACK** on the course of your choice.

GCSE/GCE/SCE ELECTRONICS	CAR MECHANICS COMPUTER
BASIC ELECTRONIC ENGINEERING (City & Guilds)	PROGRAMMING TV, VIDEO & HI-FI
ELECTRICAL ENGINEERING	SERVICING
ELECTRICAL CONTRACTING/ INSTALLATION	RADIO AMATEUR LICENCE EXAM (City & Guilds)

Course of Interest: _____ Name: _____

ICS

Address: _____ P.Code _____
International Correspondence Schools, Dept. EES20 312/314 High Street, Sutton,
Surrey SM1 1PR. Tel: 01-843 9568 or 041-221 2926 (24 hrs.)

SPECIAL NOTICE TO READERS

Although the proprietors and staff of *PRACTICAL WIRELESS* take reasonable precautions to protect the interests of readers by ensuring as far as practicable that advertisements in *PRACTICAL WIRELESS* are *bona fide*, the magazine and its Publishers cannot give any undertakings in respect of claims made by advertisers, whether these advertisements are printed as part of the magazine, or are in the form of inserts.

While the Publishers will give whatever assistance they can to readers having complaints, under no circumstances will the magazine accept liability for non-receipt of goods ordered, or for the late delivery, or for faults in manufacture. Legal remedies are available in respect of some of these circumstances, and readers who have complaints should address them to the advertiser or should consult a local Tradings Standards Office, or a Citizen's Advice Bureau, or their own solicitor.

J. BIRKETT

RADIO COMPONENT SUPPLIERS

TV AERIAL IN LINE FILTERS TYPE 1 Two FX 1588
Rings Wound with Coax Like Braid Breaker @ 95p
Type 2. UHF HIGH PASS FILTER With Coax Filters @ 95p
EX-MILITARY COMMUNICATION RECEIVER R210 2 to 16 MHz in 7 Switched Bands with BFO, NOISE LIMITER, CRYSTAL CALIBRATOR, CW, FILTER Converted to 240 Volt AC. With Pair of Headphones and Loudspeaker @ £79.80 (carr. £8).
EX-MILITARY COMMUNICATION RECEIVER TYPE R210 Unconverted @ £50 (carr. £6).
AIR SPACED VARIABLE CAPACITORS Slow Motion Drive. 200+350pF @ £2.50, 250+250+20+20+20pF @ £2.50, 180+380pF With Double Geared Drive @ £2.50, Direct Types 15+15pF @ £2.50, 10+10+20pF @ £1.50, 125+125pF @ £1.95, 208+176pF @ £2.50, 500+500pF @ £2.95. C804 Types. 5pF @ £1.95, 10pF @ £1.95, 25pF @ £2.50, 50pF @ £2.50, 150pF @ £2.95.
NUT FIXING FEED THRU'S 500V.w. 1000pF, 4700pF Both 55p each.
CRYSTAL FILTERS 21.4MHz BW 7.5kHz ITT 0248F @ £2.95, ITT 0240C 10.7MHz BW 3.7kHz @ £5, ITT 0240C 10.7MHz BW 6kHz @ £5, SE1 0C1121A 10.7MHz 25kHz Spacing @ £2.95, Side Band Filters 1.4MHz BW 2.4kHz, Upper and Lower £11.95 Pair.
MOTOROLA NICOA BATTERIES in used Condition Type NLN 58608 7.5Volt @ 75p, 10 for £6.50 (P&P £2), Type NLN 4L638 15 Volt @ 75p, 10 for £6.50. (P&P £2).
MINIATURE ELECTROLYTICS. 4.7uf 50V.w., 10uf 63V.w., 1000uf 10V.w. @ 12 For £1, 56uf 6V.w. @ 50 For £1.
ACCESS AND BARCLAY CARDS Accepted. P.&P. 60p under £5. Over Free. Unless Otherwise Stated. C.M. HDWES AND WOOD AND DOUGLAS KITS Available By Post and For Callers.

25 The Strat
Lincoln, Tel. 20767
(LN2 1JF)
Partners J.H.Birkett.
J.L.Birkett.

TRANS EMT Prio 200/250V Sec 1720V at 550 Ma for FW Bridge £55. MONITOR CRT Tr SSB RF monitor tunes 2/22Mc in 5 bands as Int AF Base for two tone test reqs wst power with circ & notes. £34.50 suitable mains trans for conv. £7.50. SIG GENS Marconi TF995A/2 general purpose unit 1.5/220Mc/s AM/FM var o/p etc tested with book £115. LASER DETECTOR HEADS with 3 cells size 3" x 3" for outdoor use with electronics digital o/p req ext L.V. power modern equip. £14.50. ROLLER COASTER COILS nom freq 2/22 Mc/s 36 trs on 2" ceramic former ext size 6 1/2" x 3" x 3" Ind 20 Uh new unused £28. AUDIO TAPE 1" on 7" spools 1800ft 4 tapes £11.50. OPTICAL ACCS. misc selection of items inc eyepiece, lens cell, lenses, mirrors, prisms mostly new £23. POWER UNIT General purpose bench unit HT/LT for 200/250V O/Ps HT variable 0 to 500V, at 100Ma to 350V & LT 6.3V AC ct at 3 amps fitted V/Ma meter, fuses, screw term etc size 13 x 8 x 13" tested with circ. £38. VARIACS General purpose 220/260V O/P 0 to 240V at 8 amps for int mounting by Philips £28. FLASH UNITS Aircraft type made by Hella for use on 24V DC will work on 12V with lower o/p tubes enclosed in weather proof fitting 3" dia, kit comprises 2 tubes with fittings power unit & connec cables £35. TUNING CAP VHF P.A. type for twin tetrode 2A + 2A P1 with 1/2" shaft new £6.50. AUDIO OSC. Advance type J11 15cis to 50Kc in 3 ranges sine wave 5 & 500 ohm D/P variable tested £28. SPEAKER Army AFV 3 ohm in case 5 1/2" dia by 3" new £11.50. R.F. ASS Spars front end units for R210 Rr 216 Mc/s in 7 bands 455Kc o/p as RF stage with valves & circ. £18.50. LARGE CAPS 4uf 7.5kV £65. AIRCRAFT T/Rx type ARC-44 compact unit intended for use in Helicopters covers freq range 24/51.9 Mc/s in 280 100Kc channels mode F.M. nom O/P 8 watts into 50 ohm, comprises T/R, remote control unit & Dynamotor P.U. reqs 24/28V DC at 5 amps, also supplied with intercom amp £35 also available with 8ft Fibre glass whip with base & Ae coupler (matching unit) and Keyer unit (part of Homming System swts between two Dipoles) £58 American origin, with circuits etc. X RAY SOURCE portable testing two part unit 40/140Kv at 0/5 Ma 230/250V one only £350 plus VAT.

Above prices include Carr/Postage & VAT.

Goods ex equipment unless stated new.

SAE with enquiry or 2x20p stamps for List 44.

A.H. SUPPLIES

Unit 12, Bankside Works, Darnall Rd, Sheffield S9 5HA.
Phone. 444278 (0742)

ICOM

IC-735.



Credit facilities available

- Small Compact Size.
- 100kHz-30MHz General Coverage Receiver.
- 100 watts.
- 105dB Dynamic Range.
- FM Standard.

- 12V Operation
- Large LCD Readout.
- 12 Memories.
- CI-V Communications Interface
- HM12 Microphone.

VISA

Icom (UK) Ltd
Unit 8/9 Sea Street Industrial Estate, Herne Bay, Kent CT6 8LD. Telephone: (0227) 369464.
Open: 9-5.30, Lunch 1-2pm. Mondays to Saturdays.



Back-Scatter

Starting date January 1 1975

Annual v.h.f./u.h.f. table
January to December 1989

Station	50MHz		70MHz		144MHz		430MHz		1296MHz		Points
	Counties	Countries	Counties	Countries	Counties	Countries	Counties	Countries	Counties	Countries	
G1SWH	67	33	71	7	93	22	60	9	—	—	362
G6HKM	57	44	—	—	82	29	50	18	32	9	321
G8LHT	56	17	34	5	79	31	53	15	8	4	302
G0IMG	69	29	41	5	56	12	27	5	—	—	244
G1DOX	36	18	49	6	66	18	29	6	16	7	241
G4ZTR	19	11	49	8	59	27	23	7	13	3	219
GW6VZW	72	32	—	—	75	21	—	—	—	—	200
G6NB	66	33	—	—	56	17	24	3	—	—	199
G8PYP	34	27	1	1	59	26	29	11	—	—	188
G4LDR	43	10	—	—	53	16	50	11	—	—	183
G4XEN	21	9	13	2	63	21	33	9	—	—	171
GD4XTT	34	9	—	—	57	15	30	11	—	—	156
GM4CXP	28	11	4	1	61	19	4	2	—	—	130
G0EVT	24	24	—	—	40	29	6	7	—	—	130
GM1SZF	33	11	—	—	57	16	5	6	—	—	128
G0EHV	—	—	44	5	62	16	—	—	—	—	127
G0FYD	3	5	—	—	88	23	4	2	—	—	125
G8XTJ	40	14	—	—	54	13	—	—	—	—	121
G3EKP	25	15	27	6	25	7	5	4	—	—	114
G4VOZ	—	—	64	8	—	—	31	7	—	—	110
G1VJP	15	4	—	—	74	12	—	—	—	—	105
G1TCH	21	23	—	—	38	15	—	—	—	—	97
GW4HBK	—	—	61	7	—	—	24	4	—	—	96
G1CEI	5	5	—	—	51	14	8	4	—	—	87
GW1MVL	—	—	—	—	56	22	3	4	—	—	85
G7CLY	—	—	—	—	58	14	4	1	—	—	77
G7CFK	43	31	—	—	—	—	—	—	—	—	74
G3FPK	—	—	—	—	51	19	—	—	—	—	70
G1GEY	4	2	—	—	—	—	34	8	2	2	52
G0HGA	—	—	—	—	32	12	—	—	—	—	44
GM1ZVJ	3	3	—	—	23	15	—	—	—	—	44
G4AGQ	—	—	12	2	7	7	6	3	—	—	36
G6MXL	2	1	4	1	7	4	8	5	—	—	33
G0HOZ	—	—	—	—	25	4	—	—	—	—	29

10. During the intense opening on November 19, HH7PV, H18W, KG4SM, PJ9EE, 8P6JW and 8P9DA were heard but not worked.

The 70MHz Band

During an aurora on November 13, **Dave Lewis GW4HBK** (GWT) worked E19FK at good strength but mentions that no other stations were copied during the evening.

G8PYP is now active with a converted Pye Europa, crystal controlled on 70.26MHz and 70.45MHz. Running 10 watts into a quarter wave vertical, Steve monitors 70.45MHz f.m. on most evenings.

GW1MVL (CWD) is hoping to be active on the band soon. He intends modifying a Pye Westminster for 70MHz f.m.

The 144MHz Band

Most of the excitement during November was provided by a number of auroral openings. Tropospheric conditions were mainly poor although there were a number of days, around the second week of the month, when conditions were enhanced.

Godfrey Manning G4GLM (LDN), better known as the *Short Wave Magazine* 'Airband' author, made a number of good contacts during the enhanced conditions on November 13. Running an FT-290R into an 8 over 8 antenna at 13 metres, contacts were made with G7AQU (HWR), G7EON (SXE) and GW3ZTH/P (GNM). The furthest contact made was with ON1ANV (JO11) over a distance of 270km.

November 15 was a good day for Vince G7ENF. In addition to working many French stations on 430MHz, contact was

made, on 144MHz, with GM4IPK (IO99) on the Shetland Islands.

Situated in the fairly rare locator square JQ03, **GODVY** made s.s.b. contacts with F60BI (IN88), GM4SIV (IO65), DH2OAA (JO42) and LA1ZE (JO28).

Dave Brown GD4XTT also had good results on November 15. Before going to work, contacts were made with DF7DJ (JO31), FD1JPH (JO10) and PA3DYY (JO21). In the evening, further QSOs were made with F6EAM (JN19), FC1LHP (JO10), FC1MOZ (JN29) and at 1912UTC for a new county, HB9DFP (JN37).

The 430MHz Band

Not much news of activity on this band but G6HKM reports that she worked 76 stations during the cumulative contest on November 14, so the stations are obviously out there somewhere.

GW4HBK reports that he experienced his first lift on the band on November 13. In an opening to northern France, Dave worked FC1ARR (IN98), FC1LFT (IN88), F6APE (IN97), F6CCH (IN96) and F6DBI (IN88). He goes on to say that you can work DX from a hole in the ground if you're patient.

G8PYP also worked the same French stations on November 13. The band was still in good shape on the following day, contacts on s.s.b. being made with F1FH (IN97), FC1EZQ (JN27) and ON5TX (JO10).

Further up country, in Lincolnshire, **GODVY**, also found the band enhanced on November 14. GM4LBV in locator IO75 was easily worked on s.s.b. Conditions on November 15 remained good, but despite hearing GB3ANG, on 432.980MHz, at 59 all day, only one contact, with G1GEY (TWR), was made to the north.

Over on the Isle of Man, GD4XTT reports that results are now much better, especially as the antenna now has a rotator. On November 6, a move from 144MHz with G0ICE (CBE) gave Dave a new county. The conditions on November 12 were excellent with both GB3SUT and GB3MLY beacons being received at many dB over S9. New counties worked included G10FA (BFD), G3NOZ (HFD), G1XYW (LEC) and G6OOX (NHM). Unlike Ela, who worked 76 stations in the cumulative contest on November 14, Dave only managed 12 contacts, the good tropo conditions having moved to the east during the day. Despite this, G6HKM (ESX), G1HLT (NOT), G4YPC (SRY) and G8NEY (WLT) were worked for new counties.

The Microwave Bands

The autumn season always provides a number of days when propagation is enhanced on 1296MHz. During the period November 13/14, Ela G6HKM worked GU8IRF, G6LEU (CNL), G8GDZ (WMD), DD9DU, ON4KSI and ON4TX. **GODVY** (LCN) also caught the good conditions on November 13, working DK2ZF (JO33) and hearing many Dutch stations.

John Acton G1DOX (AVN) reports working HB9AGE during the period of good conditions on October 3. In November, s.s.b. contacts were made with G3IMV (BKS), G4LU (SPE), G3GRO (SXW) and FC1AAR. John mentions that he has yet to work GM on either 430MHz or 1296MHz. If any GM can help with this, or if you want the county of Avon on either band, give John a call on 0272 693235.

From the *RSGB Microwave Newsletter*, edited by G3PHO and G8AGN, I learn of a new UK 24GHz wideband

record. The previous record was set up between G3FNO and G3NKL over a path length of 127km and although greater distances have been worked with narrowband equipment it has long been the ambition of many operators to better the wideband record. On October 15, G3PYB/P located at Blakey Ridge, on the North York Moors and G8AGN/P, on Beeley Moor, Derbyshire, worked each other over a 135km path. Both stations were using the Plessey GDHM32 doppler module giving a nominal 7mW output and 10.7MHz i.f.s of 180kHz bandwidth. Dishes, one 450mm and the other 600mm diameter, with the inefficient but effective "penny feeds", were in use at both ends of the path.

Those who wish to make an attempt on this record should note that the best time appears to be in the early morning when there are low temperatures and the water vapour content in the air is also low. Relative humidity is not necessarily the best indicator of optimum conditions.

VHF News

Peter Hall SM0FSK reports that following a meeting with the Swedish PTT, a number of changes are being made to the 50MHz permits. The number of experimental licences is to be increased by 75, bringing the total to 100. The restriction to transmit outside of TV transmission time has been withdrawn as has the restriction in areas which have TV transmitters on channel E3. The experimental period has been extended to December 31 1990.

GM7ASN (IO78TA) is reported to be active most nights on 144.222MHz. He is the only station in this locator square with a south facing take-off.

Those of you planning to visit the RSGB VHF Convention at Sandown Park should note that the event is scheduled for Saturday May 12 and not on the Sunday as reported in some magazines. To help you remember the date, it is on the same day as the FA Cup Final.

Introduction of 12.5kHz FM Channelling

In 1986, the RSGB VHF Committee, commenced a study to see if a move to 12.5kHz channel spacing, in place of the existing 25kHz spacing, was necessary. The study was initially set up because high band occupancy, at that time, meant that it was getting difficult for stations, particularly in city areas, to find a clear channel for communication. At a recent meeting, the VHF Committee deliberated over the results of surveys carried out at the 1989 VHF Convention and responses from postal surveys following details of the scheme in the RSGB *Radio Communications* magazine. Replies from a request inserted in the July 1989 issue of *Practical Wireless* were also taken into account as were the views of the Repeater Management Group, probably the largest specialist group in the UK directly involved with f.m. communications.

In the three years since the study

Back-Scatter

Annual c.w. leader

Station	Band (MHz)				Points
	50	70	144	430	
G4ASR	118	7	386	1	510
G4OUT	-	19	239	-	258
G0HGA	-	-	192	-	192
G4XEN	7	-	144	9	160
GM4CXP	29	1	114	1	145
G0FYD	-	-	117	-	117
GW4VVX	-	-	73	-	73
G4VOZ	-	46	-	8	54
G3FPK	-	-	32	-	32
G0FYD	-	-	31	-	31
GW4HBK	-	22	-	-	22
G4AGQ	-	10	11	-	21
G0EELY	1	-	14	-	15
GW4VVX	-	-	9	-	9

Number of different stations worked since January 1 1989

commenced, it has been noticed that band occupancy is now very much lower. Because of this and responses from interested parties, the RSGB VHF Committee feel that the general introduction of 12.5kHz channel spacing should not be implemented for the time being. The survey has been of immense value in determining the usefulness of the project and will be used, in conjunction with other input, when the committee next review the need for the implementation of 12.5kHz channelling. In the meantime, the VHF Committee will be interested to hear observations and results from any group already using 12.5kHz spacing. Details and comments may be forwarded either to myself or to the VHF Committee chairman, Peter Burden G3UBX.

Beacon & Repeater News

Iain Dunworth G4SNL (CNL) has a personal beacon operating from his home

location in Saltash (I070VJ), on 10:15/10.420GHz wideband. Iain invites any interested operator to contact him on 0742 849601 so that he can switch it on as an attended beacon.

Another microwave beacon, this one located at Danbury, Essex, is expected on the air soon. It will use the callsign **GOLKW** on 10368.960MHz.

Now in operation is the Nottingham packet mailbox **GB7LED** on 70.4875MHz. More details can be obtained from **G4XMH**.

A new v.h.f. repeater, **GB3IG** on Stornoway, came into service recently. It is operating on channel R7. Contact **GM4PTQ** if you want any more information.

Following a wait of over two years, since losing the use of its previous site, the Hereford u.h.f. repeater **GB3HC**, on channel RB6, has now come on the air, from an elevated site overlooking the city. Reports of coverage would be welcomed by the keeper, Alan Willis G4JNS.

QRZ Contest!

The Derby and District Amateur Radio Society 144MHz contest will be held on Sunday March 11 between 1300 to 1700UTC. A full set of rules is available upon receipt of a stamped addressed envelope from the club at 119 Green Lane, Derby, DE1 1RZ. Briefly the contest is all mode, with fixed and portable entries being permitted. There are two sections - Low Power, up to 30 watts maximum output and Full legal power output. Contestants exchange callsign, report, serial number and county. Contacts with G3ERD score 10 points, all others score 2 points. The final

GTH Locator Squares Table

Station	1296	430	144	Total
G3IMV	48	124	429	601
G4KUX	—	120	372	492
G3JVR	82	135	246	463
G4RGK	50	124	284	458
G3XDY	91	148	206	445
GJ4ICD	59	119	263	441
G0DAZ	27	128	277	432
G3JXN	87	134	179	400
G1EZF	—	93	263	388
G4XEN	—	111	274	385
G6HKM	46	109	217	372
G6DER	78	110	183	371
G4QEZ	49	49	249	347
DN1CAK	7	53	277	337
GARRA	—	80	255	335
G3COJ	44	103	186	333
G4SSO	—	93	229	322
G4FRE	72	146	102	320
G1KDF	37	102	180	319
ON1CDQ	7	54	251	312
G4TIF	—	110	200	310
G1LSB	—	139	170	309
G4DHF	—	—	307	307
G1EGC	23	80	198	302
G8HHI	38	110	148	296
G8PNN	64	99	129	292
G6MGL	59	89	141	289
G4NBS	63	105	119	287
G8LHT	10	91	181	282
DL8FBD	—	—	280	280
G8ATK	45	91	143	279
G4MUT	31	93	153	277
G0EVT	—	57	206	263
G4PCS	—	3	258	261
G1GEY	11	77	168	256
G3NAQ	—	80	175	255
G6STI	24	69	152	245
G6DZH	—	87	154	241
G4IGO	—	—	238	238
G3FPK	—	—	236	236
G0EHV	—	75	160	235
GM4CXP	—	31	198	229
E15FK	—	56	172	228

score is the total number of contact points, multiplied by the number of counties worked. Each county outside of the UK is scored as a county.

Station	1296	430	144	Total
G4MEJ	—	—	213	213
G8LFB	—	—	209	209
GW4FRX	—	—	204	204
G8MKD	—	49	150	199
GJ6TMM	—	48	151	199
G1SWH	—	57	141	198
G4YCD	—	—	197	197
G1JUS	—	—	192	192
G4DOL	—	—	186	186
G4ZTR	30	47	95	172
G7ANV	—	—	153	153
G6MXL	16	45	91	152
GW6VZW	—	6	143	149
G4FVK	21	49	78	148
G4AGQ	1	42	104	147
G0FYD	—	1	142	143
G1DWQ	—	—	142	142
G8PPY	—	31	105	136
GW1MVL	—	22	106	128
G1WPF	—	29	97	126
G0FEM	—	24	101	125
G8XTJ	—	—	116	116
G11MM	—	17	98	115
GM0HBK	—	—	107	107
G1OWA	—	—	103	103
GM0GDL	—	22	81	103
G1TCH	—	6	95	101
G1DDX	8	16	73	97
G1SMD	—	—	93	93
G8MEN	4	26	63	93
G7ENF	—	19	70	89
G1CEI	—	15	74	89
G4WHZ	7	—	76	83
G0ISW	—	17	59	76
G0HEE	—	—	73	73
GU4HUY	—	—	73	73
G0HDZ	—	—	64	64
G1NVB	—	—	58	58
GM0JOL	—	—	47	47
G2DHY	2	7	33	42
G7CLY	—	2	40	42
GM1ZVJ	—	—	41	41
G7AHQ	—	—	34	34

No satellite or repeater QSO's

**KEEP THE REPORTS
COMING FOR YOUR ENTRY
INTO THE TABLES**

Back-Scatter

RTTY

Reports to
Mike Richards G4WNC
200 Christchurch Road,
Ringwood, Hants BH24 3AS

RTTY Awards

Once you're up and running on RTTY, how about trying for an award of two. There are a variety of awards available from BARTG, e.g. the Quarter Century Award and the VHF/UHF Century Award.

First, the BARTG Quarter Century Award. This involves making two-way RTTY communication with amateur stations in 25 different countries. After that, stickers are available for increments of 25 up to a total of 300. If you are an s.w.l. you can still obtain the award on a heard basis.

There are three ways to claim this award. The first is to submit the necessary QSL cards for the countries being claimed, these are returned after checking. Photocopies of the QSL cards are also acceptable, but must show both sides of the card showing both callsigns. The second method is based on a check-log of the necessary contacts. You must include date, time, band, callsign worked, RST,

etc. The list and appropriate QSL cards should be examined by the Awards Manager of a national society or by two officers of a recognised radio club or society. Then the signed check-list and appropriate fee is sent to BARTG. The final method is if the stations were worked during a RTTY contest sponsored by BARTG, but you must submit the log for the award at the same time as the contest.

The cost of the Quarter Century award is: UK = £1.50, overseas = US \$6 or 30 recent IRCs. If you send your QSL cards and want them returned you should add 50p to the cost of the award.

Next, the VHF/UHF Century Award. You need proof of having made two-way

RTTY contact with the required number of stations in the 144, 432 and 1296MHz bands. The awards are available separately for each band. Stickers are available in increments of 25 up to a total of 250. On the 1296MHz band, the endorsements go up in steps of 10. Again, these awards are available to s.w.l.s on a heard basis.

The minimum number of contacts required on each band is as follows:

144MHz - 100 different stations worked/heard

432MHz - 50 different stations worked/heard

1296MHz - 10 different stations worked/heard

The three methods for claiming the

award are the same as for the Quarter Century Award. The cost for the UK is £1.50, overseas is US \$6 or 30 recent IRCs. The update stickers cost 20p for the UK or US \$1 or 3 recent IRCs overseas. Again, if you send in QSLs and want them returned add 50p or 5 IRCs to the total.

Special Event Stations

I wonder how many readers have tried using RTTY, AMTOR, etc., at special event stations where the general public are involved? I suspect not too many, which is a shame as I have found that these modes generally attract a lot of interest. Over the years amateur radio has become much misunderstood and is usually perceived either as a sort of CB or rather like the character portrayed by Tony Hancock! So it is in our own interest and that of the hobby as a whole to rectify the situation whenever we get a chance. How many times have you seen a special event station where the operator is totally oblivious to

Back-Scatter

the visitors because he is working a pile-up on eighty? The other problem of course is that s.s.b. is very difficult to understand unless you are used to it so the result is that visitors will watch for a short time and then move on having understood nothing! The RTTY or AMTOR operator can operate much more effectively especially if he or she is well organised with plenty of the standard messages stored in computer memory. The visitor can also clearly read the details of the contact on the screen. So from this you can see that RTTY/AMTOR wins on two counts. It also has a novelty value in that most people are totally unaware that such communication modes even exist.

So, having made my case let's detail a few tips that I have learned from experience.

The first and most important area is safety. With the general public around it is vital that you make sure the installation is electrically safe and that all connecting leads are tucked safely away.

Next comes the radio installation where it is absolutely essential that you have the best possible antenna and earthing system you can manage. If you use a "lash-up" not only will the performance be poor, resulting in difficulty obtaining contacts, but you will suffer all sorts of r.f. problems. For example when transmitting you may well get interference on the monitor and even r.f. in the computer, which may affect the operation of the RTTY program itself. In addition you may experience r.f. interference from the computing equipment on receive!

Make sure that the monitor or TV is easily seen by placing it up high. It may even be worth seeing if you can borrow a second monitor to be placed at the entrance to your area to attract attention.

One particular type of special event where RTTY/AMTOR goes down well is the Brownies Listening Day On The Air. These events encourage the Brownies to send messages to each other using amateur radio. I have found that the girls thoroughly enjoy using the computer keyboard to send messages, particularly as they can use the type ahead buffer to prepare the message. Most youngsters these days are surprisingly computer literate and are usually quite comfortable using a computer keyboard.

So there we are with my views on special event stations if you're interested why not approach the local Brownies or Scouts and offer your services for the next event.

The Microreader II

The review for this month is the Microreader II from Enterprise Radio Applications Ltd (ERA). This tiny self contained unit can receive RTTY and c.w. of a wide range of speeds and also includes morse tutor. Although this unit is receive only, I'm sure it will be of interest to readers of this column. One of the features that makes this very compact unit particularly appealing is the built-in liquid crystal text display.

Being self contained the external connections are very few and have been designed to be as simple as possible. The power requirements are a straight forward 12V to 16V d.c. at 150mA which shouldn't be too difficult to find. For normal operation the only other connection required is the audio from the external speaker socket of the receiver. The only problem with using the external speaker socket is that the internal speaker is usually disabled. Fortunately ERA had thought of this and provided two 3.5mm jacks on the rear panel enabling an external speaker to be connected so that you can continue to hear what you are tuned to. The impedance of the audio socket is approximately 2k Ω and thanks to a sensitivity adjustment on the rear panel can accept a wide range of input levels with 7mV as the minimum on the review model. This versatility means that it is quite feasible to use the tape recorder or fixed level output from your receiver, instead of the external speaker socket.

To keep the number of external sockets to a minimum, the audio input socket has a secondary use as the key input when using the Morse tutor feature. This does, of course, mean that the user has to swap plugs in order to use the tutor - not a serious problem!

The only other connection on the rear panel was the RS-232 socket which comprised a 3.5mm jack. Although called RS-232 it was simply a data output which would drive the receive data line of a computer or printer RS-232 port. But more of this feature later.

The front panel was very neatly laid out with the display slightly off-set to the left with the main (and only) function switch on the right. A ten-element bargraph tuning indicator and three shift indicator l.e.d.s completed the front panel.

Moving on to the operation this was controlled by a single rotary switch on the front panel. As the Microreader can resolve RTTY at various speeds and shifts as well as c.w. you may well be wondering just how all this can be controlled by one

switch. Well it's all down to some clever logic - but don't expect to be able to master this control without some practice.

Probably the easiest mode to use is c.w. which for most signals is simply a case of selecting c.w. auto. Once selected, as with all the modes, a plain English confirmation message appears on the display. This is very useful and in fact essential with this type of multi-function control.

The c.w. decoding routines in the Microreader are really very good and have been specifically designed to deal with hand sent c.w. One of the features I found most fascinating was the automatic text editor. This enabled the Microreader to insert the inter-word spaces that are so often missed from amateur c.w. To do this the Microreader uses its own directory to spot common words and abbreviations - it can also correct the odd spelling mistake! There is obviously a risk that this type of routine may in fact corrupt the received signal, but ERA have resisted the temptation to overdo the corrections and I experienced no problems whatsoever throughout the review period.

In addition to the AUTO C.W. position there were two other c.w. modes - FAST and SLOW. These were self explanatory really in that they were optimised for receiving either particularly fast or slow c.w.

The c.w. tutor was the next feature to try and I started with the practice sending option. Once this option is selected a message appears on the screen reminding you to insert the key. This message is necessary because the audio input doubles as the key input, so you have to remove one plug and insert another.

In order for the decoding logic to set up to your sending speed you have to send a few characters of which the first two or three are incorrectly displayed. Incidentally you don't have to do this at the start of each group of characters, as the unit remembers the current speed.

Once you start sending the Microreader quickly highlights any short

comings in your c.w!

On the reception side, characters were sent in the standard five character groups and you could choose letters, numbers, letters and numbers mixed or punctuation. The punctuation option was particularly useful as this is an area where many amateurs are weak. In addition to basic punctuation, this option included continental characters and procedural signals.

Moving on to the RTTY option, this was a powerful addition and in the review model was up to software revision 2.5 The options provided were 45, 50 and 75 baud with shifts of 170Hz, 425Hz or 850Hz. As with the c.w. option the rotary switch had several levels which were quite easy to get to grips with.

One useful aid was the auto facility which allowed very quick selection of the standardspeed and shift combinations, i.e. 45 baud - 170Hz.

In addition to the auto modes, all the parameters could be manually set giving the operator maximum versatility.

The only weak point with RTTY was the operation of the tuning indicator which required the signal to be adjusted so that one of the tone pair lit the centre l.e.d. whilst the other lit the end l.e.d. I found this to be a little tricky and required some practice to obtain reliable results.

Once the tuning had been mastered, the performance was actually very good even under quite difficult conditions.

So, to conclude, the Microreader II is clearly a very capable and powerful unit which belies its small size. It is also very competitively priced and by all accounts is selling extremely well.

On a personal note, I am seriously considering buying the review model which must say something about its performance!

The Microreader II is available from ERA Ltd., Unit 28, Clarendon Court, Winwick Quay, Warrington, Cheshire WA2 8QP and costs £154.95 inclusive of post and packing.

My thanks to Bill Green of ERA for the loan of the review model.



Back-Scatter

Amateur Satellites

Reports to
Pat Gowen G3IOR
17 Heath Crescent
Hellesdon, Norwich, Norfolk NR6 6DX

ARIANE SPOT-II Launch

The mission carrying the SPOT-II and the AMSAT cluster consisting of UoSAT-D and E and all the microsats has now been set for January 11 at 0135UTC with a ten minute window which, (believe it or not!) due to a postponement of the Ariane mission that was to precede it, is eight days earlier than that originally planned! If the launch is postponed beyond the ten minute window, the next opportunity comes 48 hours later. All readers are cordially invited to listen to and participate in the AMSAT launch network, on the frequencies already given in this column. The satellites will not be usable until all tests and program loadings have been completed, hopefully by late February.

ZRO Tests

The tests for the optimum satellite receive system capability dedicated to Kaz Desker K2ZRO, are proving to be very popular. (See last month's column for the brochure details). Many stations have been able to copy the Mode B 145MHz downlink produced when the associated uplink has been down to level 8, i.e. that equivalent e.r.p. put out by a hand held 2 watt transceiver. The Mode JL test of Saturday December 2 provided by W6HDO, produced a very significant downlink on 435.945MHz at level 1, slowly reducing in steps down to level 8 before it finally disappeared into the transponder hash added to by picked up solar noise.

The most surprising finding was that the presence of stations some 20dB stronger in the passband did not seem to actuate the a.i.c. sufficiently to cause the gradually weakening signal to drop out at any time during the test, which is certainly not the case on the B mode, nor on the Mode A RS system. It all reinforces the realisation that success with satellites

arises from an optimum receive system and the minimal transmitting requirements. The only reason that this does not always work is due to the presence of those who practice the opposite, whom we term the 'alligators'.

MIR

The new 12.5 x 4.35m, 20 tonne, Kwant-2 'D' module which was sent up by a PROTON launch to MIR on November 26 could be seen by eye soon after dusk as it neared the manned space station. It was due to dock on December 2, but had to be rocked first in order to unfold one of its large solar panels that was jammed. On December 1 it was some 12 minutes of time from MIR, on December 2 only 20 seconds, and the sighting of December 3 showed only one bright object. Kwant-2 would appear to be painted white as, although a little smaller, it seems far more reflective than MIR itself.

It was hoped that the wait for the module would have given a little more free time to the Alex pair to operate their amateur radio experiment on 2m f.m., but no reports indicating this have evolved. Indeed, from December 1-3 it would have proved difficult, as the 145.625MHz audio from the cosmonauts was muffled, far weaker than normal, and had a distinct echo, so indicating that space helmets were being worn ready for EVA.

The orbiting space station has proved very difficult to track over the past month as before the latest Keplerian elements could be received, the manned satellite had been pushed up to higher orbit once again. The reason for the elevation is

thought to be due to the fact that compensation burns for escalating drag during solar highs may prove difficult once the new module is attached, as the station would be non-symmetrical, unbalanced and difficult to manoeuvre.

For this reason it is hoped that the latest stop press element set given last in this column under the heading Keplerian Elements may hold until the next big 'T' module launch, probably on 30 January. That should arrive about a week later in early February just before the new crew go up on February 10 for a year long mission. The current crew are due to return on February 19. The final mating of the second module will permit re-balance of the the space station and manoeuvrability will be simplified again.

The new module with its 'APAS' docking system will permit the larger BURAN shuttle to go to MIR in 1991. As yet there is no life support system finalised for this shuttle, so far more work is needed before it can be flown manned. The smaller 'PETISHKA' (Little Bird) shuttle has a docking system and manipulator attached, and may go first.

OSCAR-13

A-0-13, following the solar flare induced IHU memory loss reported last month, was reloaded back on again only to be wiped out again on Sunday December 10, when the 'hot' side of the sun re-appeared facing earth. Further reports arrive of satellite losses, the latest being SOLARMAX, brought out of orbit by the very conditions it was researching, i.e. the solar maximum data. The latest operating

schedule for the U-0-13 satellite as from November 22 until further notice is as follows:

Mode B Mean Anomaly 000 to Mean Anomaly 110.

Mode JL Mean Anomaly 110 to Mean Anomaly 145.

Off from Mean Anomaly 145 to Mean Anomaly 150.

Mode B Mean Anomaly 150 to Mean Anomaly 255.

The Mode S beacon will be switched on from Mean Anomaly 146 to 147, and the Mode S transponder will come on from MA 147 to 160, in tandem with Mode B. From MA 225 to MA 235 the transponder will switch from the beams to the omnidirectional antennas, and only very low power uplinks will be needed at this time.

Phase-III-D

AMSAT-DL announce that building has commenced of the 200-400kg, 250W powered Phase-III-D satellite intended for a high altitude Molniya orbit (similar to OSCAR-10 and 13) has now commenced. Provision of funding for the project has been confirmed by the West German government, who exhibit an enthusiasm for space research not demonstrated in the UK.

RS-12/13

Brian Cooper G4RHZ of Doncaster provides some valuable indicators as to when we might expect the launch of the new Soviet RS transponders with the coming COSMOS satellites. He is able to decode the RTTY, like 80 baud TLM, and is a mine of information on the Soviet NAVSATS. He points out that there are four satellites in the civilian NAVSAT system and that until the launch of NADEZHDA-1 on July 4 there had been no such suitable common carrier. Unfortunately, NADEZHDA-1 carried a COSPAS/SARSAT package and thus could not carry RS-12/13 as well.

He points out that the military COSMOS 2004 navigational satellite launched on 22 February 1989 replaced COSMOS 1981, whilst COSMOS 2016, also military, launched on April 4 replaced COSMOS 1934. COSMOS 2026, another military NAVSAT launched on June 7 has yet to be replaced, as is NAZ-1, the civilian satellite launched July 4 or COSMOS 2034 launched July 27, a further military satellite. He tells how each satellite in the civilian system carries the group number 11, 12, 13 or 14. Under 11 comes COSMOS 1553 and 1791, under 12 COSMOS 1727 and 1861, under 13 is 1655, and 14 consists of COSMOS 1574 and 1816.

As the RS 145/2MHz transponder could not tolerate QRM from COSMOS 1861 TX, it must be switched off as a NAVSAT No. 12 satellite, the role for which is undoubtedly currently being undertaken by COSMOS 1727. He is unsure which satellite NAZ-1 replaced, but thinks it could be a No. 11 satellite. "The next civilian satellite will be launched when any of the listed satellites fail," writes Brian. "This

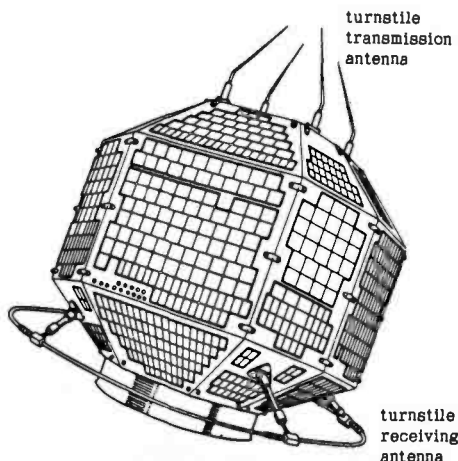

Fig. 1a: External appearance of JAS-1b

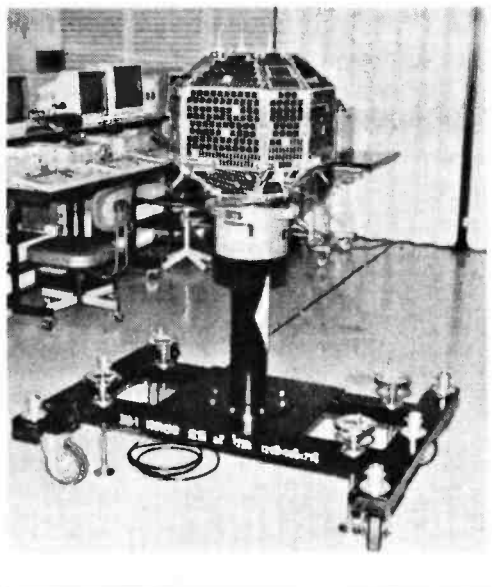

Fig. 1b: The latest photograph of JAS-1b

Back-Scatter

Keplerian Elements

Satellite	NOAA 9	NOAA 10	NOAA 11	METEOR 2/15
Int. Design	84-123A	86-073A	88-089A	87-001A
Object No.	15427	16969	19531	17290
Element Set	448	298	155	303
Epoch Year	1989	1989	1989	1989
Epoch Day	304.03231235	304.05683889	300.29885864	304.74547094
Inclination	99.1560	98.6277	98.9517	82.4647
RAAN	293.7436	331.9083	243.7772	44.2395
Eccentricity	0.0014606	0.0013016	0.0011450	0.0011627
Arg of Perigee	294.1832	213.6616	216.8663	240.7728
Mean Anomaly	65.7812	146.3736	143.1721	119.2270
Mean Motion	14.12244368	14.23248744	14.11229706	13.83784008
Decay Rate	0.00000782	0.00000851	0.00000505	0.00000377
Orbit Number	25163	16201	5610	14250
Nodal Period	102.021720	101.23495	102.095376	104.121070
P-Drags	4.002e-06	4.259e-06	2.594e-06	2.051e-06
Increment	25.502751	25.308820	25.522888	26.159894
I-Drags	1.007e-06	1.017e-06	6.528e-07	5.127e-07
Beacon-QRG	137.620=APT	137.500=APT	137.620=APT	127.850=APT
Ref. EQX	05 Nov 1989	03 Nov 1989	03 Nov 1989	04 Nov 1989
Orbit	25234	16243	16243	14296
HHMM.MM	0130.04UTC	0013.69UTC	0115.28UTC	0143.04UTC
Degrees W	127.89	70.86	170.73	27.47

Satellite	METEOR 2/16	METEOR 2/17	METEOR 3/02	METEOR 2/18
Int. Design	87-068A	88-005A	88-064A	89-018A
Object No.	18312	18820	19336	19951
Element Set	330	166	293	90
Epoch Year	1989	1989	1989	1989
Epoch Day	304.95372454	305.15411318	304.87849350	305.06655756
Inclination	82.5508	82.5470	82.5408	82.5211
RAAN	111.1776	171.7147	78.9584	50.2017
Eccentricity	0.0011052	0.0015414	0.0014841	0.0012866
Arg of Perigee	168.8548	246.0980	158.0467	288.3030
Mean Anomaly	191.2855	113.8566	202.1238	71.6735
Mean Motion	13.83535504	13.84235000	13.16865408	13.83859491
Decay Rate	0.00000219	0.00000349	0.00000391	0.00000117
Orbit Number	11142	8863	6090	3401
Nodal Period	104.139882	104.087291	109.408316	104.115476
P-Drags	1.192e-06	1.897e-06	2.468e-06	6.364e-07
Increment	26.163735	26.150619	27.480856	26.157863
I-Drags	2.980e-07	4.741e-07	6.171e-07	1.591e-07
Beacon-QRG	137.400=APT	137.400=APT	137.850=APT	137.300=APT
Ref. EQX	04 Nov 1989	04 Nov 1989	04 Nov 1989	04 Nov 1989
Orbit	11185	8903	8903	3442
HHMM.MM	0131.38UTC	0105.41UTC	0140.18UTC	0044.57UTC
Degrees W	317.41	250.19	351.63	6.55

Satellite	OSCAR 10	OSCAR 11	OSCAR 12	RS 10/11
Int. Design	83-058B	84-021B	86-061B	87-054A
Object No.	14129	14781	16909	18129
Element Set	435	536	174	928
Epoch Year	1989	1989	1989	1989
Epoch Day	295.83948156	303.72057471	304.07884461	305.86325932
Inclination	25.9220	97.9875	50.0168	82.9235
RAAN	237.9341	358.5160	240.6055	136.4791
Eccentricity	0.6030613	0.0012243	0.0010698	0.0012688
Arg of Perigee	86.9960	254.6117	329.6461	34.6863
Mean Anomaly	336.1703	105.3640	30.3754	325.5123
Mean Motion	2.05883801	14.64246940	12.44402051	13.72019887
Decay Rate	-0.000001	0.00002983	-0.00000025	0.00000244
Orbit Number	4785	30237	14632	11827
Nodal Period	69.2	98.403081	115.652446	105.013812
P-Drags	-	1.370e-05	-	1.382e-06
Increment	175.3	24.601673	29.239349	26.379350
I-Drags	-	3.447e-06	-	3.405e-07
Beacon-QRG	145.810/.987	145.826/435.025 2401.5	435.797/.913	29.357/.403 145.857/.903 29.407/.453 145.907/.953
Ref. EQX	03 Nov 1989	05 Nov 1989	03 Nov 1989	04 Nov 1989
Orbit	4807	30315	14669	11857
HHMM.MM	0012.73UTC	0112.98UTC	0112.69UTC	0113.50UTC
Degrees W	169.40	58.81	188.98	286.78

Satellite	OSCAR 13	SALYUT 7	MIR	AJISAI
Int. Design	88-051B	82-033A	86-017A	86-061A
Object No.	19216	13138	16609	16908
Element Set	50	849	178	-
Epoch Year	1989	1989	1989	1989
Epoch Day	290.09120728	306.32756272	306.33658130	258.72253
Inclination	57.1143	51.6094	51.6251	50.0123
RAAN	186.3015	358.2784	30.1226	19.76
Eccentricity	0.6814391	0.0000875	0.0006166	0.0012
Arg of Perigee	213.3923	32.8150	262.2505	216.46
Mean Anomaly	73.7401	327.3091	97.7229	143.54
Mean Motion	2.09694922	15.47640582	15.55607235	12.44380
Decay Rate	0.00000482	0.00014459	-0.00058707	-0.00000045
Orbit Number	1027	42954	21271	14068
Nodal Period	686.6	92.983171	92.506647	115.654451
P-Drags	-	5.609e-05	2.243e-04	-
Increment	172.2	23.628780	23.511405	-
I-Drags	-	1.380e-05	5.518e-05	-
Beacon-QRG	145.812/435.651 2400.325	19.953/142.417 925.240	143.625-Voice 166.130-Data/ Ranging	29.239883
Ref. EQX	01 Nov 1989	07 Nov 1989	05 Nov 1989	15 Sept 1989
Orbit	1059	43027	21313	14068
HHMM.MM	0822.50UTC	0059.16UTC	0050.38UTC	1720.42UTC
Degrees W	342.08	86.02	40.19	234.99

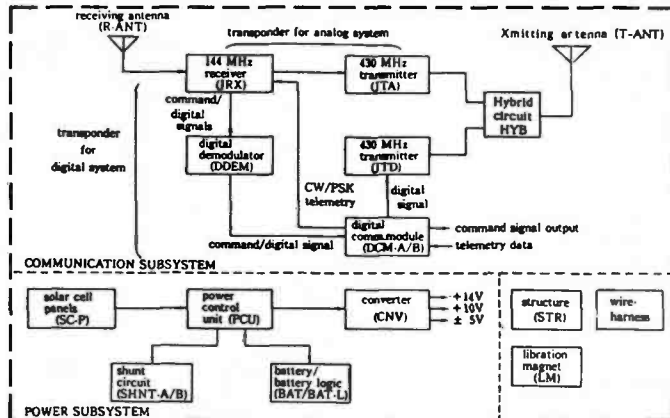

Fig. 2

will probably carry RS-12/13. If it replaces K-1861 it will appear at the same time as RS-10/11, otherwise the pass times will differ."

UFO-432

The mystery satellite that suddenly appeared on 432.883MHz has just as suddenly disappeared again, and has not been heard by any of its many followers since 2030UTC on November 11. The feedback on the possible origin of this strange amateur band intruder has been considerable, with lots of well informed opinion now available.

Mark Shepherd ZL1TRE of Auckland, New Zealand thought that UFO-432 might be Object 83-60C, an ELINT satellite known as 'Operations-0721', launched with Big Bird 18. He had originally thought it to be Polar Bear, but Greg Roberts ZS1BI correctly pointed out that the periods differed. Mark now thinks it to be 83-52C, as it was shown in the listings as still transmitting in 1987, although from his location it is not doing so continuously.

Whilst the appearance of this satellite on one of our most monitored amateur radio beacon frequencies remains a puzzle, Brian Cooper G4RHZ suggests that there is no real mystery about object 1980-52-C itself, as NASA's satellite situation report lists it as "...United States .. elements not available..." which G4RHZ interprets to say "this means it is a military object". He points out that in Geoff Falsworth's satellite 1980-1985 lists the following is listed for the 1980-52 launch:

Object	Cat.No	Period	Inc	Apogee	Perigee	Decay
80-52A	11850	88.4	96.46	212	173	6/4/81
80-52B	11851	88.9	96.46	259	171	20/6/81
80-52C	11852	112.3	96.63	1333	1331	Not Yet

As no date is given for the 1980-52C decay from orbit, it is still aloft, and may be presumed to be functional.

G4RHZ informs us that whilst 52-A was unnamed, it was probably Big Bird No.16, also known as KH9, whilst 52-B was named as Titan 3D-19, i.e. the nineteenth Titan 3D launch. He continues "52-C is not named, but is very probably a 60kg ferret satellite. Some of the Big Bird satellites carried these 60kg satellites,

but not all, as some of the earlier ones were still functional. 52-C would normally be commanded on and off, but obviously it has gone wrong, and this is the reason why it has only recently been discovered".

John Branegan GM4IHJ dismisses any possibility that UFO-432 resulted from a Shuttle launch, as KH-11 satellites have only been launched by the shuttle since 1986 to 57 degrees inclination. He points out that the orbit does resemble that of Object 1980-52-C, the secondary payload of a Big Bird 'photo recon' TITAN-3-D launch. He feels it to be far more likely that it went aloft three years ago with a KH-11 'Keyhole recon', but cannot confirm as the US ceased publication of such launches. He writes, "All we know is that several KH-11's went up together with several small supplementary payloads such as Ferrets and Embassy Comsats, so there are quite a few possible suspects for the origin of 'UFO-432'".

All about JAS-1-b

After three years of operation, OSCAR-12, alias 'FUJI', has been switched off for all time. The Japanese Radio Relay League finally succumbed to the difficulties being created by FUJI-OSCAR-12, due to the vast amount of time and energy being demanded in abortive attempts to try to maintain an operational schedule. Such was the decay of power generation due to the rapidly decaying battery and solar cells of FO-12 that in mid November JARL and JAMSAT made a joint decision to give up all command attempts, in order to devote the team effort to the new up and coming satellite JAS-1-b, its successor.

The date for the JAS-1-b launch, surprisingly, now seems to have slipped from that earlier stated, and although given as 'February 1990' no new exact launch time is yet available from the National Space Development Agency of Japan, known as NASDA. Here are the full details.

Satellite Specifications

A 50kg mass 440 wide x 470mm high spacecraft, with 26 polyhedral faces. Similar to FO-12, but 40mm wider. A line drawing (Fig. 1b) and the latest photograph (Fig. 1a) show the external appearance,

Back-Scatter

indicating the new turnstile receive and transmit antennas, with the 145MHz ring turnstile receiving antenna at the base of the side panels and the dual mode shared 435MHz turnstile transmitting antenna at the top of the satellite. Note the enlarged coverage of the 1300 solar cells. Inside resides the 70% efficient power supply regulator giving 14V, +10V, +5V and -5V and the 11 series connected 6Ah NiCad cells forming the battery stack, the analog transponder and the digital transponder, both 145MHz uplink and 435MHz downlink.

Launch and Orbit details

Lift-off is in February 1990 with the NASDA MOS-1-B Maritime Observation Satellite on a two stage H-1 rocket from the Tanegashima Space Centre, into a solar synchronous 99 degree inclination 900km orbit. As the main payload period is only 103 minutes, the solar illumination at the 99 degree inclination supplied gives eclipse for 33% of each orbit, so it is hoped that additional apogee up to 1200km may be given by the additional thrust available from the remaining fuel after MOS-1-B ejection. This would result in longer periods of solar illumination, thus better battery charge regulation, hence longer periods of operation. It would also mean the possibility of more distant DX QSOs and a gentle shift of overfly time from the initial noon and midnight passes toward dawn and dusk with time, at which time it will be in full sun.

Power supply and source

JAS-1-B will carry some 900 10 x 20mm plus some 620 20 x 20mm of the latest high efficiency dual layer GaAs solar cells, which have the added advantage of resistance to both radiation and temperature degradation. These will give an initial 11 watts of power, almost twice as much as its predecessor, and permit far longer periods of transponder operation in eclipse periods.

Thermal control

As the solar cell coverage and thermal absorption efficiency has a marked effect upon the satellite temperature, additional surfaces will be covered with paint and thermal insulation in order to provide passive control to give the optimum temperature range for NiCad battery efficiency and circuit component operation, e.g. from 0 to +40 degrees Celsius.

Attitude control and antennas

Like FO-12, the spacecraft attitude will be controlled by employing the torque generated in the earth's magnetic field by a pair of permanent magnets. The antennas will be circularly polarised and omnidirectional, used for both digital and analogue transmissions. If the spacecraft attitude is such that the analog signal is sensed as right hand circular, then the digital will be left hand circular, as they

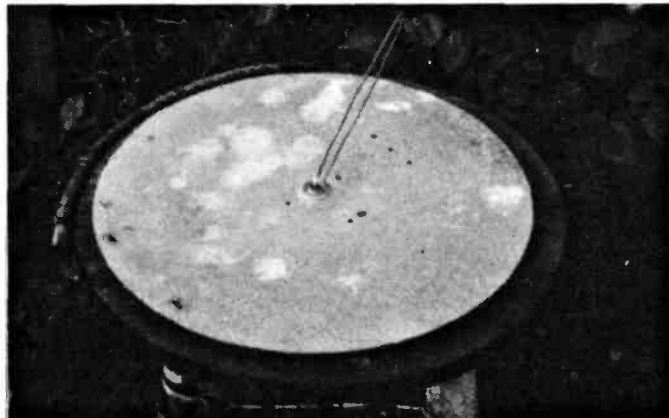

Fig. 3: The sundial antenna

have opposite feed sources. As the satellite will be toppling and tumbling for up to several months before the magnets finally give adequate stabilisation control, it is suggested that at first linearly polarised antennas be employed at the ground station. Despite the 3dB loss incurred compared to correctly circularly polarised uplink antennas, they will initially provide far better signal stability.

Beacons and transponder details

The JA beacon nominally gives 100mW on 435.795MHz, plain carrier, Morse code (c.w.) or p.s.k., and the JD beacon nominally 1 watt on 435.910, TLM in p.s.k. packet format. The c.w. TLM can contain 12 analog data items, 33 status items. The p.s.k. has 29 analog and 33 status items.

The transponder frequencies and modes are similar to those of FO-12, e.g. Mode JA analog has an inverted transponder of 100kHz bandwidth. The JD digital mode functions as a mailbox using AX.25 link level protocol, as with JAS-1/FO-12, so ground stations can use the same equipment as they have up to now for OSCAR-12.

JA mode has a linear uplink pass band from 145.900MHz to 146.000MHz, giving

a linear downlink from 435.900 to 435.800MHz within 3dB limits. A ground station uplink of some 100W e.i.r.p. is recommended.

JD mode uses bi-phase Manchester coded uplink with a bit rate of 1200baud from either 145.850, .890, or .910MHz to give a common 435.910MHz 1 watt downlink n.r.z.i. p.s.k., 1200baud. The uplink power suggested for the digital mode is also about 100W e.i.r.p. The full functional block schematic diagram of the spacecraft is shown by Fig. 2.

Sundial Antenna

Readers may recall the constructional details appearing in Oscar News (1980) and on page 51 of the June 1987 issue of *Short Wave Magazine* (as a scaled up Weather Satellite version) of the simple, versatile and inexpensive 'sundial' antenna as used for the FUJI-OSCAR-13 downlink by David Rowan G4CUO. He rightly claims it to be a "...good all rounder...". The photograph in Fig. 3, taken by David himself, is of his antenna taken by the light of the mid-day sun, showing that it can double up as both a good high angle satellite receiving antenna and a timepiece. Dave says, "JAS-1 was at 50 degrees elevation, and the shadow on the dial shows the time to be high noon". With such an antenna covering a wide area of sky, and no need for tracking, the satellite azimuth need not concern us, as it works well as soon as the spacecraft appears more than 10 degrees above the users horizon in any direction!

For those who would like to try this simple and inexpensive d.i.y. antenna, see Fig. 4. It consists merely of a circular sheet of aluminium plate, or an old aluminium based record disc, or even aluminium foil shaped and sealed round hardboard, with a central sloping quarter wave folded

radiator. For the 435MHz version, the plate needs to be 378mm in diameter, and the folded quarter wave made of 12s.w.g. brass or welding rod spaced 10mm at the base and 7mm at the bend 171mm long. One end goes to the inner of a 'N' type coaxial chassis connector and the other to an earth tag mounted at the 'N' type bolt taking it to the sheet. It is angled at 60 degrees to the flat plate. It is rugged, virtually weatherproof, and takes up minimal space, time and cost. Whilst it does not possess the gain of tracking antennas and is not able to hear much from OSCAR-13 when on Mode JL, it is adequate for the closer 435MHz downlink FUJI orbits, especially with a low-noise pre-amplifier at the antenna feed socket.

For use on the 145MHz satellite band, the radiator angle and fold spacing stays the same, but the circular sheet grows to 1131mm, and the slanted sloper to 509mm. Whilst it captures little of the distant OSCAR-10 and 13 Mode B downlink, it performed well for the late OSCAR-9, goes well for OSCAR-11, for the RS series 145MHz Mode T downlinks, and will work well in use with the forthcoming microsats.

Keplerian Elements

We are indebted to Birger Lindholm for providing the bi-monthly sets again. A small problem arises, as in the near future we shall be seeing a large increase in the number of satellites of interest that readers will need the latest data on. Rather than reduce the news within the column size limits, we shall try to shrink them to, fit the same allotted area.

John Branegan GM4IHJ points out that in the latest NASA element sets for MIR, KWANT and SOYUZ-TM-8 are given mean motions of 15.556072, 15.556276 and 15.556281 respectively, which would indicate that MIR is separating from them by about 8km per day. As they are all coupled together, John asks, "I wonder if the onboard cosmonauts are aware of this! Do they have elastic docking latches?"

Finally, there follows as a 'stop press' the latest accurately functioning available Keplerian element set for MIR, in the hope that it may provide six weeks good tracking ahead.

Epoch: 16 November 1989. 0631:48 UTC.
Inclination: 51.6249.
Right Asc. of Asc. Node: 320.4145.
Eccentricity: 0.0004287.
Argument of Perigee: 42.0968
Mean Anomaly: 318.1336.
Mean Motion: 15.553848 orbits per day.
Drag/Decay: 0.0004

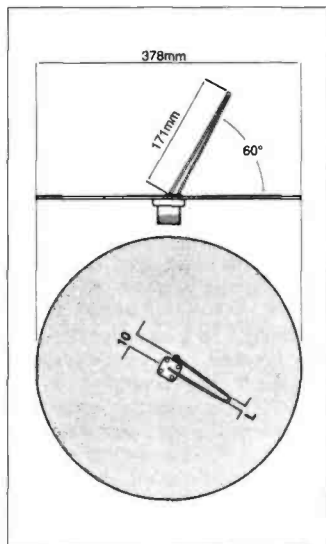

Fig. 4: DIY instructions

Don't forget to keep Pat up-to-date with your satellite activities in 1990. His address can be found at the start of this column.

Back-Scatter

CZECHOSLOVAKIA

Born 1951. First steps in Radio 1965. A Great deal in the distant BC stations reception 1970. SWL OK2-19518 and OK2KTE club station operator 1974. Ten meters beacon band monitor 1979. One of the OK-Propagation Study Group founders 1981. HF propagation regular forecaster 1986. Licensed 1988. OK0EG beacon QSL manager. House and antennas located in a village on 200 mtrs asl, marshy and woody area in the Morava river valley. Enjoys also Geography, Astronomy, Weather and Railways.

This confirms One - Two Way Contact with

dated _____ at _____ UTC on _____ MHz. Sigs _____ RST _____
Rcvr _____ Xmtr _____ Wavts out Ant _____

QSL pax via OK bureau.
P. O. Box 69, CS - 113 27 Praha 1
or direct

Loc JN67RF
Okres GKR
WAZ 14 ITU 28

Václav "Vence" J. Dosoudil
Horní 9, CS - 768 21 Kvasice

Fig. 8

Solar

From his observatory in Selsey, **Patrick Moore** kindly sent the drawings that he made of the sun's disc showing the individual spots and groups on October 25, Fig. 3 and November 3, Fig. 4, respectively. In Bristol, Ted Waring counted 63 sunspots on the 4th and 42 on the 14th.

Ron Livesey (Edinburgh) identified 4 active areas on the sun's disc on October 10, 19 and 31, 6 on days 2, 5, 13 and 26 and 7 on the 1st and 20th. Details of **Cmdr Henry Hatfield's** observations for November, with the spectrohelioscope installed at his home in Sevenoaks can be seen in Fig. 5. Henry's radio alarm for solar activity went off at 0844 on November 5 when a high level of noise was being generated by the sun on 1297MHz. He also recorded large individual bursts at 136MHz on days 6, 7, 16, 21, 25 and at 1297MHz on the 6th, 16th and 21st.

My thanks to **Neil Clarke GOCAS** (Ferrybridge) for his computer print-out, Fig. 1, showing the daily variations in solar flux throughout October and those two peaks of 236 s.f.u. on the 4th and 16th. **Ern Warwick** (Plymouth) heard solar noise on the 28MHz band at 1513 on October 22 and 0926 on the 26th.

Aurora

"The big aurora period of October 20 to 22 was large in activity but not as large as that of 13/14 March," wrote Ron Livesey, the auroral coordinator for the British Astronomical Association. He received reports of "strong aurora" from Denmark at 1845 on the 20th and "all evening" on the 21st from Scotland. "Although clear in north Scotland to allow observations to be made, it looks as if England was clouded out and missed any aurora that was going except on magnetometers," said Ron. Aurora was seen in various forms by 19 of his observers on the 21st ranging from Aberdeen, Alness, County Clare, Edinburgh, Fortrose, Kinloss, Lancashire, Morpeth, Richmond and south Scotland to France, Germany and down under to New Zealand. "Glow or unspecified forms" of aurora were reported overnight on days 3, 6, 12, 22, 23, 24, 25, 26, 29, 30 and 31 and "rayed arc or band" on the 7th and 8th and "ray bundles" on the 26th.

Doug Smillie (Wishaw) and **Gordon Hunter** (Hamilton) told Ron that auroral reflected signals were received on the 144MHz band on the 20th, 21st and 22nd. Doug noted a blackout on 7MHz on the 19th and Anthony Hopwood (Worcester) reported h.f. fadeouts on days 20, 21 and 22. Ern Warwick heard echos on some 28MHz signals at 1400 on the 13th and 14th and on the north American beacons WA4DJS on days 6, 12, 13, 14, 20 and 22, VE2HOT and WC8E on the 13th and W3VD on the 15th and 22nd. He also noted a weak auroral effect on the German beacon DK0WCY on 10.144MHz at 1715 on the 18th and **Dave Coggins** (Knuttsford) copied auroral c.w. from a GM station at 1857 on the 13th and, along with **Mark Appleby**

G4XII (Scarborough) received tone-A signals from the 28MHz beacons in Finland, Germany, Norway and Sweden after 1700 on the 17th. Also on the 17th, Dave added the beacons in England, Holland (PA0RYS), Northern Ireland, Scotland and Wales on 50MHz and the beacons in Cornwall and Wrotham, plus Germany and Holland on 144MHz to the score. To further his auroral studies Dave has purchased and assembled a v.l.f. receiver from Cambridge Kits and is delighted to find that, with the aid of a d.c. amplifier, it will drive his home-brew pen recorder. "It works very well," said Dave and I will be pleased to have his future reports on this area of the spectrum.

Sporadic-E and 'F2' Openings

I received smeary and an unblockable mixture of vision signals on the Band I television channels E2 (48.25MHz) and R1 (49.75MHz) during the early mornings of November 5 and 6. Between 0900 and 1000 on the 6th I received consistent pictures of an orchestra and a play on Ch. R2 (59.25MHz) plus very strong signals from 19 East European f.m. broadcast stations between 66 and 73MHz via a Sporadic-E disturbance which added to this early morning chaos. I used a D100 v.h.f. television converter ahead of a Panasonic video recorder for the vision and my ex-military R216 v.h.f. communications receiver to check the level of the vision sync-pulses and tune through the f.m. broadcast bands. Both receivers are fed by a chimney-mounted horizontal dipole antenna. During the month prior to November 16, **Bob Brooks** (Great Sutton) observed "plenty of 'F2'" and identified pictures from Dubai, Ghana, Iran, North Africa and Malaysia and during periods of Sporadic-E on November 1, 4, 6, 7 and 15 he received programmes and/or test cards from Czechoslovakia, Hungary, Italy, Scandinavia, Spain, Switzerland and the USSR. John Levesley G0HJL (Bransgore) found "Lots of short skip around Europe" on 28MHz on November 4.

Magnetic

The Ap index for October, shown by Neil Clarke in Fig. 2, was generally quiet

until the 18th and became unsettled before hitting peaks of 84 and 99 on the 20th and 21st and the various magnetometers used by Anthony Hopwood, **Karl Lewis** (Saltash), Ron Livesey, **David Pettitt** (Carlisle) and Doug Smillie indicated magnetic storms on days 18, 19, 20, 21, 22, 23, 26, 29 and 30.

Propagation Beacons

As usual my thanks are due to Mark Appleby, **Chris van den Berg** (The Hague), **Vaclav Dosoudil OK2PXJ** (Kvasice), Henry Hatfield, John Levesley, **Greg Lovelock G3III** (Shipston-on-Stour), **Ted Owen** (Maldon), **Fred Pallant G3RNM** (Storrington), Ted Waring and Ern Warwick for their 28MHz beacon logs from which I have combined their efforts to produce the chart seen in Fig. 7. Ted Owen reports hearing WABD send "Hilton Head" on October 27 and YO2KHP give "KN 05 OS" and Ern Warwick heard "CQ CQ QST QST THIS IS A ONE WAY TO HAMS I AM QRP 5WATTS PLEASE QSL TONY, KC6BSJ 245 UNION St SAN RAFAEL, CA. 94901" [28.278MHz] on November 14 and "de KK4FM BEACON IS LAS VEGAS, NEVADA BT" [28.286MHz]. Ern and Greg Lovelock added AL7GQ (28.275MHz), K14PJ (28.225MHz), KJ6JO/B (28.225MHz) and WABRUF (28.278MHz) to the first timers list. Readers who have heard the Czechoslovakian beacon OK0EG and would like a QSL card should send their reports to Vaclav Dosoudil, Horní 9, CS-76821, Kvasice. Vaclav's own QSL card, Fig. 8, shows that in addition to the propagation of radio waves he "Enjoys also Geography, Astronomy, Weather and Railways".

Ern Warwick also received signals on most days during this period from the Brazilian and Italian beacons PY2AMI and IK6BAK on 24.931 and 24.915MHz respectively, OH2B, ZS6DN/B, LU4AA and 4X6TU/B on 14.100MHz and infrequently PY2AMI on 18.100MHz, JA2IGY and 4U1UN/B on 14.100MHz and DK0WCY on 10.144MHz.

Dave Coggins usually hears signals from the 144MHz beacons in Angus (GB3ANG) and Wrotham (GB3VHF) daily about S1/2, but reports that GB3ANG increased to S4 at 1245 on November 7. During the opening on the 13th, Mark

Appleby heard the beacons DL0PR, GB3ANG, GB3VHF, PI7CIS, PI7ZWL and Y4IB on 144MHz and I see from the December issue of *Mid Sussex Matters*, the newsletter of the Mid Sussex ARS that one of my fellow club members Leonard Killip G0APZ (Hassocks) received a clear signal from GB3ANG during the morning of the 15th and then worked a couple of GMs for the first time on 144MHz. That what openings are for Len, hi!

Tropospheric

The slightly rounded atmospheric pressure readings seen in Fig. 6, were taken twice daily from the barograph installed at my home in Sussex. Readers in several parts of the UK received continental stations in Band II, while tropospheric openings were in progress on October 27 and November 12, 13, 14, 15, 23, 26 and 27. Conditions were very good again on the 29th when I received test cards from Belgium and programmes from France, in Band III (175-230MHz), on my Plustron TVR5D with its own rod antenna, while parked at Wakehurst Place, the National Trust gardens near Ardingly, Sussex.

934MHz

"With high pressure of 1030mb dropping to 1028mb, almost continuous tropospheric conditions were enjoyed on the three days of November 12, 13 and 14," wrote **Terry Wyatt UK-845** (Walton on Thames). He found the path north to south on the first two days and east to west on the latter. Although the contacts he made are too numerous to detail the longest distances achieved were Dorset (150km), Guernsey (290km), Leicester (155km), Norwich (190km), Suffolk (150km) and north Wales (220km). "A great deal of fog covered the country," added Terry who took full advantage of the opening and end up with a log to be proud of. John Levesley UK-627 received signals from Jersey on November 13 and both Guernsey and Jersey on the 14th and heard the Jersey stations working into Leicestershire, Oxford and Swansea.

Keep the reports coming in
1990

Back-Scatter

Broadcast Round-up

Reports to
Peter Shore

Events in Eastern Europe have continued apace in recent weeks, with holes appearing not only in the Berlin Wall but in Eastern Bloc media which, until recently most firmly toed the party line. The turn around in the Czechoslovak media was most dramatic. One week there were reports of the extremist factions which were plotting against the state, the next week interviews with the previously disowned leader of the Prague Spring, Alexander Dubcek. Listeners to Radio Prague and Radio Berlin can only now perhaps realise that they were listening to history in the making. I am including the current schedules for several East European broadcasters to help you tune in and hear what is being said now.

Glasnost continues to permeate the Soviet electronic media, too. A report recently appeared in Radio Vilnius' English language DX programme which explained about the Lithuanian Radio monitoring service. It seems that until recently, although individual listening to foreign radio stations was discouraged, with extensive jamming, Communist Party bosses. "unwilling to expose their tender ears to the noises created on air, preferred to read comfortably the next morning the corresponding texts" of broadcasts which the monitoring service prepared overnight. The monitoring station is located near the Nemiezis settlement, about 10km south-east of Vilnius. It has eight antennas, with the largest of them a Yagi directed to the south-west, together with what were described in the radio station's report as two horizontal and five other (perhaps dipole) short wave antennas. Soviet made professional communications receivers are used and Hungarian tape machines record the programmes which are translated and transcribed by TASS staff. Not quite as comprehensive as the BBC monitoring service, but until now a completely unknown and secretive operation. It is suspected that there are several other major monitoring stations around the Soviet Union, with a large complex near Moscow. This is reputed to supply transcripts of early morning BBC World Service current affairs programmes to high ranking Foreign Ministry staff, in order that they know what is going on in the world at the start of their day.

The Radio Vilnius DX programme has also reported on the transmitter near Moscow used to relay Lithuanian Radio's home service to the Soviet capital. This is a former jamming transmitter adapted to short wave broadcasting, located on the borders of the eastern suburbs of the city. Power is just 10kW and telephone lines feed the signal, whilst the antenna beams the signal east and north-west, leading to different reception conditions within the city. In southern parts of the city, co-channel interference from the Radio Moscow Krasnoyarsk transmitter is observed on 6.01MHz, whilst evening reception of the signal on 9.675MHz is reported as impossible because of interference from strong European stations. Relays of Latvian and Estonian home services come from this site, too.

The prospect of Danish broadcasts from Norwegian transmitters seems to have receded further into the future. Danmarks Radio has told the government that it is unable to sign the agreement with the Norwegians since the station does not know how much money will be available from an increased licence fee to pay for the new service. However, the head of Danmarks Radio's short wave service is still optimistic that the relays could start early in 1990. At the end of 1993, Danmarks Radio will decide on whether a new transmitter site should be built in Denmark, or whether the station should participate with the Norwegian authorities in building new joint transmitter sites. In the meantime, the duration of Danmarks Radio's short wave programmes has been reduced from 52 to 25 minutes each, although relays of domestic programming remains unchanged.

European Stations

All time UTC (=GMT)

Here are the schedules of English to Europe from East Bloc countries:

Czechoslovakia - Radio Prague
1530-1625 on 21.505, 17.705, 15.155, 15.11, 13.715, 11.99, 11.685, 9.605, 7.345 & 6.055MHz

1800-1830 on 7.345 & 5.93MHz
1900-2000 on 7.345 & 5.93MHz
2200-2300 on 6.055 & 1.287MHz
Interprogramme
0630-0700 on 9.505, 7.345, 6.055 & 1.287MHz

0700-0900 & 0900-1200 on 9.505, 7.345, 6.055 & 1.287MHz
2300-0055 on 9.625, 6.055 & 1.287MHz

English is interspersed between Czech, Slovak, German and French language.

German Democratic Republic - Radio Berlin International
0600-0645 on 13.61, 11.81, 9.645, 6.115 & 5.965MHz
0845-0930 on 21.54, 21.465*, 9.73*, 7.185*, 6.115 & 6.04MHz
1045-1130 on 6.115MHz
1200-1245 on 17.775, 13.69, 9.665 & 6.15MHz

1400-1445 on 6.115MHz
1445-1530 on 9.73MHz
1645-1730 on 9.73 & 7.295MHz
1815-1900 on 9.73, 7.295 & 7.26MHz
2045-2130 on 6.115 & 1.395MHz
2245-2330 on 9.73 & 5.965MHz
* = not Sat or Sun

Hungary - Radio Budapest
1900-1930 on 15.16, 11.91, 9.835, 9.585, 7.22 & 6.11MHz Tuesday only
1930-2000, 2100-2130 on same frequencies

Yugoslavia - Radio Yugoslavia
0100-0145 on 11.735, 6.005 & 5.98MHz
1930-2000 on 17.735, 7.215 & 5.98MHz
2200-2245 on 11.735, 9.66, 9.62 & 7.215MHz

Radio Mediterranean in Malta transmits English between 2230 and 2330 on 6.11MHz, in parallel with m.f. channel of 1.395MHz.

Radio Station Peace and Progress in English for Europe is heard at 2200 on 11.98, 9.58, 9.61, 9.775, 7.205, 7.215, 7.34, 7.36, 7.44, 5.905, 6.145, 4.795 and 1.386MHz.

African & Middle Eastern Stations

Radiodiffusion Nationale du Burundi has moved from 3.30MHz, and now relies entirely on 6.14MHz, making it a difficult catch in the United Kingdom. English is carried Monday to Friday for an hour starting at 1500.

Radio Baghdad in Iraq is now broadcasting its English service to Europe on 13.66 at 2100 until 2250.

Libya has been noted during the evening on new 15.435MHz with Arabic in parallel with 15.415MHz at around 1900.

The Voice of Nigeria continues to experience transmitter problems, with all but the West African services off the air. As a result, programmes are transmitted entirely on the frequency of 7.255MHz, with English between 0455 and 0600, 0800 to 1100 and 1400 until 1700. French is at 0600-0700, 1200-1400 and 1800 until 2200. Hausa is heard 0700-0800 and 1700-1800.

TWR Swaziland in English uses 15.21MHz at 1600-1700 and 1800-1845.

Asian & Pacific Stations

The English service of Radio Afghanistan operates to Asia between 0900 and 1030, but is audible in Europe on 17.655 and 21.60MHz, both from transmitters in the USSR.

AWR-Asia from Guam has English at 0000 on 15.125, 0200 on 13.72 (weekdays only) and 2300 on 15.125 at weekends.

Radio Japan in English to Europe is now:

0700-0800 on 15.325, 17.89 & 21.69MHz
2100-2130 & 2200-2400 on 11.835MHz

Radio Enga in Papua New Guinea could be a good catch - it has started to use 2.41MHz. To take part, dial 010 (from the UK) 593 2 241560. This will connect directly to the phone-in studio.

English services from Radio Veritas Asia seem to be on different frequencies from those listed on the station's schedule, which suggests at 0130 that 15.22 and 15.36MHz should be heard, although it appears to be operating on 15.46 and 17.795MHz variable to 17.80MHz. At 1500, 15.445 and 9.525MHz are listed, but 11.74 and 15.445MHz have been noted.

North, Central & South American Stations

RAE Argentina now has two transmitters working, having had one off the air following a failure over a year ago. English is now at 1630, 2100, 0100 and 0300 (following the country's time change in October). Frequencies to try are 15.345 and 11.71MHz.

Radio Canada International's German Service seems to have won a reprieve since it is still on the air at the time of writing. English services to Europe are now:

0615-0630 on 11.84, 9.76, 9.74, 7.155, 6.15 and 6.050Hz*

0645-0700 as 0615*
1545-1600 on 21.545**, 17.82**, 15.325, 15.315, 13.65**, 11.935, 11.915 & 9.555MHz

1715-1730 on 21.545, 17.82, 15.325, 13.65, 7.235 & 5.995MHz

1930-2000 on 17.875, 15.325, 11.945, 7.23 & 5.995MHz*

2200-2300 on 11.945 and 9.76MHz (C8C relay Mon-Fri, RCI at weekends)

English to Africa:
1800-1830 on 17.82 & 15.26MHz (to 1900 at weekends)

1900-1930 on 17.82 & 15.26MHz
2130-2200 on 17.82, 15.15 & 11.88MHz

* = Monday to Friday; ** = Monday to Saturday

HCJB in Quito, Ecuador has been experiencing transmitter difficulties lately, which has meant some frequencies have been off the air. A new valve for the 100kW Harris transmitter has arrived and by the time this is in print, all should be well with the Andean station. New studios are planned, to bring to nine the total in Quito and a complete upgrading of the existing five will also take place during 1990.

The current European schedule is:
0700-0800 on 9.61 & 6.05MHz
1900-2000 on 21.47, 15.27 & 17.79MHz

2130-2200 on 21.47 & 17.79MHz
For the South Pacific:

0710-0800 on 11.925, 9.745 & 6.13MHz

0800-1100 on 11.925 & 9.745MHz
A separate service is carried from 0800 until 1000 on 6.13MHz.

On 20 January 1990, the DX Partyline programme will host a phone-in at 0730 to the European continent, and at 0200 to North America. To take part, dial 010 (from the UK) 593 2 241560. This will connect directly to the phone-in studio.

HCJB now has a FAX number which can be used to send in reception reports. The number is 593 2 447263.

WCSN has English to Africa at 0100-0600 on 9.84MHz and to Europe on the same channel from 0600 until 1000. Between 1000 and 1200, programmes are beamed to North America on 6.15MHz.

Any reports for Peter can be sent via the Editorial Offices

Back-Scatter

ATV

Reports to
Andy Emmerson G8PTH
71 Falcutt Way
Northampton NN28PH

Last time I suggested that 70cm lives on and this is confirmed by **Jamie Powers G0JNK** of Ambergate. He writes, "Just a quick note to say that good old 70 is not dead - in fact I've found it quite active. From my shack five miles north of Derby I have contacted the following stations. Unfortunately not all were successful TV contacts.

"Around the Coventry area there are John G1JLT, Tony G0HOV, Len G8ONX, Dave G1GPE (Leamington) and Barry G6IKQ (Banbury). In the Birmingham area there are Arthur G5KS, Ken G1UGD and Paul G0EJL. They have regular nets in that area on Sunday mornings and Tuesday evenings.

"In the Derby area we find Pete G6KUI, Dave G8TNE, Dave G4TAY, John G6CTD, 'eyewig' Robert G7DDR and myself. Also further north near Mansfield is Chris G1UAZ and others who also have regular SSTV nets. I hope this list of callsigns will help dispel any thought that there is no activity on seventy." Excellent, and I hope to be rejoining this bunch soon myself!

SSTV Lives Too

Talking of SSTV nets we have a welcome note from **Dick G3LUI**, one of the old-stagers of SSTV.

"No doubt you will be relieved to hear that slow-scan is alive, well and living in south-east Essex. The Wednesday night net continues each week plus individual stations active on other evenings. Modes in use include 8, 16, 25, 32, 72 and 96-second frames. Several stations are equipped for high resolution pictures using the Amiga computer, Robot 1200C and the 'Wallywonga LM9000' kit. Colour is also available in 8-second frame and 25-second line sequential from Wraase, Robot 400C and WCY/ENA equipment. If anybody is interested in joining us please just call in on 144.5MHz any time after 2030 hours local - or contact G3LUI."

Good news - I know that the Essex SSTV net has several long-distance participants, so if you can get in on the 144MHz band why not try it? I presume that the use of a Wallywonga is not essential: I always thought that SSTV was a bit of a race apart but some of their equipment leaves me standing. Seriously, we could do with a letter from someone to state definitively which standards SSTV users use these days. ('Sure, we're in favour of standards - that's why we have so many of them!')

Out and About

The BATC has been attending several exhibitions during the past few months: our presence helps keep our hobby in people's minds, enables us to keep in touch with members and also introduces the hobby to people who have never heard of ATV before. One such example was the Institute of Videography's national convention during October. Held over two days at the National Motorcycle Museum (between Coventry and Birmingham), this exhibition was primarily for wedding

videographers and 'serious' devotees of the video hobby.

At the show there were presentations from all the major video suppliers and I think a fine time was had by all. The venue was pleasant without being crowded and we were able to introduce amateur television to folk who had never realised that video need not be expensive if you start doing things yourself. The institute does a useful job in co-ordinating an otherwise rather dispersed group of video users, and if you'd like to get in touch with them you can write to the Institute of Videography at PO Box 774, Erdington, Birmingham B23 7LF.

The Summer Fun Starts Here

"Summer is here at last", writes **Michael Sheffield ZL1ABS**. No, he's not out of his mind, merely resident 'down under' in New Zealand! "I have recently been out and about portable getting my 24cm f.m. ATV receive equipment into good condition. I have a home-built 10-element loop Yagi (brass elements and boom) and a Microwave Modules converter. I've added a BFR91A internally as the MM is only a diode mixer with no f. stage). This feeds a Yaesu FRG-9600, with another BFR91A ahead of the Yaesu.

"The Yaesu has an a.m. video board fitted, so its slope detection at the moment. Also the IF amp in the MM has been removed as it is too narrow-band for the 130-140MHz i.f. out I need. With Ralph ZL1TBG sending 10 watts I have copied him 26km away so far. Further improvements are underway - a MRF901 pre-amp to try ahead of the MM converter and a FM-IF to put inside the Yaesu. It's a toss-up whether I use a NE564 or the better NE568.

"The object of all this portable work is to get the gear working well enough to bridge the 30km gap between ZL1TBG's QTH and mine. A trial run idea is to get all the gear up on my roof and see what signals are like before I take the plunge with long Yagis and expensive 9913 coaxial cable.

"During the winter I have been building 70cm transmitters and receive converters for other people as part of the kit offer by the Auckland VHF Group. I also built a 2 watt amplifier for my wideband f.m. sound transmitter. This has meant a 10dB improvement in vision-sound ratio - 40 watts vision and 2 watts sound. One of my regular contacts can now hear my sound where he could not before, while another reports that there is less hiss on the sound. As the vision antenna is 13-elements and the sound antenna only 7-elements I could probably do with even more sound power.

"National VHF Field Day is December 9/10 and I have found a few hams to come north with me to a good high spot on the western coast near Mongonui Bluff. As

the distance is more than 100km to most parts of Auckland a good points score is likely. I hope to have 6 metres, 2 metres, 70cm, 23cm phone and 70cm ATV. I haven't got a working 23cm transmitter for ATV so I might take the receive gear for a trial run anyway.

"The ATV repeater in Auckland has been back on the air for a few days now as a beacon. Some problems with the video sync detector locking up meant that it is back on Quentin ZL1BPW's workbench. Oh dear, we have't had a trouble-free run of more than a week in the last five years! That's life... My savings towards attending Dayton in 1990 are going well. Still I will have to keep saving over the next few months if I am to have the extra need to visit the BATC convention as well. I'll be looking at getting a 24cm FM-TV transmitter kit or built-up and high-gain aerials when I make it to the UK." Well done Michael - but how do you find time for all this?!

News from GB3ET

Back to the UK then and Clive G8EQZ advises that GB3ET, the Emley Moor TV repeater is now running on a Solent one-watt transmitter he rebuilt. This feeds a power amplifier belonging to Barry G6LIC and temporarily on loan. This is working very nicely, far better than the commercial product in use before. In due course the loan equipment will be replaced with GB3ET's own gear. Clive is also pressing ahead with plans for GB3KT, a television repeater for Kingston upon Hull. The logic is already built and running, and they are now looking for a convenient site. Clive has been promoting 24cm TV and believes that if a job is worth doing, it's worth doing well. Accordingly he is now collecting parts for a 200 watt 24cm TV transmitter using water-cooled 2C39 valves! Apparently three of these are to be built, so watch this space.

Continent Calling

Crossing the Channel, a copy of ON-Screen informs us that the Belgian ATV Working Group is in fine form. They held a convention in Lierre last September and the next will be in the Gent region during April.

From Germany it is reported by the German ATV club that the microwave managers of the national societies have decided to attempt to harmonise the microwave amateur bands across Europe and to try and achieve common allocations on a primary basis. "Pursuing this goal, even the reduction of national allocations would be tolerated as a trade-off towards European harmonisation". At the moment most of the GHz allocations are on a secondary basis and cover different segments of the bands in different

countries. In some cases international amateur contacts are not possible because of mutually exclusive allocations.

A particular problem in West Germany is on 13cm where TV broadcasters have been allotted three channels for vision links and there are seven radio channels for industry, reactors, the police and the military across the band. As these have primary status ATV operations (particularly repeater outputs) on 13cm are being restricted. What with dense packet radio activity on 70cm and loads of radar on 24, the only clear band for ATV seems to be 10GHz!

In the USA (I know it's not across the Channel!) **John KD0LO** writes from St Louis. He uses the Amiga computer for ATV captioning and is hoping to put up a fixed 10GHz vision link to his friend Dave WB0ZJP. On August 30 he reports there was a tremendous band opening and he was able to work into Ohio, Indiana and northern Illinois on 439MHz. He has been spending most of his hobby time developing a 900MHz f.m.-TV transmitter. This one is phase-locked and channelised using a synthesised local oscillator. Dave is helping the development process and the goal is to make it work both a.m. and f.m. for maximum versatility.

Back in the UK

The mystery 24cm video transmissions at Canterbury were identified to a couple of G3s (not club members) who were apparently developing the gear for commercial use. They ought to know better about setting up shop in a busy part of the band and not identifying their transmissions. My informant advises they were using 2.5 watts and an etched printed circuit board 'postcard' antenna: this kind of configuration is popular with law enforcement agencies (and buggists!).

Roy G60KB has got himself an Atari ST computer and seems very pleased with it. He is puzzled, though, why he gets line pulling and a ripple running down the screen when he records captions on a VCR. Can anyone help? During the past year the East Kent video net crowd have run four special event demonstrations in conjunction with the Dover YMCA radio club. These have aroused a lot of interest, also, with the public at large.

G7BVH is a new station belonging to Mick, a ham in Sandwich (not my joke, honest). Regular participants in the net are David G0DQI, Brian G8ZYZ, Les G3LCW and Roy G60KB. Les and Roy covered last year's Bleriot cross-channel flight for ATV and got themselves press passes to the landing site. They pooled their video gear for the best possible outfit and managed to get good footage of both the crashed attempt and the successful flight an hour later. Afterwards they edited this up for showing on the net. G0DQI has been making improvements to his antenna system on 70 and now receives P5 pictures from Roy. They have also been experimenting on 24cm and have had the best results with the panel array designed by G8LES with satellite receivers for the video.

Radio Diary

January 27: The Lancastrian Rally will be held at the University of Lancaster. **Sue Griffin G1OHH. Tel: (0524) 64239.**

February 24: The Rainham Radio Rally will be held in the Parkwood Community Centre, Deanwood Drive, Rainham, Gillingham, Kent. Doors are open from 10.15am to 4pm (10am for disabled visitors). The usual traders will be there along with a Bring & Buy stall and refreshments. Talk-in GB4RRR on S22 and SU22. **Bob GOLKE. Tel: (0634) 362154.**

March 3: The Tyneside Amateur Radio Society Rally will be held at the North-Eastern Exhibition Centre at Gosforth Park Race Course (1 mile North of Newcastle upon Tyne). The usual trade stands, Morse tests and Bring & Buy, refreshments will all be there. There's ample free parking. Talk-in on S22 and SU8. **Terry G6VEG. Tel: 091-264 8196.**

March 9-10: There will be an amateur radio show at Picketts Lock Centre, Picketts Lock Lane, Edmonton, London N9. Details from: **London Amateur Radio Show, 126 Mount Pleasant Lane, Brickett Wood, Herts AL2 3XD.**

March 18: The Norbreck Amateur Radio, Electronics and Computing Exhibition organised by the Northern Amateur Radio Societies Association (NARSA) at the Norbreck Castle Exhibition Centre, Blackpool. **Peter Centon G6CGF. Tel: 051-630 5790.**

March 18: The Wythall Radio Club will be holding their 5th annual radio rally at Wythall Park, Silver Street, Wythall, Worcestershire. That's on the A435 near junction 3 on the M42, south-west of Birmingham. Rally opens at 11am. There will be three halls plus a marquee, the usual trade stands, flea market, a large Bring & Buy, bar and snacks with talk-in on S22. Admission 50p. **Chris Pettitt G0EYO. Tel: 021-430 7267.**

March 18: The Tiverton Radio Clubs Mid Devon Rally will be held at the Pannier Market, Tiverton. There's ample free parking, food and drink available, club-room open all day. Talk-in on S22 with doors opening at 10am. **G4TSW, Mid Devon Rally, PO Box 3, Tiverton, Devon EX16 6RS.**

March 25: Dover (YMCA) ARC are holding their QRP Convention and table fair at Dover YMCA ARC, Dover. Doors open from 10.30am to 4.30pm. **G0BPS. Tel: (0303) 276171.**

March 25: The Pontefract & DARS 11th Components Fair will take place in the Carleton Community Centre, Pontefract from 11am to 4.30pm. There will be the usual stands, a bookstall, Bring & Buy and a licensed bar. Talk-in on S22. Admission free. **B. Atkinson. Tel: (0977) 704067.**

April 8: The Swansea ARS are holding their 9th Amateur Radio Trade Rally in the Swansea Leisure Centre. This is situated on the A4067 Swansea-Mumbles coast road. There will be trade stands, catering facilities, a licensed bar, bookstand, Bring & Buy, etc. **Roger Williams GW4HSH. Tel: (0792) 404422.**

April 15: The Centre of England Amateur Radio Rally will be held at the Motorcycle Museum, Bickenhill, near the NEC Birmingham. It's being held in three large exhibition halls and has free ample parking. **Frank Martin G4UMF. Tel: (0952) 598173.**

April 21-22: The RSGB are holding their Convention and Exhibition at the NEC, Birmingham.

May 13: The VHF Convention will take place at Sandown Park Racecourse, Esher, Surrey.

SPECTRUM COMMUNICATIONS
MANUFACTURERS OF RADIO EQUIPMENT AND KITS

TRANSVERTERS for 2m, 4m, 6m with 10m drive. Single board with 25mW-500mW drive input, and 500mW minimum output. Low noise RX side with 15dB mini gain, no need for a pre-amp. Low spurious TX side, all outputs more than 45dB below main output. Types TRC 2-10, TRC-10, TRC6-10. PCB kit **£49.00**, PCB built **£74.00**, Boxed kit **£64.00**, Boxed built **£99.00**.
Add £6.00 to TRC-10 for repeater shift.

TRANSVERTER for 4m or 6m with 2m drive. Transverter plus interface boards for 500mW-5W drive and 500mW minimum output. Specs as above. Types TRC4-21 and TRC6-21. PCB kit **£57.00**, PCB built **£84.00**, Boxed kit **£72.00**, Boxed built **£114.00**.

TRANSMIT AMPLIFIERS for 2m or 4m or 6m. 25W minimum output, linear, RF switched, 500mW maximum input, suits spectrum transverters. Types TA2S2, TA4S2, TA6S2. PCB kit **£46.50**, PCB built **£57.75**, Boxed kit **£58.50**, Boxed built **£72.75**.

TRANSMIT AMPLIFIERS for 2m or 4m or 6m. 25W minimum output, linear, RF switched, 2.5W input, ideal for FT290, FT690. Types TA2S1, TA4S1, TA6S1. PCB kit **£37.50**, PCB built **£46.50**, Boxed kit **£42.75**, Boxed built **£55.00**.

TRANSMIT AMPLIFIERS for 2m or 4m or 6m. 25W minimum output, linear unswitched, 0.5W maximum input, ideal for MEON. Types TA2U2, TA4U2, TA6U2. PCB kit **£42.50**, PCB built **£54.00**, Boxed kit **£46.50**, Boxed built **£60.50**.

RECEIVE PREAMPS, 2, 4, 6 or 10 metres. RF switched and DC sensing. 100W power handling, gain panel adjustable 0-2dB, NF 1dB on 2m, 4m & 6m 3.5dB on 10m. 13.5V negative ground operation. Excellent performance at a reasonable price. Types RP2S, RP4S, RP6S & RP10S. PCB kit **£14.75**, PCB built **£22.25**, Boxed kit **£25.00**, Built & Tested **£35.50**.

MANY OTHER KITS FOR AMATEUR AND CB, SEND SAE FOR LIST PLEASE.

VAT & P&P INC PRICES Delivery within 14 days if available 24 hr answering.	SHOP TIMES: 9am-1pm & 2pm-5pm TUES-FRI 9am-1pm & 2pm-4pm SAT CLOSED SUNDAY & MONDAY
---	--

**UNIT B6, MARABOUT INDUSTRIAL ESTATE,
DORCHESTER, DORSET. TEL: 0305 62250**

LOSING DX?

ANTENNA TUNER to BOOST RECEPTION and reduce interference 100kHz-30MHz, for outside or INDOOR antennas, fun-to-build kit, ALL parts, coils, case etc only **£31.30**.

CAMBRIDGE KITS
45 (PB) Old School Lane, Milton, Cambridge.

Manufacturer of

ANTENNAS

FULL RANGE OF 432, 144, 50, 70MHz ANTENNAS AVAILABLE FROM YOUR LOCAL STOCKIST

For a full Glossy Brochure & Current Price List send SAE to:
ALAN KELLY COMMUNICATIONS LTD
 3 STOKE ROAD, ASTON FIELDS, BROMSGROVE, WORCS B60 3EQ
 Tel: 0527 71165 Fax: 0527 32042

LOUDENBOOMER!!!

400W O/P, Mains Powered, 9 Band HF Linear

Introductory Offer: Only **£499**, direct from the designers:-
S.R.W. Communications Ltd, ASTRID HOUSE, The Green, Swinton, MALTON, N. Yorks. YO17 0SY. Tel (0653) 697513. Please write or 'phone Steve Webb G3TPW, for more details and leaflets.

Please mention Practical Wireless when replying to Advertisements



0202
665524

HOW TO ORDER

POST AND PACKING; add 75p for one book, £1 for two or more books, orders over £25 post and packing free, (overseas readers add £1.50 for one book, £2.50 for two or more for surface mail postage) and send a postal order, cheque or international money with your order (quoting book titles and quantities) to PW Publishing Limited, FREEPOST, Enefco House, The Quay, Poole, Dorset BH15 1PP. Please make your cheques payable to Practical Wireless, payment by Access, Mastercard, Eurocard or Visa also accepted on telephone orders to Poole (0202) 665524. Books are normally despatched by return of post but please allow 28 days for delivery. Prices correct at time of going to press. Please note: all payments must be made in Sterling.



0202
665524

* A recent addition to our Book Service. O/P = Out of print, O/S = Out of stock.

RADIO

AIR & METEO CODE MANUAL

10th Edition

Joerg Klingenfuss

Detailed descriptions of the World Meteorological Organisation Global Telecommunication System operating FAX and RTTY meteo stations, and its message format with decoding examples. Also detailed description of the Aeronaualical Fixed Telecommunication Network amongst others. 289 pages £14.00

BETTER RADIO/TV RECEPTION

A. Nallawalla, A. T. Cushen and S. D. Clark

An Australian book giving guidance and advice to listeners seeking reliable reception of distant radio stations, and to DX listening hobbyists. 134 pages. £9.95

BETTER SHORTWAVE RECEPTION (USA)

W. S. Orr W6SAI and S. D. Cowan W2LX

Receivers, antennas, propagation, DX listening techniques for the short waves and v.h.f. 158 pages. £5.50

PASSPORT TO WORLD BAND RADIO 1989

This book gives you the information to explore and enjoy the world of broadcast band listening. It includes features on different international radio stations, receiver reviews and advice as well as the hours and languages of broadcast stations by frequency. 398 pages. O/P

SCANNERS (Third Edition)

Peter Rouse GU1DKD

A guide for users of scanning receivers, covering hardware, antennas, accessories, frequency allocations and operating procedures. 245 pages. £7.95

SCANNERS 2

Peter Rouse GU1DKD

The companion to Scanners, this provides even more information on the use of the v.h.f. and u.h.f. communications band and gives constructional details for accessories to improve the performance of scanning equipment. 216 pages. £9.95

SHORT WAVE RADIO LISTENERS' HANDBOOK

Arthur Miller

In easy-to-read and non-technical language, the author guides the reader through the mysteries of amateur, broadcast and CB transmissions. 207 pages. O/P

RADIOTELETYPE CODE MANUAL

10th Edition

Joerg Klingenfuss

This book gives detailed descriptions of the characteristics of telegraph transmission on short waves, with all commercial modulation types including voice frequency telegraphy and comprehensive information on all RTTY systems and c.w. alphabets. 96 pages. £8.00

THE SATELLITE EXPERIMENTER'S HANDBOOK (USA)

A guide to understanding and using amateur radio, weather and TV broadcast satellites. 207 pages. £9.25

1934 OFFICIAL SHORT WAVE RADIO MANUAL

Edited by Hugo Gernsback

A fascinating reprint from a bygone age with a directory of all 1934 s.w. receivers, servicing information, constructional projects, circuits and ideas on building vintage sets with modern parts. 260 pages. £9.95

HIGH POWER WIRELESS EQUIPMENT

Articles from *Practical Electricity* 1910-11

Edited by Henry Walter Young

A reprint of interesting practical articles from the early days of radio. 99 pages. £6.85

BEGINNERS

AN INTRODUCTION TO RADIO DXING (BP91)

R. A. Penfold

How to find a particular station, country or type of broadcast

and to receive it as clearly as possible. 112 pages. £1.95

BEGINNER'S GUIDE TO RADIO

9th Edition

Gordon J. King

Radio signals, transmitters, receivers, antennas, components, valves and semiconductors, CB and amateur radio are all dealt with here. 266 pages. £6.95

ELECTRONICS SIMPLIFIED - CRYSTAL SET CONSTRUCTION (BP92)

F. A. Wilson

Especially written for those who wish to take part in basic radio building. All the sets in the book are old designs updated with modern components. 72 pages. £1.75

QUESTIONS & ANSWERS RADIO

Eugene Trundle

Basics of electrical theory, radio and semiconductors, receivers, amateur and CB radio, and test equipment. 110 pages. O/P

THE SIMPLE ELECTRONICS CIRCUIT AND COMPONENTS Book One (BP62)

The aim of this book is to provide an in-expensive but comprehensive introduction to modern electronics. 209 pages. £3.50

TELEVISION

AN INTRODUCTION TO SATELLITE TELEVISION (BP195)

F. A. Wilson

Answers all kinds of questions about satellite television. For the beginner thinking about hiring or purchasing a satellite TV system there are details to help you along. For the engineer there are technical details including calculations, formulae and tables. 104 pages. £5.95

A TV-DXERS HANDBOOK (BP176)

R. Bunney

Information on transmission standards, propagation, receivers including multi-standard, colour, satellites, antennas, photography, station identification, interference etc. Revised and updated 1986. 87 pages. £5.95

GUIDE TO WORLD-WIDE TELEVISION TEST CARDS Edition 3

Keith Hamer & Garry Smith

Completely revised and expanded, this is a handy reference book for the DXTV enthusiast. Over 200 photographs of Test Cards, logos, etc., world wide. 60 pages. £4.95

SATELLITE TELEVISION INSTALLATION GUIDE

2nd Edition

John Breeds

A practical guide to satellite television. Detailed guidelines on installing and aligning dishes based on practical experience. 56 pages. £11.95

THEORY

COMMUNICATION (BP89)

Elements of Electronics Book 5

F. A. Wilson

Fundamentals of line, microwave, submarine, satellite, digital multiplex, radio and telegraphy systems are covered, without the more complicated theory or mathematics. 266 pages. £2.95

FILTER HANDBOOK A practical design guide

by Stefan Niewiedomski

A practical book, describing the design process as applied to filters of all types. Includes practical examples and BASIC programs. 195 pages. £25.00

FROM ATOMS TO AMPERES

F. A. Wilson

Explains in simple terms the absolute fundamentals behind electricity and electronics. 244 pages. £3.50

LEVEL II RADIO & ELECTRONICS THEORY

Ian Ridpath ZL1BCG

A sequel to Amateur Radio & Electronics Study Course, covers advanced theory to a level for most technician courses. The handwritten format aims to make the student feel these are his own notes. 169 pages. £6.70

PRACTICAL ELECTRONICS CALCULATIONS AND FORMULAE (BP53)

F. A. Wilson

This has been written as a workshop manual for the electronics enthusiast. There is a strong practical bias and higher mathematics have been avoided where possible. 249 pages. £3.95

SOLID STATE DESIGN FOR THE RADIO AMATEUR Wes Hayward W7ZOI and Doug DeMaw W1FB

Back in print by popular demand! A revised and corrected edition of this useful reference book covering all aspects of solid-state design. 256 pages £10.95

The ARRL ELECTRONICS DATA BOOK

Doug DeMaw W1FB

Back by popular demand, completely revised and expanded, this is a handy reference book for the r.f. designer, technician, amateur and experimenter. 260 pages. £8.95

LISTENING GUIDES

AIR BAND RADIO HANDBOOK

David J. Smith

Listen to conversations between aircraft and ground control. The author, an air traffic controller, explains more about this listening hobby. 174 pages. O/P

AIR TRAFFIC CONTROL

David Adair

A guide to air traffic control with maps, drawings and photographs explaining how aircraft are guided through crowded airspace. 176 pages. £6.99

DIAL SEARCH

5th Edition 1988/89

George Wilcox

The listener's check list and guide to European broadcasting. Covers m.w., l.w., v.h.f. and s.w., including two special maps. 46 pages. £3.25

FLIGHT ROUTINGS 1989

T.T. Williams

Identifies the flights of airlines, schedule, charter, cargo and mail, to and from the UK and Eire and overflights between Europe and America. 104 pages. £4.00

GUIDE TO BROADCASTING STATIONS

20th Edition 1989/90

Philip Derrington

Frequency and station data, receivers, antennas, Latin American DXing, reporting, computers in radio, etc. 240 pages. £9.95

GUIDE TO FACSIMILE STATIONS 9th Edition

Joerg Klingenfuss

This manual is the basic reference book for everyone interested in FAX. Frequency, callsign, name of the station, ITU country/geographical symbol, technical parameters of the emission are all listed. All frequencies have been measured to the nearest 100Hz. 318 pages £12.00

GUIDE TO FORMER UTILITY TRANSMISSIONS

3rd Edition

Joerg Klingenfuss

Built on continuous monitoring of the radio spectrum from the sixties until the recent past. A useful summary of former activities of utility stations providing information in the classification and identification of radio signals. 126 pages. £8.00

GUIDE TO UTILITY STATIONS

8th Edition
Joerg Klingenfuss

This book covers the complete short wave range from 3 to 30MHz plus the adjacent frequency bands from 0 to 150kHz and from 1.6 to 3MHz. It includes details on all types of utility stations including FAX and RTTY. There are 15802 entries in the frequency list and 3123 in the alphabetical call sign list plus press services and meteorological stations. 502 pages. £19.00

HF OCEANIC AIRBAND COMMUNICATIONS

3rd Edition
Bill Laver

Aircraft channels by frequency and band, main ground radio stations, European R/T networks, North Atlantic control frequencies. 29 pages. £3.50

INTERNATIONAL RADIO STATIONS GUIDE (BP255)

Revised and updated in 1988, this book shows the site, country, frequency/wavelength and power of stations in Europe, the Near East and N. Africa, North and Latin America and the Caribbean, plus short wave stations worldwide. 128 pages. £4.95

MARINE UK RADIO FREQUENCY GUIDE

Bill Laver

A complete guide to the UK s.w. and v.h.f. marine radio networks. Useful information, frequency listings and the World Marine Coastal Phone Stations. 62 pages. £4.95

NEWNES SHORT WAVE LISTENING HAND BOOK

Joe Pritchard G1UQW

A technical guide for all short wave listeners. Covers construction and use of sets for the s.w.l. who wants to explore the bands up to 30MHz. 288 pages. £12.95

THE COMPLETE VHF/UHF FREQUENCY GUIDE

Updated 1988

This book gives details of frequencies from 26-2250MHz with no gaps and who uses what. Recently updated, there are chapters on equipment requirements as well as antennas, etc. 88 pages. £5.95

THE INTERNATIONAL VHF FM GUIDE

7th Edition

Julian Baldwin G3UHK and Kris Partridge G8AUU
The latest edition of this useful book gives concise details of repeaters and beacons worldwide plus coverage maps and further information on UK repeaters. 70 pages. £2.85

THE POCKET GUIDE TO RTTY AND FAX STATIONS

Bill Laver

A handy reference book listing RTTY and FAX stations, together with modes and other essential information. The listing is in ascending frequency order, from 1.6 to 27.1MHz. 46 pages. £2.95

SHORT WAVE LISTENERS CONFIDENTIAL

FREQUENCY LIST

Bill Laver

Covering the services and transmission modes that can be heard on the bands between 1.635 and 29.7MHz. £7.95

VHF/UHF AIRBAND FREQUENCY GUIDE (Updated)

A complete guide to the airband frequencies including how to receive the signals, the frequencies and services, VOLMET and much more about the interesting subject of airband radio. 74 pages. £5.95

WORLD RADIO TV HANDBOOK 1989

Country-by-country listings of long, medium and short wave broadcast and TV stations. Receiver test reports. English language broadcasts. The s.w.l.'s "bible". 576 pages. £17.95

INTERFERENCE

INTERFERENCE HANDBOOK (USA)

William R. Nelson WA6FQG

How to locate and cure r.f.i. for radio amateurs, CBers and TV and stereo owners. 253 pages. £6.75

RADIO FREQUENCY INTERFERENCE (USA)

What causes r.f.i.? Are all r.f.i. problems difficult, expensive and time-consuming to cure? These questions and many more are answered in this book. 84 pages. £4.30

AMATEUR RADIO

AMATEUR RADIO CALL BOOK (RSGB)

Winter 88/89 Edition

Now incorporates a 48-page section of useful information for amateur radio enthusiasts. 310 pages. £7.00

AMATEUR RADIO OPERATING MANUAL (RSGB)

A mine of information on just about every aspect of amateur operating. International call sign series holders, prefix lists, DXCC countries list, etc. 204 pages. £6.16

AMATEUR RADIO SATELLITES the first 25 years

Arthur C. Gee G2UK

This souvenir publication mainly a pictorial account of the pattern of developments which have occurred over the last 25 years. 34 pages. £2.25

AN INTRODUCTION TO AMATEUR RADIO (BP257)

I.D. POOLE

This book gives the newcomer a comprehensive and easy to understand guide through amateur radio. Topics include operating procedures, jargon, propagation and setting up a station. 150 pages. £3.50

HINTS AND KINKS FOR THE RADIO AMATEUR

Edited by Charles L. Hutchinson and David Newkirk

A collection of practical ideas gleaned from the pages of QST magazine. 152 pages. £4.95

HOW TO PASS THE RADIO AMATEURS' EXAMINATION (RSGB)

Clive Smith G4FZH and George Benbow G3HB

The background to multiple choice exams and how to study for them with sample RAE papers for practice plus maths revision. 88 pages. £5.65

PASSPORT TO AMATEUR RADIO

Reprinted from PW 1981-1982

The famous series by GW3JGA, used by thousands of successful RAE candidates in their studies. Plus other useful articles for RAE students. 96 pages. £1.50

PRACTICAL IDEAS FOR RADIO AMATEURS

Ian Poole G3YWX

Offers a wealth of hints, tips and general practical advice for all transmitting amateurs and short wave listeners. 128 pages. £5.95

QUESTIONS & ANSWERS AMATEUR RADIO

F. C. Judd G2BCX

What is amateur radio? The Radio Amateurs' Exam and Licence. Technology, equipment, antennas, operating procedures and codes. 122 pages. £3.95

RADIO AMATEUR'S GUIDE TO RADIO WAVE PROPAGATION

(HF Bands)

F. C. Judd G2BCX

The how and why of the mechanism and variations of propagation in the h.f. bands. 144 pages. £8.95

THE 1989 ARRL HANDBOOK FOR THE RADIO AMATEUR

This is the 66th edition of this very useful hardback reference book. Updated throughout it has several new sections covering oscilloscopes, spectrum analysers, digital frequency synthesis, phase-noise measurement and new constructional projects. 1200 pages O/P

*THE ARRL OPERATING MANUAL

Another very useful book from the ARRL. Although written for the American radio amateur, this book will also be of use and interest to the UK amateur. 684 pages. £12.95

THE ARRL SATELLITE ANTHOLOGY

The best from the Amateur Satellite News column and articles out of 31 issues of QST have been gathered together in this book. The latest information on OSCARs 9 through 13 as well as the RS satellites is included. Operation on Phase 3 satellites (OSCAR 10 and 13) is covered in detail. 97 pages. £4.95

THE COMPLETE DX'ER

Bob Locher W9KNI

Now back in print, this book covers equipment and operating techniques for the DX chaser, from beginner to advanced. 187 pages. £7.95

THE RAE MANUAL (RSGB)

G.L. Benbow G3HB

The latest edition of the standard aid to studying for the Radio Amateurs' Examination. Updated to cover the latest revisions to the syllabus. 132 pages. £5.65

THE RADIO AMATEUR'S DX GUIDE (USA)

15th Edition

The guide contains information not easily obtained elsewhere and is intended as an aid and quick reference for all radio amateurs interested in DX. 38 pages. £2.95

THE RADIO AMATEUR'S QUESTIONS & ANSWER REFERENCE MANUAL

3rd Edition

R. E. G. Petri G8CCJ

This book has been compiled especially for students of the City and Guilds of London Institute RAE. It is structured with carefully selected multiple choice questions, to progress with any recognised course of instruction, although it is not intended as a text book. 258 pages. O/P

VHF HANDBOOK FOR RADIO AMATEURS (USA)

H. S. Brier W9EGQ & W. I. Orr W6SAI

VHF/UHF propagation, including moonbounce and satellites, equipment and antennas. 335 pages. £7.95.

VHF/UHF MANUAL (RSGB)

G. R. Jessop G6JP

Theory and practice of amateur radio reception and transmission, between 30MHz and 24GHz. 520 pages. £8.94

MAPS

IARU LOCATOR MAP OF EUROPE

DARC

This multi-coloured, plastics laminated, map of Europe shows the AIRU ("Maidenhead") Locator System. Indispensable for the v.h.f. and u.h.f. DX'er. 692 x 872mm. £5.25

RADIO AMATEUR'S MAP OF NORTH AMERICA (USA)

Shows radio amateur prefix boundaries, continental boundaries and zone boundaries. 760 x 636mm. £2.50

RADIO AMATEUR'S PREFIX MAP OF THE WORLD (USA)

Showing prefixes and countries, plus listings by order of country and of prefix. 1014 x 711mm. £2.95

RADIO AMATEUR'S WORLD ATLAS (USA)

Seventeen pages of maps, including the world-polar projection. Also includes the table of allocation of international call sign series. £3.50

DATA REFERENCE

DIGITAL IC EQUIVALENTS AND PIN CONNECTIONS (BP140)

A. Michaels

Equivalents and pin connections of a popular selection of European, American and Japanese digital i.c.s. 256 pages. £5.95.

INTERNATIONAL DIODE EQUIVALENTS GUIDE (BP108)

A. Michaels

Possible substitutes for a large selection of many different types of semiconductor diodes. 144 pages. £2.25.

INTERNATIONAL TRANSISTOR EQUIVALENTS GUIDE (BP85)

A. Michaels

Possible substitutes for a popular selection of European, American and Japanese transistors. 320 pages. £3.50

LINEAR IC EQUIVALENTS AND PIN CONNECTIONS (BP141)

A. Michaels

Equivalents and pin connections of a popular selection of European, American and Japanese linear i.c.s. 320 pages. O/P

NEWNES AUDIO & HI-FI ENGINEER'S POCKET BOOK

Vivian Capel

This is a concise collection of practical and relevant data for anyone working on sound systems. The topics covered include microphones, gramophones, CDs to name a few. 190 pages. Hardback. £9.95

NEWNES COMPUTER ENGINEER'S POCKET BOOK

This is an invaluable compendium of facts, figures, circuits and data and is indispensable to the designer, student, service engineer and all those interested in computer and microprocessor systems. 203 pages. Hardback. £8.95

NEWNES ELECTRONICS POCKET BOOK

5th Edition

Presenting all aspects of electronics in a readable and largely non-mathematical form for both the enthusiast and the professional engineer. 315 pages. Hardback. £8.95

NEWNES RADIO AMATEUR AND LISTENER'S POCKET BOOK

Steve Money G3FZX

This book is a collection of useful and intriguing data for the traditional and modern radio amateur as well as the short wave listener. Topics such as AMTOR, packet radio, SSTV, computer communications, airband and maritime communications are all covered. 160 pages. Hardback. £8.95

NEWNES RADIO AND ELECTRONICS ENGINEER'S POCKET BOOK

17th Edition

Keith Brindley

Useful data covering math, abbreviations, codes, symbols, frequency bands/allocations, UK broadcasting stations, semi-conductors, components, etc. 201 pages. Hardback. £6.95

NEWNES TELEVISION AND VIDEO ENGINEER'S POCKET BOOK

Eugene Trundle

This is a valuable reference source for practitioners in "entertainment" electronic equipment. It covers TV reception from v.h.f. to s.h.f. display tubes, colour camera technology, video recorder and video disc equipment, video text and hi-fi sound. 323 pages. Hardback. £9.95

POWER SELECTOR GUIDE (BP235)

J. C. J. Van de Ven

This guide has the information on all kinds of power devices in useful categories (other than the usual alpha numeric sort) such as voltage and power properties making selection of replacements easier. 160 pages. £4.95

RSGB RADIO DATA REFERENCE BOOK

G. R. Jessop G6JP

The 5th Edition of an essential book for the radio amateur's or experimenter's workbench. 244 pages. Hardback £8.56

SEMICONDUCTOR DATA BOOK

A.M. Ball

Characteristics of some 10000 transistors, f.e.t.s, u.j.t.s, diodes, rectifiers, triacs and s.c.r.s. 175 pages. £9.95

TRANSISTOR SELECTOR GUIDE (BP234)

J. C. J. Van de Ven

This guide has the information on all kinds of transistors in useful categories (other than the usual alpha numeric sort) such as voltage and power properties making selection of replacements easier. 192 pages. £4.95

FAULT FINDING

ARE THE VOLTAGES CORRECT?

Reprinted from PW 1982-1983

How to use a multimeter to fault-find on electronic and radio equipment, from simple resistive dividers through circuits using diodes, transistors, i.c.s and valves. 44 pages. £1.50

GETTING THE MOST FROM YOUR MULTIMETER (BP239)

R. A. Penfold

This book is primarily aimed at beginners. It covers both analogue and digital multimeters and their respective limitations. All kinds of testing is explained too. No previous knowledge is required or assumed. 102 pages. £2.95

MORE ADVANCED USES OF THE MULTIMETER BP265

R.A. Penfold

This book is primarily intended as a follow-up to BP239, Getting the most from your Multimeter. By using the techniques described in this book you can test and analyse the performance of a range of components with just a multimeter (plus a very few inexpensive components in some cases). The simple add-ons described extend the capabilities of a multimeter to make it even more useful. 85 pages £2.95

OSCILLOSCOPES, HOW TO USE THEM, HOW THEY WORK

Ian Hickman

This book describes oscilloscopes ranging from basic to advanced models and the accessories to go with them. 133 pages. O/P

PRACTICAL HANDBOOK OF VALVE RADIO REPAIR

Chas E. Miller

The definite work on repairing and restoring valved broadcast receivers dating from the 1930s to the 60s. Appendices giving intermediate frequencies, valve characteristic data and base connections. 230 pages. Hardback £20.00

SERVICING RADIO, HI-FI AND TV EQUIPMENT

Gordon J. King

A very practical book looking at semiconductor characteristics, d.c. and signal tests, fault-finding techniques for audio, video, r.f. and oscillator stages and their application to transistor radios and hi-fi. 205 pages. £10.95

TRANSISTOR RADIO FAULT FINDING CHART (BP70)

C. E. Miller

Used properly, should enable most common faults to be traced reasonably quickly. Selecting the appropriate fault description at the head of the chart, the reader is led through a sequence of suggested checks until the fault is cleared. 635 x 455mm (approx) £0.95

CONSTRUCTION

HOW TO DESIGN AND MAKE YOUR OWN P.C.B.s (BP121)

R. A. Penfold

Designing or copying printed circuit board designs from magazines, including photographic methods. 80 pages. £2.50

INTRODUCING QRP

Collected articles from PW 1983-1985

An introduction to low-power transmission, including constructional details of designs by Rev. George Dobbs G3RVJ for transmitters and transceivers from Top Band to 14MHz, and test equipment by Tony Smith G4FAI. 64 pages. £1.50

MORE ADVANCED POWER SUPPLY PROJECTS (BP192)

R. A. Penfold

The practical and theoretical aspects of the circuits are covered in some detail. Topics include switched mode power supplies, precision regulators, dual tracking regulators and computer controlled power supplies, etc. 92 pages. £2.95

POWER SUPPLY PROJECTS (BP76)

R. A. Penfold

This book gives a number of power supply designs including simple unregulated types, fixed voltage regulated types and variable voltage stabilised designs. 91 pages. £2.50

PRACTICAL POWER SUPPLIES

Collected articles from PW 1978-1985

Characteristics of batteries, transformers, rectifiers, fuses and heatsinks, plus designs for a variety of mainsdriven power supplies, including the PW "Marchwood" giving a fully stabilised and protected 12V 30A d.c. 48 pages. £1.25

QRP NOTEBOOK

Doug DeMaw W1FB

This book deals with the building and operating of a successful QRP station. Lots of advice is given by the author who has spent years as an ardent QRP'er. All the text is easy-to-read and the drawings large and clear. 77 pages. £4.95

TEST EQUIPMENT CONSTRUCTION

R.A. Penfold

Describes, in detail, how to construct some simple and inexpensive, but extremely useful, pieces of test equipment. 104 pages. £2.95

50 (FET) FIELD EFFECT TRANSISTOR PROJECTS

F.G. Rayer

50 circuits for the s.w.l., radio amateur, experimenter or audio enthusiast using f.e.t.s. 104 pages. £2.95

ANTENNAS (AERIALS)

AERIAL PROJECTS (BP105)

Practical designs including active, loop and ferrite antennas plus accessory units. 96 pages. £2.50

ALL ABOUT CUBICAL QUAD ANTENNAS (USA)

W. I. Orr W6SAI & S. D. Cowan W2LX

Theory, design, construction, adjustment and operation of quads. Quads vs. Yagis. Gain figures. 109 pages. £5.50

ALL ABOUT VERTICAL ANTENNAS (USA)

W. I. Orr W6SAI & S. D. Cowan W2LX

Theory, design, construction, operation, the secrets of making vertical work. 191 pages. £7.50

AN INTRODUCTION TO ANTENNA THEORY (BP198)

H. C. Wright

This book deals with the basic concepts relevant to receiving and transmitting antennas. Lots of diagrams reduce the amount of mathematics involved. 86 pages. £2.95

ANTENNA IMPEDANCE MATCHING

Wilfred N. Caron

Proper impedance matching of an antenna to a transmission line is of concern to antenna engineers and to every radio amateur. A properly matched antenna as the termination for a line minimises feed-line losses. Power can be fed to such a line without the need for a matching network at the line input. There is no mystique involved in designing even the most complex multi-element networks for broadband coverage. Logical step-by-step procedure is followed in this book to help the radio amateur with this task. 192 pages £11.95

BEAM ANTENNA HANDBOOK (USA)

W. I. Orr W6SAI & S. D. Cowan W2LX

Design, construction, adjustment and installation of h.f. beam antennas. 198 pages. O/S

HF ANTENNAS FOR ALL LOCATIONS (RSGB)

L. A. Moxon G6XN

Taking a new look at how h.f. antennas work, and putting theory into practice. 260 pages. £5.19

*NOVICE ANTENNA NOTEBOOK

Doug DeMaw W1FB

Another book from the pen of W1FB, this time offering "new ideas for beginning hams". All the drawings are large and clear and each chapter ends with a glossary of terms. 130 pages £5.95

OUT OF THIN AIR

Collected Antenna Articles from PW 1977-1980

Including such favourites as the ZL Special and 2BCX 16-element beams for 2m, and the famous "Slim Jim", designed by Fred Judd G2BCX. Also features systems for Top Band, medium wave/long wave loop designs and a v.h.f. direction finding loop. Plus items on propagation, accessories and antenna design. 80 pages. £1.80

PRACTICAL WIRE ANTENNAS - Effective HF

Designs for the Radio Amateur

John D Heys G3BCQ

Wire antennas offer one of the most cost-effective ways to put out a good signal on the h.f. bands and this practical guide to their construction has something to interest every amateur on a budget. 100 pages. £7.53.

SIMPLE, LOW-COST WIRE ANTENNAS FOR RADIO AMATEURS (USA)

W. I. Orr W6SAI & S. D. Cowan W2LX

Efficient antennas for Top Band to 2m, including "invisible" antennas for difficult station locations. 191 pages. £6.75

THE ARRL ANTENNA BOOK (USA) 15th Edition

A station is only as effective as its antenna system. This book covers propagation, practical constructional details of almost every type of antenna, test equipment and

formulas and programs for beam heading calculations. £12.95

THE ARRL ANTENNA COMPENDIUM (USA)

Volume One

Fascinating and hitherto unpublished material. Among the topics discussed are quads and loops, log periodic arrays, beam and multi-band antennas, verticals and reduced size antennas. 175 pages. £9.25

WIRES & WAVES

Collected Antenna Articles from PW 1980-1984

Antenna and propagation theory, including NBS Yagi design data. Practical designs for antennas from medium waves to microwaves, plus accessories such as a.t.u.s, s.w.r. and power meters and a noise bridge. Dealing with TVI. 160 pages. £3.00

W1FB'S ANTENNA NOTEBOOK

Doug DeMaw W1FB

This book provides lots of designs, in simple and easy to read terms, for simple wire and tubing antennas. All drawings are large and clear making construction much easier. 124 pages. £5.95

25 SIMPLE AMATEUR BAND AERIALS (BP125)

E. M. Noll

How to build 25 simple and inexpensive aerials, from a simple dipole through beam and triangle designs to a mini-rhombic. Dimensions for specific spot frequencies including the WARC bands. 80 pages. £1.95

25 SIMPLE INDOOR AND WINDOW AERIALS (BP136)

E. M. Noll

Designs for people who live in flats or have no gardens, etc., giving surprisingly good results considering their limited dimensions. 64 pages. £1.75

25 SIMPLE SHORT WAVE BROADCAST BAND AERIALS (BP132)

E. M. Noll

Designs for 25 different aerials, from a simple dipole through helical designs to a multi-band umbrella. 80 pages. £1.95

25 SIMPLE TROPICAL AND MW BAND AERIALS (BP145)

E. M. Noll

Simple and inexpensive aerials for the broadcast bands from medium wave to 49m. 64 pages. £1.75

THE RADIO AMATEUR ANTENNA HANDBOOK

William I. Orr W6SAI & Stuart. D. Cowan W2LX

Yagi, quad, quagi, l-p, vertical, horizontal and "sloper" antennas are all covered. Also towers, grounds and rotators. 190 pages. £6.75

COMPUTING

AN INTRODUCTION TO COMPUTER COMMUNICATIONS (BP177)

R. A. Penfold

Details of various types of modem and their applications, plus how to interconnect computers, modems and the telephone system. Also networking systems and RTTY. 96 pages. £2.95

AN INTRODUCTION TO COMPUTER PERIPHERALS (BP170)

J. W. Penfold

Covers a wide range of computer peripherals such as monitors, printers, disk drives, cassette recorders, modems, etc., explaining what they are, how to use them and the various types of standards. 80 pages. £2.50

MICROPROCESSING SYSTEMS AND CIRCUITS (BP77)

Elements of Electronics Book 4

F. A. Wilson

A comprehensive guide to the elements of microprocessing systems, which are becoming ever more involved in radio systems and equipment. 256 pages. O/P

MORSE

INTRODUCING MORSE

Collected Articles from PW 1982-1985

Ways of learning the Morse Code, followed by constructional details of a variety of keys including Iambic, Triambic, and an Electronic Bug with a 528-bit memory. 48 pages. £1.25

THE MORSE CODE FOR RADIO AMATEURS (RSGB)

Margaret Mills G3ACC

A guide to learning to send and receive Morse code signals up to the 12 w.p.m. required for the radio amateur aspiring to a Class A licence having passed the RAE. 19 pages. £2.88

THE SECRET OF LEARNING MORSE CODE

Mark Francis

Designed to make you proficient in Morse code in the shortest possible time, this book points out many of the pitfalls that beset the student. 87 pages. £4.95

introduce

The CT1600 VHF Hand Held

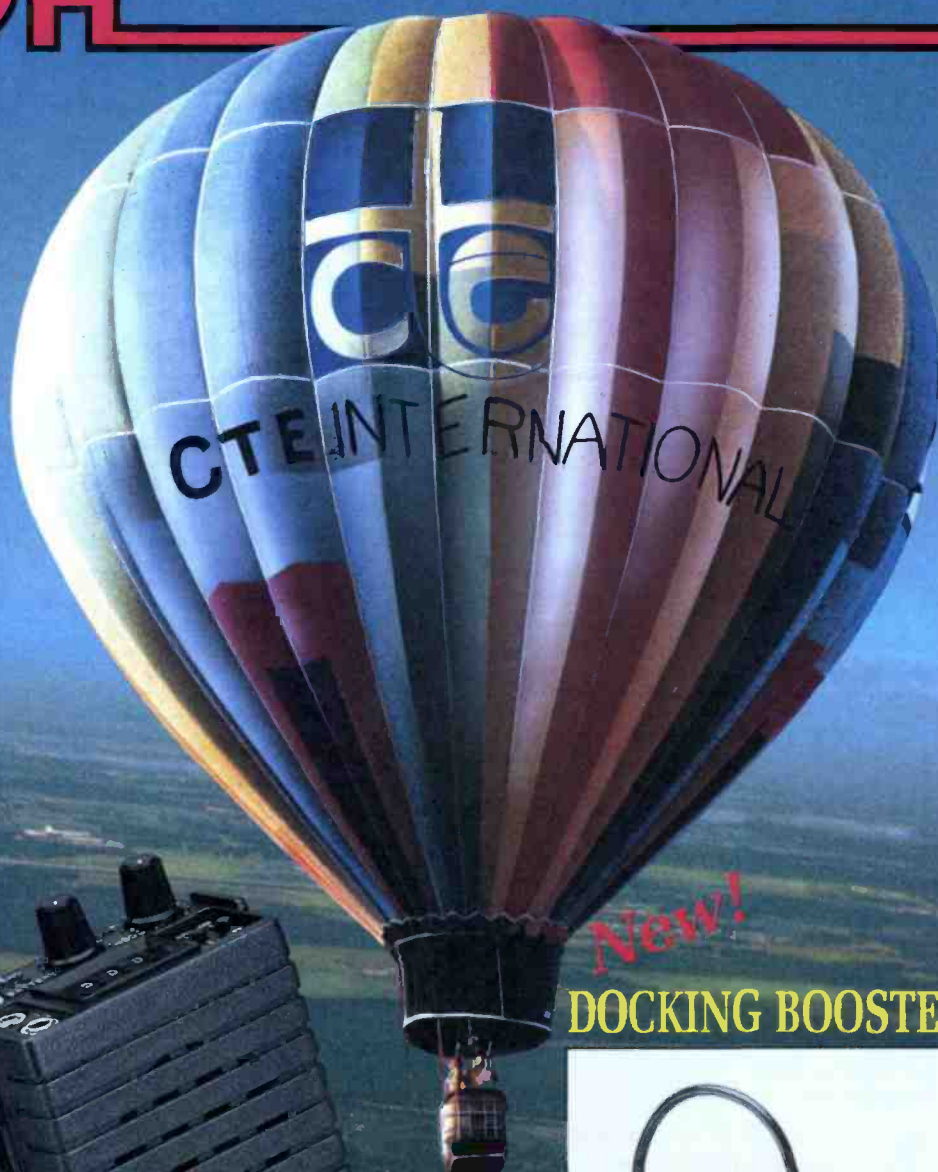

The CT1600 is a small light-weight transceiver covering the 2 metre Amateur Band. Its rugged construction and sensitive receiver make it excellent value for money.

SPECIFICATIONS:

- Fully synthesised resolution 10KHz/5KHz
- UK Model 144 - 146MHz
- Export Model 142 - 149MHz
- Repeater Shift (plus or minus 600KHz)
- Tone Burst
- 1½ / ½ Watt output
- Complete with Ni-Cad charger

INTRODUCTORY OFFER
£169



New!

DOCKING BOOSTER



Boost the output of your handheld to 25 Watts

BS25 - for Icom/Kenpro/CTE

BS23 - for Yaesu models

INTRODUCTORY PRICE **£59.95**

Available from your Local Dealer or direct from the UK Distributors:-
Nevada Communications 189 London Road North End Portsmouth

For Sale

RAYNET BASEBALL CAPS - Yellow with black logo. Send £3.90 including P&P. M.J. Hilton, 3 Highfields, Wirral, L60 7TF.

OSL CARDS. Individual and personal designs. In 1/2/3 colours. A new service from K CARDS. Send SAE for details to 289 Church Street, Blackpool FY5 3HJ.

RCS VARIABLE VOLTAGE D.C. BENCH POWER SUPPLY
1 to 24 volts up to half amp. 1 to 20 volts up to 1 amp. 1 to 18 volts up to 1 1/2 amps. D.C. Fully stabilised. Twin panel meters or instant voltage and current readings. Overload protection.



Fully variable. Operates from 240V A.C. (Connect Units via 2 x 1/2" x 1/2" x 1/2" Bins)

£39 Incl. VAT + Post £2

RADIO COMPONENT SPECIALISTS
337 Whitehorse Road, Croydon SURREY, U.K.
Tel: 01-884 1665
List, Large S.A.E. Delivery 7 days Callers Welcome Closed Wednesday

Wanted

TECHNICAL MANUAL OR CIRCUIT DIAGRAM AIRMEC SIGNAL GENERATOR. Type 365A 6733 100C. State price. Address: Allan 001, Lorong 7, Taman Bunga Raya, 08000, Sungei, Petani, Kedah, West Malaysia.

Antennas

TRAPS FOR D.I.Y. Tribander beams and Anti-T.V.I. Trap-Dipoles. Aerial D.I.Y. Bits, Baluns, Data: 28p SAE. Aerial Guide £1. G2DYM, Uplowman, Devon, EX16 7PH (03989) 215.

**PLEASE MENTION PRACTICAL WIRELESS
WHEN REPLYING TO ADVERTISEMENTS IN
THIS MAGAZINE**

Computer Soft/w & Hard/w

NOW YOU CAN SEND FAX USING YOUR SPECTRUM

JOIN THE GROWING GROUP OF FAX USERS. SEND AND RECEIVE FAX USING YOUR SPECTRUM. ALL THE BENEFITS OF OUR VERY POPULAR RECEIVE ONLY PROGRAM, AND THE ABILITY TO TRANSMIT AS WELL!! INTERFACE INCLUDES AUTO PTT, TONE GENERATOR AND DRUM SPEED GENERATOR! SEND PREPARED DISPLAYS (SCREENS) OR JUST TYPE IN YOUR MESSAGE AND SEND IT. COMPATIBLE WITH EXISTING FAX MACHINES.

PROGRAM ONLY £15.00
SUPPLIED ON TAPE. ADD £3 + 3 DISC

INTERFACE £48

A 'TRADE IN' ALLOWANCE OF £18 IS OFFERED AGAINST YOUR RECEIVE ONLY SYSTEM.

J & P ELECTRONICS LTD.
Unit 45, Meadowmill Estate, Kidderminster DY10 1HH
Tel: (0562) 753893

PC-MONITOR PROFESSIONAL for IBMPC and Yaesu FRG-8000. 1000memory channels, scanning, logbook, lots more. 5 1/4" £25.00 (requires FIF-232C interface). SIMON COLLINGS, Southwold, Harnham Lane, withington, Cheltenham, Gloucestershire GL54 4DD. Enquires welcome.

COMMODORE COMPUTERS (+4, C16, 64, 128). "MICROCOM" cw/rty tx/rx with superb morse tutor. "TURBO LOG" ultimate high speed station log. "MICROCOM INTERFACE" ready built. S.A.E. to: Moray Micro Computing, Enzie Stackhead, Buckie, Moray, AB5 2BR. (Tel. 0542 7384).

**CALL MARCIA BROGAN ON
0202 676033 FOR ALL YOUR
ADVERTISING QUERIES**

Educational

COURSE FOR CITY & GUILDS, Radio Amateurs Examination. Pass this important examination and obtain your licence, with an RRC Home Study Course. For details of this and other courses GCSE, Career and professional examinations, etc.) write or phone: THE RAPID RESULTS COLLEGE, Dept. JX31, Tuition House, London SW19 4DS. Tel. 01-947 7272 (9am-5pm) or use our 24hr Recordacall Service: 01-946 1102 quoting JX31.

RAE PAY AS YOU LEARN Correspondence. Beginners onwards. £2 lesson, SAE K. H. Green M.I.E.E. (G1NAK) "CHYLEAN" Tintagel, Cornwall PL3H 0HH. (0840) 21262.

Miscellaneous

THE SCIENTIFIC WIRE COMPANY
811 Forest Road, London E17. Tel: 01-531 1588

ENAMELLED COPPER WIRE

SWG	1lb	8oz	4oz	2oz
8 to 34	3.63	2.09	1.10	0.88
35 to 39	3.82	2.31	1.27	0.93
40 to 43	6.00	3.20	2.25	1.61
44 to 47	8.67	5.80	3.49	2.75
48	15.96	9.58	6.38	3.69

SILVER PLATED COPPER WIRE

14 to 30	10.10	5.20	2.93	1.97
----------	-------	------	------	------

TINNED COPPER WIRE

14 to 30	3.97	2.41	1.39	0.94
----------	------	------	------	------

Fluxcore Solder 5.90 3.25 1.82 0.94

Post free, please add VAT @ 15%. Orders under £3.00 add 50p. SAE for list of copper and resistance wire. Dealer enquiries welcome.

G2VF LOOP ANTENNAS COMPLETE WITH ATU FOR H.F. HAM RADIO BAND TRANSMISSION (SWR One to One 40, 15 and 10 and One Point Five to One 80 and 20) AND SWL's, AND LONG AND MEDIUM WAVE BANDS FOR BCL's. Loops 21 inches square or triangle. No special skills required. Circuits, Parts Lists with sources of supply assembly/data. HIGH FREQUENCY LOOP 80 to 10 Metres E5. LONG AND MEDIUM WAVE LOOP for BCL's E3. LONG WAVE MEDIUM WAVE AND SHORT WAVE LOOP 1500 to 10 Metres FOR THE BCL AND SWL E8. SHORT WAVE ATU FOR LOOP OR LONG WIRE ANTENNA E4. SHORT WAVE ATU BUILT IN PRE AMP FOR LOOP OR LONG WIRE E7. Pre-amp LW, MW and SWave E2. MW LOOP with pre amp ATU E3. PRE AMP FOR G2VF HF Loop or ATU E4. SAE details. All projects DIY. Metal Detector E2. Phot Copy HFD manual E4. F.G. Rylands, 39 Parkside Avenue, Millbrook, Southampton SO1 9AF. Tel. (0703) 775064.

HEATHKIT U.K. Spares and Service Centre. Cedar Electronics Unit 12, Station Drive, Bredon, Tewkesbury, Glos. Tel: (0684) 73127.

INDEX TO ADVERTISERS

AH Supplies	92	Lee Electronics	46, 76
AJH.	32	London Amateur Radio Show	97
AKD.	80	Low Electronics	10, 11, 38, 39
ARE Communications	14, 15, 64	Maplin Electronics	Cover iv, 37
Arrow	12, 13	Merlin Systems	54
Aerial Techniques	97	Nevada Communications	16, 109
Air Supply	33	Photo Acoustics	44, 45
Alan Kelly Communications	105	RN Electronics	32
Antex	53	RSGB	32
Birkett, J	92	RST Valves	80
Boscad	98	Radio Shack	112
Bredhurst Electronics	9	Randam Electronics	98
CPL.	97	RAS Nottingham	98
Cambridge Kits	105	Raycom	30, 31
Cirkit	4, 5	Revco Electronics	64
Colomor	98	Sandpiper	49
Dewsbury	58, 59	SRW Communications	105
Dressler Communications	85	South Midlands Communications	Cover ii, 6, 7, 8, 73
ERA.	98	Spectrum Communications	105
Elliott Electronics	97	Stephens James	80
Garex	54, 79	Tandy	61
Howes, CM Communications	88	Technical Software	53
ICS Intertext	92	Tennamast	92
Icom (UK)	Cover iii, 2, 3, 24, 25, 92	Ward Reg & Co	26
Lake Electronics	97	Waters & Stanton	68, 69
Langrex Supplies	80		

YOUR LOCAL DEALERS

SOUTH WALES

ELECTRO MART

Receivers, scanners, Howes Kits, components etc. part exchange welcome.

96 High St, Clydach, Swansea
Tel: 0792 818451

ASHTON-U-LYNE MAIL ORDER AND RETAIL

PROCOM Electronics

ELECTRONIC DISTRIBUTORS
Specializing in Electronic Components and Surplus

13 Clarence Arcade, Stamford Street, Ashton-U-Lyne Lancashire OL6 7PT

Open Mon to Sat
Tel: 061 343 2782

LONDON

Henry's

27MHz/934MHz Rigs & accessories in stock.
Lists - S.A.E. (A4) - 26p
Full catalogue (TG/P) - large S.A.E. £1.00
404 Edgware Road, London W2 1ED
Tel: 01-724 0323
(Open 6 days a week)

DERBYSHIRE

RILEY'S T.V. SERVICES LTD.

SUPPLIERS OF:-
SCANNERS - C.B. 27-934 MHZ - AERIALS - TEST METERS - TOOLS - TELEPHONES KITS AND CABLES

125 LANGWITH ROAD HILLSTOWN
CHESTERFIELD S44 9SP
PHONE 0246 826578
CLOSED WEDNESDAY

HERNE BAY

ICOM

ICOM (UK) LIMITED
The Official Icom Importer
Unit 8, Sea Street
Herne Bay, Kent CT6 8LD
Tel: 0227 369464
Fax: 0227 360 155
Open Mon-Sat 9-5.30,
(Lunch 1-2.00 pm)

SOUTHAMPTON

South Midlands Communications

Official Yaesu Importer

S.M. House, School Close, Chandlers Ford Industrial Estate, Eastleigh Hants SO5 3BY.
Tel: 0703 255111

PORTSMOUTH

Nevada Communications

Importers of the Nevada range of 934MHz equipment

189, London Road, North End, Portsmouth, Hants, PO2 9AE
Tel: 0705 662145

DEVON

Reg. Ward & Co. Ltd.

The South-West's largest amateur radio stockist. Approved dealer for Kenwood, Yaesu and Icom

1 Western Parade, West Street, Axminster, Devon, EX13 5NY
Tel: 0297 34918
(Closed 1:00-2:00 and all day Monday)

BUCKINGHAMSHIRE

Photo-Acoustics Ltd.

Approved Kenwood, Yaesu and Icom dealer (part exchange always welcome)

58 High Street, Newport Pagnall, Buckinghamshire MK16 8AQ
Tel: 0908 610625
(Tues-Fri 9:30-5:30, Sat 9:30-4:30)
Closed Mondays

TO FILL THIS SPACE CALL:

0202 676033

YORKSHIRE

YAESU ICOM

Alan Hooker Electronics

42, Netherhall Road, Doncaster.
Tel: 0302 35690
Open Mon-Sat 10-5pm
Closed Thursdays

MERSEYSIDE

MGR COMMUNICATIONS

ICOM - YAESU - Navico - Aerials - M.M. & Kits - Scanners - PMR - MARINE & BAND III
Part-ex welcome

48 Shrewsbury Rd., Unit 5, Milton St., Oxton, Waterloo Ind. Birkenhead L43 2HZ Est., Widnes, Cheshire
051 653 3437 051 420 2559

SOUTH WALES MAIL ORDER RETAIL

A.C.S. SYSTEMS

PACKET RADIO: ST-PC-AMIGA COMPUTERS
AMATEUR SOFTWARE FOR MOST COMPUTERS
SATELLITE TELEVISION SYSTEMS

ICS DEALER FOR DATA COMMUNICATIONS

19, CILHARU TERRACE, MOUNTAIN ASH, MID GLAMORGAN SOUTH WALES, CF46 2ND. TEL 0449 478000 S.A.E. LIST CALLERS BY APPOINTMENT 9am-5pm Mon-Sat

PLEASE MENTION PRACTICAL WIRELESS WHEN REPLYING TO ADVERTISEMENTS

WEST SUSSEX MAIL ORDER RETAIL

BREDHURST ELECTRONICS LTD.

High St., Handcross, West Sussex
Tel: (0444) 400786

Situated at the Southern end of M23. Easy access to M25 and South London.
Open Mon-Fri 9am-5pm except Wed 9am-12.30pm. Sat 10am-4pm

YAESU ICOM

GREAT NAMES FROM RADIO SHACK

The latest one is YUPITERU! - for the MVT-5000 Jupiter II hand held scanner. By Yiminy Crickets this little unit covers 25-550 MHz AM/NFM and 800-1,300 MHz NFM with 100 memories and 10 search ranges for only £299. This one from a manufacturer who is not as well known as THE BIG THREE. Amazing isn't it!

Economise with the 16 channel Bearcat BC-200FB scanner that includes search facility for £99.95 and the 200 channel BC-200XLT handheld at £249. From AOR the AR-800 at £199, AR-900 at £235 and the AR-2002 for £487. Hand held 200 channel PRO-34 for £249.95 with Ni-cads and charger and the 400 channel PRO-2005 for £329.95 we should also have the latest in this series the PRO-2024 at £179.95 by the time you read this. Do not forget we sell the IC-R7000 in original, unutilated, factory spec., for only £??? and the IC-R9000 for only £????.

Transmit on 2 with the new IC-2SET £295 and the latest goodies from ICOM. Kenwood's mystry package will be unveiled shortly and we will be happy to send you the details. Yaesu as well, we will quote for whatever you fancy. We have brand new Rockwell-Collins KWM-380 HF transceivers cheap. Used Drake equipment in stock. Drake owners get on to our list for useful items etc., that turn up.

We are clearing out ancient and modern treasures, from WW2 manuals to present day computers, including antennas, my God, the antennas, come and save a few bob on Jaybeam, Hustler, Hygain and the Avanti 10m Dual Diversity 2 edlement Quad for £89.95 to name but a few! Do you want to save more? (or spend less, depending on how you look at it!). If you are serious we can do you a money saving deal on Computers, Dot Matrix or Laser Printers, the list never ends but goes on and on... Give us a call or look us up when in London, export not a problem but a speciality.

73s - Terry G3STS

COME AND GET A BARGAIN!



RADIO SHACK LTD

188 BROADHURST GARDENS,
LONDON NW6 3AY



(Just around the corner from West Hampstead Station on the Jubilee Line)

Giro Account No. 588 7151 Fax: 01-328 5066 Telephone: 01-624 7174

ICOM

Count on us!

LISTEN TO THE WORLD IN DETAIL IC-R9000 COMMUNICATIONS RECEIVER



The world is now at your fingertips with ICOM's elite new IC-R9000, a communications receiver truly in a professional class all of its own. With the IC-R9000's continuous all mode, super wideband range of 100KHz to 1999.8MHz, ICOM's unique CRT display and numerous scan functions, local and distant spots on the globe are now within earshot in one single receiver.

The IC-R9000's versatile receive capability allows you to receive many different mode signals. Listen to AM used by broadcast stations and VHF airband. Use SSB (U.S.B./L.S.B.) and CW to receive Commercial and Amateur stations on shortwave.

Tune into CB (Citizen Band), Marine and Amateur stations using FM or use wide

FM to receive FM broadcast stations and TV signals. FSK (Frequency Shift Keying) is also built in for receiving RTTY from news agencies. With an advanced range like this you'll have no trouble in hearing stations near to home or on the other side of the planet.

Watch the IC-R9000? Using your TV set or video recorder with a video input connector, you can receive VHF and UHF TV broadcasts. Also the built in CRT can display ATV (Amateur Television) on both the 430 and 1200MHz amateur bands. With the introduction of the IC-R9000 you now have the technical quality required to enjoy HF, VHF and UHF communications. For more detailed information contact your local ICOM dealer.

Icom (UK) Ltd.

Dept PW, Sea Street, Herne Bay, Kent CT6 8LD. Tel: 0227 363859. 24 Hour.

Helpline: Telephone us free-of-charge on 0800 521145. Mon-Fri 09.00-13.00 and 14.00-17.30. This service is strictly for obtaining information about or ordering Icom equipment. We regret this cannot be used by dealers or for repair enquiries and parts orders. thank you

Datapost: Despatch on same day whenever possible.

Visa & Mastercards: Telephone orders taken by our mail order dept. instant credit & interest-free H.P.



**ORDER
YOUR COPY
OF THE NEW
MAPLIN CATALOGUE
ON SALE NOW**

Pick up a copy from any W.H. Smith for just £2.25 or post this coupon now to receive your copy for just £2.25 + 50p p & p. If you live outside the U.K. send £4 or 17 International Reply Coupons. I enclose £2.75.

Name _____
Address _____
Post Code _____

Send to Maplin Electronics, P.O. Box 3, Rayleigh, Essex SS6 8LR.

AVAILABLE FROM 10th NOVEMBER 1989 IN ALL W.H. SMITH STORES PW 90

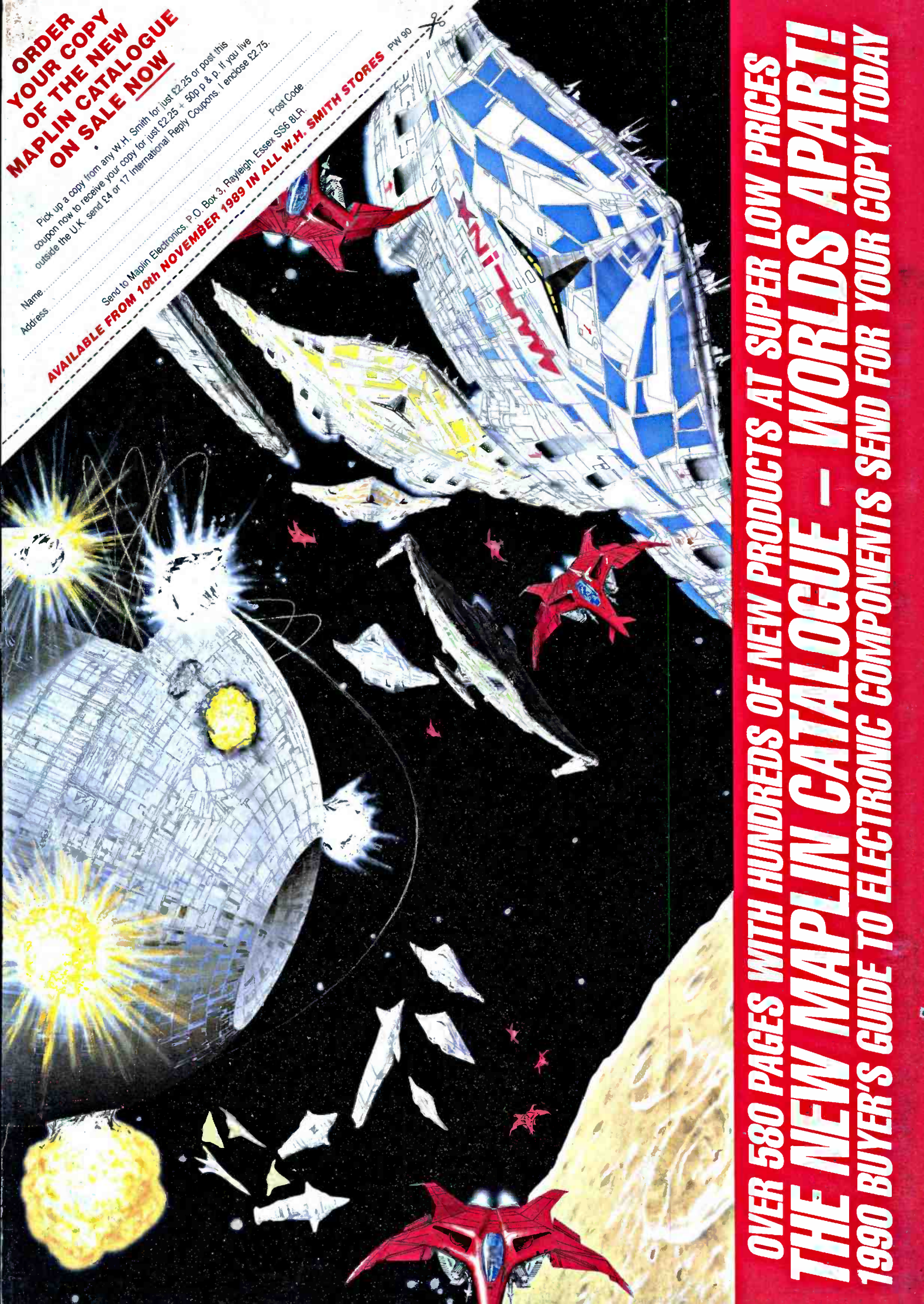

**OVER 580 PAGES WITH HUNDREDS OF NEW PRODUCTS AT SUPER LOW PRICES
THE NEW MAPLIN CATALOGUE – WORLDS APART!
1990 BUYER'S GUIDE TO ELECTRONIC COMPONENTS SEND FOR YOUR COPY TODAY**