

Pull out

**a
glossary
of
radio
terms**

**Presented free with
Practical Wireless**

November/December 1981

glossary of radio terms

introduction

This glossary is intended to help both the newcomer and the more experienced radio enthusiast to understand some of the terms which appear frequently in the pages of *Practical Wireless*. The second half of the glossary will be included in our December issue.

If the two sections of the glossary are pulled out of the centre of the magazines and slit along the top fold, they can be fitted together and stapled or sewn and folded to form a 32-page booklet for you to keep.

Using the Glossary

Any term which appears in *italic* type in an explanation is itself explained elsewhere in the glossary.

A list of common abbreviations will be found at the back of the booklet.

In the centre of the booklet, we have grouped together a number of useful tables, and you will also find there a section on terms used in digital circuits, now finding more application in radio equipment.

Within the space available, we can give only a selection of the terms used in radio communications. For further information, the following dictionaries are recommended:

A Dictionary of Electronics by S Handel
Penguin Books

Dictionary of Telecommunications by S J Aries
Butterworths

glossary of radio terms

A

absorption wave meter: A device for measuring frequency on the principle that maximum power is absorbed by a calibrated *tuned circuit* when this *resonates* with the unknown frequency.

alternating current (a.c.): A current that varies in amplitude sinusoidally and whose average value over a period is zero.

amplitude modulation (a.m.): The *modulation* of a *sinewave* carrier by a fluctuating signal so that its amplitude varies in sympathy with the signal.

AMSAT: The Radio Amateur Satellite Corporation, formed in 1969 to coordinate amateur space projects, nationally and internationally. The satellites are named "OSCAR", after "Orbital Satellite Carrying Amateur Radio".

angle modulation: *Modulation* in which the electrical angle of a *carrier wave* is the characteristic that is varied by the modulating signal. This includes both *frequency modulation* and *phase modulation*.

antenna: The part of a radio system that is used to radiate radio waves into free space and to abstract energy from incoming radio waves. An assembly of simple *antennas* arranged in space so that it has some directional characteristic is known as an antenna array.

antenna tuning unit (a.t.u.): A circuit to match the *impedance* of *antennas* to that of *receivers* and *transmitters*.

anti-node: The point, in a *standing wave*, at which some specified variable (e.g. current or voltage) is at a maximum value.

anti-VOX: A circuit to prevent a *VOX* being operated by sounds from the transceiver's loudspeaker.

apogee: The point in the elliptical orbit of a communications satellite at which it is at its maximum distance from the centre of the earth.

ASCII (American Standard Code for Information Interchange): A code used for the transmission of data between computers, etc.

attenuation: The decrease in magnitude of any kind of signal due to its transmission through equipment, lines or other transmission paths. Usually expressed as a ratio in *decibels*.

audio frequency (a.f.): Any frequency at which a sound wave is audible to the average human ear. For convention the range is considered to extend from about 15Hz to around 20kHz.

audio frequency shift keying (a.f.s.k.): A *telegraphy* system in which a *carrier wave* is modulated by *audio frequency* tones to convey a digital signal. Also called *voice frequency telegraphy (v.f.t.)*.

aurora: The luminous ionisation in the upper atmosphere near the earth's magnetic poles caused by particles from the sun interacting with the earth's magnetic field. This can severely affect the propagation of radio

glossary of radio terms

waves, the effects being particularly acute in the *v.h.f.* and *u.h.f.* bands.

automatic frequency control (a.f.c.): A system designed to keep the *receiver* in tune with a wanted transmission. Mistuning results in the production of a control voltage, which is used to adjust the frequency of the *local oscillator* so as to minimise the tuning error.

automatic gain control (a.g.c.): Also known as automatic volume control. A system intended to produce a more-or-less constant output volume over a specified range of variation in input signal level, as in a radio *receiver*.

B

balanced mixer: A modulator circuit which, fed with *carrier* and *audio frequency* signals, produces an output containing *upper* and *lower side-bands* but with the *carrier* suppressed.

balun: Comes from the term "balanced to unbalanced transformer". Used for example to couple a balanced *antenna* to an unbalanced (*coaxial*) *transmission line*.

band-pass: A term applied to amplifiers and other networks having a response that is substantially level across a defined frequency range.

baud: Derived from the Baudot Code.

The unit of *modulation* rate in *telegraphy* and data transmission.

beam: A directional flow of particles, or of electromagnetic radiation, as from a radio *antenna*. Also the region of space through which radiation passes.

beam width: The angular width of a *beam* within which the radiation exceeds some specified fraction of the maximum value, for example the half-power *beam width*.

beat frequency oscillator (b.f.o.): An adjustable frequency *oscillator* the output of which can be mixed with that of the final *intermediate frequency* amplifier to produce an *audio frequency* beat when the *receiver* is tuned to an unmodulated signal such as a *c.w.* (*Morse code*) transmission.

C

callsign: An identification code used by stations at regular intervals during their transmission.

capture effect: In *frequency modulation* reception, the suppression of the weaker signal by a stronger signal on the same frequency.

carrier insertion oscillator (c.i.o.): Replaces the suppressed *carrier* of an *s.s.b.* signal at the *receiver* to allow *demodulation*.

carrier wave: A sinusoidal oscillation

glossary of radio terms

or *electromagnetic wave* suitable for *modulation*.

channel: In communications, a band of frequencies or a specified path for the transmission and reception of electric signals.

characteristic impedance: The natural *impedance* of a *transmission line*, typically 50-75 Ω for coaxial lines and 75-300 Ω for open wire *feeders*.

citizens' band: A short-range radio-telephone service, intended for use by unskilled operators.

clipping: *Distortion* of an electrical signal by an amplifier which is unable to pass the peaks of its *waveform*; also, in *telephony*, the loss of the first part of a word, usually due to the action of a voice-operated switch.

c.m.o.s.: A semiconductor that uses both *n*- and *p*-type channel devices on the same *i.c.* It has the advantage of lower power dissipation, but also has speed and packing density limitations.

coaxial line: A transmission line consisting of two conductors arranged so that one is centred inside the other but insulated from it.

co-linear: An omni-directional *antenna* comprising of multiple elements stacked end-to-end and phased.

continuous wave (c.w.): Radio or radar waves which maintain a constant amplitude and constant frequency. Also used to describe a *carrier wave* which is keyed to convey signals in Morse code.

coverage area: The area surrounding a fixed station in which the signal strength is sufficient to provide reliable communication for approximately 90 per cent of the time.

critical frequency: It is the frequency of a wave, transmitted vertically into the *ionosphere*, below which the wave will be reflected to earth, and above which the wave will pass through the *ionosphere*.

cross modulation: In a *receiver* cross modulation may take place if a strong unwanted signal overloads the receiver's input circuits. The unwanted station will then be heard in the background of the wanted signal.

cut-off frequency: The frequency at which the *attenuation* changes from being relatively low to being substantially higher; for example the frequency above which the *attenuation* of a *low-pass filter* exceeds a specific value.

D

D-layer: Is the lowest and most weakly ionised layer affecting the propagation of radio waves. It occurs during daylight hours and is approximately 50 to 90km above the surface of the earth.

decibels (dB): A dimensionless logarithmic unit used to express the ratio of two values of power. Commonly used for expressing transmission

glossary of radio terms

gains, losses and levels. dBm indicates a reference point of one milliwatt.

de-emphasis: A means of restoring the correct relative amplitudes of the various frequencies of a complex wave after reception, where the wave has gone through a *pre-emphasis* circuit before transmission.

demodulation: The process of separating the original information from a modulated signal. The circuits or equipment used for this purpose are called demodulators or detectors.

desensitising: The overloading of the front end of a radio *receiver* when in a strong *r.f.* field.

deviation: The change in frequency of a *carrier* wave when it is *angle-modulated*.

diplex: Using a single *antenna*, *carrier* or circuit for the simultaneous transmission or reception of two signals.

dipole: A balanced *antenna*, usually half a *wavelength* long, and fed at its centre.

direct current (d.c.): Is unidirectional current which does not change in value.

direction finder (DF): A system for determining the origin of a transmitted signal, using a radio *receiver*, a directional *antenna* and associated equipment.

discone: A wideband *antenna* consisting of a cone with a disc mounted symmetrically near its apex, the elements being fed in anti-phase.

distortion: An unwanted change in *waveform*. Principal causes of distortion are non-linearity between input and output, variations in gain with frequency and non-linearity of the frequency characteristic.

double frequency (d.f.): A two-way radio circuit in which a different frequency is used in each direction, e.g. an amateur *repeater*.

double side-band (d.s.b.): Both *sidebands* are produced by the process of *amplitude modulation* and are transmitted at the same level.

driven element: In an *antenna* it is the element that is energised by the *transmitter* either directly or via a *feeder*.

dummy load: A device designed to be substituted for the normal load (or antenna) and used to absorb the output power. Usually for test purposes.

duplex: Simultaneous transmission in both directions over a communications link or circuit.

DX: Basically this means "long distance" communication, and as this also depends on the band, conditions, mode and equipment used, DX has a lot to do with difficulty as well as distance.

E

E-layer: A layer of more intense ionisation occurring at approximately 100km above the surface of the earth.

glossary of radio terms

The density decreases at night and the layer sometimes disappears.

earth: The conducting mass of the earth or any conductor in direct electrical connection with it, or at zero potential with respect to the earth. It can also mean the connection, deliberate or accidental, between a conductor and the earth. Also called ground.

effective radiated power (e.r.p.): The product of the power supplied to an antenna and its relative gain in a given direction, compared to a given reference antenna.

electromagnetic wave: Waves of associated electric and magnetic fields, each at right angles to each other and to the direction of propagation, e.g. radio waves or light.

electromotive force (e.m.f.): The property of a battery or generator which causes a movement of electricity in a circuit connected to it.

elliptical lowpass filter: The name is derived from the appearance of the graph plotted of attenuation against rising frequency response. Attenuation rises at a constant rate to the second harmonic frequency and then follows a reverse elliptic curve to peak the

WRM428

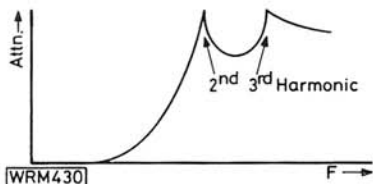
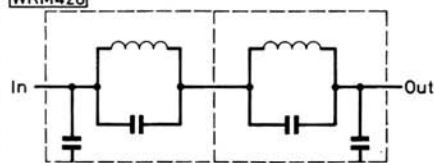

attenuation once again at the third harmonic. It is used mainly to suppress the unwanted harmonic energy produced by transmitter amplifier stages.

extra high tension (e.h.t.): High voltage (typically 500V or more) used in cathode ray tubes, TV picture tubes, etc.

extremely high frequency (e.h.f.): See frequency table.

F

F-layer: This comprises two separate layers, F1 and F2. Both exist during the daylight hours but combine at night to form one layer. These are the highest of the ionised layers for refracting radio waves.

fading: Variations in the strength of received radio signals due to changes in the propagation conditions with time.

feedback: The term for the process in which a fraction of the output signal of a device or system is returned to the input, usually to modify the overall characteristic. It may be "positive"

glossary of radio terms

(feedback in phase), or "negative" (feedback out of phase).

feeder: A general term for a *transmission line*, such as that connecting an *antenna* to a *transmitter* or *receiver*.

ferrite rod antenna: A receiving *antenna* constructed from a magnetic core in the shape of a rod. On the core are wound a number of turns of wire, replacing the usual *antenna* coils in the *receiver*.

field effect transistor (f.e.t.): Makes use of the electric field established in a *p-* or *n-*type channel of semiconductor material to control the flow of current through the channel.

field strength: The value of either the electric or magnetic field of a received radio wave.

field strength meter: An instrument for indicating *field strength*.

folded dipole: This *antenna* has an *impedance* of about 300Ω and consists of two closely-spaced parallel *half-wave dipoles*, joined together at their outer ends.

free-space loss: Is the loss between two identical *antennas* in free space, usually expressed as a power ratio in *decibels*.

frequency modulation (f.m.): *Modulation* where the frequency of the *sinewave carrier* alters with the amplitude of the modulating signal.

frequency response: The variation of transmission loss or gain in a circuit or device with changes in frequency.

frequency shift keying (f.s.k.): A *telegraphy* system in which the instantaneous frequency of the *carrier wave* is shifted between two or more values by a modulating digital signal.

front to back ratio: In a directional *antenna* it is the ratio of the radiation intensity of the main *lobe* compared to that in the reverse direction.

full scale deflection (f.s.d.): In a meter it is the maximum value for which the instrument is scaled.

fundamental frequency: The basic (lowest) frequency present in a complex wave. Also the basic frequency of a crystal oscillator driving a frequency multiplier chain.

G

gain: An increase in signal power, usually expressed as the ratio of output power to input power in *decibels*.

grid dip oscillator (g.d.o.): A portable instrument for measuring *r.f.* using an *oscillator* and a grid-current meter. *Resonance* is indicated by a sharp dip in the reading of the meter. The modern version uses a transistor instead of a valve.

ground: see *earth*.

ground plane: A large or significant mass that presents the effect of *ground (earth)* to an *antenna* system.

glossary of radio terms

ground plane antenna: A *unipole antenna* with radials at the base forming the *ground plane*.

ground wave: A radio wave emitted from a transmitting *antenna* that follows the curve of the earth, also known as a *surface wave*.

guard band: A band of frequencies left vacant between two adjacent *channels* to prevent *mutual interference*.

H

half-wave dipole: A dipole *antenna* having an electrical length equal to half the operational *wavelength*.

harmonic: A sinusoidal component of a *waveform* that is a whole multiple of the *fundamental frequency*.

harmonic distortion: *Distortion* caused by non-linearity, for example by overloading an amplifier, producing an output that contains unwanted *harmonics*.

helical antenna: An *antenna* consisting of a conductor wound into a helix.

helical filter: This device comprises a high *Q* resonant circuit combining the elements of a conventional *LC* network with those of a resonant cavity. These devices are usable over the *v.h.f.* and *u.h.f.* bands for filtering applications. ▶

Hertz (Hz): The unit of frequency, equal to one cycle per second.

high frequency (h.f.): See frequency table.

high-pass filter: Comprises a frequency-selective network showing little *attenuation* to frequencies above a defined cut-off value, but heavily attenuating all lower frequencies.

high tension: (h.t.): Used to describe the anode supply for valved equipment (typically 60-600V), or the collector supply for transistorised equipment (typically 3-75V).

hybrid junction: A *microwave* junction that is a directional coupler with a 3dB coupling factor.

I

image frequency interference: Also known as second channel interference. *Interference* from a signal on a frequency differing from the *local oscillator* by the *i.f.* It is always higher

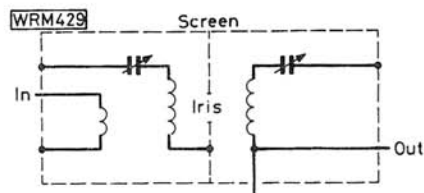

glossary of radio terms

than the *local oscillator* frequency when the wanted signal is lower, and vice versa.

image rejection ratio: A measure of a receiver's ability to reject unwanted *image frequency* signals, usually expressed as a ratio in *decibels*.

impedance: Is the ratio of the voltage to the current in an *a.c.* circuit.

integrated circuit (i.c.): This consists of transistors, diodes, resistors and capacitors with all the necessary connections to form a circuit, for example an amplifier, and this is made on a single piece of semiconductor material. The result of this is miniaturisation and increased reliability.

interference: The term for any form of unwanted energy of a sufficient level to degrade the reception of a wanted station.

intermediate frequency (i.f.): The frequency resulting from mixing the incoming signal and the *local oscillator* output in a *receiver*.

intermodulation: The *modulation* of the components of a complex wave with each other to produce the sum and difference of the frequencies concerned, appearing as *distortion*.

ionosphere: The part of the earth's atmosphere in which the propagation of radio waves is affected by the ions and electrons present. This region is usually 50km and above from the earth's surface.

ionospheric scatter: When propagation of radio waves results from scat-

tering in the lower E region of the *ionosphere*.

K

key clicks: *Interference* caused by a *telegraphy transmitter* on an adjacent channel, due to a badly designed keying circuit.

L

limiter: A device where the output is automatically prevented from exceeding a certain pre-set value. A *limiter* may be used to remove incidental *amplitude modulation* and noise from a *frequency modulated* signal.

limiting: The action performed by a *limiter*.

linear amplifier: An amplifier where the output rises linearly with its input.

loading: A method of increasing the electrical length of an *antenna*, by adding inductance or capacitance somewhere along its length, to make it resonate at a lower frequency.

continued on page twenty-two ▶▶▶▶

glossary of radio terms

tables, data and symbols

CONTENTS

Circuit Symbols:

Inductors, Resistors, Capacitors	12
Transistors, Diodes	13
Relays, Switches, Batteries, Indicators, Wiring	14
Logic Symbols, Miscellaneous	15
Logic Terms	16
Fuse Codes	17
Semiconductor Codes	18
SI Units	19
Frequency Bands	20
RST Code, Frequency Limits	21

INDUCTORS

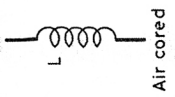

Air cored

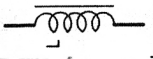

Iron cored

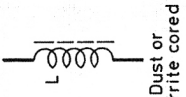

Dust or ferrite cored

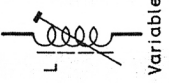

Variable



Tapped

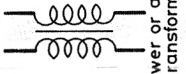

Power or audio transformer

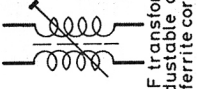

RF transformer (adjustable dust or ferrite core)

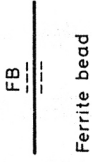

Ferrite bead

RESISTORS

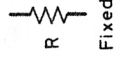

Fixed



Variable (potentiometer)

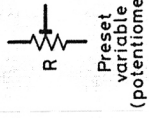

Preset variable (potentiometer)

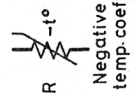

Negative temp. coeff.

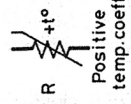

Positive temp. coeff.

Thermistors

CAPACITORS

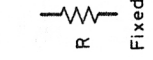

Fixed

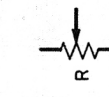

Variable

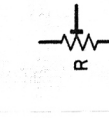

Preset variable

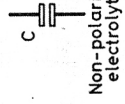

Non-polarised electrolytic

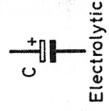

Electrolytic



Feed-through

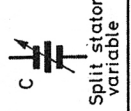

Split stator variable



Differential

BI-POLAR TRANSISTORS

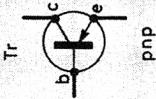

pnp

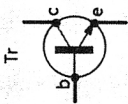

npn

FIELD-EFFECT TRANSISTORS

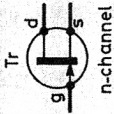

n-channel

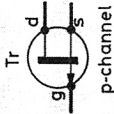

p-channel

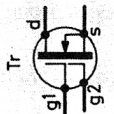

dual-gate
n-channel

Mosfet
(depletion type)

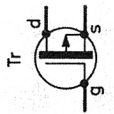

single-gate
p-channel

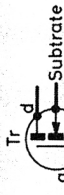

n-channel

Mosfet
(enhancement type)

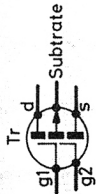

p-channel

UNI-JUNCTION TRANSISTORS

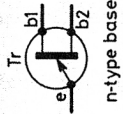

n-type base

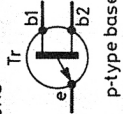

p-type base

DIODES



Rectifier diode



Zener diode



Tunnel diode



Varicap diode



Thyristor (p-gate)



Thyristor (n-gate)

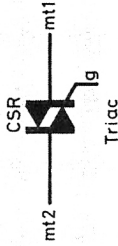

Triac



Light-emitting diode

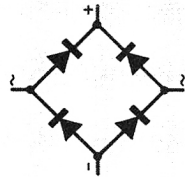

or

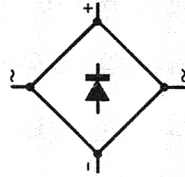

Rectifier bridge

WRM452

BATTERIES

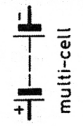
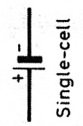

INDICATORS

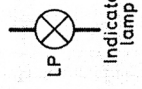

Meters

RELAYS & SWITCHES

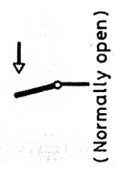
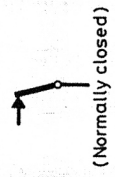
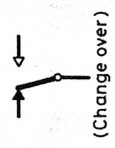
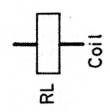

Contacts

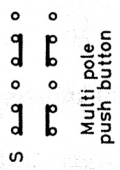
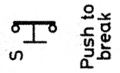
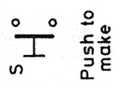
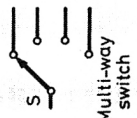
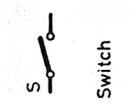

WIRING & CONNECTORS

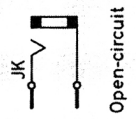
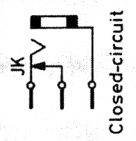
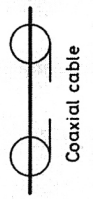
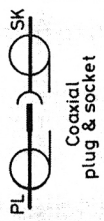
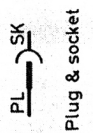
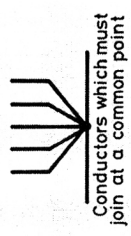
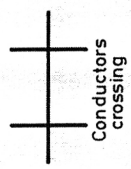
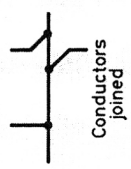
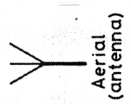
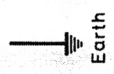
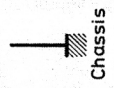

Telephone jacks

LOGIC SYMBOLS

US standard
MIL-STD-806B

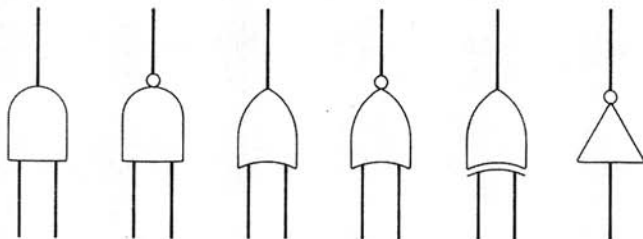

British standard
BS3939

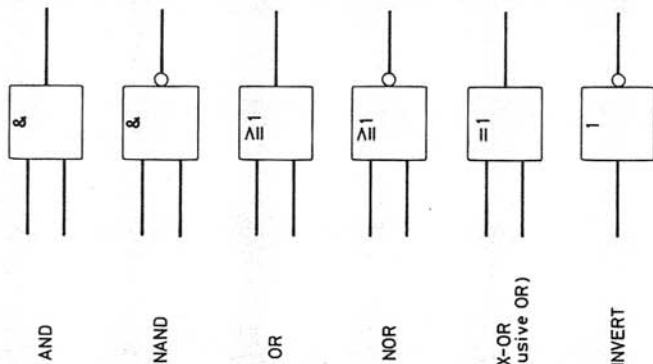

MISCELLANEOUS

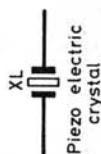
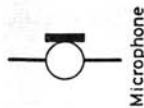
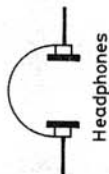

Mechanical linkage
(between sections of a switch, variable capacitor, plug, socket, etc.)

glossary of radio terms

AND gate: A digital circuit which gives a 1-level output only when all its inputs are taken to a 1 level.

Binary: A number system using only numerals 0 and 1.

Digital: Having only two states (called ON and OFF, HIGH and LOW, 1 and 0). Circuitry using digital techniques.

EAROM: Electrically Alterable ROM. This uses Metal Nitride Oxide Silicon to form a memory which can be erased and rewritten electrically.

EPROM: Erasable Programmable ROM. This is a general term used to refer to ultra-violet-light erasable *PROMs*.

EXCLUSIVE OR: An *OR gate* which gives a 1-level output when any one but not more than one of its inputs is taken to a 1 level.

Inverter: A digital circuit whose output is always the opposite to its input—a 1-level input gives a 0-level output and vice versa.

LSI: Large Scale Integration. A very high density of circuit functions on one single device possible due to solid-state micro electronics technology.

MPU: Microprocessor Unit. A collection of gates and flip-flops on a LSI chip arranged so they obey general purpose instructions externally stored.

NAND gate: A digital circuit comprising an *AND gate* followed by an inverter, so that its output is at 0 level only when all its inputs are taken to a 1 level.

NOR gate: A digital circuit comprising an *OR gate* followed by an inverter, so that its output is at 0-level when one or more of its inputs are taken to a 1 level.

OR gate: A digital circuit which gives a 1-level output when any one or more of its inputs are taken to a 1 level.

PROM: Programmable Read Only Memory. These are widely used to hold *MPU* programs, and can be programmed by blowing fuse links, storing a charge on the gate of a MOS device or making links by migration.

RAM: Random Access Memory. An i.c. containing an array of digital memory cells. Data can be written into and read out of the cells at will, and changed as often as required.

ROM: Read Only Memory. An integrated circuit containing an array of digital memory cells, programmed with data at the time of manufacture. The data can be read out at any time afterwards but cannot be altered. Radio applications include storing frequency data for an MPU-controlled tuner or Morse code characters for a Morse generator.

glossary of radio terms

Truth Table: A "shorthand" way of expressing the relationship between input and output levels of a logic gate. For example, an *AND gate* with two inputs A and B, and output Y:

A	B	Y
0	0	0
0	1	0
1	0	0
1	1	1

Fuse Colour Code

Rated Current	Colour	Rated Voltage	
		a.c.	d.c.
50mA	Pink	1000	1000
60mA	Black	1000	1000
100mA	Dark Grey	1000	1000
150mA	Red	1000	1000
250mA	Dark Brown	1000	750
500mA	Yellow	750	350
750mA	Green	500	300
1A	Azure Blue	350	250
1.5A	Sky Blue	250	250
2A	Violet	250	250
3A	White	250	32
5A	Black/White	250	32
7A	Orange	150	32
10A	Orange/Black	100	32
15A	Orange/Green	50	32
20A	Orange/Violet	32	32
25A	Orange/White	32	32

1in Fuse (BS1362) for 13A plugs

Rated Current	Colour	Rated Voltage a.c.
3A	Red	240
5A	Black	240
7A	Black	240
10A	Black	240
13A	Brown	240

Fuses

European Type-code	
F	Quick-blow fuses
MT	Semi-slow-blow fuses
T	Slow-blow fuses

glossary of radio terms

Pro Electron Semiconductor Coding

First letter	(Material)
A	Germanium (or other material with band gap 0.6 to 1.0eV)
B	Silicon (or other material with band gap 1.0 to 1.3eV)
C	Gallium-Arsenide (or other material with band gap of 1.3eV or more)
R	Compound Materials (eg Cadmium-Sulphide)

Second letter	(Type)
A	Diode (signal, low power)
B	Diode (variable capacitance)
C	Transistor (low power, audio frequency $R_{th\ j-mb} > 15^{\circ}C/W$)
D	Transistor (power, audio frequency $R_{th\ j-mb} \leq 15^{\circ}C/W$)
E	Diode (tunnel)
F	Transistor (low power, high frequency $R_{th\ j-mb} > 15^{\circ}C/W$)
G	Multiple of Dissimilar Devices—Miscellaneous (e.g. oscillator)
H	Diode (magnetic sensitive)
L	Transistor (power, high frequency $R_{th\ j-mb} \leq 15^{\circ}C/W$)
N	Photo-coupler
P	Radiation Detector (e.g. high sensitivity phototransistor)
Q	Radiation Generator (e.g. light-emitting diode)
R	Control and Switching Device (e.g. thyristor, low power)
S	Transistor (low power, switching $R_{th\ j-mb} > 15^{\circ}C/W$)
T	Control and Switching Device (e.g. thyristor, low power $R_{th\ j-mb} \leq 15^{\circ}C/W$)
U	Transistor (power, switching $R_{th\ j-mb} \leq 15^{\circ}C/W$)
X	Diode (multiplier e.g. varactor, step recovery)
Y	Diode (rectifying booster)
Z	Diode (voltage reference or regulator-transient suppressor diode, with third letter W)

JEDEC Semiconductor Code

This consists of a figure denoting the number of semiconductor junctions followed by the letter N followed by a serial number. So that:

1N . . . is a one-junction device, e.g., a diode

2N . . . is a two-junction device, e.g., a transistor

3N . . . is a three-junction device, e.g., dual-gate f.e.t., s.c.r.

glossary of radio terms

SI UNITS

Physical Quantity	Unit	Symbol
Length	metre	m
Mass	kilogram	kg
Time	second	s
Electric current	ampere	A
Thermodynamic temperature	kelvin	K
Luminous intensity	candela	cd

DERIVED UNITS

Quantity	Name	Symbol	Definition
Force	newton	N	kg m/s ²
Work, energy, quantity of heat	joule	J	Nm
Power	watt	W	J/s
Electric charge	coulomb	C	As
Electrical capacitance	farad	F	As/V
Electrical potential	volt	V	W/A
Electrical resistance	ohm	Ω	V/A
Frequency	hertz	Hz	1/s
Magnetic flux	weber	Wb	Vs
Magnetic flux density	tesla	T	Wb/m ²
Inductance	henry	H	Vs/A
Luminous flux	lumen	lm	cd sr
Illumination	lux	lx	lm/m ²

Multiples and Sub-Multiples of Units

Multiplication factor	Prefix	Symbol
10 ¹²	tera	T
10 ⁹	giga	G
10 ⁶	mega	M
10 ³	kilo	k
10 ²	hecto	h
10 ¹	deca	da
10 ⁻¹	deci	d
10 ⁻²	centi	c
10 ⁻³	milli	m
10 ⁻⁶	micro	μ
10 ⁻⁹	nano	n
10 ⁻¹²	pico	p
10 ⁻¹⁵	femto	f
10 ⁻¹⁸	atto	a

glossary of radio terms

Broadcast Bands

Frequency limits	Wavelengths
148.5-238.5kHz	2000-1053m (long wave)
526.5-1606.5kHz	571-187m (medium wave)
2.3-2.498MHz	120m
3.2-3.4MHz	90m
3.95-4.0MHz	75m
4.75-5.06MHz	60m
5.95-6.20MHz	49m
7.1-7.3MHz	41m
9.5-9.9MHz	31m
11.65-12.05MHz	25m
13.6-13.8MHz	22m
15.1-15.6MHz	19m
17.55-17.9MHz	16m
21.45-21.85MHz	13m
25.67-26.1MHz	11m
47.0-68.0MHz	4-6m
87.5-108MHz	3m
174-230MHz	1.5m
470-960MHz	30-60cm
11.7-12.5GHz	2.4-2.5cm

Amateur Bands

1.8-2.0MHz	160m	47-47.2GHz	6mm*
3.5-3.8MHz	80m	75.5-81GHz	3mm*
7.0-7.1MHz	40m	119.98-120.02GHz	2.5mm*
10.1-10.15MHz	30m*	142-149GHz	2mm*
14-14.35MHz	20m	241-250GHz	1.2mm*
18.068-18.168MHz	17m*		
21.0-21.45MHz	15m		
24.89-24.99MHz	12m*		
28-29.7MHz	10m		
70.025-70.05MHz (UK)	4m*		
144-146MHz	2m		
430-434MHz	70cm		
1.24-1.325GHz	23cm		
2.3-2.45GHz	13cm		
5.65-5.85GHz	5cm		
10.0-10.5GHz	3cm		
24-24.25GHz	1cm		

*Allocations are subject to some national variations, amateurs have only secondary user status on some bands or parts of bands. New and revised allocations resulting from WARC '79 come into effect in January 1982, except for some bands where existing users must transfer to new allocations. For example, the new amateur bands at 18 and 24MHz will not be immediately available in all countries.

glossary of radio terms

RST Code

Readability	
R1	Unreadable
R2	Barely readable, occasional words distinguishable
R3	Readable with considerable difficulty
R4	Readable with practically no difficulty
R5	Perfectly readable
Signal Strength	
S1	Faint, signals barely perceptible
S2	Very weak signals
S3	Weak signals
S4	Fair signals
S5	Fairly good signals
S6	Good signals
S7	Moderately strong signals
S8	Strong signals
S9	Extremely strong signals
Tone	
T1	Extremely rough hissing tone
T2	Very rough a.c. note, no trace of musicality
T3	Rough, low-pitched a.c. note, slightly musical
T4	Rather rough a.c. note, moderately musical
T5	Musically modulated note
T6	Modulated note, slight trace of whistle
T7	Near d.c. note, smooth ripple
T8	Good d.c. note, just a trace of ripple
T9	Purest d.c. note

Frequency table

Frequency band	Frequency limits	Wavelength limits	Waveband
v.l.f.	below 30kHz	above 10km	
l.f.	30kHz-300kHz	10km-1km	l.w.
m.f.	300kHz-3MHz	1000m-100m	m.w.
h.f.	3MHz-30MHz	100m-10m	s.w.
v.h.f.	30MHz-300MHz	10m-1m	
u.h.f.	300MHz-3GHz	1m-10cm	
s.h.f.	3GHz-30GHz	10cm-1cm	
e.h.f.	30GHz-300GHz	1cm-1mm	

Frequencies above 1GHz are considered to be "microwaves".

glossary of radio terms

▶▶▶ continued from page ten

lobe: The area of the *radiation pattern* of an *antenna* that has maximum radiation.

local oscillator (l.o.): An *oscillator* whose output frequency is mixed with the received signal to produce the sum and difference frequencies, one of these being the *intermediate frequency* of the *receiver*.

log periodic antenna: An *antenna* that gives a flat response over a wide band. It resembles a *Yagi*, but all elements are driven. The name comes from the lengths and spacings of the elements, which follow a logarithmic progression. ▶

long wave (l.w.): See frequency table.

long wire antenna: An *antenna* consisting of one or more conductors, generally long compared to the operating *wavelength*, and of a random length.

loop antenna: An *antenna* consisting of one or more large turns of wire forming a closed circuit. May be circular or rectangular in shape.

lower side-band (l.s.b.): The *side-band* containing all frequencies below the *carrier* frequency which has been *amplitude modulated*.

lowest usable frequency (l.u.f.): The lowest frequency that can be used for point-to-point communication via the *ionosphere* at a particular time.

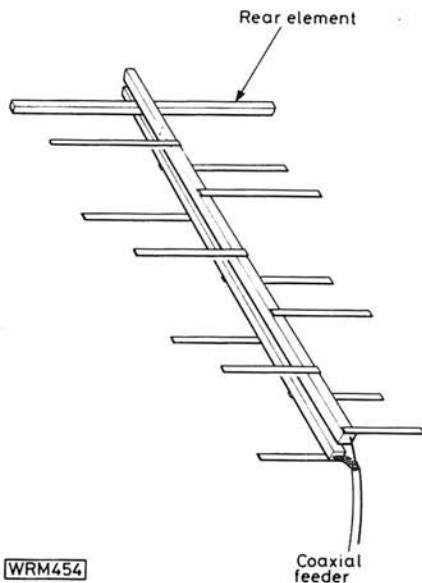

WRM454

low frequency (l.f.): See frequency table.

low-level modulation: The *modulation* of a signal at an early stage in a *transmitter*, where the power level is low compared with the output power.

low-pass filter: A frequency selective network offering very little *attenuation* to frequencies below the pre-set cut off level, but attenuating all higher frequencies.

glossary of radio terms

low tension (l.t.): This is generally used to describe heater or filament supplies in valved circuits. Usually less than 15 volts.

M

maximum usable frequency (m.u.f.): The highest frequency that can be used between two points at any time for communication via the *ionosphere*.

medium wave (m.w.): See frequency table.

modulated continuous wave: A *carrier wave* modulated by a steady *audio frequency* tone.

modulation: The process, or the result of the process, in which some characteristic of one wave (e.g. a *carrier*) is varied in sympathy with some characteristic of another (e.g. speech). See also *amplitude modulation* and *frequency modulation*.

modulation index: A measure of modulation depth in *angle-modulated* transmitters. It is equal to the ratio $\Delta f_o/f_m$, where Δf_o is the deviation of the carrier frequency, and f_m is the modulating frequency.

moon bounce: Also known as e.m.e. (earth moon earth). Where two stations on different parts of the earth can communicate with each other by reflecting radio signals from the moon when it is visible to both.

Morse code: A telegraph code, invented by Samuel Morse, in which the characters are formed from single elements called dots and dashes. Also known as *c.w.*

MOSFET: A **M**etal **O**xide **S**emiconductor **F**ield **E**ffect **T**ransistor.

multimode: Usually referring to a *transceiver*, signifying its capability of transmitting and receiving using various modes of operation, e.g. *amplitude modulation*, *frequency modulation*, *upper side-band*, *lower side-band* and *c.w.*

multiplexing: The method of combining a number of signals so that they can share a common transmission *channel*.

muting: Also known as *squelch*. The process of inhibiting the output of a radio *receiver* by automatically reducing its gain in the absence of an input signal.

N

narrow band frequency modulation (n.b.f.m.): A form of *frequency modulation* where the *deviation* is reduced so that the radiated signal occupies no more *bandwidth* than an *amplitude modulated* signal carrying the same information.

"netting": Adjusting a transmitter so that it will operate on the same frequency as a distant station whose signal can be heard, often by tuning for *zero beat*.

glossary of radio terms

Nickel Cadmium cell (NiCad): A rechargeable cell which uses a mixture of nickel hydroxide and nickel oxide at the anode and cadmium at the cathode, in an electrolyte of potassium hydroxide.

node: The point, in a *standing wave*, at which some specified variable (e.g. voltage or current) is at a minimum value.

noise factor: The ratio of the total output noise power of an amplifier when the input is terminated by an *impedance*, to the noise power that would be solely caused by this input termination.

noise level: The average noise power in the frequency range of interest.

noise limiter: A circuit that prevents the amplitude of the random noise exceeding the peak amplitude of the wanted signal.

O

omni-directional antenna: An *antenna* having a non-directional *radiation pattern*, for example a vertical *dipole antenna*.

operational amplifier: A direct-coupled amplifier with a high input *impedance* providing a voltage gain of 100 to 100 000 or more.

OSCAR: See *AMSAT*.

oscillator: A circuit that converts *direct current* into *alternating current*, the frequency of which is determined by the physical constants of the circuit.

P

parabolic reflector: A concave reflector of radio waves shaped so that all rays from the focus will be reflected in a direction parallel to the axis, and vice versa.

parallel tuned circuit: This circuit has a very high *impedance* at its *resonant frequency* and is often called a rejector circuit, or *trap*.

parasitic element: An element, in an *antenna* system, that is not connected to the *transmitter* or *receiver* directly or by a *feeder*. It affects the directivity of the system by re-radiating received energy.

peak envelope power (p.e.p.): Is the average power supplied to the *antenna* during one *r.f.* cycle at the peak of the *modulation* envelope.

peak to peak amplitude: Is the value given between the highest maximum and the lowest minimum of a waveform in one period.

perigee: The point in an elliptical orbit of a communication satellite at which it is at its minimum distance from the centre of the earth. Opposite of *apogee*.

glossary of radio terms

phase locked loop: A circuit which produces an output voltage of polarity and level proportional to the phase difference between two input signals. The output may be *d.c.* and used to control the frequency of an oscillator (*automatic frequency control*) or it may be *a.c.* at *audio frequency*, when the circuit can be used as a *f.m. demodulator*.

phase modulation: A type of *modulation* where the phase of the *sinewave carrier* is varied in accordance with a modulating signal.

pi-network: This network is made up of three *impedance* branches and derives its name from its likeness to the greek letter π . It is widely used for filtering in *transmitters* etc.

polar diagram: A graph plotted using polar co-ordinates showing the radiation of an *antenna* in any particular plane.

polarisation: A fundamental property of a wave characterised by the direction of the electric field.

power amplifier (p.a.): An amplifier designed to increase the power of a signal applied to its input.

pre-emphasis: A means of increasing the amplitude of some frequencies with respect to others in the same complex wave.

printed circuit board (p.c.b.): An electrical circuit where the wiring connections are actually printed in copper track on the board.

Pro-Electron coding: A European

standard method of coding semiconductors which indicates the material used and the application of the device. (e.g. BC107).

pulse code modulation: The process by which an analogue signal is sampled, quantised and converted by coding into a digital signal.

push to talk (p.t.t.) switch: Also known as a *pressel switch*. A switch that can be used to control the transmit/receive changeover in a *simplex* circuit.

Q

Q code: An internationally agreed code, the purpose of which is to cut down transmission time in *Morse code* communications.

quarter wavelength line: A section of *transmission line* with an electrical length of one quarter of a *wavelength* at the *fundamental frequency* of operation.

quiescent current: The standing current flowing in a circuit without a signal being applied.

R

radiating element: The part of an antenna from which electromagnetic energy radiates.

glossary of radio terms

radiation pattern: The graphical representation using the appropriate co-ordinate system for showing the radiation from an *antenna*.

radio frequency (r.f.): A frequency that can be used for radio communication, usually regarded as being between 15kHz and 3000GHz.

radio frequency interference (r.f.i.): The *interference* with reception of a wanted signal by another signal or by *radio frequency* disturbances such as atmospheric noise.

RAYNET (Radio Amateurs Emergency NETwork): Set up to assist the authorities in providing communications during disaster relief operations.

reactance: This may be inductive or capacitive and is the "imaginary" part of *impedance* which is not due to resistance.

receiver (RX): The part of a communications system in which electric waves or currents are converted into audible signals.

receiver incremental tuning (r.i.t.): A control which allows the receive frequency in a *transceiver* to be varied slightly either side of the transmit frequency to allow "netting" with a distant station. Typical range up to ± 5 kHz.

refraction: The phenomenon whereby the path of an *electromagnetic wave* is bent as it passes from one medium into another in which the velocity of propagation is different.

repeater: For amateur use, a device built to enhance communications between radio stations normally unable to contact each other due to obstructions such as local terrain or low power.

resonance: This condition occurs in a tuned circuit or *antenna* when the capacitive *reactance* balances out the inductive *reactance*. Therefore *resonance* can only occur at a single frequency in a circuit.

rig: See *transceiver*.

root mean square (r.m.s.): Is the square root of the average value of the squares of a recurring variable quantity taken over a complete cycle.

RSGB (Radio Society of Great Britain): It is the national society for radio amateurs in the UK, and it is there to promote amateur radio.

RST code: A code used in *telegraphy* for describing signal reports.

RTTY (RadioTeLeTYpe): A teleprinter system operating over radio circuits, and using *f.s.k.* or *a.f.s.k.*

S

"S" meter: A meter calibrated in "S" points, useful for making comparisons between received signal strengths.

glossary of radio terms

Schottky diode: A semiconductor diode rectifier for *microwave* applications.

second channel interference: See *image interference*.

selectivity: A measure of the ability of a *receiver* to discriminate between a wanted signal on one frequency and unwanted signals on other frequencies.

semi-duplex: A radio circuit in which one station can transmit and receive simultaneously (*duplex*) but the other station cannot (*simplex*).

sensitivity: A measure of the ability of a *receiver* to respond to weak signals.

series tuned circuit: Also known as an acceptor circuit, this circuit has very little *attenuation* at the *resonant frequency* of the circuit.

short wave listener (s.w.l.): A radio enthusiast who listens in on the *short wave* broadcast and amateur bands.

short waves (s.w.): See frequency table.

side-bands: The frequency bands above and below the *carrier* containing the frequencies produced during the process of *modulation*.

sidetone: A tone output from a Morse key or *transmitter* which allows the operator to monitor his own sending.

signal-to-noise ratio: Is the ratio of the magnitude of a signal to that of the noise at the same point in a circuit, usually expressed in *decibels*.

simplex: A term denoting the ability to transmit in either direction over a link

or circuit, but not simultaneously.

SINAD ratio: Is the ratio of the signal-plus-noise-plus-distortion to the noise-plus-distortion at the output of a *receiver*, usually expressed in *decibels*.

sinewave: A wave whose displacement is the sine (or cosine) of an angle proportional to time or distance.

singing: Is unwanted self-oscillation in a transmission system caused by positive *feedback*.

single side-band (s.s.b.): Is a method of operation in which either the *upper side-band* or *lower side-band* of an *amplitude modulated* wave is transmitted. The other unwanted *side-band* is filtered out.

skip distance: For a transmission on a given frequency at a specific time, the smallest distance in a given direction from the *transmitter* at which reception by ionospheric reflection is possible.

skywave: The portion of a radiated wave which travels outward from the earth's surface and may or may not be refracted in the *ionosphere*.

slot antenna: Is a general term for an *antenna* formed by cutting one or more correctly dimensioned slots out of a metal conducting surface.

solar flare: A violent eruption on the surface of the sun, associated with sun spots and giving rise to intense radiation.

space wave: Is a radio wave that travels between a transmitting *antenna* and a receiving *antenna* situated above the earth.

glossary of radio terms

spectrum: A continuous band of frequencies within which waves have some common characteristics. For example the *radio frequency* spectrum.

splitter: Is a device having one inlet and two or more outlets so that signal energy applied to the input is divided between the outlets.

sporadic E: When an area of the *E layer* experiences an unusually high level of ionisation, allowing propagation over unusually long distances at v.h.f.

spurious emission: Is any unwanted *radio frequency* energy emitted by a *transmitter*.

squarewave: Is a periodic wave that alternately assumes one of two fixed values, with the transition time between these two levels being negligible.

squelch: See *muting*.

standing wave: For a *transmission line* is the field pattern created by two waves of the same frequency but propagating in different directions.

standing wave ratio (s.w.r.): The ratio of the magnitude of an *anti-node* compared to a *node* in a *standing wave*.

standard wire gauge (s.w.g.): A common gauge for indicating the diameter of wire.

sudden ionospheric disturbances (s.i.d.): A short-lived abnormal increase of the ionisation in the *D* and *E layers* in the *ionosphere* resulting in a sudden radio fade-out.

superheterodyne receiver: A radio *receiver* where the received signal is frequency changed to an *intermediate frequency*, so that adequate gain and selectivity are more easily obtained.

surface wave: See *ground wave*.

T

telegraphy: A system of telecommunication for the transmission of graphic symbols, usually letters and numbers, by the use of a signal code.

telemetry: A process in which variable quantities are measured at some remote point, the results of the measurements being transmitted by radio to a central point where they are recorded.

telephony: A branch of telecommunications providing for the exchange of information in the form of speech.

television interference (TVI): *Interference* caused to domestic TV reception by a nearby radio *transmitter*.

time division multiplexing: A multiplex system in which a number of digital signals are interleaved in time for transmission over a common channel.

time-out: An enforced action taken automatically at the end of a predetermined period. Used in most amateur *repeaters*.

glossary of radio terms

transceiver: A combined transmitter/receiver, in which some circuits (e.g. *v.f.o.* or side-band filter) are used for both transmission and reception. Often called a "rig".

transient: A term applied to the phenomena, usually damped oscillations, which take place in a system owing to a sudden change of conditions, and which persist for a relatively short time after the change has occurred.

transmission line: See *feeder*.

transmitter: A device which converts audio, video or coded signals into modulated *radio frequency* signals which can be propagated by *electromagnetic waves*.

trap: See *parallel tuned circuit*.

trapped dipole: This consists of an *antenna* whose length is resonant at the lowest frequency band to be used. A *trap* is then inserted at the length corresponding to the next highest frequency; this effectively shortens the *antenna* to the position of the *trap*.

travelling wave tube: An electron tube used to amplify *ultra-high* and *microwave* frequencies.

troposcatter: A *microwave* radio link relying on energy scattered in the *troposphere* to provide communication between a *transmitter* and a *receiver* located beyond the radio horizon.

troposphere: A region of the earth's atmosphere extending from the earth's surface to a height varying from 18km at the equator to 6km at the poles.

tuned circuit: A circuit in *resonance* at a designed frequency.

tuned radio frequency receiver (t.r.f.): An *amplitude modulated receiver* with one or more stages of *radio frequency* amplification preceding the detector.

U

ultra high frequency (u.h.f.): See frequency table.

unipole: An unbalanced *antenna*, consisting of a single radiating element perpendicular to the *earth* or a ground plane, and fed at the *earth* end.

upper side-band (u.s.b.): The *side-band* containing all frequencies above the frequency of the *carrier* which has been *amplitude modulated*.

V

variable crystal oscillator (v.x.o.): A crystal controlled *oscillator* whose output frequency can be varied over a limited range.

variable frequency oscillator (v.f.o.): An *oscillator* whose output frequency can be varied.

glossary of radio terms

very high frequency (v.h.f.): See frequency table.

voice-frequency telegraphy: See *audio frequency shift keying*.

voltage controlled oscillator (v.c.o.): An *oscillator*, the output frequency of which is controlled by an external voltage.

VOX: "Voice-operated transmit", a circuit giving automatic changeover of transmit/receive in a *simplex* circuit. Sometimes called VOC—"Voice-operated carrier".

W

waveband: A band of *wavelengths* defined for some given purpose, for example the medium waveband used for broadcasting.

waveform: The shape of a wave obtained by plotting some characteristic against time.

waveguide: A *transmission line* consisting of a system of boundaries for guiding electromagnetic energy, and generally taking the form of a hollow metallic conductor, either circular or rectangular.

wavelength: The distance between two points of corresponding phase in consecutive cycles.

whip antenna: A simple vertical unipole *antenna* supported on an insulator.

wobbulator: A signal generator whose frequency can be periodically swept across a selected range.

X

X-band: Radar (*microwave*) frequencies from 5.2GHz to 10.9GHz.

Y

Yagi antenna: An end-fire array consisting of a driven dipole element and a number of secondary parasitic elements arranged side by side.

Z

zero-beat: The tuning of two oscillators to identical frequencies, so that the audio frequency beat between them is reduced to a very low frequency, ideally zero. For example, tuning a receiver to an incoming signal so that the b.f.o. is on exactly the same frequency as the received carrier wave.

glossary of radio terms

abbreviations

a.c.	alternating current	n.b.f.m.	narrow band frequency modulation
a.f.	audio frequency	p.c.b.	printed circuit board
a.f.c.	automatic frequency control	p.e.p.	peak envelope power
a.f.s.k.	audio frequency shift keying	p.t.t.	push-to-talk
a.g.c.	automatic gain control	r.f.	radio frequency
a.m.	amplitude modulation	r.f.i.	radio frequency interference
a.t.u.	antenna tuning unit	r.i.t.	receiver incremental tuning
b.f.o.	beat frequency oscillator	r.m.s.	root mean square
CB	citizens' band	RTTY	radio teletype
c.i.o.	carrier insertion oscillator	RX	receiver
c.w.	continuous wave	s.h.f.	super high frequency
dB	decibels	s.i.d.	sudden ionospheric disturbance
d.c.	direct current	s.s.b.	single side-band
DF	direction finder	s.w.	short wave
d.f.	double frequency	s.w.g.	standard wire gauge
d.s.b.	double side-band	s.w.l.	short wave listener
e.h.f.	extremely high frequency	s.w.r.	standing wave ratio
e.h.t.	extra high tension	t.r.f.	tuned radio frequency
e.m.f.	electromotive force	TVI	television interference
e.r.p.	effective radiated power	TX	transmitter
f.e.t.	field effect transistor	u.h.f.	ultra high frequency
f.m.	frequency modulation	u.s.b.	upper side-band
f.s.d.	full-scale deflection	v.c.o.	voltage controlled oscillator
f.s.k.	frequency shift keying	v.f.o.	variable frequency oscillator
g.d.o.	grid dip oscillator	v.h.f.	very high frequency
h.f.	high frequency	v.x.o.	variable crystal oscillator
h.t.	high tension		
Hz	hertz		
i.c.	integrated circuit		
i.f.	intermediate frequency		
l.f.	low frequency		
l.o.	local oscillator		
l.s.b.	lower side-band		
l.t.	low tension		
l.u.f.	lowest usable frequency		
l.w.	long wave		
m.u.f.	maximum usable frequency		
m.w.	medium wave		

**THE RADIO
MAGAZINE**

**read
Practical
wireless
every month**