

● MAKING AN F.M. TUNER ●

PRACTICAL 1/3

APRIL
1957

EDITOR: F.J. CAMM

WIRELESS



For maximum reliability

'LECTROPACK' ETCHED FOIL ELECTROLYTICS

The Constructor depends upon the reliability of the components he uses. The fact that so many designers specify T.C.C. Condensers is evidence of their supremacy.

T.C.C. "Lectropack" Dry Electrolytic Condensers are robust yet compact and employ ALL-ALUMINIUM non-corrosive internal construction. The range below is a useful guide to the types available.

Capacity µF.	D.C. Volts		Ripple Current Max. M/A	Dimensions in inches		T.C.C. Type No.	List Price
	Wkg.	Surge		L	D		
60 - 100	275	325	450	4½	1½	CE 37 HE	16/-
60 - 250	"	"	530	4½	1½	CE 60 HE	28/-
100 - 200	"	"	650	4½	1½	CE 60 HEA	28/-
100	350	400	450	2½	1½	CE 10 LE	13/6
200	"	"	770	4½	1½	CE 36 LE	24/-
60 - 100	"	"	500	4½	1½	CE 36 LEB	23/-
60 - 250	"	"	500	4½	1½	CE 60 LEB	34/-
100 - 100	"	"	550	4½	1½	CE 36 LEA	26/-
100 - 200	"	"	700	4½	1½	CE 60 LEA	33/-
60	450	550	450	3½	1½	CE 38 PE	14/-
60 - 100	"	"	500	4½	1½	CE 60 PE	29/-



List 140c contains the extended range.



THE TELEGRAPH CONDENSER CO. LTD

RADIO DIVISION : NORTH ACTON · LONDON · W3 · Telephone : ACOm 0061

HIGH FIDELITY AT REALISTIC COST!

H.F. 1012. 10" Hi-Fi Unit
£4. 19. 9 ▶

See and hear these
and all other W.B. lines
at our London Office
(109 Kingsway, W.C.2)
any Saturday between
9 a.m. and 12 noon.

H.F. 1214. Full
Range 12" Unit
14,000 gauss
£9. 15. 6

◀ T.816. Special 8" Mid-
Range and High Frequency
Unit. 16,000 gauss
magnet. £6. 10. 0

Tweeter Units
£4. 4. 0 & £12. 12. 0

The New W.B.12
High Fidelity
Amplifier
Price £25

Ready to assemble
Cabinets from
£5. 10. 0
TV and Record Storage
Cabinets
£9. 14. 3 & £10. 4. 9

★
Details of all the outstanding W.B. products on request

WHITELEY ELECTRICAL RADIO CO. LTD · MANSFIELD · NOTTS



Practical Wireless BLUEPRINT SERVICE

PRACTICAL WIRELESS

No. of
Blueprint

CRYSTAL SETS

2/- each	
1937 Crystal Receiver ...	PW71*
The "Junior" Crystal Set	PW94*
2/6 each	
Dual-Wave "Crystal Diode"	PW95*

STRAIGHT SETS

Battery Operated

One-valve : 2/6 each	
The "Pyramid" One-valver (HF Pen) ...	PW93*
The Modern One-valver	PW96*
Two-valve : 2/6 each	
The Signet Two (D & LF)	PW76*

3/6 each	
Modern Two-valve (two band receiver) ...	PW98*

Three-valve : 2/6 each	
Summit Three (HF Pen, D Pen)	PW37*

The "Rapide" Straight 3 (D, 2 LF (RC & Trans))	PW82*
---	-------

F. J. Camm's "Sprite" Three (HF, Pen, D, Tet)	PW87*
--	-------

3/6 each	
The All-dry Three ...	PW97*
Four-valve : 2/6 each	

Fury Four Super (SG, SG, D, Pen)	PW34C*
---	--------

Mains Operated

Two-valve : 2/6 each	
Selectone A.C. Radiogram Two (D, Pow) ...	PW19*

Three-valve : 4/- each	
A.C. Band-Pass 3	PW99*

Four-valve : 2/6 each	
A.C. Fury Four (SG, SG, D, Pen)	PW20*

A.C. Hall-Mark (HF Pen, D, Push Pull) ...	PW45*
---	-------

SUPERHETS

Battery Sets : 2/6 each	
F. J. Camm's 2-valve Superhet	PW52*

Mains Operated : 4/- each	
"Coronet" A.C.4	PW100*
AC/DC "Coronet" Four	PW101*

No. of
Blueprint

SHORT-WAVE SETS

Battery Operated

One-valve : 2/6 each	
Simple S.W. One-valver	PW88*

Two-valve : 2/6 each	
Midget Short-wave Two (D, Pen)	PW38A*

Three-valve : 2/6 each	
Experimenter's Short-wave Three (SG, D, Pow)	PW30A*

The Perfect 3 (D, 2 LF (RC and Trans)) ...	PW63*
--	-------

The Band-spread S.W. Three (HF, Pen, D, (Pen), Pen)	PW68*
--	-------

PORTABLES

2/-	
The "Mini-Four" All-dry (4-valve superhet)	*

MISCELLANEOUS

2/6 each	
S.W. Converter-Adapter (1 valve)	PW48A*

The P.W. 3-speed Auto-gram (2 sheets), 8/-	
---	--

The P.W. Monophonic Electronic Organ (2 sheets), 8/-	
--	--

TELEVISION

The "Argus" (6in. C.R. Tube), 3/-	
The "Super-Visor" (3 sheets), 8/-	
The "Simplex"	3/6*

The P.T. Band III Converter	1/6*
-----------------------------	------

All the following blueprints, as well as the PRACTICAL WIRELESS numbers below 94 are pre-war designs, kept in circulation for those amateurs who wish to utilise old components which they may have in their spares box. The majority of the components for these receivers are no longer stocked by retailers.

AMATEUR WIRELESS AND WIRELESS MAGAZINE

STRAIGHT SETS

Battery Operated

One-valve : 2/6	
B.B.C. Special One-valver	AW387*

Mains Operated

Two-valve : 2/6 each	
Consoelectric Two (D, Pen), A.C.	AW403

SPECIAL NOTE

THESE blueprints are drawn full size. The issues containing descriptions of these sets are now out of print, but an asterisk denotes that constructional details are available, free with the blueprint.

The index letters which precede the Blueprint Number indicate the periodical in which the description appears. Thus P.W. refers to PRACTICAL WIRELESS, A.W. to Amateur Wireless, W.M. to Wireless Magazine.

Send (preferably) a postal order to cover the cost of the Blueprint (stamps over 6d. unacceptable) to PRACTICAL WIRELESS, Blueprint Dept., George Newnes, Ltd., Tower House, Southampton Street, Strand, W.C.2.

No of
Blueprint

SHORT-WAVE SETS

Battery Operated

One-valve : 2/6 each	
S.W. One-valver for American	AW429*

Two-valve : 2/6 each	
Ultra-short Battery Two (SG, det Pen)	WM402*

Four-valve : 3/6 each	
A.W. Short Wave World-beater (HF Pen, D, RC, Trans)	AW436*

Standard Four-valver Short-waver (SG, D, LF, P)	WM383*
--	--------

Mains Operated

Four-valve : 3/6	
Standard Four-valve A.C. Short-waver (SG, D, RC, Trans)	WM391*

MISCELLANEOUS

Enthusiast's Power Amplifier (10 Watts) (3/6)	WM387*
---	--------

Listener's 5-watt A.C. Amplifier (3/6)	WM392*
---	--------

De Luxe Concert A.C. Electrogram (2/6)	WM403*
---	--------

QUERY COUPON

This coupon is available until April 6th, 1957 and must accompany all Queries, sent in accord with the notice on our "Open to Discussion" page. PRACTICAL WIRELESS, April 1957.

MAXI-Q

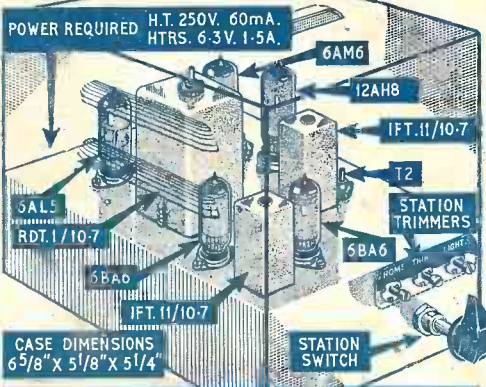

PRE-SET F.M. TUNER

Stop Press: "MAXI-Q" VARIABLE F.M. TUNER UNIT assembled and valved at £9.19.6, inc. P.T. "OSRAM" F.M. TUNER completely assembled and valved at £16.16.0, inc. P.T.
"MAXI-Q" 60 kc/s TAPE DECK OSCILLATOR COILS, TDO.1—For high impedance Erase Heads (Truvox, etc.), 5/-. TDO.2—For low impedance Erase Heads (Brenell and Collaro), 5/-.

V.H.F./F.M. HOME, LIGHT AND THIRD PROGRAMMES INSTANTLY SELECTED AT THE TURN OF A SWITCH

Full constructional details, point-to-point wiring diagrams and alignment instructions for building the "MAXI-Q" PRE-SET F.M. TUNER and also the VARIABLE TUNED version are given in Technical Bulletin DTB.8, 1/6.

Completely punched Chassis, Screens and Bronze finished Cover, 19/- Station Indicator Plate, 1/1. 3 Position Switch, 4/3. Station Condenser Trimmers, 3-9pF, 2/- each.

RATIO DISCRIMINATOR TRANSFORMER, RDT.1/10.7 Mc/s. Secondary winding of bifilar construction, iron dust core tuning, polystyrene former, silver mica condensers. Can size: 1 1/2 in. square x 2 1/2 in. high, 12/6.

I.F. TRANSFORMER, IFT.11/10.7 Mc/s. Miniature I.F. Transformer of nominal frequency 10.7 Mc/s. The "Q" of each winding is 90 and the coupling critical. Can Size: 1 1/2 in. x 1 3/16 in. square, 6/-.

COILS TYPE L1, T1 and T2. Specially designed for use in this unit are wound on polystyrene formers complete with iron dust core tuning, 3/11 each.

THE "MAXI-Q" PRE-SET F.M. TUNER. is available completely wired, assembled, valved and housed in a sturdily made bronze finished cover at £8.11.5, plus £3.8.7 P.T., total £12.0.0.

GENERAL CATALOGUE covering technical information on full range of components, 1/-, post free.

DENCO (CLACTON) LTD., (DEPT. P.W.) 357/9 OLD ROAD, CLACTON - ON - SEA, ESSEX

REPANCO HIGH-GAIN COILS

DUAL-RANGE MINIATURE CRYSTAL SET COIL with circuit. Type DRX1.. 2/6.

DUAL-RANGE COIL with Reaction. With 2 mains, 2. battery and transistor circuits. Type DRR2. 4/-.

MATCHED PAIR DUAL-RANGE T.R.F. COILS with Reaction. With battery, mains and feeder unit circuits. Type DRM3. 8/- pair.

PAIR DUAL-RANGE SUPERHET COILS with mains and battery circuits. Type SH4. 8/- pair.

FERRITE ROD AERIAL. Long and Medium wave. Complete with fixing brackets. Type FRI. 12/6.

MINIATURE I.F. TRANSFORMERS. Pre-aligned 465 kc/s. 13/16 in. x 13/16 in. x 1 1/2 in. For battery or mains receivers. Type MSE. 12/6 pair.

TRANSISTOR COMPONENTS

Dual Range Super Sensitive Ferrite Slab Aerial Type F.S.2. 13/6.

Combined Oscillator and 1st I.F. Transformer (315 Kc.). Medium and preset Long Wave Type O.T.1. 11/6.

2nd I.F. Transformer (315 Kc.) Type T.T.2. 5/-.

3rd I.F. Transformer (315 Kc.) Type T.T.3. 5/-.

Push Pull Interstage Transformer Type T.T.4. 8/6.

Push Pull Output Transformer Type T.T.5. 8/-.

(Trade Supplied.) Post 3d. on all orders.

RADIO EXPERIMENTAL PRODUCTS LTD.
33, Much Park St., Coventry Telephone: 62572

CONSTRUCTORS build these at

DOWN-TO-EARTH PRICES

PERSONAL PORTABLE RADIO 30/-

This little set was designed to give you a real personal portable radio that you can enjoy anywhere without disturbing others. Use it on camping trips, in bed in your office, or just anywhere.

Send 2/- for layout, Wiring diagram and Components Price List.

1 v SHORT-WAVE RADIO

- ★ Covers 10-100 metres.
- ★ World-wide reception
- ★ Low drain valve.
- ★ Picture diagram and instructions for beginners.
- ★ Assembling time 1 hr.

This 1 valve S.W. receiver can be built from our list of components for 30/-, including valve and 1 coil covering 20-40 metres. Provision is made to increase to 2 or 3 valves if required. All components can be purchased separately and are colour-coded so that the beginner can build this set quite easily.

Post and packing: Under 10/- add 9d.; under 40/- add 1/6; over POST FREE.

Send 2/- for specification, wiring diagram, layout and price list to:—

R.C.S. PRODUCTS (RADIO) LTD
11 OLIVER ROAD, LONDON, E.17. Mail order only.

SIMPLE AS A. B. C. — CHEAP TO BUILD RADIOS!

Build This TRANSISTOR POCKET SET

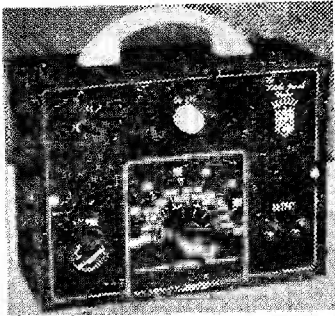

47/6 Build this exceptionally sensitive double triode radio. Uses unique assembly system and can be built by anyone without any radio knowledge whatever in 45 minutes. Handsome black-crackle steel case with specially made black and gold dial with stations printed. Size of radio only 6 1/2 in. x 5 in. x 3 in. Covers all Medium and Long waves—uses only one all-dry battery. H.T. consumption only 1 to 1.5 mA. Uses personal phone. Ideal for Bedroom, Garden, Holiday, etc. Many unsolicited testimonials. Mr. Norton of Oxted writes: *Yesterday evening on the Medium waveband, I counted 32 separate stations. I am very pleased with the set, which is well worth the money.* **BUILD THIS "SKYPOCKET" NOW!** Total building cost—Everything down to last nut and bolt—47/6 (Postage, etc. 2/-) with full set of clear, easy-to-follow plans. (Parts sold separately. Priced Parts Lists, etc., 1/6.)

WE'VE DONE IT AGAIN! In response to a great many requests we have designed this "SKYPIXIE" Vest-Pocket TRANSISTOR RADIO which gives a superb performance. It is powerful and highly sensitive. Size only 4 1/2 in. x 3 1/2 in. x 1 in. weight under 7 ozs. 1—yet it is a TWO-STAGE receiver covering all medium waves, working entirely off a tiny "port-light" battery which costs 6d.—fits inside the case—and lasts many months. Uses personal phone and has push-button LUMINOUS On/Off Switch. Every part tested before despatch! **SPECIAL STEP-BY-STEP PLANS** for ABSOLUTE BEGINNERS. Total building cost including case, transistors, etc.—everything down to the last nut and bolt—ONLY 49/6 with plans. Postage, etc., 2/- C.O.D. 1/6 extra. (Parts sold separately. Priced parts list, etc., 1/6.) As the building cost is absolutely "rock bottom" (it might increase later) **DEMAND WILL BE VERY HEAVY—RUSH YOUR ORDER TO-DAY!**

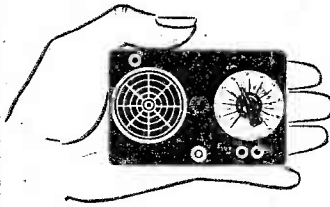

FOR ONLY **49/6**

LOOK!



BUILD THIS POCKET RADIO FOR ONLY 37/6

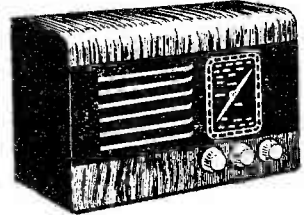

Total building cost including choice of beautiful walnut veneered cabinet or ivory or brown bakelite. This is the lowest possible price consistent with high quality. No radio knowledge whatever needed... can be built by anyone in 2-3 hours, using our very simple easy-to-follow diagrams. The terrific new circuit of the "OCEAN-HOPPER" covers all medium and long waves with optional negative feedback, has razor-edge selectivity, and exceptionally good tone. Price also includes ready drilled and punched chassis, set of simple easy-to-follow plans—in fact, everything! All parts sparkling brand new—no junk! Every single part tested before despatching. Uses standard octal-base valves: 6X7G high-frequency pentode feeding into 6J5G anode-bend detector triode, coupled to 6V6G powerful output beam-power tetrode, fed by robust rectifier. For A.C. Mains, 200-250 Volts (low running costs—approximately 18 Watts!). Size 12 in. x 6 in. x 5 in. Build this long range powerful midset NOW. All parts and set of plans, £5.7.6. (Post and packing 3/-) Parts sold separately. Priced Parts List, 1/6.

107/6

BUILD THIS A.C. MAINS 'FRYING-PAN' SET FOR ONLY 77/6

BUILD YOUR MOTHER OR WIFE this frying-pan radio! Highly sensitive circuit covering all Medium and Long Waves. Has normal size speaker and gives excellent tone due to wall "baffle" effect. Ideal for the kitchen, bedroom, etc. Robust design. For A.C. mains 200-250 volts. **TOTAL BUILDING COST** including mirror-finish frying-pan, double-triode valves, step-by-step beginner's plans, nuts, bolts, etc., ONLY 77/6. Postage, etc. 2/6. C.O.D. 1/6 extra. (Parts sold separately. Priced parts list, etc., 1/6.) **SEND NOW!**



AT LAST! In response to many requests we now present the **DOUBLE TRIODE "SKYPOCKET"**, a beautifully designed precision **POCKET RADIO**. No radio knowledge needed. **EVERY SINGLE PART TESTED BEFORE DESPATCH!** our simple, pictorial plans take you step-by-step. This set has a remarkable sensitivity due to painstaking design. Covers all medium waves 200 to 550 Metres. Size only 5 1/2 in. x 3 in. x 2 in. In Strong, Transparent case with panel, cover and ivory dial. A really personal phone, pocket-radio WITH **DETACHABLE ROD AERIAL**. Self-contained all-dry battery operation. Average building time 1 hour. Total Building Cost—including Case, Double Triode Valves, etc., in fact, everything down to the last nut and bolt—ONLY 37/6, with plans, Postage, etc., 2/- C.O.D. 1/6 extra. (Parts sold separately. Priced Parts List, etc., 1/6.) Demand is certain to be heavy—**SO SEND TODAY!**

COMPONENT BARGAINS!

- LOUDSPEAKERS**—Permanent Magnet, new 5 in., only 19/6! New 2 in., only 13/6.
 - RECORD CHANGER UNITS**—3 speed, autochange ONLY £7.19.6
 - METAL RECTIFIERS**—Contact-cooled, 250 volts, 50 mA. midset, only 7/3.
 - CABINET'S**—Beautiful walnut veneer, normal, midset type with drilled and punched chassis, dial backplate, drum, pointer screws, etc. ONLY 23/6.
 - HEADPHONES**—Brand new high-resistance boxed (not surplus). Bargain at 14/6.
 - COILS**—Pair of matched T.R.F. coils medium and long waves with reaction. Only 8/-.
 - FIAMENT TRANSFORMERS**—200-250 volts in 6.3 a. 4 amp. out. 6/-.
 - OUTPUT TRANSFORMERS**—Midset type new, matching 10 3 ohms, 5/8.
 - MIDGET COILS**—Medium and long waves with reaction and iron-dust core, bargain, 4/-.
 - TRANSISTOR AND CRYSTAL DIODE COILS**—Triple wound, give exceptional selectivity and high "Q". Only 4/-.
 - CRYSTAL DIODES**—Wire-end, very sensitive, similar to OAT0. Only 4/6.
 - TRANSISTORS**—Junction type, very sensitive, each one tested before despatch. Only the best at 12/6.
- POST AND PACKING** please add 1/6 up to 10/-; 2/- up to £1; 2/6 up to £2. All enquiries enclose S.A.E. (C.O.D. 1/6 Extra.)



CONCORD ELECTRONICS
69, PRESTON STREET BRIGHTON

Dept. PWH

Orders receive prompt attention. Cheques accepted. Cash on delivery 1/6 extra. Suppliers to Schools, Universities, Government and Research Establishments. Complete range of components and valves stocked. CALLERS WELCOME. Shop Hours: 9 a.m. to 6 p.m. (1 p.m. Thursday). Repel no C.O.D. abroad.

ALL MAINS AMPLIFIER

19/6

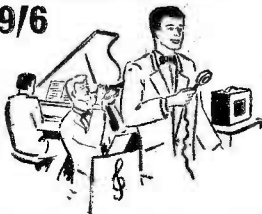

Construct a powerful three-valve mains amplifier. Ideal for dances, parties, etc. Complete less chassis, cabinet and speaker (available if required). Data 16 (free with parts).

"CHIMELITE"



It is a hall light as well as a double chime and you can make it in a couple of evenings for the total cost of only 19/6 including instructions, post, etc. 2/- data available separately price 2.-

MINIATURE COMPONENTS for transistor sets, deaf aids, etc. Made by Fortphone and other famous firms.

Intervalve transformer, N22 ...	10.-
Intervalve transformer, N23 ...	10.-
Push pull input transformer, A203 ...	15/6
Push pull output transformer, A204 ...	15/6
Earphone type 'L' 250 ohm ...	18.-
Plastic cartip ...	2/9
Tinsel flex and plug for earphone	5/-
Slide switch ref. SW5 ...	4.-
Pots with switch 1 meg. ...	2.-
Very small resistors, many values ...	6d.
Very small condensers, prices from	6d.
Tinsel leads without plugs ...	6d.
Deaf aid cases with clip for pocket ...	2/6
Plastic box with lid 4 1/2 x 3 x 1 1/2 in.	2/6

YOURS FOR 30/- DOWN



MULLARD AMPLIFIER "510"

A Quality Amplifier designed by Mullard. Power output exceeds 10 watts. Frequency response almost flat from 10 to 20,000 C.P.S. For use with the Acos "Hi G" and other good pick-ups. Made up and ready to work is £12/10/- or £11/10/- down and 8 payments of £1/10/-, plus 10/- carriage and insurance.

TRANSFORMERS SNIP

Standard tapped mains input. Output 5 v. at 2 amp. and 350-0-350 at 30 milliamps. Equipment but guaranteed perfect. 3/6 plus 2/6 post & packing.

Note this transformer is a half shrouded drop-through type not stand up as illustrated.

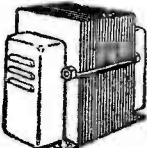

THE UNI-T.V.

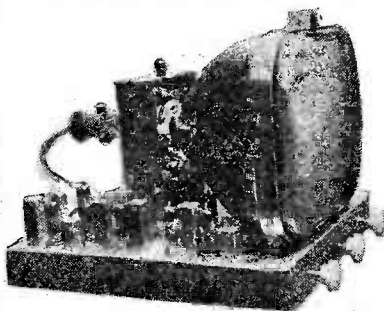

Undoubtedly the most up-to-date television for the home constructor. You can build all or only part and the set when finished will be equal to a factory-made equivalent. What other constructor T.V. has all these features?

- ★ Made up units if required.
- ★ All miniature valves.
- ★ Metal rectifier.
- ★ No expensive transformers.
- ★ 13-channel circuitry.
- ★ Multi-vibrator time bases.
- ★ Ferrucube, E.H.T. and scan coils.
- ★ 3438 Mejs I.F.
- ★ Suitable for any modern 12, 14 or 17in. tube.
- ★ Modern contemporary cabinet if required.

The building cost (less tube) is only £31 10/0. plus 10/- carriage and insurance. All parts guaranteed 12 months. Full information and data, price 3/6.

POCKET TRANSISTOR RECEIVER

Fits into the pocket. Size only 4 1/2 x 3 x 1 1/2 in. Weight only 10 ozs. Works anywhere. Uses deaf aid or ordinary earpiece. Ferrite rod aerial. No external aerial required. Uses 2 transistor. Self-contained batteries. 1/- battery, lasts months. All parts including data but not battery, case or earpiece, £2/17/6. Case now available, price 2/6.



THIS MONTH'S SNIP

Powerful electric motor, size 3in. long by 2 1/2in. diameter with speed variator suitable for operation off standard A.C. mains. Ideal for driving fan, model, car heater, dryer, etc., etc. Don't miss this snip, 12/6. plus 2/- post & ins.

THE OCTAVIAN HIGH FIDELITY AMPLIFIER

3 valve 4 watt with frequency response better than 40-15,000 C.P.S. Control panel size 8 x 2 1/2 in. comes fixed to chassis but is intended for independent mounting. Separate base and treble controls giving fullest variation of cut and lift. Separate switch, absolutely no mains hum. Remarkable value at 7 gns. or £1 deposit, plus 6/6 post & packing. Midget ceramic condensers tubular wire ended, 2,000 pf., 5/- per doz.; 500 pf., 4/6 per doz.; 1,000 pf., lead through ceramics, 8/- per doz. All post free. Special quote for 1,000 lots.



THE SKYSEARCHER

An all mains set for 19/6

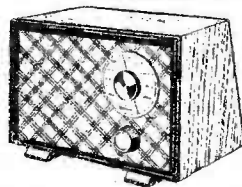

This is a 2-valve plus-metal rectifier set useful as an educational set for beginners, also makes a fine second set for the bedroom, workshon, etc. All parts, less cabinet, chassis and speaker, 19/6. Post & ins. 2/6. Data free with parts or available separately 1/6. 3-valve battery version also available at the same price.

"SNIPSCOPE"

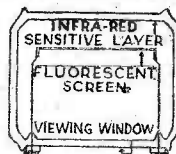

"Cat's eye" used for seeing in the dark. Will work burglar alarms, counting circuits, smoke detectors and the hundred and one other devices as will the simpler type of photo cell. Price 5/- each. Post and ins. 1/- Data will be supplied with cells if requested.

MAINS-MINI

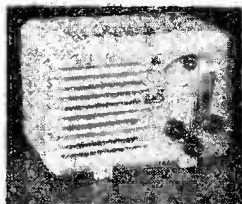

Uses high-efficiency coils, covers long and medium wavebands and fits into the neat white or brown bakelite cabinet—limited quantity only. All the parts, including cabinet, valves, in fact, everything, £4/10/0. plus 3/6 post. Constructional data free with the parts, or available separately 1/6.

FM. TUNER.

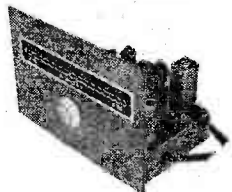

This is a high fidelity unit which although moderately priced has a performance equal to the highest priced. Its stability is very good and extremely good results have been received with the simplest of aerials as far away as Eastbourne. The unit is made up ready to work and has its own power supply for A.C. mains. Demonstration at all our branches. Price 12 gns. Post, plus insurance 5/-.

HIGH VOLTAGE TESTER

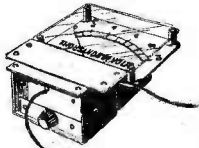

An instrument that will measure voltages up to 10,000 but which draws no current from the source, will probably be a valuable addition to your workshop equipment. It can be made entirely from odds and ends. Booklet giving full instructions, plans, etc., 2/6 post free.

HIGH SPEED RELAY

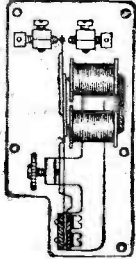

This is a miniature type relay with changeover platinum contacts. Bobbins are 250 ohms each.

Brand new—limited quantity—7/8 each, post 1/6.

MINIATURE MOTOR

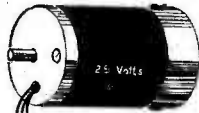

Size only 2 1/2 ins. long by 1 1/2 ins. diameter—American made—laminated poles and armature—intended for 20 volt D.C. but O.K. on lower D.C. voltages and A.C. mains, through step-down transformer—price 10/6, post, etc., 2/-.

CHASSIS ASSEMBLY



Three-colour 3-waveband scale covering standard Long, Medium, and Short wavebands, scale pan, chassis punched for standard 5-valve superhet, pulley driving head, springs, etc., to suit. Scale size 1 1/2 x 3 1/2 in. Chassis size 1 5/8 x 2 1/2 in. deep. Price 15/- plus 1/6 post. Note—This is the one that fits our 476 table cabinet.



CONNECTING WIRE

P.V.C. covered in 100ft. coils—2/9 a coil or four coils different colours, 16/- post free.

The "CRISPIAN" Portable Radio



or 35/- down and 7 payments of 3/6, ready-built chassis 30/- extra. Instruction booklet free with parts or available separately, price 1/6.

T.V. Commercialising Outfit

Do it yourself—it's really quite easy. You will manage it in an evening and we guarantee

SUCCESSFUL RESULTS OR MONEY BACK

Our parcel contains:—*I.T.A. Aerial, 36ft. I.T.A. Down Lead. I.T.A. Converter, I.T.A.—BBC Interference Eliminator.*

A special bargain price for all the above items if bought together is £8/10/- (Post and Insurance 4/6). Or £1/10/- down and 8 payments of 1/6. Instructions free with parts or available separately.

14" T.V. CABINET

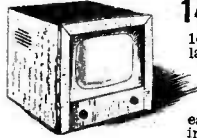

14in. T.V. cabinet of the latest styling made for one of our most famous firms—beautifully veneered and polished—limited quantity—19/6 each. Carriage and packing 3/6 extra.

RECORD PLAYER £4/10/0

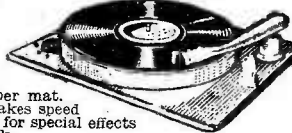

3-speed Gramophone Motor Latest rim drive 3-speed motor with metal turntable and rubber mat. Small mod. makes speed easily variable for special effects and dance work.

Hi-Fi Pick-up Using famous Cosmocord Hi-G turn-over crystal. Separate sapphire for each speed. Neat bakelite case with pressure adjustment. **Special Snip Offer This Month** The two units for £4/10/-, plus 5/- post and insurance, or made up on board as illustrated £5/10/-, plus 5/- post.

5-VALVE SUPERHET

Yours for only £1 down

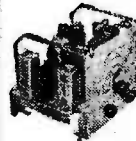

Chassis size approx. 9 1/2" x 7 1/2" x 8 1/2". First-class components. A.C. mains operation. Three waves (medium and two shorts). Complete with five valves, ready to work. New and unused. Cash price £5.19.6 or £1 down and 6 payments of £1 (carr. and ins. 7/7).

A 4-valve truly portable battery set with very many good features as follows: Ferrite rod aerials, low consumption valves, superhet circuit with A.V.C. ready-built and aligned chassis if required, beautiful two tone cabinet covered with I.C.I. rexine and Tygan. Guaranteed results on long and medium waves anywhere. All parts, including speaker and cabinet are available separately or if all ordered together the price is £7/15/- complete, plus 1/6 post and insurance.



THE CLEVELAND ORGANTONE

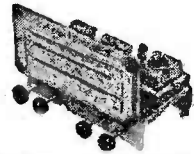

5 valve 3 waveband superhet covering Long, Medium and Short waves. Ostram miniature valves—low loss iron coils—permeability—tuned I.F.S.—full A.V.C.—variable negative feedback—gram. position—4 watts output—particularly fine tone. Chassis size 7 1/2" x 7 1/2" x 7 1/2" approx. Tested in difficult areas, where exceptional results have been obtained. Price £11/10/0 or £2/0/0 deposit, plus 7 payments of £1/10/0. Carriage and ins. 20/-.

COMPONENT BARGAINS

1 mfd. 350-volt metal cased condensers by Dублитер—small size 3/6 doz, or 36/- gross.

Philips Trimmers 0-30 pf. 1/- each or 11/- doz.

Moulded Mica Condensers, well mixed assortment 3/- doz. 30/- gross. Silver Mica, well mixed assortment, 3/- doz., 30/- gross.

50 mfd. 50 v. Bias Condensers T.C.C. 1/8 each, 15/- per doz.

Ceramic Trimmers, 5 to 30 pf., 6d. each, 5/- doz. 20 to 60 pf. 9d. each, 8/- doz. 20 to 100 pf. 1/3 each, 12/- doz.

Earpiece-microphone. American midget type 3/6 each, 36/- doz.



TRANSISTORS

Red spot replacements Mullard OC71 etc. 10/- Blue spot suitable R.F. up to 1.6 Mc/s, 15/- each. Mullard OC71 20/- Mullard OC72 30/-



W.D. CIRCUIT DETAILS

Diagrams and other information extracted from official manuals. All 1/6 per copy, 12 for 15/-.

American Service	
Sheets	R.109
A.1134	78 receiver
BC.348	76 receiver
BC.312	R2B/ARC5
R.100A	R1116A
BC.342	RA-1B
EA-1B	AR83D
R-293	AWAFA-1
R-1155	78
R-1121A	76
R-1132A, R-1481	R.T.18
R-1147	CAY-46-AAM-
R-1224A	RADAR
R-1082	A.B.-3
R-1355	Indicator 62A
B.C.1206-A/B	Indicator A.S.B.3
B-455-A (or-B)	Indicator 62
B-154-A (or-B)	Indicator 6K
B-453-A (or-B)	R.F. unit 24
Transmitter T1154	R.F. unit 26
Fifty-eight walkie talkie	R.F. unit 25
Frequency meter	R.F. unit 27
B.C.221	Wireless set No. 19
	Demobbed valves

ELECTRONIC PRECISION EQUIPMENT, LTD.

Post orders should be addressed to E.P.E., LTD., Dept. 7, Sutton Road, Eastbourne.

Personal shoppers to one of these addresses please.

266, London Road, Croydon. Phone: CRO. 6558 Half day, Wednesday.

42-46, Windmill Hill, Ruislip, Middx. Phone: RUISLIP 5780 Half day, Wednesday.

152-3, Fleet Street, E.C.4. Phone: FLEET 2933 Half day, Saturday.

29 Strand/Green Rd., Finsbury Park, N.4. Phone: ARCHWAY 1049 Half day, Thursday.

249, Kiburn High Road, Kiburn. Phone: MAIDA VALE 4921.



FOR VALVES GUARANTEED ALL TESTED BEFORE DISPATCH

Table listing various electronic components such as valves (6X4, 6X50, 6X50GT, etc.), resistors, capacitors, and other parts with their respective prices.

Table titled 'PUBLICATIONS ETC.' listing various technical books and manuals with their prices, including 'No. 134. F.M. Tuner Construction', 'No. 138. How to make aerials', etc.

MAINS TRANSFORMERS 3-way Mounting Type

Table listing transformer models (MT1, MT2, MT3) with their primary and secondary voltage specifications and prices.

OSMOR COIL PACKS. Type HO, 52/6, Type M.T.S. 52/6. H.F. stages for above, 21- each. Circuits, etc., supplied with each unit.

JACKSON BROS. TYPE U101/55 CONDENSERS. Split stators available, 3/10 pF, 3.8-27 pF, 4-35 pF, 4-45 pF, 10.9 each.

TSI LORENZ L.H. 65 Treble Speakers 39/6 each.

ELSTONE MAINS TRANSFORMERS. All to full Specification. MT/3M for Mullard 3 watt Amplifier, 35/-.

MT/MU for Mullard 5/10 Amplifier, with FM tuner and Pre. Amp., 42/6. MT/912 for GEC Amplifier 912 P1P, 40/6.

MT/912 AFM for GEC F.M. or A.M. Tuner units, 29/6.

ELSTONE OUTPUT TRANSFORMERS. OT/3 for Mullard 3 watt Amplifier, 21/-.

OT/6 for Mullard 5/10 Amplifier low loading, 45/- each. OT/8 for Mullard 5/10 Amplifier normal loading 45/- each.

OT/912 for GEC 912 P1P Tuner Unit, 45/- each.

M/FM for 1SL F.M. Tuner Unit, 29/6 each.

MAINS TRANSFORMER TEG. 200/230 volts. Secondary 250 v., 40 M/A, 6.3 v., 1.5 a., 15/- each.

3 WATT AMPLIFIER.—A.C. Mains —Neg. Feed Back, Tone and Vol. Controls. Fully wired and ready for use, 82/6 each.

TYANA SOLDERING IRON.—A.C. Heats up in 3 mins. 200/220 volts or 230/250 volts, 16/9 each.

PICCO ALL IN ONE RADIO METER A.C. or D.C. I.T. and H.T. Tests —M/A Tests. Many uses, 32/6 each.

GYMOCORD MICROPHONES.—Type MIC38—1, 50/- each. Type MIC35—1, 35/- each.

SOLOX SOLDERING IRONS, 65 watts. Oval Bts. All Voltages, 25/-, 35/- watts, Penn Bts. All Voltages, 30/8. All spares for these irons available from stock, 25 watts instrument from 24/- each.

JUST RECEIVED The new "At a glance" valve equivalent book. Over 3,000 valves listed, 5/- each. Post 3/-.

RECTIFIERS RM4, 16/6. RM1 4/6. RM2 5/6. RM3 7/6.

RESISTORS ASSORTED 1, 2 and 1 watt 12¢ per 100, brand new. Portable case 8 1/2 in. x 4 1/2 in. complete with chassis dial, etc., 35/- each, post 2/6. As above size 1 1/2 in. x 4 1/2 in., 25/- each, post 2/6. 2 gang condensers miniature, 7/6. I.F. Transformers 9/- pair.

METAL RECTIFIERS New stock full wave 12 volt 1 amp. 5/6; 12 volt 2 amp. 8/6; 12 volt 4 amp. 15/6.

WESTINGHOUSE RECTIFIERS 6BR. 1-1-16-1..... 8 - 1SR.A. 1-1-16-1..... 10 6 1SR.A. 1-1-8-1..... 4 6 1LR.A. 1-2-8-3..... 25 - 14A.86..... 19 6 14A.97..... 29 6 14A.124..... 27 6 14B.130..... 31 6 LM7..... 23 9 WX6..... 3 6

LOUD SPEAKERS All PM Types less Transformers

Table listing various speaker models (WATERHOUSE 5 1/2 in. Unit, PLESSEY 6 1/2 in. Unit, etc.) and their prices.

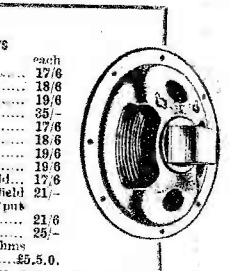

5/6 VINCER CHAMBERS VICTORIA SQUARE LEEDS I.

TERMS: Cash with order or C.O.D. Postage and Packing charges extra, as follows: Orders value 10/- add 1/-; 20/- add 1/6; 40/- add 2/-; £5 add 3/- unless otherwise stated. Minimum C.O.D. fee and postage 3/-. All single valves postage 6d. MAIL ORDER ONLY

HOME CONSTRUCTORS SAY

!! IT'S THE BEST !!

THE "SUPEREX 55" BATTERY PORTABLE RECEIVER

A first-class receiver guaranteed to give good reception throughout the country. Equal in appearance and performance to most commercial models. Cabinet size : 10 3/4" x 8 3/4" x 4 3/4". All parts available separately.

Building Cost, £7. 15. 0.

Plus 4/- Carriage.

Send 1/6 for SUPEREX CONSTRUCTION Booklet.



- FOUR VALVE SUPERHET
- LONG AND MEDIUM WAVE
- LARGE ELLIPTICAL SPEAKER
- B7G MINIATURE VALVES
- SIMPLE CONSTRUCTION



S.R. 3-4 WATT AMPLIFIER

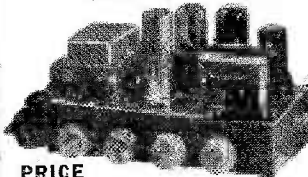

PRICE

£5. 15. 0 Plus 3/6 postage and packing. (90 days valves).

High quality three valve three watt amplifier for A.C. Mains 200/250 volts. Four controls give a wide tone variation. 3 ohm speaker output. Chassis fully isolated. Valve line-up : 6SG7, 6V6, 6X5. Bronze finished chassis size 8in. x 4in. x 5in. high. Supplied built and tested, and guaranteed for twelve months

TERMS
C.W.O.
OR
C.O.D.
U.K.
ONLY.

THE SUPERIOR BUREAU

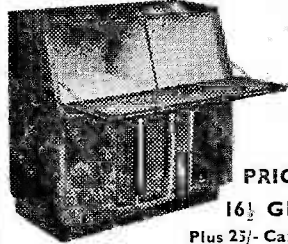

PRICE

16 1/2 GNS.

Plus 25/- Carriage

Very elegant in highly figured walnut veneer with internal panels in sycamore. Sloping radio panel size 16" long x 10 3/4" high. Uncut motor board size 15 1/2" long x 13 1/2" back to front. Lid panelled in beige leatherette. Two large storage cupboards. Speaker chamber large enough for 12" speaker. Overall cabinet size 35" high, 34" long, 16 1/2" deep.

Superior Radio supplies
37 HILLSIDE, (HARROW ROAD)
STONEBRIDGE, NW10. Elgar 3644

Wanted QUALIFIED MEN & WOMEN

PERSONAL & INDIVIDUAL TRAINING IN—

Industry and Commerce offer their best posts to those with qualifications—appointments which bring personal satisfaction, good money, status and security. As part of a modern industrial organisation, we have skilled knowledge of what is required and the best means of training personnel for present day and future requirements. We specialise also in teaching for hobbies, new interests or part-time occupations in any of the subjects listed here. Write to us to-day for further information. There is no obligation of any kind.

- | | | | | |
|---|--|------------------------|----------------------|---------------------|
| Accountancy | Civil Service | High Speed Oil Engines | Photography | Salesmanship |
| Advertising | Commercial Subjects | Industrial Admin. | P.M.G. Certs. | Secretarship |
| Aeronautical Eng. | Customs Officer | Jig & Tool Design | Police | Shorthand & Typing |
| A.R.B. Licenc'es | Draughtsmanship | Journalism | Production Eng. | Short Story Writing |
| Art | Economics | Languages | Prod. Planning | Short Wave Radio |
| Automobile Eng. | Electrical Eng. | Management | Radio Engineering | Sound Recording |
| Banking | Electrical Installations | Maintenance Eng. | Radar | Telecommunications |
| Book-keeping | Electronics | Mathematics | Radio Amateurs | Television |
| Building | Electronic | M.C.A. Licences | (C & G) Licence | Time & Motion Study |
| Business | Draughtsmanship | Mechanical Eng. | Radio & Television | Tracing |
| Management | Eng. Drawing | Metallurgy | Serviceing | Welding |
| Carpentry | Export | Motor Eng. | Refrigeration | Workshop Practice |
| Chemistry | Heat & Vent. Eng. | Painting | Sales Management | Works M'gement |
| City & Guilds Exams | GENERAL CERTIFICATE OF EDUCATION A.M.I.H., & V.E., A.M.S.E., A.M.Brit. | Dec'ting | Sanitary Eng'neering | |
| I.R.E., A.M.I.Mech.E., A.M.I.E.D., A.M.I.M.I., A.F.R.Ae.S., A.M.I.P.E., A.M.I.I.A., A.C.C.A., A.C.I.S., A.C.C.S., A.C.W.A., City & Guilds Examinations, R.T.E.B. Serv. Cert., R.S.A. Cert. etc. | | | | |

NEW! COURSES WITH PRACTICAL EQUIPMENT
in RADIO · TELEVISION · MECHANICS · CHEMISTRY
ELECTRICITY · DRAUGHTSMANSHIP · PHOTOGRAPHY ETC.

COURSES FROM 15/- PER MONTH

POST THIS TODAY

B E.M.I. INSTITUTES, Dept. 32K, London, W.4.

L O NAME

C K ADDRESS

C I am interested in the following subjects with/without equipment

A P

S (APR/57)

(We shall not worry you with callers)

1C92



FREE

The only Home Study College operated by a world-wide manufacturing organisation

EMI INSTITUTES

Associated with "H.M.V.", Marconiophone, etc., etc

COMPLETE KITS of PARTS for the "HI-FI" ENTHUSIAST

The MULLARD "5-10" MAIN AMPLIFIER

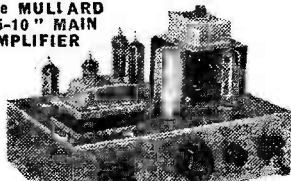

This is the very latest design and needs no recommendation from us. Our Kit is complete to Mullard's specification, including the latest GILSON ULTRA-LINEAR OUTPUT TRANSFORMER and the entire MULLARD Valve line up. ALL SPECIFIED COMPONENTS are supplied. **PRICE OF COMPLETE KIT OF PARTS £11.11.0** (Plus 5/- carr. & ins.)

STERN'S "fidelity" PRE-AMPLIFIER-TONE CONTROL UNIT
"A design for the music lover"



Briefly it has inputs for all types of MICROPHONES, HIGH and LOW GAIN PICK UPS and a RADIO TUNING UNIT. It incorporates (a) GRAM EQUALISING CONTROL. (b) STEEPCUT FILTER. (c) Continuously variable BASS and TREBLE CONTROLS and a variable OUTPUT CONTROL which enables its use with any type of Amplifier. **PRICE OF COMPLETE KIT £6.6.0** (Plus 5/- carr. & ins.). WE ALSO OFFER IT ASSEMBLED, READY FOR USE, £8.0.0.

STERN'S "HIGH QUALITY" 8-10 WATT AMPLIFIER

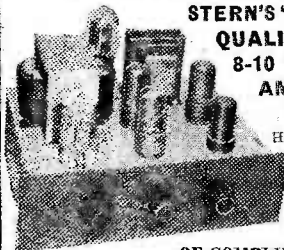

Has power supply for Radio Tuning Unit.

PRICE OF COMPLETE KIT OF PARTS (Plus 5/- carr. & ins.) **£7.10.0**
SUPPLIED ASSEMBLED AND READY FOR USE £9.10.0

Proved one of the most popular models yet offered to the HOME CONSTRUCTOR. Provides excellent reproduction up to 8 watts, employing 6V6's in push-pull, incorporating negative feedback. Provides for use of both 8 and 15 ohm speakers.

THE full SPECIFICATION and PRACTICAL BUILDING INSTRUCTIONS for these Units are available for 1/6 each. **SPECIAL PRICE REDUCTION.** We supply the two complete Kits—Mullard 5-10 and "fidelity" Pre-amplifier—for £16.18.0. We also supply both fully assembled and ready for use for £19.19.0.

MODERNIZE YOUR OLD RADIOGRAM

- ★ THE LATEST A.M./F.M. RADIOGRAM CHASSIS.
- ★ A NEW 4-SPEED AUTOCHANGER.

The NEW ARMSTRONG PB. 409 A.M./F.M. Radiogram Chassis

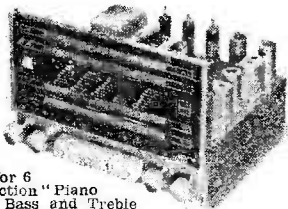

"A chassis for those who want the highest quality." ● A 9 valve line up employing the latest MULLARD preferred-type valves. ● Provides complete coverage of the V.H.F./F.M. Transmissions plus the Short, Medium and Long Wavebands. ● Has Push-Pull Output with Negative Feedback, for 6 watts peak output. ● Quick Action "Piano Key" Selectors and separate Bass and Treble Controls. ● Has "Magic Eye" Tuning Indicator. ● Dimensions 13in. x 9 1/2in. x 8in. high. Dial size 1 1/2in. x 5 1/2in. **PRICE £29.8.0.** TERMS: Credit £7.7.0 and 9 monthly payments of £2.14.0 (Plus 6/- carr. & ins.). H.P. £17.14.0 and 12 monthly payments of £1.7.3. SEND S.A.E. FOR ILLUSTRATED LEAFLET.

STERN'S NEW "Fidelity" COMBINED AM FM

Radiogram Chassis. A specially hand-made chassis providing really high quality on both Radio and Gram.

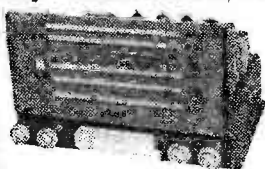

PRICE £26.15.0 (Plus 7/6 carr. & ins.). TERMS: Credit Deposit £6.14.0 and 9 monthly payments of £2.9.0. H.P. Deposit £18.7.6, and 12 monthly payments of £1.4.10. BRIEFLY IT HAS:— An 8 valve line up incorporating the latest MULLARD preferred-type valves. ● Provides complete coverage of the V.H.F. FM waveband plus the SHORT, MEDIUM and LONG waves. ● Has EL84's in Push-Pull with negative feedback of 6 watts output. ● Employs "Piano Key" Selector Switches and a Variable Tone Control. ● Contains Gram input socket for both Crystal and Magnetic Pick-ups. ● Provides for use of either 3 or 15 ohm Speakers. ● Has "Magic Eye" Tuning Indicator. ● Dimensions 13in. x 9 1/2in. x 8in. high. Dial size 1 1/2in. x 5 1/2in. SEND S.A.E. FOR ILLUSTRATED LEAFLET.

RECORD PLAYERS THE VERY LATEST MODELS GREATLY REDUCED PRICES

- TRANSCRIPTION UNITS. ARE OFFERED AT
- 3 and 4 SPEED AUTOCHANGERS. ● AUTOCHANGERS with MANUAL CONTROL POSITION. Send S.A.E. for ILLUSTRATED and DESCRIPTIVE LEAFLET.

STERN'S "F.M." TUNING UNIT

A 5-valve Tuner incorporating the latest Mullard Permeability Tuning Heart and a "Magic Eye" Tuning Indicator.

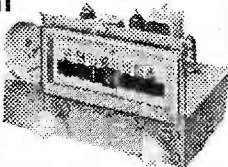

PRICE ASSEMBLED £14.10.0. (Plus 7/6 carriage and insurance). TERMS: (a) Hire Purchase: Deposit £7.5.0 and 9 monthly payments of 18/4. (b) Credit: Deposit £3.12.6 and 9 monthly payments of £1.0.7. THE COMBINED AM/FM TUNER is precisely similar in appearance to the above and incorporates 7 valves. It provides complete coverage of F.M. Transmissions and MEDIUM WAVEBAND giving a good selection of foreign stations. **PRICE £18.18.0** (Plus 7/6 carr. & ins.). TERMS: (a) Hire Purchase: Deposit £9.9.0 and 10 monthly payments of £1.1.0. (b) Credit: Deposit £4.15.0 and 9 monthly payments of £1.14.7.

AN EXCEPTIONAL "CASH ONLY" OFFER £8.15.0.

THE NEW 4-SPEED B.S.R. MONARCH

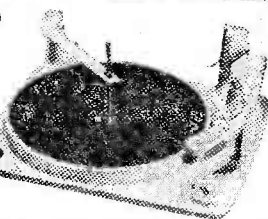

● Complete with High Fidelity Crystal "Turn-over" head which incorporates separate stylus for L.P. and 78 r.p.m. records. ● A MIXER Unit that will autochange on 7in., 10in. and 12in. records of same speed. ● Incorporates the Manual Control position.

Expressly developed for very high quality reproduction of Gram. Records and particularly suitable for high quality reproductions of the F.M. transmissions. Two models are available:

- (a) The "COMPACT 5-2" A Two-stage high sensitivity Amplifier having SEPARATE BASS AND TREBLE CONTROLS and designed to give up to approx. 5 watts with very pleasing quality. **PRICE £6.6.0.** (Plus 5/- carr. & ins.)
- (b) The "COMPACT 5-3" A Three-stage version of the "5-2" model but in this case having an additional stage and incorporating Negative Feedback. **PRICE £8.16.0.** (Plus 5/- carr. & ins.)

A separate POWER SUPPLY UNIT to operate with these amplifiers is available for £2.10.0. Has additional supply available for Radio Tuner, etc.

STERN'S "COMPACT 5" AMPLIFIERS

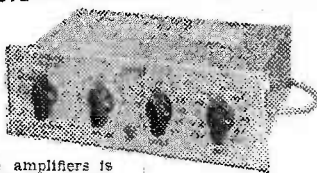

GALLERS ONLY

We have in stock various designs for HOME CONSTRUCTORS including F.M. Tuners, A.M./F.M. Tuners, Midget Battery Portable, Mains Units, etc., etc.

STERN RADIO LTD. 109 & 115 FLEET STREET, LONDON, E.C.4.

Telephone: FLEet 9812/3/4

R.S.C. BATTERY CHARGING EQUIPMENT

All for A.C. Mains 200-250 v., 50 c/c.s. Guaranteed 12 months.

ASSEMBLED CHARGERS

- 6 v. 1 amp. 19/9
 - 6 v. or 12 v. 1 amp. 25/9
 - 6 v. 2 amps. 29/9
 - 6 v. or 12 v. 2 amps. 38/9
 - 6 v. or 12 v. 4 amps. 56/9
- Above ready for use. Carr. 3/6
With mains and output leads.

HEAVY DUTY KIT

12 v. 30 amp. Suitable for Garage or firm with a number of vehicles. Mains input 200-250 v., 50 c/s. Outputs 12 v. 15 amp. twice. Consists of Mains Trans. 2 Metal Rectifiers, 2 Meters, 4 Fuses, 4 Terminals, 2 Rheostats and circuit. Only 9 gns., carr. 15/-

BATTERY CHARGER KITS

- Consisting of Mains Transformer, P.W. Bridge, Metal Rectifier, well ventilated steel case, Fuses, Fuse holders, Grommets, panels and circuit. Carr. 2/9 extra.
- 6 v. or 12 v. 1 amp. 22/9
 - 6 v. 2 amps. 25/9
 - 6 v. or 12 v. 2 amps. 31/6
 - 6 v. or 12 v. 4 amps. 49/9

BATTERY CHARGER KIT

Consisting of P.W. Bridge Rectifier 6.12 v. 5 a. Mains Trans. 0.9-15 v. 6 a. output and ammeter 49/9.

ASSEMBLED CHARGER

- 6 v. or 12 v. 2 amps. 22/9
- Fitted Ammeter and selector plug for 6 v. or 12 v. Louvred metal case, finished attractive hammer blue. Ready for use. With mains and output leads. Double Fused. Only 5/6. Carr. 2/6. 47/9



Assembled 6 v. or 12 v. 4 amps. Fitted Ammeter and variable charge selector. Also selector plug for 6 v. or 12 v. charging. Double fused. Well ventilated steel case with blue hammer finish. 69/9
Ready for use with mains and output leads. Carr. 3/9.

R.S.C. MAINS TRANSFORMERS (FULLY GUARANTEED)

- Interleaved and impregnated. Primaries 200-250 v., 50 c/s. Screened.
- ### TOP SHROUDED TOP THROUGH
- 250-0-250 v. 70 mA, 6.3 v. 2 a. 5 v. 2 a. 15/9
 - 350-0-350 v. 80 mA, 6.3 v. 2 a. 5 v. 2 a. 18/9
 - 250-0-250 v. 100 mA, 6.3 v. 4 a. 5 v. 3 a. 22/9
 - 300-0-300 v. 100 mA, 6.3 v. 4 a. 5 v. 3 a. 22/9
 - 350-0-350 v. 100 mA, 6.3 v. 4 a. 5 v. 3 a. 22/9
 - 350-0-350 v. 100 mA, 6.3 v. 4 a. C.T. 23/9
 - 0-4 v. 3 a. 23/9
 - 350-0-350 v. 100 mA, 6.3 v. 4 a. 5 v. 3 a. 29/9

ELIMINATOR TRANSFORMERS

- Primaries 200-250 v. 50 c/s. 14/9
- 120 v. 40 mA, 5-0-5 v. 1 a. 15/9
- 99 v. 15 mA, 4-0-4 v. 500 mA. 9/9

CHARGER TRANSFORMERS

- All with 200-250-250 v. 50 c/s Primaries:
- 0-9-15 v. 1 a. 11/9; 0-9-15 v. 3 a. 16/9;
 - 0-3.5-9-17 v. 3 a. 17/9; 0-3.5-9-17.5 v. 4 a. 18/9;
 - 0-9-15 v. 5 a. 19/9; 0-9-15 v. 6 a. 22/9.

SMOOTHING CHOKES

- 250 mA 5 H 100 ohms 12/9
- 150 mA 7-10-250 ohms 11/9
- 100 mA 100 H 200 ohms 8/9
- 80 mA 10 H 350 ohms 5/6
- 80 mA 10 H 400 ohms 4/11

OUTPUT TRANSFORMERS

- Midget Battery Pentode 66:1 for 8S₇, etc. 3/9
- Small Pentode, 5,600Ω to 3Ω 3/9
- Standard Pentode, 5,000Ω to 3Ω 3/9
- Standard Pentode, 7,8,000Ω to 3Ω 4/9
- Push-Pull 10-12 watts 6V8 to 3P or 15P 15/9
- Push-Pull 10-12 watts to match 6V8 to 3-5-3 or 15P 16/9
- Push-Pull 15-18 watts, 6L6, KT66 22/9
- Push-Pull 20 watts, sectionally wound 6L6, KT66, etc., to 3 or 150 47/9
- Williamson type exact to spec. 35/9

MANUFACTURERS' SURPLUS MAINS TRANSFORMERS

Primaries 250-250 v. 50 c/s. Fully shrouded upright 150 mA, 6.3 v. 3 a. mounting 425-0-425 v. 70 mA, 6.3 v. 3 a. 29/11, post 2/9. Drop Through Classis type, 250-0-250 v. 70 mA, 6.3 v. 2.5 a. 11/3.

SPECIAL OFFERS

32-32-32 mfd. 250 Dubilier small can electrolytics, 2/9 ea. Small .0005 mfd. 2-gang, 4/9 ea. Westinghouse Rectifiers 250 v. 250 mA. 7/9.

FULLY SHROUDED UPRIGHT

- 250-0-250 v. 60 mA, 6.3 v. 2 a. 5 v. 2 a. Midget type 24-3-3in. 17/6
- 350-0-350 v. 70 mA, 6.3 v. 2 a. 5 v. 2 a. 19/9
- 250-0-250 v. 100 mA, 6.3 v. 4 v. 4 a. C.T. C-4-5 v. 3 a. 26/9
- 250-0-250 v. 100 mA, 6.3 v. 6 a. 5 v. 3 a. for R1355 conversion 31/-
- 300-0-300 v. 100 mA, 6.3 v. 4 a. 5 v. 3 a. 300-0-300 v. 70 mA, 6.3 v. 4 v. 4 a. C.T. C-4-5 v. 3 a. 26/9
- 350-0-350 v. 100 mA, 6.3 v. 4 a. 5 v. 3 a. 22/9
- 350-0-350 v. 100 mA, 6.3 v. 4 v. 4 a. C.T. 0-5 v. 3 a. 27/9
- 300-0-300 v. 150 mA, 6.3 v. 4 a. 6.3 v. 1 a. for Mullard 510 Amplifier etc. 35/9
- 350-0-350 v. 150 mA, 6.3 v. 4 a. 5 v. 3 a. 33/9
- 350-0-350 v. 150 mA, 6.3 v. 2 a. 6.3 v. 2 a. 5 v. 3 a. 35/9
- 425-0-425 v. 220 mA, 6.3 v. 4 a. C.T. 6.3 v. 4 a. C.T. 5 v. 3 a. Suitable Williamson amplifier etc. 40/9
- 450-0-450 v. 250 mA, 6.3 v. 6 a. 6.3 v. 6 a. 5 v. 3 a. 69/9

FILAMENT TRANSFORMERS

All with 200-250 v. 50 c/s primaries 6.3 v. 1.5 a. 5/9; 6.3 v. 2 a. 7/8; 0-4-6-3 v. 2 a. 7/9; 12 v. 1 a. 7/11; 6.3 v. 3 a. 8/11; 6.3 v. 6 a. 17/6; 12 v. 3 a. or 24 v. 1.5 a. 17/6.

SMALL POTTED MAINSTRANSF.

Removed from New Ex-Govt. units. Primary 0-200-250-250 v. Secs. 250-0-250 v. 60 mA, 6.3 v. 2 a. 11/9 5 v. 2 a. Size 3 1/2 x 4 1/2 in.

R.S.C. BATTERY TO MAINS CONVERSION UNITS

Type BM1. An all-dry battery eliminator. Size 5 1/2 x 4 1/2 x 2 1/2 in. approx. Completely replaces batteries supplying 1.4 v. and 90 v. where A.C. mains 200-250 v. 50 c/s. is available. Suitable for all battery portable receivers requiring 1.4 v. and 90 v. This includes latest low consumption types. Complete kit with diagrams, 39/9, or ready for use, 46/9.

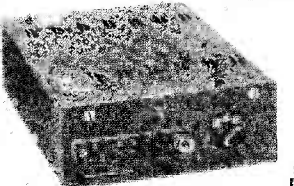

Type BM2. Size 8 x 5 1/2 x 2 1/2 in. Supplies 130 v. 90 v. and 60 v., 40 mA and 2 v. 0.4 a. to 1 amp. fully smoothed. Thereby replacing both H.T. batteries and L.T. 2 v. accumulators. When connected to A.C. mains supply 200-250 v. 50 c/s. **RECEIVABLE FOR ALL BATTERY SETS.**

VERS normally using 2 v. Accumulator. Complete kit of parts with diagrams and instructions 49/9, or ready for use 59/6.

EXTENSION SPEAKERS

Ready for use in walnut veneered cabinet.

- 6in. 2-3 ohms, 29/6.
- 8in. 2-3 ohms, 35/9.
- Very limited number.



H.T. ELIMINATOR AND TRICKLE CHARGER KIT

Input 200-250 v. A.C. Output 120 v. 40 mA. Fully smoothed and rectified supply to charge 2 v. accumulator. Price with louvred metal case and circuit, 29/6. Or ready for use, 8/9 extra.

T.V. CABINETS, Leading manufacturers surplus.

Attractive designs. Walnut veneered, with doors for 15, 16, or 17in. Tube, 43-19-6. Carr. 7/6.

MINIATURE MOTORS, 24/28 v. D.C. or A.C. made by Hoover Ltd., Canada.

Size only 2 1/2 x 1 1/2 in. Spindle 1/4 in. long, 1/4 in. diam. Brand New, 8/9.

EX-GOVT. TRANSFS., 230/250 v., 50 c/s

460 v. 200 mA, 6.3 v. 2 a. 5 v. 2 a. HEAVY DUTY OIL FILLED suitable for electric welding or soil heating. Output 12 v. 80/100 amps, £16-19. Carr. 7/6.

EX-GOVT. SMOOTHING CHOKES

- 250 mA, 5 H 30 ohms 12/9
- 150 mA, 10 H 100 ohms 11/9
- 150 mA, 6-10 H 150 ohms Trep. 6/9
- 100 mA, 5 H 100 ohms 3/11
- L.T. type 1 amp. 2 ohms 2/9

EX-GOVT. E.H.T. SMOOTHING CONDENSERS

32 mfd. 5,000 v. Cans, 2/9; 1 mfd. 2,500 v. Bakelite Tubulars, 3/8.

EX-GOVT. METAL BLOCK (PAPER) CONDENSERS

4 mfd. 500 v., 2/9; 4 mfd. 1,000 v., 4/9; 6.8 mfd. 500 v., 6/9; 8 mfd. 500 v., 4/9; 16 mfd. 500 v., 4/9; 4 mfd. 400 v. plus 2 mfd. 250 v., 1/11.

EX-GOVT. ELECTROLYTICS, Removed from unused equipment.

8-15 mfd. 550 v., 1/3; 1,500 mfd. 6 v., 1/9; 80 mfd. 50 v. with cap, 8d.

EX-GOVT. DOUBLE WOUND STEP UP/STEP DOWN TRANSFORMER

10-0-100-200-220 v. or to 5-0-175-115-135 v. or REVERSE. 80/100 watts. Only 11 v. plus 2/9 post.

EX-GOVT. CASES, Size 14-10-8 1/2 in. high.

Well ventilated black crackle finished, undrilled cover. IDEAL FOR BATTERY CHARGER OR INSTRUMENT CASE. OIL COVER COULD BE USED FOR AMPLIFIER. Only 9/9, plus 2/9 postage. Size 8 1/2 x 13 1/2 x 6 1/2 ins. with undrilled well ventilated cover, finished in stoved grey enamel. Suitable for charger or instrument case, 7/9, plus 2/9 post.

EX-GOVT. VALVES (NEW)

1X4	7/9	EF33	5/9	EF80	7/9
1B5	7/9	6V6G	7/9	EB91	7/9
3B4	8/9	6X4	8/9	EF36	4/9
5Y3G	8/9	6X5GT	7/9	EL32	3/9
5Y4G	8/9	6L6G	11/9	EL91	5/9
3Z4C	8/9	8U7	7/9	ET44	8/9
6K7G	8/9	12A6	7/9	EZ30	6/9
6B5/7GT	6/9	15D2	4/9	EB20	6/9
6SLGT	8/9	25Z4G	9/9	EL84	10/6
6SN7GT	8/9	MH4	4/9	SP61	2/9
6AT5	7/9	PCC83	9/9	3524	8/9

EX-GOVT. UNIT RDEL, Brand new, cartoned.

Complete with H.T. valves including 5Z4, E.H.T. rectifier, Transformer, Choke, etc. Only 29/9, carr. 7/6.

ELECTROLYTICS (current production) NOT EX-GOVT

Tubular Types		Can Types	
81F	450 v. ... 1/9	16 mfd.	250 v. 1/11
16F	500 v. ... 2/6	16 mfd.	500 v. 2/3
161F	350 v. ... 2/6	161F	450 v. ... 2/3
161F	450 v. ... 2/3	321F	350 v. ... 2/11
161F	500 v. ... 2/9	32 mfd.	450 v. 4/9
221F	350 v. ... 3/9	100 mfd.	450 v. 2/9
251F	25 v. ... 1/3	8-8 1/2	450 v. ... 3/11
501F	12 v. ... 1/8	10-161F	450 v. 3/11
50 mfd.	25 v. ... 1/6	32-321F	350 v. 4/9
501F	50 v. ... 1/9	32-321F	450 v. 5/9
100 mfd.	12 v. 1/9	64-120 mfd.	350 v. 7/9
100 mfd.	25 v. 2/3	100-200	mfd. 7/9
6,000 mfd.	6 v. 3/8	275 v.	... 6/9

Many others in stock.

HUNTS MOLDSEAL CONDENSERS

.005 mfd. 400 v., .01 mfd. 400 v., .04 mfd. 500 v., 5/6 doz. (one type); 1 mfd. 350 v., 8d. ea.; 5 mfd. 500 v., 1/8 ea.

R.S.C. A8 ULTRA LINEAR 12 WATT AMPLIFIER

NEW 1956 Model High-Fidelity Push-Pull Amplifier with "Built-in" Tone Control, Pre-amp stages, High sensitivity. Includes 5 valves (807 outputs). High Quality sectionally wound output transformer, specially designed for Ultra Linear operation, and reliable small condensers of current manufacture. **INDIVIDUAL CONTROLS FOR BASS AND TREBLE** Lift and Cut. Frequency response ± 3 db. 200-30,000 c/s. Six negative feedback loops. Hum level 71 db. down. ONLY 70 millivolts INPUT required for FULL OUTPUT. Suitable for use with all makes and types of pickups and practically all microphones. Comparable to the very best designs. For STANDARD or LONG-PLAYING RECORDS. For MUSICAL INSTRUMENTS such as STRING BASS, GUITARS, etc. **OUTPUT SOCKET** with plug provides 30 v. and 6.3 v. 1.5 a. For supply of a RADIO FEEDER UNIT. Size approx. 12-9-7in. For A.C. mains 200-250 v. 50 c/s. Outputs for 3 and 15 ohm speakers. Kit is complete to last nut. Chassis is fully punched. Full instructions and point-to-point wiring diagrams supplied. Unapproachable value at £7/15-0, or factory built 45/- extra. Carriage 10/-.

£7-15-0

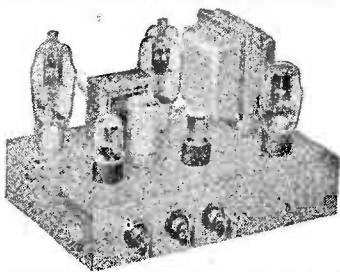

carrying handles can be supplied for 17/6. Additional input socket with associate Vol. Control so that two different inputs such as Gram and "Mike" or Tape and Radio can be mixed, can be provided for 13/- extra. Guaranteed 12 months. **TERMS** on assembled two input model. **DEPOSIT** 25/6 and nine monthly payments 23/4. **HIGH FIDELITY MICROPHONES and SPEAKERS** in stock. Keen cash prices or H.P. terms if supplied with amplifier.

R.S.C. 30 WATT ULTRA LINEAR HIGH-FIDELITY AMPLIFIER A10

A highly sensitive Push-Pull, high output unit with self-contained Pre-amp. Tone Control Stages. Certified performance figures compare equally with most expensive amplifiers available. Hum level 70 db. down. Frequency response ± 3 db. 30-30,000 c/s. A specially designed sectionally wound ultra linear output transformer is used with 607 output valves. All components are chosen for reliability. Six valves are used, 6X8, 6F8, ECC83, 807, 807, 6Z3. Separate Bass and Treble controls are provided. Minimum input required for full output is only 12 millivolts so that ANY KIND OF MICROPHONE OR PICK-UP IS SUITABLE. The unit is designed for CLUBS, SCHOOLS, THEATRES, DANCE HALLS or OUTDOOR FUNCTIONS, etc. For use with Electronic ORGAN, GUITAR, STRING BASS, etc. For standard or long-playing records. **OUTPUTS FOR KEYS, PIANO, GAMES and H.T. for a RADIO FEEDER UNIT.** An extra input with associated vol. control is provided so that two separate inputs such as Gram, and Mike can be mixed. Amplifier operates on 200-250 v. 50 c/s. A.C. Mains and has outputs for 3 and 15 ohm speakers. Complete kit of parts with fully punched ONLY chassis and point-to-point wiring diagrams and instructions. If required cover as for A8 can be supplied for 17/6. The Carr. 10/- amplifier can be supplied, factory built with 12 months guarantee, for £12/10/6. **TERMS** for assembled two input model: **DEPOSIT** 28/11 and 9 monthly payments of 28/11.

10 GNS.

SUPERHET FEEDER UNIT

Design of a high quality Radio Tuner Unit (specially suitable for use with any of our Amplifiers). Delayed A.V.C. Very high Percentage modulation of the Transmitter can be handled without distortion. The W.Ch. Sw. incorporates Gram. position. Controls are Tuning W. Ch. and Vol. Only 250 v. 15 mA. H.T. and L.T. of 8.3 v. 1 amp. required for amplifier. Size of unit approx. 9-6-7in. high. Simple alignment procedure. Point-to-point wiring diagrams, instruction and priced parts list with illustration. 2/9. Total building cost, £4/15/-. For descriptive leaflet send S.A.E.

GARRARD 8-SPEED MIXER AUTO-CHANGER RC110. For Standard A.C. mains 200-250 v. 50 c/s. Current Model. Brand new, cartoned. Provision for taking 10 records. Fitted High-Fidelity turnover pick-up head with dual sapphire point stylus for Standard or Long-playing records. Very limited number at only £8/17/6. Carr. 2/6.

LINEAR L45 MINIATURE 4.5 WATT QUALITY AMPLIFIER. Suitable for use with Garrard, E.S.B. or any other record-playing unit, and most microphones. Total negative feedback 12 db. Separate Bass and Treble Controls. For convenience when mounted in cabinet, mains switch is incorporated in control. For A.C. mains input of 200-250 v. 50 c/s. Output for 23 ohm speaker. Three miniature Mullard valves used. Size of unit only 6-5-5 1/2 in. high. Chassis is fully isolated from mains. Guaranteed 12 months. Only £5/19/6.

P.M. SPEAKERS. Suitable for use with above. Elac 7 x 4in. elliptical, 19/9. Goodmans 6in. with high flux density magnet, 19/9.

LINEAR DIATONIC 10 WATT HIGH FIDELITY PUSH PULL ULTRA LINEAR AMPLIFIER. For 200-250 v. 50 c/s. Mains. Valve line-up ECC83, ECC83, EL84, EL84, EZ81 miniature Mullard. The unit has self-contained Pre-amplifier/Tone Control stages and separate Bass and Treble Controls. Independent Mike and Gram input sockets are provided. Total harmonic distortion only 0.2% at 6 watts. Due to use of latest miniature components of proved reliability size is only 10-6-6ins. Output Matchings for 3 and 15 ohm speakers. Finished in attractive stoved Gold/Bronze hammer finish. Only 12 GNS. or Deposit 26/9 plus 10/- carr. and 9 monthly payments of 26/9. Send S.A.E. for full details.

R.S.C. 4.5 WATT A5 HIGH-GAIN AMPLIFIER

A highly sensitive 4-valve quality amplifier for the home, small club, etc. Only 50 millivolts input is required for full output so that it is suitable for use with the latest high-fidelity pick-up heads, in addition to all other types of magnetic feed-back used. H.T. of 800 v. 25 mA. and L.T. of 6.3 v. 1.5 a. is available for the supply of a Radio Feeder Unit, or Tape Deck pre-amplifier. For A.C. mains input of 200-250 v. 50 c/s. Chassis is not alive. Kit is complete in every detail and includes fully punched chassis (with baseplate) with Blue hammer finish and point-to-point wiring diagrams and instructions. Exceptional value at only £4/15/-, or assembled ready for use 25/- extra, plus 3/6 carr.

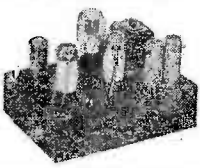

PLESNEY 12in. P.M. 3 OHM SPEAKER. Recommended for use with above A5, A7, or Linear L45 Amplifiers. Price 29/11.

R.S.C. TAI HIGH QUALITY TAPE DECK AMPLIFIER. For ALL Tape Decks with High Impedance, Playback and Erase Heads, such as Lane, Truvox, etc. (Unit can now Ready for use with latest H.P. ONLY Collaro Tape Transcriber: refer to TAI/C). For A.C. Mains 230-250 v. 50 c/s. **11 GNS.**

Positive compensated identification for recording level by Magic Eye. Recording facilities for 15, 7 1/2 or 3 1/2 in. per sec. Automatic equalisation at the turn of a knob. Linear frequency response of ± 3 db. 50-11,000 c/s. Negative feedback equalisation. Minimum microphony and hum. High output with completely effective erasure and distortionless reproduction. Sensitivity is 15 millivolts, so that any kind of crystal microphone is suitable. Only 2 millivolts minimum output required from Recording head. Provision is made for feeding a P.A. amplifier. Unit can also be used as a gram-amplifier requiring input of 0.75 v. R.M.S. Carriage 7/6. Illustrated leaflet 6d.

R.C.A. 20 WATT RE-ENTRANT SPEAKERS

15 ohm or 600 ohms matching. For Outdoor work. Only 8 GNS. **P.M. SPEAKERS.** All 7 in. diam. Goodmans, 17/9. 6in. Goodmans wafer type, 16/9. 8in. Rola, 19/9. 10in. Elac, 26/9. 12in. Plessey, 29/11. 10in. W.B. "Stentorian" 3 or 15 ohms type HP1012 10 watts, high-fidelity type. Highly recommended for use with our A8 amplifier. £4/10/9. 12in. Plessey 15 ohm 10 watts, 59/8.

PLESNEY DUAL CONCENTRIC 19in. 15 OHM HIGH FIDELITY SPEAKER with built-in tweeter (completely separate elliptical speaker with choke, condensers, etc.) providing extraordinarily realistic reproduction when used with our A8 or similar amplifier. Rated 10 watts. Price complete, only £5/17/6.

COAXIAL CABLE 75 ohms. Hn. 8d. yard. Twin Screened Feeder, 11d. yard.

SELENIUM RECTIFIERS

6/12 v. 1a.	4/11	L.T. Types H.V.
6/12 v. 2a.	8/9	6-12 v. 1a. H.W. 2/9
6/12 v. 3a.	11/9	H.T. Types H.V.
6/12 v. 4a.	14/9	150 v. 40 mA. 2/9
6/12 v. 6a.	19/9	250 v. 50 mA. 5/9
6/12 v. 10a.	25/9	250 v. 30 mA. 7/9
6/12 v. 15a.	35/9	250 v. 150 mA. 9/9

R.S.C. 3-4 WATT AT HIGH-GAIN AMPLIFIER

For 230-250 v. 50 c/s. Mains input. Appearance and Specification, with exception of output wattage, as A5. Complete Kit, with diagrams, £3/15/-, Assembled 22/6 extra. Carr. 3/6.

THE SKYFOUR T.R.F. RECEIVER A design of a 3-valve Long and Medium wave 230-250 v. A.C. Mains receiver with selenium rectifier. It consists of a variable-Mu high-gain H.F. stage followed by a low distortion anode bend detector. Power pentode output is used. Valve line up being 6K7, 6F61, 6V6G. Selectivity and quality are well up to standard, and simplicity of construction is a special feature. Point-to-point wiring diagrams, instructions and parts list, 1/9. This receiver can be built for a maximum of £4/19/6 including attractive Brown or Cream Bakelite or Walnut veneered wood cabinet 12 x 6 x 5 1/2 in.

Terms : C.W.O. or C.O.D. NO C.O.D. under £1. Post 1/9 extra under £2 : 2/9 extra under £5. Open 9 to 5.30 : Sats. until 1 p.m. Catalogue 6d., Trade List 5d. S.A.E. with all enquiries.

RADIO SUPPLY CO. 32, THE CALLS, LEEDS, 2 (LEEDS) LTD.

For a smooth
extended response curve

You need a PHILIPS

**dual-cone
loudspeaker**

Made in Holland



The special dual-cone construction of Philips high fidelity loudspeakers ensures a smooth response over the entire audible range, with efficiency and transient response of a high order. The spatial distribution of acoustic energy is excellent—even at the highest frequencies.



Both cones are driven by the same coil and magnet, resulting in similar sensitivities for high and low frequencies. The air gap has been made long and the coil moves in a homogeneous magnetic field at all times; a copper ring is incorporated in the air gap to keep the voice coil impedance constant over the whole frequency range.

Available in two sizes: 8" and 12" price 6½ gns. (tax paid) and 10 gns. respectively. There is also a single cone version in the same sizes: price £6.2.6 (tax paid) and £10.0.0, respectively.

N.B. These speakers may be used on their own or with another suitable speaker, using a crossover network

Your high fidelity dealer can obtain these loudspeakers for you.



PHILIPS ELECTRICAL LTD
E.L.A. and Musical Equipment Dept • Century
House • Shaftesbury Avenue • London • WC2
(FR633A)



MODEL 1
D.C. VOLTAGE : 0 to 500 volts.
A.C. VOLTAGE : 0 to 500 volts.
D.C. CURRENT : 0 to 500 mA.
RESISTANCE : 0 to 20,000 Ω.
Total resistance of meter : 200,000 Ω.
SENSITIVITY : 400 Ω/V.

MODEL 2
D.C. VOLTAGE : 0 to 1,000 volts.
A.C. VOLTAGE : 0 to 1,000 volts.
D.C. CURRENT : 0 to 500 mA.
RESISTANCE : 0 to 200,000 Ω.
Total resistance of meter : 4 MΩ.
SENSITIVITY : 4,000 Ω/V.

Write for a free copy of the latest Comprehensive Guide to "Avo" Instruments.

'AVO' Precision

ELECTRICAL TESTING INSTRUMENTS

A dependably accurate instrument for testing and fault location is indispensable to the amateur who builds or services his own set.

The UNIVERSAL AVOMINOR

(as illustrated) is a highly accurate moving-coil instrument, conveniently compact, for measuring A.C. and D.C. voltage, D.C. current, and also resistance; 22 ranges of readings on a 3-inch scale.

Size : 4½ ins. x 3½ ins. x 1½ ins.
Nett weight : 18 ozs.

List Price : £12 : 0 : 0

Complete with leads, interchangeable prods and crocodile clips, and instruction book.

The D.C. AVOMINOR

is a 2½-inch moving coil meter providing 14 ranges of readings of D.C. voltage, current and resistance up to 600 volts, 120 milliamperes, and 3 megohms respectively. Total resistance 100,000 ohms.

Size : 4½ ins. x 3½ ins. x 1½ ins.
Nett weight : 12 ozs.

Complete as above
List Price : £5 : 5 : 0

Sole Proprietors and Manufacturers —
AUTOMATIC COIL WINDER & ELECTRICAL EQUIPMENT CO., LTD.
Avocet House, 92/96, Vauxhall Bridge Rd., London, S.W.1. VICTORIA 3104 (9 lines)

PRACTICAL WIRELESS

EVERY MONTH
VOL XXXIII, No. 604, APRIL, 1957

EDITOR : F. J. GAMM

25th YEAR
OF ISSUE

BY THE EDITOR

COMMENTS OF THE MONTH

Editorial and Advertisement Offices :
PRACTICAL WIRELESS
George Newnes, Ltd., Tower House,
Southampton Street, Strand, W.C.2.
Phone : Temple Bar 4363.
Telegrams : Newnes, Rand, London.
Registered at the G.P.O. for trans-
mission by Canadian Magazine Post.

SUBSCRIPTION RATES

including postage for one year

Inland - - - 18s. per annum.
Abroad - - 16s. 6d. per annum.
Canada - - - 16s. per annum.

CONTENTS :

	Page
Editorial	83
Round the World of Wireless	84
A Diode and Two Transistors Receiver	86
An Improved Tape-Recorder Reel Fixture	90
A Transistorised A.F. Oscillator	91
Making a Low-Impedance Record/Play Head	93
On Your Wavelength	97
Swinging Chokes	98
The "Modern" Battery Receiver	99
An Easily Built Cross-over Unit	105
Telephone Weather Service	106
An F.M. Tuner	107
A Compact Signal Generator	113
Operating Battery Receivers from the Mains	121
Transmitting Topics	125
Programme Pointers	130
Short-wave Section	133
Open to Discussion	137

The Editor will be pleased to consider articles of a practical nature. Such articles should be written on one side of the paper only, and should contain the name and address of the sender. Whilst the Editor does not hold himself responsible for manuscripts, every effort will be made to return them if a stamped and addressed envelope is enclosed. All correspondence intended for the Editor should be addressed to: The Editor PRACTICAL WIRELESS, George Newnes, Ltd., Tower House, Southampton Street, Strand, W.C.2. Owing to the rapid progress in the design of wireless apparatus and to our efforts to keep our readers in touch with the latest developments, we give no warranty that apparatus described in our columns is not the subject of letters patent.

Copyright in all drawings, photographs and articles published in PRACTICAL WIRELESS is specifically reserved throughout the countries signatory to the Berne Convention and the U.S.A. Reproductions or imitations of any of these are therefore expressly forbidden. PRACTICAL WIRELESS incorporates "Amateur Wireless."

AMATEUR TRANSMITTING

WE have received some hundreds of letters in response to our request for readers to express their views on our monthly transmitting feature as a result of a reader's suggestion that the space would be better occupied by subjects such as tape-recording and short-wave matters. The feature, therefore, will be continued. It is pointed out that there is no other source of information for the beginner and that even experienced amateur transmitters find the feature of interest. We also intend to enlarge the amount of space we devote to the short-wave section as an aid to those who wish to listen in to amateur transmissions.

In view of the developments in tape-recording, and the large numbers of people who are now interested in this radio sideline we also propose to include more material on this topic.

THE BBC GRANT

THE Treasury has refused to accept the recommendation made by the Public Accounts Committee that the BBC should be financed by an annual grant in accord with its needs. The committee had argued that the broadcasting licence fees were strictly Government revenue. The Director General of the BBC regarded this as an attempt to undermine the constitutional independence of the corporation. At present, the BBC is financed from licence revenue under a three-year agreement with the Post Office. The Treasury defends its attitude by stating that the present arrangement enables the Corporation to plan ahead and that it preserves its independence. The Public Accounts Committee, however, criticised the agreement on the ground that it allowed the BBC to accumulate £5 million in securities. The agreement expires at the end of March.

The BBC has announced that there will be some readjustment of the present pattern of sound broadcasting towards the end of the year to meet the developing needs of the listening audience. It has undertaken a survey of the whole field of domestic sound broadcasting, and in its statement refers to the problem of rising costs in broadcasting and the need to operate both the sound and the television systems within the Corporation's income.

Our own view is that there needs to be a distinct change in the personnel in some of the BBC departments. Many of these executives still have the same outlook and apply the same methods as when broadcasting first started, and particularly in connection with television. The take-it-or-leave-it attitude is still there. Even those responsible for outside broadcasts need to be replaced, for the public has grown tired of the same old commentators. It should not be difficult to replace these. It is not a job which requires very great skill or ability.

We also think it is high time that the parlour game complex of the BBC was looked into.—F. J. C.

Our next issue, dated May, will be published on April 5th.

Round the World of Wireless

By "QUESTOR"

Broadcast Receiving Licences

THE following statement shows the approximate number of Broadcast Receiving Licences in force at the end of December, 1956, in respect of receiving stations situated within the various Postal Regions of England, Wales, Scotland and Northern Ireland. The numbers include licences issued to blind persons without payment.

Region	Total
London Postal	1,232,786
Home Counties	1,211,500
Midland	947,627
North Eastern	1,227,008
North Western	925,952
South Western	766,679
Wales and Border Counties	486,396
Total England and Wales	6,797,948
Scotland	868,010
Northern Ireland	198,072
Grand Total	7,864,030

Grant of Arms to Brit.I.R.E.

THE Council of the British Institution of Radio Engineers announces that the Institution has been granted Armorial Bearings and Supporters. The Shield of the Coat of Arms makes allusion to the pioneers of radio science, namely Professor James Clerk Maxwell and Heinrich Hertz, while the supporters are those of the 7th Duke of Devonshire, who endowed the Cavendish Laboratory, Cambridge, and of Admiral The Earl Mountbatten of Burma who played an important part in the founding of the Institution and who was President from 1946-48. The shield is surmounted by the head of Mercury, messenger to the gods. In addition a new motto has been adopted, "Scientia pro Hominibus"—science for the good of mankind.

British Portuguese Contract

AUTOMATIC TELEPHONE & ELECTRIC COMPANY LTD. has been awarded a contract for the supply and engineering of a complete U.H.F. frequency modulated wide-band radio-telephone link in Portugal. The contract was awarded by the Anglo-Portuguese Telephone Company Ltd., through Telephone and Associated Services Ltd., the consultants and purchasing agents.

The radio equipment, which is being supplied and installed by Marconi's Wireless Telegraph Co.

Ltd., consists of two Marconi type HM.200 multi-channel equipments and aerials; it is of particular interest in that it makes use of three new travelling-wave tubes for the amplification of the ultra-high-frequencies employed, and thus represents a new departure in U.H.F. point-to-point communication.

The installation, which will span the river Tagus from Lisbon on the northern bank to the rapidly expanding industrial area of Montijo in the south—a distance of some 14 kilometres—will cater initially for 60 high grade radio-telephone channels. Ultimately it will provide 240 circuits.

Mullard Service Organisation

TWO new appointments have been made within the Mullard Service Department. Mr. A. James, well known to dealers as manager of the Mullard Service Depot in Birmingham, has been promoted to a post of special responsibility at the main service department at Waddon.

He is succeeded at Birmingham

by Mr. N. T. Bird, who was formerly Mr. James's deputy. Mr. Bird's appointment became effective on December 1st, 1956.

New British Standard Supplement

THE B.S.I. has now published another Supplement (No. 5) to B.S. 530: 1948, "Graphical symbols for telecommunications." This provides functional symbols for switching diagrams, with particular application to electronic circuits. It is based on the recommendations drawn up by the Post Office Terms and Symbols Committee with the help of a number of experts who were invited to co-operate in this work.

Developments in electronic techniques have led to a corresponding requirement for new symbols for the representation of circuits and, in particular, to indicate the functional operation of circuits without the use of descriptive notes.

The system of functional symbols in Supplement No. 5 provides a circuit designer with means of indicating the logical programme of any circuit (electronic or electro-mechanical) regardless of the components used.

The supplement is also intended to help students or maintenance staff to follow the operation of

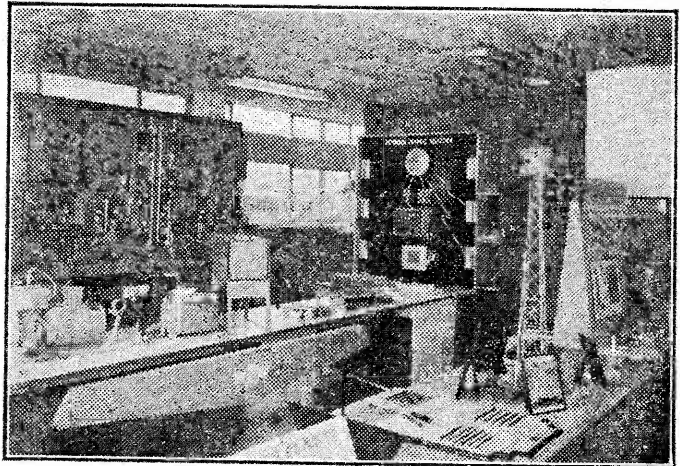

This illustration shows part of the static Marconi exhibition, given by the Marconi Company recently, and a representative selection of the items on display. In the left-hand background can be seen a Marconi U.H.F. Multichannel Repeater Unit, capable of carrying up to 600 simultaneous telephone channels in both directions, or television signals.

electronic circuits without having to refer to circuit operation notes.

Explanations of some of the terms used are included.

Copies of this standard may be obtained from the British Standards Institution, Sales Branch, 2, Park Street, London, W.1. Price 2/6.

V.H.F. For Midlands

THE BBC's Very High Frequency (V.H.F.) sound broadcasting station at Sutton Coldfield, near Birmingham, transmits the Midland Home Service on 92.7 Mc/s, the Light Programme on 88.3 Mc/s and the Third Programme on 90.5 Mc/s. As at other BBC V.H.F. sound broadcasting stations the transmissions are horizontally polarised, which means that receiving aerials will need to be fixed horizontally.

The area in which satisfactory reception is expected under normal service conditions has a population of almost $7\frac{1}{2}$ million people. It includes the whole of the counties of Warwick, Worcester, Leicester and Staffordshire; most of Derbyshire, Nottinghamshire and Shropshire, and parts of the counties of Montgomery, Denby, Flint, Cheshire, Lincoln, Rutland, Northants, Oxford, Gloucester and Hereford.

This new service will provide a valuable reinforcement to the existing long-wave and medium-wave transmissions, which are unfortunately subject to interference from foreign stations and from electrical apparatus. V.H.F. transmissions are much less susceptible to such interference and are also capable of giving much better sound quality. The V.H.F. service will thus provide greatly improved reception of the Home, Light and Third Programmes for listeners in the above-mentioned areas of the country who provide themselves with V.H.F. receivers and suitable aerials.

New Broadcasting Station in the Far East

BRUNEI, on the N.W. coast of Borneo, is to have its first broadcasting station. The Brunei State Council has approved plans for the establishment of a broadcasting system, and Marconi's Wireless Telegraph Co. Ltd. has been entrusted with the survey, planning, installation and commissioning of the technical side of the project.

The scheme includes the pro-

vision of a modern Broadcasting House in Brunei Town, a transmitting station at Tutong and an additional small studio at Seria. A receiving station is also planned.

The Broadcasting House will comprise one large and two small

studios, with the usual administrative and programme offices. It is to be fitted with the latest types of Marconi equipment, with facilities for tape recording, all types of disc reproductions and the handling of outside broadcasts.

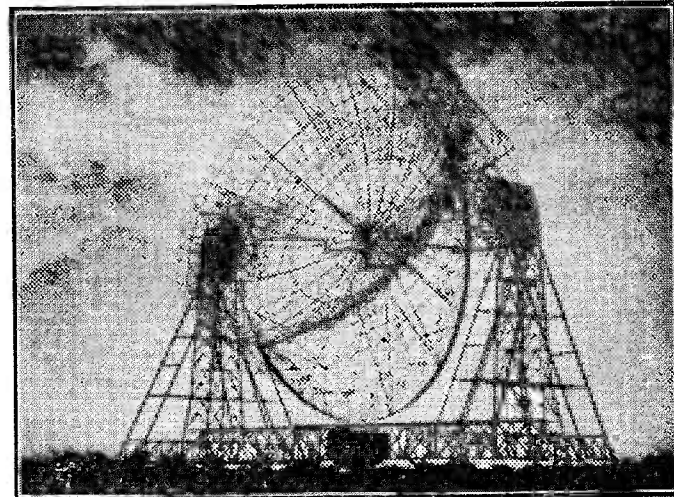

A model of the Radio Telescope at Jodrell Bank. This is a "still" from a new educational film "Mirror in the Sky," the story of the Appleton and Heaviside Layers. Made with the co-operation of Mullards.

studios, with the usual administrative and programme offices. It is to be fitted with the latest types of Marconi equipment, with facilities for tape recording, all types of disc reproductions and the handling of outside broadcasts.

Programmes from Brunei's Broadcasting House will be fed by a Marconi V.H.F. F.M. high-quality broadcast link to the transmitting station at Tutong, some 35 miles away, while another V.H.F. F.M. radio link is to be provided for engineering control purposes.

The transmitter at Tutong will be a Marconi 20 kW medium frequency equipment, feeding into a quarter-wave mast radiator 60 metres in height (approximately 200ft.). Initially, however, a pilot service will be brought into operation, with programmes being radiated from a Marconi 2 kW transmitter installed in a temporary studio building at Brunei Town.

R. D. Bangay Retires

MR. RAYMOND DORRINGTON BANGAY, Foreign Manager of Marconi's Wireless Telegraph Company Ltd., retired at the end of December after

distinction of having served in the industry longer than any other radio engineer.

His association with the company began in May, 1902, when, having qualified as an engineer at the City and Guilds Technical College, Finsbury, under Professor Silvanus P. Thompson, he entered the newly founded Marconi College, which at that time was located in Frinton, Essex. Later in the same year he went to America, where he remained for the succeeding five years.

Mr. Bangay is the author of two early text books on radio, "The Elementary Principles of Wireless Telegraphy" and "The Oscillation Valve," adopted in 1915 by the Royal Flying Corps for the intensive training of wireless operators. The first of these books was translated and published in four foreign languages (Spanish, French, Italian, Japanese) and served both in this country and abroad to give many thousands their first introduction to the mysteries of the science of radio and to lay the foundation for the world-wide reputation which Mr. Bangay has established for himself.

A Diode and Two Transistors Receiver

AN EXPERIMENTAL CIRCUIT FOR A PORTABLE OR DOMESTIC RECEIVER

MANY will not have the facility for erecting a very long and high horizontal aerial out of doors which is so necessary for the D diode-transistor Receiver, described in the February, 1955, issue on page 88, which should be studied before building this sensitive and versatile receiver.

By adding another transistor to work quite independently as an audio amplifier, with a novel form of independent bias, dwellers in flats can have loud-speaker results if the indoor aerial is correctly installed and not too far from a station.

This receiver can be used either as a diode-transistor or diode and two transistors. An outdoor aerial can be used with the advantage of receiving the more distant stations. The fidelity is very good, almost as perfect as with only one transistor, but the volume from the loudspeaker is greater.

The Basic Circuit (Fig. 1)

The variable condenser in series with the aerial (Fig. 1), is for attenuating strong signals; it also improves selectivity.

Two high-Q coils give sufficient selectivity if suitably tapped and spaced apart. The cathode of the diode which is painted red is connected to the coil tap so that the negative potentials with current are accepted and pass through the diode to the base of a p-n-p transistor which likewise accepts these half cycles. The positive half cycles are not allowed to pass and do not reach the transistor. This is the most sensitive part of the circuit and results claimed could not be obtained without a diode coupled direct to a transistor as shown.

The diode should have low D.C. resistance to forward current with small fractions of a volt, but an extremely high resistance to reverse current at several volts. A germanium junction diode may serve better.

The diode-transistor amplifies the half cycles passed by the diode. The second transistor acts purely as an audio amplifier. Separate bias and batteries are shown to isolate one transistor from the other, so that motor-boating and feed-back cannot take place. With only one battery either positive or negative feed-back is possible by reversing the connections to the primary or secondary of the intermediate transformer, especially when the accumulator is run down and needs recharging.

The two fixed capacitors act as by-pass, and the two variable for tuning. Each collector is connected to its own battery negative. Both emitters are grounded to battery positives, not to earth. The diode-transistor receives very little bias, so that they work on the lower part of their combined characteristic curve from near zero to near the bend upward, while the

amplifier transistor receives a larger bias so that it works on the upper straightest part of its characteristic curve.

The Receiver Circuit (Fig. 2)

The indoor aerial and lead to receiver consists of 50 yards (not feet) of wire. It may be a thickish single strand, but preferably an insulated flex of many strands. Plastic 5 amp. 230 volt single or, better still, 2 or 3 amp. twin flex with any type of 250-volt insulation. Join the two ends together at each extremity. If it is not convenient to install it under the roof in the loft for better reception then it may be fixed up in the same room as the receiver. Zig-zag the wire from side to side of the room, picture rail to picture rail, and spread it evenly over the length of the room with one end down to the receiver. In all cases the wire must be kept away from walls and ceilings at least 6in. Short lengths of cord or wooden brackets can be used.

Switches

S1 has five contacts for the following purposes:—

(1) for switching the aerial off. This can also be used for connecting the aerial to another receiver by means of a short length of flex from switch contact point.

(2) is for reception with an outdoor aerial when very near a powerful station and when the .0005 aerial series condenser does not attenuate sufficiently at its minimum capacity.

(3) is for normal reception of local BBC broadcasts.

(4) is for strong Continental stations. An aerial coil with fewer turns may be needed. Use 'phones for tuning.

(5) may be tried for weak stations, using 'phones. It is not recommended for general use. The selectivity is very poor. However, in this case the aerial coil is disconnected and can, therefore, be used as an efficient wave-trap for higher frequency interference close to the wanted station. Turn the aerial coil

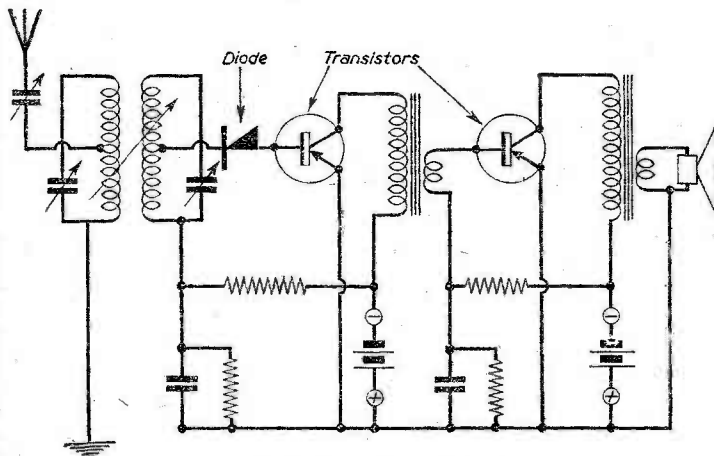

Fig. 1.—The basic circuit.

tuner to its minimum capacity. Tune in the wanted station accurately on the diode coil and then slowly increase aerial coil tuner capacity. When it is tuned to the wanted station it will be absorbed and you will not hear it; now reduce the aerial coil capacity slightly so that the wanted station is heard while the interfering stations on the slightly higher frequency are absorbed and cease to interfere. The stations on the lower frequency will, however, continue to interfere.

S-2 is for switching off both batteries when the receiver is not in use. A very small current through the bias resistors will drain small batteries unnecessarily if the switch is left on.

S-3 is for shorting the meter to prevent pivot wear. Do not leave the meter working for long periods when listening in to the same station. Use it only for making all the necessary adjustments, and cut the meter out.

S-4 consists of four switches, each having two positions and all controlled by one knob. S-4A, S-4B, S-4C and S-4D are shown in the circuit with their contacts in position two for working the receiver with two transistors.

When S4 is switched over to position one then S-4B is at off and the collector of the amplifier transistor is disconnected. S-4C is also at off and disconnects bias resistor so that no current passes through this pot. and the base of the transistor is now at earthed positive potential. S-4D switches off the second battery and connects the meter to the first battery. Now the second transistor and its transformer are isolated with most parts earthed.

When soldering up the receiver, place this four-pole two-way switch S-4 close to the transistors so that insulated leads are short.

S-5 is for optional use of bias with an outdoor

aerial when S-4 may be at one. Powerful local stations which are capable of producing 1/2 mA meter reading from the diode-transistor do not require additional bias.

Coils

Centre-tapped coils are shown for convenience. With long aerials one third the number of turns from earthed end would be better. How to find the best tap was mentioned in February, but with an indoor aerial the meter indications will be very slight. The aerial coil is connected to earth, but the diode coil earthy end goes to the pot. slider for bias.

Transistors

When both transistors are used for reception, the diode-transistor works on the lower part of their combined D.C. characteristic curve before the bend upwards, with 0.2 mA passing through from bias while the output transistor bias is adjusted to pass 1 1/2 mA current through it, so that it works from the bend upwards on the straightest part of its characteristic curve. That is as it should be. It must be remembered that a transistor without a diode has a curve slope of 100 mA per volt at base when resistance in the circuit is very low, 5 to 7 ohms, and battery can supply all the current needed. If the diode-transistor were allowed to work on the straighter upper part of their curve, then it would be equivalent to using a power output valve to drive another identical valve instead of using a suitable smaller valve as a driver. A junction diode connected to OC71 transistor could be tried with more bias current passing through them if a power transistor is used for output, with appropriate bias for it. But the volume from this receiver is adequate to satisfy most people

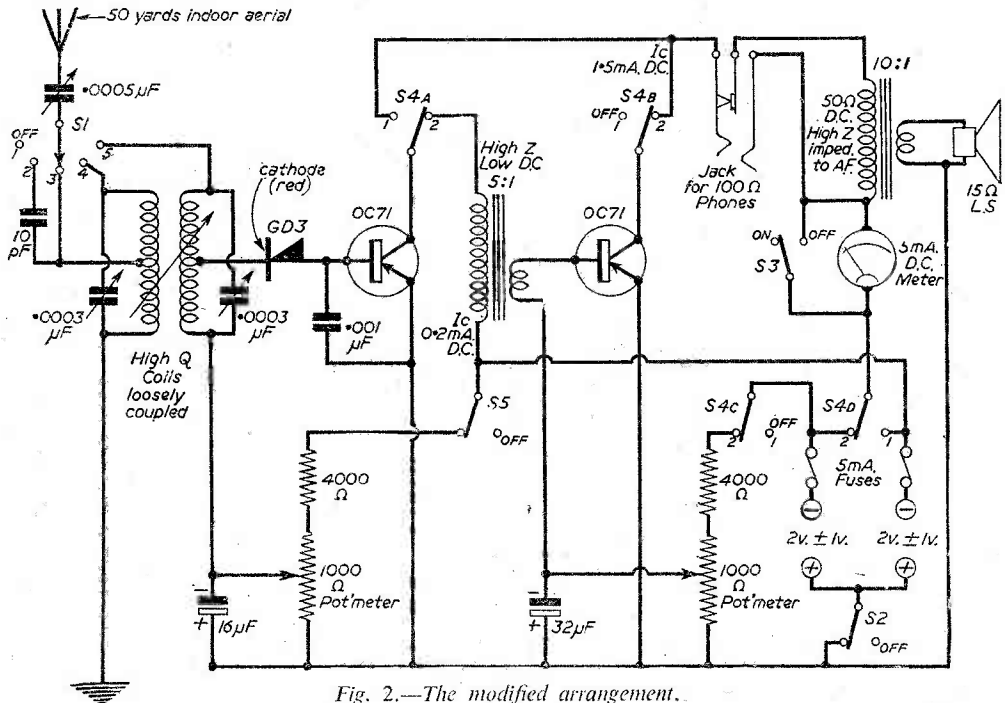

Fig. 2.—The modified arrangement.

if an efficient speaker is used and one is not in some far-away fringe area.

Transformers

The transformer described in February may be used between transistors provided it has taps for a 5 : 1 or 6 : 1 ratio, but even 10 : 1 will work. Its resistance may be higher than 50Ω so long as the Z impedance to audio frequencies is as high as possible. Remember that the lower the D.C. resistance the more efficiently will the transistor work. It will destroy itself doing it if allowed to do so.

The 5 : 1 transformer winding has fewer turns from pot. to base to supply a higher amperage at less voltage to the base. The 10 : 1 transformer is for a 15 ohms loudspeaker.

Some of the mains power transformers for very high voltage power units, with at least 500 volts, can be had on the surplus market at reasonable prices, and they work better than many very expensive audio output transformers used for amplifiers. Interleaved windings have less capacitance between layers of turns and are better for higher audio frequencies. Select those with many taps for various mains as well as for various high voltage outputs; then matching up for best fidelity is easier. For example taps marked 10-0-110-200-220-240 for mains and 40-20-375-395-435 secondary, also 6.3 volts for heaters would give the 10 : 1 ratio by using taps 395-0 and 240-200 which produces 40 for the 15 ohms speaker, or the 6.3 for a 2 or 3 ohms speaker. The 5 : 1 ratio can be had from 40-435 which totals 475 for battery negative to collector while 0-110 is used from pot. slider to base. This actually gives 4.3 to 1 and is passable.

Bias

When using diode-transistor only any bias up to $2\frac{1}{2}$ mA may be tried. 0.2 to 0.4 will give best results when weak signals produce less than 0.1 mA with S5 at off. If a station can produce 0.4 mA on its own, additional bias has little significance because the diode works more efficiently with less than 0.4 mA passing through it, and S5 at off may give better results.

Before using both transistors adjust bias for diode-transistor to be about 0.3 mA with switch S4 at one and S1 off. Then switch S4 to two, adjust bias for amplifier transistor to be about 1.5 mA, and switch on the aerial. Remember, the meter cannot show current through diode-transistor with S4 at two.

The pot. sliders should always be turned to the positive end before a battery is connected or changed for another. A small non-spillable two-volt acid accumulator or 2.4 alkali NiFe is recommended, but a $1\frac{1}{2}$ or 3 volt dry battery works quite well. The silver "Venner" alkali accumulators are ideal for small portable receivers, but they are expensive. Weaker signals need less battery voltage. Do not use more than three volts, or two $1\frac{1}{2}$ volt dry batteries in series.

If the meter does not give a steady reading during average volume from an orchestra adjust bias for a higher meter reading if meter readings rise; or reduce bias if readings drop on louder passages. If meter still moves much, attenuate or it may be a mismatch in transformer taps. If meter is steady during average musical sounds then both transistors are working at their best fidelity. But ignore sudden

meter movements or kick when suddenly music is very loud or percussion sounds are made, as during speech. It is natural for a sensitive meter to kick up on sudden peak sounds. An A.C. meter would move up for every sound made. If the meter wobbles sometimes up or sometimes down, transistors are being overloaded, so attenuate by reducing .0005 capacity; it should never be necessary to have it at maximum.

To prevent damage to transistors and meter by excessive bias when using an outdoor aerial and hunting for distant stations while powerful local one is working, a 5 mA fuse at each battery negative is very necessary in this receiver. In addition to the meter reading there is also an audio wattage which is not shown by the D.C. meter. And this audio current may have peaks of 10 mA permissible and much more when overloaded and distorting. A fuse is cheaper than two transistors and meter. You have been warned.

Other Items

Two 5 mA meters could be used with this receiver with the advantage of seeing what each transistor is doing while adjustments and tuning is in progress. I use two meters when hunting stations with an outdoor aerial, and BBC is on the air. Judging excessive volume by ear is not so easy for assessing excessive bias which does not produce much more volume, only distortion when it is much too excessive.

The 16 μF and 32 μF electrolytic capacitors may be of any working voltages 15 or more. They act as a by-pass for pot. sliders. Two pots. and two batteries are used in order to isolate completely one transistor from the other and so have better fidelity at greater volume. In an emergency one battery may be used if both negative terminals for batteries are joined together, but after listening in for some time or when the battery runs down there will be a very unpleasant background noise like running water or sifting gravel, even when volume is greatly reduced by attenuating, and this does not improve reception. Negative feedback helps a little, and larger capacitors up to 2,000 μF were tried for by-pass, only to make matters worse.

Any electrolytic should be tested before use. Connect the negative lug or lead to the positive of a voltmeter and the positive lug or lead to the positive of a battery of the same voltage as the electrolytic working voltage. When the voltmeter negative terminal is connected to the battery negative the meter reading will jump to almost full battery voltage and then slowly drop to lower readings. If after five minutes meter readings stop at, say, 3 volts leave it all connected up for a couple of days—the capacitor may reform in time. If not, reduce battery voltage from, say, 15 to 6 volts and readings should drop to nearly zero. A leakage is small enough if it shows 2 to 3 volts reading for our purpose, but a good capacitor will drop to zero, or nearly so.

A jack for a pair of 100 ohms 'phones (preferably balanced armature type) is shown connected so that the loudspeaker is switched off when the 'phones are plugged in.

Transistors are easily damaged by heat. Before soldering wind a few turns of soft string or narrow tape around the transistor lead and wet it. Use a thin copper strip bent double at one end to pinch and hold the end of the transistor lead for soldering. This will prevent excessive heat travelling along the lead down into the transistor. It would be better if transistors had pins at base as all-glass valves for small holders;

thin leads could project out of these pins for those who want them or they can be snipped off when not wanted.

Experimenter's Receiver in Four Parts (Fig. 3)

Experimenters will desire to try their transistors, etc., for all sorts of devices, but as these are expensive, one solution is to build the receiver in parts which can be used for other purposes. Terminals, or a couple of three-pin plugs, with sockets, are needed as extra.

Part A may be used alone with phones connecting collector to battery negative. This can be a small portable receiver.

Part B may be connected to part A for use with phones. This also can be a small portable audio amplifier. An additional terminal connected to base would enable the transistor to be used for other purposes alone.

Part C may be connected to A or B for use with phones or a loudspeaker.

Part D may be an extension speaker in a cabinet for connecting up to C or for other purposes.

Final Notes

The 5 mA fuses shown in circuits are not necessary if the first transistor has a 1,000 ohm resistor in series with the emitter shunted by 50 μ F electrolytic capacitor and the second transistor has 470 ohms and 100 μ F in series with emitter.

Experienced radio technicians can build this receiver with small size and high-Q coils, suitably spaced apart and each having an additional winding of fewer turns closely coupled, instead of taps, one for aerial the other for diode. Then twin-ganged condensers may be used for tuning and a switching arrangement can be added for long-, medium- and short-wave sets of coils.

All properly aligned as for mains receivers and in suitable cabinets with a loudspeaker. Much enjoyment can be had from this receiver. No valves to burn out. It is almost everlasting if carefully treated.

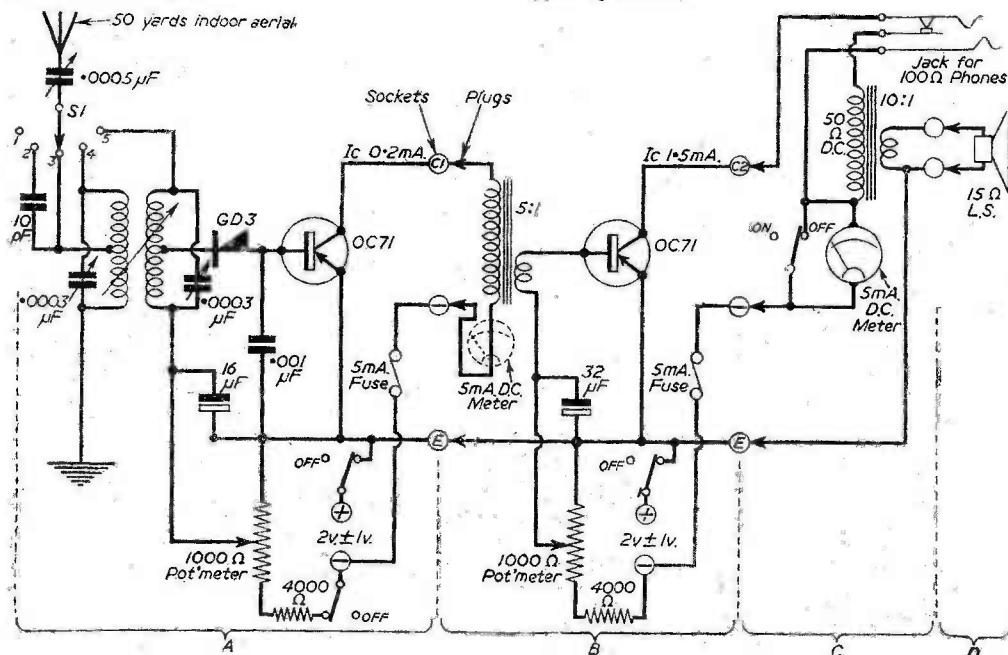

Fig. 3.—The experimenter's receiver.

Antiference "Exstat" and "VRA" Aerial Equipment

WITH the introduction of a new 18ft. vertical rod aerial, Antiference announce a new and improved range of "Exstat" and "VRA" aerial equipment.

The new aerial, which tapers from 3/4 in. to 3/16 in., is in three 6ft. sections of highest grade aluminium alloy to aircraft specification and these sections are joined by specially designed aluminium-alloy ferrule connectors providing a highly engineered 18ft. rod aerial which is resistant to corrosion and capable of withstanding winds of up to 80 m.p.h. Alternative wall or chimney mountings are available.

The aerials are supplied with or without "Exstat"

Anti-static equipment incorporating aerial and receiver transformers with Ferroxcube cores which ensure interference-free reception with maximum signal strength over a range of 10-2,000 metres. Special receiver transformers are available to provide for multi-point reception where a number of receivers are required to operate from one aerial.

Literature, showing current prices of the new aerials and accessories, is available upon application direct to Antiference Ltd., or from their appointed distributors.—Antiference Ltd., Bicester Road, Aylesbury, Bucks.

An Improved Tape-recorder Reel Fixture

A USEFUL DEVICE FOR THE HANDYMAN TO MAKE

By L. C. Mason

IN the battery-operated tape-recorder described in a recent issue of PRACTICAL WIRELESS, the take-up tape reel is mounted on a screwed sleeve, soldered to the motor spindle. To enable this to be done, the motor spindle is turned down parallel to $\frac{1}{4}$ in. The reel is then driven by tightening the upper nut on the sleeve to grip the reel, the nut being slacked off to allow the reel to run free on rewinding. The reel centre hole is opened up to $\frac{1}{2}$ in. to fit the screwed sleeve.

As turning down the spindle is a lathe job, the opportunity can be taken to make a small component which takes the place of the screwed sleeve, giving several advantages over the sleeve and nut mounting. The substitute piece gives a positive drive to all standard reels, avoids the necessity of drilling out the reel hole—possibly thereby spoiling the reel for use on another recorder—and is instantly freed on the spindle for rewind by a quarter turn of a finger nut. Reels can be dropped straight on to the spindle over the nut, whether the drive is locked or not. Furthermore, a second sleeve can be used on the paying-out spindle, enabling this spindle to be motorised for rapid power rewind.

The standard reel has a centre hole $\frac{5}{16}$ in. diameter. The motor spindle is turned down parallel to $\frac{1}{4}$ in. as directed, and a plain brass sleeve turned down to $\frac{5}{16}$ in. diameter to fit the reel hole. The sleeve is bored $\frac{1}{2}$ in. to fit the motor spindle. This is best drilled first and then reamed, for a good shakeless fit on the motor spindle. Brass rod $\frac{1}{2}$ in. diameter (or larger) is suitable, to leave a flange $\frac{1}{16}$ in. thick the full diameter of the rod. The sleeve length is not critical, but the turned portion should not be much less than $\frac{3}{8}$ in. long. Before parting off from the rod in the lathe, mark off three equidistant points round the small end of the sleeve and round the base flange. These are for three small fins or keys to engage in the three keyways in the standard reel hole.

After parting off the sleeve, hold it in the vice so as not to mark or distort it, and make short saw-cuts along the sleeve at each of the three marks. Do not cut the flange. Keep the cuts in line along the sleeve, so that the keys which are soldered in the slots lie along the axis of the sleeve.

The keys themselves are filed up from scraps of brass strip to the shape shown. Thin down the edges of the keys if necessary so that they will wedge in the slots just tightly enough to hold themselves in position. Tin the edges and small end of each key where it will contact the sleeve, and also along the line of contact on the sleeve itself. Press the keys lightly into their slots, wrap a few turns of wire around the lot to hold the pieces together, and sweat the keys in position, pressing them close home while the solder is molten.

The locking fitment for the spindle consists of a spring-loaded finger nut located on top of the motor spindle. First, place the sleeve on the spindle and add the reel, adjusting this to the correct working

height above the deck. Mark the spindle a fraction above the top of the sleeve and cut it down to the mark, filing or turning the end flat and square. Drill down the spindle and tap 4 B.A.

The nut is turned from a scrap of steel rod, reducing it to $\frac{5}{16}$ in. diameter to pass easily through the hole in the reel. Drill down the piece No. 26 to clear a 4 B.A. screw, and knurl the end for finger grip. Open up the end with a $\frac{7}{32}$ in. drill to $\frac{1}{2}$ in. deep and part off $\frac{3}{8}$ in. long. Transfer it to the vice and at the end which rests on the spindle file the end back each side until two tongues about $\frac{1}{16}$ in. wide and deep are left standing up across the diameter of the nut. Two tongues result, owing to the 4 B.A. clearing hole in the middle. Only one tongue is needed, so file one down level with the rest of the end.

Saw a slot $\frac{1}{16}$ in. deep across the drilled end of the motor spindle, and open it up with a thin file till the tongue on the nut will fit it snugly. Treat the sleeve

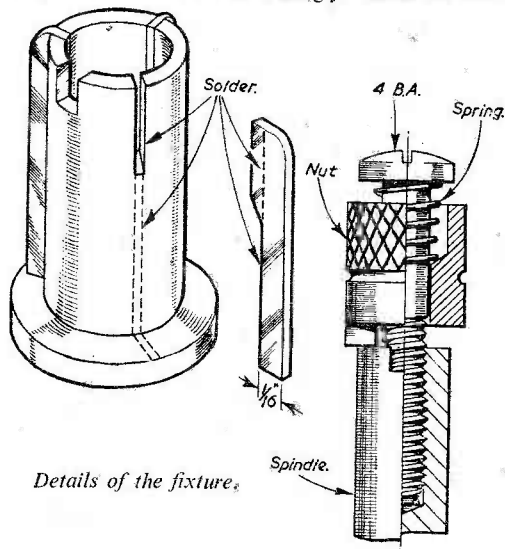

Details of the fixture.

similarly, cutting one slot midway between two keys. Assemble the nut on the spindle with a light spring seating in the larger hole in the top of the nut, a 4 B.A. screw in the spindle retaining both.

A spacer is required on the motor spindle under the sleeve to bring its top level with the spindle end. This can be a collar from a condenser spindle set-screwed in position.

The reel can be dropped on to the sleeve over the nut, whether the sleeve be locked or not. To free the drive, lift the nut against its spring and give it a quarter turn either way. To lock, turn it till it catches the spindle slot, when a slight turn of the spindle or reel will let the nut drop into engagement with the sleeve and lock it.

A TRANSISTORISED A.F. OSCILLATOR

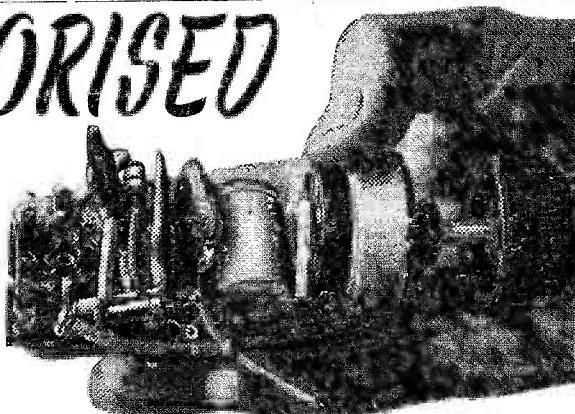

AN ACCESSORY FOR SERVICING OR
FAULT FINDING By F. G. Rayer

THE great utility of an A.F. oscillator in receiver testing is so well known that it scarcely needs emphasising. A transistor circuit has the advantages of small size, and freedom from dependence on mains supplies or H.T. and L.T. batteries. In many ways it is thus ideal.

The valve circuit shown in Fig. 1, is a well-known and popular type of A.F. oscillator, needing no iron-cored components. Each valve drives the other, and the output may be taken from one anode. The note produced can be adjusted by modifying the component values.

A transistor equivalent of this circuit appears in Fig. 2, and is that employed in the oscillator. The values are chosen to produce a fairly high frequency, but this will vary according to the actual transistors. If a lower note is desired, it can easily be achieved by increasing the value of one, or both, of the feedback coupling condensers, .05 μ F or .01 μ F being satisfactory. The 200 K. potentiometer allows output to be adjusted from maximum down to zero, and this is useful when working back through a sensitive type of amplifier. The potentiometer has a switch to interrupt the battery circuit.

Tagboard Construction

As the unit is intended to have a flexible output lead, with prod, there is no point in reducing dimensions to the absolute minimum, which makes solder-

ing difficult. Using the layout shown in Fig. 3, the completed oscillator will fit in a screening can 3 $\frac{1}{2}$ in. high and 2in. in diameter, the potentiometer knob coming on top of the can. A tagboard can then be used for wiring points, giving a rigid assembly and greatly simplifying construction.

The transistors are marked T1 and T2. "E." "B" and "C", showing emitter, base and collector connections, respectively. If the transistor leads are left full length this will avoid any danger of heat travelling along the wires and damaging the transistors, which is a very real hazard when the leads are cut short. This, and holding the leads with flat-nosed pliers, will avoid any possibility of a spoiled transistor, if the soldering iron is not applied for longer than necessary.

Paper or mica condensers are satisfactory, and $\frac{1}{2}$ or $\frac{1}{4}$ watt resistors. Since the battery lasts for many months, it is soldered in, this being simple and reliable. The zinc case is negative, and the card tube is left on the cell to avoid shorting the switch tags.

When wiring is completed and the oscillator switched on, the note should be audible in 'phones connected from the output lead to battery. Turning the control knob should adjust volume from zero.

A container could be made from paxolin tube, if no screening can is available. About 12in. to 18in. of flex, screened after issuing from the can, forms the output lead, and terminates in a test prod. The braided

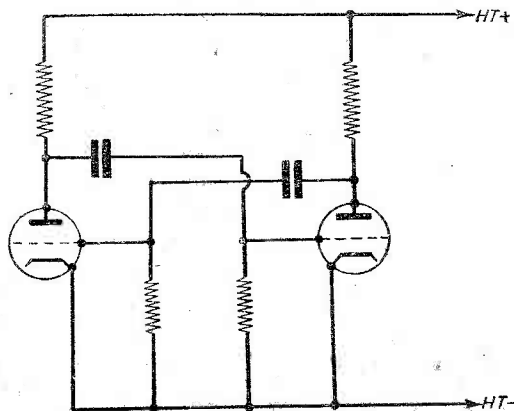

Fig. 1.—A valve multivibrator.

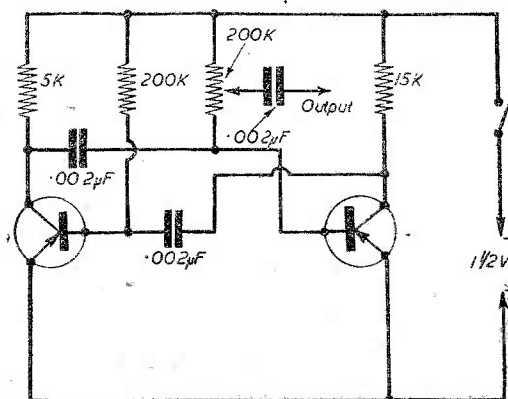

Fig. 2.—The transistor form of Fig. 1.

ing is taken to the metal container, which is wired by a short, flexible lead to the positive battery circuit. A short length of flex, terminating in a clip, also comes from this point, as shown in Fig. 4.

To use the oscillator, the clip is attached to the chassis of the receiver, and the prod worked back through the A.F. circuits, from the output stage. As more gain becomes available, the signal may be reduced by the potentiometer. Working backwards in this way will soon show where a fault is in an amplifier, or the A.F. stages of a receiver.

The usual precautions should be taken when dealing with mains receivers, and particularly circuits

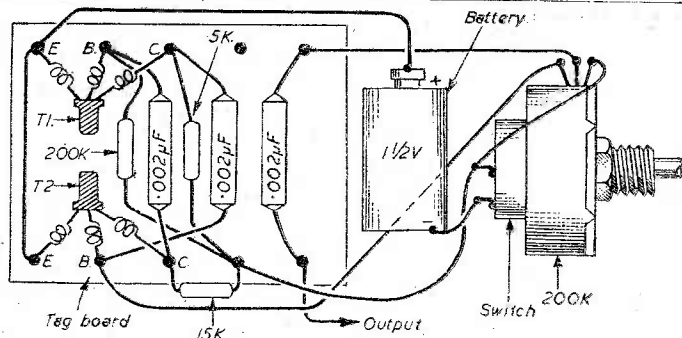
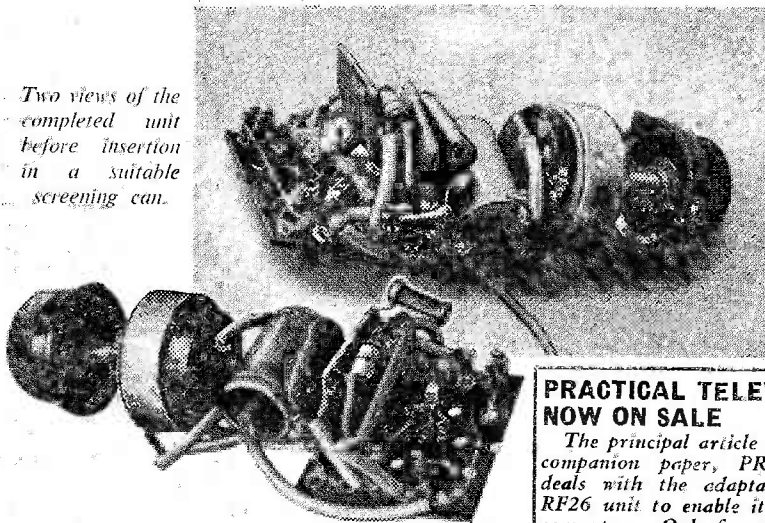

Fig. 3.—Wiring diagram of the oscillator.

Two views of the completed unit before insertion in a suitable screening can.



leave this lead disconnected, merely applying the prod to the A.F. circuits.

A Warning

No danger arises with battery receivers, of course. But with mains equipment there is always the possibility that the whole oscillator may become alive to the mains, and this should always be watched for when making any tests whatever with such receivers or amplifiers.

with a "live" chassis. For mains equipment, the .002µF condenser in series with the output lead should be mica, or of 750 volts rating. With a live chassis, a further condenser of around .05µF, 750 volts working, can be included in the "earth return" lead. In other cases it will be found that it may be possible to

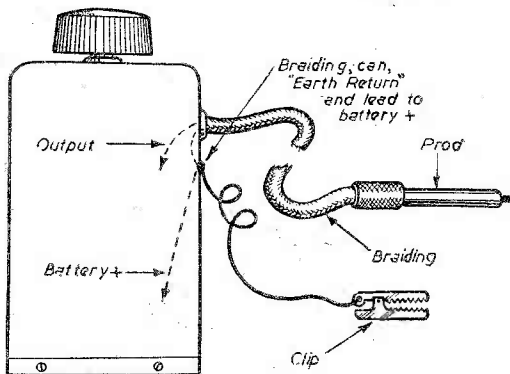

Fig. 4.—The completed oscillator in its case.

PRACTICAL TELEVISION MARCH ISSUE NOW ON SALE PRICE 1s. 3d.

The principal article in this month's issue of our companion paper, **PRACTICAL TELEVISION**, deals with the adaptation of an ex-Government RF26 unit to enable it to be used as a Band III converter. Only five additional small items have to be obtained, in addition to three coil formers, and the modification is not a difficult task. Another article in this issue deals with Shared Channel Interference, a trouble which is being met with by an increasing number of viewers as more stations come on the air on the same channel. The causes and remedies are explained.

The construction of a Bandswitch to enable one to switch from Band I to Band III, especially designed for a converter recently described, but which may also be used with other types of converter, is also given, together with an article on another Switch which does the same thing but which avoids the necessity for a Diplexer or similar items, and permits the user to retain two aerials each working separately.

The Data Sheet this month deals with the McMichael M17T Series whilst the Servicing article covers the Vidor CN4216.

Other articles deal with Unit Construction, the BBC Film Studios (Ealing), and the Beginner's Guide to Television, which this month covers the various methods of scanning which have been used in TV.

The issue is complete with the usual features—Underneath the Dipole, Correspondence, and Your Problems Solved.

Making a Low-impedance Record/Play Head

A UNIT FOR THE TAPE RECORDER DESCRIBED LAST YEAR

By B. E. Wilkinson

FOLLOWING the publication in this journal of "A Battery Operated Tape Recorder" (September, 1956) I have received many letters dealing with a variety of problems arising out of the construction of the instrument, and perhaps the greatest number of queries concerned the play/record head. There is doubtless a feeling among those who attempted to build the recorder that the cost of the head was high, when compared with the cost of other parts required. Also, the head recommended has a gap width such that two records can be made on the same length of tape. As a result of these two facts, it was decided that a play/record head must be evolved which, in the first place is cheap, and in the second place, makes one record over the complete

identical electrical impulses, amplified by means of an amplifier, and fed finally to the windings C and D on the head. The alternating current in the head then, being identical to the original sound waves, creates an alternating magnetic field in the mu-metal pole pieces A and B. The flux density at the gap E tends to become greater at the point of least reluctance, i.e., across the magnetic surface of the tape. And so, in effect, the tape becomes part of the magnetic circuit of the record head, and the alternate positive and negative magnetising of the pole pieces, by the signal, induces magnets in the iron-oxide surface of the tape. Owing to the retentivity of the oxide the magnets are not readily removed unless the tape is subjected to a strong magnetic field. As the tape is moving at the time the signal is applied, the

result is that after passing the head it has upon its surface tiny magnets the width of the tape, the number per second and the strength being identical to the frequency and the amplitude respectively of the applied signal.

During playback the reverse process takes place. The tape with the magnetised surface passing across the gap E creates flux

changes in the pole pieces A and B. These magnetic changes cut the windings of the coils and, due to Faraday's Law of Electromagnetic Induction, small EMFs circulate the coils. These are taken to the input of an amplifier, the output of which feeds a loudspeaker. Enough has now been mentioned concerning the action of the play/record head, that we may proceed with the constructional data.

Constructional Data

The materials required are all easily obtainable and comprise the following. One hexagonal brass nut of approximate diameter 1in. to 1½in., a strip of

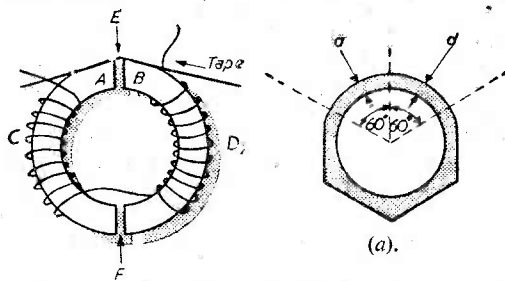

Fig. 1.—Details of the Head, and its construction from a Nut.

width of the tape. In an effort to keep the cost of the head as low as possible and yet the performance of the recorder as high as possible, I embarked upon a series of experiments in an attempt to produce a suitable head. The result of the experimentation showed that a successful play/record head could be produced with only a few tools, and no specialised material, in about four hours' continuous work. The cost of producing the head worked out at a little under half-a-crown.

The Design

The construction of a play/record head necessitates a good measure of patience and as one must understand implicitly the functioning of the component, a word or two concerning this aspect will not be amiss. Fig. 1 shows a representation of a play/record head. The pole pieces A and B are made of some magnetic material with a high permeability, but low retentivity, mu-metal generally. Around each pole piece, and wound with precision, are the coils C and D, connected in series. At E and F are gaps, the one at F being negligible, but the one at E being of the order of .001in. It is across this gap E that the tape passes. Let us consider the action of the head during recording, and playback. During recording, sound waves, fed to a microphone, are converted into

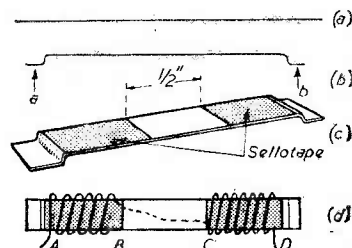

Fig. 2.—Details of the winding.

mu-metal $\frac{1}{16}$ in. wide by approximately 2 in., 40-43 s.w.g. insulated copper wire (not cotton or silk covered), small pieces of mica, two 4 B.A. nuts and bolts, lead out wire and paraffin wax.

The brass nut forms the body of the play/record head, so that if appearance is to be considered it can be neatly shaped and finished by removing the six corners with a file and buffing. However, we will concern ourselves with the necessary operations in shaping the body. Fig. 1 shows the hexagonal nut, with one corner neatly rounded so that the

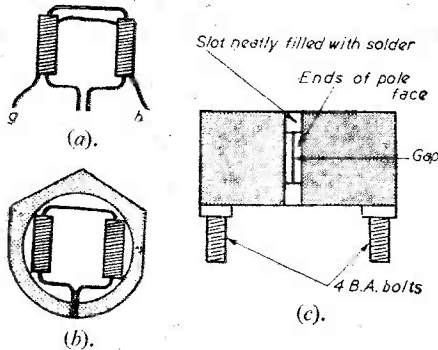

Fig. 3.—Assembly and connection data.

(thickness is constant (approximately $\frac{1}{16}$ in.) over the indicated angle of 120 deg. Now taking the point half way across this radiused surface, cut a slot with a hacksaw, the thickness of which should not exceed twice the thickness of the mu-metal we are to use. Fig. 1 (b) shows this in perspective. This part is now for the time completed and may be put on one side while the pole pieces is considered.

The strip of mu-metal should now be taken and with a fine file remove any sharpness due to cutting with shears. An excellent source of mu-metal, by the way, is from cathode-ray tube screens. These can be obtained very cheaply from ex-Government radio and electrical surplus stores, and yield a substantial quantity of the metal. In the doubtful event of mu-metal in this form being unobtainable, strip from transformer laminations is suitable, provided that it is the soft variety found generally in small audio transformers. Do not, however, use laminations from mains transformers. Once the strip is free from sharp edges it can be bent by means of small pliers into the shape shown in Fig. 2 (b). Now, to ensure that the surfaces a and b are perfectly flat and smooth, the strip is ground very carefully on a fine file or a well-oiled stone. When both faces are perfectly smooth one can undertake the winding of the coils.

Winding the Coils

Probably the most tedious task in the construction of the head, coil winding has the compensation that the more care one takes the more successful will be the resulting head. Leaving a length of about $\frac{1}{16}$ in. free in the middle of the strip, wrap around the strip as shown in Fig. 2(c) one layer only of Sellotape. Now, taking great care, about 800 turns of the fine insulated wire must be wound on the mu-metal strip in two windings each of 400 turns. Each winding should be put on in three layers, about 130 turns each

layer, so that the winding of the strip proceeds A to B, one layer, B to A, second layer, A to B third layer, whence the wire passes to C on the underside of the strip. The procedure is then repeated, C to D one layer, D to C, second layer, and C to D, third layer. The wire should be put on, each turn beside the previous one, and each layer, after being wound on, should be lightly smeared with, say, Durofix, to keep the turns secure before the succeeding layer is put on. I have mentioned that this task is tedious, but as with all tasks of this nature it is worth while to take it steadily and carefully. The operation should be carried out in strong light and those who wear glasses for reading are recommended to wear them.

Having wound the coils successfully, the pole piece is bent to shape shown in Fig. 3(a). The final shape of the pole piece should be such that when the pole faces at a are pressed together, it is rectangular. We are now ready to seal the pole piece into the body, but first a turn or so of plastic covered lead out wire should be put on each coil, and the fine leads g and h from the coils carefully soldered to the ends. This is an important point, since the coil wire is too fine to form a lead out on its own. The plastic-covered lead out wire should then be sealed to the coils with Durofix.

Clean up the shoulders of the mu-metal pole piece with fine emery cloth and tin with a soldering iron, taking care not to allow solder or flux to get on to the pole faces. Now, taking the brass body, tin the slot and the area immediately surrounding it, wiping off all the excess solder. Taking the pole piece, slide the faces between the slot, with the coils inside the body Fig. 3(b). It was mentioned previously that the magnetic gap must be of the order of $.001$ in., and we must now take steps to make this gap. From the piece of mica, carefully select slivers with the aid of a sharp knife and measure the thickness of each sliver with a micrometer until a piece between $.001$ and $.002$ in. is obtained. Now having made sure that the area of this piece is greater than the area of the pole faces, pull the pole faces apart very slightly and slip the mica in between. If the pole face is aligned correctly, the entire unit can be clamped firmly in a vice, so that the pole faces are tight against the mica. With a hot soldering iron fill up the tinned slot, ensuring that the brass edges are secure, and also that the outside of the pole faces is firmly soldered to the brass.

Completion of the play/record head now entails cleaning up the unit. The ends of the pole faces will project a little beyond the slot in the brass body. With a very fine file, and taking extreme care, as one must not crack the mica between the pole faces, file the mu-metal until it is flush with the brass. Do not file directly across the gap or directly with it, but at an incident angle, 45 deg. being reasonable. This is to avoid a jagged edge between the faces, which would neutralise the effect of the gap itself. Having done this and filed off the excess solder, the area immediately surrounding the gap must be buffed and polished. Eventually, one will see the ends of the pole faces set flush with the brass body, and the gap will appear as a very fine line.

Finally the two 4 B.A. bolts are soldered to the body as shown in Fig. 3(c), to enable the play/record head to be secured to a tape deck. The space inside the body surrounding the coils is now filled with molten paraffin wax and allowed to cool.

Built to the highest standard !

CABINETS

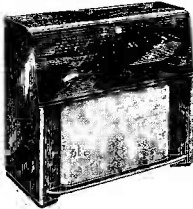

CAT. No. CAB/02. A well-designed Bureau-type cabinet in a medium size. Veneered in a highly figured Walnut. Outside dimensions, length 29 1/2 in., depth 16 in., height 32 in. Sloping control panel on right-hand side approx. 15 in. x 10 1/2 in. Removable baseboard on right-hand side, approx. 13 1/2 in. x 16 in. Large record compartment inside the cabinet, located at the top on left-hand side.
CASH ONLY 12 Gns.
Packing and Carriage 20/-.

CAT. NO. CAB/03. A magnificent Bureau-type Cabinet of the very highest quality in specially selected Walnut veneer of exterior. Light Sycamore interior with Rexine lining to match. Outside dimensions, length 34 in., depth 17 1/2 in., height 33 in. Sloping control panel on right-hand side approx. 16 in. x 10 1/2 in. Removable baseboard on right side approx. 13 1/2 in. x 15 in. Two full-sized felt lined compartments in the lower half.

CASH
16 1/2 Gns. or on Credit Terms.
Packing and Carriage 25/-.

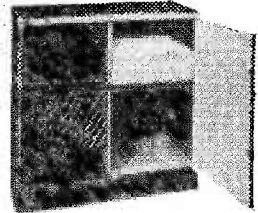
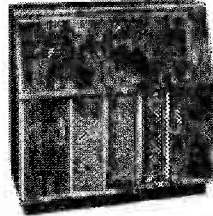

CAT. NO. CAB/04. Walnut veneered deluxe cabinet of the very highest quality with sycamore-lined interior and pull-out base, 14 in. x 16 in., on the right-hand side running on high quality ball bearings. Large silk-covered battle board with speaker cut-out on right-hand side below chassis control panel. Overall size 32 in. long x 32 in. high x 16 in. deep. 13 1/2 in. x 9 in. control panel.
CASH
£13.10.0 or on Credit Terms.
Packing and Carriage 20/-.

CHASSIS AND TUNER UNITS

CAT. NO. CR/AFM49PP. Complete radio Chassis of latest Design and Technique. 9 valves. 4 wavebands including FM/VHF Band. Push Pull output stage, including special 10 in. high-flux density speaker. A.C. 200/250 volts 50 cycles only. Suitably lit multi-coloured glass dial of the horizontal type. Slow motion tuning drive. Full provision of Automatic Volume Control. Negative feedback from output transformer secondary. Sockets provided for Aerial, Earth, Gram, Pick-up and Extension Speaker. Connections provided to Gram. Motor controlled by Chassis On/Off switch. All inductances have an exceptionally high Q value. The Audio Section is designed for first rate reproduction on Radio and Gramophone. The tone controls have been given an extra wide range to embrace all types of recordings. Size 13 in. long x 6 1/2 in. high x 7 1/2 in. deep

CASH 26 Gns. Or on Credit Terms.
Packing and Carriage 15/-.

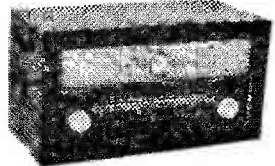

SINGLE WAVEBAND FM TUNER UNITS

Self powered. Six valves with grounded grid RF stage followed by additive mixer using a PC/85 twin triode in sealed permeability tuned unit. Two I.P. stages ensure maximum gain with 6AL5 double diode as ratio detector. Frequency coverage of 85-101 megacycles allows adequate overlap. Very finest quality throughout.

CAT. NO. FMT/A. Complete Unit in Cabinet with Magic Eye tuning. Boxed, 13 in. long x 6 in. overall depth x 7 1/2 in. high (approx.).

16 1/2 Gns. Or on Credit Terms.
Packing and Carriage 12/6.

CAT. NO. FMT/B. Chassis only excluding magic-eye. Unboxed, 11 1/2 in. long x 5 1/2 in. overall depth x 4 in. high. **CASH £13.15.0.** *Packing and Carriage 12/6.*

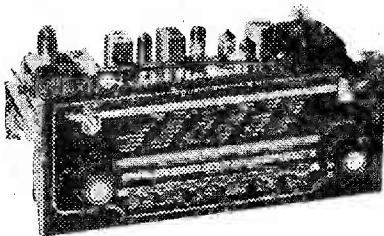

AM/FM (FOUR WAVEBANDS) TUNER CHASSIS. F.M. Short, Medium and Long. Six valves. Superhet with permeability tuned FM/VHF band. Magic Eye Tuning. FM band sensitivity of 0.9 microvolts. Minimum oscillator radiation. Less than 20 kilocycles drift. Signal to noise ratio better than 23db. Size 13 in. long x 6 1/2 in. high x 7 1/2 in. deep.

CASH 22 Gns.
Or on Credit Terms.
Packing and Carriage 15/-.

★ **LOUDSPEAKERS, AUTOMATIC RECORD CHANGERS, GRAM. AMPLIFIERS, TAPE-RECORDER** equipment, etc., available at keenest prices. Send for large illustrated Catalogue.

ALL FULLY GUARANTEED. Generous extended credit terms on orders exceeding £15. Dealers supplied at full discounts.

DOMESTIC

DIRECT SALES LTD

90 JUDD STREET, LONDON, W.C.1.

Telephone : TERminus 9876/7

PREMIER RADIO COMPANY

B. H. MORRIS & CO. (RADIO) LTD.

OPEN TILL
6 P.M. SATURDAYS

(Dept. P.W.) 207, EDGWARE ROAD, LONDON, W.2

Telephone:
AMBASSADOR 4083
PADDDINGTON 4271-2

BUILD THESE NEW PREMIER DESIGNS

2-BAND T.R.F. RECEIVER

MAY BE BUILT FOR **£5.15.0** Plus 3/- Pk. & Post.

3-Band Superhet Receiver may be built for £7.19.6 plus pk. & carr. 3/-. These two receivers use the latest type circuitry and are fitted into attractive cabinets 12in. x 6 1/2in. x 5 1/2in. in either walnut or ivory bakelite or wood. Individual instruction books 1/- each, post free.

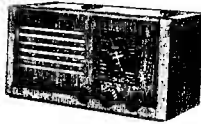

ALL-DRY BATTERY PORTABLE RADIO RECEIVER

MAY BE BUILT FOR **£7.8.0**

Plus 3/- Pk. & Postage
4 Miniature valves in a Superhet circuit covering medium and long waves. Rex-line covered cabinets 11 1/2in. x 10in. x 5 1/2in. in contrasting colours, wine with grey panel. Instruction book 1/6 post free, which includes full constructional details and list of priced components.

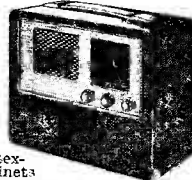

4-WATT AMPLIFIER

MAY BE BUILT FOR **£4.10.0** Plus 2/6 Pkg. & Carr.

Valve line-up 6SL7, 6V6 and 6X5. FOR A.C. MAINS 200/250 VOLTS. Suitable for either 0-ohm or 15-ohm speakers. Negative feedback. Any type of pick-up may be used. Overall size 9in. x 7in. x 5in. Price of Amplifier complete, tested and ready for use, £5.5.0 plus 3/6 pkg. and carr.

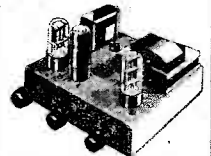

A STEEL CASE IS NOW AVAILABLE, COMPLETE WITH ENGRAVED PANEL, 15/6 EXTRA.

MULLARD AMPLIFIER KIT

Why not make the Best! All the components for model 510, PLUS preamplifier on one chassis (total six valves) may be purchased for £12.12.0, plus pkg. & post 7/6, or preamplifier and tone control in a separate unit, £14.14.0 plus pkg. & post 7/6.

NOW SUPPLIED WITH ULTRALINEAR OUTPUT TRANSFORMER

Send for the Premier WIDE ANGLE TELEVISOR booklet, 3/6 post free.

COMPACT GRAM AMPLIFIER

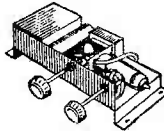

Suitable for any type of Pick-up. Volume and tone control fitted with knobs. Overall size 7 1/2in. long x 5 1/2in. wide x 2 1/2in. high. Complete and ready for use. **£2.19.6**

Plus packing & postage 2/6.

GRAM UNITS

B.S.R. 4-Speed Autochanger £9.15.0 plus 5/- pkg. & post.
B.S.R. TCS 3-Speed £4.12.6 plus 2/6 pkg. & post.

A NEW TAPE RECORDER

CREDIT TERMS DEPOSIT **£5** and 8 monthly payments of £4.18.6

H.P. TERMS 1 DEPOSIT **£20** and 12 monthly payments of £1.17.1

Cash price £40 plus packing and carriage 2/-. Case finished in Brown and Antique Fawn. Size 15in. x 12 1/2in. x 7 1/2in. with the very latest type Continental fittings. For A.C. mains 200-250 volts, 50 cycles.

SEND 2/6 STAMP FOR OUR 1957 CATALOGUE

High 'Q' Coils



4/- EACH
Iron dust cores. Clip in fixing. EXTREMELY SMALL

AMAZING EFFICIENCY For Superhet T.R.F. or Transistor operation.

Potted Coils

Iron dust cores, clip-in fixing.



5/- EACH

THE LATEST in modern technique. Ideal for crystal tuners.

All coils for Collaro Tape Transcripator pre-amp.

BIAS OSC. Coil Type QT9 **7/6**



STATION SEPARATOR

HOME-LIGHT-THIRD-LUX ETC.

10/6

Not a guaranteed cure but — A positive answer to selectivity problem.

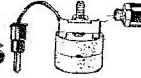

STOP!

T.V. Patterning



An easily fitted—Simple Remedy

FERRITE Rod Aerials

MW 8/9
M-LW 12/6
Also Flat wound High 'Q' frame aerials
MW 2/6 each
LW loading 4/-

F.M. COILS TRANSFORMERS

10·7 I.F.
7/- EACH
Coils for "W.W." switch-tuned circuits and for other F.M. designs.



Dial assembly for OSMOR Coils

24/6 complete
Escutcheon in bronze finish **4/-**
Other dials 5/ x 5/ 3/6 each includes spot markings for trawler band.

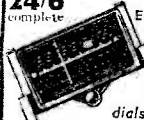

I.T.A. Converter

To fit inside T.V.
KIT complete **65/-** **£4**
Very efficient. Can be built in an evening. Full instructions etc.



OSMOR Switch-tuned F.M.

List of coils and components and full building information on request.

OSMOR COILS FREE!
ARE BEST FOR
Selectivity & Performance



FREE!

Send 10d. (stamps) for fully descriptive literature including OSMOR DESIGNS—5-Valve S'Het, Miniature ditto, Battery and Battery/Mains Receiver, Mains T.R.F. S'Het and T.R.F. Feeders. Band 3 Converters, Wiring Diagrams, Chassis Templates, Coil & Coilpack information and price lists and information on circuits in "Wireless World," "Practical Wireless," "Radio Constructor." Full Circuits included. See also Classified Advs. on page 140.

(Dept. PW9) 418 BRIGHTON ROAD,
SOUTH CROYDON, SURREY
CROYDON 5148/9



On Your Wavelength

BY THERMION

Compton or Cumpton ?

SIR COMPTON MACKENZIE tells me that Compton is not a good old Scottish name, as I suggested. He says that Compton is always and everywhere pronounced Cumpton and that it is a frequent place name in England, from Devon to Northamptonshire, occurring no fewer than 26 times. He tells me, what I do not accept, that it derives from the Welsh "Cwm" (Anglicised as Coomb and Combe), meaning a narrow valley in which is a tun or enclosure. He also tells me that Compton is often spelt as Cumptun in mediaeval documents. Moreover, he says that if Mr. Dennis Compton really did make a public protest against pronouncing his name Cumpton "whatever cumfort he may have derived from such a piece of inverted snobbery he was displaying sad ignorance and putting himself out of step with the rest of the Cumpton Company. The concise Oxford Dictionary gives 18 words in common use, in which the prefix 'com' is pronounced 'cum.'" May I say that I know a number of Comptons and none of them pronounces his name Cumpton. I am always suspicious of dictionary derivations of words and names. Many of them are obviously guesswork. Sir Compton also tells me that it is not correct that a large number of Scots are called Compton, and in support he tells me that there is only one Compton in the Edinburgh Telephone Directory. That is not proof, for it is well known that Scots gravitate south at a very early age and also that the commonest name in Scotland is Smith. However, I refuse to adopt the snobbish pronunciation of Cumpton and will close with the comment that I am glad to know that Sir Compton is such a diligent reader of this journal.

Sound Reproduction—A New Approach

A NEW system has recently been evolved by New Process Recordings, Ltd., London, for the purpose of adapting electronic circuitry to the physiological functions of the brain by modifying the sound picture and presenting it in a form which permits ready separation in two dimensions.

Although the system utilises standard monaural sources such as ordinary discs, tape, radio, television, etc., the reproduction cannot be readily distinguished from that obtained with normal, high-quality, twin-channel stereophonic tape recordings. Skilled observers have, in fact, expressed a preference for the new method.

The fundamental disadvantage of twin-channel stereophonic sound is the positional effect at the intersection of the two speakers normally used. There is no such disadvantage with the new process. On the contrary, the sound picture is preserved over the whole area except for a small space immediately in front of the speakers.

One of the principles utilised in the development of the equipment is based on the fact that the brain determines the frequency of a fundamental not by

absolute measurement but by the relative difference frequency between successive harmonics, the ear being sensitised to the fundamental upon being presented with the appropriate linear characteristic of successive harmonics.

A standard pick-up and normal turntable are used, with three-speaker system which can be extended to four speakers without any additional circuitry.

Transmitting

A LARGE number of readers have written to me on the subject of amateur transmitting who regard with displeasure any suggestion that such a feature should be expunged from the pages of this journal. Most of them, however, are transmitters themselves and are also in the trade, so they are not confronted with the financial and other difficulties which trouble the amateur with limited means. They all point out, however, that there is no other source from which they can obtain information on transmitting topics such as we publish and which they think is a definite help to the up and coming generation who wish to qualify as amateur transmitters. They also point out that this is of interest from a national point of view in that it is from amateur transmitters that the various services draw a considerable proportion of personnel for filling the more highly qualified posts. On the other hand, many of my readers tell me that they would like to see our short-wave feature extended; on this I invite the opinions of readers.

Those Police Broadcasts

IT is, of course, possible to pick up police broadcasts and I sometimes receive inquiries for a suitable circuit. Whilst it is not strictly illegal to listen in to these broadcasts it is illegal to pass on any information obtained in this way. It is, therefore, a practice not to be encouraged, and I must reluctantly decline from giving the information desired.

Do-It-Yourself

THE Do-It-Yourself movement in this country, which has reached enormous proportions and which has been aided by the production of special tools and materials for householders, is not a new movement. Radio preceded it by many years and, indeed, in its early stages there were more people making radio sets than buying them. Even to-day hundreds of thousands of people still service their own radio and television receivers. What appeared to be a complicated subject they have found, with the help of our radio handbooks and periodicals, to be comparatively easy. It is not surprising, therefore, that they have turned their attention to other aspects of the home and its equipment. Perhaps that is why so many readers of this journal also read our companion journals, *The Practical Householder* and *Practical Motorist and Motor Cyclist*.

Swinging Chokes

DETAILS OF AN EX-GOVERNMENT SURPLUS COMPONENT

By E. G. Bulley

THESSE components are available upon the surplus market, and to the newcomer to radio they seem to cause confusion as to their application. These chokes are used as the input component of choke input filters associated with mercury vapour power supplies. Choke input filters have the advantage of providing very good voltage regulation in limiting peak anode currents during the operation of the mercury vapour rectifiers.

The swinging choke is so named because of its varying characteristic, that is to say, the effective inductance varies with the direct current. This varying characteristic is the result of careful design of the choke itself, and is accomplished by having a small air gap in the core. The presence of this prevents the saturation of the core due to the high D.C. flowing through the windings. The inductance rises to a value as the D.C. flow through it decreases, and vice versa.

The inductance of swinging chokes usually lies between 5 and 20 Henrys, and as previously mentioned, they are the first component in the input filter. This is, of course, followed by a choke having a constant inductance; reference to the diagram below will clarify this point. The physical size of swinging chokes is more or less the same as constant inductance types; that is, of course, those having similar inductance values.

The critical values of inductance for swinging chokes can be calculated, so one should have no difficulty in determining the inductances required to cover the variation between a zero signal and full signal current.

Calculations

In the first place, one must determine the current taken from the power pack at no signal. This D.C. is the product of both the load and bleeder currents.

Now this current value must be substituted in Ohm's Law to calculate the load resistance. The voltage is the D.C. output from the filter to the load, so with two known values the third, namely R, can be evaluated.

With the load resistance now known, this in turn can be substituted in the equation $L = \frac{R}{1130}$, where

L is the required inductance in Henrys for a swinging choke at zero signal. This approximate value is the high figure of inductance, and likewise the same method can be applied to determine the inductance at the other end of the swing, that is at full signal. First, the D.C., followed by the load resistance, must be calculated, as previously explained, and substituted in the inductance equation.

From the second calculation, one has arrived at the approximate inductance at the lower end of the scale, and the reader can then select a choke that will swing between the two values arrived at.

Three typical components may be quoted from a present-day catalogue to give the reader an idea of the ratings of these components. The smallest is rated at 8 Henrys at 50 mA falling to 2 Henrys with 250 mA passing. The second is rated at 14 Henrys at 50 mA dropping to 3 Henrys at 250 mA and the last has a rating of 50 Henrys at 50 mA dropping to 10 Henrys at 250 mA. The D.C. resistance of the first two is 126 ohms and for the other 190 ohms.

B.I.R.E. Exam. Prizes for 1955

THE Council of the British Institution of Radio Engineers has announced the award of prizes to candidates who took part in the Graduateship Examination during 1955. These are as follows:

The President's Prize:

(awarded to the most outstanding candidate)
To A. C. Dev, a Junior Commissioned Officer in the Indian Electrical and Mechanical Engineers.

The S. R. Walker Prize:

(awarded to the candidate second in order of merit)
To G. R. Tyler, a medical laboratory technologist, in charge of the biochemistry laboratory at Sarnia General Hospital, Ontario.

The Audio Frequency Engineering Prize:

To N. G. Lolayekar, who is in charge of the Audio Engineering, Measurement, and Radio Sections of Eastern Electric and Engineering Co., Bombay.

The Electronic Measurements Prize:

To K. K. Nambiar, B.Sc., who has recently completed a post-graduate diploma course in electronic engineering at the Madras Institute of Technology.

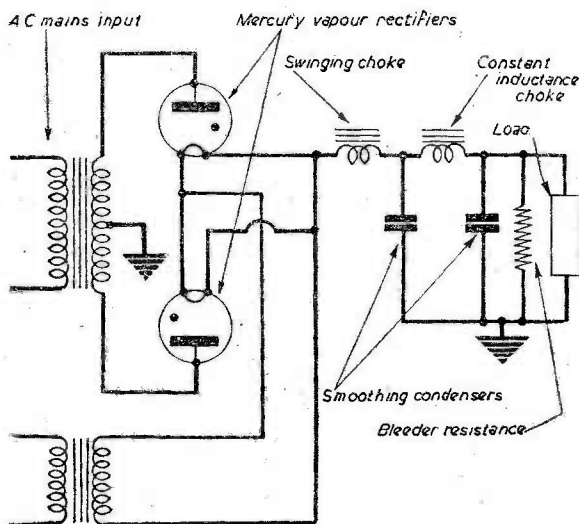

Circuit of a power supply incorporating a swinging choke

The "Modern" Battery Receiver

A SIMPLE 5-VALVE SUPERHET FOR GENERAL USE

By H. Hindle

THIS receiver is a portable, but it is not a midget or vest pocket receiver with tiny batteries that last for next to no time unless used very spasmodically. On the contrary, this is a receiver for regular usage in the home, but which can be taken in the car or for picnics on the beach or in the country or, perhaps, used as a bedroom or sickroom receiver; in fact, an "all rounder." The design was prompted, in the first place, by the predicament of members of the nursing fraternity who wanted a receiver in their private quarters, but who were forbidden to connect a mains receiver to the power supply. It was realised, however, on consideration, that such a design would have much wider appeal and that this type of receiver had been sadly neglected in the past.

What were the design considerations then for a set to fulfil this requirement? Obviously a portable type of cabinet will be a great convenience so that the receiver can be of the greatest possible use, but the cabinet must be large enough to take a reasonable size of battery. The dimensions given in this article are to suit a cabinet which was on hand but they are not critical and could be altered to suit an available case. The circuit is very stable and so long as the general layout is followed no difficulty will be experienced.

The outline of the circuit took form when considering the universal purpose of the receiver. It had to be simple to operate so that non-technical people could get good results from it, and this ruled out any T.R.F. circuit that depended on reaction for sensitivity. That can be all right in the hands of someone who understands it, but the public are now accustomed to simple, single knob tuning with an ordinary volume control and little or nothing else. So this receiver had to be a superhet. This, in fact, makes the receiver even easier to build than a sensitive T.R.F. receiver, which is much more prone to instability, so the beginner need not worry on that score.

The number of valves must be limited in a battery receiver if the battery drain is to be kept within bounds, and even with the larger size of battery to be accommodated here it is no use throwing away the precious power. By choosing superhet operation, however, we are already committed to four valves, i.e., a frequency changer, I.F. amplifier, detector and output—that is, if trick circuits are to be avoided, and that is desirable on the score of simplicity of operation and reliability. Naturally, modern, low-consumption dry battery valves are used.

Input Circuit

Conventional coils could be used in both aerial and oscillator positions, in which case an external aerial would be required, or alternatively a frame aerial could be used, serving both as aerial and as input coil. With this latter arrangement it is still practicable to use an aerial if desired, but within the

limits of the sensitivity of the combination the aerial can be avoided and the receiver becomes of much more universal use. The frame aerial was therefore chosen and fortunately the cabinet used is supplied complete with a wooden support for a frame aerial.

The signal picked up by a frame is, of course, much less than that provided by a first class aerial of a fixed installation. The directivity of the frame, however, is of advantage in avoiding interference (mains borne interference has already been avoided by using batteries) and a further advantage is the apparent improvement in selectivity by virtue of the discrimination in signals from different directions.

Subsequently, this receiver was converted to use a Ferrite rod aerial; this is described as the reader may prefer this type of aerial.

The first two valves are, as usual, the frequency changer and one I.F. amplifier, but even after this amplification the signal derived from the frame is not very large except in very unusual circumstances where the transmitter is very close to the receiver. For detector, a diode would usually be employed because it is considered to be linear and distortionless, but in actual fact the diode is linear only if the signal applied to it is of reasonable amplitude; at low amplitude of signal the diode operates differently. A more sensitive detector at low signal levels is the well-known and in earlier years the universally used leaky grid circuit which, of course, contributes some signal amplification. Though this circuit causes more distortion than the diode at higher signal strengths it is, in fact, just as satisfactory on that score at the small signal amplitudes coming from the frame. In fact, the usual diode circuit is generally followed by a high gain audio amplifying stage, actually the triode or pentode section in the same envelope. Thus the diode detector must be working on a low input signal and therefore not under circumstances most favourable for distortionless operation. For these reasons, therefore, a leaky grid detector was chosen in the present design.

A consideration of the valve characteristics of modern battery valves shows that very useful gain can be obtained at audio frequencies for negligible H.T. current and comparatively little filament current. A voltage gain of 50 times is obtainable and the low current drain is obvious from the size of load resistor, usually 1 M Ω . Even if the valve was considered as a short circuit, placing the load resistor directly across the H.T. the current flow, taking the battery voltage as 100 for convenience, would be only a tenth of a mA. A further stage of amplification in this receiver will be very useful in view of the desire to use a frame aerial and if this should be interposed between detector and output stage, where one of these very economical amplifiers can be used, it will serve the additional purpose of ensuring that the detector input is kept low by permitting more frequent use of the frame aerial unaided by external aerial. In fact, it will be seen to be better to work the receiver without external aerial whenever sufficient signal

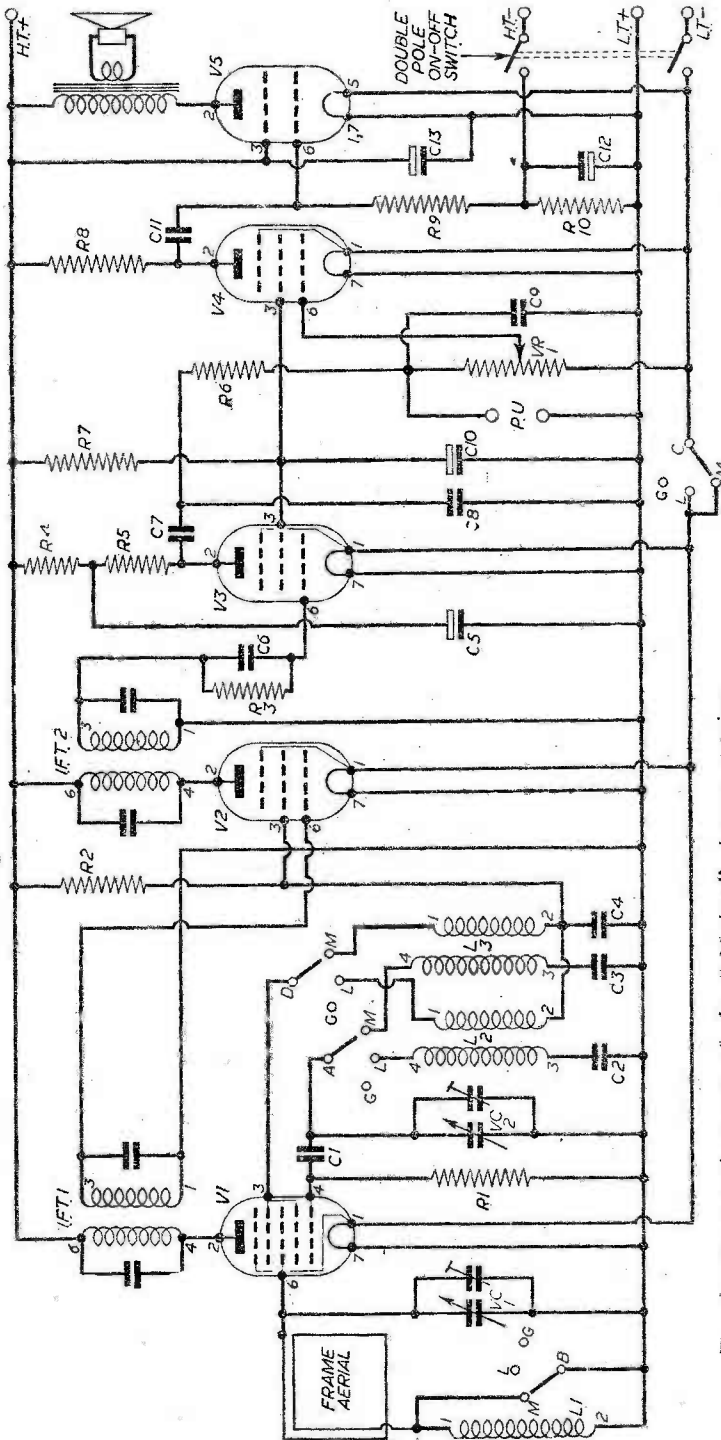

Fig. 1.—Theoretical circuit of the "Modern" battery receiver.

strength can be so obtained because the volume control will then be nearer maximum for a given volume of signal ; in other words the detector will be working on a 'smaller signal which will be better for quality.

Five valves now appear in the specification and the choice of valve types will be such as to keep down the power consumption, so the choice will clearly be the modern economy valves and for convenience of construction the modern trend of miniaturisation is followed so choice naturally fell to the B7G series.

The Circuit

The circuit of the complete receiver is given in Fig. 1. It was decided that medium and long waves should be provided. In the writer's district the long waves provide the most reliable Light programme, but in any case it seems worth while to include this, because if the set is moved about one can guarantee picking up the Light programme anywhere in the country. Short waves were not considered worth incorporating in a receiver such as this, however, as the average person never uses them and the extra complication is not worth while.

The frame aerial has to be wound to match the medium-wave oscillator coil. For long waves either a second frame could be wound or a loading coil used. The latter is more convenient, and was found to give excellent results so consequently it was adopted. For waveband switching it is only necessary to short out the loading coil on medium waves. Oscillator coils are required for medium wave and long waveband. A printed dial was provided by the suppliers of the cabinet which was used, and in order to ensure accurate calibration it was decided to use standard commercial coils with adjustable cores. Three Osborn coils are used, therefore, one long-wave loading coil, a medium-wave oscillator coil and a long-wave oscillator coil. As already stated, a frame aerial was wound to fit in the cabinet.

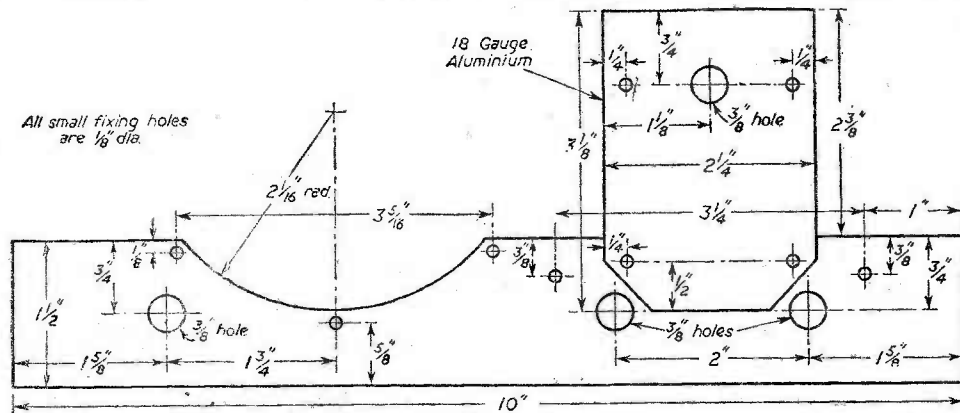

Fig. 3.—Details of the front of the chassis.

the back of the chassis to take the aerial and gramophone plugs. A dimensioned drawing is hardly necessary for this and the position of the sockets will be seen from the wiring diagram. Make quite sure, however, before drilling that the components to be used match up with the drilling diagram. No doubt, it will be found worth while to follow the usual procedure and to draw out the drilling on a sheet of drawing paper; to try on the components and, when satisfied, to use the paper as a template for marking out the chassis. Three holes to be fitted with grommets are indicated. These grommets are not absolutely necessary, but they make the chassis neater and prevent the chassis from cutting through the sleeving.

It will be noticed that no fixing holes for the valveholders are shown on the drilling diagram. The best way to deal with these is to punch out the $\frac{3}{8}$ in. holes, to drop the valveholders into the holes and to turn them until the pin sockets are disposed in the relative

positions, as shown on the wiring diagram. This is important in order to ensure that the wiring is short and follows the path taken in the prototype. Then the position of the fixing holes can be marked on the chassis and drilled.

The components can now be mounted and the illustrations will indicate clearly where these go. Notice from the wiring diagram where earthing points are required and fit soldering tags whilst assembling. Take care that the connecting pins of the I.F. transformers are in the correct positions, as indicated on the wiring diagram as identified by the numbers on the base. Before mounting the tuning capacitor solder to each of the soldering tags at the side of the component that will come over the grommet-fitted holes about 4 in. of connecting wire and feed these through the grommets as the component is mounted.

(To be continued.)

LISTS OF COMPONENTS

- | | |
|---|--------------------|
| 1 Portable cabinet. | |
| 1 Dial, dial plate, pointer | |
| 1 Outside chassis drive spindle | } To suit cabinet |
| 1 Drive drum, cord, spring | |
| 1 Output transformer, standard miniature. | |
| 3 Knobs. | |
| 1 5in. speaker (Elac). | |
| 5 Valveholders B7G (McMurdo). | |
| 1 4-pole 3-way switch, AB wafer type. | |
| 2 I.F. transformers (Wearite type M800). | |
| 1 Coil QL1 (L1) | } Osamor |
| 1 Coil QO8 (L3) | |
| 1 Coil QO9 (L2) | |
| 1 Midget 2-gang variable capacitor 500 pF (VC1, VC2) (Jackson). | |
| 1 1 M Ω volume control with 2-pole switch (Amplion). | |
| 1 Valve 1R5 (V1) | } Brimar |
| 1 Valve 3V4 (V5) | |
| 3 Valves 1L4 (V2, V3, V4) | |
| 3 100 pF capacitor (C6, C8, C9) (Dubilier type 635). | |
| 1 150 pF capacitor (C2) (Dubilier type 635). | |
| 1 300 pF capacitor (C1) (Dubilier type 635). | |
| 1 470 pF capacitor (C3) (Dubilier type 635). | |
| 3 .05 μ F capacitor (C4, C7, C11) (Dubilier type 410, 250 v.). | |
| 1 4 μ F capacitor (C10) electrolytic (Dubilier type BR, 150 v.). | |
| 1 8 μ F capacitor (C13) electrolytic (Dubilier type BR, 150v.). | |
| 1 100 μ F capacitor (C12) electrolytic (Dubilier type BR, 12 v.). | |
| 1 30 μ F capacitor (C5) electrolytic (Dubilier type BR, 150 v.). | |
| 1 680 Ω resistor $\frac{1}{2}$ watt (R10) | } Dubilier type BT |
| 1 33 K " " (R2) | |
| 2 47 K " " (R4, R6) | |
| 1 100 K " " (R1) | |
| 2 1 M " " (R3, R8) | |
| 2 2.2 M " " (R7, R9) | |
| 1 Tagboard, 3 tags plus earth. | |
| 1 Tagboard, 2 tags plus earth. | |
| 1 Two-pin socket "aerial." | |
| 1 Two-pin socket "gram." | |
| 26 s.w.g. double cotton wire. | |
| 24 s.w.g. tinned copper wire. | |
| Sleeving. | |
| 1ft. four-core cable (or two lengths of twin cable), cores colour coded. | |
| 1 4-pin battery connector. | |
| 1 Chassis 10in. x 4 $\frac{1}{2}$ in. x 1 $\frac{1}{2}$ in. with aluminium tuning capacitor support, made to suit cabinet to be used. | |
| 1 Wooden frame to take frame aerial and to fit inside the back of the cabinet, or alternatively, if desired, | |
| 1 Ferrite rod aerial, medium wave (Osamor). | |

The **NEW**
I. C. S.

LEARN-AS-YOU-BUILD

PRACTICAL RADIO COURSE

**LEARN
RADIO**

as you build your own
receiver and testing
instruments

This new addition to the unrivalled I.C.S. range of technical training courses offers you a double opportunity. Here is your chance to gain a sound knowledge of basic Radio and Electronics theory—under expert tuition—whilst building your own 4-valve radio receiver, signal generator and high-quality multi-tester.

WHAT YOU GAIN. At the end of the course you will have gained not only three pieces of equipment of permanent practical usefulness: you will have accumulated a personal 'library' of reference material—I.C.S. Instruction Manuals, expertly edited and presented—which you can keep by you always for guidance. Furthermore, you will have gained immeasurably in knowledge, through a balanced combination of study and practical work—with the specialised help of the world's largest correspondence school.

TRAINING TO SUIT YOUR NEEDS. Whether you plan to have a business of your own, to become a service engineer, to pursue a career in the radio industry, or to take up radio as a serious hobby—this course provides the ideal way of obtaining a firm foundation of essential knowledge. If you are an intending examination candidate, I.C.S. training offers you the most thorough preparation you could have.

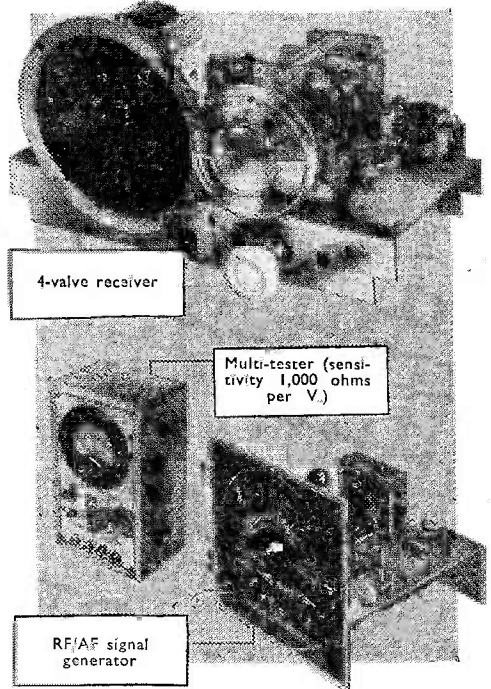

● All the equipment shown here is sent to the student as part of the course: you don't have to buy anything extra.

There are I.C.S. courses to meet your needs at every stage of your career.

Other courses include: RADIO ENGINEERING, RADIO SERVICING AND SALES, BASIC RADIO, RADAR ENGINEERING, BASIC RADAR, F.M. ENGINEERING, TELEVISION ENGINEERING, TELEVISION SERVICING, BASIC TELEVISION, ELECTRONIC ENGINEERING, INDUSTRIAL ELECTRONICS, BASIC ELECTRONICS and guaranteed coaching for professional examinations.

**POST THIS
COUPON
TO-DAY**

for a FREE book on careers in Radio, etc., and full particulars of I.C.S. courses.

INTERNATIONAL CORRESPONDENCE SCHOOLS LTD. Dept. 170 G.
International Buildings, Kingsway, London, W.C.2.

Name.....

Address

4.57

INTERNATIONAL CORRESPONDENCE SCHOOLS

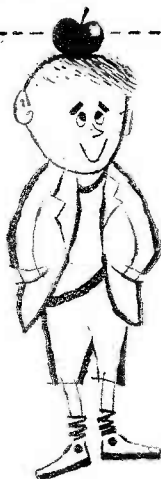

PRECISION-BUILT COMPONENTS

JACKSON "O" GANG CONDENSER

Miniature model in 1 or 2 gang, capacities up to 365 pf swing, front area $1\frac{3}{8}$ in. x $1-17/32$ in., including sweep of vanes, length 1 Gang 1 in., 2 Gang $1\frac{1}{2}$ in., Spindle $\frac{1}{4}$ in. dia. x $\frac{3}{4}$ in. long.

Aluminium vanes, cadmium plated steel chassis.

Price

1 Gang 7/6 2 Gang 11/6

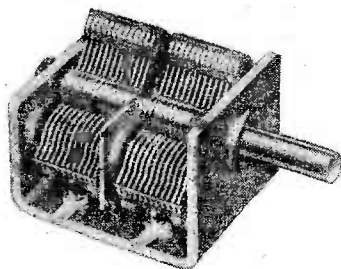

CAT. No. 5250



**IT'S RELIABLE IF IT'S
MADE BY JACKSONS!**

Please write for illustrated catalogue.

JACKSON BROS. (London) LTD.

KINGSWAY . WADDON . SURREY

Telephone : CROydon . 2754/5

HOME RADIO OF MITCHAM

187 LONDON ROAD, MITCHAM, SURREY

MIT. 3282

The full range of

EDDYSTONE

short wave components in stock.
Eddystone catalogue price 1/-.

THE BEGINNERS "SHORT WAVE 3"

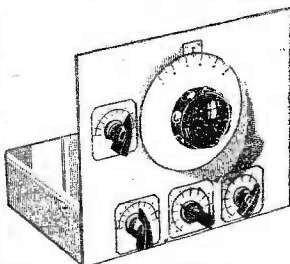

We can supply all the parts for this efficient little 3 valve A.C. operated short wave receiver. Ideal for serious long distance reception and also as stand-by set, or as a compact bedside receiver. Detailed price list will be sent on request. This set was fully described and illustrated in the Practical Wireless, Nov. and Dec. issues. REPRINT OF DATA 1/-

THE "JASON" F.M. TUNER KIT

The most successful Home Constructor design ever produced. Build yours to-day and enjoy the thrill of Hi-Fi crystal clear reception. All parts standard and in stock. Full constructional data including point-to-point and price list. PRICE 2/-.

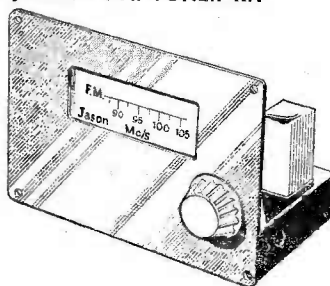

MULLARD 5 VALVE 10 WATT

Quality Amplifier

Full

Constructional
Details including
F.M. Tuner and
Price List, 3/6.

Parts stocked for Mullard Tape Amplifiers.

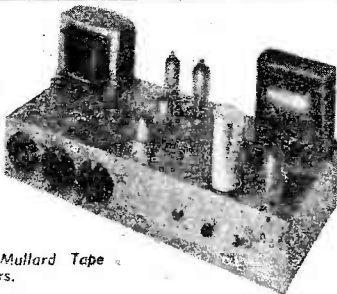

COULD THE R.E.P. 1 VALVE ALL-DRY BATTERY SET

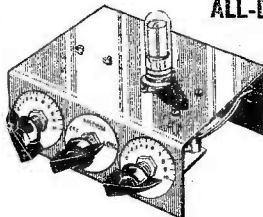

Complete kit of parts including valve 33/6, H.T. and L.T. battery 8/3, Headphones 14/- pair. Full constructional details and price list, price 9d. post paid.

An Easily Built Cross-over Unit

DESIGNED PRIMARILY FOR THE NEW LOUDSPEAKER ENCLOSURE DESCRIBED IN THE OCTOBER ISSUE

By Arthur Adams

THE description of the New Speaker Enclosure has roused a great deal of interest and from the many letters received it is evident that there are many readers who are not satisfied with their present equipment and are determined to do all they can in the search for High Fidelity.

It is really surprising to find a large number still using the old-fashioned type of *top-cut* tone control and cabinets that will boom, even with a piccolo solo. They live with it and get used to it. Some even boast of the glorious bass they have secured.

A good test for your equipment is provided by the human voice. When a talk is being broadcast, set the volume to a normal speaking level and listen to it from just outside the door of the room. It should then sound as if the person were then talking inside the room. If there is any boxiness or background

capacity in the cross-over unit which by-passes the higher frequencies across the bass speaker.

Construction

We will now describe a simple and inexpensive cross-over unit which can be easily built and assembled on a ply baseboard about the size of a postcard. Paper block capacitors are necessary, and many of the advertisers in this journal can supply these quite cheaply. Capacitors of the electrolytic type cannot be used, as the capacity build-up in these can only be secured by a D.C. potential. It should be appreciated that the audio signal is alternating and cannot provide the one-way potential which is necessary for any such build-up.

About four of these block condensers should be secured, say, two at 4 μ F and two at 2 μ F. These can be connected in parallel so that different capacities of 2, 4, 6, 8 and 12 μ F may be tried across the bass speaker.

The required inductance is made from a $\frac{1}{2}$ lb. reel of 22 s.w.g. enamelled copper wire. This is hank-wound and taped, with 1 $\frac{1}{2}$ in. inner diameter. This hank-winding often presents a difficulty to the inexperienced and a spool or bobbin may be preferred.

The core of the bobbin should be $\frac{1}{2}$ in. thick and 1 $\frac{1}{2}$ in. in diameter and the cheeks are of paxolin or cardboard 2 $\frac{1}{2}$ in. in diameter. These are glued firmly together and a hole drilled through the centre for the fixing screw. The wire may be anchored by small holes in the cheeks.

How it Works

Referring to the theoretical diagram it will be observed that the large capacity is across the bass

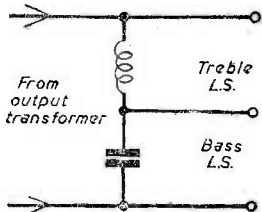

Fig. 1.—The circuit of the cross-over unit.

colouration, you may be sure the cabinet is at fault. If there is any rattling or cross modulation the amplifier or speaker equipment is suspect. In most of the radiograms the writer has listened to the feminine voice is woolly and grotesque. From outside the door of the room you should not be able to tell whether the voice is actual or reproduced. That is high fidelity.

Many readers already possess suitable speakers for the new enclosure and we can inform them of those which were used in the final tests with excellent results.

Bass	Treble	Cross-over unit
Wharfedale W12/CS	Super 3	2,000 c.p.s.
Rola G.12 (pre-war)	Plessey 6in. Ellip :	1,000 c.p.s.
Goodman Audiom 60 (Bass)	Goodman "Axierte"	1,000 c.p.s.
Goodman Audiom 60 (Bass)	Plessey 6in. Ellip :	2,000 c.p.s.

The Goodman Audiom 60 with the bass cone is recommended, as the cone resonance is well below any broadcast frequencies. Speakers with a cone resonance in the region of 50 or 100 c.p.s. should be avoided, as they are liable to accentuate any mains hum which may be present in the amplifier output.

The different frequencies shown in the cross-over units are necessary in order to accommodate different types of treble speakers. For instance, if your treble speaker shows signs of distress or a rattle when the volume is raised, the cross-over point should be lifted in order to give more work to the bass speaker. This is easily accomplished by decreasing the value of the

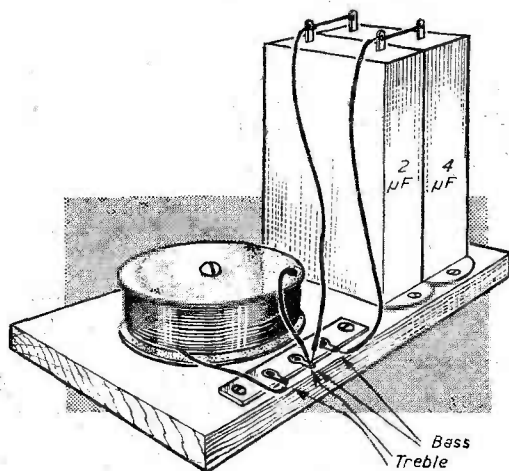

Fig. 2.—Practical constructional details. The input is taken to the two outside tags, and the two speakers are connected as shown.

speaker. This by-passes or cuts away the higher frequencies from the bass speaker, and feeds them to the treble. The size of this parallel capacity determines the position of the cross-over and how much "top cut" is applied. It will also be observed that it feeds these higher frequencies to the treble speaker with which it is in series. The inductance is in parallel with the treble speaker and its reactance or reluctance obstructs the higher frequencies and causes them to pass through the treble speaker. The inductance value also assists in the determination of the cross-over point. The higher the inductance value, the wider is the upper register. The lower frequencies pass easily through the inductance in order to operate the bass speaker.

It should be appreciated that these inductances must always be made with wire of fairly heavy gauge and low resistance. Otherwise, with an inductance of 3 ohms resistance and a speech-coil of 3 ohms, half the signal would be dissipated in the wire.

The unit described here is of the quarter-section type and cannot, therefore, present the problem of phasing or the alteration of the polarity of the loudspeakers.

The cross-over unit does not provide an abrupt cut in the frequency range or give a precise separation of the two loudspeakers. Its chief characteristic is a gradual attenuation or falling-off of the higher frequencies in the bass speaker and a gradual

roll-off of the lower frequencies in the treble.

In this way the larger excursions of the cone, which are the requirement of bass notes, are confined to the larger speaker; and the movements of smaller amplitude, which are set up by the higher frequencies, are accommodated by the tweeter.

The Values

With 15 ohms loudspeakers and a cross-over at about 2,000 c.p.s. the capacitor of 6 μ F is used (4 μ F and 2 μ F connected in parallel). This will be found suitable for speakers from 9 to 15 ohms impedance. To lower the cross-over point, increase the capacity to 8 or 10 μ F. Where speakers of 2 to 6 ohms impedance are used it will be necessary to double the capacity and use for the inductance a wire of heavier gauge to reduce the resistance, say, 18 s.w.g.

The unit described is easily accommodated in the speaker enclosure and should be fixed to the panel immediately below the treble speaker. Ensure that it is clear of the shelf when fixing.

A three-way tag-strip fixed to the baseboard will assist in the assembly and all connections should be carefully soldered. The wire from the inductance should have its enamel scraped away or cleaned with sandpaper before tinning and soldering. It will be seen from the diagrams that the centre tap is common to both speakers.

Telephone Weather Service

FOR the extension of the G.P.O. Telephone Weather Service to seven provincial centres, new recording and replay equipment has been adopted by the Post Office. Basically, this is the well-known Emidicta office dictating machine, chosen for its established reliability, its ease of handling by non-technical staff, and its adaptability to the specialised P.O. technical and operational requirements.

The Emidicta is a magnetic disc recording and replay instrument using an 11in. plastic disc coated with high coercivity magnetic material (similar to the now-popular recording tape), over the centre of which is placed a spiral tracking disc. Attached to the underside of the arm carrying the record/replay head is a toothed wheel which engages with the grooves on the tracking disc and so tracks the head across the magnetic disc. It also steps the head back as required to repeat part or all of the recording when it is caused to rotate by means of pulses supplied to it from a repeater mechanism. Erasure of the recording is made by lowering a special multi-pole permanent magnet into close proximity with the disc.

The special Emidictas supplied to the Post Office incorporate certain modifications which have been carried out by the E.M.I. technicians in co-operation with the Post Office engineering staff to enable it to produce automatically a continuous repetition of the recorded message.

An adjustable rod, sliding in a tube and capable of being locked in any desired position by the operator, is mounted on the arm carrying the head. Micro-switches are fitted at the outer and inner limits of the travel of the arm. The outer micro-switch is actuated when the head is in the correct position at the start of the disc and it initiates the recording or the replay; the inner micro-switch is actuated by the adjustable rod when the head arm reaches the end of the record-

ing; this operates the replay providing the step-back pulses which return the head to its outer position.

Operation

The machine is first switched to "Record" and the head arm is positioned so that the outer switch is just closed. At the end of the recording the machine is stopped and switched to "Replay"; the movable rod on the head arm is then adjusted so that the inner micro-switch just closes and initiates the step-back pulses. When the head arm reaches the "start" position again, the outer micro-switch closes, the pulses are cut off and the recording is reproduced in the normal way, after which the cycle of operations is repeated automatically and continuously.

During the stepping-back process the amplifier is muted, the muting being removed by the operation of the outer micro-switch. The step-back pulses are designed to return the head to the start of the disc in not more than 10 seconds even with the maximum recording time of six minutes. The outer micro-switch is provided with a fine adjustment so that the starting position of the head can be precisely located at the beginning of the recorded message.

Since the recordings will be made by many different operators, a system of delayed A.G.C. has been incorporated to ensure that the output level will remain reasonably constant. Thus changes in input levels of up to 16 db produce no more than a 3 db change in output.

The head has been designed to use replaceable pole tips, which are easy to renew and have a life of many hundred hours. To increase by as much as four times the normal life of the pole tips a highly polished disc has been developed, while to minimise the destructive effect on the pole tips of dust and grit particles which, if allowed to settle on the recording disc become embedded in its surface, a special plastic cover has been made to cover the deck.

An F.M. Tuner

A CONVENTIONAL TUNER
BUILT WITH "SURPLUS"

PARTS

By "Mark Time"

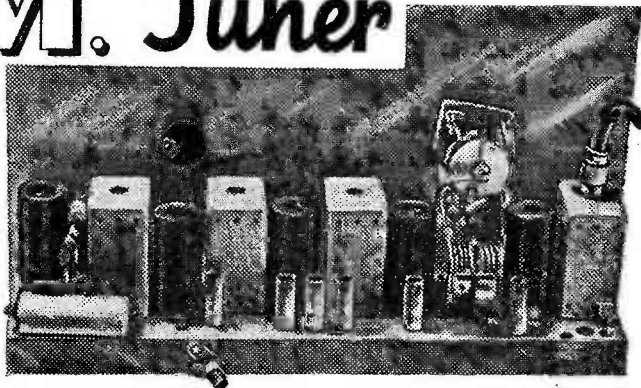

THE cheap F.M. tuner to be described was constructed from an ex-Government unit — the I.F. strip type 373, which is designed with an intermediate frequency of 9.72 Mc/s. This strip was bought in a surplus store for eight shillings; excluding valves, of course, but including a circuit diagram. It is recommended that anyone else building this tuner should obtain a circuit diagram when purchasing the I.F. strip, as it proves very useful.

The I.F. strip consists of three stages of amplification complete with four I.F. transformers. These are followed by a double diode (demodulator and a.g.c.), a noise limiter pentode and an a.g.c. amplifier. All of these have B7G bases, and this decided the type of valve to be used. The following line-up was adopted:

- V1 R.F. amplifier, 6AM6, old V1 socket.
- V2 self oscillating mixer, 6AM6, old V2 socket.
- V3 I.F. amplifier, 6AM6; old V3 socket.
- V4 limiter, 6AM6, old V4 socket.
- V5 detector, 6AL5, old V6 socket.

In a later model the 6AL5 will be replaced by two GEX34 crystals, this will lower the heater current required by the unit. The actual power supplies required by the complete unit are 20 mA at 200 volts and 1.5 amps at 6.3 volts. If the crystals are used this latter figure is reduced to 1.2 amps.

It is estimated that the total cost of the unit, including valves, if everything is purchased on the surplus market, should not exceed £4. All components required which are not in the I.F. strip have been marked with an asterisk in the components list on pages 108 and 109. Components which are taken from the original strip have their old reference in brackets on the components list.

The Intermediate Frequency of the tuner is 10.7 Mc/s; it was decided to adopt this standard frequency rather than experiment with the 9.72 Mc/s for which the strip is built. In order to bring about this change of resonant frequency of the I.F. transformers, it is necessary to change the value of the capacitors inside the cans. Only the final I.F. can, which contains the ratio detector transformer, has to have its coil rewound.

The instruments needed for final line-up are very few; a signal generator giving a C.W. output of 10.7 Mc/s and a multimeter were all that were used by the author. It must be appreciated, however, that an F.M. tuner has to be aligned much more accurately than an A.M. superhet, which will give a reasonable output with its I.F. transformers several Kc/s off peak. If, therefore, a 10.7 Mc/s signal generator cannot be begged or borrowed, it is not worth while attempting the conversion. Alternatively, it may be possible to persuade a friendly service engineer to line up the tuner for a few shillings, if your power supplies are portable enough.

Preparing the Strip for Conversion

Before removing unwanted components and drilling holes in the chassis it is best to decide whether detection is going to be by means of GEX34 crystals or 6AL5 double diode valve. The tuner in the

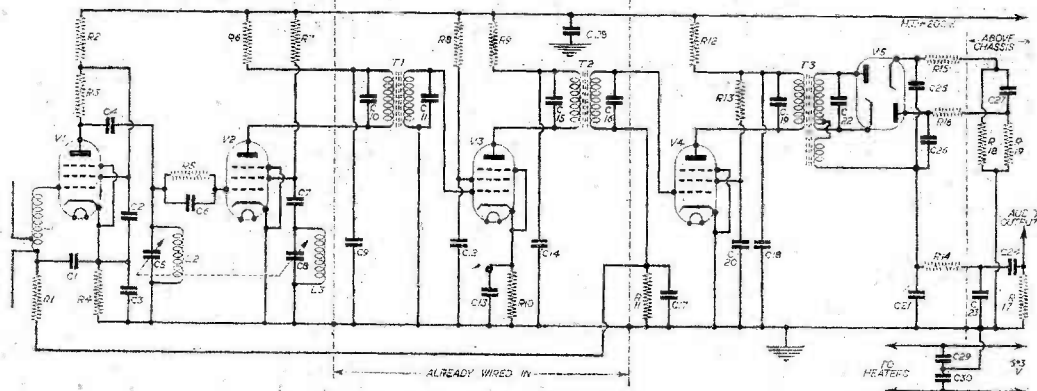
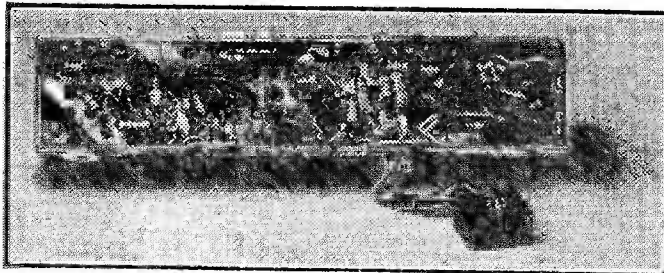

Fig. 1.—Theoretical circuit of the tuner.

illustrations uses the latter, but no decrease in performance should be brought about by use of the crystals. The 6AL5 version will be described throughout this article.

The first thing to be removed is the plug which originally carried the power supplies. This has seven wires going to it; three yellow for a.g.c. and bias, red and black for the 200 volts, and brown and grey for the 6.3 volt heaters. Of these the red, black,



Underside of the unit before modification.

brown and grey should be left untouched and the three yellow wires only removed at their source, which is on a tag strip at the side of valves 3 and 4.

Next the output cable, complete with co-axial plug, should be removed from the gain control potentiometer and stored carefully, as it also fits the aerial input socket and can be used as an aerial plug. The potentiometer itself should also be removed.

The majority of the decoupling condensers in the strip are contained in their own individual screening cans mounted on top of the chassis. There are 18 in all, and each has its circuit number painted on the outside. All of the condensers except the following should be removed from their cans when they become accessible during the stripping described.

Condensers to be left: IC13, IC14, IC15, IC16, IC27, IC29, IC30, IC31. Of these all except IC27 keep their original connections.

Proceeding next with the stripping. Having removed the gain potentiometer the next thing is to remove all wiring, and components in the wiring, in this part of the chassis, from the output of the transformer IT4 right through to where the gain control was. The heater wiring should also be

removed between valves IV4, IV5 and IV6; the valve base belonging to IV5 should be removed by drilling out the rivets. The socket marked IP2 should also be removed, together with the tag strip on the side nearest the valve base for IV6.

Transferring our attentions next to the stages prior to the transformer IT3. All the wiring and components in the wiring, excluding the heater wiring, should be removed from the aerial input up to the primary of IT3. The aerial input socket, IP1, should be removed and kept in a safe place, together with all the valve cans. The valve bases should be cleaned of all excess solder, pieces of wire, etc., on the tags. This should be done with great care, and no force used, for the tags will break easily.

The transformers IT1 and IT2 should now be removed prior to mechanical work being

done on the chassis.

Mechanical Work on the Chassis

The chassis is made of silver plated brass, and is extremely easy to work. The main constructional work involved is in fitting the I.F. transformer IT2 in the position originally held by

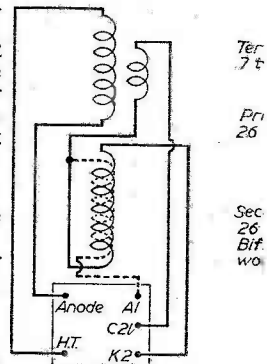
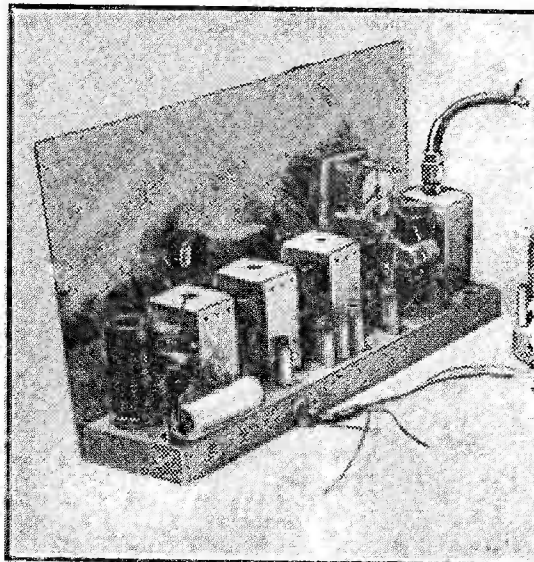

Fig. 2.—Details of



On the right is an unmodified unit, Type 373, and

COMPONENTS LIST

Capacitors

- | | |
|---------------------------------|--|
| *C1—1,000 pF Silver Mica. | *C16—70 pF Silver Mica. |
| *C2—1,000 pF Silver Mica. | *C17 (C12A)—75 pF. |
| *C3—1,000 pF Silver Mica. | *C18 (C27)—.1 μ F. |
| C4 (C8A)—75 pF. | *C19—30 pF Silver Mica. |
| *C5—0-20 pF (variable with C8). | *C20 (C1)—.01 μ F. |
| C6 (C9A)—75 pF. | *C21—330 pF Silver Mica. |
| C7 (C11A)—75 pF. | *C22—30 pF Silver Mica. |
| *C8—0-20 pF (variable with C5). | *C23—470 pF. |
| C9 (C13)—.01 μ F. | *C24 (C22)—.1 μ F. |
| *C10—70 pF Silver Mica. | *C25—330 pF Silver Mica. |
| *C11—70 pF Silver Mica. | *C26—330 pF Silver Mica. |
| C12 (C15)—.01 μ F. | *C27—8 μ F 150 v. wkg. (Electrolytic). |
| C13 (C14)—.01 μ F. | C28 (C29)—.01 μ F. |
| C14 (C16)—.01 μ F. | C29 (C30)—.01 μ F. |
| *C15—70 pF Silver Mica. | C30 (C31)—.01 μ F. |

the valve IV5. Before this can be attempted the following condenser screening cans should be removed, either with a hacksaw or by brute force. The latter method proves surprisingly successful.

The cans to be removed are : IC1, IC2, IC7, IC10, IC22 and IC23.

Next, the screening can of IT2 should be placed in the position held by IV5 and drawn around with a pencil. Using the drilling layout provided by the original position of IT2 it should now be possible to drill and file around the original IV5 valve-holder hole so that IT2 can be accommodated. A further hole should be drilled between the two secondary output holes to take the fifth connection to the ratio detector, which will be placed

inside this can.

The small screen under the position of the old aerial input socket should next be removed.

Having done this the front panel is now cut. It should be of 18 s.w.g. aluminium, 11in. long by 6in. high; the tuning capacitor has to be mounted on the panel so that it is just above the space vacated by IT2 and does not foul V1 or V2. The

capacitor shown in the illustrations is of the single hole fixing type; if, however, the bracket type is used, the bracket may be bolted to the front panel. Make sure that the screening cans can be placed on the valves.

It was decided that the 5in. diameter tuning drum was of sufficient size to form the dial. This means that the dial drive cord is in front of the panel; a nylon cord does not look unsightly. The spindle for

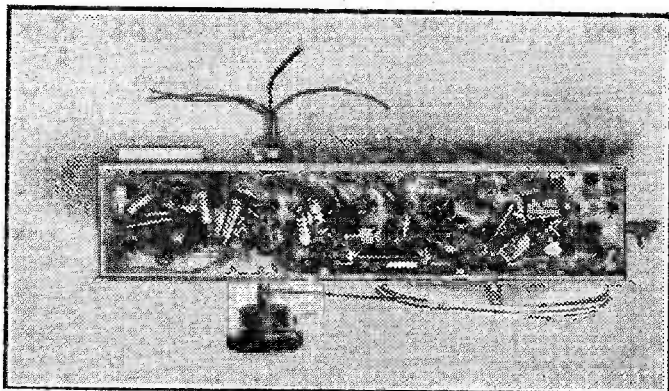

Underside after modification.

the tuning drive is simply an old volume control with the main working parts removed from the back, so that continuous rotation is possible. The cord is then limited in its axial travel by the bearing in one direction and the knob in the other. The suggested position for this spindle is level with the centre of the dial drive drum and immediately above V4. The panel then has a balanced look. Having fitted the panel by means of 6 B.A. nuts and bolts it is best to remove it and put it aside until the tuner is nearing completion. Before wiring can be commenced,

Resistors

- | | |
|--------------------------|----------------------------|
| R1 (R2)—100 K Ω . | R11 (R15)—47 K Ω . |
| *R2—6.8 K Ω . | R12 (R23)—1 K Ω . |
| *R3—4.7 K Ω . | R13 (R14)—100 K Ω . |
| *R4—270 Ω . | *R14—100 K Ω . |
| R5 (R5)—100 K Ω . | *R15—1 K Ω . |
| *R6—4.7 K Ω . | *R16—1 K Ω . |
| R7 (R3)—47 K Ω . | *R17—2.2 M Ω . |
| R8 (R9)—68 K Ω . | *R18—6.8 K Ω . |
| R9 (R7)—15 K Ω . | *R19—6.8 K Ω . |
| R10 (R8)—330 Ω . | |

Valves

- V1—4—6AM6 or equivalent
 V5—6AL5 or equivalent

Inductors and Transformers
 (Construction described in text)

- L1—5 turns 16 s.w.g.
 L2—4 turns 16 s.w.g.
 L3—5 turns 16 s.w.g.
 T1 (IT3)—I.F. transformer
 T2 (IT4)—I.F. transformer
 T3 (IT2)—Ratio detector

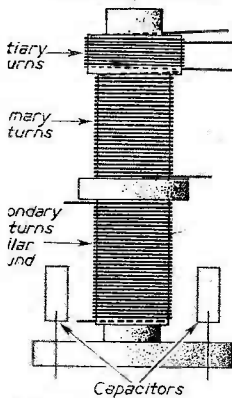
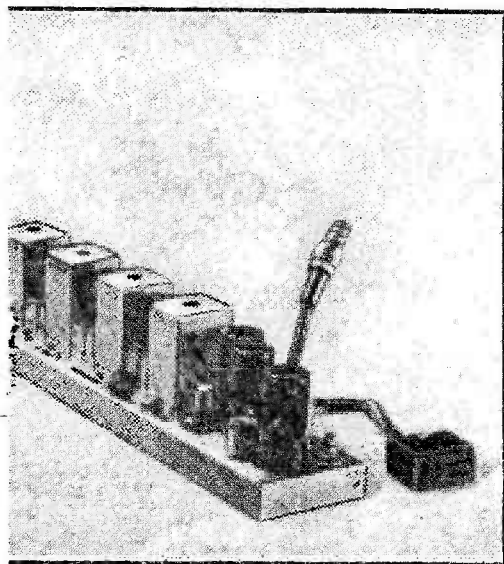

Fig. 1. I.F.T. No. 3.



View on the left the F.M. Tuner described here.

however, the transformers and coils will have to be assembled correctly.

Coils and Transformers

The alterations to the I.F. transformers IT3 and IT4 are the easiest, so they will be dealt with first. It has been proved that it is much easier to do these alterations with the transformer removed from the chassis, so the first thing to do is to lift the connections from each of the transformer terminals gently, so that they can easily be re-soldered. The screening cans are then removed and the 75 pF and 10 pF condensers unsoldered carefully. The 70 pF silver mica condensers are then soldered in place of the 75 pF ones and the cans put back. The two transformers are then replaced in circuit.

The I.F. transformer IT2 forms the basis of the ratio detector. First all the coils wound on it, and their associated condensers, must be removed. Then a third hole of about 16 s.w.g. diameter is drilled in the bottom, midway between the lead out positions for the secondary, which are coded green and white. The coding, which for the primary is red and blue, may be seen at the bottom of small holes drilled next to the lead out holes.

The primary of the ratio detector is wound at the top half of the transformer former, starting as close to the centre piece as possible. The best method of winding is to split a match in two and take a piece just a little longer than half the coil former. Leaving about 2 in. of wire for connections, one turn is taken about the extreme end of the piece of match. The primary coil, 26 turns of single cotton-covered 26 s.w.g. copper wire, is then wound around both match and former, so that when the twenty-sixth turn has been wound a turn around the match will secure the coil. It should then be covered with two layers of Sellotape.

Next, the secondary is wound. Again, this consists of 26 turns of 26 s.w.g. copper wire, but this time it is wound in a bifilar manner. This means that two pieces of wire are taken, each about 20 in. long, and 13 turns of double wire are wound on the bottom half of the former, using a match, as described above. If the bottom end of one half is then connected to the top of the other the coupling of each half to the primary will be approximately the same.

Finally, the tertiary, or third winding, is wound. This consists of seven turns of the same wire wound over the top end of the primary coil, the lower end of it being connected to the junction of the two halves of the secondary. The complete transformer is

shown diagrammatically in Fig. 2. The other components to be placed inside the screening can are the two 30 pF silver mica condensers. These are placed one across the primary and one across the secondary; the best way of doing this is to use the condenser leads as leads for the transformer and feed them

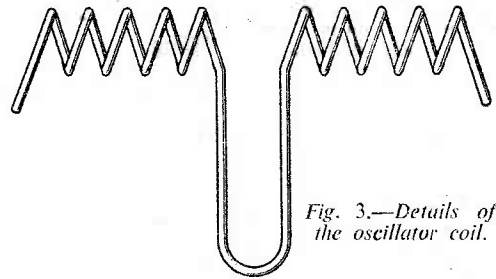

Fig. 3.—Details of the oscillator coil.

through the four original lead out holes. The ends of the coils are then soldered to them just before they leave the can. The lead from the upper end of the tertiary winding is taken straight out through the specially drilled hole. The transformer is now fixed in position.

Next to be wound is the oscillator and tuning coil, L2 and L3. This consists of four (L2) and five (L3) turns of 16 s.w.g. tinned copper wire wound initially on a normal pencil, which is removed after winding. First the five turns are wound, then the end of the wire is bent back on itself and the four turns are wound; care should be taken that they are wound in the same sense as the first five turns. The distance between the two sections should be between $\frac{1}{8}$ in. and $\frac{1}{4}$ in. The coil formed will later be mounted directly on the tuning capacitor and does not have a screening can.

Finally, we have the aerial coil. This is wound on the bottom half of the old IT1, the top half of the former having been removed so that the co-axial socket IP1, which has been removed from its bracket can be mounted in place. If the hole in the top of the screening can is opened out to $\frac{1}{2}$ in. the aerial can be plugged in when the can is in position.

The aerial coil itself consists of five turns of 16 s.w.g. tinned copper wire tapped at one and a half turns from its lower end for the aerial. As neither of the ends of the coil is earthed it is necessary to insulate the aerial socket from the can. The lead outs to the underside of the chassis can be taken through two of the original holes. Once the coil has been fixed in position the wiring of the tuner can be commenced.

Wiring the Chassis

This is best done in two halves: first the limiter and detector, then the R.F. amplifier and frequency changer.

Before commencing wiring from the circuit diagram the heater wiring should be completed by connecting the heaters of V5 to those of V4. The wiring of the limiter is very straightforward, the only difficulty being in the mounting of the 8 μ F condenser. Because of its size this has to be mounted above the chassis. (To be continued)

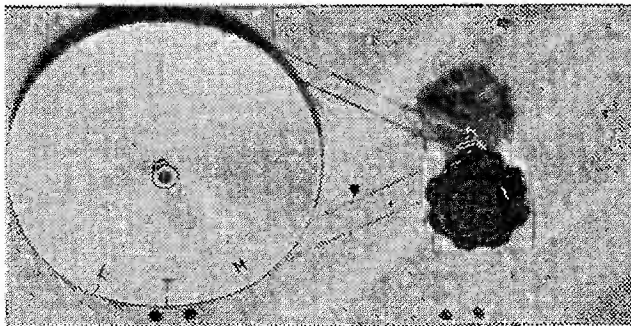

Details of the dial drive.

RISF *Quality reproduction*

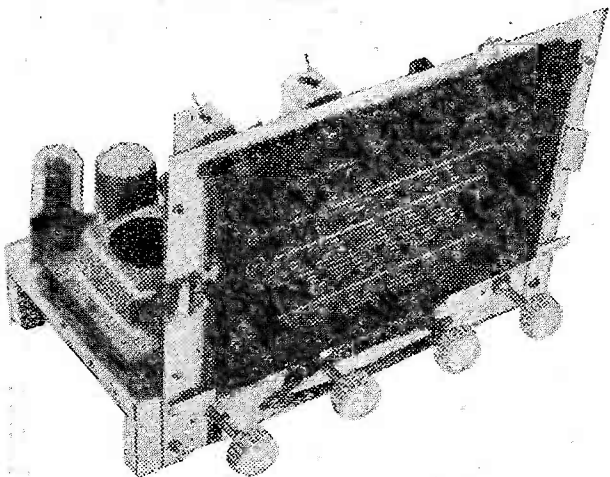

'WESTFIELD'

Five valves : superheterodyne ;
 3 wavebands : Short-Medium-Long ;
 4 Control knobs : Off/On/Tone,
 Volume, Wave-change/Gram.-Tuning.

CASH £12.12.0 or on Credit Terms:
 £3.3.0 initial payment and 8 monthly
 payments of **£1.7.5**
Packing and Carriage 12/6.

'APEX' Bureau Cabinet

in Walnut Veneered exterior and
 matched Rexine lined. **16½ Gns.**
 CASH or on Credit terms : **£4.6.8**
 initial payment and **£1.16.3** for 8
 months. *Packing and Carriage 25/-.*

★ COMPLETE RADIOGRAM

Cabinet ('Apex')	£17. 6.6
Chassis ('Westfield')	£12.12.0
Changer (B.S.R.)	£9.15.0
Speaker...	£1.10.0

Total ... **£41.3.6**

Packing and Carriage 30/-.

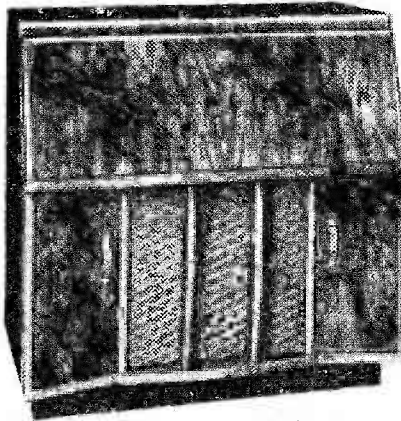

★ AUTOMATIC RECORD CHANGERS ★

COMPLETE
 CATALOGUE
 AVAILABLE
 ON REQUEST

Latest-type four-speed auto-changer, incorporating 16 r.p.m. for "talking-books" and arrangement for manual control. Fitted with high-fidelity H.G.P. 37. Crystal Turn-over Pick-up head. A.C. mains 200/250 volts. 50 cycles only.
Packing & Carriage 12/6. **£9.15.0**

Latest Garrard R.C. 88 Model fitted with G.C.2 Crystal Turn-over Pick-up head. A.C. 200/250 volts. 50 cycles.
£13.0.0
Packing & Carriage 12/6.

★ **LOUDSPEAKERS, GRAM AMPLIFIERS, ETC.**

RADIO INSTRUMENT SUPPLY FACTORY

STATION ROAD · HAROLD WOOD · ESSEX · INGREBOURNE 2935

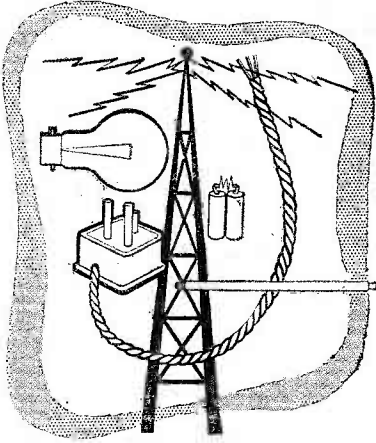

ON THE BEAM

Smith's have books on the newest developments in radio and television circuit design, construction and servicing. No matter what your problems or interests are, you can be sure of getting the books you need through your local branch of Smith's. Books not available on demand can be quickly obtained from Head Office. Lists of the standard works on any subject gladly supplied.

• Stationery and printing can also be supplied by your nearest Smith's branch.

**W. H. SMITH
& SON**
for technical books

HEAD OFFICE: STRAND HOUSE, LONDON, W.C.2

QUALITY F.M. TUNER UNIT

SPECIAL PRICE £5-12-6
(P. & P. 2/6-C.O.D. 1/6)

Circuit similar to that described in Data Publications, Ltd., Radio Reprint No. 2 (3rd Edition). Price includes all components, including chassis, dial, drive, diodes, valves, nuts, bolts and, in fact, everything needed. This is a Kit.

Alignment charge 7/6 plus 2/6 P. & P.

Fully Wired, Aligned and Tested, £7.5.0.
Extra components for Fringe Area, 12/6. Valve 9/- extra.

Power Pack Components, 30/- Booklet 2/2.

Power Pack for F.M. Tuner (both models). Fully wired and complete on chassis, 40/- (P. & P. 2/6).

Power Pack and Two-valve Amplifier on Chassis. Fully wired and working (less Speaker), 65/- (P. & P. 2/6).

Speakers. P.M. 2-3 ohm., 6½ in., 16/6 ; 8in., 20/-.

Garrard RC110 (250 v. A.C.) Mixer Auto-changers. 3-speed, £7.17.6 (plus 3/6).

See P.T. for our Band III Converters.

SEND S.A.E. FOR FULL PRICE LIST

GLADSTONE RADIO

82B, High St., Camberley, Surrey. Phone : 2633.

Open Saturdays to 5 p.m.

MAKE SOUND JOINTS SIMPLY BY USING Multicore

ERSIN MULTICORE

Contains 5 cores of extra-active, non-corrosive Ersin Flux. Prevents oxidation and cleans surface oxides.

SIZE 1 CARTON

5/-

**HANDYMAN'S
CARTON**

Suitable for 200 average joints. 6d.



Wherever precision soldering is essential, manufacturers, engineers and handymen rely on MULTICORE. There's a MULTICORE SOLDER just made for the job you have in hand. Here are some of them.

ARAX MULTICORE

FOR METAL FABRICATION

(Not wire-to-tag joints)

Contains 2 cores of Arax flux. Flux residue is easily removed with water.

SIZE 8 CARTON

5/-

Handymans Carton 6d.



**HOME CONSTRUCTORS
2/6 PACK**

In addition to the well-known Home Constructors Pack (containing 19ft. of 18 s.w.g. 60/40 alloy) a similar pack is now available containing 40ft. of 22 s.w.g. 60/40 alloy especially suitable for printed circuits.



BIB WIRE STRIPPER

AND CUTTER

Strips insulation without nicking wire, cuts wire cleanly, splits extruded flex 3/6 each



MULTICORE SOLDERS LTD.,

MULTICORE WORKS, HEMEL HEMPSTEAD, HERTS. (BOXMOOR 3659)

G.R.T. ISOLATION TRANSFORMER

Type A. Low leakage windings. Ratio 1:1.25 giving a 25% boost on secondary. 2 v., 10.8; 4 v., 10.8; 6.3 v., 10.6; 10.8 v., 10.6; 13.2 v., 10.6. Ditto with mains primaries, 12.6 each. Type B. Mains input 230/240 volts. Muffi Output 2, 4, 6.3, 7.5, 10 and 15 volts. Input has two taps which increase output volts by 25% and 30% respectively. Low capacity, suitable for most Cathode Ray Tubes. With Tag Panel, 21/- each. Type C. Low capacity wound transformer for use with 2 volt Tubes with fulling emission. Input 230/240 volts. Output 2, 2.1, 2.1-3 volts at 2 amps. With Tag Panel, 17.6 each. NOTE.—It is essential to use mains primary types with T.V. receivers having series-connected heaters.

TRIMMERS, Ceramic. 30, 50, 70 p.f., 9d., 100 p.f., 150 p.f., 17s; 250 p.f., 1/8; 500 p.f., 750 p.f., 1/9. RESISTORS. All values. 10 ohms to 10 meg., 5c., 4d., 1/2 w., 6d., 1 w., 9d., 12 w., 1/1.

HIGH STABILITY. 1 w., 1/2 w., 2 w., Preferred values 10 ohms to 10 meg. WIRE-WOUND RESISTORS 1/3 10 watt; 25 ohms—10,000 ohms..... 1/6 15 watt; 25,000 ohms—50,000 ohms, 5 w., 1/9; 10 w., 2/3.

12/6 PURETONE RECORDING TAPE

1,200 ft. on standard fitting, 7" Plastic reels. Brand new, boxed, 12/6. Spools 5" metal, 1/6; 7" plastic, 4/3. FERROVITE 1,200 ft. Plastic Tape 25/-

TOP TRANSFORMERS. Heavy Duty 50 ma., 4.5. Multitap, push-pull 6/8. Tapped small pentode, 3.9. L.F. CROKES 15/10 H. 0065 ma., 5/-; 10 H. 120 ma., 19/9; 15 H. 150 ma., 12.8. MAINS TRANS. 270-0-270, 80 ma., 6.3 v. Tapped 4 v., 4.4, 5 v., Tapped 4 v., 2 v., ditto 250-0-250, 21.2. HEATER TRANS. Tapped prim. 200/250 v., 6.3 v., 1 1/2 amp., 7/8; tapped sec. 2, 4, 6.3 v., 1 1/2 amp., 9/6; prim. 330 v. Sec. 6.3 v. 3 amp., 10.6. COPPER PLATED AERIAL RODS. 1/2 x 12 in. push fitting, 3/- each. ALUMINUM FORMERS and cone, 1 1/2 in., 8d.; 1 in., 19d. 3 in. FORMERS 5937/8 and cone, 1 1/2 in., 2 in., 3 in. 2 1/2 in. and 3 in. sq. x 1 1/2 in., 2- in., with cores.

TYANA.—Midget Soldering Unit, 200/240 v. or 220/250 v., 10/9. Solon Instrument from 24/-. LOUISPARABERS. M, 3 OHM, 12 in. 17/6. 5 in. Goodmans, 12/8. 7 in. x 1 in. Goodmans, 21/- 3 in. square, Elec., 21/-. 8 in. Elec., 22/8. 4 in. Goodmans, 18/3. 10 in. R. & A., 30/- T81 Tweeter, LH75, 8/6. 1 1/2 in. Plessey, 30/-. LOUISPARABERS. C, 6.3 v., 2- GEK34, 4/- CRYSTAL DIODES. C, 6.3 v., 2- GEK34, 4/- HIGH RESISTANCE PHONES. 4,000 ohms, 18/3 pr.

CRYSTAL MIKE INSERT by Acos, precision engineer. Size only 1 1/2 x 3/16 in. Bargain Price 6/3. No transformer required.

SWITCH CLEANER Fluid, squirt sprout, 4.3 tin. TWIN GANG TUNING CONDENSERS. 365 pf. midget 1 1/4 in. x 1 1/4 in., 10/-, .0005 Standard size with trimmers, 9/-; less trimmers, 8/-; ditto, called, 2/6; .0005 mfd. 1/4 gang, 7/6. 100 p.f., 10/6. SPEAKER FRET. Expanded Metal Silver, 15 1/2 in. x 9 1/2 in., 2/-; 14 1/2 in. x 12 in., 3/-; 4 in. GOLD COLLOID, 18 in. x 2 1/2 in., 5/-; 25 in. x 2 1/2 in., 10/-.

VALVES

Table with columns: All Boxed, 5/6, KA50, 0/6, 10/6, 1R5, 6B8, 954, 6AL5, 52A7, 7T4, 012, 6J5, 6J5, 12A17, 384, EF50, E1148, 6K7, 12K11, 3V4, EF41, EB34, 18B1, 18F50, 5U4, EF41, 9/8, HV92, ECL39, 6AM3, EF92, 806 (near), 8P41, 6AT9, 6T7, PEN 46, 6HM6, 6SK7, 8P41, 6K8, 7/6, 7/8, EL11, 68L7, 6B86, 6V60, 12BF6, EL84, 68N7, 6B86, 6X4, EL82, EL24, 6V6GT, 6D6, 6X5, HV92A, KTR30, EKC33, 6F8, 807, PEN25, MC14, EF90, 6K7GT, EF20, VP23, 12K7, 8V1, Red, EF91, 11/8, 52A1, E280, EY71, U25, PL81, 6Q7



1957 RADIOGRAM CHASSIS

THREE WAVEBANDS FIVE VALVES. S.W. 16 m.—50 m. LATEST MULLARD. M.W. 200 m.—530 m. PCR42, E341, EBC41, L.W. 800 m.—2,000 m. EL11, E240. 12 month guarantee. A.C. 200/250 v. 4-way Switch; Short-Medium-Long-Gram. A.T.C. and Negative feedback 4.2 watts. Chassis 131 x 5 1/2 x 2 1/2 in. Glass Dial 10 x 4 1/2 in. horizontal or vertical available. 2 Pilot Lamps, Four Knobs, Walnut or Ivory. Aligned and calibrated. Chassis isolated from mains. T.S.L. Tweeter Supplied Free!

10 gns. Carr. & Ins., 4/3

TERMS: Deposit £5.50 and six monthly payments of £1.

AM/FM RADIOGRAM CHASSIS

Measurements 13 1/2 in. x 5 in. x 7 in. high. Dial cut-out required only 10 1/2 in. x 2 1/2 in. 3 valve plus metal rect., gram socket, piano key wavechange, tone control, mel., long and V.H.F. wavebands. Valve line-up: ECK35, E241, E139, LAB780, EL41. For A.C. mains 100-250 v.

PRICE £16.19.6 Carriage 10/6

MATCHED SPEAKERS FOR BOTH CHASSIS 19s, 19/6; 10 in., 25/-; 12 in., 30/-.

B.S.R. MONARCH 4-SPEED RECORD CHANGERS

Brand new and fully guaranteed 12 months.

NOT JOB LINE REJECT STOCK

Designed to play 16, 33, 45, 78 r.p.m. Records, 7 in., 10 in., 12 in. Lightweight Xtal pick-up, turnover head, two separate sapphire styl, for Standard and L.P., each plays 2,000 records. Voltage 200-250 A.C.

OUR PRICE £8.15.0 each, Post Free.

Terms: Deposit £5 and 5 monthly payments of £1. Size required 14 in. x 12 in. 5 in. above and 3 in. below.

TRANSISTORS

JUNCTION TYPE (RED-SPOT) For use in Radio Control, Signal Tracers, Local Station Receivers, Oscillators, Transistor Voltmeters, Microphone Pre-Amplifiers, etc.

BRITISH 10/- each. Brand New.

May be used in place of Mullard 07L.

5 gns. Sorry—No C.O.D.

ALLDRY UNIT POWER PACK. Replaces Battery B114, etc., 69 v. plus 1 1/2 v. Size 4 1/2 in. x 2 1/2 in. x 1 1/2 in. 4-pin Socket. A.C. 200/250 v. 2A012 MAKE. LIST PRICE, 65/-.

B.S.R. MONARCH 3-speed Motor and Turntable with selecting switch for 33, 45 and 78 r.p.m. records. 100-120 v. and 200-250 v. A.C. 30 cps. Also B.S.R. MONARCH Lightweight Pick-up with Acos Xtal turnover head, separate sapphire styl for L.P. and Standard records.

SPREADSHEET, THE TWO £4.12.0 post 2/6. T.V. FREE-AMP (McMICHAEL). Tremble Channels 1 & 2. (With Amplify Output of your Band 3 Converter.) Midget size. High Gain. Ready for use. (H.T. 200 v., L.T. 6.3 v., 3 amp. required.) BRAND NEW, 25/- each.

MAINS POWER PACK for above, 25/- extra. SUPERHEAT COIL PACK. 27/6. Miniature size 2 1/2 in. x 2 1/2 in. x 1 1/2 in. High "C" Dust covered Cuts. Short, Medium, Long, Gram Switching. Single hole fixing with connection diagram and circuit. 465 Kc/s I.F.

TELETRON BAND III CONVERTER

For London, Midland and Northern I.T.A. MARK I Suitable all T.V. makes. T.R.F. or Superhet. Really wound coils, two EF90 valves, all components, punched chassis, circuit diagram, wiring plans. COMPLETE KIT for mains operation 200-250 v. A.C. £31.0.0.

As ABOVE less POWER PACK. Requires 200 v., 20 ma. H.T. 6.3 v., 1.6 a. L.T. £2.5.0. Mark II encase £1 extra each Kit

Mains Transformers to above spec. ... 10/6 Min. Contact Rect. 250 v., 50 ma. ... 8/6 B.B.C./I.T.A. aerial crossover unit ... 8/6 Punched and drilled chassis ... 3/9 Janger chassis for Mains Model ... 6/- Teletron Unit for Mains Plans ... 15/- Full plans and circuit details ... 6d.

Volume Controls 80 ohm COAX

Long spindles. Guard Semi-air spaced Poly-need 1 year. Budget. These insulated, 1 in. dia. 10,000 ohms to 2 Meg. Stranded core. 9d. yd. No Sw. S.P.S.W. D.P.S.W. Losses cut 50% 9d. yd. 3/- 4/- 4/8 STANDARD 4 in. Coax 8d. yd.

COAX PLUGS... 1/- DOUBLE SOCKET ... 1/3 SOCKETS 1/- OUTLET BOXES ... 4/3

BALANCED TWIN FEEDER, 7 ft., 6d., 80 or 300 ohms. DIELO SCREENED per yd., 40/- 80 ohms only.

WIRE-WOUND POTS, 3 watt. Pre-Set, 4 in. T.V. Type. All values 25 ohms to 50 K., 2/- each. 50 K., 4/- (Carbon 50 K. to 2 m., 3/-).

WIRE-WOUND 4 WATT. Pots, 2 1/2 in. Spindle. Values, 100 ohms to 50 K., 5/6; 100 K., 6/6.

CONDENSERS. New stock. 10/9, 5 pf. to 500 p.f., 1/2; 100 p.f., 2/0; 200 p.f., 2/6; 500 p.f., 3/6; 1000 p.f., 4/6; 1000 p.f., 5/6; 1000 p.f., 6/6; 1000 p.f., 7/6; 1000 p.f., 8/6; 1000 p.f., 9/6; 1000 p.f., 10/6; 1000 p.f., 11/6; 1000 p.f., 12/6; 1000 p.f., 13/6; 1000 p.f., 14/6; 1000 p.f., 15/6; 1000 p.f., 16/6; 1000 p.f., 17/6; 1000 p.f., 18/6; 1000 p.f., 19/6; 1000 p.f., 20/6; 1000 p.f., 21/6; 1000 p.f., 22/6; 1000 p.f., 23/6; 1000 p.f., 24/6; 1000 p.f., 25/6; 1000 p.f., 26/6; 1000 p.f., 27/6; 1000 p.f., 28/6; 1000 p.f., 29/6; 1000 p.f., 30/6; 1000 p.f., 31/6; 1000 p.f., 32/6; 1000 p.f., 33/6; 1000 p.f., 34/6; 1000 p.f., 35/6; 1000 p.f., 36/6; 1000 p.f., 37/6; 1000 p.f., 38/6; 1000 p.f., 39/6; 1000 p.f., 40/6; 1000 p.f., 41/6; 1000 p.f., 42/6; 1000 p.f., 43/6; 1000 p.f., 44/6; 1000 p.f., 45/6; 1000 p.f., 46/6; 1000 p.f., 47/6; 1000 p.f., 48/6; 1000 p.f., 49/6; 1000 p.f., 50/6; 1000 p.f., 51/6; 1000 p.f., 52/6; 1000 p.f., 53/6; 1000 p.f., 54/6; 1000 p.f., 55/6; 1000 p.f., 56/6; 1000 p.f., 57/6; 1000 p.f., 58/6; 1000 p.f., 59/6; 1000 p.f., 60/6; 1000 p.f., 61/6; 1000 p.f., 62/6; 1000 p.f., 63/6; 1000 p.f., 64/6; 1000 p.f., 65/6; 1000 p.f., 66/6; 1000 p.f., 67/6; 1000 p.f., 68/6; 1000 p.f., 69/6; 1000 p.f., 70/6; 1000 p.f., 71/6; 1000 p.f., 72/6; 1000 p.f., 73/6; 1000 p.f., 74/6; 1000 p.f., 75/6; 1000 p.f., 76/6; 1000 p.f., 77/6; 1000 p.f., 78/6; 1000 p.f., 79/6; 1000 p.f., 80/6; 1000 p.f., 81/6; 1000 p.f., 82/6; 1000 p.f., 83/6; 1000 p.f., 84/6; 1000 p.f., 85/6; 1000 p.f., 86/6; 1000 p.f., 87/6; 1000 p.f., 88/6; 1000 p.f., 89/6; 1000 p.f., 90/6; 1000 p.f., 91/6; 1000 p.f., 92/6; 1000 p.f., 93/6; 1000 p.f., 94/6; 1000 p.f., 95/6; 1000 p.f., 96/6; 1000 p.f., 97/6; 1000 p.f., 98/6; 1000 p.f., 99/6; 1000 p.f., 100/6; 1000 p.f., 101/6; 1000 p.f., 102/6; 1000 p.f., 103/6; 1000 p.f., 104/6; 1000 p.f., 105/6; 1000 p.f., 106/6; 1000 p.f., 107/6; 1000 p.f., 108/6; 1000 p.f., 109/6; 1000 p.f., 110/6; 1000 p.f., 111/6; 1000 p.f., 112/6; 1000 p.f., 113/6; 1000 p.f., 114/6; 1000 p.f., 115/6; 1000 p.f., 116/6; 1000 p.f., 117/6; 1000 p.f., 118/6; 1000 p.f., 119/6; 1000 p.f., 120/6; 1000 p.f., 121/6; 1000 p.f., 122/6; 1000 p.f., 123/6; 1000 p.f., 124/6; 1000 p.f., 125/6; 1000 p.f., 126/6; 1000 p.f., 127/6; 1000 p.f., 128/6; 1000 p.f., 129/6; 1000 p.f., 130/6; 1000 p.f., 131/6; 1000 p.f., 132/6; 1000 p.f., 133/6; 1000 p.f., 134/6; 1000 p.f., 135/6; 1000 p.f., 136/6; 1000 p.f., 137/6; 1000 p.f., 138/6; 1000 p.f., 139/6; 1000 p.f., 140/6; 1000 p.f., 141/6; 1000 p.f., 142/6; 1000 p.f., 143/6; 1000 p.f., 144/6; 1000 p.f., 145/6; 1000 p.f., 146/6; 1000 p.f., 147/6; 1000 p.f., 148/6; 1000 p.f., 149/6; 1000 p.f., 150/6; 1000 p.f., 151/6; 1000 p.f., 152/6; 1000 p.f., 153/6; 1000 p.f., 154/6; 1000 p.f., 155/6; 1000 p.f., 156/6; 1000 p.f., 157/6; 1000 p.f., 158/6; 1000 p.f., 159/6; 1000 p.f., 160/6; 1000 p.f., 161/6; 1000 p.f., 162/6; 1000 p.f., 163/6; 1000 p.f., 164/6; 1000 p.f., 165/6; 1000 p.f., 166/6; 1000 p.f., 167/6; 1000 p.f., 168/6; 1000 p.f., 169/6; 1000 p.f., 170/6; 1000 p.f., 171/6; 1000 p.f., 172/6; 1000 p.f., 173/6; 1000 p.f., 174/6; 1000 p.f., 175/6; 1000 p.f., 176/6; 1000 p.f., 177/6; 1000 p.f., 178/6; 1000 p.f., 179/6; 1000 p.f., 180/6; 1000 p.f., 181/6; 1000 p.f., 182/6; 1000 p.f., 183/6; 1000 p.f., 184/6; 1000 p.f., 185/6; 1000 p.f., 186/6; 1000 p.f., 187/6; 1000 p.f., 188/6; 1000 p.f., 189/6; 1000 p.f., 190/6; 1000 p.f., 191/6; 1000 p.f., 192/6; 1000 p.f., 193/6; 1000 p.f., 194/6; 1000 p.f., 195/6; 1000 p.f., 196/6; 1000 p.f., 197/6; 1000 p.f., 198/6; 1000 p.f., 199/6; 1000 p.f., 200/6; 1000 p.f., 201/6; 1000 p.f., 202/6; 1000 p.f., 203/6; 1000 p.f., 204/6; 1000 p.f., 205/6; 1000 p.f., 206/6; 1000 p.f., 207/6; 1000 p.f., 208/6; 1000 p.f., 209/6; 1000 p.f., 210/6; 1000 p.f., 211/6; 1000 p.f., 212/6; 1000 p.f., 213/6; 1000 p.f., 214/6; 1000 p.f., 215/6; 1000 p.f., 216/6; 1000 p.f., 217/6; 1000 p.f., 218/6; 1000 p.f., 219/6; 1000 p.f., 220/6; 1000 p.f., 221/6; 1000 p.f., 222/6; 1000 p.f., 223/6; 1000 p.f., 224/6; 1000 p.f., 225/6; 1000 p.f., 226/6; 1000 p.f., 227/6; 1000 p.f., 228/6; 1000 p.f., 229/6; 1000 p.f., 230/6; 1000 p.f., 231/6; 1000 p.f., 232/6; 1000 p.f., 233/6; 1000 p.f., 234/6; 1000 p.f., 235/6; 1000 p.f., 236/6; 1000 p.f., 237/6; 1000 p.f., 238/6; 1000 p.f., 239/6; 1000 p.f., 240/6; 1000 p.f., 241/6; 1000 p.f., 242/6; 1000 p.f., 243/6; 1000 p.f., 244/6; 1000 p.f., 245/6; 1000 p.f., 246/6; 1000 p.f., 247/6; 1000 p.f., 248/6; 1000 p.f., 249/6; 1000 p.f., 250/6; 1000 p.f., 251/6; 1000 p.f., 252/6; 1000 p.f., 253/6; 1000 p.f., 254/6; 1000 p.f., 255/6; 1000 p.f., 256/6; 1000 p.f., 257/6; 1000 p.f., 258/6; 1000 p.f., 259/6; 1000 p.f., 260/6; 1000 p.f., 261/6; 1000 p.f., 262/6; 1000 p.f., 263/6; 1000 p.f., 264/6; 1000 p.f., 265/6; 1000 p.f., 266/6; 1000 p.f., 267/6; 1000 p.f., 268/6; 1000 p.f., 269/6; 1000 p.f., 270/6; 1000 p.f., 271/6; 1000 p.f., 272/6; 1000 p.f., 273/6; 1000 p.f., 274/6; 1000 p.f., 275/6; 1000 p.f., 276/6; 1000 p.f., 277/6; 1000 p.f., 278/6; 1000 p.f., 279/6; 1000 p.f., 280/6; 1000 p.f., 281/6; 1000 p.f., 282/6; 1000 p.f., 283/6; 1000 p.f., 284/6; 1000 p.f., 285/6; 1000 p.f., 286/6; 1000 p.f., 287/6; 1000 p.f., 288/6; 1000 p.f., 289/6; 1000 p.f., 290/6; 1000 p.f., 291/6; 1000 p.f., 292/6; 1000 p.f., 293/6; 1000 p.f., 294/6; 1000 p.f., 295/6; 1000 p.f., 296/6; 1000 p.f., 297/6; 1000 p.f., 298/6; 1000 p.f., 299/6; 1000 p.f., 300/6; 1000 p.f., 301/6; 1000 p.f., 302/6; 1000 p.f., 303/6; 1000 p.f., 304/6; 1000 p.f., 305/6; 1000 p.f., 306/6; 1000 p.f., 307/6; 1000 p.f., 308/6; 1000 p.f., 309/6; 1000 p.f., 310/6; 1000 p.f., 311/6; 1000 p.f., 312/6; 1000 p.f., 313/6; 1000 p.f., 314/6; 1000 p.f., 315/6; 1000 p.f., 316/6; 1000 p.f., 317/6; 1000 p.f., 318/6; 1000 p.f., 319/6; 1000 p.f., 320/6; 1000 p.f., 321/6; 1000 p.f., 322/6; 1000 p.f., 323/6; 1000 p.f., 324/6; 1000 p.f., 325/6; 1000 p.f., 326/6; 1000 p.f., 327/6; 1000 p.f., 328/6; 1000 p.f., 329/6; 1000 p.f., 330/6; 1000 p.f., 331/6; 1000 p.f., 332/6; 1000 p.f., 333/6; 1000 p.f., 334/6; 1000 p.f., 335/6; 1000 p.f., 336/6; 1000 p.f., 337/6; 1000 p.f., 338/6; 1000 p.f., 339/6; 1000 p.f., 340/6; 1000 p.f., 341/6; 1000 p.f., 342/6; 1000 p.f., 343/6; 1000 p.f., 344/6; 1000 p.f., 345/6; 1000 p.f., 346/6; 1000 p.f., 347/6; 1000 p.f., 348/6; 1000 p.f., 349/6; 1000 p.f., 350/6; 1000 p.f., 351/6; 1000 p.f., 352/6; 1000 p.f., 353/6; 1000 p.f., 354/6; 1000 p.f., 355/6; 1000 p.f., 356/6; 1000 p.f., 357/6; 1000 p.f., 358/6; 1000 p.f., 359/6; 1000 p.f., 360/6; 1000 p.f., 361/6; 1000 p.f., 362/6; 1000 p.f., 363/6; 1000 p.f., 364/6; 1000 p.f., 365/6; 1000 p.f., 366/6; 1000 p.f., 367/6; 1000 p.f., 368/6; 1000 p.f., 369/6; 1000 p.f., 370/6; 1000 p.f., 371/6; 1000 p.f., 372/6; 1000 p.f., 373/6; 1000 p.f., 374/6; 1000 p.f., 375/6; 1000 p.f., 376/6; 1000 p.f., 377/6; 1000 p.f., 378/6; 1000 p.f., 379/6; 1000 p.f., 380/6; 1000 p.f., 381/6; 1000 p.f., 382/6; 1000 p.f., 383/6; 1000 p.f., 384/6; 1000 p.f., 385/6; 1000 p.f., 386/6; 1000 p.f., 387/6; 1000 p.f., 388/6; 1000 p.f., 389/6; 1000 p.f., 390/6; 1000 p.f., 391/6; 1000 p.f., 392/6; 1000 p.f., 393/6; 1000 p.f., 394/6; 1000 p.f., 395/6; 1000 p.f., 396/6; 1000 p.f., 397/6; 1000 p.f., 398/6; 1000 p.f., 399/6; 1000 p.f., 400/6; 1000 p.f., 401/6; 1000 p.f., 402/6; 1000 p.f., 403/6; 1000 p.f., 404/6; 1000 p.f., 405/6; 1000 p.f., 406/6; 1000 p.f., 407/6; 1000 p.f., 408/6; 1000 p.f., 409/6; 1000 p.f., 410/6; 1000 p.f., 411/6; 1000 p.f., 412/6; 1000 p.f., 413/6; 1000 p.f., 414/6; 1000 p.f., 415/6; 1000 p.f., 416/6; 1000 p.f., 417/6; 1000 p.f., 418/6; 1000 p.f., 419/6; 1000 p.f., 420/6; 1000 p.f., 421/6; 1000 p.f., 422/6; 1000 p.f., 423/6; 1000 p.f., 424/6; 1000 p.f., 425/6; 1000 p.f., 426/6; 1000 p.f., 427/6; 1000 p.f., 428/6; 1000 p.f., 429/6; 1000 p.f., 430/6; 1000 p.f., 431/6; 1000 p.f., 432/6; 1000 p.f., 433/6; 1000 p.f., 434/6; 1000 p.f., 435/6; 1000 p.f., 436/6; 1000 p.f., 437/6; 1000 p.f., 438/6; 1000 p.f., 439/6; 1000 p.f., 440/6; 1000 p.f., 441/6; 1000 p.f., 442/6; 1000 p.f., 443/6; 1000 p.f., 444/6; 1000 p.f., 445/6; 1000 p.f., 446/6; 1000 p.f., 447/6; 1000 p.f., 448/6; 1000 p.f., 449/6; 1000 p.f., 450/6; 1000 p.f., 451/6; 1000 p.f., 452/6; 1000 p.f., 453/6; 1000 p.f., 454/6; 1000 p.f., 455/6; 1000 p.f., 456/6; 1000 p.f., 457/6; 1000 p.f., 458/6; 1000 p.f., 459/6; 1000 p.f., 460/6; 1000 p.f., 461/6; 1000 p.f., 462/6; 1000 p.f., 463/6; 1000 p.f., 464/6; 1000 p.f., 465/6; 1000 p.f., 466/6; 1000 p.f., 467/6; 1000 p.f., 468/6; 1000 p.f., 469/6; 1000 p.f., 470/6; 1000 p.f., 471/6; 1000 p.f., 472/6; 1000 p.f., 473/6; 1000 p.f., 474/6; 1000 p.f., 475/6; 1000 p.f., 476/6; 1000 p.f., 477/6; 1000 p.f., 478/6; 1000 p.f., 479/6; 1000 p.f., 480/6; 1000 p.f., 481/6; 1000 p.f., 482/6; 1000 p.f., 483/6; 1000 p.f., 484/6; 1000 p.f., 485/6; 1000 p.f., 4

TRAWLER BAND R.1155s.—The latest version of this famous Communications Receiver to be released by the Air Ministry. Covers 5 wave ranges: 18.5-7.5 Mc/s, 7.5-3.0 Mc/s, 3.0-1.5 Mc/s, 1.5 Mc/s-600 kc/s; 500-200 kc/s. As used by Coast Command, Air Sea Rescue Launches, etc. All sets thoroughly tested and in perfect working order before despatch, and on demonstration to callers. Have had only slight use, and are in excellent condition. **ONLY £12.19.5.**

A.C. MAINS POWER PACK AND OUTPUT STAGE, in black metal case, enabling the receiver to be operated immediately by just plugging in, without any modification. Can be supplied as follows: WITH built-in 6 $\frac{1}{2}$ in. Speaker, **£5.5.0.** LESS Speaker **£4.10.0.** WITH 8in. Speaker, **£6.10.0.** DEDUCT 10/- IF PURCHASING RECEIVER AND POWER UNIT TOGETHER.

Send S.A.E. for illustrated leaflet, or 1/3 for 14 page booklet which gives technical information, circuits, etc., and is supplied free with each receiver.

Add carriage: 10/6 for receiver, 5/- for power pack.

WIRELESS SET No. 19 MK.II.—The famous Army Tank Transmitter-Receiver. Incorporates "A" Set (TX/RX covering 2.0-8.0 Mc/s, i.e. 37.5-150 metres), "B" Set (VHF TX/RX covering 230-240 Mc/s, i.e. 1.2-1.3 metres), and Intercommunication Amplifier. Complete with 15 valves as follows: 6 of 6K7G, 2 of 6K8G, 2 of 6V6G, and 1 ea. 6B8G, 6H5, E1148, EF50, 807, and booklet giving circuits, notes, etc. Size 17 $\frac{1}{2}$ in. x 8 $\frac{1}{2}$ in. x 12in. Magnificently made by famous American firms. **IN NEW CONDITION. ONLY £4.19.6** (carriage, etc., 10/6), OR with 12 volt Rotary Power Unit, **£5.10.0** (carriage, etc., 15/-).

OSCILLOSCOPE No. II

Made for Anti-Aircraft Command, and just released by Ministry of Supply. Manufactured by A. C. Cosser in 1952, this is a First Grade L.F. Oscilloscope incorporating a Hard Valve Time Base, with existing speeds of 1-5-40 milliseconds, but is easily converted at a cost of a few shillings to produce speeds of 3 cycles per second to 30 kc/s. Has High Class Amplifier with Fine and Coarse gain controls, plus Brightness and Focus controls, and X and Y shifts. Conservatively rated Mains Power Pack is for nominal 115 v. and 230 v. input, and is adequately fuse protected in all circuits. Tube employed is 2 $\frac{1}{2}$ in. ACR10. Will make up into an ideal workshop or servicing oscilloscope. Has grey and black engraved front panel size 19in. x 7in., depth of unit being 12in. In heavy steel transit case, in which it can be used, or removed for standard 19in. rack mounting. Complete with leads and suggested modification data. **BRAND NEW IN MAKER'S PACKING CASES. ONLY £12/10/-** (carriage 15/-).

RF UNITS TYPE 26. For use with the R.1355 or any receiver with a 6.3 v. supply. This is the variable tuning unit which uses 2 valves EF54 and 1 of EC52. Covers 65-50 Mc/s (5-6 metres). Complete with valves, and **BRAND NEW IN MAKER'S CARTONS. ONLY 25/-** each.

CLASS D WAVEMETER. Another purchase of this famous crystal-controlled wavemeter which has been repeatedly reviewed and recommended in the "R.S.G.B." Bulletin as being suitable for amateur transmitters. Covers 1.9-8.0 Mc/s, and is complete with 100/1,000 kc/s, crystal, 2 valves ECH35, two 6-volt vibrators and instruction manual. Designed for 6 v. D.C. operation, but simple mod. data for A.C. supplied. **BRAND NEW IN MAKER'S TRANSIT-CASES. ONLY £5.19.6.** Transformer for A.C. modification 7/6.

EHT TRANSFORMERS. 5.5 kV. (Rect.) with 2 v. 1 a., 79/6. 7 kV. (Rect.) with 2 v. 1 a., 89/6. 2.5 kV. (Rect.) with 2-0-2 v. 1.1 a., 2-0-2 v. 2 a. (for VCR 97 tube, etc.), 42/6 (postage 2/- per trans.).

L.T. HEAVY DUTY TRANSFORMERS. Ex-Admiralty, with 230 v. 50 cycles primary. 1. Secondaries 5, 10, 15, 20, 25, 30 volts at 5 amps. **ONLY 29/6.** 2. Secondaries 7, 14, 21, 28 volts at 12 amps. **ONLY 42/6.** (Postage on either 2/9).

INSULATION TESTERS (MEGGERs). Read up to 20 megs. at 500 volts pressure. Overhauled and in perfect order. **ONLY £8.10.0.**

A.C./D.C. BLOWERS, 220/250 volts 300 watts. Complete with filter pads, branch for dividing outlet, flexible hoses, etc. **BRAND NEW. ONLY £4.19.6.**

POCKET VOLTMETERS.—Read 0-15 volts and 0-300 volts A.C. or D.C. **BRAND NEW AND UNUSED. ONLY 18/6.**

WALKIE TALKIE TYPE 18. Covers 6.0-9.0 Mc/s. Transmitting and receiving units in metal case, complete with valves, in excellent condition. **ONLY 79/6.**

FR1196 TRANSMITTER SECTION, complete with valves FL32, EF50, CV501, and all components. **BRAND NEW. Price ONLY 12/6.**

159 RECEIVER UNIT. Contains 1 each valve, types EF50, EA50, SP61, RL37 and 24 v. selector switch. **ONLY 7/6.**

U.E.I. CORPORATION

139, Gray's Inn Road, London, W.C.1. (Phone: TERMINUS 7937)
(Open until 1 p.m. Saturdays. We are 2 mins. from High Holborn (Chancery Lane Station) and 5 mins. by bus from King's Cross.)

YOU CAN MAKE MONEY!

Our 'Know-How' shows the easy way
NO RADIO KNOWLEDGE NECESSARY

"GOOD COMPANION"

Portable

- 4 Valve Superhet
- Medium & Long Waves
- 7 guineas complete

You can't go wrong with our
"FAULTLESS TECHNIQUE"
1/- Post free.

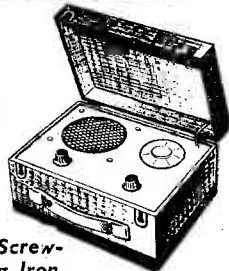

Make them all with only Screw-driver, Pliers and Soldering Iron.

The "UNIVERSAL" AC/DC.
£4.19.6.—Ideal for school-boys.

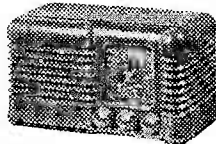

The "METEOR III" AC.
£5.9.6.—Every man can make it.

The "SIMPLEST SUPERHET." **£6.19.6.**—A perfect 5-valve set.

All plus 2/8 post & pkg. Any "KNOW-HOW" ... 1/- Post free.

Write today to:

NORMAN H. FIELD Electronics

Dept. PW, 68, HURST STREET, BIRMINGHAM, 5
Birmingham's Largest Constructors' Store



BENNETT COLLEGE

can train your mind to **SUCCESS**

WHAT CAREER DO YOU WANT?

- Building
- Carpentry
- Commercial Art
- Diesel Engines
- Draughtsmanship
- Electrical Eng.
- Fire Engineering
- Mechanical Eng.
- Quantity Surveying
- Radio Eng.
- Surveying
- Telecommunications
- Television
- Accountancy Exams.
- Auctioneer's Exams.
- Book-keeping
- General Education
- Journalism
- Languages
- Mathematics
- Police Subjects
- Salesmanship
- Secretarial Exams.
- Shorthand
- Short Story Writing
- and many others
- GENERAL CERT. OF EDUCATION**

THROUGH PERSONAL POSTAL TUITION
A FREE book vital to your career!

Read how the famous Bennett College can help you to success! Send now for this recently published FREE book, "Train your mind to SUCCESS", which tells you about The Bennett College proven success in postal tuition... and how it can help you to success in your career.

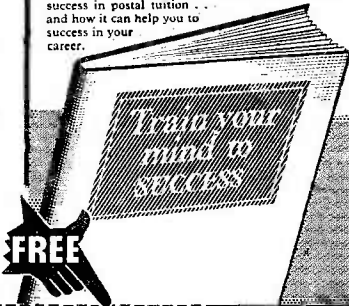

To The Bennett College (Dept. E.104N), Sheffall
Please send me, without obligation, a free copy of 'Train your mind to SUCCESS' and the College Prospectus on:

SUBJECT _____
NAME _____
ADDRESS _____
AGE (if under 21) _____ Please write in Block Letters

THIS COUPON
COULD BE YOUR
PERSONAL POSTAL
TO SUCCESS.
Send it NOW!

all bands except Band II, although this method can be used here also if a receiver such as a communications type, which covers this band, is available. Failing this, as this band is primarily used for I.F. alignment, it will generally be sufficient to spot the I.F. by injecting the modulated signal into a receiver's I.F. stage and noting the setting for maximum output. Rough, but normally quite adequate.

Varying the Note

More refined results can be obtained by beating with the output (in a similar set-up) of a calibrated generator.

Should the A.F. note not be suitable, this can be varied by adjustment of R. and C., increasing either lowers the pitch of the note, and vice versa.

Quality Diode Transistor Receiver

IN our issue dated January this year we described a receiver under the above title. In some cases, however, it appears that the reproduction of the circuit was mutilated and the connections in the output push-pull stage were indistinct. We therefore publish the circuit again below, and it will be seen if this is compared with the original that, in addition, the connection from T2 to the H.T. line has been transferred to the other side of the switch. In this manner the battery or batteries are completely disconnected.

Avoiding Damage

One or two readers have experienced great difficulty in connecting transistors in circuit without damaging them. To keep them from moving after they have been wired in circuit they may be attached to a sheet of paxolin, passing the leads through holes drilled in the sheet, or even sticking them in place with a good adhesive. Various suggestions on these lines have been made by readers, although in the original they were merely suspended in the wiring and the connections neatly taped to avoid short-circuits. So far as the actual process of making the connections is concerned, it is essential to use a

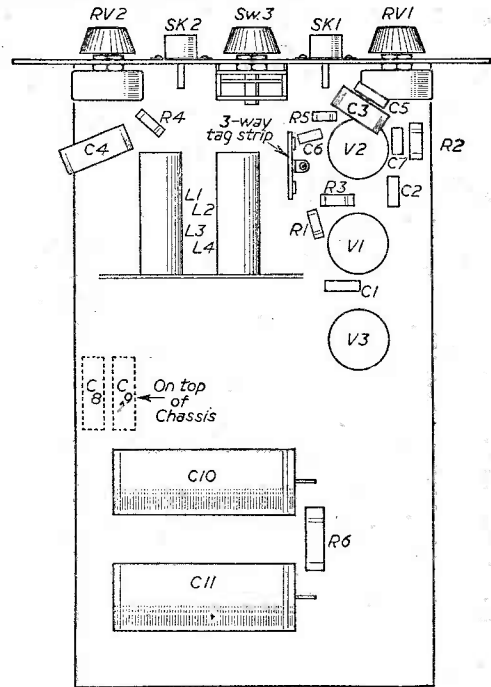
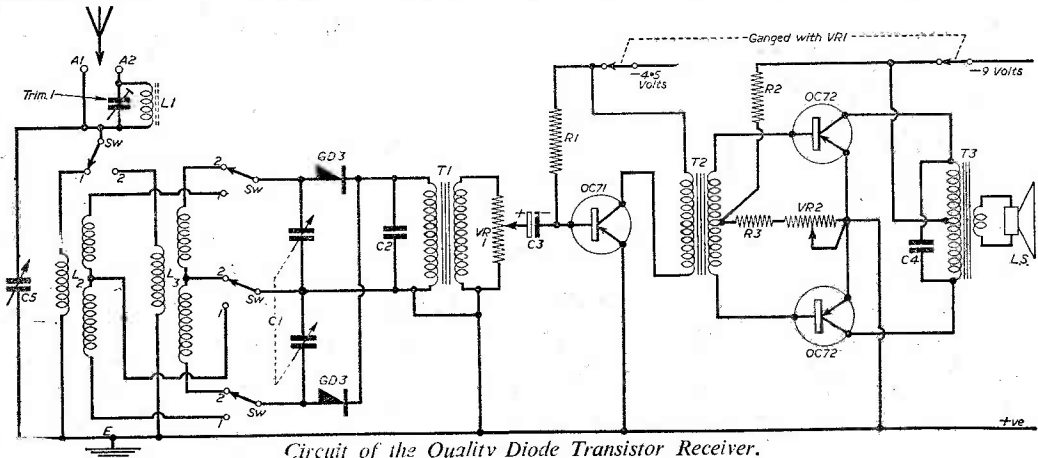

Fig. 9.—An underside view of a suggested layout.

thermal shunt to avoid the heat from the iron traveling up the leads and damaging or even destroying the transistor. The simplest shunt is a pair of pliers, but these must be placed in such a position that the majority of the lead is gripped and even then the iron must be really hot, the lead and connecting wire thoroughly clean and the iron held in position for the minimum of time. With a good electric iron, a tinned lead, and a short piece of small diameter resin-cored solder it should be possible to just touch the iron on the point and remove it almost immediately, leaving a bright, clean soldered joint.



Circuit of the Quality Diode Transistor Receiver.

BAND 3 T/V CONVERTER—185 Mc/s-199 Mc/s

Suitable for London, Birmingham and Northern Transmissions

£2-5-0 post free

A highly successful unit (*W. World* circuit), incorporating variable oscillator tuning, Midget BVA valves, etc. Chassis size 7 x 4 x 2 1/2 in. Thousands already in use. Suitable for most types of T/V sets. TRF or Superhet. Kit of parts 45/- . Blueprint 1/6. Power pack kit 30/- . Switch kit (Band 1—Band 3 Ae switching),

6/6—all Post free. Wiring and aligning of above 20/- extra. Full range of Band 3 aerials in stock. Adaptors from 7/6 per set. Indoor or outdoor dipoles with 5 yds. cable, 13/9. Band 1—Band 3 cross-over filter unit, 7/6. Variable attenuators 6 db—36 db, 7/6. BBC Break-through Filter, suitable for BBC pattern rejection, 8/6.

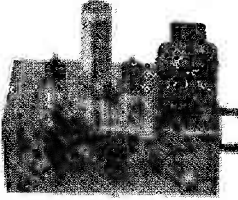

Volume Controls

Log. ratios, 10,000 ohms
—2 Megohms. Long
spindles. 1 year
guarantee. Midget Edis-
wan type.
No Sw. S.P.Sw. D.P.Sw.
3/- 4/- 4/9
Linear Ratio, 10,000
ohms 2 Megohms.
Less switch, 4/- each
Coax plugs, 1/2. Coax
sockets, 1/2. Couplers
1/2. Outlet boxes, 4/6.

TWIN-FEEDER, 80 ohms, 6d. yd.; 800 ohms, 8d. yd.
TWIN SCREEN FEEDERS, 80 ohms, 1/3 yd.
50 OHM COAX CABLE, 8d. per yd., 1/4 in. dia.
TRIMMERS, Ceramic, 4 pf.—70 pf., 9d.; 100 pf.,
150 pf., 1/3; 250 pf., 1/6; 500 pf., 1/9. PHILIPS
Bealite Type—2 to 5 pf. or 3 to 30 pf., 1/3 each.
RESISTORS.—Pref. values 10 ohms 10 megohms.

CARBON WIRE-WOUND
20% Type, 1 w., 3d.;
1/2 w., 5d.; 1 w., 6d.;
2 w., 9d.
10% Type, 1 w., 6d.;
5% Type, 1 w., 1/-
1% Hi-Strab, 1 w., 2/-

WIRE-WOUND POTS
Fra-Sect Min. T.V. Type
Knurled Slotted Knob.
All values 25 ohms to 20 K.
3/- ea., 50 K., 4/-
19in. Carbon Track
50 K. to 2 Mez., 3/-

CONDENSERS.—Mica or S. Mica. All pref. values,
3 pf. to 680 pf., 6d. ea. Ceramic types, 2.2 pf.—5,000 pf.,
as available, 9d. each. Tubulars, 450 v., Hanta
and T.O.C., .0005, .001, .005, .01 and 1/4 50 v., 5d.
39, 45, 50 v., Hants T.O.C., 1/2, 25 Hants, 1/8,
5 Hants, 1/8, 1 1/2 50 v. T.O.C. (diagonal) 2/6,
0.01, 6 K., T.O.C., 5/8, .001 to 20 K., T.O.C., 9/8.

STANDARD 3 WAVEBAND COIL PACK. Size
2 1/2 in. x 2 1/2 in. x 1 1/2 in. depth. 4 pos. Switching. Long,
Med., Short, Crum. Dust-core coils prealigned for
465 Kc/s L.F. Complete with trimmers, ready to use.
A very sensitive and efficient Coil Pack.
Manufacturer's Surplus. Bargain Offer, 27/3.

SOLOID SOLDERING IRONS (200/250 v. or 250-250 v.)
25 watt instrument type, 2/6; 65 watt Pentil
Hit Type, 2/6 1/2; 65 watt Oval Bit Type, 2/5-
Comprehensive stock of spares available.

80 ohm COAX CABLE

STANDARD 1/4 in. diam.
Polythene insulated.
GRADE "A" ONLY

8d. yd.

SPECIAL — Semi-air
spaced polythene, 80
ohm Coax 1/4 in. diam.
Stranded core. Losses
out 50%.

9d. yd.

3 w. LAB. COLVERN, Etc.
Standard Size Pots, 2 1/2 in.
Spindle. High Grade.
All Values, 100 ohms to
50 K., 5/8; 100 K., 6/6.
W/W EXT. SPEAKERS
CONTROL, 10 D., 3/-

ALL-WAVE RADIOGRAM CHASSIS
3 WAVEBANDS, 5 VALVES
S.W. 10 m.—50 m. LATEST MIDGET
M.W. 200 m.—350 m. BVA
L.M.L. 800 m.—1,000 m. SPRINGS

Brand new and guar. 4/4, 200-250 v., 4 pots, W.C.
sw. Short-Medium-Long-Crump. P.C. socket. High Q
dust core coils. Latest circuit technique, delayed
AVC and neg. feedback. O/P 4 watts. Chassis
size, 13 1/2 x 5 1/2 x 2 1/2 in. 10in. x 4 1/2 in. hor. or vert.
7 Valve De Luxe, Walnut or Ivory knobs to choice.
Aligned and calibrated ready for use. Sensitivity
and Quality at Low Cost.
Chassis isolated from mains. BARGAIN 9/9 gns.
Carr. and ins., 3/6. PRICE

8 or 10in. speakers to match, 20/- and 25/-
7 Valve De Luxe, push-pull EL41 version, 7 watt
output, £12/10/0. Carr. & ins. 3/6.

RECORD PLAYER BARGAINS

Latest Model USA BSR Monarch 4-speed auto-
changer £8.15/0, carr. 4/6. COLLARO 4-speed
Autochanger, Model RC456, 10 gns., carriage
4/6. As available.

ALUMINIUM CHASSIS.—18 s.w.g. Flou, undrilled,
folded 4 sides and riveted corners lathes fixing holes.
Strong and soundly constructed with 2 1/2 in. sides,
7in. x 4in., 4 1/2 x 9in., 6in. x 5 1/2; 1 1/2 in. x 6 1/2;
1 1/2 in. x 9in., 8 x 14in., 1 1/2 in., 10 1/2 x 6; and 1 1/2 in. x
1 1/2 in. x 9in., 10 1/2.

SCOTCH BOY, EMITAPE, etc., 1,200ft., 20/- . Long
playing, 1,800ft. reels, 45/- . Paper tape, good
quality, 1,200ft., 12/6. Reels only, 3in., 2/3. 7in., 4/3.

I.F. TRANSFORMERS—465 Mc/s

Brand new ex-manufacturer's midge! L.F.T.
size 2 1/2 in. x 1 1/2 in. dust core tuning. Litx
wound coils, High Q. Bargain offer, 7/6 pair.

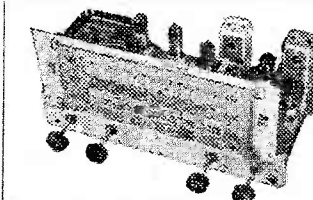

NEW BOXED VALVES GUARANTEED ALL
1R5, 1T4, DF96 9/- ECL80 10/6 PCL85 12/6
7/6 DK96 9/- EP41 10/6 PLE2 11/6
1R5, 1R4, 7/6 DL96 9/- EP80 10/6 PLE2 10/-
3R4, 3V4 8/- EABCS0 EP86 12/3 PLE3 11/6
3Z4 8/6 6/6 EP91 1/2 PY80 6/6
6AT6 8/6 ER91 1/2 EL34 15/6 P81 1/6
6X7 6/6 BC41 10/6 EL34 12/6 P82 6/6
6K9 8/6 BC33 8/6 EY31 10/6 P25 11/6
6Q7 8/6 ECU84 12/6 EZ40 5/6 UR41 9/6
6N7 8/6 BCF80 12/6 EZ80 5/6 UC42
0V6 7/6 BCF82 12/6 EY14 8/6 10/6
6X4 7/6 BC42 10/6 P81 12/6 UF41 10/-
6X3 7/6 10/6 P82 10/6 G11 10/-
DAF93 9/- EC81 10/6 PCF82 10/6 UY11 6/6

Special Price Per Set

1R5, 1T4, DF96, 1R4 or 3V4	...	27/6
DK96, DF96, DAF96, DL96	...	35/-
6K8, 6K7, 6Q7, 6V9, 3Z4 or 6X3	...	35/-

SPEAKER FRET.—Expanded Bronze anodised metal
Sin. x Sin., 2/3; 1 1/2 in. x Sin., 3/-; 1 1/2 in. x
1 1/2 in., 4/3; 1 1/2 in. x 1 1/2 in., 6/-; 2 1/2 in. x 1 1/2 in., 8/6, etc.

ELECTROLYTICS ALL TYPES NEW STOCK

Tubular Wire Ends 32+32/350 v. B.E.C. 5/6
25/25 v., 30/12 v. 1/9
30/30 v., 4/500 v. 2/3
100/25 v. 2/400 v. 2/3
8/500 v. B.E.C. 2/8
8/500 v. Dub. 2/6
8/1,800 v. Dub. 4/6
8/1,600 v. T.C.C. 5/6
16+24+8/350 v. 6/-
16/450 v. B.E.C. 3/6
16/500 v. Dub. 4/-
19+16/450 v. T.C.C. 5/6
32/500 v. Dub. 4/-
32+250/275 v. 12/3
50+30/350 v. B.E.C. 6/6
100+200/275 v. 12/6

SENTERCEL RECTIFIERS. E.H.T. Type. Fly-Back Voltages.

K825 2 kV., 5/-; K340 3.2 kV.,
6/9; K345 3.6 kV., 7/3; K350 4 kV., 7/9; K5100
8 kV., 12/9, etc.

MAINS TYPES.—RM1 125 v., 60 mA., 4/6; RM2 125 v., 100 mA., 4/9; RM3 125 v., 120 mA., 6/9; RM4 250 v., 250 mA., 16/-; RM4B type 270 mA., 17/6.

CHARGER TRANS. Prim.—0/200/250 v., sec., 0/9 v.—15 v. (for charging 6 v. and 12 v.), 1.5 a., 18/6; 3 a., 19/6; 4 a., 22/6; 8 a., 28/6.

FULL WAVE BRIDGE SELENIUM RECTIFIERS.—0 or 12 v., 1 1/2 amps., 6/9; 3 a., 18/6; 4 a., 18/6; 6 a., 24/6.

MAINS TRANSFORMERS.—Made in our own Workshops to Top Grade spec. Fully interleaved and impregnated. RADIO AND AMPLIFIER TYPES.—250 v., 60 mA., P.W. sec., 3 v. or 6.3 v., 1 a., 10c/1, 6/3 v., 2.5 v. est. HTR, 22/6, etc. C.R.T. HTR ISOLATION TYPE.—Low leakage with or without 25% sec. boost voltage. Ratio 1:1 or 1:1.25, 7 v., 3 v., 0 v. or 12 v., 10/6 ea. Ditto with mains primaries 200/250 v., 12/6. Special to order. SPECIAL TYPES.—Fro. designer's spec. Viewmaster, 35/-; Midland X33, mains trans., 55/-; Amps., 35/-; output trans., 35/-.

HEATER TRANS.—Prim. 220/250 v., 6.3 v., 1 1/2 a., or 4 v., 2 a., or 12 v., 7.5 a., or 16 v., 5 a., 7/6; 6.3 v., 3 a., 5 v., 3 a., or 4 v., 4 a., 10/6.

L.F. CHOSES.—10 v., 25 mA., 4/-; 15 H. 100 mA., 10/6; 10 H. 120 mA., 10/8; 20 H. 150 mA., 15/3; 50piper, 10/8; 50piper, 10/6. OUTPUT TRANS.—Standard pentode, 4/6; ditto tapped pentode (1R4, etc.), 4/8.

LOUDSPEAKER.—PM. 3 OHM 5in. Celest., 17/6; 6in. Celest., 19/6; 7in. Goodmans Elliptical, 18/6; 8in. Elac., 26/-; 9in. Goodmans Elliptical, 21/6; 10in. R. A., 25/-; 12in. Plessey, 35/-; 12in. Goodmans heavy duty audition 30, 15 ohms a p.e., 65/-; 3 1/2 in. Elac., 17/6.

F.M. TUNER-UNIT (87 mc/s—105 mc/s) by Jason. As described in Radio Constructor. Designer Approved Kit of parts to build this modern highly successful unit, drilled chassis and J.B. dial, coils and cans, 4 BVA miniature valves and all components, etc., for only 28/10/0 post free. SUPERIOR TYPE GLASS DIAD (as illustrated).—Calibrated to Mc/s and edge lit by 2 pilot lamps, 12/3 extra. Illustrated handbook with full details, 2/- post free.

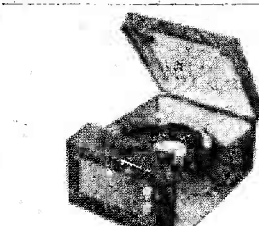
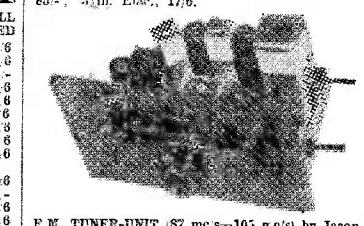

RECORD PLAYER CABINET
Cabinet size 18 1/2 in. x 13 1/2 in. x Ht. 8 1/2 in., with mount
motor board 13 1/2 in. x 12 1/2 in., £3.5/0, carr. 3/6. 2 valve
amplifier to fit above, ready wired and tested with
62in. speaker, £8.12/6, carr. 2/6. Record changers
available to suit this cabinet.

TRS RADIO COMPONENT SPECIALISTS (Est. 1946)

70 BRIGSTOCK ROAD, THORNTON HEATH, SURREY (THO 2139)

50 yards Thornton Heath Station.
Listed above are only a few items from our very large stock.
Hours: 9 a.m.—6 p.m., 1 p.m. Wed.
Send 3d. stamp to pay for Complete Bargain List.
OPEN ALL DAY SAT.



Orders: C.W.O. or C.O.D. Kindly make cheques, P.O.s, etc., payable to T.R.S. Post-Packing up to 10d. 7d., 10d. 1/1, 3d. 10d., 5d. 2s., 10d. 2/3

The NEW I.C.S. LEARN-AS-YOU-BUILD PRACTICAL RADIO COURSE

LEARN RADIO as you build your own receiver and testing instruments

This new addition to the unrivalled I.C.S. range of technical training courses offers you a double opportunity. Here is your chance to gain a sound knowledge of basic Radio and Electronics theory—under expert tuition—whilst building your own 4-valve radio receiver, signal generator and high-quality multi-tester.

WHAT YOU GAIN At the end of the course, besides the permanent, practical and useful equipment, you will have accumulated a personal "library" of reference material—I.C.S. Instruction Manuals expertly edited and presented—which you can keep by you always for guidance.

TRAINING TO SUIT YOUR NEEDS Whether you plan to have a business of your own, to become a service engineer, to pursue a career in the radio industry, or to take up radio as a serious hobby—this course provides the ideal way of obtaining a firm foundation of essential knowledge.

OTHER COURSES INCLUDE
RADIO ENGINEERING, RADIO SERVICING AND SALES, BASIC RADIO, RADAR ENGINEERING, BASIC RADAR, F.M. ENGINEERING, TELEVISION ENGINEERING, TELEVISION SERVICING, BASIC TELEVISION, ELECTRONIC ENGINEERING, INDUSTRIAL ELECTRONICS, BASIC ELECTRONICS and guaranteed coaching for professional examinations.

POST THIS COUPON TO-DAY to receive a FREE book which gives information on careers in Radio, etc., and full details of I.C.S. courses.

INTERNATIONAL CORRESPONDENCE SCHOOLS
Dept. 170H, International Buildings, Kingsway,
London, W.C.2.

Name Age
Block letters please
Address.....
Occupation 4.57.

**INTERNATIONAL
CORRESPONDENCE SCHOOLS**

ADCOLA

PRODUCTS LIMITED
(Regd. Trade Mark)

SOLDERING EQUIPMENT

ILLUSTRATED

$\frac{3}{16}$ " Detachable bit type (List No. 64)

Protective Shield (List No. 68)

Catalogues sent FREE

Telephones :
MACaulay 4272
& 3101



British and Foreign Pats.

Reg. Designs, etc.

Head Office, Sales :

**ADCOLA
PRODUCTS
LTD.**

Gauden Road,
Clapham High
St., London,
S.W.4

17in. £7.10. 14in. £5.10. T.V. TUBES 12 MONTHS' GUARANTEE

We are now able to offer this wonderful guarantee. 6 months full replacement and 6 months progressive. Made possible only by improved high quality of our tubes. Ins. & Carr. 15/6.
CONVERT YOUR 9in., 10in., 12in. set to 14in., 15in., 17in. Our pamphlet is free, and on many sets it costs only the tube to give you these giant pictures. **SPECIAL OFFER 14in., 15in. and 16in. T.V. TUBES, £5.** Perfect. See them working in our shops. **12in. T.V. TUBES, £5.** Shortage may cause delay; enquire first. We may have alternative, and can tell you delay if any. Ins. & Carr. 15/6 on all tubes.

CONVECTOR ELECTRIC HEATER 99/6

2 kilo-watt (1 or 2 units per hr.) Switched. Gilt finish. Illuminated grille. Size 26in. x 18in. x 7 1/2in. deep. 200-250 volt AC/DC. Famous Mnfr. Ideal for home, office or works. Ins. & Carr. 10/6.

COIL PACK, 3/9 3 band, including pair of 465 I.P.'s 2-gang cond., and printed dial (similar drawing FREE). Post 2/3.

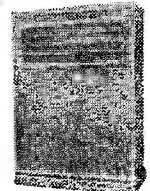

SELF FEED SOLDERING SOLO TOOLS

6v.—110v. 6v.—240v.
29/6 45/-

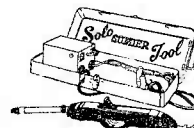

Made for the American market. Car Battery or Mains. Export quality. Export orders invited. Carrying case. Reel of Solder. Spare bits. Post 2/3.

By train Liverpool St. to Manor Pk. Stn., 10 mins.
1957 Catalogue FREE. Open Saturday all day.

DUKE & CO. (PW)

621, ROMFORD RD., MANOR PARK, LONDON, E.12.
GRA 6677-3.

Operating Battery Receivers from the Mains

HOW TO MODERNISE OLD-TYPE SETS

By W. Nimmons

THERE are probably a great many battery sets which, for one reason or another, are lying idle in attics and lumber rooms. The most potent reason for their desuetude is the trouble and inconvenience, not to speak of the cost, of battery renewals; or a set may have been giving trouble so that the owner grudged it its cost in upkeep. At any rate they now lie gathering dust, and the second-hand value of these sets is almost nil.

Sets ten, fifteen, or even twenty years old of the superhet class may, with a little trouble and patience, be converted into all-mains models which, though they may not give the variety of stations which a first-class job would give, nevertheless provide ample coverage for the unambitious listener—and that means 99 per cent. of all listeners.

Provided there is no defect in the L.F. part of the set, it can be quickly and efficiently converted. It is advisable to test with a pick-up, if pick-up sockets are provided; this will obviate subsequent difficulties should there be any defect in the coupling arrangements, such as a "dis" in the coupling condenser, or a break in the transformer windings in the case of a transformer coupled amplifier. You might be able to borrow batteries for this purpose, since they are only needed for the test, unless, of course, they are in use in another receiver.

It is a rather formidable task to change every valveholder in the set, so for the sake of simplicity two valveholders only are changed. The frequency-changer and the intermediate frequency amplifier are passed by and a detector-output arrangement is employed. This will, in suitable circumstances, put up quite a surprising performance, since the mains valves employed are much more efficient than their corresponding battery types.

Modifications

From Fig. 1 it will be seen that the original signal frequency stage of the frequency-changer is retained. If this is band-pass coupled it can still be used; it is only necessary to take the lead "X" from the former control grid lead of the frequency-changer valve.

The first and second valves should be withdrawn from their holders. The third and

fourth valveholders will need to be changed to their mains counterparts. Whether the substitution be of British octal, American octal, side-contact, etc., is left to the discretion of the individual, but two suitable valves are given in the British octal range in case of doubt. These are the Mullard TDD13C (double-diode-triode) and CL6 (output pentode). The former has a 7-pin base.

These have 0.2 amp. heaters, and it is important that any two valves chosen should have the same heater current. The heater voltage is not important, but these have 13- and 35-volt heaters respectively.

In Fig. 1 the new valveholders, components and wiring are shown in heavy lines. The components required are few in number and comprise an H.F. choke, grid condenser, grid-leak and the 0.1 μ F chassis isolating condenser. In addition there is a wavetrapp, which is useful in suppressing a powerful local station. The H.F. choke may be replaced by a resistor of about 10,000 ohms, or neglected altogether since the anode has a resistive load.

The Practical Side

The first thing to do is to remove the old valveholders, unsoldering the connections but leaving them

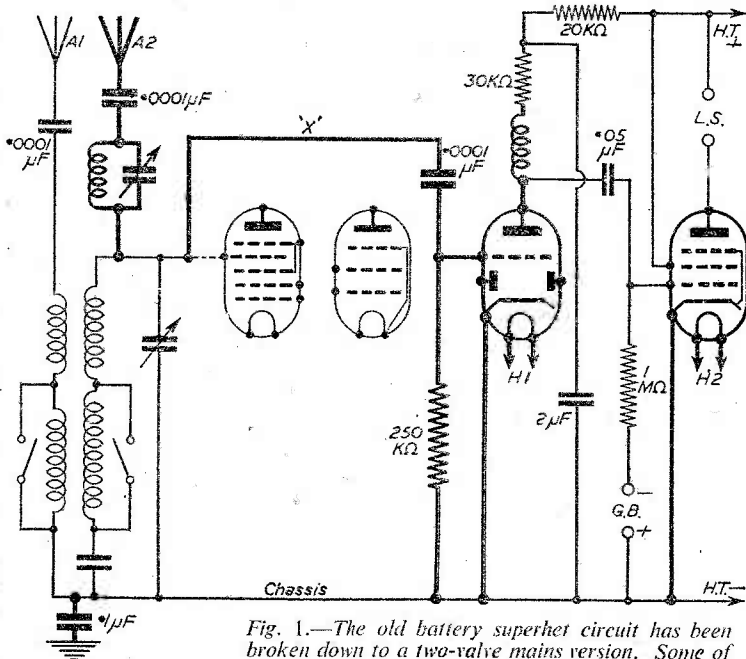

Fig. 1.—The old battery superhet circuit has been broken down to a two-valve mains version. Some of the parts are retained, and the new parts are shown in heavy lines.

ready to be soldered again to the new valveholders. The lead "X," together with the grid condenser and leak, will be above chassis, since it leads from the grid flying lead of the first valve (not used) to the top cap of the double-diode-triode mains valve (the diodes are not used). The only reason, in fact, for using a double-diode-triode valve in this position is that there does not appear to be a triode valve with the requisite impedance issued by any maker. The

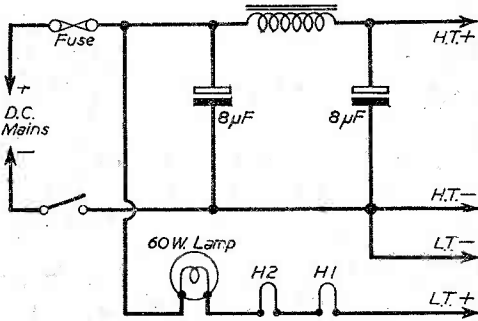

Fig. 2.—The complete power-pack, showing how the mains may be adapted to the leads of the battery set.

nearest are output triodes, and these are unsuitable for the detector position. The detector works on the power-grid principle, hence it gives good quality but is unsuitable for very weak signals.

When connecting up it would be advisable to check the load resistance of the detector. This should be about 30,000 ohms, and if much higher, say, 100,000 ohms, it should be replaced with a resistor of suitable value. The decoupling resistance should be around 20,000 ohms. In certain cases a transformer may be employed instead of resistance-capacity coupling. In this case the decoupling resistance should be 50,000 ohms, and the transformer should be parallel-fed.

The aerial arrangements include an extra aerial terminal, namely that connected to the wavetraps. The original aerial terminal may not convey enough signal to the detector; it may be rather loosely coupled, but A2 will provide a good signal and at the same time cut down interference from a powerful station. The wavetraps may be located somewhere in the cabinet.

Battery grid-bias is shown, but if automatic bias is to be used join the bottom end of the 1-megohm grid-leak to chassis, break the lead from the cathode of the output valve to chassis and insert the appropriate bias resistance, shunting it with the usual condenser.

In the interests of simplicity the oscillator coils are not shown, nor the intermediate frequency transformers, since none of these is used. No reaction is shown, but it might be possible to obtain this by connecting a reaction condenser between the anode of the detector valve and the top of the aerial coil. No guarantee, however, can be given that this will result in reaction; it depends upon the direction of the aerial winding relative to the grid winding, and since the aerial winding is not specifically designed for reaction purposes it may just as readily go the wrong way.

A wire taken from the anode and laid alongside the lead "X" will provide a certain amount of feedback, and this may be all that is necessary to bring

up the volume and sharpen the tuning since the valve need never actually oscillate.

Power Supplies

Turning to the power supplies, we have the alternatives of a purely D.C. supply or an A.C./D.C. source. The former scores on the point of simplicity; the latter, while slightly more complicated, is not unreasonably so. In fact, in the form advocated for this receiver, it is little more complicated than the conventional battery eliminator.

In this respect the fact that we are dealing with a battery set leaves us in a more fortunate position than if we were making a modification to a mains set. The mains set usually has its full complement of components, so that it is difficult to find room for any extras; whereas in the case of a battery set we have the whole compartment formerly allocated to the batteries to play with, and this not only leaves room for a power-pack but for the wavetraps as well. In actual fact the power-pack needed is extremely simple, and can be made up in the form of a unit which will go in the battery space. The A.C./D.C. version is only slightly more bulky than the one designed for purely D.C. operation.

As will be seen from Figs. 2 and 3 the two units are essentially similar, the main difference being that the A.C./D.C. version incorporates a rectifier. There are no bulky transformers, and in this respect the scheme is no whit different from the majority of universal receivers.

The two H.T. leads of the set, plus and minus, are connected to the appropriate sockets on the power-pack. Similarly, the two L.T. leads are connected to the sockets marked L.T. plus and minus. There is

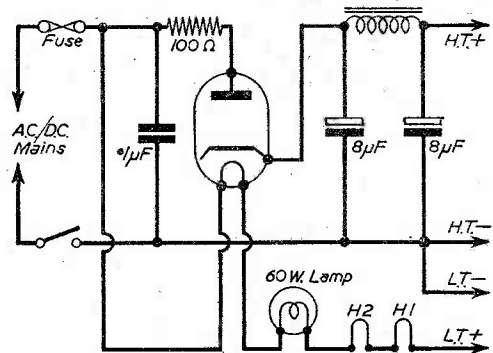

Fig. 3.—The A.C./D.C. version of the power-pack.

just one detail which may prove slightly confusing—the incorporation of the two heaters, H1 and H2, in Figs. 2 and 3. Actually, they are not present at all but are, of course, in the receiver. However, this sort of composite diagram has its use in showing the heater chain.

The 60-watt lamp can be either on top of the power-pack unit or, what is more attractive, extended leads can be made to a table lamp on top of the set where it makes a handy reading lamp.

In the case of the D.C. unit, reverse the connections to the plug if no signals are obtained. The 8 μ F smoothing condensers are adequate; these can be electrolytic, and are much better than 2 μ F paper condensers. The switch is purely optional, but is handy when the set forms a bedside companion.

NEW! THE PRACTICAL WAY

of learning **RADIO · TELEVISION · ELECTRONICS**
AMATEUR S.W. RADIO · MECHANICS · PHOTOGRAPHY · CARPENTRY, Etc. Etc.

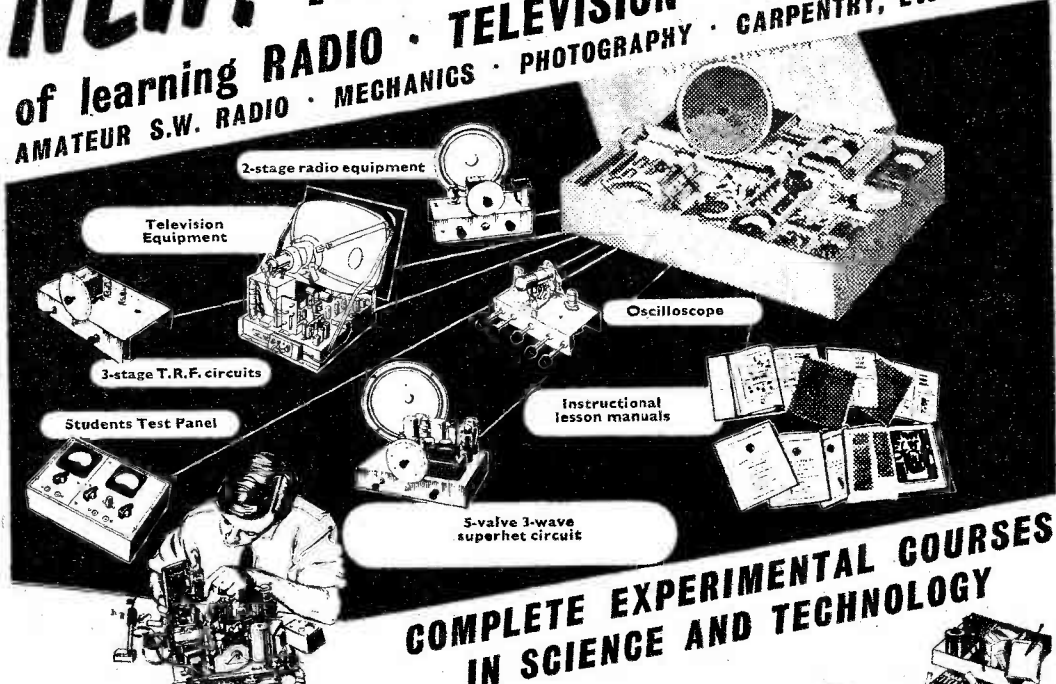

COMPLETE EXPERIMENTAL COURSES IN SCIENCE AND TECHNOLOGY

NEW... completely up-to-date methods of giving instruction in a wide range of technical subjects specially designed and arranged for self-study at home under the skilled guidance of our teaching staff.

NEW... experimental outfits and lesson manuals are despatched on enrolment and remain the student's property. A tutor is allotted to each student for personal and individual tuition throughout the course. In the case of radio and television, specially prepared components are supplied which teach the basic electronic circuits (amplifiers, oscillators, detectors, etc.) and lead, by easy stages, to the complete design and servicing of modern commercial radio and television receivers.

If you are studying for an examination, wanting a new hobby or interest, commencing a career in industry or running your own full-time or part-time business, these practical courses are ideal and may be yours for moderate cost. Send off the coupon to-day for a free Brochure and full details. There is no obligation whatsoever.

The only Home Study
College run by
a World-wide
industrial
organisation.



E.M.I.
Factories
at Hayes.

EMI INSTITUTES

- Part of "His Masters Voice" Marconiophone, etc etc

SUBJECTS INCLUDE—

- RADIO · SHORT WAVE RADIO**
- TELEVISION · MECHANICS · CHEMISTRY**
- PHOTOGRAPHY · ELECTRICITY · WOODWORK**
- ELECTRICAL WIRING · DRAUGHTSMANSHIP**
- ART, etc.**



COURSES FROM
15/- PER MONTH

FILL IN COUPON
FOR
FREE
PROSPECTUS



E.M.I. INSTITUTES Dept. 32X, London, W.4

NAME _____ AGE _____
(if under 21)

ADDRESS _____

BLOCK
CAPS
PLEASE

I am interested in the following subject(s) with/without equipment _____

APR 57 We shall not worry you with personal visits

ICAs

COMPLETELY BUILT SIGNAL GENERATOR

Coverage 120 Kc/s-230 Kc/s.
300 Kc/s-900 Kc/s. 900 Kc/s-
2.75 Mc/s. 2.75 Mc/s-3.5 Mc/s.
8 Mc/s-28 Mc/s. 16 Mc/s-56
Mc/s. 24 Mc/s-84 Mc/s. Metal
case 10in. x 6in. x 4in. Size
of scale, 6in. x 3in. 2 valves
and rectifier. A.C. mains 200-
250 v. Internal modulation of
400 c.p.s. to a depth of 30 per-
cent., modulated or unmodu-
lated R.F. output continuously
variable 100 milli-volts. C.W.
and mod. switch, variable A.F. output and moving coil
output meter. Black crackle finished case and white panel.
Accuracy plus or minus 2%. £4/19/6 or 34/- deposit and 3
monthly payments 25/-. P. & P. 4/6 extra.

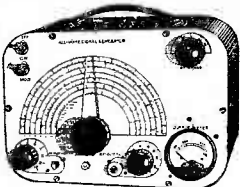
**COMMERCIAL TELEVISION
CONVERTER**

**SUITABLE ANY T.V. (except Philips)
ALL CHANNELS
NO ALTERATIONS TO SET**
Complete with built-in power supply.
230-250 v. A.C. mains. Crackle finish
case 6in. long, 3in. wide, 4in. high.
Incorporating gain control and band
switch. Illustrated with cover
removed.

£3. 19. 6 Plus P. & P. 2/6.

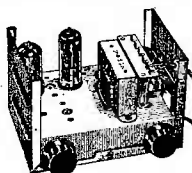
**AC/DC MULTI-METER KIT**

Comprising 2in. moving coil meter—
scale calibrated in A.C./D.C. volts,
ohms and milli-amps. Voltage range
A.C./D.C. 0-10, 0-100 and 0-500. Milli-
amps 0-10, 0-100. Ohms 0.1000 and
0-10,000. Front panel, range switch,
wire wound pot. (for ohms zero set-
ting) two toggle switches, resistors and meter recti-
fier. Complete in case, grey
hammer finish. **19/6**
Plus P. & P. 1/6.

Point to point wiring diagram 1/-. Free
with Kit.

**BATTERY CHARGER 6 or 12 v. 4 amp.**

A.C. Mains 200-250 v. Fitted ammeter, selector switch, fuses,
battery clips, indicator lamp. Incorporating G.E.C. Metal
Rectifier. Ready for use. In grey hammer finish case. Wall
fixing. 59/6. P. & P. 3/6.

TRANSISTORISED CRYSTAL SET KIT

Medium and long waves, in plastic cabinet, com-
prising transistor, tuning condenser, iron-cored coil. **19/6**
Point to point wiring diagram 1/-. Free with Kit. Plus P. & P. 1/6.

A.C. MAINS 3-VALVE CHASSIS

Comprising chassis, tuning condenser, coils, valves,
valve holders, volume-control, resistors, condensers. **19/6**
Point to point wiring diagram 1/-. Free with Kit. Plus P. & P. 2/9.

T.R.F. KIT in PLASTIC CABINET

3 valve plus metal
rectifier, A.C. mains
200-250 v. Medium
and Long waves. In
pastel blue or brown.
Valve line-up: 2
VR85s and VT52.
Size 15in. long by
9in. high by 7in. deep.
£3. 19. 6 P. & P.
4/6.

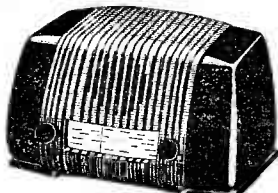

Point to point wiring diagram 1/6. Free with Kit.

RADIO & T.V. COMPONENTS (Acton) LTD.

23, HIGH STREET, ACTON, LONDON, W.3

Where post and packing charge is not stated, please add 1/6 up to 10/-,
2/- up to £1 and 2/6 up to £2. All enquiries S.A.E. Lists 5d. each.
Goods not despatched outside U.K.

MULLARD TAPE AMPLIFIERS

We stock all the components for the Amplifiers as described in
the Mullard Tape Recording Booklet.

RESISTOR KITS. LAB. All fixed and variable resistors as
specified. Model A, 33/3. Model B, 31/9.

CONDENSER KITS. Model A, 33/-, Model B, 35/-, These
kits are made up for the Brenell and Collaro Decks. If Lane or
Truvox Decks are being used this must be stated when ordering.

OUTPUT TRANSFORMERS.—Gilson OP767, 25/6. Elstone
OT/3, 21/-, Partridge SVO/1, 60/-.

ELCOM PLUGS AND SOCKETS. PO4 Chassis Plug, 3/6.
SO4T Flex Socket, 5/3.

IGRANIC JACK SOCKETS. P71, 3/4. P72, 3/10. Bulgin
jack Plugs to fit, 3/-.

BELLING LEE PLUGS AND SOCKETS. Speaker Sockets.
L316 Red and Black, 1/- each. L378 Plugs to fit, 10d. each. Co-Ax
Socket L734S, 1/-, L604S, 1/3. L734 Plugs to fit, 1/3 each.

McMURDO VALVE HOLDERS. BM9/U, 10d. XM9/UC1,
1/7. XM9/UG1, 2/3.

SWITCHES. Set of three for Model A, 32/6. One Switch for
Model B, 15/6.

BULGIN TAG BOARDS. C120, 1/3. C125, 2/3.
EQUALISER PLUG AND SOCKET. Plugs 2/3 each.
Socket, 6d.

CERAMIC STAND OFF PILLAR. 1/- each.

OSCILLATOR COILS. Brenell, 8/-, Truvox TR98, 6/9.

CHASSIS. Denco. Fully drilled. Model A, 31/6. Model B, 31/6.

VALVES. EF86—Mullard, 24/4; Alternative, 15/-, ECC83—
Mullard, 19/6; Alternative, 10/-, EM81—Mullard, 18/1. EL84—
Mullard, 16/-; Alternative, 12/-, OA71 Diode, 6/-.

KNOBS.—Bulgin K370, 1/6 each. EM81 ESCUTCHEON, 2/6.

SUNDRIES KIT. Contains all nuts, bolts, tags, wire, flex solder,
etc., 8/-.

FULLY DETAILED LIST is available free upon request. This gives prices
for complete kits and details of Power Unit Components.

WATTS RADIO

8, Apple Market, Kingston-on-Thames, Surrey

Telephone: KINGSTON 4099

G2AK This Month's Bargains

POWER UNITS in black metal case, with input and output
sockets. 200/260 v. input, output 200/250 v. 60/80 mA.,
fully smoothed and fused. Also gives 31 v. 0.3 a.D.C. and 6.3 v.
3 a. A.C. Fitted with 6X5 rectifier. 50/- each, carr. paid.

3 in. LOUDSPEAKERS. Ideal for personal portables, only
9/11 each, plus 1/- p. & p.

HI-FI EQUIPMENT. Amplifiers, speakers, pick-ups by
Grampian, Leak, Quad, Rogers, R.C.A., Spectone, W.B.,
Wharfedale, etc., available for immediate delivery.

HEADPHONES. H.R. Type 4,000 ohms, very sensitive.
Only 12/6 pr. Post 1/6. C.L.R. type (low res.) 8/6. Post 1/6.

AMERICAN BREAST MIKES. swivel head, push to
talk and lock-on switch. Excellent job. Only 12/6. Post 1/6.

BRITISH BREAST MIKES complete with pr. of H.R.
4,000 ohm phones in wooden carrying case. New W.D
stock, unrepeatable at 17/6. Post 2/-.

AERIAL WIRE. Copper, 7/25 stranded: 140ft., 10/-,
70ft. 5/-, Hard Drawn 14g.: 140ft., 17/-; 70ft., 8/6. P. & p. 2/-.

RIBBED GLASS 3in. AERIAL INSULATORS, 1/6 ea.,
or 6 for 7/6. 12 or more post free. Small Shell Porcelain.
4 1/2 d. ea., or 4/- doz.

CONDENSERS. 8μF 600 v. Trop. 750 v. normal con-
densers. NEW, ex W.D. stock, 5/6. P. & p. 1/6.

New TCC Type III. 8 mfd. 1,000 v. D.C. wk'g. (List over
£3.) OUR PRICE 10/6. P. & p. 1/9.

No C.O.D. on orders under £1.

PLEASE PRINT YOUR NAME AND ADDRESS

CHAS. H. YOUNG LTD.

Dept. 'P' 110, Dale End, Birmingham 4. (CEN 1635)

TRANSMITTING TOPICS



POINTERS ON PI TANKS

By O. J. Russell, B.Sc., A.Inst.P. (G3BHJ)

THE PI tank circuit has become almost the standardised choice for the amateur transmitter design for the DX bands. The conventional arrangement (Fig. 1) is virtually the "preferred" circuit for TVI protection.

There are a number of points, however, about the design and use of the PI network-type tank circuit which deserve attention if the optimum is to be achieved in performance. Thus the usual arrangement in an "All-band" transmitter is to arrange for covering

capacitor for 80-metre-band operation. This can be effected as shown in Fig. 4. The fixed capacitor chosen must be a high-grade, low-loss, high-voltage type. If necessary a series-parallel arrangement of high-grade, high-voltage mica capacitors may be used to enable the capacitors to operate within their R.F. ratings. The T.C.C. mica capacitors type M3KO will be found useful in such applications for transmitters around the 150-watt rating. Notice also that mica foil condensers rather than silvered mica types are preferable in such R.F. applications. The foil types will handle high R.F. currents that may damage the thin silver deposit in silvered mica types.

A further aspect of PI tank circuits is the provision of extra TVI precautions. Thus it is often assumed that fitting a PI tank circuit in a screened transmitter is all that is needed. While the PI tank-type transmitter has an advantage over some other types of tank circuit in the matter of harmonic suppression, the PI tank is not an infallible cure. Often in high TV signal areas a PI tank may make the needed improvement to clean up TVI. However, in many cases, not noticeable improvement may be effected by a PI tank circuit. This may be due to the PI tank not providing enough harmonic suppression to clean up the TVI, despite the fact that it may have very much less harmonic radiation than the original tank circuit. In such cases it is necessary to "assist" the PI tank by fitting further TVI suppression devices. In this connection

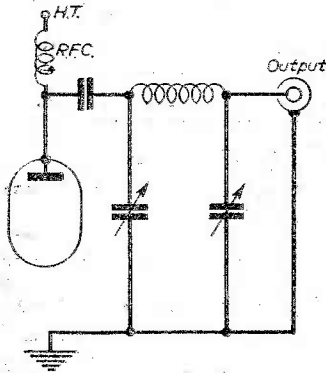

Fig. 1.—The basic PI tank circuit arrangement.

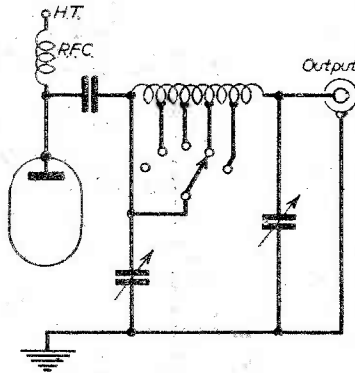

Fig. 2.—Switching arrangement for multi-band operation.

the five bands from 80 metres to 10 metres by the use of switching a tapped coil (Fig. 2). This immediately brings several problems. The first and most obvious problem is the question of coil efficiency upon the highest frequency bands. Thus, if one single tapped coil were used the efficiency upon 10 metres particularly would be low as the one or two turns of inductance would be tightly coupled to the short-circuited section of the rest of the tank coil. Accordingly the usual solution is to make the 10-metre coil a separate coil which is then free from undesirable coupling effects if it is kept away from the main tank coil (Fig. 3). This expedient might even be extended to cover the 21 Mc/s coil as well.

A further trouble on the "All-band" arrangement is the choice of tank tuning capacitor. For optimum results a large capacity is needed for efficient 80-metre operation, while upon 10 metres the required tuning capacity may be smaller than the residual strays of a large variable capacitor. Also, of course, the cost of a high-voltage tuning capacitor increases as the capacity increases, so it is desirable on both economic and technical grounds to avoid a large capacitor if this is at all possible. One way round this problem is to use a reasonable size of tuning capacitor, and to switch in an additional fixed

capacitor for 80-metre-band operation. This can be effected as shown in Fig. 4. The fixed capacitor chosen must be a high-grade, low-loss, high-voltage type. If necessary a series-parallel arrangement of high-grade, high-voltage mica capacitors may be used to enable the capacitors to operate within their R.F. ratings. The T.C.C. mica capacitors type M3KO will be found useful in such applications for transmitters around the 150-watt rating. Notice also that mica foil condensers rather than silvered mica types are preferable in such R.F. applications. The foil types will handle high R.F. currents that may damage the thin silver deposit in silvered mica types.

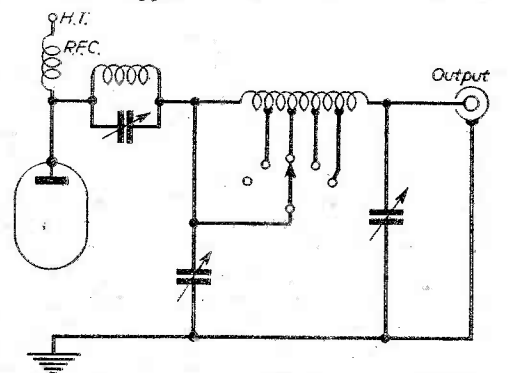

Fig. 3.—A separate coil section for 10 metres obviates short-circuit losses for H.F. operation.

do not overlook the old friend—the trap circuit resonated to the TV channel inserted in the anode circuit (Fig. 5).

A further TVI device for assisting the suppression of TVI harmonics is the "gimmick" connected

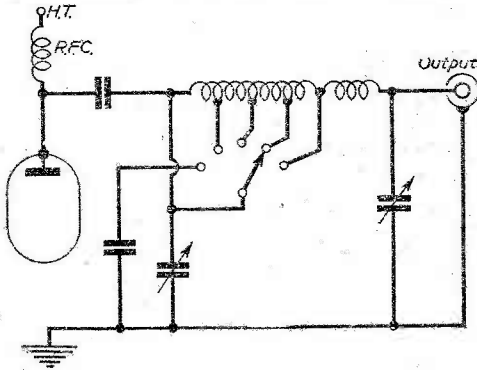

Fig. 4.—The L/C ratio required for 80-metre operation can be achieved by switching in an auxiliary fixed capacitor across the main tuning capacitor. This enables the main condenser to be a convenient size for comfortable tuning of the higher frequency bands.

directly across the coaxial output socket. This consists of a small value mica or ceramic condenser, say 50 pF, with an inductance in series with it. The inductance is adjusted by a grid-dip meter to resonate to the local TV channel. Adjustment is by squeezing together or pulling apart the turns of the inductance. A few turns wound round a lead pencil as former are all that are required for the inductance. Alternatively the adjustment of inductance may be made by adjusting for minimum TVI on the home TV receiver (Fig. 6).

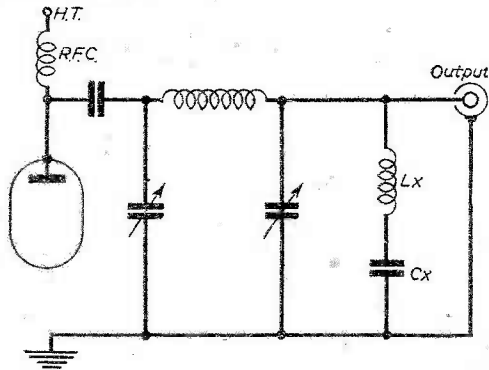

Fig. 6.—The series resonant combination Lx and Cx is tuned to the local TV channel to remove harmonic radiation from the PI tank output. An anode circuit trap may also be used in conjunction with the above "gimmick."

Output Loading

A further consideration in multi-band PI tank transmitters is the output or "loading" condenser. For the 80-metre band 1,000 pF, 1,500 pF, or even more, may be required for loading. On 10 metres

a value of around 100 pF only will be required. The usual solution is to use a two- or three-gang capacitor with the 500 pF sections paralleled for the "loading" condenser. To make the loading adjustment easy on 10 metres a switch to cut out all but one section

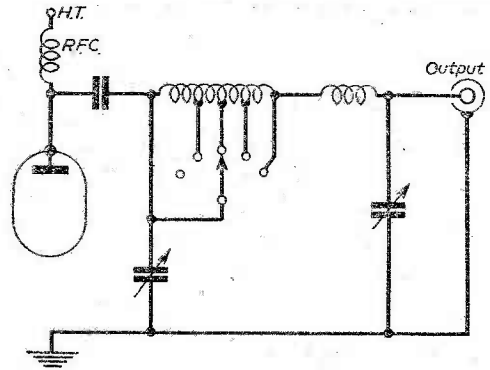

Fig. 5.—A TVI trap circuit resonated to the local TV channel may assist in reducing harmonic radiation when the PI tank itself does not give adequate harmonic suppression.

is desirable. Moreover, unless one has a two- or three-gang capacitor on hand, the purchase of a new ganged condenser bank is expensive. One way out is to use a relatively small variable condenser—say 150 pF capacitance—and to switch in a bank of mica condensers as "coarse" loading steps for the other bands (Fig. 7). The use of a "progressively shorting" type of switch is economical for this application, as in the maximum capacity position all condensers in the bank are in circuit. High-grade receiving-type mica foil condensers will be found suitable in this application.

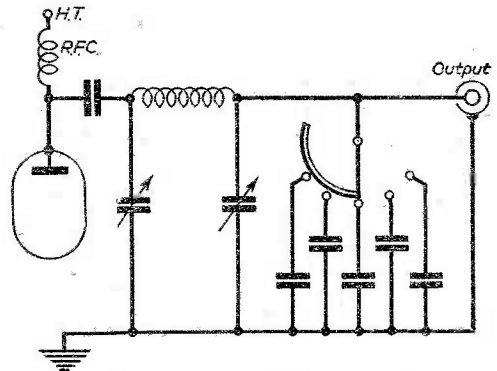

Fig. 7.—Fine and coarse loading control by means of a small variable capacitor in combination with a switched bank of fixed mica capacitors.

A further difficulty experienced with multi-band PI tank transmitters is in the choke supplying H.T. to the P.A. anode. It is extremely difficult to obtain good results from improvised chokes. Moreover, due to slight differences in winding, considerable adjustment may be necessary with the choke designs often published for home construction. This is particu-

(Continued on page 129)

LASKY'S RADIO

RECORD PLAYERS

B.S.R. 4-spd. with t.o. crystal pick-up. Auto and manual control, £8.15.0. Post 5/-.

COLLARO 4/564, 4-spd. single player with Studio O or P cartridge. £9.7.0.

NEW PURCHASE. Collaro 3-spd. Single Players 3/554. complete with Studio O t.o. crystal pick-up. £6.19.6. Post, 3/6.

B.S.R. TU8 3-spd. single player, 92/6. Post on single players 3/6.

PICK-UP BARGAIN

B.S.R. 3-spd. HGP 59/3, with crystal head and stylus. 37/6. Post 2/6.

BRAND NEW AND PERFECT 16" METAL CONE C.R. TUBES

Brief specification: 6.3 v. htr., ion trap, 14 kv. E.H.T., wide angle 70 degrees, standard 38 mm. neck, duodecal base, mag. focus and deflection. Length 17-11/16in. Circular shape. Guaranteed by us for 3 months. List £23/9/10.

LASKY'S £8.9.6 Carr. & Insur. PRICE 22/6 extra.

LASKY'S (HARROW ROAD) LTD.

42, TOTTENHAM COURT ROAD, W.I. Telephone: MUSEUM 2605.
370, HARROW ROAD, PADDINGTON, W.9. LAD 4075 and CUN 1979.

Open all day SATURDAY. Half-day Thursday.

PLEASE ADDRESS ALL MAIL ORDERS TO HARROW ROAD.

LASKY'S BATTERY PORTABLE FOR HOME CONSTRUCTION ON PRINTED CIRCUIT

CAN BE BUILT FOR

7 GNS.

Carr. & Packing 3/6 extra.

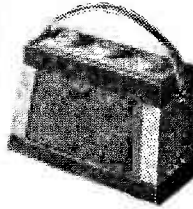

COMPLETE PARCEL contains printed circuit, all components, valves, case, diagram, and all instructions for building this latest design 4-valve superhet portable, med. and long waves.

CIRCUIT DIAGRAM, data, instructions, and chopping list, 1/6 post free.

POWER UNIT for above, also suitable for other battery portables. Complete Kit including printed circuit, 45/-.

TRANSISTORS, SPECIAL OFFER

Junction type suitable for use in local station receivers, amplifiers, pre-amplifiers, etc. Each, 10/- Post free.

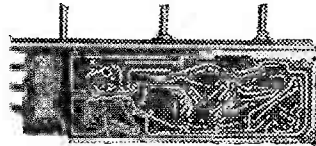

10 STAR FEATURES

- ★ PRINTED CIRCUIT, size 7 1/2 in. x 2 1/2 in.
- ★ 4-valve Superhet, med. and long waves.
- ★ Low consumption Valves. Double Battery Life.
- ★ Ferrite Rod Internal Aerial.
- ★ 3in. or 5in. P.M. Moving Coil Speaker (your choice).
- ★ Brand New T.C.C. Capacitors.
- ★ Automatic Volume Control.
- ★ New Style Contemporary Case.
- ★ Lightweight and Handsome Appearance.
- ★ Every Component available separately.

DEMONSTRATION MODELS AT BOTH OUR ADDRESSES

NOW READY! LASKY'S PORTABLE GRAM. AMPLIFIER KIT

Very small size, 6 1/2 in. x 3 1/2 in. max. height 5in. The T.C.C. Printed Circuit greatly simplifies construction. Utilises EL84 output and 6X4 rect., double-wound mains trans., tone control, 6in. x 4in. elliptical speaker and o.p. trans. LASKY'S PRICE. Complete Kit including valves, speaker and full instructions. **77/6** Post 2/6.

62A INDICATOR UNIT Containing VCR97 with Mu-Metal Screen. 21 valves: 12-EF50, 4-SP61, 3-BA50, 2-EB34. Plus Pots, Switches, H.V. Cond., Resistors, Muir-head S/M Dial, Double Deck Chassis and Crystal. **BRAND NEW ORIGINAL CASES, 67/6. CARR. FREE.**

RF94, 10/-; RF25, 12/6
RF23, 25/- **BRAND NEW WITH VALVES.** Carr. 2/6.

B.S.R. RECORD CHANGERS

Very latest type "Monarch" 3-speed with HGP37 crystal turnover pick-up. Plays mixed records. Brand new and guaranteed. Listed at 16/10/- £7/19/6, carr. paid.
B.S.R. 4-SPEED Plays mixed records. £8/15/- P.P. 3/6.

TRANSMITTER/RECEIVER

(Army Type "17" MK. II) This well-known R/T Transmitter-receiver is offered complete with Valves, High Resistance Headphones, No. 3 Handi-Kit and Instruction Book all contained in wooden cabinet.

Frequency: 44.0 to 61.0 Mc/s.
Approximate Range: 3 to 8 miles.
Variable Tuning.
Power Requirements: Standard 120 v. H.T. and 2v. L.T.

Ideal for Civil Defence and Intercommunications.

59/6 BRAND NEW.
Calibrated Wavemeter for same, 10/-.

TRANSISTORS

Junction Type (Red Spot) P.N.P. 10/- each (Tested and Complete with Data and circuits.)

N.B.—These Transistors may be used in place of Mullard OC71 or similar Transistors.

Please note that these Red Spot Transistors are ideal for most circuits including "W.W." Pocket Transistor Receiver and Transistor Amplifier. All Transistors are British Manufactured and Guaranteed. Send for circuits and Data.

PRE-SELECTED SEVEN TRANSISTOR PUSH-PULL PORTABLE SUPERHET

Just switch to your favourite Station. No tuning, no aerial or earth. Pre-select 3 stations. Complete with all components and seven Transistors. 7 x 4 Elliptical speaker. Teltron Superhet Coils and I.F.T.s. Powered by 7 1/2 v. dry battery which lasts for months. 150 Milliwatts output. All the above with Circuits, etc. £9/17/6. Carriage paid.

Or with Matched Mullard OC72s (200 Milliwatts Output) and 7 x 4 Elliptical High Resistance Speaker 30/- extra. Suitable Plastic Cabinet, easy to assemble, 18/6. Call and hear demonstration model working.

"EAVESDROPPER" THREE TRANSISTOR PERSONAL PORTABLE. No Aerial or Earth Required Pre-selected 2-station Receiver

We can supply all the components for building the above set as per "Radio Constructor" less Microphone for 77/6. Acos Mike, 15/6. Miniature Hearing Aid, 24/-.

TRANSISTOR SQUARE WAVE GENERATOR

Complete Kit with 2 Transistors, Components and Circuit 25/-.

TRANSISTOR PUSH-PULL AUDIO AMPLIFIER (150 Milliwatts Output)

Build this Push-Pull Amplifier which is ideal for Crystal or Magnetic Pick-Up Amplification. Baby Alarm, Microphone Amplifier, etc. Powered by 6 volt Dry Battery lasting for months. Complete Kit of Parts including 4 Transistors and all Components with Circuit (less Speaker), £4/10/-.

SEND STAMPS FOR NEW 1957 28-PAGE CATALOGUE OPEN MONDAY to SAT. 9-6. THURS. 1 o'clock.

HENRY'S RADIO LTD.

5, HARROW ROAD, EDGWARE ROAD, LONDON, W.2

TEL.: PADDINGTON 1008-9, 0401

TRANSISTOR SIGNAL TRACER

Complete Kit with 2 Transistors, Components and Phones with Circuit, 42/6.

INDICATOR UNIT TYPE 182A

Unit contains VCR517 Cathode Ray 6in. tube, complete with Mu-Metal screen, 9 EF50, 4-SP61 and 1 504G valves, 9 wirewound volume controls and quantity of resistors and condensers. Offered BRAND NEW (less relay) at 67/6. Plus 7/6 carr. "Radio-Constructor" "scope circuit" included.

1955 RECEIVER

Complete with 11 valves 8-SP61, 504G VU190, VR92. As specified for inexpensive T.V. In absolute new condition, 27/6, carr. 5/-.

MINIATURE I.F. STRIP TYPE "373" 9-72 MEG.

Brand new miniature I.F. Strip size 10 1/2 in. x 2 1/2 in. x 3in. high. Valve line-up 2-EF92, 3-EF91 and EB91. With circuit. Complete with valves 42/6. Less valves 8/-.

F.M. CONVERTER UNIT 88/100 Mc/s

Containing 6 valves—2 6BA6, EB91, VR137, 2-EF54. Two I.F. stages and separate local oscillator, graduated Vernier tuning. Just plug in to your radio and obtain good listening on F.M. Voltage required 250 v. 50M/A. and 6.3 v. 2 amps. £7/19/6.

ALFRED PADGETT

40, MEADOW LANE, LEEDS, 11

PHONE: CLECKHEATON 99.

RADIO VALVES with 90 days guarantee. Post 9d. per valve. Doz. lots Post Free, Less 5%.

12S17M4	832	17/6	16AC7M	
12SG7M	VR150/30			4/-
	4/-		6C4	4/-
12SH7M	PEN46	2/6	6AG5	4/-
	3/-		954	1/3
12H6M	EF50	3/-	VR92	9d.
	1/3		VR136	4/-
12SK7M	EF36	4/-	VR65	1/6
	4/-		6K7	2/-
12AH7M	6SN7	6/-	KT2	3/6
	4/-		6G6	3/6
12C8M	6SH7M		QP220	3/6
1215GT3/-		2/6	210LF	1/6
12A6M	4/6	6H6M	1/3	KT33C
9002	2/6	6H6G	9d.	CV63
9003	2/6	6SK7M		2X2
9004	6d.		3/-	VU111
8D2	1/-	6D6	3/-	ACGPEN
807		6J5GT	3/6	4/6
(BRIT)	4/-	6J5M	4/6	7/193

RX-TX SCR522, BC624A and BC625—Complete with 17 valves. Like New, £4/10/- . Less valves and relays, £1/15/- Carr., 12/-.

RX R1392—2-3 metres. Complete with 15 valves. Like New. .01 meter in good order, £4/12/- . Sets complete with valves, less meter, and not so clean, £2/15/- Carr., 12/-.

RX 1466—Brand New, less valves. Same as 1124, but tunable, 10/- Carr., 8/6.

BC929A—Tube unit, complete with 3B1 tube (tested), less 80-volt transformer and switch motor, £1/5/- Carr., 8/6. Also less valves.

BRAND NEW.—T.U.B.9 tuning unit. Less outer case, 10/- Carr., 8/-.

RX 1125—Complete with 2 8D2 valves, 5/6. Post, 3/-.

QPP BATTERY AMP.—Complete with good QPP220, and LT220 valve. Four useful transformers in this set, 6/6. Post, 3/-.

RX 1355—Brand New, less valves, and 80-volt power pack. All the parts you require for home-made TV., 6/6. Carr., 8/-.

RX R.D.F.1.—Less valves and power pack, but all the parts you require for 2-meter conversion, 5/6. Carr., 7/6.

TX 1154.—Model N. New condition. Complete with valve and two meters, 17/6. Carr., 12/-.

NEW TRANSFORMERS.—230-volt prim. 6.25 centre tapped 6.25 at 21 amps. Most useful in the garage for low-voltage line, £2/5/- Carr., 5/-.

Parts Removed from **NEW 24 UNITS.**—Brass front handle, 1/6. Post, 9d. Phillips Trimmer, 6d. Post, 3d. Aladdin coil former with slug, 4d. Post, 3d. Socket, 6d. Post, 4d. Mazda valve base, 2d. Post, 4d.

Parts Removed from **NEW BC929A Unit.**—3B1 Tube (tested), 15/- . Post/Insurance, 5/- . Pre-set small pots. 500 K., 100 K., 1 meg., 9d. each. Post, 9d. Double .1 condenser. 2.5 kv., working. Small size, 2/- . Post, 9d. Octal Valveholder, 2d. Post, 4d. Small Choke, 2/- . Post, 1/3.

Parts Removed from **NEW 1466RX.**—Valve Can, complete with top and base, 6d. Post, 6d. WX6 and WX12, 6d. each. Post, 3d. 5-1 L.F. transformer, 1/- . Post, 8d. 7-pin Valveholder, 2d. Post, 4d.

G.E.C. DIODES.—10d. Post, 2d. **SELENIUM METAL RECS.**—250 volts at 100 mills, 5/- . Post, 6d. 170 volts at 60 mills, 2/6. Post, 6d. J50. 750 volts at 5 mills, 1/6. Post, 6d.

Postage charge—If you order more than one item, send what you think's fair to cover P. and P.

FREE TO AMBITIOUS ENGINEERS!

This 144-page Book

Have you sent for your copy?



'ENGINEERING OPPORTUNITIES' is a highly informative guide to the best-paid Engineering posts. It tells you how you can quickly prepare at home on "NO PASS—NO FEE" terms for a recognised engineering qualification, outlines the widest range of modern Home-Study Courses in all branches of Engineering and explains the benefits of our Employment Dept. If you're earning less than £15 a week you cannot afford to miss reading this unique book. Send for your copy to-day—FREE.

FREE COUPON
Please send me your FREE 144-page "ENGINEERING OPPORTUNITIES"

NAME
 ADDRESS
 Subject or Exam. that interests me
 British Institute of Engineering Technology
 409B, College House, 29-31, Wright's Lane,
 Kensington, W.8.

WHICH IS YOUR PET SUBJECT?

- Mechanical Eng.
- Electrical Eng.
- Civil Engineering
- Radio Engineering
- Automobile Eng.
- Aeronautical Eng.
- Production Eng.
- Building, Plastics, Draughtsmanship
- Television, etc.

GET SOME LETTERS AFTER YOUR

NAME!
 A.M.I. Mech. E.
 A.M.I. C.E.
 A.M.I. P.E.
 A.M.I. M.I.
 L.O.B.
 A.F.R. Ae.S.
 B.Sc.
 A.M. Brit. I.R.E.
 CITY & GUILDS
 GEN. CERT.
 OF EDUCATION
 etc., etc.

BIET

SOUTHERN RADIO'S WIRELESS BARGAINS

TRANSCEIVERS. Type "38" (Walkie-Talkie). Complete with 5 Valves. In Metal Carrying Case. Ready for use. Less external attachments, 30/- per set. ATTACHMENTS for use with "38" TRANSCEIVER: HEADPHONES, 15/6; THROAT MICROPHONE with Lead & Plug, 4/6; JUNCTION BOX, 2/6; AERIAL, 2/6.

TRANSCEIVERS. Type "18" Mark III. TWO UNITS (Receiver & Sender) contained in Metal Case. Complete with Six Valves, Microammeter, etc. LESS EXTERNAL ATTACHMENTS. £4/10/-.

TRANSMITTERS. T.1154—Complete all valves, etc., etc. Perfect order. 3 frequencies. £2/7/6 in transit case. Delivered U.K.

RECEIVERS. Type "109" 0-Valve S.W. Receiver with VIBRATOR PACK for 6 Volts. Built-in Speaker, METAL CASE, £5.

BOMBSIGHT COMPUTERS. Ex-R.A.F. BRAND NEW. A Wealth of Components. GYRO MOTORS, REV. COUNTERS, GEAR WHEELS, etc., etc. Ideal for Model Makers, Experimenters, etc., £3.

LUFBRA HOLE CUTTERS. Adjustable 1/16 in. to 3/16 in. For Metal, Wood, Plastic, etc., 7/-.

RESISTANCES. 100 ASSORTED USEFUL VALUES. Wire Ended, 12/6 per 100.

CONDENSERS. 100 ASSORTED. Mica, Metal Tubular, etc., 15/- per 100.

PLASTIC CASES. 1 1/4 in. x 10 1/2 in. Transparent. Ideal for Maps, Display, etc., 5/6.

STAR IDENTIFIERS. Type I A-N. Covers both Hemispheres in Case, 5/6.

CONTACTOR TIME SWITCHES. In Sound-proof Case. Clockwork Movement. 2 Impulses per sec. Thermostatic Control, 11/6.

REMOTE CONTACTORS for use with above, 7/6.

MORSE PRACTICE SET with Buzzer on Base, 6/9. Complete with Battery, 9/6. **MORSE TAPPERS**, Std. 3/6; Midget, 2/9.

METERS & AIRCRAFT INSTRUMENTS. Only used Adjustment or with broken Cases. TWELVE INSTRUMENTS, including 3 brand new Aircraft Instruments, 35/- for 12.

CRYSTAL MONITORS. Type 2. New in Transit Case. Less Valves, 8/-.

Postage or Carriage extra. Full List of RADIO BOOKS, 2/6.
SOUTHERN RADIO SUPPLY LTD.
 11, LITTLE NEWPORT ST., LONDON, W.C.2. GERnard 6653

larly due to the avoidance of parasitic resonances in a choke covering a wide band—particularly with the 21 Mc/s band giving a two-thirds frequency ratio to 14 Mc/s. The symptoms of severe choke resonances of deleterious type are given by the P.A. current input remaining appreciable even when the P.A. is unloaded—i.e., a high minimum dip current. This usually shows up on at least one H.F. band if an unsuitable choke is used. It will sometimes be found that a neon lights only weakly at the P.A. anode, but lights brightly midway down the choke. The choke will

The previous circuit suffers from the drawback that the full peak modulated H.T. voltage is applied across the output or "loading" capacitor also. As high-voltage high-capacity capacitors suitable for output capacitor use have recently been available cheaply on the surplus market, this is not an insuperable drawback. For the amateur who already has available a receiving type of tuning capacitor in use as a loading capacitor, however, flashover will almost certainly occur. Therefore the other alternative circuit arrangement for applying the choke H.T. feed at the low-voltage end of the circuit is given in Fig. 9. This, however, requires a high-grade capacitor, as the full circulating R.F. current of the tank circuit flows through the capacitor. This may be several amps of R.F. even with modest power inputs. The value of capacitor required will depend to some extent on the total "loading" capacity needed for 80-metre operation. However, a value of 3,000 pF will be adequate generally speaking. In some instances a somewhat lower value for the blocking condenser may be satisfactory. The simplest means of obtaining a high-grade capacitor for this service is to parallel three 1,000 pF capacitors of the T.C.C. M3KO type. This gives a quite compact assembly for the blocking capacitor. A series-parallel arrangement of six 2,000 pF M3KO capacitors will provide a blocking capacitor suitable for QRO applications.

It will be noted that in the Fig. 9 circuit the use of the disc type of ceramic capacitors is not recommended, as in this application the blocking capacitor

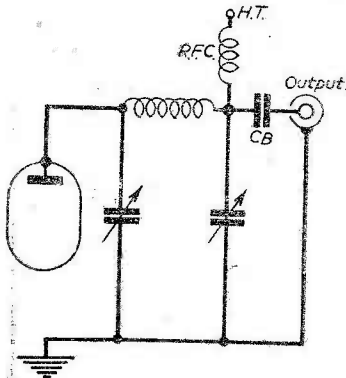

Fig. 8.—Choke resonance troubles may be obviated by "cold end" feeding. The blocking capacitor is a disc ceramic of .01 μ F and high voltage rating (CB).

also heat up appreciably. Adjustment of the choke turns and spacing may enable the trouble to be cured, but remember that wrong adjustment may throw the deleterious resonance into an adjacent H.F. band. There are chokes commercially available designed for PI tank service, but in some cases the amateur may already own a large transmitting choke of the older type which gives trouble in PI tank service.

An Alternative

The question arises as to whether it is feasible to rearrange the PI tank circuit to enable a choke giving trouble when fed direct to the anode to be efficiently utilised. The transfer of H.T. feed to a low voltage point from an R.F. point of view enables even a small receiving type of short-wave choke to perform excellently. However, there are some snags as always with such arrangements. Thus one method would be to connect the PI tank circuit as in Fig. 8. This immediately enables the choke feed to be transferred to the "cold" end of the circuit. However, we now have to use a blocking condenser to prevent H.T. being applied to the output terminal or, indeed, to prevent the H.T. being shorted to ground by any link coupling coil at the far end of the coaxial output. With this arrangement, if we wish to feed a low-impedance coaxial line, the blocking condenser must have a sufficiently low impedance and a value of some .01 μ F is required. This must be a high voltage type capable of withstanding the full peak modulated H.T. voltage, say 2 kV rating. The only really satisfactory compact capacitor type for this application is the ceramic high-voltage disc capacitor. An ultra-low-loss type of the mica capacitor standard is not necessary in this type of circuit application, but "any old" condenser will definitely *not* do for this circuit. The ceramic types can be obtained in compact disc units that are satisfactory, and although other types might be used the physical dimensions might prove a handicap.

Fig. 9.—In this variation of cold end feeding a high-grade mica foil capacitor of high voltage rating is necessary for the blocking capacitor function.

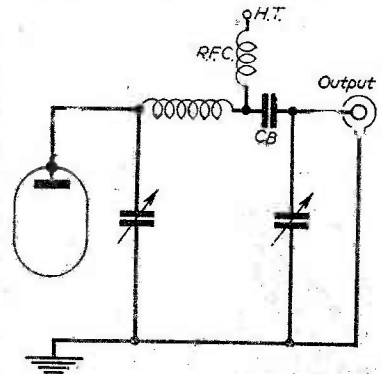

has to carry the full circulating tank current. It will be seen, therefore, that freedom from choke worries is purchased at the expense of some extra trouble over providing suitable blocking capacitors. However, a capacitor is generally trouble-free if a suitable type has been selected. This trouble may well be worth the freedom from troubles likely to be experienced when pressing an unsuitable makeshift choke one may have lying around into service in a "hot end" feed PI tank circuit. The other solution is, of course, to purchase a suitable commercial choke designed for PI tank service if one cannot operate a blocking condenser type of "cold end" feed PI tank circuit!

Finally it is taken for granted that the constants of the PI tank circuit have been selected from the design data previously published. Satisfactory operation depends upon the correct choice of circuit parameters, and these should be correct before attention is given to other possible causes of trouble in PI tank transmitters.

Programme Pointers



HOW long will the popularity of the Panel Game last? Unlike most games which cannot hope to draw the public to view them as entertainment unless they are played with consummate skill, these demand little ability yet draw millions to the radio and television set. "My Word"—their latest exemplar—is a good one for the reason that more scope is offered the participants for spontaneous and original wit than in most of the others. With Frank Muir and Denis Norden on opposite sides, plus Lady Barnett and Nancy Spain, and John Arlott in the chair, there was no shortage of this. Some excellent wise-cracking and buck-passing was indulged in by the team in their search for words from all sources and of all descriptions. It was good fun and I hope "My Word" prospers.

A second hearing of "My Word" confirms my first impression that it contains sufficient wit and originality to warrant its claim to a successful career. The story of the fat priest was a masterpiece.

Plays

Noel Coward's "This Happy Breed"—the first of a new Wednesday evening series (*The Radio Times* listed the Monday and Saturday titles, but not these), is as different from his "Blithe Spirit" or "Private Lives" as mangolds are from mushrooms. It is as if a pound of Dickens, half a pint of Wells and six Bennetts, with Frankau and Huxley to taste, had been left on the stove to simmer and completely forgotten. Telling of the adventures, but chiefly the mis-adventures, of the Gibbons family between the wars, it made one wonder at what cynical intent the author had in choosing the title. It was very well played by Doris Hare and Hamilton Dyce, with supporting cast. Adapter, Mark Oliver; producer, Audrey Cameron.

Mr. Joyce Cary's novel, "The Horse's Mouth," is justly famous, and is a rattling good story. But does it make an equally good radio play? Listening to it in the Monday evening "Against the Wind" series, I didn't think it did. The reason was that about 90 per cent., or so it seemed, of the dialogue was taken up by the two characters of Gully Jimson and Coker the barmaid, whose never varying types of humour and voice made for great monotony. The parts, however, were excellently played by Maurice Denham and Denise Bryer, with Vivienne Chatterton as Sara Monday.

St. John Ervine can always be relied upon to give us writing of the greatest stimulation and interest, whether in his original plays or his novels. John Boyd adapted his novel, "Mrs. Martin's Man," specially for broadcasting, and with the help of the Northern Ireland studio company a fine play of it was fashioned. Telling of a son who returns home after 18 years absence, and of the rather mixed reception accorded him, Gertrude Russell, Irene Bingham, J. Mageean, Elizabeth Begley, D. Hawthorne, Kathleen Feenan, G. G. Devlin and H. Goldblatt,

Our Critic, Maurice
Reeve, Reviews Some
Recent Programmes

with producer R. Mason, gave us a real Irish treat—sure they did.

Film Stars

There was a graceful and well-produced tribute to the late Humphrey Bogart, arranged in haste and taking the place of the advertised programme. Film stars who had played with him and C. A. Lejeune recalled memories rather than paid tributes. And short excerpts from Bogart's films completed the half hour. I do not remember any such homage to a screen personality before.

"Squaring the Circle," by Valentin Kataet, was a delightful Russian skit at Communism and its control over the most private and personal matters, including marriage itself. Denis Goacher, Charles Hodgson, Marion Berry-Hart, Josephine Martin, Frank Partington and Robert Sansom, narrator, made it trip along most effectively. Translation by N. Goold-Verschöyle.

"Any Questions"

The three-hundredth edition of "Any Questions" had for its panel the four longest-serving members, Mary Stocks, Jack Longland, Ralph Wightman and Arthur Street. As with all question and answer programmes the continuing popularity of "Any Questions" will depend on the quality of the ammunition brought up to serve the guns. Some of the questions already show a stereotyped familiarity; for instance, if the Government is defeated the first question immediately after is bound to be: "What do the team think of the new Government?" Or a shilling on or off the income tax at Budget time. Or "What would the team like for a Christmas present?" at Christmas time, etc., etc.

But I would issue one warning. For some time now "Any Questions" has seemed to be, whenever the opportunity offered, a forum for the uttering of anti-American sentiments. This is deplorable from any viewpoint, and as unnecessary as deplorable. A curb on it would be a public service. What is even more regrettable is that they are always vociferously cheered by the audiences.

Our Latest Handbook

A BEGINNER'S GUIDE TO RADIO

By F. J. CAMM 2nd Edition 7,6, by post 7.10

from

GEORGE NEWNES, LTD.,

Tower House, Southampton Street, Strand, W.C.2.

DIRECT FROM MANUFACTURER TO OTHER ENTHUSIASTS

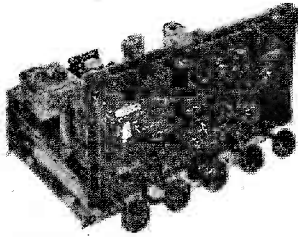

DULCI Model H.II. "The Heart of High Fidelity"

A Combined and Self-powered A.M./F.M. Tuner, Control Unit and Audio Pre-Amplifier in one Chassis designed in every detail for fine performance. Seven channel selector matching to L.P. and 78 r.p.m. Records and Tape Replay. F.M. (V.H.F.)—Short—Medium and Long Wavebands. Bass and Treble Controls giving 15db lift and cut with indicated level response position. Developed to the requirements of Connoisseurs of the higher sense of sound, with precise operation for optimum results.

PRICE £29.3.10. (inc. tax)

High Fidelity Amplifiers for 4 or 10 watts, each produced with every refinement of technical skill for superb reproduction from any source.

- D.P.A.10 Main Amplifier, 10-14 watts, £12.12.0.
- or with Tone Control Unit £15.15.0. or with Combined Pre-amplifier £19.19.0.
- D.P.4—4 watt Amplifier for Tuner £7.10.0.
- G.A.4—4 watt Amplifier with Tone Controls and Selector £9.9.0.

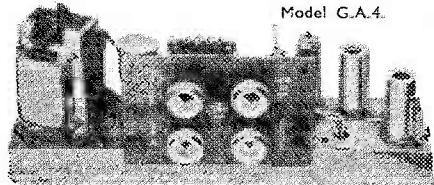

Model G.A.4.

SPECIFICATIONS ARE IMPRESSIVE—

write to Ref: P.W.

ON EXHIBITION STAND 18

Demonstration Room 125.

London Audio Fair, Waldorf Hotel—April 12, 13, 14, 15



COMPANY LIMITED. 97-99 Villiers Road, London N.W.2

(WILlesden 6678/9)

Great Britain's Valve Mail-Order House

TRANSISTORS AVAILABLE AT ONLY 10/- each

JUNCTION TYPE (SUB STANDARD)

These Transistors are extremely useful for amplification and may be incorporated in Receivers, Amplifiers, Burglar Alarms, Hearing Aids, Microphones, Pre-Amplifiers, etc., or used for Experimental Work and Electrical Controls. Apart from the above we stock the full range of First Grade Transistors, including H.F. and Silicon Types. Enquiries invited.



SERVICE SHEETS

The one you require enclosed if available in a dozen assorted of our best choice.

10/6



Chassis Cutters with Keys

The easiest and quickest way of cutting holes in sheet metal. The cutter consists of three parts: a die, a punch and an Allen screw. The operation is quite simple. Prices incl. key: Size 1/8in. 13/9; 1/4in. 14/9; 3/8in. 16in. 17/6; 1/2in. 21in. 19in. 19/6; 1 1/4in. 22in. 2 3/32in. 35/8; 2 1/2in. 40/9; 1 1/2in. sq. hole, 27in. Post 1/-.

All prices are with keys

P.F.C.O.

All-in-one Radiometer A.C./D.C.
★ Circuit Test.
★ L.T. & H.T. Tests.
★ mA. Test.
★ Valve Test.
Continuity and Resistance Tests. Complete with Test Leads.

32/6



ELECTRIC PAINT SPRAYER

REDUCED 67/6

STRIPPER

High Speed 42/6

Deposit for both 8/6 and 8 monthly payments of 15/-

9/6

REDUCED FROM 21/-

9/6

Pre-heated Electric Soldering Irons. 24 & 39 watts. Press-button switch fitted. Corrosion-free bit. Specially designed for fine work. Limited quantity. Unrepeatable bargain.

SALE of METERS Ferranti, £5. U.S.A. Triplet, £8. All-way AVO Oscillator, £12.

AMMETERS 0-30 Brand NEW and Boxed. Reduced. BARGAIN. 6/-

Special SALE Offer ROLA De-Luxe Extension Speaker. In attractive cabinet. Originally £25. Limited quantity. Post 2/6. 30/-



0.01-1" PRECISION MICROMETER

Brand new Precision Instrument. Bargain 10/-

U.S.A.F. THROAT MIKES. Brand NEW. Worth £2. 5/-

CRYSTAL SETS Complete. NEW but reduced from 22/6 to 17/6

BREAST MIKE AND HEADPHONE SETS, combined and complete. Brand New and Boxed. Only 18/- Post 2/-

THE NEW '2,000'

AUTOMATIC BLOW TORCH

Burns methylated spirit. Completely Automatic and safe for all kinds of tin and silver soldering, glass bending, etc. 2,000 deg. Fahrenheit. Post free, only 14/7



RADIO BULLS VALVES

DEMOWED VALVES MANUAL 2/6

Giving equivalents of British and American Service and Cross Reference of Commercial Types with an Appendix of B.V.A. Equivalents, and Comprehensive Price List. We have still some Valves left at very old Budget Rates (33 1/3%) which are actually sold at the old price. (1951.)

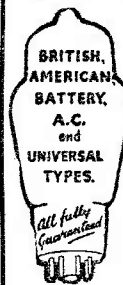

SALE

of VALVES both RADIO and T.V. Types.

Please cut out coupon below and post to us, From

2/- to 9/9

NAME

ADDRESS

TYPE OF VALVE REQUIRED

Stern's "Hi Fi" TAPE RECORDING EQUIPMENT

THE NEW TRUVOX MkIV TAPE DECK

THIS IS UNDOUBTEDLY ONE OF THE BEST TAPE DECKS ON THE MARKET. WE HAVE A FEW ONLY AVAILABLE.

PRICE **£25.10.0**

(Plus 10/- cart. and ins.)

EXCLUDING COUNTER

CREDIT TERMS: Deposit £6.7.6. and 9 monthly payments of £3.6.0.

H.P. TERMS: Deposit £12.16.0 and 12 monthly payments of £1.3.9.

SPECIFICATION:—● 3 B.T.H. shaded pole motors with silent friction drive eliminating "wow" and "flutter." ● Push button controls, electrically and mechanically interlocked (patented). ● Patented electric type push button controlled brake. ● Facilities: Record; playback; fast forward; fast reverse (a complete 1,200ft. reel can be re-spooled in less than one minute); inching to assist editing; tape loading on the drop-in principle; accommodation for reels of 7in. diameter containing 1,200ft. of standard tape or 1,800 ft. of thin tape. ● Tracking sense. To British and American standards. ● Playing times: Up to 3 hours with L.P. Tape or 2 hours with Standard Tapes. ● Two tracks, side by side, with safety gap. ● Playing time indication by precision revolution counter or large visual type indicator plate, according to choice. Positive Azimuth adjustment of Record/Player Head. With a suitable amplifier, the equipment covers a frequency range from 50-12,000 cps. at 7 1/2 in. per second. ● High Impedance Heads are designed for Super-sonic Bias and Erasing from a common oscillator. No matching transformers are required. ● The metal work is Gold Hammered finish. ● Overall size 14 1/2 in. x 12 1/2 in. from top of face of panel, overall depth 6 in. Weight 14 1/2 lb.

WE ALSO HAVE A FEW DECKS WITH REV. COUNTERS. Price £29.0.0.



THE "fidelity" TAPE AMPLIFIER Model HF/TR2 with POWER SUPPLY UNIT

PRICE **£16.0.0**

(Carriage and insurance 6/- extra).

CREDIT TERMS: Deposit £4 and 9 monthly payments of £1.10.8.

H.P. TERMS: Deposit £8 and 9 monthly payments of £1.

This amplifier has been expressly designed to meet the requirements of the enthusiasts for High Fidelity reproduction. It is based on a new design, completed by the Mullard Technicians and only really high grade components are incorporated, truly HIGH FIDELITY Recordings are obtainable whilst "Hi Fi" reproduction is assured by use of a high quality Output Transformer by Gilson. It incorporates a "magic eye" Recording Level Indicator, a two position equaliser for 3 1/2 in. and 7 1/2 in. speeds, and an effective Tone Control arrangement. Monitoring and Extension Speaker Socket are incorporated and in addition a position is provided to enable it to be used as an independent Amplifier for Gramophone Records or Radio Tuning Unit. Overall size: 11 in. x 6 in. x 6 in. high.

WHEN ORDERING, PLEASE ADVISE MAKE OF DECK IN USE. CAN BE SUPPLIED MATCHED FOR COLLARO-BRENNEL—TRUVOX.

SPECIAL OFFER!! We will supply (a) Model HF/TR2 Tape Amplifier and Truvox Mark IV Deck for **£38.10.0**.



STERN RADIO LTD

109 & 115 FLEET STREET, LONDON, E.C.4

Phone: FLEet Street 5812/3/4

Trace the Trouble
in a Trice

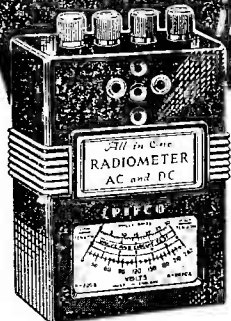

PIFCO ALL-IN-ONE RADIOMETER

- ★ Circuit Test
- ★ L.T. & H.T. Tests
- ★ mA Test
- ★ Valve Test

Use the PIFCO All-in-One RADIOMETER for the practical testing of all types of radio and electrical apparatus. You can carry out continuity and resistance tests, check H.T., L.T., and G.B. voltages, also Household Appliances, Car Lighting Systems, Bell Circuits, etc. May be used on A.C. or D.C. mains.

ONLY

Obtainable from your local dealers.

Write for informative folder to:—

★ **32/6**

COMPLETE

PIFCO LTD., WATLING ST., MANCHESTER 4
and 36-37, UPPER THAMES ST., LONDON, E.C.4

"You can rely on us"

LARGE STOCKISTS OF RADIO AND
ELECTRONIC COMPONENTS

H.P. on INSTRUMENTS, "912" and
MULLARD AMPLIFIER KITS, SOUND-
MASTER, VIEWMASTER, Etc., Etc.

RESISTORS — STANDARD, MIDGET,
HIGH STABILITY, PRECISION;
TAPPED VOL. CONTROLS, Etc., Etc.

Proprietary catalogues available to Manu-
facturers' Laboratories, Education Authorities,
etc.

RADIO SERVICING CO.,

82, SOUTH EALING ROAD,
LONDON, W.5.

EAL 5737

SHORT-WAVE SECTION

THE SERVICING DATA SHEET REMOVES DOUBTS, THE POSSIBILITY OF EXPENSIVE MISTAKES AND UNSATISFACTORY PERFORMANCE

By A. W. Mann

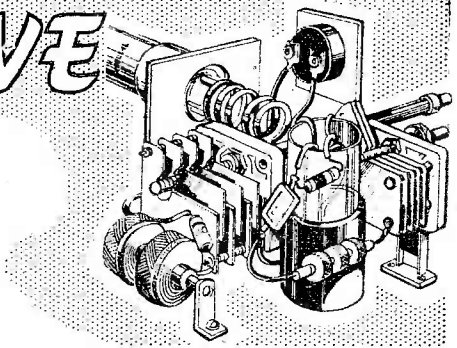

JUDGING by correspondence received following my previous article quite a number of readers listen on the short-wave bands within the range of their all-wave domestic receivers. Some are well satisfied with the results obtained whilst others, due to a falling off in performance because of ageing valves, contemplate carrying out a general overhaul.

Where requests have been made for service data correspondents have been advised to get in touch with advertisers who specialise in supplying authentic data at a very reasonable charge.

Servicing Superhets

In order to service superheterodyne receivers a reliable test meter, an accurately calibrated signal generator and some form of output measuring instrument are necessary. In addition authentic service data is essential.

Commercially designed multi-range receivers, in comparison with amateur-built models, are complicated. Designed to achieve a definite standard in performance, servicing must be carried out with a view to equalling the original sensitivity, selectivity, and all round efficiency.

Clearly guess work together with cut and try methods should be avoided.

Service Data Sheets

Service data sheets provide the set owner with a fully detailed theoretical circuit diagram, lay-out diagram, component values, check points and procedure. Also voltage and current data and aligning instructions.

Very Useful

What is the correct intermediate frequency? The data sheet supplies the required information and saves time which might be spent trying to get a rough idea as to what it is. This assures, other things being equal, accurate trimming of the I.F. amplifier.

Very likely the I.F. amplifier has band-pass characteristics. This will call for slight variations in the trimming of the primary and secondary windings of the individual I.F. transformers. Here again the data sheet gives the exact frequencies and sequence of operations.

Tuning dial settings, tone and volume control settings, recommended when aligning the signal frequency circuits on different tuning ranges and sequence of operations are also outlined.

From the foregoing examples it will be appreciated

that the cost of service data sheets generally will prove to be a sound investment.

Working in the dark provides many pitfalls. Lack of vital information when same is available at low cost cannot be excused. With suitable yet modest test equipment a knowledgeable amateur can do quite a lot. Before making a start, however, the necessary data should be obtained and carefully studied.

Tuning Range Modifications

A commonplace service job in many coastal towns is the replacement of a little used range with one covering the trawler bands.

On the face of it, just a matter of coils replacement. In actual fact there is much more to it, and anyone contemplating such modifications should be quite sure as to the availability of suitable coils as to range, physical dimensions, general design and suitability for use with a particular receiver, the I.F. of which should be known. Methods of mounting, switching, and alignment should be ascertained.

Coil manufacturers should be given the fullest information including make and year of set I.F. used. Above all be quite sure as to your ability to see the job through.

It may be that some reader of this article has carried out similar modifications without difficulty to a particular receiver and does not see eye to eye with the views expressed. Much depends on the general design of the receiver.

Valve Replacement

Revalving a receiver throughout does not assure a return to peak performance. It should not be overlooked that the receiver was aligned at the factory with the original valves fitted.

Identical types and makes show slight variations in characteristics which, while within tolerance limits, are sufficient to offset the original trimming and padding adjustments. This being so, complete realignment is most desirable and necessary to achieve peak performance.

Realignment

While I am aware that superhets are sometimes realigned without the aid of a signal generator, I am certain that peak performance is not achieved by the use of this method.

In the author's opinion a signal generator should be used together with a suitable output measuring

device. The receiver and signal generator should be allowed to warm up for at least half an hour before starting the realignment.

Valve Repairs

Loose valve bases and top caps can be repaired with special cement available from some advertisers. When it is discovered that the internal wire of the cap is broken off flush with the glass pinch of the valve envelope it would appear that a satisfactory repair is impossible.

One can at least try. Wrap a piece of used, fine grade emery cloth around a small wood block and apply very gently to the pinch and wire end. This requires great care. The idea is to polish the end of the wire without chipping the glass pinch. Do not use sandpaper. Drill a hole in a small wooden block to take the cap and hold it firmly. Mount the block in a vice.

Do not disturb the hard cement in the cap. Next apply a little soldering paste to pinch wire end, fill top cap with molten solder. Take valve and press pinch into cap and hold firmly, applying a gentle pressure until solder and cement sets. If cap is firm, test valve under working conditions.

This type of repair is easier to describe than to carry out. It may require three or four attempts, but it can be done and recently saved the author additional expense and the discarding of an otherwise good valve.

Component Replacement

It may be that some component requires replacement due to wear. This applies especially to variable tone and volume controls. The resistance value may or may not be stamped on the case. The service data sheet, however, will include the desired information.

I strongly advise readers who carry out such replacements or any in which more than one lead is to be unsoldered to label the leads individually as unsoldered. For example, a potentiometer which has a connection to each end and another to the wiper arm, should have the unsoldered leads marked left, centre, right.

Multi-switch mechanisms are sufficiently complicated without unsoldering a number of leads and adding further complication by having nothing to

indicate where they go. Indicating tags or labels will avoid mistakes and what is more reduce the time spent in doing the job.

Admitted the circuit or a separate diagram will give switch connection details which helps considerably, providing one can obtain a clear view of the switch wafer concerned. In a compact switch unit this is not always the case. To take no chances is, therefore, good policy.

Drive Mechanism

Cord drive tuning condenser mechanism at some time or other calls for replacement of the original cord due to wear or breakage. Service data sheets as a rule provide details as to the run sequence. If such information is not available, careful note should be taken and a sketch made before removing the old cord.

If at all possible obtain a service data sheet, it will help considerably, some cord drives being more difficult to replace than others.

Old Commercial Receivers

One wonders what exactly happens to old receivers of the two-range type, scrapped due to lack of selectivity. Most likely some are stored away and forgotten. This applies also to some of the earliest so-called all-wavers which, with a very restricted short-wave range and cramped dial scale, were difficult to tune, and not even a good compromise. Providing they are usable it might be worth while fitting a short-wave converter ahead of them and thus enjoy the advantages of double conversion. Much depends on the receiver, however, which must be a superhet.

One of this country's outstanding DX chasers in pre-war days used such a combination. With it he built up a staggering number of verifications, and won competition awards. Incidentally his catches were on 'phone and short-wave broadcast transmissions only.

Converters

Do not imagine, however, that short-wave converters are out-dated. Many amateurs now use this principle for 144 Mc/s reception with every satisfaction.

Battery-operated F.M. Sets

AT a meeting in London of the British Institution of Radio Engineers on January 30th, a paper was read by R. A. Lampitt, A.M.Brit.I.R.E., on "The Principles of Design of Battery-operated Frequency Modulation Receivers."

The paper was written jointly with J. P. Hannifan, A.M.Brit.I.R.E., and showed that the special requirements of battery-operated receivers generally include low running costs and the maintenance of adequate performance at reduced battery voltages. It showed also that the designer, in attempting to achieve these results, is faced with several major problems not encountered in the design of the mains operated counterpart arising from the inherent features of the limited range of 1.4 volt filament valves. Following a discussion of the above, the speaker dealt with the principles and design of the mixer stage, the I.F. amplifier and the demodulator circuit in an A.M./F.M. receiver for battery operation.

Special Aerials

METROPOLITAN TAXIS, LTD., operators of radio taxis in the London area, recently required three directional aerials to be installed on one mast, giving a 120 deg. beam from the Elephant over the West End. One of the main problems was the sensitivity of Yagis to metal and other obstructions such as guys.

This problem was solved by Skymasts, who erected a 90ft. mast mounted with two completely new-type skeleton slots and one end-fed Yagi at 12ft. intervals, the Yagi being the highest array. These slots, unlike Yagis, are unaffected by the proximity of the pole, guys or other metal.

The final result is that, although this mast is situated in a position where height is absolutely vital, and although the first slot is 12ft. lower than the Yagi, it gives a wider beam width and greater gain.

These skybeam slot aerials were designed by J-Beam Aerials, Ltd.

WEYRAD

"H" TYPE COILS— FOR MANUFACTURERS, SERVICE ENGINEERS AND INDIVIDUAL CONSTRUCTORS

A low-priced, soundly-designed Range of Coils, providing continuous coverage from 12 to 2,000 metres in 6 Bands.

The coils are supplied in individual aerial, H.F. transformer and oscillator versions for each band. Iron dust cores are adjusted by means of a threaded brass stem with a screwdriver slot which permits fine adjustment of inductance without the danger of damage to cores. Circuit connections are fixed to 4 tags at the end of the former. Single 6 B.A. mounting.

"H" type coils are recommended for many popular circuits including the "Practical Wireless" AC/DC 3-valve Superhet and are widely used for servicing and conversion purposes.

RETAIL PRICE.....3/9 EACH

ILLUSTRATED FOLDER.....3d.

A.M./F.M. RECEIVER BOOKLET 2/6.

WEYMOUTH RADIO MANUFACTURING CO., LTD.
CRESCENT STREET, WEYMOUTH, DORSET

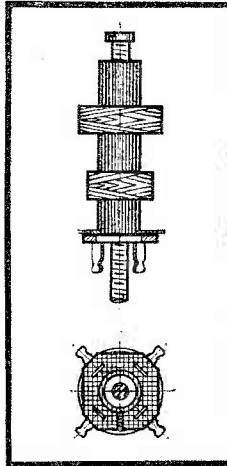

RANGES:

- Band 1—800-2,000 mtrs.
- Band 2—250-800 mtrs.
- Band 3—190-550 mtrs.
- Band 4— 90-250 mtrs.
- Band 5— 33-100 mtrs.
- Band 6— 16- 50 mtrs.
- Band 7— 12- 37 mtrs.

Coils are coded according to type and range :
HA 1 = Band 1 aerial
HO 3 = Band 3 oscillator

VALVES • SAME DAY SERVICE

All Guaranteed New and Boxed

14v. midget, 1R5, 1S5, 1T4, 1U5, 3S4, DAF91, DF91, DK91, DL92 DL94; any 4 for 27/6.

1ATGT	12/6	6L13	13/6	B36	19/6	ECH81	8/-	PCF82	11/6
1CRGT	11/-	6C7GT	9/6	CL33	14/-	ECL33	9/-	PEN36C	16/-
1HSGT	11/-	6SN7GT	7/6	D1	8/-	EP38	4/6	PEN46	6/6
1NSGT	11/-	6D4GT	14/6	D15	6/6	EP37A	8/-	PL36	16/6
1R5	8/6	6V6GT	7/-	D77	6/6	EP39	6/-	PL81	11/9
1S5	7/6	6V6GT	7/6	DAC32	11/-	EP40	11/6	PL82	9/-
1T4	7/3	6X4	7/-	DAF36	8/6	EP41	9/6	PL83	11/9
3A5	6/6	6X5GT	6/6	DC90	1/6	EP42	12/-	PY80	9/-
3C4	9/-	7B7	8/-	DF33	11/-	EP43	7/6	PY81	8/-
3Q5GT	9/6	7C5	8/-	DF96	8/6	EP40	8/6	PY82	7/-
3S4	7/6	7C6	8/-	DH76	8/6	EP85	7/6	PY83	5/6
3V4	8/6	7H7	8/-	DH77	8/6	EP86	12/6	PZ30	18/-
5U4G	8/-	7S7	9/-	DK32	12/6	EP87	10/-	SP41	3/6
6Y3GT	7/6	7Y4	8/-	DK32	9/-	EP91	6/6	SP61	3/6
6Z4G	9/-	10P1	13/6	DK96	9/6	EP92	6/6	UP5	12/6
6AK5	4/6	10P9	9/6	DL33	6/6	EL32	5/6	USC	7/6
6AL5	6/6	12A8B	10/6	DL35	11/-	EL41	10/6	U76	8/-
6AM5	5/-	12AT7	8/6	DL96	8/6	EL42	11/-	U78	7/-
6AM6	6/6	12AU5	7/6	EABC80	7/6	EL81	10/6	U804	8/6
6AQ5	7/6	12AU7	7/6	EAC31	8/6	EM33	10/-	UABC80	11/6
6AT3	8/6	12AX7	6/-	EAP42	14/6	EL75	14/6	UAC12	10/6
6BA5	7/6	12K7GT	11/6	EB91	6/6	EY80	10/6	UBC11	8/9
6BB5	7/6	12K7GT	8/6	EBB33	7/6	EZ40	8/-	UBF80	8/6
6B7	7/-	12K8GT	14/6	EBC41	10/-	EZ81	8/6	UCH42	10/3
6BR7	8/6	12Q7GT	8/6	EBB80	9/6	EZ91	10/-	UF41	8/-
6BV6	7/6	14S7	14/-	ECC40	11/6	EW4500	10/-	UL11	10/-
6CD6G	12/6	50L6GT	9/-	ECC81	8/6	EZ32	12/6	UL31	11/6
6F1	13/-	25Z4G	6/6	ECC82	7/6	HVR12A	6/6	UO9	8/-
6F6G	6/6	25Z6GT	9/6	ECC83	9/-	KT3C	10/-	UY21	14/-
6F12	6/6	35A5	11/-	ECC84	12/6	KT44	16/-	UY41	8/6
6F13	13/-	35L6GT	9/6	ECC85	8/6	KT63	7/6	UY85	8/6
6G6	5/6	35T3	10/6	ECC91	5/6	WU19	8/6	W3	10/6
6K7G	5/-	35Z4GT	8/-	ECPB8	12/6	NT	11/-	W7	8/6
6K7GT	6/-	35Z5GT	8/-	ECPB82	12/6	P61	8/6	X7J	12/6
6K8G	2/-	50L6GT	8/6	ECH35	9/6	PCC81	8/6	Y83	7/6
6K8GT	8/6	60	8/6	ECH42	10/-	PCF81	7/6	Z77	6/6

Postage 5d. per valve extra.



LOOK, ONLY £8.12.6!

BRAND NEW — NOT SURPLUS! In maker's sealed cartons. Latest UA3 "Monarch" 4-speed record-player complete with High-fidelity "turnover" head. Type HGP 37-1. Capacity of 10 Records, plays 12in., 10in. and 7in. Intermixed in any order, 78, 45, 33 and 16 r.p.m. For A.C. mains 100 to 250 volts. Exclusive "magdisk" selector gives quickest and quietest change-over. With full instructions and fixing plans. **Limited Quantity at £8.12.6, plus 4/6 Post, Packing, etc. C.O.D. 2/6 extra. SEND NOW WHILE STOCKS LAST!**—modernise your radio-gram and increase its value.

FEW ONLY AT 92/6d.



NEW in maker's sealed cartons!—limited quantity of the famous B.S.R. 3-speed record player units, exceptionally easy to fix, with lightweight pick-up, incorporating "Acos" crystal turnover head and separate sapphire styli for Standard and Long-Playing. With full instructions, and fixing plans. **Unbeatable price £2.6, plus 3/6 Post, Packing, etc. C.O.D. 2/- extra. RUSH YOUR ORDER NOW — BEFORE IT'S TOO LATE!**

VALVES, each one tested before despatch (add 6d. post and packing) — 5V6G, 7.9; 6K7G, 6.9; 6J5G, 5.9; 6SN7G, 8.-; 7193 (also usually same as 6J5), only 2.9; 3A4, 7.-.

TRANSISTOR SQUARE-WAVE SIGNAL TRACER, really ideal for fault tracing as it can be fed into L.F., I.F. and H.F. stages and a distinctive note heard, all parts, including two transistors, components and circuit, **ONLY 27/6.** Post and packing 1/3.

READERS RADIO
24, COLBERG PLACE, STAMFORD HILL
LONDON, N.16 STA. 4587

CONCORD ELECTRONICS 7
69, PRESTON STREET, BRIGHTON

BUILD THIS AUTHENTIC

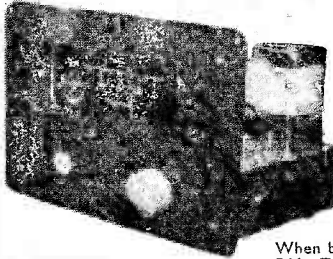

JASON F.M. KIT

4 VALVES
●
STABLE
●
EASY CONSTRUCTION

When built this famous Jason F.M. Tuner provides good sensitivity with freedom from drift and highest quality reproduction. Output 0.5 v. Chassis supplied ready punched, together with genuine exclusive Jason coil and dial assemblies, etc. Useful range—60 miles; fringe area version available. Book of the Jason F.M. Tuner (Data Publications), 2/- or 2/3 post free. Detailed price list on application.

Complete kit of quality components less valves, £5.5.0. Fringe-area version (less valves) £6.0.0. Power-pack kit, 2.1.9

● **JASON "ARGONAUT" A.M.-F.M. KITS**
For building as a tuning unit or complete self-powered receiver. Book by Data Publications, 2/- (2/3 post free)

FROM LEADING STOCKISTS, or in cases of difficulty :

JASON MOTOR & ELECTRONIC CO. Phone: SPE 7050
328, Cricklewood Lane, London, N.W.2.

Best Buy at Britain's

MINIATURE 373 I.F. STRIP. Complete with 3 EF91, 2 EF92, and 1 EB91. BRAND NEW, with circuit, 42/6, or less valves, 7/6. **TOP BAND R1155's.** Covers the 100-200 m. trawler and shipping bands, etc. In first-class condition. Thoroughly re-aligned and tested. £12.19.6. Send S.A.E. for full details of power packs, etc., or 1/3 for 14-page illustrated booklet. CR100's also available.

RECEIVERS 3853-A. Partly stripped chassis, less valves. Contains approx. 80 resistors. 60 condensers (incl. tubular metal), 10 group boards, 17 valveholders (Int., Oct., etc.). Size 12in. x 8in. x 18in. deep. With cover. UNUSED. 15/- carriage paid England only.

BARGAIN VALVES, 5/- EACH: 155, 6A07, 804, 6058, 6K7GT, 6L7, 6S7, 6SH, 7Q7, 12A6, 12SH7, 12SJ7, 12SR7, 12Y4, 15D2 (VR107), 42, 135R8, EBC8 (VR55), EF38 (VR56), EF99 (VR53), EL32 (VT52), EL50, EY91, K55DG, VR150/30. ALL GUARANTEE O.K.

VIBRATOR PACKS. Input 5 v. D.C. Output approx. 130 v. at 30 m/amps D.C., fully smoothed and R.F. filtered. Size 4in. x 5in. x 2in. Fitted with Mallory 529C Vibrotor. BRAND NEW. 12/6.

TESTMETERS. American, 1,000 ohms per volt, 20 ranges. 0-5,000 v. A.C. and D.C., D.C. m/A and amps, ohms, and dB. In polished wooden case. 6 1/2 x 6 1/2 x 4 1/2 in. Complete with leads and instructions. Guaranteed O.K. £5.19.6.

RL166 RECEIVERS. The tunable RL124. As described for conversion to car radio in June issue of P.W. Brand new and boxed. With all valves, 19/6, plus 5/6 carriage.

TWO-WAY MORSE TRAINING SETS. W/T Mk. 3. Consists of two valve oscillators (ARP12's) (one with pitch control), for one or two operators. Has provision for creating "Atmospheres". In polished oak case, 12 1/2 in. x 10 1/2 in. x 8 in., wt., 16 lbs. Complete with valves, leads, 2 keys, 7-way terminal board, circuit and instructions but less batteries and phones. Ideal for Cadets, Scouts, etc. SNIP. 19/6, plus 7/6 carriage. Headphones for above, 10/6 pair.

RESISTORS. Latest miniature insulated Dubilier 1 watt type BTS. Wire ends. Useful values. ONLY 10/- for 100 assorted! 1/2 and 1 watt, Eia, etc., 1 gross assorted, 10/-.

FIELD TELEPHONES. Army type D, Mk. 5. Buzzer calling. Ideal for building sites, farm, workshops, etc. Complete with handset and batteries. Tested before despatch. 39/6 each.

METAL RECTIFIERS. 230 v. 60 m/amps, 3/6; 230 v. 100 m/amps, 5/-.

SMALL MICA CONDENSERS. 300 pF or 500 pF d, 3/6 dozen.

PLEASE ADD POSTAGE OR CARRIAGE ON ALL ITEMS

CHARLES BRITAIN (RADIO) LTD.
11, Upper Saint Martin's Lane, London, W.C.2.
Temple Bar 0545

Shop hours 9-6 p.m. (9-1 p.m. Thursday). Open All Day Saturday.

● 1957 EDITION

THE RADIO AMATEUR'S HANDBOOK

32/6. By The A.R.R.L. Post 1/6

THE ELECTRONIC MUSICAL INSTRUMENT MANUAL. By A. Douglas. Price 35/-. Postage 1/-.

THE GRAMOPHONE HANDBOOK. By P. Wilson. Price 15/-. Postage 1/-.

AMPLIFIERS. Design & Construction. By F. J. Camm. 17/6. Postage 9d.

TELEVISION EXPLAINED. By W. E. Miller. Revised by E. A. W. Spreadbury. 12/6. Postage 9d.

H.I.-FI LOUDSPEAKERS AND ENCLOSURES. By A. B. Cohen. Price 37/6. Postage 1/-.

TRANSISTOR TECHNIQUES. Gernsback Library, No. 61. Price 12/-. Postage 8d.

RADIO VALVE DATA. Compiled by "VWV". Price 4/6. Postage 6d.

The MODERN BOOK CO.

BRITAIN'S LARGEST STOCKISTS of British and American Technical Books

19-23 PRAED STREET, LONDON, W.2

Write or call for our catalogue. Phone: PADddington 4185.

Open 6 days 9-6 p.m.

FIRST-CLASS RADIO COURSES...

GET A CERTIFICATE!

QUALIFY AT HOME—IN SPARE TIME

After brief, intensely interesting study—undertaken at home in your spare time—YOU can secure your professional qualification. Prepare for YOUR share in the post-war boom in Radio. Let us show you how!

FREE GUIDE

The New Free Guide contains 132 pages of information of the greatest importance to those seeking such success-compelling qualifications as A.M.Bric.I.R.E., City and Guilds Final Radio, P.M.G. Radio Amateurs, Exams., Gen. Cert. of Educ., London B.Sc. (Eng.), A.M.I.P.E., A.M.I.Mech.E., Draughtsmanship (all branches), etc., together with particulars of our remarkable Guarantee of SUCCESS OR NO FEE

Write now for your copy of this invaluable publication. It may well prove to be the turning point in your career.

FOUNDED 1885—OVER 150,000 SUCCESSSES

NATIONAL INSTITUTE OF ENGINEERING (Dept. 461), 148, HOLBORN, LONDON, E.C.1.

COPPER WIRE

ENAMELLED, TINNED, LITZ, COTTON AND SILK COVERED. RESISTANCE WIRES, 1 oz., 2 oz. & 4 oz. REELS. All gauges available.

B.A. SCREWS, NUTS, WASHERS, soldering tags, eyelets and rivets. EBONITE AND BAKELITE PANELS, TUFNOL ROD, PAXOLINE TYPE COIL FORMERS AND TUBES. ALL DIAMETERS.

Latest Radio Publications. SEND STAMP FOR LISTS

SPECIAL OFFER

G.E.C., B.T.H. & WESTINGHOUSE GERMANIUM CRYSTAL DIODES

1/- each. Postage 2 1/2d.

Diagrams and three Crystal Set Circuits free with each diode. A large purchase of these fully GUARANTEED diodes from the manufacturers enables us to make this attractive offer.

CRYSTAL SET
INCORPORATING THE SILICON CRYSTAL VALVE
Adjustable Iron Cored Coil.
RECEPTION GUARANTEED
Polished wood cabinet, 15/-, post 1/3
A REAL CRYSTAL SET, NOT A TOY

POST RADIO SUPPLIES
23 Bourne Gardens, London, E.4

Open to Discussion



The Editor does not necessarily agree with opinions expressed by his correspondents

A New Speaker Enclosure

SIR,—I recently constructed the folded horn speaker enclosure published in the October issue of PRACTICAL WIRELESS.

I made it out of $\frac{3}{4}$ in. plywood, glued and screwed together. It is possible, of course, that my straight edges are curved, but I failed to make the "flarepath" measurements of the two internal partitions, with respect to the outer back, agree with those shown in the diagram. These are $4\frac{3}{4}$ in., 6 in. and $7\frac{1}{2}$ in. ($6 + \frac{3}{4} + \frac{3}{4}$). If I made two, the other was out. I decided that the top end was the most important, followed by the bottom, so I adhered to these. As far as I am concerned, this made the other measurement $5\frac{3}{4}$ in., instead of 6 in. Am I alone in this dilemma?

I am not a supporter of multiple speakers with frequency dividing networks. So I was left with a nice roomy compartment, above the bass speaker section, with nothing in it. I decided to put the amplifier in it. (The ultra-linear version of the Mullard 5-10, complete with preamplifier, all in one chassis.) I made two detachable panels on each side, the left-hand side one with a window in it for the controls to come through. I cut a $1\frac{3}{4}$ in. hole near the bottom edge of each panel and three in the top of the enclosure for ventilation purposes.

I used two Philips 8 in. speakers, Model 9710M in series. The centres of these two speakers lie on the diagonal of the lower section of the front panel. These speakers have quite a remarkable performance. The high-frequency response only begins to fall off above 18,000 c/s. The bass resonance is 45 c/s.

I find the performance of the enclosure very satisfactory. Bass boost can be used without the usual aural distress.

The lining of enclosures sometimes presents problems. I use low-grade cotton wool, held in position by mosquito netting.—D. A. SHEPHERD (Singapore).

Stereophonic Recording

SIR,—I was more than usually interested in your "Open to Discussion" column this month (January). I refer to Mr. J. S. Gilbert's letter concerning stereophonic recording.

I do not for one moment doubt that a complete twin-channel recording/reproducing system can be built into a cabinet only $17\frac{1}{2}$ in. by $15\frac{1}{2}$ in. by $7\frac{3}{4}$ in., but I must disagree with the idea that two speakers included in a cabinet of this size will produce a stereophonic effect.

The whole basis of stereophonic reproduction, be it through the medium of the tape, disc, or radio, is the faithful reproduction of the volume and phase differences between the two channels.

These differences should (I repeat, should) be in every respect identical to those arriving at the ears when listening to a live performance, and it is therefore essential that in the first instance the two channels of the reproducing system must be perfectly balanced both in frequency response and phase shift, and secondly, but equally important, the separation between channels must be kept, as near as possible, 100 per cent.

Assuming that the crosstalk between channels is kept to an absolute minimum, the degree of separation will depend entirely upon the spacing and beam width of the speakers.

How then can any kind of stereophonic effect be obtained from two speakers built into a cabinet of size aforesaid?

The use of external speakers (properly spaced) will not only improve the stereo effect, it will also demonstrate the difference between stereophonic and single-channel reproduction.

Another point arises from Mr. Gilbert's letter. Am I to assume that the two channels of his reproducing system consist of separate bass and treble amplifiers? Oh, horror! I sincerely hope that I am misreading the letter; if not, then the system he is using is nothing more than a glorified crossover unit.

I would very much like to go on writing on the subject of stereophonic reproduction, but space is limited, and I must say a word or two in answer to the last paragraph of Mr. Gilbert's letter.

It most definitely is a practical proposition for anyone to make stereophonic recordings.

Given the equipment, anyone who has a certain amount of recording engineering experience can make quite a good stereo record.

But what will the equipment consist of? Naturally, it will consist of a stereo recorder, which we assume is the best available, and likewise, two microphones of the same high order. Then what? A recording studio? Or shall we settle with the lounge? Let's settle for the lounge which has been adequately damped and converted into a passable recording studio.

All that is required now is a subject to record in stereo. We certainly cannot borrow a symphony orchestra, in fact, what is there available to the amateur that will be greatly improved by a stereo recording? Unless Cousin Jack can be persuaded to march to and fro across the room while reciting the soliloquy from *Hamlet*, or some other such arrange-

Whilst we are always pleased to assist readers with their technical difficulties, we regret that we are unable to supply diagrams or provide instructions for modifying commercial or surplus equipment. We cannot supply alternative details for receivers described in these pages. WE CANNOT UNDERTAKE TO ANSWER QUERIES OVER THE TELEPHONE. If a postal reply is required a stamped and addressed envelope must be enclosed with the coupon from page iii of cover.

ment can be made, there is practically nothing available for the amateur to record in stereo.

Perhaps it won't be too long before the BBC transmit twin-channel programmes.

I look forward to meeting Mr. Gilbert again at this year's radio show; we may have something that will surprise him.—VERNON B. DE'ATH (Windsor).

F/M Results

SIR,—I have been using my home-built V.H.F. F/M receiver for some weeks now and have been pleasantly surprised by the results obtained, perhaps they would be of interest to your readers.

My location is about 250ft. A.S.L. on the north bank of the Teife estuary near Cardigan, with the ground sloping evenly down to the sea towards the south-west. To the north there is an almost uninterrupted view, and I receive the transmissions from Divis, Northern Ireland, at good strength, the distance being 185 miles. To the south, across the estuary the ground rises to about 400ft. and further south it rises to about 1,000ft. Despite this, I receive North Hessary Tor at a distance of 120 miles at about the same average strength as Divis. Some slow fading is apparent on both stations, and aircraft fading is quite frequent, but in both cases the limiter stage usually holds the output steady.

I am using an indoor dipole aerial with Pawsey stub balun, and the receiver is built around the surplus I.F. unit type 373.

In case readers wonder why I have not mentioned Blaen Plwy, I would add that although I receive its transmissions very well (even on its present low power), I am one of the English community in the district who wish to listen to the Home Service in English!

One surprising point is that I cannot receive Wenvo2 transmissions at strength sufficient to provide any entertainment value at all!—T. WINCHCOMBE (Cardigan).

The Amateur Licence

SIR,—A feeling of extreme disgust has compelled me to write this letter to you. A feeling of disgust occasioned by the mental attitude of the so-called enthusiast, who being too lazy to exert himself and surmount the requirements laid down by the authorities for the acquirement of an Amateur Transmitting licence, is continually whining and moaning that *other* people should exert *themselves* and get the nasty exams removed so that he may indulge in his passing fancy with the minimum of inconvenience to himself. A passing fancy it probably would be, for a person who has not got the guts or drive to make the effort needed to pass the simple exams and tests required by the G.P.O. would certainly soon become bored with the limited field that his imperfect knowledge opened to him, and so pass from the scene, having—in all probability—caused ill-feeling and unnecessary interference by his selfish attitude.

In reply to his excuse that he has not the time to learn, let me just say that at the time that I studied for my R.A.E. and Morse test, I was away from home from 5.45 a.m. till 7.30 p.m., leaving a very limited time for study, on top of which I was approaching middle age and consequently not so mentally receptive as I might have been.

As for the excuse that he cannot afford the fully

licensed rig, but could manage to get together a rig for a novice, I answer, piffle! One has not *got* to run high power just because one has a full licence. I have been licensed since 1950 and, except for a period of about three months when I went "QRO" with 25 watts, my power has been under 10 watts and at times under one watt! I build all my own gear (including receivers) and can honestly say that even when using the simplest of equipment, the effort to make myself eligible to operate an amateur transmitter was worth every moment spent swatting up basic principles.

Come on chaps, let's have more action and less moaning and excuses from you, it is not very difficult to amass enough knowledge to pass the exams. After all, they are only very rudimentary, and there are enough evening classes and clubs to help you. The R.S.G.B. even organises slow Morse periods on top band to give you practice, and as a last resort several correspondence schools have special courses of study for the R.A.E.

Lastly, remember that you cannot get out of anything more than you put in, and the more effort you put in to learning about your hobby, the more hours of sheer enjoyment and pleasure it will afford you.—DOUGLAS P. J. MEAD (G31DM), Chertsey.

"Amateur Radio" Novice Licence

SIR,—Every time this appears in "Open to Discussion," always the same thing happens. The Man with the Hard Work behind him appears with the bucket of cold water to snuff out the kindling flame. This time I see it is Mr. L. O. Richardson who takes up the battle in favour of this jealous fraternity who are termed "Hams." He has not even studied the situation from any angle only his own. I wonder if he spared a thought for the thousands of the afflicted of all ages, of those who are doomed to lie in bed, some for all time, of boys and young men who have nothing, only four walls and their own family circle? If Mr. L. O. R. would read the pages of recent copies of PRACTICAL WIRELESS he will find letters from the younger element (for whom this argument is primarily intended); they are begging the Editor to put them in touch with others so that they may advance their knowledge in this field. Is he aware that there are districts with no Radio Clubs within 15 miles? Young people cannot afford to travel these distances, for these also something should be done. Would Mr. L. O. R. rather see teenagers spending their pocket money on knuckle-dusters, bicycle chains, hard stone rings and coshes? Is it not better to see them round the windows of the ex-Govt. junk shops than lounging in the snack bars as "Teddies"? It is for these, Mr. Richardson, that this battle is being fought not for the Q.R.O. bods. The very reason why the Amateur Licence was instituted is that men of all nations can get together for the advancement of technical knowledge in the field of radio, without either gain or profit, and anyone who openly states he is in opposition to this should have his licence revoked.—H. WHITTAKER Manchester.

WIRELESS COILS, CHOKES AND TRANSFORMERS

8th Edition.

Price 6/-. by post 6/9.

HANNEY

offers

Components for

OSRAM 912 PLUS AMPLIFIER
OSRAM 912 PASSIVE UNIT
OSRAM 912 PRE-AMPLIFIER
OSRAM F.M. PLUS TUNER

MULLARD 510 AMPLIFIER
MULLARD 510 "A" PRE-AMPLIFIER
MULLARD 510 "B" PRE-AMPLIFIER
MULLARD 3/3 AMPLIFIER
MULLARD F.M. TUNER UNIT

"WIRELESS WORLD" F.M. TUNER UNIT
DENCO MAXI-Q F.M. TUNER UNIT

Manuals available:

912 PLUS AMPLIFIER—4/-; OSRAM F.M. PLUS TUNER—2/6; MULLARD HIGH QUALITY AMPLIFIER MANUAL (contains F.M. details)—3/6; DENCO F.M. TUNER—1/6.

Send 21d. postage, stating lists required. General Components list also available.

L. F. HANNEY
77, Lower Bristol Road Bath

TECHNICAL TRADING CO.

T.C.S. TRANSMITTERS. American 1.5-12 mc/s. 7 valves, 25 watts, 1885 modulators, high fidelity. T.C.S. RECEIVERS. 7 valve superhets to match. THIS ABOVE PAIR. 414. B28 (CR100) RECEIVERS, complete untested, £12.10. ADMIRALTY POWER PACKS. 230 v. A.C., 400 v. 80 mA. smoothed, 6.3 v. 3 A., totally enclosed, 5U4G rect., 35/- . Smoothing resistors 1,000 Ω 10 watt W.W. 1/3.

SPECIAL BARGAIN: 12 v. 4 amp. rectos, 9/6 ea. 25 doz. Full wave iron selenium heavy compact type.

SINGLE HEADPHONES, headband, 2/6. **CHOKES,** 15H, 150 Ω A/96. **RECORDING TAPE,**—Known make, 1,200ft. 16/- reel. 3 Gang .0005. Long. lin. sp. 3/6. **TIME SWITCHES,** 14 dev. 2 stage automatic, 25 amp. mercury switches, 27/6. **NEW CON- DENSERS,** 10 pf.-.5 mfd., our assortment 50 for 6/6; 100 12/-.

TELESCOPE 16 mm. **TALKIE PROJECTORS,** L518 sound/ silent, push-pull amplifier, heavy 12in. speaker, A.C./D.C. 110/250, tested, good cond., £33. Min. Cond., £33.

P.M. LOUDSPEAKERS, 7 x 4 Goodmans, 17/6; 10 x 6 ditto, 26/-; 6 1/2in., 10/-; 8in., 12/6. Ditto soiled but tested, 7/6. **NEW THROAT MILES 76.** **AMPHENOL HOLDERS,** Octal, Mazda, Noval, BTG, B9a, 6/- doz. B9G W/Scribble, 1/6 ea. Holders, Octal, 6d. Duodecal, 1/-; **MEG. POTS D.P. SWITCH,** 3 1/2in. spindle, small type, 3/6. Ditto, lin. spindle, 2/6. **RESISTANCES, ASSORTED,** 1-3 v. 4.7-10 MΩ. 2/- doz., 10/-, 100. **MIDGET CERAMIC CONDENSERS,** 10, 20, 50, 300, 1,000, 3,000, 5/- doz. Midget 16 + 16 350 v., 3/-; Midget 32 + 32, 250 v., 2/6.

MULLARD RESISTANCE CAPACITY BRIDGES, 10 to 10 MΩ, 10 pf. to 10 mfd. Good cond., 110-250 v. A.C. £4.19.0.

GUARANTEED RADIO VALVES, BOXED 24 HR. SERVICE

5Y3GT	6/6	6E32	9/6	6SK7GT	5/-	6BT7	3/9
6U4	6/6	6J5M	8/6	6SL7GT	6/6	6BT7A	6/-
6U5A	4/9	6J5GT	4/6	6SN7GT	5/3	6E91	8/-
6AG7	9/-	6J5C	3/-	6V6G	6/-	6E93A	2/6
6AK5	4/-	6J6	5/-	6V8GT	6/-	6E93	4/6
6B7	8/6	6J7G	5/-	6V6M	6/6	6E91	2/6
6B8A	6/6	6K7M	6/6	6V3A	6/-	6E93A	2/6
6C4	4/9	6E63M	9/6	6X5GT	6/-	6E91	12/6
6C5GT	6/6	6L6C	6/-	6T9	6/-	6E91	7/6
6C6	5/-	6L6M	9/6	12AT7	8/6	6E92	5/6
6D8	5/-	6SA7	7/-	12AU7	7/-	6L91	4/6
6F6G	6/6	6SG7M	5/6	2SL6GT	8/6	6T1C	4/6

Postage 1/- in £1 (1/6 in £1 Speakers/Trans.) Min. 6d. No C.O.D. 100 TELEVISION SET BARGAINS TO CALLERS AT:-

350/352, FRATTON ROAD, PORTSMOUTH PORTSMOUTH'S RADIO, TV AND TOOL SHOP

LYONS RADIO

LTD.

Dept. M.P., 3, GOLDHAWK ROAD, SHEPHERDS BUSH, LONDON, W.12.

Telephone: SHEPHERDS Bush 1729.

TSL CONCERT SOUND CORNER.

Consists of a scientifically-designed enclosure based on the most recent advances in electro-acoustics, use being made of the natural damping qualities of the normal walls of any room. Fitted with specially designed speakers, laboratory balanced and matched for perfect tone. Styled for the modern home where unobtrusiveness combined with the acme of perfection is required. The sound corner will show its outstanding advantages especially when used for reproducing modern L.P. recordings on ordinary radiograms or record players. Let this be your first step to high fidelity. Impedance 4 ohms, frequency range 35 to above 17,000 cycles, peak power loading 15 watts, normal up to 10 watts. Produced at a price within the reach of all (including P.T.). £13.16.3, carriage and ins. 5/6. Send S.A.E. for fully descriptive leaflet.

VIBRATORS,—4-pin UX base, non-synchronous types. 6 v. 8.6, 12 v. 8.6, 24 v. 5/-, Postage 1/-.

VALVE SPECIALS.—All as new and guaranteed. 6AK5, 8/6. 6AL5 7/6. 6AM5 5/6. 6AM6 7/6. 6D2 8/6. 6F12 6/6. 6CC32 7/6. 6CC81 (12AT7) 8/6. 6L32 (VT52) 7/6. 6H3 7/6. 6T61 (6L33) 8/6. 6T63 7/6. 6T66 10/6. 6KT23 8/6. Type 76 7/6. Type 80 8/6.

WAVEMETERS TYPE W.1310.—Frequency range 155 to 230 Mc/s. Contain their own built-in power packs for operation from 200/250 v. A.C. 50 cycle mains. Beautifully made and housed in copper-lined wooden instrument cases, overall size 18 x 11 x 10 ins. Complete with valves and test prod. In condition as new. PRICE ONLY £37.6, carriage 7/6.

REPANCO "THREE DEE" TRANSISTOR RADIO

For HOME CONSTRUCTORS

A New Dual Range Radio with band pass tuning using a Crystal Diode and 3 Transistors. Aiming Loudspeaker reception and low running costs from 7 1/2 volt battery. Designed for local station reception, the "Three Dee" is ideal for caravan installation, bedroom, workshop or second radio set. Chassis size 6in. x 4in. x 2 in. Speaker extra.

SEND NOW! 1/- POSTAL ORDER. For easy wiring plans and instructions.

RADIO EXPERIMENTAL PRODUCTS LTD.
33, MUCH PARK ST., COVENTRY.

VALVES

New Tested and Guaranteed

1R5	7/6	6BR7	8/6	6CH35	9/-	6EL9	11/6
1S5	7/6	6BW6	7/6	6CH32	7/6	6E24	10/6
1T4	7/6	6J5G	8/6	10-	10-	6E24	8/-
3S4	2/6	12AT7	9/-	6ECL80	10/-	6KT3C	7/3
5V4	7/6	12AU7	9/-	10-	10-	6UBC41	10/-
5Z4G	8/6	807	6/6	6E93	5/6	10-	10-
6AL5	6/6	5763	8/6	6E94	10/-	6UC42	10/-
6AM6	7/6	6E6C41	8/6	6E93	9/6	6U94	10/-
6AT6	8/-	6EBF60	8/6	6E92	4/9	6U41	10/-
6BE9	7/6	10-	10-	6EL4	10/-	6U41	8/-

MATCHED PAIRS, 6L34, 23-1-6V6G and 6T1. 17/-; 6BW6, 18/-; 6E93, 19/6; 607, 14/6 per pair.

VOLUME CONTROLS, small, long spd., L.S. 2/-; S.P. 4/-; D., 4/6. All valves.

PAPER BLOCKS, 4 mfd., 1,000 v. wks., 2/3. P. & P. 6d.
R. J. COOPER (G8BX)
32, SOUTH END, CROYDON, SURREY
Croydon 9186

W. B. SUPPLIES

96, Oldham Street, Manchester, 4.

Terms: Cash with order. Orders under 20/- add 9d.; over 20/- add 1/3 postage unless otherwise stated.

T.V. CIRCUITS & SERVICE DATA, Book 1, covering all the following sets: A4, T301, Ambassador TV7, Bush TV22A, TV24A, Ferranti 1475, ITT, 1713, 1475, IT7B, 17K9P, G.E.C. B15146C, BT543C, K.B. HF60, Masteradio T917, Murphy V210, V210C, Philco BT1753, BT1753C, Philips 1101U, Pilot TV76, CV76, CV77, Pre FV4C, P.V.C.D., Raymond 14in., Ultra VAF2, Vidon CN4216, White, Thomson and projection. All above in one book for 10/- post paid.

TYANA ELECTRIC SOLDERING IRONS 250/250 v. with fine bit, 16/9. FM Aerials 12/6. Cross-over Units for BBC/TV, 7/6. **300 Ω HYBRON FEEDER** for F.M. Radio, Bush TV, etc., 8d. yd., 7/6 doz. yds., 1/4in. Formers with can and core, 1/6, suitable for converters, etc.

CAR DROPPERS, 12 volts to 6 volts, at 5amps, 5/-.

EXTRADED METAL Speaker Fret (Gold) 12in. x 12in., 4/6. 18in. x 12in., 6/9. Combination Box Spanners 2, 3, 4, 5, 6 B.A. on one shaft, 3/11.

BOOK ON How to make T.V. Aerials for Bands 1 and 3 and VHF, giving all dimensions, etc., 2/10 post paid.

THE NEW T.S.L. High Stability FM/VHF Tuner Unit with visual tuning indicator and preset audio level, £17.10.0.

WIRELESS WORLD VALVE DATA midget, 3/6 each.

VARIABLE TYPE SWITCHES, 4 pole, 2 way, 2 pole 6 way, 1 pole 5 way with switch, all at 2/3 each. 3 pole 2 way midget 1/6. 1 pole 12 way, 2 pole 6 way, 2 pole 2 way, 3 pole 4 way, 4 pole 3 way, all long spindle, semi-midget, 3/6 each.

THE NEW APEX Band 3 Converters for Channels 2 and 9 or Channels 2 and 10, can be fitted on back of set. £5.15.0, state channel required.

COAXIAL CABLE 22ft. length 3/3.

VARIABLE CONDENSERS, air spaced, 40 pF. 11-75 PF 2/-; 75 PF Twin 3/6. 115 PF 2/6. Solid Dielectric .0005 mfd., .0030 mfd., 3/11 each. Neon Screwdrivers 110 v. to 580 v. 3/11.

RECEIVERS & COMPONENTS

ELECTROLYTICS, capacity, voltage, size, type of mounting, price post paid. 1,000 + 1,000, 6v. 1 x 3, clip. 3/3; 1,000 + 2,000, 6v. 1 x 3, 3/9; 100, 12v. $\frac{5}{8}$ x $\frac{1}{2}$, tag. 1/9; 500, 12v. $\frac{3}{8}$ x $\frac{1}{2}$, W/E. 2/-; 2,000, 12v. $\frac{1}{2}$ x 2, W/E. 3/6; 10, 25v. $\frac{1}{2}$ x $\frac{1}{2}$, W/E. 1/3; 25, 25v. $\frac{5}{8}$ x $\frac{1}{2}$, W/E. 1/3; 50, 25v. $\frac{5}{8}$ x $\frac{1}{2}$, W/E. 1/9; 1,000, 25v. 1 x 3, clip. 4/-; 3,000, 25v. $\frac{1}{2}$ x $\frac{1}{2}$, 5/6; 5,000, 25v. $\frac{1}{2}$ x $\frac{1}{2}$, clip. 6/6; 500, 50v. 1 x 3, clip. 2/9; 200, 250v. $\frac{1}{2}$ x 3, clip. 3/6; 5 150v. $\frac{5}{8}$ x $\frac{1}{2}$, W/E. 1/3; 8, 150v. $\frac{5}{8}$ x $\frac{1}{2}$, tag. 1/3; 40 + 40, 1 x 2, clip. 2/9; 200, 250v. 1 x 3, clip. 3/6; 100, 275/350v. $\frac{1}{2}$ x 3, clip. 3/-; 16 + 32 + 8, $\frac{1}{2}$ x 2, clip. 4/3; 16 + 32 + 275 v. 2 x $\frac{1}{2}$, clip. 8/6; 60 + 250, 275/350v. $\frac{1}{2}$ x $\frac{1}{2}$, clip. 6/3; 32 + 32 + 8, 350/425v. $\frac{1}{2}$ x 3, clip. 5/-; 16 + 16, 350v. $\frac{1}{2}$ x 2, clip. 3/6; 32 + 32, 350v. $\frac{1}{2}$ x 2, clip. 4/-; 2, 350v. $\frac{5}{8}$ x 2, tag. 1/-; 100, 350/425v. $\frac{1}{2}$ x 3, clip. 4/-; 50 + 50, 350/425v. $\frac{1}{2}$ x 3, clip. 4/3; 100 + 200, 350v. $\frac{1}{2}$ x $\frac{1}{2}$, clip. 7/6; 200 + 10, 450v. 1 x 3, clip. 4/-; 8 + 8, 500v. $\frac{1}{2}$ x 2, clip. 4/-; 32, 450v. $\frac{1}{2}$ x 3, W/E. 3/6; 32 + 32, 450v. $\frac{1}{2}$ x 3, clip. 5/-; 60 + 100, 350v. $\frac{1}{2}$ x $\frac{1}{2}$, clip. 6/6. All all cans, some with sleeves, all voltages, w.g.e. surge where marked, new stock, guaranteed. Television Chassis, cadmium plated steel, size 13 x 13 x 2 1/2 in. complete with 13 valveholders (9-B9A Pax., 1-B9A Cer., 2-B7G Cer., 1-Int. Oct. Amph), 20 various tag strips, cut away for metal rec., line trans., etc., 9/11 each, post paid; front and rear tube mounts to fit above chassis, 3/- pair, post paid. F.M. focus Magnets, wide angle tetrode tube, fully adjustable 9/11, post paid. Scanning Coils, wide angle, with mounting lugs, 19/6, post paid. Vision I.F.s (2nd, 3rd and 4th), freq. 34 mc/s, slug tuned, size 13/16 x 13/16 x 2 1/2 in. can, set of 3, 5/6, post paid. T.V. Rectifiers, H.W., 250v. 250mA, 2 1/2 in. fins x 4 in. long, 12/6, post paid. 100 Ω W/Pots, 3w. 1 in. spindle, 2/6, 8 mf. 600/750v. Paper Conds., 4 x 2 in. x 4 1/2, 6/8. RADIO CLEARANCE LIMITED, 27, Tottenham Court Road, London, W.1. (Telephone: Museum 9188.)

TELEVISION. — 12in. Televisions, £13/10/- each; carr. paid. TOMLINS, 127, Brockley Rise, Forest Hill, S.E.23. (FOR 5497.)

THE HIWAYMAN. A new super Portable Radio for the home constructor: All-dry 4-valve superhet with Ferrite rod aerial, easy wiring diagrams and instructions. 1/6 (post 3d.). RADIO EXPERIMENTAL PRODUCTS LTD., 33, Much Park St., Coventry.

OSMOR would like you to have Free Practical Wiring Diagrams of the latest published circuits with full lists of components required. Send 7d. (stamps) to OSMOR RADIO PRODUCTS LTD., 418, Brighton Rd., Sth. Croydon. (Croydon 5148.) (See advert., page 96.)

MAKING YOUR OWN? Telescopes, Enlargers, Projectors, or in fact anything using lenses. Then get our booklets "How to use Ex-Gov. Lenses & Prisms," price 2/6 ea. Comprehensive lists of optical, radio and scientific equipment free for s.a.e. H. W. ENGLISH, Rayleigh Rd., Hutton, Brentwood, Essex.

LOUDSPEAKERS repaired promptly. MODEL LOUDSPEAKER SERVICE, Bullingdon Rd., Oxford.

RATES: 5/6 per line or part thereof, average five words to line, minimum 2 lines. Box No. 1—extra. Advertisements must be prepaid and addressed to Advertisement Manager, "Practical Wireless," Tower House, Southampton St., Strand, London, W.C.2.

1,000's AND 1,000's of Service Sheets in stock. We can still offer sheets at hire prices and we are expecting to make still more and larger purchases of sheets, so send your enquiry at once with s.a.e. enclosed. Have you had a copy of our 60-page catalogue? No? Then also enclose 1/- P.O. You will find it well worth it. We still have a small amount of air-spaced co-ax. at 8d. per yd., 6d. postage on 12 yds. M. FOY, 6, Wykebeck Gardens, Leeds, 9.

SERVICE SHEETS, Radio, TV, 5,000 models; lists 1/-; enquiries s.a.e. TELRAY, 11, Maudland Bk., Preston.

GUARANTEED TELEVISION, 12in. Models, first-class picture, 5-channel, £29 each; carriage paid. THE GRAMOPHONE SHOP, 19-21, Brockley Rise, Forest Hill, S.E.23.

OSMOR NEWS, F.M. Switch-tuned Coilpack. Circuits and full information available shortly on request. OSMOR RADIO PRODUCTS LTD., 418, Brighton Road, S. Croydon.

SERVICE MANUALS/SHEETS, Tel/Radio for hire, sale and wanted. S.A.E. enquiries W. J. GILBERT (P.W.), 24, Frithville Gardens, London, W.12.

MIDDLESBROUGH, Largest stocks on N.-East coast, Radio, TV components, FM Kits, Gram. Cabinets, Tape Decks, Leak Amplifiers, Valves, etc. Callers only. PALMERS, 106, Newport Road. (Phone: 3096.)

AMERICAN MAGAZINES, Year's subscription "Audio" 35/-, "High Fidelity" 50/-. Spec. copies 4/- & 5/- ea. Cat. free. WILLEN LTD. (Dept. 40), 9, Drapers Gdns., London, E.C.2.

VACANCIES

FOR SKILLED CRAFTSMEN
IN GOVERNMENT SERVICE
AT CHELTENHAM

Experienced in one or more of the following:—

1. Maintenance of radio communication receivers.
2. Sub-assembly lay-out, wiring and testing of radio type chassis.
3. Cabling, wiring and adjustment of telephone type equipment.
4. Fault finding in, and maintenance of, electronic apparatus.
5. Maintenance of Teleprinters or Cypher Machines and associated telegraph equipment.

BASIC PAY: £8 11s. 4d., plus up to £2 10s. merit pay, assessed at interview and based on ability and experience.

Opportunities for permanent and pensionable posts.

Five-day week, good working conditions, single accommodation available.

Apply to: **Personnel Officer**

G.C.H.Q. (FOREIGN OFFICE)

53, Clarence Street, Cheltenham.

ALL TYPES of new radio valves wanted, small or large quantities; cash payments. R. H. S. LTD. (W), 156, Swan Arcade, Bradford, 1.

TELEVISION.—9in. Models. £7/10/-; 12in. Models. £15; all makes; working; carriage paid. TOMLINS, 127, Brockley Rise, Forest Hill, S.E.23.

BILLHEADS VALUE! 8 x 5 Blue ruled. 100 7/6, 250 15/6, 500 22/6; p. & p. 2/-; s.a.e. sample to—TAYLOR (Printer), 147, George Rd., Erdington, B'ham, 23.

SEVERAL EARLY MODELS 9in. Television, complete and mostly working, £5/5/- each; carriage paid. TOMLINS, 127, Brockley Rise, Forest Hill, S.E.3. (FOR 5497.)

VALVES

ALL TYPES of Valves required for cash. State quantity and condition. RADIO FACILITIES LTD., 38, Chalcot Road, N.W.1. (PRIMROSE 3060.)

WANTED, Valves EY51, ECL80, KT61, 6U4GT, PL81, 3524, etc., etc., prompt cash. WM. CARVIS LTD., 103, North Street, Leeds, 7

KTW63, about 200. What offers? CUMMINS, Tillingham (Tel.: 224), Ex.

ALL TYPES of unused Valves required for cash. HERMES RADIO, Glazebury, nr. Manchester.

FOR SALE

TELEVISION AND TUBE BARGAINS.—12in. 5-channel T.V., tunable anywhere, from £18/10/-; good emission S/H Tubes (12in., 14in., 15in., 16in., 17in.), 25 each; 12in. faulty T.V., £7/10/-; most makes; 120 Radios, faulty, 8/6 each. Phone: Ladbroke 1734. Call: 1070, Harrow Road, London, N.W.10., 330 yds. from Scrubs Lane.

CAR CIGARETTE LIGHTERS: 6 or 12 volts, 8/6, post free. WHITSAM ELECTRICAL PRODUCTS, 18, Woodrow Close, Greenford, Middlesex.

WANTED

WANTED, Trophy Battery 3, give Trophy 6 exchange. W. SPEARMAN, Stansfield, Sudbury, Suffolk.

EDUCATIONAL

WIRELESS.—Day and Evening Class instruction for P.M.G. Certificate of Proficiency and Amateur Wireless Licence. Morse instruction only if required, also postal courses. Apply BST, LTD., 179, Clapham Rd., London, S.W.9.

MERCHANT NAVY Wireless School, Overseas House, Brooks' Bar, M'cr 16.

RADIO VALVE SUPPLY

GLAZEBURY, NR. MANCHESTER

VALVES GUARANTEED

6AC7	5/6	12AU7	7/6	EF50	3/6	5Y3	7/-
6SH7	5/-	12AX7	7/6	ECL80	8/6	35Z4	6/6
6C4	6/6	12AC6	8/-	EF80	8/6	5Z4	7/6
6C5	6/6	EP22	5/-	PY1	8/6	RT33C	8/6
6F3	8/-	EX91	6/-	EZ30	8/-	956	2/6
6SN7	7/-	EY51	9/6	EB34	2/-	R10	4/-

Please add 6d. postage.

FREE! Brochure giving details of Home Study Training in Radio, Television, and all branches of Electronics. Courses for the Hobby Enthusiast, or for those aiming at the A.M.Brit.I.R.E., City and Guilds, R.T.E.B., and other Professional examinations. Train with the college operated by Britain's largest Electronics organisation. Moderate fees. Write to E.M.I. INSTITUTES, Dept. PW28, London, W.4.

A.M.I. Mech. E., A.M. Brit. I.R.E., City and Guilds, etc. on "no pass—no fee" terms; over 95% successes. For details of exams. and courses in all branches of engineering, building, etc., write for 144-page handbook, free. B.I.E.T. (Dept. 342B), 29, Wright's Lane, London, W.8.

CITY AND GUILDS (Electrical, etc.) on "no pass—no fee" terms. Over 95% successes. For full details of modern courses in all branches of Electrical Technology send for our 144-page handbook—free and post free. B.I.E.T. (Dept. 342A), 29, Wright's Lane, London, W.8.

LEARN IT as you do it—we provide practical equipment combined with instruction in Radio, Television, Electricity, Mechanics, Chemistry, Photography, etc. Write for full details to E.M.I. INSTITUTES, Dept. PW47, London, W.4.

T/V and RADIO.—A.M. Brit. I.R.E., City and Guilds, R.T.E.B. Cert., etc. on "no pass—no fee" terms. Over 95% successes. Details of exams. and home training courses in all branches of radio and T/V: write for 144-page handbook free. B.I.E.T. (Dept. 342G), 29, Wright's Lane, London, W.8.

MAINS TRANSFORMERS. 200/250 v. Output 250.0-250, 80 mA, 6.3 at 4 amp., suitable for use with metal rect. or 6 x 5. 7/6, p. & p. 2/6. **1 mA METERS.** 2in. square flush. Scaled 1 mA. 12/6, p. & p. 1/6. **300 V. METERS.** 2in. square flush. 7/6, p. & p. 1/6. **30 mA METERS.** 2in. round. 5/-, p. & p. 1/6. **TELEPHONE.** Type D, complete. 25/-, p. & p. 3/-.

220 V. 100 W. PREFOCUS PROJECTOR LAMPS. 1/-, p. & p. 6d. **220 V. 220 W. CARBON FILAMENT LAMPS.** 1/-, p. & p. 6d. **CHILTERN OVERLOAD TRIPS.** 30 or 60 amp. 4/6, p. & p. 2/-. **TELEPHONE HAND GENERATORS.** 7/6, p. & p. 2/-. **AC BELLS.** 4/6, p. & p. 1/6. **MORSE KEYS.** 3/6, p. & p. 1/6.

WIRELESS. See the world as a Radio Officer in the Merchant Navy; short training period; low fees; scholarships, etc., available. Boarding and Day students. Stamp for prospectus. **WIRELESS COLLEGE,** Colwyn Bay.

INCORPORATED Practical Radio Engineers home study courses of Radio and TV Engineering are recognised by the trade as outstanding and authoritative. Moderate fees to a limited number of students only. Syllabus of Instructional Text is free. "The Practical Radio Engineer" journal, sample copy 2/-. 6,000 Alignment Peaks for Superhets, 5/9. Membership and Entry Conditions booklet, 1/-. All post free from the SECRETARY, I.P.R.E., 20, Fairfield Road, London, N.8.

LEAK TL 10 POWER AMPLIFIER and POINT ONE PREAMPLIFIER.—This quality amplifier maintains the high Leak reputation of first-class workmanship and design. £28.7/- complete.

TSI HIGH STABILITY FM VHF TUNER Employs 6 valves and 10 tuned circuits combining high sensitivity with the best signal/noise ratio. £17/10/-, tax paid.

SCOTCH BOY RECORDING TAPE.—850' on 5" Spool, 28/-, 1,275' on 5" Spool, 38/-, 1,200' on 7" Spool, 35/-, 1,800' on 7" Spool, 54/-, 850' High Output Tape on 5" Spool, 31/-.

AERIANAL CO-AX CABLE.—10!d. per yard.

We are stockists of W.B. Speakers and Cabinets, Bernards and Norman Price Publications. We carry large stocks of valves, condensers, resistors and other components. Also CeKa Tools for the Radio Engineer. Send 6d. in stamps for our latest list.

RADIO HAM SHACK LTD.,
155, Swan Arcade, Bradford, I.

* * * * *

The "TYANA"

Standard Soldering Iron



- Adjustable Bit.
- Weight approx. 4 oz.
- Heating Time 3 min.
- 40 Watt economy Consumption.
- Standard Voltage Ranges. 16/9

Replacement Elements and Bits always available.

"DIPLOMA" HEADPHONES



Lightweight High Resistance (4,000 ohms). Complete with cord. 17/6

Ideal for CRYSTAL SETS and also for use with TAPE RECORDERS.

KENROY LIMITED
152/297 UPPER ST., ISLINGTON, LONDON, N.1.
Telephone: Canonbury 4905-4663

* * * * *

VALVES—Guaranteed

DAF91	6/6	VU111	3/6	6C5	6/-	6X4	6/6
EA60	2/-	W77	5/-	6P12	8/-	6X5	7/6
EBC33	7/6	024	5/-	6F17	8/-	7D8	7/6
ECC33	8/6	153	6/6	6J5	6/-	7H7	7/6
EP36	5/6	1U5	6/6	6K7G	4/6	8D2	4/6
EP30	7/-	3D3	4/6	6K7M	6/-	8D3	5/-
EP50	5/-	4D1	4/-	6SA7	8/-	9D2	6/-
EP91	8/-	6A8	7/6	6SG7M	9/6	9D6	6/-
EL32	6/-	6AK6	7/6	7/6	12BA6	7/6	
PCC84	8/6	6A6	8/6	6SN7G1	12BE6	7/6	
FY81	11/-	6AG5	8/6	8/6	12BH7	7/6	
TT11	4/-	6BE6	7/-	6U5(UX)	12K7	8/-	
VK65A	3/6	6BH6	7/6	7/6	15D2	6/-	
VK66	3/6	6BS7	7/6	6U7	6/6	50C5	8/6
VT20	3/6	6BW6	6/6	6V6	7/-	50L3	8/6

Postage 6d. extra. (Also all components.)
"Jason" F.M. Tuner Kit, complete with valves, £7.2.0, plus 2/6 post.

TELEKIT SUPPLY
104 High Street, Beckenham, Kent
Phone: BEC 3720.

RES/CAP. BRIDGE 35/- Post Paid

Checks all types of resistors and condensers

Easy to Build Up Easy to Use

READY CALIBRATED

Stamp for details of this and other kits.

RADIO MAIL, 6 Raleigh St., Nottingham

ELECTROSURP

120 Fore Street, Exeter
Phone 56687

ASTRAL RADIO PRODUCTS

"HOME RADIO," 32 page illustrated booklet. Simple wiring instructions for Crystal Set, 1, 2, 3 Valves, 8/-, post 3d. **TRF COILS.** Specified for 'Beside Push-button 4', 'All Dry 3 Band, 3', 'Push-button 4', etc., 6/6 pr., post 6d. **Push-button Unit** with modification data 7/-. **DUAL WAVE HF Coil.** Specified for 'Summer All Dry Portable', 'Modern 1 Valve', 'Modern 2 Valve', 'B 7 G Battery Miniature', etc., 4/3, post 3d. **IFT's Miniature.** 1" x 1 1/2" x 2 1/2" in cans. Extra high 'Q.' Special offer, 8/6 pr., post 6d. **K COILS.** AC, B'pass 3' 3' 3' each, post 6d. **FRAME AERIALS.** M.W., 5/-, post 3d. **H.F. CHOKE** (Gsmor Q.C.1), 6/9, post 3d. **Crystal Set Coils.** L. & M.W., 2/6, post 3d. **82, Centurion Road, Brighton**

F M and H-I-F I Components

DENCO F.M. TUNER	circuits	1s. 6d.
RADIO CONST'R. F.M.	"	2s. 0d.
MULLARD AMPLIFIERS	"	3s. 6d.
G.E.C. 912 PLUS AMPLIFIER	"	4s. 0d.
G.E.C. F.M. PLUS TUNER	"	2s. 6d.

Separate price lists available on request to

J. T. FILMER MAYPOLE ESTATE
BEXLEY, KENT
Tel. Bexleyheath 7267

OSCILLOSCOPE

(MINIATURE TYPE)



Supplied in kit form for workshop or experimental use. Complete with full instructional notes giving details of applications to radio work. Can be operated from power supply of most AC domestic radio receiver equipment or from power unit supplied as an extra.

Price £10 (inc. post/pkg.)
(Power unit, if required, £3 extra)

Order now or send stamp for further details to:

E.M.I. INSTITUTES,
Dept. S.C. 32, LONDON, W.4
(Associated with "His Master's Voice", etc.)

Morse Code operating as a PROFESSION

45 years of teaching Morse Code is proof of the efficiency of the Candler system. Send 2/6. stamp for Payment Plans and Full Details of All Courses.

CANDLER SYSTEM CO. Dept. 51.0
52B, Abingdon Road, London, W.9.
Candler System Co., Denver, Colorado, U.S.A.

SHUNTS FOR MULTIMETERS Three ranges, 10, 100, 1,000 mA for 1 mA. 100 ohm meter. 1% accuracy. 7/6. Three ranges 5, 50, 500 mA for 500 uA 500 ohm meter. 1% accuracy. 7/6. Individual Shunts for 1 mA, 100 ohm meter. 2, 2.5, 5, 10, 20, 25, 30, 100, 250, 500, 1,000 mA at 3/3 each. 1% accuracy. (Individual Shunts for 500 uA 500 ohm meter. 1, 1.25, 2.5, 5, 10, 12.5, 25, 50, 100, 125, 250, 500, 1,000 mA at 3/3 each. 1% accuracy. Special Shunts made to order at reasonable prices.

MULTIPLIERS FOR MULTIMETERS.—Do you require a 624.75 K high stability resistor to 1%? We have it (and all other Odd values (100 Ohms to one Meg.) 1 W, 2/3. **RESISTANCE RANGE KIT** for 1 mA meter of up to 100 ohms. Four Hi-Stab. Resistors (three 1%), WW pot., scale calibration, circuit. Has three ranges, 20 ohms to 5 Meg., using external battery on highest range. 1/1.

WESTINGHOUSE METER RECTIFIERS 14- each, 1 mA or 500 uA type. Or with 4 multipliers 1% H.S. 20/6.

BRIDGE RATIO ARMS for wiring into Wheatstone Bridges. 1,000 ohms tapped at 100 and 10 ohms. Pair gives ratios of 100:10, 1, 0.1, 0.01 to 1, accuracy 0.1%. 19/6 pair.

PRECISION WIREWOUND RESISTORS—Special offer of 0.1% Wirewound Resistors on Ceramic hobbing, reversed section wound, 10, 100 or 1,000 ohms only at 6.6 each. Strip-wound Resistors, 1 to 1,000 ohms 0.5%, 2/9; 0.2% ±0.01 ohm, 3/9, 1,000 to 5,000 ohms 0.5%, 3/3; 0.2%, 4/3. Your value wound to order. For sets of resistors for Decade Boxes see January issue.

WIREWOUND POTENTIOMETERS WITH HAND-CALIBRATED SCALE.—Calibrated in ratio suitable for workshop Resistance Capacity Bridge. 10/6 with circuit. Post and Packing 1/6.

S.A.E. with enquiries please.

PLANET INSTRUMENT Co.
25 Dominion Ave., Leeds, 7.

Solder with
PERMATIP
AND
PERMABIT
INSTRUMENTS
FOR
**GREATER
SOLDERING
EFFICIENCY**

The soldering bit which maintains its face indefinitely without attention. 25 models available for mains or low voltage supply. Bit sizes 3/32 to 3/8 inch. Full details in booklet S.P.10 from sole manufacturers:—

**LIGHT SOLDERING
DEVELOPMENTS LTD.,**
106, GEORGE STREET, CROYDON,
SURREY. Tel. CROYdon 8589.

RADIO AND TELEVISION COMPONENTS

All parts in stock for:
Viewmaster, Soundmaster, Telexing, etc.
Easy Terms available.
2jd. stamp (only) for Catalogue.

JAMES H. MARTIN & CO.
FINSTHWATE, NEWBY BRIDGE,
ULVERSTON, LANCs.

CABINETS AND HI-FI EQUIPMENT

We can supply any Cabinet to your own specification

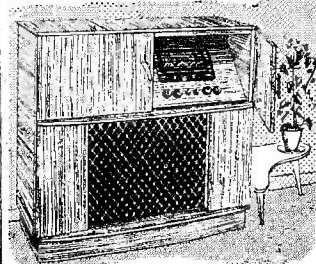

"The Continental" £24-15-0

This elegant Cabinet is the latest in our range designed in the continental style. Solidly constructed and finished in selected mahogany veneers. Available medium, light, high gloss or contemporary finish. Polished £29-15-0. We can also supply and fit this or any cabinet with the latest Hi-Fi amplifiers, tuners, transcription units, record changers, speakers, etc.

LEWIS RADIO COMPANY
120 (P.W.), Green Lanes, Palmers
Green, London, N.13
Telephone: BOWes Park 1155/6

We want to buy:—
BC312, BC342,
BC348- (R Model
only
BC221, TS174
or **5, BC610-E**

ALTHAM RADIO CO.
JERSEY HOUSE, JERSEY ST.,
MANCHESTER 4
Telephone: Central 7834/5/6

Largest stocks in Europe of Government surplus material.

ANNAKIN'S SELECTED BARGAINS
Microphone Transformers, 100-1. New, 3/6.
Electromagnetic Mikes. New, 2/7. Used, 1/6.
Transmitter Switches (1154 Trans), 3P 3W. New, 2/-.
Metal Rectifiers. Selenium 1 w. 200 v. 250 mA. 12/-. Selenium 1 w. 240 v. 30 mA., 4/6.
Copper oxide, 1 w. 150 v. 40 mA., 4/6.
Lamps, 24 v. 13 w. + 8 v. 6 w. Twin filaments. SBC. Double Contact. Box of 12. 3/4.
All above Carriage Free. Money back Guarantee. Free Lists.
25, ASHFIELD PLACE, OTLEY, Yorks.

BENSON'S BETTER BARGAINS

TRANSCEIVERS, Type 18 (Rx and Tx separate), with valves, less attachments. 50/- Type 46 (Walkie-Talkie), with 1/TP25, 2/TP23, 1/HL23(1D), 1/QP25, 1/ATP4, 2 xials, headset/mic. satchels, aerial, 65/- (carr. 7/6). **INDICATORS 62A.** VCR97, 12V/R01, 2V/R54, 3V/R92, 4/VC115, 55/- (carr. 10/6). Headphone Adapters C 410, 2/8. Condensers, block 0.05 13 kv. (GSA), 15/- Control Unit 301. Input 100/240 v. 50 c. or Bat. for remote TX control. Contains: 2 relays, 2 met. reas. 4/65, indicators, jacks, vrry case, 12 x 8 x 5 in. 55/- (carr. 7/6). Valves, V9X11, ex-new equipment, 8 for 21. **LAMPS:** Projector, 120 v. 750 w. pre-facts, 15/- Flood, 200/250 v., 250 w. E.S. R1, 4/6; Standard BC 25 v. 60 w.; 35 v. 25 w.; 40 w. 60w. or 150 w. 1/- **Transformers:** Vibrator 12-0-12 v. to 300 v. 100 mA., potted, 12/6; "C" core, input 200 v., output 6.3 v. 2 A. (three), 13/6. Flex. DRIVES, 3 1/2 in. long, 14 in. dia. end, 3/8. **VIBRATORS**, Mallory (6529C) 12 v. 4 pin, 7/8. 3 pin plug and socket (brass) on 1 yd. cable, 3/-. Bomb release, relay operating claw, with heater, 5/-. **THROAT MICS.**, new, 2/6. **BC624A** (SCR922). New condition, with 10 valves: 100/150 mc/s. Less xials and relays. 40/- (incl. 5/-). **KEYS**, music, large, covered, 10/6; small 2/8. **COMMAND RXS.** Brand new, with valves. Med. wave. 32-1.5 Mc/s. 52/1.5 Mc/s., 97/8. 1.5-3.0 Mc/s., 55/-; BC454, 2-6 Mc/s., 45/- (post 3/-). Condensers, var. shielded, ceramic, 15, 25 or 50 pfs., 1/3; 75 pfs., 3/8; butterfly 25 pfs., 1/8. **RXS 112/114** (TR1987), with 8/EPF1 2/EP191, 5 gang tuner, new, 37/6, less valves, 7/6. (Circuit 1/-). **MOTORS:** Synchron. 100 v. 3,000 r.p.m., 10VA, 10/- **SUPPRESSORS**, radio interference, ex-A.M., 5/6 (post 2/-). **BRAND NEW RE 26**, 27, 27/8 (postage 2/6); RE24, 3/25; 10/6. **DYNAMOTORS** (incl. 2/-): 12 v. to 250 v. 65 mA., and 6.3 v. 2.5 A.; 10/6. **EDDYSTONE**, 12 v. to 150 v. 75 mA., cased, 15/-; 11 v. to 300 v. 200 mA., cased, 15/- (carr. 8/6). **METAL RECTIFIERS:** 000 v. 30 mA., 6/-; 500 v. 500 mA., 10/6; 240 v. 30 mA., 3/6; 1,000 v. 30 mA., 7/8. List and enquiries, S.A.E. please! Terms: C.W.O. Postage extra. Immediate despatch. *Callers and post:* W. A. BENSON (FW), 136, Rathbone Road, Liverpool, 15. *NEF* 6855. *Callers:* SUPERADIO (W'chapel) LTD., 116, Whitechapel Liverpool, 2. *ROY* 1120

COVENTRY RADIO

Component Specialists since 1925

We have now trebled the size of our premises in order to supply a larger range of Components, Amplifiers and Hi-Fi Equipment.

Send your enquiries to:
189-191 Dunstable Road,
Luton, Beds.
New Telephone No.:
LUTON 7388-9

1-Finger Pianists

Build your own electronic keyboard and play everything! Send for free leaflet. Guitar, cello, flute and trumpet are all easy. Write now...

C & S, 10 Duke St., Darlington, Co. Durham

**YOU CAN BUILD A QUALITY
TAPE RECORDER**

with
" ASPDEN "
Tape Deck and Amplifier Kits

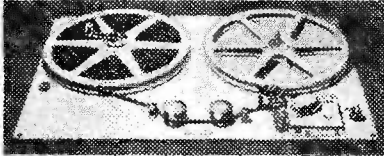

TAPE DECKS, 2 speed, twin track, easy to assemble kits, fully complete with finest motor and Ferroxcube heads.

Model 521 for 5in. spools, kit, £7/10/-

Model 721 for 7in. spools, kit, £8/10/-

Either model assembled and tested, 27/6 extra.

AMPLIFIER kit, 2½ watt, record/replay with two recording positions, neon indicator, etc., £5/18/-. Power pack kit for above, £2/18/6 (both without valves). Carr. and packing extra.

THIS TAPE DECK AND AMPLIFIER IS BEING USED IN THE ANTARCTIC BY A MEMBER OF THE EXPEDITION.

From the Equator to the Pole they are giving good service.

Mr. S., of Twickenham, writes:

"The whole assembly has a smooth sweet run, which is worthy of the most expensive deck. May I congratulate you on the fine value your deck offers."

Send a stamp for full particulars to:—

W. S. ASPDEN 10, Market St., Wesham, KIRKHAM, LANCs.

GUARANTEED VALVES

DF91	7/6	EV51	11/6	UY41	8/-	GC4	6/-
DAF91	8/6	EZ35	8/-	VP23	5/-	8G6	5/-
DL92	7/6	EZ40	8/-	VR16	7/6	9H6	2/6
DL94	7/6	GZ32	8/6	VR150/30	7/6	6J6	6/6
EA50	1/-	H83	7/6	VU111	2/-	6K7	5/6
EB34	2/6	KT33C	8/6	X65	10/6	6K8	9/6
EB91	6/-	KT41	7/6	024A	6/6	6L6	10/-
EBC33	10/-	KT66	12/6	1R5	8/6	6N7	7/6
EBF80	9/-	KTW61	7/6	1T4	7/6	6Q7	8/6
ECC33	7/6	KTW63	7/6	354	7/6	6SA7	7/6
ECC35	7/6	PL81	12/6	3V4	7/6	6SH7	7/6
ECC81	9/-	PL82	10/6	2C34	3/6	6S47	7/6
ECC84	11/-	PT81	8/6	2X2	4/-	6SK7	7/6
ECH35	10/-	PY82	8/6	5U4	8/6	6SL7	6/6
ECH81	9/-	PCF80	10/-	5Z4	8/6	6SN7	7/6
ECH42	10/-	PCF82	10/-	6AG5	6/6	6SS7	7/6
ECP82	11/-	PCC81	10/-	6AK5	6/6	6V6	7/6
ECL90	9/-	PCC84	11/6	6AL5	6/6	6X4	7/6
EC52	5/-	Perm6	8/6	6AM6	6/6	6X5	7/6
EC90	6/-	RK3	3/6	6AQ5	7/-	12A6	7/6
EF35	6/-	RL37	5/-	6AT6	10/-	12AH7	6/-
EF37A	12/6	SP41	5/-	6AG6	8/-	12AT7	9/-
EF39	6/-	SP61	5/-	6BE6	8/-	12AU7	9/-
EF41	10/-	U80	8/6	6BA8	8/6	12AX7	9/6
EF50	5/-	U82	8/6	6BP6	8/6	12BE6	5/6
EF54	7/6	UBC41	10/-	6BR7	8/6	12C6	7/6
EF55	9/-	UF41	10/-	6BW6	8/6	12J7	7/6
EF83	8/6	UL41	10/-	6B3	7/6	12K7	7/6
EF85	10/6					12Q7	8/6
EF91	8/6					12SC7	7/6
EF92	5/6					12SK7	7/6
EF95	6/6					18SH7	7/6
EK32	8/6					12SJ7	5/-
EK30	8/-					12SK7	7/6
EL32	6/6					35L6	9/-
EL33	15/-					85A2	10/-
EL38	20/-					80C1	8/-
EL41	10/-					807	7/6
EL84	10/6					832	40/-
EL90	7/-					5763	10

AMPLIFIERS

3 valve 3 watt in robust metal case with carrying handle. Complete with own Power Pack. Works off 110/250 v. A.C. mains. Ideal for P.A., Parties, Gram Amplifier, etc.
23/10/0 Post Free.
Suitable Mike, 7/6. (Suitable 8in. P.M. Speaker, 22/6.)

L.T.V. Pattern Eliminator Coils. Reject most interference caused by B.B.C. break-through. Easily fitted and complete with instructions. 5/-, post 6d. (State B.B.C. Channel).

Post & Packing 6d., Free over £1. C.O.D. 2/6 extra.

LAWRENCE ELECTRONICS,
15B, CHIPSTEAD VALLEY ROAD, COULSDON, SURREY.
Tel. Lands 9075. Open to personal callers on Saturdays only.

**MAKE THIS
MINIATURE
RADIO . . .**



£2-6-0

Post paid. Batteries extra.

This popular Miniature Receiver incorporates high "Q" technique using a ferrite rod aerial. Made possible by simple conversion of an ex-Govt. Hearing Aid (as described in *Practical Wireless*, March). Size 3½ in. x 2½ in. x 1 in. Good reception of broadcast programmes.

THE COMPLETE KIT OF PARTS includes a type OL10 Hearing Aid in perfect working order (with crystal microphone) and miniature earphone with moulded ear inset attached, Ferrite Rod 4in. x 5/16in. dia., germanium diode, components, conversion details and circuit diagram.

- ALL COMPONENTS SOLD SEPARATELY**
- Deaf Aid Unit with Earpiece £1/15/0
 - Plastic Ear Mould 2/-
 - Ferrite Rod 5/-
 - Conversion Components 4/-
 - Batteries, 1.5v. L.T. (Type D.18) 8d.
 - Batteries, 30v. H.T. (Type B.119) 4/3

HEAR THIS MINIATURE RADIO AT
PROOPS BROS. LTD. LANgham 0141
Dept. 'P', 52 Tottenham Court Road, London, W.1.
Shop Hours: 9-6 p.m., Thursday 9-1 p.m. Open all day Saturdays

*Train for a wonderful
future in*
ELECTRONICS...

... with E.M.I.

Every day the demand for the expert in electronics grows. Radio, television, radar and the whole field of industrial automation are rapidly expanding and the trained specialist assures for himself a well-paid career in this quickly developing profession. Here is your opportunity to enter for:—

1 YEAR COURSE

Full-time course in the Principles and Practice of Radio and Television. Mainly designed for the training of Radio and Television Servicing Engineers. Next courses commence in May and September, 1957.

THE E.M.I. COLLEGE OF ELECTRONICS
Dept. 32, 10 Pembridge Square, London, W.2.
Telephone: BAYswater 5131/2

The College is part of the E.M.I. Group which includes "His Master's Voice", Marconi-Phone, E.M.I. Electronics Ltd. etc. 1A53