

Spink

BEDSIDE PORTABLE TWO

Practical Wireless

9^D
EVERY MONTH

Vol. 24. No. 508. ||

Editor: F. J. CAMM

|| NOVEMBER, 1948

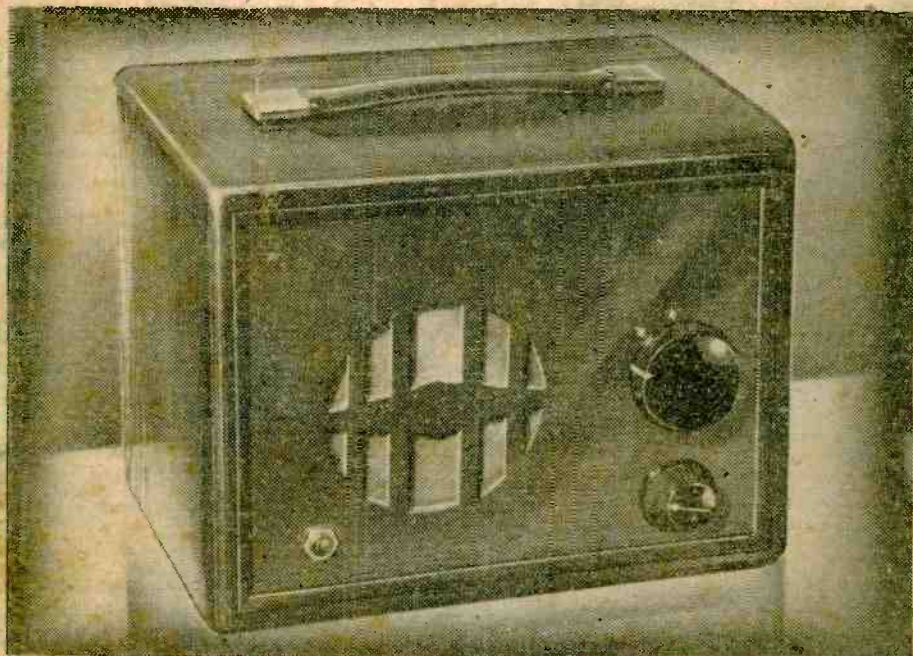

See Page 462

PRINCIPAL CONTENTS

Remote Control Switch
New E.M.I. Cameras
Microphone Amplifier
Lightweight Pick-up

Using the Oscilloscope
Winding Midget Coils
Radio Amateurs' Examination
Simple Light Cell

PREMIER RADIO CO.

MORRIS & CO., (RADIO) LTD.

ALL-WAVE SUPERHET KIT.—7 valve (plus rectifier) covering 13.8-52, 51-200, 200-550 and 900-2,100 metres. Pick-up position on wavechange switch; uses 6K7 (R.F.), 6K8 (Freq. Changer), 6K7 (I.F.), 6Q7 (2nd Det. A.V.C. and 1st L.F.), 6J7 (Phase Inverter), 2-25X6 in Push-Pull. Output Transformer matches 3 or 15 ohms negative feedback. Illuminated Glass Dial, 10 1/2 in. x 5 1/2 in. Ideal for Super Radiogram. Complete kit with valves, £13 8 10. inc. P.T. ; Wired and Tested, £15 0 0, inc. P.T.

Recommended Loudspeaker.—Rola Super G.12. 85".
ALL-WAVE SUPERHET KIT.—A Kit of Parts to build a 6-valve (plus rectifier) receiver, covering 16-50 metres. Medium and Long-wave bands. Valve line-up: 6K8, 6K7, 6Q7, 6J7, two 25A6 in push-pull. Metal rectifiers are incorporated for H.T. supply. Output impedance is for 3 and 15 ohms. The latest Wearite coil pack incorporating iron dust coils is used, making construction and alignment extremely simple. A pick-up position on the wavechange switch and pick-up terminals is provided. A complete kit, including valves, but without speaker or cabinet. Chassis size, 14in. x 6in. Overall height, 9in. Price £10 16 6, including Purchase Tax; wired and tested, £12 10 0. Suitable Loudspeakers are the GOODMAN'S 10in. 6-watt L.M. at 47 8, or for superlative reproduction, the Goodman's 12in. P.M. at 29 15 0.

NEW 2-VALVE ALL-WAVE KIT.—16 to 2,000 metres, switched coil pack ready wired and tested. 2 Mazda H123 valves, phones, H.T. and L.T. batteries, condensers, resistors, diagrams and steel case. All ready to assemble, £9 10 0.

NEW 1948 MIDGET R.F. RADIO KITS with illuminated Glass Dial. All parts including valves, M.C. speaker and instructions; 2 valves plus metal rectifier; 200-557 metres and 700-2,000 metres, 200 to 250v. A.C. or A.C. D.C. mains. State which is required. Size: 10in. x 6in. x 6in. £7 7 6, including Purchase Tax.

NEW 1948 MIDGET SUPERHET RADIO KIT with illuminated Glass Dial. All parts, including valves, M.C. speaker and instructions; 4 valves plus metal rectifier; 16-50 metres and 200-557 metres; 200 to 250v. A.C. or A.C. D.C. mains. State which is required. Size: 10in. x 6in. x 6in. £8 5 0, including Purchase Tax.

MIDGET RADIO CABINETS in brown bakelite. Can be supplied for either of the above Midget Kits at 25".

OUR NEW SEASON'S LIST IS NOW READY.
Please send stamp for copy.

GOVERNMENT SURPLUS MAINS TRANSFORMERS.—All are for use on 230 v. 50 cycle mains. These are all new and very conservatively rated.

Type	Price
3 500-0-500 v. 150 m.a. 4 v. 2.5 a., 4 v. 1 a., 4 v. 5 a., 6in. x 5in. x 4in.	35-
4 865-0-865 v. 500 m.a. Tapped at 690 v. and 760 v. 4 v. 3 a., 4 v. 4 a., 10in. x 7 1/2 in. x 9in. L.T. is separate trans. on base plate.	75-
31 40 v. 3 a., 104 v. 1 1/2 a. (auto wound), 4in. x 4in. x 5in.	21-
32 630-0-650 v. 150 m.a. and 1,000 v. at 30 m.a., 9 1/2 in. x 6in. x 6in.	40-
33 38 v. 2 a. Tapped at 32 v., 34 v., 36 v., 4in. x 4in. x 5in.	15-
34 1500-0-1500 v. 120 m.a., 4 v. 2-3 a., 4 v. 2-3 a., 7in. x 5in. x 8in. L.T. trans. is separate on base plate.	55-
42 300-0-500 v. 170 m.a., 4 v. 4 a., 8in. x 6in. x 4in.	35-
43 4 v. 20 a., 7 1/2 in. x 4 1/2 in.	25-
44 10 v. 5 a., 10 v. 5 a., 10 v. 5 a., 6in. x 4 1/2 in. x 4 1/2 in.	35-
45 2.7 k. 4 v. 1 a., 2 v. 2 a., 5in. x 4in. x 6in.	35-
46 Auto 50 v., 100 v., 150 v., 230 v., 100 v., 4in. x 2 1/2 in. x 2 1/2 in.	12 6
47 Output trans. ratios 43.5-1 and 61.5-1 secs., 2.1 ohms and 4.2 ohms, 6in. x 6in. x 6in., wt. 29 lbs.	45-
49 275-0-275 v. 120 m.a., 5 v. 2 a., 6.3 v. 2.5 a., 6.3 v. 3 a. C.T.	29-
50 12 v. 70 a., 7in. x 7in. x 8in. An ideal transformer for ground heating or welding.	60-

TANK AERIALS.—Seven 3ft. lengths of steel tube which fit into each other, making a very efficient aerial, 3 8 each. Rubber Bases to fit, 2 6 each.

LOUDSPEAKERS BY FAMOUS MAKER.

5in. P.M., 2-3 ohms	10 11
6in. P.M., 2-3 ohms	16 6
8in. P.M., 2-3 ohms	17 6
8in. P.M., 2-3 ohms	23 6
10in. P.M., 2-3 ohms	25
12in. P.M., 10 ohms	85-
10in. Energised, 2,000 ohm field	25-

THE FAMOUS R.1155 RECEIVER.—These are all Brand New and Unused. Frequency range 18 mc/s-75 kc/s in 5 wavebands. Complete with 10 valves (including Magic Eye). Completely enclosed in black enameled metal case, 18in. x 9in. x 9in. Brand name, £2 12 0. Used Models, £8 8 0.

R.1155 POWER SUPPLY UNIT (incorporating output stage).—A robust unit contained in a black enameled case, 10in. x 6in. x 6in. which matches the receiver. There are two models for 100-250 v. 50 cycles mains. Each supplies an output of 250 v. at 50 m.a., which is ample for the R.1155 with the output stage. With output stage, 70 v. Power Pack only, 50".

ALL POST ORDERS TO JUBILEE WORKS, 167, LOWER CLAPTON ROAD, LONDON, E5. Phone: Amherst 4723
ALL CALLERS TO 169, FLEET STREET, LONDON, E.C.4.

Phone: Central 2933

CLIX

LOCTAL VALVEHOLDERS

FOR LOCK-IN TYPE VALVES EBL21, ECH21, 7A7E, 7B8, etc.

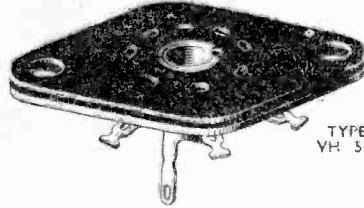

TYPE
VH 340,8

A double-plate laminated valveholder designed with 8 special sockets and centre spigot socket meeting the requirements of the B8G and B8B range of Loctal Valves.

THE GENERAL ACCESSORIES CO. LTD.

21 Bruton Street, London, W.1 Tel. MAYfair 5543

FOREMOST IN VALVEHOLDER DESIGN

VALLANCE'S SPECIAL OFFERS

MIDGET MAINS TRANSFORMER, TYPE MT/MI.—

A small upright-type transformer, suitable for signal generators, V.F.O.s, midget receivers and many other applications where size is the limiting factor. Primary, 200/230/250 volts, with electrostatic screen. Secondaries, 260-0-260 volts, 60 mfa. 0-4-5 volts at 2 amps. 0-6-3 volts at 3 amps. Dimensions, 2 1/2 in. x 2 in. x 2 1/2 in. High with four mounting feet. New and improved design. Price 23/6.

CRYSTAL DETECTORS. Cat's-whisker type, less crystal, 2/-; Semi-permanent type with two crystals, 2/6. Packets of one crystal with whisker, 6d.

HEADPHONES.—An extremely sensitive pair of lightweight 'phones of American manufacture. Ideal for crystal sets and sets with low impedance output, but can be matched to high impedance circuits with a 4:1 ratio (approx.) transformer. Complete with rubber-cushioned ear pads, leather headbands, cord and jack plug. New condition, 3/9 per pair, plus 1/- postage and packing.

ENAMELLED COPPER WIRE.—4 oz. reels, 18 and 20 S.W.G., 1 1/2; 22 S.W.G., 2/-; 24 S.W.G., 2/3; 26 S.W.G., 2/5; 28 S.W.G., 2/6; 30 S.W.G., 2/8; 32 S.W.G., 2/10; 36 S.W.G., 3/5; 38 S.W.G., 3/1; 40 S.W.G., 4/3.

BAKELITE SHEET.—1/2 in. thick. Sizes 12in. x 8in., 5/11; 10in. x 8in., 4/3; 10in. x 3 1/2; 8in. x 6in., 2/10; 6in. x 6in., 2/3; 6in. x 4in., 1/8.

CARBON THROAT MIKES.—A lightweight, compact and sensitive unit, complete with elastic strap, cord, and two-pin plug. American manufacture, brand new, 1/5.

SPEEDY POSTAL SERVICE, C.W.O. or C.O.D.

When ordering C.W.O., please include 1/- (minimum charge) for postage and packing.

VALLANCE & DAVISON, LTD.

144, Briggate, Leeds 1. Phone: 29428, 9.

Staff call sizes:—G2HHV, G6SX, G3A6D, G3CML.

INSTRUMENT Co.,

244, HARROW RD., LONDON, W.2. Cun. 0508

MAINS TRANS. Drop-through type. Primary 200-250 volts. Secondary 350-0-350 80 mA, 5 volts 2 amps. 6.3 volt., 3 amps.

Post paid **£1**

Same **TRANS.** as above, but with 4-volt tapping **£1**

instead of 6.3. Post paid

Same as above, but Stand-up type with 6.3 or 4 volt tapping. **£1**

Post paid

EX-R.A.F. AMPLIFIER 1134. Ideal for use with a microphone, or can be used as an amplifier without modification. Complete with wooden transit case. **17/6**

Post free

NUTS, BOLTS, WASHERS. Small sizes for model making. **7/6**

3 gross assorted.

SCREENED FLEX. Suitable for mikes. **10/-**

100ft.

24 VOLT MOTORS. Can be run off lower voltages but at reduced speeds. **7/6**

Post free.

MULTIRANGE TEST METER. 17 ranges AC/DC volts, milliamp and ohms. 1000 ohms per volt. **£7**

Brand new

TWIN WIRE for internal wiring, lighting points, etc. Minimum quantity **5/-**

12yds.

ALL TAYLOR METERS ON H.P. AVO's in Stock.

1155's with Power Pack, Speaker and Cabinet ready for A.C. mains **£18**

LOW RESISTANCE PHONES. Lightweight with plug-in Jack **7/6**

BC348. 28 volt. Plus 10/- packing **£18/10/-**

Fitted internal AC Power Pack. 200-250 volts. Plus 10/- packing. **£22/10/-**

2 1/2 in. FLUSH MOUNTING MILLIAMMETER. Moving coil, Bakelite case, 0-1 FSD. Brand new. Post free **13/6**

2 1/2 in. FLUSH MOVING IRON AMMETER 0-25 **7/6**

Post free

12 ASSORTED MAGNETIC RELAYS for experimental purposes. Post free **12/9**

PHOTO-ELECTRIC CELL. Dozens of applications, e.g., burglar alarms, counting, door-opening, etc. **14/6**

Light Operated Kit for above cell. **57/6**

NO C.O.D. ORDERS UNDER £1.

Write to Dept. "R"

INSTRUMENT CO.

244 HARROW ROAD, LONDON, W.2

SILENT POWER

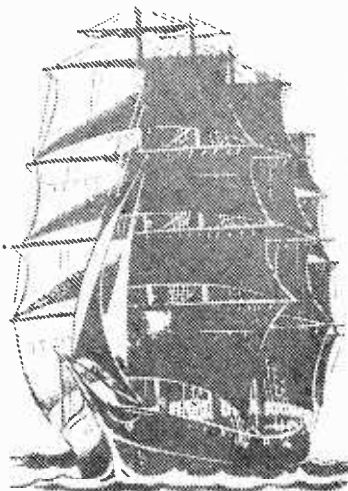

P4E

For clean, crisp reception a silent source of power is essential. Pertrix Radio Batteries give silent power.

HOLSUN BATTERIES LIMITED
137 Victoria Street
London, SW1



Products of Quality & Reliability

- MAINS TRANSFORMERS
- A. F. TRANSFORMERS
- SMOOTHING CHOKES
- THERMAL DELAY SWITCHES
- POWER RESISTANCES

Made by

OLIVER PELL CONTROL LTD

Telephone - WOOLWICH 1422
CAMBRIDGE ROW WOOLWICH S.E.18



'AVO' Precision ELECTRICAL TESTING INSTRUMENTS

Registered Trade Mark

A dependably accurate instrument for testing and fault location is indispensable to the amateur who builds or services his own set. Stocks are now available of these two famous "Avo" Instruments. If you have any difficulty in obtaining one locally, please send us the name and address of your nearest Radio Dealer.

D.C. Voltage		A.C. Voltage	
0-75 millivolts		0-5 volts	
0-5 volts		0-25 "	
0-25 "		0-100 "	
0-100 "		0-250 "	
0-250 "		0-500 "	
0-500 "			
D.C. Current		Resistance	
0-2.5 milliamps		0-20,000 ohms	
0-5 "		0-100,000 "	
0-25 "		0-500,000 "	
0-100 "		0-2 megohms	
0-500 "		0-5 "	
		0-10 "	

GUARANTEE: The registered Trade Mark "Avo" is in itself a guarantee of high accuracy and superiority of design and craftsmanship. Every new Avominor is guaranteed by the Manufacturers against the remote possibility of defective materials or workmanship.

The UNIVERSAL AVOMINOR

(as illustrated) is a highly accurate moving-coil instrument, conveniently compact, for measuring A.C. and D.C. voltage, D.C. current, and also resistance; 22 ranges of readings on a 3-inch scale. Total resistance 200,000 ohms.

Size: 4 1/2 ins. x 3 1/2 ins. x 1 1/2 ins.
 Net weight: 18 ozs. Complete with leads, interchangeable prods and crocodile clips, and instruction book.

Price: £8:10:0

The D.C. AVOMINOR

is a 2 1/2-inch moving coil meter providing 14 ranges of readings of D.C. voltage, current and resistance up to 600 volts, 120 milliamps, and 3 megohms respectively. Total resistance 100,000 ohms.

Size: 4 1/2 ins. x 3 1/2 ins. x 1 1/2 ins.
 Net weight: 12 ozs. Complete as above.

Price: £4:4:0

Sole Proprietors and Manufacturers:—
AUTOMATIC COIL WINDER & ELECTRICAL EQUIPMENT CO., LTD.
 Winder House, Douglas Street, London, S.W.1. Phone: VICTORIA 3404-9



that's JUST how it sounds on a

TRUVOX

There is something fascinating about the sound of silver clinking into a bag—and it is the true reproduction of the "noises-off" that mean so much when listening to a favourite programme—Home, Light or Third. It has taken us 18 years to achieve such realism... it's yours to-day. A range of three extension cabinet speakers is in the dealers' shops already, "Monobolt" speaker chassis in four sizes are there, too, you can hear them now. High fidelity pickups and "Wafer" speakers are well on the way. A postcard will bring full details.

MODEL BX105. One of the new range of Truvox Extension Cabinet Speakers. This model incorporates 10in. Monobolt chassis, volume control recessed in side. Beautiful Walnut cabinet with contrasting chamfers and fret motif in Maple. List Price, £5 10s.



Truvox Engineering Co., Ltd., Truvox House, Exhibition Grounds, Wembley, Middx.

TX35A

Practical Wireless

16th YEAR.
OF ISSUE

and PRACTICAL TELEVISION

EVERY MONTH
VOL. XXIV. No. 508 NOVEMBER, 1948

Editor F. J. CAMM

COMMENTS OF THE MONTH

BY THE EDITOR

Government Television Policy

LORD TREFGARNES' statement of the Government policy in relation to television is a triumph for the radio industry. Lord Trefgarne is the chairman of the Television Advisory Committee, and in the course of their investigations they have examined every television system and they reached the conclusion that, notwithstanding all that is being done in this country, as well as abroad, the existing British system is the best and they do not recommend any change.

The Postmaster-General has authorised prefatory work on further extensions using this system, and he proposes that the number of lines should not be altered for some years to come.

He thinks that the improvements in the quality of the picture resulting from alternative systems are too slight to warrant change which would render, in any case, all British television receivers obsolete. Moreover, any change at this juncture would prejudice more substantial improvements later, such as colour television.

Those who, therefore, have refrained from purchasing a television receiver because they suspected that they might rapidly go out of date have Government assurance that the present system will continue for many years to come. The 405-line system is being adopted for the Midlands station and is proposed for other British stations. It is likely that the Midlands station will be opened in the autumn of 1949. This station, although working on the same basic system as that at Alexandra Palace, will incorporate various improvements. The power of the vision transmitter will be twice as great, and that of the sound transmitter four times as great. The frequencies for vision and sound will be in the neighbourhood of 60 megacycles per second. The Post Office is providing alternative radio and cable links to bring the programmes from London to Hill Village, Sutton Coldfield, where the new station will be located. It is intended that when the Sutton Coldfield station is completed, the next will be erected in the North of England.

The Radio Industry Council, in welcoming the Postmaster-General's statement, states that the chief requirements for television development are: (a)

picture quality (it has been proved by recent television broadcasts from the studio and outside that excellent clarity, definition and general quality of the picture are ensured by the British 405-line system; (b) cheapness of sets (the British system is the best engineering compromise between maximum picture quality and minimum cost of production.

It is pointed out that the economic development of television services in Europe will depend upon the manufacture of a cheap receiver; the establishment of the greatest possible service area for each transmitter; and the provision at low cost of links by cable and radio between one station and another so that programme costs—the most expensive part of a television service—can be shared between one centre and another.

Adoption of the British system as the standard in Europe would meet all these requirements. The countries adopting it would have the additional advantages of linking themselves with a highly-developed source of programmes and of benefiting by Britain's unique experience of television in the past. They would be in a position to enjoy the technical improvements which are certain to be made in the British system in the future without fundamental alteration of the system: and equally, in due time, the advantages of any major developments which may be made in years to come.

The Radio Industry Council intends to bring these points to the attention of all concerned. In September it gave its first television demonstration abroad. This was in the British Exhibition at Copenhagen where, with the collaboration of the Danish State Broadcasting and the B.B.C., outside scenes and studio turns were televised by all-British equipment and the results seen by 10,000 people a day in British receivers in the Nimb Restaurant in the Tivoli Gardens.

Great advances have been made in British television technique as a result of the war and the use of television tubes in connection with radio location and the landing of aircraft. When several stations are operating and the demand for receivers is correspondingly increased, technical advances will be more rapid.

Editorial and Advertisement Offices:
"Practical Wireless," George Newnes, Ltd.,
Tower House, Southampton Street, Strand,
W.C.2. Phone: Temple Bar 4363.
Telegrams: Newnes, Rand, London.
Registered at the G.P.O. for transmission by
Canadian Magazine Post.

The Editor will be pleased to consider articles of a practical nature suitable for publication in "Practical Wireless." Such articles should be written on one side of the paper only, and should contain the name and address of the sender. Whilst the Editor does not hold himself responsible for manuscripts, every effort will be made to return them if a stamped and addressed envelope is enclosed. All correspondence intended for the Editor should be addressed: The Editor, "Practical Wireless," George Newnes, Ltd., Tower House, Southampton Street, Strand, W.C.2.

Owing to the rapid progress in the design of wireless apparatus and to our efforts to keep our readers in touch with the latest developments, we give no warranty that apparatus described in our columns is not the subject of letters patent.

Copyright in all drawings, photographs and articles published in "Practical Wireless" is specifically reserved throughout the countries signatory to the Berne Convention and the U.S.A. Reproductions or imitations of any of these are therefore expressly forbidden. "Practical Wireless" incorporates "Amateur Wireless."

ROUND THE OF WIRELESS

Broadcast Receiving Licences

THE following statement shows the approximate numbers of licences issued during the year ended July 31st, 1948.

Region	Number
London Postal.. ..	2,104,000
Home Counties	1,478,000
Midland.. ..	1,609,000
North Eastern	1,743,000
North Western	1,473,000
South Western.. ..	983,000
Welsh and Border	653,000
Total England and Wales ..	10,043,000
Scotland	1,064,000
Northern Ireland	186,000
Grand Total	11,293,000

The above number includes 58,250 television licences, an increase of 3,400 over the previous month.

Prosecutions in July for operating wireless receiving apparatus without a licence numbered 440.

They Have a Word For It

E. K. COLE announce that henceforth their EKCO television receivers will be known as EKCOVISION. The company has been considering the idea for some time and the new telescopic word will, they believe, be convenient to both trade and public, being a much less unwieldy way of describing their sets. There is evident general interest in the word "television" at present. The *Daily Express* has even run a campaign to find a new word. Ekco's decision is, therefore, opportune . . . and in spite of many ingenious possibilities in word-making they believe they are right in retaining "vision" as the root idea.

Radio-export Target Exceeded

RADIO exports exceeded the target and reached new records during the first half of 1948, according to an analysis—issued by the Radio Industry Council recently—of the official Customs and Excise figures.

The total value for six months was £6,297,130, an average of £1,049,521 per month as compared with a target of £1,000,000 a month. February was the only month when the target was not exceeded.

Olympic Torches

IT may now be revealed that the main contractors for the Olympic Torches were E.M.I., Ltd., at Hayes. These torches, numbering over 1,500, were used to carry the flame from Mount Olympus, in Greece, to Wembley Stadium, for the 1948 Olympiad.

First Brass Band Televised

MORRIS MOTORS, LTD., WORKS BAND was the first British brass band ever to be televised when they took part in the Television Fête at Alexandra Palace recently.

Overseas Economic Surveys

TWO further Overseas Economic Surveys in the series published for the Export Promotions Department of the Board of Trade by H.M. Stationery Office, are now available. "Iran (Persia)," price 1s., and "United States of America," price 3s. 6d.

Television Cameras in Downing Street

DURING the period, starting October 11th, when the Commonwealth Prime Ministers assemble in London, the B.B.C. is hoping to be able to televise a part of one of the meetings. This will be the first occasion on which television cameras have been installed in Downing Street.

Interference-free Plug

A SPARKING plug is now in production in the U.S.A. which incorporates a built-in 10,000 ohm resistor so that the car to which it is fitted will not be so liable to cause interference on F.M. and television frequencies. It is also claimed that the incorporation of this resistor reduces engine misfiring and lengthens the life of cylinder walls, rings and pistons.

Eire Police Radio

MARCONI'S have received an order for twin-diversity radio for the police in Eire. A main transmitter (reported to be due for installation just outside Dublin), eight H.Q. sets, 15 mobile sets and 14 receivers are included in the order.

New Norwich Station

WORK has commenced on the construction of a new B.B.C. transmitter near Norwich. With a rating of 5 kW. it is intended ultimately to replace the present 1 kW. station, and will radiate the Midland home service on 296.2 metres. A directional aerial system is to be used, consisting of two mast radiators each 126ft. in height.

New B.B.C. Wavelengths

CERTAIN changes will be made in March next to the wavelengths of a number of stations as a result of the new plan agreed in Copenhagen. Droitwich, radiating the Light programme on 1,500 metres, will use 400 kW. and remains on its frequency. The second Droitwich transmitter will use 120 kW. on 464 metres. The London wavelength will be changed to 330 metres and will not share this wavelength with any other station.

Amateur Frequency Band

THE Postmaster General announces that, as from October 1st, 1948, holders of amateur wireless station licences may use telegraphy and telephony on any frequency between 420 and 460 Mc/s, with power not exceeding 10 watts, subject to the general conditions of their licences and subject to no interference being caused with the working of other services.

I.P.R.E. Start New South-west Section

FOLLOWING quickly upon the formation of a Birmingham Section, the Institute of Practical Radio Engineers has now successfully formed a South-west Section. The inauguration meeting was held in Newton Abbot on September 1st.

Mr. R. P. B. Williams was elected chairman and Mr. F. C. Roberts, secretary. Their supporting committee will consist of Messrs. F. J. Bennett, D. H. Gibson, R. D. Knapp, E. F. McClean and W. H. Terry.

Mr. J. F. Tomlin, the president of the Institute, announced that due to the pending "Better Listening" campaign, it had been decided to postpone the proposed I.P.R.E. test equipment and servicing exhibition until early in 1949.

Stockholm Show

A PRIVATE exhibition of British radio components and associated equipment will be given in Stockholm from October 18th to 22nd. The exhibition is being held under the auspices of the Radio Component Manufacturers' Association in the Kungshallen, Kungsgatan, and is to acquaint the local manufacturers with recent advances made in this country. Admission is by invitation card obtainable by bona fide manufacturers and engineers from the R.C.M.F. at 22, Surrey Street, Strand, London, W.C.2.

"Radioman"

THIS month should see the production of a radio journal in India, bearing the above title. Mr. H. K. L. Arora, of New Delhi, has been planning this production, which is to be a technical journal.

F.M. Receivers in U.S.A.

IT is claimed that ownership of F.M. receivers in Metropolitan New York has doubled since last year. Present figures are 156,000 and the area covered in the survey which produced the figures has approximately 2.8 million radio homes.

Business Radio

WE understand that there are now approximately 110 business radio licences in force. These special transmitters, as the name implies, are used exclusively for business purposes, a typical example of which was the control, whilst passing through London, of a convoy of lorries carrying equipment for the Olympic Games.

Betatrons and Cancer

BETATRONS, according to the American publication *Science Service*, will be used next year for the first time in the treatment of cancer. It is claimed that the betatrons will produce 20 million volt X-rays 2 times more powerful than those used previously.

Speed of Light

THE actual speed of light has not yet been actually measured, but is calculated to be between 185,999 and 186,000 miles per second. An experiment is shortly to be carried out at the Worcester Polytechnic Institute, in the U.S.A.,

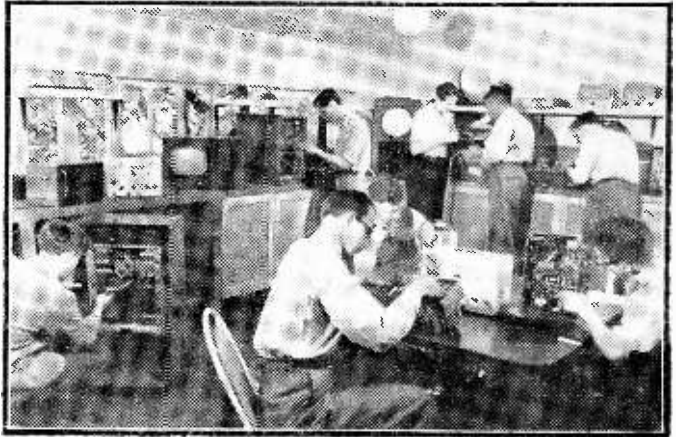

One of the laboratories at the E.M.I. Chiswick Institute. Another picture, and details of our new scholarships, will be found on page 468.

so that the exact speed can be measured. Holes are being cut in door and stairways under the supervision of Professor William B. Wadsworth.

Radio and Queues

SHEFFIELD CORPORATION is to introduce radio to its transport system in an attempt to prevent time lost by workers waiting in queues for buses. Four cars, radio equipped, will patrol the city and direct buses and trams from quiet areas to those where additional transport is needed.

"Eye of Britain"

THE B.B.C. Publications Department has recently issued a lavishly illustrated 32-page book dealing with the modern television system. It includes a description of the activities of the B.B.C. and has some very interesting illustrations of plays in progress and behind-the-scenes view of the studios, etc. The price is 2s.

Sponsored Radio

ACCORDING to a report in *World's Press News*, the South African Broadcasting Corporation has been requested by the Government to arrange for commercial broadcasting as soon as possible. It is reported that this is a result of the investigation recently carried out in which it was found that broadcasting could not be made to pay for itself.

Remote-control Switch

Describing Details of Government Surplus Selector Switch Type 10DB/6338

By ROBERT DALY

THIS switch, described in many surplus shops as a "Selector Relay Mechanism," purchased by the author for the sum of 1s. 6d., and believed by him to be of ex-Bendix origin, is admirably suited for the remote control of a radio receiver, giving the choice of four stations, or alternatively, three stations and "On-Off."

The operation of this switch is extremely

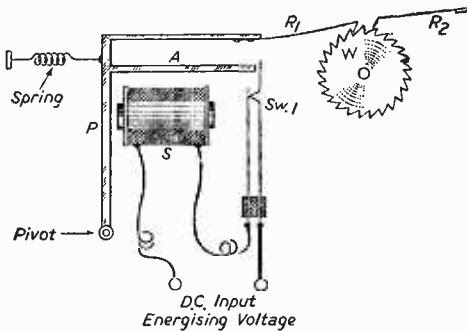

Fig. 1.—Main features of the switch.

ingenious and, in this writer's opinion, is worth 1s. 6d. to look at!

Referring to Fig. 1, the solenoid S, when suitably energised (Sw. 1 being normally closed) attracts the spring-loaded armature P, which pushes R1 over one cog of the wheel W (R2 preventing wheel W from moving backwards). Also, as attachment A is mechanically fixed to P. Sw. 1 is open-circuited which breaks the continuity of the input, and S is de-energised enabling the spring to pull P back to its original position and R consequently pulls wheel W round for one tooth. Sw. 1 now becomes closed, S is energised again, and the cycle repeats itself. It will be seen, therefore, that wheel W will (as far as Fig. 1 is concerned) move round continuously in an anti-clockwise direction.

Ganged Switch

So far, this is in effect quite a simple ratchet-type motor, and the ingenuity of the switch lies in the use of a four position Yaxley-type switch which is mechanically ganged to the wheel W, plus a further switch and "slip-ring" or disc, which will now be explained with the aid of Fig. 2.

This shows the entire mechanism except that the ratchet wheel is omitted for the purpose of clarity. Disc D and Yaxley switch Y are ganged to the ratchet wheel; Sw. 2 is now in series with Sw. 1 and S, and is normally in the "open" position, due to the recesses in disc D, as indicated in Fig. 2.

Ignoring for the moment the presence of the Yaxley switch, it is seen there is no continuity in

the input energising circuit, due to Sw. 2 being open, but the Yaxley is in parallel with Sw. 2, and if output terminal C is connected to either terminals 1, 2 or 4 (with the wheel in the position as shown in Fig. 2), Sw. 2 will be short-circuited, and the "motor" will rotate.

True, immediately the motor rotates, the Yaxley switch contacts will be broken (as it must be borne in mind that both the Yaxley and disc D rotates also), but then the rotation of disc D causes the switch Sw. 2 to be made and it will not break again until the mechanism has rotated through 90 degrees when the recess next causes it to open.

Now, a little careful study of the wiring of the Yaxley switch is called for to appreciate what is going to happen!

Let us assume that output terminal C has been connected to terminal 4. Each time one of the recesses on Disc D causes Sw. 2 to be open the Yaxley will short Sw. 2 and so maintain continuity of the input energising circuit, until the Yaxley is in such a position that position 4 is open (it being noted that although the Yaxley is a four-position switch, only three contacts are made at any one setting).

Consequently, each time C is connected to terminal 4, the "motor" will stop at the same position, and likewise with terminals 1, 2 and 3.

It now remains to connect a five-way cable (thin bell wire may be used, as the energising current is very small) as shown, and a four-position switch at the "control" end (say on the extension speaker) for selection purposes.

The output leads fitted to the selector switch

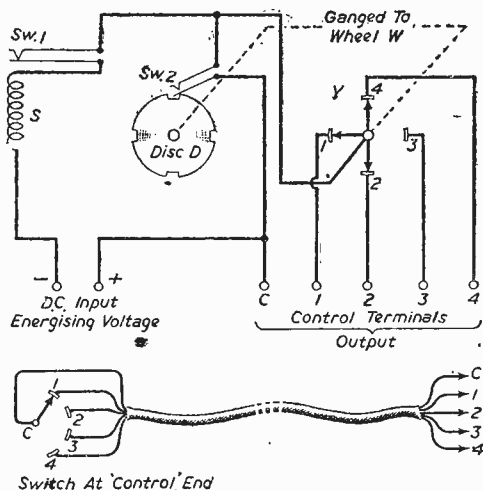

Fig. 2.—Operation of the disc, and control lead layout.

as purchased, are conveniently marked "+, -, 1, 2, 3, 4," and the "+" lead should be treated as "C" on Fig. 2. Two further leads (unmarked) are also brought out, these being connected to Sw. 1 and should be connected to a largish condenser (.1 $\mu F.$ or so) to prevent sparking and creating interference.

The actual receiver switch (which would normally control pre-set condensers for station selection) and a mains "on-off" switch, must, of course, be of the type that will rotate through 360 degrees, and provide the four positions equidistant at 90 degrees per position.

These are quite easy to obtain in the Yaxley type, and the locator should be removed as this is now quite unnecessary. It can easily be gauged to the selector switch, as each side of the selector is fitted with a spring loaded piece of metal which will make contact with a strip of ebonite fixed to the receiver switch as shown in Fig. 3. This can be clearly seen on the accompanying illustrations.

Remote Contro.

If any reader contemplates using this selector switch for the purpose of controlling the radio at several points over the house (in conjunction with extension speakers) and considers the installation of the multi-wire cable out of the question, there is an alternative method which will save on cable, namely by ignoring *all* of the output leads, and connecting a two-way cable across Sw. 2, and connecting the other ends to a push-button, as shown in Fig. 4. Now one short push of the button will rotate the mechanism through 90 deg.

The main disadvantage of this system is that it requires a little thought on the part of the operator, as, for example, if the switch is wired Light-Home-Third-Off, and the operator is listening to the Light programme and wishes to switch off, he will have to push through the Home and Third programmes before he *can* switch off! In this case, it would probably be advisable to arrange that the Home or Light programme came just before the "off," as this would ensure that (providing that he switched off before midnight) he did not switch on to a wavelength that was not radiating, resulting in the set being left on all right. These remarks do not of course apply to the first-mentioned system of operation, which is quite foolproof in this respect.

With either system lead "C" may be also utilised for one of the extension speaker leads with a consequent cable saving.

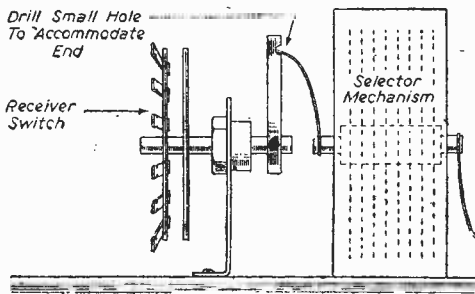

Fig. 3.—Ganging a switch plate to the mechanism.

A D.C. supply of 12 volts is ample, and the writer, by slightly easing the spring adjusting screw was able to operate the mechanism using 6 unit cells in series over a distance of 50ft. using ordinary

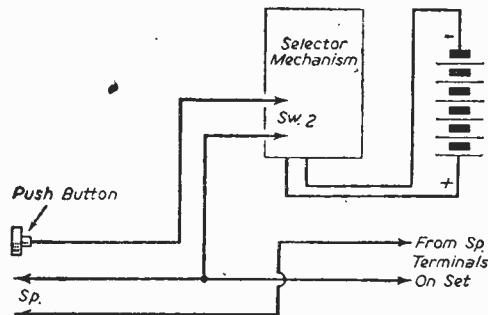

Fig. 4.—Push-button operation may be included as shown here.

22-gauge bell wire. As the operating current is small and the load imposed upon the batteries of a very intermittent nature, it is reasonable to assume a long battery life of perhaps several months.

Second Amateur Radio Exhibition

THE Second Annual Amateur Radio Exhibition, organised by the Inc. Radio Society of Great Britain, will be opened at 2.30 p.m. on Wednesday, November 17th, 1948, by Dr. R. L. Smith-Rose, Director of Radio Research, Department of Scientific and Industrial Research, and an Honorary Member of the Society. The Exhibition will remain open until November 20th (hours 11 a.m. to 9 p.m.).

The venue is the same as last year—the Royal Hotel, Woburn Place, London, W.C.1 (nearest Underground station, Russell Square. Bus routes 68 and 77 pass the door).

At the time of going to press 27 radio concerns have reserved space—a considerable increase over last year. The G.P.O. are to stage a special exhibit.

Admission will be by catalogue, price 1s., purchased at the door or 1s. 3d. on application to the Society (New Ruskin House), Little Russell Street, London, W.C.1.

A Useful Vest-pocket Book.

WIRE and WIRE GAUGES

3/6, or 3/9 by post from

George Newnes, Ltd., Tower House,
Southampton St., Strand, W.C.2

The New Emitron Cameras

Details of the Latest E.M.I. Television Transmitting Equipment
as Used for the Olympic Broadcasts

BRTAIN'S greatest success at the Olympic Games was undoubtedly the excellence of the television broadcasts. The wealth of detail and depth of focus of the pictures drew praise from competitors from all over the world, and a spokesman of the American team said publicly during a television interview that of all the things that had impressed him in Britain, television was foremost and was better than anything he had so far seen in the United States.

The E.M.I. Research Laboratories at Hayes worked day and night to complete the new mobile van and C.P.S. Emitron cameras in time for the start of the Olympic events from the Empire Pool and the magnificent results achieved must have been a source of particular satisfaction to those responsible. Even the B.B.C., normally reticent on such matters, were constrained to pay tribute in the *Radio Times* to the engineers responsible.

Mobile Van

The new mobile van, an illustration of which appears below, contains three camera channels—with an additional one for stand-by—and each of these racks is provided with a picture monitor for displaying the picture produced by the particular camera with which it is associated. The four

picture monitors (arranged in line in front of the producer and control engineer) may be seen, with a fifth picture monitor arranged centrally above them, and this displays the radiated picture which is

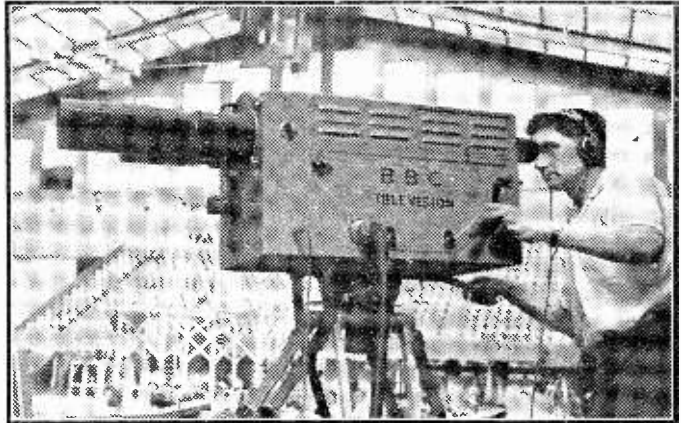

The new E.M.I. C.P.S. Emitron camera in action at the Empire Pool, Wembley, during the Olympic Games. It has a 3-lens turret and an electronic view-finder and is 50 times more sensitive than the ordinary type of television camera in use to-day.

received back by radio from the transmitter at Alexandra Palace.

Three Lenses

Facilities are provided for cutting or fading from one camera to another and all the technical equipment is extremely accessible for maintenance.

The C.P.S. Emitron cameras, one of which may be seen above, used in conjunction with this new mobile equipment, are fitted with three-lens turrets and electronic view-finders, and the cameras are 50 times more sensitive than the ordinary types of camera in use to-day.

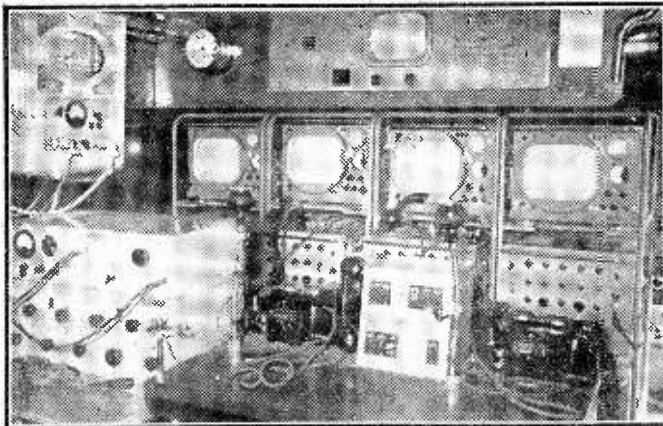

The interior of the new B.B.C. mobile television van produced by E.M.I. for use with the latest C.P.S. Emitron cameras. Three camera channels—with an additional one for stand-by—are provided. Centrally above the camera channel monitor is the monitor on which is displayed the radiated picture.

**KEEP WASTE PAPER
OUT OF DUSTBINS—
make a bundle for
urgently needed
salvage.**

A Microphone Amplifier

A. High-gain Instrument. Suitable for Moving Coil
or Ribbon Type Microphones.

By "EXPERIMENTER"

TO-DAY amateur constructors are quite competent at building loudspeaker amplifiers and obtaining successful performances from them, but the problems attending the design of amplifiers for very small inputs (such as microphone amplifiers) are not so well understood. It is the purpose of this article to review the chief difficulties likely to be encountered in building an amplifier to follow a ribbon or moving-coil microphone and to suggest ways in which they may be minimised or overcome. It should be noted that the input circuit described is suitable only for the connection of low-impedance microphones, and that a circuit of a different type is required for high-impedance microphones of the piezo-electric or condenser type. For design purposes the output voltage of the microphone is assumed to be -80 db. (relative to 0.775 volts). This output is very low, particularly for a moving-coil microphone, but this value is chosen so that there shall always be some gain in hand. The output required from the amplifier is, say, 0 db.; this is a value convenient for operating the most insensitive of high quality or P.A. amplifiers. The maximum voltage gain required from the amplifier is, hence, 80 db., more than can be obtained from a single high-slope valve, even allowing for the voltage step-up in an input transformer. Two valves are necessary, and it is a good plan to use two high-slope pentodes of the SP41 type, because they can provide more than 80 db. gain and the unwanted gain can be devoted to negative feedback. The provision of some feedback is very desirable to improve the linearity of the amplifier and to reduce valve noise and hum.

Some means of controlling gain is necessary and the method and position of the control in the circuit must be chosen with care. If a conventional grid

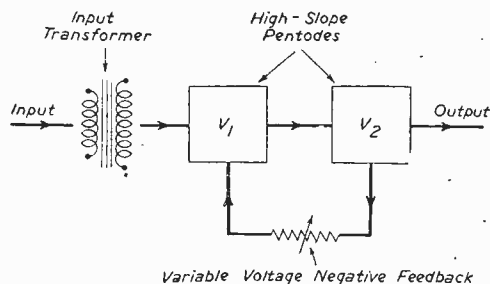

Fig. 1.—Basic circuit of the design discussed in this article.

circuit potentiometer is used, this should be situated at the input of the second valve, because there is no likelihood of the first valve being overloaded (and the second might), and it is desirable to render the hiss of the first stage as innocuous as possible.

An alternative and better means of gain control is by variable negative feedback, even though such a control has a limited range. As two valves are used, it is convenient to apply variable voltage negative feedback between the anode of the second valve and the cathode of the first. This is the method adopted in the design to be described. The basic circuit of the amplifier is now clear and is illustrated in block schematic form in Fig. 1.

As the ribbon impedance is extremely low and is appreciably less than that of even a short microphone lead, it is customary to mount a transformer

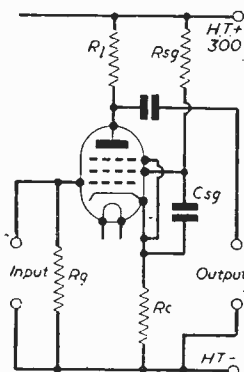

Fig. 2.—A high-slope R.F. pentode used as a high-gain A.F. amplifier.

in the base of a ribbon microphone to step-up the impedance to, say, 600 ohms. Similar measures are, or should be adopted with moving-coil microphones. Thus, the input impedance of the microphone amplifier must be 600 ohms and the turns ratio and secondary load must be chosen accordingly. Naturally, the ratio should be as large as possible, provided the transformer has the desired frequency response, but it is doubtful whether a turns ratio appreciably greater than 20:1 can be obtained in a practical component. For this ratio the secondary load should be $20^2 \times 600$ i.e., approximately 0.25 megohm. A grid-cathode circuit with an impedance as high as this is very susceptible to electrostatic pick-up of hum, and the grid-lead and valve grid cap or pin should be thoroughly screened to avoid this. The transformer also needs screening, but the pick-up here is magnetic in character and can be very severe, particularly if any mains transformers are nearby. To minimise this form of pick-up, the input transformer must be completely enclosed in a box of magnetic material of very high permeability, such as mumetal. The material should be reasonably thick, say, 1/16 inch, but if induction still occurs, the screening should be improved by using a greater thickness, or—and this is a better and cheaper method—two such boxes should be used, one mounted inside the other and spaced from it by

non-magnetic material such as brass. It is comforting to know that if this screening is well done, the microphone amplifier and its mains unit can both be mounted on one small chassis, with negligible trouble from pick-up in the input circuit.

Input Leads

To minimise pick-up in the microphone lead, this should be of the balanced type, and the secondary winding of the microphone transformer should be centre-tapped and the centre point earthed. This precaution will permit the connection of microphone leads of practically any length without appreciable pick-up. Sometimes microphone leads are screened and the braiding earthed, but the author has not found this necessary.

The voltage gain of the input transformer is 20 (26 db.), and thus the valves must provide 54 db. gain to make up the 80 db. required. It is desirable to obtain the maximum possible gain from the two valves so that the maximum of negative feedback can be used. The voltage gain of a pentode with a direct-coupled resistive load depends on the value of the load and the voltage of the H.T. supply, and to obtain very high gain, the anode load should be not less than about 100,000 ohms and the H.T. supply should be not less than about 300 volts. [It is assumed here that the screen potential is always adjusted to the optimum value for every change in operating conditions.) It is perhaps not generally realised how high the stage gain can be; as an example, an SP11 with an anode load of 150,000 ohms and an H.T. supply of 300 volts will give a gain of 250 times (48 db.), and these are the values of load and H.T. adopted in the amplifier. To obtain such

a gain it is essential to use the optimum value of screen potential and this implies the optimum value of screen feed resistor. The method of supplying H.T. to the screen indicated in Fig. 2 is preferred to the alternative method using a potential divider across the H.T. supply, as it is to some extent self-compensating for changes in H.T. voltage. Fortunately there is a simple rule for determining the best value for R_{sg} in Fig. 2. The optimum screen potential is approximately equal to the quiescent anode potential, and for maximum gain the P.D. across R_{sg} must equal that across R_1 . Over a wide range of operating conditions the anode current is a fixed multiple, usually three or four times the screen current. Suppose the anode current is three times the screen current. For equality in P.D.s across R_{sg} and R_1 , R_{sg} must be three times R_1 . As R_1 is 150,000, R_{sg} must be 450,000 ohms.

To decide the value of the screen decoupling capacitor C_{sg} , consider the screen, control grid and cathode of V_1 as the electrodes of a triode. The "anode load" of this valve is effectively the screen feed resistor and the decoupling capacitor in parallel. Since the screen potential must be as steady as possible during amplification the triode stage gain must be small. This, in turn, implies a small value of load. In practice a load of the order of 1,000 ohms is usually small enough and a decoupling capacitor of $2\mu\text{F}$, the reactance of which is 1,600 ohms at 50 c/s, is generally satisfactory. Sometimes decoupling capacitors as small as $0.1\mu\text{F}$ are used, but such values may give a loss of low-frequency response unless this is made good by feedback or other means. It is not advisable to use electrolytic capacitors for screen decoupling,

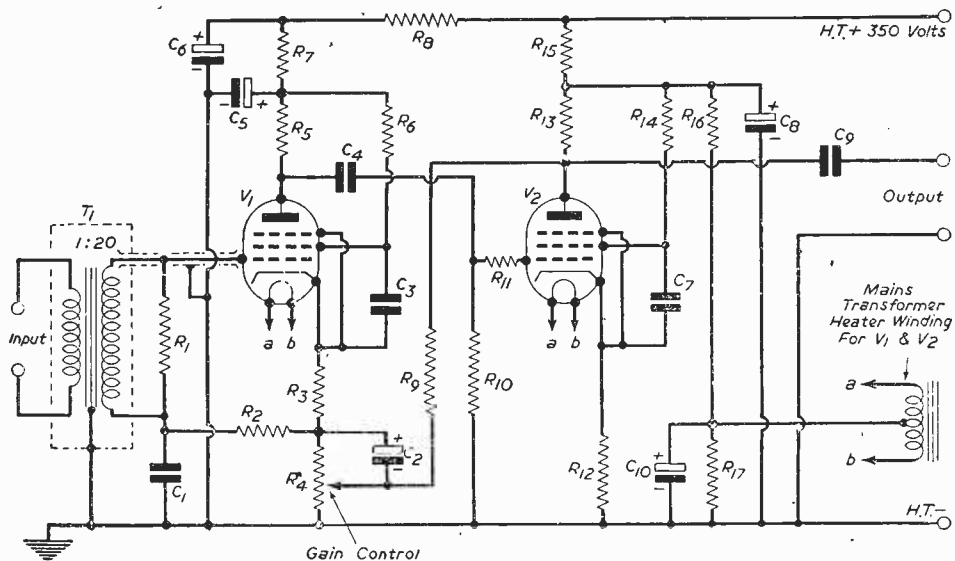

Fig. 3.—Circuit diagram. Component values are as follows:

R1	250,000Ω
R2	50,000Ω
R3	1,500Ω
R4	5,000Ω potentiometer
R5	150,000Ω
R6	500,000Ω
R7	20,000Ω

R8	10,000Ω
R9	250,000Ω
R10	250,000Ω
R11	2,000Ω
R12	1,500Ω
R13	150,000Ω
R14	500,000Ω

R15	20,000Ω
R16	250,000Ω
R17	30,000Ω
C1	0.1μF
C2	50μF
C3	2μF

C4	0.02μF
C5	32μF
C6	32μF
C7	2μF
C8	32μF
C9	0.02μF
C10	12μF

for these often have leakage currents of a fraction of a milliamp which, in flowing through the very high screen-feed resistor, can cause an appreciable reduction in steady screen potential. Good quality paper capacitors are therefore necessary at this point in the circuit. The decoupling capacitors are frequently connected between screen and earth. Whilst this is quite satisfactory if the cathode is also well decoupled to earth, it may cause unwanted effects if, as in the circuit under discussion, a feedback voltage is injected between cathode and earth. The safest course is to decouple the screen to cathode as shown in Fig. 2.

Cathode Bias Resistor

The value of the cathode bias resistor R_c may be calculated as follows. For satisfactory operation of the pentodes the anode potential preferably should not be less than about 100 volts. As the anode load is 150,000 ohms and the H.T. supply is 300 volts, it is clear that the anode current is $200/150=1.33$ mA. Assuming that the screen current is one-third of this, the cathode current will be approximately 1.8 mA. A grid bias value of -2.5 volts is satisfactory and the value of R_c is

hence $2,500/1.8$, approximately 1,500 ohms. The details of the feedback arrangements can now be considered. It is desirable that each valve should have a certain amount of current feedback independent of the voltage feedback used for controlling gain. About 10 db. of current feedback is obtained by omitting the electrolytic capacitors which are usually connected across the cathode resistors. The gain control is obtained by variable voltage feedback applied between the anode of V2 and the cathode of V1. This feedback is provided by R4 and R9 (Fig. 3) and it is clear from its position in the circuit that R4 also gives some variable current feedback on V1. It was considered unnecessary to isolate R9 from the H.T. supply by including a fixed capacitor in the circuit at this point. The direct current through the voltage feedback loop is only just over a milliamp and the steady P.D. across R4 has a maximum value of only 6 volts and does not affect the performance of V1 in any way.

The values of R4 and R9 are calculated to give a maximum of about 38 db. of feedback and this is also the volume range of the gain control.

(To be continued.)

Ex-R.A.F. Capacitors

MANY amateurs are purchasing ex-government chassis and components, and find difficulty in ascertaining the values of certain items. This applies particularly to fixed, trimmer and variable capacitors, on many of which only a stores reference is marked. These are, however, readily ascertainable, and the following

list (which is not exhaustive) will no doubt be found valuable in identifying many items which perhaps could otherwise not be used unless a capacity bridge could be employed.

All the numbers are preceded by the reference No. 10/C. Thus 10/C-14 equals .001 μ F. 10/C has been omitted for brevity from all reference numbers.

14.	.001 μ F.	2070.	3-20 pF. Trimmer.	3503.	8 pF.	10,227.	3-35 pF. Vari.
15.	5 pF.	2071.	3-18 pF. Gang.	3580.	.001 μ F.	10,228.	160 pF.
16.	10 pF.	2072.	2-8 pF. Trimmer.	3787.	16 pF.	10,229.	1,050 pF.
18.	80 pF.	2073.	10 pF.	3788.	.005 μ F.	10,230.	3-17 μ F. Vari.
96.	100 pF.	2075.	30 pF.	3789.	60 pF.	10,301.	3 pF.
97.	.002 μ F.	2076.	.003 μ F.	3790.	160 pF. Vari.	10,554.	.1 μ F.
347.	.01 μ F.	2078.	50 pF.	3791.	160 pF. Vari., 2 Gang.	10,568.	50 pF.
626.	500 pF.	2079.	50 pF.	4099.	.0003 μ F.	10,607.	15 pF.
627.	.001 μ F.	2082.	2-6.5 pF., Vari.	4100.	.0001 μ F.	10,629.	.01 pF.
792.	500 pF.	2083.	.05 + .05 μ F.	4232.	25 pF.	10,948.	20 pF.
793.	1,000 pF.	2084.	.1 + .1 μ F.	4250.	.001 μ F.	11,123.	.01 pF.
796.	.05 μ F.	2192.	.1 μ F.	4260.	93 pF.	11,124.	.02 pF.
799.	.15 μ F.	2189.	1 μ F.	4268.	200 pF.	11,125.	.05 μ F.
969.	2.5 + 2.5 + 1 μ F.	2237.	.004 μ F.	4271.	100 pF.	11,126.	.1 μ F.
969.	As above.	2238.	.25 μ F.	4501.	50 pF.	11,130.	.5 pF.
963.	100 pF.	2239.	2 μ F.	4502.	500 pF.	11,131.	.5 pF.
964.	.005 μ F.	2240.	4 μ F.	4572.	1 μ F.	11,140.	.004 μ F.
967.	1 μ F.	2335.	.5 μ F.	4632.	3 pF.	11,156.	.05 pF.
968.	.75 pF.	2428.	100 pF.	4633.	2 pF.	11,157.	.1 pF.
969.	800 pF.	2599.	25 μ F.	4922.	30 pF.	11,476.	.1 μ F.
974.	.5 μ F.	2624.	1 μ F.	4923.	160 pF.	11,482.	4 μ F.
971.	600 pF.	2625.	.01 μ F.	4995.	100 pF.	11,485.	50 pF.
972.	200 pF.	2626.	.005 μ F.	5352.	.005 μ F.	11,658.	200 pF.
974.	10-115 pF. Trimmer.	2627.	.005 μ F.	5484.	250 pF.	11,694.	.003 μ F.
976.	5-60 pF. Trimmer.	2629.	.02 μ F.	5598.	16 + 8 μ F.	11,748.	1.25 μ F.
978.	15 pF.	2630.	.05 μ F.	5645.	.01 μ F.	11,753.	.01 μ F.
979.	1 μ F.	2649.	.65 pF.	5874.	9-175 pF. Vari.	11,754.	.05 μ F.
1371.	.02 μ F.	3027.	25 pF.	5875.	3-8 pF.	11,755.	4 pF.
2001.	2 pF.	3043.	50 pF.	7901.	.001 μ F.	11,756.	.25 μ F.
2002.	4 pF.	3055.	.01 μ F.	7906.	.01 μ F.	12,114.	40 pF.
2005.	4.550 pF.	3064.	300 pF.	8009.	.0005 μ F.	12,384.	25 pF.
2006.	100 pF.	3100.	.001 pF.	8010.	.002 μ F.	12,574.	1 pF.
2007.	25 pF.	3124.	30 pF.	8275.	2 μ F.	13,194.	8 μ F.
2008.	240 pF.	3129.	5-80 pF. Vari.	8286.	8 μ F.	13,212.	16 pF.
2009.	80 pF.	3192.	.0025 μ F.	8382.	.25 μ F.	13,258.	4 pF.
2011.	.002 μ F.	3195.	.01 μ F.	9097.	1 μ F.	13,260.	4 pF.
2013.	1,320 pF.	3196.	300 pF.	9029.	.05 μ F.	13,364.	.001 μ F.
2014.	537 pF.	3303.	10 pF.	10,164.	.005 μ F.	14,211.	40 pF.
2015.	1,670 pF.	3306.	.001 μ F.	10,165.	.1 μ F.	14,616.	.5 pF.
2016.	6,170 pF.	3309.	.1 + .1 + 1 μ F.	10,221.	.05 μ F.	14,719.	2 pF.
2017.	300 pF.	3401.	.5 μ F.	10,224.	.0005 Vari.	14,757.	4 pF.
2027.	5 pF.	3402.	8-105 pF. Vari.				
2066.	3-18 pF. Trimmer.	3436.	.0001 μ F.				

(Vari. equals variable or preset.)

A Lightweight Pick-up

A Needle Armature Instrument Without Rubber Damping

By G. H. LEVERSEDGE

THE pick-up to be described has been in service for several years and gives very good reproduction. It will work satisfactorily with a needle pressure of half an ounce on the heaviest recordings, and will not be found too difficult to make by anyone accustomed to light instrument work. It is of the needle armature type, using H.M.V. Silent Stylus or Columbia 99 needles. A special feature is that no rubber is used in its construction, and there is, therefore, no fear of gradual deterioration of performance which is always present when even the best quality rubber is used for damping, or as a bearing for

best solution to this problem. There must, however, be a minimum of shake in both horizontal and vertical pivots.

Pole Pieces and Coil

The construction of the pole pieces, coil, and needle suspension are shown in Figs. 1 and 2, and a perspective view of the separated pieces is given in Fig. 3. There is not much point in giving precise and detailed dimensions, but the parts should be made approximately to the proportions shown relative to the sizes of the needle and magnet. The needle must, of course, project sufficiently far below the case to ensure that the bottom of the latter will clear the surface of the record. The pick-up is mounted on the carrier arm at an angle of 5 deg. to the vertical.

The magnet pole pieces are filed from soft iron or mild steel. The coil former can be cut from a solid piece of any suitable plastic material. A piece of celluloid cut from a tooth-brush handle will be found excellent material for this purpose as it can be filed, drilled and cut by means of a penknife. The coil is wound full with 40 s.w.g. enamelled copper wire, the D.C. resistance being about 6 ohms, and the impedance suitable to work into a 15 ohm microphone type input transformer.

Needle Suspension

We now come to the needle suspension. The base is of about 0.007in. shim brass. To facilitate needle changing, the hole through which the needle passes should be kept as small as possible; about 0.05in. diameter is sufficient as the movement of the needle is very small at this point. The springy suspension is of 0.004in. shim brass. It is bent over the top of a needle and carefully formed round it as shown in the drawings by means of a smooth-nosed pair of pliers, great care being taken not to crack the metal at any point. It is advisable to anneal this part in a small gas flame from time to time, but the "legs" must remain hard and springy and must, therefore, not be overheated. It is the sharp bend over the top of the needle which is most likely to crack and heating should be confined to this portion. The final result is a circular tube fitting snugly round the needle for not more than a third of its length. The end of this tubular portion is

the armature. The writer has made a number of different types of pick-up in the past, but this one can be said to have given a much longer period during which a somewhat musically critical experimenter could sit back and enjoy the music without anxious moments of doubt during particularly heavily recorded passages. There are no pivots, knife edge supports or rubber bearings, the needle being held in a springy metal suspension which gives free movement in the required plane and provides the necessary return torque, but restricts vibration in undesirable planes to a minimum.

The magnet used is an "Eclipse," these being now readily obtainable at most tool shops. Only the construction of the movement will be described as the casing and the design of a suitable carrier arm will probably depend on what turns up after an examination of the junk box. The writer, however, prefers a spring to support excess weight, rather than a counter-weight, as the former method is better on warped records and weight on the bottom pivot is less. The utmost freedom of horizontal movement is essential with lightweight pick-ups, and also a perfectly level turntable, otherwise the needle will not remain at the bottom of the groove at all times. Well polished and hardened steel cone pivots have been found the

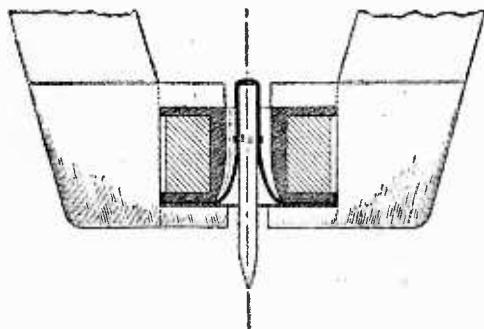

Fig. 1.—Details of the coil and pole-piece assembly.

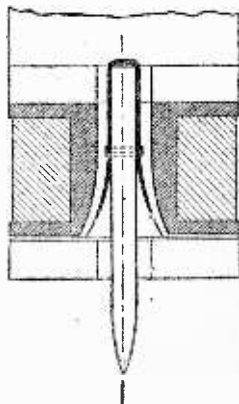

Fig. 2.—The needle in its brass "holder."

tightly bound with three turns of 35 s.w.g. tinned copper wire (5 amp. fuse wire) and soldered with the minimum amount of solder. The needle should now be a tight push fit; but if slightly slack a gentle squeeze can be given at the soldered binding, otherwise it is better to make a fresh start.

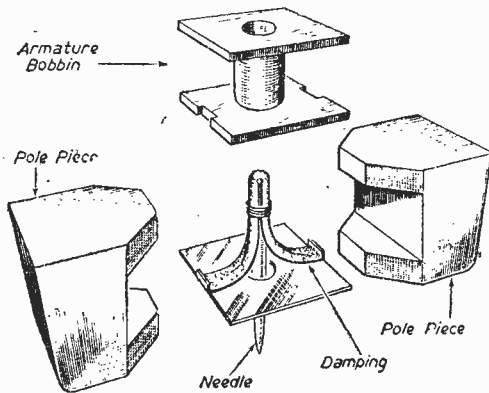

Fig. 3.—Component parts of the pick-up.

The bends forming the feet, which will be soldered to the base plate can now be made with a pair of tweezers, the simplest method of ensuring that they are made in exactly the right places being to draw the outline on a piece of paper and clamp the

piece down in the correct position by the tubular end. The tweezers can then be applied at the correct point and the legs made of exactly equal length. Mistakes cannot be corrected; you just start all over again. The forming of the tubular portion will have left shoulders which should be filed off so that the legs will taper upwards from the full width at the base to the diameter of the cylindrical part where they join the latter. The legs should be flat in the direction of their width for most of their length, but the transition to the curved tubular portion must not be too abrupt, otherwise the metal is likely to crack. There should be a slight longitudinal curve, as shown, to afford the necessary flexibility.

Assembly

The coil is now placed in position on the base plate and the spaces round the suspension packed with motor grease and cotton wool fibres. The pole pieces can now be pushed on to the coil, which should fit tightly so that the whole unit is quite rigid when assembled. The needle must be quite central between the poles which should be about 0.075in. apart.

It is convenient to provide for the pick-up to be readily detachable from the carrier arm for needle changing, but a means of rigidly clamping it to the arm is necessary in addition to the necessary plug and socket connectors. The tracking angle will, of course, depend on the length of carrier arm used.

Winding Midget Coils

Hints for Making Coils for Modern Compact Receivers

By F. G. R.

POCKET sets and similar very small receivers are becoming increasingly popular. Their construction is interesting; it offers scope for ingenuity in trying to obtain maximum results and minimum size.

As a rule there is no room for standard tuning coils. But small ones can be wound quite easily and the details following should provide guidance and suggest methods which will prove convenient.

An efficient coil for medium-wave operation is shown in Fig. 1. A tube 1/4 in. in diameter and 1 in. long is used for the former. For the grid winding, 110 turns of 32 s.w.g. d.s.c. wire are used. The turns are wound in three layers with paper or other thin insulating material between each layer.

Sixty turns of 40 s.w.g. wire are used for reaction. The ends of the windings are passed through pairs of holes in the former, and left long enough to reach to the components in the receiver. A touch of varnish will ensure that the turns do not move about. The coil takes up very little space and Fig. 1 shows connections.

Case as Former

Sometimes it is convenient to wind the coil in much the same way as a frame aerial (though pick-up will be too small for the winding to be used in this way), as illustrated in Fig. 2. This adds practically nothing to the dimensions. For a case about 2 in. by 2 in. about 25 turns are used for the grid winding, and 15 for reaction. With a 3 in. by 3 in. case 20

and 12 turns will be better. Connections are as shown: One to grid; two to earth; three to reaction condenser; four to anode.

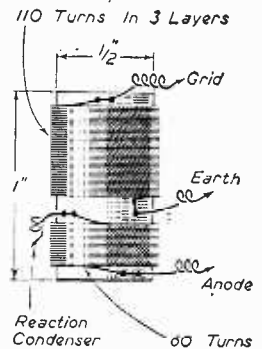

Fig. 1.—Coil dimensions and arrangement of windings.

As only a moderate high-tension voltage is used, it is best to make the reaction coupling fairly tight. Without sufficient reaction reception will be poor. If reaction cannot be obtained, the number or reaction turns must be increased.

It is usually best to start with ample turns on both windings. If it becomes apparent the wave-range is too high, a turn or two can be removed from the grid winding. This can also be done with the second winding if reaction is too fierce.

A long strip of insulating material can be glued round the case to protect the windings.

Flat and Overwound Coils

The flat coils shown in Fig. 3 can be made quite small and can often lie in position where no other type of coil could be accommodated. If wound on card the overall thickness will only be about $\frac{1}{10}$ in.

With a coil about 2 in. in diameter 20 turns can be used between the reaction condenser and tapping, with 30 between tapping and grid condenser. (If the wire is silk or cotton covered, rather more turns will be required on the grid winding.)

The last type of coil shown (Fig. 4) can be made any size from about $\frac{1}{2}$ in. by $\frac{1}{2}$ in. to 2 in. or so in

ward; in addition, the proximity of them to the medium-wave winding frequently reduces efficiency severely when the latter waveband is in use. Because of this it is usually not worth while bothering with long waves, especially as the Light Programme is also available on medium waves.

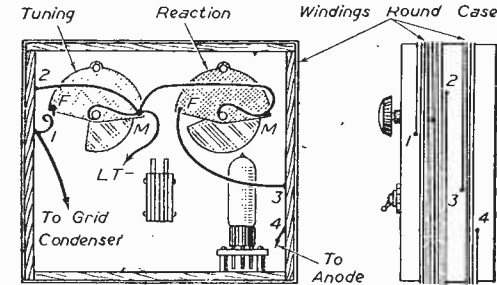

Fig. 2.—Using the containing box as a frame aerial former.

diameter, and $\frac{1}{2}$ in. or more wide. (Sometimes it can fit round a tuning or reaction condenser, thus really saving space.)

After putting on the grid winding a turn or two of insulating tape is wound on and the reaction winding placed on top of this. A 2 in. diameter coil will only require about 40 turns, with 20 for reaction. The smaller coils will require 90 to 100 turns, with 50 or 60 for reaction.

One well-known commercial receiver uses a coil wound like that in Fig. 3 as a frame aerial,

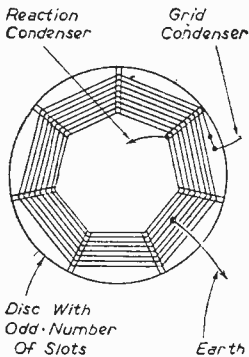

Fig. 3.—A "spider-web" coil, or flat former scheme

the disc being 4 in. to 5 in. in diameter. Other modifications will suggest themselves. Where size is of the utmost importance a coil like that shown in Fig. 1 is sometimes positioned so that a valve stands within it.

Quite frequently, long waves are not provided. The large number of turns necessary become awk-

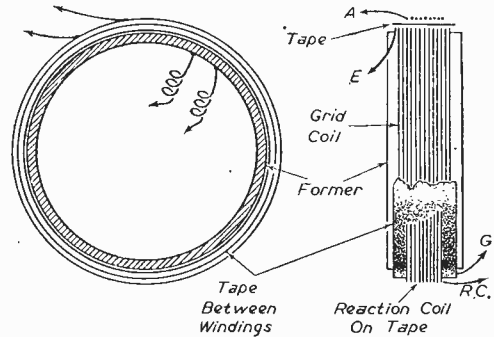

Fig. 4.—A solenoid coil with overwound sections.

European Regional Broadcasting Conference, Copenhagen

A CONFERENCE of European nations agreed at Copenhagen on September 15th on a redistribution of long and medium wavelengths used for broadcasting.

The last effective plan of these wavelengths was made at Lucerne in 1933 and since then the claims of many countries, particularly those which were in 1933 less technically advanced, have greatly increased. But the number of wavelengths available for distribution now is practically the same as the Lucerne Conference and is considerably less than the total needed to meet the requirements of all countries. Consequently, agreement has only been made possible by nations from all parts of Europe accepting less than their full requirements.

The Lucerne Plan gave the United Kingdom one long and 10 medium wavelengths. The present B.B.C. services have only been carried on by taking into temporary use one additional long and two additional medium wavelengths allocated at Lucerne to other countries. The new Copenhagen Plan gives the United Kingdom one long and 13 medium wavelengths and in some cases increased power may be used. The alterations are sufficient to ensure that the B.B.C.'s programmes can be carried on substantially as they are at present, though most of the transmitters will have to change their wavelengths. These changes, however, will not be made until the new plan is introduced in March, 1950.

The United Kingdom Delegation was led by Mr. H. Faulkner, Deputy Engineer-in-Chief of the General Post Office, who is a specialist in radio engineering. Other principal British Delegates included Mr. G. R. Parsons, of the General Post Office; Sir Noel Ashbridge and Mr. L. W. Hayes, of the British Broadcasting Corporation; and Mr. H. W. A. Freese-Pennfather, who comes from the Foreign Office.



ON YOUR WAVELENGTH

By THERMION

Fact or Fiction?

I WAS astonished at the disclosure in the newspapers that the participants in the Cinderella story broadcast in the R.A.F. Reunion Programme were not the true characters to whom the incident related. My concern is that the announcement said that they were. If you did not hear this particular broadcast, let me recount it. A young lady was brought to the microphone and asked to relate some experience of hers which had occurred during her period of service. She told of an incident where she was being taken to a dance in one of the army lorries and lost one of her dance shoes. It was found by one of the R.A.F. boys, who playfully refused to give it up unless she agreed to dance with him. She married him, and introduced the audience to her husband, whom she called on to the stage of the Albert Hall. Naturally the reporters present were interested in this human story of a modern Cinderella, and promptly went backstage to interview the happy pair. You may imagine the joy of the reporters when, instead of the usual romantic stuff, the girl shyly informed them that she was not married and that the man she had introduced as her husband was not her husband! They pursued the matter farther and interviewed Ralph Reader, who was responsible for the broadcast. He frankly admitted that they were not married and that he had introduced the item in this way because the young lady to whom the incident occurred was in Los Angeles! He then naïvely said that no harm had been done by this deception. I suggest that a great deal of harm has been done and that a serious view should be taken of it. It is misleading to the public and it is likely to cause them to cast doubts on any future announcement of a true story. The truth should not be stage-managed in this way, and I shall be glad to learn from the B.B.C. what action they are taking in the matter.

Talent

"THE B.B.C. is the champion, the guardian, the inspirer of mediocrity. They even have a name for it—'Talent.'" This is a statement by Mr. Beverley Baxter, M.P.

Brass Bands

MR. T. L. LAIDLAW wants me to turn my attention to brass bands. "Every day my ears are tortured by the cacophonous noises which come from these soulless instruments. Every day beautiful classical pieces are murdered by these bands, which appear to be unable to produce the slightest variation in tone or volume. Brass is all right in an orchestra, where in the hands of a composer such as Wagner it is very effective and gives the orchestra colour and richness of tone." I agree with this reader. I do not like brass bands either, whether it be Foden's Brass Band or the

Coldstream Guards. Certainly they are not suitable for broadcasts.

Wrong Crédits

THE RADIO TIMES, in announcing the broadcast of "The Picture of Dorian Gray," gave the credit to Constance Cox. The announcement read, "The Picture of Dorian Gray, by Constance Cox, based on the play by Oscar Wilde." This really is just a bit too much. Knowing the play from beginning to end, I was unable to see where, as broadcast, it differed from the original script, except, of course, that it had been cut. I could not discern any original work on the part of Constance Cox, and so I promptly wrote to the Director of Programmes and the Editor of *The Radio Times*, pointing out that the credit had been wrongly given. I will let you know what they have to say concerning this practice, of which I strongly disapprove. When I read it I thought perhaps it was an editorial error, but it was repeated in the announcement which preceded the broadcast.

The National Drive

FROM correspondence received, it appears that the public are unlikely to respond to the drive to improve the sales of radio receivers. None of my correspondents thinks that it will be effective. The reasons given for the drop in the sales of radio receivers include: Price too high; satisfied with the existing receiver; no need for second set because extension speakers can be employed with remote control; programmes too poor; too much dance music; the novelty of radio is wearing off; people waiting for television; expectation that purchase tax may be taken off; technical developments have not been such as to warrant scrapping existing receivers; world too unsettled; not so much money about as formerly; and, people require radiograms, but cannot get them. I pass these opinions along to the trade so that they can consider them in the light of their own knowledge. Personally, I hope that the campaign does succeed, although I should like to see more all-wave receivers available, and certainly more radio-gramophones. I think that the sale of small portables will continue to rise, in spite of the disadvantage of small batteries.

NEWNES' RADIO ENGINEER'S POCKET BOOK

By F. J. CAMM

3/6, or by post 3/9

Obtainable from booksellers, or by post from George Newnes, Ltd. (Book Dept.), Tower House, Southampton Street, Strand, W.C.2.

Using the Oscilloscope-2

In this Month's Article, H. R. McDERMOTT Describes
Methods of Modulation Measurement

THE process of frequency calibration is essentially one of frequency comparison, the unknown frequency being compared against a standard reference oscillation oscillator. Now there is no need to inquire "From where do we get one of these?" for practically every house in Great Britain has one in the form of the time-controlled 50 cycle mains. Actually, what we do is to compare the unknown frequency against the time base, which has previously been set in some simple ratio to the mains frequency. You may suggest that your time base is none too stable and inclined to drift a little, but this is not important as the process of plotting each point is completed in a very short while—well under a minute. The short-period stability of most gear is very high, even if made just reasonably

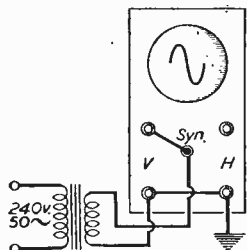

Fig. 5.—A 50 cycle supply may be obtained from the mains by means of a mains transformer.

efficient. The oscillator previously described could, quite easily, be made into a variable frequency one by simply using a double gang 1 M Ω potentiometer in place of the fixed resistors R. The calibration of a similar V.F. audio oscillator will now be described.

During the greater part of the calibration process the synchronising terminal is connected to the 50 v. 50 cycle supply, as shown in Fig. 5. The effect of this is to synchronise the time base with the 50 cycle supply, the synch. terminal being linked to the free vertical input (Y plate).

First, set the time base to run at a low frequency, say, 25 cycles, and apply sufficient synch. to lock the picture. This is done when a steady trace of two whole waves appears on the screen. The next step is to disconnect the lead between the vertical (Y) input and the synch. terminal. The time base controls are not touched, it continuing to run at 25 cycles. The oscillator output is then connected to the vertical input and its frequency altered until a single whole wave appears on the screen. At this point the oscillator and time base are working at the same frequency and therefore we mark the oscillator dial 25 cycles.

Now, at this stage, we can calibrate the oscillator, at points that are multiples of 25 cycles apart by simply varying the oscillator frequency and observing when stationary traces of two, three, or more whole waves become visible on the C.R.O. screen. At these positions the oscillator is working at two, three, etc., times the time base frequency, i.e., 50, 75, 100 c.p.s.

As you have probably guessed, there is a practical limit to the number of waves that can be easily observed and counted. This occurs at about eight times the time base frequency, after which the waves are so compressed that they become too difficult to read. The obvious thing to do, you will say, is to increase the time base frequency, and this is exactly what is done. The method is to disconnect the oscillator from the vertical input and remake the link from there to the synch. terminal. This applies to the 50 cycle mains from the transformer to the vertical input of the scope, which was our original circuit for checking the frequency of the time base. After this, we increase the time base frequency until a single whole wave appears on the screen, indicating that the T.B. frequency is now 50 cycles. The Y-synch. link is then removed and the oscillator reconnected, as Fig. 6.

We are now in a position to calibrate the oscillator from 50 cycles upwards in steps of 50 cycles, and, assuming a maximum of eight waves observed, our highest calibrated frequency, so far, is 400 cycles.

To obtain higher calibrated points we could increase the time base frequency to 100 cycles, but this would give us a highest calibrated frequency of only 800 cycles, which is not a great increase in the audio range. So what we do next is to adjust the time base to a considerably higher frequency, say, 400 cycles, and so obtain multiples of this frequency in our calibration of the oscillator.

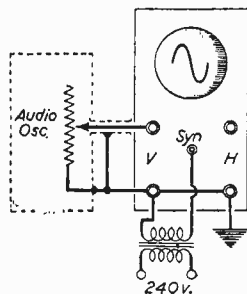

Fig. 6.—Modification required to calibrate the oscillator in 50-cycle steps.

To set the time base to this new frequency of 400 cycles may seem rather difficult, but remember that we have just calibrated our oscillator at this frequency and so we have a suitable source available to compare against the adjustable time base. The operation of setting the time base to 400 cycles is as follows:

Disconnect from the synch. terminal the 50 cycle supply and replace the link between Y and synch. terminals. Next, set the audio oscillator to 400 cycles (it still being connected to the C.R.O. vertical (Y) input) and adjust the time base until a single wave appears. You will realise that the time base is now working at 400 cycles. The whole procedure is then repeated as previously described, this time

(Continued on page 459.)

EDX.16.G.



RM

HIGH Q. T.R.F. COILS
TYPE 34/5

The choice of coils decides the performance of a T.R.F. Receiver. Users of these R.M. Coils acclaim them as the finest available. Try them yourself.

15/-
PER PAIR

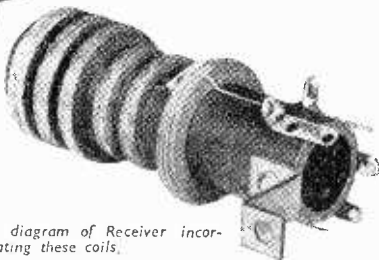

Send for circuit diagram of Receiver incorporating these coils.

R. M. ELECTRIC LTD.
TEAM VALLEY, GATESHEAD, 11

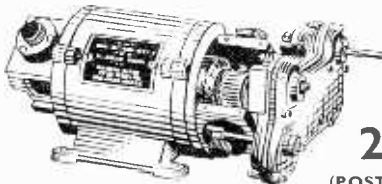

27/6

(POST FREE)

UNIVERSAL MAINS GEARED MOTORS

A brand new electric motor approx. 1'16 h.p. fitted with a 3 speed reduction gearing making it ideal for use as a coil winding machine, or to drive models. It may also be adapted for use as a universal gramophone motor. Will operate on 200-250 v. A.C. or D.C. Approx. speeds, 14, 7, and 3 r.p.m., vary according to mains voltage.

POWER PACKS

For your R1155, R1132A, etc., etc., we have the ideal A.C. power supply. Input 200-250 v. A.C. Outputs fully smoothed, 220 v. 80 m'a D.C. and 6.3 v. 4-5 amps A.C. Rack mounting equipment with built-in meter measuring input and output H.T. voltages. BRAND NEW in transit case, £4 (carr. and pkg., 10/-).

MINE DETECTORS

The famous U.S.A. model SCR 625 equipment, brand new in original cartons. An invaluable aid to location of metals underground or water by visual and audible methods. The equipment comprises a 3-valve battery-operated amplifier, search coil and pole, control box, resonator, pack, transit chest, technical manuals, spare valves, spare resonator, connecting leads, etc. etc., £10/10/-, carriage paid.

THE BURGoyNE SOLDER GUN IN STOCK, 79/6.
See September issue for technical review.

Terms: C.W.O. Remittances payable to E. & G. Distributing Corporation, Ltd.

M.O.S.

MAIL ORDER SUPPLY CO.,
Dept. P.W., 3, Robert Street,
Hampstead Road, London, N.W.1
Stebney Green 2760-3906

Callers to: 24, New Road, London, E.1.

The best—
HIGH and LOW



Exide
L.T. ACCUMULATORS
and
Drydex
H.T. BATTERIES

for better
battery radio reception

ISSUED BY THE CHLORIDE
ELECTRICAL STORAGE COMPANY LIMITED



AMBITIOUS ENGINEERS

HAVE YOU HAD YOUR COPY OF "ENGINEERING OPPORTUNITIES"?

Whatever your age or experience—whether you are one of the "old school" or a newcomer to Engineering anxious to hold your position under post-war conditions—you must read this highly informative guide to the best paid Engineering posts.

The Handbook contains among other intensely interesting matter, particulars of B.Sc., A.M.I.C.E., A.M.I.Mech.E., A.M.I.E.E., A.M.I.M.I., A.M.I.P.E., A.M.Brit.I.R.E., CITY & GUILDS, CIVIL SERVICE, and other important Engineering Examinations, outlines home-study courses in all branches of CIVIL, MECHANICAL, ELECTRICAL, AUTOMOBILE, RADIO, TELEVISION, AERONAUTICAL and PRODUCTION ENGINEERING, DRAUGHTSMANSHIP, GOVERNMENT EMPLOYMENT, BUILDING and PLASTICS, MATRICULATION, etc., and explains the unique advantages of our Employment Department.

WE DEFINITELY GUARANTEE 'NO PASS—NO FEE'

If you are earning less than £10 a week you cannot afford to miss reading "ENGINEERING OPPORTUNITIES"; it tells you everything you want to know to make your future secure and describes many chances you are now missing. In your own interest we advise you to write for your copy of this enlightening guide to well-paid posts NOW—FREE and without obligation.

BRITISH INSTITUTE OF ENGINEERING TECHNOLOGY

409, SHAKESPEARE HOUSE, 17, 18 & 19, STRATFORD PLACE, LONDON, W.1.

THE B.I.E.T. IS THE LEADING INSTITUTE OF ITS KIND IN THE WORLD

THE A.C.R.1155 COMMUNICATIONS RECEIVER. This superb R.A.F. 10 valve superhet receiver, covering 75 kc/s-18.0 mc/s. in 5 wavebands, is now available for use on A.C. mains, and complete with speaker, at ONLY £18/10/-. An illustrated, fully descriptive leaflet is available on request.

R.1132-A COMMUNICATIONS RECEIVERS. A superb U.H.F. receiver, covering 100-124 mc/s. Incorporates large 180 degrees dial with slow motion tuning, and 0-5 mA. tuning meter. Chassis tropically treated. Complete with calibration chart, circuit diagram, part lists, and valves. ONLY 99/6 (carriage, etc., 10/-).

R.109 COMMUNICATIONS RECEIVER. An ex-Army superhet, covering 1.8-8.5 mc/s. in two bands. Circuit consists of RF amp., mixer with separate local oscillator, 2 stages of combined signal detector, IF and A.V.C. and first AF, followed by an output stage. A BFO can be switched in for the reception of CW. Has built in 3in. speaker or can be used with 'phones. Power supply from 6V. D.C. source to vibrator power unit, which can be removed and set. then operated from 2v. L.T. and H.T. batteries. Complete in every way, and supplied with spare vibrator and valves and instruction book. ONLY £6/15/- (carriage, etc., 10/-).

SHORT-WAVE CONVERTERS.—Ex-R.A.F. RF units, operating from 6.3v. and 240v. IF output 7 mc/s. Types 24 and 25 operate on 5 pre-set frequencies and cover 15-30 mc/s. and 40-50 mc/s. respectively. Easily adaptable to tunable units by replacing ceramic switch with 3 engine type 15 pf condensers. ONLY 16/6 (postage 1/6) or BRAND NEW IN CARTONS. 25/- Types 26 and 27 are tunable converters, covering 50-65 and 65-85 mc/s. respectively. They are fitted with a 3in. slow motion illuminated dial. ONLY 27/6 (postage 1/6) or BRAND NEW IN CARTONS. 35/-.

C.W.O. please.

S.A.E. for Lists.

U.E.I. CORP

THE RADIO CORNER

138, Grays Inn Road, London, W.C.1

Phone : TERminus 7937.

Open until 1 p.m. Saturdays ; we are 2 mins. from High Holborn, 5 mins from Kings Cross.

Southern Radio's Wireless Bargains

BENDIX COMMAND RECEIVERS.—Type B.C.453 (190-550 kc/s), B.C.454 (3-6 megs.), B.C.455 (6-9 megs.). Complete with Six Valves : (3) 12SK7 ; (1) 12SA7 ; (1) 12AB6 ; and (1) 12AG6. Brand New in sealed cartons, 35/- each, plus 1/6 postage. These Receivers are ideal for quick conversion to Q Fivers, Car Radios and standard Receivers.

A few only of B.C.455 modified to 28-41 megs. ; ideal for television sound, 50/- each, plus 1/6.

"DELCO" HAND GENERATORS, 6 volts 4 amps. Hand-speed 110 r.p.m. Brand new with spare brushes, 17/6 each.

"CONTACTOR" TIME SWITCHES by Venners or Smiths. Beautiful clockwork 10-hour movement. Adaptable for time switches or master clocks. Brand new in soundproof case, 15/- each, plus 1/4.

BENDIX RADIO COMPASS RECEIVERS, type MN 26Y. Ranges : 150-325 kc/s, 325-695 kc/s and 3.4-7 megs. Twelve valves : (2) 6N7, (5) 6K7, (1) 6B8, (1) 6F6, (2) 6J5 and (1) 6L7. Complete brand new with 28-volt Generator. £5, plus 10/- carriage and packing.

R.A.F. BOMBIGHT COMPUTERS, complete with Sperry Gyro, (3) 28-volt Motors, Gearing, Barometric Bellows and Counters, etc., etc. Ideal for model makers and experimenters. Brand new, 55/-, plus 5/-.

MOVING COIL HEADSETS.—Headphones and microphone with lead and plug. Brand new, 12/6.

Lufbra Hole Cutters.—Adjustable for use on wood, metal, plastics, etc., 5/-, plus 4d. R.A.F. Morse Keys, 1/8, plus 4d. 15/- per dozen, plus 1/-, Permanent Crystal Detectors, 2/6, plus 3d. Throat Microphones, boxed with lead and plug, 5/-, Recording Blanks, 3 1/2 inches, 1/- each, plus 3d. ; 10/6 dozen, plus 1/-, Westectors, WX6 and W112, 6/- per dozen, plus 4d. Lucas Inspection Lamps complete with lead and plug, 3/6. Tannoy Carbon Mike Inserts, 2/6, plus 3d.

BATTERIES.—M.C.R.I. 90 volts and 71 volts, 6.6 plus 9d. 671 volts "Ever-Ready Minimax" for personal sets, 5.6 plus 9d. 15/- per dozen, plus 1/-, plus 1/- ; 221 volts and 45 volts combined, 5/6 plus 9d. ; sealed cartons of four, 20/- plus 1/-, 221 volts, 4/6, plus 6d. Sealed cartons of four, 16/-, plus 1/-, 11 volts, ideal for bell batteries, etc., 3/- each plus 6d. Sealed cartons of six, 16/-, plus 1/-, All Batteries unconditionally guaranteed. All Radio Publications previously advertised still available. Full list of publications 21d.

SOUTHERN RADIO SUPPLY, LTD.

46, Lisle Street, London, W.C. Gerrard 6653.

obtaining points 400 cycles apart. If higher frequency calibrated points are required it is an easy matter to set the time base to some higher frequency and obtain multiples of this for calibration purposes. In all cases, the freshly-calibrated *highest* range is used to set the time base still higher. Mention might be made of the vertical input and the Y input; they are, of course, the same thing, the Y input producing the vertical deflection and the time base producing the horizontally axis via the X plate. It should be noted that it may be necessary to use an amplifier to produce sufficient vertical height of the trace if the oscillator output is low.

If such an audio oscillator is built there will be found a surprising number of uses for it, varying from the production of audio response curves to the measuring of transformer ratios, apart from many experiments with your transmitter, some of which will now be described.

At the Transmitter

Many transmitting amateurs without a C.R.O., when queried on the subject, will answer to the effect that they have managed for so many years without one that they do not consider it worth while to make even a basic 'scope for test purposes. Happily, however, this point of view is limited. It might be noted here that the C.R.O. is not only the *best* instrument

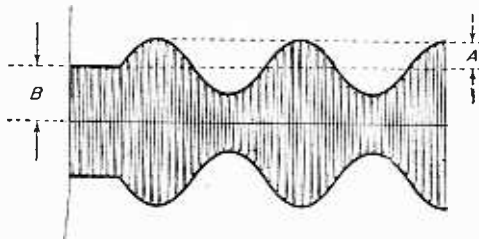

Fig. 7.—Modulated C.W.

for observing all phenomena that can be made to produce a voltage change, but it is the *only* instrument that shows, at a glance, so much accurate qualitative and quantitative information. However, to return to the transmitter.

Probably the most interesting topic in this field is modulation, many amateurs aiming at "B.B.C. quality," whilst other, perhaps wiser, individuals are content with a fairly restricted range of audio frequencies so as to pop up from a "hole" in the ether of a busy amateur band without causing too much annoyance to fellow transmitters. No matter which pathway you tread, the C.R.O. will enable you to set up your transmitter, be it half-watt or half-kilowatt output, so that it delivers its maximum output with the least possible trouble. In this article, particular attention will be paid to modulation, but other, just as important, adjustments will not be forgotten.

Consider a modulated continuous wave as in Fig. 7. The carrier amplitude is B and the amplitude of modulation A. The ratio A/B gives us an indication of the degree of modulation applied to the carrier, and it is obvious that if we increase A and

make it equal to B, then at this point the highest possible modulation level exists, i.e., modulation percentage equals 100. From this, we have that

$$\text{Percentage Modulation} = \frac{100A}{B}$$

You probably know of the advantage of a high modulation level, this being that the total energy radiated from the aerial is increased considerably. If our carrier output is 10 watts, then when modulated 100 per cent., the radiated power will be 15 watts. The formula connecting modulation level and power output is

$$\text{Total power radiated} = \text{Carrier Power} \left\{ 1 + \frac{(\% \text{ Modulation})^2}{2} \right\}$$

E.g., with 85 per cent. modulation of a 10-watt carrier:

$$\text{Total power radiated} = 10 \left\{ 1 + \frac{(0.85)^2}{2} \right\} = 13.6 \text{ watts.}$$

You may say, "Why bother with all this, just modulate at 100 per cent. and that's that." But this is not quite all; as with many similar radio

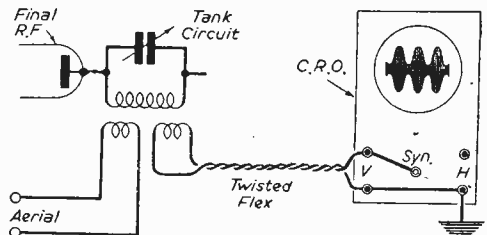

Fig. 8.—Method of observing the wave envelope.

matters, there's a snag! The trouble being that the upper and lower modulation sideband frequencies may beat with each other and so produce higher frequencies which tend to interfere with neighbouring stations, and in any case are not desirable because of the distortion so introduced. These effects can be greatly reduced by limiting the modulation level to about 85 per cent. Also, there is the obvious remedy of limiting the highest modulating frequency to, say, about 4 kc/s, and at the same time enabling us to increase the percentage modulation, and the radiated power. This latter course is probably the better, for the amateur at least, so as to get the most out of his "rig." In addition, your favourite band is not your own property, and the other fellow likes to make contacts just as much as you do. So let the motto of every amateur be "Fewer high modulation frequencies."

As we have seen, the percentage modulation is a major factor in the efficient operation of a 'phone transmitter, and we will now consider the C.R.O. as a means of measuring this all-important process.

Modulation

It must be emphasised that if we wish to use the C.R.O. amplifier to increase the dimensions of the picture, it must be capable of responding favourably to the frequency under consideration. If the internal amplifier is not suitable for this purpose, then one must be built, using the usual constructional methods.

The first method of measuring modulation percentage is known as the Wave Envelope Method, and is so called because of its utilising the actual envelope of the modulated wave. The equipment is set up as shown in Fig. 8. The output from the transmitter is fed into the 'scope by a twisted lead

'scope vertical amplifier to secure adequate height of the trace. The time-base is switched on and adjusted to some sub-multiple of the modulation frequency so as to give three or four whole waves on the screen. For a 400-cycle modulating tone and a picture of three whole waves on the screen, the time base frequency would be 133.3 cycles per second, similar to Fig. 9A being the trace. Synchronism is applied to the vertical input so as to lock the picture.

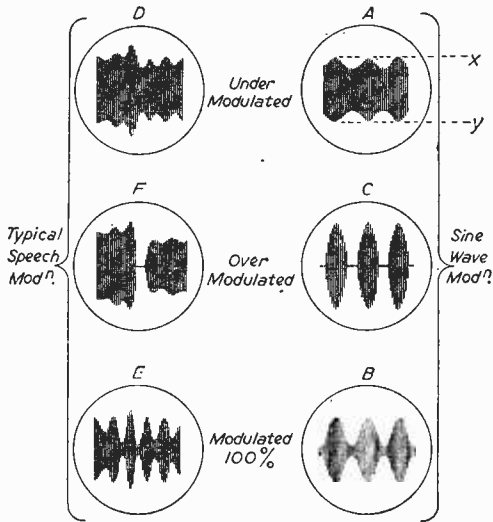

Fig. 9.—Typical modulation traces.

If the modulator gain control is now advanced, the picture height will increase and the "troughs" of modulation will be seen to approach the horizontal base axis of the oscillogram. When they are just touching, as in Fig. 9B, the 100 per cent. modulation level is reached and further advancement of the modulator gain control, resulting in over-modulation, will show a picture similar to Fig. 9C.

It should not be necessary to say that these tests should be conducted off the air, a dummy aerial capable of absorbing the full output of the transmitter being used. Disregard of this will result, especially on the over-modulation test, in all listening neighbours rising as one and shouting "Down with all amateurs!"

The modulation percentage is easily checked by referring to Fig. 7; it will be seen that this is very much the same as the picture that we have just obtained. Take a millimetre rule, or use the transparent graticule, if one is provided, and measure A and B. The formula $100A/B = \text{Percentage Modulation}$ provides the answer to our problem. To obtain most accurate results, the picture size should be increased as large as possible without touching the edges of the tube screen. To do this, it may be necessary to increase the amplifier gain and/or increase the coupling or number of turns of the pick-up coil.

(To be continued.)

from a few turns of wire near the tank circuit—ordinary flex will do if nothing better is to hand. An audio oscillator of good waveform is then fed to the modulator input and the transmitter switched on. Because of the small pick up of the C.R.O. coupling coil, it will be found necessary to use the

Simple Light Cell

A Novel Chemical Idea for the Experimenter
By GREGOR DRUMMOND

MANUFACTURED photo-electric cells are fairly expensive, but a simple model can be made at home quite cheaply. The materials required are merely a strip of copper, a strip of lead and a little salt solution.

The first step is to find some clear-glass container, such as an uncut tumbler or a small museum jar. This is almost filled with water, a pinch of salt added and the mixture stirred until all the salt has dissolved. Next, the strip of copper must be activated.

To do this, hold the strip in a gas flame until it is completely covered with black copper oxide. Then wash it in dilute nitric acid, which will remove the oxide. Scrape a small area on one side until it is bright and solder a length of wire to it. Cover this side with nail varnish or some other sort of lacquer. (This is not absolutely necessary, but it reduces the amount of "dark current," which will be described later.)

Now fix the copper strip in the jar so that it is not entirely submerged, with the varnished side innermost. Attach a piece of wire to the lead strip and fix it up opposite the copper one.

If the wires are now connected to the terminals of a microammeter the needle will show a small deflection. This is due to the "dark current" generated by the passage of ions in the solution from one strip to the other. But if the oxidised surface of the copper is exposed to bright light the passage of ions is increased and the needle will register a large rise in electrical current.

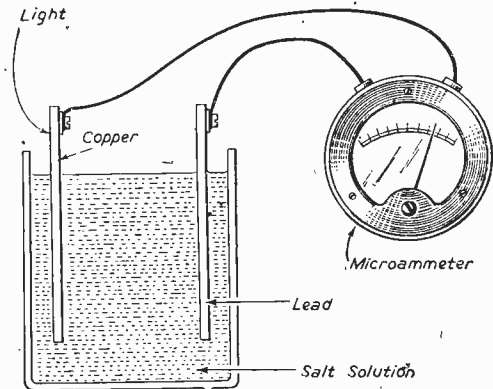

Arrangement of the meter and chemical cell

Practical Hints

R.F. Indicator

A PIECE of polystyrene rod, $\frac{7}{16}$ in. in diameter, 6 in. long, is drilled to a depth of $2\frac{1}{2}$ in. with a $\frac{3}{16}$ in. drill. The neon indicator tube NE14 is cemented into the polystyrene rod and left to dry. The cement can be made from the polystyrene that is drilled out, by adding the drillings to a suitable solvent such as amyl acetate. This cement should be thick and should be poured into the hole before pushing the neon tube home.

The indicator can then be safely used as an R.F. probe, and will not only safeguard the amateur from nasty shocks but will denote the presence of

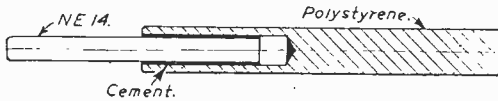

An R.F. tester for the amateur transmitter.

R.F. energy. Where the R.F. is more concentrated, the tube will glow the whole length of its structure and, likewise, if the R.F. field is weaker, the glow inside the tube will not be so dense. The indicator will also show if the transmitter is oscillating.—L. D. BULLY (Southgate).

Low-loss Lead-in Insulator

AN efficient but simple means of converting the standard lead-in tube to a low-loss type can be made by the following simple method. First, immerse the thick type of ebonite lead-in tube in a jug of very hot water to assist in bending approximately $\frac{1}{4}$ in. of the tube to an angle of 45

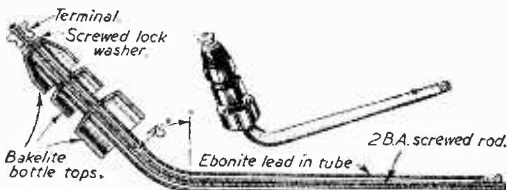

Modifying a lead-in tube.

deg. Then procure three slightly different size bakelite caps from medicine bottles, etc. These are then drilled in the centre to take the brass rod. Next cut off two short sections of ebonite ($\frac{3}{16}$ in. long) from the angle end of the tube and use these as distance pieces between the three caps. Thread on the caps and distance pieces and screw up terminal ends to complete.

As a note of interest a 500 volt megger test was made between this insulator and earth during very wet conditions and a test of between 20-30 megohms was recorded.—F. F. TOWNDROW (Newquay, Cornwall).

THAT DODGE OF YOURS!

Every Reader of "PRACTICAL WIRELESS" must have originated some little dodge which would interest other readers. Why not pass it on to us? We pay half-a-sovereign for every hint published on this page. Turn that idea of yours to account by sending it in to us addressed to the Editor, "PRACTICAL WIRELESS," George Newnes, Ltd., Tower House, Southampton Street, Strand, W.C.2. Put your name and address on every item. Please note that every notion sent in must be original. Mark envelopes "Practical Hints."

SPECIAL NOTICE

All hints must be accompanied by the coupon cut from page iii of cover.

"Crackle Finish"

HERE'S a dodge for the "crackle enamel" enthusiasts. I had previously searched everywhere for a recipe, but they all stated that the article had to be "cooked." Unfortunately, members of the family disapproved of my using the oven for experiments. I discovered after spilling a drop of amyl acetate on some tacky cellulose paint that it cracked beautifully. So I sprayed the articles with amyl acetate after having allowed the cellulose paint to become nearly dry. An old scent spray was used, and the spraying was as evenly distributed as possible; after spraying once over, the desired "crackling" appeared.—P. D. Jenkins (Cardiff).

Screening Cans for "Peanut Valves."

FINDING the B7G type valveholder with screening can retainer type difficult to obtain, and rather expensive, I made up some as follows. I obtained some old torch batteries of the Ever Ready type and of the following dimensions: $1\frac{1}{2}$ in. long and $\frac{3}{4}$ in. diam. I then cleaned out the case by heating and removed all traces of wax, etc., in hot soapy water. On to the case I soldered two small feet and drilled a $\frac{3}{16}$ in. hole in the top. I then obtained some small washers of very spongy rubber and inserted in the can as shown in sketch. The feet can be drilled to suit the fixing bolts of valveholder or two small tapped holes in the chassis. This provides excellent protection for these rather fragile valves and also retains them effectively.—R. L. Woods (Leicester).

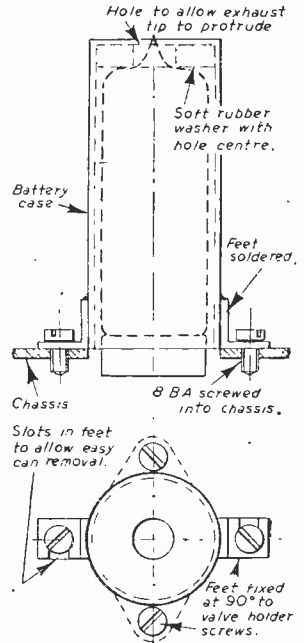

A simple screening idea for midget valves.

DUSTBIN MENACE

Waste Paper thrown out as rubbish means dollars lost to Britain, so save every scrap.

IN designing the portable about to be described, the object was to produce a compact and completely self-contained battery set, capable of giving moderate reception of the Light and Home Service programmes, and containing only standard size components usually to be found in most spare boxes.

It was found, with the overall size contemplated, that only two standard sized valves could be accommodated. Whilst a conventional two-valve arrangement of detector with reaction, followed by a stage of audio amplification, might, with careful design, give the desired results for a small room, one stage of radio-frequency amplification is generally necessary for portables, as the pick-up from a frame aerial is so small compared with the ordinary single-wire aerial.

The author decided, therefore, to include one

Bedside Porta

A Two-valve Receiver of Sma

By R. L. G.

itself from the old reflex days, when economy in valves was important. In the present instance we are concerned more with the saving of space. Other types of frequency-changing valves of the radio-frequency pentode class may be found suitable, but the valve used must have the signal grid connected to the top cap.

The Circuit

This is seen in Fig. 1, and as will be noted, apart from the double use of V1, the circuit follows the conventional three-valve arrangement, consisting of one stage of radio-frequency amplification, leaky-grid detector and a pentode output stage.

The radio-frequency input signal from the frame aerial, tuned by C1 section of the twin-ganged condenser, is amplified at R.F. in the first section of V1.

An efficient H.F. choke (H.F. choke 1) in the anode circuit of this valve by-passes the H.F. oscillations through a small pre-set condenser C5, to the tuned circuit C2L1, connected via condenser C4 to the grid of the second section of V1. C4 and R1 constitute the normal rectifying functions. Reaction effect is obtained by L2 and variable condenser C6. C7 is a small by-pass condenser for stray R.F. currents that may pass H.F. choke 2.

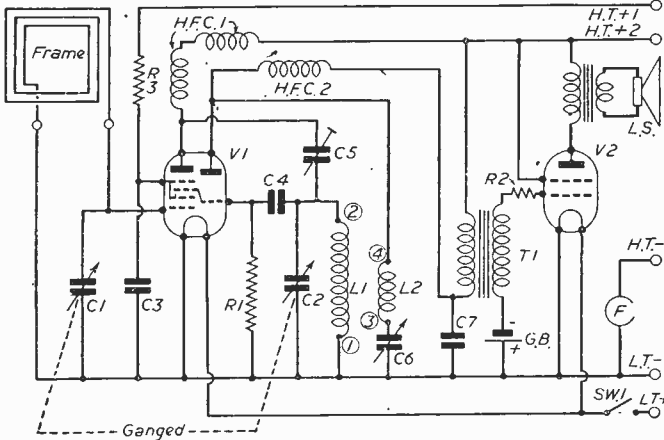

Fig. 1.—Theoretical circuit of the Portable Two. Component values may be seen in the list below.

stage of radio-frequency amplification, by making use of a double valve, of the triode-hexode class, using its two sections to provide the radio-frequency stage and the detector stage of the set, and following this by a pentode output stage. Thus, with only two valves, results comparing favourably with a three-valve layout are obtained.

It might be as well to point out, at this stage, that this is not one of the one-time popular "Reflex" arrangements. In this system, the single valve was made to do the work of two, by feeding back the rectified audio current to the H.F. valve for amplification at audio frequency. The scheme adopted in this set is somewhat different and definitely more stable in operation.

The T.H.2 triode-hexode valve used is, of course, normally used as a frequency-changing valve in superhets, and has an H.F. section and oscillator section. The first is used in its normal manner, whilst the oscillator section is used as a normal leaky-grid detector stage. The author does not claim originality for this feature, which has been quite well tried and, of course, really introduced

LIST OF COMPONENTS

- One twin ganged tuning condenser .0005 μ F with trimmers, C1, C2.
- One reaction condenser, .0003 μ F solid dielectric type, C6.
- C3—0.1 μ F } Tubular paper type
- C4—.0003 μ F } (non-inductive type).
- C5—Pre-set type .50 pF.
- C7—R.F. by-pass .100 pF.
- R1—2 megohms ($\frac{1}{2}$ watt).
- R2—15,000 ohms ($\frac{1}{2}$ watt).
- R3—1,000 ohms ($\frac{1}{2}$ watt).
- Three all-wave H.F. chokes (Eddystone No. 1,966).
- One small Audio transformer, maximum height 2in.
- One 7-pin chassis-mounting type valveholder for V1.
- One 5-pin chassis-mounting type valveholder for V2.
- One 4-pin chassis-mounting type valveholder for coil.
- Two stout brass brackets for fixing coil.
- One on-off switch.
- One fuse holder with fuse.

ble Two

Dimensions

The rectified signal is then passed on to the grid of the pentode output valve V2 via an audio transformer T1. R2, a grid stopper, acts as a final choke to any R.F. currents that may be present in T1.

H.T.+1 supplies the screen voltage to V1; C3 being the normal R.F. by-pass condenser, whilst H.T.+2 supplies the anodes of both valves. The author found it unnecessary to include a decoupling resistance and condenser in series with the primary of T1, but this might be incorporated should any instability be experienced. The value of such a resistance should not however exceed 5,000 ohms, or the anode voltage will be reduced too much for quality results.

General Layout of Chassis

This can be clearly seen in the two drawings Fig. 2 and Fig. 3.

Fig. 2 shows the complete set, as viewed from the rear. The twin-ganged tuning condenser is seen on the extreme left and the detector and reaction coil immediately below it, under the chassis. The T.H.2 valve is adjacent to these and its top grid connection allows short wires to frame aerial tag board and to the front section of the ganged tuning condenser.

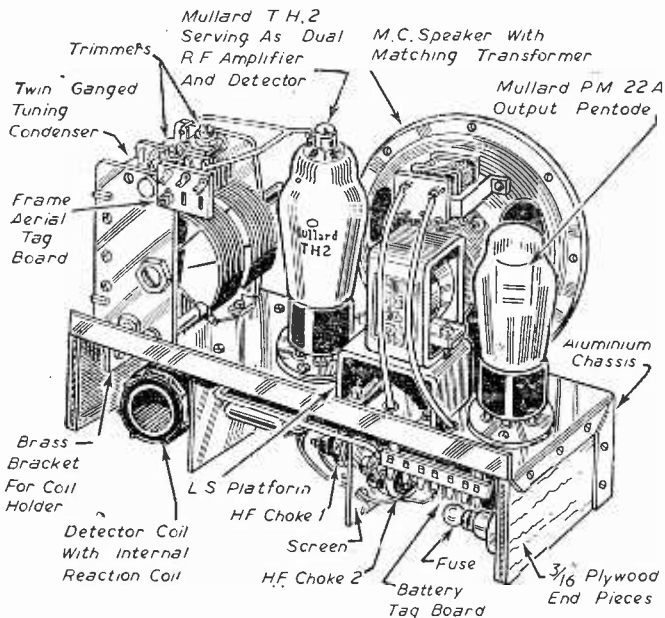

Fig. 2.—A general view of the completed receiver out of its cabinet, with all main parts identified.

The pentode output valve is arranged on the extreme right. The miniature moving-coil speaker, complete with matching transformer, is mounted on a raised metal platform fixed to the chassis immediately between the two valves. This platform was found necessary to allow the speaker to be set back level with the front edge of the chassis. As speakers vary in size and design, it is possible

TOOLS AND MATERIALS

- one 7-point tag board for battery connections.
- one 2-point tag board for frame connections.
- one Mullard TH2 or equivalent.
- one Mullard PM22A or equivalent.
- one small size moving-coil speaker with matching transformer, maximum size 5in. diameter.
- one 8-ribbed coil former 1 1/2 in. diameter. 4-pin.
- one 1/2 in. diameter paxolin tubing, 1 1/2 in. long (reaction coil).
- one 1/2 in. frame aerial wire or reel of 22 D.C.C. copper wire.
- one sheet of aluminium for chassis and sub-panels.
- one ply for casing of set and frame aerial.
- one sheet of plywood for outer case.
- one leather strap and brackets.
- one tuning knob, 2in. diameter.
- one tuning knob (reaction), 1 1/2 in. diameter.
- one standard H.T. battery 120 volts, with tapplings.
- one 9-volt grid-bias battery.
- one Varley dry accumulator, V20.
- connecting wire, sleeving, flex, setscrews, etc.

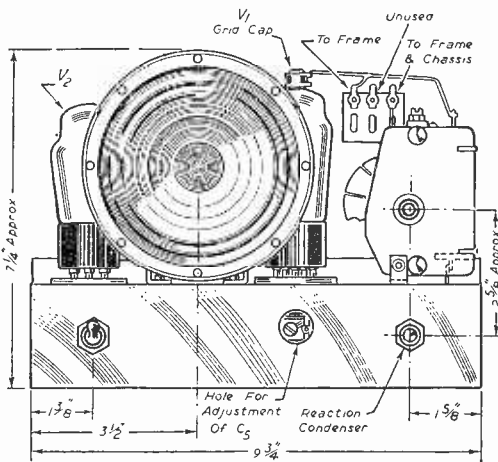

Fig. 3.—Front view of the chassis, with main dimensions.

that this platform may have to be modified considerably where other types are employed.

It will be noted that very little wiring is necessary above chassis. By the way, the tag nearest the tuning condenser, to which the tag-board has been

Chassis Construction

The chassis and its sub-panels were constructed from fairly stout gauge aluminium. When bent into its final form the chassis has one completely boxed-in end, and one open end. Both ends have three-ply end pieces, however. The closed-in end is for screening of the coil.

The chassis blank (in the flat) with the main dimensions, as made by the author, is shown in Fig. 4, whilst a view of it in its final form, complete with speaker platform, is shown in Fig. 5.

The irregular shapes of the valve base clearance holes were made by drilling $\frac{3}{16}$ in. diameter holes at pin centres, and cutting out the blank by means of a metal fretsaw, afterwards filing off all sharp corners. The holes, however, could be plain circular cut-outs, if the necessary circular cutter is available. A check should be made of the centres and positions of the fixing screw holes in the valveholders used, as types vary somewhat.

The large clearance hole for the lead going to bottom soldering tap of the back section of the tuning condenser is best found by a temporary positioning of the condenser, before drilling. The holes for the fixing brackets can then also be ascertained. When finally fixed, the outer edge of the ganged condenser should be approximately $\frac{3}{16}$ in. from the edge of the chassis. It may be found best to drill some of the holes after bending the chassis into its final shape.

(To be continued.)

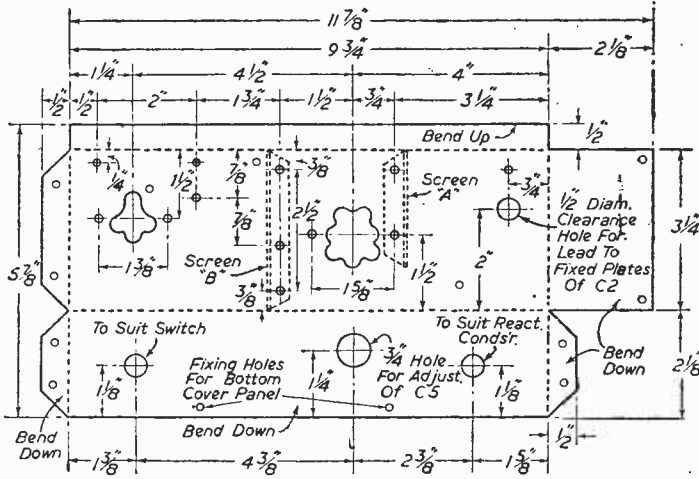

Fig. 4.—Chassis details for drilling and cutting.

fixed by one set-screw, is earthed. A lead may be taken direct to chassis, or anchored under the set-screw. The centre tag of the board was not used, the frame aerial ends merely being soldered to right and left tags respectively.

The other two connections come from below chassis to the matching transformer of the moving-coil speaker.

The two aluminium sub-panels below chassis are necessary for screening purposes, and in fact, when after wiring the bottom cover panel is fitted, the chassis is subdivided into three separate screened compartments.

The home-wound plug-in coil has been arranged in the position shown, to allow for quick alterations to it during preliminary matching operations, as it was found preferable to make modifications to the coil itself rather than to the frame aerial.

Fig. 3 shows a front elevation of the set with overall dimensions, and centres of the controls and speaker. Note the hole drilled out of the front face of the chassis, for easy adjustment of pre-set condenser C5. Best results will be found at one setting of this condenser, but it is not over critical.

As no slow-motion drive has been possible, a large 2 in. diameter ebonite knob will be found best, as tuning is quite sharp. The more normal size knob may be used for the reaction control.

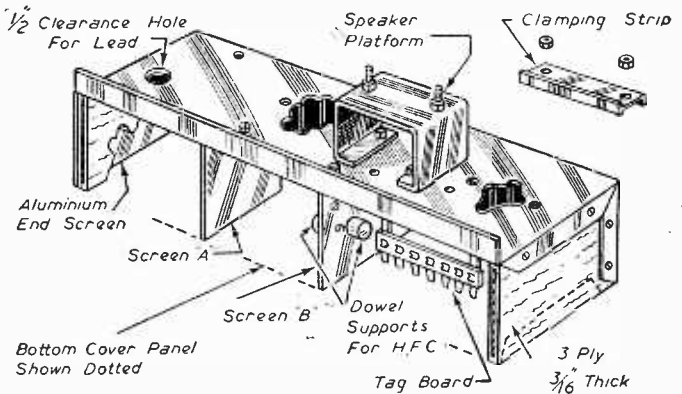

Fig. 5.—How the chassis is completed with plywood ends, and other essential details.

MINISTRY APPEALS TO HOUSEWIVES
Keep Waste Paper separate, dry and clean for salvage.

Radio Amateurs' Examinations

The 1948 Test Paper and a Report on the Results

IN order that prospective transmitting amateurs may gain some idea of the standard required by the G.P.O. Examinations, we again give the full Test Paper set in May last. The City and Guilds of London Institute have reported on this Examination and their report follows the Paper.

1948 Radio Amateur's Examination:

All questions should be attempted. Use should be made of diagrams where applicable. The maximum possible marks obtainable are affixed to each question.

1. How is a low-power transmitter likely to interfere with broadcast reception? What steps would you take to prevent such interference? (15 marks.)

2. What steps should be taken by the holder of an amateur transmitting licence to ensure full compliance with the requirement that a full record should be kept of all transmissions? (15 marks.)

3. Give a brief description of a suitable receiver for the 58.5 to 60 Mc/s frequency band, and explain how it works. (15 marks.)

4. How is the input power to the last stage of a transmitter measured? What is understood by the "efficiency of operation" of this stage and how is this connected with the permissible anode dissipation? (15 marks.)

5. Describe briefly how the ionosphere influences the propagation of radio waves, and how propagation differs between the 1.7 to 2.0 Mc/s band and the 58.5 to 60 Mc/s band. (10 marks.)

6. What advantage is gained from using a piezo-electric crystal oscillator in a radio transmitter? Give a diagram of a crystal controlled stage for a short-wave transmitter. (10 marks.)

7. Describe a transmitting aerial suitable for one of the amateur bands, indicating the main features of the design and any directional properties. Illustrate your answer with a diagram. (10 marks.)

8. What is the effect of connecting two capacitors (a) in series, and (b) in parallel?

What is the total effective capacitance when four capacitors, each of 100 μF are connected in a series-parallel arrangement consisting of two parallel paths, each of which contains two capacitors in series? (10 marks.)

Report on the Papers

The following general report is given on the papers as a whole and is not necessarily applicable to the work from individual schools.

No. of Candidates	No. of Passes	No. of Failures	Percentage of Failures
Home 687	518	169	24.6
Overseas 13	10	3	23.1

Candidates' work in the 1948 Radio Amateurs' Examination, as compared with the previous examinations, was generally of a much higher standard both technically and in the manner in which the questions were answered. It was apparent that more adequate preparation had been made for

this year's examination. With very few exceptions, all questions were attempted by the candidates. A report on the questions follows:

Question 1 (transmitter interference): Fairly well done by most candidates.

Question 2 (log requirements): Very well done by practically all candidates.

Question 3 (60 Mc/s receiver): A fair number of the candidates illustrated their answers with excellent diagrams, but the majority handicapped themselves to some extent by using block diagrams, or by describing the converter circuit, without following it up with the succeeding stages.

Question 4 (input power): The first two parts of the question were very well answered by practically all candidates, but many found the third part of the question, in connection with permissible anode dissipation, difficult to answer.

Question 5 (wave propagation): Fairly well done by the majority of the candidates. A fair number failed to describe how propagation differs between the 1.7 Mc/s and 60 Mc/s band.

Question 6 (crystal oscillator)

Question 7 (transmitting aerial)

Question 8 (calculation)

} Very well done
} by practically
} all candidates.

Radio Vans and Farmers

TWO-WAY radio telephony is playing its part in helping Scottish farmers get in the harvest in the quickest possible time.

Mr. Daniel Ross, Lanark dealer for Britain's famous Ferguson tractors, has equipped his five service vans and his headquarters with radio so that help may be sent with the least possible delay to any of his 200 to 300 customers who run into trouble with their equipment.

At a time when any hold-up in farming may mean food spoiled, farmers working in the remotest Lanarkshire hill-villages can have help sent to them by radio almost as quickly as if they lived close to large towns.

With a fixed station in Lanark town, Mr. Ross keeps in continuous touch with his service vans as they travel about the country on their routine day's service work and plots their position on a map in his office. As soon as an S O S is received from a farmer, the nearest service van can be directed to the scene of the hold-up and very often a minor adjustment can be made in a few minutes where, without radio-aid, the farmer might have been inactivated for half a day or more.

Mr. Ross uses Pve equipment for his five mobile and one fixed station and they operate on a frequency of 73.275 megacycles. According to the G.P.O., the Simplex single-frequency working equipment is the first of its type to be used by a commercial concern in this country. Output of both the fixed and the mobile stations is 12 watts R.F.

The aerial of the fixed station is 850ft. above sea level and although there are a good many high hills in the area the fixed transmitter has an average working range of about 25 miles, while from high ground a range of 40 miles has been achieved.

Landlord and Tenant

An Explanation of an Important Act of Great Value to the Small Trader

By A BARRISTER

HAVING regard to the fact that the large majority of traders are entirely unacquainted with the valuable rights conferred on them by the Landlord and Tenant Act 1927, and that literally thousands of pounds are thrown away every year as the result, a brief survey of their position with practical hints as to the measures that they should adopt to protect their interests, may be usefully made.

A classical example of the unfortunate results of such ignorance of the law may be given. A landlord owned a number of shops, all let under separate leases to different traders. All the leases were due to expire at the same time. Only one of the tenants was aware of his position under the Act. He took the precaution of serving his notice claiming a new lease, in time, and of commencing his proceedings also in time, and obtained very advantageous terms. The other tenants who had neglected to observe the requirements of the Act were not in a position to bargain with the landlord, and had to choose between accepting the landlord's terms as to rent and otherwise, or vacating the premises where they had built up a very valuable goodwill.

Now the underlying object of the Landlord and Tenant Act 1927 is not to compensate the tenant for the whole of his loss, but merely to the extent of the landlord's gain. Thus a tenant executes improvements to the premises, which result in addition to their letting value when the tenant leaves, and the landlord gets the benefit. What the Act says is that the landlord must compensate the tenant for this benefit. Further, the Act enables a tenant to carry out improvements to the premises even against the landlord's wishes. But—and it is here that tenants usually go astray—the Act provides that a certain procedure must be strictly observed by the tenant if he desires to enjoy these statutory benefits.

Goodwill

Again, take the case of goodwill. A trader and his predecessor in title may have built up a very valuable goodwill by several years' trading. When the tenant goes the landlord gets the benefit of this goodwill. He can let the premises to another trader at a very much enhanced rental. The newcomer is only too pleased to pay more in return for the advantage of stepping into the shoes of the old tenant and getting the benefit of his custom. Here again the landlord must compensate the tenant for this goodwill which will remain behind. But what is more, as compensation usually is not good enough for the tenant, he is allowed by the Act in certain circumstances to compel his landlord to grant him a new lease of the premises.

And if a new lease is ordered the landlord can charge only the ordinary market rental value of the premises on the basis of the letting being a first letting. The tenant can be granted a new lease for a further term which, however, may not

exceed 14 years. But here again the Act lays down a strict procedure which must be followed by the tenant. In this respect as well, tenants usually allow the grass to grow under their feet until it is too late. And then they must stand by and see the value of their goodwill pass into the hands of their landlord.

Qualifying Period

Before a tenant can be entitled to compensation for goodwill or a new lease it is essential that the trade should have been carried on on the premises by the tenant or his predecessors in title for a period of at least 5 years.

Further, it is necessary to show that a substantial portion of the goodwill will remain behind attached to the premises and that in consequence the landlord will be able to command a higher rent for the premises.

If a tenant can establish these facts he will usually be entitled to a new lease, though, strictly, a new lease cannot be granted unless it is shown that the amount of the compensation recoverable under the Act—which is necessarily limited—will not compensate the tenant for the loss of goodwill he will suffer if he has to vacate the premises.

These may be regarded as the substantive conditions which must be established. But there are conditions relating to procedure which are also of vital importance. These conditions are really very simple, but time and again they are overlooked.

What the Act requires the tenant to do is to serve the landlord with a notice of claim and to serve it within the time limits laid down. If the notice is even a day out of time nothing can be done at all, and all rights will be lost. Whether the claim is for *improvements* or for *goodwill*, or for a *new lease*, the time limits for the service of the notice of claim are the same.

Where the tenancy expires automatically by effluxion of time, the notice must be served at least 12 months before the tenancy is due to expire; where the tenancy is determined by a notice to quit, the notice of claim must be served within one month from the date of the receipt by the tenant of the notice to quit.

Furthermore, if a new lease is being claimed proceedings *must* be commenced at least nine months before the tenancy is due to end, or if a notice to quit has been served, then within two months of the receipt of the notice to quit.

MASTERING MORSE

By the Editor of "Practical Wireless"

3rd Edition.

1/-, or 1/2 by post, from George Newnes, Ltd.,
Tower House, Southampton Street, Strand, W.C.2.

Amateur Transmitting Valves

The Care and Maintenance of Ex-Service Valves

By E. G. BULLEY

MANY amateur transmitters are operating for the first time, and no doubt, the newcomer to transmitting has purchased at some time or other surplus Government transmitting valves which are suitable for the amateur station. This article is written to explain how with careful handling, in actual operation, these valves can be made to last quite a long time.

The life of the valve is perhaps the most important factor to the amateur, the reason being that these valves are usually fairly expensive to replace, although every effort is being made by the manufacturers to bring them well within the amateur's pocket.

Radio transmitting valves although of rugged and robust construction are in some respects unlike the receiving types, because they require a certain amount of care when being installed in any equipment. The bulb, for instance, becomes very hot during the continuous operation of the valve. It is therefore essential to install the valve in a well ventilated position so as to allow for a free circulation of air around the bulb. Leads taken to the various electrodes must be suitably screened and large enough to handle the R.F. energy that is flowing in the circuit, otherwise excessive heating will result in the leads, which will eventually be conducted to the valve seal and result in its destruction. These leads should not on any account be allowed to come into contact with the glass bulb during the operation of the valve, as metallic objects touching hot glass may cause the glass to crack.

Heaters or Filaments

The emitting electrodes in transmitting valves are usually directly heated, although there are many types that employ indirectly-heated cathodes. However, valves which are intended for amateur use are low or medium power types. These use as the emitting electrode either a thoriated tungsten filament or an oxide coated cathode, the former type being directly heated, whereas the latter is indirectly heated. Earlier types of amateur transmitting valves did employ pure tungsten filaments, but this type of filament is now only used in high-power types such as those used in commercial broadcasting or industrial equipments. But to enable the reader to appreciate fully the actual filament characteristics, it will be necessary to review all three types, so that whatever type of filament is encountered the life of the valve can be safeguarded.

Pure tungsten filaments can be within certain limits slightly overrun, but it is inadvisable to do this as it will only shorten the life of the valve. On the other hand, however, if the filament is underrun a lower filament emission will result, due to the lower operating temperature of the filament, but a much longer life can be expected.

This, however, is only possible if the valve in question is operated at a reduced frequency at which it is designed to operate and where full emission is not required.

In the case of thoriated tungsten filaments, it is essential that the filament voltage applied must not vary within plus or minus 5 per cent. of its rated value, otherwise, if the voltage is too high, the thoria content of the wire will evaporate from the filament surface at a much faster rate than the thoria content can diffuse to the filament surface. This will result in a large drop in the filament emission, in fact, it will eventually be equal to that of pure tungsten because the filament has become stripped of the thoria content.

A Warning

Thoriated filaments should not be underrun, because loss of emission will still result and the life of the valve would not be increased as in the case of pure tungsten filaments.

In the actual circuit wherein a thoriated tungsten or oxide coated cathode valve is used, it is advisable to connect a suitable voltmeter across the filament terminals; this will ensure that the filament voltage is not reduced or exceeded. Idle periods of transmission can deteriorate the valve or valves, so it is advisable that the filament should be operated at its full rating without any other electrode potentials being applied.

Transmitting valves of the thoriated filament type can be operated from an A.C. or D.C. supply. The latter is sometimes used to avoid hum, but the former is mainly used because of the convenience.

Oxide-coated Cathode

The last emitter to consider is the oxide-coated cathode. Care must be taken when operating this type because, should the cathode be overrun, cathodic sputtering may result and the adjacent electrodes become contaminated with the coating material. This contamination will cause emission to take place from the affected electrodes and it is essential that this be avoided at all costs.

The next consideration is that of the maximum anode dissipation. This rating is an indication of the maximum power that can be safely dissipated by the anode. Failure to keep to or within the specified value, will affect the life of the valve and in some cases destroy it.

The maximum dissipation rating can be exceeded if the anode current rises. This can sometimes be traced to the failure of the grid bias. This bias is usually obtained from a D.C. supply, grid leak or by means of a resistor in the cathode circuit. The grid leak method is not advisable, because should the driver stage fail, the valve will automatically lose its bias voltage and so result in the anode drawing excessive current.

To prevent the anode dissipation from being

exceeded, it is advisable to include a fuse or relay in the anode circuit, so that, should the anode draw excessive current, the fuse or relay will safeguard the valve as well as subsidiary equipment. In the case of tetrodes, the fuse or relay should be connected in the common H.T. supply to the anode and screen grid; this will safeguard the valve in the event of an overload.

Additional Safeguards

Further precautions can be taken in this respect, i.e., a suitable milliammeter can be included in the anode circuit of the transmitting equipment. By so doing, a constant check can be kept on the anode current during the operation of the transmitter.

Another important point is that of the grid dissipation. This maximum figure should never be exceeded because grid emission will result or alternatively the grid will become damaged or distorted due to the excessive heat. This factor can be the result of too much bias which usually results in an increase of driving power.

It can be stated, therefore, that the maximum ratings of any transmitting valve should never be exceeded if the valve is being operated at the maximum specified frequency. This is of the utmost importance, but should the valve be required to operate at a higher frequency than that laid down by the manufacturer, it is essential that the D.C. anode voltage and power input be reduced accordingly.

Electronic Scholarship Scheme

An E.M.I. Institutes Development

THE science of electronics, which has already profoundly affected mankind under the rather more familiar headings of radio, radar and television, has now become a powerful weapon in Britain's all-out recovery drive.

The application of electronics to industrial processes is saving valuable man-hours in ever-increasing measure and may well prove to be an important key factor in Britain's Number One problem: how to lessen the gap between imports and exports by obtaining increased production when, to all intents and purposes, the nation's man-power is already fully employed.

To this end the scientists are racing on. Almost every day brings to light still more ways in which electronics can help industry by speeding production, and industry is quick to respond. But is Britain equal to the resultant increasing demand for electronically trained personnel?

Sir Ernest Fisk, managing director of Electric and Musical Industries, Ltd., who is perhaps more concerned with the whole science of electronics than any other man in this country, was quick to foresee from the outset the dangers of technical progress being hampered by lack of electronically trained personnel. He therefore inaugurated a wide range of apprenticeship schemes for youth within the vast factories at Hayes, and for more specialised training he founded E.M.I. Institutes as an integral unit of the E.M.I. Group, under Professor H. F. Trewman, M.A. (Cantab.), M.I.E.E., M.I. Mech.E.

The enterprising venture of a specialised training college backed by Britain's leading electronic organisation proved a success from the word go, and to-day E.M.I. institutes enjoy a world-wide following, and are recognised by the

Ministries of Education and Labour and by educational authorities all over the country.

Still further encouragement to the youth of this country to take up careers in electronics is forthcoming by the announcement recently that Electric and Musical Industries, Ltd., is now to sponsor two scholarships tenable at E.M.I. Institutes. These scholarships, details of which may be obtained from the Principal of E.M.I. Institutes at 43, Grove Park Road, Chiswick, London, W4, are to be decided by open competition through recognised educational authorities.

To whatever extent the science of electronics may be recruited in Britain's recovery drive—and the potentialities are enormous—the energetic and timely action of Sir Ernest Fisk in providing comprehensive training facilities for personnel should go a long way towards ensuring that future progress is not hampered by man-power shortage.

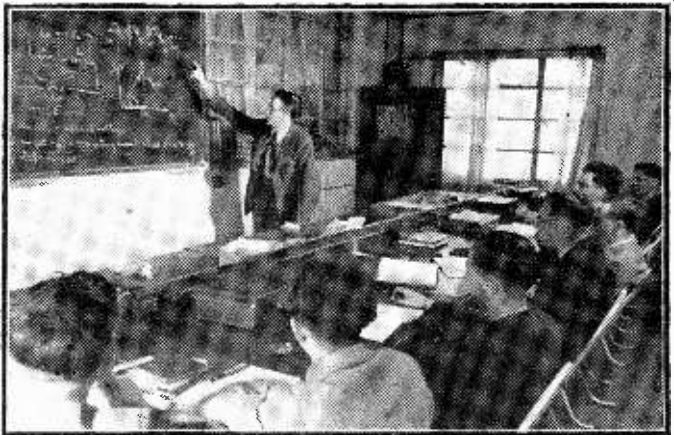

One of the class rooms at the E.M.I. Institute at Chiswick. A view of one of the practical laboratories may be seen on page 445.

Underneath the Dipole

Television Pick-ups and Reflections. By "THE SCANNER"

THE Olympic Games proved to be a triumph for British television if for nothing else! The British lack of success in the arena was fully reported in our utility size newspapers, and on the films and radio, but nowhere was the atmosphere of the historic event conveyed so well as it was via television. The new supersensitive cameras transmitted pictures of fine definition and must have compared most favourably with the American image-orthicon cameras about which we have heard so much. Special praise is due to the operators of these cameras and also to the producers or editors, whose selection of shots was most expertly carried out, making the most of a wealth of material. It is the slick editorial handling of such transmissions, the timing of the "cuts" from long shot to close-up, the use of panoramic shots and audience reactions, married to a really "live" commentary, which combine to give a polished entity. This was indeed television at its best.

Camera Angles

The choice of camera angles is not always so successful in the studio transmissions. Too often does one see close-ups of dancers with their feet out of picture, or shots of actors with candelabra or other "busy" pieces of scenery apparently growing out of their heads. Part of the trouble is due to the arrangement of the scenery and stage properties. It is far better from the viewers' point of view, for instance, for variety artistes to do their acts in front of curtains rather than the hackneyed garden trellis-works so often inflicted upon us. Apart from their phoney ugliness, they form a background which tires the eye and makes fantastic non-linear shapes near the edge of the cathode ray tube. But curtains can be equally distracting if they are vividly patterned. A particularly bad example was seen recently in a "Crossword" feature, in which a chequered curtain of high contrast appeared to give a deathly pallor to the faces of Harold Warrender and the other artistes. The choice of camera angles for dancing turns and musical comedy shows is frequently faulty. Apart from the cutting out of feet already mentioned, an equally annoying angle is the high-angle long shot, which foreshortens the artistes' legs and turns them into grotesque shapes. Curiously enough, low angle shots, with the camera on the floor, gives a type of distortion which is usually acceptable and sometimes highly effective. These are points which seem to be much more appreciated by the dramatic producers, who do not often err in this respect.

High Comedy

Drawing-room and evening-dress comedies, when put on the films, have always required the sure touch of a director who is also a first-class technician. Poor technical qualities and lack of smoothness and polish, which might be tolerable for a melodrama or a slap-stick comedy, are quite unacceptable in

the presentation of the boiled-shirt delicacies of the cinema. The same applies to television. W. Somerset Maugham's light and frothy comedy "The Unattainable" was put over on television with a smoothness that was reminiscent of the svelte Lubitch films of 10 years ago. The producer, Stephen Harrison, tried a technique more on film lines than other B.B.C. producers have been following lately, and his use of multiple cameras in static positions with very little camera tracking was completely successful. This success was the result of Harrison's most expert handling of the switches which changed over from one camera to another; the timing of the "cuts" was exact, and the choice of camera angles did not require the viewer to perform mental acrobatics in order to remember the geography of the setting. This was television production of the straightforward type at its best. The playing by the artistes was exquisite, particularly by Gillian Lind, Marian Spencer and Ellen Pollock, and Somerset Maugham's witty dialogue lost not one of its "wisecracks," to use a horrible modernism!

The Way Ahead

So the 405 line standard is to stay with us for many years! At last, the real and definite decision will enable manufacturers to lay down plant with confidence, to produce more and more television receivers at—we hope—a less and less price. The next move is now with the B.B.C., who will be pressed to open television transmitting stations in Birmingham, Manchester and Glasgow as soon as possible. That is probably the order in which these stations will be completed, with the Birmingham station in full operation by the autumn of 1949. I must say that it seems a very long time for Birmingham to have to wait, not to mention further long time lapses before Manchester and Glasgow can operate. But anyone in the radio or electrical business knows the terrible delays in the delivery of switchgear, transformers and other components, and the difficulty of making do with second-hand "just-as-goods." But there is also the question of the radio or landline link to be considered, since the majority of programmes will be transmitted from London. The costs will be tremendous, but the B.B.C. will be rewarded by colossal increases in the number of television licences issued. I can't help thinking that the photographic recording of television will make rapid progress, however, and become the principal means of re-transmission at provincial television transmitters and for "reissues" from London.

We already know that rapid strides have been made in the scanning of cine film, and that very great improvements in the television transmission of film will be made at the Alexandra Palace within the next few weeks. I have myself seen large-screen reproduction of 35 mm. cine film on "closed circuit" and also on an experimental wireless link which was of far greater definition than the present

average studio transmission from the Alexandra Palace. The improvement in quality was achieved on the 405 line standard.

Temporary Stations?

The photographic recording of all television material is a natural development. I venture to suggest that it would prove a most valuable form of export, bringing in dollars and circulating abroad the British point of view. Film records of our best television plays should certainly command a good price in the American television field, with its dozens of transmitters. Such film records could also be used in one or two provincial areas in Britain, transmitted from temporary or mobile transmitters of small power, pending the completion of the large permanent transmitters. The successes of the small relay stations at Leeds, Hull, Plymouth and Edinburgh in the early days of broadcasting may have their equivalent in these television days. After all, mobile transmitters have been used for Continental demonstrations of the British system.

I think it was in 1924 that no fewer than eleven 200-watt relay stations were erected in less than twelve months in such places as Plymouth, Edinburgh, Dundee, Liverpool, Leeds, Bradford, Hull, Nottingham, Swansea, Sheffield and Stoke-on-Trent. A simple form of transmitter was designed by the B.B.C. Research Department, then under Capt. A. G. D. West (who is now the technical chief of Cinema Television, Ltd.) and each station had its own broadcasting studio in addition to a landline connection with London station. The aerials were,

in most cases, suspended from factory chimneys, and those at Dundee, Leeds, Liverpool and Nottingham gave particularly good results owing to their height and situation. Hull and Swansea aerials were suspended upon masts 100ft. high and were less satisfactory. The Edinburgh transmitter was situated in the University and was notable for its counterpoise, necessary on account of earthing difficulties. Most of these sites, and similar ones in Glasgow and Manchester, would lend themselves to a scheme of temporary television transmitters of limited range. And what a wonderful site could be made at the top of the Blackpool Tower!

In 1924, these makeshift little transmitters and their studios were put into operation at the rate of one per month, by a company called "The British Broadcasting Company Limited," which was a private company, the share capital of which was largely owned by several of the leading electrical companies. Quick decisions were made by its managing director, J. C. W. Reith, and its leading engineers, Eckersley, Ashbridge and West. With all the goodwill in the world, it would be quite impossible for the present committee-ridden B.B.C. to make quick decisions, or to embark upon any policy that has not been thoroughly chewed over by some outside committee of non-experts. We must not forget that 1924 was before the days of "forms in triplicate." I have an idea that some of these pink forms were cleverly evaded by the men who accomplished the magnificent television results of the Olympic Games on apparatus which was partly improvised.

Southend Radar Installation.

Details of the Recently Installed Navigation Aid

MARINE INSTRUMENTS, LTD., have installed, at the end of Southend Pier, a Kelvin-Hughes Marine Radar installation which was formerly opened by the Mayor of Southend, Alderman S. F. Johnson, on Monday, August 23rd.

The new radar station will be used by the makers for testing marine radar equipment and carrying out research in radar technique under conditions which closely approximate to sea-going conditions, the set being a mile-and-a-third from the shore and adjacent to busy shipping lanes.

In addition, training facilities will be provided for radar engineers and ship's officers in the operation of marine radar equipment.

An opportunity has also been provided for members of the public to see radar in operation for the first time under service conditions. A repeater console has been fitted on the pier at deck level for the use of visitors.

The set used at Southend is the standard marine unit produced by the makers, which has recently been granted the type-approved certificate of the Ministry of Transport, and it meets the stringent performance standard which is demanded by the Ministry. Objects at any distance in a horizontal plane from 40 yds. to 27 miles can be picked up on the indicator.

Aerial System

The radiator comprises a simple cheese reflector of 5ft. horizontal and 4in. vertical aperture excited by a horn coupled via a waveguide to the transmitter.

- | | |
|--------------------------|--|
| (1) Horizontal beamwidth | } <i>Measured as the full angle to the half-power points, i.e., 6 db down.</i> |
| 1.5 deg. | |
| (2) Vertical beamwidth | } |
| 27 deg. | |

Side lobes are less than 5 per cent. of the main beam amplitude.

The scan is of continuous 360 deg. rotation, generally clockwise, at a speed of 30 r.p.m.

The aerial system is not position stabilised, but the wide vertical beamwidth provides adequately for roll up to ± 10 deg.

A thermostatically controlled heater is included in the aerial head to overcome icing troubles.

Display

A 9in. magnetic cathode ray tube, with a double screen of long afterglow, is provided (VCR 516 or CV 262 or a fluoride equivalent). The time base generators provide a sweep of from 1 to 27 miles full scale deflection, variable continuously from 1 to 5 miles, and then by switch to 9 or 27 miles. The auxiliary display used for chart comparison

purposes incorporates a continuous control from 1 to 27 miles.

An illuminated bearing cursor is provided, and this will permit of bearings being taken to an accuracy of 1 deg. at the edge of the screen.

Range calibration is provided either in the form of a series of concentric rings at fixed range intervals, or a single ring known as a range marker; the distance of this ring from the centre being adjusted by an accurately calibrated control.

1-5 mile range . . . 1,000 yard calibrator rings.

5 " " . . . 2,000 " " "

27 " " . . . 4,000 " " "

The range marker is arranged to cover 0-9 miles and is useful on all ranges. The calibration holds when ranges are switched.

An electronic mark is provided to indicate the ship's head. This mark is optional and may be switched in or out at will. The equipment can be calibrated in metres if required.

Power Supply

Exclusive of de-icing heating power the equipment consumes approximately 2 kilowatts at either 110 volts D.C. or 220 volts D.C. A motor generator is provided, and this, in conjunction with a regulator and remote starter panel, admits of the equipment being operated on a supply of relatively poor regu-

lation. The generator is arranged normally to cater for a voltage range of 90-130 volts D.C., or correspondingly for a 220-volt supply.

Wavelength

3 centimetres approximately.

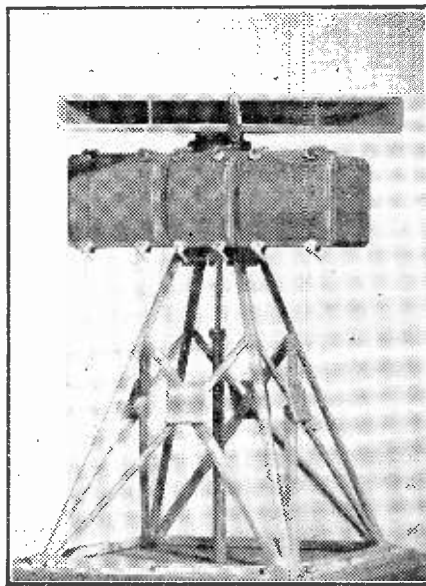

Scanner Assembly of the installation.

Approved Frequency Band

9434 Mc/s-9524 Mc/s.

Pulse

- (1) Peak power 30 kilowatts.
- (2) Width 0.2 microsecond, *i.e.*, 35 radar yards.
- (3) Recurrence 1,000 p.p.s. approximately.
- (4) Generator.

A triggered hydrogen thyratron coupling an inductively charged artificial line into a pulse transformer, which latter drives a magnetron.

Receiver

A common T.R. system is employed, using gas switches duplexing.

T.B. cell, QGS 100. T.R. cell, CV 221.

Local oscillator (a reflex Klystron), CV 720.

Mixer (crystal), CV 253. (Both for receiver signal and A.F.C. signal.)

I.F. amplifier frequency 60 Mc/s. I.F. amplifier bandwidth 10 Mc/s.

Loudspeaker Developments

With reference to the article with the above title in our September issue we are asked to point out that the loudspeaker referred to as the "Endsleigh" is known as the Ian Bailey Corner Horn Concert Reproducer and is obtainable from Endsleigh Radio Company of 1102, London Road, Leigh-on-Sea, Essex.

The price of the Goodman's Axiom 12 speaker is 8 guineas, and not 9 guineas as stated on page 368 of the September issue.

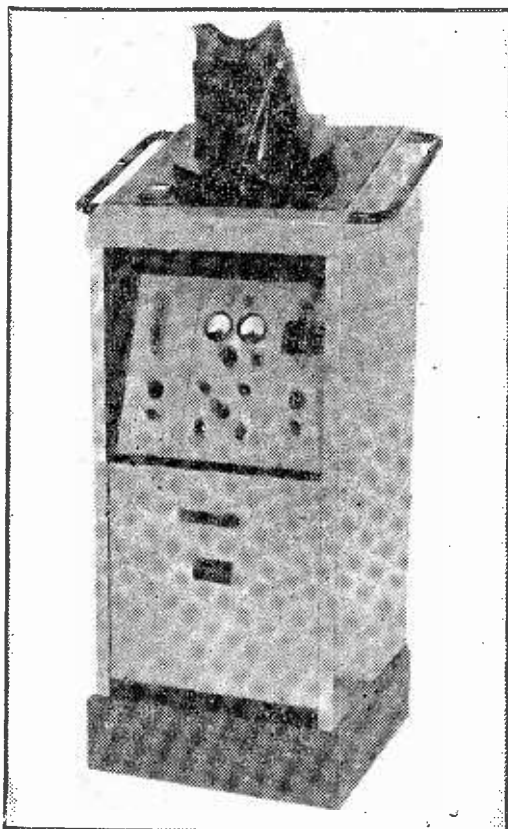

The Console of the Kelvin-Hughes Radar Set.

Trade Notes

New Taylor Instruments

THE tendency with modern measuring instruments is for a reduction in size. At the same time there is a demand for long and clear scales. These two apparently incompatible features have been effectively achieved in the new Taylor Series 415 sector shape instruments. Occupying little space (four instruments can be mounted in a 1ft. square), modern in design, and in attractive moulded cases, they are ideal for charging boards, control panels, electronic and electro-medical equipment.

These instruments are now available as moving coil ammeters in ranges from 0.10 micro-amps. upwards; as moving coil voltmeters from 0.5

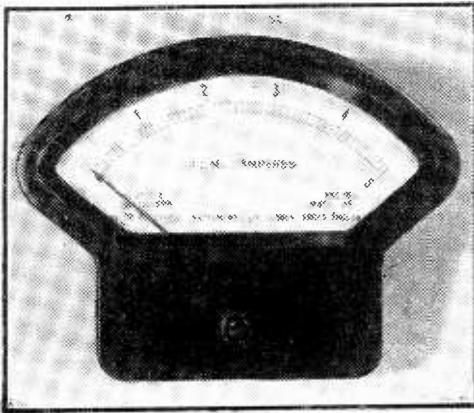

The new Taylor sector meter.

milli-volts upwards; as rectifier ammeters from 0.25 microamps. upwards, and as rectifier voltmeters 0.1 volts upwards.

Thermocouple instruments are also available, and shortly the series will be extended to cover moving iron ranges.

Superhet Permeability Tuning Unit

THE Weymouth Radio Manufacturing Company have produced a complete tuning unit for superhet operation (intermediate frequency 470 kc's.) covering wavebands of 200-540 and 1,000-2,000 metres, in which tuning is effected by the cam follower system giving 360 degree rotation of the spindle.

Wave change switching is automatically cam operated at zero and 180 degrees, thus allowing the use of an "acroplane" type scale in which the top half is devoted to the medium wave and lower half to the long waveband. (A suitable scale can be supplied by the makers.)

Extremely high sensitivity and selectivity is attained by the use of this unit, being in no small measure due to the very favourable L/C ratio

employed. The maximum capacity across the tuned circuit is 150 pF. and therefore, while the performance at the high frequency ends of the two bands is exceedingly good, it improves very considerably towards the low frequency end by virtue of the greater insertion of tuning cores and consequent increase of inductance, giving an even more favourable L/C ratio. This fact is of particular interest in view of the Third programme being only receivable on 524 metres in many areas.

Tracking is extremely satisfactory and has proved, in practice, to be even better than that usually obtained with the normal condenser tuning system. The standard unit is supplied complete with basic circuit diagram for either mains or battery operation, and it is noteworthy that an excellent performance is obtainable with H.T. supply voltages as low as 90 volts by using Mullard DK52 or equivalent frequency changers.

The retail price is 45s., and the makers inform us that the delivery position has very considerably improved and the units are now available from stock.

Two New Philips Television Models

PHILIPS ELECTRICAL, LTD., announce the introduction of two new television receivers. They are the Table Model 383A (illustrated below), and the Console Model 663A.

Model 383A is the new table model for vision and sound only. The horizontal-style cabinet is carried out in polished mahogany, giving this receiver a particularly distinctive and attractive appearance. It incorporates a 9in. tube and the picture quality is of a very high standard.

The Console Model 663A is a handsome piece of furniture in mahogany. The specification includes a 12in. tube, and in addition a very efficient seven-valve all-wave broadcast receiver giving extremely good reception on the long, medium and short wavebands, with first-class quality of reproduction. The prices are:— Model 383A, £61 14s. 5d. Model 663 A, £110 4s. 4d.

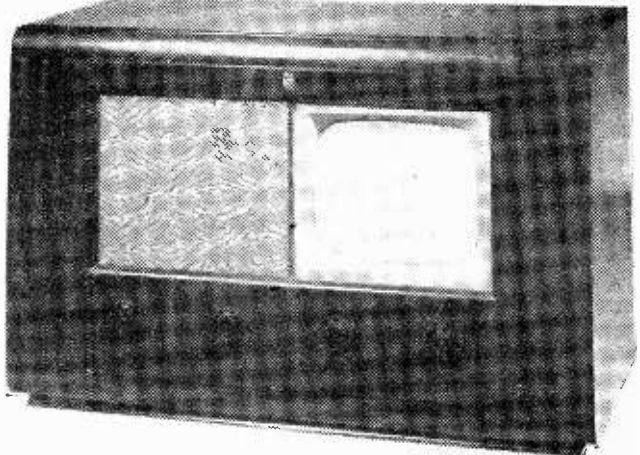

Philips' new table model television receiver.

MINE DETECTORS

The picture shows the "G.L." digging with his Mine Detector. We do not recommend that you buy one for this purpose, but there are hundreds of applications such as treasure hunting—locating buried pipes, locating metal in trees before sawing, etc., etc., which only a mine detector can perform. We can offer the famous American SCR.625, complete and brand new, ready to operate as soon as batteries are connected.



The kit comprises:

- (a) The exploring rod assembly, consisting of the Search Coil—Control Box—Handle—Visual Indicating Meter, Test Button—ON-OFF Switch, etc.
- (b) Amplifier containing the battery compartment and the amplifier chassis.
- (c) 2 Resonators which are Receivers R-14 mounted in metal cases.
- (d) The instruction manual, 70 pages of useful information—including circuit diagrams, operational and maintenance notes, etc.
- (e) Haversack for carrying equipment when in use.
- (f) Complete set of spare valves.
- (g) Suit case type wooden container for transporting the whole outfit.

The price of the complete outfit if £10.10.0, including carriage. Order Item No. 249. The 70 page instruction book can be supplied separately. The price is 7.6. post free. Order Item No. 249b.

DATA BOOKS.—Copied from official publications, giving circuit diagrams, component values and useful notes: TR1195-B.C.342—BC.348—BC.312—BC.221-R.208-R.103A—R.107—M.C.R.1—R.1155—W.8.22—R.T.18—W.8.19—R.1110a—all at 2/3 each, also Walkie-Talkie 58.3.6. "Demobbed" valves 2.6. List free on application with stamp. 200 bargains described.

If you wish you may pay by instalments, but you must send a deposit of at least 25 per cent. with your order.

W.D. SALES, 7 Electron House, 42-46, Windmill Hill, Ruislip Manor, Middlesex.

MIDCO RADIO

New Season's Catalogue Now Available.

Television Components : Radio Hearts ; Coil Packs ; Coils ; Audio Amplifiers ; Mains Transformers, etc. etc.

Coil Packs: 5/ker. L.M.S. 33/-; With RF Stage, 50/-; Three S.W. Bands, 10-100 m. s/het., 33/-, 160pf. tuning. **Radio Hearts:** From 84/17/6.

Amplifiers, from 10 watts, £10 ; Mains Transformers, 350v. 80 mA., with 6.3v. and 5v. fully shrouded, 25/6 ; I.F. Transformers, 465 kc/s perm. tuned, 14/- pair. Coils s/het., 12-2000 m 2/9 ; TRF Pairs, 8/6. Terms C.W.O. or C.O.D. over 5/- ; 4d. stamp brings illustrated list.

MIDLAND RADIO COIL PRODUCTS, 19, Newcomen Road, Wellingborough.

H.A.C.

Short-Wave Equipment

Noted for over 15 years for Short-Wave Receivers and Kits of quality

One Valve Kit, Model "C" .. Price 20/-
Two " " " " "E" .. " 43/-

These kits are complete with all components, accessories, and full instructions. Before ordering send stamped, addressed envelope for descriptive catalogue.

Note new sale address:—
"H.A.C." SHORT-WAVE PRODUCTS
(Dept. TH) 66 New Bond Street, London, W.1

DUNK & HEALEY

6V6G—Brand new and guaranteed, 7/6. EF50.—In original manufacturer's cartons, 7/6.

S. G. Brown's Headphones.—5000Ω, impedance brand new, 12/6.

4 mfd. 500 v.w. Paper Condensers : metal case soldering tags, 2/- ; 4 mfd. 750 v.w., 4/-
CHOKES.—10H 300 mva. tropicalised, 12/6.

TRANSFORMERS.—40v., 2 amp., 230v. 50 cps. Primary. Heavy cast shrouds, fitted terminal block; ample room for additional windings, 16/-.

RELAYS.—12v. 4-gang 2-way change-over, 6/-.

Mail order only. Money back guarantee with all goods. Please add 8d. for post.
67, OSNABURGH STREET, LONDON, N.W.1.

AN INDICATOR UNIT

FOR 50/-

Brand new type 73 Indicator units in maker's cartons.

SPECIFICATION: 3in. C.R. Tube VCR. 1.5A. 4 H.F. Pentodes VR.57 (SP.41) 1 Double Diode VR.74 (EB.4) 1 Diode VR.92 (EA.50) 4 Position 10 wafer wavechange switch. Two high speed relays. Many microcomponents, resistors, condensers, transformer's, viewing hood, etc. All in PRV metal case 1in. x 1 1/2in. x 1 1/2in.

NOTE: VCR.136A (Sim.ECR.55) has 4v. I.A. heater and needs 1.500 v. H.T. It is the best type for oscilloscope work with a fine green trace of 5 milliseconds duration. The indicator in maker's carton for 50/- plus 10/- for carriage by passenger train.

A. McMILLAN,

5, Oakfield Road, Bristol. 8.

Most People Stop

at PALACE GATE!

Many people, on buying an Amplifier make a tour from manufacturer to manufacturer. But most people stop at Palace Gate, where the 'Concerto' and the 'K1' are demonstrated. There must be a reason! Write today enclosing 5d. in stamps for new 16-page copiously illustrated catalogue and interesting information on the complete range of Amplifiers and Tuning Units, in kits or complete form and a new corner chamber, supplied with or without loudspeaker, to Dept. P.W.1. Deferred Terms are now available.

Charles
AMPLIFIERS

at PALACE GATE
KENSINGTON, W.8

Phone: WESTern 3350

CALLING AMATEURS with BUCCLEUCH Precision Built Equipment

Steel Chassis Smooth Black, 17in. x 10in. x 2 1/2in., 9.9. 17in. x 10in. x 2in., 8.9.

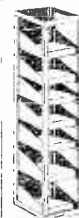

CRACKLE
19in. x 3 1/2in., 4/-
19in. x 7in., 6.9.
19in. x 8 1/2in., 7.9. 19in. x 10 1/2in., 8.9.
Angle Brackets, 12in. long, pr. 7.6. (Brought aluminium, same cost.)
RACK ASSEMBLY (Rigid 4-pillar), 3 1/2in., £2 5s. 6.3in., £3 5s. Chassis to order. Charges are as example, depth less than 3in. Example: 7in. x 3in., 2in. totals 14in., at 6d. per inch = 7/-, Drilling Charges, Holes up to 1in., 3d. 1in., 1d. or 1 1/2in., 9d. each. Large, 2.3. Small square, 2.3. Large square, 3.6.



BUCCLEUCH RADIO MANUFACTURERS 1 & 2 Melville Ter., Edinburgh, 9.

HIGH "Q" IRON CORED COILS

of unsurpassed quality for Discharging Amateurs

AERIAL, I.F. OR OSCILLATOR, short, medium, or long wave, size of former 1in. x 1in., 3.9 each.
INPUT FILTER, 185 Kcs., parallel or series tuned, 3.9 each.
DUAL WAVE COILS, medium and long wave aerial and H.F., 9.6 pair.
I.F. TRANSFORMERS, standard, 185 Kcs., permeability tuned, size 1in. square x 3 1/2in. high, 8.6 each.
All coils fitted with adjustable iron cores, and supplied with circuit diagrams.

TERMS: Cash with order or C.O.D. on orders over £1.
TRADE INQUIRIES INVITED
MONOCHORD RADIO
(Established 1929)
17, Streatham Hill, London, S.W.2
Phone: Tulse Hill 1051.

TELERADIO.

TELEVISION COMPONENTS

Constructional Booklet (Elec. Eng.)	£ s. d.
Complete Chassis Assemblies with gantry, etc.	2 8
Separate Chassis	4 4 0
1. Vision unit chassis fitted with screens, all valve holders and fully drilled	1 2 6
2. Sound unit chassis complete as above (incl. coil formers)	17 6
3. Time Base chassis with valve holders, etc.	1 2 6
4. Power Pack chassis with holders and fully drilled	1 0 0
Separate Mains Transformers	
E.H.T. 5,000v. 1 ma	3 7 6
L.H.T. 4v. and 6v. 350v. to E.E. specification	3 19 6
Deflector Coils	
Grade 1 for 35 mm. tubes	1 10 0
Superior quality, type 7840	2 2 0
Focus Coils	
3,000 turns 29 swg. 115 ohms	1 12 6
Line Transformers	
Min. ind. 1 hv., 100 ohms for EL36 or Pen 46	2 5 0
Ind. 125 hv., 120 ohms. Ratio 9.6	2 5 0
Line Blocking Transformers	9 0
Also 9in. and 12in. Cathode Ray Tubes at current prices. (Callers only, due to transport difficulties.) Smaller components stocked where possible. Complete kits available.	
The TELERADIO Co. Head Office	
157, Fore St., N.18	
Also 608, High Road, N. 17, and 224, Chingford Mount Road, E.4	



NEW G.P.12 CRYSTAL PICK-UP with permanent sapphire stylus

—was fully described in *The Wireless World's* recent article "Crystal Pick-Ups — Basis of Design for Fidelity Reproduction."
This remarkable pick-up, which represents the ultimate in high-fidelity reproduction, is now available in limited quantities through your radio dealer, price 104/- incl. P.T.



FREE ILLUSTRATED FOLDER describing this new pick-up may be obtained by returning the coupon below.

TO COSMOCORD LTD. ENFIELD, MIDDLEX.

Please send folder of ACOS Pick-ups.

NAME _____
ADDRESS _____
P.V. _____

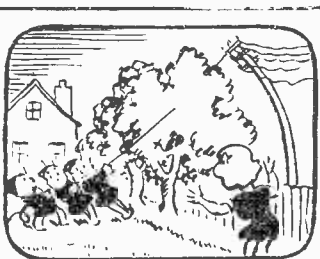

The "Fluxite Quins" at Work

"An aerial needing repair!
Set up without FLUXITE, I'll swear.
Pull hard, it's got fixed,"
Cried OO. "You're all mixed.
That's the telephone wire you've got there."

See that FLUXITE is always by you—in the house—garage—workshop—wherever speedy soldering is needed. Used for over 40 years in government works and by the leading engineers and manufacturers. Of all ironmongers—in tins, 10d., 1/6 and 3/-.
●

To CYCLISTS: For stronger wheels that will remain round and true, there's a time tested tip. Tie the spokes where they cross with fine wire and SOLDER. It's simple — with FLUXITE — but IMPORTANT.

The FLUXITE GUN puts FLUXITE where you want it by a simple pressure. Price 1/6, or filled, 2/6.



FLUXITE

IT SIMPLIFIES ALL SOLDERING

Write for Book on the ART OF "SOFT" SOLDERING and for leaflets on CASE-HARDENING STEEL and TEMPERING TOOLS with FLUXITE, also on "WIPED JOINTS." Price 1d. EACH.
FLUXITE LTD. (DEPT. W.P.), BERMONDSEY ST., S.E.1.

SPARKS' DATA SHEETS

Provide detailed Instructions with Clear, Full-size Constructional Prints of Tested and Guaranteed Designs.

THE "CONQUEST"
My Latest Design. A Very Efficient A.C. D.C. ALL-WAVE SUPERHET Five Valves, including Rect., Delayed A.V.C. 4 Watts Output, P.U. Connections, Good Range, Selectivity and Quality 2/9

THE "CRUISER" All-dry T.R.F. 3-Valver for use with short aerial 2/6
THE "CUR" A.C./D.C. 2-Valver Plus Rect. Med. and Long waves ... 2/6

THE "CADET" A.C./D.C. 4 Watt Amplifier. Ideal for P.U. 2/6

THE "OLD FOLK'S TWO." An A.C./D.C. 2-Valver, plus Rect., having Station Selection by Switch ... 2/9

THE "CHALLENGER." An Outstanding A.C. D.C. Portable for use in any room without aerial or earth: 3-Valve T.R.F. circuit, plus Rect. 2/9

A.C. TWO-VALVER (Plus Rect.), M/L Waves. Fine Power and Tone 2/6

A.C. THREE-VALVER (Plus Rect.), T.R.F. Circuit, M/L Waves ... 2/9

MANY OTHER DESIGNS for Sets, Portables and Amplifiers. Stamp for List and with order. Prompt Service. Components supplied.

L. ORMOND SPARKS (P),
9, Phoenix Road, Brockley, S.E.4
(Nearest Station: Ladywell S.R.)
(Phone: Lee Green 0220.)

CHARLES BRITAIN (RADIO), LTD.
11, Upper Saint Martins Lane, London, W.C.2.



BEST BUY AT BRITAINS

MAKING A SCOPE? Test Set 74 is the ideal unit for this purpose. It works straight off the mains and we can supply detailed instructions for making a scope which any schoolboy can follow. Details as follows. Size of case 18in. x 12in. x 9in., 1, 6Q7; 1, 6J5; 1, EA50; 1, 5Z4; 1, CV6; 5, 5P61; 1, HVR2A; 3in. Tube VCRI39A. Complete with the necessary mains supply and smoothing, etc. All instruments tested before despatch. Price with full instructions, £6/10/0, or less instructions, £5/10/0, plus 15/- carriage.
TYPE 26 R.F. UNITS, tuned 5 metres Converters. Brand new in makers cartons. Price 27/6, post free.
R1124 RECEIVER—Range 30-40 mc/s; contains six new valves, 3, 9D2; 1, 8D2; 1, 15D2 (Frequency Changer); 1, 4D1; 24 ceramic trimmers, 6 Ceramic valve-holders, 6 valve screening cans, 30 resistors, 3 potentiometers, mica and tubular condensers, ceramic coil formers, 5-way 4-bank switch with long spindle and I.F. transformers, etc., a real buy at only 19/6, plus 2/6 carriage and packing.
BRITISH I.F.F.—Complete in case, size 12in. x 8in. x 12in. Contains 10 valves, 1 motor generator, numerous relays, potentiometers, resistors, etc. The generator, which is complete with all gears, etc., can easily be converted to a small motor for A.C. or D.C. operation. This really is a genuine bargain, at only 19/6, plus 5/- carriage and packing.
Hundreds of other lines in stock. Many special bargains for callers. Shop hours, 9 a.m. to 6 p.m. For the convenience of customers we are now remaining open all day Saturday. Phone: TEMple Bar 0545.

Programme Pointers

This Month, Our Contributor, MAURICE REEVE, Deals with
the Subject of Running Commentaries

THE chief broadcasts during the summer months are, I suppose, the sporting commentaries and the Promenade Concerts. The former take precedence during the day and the latter in the evening. But whilst the latter are of a uniformly high standard with a general upward trend—witness this season's acoustical experiments in the Albert Hall, to the advantage of those inside as well as outside the Hall—the former are certainly no better than the generally poor level on which they have always rested, but are, if anything, below it.

For years now the art of commentary has been stabilised in a groove. A small handful of adjectives are repeated *ad nauseam*—the "impressive" scene afforded by Wembley Stadium at all sporting contests, a "long, raking kick" at Rugby football, "a four all the way" at cricket, etc., etc. Similes and descriptions are just the same. If a cricketer wears his cap at a jaunty angle, for example, we are not only told so at every match in which he appears, but every time he comes out to bat, is put on to bowl, or does a smart bit of fielding. Again, if he is the youngest player ever to have accomplished whatever it is he has just accomplished, or the oldest, or the fattest, or the thinnest, we are told so, and told so, and told so, again and again.

Of few broadcasting activities can it be truthfully said that no improvement has been made over the last 10 to 15 years. But I do feel that this is no exaggeration so far as sports commentaries are concerned, and Test matches in particular. As these are given far more time on the air than any other sporting event and should, I feel sure, be at least as exciting as any other, if even only for their rarity, I would like to go into the question in some detail. They were, as a matter of fact, the most boring and exasperating broadcasts imaginable, and the commentators themselves must be held chiefly responsible.

It can be taken as an axiom that the shorter the event and, in consequence, the shorter the commentary needed, the better it will be. The Derby or the Grand National are perfect examples. But when the race itself takes about five minutes at the most, plus ten minutes for description of the scenes and the field, it is difficult to imagine anyone not being able to give a reasonably good account of himself, excellent as Raymond Glendenning always is. But where the event is drawn out over several days and is frequently static over long periods, as in a Test match, the gifts of the first-class commentator should shine at their brightest. It is, alas, where they completely fail. They are totally unable to convey the drama and tenseness of the scene, except for the shortest periods, as opposed to the rush, bustle and excitement of Wimbledon or Aintree. And they are not always as knowledgeable of the game as they should be—witness their frequent inability to detect a catch off a bump ball and their joining in the

jubilation of the crowd whenever such a catch is made. Rex Alston's description of an imagined catch in the slips during the fourth Test: "He's caught in the slips—no, he isn't—he would have been had second slip been a yard to his right," deserves to go down as a classic example of wishful thinking. As does his crowd description during a shower of rain or something: "The ground presents a marvellous sight, absolutely marvellous. The men in their shirts, the women in their blouses. . . ." No wonder the poor men can only make recourse to the constant and never-ending repetition of the score card.

Repetitions

The card of the match is read to us at least six times in the first half hour of play, it is repeated at the close and commencement of every session of play, at the fall of every wicket, at the close of play, at every interruption through rain, the number of repetitions depending on the length of the interruption—every time a new programme comes on the air or goes off, as well as on numerous other occasions as circumstances permit. Terrible, shocking and wearisome in the extreme. And totally unnecessary if the commentators were able to "put the thing over" as Howard Marshall used to. John Arlott, probably the best and certainly the wittiest of the team, as E. W. Swanton is the most knowledgeable, is the worst offender in this respect.

A word in conclusion on the "expert commentaries from time to time." Here is a typical example, and they never vary. The event, say, a catch, described thus: "So-and-so has driven a ball from So-and-so high past mid-on. So-and-so's racing for it. Yes, he's out. So-and-so's out, magnificently caught; he had to run quite thirty yards but he judged the flight of the ball beautifully and held it as it came down at an awkward angle. Now we'll see what Arthur Gilligan has to say about it. Come in, Arthur, and tell us what you thought of that catch." Enter Arthur. Arthur: "Well, Rex, I think your description was absolutely correct and I agree with you entirely. So-and-so drove that ball of So-and-so's high past mid-on and So-and-so, judging its flight beautifully, raced round, I should say, thirty yards, and held it as it was coming down at a very awkward angle." Then follows the *n*th repetition of the score card and the new batsman prepares to receive his first ball.

Serialisation

The Australians will not be here again for four years. Is it too much to hope that their broadcast will be on entirely different lines? I am convinced they can and should be among the most exciting and dramatic of all outside broadcasts, if put in the right hands. If, however, the boredom and monotony of this season's series cannot be overcome, better scrap them altogether and let the score card be read out, say, once every hour.

The successful adaptation for broadcasting of

the full-length novel has also not yet reached perfection, though much success has been achieved. The current serialisation of Bennett's "The Old Wives' Tale" suffers from too much retrospective commentary by the narrator who, instead of pointing a guiding finger, as it were, down the road the story is going to take, takes too much of the story-telling on his own shoulders. Neither the cast nor the story are sufficiently left to their own job; it is as though they were not trusted to "come over" without his constant interference. They would, and with benefit to the dramatic sweep of the story which would be heightened, if he made his presence a little scarcer.

I felt that Ruth Draper's performance, July 8th, lost by the absence of her compelling and bewitching personality. One must be able to see this distinguished artist as well as to hear her, if we are to get complete satisfaction from her incomparable performances.

"The Shop at Sly Corner," July 31st, was very good. This inconsequent little thriller, whose

success on the West End stage seemed to be so much beyond its intrinsic merits, made a most effective radio play, with the narrator telling us just sufficient to remind us who saw it of what it looked like, and no more. Those who didn't had their imagination sufficiently aroused to picture the scene for themselves. The result was, and usually is, in "Saturday Night Theatre," that the story unfolds itself naturally with the climax left to itself to reach whatever heights it is capable of reaching of its own accord, with much more effective results.

I still think that, day in and day out, the "Children's Hour" offers a more uniformly high standard of wireless entertainment than any other item in the programme. The way its organisers range over the wide world for material, which always pleases somebody all the time, is an example for everyone engaged in programme building to emulate. Although it admittedly offers its wares to a less critical and sophisticated audience, it is pleasing that audience more constantly than any other programme.

News from the Clubs

PETERBOROUGH AND DISTRICT RADIO AND SCIENTIFIC SOCIETY

Hon. Sec.: S. Woodward, 72, Priory Road, Peterborough, Northants.

THE society has its own transmitter which has been built by club members and is housed in the Club House. Call is G3DQW.

Meetings are held in the Club House every Tuesday and Thursday evenings, at 7.30 p.m., and also on Sunday mornings, at 10.45 a.m. Tuesday evenings are devoted to a class for members wishing to take the examinations for a Transmission Licence, and the transmitter is also on the air. General lectures are given on Thursday evenings, including a monthly lecture on television and one on radio valves.

The society held a Radio Exhibition in the Town Hall, Peterborough, in September, where local radio traders and the G.P.O. had stands. The exhibition was organised to let the public know the work of the society and to raise funds.

READING AND DISTRICT AMATEUR RADIO SOCIETY

Hon. Sec.: Alex Mercer (Scribe), 23, Oakley Road, Caversham.

MR. J. DEE (G3BAE) recently gave a talk on methods of overcoming television interference. Designs for, and the location of, harmonic filters and stubs within the transmitter were discussed, particular attention being paid to the screening of these elements, to overcome the effects of radiation from the filter itself.

Seven groups, comprising 32 persons in all, took part in a five metre direction finding contest in the Mortimer region. Equipment was such as could be carried by walkers or cyclists, and points were allocated for accuracy of bearings, rather than speed in locating the transmitter. Two groups did succeed in locating the TX in the two and a half hours of the contest.

The maps from the D.F. contest were examined at a later meeting, and points of interest discussed. Mr. Guy (G8TH) was declared the winner of the contest. Mr. Dee then continued his talk on T.V.I. from the previous meeting, and finally ideas for a further field-day were discussed.

LIVERPOOL AND DISTRICT SHORT WAVE CLUB

Hon. Sec.: W. G. Andrews, 17, Lingfield Road, Broadgreen, Liverpool, 14.

THE main item on the July agenda was a business meeting from which emerged the programme for the forthcoming season. One period per month is now devoted to the solution of members' knotty problems, when all hands come forward with advice and (it is hoped) the solution.

A short talk was also given by G3DYW on an electronic "bug" built during his seagoing career. It was agreed that an unbalanced multivibrator would work much better than the switched L.F. squeezing oscillator described.

Meetings are held every Tuesday, at 8.0 p.m., at St. Barnabas Church Hall, Penny Lane.

TEES-SIDE AMATEUR RADIO SOCIETY

Hon. Sec.: H. Walker (G3CBW), 9, Chester Street, Middlesbrough.

THE society now have their own Club Headquarters, situated at 400, Lintorpe Road (top floor), and opposite St. Barnabas Church, Middlesbrough, which will comprise clubroom transmitting room and workshop when completed. All who are interested in amateur radio, whether licenced ham or short-wave listeners, are invited to the clubroom, or, better still, get in touch with the secretary at the above address. Lectures have been given on aeriels and radar. There is to be a radio course and Morse class.

STOURBRIDGE AND DISTRICT AMATEUR RADIO SOCIETY.

Hon. Sec.: W. A. Higgins, 35, John Street, Brierley Hill, Stalls.

A MEETING of the above society was held in the Science Block of King Edward VI School, Stourbridge, on Tuesday, August 10th, at 7.45 p.m. Considering absences owing to holidays the attendance was good and members listened attentively to the second part of Mr. Rigg's talk on "The Use of the Cathode Ray Oscilloscope." Mr. Rigg gave practical illustrations on his oscilloscope of valve characteristics, modulation percentages, amplifier distortion and frequency synchronisation. A very hearty acclamation was accorded to Mr. Rigg for a truly outstanding talk and demonstration. Mr. Rigg replied saying the pleasure had been as much his in having such an enthusiastic audience.

The next society meeting will be on "Building a Superhet Receiver," and will be given by Mr. Bills (G3CIG), of Kluver, a society member.

THE RADIO SOCIETY OF HARROW

Hon. Sec.: J. R. Pickett, 93, Whitmore Road, Harrow, Middlesex.

MEMBERSHIP of the above Society continues to increase, and a full season's programme has been arranged. This includes a talk and demonstration on October 19th by Messrs. Devoe, and a constructional competition for the Challenge Cup, entries to be judged on December 7th.

Recent talks included "Quality Reception of B.B.C.," "F.M. Transmission" and "Five-metre Antennae."

The Society transmitter will be on the air shortly and various tests will be carried out.

New members are cordially invited to contact the Hon. Sec. for full details. Meetings are held every Tuesday evening at Northwick Tearooms, Kenton Road, Kenton, from 7.30 to 10 p.m.

WORTHING AND DISTRICT CLUB

Hon. Sec.: Mr. F. T. Tooley, 62, Becket Road, Worthing.

THE Worthing and District Group of the R.S.G.B. has been reformed into the Worthing and District Amateur Radio Club, in order to admit non-R.S.G.B. members to its ranks, thus widening the scope of the club.

Meetings are held on the first Thursday in each month at Oliver's Cafe, Southfarm Road, at 7.30 p.m.



Meters

As specified in PRACTICAL WIRELESS, April and June, the best bargain on the radio market. Stocks running low, but we still have:

- FLUSH, 2 1/2 in. square
- 0/5 milliamps..... 5/9
- 0/5 amp. R.F. with thermo-couple 5/9

Four of these meters (2 of 0/5 mA and 2 of 0/5 amps. R.F.)
Four for 21/-
per post 22/-

Also 0/150 milliamps..... 6/6
ALL NEW AND IN MANUFACTURERS' BOXES

Microphone Testers

Air Ministry stock in mahogany case 6in. x 5in. x 5in. with hinged lid. Contains 0/10 volt meter (fundamental 0.1 mA), high-grade mic. trans. and many useful components. Sold elsewhere at 45/- Our price 32/6.

Condenser Bargains

Stock clearance lines, all 100% perfect.

- T.C.C. tub. 350v. .03—3d.
- „ „ 450v. 1 mfd.—6d.
- „ Mica 350v. .005—6d.
- „ Metal 350v. .5—2d.
- „ „ 1,000v. 4 mfd.—5/-
- „ „ Elect. 150v. 8 mfd.—6d.
- Dublrier Mica 350v. .01—1/3
- Sprague tub. 1,000v. .01—9d.
- U.I.C. Silver Mica 1% .01—2/6

POST CUSTOMERS.—
Please add 1/- extra on orders.

WEBB'S RADIO, 14, SOHO ST., OXFORD ST., LONDON, W.1.

Note our SHOP HOURS : 9 a.m. to 5.30 p.m.
Sats. 9 a.m. to 1 p.m.

Telephone: GERrard 2089.

ETA

FOUR STATION SUPERHET TUNER

A complete pre-set tuning unit, for use in superhet circuits, which can be set to select any three M.W. and one L.W. station. Exceptional sensitivity and stability are achieved by the use of a new type of inductor. Supplied with full instructions and a complete receiver design.

Price 33/- Purchase Tax 7/2

I. F. TRANSFORMER

A midget I.F. transformer for 465 kc/s. which sets a new standard of efficiency. Size: 1 1/4 in. diam., 2 1/2 in. high. Trimming of both sections effected above chassis.

Price 7/- each

ETA Components are obtainable from your local dealer or direct from

ELECTRO TECHNICAL ASSEMBLIES
West Hill,
St. Leonards-on-Sea, Sussex

MAINS TRANSFORMERS

19/6 POST PAID

NEW GOODS—NOT SURPLUS

Primary for 200/230/250v. Drop through type with top shroud. H.T. 250-0-250 or 300-0-300 or 350-0-350v. 80 mA. Universal L.T.'s 4.6.3v 4A C.T. 4.5v. 2A.

VALVES

A few of the types in stock—all at reduced P. Tax Rates. Valves sent C.O.D.: Brimar 7D3, 7D5, 8A1, 9A1, 9D2, 10D1, 11D3, 11D5.

Cossor : 2P, 13SPA, 40SUA, 41MHL, 41MP, 41MTL, 41MXP, 43U, 210PG, 210SPT, 210VPA, 240QP.

Marconi-Osram : 304, D63, DH63, DL74, H30, N30, H63, HD14, HD24, HL2, HL2 K, KT2, KT33C, KT41.

Mazda : AC/PEN, AC2/PEN DD, AC5/PEN DD, AC HL, DD207, PEN 44, PEN 45, PEN 393, PEN DD 2020, UJ5, UJ6, UJ7, U403, VP23, VP41, VP133, VP210.

Mullard : 2D4A, AC044, AZ1, AZ31, CI, CIC, CBL1, CBL31, CL4, CL33, CY1, CY31, PM2A, PM22A, PC2, FC2A, PEN36C, TH30C, UBL21, UG121.

Tungsram : PP4A, APP4B, APV4, AS4120, AS4123, HL2, LP220, MH4105, P215, PP215, PP35, V30, PV495.

American Types : IA5, IA7, IC5, IH5, IN5, IR5, IS5, IT4, 3C5, 5U4, 5V4, 6Y3, 5Z3, 5Z4, 6A7, 6AR, 6C5, 6D6, 6K3, 6K7, 6J8, 6L6, 6L7, 6U7, 6P6, 6V6, 42, 80.

MINE DETECTOR AMPLIFIERS

3 valve R.C. Midget Amplifiers with three IT4 valves in ceramic holders. 22 6.

3 AMP LINE (GRID)

60 70 ohms per ft. 2 way. 1 3/4 yd. : 3-way. 1 1/2 yd.

UNDRIILLED ALUMINIUM CHASSIS

Heavy gauge, 16 S.W.G. Polished. 3in. deep, 4 sides. 10in. x 6in., 10in. x 8in., 8 1/2 in. x 9in., 10 1/2 in. x 9in., 16in. x 8in., 11 1/2 in. x 9in., 12in. x 8in., 12in. x 10in., 12in. x 12in.

NEW GOODS ONLY, C.W.O. or C.O.D. POST FREE OVER 5/-

COULPHONE RADIO

The Return of Post Mail Order Service.

58, Derby Street, Ormskirk, Lancs.

Send 21d. stamp for 32 page catalogue

GALPIN'S

ELECTRICAL STORES
408, HIGH STREET, LEWISHAM,
LONDON, S.E.13.

Telephone : Lee Green 0309.
Near Lewisham Hospital.

TERMS : CASH WITH ORDER. NO C.O.D.

ROTARY CONVERTERS EX-ADMIRALTY 110 volts D.C. to 230 volts A.C. 50 cyc. 1 phase rated at 200 watts but capable of 550 watts continuous rating, weight approx. 100 lbs., 28/10/- each, carriage 10/-. Another Ex-R.A.F. 12 volts D.C. input, 220 volts A.C. 50 cys. 1 ph. at 100 watts output approx. weight 15lbs., as new, 85/- each, carriage 3/6.

VARIAC TRANSFORMERS. Input variable between 200/240 volts output constant at 220 volts at 7 1/2 amps., 90/- each, carriage 5/-.

ELECTRIC LIGHT CHECK METERS (Watt Hour). A.C., 50 cys., 200/250 volts, 5 amp. load, 18/6, post 2/-; 10 amp., 21/-, post 2/-; 20 amps., 25/-, post 2/-: also a few only Pre-Payment 11-slot type, 20 amp. load, less coin box, complete with synchronous motor, 35/- each, carriage 3/6.

EX-R.A.F. INDICATOR UNITS, type 48A, new, boxed, consisting of 2, 3 1/2 in. motor, type 138A, also time base, 50/- each.

MOTOR ALTERNATORS, EX-R.A.F., as new, 230 volts 50 cys. 1 phase input, 250 volts 625 cys. 1 phase at 24 amps. output, 75/- each. Ditto, 1,725 cys. output, 85/- each. CIP.

EX-NAVAL 1in. SPARK COILS, approx. 3,000 volts from 6 volts supply, 8/6. G.P.O. Galvanometers, reading 30/0/30, vertical, type, 8/6 each. Ex-R.A.F. Impulse Transformer (Magnatron), output believed to be approx. 1,500 volts at 3 kV.V., for 1 ms., 7/6 each. Variometers for No. 19 Mk. II Receivers, 6/4 each.

EX-NAVAL (CROMPTON PARKINSON) PRONG-TESTERS, 0 to 100, and 0 to 400 amps., new, in leather carrying case, 90/- each. A.C. V/Meters, 0 to 300 6in. scale, calibrated 50 cys., 37/6 each.

EX-R.A.F. CRYSTAL MONITORS, type 2, complete in wooden carrying case, the frequency depending on crystal used 5/- each. Short Wave Aerial Coupling Units (Wavemeters), 5/- each.

FRACTIONAL H.P. MOTORS, 110 volts with LAMINATED Fields (Ex-Naval Fan Motors). These need slight attention, to brushes or leads. 10/- each. Westinghouse (Blasting) Galvanometers, Moving Coil, very low deflection, 15/- each.

LARGE TYPE RECTIFIERS. Output 50 volts at 1 amp. 1/2 wave, input voltage 70/75 volts, 17/6. Tannoy P.M. Speakers (Small Hailers), 7 ohm. speech coil, complete with output Transformer, 15/-.

MAINS TRANSFORMERS, by well-known makers, input 200/250 volts, output 1,000/0/1,000 volts at 500 ma., 75/-, Another 1,150/0/1,150 v. 500 ma., 85/-, Another, with two 7.5 v. two 6.3 v. and one 4 v. winding all at 10 amps., 37/6.

CONDENSERS, 4 M.F. at 2,500 v. wkg., 15/-, M.F., ditto, 25/-.

SPECIAL OFFER METERS, all new boxed. Moving Coil, first grade instruments, 0 to 20 volts, 10/- each, or 3 for 25/-; 0 to 40 volts, 12/6 each; 0 to 100 amps., 15/- each, all 2in. scale. 0 to 20 volts, A.C., calibrated, 50 cycles, 25/- each, 0 to 4 amps., thermo-coupled, 25/- each.

MAINS TRANSFORMERS, as new, input 230 volts, 50 cycles, output 12 volts at 8/1 amps., A.R.P. shelter transformers, 25/- each, post 2/-.

EX-R.A.F. RF UNITS (new) packed, containing 6 valves, all 6.3 heaters, including grounded grid triode, also a miniature 24-volt motor (universal) and approx. 80 resistances and condensers, all mounted on silver-plated chassis, to clear, 37/6 each, carriage paid.

COVENTRY RADIO

COMPONENT SPECIALISTS SINCE 1925

HAVE YOU RECEIVED OUR 1948/9 NEW RADIO COMPONENT CATALOGUE ?

THE FIRST ISSUE WAS SOLD OUT IN 14 DAYS. THE FINEST GUIDE OF PRICES TODAY, DETAILS OF HUNDREDS OF DIFFERENT NEW COMPONENTS. NEW ISSUE NOW READY. SEND 3d. IN STAMPS.

EQUIVALENT LIST OF SERVICE VALVES, NOW READY. PRICE 6d. (CV., VR., VT., ARP Nos. TO COMMERCIAL TYPES).

COVENTRY RADIO

DUNSTABLE ROAD, LUTON. Phone : Luton 2677

TORBAY ELECTRIC 48 HOUR SERVICE

We guarantee to despatch all orders on the same day that they are received. This means that in most cases you are actually fitting the component into your rig only 48 hours after writing out the order.

ALL ORDERS CARRIAGE FREE

Our 12 page catalogue gives full details of the items stocked; why not write for a copy? It's entirely free, send a postcard. Some of the items taken at random.

BC453, the Qser, we have a special illustrated leaflet dealing with this, send for a copy. Type 10 remote control units, £12. 1154 Transmitters, £8, B.C.503, 10 valve receivers, £7 10s. 0d. 5130 voltage stabilizers 5- each. High Res. headphones, 8/6. 25 mfd. 2kVW at 13. National HRO slow motion dials, Iron cores for coils, not very often that you see these. 4d. each. Agents for everyone, Belling-Lee, Brimar and S.T.C., Denco, Gardeners, Mulrhead, Partridge, Taylor, Wearite, Woden, etc. Send for that catalogue now, there's bound to be something that you want.

TORBAY ELECTRIC, 43, Colley End Park, Paignton, S. Devon.

LASKY'S RADIO

NOVEMBER SPECIALS

EX. A.M. UNIT, Type 567c ww. Brand new and unused in maker's original cartons. Containing 11 new valves: 2 5Z4g, 2 5U4g, 1 SU2150A, 1 6X5GT, 1 EF50, 1 CV137, 2 VS70, 1 6V6g. Dozens of various components, including high voltage condensers, pot meters, resistances, condensers (8 mfd. 500 v.w.), chokes, etc. Totally enclosed in metal case. Size 12in. x 11 1/2in. x 8in.

LASKY'S PRICE 39 6s. Carriage 4 6 extra. EX. A.M. MODULATOR UNIT Type 64, Containing 7 valves: 2 EF50, 1 807, 2 high voltage rectifiers CV54, 1 CV85 (Special Type), 1 CV73, 3 Relays. High voltage condensers, resistances, pot meters, and other components. Enclosed in case size 10in. x 8in. x 6in. Weight, 35lbs.

LASKY'S PRICE 22 6s. Carriage 5- extra. EX. A.M. RECEIVER Type 3515. Contains 21 valves: 10 VR65, 1 EA50, 1 EB34, 5 VR56, 1 VR53. Hundreds of components, condensers, resistances, relays, I.F. strip, coils, etc. (The I.F. strip in this receiver can be removed and used as a separate unit.) The whole receiver is totally enclosed in a metal cabinet size 18in. x 12in. x 9in. Weight, 25lbs.

LASKY'S PRICE 39 6s. Carriage 4 6 extra. EX. A.M. P.P.I. INDICATOR U.F.S. Containing 12 valves and two cathode ray tubes. 6in. VCR517 and 2 1/2in. VCR139A. Dozens of components. 5 EF50, 3 VR65, 4 EA50. Resistances, condensers, transformers, coils, etc. Enclosed in case size 12in. x 9in. x 13in. Weight, 40lbs. Set supplied with all valves.

LASKY'S PRICE 59 6s. Carriage 7 6 extra. The above units are only a few of the amazing bargains from our extensive stocks. Write to-day for our latest bulletin (enclose 2d. stamp) of other ex-Government bargains. We have the unit you want.

LASKY'S RADIO.

370, Harrow Road, Paddington, London, W.9 (opposite Paddington Hospital).

Telephone: Cymningham 1979.

Hours: Mon.-Sat. 9.30 a.m. to 6 p.m., Thurs. half day.

H.P. RADIO SERVICES LTD.

OFFER

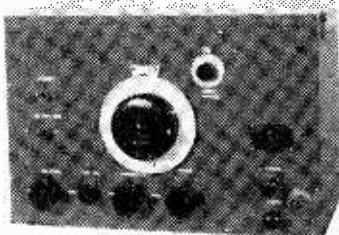

Brand New Ex-R.A.F. R1224a Battery Communication Receiver.

5 Valve Superhet of Exceptional Efficiency. 3 Wavebands: 30-70 m., 70-150 m., 150-300 m. Valves: 2 VP23s, PC2A, HL2, PM2A, all included. Has R.F. Stage, Muirhead precision Dial, Two Output jacks, Low H.T. Consumption. Cabinet finished AIR MINISTRY grey. Size 15in. long, 10in. high, 9in. deep. Requires Aerial, 120 v. H.T., 2 v. L.T., 9 v. G.B. and Loud Speaker or 'phones to put into immediate operation. A Super DX receiver. Easy operation. All leads marked. Ideal for the Radio Amateur, Yachtsman, Lighthouse Keeper, Met. Stations and all remote locations.

Price £5 10s.. Carriage Paid per pass. train. Instant Delivery. Satisfaction Guaranteed or Money returned with 7 days.

H.P. RADIO SERVICES LTD.

Britain's Leading Radio Mail Order House, 55, COUNTY ROAD, WALTON, LIVERPOOL 4

Tel.: Aintree 1445. Established 1935. Staff Call Signs G3DLY, G3DGL.

W.B.L. FOR THE HOME CONSTRUCTOR

We specialise in supplying complete kits and individual component parts for all circuits described in this journal.

5 VALVE A.C. MAINS SUPERHET KIT, 3 waveband, 16.5-50, 200-550, and 800-2000 metres, complete with valves and speaker, £14 17s. 1d.; also supplied to cover 12.5-37, 36-120, and 200-550 metres. (A.C. D.C. version, £12 7s. 4d.) Wiring diagram and instruction sheet, 2/9 post free.

ALUMINIUM CHASSIS (22 gauge), 8in. x 6 1/2in. x 2 1/2in., undrilled 5-, drilled to own specification at extra cost.

SCREW GRIP TOOL. (For working screws into awkward corners.) 1/9 post free.

POCKET VOLTMETER, moving coil, ranges 0.15 and 0.250 volts, D.C., 18.6.

KIT OF METAL TAGS, ETC. A strong cardboard case containing 13 boxes of approx. 100 each of different Solder Tags, washers, metal lead ends and self-tapping screws, 25-.

TELEVISION COMPONENTS. Guaranteed suitable for "Electronic Engineering" designs. Scanning Coils, 35-; Focus Coil, 33-; Line Transformer, 27.6. E.H.T. Transformer, £3 5s. Mains transformer, £3 15s.

Send 2d. stamp for our Brochure of Kits. Also details of our Practical How-to-Build-it Books, complete instructions and designs for the HOME CONSTRUCTOR.

HENBEST BROS., LTD.,

26, Green Lanes, London, N.13

Telephone: BOWES PARK 6289.

DO YOU FIND RADIO HARD WORK ?

To do anything really well involves hard work, but that is where we come in. Our technicians have designed really special coils and assembled them into units, together with all switching, trimmers, padders, iron cores, etc. All you do is wire the remainder of your circuit. These packs are 3-wave superhet, T.R.F., superhet with RF stage, push-button with gram, switching, etc. Send for your gift copy of "The Home Constructor's Handbook" of tested circuits, hints, formulae, components, etc. See how really easy and cheap radio can be! Space doesn't allow details, but you'll be amazed at our parts prices—about half the price you normally pay!

Send NOW for this 2 6 book which we are offering for a limited period ONLY for three 2d. stamps for postage, etc. Be introduced to our profit-sharing scheme! Earn easy money in your spare time!

RODING LABORATORIES (Electronics), Dept. P, 70, Lord Avenue, Ilford, ESSEX.

A FREE BOOK on Morse Code Training



There are Candler Morse Code Courses for Beginners and Operators.

Send for this Free "BOOK OF FACTS" It gives full details concerning all Courses.

THE CANDLER SYSTEM CO. (S.L.O.) 121, Kingsway, London, W.C.2.

Candler System Co., Denver, Colorado, U.S.A.

BULGIN

A Name famous in Radio



A. F. BULGIN & CO., LTD.

Bye Pass Road, Barking, Essex

Tel: Rippleway 3474 (5 lines).

Impressions on the Wax

Review of the Latest Gramophone Records

THE piano is featured prominently in the latest releases, the first being Artur Schnabel's interpretation of Brahms Intermezzo in E Flat Major, Op. 117, No. 1, and Intermezzo in A Major, Op. 116, No. 2, on *H.M.V. DB6505*. The first of these two Intermezzi has a few lines of poetry at the head of the score taken from a German version of Lady Anne Bothwell's lament, "Baloo, my Babe." It is one of Brahms' simplest and most popular piano pieces, though by no means easy to interpret successfully. Artur Schnabel plays the tune with great feeling, and conveys admirably the darker mood of the middle section. This great artist's handling of the somewhat less familiar A Minor Intermezzo is equally fine.

Chopin's famous Polonaise in A Flat has again been recorded and this time by Louis Kentner, on *Columbia DX1502* and, finally, two more of Chopin's works, Nocturne in B Major, Op. 32, No. 1, and Waltz in A Flat Major, Op. 34, No. 1, are played by Ponishnoff, on *H.M.V. C3773*.

At one time during political conflict between Finland and Russia the performance of Finlandia was forbidden. This tone-poem is so intensely national in sentiment that it has become almost a patriotic anthem for the Finns. Its melodies create the impression of its being a fantasia on genuine national airs; but the composer has stated emphatically that "the thematic material of Finlandia is entirely my own." Finlandia is, then, a national epic whose spontaneity is the result of infinite skill. It is early Sibelius, and it has for a long time been the most familiar of his works in Britain. Nevertheless, its fame endures, and a new recording of it under Nicolia Malko's spirited direction of the Philharmonia Orchestra, on *H.M.V. C3767*, will tempt many collectors.

Orchestra Recordings

First of the many orchestral recordings this month is Mendelssohn's well-known Overture "The Hebrides" (Fingal's Cave), which is in two parts on *H.M.V. C3770*. I have no hesitation in saying that music lovers will be only too eager to hear this record, which is beautifully played by the Halle Orchestra, under the able baton of John Barbiroli.

Bethoven is always a popular choice and this month we have two recordings of this composer's works. First is a spirited rendering of his Overture "Coriolan," Op. 62, by the Vienna Philharmonic Orchestra, conducted by Wilhelm Furtwangler, on both sides of *H.M.V. DB6625* and, secondly, his Romance No. 2 in F. Major, Op. 50 features Gioconda De Vito on the Violin accompanied by the Philharmonia Orchestra, conducted by Alberto Erede, on *H.M.V. DB6727*.

Another interesting recording is supplied by the Royal Opera House Orchestra, Covent Garden, conducted by Hugo Rignold, with Messenger's "Les Deux Pigeons" Ballet music. It occupies four sides of two 12in. records, *H.M.V. C3778-9*.

Once again Kostelanetz has succeeded in re-introducing two popular tunes in a new guise

with his latest recording on *Columbia DX1504*. Under his skilful baton Cole Porter's "I've got you Under my Skin" is presented in a distinctive and colourful music setting. On the reverse side is another evergreen, "In the Still of the Night," which is always popular whenever it is played.

Variety

Here we have a wide selection and readers can make their choice from the following. Gwen Catley has recorded "The Nightingale and the Rose" and "I'll Have Revenge" (Vengeance Aria) from "The Magic Flute," on *H.M.V. B9674*. Both pieces are satisfactory vehicles for this artist's astonishing technique.

"To the Children" and "In Summertime on Brecon" is sung by that talented baritone Robert Irwin, on *H.M.V. B9673*, whilst Dinah Shore sings two romantic ballads, "The Best Things in Life are Free" and "I'm Yours," on *Columbia DB2438*.

Light orchestrations are supplied by Peter Yorke and His Orchestra with "Say it Every Day" and "Souvenir De Paris," on *Columbia DB2441*, and the Queen's Hall Light Orchestra with "Portrait of a Lady" and "Music in the Air," on *Columbia 2436*. The popular "Chicken Reel" coupled with "Fiddle Faddle" has been recorded by the Boston Promenade Orchestra, conducted by Arthur Fiedler, on *H.M.V. B9676*, and George Melachrino conducts his string orchestra through "Moonlight Serenade" and "Portrait of a Lady," on *H.M.V. B9678*.

Of interest is Three Marches—"Blue Bonnets," "Bonnie Dundee" and "Dovecot Park," coupled with "Mist Covered Mountains" (Slow Air) and "High Isles" (March), played by the Bowhill Colliery and District Pipe Band, on *Parlophone F3381*. This band won the world championship at Edinburgh in 1947.

Dance music is supplied by Larry Green and His Orchestra with "Far-away Island" and "Either it's Love or it Isn't," on *H.M.V. DB1213*, and Roberto Ingliz and his Orchestra with "Taboo-Afro-Cubano" and "Dengozo-Samba," on *Parlophone R3129*.

If you like swing, then you should listen to "Disc Jockey Jump" and "Hop, Skip and Jump," played by Gene Krupa and his Orchestra, on *Columbia DB2386*, and Benny Carter and his Orchestra with their recording of "Plymouth Rock" and "Melancholy Lullaby," on *Columbia DB2385*. Finally, there is a wide selection of all the latest popular numbers played by leading British bands.

SAVE THAT CARTON

Every empty breakfast-food, sugar, cigarette, soapflake packet, is urgently needed for salvage.

MAINS TRANSFORMERS

Improved Machines improve Production and lower Costs. OUR NEW MULTI WINDERS are turning out thousands of Mains Transformers each week. HENCE we can pass this saving on to our many friends. LOOK!

Primary: 200/250 v. Sec. 350-0-350 v. 80 m.a., 6.3 v. 3 a., 5 v. 2 a.; or 250-0-250 with 4 v. or 6.3 v. heaters. All fully shrouded.

Prices better than pre-war.

Drop thro' chassis type 17/6
Chassis Mounting 19/6
Postage, 1/1d.

H. W. FIELD & SON LTD.,
Cable Works, Station Road,
Harold Wood, Essex.
Ingrebourne 2642

FOR G200 RADIO

POWER SUPPLY UNIT No. 4. 12 volts D.C. input. 250-300 volts H.T. contains 4 metal rectifiers, vibrator, smoothing circuits, etc. Ideal for Car Radio. 19/6 each, or converted for 230 v. A.C. Mains to give 400-300 volts H.T. together with 4-5-6.3-12.6 volts for heaters, 45/-.

GUARANTEED VALVE BARGAINS. 6L5, 6J5gt, RL16 (VR137), 2X2a, KTW61, 5J- each. 6AC7, 6SA7, 6SN7, 6SG7, 6SH7, 6SK7, 6J6 each. 6K7, 6J7, 6K8, 6L7, 6C6, 6B8, 9J6 each.

TRANSMITTING VALVES. RK34 (CV18), 6J6, PT15, 2C26, 6J6, 12J6, 832, 35T, 35J- each. Int. Octal Valveholders, 4/6 doz.

A. C. HOILE,
VILLAGE, MAIDSTONE.
Loose 83579.

WE OFFER

A large range of used and new Test Equipment, Converters, Recorders, Amplifiers, Motors, Transformers, etc.

All guaranteed and at very attractive prices.

We buy good modern used equipment of all types for spot cash.

UNIVERSITY RADIO LTD.

22 LISLE STREET, LONDON, W.C.2
Tel.: GER 4447 and GER 8582

THESE ARE IN STOCK

THE AMPLIFICATION AND DISTRIBUTION OF SOUND, by A. E. Greenlees. 16s. Postage 6d.

RADIO LABORATORY HANDBOOK, by M. G. Scroggie. 12s. 6d. Postage 4d.

VALF. TECHNIQUE, by A. J. Bayliss and E. J. Williams. 3s. 6d. Postage 2d.

RADIO RECEIVERS AND TRANSMITTERS, by S. W. Amos and F. W. Kellaway. 25s. Postage 6d.

RADIO ENGINEERING, by F. E. Terman. 42s. Postage 9d.

WIRELESS SERVICING MANUAL, by W. T. Cocking. 10s. 6d. Postage 4d.

RADIO UPKEEP AND REPAIRS, by A. T. Witts. 7s. 6d. Postage 4d.

RADIO SERVICE TEST CLEAR, by W. H. Czazaly. 6s. Postage 4d.

TELEVISION RECEIVER CONSTRUCTION—Ten Articles from "Wireless World." 2s. 6d. Postage 2d.

THE MATHEMATICS OF WIRELESS, by Ralph Stranger. 7s. 6d. Postage 4d.

FUNDAMENTALS OF RADAR, by S. A. Knight. 10s. Postage 4d.

THERMIONIC VALVE CIRCUITS, by E. Williams. 12s. 6d. Postage 4d.

WORKED RADIO CALCULATIONS, by A. T. Witts. 6s. 6d. Postage 4d.

RADIO HANDBOOK SUPPLEMENT. 2s. 6d. Postage 4d.

We have the finest stock of British and American radio books. Complete list on application.

THE MODERN BOOK CO.
(Dept. P9) 19-23 Praed Street,
London, W.2

PRATT'S RADIO,

1070, Harrow Rd., London, N.W.10.

(Old Scrubs Lane). Phone: LAD. 1794.

AMPLIFIERS.—Collego AC10C, 10

4-valve, separate mike stage, separate

mike and gram, inputs and faders, tone

control, A.C. feedback. Price, £8/18 6.

Model AC15E.—15 watt 6-valve, with

Push-Pull output stage. Feedback over

2 stages. Separate mike stage. Sepa-

rate mike and gram, inputs and faders,

tone control, complete with case. A.C.

Supplies H.T. and L.T. to radio feeder

unit, £14/14 0. Model U10E.—10 watts

output, similar to AC15E, but for D.C.A.C.

mains. Complete with case, £12/12 0.

Model U10C.—Similar to U10E, but chassis

type amplifier, £10/18 6. All above match

3.8 and 15-ohm speakers. Model AC4C.—

A.C.4 watt, chassis, 1 pick-up or radio

amplifier, 3 valves, Feedback. Complete

with o.transfr. (3 ohms), £5/9 6. Model

U4C.—As AC4C but for D.C.A.C. mains,

£5 5 0. Demonstrations available.

AMPLIFIER ACCESSORIES.—Speakers,

Goodmans 12in., 130 ohm, £10/10 0.

7.5in. 200 ohm, 20/6. Bola 8in.

24"; Microphones, Rothermel Crystal

105"; Pick-ups, Rothermel Crystal 60";

Gramophone Motors, "Conrad" constant

speed with 9in. turntable, A.C. £2 5.

MISC. "ELL. ANEOL'S."—Wearite P. Coils,

3"-each. Dual range Coil with reaction,

4 6"; Standard I core I.F.s, 465 kc/s, 13 9";

Wearite £1; Wearite M400, 21"-pair;

Midget I-valve Xformers, 3-1, 6.3, 5-1 6 6";

Speaker Xformers; Pentode 5 9. Midget

Universal 4 6; Sw. Multi-radio, 7 6; 30-watt

23 9; Class B Driver 7 6; Mains Xformers,

Shrouded 350-0-350v, 6v, 5v, 80 m.a., 23 6.

100 m/a (also 4v, 4v), 27 6; 150 m/a Un-

shrouded, 35/-; Presets, 50 pf, 10d., 100 pf,

1 3, 250pf, 2/-; .0005 2 3, Linkcord, 2 2 way,

60 ohms ft., 8d. ft. Voltage Droppers, with

ft., .2a (1,000 ohm), .3a (800 ohm), 4 10 each.

Speakers: 5in. P.M. w.tr., 17 6; 5in.

P.M. 1 tr., 13 6; 8in. P.M. 19 6. Octal

bases, 6d.; Condensers: 25 mfd., 25s. 1 8;

8 mfd., 500v, 3 6; 18 mfd., 450v, 3 6; 10

16, 450v., 7 9, etc. Dielectric Variables,

.0003 and .0005, 3/-.

VALVES.—PRACTICALLY ANY STANDARD

VALVE AVAILABLE EX-STOCK. C.O.D. or

C.W.O. Post paid over 41. New goods only.

MORTONS

MAKE A CRYSTAL SET FOR SIX

SHILLINGS.—Two components only re-

quired. A special coil ready wired to

terminals. Price 3/6 (instructions enclosed),

and a dustproof detector, price 2/6, or

6/- the two post-free.

HEADPHONES.—Suitable for crystal

set, 7/6 pair. Post free.

MOVING COIL MICROPHONES in

bakelite case, 6/- post free.

SIMPLE HOME TELEPHONE.—Can

be used by a child. Nothing to give shocks

or go wrong. A great novelty. Complete

with connecting wire and ready for use.

10/- post free.

RADIO CABINETS.—Moulded bakelite.

Size 11 1/2in. x 6 1/2in. x 5 1/2in. Supplied with

attractive two colour glass dial and back-

plate. Ready drilled chassis. 5in. loud-

speaker, and S.M. drive. £3 complete plus

1/6 post-pkg. Post orders to

MORTONS

13, Camden Road, Walthamstow,

London, E.17

Callers to 17, Station Road, Walthamstow,

E.17. Near St. James's Street Station, on

685 or 687 trolley bus route.

Trade Supplied.

SPECIAL NOTICE.—We have just

opened this new depot at 17, Station Road,

where we shall be delighted to greet our

customers in person.

L-R'S IN STOCK

CASH OR EASY TERMS

GOODMANS' "AXIOM TWELVE"

SPEAKER UNIT. One of the finest quality

speakers available to-day. Cash price

£8 8 0

AVO MODEL 7 Cash price £19 10 0

VALVE TESTER, complete £16 10 0

And practically the whole AVO range

SPECIFICATIONS OF THE ABOVE

ON REQUEST

*We can supply on convenient terms much

of the Radio and Electrical Equipment at

present available, all transactions being

strictly between customers and ourselves.

Please let us know your requirements.

THE LONDON RADIO SUPPLY CO.

(Est. 1925)

BALCOMBE, SUSSEX

Open to Discussion

The Editor does not necessarily agree with the opinions expressed by his correspondents. All letters must be accompanied by the name and address of the sender (not necessarily for publication).

National Concert Hall

SIR,—I have just been reading Maurice Reeves' article in your July issue, with regard to a proposed national concert hall.

Mr. Reeve voices the opinion that taxpayers would not view with favour a proposal that a national concert hall be built in London and so benefit only Londoners.

Does he not forget the fact that London is the largest city in the country and therefore not only contains more taxpayers but more potential patrons of the concert hall?

There is also the fact that the transport systems serving the outlying districts of London are far better than those serving similar districts around provincial cities, thereby increasing still further the potential patronage of such a hall.

Most provincial cities are already well equipped with concert halls—the Philharmonic Hall in Liverpool, to mention but one.

In any event, is not London the most appropriate place for a national concert hall, being the national capital and the birthplace of the Proms?—R. MAYNEORD (Halton).

Measuring Meter Resistance

SIR,—In your June issue you have an article on measuring meter resistance. I read it with interest, but thought it a very complex way of doing a relatively simple job, especially as it involves so much calculation where a small error

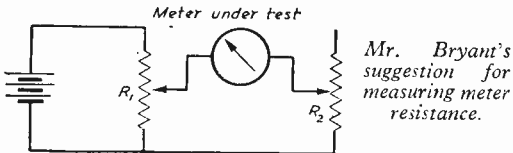

could produce a large mistake, so I would like to give my method of doing the same job.

The equipment needed is a battery, two wire-wound potentiometers and an ohmmeter, and, of course, the meter to be measured.

Set up as follows:

Set R_2 to zero ohms then advance R_1 until meter reads full scale. Now advance R_2 until meter reads half scale. Using ohmmeter, measure amount of R in circuit and that is value of meter resistance.

There are no mathematical calculations and the accuracy of the test lies in the accuracy of the ohmmeter and care in reading same.—G. BRYANT (Salisbury).

Correspondents Wanted

SIR,—I am a licensed Norwegian amateur, living near Bergen. I want to practise my knowledge of the English language (and to get it

corrected) and would like to correspond with an English licensed amateur of my own age (30 years).

I am working a 45 watts Tx on 80 mtr. cw., and hope to come on the air on "fone" soon.

At the same time I will take this opportunity of thanking you for a very fine magazine with many practical hints for the amateurs.—JINN JORGENSEN, LA5XA, c/o De Forenede Motorfabriker, Bergen, Norway.

SIR,—I have recently been released from the Services after having served in the R.A.M.C. out in Germany, and whilst sorting out some of my old rig I have acquired a renewed enthusiasm in short-wave radio construction; in fact, I have decided to try for a P.M.G. amateur transmitting licence. Therefore, I would like to make contact, through your most excellent magazine, with someone about my own age (20 years) equally interested in short-wave radio construction and who is within reasonable distance from my home.—L. A. ROUSE, 3, Gold Hill, Saffron Lane, Leicester.

Better Listening Campaign

SIR,—I have read with interest your article in this month's issue of PRACTICAL WIRELESS, "Campaign for Better Listening," and feel that such a campaign is badly needed. But as a sales campaign I fear it must be doomed to failure or limited success.

If enthusiasm for listening counts for anything, then I must take 100 per cent. marks, and nothing would give me greater pleasure than to see my home adequately fitted with radio and television.

In other words, to a radio retailer I should be a good potential customer, because he hasn't first to convince me that I need a television set and a couple of radios. But, in fact, I am not a good potential customer because I haven't the necessary medium with which to purchase my radio requirements.

My financial position is no worse than average, in fact, probably a little better, but still I cannot buy radio sets *ad lib.*, neither can the millions of other average families. It is this fact that it seems so difficult for the Government and manufacturers to understand. An average family to-day cannot get sufficient of even the more necessary commodities such as food, clothing, furniture, etc. This is not because the goods are not to be had. They are (with the probable exception of food), but there isn't sufficient money to buy them. The Government phrase, "Too much money chasing too few goods," to my mind is utterly ridiculous. If this were the case shops would be empty instead of full; and what shops are more full than radio shops!

Perhaps we amateurs are a little more fortunate than most; we can at least make our own sets at a fraction of retail prices in these days of surplus equipment. Even so, I have an incomplete receiver on the bench awaiting some of its more expensive

parts, and I am now calculating how many cigarettes I will have to give up to buy a mains transformer, but perhaps the youngster will need a pair of shoes instead.—D. J. W. BAILEY (S.E.5).

SIR,—I am writing in response to your invitation in the leading article in the issue for September, regarding the forthcoming campaign for better listening.

I agree entirely that there is too much dance music in the B.B.C. programmes. Could not one station, say, the long-wave, radiate a continuous programme of light, light classical and band music, which would fulfil the purpose of "Music while you work," but could be tuned in at any time.

I know of some who have resorted to a gramophone pick-up, as they consider programmes so poor, but good though it can be, it is not a substitute for continuous radio listening.

Referring to the demand for receivers, it seems necessary to get people informed of what is to be obtained, as the majority simply *do not know*, and are obliged to find out for themselves the troublesome way, i.e., by bitter experience.

The trade prefers to sell sets than parts for constructors, but even if a man does no more than get lost in the labyrinth of developments in a pursuit which, for speed and novelty, excels all others, he will, more than likely, come to the point of buying one or more trade sets!—M. KEVIN HUGGARD, Co. Dublin.

C.R. Tube Data

SIR,—Reference to the letter published in the September issue of PRACTICAL WIRELESS from Mr. Paul Telco. The V.C.R.97 tube is quite suitable for any voltage between 800-2,500 and Mr. Telco is quite incorrect in saying that this tube will not work with less than 2,000 volts.

A very good picture can be obtained with only 800-900 volts. Mr. Telco will find he will have no difficulty whatever in getting a first-class picture even with EHT as low as 800 volts, although with this voltage it is desirable to view in almost total darkness.

I feel that Mr. Telco's letter may deter other readers from using the V.C.R.97 whereas, in fact, this is an excellent tube for making an experimental television receiver.—B. K. ROWELL, G5RL (St. Ives).

SIR,—With reference to my home-built televisor, and the note which Mr. Telco made re the E.H.T., a word from me and an explanation may help those people who are using V.C.R.97 on a low voltage for television purposes.

One of the advertisers in PRACTICAL WIRELESS sells a 1,000 volt oscilloscope kit which includes everything necessary for the E.H.T., although in my own case I found it necessary to place an additional smoothing condenser in the circuit, as the picture was modulated with a dark hum bar.

Mr. Telco states that he obtained 987 volts from his power pack; this I am rather inclined to doubt as when rectification and smoothing losses, also the small current drain (about one-third of a milliamp), are taken into account, I think you will find the voltage applied to the tube is considerably less than 987.

My apologies to those people to whom I have not yet replied but I am slowly working my way through the letters. I am doing a little experimenting with a considerably higher voltage (2,700) on the tube and greater output from the time-bases. In conclusion, I would say that if anyone is stuck and the problem seems insurmountable, if they would care to ring me at home (WORDSWORTH 6843) I would be glad to have a chat with them and give what assistance I can.—J. ETHERDEN (Kenton).

Straight v. Superhet

SIR,—I quite agree with Mr. J. R. Davies' remarks on superhet construction. I have constructed several superhet receivers, mostly from "junk" components, and consider the 3-valve superhet, consisting of F.C.-I.F.-det./out. far superior to the average "straight" receiver, and quite simple to build.

This 3 valve line-up will receive the B.B.C. Light Programme on 261 metres quite well, without interference from the powerful B.B.C. European Service on 267 metres, but on the "straight" sets I have either constructed or handled in *this locality*, it is almost impossible to eliminate the European Service, and wave-change switching has to be incorporated to receive the 1,500 metre "Light" transmission.

Although a signal generator is necessary for really accurate alignment of the superhet, I find the method described in PRACTICAL WIRELESS recently quite satisfactory.—A. C. BRADFORD (Brighton).

Ex-R.A.F. Equipment

SIR,—There have been a considerable number of letters from readers, regarding the ex-W.D. No. 18 Mark III receiver. No writer appears to realise that this receiver, in itself, is incomplete. This set forms part of a transmit/receive apparatus, the aerial tuning unit being common to both transmitter and receiver. The effect of the aerial tuning is quite considerable, and any receiver, without the transmitter, should have an aerial tuning unit incorporated. Normally the two pieces of apparatus are coupled together, the receiver getting its power supplies through the transmitter.—L. H. STEVENS (Denbigh).

Ex-Government Surplus

WILL readers please note that under no circumstances can we undertake to modify ex-Government surplus stock to suit individual requirements, and we shall be glad if our advertisers will take note that, in selling such apparatus, they should not advise readers wishing to adapt such apparatus to write to us. We must also point out that this apparatus is not covered by the makers' guarantee.

At the same time we must regretfully discontinue the lists which we have previously published on this page asking for readers' assistance in regard to ex-Service equipment as it has now assumed such large proportions.

CLASSIFIED ADVERTISEMENTS

RATES: 3/- per line or part thereof, average five words to line, minimum 2 lines. Box No. 6d. extra. Advertisements to be prepaid and addressed to the Classification Manager, "Practical Wireless," Tower House, Southampton St., Strand, London, W.C.2.

Eleventh Sale.

G. R.

By Order of the Minister of Supply,
WITHOUT RESERVE

**STOKE ORCHARD AIRFIELD,
NEAR CHELTENHAM, GLOS.**
A sub-site of No. 7 Maintenance Unit,
R.A.F., about 1/2 miles from Cheltenham,
5 from Tewkesbury and 12 from Gloucester.

J. PEARCE POPE & SONS
Will sell by Auction a large quantity of
**SURPLUS AMERICAN RADIO AND
ELECTRICAL EQUIPMENT**
Including

Radio Receivers, Modulator Units, Amplifiers, Rectifiers, Loudspeakers, Motor Generators, Dynamotors, Voltage Control Units, Transformers, Condensers, Switches, Sockets, and extensive quantities of other radio spares,

on
FRIDAY, OCTOBER 29th, 1948
At 11 o'clock punctually.

View Days: Wednesday and Thursday, October 27th and 28th, from 10 a.m. to 4 p.m., also on day of sale from 9 a.m. to 11 a.m. Catalogues, price 6d. each (postal orders only, may be obtained from

J. PEARCE POPE & SONS, St. Aldate Chambers, GLOUCESTER. Phone 21274/5.
ADMITTED BY
CATALOGUE ONLY.

EDDYSTONE Short-wave Radio, Stratton and Co., Ltd., are now in a position to consider applications for a limited number of registered dealerships in areas not already covered. Applications are invited from expert and enthusiastic short-wave specialists at home and abroad. Write Stratton and Co., Ltd., Eddystone Works, Alvechurch Road, West Heath, Birmingham, 31.

RADIO Constructor's Catalogue. 20-page Catalogue, packed with hundreds of items of interest to the constructor, service engineer and experimenter, plus details of our Technical Query Service. Price 4d., post free.—Cussins and Light, Ltd., The North's Leading Radio Engineers, King's Square, York.

RECEIVERS & COMPONENTS

KITS IN SEMI-WIRED STATE. Complete in every detail. All main components mounted and wired. Beautiful walnut cabinet, 13in. x 8in. x 6in. deep. M/L wavebands, 3 valves + A.C. D.C. mains; simplest instructions and circuit included; 4 controls; vol./off, tone, w.c. tuning; wiring time 1 hour. £7/16 10/- in postage. C.O.D. or C.W.O. and enquiries from:—Lewis Radio Kits (Dept. B2), 322, High Road, Wood Green, London, N.22. Phone: Wood 5997.

GLEN RADIO for quality components at lowest prices. Send for lists.—411, Union St., Aberdeen.

BRAND NEW ex-Government Stock at Really Keen Prices. 6 valve Beacon receiver, 6SA7, 6SK7, 6SF7, 2-25L6, 200-400 k/c/s. 4 x 4 x 7 1/2, castor convertible 200-1000, 11-way switches in panel, case, 200-4 valve amplifiers, 2 7Cs, 7F7, 7Y4, 10/-; 2 valve pre amplifier, 6SL7, 28D7, 12/6; 2 valve battery amplifier type A1134, QPP output, packed in wood case, 15/-; new mains transformer, 350-0-350, 16 m.a., 6.3 v. 3 amps, 5 v. 2 amp. half-exposed, 22/6; 24 volt relay unit, 4/6; sh-w.D. VR91 equiv. EF50, 8/6; good quality lead and phone jack, 1/6; low impedance headphones and supply, 8/-; Bendix Radio Compass Units, No. B.C. 433, 16 m.a. with control box, limited factory, £4 10s.; modulator units, B.C. 456 B, 15/-; B.C. 455 B, short wave receiver, complete with dynamotor, 55.-; 16 m.m. gun type camera, £2 7s. 6d.; compressors with driving spindle, £1 5s.; compressors without driving spindle, 15s.; suppressors 1/- each; we are stockists to Avco, Pullin meters, Connoisseur, Goldring pickups, etc., Wharfedale, Goodmans, Bryce, Elstone, Eddystone, Raymart, Tungram, B.V.A., etc. Carriage 7d. Orders over 20/- carriage paid. The Super Radio Company (Bradford), Limited, 39, Bank Street, Bradford, Yorkshire.

SPECIAL OFFERS.—1155s. as new, 10 valve, £7, few only. Power Pack to suit as per W.W. inc. 6F8 output, £5/5 0. 10 mfd. 1,000 v. T.C.C. block paper cond., 7/6. 92k Ext. Speakers, excellent value, Trugnol v.c. 8in. Grampian unit, 35/-. Cabinet only, 15/6. Unit, 16/6. V.C.S., 6/-—All goods guaranteed. Post paid over 10/-—G. A. Taylor, 125, Manchester Rd., Denton, Manchester.

BEST VALUE: Vet. All Brand New, M.C. Phones and Mic. Boxed, 5/6. Super American Throat Mics. Boxed, 4/- Type 26 Converters, 37/6. 350-0-350 6v. 5v. Mains Transformers, 90 m.a. 19/- . 5 mfd. 3,500v. Condensers, 5/- each, 1 mfd. 2,500v. Cond., 2/- . Boxed, 807's at 10/- 504G at 9/- 524, 8/- . R107 Receiver, perfect, £16/10/- 6SN7GT Valves at 8/- 5in. M.C. Speakers at 15/6. 1 mfd. 600v. Aerovox Condensers, 9/6 doz. BC348 Receivers, £16/10/- . Ceramic Coil Formers, 4 1/2in. x 2in. diam. threaded, 4/6. 7-Complete Vibrator Packs, 12 volts input, 200v. at 70 m/a smoothed D.C. output, 2id. stamp for many other super buys.—Radio Constructors, 28, Spital Hill, Sheffield. Direct Agents for Labgear and Denon. Enquiries welcome. Trade supplied. **EVERYTHING** for the wireless constructor. Send stamp for price list.—H. Tabner, 118, Nightingale Road, Hitchin, Herts.

ELECTRO CONDENSERS.—500v. 8 mfd. 3/-; 4 mfd., 2/8. Mains Transformers, 27/- All new stock. Send for cat-price list to 384, Two Mile, Kingswood, Bristol.

SHLEUMER Metal Rectifiers.—Any output up to 24 v. 5 a., 16 discs, 4 1/2in. dia., 20/- each. 10 in. No. 6, no extra charge for 15 plus aircraft items. Send 1d. S.A.E. to K. R. Whiston, 22, Hall Street, New Mills, Stockport.

MCR1 receiver complete as new. Offers, 22, Ivorah Avenue, N.W.10.

TESTED GOODS.—Volume controls, 1/6. M.C. Mikes w/switch, 5/-. Dual-range crystal kits, w/circuit, 2/6. 5in. P.M. speakers, 10/11. 8in., 17/6. Multi-range speakers, 12s. midset, 3/6. Intervalve, 2/6. Miko, 1/6. Rotary switches, most types, 1/6. List 2id. Carter's, 67, Bell Lane, Marston Green, Birmingham.

R442A Metered Aerial Relays, 6/- . Metal Rectifiers, 600v. 30m.a. 3/-; 60v. 20 m.a. 2/6 + 1/2s. J.A.S. Octals, 1/4v. 1259, 1291, 11N5, 11C6, 5/6. Headsets, 12s. with Mic., 6/6. L.F. chokes, 300 ohm 100 m.a., 4/6. Wirewound pots, 12 ohm, 5 amp., 200 ohm, 5a. 6/- . Pyrex lead-ins, 1/- . Bakelite pulleys, 6d. Crystals 8 m/cs, 5/-; 7010, 7500, microammeters 0-100 2/4, 250 3/6. Condensers, 30mF 100v., 1/6; 0.1mF 1,000v., 1/- . 001mF 500v., 9d. Modulator Units, BC456A 3v., 17/6; T207A Klystron, 5/6; I.P.F. (13 valves), 22/6. Yaxley's 3-pole 8-way 0.3mk 3.6 4-volt 2-way, 2/6. Eobel lampholders, 1/3; shaded 1/9. BC340 Control boxes, 7/6. 2in. M.C. 0-1 Ammeters, 7/6; 3in. MI 20v., 7/6. Valves: EB34, SP41, SP61, 3/6; 6SN7-6SL7, KTW62, 5R4G, 6/- . General Clockwork Impulse Generators, 15/- . Rx Unit 194, £4. 4 valves, 6/6. C.W.O., S.A.E. all enquiries.—Benson, 308, Rathbone Road, Liverpool, 13.

SHOP BY POST. We pay all carriage, packing and postage. High grade ex-Government and new goods of the highest quality by all leading makers. Send 2id. stamp to order for our bargain list. Here are a few examples of the value we offer: Metros 0-350 or 0-500 mA, H.F., 3/11; 0-500 micro amp. scaled 0-15, 0-600 volt, 6/6; Weston Backward Reading 0-1 mA, scaled 0-120, make ideal S meter, etc., 4/11; G.P.O. 200 mA, 25 v. 2A, receiver, £2 11/- 230 volt motor approx. 1 h.p., 5/11; 230 volt 4 h.p. int. rating, 79/6; Twin, tough rubber-covered cable, 5/- doz. yds.; R.A.F. carbon microphones, 2/6; rectifier units include transformers and metal rectifier, 230 volt, 10 v. 250 mA, 1/1; 15-4 valve, 0005 tuning condenser with trimmers, all new in boxes, 6/6; J. B. slow motion drive with knob and dial, 2/9; wave-meter type 1117, complete with matched valves and charts in transit case, 75/-; battery eliminator 230 volt A.C. in 120 v. 30 mA, stabilised out all new, 35/-; camera control units make time switch, etc., for 12 or 24 volt A.C. or D.C., 20/-; 6B series radar units, include 6in. tube, 600V, 8 valve, etc., 100/-; 100v. 70v. receiver units containing volt motor generators, 11 standard valve resistances, condensers, relays, etc., 39/6. We are agents for Woden transformers and electronic equipment and invite your enquiry. Woden Wireless Stores (Mail Order Dept.), 20, Stoney Road, Wolverhampton, or (Callers Only), 40, Stafford Street, Wolverhampton.

POST-WAR RADIO at pre-war price! The N.R.S., "Fidelity" 5-valve A.C./D.C. Medium and S.W. Superhet, neg. feedback, all active 2-colour picture, complete, guaranteed, 99 kns., incl. tax and delivery. Exhaustive **Constructional Manual** enabling even beginners to build a powerful 5-valve 3-waveband A.C. Superhet of exceptional power and range, price 5/-; all parts available, inc. figured walnut chassis, A.C./D.C. model, too. Also our ever-popular T.R.F. 3-valver (mains), complete kit with cabinet, 28/10/- . We Now Announce 4-valve All-dry Battery version of our "Overseas 5/-" by popular request; Constructional Manual, 3/- . The **M.N.S. Audio Amplifier** for A.C. 200-250 v., 4 wats. undistorted, 3 valves, pickup and tuner inputs (volts available), volume, tone and neg. feedback controls; complete, tested, £5/19/6. Send 2id. note for leaflets on above and special P.P. Bargain List, Heater transformers, 6.3 v. 1.2 amp., 12/6 (11/-) . Universal type tapped 4v., 5v. and 6.3 v., 12 wats., 17/6. Iron-core I.P.S., 465 kc/s. standard or midset, precision adj., £5/19/6. Sprawl valves: E.M.I. 5in., 11/6; Goodmans, etc. 6in., 19/-; R.A. 8in., 21/-; Rola 10in., with trans., 25/- . Standard output trans., 6/6; multi-ratio, 8/6. Wharfedale Golden, 3 and 15 ohms, 75/- . **Gramophone Equipment:** A.C. gram. motors, 8in., table, 75/-; Collaro, ditto, with 12in. table, variable speed, 118/4; Collaro motor/pickup/auto-stop combined unit, A.C., £9; A.C./D.C., £12/18/9. 8in. 5/8 carr. Plessey super-quick action A.C. Record Changers, with mag. Pickup, £18/9/6. 8 1/2 carr. Ex-coar. P.P. tested 100 per cent., 6/5G, 6/5GT, EB3C, EP50, 5/6 (5/-) . **Brand New Valves**, best makes only, guaranteed: EF36, EF39, EL32, ECH35, 15D2, 6X5, 5Z4, 8/- (7/6); 6K8G, 6S7, 6KT6, 6V6, 6V6G, 6R6, 6F6, 6N7, 6N7G, ECC31, 6SN7GT, 6J7G, KTY30, FW-500, 5U4G, U52, 10/- (9/-); 6L6, 6L6G, 6L6 (12-10); PX25, 15/- . Matched pairs gladly supplied. We specialise in Instruments by mail order, 2id. for advice and details AVO catalogue, TERMO, C.W.O. or C.O.D., bracketed prices lots of three, postage extra under £5. N.R.S., 102, Parkhill Rd., London, N.W.3. Tel.: Gulliver 1453.

"TELEVISION."—Build your own receiver in 24 hours, unit-construction (not ex-Govt.). Everything provided, including 10 blueprints (practical and theory) also step by step instruction guide, all parts can be supplied separately. You must use our new improved sound and vision coils circuit supplied. We supply everything Radio and Television. A personal service to the home constructor. Send 2id. stamp now for free literature. All enquiries to the office, T-H Products, 92, Leathwaite Road, Clapham Common, S.W.11. Phone: BAT. 4869.

ALUMINIUM chassis and panels, any size, plain or punched for valveholders, meters, etc. Finished bright, grey or black, 75/- crackle, from 3/9 each. Precision built superhet coil packs, 3 waveband, aerial and oscillator type, 37/6, ditto with H.F. stage, 43/- 46/6. IFTs iron cored, 15/6 pair. Data sheets on request. Prompt delivery. EAD, 13, Bence Lane, Darton, Barnsley.

TELEVISION KITS and Complete Chassis. Amplifiers, 5-500 wats. Feeder Units, 75/- . The complete range of Denco Products, including the latest C77 Turret (with R.F. stage). Also 5 and 10 waveband Gram Chassis covering 3-60 mc/s. and 150-1,500 kc/s. S.A.E. for leaflet of prices. Items, or illustrated catalogue, price 3d. Masons (PW) Wivenhoe, nr. Colchester.

HARRY JAMES PRODUCTIONS, 270, Leith Walk, Edinburgh, 6. Mail Order Specialists, C.O.D. or Cash with Order. Electrolytics, new, not W.D. surplus. B.I. Hints, etc., 8 mids., 3/2; 16 mids., 5/3; 15-8 mids., 6/3; 8-6 mids., 6/- 4 mids., 2/9; 12 mids., 25/-; 2 mids., 9/-; 6 mids., 2/9. T.R.F. Chassis, 3/6. T.R.F. Coils, M & 7/9 pair. Condensers, 0.1, 0.01, 0.05, 500-20, 6d. each. Variable 2 gang, 0.0005, 12/-, with Trimmers, 13/6. Loudspeakers, 5in. P.M. 12/6. 8in. 100 ohms, 19/6. 8in. 500 ohms, 29/6. 8in. P.M., 25/- . Volume Control, Long Spindle, M. 5/6; L/S, 3/6. Mains Transformers, 350-0-350, 6.3 v. and 5 v. or 4 v. Heaters, 30/- . Output Multi Ratio, 9/- . Valve Holders 5 pin, with and octal, 7d. each. Amphenol type, 9d. each. Voltages 0.2 amp., 4.2 amp., 100 ohms, 3/9; 0.3 amp., 800 ohms, 4/9. Line cord, best quality, 0.8 amp. 3 core, 9d. per ft. Special Offer, 0-1 milliamp. metres, suitable for multi meters, etc., price 12/6. Also Wires C.O.D. Woden Stores of British and American types. Enquire for anything in Radio, S.A.E. for lists.

Practical Wireless BLUEPRINT SERVICE

SPECIAL NOTICE

THESE blueprints are drawn full size, and containing descriptions of these sets are now out of print, but an asterisk beside the blueprint number denotes that constitutional details are available, free with the blueprint.

The index letters which precede the Blueprint Number indicate the periodical in which the description appears: Thus P.W. refers to PRACTICAL WIRELESS, A.W. to Amateur Wireless, W.M. to Wireless Magazine.

Send (preferably) postal order to cover the cost of the Blueprint (stamp over ad. unrepayable) to PRACTICAL WIRELESS Blueprint Dept., George Newman, Ltd., Tower House, Southampton Street, Strand, W.C.2.

PRACTICAL WIRELESS	No. of Blueprint	Description	Code
CRYSTAL SETS			
Blueprints, 1s. each.			
1937 Crystal Receiver	PW71*		
The "Junior" Crystal Set	PW94*		
STRAIGHT SETS. Battery Operated.			
One-Valve: Blueprints, 2s. each.			
AB-Wave Unipen (Pentode)	PW31A		
Beginners' One-valver	PW85		
The "Franklin" One-valver (HF Pen)	PW93*		
Two-valve: Blueprints, 2s. each.			
The Signal Two (D & L P)	PW76*		
Three-valve: Blueprints, 2s. each.			
Selectone Battery Three (D, 2 LF (Trans))	PW10		
Summit Three (HF Pen, D, Pen)	PW45*		
Hill-Mark Cadet (D, LF, Pen (RC))	PW48*		
P. J. Cannon's Silver Souvenir (HF Pen, D (Pen), Pen) (All-Wave Three)	PW49*		
Cameo Magnet Three (D, 2 LF (Trans))	PW51*		
1936 Sonotone Three-Four (HF Pen, HF Pen, Westector, Pen)	PW53*		
Battery All-Wave Three (D, 2 LF (RC))	PW55*		
The Monitor (HF Pen, D, Pen)	PW61*		
The "Duck" All-Wave Three (D, 2 LF (RC & Trans))	PW72*		
The "Ripple" Straight 3 (D, 2 LF (RC & Trans))	PW82*		
P. J. Cannon's Oracle All-Wave Three (LF, HF, Pen)	PW78		
1934 "Arband" All-Wave Three (HF Pen, D, Pen)	PW84*		
P. J. Cannon's "Sprite" Three (HF Pen, D, Pen)	PW87*		
The "Hurricane" All-Wave Three (SG, D, Pen, Pen)	PW89*		
P. J. Cannon's "Push-Pull" Three (HF Pen, D (Pen), Pen)	PW92*		
Four-valve: Blueprints, 2s. each.			
Beta Individual Four (SG, D, LF, D, B)	PW17*		
Nelson Class B Four (SG, D (SG), LF, Cl, B)	PW34*		
Pure Four Super (SG, SG, D, Pen)	PW46*		
Battery Hill-Mark 4 (HF, Pen, D, Push-Pull)	PW48*		
"Acme" All-Wave 4 (HF Pen, D (Pen), LF, Cl, B)	PW90*		
The "A" Individual Four (HF Pen, HF Pen, D, Pen (RC))			
Mains Operated			
Two-valve: Blueprints, 2s. each.			
Selectone A.C. Radiogram Two (D, Pen)	PW10*		
Three-valve: Blueprints, 2s. each.			
Double-Diode-Triode Three (HF Pen, D (LF), Pen)	PW23*		
D.C. Ace (SG, D, Pen)	PW25*		
A.C. Three (SG, D, Pen)	PW29*		
A.C. Leader (HF Pen, D, Pen)	PW35*		
30 C. Premier (HF Pen, D, Pen)	PW36*		
Unipen (HF Pen, D (Pen), Pen)	PW50		
P. J. Cannon's A.C. All-Wave Silver Souvenir Three (HF Pen, D, Pen)	PW54*		
"All-Wave" A.C. Three (D, 2 LF (RC))	PW56*		
A.C. 1935 Sonotone (HF Pen, HF Pen, Westector, Pen)	PW70*		
Mains Revco All-Wave 3 (HF Pen, D, Pen)	PW72*		
Four-valve: Blueprints, 2s. each.			
A.C. Pure Four (SG, SG, D, Pen)	PW20*		
A.C. Pure Four Super (SG, SG, D, Pen)	PW34D		
A.C. Hish-Mark (HF Pen, D, Push-Pull)	PW45*		
Universal Hill-Mark (HF Pen, D, Push-Pull)	PW47		
SUPERHERTS			
Battery Sets: Blueprints, 2s. each.			
45 Superhet (Three-valve)	PW40		
P. J. Cannon's 2-valve Superhet	PW52*		
Mains Sets: Blueprints, 2s. each.			
A.C. 45 Superhet (Three-valve)	PW43		
D.C. 45 Superhet (Three-valve)	PW42*		
SHORT-WAVE SETS. Battery Operated			
One-valve: Blueprint, 2s. each.			
Simple S.W. One-valver	PW88*		
Two-valve: Blueprints, 2s. each.			
Midget Short-wave Two (D, Pen)	PW28A*		
The "Pilot" Short-wave Two (HF Pen, Pen, Pen)	PW91*		
Three-valve: Blueprints, 2s. each.			
Experimenter's Short-wave Three (SG, D, Pen)	PW30A*		
The Project 3 (D, 2 LF (RC and Trans))	PW63*		
The Radiogram S.W. Three (HF Pen, D (Pen), Pen)	PW65*		
PORTABLES			
Three-valve: Blueprints, 2s. each.			
P. J. Cannon's L.P. Three-valve Portable (HF Pen, D, Pen)	PW65		
Darcy Fly-weight Midget Portable (SG, D, Pen)	PW77		
Four-valve: Blueprint, 2s. each.			
"Top" Portable 4 (D, LF, LF, Pen)	PW86*		
MISCELLANEOUS			
Blueprint, 2s.			
S.W. Converter-Adapter (1 valve)	PW48A*		
AMATEUR WIRELESS AND WIRELESS MAGAZINE CRYSTAL SETS			
Blueprints, 1s. each.			
Four-station Crystal Set	AW427		
Lourenz Tuning Coil for AW427	1s.		
1934 Crystal Set	AW444		
100-mic Crystal Set	AW450		
STRAIGHT SETS. Battery Operated.			
One-valve: Blueprint, 2s. each.			
30 C. Simple One-valver	AW387*		
Two-valve: Blueprints, 2s. each.			
Full-volume Two (SG det, Pen)	AW392		
A Modern Two-valver	WM400*		
Three-valve: Blueprints, 2s. each.			
45 2s. 20 C. (SG, D, Trans)	AW419*		
Lourenz Ranger (SG, D, Trans)	AW422*		
45 2s. Three De Luxe Version (SG, D, Trans)	AW435		
Transportable Three (SG, D, Pen)	WM274		
Economy Pentode Three (SG, D, Pen)	WM337		
"W.M." 4934 Standard Three (SG, D, Pen)	WM351		
43 2s. Three (SG, D, Trans)	WM354		
1935 45 2s. Battery Three (SG, D, Pen)	WM371		
PTP Three (D, Pen)	WM389		
Certainty Three (SG, D, Pen)	WM393		
All-wave Whining Three (SG, D, Pen)	WM400		
Four-valve: Blueprints, 2s. each.			
67s. Four (SG, D, RC, Trans)	AW370		
Self-contained Four (SG, D, LF, Cl, B)	WM353		
Intercom Straight Four (SG, D, LF, Trans)	WM350		
25 2s. Battery Four (HF, D, 2LF, Pen)	WM384		
The H.K. Four (SG, SG, D, Pen)	WM394		
The Auto Straight Four (HF Pen, HF Pen, HF Pen, Pen)	WM404*		
Five-valve: Blueprints, 3s. each.			
Super-quality Five (2 HF, D, RC, Trans)	WM220		
Class B Quadradialy (2 SG, D, LF, Cl, B)	WM24		
New Class B Five (2 SG, D, LF, Cl, B)	WM340		
Mains Operated			
Two-valve: Blueprints, 2s. each.			
Consolotropic Two (D, Pen, A.C.)	AW463*		
Economy A.C. Two (D, Trans, A.C.)	WM286		
Three-valve: Blueprints, 2s. each.			
Manofani A.C. Three (HF, Pen, D, Pen)	WM374*		
£15 15s. 1936 A.C. Radiogram (HF, D, Pen)	WM401*		
Four-valve: Blueprints, 3s. each.			
A.C. Me at Pen (2 SG, D, Pen)	WM329		
Paris Double Radiogram (HF, Pen, D, LF, P)	WM386		

SUPERHERTS	
Battery Sets: Blueprints, 3s. each.	
"Arcy" Four	WM353*
The Request All-Wave	WM497
Mains Sets: Blueprints, 2s. each.	
Herzode Super Three A.C.	WM359*

PORTABLES	
Four-valve: Blueprints, 3s. each.	
Holiday Portable (SG, D, LF, Cl, B)	AW393*
Family Portable (HF, D, RC, Trans)	AW447*
Tyres Portable (SG, D, 2 Trans)	WM387*

SHORT-WAVE SETS. Battery Operated	
One-valve: Blueprint, 2s. each.	
S.W. One-valver for America	AW429*
Round Short-waver	AW432*
Two-valve: Blueprints, 2s. each.	
1 1/2 short Battery Two (SG, det, Pen)	WM402*
Home-made Coil Two (D, Pen)	AW449

THREE-VALVE: Blueprints, 3s. each.	
Experimenter's 3-valve Set (D, Trans, Super-regen)	AW438
The "Chirp" Short-waver (SG, D, P)	WM380
Four-valve: Blueprints, 3s. each.	
A.W. Short-wave World-beater (HF Pen, D, RC, Trans)	AW456*
Standard Four-valver Short-waver (SG, D, LF, P)	WM383*
Superhet: Blueprint, 3s.	
Simplified short-wave Super	WM397*

Mains Operated	
Two-valve: Blueprints, 2s. each.	
Two-valve Mains Short-waver (D, Pen), A.C.	AW453
Four-valve: Blueprints, 3s.	
Standard Four-valve A.C. Short-waver (SG, D, RC, Trans)	WM391*

MISCELLANEOUS	
S.W. 1-valve Converter (Price 1s.)	AW329
Enthusiast's Power Amplifier (10 Watts) (3-)	WM367*
Liljener's 6-watt A.C. Amplifier (3-)	WM362*
Radio Unit (2s) for WM392 (2s)	WM395*
Harris Electrogram battery amplifier (2-)	WM390*
De Luxe Concert A.C. Electrogram (2-)	WM403*
New Style Short-wave Adapter (2-)	WM378
B.L.D. L.C. Short-wave Converter (2-)	WM405*
Wilson Tone Master (2-)	WM406
The W.H. A.C. Short-wave Converter (2-)	WM405*

HINTS COUPON

This coupon is available until Nov. 6th, 1948, and must accompany all Practical Hints.

PRACTICAL WIRELESS, NOV., 1948

Published on the 7th of each month by GEORGE NEWMAN, LIMITED, Tower House, Southampton Street, Strand, London, W.C.2. and printed in England by W. SPEIGHT & SONS, LTD., Exmoor Street, London, W.10. Sole Agents for Australia and New Zealand: GORDON & GOTCH (A SIA) LTD. South Africa: CENTRAL NEWS AGENCY, LTD. Subscription rates including postage: Island 10s. 6d. per annum; Abroad 10s. per annum. Registered at the General Post Office for the Canada Magazine Post. CONDITIONS OF SALE AND SUPPLY: This periodical is sold subject to the following conditions, namely, that it shall not, without the written consent of the publishers first given, be lent, re-sold, hired out or otherwise disposed of by way of Trade except at the full retail price of 5d., and that it shall not be lent, re-sold, hired out or otherwise disposed of in a mutilated condition or in any unauthorized cover by way of Trade; or affixed to or as part of any publication or advertising, literary or pictorial matter, whatsoever.

Features of the
'SENIOR' MODEL

P.M. Unit: 9" diameter.
Capacity: 7 watts.
Magnet flux density: 12,000 gauss,
total flux 47,000 lines.
Magnet in Alcomax, one of the
most efficient permanent magnet
alloys yet produced.
Volume controls: constant-
impedance type.
Basins: die-cast in non-ferrous alloy.
Cabinet in polished walnut veneer,
size 14½" x 12½" x 7".
TRANSFORMERS (when
required): Universal ratio type
transformers, tapped to match high
and low impedances or connection
direct to speech coil.

Price £5. 15. 6.
(without transformer) £5. 2. 6.

'JUNIOR' MODEL

Cabinet size: 13½" x 11½" x 6½".
P.M. Unit: 8" diameter.
Capacity: 6 watts.
Magnet flux density: 10,000 gauss,
total flux, 39,500 lines.
Price £5. 0. 0
(without transformer) £4. 10. 6

'CADET' MODEL

Cabinet size: 12½" x 10½" x 5½".
P.M. Unit: 7" diameter.
Capacity: 3½ watts.
Magnet flux density: 8,000
gauss, total flux 31,600 lines.
Price £4. 10. 0
(without transformer) £4. 0. 0

Compare Quality & Price
in
**EXTENSION
SPEAKERS**



Stentorian

The finest EXTRA Speaker for any set



WHITELEY ELECTRICAL RADIO CO LTD · MANSFIELD · NOTTS

CLYDESDALE

For Bargains in Ex-Services Electronic Equipment

R1155 RECEIVER

A 10 Valve Communication and D.F. Repr. for 18-3 mcs. 1,500-600
Kcs. 500-75 mcs. in 5 W.B. complete with valves, Circuit and
plugs, etc. in metal case 16½" x 9" x 9 ins. less power pack.

CLYDESDALE'S £12/12/0 ea.

PRICE ONLY

Carriage and Packing Paid. Full details on request—



Brand New. RADIO COMPASS RECEIVER UNITS by Bendix Aviation Corp.

Comprising: BC-433-A or C. 15
valve s'het. revr. Covers Med.
and Long Wave 150-1,500 metres
in 3 switched-bands in metal
case 8in. x 2½in. x 1½in. Plus
BC-434-A Control Box with "S"
Meter, etc. in metal case 7½in. x
4in. x 7½in. Plus Flexible Tuning
Drive. Plus Indicator -1-81-A.
Plus Indicator -1-82-A. Plus
Service Instruction Book con-
taining full data, and circuit for
entire SCR-295-A (or C) Radio
Compass Equipment.

CLYDESDALE'S £6/15/-
PRICE ONLY

per set. Carriage Paid.
Set of 'Radio Compass' (SCR-
269-A or C) Circuits available
at 2/6 per set. Post Paid.

Brand New. Ex-R.A.F. A1134 BATTERY AMPLIFIER.
Two Stages. Two Valves. VR21(PM2HL) VR35(QP22B). with
Mlc. QPP input and output transformers, for inter-com. w.
pre-amp. or mod. Unit. Complete in metal case 7in. x 5in. x
4½in. finish black. With Circuit.

CLYDESDALE'S 15/- each Post Paid.
PRICE ONLY

Only a few. JUNCTION PANEL 10013336 for the A1134.
Contains matching sockets, terminal blocks, etc., mtd. on a
board 8in. x 4in.

CLYDESDALE'S 4/6 each. Post Paid.
PRICE ONLY

Brand New. BEACON RECEIVER. BC-1206.

A midset S'het. in metal case 5½ x 4½ x 4½ins. for 200-400 Kcs.,
with 6 valves: 6SA7, 6SF7, 6SK7, 6K7 metal, 2 25L66T, for
24 volts, miniature 3 gauss condenser, dial and knob, V/C W/S
I.F. trans., etc. finish black.

CLYDESDALE'S 37/6 each. Post Paid.
PRICE ONLY

New—Unused. BC-1206 as above, but with all glass valves,
finish grey.

CLYDESDALE'S 27/6 each. Post Paid.
PRICE ONLY

BRAND NEW. 12 VOLTS 75 a.h. ACCUMULATOR.
In waxed Teak box with hinged lid, metal carrying handles
at sides. Wing nut terminals. Size 16in. x 6in. x 1½in.
high.

CLYDESDALE'S £5 each. Packed in a wood box.
PRICE ONLY
Carriage Paid.

Any length of Top Grade Co-axial Cable 52 ohms 12 mm.

CLYDESDALE'S 6d. per yard.
PRICE ONLY
Minimum length 20 yards. 10/- Post Paid.

Circuits available: T.1154 2/3. R.1155 1/3. B.C. 348 1/3. R116
2/3. M.C.R.1 2/9. R.1124. R.1125 and P.U. 1/9. R.1224 1/3. I.F.F.
(U.S.A.) 1/9. SCR-374-N (Command Eq) 4/6. SCR-269-A
(Compass) 2/6. A.1134 1/3. all post paid.

ALSO LARGE SELECTION VALVES, TRANSFORMERS, ETC.

Send now for new illustrated lists; print name and address.

CLYDESDALE SUPPLY CO., LTD.

2, BRIDGE STREET, GLASGOW, C5.

'Phone SOUTH 2706/9

Visit our branches in Scotland, England and Northern Ireland