

## A MIDGET PORTABLE

# Practical Wireless

9<sup>D</sup>  
EVERY  
MONTH

*Editor*  
F. J. CAMM

Vol. 21 No. 472

NEW SERIES

OCTOBER, 1945

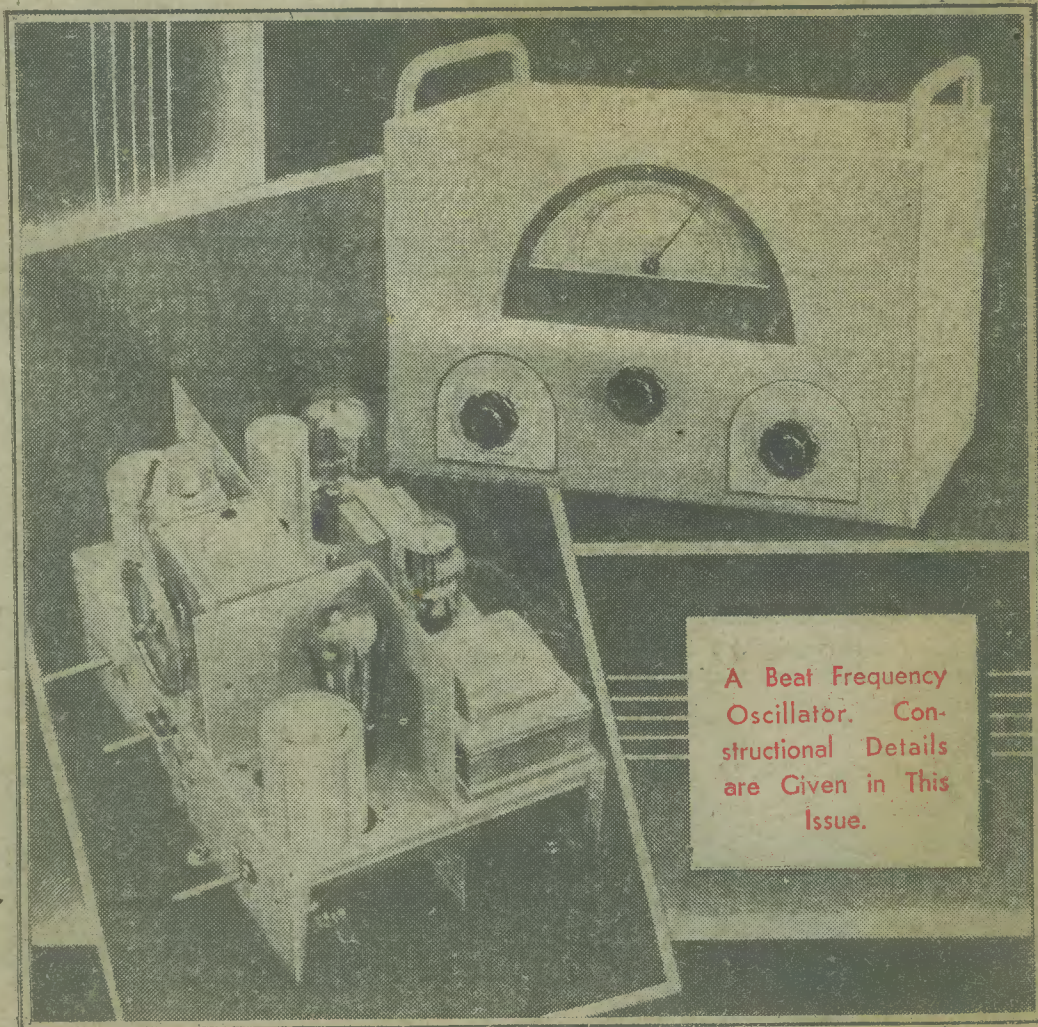

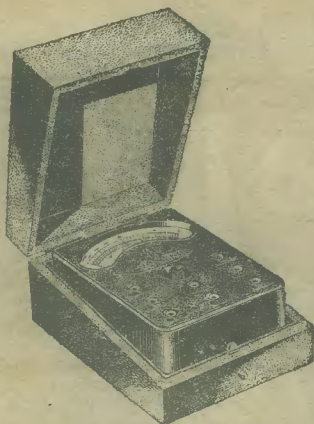

### The D.C. Avominor

Electrical Measuring Instrument

A 2½-inch moving coil meter for making D.C. measurements of milliamps, volts and ohms. The total resistance of the meter is 100,000 ohms, and full scale deflection of 300 v. or 600 v. is obtained for a current consumption of 3mA. or 6mA. respectively.

Supplied in velvet lined case, complete with pair of leads, interchangeable testing prods and crocodile clips, and a comprehensive instruction booklet.

Size: 4" x 3" x 1½".

# 'AVO'

Registered Trade Mark.

## Precision ELECTRICAL TESTING INSTRUMENTS

"AVO" Instruments, by their simplicity, extreme versatility and high accuracy, make possible that economy of time which is the essential feature of servicing and maintenance.

These two compact pocket-size instruments, with the "Avo" high standard of accuracy, are particularly recommended where extremely small size and economy of weight are primary considerations.



### The Universal Avometer

Electrical Measuring Instrument

An accurate moving coil meter providing 22 ranges of readings of A.C. voltage, D.C. voltage, current and resistance, on a 3-inch scale. Total resistance 200,000 ohms. Self-contained for resistance measurements up to 20,000 ohms, and by using an external source of voltage the resistance ranges can be extended to 10 megohms. The ohms compensator for incorrect voltage works on all ranges. Suitable for use as an output meter when the A.C. voltage ranges are being used. Complete with leads, testing prods, crocodile clips, and instruction booklet.

Size: 4½" x 3½" x 1½".

Orders can now only be accepted which bear a Government Contract Number and Priority Rating.

Sole Proprietors and Manufacturers:—

**AUTOMATIC COIL WINDER & ELECTRICAL EQUIPMENT CO., LTD.**  
Winder House, Douglas Street, London, S.W.1

Phone: VICTORIA 3404-8

The

## TAYLOR A-C BRIDGE

MODEL 110A

These instruments give quick and accurate measurements of Capacity and Resistance. There are six Capacity ranges covering from .00001 to 120 mfd. and the Power factor can also be measured on each range. Six Resistance ranges are available measuring from 1 ohm to 12 megohms. This bridge is A.C. mains operated and a leakage test is also available for detecting leaky paper or mica condensers.

Price £14 14s. 0d.

Please write for technical leaflet.

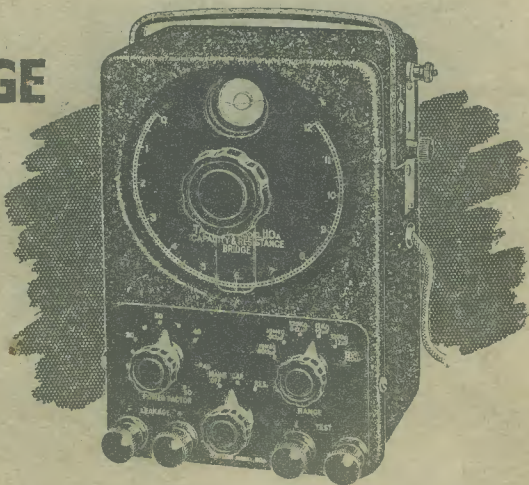

**6** RANGES OF CAPACITY  
RANGES OF RESISTANCE

Send your enquiries to:—

**TAYLOR ELECTRICAL INSTRUMENTS LTD**

419-424 MONTROSE AVENUE, SLOUGH, BUCKS.  
Tel: Slough 21381 (4 lines) Grams: "Taylins", Slough.

# Taylor

electrical instruments

# Practical Wireless

13th YEAR  
OF ISSUE

and PRACTICAL TELEVISION

EVERY MONTH.  
Vol. XXI. No. 472. OCTOBER, 1945.

Editor F. J. CAMM

COMMENTS OF THE MONTH

BY THE EDITOR

## Radar

ONE of the outstanding technical developments achieved in this country during the past 15 years is radiolocation, or radar to give it its shorter name. It made possible the chain of warning stations against enemy raiders which was ready at the outbreak of war with Germany; the devices used by night fighters, bombers and coastal aircraft; the Royal Navy's warships and the Army's ground defences, searchlights which pointed unerringly at night towards enemy aircraft, navigational aids which enabled ships and aircraft to determine their position to within a few yards in any visibility where once a mile or several miles was the smallest margin; methods by which bombing could be controlled many miles away, or equipment carried in the aircraft to give a moving map of the country below even in darkness.

Radar is the name for the technique of using high-powered wireless pulses or brief rapidly recurring bursts of radio energy which in most applications of the system are reflected from solid objects. The direction and other characteristics of the echo are used for locating such objects. The time taken for the echo to return to the transmitting point is measured—in almost all systems visually—by causing variations in the appearance of a pattern of light on a cathode-ray tube—and so used to find the distance of the solid object. An aircraft giving a quick wireless echo is nearer at hand than one giving a more delayed echo.

Our experiments commenced in 1934 when the Air Ministry realised that there were no known means by which the country could be successfully defended against air attacks in the war which then seemed certain to come, and they set up the Committee for the Scientific Survey of Air Defence and invoked the aid of The National Physical Laboratory. By December, 1935, the experimental work was sufficiently advanced for the Air Ministry to decide on establishing a chain of five radar stations on the coast of England, and in August, 1937, 15 additional stations were added. By March, 1939, a continuous chain of stations from Scotland to the Isle of Wight was completed. Each station was a combined transmitter and receiver.

### Ultra-short Wavelengths

AS soon as the principle had been clearly established that pulses of energy on about 10-metre wavelengths and a few millionths of a second duration could be transmitted to "floodlight" a wide space and that all aircraft in that space would give an indication of their presence and a precise measure of distance from the station, the determination of direction was accomplished by adapting existing wireless direction-finding technique. That meant that the position of an aircraft could be fixed in two dimensions. However, it was necessary also to determine the third dimension, namely, the altitude. This was accomplished by comparing the strength of the received echo at two sets of aerials at different heights above the ground. Results were obtained with striking accuracy, and the problem of identifying friend from foe was achieved by providing a device in friendly aircraft which gave a radar echo signifying "friend." We were enabled by this means to direct aircraft flying over Berlin to drop their bombs at a precise moment over the predetermined target, and this was found especially useful in times of fog or poor visibility. The applications of radar to shipping and navigation in peace, for landing aircraft in fog and darkness, and in avoiding collisions at sea and in the air, are obvious. We shall, in later issues, deal with the technical aspects of radar.

### "Radio Valve Pocket Data Book"

THE valve data sheets recently published in this journal have, because of popular demand, now been produced in vest pocket book form at 5s., by post, 5s. 6d. The book contains 200 pages, fully indexed, and in addition to the tables a great deal of new matter has been included. There is a glossary of terms, a chapter on valve constants and characteristics, and methods of plotting them, formulae, list of valve equivalents, abbreviations, symbols, units and prefixes, standard units, valve leg spacing, and other matter associated with valves. The book is strongly bound in red cloth with gilt lettering. Copies may be obtained from the Publisher, George Newnes, Tower House, Southampton Street, Strand, London, W.C.2.

Editorial and Advertisement Offices :  
"Practical Wireless," George Newnes, Ltd.,  
Tower House, Southampton Street, Strand,  
W.C.2. Phone : Temple Bar 4363.  
Telegrams : Newnes, Rand, London.  
Registered at the G.P.O. for transmission by  
Canadian Magazine Post.

The Editor will be pleased to consider articles of a practical nature suitable for publication in "Practical Wireless." Such articles should be written on one side of the paper only, and should contain the name and address of the sender. Whilst the Editor does not hold himself responsible for manuscripts, every effort will be made to return them, if a stamped and addressed envelope is enclosed. All correspondence intended for the Editor should be addressed : The Editor, "Practical Wireless," George Newnes, Ltd., Tower House, Southampton Street, Strand, W.C.2.

Owing to the rapid progress in the design of wireless apparatus and to our efforts to keep our readers in touch with the latest developments, we give no warranty that apparatus described in our columns is not the subject of letters patent.

Copyright in all drawings, photographs and articles published in "Practical Wireless" is specifically reserved throughout the countries signatory to the Berne Convention and the U.S.A. Reproductions or imitations of any of these are therefore expressly forbidden. "Practical Wireless" incorporates "Amateur Wireless."

# ROUND THE WORLD OF WIRELESS

## New I.E.E. President

THE Institution of Electrical Engineers recently announced the results of the ballots for the officers and council of the Institution for 1945-6.

The new president, who succeeds Sir Harry Railing, is Dr. P. Dunsheath, who is a director and chief engineer of W. T. Henley's Telegraph Works Co., Ltd.

Dr. Dunsheath has had a distinguished career with this company which he joined in 1919 for the purpose of reorganising the Research Department. He has been responsible for many improvements in the design and manufacture of electric cables, particularly in the super-tension field, and in 1924 was awarded the Medal



*Dr. P. Dunsheath, the new president of the I.E.E.*

of the Royal Society of Arts for a paper on "Science in the Cable Industry."

He became a full member of the Institution of Electrical Engineers in 1921, having been an Associate Member since 1912.

Dr. Dunsheath has held office twice as Member of the Council of the I.E.E., serving as Chairman of the Transmission Section 1936-1937, and as Vice-President 1940-1943. In 1942 he was appointed Chairman of the Research Committee which office he still holds, and was reappointed Vice-President in May, 1945.

He is the author of many papers and articles on electrical engineering, physics, the organisation of research and education in industry.

## New Philips Factory

PHILIPS Lamps, Ltd., are to open a factory in Hamilton, Lanarkshire, Scotland, and production may commence before the end of this year. The factory, which is almost completed, will produce radio receivers and components, and will employ about 5,000 operatives.

## B.B.C. Weather Broadcasts

THE Air Ministry recently announced the change that has been made in the arrangements for the issue of weather forecasts and warnings of gales, frosts or snow in the broadcasts of the B.B.C.

The general forecasts (and the forecasts for farmers and for shipping) of weather in the United Kingdom and surrounding areas for the next 24 hours and a brief "outlook" of the weather expected after that period (hitherto issued at 8.15 a.m. and 6.15 p.m.) will be issued at 7.10 a.m., 8.10 a.m. and 6.10 p.m. in the Home Service programme. These forecasts will be broadcast also on all Regional wavelengths.

On Sundays there will be no issue at 7.10 a.m.

The forecasts will be preceded by warnings of gales, frosts or snow if such conditions are indicated. Warnings of gales, frosts or snow will also be broadcast immediately they are issued by the Meteorological Office, Air Ministry; on the 1,500 metre wavelength used for the B.B.C.'s new alternative programme. Any service which requires to receive these warnings as early as possible should therefore listen on the 1,500 metre wavelength.

A brief general forecast will also be provided for inclusion in the news bulletin issued by the B.B.C. at 9 p.m. on the Regional wavelength.

## Ekco Car Radio

IT is announced that E. K. Cole, Ltd., intend to put two new car radio receivers on the market as soon as the sales policy for this equipment has been finally decided. One set is a single-unit receiver combining the chassis, speaker and controls in one small metal case, with cables for coupling to the aerial, earth and battery.

The other is a three-unit model comprising the receiver, the speaker and a remote-control unit. The latter embodies a combined volume control and on-off switch, station selector and a tone control.

## Post Office Appointments

THE Postmaster General, the Right Honourable the Earl of Listowel, has appointed Mr. G. R. Par ons to be his Principal Private Secretary, and Miss P. M. James to be his Assistant Private Secretary.

## Cossor Technical Service

L. A. WOODHEAD has been appointed the new manager of the Cossor technical service department, which has been revived as a full-time service.

Mr. Woodhead has been with the firm for 15 years, and he will deal with all technical inquiries on Cossor valves, radio, cathode-ray tubes, television and domestic electrical appliances.

## Victory Letter Telegrams

CABLE AND WIRELESS, LTD. announce that VLT (Victory Letter Telegram) messages from U.S. Forces in Great Britain may now be filed at all Cable and Wireless, Ltd. offices and all postal telegraph offices in the United Kingdom.

The VLT service is open in the United Kingdom to members of the United States Forces and attached civilian personnel only.

VLT's are being carried from this country at rates varying, according to destination, from 3d. per word (minimum 2s. 6d.) to 5½d. per word (minimum 4s. 7d.).

## Two-minutes' Wireless Service to Australia

RUSH reports of the play in the England-Australia test match, which began at Lords on Saturday, July 14th, were transmitted to Australia over the Cable and Wireless routes within two minutes, and descriptive matter in 10 minutes.

This service, which represents a near return to the pre-war flash service, was carried out despite heavy demands still made on the company's circuits by the Japanese war.

In order to provide it a special telegraph office was opened on Lord's ground, connected by tele-printer and telephone to the Australian beam wireless circuit in the company's London telegraph station. A press liaison officer and a staff experienced in press telegraph work were assigned to the service,

### G.F.P. Time Changes

**F**ROM July 15th, when Double British Summer Time ended, certain G.F.P. programmes will be heard in this country at different times.

The 7 a.m. News Bulletin will last for 15 minutes; other daily bulletins will be heard at noon, and at 3, 4 and 6 p.m.; Home News from Britain at 2.10 p.m. instead of 3.10 p.m.; Radio News Reel at 3.1 p.m.; World News and Home News from Britain at 8 p.m.; and Home News from Canada at 8.10 p.m.; News Headlines will be read an hour earlier than at present, and will be broadcast at 8, 10 and 11 a.m., 1, 3, 9, 9.58 and 10.58 p.m.

From Monday to Saturday there will be a five-minute News Summary at 8.1 a.m., instead of the 15-minute News Bulletin. "Sidelights from To-day's Papers" will be heard at 11.2 a.m., and the Daily Service at 11.10 a.m. Sunday's Weekly Newsletter comes at 11.2 a.m.

**Sundays.**—"Variety Bandbox" will be broadcast at 5 p.m., with a recorded repeat on Tuesdays at 1.1 p.m. "Stanclli Throws a Party" is at 7.30 p.m., and the repeat on Wednesdays at 2.30 p.m.

**Mondays.**—"Facts and Figures" is at 4.30 p.m., and "Welsh Half-Hour" at 9 p.m., with a repeat on Tuesdays at 10.30 a.m.

**Wednesdays.**—"Scottish Half-Hour" is at 5 p.m., with a repeat on Thursdays at 10.30 a.m.; and "Round the Halls" on Wednesdays at 8.15 p.m.

**Thursdays.**—"The Jack Benny Programme" is at 10.1 a.m., with a repeat on Saturdays at 10 p.m. A repeat of the Home Service programme, "Tuesday Serenade," will be heard at 1.1 p.m.; "Strike a Home Note" at 4.30 p.m., with a repeat on Fridays at 9.30 a.m.; "Hospital Mailbag" at 7 p.m., with a repeat on Fridays at 11.15 a.m.; and "Navy Mixture" at 8.15 p.m., with a repeat on Mondays at 3.15 p.m.

**Fridays.**—"Mail Call" is at 10.1 a.m.; "World Affairs" at 4.15 p.m.; "Merry-Go-Round" at 6.15 p.m., with a repeat on Wednesdays at 1.1 p.m.; and "Your Questions Answered" at 7.30 p.m.

**Saturdays.**—"Shipmates Ashore" is at 5 p.m.; "Atlantic Spotlight" at 5.30 p.m.; and "Music from the Movies" at 8.15 p.m., with a repeat on Fridays at 1.15 p.m.

Part of the equipment of a mobile radar unit. The illustration shows a transmitter with front panel removed for checking valve filament voltages on a built-in master voltmeter.

### Listening to the B.B.C. in Yugoslavia

**A** BRITISH officer who parachuted into Croatia twelve months ago, and who recently returned from Zagreb, tells an amusing story about the influence of the B.B.C.

After the Partisan General heard via the B.B.C. that hostilities had ceased, he told the officer to go ahead in his jeep. He motored ahead of the advancing columns and was met first by mortar fire and later by machine-gun fire. Finding he could not get through, he returned to the Partisan Commander to explain the situation. The Commander indignantly asked, "Don't they listen to the B.B.C.? The war's over." A courier took the message, stating that the B.B.C. said the war was over, to the enemy and, shortly afterwards, on receipt of the message, twenty-five of the enemy surrendered.

Listening to the B.B.C. was regarded almost as a duty by the serious-minded Partisans. It was a regular daily habit; supper, B.B.C., bed, and each receiving set was surrounded by a large group of 80 to 100. When the new schedule started, a number of people asked, "Does this mean we should now listen to Belgrade?" Until that time, their own station had never seriously competed, in interest, with the B.B.C.

### B.B.C. Broadcasts to Japan

**N**EARLY two years ago the B.B.C. introduced "A Programme for Japanese Listeners" into its broadcasts to the Far East, despite the fact that its potential audience was believed to be small. No one in Japan, apart from a limited number of privileged officials, is allowed to possess a short-wave set. And, as yet, none of the Allies fighting Japan is near enough to that country to reach it regularly on medium waves.

Is it worth while to talk to such a scanty audience? The B.B.C. is convinced that it is. For, although the true facts about much of what is happening in the world are withheld from the mass of the Japanese people, their leaders are well informed. And it is almost certain that however small may be the number of those who actually hear the broadcasts from London, a verbatim report of what the B.B.C. says is placed each morning on the table of the more important Government officials

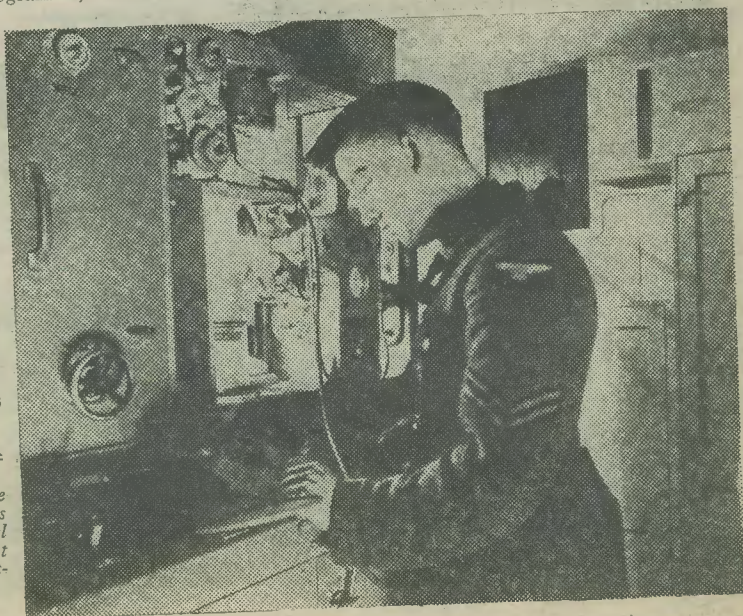

# An All-wave Two

Constructional Details of a Receiver for the Reception of Medium and Short Waves

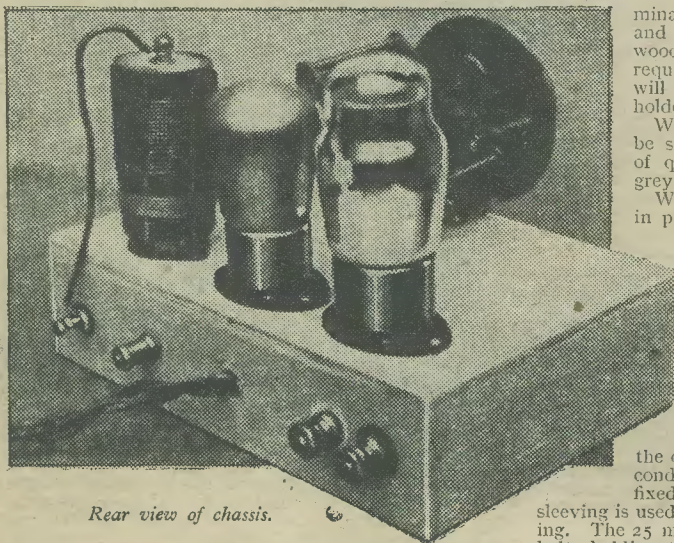

Rear view of chassis.

**T**HIS is a straightforward receiver which will provide speaker reception of the more powerful radiations on medium and short-wave bands. Phones can be used for distant listening and practically any frequency can be tuned by inserting a suitable coil. A refinement is provided in the form of automatic bias, which simplifies battery connections considerably.

The circuit is shown in Fig. 1. With reception on the higher wavebands in mind a .0005 mfd. tuning condenser is used, and this should be of the type fitted with a good slow-motion drive, or an exterior drive can be added to it. A pentode output stage is used, fed from the detector by means of a parafeed transformer to secure maximum gain with stability. A resistor is used instead of a reaction choke, and this will be found satisfactory over all the wavebands used. The coils have a separate coupling winding to reduce aerial damping, and details of the number of turns used will be found in the table.

## Construction

The chassis is 5½ in. by 7½ in., and the runners are approximately 2 in. deep. The top is made from a piece of 3-ply., as also are the front and back runners. The two side runners are of thicker material (about ¾ in. being suitable) to permit of the top, front and back being screwed to them. Reference to Fig. 2 will show the arrangement of these pieces.

Two holes are drilled in the front runner, each about 1½ in. from the outside to accommodate the on/off switch and reaction condenser. Five holes are drilled in the back runner for speaker, aerial and earth ter-

minals, and the battery leads. The speaker and aerial terminals are insulated from the wood with suitable washers, but this is not required with the earth terminal. Three holes will also need to be drilled for the valve-holders, as shown in Figs. 2 and 3.

When the chassis is completed it should be sand-papered round and given a coating of quick-drying paint. A suitable colour is grey.

When dry, the valve-holders are secured in position with small bolts, positioning the sockets as in the diagrams. A component-mounting bracket is also fixed centrally near the front for the tuning condenser. The switch and reaction condenser are mounted on the front runner, and the L.F. transformer upon the side runner as shown. All other parts are suspended in the wiring.

## Wiring

This should be carried out as in Fig. 2. Only two leads pass through the chassis, the moving plates of the tuning condenser going to the earth terminal and the fixed plates to the grid condenser. Insulated sleeving is used if there is any possibility of wires touching. The 25 mfd. condenser is connected to one of the bolts holding the component-mounting bracket (which will be connected to earth via the tuning condenser) to hold it secure.

The leads from the transformer will be long enough to reach to the connecting points, and care must be taken not to pull them or they may come adrift from the bobbin of the component.

Soldered joints will be needed at some points, but if tinned-copper wire is used, and the iron is sufficiently hot and clean, no difficulty should arise. A trace of some suitable flux should be put upon the joints before soldering.

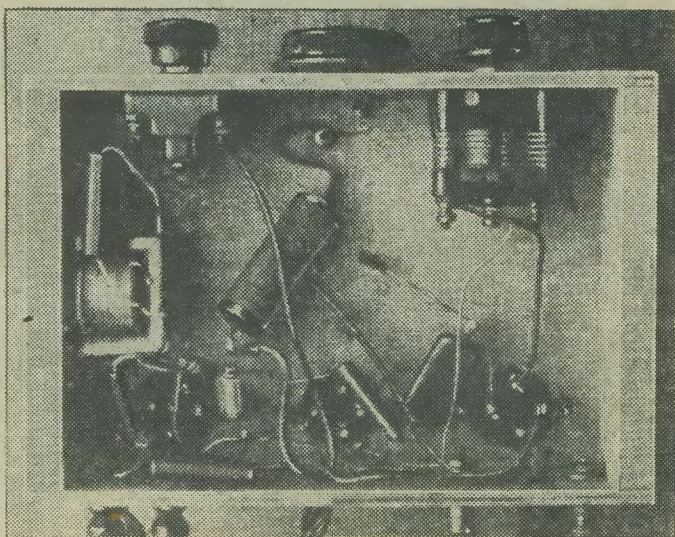

Sub-chassis layout and wiring

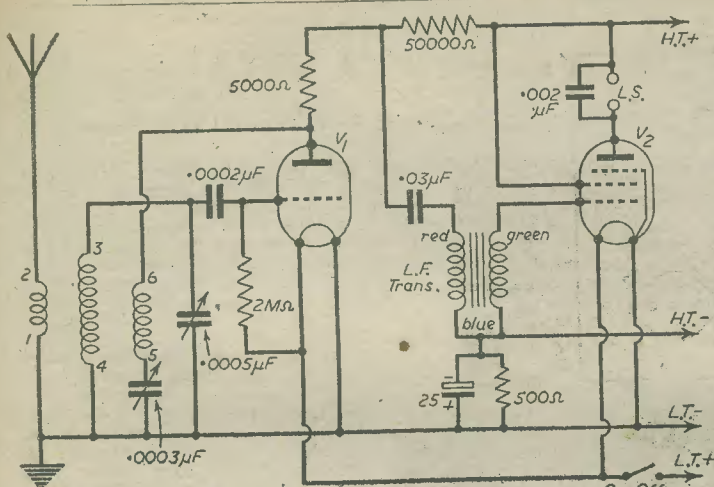

Fig. 1.—Theoretical circuit of the All-wave Two.

There are only four battery leads, and 3-ft. lengths of flex can be used, fitting the ends with spade terminals and plugs. All the leads pass through a hole in the rear runner.

The aerial terminal has no connection below the chassis, but a flexible wire goes from it to the top terminal of the coils (see Fig. 4). This terminal is used because

coils are made up on old valve-bases and otherwise the aerial coupling winding will have to be omitted, or the reaction coil connected to earth, which would give particular disadvantages, especially on short waves. The only alternative is to use valve-bases with more pins, if they are to hand, although the top terminal does not present much difficulty in actual use.

**Coils**

Winding details of these will be seen in the table. All windings should be in the same direction, and the ends connected as shown in Fig. 4, where the ends are numbered to agree with the numbers shown in Fig. 3. The reaction and aerial coupling windings are approximately  $\frac{1}{4}$  in. from the central grid winding, and all the ends of the windings are taken through small holes into the former. Point 2 is connected to the terminal, mounted upon a disc which is a push-fit in the top of the former, and the other points are taken down through the valve-pins and soldered in the usual manner.

Windings details are for a former  $\frac{1}{4}$  in. in diameter. The actual size may vary with the valve bases used, but is not very critical. If a larger size is used, and it is found that a coil will not tune to a sufficiently low wavelength, then a few turns can be removed from its

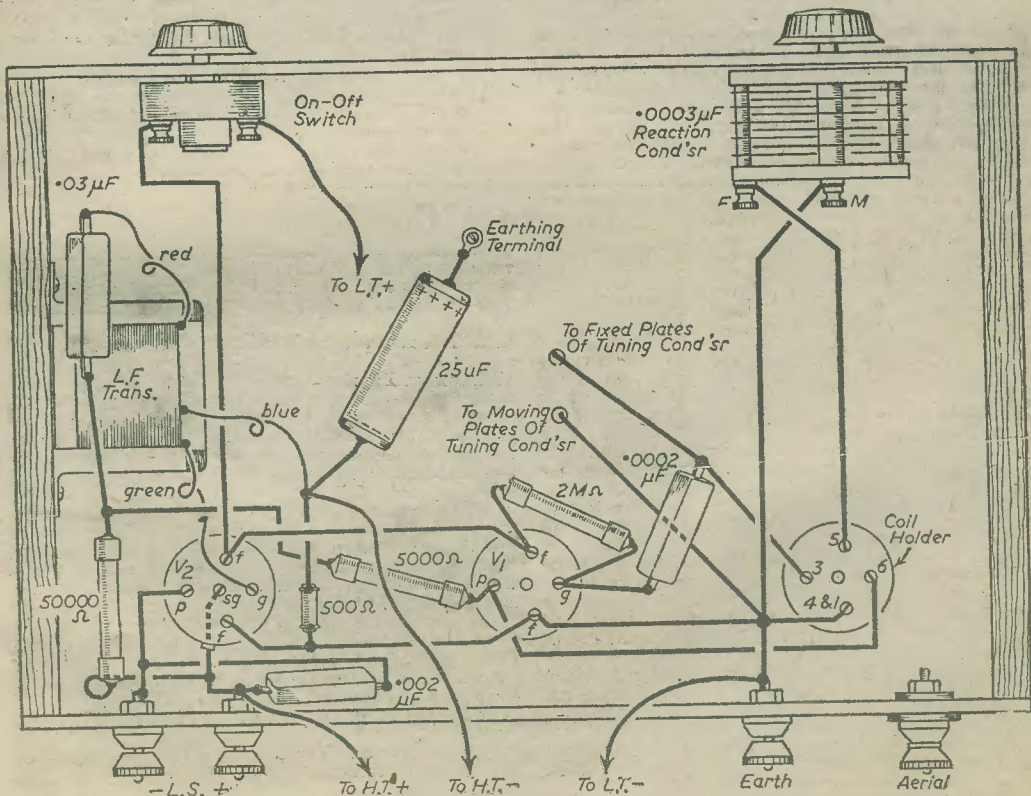

Fig. 2.—Wiring diagram of the All-wave Two.

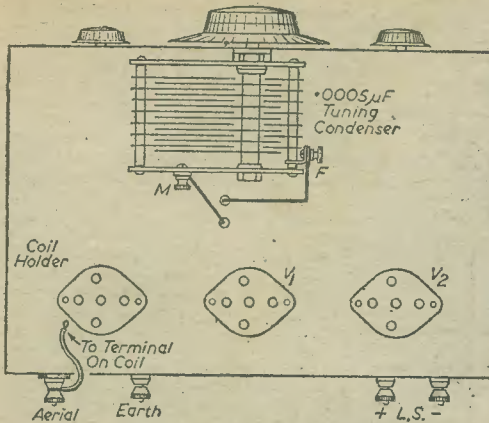

Fig. 3.—Top of chassis layout, showing positions of tuning coil and valve holders.

windings. Elbonite or paxolin tube is suitable for the coils, although the use of a ribbed former for the short-wave coils will give some slight improvement. Ribs can be made by gluing slips of insulating material around the former, and this is particularly recommended if the tubes are made up from glued brown paper, or are of cardboard.

#### Operation

When completed the valves should be inserted—the HL2 type in the central holder and the 220HPT in the holder by the speaker terminals. A speaker is then connected. It must be of the high-impedance type, such as a moving-coil model with output transformer for pentode-valve. The aerial used should, for preference, not be too long; if it is, a pre-set condenser should be connected in series with it.

Stations will be found by tuning with the central control, the reaction control being turned to bring volume up to maximum if required. On the short-wave-bands the reaction control will be rather critical, and

it should be kept so that the receiver is almost upon the point of oscillation. If this is not done very few short-wave signals will be picked up. It will probably be best to try the medium-wave band first (using the coil with most turns); with the short-wave coils there should be no difficulty in picking up the more powerful American stations on the 19- and 25-metre bands at satisfactory loudspeaker volume in the late afternoon and evening.



Fig. 4.—Coil and tappings.

The grid bias will be automatically right for whatever H.T. voltage is used, but if more economical running is required, and a loss of volume can be tolerated, the bias resistor may be increased from 500 to 700 ohms.

#### COIL DATA

	Grid Winding	Reaction	Aerial Coupling
Coil 1.	5½ turns 18 S.W.G. wire spaced by diameter of wire.	4½ turns 30 S.W.G. close wound.	2½ turns of 30 S.W.G. wire spaced slightly.
Coil 2.	12 turns 20 S.W.G. wire spaced by diameter of wire.	9 turns 32 S.W.G. close wound.	5 turns of 30 S.W.G. wire spaced slightly.
Coil 3.	20 turns 22 D.C.C. S.W.G. wire close wound.	14 turns 32 S.W.G. close wound.	7 turns of 32 S.W.G. close wound.
Coil 4.	90 turns 32 S.W.G. enam. close wound.	50 turns 36 S.W.G. close wound.	20 turns of 30 S.W.G. close wound.

## Forces Educational Broadcasts

ON September 3rd the B.B.C. began a new series of educational broadcasts for Forces listeners. The broadcasts will be heard in the Light Programme three times daily. There will be two in the morning and one in the afternoon from Monday to Friday and three on Saturday morning.

These programmes have been asked for by the Services and are directed to groups of men and women in the Forces who are awaiting demobilisation and meet in classrooms with an instructor present. The broadcasts are supplementary to the wider scheme whereby men and women awaiting demobilisation from all three Services are paraded for six to eight hours a week for educational purposes.

The scheme is known in the Navy and the R.A.F. as E.V.T.—Educational and Vocational Training—and in the Army as A.E.S.—Army Education Scheme. Although it is compulsory and in parade time, there will be a wide element of choice. For several months instructors of all ranks have been passing through training schools in preparation for these schemes, and they have been given special instruction in the use of radio in the classroom.

The broadcasts will be heard on sets specially provided for educational purposes and in huts or rooms reserved for listening.

The aim of these educational broadcasts for the Forces will be to help members of the Services to understand and enjoy better the world to which they are returning, and to reduce as far as possible the gap between Service and civilian experience. This is a new departure in

broadcasting and the B.B.C., anxious to learn from experience, has made arrangements to find out how the programmes are being received in the units themselves. Particulars of all these series are being made known to the men and women of the different Services through their Education Officers and Service magazines.

#### Well-known Broadcasters

Many well-known broadcasters are taking part in the scheme, including S. P. B. Mais on English literature, Reginald Jacques on "Listening to the Orchestra," Douglas Houghton on "How the Rates are Spent," and Ruth Drew on domestic affairs of many kinds.

There will be talks on industrial Britain called "Job in Hand," when George Darling will bring to the microphone speakers representing various staple industries. Asa Briggs, a historian who is himself in the Army, will talk on the important social and economic changes in the period between the end of the nineteenth century and the rise of modern industry.

An advanced series on books will include talks by Colonel Walter Elliot, Colin Brooks, and W. E. Williams, Director of A.B.C.A. Readings intended either to introduce listeners to the pleasures that await them, or to encourage those who already enjoy books to re-read their favourites, or to meet a new friend, will be given by V. C. Clinton-Baddeley, W. E. Williams, Eric Gillett, and Janet Chance. The first six books are "Pickwick Papers," "Wuthering Heights," "Barchester Towers," "Mill on the Floss," "Martin Chuzzlewit" and "Pride and Prejudice."



# A Practical Bandset System

Ensuring Consistent Dial Readings

By 2ATV

THE other day I visited a friend and found him, as usual, trying out a receiver that he had just constructed. The set was a battery TRF<sub>3</sub>, now at the "hotting up" stage, and it certainly seemed to be well up to standard. A goodly number of stations

tuning condenser. The system being used in this instance was the ordinary parallel arrangement shown in Fig. 1. The winding L<sub>2</sub> is tuned by various capacities across it, consisting of the bandset condenser C<sub>1</sub>, the bandspread condenser C<sub>2</sub>, the grid condenser C<sub>3</sub> in series with the grid/filament (cathode) capacity of the valve, the capacity of the wiring, and the self-capacity of the winding L<sub>2</sub> itself. These are all fixed, with the exception of C<sub>1</sub> and C<sub>2</sub>, and thus play no part in our calculations.

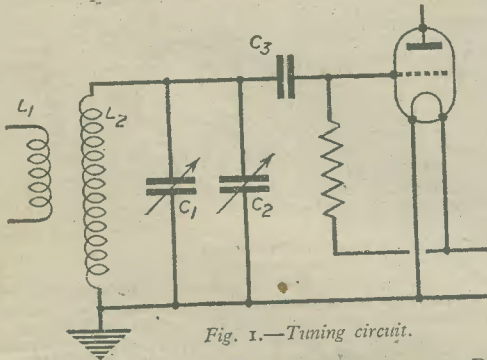

Fig. 1.—Tuning circuit.

were tuned in around the dial, many of them DX. The one fault that I could see, confirmed when it came to my turn to handle the controls, was that tuning was not all that it might be. Now the said friend has not long taken up short-wave work, and though the tuning condensers used were the usual 160 uF., the slow-motion drive had a ratio of some 6 to 1 only. On top of this, the circuits were loosely coupled and, therefore, fairly selective, the results being that considerable "fiddling" was necessary before a signal could be properly tuned in.

There followed a discussion on tuning in general, and, of course, "bandspread" cropped up. My friend quickly got the hang of the various systems used, and I left him with the intention of getting a small variable condenser and trying the idea for himself.

Later, I went to see how things were going, and found some more problems had arisen. All had at first gone well, and on test the tuning was found to be much easier. The difficulty now was that a very small error in setting the bandset condenser meant a difference of a few degrees in the bandspread reading. In itself this did not matter, but it was serious when a consistent reading was needed for logging purposes. My friend knew of the Eddystone bandspread unit, in which the bandset condenser is not continuously variable, but provided with a locator permitting any one of 10 positions to be used, each being covered by the bandspread condenser. We decided a similar arrangement would solve his trouble, and settled down to talk over ways and means of converting his present set-up, using the existing condensers for the sake of economy. It would appear from correspondence that many readers are interested in this subject, and the following summary of the points raised in our deliberations are therefore given in the hope that these readers will find them of assistance.

### Mechanical Location

A precision type of drive and dial would, of course, have solved the setting problem, but in the absence of this it was agreed that the best solution was some form of mechanical location. It was while discussing this that my friend trotted out a common misconception. Said he: "Well, all we've got to do is use a 15 uF. for bandspreading, which means a locator plate with 11 equally spaced positions."

Now let us take the two points raised in this statement and consider them in turn. In the first place, the amount by which the capacity of the tuned circuit is capable of being varied is not equal to the rating of the

Now as to the equality or otherwise of the distance between the positions of the bandset condenser, this will depend on the shape of the vanes, that is to say, the "law," or curve of change in capacity per degree of rotation. This information is, unfortunately, not readily available; so that the actual settings of the bandset condenser will have to be found by a system of trial and error, involving identification of the stations received at either end of the bandspread coverage, unless, of course, a signal generator is on hand.

### Location Method

Coming to the actual method to be used for location, it is obvious that what we are doing is simply to replace a continuously variable condenser by a series of different capacities switched into circuit as required. There is

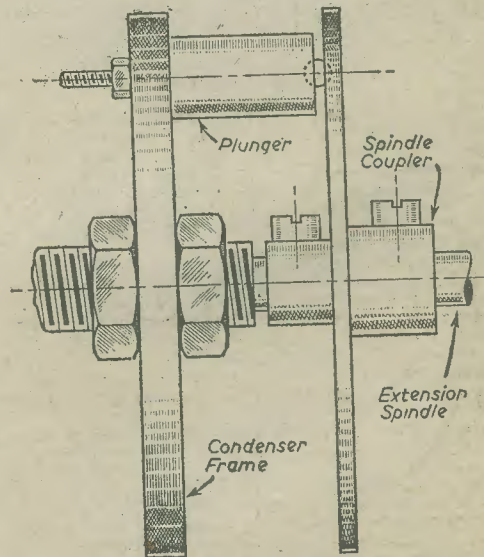

Fig. 2.—End elevation of complete locating mechanism.

thus no need for any elaborate bandset dial, all that is necessary being a pointer knob and a dial plate with the correct number of indicator points at appropriate spacings. The plate itself can be easily made by drawing with indian ink on thick cartridge paper, this then being protected by thin sheet celluloid or Perspex. Where the means are available, a better effect is obtained by using aluminium sheet stamped with number dies, the sheet then being cleaned up with emery paper, and frosted by immersion in a strong soda solution. Finally, the indents are filled in with cobbler's heel-ball or a similar hard wax.

The actual locating mechanism is likely to present more difficulty, but the arrangement shown in Fig. 2 is suitable for construction by those readers possessing only hand tools. Better results can, of course, be obtained by those fortunate enough to have access to a lathe.

### The Mechanism

Fig. 2 shows an end elevation of the complete mechanism. The locator plate, shown also in front elevation at Fig. 3, consists of a disc of thin sheet metal, preferably springy steel. The diameter will be determined by the available space. The disc is attached to the condenser spindle by a brass bush, and it is suggested that this is best achieved, where facilities are restricted, by using a spindle coupler of the type shown in Fig. 4. These couplers are readily obtainable for a few pence each at most radio shops. It is essential that the disc should remain squarely at right-angles to the spindle, and the best way to ensure this is to turn down a portion of the length so that a shoulder is formed, as indicated by the broken outline in Fig. 4. Where there is no lathe, a hand-drill can be pressed into service.

The coupler is mounted on a short length of old spindle, or  $\frac{1}{8}$  in. rod, preferably with a flat on it, and locked tight by the grub screws. The spindle is then gripped firmly in the chuck jaws and the wheel-brace fastened securely in a bench vice, thus forming a hand-driven headstock. The work is then rotated at a steady speed in a direction towards the operator and the surplus metal removed with a file. It will be found that the latter has an awkward tendency to wander away from where it is wanted, and in order to overcome this it is best to start off by holding the file at an angle, so that a "V"-shaped cut is made, then gradually bringing the file into a parallel position as the work proceeds. It may be remarked that this method will not produce a truly concentric shoulder, but this does not matter. The important points are that the horizontal portion should be parallel with the spindle, and the shoulder itself dead square.

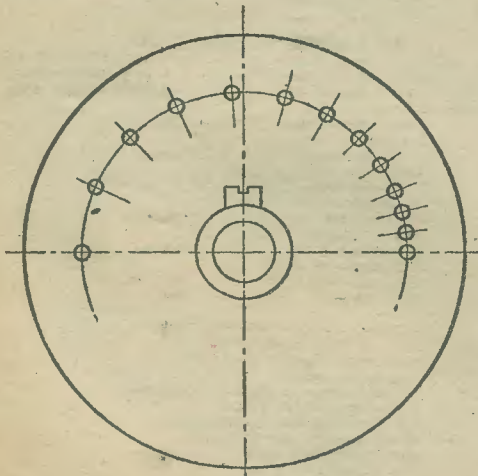

Fig. 3.—Front elevation of locator plate.

The clearance hole in the disc can now be cut out, and the two parts sweated together. The fact that steel has to be soldered should cause no undue anxiety: a touch of Fluxite and a really hot iron will do the necessary. Do not forget to tin the surfaces separately before bringing together for the final operation. The clearance hole will be somewhere around  $\frac{7}{16}$  in. diameter, so a small pilot drill should be put through first, followed by a  $\frac{1}{8}$  in. one, and the hole carefully finished with a file to

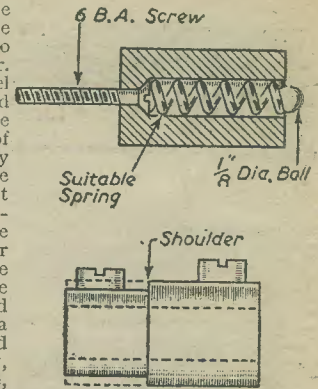

Fig. 4.—Plunger mechanism.

fit the coupler. Any small deviation of the hole from the centre of the disc will not affect matters, except from the point of view of appearance as the locator plate rotates.

The next part to be tackled is the plunger mechanism, shown in section at Fig. 4. Where this can be turned up on a lathe, the body and screw can be made in one piece, and the latter can with advantage be increased to 4 B.A. If the component has to be built up, the screw is limited in size to 6 B.A., and should therefore be of steel to withstand shearing stresses. The body is made from brass stock, either hexagon, round, or square section. The length will depend on the condenser used, but is not critical as the locator plate can be moved along the spindle to suit. After the ends have been squared up, a No. 32 drill should be pushed right through, followed by a  $\frac{1}{8}$  in. drill to within a short distance of the end. This last drill should cut slightly over-size, so that the ball is a good sliding fit in the bore; if it is too small, re-grinding a little off-centre will do the trick.

### The Locator Plate

This completes the mechanism, with the exception of the holes in the locator plate. This is where we really *must* use extreme care, as it is essential that these holes are at the correct distance radially from the centre of the condenser spindle. The best way to ensure this is to mount the whole gear in position, with a clearance of not more than  $\frac{1}{16}$  in. between the plunger body and the disc. It is a good plan first to coat the face of the disc, facing the plunger with button polish to which a small amount of colouring pigment, such as Prussian blue, has been added. The spindle should then be rotated and any necessary adjustment made to the disc so that the amount of clearance remains sensibly constant. After a few revolutions it will be found that the ball has clearly marked the disc with the path of its travel.

The next step is to determine the spacing between the holes, and to do this the following procedure is suggested. First choose a night when the whole range is "lively," and commence by setting the bandset condenser at minimum. Make a mark with a scriber on the disc, exactly over the centre of the ball. Then tune in a station by means of the bandspread condenser, with the latter nearly at maximum capacity. Return to minimum capacity and tune in again to the same station with the bandset condenser. Make another mark, again exactly over the centre of the ball. Leaving the bandset in this position, tune in another station by means of the bandspread condenser, return it to minimum, and retune by the bandset. Make another mark, and repeat the procedure until the required number of points is obtained.

Remove the disc from the assembly, and inscribe with lines running from the centre to each of these marks. Where the lines intersect the mark made by the ball, "pop" with a centre-punch and push through a  $\frac{5}{16}$  in. drill.



# ON YOUR WAVELENGTH

By THERMION

## The Problem of Pitch

**T**HE question of an international standard of pitch for musical sounds has been one keenly debated since the invention of the diatonic scale. We are still without uniformity, and throughout the world there is a variety of frequencies for the basic middle C upon which the frequencies of the other notes in the scale depend. In this country pianos are normally tuned using a frequency of 256 cycles per second for middle C—the white note opposite the lock! But then we also use to some extent concert pitch, which is higher in pitch than the so-called standard pitch of 256 c.p.s.

With such a variety of pitches it is not surprising that no one has yet decided which is the best pitch for a particular composition, nor do we know which particular pitch was used by the composer. The harmony of a musical composition can be radically changed by altering the pitch, and it seems to me and others that the time has come for the introduction of a universal standard of musical sounds. The French Federation of Manufacturers of Musical Instruments has recently considered this matter and reached the conclusion that the world is musically out of tune. If music is an international language it should be standardised and make use of a standard musical grammar, so to speak. It may be this lack of standardisation that has caused many critics to adversely criticise a composition which, played on an instrument tuned to the correct pitch as intended by the composer, would invoke his adulation. In the days of the meistersingers and minnesingers, vocal numbers were rendered in a pitch somewhat similar to that which we use to-day. If, however, those same numbers were played on a spinet, a harpsichord or a clavichord the pitch was about three semi-tones lower; that is to say, the note A would become F sharp. Yet with the organs of the period the pitch was more than two semi-tones higher than the vocal pitch, which would mean that A became B. In Germany and France even greater variation existed until the 19th century when the musical pitch was increased in every country.

## Philharmonic Pitch

**I**T was in 1813 that the Philharmonic Society introduced a definite pitch for the note A, which they fixed at 452.5 vibrations per second. This became known as the Philharmonic pitch.

Other countries unfortunately did not follow suit. Germany, for example, preferred to believe that she was the leader of musical thought and opinion, and pointed to the melodies of their composers played to German standards in support of their retention of existing German pitch.

Italy and France thought the same and so unanimity was not reached. But at the end of the 19th century the French Government adopted what was known as the French pitch of 435 vibrations and this was adopted by England.

English military bands would not, however, conform to the new standard and adhered to the old Philharmonic pitch, with the obvious result that they could not play with an organ accompaniment or combine with a French band without most discordant results.

It was not until 1929 that English military bands agreed to conform with the general practice of English orchestras.

It was the intention just before the war to hold an international conference with the object of arriving at a standard pitch for all musical instrument manufacturers, but the war intervened. It is high time that the whole musical world was put in tune. The French manufacturers are now proposing that the radio networks of every country should broadcast an A (la in the tonic, sol-fa notation) at a pitch generally agreed upon—a sort of musical time-signal. This would enable musical instrument manufacturers to standardise their instruments and it would tend to make them cheaper.

This is a matter which should not be left, however, to continental powers. We have in this country an institution with long experience in sifting evidence where confusion exists and arriving at standards which are internationally acceptable. I am referring to the British Standards Institution, and I suggest that this is a matter with which they should concern themselves. Let us take the lead. We have little if anything to learn from France or Germany in this respect and we do not want always lamely to follow other nations like a gas meter which can register but cannot vote!

## Grumble from a Reader

**M**R. A. MURPHY, of Canning Town, in the course of a friendly letter, raises a mild grumble because we occasionally advertise in the editorial pages, books published from the offices of this journal. Surely, that is a service to readers, to draw their attention to books in which they may be interested. If an article happens to fall a little short, these boxes as they are termed are inserted to fill the vacant space and it is a practice which is adopted throughout the publishing trade. I hope, therefore, that readers do not consider them in the same light as a blot on an examination paper.

## "NO TALKEE SAMEE LIKEE"

[An American radio journal has made the suggestion that we need a universal auxiliary language. There have already been several attempts to devise one, but none of them have met with any great success.]

There was a common language once  
When men lived up in trees,  
And leapt about from branch to branch,  
Tormented by their fleas.  
"Whooh-Whooh" the loving suitor howled  
To sweetheart up above,  
Which in the language of those days  
Meant, "You're the girl I love."  
She dropping down to lower branch,  
Her charms to let him see,  
And scratching hard replied "Wah-Wah,"  
Which meant "You're telling me."

No hopes to-day of climbing back,  
We've lost our blinking tails,  
A common language now to find  
Imagination fails.  
Though crude attempts are often made  
Which many folks dislike,  
The monkey-noises crooners make  
When posed before the mike.  
Apart from these for prose or verse—  
For ballad or for song,  
Most races of the world will still  
Prefer their native tongue!

"Torch"

## Our Roll of Merit

Readers on Active Service—Fifty-eighth List.

- L. N. Fennelov (Sigm., Royal Signals).
- F. Gameson (L.A.C., R.A.F.).
- E. Hanson (L/cpl., R.E.).
- M. A. Thompson (Cfn., R.E.M.E.).
- J. S. Framer (Sgt., R.A.F.).
- A. West (L.A.C., R.A.F.).
- N. Bouchier (A/C1, R.A.F.).
- R. Taylor (A/C1, R.A.F.).

# A Midget Portable

A Lightweight Portable, which is Easy to Construct and which Costs Approximately 30/-

By A. P. CASPERS

**T**HE midget receiver here described is eminently suitable for cyclists, hikers, and for other purposes where small size and portability are desiderata. As will be seen from the circuit, it is designed around 1C5GT/G valve. The advantages of this circuit are:

(1) The 1C5GT/G valve has a length of 2½ in. This would help to ensure a small set.

(2) The valve only requires some 15 volts H.T. and 1.5 volts L.T. in the finished set to function efficiently. This means that a couple of grid bias batteries can be used in series to give both H.T. and L.T. Again, space is conserved.

(3) The parts needed are few, and, even if these parts are bought new, the total cost, including batteries, is only about 30s.

(4) Owing to the type of battery used, the upkeep can be kept very low indeed.

(5) The circuit is very simple, and the construction is also simple and straightforward.

Thus, the combination of the points enumerated above not only ensure a small portable set, but also one which is easily and cheaply built, and once built can be maintained at low cost.

## Plan

The plan is shown below, and it can be seen that the set is built around the one 1C5GT/G, which acts as a detector and amplifier combined. The H.T. voltage is supplied by two grid bias batteries joined in series. These batteries also give the L.T. supply.

The aerial and coil are combined as a frame aerial.

The circuit diagram (Fig. 1) shows that comparatively

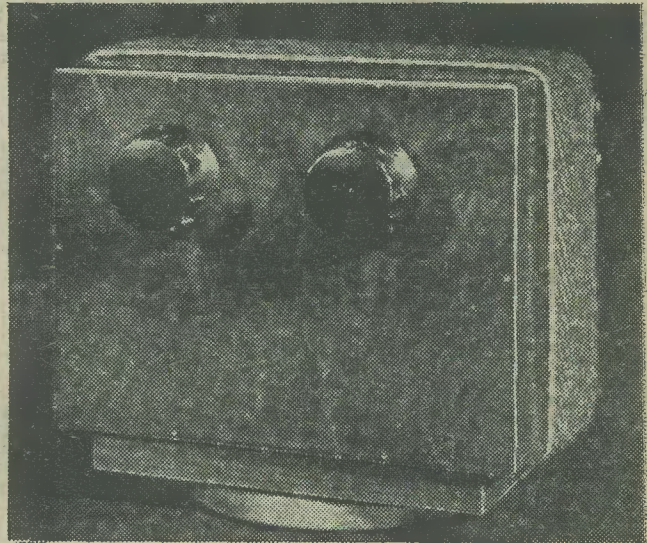

*The completed receiver. It weighs approximately 3 lbs. complete with phones.*

few parts are needed, and these parts can be quite easily obtained, since we are dealing with a medium wave set.

## Construction

The components are housed in a wooden cabinet, which can be easily made from 3-ply wood, although a slightly thicker wood is recommended. In the author's case 3-ply oak was used with success.

The number of pieces of wood, and the size of each piece is given in the following table (the figures being given for 3-ply oak):

Top and bottom .. ..	3½ × 5½
Front and back .. ..	5½ × 4½
Sides .. ..	3½ × 3½

These pieces are then drilled for holding the switch, condensers and plugs.

The necessary data needed for this is given in Fig. 2.

Fig. 2 shows that the hole for the switch is drilled ¾ in. back from the front of the piece of wood and ¼ in. down from the top of the same piece of wood.

The holes for the condensers are made 1¼ in. down and 1 ½ in. in.

In Fig. 2 the positions of the phone plugs are shown. It can be seen that these are placed respectively ¼ in. and ½ in. down from the top of the piece of wood, and both ¾ in. in.

Once the whole wooden cabinet has been assembled (panel pins can be used for this) we are able to proceed with the winding of the frame aerial.

This consists of 36 turns of silk-covered copper wire (approximately 60ft.), which acts as a grid winding and 10 turns which act as a reaction winding. The wire is wound as shown below, and care should be taken to ensure that the turns of each set of windings lie next to each other, and that the wire is quite tightly wound. Note that a ¼ in. gap is left between the grid and the reaction windings.

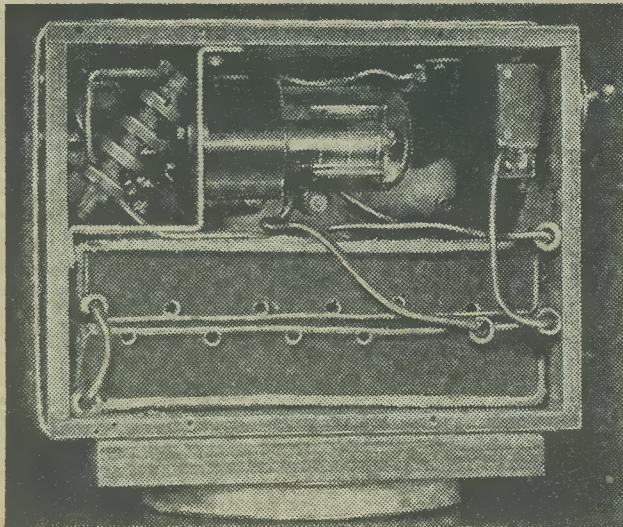

*The receiver with back removed to show positions of main components.*

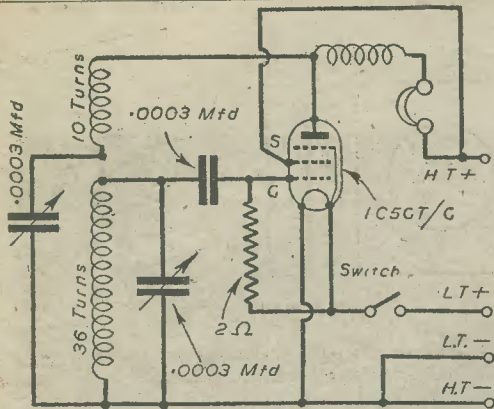

Fig. 1.—Circuit diagram, and underside view of valve-holder.

set. Another idea was to substitute a turntable for the strips of wood. This meant that the set could now be rotated, a factor which would considerably aid the tuning in of a station. At the same time any of the above ideas would prevent the set from becoming scratched.

Finally, it is suggested that the set be french polished. If this is done carefully a very fine effect can be produced, especially if oak is used. Furthermore, the set is less easily scratched, and is rendered less liable to damage resulting from exposure to damp.

Connecting up the Batteries

Some mention must now be made about the method of wiring up the grid bias batteries. Two batteries—joined in series—are used to supply both H.T. and L.T.

Fig. 3 should explain any further difficulties which might arise over the windings.

The ends of the windings are soldered to the tags of a terminal strip, and connections are taken from the terminal strip to other components. The rest of the components are then fixed into position in the following manner:

The all-important point to be remembered is that the -9 volts shown on the G.B. battery must be taken as true negative. Thus it will now follow that the -7½ volts shown are the same as 1½ volts positive, -6 volts equals 3 volts positive and so on.

Now if this above point is kept in mind, no undue difficulty should be experienced in the interpretation of the next drawing shown, (Fig. 6.) Here the two G.B. batteries are shown joined in series. The figures inside the battery outline give the voltages shown on the side of any typical G.B. battery. The figures outside give the true voltages after joining the batteries in series.

It will be seen that the L.T. connections are reversed, the L.T. + being placed at 0 volts and the { L.T. -  
{ H.T. - in 1½ volts. This does not affect the efficiency of the set and relieves the strain, which would be caused, on the battery, if the connections were the other way round.

Between the H.T.- and H.T.+ there is a difference of potential of 16½ volts.

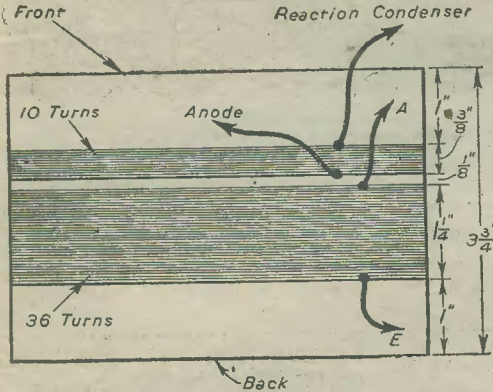

Fig. 3.—Details of winding of the frame aerial.

A strip of metal is cut out to fit behind the front panel, and the variable condensers are fitted into position behind this. The size of the strip should be 4½ in. x 2 in.

From Fig. 5 can be seen the position of the rest of the parts making up the set. No difficulties should be encountered here.

The valve-holder is constructed from a piece of aluminium or any other suitable material, and should be 4½ in. long and 2 in. broad. This strip is then bent along the dotted lines and cut as shown in Fig. 4A, so as to give the final result shown in Fig. 4B.

The arrangement shown is so designed to keep the wiring short, a factor which must not be overlooked if the greatest efficiency is to be desired. In addition, the reader is reminded that it is best to solder all connections, at the same time making sure that every joint is firm. Also, it is best to join all ground connections to a single point on the metal plate behind the condensers.

As a final additional precaution it is advisable to check all wiring and the direction of the coil windings.

There is a danger that the frame aerial might become worn if the set is left in this state after the wiring up is finished. It was found that good results were obtained if something was wrapped around the frame aerial and then adding two strips to the under-surface of the

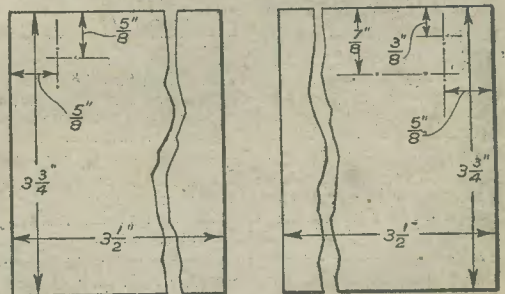
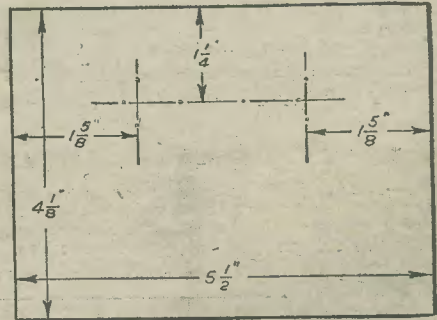

Fig. 2.—Data showing positions of holes for switch, condensers and plugs.

**Tuning**

The set tunes in a similar manner to any regenerative receiver. The tuning dial is first set approximately to the station it is desired to receive and the reaction control is advanced until a soft hiss is heard in the phones. At this point the set is in its most sensitive condition. The tuning dial is then rotated until the carrier wave of the station is heard. The reaction is now eased off till the station is rendered intelligible.

If the breaking into oscillation is erratic then all the joints should be examined to ensure that none is loose. A poor joint is often the cause of the trouble.

Should there be no form of reception whatsoever even after other faults have been eliminated it is advisable to review the frame aerial. Make quite sure that there is no break, that the distance between the grid and reaction coils is  $\frac{1}{2}$  in. and that both the turns are wound in the right direction.

Since this set is so small it can easily be stowed away in some odd corner of a haversack along with a pair of earphones. In this way the set can be carried about from place to place. Should the reader wish to listen to the set while carrying it about he could construct a small carrier from some webbing.

It might be noted that the total weight of the set

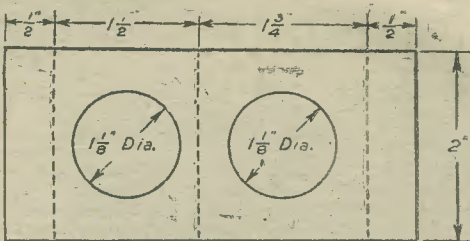

Fig. 4 (a).—Valveholder, showing where the metal is bent to obtain finished holder.

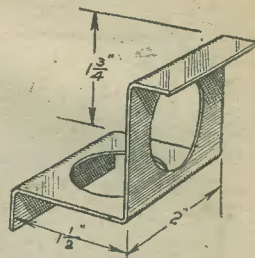

Fig. 4 (b).—Finished valveholder.

complete with batteries and a turntable is only  $2\frac{1}{2}$  lb. The addition of earphones brings the weight up to about 3 lb.

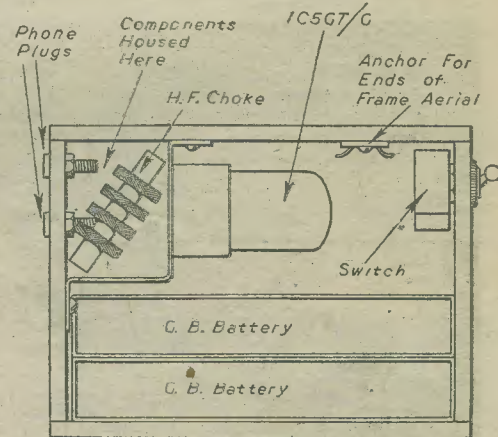

Fig. 5.—Back view of receiver showing position of parts.

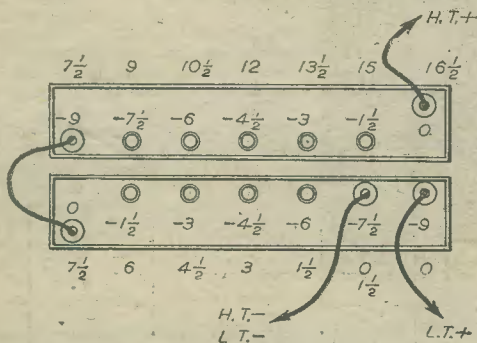

Fig. 6.—The two G.B. batteries joined in series. Figures inside the battery outline give the voltages shown on the side of a typical G.B. battery and the figures outside give the true voltages after joining the batteries in series.

**COMPONENT PARTS**

- Two .0003 variable condensers.
- One .0003 fixed condenser.
- One 2 meg. grid resistance ( $\frac{1}{2}$  watt).
- One H.F.C.
- One 1C5GT/G valve.
- One Bulgin switch.
- One pair of phone plugs.

**Filament Welder Saves Valves**

THE shortage of parts and valves has not been accompanied by a shortage of new ideas and means of keeping radio receivers in operation. For example, a worthwhile percentage of burned-out valves have been returned to service by welding their filaments.

A high voltage is usually connected across the defective filament for a short period of time. Unfortunately, it is altogether too easy to keep the voltage on too long, thus not only repairing the valve, but immediately burning it out again—this time for good.

A far greater chance for making a good weld is contained in an invention by Norman A. Hendry of Portland, Mich. (U.S. Patent No. 2,371,327). Instead of connecting the voltage source directly to the valve, he first charges a condenser and then discharges it through

the filament to be repaired. In this way there is direct control over the maximum value of the current flowing as well as the interval of time. Further, the exponential nature of the discharge permits tempering of the filament, which might otherwise become brittle and susceptible to overload.

Correct values to use for different types of filament have been discovered by Mr. Hendry after experiment and are listed in the table.

A preferred layout includes a source of direct current, several taps for desired outputs and a switching arrangement for charging and discharging the condenser. The circuit can be easily and conveniently built into a cabinet with provision for welding valves with different bases.—(Radio-Craft).

# Your Service Workshop-15

## Constructional Details of a Beat Frequency Oscillator

By STANLEY BRASIER

**T**HE beat frequency oscillator, although not of absolute necessity in the service workshop, is of immense help in many tests. Even a simple battery instrument is useful, but in order to overcome the drawbacks of battery drive, and to be more in keeping with the other apparatus described in the "Service Workshop" series, the instrument shown in these pages was designed. Most readers will be aware of the function of a B.F.O., but for those who are not, an explanation follows.

Put simply, its purpose is to reproduce in an orderly

frequency and the oscillator frequency appears at the anode of the mixer as the desired I.F. In the superhet receiver this I.F. must be the same, irrespective of the frequency to which the signal circuit is tuned, so  $L_2, C_2$  must always be at a frequency 465 kc/s higher. In practice, it is usually accomplished by means of special ganged tuning condensers.

In a B.F.O., however, the frequency appearing at the anode of the mixer valve must be variable, so while the circuit is arranged in much the same manner as the superhet, the tuning arrangements require to be different.

Reference to the circuit diagram of Fig. 2 will show that the oscillator comprising  $V_1, L_1, VC_1$  and its associated components feeds into the signal grid of the mixer valve  $V_2$ .

This oscillator is fixed tuned to a certain frequency. The signal from oscillator 2, comprising  $L_2, VC_2$  and the triode section of  $V_2$  will obviously combine with the signal from  $V_1$  and any difference between their frequencies will appear at the mixer anode. If the difference is small, say a few hundred cycles, then this signal will come well into the audible range (unlike the superhet where an I.F. of 465 kc/s is well outside it) and can be passed on to an L.F. amplifier in the usual way.

The adjustment of the tuning circuit  $L_2, VC_2$  is such that when  $VC_2$ , which is the main control, is at minimum capacity, the frequency is the same as that to which  $L_1, VC_1$  is tuned. Under these conditions there is no difference frequency and therefore no signal. But immediately the capacity of  $VC_2$  is increased a signal of a few cycles will be produced and further increase will cause the signal to rise in pitch or tone until, at the maximum position of  $VC_2$ , it is at the highest wanted

frequency or, if required, just out of the audible range. Although the first oscillator is fixed tuned, it is necessary to provide for some limited manual adjustment of its frequency by making  $VC_1$  variable. This control makes it possible for the instrument to be subsequently adjusted to zero frequency when the pointer of the main control ( $VC_2$ ) is in that position.

In considering the fixed and variable tuned oscillators in a B.F.O. we might, in a final endeavour to understand their action, compare them with a broadcasting station and a receiver where the fixed oscillator could be equivalent to the station, and the variable one to the oscillating receiver except that, in this case, a beat note would be obtained at either side of the silent point, and, as we said before, all in the space of a few degrees.

and controlled manner, the tones and whistles which emanate from the loudspeaker when a reacting detector receiver is badly operated. You know how, when tuned to a strong station with the receiver oscillating, the beat note may be varied from a deep sound right up to a high-pitched one and on into inaudibility—all this in the space of a few degrees.

With the B.F.O. however, the range of beat notes, from very low to very high, is spread out over the whole dial of the instrument so that the exact frequency of oscillation or, in other words, the exact musical note, may be reproduced by adjustment of a suitable control. In addition to this, the strength of any note must be capable of being varied from nil to maximum and at all times the note must be fundamentally pure.

### Principle of Operation

The principle on which most B.F.O.s are designed in order to achieve the foregoing conditions is rather similar in basic operation to the superhet receiver—a system with which most readers will be familiar. Fig. 1 shows a representative diagram of the frequency-changer section of a superhet where  $L_1, C_1$  are the signal circuit and tuned to say 1,000 kc/s.  $L_2, C_2$  are the oscillator circuit and (assuming an I.F. of 465 kc/s) will be tuned to 1,465 kc/s, so that the difference between the signal

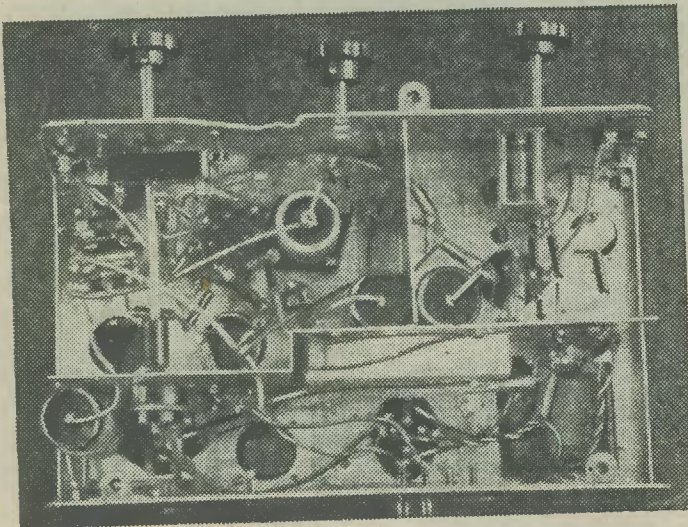

View of sub-chassis of the B.F. oscillator. The casing and above-chassis view of this unit are shown on the cover of this issue.

### Avoiding "Pull-in"

Mention of the silent point brings to mind one of the greatest difficulties in designing a B.F.O.—that of "pull-in," which is the name given to a condition whereby two frequencies, separated by a few cycles tend to combine, due to one pulling into step with the other. One well-known method of overcoming the difficulty is to employ as the mixer a valve of the triode hexode type, which, due to its particular construction, is very helpful in preventing "pull-in." Reference to

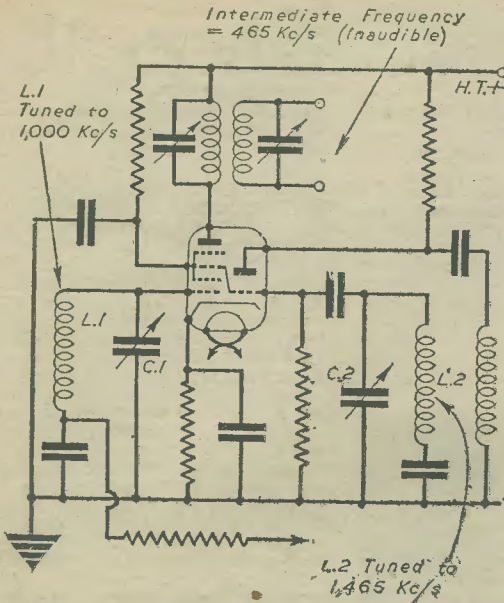

Fig. 1.—Frequency-changer section of superhet receiver referred to in the text.

the circuit diagram of Fig. 2 will show that such a valve has been incorporated, and also that its triode section is utilised as the variable oscillator. The valve for the fixed oscillator  $V_1$  may be any good medium impedance triode such as Osram M.H.L.4, or equivalent. From the foregoing the circuit will now be understood so far as  $V_1$  and  $V_2$  are concerned, so it remains only to deal with the audio signal from the anode of  $V_2$ , which passes through the high-frequency filter made up of HFC1, HFC2,  $C_9$  and  $C_{10}$ . The purpose of this

is to eliminate certain unwanted signals, which are present as well as the wanted AF. From here the AF voltage developed across the load resistor  $R_{12}$  is passed on via resistance-capacity coupling to  $V_3$ , which performs the ordinary function of L.F. amplifier.  $R_{13}$  is for the purpose of limiting the input to the output valve, so that, in the interests of purity, this valve is working well within its rated capabilities. If more volume is required there is no reason why a pentode output valve should not be fitted in place of the power valve shown.

It will be noted that no special arrangements for the output have been made, in the writer's case; it is fed into a large multi-ratio output transformer. It is not unusual, however, to provide for choke-capacity or resistance-capacity coupling so that the output from the instrument may be fed into a service oscillator or signal generator.

The hum level must be practically nil, and for this reason full wave rectification has been employed and particular attention given to the decoupling arrangements of all valves, and it will be noted that grid and anode "stoppers" have been included in the appropriate connections to the output valve. Incidentally, suitable valves are Osram ML4, Mazda AC/P, or equivalent types.

**Construction**

Turning now to practical considerations and to the construction of the instrument, the photographs show that it follows normal receiver layout except that screening is provided. It may be found, however, that the screens on the top of the chassis are unnecessary, but were included in the original design as an extra precaution. The screens which divide the various sections of the circuit under the chassis are *certainly* necessary, and are best made in aluminium, copper, or brass. The choice of a chassis should be carefully made, because the whole instrument must be absolutely firm and mechanically stable. So it is wise to select a really sound chassis that will not warp or twist under the weight of the various components. These should also be well made, and of the best quality available. However, it will be as well to consider them all briefly in case there are any snags from the reader's point of view, although they can all be standard parts.

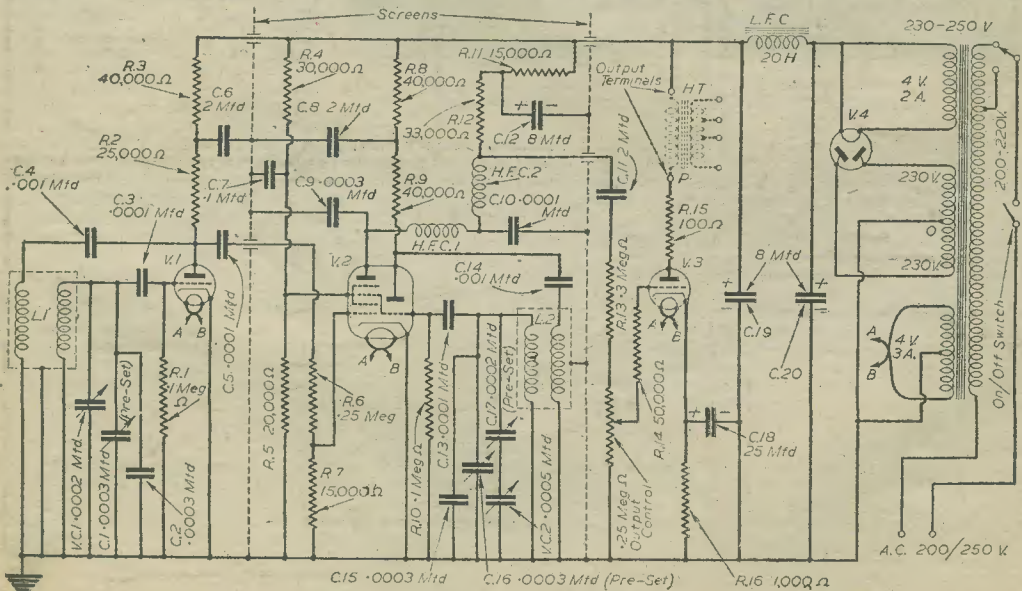

Fig. 2.—Circuit diagram of the beat frequency oscillator.



The mains transformer was specially wound to provide for an A.C. input of 200-250 volts and to give on its secondary windings 230-0-230 v. at 50 mA. for H.T., 4 v. 3 a. C.T. for valve heaters and 4 v. 2 a. for the full-wave rectifier heater. Particulars of the windings, assembled on a core having a cross-sectional area of  $1\frac{1}{2}$  sq. in., are as follows: Primary, 1,680 turns of 32 gauge enamelled wire tapped at 1,540 for 200-230 volt. High tension secondary, 3,220 turns of 40 gauge enamelled, tapped at 1,610 turns (centre tap). L.T. secondary, 30 turns of 18 gauge enamelled, tapped at 15 turns (centre). L.T. secondary for rectifier 30 turns of 20 gauge enamelled. All windings calculated at seven turns per volt. If the cross-sectional area of the core is 1 sq. in., which is a typical size for many lamination stacks, then eight turns per volt should be allowed. All windings must, of course, be well insulated from each other and also from the core. No primary screen was provided in the original transformer, because there was only just sufficient room for the windings, but it would be definitely advantageous to do so, if possible. It should be arranged so that the primary winding is enclosed by a layer of copper foil, the ends of which do not connect electrically, i.e., by leaving a slight gap or by insulating any overlap of the foil. A wire is then soldered to it for connection to earth. The winding of the secondaries may then be proceeded with. A standard transformer having an H.T. winding of 250-0-250 v. may be used, providing the necessary precautions are taken to restrict the H.T. on the output valve to 200 v. This seems to be the maximum for most valves of this type, and it is therefore unwise to exceed it.

The smoothing choke may be any good quality component having an inductance of 20 henries or thereabouts. The two 8 mfd. electrolytic condensers used for smoothing are of the cardboard type and are mounted, one on top of the other, under the chassis in the position indicated. The other condensers are all of the tubular type except C12, that used for decoupling the hexode anode, which happens to be of the can type. It is not

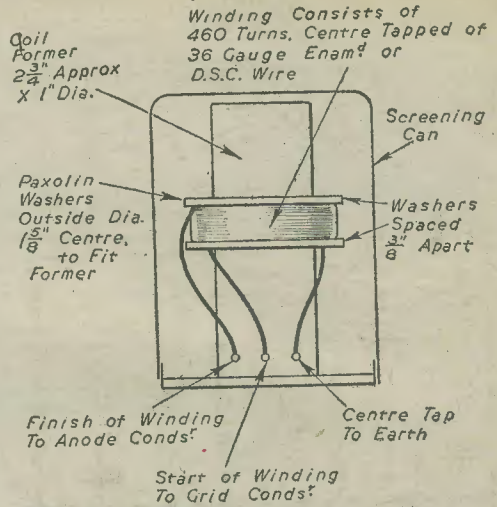

Fig. 3.—Details of the coils (two required).

essential, though, and the block type may be used if desired.

The 0.25 megohm output control, with which is incorporated the on-off switch, should be preferably of the graded or log. type. Dealing now with the H.F. side of the instrument, the main variable condenser should be of really sound construction and securely mounted if stability of frequency is to be expected. In this respect it will be noted in the model shown that a single-gang type condenser is used. This naturally

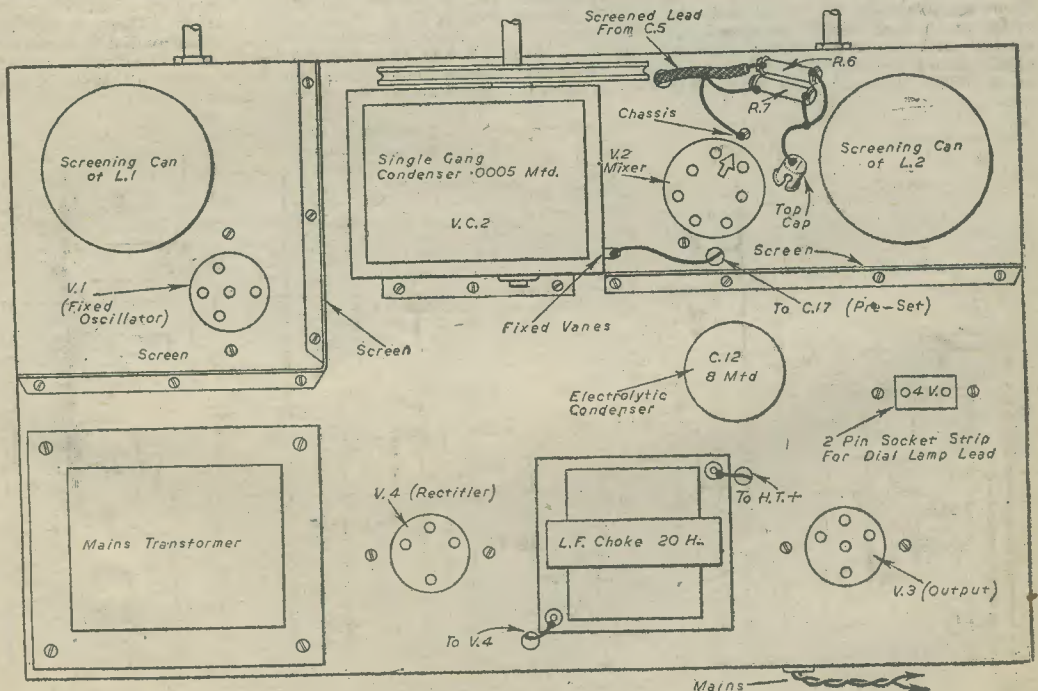

Fig. 4.—Layout of components on top of chassis.

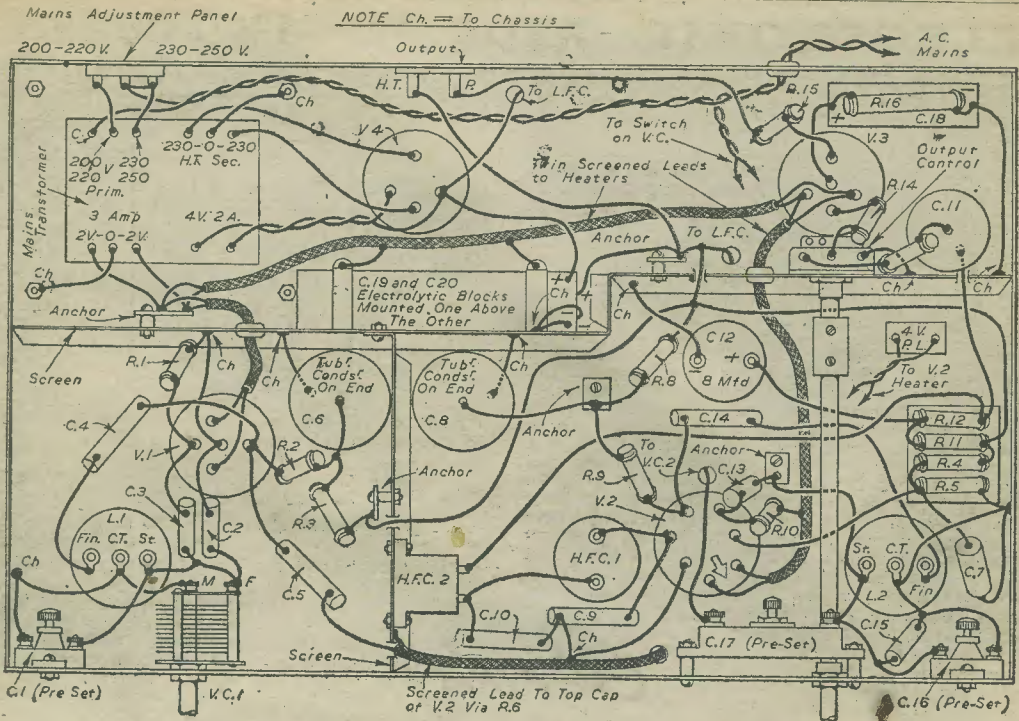

Fig. 5.—Component layout and wiring diagram of underside of chassis.

permits of a firmer mounting than the one-hole fixing type, although, of course, it is not difficult to devise a secure mounting for this if the single gang is not available. Another idea is to use a small 2-gang assembly, leaving one section unconnected. The foregoing remarks also apply in some measure to VC1, the "set zero" condenser although this control, once set, is not subjected to constant use.

**Coils**

The coils, whilst being important, are extremely simple to make and wind. It will be noted that they are screened and for this purpose commercial I.F. transformer assemblies complete with cans were used. These, or ordinary screened coils are usually to be found in the junk box so that, after stripping the former of its windings, it is a simple matter to provide for the coils shown in Fig. 3. The former should be rin. diameter, but this appears to be quite a normal size for most screened coils. If enamelled wire is used it is important to see that the centre tap, if it leads out across the windings, is thoroughly insulated from surrounding turns. For various reasons, it would be somewhat more satisfactory to employ D.S.C. wire if it is available. The H.F. chokes are screened, and the best quality components available should be used. The small fixed condensers are of the non-inductive tubular type and so for that matter are the 2 mfd. decoupling condensers, but here again it is immaterial which type is employed so long as the working conditions are fulfilled.

**Assembly**

Before commencing the assembly of the components it is necessary to make and fit the screens to the underside of the chassis. Incidentally, the chassis shown was rather deep, the only advantage being that it gives more room for components and for working. The screen which runs from left to right of the chassis, dividing off the power supply and output stage from the H.F. sections, is in one piece and that separating the two oscillators is fixed to it at right angles in the appropriate position. Before finally fitting the screens it will be necessary to drill the holes in them through which the wires pass and also for the output control which is

*(Continued on page 459)*

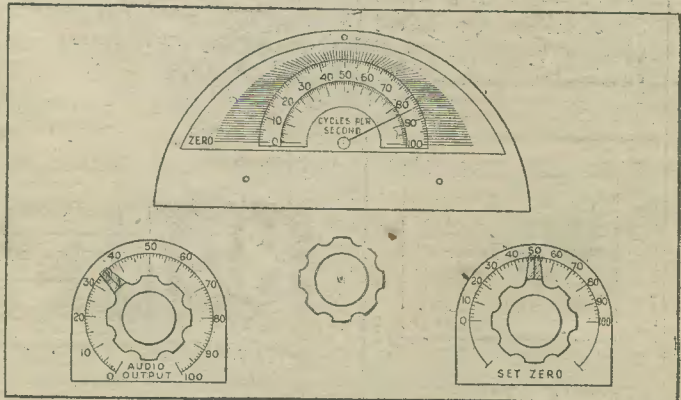
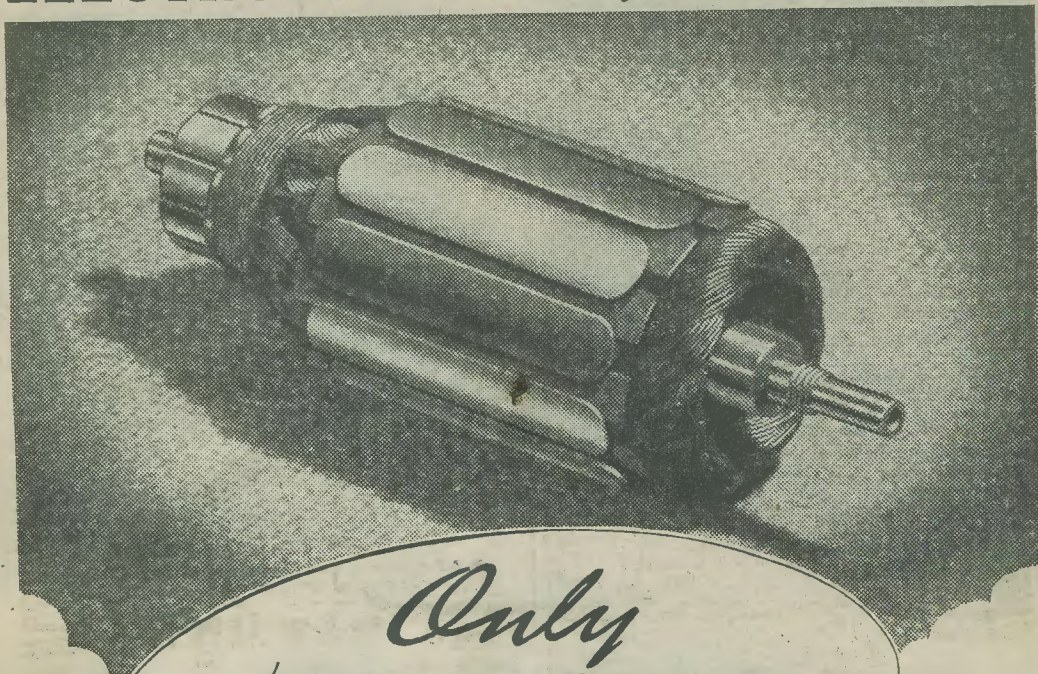

Fig. 6.—Layout of front of cabinet, showing how the scales are marked out. The space round the outer edge of main scale is for calibration.

# ELECTRONIC AIDS for INDUSTRY



*Only*  
**1/1000th of an oz.**  
*out of balance*

ANY engineer will tell you that perfect balance has always been the limiting factor in the design of high speed rotating parts. For unless the component is accurately balanced, statically and dynamically, it will set up destructive vibrations which affect the efficiency of the whole machine and curtail its useful life. Hitherto balancing a high speed armature, for instance, has been a tedious, highly skilled operation. But now electronics can do it with far greater accuracy in a fraction of the time.

**—yet Electronics discovered it!**

Indeed, unbalance as small as one-thousandth part of an ounce can be detected—even a movement of .000025" can be located and measured. As Capacitor manufacturers we are vitally interested in the progress of Electronics. For Hunts' Capacitors, used by all the leading Radio manufacturers, are now to be found on much of the land, air and sea equipment in the service of the Allied Forces where their dependability under the most exacting climatic conditions has been freely recognised.

**HUNTS**  
 TRADE MARK  
*capacitors*

A. H. HUNT LTD • LONDON • S.W.18 • ESTABLISHED 1901

GA

## LET ME BE YOUR FATHER

You need help and fatherly advice in difficult times like these. I am in the position to give that to you free.

We teach nearly all the Trades and Professions by post in all parts of the world.

The most progressive and most successful Correspondence College in the world.

If you know what you want to study, write for prospectus. If you are undecided, write for my fatherly advice. It is free.

Distance makes no difference.



## EARNING POWER IS A SOUND INVESTMENT

### DO ANY OF THESE SUBJECTS INTEREST YOU ?

- |                          |                                  |             |                             |                   |                   |                               |                      |                   |         |             |         |   |              |   |                      |                                     |                   |               |                         |                |                         |                                     |                               |  |                   |                   |                         |                      |                      |           |            |           |             |               |            |                      |                                |                   |             |                                |                    |               |                |              |                        |  |                        |                             |                     |                           |                        |                             |                        |            |                           |                    |                  |              |                      |                     |                  |                    |                        |           |                         |                          |            |                        |                              |                                |         |                                   |                |
|--------------------------|----------------------------------|-------------|-----------------------------|-------------------|-------------------|-------------------------------|----------------------|-------------------|---------|-------------|---------|---|--------------|---|----------------------|-------------------------------------|-------------------|---------------|-------------------------|----------------|-------------------------|-------------------------------------|-------------------------------|--|-------------------|-------------------|-------------------------|----------------------|----------------------|-----------|------------|-----------|-------------|---------------|------------|----------------------|--------------------------------|-------------------|-------------|--------------------------------|--------------------|---------------|----------------|--------------|------------------------|--|------------------------|-----------------------------|---------------------|---------------------------|------------------------|-----------------------------|------------------------|------------|---------------------------|--------------------|------------------|--------------|----------------------|---------------------|------------------|--------------------|------------------------|-----------|-------------------------|--------------------------|------------|------------------------|------------------------------|--------------------------------|---------|-----------------------------------|----------------|
| Accountancy Examinations | Advertising and Sales Management | Agriculture | A.M.I. Fire E. Examinations | Applied Mechanics | Army Certificates | Auctioneers and Estate Agents | Aviation Engineering | Aviation Wireless | Banking | Blue Prints | Boilers | Book-keeping, Accountancy and Modern Business Methods | B.Sc. (Eng.) | Building, Architecture and Clerk of Works | Builders' Quantities | Cambridge Senior School Certificate | Civil Engineering | Civil Service | All Commercial Subjects | Commercial Art | Common Prelim. F.I.E.B. | Concrete and Structural Engineering | Draughtsmanship. All Branches | Engineering. All branches, subjects and examinations | General Education | G.P.O. Eng. Dept. | Heating and Ventilating | Industrial Chemistry | Institute of Housing | Insurance | Journalism | Languages | Mathematics | Matriculation | Metallurgy | Mining. All subjects | Mining. Electrical Engineering | Motor Engineering | Motor Trade | Municipal and County Engineers | Naval Architecture | Novel Writing | Pattern Making | Play Writing | Police, Special Course | Preceptors, College of Press Tool Work | Production Engineering | Pumps and Pumping Machinery | Radio Communication | Radio Service Engineering | R.A.F. Special Courses | Road Making and Maintenance | Salesmanship, I.S.M.A. | Sanitation | School Attendance Officer | Secretarial Exams. | Sheet Metal Work | Shipbuilding | Shorthand (Pitman's) | Short-story Writing | Short-wave Radio | Speaking in Public | Structural Engineering | Surveying | Teachers of Handicrafts | Telephony and Telegraphy | Television | Transport Inst. Exams. | Viewers, Gaugers, Inspectors | Weights and Measures Inspector | Welding | Wireless Telegraphy and Telephony | Works Managers |
|--------------------------|----------------------------------|-------------|-----------------------------|-------------------|-------------------|-------------------------------|----------------------|-------------------|---------|-------------|---------|---|--------------|---|----------------------|-------------------------------------|-------------------|---------------|-------------------------|----------------|-------------------------|-------------------------------------|-------------------------------|--|-------------------|-------------------|-------------------------|----------------------|----------------------|-----------|------------|-----------|-------------|---------------|------------|----------------------|--------------------------------|-------------------|-------------|--------------------------------|--------------------|---------------|----------------|--------------|------------------------|--|------------------------|-----------------------------|---------------------|---------------------------|------------------------|-----------------------------|------------------------|------------|---------------------------|--------------------|------------------|--------------|----------------------|---------------------|------------------|--------------------|------------------------|-----------|-------------------------|--------------------------|------------|------------------------|------------------------------|--------------------------------|---------|-----------------------------------|----------------|

If you do not see your own requirements above, write to us on any subject. Full particulars free.

### COUPON-CUT THIS OUT

To DEPT. 104, THE BENNETT COLLEGE, LTD., SHEFFIELD.

Please send me (free of charge)

Particulars of..... (Cross out line which does not apply.)  
 Your private advice  
 about.....

PLEASE WRITE IN BLOCK LETTERS

Name.....

Address.....

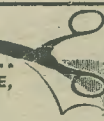

## Useful Books

### SHORT WAVE RADIO

By J. H. Reyner. An invaluable volume, recommended to all students of radio engineering as a reliable textbook on modern developments in the use of the short, ultra-short and micro waves. Fourth Edition. 10s. 6d. net.

### CATHODE-RAY OSCILLOGRAPHS

By J. H. Reyner. Discusses theory and shows its application in practice. Intensely interesting and helpful to radio men. Second edition. 8s. 6d. net.

### A FIRST COURSE IN WIRELESS

By "Decibel." A handy guide to wireless for beginners. Clearly and simply written, it forms an excellent introduction to more-advanced works. Second edition. 5s. net.

### ELEMENTARY HANDBOOK FOR WIRELESS OPERATORS

By W. E. Crook, A.M.I.E.E., A.F.R.Ae.S. This book, written by an R.A.F. Instructor, is ideal for the man who wants to become a wireless operator. It gives all the essential information in a clear, easy-to-understand manner. Second edition. 4s. net.

N.B. Paper rationing means a shortage of books. The one you want may be temporarily out of stock.

## PITMAN

PARKER ST., KINGSWAY, LONDON, W.C.2.

**Varley**

**THERMAL DELAY SWITCHES**

PROTECT YOUR RADIO EQUIPMENT

★ 4 VOLT · 5 VOLT · 6.3 VOLT HEATERS ★

**OLIVER PELL CONTROL LTD**

CAMBRIDGE ROW · WOOLWICH · S.E. 18

TELEPHONE: WOOLWICH · 1422

## COVENTRY RADIO

COMPONENT SPECIALISTS SINCE 1925.

### 1925 to 1945

This month completes 20 years of service to the public. We have endeavoured to offer good quality components at reasonable prices with really prompt service. We are now extending our range of goods and we hope to still further improve our service.

May we send you our ANNIVERSARY LIST of Components. Price 1d. Ready mid-September.

**THE COVENTRY CO.,**  
 191, Dunstable Road, Luton.

mounted on the screen near the output valveholder. The control spindle is extended to the front of the chassis by means of a length of  $\frac{1}{16}$  in. diameter rod and a metal or ebonite coupling bush.

**Wiring**

The connections to all valve heaters are made with twin-screened cable, the outer casing of which is securely bonded to the screens or chassis at any convenient point. For the rest, thick wire, say 18 s.w.g. and sleeving should be used in order to ensure rigidity and it is, of course, necessary that all connections be really sound. Note also that the lead from C<sub>5</sub>, which runs along the underside of the chassis and up to the top cap of V<sub>2</sub>, via R<sub>6</sub>, is screened. Most of the resistors associated with the mixer valve are mounted on a small group board, but where any resistor or small condenser is suspended in a long run of wire, it is advisable to provide anchorage points so that no possibility exists of the parts moving slightly through vibration.

**Testing**

Before the B.F.O. will function correctly adjustments have to be made so that, as explained previously, both oscillators are tuned to the same frequency or wave length. This may be achieved with the aid of a signal generator or oscillator, but if such an instrument is not available, the long-wave band of a T.R.F. receiver will serve the purpose, providing that it can be made to oscillate. The external or test oscillator should be adjusted to approximately 1,500 metres and its output fed via a dummy aerial or small fixed condenser into the grid circuit of the fixed oscillator V<sub>1</sub>. The triode grid of the mixer valve is temporarily shorted to earth and VC<sub>1</sub>, the "set zero" condenser, adjusted to roughly half its capacity. The circuit of V<sub>1</sub> is now tuned by means of the pre-set condenser, C<sub>1</sub>, so that it resonates or heterodynes with the test oscillator. The exact wavelength used is immaterial, so long as both oscillators are eventually tuned to it. Having dealt with V<sub>1</sub>, its grid should be shorted to chassis, while that

to approximately the half-way position, as before. Then the value of the two pre-set condensers C<sub>1</sub> and C<sub>16</sub> is adjusted until a point is reached where no sound can be heard. Actually, it will be found that if the pre-set condensers are set to their minimum capacity a slight adjustment of one of them (which one must be found by experiment) will be all that is necessary. Having adjusted the instrument to a point where no sound can be heard, the main control VC<sub>2</sub> should be increased very slowly until a "pop pop pop" sound is heard in the speaker.

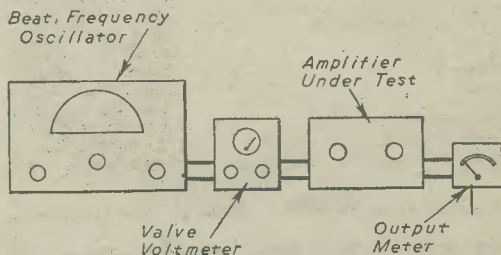

Fig. 8.—Set-up for measuring frequency response of L.F. amplifier.

This will indicate that the B.F.O. is functioning on a very few cycles per second, so few, in fact, that the beats do not resolve themselves into a note. Further increase of VC<sub>2</sub>, however, will increase the frequency and therefore the pitch of the note, so that at maximum capacity the note just passes out of audibility. If this state of affairs exists before the condenser is at maximum, or if, with the condenser in that position, the note is not high enough, the pre-set condenser C<sub>17</sub> will need adjusting. This component alters the effective capacity of the main control and a point will be found where, by rotating VC<sub>2</sub> from minimum to maximum, the note starts from zero and rises gradually to a pitch where it becomes only just audible. This, of course, is the ideal condition.

A simple, but effective means of providing the main condenser with a slow motion drive is by fitting a large pulley to its spindle and a small one to a shaft which carries the actual operating knob. Strong cord and a small spring is then arranged to provide a drive between the two. The idea can be seen from the top chassis' photograph. The control for A.F. output needs no comment and the "set-zero" control is practically self-explanatory, its purpose being to adjust the beat note to zero when the pointer of the main condenser is at 0 deg. on the scale.

The writer was fortunate in being able to secure the use of a cathode-ray oscilloscope for the purpose of checking over this instrument and it can be stated that the wave-form throughout the whole A.F. range is excellent. This indicates, of course, that the notes may be regarded as pure tones—a necessary quality in any A.F. source. The above conditions, however, apply only when a really good output transformer is used, i.e., one having a large and weighty core and correctly proportioned windings providing the right ratio for the speaker employed. The ordinary type fitted to most speakers is really too small to provide the necessary inductance, and saturation of the core occurs, particularly at low frequencies, thus, the wave form, as viewed on the cathode-ray oscilloscope, assumes a rather distorted character.

**Cabinet**

The cabinet may be constructed of wood or metal, the latter is preferable because then the apparatus is completely screened, thus minimising any coupling between it and other instruments that may be in use. A full vision scale is provided, but in spite of this the metal cabinet design is such that the screening is still complete. It is a useful scheme to adopt for any test apparatus, so the details may be useful. The cabinet front—or panel, if such is used—is cut out to suit any

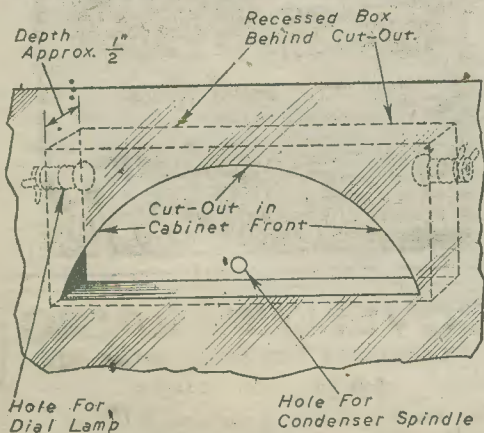

Fig. 7.—Showing arrangement of metal box behind panel cut-out which ensures complete screening.

across the other oscillator grid is removed so that it may be adjusted similarly. In this case, VC<sub>2</sub>, the main control, should be set to minimum capacity before adjustments are carried out by means of the pre-set condenser C<sub>16</sub>. After removing the short from the grid of V<sub>1</sub>, adjustments will be complete and the test will also have proved that both oscillators are functioning satisfactorily.

If desired, the B.F.O. may be adjusted by ear in quite a simple manner. To do this VC<sub>2</sub> is set to zero and VC<sub>1</sub>

particular fancy, i.e., oblong, semicircular, etc., and then a metal box is constructed of a size approximately  $\frac{1}{2}$  in. larger all round than the panel cut-out and about  $\frac{1}{2}$  in. deep and fitted symmetrically behind the cut-out. It is fixed either by soldering, welding, or by nuts and bolts and must make good contact with the cabinet. A hole is provided at the point where the spindle of the condenser carrying the pointer will protrude. The idea is shown in Fig. 7 and applies to this particular instrument. The scale (marked out in ivoryine to special design, see Fig. 6) is fitted into the recessed box and stuck to the back with a little adhesive. All that remains is to construct a suitable escutcheon of any desired shape. This is not difficult, for it is only necessary to cut a piece of tin plate of suitable gauge to the desired outside shape and then remove the centre portion with the aid of a fretsaw. A strip of metal about  $\frac{1}{2}$  in. wide is next soldered around the inner edge at right angles to it, thus forming a recess behind which a thin piece of glass is fitted. This may be obtained, cut to shape, from a glazier and is held in place by small clips soldered to the back of the escutcheon. When the escutcheon is fitted into the panel cut out, the pointer should have sufficient clearance to travel freely between the scale and the glass. Provision is also made for flood-lighting the dial by fitting pilot lamps into the holes shown in Fig. 7. We have thus an extremely good-looking and efficient full-vision slow-motion dial at a cost of practically nil. The procedure for assembly is to slide the chassis into the cabinet from the back, fix pointer to spindle, and fit escutcheon. The cabinet has, of course, a back which must make good electrical contact to ensure perfect screening. It is also fitted with an earth terminal.

#### Calibration

In order that full advantage may be taken of the B.F.O. it is necessary that the instrument be calibrated in cycles per second, and in this connection the amazing usefulness of the cathode-ray oscilloscope again becomes apparent, for the process is then a comparatively simple matter. Few readers, however, will have access to such an instrument, and it is therefore necessary to consider other means of calibration. One method, open to practically everyone, is to make use of a piano, and providing that it is in tune the method is reasonably accurate, especially if one has a good ear for music. Another way is to use gramophone records of pure tone constant frequencies. The B.F.O. may then be adjusted, and its note synchronised by ear with the known frequency being generated from the record. This is not as difficult as may be imagined, for there is no doubt about the point at which the two frequencies coincide. When they are slightly different, one can discern a sort of double beat or throbbing note, which vanishes at the exact point where they pull into step. This method of calibration may also be used in conjunction with tuning forks, or, in fact, any audio source of known frequency which may be available. Even a few points fixed throughout the range will be sufficient to enable a graph to be plotted showing frequency against dial readings and from which intermediate values may be read off. Before leaving the question of calibration, it is useful to remember that there are always two accurate sources of A.F. available, one being the time controlled 50-cycle A.C. mains, the other being the 1,100 cycle tuning note radiated by the B.B.C., although to make use of the latter one needs to be rather enthusiastic.

#### Applications

One of the most useful applications of the B.F.O. is in checking the frequency response of an L.F. amplifier or the L.F. section of a receiver. For a test of this nature it is essential that the output level of the B.F.O. (and therefore the input signal fed into the amplifier under test) is constant at all frequencies. One useful instrument for this purpose is the valve-voltmeter, since it is independent of frequency and, in fact, is often incorporated in the better class B.F.O.'s as one complete instrument. The resultant output from the amplifier under test is then recorded on an output meter, which

may consist of an A.C. voltmeter of suitable range. If the amplifier were a big one it would be necessary only to feed a small signal into it, that is why the valve-voltmeter, being one of the most sensitive instruments of its type, is often used to record small outputs from the B.F.O. If the output meter used has no provision for an artificial load it would be necessary, assuming the L.S. was not in use, to connect a resistor across the output meter in the diagram (Fig. 8), the ohmic value being the same as the speech coil of the L.S. normally used in conjunction with the amplifier's output transformer.

Another use for the B.F.O. is in detecting the frequency at which a loudspeaker has developed a rattle. Not that we want to know the frequency particularly, but it is useful to be able to feed into the speaker a sustained note at the frequency at which it vibrates. Under these conditions it is most convenient to work on until the rattle is cured.

By connecting the B.F.O. to the "external modulation" terminals of a service oscillator, the latter instrument is then provided with variable modulation on any H.F. signal generated. To do this the B.F.O. must be provided with resistance capacity output by joining a 3- or 4-watt resistor across the output terminals, and a 2 mfd. condenser connected to the "anode" output terminal. The input to the service oscillator is then taken from the other side of this condenser and the earth line of the B.F.O. respectively.

## Radio Robot Plane

ONE of the most startling possibilities in future air warfare appears to be the development of radio-controlled robot airplanes that can accompany heavy, long-range bombers to their distant objectives.

As part of the bomb load, these huge flying fortresses could each carry a number of tiny radio-controlled planes. These planes would have folding wings so that they could be stowed away in the fuselage of the larger mother ship, the robot planes being staggered to fit with the least possible interference in the faired-away interior. They would have small and inexpensive engines and the required output, fed from fuel tanks of rather small capacity, since their radius and duration of action would be intentionally limited. They will carry a gyro pilot, controlled by robot mechanism set by radio impulses transmitted from the mother plane, as well as several bombs and smoke-screen gas tanks. The bombs could be detonated by radio.

In no branch of aerial warfare has there been any weapon exhibiting the versatile possibilities that these radio robot planes incorporate. They could be hung upon special hooks within the fuselage and the crew could lower them through the fuselage doors, open and lock the wings, start the engine, check the radio control, and release them for free but controlled flight within the visual range of the radio control operators. Carrying their timetable bomb load, they could be directed into formations of enemy aircraft to create havoc among them, and divert and prevent attacks upon the bombers themselves. They could be sent into enemy ground objectives with more accuracy and with less danger to the bombers than any precision-aimed free bomb drops. They could precede or surround the bombers they protect, sometimes emitting smoke screens to confuse the enemy aircraft.—*Radio-Craft*, (U.S.A.).

## WIRE AND WIRE GAUGES

By F. J. CMM.

3/6 or by post 3/9 from

George Newnes, Ltd., Tower House, Southampton St., London, W.C.2.

# Characteristics of Luminescent Materials for Cathode-ray Tubes

Précis of a Discussion at a Meeting of the Radio Section of the Institution of Electrical Engineers, held on Tuesday, May 15th, 1945

THE discussion was opened by Mr. C. G. A. Hill, B.Sc., who stated, in his introductory remarks, that the accuracy with which the characteristics of a particular cathode-ray tube screen could be predicted from a knowledge of the phosphors before they were applied to the bulb was still very limited and varied considerably with the type of phosphor. This was chiefly due to insufficient control in some stages of tube manufacture and of some of the materials used.

Although several thousand different materials had been tried, the phosphors in common use could be classified, on the basis of both chemical composition and luminescent behaviour, into the following three groups:

- (1) Zinc and zinc-cadmium sulphides activated by silver, copper or manganese, or without added activator.
- (2) Manganese-activated silicates, borates or phosphates of zinc or cadmium, with various matrix additions.
- (3) Tungstates of a number of divalent metals.

## Emission Spectra

The emission spectra of the first group were usually complex, the relative intensities of the bands being very sensitive to (a) the concentrations of activators, (b) the heat treatment of the phosphor, (c) the temperature of excitations, and (d) the intensity of excitation. The sensitivities to factors (b), (c) and (d) were dependent on (a). Factor (b) might cause trouble during the baking of the tube, while (d) caused reversible colour changes as the exciting intensity was varied.

The manganese-activated oxygen-containing phosphors emitted a range of colours between green and red in which the emission spectrum depended on the composition and heat treatment of the phosphor. Unlike the sulphides, they were not affected by normal baking temperatures, and there was no change in the emission spectrum with intensity of excitation, although subjective changes might occur.

The tungstates emitted very broad bands, usually extending from the near ultra-violet to about 6,000 Å, the colour being blue or bluish white. Their spectra were determined by their composition, but were not sensitive to any of the other factors mentioned above.

New materials about which little was at present known included a number of alkaline-earth silicates activated by europium, cerium or other rare elements. They were claimed to emit in the blue and near ultra-violet.

A wide range of materials was available for white television screens. For colour television the best emission spectra depended on the system of transmission used. From purely optical considerations, the best solution was to choose three phosphors with colour co-ordinates as close as possible to the spectral locus in the blue, green and red, and to avoid the use of filters in front of the viewing screen. The emission spectra must always be matched with the spectra sensitivities of the pick-up devices to assure good colour rendering.

## Phosphorescence

Space forbade any full discussion of this complex aspect of luminescent materials, and generalisations were of little value here. It might be of interest to note that decay periods of the order of  $10^{-8}$  sec. represented a lower limit for any material, since the life of the excited states of a gas atom was seldom less than this. It had to be emphasised that, although the phosphorescent

characteristics of a material were not affected by normal tube-processing, the decay rate of a comparatively simple and well-known phosphor, such as willemite, could be varied over a wide range by suitable preparation. The same also applied to many other phosphors.

## Efficiency

In considering the efficiency of cathode-luminescent material, it was important to distinguish between real variations in the efficiency of conversion of electronic energy into light and those effects due to the electrical properties of the screen. For most materials, the light output increased linearly with the current density up to a point, after which the increase was less rapid. The point at which saturation first appeared and the subsequent rate at which the light output increased with current density were independent of the voltage, but varied widely for different materials and for the same material in different assemblies. They also depended on the rate of scanning.

The relationship between light output  $L$  and screen voltage was usually expressed by a power law of the type:  $L = Af(i)(V - V_0)^n$ , where  $A$  was a constant,  $i$  the current density,  $V$  the screen voltage, and  $V_0$  a constant "dead voltage." Values of the exponent  $n$  between 1.0 and 3 had been reported, but there was little consistency in the literature. A similar uncertainty existed concerning the value of  $V_0$ , which had been claimed to be zero in certain cases. It appeared that both these "constants" were affected by tube-processing, and might also be permanently changed by subjection to high-voltage bombardment.

Sulphide phosphors in general showed a greater efficiency than other types; the reason for this might be connected with their excitation spectra under ultra-violet excitation. Assuming a quantum efficiency of 80 per cent. (which was commonly found) the energy conversion for sulphides excited by  $\lambda = 3,650 \text{ Å}$  was about 60 per cent., whereas for silicates and tungstates excited by  $\lambda = 2,500 \text{ Å}$  it was about 40 per cent. These figures represented roughly the energy efficiencies of the luminescent centres themselves, and would be theoretical maxima where all the energy of the incident electron beam was transferred to the centres. In practice a 10 per cent. conversion appeared to be the present upper limit.

## Secondary Emission

The secondary-emission characteristics of a screen, combined with the geometry of the tube, determined the voltage of the screen relative to that of the accelerating electrode, and hence the effective energy of the electrons striking it. At low voltages the secondary-emission ratio was less than unity, and the screen (if it was on a non-conducting support) repelled the incident beam. As the accelerating voltage was raised, the screen suddenly lit up when the secondary emission ratio reached unity. On raising the voltage still further the ratio again fell, and the screen became negatively charged with respect to the accelerating anode. Eventually the voltage of the screen relative to the cathode became constant, although the anode voltage was further increased. This maximum attainable screen voltage was extraordinarily sensitive to surface contamination of the phosphor, to its past history, and to the rate of scanning. Thin screens on conducting supports did not suffer from this effect. Various methods of increasing the secondary emission of phosphors had been suggested, but little information was available as to their effectiveness.

# Characteristics of Luminescent Materials for Cathode-ray Tubes

Précis of a Discussion at a Meeting of the Radio Section of the Institution of Electrical Engineers, held on Tuesday, May 15th, 1945

THE discussion was opened by Mr. C. G. A. Hill, B.Sc., who stated, in his introductory remarks, that the accuracy with which the characteristics of a particular cathode-ray tube screen could be predicted from a knowledge of the phosphors before they were applied to the bulb was still very limited and varied considerably with the type of phosphor. This was chiefly due to insufficient control in some stages of tube manufacture and of some of the materials used.

Although several thousand different materials had been tried, the phosphors in common use could be classified, on the basis of both chemical composition and luminescent behaviour, into the following three groups:

- (1) Zinc and zinc-cadmium sulphides activated by silver, copper or manganese, or without added activator.
- (2) Manganese-activated silicates, borates or phosphates of zinc or cadmium, with various matrix additions.
- (3) Tungstates of a number of divalent metals.

## Emission Spectra

The emission spectra of the first group were usually complex, the relative intensities of the bands being very sensitive to (a) the concentrations of activators, (b) the heat treatment of the phosphor, (c) the temperature of excitation, and (d) the intensity of excitation. The sensitivities to factors (b), (c) and (d) were dependent on (a). Factor (b) might cause trouble during the baking of the tube, while (d) caused reversible colour changes as the exciting intensity was varied.

The manganese-activated oxygen-containing phosphors emitted a range of colours between green and red in which the emission spectrum depended on the composition and heat treatment of the phosphor. Unlike the sulphides, they were not affected by normal baking temperatures, and there was no change in the emission spectrum with intensity of excitation, although subjective changes might occur.

The tungstates emitted very broad bands, usually extending from the near ultra-violet to about 6,000 Å, the colour being blue or bluish white. Their spectra were determined by their composition, but were not sensitive to any of the other factors mentioned above.

New materials about which little was at present known included a number of alkaline-earth silicates activated by europium, cerium or other rare elements. They were claimed to emit in the blue and near ultra-violet.

A wide range of materials was available for white television screens. For colour television the best emission spectra depended on the system of transmission used. From purely optical considerations, the best solution was to choose three phosphors with colour co-ordinates as close as possible to the spectral locus in the blue, green and red, and to avoid the use of filters in front of the viewing screen. The emission spectra must always be matched with the spectra sensitivities of the pick-up devices to assure good colour rendering.

## Phosphorescence

Space forbade any full discussion of this complex aspect of luminescent materials, and generalisations were of little value here. It might be of interest to note that decay periods of the order of  $10^{-8}$  sec. represented a lower limit for any material, since the life of the excited states of a gas atom was seldom less than this. It had to be emphasised that, although the phosphorescent

characteristics of a material were not affected by normal tube-processing, the decay rate of a comparatively simple and well-known phosphor, such as willemite, could be varied over a wide range by suitable preparation. The same also applied to many other phosphors.

## Efficiency

In considering the efficiency of cathode-luminescent material, it was important to distinguish between real variations in the efficiency of conversion of electronic energy into light and those effects due to the electrical properties of the screen. For most materials, the light output increased linearly with the current density up to a point, after which the increase was less rapid. The point at which saturation first appeared and the subsequent rate at which the light output increased with current density were independent of the voltage, but varied widely for different materials and for the same material in different assemblies. They also depended on the rate of scanning.

The relationship between light output  $L$  and screen voltage was usually expressed by a power law of the type:  $L = A(i)(V - V_0)^n$ , where  $A$  was a constant,  $i$  the current density,  $V$  the screen voltage, and  $V_0$  a constant "dead voltage." Values of the exponent  $n$  between 1.0 and 3 had been reported, but there was little consistency in the literature. A similar uncertainty existed concerning the value of  $V_0$ , which had been claimed to be zero in certain cases. It appeared that both these "constants" were effected by tube-processing, and might also be permanently changed by subjection to high-voltage bombardment.

Sulphide phosphors in general showed a greater efficiency than other types; the reason for this might be connected with their excitation spectra under ultra-violet excitation. Assuming a quantum efficiency of 80 per cent. (which was commonly found) the energy conversion for sulphides excited by  $\lambda = 3,650$  Å was about 60 per cent., whereas for silicates and tungstates excited by  $\lambda = 2,500$  Å it was about 40 per cent. These figures represented roughly the energy efficiencies of the luminescent centres themselves, and would be theoretical maxima where all the energy of the incident electron beam was transferred to the centres. In practice a 10 per cent. conversion appeared to be the present upper limit.

## Secondary Emission

The secondary-emission characteristics of a screen, combined with the geometry of the tube, determined the voltage of the screen relative to that of the accelerating electrode, and hence the effective energy of the electrons striking it. At low voltages the secondary-emission ratio was less than unity, and the screen (if it was on a non-conducting support) repelled the incident beam. As the accelerating voltage was raised, the screen suddenly lit up when the secondary emission ratio reached unity. On raising the voltage still further the ratio again fell, and the screen became negatively charged with respect to the accelerating anode. Eventually the voltage of the screen relative to the cathode became constant, although the anode voltage was further increased. This maximum attainable screen voltage was extraordinarily sensitive to surface contamination of the phosphor, to its past history, and to the rate of scanning. Thin screens on conducting supports did not suffer from this effect. Various methods of increasing the secondary emission of phosphors had been suggested, but little information was available as to their effectiveness.



### Mechanical Properties

In view of the many undesirable effects which might arise through the use of binders, methods had been developed for forming screens without their use. These relied on the adhesion of small particles to a glass surface being a function of their particle size, a sharp maximum being obtained at about  $\frac{1}{32}$  in. diameter. The question of optimum screen thickness had been very much neglected; this thickness depended on the particle-size distribution of the phosphor and the accelerating voltage to be used.

### Stability

The general stability of sulphide materials was lower than that of silicates and tungstates, both in respect to chemical attack and to bombardment by electrons and ions. So far little was known of the reactions which occurred during screen burning, though the "development" of metal atoms by the electron beam was a possibility at high voltages. Contamination of the screen by those poisons which affected the phosphors during their synthesis would also cause increased susceptibility to burning.

Several properties of luminescent materials had not as yet been applied in cathode-ray tubes. These included the effects of low and high temperatures on the phosphorescent characteristics, changes in dielectric constant and conductivity which accompanied luminescence, and the effects of infra-red radiation.

In the discussion which followed it was generally agreed that our present-day knowledge of the fundamentals underlying cathode-ray-tube screen behaviour was incomplete. A broad attack on the problems, with full collaboration between chemists and physicists, and dealing with the optics and electron-physics of screen behaviour on a logical basis, was urgently needed.

The use of the term "phosphorescence" was criticised on the grounds that this term was more commonly used in connection with long afterglows. "Luminescence" was suggested as a term which carried with it no implication of the mechanism of the afterglow. As decay times could range from  $10^{-6}$  sec. to  $10^{-2}$  sec. or longer, and as the mechanism included both ionisation effects and interatomic effects, the use of a neutral term was desirable. An alternative proposal was that the use of "phosphorescence" should be restricted to occasions where there was ionisation, and that where no ionisation took place the term "luminescence" should be used.

### "Electron Traps"

In remarks on the mechanism of the excited lumines-

cence it was explained that with some phosphors ionisation was always associated with the existence of electron traps. There was no evidence that long afterglow times were related to the time spent by electrons moving freely in the conduction band. The electrons were actually caught in storage centres or electron traps, from which they could escape only by deriving energy from the thermal vibrations of the lattice. Shallow electron traps gave short delay times, and deep electron traps gave long delay times. If the energy level of the thermal vibrations were reduced by cooling to liquid-air temperatures the times were greatly increased. The various trap depths could be studied by cooling the phosphor to liquid-air temperatures, filling the electron traps by exposing the material to an electron beam and then raising the temperature.

As various trap levels become freed, bursts of light indicated the escape of electrons from the traps. The electron traps behaved in the lattice like ions, and excitation involved no change of polarisability. When only the luminescent centres were involved there was no change of dielectric constant, though this changed when the electrons passed through the conduction band. This view was in conflict with the idea that electrons must pass through the conduction band in passing from the luminescent centres to the electron traps. An alternative demonstration of the existence of deep electron traps was provided by the first excitation of freshly prepared phosphors. Some materials took as long as a minute to reach full fluorescence, as all the deep traps had to be filled.

The difficulties experienced from the extreme susceptibility to contamination of some phosphors was stressed. The sulphides presented particular difficulties in this respect, and also in grinding operations. For this reason it was urged that any studies of phosphors should be carried out with very great care. The use of demountable tubes and improved photometric methods was urged for studying coloured phosphors.

The importance of visibility as the ratio of trace brightness to background illumination was discussed. Suggested methods of increasing visibility involved increases in the efficiency of screens and guns, although it was doubted whether the suggested screen gain would in fact be obtained. It was also stated that the user would prefer a square afterglow characteristic, and this was, in fact, often obtained when due regard was paid to the logarithmic characteristic of the eye. Another user demand was for freedom from screen burning; a quality often forgotten, but needed for service and industrial applications, was good screen adhesion. Screens should resist any violence which did not disturb the gun or damage the bulb.

## Theatre Organ Broadcasts

**T**HEATRE organ broadcasts, of necessity restricted during the lean years of war, are now being offered to listeners on a more lavish scale. Under the old system no more than eight programmes were heard each week; now there are nearly two dozen to choose from. Most of them are in the Light Programme, four or five in the Home Service, and the remainder in the Overseas Service.

The most frequently heard of all theatre organists is, of course, the B.B.C. staff organist, Sandy Macpherson, who does four regular weekly programmes and often other straight recitals too. Sandy can be heard in the "Twilight Hour" on Sunday evenings in the Light Programme; in "I'll Play to You" on Tuesdays in the same service (this broadcast is also heard by Overseas listeners); playing his request programme, "From My Post Bag," on Thursdays in the Home Service; and in his own special production with a guest artist, "String Along with Sandy" in the Light Programme (and General

Overseas Service) on Fridays. Every four weeks "I'll Play to You" is broadcast from a cinema in a different part of the country, instead of from the usual studio. It is then played by the local organist and addressed to people in the area, and Sandy introduces the programme and the items.

Reginald Foort is heard twice a week, in "Theatre Organ Plus" on Saturday afternoons, when he brings other artists to the microphone with him, and in his weekly straight programme given on different days of the week. Other organists frequently broadcast in both the Home Service and Light Programme, and Sandy Macpherson is responsible for supervising these programmes, with the exception of those broadcast in the Regional Home Services, besides all his own work at the console. It is very much a full-time job, but despite such an increase of work Sandy still finds time to give his weekly talk, "Sandy Macpherson Speaking to the Forces," on Saturdays in the General Forces Programme.

# Applications of the 0-1 Milliammeter



**T**HE moving coil milliammeter—reading 0-1 milliamps—is an instrument upon which many other useful instruments are based, and although the subject has been discussed in these pages before, there are still a large number of radio enthusiasts who fail to appreciate its usefulness.

They know, perhaps, that it can be used on higher ranges of milliamps, and also for voltage measurements as in Fig. 1, but what of the ohm-meter, the valve voltmeter, the output meter, the A.C. current meter, etc.?

Once one is in possession of a suitable meter it can be conveniently adapted for all the instruments suggested above.

Where a current of only 1 mA is flowing through a circuit, as in Fig. 2, it is very sensitive to small changes of voltage and resistance. For example, if an additional resistance of 3,000 ohms were inserted into the circuit at point X, the current as shown by the meter M, would fall to .5 mA, and a resistance of 30,000 ohms would show a reading of .1 mA.

## Ohmmeter

Thus, by reason of its sensitivity the 0-1 m/ammeter provides the basis for a simple ohmmeter which is accurate enough for all ordinary purposes over a fairly wide range.

Provided that the scale is of average length, it is possible to read accurately values of from 50 ohms to 200,000 ohms, so that all the useful sizes are provided for. In actual practice the circuit of Fig. 2a would be used, where R.V. is a variable resistance of 1,000 ohms, R<sub>1</sub> a fixed resistance of 2,500 ohms, and B, a 3-volt dry battery.

When set up, the test terminals are short-circuited temporarily while R.V. is adjusted for exact full scale deflection of M. Subsequently, any unknown resistance joined to "test," will show a meter reading provided that it is under ¼ megohm or so. Of course, R and R.V. may be combined in one variable resistance of 3,500 ohms, or R could be 500 ohms and R.V. 3,000 ohms,

## Its Uses in Radio Servicing and Testing

but a value for R.V. of 1,000 ohms gives about the best control for setting zero.

For the accurate measurement of resistances above 200,000 ohms, it becomes necessary to employ a much higher additional voltage—usually connected externally in series with the test terminals. Under these conditions it should be realized that the test terminals must not be short-circuited (except through a high resistance), otherwise serious harm may be done to the meter movement.

## A.C. Voltmeter

The measurement of A.C. voltages is a necessary requirement when servicing mains receivers, and the instrument under discussion, when adapted, is ideal for the purpose. A moving coil meter, however, will only read direct current, so that an A.C. voltage needs to be rectified in much the same way that rectification is required in an A.C. receiver, only on a much smaller scale.

The circuit of Fig. 3 shows how this is achieved with the aid of the Westinghouse Meter Rectifier (1 mA type). Great care should be exercised when handling these rectifiers, as although they are quite robust for their size, any undue heat applied in making connections may cause harm. Damage will also be caused if wiring on the D.C. side becomes disconnected, so that it is essential to make certain that these connections are absolutely sound. For this reason also it is suggested that any fuse on the D.C. side should be short-circuited.

In calculating the series resistances for the direct current voltmeter, it is only necessary to multiply the desired full scale reading by 1,000. In the case of the A.C. voltmeter, however, things are not quite so easy owing to the fact that the voltage drop across the rectifier, among other things, has to be taken into consideration. Bearing in mind this fact, and also that the resultant resistance values are not always standard, it is more satisfactory generally to obtain carbon resistances of a value lower than those shown in Fig. 3 and by filing away the carbon—equally all round—it can gradually be brought to the correct value.

This can be done by actually calibrating each range. Assume, for example, that a standard 50 cycle mains

supply showed 230 volts as measured on an A.C. meter of known accuracy.

With the meter set up as in Fig. 3, it would then be a simple matter to adjust R.3 (by filing)

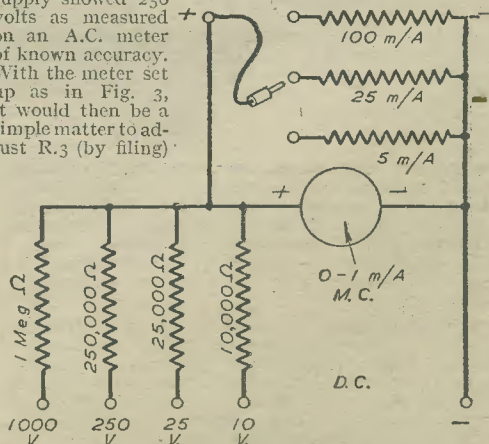

Fig. 1.—The usual method of adapting the meter for D.C. volts and mA.

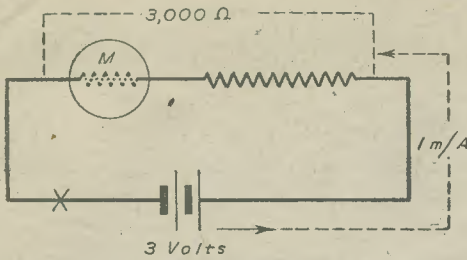

Fig. 2.—A simple illustration of Ohm's Law.

until the pointer shows exactly 230 volts. The same source of calibration may be used on the 500 volt and 1,000 volt ranges. In dealing with the lower ranges, however, it is convenient to make use of the secondary

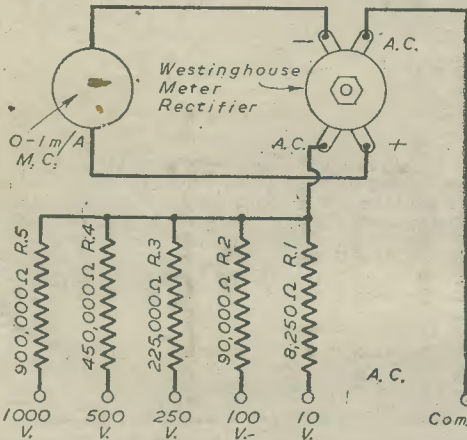

Fig. 3.—The method of adjusting the series resistances for A.C. volts is described in the text.

outputs of a transformer, checking these if possible with another A.C. voltmeter.

Failing this, it is necessary to remember that the correct current load must be applied before the rated voltage output can in any way be relied upon. Particularly is this so in the case of a 4-volt winding where if the load of, say, 4 amps. is not applied the voltage would be nearer 4.6, thus causing a very inaccurate calibration.

With the rectifier type of meter there occurs quite a fair amount of scale distortion up to about 10 volts. The discrepancy can be eliminated, however, by employing a potential transformer, which steps up the measured voltage to a higher value, or by arranging a special scale calibration for any low voltage range. This is the simplest arrangement, and a graph could be drawn up similar to that shown in Fig. 4, where voltage is plotted against scale divisions.

On the higher ranges, of course, the effect is negligible, and has not to be taken into consideration.

**Output Meter**

When it is desired to measure the actual voltage output from a receiver, some form of indicator is essential, and the A.C. voltmeter is very suitable for the purpose.

The connections are shown in Fig. 5, where it will be observed that the meter—switched to a suitable range—is joined across the output transformer primary. If the speech coil is disconnected at X so that the sound is silenced it becomes necessary to connect a "dummy,"

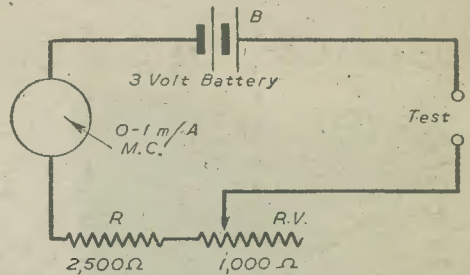

Fig. 2A.—The circuit of Fig. 2 rearranged for use as a practical ohmmeter.

load, as it were, across the primary. The value of this load or resistance should be equal to the recommended load of the output valve in use—usually 10,000 to 12,000 ohms for mains pentodes. The most useful voltage range to employ would be 100 or 250 volts (full scale) according to the power output.

**A.C. Ammeter**

For the same reason that a potential transformer is advisable on a low voltage range of the A.C. voltmeter, a current transformer is required for taking measurements of A.C. milliamps and amps.

It is easy to understand this, since, if the A.C. meter had shunts connected across it—as in D.C. practice—the meter would on all ranges be virtually a very low reading voltmeter. Thus, the scale error would be apparent in its most distorted form, and on no range would the reading be linear. If, however, the current transformer is used the discrepancies are overcome.

The design for a suitable transformer is shown in Fig. 6. It covers three very useful ranges, namely, 100 milliamps, 500 milliamps and 2.5 amps. The method of winding should be particularly noted, especially that of the single turn. It is obvious that a one-turn winding on a transformer is very critical, therefore, it should be made exactly as shown if errors are to be avoided.

The A.C. ammeter with the transformer specified will read exact at half scale deflection, but there will be a slight error at full scale. Since this amounts to only 0.45 per cent. (high) at 50 cycles, it is practically negligible for all but the most precise measurements.

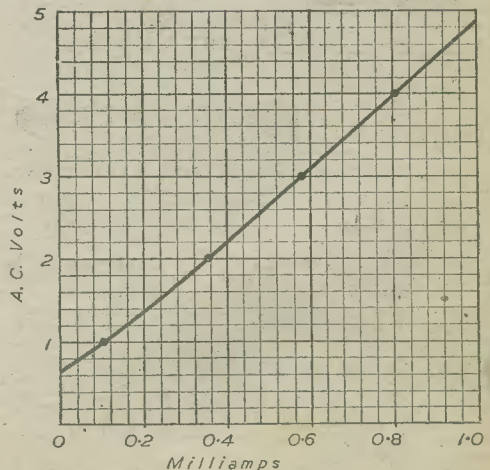

Fig. 4.—A graph for reading A.C. volts on a low voltage range.

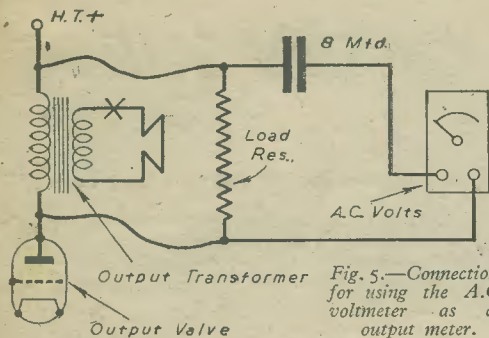

Fig. 5.—Connections for using the A.C. voltmeter as an output meter.

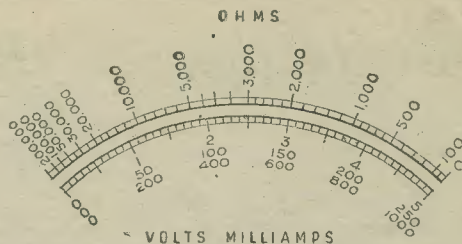

Fig. 8.—A convenient scale calibration applicable to many ranges.

**Valve-voltmeter**

The valve-voltmeter, owing to its high input impedance, provides a means of making accurate measurements across sources of high impedance—both A.C. and D.C.—up to very high radio frequencies. It is, therefore, indispensable where, for instance, voltage readings across tuned circuits are required, because no ordinary voltmeter can do this.

The milliammeter under discussion—in its ordinary D.C. form—provides the basis around which a simple valve-voltmeter may be designed. Fig. 7 shows a representative circuit, where a suitable valve V, is connected on the anode bend principle. It is biased negatively to the point of cut-off, that is, until the anode current as shown on M, is nil. Thereafter, any voltage applied across the input terminals of the instrument

will cause the anode current to rise, consequently showing a reading on M.

Thus, it is possible to calibrate the meter for very accurate measurements. Shunts may be used to increase the range of M, if the anode current of V, demands it.

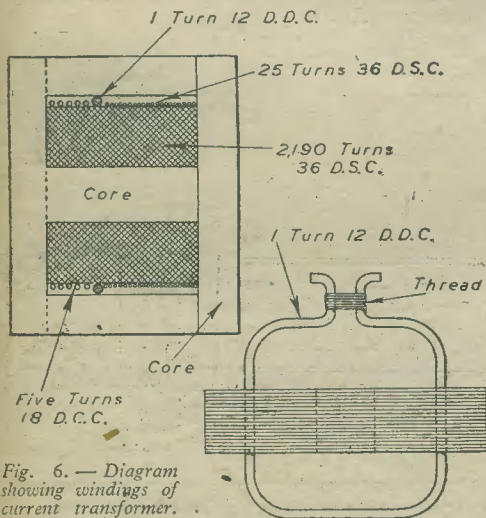

Fig. 6.—Diagram showing windings of current transformer.

In the winding space available, the following windings can be wound:—Secondary, 2,190 turns of No. 36 D.S.C.; 100 turns per layer. This winding should be covered with a layer of 10 mil. varnished paper or similar material, and the following primary windings then wound on in one layer:—For the 100 m.a. range, 25 turns of No. 28 D.C.C. wire. For the .5 amp. range, 5 turns of No. 18 D.C.C. wire. For the 2.5 amp. range, 1 turn of No. 12 D.C.C. wire. It is important that the start and finish of each primary winding be brought out on the same side of the laminations. The laminations must be inserted from alternate ends so that the lamination joints are interleaved.

Materials required:—33 pairs "Mumetal" No. 70-T laminations (Telegraph Construction and Maintenance Co., Ltd., London, S.E.10). 1 bobbin No. 70—F.S.C. (W. Bryan, Savage, Ltd., London, N.W.9). 2 ozs. No. 36 D.S.C. wire for secondary. Small quantity of Nos. 28, 18 and 12 gauges D.C.C. wire for primary windings.

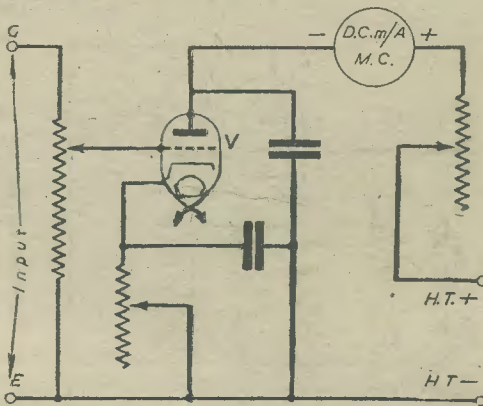

Fig. 7.—Basic circuit arrangement of the valve-voltmeter.

The actual voltage range of the valve-voltmeter may be increased by arranging for some form of input potentiometer as shown in Fig. 7, or by increasing the applied negative bias.

Having discussed many useful instruments in which the 0-1 milliammeter may be utilised, it might be as well to consider its scale calibration. If it is merely marked off into divisions for one milliamp, and one uses it for some of the uses outlined, it is advantageous to calibrate additional markings on the lines of Fig. 8, as the ranges shown have been included with due regard to all ranges one might use. Obviously it is not possible, or necessary, on a comparatively small dial, to mark in all ranges, but with those shown one is able to read ranges of 1, 5, 10, 25, 50, 100, 250, 500 and 1,000 with ease. Thus, for reading volts and milliamps this scale arrangement is most convenient.

The test instruments outlined in this article are but a few of the uses to which the low reading milliammeter may be put, but it serves to show how much can be done with one instrument of a suitable type.

It is, of course, convenient to construct a universal tester combining all the foregoing functions, an example of which is shown in the illustration. It is a home-constructed portable test meter adaptable to many uses and includes a capacity bridge for checking the value of small fixed condensers, the indicator in this case being by the buzzer and 'phones method.

The Westinghouse Brake and Signal Company, to whom the writer is indebted for details of the current transformer, wish it to be stated that orders for their meter rectifiers cannot be accepted by them unless a priority number can be quoted.

# Introduction to the Cathode Follower

By C. HEYS

THE cathode follower, which comprises a valve having the load resistance in the cathode circuit, is finding increasing use in P.A. amplifiers and television circuits. The output is taken from across the cathode load resistance and is in the same phase as the input, but is slightly less in magnitude. There is therefore no voltage magnification; in fact there is a slight attenuation. One of the main advantages of the cathode follower is that it can possess a very low output impedance in the order of a few thousand ohms, and can be used very successfully as an impedance matching device, i.e., a form of impedance transformer.

The basic cathode follower circuit is shown in Fig. 1. The input voltage  $V$  is derived from the previous amplifier,  $R$  being the cathode load resistance; it is

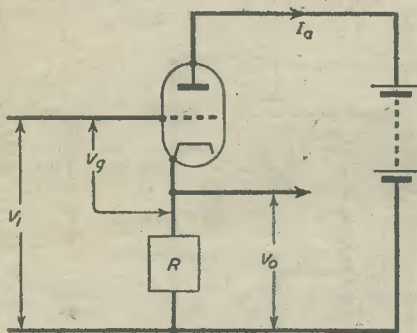

Fig. 1.—Basic cathode follower circuit.

the output voltage  $V_o$  from across this resistance which is passed on to the next stage.

We can now show that the output voltage does not depend upon a high value of load resistance  $R$ . The equivalent A.C. circuit of the cathode follower is shown in Fig. 2, where:

- $\mu$  is the amplification factor of the valve,
- $r_a$  the anode impedance of the valve,
- $V_g$  the input voltage between the grid and cathode,
- $R$  the cathode load resistance.

From Fig. 1 we have  $V_g = V_1 - I_a R$   
 From Fig. 2  $\mu V_g = I_a R + I_a r_a$

$$= I_a (R + r_a) \dots \dots \dots (i)$$

substituting  $V_1 - I_a R$  for  $V_g$  in (i) we obtain

$$\mu(V_1 - I_a R) = I_a (R + r_a)$$

$$\text{or } \mu V_1 = I_a (\mu R + R + r_a)$$

$$\therefore I_a = \frac{\mu V_1}{\mu R + R + r_a} = \frac{V_1}{R + \frac{R}{\mu} + \frac{r_a}{\mu}}$$

$$= \frac{V_1}{R \left( 1 + \frac{1}{\mu} \right) + \frac{r_a}{\mu}}$$

As  $\frac{r_a}{\mu} = \frac{1}{g}$ ,  $g$  being the mutual conductance of the valve,

$$\text{we have } I_a = \frac{V_1}{R \left( 1 + \frac{1}{\mu} \right) + \frac{1}{g}}$$

In most valves, particularly H.F. pentodes,  $\mu$  the amplification factor is large, therefore  $\frac{1}{\mu}$  must be small

and we can assume that  $R \left( 1 + \frac{1}{\mu} \right)$  for all practical

purposes evaluates to  $R$ . Therefore  $I_a = \frac{V_1}{R + \frac{1}{g}}$

As  $I_a$  is the current flowing through the cathode load resistance  $R$ , the output voltage  $V_o$  developed across this cathode resistance will be the product of anode current and the load resistance, i.e.,  $V_o = I_a R$ ,

as  $I_a = \frac{V_1}{R + \frac{1}{g}}$  the output voltage  $V_o$  can therefore be expressed as:

$$V_o = \frac{V_1 R}{R + \frac{1}{g}}$$

$$\text{or } \frac{V_o}{V_1} = \frac{R}{R + \frac{1}{g}}$$

The expression  $\frac{V_o}{V_1}$  represents the overall stage gain of the cathode follower.

Referring to the latter part of the expression  $\frac{R}{R + \frac{1}{g}}$

will always work out as slightly less than one. We see then that the cathode follower gives an output voltage slightly less than its input voltage, and is not affected by being connected to an impedance as low as a few thousand ohms. When dealing with high frequency amplifying circuits such as is met with in television receivers, the interelectrode capacity between the grid and cathode becomes troublesome at these high frequencies and offers a low impedance across the input of the amplifying stage. It is here where the cathode follower can be used to advantage as a matching device.

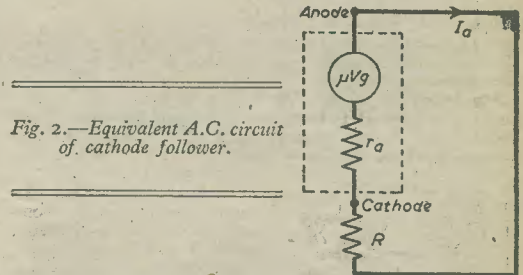

Fig. 2.—Equivalent A.C. circuit of cathode follower.

**REFRESHER COURSE IN MATHEMATICS**

By F. J. CAMM.  
8/6, by post 9/-

**THE SLIDE-RULE MANUAL**

By F. J. CAMM.  
5/-, by post 5/6

From: **GEORGE NEWNES, LTD.,** Tower House,  
Southampton Street, Strand, W.C.2.

# Practical Hints

## Negative-feedback Tone Control

**I** APPEND details of a novel negative-feedback tone control that I have experimented with after many failures with the normal variable resistance-condenser combination.

The only critical values are the .0005 condenser, and the potentiometer, which should not be above 50,000 ohms or control will be poor. This can be used with any output valve (mains or battery), R.C. or transformer coupled. It is well worth the extra condenser to have a smooth tone control.—  
A. M. REID (Newcastle).

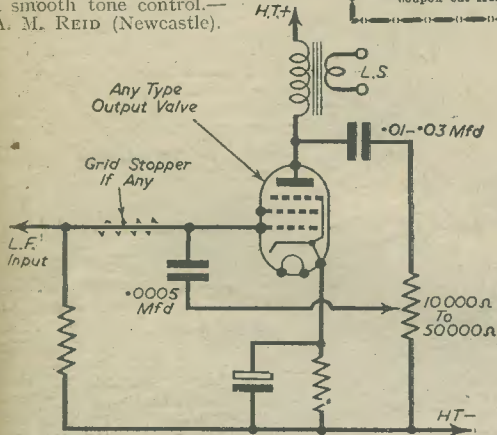

Circuit diagram of a negative-feedback tone control arrangement.

## Visual H.T. Leakage Indicator

**T**O avoid serious burn-outs of mains transformers of radio receivers and amplifiers, etc., I devised the following simple H.T. leakage indicator.

By inserting a suitable torch bulb in the centre tap lead of the H.T. secondary winding between transformer and chassis, a good idea of the H.T. leakage in any part of the instruments so protected can be obtained visually.

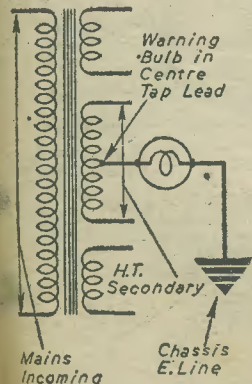

Diagram indicating how a torch bulb is used for showing H.T. leakages.

Firstly, determine the approximate H.T. consumption in milliamps, add a fair margin above this figure—say 50 or 100 per cent.—and choose a bulb which is rated to give full brilliance at the resultant figure obtained, as in the example following:

It will be noticed that at the full working load of the receiver, etc., the bulb will not show much signs of being illuminated or, if any, a very low glow will appear. This will be the datum point, assuming the instrument is in good order at this time. Should a H.T. leakage develop, an increase in the glow of the

**THAT DODGE OF YOURS!**

Every Reader of "PRACTICAL WIRELESS" must have originated some little dodge which would interest other readers. Why not pass it on to us? We pay half-a-guinea for every hint published on this page. Turn that idea of yours to account by sending it in to us addressed to the Editor, "PRACTICAL WIRELESS," George Newnes, Ltd., Tower House, Southampton Street, Strand, W.C.2. Put your name and address on every item. Please note that every notion sent in must be original. Mark envelopes "Practical Hints."

**SPECIAL NOTICE**

All hints must be accompanied by the coupon cut from page 471 of cover.

bulb will be seen varying in intensity according to the amount of leakage.

Should the leakage reach a higher value than the bulb-rating (m/amps.) the bulb will "blow," acting as a fuse, thus protecting the transformer from serious overload.

If the bulb is mounted in a conspicuous place about the receiver it will afford a good guide of its condition as to H.T. leakage each time the set is switched on, and if its warning is heeded a fault can be traced before serious trouble develops.

Examples for choosing the right bulb are given below.

- (1) Average 5-valve receiver—Total H.T. consumption .. .. . 60 m/amps.  
Add margin of, say, 100 per cent. of load .. .. . 60 m/amps.  
Required total rating, approx. .. 120 "  
Choose 3½ volt .15 amp. bulb .. 150 "

The constant loading on the bulb will be 60 m/amps. not quite enough to make the filament glow, but an increase of load by a few m/amps. due to H.T. fault, will begin to create a glow and perhaps good light when it would be a warning to look around for trouble.

- (2) Average H.T. consumption of larger set, say .. .. . 100 m/amps.  
Add margin of, say, 100 per cent. of load .. .. . 100 "  
Required total rating .. .. . 200 "  
Choose 2½ volt .2 amp bulb .. 200 "

The constant loading on the bulbs will be 100 m/amps. The glow on the bulb filament will be of a very low order at 100 m/amps. but will increase as H.T. faults develop.—E. COOMBS (Widnes).

## A Simple Morse Oscillator

**I** RECENTLY required a morse oscillator for practising with a friend, and I desired it, if possible, to work a loud speaker. After several attempts I devised the

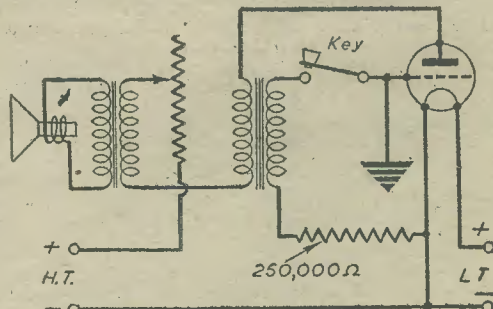

Theoretical circuit diagram of a simple morse oscillator.

following method. It will work an 8-in. M.C. speaker at ample volume for the normal room.

The potentiometer in the H.T. lead which is used as pitch control will vary with the valve used. I used a Marconi DEL 210 and 0-50,000 megohm was found to give ample pitch variation. It may be found necessary to earth the grid of the valve to prevent a continuous whistle in the speaker. The transformer is a L.F. inter-valve transformer.—G. LAURENCE (Whetstone).

# Automatic Gramophone Record Repeater

Constructional Details for a Simple Repeater for 7 or 8in. Records

By "EXPERIMENTALIST"

**H**AVE you ever tried to dance to gramophone music? Alternatively, have you ever tried accompanying such music on an instrument, such as the piano, violin, accordion, sax or clarinet, etc.? If so, you will have experienced the annoyance of having to re-set the pick-up, or sound-box, as the case might be, on the record and re-start the motor each time the recording reaches its conclusion.

The repeater here described is a more simplified version, constructed from thin wood and sheet celluloid, with a "pre-set" hole adjustment accommodating the requirements of most 7in. and 8in. records.

The same device can be enlarged to take roin. discs, but with certain alterations to the shape and some of the sizes. An attempt was made to design a repeater which would accommodate 7in., 8in. and roin. discs,

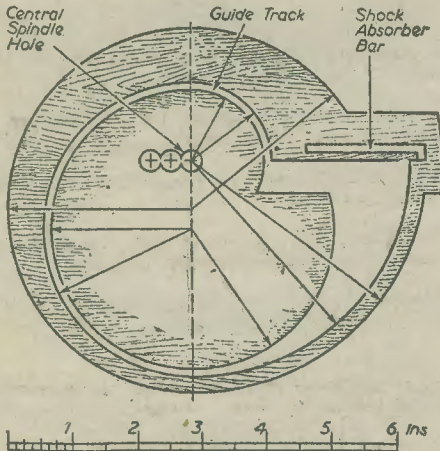

Fig. 1.—The main shape, showing radius positions for the compasses.

but owing to the numerous variations of the width of the sound tracks in each case, an "all-round" repeater is not feasible.

It was found that the 8in. repeater could be made to suit 7in. discs. It is possible, therefore, to design a repeater, to suit 8in. and roin. records. This, together with a new "racking" adjustment principle, will be dealt with in another article on the subject.

### Playing Duration

Now, tests applied to a double-spring Garrad gramophone motor show that it is capable of playing roin. records three times with a single winding. As roin. discs, like the long-playing 8in. discs, play for 2½ minutes, such can be repeated three times to give 7½ minutes continuous music, since the repeater is self-automatic and re-sets the pick-up, or sound-box, almost at once. Of course, if an electric gramophone is used, the record can be repeated indefinitely, or at least, until the needle—or record—wears out!

Thus, having "set" the repeater and wound up the gramophone motor fully, one can have 7½ minutes of trouble-free practice music for dancing or instrumental purposes. With exception of the fitting of fresh needles

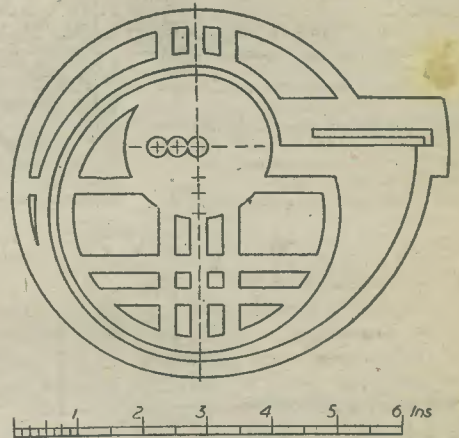

Fig. 2.—A simple fretted design which helps to reduce weight.

and the motor winding, no other attention is necessary. Gramophone record dealers—who invariably use electric-operated gramophones for the playing of records to customers or the general public—are sure to welcome such a device, as it enables them to leave the gramophone (which becomes self-automatic) unattended for long periods.

### How The Repeater Works

Before constructing the record repeater illustrated at Fig. 4, you may wish to know just how the device operates. It is the rotation of the gramophone turntable, plus the record on top of it, which "works" the repeater.

The main shape is shown at Fig. 1. This, cut from a flat piece of ½ in. plywood or 1/16in. xylonite or ivoryine

(Continued on page 475)

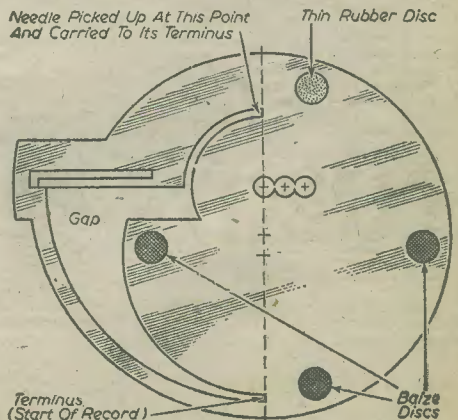
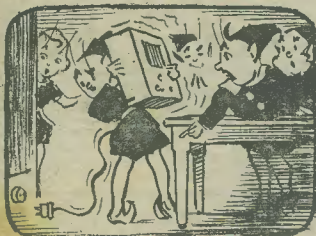

Fig. 3.—A back view, showing how celluloid is cut. with position of the thin rubber and felt pads.



The "Fluxite Quins" at Work.

"The fault in this set, I've detected, Much sooner than I half expected."  
 "It's FLUXITED," said OH,  
 "Yet the darn thing won't go!" ...  
 "Why don't you try it connected?"

See that FLUXITE is always by you—in the house—garage — workshop — wherever speedy soldering is needed. Used for over 30 years in government works and by the leading engineers and manufacturers. Of all ironmongers—in tins, 8d., 1/4 and 2/8.

Ask to see the FLUXITE POCKET BLOW LAMP, price 2/6.

To CYCLISTS: Your wheels will NOT keep round and true unless the spokes are tied with fine wire at the crossings and SOLDERED. This makes a much stronger wheel. It's simple — with FLUXITE—but IMPORTANT.

The FLUXITE GUN puts FLUXITE where you want it by a simple pressure. Price 1/6, or filled, 2/6.



ALL MECHANICS WILL HAVE

**FLUXITE**  
 IT SIMPLIFIES ALL SOLDERING

Write for Book on the ART OF "SOFT" SOLDERING and for Leaflets on CASE-HARDENING STEEL and TEMPERING TOOLS with FLUXITE, also on "WIPE JOINTS." Price, 1d. EACH.

FLUXITE LTD. (DEPT. W.P.)  
 BERMONDSEY ST., S.E.1.

*It's the hidden details that count*

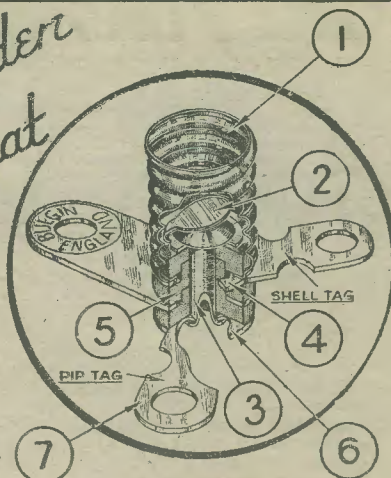

*The choice of Critics*

Rolled Shell Miniature Edison Screw Lampholders to B.S.98/E.10.

- 1—Threaded shell with dimensions and details to B.S. 98-10 mm. "MES," silver-plated.
- 2—Central "pip" contact of spring phosphor-bronze to ensure good contact, silver-plated.
- 3—Central rivet of solid steel ensuring permanently tight and positioned assembly.
- 4—Locking teeth on "shell" contact solder tag, ensuring contact and preventing unintended rotation.
- 5—Stepped insulant washers preventing short-circuit and permitting comparatively high-voltage working conditions.
- 6—Toothed solder tag locks to rivet turnover, fixing position and ensuring contact to "pip" contact.
- 7—Dual purpose soldering tags coated pure tin and accepting "threaded" or "wound" wiring; fixing bracket, normally "dead," may contact with shell and replace the shell tag.

Over 140 types in production.



**A. F. BULGIN & CO., LTD.**

BYE-PASS ROAD, BARKING, ESSEX.

Telephone: RIPPLEWAY 3474 (5 lines)



# GALPINS

**ELECTRICAL STORES**

408, HIGH STREET,  
LEWISHAM, LONDON, S.E. 13.

TERMS : Cash with Order. No C.O.D.  
All prices include carriage or postage.

**ELECTRIC LIGHT CHECK METERS**, first-class condition, electrically guaranteed, for A.C. mains, 200/250 volts 50 cy. 1 phase 5 amp. load, each **12/6**.

**AUTO TRANSFORMER**, step up or step down, 500 watts, tapped 0-110-200-220-240 volts, **£3 10s**.

**MOVING COIL AMPMETER** by famous maker. 2in. dia., flush mounting, reading 0-10 amps. F.S.D., 20 m/A, price **27/6**.

**METAL RECTIFIERS**, large size, output 50 volts 1 amp., **35/-**.

**SMALL MAINS TRANSFORMERS**, input 230 volts, output 11 volts 1 amp., **11/-**.

**METAL RECTIFIERS**, large size, output 12 volts 1 amp., **17/6**.

**TRANSFORMER CORE** for rewinding only, complete with clamps, size approx. 2½ kW., price **25/-**.

**50 VOLT MOTOR**, D.C., input 4 amps., ½ h.p., ball bearing, double ended shaft 2in. dia., slow speed, only 500 r.p.m., shunt wound, condition as new, also make good slow speed generator. Price **50/-**.

**MOVING COIL METERS**, all 2in. dia., flush mounting, 0.5 m/A, **40/-**; 0.20 m/A, **40/-**; 0.25 m/A, **40/-**; 0.50 m/A, **37/6**; 0.150 m/A, **35/-**; 0.300 m/A, **35/-**.

**MOVING COIL METERS**, all flush mounting, 2in. dia. 0.5 amps, **30/-**; 2½in. dia. 0.10 amp., **35/-**; 2½in. dia. 0.1 amp., **30/-**; 2½in. dia. 0.30 v., **35/-**; Weston Galvo, 2½in. dia. 30-0.30, **55/-**.

**METAL RECTIFIERS**, outputs, 6 v. 1 amp., **12/6**; 6 v. 2 amp., **25/-**; 9 v. 2 amp., **37/6**; and 12 v. 4 amp., **50/-**.

**ROTARY CONVERTORS**, 210 v. A.C. to 150 v. A.C. at 600 watts, **£10**; ditto 230 v. D.C. to 150 A.C. at 700 watts, **£10**; ditto 460 v. D.C. to 300 v. A.C. at 4 kW., **£25**.

**EPOCH SUPER CINEMA Speakers**, 15in. cone, 20 watt output, 6 v. field, no energising, **£6 10s**.

**H.T. TRANSFORMER**, input 200-250 v., output 3,000-2,500-0-2,500-3,000 v. at 1,200 milliamps, rating 7 kW., **£20**.

**COOLIDGE TUBE filament transformers**, 230 v. input, 11 v. output, fitted H.T. insulator, insulation 100,000 volts to earth, **£5**.

**LARGE HEAVY DUTY CHOKES**, weight 24lb., wound heavy gauge wire, suitable for rewinding as auto transformers up to 1 kW., price **25/-** each.

**LARGE PAXOLINE PANEL**, size 14 x 7 x ½in., fitted massane switch arm, 12 large studs and contact blade, very smooth action, price **7/6** each.

**ELECTROLYTIC CONDENSERS**, 2,000 mf., 2½ v. working, **10/-** each.

**BLOCK CONDENSERS**, 2 mf., 1,500 v. D.C. working, **7/6** each.

**BELL TRANSFORMERS**, output 3-5-8 volts, **6/-** each.

**MOTOR BLOWER**, fitted 12 v. D.C. motor, sorococo fan type, 2in. dia. inlet and outlet, very powerful, **45/-**.

CLOSED half-day Thursday.  
OPEN all day Saturday.



## EDDYSTONE COMPONENTS

A preliminary range of Eddystone high-efficiency components are available for bona fide maintenance work, etc.

916 Stand-off Insulators	...	1/3
999 Aerial Insulators	...	1/-
1019 Midget Stand-off Insulators	...	6d.
1018 Lead Through Insulators	...	2/6
6-pin Coil Formers, Plain	...	2/9
3-Threaded	...	3/-
1090 Former	...	6/-
964 Coil Base, 6-pin chassis	...	1/9
1094 Microdenser	5/20 mfmd.	5/6
1129	5/42	6/-
1093	6/62	6/6
1130	5/100	7/3
1131	160	7/6
1044 Pointer Knob, small, 1½in. long	...	6d.
1027	23/16 in.	1/-
1076 Instrument Knob, 2½in. diam., Brass insert	...	2/6
1089 Instrument Knob, 1½in. diam., Brass insert	...	1/9
2426P Skirt Knob, overall diam. of flange, 1½in.	...	1/6
978 Air Dielectric Trimmer, Pre-set 5/60 mfmd.	...	5/-
1013 Air Dielectric Trimmer, as 978, with ½in. spindle	...	5/6
339 Split Stator Condenser, Butterfly wing type	...	12/6
1010 H.F. Choke, 1.25 mh, 5/180 metres, 50 m/A	...	2/-
1022 H.F. Choke, 1.5 mh, TX type, 250 m/A	...	3/-
1011 U.H.F. Choke, 2.5 to 12 metres	...	1/6
1066 All Wave Choke, 17.9 mh, 12.5 to 2,000 metres	...	2/9
1009 Flexible Coupler, insulated	...	2/6

The above components are mostly types already familiar to the discriminating engineer; new EDDYSTONE designs will fulfil modern development needs in VHF and miniature equipment. Watch advertisements for advance information on new equipment embracing all S. W. communication requirements.

## WEBB'S

stock all makes of good  
Communication gear.

Send 2½d. stamp for

### WEBB'S "INTERIM" CATALOGUE.

WEBB'S RADIO, 14, Soho St., Oxford St., London, W.1. Telephone, GERRARD 2089

Note our revised SHOP HOURS:—  
9 a.m. to 5 p.m. Weekdays. 9 a.m. to 1 p.m. Sat.

# M. WILSON Ltd.

(Late Austerity Radio Ltd.)  
Same Management

Circuit No. 19.  
**MIDGET SHORT WAVE CONVERTER**, 12-35, 34-100, 91-261 metres. Triode-Hexode P.C. international Octal Valve. Can be fitted to any standard receiver. Battery. Full specification on application. State type required.

**GRAMPHONE AMPLIFIER CHASSIS**. Assembled on black crackle-finished chassis fitted with separate tone control. Volume control with on/off switch, sockets for microphone, gramophone and extension speaker. Hum free, good quality reproduction. A.C. only. Input 200/250 v. Size overall 8 x 6 x 7½in. Ready to play. Prices include valves and speaker.  
4-Valve 4-Watt ... 10 Gns.  
4-Valve 6-Watt with PX4 output ... 12 Gns.  
Theoretical and practical blue prints of the above available separately, 3/6 per set.

Circuit No. 20 (Tropical or Non-Tropical).  
**9 VALVES A.C. SUPERHETRODYNE RECEIVER**, with R.F. Stage. Two frequency-changers in push-pull to minimise damping. One stage of I.F. One double diode triode followed by phase inverter valve feeding 2 6 L6's in push-pull, with negative feedback. Beat Frequency Oscillator. It has an exceedingly good signal to noise ratio. Waveband range, 5,200 metres. Complete set of blue prints and list of parts, 5/-.

**BLUE PRINTS** of the following circuits. 1 Theoretical and 2 Practical, 3/6 per set.  
No. 1.—A.C.T.R.F. 3 Valves Medium Wave only.  
No. 2.—A.C.T.R.F. 4 Valves. Long, Med and Short.  
No. 3.—A.C.T.R.F. 4 Valves Short Wave only.  
No. 5.—A.C. Superhet 4 Valves L, M. and S.  
No. 6.—A.C.D.C. Superhet 4 Valves, L, M. and S.  
No. 7.—Battery T.R.F., 3 Valves, L, M. and S.  
No. 9.—Battery, T.R.F., 3 Valves Short Wave only.

**2 NEW CIRCUITS**.  
No. 17.—Small Communication Type A.C. and A.C.D.C. Superheterodyne Receivers. Brief specification, 6 Wavebands, 5-2,000 metres. Radio Frequency stage, 7 Valves Int. Octals, including beat frequency Osc. and rectifier. 465 Kcs. Overall measurements, 16in. x 8in. x 8in. in black crackle finish. Blue prints 5/- per set of 3.

No. 8A.—As above. Battery 4 Valve Superhet, 3 Wavebands, 16-50 metres, 200-557 metres, 700-2,000 metres. 1.4v. Valves. Blue prints 3/6 set of 3.  
Priced List of Components sent with each set of Blue Prints.

**MAINS TRANSFORMERS**, to suit all circuits, built to specification. See last month's advertisement for Standard Models.

**WESVECTORS**, WX6, 4/-.  
**ULTRA S.W. COILS** (plus-in) air spaced, silver copper wire, R.F., H.F. and Osc. Range 1, 4.5-8 m., Range 2, 9.5-17 m., 2/8 each; 6/6 set of 3.

**3 WAVEBAND COILS**, 16-50, 200-550 and 900-2,000 m. (on one former), A. and H.F. also A and Osc., 12/6 pair.  
Toggle Switches. Miniature, on-off, single pole. 2/8. D.P., D.T., 4/3.  
Metal Rectifiers, small, chassis mounting 45 volts, 40 ma., 7/6 each.

Chassis, silver sprayed, undrilled, 10 x 8 x 2½, 7/6. 8 x 6 x 2½, 4/6.  
Small 2-gang .0005 Condensers fitted with 4 push button switch. 3/6.

**TO OVERSEAS TRADERS!** Wholesale and Retail Enquiries are invited.

Orders can be executed for B.L.A., C.M.F. and S.E.A.C. customers.

**307, HIGH HOLBORN,**  
LONDON W.C.1. Phone. HOLborn 4631

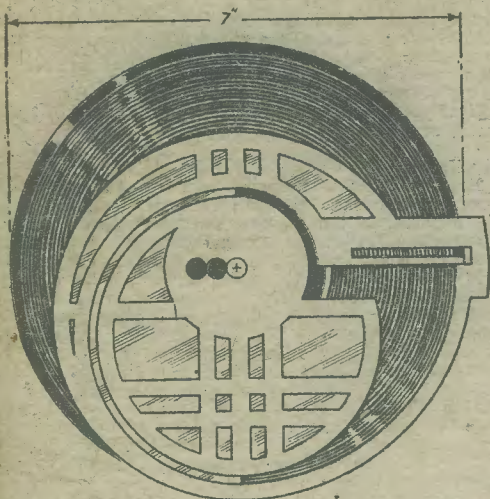

Fig. 4.—The completed repeater in its "First" position on the 7in. record.

material, or hard, stiff cardboard, is backed with thin celluloid sheeting in which a "gap" is cut (see Figs. 3 and 4). The latter gives needle space on the record surface.

Having the record on the turntable, with the repeater set on top, the pick-up needle is set on the record in its usual position near the edge for playing. The needle must be fixed in its holder to project  $\frac{3}{16}$  in. for "clearance" purposes, as will be seen later on.

The needle goes in front of the shock absorber bar. Now, as the record revolves, the bar bears upon the needle and it thus keeps the repeater from turning with the record—up to a certain point. As the needle travels, spiral by spiral, towards the centre of the record, it nears the guide track. Moving away from the shock absorber bar, the repeater is released and immediately goes around with the record.

The needle, moving into the guide track, is "lifted" from the record surface by the thin celluloid base and "carried" through the remainder of the guide track

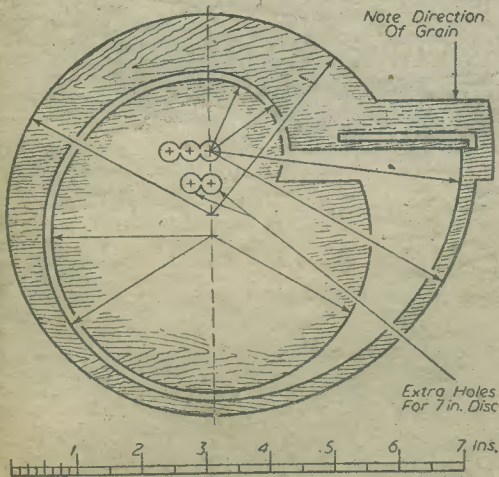

Fig. 5.—Main shape of the 8in. repeater. Radius sizes can be obtained by applying scale provided.

and ultimately deposited on the record when it reaches its terminus. The terminus of the repeater means the re-start of the record again, and so the whole business goes on, automatically repeated over and over. Owing to the depth of the guide track, plus the opening in the celluloid base and the pads beneath, the pick-up needle must project about  $\frac{3}{16}$  in. from its holder.

It will be seen that the shock absorber bar is a "stop" designed to overcome the slight concussion that arises when the needle meets it. The two extra spindle holes cut in the repeater enable the needle to be released from the stop so the recording finishes suitably. Another reason is that some recordings are of shorter duration than others. Consequently, the distance of the sound track from the spindle hole is often greater by  $\frac{1}{16}$  in.

Such records, with the repeater in its "first" hole position, cannot be automatically released, as the needle does not travel far enough along the stop bar, hence the extra spindle hole positions, which bring the bar end into alignment with the final spirals.

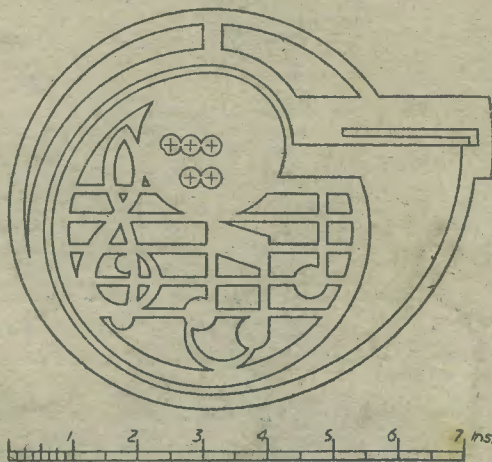

Fig. 6.—Attractive fretwork design for the 8in. repeater.

**Making the Repeater**

To make the repeater, mark out, with the aid of compasses and the scale rule provided, the main shape (Fig. 1) on  $\frac{1}{4}$  in. plywood, preferably a flat, scrap piece, if you possess it. Work from a central vertical line and begin by scribing the smaller radius lines, the radius being 1  $\frac{1}{16}$  in.

Scribe the left-hand curves first, then scribe the opposite curves. All curves should meet evenly at the centre line. Incidentally, it is imperative that the shaping is perfect. After all, a great deal is expected from the special shape.

Having pencilled on the main shape, with the grain of the wood running in the direction indicated, it is advisable to fit the pieces to reduce the weight. A simple design is suggested at Fig. 2. A fine fretsaw is used in cutting the two parts to shape.

Cut the inner "frets" first. The gap and guide track is then cut in one piece from the main shapes, thereby separating them. It is used later for "packing" when gluing the main shapes to the celluloid sheeting; it keeps the parts in true alignment.

**The Celluloid Backing**

When making his experimental models, the writer used old, exposed X-ray film (obtained by a friend employed at a local hospital), including thin rhodoid material. The exposed film was undeveloped, the sheets measuring 10 in. by 12 in. and 12 in. by 15 in.

X-ray film, of course, is coated on both sides with photographic emulsion and this needs to be removed

by steeping the film (cut to size) in lukewarm water containing a couple of tablespoonfuls of washing powder, following which the softened emulsion is scrubbed off with a nail brush and the blue-tinted film rinsed under a tap and dried with a cloth. Repeaters backed with coated film, by the way, were found not to work so easily, as the needle point has a tendency to "stick" in the emulsion surface. Cleaned film, or thin, transparent celluloid sheeting, such as rhodoid, is the best stuff to use.

Having cleaned a suitable piece of the film, apply a thin smearing of glue to the back of the outer repeater shape and press it down on the celluloid. Fit the waste cutting of wood previously mentioned within it unglued, then apply glue to the central shape piece and press into position. Allow the glue to set partly, then carefully remove the waste wood, set the work on a flat surface and place weights on top, such as heavy books or two smoothing irons.

#### Cutting the Gap

When the glue has thoroughly set, trim the film flush with the outer edges of the shape, using scissors. A penknife is used when cutting the gap (see Fig. 3). The work is reversed so the film is uppermost. If, however, the backing is set on a flat, wooden surface, the gap can be scored with the tip of the penknife blade, the plywood shapes acting as a template; the scored film is easily broken by pressing it in (via the back) with the fingers; trimming is done with the penknife.

Ordinary glue does not get a good grip on a celluloid surface. Its adhesive properties are improved if the

film is roughened slightly by rubbing with fine glasspaper.

Having cut the gap, the edges of the wood are glasspapered smooth with a fine grade of glasspaper. The guide track edges should be rounded slightly. Excess traces of glue must be removed from the "carrier" half of the track, otherwise the needle, traversing the track, may stick.

#### The Pads

Now, in order that the repeater will turn with the record when released by the pick-up needle, small pads are adhered to the backing in the positions shown. You need a  $\frac{1}{2}$  in. disc of thin rubber and three  $\frac{1}{4}$  in. discs of thin green baize.

Note the position of the rubber disc which, by the way, can be cut from an old bicycle air-tube and stuck on with rubber solution or glue. The felt pads must not be too thick; their position, like that of the rubber disc, is important. Pads cut from leatherette will serve if baize is not available, including thin chamois leather.

#### An 8in. Record Repeater

As few readers may possess 7in. records, a design for a repeater suitable for 8in. records is detailed at Figs. 5 and 6. This model is made in exactly the same way as the 7in. model described.

Two extra spindle hole positions are provided. These enable the repeater to be partly used on 7in. discs. Results, in some cases, may not be too satisfactory, since the guide track, at the beginning, is very eccentric with the centre of the 7in. discs. The same repeater on 8in. records gives a fair performance, considering its primitive adjustment principle.

## Third Commonwealth and Empire Conference on Radio for Civil Aviation

**T**HE release, during the period of the Third C.E.R.C.A. Conference, of information about radar in war makes it easier to explain that part of the work of the Conference which dealt with radar in peace. It is worth saying again, briefly, what radar does. It has two main subdivisions, primary radar, which measures from a single station, which may be on the ground, in a ship, or in an aircraft, the distance and bearing of a ship or the distance bearing and flying height of an aircraft, without any co-operation from the "target" craft. It can be made to present this information in a variety of ways to suit the convenience of the consumer and with accuracies which can, to an astonishing degree, be carried to such extremes as the consumer is prepared to pay for in cost, complexity, weight and bulk. This was the predominant radar of war.

But there was born, simultaneously with primary radar, the other great subdivision, secondary radar, which is not based on the pessimistic assumption that the other fellow won't play. We can put into the craft to be located a comparatively small box called a responder, which speaks only when it is spoken to, and only when spoken to in the right radar language. Then it answers automatically with a louder voice than that of the relatively inert echoing mass of the craft, and it can convey coded information, in this magnified response, about the identity of the target craft and about other things which can be included in the coding. Moreover, it can answer on a wavelength different from that of the radar "interrogation," and this lets us discriminate its reply from the mass of primary radar echoes from hills and hangars and houses which might otherwise overlay it. So if we can put in our aircraft a suitably light, reliable and inexpensive radar responder, we can get greater location distances, clearer indications and consequently more accurate location, and additional information such as individual identity. Secondary radar, if the radio engineer can give the user the right kind of responder, is the most powerful radar implement of peacetime, and was a very vital part of wartime radar.

#### Position-finding Systems

There are also position-finding systems, using exactly the same principles as do primary and secondary radar, which enable a craft carrying, not a responder, but a radar receiver, to find its own position on the map, by measuring in the craft itself the differences in the time of arrival at the craft of radar signals from two or more ground stations. There are systems in which the same kind of information can be obtained in the craft by letting it carry the radar station and putting the responder, now a "radar responder beacon," on the ground.

The adaptation, to the needs of civil aviation, of the wealth of diverse techniques falling into these four main subdivisions is a pressing need. It is a major contribution to the overall problem which was stated by the leader of the U.S. Delegation to the Conference in these words: "How we can most effectively and at the same time most inexpensively guide commercial and private planes from their starting place to their destination in safety and in all kinds of weather."

The adaptation requires the intimate mingling of the expert opinions of the pilot, navigator, ground controller, radio engineer and administrator, from the earliest planning stage. The process is the exact counterpart of that described by Lord Swinton as having been essential to the wartime development and application of radar.

Very briefly, this is what radar will eventually do for civil aviation:

1. It will greatly assist navigation, by making it possible for the position of an aircraft to be determined much more accurately than by other methods.
2. It will give the airfield greater and more flexible control (where necessary) over aircraft; and it will give to the ground authorities additional information, such as individual identity of aircraft.
3. It will act as a collision warning.
4. By fitting radar responders in dinghies, air/sea rescue work will be greatly facilitated.

It is possible that, if current research is successful, it may be possible to detect and pinpoint areas of bad weather more accurately than hitherto.

# Impressions on the Wax

## Review of the Latest Gramophone Records

### H.M.V.

IT was in the early part of 1791 when Haydn visited London at the invitation of the impresario Solomon and it was for this visit that Haydn wrote two groups of six symphonies. These were performed at Solomon's concerts during 1791-2, and 1794-5, and it is the C Major Symphony (No. 97), which formed part of the first group, which has been recorded by the London Philharmonic Orchestra, conducted by Sir Thomas Beecham, on *H.M.V. DB6222-24*.

About the time of Haydn's visit, contemporary composers, and the world of music in general, were being greatly influenced by the symphonic works of that great master Mozart, and it is quite pertinent to suggest that Haydn himself was not outside the influence exerted by the noted, and one could say, the last, Mozart symphonies of 1788.

The "Symphony No. 97 in C Major" is in four movements, *adagio* leading to *vivace*; *adagio ma non troppo*; *menuetto (allegretto)* and *trio*; and *finale (presto assai)*. As so often is the case with Haydn, a slow introduction leads up to a bold statement by the full orchestra of the first subject. The second is more fragile, and this is followed by a theme and variations which takes us to the minuet and trio. The *finale* finds Haydn in a bright and gay mood, but still the great musician. The symphony reveals the high qualities of its composer: his charming scoring and his undoubted capabilities as a brilliant symphonist, even if he lacks some of the finer subtleties of Mozart.

Sir Thomas Beecham, together with the London Symphony Orchestra, gives, as one would expect from such a combination, a superb performance, and the recording is one which will have wide appeal and receive due praise. From the 1911 H.M.V. record list for this month, I select the following: *D.41848-49* for the wonderful performance by Jose Iturbi—Pianoforte—and for the compositions he has recorded. They are four pieces by Chopin which will be recognised and appreciated by most and in particular by those who have seen the film "A Song To Remember," in which, incidentally, Jose Iturbi was the actual pianist.

The four pieces were composed in 1834, but it was not until Chopin's death, that the "Fantasia-Improvisata In C Sharp Minor" was found in his portfolio, and it was some 20 years later before it was actually published. The two records contain the composition mentioned above, and "Waltz In D Flat" on the first record, and "Waltz In C Sharp Minor" and "Mazurka In B Flat" on the second. The works are delightful and rather sparkling, though certain passages in the Waltz in C Sharp Minor demand great skill and delicacy in their rendering. Jose Iturbi, however, gives a perfect performance, rich in expression and understanding.

Those who have been unable to hear Webster Booth and Anne Ziegler in person in "Sweet Yesterday" at the Adelphi Theatre, London, will welcome *H.M.V. B9428* and *B9429*, while those who have seen the show will be equally interested in securing these exclusive recordings, so that they can hear these two charming voices at will. The songs they have selected are "Life Begins Anew" and "Tomorrow," which form two delightful duets, on *H.M.V. B9428*, and "Morning Glory" which is sung by Webster Booth and Chorus, and "Sweet Yesterday" which Anne Ziegler renders for us in a truly pleasing manner, on *H.M.V. B9429*. In previous reviews I have given my opinion of these two talented and perfectly matched artists, and these recordings form yet another delightful example of superb balance and understanding, and of the true quality of their voices and production. I strongly recommend these records. For dance enthusiasts, I select *BD5893*, on which can be heard Eric Winstone and his Band playing two pleasing fox-trots, "Anywhere" and "Laura," the vocals being taken by Julie Dawn and

Alan Kane respectively. Joe Loss and his Orchestra—with Harry Kaye taking the vocal parts—have also selected two fox-trots, their titles being "A Friend Of Yours" linked with "Just A Prayer Away" on *H.M.V. BD5895*. Two good numbers.

### Columbia.

THE latest recording by the City of Birmingham Orchestra, conducted by George Weldon, is one which will be welcomed by all lovers of Sullivan's—of Gilbert and Sullivan fame—brilliantly sparkling compositions. It is not one of the noted series of Savoy operas, but the "Overture Di Ballo," which, unlike his one attempt at grand opera, does not reveal any of the effects so often created by one trying, shall I say, something more ambitious, more serious and heavier, than one's more normal work. The overture is a fine example of Sullivan letting his true melodic talent and his exceptionally fine craftsmanship run free, with the result that it is a comparatively easy work, very attractive and certainly most pleasing. The composition is in dance rhythm, but its structure follows the generally accepted classical form, consisting of exposition, development and recapitulation. The performance by the City of Birmingham Orchestra is of the highest order, and I strongly recommend all to hear the recording on *Columbia DX1200*.

Frank Sinatra has two new recordings this month; they are on *Columbia DB2181*, their titles being "If You Are But A Dream" (adapted from Rubinstein's "Romance") and "Kiss Me Again." This record will, no doubt, have a wide appeal to all Sinatra's followers, therefore, if you like his style and voice, I suggest that you make a point of hearing it.

Andre Kostelanetz and his Orchestra have made a fine record—*Columbia DB2182*—with I. and G. Gershwin's "The Man I Love," which occupies both sides of the disc. Kostelanetz's Orchestra is well constructed and balanced, and under his conductorship they always put up a performance worthy of note.

Felis Mendelssohn and his Hawaiian Serenaders continue their "Hawaiian Memories (No. 6)" on *Columbia FB3127*. Harry Brooker is featured with his Electric Guitar, and Kealcha-Life takes the vocals. The Memories introduces some good tunes well presented.

Paula Green and her Orchestra—directed by Peter Akister—offer "Ac-cent-tchu-ate The Positive" and "Dream" on *Columbia FB3128*. Lou Prager and his Orchestra—from the Palais de Danse, Hammersmith—have recorded "Doggin' Around" and "Bring On The Drums," the latter being by Lou himself. Two attractive numbers in distinctive style, on *Columbia FB3129*.

Turner Layton is well up to form on *Columbia FB3131* singing "After A While" and "I Don't Care If I Never Dream Again," the latter being from the film "Here Come The Co-eds."

Victor Silvester and his Ballroom Orchestra have two good numbers, well orchestrated and presented, on *Columbia FB3133*. They are "Dream," a quickstep, and "The Wedding Waltz."

### Parlophone.

HARRY PARRY and his Radio Sextet will be appreciated by those who like their music "hot" when they listen to *Parlophone R2976*, on which Harry and his boys have recorded "One O'clock Jump" and "I'll Remember April." Joe Daniels and his Hot Shots, in "Drumsticks," given proceedings with "King For A Day" and "Clarinet Marmalade"—(I often wonder who coins these titles).

### Regal.

ONLY one this month, and that is by our old friend George Formby and, of course, his Ukulele. He sings, in his own inimitable style, "Up In The Air And Down In The Dumps" and "She's Got Two Of Everything," two very cheerful little numbers.

# Open to Discussion

The Editor does not necessarily agree with the opinions expressed by his correspondents. All letters must be accompanied by the name and address of the sender (not necessarily for publication).

## Servicing

**S**IR,—I have had considerable experience with both civilian and Service radio/wireless mechanics and with the latter I am not impressed.

These self-styled experts will discover that dealing with public property is quite a different matter, when awkward sets cannot be returned to stores and damages have to be made good.

I am quite familiar with the "extensive course of radio theory" mentioned by Mr. Pinnington (July).

Perhaps he can explain why, during trade tests and other examinations, it is of those very fundamental principles the average Service trained man knows least, and their knowledge of workshop practice so deplorable. Would he, I wonder, care to pay them their present effective salaries for the amount of useful work they do?

Very few of these men would last at the job I regard as real servicing, that of employment in the servicing department of a radio dealer's establishment, where there are no special courses on standardised equipment and where you are required to deal with a tremendous variety of apparatus, giving to customers the prompt attention competition demands, together with genuine service. In this respect, during pre-war years, there was much to be desired, the public, in my opinion often having had a raw deal.

As far as salary is concerned the repair man cannot expect to receive more than he earns. This is in proportion to volume of trade and the nature of his work.

To meet the expenses of his department, obtain his own salary and provide a margin of profit for his employer is a full-sized man's job.

Speed and efficiency is the way to success in servicing and work is often performed under very difficult conditions at customer's own premises.

With few exceptions, the many mechanics I have known are not sufficiently competent, or possess the technical ability to impress a critical employer, or stand up to competition from within their own service room. Many seem to imagine a City and Guilds certificate to be the key to unlimited opportunity.

After the war, as servicing manager at my place of employment, I hope to take part in the selection of staff and I shall engage keen responsible radio men, those who have chosen a career in radio because they love the work and take pride in it, not those whose sole interest lies in their cash receipts on Saturdays. I shall put them on an "I pay as you earn" system at first to gauge their merits and quickly weed out the meddlers, of which this vocation has always been overcrowded.

A compulsory Service Engineer's licence would save me the trouble and be a big step towards raising the status of the qualified repairer and the standard of a greatly abused public service, eliminating the menace of the unskilled amateur.

Mr. Firth (December) is quite correct when he states that a radioman must be right on top of his job, and I can hardly imagine what some of my Service comrades would do with a frequency mod. change-over job or a television receiver, many to whom an oscilloscope is a novelty. My advice is for them to return to their former occupations where they may be worth something and perhaps earn a good wage.—E. PRYNE, Corporal, R.A.F., East Fortune.

## L.T. and H.T. Switching

**S**IR,—Your correspondent, F. Brooks, is quite right regarding L.T. and H.T. switching—or else every circuit designed and printed by "P.W." is utterly wrong, and one must really admire the Editor's patience in this and other matters. If the circuit of the current

to a valve is considered it will be seen that there is no direct line from H.T. plus to minus, therefore current cannot flow, but the direct L.T. line must be broken, and the valve ceases to function. If anyone does know of a method of working valves on H.T. to anode alone, I, personally should be glad to hear of it.

It ought to be mentioned that most commercial battery sets break the circuit of H.T.—L.T. and G.B. and include a fuse as a further precautionary measure, purely to isolate current should adventurous owners probe where angels fear to tread.—S. E. CARTER (Chelmsford).

**S**IR,—In reply to F. Brook (Maidstone) in "Open to Discussion" of the August issue, I now notice that his argument was concerning battery valves. The manner in which he submitted his article, I was under the impression that he was referring to mains valves.

Unhappily I was not in possession of the issue of PRACTICAL WIRELESS he refers to, to discover what the query was all about. Under these circumstances I tender an apology to him in the abrupt manner I worded my missive, which I purported to be about indirectly heated valves which require a small period of heater warming before H.T. is applied on the anode. No doubt he has already known that where indirectly heated valves are employed, indirectly heated rectifiers are employed to compensate heater warming, before the H.T. is applied.

Certainly directly heated valves (battery valves, etc.) are quite safe to have H.T. on before L.T. is applied, and no damage can result. I sincerely hope this letter will "clear the air."—J. SHINE (Suffolk).

## Mains Consumption

**S**IR,—I was rather surprised when reading the paragraph on "Mains Consumption" on page 362 of the current issue (August, 1945) of your paper.

The meter may or may not be 100 per cent. correct and probably isn't, but the supply authorities may be depended upon to see it is not very far out and anyhow the householder pays in accordance with the meter reading.

I would suggest to those interested to examine their supply meter and read the design details.

It will be found, among other things, that a certain number of revolutions of the meter disc are required per kilowatt hour (in my case it is 1,500).

The meter disc is usually marked with a spot of black or red paint which will enable anyone to record the time of one revolution by the second hand of a watch or with a stop watch if available.

If the watch is held near the meter it is quite easy to keep the eyes on the watch and the meter disc.

Switch off every electricity consuming unit in the house and then switch on the wireless set and wait for the mark on the meter disc to come round and then take the time it takes to make one revolution.

Then  $\frac{1}{1,500} = .00066$  k.w. hours per revolution.

If the disc takes say 30 seconds to make one revolution this would  $\frac{1}{30} = .033$  revs. per second and 119 revs. per hour. Then  $119 \times .00066 = .0785$  k.w. or 78.5 watts.

Say the mains voltage is 230 then the current will equal  $\frac{78.5}{230} = .34$  amperes. This method is simple and the financial cost is just nothing.—R. KIRLEM (B'ham).

(Continued on page 480)

**COULPHONE RADIO**

PROMPT MAIL ORDER SERVICE  
NEW GOODS ONLY

- Orders over 5/- post and packing free.  
Tunggram and B.V.A. Valves. Over 2,000 in stock. List prices.  
Mains Transf. 350v.-0-350v. 100 mA.  
4v. 2a. 4v. 21a. or 6.3a. 5v. 2a., 26 6.  
Transf. Bobbins, as above... 15 6  
P.M. Speakers less transf., 31in., 29/-; 6in., 21 6; 5in., 21/-; 8in., 22 6; 10in., 35/-.  
With pen. transf., 6in., 27/-; 8in., 27 6, 10in., 32 6.  
8in. M.T. 1,200 ohm. field pen. trsf., 32 0.  
Power-Pen. Output Transf., 40mA. 8 6  
Parafed L.F. Transf., 4:1 ... 6-  
Push-Pull L.F. Transf. ... 17 6  
5-way Cable, 10d. yd., 3-way, 6d. yd.  
Mains Dropper Resistors, 800 ohms.  
2 adj. taps, 3 amp. with fixing feet 4 6  
Push-back Wire, 50ft., 2 9; 100ft. 4 0  
Carbon Resistors, 1 w. 6d.; 1 w. 9d. Standard values 50  $\Omega$  to 5 meg.  
Resin Cored Solder ... 4/- lb.  
Tinned Copper Wire, 1 lb. ... 2 3  
Sleeving, 2mm. A.F.D. Specf. 2d. yd.  
Moving Coil Microphone ... 95/-  
Mike Floor Stand, chromium ... 42/-  
Tubular and Silver Mica, all sizes.  
Valve-holders, Eng. & Amer., 6d. each.  
Vol. Controls with sw., 4 9, less sw. 3 6  
Smoothing Iron Elements, 450w. 3 3  
Fire Spirals, 750 w., 2/-; 1,000 w. 2 6  
Staneco Soldering Irons, 230v. 17 6  
Speaker Field Coils, 2,000 ohms. 9 6  
Smoothing Chokes, 15 Hy. 200 mA. 200 ohms ... 21-  
Tuning Condensers, .0005 with trimmers, 2 gang, 11 6; 3 gang, less tr. 13 6  
Tuning Coils, M. & L. wave, with reaction circuit ... Pair 12 6  
Milliammeters, 41in., B.S., 1st grade, 6/- mA., Knife edge pointer ... 7 0  
Electrolytic Condensers, Limited supplies, 8mfid. 450v., 3 9; 2mfid. 350v., 3 6; 25mfid. 25v., 50mfid. 12v., 2 6; 25mfid. 50v., 3/-; 50mfid. 50v., 3 3.  
Line Cord, 3 amp., 60 ohm per ft., 2 and 3-way, 3 6 per yard.  
Stamped addressed envelope for list.

**NEW LONGTON, Nr. Preston**



They say they'll release me for a 35L6."

(Courtesy "Radio-Craft," New York.)

This chap is free now — thanks to BULL'S, who immediately sent (as usual) the right valve.

From our stock of 10,000 valves we can supply nearly all types required. Please order G.O.D. Under 10/- C.W.O. 21d. with Enquiries. B.O.T. prices.  
MULLARD, MARCONI, OSRAM, MAZDA, COSSOR, BRIMAR, PHILIPS, FERRANIL, EVER-READY, TUNGSRAM, HIVAL

also AMERICAN Midgets and Acorns. VALVES AND ADAPTOES  
In cases where we cannot supply the exact valves or equivalents we can get your set going with a valve and adaptor, the additional cost being 4/6.

MODERN AIDS  
A.C./D.C. MULTI-METERS, 28/17/6.  
TESTSCOPE, fault-finding pocket instrument enabling 20 A.C./D.C. Tests, 37/6.

TRIMMER TOOL KITS, 14 tools in wallet, 30/-.  
SOLDERING IRONS (state voltage), 13 6. Universal model, 22/-.  
FLIK-O-DISK, a novel calculator of Ohm's law, 6 6.  
MOVING COIL METERS, 30 amps., charge, discharge, 19 6.  
CAR AERIALS, telescopic, nickel plated, 21/-.  
FLAT IRONS, 200-240 v., with Hex., 27 6.

RADIO LITERATURE  
Television 1/-.  
Test Gear Construction, 1/6.  
Amplifier Manual, 2/-.  
Equivalents Charts, 1/7.  
Manual of Circuits, 2/-.  
Short Wave Handbook, 2/-.  
American Midgets, 2/7.  
Wireless Terms Explained, 3/-.  
Manual of Br. and Am. Valves, 3 6.  
Radio Inside Out, 4 6.  
Radio Simplified, 4 6.  
Basic Radio, 5/-.  
Introducing Radio Servicing, 6/-.  
Receiver Circuits Book, 6/-.  
Various Service Sheets, dozen, 10 6.  
Various Service Diagrams, dozen, 7 6.  
Giant World Radio Map, 5/-.

COMPONENTS  
LINE CORD, 2-core, 3 amp., 60 ohms, per foot, 1-; 3-core, 3 amp., 60 ohms, per foot, 1 1; 3-core, 15 amp., 100 ohms, per foot, 1 2.  
SPEAKERS, 8in. Rola, less transformer, 23/-; 6in. Celestion, with transformer, 27/-; 3 1/2in. Goodman, less transformer, 30/-.  
TWO-GANG CONDENSERS, Special midget condensers, with trimmers, 15 6.  
THREE-GANG CONDENSERS, Standard type, 12 6.  
MAINS TRANSFORMERS, RME 200/230 volts 300-0-300, 4 v. 4 amps., 4 v. 2 amps., 6.3 v. 3 amps., 5 v. 2 amps., 37 6.  
SPEAKER TRANSFORMERS, Universal output (Pentode and Power), 6 9. Universal model, 9/-.  
VOLUME CONTROLS, Most values in stock, with switch, 6/-.

EXPORT ORDERS INVITED  
**J. BULL & SONS,**  
(Dept. P.W.)  
246, HIGH ST., HARLESDEN, N.W.10

**RADIO SALES**

BCM/SALES, LONDON, W.C.1

- Full list for 1d. stamp.  
GOODMANS 3 1/2in. P.M. less trans., 3 ohm. 30/-.  
EXTRA SMALL Celestion 2 1/2in. P.M. less trans., 27 6.  
ROLA 5 1/2in. P.M. with trans., 28 6, few.  
CELESTION 6 1/2in. P.M. with trans., 28 6.  
ROLA 8in. P.M. with trans., 28 6.  
I.F. TRANS. iron cored 465 kc-canned, 10/- pair.  
M.W. COILS, 4 6 pair.  
OSC COILS (465 kc.), 2/3 ea.  
SMALL TWIN GANG .0005 trimmers, feet, 15/-.  
DROPPERS, 3 or 2 x 2 taps and feet, 5 6 and 4 6.  
SPEAKER TRANS., multi ratio, 7 6, 3 w pen 7 6, midget pen 6/-.  
CHOKES, midget L.F. 7 6, 60 m/a. 15 Hy.  
50 ASSTD. Condensers, 61.  
SEND us your queries and SAE, we always help when we can.  
RESISTORS, 1 w. 9d., 1 w. 6d., 1 w. 4d.  
TUBULARS, .0001-.0005 9d., .001-.011 1-.1 9d., 5 2 6.

SMALLS, Tin copper wire 6d. coil, resinous 6d. coil, sleeveing 3d. varg tags, 2 4 and 6 B.A., 2/- gross, crystals 6d. ea., valveholders, all Brit. and Amer. types except side contact.  
We can't list everything; ask for C.O.D. if it's not here, otherwise c.w.o. plus postage.

Full list 1d. stamp to:

**RADIO SALES**  
BCM/SALES, LONDON, W.C.1

**YOU can become a first-class RADIO ENGINEER**

We are specialists in Home-Study Tuition in Radio, Television and Mathematics. Post coupon now for free booklet and learn how you can qualify for well-paid employment or profitable spare-time work.

**T. & C. RADIO COLLEGE**  
NORTH ROAD, PARKSTONE, DORSET.

(Post in unsealed envelope, 1d. stamp.)  
Please send me free details of your Home-Study Mathematics and Radio Courses.

NAME .....

ADDRESS .....

P. 65.....

**THESE ARE IN STOCK**

- RADIO RECEIVER DESIGN. By K. R. Sturley, Ph.D., B.Sc., M.I.E.E. Part I, 28/- Postage 7d.  
NEWNES TELEVISION MANUAL. By F. J. Camm. 6/- Post 4d.  
THE MATHEMATICS OF WIRELESS. By E. Stranger. 7 6. Post 4d.  
PRACTICAL WIRELESS CIRCUITS. By F. J. Camm. 6/- Post 4d.  
WORKED RADIO CALCULATIONS, graded practical examples. By A. T. Witts, A.M.I.E.E. 6 6. Post 3d.  
AN EXPERIMENTAL COURSE IN THE FUNDAMENTAL PRINCIPLES OF RADIO. By R. H. Humphry, M.Sc., F.Inst.P. 12 6. Post 4d.  
INTRODUCTION TO ELECTRICITY AND RADIO. By T. H. Turney, Ph.D. 7 6. Post 4d.  
CATHODE-RAY OSCILLOGRAPHY. By J. H. Reyner, B.Sc., A.C.G.I., D.J.C., A.M.I.E.E., M.Inst.R.E. 8 6. Post 4d.  
SHORT-WAVE RADIO. By J. H. Reyner, B.Sc., A.C.G.I., D.J.C., A.M.I.E.E., M.Inst.R.E. 10 6. Post 4d.  
THE WIRELESS WORLD VALVE DATA. Operating conditions and base connections of the principal types and makes. 2/- Post 2d.  
VALVE REPLACEMENT MANUAL. For Radio Service Engineers. By A. C. Farnell and A. Woffenden. 6/- Post 2d.  
INTRODUCTION TO VALVES. Including reference to Cathode-ray Tubes. By F. E. Henderson. 5/- Post 3d.  
Apply for complete Radio List, Price 1d.  
**THE MODERN BOOK CO.**  
(Dept. P.4.)  
19-23, Praed Street, London, W.2.

## Radio Nacional de España

**S**IR,—A note to inform you of further alterations in the European and American broadcasts of Radio Nacional de España in Madrid. I have just been informed of the following:

*American Service.*—Commenced on Wednesday, June 20th, the beamed-transmission to Latin-America was formally opened by General Franco, after three months of testing. This is sent out over the new 40kw. Arganda station on 32.2 metres (9,320 kc/s) and begins at 1 or 1.30 a.m. D.B.S.T. and lasts until 3 or 3.30 D.B.S.T.

*European Service.*—As from Sunday July 1st, and on successive Sundays, the following programme will be broadcast over the same station: 8 p.m. D.B.S.T. Concert for Europe, announced in the usual main European languages; 8.45 p.m. news in various languages; 9.30 p.m. another Concert, lasting until 10 p.m. This is the first Sunday European broadcast to come from Spain for over six years.

As from Monday, July 2nd, the usual English broadcast will take place at 9.15 to 10 p.m. D.B.S.T. over 32.2 metres, and also, I believe, 42.83 metres.—K. DOBSON (Chichester).

## Phase in Amplifiers

**S**IR,—I read with interest the article on phase in amplifiers, etc., and would put forward the following. When any point in an A.C. circuit is instantaneously positive, this is shown by drawing it above the zero line in a graph, and vice versa. This convention is universal. But what is the convention regarding the direction of flow of current? Consider an A.C. generator working into a purely resistive load, one generator terminal being live and the other earthed. When the live terminal is positive, we show the current at that instant above the zero line, in phase with the voltage. At this instant electrons are flowing from the load towards the generator, as electrons always flow from negative to positive. When the live terminal changes polarity, both curves go under the zero line. All this is common knowledge, and it establishes the convention for representation of current flow.

When a valve is considered as a generator of voltage  $\mu E_g$ ,  $E_g$  being the grid voltage, and the anode the live terminal of the generator, in what respective directions do the electrons flow, relatively, in the anode circuit, as the grid changes polarity? When the grid is positive, the electrons which we must consider to act as the A.C. component of the anode current flow from the anode towards the load, and cause an increase of the steady anode current. When the grid is negative they must be supposed to flow in opposition to the steady anode current, and cause it to decrease, as we know it does. (I am considering a valve with resistance anode load.) I don't think any reader will have been able to point out any flaw in the foregoing reasoning; let him mark what it leads up to. If we draw the curves of grid voltage and A.C. anode current according to the accepted convention referred to in the first paragraph, we find that the A.C. anode current is *not* in phase with the grid voltage, but in antiphase, and should be drawn on the opposite side of the zero line, in phase with  $\mu E_g$ , which is antiphase to grid voltage.

I know that in most diagrams showing anode current and its superimposed A.C. component the whole is drawn above a zero line, on the principle that increases above zero are generally shown by an upward movement. This does no harm, but when we are concerned with precisely showing the real phase relation of grid volts and anode A.C. current, we must use the same convention for the two, or we shall get wrong results. The vital thing to be remembered is that with A.C. current curves the half-cycle curves above and below the zero lines both equally represent magnitude of current; down from the zero line is an increase as much as up from it. It is direction of flow that is changed, not magnitude.—A. D. GRIFFITHS (Wrexham).

## Direct Disc Recording

**S**IR,—Mr. R. W. Lowden's series of articles on "Direct Disc Recording," which commenced in your October, 1944, issue, is a useful contribution to the literature on this subject, which I know has been appreciated by many recording enthusiasts, particularly beginners, from the correspondence I have received from B.S.R.A. members seeking back numbers, etc.

A small but very important omission in Fig. 4 (p. 387, August P.W.), showing Dr. Otto H. Schmitt's cathode phase inversion circuit is the lack of a 0.1 or 0.25 meg. resistor from the valve grid side of each 0.1 mfd. P.X.25 coupling condenser to earth. Valve longevity is helped by proper biasing! Also the value of the top 354V valve's anode resistor should, of course, be 40 K $\Omega$ , i.e., 40,000 ohms.

Finally, may I say how interesting it was to read "Experimentalists'" description (September issue) of the "cracked record" dodge? Many old gramophone enthusiasts must have stumbled on this effect, as I did years ago in efforts to repair broken discs, which were used later with amusing results at parties! Incidentally, the proper direction of rotation of a record is "clockwise" and not "anti-clockwise" (see p. 403, second column, line 16).—D. W. ALDOUS (Torquay).

## Condenser as Resistor?

**S**IR,—In his letter in the September issue of PRACTICAL WIRELESS, Mr. S. N. Radcliffe (Dorset) comments unfavourably on my letter in the August issue, which referred to the use of a condenser in place of a resistor as a means of voltage-dropping. Furthermore, to give emphasis to his arguments, he has misinterpreted and misrepresented my statements. His rather unfortunate remarks disclose a lack of knowledge of his subject.

My object in writing was not to discourse on the merits or demerits of the two methods of voltage-dropping, but to show that there was a surge of current in the circuit, as opposed to Mr. C. E. Hedley's statement that the current built up slowly to its correct value. This object I think I achieved.

Mr. Radcliffe in his letter says: "If we follow Mr. Baker and assume zero 'cold' resistance . . ."

Now I did not at any time assume the "cold" resistance of the heaters to be zero. To quote my own words, I said: "The resistance of the heaters at .3 amps. is 230 ohms, but when cold, the resistance is so low that it can be neglected in the expression for impedance." This is common practice, as the error introduced is very small. That this is so may be proved as follows:

Taking Mr. Radcliffe's own figure of 50 ohms as the cold resistance, then Impedance  $Z$

$$= \sqrt{50^2 + 731.1^2} = \sqrt{2,500 + 534,600}$$

$$\therefore Z = 732.8 \text{ ohms.}$$

Thus there is a difference of only 1.7 ohms when the resistance is taken into account. This represents an error of about .2 per cent., which, in a calculation of this kind, is indeed negligible. Mr. Radcliffe, in furtherance of his argument, has neglected a resistance of 50 ohms in a purely resistive circuit of 590 ohms total resistance, which is sheer nonsense.

Mr. Radcliffe goes on to say that I showed the worst surge obtainable to be .3146 amps. This is not the case. I showed that there was a surge of current without mentioning the worst surge, which occurs under transient conditions.

In other words, I proved my point without introducing this difficult subject, as will have been noticed by the more technical readers of PRACTICAL WIRELESS.

There is no doubt that transient conditions in A.C. theory is a difficult subject, but in view of the present controversy perhaps I may be permitted to give here a brief, non-technical, explanation of when the highest current surge does occur. If I gloss over a point here and there I trust readers will not be too harsh in their criticism.

The highest surge of current in a condenser-resistor combination of the type under discussion occurs at the moment of switching on, depending on the mains voltage

at that moment. The generator supplying the current may be just commencing its cycle, or it may be at the peak of its cycle, or even somewhere in between. It's just a matter of luck what voltage is actually applied to the circuit.

Now the condenser is in an uncharged condition, and no P.D. will appear across it until it begins to charge up. Suppose the mains voltage to be at its peak in the split second of switching on. This is applied to the circuit as a whole. The voltage across the condenser is  $\frac{I}{\omega C}$  but it is as yet still uncharged. If it is uncharged, it means that it has had no current. Therefore the condenser voltage is  $\frac{0}{\omega C}$  or 0.

The peak voltage of 325 volts is applied to the valve heaters. The current is  $\frac{325}{50}$ , or a surge current of 6.5 amps., which flows for a fraction of a second, decreasing rapidly as the condenser becomes charged.

Present-day valves will stand a lot of misuse, but they are not built to stand shocks of this nature. Continuous use in a circuit of this type may prove very disappointing to the user.

It was for this reason that I advised readers to use the resistor method of voltage-dropping. The resistor takes the full brunt of the voltage immediately, and although there is a surge of current through the heaters, it is not accompanied by a heavy voltage.

If the capacitor method were really practicable, it would have been used commercially for small A.C. sets, razors, etc.

The principle is not new. I remember it being used at school nearly thirty years ago. A condenser was placed in series with a lamp in order to demonstrate the existence of a current in the circuit.

I trust that the foregoing will clear the air a little, but in the event of further controversy, may I suggest that our respected Editor gives his opinion?—RANSOME C. L. BAKER (Mitcham).

### Service Engineers

**SIR**,—Your remarks about J. P. Coyle's letter concerning, "Service service engineers" are, in my opinion, quite wrong.

To do any serious servicing in the radio section of the R.A.F. an exceedingly good knowledge of radio theory is required. The circuits of the majority of service radio equipment are more complex than any I personally have met.

Speaking of some of the so-called civilian "radio engineers" of "civvy street," their way of servicing seems to be a series of quite unconnected dabbings about with a piece of wire, a .1 condenser and a resistance. They have a blind faith in these three things, thinking they will cure anything.

Half of them have no idea how to use a "scope," oscillator, or multi-range meter. In fact, I would suggest that more radio components are destroyed by the incompetent civvy "engineer" than were ever wrong in the set before he tried to "service" it.—A. BEECH (Dunmow).

(This correspondence is now closed.—Ed.)

### A Universal Language

**SIR**,—With regard to your article in the September number of PRACTICAL WIRELESS, I should like to say that I, an Esperantist and a Radio Ham, agree with everything you have said about the advantages of a universal language, but only an international auxiliary language (*internacia helpa lingvo*).

What a very small percentage of the total number of stations receivable on our wireless sets are we able to understand. I wonder how many people ever require that tuning knob on their sets.

Now quoting from the article in P.W.: "How can an international language overcome the differences between, say, English and French or German?" By international

language, as distinct from your use of the word *universal* language, I infer that you mean a language which is not a national language, in other words, one like Esperanto or Volapük. Well, if a language of this kind, one which is neutral to the Englishman and the Frenchman, cannot overcome or at least minimise these differences, how can we expect English or German to do it? Esperanto can overcome these differences; I know it can, I've tried it. My French and Swedish pen-friends might just as well live in London, Manchester or Glasgow when they write in Esperanto, but when they try their hand at English they are foreigners even though they can easily make themselves understood in English.

Because, to quote again, national pride in a language, its idioms, colloquialisms, and the fact that a particular language is designed around national characteristics rather than upon the rules of orthography, etymology, syntax and prosody, English can never satisfactorily become an international or universal language which will help nations to understand one another until other nations have our national pride, use our idioms and our colloquialisms. When will they do that?

Basic English, a language even baser than pidgin English, does not really deserve mention, but, because it has enjoyed recently so much publicity let me say a few words about the project. Imagine being restricted to 18 verbs, as you are in basic, with only a periphrastic substitute for any other verb you may wish to use, e.g., "to move" becomes "to give a thing a move."

Other comparisons of basic with English are: rich—moneyed; to buy—to give a price for; he forgot the bottle—all memory of the bottle went out of his head; I have heard of you—I was conscious who you are; lie hidden in a cave—have their resting place in a stone hollow.

—No! Mr. Ogden's jigsaw puzzle may be interesting to people who wish for Anglo-American prestige, but it certainly is not a language.

One of the objections to Esperanto in the P.W. article is that the word sounds too Spanish and therefore other countries would object. How much more are they going to object if a language which is, not just sounds like, another country's national language.—J. C. D. SMITH (Burnley).

(We have received many similar letters from parties not altogether disinterested.—Ed.)

### Transformer Testing

**SIR**,—I would like to point out an error in H. Gottschalk's letter about his transformer testing unit which appears in the September issue of PRACTICAL WIRELESS. In it he says that the current passed by the bulb is .068 mA. This should read either .068 amps or 68 mA.

I am a keen short-wave listener and enclosing some information about some recent stations which I have received.

Finland: Uses three wavelengths for its 13.15 hours transmission. They are OIE 25.47 m., OFD 31.57 m. and OIX4 19.75 m.

Sweden: SBT 19.79 and SBO 25.63 are on the air each Sunday at 16.00 hours with a news commentary. 19.79 and 27.7 m. are used for the 18.40 daily news bulletin.

Brazil: PRL8 25.6 m. gives a strong signal at 20.30 each weekday.

Australia: VLC2 30.99 m. and VLG5 25.25 m. are on the air at 17.15 each day.

Switzerland: HEO4 29.02 m. has now been replaced by a transmitter on 18.9 m. for the 20.15 programme. Stations in the 25 and 27 mb. are used for the 16.00 transmission on Tuesdays.

Canada: Now uses CHTA 19.71 m. for the day transmissions and CHLL for the night. The latter is on 25.6 m.

Czechoslovakia: Prague is on the air each day at 21.30 on 31.41 m.

Turkey: TAP 31.7 m. comes on the air each day at 17.45 hours with a news broadcast. On Mondays, Thursdays and Sundays there is also a special programme at 21.30.



On August 8th I heard Vatican City on about 31.41 m. at 19.15 hours. All times are B.S.T.—N. F. HODGES (Stourport).

### Criticism

**SIR**,—I have been a reader of your paper for six years now, but, although I have never written to you before, I felt I must add a word of praise to my first letter.

Being employed in the radio side at sea, I do not have my copies of PRACTICAL WIRELESS mailed to me, but let them accumulate at home ready for the next trip. In this way general improvements in the articles become more obvious than to one who reads each issue as it comes out.

There are, to put it roughly, three main improvements which strike me in the issues which accumulated over the last 14 months.

The first of these is the use of International octal valves in circuits described. I do not believe that these are any more efficient than the modern British valves. But at hand I have a "R.C.A. Tube Manual," which gives all the data on all the valves which makes circuit designing a pleasure rather than an exasperating search through odd catalogues and data slips. Furthermore, it contains tables for resistance coupled amplifiers and an interesting chapter on valve applications.

After the war I think the British valve manufacturers will see that it will pay to produce standard valves rather than types which are bought as replacements merely because no other type will do. An outstanding example of this is the Mazda octal. What advantage can this base have over the standard octal? Now when so many thousands of Servicemen are skilled in radio they will not only know what they want themselves, but will be called in by friends and relatives to help in the choice of the post-war domestic receiver.

The second improvement is the drift from battery to mains circuits. A battery receiver now and then is tolerable, but surely there are not so many homes left which cannot boast of some kind of mains supply? A mains set can easily be converted to work on D.C. if octal valves are used by using a high voltage heater output valve. If the D.C. supply is low voltage a suitable series-parallel arrangement can usually be found, and a vibrator pack employed for the H.T. Receivers using this idea are especially common in South America outside the cities where American made "Wincharger" wind-driven generators are popular. These charge 32-volt accumulators.

I think there are many beginners in radio who make battery sets of the simpler grades merely because they think that mains-operated equipment is expensive, full of mysterious snags, and totally beyond their comprehension. PRACTICAL WIRELESS is helping to remove this idea by such articles as "An Economical One-Valver" in the February, 1944 issue, for it is obvious, even to a beginner, that the heater transformer is as cheap as the accumulator, and even cheaper if the common bell transformer tapped at 4, 6 and 8 volts is used. A further improvement in this article would have been to explain how a 6C5 with grid strapped to the plate could be used as half-wave rectifier. A resistor could be used in conjunction with a double electrolytic to provide smoothing and the two heaters run in parallel off the transformer or in series with a dropper resistor from the mains. A suitable warning re earthing should be added, and also that with the 6C5 anode direct to the mains about 300 V.H.T. are present, so it is advisable to take this connection to a tap on the dropping resistor not so far above the positive end of the heater line!

And, finally, the technical articles are good. While some are not only interesting, but helpful in explaining faults which might well have happened in the last set one built, other articles prepare one for the future such as those on frequency modulation and television.

There are one or two slips which stand out which may confuse a few, but in these days of shortage of staff can be overlooked by the majority. Among these on page 93, February, 1944, under "Non-linear Distortion," it states: "The anode bend detector

almost inevitably causes distortion. The leaky grid detector is normally free of it." This is obviously the wrong way round. In the same issue, in the article referred to earlier in this letter, it gives a 6L6 as an alternative detector to the 6J7. This would be rather drastic on the phones as well as the  $\frac{1}{2}$  amp. heater transformer, as the 6L6 takes .9 amp., so it would appear that the 6C6 is the intended valve. The Brimar valve table in the September, 1944 issue has gone astray from the 6N6 direct-coupled power amplifier, which it claims to be a frequency changer down to the bottom of the list with the exception of two.—GORDON H. BROWN (Dominican Republic).

### Switching

**SIR**,—In support of J. Shine (Bury St. Edmunds) who writes in the July issue, I feel bound to criticise the statements of F. Brook (Maidstone) regarding the absence of harm to valves in connecting the H.T. before the L.T.

I have had considerable experience with radio apparatus and with transmitters in particular. With the majority of transmitters I have had dealings with, and more so those in the high power classes, one invariably finds that the switching arrangements are such that the filaments are switched on before the H.T. and switched off after the H.T. This precaution would not be taken without reason; and whatever reasons apply to transmitter valves must also be applicable to receiver valves, which are fundamentally the same. As far as my theoretical knowledge allows me I understand the reason to be as follows: To consider D.H. valves, they possess thoriated tungsten filaments, or filaments having a layer of oxide as the emissive surface. In the former case the emissive surface is composed of a layer of thorium approximately one atom thick, and in the latter the oxide lays little thicker. The anode already being at a high positive potential in respect to the filament the L.T. is switched on. The increasing thermal agitation of the molecules imparts a correspondingly increasing velocity to the negatrons of the surface atoms already in a state of tension due to the applied H.T., and before they attain the necessary velocity to leave the surface of the emitter and form a space charge, from which the anode current is normally drawn, they are pulled by the plate potential from their position to itself. A process which can only prove injurious to the emissive surface of the filament. Furthermore this sequence of events is not equally spaced along the filament, the centre heating much quicker than the ends, due to their connection to the cooler supports, one part of the filament would become weaker much quicker therefore than another. Also the potential difference between one end of the filament to anode and the other end to anode must be considered.

With regard to I.H. valves the same must apply, damage to the emissive surface of the cathode being in question, a difference being in the equipotential surface of the cathode and its equal rate of heating. I can therefore only foresee a shorter than normal life to F. Brook's valves and those of his supporters.—H. F. NORMAN (Hastings).

### Standardised Terms

**SIR**,—In his letter on Standardised Terms, H. F. Norman uses the term "Positron" to describe "the positive charge present in varying numbers in the proton"; and the "neutron" as "the corpuscular mass also present in the proton."

I would like to disagree with H. F. Norman. As far as my own knowledge of atomic physics goes, I understand the positron to be a particle (if I may use the term for want of one better) with the mass of an electron, but a positive charge equal to that of a proton; it thus becomes a "positive electron" or "positron."

The neutron, on the other hand, is a "particle" with the approximate mass of a proton, but with no electrical charge. It is, incidentally, believed to be a proton and electron in very close association, so that their opposing charges are effectively cancelled.—E. HAMMONDS (Yatesbury).

# FIRST-CLASS RADIO COURSES . . .

## GET A CERTIFICATE!

### QUALIFY AT HOME—IN SPARE TIME

After brief, intensely interesting study—undertaken at home in your spare time—YOU can secure your professional qualification. Prepare for YOUR share in the post-war boom in Radio. Let us show you how!

#### FREE GUIDE

The New Free Guide contains 132 pages of information of the greatest importance to those seeking such success compelling qualifications as **A.M.Brit.I.R.E., A.M.I.E.E., City and Guilds Final Radio, Matric., London, B.Sc.(Eng.), A.M.I.P.T.E., A.M.I.Mech.E., Draughtsmanship (all branches), etc.**, together with particulars of our remarkable Guarantee of

#### SUCCESS OR NO FEE

Write now for your copy of this invaluable publication. It may well prove to be the turning point in your career.

**FOUNDED 1935—OVER 150,000 SUCCESSSES—**

### NATIONAL INSTITUTE OF ENGINEERING

(Dept. 461), 149, HOLBORN, LONDON, E.C.1.

## WIZARD 4-VALVE UNIVERSAL MEDIUM WAVE, also DORSET 3-VALVE BATTERY RECEIVER

Build your own set. Simplicity itself. Both give splendid tone and volume. Very clear point to point wiring instructions, circuit diagram, full-size component lay-out drawings. British valves. Any components sold separately by us. Your queries answered free S.A.E.

**WIZARD 4-valve Receiver** circuit, including alternative wiring for 7- and 5-pin valves, 5/-

**DORSET Battery 3 circuit**, including additional instructions for fitting tone control and pick-up, 3/6.

No Callers. Write—**WELDONA RADIO ACCESSORIES LTD.**, 23, Burlington Road, Swanage, Dorset.

# A FREE BOOK

for all interested in

## MORSE CODE TRAINING.

There are Candler Morse Code Courses for Beginners and Operators.

Send for this Free "BOOK OF FACTS" It gives full details concerning all Courses.

**THE CANDLER SYSTEM CO. (S.L.O.)**  
121, Kingsway, London, W.C.2.

Candler System Co., Denver, Colorado, U.S.A.

## CLASSIFIED ADVERTISEMENTS

### LITERATURE, MAPS, etc.

**BRITISH SHORT-WAVE LEAGUE.**—S.A.E. for membership details and sample monthly "Review." The S.W. Listener's Handbook, 2/9 post free. Write NOW to H.Q., 53, Madeley Rd., Baling, London, W.5.

**RADIO SOCIETY OF GREAT BRITAIN** invites all keen experimenters to apply for membership. Current issue "R.S.G.B. Bulletin" and details, 1/- below.

**AMATEUR RADIO HANDBOOK** (300 pages), paper cover, 4/-; cloth, 6/6. Radio Handbook Supplement (140 pages), paper cover, 2/9; cloth, 5/-—R.S.G.B., 28-30, Little Russell Street, London, W.C.1.

**WEBB'S Radio Map of the World.** Locates any station heard. Size 40in. by 80in., 4/6, post 6d. On linen, 10/6, post 6d.—Webb's Radio, 14, Soho Street, London, W.1. GERrard 2089.

### MORSE & S.W. EQUIPMENT

**MORSE Practice Equipment** for class-room or individual tuition. Keys, audio oscillators for both battery or main operation. Morse Radio, 41, Sono Street, London, W.1. Phone: Gerrard 2089.

"H.A.C." Short-wave Receivers. Famous for over ten years. Improved one-valve model now available. Complete kit of components, accessories, with full instructions, now 19/3, postage 6d. Easily assembled in one hour. S.A.E. for free catalogue.—A. L. Bacchus, 109, Hartington Road, London, S.W.8.

### RECEIVERS & COMPONENTS

#### MOVING COIL HAND MICROPHONES P.M.

Powered by Alni Magnets, 45 ohms, 4in. Coil, fitted with switch in handle, 12/6 each. Moving Coil Headphones, P.M. Enclosed by Alni Magnets, 45 ohms, 4in. Coil. Ideal for Mikes, Miniature Loudspeakers, etc. 1 1/2in. overall in Bakelite cases with 3in. front flange, 7/6 each. Per pair with headband, 16/6.

Three headphones fitted with elastic bands, phone plug, etc. 7/6 each.

**Synchronous Motors**, "Sangamo," 200-500 volts A.C. 50 C. Self-starting, fitted Reduction Gears. Ideal Movements for Time Switches, Industrial, Dark Room, Electric Clock, etc.

**Rotor Speed 200 r.p.m.** Final Speeds available: 1 rev. 12 mins., 22/6; 1 rev. 30 mins., 25/-; 1 rev., 60 mins., 25/- Consumption 2 1/2 watts. Size 2 1/2 x 2 1/2 x 1 1/2. Cash with order. Registered post and packing 1/2 extra.

**15 Amp. Mercury Switches**, enclosed bakelite tubular cases, 2 1/2in. x 1 1/2in., fitted swivel saddle, connector block, etc. 5/6 each.

**Wave-wound Non-inductive Resistances.** 2 watt. Ideal for Meter Shunts, Resistance Boxes, etc. 2 1/2 per cent. accuracy, wound on bakelite bobbins, 1 1/2in. x 1 1/2in. One of each of the following ratings, 25, 50, 100, 200, 400, 600, 1,000 and 2,000 ohms, 5/6 per lot, postage and quantities available.

**Electro Magnets**, 200-250 volts A.C. Resistance 320 ohms. 1 1/2 x 1 1/2in., 3/6 each.

**Rev. Counters, Ex-Meters**, drum type, 0-999 Automatic, reset to zero on completion, 3/6 each.

#### Terms—Cash with Order.

**H. FRANKS, SCIENTIFIC STORES,** 58, New Oxford Street, W.C.1. Phone: MUSEUM 9594.

Large selection of differential reduction gears, meters, relays, etc. for Callers only **ANNUAL HOLIDAYS—**Our Postal Dept. will be closed from Sept. 3-15. Callers only please between these dates.

**REWINDS and Radio Spares.** Armatures, Fields, Transformers, Pickups, Fractional H.P. Motors, Speakers, New Cones and Speech Coils fitted. All work guaranteed and promptly executed. C.O.D. Postal Service. Send S.A.E. for list Valves and Radio Bargains.—A.D.S. Co., 261/5, Lichfield Road, Aston, Birmingham, 6.

**WANTED.** Colvern Coil Unit with 2 stages.—H. F. Burden, 31, High St., Rawmarsh, Rotherham.

**FR&C Power Unit**, combined with triode charger, 62/-; 200-250 volts, L.T., 2-4-6. A.C. mains.—121, Nottingham St., Sheffield.

**WANTED** back numbers P.W. State price. Also offer regular subscriber 1/6 a copy after use.—C. De Whalley, 15, Park Avenue, Farnboro, Kent.

**SALE.** S.W. 1-v-1 Battery Rx. L.F. Transformers.—5, John Street, Cambridge.

# TRANSFORMERS

## and Components for Constructors

Transformers for Audio Amplifiers and Receivers.

Type		Price
V74.	350/0/350 v. 75 m.a., 4 v. 2 1/2 a, 4 v. 4 a, etc.	30/-
V76.	As above but 5 v. 2 a, 6.3 v. 4 a, etc.	30/-
V4.	350/0/350 v. 100 m.a., 4 v. 2 1/2 a, 4 v. 4 a, etc.	32/-
V6.	As above but 5 v. 2 1/2 a, 6.3 v. 4 a, etc.	32/-
K450/H.	450/0/450 v. 250 m.a., 4 1/2 v. 3 a, and two 6.3 v. 4 a, etc.	50/-
OP6.	Multi-ratio 15 watt output	36/-
OPIK.	Multi-ratio 50 watt output	52/-
KIV3.	Sectionalised driver, 3/1	40/-
DV3.	Driver trans. 15/20 watt amplifiers	15/-

**Audio Amplifier Circuits**, for 15 watt, 20 watt and 32 watt, 2/6 each. Speakers, Condensers, Resistances, etc., available.

A 2 1/2 stamp brings you our Transformer Catalogue T55, and Audio Units Catalogue V65. Requests to Dept. "P.W.," please.

## RADIO INSTRUMENT CO.,

294, Broadway, Bexley Heath, Kent

## PRATTS RADIO

1070 Harrow Road, College Pk., HARLESDEN, N.W.10 (Nr. SCRUBS LANE)

**SPEAKERS**—P.M. less transr., 2 1/2in., 25/-; 3 1/2in., 28/6; 5in., 21/-; 6 1/2in., 21/6; 8in., 29/- With pen. transr., 6 1/2in., 25/-; 8in., 27/6; 10in., 38/6; Mains on 6 1/2in., 27/6; 8in., 30/- (inc. transr.). Speaker transr., pentode, 5/9; Midget, 5/9. Heavy duty, 7/6. Multi-ratio, 9/- Power/pentode, 6/-

**LINECORD**—3 amp., 60 ohms per ft., 2 watt, 2/6; 3 way, 2/9 each.

**VOLUME CONTROLS**, less switch, 3/6. With switch, 5/6.

**SMOOTHING CHOKES**—Midget, 360 ohms, 5.9; 500 ohms, 60 m.a., 6/6; 100 m.a., 32 hy, 1,000 ohms 15/6.

**VARIABLE CONDENSERS**—Midget, .0005 2-gang, 10/9. With trimmers, 11/6.

**MAINS TRANSFORMERS**—350-0-350, 4v. 5a., 4v. 2 1/2a., or 6.3v. 2 1/2a., 5v. 2a., 26/6.

**ELECTROLYTIC CONDENSERS**—(All 450v. wkg.) 8 x 8 mfd., 6/6; 16 x 8 mfd., 7/-; 8 mfd. 43, 25 mfd. 25v., 2/2 each.

**EXTENSION SPEAKER**—8in. with cabinet, 42. Intervalve transr., 3-1, 7/-; Driver class B, 7/- each.

**I.F. transfs.**, 465 kc/s. Ironed cored, 17/- pr. **BRUSH CRYSTAL MICROPHONES**—63/- each. Toggle switches, S.P.S.T., 2/6 each. Control knobs, 7d. each. Pointer type, 10d. each. M.W. dials, 1/6 each. Valve holders, 7d. each. M.W. coils, 5/6 pr. Voltage droppers (tapped), 3 amp., 800 ohms, 5/-; .2 amp., 1,000 ohm, 4/9 each. Push back wire, 12 yds, 2/-; 100 yds, 15/-.

**VALVES**—6V6, 6F6, 5Z4, 6K7, 6J7, 6K8, 6AR, 6X5, 6E8, 6Q7, 6P7, 75, 80, MS4B, VMS4B, Ven. A4, F4, T4B, M40, V4A, KT2, HL2, TDD4 U4, UR1, EBL1, EF9, 2D4, pen. 4020 Dd, etc., at controlled prices.

S.A.E. for list or enquiries. Orders over 10/- post free. C.W.O. or C.O.D. Buses 662, 664, or 18B pass door.

NEW GOODS ONLY.

**CASTLETON RADIO.** Wireless Bargains. Plessey 4in. P.M. speakers with transformers, 27/- each; 10in., no transformer, 30/-; 8in. P.M.s, less transformer, 7/-; with transformer, 29/-; 5in., 23/- each; 4 1/2 in. P.M.s, 1,500 ohm field with transformer, 28/- each; line cord, 3 amp. 55 ohms per ft., 2/6 yd. Mains droppers, 5/- each. .0005 twin gang condensers with trimmers, 12/- each. Aerial and H.F. coils, 4/8 pair; Mains transformers, 350-0-350, 120 mA., 4 or 6 volt h.f., 29/- each; 3 amp. 500 volt., 5/- each; Mansbridge type, 16 m.f., 10/- each; Resistors, our selection, 10/- each; Electrolytics, .0015, .0022, 2d. each. Please add postage on orders under £1.—Castleton Radio Service, 10, Castleton Avenue, Stretford, Manchester.

**VALVES.**—HL.2 5/10; TDDA.2 354V. M.L4. 1H5G. 9/2; INS6. IC5G. VP2. KT2. PM22A. 1W4350. U50. 80. 11/-; ACO.44. P24. TDDA. MHD4. 6R7G. 607G. 11/7; X24. 5P4. VP4B. Pen.44. 18. 6R7G. 6J7G. 6V8G. 25A6G. 2A5G. FC4. 6K3G. 6F7. 14/-; Pen.5DD. Pen.45DD. 15/3. Incorporated I.F. transformer, 465 kc/s. in can., 7/6. Midget A and H.F. coils. M.W. circuit, colour coded, 5/- per pair. Tubulars, .0001 to .01, 8d. 1 mfd., 1/-; octal plug and socket, 2/3. Speakers, all sizes, mains and output transformers, electrolytics, etc. Write for list.—Radio Supplies, 58, Hughes Avenue, Horwich, Lancs.

**WANTED,** new or second-hand, British Radiophone 3 gang coil unit type 2 R.F. Also Wearite Uni-gen dual-range coil. Particulars to—Topherson, "Blythe Hill," Broughty Ferry, Dundee.

**CHARLES BRITAIN RADIO (K. H. Ede)** offers new and used bargains this month. **MAINS TRANSFORMERS,** 350-0-350 v. or 6 v. heaters, shrouded type with mains tap in top, used but perfect, £1 ea. Steel chassis, size 10 x 2 1/2 ins., drilled 5 valves and hole for trans., 2/- ea. Ass'd resistances stripped from Ekco chassis, all useful values, 3/6 doz. Ass'd mica condensers, new and used, various makes, 3/6 doz. Ass'd mica trans., inc. 1's, new and used, 4/6 doz. Mains energised speakers ex Ekco, with new cones and fields, 1,000 or 5,000 ohm, 2/6 ea.

**THE FOLLOWING** components are new and in perfect condition. All-wave aerial coils and oscillator coils covering all bands, long, medium, and short, with circuit diagram, 14/- per set. T.R.F. coils, short and medium with trims., 10/- pr. P. type coils, medium wave only, A. Osc., and H.F., 2/- ea. Two-gang condensers with trims., 12/9 ea. Mains transformers, Litz wound, iron cores with trims. and AL cans, 12 pr. (465 k/c). Amphenol valveholders, Int. Octal or British Octal, 7/6 doz.

**THIS MONTH'S SPECIAL OFFER.** Small moving coil mikes, can be used as tweeters, etc., 3/6 ea., or slightly damaged, 2/- ea.

**Send for our New List.** Terms, cash or c.o.d. over £1.—Charles Britain Radio (temp. address), "Eureka," Surrey Gardens, Effingham, Surrey.

**I.A.** thread screws, one gross useful sizes, 2/6; ditto nuts, 2/6 gross; assorted gross screws and nuts, 2/6; ditto, brass washers, 1/6 gross; fibre washers, 1/6 gross; assorted soldering tags, 2/- gross; assorted small eyelets and rivets, 1/3 gross. Large stock of screws, etc. Spare requirements, S.A.E. Rubber-covered stranded copper wire, 1d. yard; heavier quality, 1 1/2d. yd.; heavy quality, 2 1/2d. yd.; ideal for aerials, earths, etc. Single cotton-covered tinned copper wire, 1/6g., 12 yds. 9d.; 50 yds., 3/-; tinned copper braiding wire, 10 lb., 6/6; 6 lb., 3/6; ditto, rubber-covered, 12 yd. coil, 1 1/2d.; ditto, 6 lb., 2/3; finest quality push-back wire, 20 yds. 2/3; twin bell wire, 12 yds., 1/9; ditto, heavier quality, 12 yds., 2/3; ditto, flat rubber-covered, 3d. yard; twin flat braided electric cable, 6d. yd.; Wood's metal stick, 2 1/2 in., by in., 1/-; Cotton-covered copper industry ment wire, 4 lb. reels, 18, 20, 24, 1/6; 25, 28g., 1/9; 30, 32g., 2/-; 34, 38g., 2/3; silk-covered ditto, 2 ozs. reels, 24, 26, 28g., 1/6; 30, 32, 34, 36g., 1 lb., 42s., 2/9; 16g., double silk-covered, 1 lb., 5/-; 18g., enamelled, 1 lb., 3/6. Sensitive permanent crystal detector, Tellurium-Zincite combination, complete on base, guaranteed efficient, 2/6; Glass tube crystal detectors, complete, 2/-; reliable crystal cat's-whisker, 6d. Reconditioned headphones, complete, 4/0 ohms, 12/6. All postage extra.—Post Radio Supplies, 33, Bourne Gardens, London, E.4.

**FOR SALE.**—Class B speaker, unit, as new—105, St. Owen St., Hereford.

### POST-WAR TELEVISION

The advance in Radio Technique will offer unlimited opportunities of high pay and secure posts for those Radio Engineers who have had the foresight to become technically qualified. How you can do this quickly and easily in your spare time is fully explained in our unique handbook. Full details are given of A.M.I.E.E., A.M. Brit. I.R.E. City & Guilds Exams., and particulars of up-to-date courses in Wireless Engineering, Radio Servicing, Short Waves, Television, Mathematics, etc., etc.

**We guarantee "NO PASS—NO FEE."** Prepare for to-morrow's opportunities and post-war competition by sending for this very informative 112-page guide NOW—FREE and without obligation. **BRITISH INSTITUTE OF ENGINEERING TECHNOLOGY** (Dept. 242), 17, Stratford Place, London, W.1.

### VALUE! MATT has it

**LINE CORD.**—2-way, 2/6 per yd.; 3-way, 3/- per yd. (approx. 60 ohms per foot).

**SPEAKERS.**—"Celestion," P.M., 2 1/2 in., less trans., 27/-; 8in. P.M., with trans., 27/6; 6 1/2 in. P.M. (multi-radio trans.), 28/6; "Rola" 6 1/2 in. P.M., with trans., 28/6.

**Two-gang Condensers.**—,0005, with trimmers, 12/6. Midget Coils, H.F. and Aerial, 3/- per pair.

**Valve Holders** (all types).

**Volume Controls,** less switch, 2/9; with switch, 3/9.

**Mains Transformers,** 4v. and 6v., 27/6. **Reverend** (Crystal) Pick-ups, metal, S8, £33/16. **Enlon** do. L.S., £3/18/9.

**Condensers.** (All types in stock, 2's, 5's, 16's, 20/20, 500v. working, 1/. 01, 25, .05, 25 x 25, etc).

**Resistances,** 1 to 1 watt. All values, 1/- each; 9/6 doz.; 1 watt, 6/6 doz.

**ACCUMULATORS,** Glass, 2v. 45 amp., 14/6 Do. Celluloid Portable, 2v., 17/6.

Let us quote you for ALL your requirements. Cash with order, plus postage.

### MATT RADIO SERVICE (Kingston 4881)

152, Richmond Road, Kingston-on-Thames, Surrey.

### SILVER PLATING SETS

as supplied to Electroplaters, but in miniature, for small parts, etc., instructive small sets, 19/- inc. post. Send 2d. stamp for printed folder. Materials for use with Electric Current, permanent Electroplating is carried out. Regret that no materials for Chromium, Nickel, Gold or Copper can be supplied owing to permits being required.

### ARGENTA PRODUCTS (D.B.)

40, Harrogate Road, LONDON, E.9

### BERRY'S (SHORT WAVE) LTD.,

for Quality Radio and Electronic Products including: P. Coils 2/3 and 2/6 I.F.'s, 7/6 each. Muhrhead 4.1 P.M. Dial with driving head, 35/-; 5-1, 25/-; S.M. Drive caution lamp and glass, 8/6. Speakers, 2 1/2 in., 27/-; 3 in., 30/-; also 5 1/2 to 12 1/2 in. Jacks and Jack-plugs, 2/6 each. Variation 20w. Amplifier for Mains or Battery, £19.18.9. Ceramic trimmers, condensers, stand-offs, formers, valve bases, etc. Valveholders, Single 2/6, Twin 3/6. Volume Controls, 4/3, with wick, 5/3. Send S.A.E. for complete list. "P" 2/-.

25, HIGH HOLBORN, LONDON, W.O.1.  
Phone: Holborn 8231

### DUAL TESTOSCOPPE

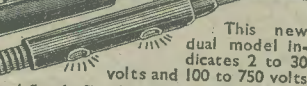

This new dual model indicates 2 to 30 volts and 100 to 750 volts

Send for leaflet (A 24) on "Testing"

### RUNBAKEN-MANCHESTER

### THE SIMPLEX FOUR

Complete constructional data, comprising full-scale layout and wiring diagrams, instructions, etc. for the construction of this 4-valve A.C./D.C. medium wave T.R.F. Midget receiver. (Total cost of construction minus cabinet £9.) A proven success. Per copy 4/6.

**MIDGET** polished wooden cabinet, 35/-; **MIDGET** coils, aerial and H.F. medium wave, T.R.F. high gain coils, ideal for the T.R.F. Midget, 7/6 pair; ditto, medium and long coils, 10/- pair; Midget aerial and oscillator coils, medium wave, for use on I.F. 465 kc/s, pair, 7/6; Midget ditto, short wave, pair, 8/-; aerial and oscillator, all wave superhet coils, for use with I.F. of 465 kc/s, with circuit diagram, 15/- set. **MIDGET** I.F. transformers, I.F. 465 kc/s, pair 15/-; standard size transformers, 12/6 **MIDGET** variable 2-gang .0005 mid condenser, 13/6.

Comprehensive stocks of all components, send for monthly list, 2d. stamp with all enquiries please, postage on all orders.

**O. GREENLICK,** 34, Bancroft Road, Cambridge Heath Road, London, E.1. Stepney Green 1334.

**New Stock!** Electrolytics, 8 mfd.s., 200 v., 2/8. 9 mfd., 450v., 4/-. 4 mfd.s., 450v., 3/8. 8 mfd., 450v., 5/6 mfd.s., 450v., 6/3. **Fixing Clips,** 3/- doz. extra. Post orders only.—A. Hucksels, "Hazlejohn," Crofton Lane, Huddington, Kent.

**GRAM** motor, pick-up, turntable, mounted; A.C.; £5.—Phone Mac 2591 after 7.

### SPARKS' DATA SHEETS

Full constructional details, circuit, and full-size prints of assembled and wiring plans of Tested and Guaranteed Designs. **LATEST RELEASES.**—Midget All-dry portable, three valves, med-wave, L.S.-size, 2/6; Midget All-dry Battery Two-valver, powerful tone sigs., 8 v. H.T., size 5 1/2 x 5 1/2 in., med-wave, £1. Radio Unit H.F. Plus infinite Impedance Detector for use with mains-operated quality amplifier, med-wave, 2/6; A.C. Radiogram, for quality radio and P.U. reproduction, P.P. output, 8 watts, med-wave, 3/6; A.C. 8-watt Amplifier, P.P. output, tone and vol. controls, ideal for quality P.U. reproduction, 2/6; Three-Valve Amplifier (Battery) P.P. output, 2/6.

**OTHER DATA SHEETS.**—Electric Guitar Units, 5/-; Electronic One-String Fiddle, 3/6; Trans-curtain Mike, 2/8; A.C. Charger, 2/6; D.C. Charger, 2/-; Shocking Coil, 2/6.

**AMPLIFIERS.**—6-8 watt A.C./D.C. Amplifier, portable, 60/-; 5-watt P.P. output, 3/6; 31-watt A.G. Amplifier, 2/6; Two-Valve Amplifier (Batt.), 2/6.

**SETS.** With full coil details.—A.C. Two-Valver, 2/6; Three-Valve "Straight" Set, (Batt.), 2/-; Crystal Set, 1/6 (All med-wave only). 16-watt Super Two-Valver (Batt.), Edgystone or Premier, 2/6.

**TECHNICAL.**—Ohm's Law Automatic Bias Circuits, Colour Code (R. and C.), 1/3 each, or 3/3 the three.

Please include stamp with order, enquiries for detailed list. **LORMOND SPARKS (P)**, The Constructor's Consultant, 9, Phoebeth Road, Brockley, S.E.4.

### SITUATIONS VACANT

**"ENGINEERING OPPORTUNITIES"** FREE 112-page guide to training for A.M.I.E.E., A.M.I.E.E., and all branches of Engineering and Milling. Full of advice for expert or novice. Write for free copy and make your peacetime future secure.—B.I.E.T. (Dept. 242B), 17, Stratford Place, London, W.1.

### TUITION

**LEARN MORSE CODE** the Candier Way. See advertisement on page 463.

**WIRELESS.**—Students of both sexes trained for important appointments in all branches of Radio and Television. Board accepted. Low inclusive fees. College in ideal surroundings; 2d. stamp for Prospectus.—Wireless College, Colwyn Bay.

**THE Tuition Board of the Institute of Practical Radio Engineers** have available Home Study Course covering elementary, theoretical, mathematical, practical, and laboratory tuition in radio and television engineering; the text is suitable coaching material for P.P.R.E. Tuition entry and progressive exams. The syllabus of pre-war rates—are moderate. The syllabus of Instructional Text may be obtained, post free, from the Secretary, Bush House, Walton Avenue, Henley-on-Thames, Oxon.

# Practical Wireless BLUEPRINT SERVICE

## SPECIAL NOTICE

THESE blueprints are drawn full size. The issues containing descriptions of these sets are now out of print, but an asterisk beside the blueprint number denotes that constructional details are available, free with the blueprint.

The index letters which precede the Blueprint Number indicate the periodical in which the description appears: Thus P.W. refers to PRACTICAL WIRELESS, A.W. to Amateur Wireless, W.M. to Wireless Magazine.

Send (preferably) a postal order to cover the cost of the Blueprint (stamps over 6d. unacceptable) to PRACTICAL WIRELESS, Blueprint Dept., George Newnes, Ltd., Tower House, Southampton Street, Strand, W.C.2.

### PRACTICAL WIRELESS

No. of F. J. Cannon's A.C. Superhet 4 .. — PW59\*  
Blueprint. F. J. Cannon's Universal 24 Super-  
.. .. — PW60  
.. .. — PW73\*

### CRYSTAL SETS

Blueprints, 6d. each.  
1927 Crystal Receiver .. .. — PW71\*  
The "Junior" Crystal Set .. .. — PW74\*

### STRAIGHT SETS. Battery Operated.

One-Valve : Blueprints, 1s. each.  
All-Wave Unipen (Pentode) .. — PW31A\*  
Beginners' One-valver .. .. — PW85\*  
The "Pyramid" One-valver (HF Pen) .. .. — PW93\*  
Two-valve : Blueprint, 1s.  
The Signet Two (D & LF) .. .. — PW76\*  
Three-valve : Blueprints, 1s. each.  
Selectone Battery Three (D, 2LF Trans.) .. .. — PW10  
Sunmit Three (HF Pen, D, Pen) .. — PW37\*  
All Pentode Three (HF Pen, D (Pen), Pen) .. .. — PW39\*  
Half-Mark Cadet (D, LF, Pen (RC) F. J. Cannon's Silver Souvenir (HF Pen, D (Pen), Pen) (All-Wave Three) .. .. — PW45\*  
Cameo Midget Three (D, 2 LF (Trans.) .. .. — PW49\*  
1936 Sonotone Three-Four (HF Pen, HF Pen, Westcoter, Pen) .. .. — PW53\*  
Battery All-Wave Three (D, 2 LF (RC) .. .. — PW55\*  
The Monitor (HF Pen, D, Pen) .. .. — PW61\*  
The Tutor Three (HF Pen, D, Pen) .. — PW62  
The "Celt" All-Wave Three (D, 2 LF (RC & Trans.) .. .. — PW64\*  
The "Rapids" Straight 3 (D, 2 LF (RC & Trans.) .. .. — PW82\*  
F. J. Cannon's Oracle All-Wave Three (HF, Det. Pen) .. .. — PW78\*  
1935 "Triband" All-Wave Three (HF, Pen, D, Pen) .. .. — PW84\*  
F. J. Cannon's "Sprite" Three (HF Pen, D, Tel) .. .. — PW87\*  
The "Hurricane" All-Wave Three (SG, D, Pen, Pen) .. .. — PW89\*  
F. J. Cannon's "Push-Button" Three (HF Pen, D (Pen), Tel) .. .. — PW92\*  
Four-valve : Blueprints, 1s. each.  
Beta Universal Four (SG, D, LF, C, B) .. .. — PW17\*  
Nucleon Class B Four (SG, D, SG), LP, (C, B) .. .. — PW34B\*  
Fury Four Super (SG, SG, D, Pen) Battery Half-Mark 4 (HF, Pen, D, Push-Pull) .. .. — PW46\*  
"Acme" All-Wave 4 (HF Pen, D (Pen), LF, C, B) .. .. — PW63\*  
The "Admiral" Four (HF Pen, HF Pen, D, Pen (RC)) .. .. — PW90\*  
F. J. Cannon's "Libri" All-Wave Four (HF Pen, D, LF, P) .. .. — PW67\*

### Mains Operated

Two-valve : Blueprints, 1s. each.  
A.C. Twin (D (Pen), Pen) .. .. — PW16\*  
Selectone A.C. Radiogram Two (D, Pow) .. .. — PW19\*  
Three-valve : Blueprints, 1s. each.  
Double-Diode-Trio de Three (HF Pen, DDE, Pen) .. .. — PW22\*  
D.C. Ace (SG, D, Pen) .. .. — PW25\*  
A.C. Three (SG, D, Pen) .. .. — PW29\*  
A.C. Leader (HF Pen, D, Pow) .. .. — PW35B\*  
D.C. Premier (HF Pen, D, Pen) .. .. — PW36A\*  
F. J. Cannon's A.C. All-Wave Silver Souvenir Three (HF Pen, D, Pen) "All-Wave" A.C. Three (D, 2 LF (RC)) .. .. — PW50\*  
A.C. 1936 Sonotone (HF Pen, HF Pen, Westcoter, Pen) .. .. — PW56\*  
Mains Record All-Wave 3 (HF Pen, D, Pen) .. .. — PW70\*  
Four-valve : Blueprints, 1s. each.  
A.C. Fury Four (SG, SG, D, Pen) A.C. Fury Four Super (SG, SG, D, Pen) .. .. — PW34D  
A.C. Half-Mark (HF Pen, D, Push-Pull) .. .. — PW45\*  
Universal Half-Mark (HF Pen, D, Push-Pull) .. .. — PW47\*

### SUPERHETS

Battery Sets : Blueprints, 1s. each.  
65 Superhet (Three-valve) .. .. — PW40  
F. J. Cannon's 2-valve Superhet .. — PW32\*  
Mains Sets : Blueprints, 1s. each.  
A.C. 23 Superhet (Three-valve) .. — PW43\*  
D.C. 15 Superhet (Three-valve) .. — PW42\*

.. .. — PW59\*  
.. .. — PW60  
.. .. — PW73\*  
.. .. — PW85\*  
.. .. — PW93\*

### SHORT-WAVE SETS. Battery Operated

One-valve : Blueprint, 1s.  
Simple S.W. One-valver .. .. — PW88\*  
Two-valve : Blueprints, 1s. each.  
Midget Short-wave Two (D, Pen) The "Plect" Short-wave Two (D (HF Pen, Pen) .. .. — PW91\*  
Three-valve : Blueprints, 1s. each.  
Experimenter's Short-wave Three (SG, D, Pow) .. .. — PW30A\*  
The Prefect 3 (D, 2 LF (RC and Trans.) .. .. — PW63\*  
The Band-spread S.W. Three (HF Pen, D (Pen), Pen) .. .. — PW65\*

### PORTABLES

Three-valve : Blueprints, 1s. each.  
F. J. Cannon's ELF Three-valve Portable (HF Pen, D, Pen) .. .. — PW65\*  
Parvo Lightweight Midget Portable (SG, D, Pen) .. .. — PW77\*  
Four-valve : Blueprint, 1s.  
"Imp" Portable 4 (D, LF, LF (Pen)) .. .. — PW86\*

### MISCELLANEOUS

Blueprint, 1s.  
S.W. Converter-Adapter (1 valve) .. — PW48A\*

### AMATEUR WIRELESS AND WIRELESS MAGAZINE

CRYSTAL SETS  
Blueprints, 6d. each.  
Four-station Crystal Set .. .. — AW427\*  
Lucas Tuning Coil for A.W.427, 6d. 1934 Crystal Set .. .. — AW444  
150-mhz Crystal Set .. .. — AW450\*

### STRAIGHT SETS. Battery Operated.

One-valve : Blueprint, 1s.  
B.E.U. Special One-valver .. .. — AW387\*  
Two-valve : Blueprints, 1s. each.  
Melody Rouser Two (D, Trans.) .. — AW388\*  
Full-volume Two (SG, Det. Pen) .. — AW392\*  
A Modern Two-valver .. .. — WM409\*  
Three-valve : Blueprints, 1s. each.  
45 5s. S.R. 3 (SG, D, Trans.) .. .. — AW412\*  
Landscape Rouser (SG, D, Trans.) .. — AW422\*  
45 5s. Three De Luxe Version (SG, D, Trans.) .. .. — AW435\*  
Transportable Three (SG, D, Pen) Simple-Tune Three (SG, D, Pen) Economy Pentode Three (SG, D, Pen) .. .. — WM327\*  
"W.M." (1934 Standard Three (SG, D, Pen) .. .. — WM351\*  
43 3s. Three (SG, D, Trans.) .. .. — WM354\*  
1935 25 6s. Battery Three (SG, D, Pen) .. .. — WM371\*  
P.P.P. Three (Pen, D, Pen) .. .. — WM389\*  
Certainly Three (SG, D, Pen) .. .. — WM393\*  
Milestone Three (SG, D, Trans.) .. — WM396\*  
All-wave Whining Three (SG, D, Pen) .. .. — WM400

Four-valve : Blueprints, 1s. 6d. each.  
65s. Four (SG, D, RC, Trans) Self-contained Four (SG, D, LF, C, B) .. .. — WM331  
Landscape Straight Four (SG, D, LF, Trans.) .. .. — WM350  
25 5s. Battery Four (HF, D, 2LF) The H.K. Four (SG, SG, D, Pen) The Auto Straight Four (HF, Pen, HF, Pen, DDE, Pen) .. .. — WM404\*  
Five-valve : Blueprints, 1s. 6d. each.  
Super-quality Five (2 HF, D, RC, Trans) .. .. — WM320  
Class B Quadradyné (2 SG, D, LF, Class B) .. .. — WM344  
New Class B Five (2 SG, D, LF Class B) .. .. — WM340

### Mains Operated

Two-valve : Blueprints, 1s. each.  
Consecutive Two (D, Pen) A.C. Economy A.C. Two (D, Trans) A.C. Three-valve : Blueprints, 1s. each.  
Hummer A.C. Three (SG, D, LF, C, B) .. .. — AW383\*  
Mantovani A.C. Three (HF, Pen, D, Pen) .. .. — WM374\*  
£15 15s. 1936 A.C. Radiogram (HF, D, Pen) .. .. — WM401\*  
Four-valve : Blueprints, 1s. 6d. each.  
All-Metal Four (2 SG, D, Pen) .. — WM329  
Harris Jubilee Radiogram (HF, Pen, D, LF, P) .. .. — WM386\*

SUPERHETS  
Battery Sets : Blueprints, 1s. 6d. each.  
"Varsity" Four .. .. — WM395\*  
The Request All-Waver .. .. — WM407

Mains Sets : Blueprints, 1s. each.  
Heptode Super Three A.C. .. .. — WM350\*

### PORTABLES

Four-valve : Blueprints, 1s. 6d. each.  
Holiday Portable (SG, D, LF, Class B) .. .. — AW595\*  
Pauilly Portable (HF, D, RC, Trans) .. .. — AW447\*  
Tyers Portable (SG, D, 2 Trans.) .. — WM367\*

### SHORT-WAVE SETS. Battery Operated

One-valve : Blueprints, 1s. each.  
S.W. One-valver for America .. .. — AW429\*  
Round Short-Waver .. .. — AW432\*  
Two-valve : Blueprints, 1s. each.  
Ultra-short Battery Two (SG, det. Pen) .. .. — WM402\*  
Home-made Coil Two (D, Pen) .. .. — AW440

Three-valve : Blueprints, 1s. each.  
Experimenter's 5-metre Set (D, Trans, Super-regen) .. .. — AW438  
The Barrier Short-waver (SG, D, P) .. .. — WM390\*

Four-valve : Blueprints, 1s. 6d. each.  
A.W. Short-wave World-beater (HF, Pen, D, RC, Trans) .. .. — AW496\*  
Standard Four-valver Short-waver (SG, D, LF, P) .. .. — WM383\*  
Superhet : Blueprint, 1s. 6d.  
Simplified Short-wave Super .. .. — WM397\*

### Mains Operated

Two-valve : Blueprints, 1s. each.  
Two-valve Mains Short-waver (D, Pen), A.C. .. .. — AW453\*

### MISCELLANEOUS

S.W. One-valve Converter, Price 6d. .. .. — AW329  
Enthusiast's Power Amplifier (1/6) Listener's 5-watt A.C. Amplifier (1/6) .. .. — WM392\*  
Radio Unit (2v) for WM392 (1/-) Harris Electrogram battery amplifier (1/-) .. .. — WM399\*  
De Luxe Concert A.C. Electrogram (1/-) .. .. — WM403\*  
New Style Short-wave Adapter (1/-) .. .. — WM388  
Short-wave Adaptor (1/-) .. .. — AW436\*  
B.L.D.J.C. Short-wave Converter (1/-) .. .. — WM405\*  
Wilson Tone Master (1/-) .. .. — WM406  
The W.M. A.C. Short-wave Converter (1/-) .. .. — WM408\*

## HINTS COUPON

This coupon is available until October 8th, 1945, and must accompany all Practical Hints.

PRACTICAL WIRELESS, October, 1945

All applications respecting Advertising in this Publication should be addressed to the ADVERTISEMENT DIRECTOR, GEORGE NEWNES, LTD., Tower House, Southampton Street, Strand, London, W.C.2. Telephone : Temple Bar 4363.

CONDITIONS OF SALE AND SUPPLY : This material is sold subject to the following conditions, namely, that it shall not, without the written consent of the publishers first given, be lent, re-sold, hired out or otherwise disposed of by way of Trade except at the full retail price of 9d., and that it shall not be lent, re-sold, hired out or otherwise disposed of in a mutilated condition or in any unauthorised cover by way of Trade; or affixed to or as part of any publication or advertising, literary or pictorial matter, whatsoever.



## FOR THE RADIO SERVICE MAN, DEALER AND OWNER

The man who enrolls for an I.C.S. Radio Course learns radio thoroughly, completely, practically. When he earns his diploma, he will **KNOW** radio. We are not content merely to teach the principles of radio, we want to show our students how to apply that training in practical, every-day, radio service work. We train them to be *successful!*

### INTERNATIONAL CORRESPONDENCE SCHOOLS

Dept. 94, International Buildings,  
Kingsway, London, W.C.2.

Please explain fully about your instruction in the subject marked X.

Complete Radio Engineering  
Radio Service Engineers  
Elementary Radio

If you wish to pass a Radio examination, indicate it below.

British Institute of Radio Engineers  
P.M.G. Certificate for Wireless Operators  
City and Guilds Telecommunications  
Wireless Operator, R.A.F.  
Wireless Mechanic, R.A.F.

Special terms for members of H.M. Forces and discharged  
and disabled members of H.M. Armed Forces.

Name..... Age.....

(USE BLOCK LETTERS)

Address .....



(Use penny stamp on unsealed envelope.)

## Use **ERSIN** **MULTICORE** **SOLDER**

contains 3 cores of  
non-corrosive Ersin Flux

Radio Experimenters are now able to use "The finest Cored Solder in the World," Ersin Multicore. The three cores of extra active flux ensure speedy soldering and eliminate high resistance or dry joints.

Available from electric and radio shops, ironmongers, etc.

Nominal 1-lb. reels:

13 S.W.G. 4/10 ea.

16 S.W.G. 5/3 ea.

Size 2 cartons:

16 S.W.G. 6d. ea.



**MULTICORE SOLDERS LTD. COMMONWEALTH HOUSE,  
LONDON, W.C.1. Tel. CHAncery 5171/2**

# AMBITIOUS ENGINEERS

## HAVE YOU HAD YOUR COPY OF "ENGINEERING OPPORTUNITIES"?

Whatever your age or experience—whether you are one of the "old school" or a newcomer to Engineering anxious to hold your position under post-war conditions—you must read this highly informative guide to the best paid Engineering posts.

The Handbook contains among other intensely interesting matter, particulars of B.Sc., A.M.I.C.E., A.M.I.Mech.E., A.M.I.E.E., A.M.I.A.E., A.M.I.P.E., A.M.Brit.I.R.E., CITY & GUILDS, CIVIL SERVICE, and other important Engineering Examinations, outlines courses in all branches of CIVIL, MECHANICAL, ELECTRICAL, AUTOMOBILE, RADIO, TELEVISION, AERONAUTICAL and PRODUCTION ENGINEERING, DRAUGHTSMANSHIP, GOVERNMENT EMPLOYMENT, BUILDING and PLASTICS (the great peacetime careers), MATRICULATION, etc., and explains the unique advantages of our Employment Department.

## WE DEFINITELY GUARANTEE 'NO PASS—NO FEE'

If you are earning less than £10 a week you cannot afford to miss reading "ENGINEERING OPPORTUNITIES"; it tells you everything you want to know to *make your future secure* and describes many chances you are now missing. In your own interest we advise you to write for your copy of this enlightening guide to well-paid posts NOW — FREE and without obligation.

## BRITISH INSTITUTE OF ENGINEERING TECHNOLOGY

409, SHAKESPEARE HOUSE, 17, 18 & 19, STRATFORD PLACE, LONDON, W.1.

## THE B.I.E.T. IS THE LEADING INSTITUTE OF ITS KIND IN THE WORLD

Published on the 7th of each month by GEORGE NEWNES, LIMITED, Tower House, Southampton Street, Strand, London, W.C.2. and printed in England by THE NEWNES & PEARSON PRINTING CO. LTD., Exmoor Street, London, W.10. Sole Agents for Australia and New Zealand: GORDON & GOTCH, LTD. South Africa: CENTRAL NEWS AGENCY, LTD. Subscription rates including postage: Inland 10s. 6d. per annum; Abroad 10s. per annum. Registered at the General Post Office for the Canadian Magazine Post.