

WAR-TIME A.C. TWO

Practical Wireless

9^D
EVERY
MONTH

Editor
F. J. CAMM

Vol. 8. No. 437.

NEW SERIES.

NOVEMBER, 1942

UNIVERSAL OUTPUT UNIT

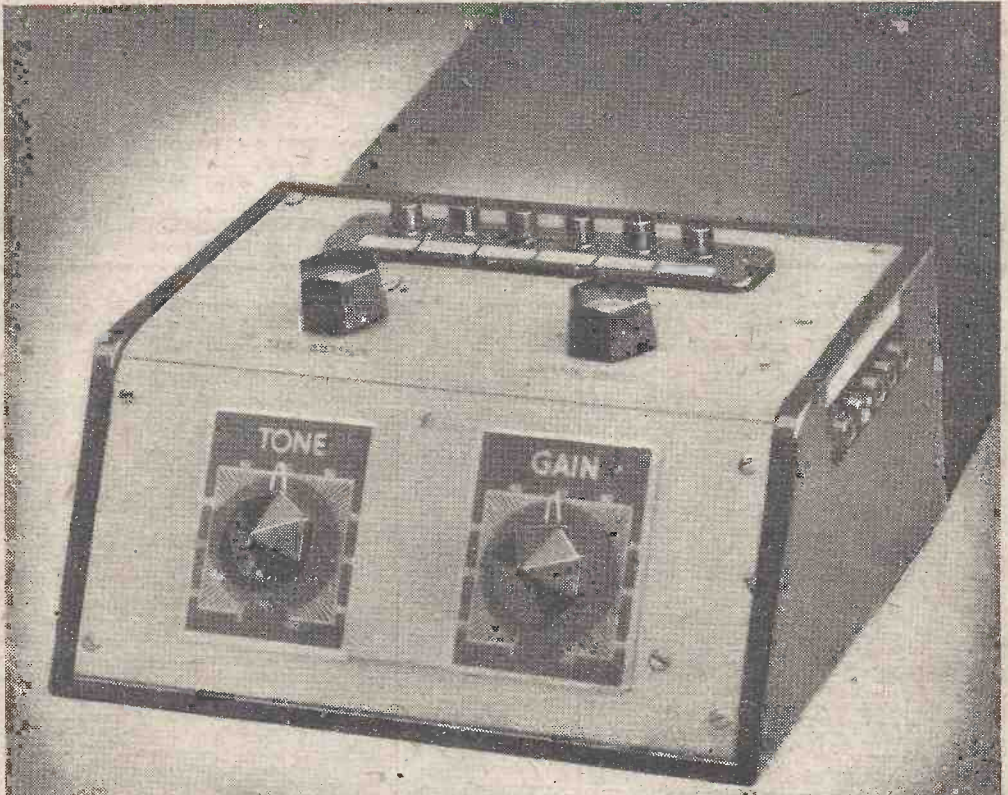

A handy instrument for the experimenter. It has many applications in the radio workshop. Constructional details are given in this issue



Regd. Trade Mark

ELECTRICAL MEASURING INSTRUMENTS

Some delay in delivery of Trade Orders is inevitable, but we shall continue to do our best to fulfil your requirements as promptly as possible.

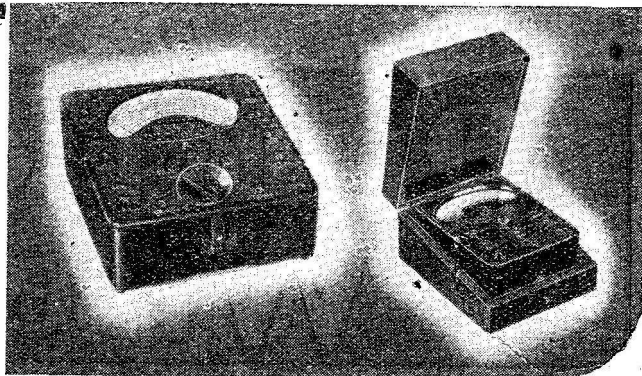

Universal AvoMinor

D.C. AvoMinor

THE world-wide use of "AVO" Instruments is striking testimony to their outstanding versatility, precision and reliability. In every sphere of electrical test work they are appreciated for their dependable accuracy, which is often used as a standard by which other instruments are judged. There is an "AVO" Instrument for every essential electrical test.

Sole Proprietors and Manufacturers :-

The **AUTOMATIC COIL WINDER & ELECTRICAL EQUIPMENT Co., Ltd.**, Winder House, Douglas Street, London, S.W.1.

Phone : VICTORIA 3404-7.

PREMIER RADIO

NEW PREMIER S.W. COILS

4- and 6-pin types now have octal pin spacing, and will fit International Octal valve-holders.

Type	4-pin Type Range	Price	Type	6-pin Type Range	Price
04	9-15 m.	... 2/6	06	9-15 m.	... 2/6
04A	12-26 m.	... 2/6	06A	12-26 m.	... 2/6
04B	22-47 m.	... 2/6	06B	22-47 m.	... 2/6
04C	41-94 m.	... 2/6	06C	41-94 m.	... 2/6
04D	76-170 m.	... 2/6	06D	76-170 m.	... 2/6
04E	150-350 m.	... 3/-			
04F	255-550 m.	... 3/-			
04G	490-1,000 m.	... 4/-			
04H	1,000-2,000 m.	... 4/-			

New Premier 3-Band S.W. Coil, 11-25, 25-38, 38-66 m., 4/9.

Rotary Wave Change to suit above. 1/6.

SHORT-WAVE CONDENSERS

Trolit insulation. Certified superior to ceramic. All-brass construction. Easily ganged.

15 m.mfd.	... 2/4	100 m.mfd.	... 3/-
25 m.mfd.	... 2/6	160 m.mfd.	... 3/7
40 m.mfd.	... 2/6	250 m.mfd.	... 4/-

S.W. H.F. Chokes, 10-100 m., 10/-d. High grade Pie-wound, U.S.A. type, 6-200 m., 2/6 each.

PREMIER REPLACEMENT VALVES

4-volt. A.C. types, 5-pin. ACHL, ACSG, 5/6 each.

MOVING COIL SPEAKERS

Rota 5" P.M. Speakers. 3 ohms Voice Coil, 21/- with output transformer, 25/-.
Goodmans and Celestion 8in. P.M. Speaker, 25/-.
8in. 2,000 ohm Field, 25/-.
Speakers are complete with output transformer.

MR1 UNIVERSAL 4-WATT OUTPUT TRANSFORMERS

Tapped for Power, Pentode, and Push-Pull, suitable for 2 and 7/9 ohms speech coil, 7/6.

"SPECIAL OFFER"

Mains Transformers. Primary, 220-230 v.; secondary, 250-0-350 v., 100 ma., 5 v., 2 a. not C.T., 6.3 v., 3 a., C.T., 21/-.

"LEARNING MORSE?" Then purchase one of the new practice Oscillators.

Supplied complete with valve, on 27/6 steel chassis

Practice Key, 3/3; TX Key, 5/9.

Super Model, on Wooden Base, 10/6.

Browns' Headphones, 17/6 pair.

3 Henry Chokes, 10/-.

PREMIER MAINS TRANSFORMERS, CHOKES AND VALVES. Still available. Send for lists.

MATCHMAKER UNIVERSAL OUTPUT TRANSFORMERS.

Will match any output valves to any speaker impedance.

11 ratios from 13:1 to 80:1. 5-7 watts, 20/-, 10-15 watts, 26/-.

I.F. TRANSFORMERS

Iron-cored 450-470 kc/s. plain and with flying lead, 5/6 each.

PREMIER BATTERY CHARGERS FOR A.C. MAINS

Westinghouse rectification complete and ready for use. To charge 6 volts at 1 amp. (also tapped for 2 and 4 v.), 29/6. 12 v. 1 a. (also tapped for 2 and 6 v.), 37/6. 6 v. at 2 a. (also tapped to charge 2 and 4 volts), 45/-.

PREMIER 4-WATT A.C. AMPLIFIERS

Each Amplifier is completely wired and tested. Selected components. Valves and Energised Moving-Coil Speaker, £5 5s.

PREMIER MICROPHONES

Transverse Current Mike. High grade large output unit. Response 45-7,500 cycles. Low hiss level, 23/-.

Moving-coil Mike. Permanent magnet model, requiring no energising. Response 90-5,200 cycles. Output .25 volt average. Excellent reproduction of speech and music. 63/- Super Model, £5 5s. Microphone Transformers, 10/- each. Chromium Collapsible Type Microphone Stand, 52/6.

H.F. Eliminators, 150 v. 30 mA. output, 41/6; ditto, with 2 v. 1 A. charger, 52/6. 2,000 ohms 25 v. Resistances with 5 tapping clips. 2/-.

Mains Resistances, 660 ohms, 3 A. tapped 360 +150+60+60 ohms, 5/6. 1,000 ohms, 2 A. tapped at 500, 800, 700, 600, 500 ohms. 4/6.

2 Way Line Cored Resistance, 50 ohms per foot. Price 1/4 per foot.

Valve Screens for International and U.S.A. types, 12 each.

Push-Back Connecting Wire. 2d. per yd. Resin-Cored Solder. 7/2 per Coil.

ALL ENQUIRIES MUST BE ACCOMPANIED BY A 21d. STAMP.

ALL POST ORDERS TO : JUBILEE WORKS, 167, LOWER CLAPTON ROAD, LONDON, E.5. (Amherst 4723).

CALLERS TO : Jubilee Works, or 169, Fleet Street, E.C.4 (Central 2833).
or 50, High Street, Clapham, S.W.4 (Mascallay 2381).

Practical Wireless

and PRACTICAL TELEVISION

EVERY MONTH
Vol. XVIII. No. 437. NOVEMBER, 1942

Editor F. J. C. AMM

Staff:
L. O. SPARKS.
FRANK PRESTON.

COMMENTS OF THE MONTH

BY THE EDITOR

B.B.C. Feature Programmes

THE B.B.C. has departed from its original policy of producing most of its programmes from the inside. They had formerly presumed that five or six people inside the B.B.C. could devise a succession of programmes, year in and year out, which would satisfy the taste of every listener. The general criticisms of B.B.C. programmes have had the useful effect of breaking down the former B.B.C. iconoclastic policy of take it or leave it, or listen and like it, no doubt due to the changes which have taken place in recent years in the B.B.C. personnel. While they have broadened the scope of the programmes, they have narrowed them in some respects by the recent ban, to which we drew attention at the time, of expunging from all script the mild expletive.

They have considerably widened their ambit in other directions. They are encouraging people outside their employ to submit ideas for programmes, and they are more amenable to suggestions than they were some years ago. The present programmes are in the nature of an experiment. We are now having true stories of individual families designed to show the effect of the war on family life. We are having experimental workshop programmes, while the spirit, personality and achievements of famous men of the past is an interesting innovation.

"London Revisited" is a further introduction. This series is written by modern writers in the style of the period of those brought to the microphone in imagination. They include Jane Austen shopping, William Pitt at the House of Commons, Johnson's biographer, Boswell, revisiting Gough Square, Pope at Twickenham, and Shakespeare returning to the theatre.

As well as the features like "Marching On" and "Into Battle," programmes are being planned to celebrate the achievements of the fighting Services, to explain their organisation and their place in the general strategic scheme. These include "With the Navy in Action," reconstruction of operational trips, arranged with the Admiralty and covering the work of mine-sweepers, trawlers, submarines and rescue tugs. Two full-length naval programmes are "The Story of the Ark Royal" and "Malta and the Mediterranean Naval War." "Britain's Modern Army" will be a series of 15-minute programmes following the series "The Navy's Here" in October. Full-length Army features include programmes entitled "They Died with their Boots Clean," a documentary on the spirit of the Guards; "The Yanks in Britain," dealing with the A.F.F.; "The Commandos" and "British Soldier," a composite picture of the ordinary British soldier who has fought all over the world since the beginning of the war.

These are all sound programme

ideas which will meet with general approval. They provide opportunities for British people to get their work broadcast, and sampled, and thus considerably widen the opportunities for writers and musicians. If it eventually spells the death-knell of the absurd outpourings of Tin' Pan Alley it will have performed at least one other useful task.

Blueprints and Instructions

MANY of the issues containing instructions for building receivers for which we supply blueprints are out of print. The blueprints themselves are, of course; sufficiently explanatory to enable a successful receiver to be built without further instruction by those with a reasonable knowledge of set construction.

So that the beginner may receive the benefits of descriptive instruction, we are this month commencing a series of reprinted instructions covering those issues which are out of print. Where components are no longer available, in most cases we are able to suggest alternatives. There is particularly a shortage of coils, and our handbook "Wireless Coils, Chokes and Transformers" will be of assistance.

Wireless Clubs

IT was inevitable that the membership of wireless clubs would be rapidly depleted in the earliest days of the war. Members of clubs had a specialist knowledge which the country is turning to good account. Thus, most of the larger clubs are moribund for the duration of the war.

This accounts for the absence of club reports in our pages. It is a movement which will revive after the war, and the set shortage which has given rise to a great increase in set construction at home will provide a large number of enthusiasts as possible members when the war is over. It has always been our policy to encourage clubs, and club reports have regularly formed a feature of this journal. Members of clubs in the remotest parts of the world continue to take the liveliest interest in radio, as is evinced by their letters.

End of Volume XVIII

THIS issue completes Volume 18—the first volume of the new series in the smaller and handier size. Readers should have their copies bound. Volume 18 completes the first ten years of its existence. It was on September 24th, 1932, that No. 1 of PRACTICAL WIRELESS was published. Soon after it absorbed its old-established rival *Amateur Wireless*. All except one of its early competitors have since ceased publication.

Editorial and Advertisement Offices:
"Practical Wireless," George Newnes, Ltd.,
Tower House, Southampton Street, Strand,
W.C.2. Phone: Temple Bar 4363.
Telegrams: Newnes, Band, London.
Registered at the G.P.O. for transmission by
Canadian Magazine Post.

The Editor will be pleased to consider articles of a practical nature suitable for publication in PRACTICAL WIRELESS. Such articles should be written on one side of the paper only, and should contain the name and address of the sender. Whilst the Editor does not hold himself responsible for manuscripts, every effort will be made to return them if a stamped and addressed envelope is enclosed. All correspondence intended for the Editor should be addressed: The Editor, PRACTICAL WIRELESS, George Newnes, Ltd., Tower House, Southampton Street, Strand, W.C.2.

Owing to the rapid progress in the design of wireless apparatus and to our efforts to keep our readers in touch with the latest developments, we give no warranty that apparatus described in our columns is not the subject of letters patent.

Copyright in all drawings, photographs and articles published in PRACTICAL WIRELESS is specifically reserved throughout the countries signatory to the Berne Convention and the U.S.A. Reproductions or imitations of any of these are therefore expressly forbidden. PRACTICAL WIRELESS incorporates "Amateur Wireless."

The fact that goods made of raw materials in short supply owing to war conditions are advertised in this paper should not be taken as an indication that they are necessarily available for export.

ROUND THE WORLD OF WIRELESS

Messages from the Forces

IT is reported that cable and wireless now handle 200,000 Expeditionary Forces' messages each week.

Radio Station Blown Up

A FEW weeks ago an explosion destroyed the buildings of the short-wave station CXA2 (Radio Continental). The cause has not been determined, but the station is on the British and American black-lists.



The chief officer of the cable ship "Iris" giving telephone instructions to the ship from a cable hut on shore.

Pocket Radio Sets

IT was revealed at the Institute of Radio Engineers' Conference in Cleveland, Ohio, that after the war radio sets which can be carried in the pocket will be available. The sets will have valves the size of peanuts, and will be provided with crystal reproducers which fit into the ears.

Radio on the Russian Front

IT is reported that the Red Army propaganda department employ mobile broadcasting units along the front line. The portable loudspeaker apparatus is usually placed on a lorry, and before sunset the broadcasters—four or five specially trained Red Army men—go out and carefully study the terrain, and the route along which the lorry will travel. Then they choose a suitable place for the loudspeaker, generally on a height where sound can carry farthest. Then, from a concealed post the broadcast begins, giving bulletins about the situation on the front, about events abroad, and in Germany, about the crimes of the Nazi leaders, and many things which Goebbels considers taboo. These broadcasts are made at night, but in the daytime the same apparatus is used to broadcast concerts of records for Red Army men off duty.

B.B.C. Programme Changes

BIG programme changes are being planned by the B.B.C. for winter radio entertainment. They include longer periods for symphony concerts: better listening times for plays; and variety in the Forces programme will be simpler in form and presentation. In these programmes it is proposed to have fewer scripted shows and more bright, light music, and straightforward dance bands, often with a variety turn introduced into the musical programme.

Death for Listening to B.B.C. News

A RECENT report from Stockholm states that a resident of Wetzlaro has been executed, and a listener of Oldenburg sentenced to three years' penal servitude for listening to B.B.C. broadcasts and "trying to undermine German people's powers of resistance."

Midget Radios for Germans

WITH a view to cutting out the B.B.C. the manufacture of radio sets in Germany and German-occupied countries is to be restricted to a new midget-type which has no short-wave band. The object is to stop people listening to broadcasts from Allied countries, many of which transmit on the short-wave bands. The new set is designed for the reception of broadcasts from Deutschlandsender station, and local transmitters only.

Eire Suspends Duty on Dry Batteries

IT is reported that the Government of Eire have issued an Order suspending the import duty on dry batteries and component parts thereof, and certain kinds of electric wire or cable.

Wireless Licences in New Zealand

WIRELESS receiving licences in New Zealand have now reached a total of just over 367,000. This is an increase of about 13,900 over the past 12 months.

All-India Radio

THE improvement of programmes, and the construction of new broadcasting stations, are now engaging the attention of All-India Radio. Increasing the power of stations already in operation is also being considered with a view to bringing radio into more homes. The number of listeners in British India has been growing steadily, and is now estimated at 750,000.

Wanted—Your Old Gramophone Records

THERE has been a ready response to the National Campaign for the salvage of old gramophone records. Tens of thousands are still required, and householders are asked to communicate that they have some records to give by placing one of the discs or a record bag in the window. A pencilled note, "Call after 7 p.m.," or whatever is a convenient time for handing over the records should be written on the bag.

Every member of the British Legion identified by his membership badge is automatically an accredited collector. He will be pleased to co-operate by carrying the records to his local branch. Where there may be heavy loads boy scouts and other youth organisations will lend a hand with their trek carts, or a borrowed tradesman's truck.

It is hoped in this way to collect the many millions of records which are still needed for their shellac. Wherever convenient, donors should take the records to the local branch of the British Legion themselves. Not a single record must remain uncollected. The British Legion and the Hospital for Sick Children, Great Ormond Street, London, will jointly benefit from the proceeds of the sale of all records, and the salvaged shellac will be used again to make new discs.

"Answering You" Programme

AS an experiment a completely unscripted programme like the "Brains Trust" was included recently in the "Answering You" programme which has now started on its second year of broadcasting. All speakers were warned of the type of question they would have to answer so that they could prepare factual data beforehand. From numerous letters containing questions, received each week at the New York office of the B.B.C., a quantity are selected and cabled to London, where they are considered by the producer, Mary Adams, who then chooses her speakers for the coming week. A census of a year's questions has shown that Americans are anxious to know about social changes in Great Britain caused by the war and what the British public think about Anglo-American relationships. Later in the year it is hoped to arrange a two-way programme with a panel of American speakers in New York answering some "difficult" questions from British people anxious to learn about America, in addition to the speakers from London.

More Broadcasts on Martial Music

BRIGHT martial music played by military bands is now a regular feature of B.B.C. programmes. Since the war there has been a big increase in the engagements offered to Service bands, and four-fifths of the programmes have been broadcast on the Forces wavelength. About 30 of the best Service bands, including most of the staff bands like the Guards, Artillery, Marines and R.A.F. Central Bands, broadcast frequently. Since the war broadcasts by military bands have increased to 40 a month, including those given by the B.B.C. Military Band.

Before the war, band music was composed of programmes by the B.B.C. Military Band, brass bands and about two Service bands a month. The brass bands were selected from a rota of 180, which took their turn to broadcast. In a total of ten band periods a week at present, four are given by the B.B.C. Military Band and the others are divided equally between Service bands and amateur brass bands.

Tennyson's Voice

ALFRED LORD TENNYSON, at the age of 80 (that is to say in 1889), recited some of his poems, and they were recorded by Thomas Edison. His grandson, Mr. Charles Tennyson, recently stated that these records would be played before a meeting of the Poetry Society this month. It will be recalled that Gladstone's voice was recorded during his period. These two voices are amongst the earliest recordings. Parts of "Maud" and "The Charge of the Light Brigade" are among the recordings. The original wax cylinders are now in the Science Museum, so the original records will not be played. Mr. Charles Tennyson has had copies made.

Remote Readers

WE continue to receive large numbers of letters each month from readers on Active Service overseas. We propose to award a book each month to the sender of the letter received from the most remote part of the world. Envelopes should be marked "Book." We are glad to know that in spite of war-time difficulties readers overseas are still able to obtain this journal.

Radio Brains Trust

THE second session of the Radio Brains Trust took place on September 26th at the Institution of Electrical Engineers, Savoy Place, Victoria Embankment, London. Questions should be addressed to the Chairman, Radio Brains Trust, 16, Ashridge Gardens, London, N.13.

British Institute of Radio Engineers

THERE was a Members' Meeting of the London Section of the B.I.R.E. at the F.B.I., Tothill Street, Westminster, on September 25th. After the president's address, delivered by Sir Louis Sterling, a paper was read by J. Robinson, M.B.E., on "Aspects of Modulation Systems." It was followed by a discussion.

R. Neale (G6NZ)

WE regret to record the death of a well-known amateur transmitter, Reginald Neale (G6NZ). He had been a member of the R.S.G.B. since 1924, and obtained his licence in 1920. He died suddenly in his garden. He was 40 years of age, and a well-known member of the R.S.G.B.

Feature Programmes

RADIO Documentary and Feature Programmes will continue the process of experiment, expansion and consolidation in the next few months. True stories of individual families designed to show the effect of the war on ordinary life, and the extent of the war effort of millions, particularly women, are being broadcast in the series, "The Family at War."

"New Radio" will deal with experimental workshop programmes, designed to stimulate new forms of expression at the microphone and to attract new writers to broadcasting.

"Let Us Now Praise Famous Men" is a series dealing with the spirit, personality and achievement of such men as Shakespeare, Sir Walter Raleigh, Nelson, Sir Christopher Wren, Sir Isaac Newton, Milton, Nurse Cavell, and Florence Nightingale. Other feature programmes are: "London Revisited" bringing to the microphone in imagination famous literary men of the past who ask questions; "Award for Industry," produced in co-operation with the Ministry of Production, which puts a spotlight on factories and groups of workers, rather than on individuals.

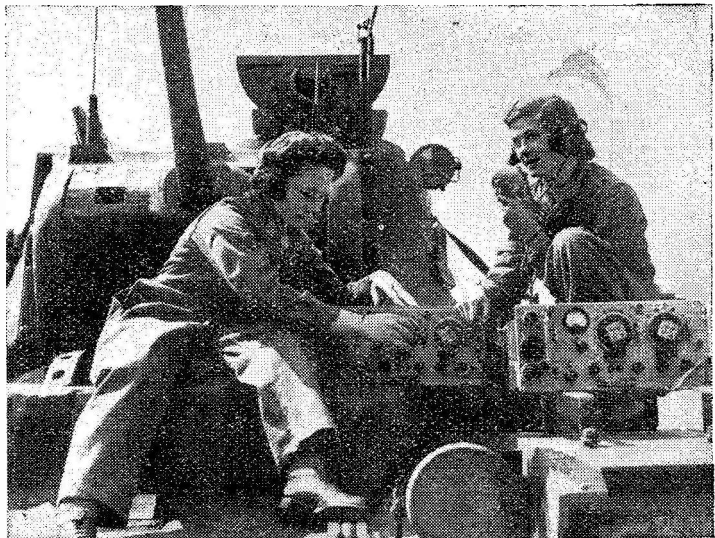

Radio trained A.T.S. girls testing wireless equipment before fitting it into a tank.

War-time A.C. Two

A Simple Pre-tuned Set for General Use

By S. C. MURISON

SOME time ago the writer designed a large superhet which incorporated a straight section with preset tuning of two stations, and a gramo. position. As the components for the superhet section of the set proved difficult to get the writer had to be content with a simple set built to the circuit given in Fig. 1. This will be seen to have no power supply of its own. Suitable units will be mentioned later.

The set is a very simple arrangement, the aerial feeding straight into the grid of V_1 (an AC/HL). The grid also goes to the pole of a four-way switch plate of the Yaxley pattern. The contacts of this switch go to the tuning circuits (through suitable condensers) and direct to the pick-up. The reaction circuits are not changed by the switch.

Any suitable coils (which means nearly all coils) can be used in the tuning circuits if care is taken in their mounting to see that their cores are at right angles. The ones used in the original were made at home by winding for each coil 60 turns of 28-s.w.g. insulated wire on to formers 1½ in. diameter. It will be understood that two windings of 60 are needed for each coil, one for tuning and the other for reaction. Such coils suit the values of the preset condensers given, but if either the coils or the values of these condensers are changed due allowance must be made. The presets are normal types, and not of the temperature compensating type. They have proved satisfactory in use, but if the compensating type are available they should be used.

Choke Filter

The detector feeds the output valve (an AC2/PEN) via a transformer, which should be shielded to avoid interaction. Volume control is effected in the grid circuit of the AC2/PEN. A condenser of .0002 mfd. by-passes any stray H.F. from the output valve grid to earth. The output to the L.S. is by a choke filter which

is better from the quality point of view, apart from the safety gained by keeping the H.T. within the set. The choke can be of any type provided that it can carry roughly 35m.A. The filter condenser in the original was of 2 mfd., and although this proves very satisfactory in use a larger value can be tried.

Bass response is good in any case, and better on gramo. when negative feed-back is applied from AC2/PEN via R_1 and C_1 to the cathode of AC/HL. Variation of the tone can be obtained at any setting of the switch by sliding a condenser of .1 mfd. along R, the other side of this condenser being tied to earth. A switch plate is provided to take care of the negative feed-back circuits. A switch plate is also provided to give visual indication at a glance of the switch setting. Any type of bulb-holders may be used to hold the four bulbs employed. Home-made ones from the tray of a smoker's match-box were used by the writer.

It will be seen that the lamps are wired from one side of the heaters to earth. This assumes, of course, that the centre tap of the heater windings is joined to earth, and that 3.5 v. bulbs are used. If one end of the heater windings goes to earth 8 v. bulbs must be used. Any type of hole can be made to show the position, but the writer prefers ¼ in. holes just above the position names.

Power Unit

This brings us to the subject of power supplies, as the set has none incorporated. Any unit which can supply 2.05 a. at 4 v. and 40 m.A at 250 v. approximately may be used. Any form of construction is suitable, though a baseboard is most convenient.

It is not proposed to describe a standard arrangement using a full-wave valve rectifier, as such valves are very scarce. Transformers, too, may prove difficult to obtain, so we shall assume that only heater windings are available. A model train transformer and a suitable

resistance could be used, but, if possible, obtain from a local dealer a transformer with the H.T. windings destroyed. Failing this, you must press into service any other transformer. Should you use a series resistance in the heater circuit make sure that it is of adequate current carrying capacity.

Fig. 2 shows how an old triode such as an ML4 can be used as a half-wave rectifier without its own H.T. supply windings.

A metal rectifier can be used with ease in the circuit,

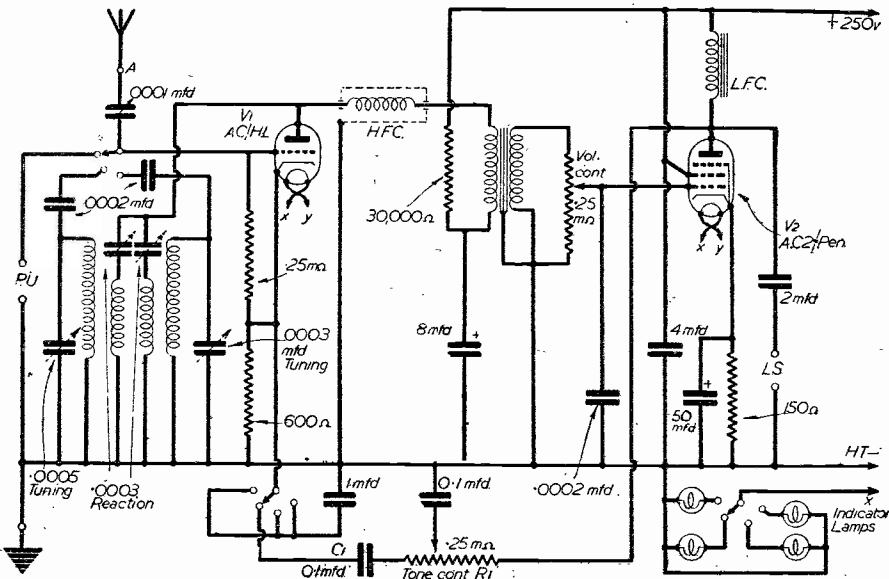

Fig. 1.—The complete theoretical diagram of the receiver, showing pre-tuned circuits and switching.

This was over 6in. long in the writer's case, but stable operation was obtained even on the gramophone position, where 12in. of plain twisted flex joined the set to the pick-up.

The setting of the presets is an easy matter for anyone who has used a straight set before. For those who have not, it is mentioned as a help that the switch should first be set so that the .0005 mfd. tuning preset is in circuit, then the reaction preset is turned till oscillation is nearly obtained. Should you inadvertently put the set into oscillation, quickly take it out of oscillation, otherwise it will annoy neighbours. When the reaction is set, the tuning can be done by rotating the tuning preset. When the station is tuned in, a final touch of the reaction may assist tone or volume. With the smaller tuning preset in circuit tuning of a station on a lower wavelength can be carried out. In theory a small value of tuning capacity helps to increase volume, so that the smaller value of preset should be used for stations on a low wavelength although they may also be within the coverage of the larger preset tuner. As the reaction circuits have a common connection at the AC/HL anode the tuning is slightly interdependent. This is not serious enough to warrant the use of a fourth switch for the reaction circuits. Nor does it make tuning any harder than usual on pre-tuned sets.

Before we leave the actual making of the set it might be mentioned that a manual tuning arrangement could readily be arranged by fixing up another coil and tuning condenser of normal pattern, with a fully variable reaction condenser just in the same way as the pre-tuned circuits are arranged.

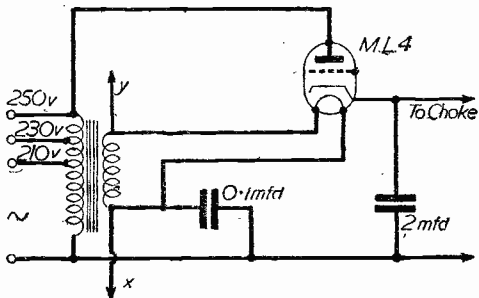
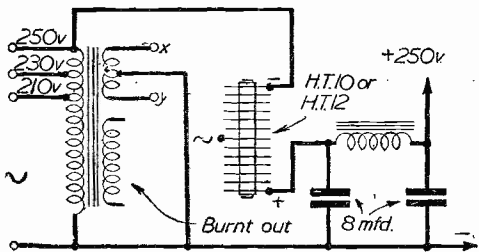
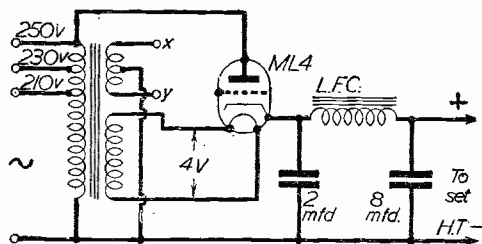

Fig. 2.—The three rectifier circuits described by the writer. The warning should be noted re isolating earth lead.

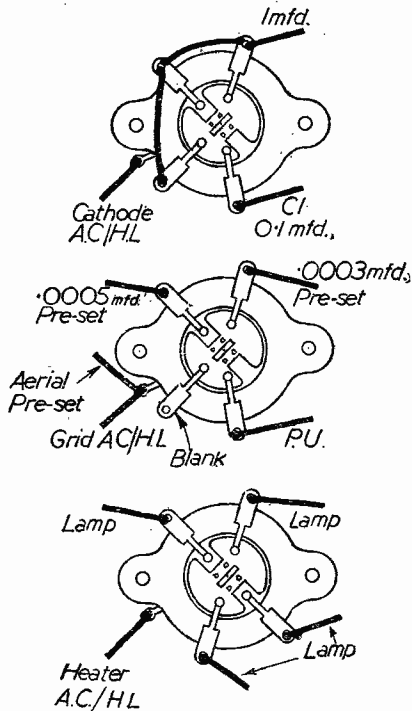

Fig. 3.—The wiring of the three-section switch. It can be simplified by cutting out the indicator lamps circuit.

LIST OF COMPONENTS

- One .0001 mfd. preset condenser (Telsen or other with low minimum).
- Three .0003 mfd. preset condensers (Telsen or Formo).
- One .0005 mfd. preset condenser (Telsen).
- Three .0002 mfd. tag type condensers (Dubilier or Helvensens).
- One .25 megohm volume control without switch (Dubilier or Erie).
- One .25 megohm volume control with switch (C.T.S. in original or as above).
- One 1 mfd. condenser, 250v. paper (T.C.C.).
- One 25 mfd. 25v. working condenser electrolytic type (T.C.C.).
- One 4 mfd. condenser, 250v. (Mullard in original, but any other such as above).
- Two .1 mfd. condensers, 350v. (T.C.C.).
- One 2 mfd. condenser, 250v. (T.C.C.).
- Two tuning coils (see text).
- One screened H.F. choke (Wearite in original, any good screened type).
- One Shrouded L.F. transformer (Ferranti).
- One 8 mfd. 500v. type (T.C.C.).
- One 20 henrie choke (Igranic in original, any good type).
- One .25 megohm 1-watt resistor (Dubilier).
- One 30,000 ohm 1-watt resistor (Dubilier).
- One 4-way 3-pole switch (Yaxley or similar make).
- One 600 ohm resistor 1-watt type (Dubilier).
- One 150 ohm resistor 1-watt type (Dubilier).
- One 5-pin valveholder (Benjamin or other good make).
- One 7-pin valveholder (as above).
- Four bulb-holders (Bulgin or home made).
- One AC/HL (Mazda).
- One ACZ/PEN (Mazda, or AC/VP1 if lower volume can be tolerated).
- One power supply (see text for outputs needed).
- Four bulbs for the indicator (text gives the voltage needed for each type).
- One loudspeaker.
- Panel, baseboard, wire, screws, and foil if available.

Alternative Output Valve

Many readers may not be able to get the specified output valve, so some notes on how to use a little used valve (in the past few years, at least) in place of the AC2/PEN are given here. The output from such schemes is not great, nor is the quality good, but they are appended to allow readers who might not have been able otherwise to get the set going. The idea of using a triode in place of the pentode will work, but the volume may be very small and, in addition, there is no use for the negative feed-back. An extra stage to feed a triode can be used but care in the decoupling will be needed.

Fig. 5 shows the idea suggested by the writer. The little used valve is the Mazda AC/VPr (now superseded by the AC/NP2), which has top cap connection to anode. In Fig. 5 it will be seen that no notice is taken of the metalising, or the suppressor grid; they can be earthed with a slight reduction in volume and no effect in tone. The makers of a valve so used may not consider it to be covered by any guarantee, so care should be taken to allow the guarantee period to expire first. The output of such an arrangement is roughly 18 per cent. of the AC2/PEN arrangement.

Other modifications are the omission of C_1 , and of wiring the 1 mfd. condenser straight across the 600 ohm resistor. This removes negative feed-back on gramophone. A separate detector—a pentode—would be best, and can be wired to the fourth tag of the tuning switch plate.

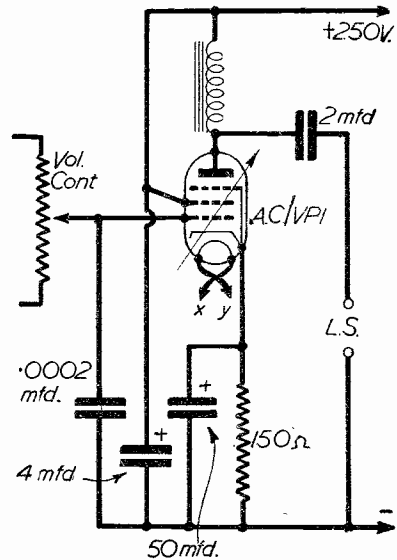

Fig. 5.—An alternative output circuit using a Mazda AC/VPr.

Locating Loudspeaker Defects

THE modern moving-coil loudspeaker is remarkably robust, but now and again certain defects appear.

These are of two kinds, one of which results in a complete cessation of signals, and the other in a much weakened response with lack of "bite."

The cause of a complete stoppage of signals is usually a break in the primary winding of the transformer, though the speech coil may also be affected; or in the case of an energised speaker a break in the field winding.

In the case of weakened signals, usually of a "tinny" quality, the defect is probably due to shorted turns in the transformer, though bad centring of the speech coil in the gap should not be ruled out.

With the loudspeaker removed from the cabinet, a series of simple tests can be made which makes the tracking down of the fault a routine matter, and the fault, once found, can be dealt with in the prescribed manner.

Cessation of Signals

First, as regards complete cessation of signals, the transformer should be first suspected. It is presumed, of course, that it is first ascertained that the speaker is at fault; this can be done by connecting another speaker to the set. A milliammeter and battery will soon tell if the primary is interrupted, or a simple test with 'phones and dry cell will achieve the same result. The break is usually due to corrosion of the wire, and it is sometimes possible to tell when such corrosion is occurring by the faint crackling sound from the speaker when the set is switched off. In this case it is usually necessary to re-wind the transformer; or to unwind the wire until the break is found, and then solder the broken ends together and wind on the old wire again.

When this is done there is a simple test to see if the primary and secondary are working properly. This is to connect the primary to the set, tune in a loud signal, and connect a flash-lamp bulb across the secondary. The bulb should light up flickeringly in sympathy with the speech or music.

If the bulb lights up and yet the speaker fails to work when the speech coil is inserted in place of the bulb, then the speech coil itself, or the leads going to it, must be at fault. This can be ascertained with certainty if

an accumulator be connected to the leads going to the speech coil. The speech coil, and of course the cone assembly, should kick vigorously when this is done if everything is in order. Not more than two volts should be applied for this test or there is a danger of damaging the assembly, but an accumulator should be used in preference to a dry cell, as the latter may not be capable of supplying enough current; that is, it may cause the cone to emit fairly loud crackles and thereby deceive you into thinking that everything is in order, whereas there may be a high-resistance joint or other source of inefficiency.

Shorted Transformer Winding

As regards shorted turns in the primary winding, it is difficult for the amateur to spot these with certainty without elaborate and costly apparatus: the best that can be done is to suspect shorted turns when all other parts of the speaker are in order and the reproducer performs indifferently. The remedy is a re-wind. It is not likely that anything will be found wrong with the secondary, due to the much coarser wire employed, but it is just possible that the enamel may have chipped off the wires and that two adjacent wires may be making contact. In this case they will absorb energy from the transformer and reduce the overall efficiency.

It is scarcely likely that inefficiency will result from any lessening of the strength of the magnetism in a permanent magnet speaker, unless this has been dropped or subjected to heat. An energised speaker, on the other hand, may be working below par either because of shorted turns in the field winding or because it is not receiving the full voltage for which it was intended, or again because the consumption of the set is reduced by a falling off in emission of the valves, particularly the output valve. In this case the renewing of the valves, or the output valve alone will effect a considerable improvement.

In all cases the speech coil must be accurately centred in the gap, if full efficiency is to be obtained. Past issues of PRACTICAL WIRELESS have explained how this should be done, so it will not be necessary to repeat it here.

Converting a Superhet

Simple Methods of Converting Various Types of Superhets to Straight Receivers

By W. NIMMONS

IT is safe to assume that a considerable proportion of the idle receivers in this country to-day are superhets. The frequency-changer valve is the most common cause of failure, and when spares are not available the set must perforce be dumb.

Aside from the broken down superhets there must be a proportion whose owners would welcome something simpler. Big sets are out of place in war-time, and it is possible that a two or three valve set would give all that

The best we can do is to ignore the oscillator coil, and take the grid lead of the aerial coil to the grid of the double-diode-triode valve, interposing a condenser and grid leak to give leaky grid rectification. This converts the set into a 0-V-1 receiver, and since the double diodes are not needed they should be put out of action by removing their respective leads from the valve-holder.

A 1-V-1 Receiver

If a 1-V-1 receiver is required we can take the grid

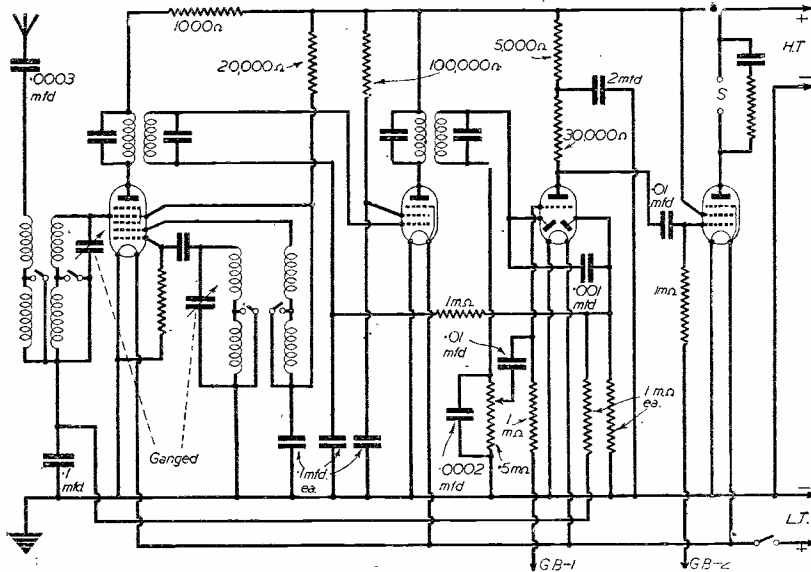

Fig. 1.—A common type of superhet. The text describes how this may be "broken down" into a simpler circuit.

the owner requires, while at the same time effecting a considerable economy in current consumption.

With this in mind it is worth while considering if a superhet can be "broken down" into something simpler. Let it be said at once that this presents no insuperable difficulty. In fact, it is a relatively simple operation, providing the owner is fairly familiar with the layout of the receiver to be operated on. With this proviso we will proceed to show how the conversion can be carried out.

Fig. 1 shows a common type of superhet. It comprises aperiodic coupling before the frequency-changer valve, an intermediate stage of H.F. amplification, followed by a double-diode-triode valve and output valve. Where should we begin to break this down into a simpler circuit?

It might appear at first sight that all we have to do is to transfer the grid leads from the aerial and oscillator coils to the I.F. and detector valves, thus cutting out the frequency changer and making the set into an H.F., detector and L.F. affair. This, however, would not do, as the aerial coil and oscillator coil are out of step with each other, and rotation of the gang condenser would not bring in any stations.

lead of the aerial coil to the grid of the I.F. valve (instead of to the grid of the frequency changer). This will give the stage of H.F. amplification, but what about the

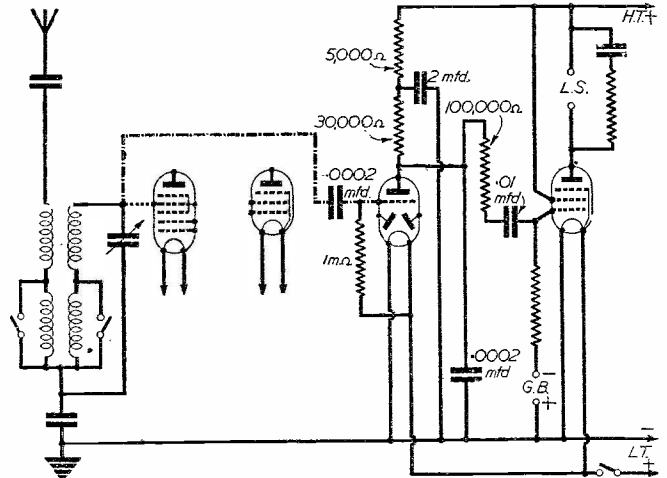

Fig. 2.—The 0-V-1 circuit with all the valves in position.

tuning of the detector valve? Remembering that the oscillator coil is wrongly tuned (and it is the only other coil connected to the gang condenser, the I.F. coils having fixed tuning) the best thing to do would be to use choke coupling. This is simply an H.F. choke connected between the grid of the double-diode-triode valve and the earth line, with, of course, the usual grid condenser and grid leak. This is "fed" from the anode of the H.F. valve by a .0005 mfd. condenser, and it will also be necessary to connect an H.F. choke between that anode and H.T. positive.

Instead of leaky-grid rectification we can use anode-bend. This can be done by interposing a grid-bias voltage of from $4\frac{1}{2}$ to 9 volts between the bottom end of the H.F. choke and the earth line. When this method of rectification is employed no grid condenser or grid leak is used.

Fig. 2 shows the o-V-1 circuit referred to above, with all the valves in position, but with only the essential components. The changes in the wiring are shown in broken lines. It is only necessary to remove the valves not in use to prevent undesirable effects, and to save current.

Fig. 3 shows the r-V-1 circuit, where the same remarks apply. In either of these cases volume may be increased by substituting an L.F. transformer for the resistance-capacity coupling shown. This should preferably be parallel fed or auto-coupled.

In those superhets where an H.F. stage is used before the frequency-changer we have the aerial coil before the H.F. valve, the intervalve coil before the frequency changer, and the oscillator coil; each of these coils is tuned by one section of a 3-gang condenser. Fig. 4 shows the circuit diagram of such a superhet.

Using a Tuned Stage

We have seen that the oscillator coil is useless when we want to break down a superhet into something simpler.

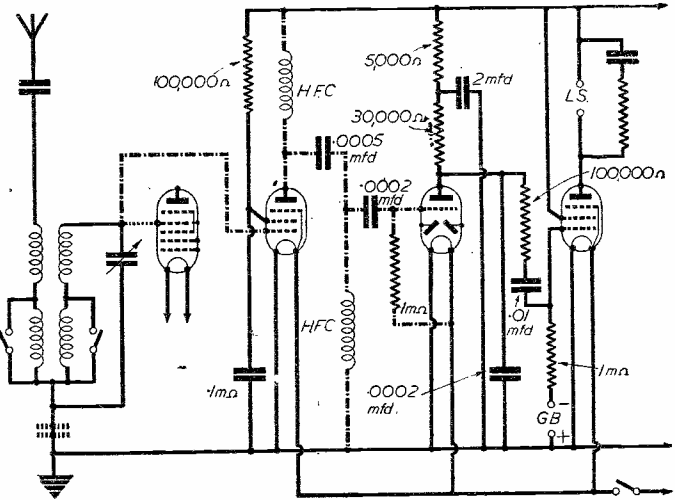

Fig. 3.—The covered 1-V-1 circuit.

This leaves us with two coils which are accurately matched, and we can employ these to construct a r-V-1 circuit such as that considered above, but with the difference that a tuned stage can be used instead of the untuned choke-coupled stage. This will give greatly improved results. Fig. 5 shows the necessary modifications.

As it is unlikely that the A.V.C. effect would be desirable in the modified circuit, and since the rectifying diode requires a rather big input voltage to operate efficiently, Fig. 5 shows the double-diode-triode valve with the diodes inactive. On the other hand, if we want to retain the rectifying diode (without A.V.C.) we can, after removing all other wires from the valve-holder of the D.D.T. valve, strap the two diode anodes together,

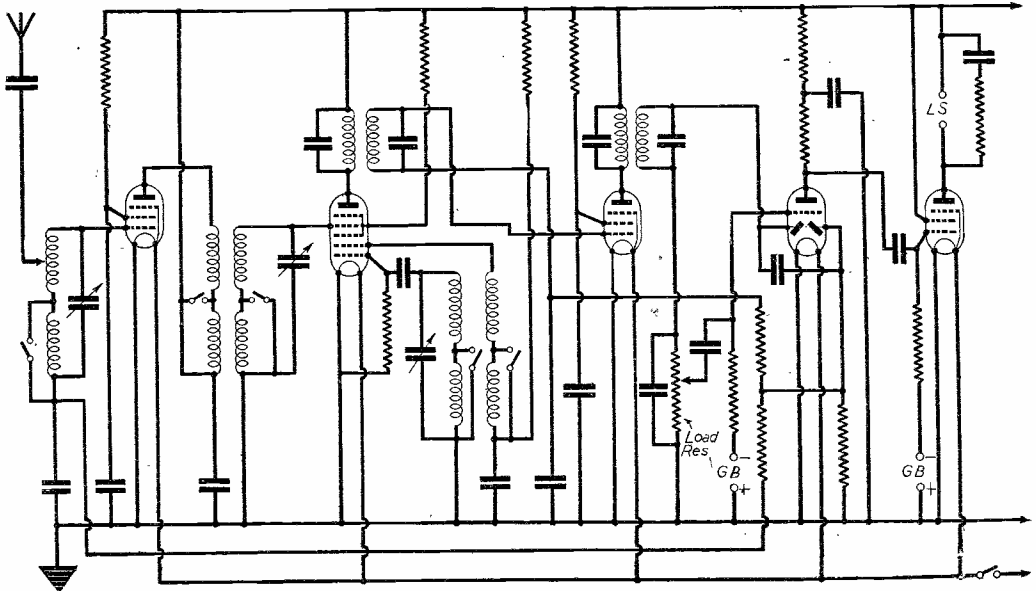

Fig. 4.—Theoretical circuit diagram of a 5-valve superhet.

and take the grid lead to these instead of the grid of the D.D.T. valve. At the bottom end of the grid coil we insert a .5 megohm load resistance, shunted by a .0002 mfd. condenser. The load resistance is the element of the volume control, the slider of which goes via a .01 mfd. condenser to the grid of the D.D.T. valve. Another resistance, of 1 megohm, serves to supply the grid-bias. Reference to the relevant part of Fig. 4, in which it will be seen that the load resistance is situated at the bottom end of the I.F. transformer, should clear up this point.

There is yet another type of superhet which is met with. This has a frequency changer as the first valve, but this is preceded by two band-pass coils, with their associated sections of the gang condenser. Fig. 6 shows the circuit, and those readers who have followed our remarks thus far will, we feel sure, be competent to tackle this or any other type of superhet in converting it into the design of their choice.

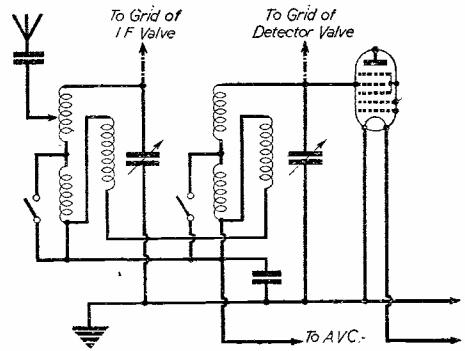

Fig. 6 (above).—Part of the circuit of a superhet.

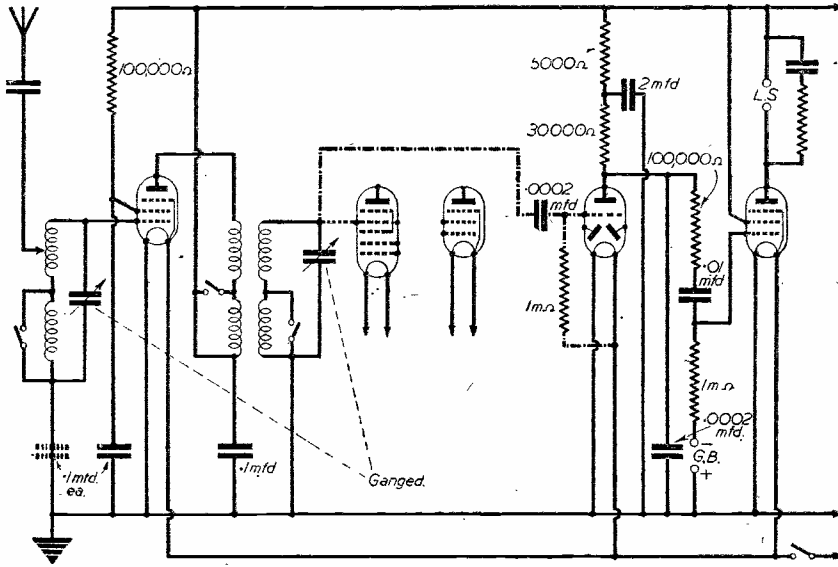

Fig. 5 (left).—Modified circuit of the superhet of Fig. 4 for converting to a 1.V.1 circuit. Note that the diodes of the D.D.T. valve are inactive.

Books Received

PROBLEMS IN RADIO ENGINEERING. By E. T. A. Rapson, A.M.I.E.E. Published by Sir Isaac Pitman and Sons, Ltd. 150 pages. Price 5s. net.

THE problems given in this book, which is a fifth edition, were collected and classified to facilitate the class-work in radio engineering at Southall Technical College. They are drawn from past examination papers of the City and Guilds of London Institute and other Institutions, the problems embracing such subjects as electrical communications, radio communication, and telegraphy and telephony. Descriptive examples have been included as a guidance for private students.

SHORT-WAVE RADIO. By J. H. Reyner, A.M.I.E.E. Published by Sir Isaac Pitman and Sons, Ltd. 186 pages. Price 10s. 6d. net.

IN this book the author presents a non-mathematical résumé of short-wave radio development. A sound knowledge of ordinary radio technique is assumed, but, even so, many more specialised branches of the subject have had to be treated briefly, though references quoted will enable the student to follow the matter up, if he so desires. In this third edition certain sections have been

expanded, including the chapter on receiver design. Frequency modulation has been dealt with in a separate chapter.

INTRODUCTION TO VALVES: INCLUDING REFERENCE TO CATHODE-RAY TUBES. By F. E. Henderson. Published by *The Wireless World*, on behalf of the General Electric Co., Ltd., of England. 111 pages. Price 4s. 6d.

THE writer of this book is a prominent member of the Osram Valve Department, and his many years' association with thermionic valves and cathode-ray tubes enables him to cover the subjects in a manner which is bound to have a wide appeal.

The book is primarily intended for those who already possess a knowledge of the fundamental theories of electricity and magnetism, but who have not yet become familiar with electron devices such as thermionic valves and cathode-ray tubes. The 111 pages—including 130 illustrations—however, contain such a vast amount of information that the service engineer and advanced radio amateur will find the work a valuable asset, while the student will have at his disposal a book which will greatly assist him during his studies, and provide the answers to most of the problems he is likely to encounter. We recommend it with confidence.



ON YOUR WAVELENGTH

By THERMION

Musical Frequencies

A COLLEAGUE has set me wondering on the subject of the diatonic scale and the frequencies of musical notes. Almost everyone knows that the diatonic scale consists of seven notes—C, D, E, F, G, A, B, being the scale starting from middle C. We all know that suitable combinations of those notes produce harmony. He wonders why the band of frequencies encompassed between middle C and C one octave higher is not divided into equal periods. The middle C on the piano corresponds to a frequency of 254 vibrations per second. The relative rates of vibration of the notes are C, 24; D, 27; E, 30; F, 32; G, 36; A, 40; B, 45; C, 48. When the vibrations of two notes struck at the same time are as 2 is to 1, the interval is an octave. When the vibrations are as 3 is to 2, the interval is a fifth; as 4 is to 3, a fourth; as 5 is to 4, a major third; as 6 is to 5, a minor third; and as 5 is to 3 a major sixth. The vibration numbers of the diatonic scale must bear the above relation to each other, but their absolute values are matters of convention. The French standard pitch makes the middle C 261 vibrations per second; the Stuttgart pitch (adopted by the Royal Society of Arts) makes it 264; while modern concert pitch makes it 276. In physics the middle C is generally taken as 256. I am not well versed in the history of music, and I invite the assistance of readers who may have studied the matter. I should like to know, first, who invented the diatonic scale. Secondly, why the frequencies of the musical notes were settled according to the table which I give below; thirdly, why we should not have a scale of 10, 12, or more notes, and why in any case there are not half-tones throughout the octave. The middle octave on the piano proceeds thus: C, C sharp, D, D sharp, E, no sharp, F, F sharp, G, G sharp, A, A sharp, B, no sharp, C. Could harmony be obtained from any other arrangement of the frequencies? Bearing in mind that the range of frequencies on a pianoforte covers the band from 26 to 4,096 vibrations per second, the steps between the notes are rather coarse. Here is a table of the frequencies:

A	26	G	96	F	341	E	1,280
B	30	A	106	G	384	F	1,365
C	32	B	120	A	426	G	1,536
D	36	C	128	B	480	A	1,706
E	40	D	144	C	512	B	1,920
F	42	E	160	D	576	C	2,048
G	48	F	170	E	640	D	2,304
A	53	G	192	F	682	E	2,560
B	60	A	213	G	768	F	2,730
C	64	B	240	A	853	G	3,072
D	72	C	256	B	960	A	3,413
E	80	D	288	C	1,024	B	3,840
F	85	E	320	D	1,152	C	4,096

It will be observed that they do not seem to follow either an arithmetical, geometrical, or harmonical progression. Sir James Jeans has written a most interesting volume on the subject, which deals with it mathematically, but still leaves my questions unanswered.

History Repeats Itself

HISTORY from the beginning of the 18th century will be vastly different from the history which preceded. Much of history which has been recorded up to that time is a matter of guess, and cannot be accepted without doubt. Historians are rather apt to paint rosy pictures of people and incidents, and to omit important facts.

There is a lot we do not know about Alfred the Great, who founded the British Navy. We are expected to remember him because he allowed the cakes to burn. There is the stupid story of Bruce and the Spider, which I flatly refuse to believe. There is the argument as to whether Bacon wrote Shakespeare's plays. These will remain matters of conjecture. Science got into its stride in a large number of fields in the 18th century, and independent experiments led up to the invention of the gramophone, wireless telegraphy, and finally wireless telephony. A man nowadays cannot escape from injudicious remarks by saying that he was wrongly reported. Speeches are recorded on steel tapes, and the voices are broadcast to the world. History will be exactly recorded. How remarkable it is that we may still hear the voices of the dead at any time we wish. Those voices can be broadcast over and over again. I am reminded of this by the statement of the grandson of the late Alfred Lord Tennyson, poet laureate, that he proposes to broadcast recordings of his grandfather reciting extracts from "Maud" and "The Charge of the Light Brigade." The original records are in the Science Museum, but copies have been made. What a pity it is that we cannot hear the voices of Shakespeare and Schubert, and Darwin, and other famous men.

A Chance for New Writers

THE broadcast feature "New Radio," is designed to attract new writers to broadcasting. This move is wise, for in the past there has been too much "resident" feature writing, and with a form of entertainment which appeals to millions who by that form of entertainment must know the type of matter required, there should be an incentive for those with the necessary ability to contribute material. The opportunities should be made available to all in this most democratic form of entertainment. It is said that one has to assume a foreign name to be successful in music, art and literature, for as a nation we seem to view with contumely the work of our own people. The J.B.C., by providing suitable encouragement, can discover the native genius which is latent in us all (and which this war has amply demonstrated) and give a terrific fillip to education. Education means to lead out, from the Latin *educatus*, from *e*, out, and *duco*, to lead. Perhaps the mistake made by our seats of learning is to presume that it means to *crum in*.

Reveille

Wake, British bards! The time is ripe,
Together let us rally,
And with united front set out
To conquer Tin Pan Alley.
Think of the songs our fathers sang,
And how they stir the blood;
And how they helped the common man;
When tyrants he withstood.

They helped our fighting men to march,
And to no foeman bend,
And by the courage they inspired
Brought victory in the end.
What have we now but gibberish foul,
From jungle savage learned;
Horrible noise and moaning dirge
Our fathers would have spurned.

Our native talent is not dead—

It only sleeps. Indeed,

It only needs encouragement,

The B.B.C. should lead.

Then British songs and music

Would come into their own,

And Tin Pan Alley and its tripe

At last be overthrown.

—"Torch,"

P.W. Blueprint Service

To Assist Purchasers of Blueprints Covering "P.W.," "A.W." and "W.M." Designs, we are Reprinting the Essential Details of Those Sets for which Issues are No Longer Available

PRIOR to September, 1939, we adhered to a solus specification for our individual designs, and we requested all constructors to use the components we specified. The object of this policy was to ensure as far as possible the same high degree of efficiency from the sets constructed by our readers as that obtained from the original design, constructed and tested in our laboratories. In addition to this, we backed all our designs with a free service, provided that the constructor adhered to our specification and blueprint.

During the present conditions, however, it is no longer possible for us to insist on a solus specification—for reasons now obvious to all constructors—therefore we have to remind purchasers of our blueprints that we

therefore we advise readers to keep their eyes open and explore every possible source of supply, commencing with those dealers who carry stocks of surplus components, many of whom advertise in PRACTICAL WIRELESS.

Readers are also advised to obtain "Wireless Coils, Chokes and Transformers" (price 6s., or by post, 6s. 6d.), and "Practical Wireless Circuits" (price 6s. 6d., post paid.)

Lucerne Dual-range Coils

The A.W. Lucerne Dual-range Coils were first described in the issue of *Amateur Wireless* of January 27th, 1934, the object of the designers being to produce components

which could be made by the home constructor at a very low cost, and without previous experience.

The construction and characteristics are such that the coils are suitable for many circuits; in fact, quite a number of receivers were designed around them, and it is still possible to secure blueprints of two of them.

Constructional Details

The construction is shown in Fig. 1, where it will be seen that two formers are used, one fitting inside the other and kept in position by four fixing screws and distance pieces, the outer former being used to provide connecting points by the terminals shown.

The theoretical circuit is shown in Fig. 2, and it will simplify matters if both diagrams are studied when making and connecting the various windings. The tappings are provided to secure the highest degree of selectivity possible with a coil of this type, but it must

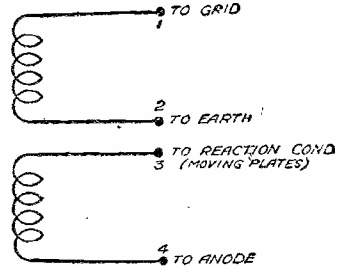

Fig. 3.—The theo. of the "A.W." home-made S.W. coils.

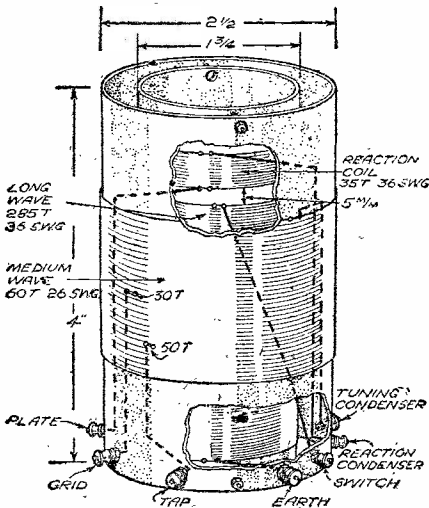

Fig. 1.—The Lucerne dual-range coil can be used in many "straight" circuits.

cannot guarantee that the components used in the original design will now be obtainable. Also, it may be necessary for the constructor to modify the blueprint wiring—and perhaps the layout—to suit such parts as are now obtainable. Provided that care is taken when selecting alternative components, to ensure that they have the same values as those specified, and that they are of good make, it is not likely that any appreciable loss of efficiency will be experienced.

Coils represent the greatest difficulty. Many types are no longer in production, but, against this, it is often possible to secure suitable alternatives from some of our advertisers who deal in surplus components. When purchasing these components, we would stress the advisability of securing a copy of the coil connections and/or the theoretical circuit of the windings.

For those who are prepared to make their own, we give complete details in this issue of the Lucerne dual-range coils, which are quite suitable for the majority of one, two, or three valve "straight" receivers.

It is not possible for us to recommend any one firm from whom a complete kit of parts might be obtained,

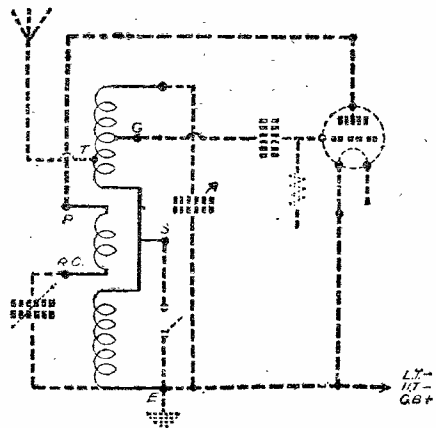

Fig. 2.—The theoretical circuit, showing connections, of the Lucerne coil, which provides a reasonable degree of selectivity.

be understood that, efficient as the coils are, they cannot be expected to compare with modern iron-cored types. For the reaction coil, the winding connected to the terminals "plate" and "reaction condenser," 35 turns of 36 S.W.G. enamelled wire is required, while for the long-wave section, i.e., the coil connected to the "earthy" end of the medium-wave winding and the terminal "switch" and the "earth" terminal, 285 turns of the same wire is necessary.

The reaction and long-wave windings are wound on the inner former, there being a distance of 5 mm. or about 1/5in. between them. It is advisable to note, at this point, that the actual position of the reaction coil in relation to the medium and long-wave windings

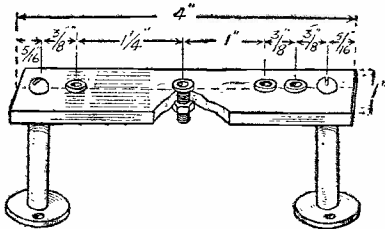

Fig. 5.—Dimensions of the holder for the coils shown in Figs. 3 and 4.

is very important, if smooth and adequate reaction is to be obtained on both wave-bands.

The above remarks also govern the position of the L.W. winding to that of the M.W.; actually the top ends of both windings should be level with each other, otherwise there will be excessive or a loss of reaction on one wave-band.

The medium-wave grid coil consists of 60 turns of 26 S.W.G. enamelled wire, and tappings are taken at the 30th and 50th turns from the upper end. Note the connections to this coil; the commencement goes to the "tuning condenser" terminal; the first tap (30th turn) to "grid"; the second tap (50th turn) to "tap"; and the end of the coil to "switch" and the start of the L.W. winding.

The following blueprints of receivers using the Lucerne Coils are still available: Four-station Crystal Set, No. A.W. 427; Lucerne Ranger (S.G.3 Valve), No A.W. 422.

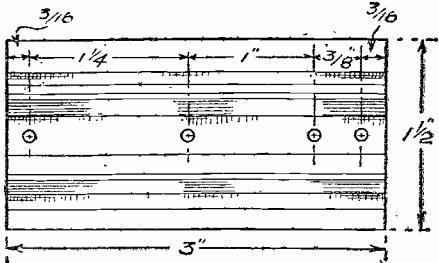
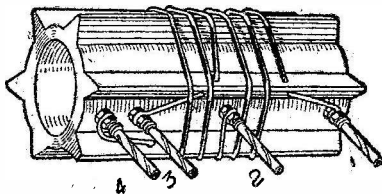

Fig. 4.—Constructional details of the 'A.W.' S.W. coils, showing location of pins.

The "A.W." Home-made S.W. Coils

These coils are so designed that a wave-range of 12 to 175 metres is covered with three coils.

Their construction is very simple, while their efficiency, if good quality formers are used, compares very favourably with some commercial products costing many times their price. The theoretical circuit is shown in Fig. 3, and the constructional details in Fig. 4.

The base or holder is shown in Fig. 5, and it will be noted that the arrangement is such that very low inter-pin capacity is present.

Winding Details

The material required is: three pieces of ebonite tubing of the six-ribbed type, 3ins. long, and with a diameter of 1 1/2ins.; twelve Clix valve pins, with three nuts on each pin; approximately 7ft. of 20 S.W.G. tinned copper wire, and 14ft. of 20 S.W.G. enamelled. The tinned copper wire is used for the two smallest coils, and the enamelled wire for the third or largest coil. The first coil covers a wave-band between 12 and 28.5 metres, and consists of three turns for the grid coil (connections 1 and 2), and three turns for the reaction (3 and 4), each turn being spaced 1/4in.

The second coil, 19 to 59 metres, has 8 turns for the grid, and 5 turns for the reaction coil. The spacing being the same as for the other coil.

The largest coil covers the 55 to 175 metre range,

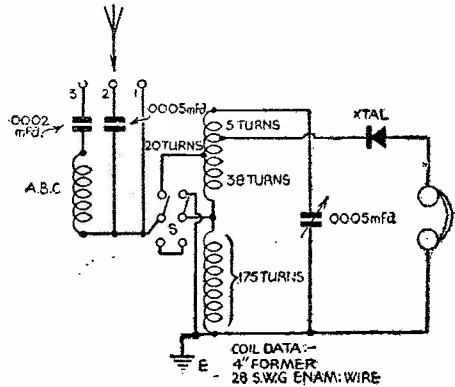

Fig. 6.—The complete circuit of the 150 Mile Crystal Set.

and consists of 23 turns of enamelled wire for the grid, and 10 turns of the same wire for the reaction, but in this case the turns are wound on without any spacing.

The wave-range specified is with a tuning condenser of .00025 mfd. capacity, and a reaction condenser of the same value.

Before commencing the winding operations, drill the holes for the valve-pins, and fit the pins in position ready for anchoring the wire. It is always advisable to stretch the wire before winding, thus removing any kinks. If it is intended to solder the wire to the pins, be careful not to overheat the pins, which would cause them to become loose in the ebonite.

Coil Holder

All the dimensions are given in the diagram, and it is essential that the various points are marked accurately (the same applies to the coil formers), otherwise the pins will not engage with the sockets.

These coils are used in many short-wavers, and it is still possible to obtain the blueprints mentioned below, from these offices.

- The Roma Short-waver (1 Valve) A.W.452
- The Home-made Coil Two (S.W.) A.W.440
- Short-Wave Adapter A.W.456

The 150-mile Crystal Set, A.W. 450

The theoretical circuit is shown in Fig. 6, from which

it will be seen that three tappings are required, apart from the two end connections.

The coil consists, in all, of 213 turns of 23 S.W.G. enamelled wire, the first tapping being taken at the 5th turn from the aerial end of the coil. The second tapping is at the 20th turn, and the third at the 38th, this forming the end of the medium-wave winding.

The long-wave section is formed with 175 turns of the same wire; in fact, it is really a continuation of the medium-wave winding, there being no need to break the wire.

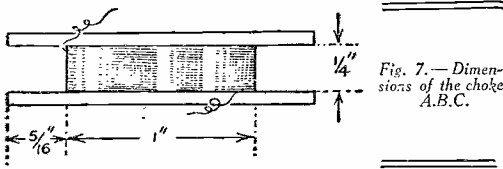

Fig. 7.—Dimensions of the choke A.B.C.

Each end is made fast to the former by small bolts, or by threading it through a couple of small holes; care must be taken to see that the tappings are quite secure.

The switch S is a "double-pole double-throw," and is used to change over the aerial connection from the medium-wave tapping to the long-wave tapping, at the same time shorting out the L.W. section when medium waves are being received. Any reliable make of switch can be used.

The component A.B.C. is an inductance which is embodied in the aerial circuit to prevent the medium-wave stations breaking through when L.W. transmissions are desired. It consists of a simple bank wound coil, of 200 turns of 34 S.W.G. wound in a slotted former 1 in. wide, the diameter of the former (Fig. 7) being 1 in.

One end of A.B.C. is connected to a separate aerial terminal via a .0002 condenser, and if any interference is experienced from M.W. stations when receiving an L.W. station, the aerial should be connected to this terminal. For M.W. reception, the better of the other two aerial connections should be used, i.e., according to the aerial arrangements in use. A.2 will give the most selective results.

The 1934 Crystal Set

This receiver (blueprint number A.W. 444) was described in the issues of *Amateur Wireless* of August 4th and September 22nd, 1934.

The complete circuit is shown in Fig. 8 and the coil constructional details are also given.

The coil former is a length of six-ribbed ebonite tube,

the dimensions being 2 1/2 in. long by 3 1/2 in. in diameter.

Tappings are taken at the points indicated in the diagram, and an anti-break-through choke, the same as for the previous set, is included in the aerial lead, a switch being connected in parallel to cut it out of circuit when medium waves are being received. The wire required for the coil is 22 S.W.G.

The potentiometer has a resistance of 400 ohms and is of the baseboard mounting type; the tuning condenser is of .0005 mfd. capacity, while the dry battery can be a small 1.5 volt cell.

"Wireless Magazine" Designs

There are still blueprints of several *W.M.* designs available, for which the associated issues are out of print, so we give the component specifications of some still suited to modern conditions.

The Economy A.C. Two (W.M. 286)

This circuit, Fig. 9, is of the Det. and Pentode type, employing valve rectification, and it is ideal for local station reception and pick up work.

*As the specified coil is no longer available, a modern iron- or air-cored coil should be fitted; the Lucerne dual-range coil would be quite satisfactory.

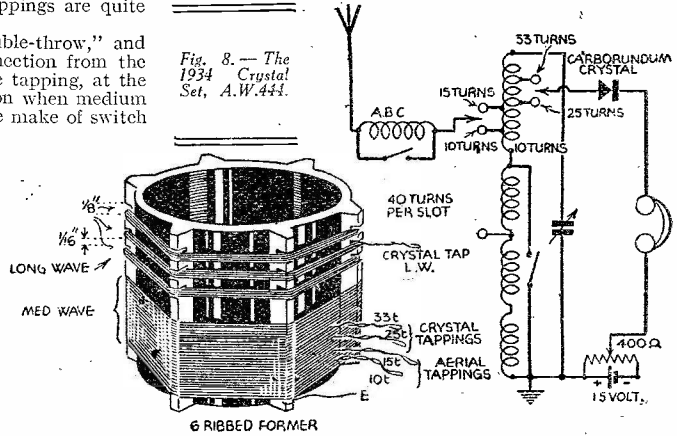

Fig. 8.—The 1934 Crystal Set, A.W. 444.

The "W.M." 1934 Standard Three (W.M. 351)

This is a straightforward S.G. three receiver (Fig. 10) the valve combination being an ordinary screen-grid high-frequency amplifier, leaky grid detector and pentode output; ganged tuning is embodied and P.U. terminals fitted.

Baseboard construction is used, the size being 12 in. by 6 in., while the layout is very simple, and one which lends itself to modifications if one should wish to experiment.

Fig. 9.—The Economy A.C. Two, W.M. 286, a two-valve capable of giving very satisfactory results.

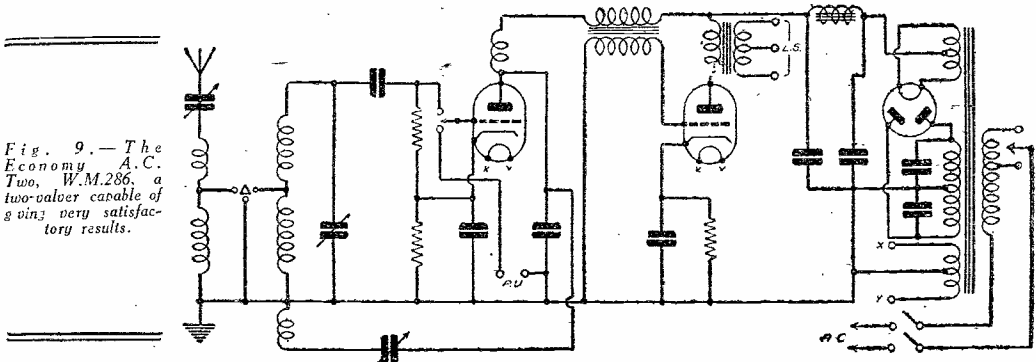

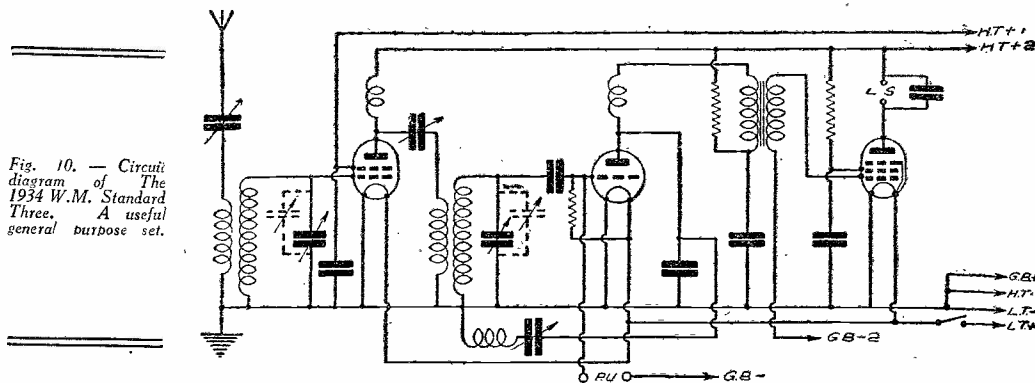

Fig. 10. — Circuit diagram of The 1934 W.M. Standard Three. A useful general purpose set.

It is hardly necessary to give the complete component list, as the various items are standard and, in view of the fact that some of the specified parts are no longer obtainable, any good components on hand could be used.

The coils are the only items which call for any comment. Those specified are the Telsen W.349, and as it may be rather difficult to obtain these, any reliable make of dual-range coil can be substituted, provided the wiring is modified to suit.

punch and good range, and yet also desire to receive the medium-wave stations. With the coil unit specified, the Goltone Colonial Universal, the wave-range is from 14 to 500 metres, a very useful and efficient arrangement.

A tuned H.F. stage is employed on all wave-bands, while the pentode output makes sure of ample L.S. strength on the majority of transmissions during normal conditions. Wooden chassis construction is specified with an aluminium panel, while valve rectification takes care of the mains side of the circuit.

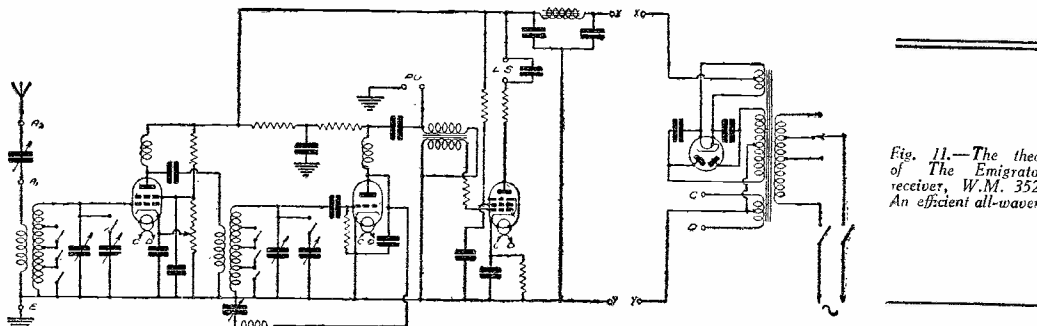

Fig. 11.—The theory of The Emigrator receiver, W.M. 352. An efficient all-waver.

The valves required are:

- 1 Mazda S.G. 215 or Cossor S.G. 215.
- 1 Mazda H.L.2 or Cossor 210 Det.
- 1 Mazda Pen. 220 or Cossor 220 HPT.

The Emigrator Receiver (W.M. 352)

This receiver appeals to many short-wave enthusiasts who require an A.C. operated outfit, capable of plenty of

Even if the specified coil unit is not employed, the circuit forms a very efficient basis for a pure short-wave or an all-wave receiver, making use of one of such all-wave coil units as might be obtainable.

The two switches are Bulgin baseboard on-off type S80B, with 6in. by $\frac{5}{32}$ in. extension rod, and K.14 knob with reducing sleeve.

Valves—1 Mazda A.C. S.G. V.M., 1 Mazda A.C./H.L., 1 Mazda A.C.2, Pen., 1 Mazda U.U.2, or Mullard I.W.2. Mains Transformer—Primary 200-250 volts. Secondary, 250-0-250 volts, 60 milliamperes. L.T. 2-0-2 volts at 3 amperes. 2-0-2 volts at 1 ampere.

The smoothing choke is of the 30 henry 50 mA type, and the L.F. transformer ratio is 3 : 1 or $3\frac{1}{2}$: 1.

It is very doubtful whether the switches specified for this receiver will now be obtainable, but it should not be a difficult matter to convert other types or even make a simple and effective arrangement from odd parts.

It should be noted that in the majority of circuits using an L.F. transformer, the ratio of the component is not supercritical. When H.F. chokes are being selected for use in mains operated circuits it is always advisable to use screened types whenever possible. If a wooden chassis has to be used instead of a specified metal one, it is essential that all earthing connections shown on the blueprint or diagram as being connected to the chassis should be taken to the earth terminal, either direct or via a stout earthing wire arranged to pass across the underside of the chassis.

(Details of other designs will be given next month.)

LIST OF COMPONENTS FOR THE ECONOMY A.C. TWO.

- 1 H.F. Choke.
- 1 L.F. Choke.
- *Coil : Lotus Dual Range.
- Condensers, Fixed : One .0001 mfd., one .001 mfd., one .1 mfd. plus .1 mfd., Type 1,000 volt, A.C. test ; two 1.0 mfd., Type 1,500 volt, D.C. test ; two 4 mfd., Type 1,500 volt, D.C. test.
- Condensers, Variable : One .0005 mfd., with S.M. Dial ; one Polar Compax. .0003 mfd. ; one Polar Pre-set .0003 mfd. max.
- Panel : Ebonite, 9in. x 6in.
- Valveholders : Three W.B. 5-pin type.
- Resistances : One 600 ohm, one 1,000 ohm, one 1 megohm grid leak.
- Valves : One Mazda A.C./H.L., one Mazda A.C./P., one Mullard D.W.2.
- Switches : One Bulgin, Type S88 ; one Bulgin, Type S86 ; one Three-point push-pull.
- Transformer : 250-0-250 v. 60 mA ; 4 v. 1 amp. ; 4 v. 2 amp.
- Transformer Output : 1 Ferranti OPM8.

Radio Examination Papers—12

Another Selection of Questions, With Appropriate Answers, by THE EXPERIMENTERS

1. Co-axial Cable

THIS name is given to a type of cable in which there is a central wire surrounded by, but insulated from, a metal or metal-braided tube. The central wire is usually insulated from the outer case by means of star-shaped washers, or by beads. The object of these is not only to provide insulation, but to reduce the capacity between the two conductors to a minimum; this is done by having the smallest possible amount of solid dielectric. Another advantage resulting from the use of a number of separate insulators is that the cable may be made flexible.

In use, both inner wire and outer casing, which may be described as a screen, are used. Normally, however, the metallic case is used for the earth-return connection. The most extensive use of co-axial cable is for connecting an aerial to a receiver or transmitter, particularly when the aerial is some distance away from the equipment. In this case, the central wire acts as the lead-in, while the outer case is securely earth bonded, and provides the earth connection to the set. Co-axial cable may also be used as feeder from a dipole aerial, in which case both wire and casing may be "live."

This kind of cable has low losses, both in the way of H.F. resistance and radiation. In fact, it is non-radiating and when used for a receiver aerial has no pick-up. Consequently it is possible to site the aerial in a good spot well away from buildings and other earthed objects, and to run the lead-in of co-axial cable underground to the receiver or transmitter.

Before the war, when car-radio was permitted, co-axial cable was often used for the lead-in. The aerial could be above the roof of the car, and the co-axial would not pick up static generated by the ignition equipment.

2. Harmonics

Harmonics may be described as spurious frequencies, which occur at multiples of the original or fundamental frequency. Thus, a musical note having a frequency of 1,000 cycles per second might be accompanied by other tones of 2,000, 4,000 and 6,000 cycles per second. In passing it should be noted that it is normally only the even harmonics (second, fourth, sixth, etc.) which are heard.

It is these harmonics—often described by musicians as overtones—which give different musical instruments their

individual "tone." For example, middle C sounds quite different when played on a violin to what it does when played on a piano. And yet the fundamental frequency is the same in both cases: it is in the number and relative strengths of the harmonics or overtones that the difference occurs. Thus, if there were no harmonics, all instruments would sound alike.

Mention was made above of the fact that it is generally the even harmonics which are produced. When odd harmonics occur the result is usually unpleasant, as it often is when using an output pentode without any tone correction. With push-pull output the odd harmonics tend to be cancelled out; that is the reason for the often-better reproduction from a push-pull stage.

Harmonics on radio-frequencies can be distinctly troublesome, and they are seldom desirable. Obviously, the risk of causing interference is far greater if a transmission made on 100 metres can also be heard on 50, 25 and 12.5 metres! It is customary to take steps to suppress all harmonics on radio-frequencies. Nevertheless, harmonics can be very useful when using a wavemeter, since it may be possible to calibrate on a number of frequency ranges when using an instrument primarily intended to cover only a

(Continued on page 523.)

SPECIMEN QUESTIONS

1. What is a co-axial cable or feeder? For what purpose is it generally employed, and why?
2. Explain briefly what is meant by the term "harmonics," and state why harmonics are generally desirable in audio-frequency reproduction, but seldom in radio-frequency generation.
3. How would you prepare a tuning or calibration chart for a receiver, given a modulated-oscillator type of wavemeter? Illustrate your answer by means of a typical chart or graph.
4. If there was a background "ripple"—as distinct from mains "hum"—in the reproduction from a speaker used with a P.A. system, what steps would you take to overcome the trouble?
5. What are the so-called X-plates and Y-plates of a cathode-ray tube, and why are they so named?
6. An experimenter requires capacitances of .0005 mfd. and .006 mfd., but the only fixed condensers available are: 2-.01 mfd.; 1-.001 mfd.; 2-.0002 mfd. and 1-.0001 mfd. How can he obtain the required values?

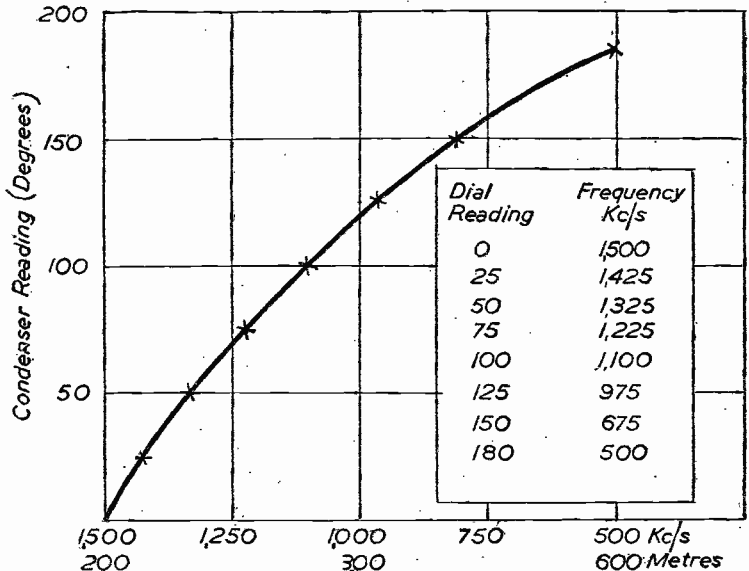

Fig. 1.—The usual form of tuning or calibration curve for a receiver with, inset, a table of condenser readings and frequencies from which the curve was drawn.

Murphy

A 56V TELEVISION RECEIVERS

JUST RECEIVED!

We have only a small number of these Television Sets to offer. They are complete in pedestal cabinets (size 18in. x 18in. x 34in. high), with 15 Valves + 3 Rectifiers, Cathode Ray Tube Type CRM91 (picture size 7½in. x 6in.), 10in. M.C. Speaker. Altogether a first-class job such as Murphy always make. This Receiver was designed to receive Television, Sound and Vision. Price, carr. extra **£28**

ROLA SPEAKERS

Brand new Rola Sin. P.M. moving coil, with transformer for super power or pentode valve. Fine cadmium plated chassis, 27/6 ; 10in., 39/6.

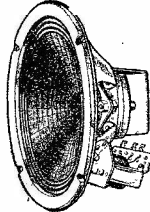

CELESTION Sin. P.M. moving coil, pentode output. New, 25/6.

GOODMANS Sin. P.M. moving coil Universal transformer, suitable for all output valves, 27/6.

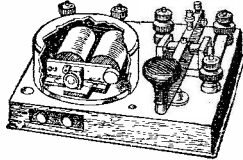

G.P.O. MORSE KEY & BUZZER UNIT

We have only a small number of these instruments left. Made for professional use. All parts of heavy solid brass mounted on mahogany base. The Key is fitted with platinum contacts. An excellent opportunity for those requiring a robust unit which will give years of service. Price 45/-.

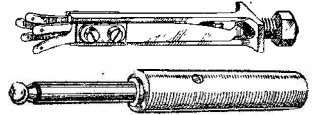

PLUGS AND JACKS

These ex-Govt. Jacks have powerful phosphor-bronze springs ensuring a perfect contact. Overall length, including ½in. threaded shank, 3½in. Supplied with best quality Plug (as illustrated), 5/6. Plugs only, 2/-.



TABLE MICROPHONES

A new hand table microphone, fitted with the famous ROTHERMEL D104 Microphone insert housed in new metal casing, mounted on heavy stand and base as illustrated, with joint for angle adjustment. 50-80,000 cycles output level 60 d.b. Price 82/6.

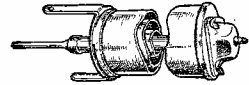

PHILIPS TRIMMER CONDENSERS

Non-drift air di-electric, 60 m.mfds., suitable for S.W. work. 1/3 each.

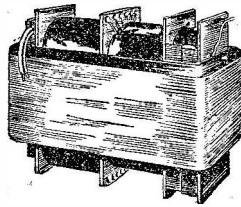

PHILIPS HIGH VOLTAGE TRANSFORMERS

These transformers are robust in construction and weigh approximately 13½lbs. Dimensions : 5½ by 5½ by 4½in. Specification : 350-0-350 v., 70 m.a. Four tappings giving 4 v. 3 amps., 6.3 v. 4 amps., 4 v. .65 amp. and 4,000 v. at 3 m.a. Input 100/250. Carriage forward. Free Wiring diagram. Price 82/6.

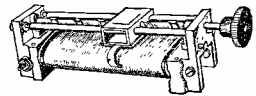

VARIABLE POTENTIOMETERS

380 ohms 10 watt. Low price to clear. 7/6 each.

PHILIPS SMOOTHING CHOKES

Brand new, well-built chokes, 60 ohms D.C. resistance 100/120 m.a., Size : 2½in. by 2½in. by 1½in., 5/6 each. Also 400 ohms D.C. resistance 60 m.a., Size : 1½in. by 1½in. by ½in., 3/6 each.

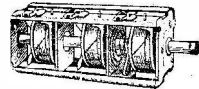
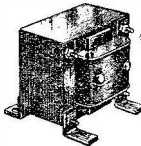

PHILIPS 3-GANG CONCENTRIC SPIRAL VANE CONDENSER

6005 mfd. without trimmers. As used in Philips well-known Push Button receivers. Price 4/6.

BAIRD TELEVISION POWER PACK & AMPLIFIER CHASSIS

Includes heavy mains transformer 350-0-350, 120 m.a., with 4 tappings. High voltage transformer for supplying C.R. tube. Various condensers including 16 x 16 mfd. 550 v. working, 1-16 mfd. 450 v. working, 50 x 50 x 2 mfd. B.I. Electrolytics, etc. Pentode output transformer : chokes :

resistors ; trimmers ; bias electrolytics : mica and tubular condensers ; short-wave coils, etc. Workmanship and components are of the highest quality. Valve diagram free. Carriage forward. Add 2/6 for packing. **£3.17.6**

LONDON CENTRAL RADIO STORES

See also our classified advertisement on page 548.

Cash with order. No C.O.D. No orders accepted from Eire or N. Ireland. Postage must be included.

23, LISLE STREET, GERrard 2969 LONDON, W.C.2

YES! BE PREPARED

Times are difficult, but that is no reason why you should not be looking confidently forward to the future. Your future will be what you make it. Use your spare time to increase your earning power, then war or no war your future will be secure.



EARNING POWER IS A SOUND INVESTMENT

DO ANY OF THESE SUBJECTS INTEREST YOU ?

- | | |
|---|--------------------------------|
| Accountancy Examinations | Metallurgy |
| Advertising and Sales Management | Mining. All subjects |
| Agriculture | Mining. Electrical Engineering |
| A.M.I. Fire E. Examinations | Motor Engineering |
| Applied Mechanics | Motor Trade |
| Army Certificates | Municipal and County Engineers |
| Auctioneers and Estate Agents | Naval Architecture |
| Aviation Engineering | Novel Writing |
| Aviation Wireless | Pattern Making |
| Banking | Play Writing |
| Blue Prints | Police, Special Course |
| Boilers | Preceptors, College of |
| Book-keeping, Accountancy and Modern Business Methods | Press Tool Work |
| B.Sc. (Eng.) | Production Engineering |
| Building, Architecture and Clerk of Works | Pumps, and Pumping Machinery |
| Builders' Quantities | Radio Communication |
| Cambridge Senior School Certificate | Radio Service Engineering |
| Civil Engineering | R.A.F. Special Courses |
| Civil Service | Road Making and Maintenance |
| All Commercial Subjects | Salesmanship, I.S.M.A. |
| Commercial Art | Sanitation |
| Common Prelim. E.J.E.B. | School Attendance Officer |
| Concrete and Structural Engineering | Secretarial Exams. |
| Draughtsmanship. All Branches | Sheet Metal Work |
| Engineering. All branches, subjects and examinations | Shorthand |
| General Education | Shorthand (Pitman's) |
| G.P.O. Eng. Dept. | Short-story Writing |
| Heating and Ventilating | Short-wave Radio |
| Industrial Chemistry | Speaking in Public |
| Institute of Housing | Structural Engineering |
| Insurance | Surveying |
| Journalism | Teachers of Handicrafts |
| Languages | Telephony and Telegraphy |
| Mathematics | Television |
| Matriculation | Transport Inst. Exams. |

If you do not see your own requirements above, write to us on any subject. Full particulars free.

IF YOU ATTEND TO THIS NOW IT MAY MAKE A WONDERFUL DIFFERENCE TO YOUR FUTURE

COUPON

CUT THIS OUT



To DEPT. 104, THE BENNETT COLLEGE, LTD., SHEFFIELD.

Please send me (free of charge) Particulars of..... (Cross out line Your private advice..... which does about..... not apply.)

PLEASE WRITE IN BLOCK LETTERS

Name.....

Address.....

PITMAN

INTRODUCING RADIO RECEIVER SERVICING

By E. M. Squire. Handy and concise, and gives readers a sound knowledge of receiver operation and equipment without unnecessary theoretical frills. A practical book for practical men. 6s. net.

RADIO SIMPLIFIED

A.T.C. cadets will be looking forward to this follow-on book by John Clarrieoats—to be remembered for his "Radio Simply Explained." This time the author goes farther, and deals more fully with modern radio practice. A masterpiece of compression, elucidation and instruction. 4s. 6d. net.



Pitman's have in their guide to Technical books every type of Radio book for Radio Mechanics and Wireless Operators, from the simple to the advanced. Why not write for our list, post free, from :

Sir Isaac Pitman & Co., Ltd.

BOOKS PARKER ST., KINGSWAY, W.C.

DAGENITE

AND

PERTRIX

—the dependable

BATTERIES

FOR
RADIO, CARS
MOTOR CYCLES
COMMERCIAL
VEHICLES
ETC.

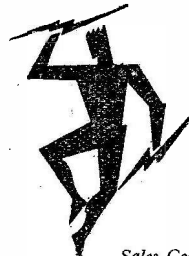

Sales Concessionaires:

HOLSUN BATTERIES LIMITED

137 Victoria Street, London, S.W.1 D.9

single waveband. This is not always an advantage, of course, particularly on high frequencies, where there may be a danger of confusing the fundamental with the second harmonic, or the second harmonic with the fourth, and so on.

3. Receiver Calibration

After setting the wavemeter to a frequency within the waveband covered by the receiver and switching on both wavemeter and set, the latter should be tuned until the note generated by the wavemeter can be heard at maximum strength. The meter should then be moved farther away from the receiver, or its output reduced when an attenuator is provided, until the generated note is only just audible in the phones or speaker with the receiver adjusted to its most sensitive condition.

At this stage, the wavemeter should be tuned to a frequency near to one end of the receiver tuning range. The set is then tuned as before for maximum signal, if necessary moving the meter still further away so that the tuning of the receiver is critical. A note should then be made of the frequency as indicated by the meter scale, and also of the tuning condenser setting on the receiver.

This process should be repeated after tuning the meter to a point further along the waveband. After making a list similar to that shown in Fig. 1 a graph can be drawn on squared paper, as also illustrated in Fig. 1.

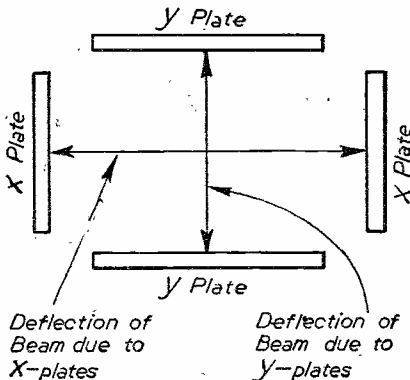
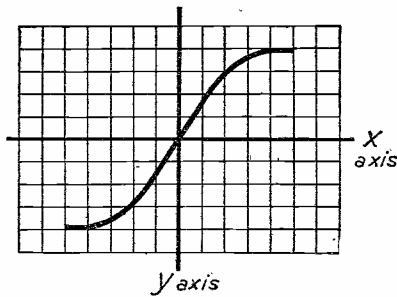

Fig. 2.—This diagram explains the reason for giving the names "X" and "Y" to the deflector plates of a C.R. tube. A simple algebraic graph is shown above.

When carrying out the calibration, any manual volume control on the receiver should be kept at maximum, while reaction should be set near to oscillation point but not so near that there is any danger of instability. If A.V.C. is provided, it should be put out of action, since if it is in use tuning appears to be flattened; in some instances the loudest note may be obtained when the set is slightly off tune.

4.—Background "Ripple."

Noise of the kind described can generally be traced to insufficient earthing of the amplifier and associated equipment. The first step should be to see that the chassis is earthed, and that all screened leads to microphones, pick-ups and the like are well bonded to the chassis. In the case of long screened leads it is often

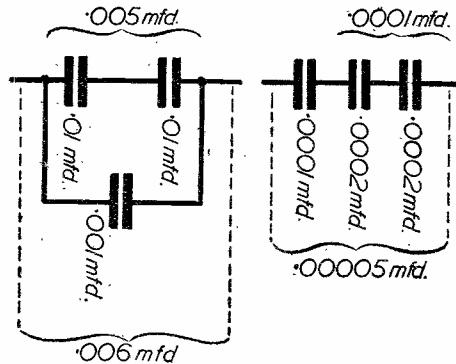

Fig. 3.—How required capacities can be obtained by connecting condensers of other capacities in series and parallel.

necessary to provide a number of earth connections at points along the leads:

If the microphone is on a metal stand, the stand also should be earth-bonded. In some cases it is also found advantageous to earth the frame of the gramophone motor.

5.—C.R.-tube Deflector Plates

There is no difference between the X-plates and Y-plates of a cathode-ray tube. Both are used to cause the electron beam to be moved laterally in order to make a track along the fluorescent screen. The plates are in parallel pairs, and the tube is so mounted in the oscilloscope so that the plane of one pair is vertical, and the plane of the other horizontal.

When the tube has been so mounted, the plates which are in a vertical plane are described as X-plates, and those which are in the horizontal plane are called Y-plates. The reason can be found by referring to algebraic graphs, where the two axes are described as the X and the Y axis. The X axis is horizontal and the Y axis is vertical, as shown in Fig. 2.

Now it will be seen that the vertical deflector plates in the C.R. tube attract and repel the electron beam toward and away from them, and therefore that a horizontal line is traced on the screen; that is the X axis. If the X plates are out of use and the deflecting voltages are applied to the other pair of plates a vertical line (or Y axis) is traced. Hence the names.

6.—Connecting Condensers.

Before attempting to find suitable combinations of fixed condensers to give the necessary overall values, it should be borne in mind that the capacity of a condenser is reduced if another condenser is wired in series with it, and increased if one, or more, condensers are connected in parallel with it.

The value of .00005 mfd. is only half that of the smallest condenser available, so it is evident that series connections only can be considered. To find the overall capacity of condensers in series we use the formula:

$C = \frac{1}{\frac{1}{C_1} + \frac{1}{C_2} + \frac{1}{C_3} + \dots}$ etc. From this it follows that when two condensers of equal capacity are wired in series the resulting capacity is one-half that of the separate condensers. It may be seen, then, that if the two .0002-mfd. condensers are connected in series the overall capacity will be .0001 mfd. And if the .0001-mfd.

condenser is wired in series with this series pair the capacity will again be halved, to .00005mfd., which is the value required. See Fig. 3.

To obtain the value of .006mfd. we might start by putting the two .01-mfd. condensers in series. This will give a capacity of .005 mfd. To bring this to the required value of .006 mfd. we may connect the .001-mfd. condenser in parallel with the series pair, as indicated in Fig. 3. This is because the total capacity of condensers in parallel is equal to the sum of the capacities of the individual condensers.

When a number of fixed condensers is available, it is normally possible to provide almost any capacity that may be needed in an experimental circuit. Where high-frequency circuits are concerned, however, care should be taken that the condensers are placed as close together as possible, so that very short leads may be used between them. It is also desirable that they should be mounted edge-on to the metal chassis so that the capacity to earth is not excessive. Where possible they should be placed some little distance away from the metal chassis, being either suspended in the wiring or fitted to a vertical sheet of paxolin.

Servicing Mains Receivers

AC/D.C. Circuits. Outstanding Features. Preliminary Tests

WITH Universal or A.C./D.C. receivers, which are designed to operate on alternating and direct current mains, the first tests are slightly different from those applicable to A.C. circuits. For those not familiar with "Universal" operation, a brief description will help to make the tests more clear, and show why it is necessary to handle such receivers with caution.

When a mains receiver is designed for operation off A.C. mains, a transformer is incorporated between the mains supply leads and the actual circuit of the apparatus. This transformer serves the dual purpose of isolating the circuit—as regards *direct* connections—from the mains, and of increasing and/or decreasing the mains voltage to that required for the operation of the circuit. It is quite usual for the transformer to have two or more secondary windings; one capable of supplying the rectifier with a voltage higher than that of the mains, and one or more having a very much smaller number of turns forming their windings, for the supply of the low voltage for the heater circuits. A mains transformer is not an essential part of the rectifying circuit—apart from the dual functions mentioned above—but it is necessary for some form of rectifier to be included in an A.C. operated circuit, to ensure that the supply is converted or rectified to direct current for the H.T. required for the valve circuits.

An A.C. receiver embodying a mains transformer cannot be operated off direct current supplies; if, through any misunderstanding, the two happened to be connected together, the primary winding will be burnt out or the mains fuse will blow, therefore it is very necessary for the would-be service engineer to make sure that the mains are A.C., or that the receiver is of the universal type. These remarks may, to some, seem to be quite unnecessary, but the writer has come across so many cases of A.C. sets being plugged into D.C. supplies that he feels quite justified in stressing the point.

Circuit Requirements

From the above remarks it will be obvious that a universal set will not include a mains transformer, but it will incorporate a rectifier of the valve or metal type. The rectification is half-wave; therefore, it is usual for good smoothing facilities to be provided. Typical A.C./D.C. heater and rectifier circuits are shown in the diagram, the rectifier circuit consisting of V_5 and the smoothing condensers C_1 and C_2 . It should be noted

that one side of the mains is connected to the anode of the rectifier, and the other side to the chassis or negative line. When the receiver is connected to A.C. mains the mains plug can be inserted either way round, as there is no question of polarity, but if the supplies are D.C. it is essential for the plug to be inserted in the correct manner to ensure that the positive side of the mains is connected to the positive line of the receiver, otherwise the circuit will not function.

Voltage-dropping Resistor

The resistor R_m could be likened to the transformer in an A.C. set, but *only* from the point of view of reducing the mains voltage to that required by the heaters of the valves. It should be noted that the heaters, and the dial-light, are all connected in series with the resistor R_m , one end of which is connected to the mains. The circuit thus formed is completed by one side of the final heater

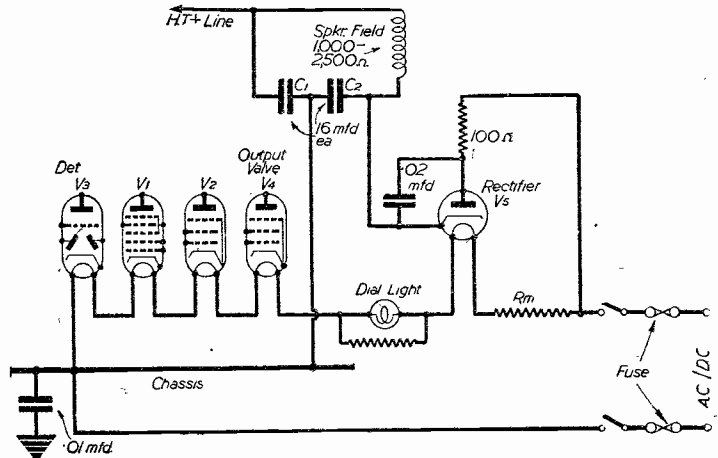

The skeleton circuit of an A.C./D.C. four valve-plus rectifier, showing the fundamental wiring of the heater and rectifier circuits.

being returned to the chassis which, as shown, is common with the other side of the supply.

In some circuits, a resistor is connected across the dial-light, its object being to prevent the heater circuit being broken if the dial-light bulb collapses. In others, the bulb is tapped off across a portion of R_m —connected in series with the H.T. supply—while others embody a small mains voltage type of bulb.

The heaters of the valves can have different voltage ratings, but their current consumption *must* be the same; this is due to the fact that they are in series with each

Time Bases

Further Considerations in Design, and the Action of Single-line Units

By S. A. KNIGHT

(Concluded from page 474, October issue).

SINCE the movement of the tube spot depends for its speed of traverse on the time of charge, it is plain to see that by variation of either of these components the frequency of the time base sweep may be varied. By using a pentode valve as the constant current device in place of the resistance and arranging a switch to select any one of a set of fixed capacities controls for both coarse and fine adjustment of sweep frequency—velocity as it is commonly called—are readily to hand,

electrons to be freed from the gas atoms which join the anode-bound stream and race themselves to the positive conductor. The gas atom is ionised in this way, and a formation of slow-moving ions thus begins to move towards the cathode of the valve. One electron on its journey across the inter-electrode space may ionise several gas atoms by this process of collision, and the build up of valve current, by the addition of the anode moving negative electrons and the cathode moving positive ions, reaches a very high value almost instantaneously. Correspondingly, the D.C. resistance of the valve decreases rapidly.

If now the anode voltage is reduced, it will be found that deionisation—the ions regrouping again into uncharged gas atoms—does not take place at the same potential as ionisation did. It will occur at a little lower down the anode voltage scale as the figure shows, perhaps in our example at 40 volts.

If this valve, then, were connected in parallel with the condenser of the time base circuit, the latter will initially charge up to 50 volts, discharge to 40, recharge to 50, and so on.

Obviously this is useless for a time base sweep control, as the maximum voltage variation applied to the plates of the C.R. tube would be 10.

Similarly, in the case of a simple neon—the difference between striking and extinguishing voltage would represent the maximum variation applied to the deflectors; in an average neon this would be about 20-30 volts. (Fig. 10.)

The Thyatron

By inserting a grid into the diode, and making it a triode, a big improvement is brought about to the previous case. By making the grid sufficiently negative it is fairly obvious that a much higher anode voltage will have to be applied in order to bring about ionisation.

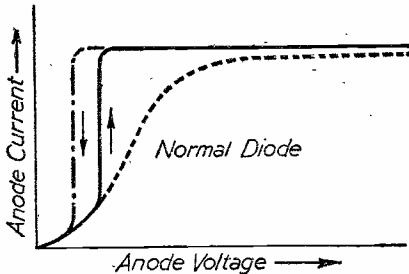

Fig. 9.—Curves showing the behaviour of a simple gas-filled diode.

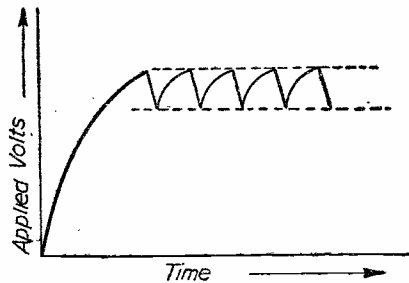

Fig. 10.—The difference between striking and extinguishing volts of a neon lamp is shown by the curve.

the coarse control being the condenser selection and the fine control the progressive current variation by adjustment of the pentode screen voltage. Fig. 8 shows this circuit in operation.

The Discharging Device

We now come to what is probably the most important part of any time base circuit—that is, the device which was marked as X in Fig. 3, and which is the arrangement whereby the condenser is made to rapidly discharge at the end of its charging cycles.

The most common device is one employing a gas-filled triode called a Thyatron—that is, a valve into which a certain amount of inert gas has been introduced during manufacture.

Consider the device firstly as a gas-filled diode, even a neon lamp. The action of these is shown essentially in Figs. 9 and 10 respectively; in the case of a gas diode, initially the anode current will commence to follow the usual characteristic as for a normal valve. It is when the anode voltage has reached a value of, suppose, 50 volts that a change occurs and the valve is suddenly saturated.

At this anode potential the electrons inside the tube have attained sufficient velocity to cause ionisation of the gas atoms. Collision between the electrons and the heavier gas atoms present in the valve cause "spare"

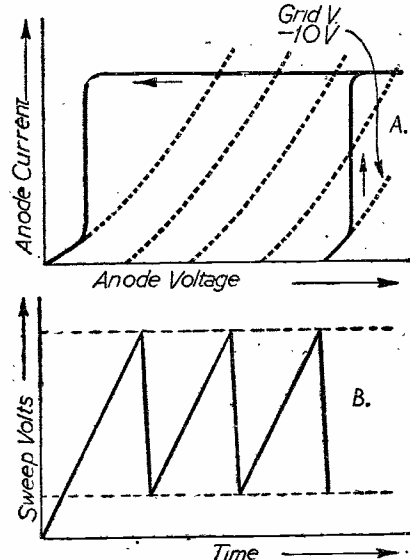

Fig. 11.—(A) The effect of grid voltage, when applied to a Thyatron, on the ionisation of the gas. (B) The output waveform of a Thyatron when connected in parallel with the discharge condenser.

Suppose the gas to have an ionisation potential of 40 volts; then, with the grid zero and taking no part in proceedings, an anode potential of 40 volts will cause the valve to strike just as in the case of the diode.

Now if the grid is made a few volts negative with respect to the cathode, the anode voltage may have to be increased up to perhaps 80 volts before the gas is again ionised and the valve heavily conducts. It is the increase in anode volts required to overcome a charge of one volt on the grid that is called the ratio of control of the thyatron—in this case it would be 20 if the grid were 2 volts negative.

Therefore it will be seen that if the grid were made 10 volts negative, ionisation would not take place until the anode had been raised to 240 volts (10×2)+40.

But now the real value of the thyatron asserts itself, for by reducing the anode potential it is found that deionisation does not take place a few volts below the striking voltage as in the case of the diode. The valve remains ionised, in fact, until the anode has fallen well below its striking value for the grid at zero—in our example, below 40 volts.

This is because the positive ions seem to form a space charge "shield" around the negative grid immediately ionisation takes place and prevent the grid from exercising any control at all until the anode has fallen well under the 40 volt mark.

The output waveform, then, of the thyatron if it is connected in parallel with the discharge condenser, will approximate to that shown at B, Fig. 11. At least 200 volts amplitude is obtained and applied as the deflection voltage, resulting in a satisfactory trace.

Thus the thyatron is very good as the discharge valve, and control of the bias will be seen to control the striking potential and consequently the amplitude of the sweep. Since reduction of the latter also reduces the duration of each sweep, the time base frequency is affected.

Practical Time Base Circuits

There are several kinds of time bases and time base circuits. There are line, elliptical, circular and even spiral figures into which the spot can be moved as the time axis, and the circuits employed are numerous and varied.

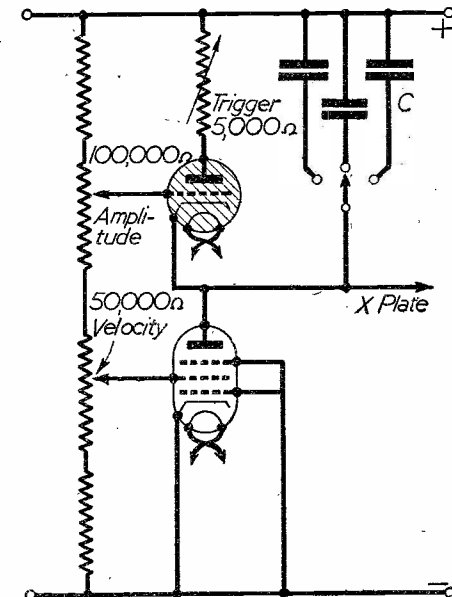

Fig. 12.—A thyatron with a pentode valve acting as a constant current device.

Main types for ordinary line time base sweeps are either gas or hard valve circuits. Circular sweeps can be readily obtained without the use of any valves at all.

We will deal fairly exhaustively with a few types of both gas and hard valve circuits, such circuits as could be easily constructed by the home experimenter on standard components and capable of a lot of experiments being made with them.

First, a simple circuit employing a thyatron with a pentode as a constant current device. (Fig. 12.)

Typical values are given, though actually these could be modified in practice by the constructor to improve performance and to suit any particular tube or power pack arrangements he might have.

The charging condensers marked C could have values

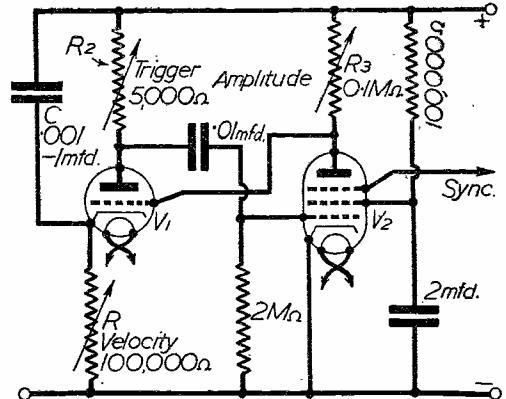

Fig. 13.—A simple Puckle circuit suitable for amateur experimenters.

say, .0005 μ F, .001 μ F, .005 μ F, .01 μ F, 0.1 μ F, 0.5 μ F and 1 μ F, and would cover a wide range of frequency when used in conjunction with "overlap" between the capacities provided by the velocity control on the screen of the pentode.

The function of the circuit is as follows: Initially the condenser C is discharged, therefore as no potential exists across its terminals both plates must be equal in potential, i.e., the anode of the pentode and the cathode of the thyatron are equal to the maximum H.T. supply. Moreover, the grid of the thyatron is clearly at a negative potential with respect to its cathode and does not, therefore, conduct. As C charges the voltage difference across it increases so that the bottom plate begins to run negative with respect to H.T. positive. So also do the anode of the pentode and the cathode of the thyatron, with the result that the difference of potential across the anode and cathode of the latter is increasing and the cathode is moving "down" to the same potential as is present on the grid.

Either of these effects would normally cause a rapid ionisation of the gas, but when both occur together, as in this instance, the striking is practically instantaneous. The condenser C is, therefore, rapidly discharged until the voltage has fallen to the region of 30 volts, when the thyatron again is cut off and the whole cycle repeated.

By inserting a small variable resistance in the anode lead of the gas valve, value of some 5,000 Ω , the time of the discharge, or flyback period, may be readily varied and used as a fine control of velocity. A control of this nature is not really a necessity, but is a simple refinement for any time base circuit. It is called a trigger control.

The X plates are connected as shown and the electron beam passing between them experiences the change of potential occurring across the condenser C. The spot thus scans the tube face, and is rapidly returned to its starting position during the discharge period ready for the next cycle. The constant current pentode may be

Practical Wireless BLUEPRINT SERVICE

PRACTICAL WIRELESS No. of
Date of Issue. Blueprint.

CRYSTAL SETS
Blueprints, 6d. each.
1937 Crystal Receiver PW71
The "Junior" Crystal Set PW94

STRAIGHT SETS. Battery Operated.
One-valve: Blueprints, 1s. each.
All-Wave Unipen (Pentode) PW31A
Bestmeyer's One-valver PW85
The "Pyramid" One-valver (HF Pen) PW93
Two-valve: Blueprint, 1s.
The Signet Two (D & I P) 7.6d PW76
Three-valve: Blueprints, 1s. each
Selectone Battery Three (D, 2 LF (Trans)) PW10
Summit Three (HF Pen, D, Pen) PW37
All Pentode Three (HF Pen, D (Pen), Pen) PW39

Half Mark Cadet (D, LF, Pen (RO) F. J. Camm's Silver Souvenir (HF Pen, D (Pen), Pen) (All-Wave Three) PW49
Cameo Midget Three (D, 2 LF (Trans)) PW51
1936 Sonotone Three-Four (HF Pen, HF Pen, Westector, Pen) PW53
Bery All-Wave Three (D, 2 LF (RC)) PW55

The Monitor (HF Pen, D, Pen) PW61
The Tutor Three (HF Pen, D, Pen) PW62
The Centaur Three (SG, D, P) PW64
F. J. Camm's Record All-Wave Three (HF Pen, D, Pen) PW69
The "Colt" All-Wave Three (D, 2 LF (RC & Trans)) PW72
The "Rapid" Straight 3 (D, 2 LF (RC & Trans)) PW82

F. J. Camm's Oracle All-Wave Three (HF, Det, Pen) PW78
1938 "Trihand" All-Wave Three (HF Pen, D, Pen) PW84
F. J. Camm's "Sprite" Three (HF Pen, D, Pen) PW87
The "Hurricane" All-Wave Three (SG, D (Pen), Pen) PW89
F. J. Camm's "Push-Button" Three (HF Pen, D (Pen), Det) PW92

Four-valve: Blueprints, 1s. each.
Beta Universal Four (SG, D, LF, (Cl B)) PW17
Nucleon Class B Four (SG, D (SG), LF, Cl B) PW34B
Fury Four-Super (SG, SG, D, Pen) PW34C
Battery Half-Mark 4 (HF Pen, D, Push-Full) PW46

"Acme" All-Wave 4 (HF Pen, D (Pen), LF, Cl B) PW83
The "Admiral" Four (HF Pen, HF Pen, D, Pen (RC)) PW90

Mains Operated
Two-valve: Blueprints, 1s. each.
A.C. Twin (D (Pen), Pen) PW18
A.C. D.C. Two (SG, Pow) PW31
Selectone A.C. Radiogram Two (D, Pow) PW19
Three-valve: Blueprints, 1s. each.
Double-Diode-Triode Three (HF Pen, DDT, Pen) PW23
D.C. Ace (SG, D, Pen) PW25
A.C. Three (SG, D, Pen) PW29
A.C. Leader (HF Pen, D, Pow) PW35C
D.C. Premier (HF Pen, D, Pen) PW33B
Unique (HF Pen, D (Pen), Pen) PW38A
Armada Mains Three (HF Pen, D (Pen)) PW38

F. J. Camm's A.C. All-Wave Silver Souvenir Three (HF Pen, D, Pen) "All-Wave" A.C. Three (D, 2 LF (RC)) PW54
A.C. 1936 Sonotone (HF Pen, HF Pen, Westector, Pen) PW56
Mains Record All-Wave 3 (HF Pen, D, Pen) PW70

Four-valve: Blueprints, 1s. each.
A.C. Fury Four (SG, SG, D, Pen) PW20
A.C. Fury Four Super (SG, SG, D, Pen) PW34D
A.C. Hall-Mark (HF Pen, D, Push-Pull) PW45
Universal Hall-Mark (HF Pen, D, Push-Pull) PW47

SUPERHETS.
Battery Sets: Blueprints, 1s. each.
43 Superhet (Three-valve) PW49
F. J. Camm's 2-valve Superhet PW62

Mains Sets: Blueprints, 1s. each.
A.C. 25 Superhet (Three-valve) PW43
A.C. 20 Superhet (Three-valve) PW42

F. J. Camm's A.C. Superhet 4 PW59
F. J. Camm's Universal 44 Superhet 4 PW60
"Qualitone" Universal Four PW73
Four-valve: Double-sided Blueprint, 1s. 6d.
Push Button 4, Battery Model 22.10.38 PW95
Push Button 4, A.C. Mains Model

SHORT-WAVE SETS. Battery Operated.
One-valve: Blueprint, 1s.
Simple S.W. One-valver PW88
Two-valve: Blueprints, 1s. each.
Midget Short-wave Two (D, Pen) The "Fleet" Short-wave Two (D (HF Pen, Pen) PW28A
Three-valve: Blueprints, 1s. each.
Experimenter's Short-wave Three (SG, D, Pow) PW30A
The Prefect 3 (D, 2 LF (RC and Trans)) PW63
The Band-Spread S.W. Three (HF Pen, D (Pen), Pen) PW68

PORTABLES
Three-valve: Blueprints, 1s. each.
F. J. Camm's ELF Three-valve Portable (HF Pen, D, Pen) PW65
Parvo Flyweight Midget Portable (SG, D, Pen) PW77
Four-valve: Blueprint, 1s.
"Imp" Portable 4 (D, LF, LF (Pen)) PW86

MISCELLANEOUS
Blueprint, 1s.
S.W. Converter-Adapter (1 valve) PW48A

AMATEUR WIRELESS AND WIRELESS MAGAZINE

CRYSTAL SETS.
Blueprints, 6d. each.
Four-station Crystal Set AW427
1934 Crystal Set AW444
150-mile Crystal Set AW450

STRAIGHT SETS. Battery Operated.
One-valve: Blueprint, 1s.
B.B.C. Special One-valver AW387
Two-valve: Blueprints, 1s. each.
Melody Ranger Two (D, Trans.) AW388
Full-volume Two (SG det, Pen) AW392
A Modern Two-valver (D, Pen) WM409

Three-valve: Blueprints, 1s. each.
45 5s. S.G. 3 (SG, D, Trans) AW412
Lucerne Ranger (SG, D, Trans.) AW422
45 6s. Three: De Luxe Version (SG, P, Trans.) AW437
Tri-Portable Three (SG, D, Pen) WM371
Simple-Tune Three (SG, D, Pen) WM327
Economy Pentode Three (SG, D (Pen)) WM337
"W.M." 1934 Standard Three (SG, D, Pen) WM351
43 3s. Three (SG, D, Trans) WM384

1935 45 0s. Battery Three (SG, D, Pen) WM371
FTV Three (Pen, D, Pen) WM389
Certainty Three (SG, D, Pen) WM363
Miniature Three (SG, D, Trans) WM306
All-Wave Winning Three (SG, D, Pen) WM400

Four-valve: Blueprints, 1s. 6d. each.
65s. Fury (SG, D, RC, Trans) AW370
Self-contained Four (SG, D, LF, Cl B) WM331
Lucerne Straight Four (SG, D, LF, Trans) WM350
45 5s. Battery Four (HF, D, 2LF) WM381
The H.K. Four (SG, SG, D, Pen) WM384
The Auto Straight Four (HF, Pen, HF Pen, DDT, Pen) WM404

Five-valve: Blueprints, 1s. 6d. each
Super-quality Five (2 HF, D, RC, Trans) WM320
Class B Quadradny (2 SG, D, LF Class B) WM444
New Class B Five (2 SG, D, LF Class B) WM340

Mains Operated.
Two-valve: Blueprints, 1s. each
Consoelectric Two (D, Pen) A.C. AW403
Economy A.C. Two (D, Trans) A.C. WM286
Three-valve: Blueprints, 1s. each.
Home Lover's New All-Electric Three (SG, D, Trans) A.C. AW383
Mantovani A.C. Three (HF, Pen, D, Pen) WM374
415 15s. 1936 A.C. Radiogram (HF, D, Pen) WM401

Four-valve: Blueprints, 1s. 6d. each.
All Metal Four 2 SG, D, Pen) WM329
Harris' Jubilee Radiogram (HF, Pen, D, LF, P) WM386

SUPERHETS.
Battery Sets: Blueprints, 1s. 6d. each.
"Varsity" Four WM395
The Request All-Waver WM407

7.6d PW76
PW93
PW31A
PW85
PW93
PW28A
PW91
PW30A
PW63
PW68

PW88
PW28A
PW91
PW30A
PW63
PW68

PW65
PW77
PW86

PW48A

AW427
AW444
AW450

AW387
AW388
AW392
WM409
AW412
AW422
AW437
WM371
WM327
WM337
WM351
WM384

WM371
WM389
WM363
WM306
WM400

AW370
WM331
WM350
WM381
WM384
WM404

WM320
WM444
WM340

AW403
WM286
AW383

WM374
WM401
WM329
WM386

WM395
WM407

These Blueprints are drawn full size.
Copies of appropriate issues containing descriptions of these sets can in some cases be supplied at the following prices which are additional to the cost of the Blueprint. A dash before the Blueprint Number indicates that the issue is out of print.
Practical Wireless (issues dated prior to June 1st, 1940) 4d. Post Paid (issues dated June 1st to July 27th, 1940) 5d. Post Paid (issues dated September, 1940, to November, 1941) 7d. Post Paid (issues dated December, 1941, and after) 10d. Post Paid
Amateur Wireless 4d.
Wireless Magazine 1/4
The index letters which precede the Blueprint Number indicate the periodical in which the description appears: Thus P.W. refers to PRACTICAL WIRELESS, A.W. to Amateur Wireless, W.M. to Wireless Magazine.
Send (preferably) a postal order to cover the cost of the Blueprint, and the issue (stamps over 6d. unacceptable) to PRACTICAL WIRELESS Blueprint Dept., George Newnes, Ltd., Tower House, Southampton Street, Strand, W.C.2.

Mains Sets: Blueprints, 1s. each.
Heptode Super Three A.C. WM350

PORTABLES
Four-valve: Blueprints, 1s. 6d. each.
Holiday Portable (SG, D, LF, Class B) AW393
Family Portable (HF, D, RC, Trans) AW447
Tyrus Portable (SG, D, 2 Trans) WM397

SHORT-WAVE SETS. Battery Operated.
One-valve: Blueprints, 1s. each.
S.W. One-valver for America P.W.15.10.38 AW429
Roma Short-Waver AW452

Two-valve: Blueprints, 1s. each.
Ultra-short Battery Two (SG, det Pen) WM402
Home-made Coil Two (D, Pen) AW440
Three-valve: Blueprints, 1s. each.
Experimenter's 5-metre Set (D, Trans. Super-regen) AW438
The Carrier Short-waver (SG, D, P) WM390

Four-valve: Blueprints, 1s. 6d. each.
A.W. Short-wave World-beater (HF, Pen, D, RC, Trans) AW436
Empire Short-waver (SG, D, RC, Trans) WM313
Standard Four-valver Short-waver (SG, D, LF, P) WM383
Superhet: Blueprint, 1s. 6d.
Simplified Short-wave Super WM397

Mains Operated.
Two-valve: Blueprints, 1s. each.
Two-valve Mains Short-waver (D, Pen) A.C. AW453

Three-valve: Blueprints, 1s.
Emigrator (SG, D, Pen) A.C. WM352
Four-valve: Blueprint, 1s. 6d.
Standard Four-valve A.C. Short-waver (SG, D, RC, Trans) WM391

MISCELLANEOUS
S.W. One-valve Converter (Price 6d.) AW329
Enthusiast's Power Amplifier (1/6) WM387
Listener's 5-watt A.C. Amplifier WM392
Radio Unit (2r.) for WM 392 (1/2) Harris Electrogram battery amplifier (1/-) WM399
De Luxe Concert A.C. Electrogram (1/-) WM403
New Style Short-wave Adapter (1/-) WM388
Trickle Charger (6d.) AW462
Short-wave Adapter (1/-) AW456
Superhet Converter (1/-) AW477
B.L.D.L.C. Short-wave Converter (1/-) WM405
Wilson Tone Master (1/-) WM406
The W.M. A.C. Short-wave Converter (1/-) WM409

FREE ADVICE COUPON
BUREAU
This coupon is available until November 7th, 1942, and must accompany all Queries and Hints.
PRACTICAL WIRELESS, NOV., 1942.

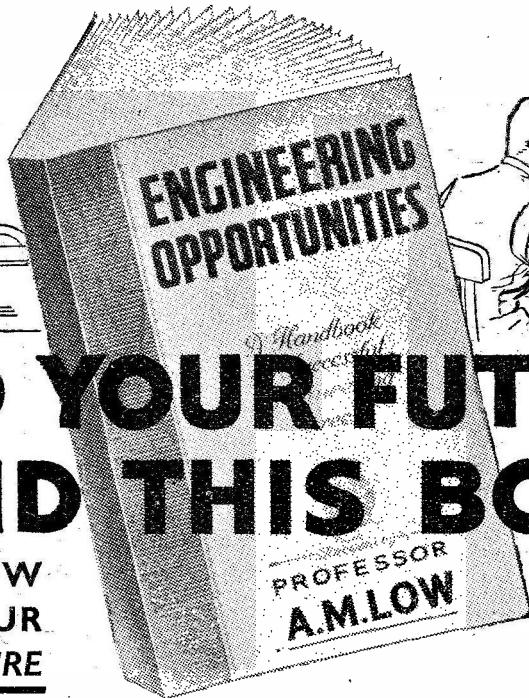
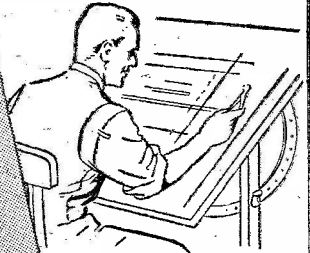
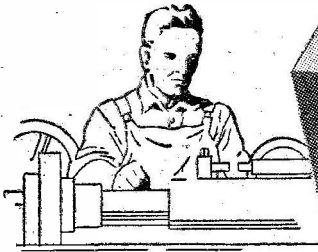

BUILD YOUR FUTURE ROUND THIS BOOK

IT TELLS HOW TO MAKE YOUR FUTURE SECURE

In the more competitive days of peace, technical training will be a vital necessity to the Engineer who wishes to safeguard his position and make advancement. "ENGINEERING OPPORTUNITIES" will show you how to secure this all-important technical training quickly and easily in your spare time. This 112-page book is full of valuable information and explains the simplest way of preparing for recognised Examinations. Among the courses described are:

A.M.I. Mech.E.

Inst. of Production Engineers.
Mechanical Engineering.
Draughtsmanship.
Tracing.
Works Management.
Jig and Tool Design.
Maintenance Engineering.
Diesels.
Inspection.

A.M.I.E.E.

City and Guilds.
Electrical Engineering.
Installations.
Electricity Supply.

A.M.I.C.E.

Civil Engineering.
Structural Design.

L.I.O.B.

Building Construction.
Clerk of Works.

A.F.R.Ae.S.

Air Ministry Licences.
Aeronautical Engineering.

A.M.I.A.E.

Repair Certificates.
Automobile Engineering.
Garage Management.

A.M. Brit. I.R.E.

Wireless.
Radio Servicing.
Television, etc., etc.

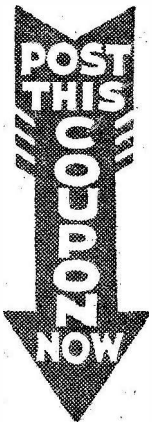

Special Courses for London Matriculation and R.A.F. Mathematics.

If you are earning less than £10 a week you cannot afford to miss reading "ENGINEERING OPPORTUNITIES." Write (or forward the coupon) for your FREE copy immediately.

**WE DEFINITELY
GUARANTEE
"NO PASS
-NO FEE"**

BRITISH INSTITUTE OF ENGINEERING TECHNOLOGY
 409a, SHAKESPEARE HOUSE, STRATFORD PLACE, LONDON, W.1.
 Please forward FREE and post free your 112-page handbook, "ENGINEERING OPPORTUNITIES."

Name..... Address.....

THE B.I.E.T. IS THE LEADING INSTITUTE OF ITS KIND IN THE WORLD

Published on the 7th of each month by GEORGE NEWNES, LIMITED, Tower House, Southampton Street, Strand, London, W.C.2, and printed in England by THE NEWNES & PEARSON PRINTING CO., LTD., Exmoor Street, London, W.10. Sole Agents for Australia and New Zealand: GORDON & GOTCH, LTD., South Africa: CENTRAL NEWS AGENCY, LTD. Subscription rates including postage: Inland 12s 6d per annum; Abroad 10s. per annum. Registered at the General Post Office for the Canadian Magazine Post.