

OCTOBER 1979

Australia 95c; Malaysia \$2.75; New Zealand 95c

55p

TELEVISION

SERVICING-VIDEO-CONSTRUCTION-DEVELOPMENTS



COLOUR RECEIVER OPTIONS
PART 1-ADDING TELETEXT
SERVICING PORTABLES
THE SECAM COLOUR SYSTEM

PHD COMPONENTS
RADIO & TV COMPONENT DISTRIBUTORS
 UNIT 7 CENTENARY ESTATE
 JEFFRIES RD ENFIELD MDDX
 MAIL ORDER ONLY TELEX 261295

ALL COMPONENTS OFFERED SUBJECT TO AVAILABILITY. WE RESERVE THE RIGHT TO SUBSTITUTE REPLACEMENTS SHOULD THE ORIGINAL PART BE OUT OF STOCK OR UNAVAILABLE!
PLEASE ADD 0.35p per parcel post and packing.

SEMICONDUCTORS

AA113	0.16	BC117	0.20	BU208/02	3.00
AA116	0.16	BC119	0.20	BU2355	1.50
AA117	0.16	BC125	0.20	BU406	2.00
AA119	0.16	BC126	0.20	BU406D	2.00
OA91	0.12	BC136	0.20	BU407	2.00
OA95	0.12	BC137	0.20	BU407D	2.50
OA202	0.18	BC138	0.20	BZ3089	2.50
BA100	0.18	BC139	0.40	R2010B	2.50
BA102	0.10	BC140	0.40	R2540	3.00
BA130	0.15	BC142	0.40	ME0402	0.20
BA154	0.10	BC143	0.40	ME0412	0.20
BA155	0.20	BC147	0.40	ME4003	0.15
BA164	0.12	BC148	0.15	ME6002	0.20
BAX13	0.16	BC149	0.15	ME8001	0.20
BAX16	0.08	BC153	0.15	MJE2995	1.50
BAY38	0.16	BC154	0.15	NJE3005	1.00
BY206	0.20	BC157	0.15	MP8113	1.20
IN4148	0.04	BC158	0.15	MPSU05	1.00
BY126	0.20	BC159	0.15	MPSU55	1.00
BY127	0.15	BC160	0.40	TIP2955	1.30
BY133	0.22	BC161	0.40	TIP3055	1.30
BY164	0.50	BC170	0.15	TIS300M	0.60
SKB2/08	1.00	BC171	0.15	TIS91M	0.15
BY238	0.15	BC172	0.20	2N2904	0.50
BYX10	0.18	BC177	0.20	2N2905A	0.50
IN4001	0.10	BC178	0.20	2N2905	0.50
IN4002	0.10	BC179	0.20	2N3253	0.20
IN4003	0.12	BC182L	0.15	2N3705	0.20
IN4004	0.12	BC183L	0.15	2N3707	0.20
IN4005	0.12	BC184L	0.15	2N3710	0.20
IN4006	0.14	BC184LC	0.15	2N3955H	0.75
IN4007	0.16	BC186	0.30	TAA350	3.00
IN5407	0.33	BC187	0.30	TAA550	0.60
BR100	0.50	BC203	0.15	TAA570	1.80
BR101	0.60	BC204	0.15	TAA611	1.75
BRV39	0.60	BC205	0.15	TAA830S	2.50
TIC1160N	1.50	BC206	0.15	TAA861B	2.00
BT119	2.50	BC207	0.15	SN76540N	1.50
BT120	2.50	BC208	0.15	TAD100	2.00
BYX 71-1600	0.60	BC209	0.15	TBA120AS	0.75
2N444	1.50	BC212L	0.20	TBA231	1.00
TV106 2	1.50	BC213L	0.15	TBA4800	1.00
BYX88CZV7	0.10	BC214L	0.15	TBA5200	2.00
BZV88 3V0	0.10	BC225	0.40	TBA5300	2.00
BZV88 3V2	0.10	BC230	0.15	TBA5400	2.00
BZV88 3V6	0.10	BC232	0.15	TBA5400	2.00
BZV88 3V9	0.10	BC251A	0.15	TBA560	3.00
BZV88 4V3	0.10	BC301	0.40	TBA550Q	3.00
BZV88 4V7	0.10	BC303	0.50	TBA590C	2.00
BZV88 5V1	0.10	BC307	0.15	TBA560CQ	2.50
BZV88 5V6	0.10	BC308	0.15	TBA570	2.50
BZV88 6V2	0.10	BC327	0.15	TBA5700	2.50
BZV88 6V8	0.10	BC328	0.15	TBA641Bx	3.00
BZV88 7V5	0.10	BC337	0.15	TBA641Bx11	4.00
BZV88 8V2	0.10	BC338	0.15	TBA651	3.00
BZV88 9V1	0.10	BC547	0.15	TBA720A	1.50
BZV88 10V	0.10	BC141-10	0.80	TBA730	1.50
BZV88 11V	0.10	BD115	0.50	TBA760	2.00
BZV88 12V	0.10	BD124	2.00	TBA750Q	2.00
BZV88 13V	0.10	BD131	0.70	TBA800	1.00
BZV88 15V	0.10	BD132	0.60	TBA810S	2.50
BZV88 18V	0.10	BD133	0.70	TBA820	2.00
BZV88 20V	0.10	BD134	0.70	TBA820	1.50
BZV88 22V	0.10	BD144	2.50	TBA920Q	2.00
BZV88 27V	0.10	BD159	2.80	TBA990	2.00
BZV88 33V	0.10	BD238	0.50	TBA990Q	2.00
BZX61 7V5	0.25	BD380	0.70	TCA270SA	1.00
BZX61 8V2	0.25	BD441	0.70	TCA300	1.00
BZX61 9V1	0.25	BD537	0.70	TCA940	2.00
BZX61 10V	0.25	BD538	0.70	TDA1170	2.00
BZX61 11V	0.25	BD507	0.70	TDA1200	2.00
BZX61 12V	0.25	BD508	0.75	TDA1270	4.00
BZX61 13V	0.25	16181	1.20	TDA1412	4.00
BZX61 15V	0.25	16182	1.20	TDA2020	4.00
BZX61 16V	0.25	BD709	1.00	SN76115N	1.00
BZX61 18V	0.25	BD710	1.00	SN76227N	1.20
BZX61 20V	0.25	BD442	0.70	SN76300	1.00
BZX61 22V	0.25	BD379	0.50	SN76511N	1.00
BZX61 24V	0.25	BF117	0.60	SN76003N	3.00
BZX61 27V	0.25	BF118	0.60	SN76013N	2.00
BZX61 30V	0.25	BF152	0.40	SN76013ND	2.00
BZX61 33V	0.25	BF154	0.20	SN76013ND	2.00
BZX61 36V	0.25	BF157	0.70	SN76023ND	2.00
BZX61 39V	0.25	BF158	0.40	SN76033N	2.00
BZX61 42V	0.25	BF160	0.60	SN76101N	2.00
BZX61 47V	0.25	BF163	0.60	SN76110N	2.00
AC107	0.35	BF167	0.50	SN76226DN	2.00
AC127	0.50	BF173	0.50	SN76227N	1.20
AC127/01	0.60	BF177	0.50	SN76532N	2.00
AC128	0.60	BF179	0.50	SN76533N	2.00
AC128/01	0.60	BF180	0.50	SN76544N	2.00
AC141	0.50	BF181	0.60	SN76604	1.00
AC141K	0.60	BF182	0.60	SN76659N	1.00
AC142	0.40	BF183	0.50	SN76666N	1.20
AC142K	0.60	BF184	0.50	SL901B	6.00
AC176	0.60	BF185	0.50	SL917B	8.00
AC176/01	0.60	BF194	0.15	TBA3960	2.00
AC186	0.40	BF196	0.15	TDA440	2.50
AC187	0.40	BF197	0.15	SN76001N	2.00
AC187K	0.60	BF197	0.15	TBA520	2.00
AC188	0.40	BF198	0.15	TBA120S	1.00
AC188K	0.60	BF199	0.15	UA7824	0.50
AD140	1.50	BF200	0.15	TBA396	2.00
AD142	1.60	BF224	0.15	TCA270SQ	1.00
AD143	1.50	BF240	0.15	TDA2030	8.00
AD145	1.50	BF241	0.15	TDA2140	6.00
AD148	1.00	BF256LC	0.50	TDA2150	6.00
AD161/2	1.50	BF257	0.50	TDA2180	6.00
AD162	0.70	BF258	0.50	TDA1230	3.00
AD262	1.50	BF271	0.60	TDA3089	2.00
AF114	0.60	BF273	0.20	TDA185AM	2.00
AF115	0.60	BF274	0.25	MC1349P	0.25
AF116	0.60	BF336	0.50	SA4661	0.60
AF117	0.80	BF337	0.50	SAS560S	2.00
AF118	0.60	BF338	0.50	SAS570S	2.00
AF121	0.60	BF355	0.80	SN7400N	0.40
AF124	0.60	BF458	1.00	SN7413N	0.90
AF125	0.60	BF459	1.00	SN74122N	1.00
AF126	0.60	BF143	0.50	SN74141N	1.00
AF127	0.60	BFX29	0.50	TBA396	1.80
AF139	1.00	BFX64	0.50	TBA3960	1.80
AF239	1.00	BFX88	0.50	TBA950	4.00
AL102	3.00	BFX89	0.50	TCA800	4.00
AU107	3.00	BFY50	0.50	TCA800Q	4.00
AU110	3.00	BFY51	0.50	TDA1180	3.00
AU113	3.00	BFY52	1.50	TDA1190	3.00
AL103	3.00	BFY90	1.20	TDA2002H	3.60
AY102	3.00	BF381	0.50	TDA2580Q	5.00
BC107	0.20	BFR39	0.30	TDA2600	5.00
BC108	0.20	BFR79	0.30	TDA2640	3.00
BC113	0.15	BFR81	0.30	TDA3950	3.00
BC114	0.15	BFR89	0.50	TAA621 AX1	3.30
BC115	0.20	BF259	0.25	TBA625X5	2.00
BC116	0.20	BDX32	2.50	TCA830S	2.00
	0.20	BU206	1.60	TDA2020/A2	5.00

PHD COMPONENTS
MULTISECTION CAPACITORS

DECCA 400 400/350	3.72
DECCA 80/100 400/350 + 800/250	4.00
GECC 200 200 150 50/350	3.00
GECC 1000 2000 300	2.10
GECC Philips GB 800/250	2.10
GECC Philips GB 600/300	2.50
ITT/KB 200 200 75-25/350	3.00
ITT CVC 20 200/400	2.20
Philips C11 470/250	1.50
PYE 601 200-300/350	2.80
PYE 1000 1000/40	0.90
PYE 731 800/250	2.50
RRI 2500/2500/30	1.30
RRI 600/300	2.50
RRI 300 - 300/300	2.50
TCE 950 100 300 100 16	1.00
TCE 1400 150 100 100 100 150	3.70
TCE 1500 150 150 100	2.10
TCE 3000 3500 175 400 + 100 + 100 350 70	2.10
TCE 3000 3500 220 100	0.70
TCE 8000 8500 2500 2500 63	1.50
TCE 8000 8500 700 200	1.00
TCE 8000 8500 700 350	1.00
TCE 9000 400 400	3.00
TCE 9500 220 400	2.20

VALVES - ALL VALVES
"MAZDA" BRAND

DY/86/87	1.20
DY802	1.20
ECC82	1.10
ECC84	1.35
ECH83	1.00
ECH84	2.00
ECL80	1.50
ECL82	1.30
ECL86	1.50
EF80	1.20
EF95	0.70
EF183	1.10
EF184	1.10
EL34	3.00
EL84	1.40
GY501	2.40
PC97	1.60
PC300	1.75
PCF80	1.50
PCF802	1.50
PCF806	2.50
PCL 52	2.00
PCL84	1.50
PCL85/80S	1.50
PCL86	1.50
PD600/510	5.00
PF1200	3.00
PL36	2.00
PL81	1.00
PL504	1.60
PL508	2.40
PL509	2.20
PL519	5.00
PL802	3.20
PV88	1.80
PV500A	2.40
PV800/901	1.40
UCL22	1.50
30FL2 1	1.60
PCF805	1.00
PCF808	1.50

MAINS DROPPERS

TCE 140 128 - 16, IK7 - 116 - 462, 126	1.10
TCE 1500 350 - 20, 148, IK5, 317	0.90
TCE 1600 18 Thermal Link 320 - 70, 39	1.00
TCE 300 3500 6.1 - 100	0.60
TCE 800 56 + 1K, 47, 12	0.90
Philips GB 2.2 - 68	0.60
Philips 210 30 - 125, 2K85	0.50
Philips 210 118 + 148	0.60
[Link]	
RRI 141 154 + 50 - 16 84	0.60
RRI AR642 10 - 14 - 156	0.90
GEC 27840 10 - 15 - 19 - 10 - 63 - 188	1.00
GEC 2000	0.80
PYE 731, 735 56 - 27	1.00
PYE 11009 60 - 70 - 173 - 26 - 16 - 17	1.00
- 19	

DIRECT REPLACEMENT PARTS

173 Tuner (Repl Ele 1043/05)	8.00
4 443MHz Crystals	2.00
Cut Out TCE 3500	2.00
Cut Out GEC	2.50
Cut Out TCE 8500	2.00
TV18 Rectifier Stick	2.00
TV20 Rectifier Stick	2.00
VA 1104 Thermistor	0.60
Transducer TCE 3000	1.50
AEG Tuner (Repl Ele 1043/05)	9.00
Aeriel Isolator Kit	1.00
Philips GB Lopt	12.00
PYE 691/697 Lopt	1.00
Bush A 774 Lopt	18.00
Decoder Panel Autovox 2282	10.00
Degaussing Panel Autovox 2282	2.00
Sound Q P Panel Autovox 2282	4.00
PS Panel Autovox 2282	6.00
Comp Control Unit Autovox 2282	3.00
Field TB Unit	1.00
IF Tuner Assembly Autovox 2282	7.50
TCE 850 Lopt	1.00
TCE 900 Half Wave	0.50
Delayline SDL 141	1.20
Pye 95 150	1.50
GCE 2110 Degauss Panel	1.50

CONNECTORS

Sets of AVO Leads	10.00
Plug 13A (Box of 20)	6.50
At Coax Plugs Pack of 25	4.00
Plug Top 34 (Box of 20)	0.50
6DB Attenuator</	

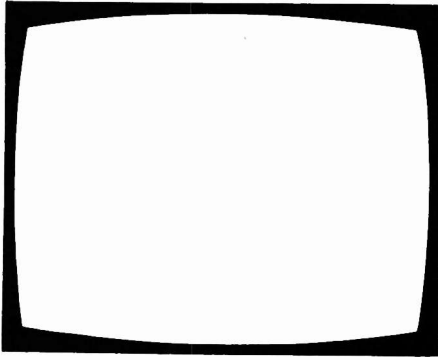

TELEVISION

October
1979

Vol. 29, No. 12
Issue 348

COPYRIGHT

© IPC Magazines Limited, 1979. Copyright in all drawings, photographs and articles published in *Television* is fully protected and reproduction or imitation in whole or in part is expressly forbidden. All reasonable precautions are taken by *Television* to ensure that the advice and data given to readers are reliable. We cannot however guarantee it and we cannot accept legal responsibility for it. Prices are those current as we go to press.

CORRESPONDENCE

All correspondence regarding advertisements should be addressed to the Advertisement Manager, "Television", King's Reach Tower, Stamford Street, London SE1 9LS. Editorial correspondence should be addressed to "Television", IPC Magazines Ltd., Lavington House, Lavington Street, London SE1 0PF.

SUBSCRIPTIONS

An annual subscription costs £9.50 in the UK, £10.50 overseas (\$21 Canada or USA). Send orders with payment to IPC Services, Oakfield House, Perrymount Road, Haywards Heath, Sussex.

BINDERS AND INDEXES

Binders (£2.85) and Indexes (45p) can be supplied by the Post Sales Department, IPC Magazines Ltd., Lavington House, 25 Lavington Street, London SE1 0PF. Prices include postage and VAT. In the case of overseas orders, add 60p.

BACK NUMBERS

Some back issues are available from the Post Sales Department, IPC Magazines Ltd., Lavington House, 25 Lavington Street, London SE1 0PF at 70p inclusive of postage and packing.

QUERIES

We regret that we cannot answer technical queries over the telephone nor supply service sheets. We will endeavour to assist readers who have queries relating to articles published in *Television*, but we cannot offer advice on modifications to our published designs nor comment on alternative ways of using them. All correspondents expecting a reply should enclose a stamped addressed envelope.

Requests for advice in dealing with servicing problems should be directed to our Queries Service. For details see our regular feature "Your Problems Solved". Send to the address given above (see "correspondence").

this month

- 623 Leader**
- 624 Teletopics**
News, comment and developments.
- 626 Letters**
- 627 Up the Family Tree** *by Les Lawry-Johns*
A visit from Aunt Tessa provokes some recollections before we get on with the faulty sets and, as had to happen, the challenge from the Red Baron . . .
- 632 Colour Receiver Options Part 1: Adding Teletext** *by Luke Theodossiou*
Adding teletext reception to the colour receiver project described last year. The simple approach adopted uses a Tifax decoder module, interface board and cable-linked keypad.
- 636 Miller's Miscellany** *by Chas E. Miller*
Various fault experiences, and a further instalment in the Guide to Coarse Servicing.
- 638 Long-Distance Television** *by Roger Bunney*
Reports on DX reception and conditions, and news from abroad. Plus guidance on the simplest way to start DXing – with a u.h.f. receiver, up-converter and v.h.f. aerial(s).
- 642 Servicing Pye Solid-State Colour Receivers, Part 2** *by Mike Phelan*
This time the signals side of the chassis, including the four-chip decoder and its adjustments.
- 646 Readers' PCB Service**
- 647 The SECAM Colour System** *by Keith Cummins*
Following a recent visit to France, Keith Cummins describes the basic principles of the French colour system and the results it gives.
- 649 Next Month in Television**
- 650 Tackling Mains-Battery Portables** *by John Law*
Mains-battery portables, with their need for voltage regulation and the multiple supplies derived from the line output stage, can be confusing to those not familiar with them. Common circuitry and faults are described.
- 653 Sinclair's New Mini TV** *by D. K. Matthewson, B.Sc., Ph.D.*
Sinclair is proposing to put into production a new miniature monochrome portable featuring a flat tube. The operation of this device is described.
- 654 TV Servicing: Beginners Start Here . . . Part 25** *by S. Simon*
Continuing with colour sets and the things that go wrong with them, this month we take a look at RGB tube drive systems.
- 658 Service Notebook** *by George Wilding*
Notes on faults and how to tackle them.
- 659 Your Problems Solved**
- 661 Test Case 202**

OUR NEXT ISSUE DATED NOVEMBER WILL BE
PUBLISHED ON OCTOBER 15

THE UNBEATABLE BRIARWOOD SERVICE

EX-EQUIPMENT SPARES

MISC. S/Output Trans.
£1 - VAT + £1 P&P
F/Output Trans.
£1.25 + VAT + £1 P&P.
Scancoils £1.50 + VAT
+ £1 P&P. Other
spares available, please
write or phone for details.

MONO TUBES

(tested)
19" Rimguard £3.00
23" Rimguard £4.00
20" Rimguard £5.00
24" Rimguard £6.00
+ £5.00 P.&P.

MONO TUNERS

6-button integrated all
at £4.00
U.H.F. P/Button D/S
£3.50. U.H.F. P/Button
S/S £4.00. Rotary £3.00
+ £1 P&P.

MONO LOPTS

All D/Standard Lopts
at £4.00 - £1 P.&P.
All S/Standard at
£5.00 + £1 P.&P.

MONO PANELS

i.e. Philips, Bush etc.
£3.50 + £1 P.&P.
Quotations for
complete
S/hand chassis if
required. (Diff. prices)

PLEASE ADD 15% V.A.T.
TO ALL ITEMS AND
OVERSEAS AT COST.
CASH WITH ALL ORDERS.

VALVES (MONO & COLOUR)

PCL82	0.10	30C1	0.10	PCC189	0.10	EF183	0.10	PL504	0.25	ECL80	0.10
PCL83	0.25	30C17	0.10	30C15	0.10	EF184	0.10	6/30L2	0.10	PL509	1.00
PCL84	0.10	PCF802	0.10	30C18	0.25	6BW7	0.10	30PL1	0.25	PY500	1.00
PCL85	0.10	PCF805	0.25	PC97	0.20	EH90	0.10	30PL13/4	0.10	GY501	1.00
PCL86	0.10	PCF806	0.10	PC900	0.10	DY802	0.10	30FL1/2	0.25	PL508	0.50
PFL200	0.10	PCF808	0.25	EF80	0.10	PY800/1	0.10	ECC82	0.10	PCF200	0.50
PCF801	0.10	PCF80	0.10	EF85	0.10	PL36	0.25	ECC81	0.10	EY51	0.15

Please note there is 25p Postage and Packing per order.

WE DO NOT SELL RUBBISH
AT BRIARWOOD TV

D/STANDARD COLOUR SPARE PANELS

	IF	LUM	CHROMA	EHT	REG	CON	S/OUTPUT	POWER	L/TB	F/TB
Bush/Murphy	5.00	5.00	6.50	—	—	5.00	1.50	5.00	—	—
GEC/Sobell	5.00	5.50	—	—	—	5.00	—	—	—	7.50
Philips	5.00	7.00	—	—	—	5.00	—	—	—	5.00
Decca	5.00	9.00	9.00	—	—	5.00	2.00 (19" only)	6.00	—	5.00
Thorn 2000	5.00	5.00	5.00	6.50	6.50	7.00	—	6.50	10.00	5.00
Pye	7.00	6.00	7.00	—	—	5.00	—	—	—	5.00
Baird	6.50	8.50	7.00	—	—	5.00	—	—	—	5.00

Postage & Packing £1.25

S/STANDARD COLOUR SPARE PANELS

	IF	LUM	CHROMA	VIDEO	CON	POWER	L/TB	F/TB
Bush 184	9.50	—	12.00	—	6.00	6.00	12.00	—
GEC Hybrid	6.00	6.50	9.00	—	5.00	—	—	12.00
Philips G6 S/S	9.50	—	10.00	—	5.00	—	—	6.00
Thorn 3000	6.00	6.00	6.00	—	5.00	20.00	20.00	6.00
Pye 691/693	6.00	6.00	8.00	—	5.00	—	15.00	5.00
Thorn 3500	6.00	6.00	6.00	6.50	7.50	20.00	20.50	6.00

Postage & Packing £1.25

Korting and other foreign
panels available on request.

COLOUR TUBES

19" £18.00
19" A49, 192 £20.00
20" £20.00
22" £22.00
25" £18.00
26" £28.00
Plus P&P £5.00

NEW Rebuilt tubes

available on request.

COLOUR TUNERS

Bush £5.00
GEC £5.00
Philips G6 S/S £5.00
Thorn 3000 £5.00
Pye 691 £5.00
Some new tuners in stock,
can supply on request. Many
Foreign Tuners also available
on request. Plus P&P £1.

COLOUR LOPTS

Most Lopts available
from £7.00. Both
British & Foreign
makes. Please ring
or write.
P&P per Lopt £1.

MISC.

S/Output transformer
from £1.50.
F/Output from £1.25.
Scancoils from £5.00.
P&P £1.
Other spares available on
request.

THORN 1500 TUNERS

NEW SPECIAL OFFER
AT £8.00

Postage & Packing £1.00

MAIL ORDER T.V.s. IN GOOD WORKING ORDER

COLOUR				MONO			
Pye	19"	£60.00	22" £65.00	26" £75.00	20" & 24" S/S	£16.00	Pye, GEC, Bush etc.
GEC	19"	£60.00	22" £65.00	26" £75.00	20" & 24" D/S	£14.00	Pye, GEC, Bush etc.
Bush	19"	£80.00	22" £80.00	26" £90.00	19" & 23" D/S P/button	£12.00	Pye, GEC, Bush etc.
Philips	G6	—	22" £63.00	26" £70.00	19" & 23" D/S Rotary	£8.00	Pye, GEC, Bush etc.

Many other makes & models available.
Please ring or write for information.

PERSONAL CALLERS
WELCOME.

Please note there is 15% V.A.T. on all the above prices.
Plus £8 P&P. England, Wales & Scotland for colour T.V.'s.
Inland N. & S. Ireland P&P £15. P&P £5 for mono T.V.'s
to England, Wales & Scotland. Inland N. & S. Ireland £7
per set.

Briarwood T.V. Limited
Britain's Mail Order
T.V. Specialists

BRIARWOOD



THE LARGEST STOCKS OF

GENUINE PART-EXCHANGED COLOUR T.V.'s IN THE COUNTRY - UNDER ONE ROOF.

REGULAR LARGE DELIVERIES EVERY WEEK INCLUDE—

Philips 511/512/G8 etc., Bush, Murphy, Thorn 3000/3500/8000/8500, GEC all models, Pye Varicap, Grundig, Telefunken, Saba, Decca Bradford, Nordmende, B. & O., Emo, Finlux, Luxor, Korting, Hitachi, Sanyo, Toshiba, etc., etc., etc.

SPECIAL LOW SUMMER PRICES

Now in operation

DUAL STANDARD FROM £5 + VAT

SINGLE STANDARD FROM £20 + VAT

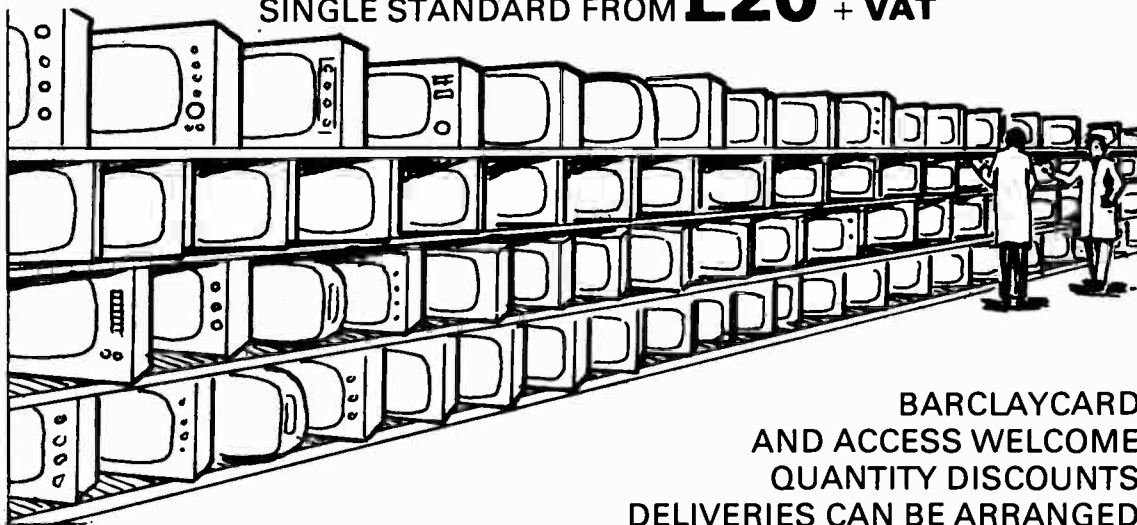

BARCLAYCARD AND ACCESS WELCOME
QUANTITY DISCOUNTS
DELIVERIES CAN BE ARRANGED

SUPERB TESTING FACILITIES AVAILABLE

**OTV TELEVISION LTD,
144A Lea Bridge Rd,
London E5 9RB.
Tel: 01-985 6111/8687**

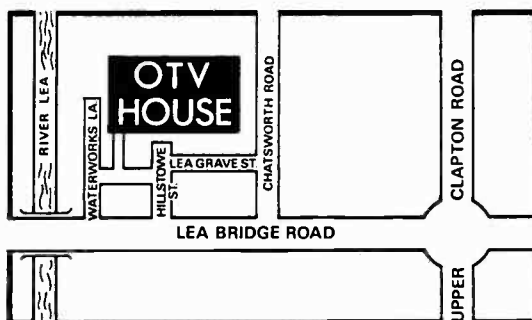

We specialise in Export

Enquiries invited from the Middle East and Third World Countries.

ARE YOU IN THE DARK? ..ABOUT OUR



COLOUR T.V. PANEL EXCHANGE REPAIR SERVICE

FULL RANGE OF
THORN · RBM · PHILIPS
PYE · INVICTA · GEC
DECCA · TELPRO
AND MANY OTHER MAKES

90 DAY GUARANTEE ON ALL REPAIRS
SAME DAY POSTAL SERVICE

We employ a large skilled Staff, who utilise some of the most sophisticated Test equipment available, inclusive of AUTOMATIC FAULT FINDING COMPUTERS together with specially designed SERVICING JIGS which in short means to you :-

HIGH QUALITY REPAIRS - AT LOW COST



ONE OFF
OR



100 OFF · NO ORDER TOO
LARGE OR SMALL

SEND FOR PRICE LIST

SEND FOR CATALOGUE
BLOCK DISCOUNTS FOR TRADE CONTRACTS

TO

Campbell Electronics Ltd.

Factory Unit E5, Halesfield 23, Telford · Shropshire · TF7 4QX
Telephone: Telford (0952) 584373, Ext. 2. Telex 35 191 Chamcon

TV LINE OUTPUT TRANSFORMERS

by FAST RETURN OF POST SERVICE

MONO LOPTS

Most makes supplied

£6.90 TRADE

£7.50 RETAIL

p&p 75p

COLOUR LOPTS

Philips G8, ITT CVC5-9, Decca Bradford series 10 & 30

£8.35 TRADE

£9.50 RETAIL

p&p 75p

WINDINGS p. & p. 50p.

Bush colour. (Hybrid quadrupler version)

£6.25

Decca CTV19/25 (non-tripler version)

Primary £6.25

EHT £7.20

Philips G6 (dual & single standard)

Primary £6.25

(EHT winding on exchange basis only)

EHT £7.20

Pye 691, 693 & 697 (please state which)

Primary £4.60

EHT £3.10

EMO 90 degree

Primary £6.25

PRICES INCLUDE 15% VAT

S.A.E. all enquiries

All lopts and windings are new and guaranteed for 6 months.

PAPWORTH TRANSFORMERS

80 Merton High Street
London SW19 1BE

01-540 3955

Technical Training in Radio, Television and Electronics

Start training TODAY and make sure you are qualified to take advantage of the many opportunities open to trained people. ICS can further your technical knowledge and provide the specialist training so essential to success.

ICS, the world's most experienced home study college has helped thousands of people to move up into higher paid jobs - and they can do the same for you.

Fill in the coupon below and find out how!

There is a wide range of courses to choose from, including:

City and Guilds Certificates:-

Telecommunications Technicians,
Radio, TV and Electronics Technicians,
Electrical Installation Work,
Technical Communications,
Radio Amateur,
MPT General Radio Communications
Certificate.

Diploma Courses:-

Electronic Engineering,
Electrical Engineering,
Computer Engineering,
Radio, TV, Audio Engineering, Servicing and
Maintenance (inc. Colour TV)
New Self-Build Radio Courses with Free Kits.

Colour TV Servicing

Technicians trained in TV Servicing are in constant demand. Learn all the techniques you need to service Colour and Mono TV sets through new home study courses which are approved by a leading manufacturer.

The ICS Guarantee

If you are studying for an examination, ICS will guarantee coaching until you are successful - at no extra cost.

POST OR PHONE TODAY FOR FREE BOOKLET.

I am interested in

Name

Address

..... Phone No:

ICS International Correspondence Schools,
Dept. M285, Intertext House,
LONDON SW8 4UJ. Tel 622 9911
(all hours)

TRANSISTORS, ETC.

Type	Price (£)	Type	Price (£)	Type	Price (£)	Type	Price (£)	Type	Price (£)	Type	Price (£)	Type	Price (£)	Type	Price (£)
AC107	0.48	AU103	2.40	BC192	0.56	BC377	0.29	BD234	0.68	BF222	10.51	BPX29	1.62	ZX500	10.18
AC117	0.38	AU107	2.76	BC204*	10.39	BC394	0.39	BD235	0.63	BF224 & J	10.22	BR101	0.53	ZX502	10.22
AC128	0.36	AU110	2.40	BC205*	10.39	BC409	0.39	BD236	0.63	BF240	10.32	BR103	0.64	ZX504	10.28
AC129	0.54	BC107*	0.16	BC206*	10.37	BC441	0.59	BD238	0.68	BF241	10.31	BR303	1.06	ZX504	10.28
AC128K	0.46	BC107*	0.16	BC207*	10.39	BC461	0.78	BD238	0.68	BF244*	10.51	BR4443	1.76	ZX504	10.28
AC141	0.65	BC108*	0.18	BC208*	10.37	BC477	0.30	BD253	1.68	BF245*	10.43	BR4443	1.76	ZX504	10.28
AC141K	0.70	BC113	0.12	BC209*	10.39	BC478	0.25	BD410	1.65	BF254	10.48	BR558	10.44	ZX504	10.28
AC142	0.60	BC114	0.22	BC211*	10.36	BC479	0.33	BD433	0.65	BF255	10.58	BSS27	0.92	ZX504	10.28
AC142K	0.65	BC115	0.24	BC212*	10.17	BC547*	10.13	BD435	0.70	BF256*	10.49	BT106	1.80	ZX504	10.28
AC151	0.31	BC116*	0.26	BC213*	10.16	BC548*	10.13	BD436	0.71	BF257	10.44	BT109	1.99	ZX504	10.28
AC152	0.36	BC117	0.30	BC213*	10.16	BC549*	10.16	BD437	0.74	BF258	10.44	BT116	1.45	ZX504	10.28
AC153	0.42	BC118	0.24	BC214*	10.18	BC550	10.24	BD438	0.76	BF259	10.54	BT119	1.48	ZX504	10.28
AC153K	0.62	BC119	0.34	BC214*	10.18	BC551*	10.23	BD519	0.88	BF282	0.73	BU102	2.85	ZX504	10.28
AC154	0.41	BC122	0.20	BC225	10.42	BC558*	10.16	BD520	0.88	BF283	0.68	BU105	11.80	ZX504	10.28
AC178	0.48	BC125	0.30	BC237*	10.16	BC559*	10.17	BD599	0.87	BF270	0.47	BU105/02	11.80	ZX504	10.28
AC178K	0.51	BC132	0.20	BC238*	10.15	BCY10	0.30	BD600	1.23	BF271	0.42	BU108	12.88	ZX504	10.28
AC179	0.55	BC134	0.22	BC239*	10.22	BCY30A	1.06	BDX18	1.55	BF272	0.33	BU204	12.80	ZX504	10.28
AC187	0.56	BC135	0.21	BC251*	10.25	BCY32A	1.19	BDX32	2.95	BF274	10.34	BU205	12.76	ZX504	10.28
AC187K	0.65	BC136	0.22	BC252*	10.28	BCY34A	1.02	BDY16A	0.63	BF336	0.63	BU206	13.09	ZX504	10.28
AC188	0.52	BC137	0.30	BC253*	10.38	BCY72	1.27	BDY18	1.55	BF337	0.65	BU208	14.88	ZX504	10.28
AC188K	0.61	BC138	0.36	BC261A*	10.28	BD115	1.35	BDY20	2.29	BF338	0.88	BU407	11.38	ZX504	10.28
AC193K	0.70	BC140	0.38	BC282A*	10.28	BD123	1.50	BDY38	1.38	BF355	10.72	BU477	2.80	ZX504	10.28
AC194K	0.74	BC141	0.44	BC283*	10.28	BD124	1.85	BF115	0.48	BF382	10.49	CI06D	0.80	ZX504	10.28
ACY17	1.20	BC142	0.36	BC286*	0.20	BD130Y	1.56	BF117	0.48	BF383	10.49	CI06F	0.80	ZX504	10.28
ACY19	2.05	BC143*	0.38	BC287*	0.28	BD131	0.82	BF120	0.55	BF387	10.29	CI11E	10.48	ZX504	10.28
ACY28	0.98	BC147*	10.12	BC288	0.40	BD132	0.88	BF121	0.55	BF451	0.43	D40N1	0.64	ZX504	10.28
ACY29	0.92	BC148*	10.12	BC287	0.49	BD133	0.70	BF123	0.48	BF457	0.48	E1222	0.47	ZX504	10.28
AD140	1.70	BC149*	10.13	BC291	0.27	BD135	10.37	BF125	0.68	BF458	0.49	ES024	10.19	ZX504	10.28
AD142	1.90	BC152	0.42	BC294	10.37	BD136	10.38	BF127	0.51	BF459	0.52	ETB72	0.46	ZX504	10.28
AD143	1.78	BC153	0.46	BC297	0.36	BD137	0.40	BF137F	0.78	BF594	10.16	MC140	10.36	ZX504	10.28
AD149	1.92	BC154	10.31	BC300	0.62	BD138	0.42	BF158	10.19	BF598	10.17	MF0402	10.18	ZX504	10.28
AD161	0.66	BC157*	10.13	BC301	0.38	BD139	0.46	BF158	10.25	BF599	10.27	MF0404/02	10.18	ZX504	10.28
AD161/162	1.22	BC158*	10.12	BC302	0.88	BD140	0.60	BF159	10.26	FR39	10.30	MEB001	10.18	ZX504	10.28
AD162	0.71	BC159*	10.14	BC303	0.64	BD144	2.24	BF160	10.20	FR40	10.29	MEB002	10.18	ZX504	10.28
AF114	0.35	BC160	0.62	BC304	0.44	BD145	0.75	BF161	0.84	FR41	10.20	MJ2955	1.30	ZX504	10.28
AF115	0.35	BC161	10.68	BC307*	10.17	BD150A*	10.51	BF163	10.85	FR50	10.29	MJ3000	1.58	ZX504	10.28
AF116	0.41	BC167B	10.55	BC309*	0.18	BD157	0.81	BF164	10.95	FR52	10.29	MJ3340	0.68	ZX504	10.28
AF117	0.42	BC168B	10.55	BC317*	10.15	BD158	0.75	BF167	0.38	FR62	10.28	MJ3370	0.74	ZX504	10.28
AF118	0.38	BC169C	10.15	BC318*	10.15	BD159	0.88	BF173	0.35	FR79	10.30	MJE371	0.79	ZX504	10.28
AF121	0.88	BC170*	10.15	BC319*	10.19	BD160	2.89	BF177	0.38	FR80	10.29	MJE520	0.85	ZX504	10.28
AF124	0.38	BC171*	10.14	BC320	10.17	BD163	0.67	BF178	0.48	FR81	10.30	MJE521	0.95	ZX504	10.28
AF125	0.38	BC172*	10.14	BC321A&B	10.18	BD165	0.66	BF179	0.68	FR88	10.42	MJE2955	1.20	ZX504	10.28
AF126	0.36	BC173*	10.22	BC322	10.28	BD166	0.88	BF180	0.53	FT41	0.48	MJE3000	1.95	ZX504	10.28
AF127	0.86	BC174A & B	10.26	BC323	1.15	BD175	0.90	BF181	0.53	FT43	0.55	MJE3055	1.22	ZX504	10.28
AF139	0.58	BC176	0.22	BC327	10.18	BD177	0.88	BF182	0.44	FW11	10.22	MPF102	10.40	ZX504	10.28
AF147	0.82	BC177*	0.20	BC328	10.18	BD178	0.92	BF183	0.62	FW30	2.58	MPS3702	10.33	ZX504	10.28
AF148	1.38	BC178*	0.22	BC337	10.17	BD181	1.94	BF184	0.44	FW59	10.19	MPS3705	10.30	ZX504	10.28
AF179	1.36	BC179*	0.28	BC338	10.17	BD182	2.10	BF185	0.42	FW60	10.20	MPS8521	10.38	ZX504	10.28
AF180	1.35	BC182*	10.15	BC340*	0.19	BD183	1.34	BF188	0.42	FW90	10.65	MPS8523	10.36	ZX504	10.28
AF181	1.32	BC182L*	10.15	BC347*	10.17	BD184	2.30	BF194*	10.14	FX29	0.35	MPS8586	10.44	ZX504	10.28
AF186	1.48	BC183*	10.14	BC348A & B	10.17	BD187	1.20	BF195*	10.13	FX50	0.42	MPSA05	10.30	ZX504	10.28
AF202	0.27	BC183L*	10.14	BC349B	10.17	BD188	1.25	BF196	10.14	FX50	0.38	MPSA06	10.32	ZX504	10.28
AF239	0.73	BC184*	10.15	BC350*	10.24	BD189	0.71	BF197	10.15	FX51	0.37	MPSA55	10.43	ZX504	10.28
AF240	1.40	BC184L*	10.15	BC351*	10.22	BD222	0.91	BF197	10.15	FX52	0.36	MPSA56	10.45	ZX504	10.28
AF279S	0.91	BC185	0.36	BC352A*	10.24	BD225	0.91	BF199	10.28	FX53	0.38	MPSA59	10.88	ZX504	10.28
AL100	1.30	BC186	0.25	BC352A*	10.24	BD232	0.91	BF200	10.28	FX90	1.98	MPSAL01	10.33	ZX504	10.28
AL103	1.58	BC187	0.27	BC360	0.59	BD233	0.62	BF218	10.42	FX25	1.62	MPSU01	0.81	ZX304	10.40

Alternative gain versions available on items marked *.

For matched pairs add 20p per pair.

LINEAR IC's		DIODES		VDR's, etc. (1)		VALVES (1)		RESISTORS					
Type	Price (£)	Type	Price (£)	Type	Price (£)	Type	Price (£)	Type	Price (£)				
BRC1330	10.93	SN7800BK	1.66	TBA240A	13.98	AA113	0.17	BY114	0.60	JW 6.8K-330K (E12)	10 of one	1000c	500c
CA8100M	2.44	SN78013N	1.56	TBA281	12.07	AA119	0.21	BY118	1.10	1W 100-10M (E24)	3p 25p	99p	£1.40
CA3005	1.85	SN78018KE	1.56	TBA395*	12.58	AA129	0.28	BY126	0.20	1W 100-10M (E12)	5p 48p	£1.96	£1.26
CA3012	1.45	SN78023N	1.56	TBA400	12.20	AA130	0.16	BY127	0.21	2W 100-10M (E6)	9p 80p	£2.80	£2.80
CA3014	2.28	SN78023ND	1.56	TBA440Q	11.84	AA203	0.42	BY133	0.35	Presets (1)			
CA3018	0.71	SN78033N	2.22	TBA500*	12.21	AA215	0.35	BY164	0.75	2W 0.220-270K	18p	0 1W (Vertical and Horizontal)	all 14p each
CA3020	1.89	SN78110N	2.20	TBA510*	12.21	AA217	0.28	BY176	2.80	4W 100-10K	22p	100, 220, 470K, 1, 2, 2.4, 7, 10, 22	
CA3028A	0.80	SN78115N	11.62	TBA520P*	12.41	AA218	0.28	BY177	0.80	7W 0.680-22K	24p	47, 100, 220, 470K, 1, 2, 5, 6, 5M	
CA3028B	1.09	SN78119N	11.62	TBA530P*	12.24	BA100	0.24	BY182	1.14	11W 100-22K	28p	all 14p each	
CA3045	3.75	SN78131N	12.10	TBA550*	12.68	BA102	0.36	BY184	0.44	17W 100-22K	33p	0 2W (Vertical and Horizontal)	all 14p each
CA3048	0.70	SN78228N	12.60	TBA550*	13.13	BA104	0.19	BY189	6.30	Vertical mounting pillars	3p	Value as 0 1W	all 14p each
CA3085	1.74	SN78227N	11.61	TBA560C*	13.18	BA110	0.80	BY190	4.90	FUSES (all packs of 10)			
CA3088	1.90	SN78228N	11.80	TBA570*	11.29	BA111	0.70	BY206	0.28	20mm Time Delay (BEA) 40mA	£3.88	20mm quick-blow (BEA) 100mA	60p

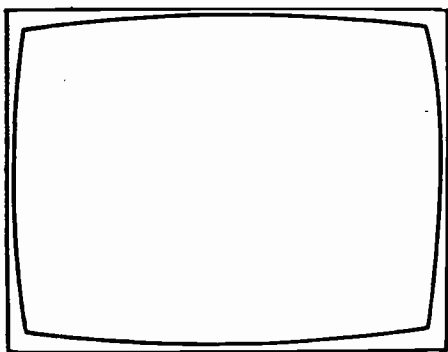

TELEVISION

The TV Data Services

EDITOR

John A. Reddihough

ASSISTANT EDITOR

Luke Theodossiou

ART EDITOR

Roy Palmer

ADVERTS MANAGER

Roy Smith

01-261 6671

CLASSIFIED ADVERTS

Colin R. Brown

01-261 5762

Teletext has been a part of the UK's TV service for some years now – full-scale test transmissions started back in 1974. Meanwhile the PO's complementary Prestel (originally Viewdata) system has been developed, and was inaugurated as a public service, in the London area, earlier this year. How are these services faring? It's an important question, since the UK's lead in TV data technology could give the industry a worthwhile boost over the next few years – UK setmakers are at present the only ones to have in operation production lines for teletext and Prestel equipped TV sets, similar services in other countries still being at an experimental stage. So how are things going?

Not too well it seems. As we reported last month, sales of teletext equipped sets have not so far reached anything like the hoped for levels. Why? Price of course is an important consideration. So too is the extent of public awareness of the service. And at bottom there's the fundamental question as to whether a genuine public requirement for such a service exists. Prestel is a rather different matter, and it's much too early yet to have any idea of the potential public response.

One key factor is salesmanship, and we don't seem to be doing terribly well here. Pye have carried out research on a cross-section of retail/rental outlets, as a result of which they have "identified a very real need to assist sales staff in selling and promoting teletext." As a result, the company is conducting a country wide series of teletext teach-ins, using audio-visual methods. The aim is to familiarise sales staff with the practical operation of teletext sets so that they can competently demonstrate and sell the sets. Well done Pye.

It seems strange to us however that such basic guidance should be necessary at this comparatively late stage. The trade and technical press have not been stinting in their coverage of the subject, the transmissions have been there for all to see, and there's been a fair amount of publicity. Yet the sales/rental of teletext sets remains a dribble.

Price is at present acting as something of a deterrent of course. A differential of £200 or so is a very real barrier. A marked decrease is unlikely until production levels rise sufficiently to affect unit costs. Overcoming this initial barrier is of course the purpose of marketing effort. And this in turn depends on someone sticking his neck out and saying "I think we can sell so many sets at a price of X – get the production lines moving." It could well be that Japanese setmakers will be the ones to finally stick their necks out in this respect. Sony are understood to have begun test production of teletext sets, and a move by Japanese setmakers could well start things rolling. Would the UK effort be submerged in the wake of such a move? That's all too possible.

The more fundamental question is whether the public really wants teletext (or Prestel for that matter)? There is no doubt about the effectiveness of the service in providing instant news. But, other than gambling addicts, how many people need instant news? The normal TV bulletins provide the latest news, and most of us can wait for them. Our newspapers fill out the background. The only advantage of teletext is its provision of a wide range of instant new flashes, and the question remains as to whether there's a genuine call for this.

Speaking at a seminar not long since, Dr. Heinz Wolff of the Medical Research Council expressed doubt as to whether people will want all the facts that electronic information services will be able to throw at them. "Universally available information systems like Viewdata are going to be a flop" Dr. Wolff commented, "most people just aren't interested".

It may sound like heresy in TV circles, but we've a sneaking suspicion that D. Wolff's view contains an uncomfortable degree of truth. Modern technology has reached the point where almost anything is possible – whether it gets done however depends on the age old principle of someone being willing to pay for it. The remarkable fact about teletext though is that it's very cheap to provide and, once production gets going, potentially cheap to receive – remember what happened with calculators.

On the Prestel side things are certainly being played coolly so far. The PO seems to feel that business users will form the service's main clientele, and this seems much the most likely outcome to us. Prestel equipment could become cheap with increased production, but the provision of much of the information is likely to remain an expensive operation, and hence costly to the user. One can imagine an addict running up huge bills with the PO! Information that would help boost sales efforts – supermarket prices/ordering, booking arrangements and so on – could come cheap. But it's hard somehow to be convinced by the picture some protagonists present of the average houseperson running his/her everyday affairs via a computer/phone/TV set link up.

Teletopics

FIFTY YEARS OF TV

The fiftieth anniversary of the start of experimental transmissions of the Baird 30-line low-definition TV system, with simultaneous sound, will occur in March 1980 (some experimental demonstrations had preceded this). To mark the occasion, the Science Museum in South Kensington is to hold a special television exhibition which will run for six months. Of particular interest will be the demonstrations of historic TV sets in working order – the section on low-definition TV will feature a live demonstration of Baird's 30-line standard, with help from technical personnel from Imperial College and Philips Electrical. Four eras – 1938, 1953, 1960 and 1970 – have been chosen to illustrate the development of high-definition TV. For each of these periods a contemporary, working receiver in a period room setting will be on show, along with a montage of representative programme material of the time. Catalogues, advertisements and press comment will be included. There will also be a section on contemporary TV, demonstrating in particular the broadening scope of domestic TV – teletext, Prestel, TV games, VCRs and so on. This section will include taped demonstrations of such recent technological developments as digital video processing. All in all the 550 sq. metre floor space exhibition promises to be of great interest – and will be entrance free!

VIDEO DISC WAR HOTS UP

Just three-four years ago the Japanese video firms were engaged in the VCR standards war in the US. Next year it looks as if a similar battle will take place over video disc systems. Philips got in first, launching their video disc system this year. As is by now well known, the Philips system employs a laser to scan the disc optically, the information being recorded on the disc as a spiral of minute pits. Sony have also been working for some time on a laser-scanned disc, while the RCA SelectaVision system has been under development for several years now. The latter uses a stylus which is in contact with the disc, the information being recorded in the form of capacitance variations along the track.

More recently, JVC have demonstrated their VHD-AHD disc system, and to all accounts the demonstration was impressive. The system seems to be a cross between the Philips and RCA approaches. The disc is tracked by a relatively large sapphire stylus incorporating a small electrode, but as in the Philips system the programme material is recorded in the form of a spiral of pits, with the stylus position controlled by a servo system which picks up control signals recorded alongside the programme track. The idea of using a relatively large stylus is to increase the stylus and disc life in comparison with the needle-in-approach approach. A stylus life of 2,000 hours and a disc life of 50,000 playings are claimed. The disc rotates at 900 r.p.m., with four fields per revolution. This gives an hour's playing time per side from the 12in. disc, twice the playing time of the standard Philips disc (but see note on extended play video discs last month). The VHD (video home disc) system is still under development however, a launch date of late 1980 being suggested.

If that wasn't enough, it seems that Matsushita (Panasonic) have decided to re-enter the field with a system of their own – the Visc-O-Pac. This is a variable speed system giving a playing time of an hour per side of the 9in. disc. The speed at the centre is 700 r.p.m., reducing to 300 r.p.m. at the outside. The disc is grooved, with the programme material recorded in hill-and-dale form, a "twist stylus" being used to translate the recorded indentations into variations in torque.

So at least five systems are at present being pursued, and as with VCRs extending the playing time seems to be one of the main lines of development. An important difference with the playback-only disc battle is the availability of programme material to the various protagonists.

FIXED-HEAD VCR SYSTEM

A fixed-head VCR system would lead to considerable simplification of course, the problem being that the tape speed would need to be considerably increased. The West German firm BASF has been working on such a system (LVR, linear video recording) for some years, and now Toshiba have announced the development of such a system, resulting in a small, lightweight VCR only 140mm. high, 250mm. wide and 330mm. deep. The cassette houses a 100 metre continuous loop of $\frac{1}{2}$ in. tape giving a playing time of an hour. The tape speed with conventional helical-scan VCR systems varies from Betamax's 1.873cm./sec to the N1700's 6.56cm./sec. The tape speed with Toshiba's fixed-head system has been increased to six metres per second, a variety of innovations having been adopted to achieve this high speed – the back of the tape is covered with a special lubricant layer for example, and there's a special capstan motor to remove irregularities in tape movement. There are 220 tracks on the tape, each taking 17 seconds to pass the head. After each pass, the head is stepped fractionally across the tape width, this operation taking 22msec: fast stepping gives rapid access to any point on the tape. Toshiba have demonstrated their new system, but have no definite marketing plans so far.

THE GRUNDIG 2 x 4 VCR

The first Grundig VCR to use the new V2000 VCR system developed by Philips and Grundig has now been announced. Unlike the Philips VR2020, the Grundig 2 x 4 features front loading. This enables it to be shelf or rack mounted, all controls being grouped along the front. The tape path is also different, following a U rather than an M arrangement. This gives fast forward and rewind with the tape either free or threaded. There's also a video-frequency output, from a seven-pin socket. It's emphasized however that there is complete compatibility between tapes recorded on the Philips and Grundig machines.

HI-FI TV

A new up-market set has been added to the Pye and Philips TV ranges, featuring a sound system built to DIN hi-fi standards (DIN 45500). While the cabinet is no larger than those used for similar 26in. models, the amplifier provides an output of 10W r.m.s. via a speaker system consisting of a 2in. tweeter and a 4in. bass unit which is housed in its own

reflex enclosure. Separate volume, bass and treble controls are concealed in a drawer in the front of the cabinet to give a smooth looking finish. There's a LED digital programme indicator, and infra-red remote control. For those who want to listen alone, a jack plug for headphones is provided. Sockets are included for recording the sound direct from the set and for feeding an additional loudspeaker. The chassis is the Philips K12, a full-specification, modular design using the 20AX tube.

A FIRST FROM JVC

The JVC Model CX500 is the first portable colour TV/radio/cassette combination to be released in the UK. The unit features a 4½in. screen, three-band (MW, LW and FM) radio and cassette recorder. It measures only 5½in. high × 17½in. wide × 13in. deep, weighing 16½lb without batteries. An interesting point for DX enthusiasts is that the sound i.f. is switchable. An a.c. adaptor is supplied, and optional extras include a car cord and a rechargeable battery pack. The suggested price is £355 including VAT.

PRESTEL EXPANSION

The PO is in the process of linking up five more computers to its Prestel network. These are all in the London area – at the Clerkenwell, Fleet, Ealing, Eltham and Wood Green exchanges. Each computer will eventually be able to provide up to 200 "ports", each of these serving 100 domestic or around 20 business users. The PO's expansion plan for the service aims to cover 60 per cent of the population by the middle of next year.

STATION OPENINGS

The following relay transmitters are now in operation:

Corfe Castle (Dorset) Southern Television channel 41, BBC-2 ch. 44, BBC-1 ch. 51. Receiving aerial group B.

Hythe (Kent) BBC-1 ch. 21, Southern Television ch. 24, BBC-2 ch. 27. Receiving aerial group A.

Shrewton (Wiltshire) Southern Television ch. 41, BBC-2 ch. 44, BBC-1 ch. 51. Receiving aerial group B.

Walsden (W. Yorkshire) BBC-1 ch. 40, Granada Television ch. 43, BBC-2 ch. 46. Receiving aerial group B.

All the above transmissions are vertically polarised.

VCR COURSE

Starting on September 25th, the Bournemouth and Poole College of Further Education is again offering its short course on videocassette recorders. The course continues over ten Tuesday evenings. Those interested can obtain details from Stuart Dade, VCR Course Organiser, Department of Technician Studies (Lansdowne Centre), telephone (0202) 20844, extension 27.

FORGESTONE TV CABINETS

Forgestone Components (Ketteringham, Wymondham, Norfolk, NR18 9RY) tell us that they can now supply ready built and finished cabinets, together with all necessary fittings (control escutcheon, knobs and back cover), for housing their successful 500 series colour receiver kit. The cabinets are made of wood with real teak veneer, and are available in two sizes – for 22 and 26in. c.r.t.s. Matching stands, in chrome and teak with castors, are also available.

DATA BOOK

The latest issue (1979-80 edition) of the invaluable Mullard Data Book is now available. The usual arrangement is

followed, with updated, abridged data on the Mullard range of valves, picture tubes, semiconductor devices, i.c.s, passive components, modules, assemblies and loudspeakers for use in domestic electronic equipment. Names and addresses of component stockists are included. The book is available at £1, cash with order, from: The Technical Press Ltd., Freeland, Oxford OX7 2AP.

MITSUBISHI'S UK MADE SETS

Mitsubishi has announced that the first sets to be produced at its Haddington, UK plant, which it acquired from Tandberg last March, will become available this month. The first model will be the 20in. CT2005. 22 and 26in. models, also sets equipped for teletext reception, will be introduced next year, when production of hi-fi audio equipment will also begin. £300,000 has already been committed to re-equipping the plant, and investment will be increased as production builds up.

REFURBISHED CTVs FOR EXPORT

A few months back we reported on Midland TV Trade Services' export activities in the refurbished colour TV set field. OTV Television are also active in this field, and have recently received substantial orders from Sri Lanka and Malaysia. Both countries only recently started colour transmissions. OTV's managing director Joe Williams commented that "the cost of new CTVs is prohibitive for the majority of the populations of these countries, so the market for good second-hand sets is healthy." Preventive maintenance to ensure reliability is part of the operation – essential in view of the lack of skilled personnel at the destination countries – and the sets are also standardised. Orders from Portugal and Nigeria are expected shortly.

TAPES ON RENTAL

Granada TV Rental have started to offer pre-recorded video tapes for purchase or rent, initially at selected outlets in the south east and west. The library ranges from feature films to documentaries. The cost of a typical feature film cassette to purchase will be around £30. Rental charges will be £5 for the first day and £3 for each subsequent day.

TELENG'S HOME ENTERTAINMENT CENTRE

Teleng, a part of the Telefusion TV rental, cable TV and retail group, have introduced a UK-made home entertainment centre based on the use of a microprocessor. The centre can be updated to a full computer for home use, and comes complete with mains adaptor and an initial programme cartridge offering up to thirty ball and paddle games. The price (£89.95p) includes a handy carrying case with storage space for five cartridges. There are at present 18 games and educational cartridges, priced at £13.95p each.

LATEST VHS VCRs FEATURE STILL PICTURES AND SLOW MOTION

The latest VCRs from Ferguson and JVC, the 3V16 and HR3660 respectively, provide slow-motion playback, at a speed which can be controlled by the user, still pictures, and double-speed playback. A new capstan and drum servo system and a newly developed video head are used to enable these additional facilities to be provided. Panasonic's new NV8610 also provides still pictures, and enables the user, by using the advance button, to move on a frame at a time throughout an entire three-hour tape if required.

Letters

BUSH CTV25

The Bush Model CTV25 and its ident/PAL switch circuit came up in *Your Problems Solved*, August. I've experienced trouble in this part of the circuit in many of these sets, and have found that the bistable will usually start up and run when 5VT6 is treated with freezer. A more permanent cure can usually be effected by reducing the value of its base return resistor 5R42 to a value below 2k Ω . If this fails, replace the trigger pulse differentiating resistor 5R36 with a 50k Ω or 100k Ω preset. I hope this information will help others who have to deal with the rather unusual arrangements used in this part of the circuit.

N. C. Newson, Lowestoft.

Editorial note: Bistable failure on the Bush Model CTV25 should, as with the ITT CVC5 and related chassis, result in no colour – though for somewhat different reasons. The original fault was green faces, something which theoretically should never be seen on the Bush CTV25 due to the ident/bistable/colour-killer detector arrangement. The Bush CTV25's decoder always seems to have needed rather careful setting up however.

For those interested, the colour-killer detector circuit is shown in Fig. 1. The outputs from the bistable circuit are applied across the two series-connected detector diodes 5D5/6, while the ident signal is fed to their junction. Both diodes conduct together on alternate lines – when 5D5's cathode receives a negative-going squarewave and 5D6's anode receives a positive-going squarewave. When the bistable is correctly phased, the waveforms are as shown: the ident signal is negative-going when the diodes conduct, so that 5D6 conducts more heavily than 5D5. The result is that 5C43 charges negatively, switching on 5VT8 which in turn develops a positive-going colour turn-on bias across its collector load resistor 5R57. If the ident signal is positive-

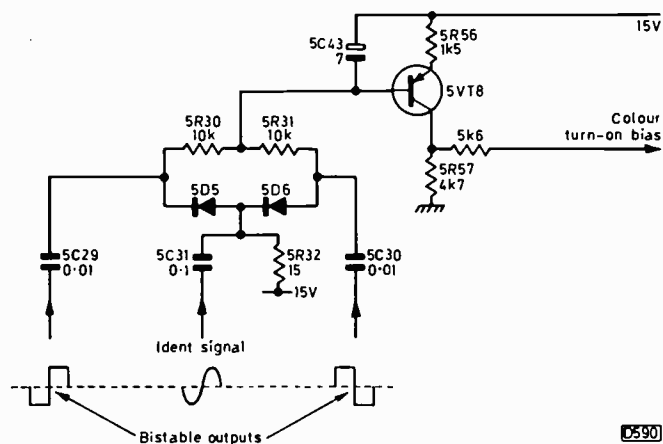

Fig. 1: Bistable/colour-killer circuit used in the Bush Model CTV25 and associated hybrid colour receivers.

going when the two diodes conduct, 5D5 conducts more heavily than 5D6 and 5C43 will not receive a negative charge sufficient to switch 5VT8 on. 5C43 will not develop a charge in the absence of outputs from the bistable circuit, since it will simply smooth out the negative and positive excursions of the ident signal.

THORN 4000 CHASSIS

I have recently had to deal with a couple of faults on a Ferguson colour set fitted with the Thorn 4000 chassis. The first was a simple matter, a short-circuit on the supply line. The mains bridge rectifiers had to be replaced, also the shattered 2A anti-surge mains fuse.

The second fault was rather more interesting, concerning the channel selector display, which is controlled by a MOS i.c. When the set is first switched on, channel one should automatically be selected. This was so, but the display indicated channel two. The same thing happened when selecting channel one – channel two would be indicated. I eventually found that when neons PL1 and PL8 were interchanged channel one was now correctly displayed on being selected, but on selecting channel eight channel two was displayed. It seemed that the channel one neon was faulty, but all that was necessary was to reverse its leads. Problem solved and set returned to owner.

Incidentally, how about an article on the 4000 chassis? It has some unusual features which could puzzle those coming across it for the first time.

M. Wright, Spennymore, Co. Durham.

Editorial note: The 4000 is not very common: it was Thorn's 110° delta-gun tube chassis. There were one or two luxury models, and we understand that quite a number were handled by Multibroadcast. Few service engineers dealing with the normal run of the mill range of receivers seem to have come across any of them. We would be pleased to hear from anyone who has experience of the chassis and its quirks.

MINI CRT REACTIVATOR

Having read the letter from S.J. Vasey in the April issue, I decided to try to reduce the size of the c.r.t. reactivator even further. After a certain amount of thought, the best course seemed to be to remove the largest component – the heater transformer. This was replaced (see Fig. 2) with a circuit consisting of three capacitors, a shunt resistor and a switch. The capacitors used are of the type employed on the line timebase panel of the Thorn 3000/3500 chassis to decouple the h.t. line, i.e. the Shizuke 4.7 μ F type. The heater switch is required to alter the reactance of the heater feed on colour, as more current is required by the heaters.

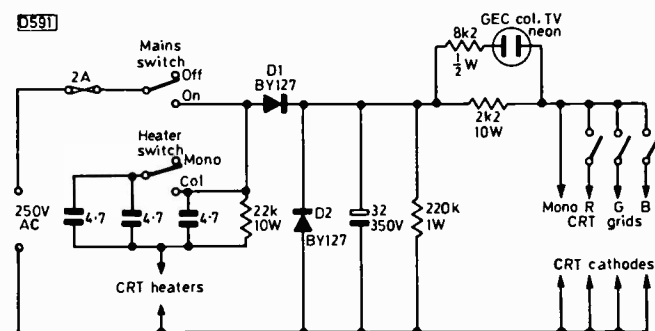
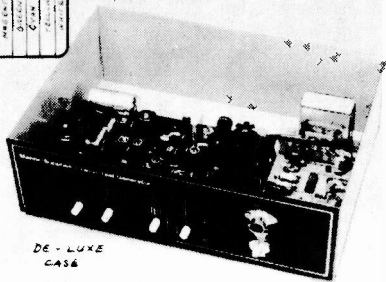
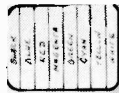

Fig. 2: C.R.T. reactivator circuit devised by C. S. Wood.

MANOR SUPPLIES

PAL COLOUR BAR GENERATOR

plus CROSS HATCH KIT (Mk. 4)



- ★ Output at UHF, applied to receiver aerial socket.
- ★ In addition to colour bars R-Y, B-Y etc.
- ★ Cross-hatch, grey scale, peak white and black level.
- ★ Push button controls, battery or mains operated.
- ★ Simple design, only five i.c.s. on colour bar P.C.B.

PRICE OF MK4 COLOUR BAR & CROSS HATCH KIT £40.25 + £1.10 P/Packing. DE-LUXE CASE £5.55. ALUMINIUM CASE £2.95, BATT HOLDERS £1.70, ALTERNATIVE STAB. MAINS SUPPLY KIT £5.55.

ALSO THE MK3 COLOUR BAR GENERATOR KIT FOR ADDITION TO MANOR SUPPLIES CROSS HATCH UNITS. £28.75 + £1.15 p.p. CASE EXTRA £1.75. BATT. HOLDERS £1.70.

- ★★ Kits include drilled P.C. board, with full circuit data, assembly and setting up instructions.
- ★★ All special parts such as coils and modulator supplied complete and tested, ready for use.
- ★★ Designed to professional standards.
- ★★ Demonstration models at 172 West End Lane, NW6.
- ★★ Every kit fully guaranteed.

MK4 DE LUXE (BATTERY) BUILT & TESTED £66.70 + £1.35 P/Packing.

VHF MODULATOR (CHI to 4) FOR OVERSEAS £4.00.

INFORMATION ON VIDEO TAKE-OFF FOR C.C.T.V.

(ABOVE PRICES INCLUDE 15% VAT)

MANOR SUPPLIES TELETXT KIT (incl. TEXAS DECODER). Wide range of facilities in colour. External unit. AE input to set. Write or call for further information. See working demonstration model! Easy to build and results guaranteed for every completed unit.

Texas XM11 Decoder £149.50 p.p. £1.10.

Auxiliary Units £101.00 p.p. £1.65.

De-Luxe Case £17.00 p.p. £1.10. (or total p.p. £2.95).

Prices include 15% VAT

Separate Price List for Individual Units available

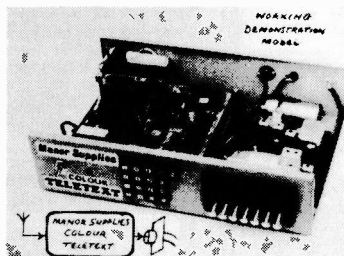

Changes from Teletext to picture without switching aerials.

Armchair control of Teletext and T.V. stations.

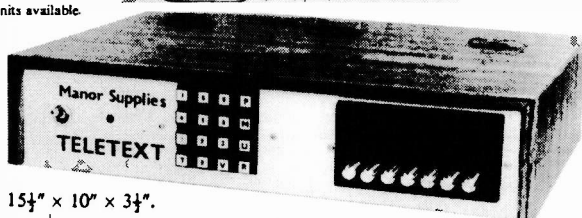

15½" x 10" x 3¼".

Now available ex stock NEW MULLARD TELETXT DECODER MODULE 6101 VML, complete and tested. Details on request.

COLOUR. UHF & TELEVISION SPARES

NEW 'TELEVISION' COLOUR RECEIVER PROJECT PARTS BEING SUPPLIED. POWER, SIGNAL & TIMEBASE. SEND OR PHONE FOR LIST. WORKING DEMONSTRATION SET NOW ON SHOW.

NEW SAW FILTER IF AMPLIFIER PLUS TUNER COMPLETE AND TESTED FOR T.V. SOUND & VISION £32.80 p.p. £1.10.

T.V. PORTABLE PROJECT PARTS AVAILABLE. SEND OR PHONE FOR LIST. WORKING MODEL AT 172 WEST END LANE, NW6.

TV TEST GENERATOR UHF MODULATOR £4.00 p.p. 40p.

CROSS HATCH UNIT KIT, AERIAL INPUT TYPE, INCL. T.V. SYNC AND UHF MODULATOR. BATTERY OPERATED. ALSO GIVES PEAK WHITE & BLACK LEVELS. CAN BE USED FOR ANY SET £12.65 p.p. 50p. (ALUM CASE £2.30 p.p. 80p.) COMPLETE TESTED UNITS, READY FOR USE (DE LUXE CASE) £25.00 p.p. £1.10.

ADDITIONAL GREY SCALE KIT £3.35 p.p. 35p.

STAB MAINS POWER SUPPLY FOR ABOVE £5.50 p.p. 80p.

UHF SIGNAL STRENGTH METER KIT £19.40 (ALSO VHF VERSION) ALUM CASE £1.75, DE-LUXE CASE £5.60 p.p. £1.10.

CRT TESTER & REACTIVATOR PROJECT KIT £24.00 p.p. £1.45

"TELEVISION" COLOUR SET PROJECT (1974) SPARE PARTS STILL AVAILABLE. ALTVE. IF COMPL. & TESTED £16.80 + £1.10 p.p.

PHILIPS 300 Series IF Panels £2.90 p.p. £1.10.

PHILIPS 210, 300 Series Frame T.B. Panels £1.15 p.p. 75p.

PHILIPS 19TG 170 Series Timebase Panels £2.90 p.p. £1.00.

BUSH A823 CONVERGENCE PANEL £7.60 p.p. £1.00.

BUSH A823 (A807) Decoder Panel £8.65 p.p. £1.10.

BUSH A823 SCAN CONTROL PANEL £2.90 p.p. 80p.

BUSH A823 IF PANEL (EXPORT VERSION) £3.25 p.p. 95p.

BUSH BC6100 IF PANEL (EXPORT VERSION) £5.75 p.p. 80p.

BUSH A816 IF PANEL (SURPLUS) £2.90 p.p. 80p.

BUSH 161 TIMEBASE PANEL A634 £4.40 p.p. £1.00.

GEC 2010 SERIES TIMEBASE PANEL £1.15 p.p. 95p.

GEC 2040 Surplus Panels, ex-rental. Decoder £5.75 p.p. £1.00.

GEC 2040 Convergence Control Panel £2.90 p.p. £1.00.

DECCA CTV25 Single Stand. IF Panel £4.40 p.p. 75p.

DECCA Colour T.V. Thyristor Power Supply. HT, LT etc. £4.40 p.p. £1.10.

BUSH TV 312 IF Panel (Single I.C.) incl. circuit £5.75 p.p. 75p.

BUSH TV Portable Eleven Volt Stab. Power Supply Unit £4.40 p.p. £1.10.

PYE 697 Line T.B. P.C.B. for spares, £2.80 p.p. £1.10.

THORN 3000 VID, IF, DEC, FTB SALVAGED £5.75 ea. p.p. £1.00.

THORN 8000/8500 POWER/SALV. SPARES £2.88 p.p. 60p.

THORN 8000/8500 TIME BASE, SALV., SPARES £5.52 p.p. 90p.

THORN 9000 LINE T.B. SALV., SPARES £8.62 p.p. £1.38.

MULLARD AT1022 Colour Scan Coils £6.90 p.p. £1.30, AT1023/05 Convergence Yoke £2.90 p.p. 95p, AT1025/06 Blue Lat. 90p p.p. 40p, Delay Lines, DL1E £1.00, DL20, DL50 £4.00 p.p. 80p.

PHILIPS G9 Signal Board Panels for small spares £4.80 p.p. £1.00.

PHILIPS G6 single standard convergence panel, inc. 16 controls, switches etc., and circuits £4.25 p.p. 95p, or incl. yoke, £5.65. G8 Decoder panels salvaged £4.25. Decoder panels for spares £2.00 p.p. 95p.

VARICAP UHF MULLARD U321 £8.97, ELC 1043/05 £6.35 p.p. 40p., G.I. type (equiv. 1043/05) £4.00 p.p. 40p. Control units, 3PSN £1.40, 4PSN £1.75, 5PSN £2.00, 6PSN £2.10, Special Offer 6PSN £1.15 p.p. 40p.

TAA 550 58p p.p. 20p. Salv. UHF varicap tuners £1.75 p.p. 40p.

BUSH "Touch Tune" assembly, incl. circuit £5.75 p.p. 85p.

VARICAP UHF-VHF ELC 2000S £9.80. p.p. 75p.

VHF ELC 1042 £6.90 p.p. 40p.

UHF/625 Tuners, many different types in stock. UHF tuners transisted. incl. s/m drive, £3.28. Mullard 4 position push button £2.88 p.p. £1.00, Ae Isol 70p p.p. 25p.

TRANSISTORISED 625 IF for T.V., sound, tested. £7.82 p.p. 75p.

HELICAL POTS, 100K. 4 for £1.40 p.p. 25p.

RBM 774 250R Mains Droppers, four for £1.15 p.p. 40p.

LINE OUTPUT TRANSFORMERS. New guar. p.p. 95p.

SPECIAL OFFER

BUSH 145 to 186SS series	£8.05	BUSH TV 125 to 139	£3.25
BUSH, MURPHY A816 series	£9.80	GEC 21141/FINELINE	£5.50
DECCA DR 121/123, 20/24, MS1700, 2001, 2401	£7.85	GEC 448/452	£1.75
DECCA MS2000, 2400	£6.70	THORN 1590/1591	£5.50
FERR. HMV, MARCONI, ULTRA 900, 950, Mk. 1	£6.80	KB VCI VCI (003)	£3.25
950II, 1400, 1500, 1580	£7.85	MURPHY 849 to 939	£3.25
GEC 2000, 2047 series, etc.	£7.85	COLOUR LOPTS p.p. £1.10.	
INDESIT 20/24EGB	£7.85	BUSH CTV 25 Mk3	£9.45
ITT/KB VC2 to 53, 100, 200, 300	£7.85	BUSH 182 to 1122 etc.	£11.30
MURPHY 1910 to 2417 series	£8.05	MURPHY Equivalents	£11.30
PHILIPS 19TG170, 210, 300	£7.85	DECCA "Bradford" (state Model No. etc)	£10.15
PYE 368, 169, 769 series	£7.85	GEC 2028, 2040	£11.30
PYE 40, 67 series (36 to 55)	£7.85	GEC 2110 Series	£12.20
PAM, INVICTA, EKCO, FERRANTI equivalents as above.		ITT CVC 5 to 9	£7.80
SOBELL 1000 series	£7.85	PYE 691, 693, 697	£20.50
STELLA 1043/2149	£7.85	PHILIPS G8	£10.15
		THORN 3000/3500 (Scan or EHT)	£7.85
		THORN 8500	£12.50

THORN MONO SCAN COILS (850 to 1500) £3.25 p.p. 95p.

THORN 950 3 Stick Tray £2.75 p.p. 55p. Others Available.

6-3V CRT Boost Transformers £3.70 p.p. 85p., Auto type £2.10 p.p. 50p.

CALLERS WELCOME AT SHOP PREMISES (Tel: 01-794-8751)

THOUSANDS OF ADDITIONAL ITEMS AVAILABLE NOT NORMALLY ADVERTISED

MANOR SUPPLIES

172 WEST END LANE, LONDON, N.W.6.

NEAR: W. Hampstead Tube Stn. (Bakerloo & Jubilee)

W. Hampstead British Rail Stn. (Richmond, Broad St.) (St. Pancras, Bedford) Bus Routes 28, 159

Mail Order: 64 GOLDERS MANOR DRIVE, LONDON N.W.11.

ALL PRICES INCLUDE VAT AT 15%

**QUARTZ LCD
5 Function**

Hours, mins, secs., month, date, auto calendar, back-light, quality metal bracelet.

£6.65

Guaranteed same day despatch. Very slim, only 6mm thick.



M1

**SOLAR QUARTZ
LCD 5 Function**

Genuine solar panel with battery back-up. Hours, mins., secs., day, date. Fully adjustable bracelet. Back-light. Only 7mm thick.

£8.65

Guaranteed same day despatch.



M2

**QUARTZ LCD
11 Function** SLIM CHRONO

6 digit, 11 functions. Hours, mins., secs., day, date, day of week. 1/100th, 1/10th, secs., 10X secs., mins., Split and lap modes. Back-light, auto calendar. Only 8mm thick. Stainless steel bracelet and back. Adjustable bracelet. Metac Price

£10.65 Thousands sold! Guaranteed same day despatch.



M3

**QUARTZ LCD
ALARM 7 Function**

Hours, mins., secs., month, date, day. 6 digits, 3 flags plus continuous display of day and date or seconds. Back-light Only 9mm thick.

£12.65

Guaranteed same day despatch.



M4

**MULTI ALARM
6 Digits 10
Functions**

- Hours, mins., secs.
- Months, date, day.
- Basic alarm.
- Memory date alarm.
- Timer alarm with dual.
- Time and 10 country zone.
- Back-light.
- 8mm thick.

£18.65



M5

**FRONT-BUTTON
Alarm Chrono
Dual Time**

6 digits, 5 flags, 22 functions. Constant display of hours and mins., plus optional seconds or date display. AM/PM indication, month, date. Continuous display of day. Stop-watch to 12 hours 59.9 secs., in 1/10 second steps. Split and lap timing modes. Dual time zones. Only 8mm thick. Back-light. Fully adjustable open bracelet. Guaranteed same day despatch



£22.65

M6

**SOLAR QUARTZ LCD
Chronograph with
Alarm
Dual Time Zone
Facility**

6 digits, 5 flags, 22 functions. Solar panel with battery back-up. 6 basic functions. Stop-watch to 12 hours 59.9 secs., in 1/10 sec. steps. Split and lap timing modes. Dual time zones. Alarm. 9mm thick. Back-light. Fully adjustable bracelet.



£27.95

M7

**ALARM CHRONO
with 9 world
time zones**

- 6 digits, 5 flags.
- 6 basic functions.
- 8 further time zones.
- Count-down alarm.
- Stop-watch to 12 hours 59.9 secs. in 1/10 sec. steps.
- Split and timing modes.
- Alarm.
- 9 mm thick.
- Back-light.
- Fully adjustable bracelet.

£29.65



M8

**SOLAR QUARTZ LCD
Chronograph**

Powered from solar panel with battery back-up. 6 digit, 11 functions. Hours, mins., secs., day, date, day of week. 1/100th, 1/10th, secs., 10X secs., mins. Split and lap modes. Back-light, auto calendar. Only 8mm thick. Stainless steel bracelet and back. Adjustable bracelet. Metac Price

£12.65

Guaranteed same day despatch.



M9

SEIKO Alarm Chrono

LCD, hours, mins., secs., day of week, month, day and date, 24 hour Alarm, 12 hour chronograph, 1/10th secs., and lap time. Back light, stainless steel, HARDEX glass.

List Price £130.00
METAC PRICE
£105.00



M10

**SEIKO MEMORY
BANK**

Calendar watch M354. Hours, mins., secs. Month, day, date in 12 or 24 hour format all indicated continuously. Monthly calendar display month, year and all dates for any selected month over 80 year period. Memory bank function. Any desired dates up to 11 can be stored in advanced. 2 year battery life. Water resistant. List Price £130

Metac Price **£79.50**



M11

**SEIKO-STYLE
Dual time-alarm
Chronograph**

Mineral glass face. Battery hatch for DIY battery replacement. Top quality finish with fully adjustable bracelet.

£35.00



M12

**HANIMEX
Electronic
LED Alarm Clock**

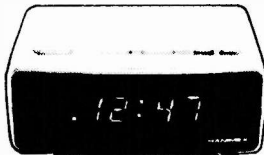

Features and Specification
Hour/minute display. Large LED display with pm and alarm on indicator. 24-Hours alarm with on/off control. Display flashing for power loss indication. Repeatable 9-minute snooze. Display bright/dim modes control. Size 5.15" x 3.93" x 2.36" (131mm x 11mm x 60mm) Weight: 1.43 lbs (0.65 kg) AC power 220V

£9.65 Thousands sold!
Mains operated.

Guaranteed same day despatch.

M13

**HANIMEX portable
LCD clock radio**



- Time set & alarm controls.
- Snooze & sleep controls.
- Wake to music or alarm.
- AM/PM indicator.
- Battery operated. No plug required.
- Receives all standard AM radio broadcasts.
- Drawing carrying case included.
- Back-light.
- Batteries supplied free.
- Quartz crystal controlled.

£17.95

M14

HOW TO ORDER

Payment can be made by sending cheque, postal order, Barclay, Access or American Express card numbers. Write your name, address and the order details clearly, enclose 30p for post and packing or the amount stated. We do not wait to clear your cheque before sending the goods so this will not delay delivery. All products carry 1 year guarantee and full money back 10 day reassurance. Battery fitting service is available at our shops. All prices include VAT.

Trade enquiries: Send for a complete list of trade prices - minimum order value £100
Telephone Orders: Credit card customers can telephone orders direct to Daventry or Edgware Rd., 24 hour phone service at both shops 01-723 4753 03272 76545.



CALLERS WELCOME
Shops open 9.30 - 6.00.

**QUARTZ LCD
Ladies 5 Function**

Only 25 x 20mm and 6mm thick. 5 function. Hours, mins., secs., day, date and back light and auto calendar. Elegant metal bracelet in silver or gold. State preference.

£9.95

Guaranteed same day despatch.



M15

**Price breakthrough
only
£18.95**



OUTSTANDING FEATURES

- **DUAL TIME.** Local time always visible and you can set and recall any other time zone (such as GMT). Also has a light for night viewing.
 - **CALENDAR FUNCTIONS** include the date and day in each time zone.
 - **CHRONOGRAPH/STOPWATCH** displays up to 12 hours, 59 minutes, and 59.9 seconds.
 - On command, stopwatch display freezes to show **intermediate (split/lap) time** while stopwatch continues to run. Can also switch to and from timekeeping and stopwatch modes without affecting either's operation.
 - **ALARM** can be set to anytime within a 24 hour period. At the designated time, a pleasant, but effective buzzer sounds to remind or awaken you!
- Guaranteed same day despatch. **M16**

Metac

**ELECTRONICS
& TIME CENTRES**

North & Midlands
67 High Street, DAVENTRY
Northamptonshire
Telephone: 03272 76545

South of England
327 Edgware Road
LONDON W.2
Telephone: (01) 723 4753

By using this circuit, the size of the complete reactivator can be reduced quite considerably – the one I've built fits into a plastic box measuring only 2 x 3 x 3½ in. A piece of equipment this size will fit easily into a standard tool box of course.

C.S. Wood, Ossett, West Yorkshire.

AMATEUR TV

Perhaps you would bring to the notice of your readers the amateur TV fraternity in Britain, represented by the British Amateur TV Club?

Amateur TV pictures are transmitted on 436.5MHz, using mainly 625-line negative modulation. For reception, a fairly common system is to use an ELC 1043 tuner with 2pF capacitors added across the varicap diodes and the tuning lines pressed closer together to increase the sensitivity, feeding the output to the Band I tuner of a dual-standard set. Using 10V of peak r.f. power, TV pictures can be received at 10-15 miles with this receiver system.

If any of your readers in the Reading, Berks area are interested in amateur TV, a demonstration could be given.

I wonder whether any readers know of any circuits for improving the line sync with weak signals, as this seems to be a major cause of picture degradation?

Amateur TV pictures can be transmitted using a class "B" amateur radio licence. For further details, write to the Radio Society of Great Britain, Gt. Doughty St., London. Steve James (G8LCL), 21 Lind Close, Earley, Reading, Berks.

Editorial comment: We're only too pleased to draw readers' attention to the BATC. For membership details, write (enclosing s.a.e.) to Brian Summers (G8GQS), 13 Church St., Gainsborough, Lincs. Telephone Gainsborough 3940. Several of our regular contributors are members of the BATC incidentally. We don't generally give much attention to amateur TV activities in this magazine for the simple reason that the BATC has its own quarterly journal which covers the field thoroughly.

Up the Family Tree

Les Lawry-Johns

I WAS busy wondering what to do when a vaguely familiar figure walked through the front door (she didn't bother to open it). "Hallo Leslie" she boomed. It was auntie Tessa. A formidable figure and an ex-hospital matron, so you didn't fool around with Tessa. "Hallo Tessa, how nice to see you after all this time. You do look well. How is uncle Ben?"

"Oh dear" said Tessa. "I thought we'd informed everyone. He passed on in June. Fancy you not knowing."

"I am sorry Tessa, you must miss him terribly. Mind you he'd done well. Must have been about eighty or so I'd have thought."

"He was eighty four, and I'm seventy now you know."

"Well I never, I would never had thought it" I ventured.

"What about you? Must be knocking on a bit yourself, though you don't look it. How do you manage to stay the same?"

"Well, it's easy really" I said modestly. "I always put my socks on standing up you see." (The magazine cannot accept responsibility for the consequences of following this advice. I tried it – Editor.)

So we exchanged other pleasantries and Tessa departed, being only on a flying visit and having to see other relatives before bouncing off back to Barnstable.

When she had gone, I pondered upon the passing of uncle Ben. He was the last of four sons and one daughter (my mum). All had been characters in their own right. For example, uncle Jeff had no time for dentists. He would have his tooth ache like most other folk, but his solution was to have a drink (more than usual) and pull the molar out with a pair of pliers, swearing and cussing everything and everybody in the painful process. Uncle Fred solved his problems with an open razor, whilst Uncle John was the bravest of all. He married aunt Lil.

It was Grandad who towered over all though. Albeit small in stature, his heavy black beard and uniform stamped him as the pirate he was at heart. Earlier he'd been first

mate of a two-funnelled winkle barge; later he became the skipper of a ferry boat, and for many years had criss crossed the Thames on the ferryboat Rose. He was sometimes on Edith, to the intense annoyance of his wife Matilda.

Navigating Techniques

His one deep secret was his failing eyesight. In short, he couldn't see, which was somewhat of a drawback since the Thames at that time was an extremely busy waterway. We concluded however that he had his own method of navigation which did not require good sight, because he had a wonderful record of accident free crossings. This he shared with his opposite number skipper, old Jewiss, who by chance was the Grandad of my friend Ernie (landlord of a pub if you remember from a previous article). Accident free that is until one night Grandad hit the Tilbury landing stage an almighty thump which shook the Rose from stem to stern and didn't do the landing stage much good either, not to mention the passengers who were convinced that they were about to meet their maker while most were totally unprepared to do so.

Grandad said it was foggy at the time, which seems a pretty poor excuse if you can't see anyway. The upshot was that he had to have a medical and parted company with Rose (and Edith).

Uncle Jeff said it was a pretty poor show, and it was obvious that the medical examiner didn't know what he was talking about as none of them did. Grandad retired, and mum had to go across the road to get his beer for him because it was dangerous for him to cross the road, not being able to see and all that.

All this was a few years ago now so I don't suppose it's of any real interest to you. I just thought I'd let you know I had a grandad (two as a matter of fact) that I can still brag

about, even if Ernie reckons his grandad was a better ferryboat man than mine.

From Russia with Love

We are getting a bit choosy in our old age about which sets we take on for repair. For example, we are not keen on tackling Rigonda portables. So when one is brought in we immediately think who we can unload it on to.

Two came in last week, and we suggested to both owners that they should take them to someone who kept the spares. For example our friend Geoff who has a shop in Moon Lane.

Within the hour Geoff was on the phone.

"Do you happen to have service sheets on these little Rigonda portables Les? Some rotten bugger told them to bring 'em to me". The penny dropped. "It wasn't you was it?"

"No Geoff. I wouldn't do that to you, you know that. As it happens I do have the sheets. Funny regulator in them Geoff, sort of like an AD149 with three legs. See you when you pop down old mate".

I mean, what are friends for? What's the point in getting older if you don't get crafty with it.

Another Portable

I got my come uppance with the next portable though. It was a Ferguson 3840, with the 1690 chassis, and was wanted for five o'clock that afternoon as it was shared by the crew of a tug and they were going on at six and expected a quiet night.

The regulated line was a bit high, because the line output stage wasn't drawing any current. The efficiency diode was intact and read right. The supply was present at the collector of the line output transistor, and this made us feel uncomfortable. Not because the voltage was there and the transistor wasn't functioning, but because it was a T6006V (BU407) and we didn't have one.

We consoled ourselves by thinking that maybe it wasn't being turned on by the preceding driver or oscillator. With the solder removed from the base and emitter it seemed perfectly good on the ohmmeter. So we checked for line drive when it was resoldered. There wasn't any (should be $-0.3V$ base to emitter). Checks showed that the line oscillator was functioning and that line drive was present at the collector of the driver transistor, though damped. "Ah ha" we exclaimed as we leapt to the wrong conclusion once again. C86 could be leaky ($0.01\mu F$ damping capacitor in series with the 82Ω resistor R89 from the collector to chassis). It wasn't.

"Oh dear, not the transformer" we panicked.

"Don't be daft, it can't be the driver transformer because we haven't got one." The logic of this was beyond question, but. "We haven't got a BU407 either."

What are friends for? Frantic phone round. "Sorry Les." "Sorry uncle Les." "Sorry Lawry."

Alone again. Up the creek without a whore, er oar, er, paddle. Are we to be defeated? Don't answer that.

Make a conclusive test. That's it. What have we got? Lot's of line output transistors for the bigger stuff. Disconnect the BU407 and hook up an R2008A. Why not?

Instant success. Nice raster and the right sized picture with the aerial in. No heatsink though, and the R2008 was running pretty warm. Decide to improvise one rather than drill the existing one which also carries the regulator transistor. The correct transistor can then be fitted as soon as we get it.

So there it was with two heatsinks for the next couple of days. It worked well. I wonder if the new BU407 will last as long as the R2008 would have done if we had left it in? We'll let you know in due course.

A Lesson Here Somewhere

Enter a local engineer. "Hey Les, you don't happen to have an Indesit T24 line output transformer do you?"

I had one. "I've got one left. Let me have the replacement as soon as you get it will you?"

"I'd rather pay for this one if you don't mind."

"Oh, all right then."

One hour later. "Can you fix our Indesit? There's smoke coming from where the metal box is." Frantic phone calls. "Sorry Les." "Sorry uncle Les." Phone suppliers. "Certainly, we'll put a couple in the post for you. You should get them in a couple of days".

Enter an Anxious Man

"I borrowed this set from my sister because our colour set went up in smoke. The picture went off after a few minutes however. She says it's down to me because she spent twenty odd quid on it only a couple of months ago, so it shouldn't have gone wrong again and it must be me."

I had a sinking feeling that this was going to be awkward. It was a Philips G24T300 or something. You know the one, single-standard version of the 210 series chassis.

"It could be the line output transformer."

"That's what she had replaced."

"Oh well, it shouldn't be that then, should it?"

It shouldn't have been, but it was. The line output transformer was obviously fairly new, but a bit more than a couple of months I would have thought.

I told him that these things are guaranteed and that he should get his sister to contact the person who had fitted it. He looked scared. "Can I use your phone?"

Although I was six feet away I heard the reason why he looked scared. He put the phone down with a shaking hand.

"My sister wants her set back tonight and it had better be in going order." It was a shame to see such a big man reduced to jelly.

So I put him in my last 210 line output transformer and charged him only what it cost me. Away he went, confidence restored, fit to fight another day. Funny how women frighten us isn't it?

Of course, only two seconds later in comes a Philips 210 which wanted a line output transformer and no one around had one. This sort of thing used to happen with triplers until those darling people at Anglia Components brought out their universal tripler unit which has made life a lot easier. Now that we are well armed, tripler trouble seems to be less frequent than it was . . . Wouldn't it be nice if there was a universal line output transformer?

A Lovely One

The next set to come our way was yet another Philips one, a 24in. monochrome set fitted with the 320 chassis. It had a really lovely (?) fault. Now as you know this is the all solid-state chassis, with a bridge rectifier feeding a thyristor which provides a regulated h.t. supply of about 160V for the line timebase and the video output stage. As you probably also know, the regulated power supply doesn't deliver its full output until the line timebase starts up and in consequence the 34V line appears. If the line output stage is not working

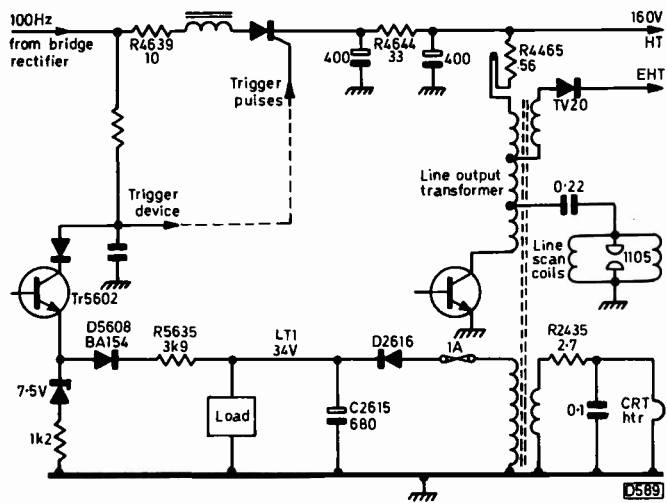

Fig. 1: Simplified circuitry showing the interconnections between the power supplies and the line output stage in the Philips 320 solid-state monochrome chassis.

or the 34V line is not intact, the h.t. line drops to below 100V (see Fig. 1).

We found the h.t. line was at 100V, with the 10Ω surge limiting resistor R4639 and the 33Ω smoothing resistor R4644 running too warm for comfort. The 34V supply was practically non-existent at the fuse for that line – fuse was intact, with virtually no current passing – and we thought that the line output stage was inoperative. In fact it was operating however, and a spark could be drawn from the exposed cone of the e.h.t. stick. This meant that the stick itself was o.k. and the line output stage functioning, but not well enough to produce the 34V line. Together with the excess h.t. current (overheating R4639 and R4644) this suggested an overload on the line output stage, but not one sufficiently severe to open the 56Ω spring resistor R4465 which supplies it.

We spent some while bumbling around until we finally unhooked the line scan coils. Immediately there was a vicious spark from the d.c. end of the e.h.t. stick, through the plastic housing. Off went the set, and we turned our attention to the scan coils – to be immediately burnt by the small spark gap (1105) wired across the line tags. Removing this and reconnecting the coils, we set the h.t. regulator to minimum and then turned on again. Everything now functioned, but not very well of course as the supply was low.

Turning up the control with a meter on the h.t. test point, we achieved 155V before the e.h.t. cracked over from the stick base. Inserting another layer of plastic solved this one, and we were then able to get full size and enough heater glow to provide a respectable picture.

Another spark gap was fitted across the coils, and the set seemed to function well enough except for a rather subdued tube heater glow which resulted in a slightly extended warm up time. The series resistor R2435 was correct at 2.7Ω, and since the heater supply winding is on the line output transformer and the rest of the line timebase functioned well we did not pursue the point, having already spent a lot of time chasing the shorted spark gap.

It was not the end of the story though, since we'd been testing on one channel selector only. When the others were checked, we found that three of the six were inoperative.

Since these were the top three we opened up the unit (Philips six-latch type, as used on the G8) and found the top plastic broken away on three of the selector strips. The top latches act on the top loop of each strip only, the lower three engaging in the loop half way down. So it was possible

to interchange the strips and render all latches fully operative and tunable.

A Bout with the Baron

I do wish people would keep their mouths shut. They've only to mention something to me and I'm blown if I don't go and dream about it. Someone was having a go at me recently because I wrote about my dreams of World War II. "Well I never" they said, sarky like. "I'd have thought at your age the first World War would have been nearer the mark". Not being quick thinking, I couldn't conjure up a suitably cutting reply. So I just drunk my beer and said nowt. But come night time I had a very queer dream.

There we were on an advanced airfield in France, lovingly tending my Sopwith Camel. Fred, Reg and me. And while we worked we sang our favourite song:

Four and twenty virgins
 Came down from Inverness
 And when the ball was over
 There were four and twenty less.

Suddenly our song was cut short, as a speck in the sky grew larger and zoomed over our field. It was a red Fokker D8 triplane, almost certainly flown by the dreaded Prussian aristocrat Baron Von Poorhoven. He seemed to throw his hand down at us before roaring away – not even attempting to shoot us up.

We ran over to the hand and found it to be a gauntlet with a note attached. It read: "up your sobby Camel." It was a challenge not to be ignored. So we prepared our trusty aeroplane and filled it full of this that and the other, singing away with renewed vigour:

The village butcher he was there
 Chopper in his hand
 He swung his chopper round and round
 And circumscribed the band.

Fred fitted and Reg rigged. Fred finely fiddled the engine until it sung a sweet song, and Reg rigged the airframe until the flying wires could be played like a harp. Perfection was the aim and perfection we achieved that day in Flanders. I donned my Didcot and helmet and wrote my note with care.

"Up your Fokker triplane" on one side, "0500 Somme" on the other.

I took off and skimmed across the trenches, ignoring the ground fire, but was slightly worried about Big Bertha lobbing shells toward Paris as I gained height for my run in at high speed across the Baron's field. I saw him standing there, looking upwards as I zoomed in, a mocking look upon his face. His scarf billowed out in the breeze, the red a bright contrast to the green field and perhaps an omen of what was to come . . . Blood.

Red and green, red and green. The blue was missing. I had to find why the blue was absent and it had to be done by five o'clock or Mr. Forth would make me paint his bridge again. I leapt out of bed. It was 4.30.

"What on earth are you up to now?" enquired my ever considerate prairie cactus.

"I've got to fight the Red Baron at 0500 and the blue's missing and, and . . ."

"What did I ever do to deserve you? It must have been something bad. Fight the Red Baron! He'd have to catch you first. Get back in bed and try not to snore and jump about."

I crept back in bed and lay there quietly while she snored and jumped about. Probably dreaming about mixing up two Yorkshires at once. These women have no imagination . . .

Colour Receiver Options

Part 1: Adding teletext

Luke Theodossiou

Now we have given you a breathing space to allow you to complete and test the basic receiver, we can embark this month on the three options we mentioned earlier, namely teletext only, remote control only, and remote control *with* teletext.

Warning

Before we start on the details, we had better make one point very clear. Each of the three options is totally self-contained, therefore constructors will have to decide in advance which *one* option they prefer. If you decide to go all the way and provide remote control with teletext, it's no good plunging into the teletext only system described in this issue and then hoping to "add" the remote control only option later. Each option has an interface board which will only accept its own circuitry – each is quite different from the others.

Choice of decoder

When the receiver was designed, the only readily available teletext decoder module was the Texas Instruments XM11. This forms the heart of our two teletext options. Unfortunately this particular unit is not entirely up to date (for instance it doesn't provide background colour) but its shortcomings are not important in our view and they don't pose any real limitations on the use of teletext as an excellent source of information.

We understand Texas are likely to be superseding the XM11 with the XM12 – which does include the latest teletext features – but we aren't certain whether the XM12 is pin-for-pin compatible with the XM11. This is a major consideration when it comes to interfacing it with the main receiver, so as soon as the XM12 becomes available we will be advising you on its suitability in our project.

There is another module now from Mullard – again, it is somewhat incompatible with our current design, but we shall be looking at this solution as well and will report on it in a later issue.

Decoding system

So far as the theory of decoding the teletext signal is concerned, we refer you to Steve Money's series of articles entitled "Ceefax/Oracle Reception Techniques" which ran from July 1975 to April 1976 in *Television*.

Very briefly, the XM11 operates as follows. The video signal from the receiver enters a data slicer, which extracts the digital information and feeds it to a clock sync circuit and a serial-to-parallel converter. The sync signals are extracted from the composite video signal and are used to provide the necessary timing. The now parallel data is fed to a framing code detector where, if teletext information is detected, a signal is passed to the character clock which

generates the character control timing signals.

Eight-bit byte information is corrected in a Hamming Code Correct block, and passed to the page decoding circuitry.

User commands are applied to the decoder via a keyboard; they are then decoded and stored in a memory. When the incoming data matches the information stored in this memory, the page decode circuit issues a "write-enable" signal, which allows the page to be written into the main memory. All information is written into the memory during the frame blanking period. In order for the page to be read out and displayed during the active video period, it is passed line by line through a latch which stores it for a short time, and then to the data control decoding circuit. This allows it to go into either the graphics or alpha-numeric mode, depending on the control code present. The information out of the character generator ROM passes through a shift register and an output buffer, and is then fed to the receiver's video channels.

Interfacing

A connection diagram of the decoder module is given in Fig. 1. The only connections to the Tifax module are the two inputs (composite video and negative-going line flyback pulse); the eight connections to the keyboard; the five outputs – R, G, B, blanking and monochrome; the +5V supply; and the earth connection. We shall look at each group in turn.

The video signal is provided by the vision detector module on the signals board. Its amplitude is made variable by VR2 and it appears on terminal 20 of connector A. In order to avoid pick-up of stray signals, it is connected to the interface board (and from there directly to pin 16 of the module) by a screened cable. This is reverse terminated by R4 to avoid reflections. VR2 is adjusted for error-free text.

The line flyback pulse is taken from pin 12 of the line

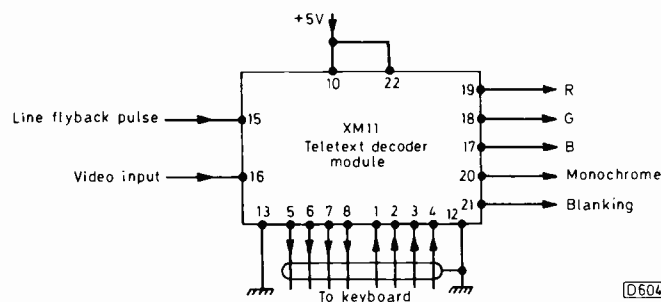

Fig. 1: Connections to and from the Texas XM11 decoder module.

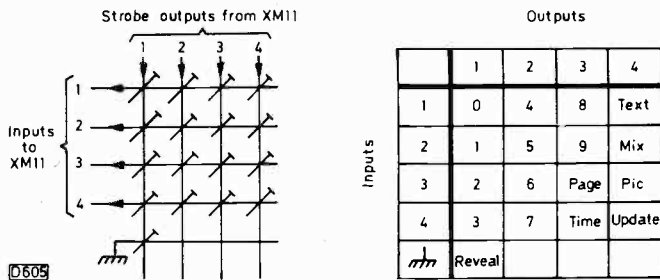

Fig. 2 (left): Keyboard matrix. Fig. 3 (right): Keyboard matrix decoding.

output transformer on the timebase board, amplitude limited by R67, and fed to the module by screened cable. The cable capacitance in conjunction with R67 will result in a CR time constant which will delay the pulse, resulting in a horizontal displacement of the display on the screen. The problem is avoided by having part of the limiting resistor on the other end of the cable and using a speed-up capacitor (C44). The value of this capacitor may be changed if required to ensure a central display on the screen.

The keyboard matrix is shown in Fig. 2. Control instructions are given to the decoder by using the four input wires and four output wires in a scanning matrix, and decoded according to Fig. 3. All outputs and inputs are normally at logic level 1. During each tv line in each field, each output goes to '0' for 12ns. In order to give a command to the decoder, one of these 12ns pulses needs to be transferred to one of the input lines for long enough – at least 50ms – to allow the module's internal 'de-bounce' circuitry to function. Similarly, there should be an interval of the same duration between instructions. The 'Reveal' command is given by shorting output line 1 to ground.

On switch-on, the decoder may go in either the 'picture' or 'mix' mode. To ensure that it starts in the picture mode, a momentary transistor switch is used which gives the decoder a 'picture' command on switch-on.

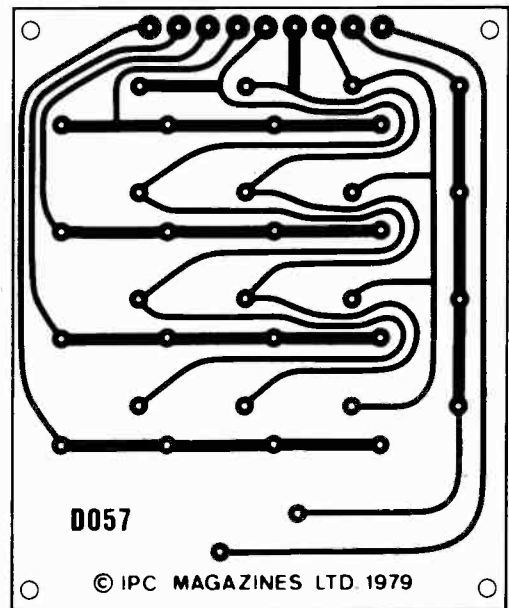

Fig. 5: Copper pattern for the keyboard pcb, reference D057.

The blanking output is used to inhibit the picture video in the receiver during the 'text' mode. When the selected page consists of a boxed display (e.g. Newsflash), the decoder automatically switches to 'picture' and the blanking output is active only during that part of the scan necessary to produce the box.

During the 'mix' mode, there is a danger of saturation, and also the legibility of the text depends greatly on picture content. Our method of avoiding these problems is to sum the blanking signal with the monochrome output. What will happen now is that the monochrome signal will be seen as a blanking signal and will therefore create black 'holes' in the picture. During mix, the three colour outputs go into a monochrome condition and the 'holes' are then at peak

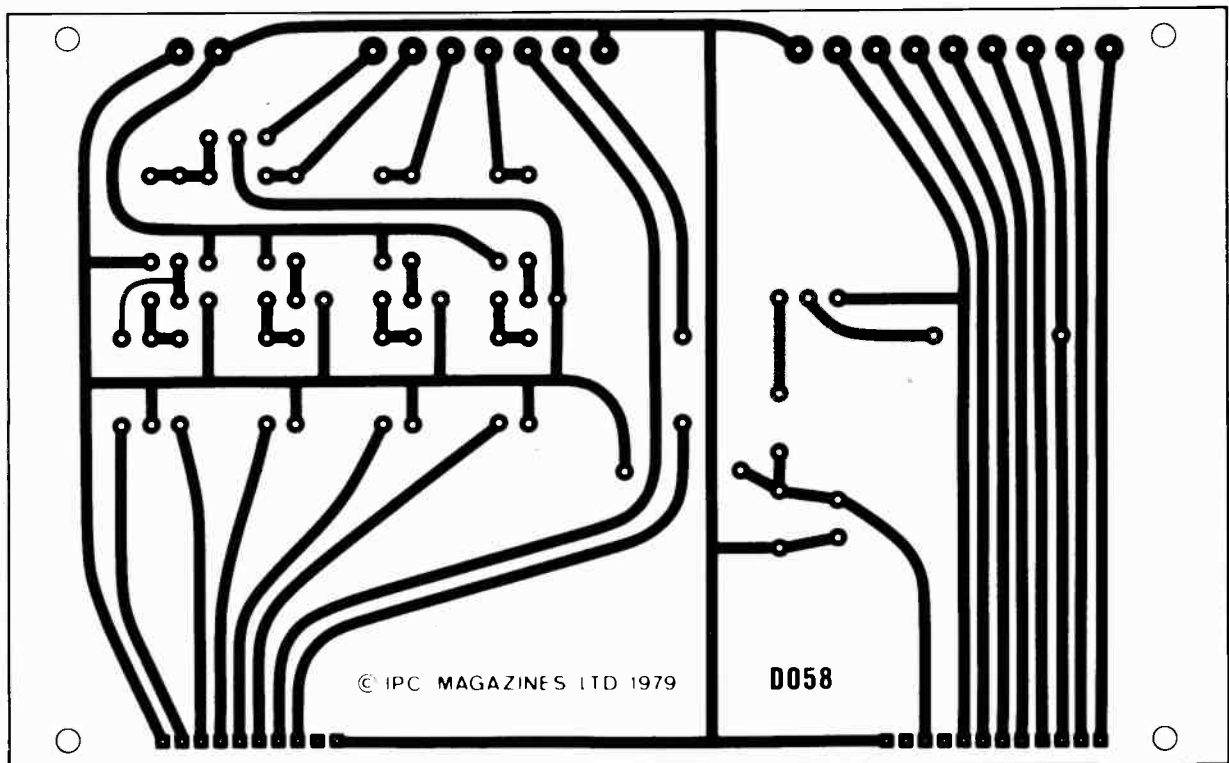

Fig. 4: Copper pattern for the interface board, reference number D058.

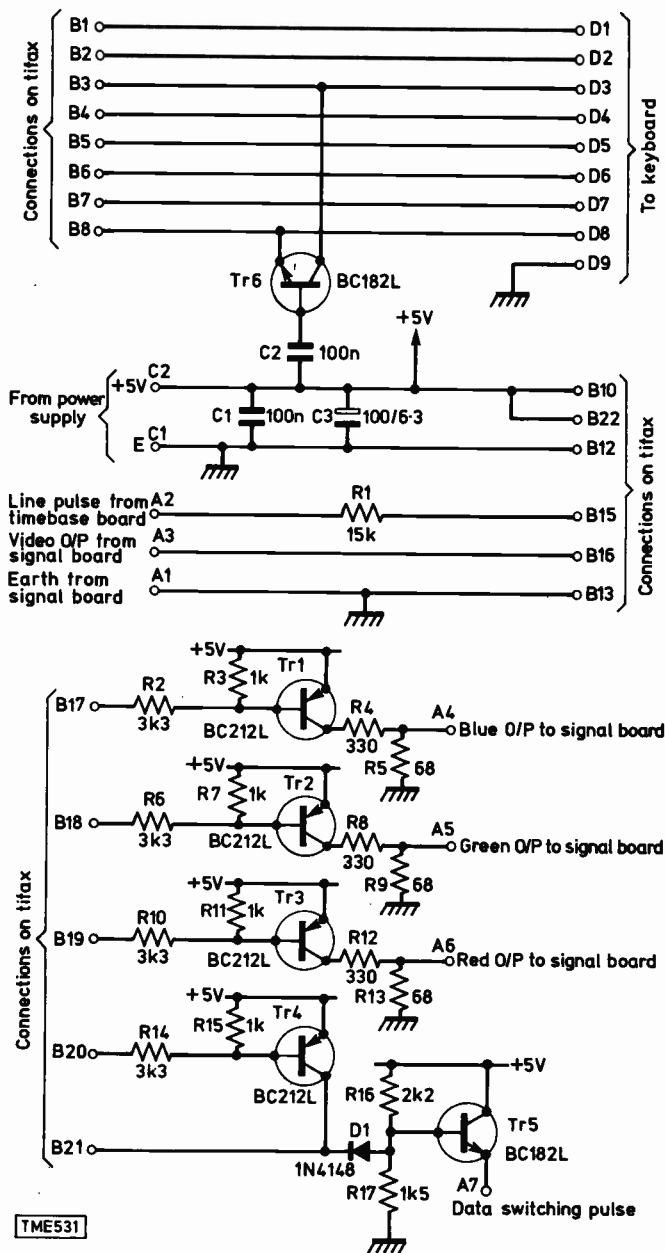

Fig. 6: Circuit diagram of the interface circuitry.

white. A small timing error is introduced by the circuitry which turns out to be advantageous – it gives a very slight shadow to the characters, making them more legible.

The RGB outputs consist of open collector transistors with 470Ω protection resistors (the blanking and monochrome outputs are similar). Each one is fed to an inverter stage on the interface board which provides positive going signals with an amplitude of 1V pk-pk which are fed to the signals board on terminals 2 (blue), 3 (green) and 4 (red) of connector A. A similar arrangement is used for the blanking output except that this is complicated by the need to sum this with the monochrome output as explained earlier. The blanking signal is applied to the signals board on terminal 1 of connector A. The +5V rail is provided by the power supply board on terminal 3 of connector F. A complete circuit diagram of the interface board is shown in Fig. 6.

Construction

Although the board itself could have been made smaller, it was decided to make it the same size as the XM11 so that with the aid of stand-off pillars it can sit on top of the

module. All connections to the XM11 come directly from the interface board at the correct physical position to enable the use of ribbon cable to the module connectors. The use of these connectors which are provided with each module, is essential, incidentally, since soldering directly onto the pin voids the guarantee.

Connecting up to the receiver is straightforward, but earth loops are disastrous. More on this point a little later. The keyboard is extremely simple to build, and connections to the interface board can be made using multiway cable for convenience and neatness. The prototype keyboard was made up using Perspex off-cuts and bonding them together using an approved adhesive.

Faults

Faultfinding is confined to the interface board and the connections to the receiver. Under no circumstances should the XM11 be tampered with – if the module is faulty return it to the supplier intact.

The first thing to check for after connecting up, is that your connections have not adversely affected the picture. If this is the case, an earth loop is the only reason. A blank screen probably means that the line flyback pulse is absent. A black bar running up or down the screen means that the video signal is absent. Display jitter or jagged characters means an earth loop. Decoding errors mean an earth loop, inadequate video signal amplitude, or inadequate aerial system (noise, ghosting etc).

As can be seen, the earth loop features rather prominently so some precautions are necessary. The screened cables supplying the line flyback pulse and the video signal must only be earthed at the timebase board and the signal board ends respectively. All cables should be kept as short as possible and away from possible pick-up areas (e.g. tube neck).

One important modification which must be made to the signals board when adding any of the options is the value of R49 – which is changed from 2k2 to 68Ω.

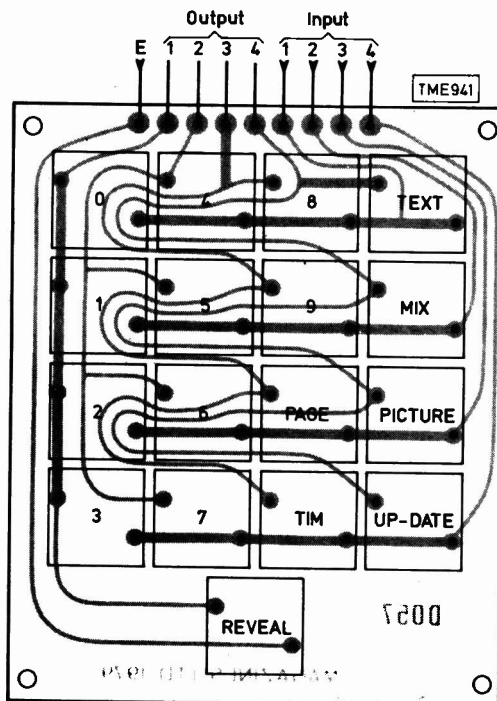

Fig. 7: Switch location diagram for the keyboard. The switches used are from RS Components type 337-611 (grey) for 0 to 9; type 337-605 (blue) for the functions except REVEAL which uses a 337-598 (red). They can, of course be varied according to personal taste.

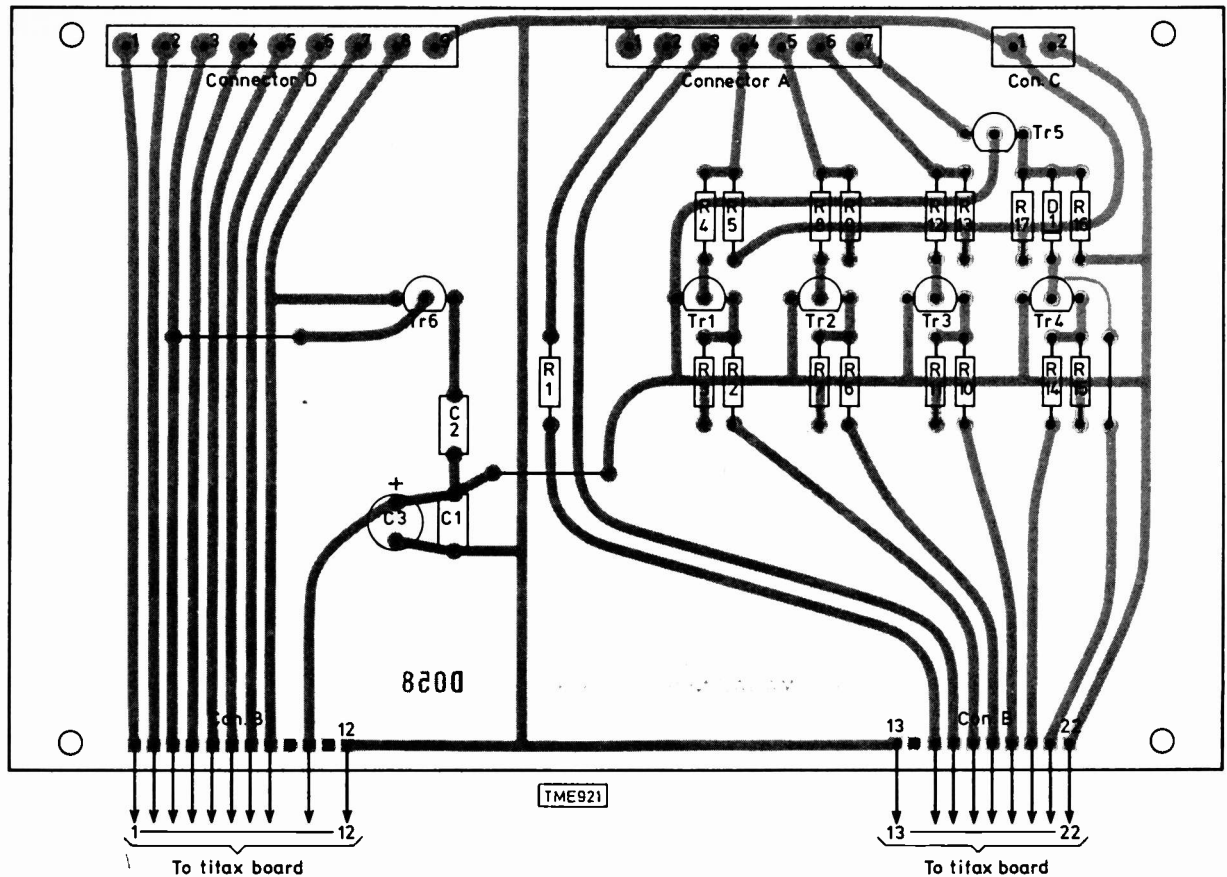

Fig. 8: Component location diagram for the interface board. Molex 0-2" connectors may be used, or the cables can be soldered directly to the board.

★ NEW ★ COLOUR BAR GENERATOR

U.H.F. AERIAL INPUT PATTERN GENERATOR CPG6-RF

All Facilities of our PG6RF

PLUS COLOUR BARS.

Produces 7 invaluable patterns.

**Robust, Battery Powered, Pocket Sized Unit,
Plugs Straight into Aerial Socket.**



W H I T E	Y E L L O W	C Y A N	G R E E N	M A G E N T A	R E D	B L U E	B L A C K
-----------------------	----------------------------	------------------	-----------------------	---------------------------------	-------------	------------------	-----------------------

FEATURES:

- ★ CROSSHATCH GRID
- ★ DOT MATRIX
- ★ VERTICALS
- ★ HORIZONTALS
- ★ WHITE RASTER
- ★ GREYSCALE
- ★ PLUS PAL COLOUR BARS;
ONLY 3 SIMPLE ADJUSTMENTS.
- ★ PG6RF OWNERS; Buy Add-On 'C6' Unit!

ORDER NOW!

PG6RF KIT £25.87 BUILT £33.35 – As per TV Review, Jan. 1979

C6 KIT £18.98 BUILT £26.45 – Add-on Colour to PG6RF

CPG6RF KIT £42.55 BUILT £63.25 – Both above combined.

These prices INCLUDE P & P and 15% VAT. Export VHF versions available.

In response to demand we have produced an add-on Colour Bar unit C6 to upgrade the PG6RF to PAL COLOUR. A MUST for TV construction or servicing! Available as a KIT or BUILT & TESTED. Kit includes all components and ready built modulator etc. Full 12 month guarantee on built units.

MAIL ORDER ONLY

Quantity Discount on application

**ACCESS
ORDERS
WELCOME**

ALSO AVAILABLE:

TECS: TECHNOLOGICS EXPANDABLE COMPUTER SYSTEM.

Full Colour Teletext; full facility Microprocessor-based, Aerial Input Decoder with extensive computing facilities. The most versatile decoder on the market. Expandable from a simple teletext decoder to a full professional computer/information centre. Send large S.A.E. for details.

SEND ALL ORDERS OR ENQUIRIES TO TECHNOLOGICS LTD. (DEPT. TV)

8 EGERTON STREET, LIVERPOOL L8 7LY. Tel: 051-724 2895.

Miller's Miscellany

Chas E. Miller

If I tell you I recently had in for repair a TV set in which lack of contrast was caused by a faulty PCL82 sound output valve, do you think you could hang on a minute or two before shaking your heads sadly? There is an explanation. You see, the aforementioned PCL82 had shorted internally, as is the wont of this particular bottle, and caused its bias resistor to burn out. (It was in a Bush TV161 by the way.) The resulting excess voltage across the associated bypass capacitor brought about its demise: it exploded violently, and rammed its aluminium case hard up against the nearby resistor 2R78, which provides coupling to the a.g.c. circuit, neatly shorting it to chassis. I'm sure these things happen only to me . . .

Speaking personally, one of the most reliable sets I've had to deal with over the last few years has been the Indesit 24in. monochrome set in its various forms. Admittedly the line output transformers are now beginning to fail, but for a long time the faults seemed to be confined to soft PY88s and eccentric PCL805s, plus the occasional defective e.h.t. stick.

The snag about this kind of performance is that one has no fund of experience to draw upon when a real stinker of a fault presents itself. Thus it was that I was called out to a set with a very odd line timebase problem. When the set was first switched on, the timebase started to work up to the point where an unsynchronised raster became visible. This lasted for no more than a couple of seconds before the line whistle sharply reduced in pitch and the picture collapsed to a single vertical line in the top half of the screen, broadening out in the bottom half to the shape popularly attributed to flying saucers. I discovered the cause of this more or less by accident, when checking voltages around the PCF802 line oscillator valve. For when I placed the meter prod on pin 2 (pentode control grid), the picture became normal. It transpired that the 1M Ω grid leak resistor had gone open, allowing a blocking voltage to built up on the coupling capacitor so that the valve cut off intermittently. This has got to be another one for the notebook!

One of the faults which, as far as I am concerned, seems to break out in spasms is failure of 0.47 μ F boost reservoir capacitors in line timebases. After a long period when the spares gathered dust, I've just had to fit three in quick succession – in a Pye 691, an ITT CVC5, and a Bush CTV174.

The first is an old favourite of course, and as usual the lack of an h.t. fuse had brought about the familiar chain of destruction – the shorted boost capacitor causing the PY500 to draw heavy current to the point where it failed, but not before it had blown the 3.3 Ω surge limiting resistor in the h.t. circuit. Incidentally, I've become so accustomed to going to the 0.47 μ F capacitor whenever I get a dead short to earth reading at the PY500's top cap on these chassis that it comes as a shock when this component is in fact innocent.

Another high risk capacitor in this chassis is the 0.1 μ F

one which bypasses the boost h.t. supply to earth after it has passed through a 100k Ω resistor (R227 and C224). When the capacitor goes short, the resistor nearly always drops in value until it too becomes a virtual dead short. This is definitely one to look for, because I recently came across a 691 chassis which had been discarded because it was thought that the line output transformer had shorted turns when the blame lay with the components just mentioned.

In contrast, I've had so many high-voltage puffers (C308, 220pF, fifth harmonic tuning) break down in the ITT CVC5 and similar models that I have to think twice when the larger capacitor fails. Fortunately there's ample fuse protection in these sets and seldom is any other damage done.

Fuses didn't save the Bush CTV174 from becoming the worst casualty however. The initial overload when the 0.47 μ F boost capacitor failed was sufficient to get wire-wound resistors in the power unit hot enough to melt solder, long before the fuse blew. One of these resistors, in the main h.t. line, came adrift from its tags and dropped on to the low-voltage side of the mains transformer, effectively shorting it out. There must have been some wonderous arcs and sparks before the mains fuse finally blew, because the transformer had dripped pitch all over the rest of the unit and there was a great scorch mark up the inside of the cabinet. The whole thing must have been within an inch of going up in a blaze of glory! Incredibly it had survived this ill treatment, and when I'd rectified the various shorts the set worked as well as ever!

Funny (?) Telefunken

When this fellow rang up and said his Telefunken 740T (709 chassis) had gone bright green (the picture, not the cabinet) and slowly faded away, I had a sense of impending doom – and I was right! Actually, the first part of the complaint was put right quite easily: an 0.01 μ F capacitor on the c.r.t. base panel had gone dead short and removed the c.r.t.'s red first anode voltage. This had in turn burned out the relative preset control.

When these components were replaced I got a picture of sorts, but one that exhibited signs of gross overloading of the e.h.t. when the brightness was advanced to a normal level. On checking the various voltages around the line timebase, I found that the boost line was high at around 1kV. What was more, the "booster-spannung" control made not the slightest difference!

From then on it was sheer frustration: none of the other specified voltages was anywhere near correct, yet none of the components involved had failed – checked by two of us working together to avoid mistakes. In the end I managed to get a measure of control over the boost voltage by replacing R492 (see Fig. 1) with a small preset of the same value. By adjusting this, the correct value of boost voltage was at last obtained. But why was this unauthorised modification necessary? With all necessary spares to hand and tried wherever needed, I would take a lot of convincing that it was due to a simple component failure. Was it a result of the initial short on the boost line due to the failed capacitor? But there was no evidence of this. No one can afford to work on a fault like this indefinitely however, so the modification was accepted.

The picture was better now, but the e.h.t. was still affected adversely by high brightness levels. Guess what: R482 (peak current limiter) didn't do anything either! This was getting ridiculous, so it was a great relief when I found that very careful adjustment of the beam current limiter control (R512) gave results that were o.k. unless the

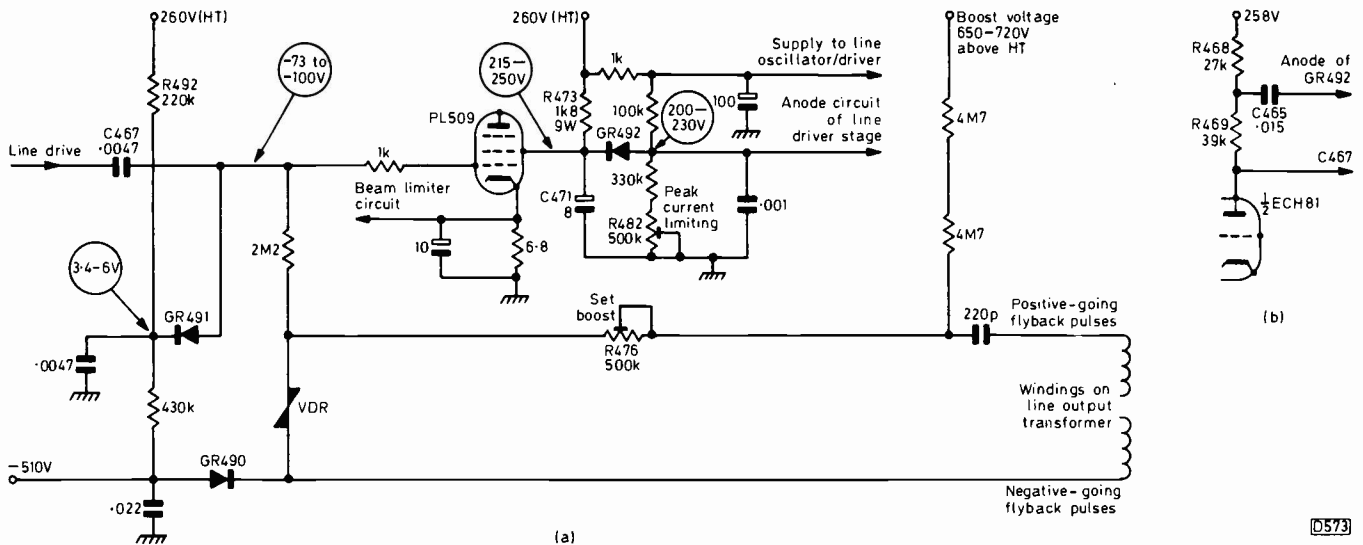

Fig. 1: Line output valve control and screen grid circuits (a), Telefunken 709 chassis. What a lot of diodes! GR491 appears to act as a clipper, while GR492 provides beam limiting. With excessive beam current the PL509's screen grid voltage will fall, GR492 then connecting to earth the junction of the driver stage's anode load resistors R468/9 via C471, thus reducing the line drive. The driver is the triode section of an ECH81, see (b), the heptode section forming the line oscillator.

brightness control was turned up much too far.

After all that, I should have left things well alone, but as R512 was noisy I decided to give it a spray with switch cleaner. I don't know what plastic R512 was made of, but the cleaner dissolved it instantly, and with a twang the wiper assembly flew apart over the print . . . I called it everything but a 'strahl-strombegrenzung'!

Guide to Coarse Servicing – 3

It was viewing day at the local auction sales, so Ike Hodge took Willy along to seek out any bargains that might be going, and to impart to his assistant some of his words of wisdom and warning. Willy paused to admire a clean looking 22in. colour set which bore a label stating "in working order – house clearance". This was written in a spidery hand. Ike noticed his interest, and asked:

"What do you make of that one?"

Willy frowned. "It looks as though it's come from a decent home" he replied. "I'd guess from the label that it belongs to some poor old geezer who's selling it because he's having to move out of his house."

Ike nodded approvingly. "Full marks" he said, then added caustically "... for being a twit. That's exactly what you're supposed to think. Just look at that control panel – it's clean all right, too clean. No old geezer did that, because it's bright right under the knobs, where customers always leave dirty marks. Let's take a look at the back . . . I thought so, no sign of dust in the ventilation slots. I'll bet you anything you like this is an old clapper that's been tarted up for sale by Rodney Bloggs, the second-hand bargain shop owner. In fact I recognise the writing, now. He must have rested the paper on brick to get that spidery effect. I think we'll leave that one well alone."

Pleased by this display of his shrewdness, Ike felt expansive and continued "you've got to keep your eyes open in a place like this. There was a Japanese colour set for sale a couple of years ago. Looked passable – until I noticed that the back screws weren't original. That made me suspicious, so I took the back off. D'you know what the crafty buggers had done?"

"What?" asked Willy dutifully.

"Only put an old monochrome tube in, and taken out all the valves, that's what! That set changed hands three times in different sales before someone apparently scrapped it.

Another time I nearly got caught buying an ITT colour set that had a ticket on it saying "in working order, owner bought new set," followed by a name and address. It was this that fooled me, because it made the whole thing look genuine. Clever, that bloke was. But as usual just a bit too clever. I'd actually bought the set, but not paid for it, when a mate of mine comes over and sees what I've got. "Watch it" he says. "I know that bloke. He's on the Datasift (national register of bad debtors). He'd never be able to buy a new set, because he can't pay." With this in mind, I took the set to the workshop and opened it up. Blimey! What a shambles! Wrong valves shoved in anyhow, and the tube emission hardly enough to move the needle on the tester. So I got this bloke who'd sold it on the phone and told him straight "either you accept a nominal fiver, or it's down to the Trades Description people". He took the fiver.

"Did you do any good with it?" enquired Willy.

"Oh yes. It took a long time mind you, but I got it going like a good 'un in the end, then sold it to a mate of mine. As far as I know it's still going strong."

They moved on to where a number of sad looking monochrome sets were grouped on a large table. Ike shook his head sadly.

"Not much good here. Not like the old days, when one of the local dealers was always putting in loads of working part-exchange sets. He used to sell the bangers as well, and I reckon someone in his firm must have had a fiddle going on, because I discovered that all the good sets were marked "spares only" while the rubbish was marked "working order". This someone had the idea of changing over the labels on purpose, so that no one would bid for the workers. They'd be sold for little or nothing to this someone's crony, who could then re-sell them at a profit. I soon put a stop to that."

"You reported it to the dealer?"

"Don't be daft!" retorted Ike. "I bought them all myself. Can't stand dishonesty like that" he added virtuously.

(Note: Ike Hodge is not based on any one person: he's an amalgam of a number of characters I've known over the years. It would be as idle to pretend that there isn't a tiny minority of cowboys in our trade as it would be to suppose that all our customers are saints. All the incidents described in "coarse servicing" are true. My intention in presenting them is to demonstrate to the honourable majority of engineers just how the other 0.001% lives!)

Long-Distance Television

Roger Bunney

WHEN I first started writing this column in 1971, following on from the previous DX-TV column in these pages, I often wondered whether there would be enough news to keep up readers' interest. Such fears have proved groundless, thanks largely to the news and reports sent in by readers – news, views and comments are always welcome. The amount of news and other items has meant that I've increasingly had to curtail details of my own reception – it seems more important to chronicle the interesting reception reported by other enthusiasts. Unfortunately, due to the magazine's long monthly production schedule (the words I'm writing on July 30th won't appear until the October issue comes out in late September) much of the "hot" news becomes history by the time it appears. It's reassuring nevertheless to be able to report that interest in DX-TV activities is thriving as never before!

There was plenty of Sporadic E reception here at Romsey during the month of July: there was also enhanced tropospheric reception at times. An interesting opening on the 2nd produced signals from YLE (Finland) at good strengths on channels E2, 3 and 4 and, at 1245, a caption on chs. E2/3 with the words "Brudo Med Studio". Thoughts of reception of one of the exotic Italian free TV stations gave way to deflation when advised by David Martin that this was in fact NRK (Norway)! Still, an interesting caption. SpE reception on the 6th seemed to last all day and into the evening, with signals arriving from all directions. The 9th produced southerly SpE signals from RTVE (Spain) and RAI (Italy), while Hugh Cocks received Gwelo, Rhodesia via transequatorial skip.

The 10th produced an evening period of SpE reception here with, unusually, TSS (USSR) on ch. R1 until 0030 local time (0230 Russian time). There was a mainly Scandinavian opening on the 11th. At 0944 NRK ch. E4 faded out, leaving a weak T05 (Telefunken) test card without identification. Any ideas? ORF (Austria) use this card from time to time, but with an identification. There

followed several consecutive days during which SpE signals were present – the 15th-19th, and again on the 21st, with reduced reception on the 24th, 27th and 30th.

Hugh received Rhodesia (ch. E2) again on the 16th, at very good strength, with both sound and vision. The signals were received here on the 18th, but with vision only and weak at that. Times were typical for TE skip reception – around 1700-1900 BST.

There was improved tropospheric reception during much of the month, thanks to the prolonged high-pressure systems that also provided hot, dry weather. The period around the 12-16th was particularly active, with W. German u.h.f. signals present in many parts of the UK. RTVE was received here in Band I (ch. E4) on the 25/26th at good strength.

In short, a very satisfactory month!

Readers' Reports

Kevin Jackson (Leeds) received the Azores (RTP) ch. E4 on the 1st, with similar programming to the ch. E3 mainland network. The Italian NCT ch. E3 outlet has been seen many times in various parts of the UK, with a modified Indian Head test card and the identification NCT. Another caption from this outlet, "NCT CANALE A UHF", is rather confusing since the station operates on ch. E3.

Gosta van der Linden (Holland) reports that a mystery Danish station on ch. E12 is now in operation. This has been seen in Holland and also by Gosta while he was staying in Denmark.

Probably the most interesting news this month has come from Ryn Muntjewerff (Holland) who received Arabic programme material on ch. E5 on June 28th. It seems that this was SpE reception from the RTA (Algerian) network. The signals were received during 1435-1510 GMT, with identification made possible by the Arabic sound. Albania and Italy were being strongly received at the time. Congratulations Ryn!

I've heard unconfirmed rumours that Gabon (Africa) ch. E3 has been received – but as yet these remain rumours!

Another "first" from Australia – reception of the u.h.f. link between WIN-4 and WIN-3 by Robert Copeman in Sydney, using an imported Philips portable receiver. The ch. 58 link serves the Brokers' Nose transmitter and the North Wollongong area.

News Items

USA: Reports sent to the FCC suggest that circular polarisation doesn't give improved coverage compared to plane polarisation, and could in some instances result in significantly increased co-channel interference via SpE. CP didn't give much improvement in Salt Lake City, Utah, though there are few high-rise buildings there. WESH-2 at Daytona Beach has recently installed a CP transmitting aerial atop its new 1,740ft. tower.

Niger: SECAM colour transmissions started in April, from temporary 100W transmitters. Several hundred receivers are in use and a TV production centre is to be completed by

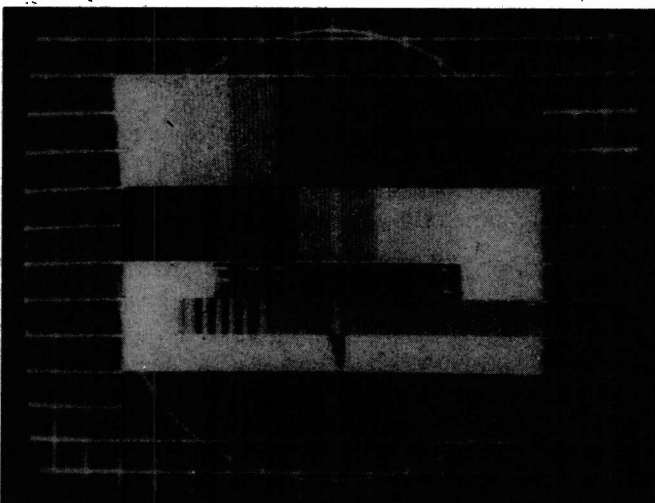

Portugal ch. E2 received in the UK by Garry Smith via single-hop Sporadic E propagation.

the middle of next year. Solar energy is used to power many communal receiving units. At Tillbery a 1W transmitter is completely solar powered.

Israel: A second TV network, commercial and independently operated, has been proposed. The transmitters would be government controlled.

Vatican: The Vatican State is planning to start u.h.f. TV transmissions – channels E21, E45 and E57 have been allocated for Vatican use.

F2 Possibilities

Since the sunspot maximum in the current cycle is expected this winter, thought should be given to the dramatic signal propagation that may occur. Sound and vision buzz from New Zealand TV have already been received in North America. New Zealand channel 1 operates at 45.25MHz vision and 50.75MHz sound, while the Australian channel 0 is 1MHz higher. Suspected channel 0 reception has already been reported from Leeds. If conditions in the F layer are better than last winter, when BBC-1 45MHz vision was received on many occasions in Australia, we might well get 12,000 mile DX-TV here. The following table may help:

	<i>Weekdays</i>	<i>Saturdays</i>	<i>Sundays</i>
TVQ-0	2100-1400	2300-1400	2310-1410
ABMN-0	2100-1140	2000-1245	2300-1310
ATV-0	2000-1300	2100-1300	2130-1300
NZ ch. 1	2300-1115	2300-1115	2300-1115

All times are GMT and apply during October-March (summer in the southern hemisphere) – add one hour outside the summer period (TVQ-0 has no summer time adjustment). These transmission times have been averaged out over several weeks, and variations may occur, in particular over Christmas, the New Year and for special sporting events (ABMN-0 concentrates on sport). Test transmissions precede these times, with the PM5544 pattern, test card F and other variations. Our thanks to Anthony Mann for his help.

From our Correspondents . . .

Topics raised by correspondents this month range from short-skip SpE to on-channel transmissions. Don Bassnet (Glasgow) noticed evening short-skip SpE on channels B1 (Crystal Palace) and B2 (North Hessary Tor) on July 3rd, while Kevin Jackson (Leeds) noted short-skip SpE from Steinkimmen (NW Germany) on ch. E2. Kevin suspects that there's a new low-power Yugoslavian station on ch. E4 – he's seen a FUBK card with the identification "JRT-SA-1".

A correspondent in Southern Ireland reported recently on tests carried out relaying an off-air signal over a further half a mile to a shielded location. Some of the tests were carried out using a pattern generator feeding a relay-type high-level amplifier linked to a Colour King bowtie aerial array. Using an amplifier at the receiver, the pattern could be received over a wooded path of two miles. I gather that on-channel amplification is used in parts of the UK, the received signal being amplified with an MATV unit and the output fed to a high-gain receiving type aerial. The aerial output can be directed into shielded and screened locations, giving an on-channel repeater at very low cost. An RTE transmitter is to be built at Foyle Valley, Co. Donegal, with a 300kW output (vertical polarisation).

Arthur Milliken (Wigan) has been using a National Panasonic Model TR5001G combined radio/cassette/TV receiver which features v.h.f./u.h.f. coverage with a

**CONTINENTAL AERIAL SPECIALISTS, RETAIL AND TRADE.
GOLDEN ANODISED, WEATHER PROTECTED, SUPERB ARRAYS.
GUARANTEED BY US FOR FIVE YEARS.
GOLDEN QUALITY IN A PLASTIC AGE.
ALL PARTS (EXCEPT COAX) EXCHANGEABLE FOR 7 DAYS.
10% DISCOUNT OFF MOST AERIALS
SPECIAL PROMOTION OFFER
15% + DISCOUNT ON PLEMI RANGE**

For new glossy, highly graphic lists & brochures send 40p & stamp only. 40p credit on 1st order.

AGENTS FOR
FUBA & PLEMI

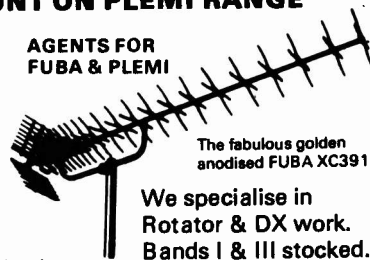

The fabulous golden anodised FUBA XC391

Stockists of the finest aerials available in Britain:
STOLLE FM aerials (W.Ger.)
FUBA TV & FM aerials (W.Ger.)
PLEMI TV aerials (Hol.)
UKW FM aerials (E.Ger.)
ANTIFERRENCE TV & FM aerials (U.K.)

We specialise in
Rotator & DX work.
Bands I & III stocked.

ASTRA (GOLDEN D.I.Y.) AERIALS

A friendly family firm. Our 25th. Jubilee Year.

D.I.Y. AERIAL SPECIALISTS FOR ALL DOMESTIC TV & FM RECEPTION
Weather exposed part of U.K.? Scotland, Wales, West Country etc. Gales, salt air corrosion problems? Want to install your aerial and forget it?
The continental aerial range from Germany and Holland having proved so fantastically successful, we are in future recommending continental aerials (especially Fuba) as our first choice for customers. In short we offer quality in a plastic age. Anodised against corrosion, guaranteed for five years, robust, high gain, easy to assemble, eye-catching superb aerials, what else, in truth could we recommend?
Over 3,000 aerials stocks: All Bands: Masts: Lashings: Wall Brackets: Rotators: Televertas: Diplexers and Triplexers: You can now mix Band 4 and Band 5, or lower Band 5 with higher Band 5, or mix FM with either, 1.5db loss approx.: Padded outlets: Directional splitters: Coax, white or brown: 300 ohm cable.

Many of our customers come from recommendation.
53 WHITEHORSE ROAD, CROYDON, SURREY.
Nr. Gloster Pub & Garage Tel: 01-684 4300
Open 9.00-5.30 MON-SAT. 01-684 5262
Closed 12.30-1.30 But Open ALL day Sat. 24 hr. answering service
FM & TV AERIALS AND ROTATORS ON DISPLAY

LOOK! Phone: LUTON
BEDS. 38716

**OPPORTUNITIES
TRADE SALES
ALL SETS GUARANTEED
COMPLETE**

**OVER SIX HUNDRED SETS
ALWAYS IN STOCK**

Pye 20T, Philips G8;
Ferguson 3-3k5

Murphy, Bush, Decca, GEC
All from

£35.00 £50.00

Square Screen, Mono's from

£5.00 ALL MODELS

Sets for spares from

£2.00

All include VAT

OPPORTUNITIES
9A, Chapel Street, Luton, Beds.
LUTON 38716

9.30-6.00 p.m. Weekdays, 10.30-1.00 p.m. Sundays.

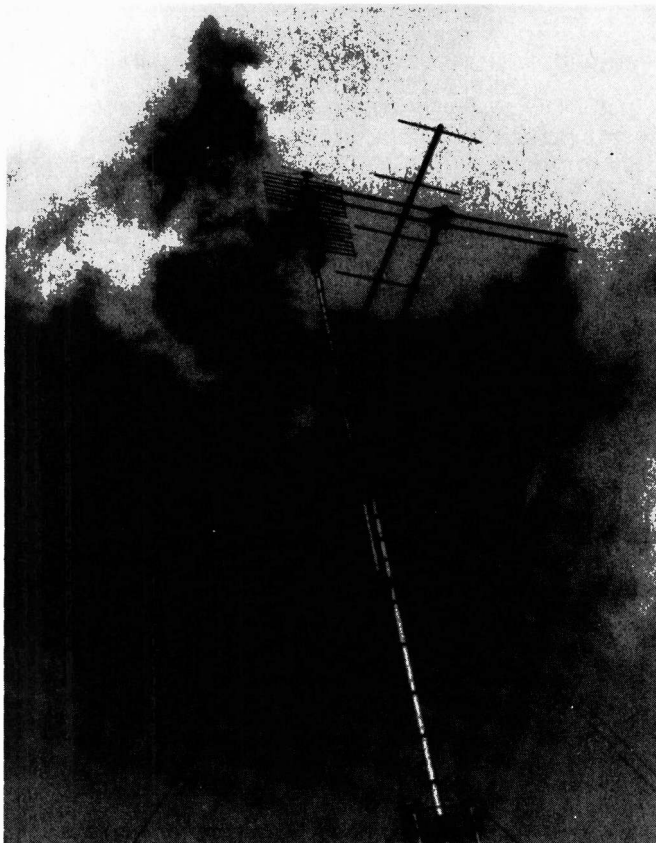

Band I, II (TV), III and u.h.f. arrays mounted on a guyed lattice mast – the upper section, carrying the aerials, can be rotated. Photo courtesy Garry Smith. Note the use of "Trumatch" dipoles to give wideband coverage of Bands I and II.

switchable 5.5/6MHz sound i.f. Some remarkable reception has been achieved, including JRT and Swiss TV, with only the small whip aerial in use.

A pleasure to hear again from John May (Orpington) who is now using a Teldis preamplifier and up-converter feeding his monochrome TV set. With this arrangement he's been able to witness on his screen signals from much of the European landmass. John has been suffering from heart problems in recent times: we all wish him well.

Hugh Cocks mentions the "extra domestic" US citizens' band at 49MHz – low-powered walkie-talkies are used at this frequency, and Hugh picked one up quite recently. An interesting phenomenon can occur along the south coast (and elsewhere, I'm sure). The Dover (Swingate) transmitter



China ch. R1 received in Holland by Ryn Muntjewerff via F2 propagation. Note the smeary video image.

receives Crystal Palace ch. B1 off-air, re-radiating it on ch. B2. The Folkestone relay is designed to pick up Dover and similarly re-transmit on ch. B4. Dover sometimes picks up other transmissions via F2 and SpE however, re-radiating them on ch. B2. Folkestone in turn transmits the signals. Folkestone has been known to re-transmit the ch. E4 NRK test card on a frequency just above ch. R2: similarly ch. R1 can appear on ch. B4. This can be confusing to say the least during a good SpE opening!

Long-Distance TV for the Beginner – 2

As described last month, a continuously tunable u.h.f. receiver can be used for DX-TV, an approach that involves the minimum financial outlay. With such a receiver plus an aerial, signals from many hundreds of miles away can be received during good tropospheric conditions. It's also possible to use the u.h.f. receiver for receiving long-distance v.h.f. signals in Band I, with a simple v.h.f./u.h.f. up-converter prior to the aerial input. The new DXer will then be able to enjoy the SpE reception that occurs during the summer months, a phenomenon that can result in Band I TV signals being propagated over many hundreds, indeed at times a few thousand, miles. Such signals can arrive at strengths ranging from a few μV to the mV level, often being in excess of the strength of local transmissions.

The E layer is a layer of ionised gas some 75 miles above the Earth's surface. Under normal conditions it reflects short-wave signals (at night, when the D layer dissolves, medium-wave signals are reflected as well) over some 2,000 miles in a single hop. Signals above a certain frequency pass through the E layer, but may then be reflected by yet another layer, the F layer. Normally, Band I TV signals pass through these two layers, out into space. At times however very intense patches of ionisation form in the E layer, a phenomenon known as Sporadic E. Incident v.h.f. signals that strike these patches are reflected back to Earth, giving reception at distances normally experienced with lower-frequency, short-wave signals. The patches of ionisation may move about, producing different signals at the receiving site – signals from different transmitters and countries. Band I signals propagated in this way are normally received at good strength. When the patches are very intense, Band II and very rarely Band III signals may also be reflected over considerable distances.

There is normally a minimum reception distance of around 500 miles, with a maximum single-skip distance approaching 1,500 miles – though tropospheric enhancement at either end of the signal path may increase this distance. At times the signal may be reflected twice, as occurs when Nigerian, Russian and Canadian signals are received in the UK. Very rarely, a triple-hop signal may be received.

SpE reception is most common during the May-July period, extending into September in a good year. There is also a noticeable peak in SpE activity in mid-winter in years when sunspots are at a minimum. Reception can occur at any time of the day or evening, the main limitation being the transmitters active at the time of the SpE opening. The direction of the signals is similarly random, though during any one season there is a tendency for signals from one direction to predominate. This year signals from NRK (Norway) were received at incredible strengths.

Mention has also been made of the F layer – there are two F layers in fact during the daytime, and it's the higher F2 layer that is of main interest to us. This layer is some 200 miles above the Earth's surface and, during the winter daytime when sunspot activity is at a maximum (as at

present), it can become intensely ionised – due to radiation from the Sun. As a result, the F2 layer will reflect signals in the lower v.h.f. channels. Since the height of the F2 layer is some 200 miles, it follows that single-hop signals will be received at thousands rather than hundreds of miles. Last winter F2 signals from deep within the USSR (reaching a time span of plus six hours) were quite common. There were also reports of possible reception of Chinese and Malaysian Band I signals.

Since F2 reception is directly related to radiation from the Sun on both a daily basis and in relation to the sunspot cycle, it follows that for optimum reception the centre of the signal path will be at roughly mid-day – the signals at plus six hours were received in the UK at 0900 with the clock (transmission end) showing 1500. As mid-day moves west, so the signals best received in the UK will come from Africa during the late morning/early afternoon period and so on.

Band I offers the DX enthusiast considerable opportunity therefore for reception with relatively simple equipment. With the promise of really distant reception this winter however I feel that any equipment available should be pressed into service.

Using an Up-converter

Fig. 1 shows how a simple u.h.f. only receiver can be used to cover the v.h.f. spectrum with the addition of a v.h.f./u.h.f. up-converter. This small transistorised unit effectively shifts the 40-250MHz spectrum (i.e. v.h.f.) to an equivalent chunk of the u.h.f. spectrum. Having done this one merely has to plug the up-converter output into the u.h.f. receiver's aerial input socket. It will then be found that the (originally) v.h.f. signals can be tuned in over approximately channels 30-60, the actual spectrum position depending on the type of up-converter used. Converters normally incorporate an r.f. amplifier stage, giving a small conversion gain with a relatively low noise figure. Such units are manufactured by both Teleng and Labgear and are available from advertisers in the magazine.

Aerials

Now that we have a means of tuning over the v.h.f. spectrum, particularly Band I (48-70MHz), the next thing we need is a suitable aerial. Since signal levels can be high, particularly with SpE propagation, even an indoor aerial can be used. An external array is to be preferred wherever possible however, either an omni-directional one or a directional one that will require rotation. It's quite easy to make a wideband Band I aerial – a couple of designs are shown in Fig. 2. A source of Band I aerial elements may be your local aerial rigger – if you explain what you are doing, he may well be pleased to give you any old aerial systems he's recently had to remove from a rooftop. For the more affluent, wideband aerial systems can be purchased. Antiference for example make three export systems that are

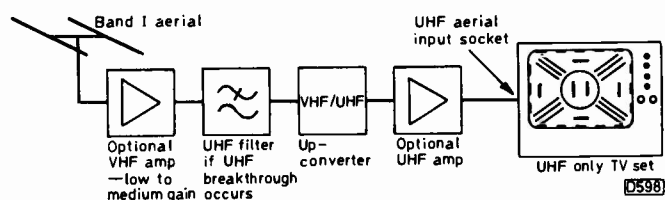

Fig. 1: Using an up-converter to give Band I reception on a u.h.f. only receiver. Preamplifiers and filters can be added as required.

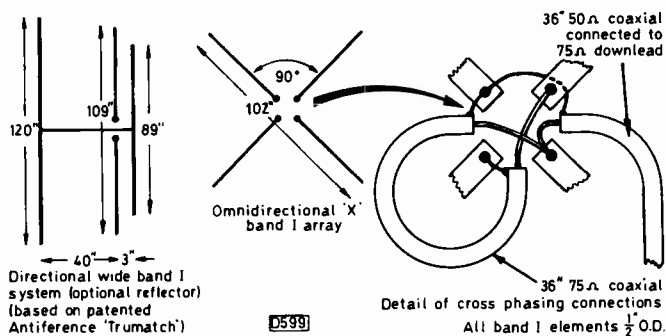

Fig. 2: Simple Band I aerial designs.

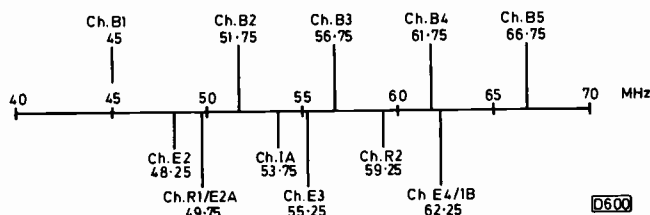

Fig. 3: Band I vision carrier frequencies.

available to order in the UK. One company (Premier) is now manufacturing several of my own wideband Band I designs, and quite a number of the old Band I/III arrays can still be obtained, though these are now normally made to order. Advertisers in this magazine will assist where difficulties are experienced in obtaining a suitable array.

Practical Aspects

Use low-loss coaxial cable of course, and a v.h.f. preamplifier may be added between the aerial and the up-converter. It should be possible to pick up BBC-1 channels to act as markers so that you can determine the v.h.f. frequencies appearing at various points along the u.h.f. tuning dial. If u.h.f. breakthrough is a problem, say from a local group A station above ch. E30, a simple u.h.f. filter can be inserted in the v.h.f. aerial lead prior to the up-converter (try a two-turn coil of about 7/8 in. diameter, shunted by a 2-10pF trimmer, these items being added in series with the centre coaxial cable conductor). A u.h.f. preamplifier can be used between the up-converter and the receiver.

The usual query I get from a new DX-TV enthusiast is what do the local 405-line BBC signals look like when displayed on the screen of the 625-line u.h.f. set? The signals appear as a white field pulse, and obviously slipping the line hold produces white lines again – with an overall black background corresponding to the video content of the signal.

New enthusiasts will doubtless wonder where and when to view. Basically, you stay on the lowest CCIR channel (say E2) if this is clear of local signals, and wait. At the time you read this, the SpE season will be over for several months while the winter F2 season will be yet to come. I'd suggest pointing the aerial (if rotatable) in an easterly direction and watching on ch. R1/E2 from about 0830 local time, then later in the day on ch. E2 with the aerial in a more southerly direction. F2 signals appear as smeary, smudgy video, making identification difficult. Russian or Chinese v.h.f. communications may be heard at the same time, causing signal breakup. Such signals can be received on even a simple aerial: given time and patience they will appear – provided you're on the right channel at the right time!

Servicing Pye Solid-State Colour Receivers

Part 2

Mike Phelan

NOW for the signal sections of the receiver. We'll start with the customer controls. The exact layout varies from model to model, but basically the volume, contrast, brightness and colour controls are of either the slider or rotary type, mounted on a printed board. Some models boast a tone control too.

The printed board with the rotary type of controls is rather a weak point: pressure on the control knobs can crack the print. The control spindles are very small in diameter, and break easily. Complete replacement panels and bare printed boards are available from the manufacturer however. Be extra careful when replacing any of the screws which screw into the cabinet front moulding: it's only too easy to break off the boss of the moulding. The only cure then is a new cabinet front – and it's not a simple thing to fit! The original is held on by glue and staples. If you don't have a staple gun, the best way to refit it is to use 6BA self-tappers and an adhesive such as Evo-Stik or Thixofix.

The tuner push-buttons are either square or round. The square ones operate separate switches mounted on a printed board, and don't give much trouble. The round type have contacts similar to those used on the hybrid Pye sets. These give quite a lot of trouble, mainly due to the contacts bending away from the potentiometer spindles. With care, they can be effectively repaired as follows. Remove the front moulding, buttons and springs, then prise off the steel retaining strip with a thin-bladed knife. The contact strip is then free to be removed in the same way. If the strip is viewed from one end, any contacts not in line will be immediately seen and can be carefully bent. Reassembly is straightforward, the only difficulty being replacement of the retaining strip over the plastic bosses which were originally punched down over it. It's possible to force it on however, one boss at a time, using a tubular object of the right size. A 6BA box spanner just fits!

The tuner gives rise to the usual types of trouble associated with this type of unit – drifting and low gain etc. Low gain can be caused by dry-joints in the r.f. stage, particularly on the dividing screen where it's soldered into the printed board, so watch out for this one. The TAA550 tuning voltage stabiliser does not seem to cause the amount of trouble here that it does in other chassis. The tendency of the tuner a.g.c. smoothing electrolytic C194 to cause weak field sync was mentioned last month.

The IF Panel

The next part of the set the signal encounters is the i.f. amplifier, which lives inside the large horizontal can next to the tuner. It follows the usual practice of putting all the filter circuitry first, followed by a three-stage broadband amplifier, then a TCA270Q i.c. which acts as a synchronous vision demodulator and also produces the a.f.c. and a.g.c. voltages. This latter i.c., with its associated circuitry, is in a separate small can.

The i.f. amplifier module causes plenty of trouble, particularly on earlier models. The reasons are twofold, though the symptoms are similar. Reason number one is

that the print is double-sided on the part of the board containing the filter coils (these are printed), and that rivets are used to link the print on the two sides. Reason number two is that the resin-encapsulated ceramic capacitors have been inserted too far into the board, the resin coating on the leads preventing them from being properly tinned (this is known to some engineers as the trouser effect . . .).

Now for the symptoms. These vary slightly depending on the exact location of the dry-joint, but there's usually a snowy picture with ringing or misalignment effects, sometimes a tunable hum bar, and occasionally the rather baffling result is that the set can be tuned in with the a.f.c. disabled, but when the a.f.c. is put back into operation it pulls the receiver completely off tune! This is caused by an alteration in the shape of the i.f. response curve, producing a peak where there shouldn't be one – the a.f.c. detector mistakes it for the vision carrier!

The cure is fairly simple, but the job must be done properly. First, remove the i.f. module completely and resolder all the rivets on the printed coils (seven in all), taking care not to melt the plastic core holders. Next, attack all the capacitors soldered to the component side of the print on the same half of the panel. Withdraw each capacitor to a distance of about 3mm from the print and resolder, rivet and all. Replace the module and all should be well. Test by gently flexing the print before replacing the can.

Failure of the TCA270Q is either total, giving a blank raster with weak or no sound, or partial, giving severe overloading and loss of sync, or smeary video. Any of these faults can be intermittent. We've also known one or two instances of dry-joints in this can, but not nearly as many as in the main i.f. can.

The only other things on the lower panel are concerned with the sound. A TBA750Q takes care of the sound i.f. strip and detector, and also contains a d.c.-operated volume control. The audio comes out at pin 12, goes through an 0.1 μ F capacitor (C237) and then goes back in at pin 1. It then undergoes further amplification up to a level sufficient to drive the class A output stage. This is similar to that employed in the Philips G8 chassis, with two BD131 transistors, one acting as a current source. Absence of an output transformer means the use of a speaker of relatively high impedance (25 Ω). A.C. feedback, via a tone control on some models, is taken from the mid-point back to the i.c. As the i.c. is d.c.-coupled to the output stage, stabilisation of the operating point with d.c. feedback is necessary. This is done by connecting the emitter of the lower output transistor through an RC network (low-pass filter to remove the audio) to the input of the driver stage at pin 1 of the TBA750.

The i.c. causes most of the troubles here, due to a thermal runaway effect in the driver stage which gets fairly hot. Later i.c.s are not as prone to this trouble. The effect is that the sound becomes distorted and goes off altogether after several hours of operation. Sometimes crackling at minimum volume is also evident, but for this fault inspect the print around the BD131s for signs of overheating, and replace both transistors if the print is at all discoloured.

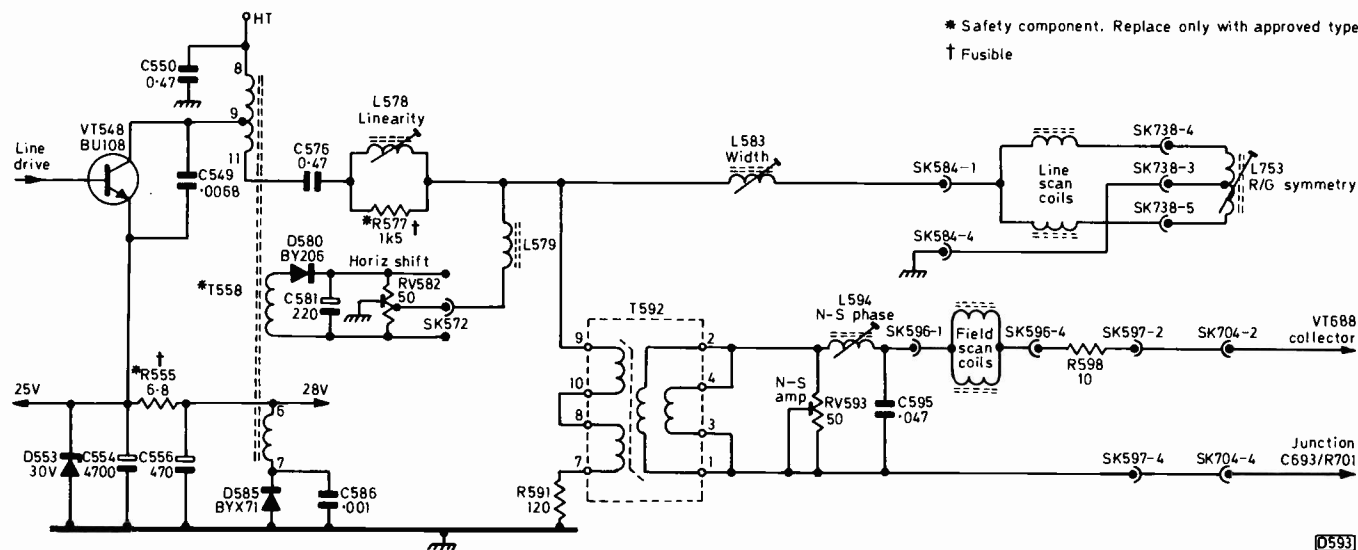

Fig. 4: The raster correction and line scan circuitry used in the Pye 725 chassis. Note that there are no connections to pins 1 and 2 of the line output transformer pulse winding.

The 330µF emitter decoupling electrolytic C257 can be responsible for low or no sound.

The Decoder/RGB Panel

Next we will look at the other panel on this frame. This contains all the luminance and chroma circuitry. The decoder is the standard Philips/Mullard four-chip package, so the circuit is very like that employed in many other receivers.

The most common fault seems to be loss of one primary colour, caused by dry-joints on the RGB output transistors VT431, VT447 and VT463. This seems to be due to the fact that they're mounted right up to the printed board – the remedy is to lift each transistor to leave a slight space between it and the board, and resolder the leads. Sometimes the transistors themselves develop intermittent emitter-base junctions, presumably for the same basic reason, i.e. expansion and contraction of the lead-out wires with change of temperature eventually cracks the glass seal and disconnects the internal connections in the device.

Another very common fault is an intermittent bright raster with flyback lines. If the thick-film load resistor unit is cold (watch it! – the metal heatsink is at h.t.), then the common h.t. connection has a break in it – replace the thick film unit, as it's impossible to resolder it successfully. In addition to the load resistors, the thick-film unit incorporates the three 27kΩ feedback resistors R428A/C/E. These tend to change value, affecting the grey scale.

If the output transistors are in a state of saturation however you have an entirely different kettle of fish. Measure the voltage at the luminance input to the TBA530 (IC425, pin 5): if it's around 1.2V this is correct and the TBA530 is probably faulty. If it's above 1.5V however the fault lies elsewhere, and the next thing to do is to verify the presence of the blanking and gating pulses at the TBA560, by measuring the voltages on pins 8 and 10 – these should be 1.0V and -0.5V respectively. If these voltages are present and correct it's fair to assume that the TBA560 is faulty. If an incorrect voltage is found however, look for dry-joints around the pulse inverter stage VT329 (BC338) and an intermittent plug SK479 below it.

More often a defective TBA530 results in an all red, green or blue raster due to the appropriate RGB output transistor being saturated.

Intermittent loss of luminance is normally caused by mechanical faults such as dry-joints on the luminance delay line, or an intermittent switch SW290 (this is incorporated for setting up purposes).

For those not familiar with the operation of the four-chip decoder, we'll explain the workings of the confusing part – the colour-killer and a.c.c./ident (accident?) detector. With only a few exceptions, discrete component decoders use a tuned amplifier for ident purposes, rectifying its output to provide the colour-killer turn-on bias, while the burst is rectified to provide the a.c.c. voltage. The use of a tuned ident stage calls for a fairly large coil in view of the low frequency involved (7.8kHz).

In the four-chip decoder a totally different method is used, so it's probably best to forget any preconceived ideas and start from scratch. The PAL switch bistable produces an output at pin 3 of the TBA990 i.c. This is a.c. coupled via C401 (0.33µF) to a coincidence detector circuit in the TBA540 i.c. Also fed to the coincidence detector are two antiphase outputs (7.8kHz squarewaves) from the burst phase detector within the TBA540. The coincidence detector output is d.c. (smoothed by C389) and goes to the a.c.c. amplifier, again within the TBA540, whose gain can be adjusted by means of RV394. There are two outputs from this amplifier: one goes (still inside the chip) to the colour-killer detector – more of this presently. The other output appears at pin 9 and goes two ways, one to the gain-controlled stage in the TBA560 i.c. and the other, for ident purposes, to pin 1 of the TBA990.

When a normal colour transmission is being received the voltage at pin 9 of the TBA540 – this is the bit worth remembering – should be in the region of 1V. Slight variations in signal amplitude are corrected by slight variations in this voltage. Thus we have an a.c.c. system: the result is a constant burst amplitude of 1.5V peak-to-peak at pin 7 of the TBA560 (burst gate output), set by means of RV394. On a monochrome signal (no input to the a.c.c./ident detector from the burst detector), the voltage at pin 9 of the TBA540 rises to 4.5V; while if the bistable is in the wrong phase (incorrect ident) on a colour transmission the voltage rises to 8V. This 8V goes to pin 1 of the TBA990, stopping the bistable on the next line, i.e. causing it to miss a count. On the next line the phase will be correct, the voltage at pin 9 of the TBA540 will fall to 1V and the bistable will start up again.

Let's consider next what happens when the voltage at pin

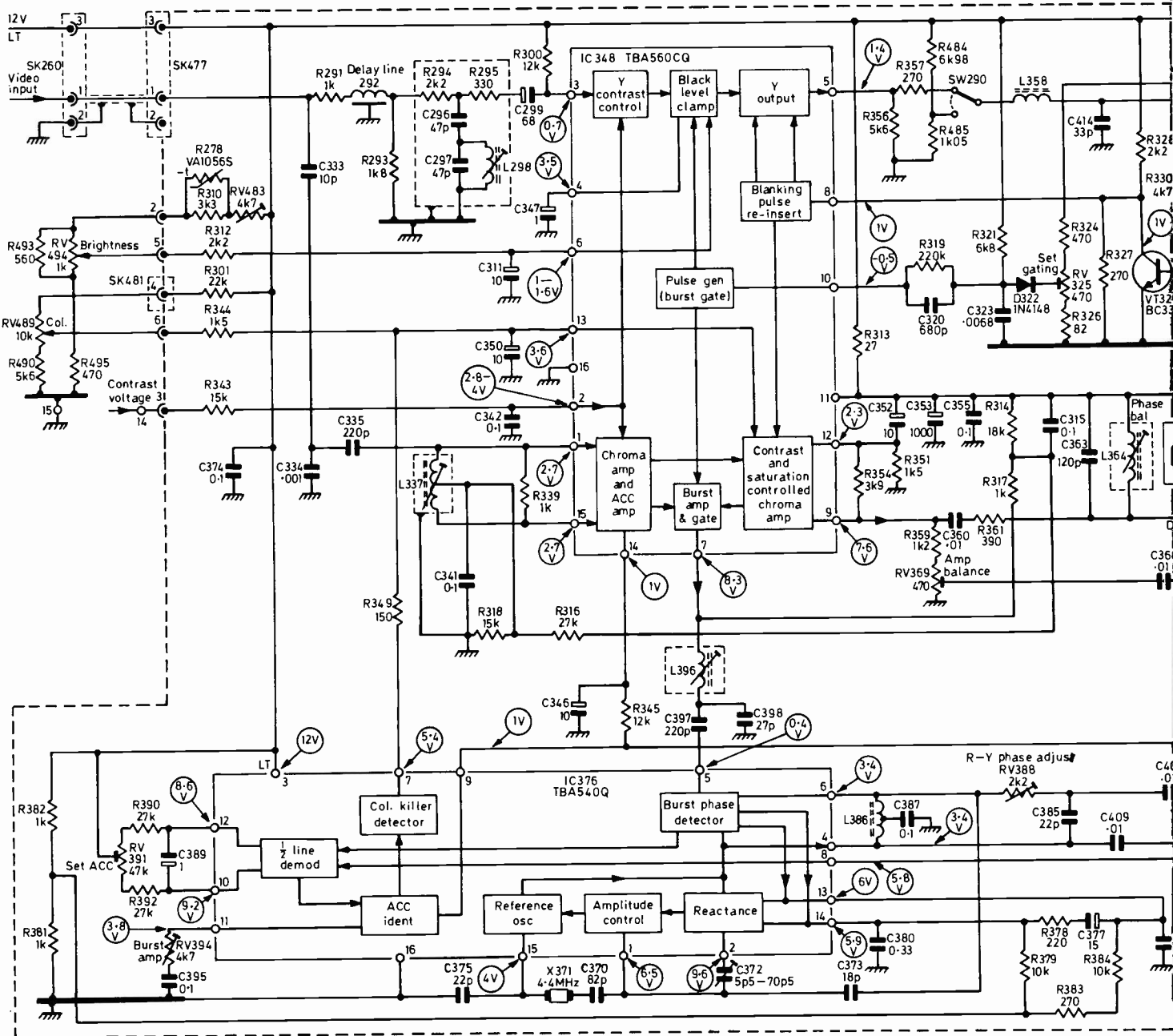

Fig. 5: The four-chip decoder

9 of the TBA540 rises to 4.5V on a monochrome transmission. As previously mentioned, this voltage goes to a colour-killer detector which is simply a transistor, also inside the TBA540, whose collector is taken out at pin 7. This point is connected via R349 to the colour control input pin (13) of the TBA560 i.c. With a colour signal present the a.c.c. detector output is 1V, the colour-killer detector transistor is cut off, and pin 7 is effectively open-circuit. When the voltage at pin 9 rises above about 2.5V, the colour-killer detector transistor is saturated, pin 7 is earthed and the chroma removed via R349.

It can be seen then that the colour-killer also operates when the ident is incorrect, and also if the bistable stops. To over-ride the colour-killer, simply disconnect one end of R349.

The important point with no colour faults therefore is the voltage at pin 9 of the TBA540. If it's zero or 8V, we know that the bistable has stopped or C401 is open-circuit. If it's 1V, check for 5.4V at pin 7 (killer transistor off). If it isn't off, the colour-killer stage in the TBA540 must be at fault. If the colour-killer stage is off, the fault is either in the TBA560 or somewhere in the signal path between it and the

output stages – but a fault in the TBA990 or TBA530 common to all three channels would be unusual. The only component fault we've had with a bearing on these d.c. voltages was when C350, which decouples the slider of the colour control, became leaky on one occasion, removing the colour.

If the voltage at pin 9 is 4.5V, over-ride the colour-killer and observe the effect – running colour due to a burst fault, or no chroma at all due to a stopped oscillator (the crystal or the TBA540) or no chroma path into or through the TBA560. Simple isn't it!

Apart from faulty i.c.s, most decoder faults seem to be of a "one-off" type. The only other fault we've had more than once has been C398 (27pF) altering in value. This gave what appeared to be incorrect ident, though this of course can't happen with this decoder for the reasons already explained. In fact, the effect is due to a severe change in the burst phase (almost reversal). It says a lot for the delay line method of PAL decoding that no blinds appear during this fault condition if the delay line circuit is correctly set up.

It's important that the d.c. levels in the RGB circuits, the tube first anode controls and the preset brightness control

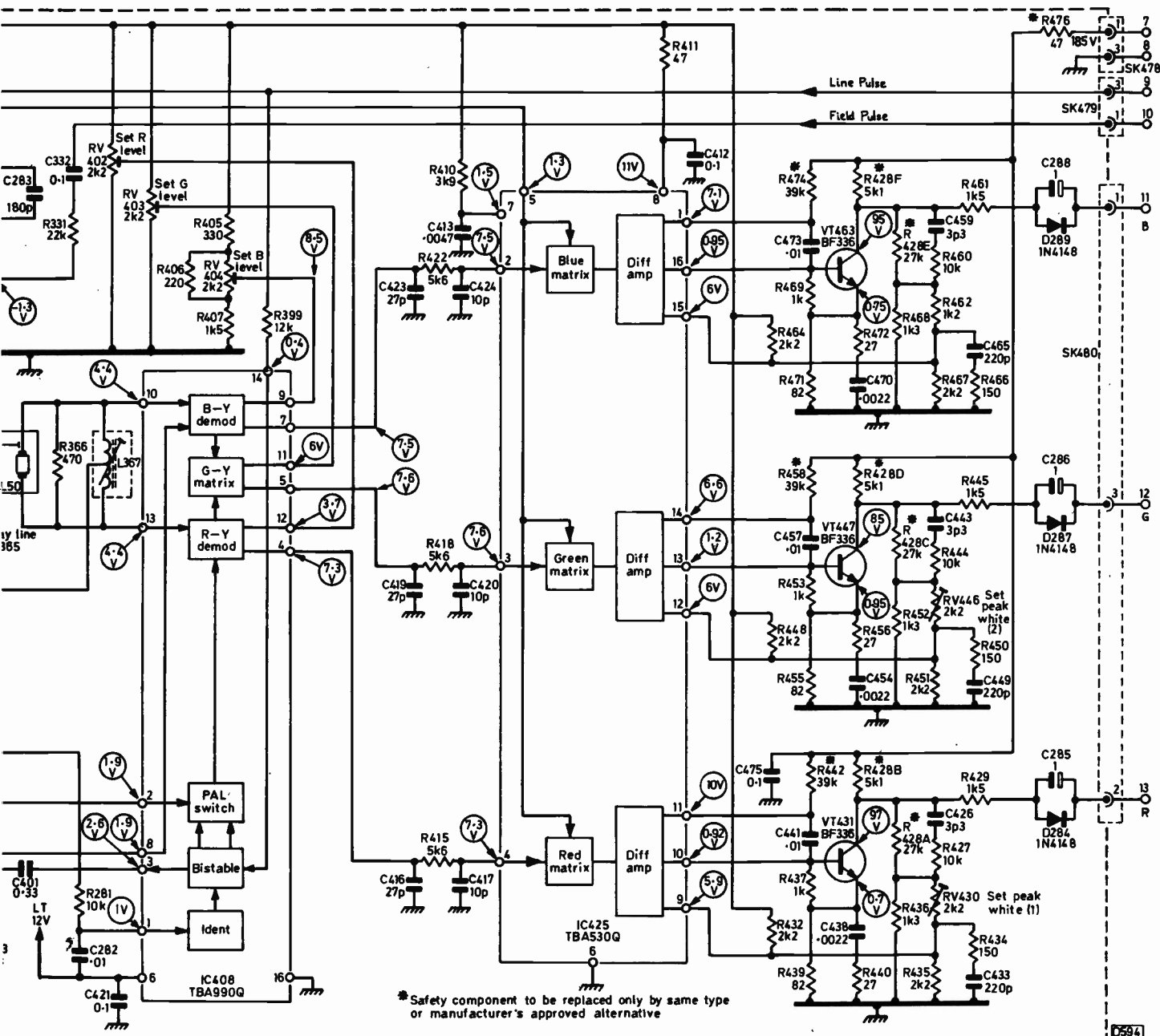

nd RGB output stages.

RV483 are correctly set up, as there's no adjustment for the beam current limiter on this chassis.

Operate SW290 in the centre of the panel to remove the luminance, and turn off the colour. Adjust the d.c. level controls RV404, RV403 and RV402 for 135V at the collectors of the blue, green and red output transistors respectively. Always adjust RV404 (blue) first, as this control affects all three voltages, and recheck all voltages after adjustment, repeating as necessary. Next turn all the first anode controls to minimum, and collapse the field scan with SW515 (below the line can). Then, preferably in a darkened room, increase each first anode control in turn until a coloured line is just visible. Personally, I find it easier to adjust these controls until the line is just *invisible* – the difference is only 20V or so. Restore switches SW515 and SW290 to their normal positions, turn the brightness and contrast controls to maximum and the colour control to its half-way position, then reduce the brightness by means of the preset brightness control RV483. Finally, slowly increase the brightness (preferably with a test card display), still using RV483, until the beam limiter just starts to operate – as shown by a reduction in contrast.

The beam limiting arrangements are a bit unusual. As with many chassis, the beam current is monitored by means of a diode (D575) which is connected between the earthy end of the e.h.t. overwinding and chassis. The contrast control is connected between the 185V h.t. line and this diode. Though it's a zener diode, it's normally positively biased at its anode, acting as an ordinary diode. When the beam current exceeds 1.5A, D575 cuts off and beam limiting is effected via the contrast control. When the voltage at the anode of D575 reaches -11V, it begins to operate as a zener diode, limiting the voltage to prevent damage to the TBA560 i.c. This doesn't of course provide protection against excessive beam current due to a fault in the RGB output stages. Protection in this event is provided by means of beam-limiter diodes (D284/7/9) between the RGB output stages and the c.r.t. cathodes.

The decoder can be easily set up on a test card, using only a meter. Over-ride the colour-killer by disconnecting R349, and set the front controls for a normal picture. Adjust RV391 (a.c.c.) for 4.5V at pin 9 of the TBA540, with no signal input. Short together pins 13 and 14 of the TBA540 (not the TBA530 as stated in the service manual)

and adjust trimmer C372 so that the colour just runs through – it's important to use a trimming tool with a very small amount of metal blade for this. Remove the short and reconnect R349.

Short out C363 to disable the delay line circuit (i.e. convert to simple PAL), then adjust first L396 for minimum blinds on B – Y and secondly RV388 for minimum blinds on R – Y. The B – Y adjustment is the one for overall phase correction, so this is the first adjustment to make – unlike most discrete component decoders, where the oscillator output is in R – Y phase. Repeat these adjustments as necessary, then remove the short-circuit across C363. If the blinds increase, the delay line circuit requires setting up.

Connect a 220-330pF capacitor from pin 7 of the TBA560 to chassis to introduce a deliberate phase error on the burst, then adjust RV369 for minimum blinds on B – Y only. Remove the capacitor and you should have a perfectly aligned decoder.

Miscellaneous Points

As mentioned earlier, one of the non-compatible panels between chassis is the tube base panel. The differences are worth noting. There are two heater current limiting resistors

R864/5. On earlier chassis these are 1.2Ω. On later chassis with quick-heat c.r.t.s they are 2.2Ω. In addition, with quick-heat tubes a 120kΩ resistor is added between the junction of resistors R850/2/4/5 in the c.r.t.'s control grid circuit and the 185V h.t. rail via SK869 and SK644 on the line timebase panel.

That just about concludes our survey of the large-screen versions of the Pye solid-state colour chassis. A final point is worth mentioning. As there's no metal chassis frame, earth continuity is maintained by a large number of green leads with push-on connectors. These must be connected in the correct order. Otherwise there'll be at best insufficient protection against tube flashover, or at worst certain parts of the circuit will have no earths and fault symptoms will appear. It's worth scribbling down a few notes therefore if all the panels have to be removed for a tube change or similar job. If, after carrying out such an operation, you get field collapse, or a bright raster with flyback lines, or an apparently dead set – recheck all earth leads!

Incidentally, if anyone's wondered what to do with the plastic transit straps on the field timebase and power supply – two of them cemented back-to-back make an ideal housing for a diode probe signal injector or similar instrument!

TO BE CONTINUED



All boards are epoxy glassfibre and are supplied ready drilled and roller-tinned.

Any correspondence concerning this service must be addressed to READERS' PCB SERVICES LTD, and not to the Editorial offices.

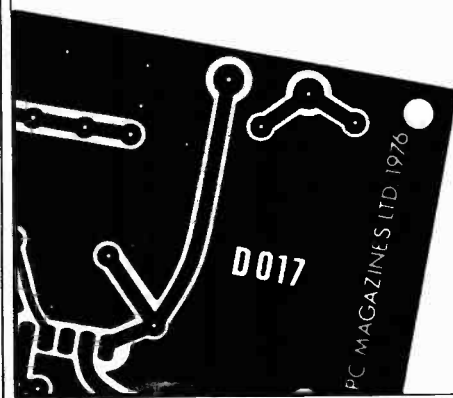

TELEVISION READERS PCB SERVICE

Issue	Project	Ref. no.	Price
November 1976	Ultrasonic Remote Control	D007/D008	£3.24 per set
December 1976	IC Sound Circuits for the Constructor	D009	£1.44
		D017	£1.44
March 1977	Teletext Decoder Power Supply	D022	£3.24
May 1977	Teletext Decoder Input Logic	D011	£10.53
May 1977	Single-chip SPG	D030	£3.30
June 1977	Wideband Signal Injector	D031	£0.79
June 1977	Teletext Decoder Memory	D012	£8.51
July/Aug 1977	Teletext Decoder Display	D013	£8.62
August 1977	Logic State Checker	D038	£1.70
September 1977	Teletext Decoder Switch Board	D021	£1.43
September 1977	Teletext Decoder Mother Board	D027	£4.36
October 1977	Teletext Decoder IF Board	D041	£6.50
Feb/March 1978	On-Screen Clock	D045	£7.03
April/May 1978	CRT Rejuvenator	D046	£2.76
May/June 1978	Test-Pattern Generator	D048	£9.15
Aug/Sept 1978	Diagnostic Pattern Generator	D051	£8.62
October 1978	Colour Receiver PSU Board	D052	£3.83
January 1979	Colour Receiver Signals Board	D053	£10.75
February 1979	Commander-8 Remote Control System	D054/5	£5.43 per set
March 1979	Colour Receiver Timebase Board	D049	£17.13
July 1979	Colour Pattern Generator	D062	£13.50
		D063	£9.15
September 1979	Teletext Decoder Options Board	D064	£8.50
August 1979	Teletext Decoder New Mother Board	D065	£5.00
August 1979	Simple Sync Pulse Generator	D067	£4.00
September 1979	New Teletext Signal Panel	11331	£8.00
October 1979	Teletext Keyboard	D057	£3.50
October 1979	Teletext Interface Board	D058	£5.00

To: Readers' PCB Services Ltd. (TV), Fleet House, Welbeck St., Whitwell, Worksop, Notts.

Please supply p.c.b.(s) as indicated below:

Issue	Project	Ref.	Price

Prices include VAT and post and packing. Remittance with order please.

NAME _____

ADDRESS _____

Post Code _____

The SECAM Colour System

Keith Cummins

THE first viable system for colour television transmission/reception was the American NTSC system. Regular transmissions started in 1954, preceding the start of colour television in Europe by more than a decade. This long period enabled European broadcasters to assess the NTSC system carefully before taking the plunge themselves. It has been said, rather unkindly, that the initials NTSC stand not for the National Television Systems Committee (the body that was set up to choose the US system) but for Never Twice the Same Colour.

Readers familiar with the historical development of colour TV will know that the PAL system is a development of the NTSC system. It was also influenced by the French SECAM system, whose development falls in time between that of NTSC and PAL. The PAL system, used throughout most of Western Europe including the UK, incorporates inherent protection against colour errors due to phase shifts in transmission. This is achieved by means of the Phase Alternation (Line) technique, from which the acronym PAL is derived. Very basically, PAL is NTSC with phase alternation added. The addition of phase alternation, or rather the polarity inversion of the R - Y colour-difference signal on alternate lines, enables the effect of colour signal phase errors to be effectively eliminated, whilst at the same time separating the R - Y and B - Y colour-difference signals prior to demodulation.

The basis of the NTSC system is the use of a suppressed colour subcarrier which is modulated in quadrature by the two transmitted (R - Y and B - Y) colour-difference signals. This means that the subcarrier phase indicates the colour at each particular point along the line. At the receiver, timed demodulators which sample the subcarrier at regular intervals provide outputs whose amplitude depend on the instantaneous phase of the subcarrier at the time of sampling. The timing is done by the local reference oscillator, which is crystal controlled and has to be locked to the fundamental phase/frequency of the subcarrier oscillator at the transmitter. The system is nice and neat, but is seriously affected by phase shifts in the overall transmission path and by any alteration in the timing of the demodulation at the receiver. The NTSC system in fact calls for great accuracy - greater than is generally realised in practice.

Because the NTSC system has no built-in protection against differential phase shifts, an error of only 5° will result in an obvious colour change in the display. A 2° error is perceptible. To compensate for this, NTSC receivers incorporate a hue control at the front of the receiver. This enables the viewer to adjust the phase of the output from the local reference oscillator, thus altering the demodulator timing so as to alter the colouring of the display. Note that the PAL system enables a phase shift of 70° to be accommodated before the equivalent distortion to a 5° shift in the NTSC system occurs.

Origin of the System

Before PAL came along, Henri de France had been examining the NTSC system to see whether anything could

be done to make the system more rugged, i.e. less susceptible to colour changes caused by phase shifts in the overall transmitter/receiver system. Any improvement would of course have to be economical from a setmaking point of view if it was to be acceptable as an alternative to NTSC. The principle that low-definition colour (the human eye is not sensitive to colour detail) could be added to a high-definition monochrome signal to give an acceptable picture had already been proved by the NTSC system. What Henri de France hit upon was the idea that if the horizontal colour definition could be reduced (by bandwidth limiting), as with the NTSC system, there was no reason why the vertical colour definition should not also be reduced.

Assuming this to be acceptable, a delay line can be used in the receiver to provide both the U and the V signals (the B - Y and R - Y signals respectively, weighted for transmission purposes) simultaneously whilst transmitting only one at a time on alternate lines. Henri de France's arrangement, the heart of the SECAM system, is shown in Fig. 1.

The U and V chroma signals are transmitted on alternate lines. The received signals are applied to a commutating switch both directly and via a 64µsec (one line period) delay line. Since the delay lasts for one complete line, U will be going in while V is coming out and vice versa. Thus both U and V are simultaneously available for application to the demodulators, one feed being taken directly off-air and the other via the delay line. All that has to be done is to employ an electronic commutating switch which changes over line by line to ensure that U and V are always routed to their respective demodulators. Note that the U and V signals are derived in exactly the same way as in NTSC and PAL: the same matrixing processes are employed, and the same fundamental luminance equation $Y = 0.3R + 0.59G + 0.11B$ must apply.

Synchronisation of the electronic commutating switch is

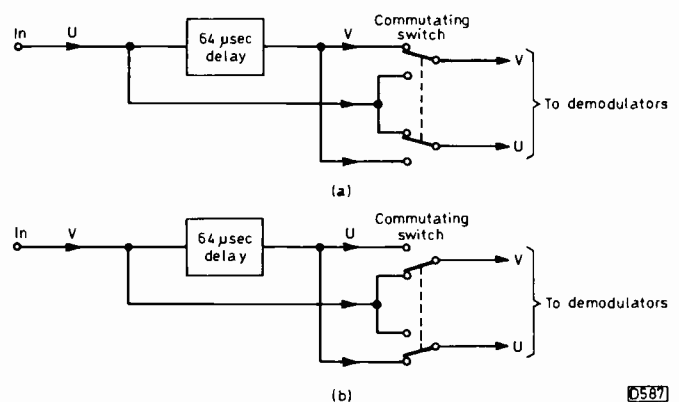

Fig. 1: SECAM decoding. (a) A line with U signal only. Both the V and the U signals are available simultaneously at the output from the delay line/commutating switch circuit however. As the U signal goes into the delay line, the V signal from the previous line comes out. (b) A line with V signal only. The commutating switch changes over line by line to feed the appropriate signals to the chroma demodulators.

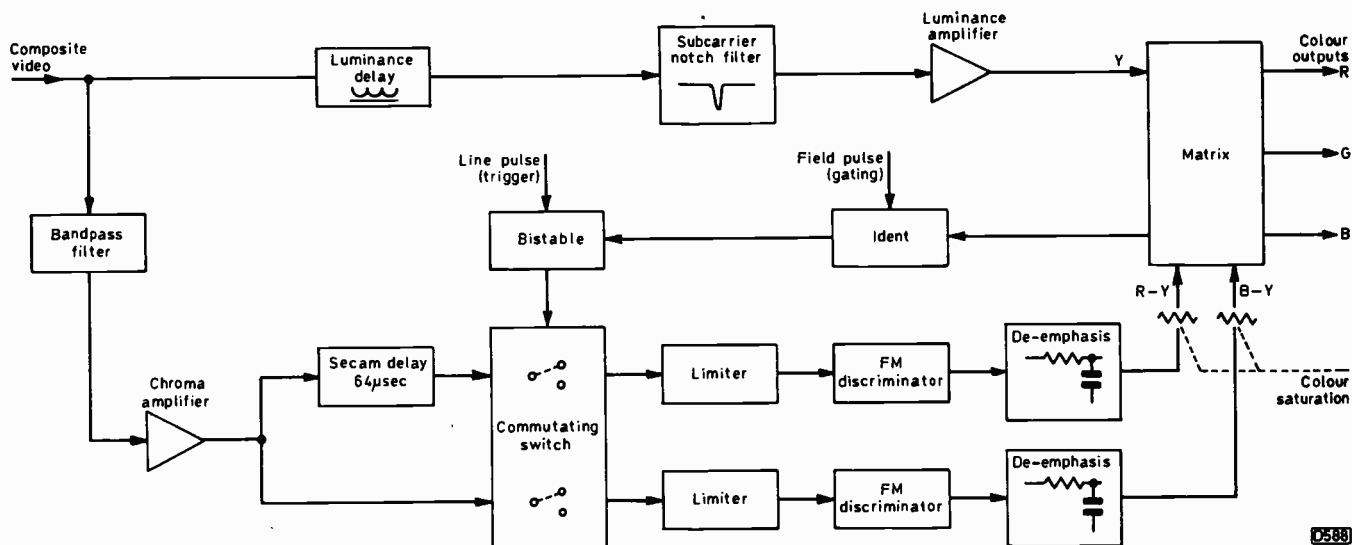

Fig. 2: Block diagram of a typical SECAM decoder.

of course needed, as in the PAL system. There is a fundamental difference here however. If the phase of the PAL switch is reversed, the V signal will be inverted (green faces) while the U signal will remain unchanged. If the phase of the SECAM switch is reversed, the U and V signals are transposed and sent to the wrong demodulators.

The SECAM system thus uses an alternating line sequence and a memory (in the form of the delay line): hence the derivation of its name from the French "sequential à mémoire".

Having set out the basic principle of the delay line and switch, it will be obvious that there can be no crosstalk between the two colour-difference signals – since they are never transmitted at the same time! And as they are not transmitted together, but sequentially, there is no need to simultaneously modulate the colour subcarrier in amplitude and phase. Instead, SECAM employs frequency modulation of the subcarrier. The f.m. captive effect protects the colour signals from other unwanted signals. A further advantage of the use of f.m. is the elimination of the crystal controlled reference oscillator as part of the demodulation process.

Basic Compromises

So where's the catch? If SECAM provides so many nice answers, how come PAL ever got off the ground?

The first problem lies in the nature of the subcarrier. It's present all the time. Readers will be aware that the PAL or NTSC colour subcarrier vanishes completely when there is no colour, and is at its greatest amplitude in areas of high colour saturation, where the vivid colour masks the subcarrier interference. The effect is usually more noticeable on monochrome receivers, where the running dot pattern caused by the subcarrier shows up in those areas where saturated colours have low luminance (i.e. saturated reds and blues).

The frequency of the SECAM subcarrier varies with the colour content of the picture. Where there's no colour the frequency is unchanged, and this can produce a disturbing interference in grey parts of the picture. Pre-emphasis of the subcarrier is used, reducing its amplitude when undeviated and increasing it with deviation. This reduces the interference by a factor of approximately four times.

A second form of pre-emphasis at video frequencies is also used. The colour signals are bandwidth restricted to 1.5MHz, then passed through a filter which introduces a

progressive lift with frequency, finally tailing off at 1.5MHz.

The pre-emphasis reduces the interference and makes the colour signal more rugged. Problems arise however because the pre-emphasis introduces overshoot on rapid colour transitions. The overshoot can be severe, in some cases over twice the actual transition being transmitted, so limiters are employed in the encoder to restrict the overshoot.

The SECAM system's basic compromises have been optimised by computer, but the system nevertheless requires more compromises than the PAL system. From the purist point of view therefore, PAL is probably the better system. It has yielded better results in non-technical subjective viewing tests – the most recent of these being in Spain, which has adopted PAL. SECAM does however provide immunity against differential phase changes, and is certainly a much more rugged system than NTSC.

The reader will observe that PAL took the best of each system – the delay line from SECAM, and the quadrature modulation of the subcarrier from NTSC. PAL also has its own unique advantage, mentioned earlier, in that the simultaneously transmitted U and V signals are separated by the comb filter action of the delay line (for PAL the delay is 63.943µsec, not 64.0µsec as with SECAM).

Synchronising the Switch

Synchronisation of the commutating switch phase in the SECAM system is achieved by transmitting the subcarrier with alternate positive and negative deviation during nine blank lines following the field sync equalisation pulses. After demodulation these signals produce outputs which when matrixed in the colour-difference circuits provide a positive output from the green matrix during the ident period. This can be used to synchronise a bistable switch, triggered by line pulses (see Fig. 2), for the remainder of the field. It will be seen that the SECAM switch can be corrected only once per field instead of once per line as in the PAL system. This ident arrangement might have to be amended (compatibly of course) if a teletext system is to be incorporated into these transmissions (at present, details of the French "Antiope" teletext system are not readily available).

Optimised System

The optimised SECAM system employs positive subcarrier deviation to produce a negative V signal, and negative deviation to produce a negative U signal. Also, the

centre frequencies for the two signals are different: the V signal is centred on 4.40625MHz and the U signal on 4.250MHz. Phase-shifting techniques are employed on a line-by-line and field-by-field basis to reduce the visibility of the interfering subcarrier signals. This is the closest that SECAM can come to the NTSC and PAL technique of precise frequency offsets which determine the absolute subcarrier frequency (our familiar 4.43361875MHz) and reduce visible interference to a minimum. A block diagram of a SECAM decoder is shown in Fig. 2: note the absence of a reference oscillator and colour a.c.c. circuit.

Since the f.m. subcarrier is limited in the receiver, the signal output from the discriminators is not a function of signal strength; the effect is the same as in any f.m. system. No colour a.c.c. is needed. To vary the colour saturation, it's necessary to adjust the amplitude of the colour signal components after the discriminators and de-emphasis circuits, but ahead of the final colour decoding matrix. The two signals must be adjusted simultaneously by the one colour control.

It may be concluded from this that the SECAM receiver offers a substantial cost advantage over a PAL one. The main sections of either receiver, i.e. the colour c.r.t., timebases, tuner, i.f. strip, delay line, power supplies etc. are the same however, so there isn't really much difference. The use of specialised decoder chips for either system now renders any difference negligible.

I suspect that trouble-shooting might be easier with a SECAM decoder than working on a PAL one. I've no direct experience in this area however – it just *looks* as if it ought to be easier. There are of course some European TV chassis that operate on both the SECAM and PAL colour systems (not a case for "vive la différence" I suspect!). At least we've been spared dual-standard colour!

A Look at the Picture

My first encounter with SECAM occurred in a Paris hotel. Because of the general euphoria of the occasion, it was a little while before I realised that I was actually watching a SECAM picture. The quality of the picture (a well-known Western series with dubbed French dialogue) appeared to be consistent and not obviously different from PAL. My viewing lasted for only a few minutes before we went out, and my next observations occurred the following day when I saw the Philips PM5544 test pattern displayed on a Sony receiver in a shop window. The quality of the pattern was excellent, and it was totally free of cross-colour flickering effects in the definition grids. Some oblique coloured stripes appeared faintly and stationary across the higher definition areas. From my observations, the SECAM system appears to work well and I saw no gross colour problems. It is significant that the system was chosen for use in the USSR.

The normal French transmission standard is now 625 lines, 50 fields, with positive vision modulation and the a.m. sound spaced 6.5MHz above the vision carrier frequency. Some old 819-line standard monochrome transmitters are still in operation, but programme origination is all now at the 625-line standard. The situation is similar to the UK, where 405-line monochrome transmissions are yet to be phased out.

If you think about it, just about every parameter of the French TV transmission system is different from ours – apart from the line standard itself! But as anyone who has been to France knows, the French always prefer to do things their way – as I discovered with the intriguing plumbing arrangements in our hotel bathroom. ■

next month in TELEVISION

● SERVICING IN THE FIELD

To run a servicing operation profitably, as many calls as possible should be dealt with on the spot. The customer will expect you to be able to give an instant diagnosis, and carry out the repair in little time. This is not always possible of course, but a surprising percentage of calls can be handled speedily by careful observation of the symptoms followed by simple, systematic checks carried out in order of probability. George Wilding explains.

● USING DIGITAL ICs

A practical account of what digital i.c.s can do and how they should be used. Starting with TTL.

● SERVICING THE PYE 713/5/7 CHASSIS

In the final instalment of his series on Pye solid-state colour receivers, Mike Phelan deals with the small-screen (18in.) models.

● ADDING VIDEO OUT TO THE NI700

The Philips NI700 VCR is designed to provide an output at u.h.f. This precludes its use with video monitors however, and makes tape editing and copying difficult. So David Matthewson and Ian Howarth devised a means of extracting video and audio signals from the machine.

● COLOUR RECEIVER OPTIONS: REMOTE CONTROL

Ultrasonic remote control of brightness, colour, volume, channel selection and switch-off. Using the ITT SAA 1024 and SAA 1130 i.c.s.

PLUS ALL THE REGULAR FEATURES

ORDER YOUR COPY ON THE FORM BELOW:

TO
(Name of Newsagent)

Please reserve/deliver the NOVEMBER issue of TELEVISION (55p), on sale October 15th, and continue every month until further notice.

NAME

ADDRESS

Tackling Mains-battery Portables

John Law

BEING confronted with a faulty mains-battery portable TV set can be a frustrating experience. One can remove the case, plug in, switch on and . . . nothing! No c.r.t. glow; no mains hum, hiss or sound; no line whistle or picture; just nothing. Where do you start?

The aim of this article is to provide general guidance, but in order to give us a practical frame of reference we'll take the Thorn 1590/1591 series of portables as a basic example. There are, after all, so many of them about.

So you've got a completely dead 1590. Take a look at the supply fuse F2 on the printed panel. If luck is with you, you'll find this blown. Early 1590s used a 2A cartridge fuse that tended to go open for no apparent reason. You can replace it with a 2.5A fuse and, if all is well, the set will be back in operation. Not all portable set repairs are as simple as this unfortunately! Any fuse can age however, and go open-circuit on its own. If the fuse is open-circuit, there are no signs of burning or discolouration, and a quick resistance check shows no short to chassis, replace it and, with fingers crossed, switch on. Note that in the 1590 series chassis there are two fuses. The other (F1), rated at 250mA, is in the feed to the mains transformer. So in the case of normal operation on battery, no results on mains, check this one. It too can go open-circuit with age, though it's far more common to find F2 open-circuit, particularly when a fault in the set has caused the fuse to blow.

This dual-fuse arrangement is used in many portables, though in some (e.g. the GEC 2114 Junior Fineline and Bush Ranger 2) the 2A fuse is in series with the battery supply only, alternative protection in the form of a fusible resistor being provided in the set's d.c. supply. We'll come back to that later.

Supply Lines

The main complication in the design of a mains-battery portable is the need for a stabilised voltage supply for at least part of the circuit – in order to avoid changes in picture size with variations in the mains or battery voltage. A series regulator is almost always used (there are exceptions however), and the heat dissipated by the regulator transistor inside the small cabinet increases the possibility of breakdown.

Another problem with portables is that while the regulated supply line is around 11-11.5V, other parts of the circuit require much higher voltages. The e.h.t. of course; around 100V for the video output stage and the brightness control; and around 300V say for the tube's first anode and focus circuits. These voltages are all derived from windings on the line output transformer, and are a further source of possible trouble and awkward faults. In most portables the line output stage also provides a boost supply of around 24-26V, which is used in various parts of the receiver. A very common arrangement, as in the Thorn 1590 series, is to operate the i.f. strip and the line driver stage from the boost supply; the line oscillator, output stage and field timebase from the regulator output; and the audio output stage from a point before the regulator (to reduce the current flowing via the regulator transistor). The c.r.t.'s heater is usually connected across the regulated supply line.

Fault symptoms, i.e. exactly how "dead" a set is, obviously depend on the arrangement of the supply lines as well as the fault present. It should be clear however that the set will show precious few signs of life if the line output stage is not working. And for this to work the line oscillator stage must function and the regulated supply must be present.

Voltage Regulation

In the Thorn 1590/1591 chassis the regulated supply is 11.6V: A few words on how it's obtained may help in finding the cause should a fault occur in this type of circuit. There are two transistors in the voltage stabiliser circuit (see Fig. 1), the regulator itself (VT21) and the control transistor VT22. The former is a pnp power device, the latter a small silicon transistor of the BC147 variety. VT21 (AD149 or similar, except in very late production sets which incorporate a silicon device producing an 11.1V stabilised supply) is mounted on a heatsink of generous proportions to ensure cool running. VT21 is fitted on the printed panel and runs cold – any signs of overheating suggest a fault condition.

In operation, 12V from a battery or about 16V from the mains rectifier circuit is fed to the emitter of the series regulator transistor VT21 via fuse F2. A 10 Ω 5W resistor (R99) is connected in parallel with the regulator transistor, and serves two purposes. When the set is working, it bypasses about a third of the current passing through the AD149, thus reducing the dissipation in the transistor. At switch on it bleeds current into the set in order to start up the regulator. The control action is achieved by using VT22 to bias the base of VT21. VT22's base is in turn biased by the "set HT" voltage potentiometer R104. 11.6V has been selected as the regulated supply voltage to ensure that the circuit is still effective when the set is switched from mains to battery operation and the nominal d.c. feed drops from around 16V to 12V or so. It is most important to adjust R104 correctly, for two reasons. First the higher voltage supplies are determined by the regulated supply: a small discrepancy in the lower voltage will be multiplied by the line output transformer in producing the higher voltage lines, with the resultant possibility of damage in the line output stage due to overloading. Secondly, the tube heater will be overrun if the regulated supply is high, and this will damage the tube. The moral is, don't use R104 as a picture size control: set it for exactly 11.6V (with a germanium regulator transistor), with the voltmeter connected between tag 24 on the printed panel and chassis.

Once the regulator output has been set to 11.6V, this level will be automatically maintained by the regulator action. Basically, VT21 behaves as a low value resistor in series with the supply: if the output voltage tends to rise, it's biased back so that a greater proportion of the input voltage is developed across it. VT22 senses variations in the level of the output voltage. Since the voltage across the 6.8V zener diode W17 remains constant, the variations appear across R102, biasing the emitter of VT22. A rise in the output voltage for example will produce a corresponding rise in the voltage across R102. Since VT22 is an npn device, its

cause must be found. The control transistor VT22 or the zener diode can be responsible: other causes may be a faulty preset potentiometer (R104) or a change in value of one of the series resistors R103 or R106. R106 should be a 270Ω, 5% ¼W type.

Line Timebase

So much for the mains input and voltage stabiliser circuits. The other key item in a mains-battery portable (as in all sets of course) is the line output stage. That used in the Thorn 1590 chassis is shown in Fig. 3. The line output transistor is VT26 which in the vast majority of these sets is a germanium pnp device (AU113) as shown – in later production a silicon npn device is used, with alterations to the base circuit and an efficiency diode added in parallel with it. W12 produces the e.h.t., and the boost diode W11 develops a 25V supply across C107. Rectifier diodes W13 and W14 with their associated reservoir capacitors C110 and C111 produce 300V and 95V lines respectively.

A common fault in mains-battery portables is a defective line output transistor. When it goes short-circuit, the fuse blows. In sets fitted with a fusible resistor in parallel with the regulator transistor this will probably be found open-circuit if the fault occurs on mains operation, the 2A fuse being open-circuit if the fault occurs on battery operation. An open-circuit line output transistor on the other hand will produce the no results symptom. The output from the regulator will be high however due to the much reduced load, and if the c.r.t. heater is across its output this will be overrun.

Breakdown of the boost diode is also a fairly common fault on mains-battery portables. An open-circuit diode removes the supply to the line output stage of course, giving the dead set symptom. A short-circuit diode gives the same symptoms, due to the loss of the boost rail and the damping effect of associated capacitors, e.g. C104 in the 1590 chassis. A high-resistance boost diode can be responsible for lack of width. It's important to use a fast-acting diode in this position. The Thorn type is a D42 – suitable alternatives are the MR854 or BY298. Ordinary silicon diodes are quite unsuitable.

The 95V and 300V supply rectifiers and their associated reservoir capacitors in the 1590/1591 (and other) chassis frequently give trouble. A short-circuit in any of these will blow the 2.5A fuse. If the leak is less severe the symptom may be no results due to the damping effect on the line output stage.

In one case the set had a history of slowly losing width: the focus and brightness dimmed, and finally the sound and picture disappeared. Fuse F2 was blown and blackened, indicating a heavy current flow as it blew. No measurable short-circuit was located, so a replacement fuse was fitted. This restored the sound and picture, though the focus was not clear and tended to vary spasmodically. The first anode supply reservoir capacitor C110 was found to have a leak which was pulling down the 300V line. A replacement cleared the fault. Note that the 95V reservoir capacitor C111 was changed from an electrolytic to a non-electrolytic type in later production, to eliminate striations. Again, the rectifier diodes need to be fast-acting types. A BY207 is suitable for the 300V rectifier, and a BA159 for the 95V rectifier.

Ballooning when the brightness control is turned up usually indicates low e.h.t. This can be due to severe loss of capacitance in the main reservoir capacitor, as we've already noted, or a faulty e.h.t. stick rectifier. The stick can also give a "rough" line symptom, or simply no e.h.t. with the rest of the set operating normally. Early versions of the

1590 chassis (i.e. the 12in. model) incorporated a separate e.h.t. reservoir capacitor, C115. This had a habit of burning up, removing the e.h.t. It can be left out.

In most portables there's no provision for width adjustment, the component values in the line output stage being chosen to give normal width when the set is operating correctly. Lack of or excessive width therefore suggests a fault condition, which should be investigated.

No e.h.t. can also be due to lack of drive to the line output transistor of course. The usual causes are a defective driver or oscillator transistor. The driver's collector voltage is unlikely to offer a clue since it's usually obtained from the boost rail, and there won't be any boost voltage.

A fault sometimes encountered on portables is a vertical white line, indicating that the e.h.t. is present but that the line scan coils are not being driven. On the Thorn 1590/1591 the cause is generally a dry-joint somewhere between the line output transistor and the coils. In some sets however the coupling capacitor can be responsible.

A common line timebase fault in the 1590/1591 chassis is loss of line lock due to unbalanced flywheel sync discriminator diodes (W9/10) or a defective electrolytic (C96, 10μF) in the reactance stage. ITT44 diodes are suitable replacements for W9/10. Any instability in the line circuit in these chassis suggests electrolytic troubles.

Testing Transistors

Many voltage regulator faults are caused by a defective regulator transistor, which can be tested using an ohmmeter. To check an AD149 say, first isolate its electrodes from the circuit. Connect the meter's red (negative) lead to the base and the black (positive) lead to the emitter. A reading of about 220Ω should be obtained (emitter-base junction forward biased). With the leads reversed a reading of about 100kΩ should be obtained. Such figures show that the base-emitter junction is in order. They are approximate, the important factor being the ratio of one to the other – at least 250:1 is desirable. A similar ratio should be obtained when the base-collector junction is tested in the same way. A check between the collector and emitter should record a very high resistance both ways.

Provided the transistor is isolated, this method of testing can be applied to any transistor (or diode for that matter) in the set, though different readings will be obtained with different classes of device – again the important factor is the ratio of the forward to the reverse bias figures.

Isolating the AU113 line output transistor in the Thorn 1590 series chassis to test it is simple since it's secured to the printed panel by two bolts, only one of which makes contact with the print. By removing this bolt and disconnecting the base and emitter leads, forward and reverse tests can be carried out.

Short-Circuits

The d.c. fuse in the power supply can fail for reasons other than those mentioned so far of course. The most likely causes are shorts in the field or audio output stages.

Power Supply Variations

Two power supply variations not so far mentioned are worth attention. First, in the ITT VC300/VC301/VC302 chassis the regulator transistor is in series with the negative instead of the positive side of the power supply, i.e. its collector is connected to chassis while its emitter is connected to the negative side of the reservoir capacitor/bridge rectifier. This can be confusing, since a

voltage check across the reservoir capacitor may reveal the full 16V while a check from the 2.5A fuse to chassis records nothing.

The other variant is the switch-mode power supply used in Indesit 12in. portables (and the GEC Models 3133/3135). This arrangement avoids the need for a mains transformer. Instead, a "pump" transistor is switched on briefly by line flyback pulses. The transistor's collector is at some 220V, while its emitter produces 17V across the inductive reservoir (the line output transformer - compare the arrangement with the Thorn 3000 colour chassis). The pump circuit seems to be reliable, which is perhaps fortunate. Less reliable are the dropper resistor (R908) and the surge limiter resistor (R909 in the earlier T12LGB, R907 in the later T12SBG). Either of these resistors may be found open-circuit, giving the dead set symptom. Another component that causes trouble in these Indesit portables is the 100 μ F 220V smoothing capacitor, which tends to dry up giving low voltages and a small picture.

The Rest of the Set

We've concentrated on power supplies and line output stages since these are the sections of a mains-battery set that tend to differ from other sets, and also give most trouble. Fault finding in other parts of the set follows the usual lines. Some of the field timebase circuits used are quite complex, and in the event of lack of field scan, i.e. a thin horizontal white line, it may be necessary to check voltages back through several d.c.-coupled stages before the source of the fault is located. In the 1590/1591 chassis this trouble is sometimes due to the 1,000 μ F coupling capacitor C78 going open-circuit. A weak picture should lead to checks in the video output stage. The transistor or its load resistor may be at fault. Alternatively the supply from the line

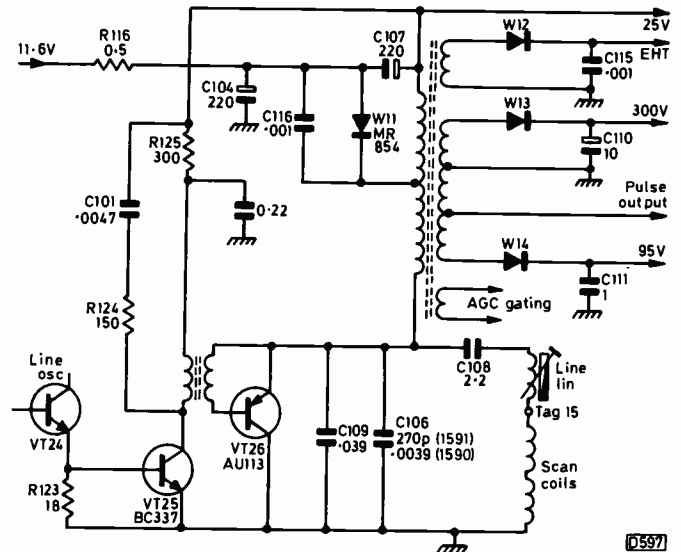

Fig. 3: Line driver and output stages, Thorn 1590/1591 portables. The line output stage also provides the e.h.t. supply, a 300V supply for the c.r.t. focus and first anode electrodes, a 95V supply for the video output stage and the brightness control, and a 25V boost rail which in these sets is used to supply the i.f. strip, sync circuitry and the line driver stage. In later production a silicon npn line output transistor is used, with its emitter returned to chassis and its collector connected to the junction C108/C106 etc.: a parallel efficiency diode is added and the base circuit amended. Note that the e.h.t. reservoir capacitor C115 is used in earlier versions of the 1590 chassis only.

output stage may be low or missing. Defective smoothing electrolytics are sometimes the cause of trouble here.

Happy hunting to you all! ■

Sinclair's New Mini TV

D. K. Matthewson, B.Sc., Ph.D.

AS mentioned in *Teletopics* last month, Sinclair recently demonstrated at their Cambridge factory their latest mini TV set. The new model is about the size of a paperback book, and has a 3in. diagonal screen. The interesting point however is that in addition to being 3in. across the screen is only $\frac{3}{4}$ in. deep! This would seem to be the first successful flat-screen TV set to be shown, and employs an interesting variation on the conventional cathode-ray tube. Yes, unlike the prototype shown recently by Sharp, no LCD or other exotic solid-state display device is used.

The new c.r.t., which has been developed by Sinclair's flat-screen research and development group, is an extension of a system originally conceived in the 1950s by an American firm. Sinclair got hold of the idea when one of their American designers, Tony Krause, joined the firm in the early 1970s. The final design as incorporated in the TV2 is elegantly simple. The tube is about 6 x 2 x $\frac{3}{4}$ in., and provides a picture about three times brighter for about an eighth of the power used by a conventional c.r.t.

The operating principles of the tube are shown in Fig. 1. The tube is constructed of two sheets of glass, with a transparent plastic front plate and a vacuum moulded plastic back. Only brief details of the innards are available, but roughly the operation is as follows. The phosphor

screen is deposited on the inside of the backing plate, the image being viewed through the transparent front screen. As a result, the picture is viewed from the same side of the phosphor screen as the electron beam strikes it, giving a very bright image.

The electron gun assembly is mounted parallel to the phosphor and transparent front screens, to one side. As in Sinclair's current Microvision model, electrostatic deflection

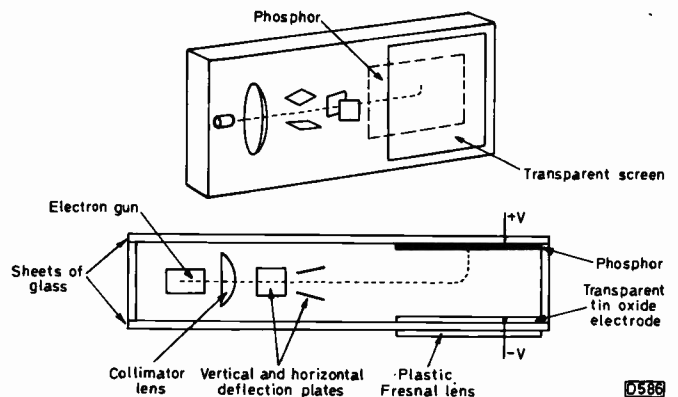

Fig. 1: Arrangement of the flat-screen c.r.t. to be used in the new Sinclair mini-TV receiver.

is used. There are in effect three sets of deflection electrodes. Two are conventional, providing vertical and horizontal deflection. The third set is of novel design and is used to deflect the beam on to the screen. Basically there are two electrodes, one on the phosphor side and the other, consisting of a transparent layer of tin oxide, coated on the inside of the front screen. The phosphor side is biased positively with respect to the front screen side of course. This electrode system is linked to the focusing system, the focusing field helping to keep the angle at which the beam strikes the phosphor constant across the screen width. The collimator lens is included to keep the raster sides parallel.

Folding the electron beam in this way would result in various forms of raster distortion, including trapezoidal distortion, without corrective measures. Both electronic and optical techniques are used to ensure that a satisfactory

picture is produced. The trapezoidal distortion is removed by applying a correcting signal to the field deflection plates to deliberately counter-distort the raster. The optical technique used is to reduce the height of the phosphor screen by about a half, while retaining the normal aspect ratio width. The image is corrected when viewed through the Fresnel lens. This technique also reduces the deflection power required.

As with previous Sinclair products, considerable thought has been given to the development of a design that lends itself to low-cost, mass-production techniques. Sinclair are at present seeking finance to enable them to get the new model into production, and trade gossip suggests that a joint venture with another company could well be on the cards. If all goes well, the Sinclair TV2 could be available on the UK market in 18-24 months. ■

TV Servicing: Beginners Start Here . . .

Part 25

S. Simon

LAST month we noted that the luminance and colour-difference signals have to be mixed together in order to produce the RGB primary-colour signals required to activate the tube's colour-phosphor screen, and saw that this mixing can be done either by the tube itself (colour-difference tube drive) or prior to the tube (RGB tube drive). We went on to illustrate typical colour-difference circuitry, and described the effects of various common faults. This month we are going to concern ourselves with the alternative RGB method of driving the colour tube. As a point of historical interest, colour-difference tube drive has not been used in current production UK chassis since the Pye hybrid colour chassis was phased out in about 1974. All UK produced solid-state colour chassis have employed RGB drive: in addition, the Decca 10 and 30 series hybrids and the ITT CVC5/8/9 hybrids employ RGB drive.

Colour Matrixing

With RGB drive we take a fairly low-level luminance signal, add it to the colour-difference signals, and then amplify the carefully measured "doses" in three amplifiers which drive the three tube cathodes. The tube's three control grids will be connected together and biased as the designer sees fit – some designers use the commoned control grids for beam limiting and/or flyback blanking.

Where do we add the luminance and the colour-difference signals? The answer is at almost any point following the G–Y matrix, i.e. the point at which proportions of the B–Y and R–Y signals are added together to recreate the G–Y signal, which you'll remember is not transmitted since it can be regenerated simply in the receiver. In the Decca 10 series chassis for example and the ITT CVC5 chassis, the luminance and colour-difference signals are added together quite early, in the collector circuits of the three preamplifier transistors, i.e. prior to the RGB driver and output stages. In the later Decca 30 and ITT CVC8 hybrid chassis the addition is carried out within

the MC1327 colour demodulator/matrixing i.c. In the Thorn 3000 and 3500 chassis on the other hand the luminance signal drives the bases of the RGB output transistors while the colour-difference signals drive the emitters, RGB matrixing thus being carried out in the output stages. To find out where the addition is done, look for the luminance delay line – the point of mixing will be found shortly after this.

The Luminance Delay Line

Another complication – the luminance delay line. What's this you may ask? Well, it's obvious that the luminance (picture brightness) and colour signals must arrive at the tube at the same time: the scanning spot travels at high speed, and if there is a difference between arrival times of the signals, say the colour is slightly late, the colouring will be displaced to the right of the luminance detail and the picture definition will be lost. Not to a very great extent, but if we want a decent picture everything must be in its right place at the right time.

What is the problem exactly? Well, as we mentioned briefly last month the picture detail is carried by the luminance signal. As the human eye is not sensitive to colour detail, colour detail is not transmitted. This means that the chrominance signal bandwidth is much less than the luminance signal bandwidth (the more detail you transmit, the greater the bandwidth required). So the bandwidth of the luminance stages in the receiver is wider than that of the chrominance stages. Now it's a fundamental fact about electronic circuits that a signal passes more rapidly through a wideband amplifier than through a narrow-band amplifier (the restricted bandwidth introduces a delay). To compensate for this, the luminance signal has to be delayed at some point to allow the colour signals time to catch up as it were. The exact delay required depends on circuit design – around 0.6µsec was typical of older colour sets. The luminance delay line must not be confused with the

chrominance delay line, which is used for totally different reasons, as we shall see when we come to consider the decoder.

The luminance delay line is an item which quite often causes trouble. It can become open-circuit. This removes the luminance signal (picture detail), leaving only vague colour blotches in some sets. Or the line's earth connection may be lost. The result of this is that the line rings, producing a multi-image effect somewhat similar to the "ghosting" you get with a poor aerial installation.

Drive Techniques Compared

Note that with RGB tube drive only three high-power output devices are required, as opposed to the four (luminance and three colour-difference) required with colour-difference tube drive. So there's a saving here. In addition, as we pointed out last month, cathode tube drive is more efficient than grid drive because the cathodes are being driven negatively with respect to first anodes as well as the grids.

There's a difference in the visual effect produced by the two systems, but this is hard to define. The nearest we can get is to say that RGB drive produces a "harder" picture which some find less pleasing than the "softer" effect produced by colour-difference drive. You could say that in audio terms it's the difference between "transistor" and "valve" sound.

Driving the Tube

Let's recap briefly on what we already know about tube drive, so that we can apply the basic principles to the RGB drive technique. If the tube's control grid is held at a steady voltage, it's the voltage variations at the cathode that produce the brightness variations, which is what picture detail is all about. When the cathode voltage rises the picture becomes darker, as the beam current is reduced. This is the same as making the control grid more negative with respect to the cathode. When the cathode voltage falls on the other hand, the display becomes brighter; and if the display device is a three-gun colour tube, and only one cathode is affected, we get more of the colour controlled by that cathode. All right?

Lack of Clamp Pulses

Remember also, as mentioned last month, that it's necessary to limit the beam current since excess current (say more than 1.5mA for a large-screen tube) will damage the tube and the e.h.t. generator circuitry. Add to this the fact that in many designs clamping pulses from the line output stage play a vital role in the operation of the RGB output stages – for example in the Thorn 3000/3500 chassis. Absence of these pulses can result in the RGB output transistors turning on hard (maximum current), leaving little voltage at their collectors and thus at the tube cathodes (RGB output stages are always d.c. coupled to the c.r.t. cathodes), with the result that the tube passes excessive current. Depending on the set's design, this may be outside the scope of the beam limiter arrangement. Say for example the beam limiter acts on the brightness or contrast (or both) circuits, which come earlier in the set's circuitry: in this case a defect in the RGB output stage(s) may not be within the capability of the beam limiter. We don't at this point wish to go into fine differences in circuit design, but merely to make the point that low tube cathode voltages (all three, this is the point) can be due to a fault not in the RGB circuits but in

the line output stage, probably the result of an open-circuit resistor or a short-circuit capacitor.

As an example, we may take the Thorn 3000/3500 chassis, where the pulses are obtained from the junction of a pair of capacitors in the line output stage. These are C519 (0.015 μ F) which is connected to the collector of the line output transistor, and C520 (7,500pF) which is connected to the line output stage sub-earth line. It's quite common for C520 to short, thus removing the 400V pulses from the luminance and the RGB output circuits. As a result, the three RGB output transistors pass excessive current, and the screen is brightly illuminated. This fault condition can continue, or further damage can be caused leading to a certain amount of confusion as to what started it all.

Tube Base Voltages

If the fault is confined to only one gun, the task is rather easier, which is what we were going to say before we got side tracked by mentioning clamp pulses. The essential starting point, in order to be logical and not take short cuts (these come later, with experience of particular chassis), is the voltages at the tube cathodes. In the type of tube most likely to be encountered, the tube base socket will be of the 14-pin variety with pins 8 and 10 missing because they would be on either side of the high-voltage focus pin 9. The red cathode will be pin 2, green pin 6 and blue pin 11.

The voltages at these pins should be roughly the same, so bearing in mind the symptoms, say excessive green or the absence of green, i.e. a magenta display, two of these voltages will be about right (say 160V) and the third may be noticeably wrong. If the screen is bright green, the voltage at the green cathode pin 6 will almost certainly be low. If on the other hand green is absent from the display, the green cathode voltage could well be high – if not, the next check should be at the tube's green first anode, where the voltage will probably be low (compared with the red and blue first anode voltages). If the fault is due to an incorrect cathode voltage, one then has to follow the trail back via the relevant output stage to the previous stage(s) as necessary. First check the output transistor and its load resistor. The fault is occasionally intermittent, making diagnosis more tricky. A useful dodge in this case is to swap over the drives. Say the fault is excessive green. One can swap over the green and red drives to the c.r.t., and see whether the fault then comes up in red, proving that the fault is in the green drive circuitry. If the fault still appears in green, check the other electrode voltages and if everything is in order you've got a defective tube.

Output Stage Resistors

Returning to output transistor collector load resistors however, we must dally a while here since a very common source of trouble resides in this area and can be misleading to the uninitiated. The RGB output stages may use separate, fairly high-wattage wirewound resistors (one for each stage). These rarely give trouble, and in any case are easily checked. Nearby you may find a carbon resistor which is connected from the collector of the R/G/B output transistor to chassis and serves simply to maintain a flow of current through the output transistor's load resistor when the transistor itself is turned off. We'll take the Thorn 3000/3500 chassis again as our example. The load resistors are 12k Ω (see Fig. 1), while the carbon resistors have a value of 56k Ω .

Now in later versions of these chassis the separate resistors (all six) were combined in a thick-film unit. This

unit is always suspect, and tends to disintegrate over a period, causing variations in grey scale (due to the varying voltages) before doing so. It is thus a primary suspect, though suspicion is often thrown on the transistors instead because the variation may occur only when the set has warmed up.

In many designs however, such as the Pye solid-state models covered elsewhere in this issue, the larger value resistor connected to the collector of the output transistor doesn't go directly to chassis but via a low-value resistor instead, the junction of these resistors providing a feedback voltage. In this type of circuit the value of the feedback resistor – 27kΩ in the Pye chassis just mentioned and the GEC C2110 series, 47kΩ in the Philips G8 chassis (see Fig. 2) – is much more critical, since it affects the output transistor's base bias. A slight change in the transistor's base-emitter bias will cause a large change in its collector current and thus the tube's cathode voltage.

Here again, if separate resistors are employed checking the values gives little difficulty – disconnect one end to do so. The feedback resistors may however (isn't there always a "however" lurking around?) be part of a thick-film unit, as in the Pye sets for example. Checking is then not at all easy, though value change can and does play havoc with the grey scale. In these Pye chassis the RGB preamplifiers are contained within the preceding TBA530 i.c. (see Fig. 5, page 644), but have separate 39kΩ load resistors connected externally (R442/458/474). The value of these resistors is also critical to the biasing of the output transistors.

Brightness Faults

Returning to the fault excessive brightness or maybe lack of brightness, what if the tube's cathode voltages are correct? The next step should be to check the first anode voltages, which should be at around 400-500V say. If not, check the value of the resistor(s) feeding the first anode preset control(s). This is a common cause of excessive or lack of brightness with some chassis. Occasionally one might find that the trouble is in the tube's control grid circuit. In the Thorn 3000/3500 chassis for example the grids are used for flyback blanking and in addition are linked to the slider of a preset potentiometer which is connected, via series resistors, between a 200V (approximately) line and a -800V line derived from the line output stage. Thus a fault reducing either of these supplies will affect the brightness. If the grid bias becomes excessive, the tube will be blacked out: if the voltage at the control grids moves positively (-800V supply absent or reduced) the picture will become brighter with flyback lines showing, sometimes giving the impression that the tube is failing or has internal leakage.

Don't expect to read heavy negative voltages on the c.r.t. grids with an ordinary multimeter: where negative-going flyback pulses are applied to the grids for blanking purposes, remember that they are of only brief duration. Under normal conditions therefore a multimeter will record only something like -3V. If in doubt, always check with the manufacturer's service manual, as there are wide divergences depending on particular circuit arrangements.

Incorrect Grey Scale

We should now be in a better position to tackle faults that affect the grey scale. We are not concerned here with the colour signals themselves, since these only alter the grey scale as set up on the receiver by the tube's first anode and drive controls. If the grey scale is not correct, the colour

signals will merely alter something that's incorrect to start with. We are concerned then with the appearance of the picture with the colour turned off or tuned out.

If the tube is healthy and the first anodes are set to give roughly the same voltage (400-500V say), inability to hold the whites and greys correctly means that the tube's cathode voltages are wrong. As we have seen, this leads us back to the colour drive panel – unless there are presets which could be faulty on the tube base panel (check with the ohmmeter with the set switched off, as the application of the voltmeter with the set switched on can give misleading results due to the alternative chassis return path provided by the voltmeter).

Assuming that the RGB (as the case may be) output transistor's load resistor is in order, we check the operating conditions in the stage which the screen colour and the cathode voltage readings suggest is at fault. Say the screen colour is cyan (blue-green). This means lack of red, so we would expect the red cathode voltage at pin 2 of the tube base to be high and that at the collector of the red output transistor also high (higher than that at the collectors of the blue and green output transistors). Moving back, the next thing to check is the output transistor's base-emitter voltage. Normally we would have said check the base voltage, but in some designs, i.e. the Thorn 3000/3500 chassis, the bases of the output transistors are coupled together and driven by the luminance signal while the emitters, which is where the difference could be, are driven by the colour-difference

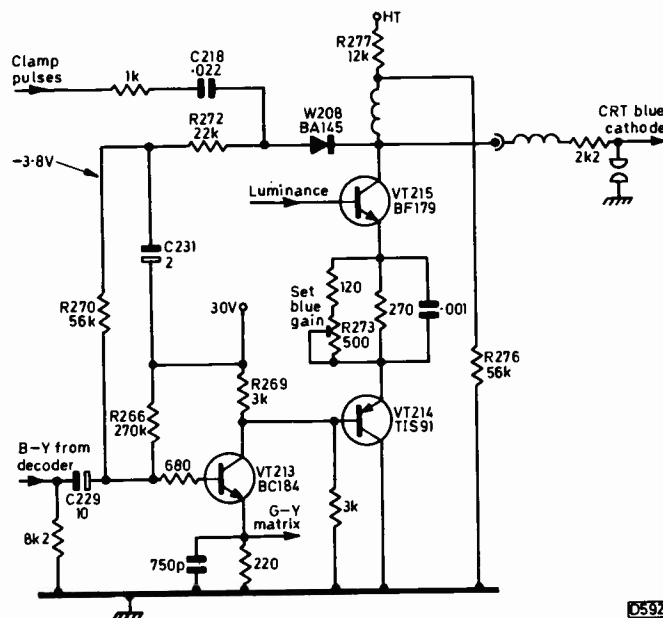

Fig. 1: The blue channel circuit used in the Thorn 3000/3500 chassis. The blue output transistor VT215 is driven by the luminance signal at its base and by the B-Y signal from VT214 at its emitter. Blue matrixing is thus carried out by the output transistor. Clamping is required because of the capacitive coupling via C229 between the decoder and the B-Y preamplifier stage VT213. A feedback clamp is used, the feedback loop being from the collector of the output transistor VT215 via W208, R272 and R270 to the base of the preamplifier transistor VT213. Positive-going clamp pulses from the line output stage switch on diode W208 during the back porch period following the sync pulse, when the signal is at black level. The right-hand plate of C218 acquires a negative charge as a result. The network R272/C231 acts as a filter, C231 acquiring a charge of -3.8V. This counters the forward bias applied to the base of VT213 via R266. The result is a stable black level. The contribution from the B-Y channel to the G-Y matrix is taken from the emitter of VT213.

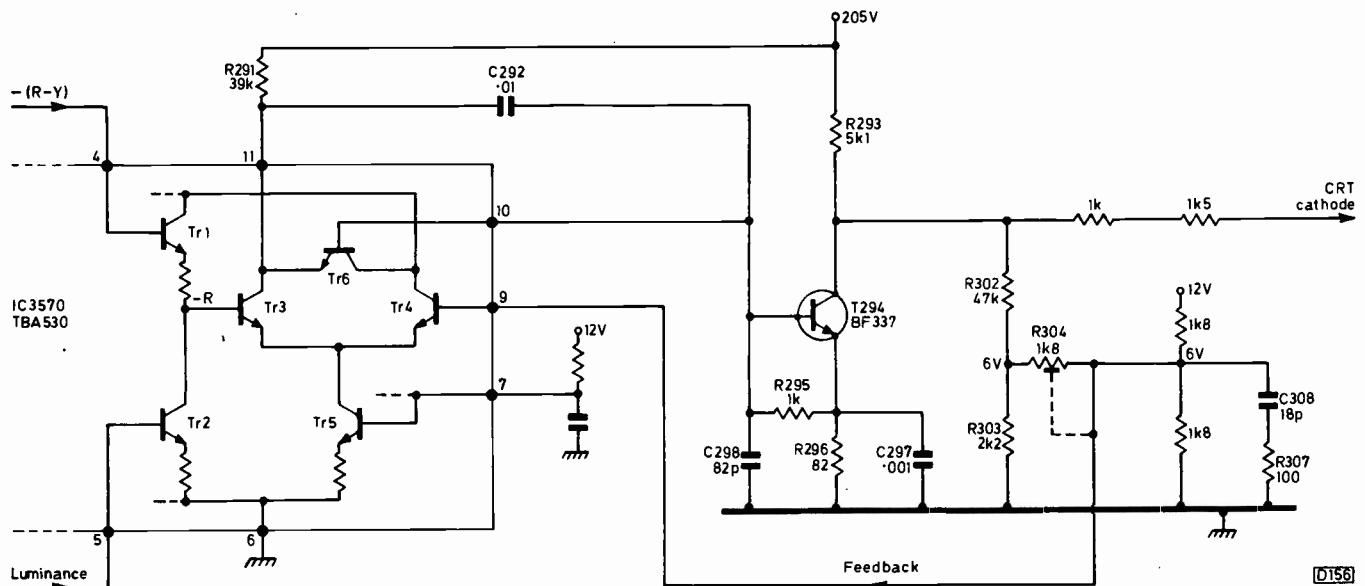

Fig. 2 The red channel circuit used in the Philips G9 chassis. A very similar circuit is used in the G8 chassis, though the component reference numbers differ. In this circuit matrixing of the luminance signal and the R-Y colour-difference signal is carried out in the TBA530 IC3570, d.c. coupling being used from the demodulators to the c.r.t. cathodes. Feedback is used to stabilise the operating conditions. In the red channel shown, the feedback is taken from the junction of R302/R303 and applied to the driver stage in the i.c. If the value of R302 changes therefore, the feedback voltage will alter and the grey scale will be affected. The red driver stage's load resistor is R291, but the output coupling is via Tr6 and pin 10, C292 simply providing an h.f. bypass for Tr6. It will be seen that alteration in the value of R291 will also affect the biasing of T294 and hence the grey scale. The equivalent resistor to R304 in the blue and green channels is a preset for highlight drive adjustment.

signals. Now as we all know, if the base and emitter of a transistor are joined together or are for some other reason at the same voltage, no current will flow through the transistor and its collector voltage will be high. In the case of our missing red we could well find however that the base-emitter voltage of the red output transistor is the same as the blue and green output transistors. This would strongly suggest that the transistor itself is at fault, being incapable of conducting. All that's required then is a quick ohmmeter check to confirm this or, better still (as ohmmeter checks are not wholly conclusive), fitting a replacement transistor without further ado. RGB output transistors are required to pass considerable currents, and therefore run hot. So the heatsink must not be omitted.

Failure of one of the RGB output transistors is a very common fault, probably due to the heat, and must rank with disintegrating thick-film load resistive elements as the most common cause of a definite drop out of one colour.

If the base and emitter voltages of the output transistor concerned are close however the transistor may not be at fault (though it could be due to base-emitter leakage), and attention may have to be turned to the driving circuit, whether this is a transistor or an i.c. It's then a matter of checking back to find where the incorrect voltages start. This cannot be far away, since the green matrixing is carried out only a little earlier in the circuit, and the fault must be after this.

Suppose we have excessive green rather than none, with the tube's green cathode voltage low. This means that the green output transistor is turned hard on (short-circuit?) or its load resistor is open-circuit. If the trouble is that the output transistor is turned fully on, we have again to find out why its biasing is incorrect. In this case it's worth checking the clamp diode, if one is present, in the output transistor's collector circuit (Rank A823, Thorn 3000/3500, Decca 10 and ITT CVC5 chassis for example). The clamping is done by feedback action, and whether the diode is open- or short-circuit the relevant output transistor will be turned hard on. The TBA530 matrixing/preamplifier type of i.c.

sometimes causes this fault (an all red, green or blue screen): in this case you will have to check the pin voltages to see which are incorrect, and maybe have to check back to the preceding i.c. if this is say a TBA990. If the TBA530 is pluggable instead of being soldered into circuit, a substitute can be tried as a quick check.

With all these faults, i.e. incorrect output stage biasing, look for faulty presets, leaky capacitors, wrong-value resistors etc. — once you've ascertained that the output transistor and its load resistor are in order. It pays to dally with the output stage though — transistors, load resistors, 39kΩ and 27kΩ resistors and what have you, as already mentioned.

Questions and Answers

Let's summarise briefly in question and answer form.

Question: The screen is magneta or purple. What does this signify?

Answer: That the tube's green gun is turned off.

Question: Where would you start?

Answer: At the tube base. Verify that the first anode voltage is present at pin 5 (with the usual type of tube base) and that it's roughly the same as the red and blue first anode voltages (pins 4 and 13). If the first anode voltage is low, ascertain why, checking the relevant first anode control, the presence of the supply, the decoupling capacitor and the cut-off switch which could be leaking across its contacts (very common with the Thorn 3000/3500 chassis). If the first anode voltage is present and is roughly the same as the other two, check the green cathode and green grid and compare these voltages with the others.

Question: If all the voltages are as they should be and there's still no green at normal brightness, what next?

Answer: You worry. Turn down the brightness and if there is then some green present it could well be that the green gun has lost emission.

Question: What can be done about this?

Answer: You can look up past issues of *Television*, build yourself a tube reactivator, and hope for success.

Service Notebook

George Wilding

Restored Results Soon Went

We find the Decca sets fitted with the Bradford chassis to be amongst the most reliable of the hybrid colour chassis, usually maintaining their high standard of factory convergence. A completely dead one came our way recently however, with a blown mains input fuse. The mains filter capacitor was o.k., so the next check was to connect the ohmmeter between the top cap of the PL509 line output valve and chassis. Only a very low reading could be obtained, and as expected the boost capacitor (C436, 0.22 μ F, 1kV) was found to be short-circuit. Replacing this, a simple matter after removing the small timebase panel, and fitting a new fuse produced very good results – for about five minutes. The picture and sound then vanished, leaving only noise on the screen.

The aerial connections were still firmly in place, and it seemed that if the tuner supplies were in order the frequency changer transistor had probably packed up – noise covers such a wide bandwidth that it can reach the i.f. stages even without the mixer stage functioning. The i.t. supplies turned out to be present and correct, and on fitting a replacement tuner first class results were restored.

The mains fuse is within an inch or two of the tuner, and had been heavily blackened. It had probably sustained a momentary arc, which had killed the mixer transistor. We've known small-signal semiconductor devices of various types come to life temporarily after breaking down due to a voltage surge etc. This also applies to some miniature voltage stabiliser i.c.s – these should always be replaced if the least bit suspect.

A Philips K70

Sets fitted with the Philips K70 chassis (Model S26K497) are rare indeed in these parts, and in fact we encountered our first example only recently. The symptom was hum from the speaker, but neither raster nor sound. The valve heaters were all glowing normally, and on swinging the hinged chassis back we found that there was ample h.t. on the top caps of the two valves in the e.h.t. can, though their glass temperatures were very low. One usually finds a PL509 or PL519 and a PY500A in a hybrid colour chassis, but in this case what we first assumed to be the PY500A turned out to be a PL504. Fortunately the circuit was available, and this confirmed that there are three valves in the line output stage (PL509, PL504 and PY500A), driven by a PCF802 line oscillator. Anyway, we came to the conclusion that the h.t. supply to the screen grids of the two pentodes must be missing, otherwise with h.t. on their anodes and with or without line drive they would be hot.

Voltage checks showed that there was no voltage at the two 100 Ω screen grid feed resistors R1201 and R1202. These are fed from the 680 Ω fusible resistor R911 in the power supply, and this was obligingly found to be open-circuit. There was no short across the h.t. line, so the only

thing to do was to resolder R911 and switch on. Sound and a perfect picture soon developed, but on giving the two pentodes a few light taps we found that small sparks, which played havoc with the picture, could be instigated in the PL509. Replacing this valve and slightly readjusting the focus completed the job.

Coloured Dots

The complaint with a Körting hybrid colour receiver was "coloured dots all over the picture". On inspection, this appeared to be due to e.h.t. arcing somewhere though the fault surprisingly vanished when the colour control was turned to minimum. We also noticed that the picture tended to expand somewhat when the brightness control was advanced, suggesting that the tripler was developing a high internal resistance. Our first move was to fit new valves in the line output stage, but as this made no improvement we next replaced the tripler. This cured both the picture "blooming" and the random coloured dots, so we came to the conclusion that in the course of going high resistance there had been sparking within the tripler's casing.

No Luminance

Quite straightforward symptoms can sometimes fool one. For example, the owner of a Pye hybrid colour set said that although there were coloured outlines on the screen, they didn't form a picture. True enough, we found that the luminance was completely absent, turning down the colour control leaving a blank, unmodulated raster. In addition, the brightness control had negligible effect. Now these sets use colour-difference tube drive, so the presence of the raster suggested to us that the PL802 luminance output valve was drawing about normal anode current. If it hadn't been conductive, the screen would have been blacked out since the PL802's anode voltage and the d.c. coupled c.r.t. cathodes would all have been at the h.t. voltage. We assumed therefore that the PL802's anode and screen grid voltages were about normal, and as the brightness control, which acts on the valve's control grid, had little effect we decided to concentrate on this part of the circuit.

As a first step we disconnected the luminance input plug on the CDA panel, to check whether the voltage here varied with adjustment of the brightness control. The small voltage here was found to vary in a normal manner, so the brightness control circuit was cleared of suspicion. After spending some time checking other components in the control grid circuit, and the continuity of the tracks, we decided that the fault could be due to the valve. A replacement made no difference to the fault symptoms however.

At this point we decided to check the anode and screen grid voltages, and found that these were both below 70V instead of something over 200V. The h.t. supply to the panel was found to be present and correct, and all relevant resistors checked o.k. On tracing along the print towards the PL802 however the voltage suddenly dropped at one of the component connections. Placing a jumper connection along the print and resoldering the connection point restored normal voltages and a normal picture. It then became clear to us that the inability of the pentode to respond to the luminance signal and to brightness control variations had been due to the valve being at virtually the cut-off point – low screen grid voltage, even more than low anode voltage, greatly reduces the anode current. This effect is made use of in valve sync separators, where the low anode and screen grid voltages hold the valve cut off until the arrival of the sync pulse.

Your PROBLEMS solved

Requests for advice in dealing with servicing problems must be accompanied by a 50p postal order (made out to IPC Magazines Ltd.), the query coupon from page 661 and a stamped addressed envelope. We can deal with only one query at a time. We regret that we cannot supply service sheets nor answer queries over the telephone.

GRUNDIG 717GB

The fault at first appeared to be a defective tube, the symptoms being uncontrollable brightness with the controls ineffective and a faint blue glow in the tube neck. When the service switch is moved to red raster or the line position however operation appears to be normal. I've since found that by turning the brightness control and the preset brightness control range preset R382 to minimum a dark screen is obtained: then gently advancing R382 produces a picture, though very dark. The picture then goes bright again. The only other trouble I've had with this set was with the VDR R704 in the degaussing circuit.

It's most unlikely that the c.r.t. is the cause of this trouble: much more likely are low c.r.t. cathode voltages. The brightness and brightness range controls operate on the luminance output stage black-level clamp in this chassis. We suggest you replace R382 and set up the video as described on page 14 of the manual. If this fails, there is probably a defective transistor in the luminance circuitry: suspect the output transistor Tr375 and its d.c.-coupled driver Tr365, and the black-level clamp transistor Tr385.

THORN 1500 CHASSIS

After about an hour the picture begins to break up horizontally, with bright flashes across the screen. After this the screen goes faint with only traces of a picture. The picture returns to normal when the set is switched off for about half an hour and then switched on again. A fault that's been present for some time is that the picture suddenly loses contrast, light pressure on the contrast control bringing it back. This doesn't cure the first fault however. The contrast control and its connections seem to be in order.

It would be advisable to replace the contrast control to start with, then check the electrolytic capacitor (C37) which is in series with it and feeds the base of video output transistor. Another electrolytic to check is C38 (12 μ F) which smooths the HT2 supply to the video output transistor's collector circuit. If necessary check the video output transistor VT9 by substitution, and ensure that its two series-connected load resistors R40/51 are of the correct value.

GEC MODEL 2028

There are a couple of faults on this dual-standard hybrid colour receiver. First some buzzing on subtitles. Secondly there's intermittent brightness. A new PL802 luminance output valve has been fitted.

To reduce the sound buzz, try a very small adjustment to L122 in the sound discriminator can T110 and check the

setting of the a.m. rejector P102. If this is not successful, it may be necessary to follow the alignment procedure given in the manual. Intermittent brightness may be due to a noisy beam current limiter preset P507 or brightness control P4. Also check plug PL5 on the timebase board for poor contacts or a dry-joint, that the c.r.t.'s first anode voltages are steady (check the feed components R529 and C527 if necessary), and for dry-joints in any of these areas.

THORN 3500 CHASSIS

There seem to be several problems with this set. First, when the picture content darkens, the picture takes on a greenish tint and shrinks by about three-quarters of an inch all round. This reverts to normal when the picture brightens. There's cramping on the right-hand side of the screen – adjusting the line linearity coil makes no difference. I changed the line output transistor and then tried to set up the beam limiter, but the picture is very dark and the voltage across R907 in the beam limiter circuit is over 5V.

Your problems all stem from the excessive voltage across R907 (should be 1.3V with the screen blacked out). First ensure that R907 (1.5 Ω) hasn't changed value – replace it if in any doubt. If the high voltage across it remains, the fault is excessive loading in the line output stage. Progressively disconnect the tripler, the shift choke L504, the first anode supply rectifier W505, the scan coils etc. When the correct voltage across R907 returns, you've found the faulty component. If the overload persists however, the line output or e.h.t. transformer is suspect.

SONY KV1340UB

There's been a low level of hum on sound since new, even with the volume control turned right down. The hum frequency seems to change if the field hold control is set to make the picture roll. The smoothing appears to be suspect, but where?

A small amount of residual hum is present in most receiver designs, and the KV1340UB is no exception. If the hum level is excessive however the following capacitors are the ones to check: C231 (220 μ F, 25V) and C246 (33 μ F, 25V) on the signals panel, and C607 and C605 (both 4.7 μ F, 160V) on the power supply panel.

GEC C2148

The neons on the touch-tuner fluctuate, those on channels not selected tending to light and flicker. Sometimes the set has to be tuned in after changing channel.

The neons do sometimes give this trouble, and it's best to change the lot – the RS type 586-015 is suitable. Check the value of R675 – if it's a 12M Ω type, change it to 4.7M Ω . If the troubles persist, replace the i.c. (ETTR6016Q).

RANK A823AV CHASSIS

The original fault was intermittent field collapse. The set was not used for several months, and now the fault is intermittent top foldover, which becomes apparent when the set's been on for an hour or so. All capacitors in the field oscillator and charging circuits have been checked by substitution, and the resistors are within tolerance.

Top foldover (slow flyback) suggests that the field output stage is not operating correctly. We suggest you check by substitution the 16029/16039 field output transistors, the mid-point voltage adjustment preset 5RV4 and the bootstrap capacitor 5C35 (250 μ F), also the AC128 driver transistor. The field scan balance control 6RV2 on the scan control panel is suspect for intermittent field collapse: also check the connections to 6L20 for dry-joints.

THORN 9000 CHASSIS

On switching on, the tube arcs badly for a few seconds, then a perfect picture is produced. The R2540 Syclops transistor has been replaced.

The discharge will do no harm provided the receiver has been correctly set up and the e.h.t. does not exceed 26kV maximum (R606 on the Syclops control panel is the set e.h.t. control) – some tubes tend to spark more than others! Remove pin 13 from the tube if it's still there – it tends to pick up a static charge and cause intermittent colour. Do this very gently and carefully.

GRUNDIG 5011

The sound and picture are normally excellent, and this situation can last for three or four days. Sometimes however there is good sound and vision for about four minutes after switching on, then the sound becomes distorted and noisy, the colour goes, and finally the monochrome picture breaks up. Retuning restores a good colour picture and sound for a few minutes, then the fault returns. This happens on all channels. The set also occasionally jumps from channel 3 to channel 1.

The first problem is that the tuner is drifting down the band slightly. If this trouble is due to the tuner, it could well be that the tuning voltage supply feedthrough capacitor C37 is leaky. If the problems lie in the 29301 electronic programme selector module however (we've often found this to be the case) it's best to return it for exchange/repair as sophisticated test equipment is required to deal with it.

KUBA PORTA-COLOUR

The trouble with this 11in. transportable colour set, which also seems to be known as the Granada Colourette, is no luminance. I've tried a new PCL200 luminance output valve without success. The fault started with it taking about ten minutes for the luminance to appear. Then after a few days the luminance packed up completely. Colour is still present – the set uses colour-difference drive.

Amongst the many unusual features of this set is the fact that the luminance drive is a.c. coupled to the common c.r.t. cathodes (the tube is an in-line gun type), with no clamping. Also the luminance delay line comes after the luminance output pentode, i.e. between the pentode and the c.r.t. cathodes. The delay line itself is a possible offender, and can be checked by simply shorting it out with a piece of wire. Otherwise, check back from the c.r.t. cathodes, including the coupling capacitor and the resistors in the luminance output stage. We've known the fault to be due to a defective output connection on the board.

ITT VC200

The set has given faultless service for some four years, apart from one unsoldered joint. From new however low signal level inputs have produced snow, while even with a local signal and a good aerial faint noisiness can be seen when the screen is closely inspected. The noise is not random however. By selective tuning with a low signal level it becomes a pattern of diagonal black-and-white lines superimposed on the picture at roughly 60 cycles per line. I suspect that this is sound-on-vision, but adjusting the 6MHz sound trap L44 makes no apparent difference.

Tune in the test card and examine the display. If the dot pattern you describe is present only on coloured areas (the the centre circle) it is a 4.43MHz colour subcarrier dot pattern. If the pattern is present over the entire screen however, roughly diagonal, moves in sympathy with the

sound and reverts to straight lines during silent periods, it is 6MHz intercarrier sound patterning. In the latter case adjusting L44 should minimize the patterning: if it has no effect, its 390pF parallel tuning capacitor C66 is suspect.

GEC 2040

I'm in the process of renovating one of these single-standard hybrid colour receivers. The first fault was no results, with the mains fuse blown. This turned out to be due to a faulty thermal cut-out in the line output stage and a defective line output transformer. Replacing these components restored results of sorts, but the line oscillator was running three times too fast – the core was missing from the line oscillator coil L501. Having obtained a just about acceptable picture, I found that on increasing the setting of the contrast control any highlights are accompanied by a kind of faint magenta or greenish bar, running horizontally. The video valves (PL802 and the three PCL84s) and the associated electrolytics have been replaced, but the fault persists – its objectionable on all but the least contrasted scenes and is present with the colour turned on or off, also with each of the first anode presets turned off.

Since you've changed the likely components in the video area, it could be that there's a small low-resistance area on the board. It would be advisable to check the electrolytics in the power supply, especially C58 (2,000 μ F) and C59 (1,000 μ F), the 20V supply smoothing and reservoir capacitors.

THORN 8000 CHASSIS

The picture has always been too wide – half the last square at each side is lost. I've tried juggling with the scan coils (at the expense of purity) and adjusting the set e.h.t. control in the power supply. As there's no width control, it looks as if modification will be necessary. Any suggestions?

We would not advise modifying a solid-state line output stage: the whole thing is carefully designed, with resonant circuit action, and unofficial modifications would be likely to result in component failure – which could prove expensive. The width is related to the e.h.t., which may be low – the higher the e.h.t., the smaller the picture. Make sure first that this is set up correctly. Then if necessary check the following capacitors by substitution: C406 (flyback tuning) 0.0015 μ F; C444 (a.c. coupling to the line output transformer) 0.47 μ F; C407 (scan-correction) 0.68 μ F. Any replacements should have the same value and ratings as the originals, and preferably be Thorn approved parts. The other (unlikely) possibility is a faulty line output transformer.

SONY KV1810UB

All that is available on the screen is a reddish hue, or reddish white. On a monochrome transmission the reddish hue is still there. Adjusting the user controls makes no difference to the fault.

Checking the c.r.t. electrode voltages should indicate the cause of the trouble. If the grey-scale doesn't alter when the drive and background controls are adjusted, the c.r.t. is faulty. It seems to us more likely however that the trouble is in the red drive circuitry. If the voltage at the collector of the red output transistor Q702 differs appreciably from that at the collectors of the green and blue output transistors, Q702 is suspect, along with the R–Y emitter-follower transistor Q157. If all three colour output transistor collector voltages are about equal, try setting up the grey-scale as described in the manual.

THORN 9000 CHASSIS

When the set is switched on from cold, only channel "1" can be obtained. If any of the other touch pads are tried, the respective neon fails to light and after releasing the pad the set reverts to channel "1". After some twenty minutes, you can change channel by keeping your finger on the appropriate touch pad: the picture is o.k., whereas before just a raster would be obtained. The fault clears completely after an hour. I've tried about half a can of freezer on the i.c., but as this doesn't restore the fault condition I've not changed the i.c.

On rare occasions we've found the channel "1" neon (LP501) or switch transistor (VT505) to be responsible for this trouble, but usually it's the chip that is faulty. Be careful with the replacement BTT6018 until you've got it connected into circuit – it's a CMOS device.

TEST CASE

202

Each month we provide an interesting case of television servicing to exercise your ingenuity. These are not trick questions but are based on actual practical faults.

A Pye hybrid colour receiver fitted with the 691 chassis arrived with the complaint "No picture, sound okay". A chat with the customer revealed that the picture brightness had gradually diminished before the raster vanished altogether. As a simple case of luminance output valve failure was assumed, the receiver was passed over to the second year apprentice for remedy, a good clean up and overall re-adjustment.

The chassis uses colour-difference drive, with a PL802 luminance output pentode driving the tube's cathodes. A blank screen is commonly due to lack of pentode cathode current, as a result of which the tube's cathode voltages rise to almost the supply line voltage, thereby biasing back the tube. In this case however the pentode's emission was well within specification, and valve replacement did nothing for the trouble. A subsequent test proved that the e.h.t. was adequate, and that the supplies to the tube's first anodes were present and correct.

By this time the apprentice had become somewhat bewildered. Before getting involved in tube replacement however he decided to get some idea of the biasing of the tube's guns by measuring the potential between the cathodes and control grids in turn. This revealed that all three guns were excessively biased, though the cathode-to-chassis voltages were normal. The control grids are fed, via 2.7k Ω protection resistors, from the anodes of the clamp triode sections of the PCL84 colour-difference output valves. The implication was thus that all three colour-difference output

GEC C2110 SERIES

The trouble with this set is sloping horizontal white lines across the screen. They are about an inch apart at the bottom, the distance between them decreasing towards the top of the screen.

These are field flyback lines. If the brightness is excessive, check the value of R507 (300k Ω) in the c.r.t. first anode supply circuit. This resistor tends to increase in value, giving excessive brightness with flyback lines. If this is not the case, the fault is in the field flyback blanking circuit. Flyback blanking pulses are obtained via C463 (0.1 μ F) on the field timebase board PC467 and fed to transistor TR201 on the chroma/luminance board PC446. TR201 drives pin 8 of the TBA560C i.c. Check C463, the board interconnecting plugs and sockets PL28-5/PL5-1, TR201 and its associated components as necessary.

stages were suffering from low triode anode voltage!

Somehow then all three colour-difference output stage clamps were passing excessive current. How could this happen, and what would be a likely cause of the trouble? See next month for the solution and for a further item in the series.

SOLUTION TO TEST CASE 201

– page 604 last month –

Despite the symptoms, the trouble with the VCR-partnered ASA Model CT6000 was eventually traced to an expired picture tube! The VCR used had an internal aerial preamplifier to allow the aerial signal to be split two ways without the normal 6dB passive loss – one way to the receiver, and the other to the front end of the VCR. This splitting is common to all domestic VCRs, but not all models incorporate a preamplifier.

Because the aerial was close to the receiver and VCR, the input and output matchings were impaired. As a result, the signal fed to the receiver was abnormally high. This brought to light the tube weakness, probably a little before it might otherwise have been noticed. There was also the possibility that the extra time the set was in use accelerated the tube's demise.

Tube replacement restored the good quality pictures of which the receiver is capable, and gave far better results with the VCR. Note however that it's generally undesirable to use a set-top aerial with a VCR, even in areas of high signal field close to a transmitter.

QUERY COUPON

Available until 15th October, 1979. One coupon, plus a 50p (inc. VAT) postal order, must accompany EACH PROBLEM sent in accordance with the notice on page 659.

TELEVISION OCT. 1979

Published on approximately the 22nd of each month by IPC Magazines Limited, King's Reach Tower, Stamford Street, London SE1 9LS. Filmsetting by Trutape Setting Systems, 220-228 Northdown Road, Margate, Kent. Printed in England by Carlisle Web Offset, Newtown Trading Estate, Carlisle. Distributed by IPC Business Press (Sales and Distribution) Ltd., 40 Bowling Green Lane, London EC1R 0NE. Sole Agents for Australia and New Zealand – Gordon and Gotch (A/sia) Ltd.; South Africa – Central News Agency Ltd. Subscriptions: Inland £9.50, Overseas £10.50 per annum payable to IPC Services, Oakfield House, Perrymount Road, Haywards Heath, Sussex. "Television" is sold subject to the following conditions, namely that it shall not, without the written consent of the Publishers first having been given, be lent, resold, hired out or otherwise disposed of by way of Trade at more than the recommended selling price shown on the cover, excluding Eire where the selling price is subject to VAT, and that it shall not be lent, resold, hired out or otherwise disposed of in a mutilated condition or in any unauthorised cover by way of Trade or affixed to or as part of any publication or advertising, literary or pictorial matter whatsoever.

TV LINE OUTPUT TRANSFORMERS (Prices include VAT at 15%)

Post and Packing 70p

BUSH	MURPHY	DECCA	PYE	GEC	COLOUR TRANSFORMERS	
TV123 TV124 TV125 or U TV128 TV134 TV135 or R TV138 or R TV139 TV141 TV145 TV148 TV161 TV165 TV166 TV171 TV175 TV176 TV178 TV181 or S TV183 or D TV183S TV183SS TV185S TV186 or D TV186S TV186SS TV191D TV191S TV193D TV193S TV198 TV307 TV313 TV315 Price £7.36	V843 all models to V979 V153 V159 V173 V179 V1910 V1913 V1914 V2014 or S V2015D V2015S V2015SS V2016S V2017S V2019 V2023 V2027 V2310 V2311C V2414D V2415D V2415S V2415SS V2416D V2416S V2417S V2419 V2423 A774	MS1700 MS2000 MS2001 MS2400 MS2401 MS2404 MS2420 Price £7.36	58 64 59 68 60 75 61 76 62 77 63 80 81 93 83 94 84 95/4 85 96 86 97 92 98 150 161 151 170 155 170/1 156 171 160 171/1 Price £7.36	8T454 8T455 8T455DST 2000DST... all models to 2044 2047... all models to 2084 2104 or/1 2105 or/1 Price £7.36	DECCA CS1730, 1733, 1830, 1835 £9.51 DECCA 30 Series Bradford Chassis £9.51 DECCA 60, 80, 100 Series £9.51 GEC Dual STD Hybrid £11.59 GEC Single STD Hybrid £11.59 GEC Single STD Solid State £9.51 ITT CVC 1 to CVC 9 £9.51 ITT CVC 20 £10.53 ITT CVC 30, CVC 32 £9.51 PYE/EKCO 725 Chassis £9.51 PYE/EKCO 731, 735, 737, 741 Chassis £9.51 PYE/EKCO 713, 715 Chassis £9.51 PHILIPS G8, G9 Chassis £9.51 PHILIPS 570 Chassis £10.53 THORN 3000, 3500 EHT and SCAN £8.48 THORN 8000, 8000A, 8500, 8800 £10.02 THORN 9000 £10.02 TELPRO All Models £9.51	
BUSH MURPHY A816 Chassis TV309 TV311 V2029 V2427 Price £10.30	INDESIT 20EGB 24EGB Price £7.85	PHILIPS 23TG170a all models to 23TG176a G24T230a... all models to G24T310 19TG170a... all models to 19TG179a G19T210a G19T211a G19T212a G19T314a G19T215a G20T230a Price £7.36	KB-ITT By Chassis: VC1 VC2 VC3 VC4 VC11 VC51 VC52 VC52/1 VC100 VC100/2 VC200 VC300 Price £8.48	SOBELL ST196 or DS ST197 ST290 ST297 1000DS... all models to 1102 Price £7.36	THORN GROUP Ferguson, H.M.V., Marconi, Ultra. By Chassis: 800, 850, 900, 950/3, 960, 970, 950/1, 950/2, 1400, 1500, 1500, 1580, 1590, 1591, 1612, 1600, 1712 Or quote model No. Price £8.48	PYE EKCO 691, 692, 693, 697 Chassis Wired in version of above Price on Application Printed Circuit Version of above £15.26
					EHT Winding PYE 691 to 697 Chassis* £3.07 Primary Winding PYE 691 to 697 Chassis* £4.60 *Please state Printed Circuit version or Wired version.	

Tidman Mail Order Ltd.,
236 Sandycombe Road,
Richmond, Surrey.

Approx. 1 mile from Kew Bridge.
Phone: 01-948 3702

Contact your nearest depot for service by-return. Callers welcome. Please phone before calling.

MON-FRI 9 am to 12.30 pm.
1.30 pm to 4.30 pm.
Closed Wednesday afternoon

Hamond Components (Midland) Ltd.,
416, Moseley Road,
Birmingham B12 9AX.

Phone: 021-440 6144.

MON-FRI 9 am to 1 pm.
2 pm to 5.30 pm.

Callers welcome. Please phone before calling.

ARE YOU

USING YOUR SPARE TIME PROFITABLY?

If not, you're losing money. Money that you could be making by selling used colour televisions from home in the evenings. In fact, provided you start correctly and know exactly how to operate, you can easily earn a substantial CASH INCOME with a starting capital of less than £20. Our new unique publication "How to Deal Successfully in Used Colour Televisions" enables you to follow in the footsteps of many experts who have a great deal of combined experience in this lucrative home business, and who have 'pooled' their knowledge to help you. After all, to follow the advice of someone who has travelled the ground before you, is to be given the best possible start. And the hundreds of valuable trade secrets, hints, tips and suggestions in the guide show exactly how anyone of average intelligence can succeed immediately.

Every aspect, from securing the first television right through to rapid expansion of sales, is covered with the detailed knowledge of experts to ensure certain success. Indexed information on almost all makes of television is presented in clear tabular form, describing performance, reliability, price and service. In particular, the tips on expanding the business are very practical, and are almost automatic when put into practice. Pages of unique advice on advertising ensure that maximum sales are secured, and sources of supply are described in detail - for both televisions and new/used spares. Monochrome sets are also covered, as are "invisible" cabinet repairs. Plus FREE on-going advice and FREE regular updating service.

You can start tomorrow - but you'll need our guide. The latest big illustrated edition is out now, and costs just £4.95 - a small price to pay for financial independence!

SAME DAY SERVICE

CITY PUBLISHING, HAYWORTH ROAD, SANDIACRE, NOTTINGHAM NG10 5LL

To: City Publishing, Hayworth Road, Sandiacre, Nottingham NG10 5LL.
Please send by return post "How to Deal Successfully in Used Colour Televisions".
I enclose cheque/p.o. for £4.95.

NAME.....
ADDRESS.....
.....

**BIG NEW EDITION
OUT NOW!**

EX-EQUIPMENT SPARES (NONE CHEAPER)

Valves - Colour and Mono

PCL82 £0.08	PCF802 £0.10	PCC86 £0.08	EY88/7 £0.08
PCL83 £0.20	PCF805 £0.20	PC97 £0.18	EY8/7 £0.08
PCL84 £0.08	PCF808 £0.08	PC900 £0.08	DY802 £0.08
PCL85 £0.08	PCF808 £0.08	EF80 £0.08	PY800/1 £0.08
PCL86 £0.08	PCF80 £0.08	EF85 £0.08	PL36 £0.20
PFL200 £0.08	PCC189 £0.08	EF183 £0.08	PL504 £0.20
PCF801 £0.08	PCC86 £0.08	EF184 £0.08	PL81 £0.08
30C1 £0.08	30C15 £0.08	88W7 £0.08	6/30L2 £0.08
30C17 £0.08	30C18 £0.20	ECC85 £0.08	U26 £0.08
PL83 £0.08	PL84 £0.08	EH90 £0.08	30PL1 £0.25
30PL13/4 £0.08	30P12 £0.08	30FL1/2 £0.20	ECC82 £0.08
ECC81 £0.08	ECH81 £0.08	ECL80 £0.08	ECL82 £0.08
PL509 £0.95	PY500 £0.95	GY501 £0.95	PL508 £0.45
PCH200 £0.45	PCF200 £0.45		

PLEASE NOTE - 25p Postage and Packing

SPEAKERS

£0.75 each

State oval or round with order.
Postage and Packing £0.25

COLOUR TUBES

(FULLY TESTED)

19" £17.00
19" A49/192 £18.00
20" £18.00
22" £20.00

Plus Postage/Packing
£8.00 per tube

MAIL ORDER COLOUR TELEVISIONS

(GOOD WORKING ORDER)

GEC 19" £55.00	22" £60.00	Postage/Packing Per set G.B. £8.00 Ireland £15.00
BUSH 19" £70.00	22" £75.00	

OTHER MAKES AND MODELS AVAILABLE - All prices inclusive of V.A.T.

Cash with order please to:-

Scarborough T.V. Trading Ltd.
Ridings House,
Depot Lane,
Seamer Road,
Scarborough,
North Yorkshire.
Tel. 0723 68087

OR
N.W. Electronics (Bfd) Ltd.
Bolingbrooke Buildings,
Bolingbrooke Street,
Bradford 5.
Tel. 0274 390121.

Manufacturers Surplus Components FIT THE RIGHT PART

300 mixed $\frac{1}{4}$ and $\frac{1}{2}$ watt resistors £1.50
 150 mixed 1 and 2 watt resistors £1.50
300 mixed Capacitors, improved pack, most types £3.75
 100 mixed **Electrolytics** £2.20
300 mixed Printed Circuit mounting **Components** for various TVs, resistors, caps etc. £1.50
300 printed circuit Resistors $\frac{1}{4}$ to 4 watt £1.00
 100 **High Wattage** TV resistors, **Wirewound** etc. £2.75
 100 mixed miniature Ceramic and Plate Caps £1.50
 100 mixed polystyrene capacitors £2.20
 25 mixed **Pots** and **Presets** £1.20
 25 mixed **TV Presets** £1.00
 20 assorted **TV VDRs** and **Thermistors** £1.20
 10 assorted **TV Convergence Pots** £1.00
 20 assorted **TV knobs**, includes push button, chrome, control types etc. Mostly Thorn and ITT £1.00
 10 **assorted Valve Bases**, B9A, ceramic, EHT, etc. £1.00
 20 assorted **Sync Diodes** blocks for various TVs £1.00
 25 assorted **Pulse Caps** high voltage £1.25
 10 **Spark Gaps** £1.00
 20 assorted **Zener Diodes** 1 watt and 400MW £1.50
 100 **Mixed Diodes**, includes zener, power, bridge, varicap, germanium, silicon etc. All full spec. £4.95

NEW

4-433 C.T.V. Crystals

Long Leads £1.00 each
 3 for £2.50

New Improved Transistor Packs

100 New and Marked Transistors including. BC148, BC154, BF274, BC212L, BF200 and lots of others only £4.95

200 Transistors as above and including 2N3055, AC128, BD131, BFY50, BC238, BC184L only £9.95

Why Buy Expensive Triplers!
 Repair your old 5 and 3 sticks at a **Fraction of the Cost.**
10 Replacement Rectifier Sticks (Thorn). £1.00

Special TV Bargain Parcels

Lots of useful parts including damaged panels, tuners, components etc. 10lb for £7.50
Hardware Pack Includes BA nuts and bolts, nylon, posidrive, self-tapping "P" clips, cable markers, clamps, fuse holders etc. £1 per lb.

THORN SURPLUS

8500 LOPT. windings £3 pair
3500 Series Scan Coils, new and boxed, complete with convergence yoke, purity assembly, static controls, leads and sockets £5.25
3500 Focus units with metrosil £1.50
3500 "625" line VHF Kit for wired systems £9.50
4 Knobs black with chrome caps to fit ITT, Thorn, GEC and most small diam. shafts **60p** per set
950 rotary transistor tuner with leads and slow motion drive £3.00
950 bottom panel complete with i.f. s switch etc. £3.00
950 line transformer (not Jellypot) £2.50
Convergence Pots with knobs. 5Ω, 10Ω, 20Ω, 30Ω. 8 of 1 type £1.00. 8 of each £3.50

SAVE THAT TUBE.

Fit our **C.R.T. Isolating Transformer**. Ideal for HTR./Cath. Shorts. 200-220-240 inputs. 750-900 MA outputs with thermal cutout. Made for **Thorn 4000 C.T.V.** but works O.K. on other sets. £2.00 each 3 for £5.00

MISCELLANEOUS

Philips G8 Tube Base Panels

Complete, but PCB's cracked, ok for spares. Focus, base, leads, plugs etc. 2 for £1

Bush CTV 25 Quadrupler Remo type Q25B. equiv. to ITT. TU25 3QK. with mounting brackets. £4.25 each. 3 for £10

GEC single standard, hybrid chassis. convergence panel. Brand new, complete with plugs and leads £2.50

Focus unit with lead, for above chassis £1.50

ITT Featherlight Super. Side Chassis, with controls. V. Cap Tuning Panel, Regulator, P/Button Switches, Bridge Rec. etc., etc. £4.95
 I.C. for above £1.00

SPECIAL OFFER

GEC transistor rotary tuners with slow drive, AE Skt. and leads **2010 Series** £1.50

KB VC3 VHF tuner with valves £1.50

KB VC3 transistor tuner "UHF" £1.50

ITT VC200 transistor tuner (Philips type) £1.50

ITT CVC5 power panel. New but five resistors never fitted £1.50

Pye 697 line and power panels, damaged or some bits missing but invaluable for spares £2.00

Pye mono mains droppers with fusible link.

147Ω + 260Ω 50p 3 for £1.00

69Ω + 161Ω 50p 3 for £1.00

Decca "Bradford" C.T.V. triplers 25KV £3.00 each 4 for £10

Portable TV EHT Sticks "Siemens TV 18 KV". Fit most portables 50p each 3 for £1.00

Pye 18" CT200 V. Cap P/B Assembly with leads and plug £1.50

EMO. On/off switch £1.00

G.E.C. S/S Hybrid Focus Assembly with lead £1.50

2 x Coax Sockets on plates suitable for various Continental T.V.s 50p

White Ceramic TV Resistors

20Ω 16W, 180Ω 11W, 13Ω 11W. 10 of any one type £1.20
 10 of each type £3.00
2-2k fusible, vertical mounting **Screen Feed** resistors 9 watt 8 for £1.00

0-47Ω $\frac{1}{2}$ watt emitter resistors 40 for £1.00

10Ω/F 400V modern Small Type 8 for £1.00

4.7Ω/F 63V 20 for £1.00

100Ω/F 16V 10 for £1.00

Bias Caps **330Ω/F 25V** 10 for £1.00

470Ω/F 25V 10 for £1.00

4,500Ω/F 35V cans 80p each

Avoid Lethal Shocks

Buy our specially designed

EHT Probe, removes high voltage charges from tubes, caps, etc. Heavily insulated with lead and earth connector **60p** each

B9A P.C. valve bases 20 for £1.00

EY87/DY87 EHT bases 10 for £1.00

PL509/PY500 ceramic bases 10 for £1.00

C.T.V. Tube bases 5 for £1.00

20mm Antisurge Fuses.

800MA, 1A, 1-25A, 1-6A. 12 for £1.00

2A, 2.5A, 3 15A 100 for £7.00

TH1 thermistors 6 for £1.00

TH3 thermistors 10 for £1.50

Aluminium **Coax Plugs** 8 for £1.00

Metal Coax Couplers 8 for £1.00

200V 1A Diodes 10D2 (equivalent to 1N4003) 20 for £1.00

Miniature "Terry" clips ideal for screwdrivers and small tools etc. 40 for £1.00

Low profile 14 pin quill **I.C. Sockets** (to fit most "Q" series I.C.) 12 for £1.00

Cassette Motors self regulating, 9V, make unknown type 9FM 90p

Rediffusion/Doric Mk 13 5 stick triplers can be modified for other sets £1.00

Portable T.V. Batt. Leads with Croc Clips and flat 2 pin socket Fits BRC sets £1.50

Miniature Level/Batt. Meters as fitted to many cassette recorders 90p

ZENERS

400MW. 4-3V, 4-7, 6-8, 7-5, 30V 10 of one type 80p
 10 of each type £3.00
1-3W. 12V, 13V, 18V, 10 of one type £1.00
 10 of each type £2.50
DIACS BR100 6 for £1.00

STABILIZERS

TAA550 4 for £1.00

GEN. PURPOSE DIODES

IN4000 30 for £1.00 **IN4003/10D2** 20 for £1.00
IN4002 25 for £1.00 **IN4148** 20 for £1.00

ULTRASONIC TRANSDUCERS

Transmitter and receiver. 40 kHz 14 mm diam. £4.25 pair

LOUDSPEAKERS

2 $\frac{1}{4}$ " Round 8Ω 70p
2 $\frac{1}{4}$ " Round 20Ω 90p
2 $\frac{1}{2}$ " Round 8Ω 80p
6" x 4" Elliptical 8Ω £1.25
4 $\frac{1}{4}$ " x 2 $\frac{3}{4}$ " Elliptical 8Ω for R.B.M. Mono T.V. £1.30

PROTECT YOUR PROPERTY

Buy a "SENTINEL" **Smoke and Gas Detector**. Uses TGS105 plug in sensor, housed in 3 $\frac{1}{2}$ " diameter diecast box. 24V. Convertible to 12V. Will activate lamp or relay.

With Data and Circuit **£16.95**

Suitable 24V Relay **£1.00**

De Luxe Fibre Glass Printed Circuit Etching kits

Includes 150 sq. ins. copper clad F/G. board. 1 lb ferric chloride 1 dalo etch resist pen. Abrasive cleaner. Etch tray plus instructions.

Special Price £4.95.

1 lb F.E. C1 To mil. spec. £1.25

5 lb F.E. C1. To mil. spec. £5.00

150 sq. in. **Single sided** board £2.00

150 sq. in. **Double sided** board £3.00

500 Watt

Dimmer Switch

Toroidal mains suppression, fused with satin aluminium knob, white.

ONLY

£3.45.

Send **40p P. & P.** on all above items; send Cheque or P.O. with order to:-

SENTINEL SUPPLY DEPT. TV

149a Brookmill Rd., Deptford, London SE8

(Mail Order address only. Callers by appointment)
 Trade enquiries for quantity welcome.

Surplus stocks purchased for cash.

NOW AT LAST . . .

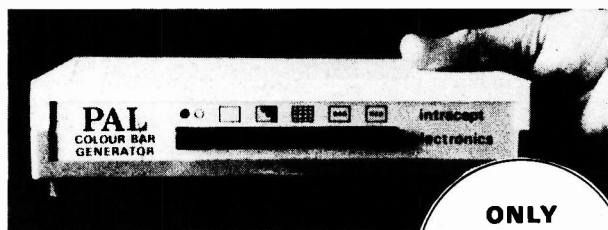

A TRULY PORTABLE COLOUR BAR GENERATOR KIT!

ONLY
£49.50
+ 15% VAT

- * Yes, truly portable – runs (for up to 10 hours) on its own built-in rechargeable battery OR direct from mains via Power Unit supplied.
- * Small enough to be carried in a Tool Case, it measures only 205mm x 143mm x 40mm, and weighs a mere 500g.
- * Push button selection provides:
 - (i) Peak White Raster.
 - (ii) Linearised Grey Scale.
 - (iii) Crosshatch.
 - (iv) Standard 75% Saturated 100% Amplitude Colour Bars.
 - (v) Red Raster.
- * Modulated UHF Output fixed at Channel 45 (Approx). Just send £58.50 (incl. VAT & P.P.) for a complete kit including a **professionally finished Case**, Ready Built Power Unit/Charger, Ni-Cad Battery Drilled & Tinned P.C.B., Crystal, 11 I.C's & Holders, Push-Button Switch Assy., Resistors, Capacitors, Transistors, Diodes, Sockets, Wire, Nuts & Bolts.

to: **INTRACEPT ELECTRONICS LTD.**,
203 Picton Road, Liverpool L15 4LG.
Tel. 051-733 3042.

ORDERS ARE SUBJECT TO AVAILABILITY AND WILL BE HANDLED IN STRICT ROTATION.

APOLLO

THE REBUILT COLOUR
TUBE SPECIALIST

£3.50 DELIVERY TO ALL GREAT BRITAIN. NO NEED TO SEND OLD GLASS. WE WILL COLLECT IT FREE ON DELIVERY.

17 to 20" **£28**
22" **£30**
26" **£34**

ALL TUBES 12 MONTH GUARANTEE

Cheque with order +£10 refundable on collection of old tubes.

Callers welcome. Please phone first.

061-799-0854 24 hour answering service.

Reg. Office:

Apollo Elektroniks,
43, Clarke Cres, Little Hulton,
Worsley, Nr., Manchester
M28 6XM

COLOUR TUBES

STANDARD TUBES

METAL BAND TUBES

Rebuilt with new Electron Guns to British Standard 415/1972. Clause 18.2.

SUFFOLK TUBES LIMITED

214, PURLEY WAY
CROYDON, SURREY
01-686 7951

Britain's Largest Independent
TV Tube Rebuilder

VIEW WELL WITH WELLVIEW TV TUBE REBUILDS

Exchange Mono

	our price	+VAT	15%	total price
CME 1601-1602	£9.30	£1.39		£10.69
A44/120WR	£9.30	£1.39		£10.69
A50/120WR	£9.30	£1.39		£10.69
AW59/23W	£11.00	£1.65		£12.65
A61/120WR	£11.00	£1.65		£12.65

Exchange Colour

	our price	+VAT	15%	total price
A44/270X-271X	£27.00	£4.05		£31.05
A47/342X-343X	£27.00	£4.05		£31.05
A49/120X	£27.00	£4.05		£31.05
A51/110X	£27.00	£4.05		£31.05
A55/14X	£32.00	£4.80		£36.80
A56/120X	£32.00	£4.80		£36.80
A63/120X	£36.00	£5.40		£41.40
A66/120X	£36.00	£5.40		£41.40
A67/120X	£36.00	£5.40		£41.40
A67/200X	£36.00	£5.40		£41.40

18 month full guarantee (Established ten years).

Send cash or cheque together with old tube with your order.

Carriage=£4.50 including VAT

ALSO YOUR VALVE SUPPLIER
NEW AND BOXED
(inclusive of VAT)

DY802=74p	ECC82=64p	EF183=78p
EF184=64p	PCC89=72p	PCF802=98p
PCL82=78p	PCL84=92p	PCL805=97p
PFL200=£1.15	PCL86=97p	PL504=£1.38
PL509=£2.82	PL519=£2.92	PY88=70p
PY800=70p		PY500A=£1.52

Postage and Packing 10p per valve. All orders over £10 Free of charge.

WELLVIEW TUBES LTD.

Unit 7, KING ROAD,
CHARFLEET INDUSTRIAL ESTATE,
CANVEY ISLAND,
ESSEX
TELEPHONE CANVEY ISLAND 65372

STANDERD T.V. TUBE

HIGH QUALITY COLOUR AND MONO-CHROME REPLACEMENT TUBES AT COMPETITIVE PRICES.

- ★ Complete New Gun fitted to every Tube.
- ★ Two year Guarantee
- ★ Every Tube Electrically Tested.
- ★ Every Tube Picture Tested.
- ★ Supplier to Major Rental Companies.

19", 20" **£22**
22" **£25**
25", 26" **£28**

11-29, Fashion Street,
London E1

Ring Standerd T.V. Tube Reguner
Tel. 01-247 3097

Build your child an exciting world of knowledge



World of Knowledge magazine is the most exciting new development in learning aids for children. All mankind's achievements — past and present — will be presented week-by-week in 10 stimulating and absorbing streams of learning using the most up-to-date graphic and illustrative techniques available.

With the authoritative backing of a team of distinguished academic advisors, headed by Lord Asa Briggs, Chancellor of the Open University, World of Knowledge is structured to provide a complete understanding of the world about us and is a unique opportunity for your children to discover the adventure of finding out.

NEW

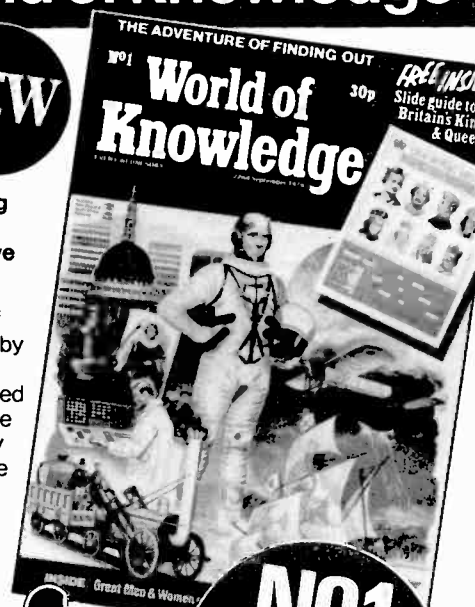

FREE IN No. 1 ISSUE

'Our Royal Heritage Slide Rule'

At-a-glance facts on all English monarchs from 1066, together with our present Royal Family-Tree.



So build your child's

World of Knowledge

No 1
ON SALE
SEPT 19
30p

Electronic components in small quantities are our speciality



Our name is probably a new one to you, but we've been supplying technicians, workshops and hobbyists for a long time now. The personal service we give seems to have been appreciated, so we are now offering a component service nationally. We don't give world shattering discounts, but our prices are very competitive; and our stock goes right through the range down to the most mundane plug or socket, which many suppliers don't even bother with. And if you only want one item — we'll sell you only one. At GEAR you're known by your name and not a number, and any problems you have — just write or 'phone and our engineers are there to help. That's what personal service is all about. SEND SAE OR PHONE FOR FREE COMPONENT/PRICE LIST. PRICES INCLUDE VAT & POST & PACKING — NO EXTRAS TO PAY. All components are manufacturers full spec. devices. (min. order by post £1.)

The Moor, Falmouth, Cornwall. Tel. 0326 312321.

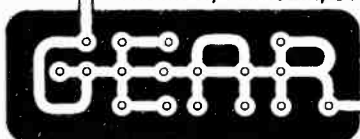

T.V. & AUDIO SERVICE CENTRE

TELEVISION ELECTRONIC DISTRIBUTION (SPARES) LTD.

412a Hanworth Road, Hounslow, Middlesex
Telephone: 01-572 4668

PANEL REPAIR/EXCHANGE SERVICE TRADE ONLY

BERRYVISION 510

EMO

THORN 2000 Series, 3000/3500 Series, 8000/8500/8800/9000 Series.

GEC Solid State 2110 Series.

PHILIPS G8 G9

RBM A802/823 AV (Ultrasonic)

DECCA Solid State 80 Series/Hybrid 30 Series.

GRUNDIG 5010/6010 GB

PYE 691, 697, 713, 723, 731

SONY 1800UB

TRADE REPAIRS ON ALL SONY COLOUR T.V.'s VERY COMPETITIVE PRICES.

3 MONTHS WARRANTY ON PANELS FROM DATE OF OUR INVOICE.

DISCOUNT FOR BULK PANEL ORDERS. CATALOGUE AVAILABLE ON REQUEST.

TV'S TV'S TV'S

THOUSANDS OF MONO TV'S IN STOCK

All makes - all sizes from £1.15. Square screens from £6.90. Clearance of 25" D/STD CTV'S (Philips 500 and GEC 2028 only). Checked complete £16.10 each, add £8 p/pkg. Earlier model S/STD (Philips 511, GEC 2040, Pye Hybrid etc) Singles tested tube & checked complete £39.10.

Quantities from £27.60 each
Singles working £48.30 each
Add £6 p/pkg

More recent S/STD CTV'S always in stock (Pye Varicaps, Bush Integrated, Thorn 3500/8000, Decca Bradford, GEC 2100, Korting, Grundig, Luxor, Japanese etc). Sold with tube tested from £46, working from £64.40.

Ring for quotations

EX-TV SPARES

RANK BUSH MURPHY 184 SERIES ETC

Decoder (Single IC) or Line Board	£13.80
I.F. Panel or Power Panel	£9.20
Convergence Panel	£6.90
Tuners	£6.90
Complete EHT Stack	£20.70

GEC HYBRID 2040/1 SERIES AND PYE HYBRID CHASSIS

Decoder or DCA (Inc. Valves)	£13.80
I.F. Panel or Convergence Panel	£9.20
Line Panel	£16.10
Tuners	£6.90

PHILIPS 511

I.F. Panel	£9.20
Tuners	£6.90
Lopt	£9.20

Any above add £1.60 postage & packing
RING FOR QUOTATIONS ON OTHER SPARES

COLOUR TUBES

(fully tested)	
25"	£18.40
19"	£20.70
22"	£25.30
26"	£29.90
Plus £4.00 p/pkg.	

MONO PANELS/TUNERS

Most types	£3.45
£1 p/pkg.	

VEGA MONOCHROME TUBES

(Brand new USSR Manufacture in Maker's Box with 12 months Guarantee)
20" Size £15.53
24" Size £17.83
Add £2.50 p/pkg.
Discounts for orders over five.

MULLARD COLOUREX/MAZDA NEW LIFE TUBE REBUILDS

(Callers only)
One year guarantee.
Any size only £30.65 plus old glass.

SPECIAL OFFER

20"/24" Single/STD PYE/EKCO/PHILIPS TYPE 230 (Plastic back) Re-furnished with good cabinet and brand new USSR tube (12 month guarantee).
20" Model £32.20
24" Model £34.50
Add £4.00 p/pkg.

ALL PRICES ARE INCLUSIVE OF VAT.

TRITEL GROUP

NORTHERN

Thornbury
Roundabout
Leeds Road
Bradford 3.
Tel: (0274) 665670

SCOTLAND

Peacock Cross
Industrial Estate,
Burnbank Road
Hamilton.
Tel: (0698) 282141

LONDON

Kingsley House
Off Avonmore Rd.
(Opp Olympia)
Hammersmith Rd.
LONDON W14.
Tel: (01) 602 2982

LONDON

395/397 Albany Road
Off Waltham Road
LONDON SE5
Tel: (01) 703 4040

WEST

Unit 4a
Bulwark Industrial
Estate, Chepstow,
Nr. Bristol.
Tel: Chepstow
(02912) 6652

MIDLAND

48/52 Pershore
Street,
Birmingham 5.
Tel: (021) 622 1023

SOUTHERN

Watling Street
Hockcliffe, North
Dunstable (on A5)
Tel:
Leighton Buzzard
(0525) 210768

MAIL ORDER SEND CWO (CHEQUES OR UNCROSSED PO'S) TO ANY BRANCH

T.V. REPLACEMENT CAPACITORS PLASTIC FILM CAPACITORS

250v AC Mains filter type. To meet the requirements of BS 2135 (Class X suppression applications) Life tested at 375v AC at 85 deg. C.

0.047mfd	35p	0.1mfd	40p
0.33mfd	55p	1.0mfd (three wire type)	60p

1000v. DC. General purpose type. Metallised polypropylene, encapsulated. Axial leads.

0.047mfd	27p	0.1mfd	34p
0.22mfd	46p	0.47mfd	62p

2kV Peak Flyback capacitors. Encapsulated, with axial leads.

1500pF	40p	4700pF	40p
5200pF	40p	8200pF	50p

ELECTROLYTIC CAPACITORS

Solder Tag and P.C. Type

600mfd 250v.	G8	150p
600mfd 300v.	G8	182p
600mfd 300v.	GEC	175p
600mfd 300v.	A823	162p
600mfd 300v.	Z179	160p
600mfd 300v.	G9	160p
400mfd 350v.	8000	154p
470mfd 250v.	G11	132p
800mfd 250v.	G9	167p
200 - 300mfd 350v.	691	205p
300 - 300mfd 300v.	A640	190p
400 - 400mfd 350v.	Decca	260p
150 - 150 - 100mfd 300v.	1500	160p
175 - 100 - 100mfd 400/350v.	3500	204p
200 - 400 - 50mfd 325v.	A816	230p
200 - 200 - 150 - 50mfd 300v.	GEC	200p
300 - 300 - 100 - 32 + 32mfd 300v.	Z146	243p
300 - 300 - 300 - 150 - 100 - 50mfd 325v.	GEC	300p
1000mfd 63v.	3500	62p
2200mfd 63v.	G9	95p
1250mfd 50v.	189	60p
4700mfd 25v.	1590	73p
1000 - 1000mfd 40v.	Pye	82p
1000 - 2000mfd 35v.	GEC	97p
2500 - 2500mfd 30v. (PC)	A823	107p

The above prices are for single items. Quantity discounts allowed.
CASH WITH ORDER PLEASE!

All the above prices include postage and VAT at 15%.

P.E. WHITE

22 York Road, Camberley,
Surrey. GU 15 4HR.

We're giving away

Trade secrets

West Midlands T.V.
Trade Sales Ltd.
021-444-6464

92 HIGH STREET
KINGS HEATH
BIRMINGHAM B14 7JZ

★ NOW OPEN ★
New Warehouse at
37-39, Jamaica St.
Bristol.
0272-48266

FOR EX-RENTAL COLOUR
AND MONO TELEVISION

Why not call in and see us... A relaxed friendly atmosphere, together with a choice of hundreds of sets at low, low prices. Colour from £15. Mono from £2. Also stands, spares, etc. Send an S.A.E. or phone, for our current price lists and area map showing how to find us. Export enquiries welcome.

QUALITY USED TV'S AT GIVE AWAY PRICES

S.S. MONO FROM £12

D.S. MONO FROM £5

S.S. COLOUR FROM £40

PRICES PLUS V.A.T.

ALL WORKERS, FRESH STOCKS WEEKLY,
QUANTITY DISCOUNTS, DELIVERY ARRANGED.
TRY US YOU WILL NOT BE DISAPPOINTED.

TELETRADERS

We have moved to our new Warehouse where we have much bigger stocks.

St. Leonard's Warehouse, St. Leonard's Road,
Newton Abbott, Devon.
Telephone (0626) 60154

PHILIP H. BEARMAN

(VALVE SPECIALISTS)

SUPPLIERS TO H.M. GOVT. Etc.

Closed 12.30-2pm. and Thurs/Sat pm

NEW valves by Mullard, Mazda, etc, we cannot supply these makes with warranty. (See our lists for explanation). Kindly verify current prices.

"QUALITY" BRANDED VALVES ONLY CARRY THE 90 DAY GUARANTEE. SEE OUR LISTS.

IMMEDIATE POSTAL DESPATCH

DY51	80p
DY86/7	78p
DY802	84p
ECC81	78p
ECC82/3	78p
ECC80	73p
EF80/85	70p
EF183	84p
EF184	84p
EH90	60p
EY51	90p
EY86/7	50p

LISTS S.A.E.

PCF802	£1.05	PL36	£1.30	U25	60p	30P12	60p
PCF805	£1.90	PL83/4	60p	U26	60p	30P11	P.O.A.
PCF806	75p	PL500/4	£1.63	6F23	60p	30P13	£1.00
PCH200	£1.30	PL508	£1.75	6F28	£1.05	30P14	£1.30
PCL82	£1.05	PL509	£3.20	20P4	60p	30P15	£1.20
PCL83	P.O.A.	PL519	£3.45	30P4/19	£1.30	Also 3AT2,	
PCL84	£1.05	PL802	£3.10	30C15/17	75p	17DW4A, 21LUB,	
PCL85	£1.20	PY800	95p	30FL1	£1.26	31JS6A, 40KD6	
PCL805	£1.20	PY801	95p	30FL2	£1.26	BY 100/127 etc.	
PD500	£3.90	PY500	£1.85	30L15	75p	all 22p each	
PFL200	£1.75	PY500A	£1.85	30L17	75p	with 10W	

Our suppliers vary prices, our prices correct at time of going to press ONLY. MINIMUM ORDER £1.00

SEND SAE FOR COLOUR

TRIPLER LIST (BRC) ALSO LATEST COMPONENTS LIST.

(Near Sub Post Office)

6 POTTERS RD., NEW BARNET

Production 30P11 & PCL83 discontinued

STOP PRESS PC92/96, PCL200, PL95, PL519. Also some Teleton types & EY500A, EL509, EL519.

Herts. Tel: 01/449-1934/5 (Tel. recording service 449/1934 only) U.K. Post 15p per valve under £25.00 (max. 80p) but 2p extra larger valves/ADDITIONAL VALVES (7p).

Any excess paid will be refunded.

TELEVISION TUBE SHOP

NEW TUBES AT CUT PRICES

EUROPEAN TYPE Nos.

	Price £	VAT £
A28-14W	18.95	2.37
A31-19W/20W	19.95	2.49
A31-120W/300W	17.95	2.24
A31-410W/510W	17.95	2.24
A34-100W	18.50	2.31
A38-160W	17.50	2.19
A44-120W	18.75	2.34
A50-120W	17.95	2.24
A59-23W	18.95	2.37
A61-120W	18.95	2.37

U.S.A./JAP. TYPE Nos.

9AGP4	19.50	2.44
190AB4/C4	17.50	2.19
230ADB4	28.50	3.56
230DB4/CT468	24.00	3.00
240AB4A	17.95	2.24
CT507	17.95	2.24
CT512	27.50	3.44
310DGB4/DMB4	23.00	2.88
310EUB4	19.95	2.49
310EYB4	18.75	2.34
310FDB4	19.95	2.49
310FXB4	17.50	2.19
310GNB4A	23.50	2.94
310HCB4	23.50	2.94
340AB4	19.50	2.44
340AYB4	25.25	3.15
340Rb4/CB4	24.50	3.06
340AHB4	24.50	3.06

Some Rebuilt Japanese & European Types Available at £14.00 + VAT £1.75

COLOUR TUBES

12VARP22	62.50	7.81
330AB22	65.00	8.12
470FUB22B	85.00	10.62
A44-271X	65.00	8.12
A47-342X	69.50	8.89
A47-343X	69.50	8.89
A49-191X	59.50	7.44
A51-220X	64.00	8.00
A56-120X	69.50	8.89
A63-120X	69.50	8.89
A66-120X	75.00	9.37
A66-140X/410X	70.50	8.81
A67-120X	82.00	10.25
A67-140X/200X	69.50	8.89
A67-150X	75.00	9.37

ALL TUBES TESTED BEFORE DESPATCH & GUARANTEED FOR 12 MONTHS! 4 YEAR GUARANTEES AVAILABLE ON MOST TYPES CARRIAGE Mono £3.00 Colour £4.00 Mainland only. Overseas Rates on Application.

TELEVISION TUBE SHOP LTD. 52 BATTERSEA BRIDGE RD., LONDON, SW11. Tel. 228 6859/223 5088

SOUTHERN VALVE COMPANY

Second Floor, 8 Potters Road, New Barnet, Herts.

Telephone 01-440/8641 Noon to 2 pm excepted

ALL NEW & BOXED, "QUALITY" BRANDED VALVES GUARANTEED 3 MONTHS. BVA ETC. ARE OFTEN AVAILABLE WITHOUT ANY GUARANTEE. (SEE OUR LISTS). QUOTES ON REQUEST.

PROBABLY THE BEST VALUE ANYWHERE

DY86 7	60p	EF86	60p	PCR6	90p	PCF802	90p	PL36	£1.30	PY500A	£1.90
DY802	62p	EF89	80p	PCR8	90p	PCF805	£1.90	PL81/81A	75p	UBF89	60p
ECC81	60p	EF183	60p	PCR9	75p	PCF808	£1.90	PLR2	40p	UCC85	65p
ECC82	60p	EF184	60p	PC900	70p	PCL82	70p	PLR3	40p	UCH81	70p
ECC83	60p	EH90	50p	PCC84	36p	PCL83	P.O.A.	PLR4	53p	UCL82	85p
ECC85	65p	FL41	£1.10	PCC85	55p	PCL84	90p	PL500	£1.30	UCL83	£1.15
ECH81	62p	EL509	£3.25	PCC89	55p	PCL85	90p	PL504	£1.30	UF89	75p
ECH84	92p	EM84/87	£1.00	PCC189	60p	PCL805	90p	PL508	£1.90	UL41	£1.10
ECL80	55p	EY86/7	50p	PCF80	90p	PCL86	90p	PL509	£3.25	UL84	£1.00
ECL82	80p	EY500A	£1.75	PCF86	65p	PCL200	£1.53	PL802	£3.10	UY41	75p
ECL86	80p	EZ80	£1.75	PCF86	65p	PD500	£3.90	PY88	95p	UY25/26	60p
EF80	43p	EZ81	50p	PCF200	£1.70	PD10	£4.45	PY800	75p	Also 3AT2, 40KD6,	
EF85	48p	GY501	50p	PCF801	65p	PFL200	£1.70	PY801	75p	17DW4A etc. etc.	

NOTE: We regret some increases, at time of going to press. Some leading makes available. L.A.T. invoices issued on request.

Minimum order £1.00

One valve post 15p, each extra valve 6p. MAX 90p LISTS & ENQUIRIES. S.A.E. PLEASE! (OR INTERNATIONAL REPLY COUPON) Large valves 2p extra. VAT INCLUDED NO AGENTS NEW UHF "MICRO" AERIAL! Only 3" x 1/4". DIAM. EZ40 & 41 75p each! IN PRICES CALLERS BAND. PRICE £3.70 INCL. POST & VAT. (625 UHF).

EMO - EUROSONIC - GRUNDIG - TELETON + ALL BRITISH MAKES ETC., ETC. ● ALL SPARES READILY AVAILABLE ● REBUILT TUBES CREDIT AVAILABLE - TRADE ONLY

Almost any TV Component supplied by return "off the shelf" e.g. LOPTX - EHT trays - droppers - OSC coils - switches - cans - smoothers - I.C.'s, etc., etc. NEW - COMBI LOPTX NOW AVAILABLE.

YOU CAN BE 95% SURE WE CAN SUPPLY ANY TV COMPONENT BY RETURN IF YOU NEED SPARES FAST - RING NOW!

ACCESS AND BARCLAYCARD ACCEPTED.

S.A.E. FOR FREE SERVICE CATALOGUE.

TELE-PORT (WTON) THE TELECENTRE, WORCESTER ST., WOLVERHAMPTON (0902) 773121

PHILIP H. BEARMAN

NEW MONO TUBES. Usually 2 Year Guarantee. Tested prior sale.

A31/410W Mullard	£18.90
A31/120 - CME1220	(A31/300)* £20.50
A34/100 - CME1420	£20.50*
A38/160 - CME1520	£20.00*
A31/510 & A34/510	£18.90 & £20.50

A50/120WR - CME2013 £18.90*

A61/120WR - CME2413 £22.10*

Note* less £1 for 1 year guarantee.

A31/510W & A34/510W. AS ABOVE.

COLOUR TUBES. Prices on application. SAE all enquiries please!

Price correct at time of going to press BUT SUBJECT TO ALTERATION WITHOUT NOTICE Telephone enquiries welcome. 19", 20" £63; 22" £73 £10 allowance old CRT.

6 POTTERS ROAD, NEW BARNET, HERTS. Tel: 01-449-1934/5. (Answering machine 1934 only) PHONE FOR SHOP HOURS.

PRICES INCLUDE 15% VAT. (Callers welcome) MAKES INCLUDE TOSHIBA, HITACHI, VEGA, MAZDA, BRIMAR & MULLARD. CARRIAGE £2.50 (Mainland); £3.50 colour; £1.75 for EXTRA Short Sea Journey. Eire Extra. POA.

NEW STOCKS ARRIVING REGULARLY. BRAND NEW! Also A59, 15W, £11.55. MULLARD A47-26WR £18.50! MULLARD. TUNGSRAM available SHORTLY.

All Mullard 2 year (NOT 1 year) GUARANTEE. (UNREPEATABLE AT THESE PRICES!) NOTE - JUST ARRIVED - NEW MAZDA A47-13W £15.75 (limited stocks)

NOT 19/25" (Subject to acceptability)

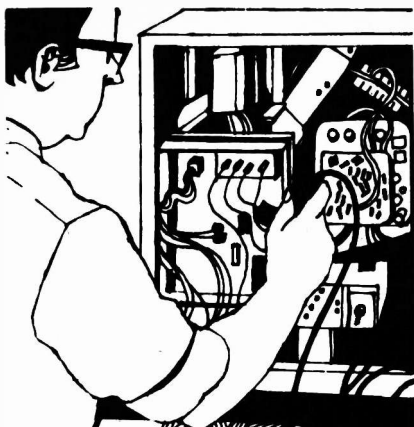

SETS & COMPONENTS

TELEVISION AERIALS

The full range of quality BASIC aerials, amplifiers, lashing kits, cables, mast, rotators and accessories can be supplied at extremely competitive prices, normally from stock. Representative examples are shown. For quotations on specific items, or general and technical application queries, please write sending S.A.E. with all enquiries. Full price lists on request.

TELENG Upconverter (4dB gain) £27-52
LARGEAN Upconverter (4dB gain) £31-90
WIDE BAND 1-3 element Aerial £19-00, 5 element £27-89
ANTIFERRE Wideband 1/111 Aerial type MH311 £38-18
TELENG 27dB 2 stage High Gain VHF Wideband Amplifier 40-300MHz £18-33
STPU2 Matching Power Supply for above Amplifier £11-33

All prices include VAT post and packing. We are happy to advise on specific installations and associated problems. A mains powered version of the single channel amplifier (JULY Television) is now available to order at £18-00 inclusive of VAT post and packing. Send S.A.E. for details. **BASC:** Aerialite, Antiferre, Jaybeam, Maxview, Walsey, Premier Industries.

SOUTH WEST AERIAL SYSTEMS

10 Old Boundary Road, Shaftesbury, Dorset.
Tel. (0747) 4370

T.V. SPARES, PANELS AND MANUALS PHILIPS · GRUNDIG

TELEVIEW 01-994 5537
194, Acton Lane, London W.4.

TELEVISIONS to the Trade. Large quantities of Mono from £2.00; Square Screen from £6.00. Colour T.V.s Working from £65. R.B.M. GEC, Pye, Thorn etc. Phone Scarborough 0723-68087-65451. Scarborough T.V. Trading, Ridings House, Depot Lane, Seamer Road, (A64) Scarborough.

VALVE BARGAINS

ANY 1-20p, 5-80p, 10-£1.25, 50-£5.50

ECC82, ECH84, EH90, PFL200, EF80, EF183, EF184, PCF80, PCF802, PCL82, PCL84, PCL85/805, PY81, PY800, PY88, PL36, PL504, 6F28, 30PL14.

COLOUR VALVES 50p EACH

PY500/A, PL508, PL509, PL519

Postage & Packing 30p, no VAT

VELCO ELECTRONICS

9 Mandeville Terrace, Hawkeshaw, Via Bury, Lancs.

WE HAVE a large quantity of 6MHz sound channel filters from converted U.K. sets and would like to exchange for 5-5MHz ones on a one for one basis. Contact or send to: **TELESERVICE**, 842 Canning Highway, Applecross 6153, West Australia.

COLOUR PANEL EXCHANGE SERVICE

BRC 3000 - 3500 8000 - 8500
Philips G8 and GEC 2110 series.

Free delivery in London area on Exchange Panels. Large stock of BRC 3500 series spares. New and S/H BRC Panels for sale. Immediate exchange on repairable panels.

Catalogue available on request.

KAY JAY TV SERVICE

34, Clouston Avenue, Northolt. Phone 884 0350.

SMALL ADS

The prepaid rate for classified advertisements is 21p per word (minimum 12 words), box number 60p extra. Semi-display setting £4.00 per single column centimetre (minimum 2.5 cms). All cheques, postal orders etc., to be made payable to Television, and crossed "Lloyds Bank Ltd". Treasury notes should always be sent registered post. Advertisements, together with remittance, should be sent to the Classified Advertisement Manager, Television, Room 2337, IPC Magazines Limited, King's Reach Tower, Stamford St., London, SE1 9LS. (Telephone 01-261 5846).

TURN YOUR SURPLUS capacitors, transistors, etc., into cash. Contact Coles-Harding & Co., 103 South Brink, Wisbech, Cambs. 0945 4188. Immediate settlement.

P. V. TUBES

12 months guarantee

Colour tubes supplied on a 'glass for glass' basis. Callers ring to arrange to bring your glass for on the spot exchange from our stocks. Lancashire/W. Yorks. deliveries by arrangement. Carriage extra per tube: Portables £1.80; Mono £3.80; Colour £4.80; incl. VAT

REBUILT MONO		REBUILT COLOUR		NEW MONO	
A28-14W 11" (Pencil) £14	17" 18" 19" 20" £28	22" £30		A31/510 12" £17	
A31-410W 12" £14	25" 28" £34	28" 110" £38		Replaces A31/120 Mullard 2 year warranty	
A31-120W 12" (Pencil) £14				A31/410	
A31-18W 12" £14				A31/510 14" £18.50	
A34-100W 14" (Pencil) £14				Replaces A34/100	
A38-180W 15" (Pencil) £14				A50/120WR 20" £12	
A44-120WR 17" £14				A61/120WR 24" £13.50	
A59-23W 23" £14					
A60-120WR 20" £11					
A81-120WR 24" £11					

Glass is required for portable rebuilt mono please.
All tube prices subject to 15% VAT

NEW MULLARD COLOUREX TUBES

ALL SIZES IN STOCK

SEND S.A.E. FOR PRICE LIST

NEW VALVES

Type	Price	Type	Price	Type	Price
30FL1/2	£1.28	EF184	83p	PCL38	82p
OY802	89p	EH90	77p	PCC85	82p
OY867	90p	EL34	£1.84	PCC89	87p
ECC81	53p	EL84	52p	PCC189	87p
ECC82/3	63p	EL84	52p	PCF80	83p
ECC85	51p	EL509	£2.55	PCF86	87p
ECC88	74p	EY88/87	52p	PCF200	£1.63
ECC80	87p	EY500A	£1.53	PCF801	81p
ECC82	87p	EZ80	51p	PCF802	83p
ECH81	56p	EZ81	51p	PCF805	£1.68
ECH84	£1.02	GY501	£1.43	PCF806	71p
ECL80	82p	GZ34	£1.78	PCF808	£1.74
ECL82	82p	KT68	£3.58	PCH200	£1.23
ECL86	77p	PC86	77p	PCL82	75p
ECC86	83p	PC88	77p	PCL84	83p
EF80	41p	PC92	85p	PCL85/85	87p
EF85	41p	PC97	77p	PCL88	87p
EF88	82p	PC900	77p	PCL88	87p
EF183	65p	PCC84	31p	P5000	£3.37
				PFL200	£1.28
				U191	48p
				UL84	£1.02
				UL84	£1.02
				U26	48p
				U191	48p

ALL VALVES ARE UNUSED - BOXED - AND GUARANTEED

Post & Packing charges 14p for 1 valve - 7p for each

Additional valve - 2p extra for large valves - max. 80p.

Post free orders over £20 - any parcel insured extra 10p.

P. V. TUBES

38A Water Street, Accrington, Lancashire. BB5 6PX

VAT No. 291-1937-45.

COLOUR TUBES

Rebuilt with new electron gun, to British Standard. High temperature pumping.

Here is what you pay.

17-18-19 inch.....	£29.00
20 inch.....	£30.00
22 inch.....	£32.00
25 inch.....	£34.00
26 inch.....	£38.00

Guarantee 2 years.

Exchange basis.

Prices negotiable for contracts.

Old Colour tubes purchased.

Carriage £5.00.

TELESTAR TUBES

575c Moseley Road, Birmingham B12 9BS.

Tel: 021-440 5712.

Publishers Announcement

Due to increases which may have taken effect since this issue went to press, we strongly advise readers to check with advertisers the prices shown, and availability of goods, before purchasing.

COLOUR TV's

Many working for disposal, trade only. All sizes and makes available.

Mono sets also available.

Ingartone (London)

24 Dames Road, Forest Gate, London E7. Tel: 01-555 5569

Ingartone (Bristol)

28 St. Thomas St., Bristol 1.

Tel: 0272 211179

VALVE LIST

ALL VALVES FULLY TESTED

Five valves or over postage paid

Under five valves postage 6p each

DY86/87	15p	PC900	8p	PCL85/805	28p
EB91	12p	PCC84	8p	PL36	28p
ECC82	10p	PCC85	28p	PL504	25p
ECL80	8p	PCC89	8p	PY32/33	15p
EF80	8p	PCC189	8p	PY81/800	15p
EF85	8p	PCC805	15p	PY801	28p
EF183	10p	PCF80	8p	U191	15p
EF184	10p	PCF86	15p	6F23	15p
EH90	13p	PCF805	28p	6/30L2	15p
EY86/87	13p	PCL82	15p	30F5	10p
PC86	15p	PCL83	15p	30FL1	28p
PC88	15p	PCL84	15p	30PL14	15p

S. W. ELECTRONICS

114 Burnley Road, Rawtenstall, Rossendale, Lancs.

ANOTHER FIRST

from

LEDCo

THE PANEL PEOPLE

Specialists in the design and manufacture of TV panels

Module 915: A state of the art direct replacement for the IF Filter/Gain Module used in the Philips 570 & Pye 713-725-735 and similar chassis. £11.45

Solid State CDA Panel for
Pye Hybrid TV £20.50
Solid State PL802 £2.45
LP1162 Equivalent £6.60

As featured in June issue of this magazine.

VAT included in price. Carriage free by 1st class post. C.W.O.

Send for details of these tried and proven components as used by the major companies.

LEDCo, 189a Livingstone Road, Thornton Heath, Surrey CR4 8JZ
Tel. 01-653 7575

TELECARE T.V. DISTRIBUTION LTD. BRISTOL AND NORTHERN IRELAND

Due to a New Policy in purchasing we are able to OFFER most makes of Colour & Mono at Lower Prices than ever before.
We can supply any quantity, nothing too big or too small. *Trade only.*

TELECARE BRISTOL	NORTHERN IRELAND
Unit 3 Whitby Road,	Bellanaleck
Brislington,	Co' Fermanagh,
Bristol.	Northern Ireland.
Phone 0272 712569	Phone Florencecourt 388

DX-TV AERIALS & EQUIPMENT
aerials manufactured to your own designs
suppliers of masts, lashings & cables

Premier, vpx22 wide band aerial uhf	£29.00
Antiferance xg21 wide band aerial uhf	£38.00
Walsey colour king wide band aerial uhf	£13.00
FM9a higan 9aimt fm stereo aerial	£28.00
Euro logperiodic 14aimt wide band vhf band III	£16.00
Stolle 2050 rotor (uses 3 core cable)	£42.00
Walsey supanova amp & p/unit w/b uhf	£38.00
Walsey supanova amp & p/unit w/b vhf	£20.00
Walsey s/nova higan amp & p/u w/b uhf	£82.00
Antiferance uf2 vhf/uhf diplexer	£2.80
Labgear 8030/8040 wide band amplifiers	£22.00
Labgear 8001 power unit (for above)	£11.50

All prices include p&p etc, cash with order please.
For price quotations on other items s.a.s. to:-
AERIAL CONTRACTORS (SOUTHERN)
28 Cuffield Road, Shoeburyness, Essex.

LOOK! THORN 3000/3500 TRIPLERS

High Quality Silicon Replacement Units
One Year Guarantee; Same Day Despatch
ONLY £3.95 inc. P.P. Add 59p V.A.T.
Quotes for larger quantities on request.
WING ELECTRONICS
13 Middle Road, Harrow HM, Middx.

TR500 UNIVERSAL T.V. TUBE TESTER

TESTS:—

- ALL COLOUR AND MONO TUBES
- EMISSION (Moving Coil Meter)

PLUS:—

- REACTIVATION
- STABILIZED HEATER AND TEST VOLTAGES
- PROFESSIONAL WORKSHOP OR FIELD INSTRUMENT
- SUPPLIED WITH FULL INSTRUCTIONS AND GUARANTEE

COSTS:—
ONLY £26.62 Incl. VAT
CASH WITH ORDER PLEASE TO
NEW DIMENSION TELEVISION
12 BUXTON ROAD, HEAVILEY,
STOCKPORT, CHESHIRE
Send stamped addressed envelope for details.
CALLERS WELCOME

TV TUBE REBUILDING

Faircrest Engineering Ltd., manufacture a comprehensive range of equipment for processing all types of picture tubes, colour and mono. Standard or custom built units for established or new businesses. We export world-wide and have an excellent spares service backed by a strong technical team.

Full training courses are individually tailored to customers requirements.

For full details of our service contact Neil Jupp

FAIRCREST ENGINEERING LTD.

Willis Road, Croydon CR0 2XX
Tel: 01-689 8741 01-684 1422/3

REBUILT CATHODE RAY TUBES IN

S. WALES

All tubes are now guaranteed for 2 years

A44 270X-A44 271X	Exchange Price	V.A.T. @ 15%
A47 342X-A47 343X	£30.00	£4.50
A49 120X-A49 192X	£30.00	£4.50
A51 110X-A51 220X	£30.00	£4.50
A55 14X	£33.00	£4.95
A56 120X-A56 140X	£33.00	£4.95
A63 120X-A63 200X	£36.00	£5.40
A66 120X-A66 140X	£36.00	£5.40
A67 120X-A67 150X	£36.00	£5.40

20AX and P.I.L tube prices are available on application.
For further details contact: **C.R.T. Services**
Tel. Llanwern (0633) 412112

URGENT TRADE NOTICE

Large quantities of good quality mono and colour TV receivers for sale, at competitive prices.

WHY NOT come to us where your custom will be welcomed and appreciated.
WE supply receivers to all parts of the UK, and to EIRE. All export enquiries welcomed.

TV WHOLESALE SUPPLIES
35 Shipston Road, Stratford-on-Avon.
TEL: 0789 4424

ELECTRONIC COMPONENTS. Send S.A.E. For List. Special Offers monthly. Radnor Supplies, 23 Arbury Road, Nuneaton, Wark's.

RE-BUILT COLOUR TUBES

19" £29.50	MONO	20" £30.50
22" £32.50	20" 24"	25" £34.50
26" £38.50	£16	

One Year Guarantee.
MATRIX TV LTD.,
112 Essex Road, London N1. Tel: 226 1111

LLOYD ELECTRONICS

63 North Parade, Grantham,
Lincolnshire

PL802/T Top Quality Solid State Valve @ £2.60 each.
Solid State C.D.A. Panel for 'Pye' 203/205 series @ £19 each.
I.F. Gain module for 'Pye' 713/731-series @ £9.50 each.
Motor speed control module for 'Hoover' washing machines. Types 3234/5/43 D.C. @ £9.50 each.

VAT & P/P Included
QUANTITY DISCOUNTS

PLEASE
MENTION

TELEVISION

WHEN
REPLYING TO
ADVERTISEMENTS

MAINS DROPPERS AND CAN CONDENSERS

Philips G8 475?	43p
Philips G8 2-2-68?	63p
Philips 210 118-148-Loop?	63p
Philips 210 30-125-2K85?	74p
Philips GT23 6-124-84?	74p
Thorn 3500	74p
Thorn 1500 350-20-148-1500-317?	90p
Thorn 1400	80p
Thorn 8000 56-1K-47-12?	90p
Pye 725 27-56?	63p
R.B.M. TV161 250-14-156?	70p
GEC 2010 8-15-17-70-63-188?	90p

2010 Covers 2013 2014 2017 & Sobell 1010 10A 13 & 1014
Bush TV165-166-171-175-176-178 70p
Murphy V1910-1913-1914-2014-2310-2311-2312 2314 70p
Bush A823 68-56? 90p

TV Condensers: - 200 + 200 ± 100 mfd 300V 45p each
150-100-100-100-150M 325V £2.00
150-150-100M 300V £1.60
175M 400V 100-100M 350V £2.05
400-400M 350V £2.65

All 2500-2500m 30V	80p	2500-2500m 63V	£1.45
Can 4700m 25V	85p	1500m 70V	80p
Cond 2200m 40V	65p	1000m 63V	£3.50
BDX32	£1.98	PL802T Special	£3.50
100-300-100-16m 300V			£1.70

Post Free, Cash with order, VAT paid.

Durham Supplies

367 Kensington Street, Bradford 8, West Yorkshire
S/S Colour £30, Mono Push Button £3. Plus VAT.
Phone Southend 559895. Any time.

QUALITY REBUILT TUBES HIGH TEMPERATURE PUMPING

Colour (2 year guarantee) from £32
Mono (including thin necks) from £12

Send or phone for full list and terms
OPEN MONDAY-SATURDAY

WELTECH PICTURE TUBES

5 Masons Avenue, Wealdstone, Harrow, Middx.
01-427 5063.

EDUCATIONAL

BETTER JOB! BETTER PAY!

GET QUALIFIED WITH ICS IN:
COLOUR & MONO TV SERVICING
COLOUR & MONO TV ENGINEERING
COLOUR & MONO TV MAINTENANCE
PLUS: Telecommunications, radio, electronics, electrical engineering, technical communications, radio communications, etc., etc.,
NEW: Self-built radio courses with free kits

Train in your own home, in your own time with ICS, the world's most experienced home study college.

RETURN THIS COUPON TODAY
FOR FREE BROCHURE!

ICS Int Correspondence Schools
M284 Intertext House, Stewarts Rd.
London SW8 4UJ. Tel: 01-622 9911

Name

Address

TELEVISION & VIDEO SYSTEMS SERVICING

15 MONTHS full-time Diploma course to include a high percentage of practical work.

- ELECTRONIC PRINCIPLES
- MONO & COLOUR TELEVISION
- CLOSED CIRCUIT TELEVISION
- VIDEO CASSETTE RECORDING
- DIGITAL TECHNIQUES
- TELETEXT & TV GAMES

Shortened courses for applicants with suitable electronics background.

Next session starts January 7th.

(Also available 2½ year course in Marine Electronics & Radar for employment as ships Radio Officer.)

Prospectus from:

LONDON ELECTRONICS COLLEGE

Dept: TT10, 20 Penywern Road, London SW5 9SU. Tel. 01-373 8721.

FOR SALE

PYE LABGEAR Teletext Decoder Brand new. Shop demonstration use only. First £200. Knavesmire Television, 74 Albemarle Road, York. Tel: York 31237.

NEW BACK ISSUES of 'Television' available 75p each post free. Open P.O./Cheque returned if not in stock - **BELL'S TELEVISION SERVICES**, 190 Kings Road, Harrogate, N. Yorkshire. Tel: (0423) 55885.

THREE G6 Colour Sets, two Single Standard £20 The Lot o.n.o. Harlow 22450.

WANTED

NEW VALVES and CRT's required, PCL805, PL504, PL509, PY500A etc. Cash waiting. Bearman, 6/8 Potters Road, New Barnet, Herts. Tel: 01-449 1934/5.

WANTED NEWNES Volumes of Radio and Television Servicing. 1971 onwards. Ring Bristol 34791. 10AM, 6PM. Also **PRACTICAL TELEVISION** all of 1969, 1970, 1971 and 1972.

LADDERS

ALUMINIUM Roof Crawlers, 12ft. - 24ft. Aluminium ext. up to 62½ft. Leaflets. Ladder Centre (TEL3) Halesfield (1) Telford. Tel: 586644. Callers Welcome.

SERVICE SHEETS

LARGE SUPPLIERS OF SERVICE SHEETS AND COLOUR MANUALS

TV Mono, Radios, Tuners, Tape Recorders, Record Players, Transistors, Stereograms, all at 75p each + S.A.E., except Colour TV and Car Radios.

State if Circuit will do, if sheets are not in stock. All TV Sheets are full length 24 x 12, not in Bits & Pieces. All other Data full lengths. Free Fault Finding Chart or TV Catalogue with order. Crossed PO's Returned if Sheets Not in Stock.

C. CARANNA, 71 BEAUFORT PARK, LONDON NW11 6BX. 01-458 4882. MAIL ORDER

MISCELLANEOUS

VIDEORECORDER SERVICE and Technical consultancy - B & B Electronics, Newark 76895. Call Steve Beeching.

C.T.V. Panels Ect lists S.A.E. No Callers. Sole, 37 Stanley St., Ormskirk, Lancs. L39 2DH.

RIGONDA AGENTS. For all spares and repairs. Fast dispatch Trade Services available. 01-476 1928. Star Radio, 272 Barking Road, London E13.

BELLS AND SIRENS

 <p>6 to 12v D.C.</p>	 <p>12v D.C.</p>
--	---

CARTERS SIREN £5.95
INDUSTRIAL SIX INCH BELL £6.95
PRICES INCLUSIVE. SEND CHEQUE. P.O. to:
CWAS ALARM
11 Denbrook Walk, Bradford BD4 0QS
 SAE for full price list of Professional Burglar Alarm Equipment.

SERVICE SHEETS

SERVICE SHEETS, Radio, TV, etc., 10,000 models. Catalogue 24p plus SAE with orders-enquiries. Telray, 154 Brook Street, Preston, PR1 7HP.

SERVICE SHEETS from 50p and S.A.E. Catalogue 25p and S.A.E. Hamilton Radio, St. Leonards, Sussex.

McCOURT Black and White repair Manuals for sale (4) with Circuit Diagram Manual £18 including post. Ring Lockwood (0262) 74337.

SERVICE SHEETS. SERVICE MANUALS PRACTICAL AND TECHNICAL BOOKS

COVERING COLOUR & MONO TELEVISIONS, RADIOS, RECORD PLAYERS, TAPE RECORDERS, ETC.

SERVICE SHEETS £1.00 PLUS S.A.E. SERVICE MANUALS ON REQUEST.

BOOKS

PRICES INCLUDE POSTAGE U.K. ONLY

TVT '78 TRANSISTOR EQUIVALENT & DATA BOOK. (A TO Z). 272 Pages	£2.75
TVT '78 TRANSISTOR EQUIVALENT & DATA BOOK. (2N, 2S, ETC.). 392 Pages	£3.80
NEWNES COLOUR TELEVISION SERVICING MANUAL by G. J. King. Vol. 1	£7.20
NEWNES COLOUR TELEVISION SERVICING MANUAL by G. J. King. Vol. 2	£7.20
NEWNES COLOUR TELEVISION SERVICING MANUAL by G. J. King. Vol. 3	£8.60
COLOUR TELEVISION SERVICING by G. J. King. 2nd Edition	£7.30
COLOUR TELEVISION THEORY by G. H. Hutson	£6.80
LONG DISTANCE TV RECEPTION FOR THE ENTHUSIAST by R. Bunney	£1.70
COLOUR TV WITH REFERENCE TO THE PAL SYSTEM by G. N. Patchett	£6.20
VIDEOTAPE RECORDING: THEORY AND PRACTICE by J. F. Robinson 2nd Edition	£9.70
TELEVISION SERVICING HANDBOOK by G. J. King. 3rd Edition	£6.10
BEGINNERS' GUIDE TO TELEVISION by G. J. King. 5th Edition	£2.65
BEGINNERS' GUIDE TO COLOUR TELEVISION by G. J. King. 2nd Edition	£2.65
CATHODE-RAY OSCILLOSCOPE AND ITS USES by G. N. Patchett	£4.00
SERVICING WITH THE OSCILLOSCOPE by G. J. King. 2nd Edition	£5.35
TOWERS' INTERNATIONAL TRANSISTOR SELECTOR. Revised Edition	£5.95

(SEND LARGE S.A.E. FOR FREE BOOK LISTS)

WE STOCK NEW AND SECONDHAND EDITIONS OF "RADIO AND TELEVISION SERVICING" BOOKS. FROM 1965-66 EDITION UP TO DATE. PRICES ON REQUEST.

BACK ISSUES OF FOLLOWING MAGAZINES AVAILABLE. CURRENT PRICE PLUS 20p POSTAGE PER COPY.
 P. WIRELESS, P. ELECTRONICS, E. ELECTRONICS, TELEVISION, ELECTRONICS TODAY, ELEKTOR

BELL'S TELEVISION SERVICES

190, KINGS ROAD, HARROGATE, N. YORKSHIRE. TEL. HARROGATE (STD 0423) 55885

OPEN TO CALLERS DAILY 9.00 a.m. TO 5.00 p.m. (HALF DAY WEDNESDAY) PLEASE INCLUDE AN S.A.E. WITH ENQUIRIES

COLOUR TV MANUALS

COVERING FOLLOWING MAKES
 PLEASE SEND S.A.E. FOR QUOTATION

ALBA, BRC, BUSH, DECCA, GEC, DEFIANT, MARCONI, EKCO, PYE, FERGUSON, DYNATRON, NATIONAL, HITACHI, INVICTA, ITT/KB, RGD, GRUNDIG, SOBELL, STELLA, SONY, MURPHY, PHILIPS, HMV, ULTRA & OTHERS.

CIRCUIT DIAGRAM MANUALS

We supply circuit diagrams for televisions in Giant Binders, covering most British 'Single' and 'Dual Standard' models, consisting of 2 volumes on colour and 1 on black & white. Price £12.50 each plus £2 post or all 3 for £37.50 post free.

**HUGE G.T. TV/RADIO/ETC. CATALOGUE
(with £4 worth of useful vouchers)**

Lists thousands of service sheets, manuals, etc. Many unobtainable elsewhere. Plus up dated Chassis Guide, newsletter, etc. Essential for every firm/engineer - Save ££s - only £1 plus large S.A.E.

S.A.E. for details of our Giant Service Sheet Collections - not available elsewhere.

**G.T. TECHNICAL INFORMATION SERVICES
76 Church Street, Larkhall, Lanarkshire ML9 1HE**

Largest stocks of manuals, etc. anywhere. £1 + large S.A.E. brings any requested full size service sheet. **Service sheets from 50p:** S.A.E. for full details of this and unique T.V. Publications. The new 1979 British Colour T.V. Repair Manual and the First Foreign Colour T.V. Repair Manual for **£4.90** each - both for **£9.50**.

S.A.E. brings full details of these and other unique publications.

Specialists in Colour & Mono T.V. Information - most manuals can be supplied by return of post at highly competitive prices.

ORDER FORM PLEASE WRITE IN BLOCK CAPITALS

Please insert the advertisement below in the next available issue of Television for

insertions. I enclose Cheque/P.O. for £

(Cheques and Postal Orders should be crossed Lloyds Bank Ltd and made payable to Television)

NAME.....

ADDRESS

.....

*Send to: Classified Advertisement Manager,
TELEVISION,
G.M.G., Classified Advertisement Dept., Rm. 2337,
King's Reach Tower, Stamford Street,
London SE1 9LS. Telephone 01-261 5846.
Rate
21p per word, minimum 12 word. Box No. 60p extra.*

Company registered in England. Registered No. 53626. Registered Office: King's Reach Tower, Stamford Street, London SE1 9LS.

N.G.T. COLOUR TUBES

**First Independent Rebuilder with
B.S.I. CERTIFICATION
(Certificate No. 004)**

12 month's guarantee: 4 year option

Tubes are processed using high temperature pumping schedules giving high definition and long life. They are then fitted with an implosion safety system approved by the British Standards Institution.

**N.G.T. ELECTRONICS LTD.,
120, SELHURST ROAD., LONDON S.E.25
Phone: 01-771 3535.**

20 years experience in television tube rebuilding.

SOUTHERN IRELAND DEALERS

We are the largest stockists in the south of Ireland of clean used T.V. sets.

**PYE - BUSH - PHILIPS - FERGUSON - KORTING
DECCA ETC.**

UHF/VHF Mono from **£18.00** each

Colour from **£125**

All Sets Tested & Cabinets Polished.

Over 2,000 sets in stock.

Visit our warehouse and see for yourself.

Delivery can be arranged.

**T.V. WHOLESALE DISTRIBUTORS LTD.
E.D.I. House, Kylemore Park West Industrial Estate,
Dublin 10. Tel. 364139 or 791995.**

Irish stockists for the new Tyne' colour sets.

EX RENTAL COLOUR TV's. THE BEST DEAL IN LONDON

OVER 2,000 in STOCK. MANY WORKING.

THORN BUSH DECCA PYE GEC PHILIPS KORTING GRUNDIG

Delivery arranged ★ Working sets available ★ Complete lorry loads available

★ Excellent stocks of Mono ★ Export our speciality.

Low, Low prices for genuine trade buyers, call and see for yourself, we would like to meet you or phone 01-997 8833/2298

Colin Butler TV Wholesale, Servier House, Horsenden Lane South, Perivale, Middx.
(New industrial estate behind Perivale underground station)

ELECTRONIC MAILORDER LTD.

VALVE BARGAINS

Any 5-80p, 10-£1.50, 50-£6.00 Your choice from the list below.

ECC82, EF80, EF183, EF184, EH90, PCF80, PCF802, PCL82, PCL84, PCL85, PCL805, PL504, PY81/800, PY88, 30PL14, 6F28, PFL200.

Colour Valves - PL508, PL509, PL519, PY500/A. All tested. 55p each.

Aerial Splitters: - 2 way, 75 OHMS, Inside Type, £2.50

AERIAL BOOSTERS

Aerial boosters can produce remarkable improvements on the picture and sound, in fringe or difficult areas.

B11 - For the stereo and standard VHF/FM radio.

B12 - For the older VHF television - Please state channel numbers.

B45 - For Mono or colour this covers the complete UHF Television band.

All boosters are complete with battery with Co-ax plugs & sockets. Next to the set fitting. Price £4.70 each.

STEREO HEADPHONES

Black - Freq. 30-18000HZ.
SAVE ££'s - PRICE £3.50

ALL PRICES INCLUDE VAT. P&P 30p PER ORDER EXPORTS WELCOME AT COST.

62 BRIDGE STREET, RAMSBOTTOM,
BURY, LANCS.
TEL: RAMS (070 682) 3036.

DISPLAY ELECTRONICS

COLOUR TUBES 2 YEAR GUARANTEE

Up to 19"	£29.50
20"	£31.50
22"	£33.50
25"	£35.50
26"	£37.50

The above prices are for standard 38mm Delta Gun Types. P.I.L. Tubes etc. Prices on application.

MONO TUBES 2 YEAR GUARANTEE

19"/20"	£11.00
23"/24"	£13.00

Carriage/Packing £3.00 on mainland. Please add 15% VAT to all orders.

CALLERS WELCOME

Late night Thursdays until 8pm
Saturdays until midday.

N.B. Customers intending to collect orders are requested to telephone in advance:— even popular types may be out of stock for short periods.

V.D.U./RADAR TUBES

We have supplied British and Foreign Airlines with rebuilt V.D.U. Tubes for several years and also have Radar Display Tubes operating on British Airfields.

Home and export enquiries for Radar Display Tubes manufactured from new (with phosphors to specification) are invited.

**WATERLOO ROAD,
UXBRIDGE,
MIDDLESEX**

Telephone: Uxbridge 55800

COLOUR T.V. SPARES

Most parts of Decca's stocked

LOPT

DECCA 10/30	£10.80
80/100	£10.20
Mono	£12.00

PHILIPS G8 £12.90

ITT 20/25/30 £10.90

BUSH A774 £15.00

TUNER CONTROL UNITS

DECCA	
4 Button	£7.50
6 Button	£8.90
7 Key	£14.00

New catalogue now ready (16p). Hundreds of correct spares listed.

Complete Working 3000 Models
£79 collected.

Ex-equip panels

3000 - Power £20. LTB £20. F/S

£8.50 Converg. £8.50 IF £10.

Video £12. Chr. £12.

Bradford

10 Decoder £16. 30 Decoder £18.

New 1590 or 1591 speakers £4.90.

Prices include 15% VAT

Package/Posting 30p per order but Transformers and Panels 75p.

BOTTOMLEY'S TELEVISION

11 Leeds Road, Hipperholme,
HALIFAX (0422) 202979

Callers Phone first. Exit 26 M62

Ex-equipment panels are complete and working but are sold on condition that they may require attention due to age.

BIRMINGHAM AND DISTRICT DEALERS/ENGINEERS

NEWS FLASH

HIGH VACUUM
QUALITY
REBUILT TELEVISION
PICTURE TUBES

COMPETITIVE PRICES

CONTRACT TERMS
AVAILABLE

2 YEAR GUARANTEE

E.G.

17" 18" 19" £29.50 + VAT £4.43

20" £32.50 + VAT £4.86

22" £34.00 + VAT £5.10

25" £37.00 + VAT £5.55

26" £40.00 + VAT £6.00

PIL Tubes our speciality.

All Prices For Tubes available on a Sound "Glass for Glass" basis otherwise £20 surcharge

C.W.O. Carr./Ins. £6.50

"Old Glass Purchased"

TUBESURE LTD.

Unit 111, Middlemore Industrial Estate,
Middlemore Road, Smethwick,
West Midlands. Telephone: 021-558 7777.

MAIL ORDER PROTECTION SCHEME

The Publishers of *Television* are members of the Periodical Publishers Association which has given an undertaking to the Director General of Fair Trading to refund monies sent by readers in response to mail order advertisements, placed by mail order traders, who fail to supply goods or refund monies owing to liquidation or bankruptcy. This arrangement does not apply to any failure to supply goods advertised in a catalogue or in a direct mail solicitation.

In the unhappy event of the failure of a mail order trader readers are advised to lodge a claim with *Television* within three months of the date of the appearance of the advertisement, providing proof of payment. Claims lodged after this period will be considered at the Publisher's discretion. Since all refunds are made by the magazine voluntarily and at its own expense, this undertaking enables you to respond to our mail order advertisers with the fullest confidence.

For the purpose of this scheme, mail order advertising is defined as:— 'Direct response advertisements, display or postal bargains where cash had to be sent in advance of goods being delivered'. Classified and catalogue mail order advertising are excluded.

3 amp 1 1/4 Fuses 2p	EHT S.Stick 18 or 20KW Triplers (ITT) £1.50 new	EHT Lead & Anode Cap 75p
Long wires	3 amp Diodes approx. voltage 1200 7p each	Star Aerial Amps £4.00
300 Mixed Carbon Film Resistors	3500 6 push button units for Thorn 3500 Varicap tuning £1.00	Channel B or C
5 of each type 1/4 Watt 1R to 2 Meg - ITT £1.50	Varicap F.M. Tuner	2200/35 15p
Red & Green L.E.D.s mixed large and small 14 for £1.00	Tuning range 78.5 to 108MHz (I.F. Panel with circuit) £2.00	2000+2000/35 25p
Convergence Panel for GEC 2040 11 pots 5 coils 2 Resistors E.T.C. New £1.50	6 position 12.5K V/Resistor Unit for Varicap 50p	2500+2500/63V 50p
(Reject Varicap Units)	Thorn Mains Lead & ON/OFF switch & Control Panel with Slider Pots 75p	4700/25 25p
ELC1042/ELC1043 50p	TBA 120A 30p	4700/30 35p
ELC2000 £1.00	TBA 120B 30p	4700/40 50p
10 Watt LP1173 £1.00	TBA 120AS 30p	1250/50 10p
IF LP1170 50p	TBA 120SB 30p	33/350 6p
AM/FM T/Unit (Seconds)		100/63 8p
AT1025/08 Blue Lateral Ass. 15p		10/350 8p
10 Watt Mullard Amps New £2.00		47/50 5p
BD 207 30p	4.7NF5KV 10p	22/40 5p
TIP 31 20p	6200PF/2000V 10p	1500/40 10p
TIP 2955 50p	180PF/8KV 10p	.005/1500V 5p
2N3583 250V/1A Output Transistor 40p	1000PF/10KV 10p	47/100V 8p
BD 252 20p	1000PF/12KV 10p	.05/100 3p
(MJE2021) NPN 80V/5A 15p	1200PF/12KV 10p	4.7/50V 5p
(SJE5451)	270PF/8KV 10p	4/350 5p
(661 pair 80W/5A pair 28p	160PF/8KV 10p	1000/25 10p
(660 90V	.1MFD 400V 5p	4.7/100 6p
40V 2A O.P. Trans B0375/6 pair 20p	.1MFD 800V 8p	2.2/100 6p
BZV 15/12R PYE 50p	.1MFD 2000V 15p	1000/10 5p
BD226 25p	.1MFD 1250V 15p	8/350 5p
BD238 25p	.01MFD 600V 5p	1/250 5p
MJE 1661 25p	.01MFD 1000V 8p	1/100 5p
XTALS T/V 4.433.610KHz 50p	.0047/500V 8p	6MHz Filters 25p
BYX 38/600R 50p	.0022 1500V 8p	3300/40 15p
BT138 Triacs 10a/600V 65p	.47 250 A/C 8p	3300/25 5p
RCA40506 Thyristors 50p	.47 1000V 35p	1500/25 10p
MJE 2955/15A 50p	.047 1000V 8p	1/350 5p
TIP 41A-42 pair 40p	.22/250AC 8p	220/10 5p
G11 Phillips Thyristors 60p	1500/100V 25p	680/100 10p
PYE Thyristors 85p	10/500V 15p	220/16 5p
2N4444-0T112 BT116	.47/100V 5p	47/63 5p
SP8385 Thorn 25p	330/25V 5p	33/63 5p
5 amp 300V Thyristors 25p	680/40V 8p	2.2/63 5p
BRC 4443 65p	22/350V 7p	22/100 8p
SCR 957 65p	330/100V 10p	4.7/63 5p
BD561-2 pair 30p	15/450V 10p	1000/40 10p
BC 365 10p	47/450V 12p	100/450 30p
BD 131 25p	470/16V 8p	22M 350V 20p
BD 183 50p	470/25V 8p	33.000 20p
AC187-8K pair 40p	470/40V 10p	PUA758PC £1.00
	470/63V 15p	MC1349P 50p
	470/100V 15p	TCEP100 £1.00
	220/25V 6p	TCE120CQ £1.00
	220/40V 6p	
	220/63V 10p	
	160/25V 5p	
	330/16V 5p	
	100/16V 5p	
	2.2/160V 5p	
	10/40V 5p	
	TBA 920 £1.00	
	TBA 920Q £1.50	
	TBA 480Q £1.00	
	TBA 550Q £1.50	
	TBA 540 £1.00	
	TBA 5400 £1.00	
	TBA 530Q £1.00	
	TBA 990 £1.00	
	SBA 550B £1.50	
	SN76003 No Heat Sink £1.00	
	SN 76003 £1.75	
	SN 76033 £1.50	
	TBA 800 60p	
	TBA 810S £1.00	
	TCA 270 £1.00	
	TCA 270Q £1.00	
	TCA 275Q £1.00	
	CA 270 £1.00	
	TBA 720A £1.50	
	TBA 510Q £1.50	
	SN76115N 50p	
	TAA 700 £2.00	
	TAA 570 £1.50	
	TBA 396 £1.00	
	SAS 570S £1.50	
	SN76666 £1.00	
	SN76660 50p	
	SN76227 50p	
	SN76544N 75p	
	TBA641BX1 £1.50	
	CA920 AW £1.00	
	TBA 750 £1.00	
	TAA 550 20p	
	SN76131N 50p	
	SN76001 £1.00	
	TBA560CQ £1.00	
	SN76530P 50p	
	SN76650N 50p	
	TDA1170 85p	
	BT822 £1.50	
	BT8224 £1.50	

SENDZ COMPONENTS
2 WOODGRANGE CLOSE,
THORPE BAY, ESSEX.
Reg. Office Only.
Callers by appointment only.
Add 15% VAT.
Add postage for all overseas parcels.

100 mixed 20mm Fuses £2.00	100 Mixed Transistors 75p	UHF Varicap Units + VHF	BY 127 10p
3500 Thorn Triplers £3.50	1 LBs Mixed Components £1.50	NEW	IN4005 4p
Triplers TS2511TDT THORN £2.50	BU 105/04 £1.00	ELC 1043/05 £4.00	IN4006 5p
Triplers TS2511TBQ PYE £1.50	BU 205 £1.00	ELC 1043/06 £4.00	BY210/400 5p
1730 DECCA £1.00	BU 108 £1.00	THORN Varicap UHF 3.500 £3.50	BY210/800 10p
GRUNDIG 3000/3010 SIEMENS TVK52 Triplers £3.00	BU 208 £1.75	New EQV ELC1043/05	BY176 50p
Triplers - DECCA £3.00	BU 500 £1.75	DECCA UHF Varicap New eqv E1C 1043/05 £4.00	BY133 10p
CS 2030 CS 2230	BU 126 £1.00	VHF/UHF AEG Varicap (New) £3.50	BA159 10p
CS 2232 CS 2233	R2008B £2.00	G8 PHILLIPS £3.50	BY184 25p
CS 2630 CS 2631	R2010B £1.25	UHF Varicap replacement	BY187 50p
CS 2632	EHT Rectifier BY212 10p	NEW VHF/UHF on panel ELC2060 £4.50	TV 20 50p
THORN - Needs Mod No 1400. 1500 Stud Multipliers £1.50	3 OFF G770/HU37 EHT 10p	Phillips T/Units UHF New £2.00	TV 18 40p
Triplers - PHILLIPS 520.540.550 £3.00	12KV 2 M/A Small 20p	VHF/UHF AEG Varicap NSE Removed from new panels £2.50	Rectifier Sticks & lead & Anode Cap
Triplers - ITT CVC5 CVC7 CVC9 CVC20/25/30 CVC8 £3.00	12KV 2 M/A Large 30p	VHF Varicap Units NSF AEG removed from Print Panels New 49.00 21.900MHZ £1.00	BYF3214 20KV Rectifier Sticks 25p each
LP1174/33 DECCA LP1194/42 PYE Triplers £4.00	EHT REC USED IN THORN 1400.1500 Triplers (x80/150) 10p	VHF Varicap (NSF) AEG New 49.00 21.900MHZ £2.00	BYF3123 18KV Wire ends 25p
G2100 GEC Tripler TVM25 £2.00	CSD 118xMH Rec THORN 3500 10p	4 Push Button T/Units UHF MULLARD £2.00	BA 248 6p
THORN 3500 THORN 8500 Focus Unit DECCA 8500 Focus Unit (Large or small) £1.00 each	220M/450V THORN 50p	AE Isolating Sockets UHF & Lead PYE & THORN 40p	BSS 68 20p
4 Push Button Units 1400-1500 THORN £3.50	700M/250V THORN 35p	DECCA 1730 Doubler £1.00	BYX55/350 10p
4 Push Button Unit 8500 THORN £3.50	175+100+100 350V 3500 THORN £1.50	Transistor UHF Units with AE Socket and leads GEC 2000 Rotary type NEW £2.00	BY 206 10p
300 Mixed condensers £1.50	400+400.350V DECCA 80p	7 button Varicap tuning heads Variable Resistor with Fascia Plate 7 Lamps £3.00	BT106 S/Type 50p
300 Mixed resistors £1.50	470+470.250V 40p	PYE 6 push button unit for Varicap Tuning £2.50	BT106 95p
30 Pre-Sets £0.50	100+200 325V 40p	4 push button unit (for Varicap Tuning) 20K New 50p	BT116 95p
100 W/W Resistors £1.50	200+200+100+32 350V 70p	DECCA Bradford Tuner 5 Button New £2.75	BT119 95p
40 Mixed Pots £1.50	150+200+200.300V 70p	BB 105 UHF BB 103 VHF BA 182 Varicap diodes 5p each	BT109 70p
20 Slider Pots £1.50	731 PYE 600/300V & BUSH 75p each	BTY80 20p	BT146 750V 25p
10 Different Types	200+200 350V 60p	3 amp Diodes 300V 10p	Thyristors 8A/800V 2N6399A 30p
Mixed Electrolytics 150 £2.00	300+300+100/32/32 £1.00	3 amp Diodes 100V 7p	Thyristors 8A/400V 52600D 30p
DP Push Button Switch ON/OFF 10p	400M 400V 40p	1 amp Bridges 100V 20p	Y827 Diodes 30p
Mains ON/OFF Push Button T/V 20p	400M 350V 50p	1 amp 400V 20p	Bridge Rec
Mains ON/OFF Rotary T/V 12p	800M 250V 30p	3 amp Bridge 25p	B30C 600A6 12p
Mains Dropper THORN 6R+1R+100R 35p	AE Power supplys 15V £1.00	W005M Bridge 15p	B30C 500 12p
Mains Droppers AD 161 69R+161 PYE 40p PAIR 60p	Flush Mounted Diplexer White 2 Coax Sockets T/V F.M. 35p		BC147C 2N3566
147+260 PYE 40p	BF 127 BC 303		BC148B BF198
(731) 3R+56R+27R 50p	BF 264 BRC 2108		BC149C BF274
100 Mixed Diodes £1.00	BF 180 BC 336		BC195 BSY79
	BF 181 BF 157		BC108 BC327
	BF 182 BC 161		BC107 BC213LA
	BC 300 BC 460		BF594 BC212LT
	AC 128 BC 350		BC158 BF195
	BC 350 E1222		2N2222 BC182L
	BF 178 BSY95A		2N390 BF594
	BF 257 BFT 43		2N4355 BC183
	BF 137 with heat sink		T1591 BC238A
	BF 185 T1P 29A		
	BF 200 TIP 32		
	AC 153K 20p each		
	GEC Sound O.P. Panel I.C. O.P. £2.50		

Coaxial plugs **14p each**
non-solderable type deluxe

Add 15% VAT.

SENDZ COMPONENTS

2 WOODGRANGE CLOSE,
THORPE BAY, ESSEX.

Reg. Office Only.

Callers by appointment only.
Add postage for all overseas parcels.