

OCTOBER 1978

Australia 85c; Malaysia \$2.50; New Zealand 85c

50p

TELEVISION

SERVICING·VIDEO·CONSTRUCTION·DEVELOPMENTS

**NEW
SERIES**

Colour Receiver Project Part 1

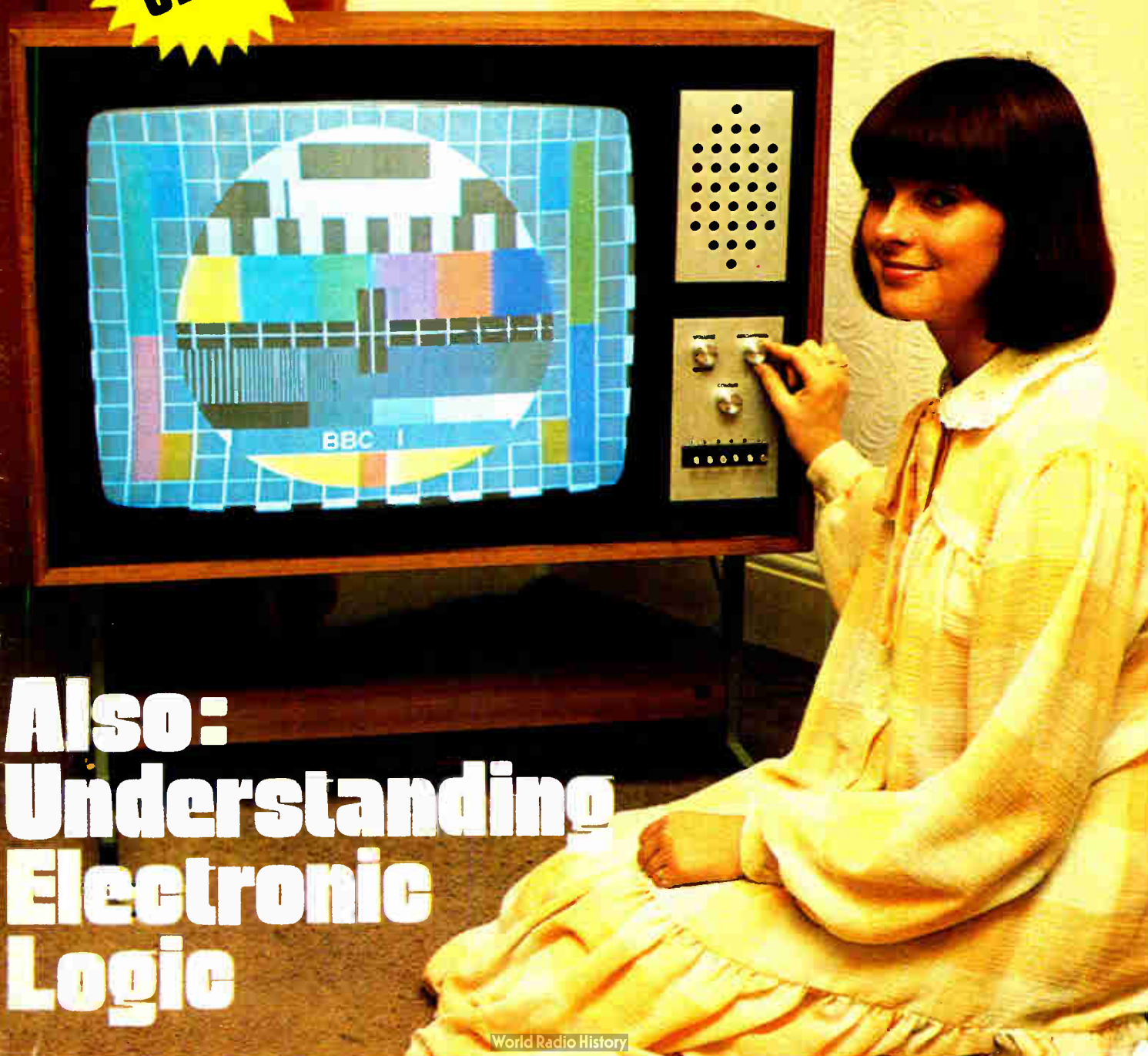

**Also:
Understanding
Electronic
Logic**

MANOR SUPPLIES COLOUR BAR GENERATOR

plus CROSS HATCH KIT (Mk. 4)

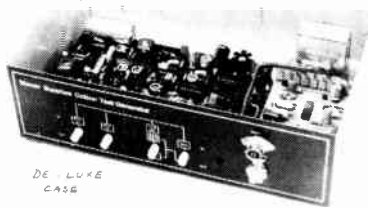

DE-LUXE CASE

- ★ Output at UHF, applied to receiver aerial socket.
- ★ In addition to colour bars, all R-Y, B-Y and Lum. Combinations.
- ★ Plus cross hatch grey scale, peak white and black levels.
- ★ Push button controls, small, compact battery operated.
- ★ Simple design, only five i.c.s. on colour bar P.C.B.

PRICE OF MK4 COLOUR BAR & CROSS HATCH KIT £35.00 + 8% VAT + £1.00 P/Packing.

CASES, ALUMINIUM £2.40, DE-LUXE £4.80, BATT. HOLDERS £1.50. ADD 8% VAT TO ALL PRICES!

ALSO THE MK3 COLOUR BAR GENERATOR KIT FOR ADDITION TO MANOR SUPPLIES CROSS HATCH UNITS. £25.00 + £1.00 p.p. CASE EXTRA £1.40. BATT. HOLDERS £1.50. ADD 8% VAT TO ALL PRICES.

- ★★ Kits include drilled P.C. board, with full circuit data, assembly and setting up instructions.
- ★★ All special parts such as coils and modulator supplied complete and tested, ready for use.
- ★★ Designed to professional standards.
- ★★ Demonstration models at 172 West End Lane, NW6.
- ★★ Every kit fully guaranteed.

MK4 DE LUXE (BATTERY) BUILT & TESTED £58.00 + 8% VAT + £1.20 P/Packing.

ALTERNATIVE MAINS SUPPLY KIT £5.78 + 8% VAT + 65p P/P. VHF MODULATOR (CH1 to 4) FOR OVERSEAS £3.50. INFORMATION ON VIDEO TAKE-OFF FOR C.C.T.V.

MANOR SUPPLIES TELETEXT KIT (incl TEXAS DECODER). Full facilities in colour. External unit. AE input to set. Write or call for further information. See working demonstration model! Easy to build and results guaranteed for every completed unit.

Texas XM11 Decoder £130.00 p.p. £1.00.
Auxiliary Units, 18K.00 p.p. £1.50
De Luxe Case £14.80 p.p. £1.00.
Add 12% VAT.
Separate Price List for Individual Units available.

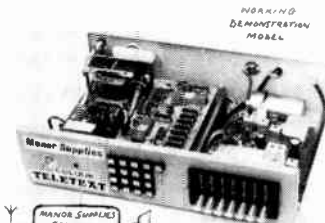

Changes from Teletext to picture without switching aerials.

Armchair control of Teletext and T.V. stations.

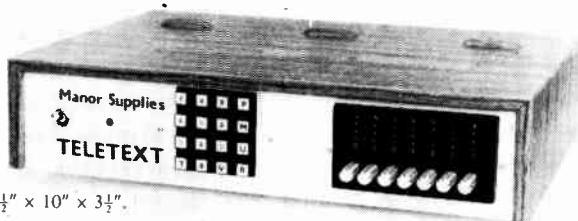

15 1/2" x 10" x 3 1/2"

COLOUR, UHF & TELEVISION SPARES

NEW SAW FILTER IF PLUS TUNER COMPLETE AND TESTED £28.50 p.p. 95p.

T.V. PORTABLE PROJECT LOPT, SCAN COILS, DRIVER £12.50; EHT RECT. 80p; ELC1043/05 £5.50, CONTROL UNIT £1.80; VIS GAIN, VIS SELECT (TESTED) £3.80; PACKS: I.C. £5.20, CAPS TANT £2.75, ELECTROLYTICS £3.20, CERAMICS £2.00, POLY-ESTER ETC. £1.35; PRESETS 90p, TRANSISTORS £3.90, RESISTORS £2.50, SEMICONDS £3.80, BRIDGE REC. £1.95, C106 90p; BYX71/600 (2) £2.40; RELAY £2.25, CONTROLS £1.18; 6MHZ FILTER 68p; COIL £1.00; AERIAL £1.00; p.p. 85p. MAINS TRANSFORMER £5.80 p.p. £1.00. OTHER PARTS AVAILABLE. WORKING MODEL ON VIEW AT 172 WEST END LANE, NW6. SPECIAL OFFER FOR SHOP CUSTOMERS, TOSHIBA 14" CRT BRAND NEW £12.50.

TV TEST GENERATOR UHF MODULATOR £3.50 p.p. 35p.*
CROSS HATCH UNIT KIT, AERIAL INPUT TYPE, INCL. T.V. SYNC AND UHF MODULATOR. BATTERY OPERATED. ALSO GIVES PEAK WHITE & BLACK LEVELS. CAN BE USED FOR ANY SET £11.00 + 45p. p.p.* (ALUM. CASE £2.00 p.p. 75p.*). COMPLETE TESTED UNITS, READY FOR USE (DE LUXE CASE) £20.80 p.p. £1.00.* ADDITIONAL GREY SCALE KIT £2.90 p.p. 30p.*

UHF SIGNAL STRENGTH METER KIT £16.80 (ALSO VHF VERSION* ALUM CASE £1.40, DE-LUXE CASE £4.80 p.p. £1.00.)
CRT TESTER & REACTIVATOR PROJECT KIT £19.80 p.p. £1.30* "TELEVISION" COLOUR SET PROJECT. MARK II DEMONSTRATION MODEL WITH LATEST IMPROVEMENTS. WORKING AND ON VIEW. SPARE PARTS STILL AVAILABLE.

SPECIAL OFFER I.F. Panel, leading British maker, similar design to "Television" panel. Now in use as alternative inc. circuit and connection data, checked and tested on colour £14.80 p.p. 95p.

STABILISER UNITS, "add on" kit for either 40V or 20V. £2.80 p.p. 35p.

PHILIPS 210 or 300 Series IF Panels £2.50 p.p. £1.00.

PHILIPS 210, 300 Series Frame T.B. Panels £1.00 p.p. 65p.

PHILIPS 19TG 170 Series Timebase Panels £2.50 p.p. 90p.

BUSH A823 (A807) Decoder Panel £7.50 p.p. £1.00.

BUSH A823 SCAN CONTROL PANEL £2.50 p.p. 75p.

BUSH 161 TIMEBASE PANEL A634 £3.80 p.p. 90p.

GEC 2040 Surplus Panels, ex-rental. Decoder £5.00 p.p. 90p.

GEC 2040 Convergence Control Panel £2.50 p.p. 90p.

DECCA Colour T.V. Thyristor Power Supply. HT. LT etc. £3.80 p.p. 95p.

BUSH TV 300 portable Panel incl. circuit £5.00 p.p. 95p.

BUSH TV 312 IF Panel (Single I.C.) incl. circuit £5.00 p.p. 65p.

BUSH TV Portable Eleven Volt Stab. Power Supply Unit £3.80 p.p. £1.00.

PYE 697 Line T.B. P.C.B. for spares, £1.50 p.p. £1.00.

MULLARD AT1022 Colour Scan Coils £6.00 p.p. £1.20. AT1023/05 Convergence Yoke £2.50 p.p. 85p. AT1025/06 Blue Lat. 75p p.p. 35p.

Delay Lines. DL1E 90p, DL20, DL50 £3.50 p.p. 75p.

PHILIPS G6 single standard convergence panel, incl. 16 controls. switches etc., and circuits £3.75 p.p. 85p. or incl. yoke, £5.00. G8 Decoder panels ex Rental £5.00. Decoder panels for spares £2.50 p.p. 85p.

VARICAP, Mullard ELC1043/05 UHF tuner £5.50, G.I. type (equiv. 1043/05) £3.50 p.p. 35p. Control units, 3PSN £1.25, 4PSN £1.50, 5PSN £1.80. Special offer 6PSN £1.00, 7PSN De Luxe £2.80 p.p. 35p. TAA 550 50p p.p. 15p. Salv. UHF varicap tuners £1.50 p.p. 35p.

BUSH "Touch Tune" assembly, incl. circuit £5.00 p.p. 75p.

VHF, ELC 1042 £4.80, p.p. 35p. on Pye P.C.B. £5.40 p.p. 85p.

VARICAP UHF/VHF ELC 2000S £8.50 p.p. 65p.

UHF/625 Tuners, many different types in stock. Lists available. UHF tuners transist. incl. s.m drive, indicator £2.85; Mullard 4 position push button £2.50, 6 position push-button £4.50 p.p. 90p. AF ISOL 30p p.p. 20p.

TRANSISTORISED 625 IF for T.V., sound, tested. £6.80 p.p. 65p.

PHILIPS 625 IF Panel incl. circuit 50p p.p. 65p.

TBA "O" I.C.s. 480, 530, 540, £2.20, 550, 560C. 920 £3.20 p.p. 15p.

HELICAL POTS, 100K. 4 for £1.20 p.p. 20p.

PHILIPS 19TG170 Mains Droppers, two for 90p p.p. 50p

LINE OUTPUT TRANSFORMERS. New guar. p.p. 85p.

BUSH 145 to 186SS series £6.95

BUSH, MURPHY A816 series £8.50

DECCA DR1. 2, 3, 121, 123.

20/24, MS1700, 2001, 2401 £6.80

DECCA MS2000, 2400 £5.80

FERG., HMV, MARCONI,

ULTRA 850, 900, 950 Mk. 1 £5.90

950II, 1400, 1500, 1590 £5.90

GEC 2000, 2047 series, etc. £6.80

INDESIT 20/24EGB £6.80

ITT/KB VC2 to 53, 100, 200, 300 £6.80

MURPHY 1910 to 2417 series £6.95

PHILIPS 19TG121 to 19TG156. £4.80

PHILIPS 19TG170, 210, 300 £6.80

PYE 11U, 368, 169, 769 series £6.80

PYE 40, 67 series (36 to 55) £3.80

PAM, INVICTA, EKCO,

FERRANTI equivalents as above.

SOBELL 1000 series £6.80

STELLA 1043/2149 £6.80

THORN MONO SCAN COILS (850 to 1500) £2.80 p.p. 85p.

THORN 850 Time Base Panel. Dual Standard 50p p.p. 80p.

THORN 3000, 3500 Tripler £5.80 p.p. 85p. Others available.

6-3V CRT Boost Transformers £2.90 p.p. 75p., Auto type £1.80 p.p. 45p.

CALLERS WELCOME AT SHOP PREMISES
THOUSANDS OF ADDITIONAL ITEMS AVAILABLE NOT NORMALLY ADVERTISED

MANOR SUPPLIES

172 WEST END LANE, LONDON, N.W.6.

(Near W. Hampstead tube stn: 28, 59 159 Bus Routes) 01-794 8751

Mail Order: 64 GOLDERS MANOR DRIVE, LONDON N.W.11.

PLEASE ADD 12% VAT TO PRICES (EXCEPT * 8%)

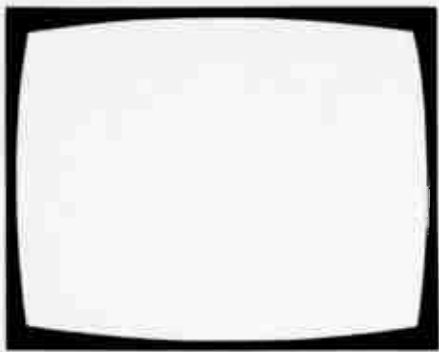

TELEVISION

October
1978

Vol. 28, No. 12
Issue 336

A. Coote

COPYRIGHT

© IPC Magazines Limited, 1978. Copyright in all drawings, photographs and articles published in *Television* is fully protected and reproduction or imitation in whole or in part is expressly forbidden. All reasonable precautions are taken by *Television* to ensure that the advice and data given to readers are reliable. We cannot however guarantee it and we cannot accept legal responsibility for it. Prices are those current as we go to press.

CORRESPONDENCE

All correspondence regarding advertisements should be addressed to the Advertisement Manager, "Television", King's Reach Tower, Stamford Street, London SE1 9LS. Editorial correspondence should be addressed to "Television", IPC Magazines Ltd., King's Reach Tower, Stamford Street, London SE1 9LS.

BINDERS AND INDEXES

Binders (£2.85) and Indexes (45p) can be supplied by the Post Sales Department, IPC Magazines Ltd., Lavington House, 25 Lavington Street, London SE1 0PF. Prices include postage and VAT. In the case of overseas orders add 60p to cover despatch and postage.

BACK NUMBERS

Some back issues, mostly those published during the last two years, are available from the Post Sales Department, IPC Magazines Ltd., Lavington House, 25 Lavington Street, London SE1 0PF at 70p inclusive of postage and packing to both home and overseas destinations.

QUERIES

We regret that we cannot answer technical queries over the telephone nor supply service sheets. We will endeavour to assist readers who have queries relating to articles published in *Television*, but we cannot offer advice on modifications to our published designs nor comment on alternative ways of using them. All correspondents expecting a reply should enclose a stamped addressed envelope.

Requests for advice in dealing with servicing problems should be directed to our Queries Service. For details see our regular feature "Your Problems Solved". Send to the address given above (see "correspondence").

this month

- 623 Leader**
- 624 Teletopics**
News, comment and developments.
- 626 Never Knock a Neck** *by Les Lawry-Johns*
Otherwise, if you've got difficult customers with you (two ignoramuses, Grace and Sid) complications can arise. Plus various sorties into the field and so on.
- 631 Next Month in Television**
- 632 Colour Receiver Project, Part 1** *by Luke Theodossiou*
An easy to build set with an up to the minute specification. This opening article describes the overall design and technical features and gives constructional details for the small power supply module.
- 638 Faults Encountered . . .** *by Dewi James*
A summary of fault conditions experienced on a variety of sets, with the emphasis on foreign receivers.
- 640 Video Notebook** *by D. K. Matthewson, B.Sc., Ph.D.*
Modifications to give improved VCR operation, and a summary of the various VCRs that used the original Philips standard.
- 642 Diagnostic Pattern Generator**
Board and component layout details for Malcolm Burrell's design featured in the August issue.
- 643 Readers' PCB Service**
- 644 Notes on the Sanyo CTP370** *by Hugh Cocks and David Martin*
Quite a number of these compact, hybrid colour receivers are around. Some common problems are discussed.
- 646 Letters**
- 648 TV Servicing: Beginners Start Here, Part 13** *by S. Simon*
This time sync separator circuits, plus sync faults and how to recognise them. With some useful tips on particular chassis.
- 652 Long-Distance Television** *by Roger Bunney*
Reports on DX reception and conditions, and news from abroad. Also a note on an interesting infra-red ENG link.
- 656 Service Notebook** *by G. R. Wilding*
Notes on faults and how to tackle them.
- 658 The Language of Logic, Part 1** *by E. A. Parr, B.Sc., C.Eng., M.I.E.E.*
Logic circuitry is being used increasingly in TV sets, so it's time to get to understand how this sort of circuitry operates. The various gates and how they are used are explained, and the operation of electronic memories, counting systems and some logic control systems described. The binary system and its use is also explained.
- 663 Your Problems Solved**
- 665 Test Case 190**

OUR NEXT ISSUE DATED NOVEMBER WILL BE
PUBLISHED ON OCTOBER 16

EX-EQUIPMENT SPARES

MONO TUBES (tested) 19" Rimguard £3.00 23" Rimguard £4.00 20" Rimguard £5.00 24" Rimguard £6.00 +£3.00 p.p.	MONO TUNERS 6 - button integrated all at £6.50 U.H.F. P/Button D/S £4.50 U.H.F. P/Button S/S £6.50 Rotary £3.00 + £1. p.p.	MONO LOPTS All D/Standard Lopts at £4.00 + £1. p.p. All S/Standard at £4.00 + £1. p.p.	MONO PANELS i.e. Philips, Bush etc. £3.50 + £1 p.p. Quotations for complete S/Hand chassis if required. (Diff prices)	MISC. S/Output Trans. £1 + VAT + £1 P&P F/Output Trans. £1.25 + VAT + £1. P&P Scancoils £1.50 + VAT + £1. P&P. Other spares available. please write or phone for details.
--	---	---	--	---

VALVES (MONO & COLOUR)

PCL82 0.10	PCF802 0.10	PCC86 0.10	EY86/7 0.10	30PL1 0.25	PL509 1.00
PCL83 0.25	PCF805 0.25	PC97 0.20	EY8/7 0.10	30PL13/4 0.10	PY500 1.00
PCL84 0.10	PCF806 0.10	PC900 0.10	DY802 0.10	30P12 0.10	GY501 1.00
PCL85 0.10	PCF808 0.25	EF80 0.10	PY800/1 0.10	30FL1/2 0.25	PL508 0.50
PCL86 0.10	PCF80 0.10	EF85 0.10	PL36 0.25	ECC82 0.10	PCH200 0.50
PFL200 0.10	PCC189 0.10	EF183 0.10	PL504 0.25	ECC81 0.10	PCF200 0.50
PCF801 0.10	PCC86 0.10	EF184 0.10	PL81 0.10	ECH81 0.10	CEY51 0.15
30C1 0.10	30C15 0.10	6BW7 0.10	6/30L2 0.10	ECL80 0.10	
30C17 0.10	30C18 0.25	ECC85 0.10	U26 0.10	ECL82 0.10	
PL83 0.10	PL84 0.10	EH90 0.10			

Please note there is 25p p.p. per order

D/STANDARD COLOUR SPARE PANELS

	IF	LUM	CHROMA	EHT	REG	CON	S/OUTPUT	POWER	L/TB	F/TB
Bush/Murphy	6.50	6.50	6.50	—	—	6.50	1.50	6.50	—	—
GEC/Sobell	6.50	7.50	—	—	—	6.50	—	—	—	7.50
Philips	6.50	9.50	—	—	—	7.50	—	—	—	6.50
Decca	6.50	12.50	12.50	—	—	6.50	2.00	8.00	—	6.00
							(19" only)			
Thorn 2000	6.50	7.50	7.50	6.50	6.50	7.00	—	8.00	15.00	6.50
Pye	7.50	7.50	9.50	—	—	6.50	—	—	—	4.00
Baird	6.50	8.50	8.50	—	—	6.50	—	—	—	6.00

Postage & Packing £1.25

S/STANDARD COLOUR SPARE PANELS

	IF	LUM	CHROMA	VIDEO	CON	POWER	L/TB	F/TB
Bush 184	9.50	—	20.00	—	8.00	6.00	15.00	—
GEC Hybrid	9.50	9.50	15.00	—	6.00	—	—	12.00
Philips G6 S/S	9.50	—	10.00	—	9.00	—	—	10.00
Thorn 3000	10.00	9.00	18.00	10.00	6.00	20.00	20.00	10.00
Pye 691/693	15.00	7.50	18.00	—	8.00	—	15.00	7.50
Thorn 3500	10.00	9.00	18.00	10.00	10.00	20.00	20.50	10.00

Korting and other foreign panels available on request.

Postage & Packing £1.25

COLOUR TUBES 19" 18.00 19" A49.192 £20 20" 20.00 22" 25.00 25" 18.00 26" 32.00 Plus P & P £4	COLOUR TUNERS Bush 6.50 GEC 6.50 Philips G6 S/S 6.50 Thorn 3000 6.50 Pye G91/697 7.50 Some new tuners in stock can supply on request. Many Foreign Tuners also available on request. Plus P & P £1	COLOUR LOPTS Most lopts available from £7.00. Both British & Foreign makes. Please ring or write. P & P per lopt £1	MISC. S/Output transformer from £1.50 F/Output from £1.25 Scancoils from £5.00 P & P £1 Other spares available on request.	G8 PANELS SPECIAL OFFER CHROMA £12.00 I.F. £10.00 POSTAGE & PACKING £1.25 PER PANEL.
--	---	--	--	--

MAIL ORDER TVs GOOD WORKING

COLOUR				MONO			
Pye 19"	£55.00	22"	£65.00	26"	£75.00	20" & 24" S/S	£16.00
GEC 19"	£55.00	22"	£65.00	26"	£75.00	20" & 24" D/S	£14.00
Bush 19"	£65.00	22"	£75.00	26"	£85.00	19" & 23" D/S	P/button £12.00
Philips G6	—	22"	£73.00	26"	£75.00	19" & 23" D/S	Rotary £8.00

Many other makes & models available.

PERSONAL CALLERS WELCOME

Please ring or write for information.

12½% V.A.T. on all prices colour & mono.

P & P £8.00 per colour set. P & P £5.00 per mono set.

WHY NOT TRY OUR EXPRESS MAIL ORDER ON ANY OF THE ITEMS LISTED.

PLEASE ADD 12½% V.A.T. TO ALL ITEMS AND OVERSEAS AT COST. CASH WITH ALL ORDERS.

BRIARWOOD TELEVISION LTD.

Preston Street, Bradford, West Yorkshire BD7 1NS Tel (0274) 306018

TELEVISION SALE

DISCOUNT FOR QUANTITY

MONO

Rotaries 19" & 23"

	£
GEC	3.00
Thorn 950 etc.	3.00
K.B.	3.00
Pye	3.00
Thorn 1400	4.50

D/S P/B 19" 23"

	£
Thorn 1400	7.00
Bush 161 etc.	7.00
Baird 660 etc.	7.00
Philips 210 etc.	7.00
Pye Olympic etc.	7.00

D/S P/B 20" 24"

	£
Bush	10.00
GEC	10.00
Philips	10.00
Pye	10.00
Thorn	10.00

S/S 20" 24"

	£
Bush 313 etc.	12.00
Pye 169 chassis	12.00
Thorn 1500	12.00
GEC series 1 & 2	12.00
Decca MS series	12.00

S/S COLOUR

	19"	20"	22"	25"	26"
	£	£	£	£	£
GEC	40	45	45	45	50
Philips	-	-	45	45	50
Thorn	65	-	65	65	85
Bush	60	-	65	65	75
Kort	-	-	65	-	75
Pye					
Varicap	-	-	60	-	70

MAINS DROPPERS

All Popular Makes now in stock e.g.
 1500 @ 60p Philips 210 @ 40p
 8000 @ 54p Bush 161 @ 40p
 G8 @ 36p Pye 723 @ 47p
 GEC 2110-41R @ 45p

PLEASE NOTE THERE IS
 12½% V.A.T.

Please note all mono sets sold as
 100% comp. No broken masks, no
 broken panels etc.
 Colour sets sold with good c.r.t.s and
 100% comp.

Working Mono £3.00 extra
 Working Colour £15.00 extra
 Supplied in 1's or 100's

**WE DO NOT SELL RUBBISH
 AT
 BRIARWOOD TV LTD
 EXPORT
 COLOUR & MONO T.V.s
 AVAILABLE READY FOR USE
 ABROAD**

BRIARWOOD TELEVISION LTD.

Preston Street, Bradford, West Yorkshire BD7 1NS.
 Tel: (0274) 308018.

All transistors, IC's, offered are new and branded. Manufactured
 by Mullard, I.T.T., Texas, Motorola etc.

Please add 12½% VAT to all items and overseas at cost.

P & P U.K. 25p per order, overseas allow for package and postage. Cash with all orders. All prices subject to alteration without notice.

TYPE	PRICE £	TYPE	PRICE £	TYPE	PRICE £	TYPE	PRICE £
AC107	0.23	BC171	0.12	BF260	0.24	1N5404	0.12
AC113	0.17	BC172	0.12	BF262	0.28	1N5406	0.13
AC115	0.17	BC173	0.15	BF263	0.25	1N540B	0.16
AC117	0.24	BC177	0.14	BF271	0.20		
AC125	0.20	BC178	0.14	BF273	0.12	VALVES	
AC126	0.18	BC179	0.14	BF336	0.35	DYB7	0.52
AC127	0.19	BC182L	0.08	BF337	0.24	DYB02	0.64
AC128	0.17	BC183L	0.07	BF338	0.29	ECC82	0.52
AC131	0.13	BC184L	0.11	BF42	0.26	EF80	0.40
AC141	0.23	BC186	0.18	BFT43	0.24	EF183	0.60
AC142	0.19	BC187	0.18	BFX84	0.27	EF184	0.60
AC141K	0.29	BC209	0.14	BFX85	0.27	EH90	0.60
AC142K	0.29	BC212	0.13	BFX8B	0.24	PCB6	0.76
AC151	0.17	BC213L	0.09	BFY37	0.22	PCBB	0.76
AC165	0.16	BC214L	0.14	BFY50	0.18	PCC89	0.65
AC166	0.16	BC237	0.07	BFY51	0.17	PC1B9	0.65
AC168	0.17	BC240	0.31	BFY52	0.18	PCF80	0.70
AC176	0.17	BC281	0.24	BFY53	0.27	PCF86	0.68
AC176K	0.28	BC262	0.20	BFY55	0.27	PCF801	0.70
AC17B	0.16	BC263B	0.20	BHA0002	1.90	PCF802	0.74
AC186	0.26	BC267	0.19	BR100	0.20	PCLB2	0.67
AC187	0.21	BC301	0.26	BSX20	0.23	PCLB4	0.75
AC188	0.20	BC302	0.30	BSX76	0.23	PCLB6	0.78
AC187K	0.34	BC307	0.10	BSY84	0.36	PCL805	0.75
AC188K	0.34	BC337	0.13	BT106	1.18	PCF200	1.00
AD130	0.50	BC338	0.09	BT108	1.23	PL36	0.90
AD140	0.65	BC307A	0.12	BT109	1.09	PL84	0.74
AD142	0.73	BC308A	0.12	BT116	1.23	PL504	1.10
AD143	0.70	BC309	0.14	BT120	2.08	PL509	2.45
AD148	0.70	BC547	0.09	BU105/02	1.87	PYB8	0.63
AD149	0.64	BC548	0.11	BU105/04	2.25	PY500A	1.60
AD161	0.41	BC549	0.11	BU126	1.40	PYB1/800	0.57
AD162	0.48	BC557	0.11	BU205	1.97		
AD161	1.30	BD112	0.39	BU208	2.49	E.H.T. TRAYS MONO	
AD162		BD113	0.65	BY126	0.09	950 MK2 1400	2.26
AF106	0.42	BD115	0.40	BY127	0.10	1500 18" 19" stick	2.37
AF114	0.23	BD116	0.47			1500 24" 5 stick	2.48
AF115	0.22	BD124	1.30	OC22	1.10	Single stick Thorn TV	
AF116	0.22	BD131	0.32	OC23	1.30	11.16K 70V	0.75
AF117	0.30	BD132	0.34	OC24	1.30	TV 20 2 MT	0.75
AF118	0.40	BD133	0.37	OC25	1.00	TV20 16K 18V	0.75
AF121	0.43	BD135	0.26	OC26	1.00		
AF124	0.33	BD136	0.26	OC28	1.00		
AF125	0.29	BD137	0.26	OC35	1.00	IC's	
AF126	0.29	BD138	0.26	OC36	0.90	SN76013N	1.20
AF127	0.29	BD139	0.40	OC38	0.90	SN76013ND	1.00
AF139	0.39	BD140	0.28	OC42	0.45	SN76023N	1.20
AF151	0.24	BD144	1.39	OC44	0.20	SN76023ND	1.00
AF170	0.25	BD145	0.30	OC45	0.20	SN76226DN	1.50
AF172	0.20	BD222/T1P31A	0.39	OC46	0.35	SN76227N	1.20
AF178	0.49	BD225/T1P31A	0.39	OC70	0.22	TBA341	0.97
AF180	0.60	BD234	0.34	OC71	0.28	TBA520Q	1.45
AF181	0.30	BD222	0.50	OC72	0.35	TBA530Q	1.20
AF186	0.29	BDX22	0.73	OC74	0.35	TBA540Q	1.45
AF239	0.43	BDX32	1.98	OC75	0.35	TBA550Q	1.60
AU113	1.29	BDY18	0.75	OC76	0.35	TBA560CQ	1.80
		BDY60	0.80	OC77	0.50	TBA570Q	1.00
		BF115	0.24	OC78	0.13	TBA800	1.00
BA130	0.08	BF121	0.21	OC7B	0.13	TBAB10	1.50
BA145	0.14	BF154	0.19	OC81	0.20	TBA920Q	1.80
BA148	0.17	BF158	0.19	OC810	0.14	TBA990Q	1.60
BA155	0.10	BF159	0.24	OC82	0.20	TCA270SQ	1.45
BAX13	0.05	BF160	0.23	OC820	0.13	TCA270SA	1.45
BAX16	0.08	BF163	0.23	OC83	0.22	TCA1327B	1.00
BC107	0.12	BF164	0.17	OC84	0.28		
BC108	0.12	BF167	0.23	OC85	0.13	E.H.T. TRAYS	
BC109	0.12	BF173	0.21	OC123	0.20	COLOUR	
BC113	0.12	BF177	0.26	OC169	0.20	Pye 691 693	4.50
BC114	0.14	BF178	0.24	OC170	0.22	Decca (large screen)	
BC115	0.12	BF179	0.28	OC171	0.27	CS2030/2232/2630/ 2632/2230/2233/ 2631	5.67
BC116	0.12	BF180	0.30	OA91	0.05	Philips GB 520/40/50	
BC117	0.13	BF181	0.34	BRC4443	0.65		5.66
BC119	0.24	BF182	0.30	R200BB	1.50	Philips G9	5.79
BC125	0.15	BF183	0.29	R2010B	1.50	GEC C2110	5.50
BC126	0.09	BF184	0.23	R2305	0.38	GEC Hybrid CTV	5.40
BC136	0.14	BF185	0.29	R2305/BD222	0.37	Thorn 3000/3500	5.50
BC137	0.14	BF186	0.30	SCR957	0.81	Thorn 800	2.42
BC138	0.24	BF194	0.09	TIP31A	0.38	Thorn 8500	5.23
BC139	0.21	BF195	0.09	TIP32A	0.36	Thorn 9000	6.10
BC140	0.31	BF196	0.12	TIP3055	0.53	GEC TVM 25	2.5D
BC141	0.22	BF197	0.10	T1590	0.19	ITT/KB CVC 5/7/8/9	
BC142	0.19	BF198	0.15	T1591	0.19		5.50
BC143	0.19	BF199	0.14	TV106	1.09	RRI (RBM) AB23	5.89
BC147	0.09	BF200	0.28			Bang & Olufsen	
BC148	0.09	BF216	0.12			4/5000 Grundig	
BC149	0.09	BF217	0.12	DIODES		5010/5011/5012/ 6011/6012/7200/ 2052/2210/2252R	
BC153	0.12	BF218	0.12	1N4001	0.04	Tandberg (radionette)	
BC154	0.12	BF219	0.12	1N4002	0.04	Autovox	6.80
BC157	0.10	BF220	0.12	1N4003	0.06	Grundig 3000/3010	
BC158	0.11	BF222	0.12	1N4004	0.07	Saba 2705/3715	
BC159	0.11	BF221	0.12	1N4005	0.07	Telefunken 709/710/ 717/2000	6.80
BC160	0.28	BF224	0.12	1N4006	0.08	Korting	6.80
BC161	0.28	BF256	0.37	1N4007	0.08		
BC167	0.13	BF258	0.27	1N4148	0.30		
BC168	0.10	BF259	0.27	1N4751A	0.11		
BC169C	0.12			1N5401	0.10		

TTLs	7494	90p	74196	100p	4093	94p	MC7242	120p*	8C108C	12p	8D234	70p	TIP29A	45p	2N2218	28p	2N4259	150p*	40411	300p	
7400	13p	7495	75p	74197	130p	4098	120p	MFC4008	120p*	8C109	12p	BF180	32p	TIP29B	50p	2N2218A	28p	2N4286	18p*	40412	60p
7401	14p	7496	90p	74198	250p	4099	145p	MFC6040	95p*	8C109B	12p	BF181	32p	TIP29C	50p	2N2219	25p	2N4287	18p*	40430	85p
7401AN	15p	7497	290p	74199	280p	4160	105p	MHQ3476	90p*	8C109C	12p	BF182	32p	TIP30	40p	2N2219A	25p	2N4288	18p*	40594	90p
7402	15p	74100	140p	74221	175p	4161	105p	MK50362	850p*	8C147	9p*	BF183	32p	TIP30A	45p	2N2220	20p	2N4289	20p*	40595	99p
7403	15p	74104	75p	74400	85p	4162	105p	MK50398	750p*	8C148	9p*	BF194	10p*	TIP30B	45p	2N2221A	20p	2N4290	20p*	40603	58p
7404	20p	74105	75p	74405	45p	4163	105p	MPO3725	85p*	8C149	10p*	BF195	12p*	TIP30C	60p	2N2222	20p	2N4291	20p*	40673	30p
7405	25p	74107	38p	74410	42p	4174	110p			8C157	10p*	BF196	12p*	TIP31A	55p	2N2222A	20p	2N4292	25p*	40841	90p
7406	40p	74109	60p	74411	44p	4175	110p	NE555	30p	8C158	10p*	BF197	14p*	TIP31B	55p	2N2228	20p	2N4293	25p*	40842	110p
7407	40p	74110	75p	74510	40p	4194	105p	NE556	65p	8C159	11p*	BF198	15p*	TIP31C	60p	2N2236	18p	2N5172	28p*	40871	90p
7408	22p	74111	75p			4408	710p	NE560	320p	8C169C	14p*	BF199	20p*	TIP32	60p	2N2369A	18p	2N5194	90p*	40872	90p
7409	22p	74116	220p			4409	710p	NE561	395p	8C172	12p*	BF200	32p*	TIP32A	80p	2N2646	50p	2N5245	40p*	Oides	
7410	18p	74118	110p	CMOS		4410	715p	NE562B	420p	8C177	17p*	BF224	20p*	TIP32B	75p	2N2904	25p	2N5296	55p*	8AX13	8p
7411	28p	74119	225p	4000	18p	4419	280p	NE565	420p	8C178	17p*	BF240	18p*	TIP32C	82p	2N2904A	25p	2N5457	40p*	0A47	8p
7412	25p	74120	130p	4001	18p	4422	550p	NE568A	125p	8C179	18p	BF241	18p*	TIP33	90p	2N2905A	25p	2N5458	40p*	0A81	13p
7412AN	28p	74121	32p	4006	95p	4433	1250p	NE566	185p	8C182	10p*	BF248	35p*	TIP33A	90p	2N2906	20p	2N5459	40p*	0A70	8p
7413	40p	74122	54p	4008	120p	4435	800p	NE567	170p	8C183	10p*	BF257	35p*	TIP33C	110p	2N2906A	24p	2N5485	44p*	0A85	15p
7416	40p	74123	75p	4009	50p	4450	290p	SFC2741	25p	8C184	11p*	BF258	32p	TIP34	96p	2N2907	25p	2N5627	45p*	0A90	8p
7417	40p	74128	85p	4010	60p	4451	290p	SN72702	60p	8C187	30p	BF259	36p	TIP34A	110p	2N2907A	330p	2N5645	420p*	0A91	9p
7420	18p	74128	85p	4011	18p	4501	18p	SN72709AN	90p	8C212	11p*	BF324	36p	TIP34B	110p	2N2926	2p	3N128	120p	0A200	9p
7421	43p	74128	85p	4012	15p	4502	120p	SN72733N	125p	8C213	11p*	BF337	36p*	TIP34C	155p	2N3053	28p	3N140	100p	0A202	9p
7422	26p	74130	110p	4013	50p	4503	85p	SN76003N	175p*	8C213L	11p*	BF340	36p*	TIP35A	220p	2N3055	55p	3N141	85p	1N914	4p
7423	38p	74132	82p	4014	110p	4505	55p	SN76013N	140p*	8C214	13p*	BF341	36p*	TIP35B	280p	2N3702	12p	3N142	110p	1N916	4p
7425	33p	74135	60p	4015	35p	4507	55p	SN76023N	140p*	8C217	13p*	BF342	36p*	TIP36A	280p	2N3703	12p	3N143	110p	1N4001/2	6p
7426	43p	74136	80p	4016	50p	4508	285p	SN76033N	175p*	8C218	13p*	BF343	36p*	TIP36B	330p	2N3704	12p	40347	65p	1N4003/4	7p
7427	40p	74137	60p	4017	100p	4510	95p	SN76110	195p*	8C237	18p*	BF344	36p*	TIP36C	330p	2N3705	12p	40348	80p	1N4005/6	8p
7428	40p	74141	85p	4018	110p			SN76115	195p*	8C237A	18p*	BF345	36p*	TIP36D	330p	2N3706	12p	40349	80p	1N4007	8p
7430	18p	74142	300p	4019	50p			SN76227	110p*	8C237B	18p*	BF346	36p*	TIP41B	80p	2N3706A	14p*	40360	40p	1N4007	8p
7431	35p	74143	95p	4020	120p			SN76680	75p*	8C238	18p*	BF347	36p*	TIP41C	75p	2N3707	14p*	40361	45p	1N4148/9	4p
7433	44p	74147	210p	4021	11p			TA450	45p*	8C238A	18p*	BF348	36p*	TIP42A	70p	2N3708	14p*	40362	45p	Zeners	
7437	38p	74148	160p	4022	100p			TA4821A	200p*	8C238B	18p*	BF349	36p*	TIP42B	82p	2N3709	14p*	40407	45p	8ZY88C	400mW
7438	38p	74150	130p	4023	25p			TA4861A	155p*	8C238C	20p*	BF350	36p*	TIP42C	82p	2N3819	25p*	40408	70p	2v7-18v	8p*
7440	18p	74151	81p	4024	80p			TAD100	150p*	8C328	18p*	BF351	36p*	TIP2955	70p	2N3820	50p*	40409	65p	8ZX79C	500mW
7441	90p	74153	85p	4025	20p			TA8120S	170p*	8C337	18p*	BF352	36p*	TIP3055	70p	2N3823	70p*	40410	65p	6v2	8p*
7441AN	120p	74154	140p	4026	140p			TB1A540Q	220p*	8C338	18p*	BF353	36p*	TIS43	34p*	2N3866	85p*				
7442	75p	74155	97p	4027	85p			TB1A550Q	330p*	8C347	18p*	BF354	36p*	TIS90	22p*	2N3903	15p*	741s	5	for £1.00	
7443	120p	74156	96p	4028	95p			TB1A550Q	330p*	8C348	18p*	BF355	36p*	TIS91	25p*	2N3904	15p*	555s	4	for £1.00	
7444	120p	74157	98p	4029	120p			TB1A641811	240p*	8C349	18p*	BF356	36p*	TIS92	30p*	2N3905	20p*	TTL 209	10	for £1.00	
7445	97p	74159	250p	4030	50p			TB1A651	180p*	8C349A	18p*	BF357	36p*	TIS93	30p*	2N3906	20p*	8AX 13	20	for £1.00	
7446	110p	74160	110p	4031	250p			TB1A800	85p*	8C349B	18p*	BF358	36p*	ZTX108	12p*	2N4036	85p*	6V2 Zeners	20	for £1.00	
7447	75p	74161	110p	4032	240p			TB1A810S	105p*	8C349C	18p*	BF359	36p*	ZTX300	13p*	2N4037	85p*				
7448	85p	74162	110p	4033	130p			TB1A820	75p*	8C349D	18p*	BF360	36p*	ZTX500	15p*	2N4038	85p*				
7450	18p	74183	100p	4034	100p			TB1A820	75p*	8C350	14p*	BF361	36p*	ZTX502	18p*	2N4039	85p*				
7451	18p	74184	120p	4035	130p			TB1A820	75p*	8C351	14p*	BF362	36p*	ZTX503	18p*	2N4040	85p*				
7453	18p	74165	150p	4036	100p			TB1A820	75p*	8C352	14p*	BF363	36p*	ZTX504	30p*	2N4041	85p*				
7454	18p	74166	160p	4037	100p			TB1A820	75p*	8C353	14p*	BF364	36p*	ZTX505	30p*	2N4042	85p*				
7480	18p	74167	320p	4038	100p			TB1A820	75p*	8C354	14p*	BF365	36p*	ZTX506	30p*	2N4043	85p*				
7470	38p	74170	280p	4039	100p			TB1A820	75p*	8C355	14p*	BF366	36p*	ZTX507	30p*	2N4044	85p*				
7472	32p	74172	850p	4040	50p			TB1A820	75p*	8C356	14p*	BF367	36p*	ZTX508	30p*	2N4045	85p*				
7473	35p	74173	190p	4041	50p			TB1A820	75p*	8C357	14p*	BF368	36p*	ZTX509	30p*	2N4046	85p*				
7474	38p	74174	210p	4042	90p			TB1A820	75p*	8C358	12p*	BF369	36p*	ZTX510	30p*	2N4047	85p*				
7475	43p	74175	95p	4043	100p			TB1A820	75p*	8C359	12p*	BF370	36p*	ZTX511	30p*	2N4048	85p*				
7476	38p	74176	130p	4044	100p			TB1A820	75p*	8C360	12p*	BF371	36p*	ZTX512	30p*	2N4049	85p*				
7480	54p	74177	120p	4045	140p			TB1A820	75p*	8C361	12p*	BF372	36p*	ZTX513	30p*	2N4050	85p*				
7481	110p	74180	110p	4046	130p			TB1A820	75p*	8C362	12p*	BF373	36p*	ZTX514	30p*	2N4051	85p*				
7482	90p	74181	320p	4047	430p			TB1A820	75p*	8C363	12p*	BF374	36p*	ZTX515	30p*	2N4052	85p*				
7483	100p	74182	150p	4048	25p			TB1A820	75p*	8C364	12p*	BF375	36p*	ZTX516	30p*	2N4053	85p*				
7484	110p	74184	250p	4049	25p			TB1A820	75p*	8C365	12p*	BF376	36p*	ZTX517	30p*</						

TV'S TV'S TV'S

THOUSANDS OF MONO TV'S IN STOCK

All makes - all sizes from £4.00.
Square screen from £8.00.

Clearance of 25" D/STD Colour Sets. (Philips 500 and GEC 2028 only) £24.00 plus £6 p/pkg.

Over 2,000 S/STD Colour TV's in stock, inc. Pye Varicaps, Bush Integrated, Thorn 3000/3500/8000, Decca Bradford, GEC 2100, Korting, Grundig, Luxor etc.
With tube tested from £48.00. Working sets from £64.00.

Earlier model S/STD i.e. Philips 511, GEC 2040, Pye Hybrid.
Quantities from £36.00 each.
Singles working from £48.00.

EX-TV SPARES

COLOUR PANELS

Only supplied for models Philips G6, RBM, GEC, EMO, Pye Hybrid varicap, Korting, Bush or Pye LTB Module.

£14.00 plus £2 p/pkg.

Chroma all models

£11 plus £1 p/pkg.

All other panels

£7.00 plus £1 p/pkg.

COLOUR TUNERS

Most makes £5.00 plus £1 p/pkg.

MONO PANELS/TUNERS

Most types

£3.00 plus £1 p/pkg.

COLOUR TUBES

(fully tested)

25" £16.00

19" £20.00

22" £24.00

26" (90°) £28.00

26" (110°) £32.00

Plus £4.00 p/pkg.

MONO TUBES

(fully tested)

19" and 23" only (Most types)

£5.00 plus £3 p/pkg.

SPECIAL OFFER:

26" EUROSONIC COLOUR TV with 110° super slim tube, electronic varicap tuner with VHF capability, slider controls inc. tint, dark teak cabinet. Complete with circuit diagram and full spares availability.

Unserviced with tube tested £58.00

Fully serviced working £78.00

Add £6.00 p/pkg. or collect any depot (except Scotland).

PLEASE ADD 12½% V.A.T. TO ALL ORDERS.

MAIL ORDER SEND C.W.O. TO TRITEL (NORTHERN AND SOUTHERN ONLY) CASH COLLECT AT ALL OTHER BRANCHES. UNCROSSED PO'S ONLY.

QUANTITY DISCOUNTS, DELIVERIES ARRANGED.



LONDON:
Kingsley House, Dff Avonmore Rd.,
(Opp. Olympia),
Hammersmith Rd.,
London W14.
Tel. (01) 602 2982.

WEST:
Unit 4a,
Bulwark Industrial Est.,
Chepstow,
Nr. Bristol.
Tel. Chepstow (02912) 6652.

SOUTHERN:
Watling Street,
Hockcliffe, North
Dunstable (on A5).
Tel: Hockcliffe
(052521) 768.

NORTHERN:
Thornbury
Roundabout,
Leeds Rd.,
Bradford 3.
Tel: (0274) 665670.

SCOTLAND:
Peacock Cross Industrial
Estate,
Burnbank Rd.,
Hamilton.
Tel: (06984) 29511.

ARE YOU IN THE DARK? .. ABOUT OUR



COLOUR T.V. PANEL EXCHANGE REPAIR SERVICE

FULL RANGE OF
THORN · RBM · PHILIPS
PYE · INVICTA · GEC
DECCA · TELPRO
AND MANY OTHER MAKES

90 DAY GUARANTEE ON ALL REPAIRS
SAME DAY POSTAL SERVICE

We employ a large skilled Staff, who utilise some of the most sophisticated Test equipment available, inclusive of AUTOMATIC FAULT FINDING COMPUTORS together with specially designed SERVICING JIGS which in short means to you: -

HIGH QUALITY REPAIRS - AT LOW COST



ONE OFF OR



100 OFF · NO ORDER TOO LARGE OR SMALL

SEND FOR PRICE LIST

SEND FOR CATALOGUE
BLOCK DISCOUNTS FOR TRADE CONTRACTS

TO

Campbell Electronics Ltd.

Factory Unit E5, Halesfield 23, Telford, Shropshire, TF7 4QX
Telephone: Telford (0952) 584373, Ext. 2. Telex 35191 Chamcon

ARE YOU

USING YOUR SPARE TIME PROFITABLY?

If not, you're losing money. Money that you could be making by selling used colour televisions from home in the evenings. In fact, provided you start correctly and know exactly how to operate, you can easily earn a substantial CASH INCOME with a starting capital of less than £20. Our new unique publication "How to Deal Successfully in Used Colour Televisions" enables you to follow in the footsteps of many experts who have a great deal of combined experience in this lucrative home business, and who have 'pooled' their knowledge to help you. After all, to follow the advice of someone who has travelled the ground before you, is to be given the best possible start. And the hundreds of valuable trade secrets, hints, tips and suggestions in the guide show exactly how anyone of average intelligence can succeed immediately.

Every aspect, from securing the first television right through to rapid expansion of sales, is covered with the detailed knowledge of experts to ensure certain success. Indexed information on almost all makes of television is presented in clear tabular form, describing performance, reliability, price and service. In particular, the tips on expanding the business are very practical, and are almost automatic when put into practice. Pages of unique advice on advertising ensure that maximum sales are secured, and sources of supply are described in detail - for both televisions and new/used spares. Monochrome sets are also covered, as are "invisible" cabinet repairs. Plus FREE un-going advice and FREE regular updating service.

You can start tomorrow - but you'll need our guide. The latest big illustrated edition is out now, and costs just £4.95 - a small price to pay for financial independence!

SAME DAY SERVICE

CITY PUBLISHING, HEYWORTH ROAD, SANDIACRE, NOTTINGHAM NG10 5LL

To: City Publishing, Heyworth Road, Sandiacre, Nottingham NG10 5LL.

Please send by return post "How to Deal Successfully in Used Colour Televisions".

I enclose cheque/p.o. for £4.95.

NAME

ADDRESS

BIG NEW EDITION
OUT NOW!

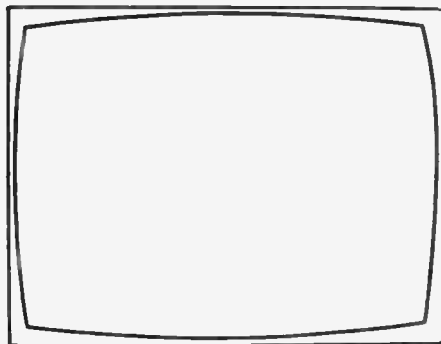

TELEVISION

Give the OBA a Chance!

EDITOR

John A. Reddihough

ASSISTANT EDITOR

Luke Theodossiou

ART EDITOR

Roy Palmer

ADVERTS MANAGER

Roy Smith 01-261 6671

CLASSIFIED ADVERTS

Colin R. Brown 01-261 5762

The government's white paper on the future of broadcasting proposes that the UK's fourth TV channel should be run by a new broadcasting authority, the OBA (Open Broadcasting Authority), and that it should be financed partly by advertising and partly by a government grant. The proposals put forward in the white paper seem to have made little public impact however, doubtless due to the unfortunate timing of the paper's publication – at the run up to a likely autumn general election.

The government has taken its time in reaching a decision, as indeed did the Annan committee in putting forward its proposals following its long enquiry into the future of broadcasting, started in 1974. We have gone on record before in supporting the idea of the OBA, and continue to do so. We don't like politics to enter these pages, since they are largely irrelevant to the concerns of a technical magazine. The decisions now necessary on the future of broadcasting in the UK have become political ones however, a matter we feel to be one for public regret. It seems to us a pity that a non-party enquiry should be set up to consider the future of broadcasting but, when it comes up with modest though imaginative proposals, the decision on whether or not to accept them gets tossed back into the party political arena. It should have been possible to have achieved an all-party approach to the question of how we are to make use of the broadcasting frequencies available to us. But, dare we mention it, there are of course considerable commercial interests at stake.

The conservative party has come out against the idea of the OBA and in favour of making the fourth channel ITV-2. It says this would be cheaper, which is true. But the cost of setting up and running the OBA would be quite marginal. You could argue that ITV-2 would be in a better position to provide quality programmes since the ability of a wholly commercial network to obtain advertising revenue would provide the cash necessary to do so. But there's the rub. You can sell advertising only if you can guarantee a substantial audience, and this automatically means heavy reliance on wide appeal programming. The conclusion seems inescapable: if we want a new TV channel which will provide something different from the present run of programmes offered to the public, it'll have to be run on different lines (the BBC is not interested in running another TV channel).

The reaction of many members of the public to a fourth channel seems to be that we've already got enough TV thank you! This is precisely why the idea of the OBA is so important, and why it should be a better solution than ITV-2. It's a question of trying to provide a wider choice, a genuine alternative to what's being broadcast by the present three networks: this is surely what the public is entitled to expect from its fourth channel when it gets one.

Since broadcasting is a matter that doesn't rate all that highly amongst the concerns of those involved in the day-to-day political life of the country, decisions on it are unfortunately all too likely to be taken at the last minute and for the wrong reasons. The decision about the fourth channel is particularly important however. We're not going to get another opportunity for a long time to set up an organisation with a fresh approach to TV broadcasting. What's required in reaching this decision is delicate judgement and imagination, but these, unfortunately, are qualities that don't tend to flourish in the hurly-burly of day-to-day politics.

It could be of course that the OBA would not turn out to be a useful source of alternative programmes: the point however is that it should be given a worthwhile opportunity to see what it can achieve. The BBC and IBA have turned out to be successful institutions. Let's see whether the OBA can also do so.

COVER

We don't need to tell you what's on the cover. Roy Palmer's daughter Vivienne. The nearby set is displaying the Philips PM5544 test pattern. A later type of field timebase i.c. was adopted for the final version of the set, giving greatly improved field linearity.

Teletopics

VIEWDATA SERVICING AND DEVELOPMENTS

GEC Semiconductors is offering a tailor-made training course in Prestel (viewdata) terminal servicing – claimed to be the first such course. A group of Granada TV Rentals engineers has already attended the course, at GEC's East Lane, Wembley centre. A company spokesman comments that GEC will prepare courses for ten or more engineers, with the syllabus tailored to meet the group's exact requirements. Costs are likely to be around £100-£150 per person – the Granada course lasted for three days, with the majority of the time being spent in the workshop doing "hands on" training. GEC Semiconductors is deeply involved in work on the specialised i.c.s required for this application. Two new purpose-designed i.c.s to allow a full typewriter keyboard to be linked to a viewdata terminal by remote control are under development by GEC. These devices, one for the transmitter unit and one for the receiver, will be able to handle up to 256 control channels. GEC comment that ultrasonic links are insufficiently flexible with this number of channels, leading to the use of infra-red links instead. Prototype versions of these i.c.s are expected to be available to setmakers by the end of the year.

According to GEC, sales of the present generation of Prestel and teletext modules are going very well, though high-volume production has not yet started. About 2,000 complete kits are understood to have been ordered from GEC. These are sold as complete printed board assemblies, a set of four separate modules being required for a complete Prestel-teletext system. The sets of boards are being sold to setmakers at around £250-£300, but GEC expect the price to fall dramatically – to around the £25-£30 mark – when specialised i.c.s for the application become available. This is expected to be within eighteen months or so.

TV INVESTMENT

An important investment programme has been announced by Mullard. £24 millions is to be spent on further improving the manufacturing facilities at the company's Durham colour tube assembly plant and in establishing a production line for 20in., 90° colour tubes at the Simonstone plant. The programme is backed by a £4.5m grant under the government's industry support scheme, and will cover a three year period. Investment at Simonstone will total £13.1m and at Durham £7.8m. There will be further investment at Washington, where the neck components for the new 90° tube will be made, and £0.9m at Crossens where the related magnetic components will be manufactured.

The investment, in what Mullard call Project Vanguard, is considered to be vital in enabling an enhanced and expanding range of colour tubes and ancillary components to be offered to meet setmakers' requirements. Mullard aim to increase their share of the UK tube market from around half in 1978 to over two-thirds by 1981 – both figures based on a total market of some 1.8 million sets. The project is also intended to strengthen Mullard's export performance – 40 per cent of tube output was exported in 1978.

Mullard's managing director Jack Ackerman commented that the government's grant is a clear recognition of the

need to maintain, through viable UK-based tube production, a healthy and prosperous TV setmaking industry in the UK.

It's interesting to note that whereas 110° deflection has come to be the accepted standard for the larger sizes of self-converging in-line gun tubes, for the smaller sizes – 20in. and below – 90° has remained the accepted standard.

Meanwhile Thorn have announced an increase in their planned investment for rationalising colour set production – from £5m to £8m. The investment will go largely into automatic production and testing equipment. Production is to be concentrated at Thorn's Gosport and Enfield plants, and the aim is to achieve internationally competitive sets and costs.

Increased demand for the Philips TX monochrome portable chassis has led to the second increase in production capacity this year at their Lowestoft TV factory.

SPONTANEOUS CHANNEL CHANGING

A reader recently sent us a cutting from a Scottish paper with a story about a set changing channels due to a budgerigar's bell. We've come across similar occurrences before – due to jangling keys and so on. Such things can happen with simple remote control systems when harmonics cause the remote control system to operate. With more elaborate remote control systems error protection is built in, the system operating only when it counts bursts of signal which it converts to pulses.

Random channel changing can also be caused by the discharge of static build up. Rank have encountered this problem on some of their current chassis, and to overcome it are now fitting a 50mm square piece of self-adhesive PVC tape across the gap in the Claylastic trim at the bottom of the c.r.t. The tape is attached along the centre line of the trim and then taken down towards the bottom of the cabinet so as not to be seen from the front. Part number of the tape is 1252 0159.

VIDEO NEWS

National Panasonic point out that while their new VHS-standard Model NV8600 VCR is compatible with other machines made to this standard it nevertheless incorporates exclusive features such as direct motor drive and a diecast chassis for operating stability and robustness, and is "not just a relabelled version of somebody else's machine". The NV8600 shares the same basic specification as other VHS machines, and is in the same price range at £750 including VAT.

There seems to have been a considerable fall-off in domestic video recorder sales in the US recently – figures as high as 50 per cent have been mentioned – which could well account for the increased interest being shown by Japanese VCR manufacturers in the European market. We might yet prove wrong, but it's never seemed to us that the VCR is likely to become a mass-market item.

IPC have entered the video market with a package of ten prerecorded videocassettes providing what they call "alternative television". The cassettes are to the Philips N1700 standard, but production of cassettes to the VHS

standard is planned to start in November. There are no plans so far to produce cassettes to the Sony Betamax standard. The packs are available only as a complete package containing the ten different tapes, and the price to dealers is £269.40 exclusive of VAT. Pack one covers sailing (58 minutes), equestrian games (52 min), the 1977 British Open Golf Championship (52 min), a history of golf (one hour), the world of birds (56 min), a history of Le Mans motor sport (52 min), angler's corner (one hour), Wimbledon 1977 (52 min), a history of Wimbledon (50 min), and skiing (58 min). A display box and point-of-sale material are included, and a national advertising campaign is planned. Further details can be obtained from IPC Video, Surrey House, Throwley Way, Sutton, Surrey SM1 4QQ, telephone 01-643 8040.

The first ever purpose-built TV games centre, called Silicon Chip, has been opened at 46 London Road, Kingston, Surrey (01-549 6657). The fittings include seven TV sets to enable devotees to try the large number of games held in stock, ranging from the simple four-game monochrome units to highly sophisticated microprocessor-based colour cartridge types such as the Optim Majestic video computer. The games can also be demonstrated on a projection unit with a 42 x 52in. screen – the projection unit itself can be supplied for £845 plus VAT.

General Instrument Microelectronics have introduced a new set of MOS microcircuits for use in cartridge-based programmable TV games systems. Known as System 8601, the circuits include a clock generator, colour encoder, modulator and a selection of cartridge microcircuits – enabling fully programmable games systems to be built at low cost.

Each games system will consist of a console into which individual game set cartridges are slotted. Each console will contain the clock, encoder and modulator as well as the game controls, switches, power supplies, etc. Each cartridge contains the individual games microcircuits plus interface circuitry. All sets will feature realistic sound generation and on-screen scoring.

Some of the cartridge-mounted microcircuits are already available, including the 8610 "Supersport" (20 games), the 8765 "Motorcycle" (8 games) and the 8603 "Road Race" set (3 games). Three more circuits – the 8607 "Target" (12 games), the 8606 "Wipeout" (24 games) and 8605 "Warfare" (10 games) – will go into production within two months, with more to follow before the end of the year.

GIM introduced the AY-3-8500, which became the video games industry's standard i.c., in 1976.

INTELLIGENT GAMES CHIP

ITT have released details of a new i.c., type SAA1080, which provides ten games and is intended for use in conjunction with ITT ultrasonic or infrared i.c. remote control systems. The SAA1080 is incorporated inside the set, the player push-button control units being connected to the remote control transmitter. The games provided are: blockade, war at sea, solitaire, master mind, nimb, game of chance, othello, nine men's morris, five in a row and wolf and sheep: the first six are played by a single player against an electronic adversary, the last four requiring two players.

DATA RECEPTION

A code of practice is in preparation to give riggers guidance on the installation of aerials for data reception (teletext). As mentioned in these pages before, ghosts constitute a serious problem with data reception. It's also vital in weak signal areas to orientate the aerial for maximum signal pickup.

Tests carried out by the IBA revealed that in some locations turning the aerial by 10° reduced the teletext signal to virtually nil, while in others a turn of 30° either way made no difference. In 67 per cent of cases studied where difficulty with reception was investigated the problem was due to a weak signal: in 33 per cent of cases the problem was a weak signal plus reflections.

EMO AND EUROSONIC SPARES

Tele-Part (13 Worcester St., Wolverhampton WV2 4LU) tell us that that French manufacturer Matra Electronique has discontinued the production of EMO colour sets, a number of which were imported into the UK. The name EMO has been taken over by L.M.E. (Le Materiel Electronique), who are handling the after sales service of Matra produced sets and have appointed Tele-Part as their UK agents to handle all matters relating to the servicing of these sets.

SERVICE NOTES FROM RANK

Switch-off spot suppression has been added to later versions of Rank's current UK-produced monochrome portable chassis T16A. The modification is simple and can be added to earlier versions if required. R57 (180kΩ) from the brightness control to the 100V rail is replaced by a BZX79/C47V zener diode, with its cathode to the 100V rail and its anode to the brightness control.

The 1-6A mains fuse (7FS2) fitted in the T20 chassis has been changed from a glass cartridge type to a ceramic tube (HRC) type.

In versions of the Z718 and T20 chassis using electromechanical tuning an 0.1μF capacitor has been added between the tuning preset sliders and the screen lead earth in order to prevent bent verticals when the a.f.c. is switched on.

TELETEXT COURSE

In response to requests from those who have attended its previous courses on teletext systems, the South London College (Knights Hill, London SE27 0TX, telephone 01-670 4488) is now offering a course which devotes more time to teletext reception. The short course consists of nine special lectures on receiver decoders and will be held on consecutive Tuesday evenings starting on October 10th. The lectures will last for approximately two hours each, and the fee for the course, which is intended for television and telecommunications technicians and engineers, is £6.50.

TRANSMITTER NEWS

The following relay stations are now in operation:

Corwen, Clwyd BBC-Wales channel 22, HTV-Wales channel 25, BBC-2 channel 28. Receiving aerial group A.

Greenhill, Dyfed, BBC-Wales channel 21, HTV-Wales channel 24, BBC-2 channel 27. Receiving aerial group A.

Kingussie, Highland, BBC-1 (Scotland) channel 40, Grampian Television channel 43, BBC-2 channel 46. Receiving aerial group B.

Montpellier, Bristol, HTV-West channel 23, BBC-2 channel 26, BBC-1 channel 33. Receiving aerial group A.

Praa Sands, Cornwall, BBC-1 channel 55, Westward Television channel 59, BBC-2 channel 62. Receiving aerial group C/D.

Truro, Cornwall, BBC-1 channel 58, Westward Television channel 61, BBC-2 channel 64. Receiving aerial group C/D.

All the above transmissions are vertically polarised.

Never Knock a Neck

Les Lawry-Johns

I didn't like the look of them from the moment they walked in. She was short and fat and an ignoramous to boot. He was short and lean with a pinched look and another ignoramous to complete the pair.

The Saga of Grace and Sid

"If we bring our set in and tell you what's wrong with it, will you put a picture valve in?" she demanded. Before I could think up a telling reply, he staggered in with an ageing dual-standard Bush.

Breaking off the conversation I'd been having with the cat, I surveyed the wreck with a pessimistic eye. "Getting on a bit, isn't it? Think it's worth doing?"

"That's a good set that is," said the self-elected female spokesperson. "It only wants a picture valve."

Having been a coward all my life, particularly when faced with a loud mouthed woman, I connected the set to the mains and stuck an aerial in the socket.

The sound came on reasonably well, but after a long delay all that appeared on the screen was a very very dim raster which did not respond to the brightness. Obviously the tube. Just to confirm this I took the back off and checked the tube base voltages. All correct, grid swinging with the brightness control setting, but with no effect on the dim raster.

I told them that all the valves in the world wouldn't help and that the tube was at fault.

"How can it be the tube?" said the brain of Britain. "There was a lovely picture on it last night, wasn't there Sid?"

"I can't see it being the tube," Sid said dutifully. "Lovely picture last night, just like Grace said."

"Well there ain't no picture on it now," I bawled. "The tube's clapped. Finished. Bugged it is." So saying I tapped the neck of the tube with the handle of a screwdriver.

A nice flash of black and white picture appeared for a split second, then relapsed back to the dim raster as before.

"Do that again," said Sid. "I saw something come on there, there must be something loose."

"Loose, loose, of course it's loose. It's loose inside the tube you twit. Look." I gave the neck another clout. On came the picture in a brief flash, then off it went again.

"Well," said Grace. "That won't cost much to put right, a little thing like that. We'll go up to two pound but no more."

"Oh yes, two pounds all right," pronounced Sid.

That was enough for me. On went the back, out came the aerial, off went the mains. "Sorry, perhaps you ought to get a second opinion. It's beyond me."

"You mean you're not going to do it?" Grace quivered with indignation.

"No I'm not and that's that."

So off they went with lots of uncomplimentary remarks clucking the air as they left.

Later that day they stalked in again.

"We came back to tell you you don't know anything about television sets. There's nothing wrong with that tube. Tell him Sid."

"You nearly made me throw that set away," moaned Sid. "But I took the back off and just cleaned the dust off from under that rubber cap on the side of the the tube and the picture is perfect. And I don't know anything about 'em."

"I do," said Grace. "I used to work in a TV factory and I'm telling you the tube ain't gone. You didn't ought to be 'ere you didn't."

Lots more was said before they went.

My fault of course. I shouldn't have knocked the neck.

I wonder what they said later when it reverted to the open-circuit condition again and there was no more dust to wipe off. I'll never know.

Troubles with a VC300

Kevin came in. He's done quite a few good turns for me in the past, so when he brought in a small ITT Featherlite VC300 which was worrying him I didn't hesitate to take the repair off his hands. The first symptom was field collapse, but the resultant white line was wriggling a bit. So we attacked the field circuit first, and quickly found one of the output transistors (T11, TIS91) open-circuit. In went another and the scan opened up, but with an undulating raster which proclaimed a nasty hum on the main 11V line. This was due to the mains bridge rectifier of course, and another went in without much ado.

This left a clear picture except for a few random flyback lines which appeared to move about the screen as though the sync was about to be lost and the picture about to roll, which it didn't and the field lock was very firm.

Flyback suppression, I mumbled to myself. Now although we've serviced these sets time and again, we were not familiar with the flyback suppression circuit and it was a bit irritating to observe that the lines would vanish for minutes at a time and then reappear, particularly if the panel was disturbed. This prompted us to diagnose (wrongly) a dry-joint or the like. Some time was spent chasing around from the field timebase to the blanking transistor T5.

At last we changed this (using a BF337 as a substitute), and were rewarded with a clear picture which lasted for about fifteen minutes before the picture became impossibly grainy with hissy sound. Back on familiar ground unfortunately. Check aerial socket, cable to tuner, remove tuner from panel. Take off covers. Put tuner back, check voltages. First stage transistor emitter voltage wrong and varying. Trace to where the emitter resistor is returned to earth via a screening peg. Nice crack around peg. Resolder. O.K.

Remove tuner, refit covers and put tuner back. No more trouble. Thanks Kev. With friends like you I don't need enemies.

Taffy's Turntable

We thought you might like to hear this one. We were asked to call to attend to a radiogram which had the complaint that although the radio section worked the turntable would not turn. We left it until there was another

COLOUR T.V. PANEL REPAIR SERVICE

We Specialise in the RBM Chassis
Types A823 - A823A - A823AV - A823B

Which covers the following Colour Television
Receiver models

BUSH	MURPHY	CO-OP
CTV182S	CV1916S	C2203
CTV184S	CV2211S	2011
CT187CS	CV2516CS	184
CTV192	CV1917	1902
CTV194	CV2212	2001
CTV199	CV2213	PLUS VARICAP
CT197C	CV2610C	TUNER MODELS
CTV1026	CV2611	
CTV1120	CV2011	
CTV1122	CV2214	
CTV1126	CV2215	
CT1226C	CV2614	

ALL REPAIRS GUARANTEED

Send large S.A.E. for details & price list to:

CALPAR ELECTRONICS LTD.,
Lilac Crescent, Beeston, Nottingham NG9 1PX
Telephone: 0602-258335

All Enquiries Welcome

PUT YOUR PANEL(S) IN THE POST &
WE'LL GET IT BACK TO YOU SHARPISH!
P.S. - WE ALSO SPECIALISE IN AVO REPAIRS

MULLARD MODULES		AD161 40p	LM1303N 155p
AT6382/15 450p		AD162 40p	LM1456 100p
ELC1043 450p		AD161-2MP 90p	LM3900N 90p
EP9000 280p		AU110 180p	MC1310P 185p
EP9001 280p		BD144 180p	MM5314 430p
EP9002 300p		BDX32 250p	MM5316 550p
LP1152 100p		BU205 220p	NE529K 150p
LP1153 400p		BU208 250p	NE555 28p
LP1165 400p		R2006B 210p	NE556 100p
LP1166 400p		R2010B 250p	NE582B 400p
LP1169 400p		BD131 36p	SN78003N 160p
LP1173 400p		BD132 39p	SN78013N 180p
LP1181 400p		BD133 48p	SN78013ND 125p
LP1400 400p		BD135 40p	SN78023N 180p
		BD136 40p	SN78023ND 125p
		BD137 40p	SN78033N 180p
		BD139 38p	SN78227N 160p
		BD140 40p	SN78228N 180p
			SN76668N 100p
			TAA300 150p
			TAA350 190p
			TAA550 50p
			TAA681B 140p
			TAA700 350p
			TAD100 160p
			TAD110 130p
			TBA120A 80p
			TBA120T 125p
			TBA4600 200p
			TBA5200 240p
			TBA5300 215p
			TBA540 230p
			TBA540Q 240p
			TBA550Q 335p
			TBA560C 335p
			TBA641A12 250p
			TBA700 200p
			TBA720 250p
			TBA750Q 225p
			TBA800 110p
			TBA810S 110p
			TBA820 100p
			TBA920Q 300p
			TBA930 280p
			TCA270Q 250p
			TCA270S 250p
			TCA760A 250p
		CA3076 200p	
		CA3085 85p	
		CA3086 190p	
		CA3089 210p	
		CA3090AQ 400p	
		CA3130 100p	
		LM300TQ5 170p	
		LM301AN 65p	
		LM307N 65p	
		LM306TQ5 130p	
		LM306N 130p	
		LM309K 100p	
		LM310TQ5 150p	
		LM311TQ5 280p	
		LM317K 32p	
		LM324N 150p	
		LM346N 200p	
		LM380N 110p	
		LM555 28p	
		LM710TQ5 60p	
		LM710NDIL 65p	
		LM723TQ5 75p	
		LM723N 75p	
		LM733N 180p	
		LM746 45p	
		555 10 for £2.50p	
S.C.R.s			
BR101 35p			
BT100A 80p			
BT101 80p			
BT106 150p			
BT107 200p			
S.C.R.957			
200p			
BC147 BC148			
BC149 BC157			
BC158 BC159			
BF194 BF195			
BF196 BF197			
100 mix £6.50			
741 10 for £2			

SPECIAL OFFER 2102-4L Rams £1.00 each

ALL PRICES INCLUDE POST AND V.A.T.

T. POWELL
306 St. Pauls Road, Highbury Corner,
London N1. Telephone 01-226 1489

CREDIT CARDS: ACCESS/BARCLAY/EUROCARD/MASTERCHARGE/VISA

Technical Training in Radio, Television and Electronics

Start training TODAY and make sure you are qualified to take advantage of the many opportunities open to trained people. ICS can further your technical knowledge and provide the specialist training so essential to success.

ICS, the world's most experienced home study college has helped thousands of people to move up into higher paid jobs - and they can do the same for you.

Fill in the coupon below and find out how!

There is a wide range of courses to choose from, including:

City and Guilds Certificates:-

Telecommunications Technicians,
Radio, TV and Electronics Technicians,
Electrical Installation Work,
Technical Communications,
Radio Amateur,
MPT General Radio Communications Certificate.

Diploma Courses:-

Electronic Engineering,
Electrical Engineering,
Computer Engineering,
Radio, TV, Audio Engineering, Servicing and Maintenance. (inc. Colour TV)
New Self-Build Radio Courses with Free Kits.

Colour TV Servicing

Technicians trained in TV Servicing are in constant demand. Learn all the techniques you need to service Colour and Mono TV sets through new home study courses which are approved by a leading manufacturer.

The ICS Guarantee

If you are studying for an examination, ICS will guarantee coaching until you are successful - at no extra cost.

POST OR PHONE TODAY FOR FREE BOOKLET.

I am interested in.....

Name.....

Address.....

..... Phone No:.....

ICS International Correspondence Schools,
Dept. 285Z, Intertext House,
LONDON SW8 4UJ. Tel 622 9911 (all hours)

PHD COMPONENTS

RADIO & TV COMPONENT DISTRIBUTORS
 UNIT 7 CENTENARY ESTATE
 JEFFRIES RD ENFIELD MIDDX
 CALLERS BY APPOINTMENT ONLY TELEX 261295

ALL COMPONENTS PRICED EACH
 (INCLUSIVE OF VAT AT 12½%)
 NO MINIMUM ORDER CHARGE
 PLEASE ADD 35p POST & PACKING

CAPACITORS

Description	
DECCA 400-400/350V	3.25
GE 2000 200-200-150-50/350V	1.90
GE 1000-2000/35	1.83
GE/G8 600/300V	1.83
GE/G8 600/250V	1.55
RRI 800/300V	1.83
PYE 691 200-300/350	2.69
PYE 169 1000-1000/40	0.85
RRI 823 2500-2500/30	1.03
RRI 300-300/300	2.47
ITT/K8 200-200-75-25	2.86
TCE 950 100-300-100-16/275	1.83
TCE 400 150-100-100-100-15	3.51
TCE 1500 150 x 150 x 100	1.99
TCE 300/3500 175-100-100	2.16
TCE 3000/3500 1000/70V	0.69
TCE 3000/3500 220/100	0.47
TCE 8000/8500 2500/2500/63	1.41
TCE 8000/8500 700/800	0.93
TCE 8000/8500 400/350	0.93
300-300/350	2.82
100-200/275	1.41
100-200-60/275	1.41
200-200-400/350	3.05
200-200-100-32/350	1.41
125-300-100/350	1.41
300-200-100/300	1.41
2000-2000/40	0.70
300-300-100-32	1.41
300-300-100-50	1.41
220-100 47-22/340	1.41
200-100-100-150/350	1.41

DROPPERS

Dropper TCE 1400	1.06
Dropper TCE 1500	0.85
Dropper TCE 1800	0.89
Dropper TCE 3500/3500	2.16
Dropper TCE 8000	0.80
Dropper TCE 8500	0.85
Dropper Philips GB	0.42
Dropper Philips GB	0.25
Dropper Philips 210	0.63
Philips 210 (Link)	0.64
Dropper RRI 141	0.42
Dropper RRI 161	0.58
Dropper 27840	0.83
Dropper GEC 2000	0.71
Dropper PYE 11062	0.85
Dropper PYE	0.85

DIODES & RECTIFIERS

AA116 Diode	0.11
AA117 Diode	0.11
AA119 Diode	0.11
OA47 Diode	0.08
OA79 Diode	0.08
OA81 Diode	0.08
OA85 Diode	0.08
OA90 Diode	0.08
OA91 Diode	0.08
OA95 Diode	0.08
OA202 Diode	0.12
BA100 Diode	0.07
BA102 Diode	0.10
BA130 Diode	0.20
BA145 Diode	0.06
BA148 Diode	0.06
BA154 Diode	0.09
BA155 Diode	0.09
BA164 Diode	0.11
BAX13 Diode	0.11
BAX16 Diode	0.11
BAY38 Diode	0.07
BY206 Diode	0.20
SK3JF/04 Diode	0.20
IN4148 Diode	0.05
IS44 Diode	0.10
BY126 Rectifier	0.10
8Y127 Rectifier	0.12
8Y133 Rectifier	0.15
8Y164 Rectifier	0.50
8Y179 Bridge Rectifier	0.30
BY182 Bridge Rectifier	1.27
8Y238 Rectifier	0.16
8YX10 Rectifier	0.14
BY187 High Voltage Rectifier	0.30
IN4001 Rectifier	0.08
IN4002 Rectifier	0.08
IN4003 Rectifier	0.09
IN4004 Rectifier	0.09
IN4005 Rectifier	0.10
IN4006 Rectifier	0.11
IN4007 Rectifier	0.10
BY142 Rectifier	0.10
BR100	0.30
BR101	0.35
BRY39	0.35
BT116	1.70
BT119	2.00
BT120	2.00
TV106	1.40
2N4443	1.00
BT100A/02	1.50
OT112	1.60
8YX55/350	0.60
BYX55/600	0.60
8YX71/600	0.60
2N4444 Thyristor	1.27
BT109 Thyristor	1.27

TRANSISTORS

AC107 Transistor	0.20
AC126 Transistor	0.20
AC127 Transistor	0.20
AC127/01 Transistor	0.20
AC128 Transistor	0.20
AC128/01 Transistor	0.30
AC141 Transistor	0.20
AC141K Transistor	0.30
AC142 Transistor	0.27
AC142K Transistor	0.45
AC153 Transistor	0.45

AC176 Transistor	0.30
AC176/01 Transistor	0.45
AC186 Transistor	0.45
AC187 Transistor	0.30
AC187K Transistor	0.45
AC188 Transistor	0.30
AC188K Transistor	0.45
AC193K Transistor	0.45
AC194K Transistor	0.45
AD140 Transistor	1.50
AD142 Transistor	1.50
AD143 Transistor	1.50
AD145 Transistor	1.50
AD149 Transistor	1.00
AD161 Transistor	0.50
AD162 Transistor	0.50
AD262 Transistor	1.20
AF114 Transistor	0.45
AF115 Transistor	0.45
AF116 Transistor	0.45
AF117 Transistor	0.45
AF118 Transistor	0.45
AF121 Transistor	0.45
AF122 Transistor	0.45
AF125 Transistor	0.45
AF126 Transistor	0.45
AF127 Transistor	0.45
AF139 Transistor	0.60
AF239 Transistor	0.60
AF202 Transistor	0.70
AU107 Transistor	0.70
AU110 Transistor	2.70
AU113 Transistor	2.70
BC107 Transistor	0.15
BC108 Transistor	0.15
BC109 Transistor	0.15
BC113 Transistor	0.12
BC114 Transistor	0.12
BC115 Transistor	0.14
BC116 Transistor	0.15
BC117 Transistor	0.15
BC118 Transistor	0.12
BC119 Transistor	0.33
BC125 Transistor	0.14
BC129 Transistor	0.14
BC136 Transistor	0.14
BC137 Transistor	0.14
BC138 Transistor	0.28
BC139 Transistor	0.28
BC140 Transistor	0.28
BC142 Transistor	0.28
BC143 Transistor	0.28
BC147 Transistor	0.10
BC148 Transistor	0.10
BC149 Transistor	0.10
BC154 Transistor	0.10
BC157 Transistor	0.10
BC158 Transistor	0.10
BC159 Transistor	0.28
BC161 Transistor	0.28
BC171 Transistor	0.10
BC172 Transistor	0.10
BC177 Transistor	0.17
BC178 Transistor	0.17
BC179 Transistor	0.17
BC1821 Transistor	0.10
BC183 Transistor	0.10
BC183L Transistor	0.10
BC184L Transistor	0.10
BC184LC Transistor	0.12
BC185 Transistor	0.18
BC187 Transistor	0.18
BC203 Transistor	0.10
BC204 Transistor	0.10
BC205 Transistor	0.10
BC206 Transistor	0.10
BC207 Transistor	0.10
BC208 Transistor	0.10
BC209 Transistor	0.10
BC212L Transistor	0.10
BC213L Transistor	0.10
BC217 Transistor	0.10
BC225 Transistor	0.30
BC237 Transistor	0.10
BC238 Transistor	0.10
BC251A Transistor	0.10
BC301 Transistor	0.30
BC303 Transistor	0.30
BC307 Transistor	0.10
BC308 Transistor	0.10
BC327 Transistor	0.11
BC328 Transistor	0.11
BC337 Transistor	0.11
BC338 Transistor	0.09
BC547 Transistor	0.10
BD115 Transistor	0.35
BD116 Transistor	0.80
BD124P Transistor	1.80
BD131 Transistor	0.45
BD132 Transistor	0.45
BD133 Transistor	0.54
BD134 Transistor	0.54
BD135 Transistor	0.54
BD136 Transistor	0.54
BD137 Transistor	0.54
BD138 Transistor	0.54
BD139 Transistor	0.54
BD140 Transistor	0.54
BD144 Transistor	2.50
BD151 Transistor	0.60
BD157 Transistor	0.60
BD159 Transistor	0.60
BD163 Transistor	0.60
BD165 Transistor	0.60
BD175 Transistor	0.60
BD177 Transistor	0.60
BD183 Transistor	0.60
BD187 Transistor	0.60
BD210 Transistor	1.24
BD235 Transistor	0.54
BD236 Transistor	0.54
BD237 Transistor	0.54
BD238 Transistor	0.54
BD239 Transistor	0.54
BD380 Transistor	0.54
BD437 Transistor	0.54
BD439 Transistor	0.54

BD441 Transistor	0.54
BD535 Transistor	0.54
BD536 Transistor	0.54
BD537 Transistor	0.54
BD538 Transistor	0.54
BDX73 Transistor	0.80
BDV201 Transistor	2.10
BF115 Transistor	0.45
BF118 Transistor	0.45
BF121 Transistor	1.50
BF152 Transistor	1.50
BF154 Transistor	1.50
BF157 Transistor	0.50
BF158 Transistor	0.30
BF160 Transistor	2.16
BF163 Transistor	0.45
BF167 Transistor	0.45
BF173 Transistor	0.45
BF177 Transistor	0.45
BF178 Transistor	0.45
BF179 Transistor	0.45
BF181 Transistor	0.50
BF182 Transistor	0.50
BF183 Transistor	0.50
BF184 Transistor	0.50
BF185 Transistor	0.50
BF194 Transistor	0.10
BF195 Transistor	0.10
BF196 Transistor	0.10
BF197 Transistor	0.10
BF198 Transistor	0.10
BF199 Transistor	0.10
BF200 Transistor	0.10
BF224 Transistor	0.12
BF240 Transistor	0.12
BF241 Transistor	0.12
BF256LC Transistor	0.36
BF257 Transistor	0.36
BF258 Transistor	0.37
BF271 Transistor	0.37
BF273 Transistor	0.15
BF274 Transistor	0.18
BF336 Transistor	0.37
BF337 Transistor	0.37
BF338 Transistor	0.39
BF355 Transistor	0.63
BF458 Transistor	0.75
BF459 Transistor	0.75
BF443 Transistor	0.39
BFX29 Transistor	0.35
BFX84 Transistor	0.33
BFX85 Transistor	0.33
BFX88 Transistor	0.33
BFX89 Transistor	0.33
BFY50 Transistor	0.33
BFY51 Transistor	0.33
BFY52 Transistor	0.33
BFY90 Transistor	0.90
BDX32 Transistor	2.40
BU105 Transistor	1.50
BU105/01 Transistor	2.40
BU105/02 Transistor	2.40
BU105/04 Transistor	2.40
BU108 Transistor	2.40
BU204 Transistor	1.50
BU205 Transistor	1.50
BU206 Transistor	2.40
BU208 Transistor	2.40
BU208/02 Transistor	2.40
BU3265 Transistor	1.98
BU406 Transistor	1.89
BU406D Transistor	2.86
BU407 Transistor	1.50
BU407D Transistor	2.10
25C1172Y Transistor	2.40
R20088 Transistor	2.25
R2009 Transistor	2.25
R2010 Transistor	2.50
R2540 Transistor	3.00
ME0404 Transistor	0.15
ME0412 Transistor	0.15
ME4003 Transistor	0.10
ME6002 Transistor	0.15
ME6003 Transistor	0.15
MJ3055 Transistor	1.20
MJ3055 Transistor	1.20
MP8113 Transistor	0.75
MPSU05 Transistor	0.90
MPSU55 Transistor	0.90
TIP31A Transistor	0.48
TIP32A Transistor	0.48
TIP41A Transistor	0.75
TIP42A Transistor	0.75
TIP2995 Transistor	0.96
TIP3055 Transistor	0.96
TIS91M Transistor	0.21
N2904 Transistor	0.33
N2905A Transistor	0.36
N2905 Transistor	0.36
N2905S Transistor	0.36
N3055 Transistor	0.88
N3703 Transistor	0.12
N3705 Transistor	0.12
N3710 Transistor	0.12
N5296 Transistor	0.57
N5298 Transistor	0.57
N5496 Transistor	0.63
N6178 Transistor	0.90
N6180 Transistor	0.90

VALVES

DY86/87 Valve	1.00
DY802 Valve	1.20
EAC80 Valve	1.20
E891 Valve	1.10
E8C81 Valve	0.60
EF80 Valve	0.65
EC86 Valve	1.10
EC88 Valve	1.10
EC40 Series Tripler	8.50
ECC81 Valve	1.20
EC82 Valve	1.02
ECC83 Valve	1.02
EC84 Valve	1.35
EC85 Valve	1.35
EC88 Valve	0.75
EC189 Valve	1.20
ECF80	1.50
ECF82 Valve	0.65
ECF86 Valve	1.10
ECH81 Valve	0.75
ECH83 Valve	0.75
ECH84 Valve	2.10
ECL80 Valve	1.50
ECL82 Valve	1.32
ECL84 Valve	0.90
ECL86 Valve	1.60
EF80 Valve	1.20
EF83 Valve	1.70
EF85 Valve	1.20
EF86 Valve	2.20
EF89 Valve	2.45
EF91 Valve	0.60
EF95 Valve	0.65
EF183 Valve	1.10
EH90 Valve	1.90
EL34 Valve	3.25
EL36 Valve	0.90
EL41 Valve	1.20
EL81 Valve	0.90
EL84 Valve	1.35
EL86 Valve	0.75
EL95 Valve	1.50
EM84 Valve	1.20
EM87 Valve	1.50
YB6/87 Valve	0.85
EY88 Valve	0.75
EZ80 Valve	1.00
EZ81 Valve	2.00
G501 Valve	1.80
G504 Valve	2.50
GC86 Valve	1.50
GC88 Valve	1.75
PC97 Valve	0.63
PC88A Valve	1.05
PC88 Valve	1.50

EHT TRIPLERS

TCE950 Doubler	2.25
TCE950/1400 Tripler	3.50
TCE1400 (P/wd system only)	4.00
TCE1500 Doubler	3.00
TCE500 Tripler	3.50
TCE1600 1/2 Wave	3.50
Decca CSI 730/1830 Doubler	3.60
Decca CSI 910/213 Tripler	8.50
Decca 30 Series Tripler	8.50
Decca 80 Series Tripler	6.50
Decca 100 Series Tripler	8.50
GEC Hybrid 2028 Tripler	6.50
GEC 2110 Tripler Pre Jan 77	7.00
GEC 2110 Tripler Post Jan 77	6.50
ITT CV5/8/8 Tripler	6.50
ITT VC20/25/30 Tripler	8.50
Philips 520 Tripler	6.50
Philips 525 Tripler	6.50
Philips G8 Tripler	6.50
PYE 691/693/697 Tripler	6.50
PYE 713/725 Tripler	6.50
Philips 570 Doubler	6.50
RR1823 Tripler	7.00
RR12179/823 Tripler	6.00
TCE3000/3500 Tripler	6.50
TCE4000 Tripler	8.00
TCE8000 Tripler	3.00
TCE8500 Tripler	6.00
TCE9000 Tripler	6.50
TKV52 Continental Sets	6.00
Korting 90% Tripler	6.50
Autovox Tripler	6.50

MISCELLANEOUS PRODUCTS

Sets of Avo Leads	9.50
ELC1	

call in the area and then popped in to see old Taffy.

"What's wrong Taff?" Taffy growled and gurgled as was his wont (he'd had a few during the lunch hour) so we decided to find out ourselves.

Usually this type of BSR changer grinds to a halt due to old, thick grease on the centre spindle. This stops the motor rotating, which it doesn't like and is thereafter reluctant to spin again even when completely free. It has to be spun a few times with perhaps a spot of oil on the top bearing until it gets its magnetism sorted out when it will then start up on its own. The turntable did indeed seem to be stuck fast on the centre spindle. Having freed it and lifted it off we were prepared to clean the centre spindle and the turntable bush, and lightly oil them. We were not prepared for what we found however. There was no motor fitted.

"Taff, Taff. Are you there Taff?"

"Whassermatchure, woswrong?"

"There's no motor in your radiogram Taff."

"No motor, no motor, Wodyoumean no motor? Theremusbe one. The radio's been going all morning. Matter of fact" – as his head cleared he climbed on his dignity – "matter of fact the thing's been working for six months on Radio Two. Never shift it."

"You don't need the motor to work the radio Taff. It only turns the records round."

"You'll have to ask the wife about that. She looks after all that sort of thing. She fixed it some time ago when the music was going slow. The music has been all right since but I haven't played any records you see."

"Is the wife around Taff?"

"No, she's in Finland. She sent me this greetings record but I can't play it because it won't go round. That's why I asked you to call."

Back to square one.

Feeling somewhat baffled, I went back to the radiogram and Taff wandered off to another room, grumbling to himself. Removing the rear cover of the gram, we found the motor on the floor of the cabinet, still with its leads connected. Switching on the juice made the motor buzz, but it wouldn't go round. Applying a drop of oil to the top bearing and raising the spindle up and down a few times seemed to free it off. Spinning it by hand helped it to start and away it went after that on its own. A careful search also located the three circlips which hold the motor fixings on top of the rubber bushes, so back the lot went and having cleaned off the centre spindle and bush the turntable spun freely.

"O.K. now Taff. Where's the record the wife sent you?"

In came Taff. Mumble, mumble. Eventually he found it. His wife's message was loud and clear. After the first greeting, she said. "You'll have to get the gram done before you can play this. Tell the man that the motor is underneath because I couldn't get the clips back and it won't go round anyway."

Taff gave me a baleful look. "If you'd played that before you started, you'd have known where the motor was." I quit.

Distorted Picture

The next call was nearby. I wish I hadn't bothered. It was yet another Pye 691 hybrid colour set.

The complaint was a distorted picture. Folded up from the bottom, then widespaced lines up to two thirds, then a bright kink, then severe compression up to the top.

The owner sat at the table and gave me his advice.

"It won't take long to do. The last chap fixed it in a couple of minutes with a screwdriver. I suppose it'll take

you longer if you're not used to the set."

"Why didn't you get him to come back and do it again?"

"He doesn't do them now. He gave me your phone number, so I thought I'd give you a chance if you're just starting up."

Off came the back cover. The field output transistors were the older BD124 types on the horizontal heatsink. Check these. Apparently in order. Check the AC128 driver transistor. Again o.k. Check resistors, o.k. Check electrolytics in turn, disconnecting each first. All had capacitance, none showed any significant leakage. Legs aching, panic setting in. No spare panel, no service manual. Check diodes, o.k. All supply voltages present and mid reading on BD124s not far out. Try presets. Produce weird effects but nothing of any value. Could be on convergence panel? Some messy work had been done here. Give up.

"Sorry, it'll have to go back to the workshop."

He sat at the table and drummed it with his fingers. "The last chap said it would need a panel before long. Have you got one?"

"Yes, but I'm not sure that's the answer."

"Can I have it back for tonight? – it's not much fun looking at the portable."

"It's not much fun sorting this out either!"

So load the thing into the waggon and take it back to the shop. Back at the ranch there were lots of other things to sort out but we finally got on to the Pye. Try another field panel. No joy. Open up the convergence panel and make good scorched connections, poor pots and dry joints. Check electrolytics. No joy.

Check continuity of circuit from field panel to convergence and to scanning assembly. All o.k. ... Scanning assembly ... Oh no! Try to check windings and thermistor. Not conclusive, only confusing.

Lady wants leads soldered on to transistor radio battery box which is falling to pieces anyway. Fit new box and connectors. Back to Pye.

Have we got a spare scanning assembly? Yes. Strip off tube base, blue lateral, convergence assembly and scan coils. Fit new coils, connect up but can't find one lead. Finally find it jammed up behind front of new assembly. Check connections, refit convergence, blue lateral assembly and base socket. Won't go on properly. One tube pin bent. Get it on.

Make sure all is in order. Switch on. Joy at last. Set up and converge. Return set to owner.

"Picture's not as bright as it was before you took it." Fit new PL802. No picture at all. Remove CDA panel and make good deteriorated soldering and small cracks around PL802. Nice bright picture.

"How much?! You blokes must be making a fortune at this job."

No Signals

I thought I'd make an early start the following afternoon, as I'd an uneasy feeling that things were not going to be plain sailing. Four colour sets and one mono, no two the same (for a change).

We made the nearest one the first call. This turned out to be Mr. Peacock's Dynatron. The Pye group chassis fitted was a 697. No picture, no sound except a loud hissing noise. That was Mr. Peacock's description. Bright as a new pin we first made sure that the aerial plug was in. It was.

Take the back off. Wave a neon over the line output section. Lights up, plenty of juice over that side. Check h.t. on CDA panel. None except at supply plug and socket on the right side of panel. Easy. Remove panel and note nasty

black mark round track from socket. Clean up and jump a lead from the socket to the nearest relevant solder blob. Assemble and clip up. Switch on.

Sound o.k. Picture arrives after a time. Tune in after battle with remote control and receiver buttons. No colour. Check here, there and everywhere (Mr. Peacock watching). Find plug out of decoder panel, probably caused by upending CDA panel. Refit plug. Colour returns to screen and to my cheeks. Mr. Peacock was looking mystified.

"I thought the sound side was all transistor" he said.

"It is."

"Well, when you were checking with your meter, why did you mutter to yourself about no h.t. I always thought transistors could work on low voltage."

Oh Gowd, I thought. Here we go again.

"The transistors were being supplied. That's why they were hissing at us. But the tuner wasn't tuning you see."

"Oh I see. The tuner needs h.t. Fancy that."

I was in a hurry so I didn't go on any further and left him thinking that tuner transistors must be pretty hefty devices.

Very Dark Picture

The next call wasn't far away. This was to a Ferguson set with a 3500 chassis. I was only praying that the tripler hadn't gone and bugged up the e.h.t. transformer, which appears to be our lot of late. Mrs. Dewdrop answered the door.

"Hallo Les," she greeted me.

"Hallo Dorothy, doing some decorating I see."

"Yes, I hang one strip of paper per day so I don't get bored with it." It takes all sorts to make a world, but that's about the daftest thing I've heard for a long time. It's not my business however and I wasn't going to ask what she did the rest of the day.

So we attacked the TV. In fact there was a very dark picture in the background, so the tripler was o.k. after all.

A dark picture on a 3500 means that the beam limiter should be the first item to receive attention. R907 (1.5Ω) should have about 1.5V across it (manual states 1.3V). If the voltage is higher, the brightness is backed off. The line timebase current flows through this resistor to earth so the resistor monitors the line output stage current and, if the circuit is not defective, it limits the beam current.

The voltage across R907 read over 3V, so there was either excess current flowing due to a fault in the line output stage or the resistor was not all that it should be. The dark picture seemed to be of the right size, and the c.r.t. first anode voltages on the convergence board were well up.

So we switched off and measured the 1.5Ω resistor which read 3Ω. We'd thoughtfully put a packet of 1.5Ω wirewounds in the box (spares box, not the TV) so it didn't take long to put a new one in. The voltage was now nearly 2V, which was still high. Checking around showed no faults, and the picture was good with plenty of brightness. So we didn't argue with it. By this time Dorothy had hung her daily strip, so all work was now complete.

Smoking Bush

Off we went to the next set, a Bush monochrome one that had smoked. It was an elderly dual-standard 23in. receiver (TV148 series).

Investigation showed that one of the h.t. feed resistors on the left side lower electrolytic block had been cooking. This was 3R59, 3.3kΩ. It feeds one lead over to the timebase panel, another over to the receiver unit. There was a low resistance reading to earth, and unplugging the leads proved

that the short was on the receiver unit. So we disconnected the system switch and swung down the chassis in order to peer behind it with the aid of our little torch. The tracks lead off here and there, but a close look on the component side revealed a blackened disc ceramic. Snip, snip and out it came. No short. In went another disc with the right voltage on it but the capacitance somewhat smudged. Swing up chassis. Make sure plugs are in and system switch is in 625-line position.

Switch on. Nice noisy raster, lovely rushing noise on sound. Plug in aerial. Push in buttons. Nothing to speak of at all. Check that aerial is in u.h.f. socket, ignore the three buttons which give whistle (who wants 405?). Finally tune in terrible picture. Oh dear. Surely the smudgy disc capacitor couldn't do this?

Call Mr. Latterly who assures me that the picture was good before the smoke. Then he noticed what I was trying to tune in. It was a BBC-2 test card.

"We never get BBC-2."

Wearily I plugged the aerial into the v.h.f. socket and selected the other buttons for 405. Bright BBC-1, not bad ITV.

"That's more like it. Did you think we had a BBC-2 aerial?"

Intermittent Colour

Feeling a little tattered we moved on to the next casualty, which we confidently thought to be a 3000 chassis HMV. On turning it round and seeing the row of knobs on the left side realisation burst. It was a 2000 chassis, and since the complaint was no colour I was frightened. This was mainly because we don't meet many 2000 chassis, and those we do meet generally need only power components – zeners, wire wounds etc.

The lady of the house refreshed my memory of the complaint. No colour for some time and then it tries to come in and sometimes does, but never right away.

"Is there anything I can get you?" she asked solicitously.

"Do you think I could have a mirror and a hairdryer?"

She looked at me and my hair. "It does look a little rough, but do you think this is the right time to do something about it?" she ventured.

I combed my hair viciously. "I need them for the set, not for me. The dryer to warm things up a bit and the mirror to see when the colour comes in."

She went out and I remembered that I had a dryer in the spares box in the van. This was just as well because when she came back she was wheeling an enormous hooded affair on a stand.

She did however have a suitable mirror, so with this propped up in the right position and my dryer blowing away like made we were ready to attack the enemy.

The decoder board is at the bottom centre and we carefully covered the suspect areas with hot heat. Chrominance amplifiers, colour killer and reference oscillator, nothing escaped our ruthless scorched earth policy. It didn't do much good though, except for occasional half-hearted bursts now and again.

I tried to be clinical, though this never really comes off. Remove panel in its entirety and examine closely. So we unplugged the plugs and removed the board. We looked and looked, checked here and there and finally pronounced our judgement: "buggered if I know."

So back went the panel, in went the plugs and on went the set. Glorious colour. Considering the age of the tube, it was well nigh perfect. A tweak up on the gray scale and nothing was left to be desired.

"Aren't you clever," said Mrs. Post.
 "I suppose I am really" I admitted.
 "What was wrong then?"
 "Er, there was apparently an intermittency in the chrominance interconnecting connections you see."
 "You mean a poor connection."
 "Yes, I suppose you could say that."
 "And the hairdryer found it?"
 "Er, no. It might have done but it didn't. Perhaps it will next time." So off we went again. So much for the 2000. Kids' stuff really. Sets like that don't frighten me.

Ah Doric, I Knew Him Well

Which left one. Ah Doric, I knew him well.
 As a matter of fact it was the first time one of these sets had come my way. I'd no servicing information on it, which doesn't make a lot of difference because I have great difficulty in reading anything anyway. I always seem to try to do things first and then have a go at reading the instructions afterwards. The owner however had a complete manual, which was presented to him when he retired from his firm a couple of years ago – together with the set of course.

I was amazed to find the imposing looking set in front of the window, with the coaxial cable connected to a small set-top aerial which was perched in the centre of the carpet.

"Do you always have the aerial there?" I asked.
 "Most of the time," he said. "Except when we want BBC-2 when we put it on top of the set."

The reception area wasn't all that good, and it seemed a clear cut case of spoiling the ship for a hap'th of tar. Our's is not to reason why however.

Apparently the picture would completely lose it's "body" after an unspecified period, becoming a sort of plastic near negative with only some colour noise in the background.

Without consulting the manual, this suggested an i.c. or transistor failure somewhere between the detector and the splitting point of the luminance and chrominance signals. Wherever that was.

So we consulted the manual and got involved with an "SF" panel which we eventually found wasn't there (only on cable receivers it said). We had another go and found the relevant panel for "aerial" receivers, ending up on the top of the decoder panel around some likely looking BC148s.

Since the picture was acceptable at that moment, the voltages tallied with those given in the manual. When the "plastic" condition occurred, the voltages on one went haywire.

Consulting the circuit again we found that this was d.c. coupled to the preceding one which was reading right. So the d.c. coupling wasn't.

In fact the coupling agent was the luminance delay line so we hadn't got our diagnosis right in the first place. The one thing we didn't have with us was a luminance delay line, but to prove the point we jumped a lead across the suspect one and the picture stayed on and the voltage remained right. We expected a degraded colour picture, but it was as good as it had ever been with the aerial in the centre of the carpet (what's a ghost or two when you already had three!)

We told Mr. Sparerib that we would be back with a delay line later, but that he wouldn't notice the difference until he had a better aerial.

So back to the workshop, to the turntables that won't turn, the auto-ejects that won't eject, the cartridge player that went bang and the telly's which won't tell.

next month in

TELEVISION

● ELIMINATING GHOSTS

One of the most trying reception problems is ghosting, the reception of reflected signals that don't coincide with the direct one. Apart from giving an unacceptable picture, ghosts play havoc with teletext signals. There are various ways of alleviating the problem, but a certain amount of experiment is usually necessary. The best solution is the use of adjustable stacked arrays. Bill Wright explains how to go about this.

● VERSATILE REMOTE CONTROL SYSTEM

Plessey's latest remote control system is claimed to be the most versatile yet, using two purpose-designed i.c.s. Pulse-position modulation is used to provide high rejection of spurious signals and thus error-free operation. The signals can be transmitted via either an ultraviolet or an infra-red link. The system can be adopted for other purposes as well.

● FAULTS ON THE 9000 CHASSIS

In 1975 Thorn once again startled the TV industry with the introduction of the 9000 colour chassis with its Syclops combined chopper regulator/line output stage. John Coombes provides a summary of faults and servicing hints based on three years' experience of the chassis.

● VARICAP TUNER CHANNEL DISPLAY

Alan Dampier describes a novel circuit using LEDs to show which channel has been selected by a varicap tuner. An incidental advantage is that maximum brightness corresponds to correct tuning. The system is useful mainly as an aid to DX-TV reception. The prototype caters for twelve channels, but the number can be reduced or increased as required.

PLUS ALL THE REGULAR FEATURES

ORDER YOUR COPY ON THE FORM BELOW

TO (Name of Newsagent)

Please reserve/deliver the NOVEMBER issue of TELEVISION (50p), on sale October 16th, and continue every month until further notice.

NAME

ADDRESS

Colour Receiver Project

Part 1

Luke Theodossiou

GREAT changes in TV receiver techniques have occurred over the past few years. It doesn't seem all that long since a large, clanking mechanical tuner fed a substantial, hand-wired chassis with an array of things that lit up. If the tube was a colour one it would have a large deflection yoke, another large assembly for radial convergence, and a number of other bits and pieces. There were masses of adjustments, and the least said about the power consumption the better. We've been going through a period of rapid change however. Everything from the tuner to the tube has undergone substantial development. Tiny tuners can be digitally controlled, the latest colour tubes have as little impedimenta as the monochrome tubes of a few years ago, and what lies between can be taken care of by a compact array of solid-circuit electronics.

It seemed time for a fresh look at a colour receiver project for the constructor. Since an up-to-the-minute colour receiver contains less than a monochrome set a decade ago, neither construction nor setting up should present much trouble, while a receiver that utilises as many of the latest techniques as possible provides a very useful lesson in the present state of the art. So here we go.

Design Philosophy

Perhaps the biggest problem we had was in deciding just where to call a halt and say the design must stand as we can do it at a particular point in time. Had we waited another year for example we could have used some of the more sophisticated i.c.s we know are in the pipeline. Although the overall rate of development is fast however, individual devices often take a considerable time to get from the development sample to the off-the-shelf stage. Setmakers are confronted with the same problem of course. The answer is to divide the chassis up into a group of modules which can be updated as developments reach the stage of full-scale production.

The overall emphasis has been to make the receiver as simple as possible consistent with high-quality reproduction. Commercial setmakers have the same basic aim. With production costs constantly rising, simplicity in design is essential in order to maintain competitive prices while at the same time making the profit necessary to remain in business. The only way in which this can be done is to minimise the amount of individual circuit alignment and testing required in the factory and to reduce the component count as far as possible. The ultimate result is increased efficiency all round. One great advantage that a project for the individual constructor has over the production of a commercial receiver is that decisions on capital investment don't have to be made. Thus the design of the set can be altered without having to take into consideration the possibility that a lot of costly assembly equipment may have to be scrapped or altered. This doesn't mean we've been chopping and changing the set up till the last minute. Well,

not quite. But what it does mean is that we've got some slight edge over commercial designs in terms of being able to adopt new techniques and devices.

The accompanying photographs show how little hardware is required in our design. No currently available commercial set uses so few components. The problem of engineering a project doesn't stop with getting hold of a handful of samples and finding out that good reproduction can be obtained however. In the interests of reliability, detailed component specification is necessary. It's also essential to ensure that at least one supplier is available for every component.

Warning!

The use of printed circuit boards, which will be available to readers through Readers' PCB Services Ltd., and components as specified guarantees a project which the constructor with some experience and knowledge should be able to tackle with confidence. But though it may all look very simple, if you haven't had much experience and have little understanding of what the circuits are doing you'd probably do best to enlist the help of a friend who has. Very high voltages (an e.h.t. of around 25kV) and substantial currents are involved, with the result that mistakes can be expensive.

The Project in Outline

With the exception of a few components which for obvious reasons are attached to the cabinet all the components are arranged on four printed-circuit boards – including the tube base panel. The first one, which we are describing in this first article, is the power supply board which feeds the receiver with all the supplies required. Subsequent articles will deal with the other boards in turn, and we suggest that constructors build each section up as it's published. In this way the total cost will be spread over several months. Having dealt with each board in turn, interconnection details, testing and setting up procedures and some hints on fault-finding will be given. There will then be a couple of important options: an ultrasonic remote control unit (the editor, who tends to keep away from constructional items because he has difficulty remembering which end of the soldering iron is which, has enjoyed playing with this), and a built-in teletext decoder unit.

Technical Features

We felt that mains isolation was a very desirable feature, not only from the point of view of safety, but because it allows the use of direct connections in and out of the receiver – to a high-fidelity audio system for example. So a mains isolating transformer was one of the starting points in the design.

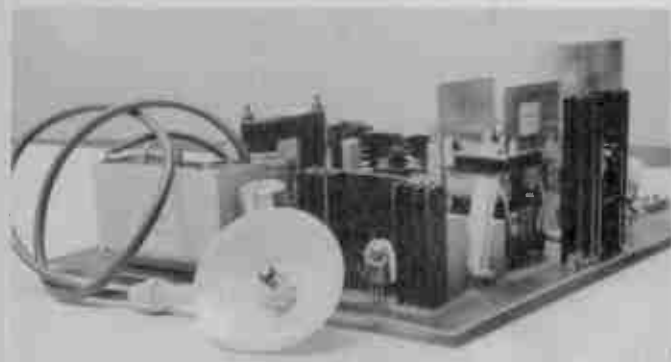
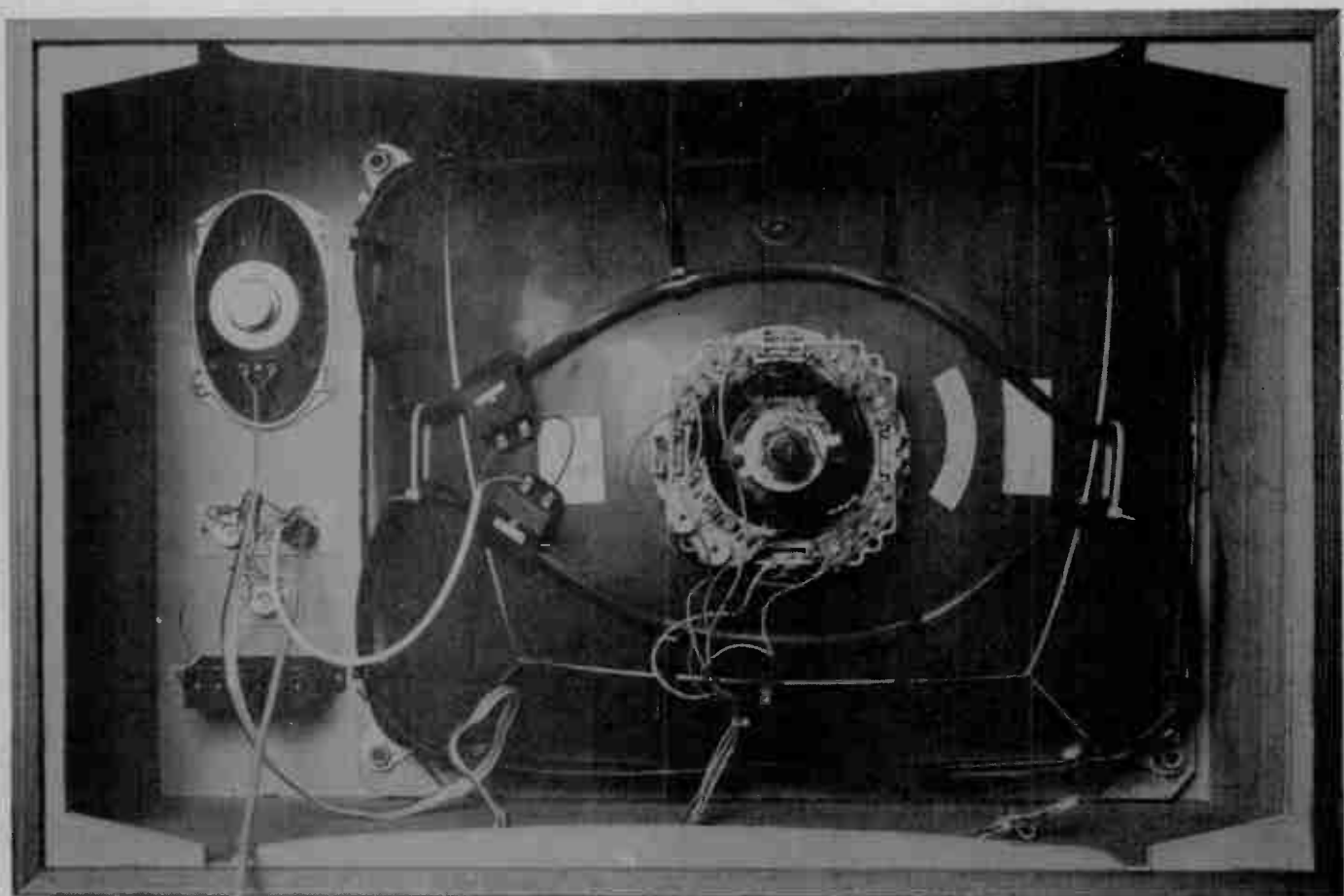
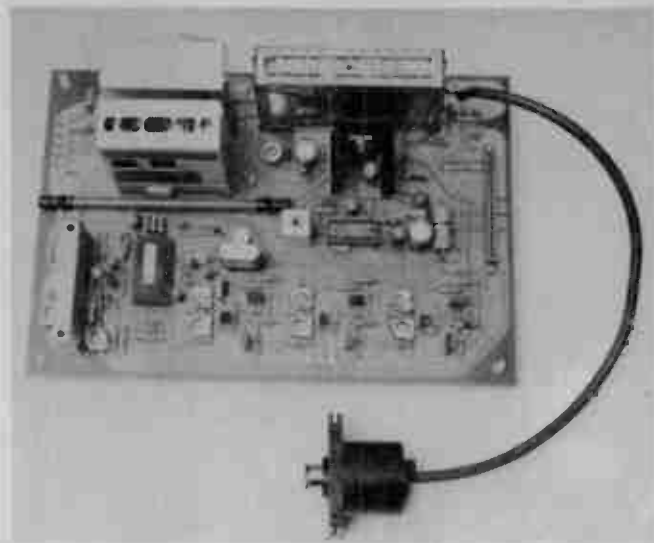
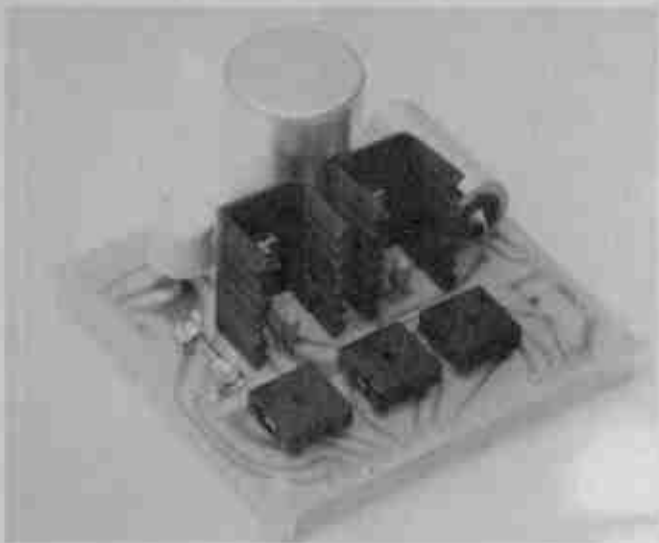

Above: Rear view with all boards removed, showing the cabinet-mounted components (except for the mains transformer).

Top left: The power supply board (Molex connectors not fitted).

Top right: The signal board, which includes the decoder and RGB output stages and provides a mounting for the tuner and i.f. modules.

Left: Profile view of the timebase board.

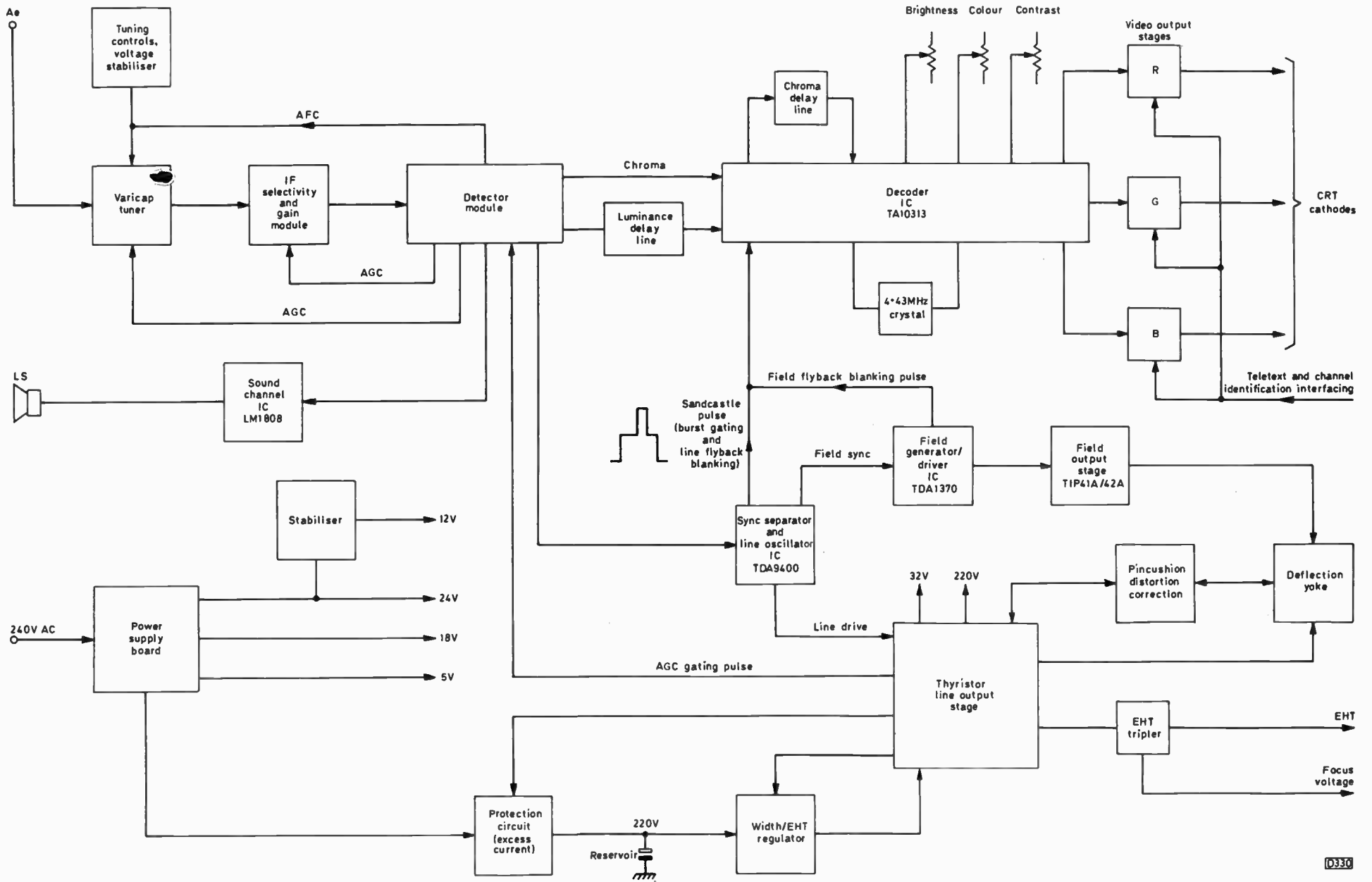

D330

Fig. 1: Block diagram of the complete receiver.

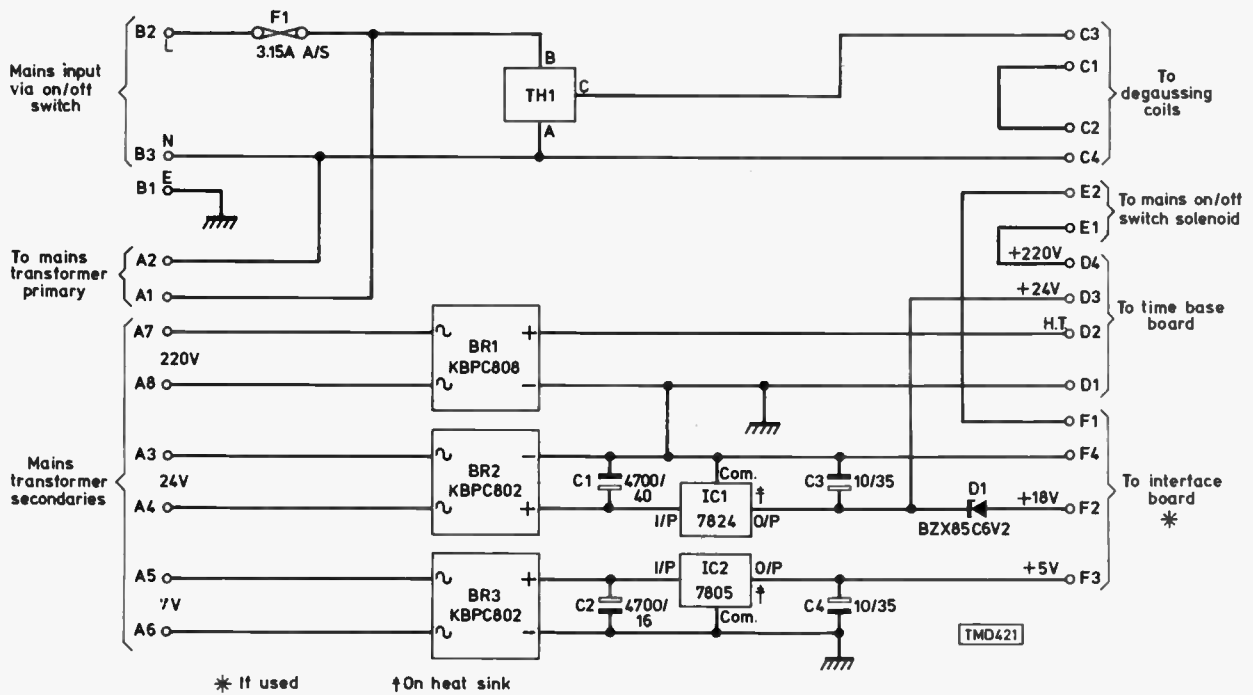

Fig. 2: Circuit diagram of the power supply section. The h.t. reservoir capacitor is on the timebase board, along with the excess-current protection and width regulator circuits.

COST

At the time of going to press it has not been possible to cost the project, and it's likely to be a while before we can provide an estimate. This is simply because many of the components used in the prototypes have been manufacturers' samples, and it's not yet known at what prices suppliers will be able to offer them to individual customers. We will publish an estimated likely overall cost as soon as this is possible. Meanwhile, those interested should watch the advertisement pages over the next couple of months. Bear in mind that the aim of the exercise is not to undercut the cost of commercially produced sets, but to see how the latest technology can be exploited to provide a simple yet high-quality design suited to one-off construction.

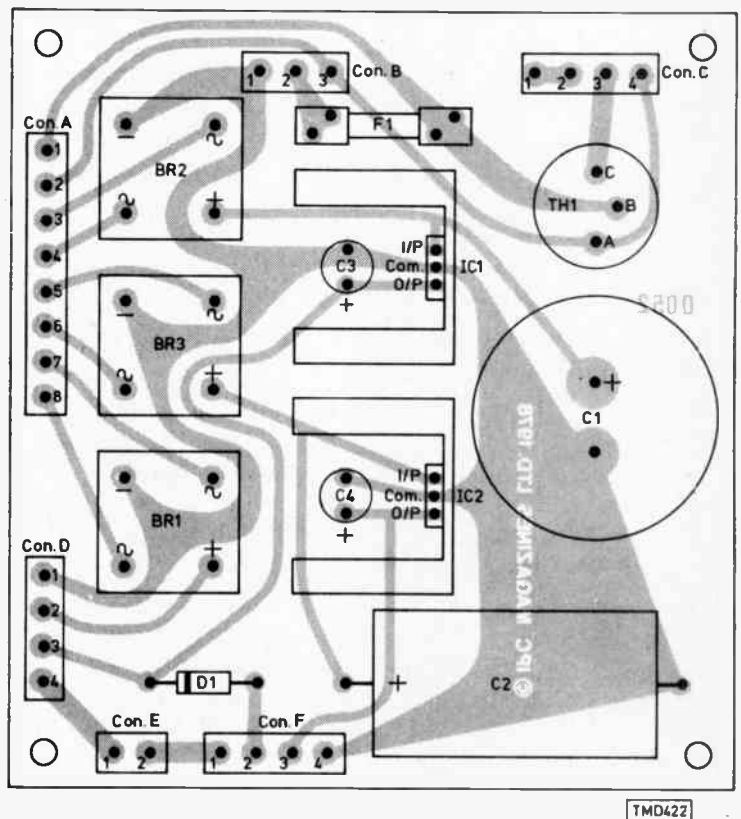

Fig. 3: Power supply board component layout.

★ Components list: power supply board

BR1	KBPC808 (or RS Components 262-084)
BR2, 3	KBPC802 (or RS Components 262-078)
TH1	2322-662-98009 (Mullard) or PT37P (ITT)
C1	4700 μ F 40V Siemens can B41070
C2	4700 μ F 16V Siemens tubular B41010
C3, 4	10 μ F 35V tantalum bead

D1	BZX85 C6V2
F1	3.15A anti-surge 20mm
Misc.	P.c.b. fuse clips; 0.2in. pitch p.c.b. connectors
P.c.b.	D052 from Readers' PCB Services Ltd.

Mains transformer: Primary: 240V
 Secondaries: 220V, 1A
 24V, 2A
 7V, 2A

The mains transformer will be available from regular advertisers in the magazine.

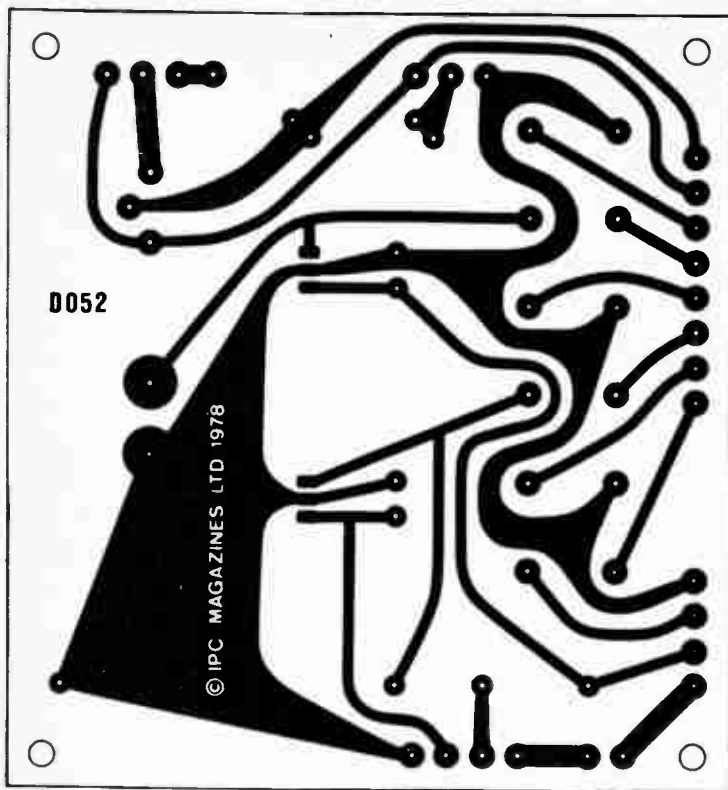

Fig. 4 (left): Power supply board print pattern. Scale 1:1.

Right: This month's board: the power supply unit.

Far right: View of the tube neck components, which are all preset and sealed.

Below: The c.r.t. base board. In view of the safety factors involved (high focus voltage, spark gaps etc.) this is a ready-made unit. Different connections will be used.

Apart from mains isolation, other major features of the design include:

- Use of the latest pin-diode varicap tuner.
- Prealigned i.f. modules.
- A single-chip colour decoder.
- Class AB RGB output stages.
- A single-chip sound channel.
- A thyristor line output stage.
- Single-chip field oscillator/driver with a pair of discrete output transistors.
- Use of one of the latest sync separator/line oscillator i.c.s.
- A 110° RCA self-converging, precision-in-line (PIL) tube with integral, toroidally wound scanning yoke.

Choice of CRT

The use of the RCA PIL tube was fundamental to the whole concept of the set. The reasons for choosing it instead of one of the other in-line gun tubes currently available are worth mentioning therefore. First, it was felt that the RCA tube is particularly easy for the constructor to use, since the neck components are all permanently attached to the tube and thus don't require any setting up. Another desirable feature is that no convergence adjustments at all are required, unlike some in-line gun tubes which still require some adjustments, though very few, to take manufacturing tolerances into account. Finally, the author prefers the overall focus performance of the PIL tube. The latest generation of these tubes is being used, with the super-arch mask and with higher transmission glass and pigmented phosphors to provide increased brightness and a greater contrast ratio. Pricewise there's little difference between the tubes available. RCA have appointed Solus (Electronics) Ltd. of Kirkwood Road, Cambridge CB4 2PF as agents for

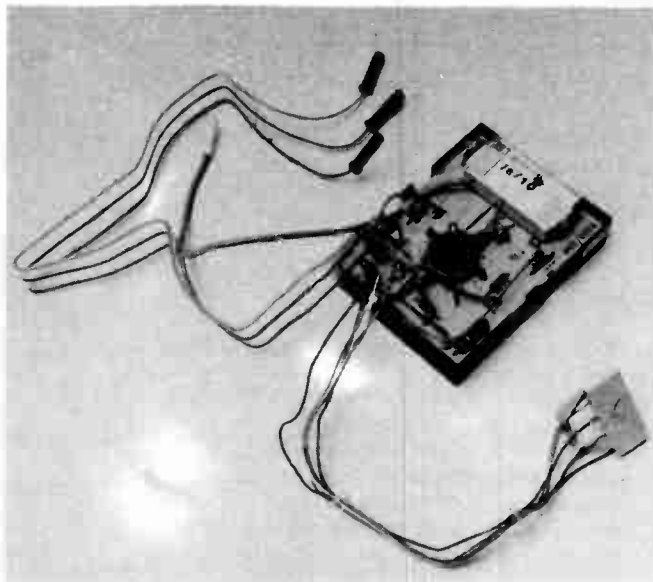

the supply of these tubes in the UK. The tubes can be obtained by individual readers directly from Solus.

Options

The options which make the basic receiver more versatile involve the incorporation of a Trifax module for teletext decoding, with an interface board, and a remote control system which calls up the teletext pages in addition to controlling the channel, brightness and colour. We suggest that constructors wishing to include these options should use the larger, 26in. (67cm) tube since a full page of teletext is rather tiring to read on the smaller size screen. The alternative is to use a 22in. (56cm) tube. This is a matter of preference of course and the decision is left entirely to the individual constructor. The only components

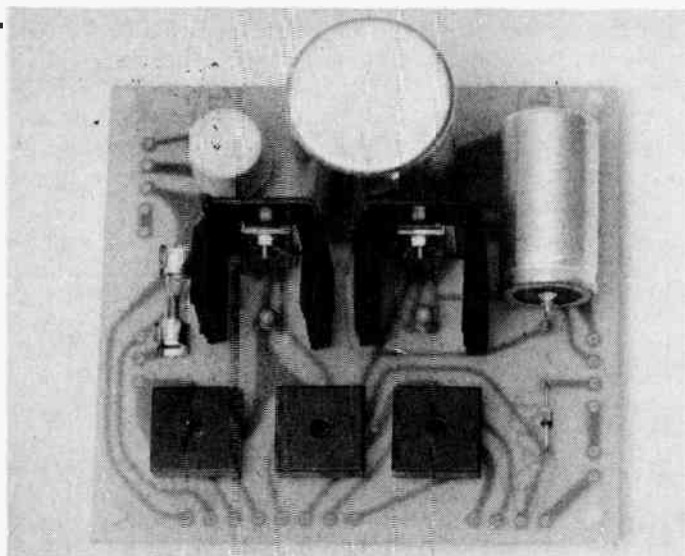

which change (apart from the cabinet of course) are the degaussing coils and retaining clips.

Block Diagram

Fig. 1 shows the basic receiver in block diagram form. The receiver section is straightforward and conventional, though extremely compact due to the use of two preassembled i.f. modules and the single RCA TA10313 i.c. for colour decoding. This i.c. provides R, G and B outputs to drive the class AB output stages. Amongst the advantages of class AB circuits are the reduced dissipation, absence of a high-dissipation load resistor, low output impedance and tolerance to supply voltage variations. An LM1808 i.c. takes care of the intercarrier sound amplification and demodulation, and provides a 2W audio output.

Thyristor Line Output Stage

The main feature that might cause some surprise is the use of a thyristor line output stage, since this is inherently more complex than a transistor line output stage. The latter would involve a fairly complex h.t. regulator circuit however, while a very simple width/e.h.t. regulator system can be used with a thyristor line output stage. Overall therefore, taking both the power supply and line output stage into consideration, the use of a thyristor line output stage is the simpler solution. It's also ideal for driving the PIL tube with its low-impedance, toroidally-wound deflection coils.

The Power Supply

The power supply circuit is shown in Fig. 2. It's very simple since the regulator and excess current protection circuits form part of the timebase module, while the 220V supply required for the RGB output stages and the 32V supply required for the field timebase are derived from the line output transformer.

The mains transformer has three independent secondary windings each feeding a bridge rectifier. Knowing the problems that bridge rectifiers cause in commercial receivers, we decided to use some fairly beefy ones. These are rated at 6A continuously and can withstand very high peak currents.

The h.t. reservoir capacitor is on the timebase board,

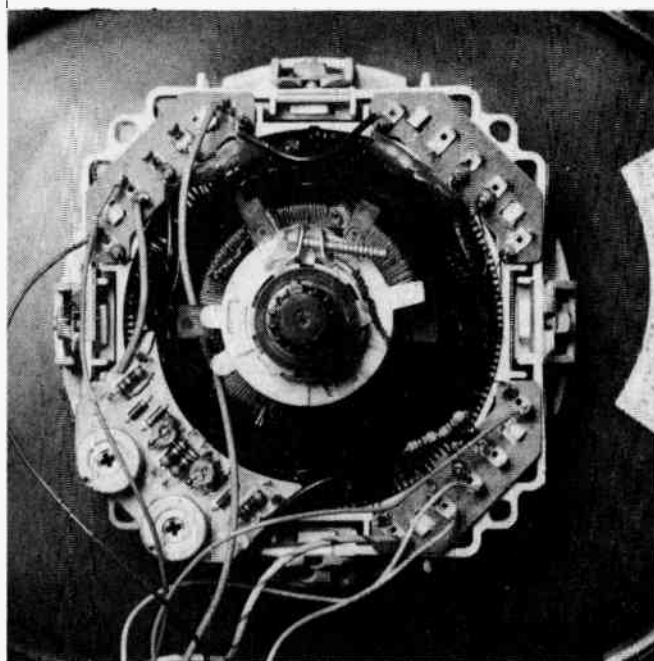

with the associated protection and regulation circuits, and these will be described when we come to deal with this board.

The main l.t. supply is stabilised by a 24V regulator. The use of a zener diode in series with the 24V rail provides the 18V supply required by the remote control receiver circuitry.

The third secondary provides, after rectification and regulation, the 5V rail required by the Tifax module and some of the interfacing circuitry.

The basic remote control system enables the set to be switched off but not on. To obtain the latter function, a special switch incorporating a solenoid is required. The power supply board contains some link connections to enable this to be added.

If teletext and remote control are not required, D1, BR3, C2, IC2 and C4 will not be needed and can be left off the board. They can obviously be added at a later date if you decide to add the options.

Degaussing Circuit

A double positive-temperature-coefficient (PTC) thermistor controls the degaussing action. This device is produced by both Mullard and ITT and results in the simplest possible degaussing circuit, dispensing as it does with the usual resistor.

Non-isolated Chassis

Some constructors may wish to dispense with the mains transformer, operating the set without mains isolation. This is perfectly feasible, though we don't recommend it. If this course of action is adopted, it's essential that the mains earth connection is not used and that the c.r.t. clamp band is connected to chassis via an RC network. We'll describe this when we come to deal with the tube. With a non-isolated set a 24V, 2A mains transformer will be required, while if teletext and remote control are added a 5V supply will also be necessary. These supplies can be obtained either from separate transformers or a combined transformer. In either case it's essential that the transformer(s) are adequately rated.

CONTINUED NEXT MONTH

Faults Encountered...

Dewi James

I think the main reason I enjoy TV servicing so much is the variety of sets that come in for repair. That's perhaps one of the advantages of working for an independent dealer.

Hitachi CSP680

Take the Hitachi CSP680 colour set that came in the other day. The initial fault displayed was no sound or raster, though the line timebase whistle was present and the e.h.t. sigh could be heard. Then after about thirty seconds a blueish horizontal line appeared on the screen, indicating that the field timebase was inoperative. The regulated 120V h.t. line measured high at 145V. The real problem however was no 12V l.t. supply. This is obtained from a rectifier (CR25) which is fed from a tap on the line output transformer. Absence of this supply is often due to a short-circuit in the tuner unit, but there was no short-circuit this time. The rectifier itself proved to be all right, and there was a line-frequency waveform at its anode – we realised later that its amplitude was very low. The fault was eventually traced to an open-circuit connector in the lead from CR25 to the line output transformer – an open-circuit in the d.c. sense, as there was sufficient capacitive coupling within the connector for the line-frequency waveform to appear at CR25's anode.

The moral I suppose is that I should read my instruments from time to time instead of using them merely as indicators. The fact that there was a waveform at the correct frequency at the diode's anode was no reason to assume that there should be a d.c. output.

Sony KV1810UB

Another recent encounter was with an 18in. Sony colour set – a KV1810UB. It came in completely dead, with the 2.5A mains fuse F601 blown. It was simple enough to ascertain that the chopper and line output devices were both short-circuit. These are gate-controlled switches, type SG613, a sort of cross between a transistor and a thyristor. Replacing them and fitting a new fuse restored the set to normal operation, but back it came two days later with the same fault. Another two days passed and back it came again (remember the story "half way down I met the bricks half way up?"). As the trouble seemed to be intermittent we decided to see what advice Sony could give. Replace C624 (47 μ F 25V) which decouples the 19V rail on the power regulator board and the flyback tuning capacitor C542 (1,800pF, 1.5kV) on the timebase (VH) board they said. This advice proved correct.

Sony suggest the following quick checks on this set where the problem is no sound or raster:

(1) Check F601, the chopper SGS Q603 and the line output SGS Q510.

(2) Measure the resistance between the 130V stabilised rail and chassis both ways. The reading should be 500 Ω one way (positive to pin 19 of the power regulator board,

negative to chassis) and 6k Ω the other way (negative to pin 19, positive to chassis). If low suspect the field output transistors Q503/4 or the sound output transistor Q901.

(3) Measure the resistance between the 19V rail and chassis both ways. The reading should be 350 Ω with positive to pin 17 of the power regulator board and negative to chassis, and 500 Ω the other way round. If low, suspect the line driver transistor Q509 or the chopper SGS driver transistor Q604.

Since the power supply operates as a closed-loop system, depending for its operation on pulses obtained from the line oscillator, it may be necessary when fault finding to connect an external 19V supply to the l.t. rail. Connect between pins 15/16 (chassis) and pin 17 of the power supply board, with a silicon diode in series with the positive side to provide protection against voltage surges.

Wouldn't it be nice if all switch-mode power supply faults involved smoke and burnt bits? For an account of the operation of the KV1810UB's switch-mode power supply see the July 1977 issue of *Television*.

Kuba Florence

A Kuba Florence 26in. colour set appeared on the bench the other day with the fault very little brightness. It didn't take long to discover that the trouble was lack of c.r.t. first anode voltage. Now the c.r.t. first anode supply is rather unusual, though those familiar with the Philips G6 chassis will recognise the idea (see Fig. 1). The first anode preset controls are connected between a 410V supply derived from the boost rail and a "floating" supply which is obtained by rectifying \pm 350V line flyback pulses. The pulses are fed via C584 and C585 to diode D580 for rectification, and the trouble was that C585 (0.0047 μ F, 1.25kV working) was short-circuit.

Another of these sets displayed a picture whose bottom half was completely missing. The voltages in the field output stage were completely wrong. A glance at the circuit diagram revealed that the field output stage is connected between +25V and -27V supplies: the latter was missing. So the fault was in the power supply, where the shunt regulator transistor TR602 (TIP31) was found to be defective, a replacement restoring normal scan. Shades of the Pye hybrid colour chassis.

A fault we get from time to time on these sets is brightness troubles due to the beam limiter diode D104. The latter is connected between the BD115 luminance output transistor and the cathodes of the c.r.t. It operates in the same way as in several monochrome sets such as the Pye

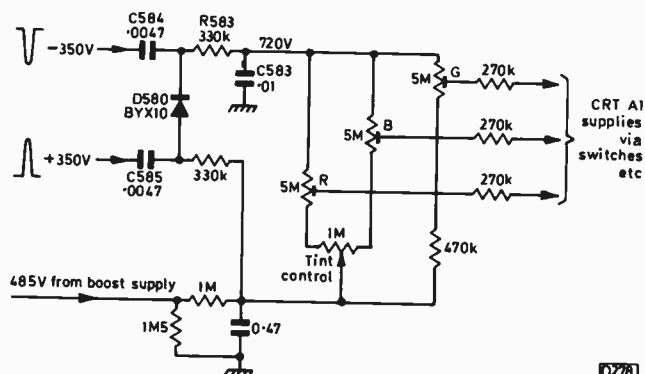

Fig. 1: The c.r.t. first anode supply circuit used in the Kuba Florence. When D580 conducts, the right-hand plate of C584 is charged positively. R583 and C583 provide smoothing. C584 and C585 are rated at 1.25kV.

Video Notebook

D. K. Matthewson, B.Sc., Ph.D.

Obtaining Preview on the N1502

One of the more popular modifications to the Philips' N1500/1501 series of VCRs was one which enabled a picture to be displayed in the fast forward/rewind positions (see May 1977 *Television*, page 382) so that the operator could get an idea of the whereabouts on the tape of different scenes. The modular construction of the N1502 is rather different from the open p.c.b. layout of its predecessor however, and to obtain the same preview effect a different approach is required. Examining the service manual is not very rewarding, as all the functional units are shown as "black boxes", with none of the internal circuitry shown. The only circuits shown in detail are the standard boards such as the power supply etc.

After some head scratching it was discovered that the stop-motion button could be pressed into service to give the desired effect. This entails linking pins 1 and 2 on SK8. After this has been done, depressing the stop-motion button will result in the VCR displaying the off tape signal: the incoming audio signal is also suppressed.

Improved Auto Stop: N1700

Here's an official modification to the N1700 to improve the operation of the automatic stop. Remove R123 from panel 11 (circuit C in the manual), reduce the value of R135 from 220k Ω to 100k Ω , and add a BAW62 diode in series with a 220k Ω resistor between the junction of R124/C116 and the +11 (40V) supply. The latter assembly should be mounted in an insulating sleeve on the print side of the panel, with the resistor connected between the output from bridge rectifier D103 and the anode of the diode, and the diode's cathode connected to the junction of R124/C116.

Grundig Super Video System

I was interested to see the new Grundig four-hour VCR at the 1978 Audio-Visual exhibition. The new format used is called Super Video (SV), the special cassettes having metal guide rollers and cut-out lugs to tell the VCR that the tape is of the SV type. Novel features of the SV4004 VCR are a ten-day digital clock and a control which alters the crispness of the displayed picture.

G8 Chassis VCR Modification

A Philips colour set fitted with the G8 chassis had been in use as a VCR monitor for a considerable while without any problems occurring, but it was noticed that when the VCR was switched to the still frame position all the colours were washed out with green. In the play position everything was normal, but those green faces on still frame. . . . Though not important for everyday use, we decided to delve into the G8. After some thought we decided that the problem was due to the signal phase relationships being distorted in the still mode. The following modification solved the problem, giving us nice pink frozen faces. R7190 in the feed from the ident stage to the TBA520Q i.c. was increased in value to

5.6k Ω (from 2.7k Ω), and a 5.6k Ω resistor was added between the junction of R7190 and the capacitor (C7206) in series with it and chassis. The ident coil L7205 was then adjusted for optimum effect.

Philips VCRs: Models and Derivatives

I've received several requests for details on the similarities and differences between the various VCRs that have been produced using the Philips' standards. It seems an appropriate time to clarify the position.

The basic specification of the original Philips system (CCIR-PAL) was as follows:

Tape speed: 14.29cm/sec.

Tape width: 12.5mm.

Video bandwidth: 3MHz colour, 3.2MHz monochrome, -26dB.

Video signal-to-noise ratio: 40dB.

Audio bandwidth: 80Hz-12.5kHz \pm 4dB.

Audio signal-to-noise ratio: 40dB.

Colour system: Heterodyned.

N1500: This was the designation of the first Philips machine designed to the above specification. It first appeared in the UK in 1973. Suffixes indicate which national TV system the machine is designed for, and this arrangement has been continued with all following VCRs. The suffixes are as follows:

/00 47-88, 174-230 and 470-870MHz, PAL B and G, Europe (not OIRT).

/15 47-88, 174-230, 470-870MHz, PAL I, UK.

/29 470-870MHz, SECAM L, France.

/43 174-254, 470-862MHz, PAL I, S. Africa.

/45 v.h.f. and u.h.f., PAL B and G.

/65 As/15 but 220V instead of 240V.

In addition to the u.h.f. input and output sockets the machine had two DIN sockets, one for audio input/output and the other for supplying separate chrominance, luminance and a 12V d.c. output to connect to certain television sets.

The N1500 was the original off-air, aerial input machine, incorporating a cooker type mechanical time switch. There were several variants, including the following two, most being designed for video inputs/outputs as well as u.h.f. inputs/outputs.

N1500M: An official variant designed to operate with video as well as u.h.f. signals. Depressing channel selector number six changed from off-air to video input. There were separate, buffered sound and vision outputs.

Various dealers and individuals carried out their own modifications to provide similar features, especially as the N1500M was often in short supply. Many of these modifications can cope with only monochrome video input, though a colour video output would be provided from a colour tape. The reason for this is related to the manner in which Philips process the chrominance and luminance signals separately, necessitating a complex arrangement of chokes and inductors.

N1500CM: A version of the N1500M, produced in small numbers, intended as a master machine for use in copying suites.

European equivalents: Various other European firms produced machines to the original Philips standard, including Telefunken and Skantic. The Skantic 5631 was imported in small quantities when other machines were in

short supply. The Telefunken and Skantic VCRs had identical chassis to the N1500.

The Grundig BK2000 and BK2500 were imported for a time and were rather more sophisticated than the basic N1500. The de-luxe BK2500 had video input/output facilities. Both sound tracks were used in the two machines, which had mechanical digital clocks of the falling letter-type.

Radio Rentals 8200 and 8201: These machines are based on the N1500 and were produced in quite large numbers. They were intended mainly for schools' use in conjunction with a suitable RR (Thorn) colour receiver such as the 22in. Model 1714. They differ from the N1500 in having a camera input socket but no off-air tuner unit or timer. There are DIN and multipole connectors for the video signals and separate audio input/output sockets. The multipole video connector was intended to couple the VCR to a suitable TV set, carrying the audio signal as well. The differences between the two machines are small but significant. The original 8200 was designed to give and receive video signals with separate chrominance and luminance components. The 8201 operates with a conventional composite 1V peak-to-peak signal. An adaptor was produced to enable the 8200 to be used with a composite signal. Inside, the 8201 is almost pure N1500, though Thorn use paxolin instead of fibreglass PCBs.

To make these VCRs more versatile, Thorn produced an off-air tuner-timer unit which fits on top of the VCR and is connected via a multiway plug. The timer can be battery operated to provide a back-up against mains failure.

N1501: The second Philips VCR was essentially a reboxed and slightly modified version of the N1500. Modifications include the provision of a stop-motion facility, tracking meter indication on playback, and some other minor alterations. Most spares are common to the N1500.

N1501M: The video input/output version of the N1501, similar in many ways to the N1500M.

LDL6269/01: Very similar to the N1501M, with in addition a video crispener circuit. Supplied by Pye Business Communications. Uses a Philips designed colour capable circuit, though of different design to the Austrian produced Philips machines.

N1460: A playback only machine produced by Philips for about six months. Ideal for use in libraries, lecture rooms etc. Many of the boards and mechanical parts are common with the N1501. The standard version had output at u.h.f., though again several dealers modified the machines to give separate sound and video outputs. An interesting feature is the P65 panel which suppresses the white flyback dots sometimes apparent during playback of recordings on some sets (see *Television* May 1977).

N1520: One of two electronic editing VCRs produced by Philips, mechanically very similar to the original N1500. Much of the electronics differ since they have to cope with the pulse counting and servo adjustment for editing. No off-air tuner or timer is provided, but there are video input/output and u.h.f. output facilities. The sound can be fed in or extracted as either a 600Ω balanced line or a high-impedance signal.

There were several official modifications, some quite major. The audio record and playback track selector PCB was replaced for example, to enable one track to be monitored whilst dubbing new sound on to the other: the



The Philips V100/15 monochrome camera.

two PCBs are quite dissimilar! The N1520 is the only VCR in the Philips range to make use of both sound tracks. In view of the complexities of this machine, the cost of the manual and its supplement is well worthwhile.

N1502: Built to the original specification but very different from the N1500 derived machines, both in style and design. Incorporates an off-air tuner, timer, etc. Most of the electronics are contained in modules which plug into a mother board. This main PCB is linked to the other bits of the VCR by means of plugs and sockets. This makes maintenance on a module swapping basis very easy, but even the Philips manual gives no clues about the innards of the modules, which are supposed to be returned to Philips for servicing. This means that true fault-finding is not at all easy. The main PCB remains of discrete component design, as are the three-day digital timer and a few other small PCBs. The standard version has u.h.f. input/output and audio input/output sockets.

N1512: A video input/output version of the N1502. The difference consists of one plug-in PCB which copes with all the input/output functions. The additional PCB should be available for around £25 for those who want to modify an N1502, but at the time of writing there are no spare boards in the UK. Selection of video input is by selector number eight.

N1700: The latest Philips offering, using the LP (long play) format which gives up to two and a half hours' playing time. Similar externally to the N1502, but quite different internally. Instead of TTL i.c.s, the logic circuits employ CMOS technology. This helps keep the current consumption down. The VCR is an improvement on the N1502 mechanically, the new motors giving a very rapid rewind and wind time. There's no commercial video input/output version, Philips' policy being to keep the N1700 as a domestic only use machine. A perusal of the manual however indicates that video output and monochrome input could be arranged on similar lines to the N1500. For further details, see *Television* April 1978.

LDL1100: A very sophisticated battery-operated portable VCR available from Philips and Grundig. Designed to the original Philips format but intended for high-quality ENG work. Includes full electronic editing, with an auto-edit facility to ensure clean transitions between camera shots. Other features include an electronic tape timer, solenoid-operated tape transport, remote control, etc. Originally

intended for operation with the Hitachi/Philips colour camera, but can also be used with the Grundig ENG camera.

Grundig: Grundig have had a stake in the VCR market for some time, with a large range of machines. Some are similar to the Philips designs but some are unique. The BK3000 and VCR3000 are broadly similar to the N1502 and

N1512: the BK4000 and VCR4000 are similar to the N1700 and a video input/output adapted N1700 respectively. The recently announced SVR4004 provides four hours' playing time. The dual-standard VCR5000AV can record and play back both N1500 and N1700 type tapes: playback selection is automatic. See also the earlier comments on the BK2000 and BK2500.

DIAGNOSTIC PATTERN GENERATOR PCB DETAILS

D051 SIDE 2

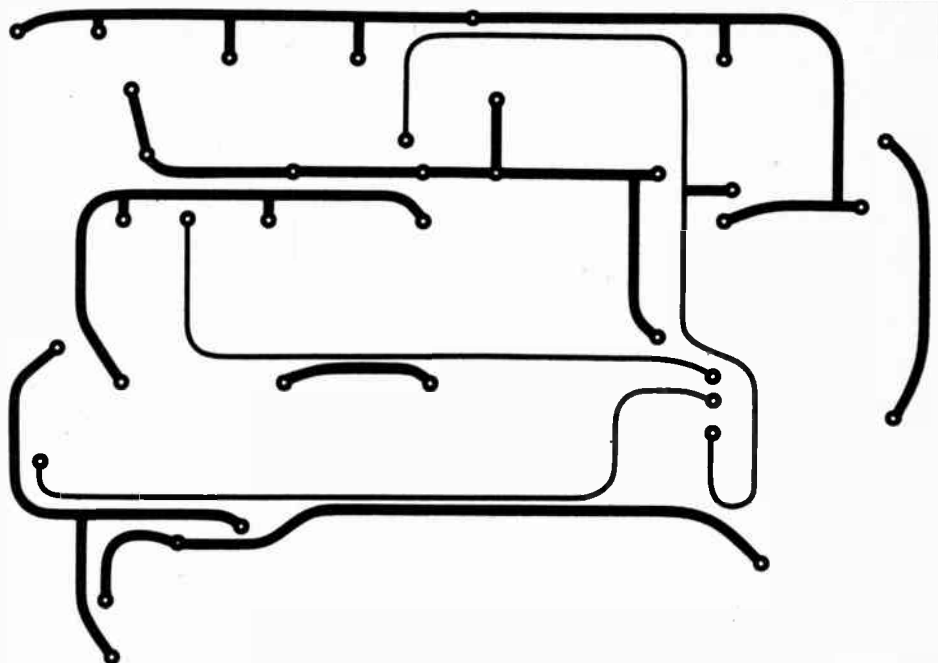

© IPC MAGAZINES LTD. 1978

D051 SIDE 1

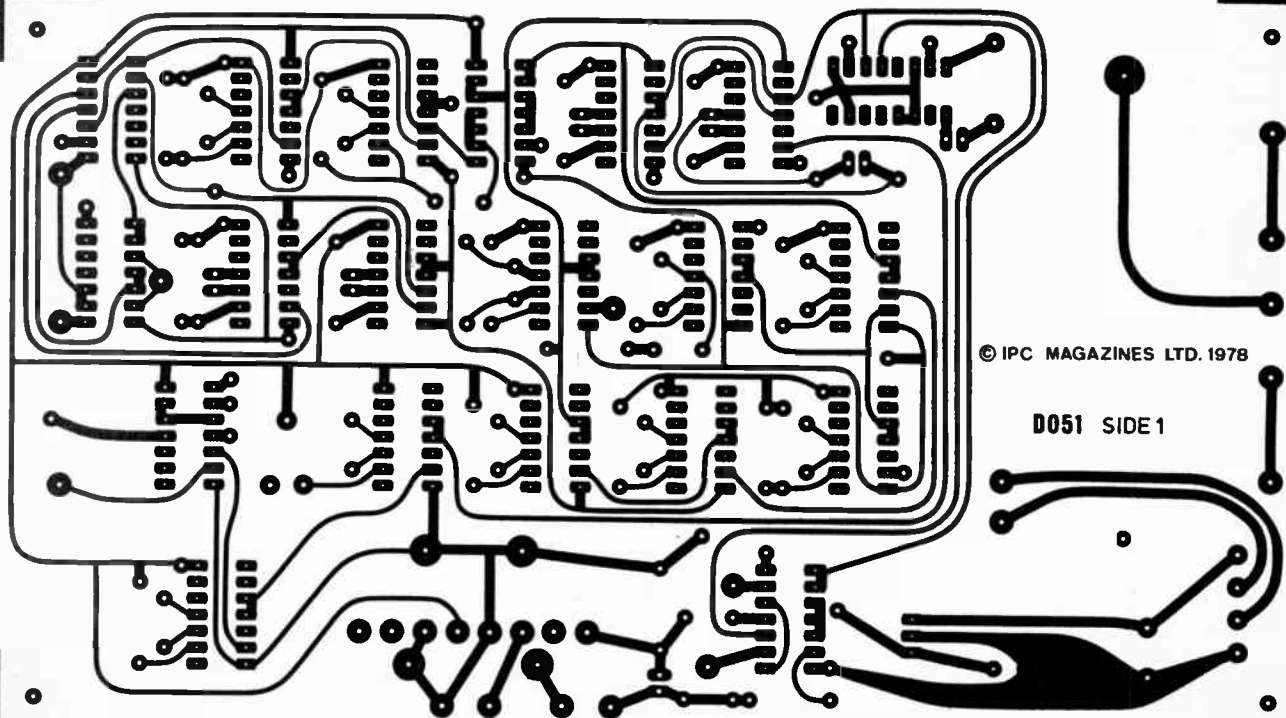

Top and underside print patterns. The actual board size is 8 x 4½ in.

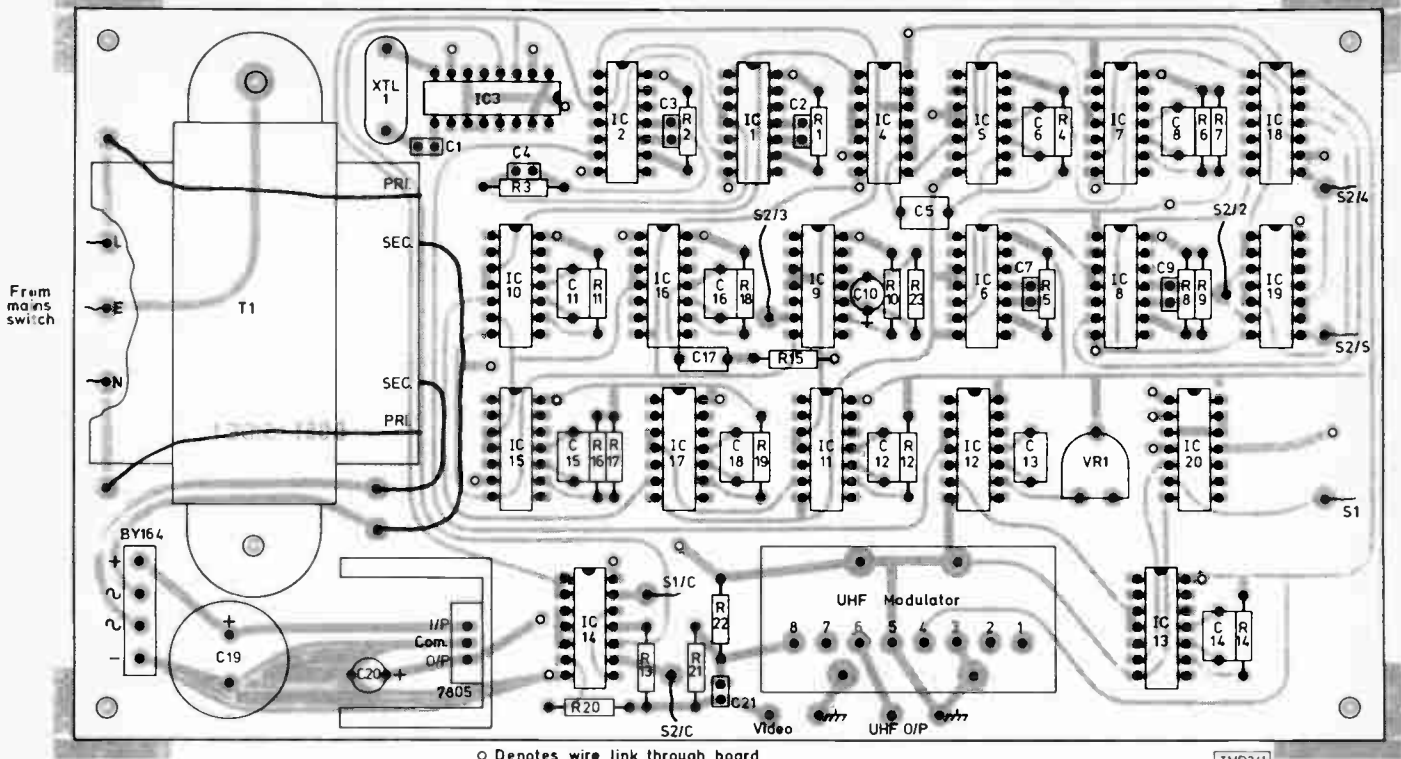

Diagnostic pattern generator PCB component layout.

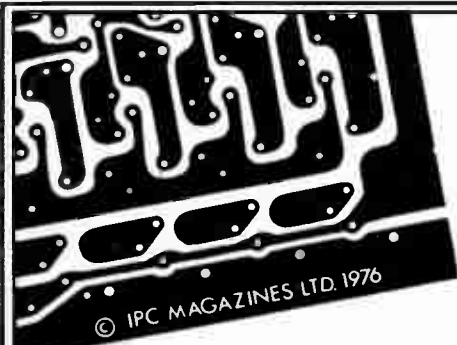

All boards are epoxy glassfibre and are supplied ready drilled and roller-tinned.

Any correspondence concerning this service must be addressed to **READERS' PCB SERVICES LTD.**, and not to the Editorial offices.

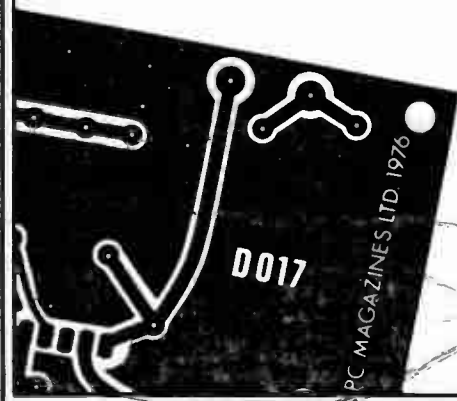

TELEVISION READERS PCB SERVICE

Issue	Project	Ref. no.	Price
November 1976	Ultrasonic Remote Control	D007/D008	£2.95 per set
		D009	£1.25
December 1976	IC Sound Circuits for the Constructor	D017	£1.25
		D018 + u.h.f. mod. board	£3.90 per set
Jan/Feb/March 1977	TV Pattern Generator		
March 1977	Teletext Decoder Power Supply	D022	£2.95
May 1977	Teletext Decoder Input Logic	D011	£9.80
May 1977	Single-chip SPG	D030	£3.00
June 1977	Wideband Signal Injector	D031	£0.65
June 1977	Teletext Decoder Memory	D012	£7.90
July/Aug 1977	Teletext Decoder Display	D013	£8.00
July/Aug 1977	TV Games in Colour	D034	£3.80
August 1977	Logic State Checker	D038	£1.50
September 1977	Teletext Decoder Switch Board	D021	£1.25
September 1977	Teletext Decoder Mother Board	D027	£4.00
September 1977	Touch Tuning System	D051/D052	£4.00 per set
October 1977	Teletext Decoder IF Board	D041	£6.00
December 1977	Monochrome Portable Receiver	D032	£15.00
Feb/March 1978	On-Screen Clock	D045	£6.50
April/May 1978	CRT Rejuvenator	D046	£2.50
May/June 1978	Test-Pattern Generator	D048	£8.50
Aug/Sept 1978	Diagnostic Pattern Generator	D051	08.00
October 1978	Colour Receiver PSU Board	D052	£3.50

To:— Readers' PCB Services Ltd. (TV), Fleet House, Welbeck St., Whitwell, Worksop, Notts.

Please supply p.c.b.(s) as indicated below:

Issue	Project	Ref.	Price

Prices include VAT and post and packing. Remittance with order please.

NAME _____

ADDRESS _____

Post Code _____

Notes on the Sanyo CTP370

Hugh Cocks and David Martin

THE phone rang one morning. "Do you mend Japanese TVs?" enquired a voice. "What make?" I asked. "A Sanyo" the voice replied. Relief spread through my mind that it was not a similar sounding Japanese make with four letters. Little did I know what was in store however . . .

Initial Complaint

The set concerned turned out to be a CTP370, which is somewhat unusual in being of hybrid design, with valves in the timebases, audio and video sections and transistors elsewhere. The valves are all familiar types except for the e.h.t. rectifier which is an oriental 3BS2A. The complaint was no sound or picture, and there was an upper expenditure limit as the owner had just bought another set. On removing the back I discovered that the e.h.t. rectifier had been removed by the previous "repairer". This looked ominous to say the least, so I thought it prudent to take the set back to the workshop.

On switching the set on the valve heaters lit up and h.t. was present but there was no l.t. The c.r.t. didn't light up – its heater supply is derived from a secondary winding on the mains autotransformer. This transformer (see Fig. 1) also supplies 120V to the degaussing circuit, with the l.t. supplies being derived from a 71V tap. The h.t. and valve heater supplies are derived from the mains directly – doubtless in countries with 120V mains supplies the transformer is used to step up the voltage for these supplies.

Defective Mains Transformer

To cut the story short, I found that the chassis end of the transformer had been disconnected. Connecting it blew the cutout (no fuses at all in this set!). The last person who had found the transformer defective had left the l.t. rail connected, so that nearly the full mains voltage was applied to the l.t. supply. After removing the chassis to gain access to the power supply components, which are mostly hand-wired on tagstrips on the rear metalwork, I found that the l.t. smoothing resistors had gone open-circuit while the capacitors looked a bit sick. Hooking in a substitute transformer and new resistors and capacitors brought some sound – less picture of course since there was no e.h.t. rectifier.

In view of the expenditure limit I decided to consult the owner – and ended up buying the set for a small sum. Had I known what was to come I'd have asked to be paid to take the set away!

AGC and EHT Variations

Not being very fond of valve e.h.t. rectifiers I decided to instal a Thorn e.h.t. stick rectifier of the type used in the 8000 chassis. The screen then lit up, but I found that the set would overload on even the weakest of signals regardless of the setting of the a.g.c. control on the rear panel, where a multitude of presets live. Prodding this panel would produce

proper a.g.c. action – and wild e.h.t. variations. Access to the print side of the panel is poor to say the least, and becoming exasperated with the set when the e.h.t. stick finally succumbed to panel prodding I passed it to David Martin who felt brave and wanted a cheap colour set. In between prodding the rear panel I'd replaced the "burst amplifier-2" transistor Q405 (2SC65Y) in the non-PAL decoder, because of unlocked colour picture V components (there are separate V and U reference oscillators). A BF178 gives a good account of itself in this position. Miraculously this was the only casualty when the l.t. line had experienced the onslaught.

Boost Circuit Short

Before handing over to David Martin to continue the story, some notes on another CTP370 that came my way while preparing the original draft of this article. On switching on, the PY500A boost diode glowed fiercely accompanied by violent arcing on the deflection board which carries the PCL805 field timebase valve, the ECC82 line oscillator/a.f.c. valve and the PCL86 audio valve. The feed from the boost rail to the triode section of the PCL805 comes via the height control VR710 (see Fig. 2) which is mounted on the rear panel: it's then taken via a long length of wire to a large $1M\Omega$ resistor (R322) just below the PCL805. This resistor is very close to the earthing print, and a conductive path had formed between the supply end of the resistor and the earthing print. This short-circuit had lowered the value of R706 ($100k\Omega$) in series with and adjacent to the height control to a few ohms, while R910 near the PY500A had also fallen in value, thus presenting a low-impedance path from the boost rail to chassis.

As the print on the deflection panel at the point of arcing was beyond repair I made a wire junction between C320 and R322 above the board. If R706 is left in position with reduced value incidentally the result is full scan with very weak field sync and field frequency variations with brightness. The height control VR710 appeared to have survived due to having been set at minimum resistance: had it been set midway, doubtless it too would have needed changing.

This set gave me an opportunity to inspect the official e.h.t. rectifier. Suffice it to say that the noise coming out of the X-ray can is reminiscent of dual-standard sets – i.e. arcing and corona discharge. Thank heavens there's no PD500 lurking in the can. Now over to David who takes up the story of the original set.

More EHT Problems

After taking the set over from Hugh I installed two 20kV rectifier sticks in series and set about mending the earthing crack on the rear panel. By this time the line output transformer voiced its disapproval and gave the job up. A new transformer was fitted – and a nasty 33kV was obtained. I switched off quickly and completed repair of the crack – towards the bottom of the board, on the left-hand side looking from the rear. On switching on again there was

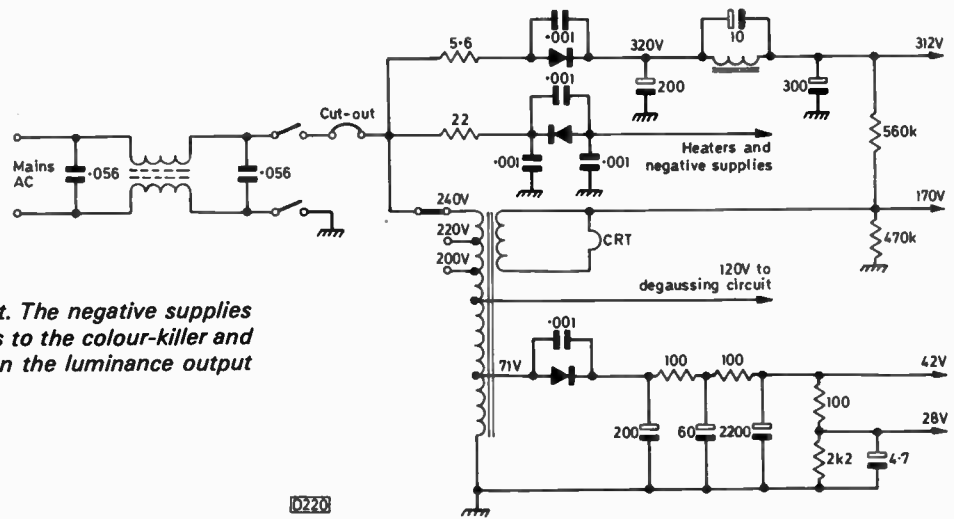

Fig. 1: The basic power supply circuit. The negative supplies consist of a -10V rail and other feeds to the colour-killer and brightness controls. The latter acts on the luminance output pentode's control grid.

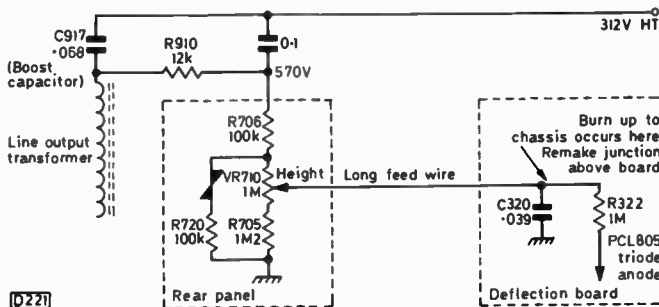

Fig. 2: Simplified circuit showing where the burn-up which shorts the boost rail occurs.

good a.g.c. action and "nice" e.h.t. O.K. so far then.

Width Circuit Fault

D702 in the width/e.h.t. stabilisation circuit (see Fig. 3) was then found to be short-circuit and was replaced with a BY127. I shudder to think of the X-rays that would have been present with the original e.h.t. rectifier fitted. Moral: when servicing one of these sets, check the e.h.t. and buy a Geiger counter... The e.h.t. rectifier sticks were not very satisfactory, so we fitted another Thorn 8000 rectifier stick which has worked well for several months.

Faulty Presets

I found that the presets on the rear panel were prone to poor wiper contact - many of the gremlins in this set live on this panel. I haven't yet encountered the a.g.c. problem mentioned by Peter Murchison in the August 1977 issue (overloading due to R157 or R158 in the a.g.c. circuit being defective), but C914 (47pF) which feeds the gating pulses from the line output transformer to the anode of the PCL84 (triode section) a.g.c. gate gave problems, resulting in intermittent overloading.

Valve Consumption

After dealing with these various faults and setting up the receiver a good picture was obtained. I've had a lot of valve problems however - doubtless due to the high working temperature inside the small cabinet. Amongst the problems have been brightness drift due to the two PCL84 video amplifiers, horrible colours due to the ECC82 colour-difference output valves, and the usual PCL805 problems. The PCL86 audio valve hasn't given any trouble however. The

0220

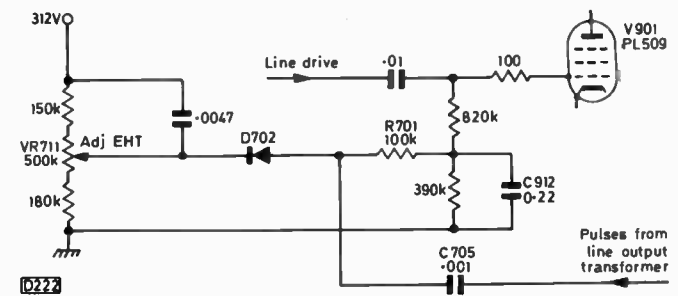

0222

Fig. 3: The width/e.h.t. stabilising circuit. A diode (D702) is used instead of the more common v.d.r. D702 is normally cut off by the positive bias applied to its cathode from the preset VR711. A positive-going line flyback pulse switches it on at the end of each line however. When D702 switches off, a negative charge proportional to the flyback pulse amplitude is left on C705. This is filtered by R701/C912 and is used to bias the control grid of the PL509 line output valve. The same basic system is used for feedback clamp circuits in a.c. coupled RGB channels. VR711 adjusts the point at which D702 conducts during the flyback pulse and thus the e.h.t. obtained from the line output stage.

latest problem is almost continuous demise of the PCL84 (triode section) sync separator. Roughly once a week sync is more or less lost and a replacement valve provides a cure. All the voltages are correct, so for the moment we're putting it down to a dud batch of valves.

Conclusions

The transistor side of the set has for the most part proved reliable. This is just as well, since access to some of the transistors is quite difficult. The chassis is quite easy to remove from the cabinet, and this is often necessary when a component needs to be replaced. Be careful not to foul the convergence board on the tube neck when withdrawing the chassis.

When working, the set gives a good picture. I've had it in full domestic use for several months, and the set is also a good one for DX use due to the rotary u.h.f. tuner and the colour-killer threshold control on the rear panel. The latter enables weak colour signals to be resolved. The unusual decoder gives quite good colour - if setting up is necessary, the full manual should be obtained. Many people believe that the model is quite old, but this one is stamped September 1974.

One hopes that no other reader will encounter all these faults on one set. The mind boggles at the repair bills had Hugh's original customer decided to keep the set going! ■

Letters

COMMON FAULTS

Following the article on the Thorn 1590/1/3 series of portables (August issue) I thought you might like to include a note on the following common fault in the line output stage. The reported fault is lack of line scan, which I've normally traced to dry-joints on the line output transformer and flyback tuning capacitor C109. On some sets however a burn mark will be seen around the circumference of the winding when the transformer is examined, and in this case it's necessary to replace the transformer, the line output transistor VT26 and resolder C109, also checking that there are no other dry-joints in the area. I've also found on several occasions that the a.g.c. gating diode W1 has failed when this fault has occurred.

Another fault that's showing up with increasing frequency is intermittent loss of field scan on the earlier Pye hybrid colour chassis (691, 693). If the usual items are checked to no avail look for a dry-joint on smoothing panel B – normally at R313 or a wire which carries the 20V (B) supply to the edge connector.

I hope these tips will be of help to other readers. – M. Brett, T. Eng. (CEI) AFSERT, Sidcup, Kent.

VCR CONVERSIONS

I would like to thank your contributors who wrote about their successful experiments in converting 1500 series VCRs to the long-play standard, and to confirm their findings using an additional tape servo, 1700 series head and reducing the diameter of the capstan and pulley.

To complete the conversion I found that it was possible to modify the clock-timer to extend the switching period. This can be done as follows. Dismantle the front section of the clock mechanism by removing the hands and releasing the four split spring washer clips, also removing the front timing disc. The modification involves carefully elongating the three radial slots in the plastic time setting gear – I used a small Swiss file to do this – extending the cutout on the periphery of the period setting gear, and extending the

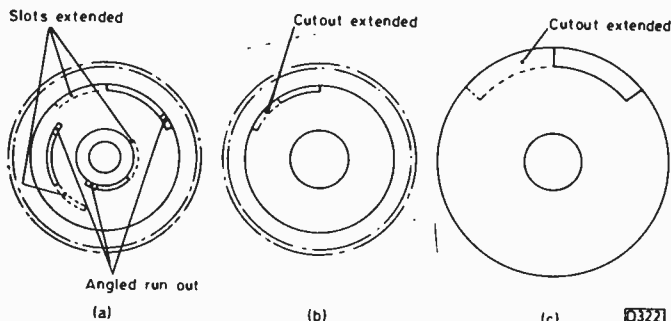

Fig. 1: Modifications to the Philips N1500 series VCR clock-timer to extend the switching period to convert to the N1700 standard. (a) Time setting gear. (b) Period setting gear. (c) Front timing disc plate.

timing cutout on the front timing disc (see Fig. 1). The amount of elongation was determined using dividers to measure the chordal length of the remainder of each slot after inserting the mating trip plate, with trips against the runout position. – S. J. Humphrys, C.Eng., M.I.Mech.E., Welwyn, Herts.

PHILIPS COLOUR RECEIVERS

I'd like to correct an error which occurred in the final instalment (Part 3) of my article on the Philips G8 chassis. This was in the instructions given on page 543 of the August issue for setting up the decoder. In the second paragraph, it's L7007 that should be adjusted for minimum hanover bars on R – Y, not L7003. The third paragraph "L7007, the burst phase detector transformer, is best left undisturbed" should be deleted. I hope this hasn't caused anyone any difficulty.

In the same issue Andy Denham mentions a tricky problem on this chassis, intermittent no sound or raster. I've had this one a few times and the cause has always been a dry-joint, either on one of the 1Ω wirewound resistors in the base circuits of the pair of line output transistors or on one of the four tags carrying the connections from the two secondary windings on the driver transformer to the top panel. It's impossible to provoke the fault once the set is operating normally, presumably because it's due to the line oscillator running from a slightly reduced supply before the line output stage starts up, not enough drive being produced to "bridge that gap".

The weak raster on the Philips G6 chassis (*Your Problems Solved*, page 551) is presumably a case of excessive brightness. A common cause of this is the zener diode (X2154) in the cathode circuit of the PFL200 luminance output pentode going short-circuit. Replace it with a BZX61/C4V7. – Mike Phelan, Holmfirth Yorkshire.

TRIPLER CONVERSION

While digging through an ever growing pile of faulty old TV sets I came across a Bush TV161 which didn't look too bad. After replacing the dropper resistor and h.t. rectifier the set came to life, so it was left on for an hour or so to see what would happen. On checking, sound o.k., no raster, due to the overwinding on the line output transformer having gone. Before scrapping the set I decided to experiment with an e.h.t. tripler, as outlined in a previous issue of *Television* (see March 1976) in connection with the Decca CTV25 colour receiver.

I removed the overwinding completely, connecting the top cap of the PL504 to the input of a tripler for the 24in. Thorn 1500 chassis. I then fitted a 220pF , 12kV capacitor from the cathode of the PY88 to chassis to adjust the tuning. Being a coward, I next persuaded the wife to switch the set on while I hid... Not hearing any strange noises, I came out of hiding and found a good picture with perfect

sound. The width was a bit excessive, so the value of the capacitor added was reduced to 180pF. This corrected the width on this particular set.

I'm now trying to fit the tripler in the space vacated by the redundant DY802 e.h.t. rectifier and its base. When completed, this will have been a very good and cheap repair. Perhaps the idea may be of use to other readers as an alternative to buying a new line output transformer for an elderly set. — P. Naylor, *Aston, Birmingham 6.*

CONVERGENCE MODIFICATION

Mention was made in the August *Your Problems Solved* of repeated failure of the R/G parabola control R1934 on the convergence board of the Philips G8 chassis. There's an official modification I thought you'd like to know to overcome this problem on earlier convergence boards — by fitting up-rated controls and adding a resistor. The details are as follows: change R1934 to part no. 103-17042 (10Ω) and R1933 to part no. 103-17091 (20Ω), and add a 15Ω resistor (part no. 113-87201) from the junction of R1933/4 to the junction of R1919 and the R/G tilt control L1917, i.e. in parallel with R1934 and R1919. This modification seems to be fairly reliable using the Philips approved parts. — P. Cole, *St. Austell, Cornwall.*

HEATER CHAIN ORDER

I read with interest B.C. Alabaster's letter in the August issue on the order of the heater chain. This problem of 50Hz hum was new to me and I've been unable to find any reference to it in the usual textbooks. Anyway, I decided to try out an experiment to see what would happen. I got an old Bush set (Model TV 135U) which was displaying a good, clean picture and reversed the order of the heater chain so that the tube heater was first in line and the line output valve last. Once the picture came on, a lovely 50Hz hum bar was found travelling up the picture! Having satisfied myself on that point, I then short-circuited the boost diode's heater and cathode (the boost diode is second in the chain in these sets, after the line output valve). As a result the boost diode glowed brilliantly while all the other valves, except for the line output valve which was now down at the earthy end of the chain, appeared to be near normal. The fuse didn't blow, even after a couple of minutes. What did happen was that the boost diode blew up, it's heater going open-circuit. I can't say that this would be the case on other chassis of course. — Robin D. Smith, *Knebworth, Herts.*

SERVICING ACROSS THE CHANNEL

I've been reading with interest the correspondence on TV cowboys in *Television*. The situation here seems to be worse still from the customer's point of view. According to the Federal Union of Consumers' magazine *Que Choisir?* you're sure to run the risk of being swindled if you 'phone the first servicing company whose number comes to your attention when your set goes wrong. The magazine explains that servicing companies are interested in doing as much servicing as possible rather than maintaining sets in working order, so jobs are done as quickly as possible with the greatest possible number of parts being involved. The magazine conducted a small test, calling in seven firms to repair a set with an open-circuit fuse. Components in perfect condition were changed, sometimes being replaced by secondhand ones... when the fuse was not simply

shorted with wire! Though the cost of the correct fuse was not more than one franc the prices invoiced ranged from 47F to 304.77F, with the total cost of the repair varying between 190F and 414.20F (from about £20 to nearly £50). *Que Choisir?* concludes that it's better to call the setmaker or retailer. — Thierry Weber, *Paris, France.*

RECOMMENDATION FOR RECONDITIONING

Keith Cummins may have a couple of Thorn 2000 chassis still giving good results but, as someone who spends most of his time reconditioning colour sets for sale, I'm happier with hybrids. In common with J. Pierce (June letters) I've found that the best chassis for this purpose is the GEC one. I sell both the dual-standard (modified for single-standard operation) and single-standard versions and obtain reasonable periods of operation from both. I've had the dual-standard version working for over a year after reconditioning and then with only minor faults. I'm quite sure I'd rather face a line output stage fault in a hybrid set than one in a solid-state chassis. Valves are obtainable much more cheaply, with nearly all sets using the same type, and one always has that second chance not available with a solid-state line output stage. — J. Broadhead, *Leeds, Yorkshire.*

CRT REACTIVATOR

Other readers may be interested in the c.r.t. reactivator design shown in Fig. 2. Before I built this I had been using the one published in the February 1973 issue of *Television*. That one fed the c.r.t. heater from the mains via a 100W bulb, and had just a 15W bulb in the grid-cathode emission circuit. I felt that it was probably limited to monochrome tubes, and had insufficient kick to clear some monochrome tubes. The design shown in Fig. 2 clears both colour and monochrome tubes. It uses a transformer with 6V/2A and 240V/40mA outputs. To get an extra kick for clearing the grid-cathode path, a 15μF capacitor is added across the output. I first tried this after having no luck with a 23in. monochrome tube: it came up like new after adding the capacitor! The connectors are similar to those used for pickup cartridges: they were made from a small piece of tin can by squeezing around a needle the size of a c.r.t. pin, finally covering with tape.

In use, connect the heater leads to each side of the key, then the red lead to the grid and the black lead to the cathode, with SW2 closed. For slow tubes it may be best to start with SW2 open for about ten seconds to allow the 15μF output capacitor to charge. For colour tubes the heater leads are again connected to each side of the key, then each gun is cleared by connecting the red and black leads to pins 2/3, 6/7 and 11/12. Switching the mains on and off several times clears much better. — G. T. Jones, *Pwllheli, Gwynedd.*

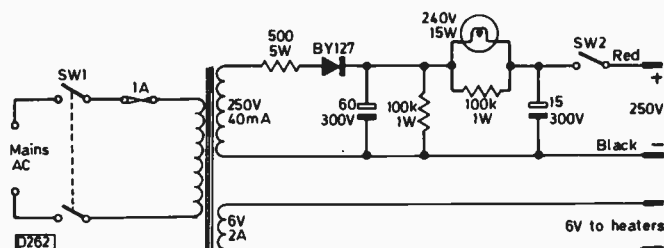

Fig. 2: Colour and monochrome c.r.t. reactivator suggested by G. T. Jones.

TV Servicing: Beginners Start Here . . .

Part 13

S. Simon

As we've seen, the line timebase deflects the c.r.t.'s beam from side to side of the screen while the field timebase deflects the beam downwards so that successive lines fall below each other. As a result, a complete picture is built up on the screen, and due to the speed at which these processes occur and the persistence of human vision the eye sees this complete picture rather than the scanning spot. A vital aspect of television is synchronisation, i.e. ensuring that the television receiver's horizontal and vertical scanning are kept in synchronism with the original signal source, be this a camera or whatever (VCR, TV games unit or pattern generator maybe). Without synchronisation, the display would be a jumble; with weak synchronisation, the result is ragged verticals with unreliable field hold, i.e. a tendency for the picture to roll upwards or downwards.

Synchronisation is effected by adding sync pulses to the video signal at the signal source, i.e. studio, outside broadcast unit, etc. The line sync pulse occurs at the end of each line, to start the c.r.t. beam flying back to the left-hand side of the screen before the beginning of the next line. Likewise field sync is effected at the end of each field, to get the beam to return from the bottom to the top of the screen. This is a longer period than the line flyback time, the field scanning being relatively slow (at 50Hz while, with 625 lines, the line frequency is 15,625Hz). During the time allotted for the field flyback, a group of pulses is transmitted: these are integrated to give a single, large pulse which is used to lock the field oscillator.

Since the beam has to return to the left-hand side of the screen at the end of each line, and from the bottom to the top of the screen at the end of each field, these processes taking a certain finite time, there's plenty of time available for the necessary synchronising pulses (it's the leading edge of the pulses that initiates the actual flyback). We can set arbitrary points for the black and white levels of our video waveform – provided we keep to them. As Fig. 1(a) shows, with a standard 1V video signal 0.7V is taken as the extreme from black to white. This leaves us with 0.3V which is "blacker than black" and can be used for the sync pulses. We want the screen to be blanked out anyway while the line and field flyback are occurring, so this is a convenient arrangement.

The waveform in Fig. 1(a) is a typical line waveform. The signal rests at black level for a short period before and after the actual sync pulse – the front and back porch respectively. Otherwise the signal might have to drop from peak white to zero and back again instantaneously, which is impossible. The relatively long back porch gives us a convenient point at which to add a colour sync signal, but we must leave that aside until we come to colour later.

Field synchronisation is a more complex business since with 625 lines each complete picture consists of two interleaved fields of 312½ lines each. Interleaving, or interlacing as it's called, is used to reduce picture flicker

and save bandwidth, but we don't need to go into the theory of that. From the practical aspect those half lines mean that successive fields begin and end at different points along a line. This results in a rather complex field sync signal, while if precise field sync is not maintained the complementary fields will not interleave exactly and the spacing between lines will alter, giving loss of vertical definition.

The video signal is generally used to drive the cathode of the c.r.t. It must be negative-going for peak white therefore, i.e. inverted as shown in Fig. 1(b). This is equivalent to driving the grid positively. Now suppose that we apply the signal shown in Fig. 1(b) to a stage which is so biased that it does not conduct until the input signal rises above 70% of its maximum amplitude. It will pass the sync signals only of course. This is the simple principle of the sync separator. Ah, you might say, but how do we distinguish between the line and field sync pulses? This is again a simple matter. Since the line pulse frequency is much higher than the field pulse frequency, simple time-conscious filter networks can be used to separate the pulses and send them on their separate ways to synchronise the line and field timebases.

Flywheel Line Sync

We're rather fortunate in the UK in that TV reception conditions are generally good. This is reflected in the comparative simplicity of the sync separator circuits used. Many imported sets use quite elaborate sync separator circuits in order to guard against the effects of noise and so on. But even in the UK the line sync pulses are not used directly to synchronise the line timebase. Instead, they are fed to a circuit which compares their timing with that of the flyback pulses produced by the line output stage. Any disparity results in a control voltage which is used to adjust the line oscillator frequency. This system is called flywheel line sync, and was mentioned in some detail in an earlier instalment.

Sync Separator Circuits

First however the sync pulses have to be separated from the rest of the video signal. It's essential that the sync separator does not pass any picture information – otherwise the picture information will also be present at the output of the sync separator and will confuse the timebases. The biasing of the sync separator is quite an important point therefore in maintaining good sync performance.

Let's start with valve sync separator circuits. We've already made the point that a valve can be biased towards cut-off by applying a positive voltage to its cathode – positive with respect to the control grid voltage that is – or alternatively by doing things the other way round, i.e. applying a negative voltage to its control grid, with the

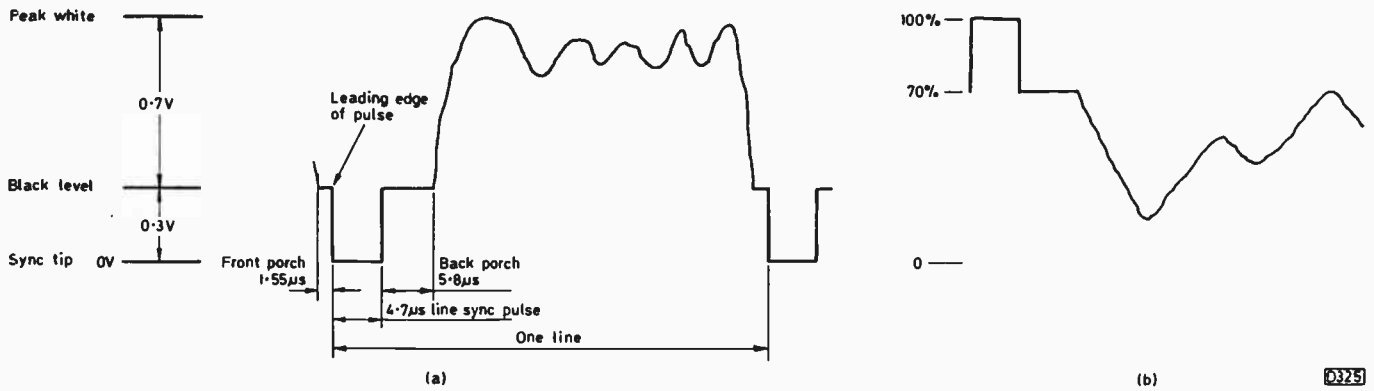

Fig. 1: (a) Position of the line sync pulse in the video waveform. (b) Positive-going sync pulses are applied to the sync separator and to the c.r.t. cathode (with cathode c.r.t. drive).

cathode taken directly to chassis say. In considering valve audio circuits last month we saw how the control grid can be negatively biased by applying the signal via a capacitor and using a high-value resistor between the control grid and chassis. The high-value resistor ensures that the plate of the capacitor connected to the valve's control grid retains an average negative charge, thus providing the required bias. This is the approach used with valve sync separator stages. A typical example is shown in Fig. 2, where it will be seen that the charge developed by the coupling capacitor C70 is -26V.

Consider again the waveform shown in Fig. 1(b). The valve is biased off until the input rises above 70%, signifying that there is a sync pulse present. Note however that once the waveform rises above 70% it moves rapidly to 100% and stays there until the end of the pulse. This means that the valve is being switched into heavy conduction for brief periods. When a valve conducts heavily current will flow in the control grid circuit, i.e. the control grid and cathode will act as a rectifier diode, and in consequence the grid coupling capacitor will receive a negative charge. This is exactly what we want: we use a high-value resistor in the grid circuit so that this charge remains, holding the valve cut off between sync pulses.

Since the negative charge acquired by the capacitor is proportional to signal strength, we also have a simple measure of the signal strength. The voltage can be used therefore to provide the a.g.c. action.

We can use the same biasing technique to operate a transistor as a sync separator. A.G.C. doesn't come in here however. With the 625-line system the sync pulse tip represents maximum signal modulation (it represents zero modulation with the 405-line system). Thus on 625 lines a simple peak detector can be used to measure the sync pulse amplitude for a.g.c. purposes. The use of the 625-line system and transistors as sync separators started at much the same time, making it unnecessary to complicate

transistor sync separator circuits by linking them to the a.g.c. system.

As we've said, time-conscious filters are used to separate the field and line sync pulses. The series of field sync pulses usually charge a capacitor through a resistor (integration). The components involved in Fig. 2 are R69 and C72. The important things here are that the correct component values are chosen and that the components keep to their original value. There are occasions when they don't and the signals get mixed up. This is usually due to a capacitor failing to do its job.

Recognising Sync Faults

It's easy to confuse timebase faults with sync trouble, and whilst it's a simple matter to trace the sync signal from the video amplifier through to the output of the sync separator etc. with an oscilloscope we have to assume that the reader does not have this advantage. Some practical tips can be of more value therefore than nice pictures of waveforms, however useful these are to those who have more elaborate equipment. Those possessing such items, plus the knowledge to use them (correctly), will hardly be reading these articles anyway.

Poor Sync

There are one or two points to remember before we start. Most line timebases work in conjunction with a flywheel sync circuit which tends to keep the line steady even when the sync signals are weak. Therefore weak sync will most often be seen by the inability to lock the field timebase firmly. By this we mean that the picture tends to roll up or down, with no positive lock. The ideal is to use the field (frame) hold control so that the picture starts to roll downward, then adjust it so that the picture rolls up and almost "clicks" into lock, with a degree of further rotation of the control having no effect. With this happy state of affairs established, the control should be returned to the setting where it just caused the picture to roll up and lock, this being the point where the timebase is being triggered at the most sensitive part of the oscillator's cycle (slightly slow).

An interlace diode is often included in the sync feed to the field oscillator, and this can give rise to weak field hold, the sync separator itself being perfectly in order. It's helpful therefore to note the effect of the line hold control before jumping to conclusions. The writer is and always has been an expert at jumping to conclusions. Many hours have been wasted in the pursuit of this sport, when careful observation and checking could have wrapped the job up in no time.

The average type of line oscillator circuit is quite tolerant of

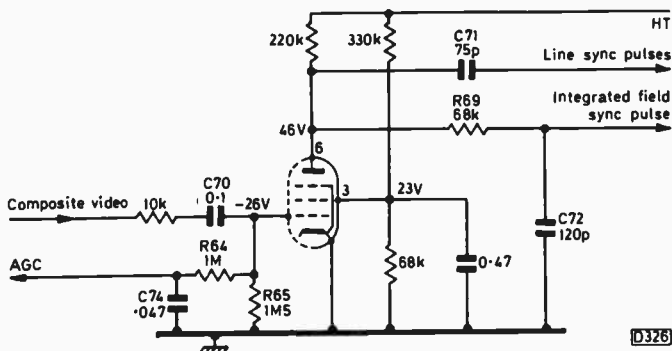

Fig. 2: A typical valve sync separator circuit—from the ITT/STC series of monochrome dual-standard chassis.

the line hold control setting. Adjusting this control should result in the picture moving sideways before hold is completely lost. Weak sync will result in a more critical setting, thus giving an indication that the reason for the poor field lock is in the sync stage or perhaps before this (in the video stage or a.g.c. circuit in some cases). It will have been noted that the sync pulses are at one extreme of the signal waveform (in the "blacker than black" part). Thus if the video amplifier is not biased to operate at the mean centre of its characteristic curve, the sync pulses could be considerably impaired or crushed. The same effect occurs if the input to the video stage is excessive, and can also occur in the i.f. strip if the a.g.c. bias is incorrect. Thus it's prudent to reduce the setting of the contrast control to see if this improves the sync performance.

A quick check on the video output stage voltages and those of the sync separator can be very revealing if one knows the approximate readings to expect. For example, to return to our Thorn 1500 chassis for a moment, poor sync is nearly always the result of R44 increasing in value (47kΩ to pin 7 of the 30FL2, see Fig. 3): a voltage check here will show whether or not this is so. If the reading is much below 60V, suspicion should fall on the resistor. The sync will hold when the voltage starts to fall below 60V as the resistor goes higher in value, implying that 47kΩ is not a critical value. Once the resistor's value starts to rise however it will certainly not stop (or obligingly fall), and the resistor should be changed for one of higher wattage as a matter of routine.

If all is well at this point one should check over the video stage generally. The electrolytic capacitor C38 should not be above suspicion, as when this dries up and no longer functions a further 8.2kΩ resistor enters the signal circuit in the shape of R126 and the designed operating conditions are drastically changed. Likewise C37 can leak, thus altering the video transistor's base voltage (strictly speaking base current) and pushing the sync pulse response "into the red" as it were.

Thus there are many factors to take into consideration, and each chassis (or series of models) has its own habits or traits which when enough have been serviced enable the repairer to pounce quickly upon the most likely component. What's sauce for one model is not necessarily sauce for another. Only experience provides the quick remedy, or a close study of the experiences of others if this valuable knowledge is available.

The alternative is a good working knowledge of the factors involved and a methodical approach whatever the basic design. We offer below some practical examples of our own experience over the last few years.

Faults in Valve Circuits

Whilst the valve in a valve sync separator circuit may well be at fault, resistors are the primary cause of poor sync performance. We've already mentioned the 1500 chassis. A similar case occurs with the GEC Series One chassis. Here a PFL200 valve performs the functions of video amplifier and sync separator. Although the valve may well be responsible for weak sync, in the majority of cases R141 (again 47kΩ) in the screen grid circuit will be found high.

In an earlier series of models (many still in use), namely the ITT/KB VC1 to VC52 chassis, a PCF80 valve was used with the pentode section as the sync separator (see Fig. 2). Whilst this valve can give trouble, again the resistors are more likely to be responsible, the likely ones having values of 330kΩ and 220kΩ (the screen grid and anode resistors). Both tend to go high in value. They can easily be

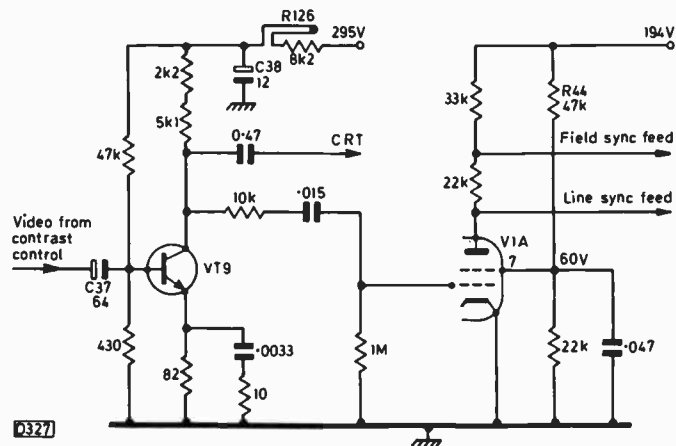

Fig. 3: The video output and sync separator circuits used in the Thorn 1500 chassis.

found by tracing the leads back from valve pins 3 and 6 to the tag panel. 330kΩ (orange, orange, yellow), 220kΩ (red, red, yellow).

In some chassis the sync circuit itself is rarely at fault. In the Bush TV161 series of receivers for example the cause of poor sync is more likely to be found in the a.g.c. circuit, where the setting of the contrast control is quite critical. This is also the case with some Philips receivers. As far as the Bush series is concerned however a likely culprit is indeed in the sync stage and is C48 (8μF) – especially if this is a white component! We have referred to this item in a previous article (capacitors and their habits) so there is no point in labouring the point here. Suffice it to say that the capacitor is below the PFL200 valve.

Transistor Sync Separators

Transistor sync separator circuits can be complicated, but not necessarily so. In the popular Pye dual-standard and single-standard colour sets (Dynatron, Ekco, Invicta etc.) for example there's a fairly simple and easy to check stage (VT7, see Fig. 4). The transistor is a BC147 which can be checked in moments with an ohmmeter switched to the low ohms range (remember the drill, check an npn transistor with the black probe to the base, low reading of about 30Ω with the red probe to the collector or emitter, high reading with any other connection). In fact the transistor will usually be found to be in order, the main suspect being the 4.7MΩ resistor R33 which "turns on" the base current. The diode D3 is easy to check with the black probe to the emitter of VT7 and the red probe to chassis to produce some sort of deflection on the low ohms range, but not with the probes the other way round.

In most other receivers with transistor sync circuits if the trouble is known to be in the sync separator stage(s) the transistors are the main suspect(s), but the associated resistors and capacitors may need to be separately checked. In some Philips colour sets of Swedish origin for example a multi-transistor circuit which it is not easy to follow is used. The collector of one of the transistors is fed from the h.t. line via two resistors in series, and our experience here is that these resistors are the items likely to give trouble. So,

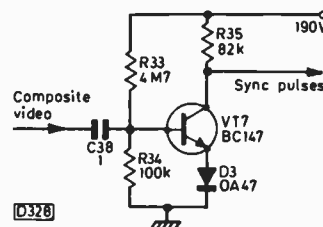

Fig. 4: The simple transistor sync separator circuit used in the Pye hybrid colour chassis.

coupling this up with what has been related before we can expound Simon's Second Law: if there are small sized resistors connected between the h.t. line and a fairly low voltage point, check them.

Misleading Symptoms

Quite often the symptoms presented on the screen suggest that there's a fault in the sync or even the video stage when the fault is not in these circuits at all. There are usually clues however which the more experienced (or clued up) will observe – but this series is not intended for them anyway.

A common condition is where the picture cannot be locked horizontally, i.e. it will bend or drift one way or the other but will not lock. The line hold control may or may not affect the condition, depending on the circuit. If the field (vertical) lock is solid the fault is unlikely to be in the sync separator circuit.

If a PCF802 valve is used in the line oscillator circuit, this must be the first suspect. If replacing the valve fails to improve matters the trouble is probably in the flywheel sync circuit, which we've already described (see Part 5 and the letter in the April issue). One tends to think in terms of the original sync pulses being lost on route to the flywheel sync circuit (this could be the case) but all too often, and it's most important to remember this, the feedback pulse from the line output stage has gone astray instead. The feedback path normally consists of a capacitor and a resistor in series between a winding on the line output transformer and "one side" of the discriminator diodes. In the 1500 chassis the resistor is R51 (220k Ω) and the capacitor C45 (0.001 μ F) – see Fig. 1, page 190, February. While these components don't give much trouble in the 1500 chassis, in some other chassis the resistor is very often at fault. This seems to be because the pulse is derived from a high-energy point in the line output stage. The capacitor usually puts up with this sort of stress but the resistor (usually carbon) deteriorates. If it increases in value to become well nigh open-circuit the result is that the picture falls about horizontally or is just a mass of lines. All too often however the resistor is not so obliging in its manner of deteriorating.

In the Pye group hybrid colour chassis for example the resistor has an original value of 47k Ω but in the process of deteriorating it falls to a very low value (discolouring in the process). The high energy is then transferred to the discriminator diodes, which are totally unable to cope and thus also end up on the funeral pyre. So the lesson here is to suspect the PCF802 but first check on the condition of R203. If it's discoloured, change it and check the diodes D40 and D41 if the line hold is lost. If R203 is not discoloured check R210 which is in series with the line hold control and also tends to change value.

The little Indesit portable Model T12 also tends to have line sync troubles. Here the reference pulse feedback resistors are R913 and R915 (Model T12LGB, see Fig. 5). These and the 2.2M Ω resistors R412-R413 on either side of the discriminator balance preset R414 are suspect if TR404 etc. read right.

Use of Integrated Circuits

Many receivers don't use discrete components in the video processing and sync stages. Chips are used instead and these are the main suspect if the sync is poor or is lost.

A commonly used video/sync i.c. is the TBA550, and this often has to be replaced before sync can be restored. Since this chip performs several functions however it can

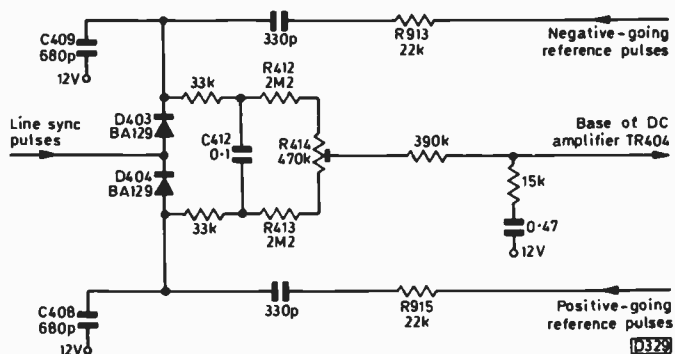

Fig. 5: The flywheel line sync discriminator circuit used in the Indesit T12LGB monochrome portable. A similar circuit is used in the ITT CVC5-CVC9 series of colour chassis. This is an example of a circuit in which both positive- and negative-going flyback pulses are fed back to the discriminator from the line output stage. This particular circuit has a wider than normal locking range due to the action of C412 which is connected between the voltage summing points that determine the output fed to TR404. The designer uses the 12V rail as a signal "earth" in this area.

give rise to many and varied symptoms. Loss of sync is only one of them. Others include a picture with a "washed out" appearance (poor video response), tending to lead the uninitiated to think that the tube has lost emission.

On some occasions (certainly not all) some local heating and rapid cooling can help to identify the faulty item. To this end a small hairdrier with a narrow nozzle is often an immense help, along with one of the several freezing aerosols available.

Before condemning an integrated circuit verify the voltages at the various pins.

Where these are absent or low, check any associated electrolytic capacitor for leakage.

KEEP YOUR COPIES OF

Television

CLEAN AND TIDY

IN THE TV EASI-BINDER

The Easi-Binder holds twelve issues and is attractively bound in black with the title blocked in gold on the spine together with the current (or last) volume number and year. For any previous volume a set of gold transfer figures will be supplied.

Due to the change in size during Vol. 25 a large capacity binder is available to take 16 copies from July 1975 to October 1976 (Vols. 25 and 26) and a separate binder is required for the eight smaller copies of Vol. 25. Later volumes revert to 12 magazines per binder.

When ordering please state the year and volume required, and your name and address in **BLOCK LETTERS**.

Priced at £2.85 including UK post and VAT, TELEVISION Easi-Binders are available from the Post Sales Dept., IPC MAGAZINES LIMITED, Lavington House, 25 Lavington Street, London SE1 0PF. Overseas post 60p extra.

Long-Distance Television

Roger Bunney

JULY was an active month, with both Sporadic E and F2/TE reception abounding. High-pressure systems gave improved tropospheric conditions during part of the month, though there was nothing very spectacular. An extremely large sunspot group at the centre of the Sun produced a giant flare and radio blackout on the 14th, but there have been no reports of Aurora or other associated phenomena unfortunately. Most strange!

Month's Log

My own log shows that the month was an active one, but the only important event was reception of Rhodesia ch. E2 on July the 8th at 1800. There was a good Sp.E opening that day, and it was interesting to see DR (Denmark) ch. E3 over a short skip distance carrying the PM5544 test pattern (at 1842). There were Sp.E openings here at Romsey on the following days:

- 1/7/78 ORF (Austria); TVP (Poland); RTVE (Spain); also unidentified signals.
- 2/7/78 Mostly unidentified programmes from Eastern Europe.
- 3/7/78 TSS (USSR); SR (Sweden).
- 5/7/78 DFF (East Germany); RTVE.
- 8/7/78 RAI (Italy); TVP; DR; JRT (Yugoslavia); RTVE. Also Rhodesia via TE.
- 9/7/78 Unidentified programmes.
- 10/7/78 TSS; JRT; RAI; CST (Czechoslovakia); Switzerland.
- 11/7/78 TSS (up to ch. R4); TVP; DR; DFF; WG (West Germany); JRT; RAI.
- 12/7/78 RTVE; very weak unidentified ch. E2 signals from the south at 1852.
- 14/7/78 Improved tropo – several Band III French 625-line signals (PM5544 test pattern) carrying the Paris studio identification “BUTTES CH”.
- 15/7/78 RTVE; RAI; SR; TSS; MTV (Hungary).
- 16/7/78 SR; NRK (Norway).
- 17/7/78 TSS; NRK.
- 18/7/78 RTVE; unidentified programmes from Eastern Europe.
- 20/7/78 Unidentified programmes from E. Europe; CST ch. R1 noted with EZO test pattern and the identification “PRG-1” (Prague 1 or Programme 1?).
- 25/7/78 TSS; TVP; NRK; SR.
- 26/7/78 RTVE; RTP (Portugal).

Readers' Reports

On June 28th Clive Athowe (Norwich) received Gwelo ch. E2 between 1650-1715, with a lady announcer and a clear identification slide (this was also seen by Hugh Cocks in S. Devon) with signals at “fair strength”. July 1st brought John Lees (Cirencester) a mystery signal on ch. E2 – from 1930 onwards – a very blurred southerly signal showing

African people in a news programme with an obvious military content: at 2012 the sound channel broke through – in French! Any ideas? The only possible southerly countries that use French and system B transmissions are Chad and the Central African Republic. If any readers can help please do so. This isn't the first time that French ch. E2 sound has been received.

Mike Allmark (Leeds) reports a good Aurora on the 4th, giving all the BBC-1 Band 1 Scottish stations plus NRK ch. E4 at good strengths, also Sandale ch. B6 and NRK Stoord ch. E5. Kevin Jackson (Leeds) received RAI ch. ID (E5) via Sp.E on the same day.

The 7th produced Amman, Jordan ch. E3 via multiple-hop Sp.E in Devon at 1900, with single-hop JRT. A few minutes earlier CLT (Lebanon) ch. E4 was received. It's interesting to note Hugh's comment about a characteristic rumble on the Amman signal – broad thick bars on vision. Gwelo ch. E2 appeared again “very ghostly” the same day, with an accompaniment of Arabic harmonics throughout Band I.

Clive Athowe reports Gwelo ch. E2 again on the 8th, between 1754-1830 via F2/TE, with the usual spiral crest identification slide – a very strong signal this time!

Following an improvement in southerly tropo on the 9th the scene changed, with the Canary Islands ch. E3 on the 10th, a clear “RTVE IZANA CANAL 3” being seen by several observers at 1300 and again at 1720. With the propagation path open to the south Gwelo, Rhodesia strangely didn't appear but NTV (Nigeria) Sokoto ch. E3 did! – at fair strength, using the globe slide as shown before in these pages. Only David Martin (Shaftesbury) noted this slide, but Hugh logged programmes a little later. Back to Clive Athowe who logged Gwelo on the 9th, RAI ch. D on the 10th and signs of F2 reception at 1800-1900 on the 11th with in addition local Italian f.m. stations at 103MHz as late as 2230.

After a four day pause Clive wrote again on 15th to



TSS (USSR) news caption received by Steve Birkhill (Sheffield) at 4GHz from the Statsionar-2 satellite.

report a ch. E2 signal with coloured gentleman (white hair and glasses) – a very strong signal at 1845, suspected to be Nigeria. Gwelo was received again at Norwich on the 17th (1827-1831) and 18th (1839-1855), this time with a second co-channel signal! Both Hugh and Clive received Rhodesia on the 21st between 1630-1830, with English language sound and commercials. RTVE ch. E2 fought with the signal and eventually swamped it at 1830.

At a tangent, we have received a number of reports of test patterns, colour bars etc. being seen during the evenings at times when programmes are normally on the air. These ch. E3, 4 signals are most likely to have originated from the now numerous transmitters being operated in Italy under the "free station" umbrella.

This long list indicates improving conditions.

News Items

Holland: A report from Brian Fitch suggests that the ch. E4 (and u.h.f.) transmitters at present sited at Lopik will be moved to central Holland, due mainly to four new 500kW short-wave transmitters being constructed.

Eire: RTE is manufacturing special u.h.f. filters to enable viewers to continue to view the relatively weak UK u.h.f. signals alongside the new high-powered RTE-2 transmitters as and when they come into service. We are hoping to include further information on these low-loss filters shortly.

WARC 1979: At the World Administrative Radio Conference in 1979, which will deal with the revision and allocation of radio frequencies, the EBU will ask for an increase in the spectrum available for broadcasting. The 26MHz band, at present an international short-wave broadcasting band, is to be suggested as a potential satellite broadcasting band. Of greater importance however is the demand for retention of Band I 47-68MHz and Band III 174-223MHz (with a 7MHz extension). An extension of Band II (currently f.m. radio) to 108MHz is suggested. The conference will be held at Geneva.

Satellites: The Japanese BSE satellite is now in operation. The 12GHz television tests involve two colour channels.

Publications

Two new books published by the IBA are strongly recommended. *A Broadcasting Engineer's Vade Mecum* is an invaluable compendium of reference information ranging from basic measurements through decibels, light, propagation, channel allocations, TV systems in various countries to aerial and noise measurements and much more. Even more exciting is *Satellites for Broadcasting*. This is a must for all enthusiasts and includes many articles on both transmitting and receiving systems and associated information. The article on "Low-Cost Satellite Receiving Techniques" by Pat Hawker is particularly worthy of close study. Copies of these publications can be obtained at £1.50 each from the Chief Accountant, IBA, Crawley Court, Winchester, Hants SO21 2QA (make crossed cheques/POs payable to the Independent Broadcasting Authority).

From Our Correspondents . . .

Whilst watching Southern ITV on June 19th Francis Jimenez (St. Mary's College, Twickenham) noticed an announcement that the u.h.f. service was suffering from tropospheric interference. On tuning to the v.h.f. Band I spectrum Francis was able to watch the Norwegian weather forecast followed by the Icelandic test card "RUY

WE OFFER A UNIQUELY HELPFUL AERIAL SERVICE TO PUBLIC AND RETAILERS. WE WILL ADVISE. RECOMMEND AND EXCHANGE EQUIPMENT. QUALITY BRANDS ONLY STOCKED. WHY CHEAT THAT EXPENSIVE TV/FM SET AND YOURSELF. 10% DISCOUNT OFF AERIALS.

9" x 4" S.A.E. Dept TM for mail order lists. For specific advice please phone or call.

LONDON AGENTS FOR FUBA & PLEMI

Stockists of the finest aerials available in Britain:

FUBA TV & FM aerials (W.Ger.)
PLEMI TV aerials (Hol.)
UKW FM aerials (E.Ger.)
ANTIFERRECE TV & FM aerials (U.K.)
JAYBEAM TV & FM aerials (U.K.)



The fabulous golden anodised FUBA XC391

We specialise in Rotator & DX work.

ASTRA (D.I.Y.) AERIALS

A friendly family firm. Now Established 24 years

D.I.Y. AERIAL SPECIALISTS FOR ALL DOMESTIC TV & FM RECEPTION
Weather exposed part of U.K.? Scotland, Wales, West Country etc. Gales, salt air corrosion problems? Want to install your aerial and forget it?
The continental aerial range from Germany having proved so fantastically successful, we are in future recommending continental aerials (especially Fuba) as our first choice for customers. In short we offer quality in a plastic age.
Anodised against corrosion, guaranteed for five years, robust, high gain, easy to assemble, eye-catching superb aerials, what else, in truth could we recommend?

AERIALS & PARTS EXCHANGEABLE UNTIL SATISFIED. BONA FIDE TV/FM TRADE. COUNTER SALES ONLY.

Over 3,000 aerials stocks: All Bands: Masts: Lashings: Wall Brackets: Rotators: Televertas: Diplexers and Triplexers: You can now mix Band 4 and Band 5, or lower Band 5 with higher Band 5, or mix FM with either, 1.5db loss approx.: Padded outlets: Directional splitters: Coax, white or brown: 300 ohm cable.

Many of our customers come from recommendation.
53 WHITEHORSE ROAD, CROYDON, SURREY.
Nr. Gloster Pub & Garage Tel: 01-684 4300
Open 9.00-5.30 MON-SAT. 01-684 5262
Closed 12.30-1.30 But Open ALL day Sat. 24 hr. answering service
FM & TV AERIALS AND ROTATORS ON DISPLAY

LOOK! Phone: LUTON, BEDS. 38716

OPPORTUNITIES TRADE SALES

START AT £25 INC. VAT!!

FOR D/S COLOUR TV's
G.E.C., Philips, Murphy, Decca, Ferguson

S/S COLOUR TV's
Philips, G.E.C., Telefunken, Decca, Ferguson

FROM £40 INC. VAT!!

MONO TV's, all makes from
£5 INC. VAT

SQUARE SCREEN, all models
£12 INC. VAT!!

Deliveries arranged if necessary.

**HUNDREDS OF SETS EACH WEEK TO BE
DISPOSED OF AT GIVE-AWAY PRICES.**

OPPORTUNITIES

**9A, Chapel Street, Luton, Beds.
LUTON 38716**

9.30-6.00 p.m. Weekdays, 10.30-1.00 p.m. Sundays.

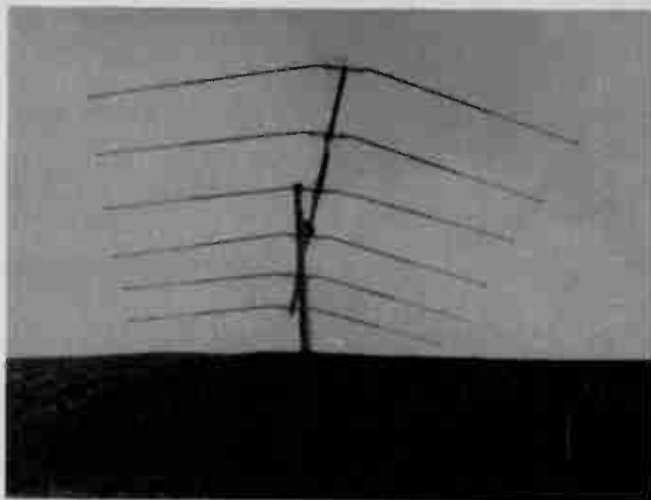

Chris Wilson's ch. E3-4 log-periodic array. Note the angled elements to reduce the beamwidth and increase the gain.



Lopik (Holland) ch. E4 picked up via Chris Wilson's log-periodic aerial with the aerial on beam.



Much reduced signal pick-up from Lopik (ch. E4) with Chris Wilson's log-periodic 30° off-beam.

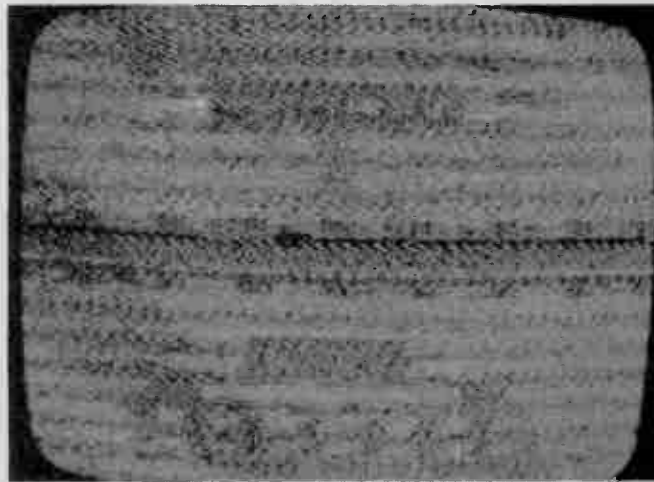

Lopik ch. E4 with the aerial 45° off-beam: with increasing off-beam rotation the signal disappears into the noise.

ISLAND" on ch. E4. He later noted Budapest and Yugoslavia (test card with identification "JRT BGRG1").

Frank Lumen and his friend Don have been conducting Sporadic E reception experiments. On June 19th Don received CST ch. R2 whilst Frank was receiving JRT ch. E4. On comparing notes it was found that neither could receive the other's signal despite being only five miles apart! John Cowan at Ayr, some 30 miles distant, received Italian and Yugoslav signals on the 1st and 2nd respectively, but neither of these two signals were seen at Frank's or Don's (Glasgow) locations despite the same channel being tuned in. This selective reception has been noted before: any suggestions from readers as to why?

Kevin Jackson (Leeds) has been in touch with the RSGB Propagation Study Committee following his reception of certain Scandinavian signals via Aurora. The committee is anxious to obtain information on signal reflection for a close study of auroral ionisation drift. To this end if any enthusiast receives an Auroral signal from a definite transmitter the RSGB would appreciate a note on the reception. Information needed is of the station/country, time, duration of signal and if possible the aerial beam heading. Send observations to the I.A.R.U. Auroral Co-ordinator, RSGB Propagation Committee, Mr. C. Newton, 61 Merriman Road, Blackheath, London SE3 8SB. If there is any query enclose an SAE but important questions only please.

Robert Copeman's friend in Dunedin, NZ, quite

unintentionally received CBN-8 TV Orange NSW, Australia on her TV ch. 6 position (this corresponds to the Australian ch. 8), indicating more Band III Sp.E. You may recall that Robert Copeman received Samoa ch. A2 (KVZK-TV 2) on Christmas Day 1976!

Log-periodic Aerial Design

Chris Wilson has constructed a Band I log-periodic array with certain modifications that depart from convention. The elements are bent forwards to increase the forward gain (by restricting the forward beamwidth and side lobe radiation). His design (see Fig. 1) is for chs. E3-4 inclusive, but a seventh element can be included to improve ch. E2/R1 performance. The photos show the performance on a ch. E4 Lopik signal.

Infra-red Link

A development of increasing importance in broadcasting is ENG, electronic news gathering, which was the subject of an article in the August 1976 issue of *Television*. Numerous US TV companies now use this technique which has only recently come to be accepted by UK broadcasters. Basically, ENG is the use of a small TV camera instead of a film camera for news coverage, the camera's output being recorded on to videotape or transmitted back to base via a microwave link (in the 13GHz band). The advantage of course is speed, since film has to be developed.

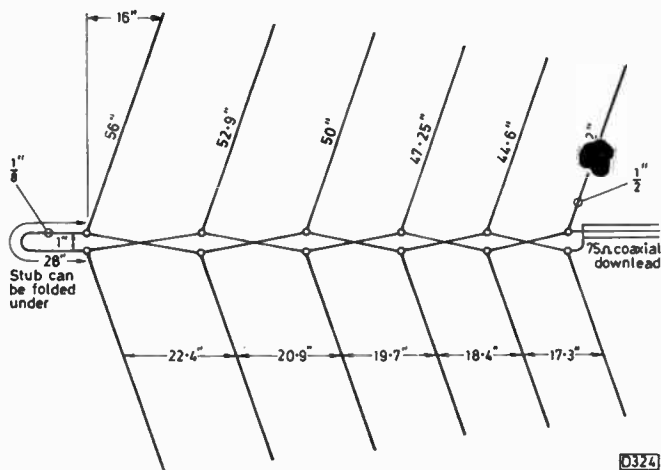

Fig. 1: Six-element log-periodic aerial array designed by Chris Wilson for reception of channels E3-4. A seventh element could be added to extend the coverage to channel E2/R1: this would have 59in. sections with a spacing of 24in. and the stub increased to 30in. Note that the design does not follow strict log-periodic calculations.

An interesting development of this technique was required at KSL-TV, Salt Lake City. A conventional microwave link licence couldn't be obtained for a 780ft. part of the proposed link, whilst renting a coaxial cable link was prohibitively expensive. The solution adopted was to use an infra-red light beam for which no licence was required. The system gives a flat bandwidth of over 10MHz, while the transient response is improved because no bandwidth limiting filters are required. A couple of problems have been experienced however. The inclination of the receiver at 35° facing west means that for a short period during a week or so in the summer the sun passes across the receiver's field of view, giving an increase in the noise level. A winter problem, again degrading the signal, results from snow build up in front of the receiver's lens.

The infra-red source transmits the modulated light via an optical filter to give a narrow beam. The beam in practice spreads to a diameter of approximately 10ft. at a distance of 2,000ft. At the receiver, a lens assembly focuses the light through a bandpass filter on to a silicon avalanche photodetector – the bandpass filter resembles a piece of flat black glass and is basically an optical resonator designed to pass only the infra-red information, suppressing interference from other light sources such as the sun, street lighting, etc. The silicon avalanche detector both amplifies and recovers the video signal along with the sound subcarriers (there are two 15kHz f.m. sound channels on 10MHz subcarriers on the same infra-red beam). Further processing and clamping are then used to remove propagation fluctuations.

Circular Polarisation

Another development, circular polarisation, was the subject of an article in the October 1976 issue of *Television*. This is gaining popularity in N. America for both TV and f.m. radio broadcasting, the advantages being felt in metropolitan areas where high buildings cause severe ghosting. A circularly polarised transmission has either left- or right-hand polarisation, but the important point is that the polarisation sense of a reflected signal is reversed. This means that a correctly polarised receiving aerial will give minimum output from reflected signals. A recent article in the *RCA Broadcast News* suggests that circularly polarised TV "is here to stay", some off-screen shots demonstrating the dramatic improvement in reception achieved in difficult areas by using circular polarisation.

U.H.F. GREYSCALE AND PATTERN GENERATOR PG6RF



PRODUCES SIX INVALUABLE PATTERNS:—

- ★ CROSSHATCH GRID
- ★ DOT MATRIX
- ★ VERTICALS
- ★ HORIZONTALS
- ★ WHITE RASTER
- ★ 8 BAR GREYSCALE

ONLY REQUIRES CONNECTION TO U.H.F. AERIAL SOCKET.
9V BATTERY OPERATED.

TECHNALOGICS now gives you the opportunity to set up colour television receiver the professional way.

This pocket size, battery powered unit (consumption less than 6m.a.l) based on latest CMOS technology, enables you to set up: static convergence, dynamic convergence, picture geometry, colour purity, focus, beam limiting, Grey-scale tracking, black level, clamping etc. by selecting one of the six patterns generated by the PG6RF on channel 36 (for U.K. 625-line standard T.V. sets).

Available either ready built and tested or in D.I.Y. kit form. The kit consists of all components, glassfibre p.c.b., tough plastic box with full instructions (modulator pre-built for ease of construction). Ready built and tested guaranteed for 1 year.

KIT £21.50 BUILT £28.00 + 50p p&p all subject to 8% VAT

STILL AVAILABLE:

LOGISCAN MK II COLOUR TELETEXT DECODER

YOU CAN NOW BUILD A TELETEXT DECODER TO THE LATEST BBC/IBA/BREMA SPEC. (N.B. Many other decoders are not to full spec.)

Available with full technical back-up in easy to build form for £205 Kit, £265 ready built and tested or in module form, price on request, all subject to 12½% VAT.

DISCOUNT PRICES FOR TTL LS AND LOCOS INTEGRATED CIRCUITS ON REQUEST.

DETAILS LARGE S.A.E.

MAIL ORDER ONLY

TECHNALOGICS

8 EGERTON STREET, LIVERPOOL L8 7LY

TV LINE OUTPUT TRANSFORMERS

ALL MAKES SUPPLIED PROMPTLY by our

RETURN OF POST MAIL ORDER SERVICE

All Mono Lopts at the one price

£6.45

BONA FIDE

TRADE

£7.00 RETAIL

(V.A.T. INCLUDED AT 12½%)

Postage and Packing 70p

All Lopts NEW and GUARANTEED for SIX MONTHS

WE ALSO SUPPLY SEPARATE WINDINGS FOR THE FOLLOWING COLOUR L.O.P.T.S
Pye 691 or 697 Chassis.

Bush CTV 25 Mk. 1-2-or 3.

Decca CTV 25 Non-Tripler Version.

Philips G.6 Single or Dual (Overwind for this Model on Exchange Basis Only).

Philips K.70 Underwind Only.

EMO 90°

COMPLETE L.O.P.T.S

Philips G.B. ITT C.V.C. 5-9 and Decca Bradford.

Prices for the above Colour L.O.P.T.S and Windings on application.

S.A.E. all enquiries.

PAPWORTH TRANSFORMERS

80 MERTON HIGH STREET, LONDON S.W.19

01-540 3955

Service Notebook

G. R. Wilding

Checking Transistor Stages

While substitution is a common way of checking suspect transistors, nevertheless the need to obtain and fit a replacement takes time so that it's best to check first to make sure that the suspect is faulty.

As a general rule, if the voltages are correct, particularly at the base and emitter, a transistor can be considered to be operational. With a normal silicon amplifier transistor – as distinct from a sync separator, pulse amplifier, oscillator or a.g.c. stage – the base voltage should be about 0.6-0.7V above the emitter voltage, the latter voltage depending on the value of the emitter resistor and the current flowing through it. To confirm that a transistor's emitter voltage is the result of its current flowing through the emitter resistor, short-circuit the base-emitter connections. The result should be to reduce the emitter voltage to zero – unless there's a stabilising resistor between the emitter and one of the supply lines. In this case a small emitter voltage should still be present, but noticeably less than the normal, correct value.

On occasions you may find that the base voltage is nearly normal but that the emitter voltage is only slight, with the collector voltage at the supply rail potential. In this case the collector-base junction is probably open-circuit. The small emitter voltage is due to the base-emitter current flowing through the emitter resistor. If the base-collector junction is short-circuit, the collector, base and emitter voltages will all be much the same.

With the base-emitter junction open-circuit there'll be zero emitter voltage and the collector will be at the rail potential. The latter will also be the case with a short-circuit base-emitter junction, but this time the base and emitter voltages will be the same.

If you have an i.f. strip or chrominance channel giving zero or negligible output and all the voltages are correct, then you've a coupling, tuning or load problem. If the interstage coupling is capacitive, there could be an open-circuit or dry-jointed capacitor. With the coils or transformers capacitively tuned, there could be an open-

circuit or changed value capacitor thus mistuning the stage, or a short-circuit capacitor thus removing the load altogether.

Incorrect voltages in gain-controlled i.f. stages are often due to a fault in the a.g.c. circuit. Excessive forward bias will result in the controlled stage(s) being driven into saturation where it/they will be unable to respond to the signal voltage. Under this condition all three voltages will be about the same, as occurs when there's a collector-base short-circuit or heavy leak, though if you measure carefully you will usually find that the base voltage is a fraction of a volt above the emitter and collector voltages, due to both junctions being forward biased.

Occasions sometimes arise when one or more transistors are simply under or over biased, resulting in either case in markedly reduced gain. For example, a Pye colour receiver fitted with the 697 chassis recently came our way, the complaint being weak contrast and lack of saturation even with the controls fully advanced. Absence of grain on the picture indicated that the fault was after the tuner, while the low colour strength suggested that there was reduced signal amplitude at the chrominance signal take-off point, i.e. at the emitter of the first video phase splitter transistor VT5. Naturally the first thing to check was the preceding detector diode, but this was found to be in order. VT5's voltages were all normal, but on working back to the final i.f. amplifier transistor VT4 (see Fig. 1) we found the base and emitter voltages both markedly above the correct figures. The collector voltage was correct, but since the load consists of the low d.c. resistance of the final i.f. transformer's primary winding no change was to be expected. The base bias for this transistor is provided by a potential divider, R18 (8.2k Ω) to the 20V supply line and R17 (2.2k Ω) to chassis, so it seemed that either the former resistor had fallen in value or the latter increased in value or gone open-circuit. Since only very small currents flow in such resistors, value change is very rare. What had actually happened was that the lower resistor R17 had become dry-jointed. As a result, the transistor's base voltage had increased, raising its forward bias but reducing its gain. On resoldering R17, normal voltages and correct contrast and saturation were restored.

No Results: Thorn 3000 Chassis

The complaint with a Thorn colour set fitted with the 3000 chassis was no sound or picture, though we found that sound was present for a fraction of a second after switching on. Tests on the power supply panel revealed that there was no chopper rail, though the 2.5A fuse was intact. On checking the three-section dropper resistor R605/6/7 the first section, which acts as a surge limiter, was found to be open-circuit. In most receivers an open-circuit section of a multiple dropper resistor can be shunted by a replacement, but in these sets there's no safe way in which this can be done. So although sections of this dropper don't break down very often, a complete replacement component is a must for the spares stock.

Severe Line Tearing

The trouble with a hybrid, single-standard GEC colour set was two-inch wide bands of severe line tearing which moved slowly up the screen, tripping the field timebase when they reached the top. Poor heater-cathode insulation in the PCF802 line oscillator valve was the first suspect, but a replacement valve brought no improvement. Inadequate h.t.

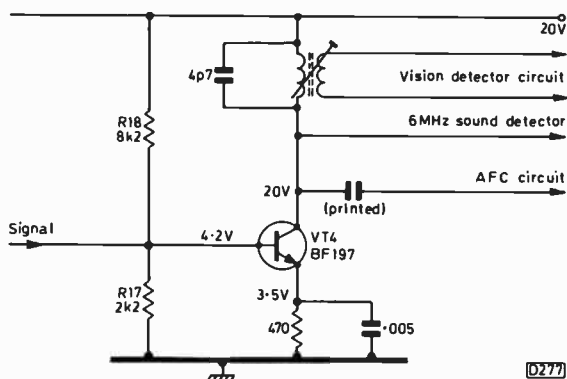

Fig. 1: Final i.f. stage, Pye hybrid colour chassis.

smoothing was ruled out since there was no hum from the speaker while the only raster disturbance was the bands of tearing. Attention was turned to the smoothing of the l.t. supply therefore, and it was found that on contacting a 64 μ F test capacitor across the 2,000 μ F smoothing capacitor C58 the line tearing was greatly reduced. Clearly the capacitance of this electrolytic had greatly decreased, and although the accompanying reservoir section of the can appeared to be good the complete unit was replaced. Apart from anything else, it's usually awkward to wire replacement capacitors and mount them securely on compact colour chassis.

Top Cramping

The raster on a Thorn portable fitted with the 1590 chassis was cramped, mainly in the top half of the screen. This suggested that one of the field output transistors was faulty, but voltage checks back through the complementary symmetry driver stage to the preceding "linearity amplifier" transistor VT16 showed that the incorrect voltages started in this stage – all three stages are direct coupled. The two diodes associated with VT16 both proved to be in order, so as all nearby resistors looked and tested normal the transistor was changed. This restored correct voltages and a normal raster, though the defective transistor was found to give acceptable forward and reverse readings across its two junctions. In all d.c. coupled transistor circuits, concentrate on the first stage where incorrect voltages are found.

Field Collapse

The trouble with a hybrid single-standard GEC colour receiver was field collapse, and on inspection we found that the 560k Ω resistor (R526) feeding the height control had burnt out. The resistor forms part of an RC filter with C519 (0.01 μ F), and suspicion naturally fell on this capacitor. An ohms test showed that the capacitor was o.k. however, but as the panel was badly charred where R526 had been we gave it a thorough clean up – charred paxolin can become conductive. On fitting a new resistor to the cleaned up panel a raster of only about half the normal height was obtained, while the resistor soon began to overheat. Although it looked perfect, the only conclusion we could come to was that the associated height stabilising v.d.r. (VDR500) was faulty, falling to a very low resistance. Removing the v.d.r. produced grossly excessive height – as one would expect since R526 and the v.d.r. form a potential divider. The point was proved however, and a replacement v.d.r. produced a normal raster.

Intermittent Field Failure

Now and then we all come across a printed board on which a fault either appears or clears when the board is tapped or pressure is applied to it in a particular area. Where there's no visual indication as to where the fault lies, the temptation is to resolder all connections in the suspect area. All too often however this produces no improvement, while there's always the risk of inadvertently connecting adjacent tracks with a blob of solder. Far better, wherever possible, to keep a meter connected to relevant points in the circuit in order to see where voltage changes occur when the board is tapped or pressure is applied.

This was brought home to us the other day when we had a case of intermittent field collapse on a set fitted with the Thorn 1500 chassis. Naturally the first move was to try a

new PCL805, but the fault remained. We then found that the fault could be instigated by rocking the valve to one side, suggesting either a defective valveholder or a dry-jointed pin connection on the board. Inspection of the valveholder sockets showed that they were all in order however, while the pin soldering was equally faultless.

Next move therefore was to check voltages around the valveholder connections, noting the effect produced by valve displacement. There was a distinct fall in the voltage at pin 1 (triode anode) when the fault was present, indicating that the valve was then failing to oscillate – the absence of negative bias generated at the grid during oscillation would result in increased anode current. So the fault could lie in either part of the circuit, the two sections of the PCL805 being connected as a cross-coupled multivibrator. Failure of the pentode would also result in failure to oscillate therefore. Moving the test prod to pin 2 (triode grid) confirmed the absence of negative bias when the valve was pushed to one side, and on moving to pin 6 (pentode anode) it was found that there was zero voltage under the fault condition.

Had a short-circuit been responsible, the resulting very heavy current, limited only by the d.c. resistance of the output transformer's primary winding and the smoothing circuit, would have blown the fuse. Absence of h.t. had to be due to a break in the feed therefore. Checking on the panel revealed that while there was always h.t. at one of the output transformer's primary winding connection tags, the voltage at the other one fell to zero when the valve was pushed over. Closer inspection revealed the inadequacy of the soldering at this tag. The surprising thing about this fault is that although the transformer is mounted at one corner of the board, the field collapse could be instigated only by pressure on the valve which is mounted well away.

Faults Encountered

– continued from page 639

Perhaps the most difficult portable set fault we've had of late however concerned a Bush Model TV300. The set would work perfectly for hours on end, after which the peak whites would begin to smear, the symptom becoming progressively worse until the set gave an excellent imitation of a faulty tube. One clue that presented itself however was that the collector voltage of the video output transistor TR10 was very low when the fault condition was present. The supply for the video output transistor comes from a rectifier which is fed from the line output transformer. There are two electrolytics involved in this supply, the reservoir capacitor C519 and the smoothing capacitor C520, both 1 μ F. Replacing them cured the fault. I've since discovered that this trouble is not so rare, so before condemning the tube in these sets check these two capacitors first.

Indesit T24EGB

Finally, large screen monochrome sets. We've a number of Indesit Model T24EGB receivers out on rental. By and large they've turned out to be reliable, the only major weakness being the line output transformer. One set gave us a very poor picture however, of muddy appearance with pronounced vision hum. The sound was unaffected. Electrolytic trouble again, this time C914 (500 μ F). It's the reservoir capacitor in the 24V supply, which is derived from the earthy end of the heater chain.

The Language of Logic

Part 1

E. A. Parr, B.Sc., C.Eng., M.I.E.E.

IN THE past few years many TV engineers have been casting nervous glances over their shoulders at the quiet intrusion of digital techniques into television systems. These digital circuits call for a certain change of attitude, but worse is the large number of specialised terms that digital engineers use. An engineer I know (brought up like me on ECC83s) summed it up by saying "I understand the words, I just don't understand them when they are put together to make a sentence."

This article is intended as a newcomer's primer to logical circuits, and is arranged in two basic sections. The first is a description of basic electronic logic ideas, the second being a dictionary of common terms.

It's interesting to note that communications engineering is returning to digital circuits after a gap of several decades: early forms of communications (from the heliograph through the telegraph to morse code) were all digital.

What does "digital" mean?

In most electronic circuits, information (such as speech) is represented by voltages. In a standard 1V peak-to-peak CCTV signal for example, a voltage span of 0.7V covers the entire range from black to white. In theory at least any shade of grey can be represented and there is infinite resolution.

In a digital system, only two voltages are present. These are called "0" and "1". One of the most common digital systems used is the so called TTL (transistor-transistor logic) family. This uses voltages of 0.2V for the 0 state and 3.5V for the 1 state. Digital circuits are therefore very similar to switches and relays which both have two states: on/off; energised/de-energised.

At first sight, a circuit using only two voltages would seem a bit useless (like the hovercraft steamroller). After all, who wants a TV that could display only black or white? This is valid, but there are areas where digital systems come into their own: control, number crunching and information transmission.

Control engineering is the design of systems that originally used relays. There are many industrial control devices that have two states – relays, contactors, valves (hydraulic and steam), switches etc. These can in turn be controlled by digital circuits built round statements like "If signal A is present, and signal B, but not signal C then energise output X".

Number crunching is the use of digital systems to represent numbers. At the simplest level we can display the

channel number on a TV set. At the complex end we have calculators and computers.

Finally we have information transmission. The information to be transmitted (which can be anything from a TV signal from Mars to the water level in the local reservoir) is converted into a sequence of digital on/off signals representing numbers. These digital signals are sent down the transmission path and at the receiving end they are converted back to voltages to produce the TV picture or drive the level gauge in the distant control room. Note that this implies two limitations. First the signal can change only in fixed steps, i.e. it's not continuously variable. Secondly the signal is sampled only at intervals. In the design of a system, the minimum step size (accuracy) and sample rate (frequency response) first need to be defined.

Most digital systems combine the three digital techniques. In Teletext for example, we have control, number crunching and information transmission all at once.

Logic Gates

Control systems are the easiest to understand, following, as they do, the basic concepts of relay design. Control systems are built round circuits called "gates". These have one or more inputs and one output. The relationship between the input and output is defined for all possible circumstances. Surprisingly, there are only a few types of gates. These will now be described.

First the and gate, whose symbol is shown in Fig. 1. The inputs can be in only the 0 or 1 state. The output is at 1 when all the inputs are at 1. We can thus draw a chart of all the possible conditions – this is called a truth table:

Input A	Input B	Output X
0	0	0
1	0	0
0	1	0
1	1	1

In many ways the and gate is similar to the relay chain shown in Fig. 2.

Occasionally you may see "logical equations". These express the logical operation being performed in mathematical form. The symbol for the and operation is a dot (·) and our gate can be expressed as: $X = A \cdot B$. And gates are available with up to eight inputs.

In the case of an or gate the output is at 1 when any input is at 1. The symbol is shown in Fig. 3 and the truth table is:

A	B	X
0	0	0
0	1	1
1	0	1
1	1	1

The or operation is represented by a plus sign (+) and the logic equation is: $X = A + B$. As before, this has an

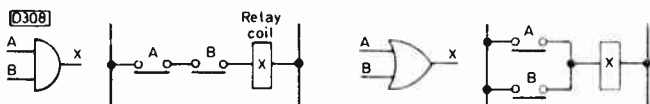

Fig. 1.

Fig. 2.

Fig. 3.

Fig. 4.

analogy in relay designs. Fig. 4 shows the relay analogy. Or gates are available with up to eight inputs.

Inverters have one input and one output. The output is the opposite binary state to the input. The symbol for an inverter is shown in Fig. 5, the small circle on the output denoting inversion. Inversion is sometimes called negation. The truth table is simple:

A	X
1	0
0	1

In a logical equation, inversion is denoted by a line above the letter concerned, thus \bar{A} . This is said "bar A". The logic equation is: $X = \bar{A}$. Inversion is similar to a relay normally-closed contact. By definition, there can be only one input to an inverter.

The nand gate is an and gate followed by an inverter. Its symbol is shown on Fig. 6, the circle on the output showing inversion. The truth table is:

A	B	X
0	0	1
0	1	1
1	0	1
1	1	0

This might appear a rather useless gate, but in fact it's the most common type of gate. The reason for this lies in its flexibility. It can be used as an and gate, an or gate or as an inverter by being clever with the logic design. We'll return to this when we come to positive and negative logic.

The logic equation is: $X = (\bar{A} \cdot \bar{B})$. Nand gates are available with up to eight inputs.

The nor gate is an or gate followed by an inverter. Its symbol is shown in Fig. 7. As before, the circle shows inversion. The truth table is:

A	B	X
0	0	1
0	1	0
1	0	0
1	1	0

The logic equation is: $X = \overline{(A + B)}$. Nor gates are available with up to eight inputs but are rarely used in logic designs.

The exclusive-or gate has only two inputs. The output is at 1 when the two inputs are in different states, at 0 when the two inputs are the same. The symbol is shown in Fig. 8. The truth table is:

A	B	X
0	0	0
0	1	1
1	0	1
1	1	0

The logic equation symbol for exclusive or is \oplus , hence the equation is: $X = A \oplus B$.

The exclusive-or gate is made by the logic combination shown in Fig. 9. This has the logic equation:

$$X = \overline{(A \cdot B)} + (\bar{A} \cdot \bar{B})$$



Fig. 5.



Fig. 6.



Fig. 7.

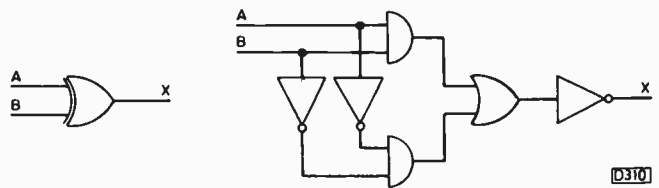

Fig. 8: Exclusive-or gate symbol.

Fig. 9: Internal arrangement of an exclusive-or gate.

It will be left to the reader to convince himself that this is the same logic and equation as the exclusive-or.

If this seems complicated, take heart. Exclusive-or gates are normally encountered only in fairly complex number crunching systems.

By definition, an exclusive-or gate is available only with two inputs.

That completes the basic family of logical gates.

Positive and Negative Logic

Manufacturers define the voltage for logic levels. For TTL a 1 is 3.5V and a 0 is 0.2V. If the 1 is more positive than 0 the logic is described as positive logic. If the 1 is more negative it is described as negative logic. TTL is therefore positive logic. A logic system I once worked with which had a 1 of -3V and a 0 of +3V was negative logic.

In theory, negative logic should have a small circle at the corresponding inputs and outputs. The logic symbols for a negative logic or gate and nand gate are shown on Fig. 10.

The small circle at the output of a conventional positive nand gate means, in effect, that the state at the output when the input conditions are satisfied is the more negative.

As the vast majority of logic systems use positive logic (TTL, RTL, DTL, ECL, CMOS) you probably think this is academic. Consider however the circuit shown in Fig. 11. This has the truth table:

A	B	C	D	X
0	0	0	1	0
0	0	1	0	0
0	0	1	1	1
0	1	0	0	0
0	1	0	1	0
0	1	1	0	0
0	1	1	1	1
1	0	0	0	0
1	0	0	1	0
1	0	1	0	0
1	0	1	1	1
1	1	0	0	1
1	1	0	1	1
1	1	1	0	1
1	1	1	1	1
0	0	0	0	0

which means it has performed

$$X = (A \cdot B) + (C \cdot D)$$

In some odd way, gate three has performed like an or gate. To see why, let us take the operation a step at a time. The output of a nand gate in terms of voltage is:

A	B	X
0.2	0.2	3.5
0.2	3.5	3.5
3.5	0.2	3.5
3.5	3.5	0.2

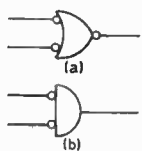

Fig. 10: Negative or (a) and nand (b) Gates.

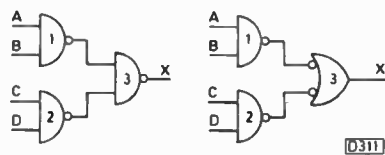

Fig. 11.

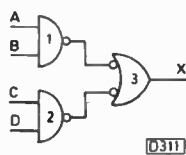

Fig. 12.

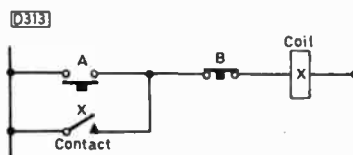

Fig. 14.

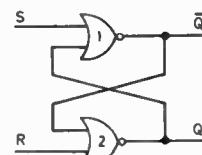

Fig. 15.

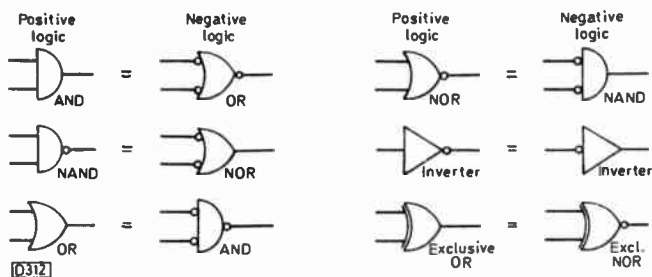

Fig. 13: Demonstrating the interchangeability of positive and negative logic.

If we define 1 as 0.2V and 0 as 3.5V we get:

A	B	X
1	1	0
1	0	0
0	1	0
0	0	1

which is a nor gate in negative logic. In Fig. 11 gates one and two give a 0 out for $A \cdot B$ and $C \cdot D$. Gate three then acts as a negative logic nor gate on the signals from gates one and two.

In theory, Fig. 11 should be drawn as Fig. 12.

It's only honest to say that very few people bother, least of all the author, and it's usual to find logic drawings done entirely with positive logic symbols even though negative logic might be performed at places inside it.

This flexibility is the reason for the common usage of nand gates rather than and gates.

As might be expected, there is a similar interchangeability between other gates. The positive logic gates above when used as negative logic change as below:

Positive logic	Negative logic
and	or
or	and
nand	nor
nor	nand
inverter	inverter
exclusive-or	exclusive-nor (an exclusive-or followed by an inverter)

Non trusting readers should draw up the truth table for each gate, replace it with voltages, then replace the voltages with $1 = 0.2V$ and $0 = 3.5V$.

The interchangeability of positive and negative logic gates is summarised in Fig. 13.

Memories

In logic it's often necessary to remember that something has happened. This is equivalent to the latching relay network shown in Fig. 14. Relay X is energised when button A is momentarily pressed, and stays energised until button B is pressed.

The simplest way of making an electronic memory is to use two nor gates as shown in Fig. 15.

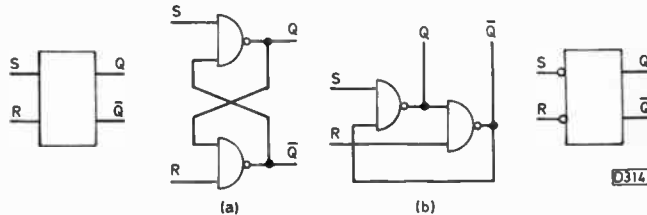

Fig. 16 (left): SR flip-flop symbol.

Fig. 17 (centre): Nand gate flip-flop (a). This is sometimes drawn as shown in (b).

Fig. 18 (right): Active low SR flip-flop symbol.

We have two inputs labelled S and R and two outputs labelled Q and \bar{Q} (pronounced bar Q remember). Let us assume that S is at 1 and R at 0. Because $S = 1$, $\bar{Q} = 0$. At the input of gate two we have $R = 0$ and $\bar{Q} = 0$. The output of gate two is thus $Q = 1$. This has no effect on gate one.

Let us now take S to 0. We have $S = R = 0$. On gate one we have $S = 0$ and $Q = 1$ so the output of gate two stays $Q = 0$. On gate two we have $R = Q = 0$, so the output of gate two stays $Q = 1$. With $Q = 1$, gate two is unaffected. The circuit remains with its outputs: $Q = 1$, $\bar{Q} = 0$.

Let us now take R to 1. The output of gate two, Q, goes to a 0. At the input of gate one we have $Q = 0$, $S = 0$. The output of gate one, \bar{Q} , goes to 1. At gate two's input we now have $\bar{Q} = 1$ and $R = 1$. The output of gate two stays $Q = 0$.

If we now take $R = S = 0$, as before, nothing will change and we are left with: $Q = 0$, $\bar{Q} = 1$.

The circuit thus has two stable states. The first is $Q = 1$, $\bar{Q} = 0$, when the S input was last at 1. The second state is $Q = 0$ and $\bar{Q} = 1$, when the R input was last at 1.

The first state is known as the "set" state and the second

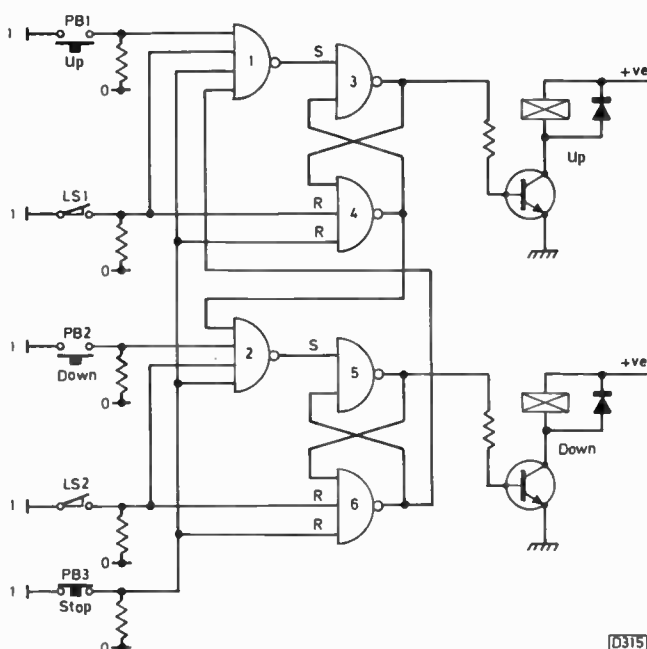

Fig. 19: Control system for a car lift.

as the "reset" state. Not surprisingly the S input stands for set and the R input for reset. (The reasons for the use of Q are lost in the mists of time.)

This circuit is known as an RS memory. It's also called an RS flip-flop or an RS stasticiser (or stat for short). Often the RS label is omitted and it's simply called a flip-flop or stat. It has it's own circuit symbol, shown in Fig. 16.

It's possible to construct an RS memory from nand gates as shown in Fig. 17. This is set and reset by 0 at the inputs (rather than 1 in the nor constructed memory shown in Fig. 15.) We thus have:

- a 0 on the S input sets Q to 1 and \bar{Q} to 0;
- a 0 on the R input resets Q to 0 and \bar{Q} to 1.

The nand constructed RS memory has the symbol shown in Fig. 18.

As with the gates, the circles show that the set and reset are active for a low signal.

An RS flip-flop is not the only type of memory. Other common types are the D type, toggle and JK flip-flops. These will be dealt with in the dictionary part of the article.

These then are the basic elements of digital control. Other more complex devices (such as monostables) will be dealt with in the dictionary.

Typical Control Scheme

A typical (but somewhat trivial) example of a control scheme is shown in Fig. 19. The device being controlled is a garage car hoist. There are three push buttons: PB1 up; PB2 down; and PB3 stop. Once the up button is pressed the lift goes up until limit switch LS1 opens or the stop button is pressed.

The operation is obvious, but there are a few points to note. Gates three and four form an RS flip-flop, activated by 0 at the S input. The flip-flop can be reset by a 0 at either of the two R inputs of gate four. Setting the flip-flop energises the up relay.

Gate one inhibits the setting of the up flip-flop if LS1 is open, the stop button is pressed or we are already going down (the latter being the purpose of the link from gate six, the Q output of the down memory).

Gates two, five and six behave in a similar manner to energise the down relay.

Both flip-flops are reset if the stop button is pressed.

Most television control schemes tend to be more complex than a car hoist, but the same basic gate functions apply. In addition, most TV logic systems operate at far higher speeds than the average relay system!

Number Crunching (or One Ten Buckle My Shoe)

Number crunching is the use of digital techniques to handle numbers. Before we can deal with the actual circuits we must, I'm sorry to say, indulge in a little mathematics.

We are used to counting in units, tens, hundreds etc., so the number 4057 means "four thousands plus no hundreds plus five tens plus seven units". This is counting to the base of ten.

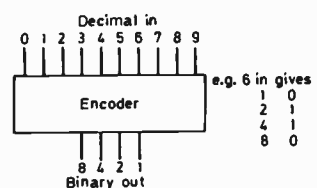

Fig. 20: Encoder.

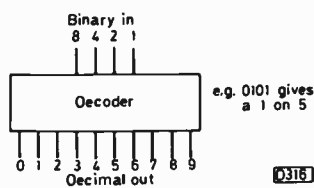

Fig. 21: Decoder.

It's possible to make a number system to any base. The only reason we use ten is simply because we have ten fingers. If the inhabitants of a planet round Alpha Centurai had six fingers they would probably count:

Base 6 0 1 2 3 4 5 10 11 12 13 14 15 or
Base 10 0 1 2 3 4 5 6 7 8 9 10 11.

In Alpha Centuria, 14 means "one six plus 4 units"; 351 would mean "3 times 36 plus 5 sixes plus one unit."

Suppose we now want a number system based on two (don't ask awkward questions like why, all will suddenly come like day). This peculiar number system could only have two symbols 0 and 1. The columns (units, tens, hundreds and thousands in decimal) would be 1,2,4,8,16 etc. and we would count

0	0
1	1
2	10
3	11
4	100
5	101 etc.

This number system is called binary. Remembering that each column stands for 1, 2, 4, 8 etc., we can look at the binary number 1011011.

We start taking units at the right (as usual) and say that this is:

one unit	1
plus one 2	2
plus no 4	0
plus one 8	8
plus one 16	16
plus no 32	0
plus one 64	64
Total	91 in decimal

All this may seem academic and laborious. After all, it's easy to write 91: 1011011 is laborious and a bit meaningless - imagine what 4057 would be like in binary (111111011001 actually).

But because we have only two symbols with this system, 0 and 1, it's very easy for electronic digital circuits to handle numbers in binary form. The large numbers of gates necessary to handle large numbers is no problem, since gates and flip-flops are cheap. The circuits won't get confused, like we would, with the binary numbers. The only restriction is that inputs to the system should be decimal, and outputs decimal, so that they are intelligible to us.

Decimal inputs are converted into binary form by a chip called an encoder. This takes in a 1 on one of the input lines and produces the correct binary pattern on the output (see Fig. 20).

Note that the binary output will be in the range 0000 to 1001. Incidentally, it's usual to draw diagrams with the smallest column to the right and the largest (in this case the column representing 8) to the left.

A binary digit is known in the jargon as a bit.

Readers might like to try to work out what goes on inside an encoder - it's just a load of or gates.

The opposite chip is called a decoder. This takes in a four bit binary number (as the jargon says) in the range 0000 to 1001 and puts a 1 on the corresponding output line (see Fig. 21).

Readers might again like to work out its innards. You will need a collection of and gates and inverters. As a start, the circuit for the 6 decode is shown in Fig. 22.

We can easily design an adder using gates. This is not

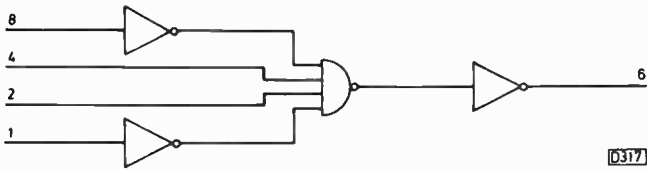

Fig. 22: Internal logic for decoding "6".

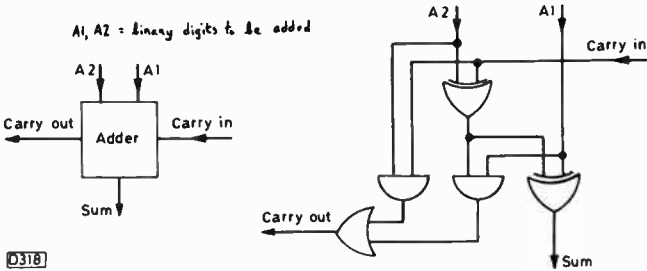

Fig. 23 (left): One-bit binary adder.

Fig. 24 (right): Internal logic of a one-bit binary adder.

really the place to go into the intricacies of binary arithmetic circuits, but to add two binary digits (i.e. two bits) we need three inputs: the two bits to be added, and the carry bit from the lower column. We produce the answer bit plus a carry bit to the next highest column (see Fig. 23). The truth table for this is:

X	Y	Carry in	Sum	Carry out
0	0	0	0	0
0	0	1	1	0
0	1	0	1	0
0	1	1	0	1
1	0	0	1	0
1	0	1	0	1
1	1	0	0	1
1	1	1	1	1

The logic required to do this is relatively simple (see Fig. 24), but chips are available to do this. These are usually four bit adders, with carry into the bottom bit and carry out from the top so that 8, 12 bit adders can be made.

With an encoder, a decoder and an adder we can make a very simple adding machine. We have two decade switches SW1 and SW2, the outputs of which are encoded into binary form by IC1 and IC2. The two four-bit numbers are

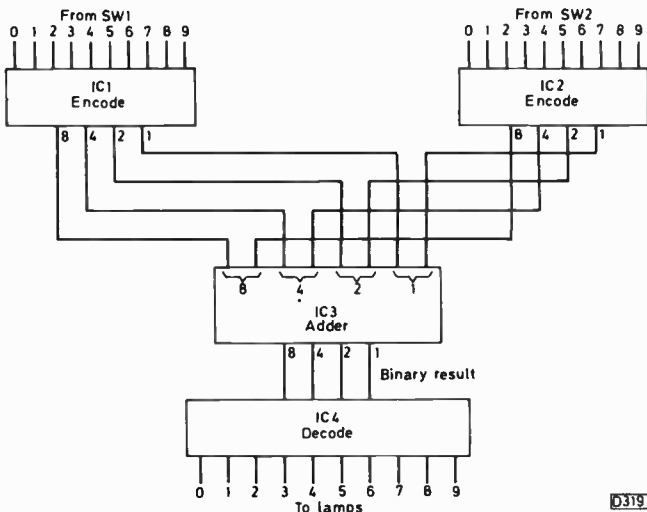

Fig. 25: Simple adding machine.

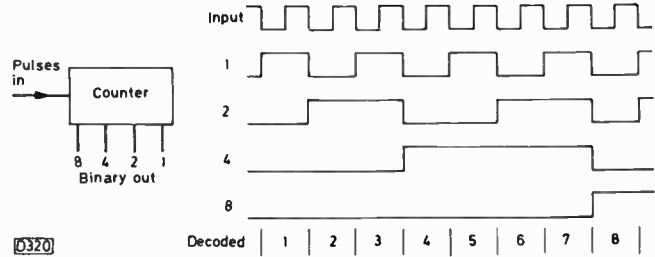

Fig. 26: Binary counter.

added by IC3 and the result (again in four bits) is decoded by IC4 to light one of the ten output lamps. Note that the result must be in the range 0-9. The adder will work with 7 + 2 but not 7 + 5 (see Fig. 25).

One final component of number crunching systems is a counter. This is constructed around the toggle flip-flop (described in the dictionary) but for our purpose here it's a box with one input and four outputs (see Fig. 26).

This counts pulses at its input, giving the answer in binary form at the output.

There are many variations on counters. They usually have a reset pin so that they can be reset to zero (0000). Counters are also available that can be preset to a given number before counting commences. Finally counters are available for counting up or down.

It's hard to believe, but even the largest computers in the world are just a collection of the control and arithmetic elements described so far.

Data Transmission

Finally we have the use of digital techniques to transmit analogue signals (e.g. conventional video or audio waveforms) by digital methods. All data transmission systems have a common block diagram (see Fig. 27). The input

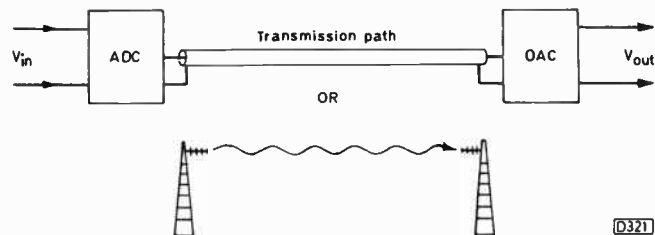

Fig. 27: Block diagram of a digital transmission system.

voltage is converted into a digital signal by a device called an ADC (see dictionary for further details). The digital signal is sent along the transmission path and at the receiver a DAC converts the digital signal back to an analogue one.

A somewhat pointless exercise you might think. The system does have some great advantages however. For example, a digital system cannot produce distortion due to differential phase and non linearities. Because the signal is simply on or off, it has excellent noise rejection. And with error correcting codes the transmission can be made almost error free.

Digital transmission has been used by the GPO for telephone links for some time, and TV pictures are linked to some IBA and BBC transmitters by digital links.

An interesting mixture of data transmission and number crunching techniques is the digital standards converter, where a 525-line TV signal is digitised, processed then re-assembled as a 625-line signal.

TO FOLLOW: DICTIONARY OF LOGIC TERMS

Your PROBLEMS solved

Requests for advice in dealing with servicing problems must be accompanied by a 50p postal order (made out to IPC Magazines Ltd.), the query coupon from page 665 and a stamped addressed envelope. We can deal with only one query at a time. We regret that we cannot supply service sheets nor answer queries over the telephone.

PYE HYBRID COLOUR CHASSIS

The contrast on this set is very weak, the picture being neither as crisp nor as bright as it was. The screen is fully illuminated, with little grain in the picture, which improves somewhat with time. The sound is perfect and the colour seems to be o.k. though perhaps it could be improved with more contrast.

First check the PL802 luminance output valve on the left side, and the voltages in this stage to see whether the circuit is otherwise fault-free. If everything seems to be in order here transfer attention to the i.f. panel, where VT6 which drives the contrast control, and its input coupling capacitor C36 (50 μ F), are suspect. If necessary check the final i.f. transistor VT4.

ITT VC200 CHASSIS

When the set was first bought some years ago it was noticed that the brightness control had to be advanced beyond three-quarters of full rotation before the picture appeared, and usually had to be set at maximum for good contrast. The picture was very good though, so we left things alone. Faces are now a little too dark for pleasant viewing with artificial lighting however. The screen is well lit without a signal.

Component tolerances can combine to give an inadequate brightness range on this chassis – this seems to be borne out by the variations in the brightness control resistor network found in production. Try reducing by half the value of the resistor (R169, 47k Ω) connected between the brightness control and chassis; if necessary, increase the value of the resistor (R165, 4.7k Ω) between the HT4 rail and the brightness control by one or two preferred values.

PYE 169 CHASSIS

There's sound and a full-sized picture, but it's very dim. The contrast control works, and the brightness control has some effect. The line timebase valves have all been renewed and the h.t. lines are present – slightly high.

The voltage-dependent resistor between the brightness control and chassis sometimes changes value to cause this trouble. It's type E299/DD/P352. A check is to raise the normal voltage range of the brightness control by connecting a 100k Ω resistor in parallel with R35 which is between the HT3 rail and the other end of the brightness control. If this doesn't do the trick, check the voltages in the video output stage.

PYE 731 CHASSIS

The picture suffers from a high-frequency flicker, taking about two hours to settle down after switch on.

The trouble is very often due to the over-voltage protection circuit preset control RV879 being incorrectly set. Adjust it and RV916/7 (fine and coarse h.t. setting respectively) as set out in the manual. If the trouble persists, R924 (8.2M Ω), the trigger diac D892 and the thyristor rectifier D888 (type 2N4444 with heatsink now the recommended type) are suspect.

HITACHI CNP192

This set gives a reasonable picture though there are some minor faults. First there's a slightly shaded band down the left-hand side of the screen. The verticals tend to bend to the right, and there's a slight purple patch at the top right-hand corner, noticeable mainly on monochrome.

The purple patch is likely to be due to tube magnetisation, which should be removed by repeated use of the set's degaussing circuit. If not, it can be cured by using an external degaussing coil. If the verticals tend to quiver as well as bending to the right, check the setting of the line oscillator coil T701 (line hold) and the flywheel sync discriminator diodes CR32/33. When adjusting T701, earth terminal B2 (input to the flywheel sync phase splitter) with an 0.1 μ F capacitor. If the bending increases towards the edge of the screen and there's a tendency to pincushion distortion there could be a fault on the small side pincushion correction board. Correction adjustment is provided by R627 and L601 which are mounted just above the board. Unless you're sure that the vertical bending is associated with pincushion distortion however these controls should be left alone. The narrow band down the left-hand side could be due to a fault in the line output stage, but can sometimes be caused by a weak aerial input signal, especially if the lead is trailing close across the back of the set.

PYE 693 CHASSIS

There's a good picture on BBC-1 and -2, but on ITV the field slips and rolls rapidly. The fault is not due to the appearance of advertisements but occurs mainly when the picture contains a large white horizontal patch. Switching to either BBC programme will restore a steady picture and may restore ITV on switching back, but the picture will roll again as soon as the critical picture content occurs on ITV. The signal strength is good, and adjusting the field timebase controls has no effect on the fault.

This problem can be caused by the preset contrast control RV3 on the i.f. panel being over-advanced. It's more likely however that the trouble is in the sync separator stage. The most likely culprit here is the base bias resistor R33 (4.7M Ω) which tends to increase in value. If necessary, also check the load resistor R35 (82k Ω), the transistor itself (VT7, BC147) and the two diodes D3 and D4. All these are on the right-hand side of the panel.

ITT/STC VC4 CHASSIS

The trouble with this set is excessive buzz on 625 lines.

Replace the ratio detector diodes D1 and D2, using OA90s or OA91s, and the reservoir capacitor C103 (6.4 μ F, 4.7 μ F will do). Then carefully adjust the balance control R111 and the cores of the 6MHz tuned coils L56, L58 and L55 for minimum buzz. L56 and L58 are in the large rear can, while L55 is the top core in the can nearest the mains switch – of which beware!

THORN 8800 CHASSIS

After about six hours the touch-tuned channels start to flash from 1 to 6 in short bursts. The overload cut-out then operates. If this is reset, the same thing happens after about a quarter of an hour. Resetting the cut-out will then result in it opening each time the set is switched on again.

If there's no sign of sparking or arcing around the c.r.t. base, anode connector or the line output stage, it's likely that the e.h.t. rectifier is faulty. First make sure that the c.r.t. aquadag is well bonded to the spark gap on the tube base however.

PHILIPS 11TG190AT

There's no raster on this set, the c.r.t. first anode voltage being 12V instead of 315V. The line output transformer and the diode and capacitor which produce the c.r.t. first anode supply have been replaced – with the capacitor removed the voltage rises to about 80V and a dim raster with vertical bars appears. The line output transistor voltages seem to be correct.

You don't say whether the voltage regulator is working normally. Check the current through the 2A fuse – should be about 1.5A. If this is low, check the three transistors in the regulator circuit – the AC128 is the most likely culprit. Make sure that the output is 11V (set by R4043) – measure between the collector of T1513 (AD149) and chassis. Also ensure that the replacement line output transformer has the same colour coding for the wiring – different suppliers are not too careful about this. Check the diodes in the line output stage – X2013/4/5/6. Is the sound section working? If not, there could be a heavy current drain here. Another suspect is the boost capacitor C2096. The system switching could be in need of cleaning of course.

DECCA 30 CHASSIS

There's colour loss on this set. The picture appears in full colour when the set is first switched on, but once the set's got warm the colour fades out, leaving a good monochrome picture. During the course of the evening the colour may return for a short period, but will then fade out again. Another decoder panel was tried, but the trouble remains.

This sort of trouble is usually due to intermittent failure of the second chrominance amplifier TR206, the delay line driver TR207 or the crystal. TR206's emitter is decoupled by an electrolytic C224 (33 μ F) which can sometimes play tricks. Another electrolytic worth checking is the colour-killer reservoir capacitor C232 which is also 33 μ F. If you're sure that the replacement panel is o.k. however check whether the 25V supply line is correct during the fault, and ensure that the leads to the colour control are making good contact. If these points are in order, concentrate on the pulse feed to the decoder via PD10: if the pulses are mistimed, distorted or absent the result will be no colour.

THORN 1590 CHASSIS

There are five dark vertical bars, each an inch wide and an inch apart, superimposed on the picture. They are still present with no signal.

If there's no damping resistor across the line linearity coil L15 try adding one (560 Ω). If this doesn't do the trick, check the 95V supply reservoir capacitor C111 (1 μ F) which is a non-electrolytic type in later production sets. Further possibilities are the flyback blanking clipper diode W15 and the 300V supply reservoir capacitor C110 (10 μ F).

GRUNDIG 1500GB

When the set is first switched on a weak, negative monochrome display appears, with weak field and line hold. A strong colour picture with good field and line lock comes on after a couple of minutes.

This problem is usually traceable to poor joints in the early vision i.f. stages. If you are lucky, you'll find the cause of the trouble on the luminance delay line or one of the small post-detector chokes – L351 or those in the i.f. can. The fault might be buried in the rather inaccessible i.f. strip however. Careful tapping and probing should tie it down.

GEC C2110 SERIES

The set behaves perfectly for long periods, with a good colour picture, then it flicks and a greenish tinge appears. It then flicks back to normal colour. These flicks between normal and greenish colour seem to be more prevalent when the set has thoroughly warmed up, but can occur at any time.

The fault could be due to several different things, but we've usually found it to be due to the small 2.2k Ω preset control P303 (set G – Y level) which feeds pin 11 of the chrominance demodulator i.c. (IC301, TBA990) on panel PC457. Moving the body of the control with a finger is generally sufficient to establish its guilt, although a dry-joint to the panel could be the cause.

THORN 1590 CHASSIS

There's brightness trouble on this set, sometimes an intermittent change in brightness level, more often a slow change in the brightness, leaving the picture over bright. The brilliance and contrast controls are o.k., and there's no detectable change in the voltage fed to the brightness control. The voltage at the collector of the video output transistor is on the high side, while the d.c. voltage at the cathode of the c.r.t. can be seen to be changing very slowly. The board has been checked for cracks and dry-joints and the 95V supply reservoir capacitor has been replaced.

The fact that the voltage change can be measured at the c.r.t. cathode suggests that the trouble is in the video circuit. We suggest you replace the output transistor's collector load resistor R51 (6.8k Ω) and if necessary check by substitution the video output transistor VT9 and the preceding, d.c.-coupled emitter-follower VT6. Other possibilities are C36 (4.7 μ F) which smooths the bias applied to VT6 and C51 (100 μ F) which is in series with the slider of the contrast control. Use of a hairdryer and freezer aerosol may help locate the culprit. If you are unlucky, the c.r.t. could be faulty with a grid-cathode leak.

ITT CVC5 CHASSIS

The trouble with this set is intermittent poor focus. On one recent occasion the focus was so bad that the picture seemed to be broken up. I've checked the high-value (4.7M Ω) resistors in series with the focus VDR and the 2.2M Ω resistor in series with the c.r.t.'s focus electrode visually and for dry-joints, but they seem to be in order.

It's still worth changing these three resistors since they can be responsible for this trouble. The symptom is often due to invisible corona discharge and leakage at the two spark gaps associated with pin 9 on the c.r.t. base panel however. Clean them with methylated spirit, and slightly enlarge them with a small file. Make sure that pin 9 is making good contact with its socket.

ITT VC200 CHASSIS

It takes anything up to an hour for the picture to reach the correct brightness. It's very dull, and out of focus around the edges. The line output stage has been checked thoroughly, and new valves have been fitted. Valve voltages seem to be correct but the c.r.t. first anode voltage is about 450V instead of the 660V quoted on the circuit. The brightness control has to be fully advanced. The focus control measures about $1.5M\Omega$ instead of $2M\Omega$.

The focus potentiometer often does fall in value, reducing the c.r.t.'s first anode voltage. Under normal circumstances however we find that the c.r.t. first anode voltage rarely

attains the 660V claimed. The symptoms you quote suggest that the c.r.t. is almost certainly low emission. Reactivation may improve it for a while, but a regunned tube would be a lasting cure.

THORN 8500 CHASSIS

The trouble with this set is that there are horizontal shadows, varying in width, across the picture.

If the bars are not "lined up" with the picture features (smearing), check the a.g.c. smoothing capacitor C111 ($10\mu F$). If the effect is heavy, picture-dependent smearing, check the luminance coupling capacitor C174 ($3.3\mu F$).

stage components, including the BF391 transistor, were replaced but the fault would still occur. The components and the printed circuit board in this area were subjected to heat and freezing liquid, but the fault could not be encouraged to develop in this way.

What was the most likely cause of the trouble, and what significant clue, if any, was overlooked by the service technician? See next month for the solution and for a further item in the series.

SOLUTION TO TEST CASE 189

— Page 608 last month —

Receivers using an ECC82 multivibrator field generator are very susceptible to small changes in value of the anode load resistors, particularly the resistors connected to the anode of the second triode section, i.e. in the field charging circuit. This is one reason why a VDR is used to stabilise the supply against load variations. It's not possible to determine whether a resistor is subject to such value variations merely by measuring it with an ohmmeter; neither is it possible to achieve a sensible reading by measuring the anode potential with a $1,000\Omega/V$ meter!

The symptom described is very often caused by slight electrical inconsistency in one of the resistors in series with the height control. The only way to prove this is to extract the suspect component and solder in a replacement.

It was discovered that the $560k\Omega$ resistor (R526) connected to the top of the height control was causing the trouble, a good quality replacement completely curing the effect. It was not possible to detect any fault in the extracted resistor by making an ordinary ohmmeter test: a fair current has to flow through the resistor before the fault occurs.

QUERY COUPON

Available until 16th October 1978. One coupon, plus a 50p (inc. VAT) postal order, must accompany EACH PROBLEM sent in accordance with the notice on page 663.

TELEVISION OCT 1978

TEST CASE

190

Each month we provide an interesting case of television servicing to exercise your ingenuity. These are not trick questions but are based on actual practical faults.

A Thorn monochrome mains/battery portable, Model 3845 (1690 chassis), would work for hours on end on its loop aerial without trouble. Sound and vision sensitivity were both remarkably high, and the picture was of good quality in all but difficult areas. Every now and again however the screen would gradually brighten, and the contrast would decrease until eventually the picture was only vaguely discernible below the high screen brightness.

Sometimes the effect would clear on its own, either gradually as it started, or suddenly, the screen then clearing and the contrast reverting to normal. The fault condition sometimes occurred a short period after switch-on, or during a programme sequence after the set had been working for several hours.

After operating normally on the test bench for most of a morning the symptom suddenly occurred. Quick adjustments were made to the controls in an endeavour to gain some idea of the whereabouts of the fault. It was found that the range of brightness control was curtailed when the fault was present, and that the contrast control had hardly any influence at all on the "brightened-out" picture in the background. Before further tests could be made the fault cleared!

The fault lasted a little longer the next time, allowing measurements to be made at the tube base connector. It was found that both the cathode and grid potentials were on the low side, particularly the cathode potential, which tended to fluctuate with brightness change more than would be expected as a result of picture signal brightness changes. At this stage a test prod was unwittingly knocked against the tube neck and the fault cleared.

It was found that the fault could be cleared by switching the set off and then on again quickly. Various video output

Published on approximately the 22nd of each month by IPC Magazines Limited, King's Reach Tower, Stamford Street, London SE1 9LS. Filmsetting by Pacesetters, London SE1. Printed in England by Carlisle Web Offset, Newtown Trading Estate, Carlisle. Distributed by IPC Business Press (Sales and Distribution) Ltd., 40 Bowling Green Lane, London EC1R 0NE. Sole Agents for Australia and New Zealand - Gordon and Gotch (A/sia) Ltd.; South Africa - Central News Agency Ltd. "Television" is sold subject to the following conditions, namely that it shall not, without the written consent of the Publishers first having been given, be lent, resold, hired out or otherwise disposed of by way of Trade at more than the recommended selling price shown on the cover, excluding Eire where the selling price is subject to VAT, and that it shall not be lent, resold, hired out or otherwise disposed of in a mutilated condition or in any unauthorised cover by way of Trade or affixed to or as part of any publication or advertising, literary or pictorial matter whatsoever.

leap forward with the new generation

Forgestone 500

high quality colour television receiver

the successor to the highly successful 400 Series.



- *Pin diode tuner
- *Glass epoxy printed circuit panels
- *Full technical construction manual
- *20AX Hi-Bri tube
- *Eleven integrated circuits
- *Ready built and aligned IF module
- *High quality components
- *Modern and period cabinets
- *All solid state
- *Fully isolated and protected power supply
- *Diode split L.O.P.T.
- *Low consumption

TELETEXT DECODER KITS available for Forgestone 400 and 500 models, include assembled and tested LSI Module, power unit, interface panels, keypad and complete instructions.

Buy as you build. All Forgestone Kits are for the constructor of today, sections of the Kit are available separately. Please send stamp for further details of these quality products.

Forgestone Colour Developments Limited

Ketteringham, Wymondham, Norfolk, NR18 9RY
 Telephone: Norwich 810453 (STD 0603)
 Telephone or Mail Orders accepted on Access/Barclaycard

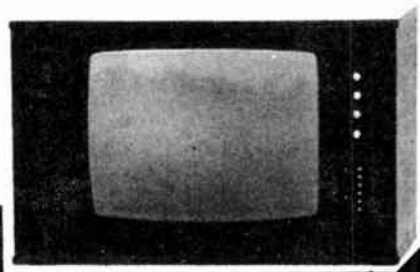

BENTLEY ACOUSTIC CORPORATION LTD.

The Old Police Station, Gloucester Road, LITTLEHAMPTON, Sussex.

PHONE 6743

ALL PRICES INCLUSIVE OF V.A.T. AT 12½%. NOTHING EXTRA TO PAY

OA2	£1.20	6DT6A	0.85	30C17	0.90	ECC88	0.72	EZ80	0.42	PY33/2	0.50
OB2	0.40	6E5	1.00	30F5	0.70	ECC189	1.00	EZ81	0.45	PY81	0.60
1B3GT	0.55	6E6W	0.85	30FL2	2.25	ECC8072.80		GY501	1.40	PY82	0.40
5CG8	0.75	6F1	0.80	30L15	0.75	ECF80	0.65	GZ32	1.00	PY88	1.12
5R4GY	1.00	6F6G	0.70	30L17	0.70	ECF82	0.50	GZ33	4.00	PY500A	2.05
5U4G	1.00	6F18	0.60	30P12	0.74	ECF86	0.80	GZ34	2.25	PY800	0.60
5V4G	1.00	6F23	1.00	30P19	0.90	ECH35	2.00	HN309	1.70	PY801	0.60
5Y3GT	0.65	6F28	0.85	30PL1	2.20	ECH42	1.00	KT66	3.50	PZ30	0.50
5Z3	1.40	6GH8A	0.80	30PL13	1.30	ECH81	0.55	KT88	6.75	QQV03/10	
5Z4G	0.75	6GK5	0.75	30PL14	1.50	ECH84	0.75	P61	0.60		2.00
6/30L2	0.90	6GK6	2.00	50CD6G		ECL80	0.55	PC86	0.80	QV06/20	
6AC7	0.70	6GU7	0.90		4.00	ECL82	0.60	PC88	0.80		4.70
6AG7	0.70	6H6GT	0.50	85A2	1.40	ECL83	1.50	PC92	0.65	R10	5.00
6AH6	0.70	6J5GT	0.65	807	1.10	ECL86	0.64	PC97	0.75	R19	0.75
6AK5	0.45	6J6	0.35	5763	3.65	EF22	1.00	PC900	0.65	UABC80	
6AM8A	0.70	6JU8A	0.90	AZ31	1.00	EF40	1.00	PC884	0.39		0.45
6AN8	0.78	6K7G	0.50	AZ41	0.50	EF41	1.00	PCC85	0.47	UAF42	0.70
6AQ5	0.75	6K8G	0.50	DY51	2.00	EF80	0.40	PCC89	0.49	UBC41	0.70
6AR5	1.05	6L(M)7	1.50	DY86/7	0.52	EF83	1.70	PCC1890.60		UBC81	0.55
6AT6	0.60	6Q7G	0.75	DY802	0.50	EF85	0.45	PCF80	0.80	UBF80	0.50
6AU6	0.55	6SA7	0.70	E80CF	6.00	EF86	0.52	PCF82	0.45	UBF89	0.39
6AV6	0.65	6SG7	0.70	E88CC	1.20	EF89	0.55	PCF86	0.57	UC92	0.50
6AW8A	1.15	6SJ7	0.70	E80F	5.50	EF91	0.70	PCF200	1.55	UCC85	0.50
6AX4	0.75	6U4GT	1.00	E188CC	5.00	EF92	0.70	PCF201	1.45	UCF80	0.80
6BA6	0.65	6V6G	0.50	E280F	12.50	EF183	0.50	PCF801	0.49	UCH42	1.00
6BC8	0.90	6X4	0.95	EAS0	0.40	EF184	0.50	PCF802	0.80	UCH81	0.60
6BE6	0.70	6X5GT	0.50	EABC80		EH90	0.75	PCF805	2.25	UCL82	0.75
6BH6	1.10	9D7	0.70		0.48	EL34	2.50	PCF806	0.70	UCL83	1.00
6BJ6	0.75	10C2	0.70	EAF42	1.00	EL41	1.00	PCH2001.20		UF41	0.70
6BK7A	0.85	10DE7	0.80	EAF801	1.50	EL81	1.00	PCL82	0.62	UF42	1.00
6BN8	1.50	10F1	1.00	EB91	0.25	EL84	0.48	PCL83	1.20	UF80	0.40
6BQ7A	1.40	10F18	0.65	EBC41	1.00	EL85	0.95	PCL84	0.65	UF85	0.50
6BR7	1.00	10P13	0.80	EBC81	1.00	EL90	2.50	PCL86	0.85	UF89	0.52
6BR8	1.25	10P14	2.50	EBF80	1.00	EL360	2.50	PCL805	0.85	UL41	0.90
6BW6	3.75	12AT6	0.45	EBF89	0.40	EL506	2.00	PFL200	1.35	UL84	1.90
6BW7	0.65	12AU6	0.50	EC86	0.84	EL509	2.50	PL33	1.00	UM80	1.00
6BZ6	1.50	12AV6	0.60	EC88	0.84	EM80	1.00	PL36	0.80	UY41	0.70
6C4	0.50	12BA6	0.50	EC92	1.00	EM81	1.00	PL81	0.49	UY85	0.70
6C9	2.00	12BE6	0.85	EC97	0.75	EM84	1.00	PL81A	0.75	UY19	4.00
6CB6A	0.65	12BH7	0.68	ECC33	2.00	EM87	1.45	PL82	0.50	UZ5	1.00
6CD6G	4.00	13D8	2.00	ECC35	2.00	EY81	1.50	PL83	0.50	J26	0.90
6CG8A	0.90	19AQ5	0.65	ECC40	1.00	EY83	1.50	PL84	0.50	U191	0.50
6CL6	0.75	19G6	6.50	ECC81	0.52	EY87/6	0.45	PL95	1.00	U301	1.00
6CL8A	0.95	19H1	4.00	ECC82	0.62	EY88	1.00	PL504	1.05	U404	0.75
6CM7	1.00	20P1	1.00	ECC83	0.62	EY800	1.45	PL508	1.85	U801	1.00
6C05	0.90	20P4	0.84	ECC84	0.50	EZ40	1.00	PL509	3.10	X41	1.00
6DE7	0.90	30C15	1.00	ECC85	2.50	EZ41	1.00	PL519	3.75		

All goods are unused and boxed, and subject to the standard guarantee. Terms of business: Cash or cheque with order only. Despatch charges: Orders below £25, add 50p extra per order. Orders over £25 post free. Same day despatch. Terms of business available on request. Any parcel insured against damage in transit for only 5p extra per parcel. Many other types in stock. Please enclose S.A.E. with any enquiries. Special offer of EF50 VALVES, SOILED, BUT NEW AND TESTED £1 EACH.

SUMMER SALE!!!

Due to a special bulk-contract purchase we have thousands of sets that must be cleared regardless of cost! Many, many bargains too numerous to list, with extra discounts for callers - e.g. Bulk lots (30 or more) mixed MONO @ £1.50 ea. (Sell out at over £15 ea after service). We don't mind our customers making 1000% profit on a £50 investment, it keeps them coming back for more! Most types of COLOUR TV available for HOME and EXPORT markets at discount prices.

Send stamp, or phone for 1978 Catalogue.

West Midlands TV Trade Sales,
 92 High Street, Kings Heath, Birmingham B14 7JZ.
 021-444 6464

SOUTHERN IRELAND DEALERS

We are the largest stockists in the south of Ireland of clean used T.V. sets.

BUSH - PHILIPS - FERGUSON - KORTING DECCA ETC.

Mono D/S from **£15.00** each
 Colour from **£120**

All Sets Tested & Cabinets Polished.

Over 2,000 sets in stock.

Visit our warehouse and see for yourself.

Fresh Stocks Weekly.

Delivery can be arranged.

T.V. WHOLESALE DISTRIBUTORS LTD.

E.D.I. HOUSE,

**Kylemore Park West Industrial Estate,
 Dublin 10. Tel. 364139 or 791995.**

Manufacturers Surplus Components

FIT THE RIGHT PART

300 mixed $\frac{1}{2}$ and $\frac{1}{4}$ watt resistors £1.50
 150 mixed 1 and 2 watt resistors £1.50
 200 mixed Capacitors, most types £3.30
 100 mixed Electrolytics £2.20
 300 mixed Printed Circuit mounting Components for various TVs, resistors, caps etc. £1.50
 300 printed circuit Resistors $\frac{1}{2}$ to 4 watt £1.00
 100 High Wattage TV resistors, Wirewound etc. £2.20
 100 mixed miniature Ceramic and Plate Caps £1.50
 25 mixed Pots and Presets £1.20
 25 mixed TV Presets £1.00
 20 assorted TV VDRs and Thermistors £1.20
 10 assorted TV Convergence Pots £1.00
 20 assorted TV knobs, includes push button, chrome, control types etc. Mostly Thorn and ITT £1.00
 20 assorted Valve Bases, 89A, ceramic, EHT, etc. £1.00
 20 assorted Sync Diodes blocks for various TVs £1.00
 25 assorted Pulse Caps high voltage £1.00
 10 Spark Gaps £1.00
 20 assorted Zener Diodes 1 watt and 400MW £1.50
 100 Mixed Diodes, includes zener, power, bridge, varicap, germanium, silicon, marked, unmarked etc. £3.30
New Improved Transistor Packs
 100 New and Marked Transistors including, 8C148, 8C154, 8F274, 8C212L, 8F200 and lots of others only £4.95
 200 Transistors as above and including 2N3055, AC128, 8D131, 8F50 only £9.95

500 untested Diodes some marked, signal, zener, sync, etc. Random checks showed over 70% good £2.95

Special TV Bargain Parcels

Lots of useful parts including damaged panels, tuners, components etc. 10lb for £7.50

Hardware Pack

Includes BA nuts and bolts, nylon, posidrive, self-tapping "P" clips, cable markers, clamps, fuse holders etc. £1 per lb.

THORN SURPLUS

3500 Series Scan Coils, new and boxed, complete with convergence yoke, purity assembly, static controls, leads and sockets £5.25
 3500 Focus units with metrosil £1.00
 8000 L.O.P.T windings £2 pair
 1500 multi caps £1.00
 150 + 150 + 100µF
 3500 "625" line VHF Kit for wired systems contains, tuner, valves, power supply, knob, escutcheon, aerial socket panel, filter unit, hardware, and instructions suitable for Ireland or anywhere without full UHF coverage £9.50
 1400 transistor tuners with leads 4 P/B £3.50
 4 knobs black with chrome caps to fit above or most small diam. shafts 60p per set
 1500 bias caps 160µF 25V 10 for £1.00
 950 rotary transistor tuner with leads and slow motion drive £3.00
 950 bottom panel complete with i.f.'s switch etc. £3.00
 950 line transformer (not Jellypot) £2.50
Convergence Pots with knobs. 5Ω, 20Ω, 30Ω, 100Ω 10 of 1 type £1.00 10 of each £3.50

MISCELLANEOUS

GEC single standard, hybrid chassis. Convergence panel. Brand new, complete with plugs and leads £2.50
 GEC transistor rotary tuners with slow drive, AE Skt. and leads 2000 Series £2.50
 KB VC3 transistor tuner ITT CVC5 power panel. New but five resistors never fitted £1.50
 Pye 697 line and power panels, damaged or some bits missing but invaluable for spares £2.00
 Pye mono mains droppers with fusible link. 147Ω + 260Ω 50p 3 for £1.00
 Decca "Bradford" C.T.V. triplers 25KV £2.50 each 5 for £10
 G8 Thyristor OT112 £1.00 3 for £2.50
Portable TV EHT Sticks
 "Siemens TV 18 KV". Fit most portables 50p each 3 for £1.00
White Ceramic TV Resistors
 20Ω 16W, 135Ω 15W, 86Ω 11W, 105Ω 10W 10 of any one type £1.00 10 of each type £3.50
 2.2k fusible, vertical mounting Screen Feed resistors 9 watt 8 for £1.00
 0.47Ω $\frac{1}{2}$ watt emitter resistors 40 for £1.00
Avoid Lethal Shocks
 Buy our specially designed EHT Probe, removes high voltage charges from tubes, caps, etc. Heavily insulated with lead and earth connector 60p each

89A P.C. valve bases 20 for £1.00
 EY87/DY87 EHT bases 10 for £1.00
 PL509/PY500 ceramic bases 10 for £1.00
Out Door Triplexers Band I, II and UHF 3 for £1.00
20mm Antisurge Fuses.
 800MA, 1A, 1.25A, 1.6A, 2A, 2.5A, 3-15A 12 for £1.00
 100 for £7.00
 DY51 EHT Rec. 50p 3 for £1.00
 BR101 5 for £1.00
 T8A120A 50p 3 for £1.00
 SN76115N (equiv. MC1310) £1.00
 3 for £2.00
 TH1 thermistors 6 for £1.00
 TH3 thermistors 10 for £1.50
 Aluminium Coax Plugs 8 for £1.00
 470µF 25V 10 for £1.00
 BC148 12 for £1.00
 BF200 6 for £1.00
 BD131 4 for £1.00
 BC184L 12 for £1.00
 ME0412 10 for £1.00
 BC238 10 for £1.00
 BD561 3 for £1.00
 BD562 3 for £1.00
200V 1A Diodes 10D2 (equivalent to 1N4003) 20 for £1.00

Storage Boxes with transparent, lids can be hung up or stacked. Ideal for components 3" x 4" $\frac{1}{2}$ " high 6 for £1.00 1" high 4 for £1.00
 Miniature "Terry" clips ideal for screwdrivers and small tools etc. 40 for £1.00
 Low profile 14 pin quill I.C. Sockets (to fit most "Q" series I.C.) 12 for £1.00

Send 40p P. & P. on all above items send Cheque or P.O. with order to:-

SENTINEL SUPPLY DEPT. TV
 149a Brookmill Rd., Deptford, London SE8
 (Mail Order address only. Callers by appointment)
 Trade enquiries for quantity welcome.
Surplus stocks purchased for cash.

COLOUR TUBES STANDARD TUBES

METAL BAND TUBES

Rebuilt with new Electron Guns to British Standard 415/1972. Clause 18.2.

SUFFOLK TUBES LIMITED

214, PURLEY WAY
CROYDON, SURREY
01-686 7951

Britain's Largest Independent
TV Tube Rebuilder

ELECTRONIC MAILORDER LTD.

VALVE BARGAINS

Any 5-80p, 10-£1.50, 50-£6.00 Your choice from the list below.

ECC82, EF80, EF183, EF184, EH90, PCF80, PCF802, PCL82, PCL84, PCL85, PCL805, PL504, PY81/800, PY88, 30PL14, 6F28, PFL200.

Colour Valves - PL508, PL509, PL519, PY500/A. All tested. 55p each.

Aerial Splitters: - 2 way, 75 OHMS, Inside Type, £2.50

AERIAL BOOSTERS

Aerial boosters can produce remarkable improvements on the picture and sound, in fringe or difficult areas.

B11 - For the stereo and standard VHF/FM radio.

B12 - For the older VHF television - Please state channel numbers.

B45 - For Mono or colour this covers the complete UHF Television band.

All boosters are complete with battery with Co-ax plugs & sockets. Next to the set fitting. Price £4.70 each.

600V - 1 AMP. SILICON RECTIFIERS

PRICE 10 - 50p 100 - £4.00

ALL PRICES INCLUDE VAT. P&P 30p PER ORDER. EXPORTS WELCOME AT COST.

62 BRIDGE STREET, RAMSBOTTOM,
BURY, LANCs.
TEL: RAMS (070 682) 3036.

COLOUR T.V. SPARES

Are you repairing a Decca or Thorn?
We can supply most spares - fast!

Here are some examples:-

DECCA All parts stocked for the 10, 30, 80 and 100 series. LOPT £10.50. Tuner control units, 4 Butt. £6.30, 6 Butt. £8.40. 3R9 R603 52p. Cut-out £1.48. Focus £3.25. Fusibles 61p. Vol/switch £1.36. Tripler £9.00. Converg. pots 48p. Line osc. coil 95p. Mains Tx. £7.30. 80 or 100 Droppers £3 pair. All IC's stocked. Mono Dropper £2.05. Mono LOPT £11.

THORN 3000. Tripler £9.90. PSU Dropper £1.32. 1000mfd £1.20. Mains Tx £10.44. Cond. can £3.57. Focus £3.98. Cut-out £1.48. 1500. Dropper £1.30. E.H.T. Tray £4.15. 8500. 9000 Triplers £8.50 each. 12" Portable (1590) Speaker £4.50 Batt. Socket £2.50. Vol/Sw £2.60

Most Makes:- Triplers, Droppers and Condenser Cans.

All orders are processed on day of receipt. Send 14p stamps for our catalogue (free with an order). Prices include VAT (12½%). Please add 25p for P. & P.

BOTTOMLEY'S TELEVISION
11 Leeds Road, Hipperholme,
HALIFAX

Phone HX (0422) 202979.

CALLERS - Phone first
NEW ENLARGED CATALOGUE NOW
READY

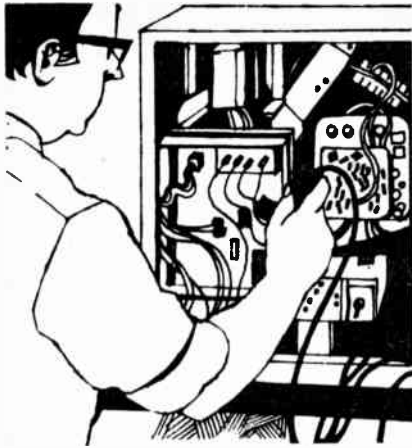

SETS & COMPONENTS

VALVE BARGAINS

ANY 1-20p, 5-80p, 10-£1.25, 50-£5.50

ECC82, ECH84, EH90, DY86/7, EF80, EF183, EF184, PC86, PC88, PCF80, PCF802, PCL82, PCL84, PCL85/805, PCL86, PY81, PY800, PY88, PL36, PL504, 6F28, 30PL14.

COLOUR VALVES 50p EACH
PY500/A, PL508, PL509, PL519.

Postage & Packing 30p, no VAT

VELCO ELECTRONICS

9 Mandeville Terrace, Hawkshaw, Via Bury, Lancs.

PL802/T Top Quality

Solid State Replacement Valve

£2.50 each
C.W.O.

Lloyd Electronics,
83 North Parade,
Grantham,
Lincs.

TELEVISIONS to the Trade. Large quantities of Mono from £4, square screen from £8. Colour TVs working from £65. R.B.M. GEC, Pye, Thorn, etc. Phone Scarborough (0723 68087 65451. Scarborough TV Trading, Ridings House, Depot Lane, Seamer Road, (A64), Scarborough.

EX RENTAL TV

19" UHF 625 £4.50
23" UHF 625 £6.00
Colour from £40.00

EDWARDS & SONS

103 Goldhawk Road, London W12
Tel: 01-743 6996

MAINS DROPPERS

Philips G8 4752	40p
Philips G8 2-2-6852	60p
Philips 210 118-148-Loop52	60p
Philips 210 30-125-2K8552	70p
Philips GT23 6-124-8452	70p
Thorn 3500 6-1-10052	70p
Thorn 1500 350-20-148-1500-31752	85p
Thorn 8000 56-1K-47-1252	85p
Pye 725 27-5652	60p
R.B.M. TV161 250-14-15652	65p
GEC 2010 8-15-17-70-63-18852	85p

2010 Covers 2013 2014 2017 & Sobell 1010 10A 13 & 1014
Bush TV 165-166-171-175-176-178 65p

Murphy V1910-1913-1914-2014-2310-2311-2312 2314 65p
TV Condensers: 200 + 200 ± 100 mfd 300V 42p each
150-100-100-100-150M 325V £1.90
150-150-100M 300V £1.50
175M 400V 100-100M 350V £1.95
400-400M 350V £2.50

Post Free, Cash with order, VAT paid.

Durham Supplies

367 Kensington Street, Bradford 8, West Yorkshire

TURN YOUR SURPLUS capacitors, transistors, etc., into cash. Contact Coles-Harding & Co., 103 South Brink, Wisbech, Cambs. 0945 4188. Immediate settlement.

SMALL ADS

The prepaid rate for classified advertisements is 18p per word (minimum 12 words), box number 60p extra. Semi-display setting £3.50 per single column centimetre (minimum 2.5 cms). All cheques, postal orders etc., to be made payable to Television, and crossed "Lloyds Bank Ltd". Treasury notes should always be sent registered post. Advertisements, together with remittance, should be sent to the Classified Advertisement Manager, Television, Room 2337, IPC Magazines Limited, King's Reach Tower, Stamford St., London, SE1 9LS. (Telephone 01-261 5846).

CONDITIONS OF ACCEPTANCE OF CLASSIFIED ADVERTISEMENTS

1. Advertisements are accepted subject to the conditions appearing on our current advertisement rate card and on the express understanding that the Advertiser warrants that the advertisement does not contravene any Act of Parliament nor is it an infringement of the British Code of Advertising Practice.
2. The publishers reserve the right to refuse or withdraw any advertisement.
3. Although every care is taken, the Publishers shall not be liable for clerical or printers' errors or their consequences.

SETS & COMPONENTS

INGERTONE

For ex-rental colour and mono televisions

De-controlled sets suitable for re-rent or sale.
A good selection always available, many working.
Good testing conditions.
Trade only.

LONDON

24 Dames Road
London E7
01-555-5569 01-555-2200

BRISTOL

28 St. Thomas Street
Bristol 1
0272-211179

American Dynascan Tube Restorer & Analyzer,

Now available in this country.
For full details write or telephone:-

T.V. WHOLESALE,
12 Front Street, Whitley Bay.
Tel: 532561 or 512276.

TIRRO ELECTRONICS the mail order division of RITRO ELECTRONICS UK offers a wide range of components for the amateur enthusiast. Large SAE or 20p brings list. GRENFELL PLACE, MAIDENHEAD, BERKS. SL6 1HL.

BREAKING TV'S

Over 200 TV's to be disposed of, for Spares or Complete. Almost any Mono spare available (Tested). Any Mono Tube £5 + £1.25 p & p.

SPECIAL OFFER:- BRC 1400 Chassis, complete, working order. incl. valves, less tuner, £6 + £2 p & p. Many colour spares available. S.A.E. please with enquiries.

KNAVESMIRE T.V.,

74, Albemarle Road, York.
Tel: York 31237.

VALVE LIST

ALL VALVES FULLY TESTED

Five valves or over postage paid
Under five valves postage 6p each

DY86/87	15p	PC900	8p	PCL85/805	20p
EB91	12p	PCC84	8p	PL36	20p
ECC82	10p	PCC85	20p	PL504	25p
ECL80	8p	PCC89	8p	PY32/33	15p
EF80	8p	PCC189	8p	PY81/800	15p
EF85	8p	PCC805	15p	PY801	20p
EF183	10p	PCF80	8p	U191	15p
EF184	10p	PCF86	15p	6F23	15p
EH90	13p	PCF805	20p	6/30L2	15p
EY86/87	13p	PCL82	15p	30F5	10p
PC86	15p	PCL83	15p	30PL1	20p
PC88	15p	PCL84	15p	30PL14	15p

AND MANY MORE AVAILABLE

S. W. ELECTRONICS

114 Burnley Road, Rawtenstall, Rossendale, Lancs.

BRC 2000, 3000, 8000, 9000.

Philips G8, Pye 691, 697, 713
Bush Murphy 802, 823.

G.E.C. 2100 Single Standard Hybrid
Panel Repair/Exchange Singles or Bulk.

MODULAR ELECTRONICS

160 Brabazon Road, Hounslow, TW5 9LP.
Telephone 01-897 0976.

Colour T.V. Spares

Brand New Top Quality Components

E.H.T. Triplers

Philips G8 £6.50; Pye 691 £6.00; Thorn 3000 £6.50; 3500 £6.50; 8000 £4.00; Thorn 8500 £7.00; 9000 £7.00; Korting Hybrid £6.80; Grundig Hybrid £9.00.

Mains Capacitors

Philips G8, RRI. GEC. 600MFD. 300V £2.25; Pye 691 200-300MFD. 350V £3.00; Thorn 3000/3500 175-100-100 £3.00; Thorn 1000MFD. 70V 80p; RRI. 2500+2500 30V £1.25.

Semiconductors

BT119 £4.00; BT120 £4.00; TV106 £1.70; BU208 £2.80.

All prices inclusive. Please add 30p for p. & p. Thousands of parts in stock for British and Foreign TVs.

Terry Gallagher,

TV Spares Specialist
20 Oakworth Green, Beechwood,
Middlesbrough,
Cleveland TS4 3ES.

Office Only, No Callers, Thank You.

RE-BUILT COLOUR TUBES

19" £29.50 20" £30.50
22" £32.50 25" £34.50
26" £38.50

One Year Guarantee. Personal Callers Only.
MATRIX TV LTD.,
112 Essex Road, London N1.

KORTING COLOUR T.V.s 22" and 26" screen size available. Perfect working order £80 each, non workers from £50. Full back up spares available. Tel: Mr. Wilson, Bradford (0274) 665670.

TV SPARES

PHILIPS · TCE · GRUNDIG
TELEVIEW

01-994 5537 194 ACTON LANE,
LONDON W.4.

SURPLUS STOCK

Colour Tubes Used from..... £10
S/S Colour Tubes New from £25
 Inline-Gun (20AX) Colour
Tube New from £25
 Portable Tubes Mono available.
S/S Colour Sets Murphy 823 £60
S/S & D/S Mono from £5
RING: JEFFRIES 01-845 2036

FOR SALE

TELECARE

BRITAIN'S LARGEST USED T.V. DISTRIBUTOR.

Large Quantities of Mono and Colour T.V.'s.
Working. At Very Competitive Prices. Makes include

**R.B.M THORN G.E.C. PYE
PHILIPS GRUNDIG NORMANDIE**

LONDON
Unit B1, Eley Rd., Eley Estate,
Edmonton,
London N18.
Tel: 01-807 5908/9 807 5900

N. IRELAND
Bellenaleck Quay,
Bellenaleck,
Co. Fermanagh,
Tel. Florencecourt 388

BRISTOL
Unit 3, Whitby Rd.
Trading Estate,
Brislington, Bristol.
Tel: 0272 712569

TV TUBE REBUILDING - for all supplies, equipment, plant and training - Western-Whybrow Engineering, Praa Sands Cross, Penzance (0736) 761 2265.

COLOUR TUBE Rejuvenator. Lasting results. Professional, Solid-State workshop instrument. £14.95 inc. P & P, VAT, C.W.O. New Dimension Television, 12 Buxton Road, Heaviley, Stockport, Cheshire.

NEW BACK ISSUES of "TELEVISION" available 70p each post free. Open P.O./Cheque returned if not in stock. Bell's Television Services, 190 Kings Road, Harrogate, N. Yorkshire. Tel: (0423) 55885.

PHILIPS VCR. perfect order. Spare heads, Tapes, Crispener, £365 ono. Leicester 292750.

"DORAM" T.V. Pattern Generator £20. Working Panels for 19" BRC 3000 offers. S.A.E. please, D. Clarke, Hillside, Butchers Hill, Shorne, Nr. Gravesend, Kent.

LADDERS

ALUMINIUM Roof Crawlers. Sizes 12ft.-24ft. Also aluminium ext. up to 62½ft. Leaflet. Ladder Centre (TEL2), Halesfield (1), Telford. Tel: 586644. Callers welcome.

EDUCATIONAL

BETTER JOB! BETTER PAY!

GET QUALIFIED WITH ICS IN:

COLOUR & MONO TV SERVICING
COLOUR & MONO TV ENGINEERING
COLOUR & MONO TV MAINTENANCE
PLUS: Telecommunications, radio, electronics, electrical engineering, technical communications, radio communications, etc., etc.,

NEW: Self-build radio courses with free kits

Train in your own home, in your own time with ICS, the world's most experienced home study college.

RETURN THIS COUPON TODAY
FOR FREE BROCHURE!



Int Correspondence Schools
2842 Intertext House Stewarts Rd.
London SW8 4UJ. Tel: 01-622 9911

Name

Address

TELEVISION TRAINING

18 MONTHS full-time course for beginners to include all the undermentioned subjects. Short courses, combining, one or more subjects, for applicants with suitable education and electronics background such as C & G, HND, BSc etc.

- 13 WEEKS TECHNICAL MATHEMATICS & ENGLISH
- 13 WEEKS ELECTRONICS & RADIO
- 13 WEEKS MONOCHROME TELEVISION
- 13 WEEKS COLOUR TELEVISION
- 13 WEEKS VIDEO CASSETTE RECORDING & CCTV

The training incorporates a high percentage of practical work.

Next session starts on Jan 8th.

(Also available 2½ year course in Marine Electronics & Radar for employment as ships Radio Officer.)

Prospectus from:

LONDON ELECTRONICS COLLEGE

Dept. BTT10, 20 Panywern Road,
London SW5 9SU. Tel. 01-373 8721

BOOKS & PUBLICATIONS

SIMPLIFIED TV Repairs. Full repair instructions individual British Sets £4.50, request free circuit diagram. Stamp brings details unique. TV Publications, (Auset), 76 Church Street, Larkhall, Lanarkshire.

SERVICE SHEETS

LARGE SUPPLIERS OF SERVICE SHEETS AND COLOUR MANUALS

TV, Radio, Tape Recorders, Record Players, Transistors, Stereograms, Radiograms.
All at 75p each except Colour TV & Car Radios

TV Sheets full-length, 24 x 12. All other sheets also full-length.

Please state if circuit will do if service sheet is not in stock, large s.a.e. with all enquiries and orders otherwise cannot be attended to. Uncrossed P.O.'s or crossed Cheques returned if service sheets are not available. Mail order only or phone 01-458 4882. Free TV fault tracing chart catalogue on request with order. **NO CALLERS**

C. CARANNA, 71 BEAUFORT PARK, LONDON, NW11 6BX NO CALLERS PLEASE

Reg. Office: Rear 14 Queen's Parade, North Ealing, W5 SERVICE SHEETS - COLOUR TV SERVICE MANUALS

Service Sheets for Mono TV, Radios, Record Players and Tape Recorders 75p.

Please send large Stamped Addressed Envelope.

We can supply manuals for most makes of Colour Television Receivers by return Post.
**B.R.C. PYE EKCO PHILIPS ITT/KB SONY G.E.C. HITACHI BAIRD ULTRA INVICTA
FERGUSON H.M.V. MARCONI AND MANY MORE. LET US QUOTE YOU.**

Please send a Stamped Addressed Envelope for a prompt reply.

COMPREHENSIVE TV REPAIR MANUALS BY J. McCOURT

Mono Volumes 1, 2, 3 and 4. Colour Volumes 2, 3 and 4.

A must for the repair man, loaded with faults and cures, all at £4.00 each plus 40p post. Build yourself 'The Colour TV Signal Injector', manual! £1.45. Manual with printed circuit £2.30 post paid. The McCourt circuit diagram manuals Mono and Colour. Send S.A.E. for full details.

Export enquiries welcome. International Reply Coupon please. Mail only to:

G. T. TECHNICAL INFORMATION SERVICE
10 DRYDEN CHAMBERS, 119 OXFORD ST., LONDON W1R 1PA

SERVICE SHEETS. SERVICE MANUALS PRACTICAL AND TECHNICAL BOOKS

COVERING COLOUR & MONO TELEVISIONS, RADIOS,
RECORD PLAYERS, TAPE RECORDERS, ETC.

SERVICE SHEETS 75p PLUS S.A.E. SERVICE SHEET CATALOGUE 50p

BOOKS

PRICES INCLUDE POSTAGE U.K. ONLY

TVT '77 TRANSISTOR EQUIVALENT & DATA BOOK. (A TO Z). 272 Pages	£2.25
TVT '78 TRANSISTOR EQUIVALENT & DATA BOOK. (2N, 2S, ETC.). 392 Pages	£3.30
NEWNES COLOUR TELEVISION SERVICING MANUAL by G. J. King. Vol. 1	£7.20
NEWNES COLOUR TELEVISION SERVICING MANUAL by G. J. King. Vol. 2	£7.20
NEWNES COLOUR TELEVISION SERVICING MANUAL by G. J. King. Vol. 3	£8.60
COLOUR TELEVISION SERVICING by G. J. King. 2nd Edition	£7.30
COLOUR TELEVISION THEORY by G. H. Hutson	£6.80
COLOUR TELEVISION PICTURE FAULTS by K. J. Bohlman	£2.90
COLOUR TV WITH REFERENCE TO THE PAL SYSTEM by G. N. Patchett	£6.20
TELEVISION (COLOUR & MONOCHROME) Part 3 by G. N. Patchett	£4.35
TELEVISION SERVICING HANDBOOK by G. J. King. 3rd Edition	£6.10
BEGINNERS' GUIDE TO TELEVISION by G. J. King. 5th Edition	£2.65
BEGINNERS' GUIDE TO COLOUR TELEVISION by C. J. King. 2nd Edition	£2.65
CATHODE-RAY OSCILLOSCOPE AND ITS USES by G. N. Patchett	£4.00
SERVICING WITH THE OSCILLOSCOPE by G. J. King. 2nd Edition	£5.35
TOWERS' INTERNATIONAL TRANSISTOR SELECTOR. Revised Edition	£5.95

(SEND LARGE S.A.E. FOR FREE BOOK LISTS)

WE STOCK NEW AND SECONDHAND EDITIONS OF "RADIO AND TELEVISION SERVICING" BOOKS.
FROM 1965-66 EDITION UP TO DATE. PRICES ON REQUEST.

BACK ISSUES OF FOLLOWING MAGAZINES AVAILABLE. CURRENT PRICE PLUS 20p POSTAGE PER COPY.
P. WIRELESS, P. ELECTRONICS, E. ELECTRONICS, TELEVISION, R. CONSTRUCTOR, ELECTRONICS TODAY, ELEKTOR.

BELL'S TELEVISION SERVICES

190, KINGS ROAD, HARROGATE, N. YORKSHIRE. TEL. HARROGATE (STD 0423) 55885

OPEN TO CALLERS DAILY 9.00 a.m. TO 5.00 p.m. PLEASE INCLUDE AN S.A.E. WITH ENQUIRIES

COLOUR TV MANUALS

COVERING FOLLOWING MAKES

ALBA, BRC, BUSH, DECCA, GEC,
DEFIANT, MARCONI, EKCO, PYE,
FERGUSON, DYNATRON,
NATIONAL, HITACHI, INVICTA,
ITT/KB, RGD, GRUNDIG, SOBELL,
STELLA, SONY, MURPHY,
PHILIPS, HMV, ULTRA.

PLEASE SEND S.A.E. FOR QUOTATION

"COMPREHENSIVE TV REPAIR MANUALS" by McCourt. In six Volumes

These unique Books save time and money on repairs and cover most British Colour & Mono sets. Price £4.50 per volume plus 40p POST, or complete 6 volumes for only £27.00 POST FREE.

SERVICE SHEETS, Radio, TV, etc., 10,000 models.
Catalogue 24p plus SAE with orders/enquiries.
TELRAY, 154 Brook Street, Preston, PR1 7HP.

SERVICE SHEETS for Radio, Television, Tape
Recorders. Stereo etc. With free fault-finding guide,
from 50p and S.A.E. Catalogue 25p and S.A.E.
HAMILTON RADIO, 47 Bohemia Road, St.
Leonards, Sussex.

Please mention
TELEVISION
when replying to
advertisements.

WANTED

WANTED: Clean new semiconductors, I.C.'s etc.
Good prices paid. Hewitts, 52 Barkby Road, Syston,
Leicester.

NEW VALVES and CRT's required, PCL805,
PL504, PL509, PY500A etc. Cash waiting. Bearman,
6/8 Potters Road, New Barnet, Herts. Tel:
01-449 1934/5.

WANTED Television Engineers Case - Old Type
(with valve holders etc.). Heyworth, 45 Wynter Lane,
Tilston, Malpas, Cheshire.

MISCELLANEOUS

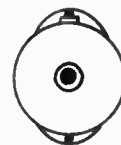

6 to 12V D.C.

BELLS AND SIRENS

Carters Siren £6.53
Industrial Six
Inch Bell £8.27
Prices inclusive

Send Cheque, P.O. to
CWAS ALARM
11, Denbrook Walk
Bradford BD4 0QS
S.A.E. for full Price List

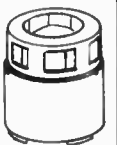

12V D.C.

UP TO £75 paid for repair information on
British/Foreign TV Sets. Full details from TV
Technic, 76 Church St., Larkhall, Lanarkshire
ML9 1HE.

ORDER FORM PLEASE WRITE IN BLOCK CAPITALS

Please insert the advertisement below in the next available issue of Television for

insertions. I enclose Cheque/P.O. for £

(Cheques and Postal Orders should be crossed Lloyds Bank Ltd and made payable to Television)

NAME

ADDRESS

.....

Company registered in England. Registered No. 53626. Registered Office: King's Reach Tower, Stamford Street, London SE1 9LS.

Send to: Classified Advertisement Manager,
TELEVISION,
G.M.G. Classified Advertisement Dept., Rm. 2337,
King's Reach Tower, Stamford Street,
London SE1 9LS. Telephone 01-201 5946.
Rate
18p per word, minimum 12 words, Box No. 60p extra.

PHILIP H. BEARMAN

(VALVE SPECIALISTS)

SUPPLIERS TO H.M. GOVT. Etc.

NEW valves by Mullard, Mazda, Telefunken, Tungstam, etc.

"QUALITY" BRANDED VALVES ONLY CARRY THE 90 DAY GUARANTEE, SEE OUR LISTS.

IMMEDIATE POSTAL DESPATCH

LISTS S.A.E.

QUOTED PRICES INCLUDING 8% ALLOWANCE IN LIEU OF GUARANTEE

PRICES FROM JUNE 1978 INCL. 12½% VAT

DY86/7 75p	GY501 £1.60	PCF802 £1.00	PL36 £1.20	U25 60p	30P12 70p
DY802 80p	PC86 95p	PCF805 £1.60	PL84 70p	U26 60p	30PL1 £1.45
ECC81 75p	PC88 95p	PCF808 £1.70	PL504 £1.50	6F23 60p	30PL13 £1.00
ECC82/3 75p	PC97 80p	PCH200 £1.25	PL508 £1.55	6F28 £1.05	30PL14 £1.20
ECL80 70p	PCC84 35p	PCL82 £1.00	PL509 £3.00	20P4 70p	30PL15 £1.10
EF80 65p	PCC89 75p	PCL83 90p	PL802 £2.85	30C1 90p	Etc., Etc.
EF183 80p	PCC189 75p	PCL84 £1.00	PY81/83 90p	30C17 80p	
EF184 80p	PCF80 95p	PCL85 } £1.20	PY800 90p	30FL1 } £1.20	BY 100/127 etc.
EH90 80p	PCF86 95p	PCL805 } £1.20	PY801 90p	30FL2 } £1.20	all 21p each
EY51 85p	PCF200 £1.60	PD500 £3.60	PY500 } £1.75	30L15 75p	with 10W resistor.
EY86/7 50p	PCF801 90p	PFL200 £1.35	PY500A } £1.75	30L17 75p	

(Correct at time of going to press ONLY.)

MINIMUM ORDER 80p!

ENQUIRIES

WELCOMED

ON OUR

VAST

RANGE

TELEPHONE

ENQUIRIES

WELCOMED

NOTE

Any excess paid will be refunded.

SEND SAE FOR

COLOUR & MONO

TRIPLER LIST (BRC)

ALSO LATEST

COMPONENTS LIST.

(Adjacent to Post Office) 6 & 8 POTTERS RD., NEW BARNET

STOP PRESS PC92/96, PCL200, HERTS. Tel: 449/1934-5 (Robophone on 449/1934)

PL95, PL519 available!

Also EY500A, EL509 etc.

HUNDREDS OF OTHER TYPES AVAILABLE, VAST STOCKS.

See separate Component, CRT and Transistor List. Many obsolete types available.

I.R.C. or S.A.E. with enquiries please. Please verify current prices due to inflation etc.

Overseas Post @ Cost. U.K. Post 14p per valve under £20.00 (max. 80p) but

2p extra larger valves/ADDITIONAL VALVES 7p.

Short supply.

(CLDSED 12.30-2 p.m. DAILY. DPEN SAT. A.M. ONLY)

TELE-PART

REBUILT TUBES — TWO YEAR GUARANTEE

17" 18" 19" £32

20" £33 22" £35 25" £38 26" £42

CASH OR CHEQUE + 12½% VAT

AND OLD CRT WITH ORDER

ADD £3.50 CARRIAGE

ENQUIRIES FOR OTHER SIZES WELCOME

ACCESS AND BARCLAYCARD ACCEPTED

TELE-PART (WTON) THE TELECENTRE, WORCESTER ST., WOLVERHAMPTON (0902) 772293

SOUTHERN VALVE COMPANY

Second Floor, 8 Potters Road, New Barnet, Herts.

Telephone 01-440/8641

MAIL ORDER ONLY

MINIMUM ORDER 80p

ALL NEW & BOXED, "QUALITY" BRANDED VALVES

GUARANTEED 3 MONTHS. BVA ETC. HAVE

6% ALLOWED IN LIEU OF GUARANTEE!

ALREADY DEDUCTED FROM OUR PRICES!

NOTE: PLEASE VERIFY CURRENT PRICES. Correct only at time of going to press.

Some leading makes available.

VAT invoices issued on request.

DY86/7 53p	EF86 54p	GY501 £1.40	PCF802 80p	PL36 90p	PY500A £1.75	U25 60p	UBF89 41p
DY802 53p	EF89 55p	PC86 75p	PCF805 £1.60	PL81A 65p	UBF89 41p	U26 60p	UCC85 50p
ECC81 54p	EF183 55p	PC88 75p	PCF806 75p	PL82 30p	UCC85 50p	6F23 60p	UCH81 58p
ECC82 60p	EF184 55p	PC97 72p	PCF808 £1.70	PL83 46p	UCH81 58p	6F28 £1.05	UCL82 70p
ECC83 54p	EH90 60p	PC900 65p	PCL82 63p	PL84 50p	UCL82 70p	20P4 70p	UCL83 90p
ECC85 52p	EL41 90p	PCC84 35p	PCL83 80p	PL500 } £1.10	UCL83 90p	30C1 90p	UF89 52p
ECC81 55p	EL509 £2.90	PCC85 52p	PCL84 65p	PL504 } £1.10	UF89 52p	30C17 80p	UL41 85p
ECH84 85p	EM84 90p	PCC89 30p	PCL85 } 70p	PL508 £1.50	UL41 85p	30FL1 } £1.20	UL84 70p
ECL80 52p	EY86/7 46p	PCC189 55p	PCL805 } 80p	PL509 £3.00	UL84 70p	30FL2 } £1.20	UY41 55p
ECL82 62p	EY500A £1.50	PCF80 80p	PCL86 80p	PL802 £2.90	UY41 55p	30L15 75p	UY85 60p
ECL86 70p	EZ80 42p	PCF86 60p	PCL200 £1.40	PY88 75p	UY85 60p	30L17 75p	U25 60p
EF80 41p	EZ81 44p	PCF200 £1.50	PD500 £3.60	PY800 60p	U25 60p	30L17 75p	U26 60p
EF85 45p		PCF801 55p	PFL200 £1.35	PY801 60p	U26 60p		

One valve post 13p, each extra valve 6p.

MAX 80p LISTS & ENQUIRIES, S.A.E. PLEASE!

Large valves 2p, each extra.

ALL PRICES INCLUDE VAT @ 12½%.

ENQUIRIES WELCOMED FROM TRADE & RETAIL (same prices)

PHILIP H. BEARMAN

6 & 8 POTTERS ROAD, NEW BARNET, HERTS. Tel: 01-449 1934/5

NEW MONO TUBES, Usually 2 Year Guarantee. Tested prior sale.

A31/410W Mullard	} £18.00 (A31/300)
A31/120 - CME1220	
A34/100 - CME1420	£19.50*
A38/160 - CME1520	£21.00*
A44/120WR - CME1713	£21.00
A50/120WR - CME2013	£18.00*
A61/120WR - CME2413	£21.00*

Note* less £1 for 1 year guarantee.

PRICES INCLUDE 12½% VAT.

MAKES INCLUDE TOSHIBA,

MAZDA, BRIMAR & MULLARD.

CARRIAGE £1.50 (Mainland);

£1.25 Extra Short Sea Journey.

Eire Extra

COLOUR TUBES. Prices on application. SAE all enquiries please!

Prices correct at time of going to press but subject to alteration without notice.

Telephone enquiries welcomed. 19", 20" £60; 22" £68.00 £5 allowance old CRT.

TELEVISION TUBE SHOP

NEW TUBES AT CUT PRICES

A28-14W	£18.95
A31-19/A31-20W	£19.95
A31-410W	£17.95
CME1220/A31-120W	£17.95
CME1420/A34-100W	£17.50
CME1520/A38-160W	£17.50
CME1906/A47-13W	£12.50
CME2013/A50-120	£17.95
CME2313A59-23W	£18.95
CME2413/A61-120W	£18.95

SPECIAL OFFER

FOR K.B. FEATHERLITE VC11

TSD 282/217.....£8.50

JAPANESE etc. TUBES

9AGP4	£17.50
190AB4	£15.00
190CB4	£15.00
230ADB4	£18.95
230DB4/CT468	£20.00
CT507	£17.95
240AB4A	£17.95
310DMB4/DGB4	£19.50
310DWB4/DJB4	£19.50
310EDB4	£18.75
310EUB4	£19.50
310EYB4	£16.50
310FDB4	£19.95
310GNB4A Equivalent	£19.95
310HCB4	£19.95
340AB4	£19.50
340AYB4	£23.00
340CB4	£23.00
340RB4	£23.00
340AHB4	£24.50

Some Rebuilt Japanese Tubes Now Available at £14 + V.A.T.

COLOUR TUBES

12VARP22	£62.50
330AB22	£67.50
470FUB22B	£85.00
A44-271X	£65.00
A47-342X	£69.50
A49-191X/120X	£52.00
A51-220X/510DJB22	£64.00
A56-120X	£69.50
A56-140X/410X	£62.00
A66-120X	£75.00
A63-11X/120X	£69.50
A67-120X	£82.00
A67-150X	£69.00
A66-140X/410X	£70.50

ALL TUBES GUARANTEED 12 MONTHS

CARRIAGE:

Mono £2.00 Colour £3.00

N. Ireland £4.00

ADD 12½% VAT TO ALL PRICES

TELEVISION TUBE SHOP

52 BATTERSEA BRIDGE RD.,

LONDON, SW11.

Tel. 228 6859/223 5088

TELE-PART (WTON) THE TELECENTRE, WORCESTER ST., WOLVERHAMPTON (0902) 772293

A. & S. T.V. Components
3 High Street, Elstree
Hertfordshire
Tel: 01-207 0520

APPOINTED G.E.C. STOCKISTS – Quick Mail Order Service. Available L.O.P.T's. Panel Boards, Scan Coils, Tuners etc.

Also available: Disc Capacitors, Ceramic Pulse type 1-12 KV, Electrolytic Condensers, various types and Transistors and I.C.'s etc., a few listed below at **FANTASTICALLY** reduced prices. We are able to supply **WHOLESALE, RENTAL COMPANIES and TRADERS. NO BULK PURCHASE REQUIRED** – only a minimum purchase of £100 to obtain quotations usually given up to £10,000 lots. For Engineers and D.I.Y. enthusiasts we give **10% DISCOUNT** on £15 (excluding VAT) and **20% DISCOUNT** on £25 (excluding VAT) purchases. A few Transistors and most I.C.'s have been **CUT IN PRICE** and are only available, whilst stocks last, at these prices.

I.C.'s

Transistors

TAA700	£1.35	AC127	25p
TAA550B	30p	AC128	25p
TBA120AS	72p	AC188	20p
TBA120SQ	72p	AD149	65p
TBA240A	£2.00	AD161	42p
TBA480Q	£1.25	AD162	42p
TBA520Q	£1.30	AF139	36p
TBA530Q	£1.10	AF178	53p
TBA540Q	£1.30	AF239	42p
TBA550Q	£1.75	BC107	10p
TBA560CQ	£1.25	BC108	10p
TBA750Q	£1.20	BC109	10p
TBA800	£1.00	BC147	8p
TBA673	£1.65	BC148	8p
TBA920Q	£1.55	BC159	10p
TBA990Q	£1.60	BC187	15p
TCA270Q	£2.00	BC337	12p
TCA800Q	£2.20	BD131	45p
CBF16848N	£1.00	BD132	45p
ETTR6016	£2.10	BD253	£1.85
SN16861AN	£1.50	BDX32	£2.30
SN16862AN	£1.50	BF180	31p
SN1686ING	£1.50	BF196	13p
SN76013ND	£1.10	BF197	12p
SN76013N	£1.50	BF258	58p
SN76544N	£1.60	BF336	33p
		BF337	36p
		BF362	45p
		BFY50	20p
		BU105/04	£1.50
		BU108	£1.80
		BU208	£2.00
		BU208A	£2.75
		2N1711	30p
		R2008B	£1.65
		R2010B	£2.00
		RCA16334 = R2477	96p
		RCA16335 = R2501	96p

Diode's

BY126	14p
BY127	15p
BY164	58p
BY238	16p
BZV15/24R	40p
BZV49/B	20p
BZX79	20p
OA90	7p

Rectifier

TV20	£1.25
------	-------

Dropper

G8 2.2 ohms - 68R	55p
-------------------	-----

Thyristors

BT106	90p
TV106	£1.00
TV106-2	£1.20

Condensers

1000 + 2000	
35V wrkg.	60p
300 + 300 + 100 + 50 + 150	
350V DC	£1.85

ALL GOODS OF HIGH QUALITY AND BRANDED e.g. AEI, TELEFUNKEN, TEXAS, FAIRCHILD etc., TERMS C.W.O. - VAT 12½% - MINIMUM ORDER £10 - P & P 50p.

Further postage may be needed pending weight and value of order at G.P.O. rates.

DISPLAY ELECTRONICS

**COLOUR TUBES
 MONOCHROME TUBES
 VDU/RADAR TUBES**

REBUILT IN OUR OWN FACTORY IN N.W. LONDON

Customers are asked to note that as a result of the continuing high demand for our products we shall be moving into a new purpose built factory towards the end of the year. Until that time we shall be pleased to deal with enquiries on

WEST DRAYTON 43904

When we move our new number will be

UXBRIDGE 55800

FOR YOUR GUIDANCE

VALUE ADDED TAX

Unless otherwise shown, all prices in advertisements are inclusive of VAT. Where prices are exclusive, readers should ensure that they have added the correct amount of VAT before ordering.

Export orders are not subject to the addition of Value Added Tax.

REBUILT TV TUBES

MONO, WITH TWO YEAR GUARANTEE

A 28 - 14W; A 31 - 410W. And all thin neck tubes for portable TVs, including Japanese types

£14.00

CME 1601/2, CME 1713, CME 1908, CME 1913, CME 2013, CME 2313, CME 2413.

A 44 - 120W, A 47 - 11W, A 47 - 26W, A 50 - 120W, A 59 - 11W, A 59 - 23W. And similar types all available, only two prices.

Up to and including 20"

£11.50

23" & 24"

£12.75

COLOUR TUBES

Normal Guarantee 1 year, extendable for 4 years (details on Guarantee cards).

All types except Sony, Trinitron & P.I.L.

12" - 20" inc. Japanese

£29.50

22"

£33.00

25" & 26"

£37.50

Please add 12½% V.A.T. to all orders. Cash or cheque with order.

Carriage £3.75 inc. V.A.T. anywhere on mainland.

All prices quoted assume the return of your old tube in rebuildable condition.

Same day despatch. Advance replacements for some types against deposit. Please enquire.

CALEY TUBES

17-35 Bangor Road, Edinburgh EH6 5JY. 031-554 4200.

Callers Welcome.

40V, 2A O.P. Trans NPN PNP BD375-6 Pair 20p	£3 Each 10 Watts Mullard Modules LP1173	Convergence Panel for GEC 2040 £2.00	BT106 Special Type 60p Y827 Diodes 30p SN76227 50p
AD161 - 162 Pair 60p	£3 New	11 Pots 5 Coils & Resistors etc	TBA 510 £1.00 TBA 540 £1.00 TBA 396 50p
For Varicap 7 Push Button Units with Variable Resist- ance, Fascia Plate & Lamps £2.00	BF258 20p BC303 20p BD207 30p BF157 15p BC238A 10p BC148B 10p TIP31A 20p TIP2955 50p BF195 10p	220 MFD 450V 50p	Bridge Rectifiers B30C600A6 15p B30C500P 15p
6 Push Button Units with Variable Resist- ance for Varicap with Fascia Plate £2.00	8A 800V Thyristors 35p 2N6399A	MODULES Reject Units VHF ELC1042 50p	RCA Line Output Transistor for use in Low Impedance Line Output Circuits 75p
For Varicap 4 Push Button without Fascia Plate 20K 75p	7A/Thyristors 400V S2600D 35p	10 Watt LP1173 £1.00 I.F. LP1170 50p AM/FM LP1179 50p	BT119 £3.00 BT109 60p BT146 60p
Transistor BF180-1 UHF Tuner Unit with AE Socket & Leads. G.E.C. Rotary Type £1.35 New	16172 RCA BT119 Type £1.00	IN2069A 5p	RCA 536 O/P IC
New VHF/UHF Varicap Units AEG £3.00	AT1025/08 Blue Lateral Ass. 25p E1222 15p BSY95A 7½p 2N930 7½p 4-7NF 5kV 10p	Triple LP1174 Mullard £3.00 TIP 29A 25p TIP 32 25p	

SENDZ COMPONENTS

2 WOOD GRANGE CLOSE,
THORPE BAY, ESSEX.

Reg. Office only -
Callers by appointment only. Thank you.
Free Postage applies in U.K. only.

PLEASE ADD 12½% VAT

TV	LINE OUTPUT TRANSFORMERS All items new and guaranteed	MONO TRANSFORMER £7.45 <i>(No Extra for Carriage)</i>	
		VAT @ 12½% .93 DISCOUNT FOR TRADE. TOTAL £8.38	
BUSH TV102C TV103 or D TV105 or D TV105R TV106 TV107 TV108 TV109 TV112C TV113 TV115 or C TV115R TV118 TV123 TV124 TV125 or U	DECCA DR1 DR2 DM3 DR3 DR20 DR21 DR22 DR23 DR24 DR29 DR30 DR31 DR32 DR33 DR34 DM35 DM36 DM39 DR41 DM45 DR49 DM55 DM56 DR61 DR71 DR95 DR100 DR101 DR121 DR122 DR123 DR202 DR303 DR404 DR505 DR606 666TV-SRG 777TV-SRG MS170C MS2000 MS2001 MS2400 MS2401 MS2404 MS2420	MURPHY V843 all models to V979 V153 V159 V173 V179 V1910 V1913 V1914 V2014 or S V2015D V2015S V2015SS V2016S V2017S V2019 V2023 V2027 V2310 V2311C V2414D V2415D V2415S V2415SS V2416D V2416S V2417S V2419 V2423	
PHILIPS 17TG100u 17TG102u 17TG106u 17TG200u 17TG300u 17TG320L 19TG108u all models to 19TG164a	EKCO T418 TO T546	19TG170a ... all models to 19TG179a G19T210a G19T211a G19T212a G19T314a G19T215a G20T230a all models to G20T328 21TG100u 21TG102u	
BUSH A816 CHASSIS £11.00	GEC 8T454 8T455 8T455DST 2000DST ... all models to 2044 2047 ... all models to 2084 2104 or /1 2105 or /1	KB-ITT By Chassis: VC1 VC52 VC2 VC52/1 VC3 VC100 VC4 VC100/2 VC11 VC200 VC51 VC300 Or quote model No. INDESIT 20EG8 24EG8	PYE 11u 40F 58 64 81 93 161 31F 43F 59 68 83 94 150 170 32F 48 60 75 84 95/4 151 170/1 36 49 61 76 85 96 155 171 37 50 62 77 86 97 156 171/1 39F 53 63 80 92 98 160
BAIRD PLEASE QUOTE PART NO. NORMALLY FOUND ON TX. BASE PLATE 4133, 4123, 4140 OR 00062.	EMO WINDING 90%	SOBELL ST196 or DS ST197 ST290 ST297 1000DS ... all models to 1102	THORN GROUP Ferguson, H.M.V., Marconi, Ultra. By Chassis: - 800, 850, 903, 950/1, 950/2, 950/3, 960, 970, 980, 981, 1400, 1500, 1500 (24"), 1580, 1590, 1591, 1592, 1600, 1612, 1613. Or quote model No.
COLOUR TRANSFORMERS ITT CVC1 TO CVC20 CHASSIS PHILIPS G8 CHASSIS DECCA CS1730 GS1830 DECCA 30 SERIES BRADFORD CHASSIS £9.50 + £1.19 VAT. TOTAL £10.69	AB16 Chassis £11.00		
Tidman Mail Order Ltd., 236 Sandycombe Road, Richmond, Surrey. Approx. 1 mile from Kew Bridge. Phone: 01-948 3702	MON-FRI 9 am to 12.30 pm. 1 30 pm to 4.30 pm.	Hamond Components (Midland) Ltd., 416, Moseley Road, Birmingham B12 9AX. Phone: 021-440 6144.	MON-FRI 9 am to 1 pm. 2 pm to 5.30 pm.
Contact your nearest depot for service by-return. Callers welcome. Please phone before calling.			
COLOUR TV LINE OUTPUT TRANSFORMERS E.H.T. RECTIFIER TRAYS (Prices on application)			

AD 161-162	pair 60p	50 Mixed Diodes	£1.00	Thorn 1590 Mains Lead & On/Off Switch & Control Panel with 3 Slider Pots	£1.00	TBA920Q	£2.00
40 M/A	20MM Fuses Mixed Values Anti Surge and Quick Blow 30 tc. £1.00	1N5349 Diode } 10p	EACH	Reject VHF Varicap Units UHF	50p	SN76003N	£1.50
160 M/A		400 MFD/350V		50p	AE Isolating Socket & Lead	45p	SN7660N
250 M/A		Mullard UHF T/Units	£1.50	6 Position 12.5k V/Resistors Units for Varicap	50p	1N4148	3p
800 M/A		300 Mixed Condensers	£1.50	EHT Rectifier Sticks Used in Triplers x80/150 } 10p	EACH	BF198	7p
1 Amp		300 Mixed Resistors	£1.50	CSD118xMH } 10p		BF274	5p
1.5 Amp		30 Pre-sets	50p	CSD118xPA	12p	BA159	10p
1.6 Amp		100 W/W Resistors	£1.50	3 Off G770/HU37 EHT Rec. Silicone, used in Tripler	15p	BY184	25p
2 Amp		40 Mixed Pots	£1.50	Bridge Rectifiers 3 Amp	40p	BY187	50p
3 Amp		20 Slider Pots	£1.50	1A 100v	20p	TAA550	20p
3.5 Amp		Mixed Components 1lb for	£1.50	2A 100v	25p	TBA396	£1.00
4 Amp	BD116	30p	W005M	20p	TBA510Q	£1.00	
3500 Thorn Triplers			BY127	10p	TBA480Q	£1.00	
LP1193/1 Mallard			1N4005	20 for £1.00	TBA550Q	£1.50	
TK25KC15BL			1N4006	20 for £1.00	TBA720A	£1.50	
Ex Panel Pye			1N4007	20 for £1.00	TBA790B131	£1.00	
TS2511TBH GEC			BYX94 1200v 1 Amp.	15 for £1.00	TBA800	95p	
TS2511TBK Rank 823			BB105 UHF		SN76115N	£1.00	
TS2511TDT Thorn			BA 182 Varicap Diodes		TAA700	£1.50	
TS2511TBQ Pye			BB103 VHF	12 for 60p	TBA530Q	£1.00	
TS2511TCE			BY176	£1.00	TBA550	£2.00	
TS2511TCF			BA248	7p	SN76227N	£1.00	
1730 Decca			BY133	10p	SN76544N	50p	
Mains Droppers			BYX55/350	10p	SN76640N	£1.00	
69R + 161R Pye	40p		BY210/400	5p	SN76033N	£1.00	
Rank/Bush Mains Dropper			BY206	15p	TBA120A	50p	
302R/70R/6R2	40p		BT106	95p	TCA270Q	£2.00	
147R + 260R Pye	40p		BT116	95p	TCA270SQ	£1.00	
Thorn Mains Dropper			BY212	15p	Star Aerial Amps CHANNEL B+C	£4.00 EACH	
80R/6R/054R/720R/317R	40p		12 Kv Diodes 2 M/A	30p	TV18	40p	
Thorn Mains Droppers			18 Kv BYF3123 Silicone	30p	TV20 BYF3214 Rectifier Sticks & Lead	50p	
6R + 1R + 100R	35p		160PF 8Kv	100M 50v	R2010B	£1.25	
Thorn Mains On/Off Switches, Push Button or Rotary	15p		270PF 8Kv	330M 10v	R2008B	£2.00	
Thorn 2000 & 3000 Series Hearing Aid External Loudspeaker Unit	£2.00		1000PF 10Kv	330M 25v	BU105	£1.00	
470M/100v	25p		1200PF 10Kv	330M 35v	BU105/04	£1.00	
Focus Unit 3500 Thorn	£1.00		1000PF 12Kv	330M 50v	BU205	£1.00	
Thorn 8500 Focus Unit	£1.00		160M 25v	330M 63v	BU208	£1.75	
4 Push Button UHF Unit 1400 - 1500 Series and 8500	£3.50		220M 25v	470M 25v	BU108	£1.75	
D.P. Audio Switch	7½p		1000M 16v	470M 35v	BD130Y	20p	
4 Push Button Unit for Varicap	£1.00		220M 35v	470M 40v	2N3055	40p	
7 Push Button Unit for Varicap	£2.00		220M 40v	47/63	BRC1693 Thorn	60p	
RIZ243619 Replacement for ELC 1043			220M 50v	300PF 6Kv	BD138	20p	
UHF Varicap new	£2.50		470M 25v	8M/350v	BD252	20p	
BF127 BC350 BF194			22M 315v	10p EACH	Audio O/P Trans.		
BF264 BF178 BF184			SN76533N	£1.00	RCA16572 }	40p	
BF180 BF257 BC460			TBA990	£1.00	RCA16573 }	PAIR	
BF181 BF137 BF395			SN76660N	50p	SCR957	65p	
BF182 BC161 BC263B			SN76650N	£1.00	BRC4443	65p	
BC300 BF185 BF273			TBA560Q	£2.00	5A-300 }	25p	
AC128	15p EACH		TBA540Q	£1.00	TIC106 Thyristors }	EACH	
3300/40v	680/40v		TBA54Q	£1.00	RCA40506 Thyristors	50p	
680/50v	220/63v		TIS91	25p	BC108	7p	
2200/10v	12½p EACH		TAD100	£1.00	BD610 }	50p	
2N930	BC183		SAB550	£1.50	BD619 }	PAIR	
2N2222			TBA530	£1.00	MJE2955	50p	
2N3566	7½p EACH				TIP2955	50p	
BF336	30p				BC188	10p	
MJE2021 90V 80V }	15p				BC149C	7p	
SJE5451 5A }	EACH				Aerial Amp Power Supplies 15 volts	£1.00	
90V 661 NPN }	28p						
80W 5A 660 PNP }	PAIR						
EHT lead & anode cap	25p						
		200+200+100M 325v	40p				
		470+470M 250v	40p				
		100+200M 325v	30p				
		200+200+100+32M 350v	70p				
		150+200+200M 300v	50p				
		800M 250v	20p				
		600M 300v	£1.00				
		400M 400v	£1.00				
		800+800M 250v	60p				
		300+300+100+32+32 300v	£1				
		200+100+100M 350v	70p				
		100M 450v	25p				
		33/450v	25p				
		47M 450v	25p				
		680M 100v	25p				
		6800M 40v	35p				
		100M 350v	20p				
		22M 350v	20p				
		3300M 10v	30p				
		15000 40v	50p				
		2-2/63v	10M 40v				
		220M 10v					
		2-2M 100v					
		22M 100v	5p				
		4-7M 63v	EACH				
		Plessey Green Condensers					
		2200M 16v	1000M 50v				
		1000M 10v	1500M 25v				
		4700M 25v	1000M 10v				
		680M 63v	1500M 40v				
		1000M 63v	1000M 25v				
		3000M 16v	1500M 50v				
		330M 100v	4700M 16v				
		4700M 10v	1000M 16v				
		1000M 63v	100M 63v				
		3300M 25v	12½p				
		1000M 40v	EACH				
		6 Push Button Unit for Varicap Thorn 4000	£2.00				
		6 Push Button Unit with Cable Form for 1590 series for Varicap Tuner	£1.00				
		VHF Varicap Units New	£2.50				
		VHF Varicap Units New, 49-00-219-00 MHZ	£1.50				

SENDZ COMPONENTS

2 WOOD GRANGE CLOSE,
THORPE BAY, ESSEX.

Reg. Office only -
Callers by appointment only. Thank you.
Free Postage applies in U.K. only.

PLEASE ADD 12½% VAT